

FEBRUARY 1923

25 CENTS

RADIO



**IN THIS
ISSUE:**

S. G. McMEEN
V. F. GREAVES

V. G. MATHISON
LAWRENCE MOTT

E. W. STONE
B. F. McNAMEE

Announcing the New Cunningham Amplifier Tube



Filament potential	5 volts
Filament current	.25 amp.
Plate Potential	20 to 100 volts
Plate impedance	16,000 ohms
Amplification constant	6.5

Type C-301-A List Price \$9.00

The most efficient vacuum tube ever placed on the market for amateur and experimental use. The engineers of the General Electric research laboratories have at last succeeded in perfecting a tube that every owner of a radio set has been waiting for.

Greater Power Amplification Only $\frac{1}{4}$ Amp. Filament Current

THIS new and improved Cunningham C-301-A Amplifier is a high vacuum tube designed for use as an amplifier and detector, containing a new Tungsten Filament, the characteristics of which are long life, low power consumption, low operating temperature and greater power amplification than any previous amplifier tube. The tube has a standard four prong base, and the glass bulb has the same dimensions as the C-300 and the C-301.

The greatly reduced filament current permits the use of four of these tubes without exhausting the A battery any faster than when using one of the previous type of amplifier tubes.

Complete instructions for the care and efficient operation of this new Amplifier Tube are packed with every tube.

Insert a C-301-A in your amplifier set today. Note the improved quality and increased audibility.

The Cunningham Technical Bureau is at your Service. Address your problems to Dept. R

248 First Street
San Francisco, California

154 W. Lake Street
Chicago, Illinois

Burgess, the *Radio* Battery

Specified by radio engineers—designed and built by wireless specialists—and recommended by the leading manufacturers of radio equipment.

Burgess Radio Batteries, the result of years of careful experiments are built under exacting manufacturing standards which must meet the requirements of strict laboratory formulae and tests—a supervision that insures their perfect operation.

For professional or amateur radio use, where noiselessness, long life, high capacity and uninterrupted,

dependable service are essential, Burgess has no superior.

Burgess Batteries are built for both "A" and "B" circuits. The Burgess No. 6 is used and found most satisfactory on the "A" or filament circuits equipped with the new type one and one-half volt vacuum tubes. The Burgess "B" Battery is everywhere recognized as the Standard of Quality in the wireless field.

BURGESS BATTERY COMPANY

Engineers — Dry Batteries — Manufacturers

FLASHLIGHT—RADIO—IGNITION—TELEPHONE

General Sales Office: Harris Trust Building, Chicago
Laboratories and Works: Madison, Wisconsin

Branches: — New York Boston Washington St. Paul Kansas City New Orleans

In Canada: BURGESS BATTERIES, Ltd.
Winnipeg, Toronto, Montreal

BURGESS RADIO BATTERIES

"ASK ANY RADIO ENGINEER"



Tell them that you saw it in RADIO

RADIO

Established 1917 as Pacific Radio News

Volume V

for FEBRUARY, 1923

Number 2

CONTENTS for FEBRUARY, 1923

	Page
Radiatorial	9
Multiplex Arc Radio	10
<i>By VOLNEY G. MATHISON</i>	
The Versatile Vacuum Tube	13
<i>By SAMUEL G. MCMEEN</i>	
The Armstrong "Radio Flivver"	15
<i>By V. FORD GREAVES</i>	
The Vacuum Tube as a Detector and Amplifier.....	17
<i>By ELLERY W. STONE</i>	
The Operator's Audion	19
<i>By VOLNEY G. MATHISON</i>	
Worth, A Tale of Loyalty	21
<i>By MAJOR LAWRENCE MOTT</i>	
One Tube Receiving	22
<i>By CARLOS S. MUNDT</i>	
Some Facts About Antennas	23
<i>By FRANCIS J. ANDREWS</i>	
Making a Tube Rectifier	25
<i>By STUART A. HENDRICK</i>	
How to Build a Loop Aerial	27
<i>By OTHERUS GORDON</i>	
Preserving Your Ear	28
<i>By H. MAC D. HASSELL</i>	
Reading Wavelengths on The Receiving Set	29
<i>By B. F. MCNAMEE</i>	
Eliminate The Ox-Drivers	30
<i>By GEO. C. TICHENOR</i>	
A Practical Radiophone	31
<i>By PHILIP R. TARR</i>	
Motor First Aid Via Radio	32
News of the Broadcasters	33
Digest of Recent Radio Patents	34
Queries and Replies on C. W. Practice	35
<i>By GERALD M. BEST</i>	
Letters to The Editor	36
News of The Amateur Operators	37
News Apparatus and Supplies from the Radio Manufacturers...	39
Calls Heard	41

RADIO is Published Monthly by the
Pacific Radio Publishing Co., Inc.,
Pacific Building, San Francisco, Calif.

ARTHUR H. HALLORAN, *Editor.*
LAWRENCE MOTT, *Associate Editor.*
LOUIS TREVISO, *Art Editor*
GERALD M. BEST, *Technical Adviser.*
O. SCHUWENDT, *Engineering Draughtsman.*
H. W. DICKOW, *Advertising Manager.*

Branch Offices: 17 West 42nd St., New York City, Telephone Longacre 8248, 6442 Ingleside Ave., Chicago; 761 Spitzer Bldg., Toledo, Ohio; 52 Irving Street, Boston; 1102 Republic Bldg., Kansas City, Mo.; Suite 511, 456 So. Spring St., Los Angeles, Calif., Telephone 12050; M. C. Mogensen & Co., Inc., Securities Bldg., Seattle, Wash. 2218, 3rd W., Seattle, Wash., Tel. Elliot 1903.

Advertising Forms Close on the First of the Month
Preceding Date of Issue

Issued Monthly, 25c a copy. Subscription price \$2.50 per year in the U. S., \$3.00 per year elsewhere. Instructions for change of address should be sent to the publisher two weeks before the date they are to go into effect. Both old and new addresses must always be given.

Entered as second-class matter at the Post Office at San Francisco, Calif., under the Act of March 3, 1879.

Copyright, 1923, by the Pacific Radio Publishing Co.

Forecast for March Issue

Arthur L. Munzig gives full details for building an efficient broadcast receiver employing a variometer and single tube.

Volney G. Mathison has resumed his Samuel Jones stories and has written one for March RADIO that takes the reader to Mars and back again.

Jerome Snyder interestingly discusses some of the problems introduced by radio broadcasting and suggests some practical remedies for their solution.

D. B. McGown, in the second of his series of articles on the operation and care of motors and generators, will deal with alternating current equipment.

Several articles which were crowded out of this issue so as to make room for matters of immediate news interest will appear in the next issue. Included among these are several helpful construction kinks.

In "Radio Outlets" Stanley E. Hyde gives some practical instructions for making a workmanlike job of a radio installation. This has to do not with the receiving set itself but with the auxiliary wiring.

As G. M. Best's promised description of how to make a small radiophone using ordinary amplifying tubes was not quite ready for the February issue, it has been held up and will be published in the next issue without fail.

R. M. Barbier has found it possible to use the same tubes on either radio or audio frequency amplification as one or the other may be desired. He gives a diagram of connections which will enable anyone else to do likewise.

Assignments Nos. 11 and 12 in the University of California correspondence course in Elementary Radio by Ellery W. Stone are concerned respectively with "The Armstrong Principle of Regeneration" and "Tube Transmitting Circuits."

Samuel G. McMeen has been doing some research into the more convenient ways of producing radio-frequency amplification as well as making some notes on the not-yet-trite subjects of receiving and transmitting apparatus. The results of this work will appear in early numbers.

“The wise man looks into space,
and knows there is no limit to dimension.”

said **Chuang Tzu**.

The wise Radioist bridges the greatest
distances with a

Grebe Receiver.

Doctor Mu.



A LONG RECORD of unequalled
performance has won for the
Grebe Receiver the unqualified en-
dorsement of all good dealers.

“Musings of Doctor Mu” — the
story of the development of the Per-
fect Receiver, free upon request.

GREBE RADIO

A. H. GREBE & CO.
INCORPORATED
RICHMOND HILL, N. Y.



Licensed under
Armstrong U. S.
Pat. No. 1113149





Crime at Clover Corners!



Radio Fans Are Buying Again Sell Them Rectigons!

Every vacuum tube wireless receiving set requires a storage battery for efficient operation. And every storage battery requires frequent recharging. Hence, the big market for Rectigons.

Your own radio customers will be interested in Rectigons and the safe, economical and easy means they provide for recharging batteries at home.

The Rectigon has no moving parts to get out of order. Requires no attention and is automatic in operation. It is light in weight and portable. Current consumption is very small.

Rectigons are also suitable for recharging auto batteries, which make the number of prospects still larger.

Stock Rectigons now. Our nearest agent-jobber can supply you.

Westinghouse Electric & Manufacturing Company
East Pittsburgh, Pa.



This new Rectigon Folder is specially designed to help you sell to radio enthusiasts. Get a supply from one of our agent-jobbers to keep on your counter.

Westinghouse

Tell them that you saw it in RADIO



If you had a dozen ears

You would need them all to hear what you get nowadays with a single-circuit receiver.

With several hundred powerful broadcasting stations, all operating on one narrow wave band, it takes real selectivity and sensitivity to get a satisfactory radio programme.

The Paragon three-circuit receiver gives you any station you want when you want it—and no other. Clear, complete programmes without interruption or disturbance. A modern, high grade, scientific instrument built right to give results.

Ask some experienced amateur what he knows about

PARAGON

Reg. U. S. Pat. Off.

RADIO PRODUCTS

The amateur will tell you that the Paragon three-circuit receiver, because of its greatly superior selectivity and sensitivity, can pick and choose between broadcasting stations of about the same signal strength with less than one per cent differential.

This means that with a Paragon receiver you get what you want when you want it—complete messages and clear music from the station you tune in on, without interruption and jamming. Until you have listened in with a Paragon three-circuit receiver, you cannot guess the real pleasure and fascination of radio.

Paragon receivers are built by the Adams-Morgan Company, which has been a pioneer throughout the modern development of radio. Paragon was the first regenerative receiver manufactured. Paragon effected the first transcontinental reception (not prearranged) from New York to California. Paragon effected the first transatlantic amateur reception. Dur-

ing the war Paragon receivers proved superior to all others in the interception of enemy signals by the United States army and navy.

Long before broadcasting popularized radio with the general public Paragon equipment was the choice of the experienced amateur. He will tell you today that if you want quality and satisfaction, Paragon Radio Products are the best and safest buy on the market.

An Illustrated Catalog of Paragon Radio Products Is Yours for the Asking

DEALERS—The Adams-Morgan Company has an interesting proposition to make to reputable radio dealers who believe in quality merchandise. Details on request.

ADAMS-MORGAN COMPANY
2 Alvin Ave., Upper Montclair, N. J.

Type RD-5 Regenerative Receiver and Detector—\$75.00
Type A-2 Two-Stage Amplifier—\$50.00
(Licensed under Armstrong Patents)



Also Manufacturers of PARAGON	
Radio Telephone	Amplifier
Transmitters	Transformers
V. T. Control Units	Control Dials
Rheostats	Amplifiers
Potentiometers	Receivers
V. T. Sockets	Switches
Detectors	Variometers

Pacific Coast Representatives: GLOBE COMMERCIAL CO., 709 Mission Street, San Francisco, Cal.

MAGNAVOX RADIO

"A Public Institution"

THE real progress of radio is shown by the illustrated magazines and newspaper supplements—nobody follows the popular thought closer than the "art editor."

The preponderance of Magnavox equipment in these illustrations of novel and interesting radio uses, indicates how the Magnavox Radio, like the Morse Telegraph or the Bell Telephone, is becoming a "public institution."

R-2 Magnavox Radio with 18-inch horn

This instrument is intended for those who wish the utmost in amplifying power: for clubs, hotels, dance halls, large audiences, etc. It requires only .6 of an ampere for the field.

Price **\$85.00**

R-3 Magnavox Radio with 14-inch horn (as illustrated)

The ideal instrument for use in homes, offices, amateur stations, etc. Same in principle and construction as Type R-2.

Price **\$45.00**



Model C Magnavox Power Amplifier

For use with the Magnavox Radio and insures getting the largest possible power input.

2-stage **\$ 80.00**

3-stage **110.00**



No Wireless Receiving set is complete without



To enjoy all that radio offers in the way of daily concert, lecture and news, ask your dealer for a receiving set equipped with Magnavox Radio, the Reproducer Supreme.

The Magnavox can be used with any receiving set of good quality—the better the set, the more Magnavox can do for you.

Magnavox products can be had of good dealers everywhere. Write our nearest office for copy of new illustrated folder. Our interesting new booklet (illustrated in three colors) will be sent on request.

The Magnavox Co., Oakland, California
New York: 370 Seventh Avenue



MAGNAVOX
Radio
The Reproducer Supreme

Two Supreme Achievements in Radiolas

Radiola Grand

TRADE MARK REG. U.S. PAT. OFF.



RADIOLA GRAND and Mahogany Stand with "B" Batteries, tubes and full instructions, \$350.00

The finest principles of radio detection, amplification and loud speaking are embodied in the new RADIOLA GRAND.

The RADIOLA GRAND has been especially designed to receive broadcasting stations operating on the standard wave lengths of 360 and 400 meters, but an additional range is available up to 550 meters. By means of a new type of Loud Speaker, the entire family may receive broadcasted music and other entertainment and instruction.

A telephone jack is provided in order that head telephones may be employed for the reception of broadcasting over great distances.

Radiola IV

TRADE MARK REG. U.S. PAT. OFF.

RADIOLA IV is a self contained console-type broadcast receiver. The cabinet contains a regenerative receiver, a detector, two stages of audio frequency amplification, a new loud speaker of unsurpassed tone quality and all necessary batteries.

RADIOLA IV is not only a highly efficient receiver, embodying the latest developments in design, but is also a thing of beauty that will grace a drawing room or library.

Both of these Radiolas provide exceptional long distance as well as local reception.

Ask your nearest dealer to show you the Radiola line.



RADIOLA IV, complete with 4 tubes (1 spare), all batteries, headset with telephone plug and silk covered leads for antenna and ground, \$275.00

"There's a Radiola for every purse"



This symbol of quality
is your protection

Radio  **Corporation**
of America

Sales Department, Suite 2069 District Offices

233 Broadway
New York

10 So. La Salle Street
Chicago, Ill.

433 California Street
San Francisco, Cal.

Radiotorial Comment

AT once the strangest and yet most natural characteristic of *genus radio bug*, a characteristic that distinguishes novice and amateur alike, is the joy of long distance reception. The greater the distance heard, the greater the pleasure experienced. By affirming "Every day and in every way I am hearing further and further," they are actually accomplishing it. The most popular broadcasting station would be that which would can the canned music, eliminate the personal artists, and steadily repeat "This is Kay Tee Did in the Land of Oz." The proverbial prophet who was without honor in his own country had nothing on the broadcaster in his own city. Though usually a case where distance lends enchantment, the distant station invariably has the best modulation and the "far superior" program.

TO meet the demands of sensationalism, some writers on radio subjects apparently run out of facts and have to draw upon their imaginations to an extent that is injuring the cause of good radio. These ravings are so weird and fantastic that the reader sometimes suspects that they come from a brain disordered by the drug whose traffic the anti-narcotic forces are trying to stamp out. Future possibilities and impossibilities are played up as present accomplishments, and the reader's expectations are raised so high that the actual wonders of radio lose their charm after the dupe has been disillusioned.

First in this museum of absurdities are the constantly repeated reports of power transmission by radio. Steinmetz, a recognized authority on electrical subjects, has definitely shown its present impracticability. Even when the technical problems are solved, if ever, there will remain the business problem of financing a power project whose supply can be tapped by the unauthorized as readily as does the eavesdropper listen in on the Catalina radio telephone.

Another favorite subject of these romancers, a subject savoring of the water-witch and the divining-rod, is the location of ore bodies by radio. The garbled reports of such feats as come from Germany and Italy have not yet been substantiated by investigators. There are too many unknown variables in the propagation of high frequency electromagnetic waves to allow any safe credence to be placed on the results obtained in underground transmission. The money spent with the hope of gain from such experiments would be far more profitably invested in a diamond drill or even in a pick and shovel.

But the acme of foolishness is the claim that radio has

established communication with the spirit world. Fakers of the worst description are preying upon the credulous with a jargon of science and mysticism, fleecing their victims, and then passing on to new fields. We realize that these words of warning are not needed by the readers of RADIO, but should they come across these absurdities, they are urged to brand them as lies and thus help preserve the good name of radio.

AT last comes word that the Kellogg-White federal radio control bill is being given serious consideration by Congress. Based upon the findings of the Radio Conference at Washington last Spring, this bill gives supervision of all radio communication, excepting strictly governmental business, to the Department of Commerce. After the hearing has been concluded by the Merchant Marine Committee, it is hoped that the bill will soon come up for vote.

As to its immediate necessity there is no argument. More than ten years have elapsed since the last legislation on radio. The Radio Act of 1912 is as inadequate to control the stupendous radio traffic of today as would be automobile traffic laws of that ancient vintage. The most serious trouble is in connection with broadcasting. There are today 569 broadcast stations in regular operation, whereas two years ago there were none. These stations interfere not only with each other but also with governmental, commercial, and amateur transmission. On the 2nd of January one Pacific Coast broadcaster completely upset the initial operation of the Navy's Fanning relay circuit for some reason that has not yet been technically explained. A person midway between two powerful broadcast stations is unable to hear either of them satisfactorily. Broadcast interference with amateur communication is fully as serious as amateur interference with broadcasting.

Most of these difficulties will be solved by giving the Department of Commerce the power to assign wavelengths, approve apparatus, and to otherwise supervise the situation. With real power to act, the present feud between broadcasters and amateur operators can be quickly settled. The injustice of a suit brought by a broadcast listener to suppress as a public nuisance an amateur who is operating within the present legal requirements, and who is willing to cooperate, would be avoided. As it is, a Radio Inspector is practically helpless. Radio cannot go ahead without regulation, so the early passage of the new bill is a consummation devoutly to be wished.

Multiplex Arc Radio

By Volney G. Mathison

This is another article published in response to many requests for more information about arc transmitters. It tells of recent developments in commercial transmission practice, including an account of how arc "mush" is being eliminated. This installation is an interesting illustration of successful competition of radio with wire telegraphy.

PROBABLY every radio enthusiast in the central and western part of the United States who owns a long-wave receiving set has listened to one or more of the flock of mysterious "no-call-letter" continuous wave transmitters which may be found on the air at any time of the day on various wavelengths between 3,000 and 10,000 meters, rushing through countless scores of "blues," "blacks," and "NLS,"—messages pertaining to wheat and prunes, pork and pig-iron, and a thousand and one other matters.

It is not unlikely that the amateur possessing sufficient receiving skill to read these streams of rapidly sent messages will surmise that he is listening to some sort of overland radio system, and may enviously picture a family of busy brasspounders sitting among fascinating mazes of meters and inductances, while powerful motor-generators hum complacently in adjoining power-rooms. But in this fancy he would be entirely wrong—except, indeed, that the operators are busy.

All of these clear, bell-like signals emanate from the arc transmitters of an elaborate commercial radio system which is owned and operated by the Federal Telegraph Company. The system may be said to be centralized at San Francisco, from which point it extends north to Portland and Seattle, and south to Los Angeles and San Diego. Regular

domestic telegraph service is rendered between these cities, in direct competition with the Western Union and Postal Telegraph companies.

The San Francisco terminal, to which the equipments in the other cities correspond, consists of six transmitters and six receiving circuits, which are operated simultaneously. The six arc transmitters are placed in one station, as the accompanying photographs show; and their six separate antennas are suspended from a single 626-foot guyed steel mast. This station is situated on a 100-acre tract of marsh land, approximately thirty miles

south of San Francisco, but by means of relay keys and distant-control lines, all of the actual sending is done from the company's main offices, which are in the heart of the city.

Out in the transmitting station the mechanical controls of the arcs are concentrated on sectional panels placed side by side, forming a large board, at which an expert arc man is stationed to attend all six transmitters. Radio engineers of the U. S. Navy have expressed much surprise at this demonstration of the practicability of one man attending a large battery of transmitters, and it is



The six arc-convertors of the San Francisco terminal.

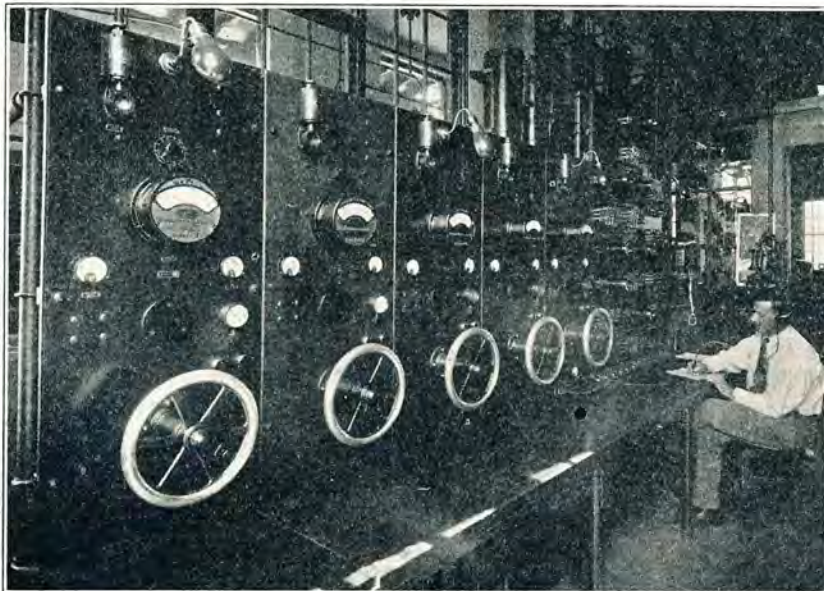

Section of control board adjoining arc room, where the station engineer attends the arcs. He is now occupied at a local circuit through which he gets warning when an arc flutters.

probable that the government eventually will install some similar equipment.

Large, light-running hand-wheels on the board are connected through rotating shafts to the carbon-holders of the converters in the adjoining arc room. Upon the control panels are also mounted voltmeters and ammeters showing the current input to each arc, current input regulators, radiation ammeters, and automatic alcohol feeding devices whereby denatured alcohol is fed through copper tubes to the various arc chambers where it forms the necessary hydrocarbon gas.

At one end of the switchboard is mounted apparatus pertaining to the relay-key systems and to a local calling circuit, by means of which the chief operator in the down-town offices can call the station engineer's attention to any arc that is not functioning properly. It has been found that despite the similarity of the many transmitting circuits, each arc has—like a young lady—its in-



Daly City receiving station. The five loops, and another loop not shown, are connected to six receiving sets inside, from which the head telephone leads are extended through buried conduit to the city offices far below.

dividual little foibles; some of them are inclined to become a trifle flighty at times, while others will burn quietly for hours without a single adjustment of their carbons. This indicates the tremendous improvement of the arc-converter accomplished by the designing engineers since 1909, when Poulsen brought his original twelve-kilowatt model from Denmark to San Francisco—an arc that would hardly burn for thirty seconds without attention.

One of the arcs is of only two-kilowatt input; three are of five kilowatt; and two of thirty kilowatt. Another five-kilowatt convertor is being built and soon will be installed. The four smaller arcs work south to Los Angeles,

an airline distance of 341 miles, while the two thirties work north to Portland, a distance of about 530 miles. Despite the fact that daylight transmission is maintained and that many mountains intervene between the cities, it has been found unnecessary to operate the arcs, with the exception of the two-kilowatt, at more than a mere fraction of their full power.

Through the highly perfected design of these transmitters the resistance in the oscillating or antenna circuits has been reduced to such a low point that a direct current potential of less than 325 volts suffices at the converter anodes. The construction engineers built a large circular-shaped counterpoise ground for

this station, which is supported on wooden poles about twelve feet above the earth. This counterpoise was found efficient when used with two or three transmitters, but when six arcs were brought into operation, it became unsatisfactory. At present a conventional ground system of buried copper plates is employed.

Much credit is due to the builders of this station, not only for their having cut out undesirable radio-frequency reactions of the oscillating circuits upon one another, but especially for having entirely eliminated all "mush" and harmonics. This achievement, which is all the more noteworthy because of the nearness of the transmitters and an-



Tuning inductances, relays, and signal control apparatus of one of the six transmitters.



All these boys in the city office have to do is to see how fast they can telegraph. Two are sending and two receiving. There is a table like this for every two arcs.

tennas to one another, has been affected largely through the use of quasi absorption-circuit signalling controls. No compensating waves are employed; in other words there are no currents flowing in the antennas at any time except when the relay keys are depressed.

Through the efforts of the Federal Telegraph Company the Navy has been persuaded to adopt this signal control system in their arc stations, which will effectually eliminate all mush and probably some of the harmonics; although a good many of these latter apparently are reradiations from oscillating stays, and would therefore require a different remedy.

Not a little of the success of this interesting multiplex radio system is due undoubtedly to the extraordinary receiving circuits which are being used.

Like the transmitters, the receiving apparatus is all placed outside the city.

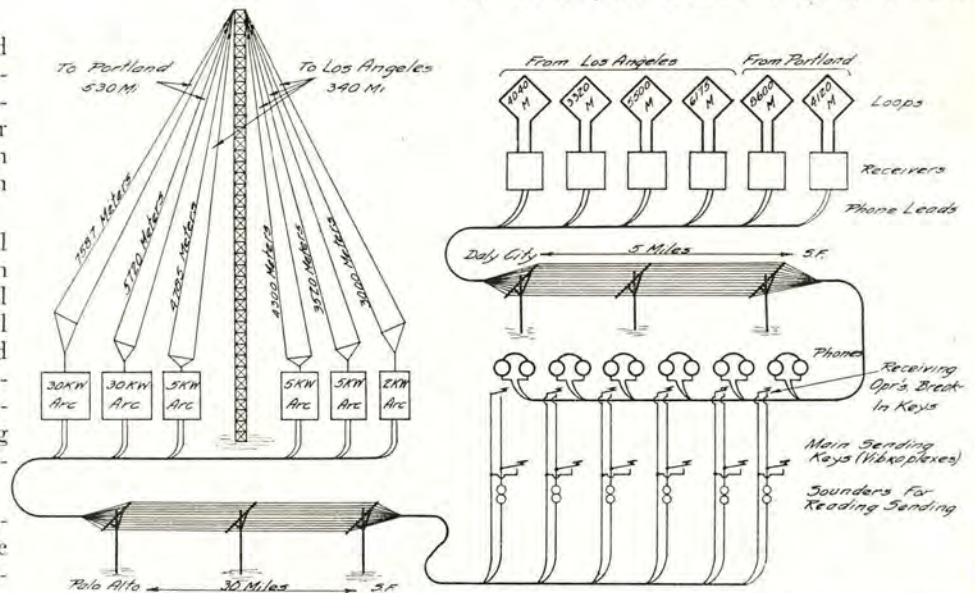

Working plan of the San Francisco terminal. The terminals in the other cities correspond to this one. Sending and receiving operators sit side by side, and corrections asked for at the other end are spoken aloud at the tables.



1,000 K.W. arc-converter. The frame and field poles contain 100 tons of soft steel. A station on the Pacific coast for working the Orient is projected, which would employ one of these units, operated on an antenna 1,000 feet high, and expected radiation of 750 amperes.

At San Francisco, the receiving station is situated up on the crest of a mountain near Daly City. Here in a small wooden house are six separate receiving sets, the head-telephone leads of which are extended over a set of twelve wires to the central offices in the city far below.

It is greatly to be regretted that a description of the actual receiving equipment cannot be given, for some remarkable circuits are employed, but unfortunately, owing to new and important developments, the engineers are unable to permit the publication of any details at the present time.

It may be said, however, that loops are employed for receiving, a separate

loop for each receiving set, and no aeri- als are used except very small ones suspended just above the loops. These aeri- als comprise part of special unidirectional circuits whereby signals will be received from one direction only. Up in this lonely station on the mountain top, a trained expert attends the many instruments, or amuses himself by listening in on the hard-working boys down-town.

It will be evident from the foregoing that the main thing the telegraphers in the city offices work on is their typewriters. Each operator's equipment consists only of a pair of phones, a key, and a "mill." An ordinary telegraph sounder connected into his key circuit

enables him to listen to his own sending. The local circuits also enable him to tell the engineer out at the transmitting station to put out an arc when business on his "wire" gets slack, which is seldom.

So nearly perfect are the receiving circuits that the operator almost never hears a stray signal, a harmonic, a shot of static, or a radiophone concert,— nothing in fact but the signals of the fellow at the other end. Telegraphing is carried on at a usual speed of thirty-five to forty words a minute. These operators, who are regular licensed radio men, receive at present a salary of \$160 a month and approximately \$1.28 an hour for time over eight hours. They do not work on Sundays.

This remarkable radio system has been evolved from a comparatively small duplex wireless system which the Federal Telegraph Company operated in 1914. Distant control single arc transmitters were then employed; but at that time receiving aeri- als were strung on the city office buildings and the operators had their receiving apparatus before them. A heavy traffic has been built up, not only through the offering of attractive message rates, fifteen words being transmitted for the usual price of ten, but especially because of the extreme rapidity of the service.

Although sending and receiving at the same time is nothing new in radio, this is the first time that six transmitters have ever been operated simultaneously in one station. Likewise here has been developed one of the first receiving circuits that will respond to a single low-powered distant transmitter without picking up interference from any of the many other arcs belonging to the same system or from any of the countless other stations operating in the vicinity. Here, indeed, is an ultra-modern demonstration of the titanic possibilities of continuous wave radio.

The Versatile Vacuum Tube

By Samuel G. McMeen

This is an authoritative account of some of the many uses to which the triode may be put. These uses include not only the applications to radio but also those to wire telephony and to electric power transmission. The author is a consulting engineer specializing in telephony and telegraphy. He shares with the rest of the world a deep interest in the newest communication art and writes of the device that has turned out to be radio's greatest stimulus.

THOSE who are interested in the art and science of radio communication must have an interest in that marvelous device that is at once the heart, the brain and the nervous system of any radio apparatus except a crystal set. We are wholly in accord with the authority who calls the three-electrode vacuum tube an element "that can be justly be placed in the same category with such fundamental devices as the steam engine, the dynamo and the telephone." This is the highest praise, but it seems to be entirely warranted by the facts, though the vacuum tube in question is not a unitary operating apparatus, but only an essential part of such.

Three steps were required to carry the mind of man from nothing to the thermionic tube as we know it today. Step one was taken when the incandescent lamp was born. Step two when the same genius added the plate to an incandescent lamp. Here the matter rested for years, when De Forest added a grid, and the thing was done.

But did you notice that we have already called the device by several names, and are only well begun talking of it? That happened to be intentional this time, but it will be well, we think, to call the roll at once, and see by what variety of names the thing is really known. Here is a list, though probably some of the names are escaping us: Audion, Vacuum tube, Three-electrode thermionic tube, Thermionic tube, Triode tube, Pliotron, Hot-cathode tube, Detector, Amplifier, Oscillator, Generator, Oscillation generator, Modulator, Demodulator, Repeater, Telephonic relay.

Some of the names in the list are of course functional, describing the uses of which the device is put rather than its form. Descriptively, the names "three-electrode thermionic-tube" and "hot-cathode tube" have their points, but both are too long for daily use. "Audion" has a claim on us because the father of the device so named it, and also because it is somewhat descriptive of one of the great powers of the thing itself. But there are so many of those powers that the name fails in the respect that it is limited, though it was fully descriptive of the known powers of the tube when the latter was first created.

The name "vacuum tube" is objectionable because there are many kinds of tubes that have the air pumped out



Samuel G. McMeen

of them. Every incandescent lamp is just as much of a vacuum tube as is an audion.

"Triode tube" is open to nearly the same objection, in that it will apply equally well to any sort of a tube having three electrodes, whether they are arranged for these purposes or not, and whether there is any air inside or not.

"Pliotron" is a coined name, like "audion," has the negative virtue of Greek parentage, and does not describe as clearly as the latter what the coiner had in his mind.

"Hot cathode tube" describes any tube with a hot inner terminal that is connected to the negative pole of an external circuit, and while it describes something it describes too much.

The last nine names on the list, beginning with "detector" and ending with "telephonic relay," have their origin in the uses to which the tube is put, and we must in all fairness use them only with relation to those special uses, wherein they will apply very well.

But if you have been checking the list while we have been talking we suppose you noticed that we omitted any comment on the name "thermionic tube." As nearly as possible in short space, it seems to us that this describes the device as a unitary thing, without reference to the uses for which it may be chosen, but with rather strict reference to the way it works. For it is clearly the belief of those who should

know that the operation of all thermionic tubes always involves, first, the existence of heat in the filament, and second, the disengagement from that filament of electrons which pass to the positively charged plate because they are themselves negatively charged. The name is faulty in that it suggests ions instead of electrons; it is good in that it suggests heat, and by a familiar syllable.

All this may have seemed like a heap of talk about mere names, but what we have been hoping as we have been telling it is that some one or more of our unseen radio audience may have some obscurity illuminated, or be saved a possible misunderstanding, rather than to have hoped that the matter was highly entertaining.

But the uses of the thermionic tube are of interest to us all, and when we speak of uses we refer to those that are known now, and fearlessly predict that these are not all the possible applications. It is a subject of some amusement to those that have seen the vision of the tube that electrical-power engineers are as yet so callous to the tube's appeal. When they are awake to that appeal we may expect startling revisions in electrical-power practice.

Things Tubes Can Do.

THE late Elbert Hubbard used to say, "There are only two things about a man that matter: 'Who are you?' and 'What do you do?'" We have seen some of the names of the tube; let us recall some of the things it can do, and incidentally how it does them.

The first-discovered power of a thermionic tube was that of detection. This is the power of turning inaudible high frequency radio currents into low frequency currents that will operate a telephone receiver. The currents coming from the antenna or aerial are incapable of giving sounds in a telephone receiver for two reasons. For one thing, they are too weak and for another they alternate too rapidly. The human ear can not apprehend sounds having vibration-frequencies faster than say 30,000 per second, nor can the telephone receiver respond to frequencies anywhere near that high. But the tube has the power of varying direct current in its plate circuit in response to changes in the voltage of its grid. If, therefore, the grid be arranged to feel for the varia-

tions in the stream of radio-energy in the aerial it will interpret those variations into the plate circuit, thence into the telephone receiver and so into sounds.

This transforming power of the tube is present whether the frequency of the received energy is high or low; the same tube will receive waves of lengths varying from ten meters to twenty thousand. No change is required in the tube in this wonderful range from 30,000,000 down to 15,000 cycles per second. No other electrical device has such a breadth of ability.

All of this power is the result of the ability of the grid to control, by its own potential, the stream of electrons passing from the filament to the plate. As long as the filament is hot there is such a flow of electrons to the plate, each with its negative charge, and this flow is controlled in the amount of its volume by the degree of charge on the grid. It is a true case of the mere *condition* of one object controlling the *action* of another, one of the most economical concepts the mind can imagine.

As An Amplifier.

THE same power that enables the tube to detect enables it to amplify what it receives from another tube or from any other source in which there is present the very usual condition of varying potential which the grid can observe and utilize. Likewise, the output from the plate of an amplifier tube can be carried to the grid of a second amplifier, and so on in a series. A dozen or more tubes can thus be connected "in cascade," with the result that the original energy is magnified many thousands of times.

This ability to amplify, like the ability to detect, is independent of the frequency of the received energy. That is, the frequency may be relatively low, on the order of sound waves, say an average of 800 cycles per second, or it may be very high, of radio frequency, say up to 30,000,000 cycles per second. In the first case the amplifiers can be placed after the detector, and in the second before it. In this latter case weak signals or speech can be picked up and amplified, then passed to the detector, then, if desired, amplified at the now existing hearable frequency. It is regular practice today to use both of these methods of amplification in the same set, the high frequency amplifiers preceding and the low frequency amplifiers following the single detector tube. In this way the outfit can make audible speech and signals that would not be audible in the least degree with a detector tube alone, or in many cases with any number of amplifiers following the detector.

It is in the detector that the frequency is brought into the realm of sound. Before detection the frequency of the en-

ergy is high and afterward it is low. For this reason the two methods of amplification are known respectively as "radio-frequency" and "audio-frequency" amplification.

As An Oscillation Generator.

THE same tube that can detect and amplify can also transform direct current into alternating current of practically any desired frequency. This happens, from the nature of radiation, to be a gift to the communication art almost as great as that of the detecting powers of the tube. For the purpose of radiation the electric energy that carries the message must alternate many times a second, and the means of getting a smooth stream of such high-frequency were few at the time this property of the tube was discovered to exist. One of the previous ways was the use of the electric arc and the other the use of machines of the dynamo type, with many poles and very high speed of rotation of the moving part. Neither of these ways has the order of simplicity and ease of control of the tube, nor can the methods be made serviceable in small units.

Both are adapted to the longer wavelengths and fail at the shorter ones. They are therefore out of the question for all amateur experimentation and for many commercial purposes such as broadcasting.

When a tube acts as a generator it receives direct current and gives an alternating one, the frequency of the latter being under control within wide limits, even down to a few cycles per second. It is this combination of abilities that makes the oscillator so promising a device for power-transmission work in the future.

Using a single oscillating tube, both speech and signals may be transmitted, by arranging that the telephone transmitter may absorb a portion of the generated current. For telegraphy the absorption apparatus may be omitted.

As a Modulator or Demodulator.

WITHOUT change from the form adapted to detect, amplify and oscillate, a tube may modulate. That is, it may be used to vary the output of an oscillating tube in response to speech. The cycle of happenings then is: Speech into a telephone transmitter produces an alternating current of, say, 800 cycles per second. This current is allowed to change the potential of the grid of a modulator tube, which in turn affects the output of an oscillating tube, the resulting output being carried to the aerial for radiation. To modulate means to change; the office of the modulator is to change the otherwise smooth stream of high-frequency energy from the oscillator into a form similar to that of the speech to be radiated.

As a Demodulator.

WHEN used with the system of wire-directed radio telephony first proposed by General Squier, the tube sometimes is called a demodulator. In this office, it is required that it act to convert the incoming high frequency wire-carried waves into lower frequencies, corresponding to the voice frequencies that originally modulated the oscillator output. It is by that action closely paralleling the action of a detector. The principal difference is that the latter is used on strictly radio work, and the former on wire-directed or "carrier" service.

As a Telephonic Relay.

BY "carrier service" is meant telephony or telegraphy wherein the message is passed over wires, not by direct currents or by alternating currents of voice frequency, but by the much more rapidly alternating currents produced by oscillator tubes. By this means a number of conversations are possible over the same wires at the same time without interference. One pair of wires can transmit half a dozen voice messages and a number of telegraph messages at the same time, the carrier currents all intermingling enroute but being sorted out into their separate terminal destinations without any loss of secrecy. And at intermediate points on the line these carrier currents are amplified while still intermingled. This process is one of the larger marvels of the tube's repertoire.

From the earliest days of the telephone engineers sought for a method of reinforcing the small currents of speech so as to enable long distance service to be as satisfactory as local service. The voice currents issuing from the speaking station attenuate rapidly in their passage over a long line, and in even the best lines of two plain copper wires they reach about the limit of commercial volume in say seven hundred miles. This, in a country like ours, is much too short a distance. In telegraphy, groups of relays are inserted in the long lines at intermediate points, and these receive the weakened signals and send out stronger ones exactly like them, enabling the longer distances to be worked successfully. This is just what the telephone engineers wanted to accomplish in their own art, but many obstacles intervened. Finally Shreeve produced an electro-mechanical relay and a set of associated circuits that did the thing, and soon thereafter it was found that the vacuum tube could be used for the same purpose as the electro-mechanical relay. While the Shreeve relay does its work excellently, the tube relay is ideal for the reason that there are no moving parts larger than parts of atoms, no requirements of adjustment, and no de-

Continued on page 50

The Armstrong "Radio Flivver"

By V. Ford Greaves, Engineer Federal Telegraph Company

Here is a one-tube super-regenerative hook-up that actually works on wavelengths of from 190 to 400 meters. It represents a great simplification over the original Armstrong circuit and is comparatively easy to operate. Complete directions are given for construction and operation. Included also is an account of a novel "bank-wound" loop.

THE author claims the distinction of being one of the first (if not the first) amateurs in the country. My first antenna was constructed on the chimney of my father's home in the middle west during 1898. The fan-shaped antenna was connected in series with a ball-bearing coherer and an ordinary telegraph sounder to ground, by which arrangement I expected to get signals from England where Marconi was then conducting his early tests. I was not discouraged by the fact that my apparatus did not work, but have continued my efforts at intervals over a period of nearly twenty-five years, and while my radio activities have been confined mostly to government and com-

perform a double function; and the one-tube circuit in which one tube performs all three functions. Editors of radio magazines and others have published many variations of these circuits, some including complicated filters and audio frequency amplification.

Recently the amateur interest in super-regeneration seems to have subsided considerably and the general opinion appears to be that the circuits are remarkable but too critical of adjustment even for the more experienced. In fact, there are many who have never succeeded in getting results even with detailed diagrams and constants.

In his talk before the Radio Club of New York, Major Armstrong is quoted

as having said that the superheterodyne was the Rolls-Royce of radio reception and that the one-tube super-regenerative receiver was the "Radio Flivver." During the early part of my experience with super-regeneration I often wondered if Armstrong got his idea because the one-tube outfit was inexpensive or because it was so noisy.

My comparatively easy conquest of the three and two-tube super-regenerative circuits soon convinced me that my only interest lay in the one-tube circuit, or the "Radio Flivver."

In its most complex form, the one-tube circuit is indeed critical to adjust; that is to say, not exactly critical as we understand the word in connection with adjusting a standard regenerative receiver, but critical as the word might be used in connection with trying to hit upon the combination to a safe by trial. One evening in the course of my experiments, I laid the telephones on the table and walked about the room. In the course of a minute or two I was startled by loud music suddenly coming in, in the middle of a record. Returning to the apparatus I found that it had apparently adjusted itself and was operating in every way as it should. I then found that adjustments of the variable units could be changed slightly without losing the combination, but if any one variable was changed enough to cut out the music, then it again became necessary to try various new combinations, and it seemed to be largely a mat-



Fig. 1. One-Tube Super-Regenerative Receiver

mercial operation and engineering, my interest in the amateur and broadcasting fields is intense.

The new Armstrong super-regenerative circuits, as published several months ago, excited my amateur instinct, as they did that of thousands of others, and I decided to try them. As I understand Major Armstrong's paper published in the *Proceedings* of the Institute of Radio Engineers, super-regeneration is a combination of radio frequency amplification, detection and oscillation with three or less tubes, producing a volume of amplification far in excess of that possible with detector, regeneration and two-step audio frequency amplifier, especially in the range of short wavelengths.

There is one three-tube circuit in which each tube performs one of the three functions; two two-tube circuits in which one of the tubes is forced to

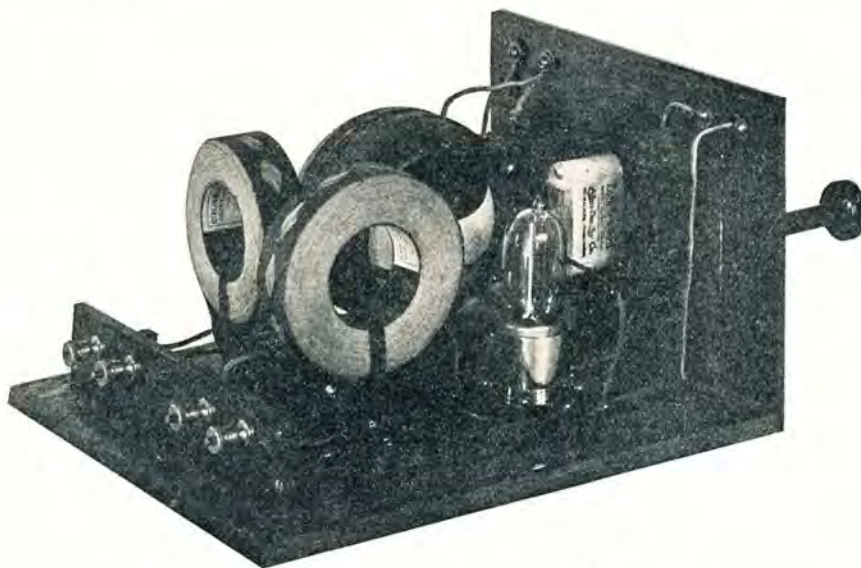

Fig. 2. The "Insides" of the Armstrong "Radio Flivver"

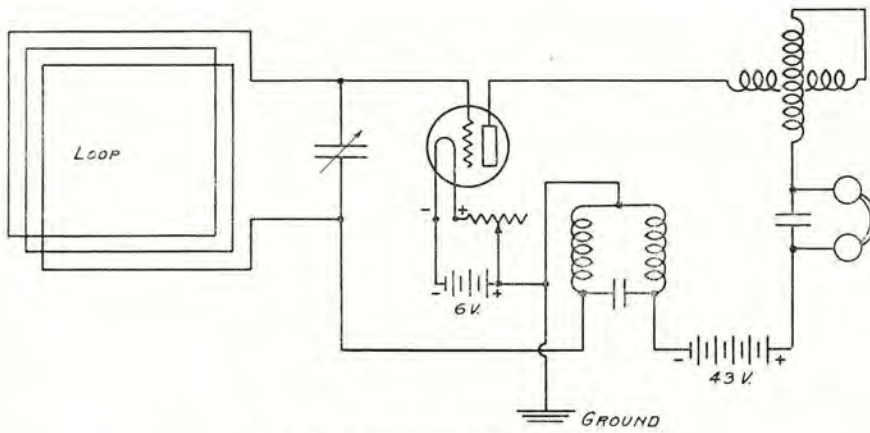

Fig. 3. Elementary Circuit Diagram

The parallel loop coil and the feed back coil shown in Armstrong's published circuits have been omitted in favor of the tuned plate circuit by means of a standard variometer. The variable condensers across each of the large "honey-comb" coils have been substituted by a fixed condenser across both coils. Thus the adjustable elements have been reduced from six to three; i.e., the loop tuning condenser, the plate variometer and the filament rheostat. The diagrams are self-explanatory and show the constants.

The arrangement of the various parts in the assembly is somewhat essential. The honey-comb coils should not be too

ter of luck when a new combination was found. Without serious study, this condition seems to indicate the possibility of a proper phase relation between two or more of the various cycles, or harmonics of cycles, taking place within the circuits, which, when established, may be somewhat self-maintained as in the case of a synchronous motor.

It is claimed for super-regeneration that the amplification increases inversely as the square of the wavelength. That is to say, super-regeneration works better on short waves than on long ones. For an excellent discussion on this subject, the reader is referred to an article in the December 1922 issue of RADIO by Walter Emmet, entitled "Are Shorter Wavelengths Worth While?"

There is considerable latitude in the arrangement of the super-regenerative circuits and choice of constants, depending upon the results desired and the kind of service to be received; whether C. W., telephone broadcasting, or spark.

It is believed that the design and constants of such a receiver, constructed by the author and demonstrated under various conditions, will be of interest to many. This particular circuit was designed for broadcast reception only on 360 meters, but has a range from 190 to 400 meters. With a two foot loop and one tube, this receiver is a better amplifier than average antenna, detector and two-step audio, and almost equal to antenna, detector, regeneration and two-step. Compared on the same loop, it is about equal to two stages of radio frequency amplification, detector and two-step audio.

At 360 meters, the "Radio Flivver" is not, strictly speaking, a long distance receiver, although under favorable circumstances distances from 400 to 800 miles have been covered. It is more of a loud speaker or power amplifier at distances up to 25 or 50 miles. However, on the shorter wavelengths, say below 200 meters, the distance is increased with the amplification.

The most interesting and perhaps the most appropriate application of the "Radio Flivver" is in the automobile, where a one-tube outfit with a one or

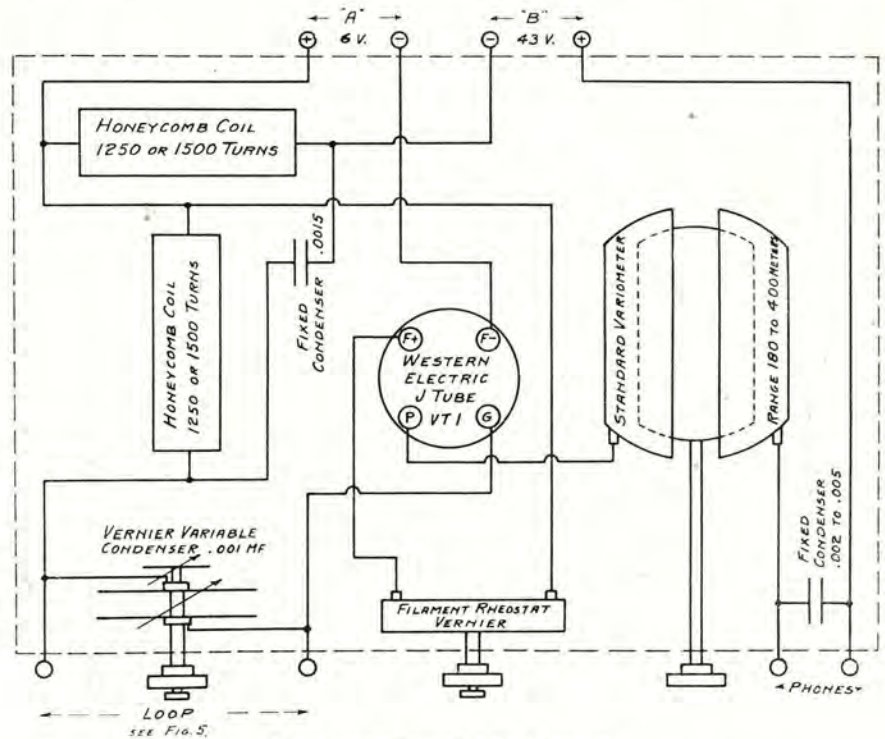

Fig. 4. Detailed Wiring Diagram

two foot loop is not only inexpensive but compact and inconspicuous compared to the elaborate rigging and multiple tube outfits of which we have seen so many pictures.

It is interesting to note that the writer has had no success in coupling the super-regenerative receiver to an antenna. At least the results are no better than with a small loop. If the antenna is sufficiently loose-coupled to reduce the noises, then the signals are reduced to loop strength.

By slight sacrifice in the total volume of amplification, it is possible to simplify the circuit and reduce the number of adjustments to a degree which practically eliminates the so-called critical or difficult manipulation and yet have a receiver which is indeed a marvel and opens up a new radio field.

The photographs, Figs. 1 and 2, are two views of the home-made panel and cabinet assembly. Fig. 3 is the elementary diagram and Fig. 4 is the assembly or wiring diagram.

close to the variometer and are set at right angles to each other, forming a "T," a position of minimum coupling. There is no necessity for or advantage in varying the coupling between these coils. The loop tuning condenser and filament rheostat must both have vernier or fine adjustments. An important element is the tube. I have been unable to get results with any but a Western Electric oxide-coated filament tube, and it must be burned considerably brighter than normal. It also appears that grounding the filament or "A" battery to a water pipe, or to the frame of the car in the case of an auto installation, makes the adjustments even less critical and sometimes increases the signal strength.

In making adjustments and tuning for a station the following should be noted. When the filament is lighted, a very shrill continuous whistle should be heard which will almost disappear when the proper adjustment is found.

Continued on page 52

The Vacuum Tube as a Detector and Amplifier

By Ellery W. Stone

This constitutes the ninth and tenth assignments in the correspondence course in Elementary Radio being conducted by the Extension Division of the University of California. Herein is simply told the elements of vacuum tube theory.

IN the first assignment, we observed that a metal, differentiated from such insulators as wood and glass, is a conductor of electricity, because the atoms of metals are not closely knit structures of positive and negative electrons. The atom of a metal appears to be of such assembly that at least one negative electron is able to leave the ring (or rings) of negative electrons surrounding the positive nucleus and is thus free to move about within the metal. This makes possible a concerted movement or drift of negative electrons within a metal which may actually constitute the passage of an electric current.

Ordinarily, both the atoms and the free electrons of a metal are in quite rapid vibration. In fact, the velocity of their somewhat aimless to and fro movement is several hundred feet per second. We learned in the second assignment that as we apply heat to any substance, we increase this atomic vibration. With a metal, the application of sufficient heat will so increase the velocity of the free electrons and the atoms that the electrons, and even some of the atoms, are driven clear of the metal into the surrounding space. This atomic and electronic "evaporation" is enhanced if we diminish the pressure of the gas surrounding the metal and hence it is quite pronounced in a vacuum.

The radiation of electrons from a heated metallic substance constitutes the fundamental basis on which the modern vacuum tube was developed. It is sometimes spoken of as the "Edison Effect" since it was first observed by Edison about 1890 in the manufacture of electric lamps. Edison, however, did not then realize its significance and did not thoroughly understand it. He discovered that if an electrode were sealed into an electric lamp and insulated from the filament, it became negatively charged when the filament was lighted. This phenomenon was assumed to be due to the radiation of negative electrons.

As was stated in the last paragraph, if the filament is heated sufficiently, actual metallic atoms will be radiated from it in addition to the negative electrons. It is the radiation of these atoms, not of the electrons, which blackens the inner wall of an ordinary lamp after long use.

Fig. 59 represents a small electric lamp in which an additional electrode (a small plate of metal) has been sealed. When the filament is lighted there will be an emission of free electrons from the filament surface. Now, if we connect a battery, called a "B" battery, in the

plate circuit so that the plate will have a positive potential, and attach the other end of this circuit to the filament, a current of electricity will flow. This is caused by the attraction of the electrons, which are negative electrical charges, toward the positively charged plate.

It has been previously shown, however, that current will flow only from a zone of high potential to one of low potential. Hence the current will flow from the plate to the filament against the electron flow, since the plate is

The device shown in Fig. 59 is termed a *Fleming valve*, named after its inventor, J. A. Fleming of London, who brought out his invention in 1904 as a natural result of his investigations of the Edison Effect. He realized that such a device, based on the Edison Effect, would have the properties of a rectifier since it would pass current between the plate and the filament in but one direction.

In the seventh assignment, we learned that crystal detectors function as de-

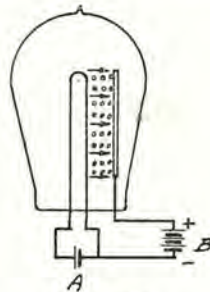

FIG. 59

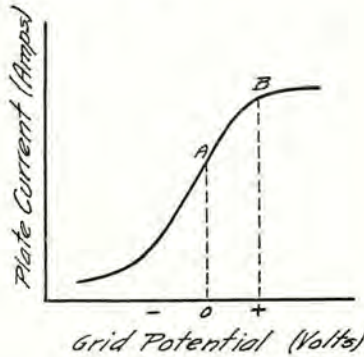

FIG. 61

Fig. 59. Two-Electrode Vacuum Tube
Fig. 61. Relation between Grid Potential and Plate Current

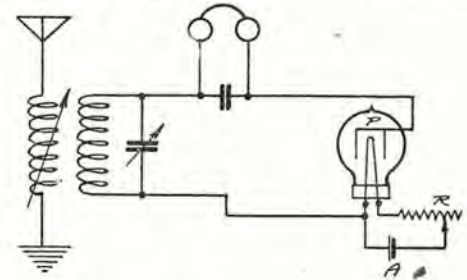

FIG. 60

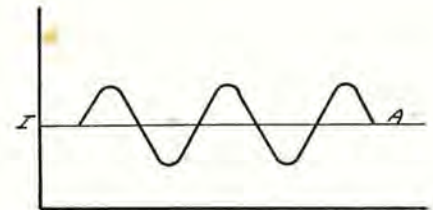

FIG. 62

Fig. 60. Fleming Valve as a Rectifier
Fig. 62. Graph of Plate Current with Alternating Potential

maintained at a higher potential than the filament. The fact that the current flows in the opposite direction from the stream of electrons is a little hard to understand, but the explanation above gives the reason. Another method of reasoning might be followed if you consider that the flow of negative electrons from filament to plate is the same as the flow of an equivalent number of positive charges from plate to filament. It was this current flow which first brought Edison's attention to what is now known as the Edison Effect. If the "B" battery is reversed so that the plate will be negatively charged, then no current will flow in the circuit between plate and filament, since the negative free electrons are repelled by the negative plate potential.

tectors of radio waves due to their property of unilateral conductivity or rectification. The Fleming valve, therefore, as shown in Fig. 60, may be substituted for the crystal detector in any standard receiving circuit.

The filament of the valve is usually made of tungsten and is lighted from a storage battery, A, connected in series with a variable resistance or *rheostat*, R, which serves to vary the current through the filament. The battery used to light the filament may be a storage battery or dry cells in sufficient quantity to give the proper voltage and is commonly called the "A" battery.

The operations of tuning the loose coupler and the secondary variable con-

densers are exactly as have been previously described. The radio frequency potential is tuned to a maximum across the terminals of the variable condenser and impressed across the plate and filament of the valve or vacuum tube. Due to its property of rectification, the valve permits a series of direct current impulses to charge the small, fixed condenser connected across the telephone receivers. (At this point, you should review that part of the seventh assignment which treats of the action of the crystal detector.)

The Fleming valve proved to be considerably more sensitive than the crystal detector and had the advantage of being easily operated, the only adjustment being that of the battery rheostat. However, it was soon superseded by the *audion*, or vacuum tube as it is more commonly termed.

The modern vacuum tube was invented by Dr. Lee de Forest, an American radio engineer, in 1906. It differs from the Fleming valve only in the addition of a third member, the *grid*. The grid is placed between the filament and the plate and is so constructed that the electrons radiated from the filament may pass through it to the plate. In order that the grid shall not obstruct the electronic flow, it is usually made of fine wire either in the form of a spiral or lattice completely surrounding the filament, or in a flat zig-zag grid placed on either side of the filament.

When the filament is heated to a temperature sufficient to cause a prolific emission of negative electrons, the space around the filament becomes negatively charged just as though it were a solid, metallic substance. This negative charge surrounding the filament is called the *space charge*. This space charge, being of the same polarity or sign as that of the electrons, tends to repel more negative electrons which might be driven off from the filament. Or we may say that the radiation of negative electrons from the filament tends to leave it positively charged, with the result that this unlike charge on the filament tends to attract some of the free electrons back to it. There is, therefore, a limit to the number of electrons which can be radiated from the filament to the plate of the Fleming valve due to this negative space charge.

If we apply a positive potential to the plate, as shown in Fig. 59, this unlike charge will tend to attract the electrons to it so that the majority of them will not return to the filament. As we increase the "B" battery potential on the plate, more and more electrons are attracted to it from the filament. As we have previously seen, the stream of negative electrons from the filament to the plate is equivalent to a flow of positive electrons from the plate to the filament. This flow of current from the

plate to the filament, under the influence of the positive potential on the plate is termed the *plate current*. Consequently, with increased plate potential, there is an increase of plate current.

This phenomenon might be considered to be in accordance with Ohm's Law, since with an increase in E there is an increase in I . However, the plate current in a vacuum tube does not follow Ohm's Law, as can be seen from a consideration of the following.

At moderate potentials of the "B" battery, only a few of the electrons are attracted to the plate. The rest, under the influence of the negative space charge, are returned to the filament. For a fixed value of filament current, and hence electronic radiation, more and more electrons are attracted to the plate as the plate potential is increased until finally all of the electrons which are radiated in a given length of time reach the plate. At this point, the negative space charge is completely neutralized or annulled by the positive plate potential. Any further increase in the plate potential will not increase the plate current, since all of the electrons which can be radiated are now flowing between the filament and the plate. The plate current is therefore said to be *saturated*.

Now if we should set the plate potential at a fixed amount, and commence to increase the filament current from a zero value by varying the series rheostat, we shall increase the plate current gradually to the point where the space charge is neutralized by the "B" battery potential. Any further increase in the filament current or electronic emission, will not increase the plate current since the additional electrons will be returned to the filament under the influence of the negative space charge. Again, the plate current is said to be saturated.

Thus, whether we leave the electronic emission (filament current) constant and vary the plate potential, or whether we leave the plate potential constant and vary the electronic radiation, the plate current will be increased only up to that point where the space charge is neutralized by the plate potential.

By interposing the grid between the filament and the plate, De Forest provided a means for controlling the space charge and hence the plate current. When the grid is positively charged, it tends to reduce the space charge and hence to increase the plate current. When it is negative, the space charge is assisted, since a greater number of electrons are returned to the filament and the plate current is reduced.

Fig. 61 shows the curve which represents the relation between grid potential and plate current.

Such a curve is obtained by recording the various values of plate current for different potentials impressed on the grid, and plotting these results on graph

or cross-sectioned paper. Grid potentials are laid out horizontally and plate current vertically. From the curve, it will be seen that when the potential on the grid is zero, the plate current has approximately one-half of the maximum value which it can attain. When sufficient positive potential value is applied to the grid, the plate current will become saturated, as indicated by the upper flat portion of the curve, B . Conversely, a negative charge on the grid will reinforce the negative space charge and the plate current will be reduced below the half-way point, A .

In Fig. 62, the horizontal line IA represents the constant plate current which will flow when the grid is at zero potential. This current has a value indicated at the point A of Fig. 61. If we apply a slight, alternating potential to the grid, the plate current will assume the alternating form shown by the heavy line in Fig. 62.

The vacuum tube will thus be seen to resemble in principle an ordinary telegraph relay in that feeble impulses in the grid or input circuit of the tube will be faithfully reproduced in the plate or "local" circuit. Due to the steepness of the curve in Fig. 61, however, only a very slight change in the grid potential is required to produce a very large fluctuation of the plate current. It is this property of a tube which makes it an amplifier. The very small amount of energy contained in the received radio wave when impressed on the grid releases a relatively large amount of energy in the plate or "B" battery circuit.

We may compare this principle of tube action to a pistol, in which the light pressure of the finger on the trigger releases a large amount of stored energy in the cartridge. The trigger is the grid, the finger pressure is the potential of the incoming wave, the stored energy of the powder is the "B" battery, and the propelled bullet represents the plate or "B" battery current.

Fig. 63 shows the "hook-up" commonly employed when using the vacuum tube as a detector. P and S represent the primary and secondary of a loose coupler; VC the secondary tuning condenser; SC a small stopping condenser, employed for the same purpose as in crystal detector receivers; F , G and P the filament, grid and plate, respectively, of the vacuum tube; A the "A" or storage battery, usually 6 volts; R the variable resistance or rheostat for controlling the filament current; and B the "B" or plate battery, usually about 23 volts.

As a detector, the vacuum tube makes use of both its rectifying and amplifying properties. The filament is heated to the proper temperature by the "A" battery and the required positive charge is impressed on the plate by the "B" battery. The received radio current, when

Continued on page 72

The Operator's Audion

By Volney G. Mathison

Herein is discussed a moot question in a sane and reasonable manner, the conclusion being that good service requires that the operator possess an audion. This is the concluding installment of the author's series on "The Professional Radio Operator."

THERE has been a great deal of contention over the question of whether the commercial radio operator should make a practice of using privately-owned audion receiving apparatus when he finds himself assigned to a ship where nothing better than crystal-detector equipment is provided by the owning or leasing company. Since many operators are doing so, numerous opinions on the matter have been aired in the different radio publications, and arguments on both sides set forth;—arguments correct in some points, but conspicuously defective in others, and showing a lack of clear thinking and broad treatment.

The spirit in which most of the criticism of the use of privately-owned audion apparatus is made is remarkably typified in a letter that was published some time ago in a wireless magazine—a letter so long that space will not permit its being reproduced in full here; but a few extracts illustrative of its nature and of the nature of almost all arguments against the use of private equipment are well worth giving.

After asserting that the use of privately-owned apparatus is against the rules of the wireless companies (which is absolutely untrue, nearly all companies nowadays approving its use), the writer goes on to ask:

"Is it not a fact that years and years before there was such a thing as audions, that the radio business was conducted just as satisfactorily as it is today? I am ready to state that it was conducted more satisfactorily. So the service company has full right to expect the operators of 1921 to be as capable as they were in 1910 or 1912. It takes no ability to receive with an audion, but it is an *art* to get business through with a crystal detector.

". . . It is unlawful—or so they say—to use the amateur audion for commercial work. If it is unlawful for the service or steamship company to make use of the audion, I gather that it is equally unlawful for the operator to use it. Some operators are so very accommodating that in order to get time signals and a few items of press, they violate the injunctions and counter-injunctions of the courts. After all, you must be looked upon by different interested parties as a perfect fool!"

After delivering this pop-gun barrage, the writer pants through another paragraph trying to discuss some things which he does not understand; and then he loads up for another sarcastic broad-

side with the assertion that the radio operator has no more right to bring aboard ship any private apparatus "than the master has to throw the life-boats overboard and replace them with something else of his own fancy."

". . . This practice of every operator making up some sort of a 'rig' any old way must be stopped. . . . It is a perfect disgrace to behold what one sees on some ships. Loose wires all over, bare joints and switches, hundreds of holes drilled in tables, bulkheads, and ceiling, the whole affair looking like it had just emerged from a typhoon.

". . . Is it such a great stunt in these days to hear Germany in the Pacific that it is worth \$300 to \$400 of your money in order to do so? Did you ever see a chief engineer bring a

magazine in which this letter appeared, of long-distance records that he established aboard ship with his own private receiving equipment.

It is a part of the art of the sophist, even though he be only a crude sophist, to drag into an argument various considerations that are not vitally related to the question at issue; and this is what is done by those who pretend to oppose the use of a privately-owned audion on shipboard when they assert that such use of it is "unlawful,"—meaning that certain vacuum-tube patents are thereby infringed.

The question really is this: Should audion receiving apparatus be furnished by the radio operator or by the ship-owner? What have patent questions to do with it? The illegality, if any,



The crystal detector goes into the ash-can! Here is a standard Radio Corporation shipboard receiving set, consisting of a remodelled 106 tuner with regenerative circuit, a detector-tube unit, and two-step amplifier. These instruments replace all cerusite, galena, and carborundum detector apparatus formerly used.

feed pump of his own aboard because the ship's pumps were not satisfactory? Did you ever see the captain purchase a whistle and install it because the ship's whistle was not loud enough? This apparatus cost no more than a good receiving set. Why should you be the only 'mutt' on the vessel? If you are an experimenter, stay at home and experiment. Bring out something worth while, and don't go around and make a mess of every ship station you come to, and, incidentally, make a fool of yourself and the rest of us."

This is enough to give the reader an idea of the sort of arguments that are usually adduced against the use of privately-owned apparatus on shipboard. In this letter, it is seen that the writer (an operator himself) spends much of his strength in stigmatizing operators who use private equipment as meddling experimenters, and fools. In making this assertion the writer was perhaps referring especially to himself, since he had been boasting but a short time before, in the pages of the same wireless

of the use of the vacuum-tube on shipboard is similar to that illegality which would be involved if a woman, having bought some new ultra-efficient washing-machine, patented, and licensed to be used only for washing chemises, should use the machine for washing a pair of her husband's pink-striped pajamas. Strictly speaking, she would be a law-breaker—but whose conscience would be troubled?

It would seem that the statement of the question, should audion receiving apparatus be furnished by the radio operator or by the ship-owner, is in conflict with the assertion quoted above to the effect that receiving on an audion requires no ability, whereas getting results with a crystal detector is an "art." The inference of this assertion is that the use of an audion is unnecessary—that it is a confession of incompetency; and that the operator—if only he is expert enough—can do just as well with a piece of piano-wire and a chunk of lead-ore as he can with a modern vacuum tube.

The author of such a statement will probably also insist that a man can shoot as far with a blunderbuss of the Middle Ages as he can with a latest model high-powered hunting-rifle—if only he is an artist at shooting;—or that a dextrous old maid with a spinning-wheel of the days of the Revolutionary War can hold her own with a twentieth-century Jacquard loom. Such a one presumably will also maintain that a barn lantern can be made to cast as powerful a beam as a battle-ship's search-light—that is, provided you know how to trim the wick. All this, of course, is to be smiled at; so, likewise, no one need dispute the fact that the veriest beginner can do more with an audion detector than the super-operator might accomplish with a warehouse full of cerusite and galena.

But, at the same time, the universally recognized fact that the vacuum tube is a necessary device for efficient radio communication by no means promises the conclusion, as some appear to believe, that the radio operator should furnish himself with an audion—it points to exactly the opposite. By so much as the vacuum tube detector is a needful, indeed an indispensable part of the modern shipboard radio station, by just that much does it devolve upon the owner of that shipboard radio station to supply it. If the ship-owner wishes to enjoy the incomparable advantages of modern radio equipment over obsolete junk, is it not clearly up to him to furnish that modern equipment, or—and this is the same thing—request his wireless leasing company to do so?

This, of course, is too evident to need argument; and yet, paradoxically enough, the lack of vacuum tube receiving equipment on shipboard is *not* the fault of the ship-owner,—as I shall try to show in a moment.

It has been asserted that the radio operator is justified in bringing aboard ship private apparatus for his personal convenience, so that he does not substitute any integral part of the equipment, as for instance the motor-generator or the sending-transformer. In so far as this statement refers to vibroplex-keys or expensive telephone receivers, it is correct; but who will dispute that the audion detector is not as truly an integral, an essential, part of the modern radio receiver as are the motor-generator and the sending-transformer of the transmitter?

It has also been pointed out that navigating officers provide their own expensive sextants; but this is an erroneous comparison. Sextants are very delicate and finely-adjusted instruments, not adapted to promiscuous handling. Ship-owners would furnish sextants as well as they supply the rest of the ship's navigating equipment—in some cases they have furnished them—but, for the reason just given, mates and masters do

not care about them. Even were this not true, two wrongs do not make a right.

The writer of the blatant letter partly quoted above, on the other hand, remarks caustically that chief-engineers and captains do not bring aboard their own private feed-pumps, whistles, and life-boats; but he forgot to mention, or perhaps does not know, that government steamboat inspectors pass upon life-boats, whistles, and feed-pumps; and if anything is found wanting in them, the vessel can not sail.

It may be returned that likewise the government radio inspectors pass upon the ship's wireless equipment; and that they do not require the installation of audions. While this is true, it must be remembered that the authority of the radio inspector, in the matter of apparatus, is extremely circumscribed,—especially in the cases of cargo steamers or any other vessels that are voluntarily equipped. On these ships, he has no authority to require *anything*. Radio is ten years ahead of our radio laws. We have had no important radio legislation since 1912; whereas the radio art itself has in this short time been completely revolutionized.

And here we come again to the assertion that the absence of audion equipment on shipboard is no fault of the ship-owner. Marine radio has always been so largely in the hands of the wireless leasing companies that the executives of the steamship concerns know virtually nothing about the technical side of it. If they had any conception of the inestimable value to themselves of a device that they can buy for less than one hundred dollars, they would immediately see to it that they had it. Generally speaking, the ship-owners are in ignorance of the necessity of vacuum tube detecting and amplifying apparatus for reliable and efficient radio service.

The U. S. Navy and the Shipping Board have provided audion detector apparatus upon almost all their vessels, and in many cases amplifiers. At least one manufacturer of privately-owned shipboard wireless outfits is doing likewise, while the Radio Corporation of America has installed first-class up-to-date audion detectors, one or two step amplifiers, and regenerative circuits upon every ship that carries the Corporation's leased radio equipment.

From the foregoing it seems to be clear that the thing the radio operator must do is to strive by every means at his command to convince the ship-owner that audion equipment on his vessels is of value to him almost beyond any price. A great many operators never think of trying to get the steamship companies to buy anything for them. I have in mind an occasion when just one brief request by a radio operator to the owners brought to his ship a complete audion-detector and one-step amplifier, a fila-

ment-lighting battery, and the necessary battery-charging apparatus.

When the operator is on a ship where no audion equipment has been provided, perhaps the best thing for him to do is to furnish his own, installing it as neatly as he is able, so as to avoid the "hundreds of holes" of our frenzied friend; and then try to impress upon the captain its incomparable superiority. Get out press five thousand miles at sea; put through ship's business fourteen days from port; get time signals round the world;—then call the master's attention to the fact that this could never be accomplished without the audion. When the "B" battery becomes exhausted, or when the tube has delivered its allotted hours, ask him to order renewals for you on the ship's requisition, first advising him of the slight cost of the required articles.

Or, better still, make out a requisition of the apparatus needed for an audion detector and amplifier set, asking only for what you feel is absolutely necessary, and then write the best letter you know how explaining the essential nature of the equipment; point out that its first cost need not be more than eighty or ninety dollars; that the cost of renewal tubes and "B" batteries will not amount to over thirty dollars a year; and then try to get the captain to endorse the letter and send or take it up to the office of the steamship company.

In putting through requisitions for audion equipment or for renewals, it is usually important to follow them up in order to get action. Try to have a short talk with the company's purchasing agent, or whoever has charge of the ship's buying, giving him the address of the place where you think the apparatus may best be purchased; and always name a wireless store or company in the city where the steamship company offices are situated,—not some distant one necessitating mail orders. It must always be kept in mind that individual units of radio equipment are things which the steamship company executives have never before bought, and probably do not know very much about.

When the active co-operation of the captain can be obtained, the operator usually will be able to get an order from the steamship company on some specified wireless supply-house, thereby enabling him to do the actual buying of the apparatus himself. When possible, this is of course the best way.

If the ship has a leased set, the owner may object to buying any apparatus on the ground that the wireless company ought to furnish it—which is perhaps true;—but then the operator can only point out that the wireless company has not furnished it, and urge the owner that it is to his own best interests to buy it anyway.

If the operator fails in gaining the ear of the captain, there should be no



Wallowing easily along, the "Perseus," cargo carrier, pushed her fat forefoot through the moonlight at her unvarying 9 knots—the smoke rolled blackly away from her stack.

Worth, a Tale of Loyalty

By Major Lawrence Mott

Only one who knows men—and radio—can write such a story as this. It has a heart interest that grips and holds the reader to the end. Its flavor is one that will appeal to the practical operator as well as to the amateur. It seems destined to live as the classic of radio fiction.

HE was a little boy—such a little boy—for 14 years of age. Fourteen pinched years had he existed—not years of actual, physical want, but years of soul and heart starvation for just a penn'orth—even—of that which Humanity—by-and-large—knows as "love," "sympathy," "encouragement."

Mathias Z. (standing for Zebediah) Ellison, owner of a very good farm, as farms go, in Vermont—and the boy's father—did not mean to be hard; did not mean to be unkind, to the lad. Indeed he would have resented the imputation vigorously. But with the mother's passing to Easier Places, some five years previously, there had also passed "sentiment" from the farmer's existence.

Thenceforward it had been one long drive for the eternal dollar—with a parsimony, a thrift, that became—in Mathias—an obsession. The cheapest, most simple of foods, and rough-made, sweat-shop clothing, pleased him vastly, and had to suffice for the boy—Walter—and for an unfortunate, soul-shutter'd girl of seventeen—a niece of Ellison's—who was at once cook and general utility "man" around the farm buildings.

"HEY! Come down out o' that! What in time'r you a doin' of—in that loft? Dreamin' 'bout that fool wireless stuff, I s'pose! 'Member what happened to you, when I ketched you with the last book! Go down in the lower pasture and fetch up the cow!"

Well did the boy remember—when his father had found him, eagerly poring over a radio manufacturer's catalog, that he had picked from the post office waste paper basket. Though time is merciful—in the matter of the keener edges of memory—long, still dark welts on his back, that hurt did he lie on them, prevented his forgetting too easily.

He slunk quickly past the towering farmer, dodged the cuff that was aimed at him, and wearily set out after the brindled cow, picking his barefoot way carefully—for Mathias Ellison held with "no sich foolishness" as shoes and stockings, till "snow flew," and it was bitterly cold this late afternoon in October.

The last rays of the sun kissed the sveltly-rising hillsides, and by the warmth of its caress, brought out their multitude of autumnal hues—bronze and gold, crimson and rich yellow—

amber and sienna—the colors blended in one gorgeous mass—rising up against the blue and green-grey of the cloudless skies. The air was still, save for the *tinkle-ting* of the bells of the herd in the pasture below.

THE evening meal—meagre as always—was eaten in silence. Boy and girl ate timidly—shivering, did they but clink spoon 'gainst the coarse china-ware.

Ellison filled his pipe—"heave some wood on!" he said gruffly—and the lad put two logs on the smouldering embers in the gaunt, stark fireplace.

"Not two at once, fool! More'n half the heat goes up the chimbley, anyway!"

And Walter burned his fingers in his haste to take one log off.

Flora—the girl—sewed furiously at some much-patched clothes, what tho' the single lamp gave but a sickly light, and there was no sound save for a little, cold wind, that mournfully whimpered and sighed about the house, and gently shook the aspen leaves.

"Drat such fool notions!" the farmer threw the local weekly across the room—"Al-lus talking about schoolin' an' larnin'—and sayn' as how children over 8 *must* go to school! *Ha!*" — he snorted—"look at me! I never went to no 'school'! Teacher come to see my paw, one day—said's how I'd orter — and paw, he licked him proper! 'Lowed he knowed whut was best for his

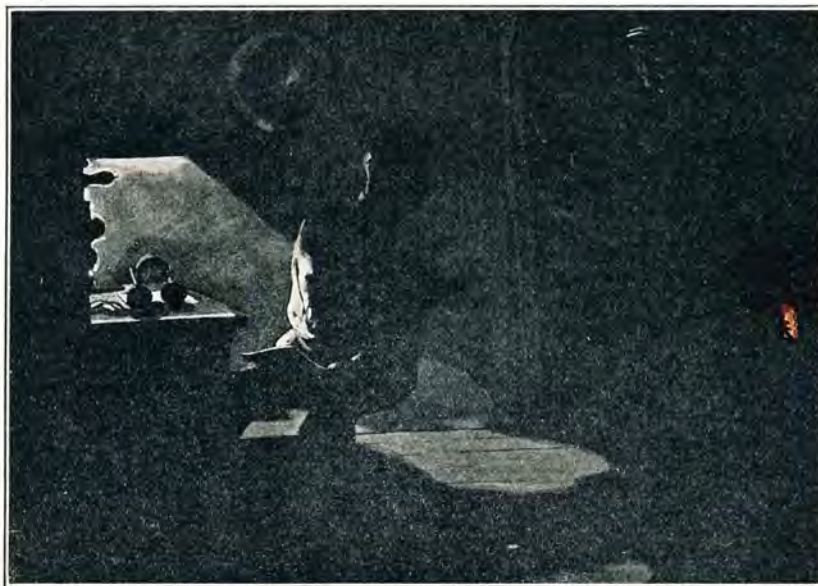

It was but the continuation of one motion for Ellison to pull open a drawer, take out an automatic—"I wouldn't—if I were you!"

Continued on page 56

One Tube Receiving

By Carlos S. Mundt

Here is another good answer to the question of simplicity versus complexity in receiving circuits, and for the one-way purse it beats the cat's whisker. The author is the instructor in physics at the high school at Piedmont, Calif. The beauty of this hook-up is that it works equally well on spark, C. W., and phone.

NOWADAYS, with the multitude of many-stage amplifiers, super-regenerators and super-receivers, the ardent radio phan doesn't know just what to think. He would very much like to dabble in radio frequency amplification, but suffers a dizzy spell when cataloging r.f. transformers and tubes. He yearns for a couple of extra stages of audio frequency, so as to show just how much the radio art will produce, but again dizziness overtakes him when he lists the a.f. material. And last, but not least, a SUPER—but diagrams, lengthy articles, complex circuits, money as an outgoing tax—all cause him to pause and breathe Mr. Armstrong's name with reverence.

"So," says he, "Waddy gonna do about it?"

Answer: Take that good old detector tube and make it work overtime!

How? Follow instructions "as is," or, as Mr. Gibbons states, "proceed thusly:"

Obtain, by hook or crook (the latter is easiest), the following apparatus:

- One variocoupler (Remler is good).
- One .001 variable condenser.
- One .0005 ditto.
- One switch and five contact points.
- One battery clip (copper).
- Necessary phones, antenna, tube, etc.

Connect as per diagram often given for the so-called "single coil regenerative" with the following exceptions:

1. The .0005 v.c. is the by-pass condenser, bridging phones and "B" battery.
2. On that side of this v.c. away from the tickler (secondary) of variocoupler attach the copper battery clip.

On the lower waves you will find the set to operate remarkably well, and with the .0005 at about mid value and tube pushed a bit the C. W. sigs just roll in as fast as you can log them. Further, the .0005 will adjust the C. W. note to any you wish.

The radio phone sigs on 360 to 425 are all anyone can desire. Ever hear of phone sigs so loud you can hear them all over the room on one tube and loud speaker? Try 'em once.

Now for the next little trick. Disconnect the copper battery clip of the .0005 and attach it on the opposite side

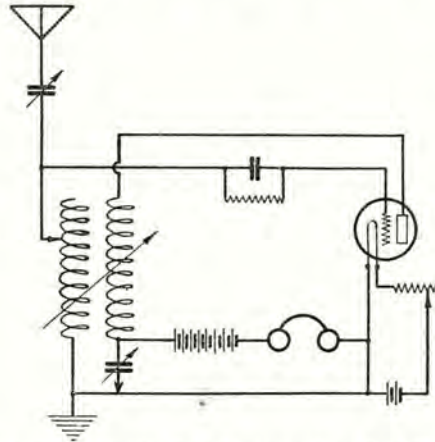

Modified Single Coil Regenerative Hook-Up

of the tickler from which the v.c. is connected.

All of us like to listen-in on 600 meters so as to hear how it is done in commercial work. Well, KPH and KFS will tear your ears off with this *tuned tickler*, and as for other distance VAE and KOK come in enough to cause QRM at times. For the ships, just look below at the result sheet.

The big advantage of this set is its universality—spark, C. W. and phone all being received with equal facility. Many people claim this circuit to be "broad," but the writer claims that skill in operation will offset much of that. One one-hundredth of a dial scale will

tune out a nearby phone and bring in the L. A. phone.

So far I have passed this along to several fellows and when I see them the next time they say "I'll say she do—and I'm going to put it in permanently." So here I am, passing it on to you.

Results at 6AJ using above set—two-wire antenna, 85 feet long, 30 feet high, water pipe ground—September-November, all before 9 P.M., P.S.T.—

Amateurs (distant only): 6GD, 6ZH, 6ZR, 6RM; 7NY, 7HJ, 7XC, 7AF, 7TQ, 7BJ, 7ZK, 7MF, 7ZO, 7FH, 7OT, 9ZAF, 9AMB, 9BJI, 9APS, 9AVZ, 9BXQ, 9BZI, 5KC, 5ZA, 9CNS, 9BEY.

Phones (distant only): KGG, KZN, KFI, KWH, KFAF, KGW, KDPT, KOG, KFAD, KUY.

Ships (distant only) only such listed as position reports were actually copied: Sept. 20—KDPR 491 mi. south of San Pedro; KDBZ 1165 mi. from San Pedro. Sept.—NISX 12 mi. from NPL. Oct. 30—KEPG 102 mi. south of San Pedro.

When using this set at my former location, Concord, Calif., I was able to log, among many others, 8ZP and 8AGZ, the former on spk., latter C. W. Written confirmation received from both.

Tuning is nearly entirely by the .001, the by-pass controlling regeneration. A vernier on the former helps a great deal.

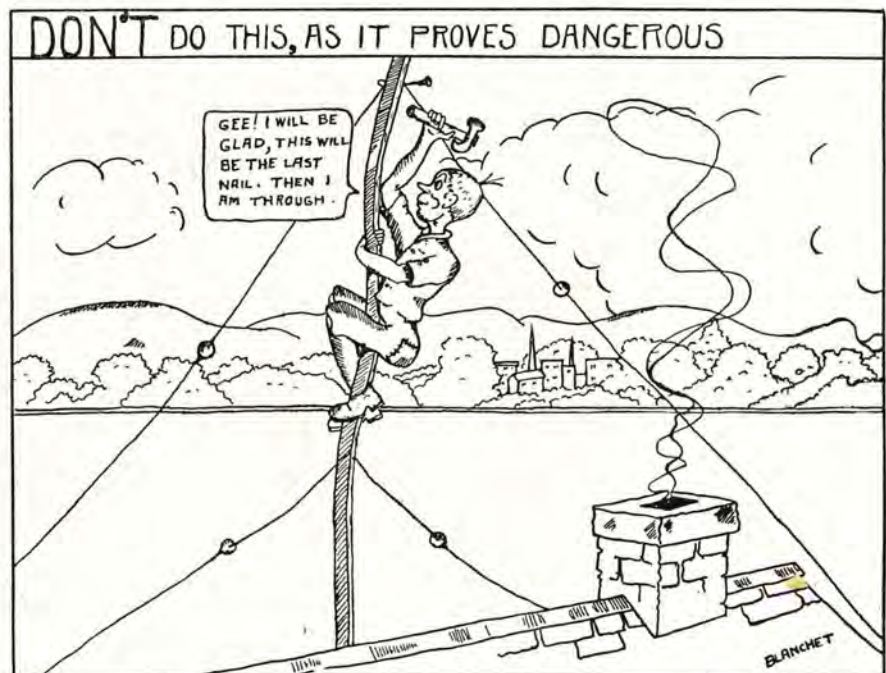

"Some Facts About Antennas"

By Francis J. Andrews, Radio Engineer

The most important, and the most neglected, factor in good radio transmission and reception is the antenna. Here are some practical suggestions that make for greater efficiency.

A CERTAIN big city newspaper set out to broadcast radio concerts throughout its district. It erected two lofty poles and strung antenna wires between. It installed expensive transmitting equipment. It hired a splendid jazz orchestra. But when it started to send out its programs, something funny happened. Pete Everett, on East 73rd street, tuned in right away and enjoyed that jazz music to the last lilting note. But Walt Clark, on West 69th street—though he adjusted, and tinkered and tuned to the limit of his patience—couldn't hear a solitary note. Nor for that matter could anybody else in Walt Clark's neighborhood.

systems. (Some antennas, of course, are used for both receiving and transmitting). The two general classes may be subdivided again into three groups—inside, outside, and coil or loop antennas.

While the last year has seen many styles of receiving antennas grow in favor, the old-style outside antenna still holds its own. The inverted L, the T, and the single wire straight aerials are the commonest forms of outside aerials.

The inverted L aerial, or antenna, gets its name from its shape. (See Fig. 1). It is widely used and with good results, though it has one defect—its directional property. This defect sometimes is turned to advantage. It receives

from the end nearest the receiving equipment.

The T aerial, as its name implies, is T-shaped. (See Fig. 2.) It is free from the directional properties of the inverted L type—it receives messages from any direction with equal ease. Four or more wires, at least 30 in. apart, make up the typical T aerial. The flat top portion is about 100 feet long, and the lead-in drops from the exact center of the wires. The aerial should be at least 30 ft. above the ground.

The inverted L and T aerials are excellent for stations that both receive and transmit on the same aerial. The T type, on the whole, is best for amateurs. The "ham" who doesn't want to transmit, however, will find a single wire aerial most satisfactory. This aerial should be about 100 ft. long and not less than 50 ft. high. Take off the lead-in from the end nearest the apparatus. It is a good stunt to have the aerial wire and lead-in all one piece, thus eliminating the necessity of joining two separate pieces together. (See Fig. 3.)

No matter what the type of antenna is, certain precautions must be taken. If you don't insulate properly you are bound to fail. Figs. 1 and 2 illustrate the proper method of insulating an antenna. There are a number of good insulators on the market. Personally I prefer the glazed porcelain type, as they do not absorb moisture. Always install *oversize* insulators, (insulators able to withstand more than a normal current) if you are contemplating or are transmitting. Then you will be ready for any emergency.

Stranded phosphor bronze wire is the best for the antenna. This wire has great tensile strength. Furthermore,

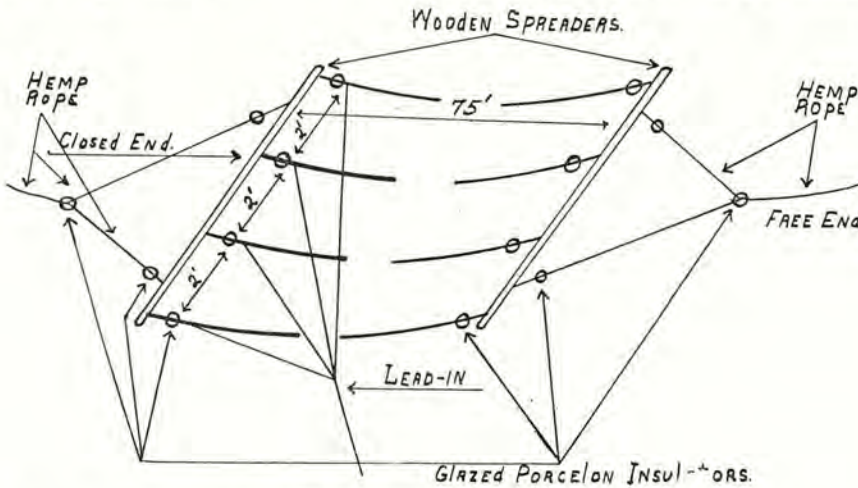

Fig. 1. Inverted "L" Aerial

Experts investigated and laid the blame at the door of an adjacent office building. East of the aerial, it seemed, were no obstructions. The radio waves went pulsating through the ether without interference. Fine for Pete Everett. But on the west towered that giant office building. It was innocent looking enough, as office buildings go, but every time the orchestra played it absorbed or broke up the radio waves to such an extent that the whole west side went concertless. The newspaper moved the station uptown, out of the way of office buildings and now Walt Clark enjoys jazz music too.

Moral—the fellow who puts up his antenna near a big tree, or a tall smoke-stack, or any other formidable obstruction, is in for a lot of trouble. Antennas are like army mules—you've got to handle them carefully.

In this article I am going to tell you some things about antennas and how to get the best results with them.

Antenna systems may be divided roughly into two general classes—receiving antenna systems and transmitting

loudest only when its closed end, the end with which the lead-in is connected, is pointing towards the transmitting station.

Most satisfactory aerials of the inverted L type employ four or more wires, at least 2 ft. apart and about 75 ft. long. The aerial is 30 ft. above the ground or higher. The lead-in is taken

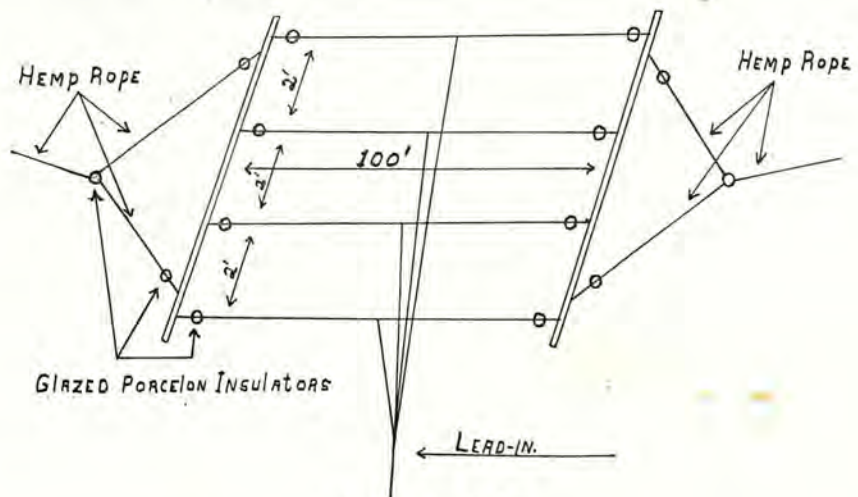

Fig. 2. "T" Aerial

being stranded, it has a larger surface than solid wire. This is of particular advantage in transmitting. Stranded wire is also more flexible than ordinary wire. I recommend 7 strand, No. 18, B & S.

The spreaders, or wooden bars to which the antenna wires are attached, ought to be made of spruce or ash. Whatever spreader you select, be sure that it is strong enough to stand the strain.

Select your halyards, or the rope strung from the two poles that support the antenna, with extreme care. Get the best grade of weatherproofed hemp. The cheap kinds shrink in wet weather,

six-foot lengths of pipe into the ground, connect them with wire, and join the waterpipe by wire to the pipe lengths, thus forming one grounding system. If you find it impossible to ground to a waterpipe, bury several square yards of copper sheeting 6 ft. under ground.

For radio telephone transmission, a counterpoise is employed, with great success, in place of a ground. The theory of the counterpoise is too lengthy for discussion in this article. The counterpoise itself is a second antenna, somewhat larger than the main antenna, stretching about three feet above the ground, from which it is thoroughly insulated. The lead-in from the counter-

Coil or loop aeralis, because of their compactness, are popular. A loop aerial for receiving, if coupled with a good receiver, need not be over 4 ft. square, and may take a highly artistic and tasteful form, a form that will harmonize with the artistic furnishings of a living room or parlor.

For example, I have seen an ordinary phonograph that receives concerts and amplifies them through the horn, just as it also plays a record. It does this by virtue of two loops, batteries, and other receiving equipment all fitting snugly in the inside of the cabinet. No outside connecting wires are necessary. Such is one advantage of the small loop or coil antenna. The directional properties of the loop antenna are in its favor, for by shifting it to a position parallel to the transmitting stations, i.e., broadside to the approaching waves, the message or speech will be more audible. Thus, by trying the coil in various positions, the direction of a given transmitting station can be found. Again, by shifting the coil one can tune out stations that are transmitting simultaneously on the same wavelength.

But regardless of the development of the loop or coil antenna, the outdoor antenna is still the "ham's" favorite for all-around service. It's a lot more fun to erect and it receives over a greater distance.

AN A.C. RADIO TUBE

A practical alternating current radio receiving or amplifying tube, as described in December *Electric Journal*, has been developed by the research department of the Westinghouse Elec. & Mfg. Co. This tube operates satisfactorily with an a.c. filament supply of .85 ampere at about 5.5 volts and an ordinary B battery for plate supply. The heating element is a V-shaped tungsten filament encased in an insulating tube of refractory material which in turn is placed in a nickel sleeve coated on the outside with a mixture of barium and strontium oxides. The alternating current heats the filament and the heat is conducted to the oxide-coated surface so as to cause the continuous emission of electrons without the usual a.c. hum due to changes in voltage, magnetic field and temperature. The grid is a helix and the plate a cylinder of nickel. For a given voltage amplification the new tube has an impedance of about half that of the ordinary direct current tube, thus giving better results for detection and audio and radio frequency amplification. With these tubes it is possible to also use the electric light wires as an antenna. Thus a set used in this way need have no outside connections except the cord running to the lamp socket. For a permanent installation these tubes are more efficient, convenient and economical than those requiring a storage battery or dry cells for filament current supply.

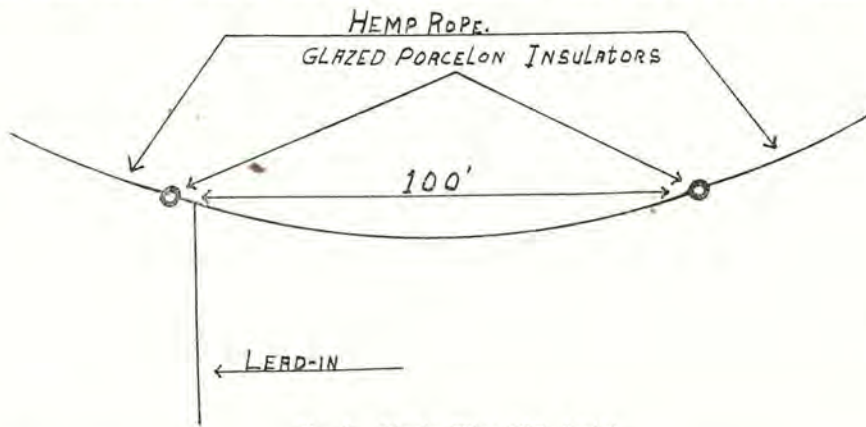

Fig. 3. Single Wire "T" Aerial

and often, because of the strain, snap in two. Never draw your antenna wires taut. Allow some slack for wind and snow.

Profiting from the experience of the big-city newspaper, be careful where you erect your poles. Don't put your antenna near a tall tree. Every leaf of that tree is a miniature antenna, absorbing radio waves for all it is worth. Shun also, smokestacks, windmills, tall buildings—all greedy absorbers of radio waves.

Never stretch your aerial over or under an electric line. The instant one of your wires comes in contact with a wire from the electric line—because of a high wind or some other not unusual cause, anyone operating the apparatus will get a terrific, perhaps fatal, shock. For that matter never stretch an aerial parallel to a nearby electric line. The electric line will charge your wires with electricity by induction, and interfere with receiving. If you are transmitting and your aerial is parallel to an electric line, your wires are apt to induce a charge in the electric lines which may ruin the entire system in your neighborhood, thereby causing you to get in wrong with the electric company. If on the other hand, you situate your aerial at right angles to the electric line, you minimize the chance of an induced charge.

Take great pains with your grounding system. If the soil is moist, solder your ground wire to the waterpipe at the point where it enters the house. Drive some

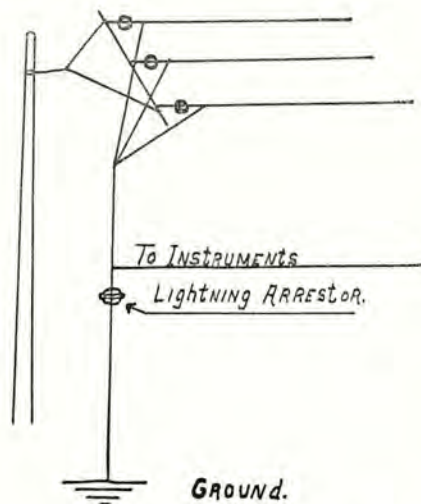

Fig. 4. Lightning Arrester Connection

poise takes the place of the customary ground wire.

Equip yourself with one of the standard lightning arresters. The cost is small, and by so doing you square yourself with the fire insurance companies. Fig. 4 illustrates the connecting of a lightning protection device. So much for outside antennas.

With the popularization of radio, came the inside aerial, employed almost entirely in receiving messages. The inside antenna may take almost any form, from a miniature T aerial to a homemade contraption involving the gas range or the bed spring. It naturally will not receive from as great distances as the outside antenna.

Making a Tube Rectifier

By Stuart A. Hendrick 2, B.J.G.

Simple instructions are here given for the construction of a two-ampere hour and a six-ampere hour tube rectifier for charging storage batteries. These directions include full details as to transformer core assembly and coil windings. They have been successfully tested out a number of times and closely approximate the theoretical dimensions given by formulas.

If you have 110 volts, A.C. available you will be able to rectify it and reduce the voltage to make it suitable for charging storage batteries by means of either one of two rectifiers to be described herein. The first one is a two ampere size and is suitable for charging small batteries of from ten to fifty ampere hour capacity. For those who have large capacity batteries and want to have them charged more rapidly a six ampere model will be described.

The bulbs used in the outfits described are known as Tungar or Rectigon tubes and may be obtained from almost any radio dealer at a cost of four simoleons for the two ampere size and eight spondulicks for the big fellow. These are two-electrode vacuum tubes, as distinguished from the three-electrode tubes used as detectors and amplifiers.

Get a two-ampere bulb first and obtain or buy an Edison porcelain base socket to fit the bulb. The next thing needed is a step-down transformer, having a 2 volt secondary capable of delivering 10 amperes and a 15 volt secondary capable of giving 2 amperes. The 2 volt secondary is for lighting the filament of the rectifier tube and the fifteen volt winding furnishes the alternating current to be rectified and used for charging the battery. As very few will have a transformer on hand to meet these requirements, one will have to be constructed according to the following data: *

With any transformer the core is the first consideration. When designing a transformer, for amateur use, the only dimensions of importance are the height of the strips when piled up, as well as the width; in other words, the cross section of the core. The length of the legs or sides depend on the size of the coils to be wound upon them, so they should be made long enough to leave plenty of room for the windings.

The number of turns of wire in the coils is inversely proportional to the cross-section of the core in square inches, that is, as the core grows larger, the number of turns decreases. Therefore, a large core will cut down the cost of the wire to be used.

The core may be obtained from any company that manufactures transformers, for two or three dollars at the most. However, quite a few may desire to make the core. Black sheet iron may be used, although silicon steel is better. It should be about .016 in. in thickness

(about sixty thicknesses to the inch). Any tinsmith will cut it into strips of the proper width for a nominal sum or you may even do this yourself if you are ambitious.

Table 1 gives cross-sectional dimensions of eight sizes, any one of which may be used. The core is built up by the usual overlapping method as shown

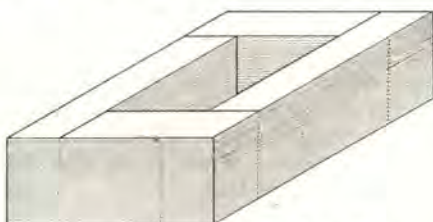

Fig. 1. Method of Stacking Core

in Fig. 1. The cross section of the core in this case was 1 1/4 in. x 1 in. and was 5 in. long and 5 in. wide.

The coils are wound over blocks of wood, having dimensions 3/16 in. greater than the width and height of the core and as long as the coil is to be. These blocks should be split diagonally as shown in Fig. 2. The split allows the wood to be very easily removed from the winding after it is finished. The coil is then taped by threading the tape through the center of the coil and

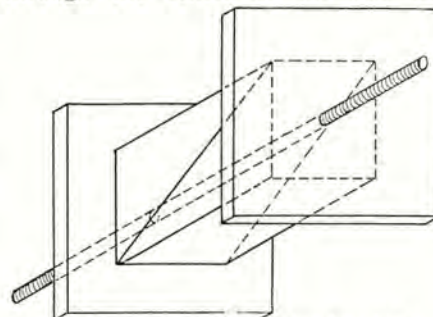

Fig. 2. Split Blocks for Winding Coils

around the outside, lapping each turn over the preceding one until the whole coil is covered.

After the coils are finished the core is built up inside of them by putting in a strip one side and then one from the other side and vice versa until it is built up to the proper thickness. Some sort

of wooden or metal frame should be built to hold and clamp the transformer core to keep the laminations from humming.

The primary coil of one of the transformers constructed had 605 turns of No. 20 D.C.C. wire, the secondary had 85 turns of No. 18 D.C.C. wire and the filament winding had 12 turns of No. 14 D.C.C. wire, tapped in turns of one from the seventh to the last, because of the variation in bulbs. Eleven turns are in use at present.

The wiring diagram is given in Fig. 3. The wire marked negative goes from the anode of the tube to the negative side of the battery.

The operation of the outfit is as follows: The 2 volt winding keeps the filament incandescent, while the 15 volt

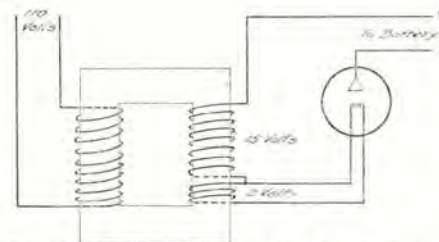

Fig. 3. Wiring Diagram for Small Tungar

winding supplies the alternating current of which only half passes through the bulb, which acts as a valve, thereby supplying a pulsating direct current which is suitable for battery charging. A blue glow directly above the filament indicates that the rectifier is connected to the battery and is working properly. If the blue glow fails to appear, the end of the 15 volt winding should be connected to the other side of the filament, instead of the side it happens to be on. If then the blue glow fails to appear, the filament should be lighted more brightly, or more turns of wire put on the 15 volt winding to give a higher voltage.

The transformer may be mounted in a box, but the bulb should be on the outside, as it develops heat while being used. This little rectifier consumes about fifty watts; filament 20 watts,

Cross Section of Core in Inches	
Silicon Steel	Black Iron
1 1/2 x 2	3 x 2
1 1/4 x 2	2 1/2 x 2
1 1/2 x 1 1/2	1 1/2 x 3
1 1/4 x 1 1/2	1 1/4 x 3
1 x 1 1/2	2 x 1 1/2
1 1/4 x 1 1/4	2 1/2 x 1 1/4
1 x 1 1/4	2 x 1 1/4
1 x 1	1 x 2

TABLE 1

Turns per volt	Turns of No.14 Fil.	Turns of No.20 110V Pri.	Turns of No.1815V Sec.
2.5	5	275	38
3.	6	330	45
3.5	7	385	53
4.	8	440	60
4.5	9	495	68
5.	10	550	75
5.5	11	605	83
6.	12	660	90

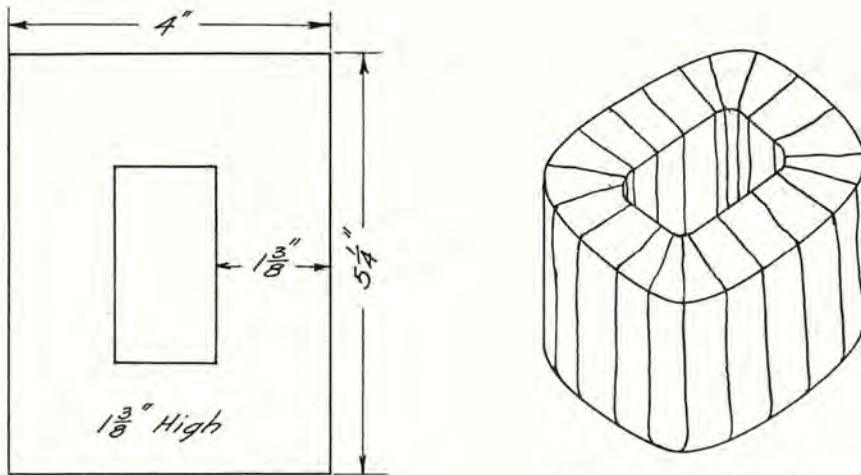

Fig. 4. Core and Coil for 6-Ampere Outfit

copper and iron losses 20 watts and charging current 10 or 12 watts. A 6 volt-60 ampere hour battery will cost about 12 to 16 cents to charge, including depreciation of the bulb. With careful handling a bulb will last two or three years. The rectifier may be used to charge any 6 volt battery.

As a suggestion, the 15 volt winding may be tapped in the center during the construction, thereby giving two 7 1/2 volt secondaries, which may be used for filament lighting purposes in your new C. W. outfit. Of course you cannot charge your battery while using the C. W. set.

With the foregoing data any one ought to be able to construct this rectifier, which certainly will be the most useful piece of apparatus in your station.

Six Ampere Outfit.

The transformer in this case should be an auto-transformer, that is, all the coils are in the primary circuit and parts of them are also used as secondaries at the same time. This saves much space and time in construction.

Only one size of core is given, that being shown in Fig. 4. The cross-section is 1 3/8 in. x 1 3/8 in. and the winding legs are 5 1/4 in. long while the other sides are 4 in. long. This size is for silicon steel only and if the core is made of common black sheet iron the cross-section should be doubled or made

How To Tape Coils

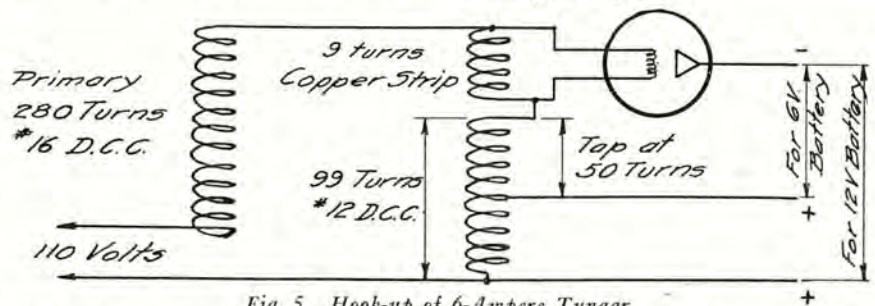

Fig. 5. Hook-up of 6-Ampere Tungar

1 3/8 in. x 2 3/4 in. The length of the sides will remain the same. Sheet iron has only one-half the permeability of silicon steel, therefore the core must be made twice the size.

The primary coil has 9 layers of No. 16 D.C.C. wire, 8 layers of 32 turns

and 1 layer of 24 turns, which will make a total of 280 turns on the primary.

The secondary coil has 5 layers of No. 12 D.C.C. wire, 4 layers of 24 turns and 1 layer of 3 turns, which makes a total of 99 turns on the secondary.

The filament winding is put around the outside of the secondary winding and is made up of 9 turns of 3/16 in. x 1/16 in. copper strip, which gives a voltage of 2 3/4 and 20 amperes for lighting the filament.

The coils should all be wound in the same direction and when connected in series great care must be taken to get them connected so as not to have the flux from one coil going in the opposite direction of the others.

From Fig. 5 it will be seen that this rectifier may be used for 12 volt batteries as well as 6 volt batteries or 2-6 volt batteries in series. Fig. 5 also shows how the windings are connected.

The primary is put upon one leg of the transformer and the secondary on the opposite one with the heavy filament winding on top of it.

In all cases the large rectifier is recommended because it does the job quicker and gets the battery back into service sooner than would be possible with the smaller one. Besides, in all probability, you will build the large one when you get a bigger battery, so why not build it at first?

Several of these rectifiers have been built and in every case the person who took the trouble to build one was more than satisfied with the results obtained. So, therefore, go ye and do likewise.

THE NEW SODIUM TUBE

A new detector tube using metallic sodium as the electron source was recently demonstrated before the Institute of Radio Engineers by Harold P. Donle, chief engineer of the Connecticut Tel. & Tel. Co., Meriden, Conn. This tube employs a filament to heat a sodium anode the electrons from which are collected on a U-shaped plate whose potential may be varied from 10 to 30 volts without noticeably affecting the strength of the signals. Although it employs no grid it is claimed that this tube gives loud signals for wavelengths below 1000 meters without distortion than does the usual gaseous-content three electrode tube. Furthermore it does not radiate from a receiving set so as to interfere with nearby receivers, nor is it affected by body capacity.

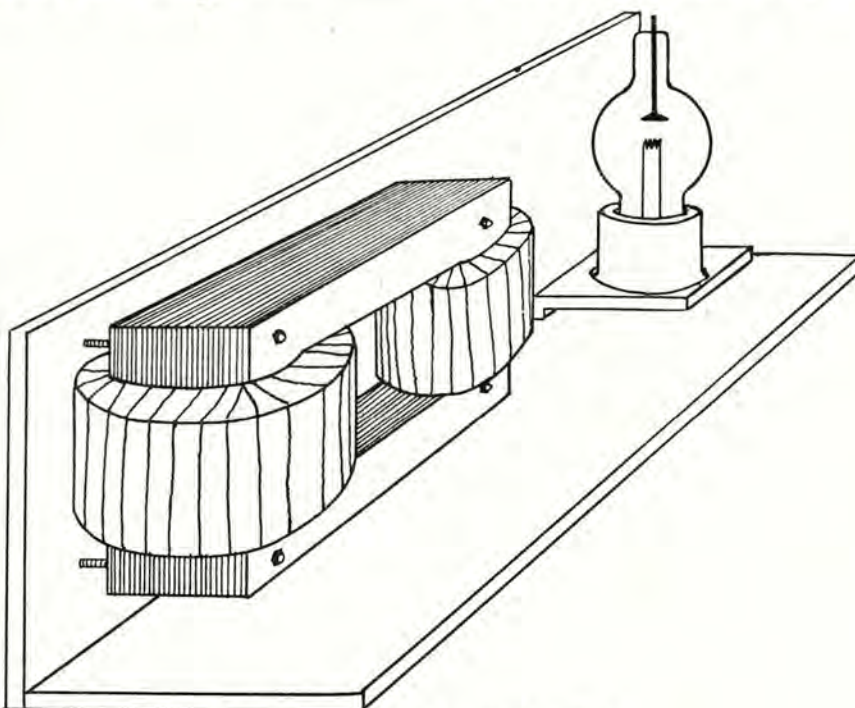

Fig. 6. Method of Mounting Tungar

How to Build a Loop Aerial

By Ortherus Gordon

To avoid the usual unstable botch resulting from novice efforts to construct a loop aerial the directions and dimensions given in this article should prove effective. It is designed for broadcast reception.

THE advantages of a loop aerial to those who have two or more steps of amplification are so numerous that many amateurs are taking to making their own. A loop, for instance, reduces static to a minimum, while its directive powers bring in one particular station to the exclusion of others. On the other hand, however, a loop is a poor absorber of radio energy, and therefore requires a sensitive set of instruments. For this reason, it finds its greatest usefulness with the super-regenerative receiver. It cannot be used with a crystal detector.

Building a loop is not as easy as it looks. It must not only stand upright but it must also revolve, a combination of demands which puts the ambitious amateur in difficulties. Too many home-made loops are either top-heavy or not heavy enough, with the result that the cross arms sag, the wood splits and the whole affair looks as if it had been hit by something more destructive than a radio wave.

The design presented in the accompanying drawing shows a loop construction which will stand a reasonable strain on all of its parts. Wood is used

throughout and the dimensions are those which have proved about right for broadcast reception. The actual loop is 3 ft. square and has 11 turns of wire spaced $\frac{1}{2}$ in. apart. It stands 5 ft. high when fitted with a base as shown in the sketch. This height, however, can be regulated by increasing or decreasing the length of the central rod.

The material for the loop frame is all $1\frac{1}{2}$ in. x 1 in. stock, preferably of oak, although a softer wood will do. Twelve feet of this stock is enough, and it is sawed into one piece 3 ft. long, another 5 ft. long and four others 7 in. long. These pieces are then cut as shown in the detail drawings, so that when the frame is ready to go together, one piece fits into another without any trouble.

All the joints ought properly to be riveted, but they may be bolted. Do not use screws. Right angle joints of this nature and screws do not get along very well together, and experience warns one to steer clear of the mixture. If the 7 in. cross pieces do not rivet solidly as they should, the use of angle irons or shelf brackets is suggested. These may be procured at any hardware shop.

The need for the two square centerpieces is obvious. Otherwise there would be nothing to strengthen the extremely frail joint at the center. These reinforcing "plates" may be of wood or metal. They are shown here as $\frac{1}{2}$ in. wood, and are either riveted or bolted in place.

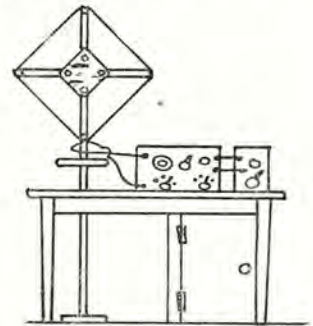

Fig. 2. Suggested Loop Mounting

The windings are spaced $\frac{1}{2}$ in. apart, and there are 11 turns on the frame. The wire may be thick or thin, insulated or uninsulated. If bare wire is used, all the woodwork should be well dried and varnished. About No. 18 is right, for the size of the wire, while No. 22 is the smallest that can be used with any success. For 11 turns on a 3 ft. loop, 95 ft. is the length of wire needed. Binding posts may be placed as suggested by the drawing, or clips may be used to vary the number of turns—providing, of course, that bare wire has been used for winding the loop.

The dimensions given may be changed to suit the wishes of the builder. Remember, however, that as a general rule, a large loop with a small number of turns gives better results than a small loop with a great many turns. A 4 ft. loop, for instance, needs only 6 turns of wire to make it about right for broadcast reception.

The base is an individual problem. If the loop is to stand upon its own feet, perhaps the one offered in the drawing embodies as practical an idea as any. The amateur who dreams of a loop that will turn on a baseboard with the ease of ball bearings has another dream coming when he tries to work such a thing in actuality. If, however, the central rod of the instrument can be passed down through the top of a table, and then set into a socket on the floor, the problem is simplified to some extent (See Fig. 2.) Then the loop may be turned by means of a handle or a wheel, placed within easy reach of the operator.

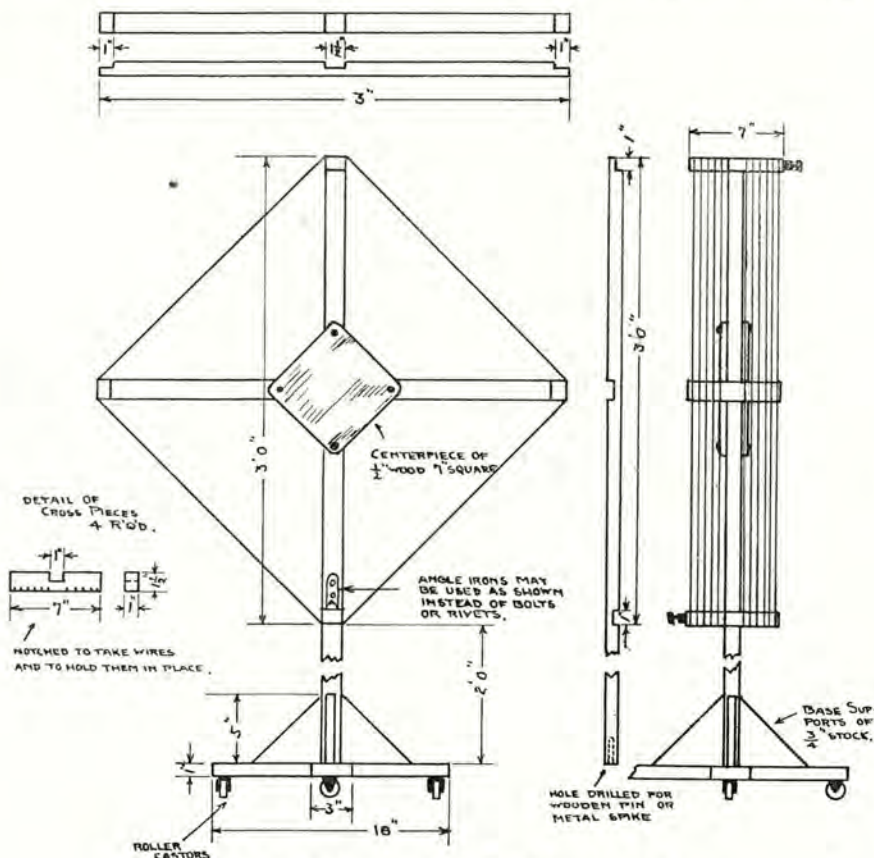

Fig. 1. Details for Loop Aerial Construction

"Preserving Your Ear"

By H. MacD. Hassell

Knowing the "why" of things aids the doing thereof. The author tells why good operators go stale in copying code and gives some practical corrective suggestions. As he is senior operator on the "H. F. Alexander," ex "Great Northern," he knows whereof he writes.

THE few ideas I am going to set forth here are addressed chiefly to commercial operators. However, amateurs who look forward to pounding brass commercially will do well to note these facts for future use. Standing watch on a commercial station, ship or shore, is a treasured dream of many a boy who will surely realize his wish if it is accompanied by several grains of stick-to-it-iveness. But, your hopes will be realities only in so far as you submit to considerable self discipline. All commercial operators will admit numerous sins of omission. Very many will admit that they are not as good operators as they have been at some time during their career.

Any operator who has stood a fair number of watches in his time will bear me up in saying that there comes a period when his ability to copy fast sending shows a marked falling off. Something appears to be wrong with the workings of his hand in conjunction with his brain. Whether the traffic is being copied on a typewriter or with a pencil, the operator is quite aware of the sense of what he is copying but his hand refuses to get it down properly. The whole trouble is this: he lacks coordination of all his faculties.

Coordination of brain and muscles to the nth degree made Jack Dempsey what he is. The same is true of Bill Tilden, tennis champ, and many others whose name is legion. Good coordination is nowhere more important than in telegraphy. To retain* this faculty is extremely hard under the conditions involved in a wireless operator's job.

Explained simply, copying amounts to this: his education has taught the operator that when he hears "di dah" to inscribe the letter "a." He does it almost unconsciously. The nervous system employed in that action is just as substantially a circuit as that of his receiving set. The operator's ear receives the stimulus, "di dah," and an impulse courses along the neurones to the brain. From having done the same thing many times before, the brain immediately communicates through the neurones with the muscles necessary to inscribe the letter "a."

That is a long explanation for so simple a process. But the same action takes place in all copying. The lines of communication between ear, brain and muscle are very delicate and are interwoven in an extremely complicated manner. Each stimulus has its corresponding muscular reaction. When an

operator gets stale—"isn't as good as he used to be," the lines of communication have become blurred; the stimuli shoot off on the wrong tracks.

Consider for a moment a simple analogy. When someone digs your ribs unexpectedly, you jump skyward. Next time he digs you don't jump quite as high. If he continues to dig, it soon does not worry you at all. What has happened? You have become negatively adapted to the stimulus.

An operator becomes stale because he lets signals buzz in his ears without copying them. Worse still, he often does not even get the sense of them. His faculties become dulled. His senses lose their ability to react quickly. When stimuli come, they get off the tracks and often reach no muscles at all in the maze of communicating nerves.

The above situation is when the operator lacks coordination. His machine-like nervous system is out of gear.

Why is it that an experienced operator hangs his phones on the wall when he is typing a letter? Why does the Associated Press operator turn off his set when he is through receiving? The answer is the same: the operator must have all his senses alive and active when he turns to copying again. His nerves must be responsive to their stimuli.

All operators have tried to read books with the phones over their ears. To stop reading and try to copy after a period of time has elapsed is difficult.

I say it is an evil hard to avoid. Not every wireless job offers the opportunity or the necessity of copying everything that comes through. Neither is it feasible to turn off one's set when one wishes to read. Experience has offered one solution for the problem.

Most operators have one ear better than the other, that is, the faculties of one organ appear to be more fully developed than those of the other ear. Obviously the ears work independently in regard to communication with brain and muscle. Well, preserve your good ear. Do your standing by with your second grade ear and do your copying with both of 'em.

Does that sound like folly? I have tried it out standing watch twelve hours a day for twenty-seven days in each month. And it works remarkably well.

With the advent of radiophone entertainment it is deplorably easy to sit listening to music with signals buzzing in one's ears. This applies to commercial men as well as amateurs. Operators should cultivate the habit of tuning out

the code altogether when listening to radiofonic entertainment, especially if receiving on both ears.

Getting stale is no joke. I have known men to learn the code and make no attempt to copy what was coming over the air continuously. Result was, when he did want a license, all his powers of concentration were not sufficient to undo the bad work wrought by becoming quite negatively adapted to the code. Of course, the ailment isn't incurable, but it behooves all those who are stepping up in the ranks to be careful of that very serious bugaboo.

STATION CALL LETTERS

The station license issued for the operation of an amateur transmitting station in the United States designates a call which is to be used by that station at all times. This call consists usually of a number followed by two letters, as 1AB, but may consist of a number followed by three letters, as 1ABC. The number is the number of the radio district in which the station is located. Experiment stations have calls consisting of a number followed by two or three letters of which the first one is X, as 1XA. Technical and training-school stations have calls consisting of a number followed by two or three letters of which the first one is Y, as 1YA. Special amateur stations have calls consisting of a number followed by two or three letters of which the first one is Z, as 1ZA. It is unlawful for any transmitting station at any time to sign any call except the call assigned in its station license. No station is allowed to transmit until a station license is issued. The radio regulations formerly provided that after an application for a station license had been filed and pending the issue of the station license, a provisional call could be used and the station could transmit; this provision has been repealed.

Canadian amateur stations are assigned calls consisting of a number followed by two or three letters, like the calls assigned to amateur stations in the United States. The Canadian stations having calls beginning with the numbers 1, 2 and 3 are in the southeastern part of Canada, somewhat near to the United States stations having calls beginning with 1, 2, 3. Therefore it is possible for a Canadian station having a call, say 1AB, to work with a United States station having the same call 1AB.

Reading Wavelengths on the Receiving Set

By B. F. McNamee

Here is a method whereby any amateur with a receiving set can determine the wavelength of incoming signals from a transmitter. Simple directions for construction and hook-up are given.

A SIMPLE wavemeter consists of a coil and a condenser connected as in Fig. 1. When used to measure the wavelength of a sending station a sensitive high-frequency current meter is added to it as in Fig. 2.

At the sending station there is a large amount of energy available, and the coil

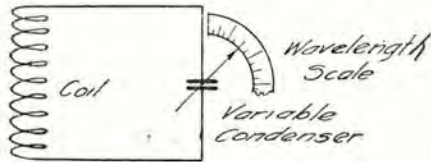

Fig. 1. Simple Wavemeter

of the wavemeter is brought near the output coil or even near the ground lead. The wavemeter condenser is then varied until the greatest current is shown by the meter. The wavemeter circuit is in tune with the station at this point, and the wavelength is usually marked on the condenser scale or dial.

This method cannot be used at the receiving station because the amount of energy received is too minute to affect the current meter. With a regenerative receiving set, and a simple wavemeter as shown in Fig. 1, it is possible to measure accurately the wavelength of the received station.

Increase the regeneration until the station in question is being received the loudest with the set oscillating. In the case of a C. W. or telephone station, the usual heterodyne note will be received, and it should be tuned just half way between the two loud points. Then, without changing the adjustments in any way, bring the coil of the wavemeter near the

secondary or grid circuit coil. Vary the wavemeter condenser until a click is heard in the telephones. If the click is not at a well defined point, or if a double click is heard, the wavemeter coil is perhaps too near the secondary. Remove it until the click is just audible and sharply defined on the scale of the condenser. The wavelength is then read directly from the condenser scale.

The reason for the click is a change in the plate current. When the wavemeter circuit is tuned to the wavelength at which the set is oscillating, it receives energy and causes the set to either stop oscillating, or produce weaker oscillations. In other words it has the same effect as placing the finger on the grid condenser terminal, and the resulting click is the same.

If one wishes to be even more accurate, a sensitive galvanometer may be connected across the grid condenser to measure the direct current in the grid circuit. The filament end of the secondary must in this case be connected to the negative side of the filament. When the set is oscillating there will be a flow of direct current through the galvanometer, and this current will decrease as the wavemeter circuit is brought into tune. Take the reading on the wavemeter when the grid current is lowest.

A wavemeter may be easily constructed. An enclosed variable condenser, .001 mfd. capacity, very rigidly built, should be obtained. Remler-Giblin inductance coils may be used; they should be taped, and heavy leads not more than 8 or 10 inches long brought out for connection to the condenser. One or more coils may be used, according to the wavelength range desired. A group to cover the entire range of used wave-

lengths with a .001 variable condenser is as follows:

- 35 turns, 150 to 550 meters.
- 150 turns, 550 to 2300 meters.
- 600 turns, 2300 to 10,000 meters.
- 1500 turns, 5000 to 24,000 meters.

The wavemeter must be calibrated from a standard, or from one which has

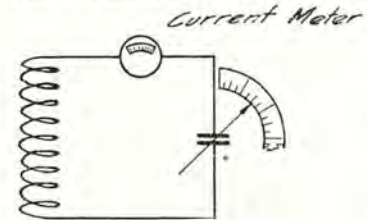

Fig. 2. Wavemeter with Current Meter

been so calibrated. One can usually find in each locality a radio firm or a college laboratory fitted up to do such work, and who will make only a small charge for it. The dial on the condenser may have a different row of figures on it for every coil, or it may be marked off in degrees, and a curve may go with each coil, giving the wavelength corresponding to each degree for that particular coil.

A loose-coupled regenerative receiving set may have its secondary condenser dial calibrated in wavelengths, but it will not be as accurate as the meter mentioned above. It will serve nicely, however, to find any particular station when we know its wavelength. The reason it is not accurate is because a change in the coupling, the regeneration, the grid leak, the plate voltage, or the filament current, will alter the setting of the secondary condenser sometimes several degrees, for any particular wavelength.

BROADCAST FROM RADIO "KNUT"

(Being actual letters received in the daily mail of a Radio Editor who is at present in a nice, sunny sanatorium with nothing to do but play with an Armstrong super-regenerative circuit.)

Dear Mr. Editor: How far will a crystal work and what is the battery cost per day if I use it all the time during concert? Could you give me a dealer or so?—MMJ.

Dear Sir: Thanks very much for yer concert las p.m. the modulation was xellent but it was not vary clare in partz. we are entile to better and hop you will shrtly. Yrs—SFT.

Mr. Editor: I am living in an apartment where the landlord objects to an aerial for radio. Could I sneek up on the roof at night and use a clothesline or is this pro-

hibited? Several friends are waiting for your reply.—Sincerely, KL.

Mr. Editor: Which is better—catwhisker or variometer? I can bye both as money is no object only that I want to hear well.—Very truly—HJF.

Mr. Editor: My wife's sing very good, with little training but good nice voice for radio. Could you use? I request ans.—Very yrs—TG.

Radio Editor: Can you tell me does the grid leak go in antenna or across A battery. I have tried both, but cannot see any difference as set will not work either way. Yrs truly—FDS.

Editor sir: You make me sick. I buy radio which I make from diagram as shown, and by wrong connection burn up three lamps—foeuy! If you had not printed, it

would have been in for me \$15 or less. Your connection maybe all right but not for ignoramus like self. Thanking you, remain, yrs—GHK.

Dear Sir: Could you please tell me, not for publication, if it is all right to run a still in same house with radio? Would this annoy receiving coils? The still is copper.—Yrs—JFG.

Editor Radio: If I learn the radio code could I get a position as lady operator with gentlemanly captain, on liner? I am eighteen but not a flapper and mean business. Would like to go to sea with right man. Would appreciate reply. Yrs.—Miss FGH.

Radio Editor: In hanging aerial can I cross high tension wires and how do I get over without killing myself? My wife's brother is a pole climber and I can arrange that, if I know just how.—Yrs.—GYT.

Continued on page 30

Eliminate the Ox Drivers

By Geo. C. Tickenor, 6AQA

WHAT would you say if a stone wheeled ox cart, a couple of centuries out of date, went lumbering down the main street of your "home town" tying up all traffic, delaying all street cars and holding back hundreds of automobiles? Not only that, but suppose the driver absolutely refused to get out of the way saying, "Well, I get there just the same, don't I?" If it did hap-

pen, the chances are that you would like to wring his neck, and undoubtedly would if you found the opportunity. Now then, what has the above to do with radio? Just this: the above is taking place every day in amateur radio, and as yet no one seems to have the nerve to "wring the ox cart driver's neck." To get down to plain facts, the ox cart driver is the narrow-minded fellow who today transmits with a spark set!

pen, the chances are that you would like to wring his neck, and undoubtedly would if you found the opportunity.

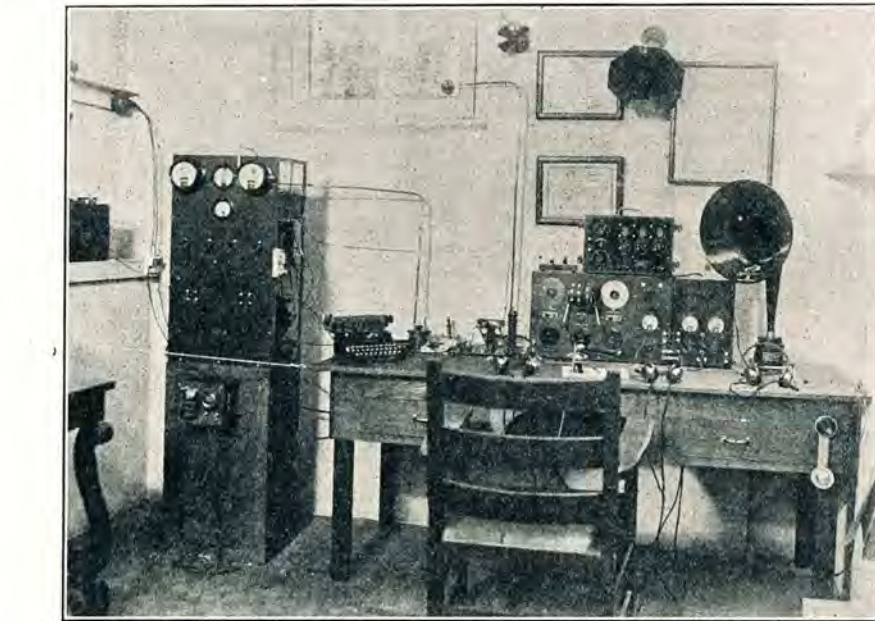

Twenty-Watt Transmitter and Receivers at 6AQA

pen, the chances are that you would like to wring his neck, and undoubtedly would if you found the opportunity.

Now then, what has the above to do with radio? Just this: the above is taking place every day in amateur radio, and as yet no one seems to have the nerve to "wring the ox cart driver's neck." To get down to plain facts, the ox cart driver is the narrow-minded fellow who today transmits with a spark set!

Sit down at your set—put on the phones—and listen in. From the minute the kids get out of school until their folks make them go to bed, which isn't half as early as it should be, they "play around" with their pre-historic outfits, "testing" or working the fellow in the next block on one kilowatt.

You may listen any afternoon to spark sets on full power running continuously for from five to ten minutes. Then the word "TEST" will be sent for a half hour or so, and finally he will call his friend and ask "H-O-W D-O I C-O-M-E I-N T-O-D-A-Y?" Now I used to have a spark set a few years ago, but I'm darned if I had to run the thing for three hours each afternoon in order to keep it working right. Don't any of these poor, dumb specimens of humanity know that if they would keep

off the air and listen-in for a change they could hear stations that are hundreds of miles away, and possibly surprise themselves by working those stations? So much for the fellow who "tests." Now for the one who does work fairly distant stations and handles messages but who also does it on a spark set.

Don't come whimpering and say "A C. W. set costs too much." It costs no

more than a spark does,—and we all know it. It does take a normal amount of intelligence to build and properly work a tube set, and the lack of this intelligence is undoubtedly the reason a few mentally deficient beings in every town still pollute the air with the infernal crash of an antique spark set. There can be no other reason. The only thing I can't understand is why those who *have* normal reasoning powers put up with the others. The autoists would never permit the antediluvian ox cart on the streets today; then why is the spark fiend permitted to rend the air from 150 to 600 meters with a din that makes riveters in a boiler factory sound like a churchyard at midnight in comparison? Please understand me,—I'm not advocating the use of force against the spark-hound, but when the innumerable advantages of a tube set are set forth, and are universally recognized, as they are today, I fail to see how any person can be so ancient and narrow-minded to persist in using a spark.

Lest some of you who read this and "feel hurt" should imagine it is written "by some old crab who wants to listen to the broadcasting stations and can't read code," I want to tell you you're wrong. I started in the game in 1911,

holding the call "3NG" (which was most appropriate at the time) in 1913 at Swarthmore, Penn. The early days of the war found me at NAF, Newport, R. I. Today I am "6AQA" on C. W. and am hoping that the day will come soon when all amateur sparks will be forced off the air by government legislation if they won't "come around to C. W." of their own free will.

My station, as shown in the accompanying picture, is located on the roof of the Athletic Club at Los Angeles, Calif. The aerial is supported by two steel masts 58 ft. above the roof and consists of 5 wires in the inverted L type. The lead-in is a 6-wire cage of 10 in diameter. The counterpoise is made of 14 wires on 26 ft. spreaders and lies directly under the aerial. The height of the aerial above the street is 208 feet.

The transmitter uses four 5 watters in a Hartley circuit, the radiation being 3.8 thermo-couple amperes on straight C. W. and 1.2 on voice, moving up to 2.1 when the voice is impressed on the circuit. The plate voltage is about 550. The motor-generator is mounted behind the lower part of the panel, following the practice of most commercial transmitters.

The receiving sets are a Kennedy Universal (on the table at the extreme left of the picture) and two stage amplifier to match,—a home-made "Universal" set and two step using the CR-5 circuit for short waves and duo-lateral coils for long waves. The small set on top of this is a special portable outfit (also home made) with a range of 150 to 3000 meters. It consists of detector and two steps and has the "B" batteries inside, there being 22 volts on the detector tube and 60 on the amplifiers. There are four 6-volt storage batteries of Willard make; two being of 150 amp. hours capacity each and the other two of 80-100 amp. hours capacity. These are "kept in spirits" with a Hom-charger which is mounted on the transmitter pedestal. There are four pairs of Western Electric headsets, two Radio Magnavox and a special wall type of loud speaker. The "mill" is a Corona.

BROADCAST FROM "KNUT"

Continued from page 29

Editor of Radio: I am Chinese boy L. H. of 10 yrs and thinking of building radio. Can I hear American music if I use Chinese material buy locally? Please response for stamps attach. Sincerely yrs.—LH.

* * *

Editor Radio: In your diagram printed yesterday you say positive of B bat must go to plate. Is this always? I have heard signals without B bat at all. Is this a freak or a cheaper system?—Thanking you for a reply, remain—yrs—ADF.

A Practical Radiophone

By Philip R. Tarr, 8ALT

There are few amateur stations that in appearance and performance excel 8ALT. The author gives the salient features of his station's equipment and control.

BEFORE going into detail concerning the set in question, I wish to impress upon those of you who may take interest in this construction that you will be more than repaid by building along these lines. It was built with three objects in view, namely, looks, ease of operation, and efficiency. Quite a few beside myself have operated this set and all fully agree that I have attained the three objects.

All controls are within half an arm's length of the operator, and the motor generator set is well isolated three floors below, thus effecting perfect quiet while operating.

I cannot go farther without thanking those who have been so kind as to write me lengthy reports and send me cards concerning the reception of my signals. With no exceptions all have reported the signals as loud, good of tone and steady. All districts except the sixth and seventh have been worked (on voice). The continuous wave signals have been reported several times in British Columbia and California and have been logged in Hawaii. 6XAD was worked November 18th 11:12 PCT, and again November 21st 3:55 a.m. PCT. Each time his signals rolled in in the best of shape though through local QRM. I wish to state that 8ALT has also been heard in Plymouth, England, on a single circuit receiver with detector only. The letter received is unsigned but requests me to operate at such times as specified therein. As 8ALT is a reassigned call and Mr. Hillman, the former holder of this call, was not at home at the time, he did not forward the letter to me until the scheduled dates were well passed. The log of the letter and my log coincide. The writer, also, states that he logged

3AQR, 3BG, 8BSS, and 8AQO on September 12th.

The antenna at this station consists of a four-wire box, 4 ft. across and 70 ft. high at one end with a slight slope to the other. A wood mast with a section of 10 ft. pipe is used for support. The counterpoise is fan-shaped and well

come closer than ten feet until on the binding posts of the set.

Three receiving sets may be used at will. The large set, which can hardly be seen at the left of the picture, consists of Reinartz tuner or variometers. The output of each detector may be switched to an included two-step. The

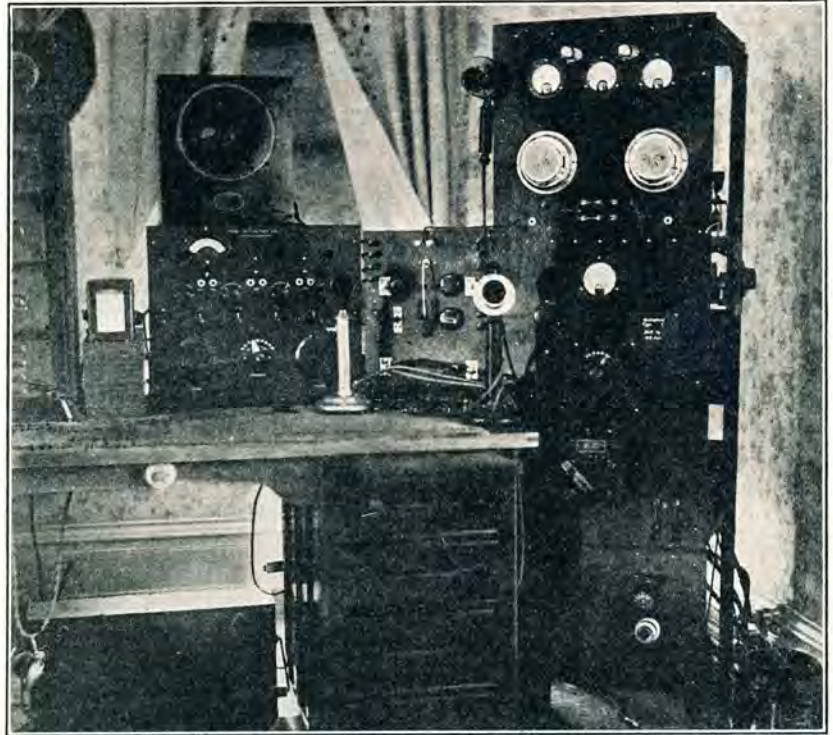

Radiophone Transmitter and Receiver at 8ALT.

spread out under the antenna. Ground connection is also used, this connection being directly below the operating room and consisting of buried metal sheets and water pipe connections. The lead-in is also a box type and at no point do the incoming leads of counterpoise and aerial

equipment used ordinarily is a straight regenerative and detector with three steps of amplification. Western Electric tubes are used in the amplifiers in connection with a 180-volt unit made by Ki-Ko.

The transmitter circuit is the tickler arrangement with Heising modulation and either speech amplifier or two modulators. At present, however, 350-watt tubes are used and a radiation of 4 amperes (thermo couple) is obtained on voice, using one oscillator and 6 amperes with three tubes in parallel.

The constant current choke is of the 6 henry type with a variable air gap in the core. The high frequency choke is mounted on a Micarta tube 4 in. in diam. with 260 turns of No. 18 DCC wire.

The plate and grid condensers are of copper and mica, 3 x 5 in. with four plates in all.

The filament filter is of the Campbell type "low pass." The high voltage d.c. filter system is made ultra efficient by "building up" the high voltage side.

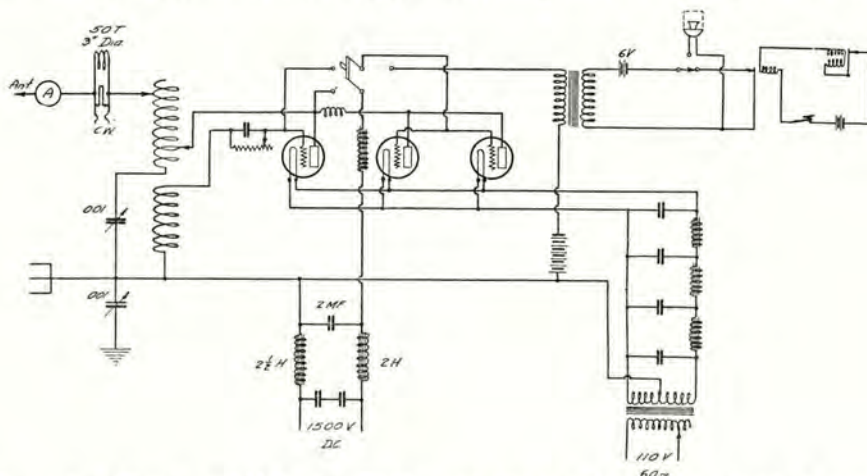

Transmitter Circuit at 8ALT using Tickler with Heising Modulation and either Speech Amplifier or Two Modulators.

When tuning for modulation the set is adjusted so that radiation will increase at least $\frac{1}{4}$ ampere when speaking in the microphone. Bias battery is then cut in until the increase when modulating is approximately 2% that of the total radiation. Although a little against theory, this system has never failed to give the best of results.

The microphone is a 229 Western Electric and is mounted in a piece of 3-in. tubing, 5 in. long. This is bad practice, however, unless experienced in using a microphone in this form. Nine times out of ten when this method is employed only high notes are heard and a jumble results. But by practice, I will guarantee this to surpass the open microphone in all ways. The lips should be placed at the upper part of the front and inside with a slight downward tilt of the tube. The breath must be depressed and a strong monotone should be used. Care should be taken to pronounce each word slowly and distinctly. All DX tests have shown this arrangement to be far superior. In fact, this arrangement will give a deflection equal to 80% that of a well adjusted buzzer, while the average microphone deflects little over 40%. In every case mention of the fine qualities of the voice have been made.

Magnetic relays are used for change over and can be operated from the microphone, or control board to the left of the set.

The motor generator is of Esco make and is driven by a 1 h.p. General Electric motor. This unit supplies 1500 volts d.c. for the plates. A large field rheostat allows a range from 900 to 1500 volts, which is controlled from the radiophone panel. Adequate circuit breakers and fuses have been installed with all inside wiring encased.

In conclusion, I wish to again thank those who have given me aid in numerous tests conducted here. I wish to thank, in particular, Mr. Armstrong of the Radio Specialties Company for his aid and information in construction. Others hearing this station, or desiring to conduct tests, please write to P. R. Tarr, Dawson, Pa.

POLAND'S TRANS-OCEANIC RADIO STATION

Direct radio communication between Warsaw and New York will be possible with the completion early in 1923 of a high-power station at Warsaw and a receiving station at Grodzisko, 20 miles to the west. The stations are being constructed under the direction of the engineers of the Radio Corporation of America. Two 400-ft. towers support the aerial. Power is furnished from a 750 h.p. station turbo generator unit and a 750 h.p. Diesel engine unit. Remote control allows all sending and receiving to be done at a central office in the business center of Warsaw.

MOTOR FIRST AID VIA RADIO

Motor first aid via radio is being being furnished autoists along the coast route between San Diego and Los Angeles. An automobile truck, equipped with radio apparatus for both sending and receiving and carrying auto parts, supplies and accessories, is on the road 24 hours a day furnishing free service to motorists in trouble. The driver-operator, W. H. Long, is on the payroll of the Boulevard Express company, and is constantly in communication with both the Los Angeles and San Diego offices of the firm.

At the San Diego office of the express company there is no radio sending outfit. So Lester Picker, 16-year-old crippled boy, known throughout Southern California as the "radio cop," was



Radio Equipped Trouble Truck

pressed into service. He has one of the finest outfits in the country and, although he is bed-ridden, his outfit is placed so that he can operate it without trouble. He communicates with the Boulevard Express company's office and relays messages between their office and the radio truck. Young Picker has been confined to his bed for more than a year as the result of a fall from a wireless aerial and physicians say he may never walk again. Since that time his only interest in life seems to be radio and wireless telegraphy and he is known as one of the finest operators in Southern California.

It was first planned to have the radio truck render service only to cars owned and operated by the Boulevard Express company. Then Chas. Boynton, manager of the company, decided to take in other firms to share the expense of operation with him and render service to any motorist in trouble. U. S. Grant of the U. S. Grant Auto Equipment com-

pany of San Diego, furnishes the tires for the truck. Ralph Hamlin, Inc., furnishes all lubricating oil and the



Lester Picker, the "Radio Cop"

Pickwick Stages contribute monthly toward the gasoline expense.

The car is fully equipped to render almost any kind of service and has been doing exceptionally good work during rainy weather pulling stalled machines out of the mud in the Capistrano detour. The truck is a GMC with a covered body. Inside are kept supplies and accessories, besides a complete camping outfit and the radio paraphernalia, with the exception of the aerials, which are stretched across the top of the car.

Long, the driver-operator, also furnishes market reports on produce to ranchers along the route of travel each day. The sending power of his apparatus is 20-watt C. W. transmission and 10-watt telephone transmission, with a wavelength of 200 and 550 meters.

PROPERTIES OF ELECTRICAL INSULATING MATERIALS

Technologic Paper No. 216 from the U. S. Bureau of Standards treats of the "Properties of Electrical Insulating Materials of the Laminated Phenol-Methylene Type," being written by J. H. Dellinger and J. L. Preston. These materials are made by building up sheets of paper, fiber or fabric which have been previously impregnated or coated with phenolic varnish (bakelite, condensite or redmanol) to some desired thickness and then subjecting the stack to great pressure in a heated hydraulic press. Reports are given as to tests of radio-frequency phase difference or power loss, dielectric constant, and flash-over voltage, direct-current surface resistivity and volume resistivity, tensile strength, modulus of elasticity (tensile), proportional limit, modulus of rupture, modulus of elasticity (transverse), Brinell hardness, scleroscope hardness, impact strength, permanent distortion, density, moisture absorption, machining qualities, thermal expansivity, and the effects of heat, acid, and alkali.

The data on these properties have been arranged in such a manner as to be conveniently available for reference, either by a person desiring detailed information or by a person interested only in a general way in the more important properties.

Brief comparisons are also made of the properties of these materials with the properties of hard rubber and vulcanized fiber. This publication may be obtained for 30 cents from the Superintendent of Documents, Government Printing Office, Washington, D. C.

NEWS OF THE BROADCASTERS

BROADCASTING AT HAVANA, CUBA

By B. H. WURM

STATION PWX, located at Havana, Cuba, is owned by The Cuban Telephone Company, associated with The International Telephone and Telegraph Corporation of New York. The inauguration of this station took place on Oct. 10, 1922, with an address to the people of the United States, delivered by President Zayas of the Republic of Cuba, and has been presenting regular programs every Wednesday and Saturday nights since. The program commences at 8:30 P.M. Havana time, which is one half hour earlier than Eastern Standard Time. These programs are broadcasted on a wavelength of 400 meters. A feature is that announcements are made in both Spanish and English.

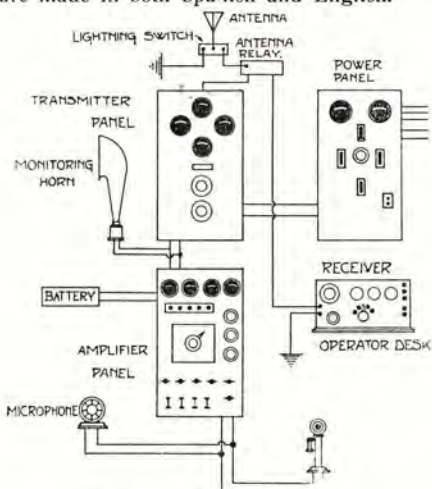

Station PWX Layout

Results from this station have been exceptionally good, reports having been received from all parts of the States, the most distant point being Prince Albert, Saskatchewan, Canada, about 2300 miles. The writer attributes these good results to the good location of the station. Cuba is surrounded entirely by water and has no mountains to speak of to distort the waves on their travel. There are no steel buildings, metal structures, bridges, etc., to absorb the radiated energy.

The station is laid out as follows. A large room is set aside to receive the artists. In this room is placed a Western Electric horn which is connected to receiving apparatus in the operating room. This allows the artists, who are waiting for their turn, to hear the other parts of the program.

Next to this room is the studio, arranged for proper acoustic conditions. Here we also find sounding boards which can be arranged in any location desired. The operating room is next to the studio, communication between the two rooms being maintained by a light control and telephone system which enables the operator to keep in constant touch with the announcer and vice versa. One telephone light, used instead of a bell, operates with the lift of the hook.

The aerial consists of three wires supported by two steel towers 120 ft. apart. The lead-in is 170 ft. long, taken from the center of the antenna, making a T. The towers are built upon a building which is 65 ft. high.

The transmitter consists of a standard Western Electric 500 watt outfit. This apparatus employs a 5 h.p. motor generator which supplies 1600 volts to the plates and 15 volts to the filaments. The transmitter proper has one 50 watt speech input tube, two 250 watt oscillator tubes, and two 250 watt modulator tubes. The Heising circuit is used for modulation.

WGY HEARD ACROSS ATLANTIC

WGY, the General Electric Company's radio broadcasting station in Schenectady, N. Y., has successfully transmitted a musical program across the Atlantic Ocean, according to word received from Dr. W. R. Whitney, director of the company's research laboratory who is traveling abroad. Dr. Whitney states that he talked with Chief Radio Operator Black of the S. S. America, who stated that while the ship was docked in Cherbourg, France, he picked up an entire evening's program from WGY and that the signals came in so clearly that when he laid the phones on his table the music was audible in the radio cabin.

reproducing it with perfect clearness. The machine was set up in a hotel in Washington ten days before. The Vice President and the War and Navy Secretaries spoke into a small recording horn. As they did their voices caused a small diaphragm to vibrate to which is attached a tiny mirror, scarcely smaller than the head of a pin. This oscillation or flickering of the mirror reflected a beam of light upon a moving photographic film, thus recording the human voice accurately with the overtones, the delicate shadings of speech, and other characteristics which make one voice sound different from another.

The film was taken to Schenectady and was broadcast twice on Christmas eve from the WGY studio, the first time at 7:30 o'clock

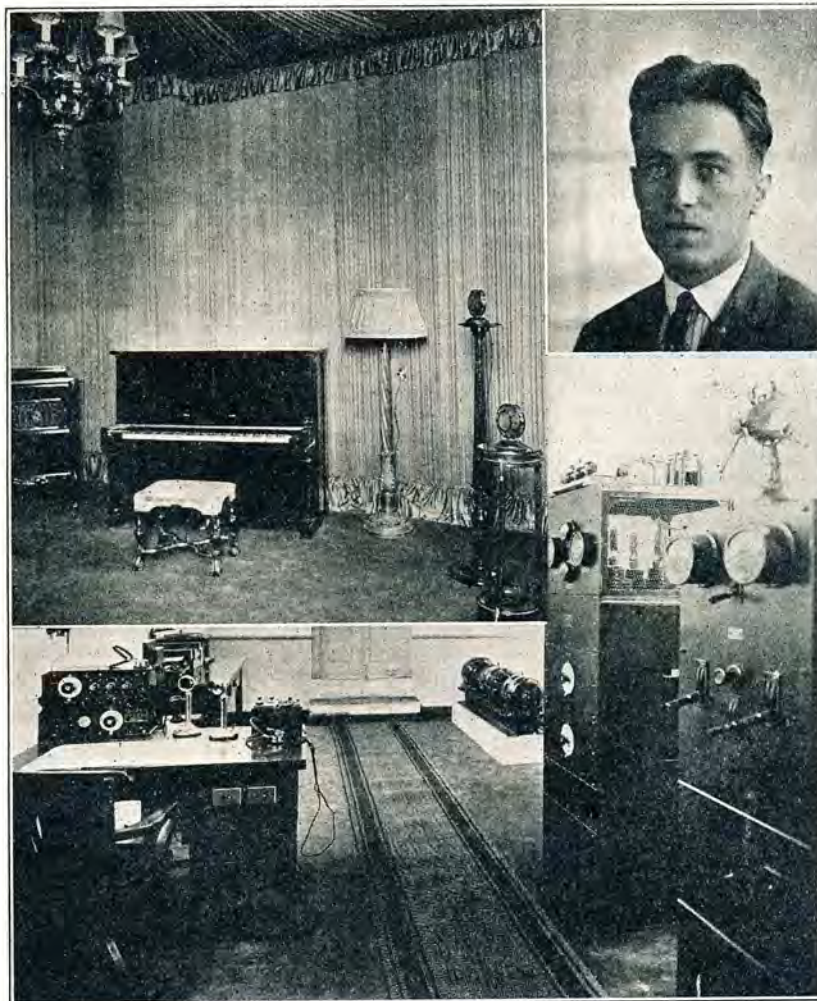

PWX, Havana, Cuba, B. H. Wurm in Charge

BROADCASTING WITH THE PALLOPHOTOPHONE

Christmas greetings to the people of the United States from Vice President Calvin Coolidge, to the active and ex-service men in the U. S. Army from Secretary of War Weeks and to the active and ex-service men in the U.S. Navy from Secretary of Navy Denby were broadcast on Christmas eve from WGY, the high power radio station of the General Electric Company at Schenectady, N. Y. This was the first time that three leading executives of the country ever attempted to extend their greetings in a way that reached the four corners of the country simultaneously.

This feat was made possible by use of the Pallophotophone, a new General Electric device for photographing the voice and later

during the regular Christmas program and again at 10:30 o'clock for radio fans in the western states who were listening.

In reproducing, the film is passed before a strong ray of light and the zig zag markings on it—the sound waves photographed—create electric waves which pass through an arrangement of vacuum tubes and produce sound waves again which are sent directly into the radio broadcasting apparatus without the use of a microphone or any sort of a pick-up device ordinarily used.

This feat of recording the speech of a person in a distant city is believed to have introduced an entirely new element in radio broadcasting—the possibility of making a master record and broadcasting it days or weeks later from any radio station in the country.

DIGEST OF RECENT RADIO PATENTS



R. Brown, Pat. No. 1,433,599: Oct. 31, 1922. Radio Circuit.

In order that signals may be transmitted from antenna *A* at the same time that signals are received from antenna *RA* where both antennae are relatively close, an arrangement is provided for alternately rendering these antennae ineffective at a rate intermediate between the signaling frequency and the carrier frequency. To accomplish this result, thermionic commutators *TI* and *RI* are inserted in both circuits, and the grid potentials of these tubes are controlled from a source of high frequency in an alternate manner, so that while commutator *TI* is active, commutator *RI* is inactive, and vice versa. In order to secure as good results as possible, a distorting tube *DT* is inserted between source *O* and the commutators, whereby potentials of flat-topped wave form are supplied to the commutator grids.

H. W. Weinhart, Pat. No. 1,432,931: Oct. 24, 1922. Electric Discharge Device.

In order to increase the power of a thermionic device, the anode *4* is made in the form of a tube which may be kept cool by the circulation of water or oil. In this way the effect of the electron bombardment to raise the anode temperature is nullified. The grid *3* is shown in the form of a helix surrounding the anode, and the incandescent cathode as a filament placed near the grid.

W. H. Nottage, Pat. No. 1,432,354: Oct. 17, 1922. Radio Signaling Apparatus.

This scheme is used to relay a signal sent by wire, by the aid of radio, or, vice versa, to relay a radio signal over a wire circuit. A Wheatstone bridge arrangement having arms *A*, *B*, *C* and *D* is used for this pur-

pose; arms *A* and *B* are connected respectively to a wire system *E* and to an artificial line *F*, the equivalent of *E*. The other two arms have impedances *C'* and *D'*. The radio receiver is connected between arms *A* and *B*, and between arms *C* and *D*, while the radio transmitter is connected to the other diagonal of the bridge. Radio signals from the radio receiver cannot affect the radio transmitter if the circuits be properly proportioned. On the other hand, audio signals from the system *E* can affect only the radio transmitter, since the receiver is tuned to be sensitive only to radio frequencies.

E. W. Kellogg, Pat. No. 1,434,707: Nov. 7, 1922. Radio Receiving System.

A number of widely separated receiving antennae *1, 2, 3, 4, 5* is provided, each connected by lines to a central control station. By choosing properly those antennae which happen to receive under most favorable conditions, the effect of static may be almost eliminated. In order that the signals from more than one antenna may be properly combined when necessary to obtain the best results at the main receiving apparatus *28*, phase shifters *27* may be provided in each antenna control circuit; furthermore a source *16* of comparatively low frequency transmits to the antenna detectors a control current, which with the aid of apparatus *18* is in that the shielding is effected at audio frequency, so that whenever a disc tooth is interposed between the coils, there is not a complete interchange of energy between the two circuits. In order to maintain the load on the source *J* constant, another circuit *U-S* may be used, which has characteristics similar to the antenna circuit, and arranged near disc *L* so as to be coupled to the generator

circuit whenever the antenna circuit is decoupled, and vice versa.

H. H. Beverage, Pat. No. 1,434,984: Nov. 7, 1922. Radio Receiving System.

The described scheme involves the use of a long horizontal antenna *1, 2* grounded at its ends. With such an antenna signals may be received with greatest intensity from stations which are approximately in line with the antenna. Due to the electrical constants of the lines, however, it is found that signals from a station reach their maximum intensity at the end of the antenna farthest from the station, and this effect may be augmented by the proper choice of antenna constants. It is thus possible to receive signals from opposite directions by the aid of detectors inserted at each end of the antenna. With the present arrangements, however, the detectors *21, 24* may both be located at the same end; in the case of detector *21*, using the amplifier *11*, signals from the right are received, while amplifier *12* and receiver *24* serve to detect signals from the left. In the latter case the antenna itself is used to transmit the received signals from the right hand end, by the aid of the transformer *7-8*.

H. C. Egerton, Pat. No. 1,426,826: August 22, 1922. Re-Electron Discharge Device Circuits.

Since an excessive positive charge on the grid of a three-electrode thermionic device such as *5* is undesirable, it is proposed to permit this charge to leak off through a unilateral conducting device. Thus a two-electrode device *15* may be connected between the grid *17* and the filament *19*, so arranged that current can pass only from *17*, through *16, 18* and to *19*, but not in the opposite di-

Continued on page 55

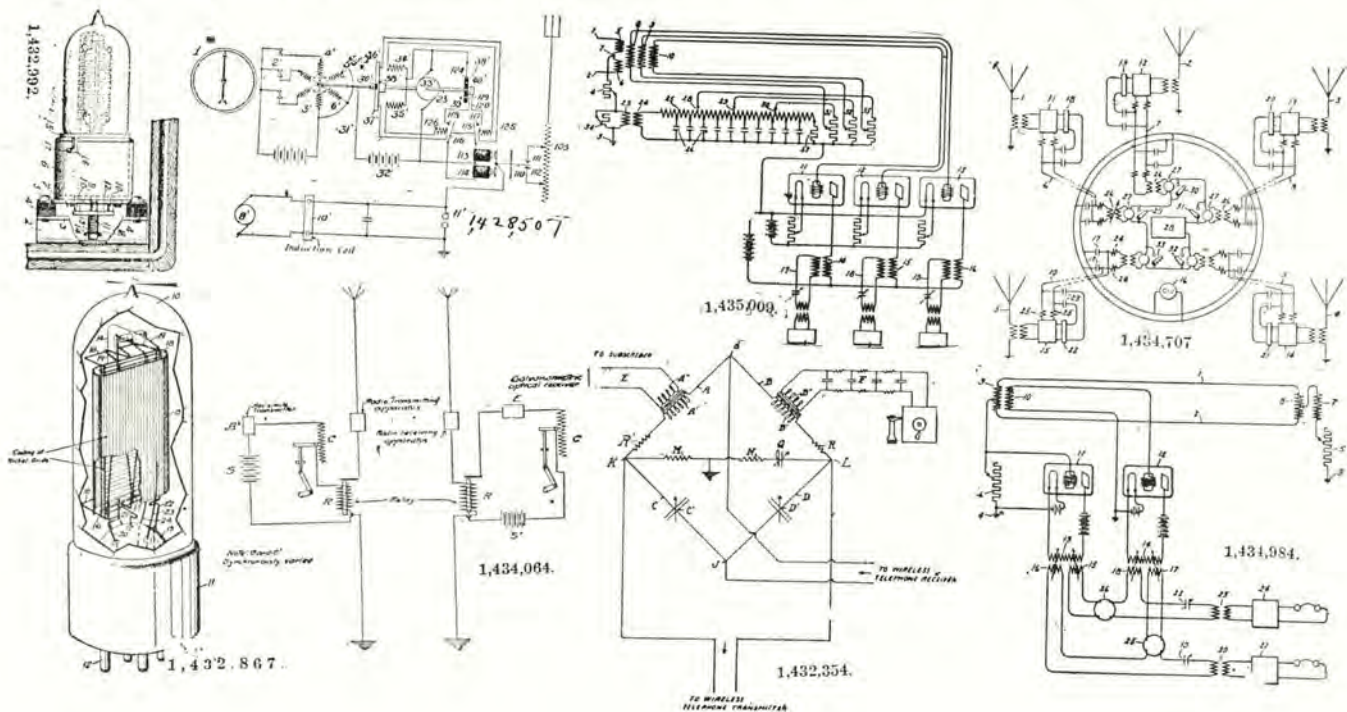

QUERIES & REPLIES

ON C.W. PRACTICE

BY
Gerald M. Best
TECHNICAL ADVISOR



Please publish a circuit to efficiently operate a detector and 2 stages using WD-11, Westinghouse tubes, with loud speaker and Ducon plug.

E. W. S., Waldwick, N. J.

The circuit you wish is shown in Fig. 1.
1. You will not get enough energy out-

pipe iron as good for making transformer cores as silicon steel? What causes one cell of a storage battery to run down faster than the other two?

-P. G., Lemoore, Calif.

Would suggest that you write to one of the many storage battery companies

Calif., its manufacture being discontinued some time ago. It is a soft tube, and is used mostly as a detector or oscillator. The Radiotron and Cunningham tubes, which are identical, replaced the Audiotron, and have the advantage of a base, and improved operating characteristics.

I would like to have some information relative to Armstrong's new super-regenerative circuit. R. D., Miami, Texas.

Two articles on the super-regenerator were published in September RADIO. Another appears in this issue.

Kindly furnish me with a circuit with detector and three stage audio frequency amplifier, using plugs and jacks for cutting out the various stages.

M. L., Yakima, Wash.

The circuit appears in Fig. 3. The choke coil in the last stage is a Wayne bell ringing transformer, using the primary winding only.

Please tell me, through your columns, what is wrong with my circuit, as I cannot hear anything except the local stations. O. A. C., San Francisco.

Your circuit appears to be correct and your trouble probably lies in the method of tuning. Perhaps your tube is a poor oscillator and will not regenerate with the tickler you are using.

Please furnish me with a circuit for phone and C. W., using Mullard English

put from a WD-11 tube to give very much volume with a loud speaker. Suggest your using WD-11 tubes for the detector and first stage, and one of the larger tubes for the last stage, if you wish to have considerable volume in the loud speaker.

I have a 1/2 k.w. Packard transformer, the secondary of which is wound in two sections. Could I use one of the secondary sections alone for supplying plates of two 5-watt tubes, by rewinding the primary with more wire?

G. W. K., 9BTJ, Amherst, Wisconsin.

Such an arrangement would be pure guesswork, and I would advise you to make new windings for both primary and secondary. If you will tell me the cross sectional area of the core, and whether it is of silicon steel or iron, I will give you the necessary information to wind the coils.

Please publish a circuit using two 50-watt tubes, with 5-watt speech amplifier, with the reversed feedback system, for C. W. work. B. L., Los Angeles, Calif.

The circuit is shown in Fig. 2.

Where and from whom can I buy moulds for casting the standard size lead plates for storage batteries? Is stove-

who advertise in this issue. In general a core made of stovepipe iron requires about twice the area of one using silicon steel, when using the same design formulae. If one cell of your battery runs down faster than the others, it is probably defective, and should be taken to a repair shop. Sediment in the bottom of the cell, or poor separators generally contribute to such troubles.

valves, two 40's as oscillators, and two 40's as modulators, and one 20 as speech amplifier. J. F. A., Grand Forks, N. D.

See Fig. 2 for the circuit, which should fit in with the English tubes without trouble.

Starting at 140 meters, the number of turns on tubes 3, 3 1/2 and 4 inches, and size of condenser with regards to low decrement and sharp tuning in a wavemeter. Also probable range of coils.

R. K., San Francisco.

Your question is not at all clear, as you do not state what the maximum range of the wavemeter is to be.

Please publish a circuit for an efficient two-circuit tuner, for use with my detector and two stage amplifier. Please give me a circuit for C. W. and phone, using a 5 watt tube. What voltage should the transformer be, and how many cells for the rectifier?

L. L. P., Sultano, Calif.

The article by D. B. McGown, in January RADIO, presents a fine two-circuit tuner of the type you wish. Fig. 5, on page 35 of the same issue shows a

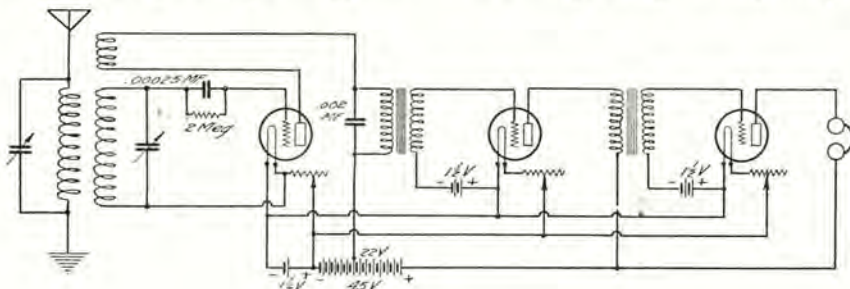

Fig. 1

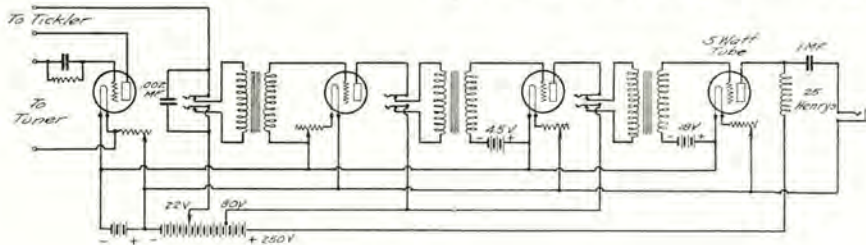

Fig. 3

What is the difference between an Audion detector and a Radiotron detector? A. J. N., Hamilton, Wash.

The Audiotron tube was made by the Audiotron Mfg. Co. of San Francisco.

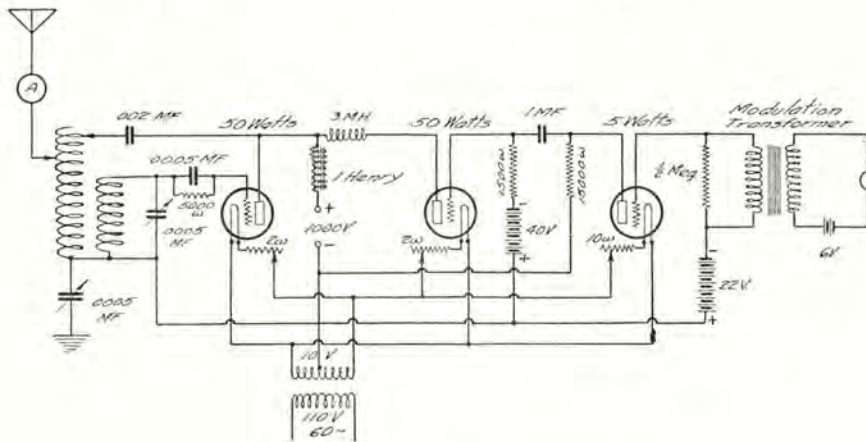

Fig. 2

circuit for a one-tube transmitter. The transformer secondary should be 550 volts, and you should have at least 12 cells in your rectifier for that voltage.

Please advise where fish paper of 5 mil thickness may be purchased. This paper is for use in winding a 10 watt C. W. transformer.

E. M. D., Orange, Texas.

Suggest you using ordinary tracing cloth such as is used for blueprints, for such cloth would furnish good insulation where the voltage between layers is as low as yours would be.

Is it likely to damage my 5 watt tube if I use it without grid condenser or leak? The radiation is doubled by omitting them.

R. H. P., Riverbank, Calif.

Not unless the plate becomes excessively hot. It is probable that there is enough capacitance in the leads of your set to make a grid condenser unnecessary.

Please publish a circuit for a one stage audio frequency amplifier to go with the "Sphinx" receiver described on page 22 of August RADIO.

M. C. B., Wheatland, Calif.

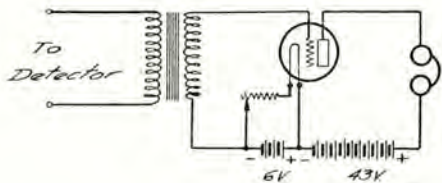

Fig. 4

This circuit is shown in Fig. 4.

Is it possible to add a Radio frequency amplifier to the Gibbons receiver described recently in your magazine?

G. E., Berkeley, Calif.

Yes, but if you do you lose all the advantages which the receiver is supposed to possess, namely, simplicity, regeneration and economy. If you wish to use radio frequency amplification, it would be necessary to use different apparatus in the detector circuit.

Please tell me what is the best type of telephone transmitting circuit for use with a portable set, for very short distances.

H. H. W., San Francisco, Calif.

See the article by the writer in next issue of RADIO, on a transmitter using the same filament and plate batteries as the receiving set. This should answer your purpose and transmit over a considerable distance.

Please tell me what is wrong with the enclosed circuit, for a one stage audio frequency amplifier connected to the Gibbons receiver described in August RADIO.

N. C., Los Angeles, Calif.

You have your "B" battery in the wrong place. See Fig. 4 for the correct circuit.

Would like to have a circuit for a Magnavox, with two-step amplifier, for use with an ordinary telephone transmitter, so that the Magnavox could be used in addressing a public carnival which our school is to have.

K. G. S., Spokane, Wash.

The circuit, with the necessary data, is shown in Fig. 5.

Please publish a circuit using two 50-watt tubes, for C. W. and telephone. Also publish a circuit for a 2 k.w. spark set. What is the difference between a radio and an audio frequency amplifier.

J. G., Beechview, Pittsburg, Pa.

See Fig. 3 for the phone circuit. This department does not publish circuits dealing with spark sets. A radio frequency amplifier is one which amplifies the incoming signals at the frequency with which they were transmitted, which is usually of a value inaudible to the human ear. The detector is attached to the output of such an amplifier. An audio frequency amplifier is one which amplifies the signals after they have been rendered audible to the ear, in the detector circuit, and usually has a frequency range of from 400 to 3000 cycles.

Kindly give me a diagram for a three-globe set using a VT-1 detector and two VT-1 amplifiers, using honeycomb coils for the tuner.

S. E. S., San Francisco, Calif.

The circuit for a detector and two stage amplifier is shown in Fig. 1. Vacuum tubes are not usually called globes, although literally they could be classed as such.

SCHEDULES OF WEATHER REPORTS BROADCAST

From Naval Radio Station (NAT), New Orleans, La.

Beginning January 1, 1923, weather forecasts and warnings for each of the States comprising the New Orleans forecast district, river forecasts, and a summary of weather conditions over the United States at 8 a.m. and 8 p. m., respectively, will be broadcast daily from the Naval radio station (NAT) at New Orleans, La.

The weather forecasts issued from New Orleans are for Louisiana, Arkansas, Oklahoma, eastern Texas (east of the 100th meridian), and western Texas (west of the 100th meridian). The forecasts for Louisiana and east Texas include, respectively, winds along the Louisiana and Texas coasts. Forecasts of stages on the Ouachita and on the lower Red and Mississippi Rivers will be broadcast only at 10:30 a.m.

The localized bulletins for the special benefit of marine interests, which have been broadcast from this radio station since June 10, 1921, as described in Weather Bureau Circular dated May 28, 1921, will be continued as heretofore.

The complete schedule (75 meridian time) is as follows:

Wavelength, 1,832 meters, spark.
10:30 a.m., State forecasts, river forecasts, and weather summary.

11:00 a.m., localized bulletin for marine interests.

5:00 p.m., storm, hurricane, frost, and cold wave warnings issued in afternoon.

10:00 p.m., State forecasts and weather summary.

Hurricane warnings and advisory messages relating thereto will be broadcast whenever issued and continued at 2-hour intervals until midnight.

LETTERS TO THE EDITOR

His Own Mother Wouldn't Know Him.

Sir: I take strong exception to the statement of G. Earle in his letter in January "RADIO," concerning the Gibbons receiver. He states any more improvements will spoil it. I differ with him. Add a few things I have used with great success in DX reception and you have an unbeatable hook-up that drags in those eastern C. W. stations every night.

As Mr. Gibbons originally stated, it was not so much on C. W. the way he had it. But I fussed around and here's the dope that'll hawl in those 5 and 8's like local stuff on tube.

Instead of a fixed grid condenser put a variable 23 plate cond. in. It can be set to tune out either spark or C. W. Sparks can

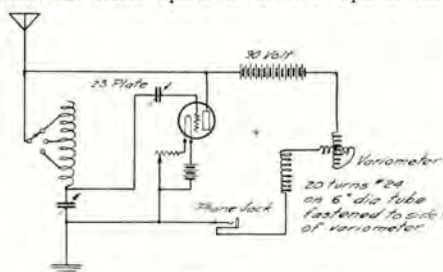

Modified Gibbons Hook-up

be eliminated absolutely. In the plate circuit we have added an inductance of 20 turns of cotton covered wire. The smaller the better, 24 is about right. Attach this inductance to your variometer in inductive relation on the side so the primary of the variometer acts as a primary on tickler affecting the inductance. Place the variometer in series with the inductance in the plate lead directly from the plate of the tube. This serves to control the oscillations very well and tunes out broadcasting QRM.

Instead of running the aerial to a honeycomb coil of 400 turns, have a tap off to the plate. I used a spider web coil of 25 turns which is tapped in 3 places, on the 6th, 10th and 15th turns. This small inductance will bring the wavelength way down, enabling one to pull in the short wave 200 DX. Arc mush will not affect his hook-up at all. I use no grid leak with this tube circuit.

I have copied 1XM, 1CIF, 1BOL, 1AAW, 1CMK, 2BKA, 2ASO, 2BQS, 3CA, 3OT, 3ZW, 4EH, 4BY, 4XG, 4ED, 4GH, 5s too numerous, 6's too numerous.

This is just to show that Gibbons hook-up can be fixed up to work on 200 meters C. W. Try it out, gang, you'll be amazed to hear those C. W.'s pouring in. 5XA at 2:30 in mid-day over 1100 miles. This was done at 6SQ on duplicate receivers.

Hoping you will print this, as I think it will help us out in our copying traffic.

SID GLASSON, 6AOR.

SALE OF SIGNAL CORP TUBES

One thousand Signal Corps Vacuum Tubes, Type VT-11, manufactured by the General Electric Company, have been declared surplus and are offered for sale to the public at a price of \$5.50 each, not more than three to any one person. These tubes have never been used, are part of the current stock of the Signal Corps, and have been released to fill an urgent demand of the amateurs of the United States for such tubes, as a part of and in connection with the training activities of the Signal Corps.

Payment must be either in cash, certified check, or postal money order made payable to the order of the Finance Officer, U. S. Army, and may be mailed to Officer in Charge, Signal Section, Chicago General Intermediate Depot, 1819 West Pershing Road, Chicago, Ill.

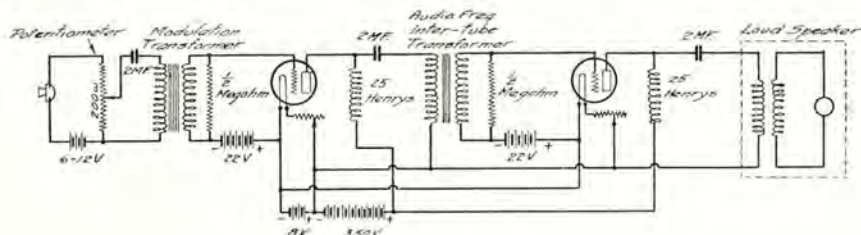

Fig. 5

WITH THE AMATEUR OPERATORS

TRANSATLANTIC TEST RESULTS

Through the courtesy of K. B. Warner, Secretary of the American Radio Relay League, the results of the trans-Atlantic amateur radio tests for the twenty-day period, from Dec. 12 to 31, 1922, are herewith presented. During the first ten nights American and Canadian amateurs transmitted while European amateurs listened. During the last ten days the Europeans transmitted and the Americans listened.

Preliminary reports indicate that 316 American and Canadian amateurs were heard across the Atlantic. The British heard 162 stations, the French and Swiss 240, while 86 American call letters were heard both in the British Isles and on the Continent. About 20 American amateurs heard European amateur signals, principally from French 8AB and from British 5WS and British 2FZ.

HEARD IN GREAT BRITAIN

First Night, Dec. 12, 1922

On schedule, code letters verified: 1BGF, 1YK, 1BCG, 2BML, 2EL, 2BQU, 2GK, 2UD, 2NZ, 2XAP, 2ZK, 2ZL, 2AWF, 3ZW, 8AQO, 8AWP.

During free-for-all period: 2BML, 2LY, 2NZ, 2ZK, 2UD, 3BGT, 3HG, 3ZY, 3BGJ, 4FB, 4OI, 4ZS, 4ZW.

Working DX: 2ZS, 2ZK, on phone, 2AWL, 2BMC, 2CJW, 3XM, 4BX, 4OI, 7PO, 8GQ.

Dec. 13, 1922

Codes verified: 1BDI, 1XM, 1AJP, 1BCG, 1BEP, 2GR, 2NZ, 2AHO, 2BML, 3BLF, 3XM, 3ZW, 8AQO, 8ATU, 8XE.

Free-for-all period jammed.

Working DX: 1BDG, 1GV, 1OR, 1YK, 2KL, 2LO, 2ZA, 2AWF, 2CSL, 2XMO, 2ZS, 3BL, 3BVL, 3ZZ, 5AAM, 5BV, 5GBZ, 8AR, 8BK, 8DB, 9IM.

Dec. 14, 1922

Codes verified: 1BDU, 1ZE, 1AJP, 1BCG, 1BET, 1XM, 1YK, 2AWL, 2LO, 2NZ, 2ZK, 2AWF, 2BQU, 2EL, 2HW, 3AUU, 3BG, 3ZW, 3ZZ, 4BY, 8AQO, 8ATU, 8UE.

Free-for-all: 1BCG, 1BDI, 1BET, 2CKL, 2AWL, 2BML, 2BQU, 3ZW, 3XM, 8BUM.

Working DX: 1CMK, 1CNJ, 2BDT, 2FP, 8AD, 8ATU, 9ZN; also 24 other stations, call letters not given.

Dec. 15, 1922

Codes verified: 1CMK, 1BET, 1BCG, 1ZE, 2AWF, 2CKN, 2FP, (incorrect; this station did not qualify and no code was assigned it); 2AWL, 2AYV, 2EL, 2ZK, 3BGT, 3ZZ.

Free-for-all: 1BDT, 1BDI, 1BET, 1RQ, 1CDX, 1CMK, 2EL, 2FP, 2LO, 2NZ, 8AQO. Also 17 unnamed stations working DX.

Dec. 16, 1922

Code verified: 2BML.
Working DX: 2TSU, 5DWP.
Something wrong here; the French had a good night, but the British report only one genuine call, the last two being obviously impossible.

Dec. 17, 1922

Codes verified: 1BGF, 1ZE, 2EL, 2ZK, 2AWL, 2GK, 3ZW, 8ATU.
Also 14 unnamed stations working DX.

Dec. 18, 1922

Codes verified: 1ASF, 1BCF, 1BET, 1AKG, 1AZW, 1BKQ, 1CJA, 1CNF, 1GV, 1XM, 1YK, 2AWF, 2AWL, 2CQZ, 2GK, 2LO, 2EL, 2UD, 2ZK, 3CC, 3AFB, 3AUU, 3BGT, 3BLF, 3NH, 3XM, 3ZW, 3BG, 4BY, 6ZZ, 8AQO, 8AWP, 8SP, 8UE, 9AUL, 9DYN.

Free-for-all: 1AZW, 1BDT, 1II, 1ZE, 2BQT, 2GK, 3EB, 3XM, 4BY, 8AXC, 8ATF, 8BX, 8BXF, 8AXE.

Also 8 unnamed stations working DX.

Dec. 19, 1922

Codes verified: 1AGK, 1GV, 1GB, 1XM, 1AJP, 1ASF, 1BET, 1BEP, 1CNF, 1YK, 2AWL, 2GK, 2ZK, 2AWF, 2BML, 2EL, 2LO, 2NZ, 2XAP, 3AFB, 3ZW, 8AQO, 8UE.

Free-for-all: 1BET, 1CMK, 2AFP, 2CQZ, 2FP, 3BFU, 3HG.



Kenneth B. Warner, Secretary A.A.R.L., and the Two-Gallon Hat Won in a Wager with M. W. Burnham that American Amateurs Would Get Across the Atlantic.

Dec. 20, 1922

Codes verified: 1BCF, 1BEP, 1CNK, 1CNF, 1AHZ, 1ASF, 1BAS, 1BGF, 1BKQ, 1CMK, 1FP, (erroneous; no such station qualified); 1GV, 1XM, 1YK, 2GR, 2CKN, 2XAP, 2CQD, 2ZL, 2EL, 2GK, 2LO, 2KF, 2AWF, 2AFP, 2AWL, 2BRB, 2BQU, 2CQZ, 2GM, 3AUU, 3BGT, 3BG, 3BNU, 3CC, 3CG, 3FS, 3XM, 3YO, 3ZW, 4BY, 4KM, 5XK, 8AWF, 8AQO, 8AXC, 8BXH, 8UB, 8UE, 8SP, 8AWP, 8BK, 8KG, 8ML, 8YD, Canadian 9AL.

Free-for-all: 1ZE, 1BKQ, 1XM, 1AJP, 1OR, 1BDT, 1II, 1BEP, 1CMK, 1BES, 1BRQ, 1BET, 2GJ, 2XAP, 2CTN, 2AWF, 2CQZ, 2BML, 2EL, 2BLP, 2FP, 2BQU, 2KG, 2CKR, 2HW, 2NZ, 2UD, 2XAO, 3BYC, 3AFP, 3CC, 3AQR, 3HQ, 3AUU, 3JJ, 3BGT, 3XR, 3BLF, 3ZW, 4BX, 4EA, 4EB, 5NK.

Also "many" unnamed stations working DX.

Dec. 21, 1922

Codes verified: 1BEP, 1CWF, (erroneous; no such call); 1BGF, 1GV, 1XM, 2AWL, 2GK, 2LO, 2BLP, 2EL, 2NZ, 2ZK, 3AUU, 3BGT, 3ZW, 4BY, 4KM, 8AQO, 8BK, 8IBF (error somewhere; no such station qualified); 8SP, 8UE, 8ATU, 8BXH.

Free-for-all: 1XB, 1XK, 1RY, 1AJP, 1BDT, 1BEP, 1BES, 1BKA, 1BMK, 1BRQ, 1CDO, 1CKP, 1CKG, 1II, 1CMK, 1OR, 1XM, 2CBW, 2XAO, 2XAM, 2ZK, 2AXO, 2BRB, 2BYS, 2CKR, 2CQZ, 3AQR, 3BLF, 3HG, 3YO, 3BFU, 3BGT, 3BNU, 3ZW, 3ZZ, 4EA, 5XK, 8ADG, 8SP.

HEARD IN SWITZERLAND

Dec. 13, 1922

Free period: 8BSS.

Dec. 14, 1922

Code verified: 8AQO. Free-for-all: 2BGL, 2RP.

Dec. 18, 1922

Code verified: 1AZW, 1XM, 2AWL, 2GK, 3AFB, 4BY, 5ZA, 8AIO.

Free period: 1AZW, 1BDT, 2CKR, 2CPD, 2RP, 3HG, 8AXC, 8CJH, 8ML.

Working DX: 1ST, 1XY, 2EL, 4EA, 8AQO, 8BRC, 8UE, 8VQ, 9CM, 9DFB.

Dec. 19, 1922

Free period: 1BDT, 1II, 2AYV, 2CBX, 2CJN, 2CPD, 2XAO, 2XAO, 3BFU, 3HG, 3OT, 3XM, 3ZW, 3ZZ, 8AQO.

Working DX: 3ZH.

HEARD IN FRANCE

Dec. 12, 1922

Codes verified: 1YK, 1BGF, 1BCG, 2XAP, 2BML, 8AQO.

Free period: 1NX, 2ZK, 2EL, 2ZS, 3HG, 3FX, 3HM.

Working DX: 1BRQ, 1MBG, 8MZ.

Dec. 13, 1922

Codes verified: 2ZK, 2AWF, 8AQO, 8ATU.

Free period: 8AQO. DX: 1BDJ.

Dec. 14, 1922

Codes verified: 1ZE, 2ZK, 8AQO.
Free period: 2NZ, 2ZK, 3ZY, 3HG, 3FA, 8UE, 8BU.

Working DX: 1BET, 1BDT, 2LI, 2EL, 8LA, 9OM.

Dec. 15, 1922

No codes verified.
Free period: 1BCG, 1YK, 1BDT, 1GV, 2AHO, 2BLF, 3XM, 3ZW, 8ATU, 8AQO.

Dec. 16, 1922

No codes verified.
Free period: 1BED, 1BGF, 1OR, 2AWL, 2BLM, 2HJ, 2XAP, 2NZ, 2ZK, 3ZY, 8ATU, 8XE.

Working DX: 2AW (probably British).

Dec. 17, 1922

Codes verified: 1YK, 2ZK.
Free period: 1BDA, 1BDI, 1BRQ, 1CDX, 1CMK, 1BCG, 2AYV, 2BGL, 2BLK, 2LI, 3BGT, 3HG, 3ZY, 6AV, 8AWF, 8AZO, 8BSL, 8BSS, 8LA, 8AQO.

Working DX: 1BAT, 1NI, 1BCG, 3XM, 8AQO.

Dec. 18, 1922

Codes verified: 1ASF, 1XM, 1BET, 2AWL, 2GK, 2LO, 2ZK, 3BLF, 9DWK.

Free period: 1BDF, 1BDK, 1BDT, 1YK, 1ZE, 1ARY, 1BCG, 2GK, 2NZ, 2RP, 2ZK, 3HZ, 3HG, 3ZV, 3ZY, 8AX, 8AZ, 8AQO, 8AWP, 8AW, 8BSY.

Working DX: 1XZ, 1GH, 1MV, 1XU, 1SOK (obviously n.g.), 2AF, 2EI, 2EL, 2AAA, 3XM, 6KA, 8AQO.

Dec. 19, 1922

Codes verified: 1AKG, 1AGK, 1ASF, 1XM, 1GV, 2GK, 2AWF, 2EL, 8AQO, 8AIO, 8BXH.

Free period: 1AGK, 1BDT, 1AKG, 1DNI, 1XU, 2CJW, 2ZK, 2CBX, 2CQZ, 2EL, 2CPD, 2ER, 2RP, 2XAP, 2XC, 2ZS, 3EX, 3HG, 3SG, 3FX, 3ZY, 6KB, 8AQO, 8AWP, 8BU, 8MZ, 9OM, 9DWC.

Working DX: 1ADL, 1AW, 1BS, 1OR, 1AGK, 1ZE, 2ZK, 3XM, 3BG, 8BTV, 8AQO, 8UE, 8BSS.

Dec. 20, 1922

Codes verified: 1BCF, 1BFP, (error; no such station qualified); 1CMK, 1CNF, 1GV, 2CQZ, 2EL, 2LO, 2XAP, 3ZW, 8AQO, 8AWP, 8BK, 8BXH, 8IB, 8ML 8UE.

Continued on page 90

REMARKABLE WORK ON ONE TUBE WITHOUT ANTENNA

By LAWRENCE R. BABIZE

I am located at Auberry, California, about 40 miles northeast of Fresno. Am operating telegraph line for Edison Co. and have installed a small receiving set and am sending a list of the amateurs I hear on one tube, without antenna. I am using telephone line 80 miles for a ground. It helps strengthen the theory of what can be done without use of an aerial.

On night of December 19th the following were heard: Homemade CR5, vry QSA. Other 6's too numerous. C. W.: 6BIQ, 6BKX, 6EB, 6EC, 6BBE, 6ZH, 6NX, 6BQ, 6BNV, 6BES, 6EF, 6BVE, 6PI, 6BQF, 6AWT, 6CC, 6GX, 6ARF, 6BM, 6BNU, 6DD, 6FE, 6BWP, 6BFP, 6AIY, 6VF, 6RM calling ZHBBAA**, 6BHR, 6BAE, 5ZA Voice and C. W., 5CN, 7ZF, 7HJ, 7TH causes QRM HR, 7ZO vry QSA working 7TH, 8BFM HRD 7:50 p.m., 9DQA, 9AYA, Canadian 4BV.

Spark 6DA vry QSA, 6PL, 6MH, 6BJU vry QSA, 6BNU, 6ABX, 6BNT, 6AHR, 6BAJ, 6BAJ, 6AJU, 6AUD, 6AWX, vry QSA, 6TF, 6KC vry vry QSA, 6AW, 6BCNQ SA, 6BCN, 6OD, 6OM.

These calls only represent just a few hours of listening and hear many other sixes of short distances from me but too numerous to log. However, I keep log of everyone I hear and anyone wishing dope on their QRK please let me know.

Have had some interesting experiments here with the set trying different phone lines as aerials and grounds. Sometimes I use one leg of the line that runs to Big Creek for antenna and use another leg of another line as a counterpoise. Music from KHJ (L. A. Times) audible one foot from phones and 600 meter sparks too numerous to log.

"DX DOPE" FROM 6ZAG, WAILUKU, H. T.

By C. J. Dow

6ZAC is excellent QSO 9AWM nightly, handling msgs direct, and in good shape. Worked him as many as 6 consecutive nights. He gets me 15 feet from fones on one step and spider-webs, when no QSS. I get him 40 feet from fones 2 steps. He's using 250 watter; I'm using 50 watter.

Dec. 5th worked both 5TC and 5SF, of Ft. Worth, Texas. It's about 3,600 miles to 'em. Dec. 6th worked 5DI, Houston, Texas, further yet. Also worked 9BJI, in Denver, few weeks ago, and gave him a msg one sending. Sez "Vy QSA" consistently. 5TC used a 5 watter to work me, while 5SF uses ten watts, and 5DI 25 watts. Hi! I have used 50 watts entirely this season.

6ZAC is no more now, as I've sold out, and am leaving for the coast in a very short time. 6ZY will uphold the Hawaiian end of amateur radio very shortly with a 500 watt transmitter.

My last list of calls heard and worked follows: 1bet, 1cmk, 1xu, 2awl, 3blf, 4bv, 5aby, (5di), 5fx, 5cn, 5ik, 5ir, 5kp, 5nn, 5px, 5qy, (5sf), 5sm, (5tc), 5jt, 5wsy, 5xv, 5xad, 5za.

(6ak), (6ajr), (6arb), (6ajf), (6asj), (6avd), (6avr), (6awt), (6bsa, phone also), 6bbh, (6bjp), (6bgh), 6bqg, (6bql), 6bvq, (6bcr), (6cc), (6ea), 6eb, 6gf, (6gr), 6gx, 6cu, (6ka), 6jd, 6pi, (6tc), (6ti), (6tq), 6xb, phone, 6xaf, (6ze), (6zi), (6zn), 6zaf, 6zg, 6zz.

7abb, 7adp, 7bb, 7bj, 7bk, (7mf), 7ri, (7sc), 7sy.

8aa, 8ab, 8acx, 8aip, 8asv, 8axn, 8axc, 8bk, 8bdv, 8cp, 8cur, 8cgv, 8ib, 8ju, 8vq, 8zac, 8zag, 8cmi.

9aap, 9aav, 9aps, 9apw, 9aou, 9aog, (9awm), 9aul, 9bbf, (9bjj), (9bed), 9bjv, 9bp,

9bgh, 9bvy, 9ccm, 9cxp, 9cuc, 9cgv, 9dtj, 9ou, 9qu, 9uu, 9xp, 9yaj, 9yv, 9zn.

Spark: (6ex), 9auu.

DX AT 6XAD FOR DECEMBER

By MAJOR LAWRENCE MOTT

Signal-ORC-USA

It gives me pleasure to add to my former DX lists—the following stations: (2FP), (3ARO), 1CNF, 1XZ, 1AUN, 2HW, 2BRD, (2BFX), 2BKJ, 2KF, 2AXF, (2EL)—Freeport, L. I., N. Y., 2AWM—East Orange, N. J., 2CMJ—New Rochelle, N. Y., H. Resch—Bayonne, N. J., J. H. Reynolds—Passaic, N. J., 2BSC, George Kline—Elizabeth, N. J., 2LO, 2AWF—in full daylight (Albany, N. Y.), 3XM, 3OT, 3BYA, 3IW, (3BLF), (3CC), 3ABW, 3TA, 3AUP, 3ZE, 4OI—Porto Rico, 4BX, Wilmington, N. C., 4BI—Lakeland, Flor., 4FS, "FZ", U. S. S. tran. *Canopus*, off North Carolina coast, 5WE, 5AU, 5ZAS, 5AL—Canadian, 5CI, 5LY, 5JL, 5AER, 5KC, 5AVH, 5CN, (7PF), 7AFH, 7RI, 8ZB, (8CKO), (8CPD), (8BYD), 8ACF, (8COL), 8OC, 8AFK, (8AZF), 8UP, 8BDA, 8AAF, 8BM, 8ADB, (8QC), 8AOL, 8CMI, (9BYA), (9BRK), 9AVX, 9CPD, (9DMA), (9AOU), (9AZP), (9CNS), (9ZN), (9DNC), (9AXU), 9CP, (9BIK), 9AJH, 9BCH, (9ARZ), 9BTA, 9CXP, (9AAW), 9BPY, 9BIJ, (9BIE), 9HW, 9BCT, (9DSL), (9CJE), 9CNY, 9QF, 9BJB, 9AFN, (9KP), (9AAV), W. Meyer—Freeport, Ill., 9AIY, 9BUG, 9DXD, (9XAC), 9CJV, 9CGD.

The correct address of 6AGJ is Chas. W. Holdiman, 565 Spencer Ave., San Jose, Calif. The name and address is incorrect in the available call-books. He is now on the air with 100 watts C. W.

9ST has been assigned to W. W. Weedfall, 3407 Olive St., Kansas City, Mo.—10 watts C. W.

SOMETHING NEW FROM 6ZY, HONOLULU

By THOS. A. MARSHALL

Hawaii has the record for DX work. This is quite true in many ways. The writer has copied amateurs from every district in the United States. On December 13th 1BCG, Greenwich, Conn., was heard in broad open daylight, which was 3:54 p.m. Hawaiian local time, sending ZHCCN his secret code group. His signals were fairly QSA, even and dependable. This is a remarkable feat considering the power he employs and the distance of over 6000 statute miles which his signals had to travel to reach Honolulu.

The following amateurs and their secret code groups were logged on the nights of Dec. 12th and 13th.

Call	Code	Time	Location
1BCG	ZHCCN	3.54 p.m.	Greenwich, Conn.
1BDI	TEST	6.18 p.m.	Orono, Maine.
2GR	GEOM de 2GR	7.05 p.m.	Nutley, N. J.
2ZS	9LT de 2ZS	6.06 p.m.	Unlisted.
3AAO	DHYDY	6.14 p.m.	Washington, D.C.
3BV	SGTTI	4.50 p.m.	West Chester, Pa.
3BLF	2 mgs sent to 4CG intercepted.	4.15 p.m.	Richmond, Pa.
5PX	SPKKY	5.02 p.m.	Fort Worth, Tex.
5EK	AICCB	6.31 p.m.	Memphis, Tenn.
5XK	ZTVVV	5.15 p.m.	Knoxville, Tenn.
6KA	TAVVU	3.58 p.m.	Los Angeles, Cal.
6ARB	PWRRQ	6.47 p.m.	San Francisco, Cal.
6ZH	BZHEH	6.40 p.m.	San Ysidro, Cal.
6RM	ZHBBAA	5.49 p.m.	Salt Lake, Utah.
6EN	GOKKI	7.10 p.m.	Los Angeles, Cal.
SZY	CCIWG	6.58 p.m.	Defiance, Ohio.
SATU	NVRRP	7.07 p.m.	Sydney, Ohio.
SBK	LURRW	4.16 p.m.	Cleveland, Ohio.
SAQ	SSAEE	4.58 p.m.	Detroit, Mich.
SBPL	OBKKY	5.11 p.m.	Swissvale, Pa.
SBEO	VTZZX	7.42 p.m.	Watertown, N.Y.
SSP	ALJGG	4.57 p.m.	Fairmont, W. Va.
9ZN	APPCX	6.23 p.m.	Chicago, Ill.
9GK	DTHHP	5.48 p.m.	Fargo, N. D.
9BEY	DRRZO	5.03 p.m.	Oak, Nebr.
9ASF	TEST	4.04 p.m.	Aberdeen, S. D.
9XAC	TFDDU	5.06 p.m.	Rock Island, Ill.
9AOU	GUIC	4.56 p.m.	Edge Grove, Iowa.
9YAJ	QGTTB	5.30 p.m.	Bedford, Iowa.
9CMK	VTXXS	4.30 p.m.	Unlisted.
9DSM	OCCQY	5.49 p.m.	Omaha, Nebr.

I have about 40 more "8" and "9" stations logged with their secret code groups but cannot publish these fellows due to limited space. Some of them are included in the following:

2pw, 2po, 3yo, 4id, 4kk, 4bv, 5ak, 5sm, 5uj, 5gi, 5tc, 5cn, 5lf, 5za, 6xad, 6cbi, 6boo, 6ber, 6cc, 6brf, 6bvw, 6if, 6biq, 6xk, 6en, 6xu, 6bjq, 6bqf, 6bpx, 6zz, 6bqc, 6bjy, 6ku, 6anh, 6ajr, 6awt, 7bj, 7adp, 7an, 7hg, 7nm, 7sc, 7sf, 8ab, 8sp, 8vy, 8azd, 8bke, 8bqc, 8ey, 8fu, 8aiw, 8dae, 8na, 8aim, 8brm, 8cur, 8asv, 8axc, 8awp, 8bdw, 8cgv, 8cgv, 8caa, 8ft, 8qk, 8ue, 8xe, 8zy, 9dqu, 9dsd, 9ps, 9kp, 9aph, 9dqm, 9avc, 9aw, 9bju, 9bri, 9bed, 9abu, 9biw, 9afk, 9blg, 9anq, 9bxq, 9bgh, 9bbf, 9bkh, 9bqv, 9bbs, 9bcp, 9bhi, 9bch, 9cr, 9ccv, 9cde, 9dxn, 9dqm, 9lz, 9zn, 9yaj, 9bji.

NEW RADIO REGULATIONS IN AUSTRALIA

New regulations for the control of wireless communication in the Commonwealth have been approved by the Governor-General, and will come into force on December 1. These regulations are very comprehensive, and provide for the control of the many new branches of the science. Important alterations in the laws governing amateur stations are contained in the regulations, and, as a result of these alterations, amateur operators will enjoy a great deal more freedom than they have had since the war.

The most important clause relating to amateur stations is one removing the ban on amateur transmission. Under the new regulations, amateurs will be permitted to use transmitting apparatus, subject to certain conditions that will be imposed by the controller of wireless (Mr. J. Malone) for the prevention of interference with commercial stations. Mr. Malone proposes that amateur transmitters shall be restricted to two bands of wavelengths. One from 150 to 250 meters shall be used for all classes of transmitting stations, and the other band, 410 to 440, will be reserved for wireless telephone transmitters and continuous wave transmitters. The following restrictions as to type of transmitter and power will be imposed:

All stations within a radius of five miles from any defence or commercial station will be limited to a power of 10 watts, and only continuous wave transmitters, modulated continuous wave transmitters for Morse signalling, or wireless telephone transmitters will be permitted within this radius. The use of "spark" transmitters will be prohibited. Outside the five-mile radius and within a radius of 50 miles from a government or commercial station all types of transmitters except those of the "plain aerial" type, will be permitted, but the power of the transmitters will be limited to 20 watts. Outside the 50-mile radius any type of transmitter, of which the power does not exceed 250 watts, will be licensed. The regulations provide that before any transmitting license is granted the applicant will be required to show that he is a bona-fide experimenter, and he will be required to furnish particulars of the experiments he proposes to carry out. Applicants must also show that they have sufficient technical knowledge and operating ability to work their transmitters without causing interference with other stations, and if required to do so by the controller of wireless must sit for an examination to demonstrate their knowledge. A fee of 5/ will be charged for this examination.

FEES AND LICENSES

Another matter of importance to experimenters is the annual license fee. Under the new regulations this fee will be reduced from £2 a year to 10/ a year for a receiving license and £1 a year for a license for both transmitting and receiving. No age limit is

Continued on page 89

NEW APPARATUS & SUPPLIES FROM THE RADIO MANUFACTURERS

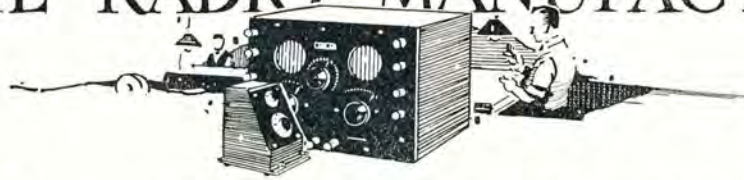

THE NEW CUNNINGHAM TUBE

Representing one of the most radical advances in the history of the vacuum tube design, the new Cunningham tube type C-301-A developed in the laboratory of the General Electric Co. has made its appearance this month and is available for general sale. This tube possesses three advantages over existing designs, in that it has greater power amplification, extremely low power consumption and longer life. In appearance, the tube is much like its predecessor, except that it is more rugged in construction, the elements being somewhat larger, and the plate having crimped edges.



The New 1/4 Ampere Cunningham Tube

The filament current is .25 ampere at 6 volts, the filament resistance averaging about 25 ohms. The current can be varied from .22 to .28 ampere without affecting the amplification, so that the tube can be used without a filament rheostat, on a six volt storage battery, through its entire discharge period. However, as current in excess of .25 ampere will materially shorten the life of the tube, a filament rheostat of considerable resistance is recommended, in order to provide the necessary protection against too high a filament current. The ordinary filament rheo-

stats of from 2 to 4 ohms will not provide sufficient resistance when used with this tube, and rheostats of from 10 to 20 ohms will be necessary for proper adjustment, where the maximum life is desired.

As the tube fits in the standard socket, it has an advantage over the so-called "peanut" or dry cell tube, which requires an adapter or special socket for use with existing radio equipment. The new tube has a high amplification constant, and will deliver a greater energy output than the older styles.

As a radio frequency amplifier it functions admirably, its low internal capacity permitting its use in radio frequency circuits. It is a good detector, requires 25 volts on the plate when used as such, and while the C-300 gas content detector is more sensitive, it will be very useful in detector circuits. As an audio frequency amplifier it will operate with plate voltages as high as 120, although a negative grid potential of at least 9 volts must be maintained with 120 volts on the plate. For a plate voltage of 80, the grid biasing voltage should be 4 1/2 volts, and for 40 volts plate, the grid voltage should be 3 volts. At the higher plate voltages it has a plate impedance of about 12,000 ohms, rising to 18,000 ohms at 40 volts plate potential, so that it will fit in any circuit designed for the C-301 amplifier.

NEW POTENTIOMETER GIVES SUPERSENSITIVE RECEPTION

The range of most receiving units can be increased considerably through the use of a properly designed potentiometer shunted across the A battery. The vernier rheostat gives just the precise control necessary for the correct electron flow from the filament of the tube, but to obtain maximum efficiency all three circuits of the triode must be adjusted with accuracy.

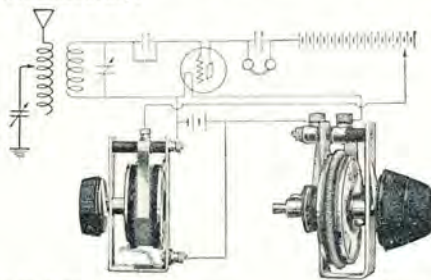

C-H "A" Battery Potentiometer

C-H Vernier Rheostat

Diagram showing use of vernier rheostat and potentiometer in radio receiving circuit.

The plate circuit is actuated by the B battery, which is usually of the dry cell type—18 to 24 volts. When properly connected, the A battery serves as supplementary voltage in this circuit, and through the medium of a potentiometer the A battery potential can either be added to or subtracted from that of the B cells. Since this potentiometer shunts the storage cell it must be of high resistance, and because of this high resistance, the control is extremely fine.

It is plain that in an instrument of this

type for use in a radio receiving cabinet, size is an important item, and to condense a resistance of more than 200 ohms into a suitable panel type instrument entails considerable engineering. The Cutler-Hammer Mfg. Company, long known as builders of rheostatic control apparatus, has just brought out a potentiometer for this work which matches exactly their well known radio rheostats. It—like the rheostats—is of the revolving drum type and beautifully finished in dull satin

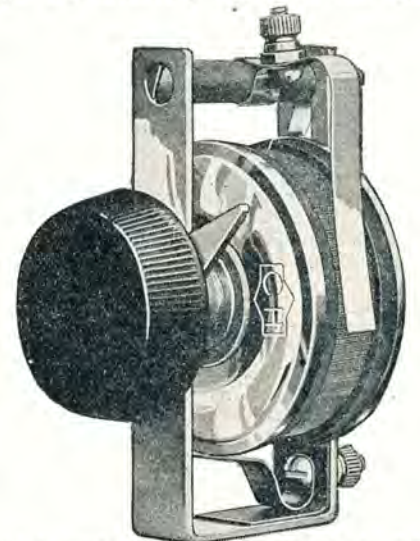

Novel construction of new C-H Radio "A" Battery Potentiometer prevents displacement and wear of resistance wire under constant usage.

nickel and ebony black. A highly polished nickel indicator and cone shaped knob of Thermoplox appear on the front of the panel, harmonizing exactly with those details of the C-H radio rheostats.

This new potentiometer is designed for long life and steady operation. A range of 300 ohms is provided and the broad, flat contact on the tightly clamped resistance unit insures that the wire will not be damaged or displaced under constant usage. The instrument is designed for panel mounting and is provided with binding posts to facilitate wiring.

NEW RADIO CATALOGS

A complete information book regarding Cunningham Vacuum Tubes is being distributed by E. T. Cunningham of San Francisco. This includes not only illustrations and specifications of the detector, amplifier and power (5, 50 and 250 watt) tubes, but also general instructions for their care and operation. A wide variety of hook-ups are given together with many graphs that will aid in getting maximum results and life.

The Radio Research Club of the Springfield (Ill.) High School is publishing an interesting four-page paper, *Radio Research*, as a local medium for exchange of experiences and ideas.

Radio Bulletin No. 180 from Betts & Betts Corp. of New York City is descriptive of the Betts visible detector amplifier type D2A, loud speaker and other radio apparatus.

RADION HARD RUBBER PANELS

So much misinformation has been broadcasted on the subject of insulating materials for radio use, particularly panels, due in part to a misunderstanding as to what are the real needs and requirements of the manufacturer, dealer and amateur, that it is well to put down some important phases of this subject for the consideration, particularly, of the man who builds his own set. Generally, insulation used in the radio industry can be divided into three broad classifications: hard rubber compounds, phenolic compounds and laminated phenolic compounds. The last two are somewhat similar in general characteristics and may be considered together.

Hard rubber is a compound of rubber with sulphur and other suitable ingredients mixed in certain proportions, depending on the use to which it is applied, and vulcanized over a pre-determined number of hours to obtain definite mechanical and electrical properties. Hard rubber has been used in the electrical industry for upwards of 70 years. It is perhaps more familiar to the consumer in the form of telephone receivers than any other electrical use to which it is applied, although there are a thousand different uses in the electrical industry where hard rubber is desirable, and from the very inception of wireless, hard rubber has been employed as insulation, particularly for panels. During the world war, for example, the American and allied governments used thousands of pounds of hard rubber for wireless work, and required very strict adherence to electrical specifications on account of the extremely high frequencies.

Radio engineers have definitely determined that there are four special characteristics which must be considered in any insulating material adopted. They are: low phase angle difference, low dielectric constant, high resistivity and non-absorbent qualities. Therefore whatever material possesses these characteristics to the greatest extent, plus the practical mechanical advantages which are also necessary, is undoubtedly the best insulating material for radio use.

Unless the best obtainable material is used, there are going to be certain current losses which substantially reduce the character of the results obtained in receiving or sending wireless messages, music or other broadcasting. In receiving, for example, the current impulses of high frequencies are all very low power, and consequently any losses whatever seriously effect the result, so it is most desirable to obtain the utmost protection by selecting an insulating medium having those properties which are most advantageous.

Hard rubber is produced in various grades for various purposes. Some grades are naturally better than others, so that merely the selection of a hard rubber panel is not enough to insure the best results. One must select the particular *grade* of hard rubber best adapted to the purpose. With this idea uppermost in mind, the American Hard Rubber Company some time ago conducted a series of experiments in their extensive research laboratories, utilizing the benefits of many years of experience in the production of hard rubber compounds, to determine the best compound that could be developed for radio work. The result of these experiments was the production of a material now known as Radion. Radion possesses excellent electrical values and definite mechanical properties for radio work.

Tests made by the U. S. Bureau of Standards show that Radion has a considerably smaller phase angle difference and dielectric constant and considerably higher resistivity than the phenolic and laminated phenolic materials tested. It also has a smaller absorption of moisture in air and in water. Furthermore Radion may be drilled without chipping and rough edges around the holes. It may be readily filed, sanded, engraved,

stamped, etc. The panels have a high, satin-like polish, or by rubbing with sandpaper may be given a flat dull finish. It is regularly made in black, brown and mahoganite colors.

The manufacturers of Radion also make the dials, having the tapered knobs and drilled to take 3/16 in. or 1/4 in. shaft with set screws; also the V-T socket, tubing and other moulded parts. The Radion antennae insulator is another item of importance, as it not only possesses the well known insulating properties of Radion to protect against leaks and losses, but it has a remarkable mechanical strain resistance for strength, having by actual test withstood a strain of 1/2 ton as against something like 400 lbs. for the ordinary aerial insulator of the same size. It is fitted with deeply imbedded galvanized, rust-proof eyelets.

ESCO 4000 WATT M.-G. SET

The latest product of the Electric Specialty Co. of Stamford, Conn., for the use of the radio transmitter is the form unit motor generator illustrated herewith. This is designed for an unusually large station. It has three generators, all driven by a 10 h.p., 220 volt, 60 cycle three phase motor. Two 1000 volt, 2000 watt generators are driven in series to produce 4000 watts at 2000 volts for plate current. One 12 volt generator furnishes 2000 watts to the filament current supply.

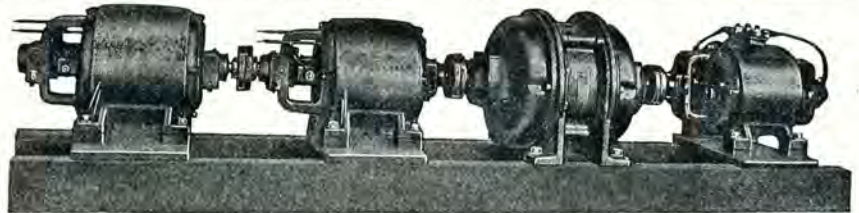

Esco Four-unit Motor Generator Set

The Electric Specialty Co. has recently received many letters from satisfied users of their radio motor generator sets. These include 1BCG, 1GR, 2NZ and 2CCD, all of whose C. W. signals have been heard in Hawaii and England. Others are 1BGF, 2ZK, 2ZL and 8AQU, all of whom were heard in England during the recent trans-Atlantic tests.

AMATEURS HEARD ACROSS THE PACIFIC

Howard A. Cookson, operator on the *China*, under date of Nov. 11, advises that on October 28, when 91 miles west of Honolulu, he heard 6CC Qsa 10 feet from phones, 6AHR Qsa all over room (Cussing MG Set), 6TI, 9ZAF (Denver).

On October 29, 361 miles west of Honolulu, he heard 8YD (East Cleveland, Ohio), and copied the following "Test de 8YD test de 8YD ex 8AGZ 8AGZ test test de 8YD 8YD ex 8AGZ" Sigs very clear and QSA. Coming in great. Distance from 8YD 5300 miles. Believe this new record for amateur reception. 6XAD, (5JH and 9ZN sigs doubtful).

October 30, 650 miles West Honolulu, 6TI. December 7, off coast of Japan, 6CC, Colusa, Calif.

Errata Note: Credit to William H. Smith, 1224 Taylor St., San Francisco, was inadvertently omitted in the caption of "The Radio Fisherman," as printed in January RADIO.

An illustrated descriptive price list from the Dubilier Condenser and Radio Corporation of New York City shows their various Radio Receiving Products, including their Ducon, their Variadon variable condenser, their Du-tec chemical rectifier to replace natural crystals and their Micadons.

RADIO EXTENSION TEACHING

The importance of radio broadcasting as a means of reaching a large number of listeners in the United States, otherwise inaccessible, is being forced home to us every day. There are in the United States between one and one and one-half million radio receivers, representing between three and four million radio listeners located within comfortable range of the speaker's voice of one of six hundred broadcasting stations, that is stations equipped to send out telephonic communications. These listeners are for the most part youthful—of school and college age. Their number is rapidly increasing and will undoubtedly, within a very few years, total many millions of such radio listeners.

The National Radio Chamber of Commerce appreciates the tremendous potentialities of this new channel of communication in the field of education and desires in some practical way to support colleges and universities in extending their influence through radio extension courses to these listeners, a large proportion of whom would not otherwise be reached. Several prominent institutions of learning in the United States have made a beginning in this direction and their reports of the encouraging success attending their efforts show us that the possibilities of the new method are not under-estimated.

Sixty other educational institutions are

broadcasting educational and musical programs, forty-seven of them being colleges and universities. The combined area nominally covered by these institutions has been estimated to be seven or eight times the total area of the United States.

England and Germany, it may be of interest to note, have quickly grasped the significance of radio telephony as a means of educational contact and preparations are being made to broadcast university extension courses in those countries.

Extension lectures may be broadcast from the college or university without in any way interfering with the local audience within the school, and it is not now necessary that the school have its own broadcasting station, but may use a powerful central station nearby connected therewith by the microphone in the lecture room. In some instances the lectures are being followed up by questionnaires and suggested reading, which are mailed to the listeners upon request and examination sheets following at the end of the course.

The pioneers are already active in the field and the situation seems to indicate not only individual but concerted action on the part of schools of recognized standing to take advantage of this wonderful opportunity.

There are, however, a great many intricate problems connected with the subject of broadcasting, which the National Radio Chamber of Commerce hopes to see solved within a comparatively short time. Their engineers have collected much data which they will cheerfully place at the disposal of those educational institutions interested and will be glad to render every possible assistance to them in reaching a clear understanding of the situation, as its only interest in the radio field is to see that radio broadcasting assumes, in the course of its evolution, a sound economic position of greatest possible usefulness.

That Satisfying Pride in Your Radio Set

You know how it is when you own anything that is really fine. You're proud of it and jealous for it and want others to appreciate it as you do. You'll feel in full measure that satisfying thrill of pride in your radio set when you own Kennedy equipment. Even such friends of yours as are not radio "fans" will admire the handsome appearance and perfect finish of your Kennedy installation. And those who are radio experts will be even more enthusiastic over its splendid performance.

KENNEDY EQUIPMENT

The Beautifully Finished and
Wonderfully Efficient

KENNEDY

Short-wave Regenerative Receiver Type 281

An ideal set for general use. Highly sensitive, selective and efficient—easy to operate—finely made in every detail. Meets the requirements of keen radio students who recognize and demand the best. Yet it is so simple to use that perfect results can readily be obtained by novices. Ask your dealer to show you the Kennedy Type 281 Regenerative Receiver, and *write* our nearest office for latest Kennedy Bulletin C-3.

All Kennedy Regenerative Receivers are licensed under
Armstrong United States Patent No. 1,113,149



The Colin B. Kennedy Company

INCORPORATED

SAN FRANCISCO

U. S. A.

SAINT LOUIS

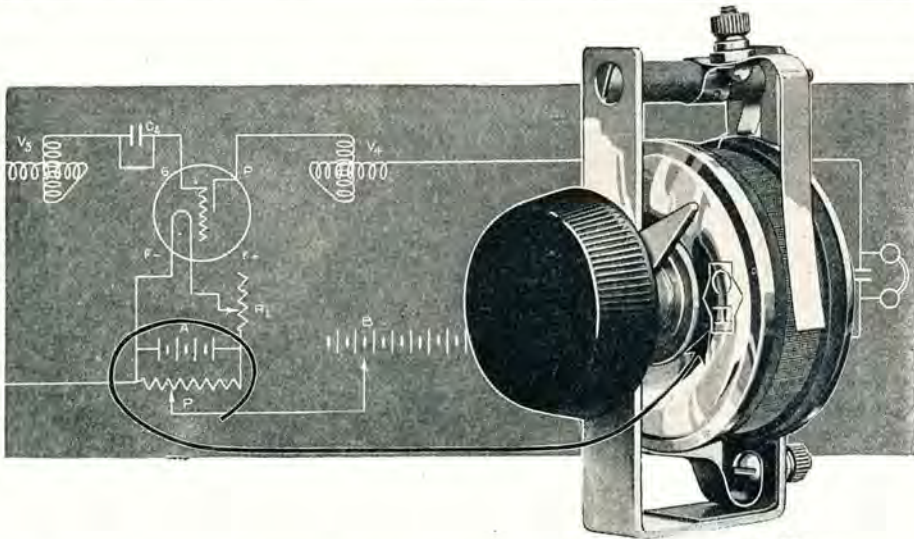

The C-H Radio "A" Battery Potentiometer

Another Opportunity to Demand C-H Protection

The C-H trade mark has made its place in the history of radio. More than a quarter million rheostats engraved with this mark of the master builder of rheostatic control apparatus are today giving satisfaction to an army of enthusiasts.

The new "A" Battery Potentiometer gives the same assurance of satisfaction in any equally vital part of your receiving circuit—the same assurance that has for more than thirty years made engineers the world over demand the C-H trade mark for protection.

This new potentiometer matches exactly the C-H Radio Rheostats in both appearance and performance. It is of the revolving drum type with a total resistance of 300 ohms. It is designed for panel mounting and finished in satin nickel and ebony black. A comfortable knob of genuine Thermoplasx and a highly nickeled pointer provide easy and positive control.

To be certain of results demand the C-H trade mark—it is your guarantee of satisfaction.

THE CUTLER-HAMMER MFG. CO.

Member Radio Section, Associated Manufacturers of Electrical Supplies
MILWAUKEE - WISCONSIN

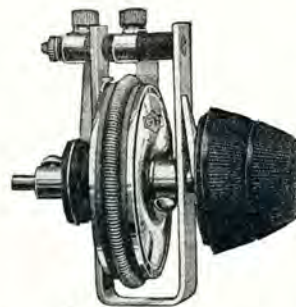

C-H Radio Rheostats

Built by Rheostat Builders

Built with the same care and precision that has made the C-H trade mark the guarantee demanded by engineers for the last thirty years. More than a quarter million now in use. Finished in satin nickel and ebony black. Panel mounting with binding posts for easy wiring. Large comfortable knobs of genuine Thermoplasx. Positive travel stops with "full on" and "full off" positions. Guaranteed mechanically and electrically perfect by the master builders of all rheostatic control apparatus.

Type 11601-H1 (with vernier) . . . \$1.50 for detector tube control

Type 11601-H2 (without vernier) . . \$1.00 for amplifier tube control

CALLS HEARD

Continued from page 42

6xad, 6xav, 6xas, 6zal(phone), 6zf, 6zx, 7aea (phone), 7bj, 7dp, 7fx(phone), 7jw, 7lu, 7lk, 7mf, 7sc, 7sy, 7tq, 7ud, 7va, 9ax.

Stations worked: 6ak, 6abx, 6agn, 6atg, 6alq, 6arf, 6ber, 6bxx, 6bmd, 6bql, 6ti, 7bb, 7bj, 7eq, 7ke, 7mf.

6ku worked 6bmd, of Taft, Cal., with just 1/10 of an amp, and was heard in L. A. at the same time. This is a distance of about 700 miles. Some low power DX. Was also heard in Ellendale, N. D., by 9ahc with .7 amp.

BY GAME, RIVERBANK, CALIF.

2xap, 2zl, 3blf, 3co(Can.), 4by, 4cg, 4eb, 4id, 4bv(Can.), 5ac, 5di, 5ek, 5eo, 5er, 5fa, 5fv, 5kc, 5my, 5nk, 5pv, 5px, 5qi, 5qw, 5sm, 5uk, 5zaca(fone & C. W.), 5xa, 5xk, 5za, 5zh, 6's and 7's too numerous to mention. 8ab, 8bk, 8bp, 8bx, 8cf, 8dr, 8ib, 8if, 8iq, 8jf, 8kg, 8ml, 8ow, 8qk, 8tf, 8uk, 8wr, 8acf, 8afd, 8ago, 8aim, 8aio, 8amm, 8anb, 8apy, 8aqo, 8ard, 8asv, 8awz, 8axn, 8azd, 8bdo, 8bdu, 8bef, 8bfx, 8bjv, 8bnj, 8bpl, 8bxf, 8bxh, 8byh, 8bzy, 8cac, 8cep, 8ogx, 8cmi, 8cnw, 8cur, 8dak, 8ecl, 8xe, 8yd, 8yk, 8ym, 8zp, 8zw, 8zx, 8zz, 8xae, 8xam, 8zaf. 9's too numerous to mention. Pone: wsb, whb, woc, ksd and many others. Anyone hearing my B batt 5 watter, pse qsl Hv wkd 75 miles daylight.

By 7EM and 6QS on Boat From Seattle to Alaska, 800 Miles North Seattle

Dec. 3.—4bv Can., 4br Can., 4ela, 5bd, 5uj, 5qy, 5xad, 5sf, 5hq, 5tc, 5px, 8dkk, 8aqf, 8bxx, 8zy, 9alt, 9ar, 9bqw, 9avc, 9aog, 9gk, 9rk, 9pw, 9aor, 9qf, 9ami, 9azi, 9cjj, 6s and 7s too numerous.

Dec. 4.—550 miles north Seattle—5bz, 5en Can., 5bq Can., 4bv Can., 9bxt, 9aul, 9ebt, 9aav, 8z, 6s and 7s too numerous.

Dec. 5th.—At Ketchikan, Alaska—3ec, Call cq, 5za, 5akt, 5aac, 5en Can., 5di, 6ak, 6arf, 6ark spk., 6apw, 6vm, 6cu, 6abx, 6pi, 6bqc, 6amk, 6aat, 6zz, 6biq, 6om, 6bjr, 6nh, 6aci, 6ku, 6rm, 6ik, 6avd, 6xad, 6ajr, 6bsa, 6ft, 6zh, 6eb, 7abb, 7jg, 7mf, 7mh, 7dc, 7aem, 7dp, 7bj, 7dl, 7ke, 7ahl, 7wk, 7mn, 7tq, 7exh, 7sc, 7fh, 7ud, 7wn, 7fr, 8zz, 8zy, 9ast, 9ami, 9dqu, 9dxn, 9ebt, 9dqm, 9dtm, 9uu, 9bvf, 9dp, 9gk, 9ccv, 9dkq.

Dec. 6.—At Juneau, Alaska—bt3, 5en Can., 5et Can., 6tu spk., 6bko, 6akt spk., 6bqz, 6en, 6abx, 6zh, 6bum, 6km, 6bft, 6ku, 6bbh, 6cc, 6acr spk., 6zi, 6fh, 6zo, 6vm, 6aag, 6nx, 6bbk, 6aat, 6arv, 7eq, 7du, 7fr, 7iy, 7afs, 7ahi, 7to, 7bj, 7hd spk., 7mf, 7qf, 7air, 7dp, 7arb, 7lr, 7afo spk, 7sc, 7ajz, 7wn.

Dec. 7th.—60 miles north Juneau—bt3, 5ac Can., 6ak, 6lv, 6cc, 6nx, 6aat, 6km, 6arf, 6ta, 6tu spk., 6cu, 6akt spk., 6tv, 6zz, 6zh, 6tc, 6dd, 6oz, 6km spk., 6sz, 6bun, 7mf, 7eq, 7bh spk., 7ve, 7aic, 7nx, 7afo, 7abb, 7bk.

Dec. 8th.—Dock Juneau, Alaska—bt3, 5en Can., 5et Can., 6cc, 6abt, 6abx, 6biq, 6nh, 6bow, 6xk, 6zh, 6ahg, 6ber, 6tu spk., 6avv, 6fh, 6aoi, 6akt spk., 6hd spk., 6auy, 6ek, 6aq spk., 6arx, 6bm, 6buf, 6gx, 6nx, 6dd, 6lv, 6bqc, 6en, 6bip, 6bju, 7sc, 7mf, 7bs, 7eq, 7uf, 7ud, 7abb, 7bj, 7agv, 7mh, 7rn, 7qf, 7kj, 7afh, 7ly, 7aio spk., 7jc, 7oj spk., 7om, 7bh spk., 7aft, 7jm, 7ri, 7wu, 7kf, 8zy, 9awm, 9avz, 9dky, 9zn (Sending all evening), 9bqw, 9bzi, 9ani, 9bbf, 9ebt, 9afk, 9dsn, 9amb, 9asu.

Dec. 11th.—300 miles south Ketchikan—2nz, 3co, 5zv, 5en (Can.), 4bv (sgtli), 4lv (thuuj)!, 5xad, 6tu spk., 6cc, 6ka, 6ark spk., 8axn, 8bxx, 8ak, 8kg calling cq, 8axb, 8btu, 8asv, 8cmi, 8ib, 8zy, 8sp, 8ue, 8aim (sbyyd), 8ow, 8cur, 8bei, 8bef, 9cxp, 9yaj, 9fy, 9awm, 9btt, 9bky, 9gk, 9bxy, 9al Can., 9awp, 9bri, 9io.

By 6AMX, 2716 Pacific Ave., San Francisco C. W.: 5ek, 5za, 6ea, 6ec, 6en, 6ff, 6lv, 6jd, 6ka, 6om, 6pi, 6rr, 6zb, 6zg, 6zh, 6zn, 6zr, 6zs, 6zv, 6zz, 6aag, 6aav, 6abg, 6ada, 6aeh, 6agp, 6ahq, 6akl, 6alu, 6apw, 6auc, 6avr, 6ba, 6beq, 6bet, 6bfp, 6bgh, 6bjc, 6bjj, 6bjq, 6bjt, 6bjy, 6bkb, 6bko, 6bxx, 6blu, 6bmx, 6bqc, 6bqd, 6bqz, 6bv, 7bj, 7bk, 7dc, 7ex, 7fr, 7hj, 7hm, 7jw, 7lu, 7mf, 7mh, 7ny, 7oo, 7ot, 7pf, 7qe, 7qt, 7ri, 7rn, 7sc, 7to, 7tq, 7tt, 7ud, 7uu, 7wk, 7aat, 7abb, 7aby, 7acg, 7adp, 7afs, 7afw, 7agv, 7ahw, 7aic, 7amf, 8bk, 9bg, 9pi, 9wd, 9ajp, 9amb, 9ami, 9apw, 9asf, 9aul, 9bji, 9cns, 9xaq, 9bq3, bt3. Canadian—4dq, 5bq, 5en, 5ct. Spark: 6gt, 6ny, 6od, 6ol, 6zh, 6zn, 6agk, 6ahf, 6atf, 6awx, 6ba, 7hd, 7kj, 7ne, 7qh, 7sj, 7yl, 7zu, 7abh, 7acn, 7adf.

By 6BEG, Los Angeles (6ak), (6bf), 6cc, 6dm, (6fh), 6gf, (6gr), 6gx, 6gy, (6ku), 6lv, 6ng, 6nx, 6oh, (6aat),

Continued on page 46



Over a Quarter Million C-H Radio Rheostats Now in Use

RADIO "A" BATTERY

POTENTIOMETER

Investigate!

WESTERN-RADIO

DEALERS SERVICE

Wholesale RADIO only

837 SO. HOPE ST. LOS ANGELES 1200 FRANKLIN OAKLAND

Small Current—Big Job!

Care in Selecting Your "B" Battery Cures a Whole Flock of Static Troubles

A LOT of radio bugs are missing a good bet when they fail to give the proper attention to the "B" Battery that supplies current to the plate circuit of the vacuum tube. In a good many cases—and this applies to the seasoned enthusiast as well as the newest novice in the ranks—it is wrongly set down that since this current is so exceedingly small it cannot be very important.

Nothing could more completely misrepresent the facts. True enough, the current supplied by the "B" Battery to the plate circuit is small—but it is precisely for that reason that even the slightest variations or disturbances are to be so carefully avoided.

In thinking of "B" Batteries keep this in mind: The current from these batteries goes directly into the fine windings of the coils of your phones. Therefore even the slightest disturbance or unbalancing of the battery is translated directly into *noise*.

Obviously the reason for carefully soldered connections, loop aerials, short leads and the elimination of useless wires is to do away with *noise* just as far as possible. The same reason should dictate the careful selection of "B" Batteries. It hardly pays to go to a great deal of trouble in taking the usual steps to eliminate static unless you also pick out a battery that is free from the hissing, sputtering and frying noises that are so often confused with static and that in common with static noises are multiplied six or seven times with each stage of amplification.

A "B" Battery that is completely in accord with the efforts of manufacturers of sets to do away with static disturbances is known as the Willard "B" Battery. This battery consists of a group of twelve glass-jar cells, assembled in oak cases and connected with heavy burned-on connectors. Due to the distance between jars electrical leakage from one jar to the next is practically impossible. As each of the cells has Willard Threaded Rubber Insulation between the plates there is no opportunity for leakage from plate to plate.

It is said by those who have carefully examined the construction of the Willard Radio "B" Battery that, in addition to its ability to give results without distracting noises, it will last—if not a lifetime—at least such a long period that it will show a material money-saving long before it begins to exhibit even the slightest sign of age.

Willard Storage Battery Co., Cleveland, Ohio



The Willard Radio "B" Battery is a 24-volt rechargeable battery. Glass jars—Threaded Rubber Insulation—screwed-on covers.



The Willard 6-volt, All-Rubber Radio "A" Battery has one-piece rubber case—Threaded Rubber Insulation—special Radio plates.



The new Willard lower priced Radio "A" Battery (Type FW) Willard-quality plates—selected wood separators—tested rubber jars, specially-designed terminals.

The New Bradleystat - a Phenomenal Success

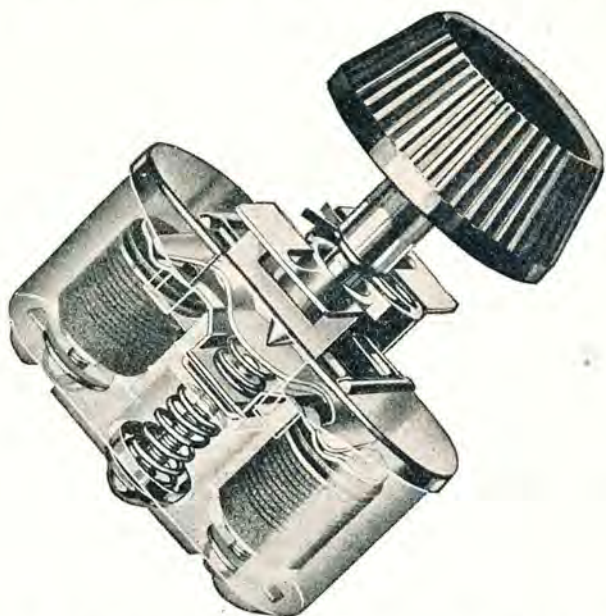

A Phantom View, Showing the Discs

These graphite discs, scientifically prepared, contain the secret of the Bradleystat. No wire rheostat can possibly give the noiseless, smooth control so eagerly sought by radio men. For both 6-volt and 1½-volt tubes, Bradleystat control is unsurpassed.

The discs have no inductance. They last forever, and laboratory tests reveal that they maintain better adjustment than the wire rheostat. Try one, tonight, and enjoy the supreme delight of Perfect Filament Control.

Allen-Bradley Co.
Electric Controlling Apparatus

288 Greenfield Avenue • Milwaukee, Wisconsin

Member of the National Radio Chamber of Commerce

Some Distinctive Features

The new Bradleystat is creating widespread interest among radio enthusiasts. Several refinements in the new model makes the new Bradleystat pre-eminent in the field of filament rheostats.



The new knob, beautifully proportioned and fluted to match the finest radio equipment, distinguishes the new Bradleystat for its splendid appearance. The new porcelain container is smaller than the older model, but the range of control is better than ever.



The name, "Bradleystat" is embossed on the new container to protect you against spurious imitations. Safeguard your radio set by insisting on genuine Bradleystats. An adjusting screw has been added in the base for setting the "cut-off" switch as you desire.

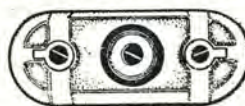

Retail Price

\$1.85

P. P. 10c extra

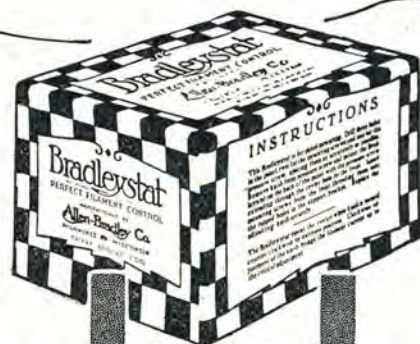

Bradleystat

REGISTERED U. S. PAT. OFF.

PERFECT FILAMENT CONTROL

Tell them that you saw it in RADIO

Radio Catalogue FREE

One copy of this complete Catalogue of Radio Outfits, parts, Dictionary of Radio Terms, Instruction Book, and Guide to Successful Radio Work—one copy is yours Free.

Simply write us a post card and we will mail the complete book to you Free, by return mail.

It quotes the lowest prices, amazingly low prices on everything for the expert and the amateur. Every improved part, the most up-to-date outfits, everything that is needed of the most modern type—at the lowest possible prices.

It gives a list of broadcasting stations, and gives much information about radio construction and operation. Every one interested in Radio needs this complete catalogue and book of instruction.

Why Pay Higher Prices?

Montgomery Ward & Co. has for fifty years dealt on a Money-Back basis, absolutely guaranteeing everything they sell. With quality absolutely assured, why pay higher prices elsewhere? Write today for this Free Radio Book and see for yourself the Saving it will bring you.

One copy is yours Free. You need only write us a post card.

Write to the house nearest you. Address Dept. 39-R.
Chicago Kansas City St. Paul Fort Worth Portland, Ore.

Montgomery Ward & Co.

— The Oldest Mail Order House is Today the Most Progressive —

CALLS HEARD

Continued from page 46

7cz, 7dp, 7gc, 7gk, 7gs, 7jw, 7mf, 7ny, 7ot, 7pf, 7qu, 7rk, 7sc, 7th, 7tm, 7to, 7tq, 7ug, 7zo, 7zu, 7zy, 8aaf, 8abc, 8azn, 8awx, 8aik, 8ala, 8axe, 8ago, 8amm, 8alt, 8bum, 8bfm, 8byn, 8bvr, 8bk, 8bvd, 8bxx, 8cur, 8cmi, 8gh, 8qy, 8ve, 8xae, 8zo, 8zy, 9aps, 9anq, 9aon, 9aul, 9awm, 9asf, 9asa, 9aja, 9asu, 9amb, 9avs, 9avz, 9ami, 9afk, 9arz, 9aup, 9bec, 9bik, 9bji, 9bqt, 9bzi, 9bds, 9bm, 9bey, 9bfd, 9bed, 9bhd, 9cns, 9cl, 9cfy, 9ccm, 9exp, 9ecu, 9ede, 9dfb, 9dky, 9dte, 9dtm, 9dsm, 9fm, 9gk, 9ii, 9pi, 9xaq, 9yaj, 9zaa, 9zt, 9zn, 9zaf. Anyone hearing 6avx accw pse qsl.

By Robert Nagle, Van Nuys, Calif.

1alw, 4eg, 4eh, 4jm, 5de, 5di, 5ek, 5kp, 5sk, 5tc, 5tj, 5za, 5zav, 5zb, 7abb, 7aem, 7aic, 7afw, 7bj, 7bmy, 7bk, 7ex, 7jw, 7ke, 7lu, 7lr, 7mf, 7ng, 7ny, 7tq, 7ub, 7wm, 7xc, 7zr, 8ago, 8aqo, 8asv, 8axb, 8axe, 8azf, 8bx, 8bz, 8cf, 8cur, 8sp, 8xe, 8yk, 8zy, 8zz, 9ajp, 9ami, 9apw, 9asf, 9aul, 9awm, 9bds, 9beo, 9bey, 9bik, 9bji, 9bjv, 9bm, 9bqw, 9brk, 9bxa, 9bxq, 9bz, 9caa, 9ccv, 9cfy, 9cmk, 9dah, 9dfb, 9dhi, 9dky, 9dte, 9dtm, 9ei, 9fv, 9fi, 9fm, 9pi, 9ps, 9uu, 9xaq, 9yaj, 9yak, 9zb, 9zn, I. C. W.

By 6BQH, 2507 E. First St., Los Angeles, Calif.

C. W.: 5di, 5tj, 5zav, 5za, 6bf, 6cc, 6fh, 6gr, 6ku, 6ag, 6aat, 6abx, 6ajf, 6aq, 6aqw, 6awt, 6atq, 6auu, 6aui, 6aor, 6bbh, 6bjy, 6bmd, 6bnw, 6qz, 6bob, 6boe, 6bql, 6bsa, 6bum, 6bvw, 6bvw, 6bwa, 6bwp, 6za, 6zb, 6zh, 6zo, 6zx, 6zz, vy qsa, 7bj, 7tq, 7ot, 7zo, 8bo, 8bcy, 9amb, 9aou, 9aul, 9awm, 9bji, 9dtm, 9dug, 9bxq, 9zaf (voice). Spark: 6tu, 6qr, 6abw, 6awh vy qsa, 6zh, 7ya, cl8.

By 7JU, Eugene, Oregon

5ct, 6nv, 6ak, 6cv, 6ih, 6ti, 6vf, 6lu, 6rk, 6gp, 6gy, 6zx, 6pi, 6vm, 6nx, 6bcj, 6bko, 6bum, 6abx, 6aat, 6awh, 6bmd, 6brg, 6atj, 6bou, 6bum, 6bqp, 6atj, 6bpc, 6auu, 6bjr, 6alv, 6bip, 6ajh, 6gd, 6akr, 6bmy, 6ast, 6alu, 7bk, 7bj, 7ex, 7ge, 7gp, 7im, 7jg, 7kj, 7lu, 7qt, 7ri, 7ud, 7wm, 7aff, 7afh, 7aic, 9ox, 9uu, 9ami, 9bef, 9ccv.

By 8KW 236 Barton St., Buffalo, N. Y.

1bka (fone), 2brb, 3bnu, 4bx, 4by, 4ea, 4ft, 4gl, 4kc, 4kt, 4lj, 5aag, 5da, 5ek, 5er, 5es, 5fv, 5jd, 5md (spark), 5nv, 5pv, 5sa, 5sm, 5tj, 5va, 5xa, 5xt, 5xk, 5za, 5zas, 5zx, 6acr, 6avd, 6xad, 7zo, 8bda, 9dky, 9zn, (3kp) Can.

By 9BJI, 3935 W. 30th Ave., Denver, Colo.

C. W.: 1bbe, 1bet, 2awf, 2bmr, 2el, 2oe, 3aau, 3acf, (5aac), 5aej, 5dn, 5ek, 5fj, 5ft, 5fv, 5gj, 5ia, 5if, 5ik, 5im, (5is), 5ix, 5jm, (5ib), 5me, 5mo, 5ou, 5pb, 5pf, (5pv), 5px, 5rj, 5rh, 5sf, 5sm, (5sr), 5nk, (5nv), (5tc), 5tj, 5tp, 5uj, 5uk, 5tm, 5un, 5uo, 5vm, 5vq, 5we, 5xd, 5xt, 5xv, 5zar, 5zh, 5zs, (6abx), (6ada), (6ah), 6ajf, (6ak), 6alx, (6apw), 6aqa, 6arf, 6atq, 6avn, (6avr), (6awt), (6bcr), 6bet, 6bhq, 6bji, 6bjc, (6bjr), (6bjy), 6bko, (6boe), (6bq), (6bqd), 6bqg, (6bz), 6bsa, 6bum, (6bum), 6cc, 6cu, (6ea), (6ec), (6fh), (6gf), (6gr), 6gx, 6km, (6lo), (6lv), 6om, (6pi), (6te), (6ti), 6uw, 6xav, (6zac), 6zaf, (6zs), 6zx, 6zz, (7bj), (7afw), 7hm, (7lu), 7ly, 7sc, (7th), 7xc, 7zo, 7zv, 8acf, 8ago, 8amm, 8ax, 8bcy, 8bdv, 8bef, 8bk, (8bke), 8bre, 8btv, 8bxh, 8bzy, 8cdz, 8cf, 8cmi, 8eve, 8dat, (8ib), 8qk, (8sp), 8sz, 8uk, 8uz, 8vd, 8yn, 8zw, 8zy, 9aao, (9abv), 9aeq, 9ahh, (9ajp), 9alr, 9anf, 9aog, 9aon, 9ap, 9aqh, 9aqr, 9arz, 9asn, (9atn), 9apw, 9aul, 9aau, (9ave), 9avz, 9aws, (9awz), 9avm, 9axa, (9baf), 9bbf, 9bef, 9bds, 9bed, 9bfj, 9bgh, 9bhd, 9bhq, (9bie), 9big, (9biz), 9bik, 9bjm, 9bjv, 9bkm, 9bil, 9bkw, 9bkw, 9blo, 9bly, 9bp, (9bqw), 9bri, 9brk, (9bsz), 9btt, (9bud), 9bv, (9bxt), (9bzi), 9byz, 9bze, (9ccv), (9ccs), 9cfi, 9cfk, 9chn, 9cip, (9ckm), 9clq, (9cmk), 9cns, 9coi, 9ctn, 9evo, 9exz, 9ecz, (9ccv), 9ewc, 9dgc, 9der, 9dge, 9dgn, 9djb, (9dky), 9dlk, (9dpl), 9dqm, 9dqu, 9dsm, (9dta), 9dr, 9dvn, 9dvw, 9dxn, 9dyg, 9dzy, 9eak, 9dzw, 9ebt, 9fk, (9fm), (9ig), 9ii, 9il, 9io, 9lz, 9nu, 9pi, (9pw), 9qf, 9ps, 9sj, 9uh, 9xc, 9yf, 9zn-icw, 9zy. Can.—3co, 4dq.

By 6bul, Provo, Utah

C. W.:—5bv, 5de, 5za, 6cc, 6ea, 6ti, 6adm, 6agp, 6atq, 6bbh, 6bin, 6bjq, 6bjt, 6bnu, 6btj, 6bvg, 6xad, 6zh, 6zo, 6zr, 7ad, 7ex, 7hj, 7hm, 7ot, 7tq, 7zu, 8aqo, 9dr, 9pi, 9pn, 9ahh, 9ami, 9anq, 9awm, 9aws, 9bbu, 9bik, 9bji, 9bjv, 9bpi, 9bun, 9bxq, 9cfy, 9ctw, 9dji, 9dky, 9dte, 9xaq, 9yah.

By 6BJC, 540 St. Andrew's Pl., Los Angeles

C. W. (during T. A. prelims): 2lo, 3yo, 5di, 5fv, 6px, 6sm, 5xad, 5za, 7aem, 7afw, 7aic, 7bj, 7bk, 7dk, 7dw, 7ek, 7jw, 7lr, 7lu, 7mf, 7ot, 7sc, 7sy, 7th, 7tq, 7zb, 7zo, 7zu, 8aqo, 8asv, 8azd, 8bef, 8bke, 8bpl, 8bxh, 8cf, 8cmi, 8ib, 8sp, 8tk, 8zz, 9amd, 9amb, 9aog, 9aps, 9aul, 9avz, 9awm, 9bds, 9bhd, 9bji, 9ccv, 9cfy, 9cns, 9dkx, 9dsm, 9dtm, 9dvn, 9gk, 9lz, 9pi, 9pn, 9zaf, 9zn. Can.—3co, 4bv, 9aw.

By 6BPB, E. N. Willis, 1254 10th St., Santa Monica, Calif.

(One tube.)
C. W.: 4km, 5za, 6aav, 6arf, 6alv, 6atq, 6bbh, 6bsj, 6bow, 6boe, 6bpr, 6cc, 6dd, 6lr, 6ti, 6vm, 6zna, 6zac, 6zh, 6zo, 6zz, 6zt, 7bj, 7cu, Continued on page 78

Investigate!
WESTERN-RADIO DEALERS SERVICE
Wholesale RADIO only
637 SO. HOPE ST. LOS ANGELES
1800 FRANKLIN OAKLAND

Get a
LEFAX HAND-BOOK free!
See page 51

Constant, steady voltage.
No battery noise in your V. T.
Easily recharged at home.
A life of from 3 to 5 years.
Jelly electrolyte, no spillage.
Clip on for any required voltage.

—A FEW OF THE REASONS WHY
SNELL CELLS
STORAGE "B" BATTERY
should be on YOUR set.
At your Radio Dealer, or

22 v., 11 cells.....	\$ 6.50
44 v., 22 cells.....	12.00
Chemical Rectifier.....	1.25

F.O.B. San Francisco
Order yours now for immediate shipment.

MANN & SNELL 6BQL 4733 Geary St., San Francisco, Ca!



Tell them that you saw it in RADIO

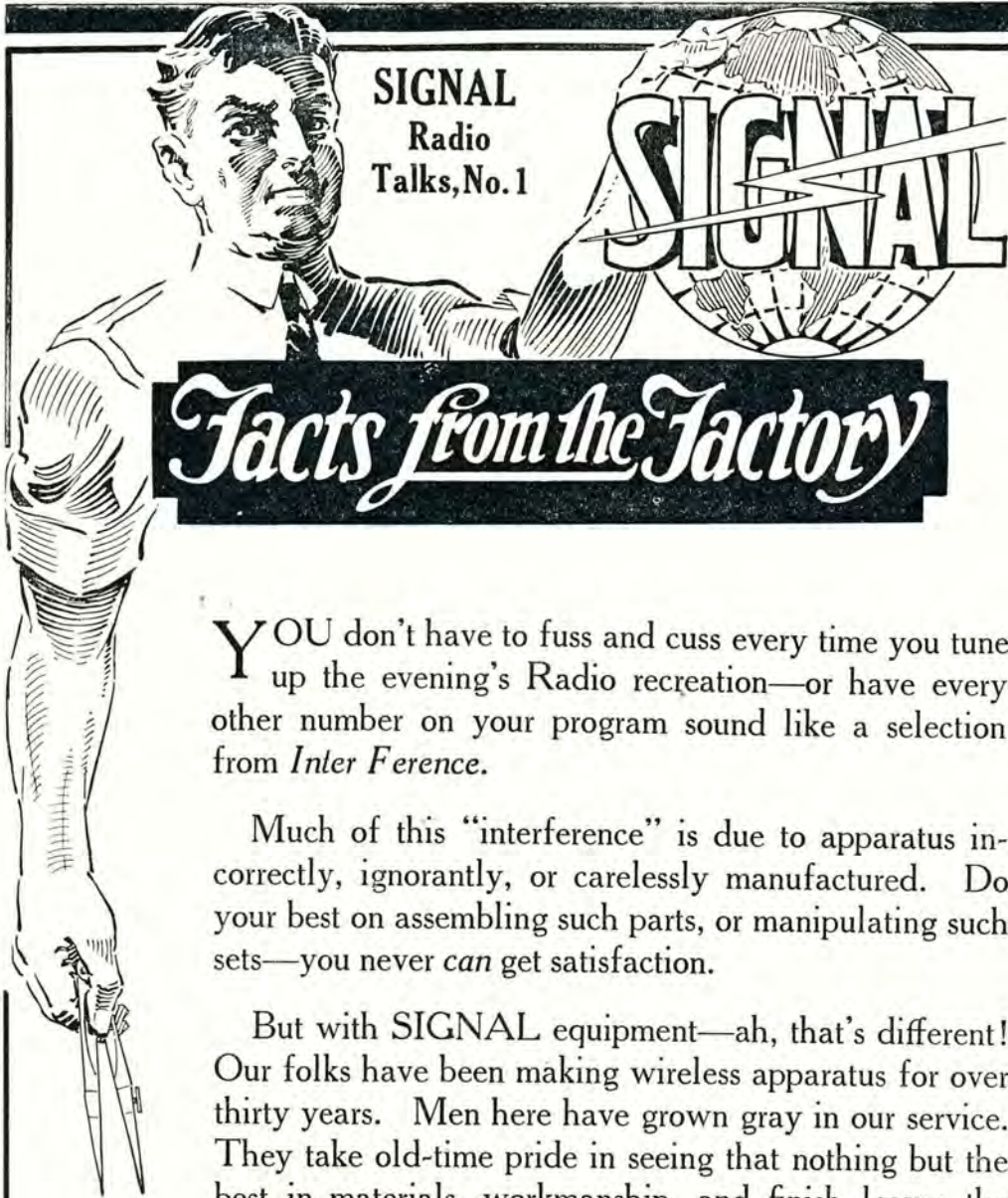

SIGNAL
Radio
Talks, No. 1

Facts from the Factory

YOU don't have to fuss and cuss every time you tune up the evening's Radio recreation—or have every other number on your program sound like a selection from *Inter Ferece*.

Much of this "interference" is due to apparatus incorrectly, ignorantly, or carelessly manufactured. Do your best on assembling such parts, or manipulating such sets—you never *can* get satisfaction.

But with SIGNAL equipment—ah, that's different! Our folks have been making wireless apparatus for over thirty years. Men here have grown gray in our service. They take old-time pride in seeing that nothing but the best in materials, workmanship, and finish leaves the SIGNAL plant.

It is made right. It looks right. It works right. If you insist on SIGNAL when you're buying Radio equipment—you will buy Radio satisfaction.

SIGNAL Electric
Mfg. Co.

Factory and General Offices:
1913 Broadway, Menominee, Mich.

Atlanta Boston Chicago Cleveland Minneapolis Montreal
New York Pittsburg San Francisco St. Louis Toronto

You'll find our local address in your Telephone Directory



**SIGNAL Tube Base
for WD 11 Tubes**

Adapted for building receiving sets using a single dry cell for filament excitation. Does away with the troublesome 6 volt storage battery, but retains the efficiency of the 6 volt tube. Legs insulated for table mounting; screws provided for panel mounting.



**SIGNAL Vernier
Rheostat**

The first successful vernier using a single knob for control. Fine adjustment is easily obtained. Simple in design and sturdy in construction. Furnished with or without knob and pointer, so dial to match others of set may be used.

(1953)

Information Coupon

Signal Electric Mfg. Co.,
1913 Broadway,
Menominee, Mich.

Please send catalog and bulletins giving complete information about SIGNAL Radio equipment to name and address written in margin.

VERSATILE VACUUM TUBE

Continued from page 14

formation of parts due to heat or other causes.

By the use of repeaters in telephone lines over long distances, therefore, the range of such service has been extended to cover not only the mainland portion of our country, but it has been carried outward to include the islands of the sea. Cuba is joined to the general system by deep-sea telephone cables, and Catalina Island in the Pacific is joined up by means of a radio link between that island and Los Angeles, California, this link cooperating perfectly with the wire-line portion of the system. The vacuum tube has liberated an entire art in a very striking way.

Consider, if you please, the case of a passenger on a trans-Atlantic liner talking from his stateroom through the land line system of the United States to a regular subscriber's telephone on Catalina Island. This is entirely a possible task, and has been done in every technical detail. Here is the route: From the ocean liner telephone to a modulator, to an amplifier, to an oscillator, to the transmitting aerial on shipboard, through the ether to the receiving aerial on the Atlantic seaboard, to radio-frequency amplifiers, to a detector, to audio-frequency amplifiers, to the long distance line, to and through a series of repeaters in that line, each using a tube or tubes, to a modulator on the California coast, to an oscillator, to the transmitting aerial, through the ether to the receiving aerial on Catalina Island, to radio-frequency amplifiers, to detector, to audio-frequency amplifiers, to the local line and so to the receiving telephone. And through all this maze of apparatus the voice current is repeatedly extinguished, then replaced by a similar—and frequently an augmented—copy of itself, coming out into the final telephone receiver in satisfying volume and quality.

We are as keenly conscious as any reader that this has been a cursory view of a broad subject, but we hope that it at least hints at our respect for the device and its applications so far as yet made, at our hopes and beliefs as to its future applications, and at our regard for those minds that brought it into being, had faith in it and set it to work.

Let us paraphrase the words of the late Judge Taylor of Indiana: "Truly no man may add a cubit to his stature by taking thought. Yet here is an example wherein men, by taking thought, have added not cubits, but many miles, to the lengths of all men's tongues and ears."

NEWS OF THE AMATEURS

The QRA of 5xAD-5QY is Orange, Texas, and not Austin, Texas.

Call 4DJ has been assigned to T. H. Nabors, Box 141, High Point, N. C.



Claude L. Gates

GRAND OPERA !

There is a nightly performance of Grand Opera. Let Tuska Reliable Radio take you, together with home comforts.

Tuska Quality Radio Apparatus is reliable in service, moderate in price. Ask for Tuska Radio at your dealers today.

The C. D. Tuska Company
47 Bartholomew Ave.
Hartford, Connecticut

TUSKA RADIO

Established 1911

Catalog Number Four contains Marvelous article on tuning Receiving Sets Ten cents brings it to you

Investigate!

WESTERN-RADIO DEALERS SERVICE

Wholesale RADIO only
637 50 HOPE ST. LOS ANGELES
1800 FRANKLIN OAKLAND

AMATEURS WANTED

To secure subscriptions to this magazine. Write for particulars!



JEWELL LIGHTNING ARRESTER

Approved by Underwriters' Laboratories, latest Code. Carbon block types (not vacuum type) using a brown glazed porcelain case which can be installed inside or outdoors. Carbon block arresters have been standard in Railway signal and telephone protection for over 20 years. Ask your dealer or write us for special circular.

PRICE \$1.10

JEWELL ELECTRICAL INSTRUMENT CO.
1650 WALNUT ST. CHICAGO

Lefax Radio Handbook

Distributed in the West by Pacific Radio Pub. Co., Inc.



The Whole Story About Radio

Told by the two Chiefs of the Radio Department of the U. S. Bureau of Standards.

Dr. Dellinger, and Mr. Whittemore, the authors of the Lefax Radio Handbook are the only authorities who have access to all the facts about Radio as well as all the New Developments. They have not only written the most complete story about Radio obtainable, but will also write up all the new developments for the YEAR'S FREE SERVICE (to be continued after that at a small cost)

LEFAX Radio Handbook is the one Book on Radio that keeps abreast of developments. As quickly as the authors learn new facts about the subject, the information is passed on to you. It comes all printed in loose-leaf form, all pages numbered and properly classified. Lefax is the only Book on Radio that doesn't, cannot grow old.

Note the little rings in the center of the book. Those rings are hinged. They are instantly opened—by a slight finger pressure—to receive the perforated pages. Once an ordinary book is bound, it cannot be changed—but Lefax can. You buy Radio information *complete* when you buy Lefax. We furnish, free for a year, pages containing additional information. You need Lefax Radio Handbook.

A FREE COPY with one subscription to "RADIO" for 18 months.

ADDITIONAL loose leaf pages are mailed to you as they are issued—free of charge for one year. Automatically keeps itself up to date. Every radio experimenter needs this book. Send for your copy today. Immediate deliveries.

The One Best Book on RADIO



LEFAX Never Grows Old

\$ 3 50

DEALERS: We are Western Distributors for this Book. Write for trade discounts!

Take Your Choice---Use Either Coupon

FREE LEFAX BOOK

"RADIO"—Pacific Bldg., San Francisco. Herewith is \$3.75. Send me a free copy of LEFAX and "RADIO" for 18 months.

Name

Address

"RADIO"

Pacific Building, San Francisco.

Herewith is \$3.50. Send one Lefax Radio Handbook to:

Name

Address



Triplex Filament Meter

Filament control by the use of proper instruments in receiving sets is the trend of the times. The Jewell triplex filament instrument, made as an ammeter or voltmeter, places on your panel the proper means for controlling the filaments of three tubes. It has a self-contained mechanism for switching to either tube and being of small size, can be accommodated on the most compact tube set.

Price \$10.00

We were the first to supply a complete line of miniature radio instruments of uniform size. Ask your dealer or write to us for complete radio circular.

JEWELL ELECTRICAL INSTRUMENT CO.
1650 WALNUT ST., CHICAGO



FREE! Send one subscription to "RADIO" and you get this Dubilier Micadon —free!

State type when ordering

"RADIO" Pacific Building, San Francisco, Cal.

BACK COPIES OF "RADIO" WANTED

Tell us what issues you have available and we will purchase them from you.

"RADIO"

ARMSTRONG "RADIO FLIVVER"

Continued from page 16

The loop should be rotated to various angles. In many cases, in metal frame buildings or in autos near wires, etc., its most favorable angle will not always be when it is pointing toward the station.

The loop tuning condenser, filament rheostat and plate variometer are of equal importance in tuning and should be adjusted alternately. The condenser and variometer adjustments bear a very definite relation to each other, which is properly indicated by a noisy rattle. The proper adjustment will be found somewhere in the middle of this noise and when the proper adjustment is found the noise will stop and the music or speech will come in clear. At this point it is interesting to note that when the broadcasting station stops the noise will commence, but if the adjustments are not disturbed, the station will come in again and the noise disappear automatically.

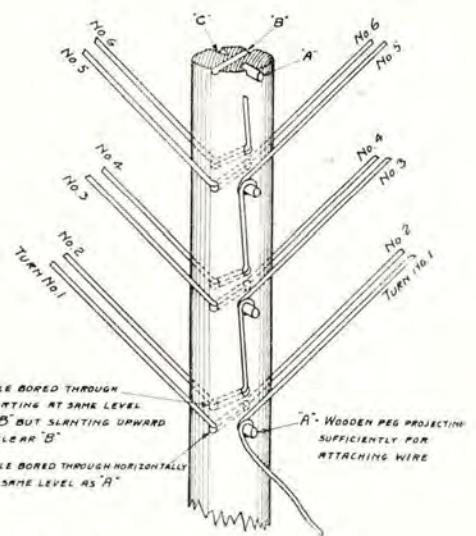
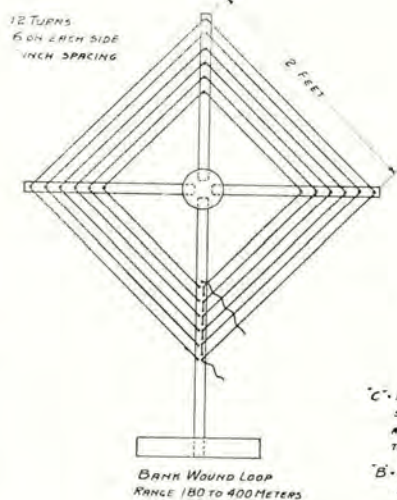

Fig. 5. "Bank-Wound" Loop

In conclusion, there is offered what is believed to be a novel design of a "bank-wound loop" which seems to have several advantages. The box frame loop is best for a sharp directive effect, but is cumbersome and clumsy. The spiral or pancake wound loop is simpler to construct but is inefficient, as the inner turns of smaller diameter are of little value. The bank-wound loop shown in Fig. 5 (360 meters) seems to combine the advantages of both types without any of the disadvantages.

BROADCASTING IN GREAT BRITAIN

The six principal manufacturers of radio equipment in Great Britain have incorporated a broadcasting company, stock ownership in which will be available to themselves and to any other manufacturer of radio receiving

equipment in the British Isles. The broadcasting Company will have a capital of £100,000, which has been guaranteed by these six manufacturers. Any bona-fide British manufacturer of wireless apparatus may join the company by subscribing to one or more shares. The president of the Broadcasting Company will be Lord Gainford. Present plans call for the establishment of eight stations at London, Birmingham, Manchester, Newcastle, Cardiff, Glasgow, Plymouth and Aberdeen.

In Great Britain amateur receiving sets have always required a license from the Post Office Department, which has supervision over all forms of communication. The license fee is 10 shillings per annum, or about \$2.20. The Post Office has agreed to pay to the Broadcasting Company half of this annual fee.

In addition to its share of the Government's license fee, the Broadcasting Company will receive from every manufacturer who is a member of it, fees, based on their sales of radio receiving apparatus for amateur use. It has been estimated that each broadcasting station will cost about \$90,000 per annum for operating and program fees, and any profits which remain after the payment of all charges will be divided among the Broadcasting Company's stockholders up to a maximum of 7½ per cent on their investment.

In order to protect the radio manufacturers from foreign competition, the Government

has agreed not to license for use any receiving station equipped with other than apparatus made by members of the Broadcasting Company.

Home-made sets can be constructed and operated under the new arrangements, provided they pay the stipulated 10-shilling government fee.

RADIO TRADE NOTES

Frank A. D. Andrea advises that T. R. Goldsborough, U. S. Patent Office, Wash., D. C., has been awarded a two-step amplifier as the winner of the prize contest recently conducted.

Investigate!

WESTERN-RADIO DEALERS SERVICE

Wholesale RADIO only

637 50 HOPE ST. LOS ANGELES 1600 FRANKLIN OAKLAND

Tell them that you saw it in RADIO

5c a week

Published under the auspices of the Pacific Radio Trade Association by the Pacific Radio Publishing Co., Inc., publishers of "RADIO."

Brings you a copy of "BROADCAST PROGRAM," the new weekly magazine devoted to radio broadcasting in Central California.

This Program Contains Broadcast Schedules, Programs of Stations, Amateur Call Letters, Cartoons, News of Broadcasters, Editorials, Long Distance Schedules, etc.

26 Issues for \$1

If you subscribe for six months we will send you a free copy of the "A B C OF RADIO"—a non-technical booklet that tells you the "How and Why" of a radio set.

BROADCAST PROGRAM
for Central California

All of the latest Broadcast Schedules—programs—station news—call letters—Editorials—Cartoons—"DX" Schedules, etc.

PRICE **5** CENTS

for week of January 14-20, 1923

\$1.00

brings it to your address every week for six months.

Subscribe Now—This Is Your Biggest Dollar's Worth Anywhere At Any Time.

Pacific Radio Pub. Co., Inc.
Pacific Bldg., San Francisco

R-2

Send "BROADCAST PROGRAM" to my address every week for six months. I enclose \$1.00. Also send me a free copy of the "A B C OF RADIO."

Name

Address

WABASH RAILWAY COMPANY
 TRAFFIC DEPARTMENT
 J. E. WATSON, PASSENGER TRAFFIC MANAGER
 BY LOUIS
 November 30 1922
 IN GREAT PLEASE REFER TO FILE 1

Mu-Rad Laboratories, Inc.
 800 Fifth Avenue
 Asbury Park, N. J.

Gentlemen:

It is a pleasure to report the result of the tests which were recently conducted on Wabash trains No. 2 and 5 with one of your Mu-Rad Radio Receivers.

The Mu-Rad Receiver with a 2' loop aerial was set up in all-steel club car placed in the middle of a train of fourteen cars which left St. Louis for Kansas City at 11:00 P.M. on the night of November 28th. Some forty persons were present in the car and were very elated at hearing on the horn the signals from the St. Louis Post Dispatch broadcasting station and from the Kansas City Star. The signals were very clear and strong up to the time the broadcasting shut down.

On the morning of November 29th a second test was made on the train running from Kansas City to St. Louis, the Mu-Rad equipment of this test being set up in the observation car. On this return trip, three stations in Kansas City, one in Wichita, Kansas, one in Jefferson City, Mo., two at Atlanta, Ga., and one in St. Louis, and the Shenectady, N.Y., station, were all picked up very clearly.

Persons who witnessed the tests considered the performance the most wonderful radio achievement they had ever seen expressing surprise at the clarity and strength of signals received on a small loop and particularly within an all steel car during daylight.

Yours very truly,
H. E. Swartz
 Passenger Traffic Manager.

The New Star in the Radio World

What the Railroad said about the performance of the Mu-Rad Set on the Wabash Express

MU-RAD
Radio Frequency Amplification

Triumphs in Test on Express Train

THE entire radio world is agog at this latest supreme achievement—the reception of radio programs inside a steel car, with no outside aerial or ground, moving at express speed—the severest test ever given any receiving apparatus.

A striking demonstration of the great sensitivity, extremely accurate selectivity and absolute simplicity of operation of Mu-Rad Receivers.

The difference between Mu-Rad and other apparatus is great enough to be worth your while insisting on Mu-Rad Receivers. Guaranteed reception of 1000 miles.

- | | |
|---|--|
| Type MA-12
3 Stages R. F. and Detector
\$128 | Type MA-13
3 Stages R. F., and Detector and 2 Stages A. F. \$160 |
|---|--|

DEALERS: Write for interesting proposition.

Mu-Rad Laboratories, Inc.
 806 Fifth Ave. Asbury Park, N. J.

*They copied all they could copy,
 But they could not copy our mind;
 We left them tearing and swearing
 A thousand miles behind.*

—Kipling



THE OPERATOR'S AUDION

Continued from page 20

harm in trying the company's offices direct, going if necessary to the highest official in the organization. There are all sorts of exceptions, of course, but as a general rule, the bigger the man, the quicker will he understand what you are trying to do. If no attention can be got anywhere, it is perhaps because the operator does not know how to set the matter forth convincingly. Ask your captain or your port-captain to read this article.

The steamship companies are keenly interested in anything that is to their advantage; that is why they put radio aboard their ships—their cargo ships at least—in the first place. The moment the ship-owner gets an idea of what the vacuum tube detector and amplifier means to the efficiency of his radio service, he will be glad to buy it. But how is he going to know of his lack, if no one tells him about it?

THE ROMANCE OF RADIO

RETURNING now to a brief concluding view of the life of the professional radio operator, some of the phases of which it has been the aim of these five instalments to discuss, it may truthfully be said that for the wireless operator who knows how to do his work, and does it; one whose merits as an officer and as a man have won for him the esteem of his fellow officers and of his captain; one who has sailed long enough to absorb the atmosphere of shipboard life and a little of the salt of the sea,—for such an one, if he be on a tramp steamer, there is a life as idyllic as ever was dreamed of by philosophers and poets, a being than whom where is none freer on earth.

And not only is he free. Travelling always, he learns much; his outlook immeasurably broadens; whereas the stationary mass of mankind see life through the figurative knot-hole of one locality or one country, he sees it standing outdoors commanding a full sweep of the horizon. Narrow beliefs, conventions, bigotry, all the cobwebs of restricted environment, are swept away. If he is likely to lose religion, of the creeds, he has the opportunity, so be he has the moral stamina, to gain a profound philosophy of life. Equally at home on a London tram or in a Singapore sampan; returning the smiles of petite Parisian style-pictures, viewing the marvelous engineering of the Panama Canal, buying a bolt of silk in Yokohama; from the cold white splendor of the Bering Sea wastes to the blazing heat of restless Mexico; today enjoying the latest musical comedy on Broadway; tomorrow gazing upon three-thousand-year-old stone giant-gods on the banks of the Yang Tse Kiang,—all these, and a

HELP! HELP! HELP! HELP!
 This is the cry of the busy Radio salesman during rush hours. The EBY SILENT SALESMAN (illustrated below) will assist the man behind the counter as it enables the customer to wait on himself—and quickly.



Price to Jobbers,
 Dealers and
 Manufacturers,
 \$1.00 Each

Full information as to specifications and prices of posts printed on back.
THE H. H. EBYS MANUFACTURING CO., PHILA., PA.

thousand things more, are of the sea-claimed man's daily life: he knows them not as the hurrying and hurried tourist, who sees little and feels less, knows them; but with the unexpressed and inexpressible understanding and knowledge of common kin with all the earth of one who lives among the constantly changing scenes of his many travels, become truly indeed an inhabitant of the world.

RECENT PATENTS

Continued from page 34

rection. The unilateral conductor in this instance is itself a vacuum tube, and its effect upon conducting away the positive charge on grid 17 may be controlled by properly controlling the resistance 24 or by inserting a source of potential 22 into the circuit.

H. H. Beverage, Pat. No. 1,434,986: Nov. 7, 1922. Radio Receiving System.

A long horizontal antenna 1, 2 of the kind described in the prior Beverage patent No. 1,434,984 is described, in which a receiver 10 is used to detect signal waves traveling from the right to the left, and there caused to affect the secondary 8 of a transformer. In order to make the detector respond only to the desired wavelength, tone traps 11, 12 and 13 may be provided between the two lines 1 and 2, which traps are tuned to the wavelengths it is desired to eliminate. In this way these interfering waves are by-passed without going through the detector circuit.

J. H. Hammond, Jr., Pat. No. 1,418,792; June 6, 1922. System for control of moving bodies by radiant energy.

A system is described in which the body may be steered automatically by the aid of a gyroscope, or else the control may be effected from a distant point by radiant energy acting upon a solenoid. This solenoid may be made to rotate the stem of a rotary valve in a step-by-step manner. Fluid under pressure from a tank is appropriately controlled by this valve to unclutch the gyroscope and to move a piston in a cylinder in either direction, and thereby to move the rudder. An auxiliary valve is used for operation in connection with the gyroscope control to check large movements of the rudder and thereby damp the oscillations of the steered body.



O. K.

You will surely approve this Better Tube Socket because our Engineers have built into it five points of excellence. Read them. You Need them ALL.

1. Positive double side grip contacts. The Bayonet slot enables this.
2. Hard rubber insulation assures a minimum of losses.
3. Rugged construction. Practically unbreakable.
4. Compact design permits close assembly.
5. Heavily nickeled for neat appearance.

IF YOUR DEALER

can't show the Coto-Coil Double Bayonet Slot Action, make him write us today for Dealer's Sample

COTO-COIL CO.

87 Willard Ave.,
Providence, R. I.



Stop Interfering With Your Neighbor's Rights By Making a Miniature Transmitting Station of your own Receiving Set.

Install a Universal Radio Receiver and Coil Unit which has incorporated in each all the fine points of Radio Engineering.

This set, by use of a coupled circuit in tuning, does not disturb nearby receiving sets by setting up oscillations of 2400 meters. This feature is highly desirable in view of the fact that such interference will eventually be eliminated voluntarily or by legislation.

The wave length range possible with Coil Unit is 180 to 6200 meters.

The Receiver is equipped with detector and two-stage audio frequency amplifier mounted in one cabinet, while the Coil Unit is in a separate cabinet.

The Universal Radio Receiver makes use of a device to PREVENT DISTORTION which, in effect, operates as a permanent 'C' battery. The set will always operate at its maximum efficiency and SIGNALS WILL ALWAYS BE CLEAR AND INTELLIGIBLE.

The wave length of the secondary circuit is tuned to that of the primary circuit by means of a variable condenser, thus giving approximately 4 times the wave length variation possible with variometer tuning.

BANK WOUND COILS, which is the best known form of winding, are used throughout. THE SELECTIVITY IN TUNING of this Receiver is obtained by the use of the coupled circuit which allows sharper and stronger signals to be received than by means of other circuits.

We guarantee the workmanship and quality of this set to be of the highest type. A demonstration of our set will prove conclusively that this set is the biggest advance yet made toward a perfect Radio Receiver. If your dealer cannot supply you, kindly write us.

Price F. O. B. Factory
Universal Radio Receiver.....\$90.00
Universal Coil Unit.....\$10.00

115 North Market **HAYES AND NEWTON** - Urbana, Illinois

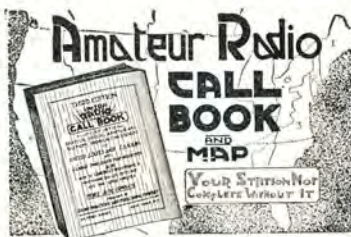

All Under One Cover!

A complete list of all Amateurs, Special Amateurs, and Telephone Broadcasting Stations of United States and Canada; also a large two-color map to record your DX work on, size two ft. by three ft.

MAILED ON RECEIPT OF \$1.00 (No Stamps)

RADIO DIRECTORY & PUB. CO.

45-D Vesey St. New York City



ERLA PLUGS

Given free with one subscription to "RADIO."

Mailing charges, 12c.

"RADIO"

Pac. Bldg., San Francisco, Cal.

LOUD SPEAKER FREE TO YOU!

Send 3 subscriptions to "RADIO" and we will send you a Trutone Loud Speaker.

See page 97

"RADIO"
Pacific Bldg., S. F.

“ESCO”

TRADE MARK

THE AMATEUR TRANSATLANTIC TESTS SHOW

(At the Time This Advertisement was Written)

That more operators succeeded in getting across with “ESCO” MOTOR-GENERATORS THAN WITH ALL OTHER MAKES COMBINED

Paul Godley is using an Esco Motor-Generator in England, 8BSS, Cazenovia, first to be heard in Switzerland—Same Station 8AQO heard in England, France and Switzerland first 8 nights. 1BGF, Hartford, first to be reported back. Very many others made remarkable records with our apparatus.

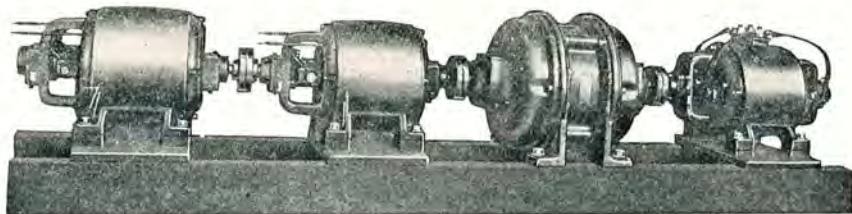

This is a Special Four-Unit Set for the Largest Broadcasting Station in Existence—a 10 h.p. 220 v., 60 Cycle, 3 Phase Motor, Two 1000 v. 2000 w. Generators Designed to Operate in Series, thus producing 2000 v. 4000 w. and One 12 v. 2000 w. Filament Current Generator.

BESIDES MAKING STANDARD OUTFITS IN OVER 200 COMBINATIONS, WE ARE CONSTANTLY DEVELOPING SPECIAL APPARATUS FOR SPECIAL PURPOSES.

Battery Charging Motor-Generators in Many Sizes.

Motors — Dynamotors — Generators — Motor-Generators

Electric Specialty Co.

(Key Address) Stamford, Conn., U. S. A.

Sold by Principal Dealers Everywhere

WORTH

Continued from page 21

own get! And I guess I've made's much as any o' 'em in this county! You two git to bed—for ye've got to be up at 3. All that firewood on the hill, 'bove Otter Brook has got to be brought in— afore somebody steals it!"

Without a "goodnight" he clumped in a neighboring room, slammed the door, and the two heard him get in bed, vibrant snores ensuing, almost forthwith.

The boy got up, tiptoed to the girl: "You wont never, *ever* tell, will ye, Flora?" he whispered in her ear.

She smiled wanly and shook her head: "Ef he catches you again, he'll mos' *kill* you!" she said, very softly.

"I don't care! Rather *be* dead than know nothin'!"

And he slipped out in the bitter cold of the star-hung night, opening and closing the door so carefully that it made no sound.

Hurrying to the wagon barn, over which there was a steep-eaved loft, he climbed to it by a ladder. Moving with the sureness bred of long familiarity, he hunted in a corner, brought out a few inches of candle and a much frayed book. He struck a sulphur match, whose first blue splutter lighted his face in a ghostly way. The candle going, he stuck it inside a box, that its rays might not leak through any chinks; and then, with a little sigh of happiness, he sat cross-legged in his tattered overalls—thin hands and feet gray with the cold—and opened the book to a page whereon was printed the international code of signals.

"A=dot-dash, B=dash-dot-dot-dot, C=dash-dot-dash-dot, D=dash-dot-dot, E=dot."

A MILE from the Ellison farm, situated on a high hill, with a sweeping view of the whole countryside, stood the pretentious country residence of U. S. Senator Briggs. From great distances its huge white colonial columns stood out sharply, and the many out-buildings, pergolas and so forth, caused the hilltop to seem as a self-contained little village. To one side of the "big house" stood a very fine mast, some 100 feet in height, that pointed as a white finger at the blueness of the great expanse overhead. At its top was a cross-arm, from whence a most efficient antenna sloped to a lesser spar, on one corner of the house. Thence the wires led, in braided form, to a huge insulator in the wall.

And by these things be it known of Robert Briggs, the Senator's only child, a youth of sixteen, utterly spoiled by an adoring mother, and suffered in silence by his father, that his latest "craze," as the Senator dubbed his various enterprises, was radio. But he was far too lazy to study with any degree of seri-

Continued on page 58

The Telmacophone in Your Home



Makes Your Radio Set Complete

You can enjoy every minute of the entertainment—hear every word and sound, clearly and distinctly. No need to change headphones from one person to the other. Everybody hears everything.

Original

\$20.00 Loud Speaker and Still The Best

Tone is produced by Original Baldwin Type C Unit and reflected into other horn. No metallic effect. Beautifully finished in black and gold.

Correctly designed—fairly priced—unreservedly guaranteed. With original Baldwin Type C Unit, complete \$20.00.

Insist on the Telmacophone. If your dealer hasn't it in stock, send us his name and order direct from this ad. Enclose \$20.00. Prompt shipment. Write for new free catalog.

RADIO DIVISION
TELEPHONE MAINTENANCE CO.
20 S. Wells Street Dept. A Chicago, Illinois



Quality Radio Exclusively

JOBBERS! DEALERS! The demand for the Telmacophone is great. Write for new catalog and discounts on our complete line. We are also distributors for the better standard lines.

Two Radio Magazines

for a little more than
the price of one



THROUGH the co-operation of the American Radio Relay League and the Pacific Radio Publishing Co., you can now subscribe to both "QST" and "RADIO" for a full year at the unusually low rate of \$2.70. Your subscription to "QST" also entitles you to membership in the American Radio Relay League.

Amateur Radio is the fad of the day. Join the ranks of the full-fledged experimenter by subscribing to "QST" and "RADIO." These progressive magazines do not feature sensational radio stunts, but they give you the "low down" on anything that's worth-while along the lines of practical radio development.

The very best radio material is published in these magazines. You will get more out of your set if you read "QST" and "RADIO" every month. The publishers will gladly send you a free sample copy of either magazine for your approval.

Save \$1.80

Every progressive Radio experimenter should read both magazines regularly

This is undoubtedly one of the most liberal magazine combinations ever made. Take advantage of it now!

"RADIO," Pacific Building, San Francisco.

Send "QST" and "RADIO" for one year. I enclose \$2.70 in full payment.

Name

Address

.....

Renew your present subscription to either magazine if you are already a subscriber. But get your subscription in by March 1st.

Results Talk!

San Francisco, Calif. Coast radio Co. El Monte, Calif. Your Miller Radio Frequency Set surprised me on two foot loop only get music from C F B N Calgary, Canada as well as Portland, Sacramento and Los Angeles just as loud as on my set when using two hundred foot aerial.

(Signed) William M. Collins

Los Angeles, Calif., Coast Radio Co., El Monte, Calif. Enclosed find my check covering invoice for Miller Receiving Set. I am having very agreeable success with this set at my mountain home in the San Bernardino Mountains, where I was unable to get signals audibly with other sets I tried. Wishing you success, I am

J. J. Jenkins.



Here's a Radio Frequency Amplifier Unit that covers all waves—if you want music, time signals, long distance arc reception—the Miller get's 'em all—and gets 'em loud and clear. These units list at \$6.50 each. If you haven't used the MILLER you haven't yet used the BEST.

Coast Radio Company Incorporated

El Monte, Calif.

Sold in San Francisco and Los Angeles by the Leo J. Meyberg Co. Honolulu Patrons, buy from the Mutual Tel. Co. Eastern Dealers and Jobbers on request.

Continued from page 56

ousness. He had mastered the code, after a fashion, and absorbed just enough knowledge, by dint of hard, professional coaching, to sneak through the Government examination—that was mandatory for his being granted a license to operate.

At the time of the examination, the radio inspector, after having read young Briggs' papers, snorted in disgust—"What a wicked waste!" he ejaculated to his assistant. "I suppose that I've got to pass him—or the Senator will raise an awful row—or his wife will, which is worse! Lord! the boys in this great land of ours, with his opportunities—with that splendid station—the finest apparatus that money can buy, and an electrical engineer to help him run it—the boys, I say, in this land—half, yes one-quarter, of his age—would pass this examination 100%; and look at that," tossing a sheet to the other, "can't even define an ohm! I don't know—" the grey-haired inspector walked to the window, looked pensively out over the endlessly-stretching roofs of the city—"I'm not criticizing, but God does seem—unfair—at times!"

ON the third floor of the Briggs' home was a huge room, devoted entirely to radio. Here were to be seen the latest types of receivers, amplifiers, loud speakers, elaborate phonographs, for music reproduction, motor-generators—all manner of expensive things were scattered here and there. And there was a large bookcase, filled with the most modern and expensive radio publications. In short, a station that, in so far as its cost and excellence were concerned, was unequalled in the country.

Moodily sitting on a table corner, one leg swinging idly, was Robert Briggs, Jr.—the owner and. . . . "operator."

Busy at a long-wave receiver, whose performance did not please him, was Hugh Mathers, Robert's "radio tutor"—as Mrs. Senator Briggs was wont to tell her friends, adding: "Robert is making great strides in his radio studies. The Senator is very proud of him! He has heard Kalamazoo, or Kamchatka, or Berlin—I have forgotten just which—but it was a very long way off!"

"Look here, Rob! Why don't you get busy, and make an effort to really study the radio game? It's the coming thing—the greatest discovery ever made, and we are only the fringes of it! With the opportunities that you have, man alive! you could be, you ought to be, the top-notch amateur of the United States!" The young professional looked—imploringly—at the rich man's son. But Briggs, Jr., stared at him—dully—

"Too darn much trouble! I don't ever have to be a radio operator—for a living—and my station is pretty widely known, as it is! I'm satisfied!" He lumbered his overly-heavy figure from

the table—"Think I'll go for a run in the new car. Have that thing working for tonight!"

Mathers watched him go, shrugged his shoulders—"I'm not going to quarrel with the easiest bread and butter a chap could make—BUT if that big lunk of ignorant conceit belonged to me, I'd"—he whistled his intents.

A ROISTERING wind lifted the dusty-dry snow—as powder—whirling it gleefully hither and yon over the broad landscape. There was an invigorating sting in the clean chill of the winter morning, and Mathers hummed gaily as he plodded along, returning to the Briggs' mansion from the village.

Save for the housekeeper and another servant, he was alone at "Viewdale," Congress being in session, Senator Briggs in Washington, while the boy and his mother, "avoided the rigors of a New England winter"—at Palm Beach.

But Mathers did not at all object to being alone. Amply supplied with every facility to further himself in his chosen profession of radio, he studied and experimented, hour after hour, and during the long night watches.

Rounding a sharp turn in the road, he came suddenly upon a strange little figure, sitting a'top a rail fence—in an old coat made of quilted patchings, a pair of rubber boots—much too large for him—a frayed tam-o'-shanter pulled over his ears, and a pair of coarse mittens. The figure did not notice his approach, and Mathers followed the line of the other's gaze. It was focussed on "Viewdale," whose buildings, a quarter of a mile away, shone vividly clear in the brilliant winter sun, and where the radio spar seemed taller than ever, against the deep blue of the skies.

"Hello sonny!"

Walter Ellison turned, in a startled way—" 'Mornin'—pretty cold!"

"Roosting on that fence is no warm proposition! What are you looking at so hard?"

"Me? Oh—I was just—just playin' wish—kind o'!" the boy answered in a forlorn little way.

" 'Playing wish'? What for?"

"That I—that I could have the chances he's got!" ducking his head toward "Viewdale." "I'd be some operator—in less'n no time—I betcha!"

" 'Operator'?" repeated Mathers, incredulously, but taking instant interest in the country lad, with his earnest, intelligent face, and honest gray eyes.

"Oh yes! Dunno why, but I'm set on learnin' to be an—an operator! An' goin' to see the wide world on—on ships. Don't seem right to stick 'round a farm, tendin' pigs and cows—if a feller has got any brains—and I—I got

Continued on page 60

Kellogg Radio Equipment for Better Results

Easy to Mount — Simple to Operate

Variometer



All Bakelite moulded variometer. Two rotor and three stator terminals. Standard wound. For panel or base mounting. No. 501.....Each \$8.00

Dial



Four-inch, all Bakelite. Non-warping, reinforced construction. No. 502.....Each \$1.25

Microphone



Standard Microphone. Super-sensitive. The result of twenty-five years experience. No. 21.....Each \$8.90

Plug



The Kellogg plug fits all jacks. It is of strong construction and handsomely finished. No. 501.....Each \$1.00

Head Set

The value of extremely light and very small head sets in Radio receiving is most evident when using Kellogg head receivers, which, however, have proved as sensitive and thoroughly efficient as they are light in weight and small in size.

Jack



Positive contacts, constant spring tension. Durable insulated frame.

No.	Each
501-4 Conductor...	\$1.10
502-2 Conductor...	.75
503-3 Conductor...	.80
504-4 Conductor...	1.10
505-6 Conductor...	1.25

Variable Condenser



This condenser is of the decimeter type and is unusually well constructed.

No. 601 11 plate with 5 plate Vernier. Knob and 4-inch Dial. Each.....	\$6.75
No. 602 11 plate without Vernier. Less Knob and Dial. Each.....	\$4.50
No. 603 23 plate with 5 plate Vernier. Knob and 4-inch Dial. Each.....	\$7.75
No. 604 23 plate without Vernier. Less Knob and Dial. Each.....	\$5.50
No. 605 43 plate with 5 plate Vernier. Knob and 4-inch Dial. Each.....	\$8.75
No. 606 43 plate without Vernier. Less Knob and Dial. Each.....	\$6.50



No. 69A

No. 69A Head Set, 2400 ohms.....	Each \$10.00
No. 69C Head Set, 2000 ohms.....	Each \$8.00
No. 74A Head Set, 1000 ohms (Single). Each	\$5.00

KELLOGG SWITCHBOARD & SUPPLY CO., CHICAGO

The first man to listen over a telephone

didn't hear very much. Today he listens with comfort and complete understanding. The difference is due to better apparatus.

The AMERTRAN

super audio frequency amplifying transformer



Price \$7

Ask your Electrical Dealer, or, sent carriage charges collect. (Wt. 1 lb.)

gives 38.6 times audibility in your receiving, without distortion. Two stages (2 AmerTrans) give 1490 times audibility. It is doubtful if the substitution of any one thing in a radio set could make such a notable improvement as the installation of AmerTrans.

American Transformer Company
Designers and builders of radio transformers for over 20 years.

174 Emmet St. Newark, N. J.

W. I. Otis, California Distributor, Rialto Bldg., San Francisco

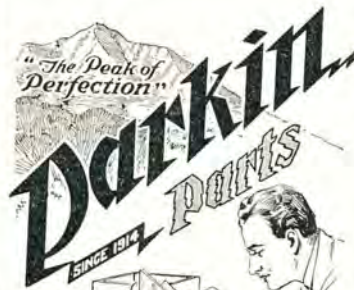

Dial-Type Rheostat

"The Peak of Perfection"

Absolutely essential to the good looks and best operation of any receiver. It matches the other dials and panel, thus improving appearance. Resistance element recessed in the back of the dial outside the cabinet, thus giving more cabinet space and preventing resistance overheating. Sold through dealers, or direct if cash accompanies order. Money back if not satisfied. Price—

\$1.50

FREE catalog

Mail this coupon

Parkin Mfg. Co.,
San Rafael, Cal.
Gentlemen: Please mail me copy of new PARKIN Catalog. Name and address of myself and of the dealer I favor, are:

MY NAME.....
STREET.....
CITY..... STATE.....
DEALER.....
STREET.....
CITY..... STATE.....

Patented Aug. 1, 1922

Tell them that you saw it in RADIO

BUILD A RADIO TELEPHONE OR C. W. TRANSMITTER

The C. W. Manual, a complete textbook on this subject, will give you the desired helpful information.

THE C. W. MANUAL contains 112 pages of practical instructional and constructional data on the design and operation of modern vacuum tube transmitters—from the smallest to the largest. It is illustrated with numerous photographs, sketches and diagrams.

Heintz and Kohlmoos,
San Francisco

Leo J. Meyberg,
San Francisco

Radio Institute of America,
San Francisco

Western Radio Electric Co.,
Oakland, Calif.

U. C. Battery & Electric Co.,
Berkeley, Calif.

J. C. Hobrecht & Co.,
Sacramento, Calif.

Western Radio Elec. Co.,
Los Angeles, Calif.

Paul F. Johnson,
Pasadena, Calif.

Southern Electric Co.,
San Diego, Calif.

Northern Radio & Elec. Co.,
Seattle, Wash.

Western Radio Distributing Co.,
Seattle, Wash.

Pacific Telegraph Institute,
Spokane, Wash.

John W. Graham & Co.,
Spokane, Wash.

Nielsen Radio Supply Co.,
Phoenix, Ariz.

Erie Book Store,
Erie, Penna.

Mutual Telephone Co.,
Honolulu

Wm. Guard & Co.,
London, Ontario, Canada

Continental Radio & Electric Corp.,
New York City

Manhattan Electric Supply Co.,
New York City

Stanley-Patterson Co.,
New York City

Pacific Radio Pub. Co.,
17 W. 42 St., New York City

Los Angeles Radio Institute,
Los Angeles, Calif.

Radio Concert Equip. Co.,
Los Angeles, Calif.

E. M. Sargent Co.,
Oakland, Calif.

The White House,
San Francisco, Calif.

Pacific Radio School,
San Francisco, Calif.

Maxwell Electric Co.,
Berkeley, Calif.

C. W. MANUAL

By Jennings B. Dow,
Lieutenant, U.S.N.

\$1 00 Per Copy
Postpaid in U. S.

How to Get a *FREE* Copy of the C. W. Manual

Send us your
subscription
to "RADIO"
for one year
at \$2.50 and
we will send
you a copy
of the C. W.
Manual
free of charge.

Use the coupon
at the bottom
of the page
and send it
to us before
you lay aside
this magazine.

!

"RADIO"
Pacific Bldg., San Francisco

I enclose \$2.50, for which you will
send me "RADIO" for one year and
the C. W. MANUAL free of charge.

Name

Address

.....

**This Book Is Published By
Pacific Radio Pub. Co., Inc.
San Francisco, Cal.**

RADIO "A & B" STORAGE Batteries CHARGED at Home For Few Cents With "PATENTED FULL WAVE" Automatic Magnetic 100-130 Volt 60 Cycle A. C. F-F RADIO RECTIFIER

Eventually You Will Buy An F-F RECTIFIER. Why Not Now? THE SOONER YOU BUY IT; THE MORE YOU SAVE

It CHARGES All 116 Volt RADIO "A" & AUTO Batteries; & All RADIO "B" & LOUD SPEAKER Storage Batteries Up To 120 Volts, In Series Inductively At Home Overnight. Disconnecting & Multiple Connections Unnecessary. Charging Circuit Separate. Nothing Like It Made. No Chance For Grounds Or Short Circuits. No Skill Required. AMMETER eliminates Guess Work. It Costs You Less To Buy An F-F RECTIFIER than To Be Without One. You PAY for ONE whether You Buy One Or Not, for It Costs An Average Of \$2. for Charging & Rentals Every Time An Auto Battery Is Charged By Others, but Only A Few Cents When You Charge Your Own From A Lamp Socket Within An F-F Battery Boosting RECTIFIER. If You Have Never Known The Delightful Feeling Of Having Your Storage Batteries Always Fully Charged For RADIO & AUTO You Will Experience A New Thrill When You Have A RECTIFIER of Your Own Which Gives You A Fully Charged Battery Overnight At A Cost of a Few Cents & A Joyful Feeling of Things Well Done. Those Who Own Them Feel Their F-F RECTIFIER is Their Faithful Friend. It Charges Automatically & Being Clean Can Be Placed Anywhere. Nothing To Slop Over Be Filled Burn Out Need Attention Or Cause Trouble. Both Waves Of Current Are Rectified Thru Infusible Carbon Rectifying Brushes. Maintaining CONSTANT EFFICIENCY uninterruptedly While Its FULL WAVE Design Delivers The RAPID TAPER CHARGE recommended By All Storage Battery Manufacturers.

They Also Charge AUTO Batteries Overnight Right In Your AUTO \$20



Patented Combination.

CHARGES AUTO & RADIO BATTERIES.

The Larger TYPES are Recommended For Heavy Batteries, or Where Time Is Limited. SHIPPING WEIGHTS Complete With AMMETER & BATTERY CLIPS 11 to 15 lbs. Purchase From Your Dealer, Or Mail Check For Prompt Express Shipment. If via PARCEL POST have remittance include Postage & Insurance Charges, or WRITE us to Ship TYPE desired C. O. D. Our F-F Battery Boosters Charge Batteries from Farm Lighting Plants & D. C. Circuits & for GROUP CHARGING Economy. Use Our 8 Ampere 12 Battery Capacity Automatic Full Wave F-F ROTARY RECTIFIER Described in ROTARY Bulletin 33-A. ORDER Now, or WRITE Immediately for FREE Descriptive RADIO & AUTO BOOSTER & ROTARY Bulletins 33-A & 33.

FRANCE MFG. CO.

General OFFICES & WORKS: CLEVELAND, OHIO, U. S. A. Canadian Distributor: The Jack V. Elliot Co., Hamilton, Ontario, Canada.

The F-F RECTIFIER is a Complete Compact Portably Handy Charging Unit which is Unfailing In Its Ability To Deliver Service Day & Night Automatically. It Will Charge A Dead Battery. Do Not Think Your Battery Is Dead & Worn Out Simply Because It Will Not Start Your Car. Buy An F-F RADIO RECTIFIER & Fill It With Life. It Saves More Than Its Cost & Lasts A Lifetime. Leave Your Battery In Car Or Where Ever It Is, Without Even Disconnecting It, Screw RECTIFIER Plug In Lamp Socket, Snap RECTIFIER Clips On Battery Terminals; Turn Switch & Battery Will Be Charged In Morning At Cost of Few Cents. Is It Not Gratifying To Be Always Ready For RADIOPHONE BROADCAST Music Sermons & News When Friends Call? Never Having To Be Careful Of, Or Tell Friends Your Batteries Are Dead & to Feel Your Car Respond Like A Greyhound, Spinning Engine With Power When You Step On The Starter. Fully Charged Batteries By Starting Car Quick Require Fewer Expensive Replacements. INSIST on The F-F RECTIFIER. Built In 7 TYPES By A Master Of The Art. So Many Thousands Are Being Sold It Has Made Possible These POPULAR PRICES

TYPE 6 Charges 6 Volt Radio "A" & Auto Batteries at 6 Amperes.....	\$15
TYPE B Charges Radio "B" Storage Batteries Up to 120 Volts.....	\$15
TYPE A-B Combination Charges "A" & "B" Radio & Auto Batteries.....	\$20
TYPE 12 Charges All 12 Volt Batteries at 5 Amperes.....	\$15
TYPE 166 Charges All 16 Volt Batteries at 12 Amperes.....	\$20
TYPE 1612 Charges All 12 Volt Batteries at 7 Amperes.....	\$20
TYPE 1626 is a Combination of TYPES 166 & 1612.....	\$28

All TYPES But "B" CHARGE AUTO BATTERIES.

Continued from page 60

a quiver in the voice—but it was sternly repressed.

"Why not?"

"Got to work! Pop keeps after me—pretty much all the time." Then he told of the loft, over the wagon barn, and of the candle stubs, that he got in one way and another.

There flashed through Mather's mind the pathos of it! This overworked, under-fed little body—far too insufficient a vehicle for a mind, active beyond the body's years—a mind that craved knowledge, and one that was willing the vehicle should suffer discomforts, punishments—if through these led the way to—progress. And in Mather's mind was the comparative picture, between this boy—and another, who had everything!

And an idea came—

"Look here, Walter! Tell you how we'll fix the old skin—I mean your father—" he corrected, hastily.

"Don't mind me. Everybody calls pop a skinflint—and worse. I'm used to hearin' it—and they're right—I guess." The words were unemotionally spoken—merely in acknowledgement of a fact.

"Well—er—we'll fix it in this way: I'll give you two dollars for two hours' of your—'helping' me—three times each week. You slip the money to him—and he'll be satisfied—won't he?"

"You bet he will! But—that don't seem right—for me to come up here, pesterin' you, and get paid for doin' it!"

"Leave that to me, son!" laughed Mathers.

"I—I don't know how to—to thank you, b-b-but I'll make good—somehow!" the lad blurted and ran from the room, clutching a \$2 bill and his precious book.

Mathers went to the window, saw the little figure scurrying down the snow-clad road, and a mistiness rose in his eyes—that blurred the peaceful landscape.

"Most of my life has been chiefly occupied in looking after my own interests—but now—" passing his hand hurriedly across his eyes, he watched the lad as far as he could see him.

For Mathers had neither kith nor kin, and, because of his voyagings up and down the seas of the world, as radio operator on all manner of vessels, he was almost—as he admitted to himself—a man without a country.

When Walter reached the farmyard gate he was greeted with a bellow of rage—

"Whar in tarnation' ye bin? Here's nigh on two hours o' the best part o' the day gone!" Ellison shook the boy, roughly.

There was no book visible—as that the boy had, with cunning foresight,

Continued on page 64

Radio Supplies All Standard Goods Immediate Deliveries

Distributors for BALDWIN, BRANDES and BASCO PHONES, FADA, FEDERAL and MONROE RECEIVING SETS, Erla, Acme, Dubilier, Chelton, Burgess, Cunningham, Magnavox, and many others. A COMPLETE line. Largest stock in the middle west. Write for latest Catalogue Dealers' New Attractive Discounts American Radio Mfg. Co. Dept. N 107 E. 13th St. Kansas City, Mo.

KING Rheo-Socket

ANOTHER RADIO SURPRISE Price \$3, f. o. b. New York City



Compact, increased efficiency, shorter connections, less wiring—brings in stations you never heard before. Make this a part of your up-to-date set. A high grade article in Red Bakelite with Phosphor-Bronze Contacts and Alloy Resistance Wire.

FOR BASE OR PANEL MOUNTING KING AM-PLI-TONE

82 Church Street New York Mrs. of the Famous KING AM-PLI-TONE Jobbers, wire or write for proposition

Investigate!
WESTERN-RADIO DEALERS SERVICE
Wholesale RADIO only
637 50 HOPE ST. LOS ANGELES
1800 FRANKLIN OAKLAND



—RADIO INSTITUTE— OF AMERICA

Conducted by the greatest and most experienced radio telegraph organization in the world.

Thorough training given in radio operating, traffic, all systems, including the latest successful commercial radio development of the G. E. Company, which, in one set, combines radio telephony, continuous wave telegraphy, and interrupted continuous wave telegraphy. This apparatus now installed in our school room.

Tuition Ten Dollars per month, for either the day or evening sessions, or both combined.

Prospectus mailed on request

RADIO CORPORATION OF AMERICA

Phone Douglas 3030

331 New Call Bldg., San Francisco

98 Worth St., New York. Phone Franklin 1144

Tell them that you saw it in RADIO

Another **ADVANCE** Product---A Precision Condenser Made in Vernier and Plain That Has Met With the Approval of Those Who Demand the Finest

Beautiful in appearance. All trimmings polished nickel.
Vernier shaft 1. threaded 8/32 adjustable by set screw 10 to accommodate any thickness panel or dial.
Bakelite bearings 7— $\frac{1}{4}$ inch shaft both ends.
Stop 9 full length of rotor.
Nickel acorn nuts 5 which insure strength.
Rotor spacers 11— $\frac{5}{8}$ inch diam., machine turned.
All spacers aluminum to .001 inch insuring perfect alignment of plates.

Stator spacers 12— $\frac{3}{8}$ inch diameter.
Spring 13 perfect contact and friction for vernier plate.
Rotor tube 2— $\frac{1}{4}$ inch diam., brass nicked.
End collar 3 Adjustable for alignment.
Mounting posts 4— $\frac{5}{16}$ inch round 6/32 so spaced to accommodate any diameter dial.
Brass nicked spacers 6— $\frac{3}{8}$ inch diam. accurately machined.
This condenser must be seen to be appreciated.

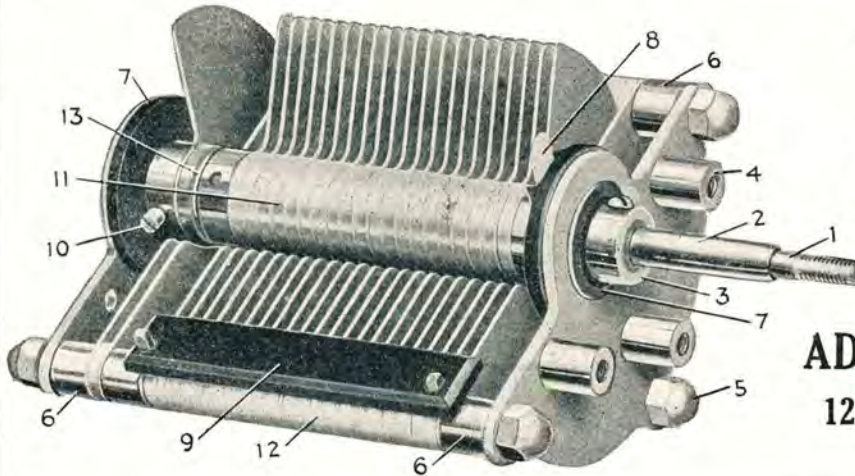

Vernier	Price	Plain	Price
		3 plate	\$1.90
		5 "	2.25
		9 "	2.75
11 plate	\$ 5.65	11 "	3.00
13 "	5.80	13 "	3.15
23 "	6.00	23 "	3.40
31 "	7.00	31 "	4.15
43 "	8.00	43 "	4.60
63 "	10.00	63 "	6.85

Liberal Discounts to Dealers and Jobbers.

ADVANCE ELECTRIC CO.
1260 West 2nd Street, Los Angeles
Engineers Manufacturers

Make Your Christmas Money Count!



Use it to replace the weak parts of your present receiving set or to build up the "De Luxe" set you have promised yourself. The ACE balanced vernier condenser or ACE panel lever switch as illustrated, are suggestions; our general catalog contains many attractive new parts. Mailed to your address for ten cents.

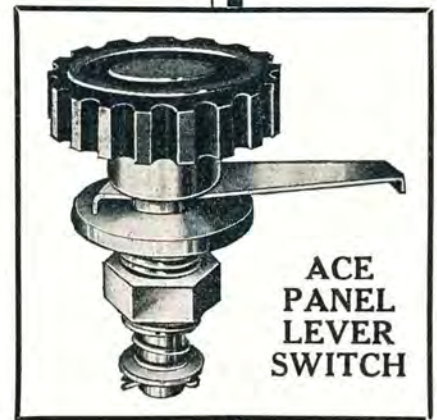

Dept. PRN

THE PRECISION EQUIPMENT CO.

2437 Gilbert Ave.

Cincinnati, Ohio

TOO LATE!

With the "Cut" of Our New

"S. R. 25" RECEIVER

— BUT —

We Can Tell You This:

We Challenge the World!

To Outperform It

2 Radio — Detector — 2 Audio

\$150.00—less tubes

And a beauty of finish that we believe unequalled.

WRITE

Hallock and Watson Radio Service

192 Park Street

"KGG"

Portland, Ore.

Continued from page 62

hidden in an old log. But he held out the \$2 bill—

"The feller up at the big house gave me this, for—for helping him—wants me to come three afternoons a week—for a couple o' hours."

"Well!"—the farmer's voice changed; he made a grab for the money—that's not so bad, bub! Not so bad! Sure—ye can go up—but, hol' on—what's he payin' ye?"—suspiciously.

"S-s-six dollars a week."

"Lot o'money, for a shrimp like you! What ye a'helpin' him of?"

"O—kinda readyin' up the place—cleanin' closets—an'—an' such. Folks all away."

"Mind ye be there on time—or I'll whale ye!" and Ellison walked off, muttering—"I'm jiggered! More money'n brains! Six dollars a week is \$24 a month—or \$188 a year—just to clean out closets an' tidy up papers, I s'pose! Well—it's time he was earnin' his keep—so it's none o' my funeral—if they wants to throw money away!"

WEEKS slipped up from the far ahead, passed under the feet of the present—and vanished in the never-to-be-again. They boy studied hard, made the most of his rare-found opportunities, and excited in Mathers an unbounded admiration for his grit and perseverance.

"You'll go much farther than I can ever hope to, laddie!" he said, earnestly, during one of the afternoon sessions. "You've got a much better memory and a natural radio mind! It took me months to grind in my skull the things that you drink up—as a sponge absorbs water—in no time!"

"Think so—*honest?*" There was an avid pleasure in the gray eyes. "But it's all thanks to you! Where would I have been, if"

"Well, well! Who is our young friend—eh?"

Mathers and the lad swung round. Senator Briggs stood in the doorway—a cheery smile lightening the strong, somewhat stern, face. Mathers thought him in Washington!

The two looked at one another; then the boy stepped forward—and told the whole story—of his determination to become a radio operator—of his father's antagonism to the idea—of his chance meeting with Mathers—of the latter's assistance—and, finally, of Mather's paying him to come, in order that he might get away from his father.

Silence in the room—when the young voice had finished its somewhat halting recital.

"Fine work!" said the Senator, abruptly, passing his hand over his face. "And I am back of both of you! Want to keep on—studying radio—son?"

Continued on page 60



Essential for Radio Success!

If you're contemplating building a radio set or if you are not meeting with the best of success with your present set, it will pay you to consider the better grade of radio devices such as STERLING has to offer.

Satisfaction is guaranteed with all



Here we are showing two very important parts to every complete and successful receiving set. A good rheostat is the key to your radio problems, allowing the full reception of clear, loud messages and concerts. The filament volt meter insures the life of your vacuum tube—a protection against premature burn-outs.

Filament Volt Meter

Movement is of the magnetic type, the result of years of manufacturing experience. Flush mounted type. Black satin finish. Lends attractiveness to set. Overall dimension 2 3/4" diam. 0-8; 0-30; 0-100 volt types. List Prices \$4 and \$5. Trade discounts on application.

Filament Rheostat

The unusually large number of turns give a fine regulation of current. It will not heat up. Adaptable to either panel or table mounting by mere loosening of set screw. List Price \$1.00 Trade discounts on application.

- OTHER STERLING RADIO DEVICES
 Portable Rectifiers.
 Filament Ammeters and Pocket Voltmeters.
 Audio Frequency Amplifying Transformers.
 Radio Frequency Amplifying Transformers.

The Sterling Manufacturing Co.

2847 Prospect Ave., Cleveland, O.



QUALITY PRODUCTS

Instruments 'Phones Loud Speakers

Send for Bulletins AI-10 and AI-20

ROLLER-SMITH COMPANY, 20 Park Place, NEW YORK

Offices in Principal Cities in U. S. and Canada

WORKS: BETHLEHEM, PA.

Tell them that you saw it in RADIO

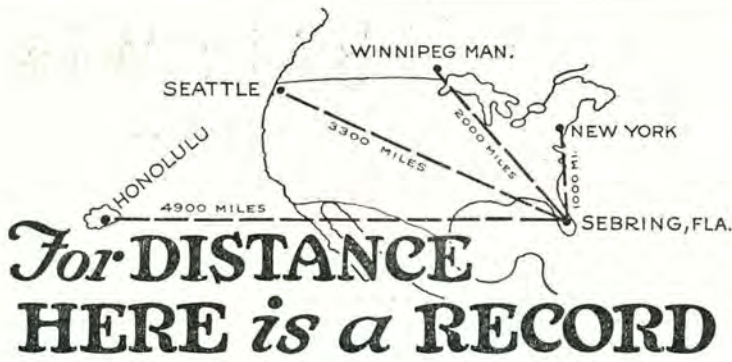

For DISTANCE HERE is a RECORD

The remarkable results achieved with Crosley Radio Instruments are equaled only by their exceptionally low cost. A man in Sebring, Fla., listening in with a Crosley Model X—price only \$55 for this 4 tube set—writes: "We are receiving from all standard stations north, east and west—from Winnipeg, Can., New York City; Seattle, Wash., and one night received three selections and two announcements from K. D. Y. X. at Honolulu.

The secret to Crosley efficiency as well as Crosley prices is our thorough knowledge of wireless applied practically to the quantity production of simplified receiving sets and parts.

A few of our models illustrated herewith give an idea of Crosley value.

Crosley Receiver Model VI

A wonderful set at a wonderful price. Combines one stage of tuned radio frequency with a tuner and audion detector. Price, without bulbs, batteries or phones, \$28.00.



Crosley Receiver Model X

The most complete receiving set on the market. A 4-tube set consisting of one detector, one stage of tuned radio frequency and two stages of audion frequency amplification. It was on this instrument that Sebring, Fla., heard Honolulu. Price, without batteries, tubes and phones, \$55.

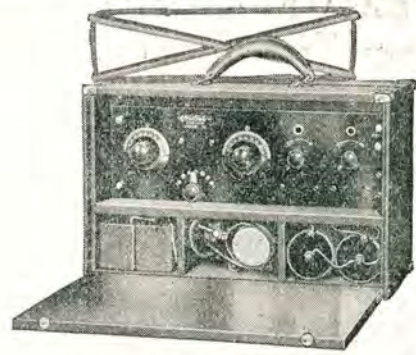

Crosley Model VI Portable

A new departure for those desiring to carry receiving outfits with them. A 1½ volt tube set that eliminates necessity of expensive "A" battery. Consists of detector and one stage of tuned radio frequency amplification. Price, without batteries, tubes and phones, \$40.00.



Crosley Receiver Model VIII

A new set offering exceptional value. Contains one stage of Tuned Radio Frequency Amplification, detector and one stage of audio frequency amplification. Also offered as a portable instrument using 1½ volt tube. Price, without batteries, tubes and phones, Regular Model VIII, \$48.00. Model VIII Portable, \$60.00.



We also manufacture complete parts for those who wish to build their own outfits. Below are illustrated a few of these. Illustrated booklet entitled "How to Build Your Own Radio Set Using Crosley Parts" will be sent upon receipt of 5c.

CROSLEY MANUFACTURING COMPANY

219 ALFRED STREET, CINCINNATI, OHIO



V-T SOCKET 50c



SOCKET ADAPTER
With Bushings and Screws,
70c. Without, 60c.
Makes it possible to use
1½ volt tubes in all
Crosley Sets.

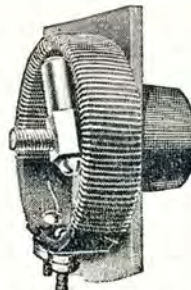

RHEOSTAT, 50c

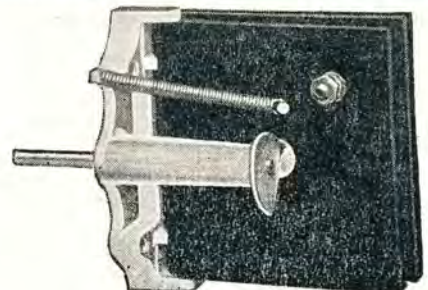

CROSLEY CONDENSER—
MODEL B.

A SUPERIOR AUDIO Frequency Transformer

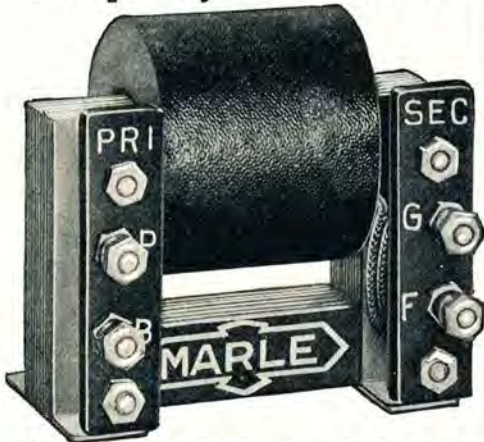

Used and Recommended by Leading Reputable Manufacturers of RADIO APPARATUS
LIST \$3.75, MOUNTED
 Write for information and discounts
 Jobbing Concessions Restricted
 Manufactured by
MARLE ENGINEERING CO.
 Orange, N. J.
 Special Prices Quoted on Unmounted Type to Manufacturers.

INTERFERENCE

Can be cut out with
 Knott Super-Vernier Condenser

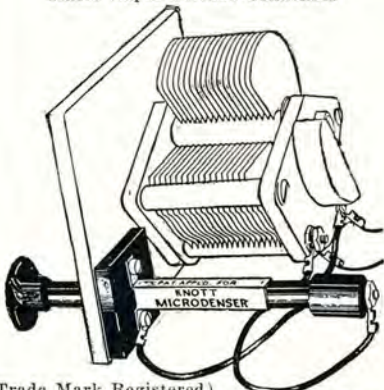

(Trade Mark Registered)
 Showing you how to connect to your condenser
 Super accurate tuning. This Micro will stretch the critical tuning point on your vernier condenser to two inches of adjustment.
 Send us \$3 and we will mail you one with connecting wires and wrench-screwdriver.
 Send 2c stamp for information about Knott instruments for selective and sharp tuning, their performance will astonish you and you will brag about what they give you.
 Jobbers, our proposition will interest you.
E. R. Knott Machine Co.
 1 Ellery Street
 Boston, 27 Mass.

Investigate!
WESTERN-RADIO DEALERS SERVICE
 Wholesale RADIO only
 837 50 HOPE ST. LOS ANGELES
 1800 FRANKLIN OAKLAND

Look Over RADIOADS on Page 93

Continued from page 64

"Oh yes, Sir—Senator, I mean!"—the words burst from his lips
 "So you shall!"
 "But my father—he won't hear of"

"We'll see about that! Come along—I'll walk home with you, now. I need some air after that train."

And again Mathers looked from the window, watching the Senator striding along, the lad almost running to keep up—while an Indian summer afternoon waned softly.

"What do you say, Ellison?" the Senator asked, after he had made a proposition to the farmer.

"Don't like it, Senator. 'Fact—won't hear of it—*nohow!* He's a farmer's son—same's I was—and he'll stay one, s'long as I'm on top o' the earth!"

Briggs heard the quivering little sigh that escaped the boy's lips.

"No chance of your changing your mind—Ellison?" he asked, slowly.

"Nope! Last word's said! God knows how long it'll take me to whale this damn nonsense that he's l'arned—outen his head, as 'tis!"—vindicatively.

"Just one moment, Ellison!"—as the angry farmer jerked the boy from Briggs' side—"I suppose that you have heard of the R.R. branch line that is coming up the Drift Bottom—soon?"

"Sure I have! I'm aimin' to get a good price for the six acres o' mine they got to cross—you betche!" And he started off again with the lad in tow.

"That 'one moment' was too short, Ellison!—Just *one* more!"

The farmer stopped at the compelling note in the Senator's voice—

"Well . . . ?" he snapped.

"It so happens, Ellison, that I can have that six acres *condemned*—by the county assessors—and appraised by a board! You will take what *they* think it worth! It's absolutely of no value—all swamp ground—better consider again—had you not—Ellison?"

The farmer's face became distorted with rage—"Take the damned brat—an' good riddance! But lemme tell ye one thing, Mister Senator Briggs—if he goes along with you—now—he needn't never expect to cross my door sill again—and that's *final!*"

"Well—lad—what is it to be? You heard your father," said the big man, quietly.

It was a strange, tense moment—while the gentle breeze of gloaming time rustled through the aspen leaves.

Then the boy spoke—"Pop—ever since mother—died, you've never given me a chance! You wouldn't let me go to school—nor you wouldn't let me read, or study, nothin'! That is, if you knew about it! You've fed me, an' given me

Continued on page 68

Tell them that you saw it in RADIO

BALDWIN PHONES

Notice New Reduced Prices

TYPE "C" BALDWIN Complete . . .	\$12.00
TYPE "E" BALDWIN Complete . . .	12.00
TYPE "F" BALDWIN Complete . . .	13.00
TYPE "G" BALDWIN Complete . . .	13.00
TYPE "C" SINGLE UNIT with Cord . . .	6.00
TYPE "C" SAME Without Cord . . .	5.50

OTHER GOOD PHONES

No. 56 Murdock	2000 Ohms	\$ 5.00
No. 56 Murdock	3000 Ohms	5.50
No. 162 Frost	2000 Ohms	5.00
No. 163 Frost	3000 Ohms	6.00
No. 53-W Federal	2200 Ohms	8.00
No. 52-W Federal	3200 Ohms	10.50
Holtzer-Cabot	2200 Ohms	8.00
Western Electric, Navy	2300 Ohms	12.00

SPECIAL—Paent or Federal Universal Plug FREE with any pair of Phones purchased from us. Order now and SAVE A DOLLAR

Mail Orders Promptly Filled

Send remittance with your order.

We Pay the Postage Charges

DAVID RADIO SUPPLY CO.

P. O. Box 596 Reedley, Calif.

NOVO "B" BATTERIES FOR RADIO

22½-45 & 105 VOLTS



NOISELESS DEPENDABLE GUARANTEED

ASK YOUR DEALER

NOVO MANUFACTURING CO.
 424-438 W. 33rd ST.
 NEW YORK

531 SO. DEARBORN ST., CHICAGO.



Dubilier Micadon Type 601

Free with one subscription to "RADIO"

(Mention Size)

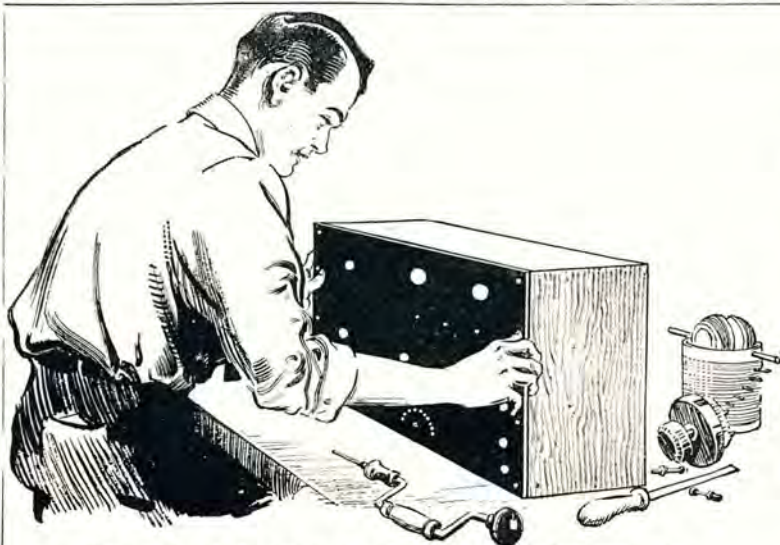

This Panel Will Improve Your Set

CONDENSITE CELORON

The best panel made is none too good for your set. Dependable insulation is vital because it has a direct bearing upon the clearness and sensitivity of both transmission and reception.

Every thinking radio enthusiast certainly wants the highest type panel he can obtain and the surest way to get it is to insist upon Condensite Celoron.

This strong, handsome, jet-black material is not merely an insulating material—it is a radio insulation made to meet high voltages at radio frequencies. That is why it will give you greater resistivity and a higher dielectric strength than you will ever need.

Make your next panel of Condensite Celoron. It machines readily, engraves with clean cut characters and takes a beautiful polish or a rich dull mat surface.

AN OPPORTUNITY FOR RADIO DEALERS

Condensite Celoron Radio Panels and Parts offer a clean cut opportunity to the dealer who is keen on building business on a quality basis. Write us today. Let us send you the facts. You'll be interested.

DIAMOND STATE FIBRE COMPANY

Bridgeport (near Philadelphia), Penna.
Offices in Principal Cities

Branch Factory and Warehouse, Chicago
In Canada: Diamond State Fibre Co. Ltd., Toronto

BIG NEW STOCK OF RADIO SETS AND PARTS

Grebe CR-5	\$80.00	Grebe CR-9	\$130.00	Kennedy No. 220	\$125.00
Grebe CR-8	\$80.00	Kennedy No. 281	\$80.00	Kennedy, No. 110	\$250.00

WE ASSURE YOU OF THE MOST PROMPT SERVICE

Our Radio Mail Order Service is gaining much popularity on account of the FAST SERVICE. We ship your order within four hours of its receipt. After you tire of waiting days—or maybe weeks—for your supplies, try Warner Brothers' Radio Mail Order Service and you will use no other. Following are a few items that we have in stock:

VARIABLE CONDENSERS		AMPLIFYING TRANSFORMERS		RADIO FREQ. TRANSFORMERS	
.0003 11 Plates Signal	\$3.00	ATWATER KENT	\$5.50	UV1714	\$8.50
.0005 21 Plates Signal	3.50	UV-712 Radio Corporation	7.00	Radio Service Co.	6.00
.001 43 Plates Signal	5.00	231A GENERAL RADIO	5.00	AEROVOX	4.50
.0015 63 Plates	7.20	A2 ACME semi-mounted	5.00	ACME	5.00
.001 43 Plate Warner	4.00	Thordarson	4.50	STORAGE BATTERIES	
.0005 23 Plate Warner	3.50	BRYANT	5.00	6 Volt 70 A. H.	\$15.00
EVEREADY "B" BATTERIES		JACKS AND PLUGS		Philadelphia 6 V. 60 A. H.	16.00
No. 765, 22½ Volts	\$2.00	FEDERAL 1421 Open Circuit Jack	\$.70	LOUD SPEAKERS	
No. 766, 22½ Volts, tapped	3.00	FEDERAL 1422 Single Circuit Jack85	R3 Magnavox Radio Type	\$45.00
No. 774, 43 Volts, tapped	5.00	FEDERAL 1423 Double Circuit Jack	1.00	R2 Magnavox	85.00
REMLER APPARATUS		FEDERAL 1435 Automatic Filament Control Jack	1.00	VARIO-COUPLERS	
810 Jr. Rheostats	\$1.00	FEDERAL 1438 Automatic Filament Control Jack	1.20	REMLER 503 Cario-Coupler	\$5.40
813 3 Amp. Rheostats	1.75	PACENT UNIVERSAL	1.25	REMLER 505 Coupler on Unit Panel	12.75
330 Audion Detector Panel	8.50	RHEOSTATS		OUR OWN TYPE	3.50
331 Amp. Panel	6.00	REMLER Jr.	\$1.00	ATWATER KENT	8.00
333 Amp. Panel	9.00	FADA—with new Knob75	ATWATER KENT on Panel	13.00
96 Variable Grid Leak40	GENERAL RADIO No. 214 7 ohm or 2½ Amp. 2 ohm	2.25	PHONES	
97 Grid Condenser20	DEFOREST, new type	1.20	Federal, 2200 Ohms	\$8.00
SOCKETS		PARAGON	1.25	Federal, 3200 Ohms	10.50
156 GENERAL RADIO	\$1.25	MURDOCK 560	1.00	Cory	8.00
CROSLY Porcelain50	KLOSNER	1.50	Western Electric, 2200 Ohms	10.00
KELLOGG75	JENKINS	1.75	Dictograph, 3000 Ohms	12.00
PARKIN	1.00	FRAMINGHAM75	Manhattan, 2000 Ohms	6.00
HOPEWELL60	CUTLER HAMMER	1.00	Manhattan, 3000 Ohms	7.00
VARIOMETERS		BRADLEYSTAT	1.85	Brandes, Superior	8.00
REMLER 505 Moulded Bakelite	\$7.50	FRAMINGHAM VERNIER	1.25	Lincoln, 3000 Ohms	7.00
OUR OWN TYPE	4.50	CUTLER HAMMER, VEENIER	1.50	Frost, 2000 Ohms	5.00
ATWATER KENT	8.00			Frost, 3000 Ohms	6.00

Now that you have read the list, get that order into the mails without delay. If there is something that you want and don't see it listed here, write us anyway and we will get it for you. Our two stores save still more time in getting your apparatus in a hurry. Enjoy the pleasure of real service for a change. Send us your orders.

San Francisco.
350 Market Street
Phone Douglas 4639

WARNER BROTHERS

TWO STORES

Oakland, Cal.
22nd & Telegraph Ave.
Phone Lakeside 6223

Tell them that you saw it in RADIO

Continued from page 66

The Laboratory Technician Says:



Audibility — Plus
 Matching — Perfect
 Volume — Plus

Why Strain Your Ears?

A whisper may be understood at a distance if clearly enunciated.

"T-B-H" Head Sets reproduce clearly and naturally. No "Fuzz" or "Tinny" tone. Extremely sensitive.

Aluminum cases—hard rubber ear caps—6-foot indicated cord—very light in weight, only 12 ounces.

If your dealer does not carry them he will order them for you.

Dealers and Jobbers Write For Discounts

THE TELEPHONE BOOK HOLDER CORPORATION
 Dansville, New York, U. S. A.

clothes—o' one kind and another—but I've worked, an' worked *hard*, for everythin' I've had. Mother—she said that a feller ought to honor his father'n mother—'cause God said so; but I don't reckon—somehow—that God had any idee o' *you* as bein' anybody's father—when He said it! An' so—an' so—" he stopped, looked up at the Senator's towering height—"seein's as the Senator's willin' to give me an education—a *chance* to learn—I'm goin' with him. It's only fair to me—an' to you, too, if you'd only look at it that-a-way."

A volley of epithets poured from the farmer's lips—to which the man and boy listened in silence.

"You are *sure*, Walter?" the Senator asked.

"Yes, sir!"

"Let's go—home, then."

The strange pair walked slowly from the farmyard. At the gate the boy turned—

"Goodbye, Pop!" he called—wistfully.

But the farmer did not even turn his head.

Western Home Battery Charger

CHARGES your Radio Storage Batteries from 110 volt alternating or direct current lighting socket, of any cycle.

Keep your Battery fully charged and receive the maximum range from your receiving set. Charges Battery over night for a few cents. Has no delicate bulbs to break or burn out; no moving parts of any kind to get out of order; no adjustments to make, and will charge as many as six 6 volt batteries at one time if necessary.

Will also charge Automobile starting and lighting batteries. Shipped anywhere in the United States and Canada for \$6.85. Send 25% with order; balance C. O. D. or 2% may be deducted if full cash accompanies order.

NOW
\$6.85

Note:—We have a large quantity of high grade Radio Storage Batteries of all sizes, which we are selling at bargain prices.

Radio Dealers should send at once for our distributors' proposition. Description of our line of Chargers and Radio Storage Batteries sent upon request.

WESTERN RUBBER MOLD & BATTERY CO.

321-323 N. Crawford Ave.

Chicago, Ills.

THE *Ariadne* steamed along at a comfortable 15 knots over a moon-swept sea, and the big steam yacht's every detail of rigging was brought out in sharp relief by the brilliant light. On the after deck, sat former Senator Briggs—owner—with some business associates and his private secretary.

Just visible—as little sparklings—the lights of some vessel a few miles away to port, glinted and vanished as she rolled.

"Big freighter?" some one suggested.

"More than likely. She is not wasting coal—for speed!" laughed Briggs.

"If I had to choose, over again, I believe that I should be tempted to be a sailor! Glorious, roving life—none of the nuisances of existence ashore—plenty of fresh air—out of touch with everything, most of the time—if one so desires." Thus spoke Conrad Morton—one of the eminent Wall Street men of the day. And he sighed.

"Not out of touch—these days of radio"—corrected the owner. "I've had the most powerful plant, for its size, that I could get, installed, and you know that we've been in touch with both British and American stations, either direct, or through rapid relay with other vessels."

The conversation drifted to other matters—chiefly things financial—as the former Senator was notoriously on the bull side of the market, carrying huge numbers of stocks—commercials and R.R.'s chiefly. He liked the excitement of the game, and the need of quick thinking—he was wont to say.

Continued on page 70

RUSONITE

CRYSTAL RECTIFIER

MULTIPOINT (Patent Pending)

A Synthetic CRYSTAL DETECTOR, sensitive over its entire surface.

Eliminates all detector troubles. Extraordinary clearness and volume. Endorsed by Radio experts and press. Sold in Seal & Packages only. Join the ever-increasing Rusonite fans.

Price Postpaid, Mounted Sensitiveness Guaranteed **50c**

RUSONITE CATWHISKER

14 Karat Gold Multipoint contact. Super-sensitive **25c**

Order from your dealer or direct from us.

RUSONITE PRODUCTS CORP.

15 Park Row, N. Y. Dept. "R."

Investigate!
WESTERN-RADIO DEALERS SERVICE
 Wholesale RADIO only
 837 50 HOPE ST. LOS ANGELES *wcl* 1800 FRANKLIN OAKLAND

SIXTH DISTRICT AMATEUR CALLS
 appear in "Broadcast Program"—\$1.00 for 6 months.

Tell them that you saw it in **RADIO**

You Can Get **MURDOCK RECEIVERS**

AND OTHER MURDOCK RADIO APPARATUS

--- Why bother with any other kind?

\$5.00

2000 Ohms
No. 56
Double

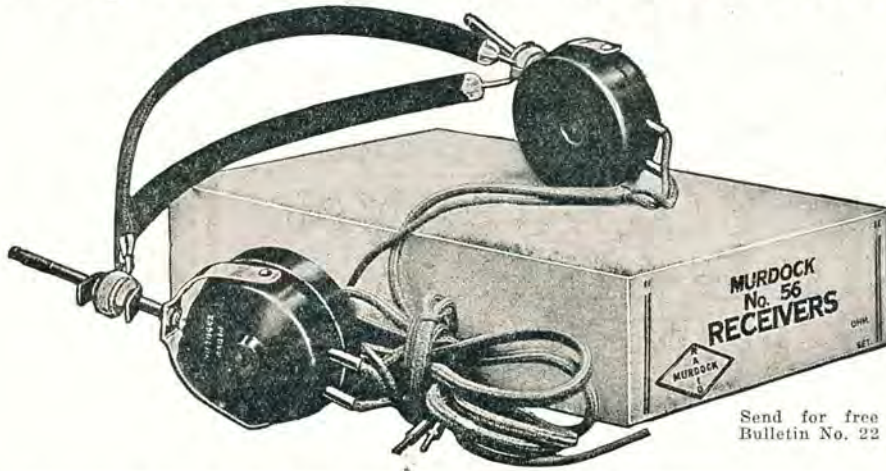

\$5.50

3000 Ohms
No. 56
Double

Send for free
Bulletin No. 22

If your dealer is not supplied send remittance direct to us and your order will be promptly filled.

MURDOCK MADE 800,000 TELEPHONE RECEIVERS BEFORE GOING INTO THE RADIO BUSINESS AND HAS MADE THE BEST RADIO RECEIVERS FOR 14 YEARS

We carry a complete stock in our Pacific Coast warehouses. Write for dealer discounts.

KEELER WHITE COMPANY

Pacific Coast Agents—**WM. J. MURDOCK CO.**—Since 1905

509 Mission Street, SAN FRANCISCO

:: ::

211 So. San Pedro Street, LOS ANGELES

Don't Waste Money, Time and Patience on Cheap, Improperly Designed Radio Parts. Insist on Getting New York Coil Company's Products, Which Insures Entire Satisfaction. Honestly Priced, Scientifically Constructed and Engineered to Deliver the Maximum Results.

JOBBER AND DEALERS get our complete literature and worthwhile discounts.

Our 180 degree Variocoupler is a masterpiece, suitable for use in any circuit. Most efficient and best constructed Coupler in existence. Price **\$4.50**
 Our Combination Mounted Variocoupler for table or back panel mounting has all taps connected and soldered—nothing else like it. Price **\$8.00**
 Our Variometers are full size, precision instruments. They are not of the competitive type. Price..... **\$4.00**
 Our Audio Frequency Transformers are the choice of leading manufacturers and radio engineers. Guaranteed to give high magnification, less distortion and better all 'round efficiency. No howling. Price..... **\$4.00**
NEW YORK COIL COMPANY'S Variable Condensers are the standard by which others are judged, containing such features as all metal frame work, adjustable bearings and positive electrical contact—
 11 Plate.... **\$1.50** 23 Plate.... **\$2.00** 43 Plate.... **\$3.00** 3 Plate.... **\$1.25**



NEW YORK ENTERTAIN-A-PHONE RECEIVING SET No. 2—Complete with detector and two stages of amplification, all in one cabinet. Contains a non-regenerative two circuit hook-up with two stages audio amplification. Results are simply a revelation. It must be operated and heard to be appreciated. Workmanship and design and material of exceptional character throughout. Of unusual interest to the jobber. Price **\$50.00**, fully guaranteed.

NEW YORK COIL COMPANY, Inc. 338 Pearl Street
New York City, N. Y.



The Hit of
Radio

New England
Products

BUILD YOUR OWN SINGLE CIRCUIT TUNER

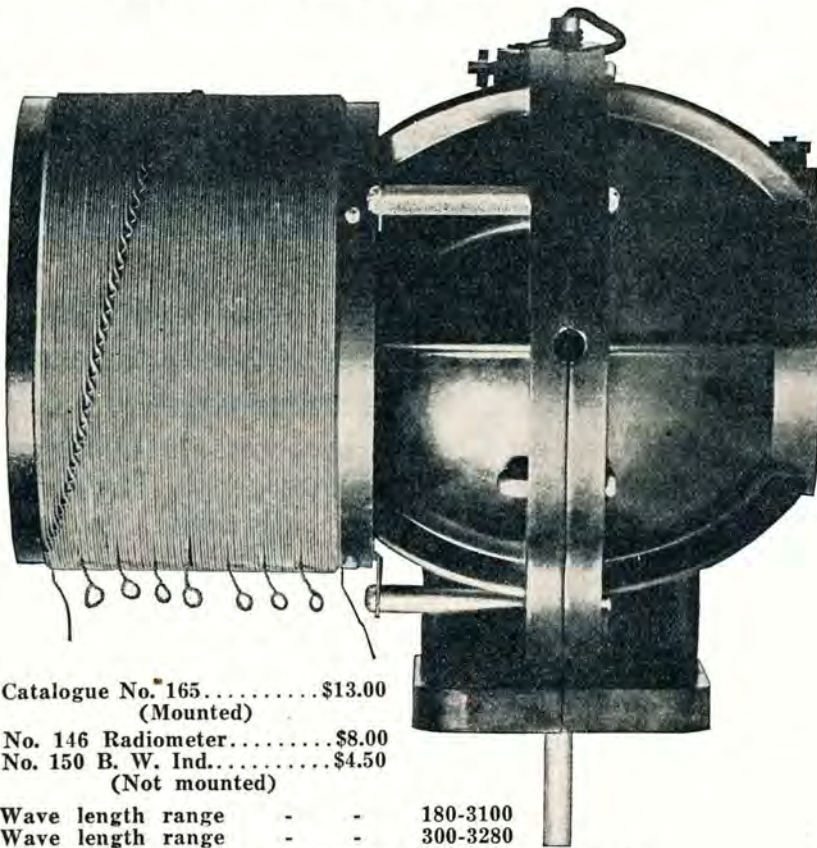

Catalogue No. 165.....\$13.00
(Mounted)

No. 146 Radiometer.....\$8.00

No. 150 B. W. Ind.....\$4.50
(Not mounted)

Wave length range - - 180-3100
Wave length range - - 300-3280

R. MITCHELL & CO.

255 Atlantic Ave.

Boston, Mass.

For 47 yrs. Mfrs. of Scientific and other equipment.
Look for trade mark on every piece.

Jobbers and Dealers, write for discounts

\$10 for \$5

You get a WESRAD AMPLIFYING TRANSFORMER Free for
securing only two subscriptions to "RADIO"

"RADIO"—Pacific Building—San Francisco

Continued from page 68

ALLOWING easily along, the *Perseus*, cargo carrier, pushed her fat forefoot through the moonlight at her unvarying 9 knots, and the smoke of her passing rolled evenly and blackly away from her stack—blotting out the stars for a long, straight space of the scintillating overhead.

Skipper Jim Lewis, his daughter, Marion, and Radio Operator Walter Ellison were comfortably ensconced on the little bridge deck—outside the skipper's quarters.

"Hard boiled"—was the term generally applied to Cap'n Jim Lewis, along the more important water fronts of the ports of the world—for he knew them all. A seaman of the old, nearly-vanished school, he held not at all with the more polite ways in which the ships' crews of modern days insist upon being treated—on board. He had gone to sea—in the dim, gone-by-the-board years—on whalers, and on full-rigged vessels—'round the Horn. As a result he was a "two-fisted" man. Not hard-hearted—by nature—but "two fisted"—nevertheless. Did one desire to make him "see red"—the merest mention of the La Follette Seaman's Bill accomplished the purpose—instantly! He detested steam, and commanded a vessel that was so driven for the simple reason that there were no captains' berths open a'board the scattered sailing ships—that eked a precarious living for their owners—principally by 'long shore hauling—and Jim Lewis detested that—also.

"So you and Marion have 'framed' the Old Man—eh?" he chuckled in his thick beard. "Want the Old Man's OK to sign articles together—do you? Well—I hold a lot by you, Walter, lad. Watched you ever since you got the berth of operator on the *Perseus*—and haven't a fault to find!"

The tall, graceful girl rose—crossed the deck and knelt beside the old sea dog. He touched the masses of dark hair with strange tenderness—for these two were inseparable, since the wife and mother had gone on the Long Cruise—and the big, rough hand was so light that it scarcely disturbed the tresses.

"How about the dollars, boy? Love has a nasty trick o' deserting the ship—when the cargo o' dollars runs low!"

Efficiently neat in his summer whites—for Skipper Lewis kept up his big ship in yacht fashion, and his officers always made a smart appearance—Walter Ellison stood very straightly against the rail, his strong figure looming in the moon brilliance—

"Well, sir—the farm is mine, as father died so suddenly that he had no time to make a will—or so the lawyers say. If he had—I shouldn't own the farm today! Owing to the railroad crossing it I ought to be—fairly well fixed. Father and I couldn't get on—

so I got out, thanks to the generous kindness and help of hello!" —he broke off, crisply—"what's that ship using her Morse blinker light for?"

All three looked across the slow-heaving, moon-laved expanse that separated the two vessels by a scant four miles.

"MESSAGE for you, sir!" the radio operator of the *Ariadne* saluted the owner smartly and gave him a folded form.

"Thanks"—turning to the others—"what's the betting that it is about the A.I.&L. deal, gentlemen?"

There was a note of hardly-suppressed excitement in the former Senator's voice, as he felt for a nearby switch, turned it and flooded the after deck in the soft glow of electric lights—cunningly stowed at the awnings' edges.

"If you make a go of this, Briggs—you will benefit some several millions' worth—eh!" pleasantly remarked one of the group, as Briggs scanned the sheet.

"Pshaw! Code again! I do not see why the offices coded a message of this kind to me! A simple 'yes' or 'no' would have sufficed. Decipher this, please!"—to the secretary—who took it and hurried below.

"Just what would it mean, Briggs—merely for the sake of supposition—if the deal—er—went against you? Supposing someone—'split'?"—asked the Wall Street man—gravely.

The Senator did not answer at once. And the sounds of disturbed waters liquidly broke the silence. Beneath them the rhythmic, thudding vibrations of the propeller came as from far away.

Then spoke Briggs, with careful precision: "It would mean a far heavier loss than I can afford, at this stage. Indeed it would be almost disastrous! And for the reason that I am out here—away from personal contact with matters—some 1200 miles out of contact, to be exact, by the noon reading, today."

"Transposed message, sir." Briggs read it—passed one hand over his eyes—read it again.

"Bring me a blank—quickly!" was all that he said, but the way in which he said it told a story that belied his apparent calmness—for the Senator was noted as being "nerve-less."

"Odd—Ryerson—that you should have made that—'supposition'—by way of conversation—as to that which would happen, if things went wrong!" Briggs re-lighted his cigar, but his hand shook—a little. "Odd—very! For that is exactly what has happened! Man I trusted—completely—has double-crossed me—been bought off, I think. Fortunately I still have a card to play—that will take the trick—but I admit that it is far too close for any great amount of comfort!"

Continued on page 80

BUY THE BEST Thordarson Condensers and Amplifiers



A New Thordarson

6 to 1 ratio audio frequency amplifying transformer. Designed for those desiring a higher transformer ratio than our standard. Unusually high and constant amplification without distortion over a broad band of audio frequencies. Core is twice the cross section of that of the ordinary amplifying transformer and is made of special 36 gauge silicon steel. The coils have low distributed capacity. The high "Thordarson" standard has been maintained throughout.

6 to 1 ratio transformer.....\$5.00
3½ to 1 ratio transformer 4.50

**Thordarson Electric
Mfg. Co.**
500 W. Huron St.
CHICAGO

Our Latest Product

The best, most flexible and most complete variable condenser on the market today at any price.

Some of its features are:

Movable and stationary plates completely shielded.

Stationary plates spaced accurately by special punched shell.

Movable plates secured by an ingeniously assembled comb separator brushing against the bearing.

Single bearing fastened directly to the shielding base plate without any dielectric.

Assembled by machine.

Lowest possible zero capacity and dielectric loss.

A Vernier can be added by anyone at any time at a very small cost.

- 13 plate .00025 M.F.....\$2.00
- with vernier, knob & dial 3.50
- 25 plate .0005 M.F..... 2.50
- with vernier, knob & dial 4.00
- 43 plate .001 M.F..... 3.00
- with vernier, knob & dial 4.50
- Vernier furnished separately if desired with knob60

WIS WIN



No.764 SERIES PARALLEL
Concealed type, mounted on formica base\$1.50
No. 754 visible type, switch alone, 65c
Our sheet of diagrams showing the many uses of this popular switch, sent free upon request.
WILLIS SWITCH & INSTRUMENT CO.
8 Kingsbury St., Jamestown, N. Y.

Tell them that you saw it in RADIO

Radio Supplies All Standard Goods Immediate Deliveries

Distributors for
BALDWIN, BRANDES and BARCO
PHONES. FADA, FEDERAL and MON-
ROE RECEIVING SETS. Erla, Federal, Dub-
lier, Chelton, Burgess, Cunningham, Mag-
navox, and many others.
A COMPLETE line. Largest stock in the
middle west.

Write for latest Catalogue
Dealers' New Attractive Discounts
American Radio Mfg. Co.
Dept. N
107 E. 13th St. Kansas City, Mo.

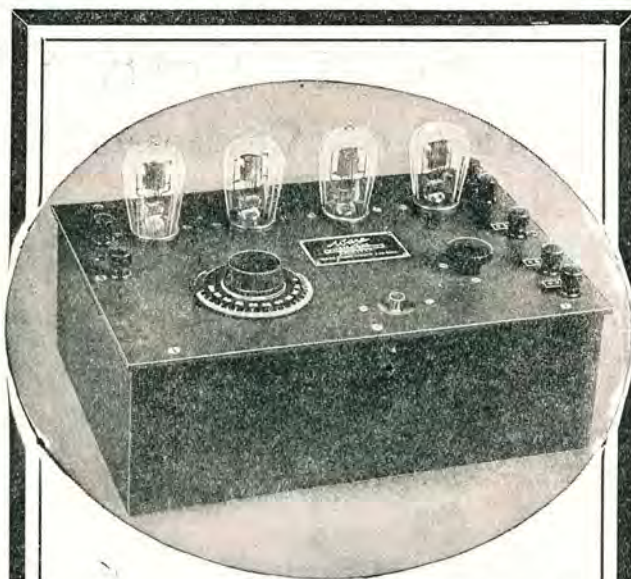

From 1000 to 3000 Miles!

This IS the Most Sensitive Receiving Set on the Market and Only

\$110.00

without tubes

On a Small Loop

This 3-Step Radio-Frequency Amplifier Detector Set WILL:

Operate in any location — steel buildings included.

Reproduce with a tone quality almost unbelievable and positively solve the problem of "static" and other interferences.

Its operation requires no technical knowledge whatsoever.

Send for Descriptive Booklet
Dealers Write for Proposition

Ware
TYPE AD2

**R-F AMPLIFIER-DETECTOR
RECEIVER**

**WARE
RADIO
CORP'N**

160-162 Duane St.
New York City

THE VACUUM TUBE

Continued from page 18

properly tuned in the antenna and secondary circuits, impresses a radio frequency potential on the terminals of the secondary variable condenser. When that side of the stopping condenser which is connected to the grid is positively charged by this radio potential, which is also impressed across the grid and filament since they are shunted or connected in parallel across the secondary condenser, a current passes from the grid to the filament. When it is negatively charged, however, the rectifying property of the tube does not permit a current to flow from the filament to the grid. Consequently, for each radio cycle or wave in an incoming train, a negative charge is given to the stopping condenser and grid. For each train of waves, there is accumulated on the stopping condenser the summation of these negative charges, exactly as in the case of crystal detector rectification.

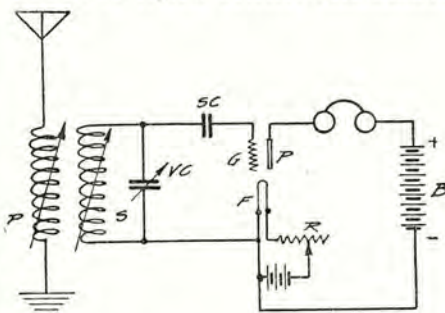

Fig. 63. Hook-up for Vacuum Tube Detector

This large negative charge causes a reduction in the plate current, as we should expect from Fig. 63.

The nature and the relation of these various currents and potentials are shown in Fig 64. The upper curve (a) shows the radio frequency potential of a wave train such as might be received from a damped wave telegraph transmitter or a radiophone. Due to tube rectification, this potential impresses the potential shown in curve (b) on the grid and stopping condenser. The summation of these negative charges on the stopping condenser is shown in curve (c) and the resultant current through the telephone receivers, the plate current, is shown in the lowest curve.

Thus, as in crystal detector reception, one impulse per wave train is heard in the telephone receivers. There is this fundamental difference, however. With the crystal detector, the energy which flows through the telephone receivers, after rectification, is actually received energy. With the vacuum tube detector, however, the telephone current, while produced by the received energy, is actually supplied by the "B" battery and in energy content is very much greater than that received. In other words, as we have previously seen, the vacuum tube detector not only rectifies

UNEQUALLED SERVICE

"DISTRIBUTING THE BEST IN RADIO"

**THE WHOLESALE
ONLY EXCLUSIVELY
RADIO HOUSE OF SERVICE**

ON THE PACIFIC COAST

Western Radio Incorporated

1121 Pine St.

Seattle, Wash.

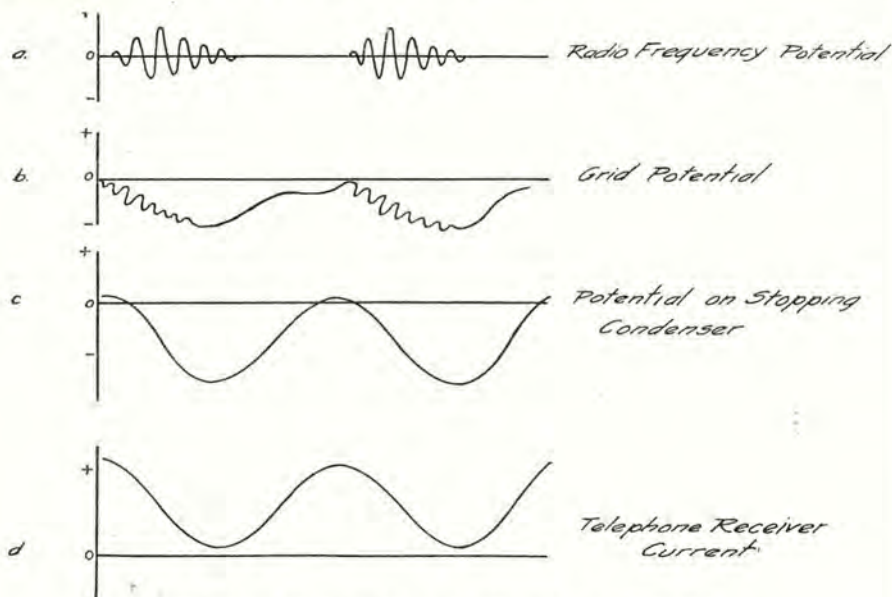

Fig. 6A. Relations of Detector Currents and Potentials

the received energy, as does the crystal detector, but amplifies it. Consequently, the vacuum tube is very much more sensitive than the crystal, and much more desirable as a detector.

There are several types of vacuum detector tubes on the market differing from each other in various ways. The detector tubes manufactured by the Radio Corporation of America, see Fig. 65, are known as *Radiotrons*. Tungsten filaments, made in an inverted V shape and operating on about 5 volts for proper filament brilliancy, are employed. The filament in such a tube is surrounded by flat grid and plate. About 23 volts positive potential is required on the plate—this voltage being ordinarily supplied by small dry cells such as are used in flash lights. Such cells are supplied conveniently assembled in compact form. The plate current is relatively small and hence dry cells can be used. Their usual life is at least a year.

The filament consumes 1.1 amperes and hence requires a storage battery for its operation.

Since four leads must be brought out from the interior of the tube—two for the filament and one each for the grid and the plate—a four prong base is used which requires a special form of socket for its operation.

Other tubes are on the market which employ metallic filaments coated with compounds—usually oxides—of calcium, barium and other rare earths. These oxides, when heated, emit electrons copiously—hence their adoption. Tubes manufactured by the Western Electric Company commonly employ these coated filaments.

The Westinghouse Company supplies a small, oxide-coated filament tube designed to operate off a standard, six-inch, 1.5-volt dry cell. The filament current is only one quarter (.25) of

an ampere so that such a dry cell will give about six months' life.

For best detector operation, it is desirable not to have the tube too highly exhausted. In fact, it is customary to interpose some inert gas, which will not assist combustion of the filament, in the tube. Argon, neon, and occasionally



Fig. 65. Radiotron UV-200

mercury vapor are used for this purpose. Gas-filled tubes, or tubes in which slight traces of air are deliberately left to enhance detector efficiency, are called "soft" tubes.

Amplifier tubes, which we shall study in the next assignment, are highly exhausted or "hard" tubes. To assist in their evacuation chemicals are used which leave the glass slightly discolored. The glass of detector tubes, however, is always clear—a characteristic which assists in their ready identification.

ASSIGNMENT No. 10

THE VACUUM TUBE AS AN AMPLIFIER

In the last assignment, we observed that a vacuum tube functions both as an amplifier and as a rectifier, due to its

Continued on page 74

Tell them that you saw it in RADIO

A new

EVEREADY "B" BATTERY



No. 767

Made up of thirty large cells arranged in five rows of six cells each, gives 45 volts and is equipped with Fahnestock Spring Clips allowing the following voltages: 16½, 18, 19½, 21, 22½ and 45 volts. This is a remarkably high quality, long life battery. Dimensions: Length, 8¾"; width, 6¾"; height, 3½" over all. Weight 9 lbs. Price \$5.50.

Two important characteristics are necessary for a satisfactory "B" battery; first, the battery must be designed for long life; second, the operation must be noiseless. The Eveready "B" battery meets these exacting requirements.

EVEREADY

Eveready "A" radio batteries are carried in stock by the best radio dealers in three different types—60, 80, and 100 ampere hour capacity. These Eveready "A" batteries have a larger capacity and give longer service and require less frequent re-charge than most other batteries of this type.

Made on the Pacific Coast by the world's largest battery manufacturers.

NATIONAL CARBON CO., INC.

599 Eighth St.,
San Francisco, Cal.

419 East 2nd St.,
Los Angeles, Cal.

Warren
Radio
Loop
Un-
Covered

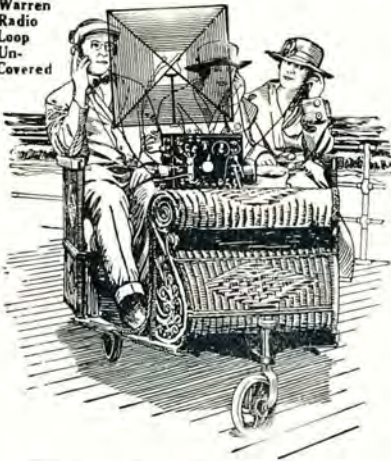

Use a Warren Radio Loop

The Up-To-Date Antenna

Makes radio more convenient and enjoyable. Eliminates all interference. Just the thing for portable sets. You can do without a tuning coil by using a variable condenser across the terminals of a Warren Radio Loop. Moisture, dust and fool-proof. Wonderfully well made.

A type for Every Purpose

Type A-737 (300-700 meters) 6 inches square—non-directional	\$10.00
Type A-7236 (175—1000 meters) 6 inches square—non-directional	12.00
Type B-2537 (300-700 meters) 18 inches square—directional	20.00
Type BL-2520 (200-18,000 meters) with honeycomb coil. 18 inches square—directional	25.00

Sold by dealers who sell the best.
Bulletin S102 sent on request

V-DE-CO RADIO MFG. CO.

ASBURY PARK, N. J.
Dept. C

PEERLESS CRYSTAL RADIO RECEIVING SET



Price \$1.50

For All Local Broadcasting of 360 to 400 Meter Wave Lengths.

No Batteries to Use.

No Dials to Adjust.

No "Tuning-In" to Do.

Simply connect Aerial to Binding Post "A," Ground to Post "G," Phones to Post marked "P," and "listen in."

Send check or money order for as many as you want to give as Christmas presents and they will be mailed at once, postage paid.

Manufactured by

Thompson-Levering Company, Inc.
Radio Dept., 351 N. 57th Street
PHILADELPHIA, PA.

You should be a subscriber



Send 10c for new and complete catalog
Dealers and Jobbers write for our discounts
EMPIRE RADIO CORPORATION
271 W. 125th Street, New York City

Continued from page 73

steep characteristic curve. As we have already seen, both its properties of rectification and amplification are made use of when the tube is employed as a detector. Its amplifying properties result from the fact that only a small amount of energy need be impressed on the grid in order that a relatively large amount of energy be sent through the telephone receivers in the plate circuit.

The fact that the tube may operate solely as an amplifier was discovered by De Forest some years after his basic invention of the grid in 1906. The practical application of this principle has not only greatly extended the tube's range of usefulness as far as radio is concerned, but has made long distance wire telephony possible. For example, in talking over the long distance telephone between San Francisco and New York, the speech currents are put through several banks of amplifier tubes at frequent intervals along the line. Such tubes are termed "repeaters" in telephone parlance, but they are of the same general type as the amplifier tubes used in radio receiving sets.

The grid circuit of a vacuum tube may be termed the *input* circuit, and the plate circuit the *output* circuit. By connecting the output or telephone receiver circuit of a detector tube to the input circuit of an amplifier tube and transferring the telephone receivers to the output circuit of the amplifier tube, we shall secure, for the average tube, about ten times the audibility or intensity obtained with the detector alone. Such a receiving set is said to employ a detector and one *stage*, or *step*, of amplification. We may increase this amplification by using an additional amplifier tube, the output circuit of the first amplifier being connected to the input circuit of the second amplifier tube. The telephone receivers, of course, are shifted from the output circuit of the first amplifier to the output circuit of the second. The amplification is now increased to about one hundred. This combination is called a detector and two stages of amplification. If a third amplifier tube is added, the intensity will be increased to about one thousand.

Theoretically, an indefinite number of amplifier tubes can be added so as to increase the intensity of received signals or music to any amount. There are certain practical limitations, however, which prevent this—i.e., the intensity of static, detector tube "noises," and interaction or "howling" between the tubes. Consequently, it is not customary or desirable to employ more than four steps of such amplification.

In connecting up tubes as amplifiers, the output circuit of one cannot be led directly into the input circuit of the next tube. Instead, a small transformer,

called an amplifying transformer, must be connected between the two, so that the primary of the transformer is connected to the output circuit of the tube whose current is to be amplified, and the secondary is connected to the input circuit of the next amplifying tube.

For most efficient results, it is desirable to have the impedances of the primary and the secondary coils of the amplifying transformer approximately equal to the resistances of the output and the input circuits, respectively. Since these resistances are of the order of 25,000 ohms or more, a great many turns of fine wire, No. 38 or No. 40 B.&S. gauge, should be used on both coils. Since the frequencies which such a transformer must carry are low or audio frequencies (the radio frequency currents having been rectified by the detector tube), an iron core may be used with efficiency. Transformers, such as loose couplers, which are designed to carry currents of radio frequency cannot employ iron cores to increase the efficiency of transformation, since such high frequencies produce losses in the iron. In order that the magnetic field produced in an amplifying transformer shall not extend beyond the transformer itself, it should be shielded in a metal case. If this precaution is not observed, the extraneous magnetic field which may result is liable to affect another amplifying transformer mounted near the first if more than one stage of amplification is employed, with the result that tube interaction or "howling" may be set up.

Fig. 66 shows the diagram of a vacuum tube detector with two stages of amplification. *A* represents the "A" batteries used to light the filaments of the three tubes and *B* the "B" batteries required to supply the plate currents in the detector and amplifier tubes. In practise, it is customary to supply one "A" battery and one "B" battery for all three tubes but in order to simplify the diagram separate batteries are shown. *P* and *S* represent the primaries and the secondaries, respectively, of the two amplifying transformers required. It will be observed that the telephone receivers are connected in the output or plate circuit of the second amplifier tube. If an additional stage of amplification were to be employed, the telephone receivers would be removed, and the leads from the plate and "B" battery connected to them would be connected to the primary of a third amplifying transformer.

As we learned in the last assignment, the tubes used as amplifier tubes are pumped to a higher vacuum than those ordinarily used as detectors. Consequently, to pass a sufficient current through them, a higher "B" battery or plate potential must be supplied. Thus, while detector tubes commonly require approximately but 23 volts, amplifier

Continued on page 76

RHAMSTINE*

WD-11

Tube Socket



Price \$1.00

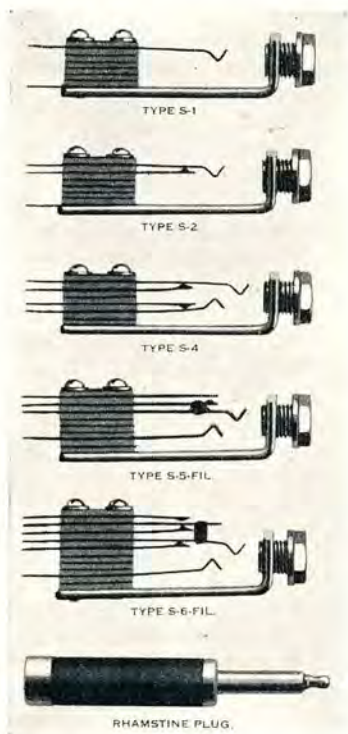

Graceful in design, it has the outstanding attractiveness of real individuality. In offering the WD-11 Tube Socket Rhamstine* has responded with a type that characterizes the high Rhamstine* Standards. Essentially a heavily plated shell mounted on a condensite-celeron ring—a design which will immediately impress you as being most practical.

The demand for the Rhamstine* WD-11 Tube Sockets will be great without a doubt.

We urge that you order your stock at once.

Rhamstine* Standard Jacks

RHAMSTINE* Plugs and Jacks represent very high quality at very reasonable prices.

A complete line of standard size Jacks is now available and the new Rhamstine* Plug is also standard and will fit all other standard Jacks.

S-1	—	60c
S-2	—	70c
S-4	—	85c
S-5	—	95c
S-6	—	\$1.20

Rhamstine* Plug, 75c

Manufactured by

J. THOS. RHAMSTINE*

2152 E. Larned St.

Detroit, Mich.

*Maker of Radio Products

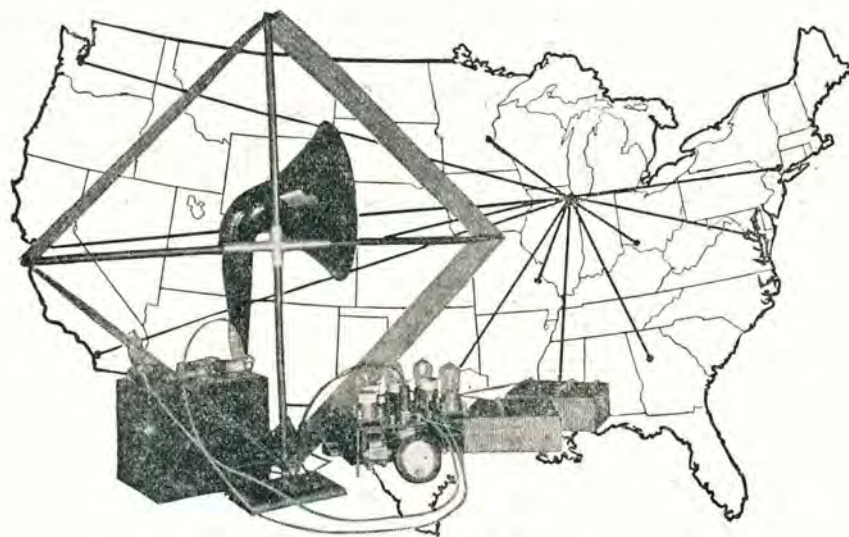

Four Tubes Now Do the Work of Seven

Again Erla offers invaluable contribution to radio science. The Quad-Six Super-Radio-Frequency Circuit—an Erla achievement—takes first place among the notable discoveries of the year.

Six stages of amplification—four radio and two audio—are secured with the use of but three amplifying tubes, and a detector, giving the efficiency of the best seven-stage circuits of conventional design.

If your home is within even the utmost range of metropolitan broadcasting stations you can now enjoy the same advantages as those who are close at hand. Moreover, outside antennae are dispensed with, a loop serving satisfactorily, except for the most extreme ranges.

Equally remarkable are the simplicity and ease of tuning, and the perfect modulation and tone character, surpassing the finest phonograph in quality and volume.

Employed exclusively in this circuit are Erla radio frequency transformers. Their unique ability to overcome the high capacitance effects of domestic vacuum tubes, as well as their own reduced capacitance, account largely for the exceptional ability of the Quad-Six in long distance work.

To obtain full information about this latest and most efficient of circuits, ask your dealer for our Special Bulletin No. 14, showing the circuit in detail, with complete directions for installing. Or write us, giving your dealer's name.

Manufactured by
Electrical Research Laboratories Dept. H
 2515 Michigan Ave., Chicago

Coast Representative
Globe Commercial Co.
 700 Mission Street
 San Francisco



Erla radio frequency transformers are unequalled in efficiency, quality and value. List price, \$1.00.



Erla bezels double the attractiveness of any receiving set. Fit 1 1/2" hole in any 3/8" to 3/4" panel. List, 20c.



Made with jeweler's precision, the strength, beauty and finish of Erla sockets are unsurpassed. List, \$1.00.

JOBBERS—Erla products are at the forefront of radio development, building business in steadily increasing volume. Write for our highly liberal terms and discounts.

Continued from page 74
 tubes must be supplied with from 40 to 90 volts. The latter value should be used if a loud speaker is to be operated off the second stage.

The negative charge which accumulates on the grid of a vacuum tube, due to its property of rectification, is of use, of course, only to "trigger" a relatively large current through the plate circuit. If distortion is not to result, however, this charge must be dissipated or carried away after it has served its purpose. A high resistance, *R* (Fig. 66), must be supplied in the grid circuit of each tube, therefore, to carry off this charge to the filament. This resistance, for obvious reasons, is termed the *grid leak*. For a detector tube, such as the Radio Corporation UV-200 tube, it should have an approximate value of 2 megohms (2,000,000 ohms). The grid leak for an amplifier tube should have a value of from 0.3 to 0.5 megohms (300,000 to 500,000 ohms). Such high resistance grid leaks are made of graphite or lavite, enclosed in an insulator such as glass. A pencil mark on paper, or some insulator, also may be used as a grid leak.

The amplification which we have been discussing is known as *voltage* amplification, its purpose being to build up a relatively high potential on the grid of the last amplifier tube so as to secure a maximum current through the telephone receivers.

However, this current, even after amplification, is still relatively small. When a loud speaker, such as the Magnavox or the Western Electric Type 10-A is to be employed, *power* amplification must be used in order that the output current of the last amplifier tube may be quite large. Power amplification differs from voltage amplification only in the respect that means must be provided for carrying larger currents. This entails the use of amplifying transformers wound with heavier wire, special tubes (usually transmitting tubes) capable of delivering large output or plate currents, and high-potential "B" batteries. With power amplification, plate potentials of from 120 to 300 volts are common for the power amplifier tubes.

Both the voltage and the power amplification which we have been considering have been employed after the received radio currents have been rectified to *audio* currents. Such amplification, therefore, is known as *audio* frequency amplification.

The gas commonly left in detector tubes, to enhance rectification and thus to increase sensitiveness, gives rise to slight tube "noises"—hissing, etc. When more than three or four stages of audio frequency amplification are employed, these tube noises are amplified to such a degree that signals are distorted if not obliterated.

CARTER "HOLD-TITE" JACKS

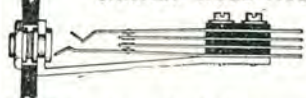

1 to 5 springs;
 price 70c to \$1.10

New design; heavy phosphor-bronze springs; no spacer washers required. Write for Bulletin on these Jacks, the well-known "TU-WAY" Plugs and other Carter products. CARTER RADIO CO., 209 S. State St., Chicago

"EURACO PRODUCTS"

(Guaranteed)

Compact — Interchangeable — Accurate
 Most Efficient



Price 60 cents per Unit
 Mfrs. of

MICA CONDENSERS, GRID LEAKS,
 MOUNTINGS

Interesting Proposition for Dealers

European Radio Company

1342 East 22nd Street Brooklyn, N. Y.

Investigate!
WESTERN-RADIO DEALERS SERVICE
 Wholesale RADIO only
 637 SO HOPE ST. LOS ANGELES
 1800 FRANKLIN OAKLAND

Tell them that you saw it in RADIO

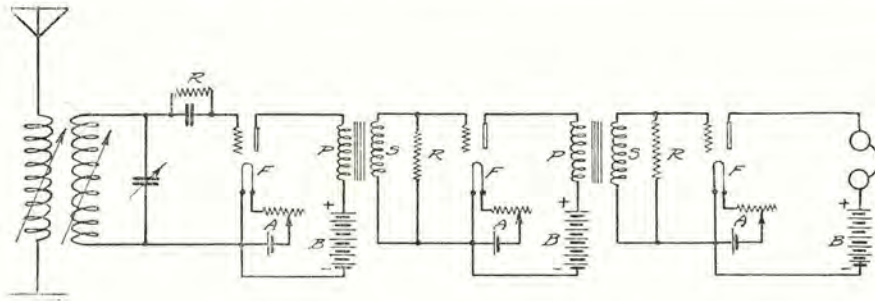

Fig. 66. Detector with Two Stages of Amplification

It becomes desirable, therefore, when additional stages of amplification are required, to interpose such stages *before* the detector tube. This means that such amplification will be at radio frequency, since the received radio-frequency current is not rectified to audio frequency until after it has passed through the detector tube. This amplification, therefore, is termed *radio-frequency* amplification.

Radio-frequency amplification is similar in a general way to audio-frequency amplification with the exception that the amplifying transformers should contain little or no iron in order that there may be no undue losses or distortion.

In Fig. 67, two stages of radio-frequency amplification, a detector, and one stage of audio-frequency amplification are shown. The received radio frequency current is first tuned to resonance, after which it is passed through the first two amplifier tubes, by means of the radio frequency amplifying transformers and thence to the detector tube where it is rectified into audio frequency current. The single stage of audio frequency amplification may be of the power type for the operation of a loud speaker.

In addition to the elimination of amplified detector tube noises, radio-frequency amplification assists in the elimination of static through the use of a loop antenna. This form of antenna consists of a square wire usually from 2 to 5 ft. in length and height, mounted in a vertical plane, and arranged so that it may be revolved. The number of turns used—from five to ten—depends upon the wavelength which is to be received. It receives from a transmitting station only when it is pointing in the direction of the transmitter. Such an antenna is not connected to the earth—

the two leads from the coil being connected in series with the secondary of the loose coupler. No primary coil is employed. In fact, the loop itself—if wound with the proper number of turns—may be the only inductance used in the receiver, in which case it would be shunted by the "secondary" tuning condenser.

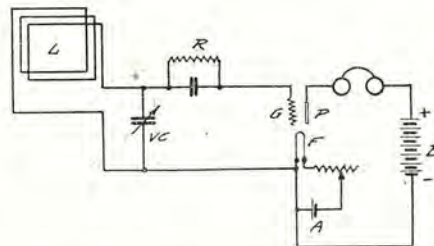

Fig. 68. Loop Antenna Connections

Fig. 68 shows a loop together with a detector tube. It should be understood, however, that for efficient results, several steps of both radio and audio-frequency amplification should be employed. The diagram is given only to show the connections of the loop antenna.

In the third assignment, we learned that radio wave propagation consists of a flow of electrons through the earth accompanied by electrostatic and electromagnetic strains in the non-conducting space above the earth. The usual type of grounded antenna makes use of all three factors of propagation, but the loop antenna is affected only by the space strains. Consequently, the energy which it can receive from a distant station is very much weaker than that which can be picked up by the usual type of antenna. Since it has marked directive qualities, however, as stated in the preceding paragraph, it follows that

Continued on page 78

The Heart of Radio Frequency

Is The Transformer

And Your Success in Getting Distance and Distinctness Depends On the Efficiency of Your Transformer

Do not condemn Radio Frequency because you have used poor Transformers. The RT-5 (150 to 300 meters) and the RT-6 (300 to 600 meters) have been tested severely by experts in various parts of the country and are proven without equal in tone quality and distance. They are an absolute necessity to the enthusiast who desires to get the best results from his radio set. With the RT-6 and RT-6A transformers, a loop receiver will operate a loud speaker on distant stations and you can easily receive wonderful programs from Chicago, Kansas City, Dallas, Atlanta, Winnipeg and other distant stations within a two thousand mile radius.

Order by type number, accept no substitute and remember that all Radio Service Laboratories Transformers are individually triple tested and unconditionally guaranteed. For sale at all reliable electrical or Radio Stores or order direct from us.

Send ten cents for new booklet on Radio Frequency with schematic diagrams—a most valuable and helpful publication for the radio amateur and expert.

Rasla Sales Corporation

National Distributor

Dept. C, 10 East 43rd St., New York City.

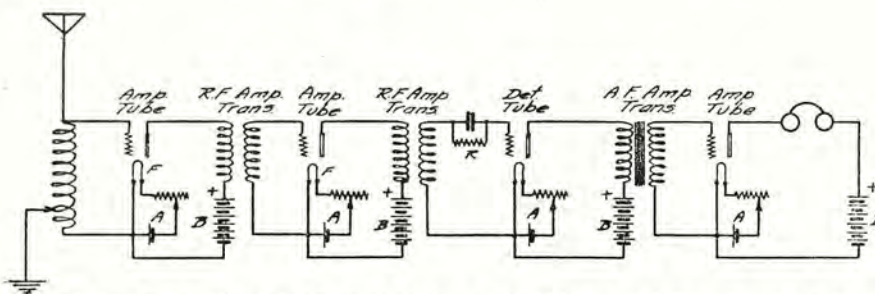

Fig. 67. Two Stages R. F. Amplification with Detector and Two Stages A. F.

Tell them that you saw it in RADIO

THE VACUUM TUBE

Continued from page 77

"static" or atmospheric electricity—a troublesome source of interference with received signals and music—will not be received on a loop antenna except when it originates in the atmosphere on the approximate line of bearing in which the loop is pointing. Since the static heard on the usual antenna originates at practically all points of the compass, the amount of static interference picked up by the loop is greatly reduced.

Since the signals or music received on the loop, however, are very weak as compared with those picked up by the elevated antenna, five or six stages of amplification must be used to secure the customary intensity in the telephone receivers or loud speaker. But we have seen that it is impracticable to employ so many stages of audio frequency amplification. Three or four stages of radio frequency amplification, therefore, together with two or three stages of audio frequency amplification, must be resorted to when receiving with the loop. Thus, the development of radio frequency amplification has made possible—through the directive qualities of the loop antenna—the elimination of a great deal of static and undesirable transmitting station interference.

The General Electric Company has developed an amplifier cabinet, Type AA-1520, which contains three stages of radio frequency amplification. This radio frequency amplifier is enclosed in a metal case to eliminate any disturbing effects of the capacity-to-earth of the body or hand, in making adjustments. It may be used in conjunction with any type of receiver and is designed to match a companion cabinet, Type AA-1400, which contains a detector and two stages of audio frequency amplification. Both cabinets are designed to be used with a regenerative tuner, Type AR-1300. The phenomenon of regeneration will be described in the next assignment.

As with audio-frequency amplification, only "hard" or amplifier tubes should be used in radio-frequency amplifiers.

CALLS HEARD

Continued from page 48

Tex, 7ly, 7zu, 7pf, 7sc, 7jw, 7iq, 7zv, 7zu, 7zo, 8anb, 8aaf, 8bxx, 8ue, 8zy, 8bvt, 8zw, 9anf, 9afd, 9ar, 9asf, 9bka, 9bun, 9bvy, 9bji, 9bik, 9cfy, 9cow, 9pkd, 9dtm, 9ei, 9gk, 9pp, 9pw, 9wq, 9xaj.

By 7ZU, Polytechnic, Mont.

C. W.: 5anv, 5aw, 5en, 5ek, 5nk, 5tj, 5xaj, 5xd, 5xt, (5za), 5zak, 5zav, 6aav, 6ajh, 6aqw, 6arb, (6avd), 6bip, (6bjq), 6boe, 6bqe, 6bvq, 6en, 6gr, (6lo), (6lv), 6pi, (6rm), 6xad, 6xwi, 6zac, 6zb, 6zh, 6zi, 6zo, 6zr, 6zv, 6zz, 7abh, 7ck, 7gs, 7jw, 7mf, 7ny, 7iq, 7wg, 7wm, 7xk, 7zo, 7zv, 8aim, 8asu, 8azd, 8vy, 8yd, 9aap, 9aeq, 9afd, 9afk, 9aiv, 9aja, 9ajz, 9ami, 9anf, 9anq, 9aog, 9aou, 9ar, 9ar, 9az, 9av, 9avm, (9avz), (9awm), (9ays), 9b, 9bey, 9bfb, 9bik, 9bii, 9bjt, 9bmm, 9bri, 9bsp, 9btt, 9bud, 9bxa, 9bxb, 9bzc, 9ccv, 9cfy, 9ciy, 9cmk, (9cns), 9cuv, 9cuc, 9ddh, 9def, 9dgg, (9djm), 9dsm, 9dta, 9dte, 9dwb, 9ew, 9iy, (9pi), 9pn, 9ps, 9uh, 9xac, (9xaj), 9yaf, 9yi, 9yu, 9zaa, (9zaf), 9zl, 9zn, 9zt.

Spark: 5uj, 5zh, 5zs, 6amk, (6ani), 6awh,

Tell them that you saw it in RADIO

6biy, 6km, 6nq, 6ot, 6qr, 7abs, (7fq), 7ge, 7gk, 7if, 7zo, 9aoj, 9aps, 9arz, (9auu), 9aza, 9bsa, 9btz, 9bxc, 9bxt, 9bzi, 9cca, (9cns), (9ctw), 9dww, 9dwm, 9fx, 9gdw, 9gk, 9tr, (9xaj), 9yah, 9yak, 9yar, 9zc, 9zn, 9zx.

Voice: (9cns), 9zab, 9xac.

Canadian—(4bv), 4dk, 5en; all C. W.

By 7QT., R. F. D. 2, Corvallis, Oregon

C. W.: (4dq) Can., 5ak, (5en) Can., 5et, 5nn, 5uj, 5vm, 5kc, 5px, 5rh, 5ve, 5xa, 5xb, 5za, 5biv, 6bh, 6bs, 6bp, (6cc), 6ch, 6cu, 6dn, 6ea, 6eb, 6fh, 6gy, 6gx, 6gf, 6ka, 6ku (fone), 6lu, 6lv, 6od, 6pe, 6pi, 6qm, 6qr, 6rm, 6sz, (6th), 6tc, 6ti, 6vm, 6xh, 6zh, 6zo, 6zn, 6zv, 6zt, (6zz), (6zr), 6aat, 6aar, 6abx, 6afn, (6agq), 6aiv, (6ajf), 6ajp, 6ajr, 6alu, 6ame, 6apw, 6aoi, 6ate, 6atq, (6avr), (6avv), 6beq, 6ben, 6boe, 6aga, 6bjq, 6bnv, 6bin, 6bjp, 6boe, 6boe, 6bow, 6bqe, 6bqe, 6bqg, 6bqr, 6xad, 7bm, 7bj, (7bk), 7eq, 7ge, 7gp, 7hi, (7hm), 7ic, 7iy, 7jg, 7jw, 7ke, 7lk, (7ly), 7ny, (7ot), (7pf), 7qe, 7qn, 7rn, 7ud, 7ui, (7th), 7sc, (7tq), 7zb, 7zk, 7zu, 7zv, 7aby, (7acg), 7adf, 7aio, 8aa, 8az, 8sz, 8bpl, 9ef, 9iz, 9zu, 9afd, 9ami, 9awg, 9asf, 9aul, 9bid, 9bji, 9bxa.

Spark: 6tu, 6ark, (6aoo), 6qr, 6auu, (7bh), (7ne), (7ri). Anyone hearing my 20-watt C. W. pse qsl.

By 5SF, 1616 Worth St., Fort Worth, Texas

C. W.: Can.—3xn, (4bv). U. S.—1bet, 1cmk, 2el, 3aay, 3bif, 3bz, 3ca, 3fs, (3yo), 3ot, 3zo, 4bb, 4bk, 4by, 4cg, 4cy, 4eb, 4fh, 4ft, 4hw, 4kl, 4km, 4ya, 6ajh, 6arb, 6avd, (6awt), 6boe, 6brg, 6bvg, 6cp, 6eb, 6ff, 6gf, 6ka, 6z, 6znc, 6xad, (7zo), 7zv, 8aaf, 8ab, 8aio, 8aim, (8alc), (8ame), 8asl, 8asv, 8azf, 8arb, 8axc, 8bdv, 8bek, 8beo, 8bfx, 8bke, 8bnh, 8bow, 8bit, (8bvr), 8bwa, (8byn), 8bz, 8bc, 8cdz, 8egb, 8egv, (8egx), (8cko), 8cqu, 8cur, 8cvt, 8cve, 8ft, 8hh, 8hi, 8ib, (8lt), 8oe, 8qk, (8sb), 8vq (iew), 8vy, 8xc, 8yu, (8zaf), 8zag, 8zd, (8zy).

By 9BJI, 3935 W. 30th Ave., Denver, Colo.

C. W.: 2awf, 2ayv, 2bgm, 2bqh, 2brb, 2el, 2fp, 2nz, 2xao, 3aif, 3aqr, 3auu, 3agt, 3bvc, 3bsj, 3zh-gra!, 4eh, 5aam, 5aar (5aby), 5aef, 5ae, 5aer, 5afq, 5be, 5ci, 5di, 5ek, 5ft, 5fv, 5gi, 5hz, 5ia, 5ix, 5ik, 5jb, 5jl, 5kp, 5lb, 5lj, 5mt, 5mu, (5mx), 5my, 5nd, (5nn), (5nv), 5nz, 5ou, 5pv, 6px, 5qi, (5qs), 5rn, (5sf), 5sk, 5ta, 5tc, 5tj, 5tp, 5tx, (5uk), 5un, (5uo), 5va, 5vo, 5sm, 5xa, 5xad, 5zae, (6abx), (6ahq), (6akl), 6amz, (6anh), (6apw), (6atq), 6awt, 6bbh, (6ber), 6bet, (6bf), 6bfp, 6biq, 6bko, (6bob), 6bqe, (6bof), 6bqr, 6brf, 6bum, (6bun), (6bv), (6bwe), (6ebi), (6cc), 6cu, 6dd, 6eb, 6ek, 6gd, 6gx, (6if), 6om, (6rm), 6te, 6uf, 6rk, (6zh), (6zn), (6zz), 7abb, (7aem), 7afw, (7bj), 7ge, 7hm, 7hj, 7lu, 7tq, 7zo, 7zv, 8ab, 8aea, 8ago, 8aim, 8anb, 8aoo, 8ard, (8asv), 8avt, 8axb, 8bey, 8bef, 8bek, 8bfb, 8bfm, (8bgl), 8bog, 8bre, 8bss, 8bsy, (8bvr), 8bxa, 8bxh, 8bxx, 8byf, 8byo, 8bwa, 8bz, 8cf, 8ego, 8egx, 8ep, 8eur, 8eva, 8eze, 8dat, 8fa, 8ib, 8iz, 8jv, 8nn, 8pd, 8qk, 8sp, 8ue, 8uk, (8sb), 8wr, 8yn, 8zaf, 8zd, 8zw, 8zy, 8zz, (9aby), (9afn), (9aig), (9aon), (9ap), (9ayl), (9bgh), (9bko), (9bqw), (9bsg), (9clw), (9cmk), (9cpi), (9cxy), (9der), (9dge), (9fm), (9lq), (9uh), (9yaf). Can. C. W.: (4bv), 4hh, 9bx.

Worked on fone: (5aby), (6zh), (9aig).

BY 6BOS—D. NEBEKER, PIEDMONT, CAL.

Spark—6ak, 6bu, 6dd, 6ea, 6eb, 6en, 6ff, 6gf, 6gn, 6gt, 6hy, 6ir, 6is, 6iv, 6jc, 6jd, 6ke, 6ks, 6ks, 6lc, 6lv, 6mh, 6mx, 6od, 6ol, 6qr, 6re, 6rr, 6rz, 6sk, 6tf, 6to, 6uo, 6up, 6za, 6zb, 6zr, 6zu, 6aak, 6aan, 6abo, 6acr, 6acy, 6adl, 6ael, 6ach, 6aew, 6afd, 6agp, 6ahp, 6ahu, 6aiv, 6aix, 6ajr, 6ajh, 6akl, 6ald, 6ali, 6aln, 6ano, 6apr, 6apy, 6ard, 6ark, 6ars, 6art, 6asc, 6atf, 6aum, 6avd, 6avm, 6awh, 6awh, 6zaa, 6zal, 6ben, 6bbe, 6bzg, 7bk, 7bh, 7br, 7bj, 7ek, 7dp, 7ed, 7fi, 7ge, 7gf, 7gj, 7gk, 7gq, 7hf, 7hi, 7iw, 7jd, 7ke, 7mf, 7mj, 7mp, 7mu, 7mv, 7my, 7nd, 7nn, 7nw, 7nz, 7oh, 7om, 7ot, 7ow, 7tj, 7to, 7vo, 7ve, 7vx, 7wg, 7ya, 7yj, 7zm, 7zj, 7zp, 7zt, 7zu, 7aea, 7kj, 7ks, 9bd, 9hm, e18.

C. W.—5za, 5zq, 6ak, 6bf, 6ea, 6eb, 6en, 6eu, 6ir, 6rg, 6rr, 6id, 6ij, 6ka, 6kc, 6kd, 6ki, 6lv, 6ny, 6pe, 6pt, 6tw, 6za, 6zb, 6zf, 6zg, 6zn, 6zz, 6xad, 6xaj, 6zac, 6zaw, 6awp, 6awx, 6bes, 6bjc, 6bjy, 6bit, 6bas, 7en, 7ln, 7nf, 7nu, 7oz, 7sc, 7at, 7tq, 7wm, 7yn, 7yt, 9zx, 9wu, 9amb, 9zaf. Anyone hearing 6BOS on spark pse QSL card. Best 73. All cards answered promptly.

By 9BXT, Giltner, Nebr.

C. W.: 1en, 1fb, 1gv, 1ii, 1ke, 1un, 1xu, 1yk, 1ary, 1bas, 1bes, 1bka, 1bkq, 1bwj, 1ckp, 1emk, 1cmp, 1eve, cy-1, 2bg, 2fc, 2fp, 2gi, 2zk, 2kp, 2nz, 2ot, 2su, 2ud, 2wr, 2xq, 2ayv, 2bbb, 2bea, 2bml, 2bmr, 2bdq, 2bub, 2brb, 2bys, 2cfn, 2ckr, 2epd, 2xao, 2xap, 2xaj, 3bz, 3fs, 3hg, 3hx, 3iw, 3lk, 3mb, 3oe, 3ot, 3rf, 3su, 3tj, 3xm, 3yo, 3zo, 3zw, 3zz, 3aqr, 3aro, 3atg, 3auu, 3bec, 3ber, 3bfm, 3bfu, 3bhm, 3bke, 3bfl, 3blz, 3bnu, 3bol, 3bof, 3bss, 3buv, 4bq, 4by, 4co, 4ea, 4eb, 4eh, 4hi, 4hw, 4ke, 4kf, 4kl, 4km, 4lj, 4lp, 4oi, 4ya, 5be, 5bw, 5en, 5di, 5dw, 5el, 5ek, 5es, 5fv, 5ft, 5ga, 5gj, 5gr, 5ik, 5ir, 5ix, 5jb, 5kc, 5kn, 5lb, 5ml, 5mo, 5my, 5mz, 5nk, 5nn, 5ns, 5nv, 5pf,

Continued on page 92



**DUPLEX VICTROLA ATTACHMENT
New Price \$3.00**

An Attachment of highest quality for making a Radio loud speaker of your talking machine and a pair of head phones. At your dealer or post paid on receipt of price. State make of talking machine when ordering.

W. B. McMASTERS
Wheeling, W. Va.

Chelsea Condensers



No 1

PRICES:

- No. 1 Table..... .001 \$5.00
- No. 2 Table..... .0005 4.50
- No. 3 Panel..... .001 4.75
- No. 3a Panel without dial.. 4.35
- No. 4 Panel..... .0005 4.25
- No. 4a Panel without dial.. 3.85
- No. 5 Panel..... .00025 3.75
- No. 5a Panel without dial.. 3.35
- No. 6 Panel vernier..... 2.90
- No. 6a Panel without dial.. 2.50
- No. 7 Table with vernier.... 6.75
- No. 8 Panel with vernier.... 6.50

Genuine Bakelite Construction

The best and most complete line of condensers in existence.

Write for our catalog No. 7

Chelsea Radio Co.
152 Fifth Street
CHELSEA, MASS.

RADIO 6OE RADIO KGO RADIO 6XR

I Ship All Over
the United States

"Everything Worth While In Radio"

AT

THE RADIO STORE

OF

PAUL FRANKLIN JOHNSON



562 East Colorado Street
PASADENA, CALIFORNIA

If you have not already received one of my RADIO
MANUALS, write for one.

Clarion Radio Headset



THE TEST TELLS

\$5.00

A headset of standard construction at a price that appeals to the average purchaser of radio apparatus. Uniform materials, improved methods of manufacture and inspection enables us to produce a headset that is a real contribution to the radio art. You may easily determine this by securing a Clarion Headset and comparing it with any other headset regardless of price.

Your dealer has the Clarion Headset in stock—or should have. If he cannot supply you, accept no substitute. Send money order direct and receive a set by return mail.

Clarion circular 21-A mailed free on request will be found interesting to Jobbers, Dealers and those interested in securing a high grade headset.

Radio Supply Company

Hornell, New York

Continued from page 71

And he wrote rapidly on the form—"Code that. It must be in N.Y. before the opening of the Exchange! How will you send it?"—to the operator.

"I got it from the *Ardathia*, sir. She is about half way between us and Cape Race, Newfoundland. I did not ask him where he got it, but he can reach Cape Race Station; more than possible that he is in communication with Atlantic Coast stations."

"Any way—provided that it goes!"

"Aye-aye, sir." The operator hurried forward.

"Allowing for difference in time, that will be in N.Y. within the margin of safety, but not much more!" His calm entirely restored, Briggs again lighted the cigar.

The flame of the match had just flickered to its end, when everything went dark on the yacht.

"What the devil. . . .?" the owner jumped to his feet and hurried forward, his guests following.

Briggs looked down the engine room skylight—"What's the matter?"—he shouted.

There was no confusion below. Engines running smoothly, but the pale yellow glimmerings of hastily lighted lanterns waved eerily to and fro among the moving masses of glinting metal.

"Something gone wrong with the generators' turbine!" bellowed a voice from the gloom—and there drifted up the sounds of many voices—calling to one another.

Stewards broke out the kerosene swinging lights.

And Briggs remembered his vital message. He hastened to the radio room—where the operator was busily connecting up the emergency storage set.

"Can you get that message I just gave—off?"

"There is no ship within 150 miles, sir, and that is my limit, with this set. But I am hooking it up, as the chief has notified me that it will be morning—or later—before the turbine can be got going. They can't see to work at it—down there."

"But—but, my God, man! that message must go! It has GOT TO GO—don't you understand?"

"Sorry, sir, but no emergency set will do over 150 miles—at the very outside!"

Aghast at the tremendous possibilities, Briggs walked to the rail—to pull himself together under the stress of this crisis. And his eyes fell on the lights of the freighter, plainly visible—as she rolled easily along—but falling astern—fast.

"What about *that* vessel? You can reach him, with batteries—can't you?"

Continued on page 82

WANT TO GET MORE DISTANT STATIONS and Bring In All Signals Clear and Strong?



THEN INSTALL

"All-American" Amplifying Transformers

(Radio and Audio Frequency)

You'll be the envy of your radio owning friends and neighbors because you'll get results that nobody can get without "All-American" Transformers.

- R-10 Radio Frequency (150-550 meters)
- R-12 Audio Frequency (Ratio 3 to 1)
- R-13 Audio Frequency (Ratio 10 to 1)
- R-21 Audio Frequency (Ratio 5 to 1)

Tell your dealer you must have "All-American" Transformers. Send for Bulletin No. 22—Free.



RAULAND MFG. CO.

35 So. Dearborn St., Chicago, Ill.



HYGRADE SPECIALS

No. 763 Eveready Variable B Battery	\$ 1.25
No. 766 Eveready Variable B Battery	2.25
No. 767 Eveready Variable B Battery	4.25
Skinderviken Transmitter Buttons	.75
2000-Ohm Murdock No. 56 Head Set	4.49
3000-Ohm Murdock No. 56 Head Set	4.98
Federal 2200-Ohm Head Set	6.50
Ditograph 3000-Ohm Head Set	7.50
6 Volt 20 Amp. Marko Storage Batteries	9.00
6 Volt 50 Amp. are	12.00
6 Volt 80 Amp. Guaranteed 2 Years	15.50
6 Volt 100 Amp.	18.50

All orders must include Parcel Post charges.
HYGRADE ELECTRICAL NOVELTY CO.

41 West 125th St. New York, N. Y.

PHANTOM-CIRCUIT

Build Your Own. This marvel of mystery, using no loop, no aerial and no ground brings in music instead of interference. We have heard stations 950 miles distant on one tube. By using WD-11 tube set can be entirely self contained. Very easy to build from our instructions, use your own spare parts, nothing complicated like radio frequency or super regenerative. Only one tuning control. Complete instructions, with hookup and photo of circuit mailed to you for 80 cents. Stamps accepted.

Vesco Radio Shop Box R-704 Vacaville, Calif.

You should be a subscriber

Be Sure and Read the Radioads on Page 93

Tell them that you saw it in RADIO

Peerless Radio Laboratories

*Manufacturers of Peerless Radio
Frequency, Receiving Sets
San Francisco*

November 1, 1922.

RADIO DEVICES CO.,
693 Mission Street,
San Francisco, Cal.

GENTLEMEN:

In compliance with your request, we wish to state that until we used the Aerovox we had no end of disappointments owing to the fact that there are so many Radio Frequency Amplifying devices of indifferent make and none seem to stand or give the satisfaction that we derive from the Aerovox in connection with the Variometer that you have been making. These two combined, we feel, are about the most important item of our set. We hope our pleasant business relationship may continue forever.

Yours truly,

PEERLESS RADIO LABORATORIES.
By ARTHUR ANNIS, President.

Arthur Annis/MR

EDW. M. JONES

*Insurance Brokers
SAN FRANCISCO, CALIFORNIA*

October 28, 1922.

AEROVOX CORPORATION,
47 Kearny Street,
San Francisco, Calif.

GENTLEMEN:

You will no doubt be interested in knowing the results obtained by me in the use of the Aerovox Inter-Tube Coupler which I installed about a month ago.

I have received the concerts from thirty-six stations in six States and Canada. These were brought in using one stage of radio frequency and one of audio frequency.

I have recommended the Aerovox to many of my friends, who are getting great results from it.

In conclusion I might add that the efficiency of my set has been increased 100% since installing the Aerovox.

Yours very truly,

Edw. M. Jones.

BOYLE & KENNA

*General Insurance
234 BUSH STREET, SAN FRANCISCO*

November 1, 1922.

RADIO DEVICES CO.,
693 Mission Street,
San Francisco, Cal.

GENTLEMEN:

I have been using your Aerovox for the last several months and have experimented with one and two stages of radio frequency amplification. I have used your published hookup with the exception of adding a variometer in the plate circuit.

I have been able to hear stations from San Diego, Cal., to Seattle, Wash., and in the interior, back to Detroit, Mich., taking in Kansas City, Mo.; Davenport, Iowa; Phoenix, Ariz.; Denver, Colo.; Salt Lake City, Utah; Great Falls, Mont., and Reno, Nevada. All of these stations, with the exception of Kansas City, Detroit and Davenport, have been received on the loud speaker.

The results have been so amazingly wonderful that I take pleasure in writing you this letter to advise you of the result.

Very truly yours,

JAMES R. KENNA.

JRK:M

AEROVOX

Radio Frequency Amplification

*is simple enough for the novice, and efficient
enough for the adept professional*



The cut shows what the AEROVOX Inter-Tube Coupler looks like. The letters show what it has done in the hands of others.

Why not find out what it will do for you?

If you cannot get it from your dealer, send his name and the price, \$4.50, to

RADIO DEVICES COMPANY *· Distributors*

693 MISSION STREET · SAN FRANCISCO

Making the most of Radio with DUBILIER Products



Screw the Dubilier Ducon into any lamp-socket, and the broadcasting station comes in strong and clear. No antenna or loop is required.

No antenna, no loop—just the Ducon in a lamp socket

Price, at your dealer, \$1.50.

Dubilier Micadons Reduce Tube Noises

Dubilier Micadons are mica condensers which are permanent in capacity. Hence they reduce tube noises due to fluctuations in capacity and greatly improve the reception.

Dubilier Micadons are made in types to meet every radio need. The price varies from 35 cents to \$1.00 each, depending on the capacity.



Micadon type 601. Connect by means of eyelet terminals to obtain desired capacity. Price 35 cents and 40 cents each, depending on capacity.

Micadon type 600. Molded case. Price 75 cents and \$1 each, depending on capacity.

BRANCH OFFICES:

- San Francisco, Cal.—709 Mission Street, Suite 701-704
- St. Louis, Mo.—Syndicate Trust Building, Suite 1409
- Washington, D. C.—Munsey Building
- Chicago, Ill.—33 So. Clinton Street
- Atlanta, Ga.—802-3 Forsyth Bldg.
- Seattle, Wash.—1925 L. C. Smith Bldg.
- Los Angeles, Cal.—337 So. Western Ave.
- Pittsburg, Pa.—704 Granite Bldg.
- Huntington, W. Va.—1028 Fourth Ave.

DUBILIER Condenser & Radio Corp.

48-50 West 4th St., N. Y.

Canadian Distributors:
Canadian General Electric Company,
Toronto, Canada

"B" BATTERIES

AN EVEREADY PRODUCT

- 43V. Batteries, tapped.....\$5.00
- 22½V. Batteries, Navy Type..... 3.00
- 22½V. Batteries, Commercial Type..... 2.00

Latter two types especially adapted to C Cunningham and Radiotron Tubes. Postage Prepaid Anywhere in U. S.

ETS-HOKIN & GALVIN

Wireless Engineers

10 Mission Street San Francisco

Continued from page 80

"Yes sir. But he's only a cargo boat. They none of them have any half-way decent apparatus. I doubt very much if he carries a regular operator. The supercargo—or the chief officer—usually fills both positions.

"Well—try it, man—try it! Never get anywhere without trying!"

And he watched, with bitter impatience, while the operator finished making connections.

"I'll call him now, sir."

The crackle of the spark was but a feeble one—compared to that under normal conditions of full power. The operator tuned—listened for some moments—shook his head—

"Doesn't answer, sir! I'll have another shot at him!"

Again the spark—very blue-white in the kerosene light—ripped through space.

"No go, sir!"—after a period of listening.

"Heavens! what am I to do? What AM I to—do?" Briggs muttered—and his operator felt the poignant distress in the other.

"Maybe I can raise him with the Morse blinker, sir? He ought to see that, even in this bright moonlight. Just a minute!"

And—presently—there went forth from the signalling light on *Ariadne's* flying bridge—dots and dashes through the night.

"What does he want?" asked Skipper Jim Lewis, as Walter Ellison intently watched the winkings that came across the soft-rolling waters.

"Asks me to stand by for an important message—says his power plant has broken down—only got his emergency set to use—excuse me for a few minutes." He hurried forward to the radio shack.

"I wonder what ship it can be? She doesn't look very large!" said the girl.

"Haven't the faintest idea! He's in no serious trouble—and the weather is fine. Run along with Walter—and find out. I'll finish my smoke in the moonlight."

The girl ran forward and looked over her fiance's shoulder as he—phones over ears—began to copy the *Ariadne's* operator.

"To ship—de SY *Ariadne*—WPOI—glad you saw my sigs OM as our generator turbine has gone flooey—no juice for anything—I've got a rush message for NY—very important—are you in touch with anyone ahead? I took 1 msg from the *Ardathia*—WCE—an hour ago—he must be about 500 miles ahead of us—think can you reach him—hw? sig. Kruse—operator—SY *Ardathia*—WPOI—K"

Ellison snapped his switch to send—and shot back:

Pacific Coast Amateurs

WE WILL SAVE YOU MONEY ON PARTS FOR YOUR SET. COMPARE THESE PRICES AND DON'T FORGET

Every item is guaranteed highest grade and perfect or money refunded.

	Regular	Our Price
Genuine Double Filament Audiotrons	\$ 6.00	\$ 4.75
WD-11 Peanut Tube—Socket Free	6.50	5.50
Cunningham Detector Tubes		5.00
Cunningham Amplifier Tubes		6.50
With each Cunningham tube purchased we will give free 1 bakelite base, metal neck socket and 1 high grade rheostat.		
Baldwin Phones	\$12.00	\$ 9.25
Western Electric Aviation Type Army Phones with Headbands Guaranteed New Stock. A Remarkable Value at the price of.....		8.00
11 Plate Variable Condensers	3.00	1.45
23 Plate Variable Condensers	3.50	1.50
43 Plate Variable Condensers	4.50	1.75
Large Size Tapped "B" Battery 22½ Volt.....	3.00	1.75
Large Size Tapped "B" Battery 45 Volts.....	5.00	3.00
All-American A. F. Transformers Shielded 10 to 1..	4.75	3.35
All-American A. F. Transformers Shielded 5 to 1..	4.75	3.35
All-American A. F. Transformers Shielded 3 to 1..	4.50	3.25
Erla Radio Frequency Transformers	4.00	2.95
Carter Radio Jacks—Open Circuit Jack.....	.70	.50
Closed Circuit Jack.....	.80	.60
Double Circuit Jack.....	.90	.70
Filament Control 4 Spring	1.00	.80
Filament Control 6 Spring	1.10	.90
High Grade Filament Rheostats	.75	.45
Moulded Variometers	5.50	3.75
Moulded Variocouplers 180 Degree	4.50	3.25
Dubilier Micons and Ducons. Switch Lever—Tapered Knob		25% off list
Switch Points.....Special at Per Dz.	.40	.17
Switch Stops.....Special at Per Dz.		.10
Tone Tested Mtd. Radiocite Guaranteed	.30	.20
Tone Tested Mtd. Million Point Mineral	.30	.20
Tone Tested Mtd. Galena	.30	.20
Grewol Always adjusted Crystal Detector	2.00	1.65
Triple Honey Comb Coil Mounting	5.00	3.50

SPECIAL SPECIAL SPECIAL SPECIAL TUSKA STANDARD LICENSED REGENERATIVE RECEIVER AND TWO STAGE AMPLIFIER COMPLETE WITH—3 Cunningham Tubes—6 Volt 100 Ampere "A" Battery—2 Large Size "B" Batteries—3000 Ohm Headset—Aerial Equipment—and Arkay Loud Speaker—In Short, Nothing Else To Buy—At The Very Special Price of...\$100.00

Send Your Order In Today! Shipments made within 24 hours. Please remit by Express or Postal Money Order. Include postage at your zone rate or shipment will be made by Express.

INDEPENDENT Radio Supply Co.

3239 Ogden Ave. Chicago, Ill.

"To WPOI—de WSIE—R—Too bad about power I can try OM—have good set here—shoot the msg—glad to help if poss. sig. Ellison—OP"

Instantly the yacht replied:
"R—many tnx—here Nr 1—de SY Ardathia—To Martbrown—NY—ck 12—July 22—10PM—generic—fulsome—atropex—affected—quando nulval—ploare submo suavis notensem nariba—sig. Briggs."

When Ellison received the signature he ejaculated in surprise—but business came first! He repeated the message back to the yacht—to ensure correctness of code spelling.

From the yacht:—"R—OK—OM—many tnx—hurry that—advise when you get rid of it—sig. Kruse."

And Ellison dashed back with—"R—what Briggs is that?"

From the yacht:—"R—x—Senator Briggs owner of yacht this is maiden cruise to England and back—sig. Kruse."

With a whoop of delight—that startled the watching girl—Ellison hopped on the key—"R—tell Senator Briggs I am Walter Ellison—he will know—answer—sig. Ellison."

The other:—"R—minute."

To the wondering girl Walter explained, in hurried words—as he listened for the reply. In a moment it came—

"Senator's compliments—says now your chance to help him out of serious matters—cul—Kruse—K."

"Watch my smoke!" Ellison shot back at the yacht—and began to call WCE—the Ardathia—some where ahead.

And the girl wondered—a little—why, under the circumstances, he did not even look at her, but alternately called—and listened—and called again. Suddenly he stiffened—eyes staring—

"Got him!" He almost fell on the key—WCE—de WSIE—have life death msg for NY can you take it? sig. Ellison—OP."

The operator on watch on the big Liner chuckled to himself: "he's in a hell of a hurry," and answered—"WSIE—de WCE—OK in 15 mins—sig Bartel—OP" and then went on to finish up a batch of passengers' messages that lay before him.

From the yacht came—"FB—OM—Senator says be sure come to his offices when you reach NY—cul—73—Sig. Kruse."

And Ellison replied:
"Surest thing you know—73—Ellison."

Then he took off the head harness—seized the wondering girl's hands and danced her about the spacious operating room—

"Hoorah! And I haven't heard from him in so long! Wrote to him—several times—but I suppose that a man as busy

Continued on page 84

"United" Variable Condensers Are "Just About Perfect"

In outward beauty—with clean-cut hard aluminum plates, ebony Bakelite ends, highly finished nickeled parts and, in the "beautiful" work they do—"United" Condensers are as near 100% good as can be imagined.

43 plate \$4.50
33 plate 4.00
11 plate 3.50

5 plate \$2.75
3 plate 2.25
postpaid



Pat. Appd. For

"United" Audio Frequency Transformers

"Staple as Wheat" in the radio industry. Magnetically shielded, in a shell of original design and finish—a beautiful piece of workmanship. Ratio 5 to 1. Insures loud, clear signals. Fully mounted.

Price postpaid\$4.50

UNITED MFG. & DISTRIBUTING CO.
536 Lake Shore Drive Chicago, Illinois

WELSH PEANUT TUBE

W. T. 501

"The Tube That Cannot Squeal"
Sold for experimental use as a detector only.



List Price
\$2.00

at your dealer or by mail postpaid.

Can be used on 3 dry cells or regular 6-volt A-Battery. Wiring diagram packed with each tube showing how to use the W. T. 501 with any crystal set. Nickel-plated socket, moulded base, double spring contacts, 40c extra.

Adaptor for V. T. sockets, 75c extra. Actual size 2 1/4 inches without base. Jobbers and dealers wire for merchandising plan.

Packed 10 in a carton, 10 cartons per case. Orders filled in rotation. Please do not ask us to open an account to ship sample tubes. Samples shipped only at list price which will be credited towards your first stock order.

RADIO RESEARCH GUILD
9-15 Clinton Street Newark, N. J.

A good article is always imitated!
Be sure you receive the

FRESHMAN Variable Grid Leak and Micon Condenser Combined



Price only \$1.00

3 POINTS TO REMEMBER

1. It is hermetically sealed in a mould to prevent moisture from affecting the grid resistance.
2. It has an unbroken range from zero to 5 megohms, allowing proper adjustment for maximum efficiency of detector.
3. It contains a tested Micon Condenser of .00025 M. F.

At your dealers—otherwise send purchase price and you will be supplied without further charge.

Manufactured by

Chas. Freshman Co., Inc.
97 Beekman Street New York City

RADIO SUPPLIES

Mail Orders Promptly Filled
WE PAY THE CHARGES
If It Is

RADIO

We Can Supply It.

U. C. BATTERY
and ELECTRIC CO.

2158 Univ. Ave. Berkeley, Calif.



Those Broken and Burned-Out
VACUUM TUBES
Can Be Repaired

and Guaranteed Too!
If your dealer does not know send direct to us.

Harvard Radio Laboratories
165 High Street
BOSTON, MASS.
Tubes returned P.P., C.O.D.

**Both Selling Fast
Because the Price
is Right!**

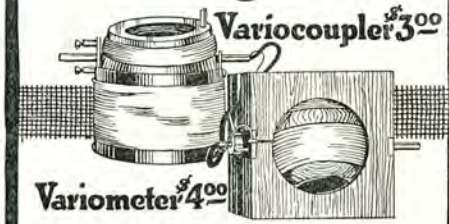

Variometer \$4.00

Variocoupler \$3.00

Set of Three

2 Variometers \$8.00
1 Variocoupler \$3.00

a "ChiRad" Special \$10.00
Send Your Order in To-day

OUR NAME PROTECTS YOU
CHICAGO RADIO APPARATUS CO.
415 So. Dearborn Chicago.

**KEEP
A DAY AHEAD**
of the headlines of tomorrow's newspapers!
Don't be satisfied with the regular broadcasted programs! Get the most out of radiol! Hundreds of radio enthusiasts are doing it!

Equip your vacuum tube set with a **FINCH RADIO RELAY** and you will automatically receive and at the same time have a permanent record of all the important and interesting news events of the world, whether or not you know the code.

Send Today for Booklet PK 2

FINCH RADIO MFG. CO.
303 FIFTH AVE. N.Y. CITY.

**—IT REPLACES
rheostats
meters
expert operator**

AMPERITE
Automatic Filament
Current Adjuster

Relieves You of all
Tube Troubles

Manufacturers
**RADIALL
COMPANY**
99 WARREN ST.
NEW YORK

\$1.10 with mounting

You should be a subscriber

Continued from page 83

as he hasn't time for a plain 'OP! Maybe my letters never got by his secretaries? Oh Goll'ies—but I am tickled at being able to be of use to him!"

"What's all the excitement, Walter?" Skipper Lewis projected his big figure within—"What's broken loose? When I heard you whoop I thought—well, I didn't know what to think—so here I am, to find out!"

"Why, sir—that's a yacht, yonder—the *Ariadne*—bound for N.Y. Her generator turbine broke down and the emergency set is all that they have to operate with. Have a most urgent message for N.Y.—and wanted to know if I could take it and pass it along. By good luck I can just reach the *Ardathia*—about half way between us and Sandy Hook. Her OP says I'm weak, but he can read me, and will accept message in 15 minutes! Lord, but—but I'm pleased!"

"But why all the great excitement?" persisted Lewis.

"Oh!—you don't know, of course! The owner of that yacht is the greatest friend I have! I have not told you of some things in my life, Skipper, because they would not have interested you; but now—that—Marion and I wish to—er—'go shipmates' I started to tell you a bit ago. The owner of that yacht is the man who took me from a farm—paid for my electrical education—saw me started right, in the radio profession. Yes sir! there is nothing that I would not do for Senator Briggs! He . . ."

"WHO did you say owned that yacht?"

Ellison looked at the Skipper in startled amazement, for a deep flush had surged over Lewis' face, and his hands clenched as he came forward a pace.

"Senator—or, rather, former-Senator Briggs, Sir."

"Let me have that message!" The Skipper held out his hand.

There was something about him that warned Ellison of impending trouble. He grabbed the paper on which he had written the coded message and thrust it in his pocket.

"Sorry, Skipper, but that is private property. I have no right to show it to anyone!"

"The yacht is in no danger?—No sickness on board?" Lewis asked with ominous calm.

"No sir!"

"Then, as commander of this vessel, I not only insist upon having that message, but I forbid your forwarding it!"

"But—but WHY?"

"Briggs was La Follette's right-hand man in putting the Seaman's Bill through—that has ruined the merchant marine of the United States—made a farce of it on the high seas of the world! And although it isn't much that

Antenella

No Antenna or Aerial Needed



Does away entirely with antenna and all outside wiring, lightning arresters, switches and all other inconveniences.

ANTENELLA enables you to enjoy Radio pleasures in any room in your house. Place your receiving set anywhere and merely attach Antenella to any electric light socket. No current consumed.

PRICE ONLY
\$2.00

At your dealers—otherwise send purchase price and you will be supplied promptly without further charge.

Chas. Freshman Company, Inc.
97 Beekman Street New York City

Loud Speaker for Any Crystal Set

The Steinmetz Amplifying unit selling for \$8.50 will enable you to hear any crystal set all over the room. No storage battery required.

All Steinmetz equipment is thoroughly guaranteed.

STEINMETZ 3000 Ohm Phones \$6.50
STEINMETZ 2000 Ohm Phones \$5.00
STEINMETZ 1000 Ohm Phones \$1.75
Equal to any \$10.00 or \$12.00 Phones made.

"Superior" Crystal Set, \$4.75
Complete catalogue, 5 cents, at your dealer or
STEINMETZ WIRELESS MFG. CO.
5706 Penn. Ave. Pittsburgh, Pa.

CRYSTAL FANS

Are you satisfied with your crystal, or do you want better results?

MOLYBDIC GALENA
A new detector just discovered is sensitive even when ground to dust.
Send 50c for one of these wonder crystals. We will refund your money if you are not entirely satisfied.

Phoenix Radio Laboratory
Box 842, Phoenix, Arizona

Investigate!
**WESTERN-RADIO
DEALERS SERVICE**

Wholesale RADIO only
637 50 HOPE ST. LOS ANGELES
1800 FRANKLIN OAKLAND

You should be a subscriber

I can do—still, by Heaven, if I can break up any plans of this Briggs—I'm the man that's going to do it—if it costs me my job! There's enough in the bank for me to live on—while I'm afloat! *Hand over that message!* I'll give you a letter—clearing you!"

He came nearer—an ugly light in his eyes.

"Very sorry, Skipper, but I cannot! This is my *one* chance to do a small favor for the man who has meant everything to me! Be fair, sir, and see . . ."

"Then I'll wreck the whole damned outfit—so that you can't send that message! *It shall not leave the ship!* Must be of great importance to that man—and so it is of more importance to me!" The now raging Lewis made a move toward the apparatus.

It was but the continuation of one motion for Ellison to pull open a drawer, take out an automatic—

"I wouldn't—if I were you!"

"So-o-o! you pull a gun on your commander, eh? *Huh!* And I suppose that you expect to marry my girl—after this! *Ha!*"—he laughed unpleasantly—reached down with a quickness that threw Ellison off his guard, wrenched loose the fire axe that was in its clip at the side of the house, and dashed on deck.

"He means to cut the antenna halyards!"—the thought flashed in Ellison's mind and he darted after the other.

Of a certainty, the Skipper was already at the foot of the mainmast, fumbling about for the supporting halyards.

"Drop that axe! *Drop it!*—or I drop you!"

Lewis stared in the muzzle of the weapon—a few feet from his head. The axe clattered to the deck.

"Now get back to the radio room!"

Lewis sullenly obeyed.

"Sit in that corner!"

The Skipper did so, his great hands twitching, a stream of soft curses flowing from his beard.

Keeping his eyes on the dangerous man—Ellison slipped on the head harness and began calling the *Ardathia*—working the key with his left hand behind his back.

And he got the distant ship—gave the coded message, that was of such import—repeating it twice—receiving the other operator's "R" and "OK"—called the yacht—reported the message received by the *Ardathia*—and ended up with:

". gudnight—OM—got a lot to do here—73's to you all—sig.—Ellison.

Then he opened the drawer again, tossed the automatic in—pulled off the phones—

"Now, Skipper, what are you going to do about it?"

Continued on page 88

"There's No Place Like Home" To Charge Your Radio Battery

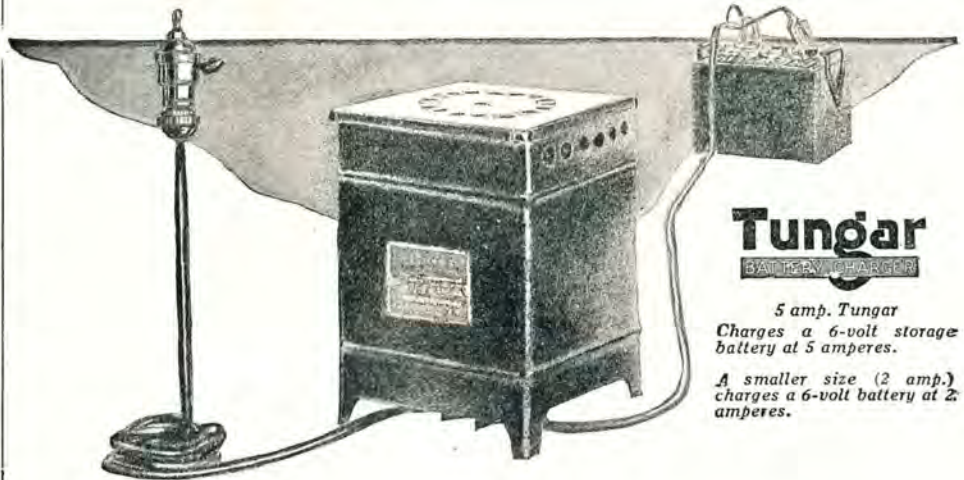

Tungar
BATTERY CHARGER

5 amp. Tungar
Charges a 6-volt storage
battery at 5 amperes.

A smaller size (2 amp.)
charges a 6-volt battery at 2
amperes.

If you use tubes in your radio receiver you use a storage battery.

If you use a storage battery it must be charged.

Charge Your Storage Battery at Home with a Tungar Battery Charger

Without taking the battery out of the house—in fact, without moving it at all—you can charge it easily and quickly at a minimum of expense, trouble and lost time.

Isn't this much better than taking the battery to a charging station, leaving it a day or two, paying from 75¢ to a couple of dollars and then carrying it back again?

The Tungar is a small, compact rectifier which connects to any a-c. lighting circuit wherever there is a socket or receptacle and requires no attention while operating. Its first cost is not high and it can be operated by anyone without the slightest danger of injuring the battery. Send for new radio booklet and prices.

Address Merchandise Dept., General Electric Company
Bridgeport, Connecticut

General Electric Company
General Office Schenectady, N.Y. Sales Offices in 35A-70C all large cities

Kearny 2778

Pacific Radio School

ARC AND SPARK SYSTEMS

Hours—10 to 12 noon
1 to 4 P.M.
7 to 9 P.M.

Send for
descriptive
circular

433 Call Bldg.,
San Francisco, Cal.

This school is equipped with KLEINSCHMIDT Automatic Telegraph System

Tell them that you saw it in RADIO

“WorkRite” REDUCES PRICES

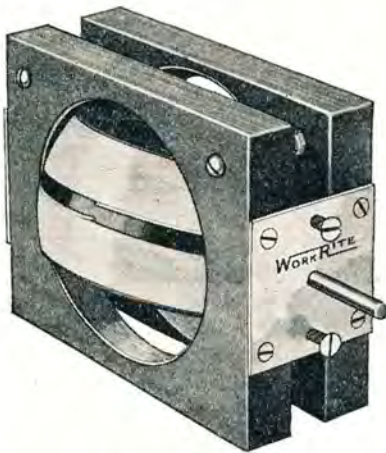

**WorkRite
Super Variometer**

The “WorkRite” Variometer is made from the finest quality mahogany, oil rubbed—a beautiful instrument. Brass parts nicked. Sixty wire turns on stator and sixty on rotor. Rotor wound with green silk. No shellac used. A perfect Variometer both technically and mechanically.

NOW
\$3.50
EACH

*Last Spring
they sold
for \$6.00 each*

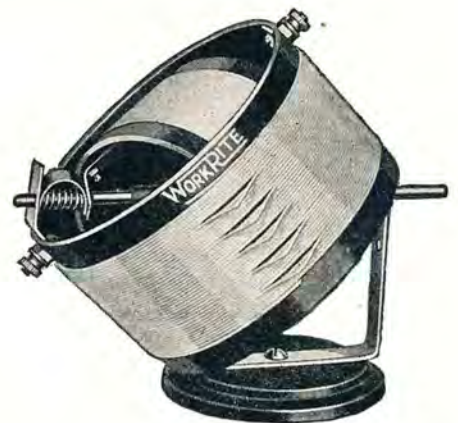

**WorkRite 180°
Super Variocoupler**

The “WorkRite” Variocoupler is being used the world over because it represents the last word in a coupler. Tunes twice as sharp as the ordinary 90 degree coupler. Made from polished Formica. Sixty wire turns on primary, forty-five on secondary. Both wound with green silk. Twelve taps. Double springs at each connection. There is no better on the market at ANY price.

THE FAMOUS “WORKRITE TUNER TEAM”

Two WorkRite Variometers and one WorkRite Variocoupler make a Tuner Team that cannot be beat for selectivity and long distance records. Concerts have been heard across the entire continent with them. Local concerts can be tuned out usually and long distance brought in.

PRICE: Due to our enormous production, we have been able to reduce prices gradually from \$6 each down to the present price of \$3.50. You have long wanted to build a high grade set with WorkRite Products—now is your chance at prices that will probably never be lower. Order yours now!

THE WORKRITE MFG. CO.
5549 Euclid Ave., Cleveland, O., U. S. A.

(BRANCH OFFICE
2204 S. Michigan Ave.,
Chicago, Ill.

“WorkRite” CONCERTOLAS

THE BIG HIT IN LOUD SPEAKERS!



Jr. Concertola \$12.00

Let the whole family and friends enjoy the wonderful concerts, lectures, and other entertainment which is free for the taking. Attach a WorkRite Concertola to your set the same as a head phone. Requires no extra batteries. **WORKS ONLY ON TUBE SETS WITH TWO STEP AMPLIFICATION.** These loud speakers are different from others. There is no metal in them, which eliminates the tinny sounds of others. Reproduces voice or music in a clear, loud tone without distortion. Just right for home use. **BOTH THE CONCERTOLA SR. AND JR. COME COMPLETE WITH OUR SPECIAL PHONE UNIT AND CORD.** ORDER NOW AND DOUBLE THE PLEASURE OF RADIO IN YOUR HOME.



Sr. Concertola \$24.00

FREE TRIAL!

Upon receipt of the price, you will be furnished with either the Junior or Senior, charges prepaid. If not found satisfactory, you may return it and your money will be refunded.

WORKRITE Super Vernier RHEOSTAT

Here is a Rheostat with unlimited adjustments. Pushing the knob in or out gives quick adjustment. Turning the knob around gives the most minute adjustment. Often turning the knob 1/32" will clear up a concert or separate two stations. You must use a WorkRite Rheostat to realize how much more efficient it will make ANY set. Indispensable for the detector tube. Equip your set with a "WorkRite" and note the difference!

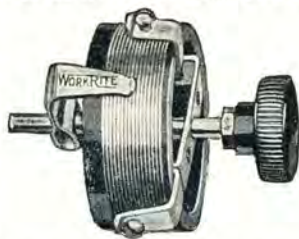

PRICE\$1.50

WORKRITE E-Z-TUNE DIAL

When you want to get very fine adjustment on your variometers, variocouplers, condensers, etc., you always grasp your dial on the outer edge for more leverage. Right there is where you will find a knurled flange that just fits your grasp on the WorkRite E-Z-Tune Dial. You can easily make a turn of a hair's breadth.



Made of the finest material, highly polished. Easily the "snappiest" dial on the market. 3 1/2" diameter. Specify whether 3/16" or 1/4" shaft.
PRICE75c

“WorkRite Products WorkRite”

Do not accept any substitute. If your dealer does not handle them, send check and we will see that you get them promptly by mail prepaid.

THE WORKRITE MFG. CO.

5549 Euclid Ave., Cleveland, O., U. S. A.

BRANCH OFFICE)
2204 S. Michigan Ave.,
Chicago, Ill.

Continued from page 85

The other's surface rage had burned itself out. He got up slowly—approached the young man—

"Nothing! But you will remember not to speak to Marion—*ever!*"

Then he went out.

The very fact of his life having been so devoid of affection, or of sentiment of any kind—caused his love for the girl to be a deep, abiding thing, with Ellison—a love that had grown in the months that she had been on board—in many journeyings—until his every thought was of her. And he felt that she would obey her father—to whom she was intensely devoted.

He sat down at the operating table and leaned his head on his arms—the weight of the price that he had paid, for his loyalty to the former Senator, crushing him.

"I'd do it again!" he said aloud—defiantly. And the quiet room echoed the sound of his voice above the *plash* of curling waters.

Minutes passed slowly—"I'd do it again!" he reiterated—thus fortifying himself against the Voices that mocked him—from within—jibbering in his ears.

"And I would not have you for a son-in-law—if you didn't—my lad!"

Ellison jumped to his feet as Skipper Lewis touched him.

There was a tense moment as the two looked in each other's eyes. Then Lewis held out his hand—

"Take it—lad! It's offered in honest apology! I'm getting on in years, and a man's apt to get . . . 'crabby.' Your loyalty to your friend—and the *worth* of that loyalty—makes you doubly desirable for my girl! Let's forget!—Can you?"

SHE was waiting—along the after boat deck.

"We—we had o-sort of an argument—a little misunderstanding, Marion. But it's all settled now. I was wrong. And as for the 'Old Man's' consent to your sailing under the same house flag—you have it! *Loyalty* is of real . . . worth! Don't ever be disloyal to one another—even in thought! I'm going to turn in—a bit tired." He turned to go—"Sure that that ship ahead got the message, Walter?"

"Very sure, Sir—he gave me his OK on it."

"That's good—that's *good!* Don't stay up too late—you two—dew is heavy—tonight."

And with a last look 'round the heaving, star-spangled, moon-beamed sea, the Skipper went for'ard to his quarters.

"What was it all about, Walter?" she asked—his arms about her.

"Oh—nothing much. Your Dad and I had a difference of opinion."

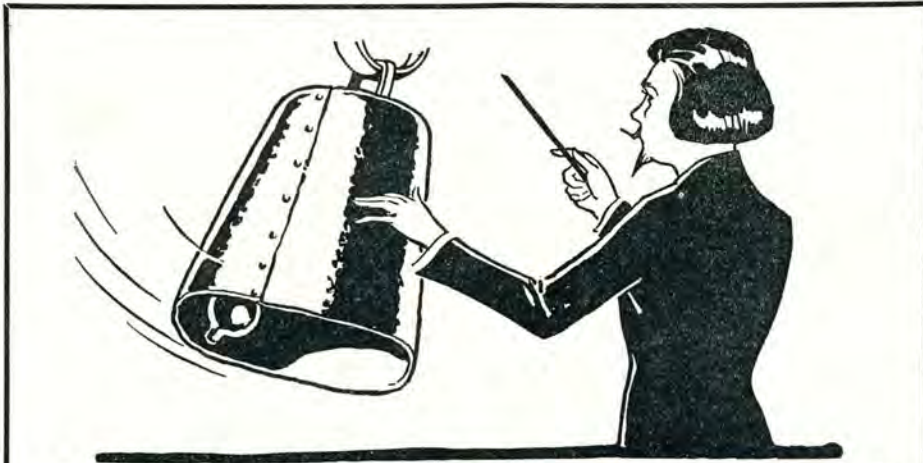

You Can't Play a Tune on a Cowbell

Nor can you receive radio music properly through "one frequency" transformers.

Most audio frequency transformers are designed to give a peak of amplification on a very narrow band of frequencies. They are adaptable to receiving telegraphic signals, but are not suitable to reception of voice and music.

The PACENT Audioformer was especially designed for radio-telephone reception and will amplify without distortion the entire audio frequency range.

For clear, faithful reproduction of music and speech, try a PACENT Audioformer.



No. 25 PACENT AUDIOFORMER

Price, \$5.00

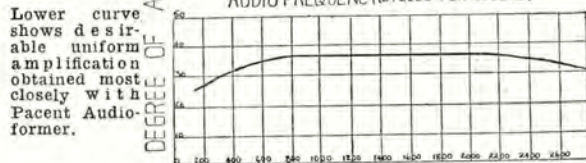
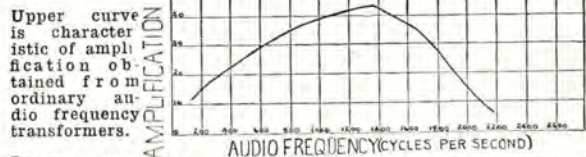

No. 25A PACENT AUDIOFORMER

Price, \$4.00

This type equipped with leads instead of binding posts, is particularly suited for manufacturers and individuals assembling their own sets.

Don't Improvise—"Pacentize"

Write for Descriptive Bulletin R-2

PACENT ELECTRIC COMPANY

INCORPORATED

Manufacturers and Distributors of Radio & Electrical Essentials
Executive Offices: 23 Park Place, New York, N. Y.

BRANCH OFFICES

Philadelphia, Bourse Bldg.
Chicago, 33 So. Clinton St.
St. Louis, 704 Pontiac Bld.



Washington, D. C., Munsey Bldg.; San Francisco, Sheldon Bldg.; Minneapolis, 827 1/2 Nicollet Ave.
Canadian and British Licenses: Colonial Radio, Ltd., Hamilton, Canada

Members, Radio Section, Associated Mfrs. of Electrical Supplies



Made for All Phones Ask Your Dealer

THEY ARE GOOD PUT THEM ON YOUR PHONES
Slip out the metal disc and slip in the MICAPHONE. Result: Clearer, better tone, all noises eliminated. Write for circular. Discounts to dealers and jobbers.
RADIO MICA PRODUCTS CO.
156 E. 43d St. New York



DUCON
\$1.50 Retail
(By Mail 5c additional)

ROSS RADIO SERVICE
693 Mission St., San Francisco

Have You Read the Radioads on Page 93?

Tell them that you saw it in RADIO

"Who got the best of—of the 'argument'?"

"We are both better off—for it!"

And the moon watched another pair of lovers kiss — while the *Perseus* thrubbed stolidly along over the shimmering waters.

AUSTRALIAN REGULATIONS

Continued from page 38

placed on applicants for licenses, but in cases where the applicant is under the age of 21 years, a responsible person will have to give a guarantee that the station will be operated in accordance with the terms of the license. Applicants for permission to use valve-receivers will be required to submit a certificate from a responsible officer of a wireless club or a postmaster showing that they are capable of receiving messages in the Morse code at the rate of 12 words a minute.

To check the erection of unlicensed stations, all dealers in wireless apparatus will be required to keep a record of their sales, and will only be permitted to sell apparatus to holders of licenses or those who are about to apply for licenses. Dealers will be required to produce their records of sales for examination by properly authorized radio inspectors.

One of the conditions upon which all licenses will be issued will be that the experimental station will at all reasonable times be open for inspection by a government radio inspector, and to check the surreptitious use of wireless apparatus all suspected stations will be regularly visited by inspectors.

Under the new regulations ship stations will be licensed at a fee of £1 a year, coast stations at £4 a year, aircraft stations (for the benefit of commercial aviation companies) at £1 a year, and portable stations at £1 a year. The portable stations have been licensed for the convenience of the troops of Boy Scouts and similar parties, who require, while travelling from one place to another, to keep in communication with headquarters. Time might evolve this class of license into a convenience for commercial travellers.

The regulations will also remove an anomaly at present existing in regard to the installation of experimental apparatus on yachts and similar vessels. Under existing regulations, these vessels are regarded as ship stations, and are compelled to carry an operator holding a commercial operating certificate, even though the apparatus may have been installed by an amateur for experimental purposes. Under the new regulations the operator of a yacht station will not be required to hold a commercial operator's certificate.

A license is provided for land stations erected in outlying districts and along air routes. In localities unprovided with ordinary telephonic communication, this type of station will be of great benefit to settlers, as it will enable them to make urgent calls for medical and other assistance.

BROADCASTING CONCERTS

Provision is made in the regulations for the control of "broadcasting" stations for the supplying of wireless concerts. Receiving stations for receiving the broadcasting only will also be licensed as a type of station. Broadcasting is an entirely new branch of wireless, and no reliable information of the experience in other countries was available when the regulations were drawn up. Thus the broadcasting regulations are in a very embryonic form, and it will be impossible to prepare satisfactory regulations for the control of broadcasting until it is known what is being done in other countries, and what plans the broadcasting companies are prepared to adopt in Australia. It has, however, been definitely decided to exclude rigorously from broadcasting programs all classes of advertisements.

In the preparation of the regulations the first consideration, of course, was to protect

ATWATER KENT

RADIO RECEIVING SET



The above set, consisting of Coupled Circuit Tuner and Detector 2-Stage Amplifier, is an ideal set for either phone or loud speaker use. Note that this set includes two stages of audio frequency amplification.

Complete Outfit, as above, wired . . . \$35.50

ATWATER KENT MANUFACTURING COMPANY
 4946 STENTON AVENUE Radio Dept. PHILADELPHIA, PA.

"LORAIN"

The coupler with the perfect mounting.



Pat. Pend.

Loose windings, twisted taps that break, noisy rotor connections, and wobbly shaft are enough to make anyone mad; use a Lorain Coupler and rid your set of these troubles. This coupler is designed to WORK.
 Price \$5.50 Post Paid.

If your dealer cannot supply you order direct. — Dealers write for discounts.
 For complete description send for circular C2.

Lorain Radio Supply Co.
 Lorain, Ohio



HIGH EFFICIENCY HEAD SETS

Army and Navy Type:
 2500 ohm, per pair.....\$10.00
 3200 ohm, per pair.....\$12.00

Swedish-American Type:
 2200 ohm, per pair.....\$8.00

Victor Type:
 Double pole, single coil, per pair..\$6.00

American Electric
 COMPANY
 CHICAGO, U. S. A.
 For 30 Years Makers of Good Telephones

You Should Be a Subscriber to This Magazine.

Investigate!

WESTERN-RADIO DEALERS SERVICE

Wholesale RADIO only
 637 50 HOPE ST. LOS ANGELES 1200 FRANKLIN OAKLAND

Tell them that you saw it in RADIO

Do Your Own Battery Charging

USE A

LEICH NON TUNE RADIO RECTIFIER

for Long Life and Satisfactory Operation
Used by the Big Trunk Line Railroads for Block Signal and Interlocking plants.

Will operate over wide range of voltage and frequency variation because It Is Not Tuned to one particular frequency.

Charge radio batteries at night—Cost equivalent to burning a 40-watt lamp. Relay lock positively prevents discharge of battery due to power failures.

There are no expensive parts on a Non Tune to wear out. We limit the current output to a point where maximum efficiency and long life are obtained.

Manufactured for both 60 and 25-cycle alternating current.



Ask your dealer or write for Bulletin No. 100-D

LEICH ELECTRIC CO.

Manufacturers
Telephones, Switchboards, Accessories

GENOA, ILL.

ANNOUNCING

The New Giblin Receiver, Detector and Two Stage Amplifier

Tuner \$15.50

Detector \$10.00

Amplifier \$24.50



\$50 COMPLETE A GENUINE PERFORMER

incorporating

SINGLE CONTROL TUNER—It is easily and quickly tuned with full efficiency on any wave-length.

DETECTOR—Receives either local or distant stations with perfect clearness.

AMPLIFIER—2 stages with separate filament control securing maximum volume without distortion.

STANDARD RADIO & ELECTRIC CO.

Pawtucket, R. I.
Liberal discount to dealers

TRANS-ATLANTIC RESULTS

Continued from page 37

Free period: 1AJP, 1BEP, 1AKG, 1BES, 1ASF, 1BET, 1AWO, 1BRQ, 1AZL, 1BWJ, 1BCC, 1CN, 1BCF, 1CNF, 1BCG, 1CKP, 1BDT, 1CMK, 1DWP, 1EJA, 1GV, 1II, 1PG, 1RD, 1UN, 1XM, 1ZE, 2AWF, 2CBW, 2AWL, 2CJD, 2AYV, 2CJN, 2BDJ, 2CKR, 2BGL, 2CQZ, 2BLK, 2EL 2BLP, 2FP, 2BML, 2GC, 2BQD, 2GI, 2BQH, 2GK, 2BQU, 2GY, 2ZL, 2LO, 2LY, 2NZ, 2RP, 2UD, 2XAO, 2XAP, 2XAO, 2ZE (error), 2ZK, 3AH, 3DLG, 3AQR, 3GN (Canuk?), 3AAU, 3HG, 3BCN, 3YU, 3BG, 3ZW, 3BGA, 3ZY, 3BGT, 3ZZ, 3BL, 3BLF, 3BLZ, 3BNU, 4BY, 4EA, 4GT, 5XK, 8ADD, 8BC, 8ADG, 8BSS, 8AGZ, 8BTB, 8AIO, 8BXH, 8QO, 8CJH, 8ATF, 8CVA, 8ATU, 8IB, 8AW, 8JB, 8AWP, 8MR, 8AZQ, 8UE, 8BR, 8YD, 8ZW, 9AUL, 9DFB.

Off-schedule: 1BCF, 1BDT, 1BES, 1BET, 1CDO, 1CDR, 1CDN, 1CK, 1CKP, 1DWO, 1II, 1IT, 1IW, 1XM, 1YK, 1ZE, 2BQH, 2CQZ, 2EL, 2RB, 2RLC (?), 2XAP, 2XAO, 3AQR, 3AZQ, 3BES, 3BL, 3BLF, 3BM, 3CC, 3HG, 3IN, 3JRB (?), 3TJ, 3XN, 3WR, 4AU, 4EB, 6ADG, 6GZ, 6MLZ (?), 8ADG, 8AM, 8AK, 8AQO, 8AQZ, 8ATB, 8ATU, 8AWF, 8AX, 8AXC, 8BSS, 8BSL, 8BSY, 8BU, 8BXF, 8CKR, 8CYH, 8IB, 8ML, 8XE, 8WR, 9DWQ.

Dec. 21, 1922

Codes verified: 1XM, 1YK, 2LO, 2XAP, 2XAP on phone, 2ZK, 3ZW, 8AQO.

Free period: 1AGK, 1ASF, 1BDI, 1BDJ, 1BDT, 1BES, 1BRQ, 1BKQ, 1CKP, 1CMK, 1CNF, 1EMK (?), 1GK, 1HRX (?), 1OR, 1XM, 1XO, 1XRAY (?—hi! Who spelled out his call letters?), 1YK, 2AFB, 2AFP, 2AWF, 2AWL, 2BML, 2BQT, 2CBX, 2CKN, 2CPD, 2CQZ, 2EL, 2FP, 2GK, 2GLF, 2GR, 2LO, 2UD, 2XAP, 2ZK, 3AFB, 3BFU, 3BO, 3BSY, 3FA, 3HG, 3KXM (?), 3XM, 3ZW, 3ZY, 4BY, 5XK, 6ZA, 8AIO, 8ATU, 8AQO, 8AVO, 8BSS, 8BU, 8NF, 8UE, 8XE, 9OX.

Off-schedule: 1AJP, 1AWP, 1BCG, 1CDO, 1FB, 1II, 1OR, 1RDE (?), 1ZE, 2CQF, 2FP, 2FW, 2KA, 2ZK, WUBA, 3BLF, 8ADG, 8AQO, 8ATU, 8BRK, 8SP, 9CJC, 9OX.

Franco-Swiss Summary

From the above reports we obtain the following summary in the same manner as for the British reception:

District	Stations Heard	Best Station
First	62	1BDT
Second	63	2ZK
Third	41	3HG
Fourth	5	4BY
Fifth	2	
Sixth	7	
Seventh	0	
Eighth	51	8AQO
Ninth	9	

Total 240

A total of 240 different stations, several from California, representing every district but the Seventh, with 8AQO easily the star.

Summary

A careful analysis of these reports, eliminating duplication of calls heard in both countries, gives the following total of individual stations crossing the Atlantic ocean in the tests.

First District	79
Second District	81
Third District	53
Fourth District	11
Fifth District	7
Sixth District	8
Seventh District	1
Eighth District	63
Ninth District	12
Canada	1

Summary of American Reception

5WS, the London station of the Radio Society of Great Britain, heard by 1BFG, 1BQD, 1OR, 1XP, 1ANA, 3BEC, 2BBB, 1MO, 3ADP, and L. D. Warner of Schenectady. Total, 10.

2FZ, Wireless Society of Manchester, heard by 1ANA, 2CQO, 2GK, 2BSK, 2BML, 3HS, 8FQ, 8AMD, 9DRR. Total, 9.

8AB, Leon Delay, Nice, France, heard by 8FQ and by C. A. Service, So. Manchester, Conn. Total, 2.

5SW, undoubtedly in error for 5WS, heard by 1RU.

2PO and 2JZ, somewhat questionable, heard by 8FQ.

Total British stations positively known to have been heard, 2. Total French, 1. Total Americans hearing European signals, 20.

HOW TO MAKE A VERNIER BLADE FOR YOUR CONDENSERS

By ARTHUR GORDON

A vernier condenser may easily be made from an ordinary standard variable condenser. All that is needed is a single blade, so fixed that it can be revolved by itself, independently of the other movable blades.

One amateur took his standard condenser apart, so that he had the stator (or fixed stack of blades) in one hand, the rotor (or movable blades) in the other, and the dial in front of him. He noticed that the uppermost rotor blade fitted against a shoulder on

was put on the other end. This thread was duplicated on the central hole of the hard rubber disk shown in Fig. 1, which disk, by the way, was cut out of an old phonograph record. In diameter, it was 1/2 in. larger than the largest diameter of the dial. The pins, which were of brass, were screwed into place, and then the vernier attachment was complete.

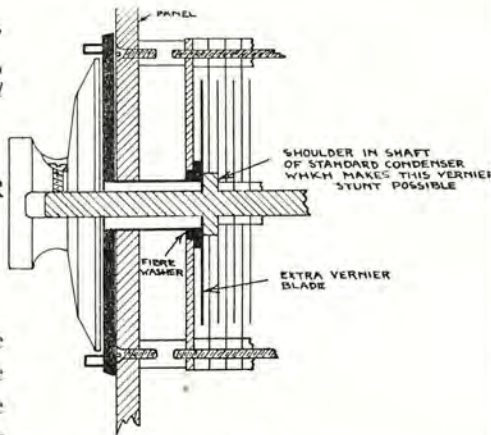

Fig. 2

In preparing the stator for the introduction of this new unit, it was necessary to add another blade. This was an easy matter and soon done. Not so easy, however, was the fitting of a fibre bushing, as shown in the assembly Fig. 2. Ordinarily, such a bushing is turned around the other way with its overlap outside; in this case, however, the overlap was put inside and used as a washer.

When the condenser was re-assembled, everything went well until the blades of the stator were tightened up. Then the ambitious amateur who was doing the job found that the vernier blade was packed in its space so tightly that it could not be moved. He had reasoned it out that the fibre washer should be just one-half the thickness of the space washers and had made it so. Theoretically this was correct, but practically the washer proved too thick. The amateur thinned it down a trifle and tried the assembly again. This time it worked perfectly. Mounting the reconstructed condenser on the panel was but the work of a moment. Of course, the shaft hole had to be enlarged to take the new diameter, but that is all. After the instrument was in place, the hard rubber disk was screwed on its shaft and the dial put on as before.

No dimensions are given with this article, for it is the idea which is important. Some amateurs may apply it as suggested while others may do something entirely different, according to the particular construction of the condensers that they now own. Whatever the method, however, the result is the same—a real home-made vernier, with all the advantages and ease of operation which distinguishes the commercial product.

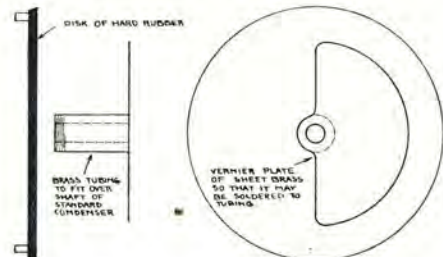

Fig. 1

the rotor shaft. Then the other blades were stacked on with a space washer between, while a nut held the whole of them tight and in place.

He then conceived the idea of using this shoulder as a space washer; adding another blade on a separate shaft, and operating it from the face of the panel by a large hard rubber disk, set with little knobs or pins for convenience in turning. A short piece of brass tubing furnished the vernier shaft. It just fit over the main shaft of the condenser. The extra blade was cut from sheet brass, not that brass is any better than aluminum, but because our crafty amateur foresaw somewhat of a soldering job in fastening the new blade to its new shaft.

When the blade was fixed on one end of the tubing, a die thread of small pitch

Fleron's Vernier Adjuster

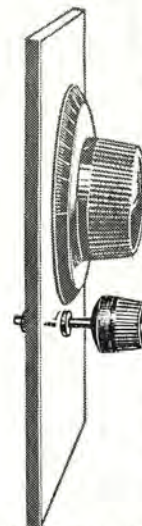

Pat. Appld. For

This ingenious little device is a necessity on every set. Sharp, close tuning is only possible with it.

Easily mounted on any set by drilling only one 5/16" hole. Its normal position is away from the dial as shown.

A slight pressure makes contact with the Dial. Vernier is then turned for accurate tuning.

Price 65c

Sold by Dealers and Jobbers everywhere

Sole Manufacturers

M. M. Fleron & Son, Inc.

Trenton, N. J., U. S. A.

Balanced Variable Condensers

Plates 1/32" aluminum.
Turned brass spacers.
Nickel plated and polished.
Binding posts provided.



Money back if not satisfied
.0005 Mfd., 24 plate, \$3.75
.001 Mfd., 44 plate, \$4.75
3 plate Vernier, 75c
A condenser that will put pep into your set!

MONTROSE MFG. CO.
1200 Bedford Ave., Dept. P
Brooklyn, N. Y.

Investigate!
WESTERN-RADIO DEALERS SERVICE
Wholesale RADIO only
837 50 HOPE ST. LOS ANGELES
1800 FRANKLIN OAKLAND

Tell them that you saw it in RADIO

WEBSTER RADIO APPARATUS



Webster 2A Single Tube Receiving Set, Nickel Trimmings, Bakelite Panel and Moulded Knobs and Dials, Walnut finished cabinet, Less Head Set and Tubes—\$30.00.



Webster 3B Audio Frequency Amplifier Unit—same fine construction as the 2A Set—Less Head Set and Tubes—\$27.50.



Webster Head Sets — carefully matched for tone—2500 ohms resistance—\$7.00.

In Webster Radio Apparatus you get real dollar-for-dollar value. It represents the finest in design and construction.

Take, for instance, the Webster 2A Receiving Set. This set is unusually easy to tune. It is ideal for local broadcasting and for distances of about 50 miles. Under favorable conditions, powerful stations located 150 miles distant and more can be distinctly received.

For use with this set we offer our 3B Audio Frequency Amplifier Unit—a combination with a greatly increased radius of reception.

Prices on Webster Receiving Sets are suitably arranged from \$30.00 to \$119.00. The Webster line of radio parts is high quality every way. It includes variometers, vario-couplers, transformers, palintrometers—in fact it is complete. If your dealer cannot supply you write for our 24-page catalogue and order direct.

WEBSTER ELECTRIC COMPANY
RACINE, WISCONSIN, U. S. A.

Dept. A
Manufacturers of the Webster Magneto
Over three quarters of a million now in use.

BRECO RADIO APPARATUS

Bring Best Results—They Are Dependable

Listed below are a few BRECO specialties: Owing to our increased facilities, we are able to reduce the prices on some of our manufactured products.

Variometers	\$7.00	Crystal Detectors	\$ 75
Variocouplers	5.00	Inductance switches complete	
Variable Condensers, 43 Plate...	4.50	with 7 points and 2 stops.....	.50
Dials, 3 in. moulded.....	4.00	Switch points03
Rheostats75	A. F. Transformers	5.00
Binding Posts, N.P. or insulated knob.....			.80
Mahogany cabinets, various sizes.....	5.00 up		
Bakelite, sheets and panels.....	per lb. 2.00		
Straight Circuit Tuner	50.00		
Detector and two stage amplifier.....	50.00		
Straight circuit tuner with detector and three stage amplifier.....	115.00		

Write for Catalogue

If your dealer cannot fill your requirements on BRECO apparatus, your order mailed to us will receive prompt attention.

BRONX RADIO EQUIPMENT COMPANY
687 Courtlandt Avenue, "Manufacturers of Quality" Bronx, N. Y. C.

CALLS HEARD

Continued from page 78

By Canadian 5EJ, Vancouver, B. C.

Spark: 6km, 6tu, 6bip, 7ix, 7oj, 7ne, 7ry, 7ve, 7agi, (7aio), 7aiy.

C. W.: 5ft, 5hk, 5px, 5sf, 5xb, 5xd, 5za, 5zag, 5zak, 5zay, 6ak, 6bx, 6eb, 6ec, 6eu, 6bu, 6en, 6ff, 6gx, 6gy, 6ka, 6lv, 6nx, 6pd, 6pi, 6qm, 6sz, 6ti, 6su, 6ur, 6uw, 6xk, 6zh, 6zn, 6zo, 6zx, 6zz, 6abx, 6ajf, 6ajr, 6alu, 6apw, 6arf, 6ark, 6amw, 6asx, 6avd, (6awt), 6bfh, 6biq, 6bmd, 6hoc, 6bod, 6lqc, 6lqq, 6lqz, 6hrf, 6lsq, 6lvq, 6ebi, 6xad, 7aw, 7ba, (7bj), 7bk, (7eu), 7dc, 7dp, 7ex, (7ey), 7fh, 7fr, 7hj, 7hm, 7ic, 7iy, 7jg, 7lr, 7lw, 7me, 7mf, 7na, 7nf, (7nn), 7np, 7ny, 7om, (7pb), (7pf), (7qf), 7qt, 7ri, 7rm, 7rn, 7sc, (7sf), 7sy, (7th), (7to), (7tg), 7wk, 7wm, 7wx, 7zb, 7zo, 7abb, 7acg, (7acx), (7adf), 7adn, 7aea, 7aem, (7afh), 7afs, (7fone), 7aft, 7afw, 7agf, (7aic), 7aiu, 8bk, 8ib, 8vy, 8yz, 8zw, 8adp, 8asy, 8axe, 8azy, 8azf, 8bvt, 8cfr, 9bk, 9bp, 9bm, 9dz, 9fh, 9fm, 9gk, 9ox, 9pn, 9ql, 9rc, 9uh, 9zn, 9aap, 9abu, 9agt, 9ajh, 9aou, 9aps, 9apw, 9asm, 9aau, 9aul, 9auz, 9awm, 9aws, 9aza, 9bbf, 9bly, 9bsz, 9cpu, 9dge, 9dky, 9dtm, 9dwk, 9elt, 9xae, 9yaj.

Canadian Spark: 5dx. C. W.: 4br, 4bv, (4dq), 4hh, (5ct). Anyone hearing 5EJ 5-watt C. W. please qsl to 1451 Balfour Ave., Vancouver, B. C.

By 7TT, 7126 54 Ave. S. E., Portland, Ore.

5di, 5aem, 5ej, 5xd, 5za, 6ak, 6bq, 6cc, 6dd, 6bp, 6eb, 6en, 6fh, 6jd, 6ka, 6ku, 6km, 6lv, 6nx, 6qm, 6rd, 6rm, 6rr, 6sz, 6tc, 6uw, 6vm, 6aat, 6abx, 6adi, 6ahq, (6ajf), 6ajr, 6alu, 6amz, 6aor, 6arb, 6arf, (6ark), 6asj, 6ate, 6atq, (6awt), 6bcj, 6bet, 6bim, 6biq, 6bmd, 6bnt, 6bob, 6bqg, 6bug, (6bum), 6but, 6byw, 6ebi, 6za, 6zb, 6zf, 6zg, 6zh, (6zi), 6zn, 6zs, 6zt, 6zw, 6zz, 6xk, 6xad, 6xar, 6xaw, (7bk), (7ny), (7ri), (7ke), 7rn, 7qn, 7ot, (7sc), 7hm, 7mf, 7iq, (7acg), 7ahi, 7abb, 7adp, 7zo, 7zu, 7zv, (7xc), 8ib, 8zy, 9bm, 9bx, 9dr, 9gk, 9pi, 9aul, 9ayu, 9bji, 9efy, 9ens, 9xaq, 9yaj, 9zn, 9zaf, M (bt3), d53, Can.—4bv, 5en, (5ct), 5en, (5go).

Spark: 6tu, 6acr, 6ark, 6akt, 7kj, 7ne.

A SUPER LOUD SPEAKER

Not merely a head-phone instrument



The Latest Development to produce a loud speaker that surpasses anything on the market at any price.

Powerful Volume Producing
Mica Diaphragm Element
Employed in An Entirely New Manner Assures Maximum Clarity With Total Elimination of Distortion

Patent Pending
THE Gottschalk

Trade Mark
LOUD SPEAKER

Will Positively Not Rattle

The Price:
\$22.00

No Metallic Ring—Beautifully Finished Moderately Priced.
Greater Volume with less energy.
Supersensitive for Long Distance Reception.

Dealers—Write at once for trade proposition.

GOTTSCHALK ELECTRIC & MANUFACTURING CO.
992 Howard St., San Francisco

A Wonderful Loud Speaker!



One of the greatest strides yet made to produce a loud speaker that honestly reproduces ---clearly reproduces---loudly reproduces--- and economically performs to your fondest expectations and delight.

Note These Features:---

Powerful volume producing mica diaphragm element encased in special base. New "non-vibrant" diaphragm seat with special attachment device to horn base. Requires no battery or other current. Requires no adjustments of any kind. No delicate parts to wear or replace. Super-sensitive. Will reproduce those "DX" signals clear and loud.

**"THE MOST FOR THE MONEY
And an Honest Guarantee"**

The Gottschalk Loud Speaker
Just Out!

The Price:

\$22.00
Complete

POSTPAID

Sent C.O.D. if one-half of purchase price accompanies order.

IMPORTANT NOTICE

This Truly Marvelous Loud Speaker carries the guarantee of the manufacturer as well as our own guarantee. If it does not work better than any other loud speaker of equal price, return it to us and we will refund your money.

**DEALERS are
invited to write
for territory and
trade prices.**

This Loud Speaker will not rattle; it has a non-metallic Horn; it is equipped with a connecting cord; it has a heavy, felt padded base; it will handle the output of a two-stage amplifier with ease.

IMMEDIATE DELIVERIES

ROSS RADI
693 Missi
SAN FRANCISC
"PROMPTER"

FEBRUARY COMBINATIONS Of Standard Radio Parts

Buy a set of parts and benefit by the "combination price" ---!

COMBINATION "A"

Parts for Regenerative Receiver.
2 Work Rite Variometers; 1 Work Rite Variocoupler; 1 Rheostat; 1 Socket; 1 Dial; 1 Grid Condenser.

\$11.25

for the above

COMBINATION "B"

Miscellaneous Small Parts.
3 Sockets;
3 Dials, 2";
3 Rheostats;
1 Grid Condenser.
All of these for

\$4.00

(Condensite Sockets and Dials)

COMBINATION "C"

Variable Condensers.
1 23-plate Vernier;
1 43-plate Plain;
1 3-plate Vernier.
All three for

\$12.50

(These Condensers are Advance Mfr.)

COMBINATION "D"

Parts for Two-Step Amplifier.
2 Transformers;
2 Sockets;
2 Dials, 2";
2 Rheostats.
All of these for

\$10.00

Everything Guaranteed

**Our Mail Order Service Has Met With Instant Success
Because We Give You the Kind of Service
That You Are Entitled To**

Even the smallest orders receive our prompt attention. Be convinced—Try us!

Promptest Mail Order Service

Your orders are filled within one hour of their receipt!

Check the supplies needed and send the order blank with your remittance. We guarantee full satisfaction or your money will be refunded without question.

O SERVICE
on Street
O, CALIFORNIA
SERVICE"

C. O. D. orders insure double satisfaction

ORDER BLANK

ROSS RADIO SERVICE, 693 Mission St., San Francisco, Cal.

- New Gottschalk Loud Speaker
- Combination "A"
- Combination "B"
- Combination "C"
- Combination "D"
- Free Monthly Bulletin Service

C. O. D.
ORDERS ACCEPTED IF HALF OF PURCHASE PRICE IS SENT

(Check off supplies wanted)

Your Name: _____ Your Address: _____

Radio Frequency Set

Build It Yourself

Under Our Own Special Instructions

All parts for tuner, detector, radio frequency and audio frequency all on one panel.

The Set You Will Want in the End
Why Not Now?

All you have to do is to put it together. Panel all drilled, including sockets, transformers, rheostats, dials, potentiometer, tuner and all parts to complete the set. "No coils to wind." Everything ready for you. Only the very best moulded parts used.

\$45.00 Set when completed.
Worth \$125.00.

Have you tried the MILLER RADIO FREQUENCY AMPLIFIER? If not, order one now—**\$6.50**—and see what you have missed.

Also the *Miller Audio Transformer*. A second to the *Radio Amplifier*.....**\$5.50**

Order one or both. If not satisfactory, your money returned. Not one has ever come back. Must be something in it. We leave it to you to see. We could tell you why they are so good BUT SEE FOR YOURSELF. There is only one price on these—no matter if you take 1 or 100.

THEY ARE MADE TO WORK
THEY DO IT
SEND YOUR ORDER NOW. GET SATISFACTION.

No C. O. D. shipments. Cash with order means prompt shipment.

Try a set of our professional headphones—\$6.50.

Make fine loud speakers.

Miller Radio and Electric Works

4103 8th Ave. So.
Seattle, Wash.

*All parts for Flewelling sets. Reinarts sets or parts. We can make anything you want.
Repair headsets and rebuild sets to suit you.*

Take Your Choice

THEY ARE FREE!



This is the New Gottschalk Loud Speaker with Baldwin Phone Element in Base. It will Not Rattle.

FREE for securing only eight subscriptions to "RADIO." The price of this Loud Speaker is \$22.00. You get it free for only \$20.00 worth of subscriptions.

This Big Subscription Offer is the most attractive one that we have made. Get busy today and secure a few subscriptions. It will be well worth your while.

Loud Speakers that answer every purpose—*free to you.*



20 Subscriptions brings you this Radio MAGNAVOX

The \$45.00 Radio Magnavox will be shipped to you free of charge for securing only 20 subscriptions to "RADIO" for one year each. This Magnavox is of the new type—consumes very little field current and is fully guaranteed to reach you in perfect condition. This instrument must be shipped by express, charges collect.

In return for a little of your spare time we will give you a Loud Speaker of Standard Manufacture.

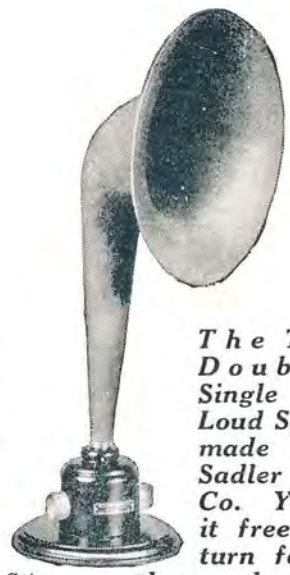

Get Something for Nothing

The Trutone Double or Single Phone Loud Speaker, made by the Sadler Mfg. Co. You get it free in return for only three subscriptions to "Radio." Please include 36c for mailing charges.

Pacific Radio Pub. Co., Pacific Building, San Francisco, Cal.

Herewith is \$.....and.....for mailing charges. Send "RADIO" for one year to the persons whose names and addresses are listed below. The premium.....is to be sent to.....

Name Address

Name Address

Name Address

*Built on the
best Engineering
Principles*



**Maximum Inductance.
Minimum Distributed
Capacity for a given
number of turns.**

The highly efficient form of winding used in the **GIBLIN-REMLER INDUCTANCE COILS** is responsible for their **SUPERIOR OPERATION**

*The construction of the most
efficient inductance coil
ever developed*

DUE to his untiring efforts to perfect compact inductances, Mr. Thomas P. Giblin has succeeded in developing the Giblin-Remler inductance coil. This coil is undoubtedly the greatest step forward in the radio art since the advent of the vacuum tube.

Built along sound engineering principles, this new coil embodies every feature necessary to obtain **MAXIMUM INDUCTANCE, MINIMUM DISTRIBUTED CAPACITY** and **MINIMUM HIGH FREQUENCY RESISTANCE** with a given length of wire and in a minimum of space.

Maximum inductance is obtained by winding the turns parallel and close together in each layer, a feature found only in the Giblin-Remler type of winding. Every turn is wound parallel to the circumference of the coil, thus having a shorter length of wire and less resistance than a turn of equal diameter than any other type of winding.

IN compact inductance coils the greatest distributed capacity occurs between layers. In this new coil Mr. Giblin utilized the fact that capacity is directly proportional to the distance between two conductors. By winding cotton yarn of high dielectric strength between layers he has reduced this undesirable internal capacity to a minimum. This is another important and exclusive feature of the Giblin-Remler type of coil winding.

The cotton yarn is wound back and forth diagonally across the layers and interwoven between turns in such a manner that there is maximum spacing, maximum insulation and minimum capacity at the point of greatest potential difference between layers. This minimum capacity at the point of maximum potential difference is a big factor in reducing the losses due to internal capacity. No other coil on the market embodies this important feature.

The results of these efficient and exclusive features of Mr. Giblin's latest form of winding is a new compact inductance coil which gives **MAXIMUM SIGNAL STRENGTH, SHARPEST TUNING,** and **MINIMUM INTERFERENCE** under any given condition.

Write for table of constants and complete information regarding these coils.

Send 10c for new 40-page Remler Catalogue containing circuit diagrams for Remler Apparatus and other useful information, including a table of inductance, capacity and wave length.

The Remler Technical Bureau is at your service. Address your problems to Dept. R.

REMLER RADIO MANUFACTURING COMPANY

Factory and Home Office
248 First Street, San Francisco, Cal.

Eastern Sales Office
154 W. Lake Street, Chicago, Ill.

This file including all text and images are from scans of a private personal collection and have been scanned for archival and research purposes. This file may be freely distributed, but not sold on ebay or on any commercial sites, catalogs, booths or kiosks, either as reprints or by electronic methods. This file may be downloaded without charge from the Radio Researchers Group website at <http://www.otrr.org/>

Please help in the preservation of old time radio by supporting legitimate organizations who strive to preserve and restore the programs and related information.