

RADIO

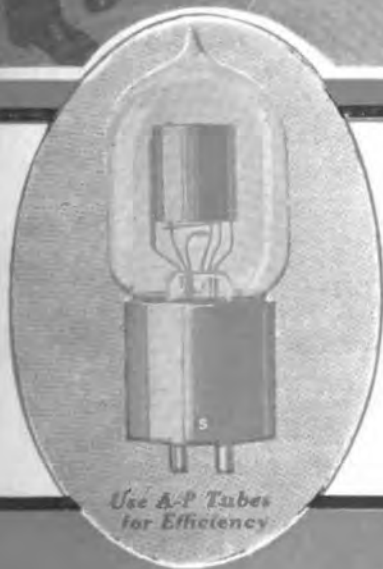
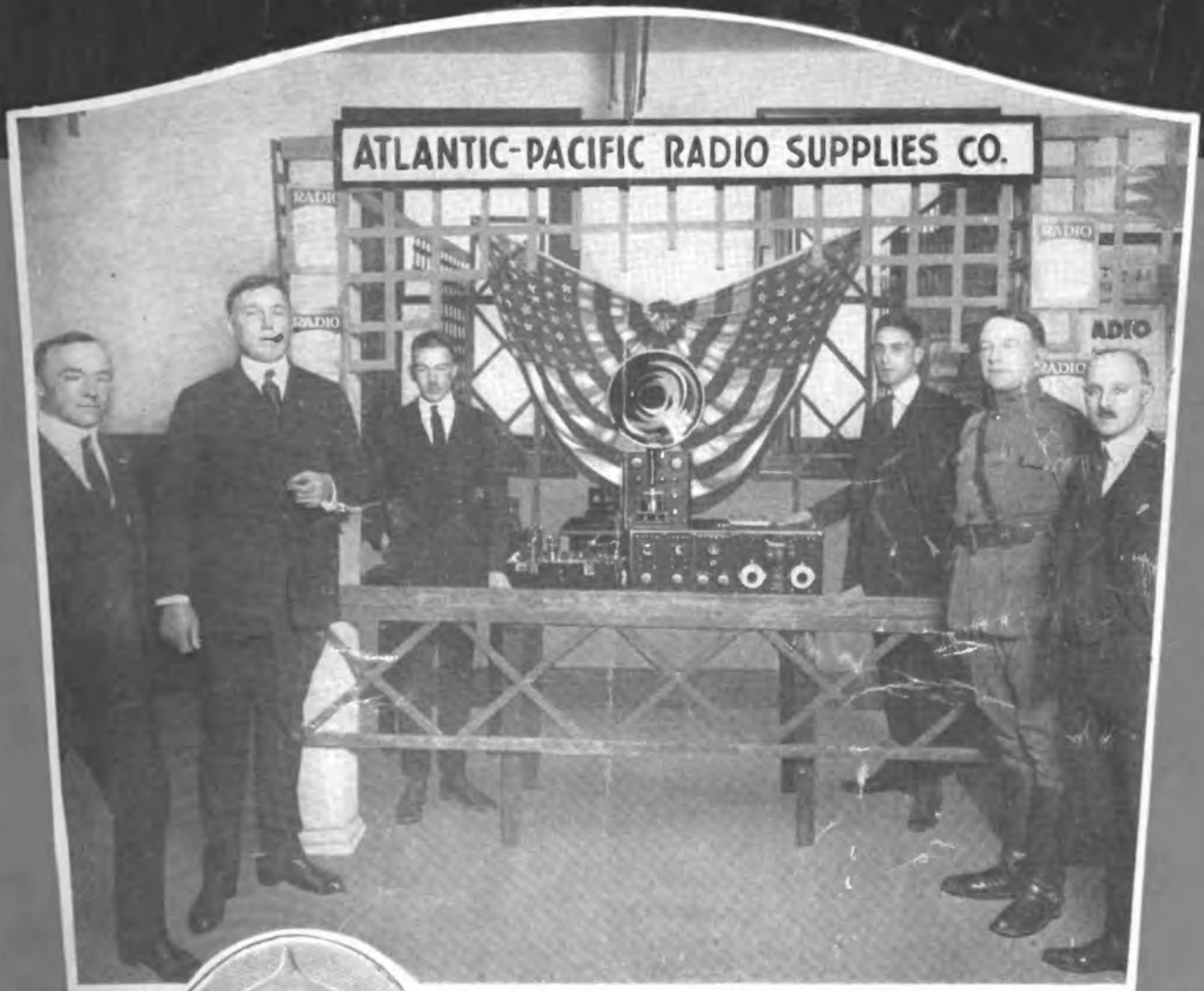

A-P Opens Pacific Radio Convention

Photograph shows Club Officials, Radio Officers and members of the A-P staff receiving the opening address by radio with A-P tubes used in de Forest inter-panel equipment and Magnavox amplifying and loud speaking apparatus. "The tubes that are used by those who know."

ATLANTIC-PACIFIC RADIO SUPPLIES COMPANY
638 Mission Street, San Francisco, California
Eastern Office, 5 Kirk Place, Newark, N. J.

Henry M. Shaw, President

VACUUM TUBES CUNNINGHAM

AMPLIFIES AS IT DETECTS

CUNNINGHAM Type C-300 Gas Content Detector Tube is the ideal tube to use in Home Receiving sets for clear reception of Radio Telephone Concerts, Market Reports and other news features which are sent out daily all over the country.

Nationally recognized as the one tube which gives the most satisfactory results for any type Receiving Set applicable to wave lengths between 100 and 3000 meters for both spark and C. W. Telegraph and Telephone, this Cunningham Detector Tube is recognized as the standard tube throughout the radio field.

In addition to its remarkable detector properties, low B. battery, quietness in operation, it is a free and persistent oscillator for regenerative amplification and C. W. reception and functions without distortion of the received signals.

The unusually fine results which have come through the operation of this tube in connection with home receiving sets have brought us many enthusiastic indorsements from users.

Write for further particulars to your nearest dealer, or write to us direct.

Cunningham
C-300
Gas Content
Detector

\$5.00



REMLER APPARATUS RADIATES QUALITY
CUNNINGHAM TUBES MEET EVERY AMATEUR REQUIREMENT



E. J. Cunningham

The trade mark GE is the guarantee of these quality tubes. Each tube is built to most rigid specifications.

Trading as

AUDIOTRON MFG. COMPANY

248 First Street
San Francisco, Calif.

154 West Lake Street
Chicago, Illinois

Stop Those Hissing and "Frying" Noises, Now!

—with Burgess "B" Batteries

HISSING, rattling, "frying" noises! Did you know that most of them are due to noisy "B" batteries?

WHEN there is static and interference, why increase your troubles with a poor "B" battery? Did you know that there is at least one "B" battery which IS noiseless, yet can be used to the last milli-ampere?

THAT battery is the Burgess. You can receive broadcast without noises if you use only Burgess Batteries. And when

you "Buy Burgess" you get high capacity and the lowest price in hours of service.

MULTI-STAGE radio frequency and audio frequency amplification is easily possible with the Burgess "B." Weak and distant audio frequency signals can be received with multi-stage amplifiers and Burgess "B" Batteries, because Burgess Batteries DO NOT drown out the signals.

THE Burgess "B" noiseless battery is the result of years of experimenting. Careful cell construction—individual insulation, moisture-proof separators and box, substantial triple seal. All under the constant supervision of Burgess Battery engineers in the big Burgess plant.

BURGESS "B" Batteries are sold by all reliable dealers in radio equipment. If you can't get the Burgess "B" from your dealer, write to—

BURGESS BATTERY COMPANY

MADISON, WIS.
CHICAGO
KANSAS CITY
ST. PAUL
WINNIPEG

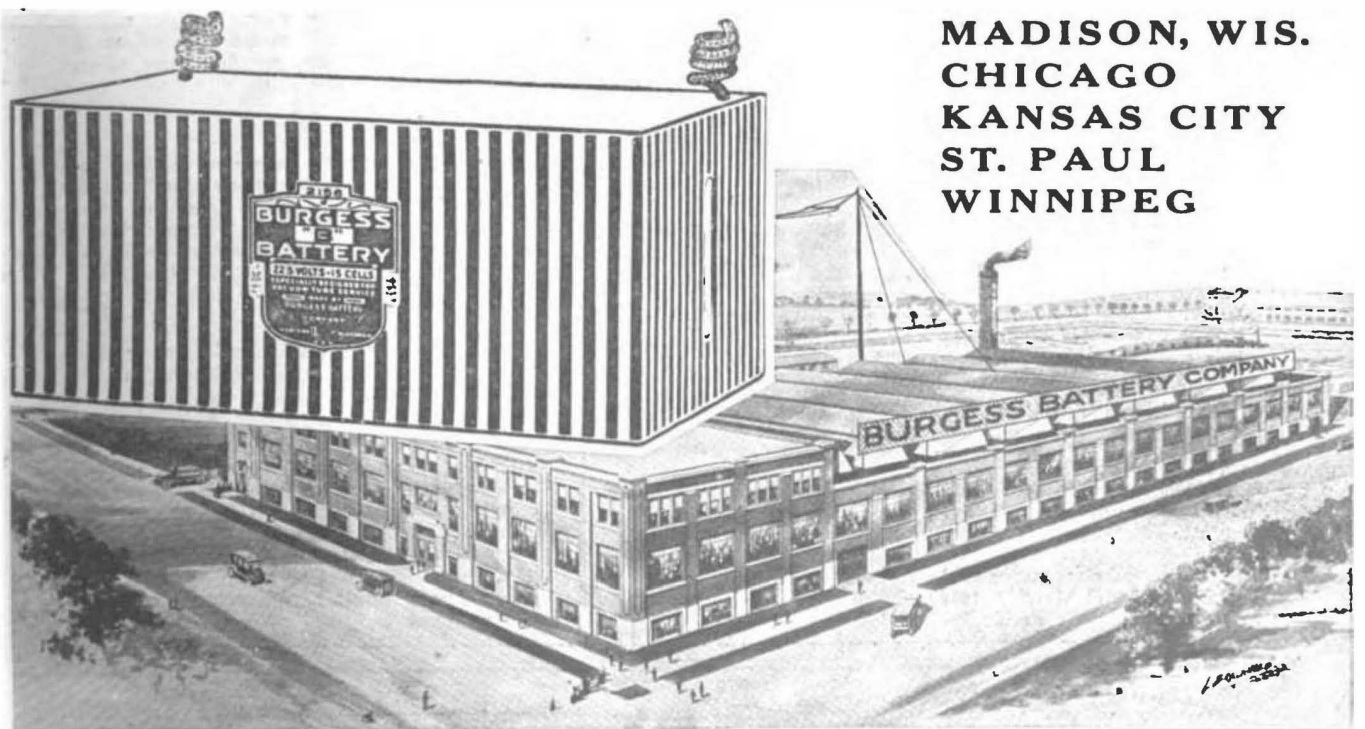

RADIO

Established 1917 as Pacific Radio News

Volume IV

for FEBRUARY, 1922

Number 2

CONTENTS for FEBRUARY, 1922

	Page
Radiatorial Comment.....	9
Radio Convention Adopts Pacific Plan.....	10
KZY—A Record Installation.....	11
<i>By ELLERY W. STONE</i>	
Construction of a Radio Frequency Amplifier from Standard Parts	13
<i>By G. M. BEST</i>	
A 150-25,000 Meter Receiver.....	14
<i>By I. A. WEIHE</i>	
The C. W. Manual.....	16
<i>By J. B. DOW</i>	
Successful Experiments with Earth Antennæ.....	19
<i>By EDWARD M. SARGENT</i>	
The Click Method of Determining Resonance.....	21
<i>By G. W. CATTELL</i>	
Amateur Radio Laboratory Measurements.....	22
<i>By D. B. MCGOWN</i>	
Modern Commercial Radio Apparatus.....	23
<i>By D. B. MCGOWN</i>	
Hodeycobe Microferris Brown.....	24
<i>By CLYDE C. YOUNG</i>	
The Kickback.....	25
<i>By VOLNEY G. MATHISON</i>	
Ease of C. W. Transformer Design.....	26
<i>By A. H. BABCOCK</i>	
Efficient Receiving Station Practice.....	27
<i>By CHAS. K. FULGHUM</i>	
C. W. Association of America.....	29
Across the Continent on 20 Watts.....	29
<i>By LAWRENCE MOTT</i>	
With the U. S. Radio Inspector.....	31
Digest of Patents.....	32
Monthly Broadcast of Radio News.....	33
New Apparatus from Radio Manufacturers.....	34
Calls Heard.....	36
Questions and Answers on C. W.....	52
<i>By GERALD M. BEST</i>	
A Radio Fable.....	53
<i>By EARL ENNIS</i>	
Jimmie's Wireless	55
<i>By A. H. HUTCHINSON</i>	
Voices of the Night.....	60
<i>By EARL ENNIS</i>	

RADIO is Published Monthly by the
Pacific Radio Publishing Co., Inc.,
Pacific Building, San Francisco, Calif.

ARTHUR H. HALLORAN, *Editor.*

LAWRENCE MOTT, *Associate Editor.*

GERALD M. BEST, *Technical Adviser.*

H. W. DICKOW, *Advertising Manager.*

Branch Offices: 147 Sixth Ave., New York City;
1307 Hartford Bldg., Chicago; 18 Boylston St., Boston;
1003 North Coronado St., Los Angeles.

Advertising Forms Close on the First of the Month
Preceding Date of Issue

Issued Monthly, 20c a copy. Subscription price \$2.00 per year in
the U. S., \$2.50 per year elsewhere. Instructions for change of ad-
dress should be sent to the publisher two weeks before the date they
are to go into effect. Both old and new addresses must always be
given.

Entered as second-class matter at the Post Office at San Francisco,
Calif., under the Act of March 3, 1879.

Copyright, 1922, by the Pacific Radio Publishing Co.

Forecast of Contributions for March Issue



Jennings B. Dow, Ensign U. S. N., and Author
of "The C. W. Manual"

Jennings B. Dow, Ensign, U. S. N., author
of the series of articles on C. W. practice running
in these columns, will treat on the design and
construction of a five-watt radiophone in the next
installment. These series will eventually be re-
printed in book form as "The C. W. Manual."

D. B. McGown, assistant radio inspector, is
the author of some practical instructions for mak-
ing a good receiver for 175-2500 meters. This
will be illustrated with photographs of a set
built in accordance with the instructions.

Another good constructional article will be
one of the contributions to the prize contest for
all-wave receiving sets, the first prize winner
being published in this issue.

Hugh R. Sprado will have some excellent sug-
gestions on elimination of interference by means
of directive reception. R. E. Lake will discuss
Vacuum Tube Circuits. B. F. McNamee, in the
course of his excellent radio articles in ideas of
one syllable, will tell about crystal detectors.

Lawrence Mott has a fine radio story entitled
"The Small Person," which will bring a thrill
to every operator.

Of course there will be some fine material
in all the regular departments, including more
complete announcement regarding proposed ac-
tivities of the C. W. Association of America,
together with a goodly supply of radio humor.
The present issue may be regarded as setting a
standard which will be maintained during the
year to come.



Confucius has said:
 "The accomplishment
 of great things
 consists
 in doing small things
 well."
 Perfection of
 detail

makes the
Grebe Receiver



What
 it is =

The Grebe CR-5 Receiver

GREBE RADIO
 Doctor Mfu.

RADIO APPARATUS

*Distributors of Reliable Radio Apparatus to Dealers, Schools, Colleges,
Radio Clubs and Experimenters All Over the World!*

"PITTS CO"
SERVICE DISTRIBUTES "RADIO
CORPORATION'S" PRODUCTS
ALL OVER THE WORLD!
TRY US AND SEE!



"PITTS CO"
NOW HAS TWO STORES! BOTH
CARRY "RADIO CORPORATION'S"
COMPLETE LINE.
ORDER TODAY!

AMPLIFIERS

No. DA Westinghouse, Detector and two stage in mahogany cabinet.....	\$68.00
No. RORK Grebe, two stage with automatic filament control jacks.....	55.00
No. RORD Grebe, Det. and two stage with automatic fl. control jacks.....	75.00
No. 2634 Amrad, Det. and two stage in mahogany cabinet. Splendid value.....	47.50

AMPLIFYING TRANSFORMERS

No. UV-712 Radio Corporation.....	7.00
No. QO Clapp-Eastham, semi-mounted.....	4.00
No. QO Clapp-Eastham, fully mounted.....	5.00
No. 50 Chelsea, new type.....	4.60

ANTENNA WIRE

"Pittsco" No. 14 Hard drawn copper (80 ft. per lb.), per lb.....	.40
500 ft. special value at.....	2.25
"Pittsco" 7 strand No. 22 tinned copper, per ft.....	.01
500 ft.....	4.25
1000 ft. Special value at.....	7.50
"Pittsco" 7 strand No. 20 phosphor bronze, per ft.....	.02
500 ft. special value at.....	7.50

"B" BATTERIES

No. 7623 Standard 22.5 Volts, small.....	1.50
No. 7625 Standard 22.5 Volts, large.....	2.85
No. 7600 Standard 22.5 Volts, variable 16½ to 22½ Volts.....	3.00
No. 7650 Standard 22.5 Volts, large, variable, 15 variations.....	3.50
No. 763 Eveready 22.5 volts small.....	2.25
No. 766 Eveready 22.5 volts large, 16½ to 22½ volts.....	3.00
No. 627 Ace, 45 volts, variable.....	3.50

COILS (Duo-lateral)

DL-25.....	\$1.40	DL-300.....	1.75
DL-35.....	1.40	DL-400.....	1.80
DL-50.....	1.60	DL-500.....	2.00
DL-75.....	1.50	DL-600.....	2.15
DL-100.....	1.55	DL-750.....	2.35
DL-150.....	1.80	DL-1000.....	2.60
DL-200.....	1.85	DL-1250.....	3.00
DL-250.....	1.70	DL-1500.....	3.50

COIL MOUNTINGS

No. LC-100 DeForest 3 coil mounting with gears, reduced price.....	6.00
No. LC-101 DeForest 3 coil mounting with gears and wooden base.....	9.50
No. 400 Remler 3 coil mounting with base and extension handles.....	6.50

CONDENSERS (For OW work)

No. UC-1014 Radio Corp. .002 MF. 3000 volts.....	2.00
No. UC-1015 Radio Corp. .0003, .0004, .0005 MFD. 7500 volts.....	5.40
No. UC-1803 Radio Corp. .000025 MF. 10000 volts.....	5.00
No. UC-1806 Radio Corp. .002 MF. 6000 volts.....	7.00

CONDENSERS (Grid and plate types)

No. UC-570 Radio Corp. .0025 MF.....	\$2.00
No. UC-569 Radio Corp. .001 MF.....	1.50
No. UC-568 Radio Corp. .0005 MF.....	1.35
No. UC-567 Radio Corp. .00025 MF.....	1.20
No. UX-543 Radio Corp. Condenser meg.....	.50

CONDENSERS (Filter type)

No. UC-1631 Radio Corp. .5 MF 750 volts.....	1.35
No. UC-1632 Radio Corp. 1 MF 750 volts.....	1.85
No. UC-1634 Radio Corp. .5 MF 1750 volts.....	1.50
No. UC-1635 Radio Corp. 1 MF 1750 volts.....	2.00

C. W. INDUCTANCES

No. UL-1008 Radio Corporation.....	11.00
No. P-1 Acme.....	8.00

C. W. POWER TRANSFORMERS

No. UP-1638 Radio Corp. 325 watts.....	25.00
No. UP-1016 Radio Corp. 750 watts.....	38.50
Acme 200 Watt 350-550 Volts Mtd.....	20.00
Acme 200 Watt 350-550 Volts unmtd.....	16.00

FILTER REACTORS

No. UP-1626 160 Milliampere.....	11.50
No. UP-1627 300 Milliampere.....	15.75

GRID LEAKS (Radio Corporation)

No. UP-1719 For 5 Watt Tubes.....	1.10
No. UP-1718 For 50 Watt Tubes.....	1.65
No. UP-516 ½, 1, 1.5, 2 or 3 megohms ea. complete with mounting.....	1.25
Grid leaks only, each.....	.75

HOT WIRE METERS

No. P-1 Roller-Smith 0-2.5 Amperes, bush mtg. Special value at.....	4.75
No. UM-530 Radio Corp. 0-2.5 Amps.....	6.00
No. UM-533 Radio Corp. 0-5 Amps.....	6.25

JACKS (Radio type)

No. 61 Patent open jack.....	.70
No. 62 Patent closed jack.....	.85
No. 63 Patent 2 circuit.....	1.00
No. 65 Patent three spring Automatic filament control type.....	1.20
No. 66 Patent five spring A. P. C.....	1.50

LOUD SPEAKERS

No. R-3 Radio Magnavox, new type horn, very latest model.....	45.00
No. P-1 Vocaloud, station type.....	30.00
No. 400-W Federal Pleiophones.....	14.00

RECEIVING SETS (Orystal)

"Aeriola Jr." Westinghouse, complete with Brandes "Superior" phones.....	25.00
"Radiola" DeForest, complete with Brandes "Superior" phones.....	25.00
Radio Service Type S-8 without phones, splendid value.....	7.50

MAGNETIC MODULATORS

No. UT-1634 ½ to 1½ Amperes.....	\$9.50
No. UT-1357 1½ to 3½ Amperes.....	12.50
No. UT-1637 3½ to 5 Amperes.....	17.00

RECTIFYING DEVICES

No. UV-216 Radio Corp. "Kenotron" 20 Watt type for UV-202 tubes.....	7.50
No. UV-217 Radio Corp. "Kenotron" 150 Watt type for UV-203 tubes.....	26.50
No. P-1 DeForest 20 Watt Rectifying tube for use with 5 watt tubes.....	7.00

RECTIFYING DEVICES (for "A" Batteries)

No. P-1 Tungar, 5 ampere type, complete with bulb.....	28.00
No. P-2 Tungar, 2 ampere type with Bulb.....	18.00
No. P-3 FF Battery Booster, 5 amp. type.....	15.00

REGENERATIVE RECEIVERS

No. CR-3 Grebe "Relay-Special" 175-680 meters.....	65.00
No. CR-5 Grebe 175-3000 meters, "Super-special" complete set.....	80.00
No. CR-8 Grebe 175-1000 meters, complete set, latest "Relay-Special".....	80.00
No. CR-9 Grebe 175-3000 meters, complete set with det. and 2 stage amplifier self contained, "A Masterpiece".....	130.00
No. RA Westinghouse, 180-700 meters, very selective, mahogany cabinet.....	88.00
No. RC Westinghouse, RA receiver and DA Det. Amplifier combined in one cabinet, a splendid unit, compact.....	130.00

TELEPHONES

No. 56 Murdock 2000 ohm double.....	5.00
No. 56 Murdock 3000 ohm double.....	6.00
No. CW-834 Western Electric 2200 ohms.....	15.00
Brandes, "Superior" with new headband.....	8.00
Brandes "Trans-Atlantica" with new headband.....	12.00
Brandes "Navy Type" with new headband.....	14.00
Baldwins Type C.....	12.00
Baldwins Type E.....	13.00
Baldwins Type F.....	14.00
Baldwins Type C unit only.....	6.00
Federal A. and N. Type 2200 ohms.....	8.00
Federal A. and N. Type 3200 ohms.....	10.50

VACUUM TUBES

No. UV-200 Radiotron detector.....	5.00
No. UV-201 Radiotron amplifier.....	6.50
No. UV-202 Radiotron 5 watt.....	8.00
No. UV-203 Radiotron 50 watt.....	30.00
No. UV-204 Radiotron 250 watt.....	110.00

Note:—All Radiotrons sent postage and insurance prepaid anywhere in U. S. A. Send us your orders for Radiotrons.

"LET 'PITTS CO' products, SUPER-SERVICE and delivery solve your RADIO problems"

SEND US YOUR ORDERS TODAY!

Send ten cents for Catalog No. 22. Over 100 pages, over 150 illustrations, over 600 items

F. D. PITTS CO., Inc., 12 Park Square, Boston, Mass. Branch—Woolworth Bldg., 193 Westminster St., Providence, R. I.

Let the Natrometer Give You Sending and Receiving Speed in Half Usual Time



Don't be cut off from other advanced amateurs because you do not know how to handle the code, or be held back because you don't know how to send and receive fast enough. Get the full pleasure from your outfit. Listen-in on and understand all the commercial stuff too. There's no fun in hearing a lot of dots and dashes. You want to know what they are saying. The Natrometer will teach you quicker than any other known method.

There is Only One Natrometer

Employing the Natrometer is like having the assistance of an expert operator to help you learn the code; an expert who can send to you accurately at any speed, slow or fast at your command any hour, day or evening. The Natrometer will do that and it never gets tired. Sends with perfect accuracy, and the speed is instantly adjusted with a small thumb-screw, from three to thirty-five words a minute. Six hundred different messages can be sent with a single dial. When you exhaust your message dial, you can exchange it for another one without cost. The Natrometer's powerful motor allows it to run for twenty minutes. The sending is as clear as a bell. No bother with static interference and no choppiness.

The Natrometer is fully covered with patents owned by the National Radio Institute. That is why there is **ONLY ONE NATROMETER**. Yet, with all of its exclusive features, it costs no more than other machines. Prices range from \$20 to \$30.

Ten Points That Make the Natrometer Best

1. Perfect commutation which eliminates inaccuracies.
2. Large, powerful driving motors (not a clock-works).
3. Audibility coil.
4. Hi-tone Buzzer.
5. Governor speed control.
6. Hundreds of message combinations with single dial.
7. Large, heavy spring.
8. Automatic dial shift.
9. Accurate and easy speed control adjuster.
10. Machine cut gears.

WRITE FOR FULL DESCRIPTION

We will gladly send you booklet telling more about the Natrometer. Just put your name and address on the attached coupon. Send no money.

Sales Department, Room No. 1003

National Radio Institute

Radio Headquarters

1345 Pennsylvania Ave., N. W. Washington, D. C.

COUPON

Sales Department, Room No. 1003,
NATIONAL RADIO INSTITUTE,
1345 Pennsylvania Ave., N. W.
Washington, D. C.

Gentlemen: Please send me by return mail your free booklet giving complete information about the Natrometer. This obligates me in no way.

Name

Address

City..... State.....

FORMICA

Made from Anhydrous Redmanol Resins
SHEETS TUBES RODS

Good Looks and Perfect Insulation!

*F*ORMICA panels for radio equipment have a splendid gloss or satin finish. They machine perfectly, and encourage neat workmanship. They give you a panel you will always be proud to show your friends. Weather will never affect its looks.

Most radio troubles are due to failure of insulation, to power loss and losses due to hysteresis. Formica has a dielectrical strength of 700 to 1300 volts per 1/1000 of an inch—and an angle of phase difference so small that hysteresis losses with currents of high frequency are negligible.

The country's greatest engineers approve your judgment when you use Formica!



Dealers: We co-operate with you. You can buy Formica in the sized sheets for which you have the greatest call, or in full sized 42x36 sheets which you can cut yourself. Write for our dealer helps.

The Formica Insulation Company

4614 Spring Grove Avenue, Winton Place
CINCINNATI, OHIO



Throughout the length and breadth of the land, thousands of families are listening to music, concerts, news of the day, lectures, weather reports, church services, etc., right in their own homes with a \$15.00 "Marvel" Radio Telephone Receiving Outfit. No longer is it necessary to have expensive apparatus or any knowledge or experience in wireless telegraphy.

Bring YOUR Home In Touch With The Outside World

Get a "MARVEL" Radio Telephone Receiving Outfit. Music, concerts, lectures, current news, sermons, Government reports, etc., will come to you daily. The cost is small—only \$15.00 complete! Nothing else is needed. Receives speech and music, etc., within a 50 mile radius of the large radio telephone broadcasting stations, and wireless telegraph messages within many hundreds of miles.

The "MARVEL" RADIO TELEPHONE RECEIVING OUTFIT, is the only COMPLETE crystal receiving outfit on the market with a wavelength range of 180 to 2,600 meters. The OUTFIT is thoroughly practical, dependable and complete. It can be quickly and easily set up for use. No source of power, no batteries, no license and no special knowledge is necessary for installation.

THE COMPLETE "MARVEL" RADIO TELEPHONE RECEIVING OUTFIT, Model 105, consists of a "MARVEL" Radio Receiver (a completely enclosed, highly efficient, crystal receiver, mounted in a handsomely finished mission oak cabinet), 150 feet of solid copper wire (for the antenna), 5 porcelain insulators, a 1,000 ohm telephone with leather covered headband and telephone cord, antenna switch, ground clamp, code chart, abbreviation chart, and COMPLETE instructions for installation and operation. Nothing else is needed.

\$15.00

Model 110, same OUTFIT, but with a 2,000 ohm double headset..... **\$18.00**

Quality Apparatus

Designed by Engineers

Popularly Priced

"MARVEL" RADIO TELEPHONE RECEIVING OUTFITS are for sale at all progressive Radio and Electrical Dealers. If your dealer has not yet received his stock of "MARVEL" OUTFITS, we will send you one prepaid on receipt of Postal or Express Money Order, or via Parcels Post C. O. D. ORDER NOW—DON'T DELAY.

Look for the Registered Trade Mark on every genuine "MARVEL" RADIO TELEPHONE RECEIVING OUTFIT (Patents applied for).

Bulletin Z-101 on request.

DEALERS: "MARVEL" RADIO TELEPHONE RECEIVING OUTFITS are nationally advertised; they are the most popular of crystal receiving OUTFITS. Get your share of the growing demand by selling them. Liberal discounts and selling co-operation are part of our sales campaign. ORDER NOW!

MARVEL RADIO MANUFACTURING COMPANY, Inc.
OFFICES and SALES DEPARTMENT: 170 Fifth Avenue, New York City

Westinghouse Radio Apparatus

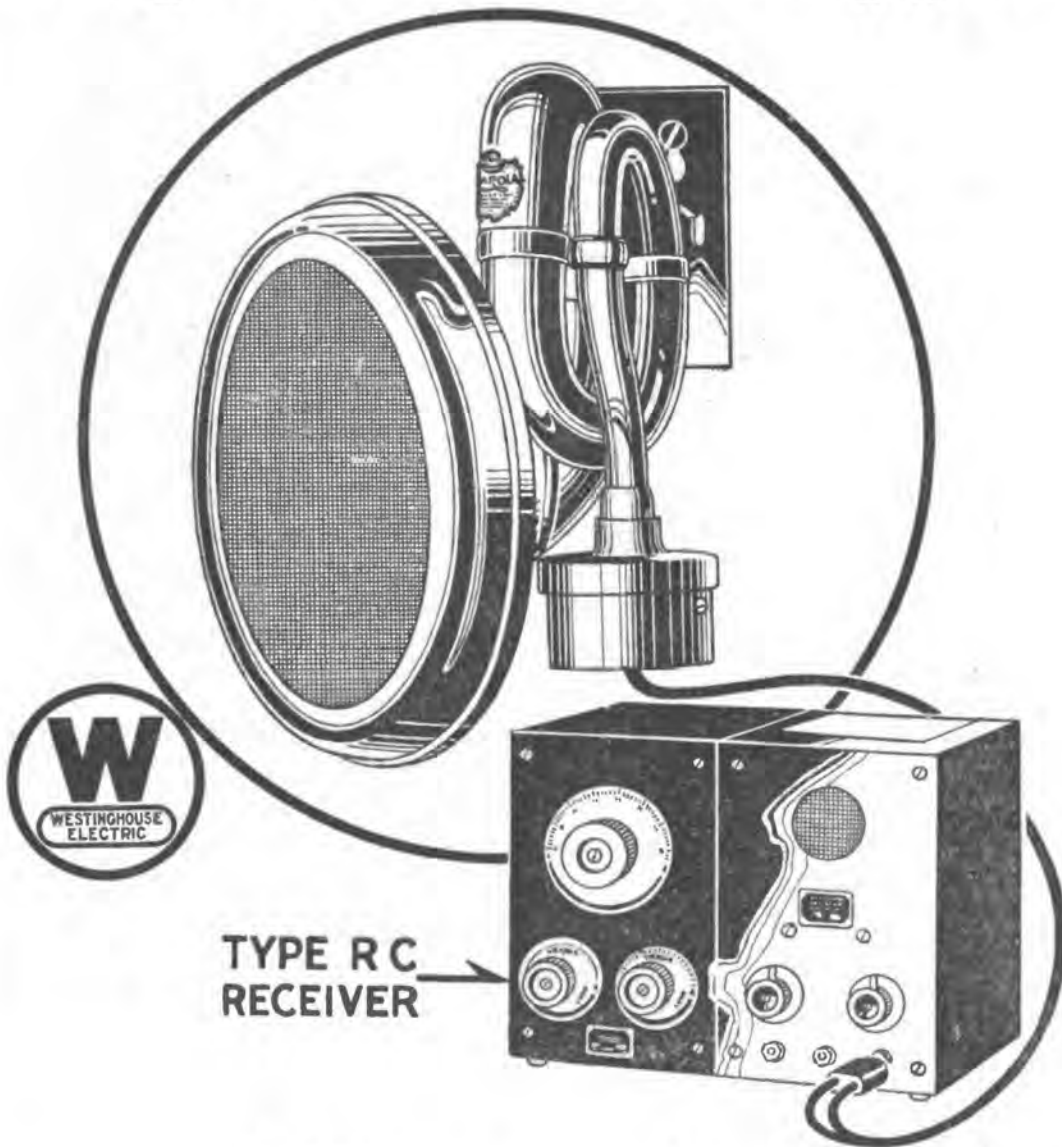

TYPE RC
RECEIVER

“Vocarola”

The loud speaker attachment that amplifies music without distortion.

\$30.00

Westinghouse Electric & Manufacturing Company

East Pittsburgh, Pa.

San Francisco, 1 Montgomery St.
Seattle, Second and Cherry Sts.

Portland, Broadway and Morrison Sts.
Salt Lake City, 2nd South and Main Sts.

Denver, 910 Fifteenth St.
Los Angeles, 7th and Spring Sts.

Westinghouse

Tell them that you saw it in RADIO

Radiatorial Comment

AN unexpected indication of the tremendous popular interest in radio concerts is found in the annual report of one of the phonograph manufacturers wherein increased sales of radio concert receivers are ascribed as a cause of decreased sales of phonographs. With the manifold advantages of radio concert reception and the increased ease of manipulation by the layman, the dream of a radio set in every home may yet become a reality. Meanwhile radio continues to boost the sale of phonograph records introduced by its aid.

MUSH is all right for breakfast, but as a steady diet it takes a hardy race like the Scotch to survive it.

When served day and night in the form of radio harmonics it is insufferable. Hence the news that the Navy has found a means for suppressing "mush" from its arc stations is most welcome. Details are not yet available for publication, but fifty-seven varieties of harmonics are claimed to have been eliminated in the case of one of the San Francisco Bay stations.

TO the boy who chafes under the restraint of being obliged to stop sending during the radio concert broadcasting hours we suggest that he utilize this opportunity to interest his parents in his radio set. Ask dad to listen to the press reports and the grand opera stars while he is smoking his after-dinner cigar. Show mother how to tune in for the afternoon or evening concerts so that she can provide novel entertainment for her guests. And as a result it will be a lot easier to get that extra ten-spot or so to purchase that long-coveted piece of equipment. Thus can you combine personal profit with the satisfaction of realizing that you are giving due consideration to the greatest good to the greatest number. Thus also you can avoid an unpleasant call from the local traffic officer, who under the new "Pacific Plan" will be backed up by the radio inspector in his demand that you stay off the air when you are liable to interfere with concert reception.

WITH pardonable pride do we announce the adoption of the Pacific Plan for the regulation of radio traffic. This suggestion, first made in December RADIO, met with the hearty endorsement of all western radio clubs, most of whom sent delegates to the convention at San Francisco. These delegates admirably assumed the responsibility of codifying the ten commandments of the air, commandments given not on stone, but on the eternal ether. Fortunate were they in having a Moses to lead them

out of the wilderness in the person of Major J. F. Dillon, universally loved and respected in radio circles. The fabled confusion of tongues at the building of the tower of Babel was not a circumstance compared to the confusion of arc, spark and tube that has been interfering with radio work. Be it especially noted that the new rules have teeth in them and are to be enforced by the authority of the radio inspector. Well known is the fact that responsibility without authority, like authority without responsibility, is doomed to failure. But where responsibility and authority are conjoined success is assured. The responsibility for enforcement rests with the local clubs to whom the radio inspector has delegated his authority.

THE past month has produced some remarkable long distance records in amateur radio transmission. There are several well authenticated cases of transcontinental reception, twenty-six messages—twenty of which were C. W.—were received by Mr. Godley in the A. R. R. L. trans-Atlantic test, and fourteen stations were reported as being heard in Hawaii, 2100 miles across the Pacific. 'Tis greatly to be desired that immediate arrangements be made for a real trans-Pacific test, a task which might well be undertaken by the new C. W. Association of America.

FOR a reputable newspaper to publish an article such as recently appeared on the front page of one of the San Francisco dailies with regard to the National Radio Company, is the cause of surprise and regret to those who know the facts. While the news of the purchase, if true, will be welcome to those who have been holding the bag of this financial fiasco for several years, its suggestion of perfected radio telephone developments is premature. Radio telephony is wonderful enough in its present day accomplishments without undue coloring by a publicity agent who sees a Sahara Desert in a grain of sand and the Pacific Ocean in a drop of water. Transcontinental wireless telephony will undoubtedly be accomplished in the near future. Transcontinental radio telegraphic communication is an established fact. But this has been done by means of continuous waves, generated by 3-electrode electron tubes, which are more efficient than the antiquated and expensive methods hitherto used by the National Radio Company. Nothing but harm can result from such sensational playing up of fiction masquerading as fact.



Some of the Delegates to the Pacific Coast Radio Convention

Radio Convention Adopts Pacific Plan

A Pacific Plan for regulation of amateur radio traffic was unanimously adopted at a convention representative of 25 radio clubs on the Pacific Coast held at San Francisco on Dec. 29th and 30th. This plan, which is published in full herewith, received the full indorsement of Major J. F. Dillon, radio inspector for the sixth district. It is to be effective after Feb. 1, 1922, throughout the territory west of the Rocky Mountains.

The convention was formally opened Thursday afternoon, Dec. 29, by a wireless address from the Meyberg station at the Fairmont Hotel introducing Mr. Sidney J. Fass as chairman of the convention committee. Mr. Fass turned the meeting over to Major Dillon as the presiding officer. Proposals submitted by the various radio clubs were read by Mr. H. W. Dickow, president of the San Francisco Radio Club, and then referred to the accredited delegates, who used them as the basis for formulating the final plan.

Adjournment was taken while the plan was being discussed so that the radio show could be inspected. After a banquet in the evening the show was opened to the public until the following night, when the convention was closed with a radio ball where many couples danced to radio music.

The exhibitors at the radio show were the Colin B. Kennedy Co., the Radio Corporation of America, Leo J. Meyberg, Radio Shop, Levy Electric Co., Warner & Linden, Pacific Radio Exchange, Heintz & Kohlmoos, Newberry Electric Co., RADIO, Atlantic-Pacific Radio Supplies Co., and California Electric Supply Co.

"PACIFIC PLAN"

1. There are five divisions of operating hours each day, as follows:

6:30 A. M. to 6:30 P. M.—Free air, work of any kind except D. X.

6:30 P. M. to 7:30 P. M. (or to concert time)—For local traffic only, using a minimum of power.

7:30 P. M. to 9:00 P. M.—Restricted to concerts in such districts as concerts are broadcasted, or in districts where there will be interference with concert broadcasting by 200 meter stations. This is to be under the control of the individual clubs, within their own sections.

9:00 to 10:30 P. M.—Period for long distance testing and messages, to L. D. stations only. Stations working this period cannot work again until after 12 A. M.

10:30 to 12:00 P. M. (midnight)—Long distance messages, ONLY for stations having regular traffic, except those who have worked during previous period.

12:00 A. M. to 6:30 A. M.—Long distance testing and long distance free air.

2. Local work shall be defined as transmission to stations up to a distance of 50 miles. All distances over 50 miles to be considered as long distance work.

3. After 9 p. m., a station desiring to operate shall listen for a period of three minutes before transmitting, to determine if any traffic is being handled, and then, if none is heard, the signal NA is to be given *once*. If answered by the signal IM, the calling station shall stand-by until the station giving the signal IM has finished, and this station shall then indicate his having done so by giving the signal CLR.

4. All radiophone and C. W. transmitters are considered as radio transmitters, and come under these regulations at all times, except that C. W. stations may work during the concert hours.

5. Each radio club shall appoint one traffic officer, and assistants, whose purpose it shall be to supervise traffic regulations in the vicinity wherein the radio club is located. The traffic officers shall be persons who are familiar with amateur operating conditions, and shall be indorsed by the Radio Inspector, after being appointed by the club.

6. Traffic officers shall use the sign TO. No station shall dispute an order given him by radio. If there is any misunderstanding, or question, use wire telephone, or make written report to the chief traffic officer.

7. The traffic officers, and their assistants, shall cooperate to the fullest extent with the U. S. Radio Inspector, and the traffic officers shall be recommended for recognition as semi-officials of the Department of Commerce. All violations of traffic ordinances shall be reported by the traffic officer to the radio club of which the offender is a member, and the club shall take immediate steps to remedy the difficulty, but shall report the matter to the Radio Inspector, if the efforts of the traffic officer, and club, fail.

SUGGESTIONS

1. Messages should be brief as possible, omitting unnecessary words, etc., and shall use cable count, and give check and origin in preamble of message.

2. Requests for QSP must be brief.

3. Complaints, suggestions, etc., shall be submitted to the clubs in their districts.

Altho not read as part of the traffic rules, the following are assumed to be self-evident, in the handling of various kinds of traffic, and were agreed in committee, without dissension.

a. Clubs shall have complete jurisdiction over all matters within their own zone, which are not covered by traffic rules. For example, if the concert schedules do not start

Concluded on page 12



View of Radio Masts and Antenna at KZY

KZY—A Record Installation

By Ellery W. Stone

PROMPTLY at midnight, on the morning of Christmas Day, the Atlantic-Pacific Radio Supplies Company formally placed in commission its new high power radio-telephone broadcasting station at Rockridge, Oakland, Calif. This station is located at the residence of Mr. Henry M. Shaw—the president of the Atlantic-Pacific Radio Supplies Company, the Moorehead Laboratories, Inc., and the Shaw Insulator Company, of Newark, N. J.—where it is planned to make extensive experiments in the broadcasting of music. Mr. Shaw's residence and the location of the radio equipment therein are excellently adapted for this purpose, the radio room opening onto a large music room on the lower floor which will permit the holding of vocal and instrumental concert numbers.

While the radio world heard this new station come into commission exactly as Christmas Day dawned, it was not aware of the strenuous efforts which were required to put this station into commission at that time, and it is believed that our readers will find this short account of the building of KZY of interest.

The antenna, the active length of which is 135 ft., is suspended between two 75 ft. masts, erected by the Pacific Gas & Electric Company. One of the masts is located on Mr. Shaw's property and the other on an elevation some distance away. It had been planned to put this station into commission on Christmas Day, and arrangements were progressing satisfactorily when it was found that the owner of the property on which the "far end" mast had to be erected, was residing at Santa Barbara. Telegrams and letters were sent him, but as he was on a vacation trip, it was found impossible to reach him.

Accordingly, Mr. Fred Anderson was sent to Santa Barbara on the evening of December 16th to endeavor to locate the owner of the property. Upon his arrival at Santa Barbara, Mr. Anderson discovered that he was in Los Angeles, and motored to Los Angeles, arriving there late that evening. The owner of the property signed an agreement giving permission to use the property for the antenna. Mr. Anderson was able to return on the train from Los Angeles that evening, arriving in Oakland on the 18th. On Monday, the 18th construction work was started on the

antenna by the Pacific Gas & Electric Company, thru the co-operation of Mr. Lee Newbert, division manager, and Mr. Worthington, construction engineer. The weather during the week preceding Christmas was very stormy and considerable difficulty was encountered in erecting the masts and laying the counterpoise ground.

While the antenna was being constructed, work had been started on the interior installation of the radio equipment.

The equipment consists of DeForest apparatus throughout, the transmitting equipment being the standard DeForest $\frac{1}{2}$ kw. set and the receiving equipment comprising the latest DeForest multiwave tuner, detector and two stage amplifier Interpanel receiving equipment. In conjunction with this receiver are employed the Magnavox loud speaker together with two-step power amplifier. The transmitting tubes are DeForest $\frac{1}{2}$ kw. Oscillions, and the receiving tubes, including those employed in the Magnavox power amplifier, are the standard A-P detector and amplifier tubes.

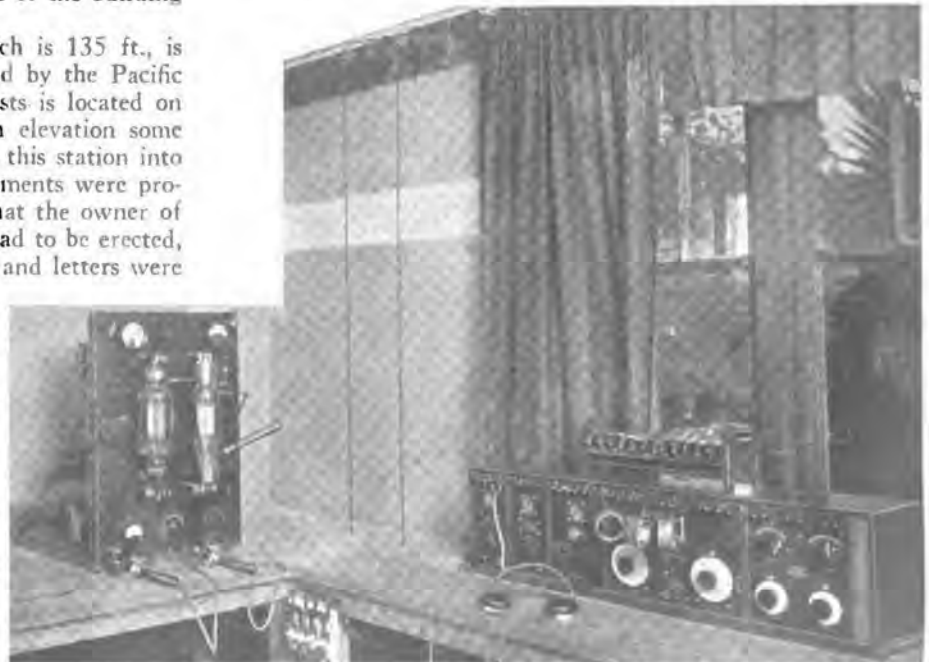

Interior View of Radio Station at KZY, Showing DeForest $\frac{1}{2}$ kw. Transmitter, and DeForest Interpanel Receiver.

Part of this equipment was formerly used at the California Theatre radio station in San Francisco, 6XC. The old station was installed in April, 1920, by Lee Deforest, Inc., and was later taken over by the Atlantic-Pacific Radio Supplies Co., when the latter company assumed western representation of DeForest Radio Tel. & Tel. Company. The California Theatre set had the distinction of being the pioneer station in the world for the sole purpose of concert broadcasting, having transmitted some 1500 concerts by radio before its removal to its more efficient location at Rockridge.

For the transmission of music, special phonographic arrangements are being made, employing devices hitherto not used for radio work. In addition to the phonograph, equipment similar to that formerly used at the California Theatre has been installed for the transmission of chamber, vocal and instrumental music. As noted above, this equipment has been installed in the music room adjoining the radio room and wires are led from this apparatus into the radio station.

Despite the short time available for the erection of this station, the first tests were held on the afternoon of December 23rd, just four days after construction had been started. Preliminary tests were kept up until the official opening of the station on Christmas morning, on which occasion Christmas carols were sent over the air by a trio, consisting of the Misses Aida, Vivian, and Barbara Baxter, daughters of Mr. A. A. Baxter, one of the directors of the Atlantic-Pacific Radio Supplies Company. This trio was accompanied by Miss Helen Culver, well known in San Francisco musical circles. Following the rendition of "Silent Night" and other Christmas carols, Mrs. W. A. Divoll, soloist at St. Peter's Episcopal Church of Rockridge, sang "O, Little Town of Bethlehem" and additional Christmas songs. The concert was closed with a formal announcement of the opening of the station and the extending of the Season's Greetings by the Atlantic-Pacific Radio Supplies Company to its radio audience.

Experiments were carried on during the week, and on the holidays of January 1st and 2nd special news reports and concerts were sent out. In the first few days of its operation, reports were received by letter and telephone, from at least two hundred radio enthusiasts who had heard these concerts.

The number of responses by telephone was so great that the telephone lines were soon congested in handling this traffic. In fact, some of the radio enthusiasts reported that they had

been kept waiting over an hour to voice their appreciation of the opening of the new station. One man in the outlying districts had tried to reach KZY by telephone for over four hours and finally resorted to the ingenious expedient of getting his Chief of Police to demand of the telephone supervisor a clear line ahead of all other calls. Needless to say, he succeeded, but the radio operator at KZY, who must have had a guilty conscience, hasn't recovered yet from the shock of the telephone operator telling him that she had a rush call from the Chief of Police for him. As the result of the tremendous demands on the telephone facilities previously installed, the Pacific Tel. & Tel. Co. rushed in another trunk line so that KZY may now be reached by calling Piedmont 8778 or Piedmont 7768-W.

At the time of writing this article, the station has only been in operation a little over a week, and reports have already come in showing reception over a distance up to 1400 miles, the *U. S. S. Vigilant* having reported, by radio, receiving the concert while off Baja California, Mexico. Reports have been received from all points in California and in Oregon, and it is expected, when sufficient time will have elapsed, to receive reports that even greater distances were covered.

Special arrangements have been made with the San Francisco *Call* and the Oakland *Post-Enquirer*, affiliated publications, to render an up-to-the-minute news service to KZY in order to carry out its news schedules.

KZY will operate on the following schedules, comprising part of the joint schedule drawn up by the Pacific Radio Trade Ass'n, and approved by Major J. F. Dillon, U. S. Radio Inspector of the Sixth Radio District.

Every afternoon except Sunday, 3:30 to 4:30 p.m.—Concert.
Every night except Sunday, 7 to 7:10 p.m.—News Service,
Sports and Foreign.

Sunday, 3 to 4 p.m.—Concert.

Wednesday, 2:30 to 3:15 p.m.—Concert.

Saturday, 8:15 to 9 p.m.—Concert.

The construction of KZY at the Rockridge home of Mr. Shaw was performed by the following engineers, under the supervision of Lieut. Ellery W. Stone, general manager of the Atlantic-Pacific Radio Supplies Company: Fred Anderson, exterior construction; B. F. McNamee and Edward M. Sargent, design and interior construction; Earl Bowen, J. W. A. Legge-Willis, S. A. Sollie, and Wm. Morelli, interior installation.



PACIFIC PLAN

Continued from page 10

until 8 p.m., in certain localities, the club may authorize the extension of the local period from 6:30 until 8 p.m., or they may subdivide the long-distance periods into directional periods if found necessary, etc., etc.

b. Special stations on 375 meters do not come under the traffic rules, except that they shall not transmit during the concert periods. When they are using the 200 meter wave for ordinary correspondence, they shall be governed by the same rules as all other stations on 200 meters.

c. No stations shall transmit concerts, or music of any kind on any wave but 360 meters, and then only during the hours provided for this class of work. No matter to be transmitted by the broadcasting stations, except music and the necessary conversation relating thereto. No 200 meter stations shall broadcast music at any time.



Aeronaut, After Tailspin: "Wireless Is Certainly a Boon to Mankind."

Construction of a Radio Frequency Amplifier from Standard Parts

By G. M. Best

AN article on the Armstrong Super-Heterodyne, by A. K. Aster, which appeared in the December number of RADIO, described the principles and operation of a home made radio frequency amplifier. So many questions with regard to this amplifier have been received that the following description of one of these sets will perhaps clear up a few of the questions, and show how such an amplifier may be constructed for a very small amount of money.

The set described by Mr. Aster involved winding a number of coils, and included a detector and one stage of audio frequency amplification. As the writer already had a detector and several stages of audio frequency amplification, it was desired to construct the radio frequency amplifier separately, and to connect it by means of a flexible cord and plug to the regular detector connections. With this idea in mind, the panel shown in the accompanying photographs was assembled, all of the materials being of the kind that are readily obtainable at any well stocked radio supply house. Four air condensers, an antenna series-parallel switch, two movable and two fixed honeycomb coil mountings, three V. T. sockets, three rheostats, condenser dials and miscellaneous parts were used, and all mounted in as compact a unit as was possible.

The panel is divided into three sections: antenna tuned circuit, heterodyne oscillator, and two stage radio frequency amplifier. Each section is separated at the back of the panel, when it is completely assembled, by a wooden partition, not shown in the illustrations. These partitions and the back of

the panel, are covered with a shield of thin copper sheeting, which is connected to ground. This shield can easily be held in place by means of small brads, holes for which can be drilled in the panel, using a very fine drill, of a gauge considerably smaller than the brads. If the brads are No. 60 size, then a No. 65 drill must be used. Unless this shield is firmly held in place, it may bulge, and ground some part of the circuit. Care should be taken to cut large enough holes in the shield to clear all apparatus that is mounted on the panel.

The antenna tuned circuit consists of two honeycomb coils, with their mountings, an antenna series-parallel switch, and two small air condensers. The tuning of this part of the set is in no way different from that of any ordinary tuned circuit, and should present no difficulty to the novice.

The heterodyne oscillator section occupies the center part of the panel, and consists of a vacuum tube, socket, rheostat and air condenser. A 1 mf. paper condenser, and two honeycomb coils necessary for the operation of the oscillator are not shown in the illustrations, as they are mounted on the partitions, which were removed to show the entire layout of the apparatus on the panel.

The two stage amplifier, with the 50,000 cycle tuned circuit consists of two tubes with their sockets, two rheostats, an air condenser, fixed condenser, and two 500 turn honeycomb coils with their mountings. Binding posts are furnished for the A and B batteries, as well as the antenna and ground connections. The final output of the amplifier is a two conductor flexible cord, with either two terminals to connect the binding posts on the regular detector, or in the case of a honeycomb coil set, a plug can be used to connect the radio frequency amplifier to the secondary connection of the detector.

The circuit shown in Fig. 1 is not a great deal different from the one shown in Mr. Aster's set, the main difference being that there is no detector shown, the two arrows indicating where the detector is to be connected. Excellent results were obtained using only 80 volts in the plate circuit of the tubes, this voltage being obtained from two 43 volt dry cell units.

The physical dimensions of the panel are 11 in. by 22 in. by 3/16 in., of either bakelite or formica, and a cabinet of the same dimensions should be provided, to house the apparatus. The inside of the cabinet should also be shielded, grounding the shield the same as was done on the panel. Use bare copper wire in making connections, and solder everything thoroughly. The cabinet should be provided with a lid, in order to replace tubes, and make slight adjustments on the honeycomb coils in the heterodyne oscillator circuit.

As Mr. Aster has already pretty well covered the operation of this type of amplifier, no particular discussion is necessary here. Some criticism is bound to result from the use of honeycomb coils in the outfit described in this article, but contrary to the opinion of a great many ama-



Front View of Radio Frequency Amplifier



Rear View of Radio Frequency Amplifier

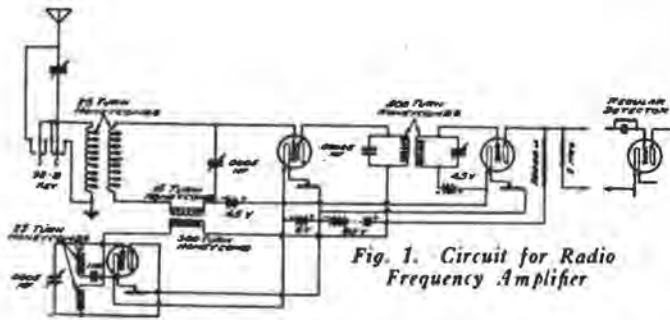

Fig. 1. Circuit for Radio Frequency Amplifier

teurs, honeycomb coils can be made to operate very efficiently on short wavelengths, if handled properly, and the results obtained by using them in connection with the Armstrong Super-Heterodyne prove that they are very well adapted for that sort of work. Not only are they more convenient than a number of hand wound coils, but the fact that they can be changed easily, and coils covering other wavelengths substituted, gives the amateur just what he wants, namely, a radio frequency amplifier that is flexible, and is not confined to a narrow band of wavelengths.

A 150-25000 Meter Receiver

The Winner in the \$25.00 Prize Contest

By I. A. Weihe

A RECEIVER that will detect, regenerate, and oscillate over the entire wavelength range is something that will be appreciated by any radio enthusiast, and is possessed by comparatively few.

The cost of a short wave regenerative set, for amateur waves, and of the honeycomb or duo-lateral coil sets, for the longer waves, is prohibitive for the average amateur.

The description of the combined long and short wave set that follows will be of special interest to the amateur with the slim pocketbook, as it can be easily made, and at a very moderate price. Anyone making this set, and taking pains with it, will find that it will compare favorably with the standard short wave sets on the market today, and the long wave set is as good as a set using honeycomb coils. The signal strength on both sets is practically the same, the only difference being in selectivity. The set described lacks the selectivity of the other sets, but otherwise they are practically the same.

This receiver consists of two separate sets, the use of either being controlled by a four-pole double throw anti-capacity switch, which is located directly above the condenser, or center dial.

The short wave part of this set has a wavelength range of 150 to 700 meters with the .001 mfd. (.43 plate) variable condenser in series with the aerial, and from 400 to 1700 meters with the same condenser in shunt with the coil. The long wave part has a range of from 1800 to 14,000 with series condenser, and 4000 to 25,000 with shunt condenser. The position of the condenser is controlled by a series-parallel switch, which is located directly under the condenser.

A single coil tuning circuit is used, with direct coupling for primary and secondary circuits, and the tickler coil is used to produce oscillations, for the reception of C. W., or for regenerative amplification of spark and fone signals. The ease and rapidity with which signals can be tuned in more than compensate for the lack of selectivity. This is one of the best circuits for the reception of C. W.

The only variable part for wavelength control is the variable condenser, it being only necessary to vary the condenser to receive anything within the wavelength of the tap used.

The following parts are needed, and can be had for about \$15.00 (no doubt most amateurs will have most of the parts around their shop, thereby reducing the cost): One panel $\frac{1}{4}$ in. x 6 in. x 1+ in. of Bakelite or Formica; three dials and knobs, three inches in diameter; one Murdock .001 mfd. variable condenser (No. 3660); one series-parallel switch; one four-pole double throw anti-capacity switch; twenty-four switch points; two switches with $\frac{3}{4}$ in. knob and 1 in. radius; two switches with $\frac{3}{4}$ in. knob and $1\frac{1}{4}$ in. radius; one piece cardboard tubing 4 in. in diameter and 3 in. long; one piece cardboard tubing $3\frac{1}{2}$ in. in diameter by $1\frac{1}{2}$ in. long; one coil of 15,000 turns and one coil of 500 turns. The coils may be honeycomb, duo-lateral or qsa inductances, or if equipped to do so the amateur can wind his own coils, and make another saving on the set. Screws make good bearings, and if you haven't any the following will answer: six 6/32 thread 1 in. or $1\frac{1}{2}$ in. long brass machine screws and six 10/24 thread 1 in. or $1\frac{1}{2}$ in. long brass machine screws and nuts.

No dimensions are shown for the holes in the panel, as

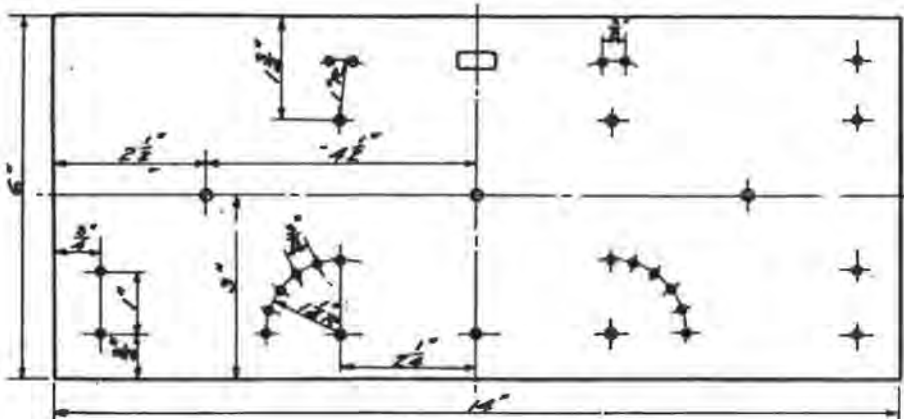

Fig. 1. Panel Layout.

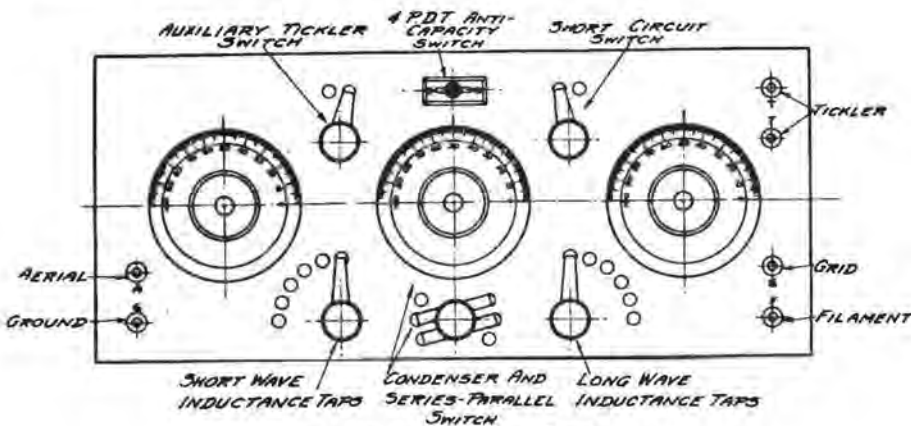

Fig. 2. Completed Panel.

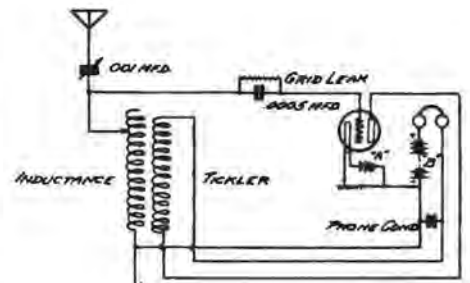

Fig. 4. Circuit Used.

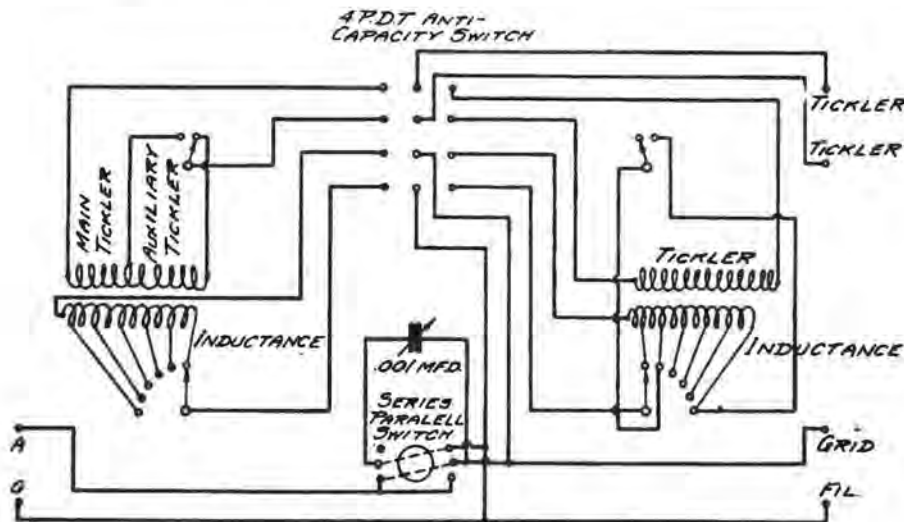

Fig. 5. Complete Wiring Diagram

they will vary for the apparatus the builders may have on hand.

The short wave part of the set, which is on the left, is nothing but a short-wave vario-coupler, with the rotor used as a tickler. To construct this, take the piece of cardboard 4 in. in diameter and 3 in. long and wind on it 60 turns of No. 24 s. c. wire. Start winding about $\frac{3}{4}$ in. from the top, and take off a tap every ten turns. The easiest and best way to do this is to make a small loop, and after the coil is finished remove the insulation and solder on wires of sufficient length to reach the switch points.

The tickler consists of 36 turns of No. 26 s. c. wire on the $3\frac{1}{2}$ in. cardboard tube. Leave $\frac{1}{4}$ in. space in the center for the 10/24 thread screws, which are to be the bearings. Solder the ends of the tickler to the heads of the screws, which come thru the large tube about $\frac{3}{8}$ in. from the top. Then solder flexible leads to the screws where they come thru the hole in the stationary coil. The stationary coil can be mounted by cutting a disk of soft wood that will just go in the bottom of the tube, and glueing it in, and putting a couple of screws thru the disk to the sub-base.

The dimensions of the tickler given are correct when the condenser is in series, but with shunt condenser it will not cause the circuit to oscillate, so an auxiliary tickler of 20 turns is placed in the bottom of the stationary coil permanently, and connected so it can be cut in or out as desired by the small two-point switch, as shown in Fig. 5.

For the long wave set, tap the 1500 turn coil at six approximately equal points, and mount as near as possible to the

end of the panel, allowing clearance for the binding posts. Cut a plug to fit the center of the coil and screw two pieces of brass to it of sufficient length to reach the panel. Use flat head machine screws for mounting and countersink so dial will cover screw heads.

The tickler is mounted in a similar manner except that the bracket must be offset so the tickler will come as close as possible to the large coil, and yet not touch it.

When receiving on waves from 1800 to 3000 meters it is necessary to short the unused part of the large coil, which is done by a small two-point switch which shorts from the second to the sixth tap, as shown in Fig. 5.

The above set has been in use at the author's station and has given excellent results, in fact much better than expected. For example, see the following list of calls heard:

"CALLS HEARD" BY 6ANK, BOX 848, SPARKS, NEVADA

Spark—6as, 6aah, 6aau, 6ahh, 6abx, 6acy, 6aow, 6aex, 6afn, 6agf, 6agp, 6ahn, 6ahp, 6aio, 6aid, 6ajh, 6akt, 6ala, 6alv, 6anp, 6ape, 6ars, 6aso, 6avb, 6avr, 6awh, 6bm, 6cl, 6cz, 6da, 6ea, 6ef, 6ex, 6fj, 6gr, 6hc, 6ic, 6ia, 6iv, 6ka, 6kx, 6lv, 6mh, 6ng, 6oc, 6ol, 6pj, 6qk, 6qr, 6lu, 6un, 6vv, 6vx, 6wh, 6wz, 6zb, 6zf, 6zu, 6zx, 6zz, 7bp, 7in, 7jd, 7ke, 7lu, 7ly, 7mf, 7mo, 7mp, 7nw, 7tj, 7vo, 7yg, 7yj, 7yl, 7ya, 7ze, 7zf, 7zk, 7zu, 9ht, 9yal.

C. W.—6abg, 6ale, 6aoy, 6aqt, 6atm, 6awv, 6cu, 6en, 6gy, 6km, 6my, 6oo, 6wv (U. S. Army, Denver, Colo.), 6wx, 6xnc, 6xad, 6xad, 6zak, 6zn, 6zz, 7go, 7rn, 7xf, 8jl, 8uj, 9amb, 9bd (Canadian), 9dva, 9wd, 9zac, 9zaf, WJK.

Phone—6wv (U. S. Army, Denver, Colo.), 6xar (daylight), 6xaj, 6xak, 6xd, 6xg, 6xw, 7xf, WJK, 9zaf (Denver, Colo., 870 miles air-line).

All of the above calls were heard on a home made receiver, and one audio-tron bulb.

(See page 56 for details of cabinet.)

The CW Manual

Second Installment

By J. B. Dow, Ensign U. S. N.

Modulating Systems

Fig. 11 illustrates the power modulator method of controlling an oscillating vacuum tube at voice frequencies and represents one of the most successful though not the most efficient method of accomplishing this. For a single tube oscillating circuit employing a tube rated under 100 watts and for multiple tube circuits employing two or three smaller tubes, this method of obtaining modulation at voice frequencies is recommended. With larger single tube circuits and circuits in which more than three small oscillator tubes are used, one of the various other methods of modulation should be used to promote overall efficiency.

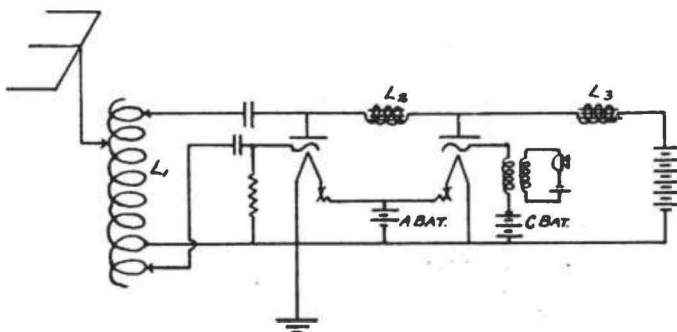

Fig. 11. Power Modulator Method of Control for Hartley Circuit.

The power modulator circuit of Fig. 11 is due to Heising and it is here used to control a Hartley oscillating circuit. In a similar manner control of a Heising oscillating circuit may be had, as in Fig. 12. In the above mentioned circuits L_1 is the low resistance inductance in the oscillating circuit, L_2 is a radio frequency choke so constructed as regards distributed capacity between turns as to prevent radio frequency currents from entering the modulator tube circuit. At the same time, this choke must offer little impedance to currents at voice frequencies. These latter currents, though pulsating in nature, behave much the same as alternating currents, in large

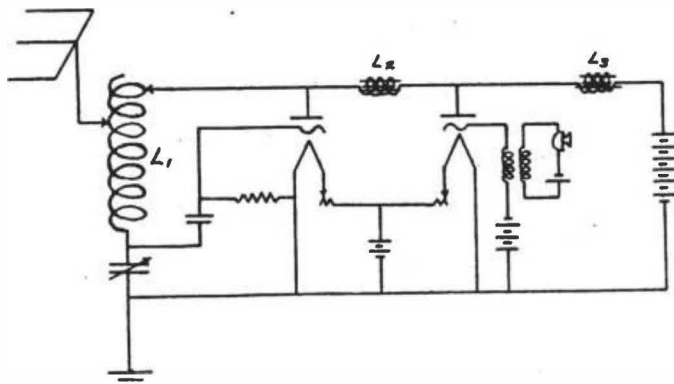

Fig. 12. Power Modulator Method of Control for Heising Circuit.

inductances. L_3 is an audio frequency choke which is placed in series with the generator supplying the required power to the plates of the oscillator and modulator tubes to insure that the current supplied by the generator will be as steady as possible. Theoretically, with a choke of the correct value for this purpose, and with other circuit constants of good proportions, the supply of current by the generator will be constant and the currents in the plate branches of the network will merely shift between the tubes. This condition is rarely found in practice, however. This may appear somewhat misleading to the layman who inserts an indicating device such

a milliammeter in the generator circuit and notices fluctuations in the current evidenced by a swaying needle. The frequencies which cause this swaying are harmonics of audio frequencies or other disturbances below the lower limit of true audio frequencies. Such an indication is however a reasonable test of modulation, though not a true indication of voice modulation.

It will be observed in Figs. 11 and 12 that a battery is placed in the circuit at C to obtain the necessary negative grid potential. The capacity grid leak resistance method of bringing about a negative potential cannot be used here as in the case of the oscillating tube.

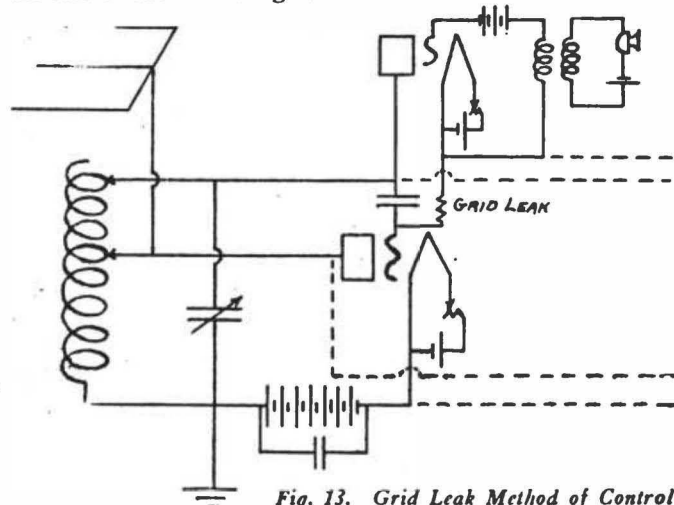

Fig. 13. Grid Leak Method of Control

In the circuits explained above the secondary of the modulation transformer is directly in series with the grid. The grid potential then is dependent upon the ratio of turns in primary and secondary, and the rate of change of current in the primary. If the potential variations thus produced on the grid are excessive or insufficient, poor modulation will result.

Fig. 14 shows another method of controlling an oscillating tube circuit at audio frequencies. This is known as the

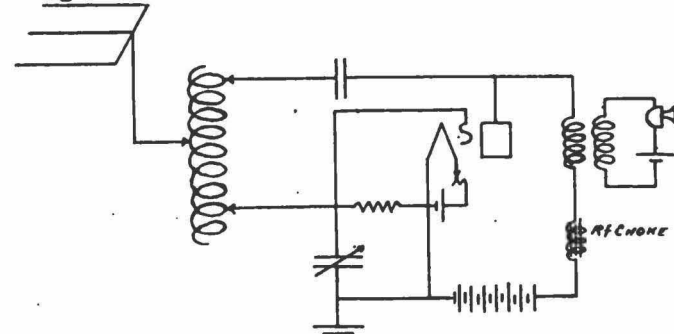

Fig. 14. Control by Modulation Transformer Secondary in Power Circuit.

grid-leak resistance method of control and consists in shunting the grid leak resistances of the oscillator tubes with the variable resistance path between plate and filament of a separate three electrode valve. The manner of controlling this latter valve is the same as that previously explained. This is a very simple method, but care must be taken in selecting the grid leak resistance values for the oscillators. By connecting several oscillators in parallel and using grid condensers and grid-leaks, one small tube may be made to con-

trol the combined output of several power oscillators. The dotted lines in Fig. 13 illustrate the method of connecting the several oscillator tubes.

In Fig. 14, control is accomplished by inserting the secondary of the modulation transformer directly in the power supply circuit. Using a simple receiving tube as an oscillator the author has obtained remarkable results with this system. It is not well adapted to the control of large power tubes, however.

Alternating Current C-W Circuits

Of late, vacuum tube transmitters designed primarily for telegraphic purposes have been utilizing the easily obtained high potential alternating currents for the necessary power supply. This is because high voltage direct current generators require considerable care and attention and are expensive.

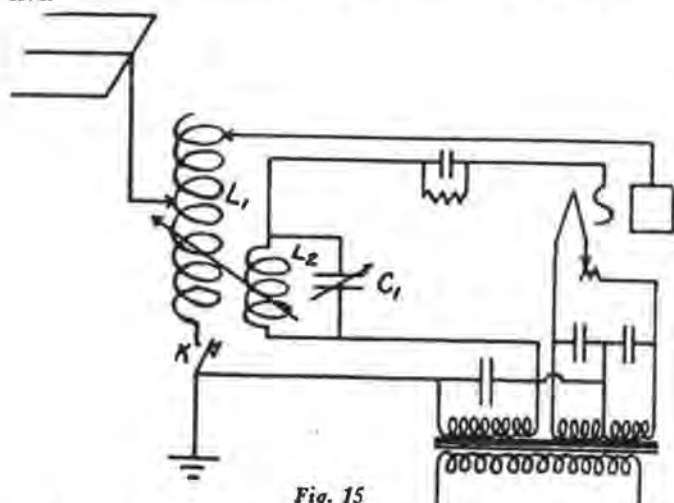

Fig. 15

One of a number of circuits employing alternating current for both plate and filament supply is shown in Fig. 15. Here a single transformer having two secondaries is used. The mid-point of the filament winding is tapped to eliminate the "hum" which would be caused by connecting the grid to one end of the winding. The transformer secondaries are bridged as illustrated in the diagram by small condensers designed to withstand the impressed electromotive forces. The correct values of these capacities will be found to be approximately .002 micro-farad in the case of the one bridging the plate supply secondary and almost any value greater than that in the case of the others. Care must be exercised in using capacities across a supply of high potential alternating current, as a power circuit involving high currents is liable to result. These currents while termed "wattless," result in large copper losses in the windings. The circuit of Fig. 15 illustrates the method referred to earlier in this chapter, of obtaining the required grid input by a variable coupling device having a fixed amount of wire in the circuit at all times. L_2 is the input inductance and is coupled to L_1 by either the sliding tube or variometer method. It is bridged with a capacity C_1 to facilitate adjustment. The conventional capacity grid leak resistance method of maintaining a negative grid potential is used. This circuit may be termed an ideal one in so far as simplicity is concerned. It oscillates easily, and is very efficient, but it possesses the disadvantage, of utilizing only one-half of the alternating current cycle. During the part of the cycle when the plate is negative no oscillations are produced. This circuit will be considered in detail later.

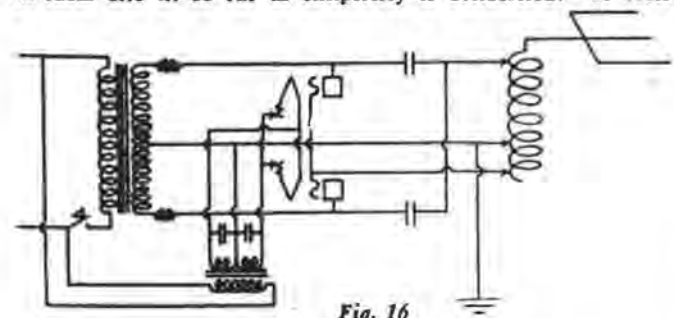

Fig. 16

lates easily, and is very efficient, but it possesses the disadvantage, of utilizing only one-half of the alternating current cycle. During the part of the cycle when the plate is negative no oscillations are produced. This circuit will be considered in detail later.

A circuit utilizing both sides of the cycle is illustrated in Fig. 16. This is a simple Hartley circuit using two tubes. The inductances L_2 and L_3 are radio frequency chokes placed in the circuit to prevent absorption of the high frequency oscillations in the distributed capacity and resistance of the transformer T. Their use is imperative in this circuit. The capacities C_1 and C_2 should be quite large, preferably in excess of .005 micro-farad each. Without these, the transformer secondaries supplying the high voltage to the plates

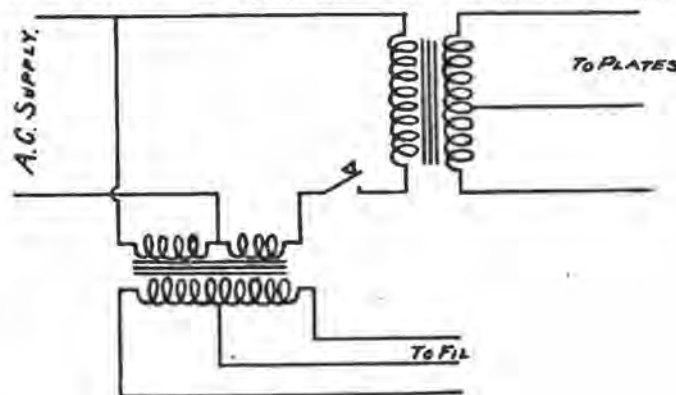

Fig. 17

would be short circuited by the inductance L_1 . The use of these is also imperative in this circuit. With a transmitting circuit of this kind using two 50 watt tubes, the author has obtained an overall efficiency of 45 per cent.

If the key is placed in the circuit at B, the life of the filaments is impaired considerably by the continuous shock to which they are subjected in transmitting. See Fig. 17 for method of lessening this shock, where it is proposed to have the filaments heated at all times, but only at their operating temperature when the key is pressed. This should meet with great favor among experimenters whose supply of tubes is limited. Since the core of the filament transformer is active at all times, the high voltage transformer must be a separate one. The filament transformer has two primary coils, one of which is connected across the alternating current supply and provides a sufficient potential difference in the secondary to heat the filaments of the tubes, the other being paralleled

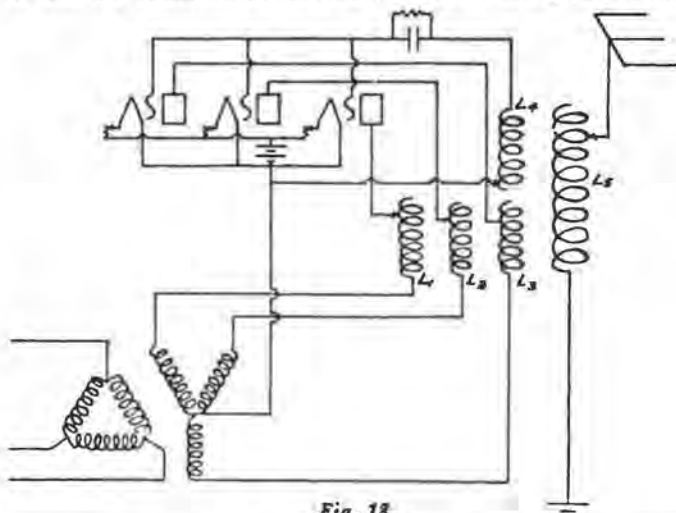

Fig. 18

with the former through the primary of the high voltage transformer when the key is held down. The currents in the two filament transformer primaries are not exactly in phase owing to the difference in impedances of the two wind-

ings, but this should cause no trouble, since the capacity of this transformer is quite low and magnitude of these currents is small.

Polyphase C-W circuits have made their *debut* into the curriculum of the experimenter of late and up to the present time, have given every indication of remaining. By the use of multiphase currents many things are gained—the low frequency note is eliminated and greater output may be obtained with less straining of the tubes. See Fig. 18 for a circuit employing three phase alternating current. In this circuit only one side of each cycle of each phase is used and instead of a disadvantage as in the case of single phase supply, this feature presents a decided advantage as the tubes are idle during a portion of the time and consequently have an opportunity to dissipate the heat generated. In the single phase circuit this idleness resulted in a low frequency hum which was objectionable, particularly when attempting to control the output telephonically. In Fig. 18, the so-called series power feed circuit is employed, which eliminates the use of radio frequency choke coils. The three inductances L_1 , L_2 and L_3 are in the plate circuits of their respective tubes only and as a result only a unidirectionally pulsating current flows. This rising and falling unidirectional current induces in the inductance L_4 the radio frequency current used as the carrier wave. L_4 is coupled inductively to L_5 to obtain the necessary grid input. Separate grid condensers and grid leaks should be used for best results, although one grid leak and grid condenser will be found quite satisfactory. Overall efficiencies of 50 per cent may be obtained with such a circuit as the one outlined above, and, as will be found below, a three phase alternating current may be employed to supply the necessary plate potential for tubes controlled telephonically.

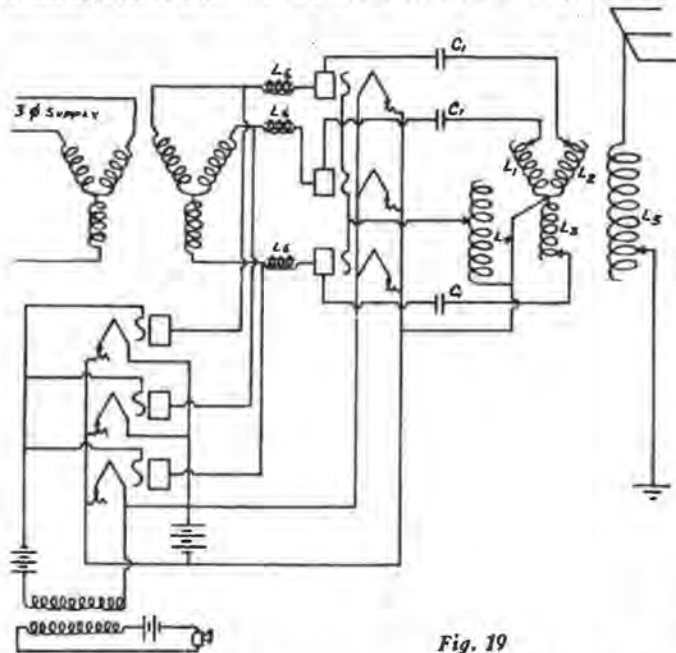

Fig. 19

Fig. 19 represents such a phone set and one which has actually demonstrated the utmost practicability. Three tubes connected as shown are used as oscillators, and Heising's system of modulation is employed to control these tubes. The inductances L_1 , L_2 , L_3 , L_4 and L_5 are coupled together. No particular difficulty presents itself in accomplishing this, for five pancake ribbon inductances of the type used in the Navy standard field equipment were used without alteration in the original experimental set used by the author and excellent results were obtained. The capacities C_1 are all in excess of .01 micro-farad and are used to prevent the transformer secondaries from becoming short-circuited through the inductances L_1 , L_2 and L_3 . A radio frequency choke coil L_4 is placed in each transformer secondary lead for reasons previously explained. It will be observed that the series power

feed circuit is not employed here as in Fig. 18. The overall efficiency of a circuit of this kind will compare favorably with one of equivalent output employing direct current, and in using the ordinary 3 phase 60 cycle supply, the audible ripple in the carrier wave is hardly appreciable during conversation.

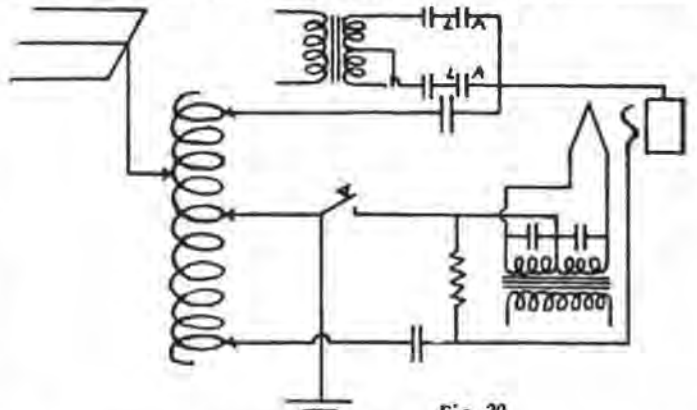

Fig. 20

The circuits that have just been considered, use unrectified alternating current on the plates of the tubes and if anything less than three phase supply is used for this purpose, difficulty will be experienced in adapting the circuit to voice modulation since a low frequency ripple will be present in the received signal. If it is desired to utilize the easily obtained high voltage single phase alternating currents for the plate supply of phone equipment, the experimenter will do well in rectifying the same in a manner suggested in Fig. 20, or by one of the various other means outlined in detail in a latter chapter. In Fig. 20 an electrolytic rectifier is used. This method, while simple, and probably the most inexpensive from the experimenter's point of view, requires more or less constant attention and is objectionable for that reason.

The Power Amplifier

Probably the most interesting improvement in vacuum tube circuits that has come out in recent years is the use of the power amplifier in radio phone circuits. Little use, however, has been made of this adjunct by the average experimenter. By way of definition to the uninitiated, the power amplifier is a device used to reproduce in greater magnitude currents having a pulsating or alternating nature. The ordinary power modulator scheme of controlling an oscillating vacuum tube circuit, (Fig. 19) is limited by the ability of the microphone through the medium of the modulation transformer to control the modulator tubes, which must, for the best results, be equal in number and power to the oscillators. This limitation results from the fact that it is very difficult to design a voice amplifier of high power that will operate without distortion.

Fig. 21 illustrates the use of the power amplifier in connection with a radio-phone set of low power represented by T. A and G are respectively the antenna and earth connections of such a set. The capacity C_1 which should be var-

Continued on page 56

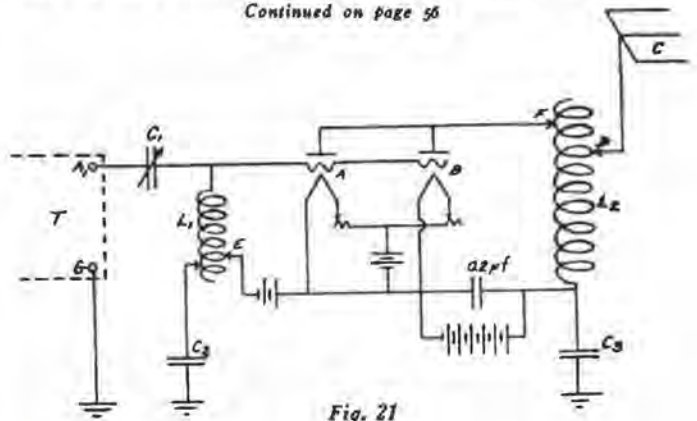

Fig. 21

Successful Experiments with Earth Antennae

A Comparison of Ground Versus Aerial Transmission and Reception

By Edward M. Sargent

SOME interesting experiments with ground antennae performed at the refinery of the Continental Mexican Petroleum Company at Tampico, Mexico, by the writer, aided by Mr. J. T. Schilling, developed a number of new facts concerning radio reception. The site was an ideal one for radio work, the refinery being located on the south bank of the Panuco river, on the edge of a large, level stretch of filled-in land. The river water is salty at this point, and as the land level is not over two feet above the water level, an excellent ground connection was obtained by driving a 2 ft. pipe into the soil. The soil is damp 2 in. below the surface, and is soggy a foot below.

The Continental Mexican Petroleum Co. had some DeForest radiophones to be installed at different points in this vicinity, and as trouble was anticipated through interference with the local Mexican station, which was across the river and less than two miles away, the ground antenna was turned to as a possible solution of the difficulty.

The first experiments were to determine whether good transmission into the ground could be accomplished. Accordingly, a ground antenna was constructed as follows: Two 3 ft. galvanized iron pipes were driven into the ground 65 ft. apart, on a line bearing N 41 degrees E. These two pipes were connected on the surface by a No. 12 weather-proof copper wire, and a radio frequency inductance of about 40 microhenries was connected in series with the wire at a point near where it joined to one of the pipes. The coil was inductively coupled to the helix of a DeForest buzzer phone which was used as a transmitter to supply continuous wave power.

The receiving antenna was laid out in exactly the same way and was placed parallel to the transmitting antenna at a perpendicular distance of 1000 ft. from it. In place of the 40 microhenry coil, a DL-50 honeycomb and a variable condenser were connected in series with this wire. It will be noted that, contrary to the usual custom, both ends of the "antenna" were grounded in each case. The DL-50 was used as the primary in a DeForest RS-500 receiving set, and no difficulty was experienced in picking up the CW from the transmitter, using a wavelength of 400 meters and a one bulb receiver. When the far end of the receiving wire was disconnected from the ground signals became weaker. The receiving wire was then swung around 90 degrees so that it pointed N 49 degrees



Fig. 1

W and the end again grounded. Signals were stronger than with either connection when the wires were parallel. Next both wires were lengthened to 125 ft., and the ends were again grounded. A marked increase in the signal strength resulted.

The receiving wire was now 125 ft. long and bearing N 49 degrees W (pointing directly at San Francisco). When tried as a receiving antenna for radio telegraph waves, it was found that 600 meter signals from the local government station, from ships in the river, and from NAY (Pt. Isabelle, Tex.), 300 miles north of Tampico, could be received easily. NAY could not be heard unless both ends of the wire were grounded. At night, NPL's 9800 meter arc was heard, but altho the higher waves were searched very carefully, no east coast arcs could be picked up. This led to the belief that the antenna might be directional, so another of similar dimensions was laid out, along a line passing through Tampico and Washington, D. C., bearing S 41 degrees W from the receiving set. On this wire WII, WGG and WSL were picked up easily, but NPL could not be heard on a detector and was just barely audible using a one step amplifier. There was very little static on either wire. No overhead antenna had been put up at that time, so there was no chance for comparison in that respect.

On the night of April 23rd, NPG, NPX, and NPL were heard working on spark on about 2000 meters. These stations were received on the NW wire and a one step amplifier receiver. On 600 meters, NPX and KPH besides one or two boats near San Francisco could be picked up by close tuning. The Admiral Farragut and another boat off Manzanillo, Mexico, were also heard. When the far end of the receiving wire was insulated, none of these stations could be heard. On the SW wire, NAA, NAR, PWA (Havana, Cuba), and

XDA (Mexico City) were all easily received.

By referring to Fig. 1, it will be noticed that the bearing of some of these stations such as PWA, NAR, NAY, XDA, and the boats off Manzanillo and Lower California varied considerably from the direction in which the wire pointed. NAY and PWA differed by nearly 45 degrees from the wire directions and could be read equally well on either. It was only when the station bearing was nearly perpendicular to the wire bearing that the signals could be entirely eliminated.

The surprising thing in all of these experiments had been the strength of the signals, and the distances from which they had been received, some of these such as KPH and NPG comparing very favorably with what could be done on an overhead antenna. Ordinarily it would seem that a wire lying along the ground and connected to ground at both ends should be nearly free from radio signals. The natural conclusion at first was that the whole system must be acting like a loop antenna with the ground forming the return side of the loop. Accordingly, a loop was constructed, the dimensions of which were equal to those of the ground wire. The loop ran parallel to the SW wire, was 125 ft. long and consisted of one turn of No. 12 weather-proof copper wire. The top wire was 3 ft. above ground and the bottom return wire one foot below the top one.

This loop was tried out against the SW ground wire, and the ground wire was found to be markedly the better. Neither NAA spark nor any of the east coast arcs could be heard on the loop, while all were easily read on the wire. This seemed to indicate that some other explanation of the action of the ground wire must be looked for.

Instead of using the ground connection under the receiving set, the two ground wires were now connected in series through the primary coil and variable condenser as in Fig. 2. Signals from NAY and XDA increased in strength noticeably, while the others were not greatly affected.

By referring again to Fig. 2, it will be readily seen that as the maximum distance between the wires (at the ends) is much less than half a wavelength, the currents induced in the two receiving wires from either NAY or XDA would be such that they would tend to neutralize each other, and the signal should be weaker using the combination than using

either wire alone. Apparently then, the signals were being picked up through the ground rather than by the wires, and the best receiving direction would be determined by the direction of a line joining the two ground pipes and not by the direction in which the wires were lying on the surface. In the case just cited, a line through the two ground pipes would run almost through NAY and would be nearer in the direction of XDA than either wire used alone.

Next, a wire 125 ft. long was laid parallel to the SW ground wire and was carefully shielded over its full length by running it through a ½ in. galvanized iron pipe. The pipe was laid along the ground and connected to a good ground at the center. The end of the shielded wire was grounded. Signals on this wire, although audible, were much weaker than on the other, and NAA could not be heard at all. However, one important point had been overlooked, namely the hysteresis losses in the iron pipe, so the experiment had to be repeated.

This time a twisted pair of No. 16 rubber-covered wires, shielded by lead conduit, was used, the wires being connected in parallel. An "antenna" of the same dimensions as the other was laid out, the conduit resting on the top of the ground, which was dry. The shield was grounded at the center. On daylight signals from WGG there now was absolutely no difference between the shielded and unshielded wires. That night, however, it rained, and as soon as the top of the ground was thoroughly wet, the signals almost completely died out in the shielded wire. When the shield was lifted clear by laying boards under it, the signals returned again to their normal strength. Grounding and ungrounding the shield at the center made a slight change in tuning adjustments, but no change in signal strength. Static, what little there was, was equal on both shielded and unshielded wires. When the wire inside the shield was ungrounded at the far end and the center of the outside shield was grounded, signals disappeared entirely.

This experiment seemed to prove conclusively that the wires themselves had nothing to do with picking up the signals, but acted merely as conductors between the two ground pipes. The fact that the shield cannot be laid on wet ground while the unshielded wire can, or can even be buried, is possibly explained by the fact that in the former case the capacity between the wire and the ground is abnormally great and hence results in a considerable decrease in the effective length of the wire. This would make it compare unfavorably with the other. The shielded wire proved to have no advantages over the unshielded and was not used.

Unfortunately, the detector tube which had been used in these experiments burned out the next day. No other tube could be found that was as good, so accurate comparisons of signal strength between the first and the later experiments cannot be made. Atmospheric conditions were rapidly getting worse, long distance signals fading out, and static getting heavier with the approach of summer.

Next, both the NW and SW wires were increased in length to 250 ft. Signals from NPL, NBA, and the east coast arcs increased in strength, although not proportionally to the increase in wire length. NAA spark seemed weaker, but no conclusions can be drawn from that as he faded completely out two days later (May 14th), and was not heard again until the latter part of July.

On these 250 ft. wires, it was found impossible to tune to 600 meters with a

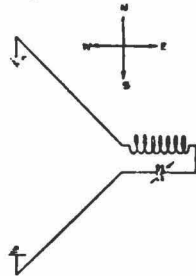

Fig. 2

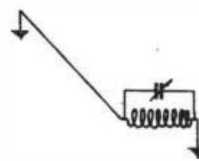

Fig. 3

primary series condenser. A "resonance click" could be found on any wave up to 475 meters, then there was a blank till 850 meters was reached, where a "resonance click" was again obtained. Above 850 meters, tuning was normal. Very few 600 meter stations could be heard, and those that could be were close by. When the primary condenser was shunted around the coil, as in Fig. 3, a "resonance click" could be found on waves between 500 and 800 meters despite the fact that the condenser was apparently short-circuited by a 5 ohm d. c. resistance (the ground resistance). This showed the presence of an abnormally high alternating current impedance in the wire at these wave lengths, and indicated that there would be a best wire length for each wavelength to be received. With a shielded wire 200 ft. long, no wavelength adjustment could be made on waves between 800 and 1300 meters. This appears to be the explanation of the fact that although on long waves there was no difference between signals on shielded and unshielded wires, on 2500 meters the unshielded wire was slightly better. The nearer the "resonance point" of the wire is to the received wavelength, the higher is the effective resistance to be overcome.

During the second and third weeks of May, the beginning of the static season, nearly all the static came in on the SW wire, the NW wire being almost clear. This showed the origin of the static to

be either northeast or southwest of us, probably the latter. After May 25th, static was equally strong on both wires, but many times would be of a different character on each, so that no balancing out system could be used.

By the latter part of May, the overhead antenna was ready for use. This consisted of a grid of 4 wires, spaced 4 ft. apart, 85 ft. high, 175 ft. long, inverted "L". We now had a means of direct comparison of signals between antenna and ground wires. Signals on the overhead antenna were considerably louder than on the ground wires, but static proportionally was much heavier, and NPL and WGG could only be read with difficulty. After the middle of June, no one but XDA could be read on account of static, and the use of the antenna was discontinued. At the same time, while the static on the ground wires was troublesome at times, it never was strong enough to seriously interfere with reception from the United States arc stations and from NBA. The presence of the overhead antenna did not greatly affect the signal strength on the ground wires. When the antenna was ungrounded, the signals on the wires were slightly stronger, but this may have been due to direct induction into the receiving set, as no attempt was made to shield it.

The "daylight effect" on reception with ground wires was different from the effect on antenna reception. On short waves, signals were weaker in daytime on both, although not weakened so much on the ground wires as on the antenna. As the wavelength increased, the daylight effect was less noticeable on the ground wires and when the wavelength of 10,000 meters was reached there was a reversal, and signals were stronger at midday from NPL, NPM, NZR and NBA than they were at midnight. On higher waves this effect increased, and the United States transatlantic arcs were all stronger in daylight than at night. On the Annapolis' wave of 16900 meters this effect was so marked that at ten o'clock in the morning signals from that station could be copied on the typewriter, while at ten o'clock at night it was hard to read them. It is possible that these stations increased their power for daylight work. The writer has no information on this, but does not remember any case in which they have had an excess of power at night, so this does not seem likely.

The primary tuning of a ground antenna, grounded at both ends, is materially different from that with any other form of antenna with the possible exception of the loop. With all ordinary forms of antenna, there is a certain maximum wavelength that can be tuned to with a given inductance, when a series condenser is used. This wavelength is limited by the capacity of the antenna.

Continued on page 14

The Click Method of Determining Resonance

By G. W. Cattell, Radio Engineer

ALTHOUGH there are several methods of determining when two circuits are in resonance, the "click" method is one of the simplest and most useful. It is particularly useful when continuous waves of small magnitude are being used. It may be considered under two heads, audible and visual.

The "audible click" method utilizes a source of continuous oscillations, such as an oscillating audion, and a pair of telephone receivers. The receivers are used to detect the resonance point and may be connected in either the plate circuit or grid leak circuit of the oscillator (See Fig. 1). Either connection will give

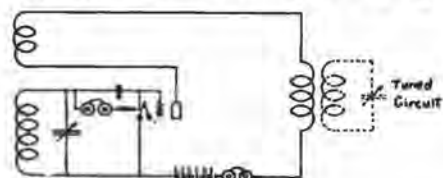

Fig. 1

practically the same sensitivity and reliability.

The circuit to be compared, hereafter referred to as the tuned circuit and shown dotted, may be inductively coupled to the plate circuit of the oscillator. The inductance or capacity of one of the circuits is varied until they are in resonance. When the resonance point is reached, or passed, a click will be heard in the telephone receivers.

Sometimes there are two points where clicks are heard. The true resonance

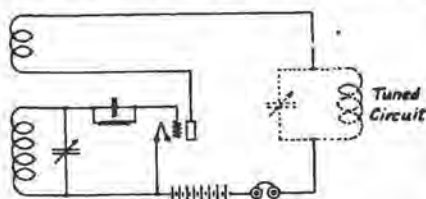

Fig. 2

point is between the two. The existence of two click points is an indication that the coupling is too tight and should be loosened.

Sometimes it is not possible to get sufficient coupling to produce a click by inductively coupling the two circuits. Such a condition may arise if the inductance is very small or the construction of the coil such that the external field is very weak. In this case, the circuit may be connected directly in the plate circuit as shown in Fig. 2. The resonance point is indicated by a click in the receivers as described before.

The tuned circuit may also be coupled to the grid circuit as shown in Fig. 3.

Another variation is to have the detect-

ing means in the tuned circuit as shown in Fig. 4. Under certain conditions this connection may be found very useful.

The "visual click" method is a variation of the one which has just been described. It is essentially the substitution of a sensitive direct current ammeter for the telephone receivers. (See Fig. 6.) The procedure is the same as when the

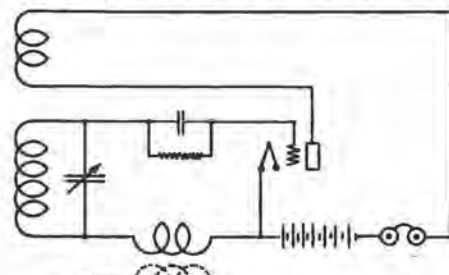

Fig. 3

receivers are used, except that the resonance point is now detected by the deflection of the meter. As resonance is approached there is a more or less sharp change in plate (or grid) current, the maximum change occurring when the two circuits are exactly in resonance.

The theory of operation of the "click" method is interesting and is given below in brief.

Inserting or coupling the tuned circuit to the oscillator is equivalent to introducing a parallel resonant circuit. As is well known, a parallel resonant circuit offers very high impedance to currents of the frequency to which it is tuned. The high impedance thus introduced tends to stop, or at least reduce the magnitude of the oscillations. If the oscillator is properly adjusted for this purpose, a change in the amplitude of the oscillations will cause a change in the magnitude of the plate and grid leak currents.

The adjustment of the oscillator has much to do with the sensitivity of the

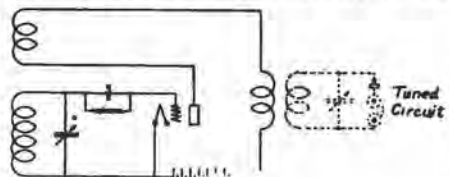

Fig. 4

circuit. By adjusting the tickler coupling, filament current, grid or bridging condenser, a critical setting may be found where the introduction of a given impedance will cause a relatively large change in the amplitude of the oscillations.

Other things being equal, the sensitivity of the method is greater if the resist-

ance of the oscillatory circuit is kept low. Similarly, the impedance of the tuned circuit will be greater if its resistance is kept low.

If the tube is operating near the lower end of the characteristic curve, the plate current will decrease at resonance. On the other hand, if the tube is oscillating near the upper end of the characteristic, the plate current will increase at resonance. This may be seen more clearly by a study of Figs. 5a and 5b.

If the indicating meter is in the grid leak circuit, resonance is indicated by a decrease in meter deflection. This is because the grid leak current is proportional to the amplitude of the oscillations:

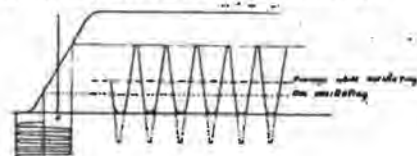

Fig. 5a

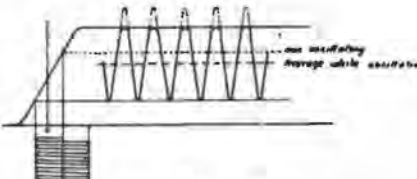

Fig. 5b

Either the visual or audible click method may be used, but the visual click method has certain advantages: (1) It is independent of the amount of noise in the room; (2) it depends upon the eye instead of the ear; and (3) in some cases the rate of change of amplitude of oscil-

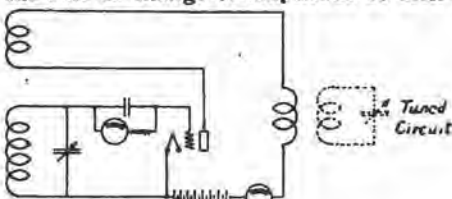

Fig. 6

lations as resonance is approached, is too slow to produce click in the receivers. (This is likely to happen when either of the circuits is high.) It is comparatively easy, however, to observe when the meter deflection is a maximum or a minimum.

The click method (audible or visual) is often used for calibration purposes or for measuring the wavelengths of a received signal.

Fig. 7 shows a scheme of connections for use in calibration work. In order to calibrate a wavemeter for example, place the wavemeter condenser at the setting desired and adjust the oscillator until resonance occurs. Then without changing the oscillator, adjust the standard

Continued on page 30

AMATEUR RADIO LABORATORY MEASUREMENTS (Continued)

By D. B. McGOWN

We will now take our 50 turn coil, and set it up as a wavemeter. Fig. 1 shows a complete system set up for wavemeter, or condenser calibration. As we have not, as yet, arranged our instruments so we can measure wavelengths, we must first proceed to make up a condenser with a calibration curve, so as to obtain the wavelength from a few simple calculations. In Fig. 1 we have an inductance,

higher capacity than this, it is very difficult, indeed, to measure wavelength using such small coils, as we first started with. So that the readings may not be "all over the scale" with this capacity, we must substitute large coils, say of about 250 turns capacity—again the use of honeycombs or similar type is suggested—and it will be found advisable to borrow these, if they are not available for use. With the larger coils, installed, we will proceed to measure the capacity of C_2 , up, either to its limit, which, if it be an .001 condenser should not be above .009 for accurate readings, or .0018 for a .002.

maximum, as the curve can be simply extended in such a manner as to be uniform with the general slope, and direction of the true, or original curve.

It is a good plan, while set up, to calibrate all the condensers available, as they may, and probably will come in handy at some future time, and it is always a very desirable thing to have condensers that are dependable, before starting to work. Care should be taken in selecting a condenser for calibration, to get one that is mechanically in the best of condition. One that is the least bit "wobbly" is absolutely useless, as it is impossible to get two consecutive readings that are absolutely the same. If the condenser has a poorly attached scale, or knob, it also had better not be used for any kind of calibration, or standardization work; one that has the knob, or pointer fastened with a simple set screw is very liable to give trouble, unless care is taken to never disturb the adjustment of the screw. A bent, broken, or flimsy pointer should also be avoided, whenever possible, and a good strong solidly made condenser is the only one that should be used for our standard.

We will now have no further use for the original standard condenser of glass plates, as we have transferred its capacity measurement to the variable one, and it is now in a much more easily handled form.

STATIC STATISTICS

By SQUAWK MCGUFF

HAM: "Understand that Mr. Mott has worked 8KW."

OLDER HAM: "Gosh, how the dickens does he get that way. I thought amateurs were limited to one KW. How does he get away with it? I'll bet the R. I. don't know it."

There lived a radio fanatic
Who had a crystal set in an attic.
He thought he heard POZ,
And was dancing with glee,
When another ham told him 'twas
static.

Sparks may come and sparks may go,
but C. W. is continuous. H. Smith.

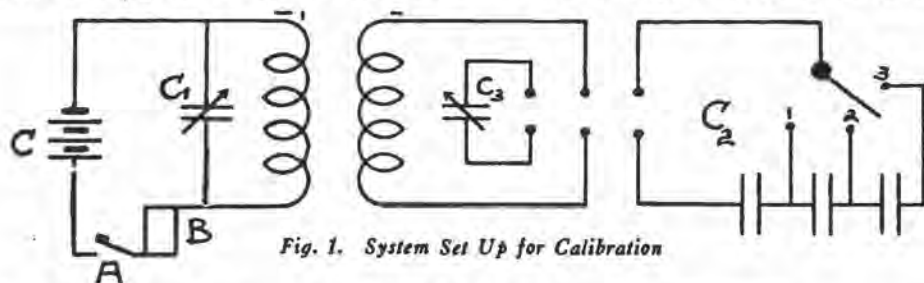

Fig. 1. System Set Up for Calibration

L_1 shunted by condenser C_1 , with a buzzer and battery connected in such a way that feeble radio frequency signals are set up. L_2 is the receiving coil, and is so arranged, by means of a double pole, double throw switch, that either C_2 , which is our known condenser, or C_3 , which is the condenser to be calibrated, may be shunted across it. L_2 is the 50 turn coil we have just made up, or a 50 turn honeycomb, and L_1 is a similar coil.

Now to indicate the resonance point between the two circuits we use the telephones and crystal detector, which is shown connected "unilaterally." When the buzzer B is started, it will send out feeble oscillations, which, if in tune, will be audible in the telephones, due to the current induced in L_2 . Now, C_1 is variable, so that with the DPDT switch thrown to the right, we may set the condenser switch, of condenser C_2 , on point 1, and adjust C_1 , until we get the loudest signal in the headset. Now, if the switch is thrown over onto condenser C_3 , and it is adjusted to resonance, we will have found one point on the capacity scale of C_3 , which is to be calibrated. This, as was stated last month, was .0003 mfd. Now, put the switch on point 2, and repeat the process. We then will have the scale value for the point of .00015 mfd, and for the third point, we will have the capacity for .0001 mfd.

This is about as low as it will be convenient to read the average condenser, and as we will in general be concerned with higher readings, we will put a "fan" blade on the switch C_2 , and reconnect this portion of the circuit, as shown in Fig. 2, which will give us a method of connecting the plates in parallel.

Starting with two plates in parallel, we will get a capacity of .0006 mfd, which can be noted as before. With a

Now a series of readings will be found, which will look something like the following:

Condenser scale.	Capacity in mfd.
8.0.....	0.0001
22.0.....	0.00015
40.0.....	0.0003
100.0.....	0.0006
160.0.....	0.0009

A curve can be plotted on ordinary cross-section paper, and the intermediate points read, so that the exact capacity on every point of the condenser scale can be read, provided it is within the limits of measurement, and the curve can even be "extended" a few degrees, with reasonable accuracy, if it is necessary to get a reading that is a short amount over the

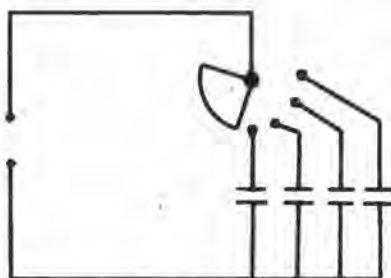
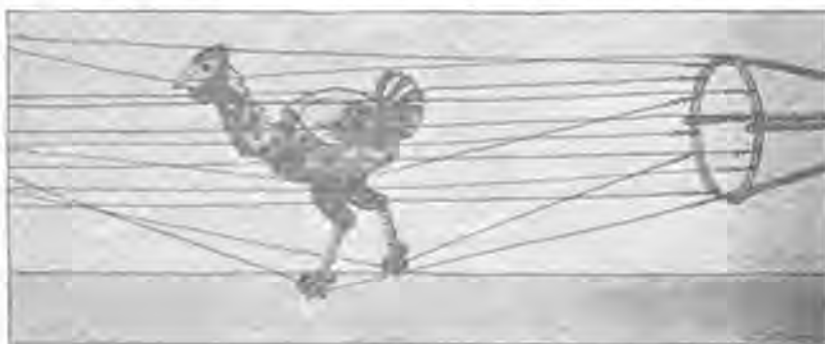

Fig. 2



"Darn These Cage Aerials, Anyway!"

Modern Commercial Radio Apparatus

I. Elementary Principles of Operation

By D. B. McGown, Assistant Radio Inspector

BEFORE describing the details of the various types and kinds of radio transmitting and receiving apparatus now in use by commercial radio telegraph companies at both their marine and shore stations, it is desirable to review the underlying principles on which this operation depends. Without some basic knowledge of the "works" it is almost impossible to convey an accurate idea of what is happening in, or to, the various apparatus.

Radio apparatus may be considered under the two general classes of damped wave and of undamped wave equipment. These two classes are naturally divided into as many groups as there are indi-

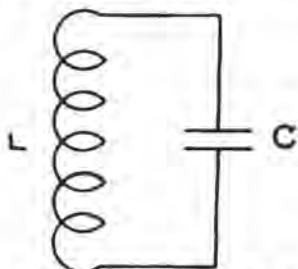

Fig. 1. Oscillatory Circuit

vidual manufacturers. But we can boil the actual theory of the apparatus down to a very few points.

All transmitters have some means of producing oscillations or radio waves. The so-called ether is necessary for the transmission of these waves. Some means must be provided for receiving or catching these same waves at a distant point. No matter what the type of apparatus, it must do these things, or we would not have a complete radio system. The waves, or trains of waves may be interrupted at certain periods, as they are in a radio telegraph transmitter, or they may simply be varied in their power, or amplitude, as is the case with a radio telephone transmitter and a few special cases of telegraph sets.

These oscillations are produced by an oscillatory circuit consisting of an inductance and a condenser connected in shunt, as shown in Fig. 1. If a charge from some external source be impressed on the condenser, C, a discharge will take place thru the inductance L. The frequency, or rapidity of this discharge, depends on the values of C and L, the resistance being neglected for simplicity's sake.

First assume that the plates of the condenser C are quite close together, and that the inductance L is made up of wire closely wound on a form. Such a cir-

cuit will be a very poor radiator of electrical oscillations.

Now suppose that we retain the inductance L, and use a condenser in the form of an antenna and ground, as shown in Fig. 2, the antenna A forming one plate of the condenser, and the ground G forming the other. If some means are used to charge the antenna, it will be found that electrical oscillations are set up in this circuit just as they were in the previous case, but with one difference. When connected to an antenna and ground of proper characteristics it will be found that energy is radiated into the space surrounding the antenna as electromagnetic waves, whose length and amplitude depend on the particular values of L and C, as well as the resistance of the circuit. These electromagnetic waves travel thru space until they reach the receiving or detecting device, and there they are caught, and their effect recorded.

The object of all radio transmitters is simply to set up oscillations in the antenna system, similar to that shown in Fig. 2, and for these oscillations to cause electromagnetic waves, which may be received at a distant station. Various means of accomplishing this are used, as will be described later.

Suppose that the antenna system exists, as shown in Fig. 2, but that instead of

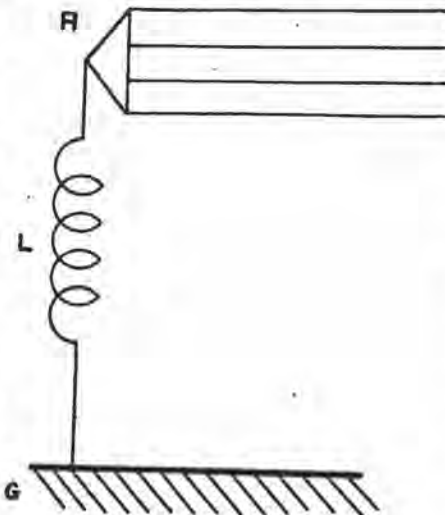

Fig. 2

the antenna's radiating energy, electromagnetic waves are impressed on it from some outside source, such as a distant transmitting station. If these impressed waves are of the same frequency as that possessed by the antenna and ground system, this system will oscillate. This oscillation, being of an electrical nature,

will not be visible or intelligible to a human being, without some indicating device. There are countless devices which might be used. An ammeter might be inserted in the circuit between the inductance L and the ground G. If the antenna was oscillating strongly enough, the ammeter would move every time the antenna was charged and discharged. This would not be very sensitive, however, and usually much more delicate apparatus is used for this purpose. These devices are known as receivers, and they, like the transmitters, will be completely and thoroughly described and explained as we proceed.

Fig. 3 is obtained by adding to Fig. 2 another circuit similar to that in Fig. 1. Here we have two circuits, both cap-

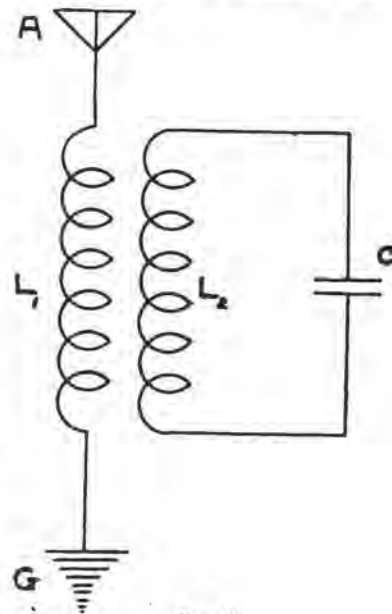

Fig. 3

able of oscillating at their own periods, or frequencies. Due to the proximity of the two inductances, L_1 and L_2 the electromagnetic lines of force which are set up around one, when a current flows thru it, induces a current in the other. If these two circuits are so adjusted that they will both have the same period of oscillation, any oscillation which takes place in one will take place in the other. Or to put it in other language, if the two coupled circuits AL_1G and L_2C are in resonance, energy will be transferred from one circuit to the other when oscillations take place. This action is made use of in all radio apparatus, either transmitting, or receiving, in ways which are modified to meet the requirements of the particular kind of action desired in the

Hodeycobe Micraferris Brown

A Weird Tale of Wireless Rejuvenation and Escape from Cannibals

By Clyde C. Young

SOMEWHERE in the Pacific rise the peaks of Zoogoo Isle, where the cannibals ply their trade. But activities on Zoogoo were dormant. The rib-steak hunters had existed on berries and dogs for many days. It remained for the good ship Rosie to break the fast when she encountered a typhoon, slid over several coral bars and rested on the bottom some 200 yards off Zoogoo. All that was left as a reminder that the Rosie had been a ship was her cabin aft, which rose clear of the water, and a mass of tangled copper that had once been a beautiful antenna.

they did not come up to expectations—well, the way of the transgressor is hard.

Thus Hodeycobe found himself summoned to appear before the mighty Monarch of the Malay. Among the Zoogoos the one person who spoke English was Tatoon, a grandson of the great chief, who had at one time been rescued by a trader, after the wreck of his catamaran in a monsoon which carried him far to sea. He had worked his way to Liverpool, and consequently had picked up snatches of English. Tatoon, therefore, was brought into play as interpreter.

"The chief says to tell you," he be-

gist of it and was told to tell Hodeycobe to proceed without delay.

The Rosie, he found, was resting on the bottom with the wireless cabin barely clear of the water. With the help of his two companions he salvaged the complete 2-K.W. auxiliary along with the receiver and a receiver of his own. Floating near the ship, they also found two ten gallon drums of gasoline, which they towed to shore for possible use in the auxiliary.

Two wet cells in the outfit that had been on charge until the Rosie met her fate, and were well up. Hodeycobe thought they would last possibly a month if he was careful with them. He also had enough wire for an elaborate antenna system.

The location was ideal. Their prison hut was near the top of the hill overlooking the ocean to the west. Two trees were conveniently near and served as masts. He had an antenna that was some 400 feet high and 180 feet long. This gave him a fundamental wave length of perhaps 500 meters.

This was exactly what he had been hoping for. He had been thinking that if he could get on the ship's wave of 600 meters and with the old gas auxiliary in action he might attract the attention of a ship or perhaps the navy, who no doubt had ships in those waters. But this island seemed to be out of the lane of travel as he had never sighted a ship from the hilltop while at work.

CHIEF UNGUS and his retinue made a tour of inspection on the third day. Hodeycobe had the receiver working in fine style. Signals were coming in. The chief was invited to put on the phones. He could hear a wireless telephone, but of course could not understand what was being said.

The prestige of Hodeycobe was enormously enhanced. The old chief regarded him in healthy awe. The guard was somewhat relaxed, but escape was impossible unless a ship should rescue them. To take a small boat and make for the open sea was a fate almost as bad as the one they now faced.

And so, with tribal feasts, hunts, fishing excursions and so on, the days wore slowly onward. Ten more days and he would be called upon to take forty years from sixty-five. He had no earthly idea how this was to be accomplished, but in the course of the confusion he might "stall" for time.

Deciding to have Hodeycobe experi-

Continued on page 62



"Where the cannibals ply their trade."

UNGUS, chief of the Tahooties, was on hand to "welcome" those who might be fortunate enough to reach the shore line. Among the few survivors were First Wireless Operator Hodeycobe Micraferris Brown and two of his race. They were escorted to a small, dirty-looking hut. The attitude of the savages was quite unfriendly and businesslike when they ventured too near the opening in the hut.

Chief Ungus had a hobby—the search for youth. The chief had passed his sixty-fifth year, but had never given up hope that he might at some time discover the fountain of youth. He had noticed the three black boy survivors and thought that they were probably men of his own race who had made great advances in the world, or perhaps were the spirits of the dead returning. Nevertheless, he was a shrewd person, this ruler of the Zoogoos. He would hold counsel with them and if

gan, addressing Hodeycobe, "that he wishes you to take forty years from his age. That if you fail to make him at least that much younger within twenty days that you are to be offered up so we may feast upon you."

"Hodeycobe's intelligence did not extend far beyond his capacity as an operator, but being a disciple of the rolling bones he was a good bluffer. Hence he resorted to politeness and tact.

"Tell de chief ah am de boy whut can pufohm dat merickle. Ah am de boy whut learned Nero' that tune on de fiddle when de built de bon fire in Rome. Ah was de man whut sent the fust wyaluss message dat Columbus arrived in America. But tell his royal highness ah must get to de Rosie and salvage de app'ratus to turn de trick."

Tatoon was not exactly sure what Hodeycobe was saying, but grasped the

The Kickback

By Volney G. Mathison, Author of the Samuel Junes Series

ALAN STIRINGER, sitting slouchily on the sofa in Captain Viericks' cabin, deftly flicked the ash from the tip of the cigarette he held between two long nervous fingers.

"We've got to ditch that nosy kid of a second operator," he was informing the podgy, bull-dog visaged master of the steamer "Bellaroba," who sat in a leather chair opposite him. "He's got onto our secret code."

Captain Viericks' blotchy face paled a little.

"How do you know?"

"Caught him with a copy of it when I happened to walk into the wireless room on his watch this afternoon," clipped off the tall, thin-faced first operator of the "Bellaroba." "He had it on the desk and was decoding that last message about the cocaine shipment——"

Viericks' coarse loose mouth had taken on an ugly twist.

"You and I are the only ones on the ship with copies of that code——"

"I know—keep your shirt on, Viericks. We've been working this game together long enough to know better than to have a row about a thing like this. I lost my code-sheet from my stateroom locker a week ago. The kid found it."

The stumpy master of the "Bellaroba" cursed.

"Then he knows we're running dope from Vancouver down to the ring in Frisco?"

"I can't say—I've taken the message out of the file, but I don't know how much he'd translated of it when I came in."

THE two men relapsed into a glum silence.

They were a strange pair, this thin, nervous wireless operator and this sawed-off, brutish-faced commander.

Alan Stiringer was a mystery to the Pacific Coast wireless men. He never associated with any of them and apparently had nothing in common with them beyond the fact that he was an operator. It was not until after the occurrence of the grim tragedy around which this tale is woven that it was learned that Stiringer was known to the police of an eastern city as a shady character possessed of a remarkable knowledge of electrical bank-vault alarm systems and the inventor of a marvelous microphonic instrument for opening combination locks. Perhaps a few close brushes with the law and a look-in through the gray stone portals of a penitentiary had led him to take up the safer pursuit of dope-running. He presumably observed that the berth of radio operator afforded op-

portunities for this business, for he went to a wireless-school long enough to pass for a license. Eventually, the partnership with Viericks, a bird of his own feather.

The antecedents of Captain Viericks have never been revealed. His captaincy of the "Bellaroba," however, is not hard to account for. The parsimonious owning company is notoriously partial to hard-faced, sour-souled captains who can squeeze out the extreme

this story to the federal people, we'll be in for a hot rake-over. You know as well as I do, we've already had rubber-heels prowling around the ship looking for dope—and the company is acting queer. They smell a rat."

"Then you would——"

The two rat-like eyes beneath Viericks' low receding forehead glittered still more beadily.

"Lose him overboard."

Stiringer leisurely blew a smoke-ring.



"Tommy put the message back in the file, but not before Stiringer opened the door."

maximum of service from their fleet of coastwise steamers with the least possible outlay of money for upkeep and wages.

CAPTAIN VIERICKS was the first to break the silence that had settled like a chilly gloom in his cabin.

"That message had enough in it to be a dead give-away," he growled, his beady eyes glinting beneath their bushy overhanging brows. "If he got all that, he knows everything."

Stiringer took a draw on his cigarette in silent assent.

"One thing is sure—we can't move any more of the stuff till we get him off the ship."

"But how are we going to get him off? If I fire him outright, and he takes

"It'd be easy to get away with—safe?"

"Absolutely."

Stiringer sat relaxed, his cigarette hanging loosely between his thin cruel lips.

"I don't think it's necessary," he said, suddenly stiffening. Perhaps he had watched a hanging behind those gray stone walls where he had once sojourned.

"I've got a better idea."

"What's that—go to jail?"

Stiringer winced.

"No. But what's the matter with doctoring up a second code-key that will give a new meaning to a message that has already been put through the first code. We'll leave this second code-sheet lying around where the kid'll run onto it; and then we'll have a faked-up mes-

Ease of C. W. Transformer Design

By A. H. Babcock

A YEAR or so ago, one of my sons came to me with a transformer core he had traded-in, and asked, "How can I tell how many turns to wind on this for a 110 volt circuit?"

Here was a practical question that demanded an answer in terms a school-boy could understand and apply to every-day use. The answer was found in such simple form that he wound that core, tried it in service, and then went around the neighborhood hunting up transformers to design—for an adequate fee—which his father did not share; another example of the manner in which a business man commercializes the technical knowledge of an engineer.

But here is where the engineer gets back at him, by publishing the information, so that any radio, or about-to-be radio, experimenter can do it himself.

Usually the problem presents itself in one of two forms:

(1) I have a transformer core; how many turns and of what size shall I wind on it;

(2) How much iron must I pile up, and how many turns must I put on it?

He who looks in books for the equations used in transformer design, finds this one:

$$E = \frac{4.44 N B A T}{100,000,000}$$
 from which he shies, as a rule, because it looks formidable. In fact, it is simple.

E = the volts of the circuit,
N = the cycles of the circuit,
B = the number of magnetic lines per square inch of the magnetic circuit.
A = the number of square inches of the magnetic circuit.
T = the number of turns.

The proper value for B usually is the sticking point, but it has been found by long experience that for small transformers, and for ordinary grades of sheet iron, such as are now being considered, we may safely use, B=75,000 for 25 cycle transformers, and 50,000 for 50 or 60 cycle transformers.

First we rewrite our equation in this form:

$$T = \frac{E \times 100,000,000}{4.44 \times N \times B \times A}$$
 and since we know N and B, we may write:

$$T = \frac{100,000,000}{4.44 \times 60 \times 50,000} \times \frac{E}{A}$$
 from which

$$T = 7.5 \times \frac{E}{A}$$

That is, for a transformer to be used on a 60 cycle circuit, we can get the proper number of turns for the primary coil by multiplying the house-circuit volts by 7.5 and dividing this product by the

number of square inches cross-section of the magnetic circuit. "EASY!"

On a 25 cycle circuit, the 7.5 becomes 12, and on a 50 cycle circuit it becomes 9; which makes that simple expression good for any power circuit likely to be used.

One example will illustrate:

Let us assume we have a core that we wish to use on a 115 volt, 60 cycle circuit for two tubes, each of which takes 1000 volts on the plate and 15 volts on the filament, to be used in a self-rectifying circuit on both half waves. The core measures $2\frac{1}{4} \times 4\frac{1}{2}$ inches; hence

$$T = \frac{7.5 \times 115}{2.25 \times 4.5} = 85 \text{ (to the nearest$$

turn), and the volts per turn = $\frac{115}{85} = 1.353$, which is the same for all coils.

Now the secondary coil must have two windings in series, each to give 1000 volts, and with a middle tap. Then the secondary turns will be $\frac{2000}{1.353} = 1478$ with a tap taken out at the 739th turn.

The filament coil must have two similar windings, each to give 15 volts and with a middle tap. Its turns then will be $\frac{30}{1.353} = 22$ with a tap taken out at the 11th turn.

For two 50 watt tubes, such as are assumed for this example, the primary current will be about 6 amperes. Allowing 1500 c. m. per ampere, the primary wire should be No. 10; and the filament winding may be the same size for a 6 ampere filament current when the filaments are in series. If they are connected in parallel, the wire should be No. 8 and the number of turns should be 11, with the middle tap at $5\frac{1}{2}$ turn (for ground connection). The size of wire on the plate coils may be No. 20 or No. 22.

One word of caution: Frequently in "Answers to Questions," transformer cores as small as 1 x 1 or even 1.5 x 2 inches are recommended. How thoughtless! Remember that the turns increase in the same ratio that the core area decreases; and that iron is cheaper than copper wire. Even more important is the labor of winding. For example, suppose the core of the transformer taken for the illustration above had been half as large; then the primary turns would have to be 170, and the secondary 2956. Think of the labor to put all those turns on, and possibly to take off in case of a burn-out; and then to put back again.

So, if you want to determine how much iron to pile up for a core, remember that about 1 to 1.5 volts per turn is

a conservative range. For trial assume 1.25 volts per turn. Then by transforming our first equation we have,

$$A = 7.5 \times \frac{E}{T} \text{ or, the area required is}$$

7.5 times the volts per turn; in this case $7.5 \times 1.25 = 9.38$ sq. in.

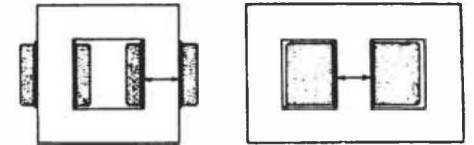

Method of Measuring Magnetic Cross Section.

The magnetic cross section must be measured at right angles to the laminations that are enclosed by the coil; the center leg when the core is built up around the coil; and either leg where the core is built up inside the coil, i. e., between the arrows in the sketches.

D. X. WORK BY 6XAC

6XAC, the Los Altos, Calif., station of the Colin B. Kennedy Co. of San Francisco, was heard on Dec. 15 at Washington, D. C., by 3JJ, Herbert A. Wadsworth, 70 V St. N. W., and by Arthur L. Budlong, 1727 First St. N. W., in the course of a pre-arranged test with 3JJ. In both cases the reception of C. W. telegraph was on one audiotron tube. In the radiophone transmission both recipients were able to get the carrier wave and know that it was being modulated, but it was too faint to distinguish words or music. The reception on a long telegraph message was QSA, two-thirds of it being copied verbatim, but the balance spoiled by interference from 9OU and 9YB. Mr. Budlong has a four-wire cage aerial 45 ft. long and uses a single-tuned circuit with Clapp-Eastham variometer and vernier variable condenser for tuning, and a Clapp-Eastham variometer in the plate circuit for regeneration. 3JJ has practically the same equipment with a 60 ft. aerial. His reception was witnessed by J. B. Davis of 113 E St. N. W. Transmission was accomplished from 6XAC with one fifty watt tube. This test was conducted to verify previously reported reception.

Efficient Receiving Station Practice

By Chas. K. Fulghum

SYSTEM and efficiency are the two things that amateurs in general disregard. In "ye olde days" of galena and silicon a soldered connection meant something, but now if you don't get XYZ because ninety per cent of your received energy is dribbling away in an inefficient antenna system all you have to do is to "hook-up" the two stage amplifier and forget that you ever used an aerial. Such practice is the common idea of "doing good work."

The suggestions in this article are the result of observation of practice in a number of stations, both of commercial and amateur rating, as well as results obtained in the writer's own laboratory. At this station the daily concerts that are transmitted from the Fairmont Hotel, San Francisco, are received regularly. Only one bulb is used. The transmitting station is of ten watts rating and the writer's installation is five hundred miles away.

The first thing that every amateur should consider is the choice of apparatus. There are any number of good models on the market today, and at the same time it is not difficult to pick up apparatus that is decidedly inferior. The best thing that I have found is to keep from using "freak" designs and to stick to the recognized standards. If you make your own apparatus there is much that can be said as to the proper design of it. A few of the things that will tend towards efficiency in home-made apparatus are:

1. Keep all leads as short as possible.
2. Be sure that every connection is an electrical connection and not just a connection. Don't forget that solder was made to use and that you can make as poor a soldered connection as in any other way.
3. If you use regenerative tuning eliminate body capacity some way. The best way is to shield your apparatus. Long handles on controls are invariably in the way.
4. Verniers are cheap if results count.
5. If you use audio-frequency amplification the best transformer that you can use is one that has no magnetic leakage. If you use other types place them so there will be no inter-coupling of magnetic fields.
6. Some very good work is still done with crystal detectors. They are cheap

and often as convenient as vacuum tubes for short distance work.

7. Use good common sense. If you haven't any there may be "hams" in your radio club that have and people are always glad to give advice.

The next thing to consider is the care of the apparatus after you have it. As there are innumerable points that might be touched on of this character the writer will but mention those that are most disregarded.

Dirt is one thing to look out for. In most stations you don't have to look out for it, it's already there. I would advise that every amateur take a course in dusting from his mother, providing she does it right. Have handy a number of cheese-cloth dust rags, and use them. Don't use oil on cloths that you dust your apparatus with. It is almost impossible to keep from getting a thin film of oil on the switch contacts when you do and often the resulting resistance will cause a lot of trouble.

If you use a crystal detector keep the dust from it. The best are inclosed in a glass case, but covering them with a jar such as jewelers use to keep dust from watch parts is a good substitute. Try heating your crystals in a test-tube to various temperatures. If you want to clean them wash them with a potassium hydroxide solution followed by a thorough rinsing in distilled water.

Keep the contacts on your apparatus clean. Fine sandpaper is a good thing to use. Switch blades of the rotary type should wipe the contacts at an angle. Keep the contacts on the plugs of your lattice coils clean and be sure they fit snug in their sockets. Rheostats and contacts on VT's should also be cleaned with fine sandpaper.

The source of power for your receiving set should also receive your attention. Dry cells are unsatisfactory for filament heating. The expense of a few sets of dry cells for such work will soon buy a good storage battery. Also for B battery work, if you can afford them, storage batteries are the cheapest in the end. If you use storage cells be sure and see that they receive proper care.

A filament ammeter is a good investment. Don't disregard its readings, though. The life of a VT is dear to every amateur, so don't mount your tubes in a horizontal position. Also, don't run your plate voltage to the danger point.

Variometers are the best variable inductances that the amateur can use, providing you have a good variometer. One with a minimum clearance between rotor

and stator and with pig-tailed connections is the best.

Observe the way that the various pieces of your set are mounted. The relation of one bit of apparatus to another often has much to do with good tuning. Capacity and inductive effects should be confined to their respective sources as much as possible.

In the operation of the receiving set try and employ a little system. Don't one day light your filaments before you close your aerial switch, and the next day close the aerial switch and adjust your receivers before you light your filaments. Owing to the variety of sets that are in use no definite information on a system of tuning can be given. A few points can be mentioned, however, that can well be observed by the reader.

When tuning in a station, don't hurry. Time flies, but often the station that you wish to get is tuned in several times before you realize it if you twirl the dials and juggle the honey-combs like you were in a speed contest. Often when you have your station you can cut down on the filament current quite a lot. Don't use amplification unless you have to. There is such a thing as sensitive ears and radio reception is a good way to acquire them.

Learn to copy on a typewriter if you can. It is a good thing if you intend to do commercial work and it is excellent training anyway. Use a machine that is as near noiseless as possible. When copying on a typewriter the use of a pair of soft rubber ear caps over the receivers is of great help in shutting out extraneous sounds.

When you are through receiving be sure and ground your aerial. Electric storms seem to be rare on the coast, but in the mountains there is danger from them. It might be mentioned here that your antenna system should be as efficient in damp weather as in dry. I mention this because I have known amateur antenna systems that were absolutely useless in wet weather.

In general it is advised that standard usages and operations are the ones to be adopted. If you get better results by an odd method of station practice, use it, but there are few such practices that will gain you anything. Distinction for the work you do as well as the way you do it is what you should aim at. DX work with a minimum of station expense is something you should work for and should you ever try commercial work you will not regret the practice. It is asked that amateurs throughout the country systemize their work for the sake of amateur radio.

REMARKABLE RECEPTION BY 6ZAC, HAWAII

Clifford J. Dow at Wailuku, Maui, Hawaii, submits a log of fourteen western stations copied by him Dec. 14-17, 1921. As he is 2100 miles from San Francisco and as this is the first time that amateur stations have been heard in Hawaii, this news will bring joy to coast workers. Especially noteworthy is the fact that these stations were read with only a loose-coupler, detector and one-stage of amplification, notwithstanding the notorious static in the Islands. Mr. Dow has an aerial 75 ft. high. His log follows:



RADIO LOG

December 14th

9:15 p.m.—7YA working 7ZT Sig "Harry."
9:16 p.m.—7YA de 7ZT "R Nr 1 R" continue wkg but arc in bad.
9:40 p.m.—7ZT de 7YA "C U Tomorrow nite. QSQ!"
9:40 p.m.—7YA de 7ZJ (Lower note than other two).
9:43 p.m.—Arc in again, but can hear 7ZJ sending mag to 7YA. Addressed to someone in "DAYTON."
9:45 p.m.—Pearl Harbor arc has strong mush wave on 350-375 meters. Forced to discontinue listening on short waves.
QRN not heavy, but bothersome. Could read all three above stations if they sent QSQ. All heard on one step of amp.

December 15th

6:45 p.m.—8XG de 6ZR "GA" (Very QSA and clear note. Comes better than KPH of any coast station.)
6:47 p.m.—8XG de 6ZR "GA."
7:00 p.m.—5IR de 5XU. (Might be 5AR or 5IF, but QRZ unreadable except when QSZ, as in calling.)
7:02 p.m.—7YA de 6ZR. Unans.
7:15 p.m.—6ZU de 6ZR. Unans.
7:17 p.m.—6AAK de 6ZR. "Fine OM sure glad to hear you on air agn. Do u hear 6XG on 370 meters! Pls drop me a line and give me the dope on this spk!"
7:22 p.m.—6AAK de 6ZR. Still working. "Wl gess tis abt all so cul. 73 de 6ZR, H. B." "Yes, am still with Meyberg, now address is 950 South Flower Street."
7:25 p.m.—7ZS de 7YA. "R QTC! QRV GA Shoot GA K!"
7:29 p.m.—6AAK de 6ZR. "QRX" (Calls 7YA, with 6AAK standing by. 7YA came right back, but evidently neither 6 stn heard him.)
7:32 p.m.—7YA de 7ZT.
7:33 p.m.—6ZX de 6ZR. 6AAK de 6ZR.
7:34 p.m.—6ZR de 7ZT. (6ZR unhears him.)
7:39 p.m.—6ZR de 7YA. (6ZR unhears him.)
7:46 p.m.—7YA wkg 6XL. Part of mag: "Boise at eleven thirty five Friday Dec. 16th will be in Spokane Saturday morning seven fifteen Dec. 17th arrive at Milwaukee station love." (Missed Sig.)
9:00 p.m.—7YL de 7YA, wkg.
9:45 p.m.—7YA working 7ZS. 7YA sigs steady all evening and fairly QSA on 1 step. With two steps will get him like living next door. Should be able copy 6ZR thru any kind of weather. QRN slightly worse than last night.

December 16th

From 6:30 p.m. to 8:30 p.m. Radio 7ZJ only station heard. Was working 7ZU during this



9AMB

period. At 8:16 p.m. called 7YM and told him, "You are causing interference, and are requested for the last time to BK." At 8:24 p.m. called 7ZU and said "R OK Nr 5 OK K." At 8:30 p.m. told 7ZU, "Sorry but QSS. ND. QTA. K." 7ZJ fairly QSA on one step. Unlistened after 8:30.

December 17th

QSA slightly worse than previous nights. Comes in hard splashes, quite close together.
7:85 p.m.—6ZK de 6ZR. Comes QSA as usual. Told 6ZK "GN".
9:07 p.m.—7YA and 7ZJ fairly QSA. QRN breaks 'em up pretty badly.
9:18 p.m.—7YA de 7ZJ. "All right OM QSU 73" (Finished).
9:35 p.m.—7YA de 7ZT (7ZT fairly QSA).
9:40 p.m.—7WA de 7ZU. "Didn't get ur QRA K."
9:42 p.m.—7WA de 7ZU. "Please QTA, K."
11:30 p.m.—Just completed regenerative hook-up, using Murdock coupler, one variable in series, detector and one step.
11:35 p.m.—6WZ and 7XF communicating as per record in attached letter.

December 18th

6:08 p.m.—Can hear two radio phones in. Can make out that music and speech are being transmitted, but very QRZ on voice. Compensating waves QSA. Could copy CW very easily. One lone sending "My Old Kentucky Home."
6:18 p.m.—5QJ de 5QA. 5QA very QSA and pretty to read. Using insect.
6:25 p.m.—Radio fones still concerting.
6:29 p.m.—5YQ de 9ZAF. 9ZAF about same QSA as 5QA, and easily read.
7:55 p.m.—9XM de 9ZAF. (Told 5YQ, "QRL OM, get u pretty gud, but QRL.")
8:01 p.m.—6IV de 5QA. Calling.
8:05 p.m.—6IV de 5QA. "QRM. QTA."
8:07 p.m.—6IV de 5QA. "QRM and QRZ OM. Please QSP 6AIF."
8:09 p.m.—6ZAC de LFY. (As per arrangement, Oahu Amateurs testing to Maui.) "Nr 1. Congratulations, Mr. Dow, on your receiver, and may you soon be able to transmit to us. (Sig) Yeager, LFY." "Will now QRX please listen on 200 meters for 6ASR." I listened for other stns on 200 meters, but unhear any, and at 8:36 p.m. NPM arc came in, with QRM all over scale. Many harmonics.
8:11 p.m.—6ZAC de LFY. Repeats above.
8:29 p.m.—6AIF de 5QA. "Gess we will make regular schedule. How do sigs compare with last nite! Am radiating about 4 1/2 amps now."
8:32 p.m.—6AIF de 5QA. "Art. Spark fine here OM, and low enuff to miss QRM. QRU, tnx."
8:35 p.m.—6QA de 5QA. Gave him long call. (Arc at MPM in all time!)
9:27 p.m.—8HT de 5QA. "R QRV K."
9:31 p.m.—8HT de 5QA. "Nr 1 OK K."
9:35 p.m.—8HT de 5QA. "To Miss! 873—rest OK—K."
9:36 p.m.—"Nr 2 R Nil."
9:40 p.m.—8HT de 5QA. "Sig Mr. and Mrs 1 ND on fone wake up everyone hi K."
9:42 p.m.—8HT de 5QA. "Yep. Just cudn't get rest. Maybe next one. Well, NM cul." Stations heard pls QSL. Hearty congratulations to u all.

CLIFFORD J. DOW,
Wailuku, Maui, T. H.

NEW DX RECORD BY 6JX

6JX, G. M. Best, Piedmont, Calif., was heard by 2AVU, Ocean Side, Long Island, N. Y., at 12:30 a.m. Arlington time, Dec. 6, 1921, while calling 7OZ. Radiation at the time was 3.5 amps, on 200 meters.

DESCRIPTION OF 9AMB

Due to his consistent work and great range, thousands of operators have heard 9AMB and will be interested in a brief account of this station, which belongs to D. L. Hathaway, 1575 Pennsylvania St., Denver, Colorado, and is operated by J. L. Hathaway. The general features are shown in the accompanying illustration.

The aerial is L type, 55 ft. long and 47 ft. high, 9 wires spaced 2 ft. apart. For some months a ground composed of buried tin, water mains and chicken wire was used. On putting up a counterpoise the radiation was the same as with the ordinary ground until Mr. Hathaway happened to find out that some inductance had to be put in the lead to the counterpoise. With the inductance in, the old radiation was nearly doubled. Later a combination of the counterpoise and the old ground was found to give slightly better results than with the counterpoise alone.

With the modified Hartley circuit he gets better results than with any other. One 50 watt tube is used. In normal use with 1200 volts and 140 milli-amperes on the plate and 9.5 volts a. c. on the filament, on a wave of about 225 meters, the radiation is 4 1/2 thermo couple amperes. A d. c. generator is used for high voltage. For sending straight C. W. a key is placed in the grid circuit. Grid modulation by chopper or voice may be used when desired for comparatively short distances.

A variometer short wave set and 3 steps of audio frequency amplification are used for receiving. Four d. p. d. t. switches are used for changing the number of steps of amplification. Nearly all the apparatus of this station is home made.

The greatest distance worked is 2FP at Brooklyn, N. Y., with whom a number of messages have been handled. Avalon, California; Houston, Texas; Canadian 4CB, and many other distant stations have been worked. The greatest distance heard was by G. C. Farmer on a vessel 3300 miles west of San Francisco. Several reports from New York state that the C. W. has been read.



C. W. ASSOCIATION OF AMERICA

The C. W. Association of America was launched at a meeting of old-time radio men held in San Francisco on Dec. 30th as an independent organization for the encouragement of continuous wave radio development. This represents a national outgrowth of the C. W. Club of America which has been conducted by Lawrence Mott until the wide-spread interest made imperative an organization with a full corps of working officers.

At the organization meeting Lawrence Mott was elected president and founder, G. G. Griffeth, sect., H. O. de la Montanya treas., and G. M. Best, consulting engineer. Arrangements were made for nine directors to represent Pacific Coast districts. Arrangements will soon be perfected for additional directors to represent the eastern districts. San Diego will be represented by 6MZ, Mr. Gray; Los Angeles by Lex B. Benjamin; Reedley, Calif., Mr. Lindsay, 6ALE; San Francisco Bay by G. M. Best and Ralph Heintz; Douglas, Ariz., by 6ZZ, Mr. Gooding, and Salt Lake City by 6ZA, I. Carr. The Portland, Tacoma and Seattle radio clubs will be asked to name their directors.

A constitution and by-laws is being perfected by the organization committee, consisting of Lex B. Benjamin, G. M. Best, A. H. Babcock, G. G. Griffeth, H. O. de la Montanya, R. P. McKenzie and D. B. McGown.

Membership will include licensed operators having C. W. stations and others interested in the development of continuous wave radio communication. All such are invited to send in their names to Secretary G. G. Griffeth, care Pacific Tel. & Tel. Co., Sheldon Bldg., San Francisco. The initiation fee is \$2.50 and dues are \$4.00 per year.

The C. W. Association of America stands for a serious effort on the part of C. W. amateurs to establish regular transcontinental transmission with a minimum of relays. The association is independent and non-competitive, standing ready to co-operate with any other group organized for similar purposes.



Radio C. W. men present at Organization Meeting of The C. W. Association of America: G. M. Best, 6JX, 109 Greenbank Ave., Piedmont, Cal.; W. H. and C. E. Rich, 6IT, 1022 Boynton Ave., Glendale, Cal.; G. G. Griffeth, 6AA, 623 Sheldon Bldg., San Francisco, Cal.; D. B. McGown, 6ZE, 1247 47th Ave., San Francisco, Cal.; O. S. Garrison, 6ZAL, 118 Fairmont Ave., Eagle Rock, Cal.; L. B. Benjamin, 6XAQ, 140 So. Oxford St., Los Angeles, Cal.; Donald Skilling, 6BCI, 2960 Linden Ave., Berkeley, Cal.; H. A. Duvall, 6EN, 4965 Wadsworth St., Los Angeles, Cal.; C. G. Esler, 6EF, 784 East 46th St., Los Angeles, Cal.; Ralph Heintz, 6AUQ, 653 Miramar Ave., San Francisco, Cal.; S. J. Wood, 6HT, 512 Watson St., Monterey, Cal.; Thos. Work, Jr., 6ACR, 181 Central Ave., Pacific Grove, Cal.; Pierce Parsons, 6VM, 633 Middlefield Road, Palo Alto, Cal.; K. W. Kent, 6ATC, Los Gatos, Cal.; A. H. Babcock, 6ZAF, Southern Pacific Co., San Francisco, Cal.; H. O. De La Montanya, 6AUL, 2830 11th Ave., Oakland, Cal.; H. W. Dickow, 6SN, 251 Duboce Ave., San Francisco, Cal.; R. P. MacKenzie, 6ALU, 1016 4th Ave., Los Angeles, Cal.

ACROSS THE CONTINENT ON 20 WATTS

By LAWRENCE MOTT

TO write an article of this kind is not as simple a matter as it would appear, at the first glance—and for the reason that, by its very nature, it tends to create the belief that I am desirous of lustily blowing my own bugle! Ere I proceed, pray let me say—in all sincerity—that these words are NOT set down in a spirit of egoism! Rather am I actuated—purely and simply—by the earnest wish that all amateurs may profit by my experiences with low-power'd ICW transmission! This because such a set that will do the work that has been done, at my station, is well within the financial reach of practically every amateur.

I would, in these lines, convey my most appreciative thanks to countless brother operators, the nation over, who have listened for my QST each night, and who have flooded me with letters, postcards and telegrams, giving me detailed reports of my signals! Such co-

operation and friendship as this cannot be too greatly extolled, and I take a very great deal of pleasure in thus publicly expressing my earnest thanks to them all! Lack of space—only—prohibits my listing ALL the cards that I have received, but as this article is intended to convince doubting minds as to that which CAN be done, economically, on ICW, I give only the reports of stations at approximately one thousand miles—and greater—distance from my residence at Avalon, Catalina Island, California—off the southern coast of California, 30 miles out on the Pacific Ocean.

As important to DX work as the transmitter, is the receiver! I feel that I should be doing a very grave injustice to a marvelous piece of apparatus, did I not say that the Grebe—CR5—has literally earned the highest praise that I can bestow! The 2-step amplifier, that has done equal marvels, is of special design, using special Western Electric tubes, and its hook-up I am not permitted to give. I would not, in thus praising the Grebe apparatus, declare that there

are not many most excellent receivers on the market! To so do would be untruthful and ridiculous! I am merely, for science's sake, reporting that which the *Grebe has done!*

Hence I begin as brief a statement of facts as possible by introducing a letter that went from 6XAD to L. M. Clement, the Chief Engineer of The Western Electric Co., New York City, at the close of a test, the furthest-west end of which I was especially honored by having been asked to be. Copy of round-robin letter follows. The signatures thereunto appended of the gentlemen who most kindly acted as witnesses on the felicitous occasion of the first radio transmission from coast to coast of voice and music, are all well known in the field of radio engineering. I would express my gratitude to them for their invaluable assistance at the test.

Now then for record of stations worked and heard. Those marked with an (x) have been actually worked. Many of the others I know, to my own satisfaction, that I have exchanged signals with, but this does not constitute "work" to my mind, hence I list them as having received word from them—by mail, etc.—of hearing my signals.

5jd, 5za, 6wv(x), 6zz(x), 7ex, 7yj(x), 7zu(x), 7fi, 7os, 8bum(x) (Poughkeepsie, N. Y.), 8lx(x) (Pittsburgh, Pa.), 8bmx, 8kw, 8kf, 8ht (all of Buffalo, N. Y.), 8jq (Washington, Pa.), 9au, 9aqr, 9aig, 9zac, 9alg, 9dva(x), 9amb(x), 9wd(x), 9ax(x) 9zaf, 9lw(x), 9zn, 9ps, 9djz, kyw (Chicago), Canadian 5cr (Victoria, B. C.), Canadian 3lj (Agincourt, Ontario), Canadian 5bx (Vancouver), Canadian 4cb (Saskatoon). And on the night of December 22nd, I heard 2ahk (Jersey City) CQ'ing that which I am morally certain was a query for 6X—? Ere this is in print I shall have verification.

Other stations heard include 2fp, New York City; Canadian 3ji, F. H. Pounset, Toronto; A. H. Williams, 1630 Adams St., Denver, 8jl; L. N. Chatterton, Cleveland, Ohio; 9duz, Ellendale, N. D., and 9rc.

Of "6" stations I have heard, it seems to me, ALL that can "percolate" to 6XAD! I began keeping a list, but 'twould require a full page (!) of RADIO to reproduce, with my added data!

ALL of the above DX, transmitting was accomplished on my 20 watt set, that was especially built for me by The Western Radio Electric Co. of Los Angeles, Calif. I mention the firm, deliberately, as it has given me the greatest possible satisfaction, in every way, and it is not justice to mention the firm whose receiver I use with so much success and omit the name of the transmitter builder! Too much may not be said for the Baldwin 'phones—that have rendered yeoman service!

I hope that the above FACTS will once-and-for-aye prove my contention, viz: that, given a good ground and antenna systems—plus counterpoise, if in

"RADIO"

December 14th, '21.

MY DEAR MR. CLEMENT:

This letter is in confirmation and further explanation of a telegram that was sent to you several hours ago.

In accordance with your request, we listened for signals from your station—commencing at 8 p.m., Pacific Coast time—with the following results:

At 8:20 p.m. we copied the following from you:
". . . of Canada—Colorado Springs—Colorado holds record—would like reports from over 1,000 miles—listen for phone now—2XB."

Immediately after this we heard voice and phonograph music from you, but could not recognize voices or tunes.

During the next two hours we followed your schedule very nicely, but could not hear anything very definite on account of bad local interference from commercial spark stations.

At 9:20 p.m., however, there was a lull in the Q. R. M., and we received the following by C. W. on a loud-speaker, which was easily heard by all persons present:

"QST—2XB—testing radio telephone—this is 2XB—Western Electric Company—463 West Street—New York City—would like letters from any ship or station more than 1,000 miles from here—listen for telephone."

Following this we again heard your speech very nicely.

In receiving from you we used a Grebe CR-5 receiver, a two-step audio-frequency amplifier and Baldwin phones, or a four-step audio-frequency amplifier and Vocaloud. The receiving antenna is 150 feet long, 94 feet at the high end and 40 feet at the low, leads being brought in from the latter. The aerial consists of four wires, average 3 feet apart, spacing. The entire set is very well grounded and has an excellent counterpoise beside.

In receiving your C. W.—or carrier wave—our receiver was in an oscillating condition, which enabled us to hear you very nicely. When listening to your speech, or music, these local oscillations distorted your quality so much that your transmission was, of course, unintelligible. We listened very carefully for your speech and music with our receiver regenerating, but not oscillating—and could not hear you at all when it was in that condition.

Finally, at 10:55 p.m.—our time—we heard you calling KUXT—V—and easily copied the following:

"De 2XB—please advise by mail if hearing this transmission at more than 1,000 miles from New York—QST—KUXT de 2XB—Phone now—phone now—phone now—QST—KUXT—de 2XB—phone—K"

Immediately after this we again heard your speech as above described. We attempted to reply to you with our 100-watt set—C. W.—on 260 meters—and then on ICW—210 meters—20 watts—signing this Station's Call—6XAD—Avalon, Catalina Island, California.

We apparently did not succeed in raising you.

We are, however, entirely confident that we can work you easily from this station—in the absence of spark interference!—and will be very glad indeed if you will arrange a schedule, and advise us of it by despatch.

The undersigned were all present, and the foregoing letter is the consensus of their opinions and observations.

We all wish to congratulate you upon this epoch-making event, and we congratulate ourselves upon being the station furthest West to have heard these remarkable results of your efforts.

Cordially yours,
LAWRENCE MOTT,
Associate Editor of RADIO.

HOWARD W. LEWIS,
Transmission Engineer, P. T.
& T. Co.

FRANKLIN HANSEN, JR.,
Senior Radio Man, Pebble
Beach Radio Phone Station.

WM. J. MONAHAN,
E. R., U. S. N.

FRANK G. BECK,
Radio Electrician, U. S. N.

any way possible—given a small transmitter, using any city's 60 cycle, a. c. current—said transmitter being built with reasonable care, on from 1.8-2.6 antenna current (being my own range, dependent on quality of city current), VAST distances may be successfully covered at LOW COST! And there never was a spark extant that can—power for power—come within 500

miles and more!—of these here-given results!

PRIZE AWARD TO 2FP

The \$10 prize for dx reception announced by Mr. Mott in December RADIO is, after due consideration of distance and verification, awarded to 2fp, New York City.

Mr. Mott's station will be open every Tuesday, Thursday and Sunday night, from 10 till 2, for long-distance work.



With THE U-S-Radio Inspector

CONDUCTED BY MAJOR J.F. DILLON

A MONTHLY DEPARTMENT OF INFORMATION FOR OUR READERS



Questions and Answers

By the Radio Inspector

Ques. Who is the head of the Radio Service, and what is his address? L. K., San Francisco, Calif.

Answer: The commercial and amateur radio interests in the United States are controlled by the Department of Commerce, and the Secretary of Commerce, Mr. Herbert Hoover, is the real head. However, the Commissioner of Navigation, Mr. D. B. Carson, is the actual administrative and executive head. His address is "Commissioner of Navigation, Department of Commerce, Washington, D. C." The head of the Sixth District is Mr. J. F. Dillon, who has the title of "Radio Inspector." His address is 215 Custom House, San Francisco, Calif., although unless you wish to correspond with him personally, address simply "Radio Inspector." His district covers California, Nevada, Utah, Arizona, and the Hawaiian Islands.

Ques. Can the Radio Inspector's Office calibrate a decremeter for me? W. R., Utah.

Answer: No, facilities are not available for this work. Suggest that you set up a vacuum tube oscillator, with a low resistance circuit, and read the decrement, as indicated. This will suffice for the instrument decrement for work as accurate as is usually needed, and will not require any special apparatus.

Ques. I have a special amateur license. It states that 300 and 600 meters are the normal wavelengths. Does this mean that I should use these normally, instead of my 200 and 375 meters wave? K. R., Los Angeles.

Answer: No. This means that these waves are simply required to cover the law, your station being licensed as a "coastal" station. According to law, you are supposed to listen on these waves at least once every fifteen minutes, while the station is in operation, and the station shall be ready to transmit on these waves, if necessary to assist some ship in distress. The use of these waves, either, or both, is absolutely unlawful, except for these purposes.

Ques. Can the limited commercial "broadcasting stations" work with any other stations, or handle relay business with special amateurs on 375 meters? H. J., Los Angeles.

Answer: No. These stations are licensed for broadcasting exclusively and are "limited" to this service by their licenses, and they are also required to observe the 300 and 600 requirement, as described in the answer to the previous question. They may not work with special stations, except under these circumstances.

Ques. Can they use any other wavelengths than 360 meters? H. J., Los Angeles.

Answer: No. According to instructions issued by the department, this is the ONLY wavelength authorized for this class of work. No stations, except those actually licensed for the purpose, may transmit music, or other broadcast matter, and this must be done on 360 meters, under a special limited commercial license. No amateurs, or others, may broadcast. The broadcasting of music on 200 meters will jeopardize the continuation of the licenses of the offender.

PROCEDURE FOR RENEWAL OF LICENSE

By D. B. McGOWN, Asst. Radio Inspector.

A large number of amateur station owners, who have been issued station licenses, are finding that these licenses are about to expire. Numerous letters and requests for instruction have been received, and they show, generally, that a good deal of doubt exists as to the proper procedure and formalities necessary to make proper application for renewal.

At the time the station license expires, or before, the station owner will receive the forms from the radio inspector's office, with a request that they be filled out and returned. These forms are sent out as follows: Form 762, in triplicate, and Form 756, in duplicate. The Form 762 is the "Applicant's Description of Apparatus," and the Form 756 is the "Application for License to Radio Operator." The forms should be filled out as requested and returned to the office, together with the licenses, both station and operator, which are to expire. This is all that is necessary for renewal, unless some error is made in the data required, in which case the applicant will be notified and requested to give the necessary information. The applicant may then operate his station as before, and the licenses will be returned to him in due time. The expiring station license will simply be returned, marked "Renewed for two years from —," and initialed by the radio inspector authorizing the renewal. New operator's licenses will be issued in all cases, and the oath of secrecy must be executed on them.

Licenses will in all cases be issued their previous call signals, and the station licenses will bear the same serial numbers. If, after three months have elapsed since the station license expired, no attempt has been made to renew the same, the call signal will be cancelled and reassigned. The operation of a station in such circumstances will be absolutely unlawful and the use of the former call letters will be considered as the transmission of false signals.

Amateurs, in general, will do well not to write impatiently a few days after they have submitted forms, asking for data as to when their license can be issued, but will wait the actual issuance of the same, which must be done in regular order.

The attention of amateurs and others is called to the unlawful tendency to use call letters at a station other than the one to which it is assigned. Call letters are assigned to a station, and not to an individual, and, unless specifically licensed as a portable station, only the call letters assigned to a specific station may be used thereat. For example, if John Bones is assigned the call 6HAM, and his station is located at 76 Blank Street, Smithville, it is decidedly unlawful for him to go over to Willy Wampus' house, at 176 Blank Street, and sign his call there, as 6HAM, whether Willy is licensed or not, it is just as illegal for him to sign 6HAM "at" 6XYZ as it is to sign the call in the first case, as it is obviously impossible for him to move his station and its geographical location from one point to another. The call of a station is issued for THAT STATION exclusively, and may not be used at ANY other location, without specific authority. Persons detected using their calls otherwise than at the station they are issued to, and for, should not be surprised if they are deprived of the use of the said call entirely.

The 1921 list of commercial and government radio stations of the United States, which includes special land stations, and the 1921 list of amateur radio stations of the United States are ready for distribution and may be procured also from Superintendent of Documents, Washington, D. C., at 15 cents per copy.

Applicants for radio-station licenses desiring to use their stations for broadcasting market reports and weather forecasts should submit with their application a letter from the Chief, Bureau of Markets, or the Chief of the Weather Bureau, indicating that this service is desired.

MODULATION PHENOMENA IN RADIOTELEPHONY

The apparatus now used for transmission in radiotelephony uses three-electrode electron tubes as an essential part of the equipment, with the exception of a few high-power stations which use high-frequency alternators.

In radiotelephony a wave of a radio frequency such as a million cycles per second is varied in amplitude or "modulated" at audible frequencies such as 1,000 cycles per second, in accordance with the wave form of the sound which is being transmitted. The device by which this modulating process is accomplished must respond instantaneously to the variations of the impressed sound wave, and must therefore have negligible inertia, in order that sound may be transmitted without distortion. The electron tube is a device which answers these requirements, since the electron stream will respond instantaneously to variations in the audio-frequency wave. The phenomena occurring in circuits for modulating radio-frequency currents may become very complex, and require careful study. Three principal methods of modulation in electron tube radiotelephone transmitting sets are recognized: First, by variable absorption of the output power of a generator of radio-frequency current, as by inserting a microphone in the antenna circuit; second, by varying at speech frequencies the operating grid voltage of a tube generating radio-frequency current; third, by varying at speech frequencies the input plate voltage of a tube generating radio-frequency current. The third method is often referred to as "plate modulation," and is the method used in commercial and military types of apparatus in the United States. Plate modulation is superior to the other methods in many respects.

Studies have been made at the Bureau of Standards of the phenomena of modulated radio-frequency waves, and the relative advantages of different methods of modulation and different circuits. The apparatus used in radiotelephone transmitting sets employing plate modulation has been analyzed as consisting of four units—the source of direct current, the modulator unit, the generator unit, and the radiator unit. Oscillographic studies have been made. Results of these studies are contained in a publication of the Bureau of Standards just issued, Scientific Paper No. 423, Operation of the Modulator Tube in Radiotelephone Sets, by E. S. Purington. Copies may be secured from the Superintendent of Documents, Government Printing Office, Washington, D. C., for 10 cents. Persons desiring information regarding radiotelephony will find this paper of considerable interest.

DIGEST OF RECENT RADIO PATENTS



Prepared by White, Prost & Evans, Patent Attorneys, San Francisco, who have been particularly active in the radio field for many years, and from whom may be obtained further information regarding any of the patents listed below.

J. Erskine-Murray and J. Robinson, Pat. No. 1,398,848, Nov. 29, 1921. Wireless Receiving and Transmitting Apparatus.

The patent describes a scheme for determining the bearing of a distant source of radiations at a receiving station. The distant transmitting station is so arranged that signals may be sent in succession along predetermined directions, which signals would then have a maximum or minimum effect along these directions. Each direction has its unique signal, so that by recognizing at the receiving station which of these signals is a maximum (or a minimum) the direction from which it is sent may be easily determined with an accuracy depending upon the number of angular directions used. The patent further describes means whereby bearings between the predetermined directions may be ascertained, and greater accuracy obtained. Thus the two-way switch *b* is provided in the receiving antenna circuit for connecting either coil *c* or *d* into the circuit, these coils being at right angles to each other. Coil *e* is arranged so that its coupling with *c* and *d* may be varied by rotation, and is connected to a receiving circuit. Coil *e* is placed in circuit when a maximum or minimum signal is received, and if the next signal is of almost the same intensity, this next signal may be received through coil *d*. The coil *e* is rotated until the two signals have equal intensities. The position of coil *e* may then be used for determining the bearing which is intermediate that corresponding to the two signals.

G. B. Crouse, Pat. No. 1,399,005, Dec. 6, 1921. Spark Gap.

This patent describes a highly quenched series gap, in which the spark is extinguished by a strong magnetic flux. In one form of the invention there is one vibratory contact and two stationary contacts, so that two gaps are formed in series. The vibratory contact is made of magnetic material, so as to direct the flux from the electromagnet toward the gap to extinguish the spark. This electromagnet also serves to vibrate the contact. The gap is common to the open and closed oscillatory circuit, in the usual manner. The stationary contacts are preferably mounted on a resilient plate, the position of which may be adjusted by set screws bearing against it. In this way the length of gap may be easily determined.

E. L. Chafee, Pat. No. 1,399,251, Dec. 6, 1921. Means for Changing the Intensity of Signals in Radiodynamic Receiving Systems.

A receiving system is described, in which there is the ordinary receiving apparatus, including detector tube 6 and telephone 15. In addition there is a circuit in parallel to this receiver circuit which by-passes the strong impulses, such as those due to static, etc., without materially reducing the weaker signals. This circuit includes thermionic tube 17, which may be caused to have the required resistance characteristics by properly adjusting the potential of its grid 20 with respect to the filament 19. The batteries 21 and 24 of this by-pass circuit are furthermore encased

in metallic sheaths 28 and 31, so as to form therewith a condenser in parallel with condenser 5, and to prevent in a great measure the electrostatic coupling of grid 8 and the other parts of the apparatus. Such a coupling would produce capacitive effects reducing the intensity of the signals.

J. H. Hammond Jr., Pat. No. 1,399,254, Dec. 6, 1921. System of Radiodynamic Control.

This patent describes a transmission system used to control the movement of a distant object, such as a torpedo. In order to accomplish this without danger of enemy interference, the object controlled is equipped with receiving circuits responsive only when two definite wavelengths are transmitted simultaneously. Furthermore, there are several stations from which the wavelengths may be controlled, the stations being at strategic points. At one station, key 41 is provided; at the others, keys 42 and 43. Thus when key 41 is depressed, the antenna A is caused to trans-

mit waves of say two thousand meters in length, and antenna B is caused to transmit waves of say two hundred meters in length. When key 42 is depressed, the wavelengths transmitted are two thousand meters and four hundred meters; when key 43 is depressed, the wavelengths transmitted are two thousand meters and seven hundred meters. While none of them are depressed, the antenna A transmits through a regular cycle of wavelengths, occasioned by the periodic variations of the inductance coils 11 and 20, which are included respectively in the closed and open oscillating circuit of transmitting system A. However, when any one of the keys 41, 42 or 43 is depressed, these coils are short-circuited at the same time that the antenna system B is automatically tuned to the wavelength associated with the particular key depressed. This tuning is accomplished by inserting the proper inductors 38, 39, 40, 44, 45 and 46 in the closed or open oscillating circuit. There

Continued on page 58

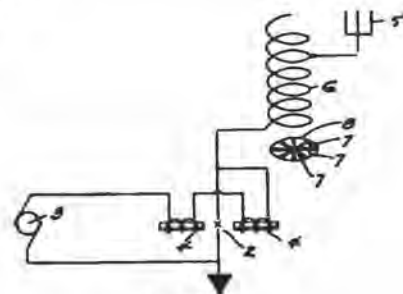
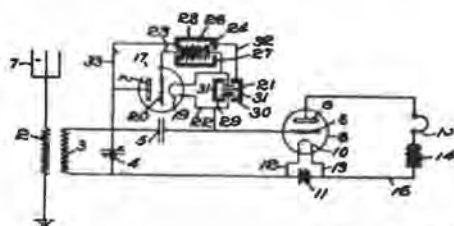
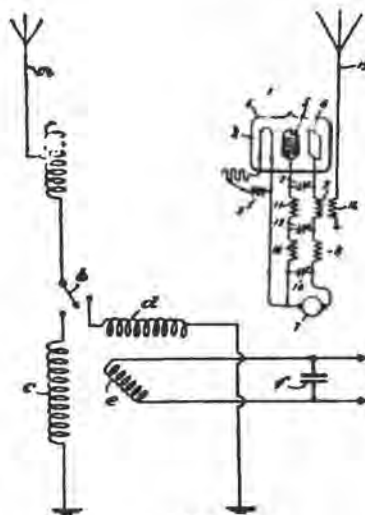
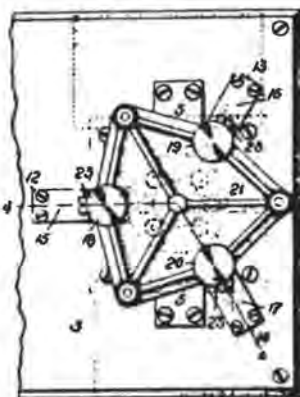
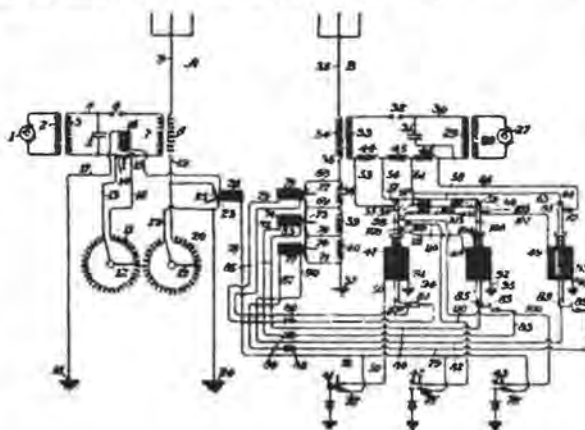

1,399,254
1,400,235
1,398,848

1,399,005
1,399,251
1,399,945

MONTHLY BROADCAST OF RADIO NEWS

H. B. Ogle, formerly 8BT, is now 6VR at Southern California Edison Company's Kern River Station No. 1, at Edison, California. He will soon be in the air with a C. W. transmitter.

Ellery W. Stone, general manager Atlantic-Pacific Radio Supplies Company, is in receipt of definite advice from K. B. Warner, Secretary The American Radio Relay League, that twenty-six different U. S. stations were heard in England during the A. R. R. L. test conducted by Mr. Godley. Of the twenty-six stations heard twenty were C. W., the majority being from New England, but running as far west as Cleveland. Mr. Godley advises that A-P amplifiers were used exclusively for amplifying purposes in the receiving equipment used by him in England.

To pick up a telephone on a liner steaming along over 1,000 miles from the Australian coast and have a talk to somebody in Sydney is a great thing. Several passengers on the Ventura recently enjoyed the experience. It began one day when one of the passengers told another of the wonderful wireless telephone installed on the ship. The news spread, and it was not long before a lady appeared at the wireless cabin with a request to be allowed to use the wireless telephone.

"Certainly," replied the operator. "Whom do you want to ring up?"

The lady wanted to talk to Professor —, at the Sydney University, and she gave the operator the number. "Sparks" busied himself with his instruments and the connection was made. Seizing the telephone the lady carried on an animated conversation with the "Professor" and left marveling at the progress of science. There was a general search for telephone numbers among the passengers, and soon they were ringing up talking to all parts of Australia.

Then somebody "spilled the beans." The telephone in the wireless room was connected with the navigating bridge, from which the jokers represented the shore end. Many of the travelers are kicking themselves yet.

On the evening of December 9 the amateurs of Visalia, California, met and formed the Visalia Radio Club. Mr. Errol Chrisman was elected president of the club, and much credit for the wonderful start of this club should go to him. There are 29 members in the club and prospects of many more joining in the near future. The club has secured quarters of their own and are to meet once a week for discussion and code practice.

Rotarians assembled recently in more than fifty towns, within a radius of 100 miles of Pittsburgh, to listen to the speeches of the Rotary Club International Vice-President, Ralph Cummings, and District Governor Roy Neville, who addressed Pittsburgh Rotarians in McCreery's dining room. They received the addresses by the aid of the wireless telephone, through arrangements made by the Westinghouse Electric & Manufacturing Company, to broadcast the speeches through its radio station, KDKA. In addition, many other people were able to hear the speeches of these prominent Rotarians. This was the

first time in history that a meeting of this nature was received by other branches of the organization at different points, without the members attending the gathering in person.

THE SAN JOSE RADIO CLUB

The purpose of the San Jose Radio Club is to promote a spirit of fellowship among the local amateurs and to give code and theory instruction to all members desiring it. For some time a club of this sort has been needed in San Jose, and now that it has been formed the members have a determination to make it a howling success. The officers are: President, Harry Engwicht; vice-president, Jack Holmes; secretary, H. Weddell; treasurer, Irwin Coffey. The club meets every Monday evening, at the residence of Frank Quement, 51 Pleasant Street. A strictly business meeting is held once a month, all other meetings being devoted entirely to radio.



A Scrap as to Whether the Next Pacific Coast Radio Convention Be Held at Houston or Dallas.

RADIO CLUB OF LONG ISLAND

The Radio Club of Long Island has held several meetings at the offices of the Ship Owners' Radio Service, 80 Washington Street, New York City, and likes its new headquarters very much. The meetings, held every other Tuesday, have been well attended. Mr. Ferguson, the president, announces that he has arranged so that any members holding amateur licenses might take turns standing watch with the regular operator at 2CAP, the Ship Owners' Radio Service amateur station.

The members recently listened to an interesting talk on code learning by Mr. Berrell of the Ship Owners' Radio Service. He explained his method of teaching sound-reading of Morse. By his process a beginner can memorize the code in a fraction of the time usually taken. After the lecture the club was allowed to inspect a compact and efficient four-tube C. W. transmitter which was being constructed in the shop. Recently a code class was organized under the leadership of Mr. Miller, 2GA, so as to help the beginners or slow-speed fellows to get their licenses. The class meets at club headquarters every Monday and Thursday evening, at 7:30 p.m. Mr. Miller found himself unable to continue, so the class is now in charge of Mr. Edward Fenn, the treasurer.

The first business report given by radio was broadcasted from 1XE Station of the American Radio and Research Corporation, Medford Hillside, Mass., on December 19, when Roger W. Babson, leading economist and business statistician, predicted the return to prosperity in the year 1922. Mr. Babson spoke for an hour and a quarter in developing his theme, and already hundreds of replies from all over the East have been received. 1XE is broadcasting every Monday evening business reports furnished by Babson's Statistical Organization, reviewing the state of business for the past week. This service is to be incorporated in the broadcasting schedules of other stations. Once or twice a month prominent business men will speak at 1XE. The business report schedule was started early in November, when Arthur Nash, president of the Nash Manufacturing Company of Cincinnati, Ohio, spoke on the "Golden Rule in Industry," on the eve of the beginning of the disarmament conference.

LETTERS TO THE EDITOR

SIR: In the past few issues of RADIO have noted several articles concerning the "jammed" 200-meter wavelength, also suggestions for bettering this condition.

Mr. Mott's suggestion for using the "holes" between the various wavelengths in common use, is a timely one, especially from 200 to 280 meters for C. W.

The RADIO inspector's suggestion for graded licenses from 150 to 200 meters is also good.

However, I believe that if the present laws were more rigidly enforced a great deal of the trouble would be eliminated.

First, the section of the radio regulations concerning decrement is the most commonly violated. Enough emphasis is not put on this part of the law. Any amateur with a little experience knows that the decrement can be kept within 75 per cent., or less than that allowed by the government, by using a little care and "elbow grease." Most of the amateurs give little thought to this—as if it were of no importance!

Second, that section of the law which states that communication must be carried on with a minimum of power. Evidently, from listening-in, this does not apply to the amateurs. How about the suspension of the owner's station license for such an offense?

Third, the amateur license requirements should require a receiving ability of fifteen words per minute. Also a fee of about \$5 should be required for a station license. Maybe this source of revenue might enable us to have a few more assistant radio inspectors.

Last, there are too many radio phone concerts. It is getting to be so that you cannot tune one completely out from the other, and when it's amplified—but who can dance to two different fox-trots at the same time?

Remember, our good old game is just whatever we make it.

Sincerely yours,

H. J. McCoy.

Berkeley, Calif.

NEW APPARATUS AND SUPPLIES FROM THE RADIO MANUFACTURERS

POWER AMPLIFICATION AT AUDIO FREQUENCIES

The demand for the reproduction of wireless speech and music in sufficient volume to be heard by many people at the same time, has changed the design of the audio frequency amplifier. Before the time of radio broadcasts an amplifier was of use only to make weak signals readable, with good signal strength. The present demand is that it reproduce with a minimum of distortion, and



Two-stage power amplifier.

also that it deliver power enough to actuate a loud speaker with the approximate resulting strength of an ordinary phonograph.

The Magnavox Company, which has for many years been building audio frequency amplifiers, has designed for the radio fraternity a new power amplifier, built in either two or three stages. By power amplifier is meant one which will give a true power output. The new Magnavox amplifiers are designed to use any of the standard power or transmitting tubes as amplifiers, these tubes to be used at or under their rated plate voltages.



Three-stage power amplifier.

Any of the modern transmitting tubes are excellent amplifiers when combined into circuits suited for them, and will give enormous amplification when used with high voltages.

In order that transmitting tubes with voltages of from 100 to 1,000 be used, it is necessary to use special amplifying transformers. These special intertube transfer coils are made by the Magnavox Company and are quite different from other types of transformers. They are open core, wound with heavy wire and highly insulated to stand large currents and high voltages. Switching from stage to stage is done with a master switch and the output does not have to be disturbed, no matter how many stages are used. This system does away with jacks and any danger arising from high voltage switching.

The design also differs from the conventional in that no input transformer is supplied. The reasons for this departure are many. It is obvious that if these power amplifiers are to be attached to receiving sets whose detector tube only uses 22½ to 45 volts, that it is not necessary for the initial transfer coil to be so elaborate as the power transformers. Then again it is necessary for the initial input coil of any amplifier to have a higher voltage ratio than the other coils. This voltage ratio also differs for different circuits. Magnavox power amplifiers are ideal to attach to a simple crystal receiver and there the input coil must be different again. Therefore, the manufacturers have given the user his choice of the initial amplifying coil or input transformer, and he should use one of the many standard makes—the type which gives him the best results on his particular set. The final output of these amplifiers will be the rated output of the tube used, both with the three-stage as well as the two-stage. The difference between the two is that the three-stage will bring up a much weaker signal to the rated output than will the two-stage.

Finally these power amplifiers were designed primarily for the distortionless amplification of music and speech in connection with the radio Magnavox. However, as these amplifiers will work successfully with any type of tube, at any voltage, they will also amplify successfully in connection with phones or with any standard type of radio receiver on the market today.

THE HALL RADIO RELAY

By J. EDWARD JONES.

The advent of the Hall Radio Relay enables all that can now be done by land-wire to be done by radio. Automatic relaying, automatic recording, printing, sending of pictures, plans, documents and handwriting are a few of the many operations that the Hall relay adds to the accomplishments of the radio station of today.

While the true worth of the relay is more or less commercial, its introduction into the amateur field will be met with approval by those who want a permanent record, whether at four or forty words per minute.

As for printing, page 20 of the January issue of RADIO, it explains itself.

The author sent that message from a standard typewriter keyboard. The only manual labor required. I fancy I hear someone say, "Printing for amateurs! Pooh, impractical!" but I say, "No, not impractical, but only just a bit ahead of the game; just the foundation of the radio structure of tomorrow."

Secrecy? Well, just try to copy a printed message with a pencil, and if you succeed the Einstein theory will be easy for you, for you will then know what he means by relativity.

The Hall apparatus, as the name implies, is a relay, i. e., the weak radio impulses are made to make and break a local circuit. This small, simple piece of apparatus can be made to operate any power; for instance, weather reports have been received from one small station, and then the relay has operated a 500-k.w. set, repeating the same message simultaneously, without any human element between. Amplification! eh, what?

The relaying properties of the apparatus are somewhat curtailed at present, due to absence of remote control in amateur stations, but the specifications of a patent published in the same January issue indicates that this difficulty is surmountable. Given that, the relay will send a message around the United States with one sending—in fact, cover the entire country—the value in this respect for press, weather, etc., is incalculable. However, as things are at present, the radio impulse can be automatically relayed to a land line or local circuit. This suggests amplification, to which there is no limit.

The Hall relay is simple and foolproof. It will operate an any receiving set. Just plug in place of, or in addition to, the regular 'phones. For its operation it requires but a weak signal—far less than the usual operator requires—and, while a child can run it, yet skillful operation will give startling results. With practice almost all Q. R. M. is eliminated, as the apparatus discriminates very closely between musical notes, either spark, or C. W., although perhaps with the latter closer regulation can be obtained. The author has frequently recorded and relayed signals completely drowned by Q. R. M. as far as the human ear was concerned.

H. C. Hopkins has resigned as publicity representative of the Westinghouse Electric & Manufacturing Company at San Francisco, to devote his entire attention to the advertising agency of Dolman & Hopkins, Call Building, San Francisco.



Exhibit of The Radio Corporation of America at San Francisco Radio Show.

PACIFIC RADIO SCHOOL

The student about to take a course in radio wants to be assured that he will secure maximum proficiency in minimum time. This assurance is given by the Pacific Radio School, an old-established institution in the Call Building, San Francisco. This claim is substantiated by personal instruction from practical operators and the opportunity to actually use the latest types of equipment.

The instructors are Mr. A. S. McKenzie, who is in charge of the school, and Mr. R. H. Pray, a former U. S. Shipping Board operator and one of the leading mid-West amateurs. Mr. McKenzie was recently presented with a handsome pair of binoculars by his students, as a token of their appreciation of the beneficial instruction received under his direction.

The transmitting equipment includes a complete 2-k.w. arc set with combined ignition key and shunt system, an Independent Company transmitter, a Kilbourne & Clarke impulse transmitter, an old type United Wireless set, and a Clapp Eastham transmitter.

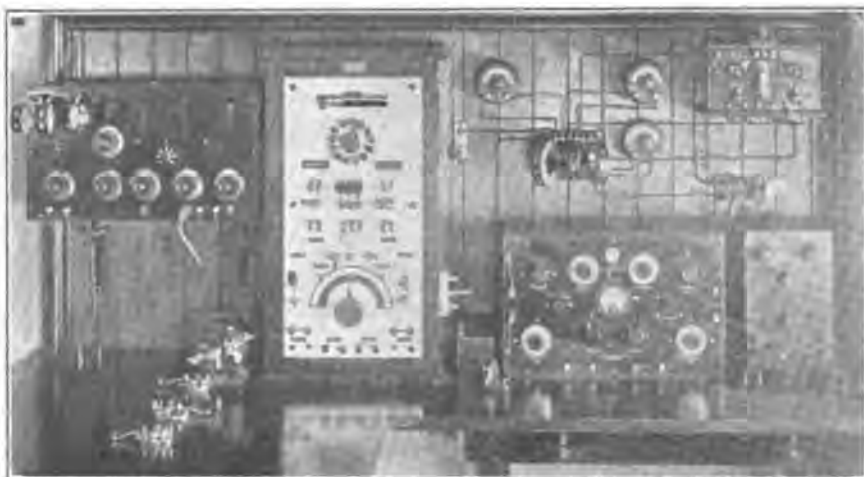

Receiving Equipment at Pacific Radio School

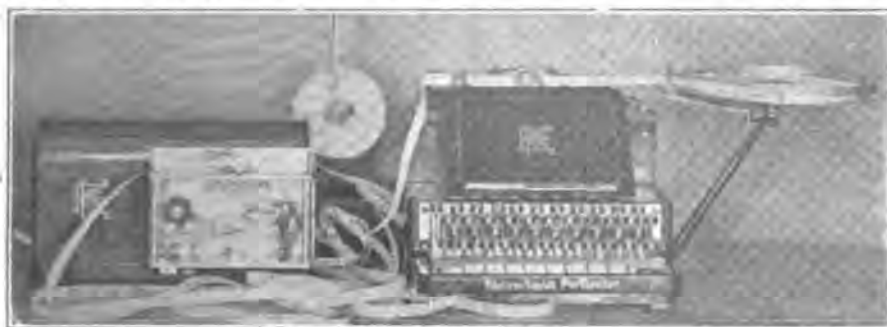

Kleinschmidt Electric Perforator

There are also five complete receiving sets, including a Kennedy Universal set and a Navy Standard Type 1420. For practice the students copy East Coast signals by means of forty phones in parallel. This school is one of the few Pacific Coast stations that heard the Clement test from New York.

This is claimed to be the only radio school in the country equipped with a Kleinschmidt electric perforator and two automatic cable transmitters. The instructors perforate a complete reel of tape every morning for the day's work. This is run at an average speed of thirty words a minute for one and a half hours. It is capable of running at any speed up to 400 words a minute. The students' receiving record is thirty-eight words.

A thorough grounding in experimental electricity is given with Swoope's "Practical Electricity" as the basis. In addition to complete apparatus for the experiments in this text, there is a Kolster decremeter, of which the students make daily use, a Tesla transformer, an audibility meter, galvanometer and other meters. The school has run at its full capacity of forty students during the past year.

BOOKS RECEIVED

RADIO QUESTIONS AND ANSWERS on Government Examination for Radio Operator's License. By Arthur R. Nilson. 86 pp., 5 x 7, published by McGraw-Hill Book Co., New York, and for sale by RADIO, San Francisco. Price \$1.00.

The purpose of this book is expressed in its title. It consists of 121 questions and answers typical of those given in the examination for license, together with valuable information regarding such examinations. The text is based upon the author's experience as director of the East Side Y. M. C. A. Radio School of New York. It is assumed that the reader understands radio theory and operation, so that the book may be used for a last-minute brushing up before the examination.

A NEW RADIO SHOP

The Newberry Electric Co. has installed a radio department in its fine new store in San Francisco. A complete line of equipment is carried for the amateurs' use. As the Newberry Company are also distributors for the Sonora phonograph, they have put the radio equipment into a booth where the purchaser may comfortably select what he wants, just as phonograph records are selected. This obviates the necessity of standing around a counter.

This enterprising company had an interesting exhibit at the recent Industrial Exposition. They are furnishing records to one of the local telephone broadcasting stations and are

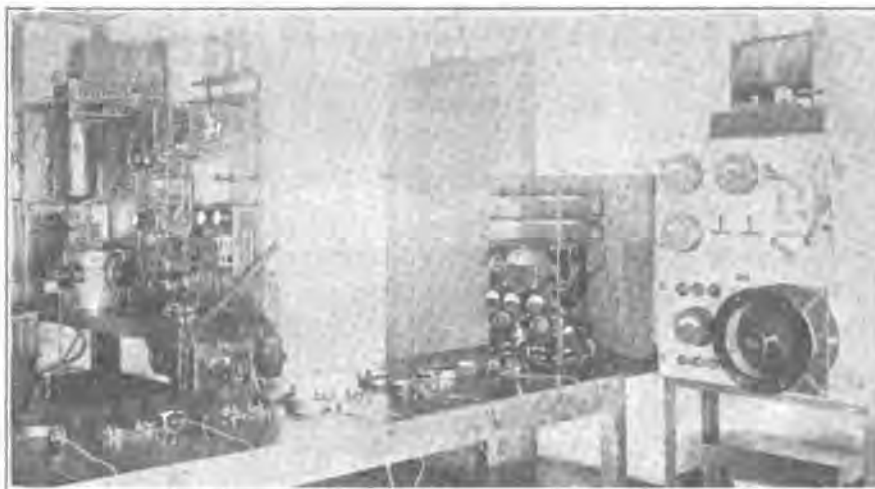

Transmitting Equipment at Pacific Radio School

NEW CATALOG

Copper Clad Steel Comp. has issued an attractive circular of information regarding the use of "Copperweld" wire for aerials, lead-in and ground connections. Its steel core gives high strength and its copper covering gives practically the same conductivity at radio frequency as copper wire of the same diameter.

A pamphlet from the Experimenter's Information Service, 45 Pinehurst Avenue, New York City, briefly describes various designs of receiving and transmitting equipment which the amateur may build for himself by aid of complete blue prints furnished for this purpose.

The Teco Radio Company, Boston, Mass., has issued a leaflet illustrating and describing its new Vernier Rheostat, which allows very fine control of the filament current for V. T. use.



Radio Booth at Newberry Electric Co. Store.

taking a leading part in the development of better service to the radio operator. C. B. Bensberg is manager of the radio department.



ORDER!

Your Radio Equipment from Us and

JUDGE

For Yourself If You Ever Received
BETTER SERVICE

A \$1,000,000.00 Receiver

WOULD N'T BE WORTH

5c

IF YOU DID NOT USE IT!

THOSE WHO USE OUR PRICE DICTIONARY
REALIZE ITS VALUE AND THE
EFFICIENCY OF

WESRAD SERVICE

A Regular Reservoir of the Best Apparatus
on the Market at Any Price and a
Delivery Service as Snappy as
a Winter's Day in Iceland!

USE THE NEAREST STORE

Western Radio Electric Co.

557 South Flower Street
LOS ANGELES

274 Twelfth Street
OAKLAND

Operating Kinema Theater Radio Phone
Los Angeles — Call KZC

CALLS HEARD



HEARD AT 71W, EUGENE, OREGON

5fo, 5za, 6ac, (6ak), 6aa, (6bm), 6bu, (6cz),
6ea, 6en, 6eo, 6ex, 6fh, 6fn, (6gf), 6go, 6he,
6hp, 6ib, 6is, 6iv, 6ka, 6ke, 6kp, (6lc), 6mh,
6mz, 6oc, 6ol, (6pj), 6pr, (6qr), 6at, 6tj, (6to),
(6tu), 6uo, 6va, 6vc, 6vm, 6vk, (6vx), 6wz,
6yc, 6za, 6zk, 6zr, 6zu, 6zx, 6aan, (6aan), 6aac,
(6abw), (6abx), 6acy, 6aez, (6aei), (6afn), 6agf,
6agp, 6ahq, (6aib), 6aif, 6aik, (6aio), 6aki,
(6ala), 6alu, 6alp, 6amk, (6anp), 6aac, 6aov,
6ape, 6apv, 6ask, (6atv), (6avb), (6avv),
(6bbr), 6bec, 6zal, (7ba), 7bc, 7bh, 7bj, (7bk),
7bw, 7br, (7bz), (7f), 7hd, 7iy, 7jd, 7kb, (7ke),
7kz, 7la, 7ld, (7ly), 7mg, 7mo, 7mp, 7nl, 7nn,
7ot, (7tj), 7to, (7vz), 7wa, 7yg, (7yj), 7yl, 7ys,
7zj, (7zp), 7zs, 7zt, 7zv, (9ax), (9bd), (Can),
9gx, 9zn.

C. W. stations—4cb (Can), 6gy, 6xp, 6zn,
6aat (fone), (6ahy), 6ale, 6arc, 6avy, 6xae,
6xad (fone), 7xf (fone), 9amb, mc.

CALLS HEARD AT 2BAK, TARRYTOWN, N. Y.

C. W.—1ze, 1zf, 1afv, 1ary, 1bcg, 1bdi, 1bqt,
1bxx, (2cc phon), (2is phon), 2gr phon, 2xi phon,
2xr phon, 2xb phon, 3aw, (3bp), 3fa, (3bx),
(3cw), 3fx, 3hg, 3mo, (3rf), 3zo, 3zy, 3aae,
3ahk, 3aku, (3biy), 4aw, 4by, 4co, 4el, 4kk,
4le, 4xc, 4ya, (8ba), 8bd, 8bu, 8dx, 8fb, 8fq,
8gv, (8ib), 8iv, (8jq), 8lx, 8mp, (8uk), (8vy),
8wo, 8zv, (8zd), (8zg), 8zj, 8zo, 8ap, 8zu-CW-
phon, 8zv, 8zz, 8abo, 8agl, 8agz, 8ahr, 8aiu,
8akp, 8alo, 8amq, 8aqv, (8agz), 8arj, 8awp, 8awp,
8bbf, 8bed, (8bfx), 8bow, (8box), 8bpl, 8ii,
(8vg), 8xi, 8xm, 8zj, 8zn, (8zv), 8zy, 8aav,
(9aj), 9ark, 9hed, 9dwj, xfl, nmw, wych phon.
Spark—lyd, 3rw, 8dk, 8dy, 8hu, 8aja, 9kf, 9ox,
9uh, 9tl, 9aap.

E. I. R. Lounsberry, Jr., 2bb, Ossining, N. Y., is
reaching out with a new 4-50 watt tube set.

R. Keasler, Nyack, N. Y., has been testing out
his 2-50 watt tube set and hopes soon to be on
the air.

Charles Benedict, principal of the North
Tarrytown High School, intends to install a
Radio Station in the new high school.

Emerson Decker, 2ua, White Plains N. Y., has
installed a tube set and is a C. W. ham now
as well as spark ham. More power to you, 2ua.

The Old Post Road Garage Radio Station,
2bak, is in receipt of a letter from Mr. J. F. J.
Maher, chief engineer, Compani Radio Telegrafica
y Telefonica Mexicano, S. A., of C. Juarez,
Chihuahua, Mexico, stating that on November
12th at twelve o'clock he heard 2bak working
8ba, Detroit, Mich., and that our signals were
perfectly audible and with that intensity that
makes reading a pleasure.

JOS. B. SLAVIN, Operator.

CALLS HEARD BY RADIO 7VE, ex-6A1K.
ALL OVER 100 MILES.

5fo, 5za, 6ak, 6gf, 6ic, 6is, 6ot, 6pj, 6qr, 6sj,
6zb, 6zx, 6zz, 6aah, 6abw, 6aez, 6ain, 6atq, 6arc,
6ark, 6avv, 6awh, 7bh, 7bj, 7bz "cm", 7cw,
7dk, 7f, 7fk, 7hm, 7in, 7ir, 7lu, 7ly, 7mf, 7mp,
7nl, 7nz, 7ot, 7zg, 7zo, 7zu, 9ry, 9ti, 9aeg, 9agn,
9aig, 9amk (cw), 9axv, 9ayv, 9doc.

6AWF, LOS ANGELES, CALIF.

5za, 6ak, 6ex, 6fh, 6fk, 6gf, 6gr, 6hc, 6kc,
6lu, 6oc, 6pj, 6pr, 6qk, 6qr, 6tu, 6vx, 6vz, 6wz,
6ze, 6zk, 6zu, 6zx, 6aah, 6aak, 6aau, 6aeh, 6afn,
6agf, 6aid, 6ale (icw), 6anp, 6ape, 6aph, 6arw,
6aud, 6avb, 6avv, 6xad (icw), 7mf.

STATIONS WORKED BY 7ZU, POLYTECHNIC
P. O. MONT.

(5hk), (5yl), (5za), (5zu), (5zz), (6aez),
(6atq), (6awh), (6ot), (6wv), (6za cw), (6zx),
(7ex), (7im) f, (7ly), (7mp), (7nl), (7rn),
(7ya), (7yj), (7yl), (7zg), (7zh), (7zt), (9aeg),
(9ae), (9aif), (9amb cw), (9aou), (9age),
(9ayv), (9ayw), (9doc), (9dva cw), (9ix),
(9jn), (9lw), (9wu), (9xm), (9yae), (9yak),
(9yal), (9zac), (9zc), (9zaf cw).

C. W. STATIONS HEARD BY 7ZU

5za, 5zz, 6xaf, 6wv, 6xnc, 6xad, 6ale, 6aat,
6zn, 6za, 7ln, 7yj, 7nr, 8mza, 9amb, 9dva, 9zaf,
9nx, 9xi, 9aej, 9dtw, 9bjv, 9dtv, cz8, wjk, wv6.

STATIONS HEARD AND WORKED BY
7KS, ASTORIA, OREGON.

6fk, (6gr), 6gx, 6km, (6lu), 6mg, 6ng, 6ol,
6pg, 6qr, 6tu, 6zk, 6zx, 6aau, 6abx, 6adc, (6agf),
6aix, 6amk, 6ape, 6aph, 6atq, 6atz, 6awh, 6awi,
7bh, (7bj), 7bp, 7dw, 7f, 7ft, 7hm, 7jm,
(7ke), (7mf), (7mp), 7nl, 7nn, 7uz, 7xa, 7ys,
7zk, 7zt, Can, 9ax, (Can, 9bd).



Radiotron
250-Watt
Transmitter



Faradon
Mica Coupling
Condenser



325-Watt
C. W. Power Transformer

C. W. Apparatus of Quality

for the Radio Amateur and Experimenter



AS Western Jobbers for the Radio Corporation of America, we carry the most complete, carefully selected stock of dependable radio equipment for the amateur to be found in the West. We have chosen only such lines as we can heartily recommend.

SEND us twenty-five cents for the Radio Corporation's new C. W. Manual and Catalog. This book contains much timely and valuable information as to circuits, general design of amateur stations, radio regulations, and apparatus for completely equipping stations of various sizes.



DEALERS:

In addition to the high class receiving units of our own manufacture, we are jobbers for the following lines and carry large stocks in San Francisco.

Radio Corporation of America (Including apparatus of General Electric Co. and Westinghouse Electric and Manufacturing Co. manufacture)

General Radio Co.,
Adams Morgan Co., (Paragon),
Remler Radio Mfg. Co.,
Federal Tel. and Tel. Co.,
Signal Electric Mfg. Co.,

Burgess Battery Co.,
Wm. J. Murdock Co.,
Magnavox Co.,
Baldwin Telephones,
Wireless Press Books



150-Watt
Kenotron
Rectifier

THE COLIN B. KENNEDY COMPANY
INCORPORATED
RADIO EQUIPMENT OF QUALITY

RIALTO BUILDING

SAN FRANCISCO

Announcing

a new and conveniently situated radio store in San Francisco

Buy your radio apparatus with the same convenience as you buy a phonograph—in the comfort and seclusion of a separate room. No standing around at the counter.

A complete line of standard apparatus of high quality sold by electrical experts. Radio telephone receiving sets a specialty.

Large line of Kennedy, Remler, Radio Corporation, Murdock, Chelsea, Brandes, Baldwin, DeForest, Magnavox and all other well known apparatus.



Illustration shows our loud speaker for concert and signal reproduction. This loud speaker consists of a Baldwin phone, cord and plug, attached to a papier-mache horn, 36 inches long. Elimination of the familiar and undesirable "tin" effect of a metal horn.

Hear the music all over the house with this loud speaker.

Price, \$9.60 (without plug)

J. E. Newbery Electric Company

359 Sutter Street, San Francisco
Next door to the Spring Valley Water Company

CALLS HEARD ABOARD S. S. "WEST HAVEN" (KJY).

5xu—2014 W. NW. of Cape Mala, Republic of Panama, Nov. 13th, 9:45 p.m., 75th meridian time. (QSA)

5xu, 6ot, 6qr, 6zm, 7ya, 7yl, 7zj (qsa)—90 miles south of Columbia River Bar.

6aef, 6ajr, 6aj, 7ba, 7ka, 7xa, 7ze, 9ax—80 miles south of Tatoosh.

6agf (6wg) Stockton, Calif. Phone (qsa), 6lc, 6zx, 7zj, 7zu—Off Cape Mendocino, California.

CALLS HEARD BY CHAS. F. BURDICK, RADIO 708, CASPER, WYO. (ONE TUBE).

Spark—5bm, 5fo, 5hk, 5if, 5ir, 5jl, 5nc, 5pu, 5qa, 5xu, 5za, 6aez, 6amb, 6awh, 6aeg, 6ef, 6ot, 6qr, 6zu, 6zx, 7d, 7in, 7jq, 7lu, 7ly, 7mo, 7mp, 7xi, 7ya, 7zg, 7zh, 7zo, 7zs, 7zu, 9abv, 9acn, 9aeg, 9afx, 9agn, 9agr, 9alf, 9aig, 9anf, 9ang, 9ano, 9aou, 9aqe, 9atn, 9auo, 9ave, 9ava, 9awx, 9axu, 9ayu, 9dag, 9dba, 9deb, 9dih, 9duc, 9doc, 9dpp, 9dsd, 9dug, 9dze, 9dzi, 9ee, 9et, 9fx, 9hi, 9hm, 9ht, 9if, 9jn, 9lc, 9lf, 9lw, 9oa, 9oo, 9ps, 9ry, 9tl, 9tl, 9wu, 9xi, 9yae, 9yak, 9zn.

C. W.—Canadian 4cb, 6ale, 6wv (Denver), 6xad, 7xf, 8iq, 9aja, 9amb, 9bbf, 9bex, 9dcy, 9dzq, 9fo, 9nx, 9rv.

STATIONS OVER 300 MILES DISTANT HEARD AT 6JX AND 6XAF, PIEDMONT, CALIF.

Spark—5za, 6da, (6ea), 6en, 6er, 6fk, 6gt, 6kp, 6ky, 6lc, 6mh, 6od, 6ol, 6qr, 6uo, 6za, 6zb, 6zc, 6ak, 6ac, 6ad, 6aei, 6ahp, 6aib, 6alj, (6amn), 6aqa, 6aw, 6atf, 6avd, 6awi, 7bh, 7bj, 7bk, 7br, 7fi, (7hf), 7in, 7iw, 7jw, 7kb, 7ke, 7mf, 7nl, 7ot, 7zj, 7zp, 7zt, 7zu, 7ya, 9bd (Canadian).

C. W.—(6df), (6aaz), 6avy, 6awv, 6xad, 6zak, 6zb, 7oz, 9dva.

CALLS HEARD AT 80M, LOS ANGELES, CALIF.

5if, 5za, 6cv, 6ex, 6gf, 6gr, 6gt, 6gx, 6hc, 6ic, 6ji, 6kc, 6km, 6lu, 6ng, 6oc, 6oh, 6pj, 6pr, 6qr, 6to, 6tu, 6tv, 6uo, 6vx, 6wo, 6wz, 6za (cw), 6zb, 6ze, 6zk, 6zu, 6zx, 6zz, 6aa, 6ab, 6ac, 6ad, 6ae, 6af, 6ag, 6ah, 6ai, 6aj, 6ak, 6al (cw), 6am, 6an, 6ap, 6ar, 6as, 6at, 6av, 6aw, 6ba, 6bb, 6bc, 6bd, 6ad (cw), 7in, 7jd, 7mf, 7ij, 7ya, 7yg, 7za, 7zj, 7zt, 9amb (cw), 9dva (cw).

CALLS HEARD AT 9BD, BABBON HOTEL, VANCOUVER, B. C.

C. W.—(rb), 4cb, 9ba, "5" to numerous, (6ah), (6as), (6ak), (6ale), (6ark), (6agf), 6aid, 6afn, 6aat, 6aua, 6agt, (6abx), (6amk), 6cp, (6ch), 6en, (6ex), (6hc), (6gr), (6jz), (6kl), 6qs, 6vk, (6vx), (6tv), (6tu), (6vm), 6hp, 6oc, 6po, (6awv), (6wz), 6ot, (6pr), (6zx), (6lu), 6xac, 6xad, (6qr), 6ze, 6fh, 7ag, (7bk), (7bb), (7br), (7bj), 7bb, 7ex, 7go, 7ge, (7kb), 7mo, (7d), 7iw, 7nw, (7nl), 7nn, 7oz, 7iy, (7fb), 7jd, 7yg, (7ya), 7wa, (7yz), (7hn), (7hf), (7ks), (7tj), 7zb, (7zt), 7zj, (7zs), 7re.

CALLS HEARD AND WORKED AT 7ED, PORTLAND, ORE.

4cb Canadian-cw, 5xu, (6ak), (6bb), (6ch), (6cp), 6cv, (6ea), (6eb), 6en-cw, (6fh), 6fn, 6g, 6gp, (6gr), (6gx), 6hc, 6hy, (6ic), 6im, (6ia), 6je-cw, 6ka, 6kc, 6km, 6lu, (6oc), 6pj, 6pr, (6qr), 6qt, 6sk, 6tu, 6vm, (6vx), (6wz), 6pk & cw, 6xh-cw, 6ze, 6zn-cw, (6zu), 6zx, 6aat-cw, (6abx), 6acy, 6aei, 6afn, (6afo), (6agf), (6aid), 6ajh, (6ale-cw), 6alu, 6am-cw, 6ang, 6ape, 6atv, 6avv, 6awh, 6awt, 6xaf-cw, 7ay, (7ba), 7bh, (7bk), 7ex-cw, (7in), (7iw), (7iy), 7jf, 7kg, (7kj), (7lu), (7mf), 7mo, 7mp, 7nj, (7nl), 7nn, 7nw, 7oz, 7po, (7tj), (7ya), (7yl), 7zp, (7zu), 9ax Canadian, (9bd Canadian), 9amb-cw, 9zac. This station also handled 107 messages, starting Oct. 15th and ending Nov. 1st.

CALLS HEARD AT 6BDQ, COALINGA, CALIF.

5za, 6an, 6al, 6au, 6aw, 6ba, 6bc, 6bd, 6bg, 6cb, 6da, 6dn, 6do, 6dr, 6du, 6ea, 6eb, 6ex, 6fn, 6fk, 6gr, 6go, 6gw, 6ia, 6jd, 6jz, 6kc, 6lc, 6lw, 6lx, 6na, 6ng, 6nr, 6od, 6oa, 6ot, 6qr, 6rn, 6sk, 6uo, 6wl, 6ya, 6zb, 6ze, 6zu, 6zk, 6zr, 6zi, 6zh, 6zx, 6zz, 6ba, 6aa, 6ac, 6abv, 6aiw, 6ajl, 6ard, 6avy, 6asp, 6ask, 6aun, 6afa, 6amk, 7nn, 7bd, 7jd, 7ys, 7yj, 7zu, 7zj calling 9fx, 8zz, 9yal, cli. Radiophones—6gx, 6xw, 6xac, 6xad, 6xae, 6xaj, wjk, 6wv Denver, Reynolds Radio Co., Denver, Colo.

CALLS HEARD AND WORKED AT 6ASJ, OAKLAND, OCT. 1st to JAN 1st.

Spark—6acy, 6ade, 6agf, 6ahp, (6alb), 6aif, 6amn, 6avb, 6awj, 6cv, 6da, 6ea, 6eb, (6ef), 6fk, 6ft, 6gf, 6gk, 6gp, 6gr, 6gs, 6ka, 6kc, 6ky, 6lu, 6mh, 6ol, 6pc, 6qr, 6ak, 6tf, 6to, 6tv, (6wd), 6wr, 6zb, 6zn, 6zr, 6zu, 6zz, 6zal, (7bb), 7bk, 7bj, 7cc, 7ej, 7ga, (7hf), 7iw, 7jd, 7jw, 7ke, (7mf), 7tj, 7ya, 7yl, 7ys, 7zj, 7zt, 7zu, 9ax, 9bd Canadian.

C. W.—5za, (6aat), (6ale), (6aoy), (6oz), 6avy, (6jd), 6xad, 7go, 7oz, 7zf, (cw and voice).

HOMCHARGE YOUR BATTERY for A Nickle

A PERFECT RECTIFIER AT LAST, FULLY AUTOMATIC AND FOOLPROOF IN EVERY RESPECT. IT CAN BE OPERATED BY ANYONE

THE HOMCHARGER

Connects to any alternating current lamp socket, gives a taper charge—will fully charge any "A" battery overnight. It is self-polarizing. Connect your battery either way and it will always charge. Automatically disconnects battery when power is interrupted. Restarts charging when connections are restored. Adjustable for wave form, frequency and voltage. Contains only one moving and two wearing parts, lasting thousands of hours, replaceable as a unit for \$1.00. The highest charging rate, greatest of efficiency, and simplest of any rectifier selling for less than \$100. Bulletin 828 prove it. Ask for your copy. Manufactured in sizes for charging three or six cell batteries from both alternating and direct current circuits. Cannot injure battery—will last a lifetime—approved by underwriters—satisfaction guaranteed. For sale by all Radio, electrical and accessory dealers or direct express prepaid for purchase price—\$18.50.

ATTENTION MOTORISTS:

Send for special bulletin 88 showing how easy it is to "HOMCHARGE" your battery.

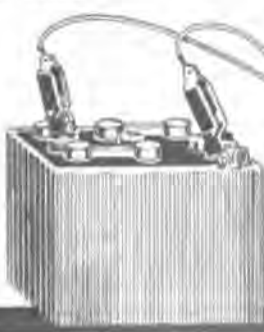

The Automatic Electrical Devices Co.

117 WEST THIRD ST., CINCINNATI, OHIO.

Canadian Distributors—Howley & Moody, Ltd., Toronto

SAVE TIME—SAVE DOLLARS

BUY FROM US IF YOU WANT ACTION!

Seattle NORTHERN Seattle

OUR NEW CALL IS
K F C

INTELLIGENT—RADIO
SPEEDY—RADIO
RELIABLE—RADIO

MOST COMPLETE
STOCK IN THE
PACIFIC NORTHWEST

Chelsea

No. 1 Mounted 0011.....	\$5.00
No. 2 Mounted 0008.....	4.50
No. 3 Unmounted 0011.....	4.50
No. 4 Unmounted 0008.....	4.00
3/16 Bakelite Dial and Knob.....	1.00
1/4 Bakelite Dial and Knob.....	1.00
21 Variable Grid Leak.....	3.00
31 Oscillator.....	3.00

General Radio

0-1 Hotwire Meter.....	\$7.75
02 1/4 Hotwire Meter.....	7.75
0-5 Hotwire Meter.....	7.75
0-10 Hotwire Meter.....	7.75
231A Amplifying Transformer.....	5.00
231M Modulation Transformer.....	5.00
214 2 1/2 Amp. 2 ohm Rheostat.....	2.50
214 1 1/2 Amp. 7 ohm Rheostat.....	2.50
158 Socket Bakelite.....	1.50

Vacuum Tubes

G300 Cunningham Detector.....	\$5.00
G301 Cunningham Amplifier.....	6.50
G302 Cunningham 5 Watt Power.....	8.00
G303 Cunningham 50 Watt Power.....	30.00
AF ELECTION RELAY.....	5.00
AF VT Amplifier.....	6.50
DE FOREST Rectifier.....	9.75
RADIOTRON 250 Watt Power Tube.....	110.00

Sockets

92 REMLER Socket.....	\$1.50
156 GENERAL RADIO.....	1.50
550 MURDOCK.....	1.00
E300 DE FOREST.....	1.60
DE FOREST Moulded Bakelite.....	1.40
RADIO SERVICE Triple Socket.....	3.50
RADIO SERVICE Double Socket.....	2.50
VICTORY Shell-Less Socket.....	1.00
GROSLY Porcelain.....	.60

Variometers

REMLER 505 Moulded Bakelite.....	\$6.00
RADIO SHOP.....	5.75
RADISCO.....	7.00
CLAPP-EASTHAM.....	6.50

Vario-Couplers

REMLER 503 Vario-Coupler.....	\$5.40
MURDOCK Vario-Coupler on Unit Panel.....	8.50
REMLER 505 Coupler on Unit Panel.....	12.75
RADIO SHOP Vario-Coupler.....	4.75
CLAPP-EASTHAM.....	6.50

Westinghouse Apparatus

RA Short Wave Tuner.....	\$65.00
DA Detector Two Stage Amplifier.....	65.00
CB Loading Coil.....	5.00
EC Short Wave Receiver with Det. 2 step.....	125.00
DB Crystal Detector.....	5.00
EE Aerola Jr. Receiver.....	25.00
AD Antenna Outfit.....	7.50
PA Antenna Protective Device.....	2.00
SA Lightning Ground Switch.....	4.00
ME 100 watt MG Set 500VDC 110-V., 60 Cycle, Ac.....	85.00
MH 250-watt MG Set, 1000VDC, 110-V., 60 Cycle, AC.....	145.00
Rectigon 2 1/4 A Battery charger.....	18.75
Rectigon 6A Battery Charger.....	29.50
Rectigon 2 1/2 Renewal Bulb.....	4.40
Rectigon 6A Renewal Bulb.....	8.80
LS Victrola Attachment.....	15.00
LS Grafonola Attachment.....	15.00

Remler Apparatus

810 Jr. Rheostats.....	\$1.00
811 Rheostats.....	1.75
813 3 Amp. Rheostats.....	1.75
92 VT Socket.....	1.50
330 Audion Detector Panel.....	8.00
331 Amp. Panel.....	6.00
333 Amp. Panel.....	9.00
400 3 Coil Mounting.....	6.50
96 Variable Grid Leak.....	.80
97 Grid Condenser.....	.35
503 Variocoupler.....	5.40
500 Variometer.....	6.00

Wireless Shop Variable Condensers

		Approximate Maximum Capacity	
No. 20	2 Plate, Vernier Condenser.....		\$2.00
No. 70	7 Plate, .0001 m. f.....		3.35
No. 130	13 Plate, .0002 m. f.....		2.75
No. 170	17 Plate, .0003 m. f.....		3.15
No. 230	23 Plate, .0005 m. f.....		3.60
No. 310	31 Plate, .0007 m. f.....		4.30
No. 430	43 Plate, .001 m. f.....		5.25
No. 630	63 Plate, .0015 m. f.....		7.50

Remler QSA Honeycomb Coils

Type Number (No. of Turns)	Wave Length Range with .001 Mf Cond.	M't'd	UnM't'd
L25.....	170—375	\$1.40	\$0.50
L35.....	200—515	1.40	.50
L50.....	240—730	1.50	.60
L75.....	330—1030	1.60	.60
L100.....	450—1460	1.65	.65
L150.....	660—2200	1.60	.70
L200.....	860—2850	1.65	.75
L200.....	1120—4000	1.75	.80
L300.....	1340—4800	1.75	.85
L400.....	1860—6300	1.80	.90
L500.....	2340—8500	2.00	1.00
L600.....	2940—12000	2.15	1.15
L750.....	3100—15000	2.35	1.35
L1000.....	5700—19000	2.60	1.60
L1250.....	5900—21000	3.00	2.00
L1500.....	7200—25000	3.50	2.50

Rheostats

REMLER Jr.....	\$1.00
FADA—with new Knob.....	1.00
GENERAL RADIO No. 214 7 ohm or 2 1/2 Amp. 2 ohm.....	2.50
DEFOREST, new type.....	1.75
PABAGON.....	1.75
MURDOCK 580.....	1.00

**BALDWIN'S NEW
PRICES!**

Type C, Set..... \$12.00
Type E, Set..... 13.00
Type F, Set..... 14.00

Amplifying Transformers

UV-712 Radio Corporation.....	\$7.00
231A GENERAL RADIO.....	5.00
226W FEDERAL.....	7.00
A2 ACME, unmounted.....	4.50
A2 ACME, semi-mounted.....	5.00
A2 Fully mounted.....	7.00

Jacks and Plugs

FEDERAL 1421 Open Circuit Jack.....	.70
FEDERAL 1422 Single Circuit Jack.....	.85
FEDERAL 1423 Double Circuit Jack.....	1.00
FEDERAL 1435 Automatic Filament Control Jack.....	1.20
FEDERAL 1438 Automatic Filament Control Jack.....	1.55
WESTERN ELECTRIC Plugs.....	2.00
FEDERAL Plugs.....	2.00
PACENT UNIVERSAL.....	2.00
NEW FEDERAL Universal Plug.....	1.75
BHAMSTONE Plug and Jack, complete.....	1.50

OUR PRICE LIST BRINGS RADIO SMILES O'ER MANY RADIO MILES
HAVE WE SENT YOU YOURS?

Northern Radio & Electric Co.

606 PINE STREET, SEATTLE, WASH.

OPERATING THE SEATTLE POST INTELLIGENCER'S RADIO TELEPHONE NEWS AND CONCERT BROADCAST

Send for Concert Schedule

Tell them that you saw it in RADIO

Attention Bugs—

Are you wise or do you just think you are? Are you going to profit by the other fellow's experience or are you going to pay dearly for your own? Is it possible that there are still amateurs who do not know what E.I.S. means? Don't stay in the rut and don't be so sure that Radio is an open book to you. E.I.S. has accomplished more for the amateur in the past year than any one factor and is daily making some Bug happier than ever.

Several months ago we sent our sales manager to the Pacific Coast to establish a chain of connections for the good of the game and as a result every first class dealer from Coast to Coast carries a complete line of our BLUEPRINTS.

Ask yourself why—they know the game better than you, they know these BLUEPRINTS are the highest class work obtainable and are positively FOOLPROOF, they cover every conceivable branch of radio, they enumerate the most minute detail and why shouldn't they, they were only drafted after models had been perfected to the highest degree by final authorities. What is it you want to build and cannot afford to buy as a finished product, what is it that you have built and wish to improve upon, let us solve your difficulty, we answer your questions gratis, we have but one thing to offer and that is SERVICE. Send a self addressed envelope and receive one of our bulletins free, covering twenty-two up-to-date receiving and transmitting devices, select the one you have your heart set upon and then let us make its assembly the simplest kind of task for you, or better still, ask to see our BLUEPRINTS at your local dealers (below are a few) and you will be looking right into the heart of Radio. Each print 21 x 28.

The Following Dealers Stock Our Blueprints:

F. D. Pitts, Boston
 Atlantic Radio, Boston
 Continental Radio, N. Y.
 Manhattan Elec. Co., Chicago
 Dreyfuss Sales Corp., N. Y.
 Detroit Elec., Detroit
 Phila. School of Wireles
 Chicago Radio App., Chicago
 Telephone Maintenance, Chicago
 Comm. Edison Co., Chicago
 Wolfe Elec., Omaha
 Western Radio Elect. Co., Oakland, Cal.
 Western Radio Elect. Co., Los Angeles, Cal.
 Martin Elec., Waynesville, N. C.

Precision Equip., Cincinnati
 Scientific Exp., Montreal
 Salton Radio, Winnipeg
 Marconi Co., Vancouver
 Northern Radio, Seattle
 Stubbs Elec., Portland
 Northwestern Radio, Portland
 Leo J. Meyberg, San Francisco
 Leo J. Meyberg, Los Angeles
 Cope & Cornwell, Salt Lake
 Central Radio, Kansas City
 Karlowa, Davenport
 Manhattan Elec. Co., New York
 Western Radio, Kansas City

Write for Bulletin "R"

Experimenters Information Service

45 Pinehurst Ave., N. Y. C.

CROSLY RADIO APPARATUS

"Better—Costs Less"

Crosley V-T Sockets.....	.80
Crosley Variable Condenser without knob and dial.....	1.25
With knob and dial.....	1.75
Mounted in cabinet with knob and dial.....	2.50
Harko Radio Receiver.....	9.00
Single phone, 125 feet antenna wire, insulators etc.....	6.00
Complete set.....	15.00
Crosley Magfon.....	10.00
Crosley Cabinets—	
In gum.....	\$2.50 to 5.25
In mahogany or quartered oak.....	\$3.85 to 10.80
Crosley Rheostats Model "A".....	.60
Model "B".....	1.25
Crosley Binding Posts, each.....	.08
Dozen.....	.90
Crosley Tap Switch, each.....	.40
Switch Taps, each.....	.03
Dozen.....	.30
Hundred.....	2.50

CIRCULARS ON REQUEST

Every article guaranteed to give absolute satisfaction or money refunded. If your dealer can't supply you, send us his name and order direct.

CROSLY MANUFACTURING CO.
 Dept. Radio P-3 Cincinnati, O.

Immediate Delivery

on all standard makes of Radio Apparatus. No matter what instrument you desire, send us your order for quick shipment. Chicago Amateurs: Come and inspect our new apparatus. Open all day Saturday.

Chicago Radio Apparatus Co.

Inc.

508 South Dearborn St. Chicago, Ill.

"SOS" - "SOS" - "SOS"

RADIO SUPPLIES

Detector panels, \$6. Amplifier, \$11.

Write for prices on other apparatus.

QST RADIO SHOP

3265 BELMONT AVE. FRESNO, CAL.

THE KICKBACK

Continued from page 25

sage sent out from shore on purpose to give him a chance to decode it. When he deciphers it through the two code-keys, as he'll have to do to make it readable, it'll get him all mixed up about that cocaine message which he had no chance to put through this new second code."

Captain Viericks' face wore an expression of sour blankness. For a moment, Stirling sat thinking.

"We can elaborate on that idea," he exclaimed, suddenly. "When we have the bunch in Frisco send us the fake message for the kid to bite on, why not have it fixed up so that when it's deciphered with the first code it won't make clear sense, but when it's deciphered again with the second code-key, it'll appear to be from the steamship company and will read so as to give the impression that the owners are plotting to have the 'Bellaroba' wrecked or sunk for the insurance money she is good for. We'll make the kid believe that his translation of that dope message was all a mistake—and we'll scare him off the ship at the same time."

"I don't follow you, Stirling."

"Listen. Make it seem that these codes of ours really belong to the steamship company; and when a message is put through the first code it may happen to read as if it were something about dope-running or any other thing at random, but when decoded the second time it means something entirely different—a sort of double-code scheme. Then we'll have a phoney message shot out to us on the kid's watch, and when he gets busy and decodes it on the sly, it'll apparently be from the steamship company and will read to the effect that they are ready for us to put the old 'Bellaroba' on the rocks—or something of that sort. If that doesn't send the kid skipping ashore, bag and baggage, then I'm no judge of these schoolboy operators."

Viericks rubbed his canine jaw.

"It's a complicated scheme," he grunted.

"Not at all," differed Stirling. "And it'll kill two birds with one stone—it'll throw him off the dope-smuggling track and scare him off the ship, all in one shot. I'll frisk his dunnage before he gets ashore, to see that he don't pack the codes off with him for evidence against us; and if he goes and spills the story of the ship-wrecking plot, he'll get the horse-laugh, because of course the 'Bellaroba' will keep right on plugging up and down the coast, the same as always."

"You've got cold feet—you know the other way would be quicker and easier," growled Viericks, surlily. "He wouldn't be the first one I've lost overboard."

MEANWHILE, the unwitting subject of the sinister conference in Captain Viericks' cabin was faithfully

standing his watch in the wireless cabin of the "Bellaroba."

Tommy Dennis was a clean-cut typical American youth, who had worked his way through school and who was now trying to help support a widowed mother and a younger sister. Tommy was, as he frankly admitted, but a hopeful beginner in commercial radio, the "Bellaroba" being his first assignment. He had waited for an interminably long time to get a job and he was intensely anxious to keep it. He was sincerely trying to please the sneering, currihtempered first operator of the "Bellaroba," but now after six months of vain efforts to do this, he was nearly ready to believe that it was impossible.

He had been told in the beginning that it would be. The "Bellaroba" was known the length of the Pacific Coast, from San Diego to Seattle, as the wireless operators' misery-ship; and the dreaded assignment of experienced brass-pounders when a newly-fledged victim was not at hand. The wireless company knew all about it, and would long since have dismissed summarily the universally-detested Stiringer but for the morose master of the "Bellaroba," who on one occasion had surlily informed the radio company's manager that his first operator was not to be interfered with under any circumstances.

Not long after coming aboard the ship, Tommy, in an excess of curiosity, had inquired of Alan Stiringer as to the source and contents of the mysterious code-messages that were being constantly sent and received on the "Bellaroba." Tommy's curiosity was rudely rebuffed, however, by a snarly command to mind his own business. Naturally, the young operator's suppressed interest in the strange messages secretly increased enormously; and when one day he chanced to find lying on the floor in the operator's sleeping-cabin a loosely-folded sheet on which was a typewritten code-key, he had been unable to resist the desire to keep it to see if it would work on the coded telegrams.

But the very first time that Tommy got out the code-sheet to apply it to one of the mysterious messages, which he had just received from N-P-E, Alan Stiringer unexpectedly came walking down the deck toward the wireless cabin. In a cold fright, Tommy hastily put the message back in the file and stowed the code-sheet in his pocket—but not before Stiringer opened the door and saw enough to comprehend what was going on. The next time Tommy came on watch, the message had disappeared from the file, thus he never had an opportunity to decode so much as one word of the telegram that was causing Stiringer and Captain Viericks such great concern.

Uncivil as had been Stiringer's treatment of his second operator before this incident, he assumed a still more harshly



Type 247 Condenser.

ANOTHER GENERAL RADIO

Accomplishment

For many years the General Radio Company has been supplying the research and educational institution laboratories throughout the country with high-grade radio apparatus suitable for research work. Only instruments of the finest quality are accepted in this class of work. The experience obtained in this line has enabled us to design instruments for the citizen radio field that represent the latest developments in engineering and mechanical skill.

The newest instrument in this line is the variable air condenser illustrated above. Here is an instrument of laboratory quality, yet selling at a price within reach of the experimenter.

Examine some of its features:

Capacity Scale: In addition to regular scale divided into 100 equal divisions, the dial is also graduated in micromicrofarads, thus showing capacity at any setting.

Low Dielectric Loss: Hard rubber is the only solid dielectric used. Quantity used is small and is so placed with respect to the electrostatic field that the dielectric hysteresis losses are kept a minimum. This is a very important feature in obtaining sharpness of tuning, and one which is commonly overlooked in condenser construction.

Plates Soldered Together: Resistance is reduced and kept constant. Capacity, also, kept constant.

Heavy Zinc Plates Adequately Spaced: Danger of short circuiting minimized.

Special Spring Bearings: Tension always remains the same. Good contact insured.

Thrust All on One Bearing: No short circuiting if distance between bearings is changed.

Low Zero Capacity: Makes wide range possible.

Metal Case Grounded to Rotary Plates: Shields condenser, reducing capacity effects of hand while tuning.

You cannot afford to deny your set the advantages of this condenser. Give the long distance messages a chance.

Inspect this condenser at your local dealer's.

Type 247 Condenser, Completely Mounted, Capacity .001 Microfarad

PRICE \$5.50

MAY ALSO BE SUPPLIED UNMOUNTED FOR PANEL MOUNTING

Send for Free Radio Bulletin 910 C

GENERAL RADIO CO.

MASSACHUSETTS AVENUE AND WINDSOR STREET.

Cambridge 39, Massachusetts

Standardize on General Radio Equipment Throughout

SOMETHING NEW

Made to Please You and Priced to Please
Your Pocketbook

By departing from conventional design in audion sockets we have combined the advantages of all, the disadvantages of none and a price lower than any. Think of it—a sturdy, easily mounted socket that is heat proof, has bakelite-dielecto insulation, handy binding posts, etc., all for 75c.



Type 126, Tube Socket
Price 75c Postpaid

And here's a smooth running rheostat that takes panel space 2 inches in diameter, needs one hole to mount, has six ohm resistance, all off and all on positions and a brass panel bushing. Priced at 90c.



Type 122 Rheostat
Price 90c Postpaid

THE WILCOX LABORATORIES

LANSING, DEPT. J., MICHIGAN

Tell them that you saw it in RADIO

NORTHWESTERN RADIO

A Superior Line of Receiving Apparatus



Detector and two stage amplifier Type SR-2.
Size of panel 10 1-2x12 3-4. Complete less
tubes and battery \$70 f.o.b., Portland.

A detector and two stage amplifier that will give you results. This instrument is in use in many stations in the Northwest and its performance is a proven fact. You must see this set to appreciate its value. Material and workmanship are the best.

Specifications—Panel quarter inch grade XX bakelite dilecto. Gorton pantograph engraving. Oak Cabinet finished in flemish oak.

Knobs and dials are machined from sheet bakelite and turn TRUE. All socket supports are constructed of bakelite and cast aluminum.

Write for Catalog

NORTHWESTERN RADIO MANUFACTURING CO.

1556 East Taylor Street

Portland, Oregon

WE USED OUR BEAN

IN DESIGNING

THE PARKIN DIAL RHEOSTAT (pat. pending) and by mounting the resistance element in a circular groove in the back of a 8" molded Bakelite dial eliminated one part and saved you the cost of a dial. The groove being recessed, allows the dial to clear the panel by the usual distance of 1-16". An off position is provided and a stop on the dial engages the stationary contact at the extreme positions. The 360-degree rotation insures fine adjustment. A brass bearing insures a true running dial and smooth action.

All figures and graduations are filled with brilliant white enamel. All brass parts nickel plated. Bakelite knob. Resistance is 5 ohms, carrying capacity 2 amps.

No. 77 Parkin Dial Rheostat, postpaid.....\$1.75

FOR SALE BY ALL LEADING DEALERS

Send for free catalog, No. 3, describing our complete line.

Dealers: Write for proposition.

PARKIN MFG. CO.

SAN RAFAEL, CALIF.

A VACUUM TUBE FREE

Send us three subscriptions to "RADIO" and we will send you a Vacuum Tube of any Standard make. (Receiving tube only)

RADIO Pacific Building San Francisco

Tell them that you saw it in RADIO

acid demeanor toward him now. As the "Bellaroba" approached Vancouver, Captain Viericks filed an arrival message while Tommy chanced to be on watch. Ten minutes later, Stirlinger came in and found the message lying on the desk, waiting to be sent.

"What's the matter?" he snapped. "Why haven't you sent that?"

"V-A-B is receiving a message from a ship off-shore," hurriedly explained Tommy. "I don't want to break in till he stops—"

"Never mind who he's working—call him—bust him up!"

"It's against the regulations—and it's a mean thing to do—"

"Get out of that chair, you whining little fool!" snarled Stirlinger. Throwing himself down into the seat, he snatched at the key and crashed into V-A-B with full power, until the long-suffering Point Grey operator stopped everything to clear and get rid of him.

All during the return trip down the coast to Los Angeles, Tommy fancied that he could feel something ominous impending aboard the "Bellaroba." Nothing unusual happened, however, until the steamer sailed from San Pedro for San Francisco and north. Tommy relieved Stirlinger as usual at midnight; and as the first operator left the cabin, a paper fluttered out of his coat-pocket. Picking it up, Tommy stepped out on deck and called after Stirlinger, but the first operator had already gone below.

Knowing that a scathing reprimand awaited him should he leave the wireless-house unnecessarily while on watch, Tommy went back inside and put on the phones. Alan Stirlinger often neglected his watch by the hour, but Tommy was not so privileged.

Glancing at the paper that Stirlinger had dropped, Tommy saw with surprise that it was another secret-code device. On the corner was the inscription, "Use after decoding with first key."

As Tommy sat puzzling over this, he heard K-P-H calling him. He gave an answering call, and the San Francisco station sent him one of the coded messages which came so frequently. Calling a quartermaster, Tommy sent the telegram to the captain's cabin. In a few minutes the man returned, bringing an answering message, also in code.

Tommy sent it off to K-P-H and then settled down on the long monotonous watch to six o'clock. Sitting in the silent wireless cabin tuning the signals of an occasional off-shore ship working to land through the clear, quiet hours of the early morning, Tommy's attention reverted persistently to the strange messages he had just received and sent. Who were these recondite telegrams from, and what sort of information could they contain that they had to be sent so mysteriously?



Why MAGNAVOX Equipment Is Necessary In YOUR Set

THERE is no substitute for the RADIO MAGNAVOX. It is standard equipment, tested and approved by the radio fraternity, and no set now is complete without one. It supplies the means by which music, news, speeches, conversations, signals, etc., received by radio can be reproduced so loud and clear, and true to the original that any number of people may hear them and enjoy them simultaneously, depending on the amount of amplification.

Because the strength of sound depends on the amount of current in the movable coil, and the strength of the magnetic field, the effectiveness and volume of the MAGNAVOX can be greatly increased by hooking up with one of the new MAGNAVOX two or three stage POWER amplifiers. This assures the MAGNAVOX receiving the greatest possible power input because these amplifiers are designed to use transmitting tubes and high plate voltages. They are also designed especially for the amplification of music and speech, eliminating danger of distortion.

YOU WILL eventually have this equipment. Why postpone such enjoyment? MAGNAVOX equipment is simple and free from complex adjustments. Any one can hook it up and operate it without trouble. Nothing can take its place. See your dealer today and obtain maximum efficiency and results from your set.

THE MAGNAVOX CO., General Office and Factory OAKLAND, CALIFORNIA
 NEW YORK OFFICE, 370 Seventh Ave., PENN. TERMINAL BUILDING
When writing please address the MAGNAVOX office nearest you



MAGNAVOX equipment is sold thru dealers. Accept no substitute. Look for this trade mark on each instrument. If your dealer cannot supply you write our nearest office. Send for folder illustrating and describing the Radio MAGNAVOX, the famous movable coil, and other MAGNAVOX equipment complete. Free. Send for it now.

MAGNAVOX



The reproducer with the movable coil

TYPE B-3 (Illustrated). The RADIO MAGNAVOX, the standard loud speaking reproducer for amateur and home use, no set complete without it, has 14" horn and takes only one ampere to energize the field—\$45.

TYPE B-2. Largest size, with 18" horn and field switch. Maximum efficiency obtainable using only one-half ampere in field—\$100.

MAGNAVOX POWER AMPLIFIERS

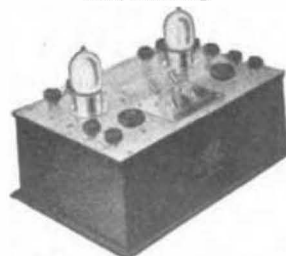

TYPE AC-3 Model C. 3 stage, a new type, using transmitting tubes and high plate voltages. Designed for the amplification of radio speech and music without distortion, and will give maximum output to energize your MAGNAVOX, or any type of receiver. Master switching, mahogany case, sits flat or on edge—\$110.
AC-2 Model C (Illustrated). Exactly as the three stage except two stages—\$80.

THERE IS NO SUBSTITUTE FOR THE RADIO MAGNAVOX

Tell them that you saw it in RADIO

"All things, whatsoever ye would that men should do to you, do ye even so to them."

*So spake the Great Teacher
We can only obey*

**The Port Arthur Radio Laboratory
PORT ARTHUR, TEXAS**

Our Catalog is ready. Write.

THE MODULATOR

Published by Members of the
RADIO ASSOCIATION OF GREATER NEW YORK

"Written for Amateurs by Amateurs"

THE MODULATOR

*Is the only Magazine devoted exclusively to C. W. Real practical
"How to Make" articles, written by men who know.*

Subscribe now at \$1.00 per year, as the rate
will soon be raised to \$1.50. Help your brother
amateur put it over.

THE MODULATOR PUBLISHING COMPANY

179 Greenwich St., New York City.

Tell them that you saw it in RADIO

The hours dragged slowly by. The last Orient-bound tanker operator had cleared and gone to sleep, and the six-hundred meter tune brought in nothing but an occasional faint splatter of static. Tommy's thoughts ran steadily on the two secret messages he had handled and he asked himself with increasing insistence what harm could arise were he to try to decode them with the code-keys that had fallen into his hands. Perhaps it wasn't exactly right; the contents of the messages were none of his affair. But Tommy argued with himself that no one need know anything about it; whatever he learned he could keep to himself just as well as he respected the secrecy of the ordinary run of messages handled aboard the "Bellaroba."

Tommy's curiosity eventually bested his conscience; and taking the shorter telegram from the file, he attempted to decode it with the first code-sheet. The result was a jumble of words and half-sentences as meaningless as the original. For a while Tommy was perplexed, but he soon grasped the purpose of the second code-key that Stinger had dropped and with it he decoded the message a second time.

The result was amazing. In a few minutes the skilfully-coded telegram had become plain English:

"Bellaroba scheduled undergo annual inspection next trip. Your defective port boiler will be condemned by inspectors therefore must carry out plans this trip or we are out fifty thousand."

Though there was no signature, the text showed Tommy that it must be from the steamship company. But now he knew scarcely any more than he did before. What was the meaning of that "carry out plans this trip?"

Tommy transferred his attention to the replying message. As he decoded it, his eyes opened wide and his face grew pale.

"Weather too clear last few trips. Must have stormy weather to keep insurance company from charging intentional sinking, but will put ship on Fox Rocks this trip. Strong inshore currents there well-known, will make job safe if pulled at night."

Tommy sat frozen to his chair. So this was the plan that was to be carried out. The steamship company was plotting to wreck the "Bellaroba" for the insurance money! It would never have occurred to Tommy to doubt the evidence of those two decoded messages. People burnt houses and wrecked automobiles to collect the insurance—so why not sink a ship?

WHEN the "Bellaroba" berthed at her pier in San Francisco for her usual four-hour stop, Tommy went down the gangway, his valise in his hand. If the "Bellaroba" was going to be sent to the bottom, he was not going with her.

Tommy was no coward; he had his mother and sister to think of. For their sake, if for no other reason, he could not afford to risk his life in an old steamer that a scoundrelly corporation was planning to wreck. Tommy felt certain that while undoubtedly the unscrupulous captain and the sneering first operator would take precautions to insure their own safety, at least a part of the ship's complement would meet their death.

It was a worried and miserable Tommy that rode uptown on a clanging Kearny Street car on his way to the wireless company's office. Now that he had quit the "Bellaroba," when would he get another ship—if ever. He had waited months for that first assignment, and here he was facing the cheerless prospect of another long wait on the beach. He knew that the static-room was jammed every day with an army of ship-less operators, many of them old-timers, and now he would undoubtedly find himself at the very bottom of that frightfully-long waiting-list. At the door of the office, Tommy hesitated, torn by his doubts and fears. What should he do? Drifting back down to the street, he walked slowly up to the nearest square and sat down on a bench to think it over a while longer.

Hours flew and still he sat with his grip between his feet, undetermined. Before he went off the ship Tommy had put the two code-keys and copies of the sinister messages he had decoded in his valise; and now as he sat in the square trying to decide what he should do, it gradually became clearer and clearer to him that the only right thing to do was to take all that incriminating evidence down to the custom-house and give it to the steamship inspectors. The steamship company might laugh him to scorn; but at least he would thwart their conscienceless plot to wreck the "Bellaroba" and cause the death of many innocent people. Perhaps the steamship people would use their influence to keep him from ever getting another ship—well, let them. His conscience would be clear.

But when Tommy opened his valise to take out the code-sheets and the messages, he could not find them. He had put them right on top, and now they were gone. Somebody had taken them from his grip before he left the ship.

Tommy began to realize that he was the victim of a cruel hoax. Who but Alan Stringer would have done this? With deliberate malice he had schemed it all, and Tommy could see why. The first operator wanted to frighten him off the ship. So that was the secret of the whole miserable business, was it! Well, plotting Mr. Stringer would have to hatch up a better scheme than that. Burning with indignation, Tommy snatched up his grip and boarded a street-car bound for the water-front. Twenty minutes later he was at the steamer's

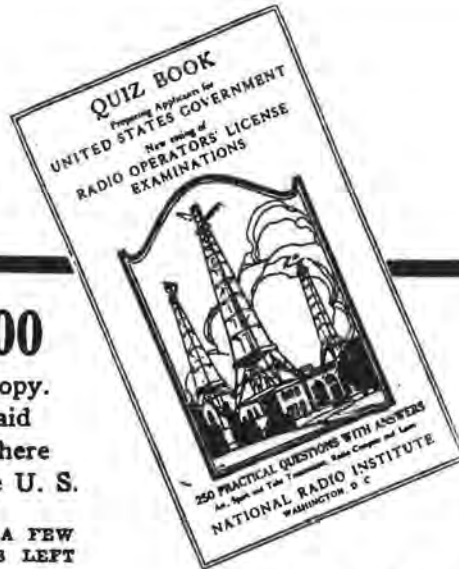

\$1.00
Per Copy.
Postpaid
Anywhere
In the U. S.

ONLY A FEW
COPIES LEFT

U. S. Govt. License Examination Questions Answered

A Wonderful Book

THIS BOOK, "New License Quiz Book for Govt. First Class License Examinations," is the first edition printed with the new rules, regulations and gradings laid down by the Government on July 1, 1921. Every amateur expecting to take examination for license needs this book. It gives the answers to 250 questions, many of which will be helpful in the examination. It gives practical equations, international laws and regulations, official gradings, diagrams, definitions and other important information,—invaluable to the candidate for government examinations.

"License Quiz Book for Government First-Class License Examinations"

This is the first edition ever printed of this book of 250 important questions. It is just off the press, compiled and published by the National Radio Institute, the world's best known wireless school. No amateur or wireless professional can afford to miss it. Nicely bound, with 80 fine illustrations, and chock full of information you need—now only \$1 with the coupon below.

When are you going to take your examination? You will find this volume the greatest possible help. Don't run a chance of failing your exams! This book gives the very latest information on the very things you must know. Not only the new government rules, regulations and gradings, but also lots of information about the latest investigations and discoveries.

The contents panel shows how complete this book is.

Contents

Information Concerning Method of Conducting Examinations and Places Where They are Held.
Radio Symbols.
Technical Words and Terms Made Clear.
Life and Duties of an Operator.
Terms and Definitions.
Radio Instruments.
Transmitters, Covering Spark, Arc and Tube Sets.
Types of Antennae and Aerials.
Damped Wave Receivers.
Latest Types of Undamped Receivers.
International and U. S. Radio Laws and Abbreviations.
Radio Compass and Its Uses.
Exhaustive Treatise of the Storage Battery.
Helpful Equations and Tables for Solving Radio Problems.
Continuous Wave Receivers.
Valuable Information to Help You in Securing Your License Examination.

For Sale by

LEO J. MEYBERG CO.
WARNER & LINDEN
WESTERN RADIO ELEC. CO.
NORTHERN RADIO ELEC. CO.
REYNOLDS RADIO CO.

Get a Copy from your nearest dealer

106 Pages

of Valuable
Radio Inform-
ation

COUPON

RADIO

485 Pacific Bldg.,
San Francisco, Calif.

Please send me by return mail the "License Quiz Book for Govt. First Class License Examination." I enclose \$1.00.

Name.....Age.....

Address.....

City.....State.....

Exclusively Distributed
in the West by Pacific
Radio Pub. Co., Inc.

"ILLINOIS" THE RELIABLE

MADE RIGHT - STAYS RIGHT



STYLE No. 1.



STYLE NO. 2.

Three Styles: No. 1, Panel; No. 2, Open Type as shown; No. 3, Fully Encased. Anti Profiteer. Less than pre-war prices. Fully assembled and tested.

	Style No. 1	No. 2	No. 3
87 Plates,	\$7.00	\$8.00	\$8.50
45 "	8.50	4.50	4.75
28 "	2.75	3.75	4.00
18 "	2.25	3.25	3.50

Money back if not satisfied. Just return condenser within 10 days by insured Parcel Post.

Options:—With Style No. 1—Instead of Scale and Pointer, a 3. inch Metal Dial at 50 cents extra, or a 3. inch Bakelite Dial at \$1.00 extra. Large Knobs. Both excellent values. Or we will, if desired, supply the Condenser with smooth 3/16 inch center staff, without Scale, Knob and Pointer, at 15 cents off the list to those who prefer to supply their own dial.

Vernier with single movable plate applied to 18, 28 or 48 plate condenser, \$3.00 extra.

We allow no discounts except 5 per cent on orders of 6 or more.

Sent Prepaid on Receipt of Price

Except: Pacific States, Alaska, Hawaii, Philippines and Canal Zone add 10c. Canada add 25c.

Foreign Orders other than Canada not solicited.



VERNIER

G. F. JOHNSON, 625 Black Ave.

Springfield, Illinois

THE OSCILLATOR

Published by THE RADIO ENGINEERING SOCIETY of PITTSBURGH, Inc.

Ten Cents Per Copy : One Dollar Per Year

Address

BUSINESS MANAGER
5590 POCUSSET STREET, SQUIRREL HILL
PITTSBURGH, PA.

Variometers Couplers \$3.75 Each

Wound but unassembled
\$3.00 Each

These instruments embody best workmanship and materials, all wooden parts genuine mahogany, coupler primary wound on Formica tubing. Wound to assure maximum results for short wave work. Shafts 3/16 inch. With Chelsea Dial and Knob \$1 extra. Send for bulletin describing panels, parts and other apparatus.

FREDERICK WINKLER, JR.
304 Columbus Av., New York, N. Y.

U. S. STORAGE BATTERIES

For wireless use operating toy trains, motors, etc.

SPECIAL PRICES

6 Volts	40 amp (4 Volt 7)	\$10.00
6 Volts	80 amp (4 Volt 10)	13.75
6 Volts	80 amp (4 Volt 12)	17.50
6 Volts	80-100 amp (4 Volt 15)	22.50

Every battery unconditionally guaranteed for one year. Shipped ready for use. Add 75 cents for special crating, 10% off above prices on orders from West of St. Louis to offset freight rates. Dealers and Jobbers write for discounts and exclusive territories. If your dealer hasn't U. S. Batteries send money order or check direct.

U. S. STORAGE BATTERY CO.
Far Rockaway, N. Y.
Middle West Distributors
Simon Pevsner, 615 Jones St., Sioux City, Ia.

RTS

The New RTS Standard Detector Panel will please all amateurs. Sent complete without tube two bat- 5.95 Postpaid by In-teries for only 5.95 insured Parcel Post

Send for complete circulars now
Radio Testing Stat'n, Dept. A, Binghamton, N.Y.

Toll them that you saw it in RADIO

pier—but he was too late. The "Bellaroba" had sailed.

Forlorn and filled with many forebodings, Tommy haltingly entered the wireless company's office, just at closing time. Everybody had already gone, except worried-looking Manager Edbrooke, who was busy on the telephone. The moment he caught sight of Tommy, he replaced the receiver on the hook with a relieved expression and turned to the young operator.

"What are you doing here—hasn't the 'Bellaroba' sailed?"

"Yes—I—I missed her!" And then trembling, Tommy began to pour forth his explanation. In a moment, however, Edbrooke with a short gesture checked his torrent of words.

"Never mind—we know Stinger. You did pretty well to stick it out with him six months—no operator ever stayed six weeks with him before. I suppose the 'Bellaroba' went to sea with only one operator, but we weren't notified, so it's the captain's and Stinger's funeral, not ours. Do you want another job—right away?"

"Another job!" gasped Tommy, hardly believing his ears.

"A call came in five minutes ago for an operator to take out the 'Falcon', sailing from pier twenty-one in half an hour. She's a fine little steam-yacht—a one man job. You're not in line for anything like her, but the only old man I can get on the phone right now lives way over in Berkeley and it'll take him over an hour to get down town. Make a bee-line to pier twenty-one and get aboard. The job's yours."

ABOARD the "Bellaroba" lunging northward around Point Reyes in a rainy southwesterly gale, another conversation was taking place in Captain Viericks' cabin.

"Well, it worked," exulted Stinger, bracing his chair with his long, thin legs to keep it from sliding with him as the ship rolled and pitched sharply. "The meddling monkey packed his clothes and skipped."

"Yes—and we're at sea with only one operator," Viericks reminded him, sourly. "There's a heavy fine for taking a passenger ship to sea without two wireless operators."

"Don't worry about that—it's easily fixed," Stinger assured him. "Put in the ship's log that we found a licensed radio operator among the passengers and signed him on for the run north to save having to turn the ship back. I'll fake the wireless log to show a continuous watch; and when we get to Seattle, I'll go and hunt up another operator."

The swift little steam-yacht "Falcon," also bound for Seattle, steamed out through the Golden Gate hardly an hour behind the "Bellaroba" and plunged likewise into the winter's storm that was



Merely connect this receiver to an aerial and ground—push a switch—that's all. A child can operate it

The Radiola

A non-regenerative Receiver that reproduces radio concert music to the highest degree of satisfaction

MAGNAVOX

Reproducer with the movable coil attached to a specially constructed sound box results in maximum volume of sound with a minimum of distortion.

Dealers: Our proposition and discount is unusually attractive.

No home is complete without a Radiola.

THERE is radio music in the air during several hours of the day and evening.

This music can be brought directly to your home—the living voices of your favorite artists reproduced by radio in the privacy of your drawing-room. The symphonious preludes and sonatas—the eccentric movement of the fox-trot or jazz—the regular broadcast of radio news of the world—market reports—stock quotations and instructive radio lectures—all of these, and more, can be enjoyed by you if your home includes a Radiola.

No knowledge of electricity or radio is required to operate this instrument. No complicated tuning or electric circuits to juggle—nothing to get out of order. Simplicity has been the keynote in constructing and developing the only instrument of its kind on the market—The Radiola. It is not an experiment. Extensive research work by radio experts in our laboratory has resulted in offering to the public the highest type of radio concert receiver known. It must not be confused with the usual type of phonograph as no records, disc or cylindrical, are used. It has been named the Radiola because it picks up the concerts from the air—the best in music that

is broadcasted daily for the pleasure of mankind. The Radiola is a complete radio receiver. The tuning instruments, amplifiers, batteries, loud speaker and adjustment controls are all combined into one unit. A storage battery for filament lighting and a rectifier for battery charging, as well as a hydrometer test set, are compactly arranged in the lower portion of the Radiola cabinet. A storage battery charge and discharge switch is connected in such a manner as to allow charging of the battery whenever necessary. In view of the fact that the various radio telephone stations in and around San Francisco are all operating on the same wave length it will not be necessary to make bothersome tuning adjustments to pick up these stations. Just push the switch—and listen. Three or four steps of power amplification in conjunction with the Magnavox Radio Reproducer will allow of any desired intensity of the receiving signals. Suitable connection posts are provided for the aerial lead and ground wire—the only exterior devices necessary for operating the Radiola. The complete equipment can be installed in any home in a few hours and expert radio service will be rendered to the purchaser of every Radiola.

Prices and Specifications on Application

The World Brought to Your Home With the Radiola

WILSON & McGUIRE CO., Inc.

Manufacturers of the Highest Grade Radio Concert Receivers in America

1004 Treat Avenue, San Francisco

WRITE FOR DESCRIPTIVE RADIOLA CIRCULAR

Warning!

**Dangerous, Expensive
"Short" Curve Ahead!**

That new VACUUM TUBE on your set is doomed to quick destruction from an accidental "short" unless you protect it with the

RADECO SAFETY FUSE

(Pat. Pending)

A tiny fuse that slips directly on the filament terminals and prevents blowing out from excessive high amperage. Fits any standard bulb used in any standard socket.

Now, when conditions are right for best wireless results, save money and time by using RADECO Safety Fuses on your set.

Sizes:

1, 1½, 2, 2½, 3 amp. Fits any Tube in any socket.

Radio Equipment Co.

630 Washington Street
Boston, Mass.



Pin \$1 to this advertisement
and receive 4 Radeco Safety
Fuses. Send today.

FOUR FOR

\$1

WIRELESS CATALOGUE

WHETHER you are interested in a complete radio receiving outfit, or a half a dozen binding posts, you'll find the particular instrument, best for your needs, in Corwin's catalogue. Send 10 cents, (credited to your first order) for your copy today! Where's the nearest mail box?

A.H. CORWIN & CO.
4 West Park St. Dept. G
Newark, New Jersey

blowing outside. All the way up the coast the trim vessel swept before the shrieking gale, which steadily increased in fury and pushed up a mountainous westerly sea, crisscrossed by a sharp, jouncing chop that boarded the yacht occasionally with jarring deluges and sent white gushers of sea-water flying the length of the ship.

The second day out, the wind suddenly abated a little and switched around to the westward, bringing a dank, blanketing fog which came swirling over the water in eddying, wind-torn wisps, turning the day into a damp murky twilight through which the towering greasy swell looked like dead gray walls looming and disappearing, monotonously. The gloomy, fog-streaked daylight at length gave way to darkness, and through the night the "Falcon" bounced restlessly in the trough of the turbulent sea.

At two o'clock in the morning Tommy was called out by the worried captain.

"We think we glimpsed some steamer's range-lights through the fog just now, way inshore—better send out a call and if there really is a ship in there, tell him he's running into danger. We've been taking soundings since midnight and just picked ourselves up heading dead on Blanco. There's a strong current setting in here, tonight."

THE steamer "Bellaroba," lunging on over the crests of the seas through the drizzly fog had, according to her dead-reckoning, made Cape Blanco, that treacherous Hatteras of the Pacific; and shortly before two o'clock the officer on watch hauled her in on the more northerly course to Cape Flattery. Her deck-lights turned out now, the big steamer swept on through the night, a great black spectre in the chill wet mist.

A light burned in the radio cabin, but the phones were hanging on the tuner. It was the time when the second operator should be standing his watch, but thanks to Captain Viericks and Alan Stinger, there was no second operator there; no one to hear the repeated calls from the "Falcon" that impinged futilely on the "Bellaroba's" antenna; no one to copy those few words of warning flashing over the fog-shrouded seas which would have reversed the steamer's engines and checked her in her swift course to destruction.

Suddenly there was a thudding of fear-winged footsteps flying along the deck; and hoarse shouts arose from the bridge of the ill-fated "Bellaroba." Above the awful booming of breaking rollers dead ahead, the wild clang of the engine-telegraph came up from the depths of the ship, a sharp, metallic alarm of imminent catastrophe. Ten seconds afterward, there began a jarring, thundering crash, followed by a terrific rending of metal, as if some mighty hand were tearing out the ship's vitals. The lights

Consider this

You probably have a lot of excess radio equipment on hand that you have no further use for. You may want to exchange it for something more useful. Or perhaps you want to sell it outright for a reasonable price. Then again—you may want to buy some good used apparatus at an equally attractive price.

Here's How:—

Advertise in the
Classified Columns
of "RADIO"

The rate is only three
cents a word

and almost 20,000
radio bugs will
read your Ad.

The classified columns of
"RADIO" are business getters

Remember this

Many of our readers need just
what you have for sale.

The Classified Ads on
page 75 will interest you.

Read Them

If you want to buy really good
apparatus at attractive prices.

Use Them!

If you want to dispose of some
of your present equipment.

Send us that little Ad
for the next issue of
"Radio" right now!

went out; the throbbing of the engines ceased; then above the deafening reports of splitting steam-pipes there arose a shuddering rumble like the roar of a thousand onrushing express-trains, and a hurtling deluge of sea-water swept over the "Bellaroba," smashing life-boats to splinters, uprooting ventilators, shattering cabins, and sending foaming white tongues into the innermost parts of the ship. Steel stays shot skyward, spurting fire from their torn ends, the two masts went down, and the doomed vessel rolled over in her death throes.

Three hours later the dull light of a gloomy dawn found lying among the Fox Rocks of Cape Blanco a capsized, broken shell, over which the seas rolled in grayish, foam-flecked masses.

THE END

COMMERCIAL RADIO APPARATUS

Continued from page 23

apparatus, as whether a set is to be used for sending or receiving.

As an example, a spark gap may be placed in series with the condenser C and the inductance L_2 , in Fig. 3. With some means of charging the condenser to a potential high enough to overcome the resistance of the spark gap, the condenser will discharge, and create oscillations in the antenna circuit. The usual means of charging this condenser is an induction coil, or high potential transformer, with which the reader is doubtless familiar. It is possible, however, that a vacuum tube, or other source of energy be used to charge the condenser, altho we are not ready at this time to go into details as to how this can be accomplished.

The same apparatus may again be used for receiving. If we use the apparatus shown in Fig. 3, but attach a device of some kind to the circuit L_2C , we can observe an indication every time the circuit is set into oscillation. It can only be set into oscillation by the antenna's picking up passing currents from the space surrounding the antenna, which currents should be of the same frequency as the natural vibrating frequency of the antenna and ground system, ALG.

A device used to indicate the presence of electrical oscillations is called a detector, and countless numbers of them exist, but all of them are only means for changing the oscillations, or making their presence known to an observer. Very few detectors are sensitive enough to indicate feeble oscillations, but those few are so wonderfully and extremely sensitive that they convert almost inconceivably small amounts of energy into signals.

It will be found that all radio apparatus operates on the principles outlined above.

The next installment will explain in detail the navy standard transmitter.

The Last Word in Amplifiers

—A Companion Piece to Our HR Receiving Set Advertised in RADIO Last Month



In last month's issue of this magazine we introduced to RADIO readers the new CLAPP-EASTHAM Type HR Regenerative Receiving Set—licensed under Armstrong U. S. Patent No. 1113149. We sell this set complete for only \$35 yet absolutely guarantee it to give results equal or superior to any on the market regardless of price. We promised you that this set would surprise you and your friends by its easy control and the wonderful distances at which it picks up signals, voices, music—and the great clearness and loudness with which these signals come in.

Now we want to tell you about the companion piece to this remarkable receiver—the new CLAPP-EASTHAM

Type HZ Two-Stage Amplifier

equipped with our new "Maximus" Amplifying Transformers. Amplifies weak signals hundreds of times—sounds almost inaudible are made to ring throughout a large room. Convenient switching arrangement permits use of Detector only, one

stage of amplification, or two stages. This Amplifier exactly matches our HR set in size, finish and arrangement of binding posts, yet is equally effective with receiving sets of other types and makes. Price complete \$35. Write us for full details and name of nearest dealer.

Clapp-Eastham Company

Radio Engineers and Manufacturers

140 MAIN STREET

CAMBRIDGE, MASS.

California Representatives: LEO J. MEYBERG CO., San Francisco and Los Angeles

BAKELITE-DILECTO

The standard insulating material for all radio work. Water-proof, permanent, strong, used by all important manufacturers of wireless apparatus and others requiring the utmost in insulation.

Furnished in sheets, rods and tubes

We also manufacture VULCANIZED FIBRE in sheet, rods and tubes and CONITE, a special insulation in sheets or rolls, from .005" to .020" thick.

Let us show how our standard products can be made to solve your insulation problems. Pacific Coast dealers carry a full stock of Bakelite-Dilecto, Vulcanized Fibre, Continental-Bakelite and Conite.

THE CONTINENTAL FIBRE CO.

NEWARK, DELAWARE

DUCOMMUN HARDWARE CO., 219 Central Ave., Los Angeles, Cal.
CALIFORNIA ELECTRIC SUPPLY CO., 643 Mission St., San Francisco

233 Broadway, New York City
525 Market St., San Francisco, Cal.
301 Fifth Ave., Pittsburg, Pa.

332 S. Michigan Ave., Chicago, Ill.
411 S. Main St., Los Angeles, Cal.
89 Wellington St. W., Toronto, Ont., Canada.

Tell them that you saw it in RADIO

New Catalog E6 **FREE**
Just off the press

RADIO E6

Keep up-to-date. Learn about all the big recent improvements in radio apparatus. 84 pages chock full of best and biggest values of America's 51 leading manufacturers. Most complete, includes everything.

TWO N-S LEADERS:
Red-Head Radio phones, 3000 ohms, military head band with cord complete, per pair **\$8**

Arlington Tested Crystals, Galena or Silicon. Certified super-sensitive. Per crystal **25c**

24-Hour Service
We Pay All Shipping Charges
Get the Latest
Don't Buy Till You See This Catalog

Writes for Big Free Catalog Today

THE NEWMAN-STERN COMPANY
Newman-Stern Bldg. Cleveland, Ohio

"B" BATTERIES
AN
EVEREADY
PRODUCT

48V. Batteries, tapped.....\$4.50
22½ V. Batteries, Navy Type..... 5.00
22½ V. Batteries, Commercial Type..... 2.00

Letter two types especially adapted to Cunningham and Radiotron Tubes. Postage Prepaid Anywhere in U. S.

ETS-HOKIN & GALVAN
Wireless Engineers
10 Mission Street San Francisco

Assemble Your Own Apparatus

We are now manufacturing Radio apparatus of improved designs, and furnish stock parts for those who desire to build their own cabinets. These prices can not be beat.

COMPARE THESE PRICES

Triple Honeycomb Mounting (for panel mounting).....\$5.00
Variometer wood parts (unassembled and unmounted)..... 2.00
Miniature D. P. D. T. panel Switch... 1.00
Vario-coupler Rotor......60

"Paragon" equipment is not merely assembled - - - but BUILT.

Send 10 cents for Bulletin and future announcements.

PARAGON ELECTRIC CO.
215 North 6th Street, H.
Newark, New Jersey

Send for **ABC** Catalogue

Brand new—16 page—two color ABC Catalogue just off the press, profusely illustrated from cover to cover. It describes in detail the unusual features of ABC UNITS built on the sectional system so that you can gradually add to your section just like a sectional bookcase. Also describes fully ABC Coils; ABC Saco-Clad Transformers; ABC Variable Condensers and a complete line of small parts.

Valuable information about Wireless Telephone broadcasting is also included. Prices quoted represent a new low level for apparatus for recognized quality. Send ten cents today for your copy of the new ABC Catalogue. Request Catalogue X2.

WIRELESS EQUIPMENT CO. Inc.
32 Austin Street, Newark, N.J.

CLICK METHOD
Continued from page 21

wavemeter until it too is in resonance with the oscillator. The wavelength corresponding to the condenser setting may

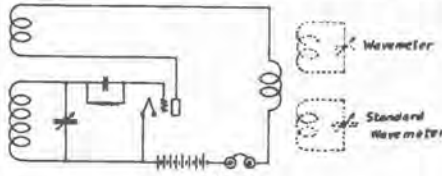

Fig. 7

now be read directly from the standard wavemeter. Any number of points may be similarly taken and the results plotted if so desired.

Fig. 8 shows how the click method may be used to measure the wavelength of a received signal. Adjust the oscillating audion (or heterodyne) to zero beat

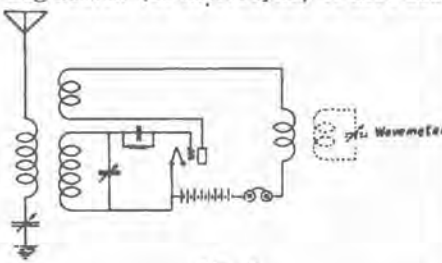

Fig. 8

note. Couple the oscillator circuit to a wavemeter and adjust the latter until resonance is obtained. The wavelength of the incoming signal is that now indicated by the wavemeter.

The click method may be used in many other ways and those mentioned here are but indicative of its usefulness.

Question: How may an amateur test his transmitter before applying for a license?

Answer: With a dummy antenna, or special permission to test may be granted by a radio inspector, before the license is granted. This will NOT allow any transmission of messages, however, as this cannot be done until the licenses are actually issued, and signed by the inspector issuing them.

Question: Are signals sent on a test buzzer conductively coupled to a receiving set employing a vacuum tube in an oscillating or regenerative condition, considered as coming from a transmitting station, and should a station communicating by the above method be licensed?

Answer: Yes, such stations must be licensed, as they are actually radiating and transmitting signals. Even tho such stations are licensed, care should be taken not to transmit on any wave length, except those specified in the license, as a receiver is capable of very rapid and easy adjustment to various wave lengths.

Tell them that you saw it in RADIO

BANG
Smashing "B" Battery Prices
"WIZARD"



From Manufacturer to User
All Batteries Sent Postpaid

Announcing:
Wizard's 2 new improved type "B" Batteries

No. 1632, 1 Tap, 45 Volt Variable Battery. Size 6 in.x6 in.x2¾ in. Price \$2.80. Weight 3¼ lbs.

No. 1630, 5 Taps, 27 Volt Variable Battery. Size 6x3x2¾ in. Price \$1.80. Weight 2½ lbs.

These new types are not made of the same size cells as a small size "B" Battery. The volume of a cell used in these types is 4.7 cubic inches, as compared with 2.5 cubic inches, the volume of a cell used in the small "B's".

You can easily see that the life of these two types are almost double the life of the small "B's".

No. 1632 has one tap at 22½ volts. These prices seem unbelievable, as do all other "WIZARD" prices, but are made possible only by dealing direct with the consumer.

Look for our February issue ad for low prices on wireless apparatus.

Out. No.	Size.	Taps	Volt- age.	Wt. lb.	Price
1623	Plain	3½x2¼x2	22½	1	\$1.00
1623	Variable	3½x2¼x2	5	22½	1.20
1625	Plain	6½x4 x3	22½	5	1.85
1625	Variable	6½x4 x3	5	22½	2.25
1626	Plain	6½x8 x3	45	10	3.75
1626	Variable	6½x8 x3	8	45	4.15

Send all money orders to
Wizard Battery Co.
1315 42nd St., Brooklyn, N. Y. Dept. P

500 Volt Generators
\$35.00

185 Watts, ball bearing 48 segments in commutator, shunt wound, our own make.

IF YOU DO YOUR OWN WINDING

We supply parts complete excepting wire, for \$18.00.
¼ H. P. 1800 R. P. M. 60 cycle 110 V. Motors, \$18.40 each.

STORAGE BATTERIES; heavy duty 60 amperes hour, large plates; can be used for automobiles, \$21.00 each.

All of the above F. O. B. Canton, O.

The Electric Motor & Engineering Co.
CANTON, OHIO

For radio men who buy carefully—a genuine CESCO Amplifier for \$12.50, and a “Pen Brand” variable condenser with binding posts for \$2.10

The “Pen Brand” variable condenser has been developed to meet the needs of advanced radio for a more efficient and more convenient condenser at a lower price. The “Pen” has two binding posts to which connection can be made without soldering, the only unmounted condenser manufactured with binding posts. Another exclusive feature of the “Pen” condenser is a special adjusting screw, by means of which the plate adjustment can be stiffened to prevent the variable plates from slipping after the desired wave length has been secured. The best condenser of this type at any price, and priced the lowest of any.

- | | |
|-------------------|-------------------|
| 3 plate — \$2.10 | 11 plate — \$2.60 |
| 23 plate — \$3.45 | 43 plate — \$4.60 |

The CESCO 1-stage amplifier, as shown at the right, is a winner and a wonder at the price. Neat, compact, durable, efficient, and beautifully finished. Made of XX Bakelite, the tube socket of the 4-prong type to accommodate any standard up-to-the-minute tube. General Radio amplifying transformer, Remler rheostat, and Murdock socket—standard parts, which in the careful process of CESCO manufacture brings it up to the prevailing high quality of other CESCO apparatus, and following the usual CESCO policy, marked at a price which makes it the best buy on the market. Every one fully guaranteed. Price, mailed postpaid to any address in the U. S., \$12.50.

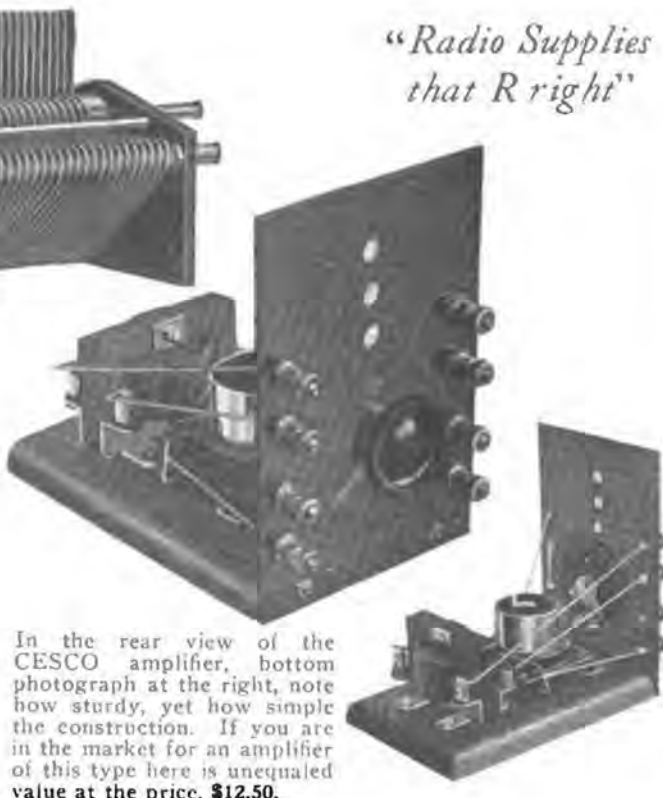

“Radio Supplies that R right”

In the rear view of the CESCO amplifier, bottom photograph at the right, note how sturdy, yet how simple the construction. If you are in the market for an amplifier of this type here is unequalled value at the price, \$12.50.

Mail your orders at once. Don't delay. The demand for this apparatus is big, and we cannot promise prompt delivery to meet the demand of both wholesale and retail trade unless orders are mailed promptly. CESCO guarantees the quality. The price speaks for itself. Enough said.

CALIFORNIA ELECTRIC SUPPLY CO.
 643 MISSION STREET, SAN FRANCISCO, CALIFORNIA
San Francisco radio men—note our convenient central location at Mission and New Montgomery Streets

Radio supplies that R right

"M. P. M."

means

"Million-Point Mineral"

The

Perfect Detector Crystal
(Direct from the mine)

At your Dealer, or write—

Million-Point Mineral Co.

1254 Clay St. San Francisco

Dealers—Write at once for attractive trade proposal

LEARNERS SETS



With code, instructions, and the AJAX BUZZER, \$1.80.
80c—AJAX HYTONE BUZZERS—80c external tone adjustments. All postpaid.
AJAX ELECTRIC CO.
8 Palmer St., Cambridge, 38, Mass.

NEW MOTORS FOR ALL PURPOSES STANDARD MANUFACTURERS PROMPT DELIVERY

ALL SIZES UP TO 5 H.P.
We Specialize In Small Motors & Generators
ALL PHASES AND FREQUENCIES IN STOCK AT ALL TIMES.
Largest exclusive Mail Order Small Motor dealers in the world.
CHAS. H. JOHNSTON, Box 33, West End, Pittsburgh, Pa.

WIRELESS, TELEPHONE GENERATORS
500 VOLT - 100 WATT - 3400 R.P.M.
FOR MOUNTING MOTOR GENERATOR SETS.
\$28.50
WRITE FOR CATALOG

CONNECTICUT RADIO EQUIPMENT

Variable Condensers, Transmitters, Head Bands, Panel Switches, Etc.

Connecticut Tel. & Elec. Co., Meriden, Conn.

Special This Month Only

- Chester's three inch Dial 8.90
- Amplifying Transformer 3.50
- Plug and Jack complete 1.50
- Crosley Socket60

Let Us Quote You on That Radio Set
CITIZEN'S RADIO SERVICE STATION

P. O. BOX 155 MATTOON, ILL.

Queries and Replies on C. W. Practice

By Gerald M. Best

Question: Please publish the wiring diagram of a 50-watt phone and C. W. transmitter using two 50-watt tubes, 1500-volt motor generator and other necessary apparatus.—G. E. W., Billings, Mont.

Answer: A single coil circuit for the transmitter you desire is shown below.

peres of plate current without the plate becoming red, when the same tube will pass 125 mills continuously on d. c., both a. c. and d. c. voltages being 1250?—H. L. G., Douglas, Ariz.

Answer: If you are using 1250 a. c., you will have a peak voltage of 1.4 times

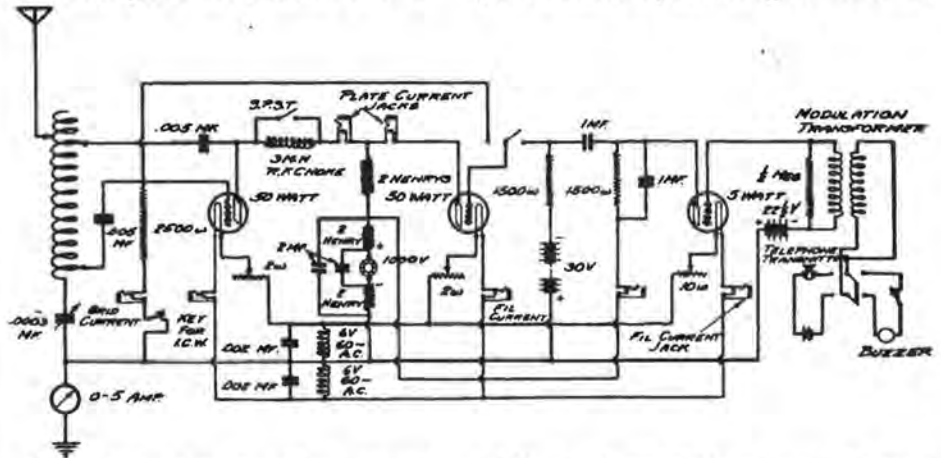

Question: Could the potentiometer which is mounted on the Remler detector panel be used to balance out the a. c. hum, when lighting the detector filament from a 110 to 6-volt step-down transformer?—C. M. E., Athena, Ore.

1250, or about 1750 volts, which will overload your tube, thereby producing overheated plates. Your tube will no doubt have a longer life if you do not operate it at a voltage greater than its rated input, which I assume is 1000 volts d. c.

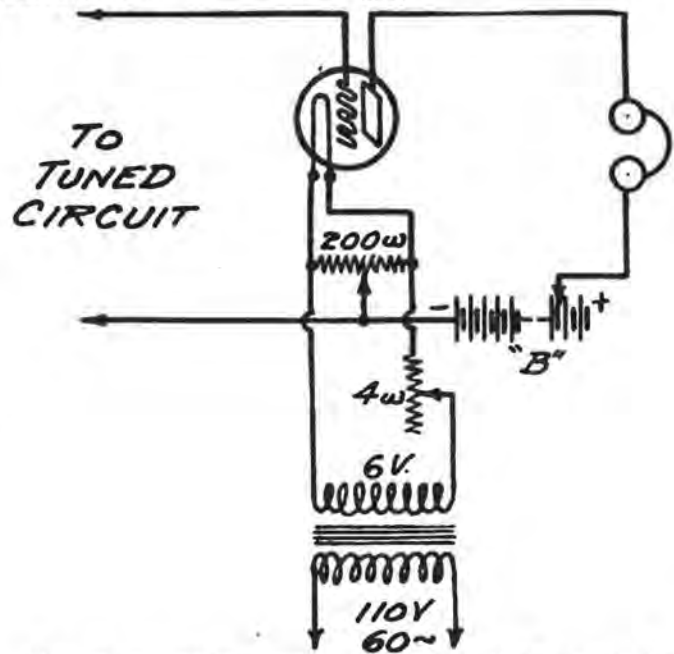

Answer: No, as this potentiometer is tapped at certain fixed points, and you probably could not locate its exact center. A slide wire resistance of about 200 ohms will give the best results, as shown herewith.

Question: Why will a 50-watt tube not pass more than 60 milli-am-

peres of plate current without the plate becoming red, when the same tube will pass 125 mills continuously on d. c., both a. c. and d. c. voltages being 1250?—S. M. F.

Answer: You did not state whether it was a. c. induction from nearby lighting circuits or local troubles in your amplifier. Try grounding the negative of your "B" battery, and the cores of your

amplifying transformers. If this does not help matters, you will probably have to shield the inside of your cabinet with thin copper sheeting, being careful to ground the shield thoroughly.

Question: Using a Gurney Duplex Set, what would be the best aerial 40 feet high to receive the 360-meter music? My supports are 135 feet apart.—A. C.

Answer: A single wire 40 feet high and 135 feet long would be ample for 360 meters. If the cost of wire is no object, two wires 135 feet long would not raise the fundamental wavelength greatly and might improve reception.

Question: I have a type UL 1008 Oscillation Transformer for my C. W. set. This transformer has only four places to connect to and I have five connections, aerial, ground, filament, grid and plate. How may these connections be made—P. B., Quincy, Calif.

Answer: C. W. and I. C. W. circuits shown in the Radio Corporation catalog all show the antenna and grid connections brought to a common terminal, thereby permitting the three remaining terminals to be connected to the filament, plate and ground.

A RADIO FABLE
By EARL ENNIS

Once there was a Prohibition Sleuth who hadn't made an Arrest for a long Time. And his Boss called him in and gave Him the merry Raspberry, telling him that a Bird in the Hand was better than a Drink in the Dark and to get busy or there would be a Vacancy behind his Badge.

So the Sleuth went out with his dark Lantern and his Sniffing apparatus. And he gum-shoed around. And after awhile he saw a Light in a Woodshed. So he crawled on his Stomach over a Dog-House, and through a Pig Sty, and under a Sewer Pipe and peeked through a Crack. There were Two young Men in the Shed and they were very intent on their work.

The Sleuth polished up his Badge with his Sleeve and listened carefully. When he had heard a lot of Words, he opened the Door and informed the Youths that he represented Uncle Sam, the well known Owner of America.

"I heard what you said," he announced. "You can't heterodyne Annapolis in this country. It's against the Volstead act."

"But . . ." said the Youths.
"Shut up," said the Sleuth. "I know my Business. Give me that bottle while I complete my case."

So the Youths handed him a bottle and he took a drink of pure Sulphuric Acid and fell dead over the Rectifier.

Moral—Study radio and save Insurance!

MAIL ORDERS

Here's a bunch of good news for the out-of-town radio bugs who want radio apparatus in a hurry:—

Warner & Linden—through their large San Francisco and Oakland stores — announce the establishment of a FAST and RELIABLE radio mail order service.

The following products are in stock and ready for immediate delivery:

Radio Corporation

Everything from tubes to transformers

A-P Vacuum Tubes

All types at usual prices

Kennedy Equipment

The high-grade popular line

Telephone Receivers

Baldwin—Murdock—Brandes

Remler Radio

A most complete line

Cunningham Tubes

From the smallest to the largest

Eveready Batteries

For Plate and Filament use

Battery Charges

Tungar and Rectigon types

In addition to the above we have an unusually large stock of almost every-make of radio Equipment On The Market

SPECIAL The New 6-Volt 70 A.H. Storage Battery — Just Out **\$16.00**

Made especially for Warner & Linden. Built for long and hard service—at a price that will interest you. Your Battery Troubles End if You Get One of These.

NO ORDER IS TOO SMALL

Whether you want a generator or a foot of wire—we will give your order the same prompt and careful attention.

—Our many satisfied customers are our Best Boosters—

Let us know your wants. A radio man with 10 years experience will tell you what's best for that new radio set you are building

Glance thru the advertising pages of any radio magazine—decide what you want—and send us the order NOW. We will fill it IMMEDIATELY.

If your particular equipment is not available we will advise you at once.

WARNER & LINDEN

San Francisco.
350 Market Street
Phone Douglas 4639

TWO STORES

Oakland, Cal.
22nd & Telegraph Ave.
Phone Oakland 3209



C. W. Condensers
.0004 M. F. . . . \$4.75
.0006 M. F. . . . 5.50

K. D. Condensers
11 Plate \$1.80
21 Plate 2.25
41 Plate 3.20

Add P. Post



Tresco Binding
Posts, 10 for \$1.00
Add P. P.

A 24-Page Catalog for 10c

TRESCO

Davenport, Ia.



SPECIAL

"Q. S. T." and "RADIO" 1 year \$3.25

Order Now and Save 75c

RADIO, PACIFIC BLDG., San Francisco

Tell them that you saw it in RADIO

Highest Grade Radio Apparatus



"The Very Best in Radio"

Order Direct From This Ad

Save Time

Save Money

AMPLIFIERS

Remler 331 Panel.....	\$6.00
Remler 333 Panel.....	9.00
Telmaco TDA-1 Detector and 1 step Amplifier.....	35.00
Telmaco TA-2 two-step Amplifier.....	40.00
Telmaco TDA-2 Detector and two-step Amplifier.....	45.00

AMPLIFYING TRANSFORMERS

New Thordarson fully mounted.....	\$4.00
All-American R-3, 10-1 unmounted.....	3.50
All-American R-3 semi-mounted.....	4.00
All-American R-3 mounted.....	4.50

AUDION CONTROL PANELS

Remler 330 Panel.....	\$8.00
Telmaco TD-1 Detector with Cabinet.....	15.00

ANTENNA WIRE

No. 14 Gauge Copper Wire, 1 lb.....	\$.45
No. 14 Gauge Copper Wire, 2 lbs.....	.85
No. 14 Gauge Copper Wire, 5 lbs.....	2.00
7-strands No. 22 Copper Wire, 100 ft.....	1.00
7-strands No. 22 Copper Wire, 200 ft.....	1.80

GROUND EQUIPMENT

Westinghouse 100 Ampere 600 Volt Ground Switch.....	\$4.00
Ground Clamp.....	.10

"B" BATTERIES

Stuart 5677 22½ Volt.....	\$2.25
Stuart 5674 Navy Type 22½ Volt.....	3.00
Stuart 5680 45 Volt.....	5.00
Stuart 5685 4½ Volt.....	.60

CONDENSERS

Remler 97 Grid Condenser.....	\$.35
Rowman, Murdock and Chelsea Condensers at advertised prices.	

DIALS

Remler Bakelite with Knob 3/16 or 1/4 inch.....	\$1.00
Rowman 121 Metal Dial.....	.60
Clapp Eastham 3 inch Metal Dial.....	.75
Chelsea Molded 1/4 or 3/16 inch.....	1.00

JACKS

Single Circuit for Phones.....	\$.65
Two Spring Closed Circuit.....	.75
Four Spring Open Circuit.....	.90
Three Spring Filament Control.....	1.00
Five Spring Filament Control.....	1.25

PLUGS

Standard Plug T-180.....	\$1.00
Short Radio Plug No. 132.....	1.00
Fireo Round Plug.....	2.50

These are only a few of the many good Radio Supplies listed in our catalog "P". If you haven't a copy, send for it.

Send your order today. Be sure to include postage. **MONEY BACK IF NOT SATISFIED.**
Your panels engraved with our GORTON ENGRAVER. Price 5 cents per letter.
Minimum charge \$2.00.

Dealers—We are distributors for nearly all Standard Lines. Write for our special proposition.

JEWEL FLUSH TYPE METERS

Pattern 33 D. C. Standard Readings.....	\$6.00
Pattern 54 D. C. Standard Readings.....	8.00
Pattern 64 Radio Frequency Standard Readings.....	12.00
Pattern 74 A. C. Standard Readings.....	8.00

LOUD SPEAKERS

R-3 Radio Magnavox.....	\$45.00
Vocaloud Station Type.....	30.00
Telmacophone equipped with Baldwin Unit, guaranteed to equal anything at double the price.....	15.00

RHEOSTATS

Murdock 560 Reversible.....	\$1.00
Remler 810 Panel Mounting.....	1.00
Remler 813 Panel Mounting.....	1.75
Remler Potentiometer Graphite Unit.....	.75
Lever for above.....	.45
Paragon Reversible.....	1.50

SOCKETS

Crosley Porcelain Socket.....	\$.60
Murdock 550 Socket.....	1.00
Chelsea Socket.....	1.00
Remler Bakelite Socket.....	1.50
A. A. 50 Watt Power Tube Socket.....	3.00

TELEPHONES

56 Murdock Double 2000 Ohm Re- ceivers.....	\$5.00
56 Murdock Double 3000 Ohm Re- ceivers.....	6.00
Brandes Superior Double Receivers.....	8.00
Baldwin Type C Double Receivers.....	12.00
Baldwin Type E Double Receivers.....	13.00
Baldwin Type F Double Receivers.....	14.00

TRANSMITTERS

Type T281 Microphone with Handle.....	\$6.00
Microphone and Mouthpiece only.....	2.50

VACUUM TUBES

C 300 Cunningham Detector Tubes.....	\$5.00
C 301 Cunningham Amplifier Tubes.....	6.50
C 302 Cunningham 5 Watt Transmit- ting Tube.....	8.00
ER Moorehead Detector Tubes.....	5.00
VT Moorehead Amplifier Tubes.....	6.50

VARIOCOUPLES

Telmaco Type TVC-1 without dial.....	\$4.00
Remler Type 503 without dial.....	5.40

VARIOMETERS

Telmaco Type TV-1 without dial.....	\$5.00
Remler Type 500 with dial.....	8.00

EARTH ANTENNAE

Continued from page 20

In the ground antenna, such as described here, there is not this limiting capacity, and the wavelength may be indefinitely increased by increasing the capacity of the series condenser. This is a marked advantage in favor of the ground antenna. It is a well known fact that in tuning with a series condenser in an antenna circuit, maximum signals are invariably received when the highest possible value of condenser is used. This is due to the fact that with a high condenser value, a small inductance can be used and consequently the resistance of the circuit is kept low. (Note. It must be remembered that this reasoning applies only to the primary circuit, where the important thing is to have a maximum current flow. In the secondary, where a high voltage is required, as to operate a vacuum tube, the opposite condition holds, and low condenser and high inductance are always best.)

In some of the tests at Tampico, a DL-25 coil was used as a primary to receive Annapolis, together with a series condenser of about ½ microfarad capacity. Signals with this arrangement were louder than when a DL-1000 primary was used. The use of a DL-25, however, represented an extreme case, and it was found that better signals could be received with a DL-150 primary on account of the higher degree of coupling obtainable. The necessary amount of coupling and the available size of variable condenser are the only things that limit the size of the primary coil. At Tampico a variable condenser of .006 microfarads maximum capacity was used and a DL-250 primary coil was large enough to cover all waves up to 10,000 meters.

For press reception, a ground wire 500 ft. long, bearing NW was used. On this, signals from NBA, NPL, and NPG (8600 meters) could be copied on the typewriter in daytime or night using a 2 step amplifier. Press was copied daily despite the fact that many times, during one of the press schedules, a thunder storm would be going on directly overhead. It seemed to make little difference whether the wire was on top of dry ground or under 3 or 4 inches of water after a heavy rain. The signals were always the same strength, and there was no day to day variation.

As regards the action of the ground antenna, there is a possible explanation in the fact that every radio transmitting station sends current into the ground, and that this current is sent through the ground in all directions radially from the point where the leadin enters moist earth. Theoretically, this current will travel an infinite distance around the conducting surface of the earth, its amplitude gradually diminishing and approaching zero as the distance from the

RADIO DIVISION

TELEPHONE MAINTENANCE CO.

17 N. LaSalle St. Chicago, Ill.

starting point becomes greater. A ground antenna placed in the path of this current and pointing at the transmitting station would act as a shunt around part of the earth and would receive a current depending upon the relative resistance of the earth and the wire. The longer the wire, the greater the current should be, provided the wire resistance did not increase so much as to nullify the effect of the added voltage drop due to the increased length. If the wire were placed parallel to the approaching wave front, no current should be picked up. This was found to be the case.

Regarding the "daylight effect," the writer has no explanation to offer, and can merely say that the effect described herein was also noticed by Mr. Schilling on many occasions, particularly on signals from Annapolis. It would be interesting to hear in the columns of this magazine from other experimenters who have investigated along these lines, and if possible get the results of their observations.

VOICES OF THE NIGHT

By EARL ENNIS.

From the far magnetic spaces where the Northern lights flare forth;

From the warmer Southern oceans far below;

From the distant Eastern reaches, where the oldest races live,

And the Oriental traders come and go;

Through the night come faint-sung whispers, in a score of different tones—

In a language with a queer and rhythmic flow—

And we smile in odd contentment as the conversations fit.

There all a bunch of voices that we know.

Oh, it's chatter, chatter, chatter,

From a thousand copper strands,

Through the fogs and mists and storm-winds Of a dozen different lands;

From a tanker off to leeward,

From a freighter out of sight—

It's an endless, ceaseless babble

By the voices of the night.

When old Behring Sea is frothy and the ice floes madly swirl,

And a vessel plunges northward through the dark,

There's a mighty heap o' comfort in that gabble off in space,

When you come across a friendly little spark;

When you hear far Sitka's whistle, and old Estevan's hee-haw,

And the peanut-whistle accent of an arc,

And some compass station operator wags a friendly jaw—

And you slip a ball score over for a lark.

Oh, it's chatter, chatter, chatter,

From a thousand copper strands,

Through the fogs, and mists, and storm winds Of a dozen different lands;

There are many occupations

On this footstool here below,

But they haven't got the pal-ship

Of the friendly radio.

LONGER LIFE
MORE THAN A TRADE MARK
BETTER SERVICE
A SIGN OF "B" BATTERY QUALITY



The new "Ace" 2 627-45 Volt Variable "B" Battery is rapidly creating a remarkable reputation as to "Price," Quality, Service and Weight. The special size cell construction guarantees from 50% to 75% longer life than any 2 small size "B" Batteries. 16 Taps, 30 Voltage readings of from 1½ to 45 Volts obtained. Absolutely the best "B" Battery offer ever made. Size 6 in. x 5 in. x 2½ in. —weight, 3½ lbs. Price, \$8.50. Demand "ACE." If your dealer does not carry "Ace" write to us. This list contains the six popular type "ACE" "B" Batteries.

Write for Cat. \$ 20. Ace Batteries are silent, moisture proof and absolutely guaranteed.

DEALERS:

Get in on this fast selling item.

Cat. No.	Size	Voltage	Lbs.	Taps	Price
623	Plain	2½ x 2x3½	22½	1	\$1.50
623	Variable	2½ x 2x3½	22½	5	1.75
625	Plain	3 x 4x6½	22½	5	2.50
625	Variable	3 x 4x6½	22½	5	3.00
626	Plain	3 x 8x6½	45	10	5.00
626	Variable	3 x 8x6½	45	10	6.00

NO RADIO SET COMPLETE WITHOUT "ACE"

264 Atlantic Ave. ACE BATTERY MFG. CORP. Dept. P Brooklyn, N. Y.

Phone Kearny 2778

PACIFIC RADIO SCHOOL

ARC & SPARK SYSTEMS

Hours:

1 to 5 P. M.

7 to 9 P. M.

433 Call Bldg.,

San Francisco, Cal.

Send for descriptive circular.

ARCS

are fully explained in the

"ARC RADIO MANUAL"

A most complete book dealing with the various types of arc radio apparatus for ship and shore station work.

Illustrated with many photos and wiring diagrams. You need this book if you are a commercial operator or desire to take the radio examination.

Price \$2.50 Postpaid

RADIO, Pacific Bldg., S. F., Cal.

The "QSA" Line of Equipment

COMBAT

A Storage Battery especially designed for Radio work. The only Battery with non-corroding binding posts. Write for particulars and incidentally get your name on our mailing list to receive our monthly bargain sheets.

Here is one of the many items listed for December:

Dry Cell B-Battery 45 volts \$1.85 ea.

INDEPENDENT RADIO SUPPLY COMPANY

3716 W. Douglas Blvd., Dept. P-12 Chicago, Ill.

"Better Results with Less Effort"



—RADIO INSTITUTE—
OF AMERICA

Conducted by the greatest and most experienced radio telegraph organization in the world.

Thorough training given in radio operating, traffic, and in damped and undamped systems.

Tuition ten dollars a month for either the day or evening sessions or both combined.

Prospectus mailed on request

RADIO CORPORATION OF AMERICA

Phone Douglas 3030

331 New Call Bldg., San Francisco

Tell them that you saw it in RADIO

Come and See

The largest and finest RADIO store
in California, yes even in the
whole West

If you have not seen

The Blank Radio Call Book
for Amateurs

Price \$1.50

Send for sample page

It is just the thing for recording the dial
settings for Long Distance and
Continuous Wave receiving

Altadena Radio Laboratory

90 North Los Robles Avenue
Pasadena, California

"INSULATE"

MOULDED COMPOSITION

Also

"HI-HEET" Insulations

100 Different Style Knobs, Binding Posts, etc., in Stock for Immediate Shipment

To Order
Specials
of Any Article

Insist on "INSULATE" When
Ordering Through Your
Local Dealer

GENERAL INSULATE CO.

1111 Atlantic Ave.

Brooklyn, N. Y.



THE C. W. MANUAL

Continued from page 18

able and the inductance L_1 represent a dummy antenna circuit for the radio-*phone* T. C_2 is a capacity sufficiently large as not to affect the period of oscillation of the circuit $C_1L_2C_2$ plus the internal circuit of T. This capacity together with that of C_3 are placed in the circuit to prevent a shortcircuiting of the source of high potential to the power amplifier and T. The potential variations across the inductance L_1 are impressed upon the grids of the amplifier tubes, which, with proper circuit adjustments, reproduce the output of T in greater magnitude depending upon the size of the tubes A and B. The adjustment of L_1 , while quite critical, is not difficult to make.

The proper procedure for adjusting such a circuit as shown in Fig. 21 is as follows: Adjust the circuit $C L_2 C_3$ to the wavelength desired by moving the variable contact D along the inductance. Then adjust the capacity C_1 until the antenna current is a maximum and at the same time alter the

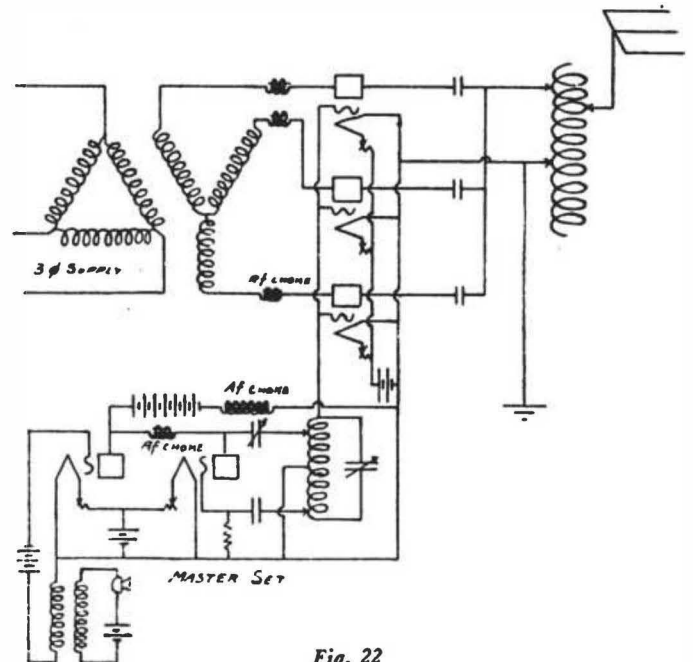

Fig. 22

position of the tap E to obtain the best value of grid potential. Last, shift the plate tap, F, until a second maximum antenna current is obtained. Using a simple arrangement of this kind employing a Western Electric Company 5 watt phone set at T and two 5 watt tubes in the power amplifier, a laboratorian at Mare Island, California, succeeded in communicating by voice with an amateur in Portland, Oregon, a distance of approximately six hundred miles. In a similar manner much larger tubes at A and B could be controlled by T, giving a greater range of communication. The details of a 10 watt power amplifier such as the one described above will be forthcoming in a later chapter.

Fig. 22 shows a 5 watt voice amplifier controlling a 5 watt oscillator which in turn controls the entire output of a 750 watt power amplifier supplied by three phase alternating current at 4,400 volts. The efficiency of such an arrangement is very great when compared to that of the power modulator system of control and very little voice distortion is obtained.

A Dependable and Serviceable Battery at Low Cost

No. 766—**EVEREADY**



Order from your regular dealer and specify No. 766 Eveready Wireless Battery.

This is just the thing for the amateur—will give long and valuable service and can be absolutely relied upon to deliver a clear, steady current.

This battery has 1 negative and 5 positive leads, each having a flat brass strip with a 3/16-inch hole in the end for connection with the binding posts. These 5 positive leads allow a range of 16½, 18, 19½, 21 and 22½ volts in steps of 1½ volts.

15 cells connected in series and packed in a strong box make this battery substantial and easily handled. All cells are solidly packed and are sealed in paraffine and packed with ½-inch of sealing wax, rendering a weather proof unit and one that will withstand practically all variations of climate and temperature. This Wireless B Battery has been standardized for use in the United States Navy.

And the price—only \$3.00.

Made in San Francisco by

NATIONAL CARBON CO., INC.
599 EIGHTH STREET



**6EN Works 1000 Miles on 10 Watts CW
You Can, Too!**

With Apparatus Designed for

RESULTS EFFICIENCY SERVICE



The "STANRAD" inductance is built for RESULTS—that's what you want—RESULTS!

It has 54 turns of copper wire wound on a 4-inch threaded formica tube. The wire cannot slip or come loose.

The margin at each end makes it easy to mount by means of brackets, mounting posts, etc.

One or two-coil winding... \$5.00
Threaded tube only... 3.75
Inductance for 100 watts... 10.00

The choke coils are wound on fiber spools. This eliminates breakdowns. Binding posts are provided for connections, and aluminum feet to simplify the mounting. The inductance, approximately 3 henrys, is enough to clear the worst hum.



500 M. A. \$7.50
150 M. A. 6.00

If your dealer cannot supply you, write direct.

STANDARD RADIO COMPANY
1048 So. Olive St., Los Angeles, California

MURDOCK No. 56 RADIO RECEIVER



3000 Ohm Double Set

3000 Ohm Double Set

\$5.00

\$6.00

Reliable Service

Unequaled Values

Guaranteed to Satisfy

Sold on 14 Days' Trial—Money Back if not Satisfied
Send for Bulletin of Other Murdock Apparatus

Wm. J. Murdock Co., Chelsea, Mass.
40 Carter Street

509 MISSION STREET, SAN FRANCISCO

\$35.00
DETECTOR AND TWO-STEP AMPLIFIER
\$35.00

Satisfaction!
That's what the Proudfoot Detector and Amplifier is built to give. *The Price* was made to fit your pocket-book.



Maximum Amplification. No Howling
Plug for fones furnished with each instrument.
Automatic filament control by plug \$10.00 additional.

Detector and One-Stage Amplifier
\$25.00
* duplicate of above only one unit less.

G. M. PROUDFOOT
361 E. OHIO ST. CHICAGO

Phone San Jose 2128-J

Established 1909
1200 Students

OUR WAR RECORD—200 Men Trained—130 Placed in Service

HERROLD COLLEGE
OF ENGINEERING AND RADIOSPECIAL ATTENTION TO EXPERIMENTERS
AND AMATEURS

467 South First Street

SAN JOSE, CALIF.

*First on the Market***Radio Frequency Transformers****Type RF-1, for Amateur Range, Price \$6.00**

Mr. Amateur: Hook up a radio transformer ahead of your detector and get acquainted with stations you have not heard before.

The Type RF-1 is a—

- Transformer of special R. F. iron core construction. (Patent pending.)
- Transformer having complete shielding.
- Transformer covering the amateur wave-length efficiently.
- Transformer giving maximum amplification per stage.
- Transformer designed by former Government radio engineers
- Commercial and special range R. F. transformers supplied

Radio Service Laboratories Asbury Park, New Jersey
INC.

Tell them that you saw it in RADIO

PATENTS

Continued from page 37

is also an interlocking scheme between the three keys 41, 42 and 43 whereby while 41 is transmitting, the other two are prevented from so doing, and while 42 is transmitting, 43 is prevented from so doing.

L. M. Clement, Pat. No. 1,395,390, Nov. 1, 1921. **Oscillation Generating System.**

An oscillation generating tube 6 is coupled directly to an antenna circuit 1, 2, 3, 5, by means of lead 7, 8, 9. The invention relates

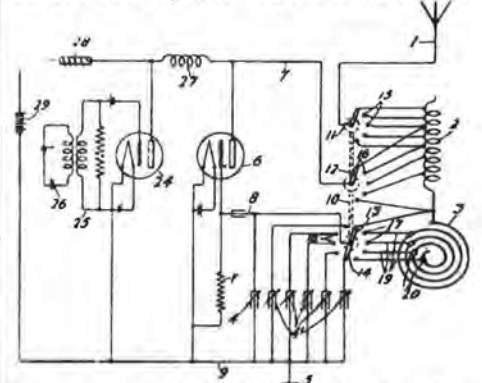

to an efficient and simple means for changing the wavelength transmitted. For this purpose, a common shaft 10 carries all the contact arms 11, 12, 13 and 14, which coact with taps to vary respectively the number of turns of coil 2 in the antenna circuit, the number of turns of coil 3 in the antenna circuit, and the capacity between the grid and filament of the tube 6. By properly choosing the points where the taps connect, it is possible by a single movement of shaft 10 to change from one wavelength to another.

J. H. Payne, Jr., Pat. No. 1,400,235, Dec. 13, 1921, method of and means for producing alternating currents.

An oscillating tube is described, in which electrostatic coupling 12, 13 and 14 are provided between the grid and plate circuits. By tuning the circuit 8, 13, 10, 14, including two of these couplings and two inductors in the grid and plate circuit, to a frequency materially less than the oscillations set up in the tube by coupling the grid and wing circuits, it is possible to radiate groups of waves of the high frequency, the group frequency being determined by that of the circuit 8, 13, 10, 14.

H. F. Elliott, Pat. No. 1,399,945, Dec. 13, 1921, radiotelegraphy.

A transmission system is described in which signaling is effected by simultaneously closing and opening a number of circuits 7 inductively coupled to the antenna loading coil 6. These circuits 7 overlap each other to the proper extent so as to eliminate any mutual induction between themselves. The closing and opening of these circuits is effected by electromagnetic switches operated from a common source.

H. J. Round, Pat. No. 1,395,987, Nov. 1, 1921. **Wireless Signaling Apparatus.**

This patent describes a scheme for keeping the wavelength of the aerial constantly equal to that of an oscillating circuit which supplies the aerial with radio energy. This is accomplished by the use of a circuit C coupled both to the aerial circuit A and the oscillating circuit B. Two windings D are provided, at right angles to each other and in circuits C and A. The member E is a secondary of an induction motor and so arranged that if the wavelength of circuit A is equal to that of C, then there is no torque exerted upon member E. If there is a difference, E rotates and operates a variometer F which is in series in the aerial circuit A, so as to bring the wavelengths into equality.

RADIO CLUB SECRETARIES!

Write for our attractive radio club subscription proposition at once.

+

Every member of your club should subscribe to

"RADIO"

+

Our new plan makes it an easy matter for everybody to subscribe—at unusually interesting rates.

+

RADIO

Pacific Bldg., San Francisco

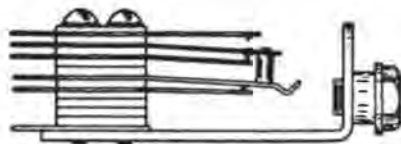
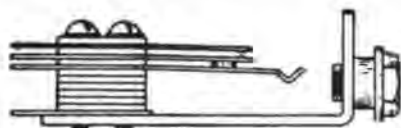

Simplify Your Radio Set

Eliminate innumerable switches and complicated controls by equipping your radio Detector and Amplifying units with

FEDERAL

Filament Control Jacks

Simplify operation; save current; make your set up-to-date and efficient.

Write for illustrated circular describing Federal Filament Control Jacks and Plugs

FEDERAL TELEPHONE & TELEGRAPH CO.,

Buffalo, N. Y.

SUNSET RADIO CLUB

At the last regular meeting the following officers were elected for the ensuing year: President, A. A. Hudgins, 6IZ; Vice-Pres., Edward Kinney, 6ACK; Secy., G. MacMullen, 6AL. Traffic Committee—Chairman, A. A. Kramer, 6EV; John F. Gray, 6MZ and A. A. Hudgins, 6IZ. Program Committee—Chairman, W. W. Dann; Lawrence Mott, Edward Kinney. The Program Committee is to arrange for a scientific paper for each regular meeting throughout the year. For the first meeting in January a paper on High Versus Low Antenna by 6ZB is announced.

6TW, Eugene R. Merritt, having returned from duty with the shipping board has assumed the head of the Radio Department at the Southern Electrical Co. and is busy visiting the various stations throughout his territory in an effort to be of assistance wherever possible.

6BAZ, Mrs. Mary Houston, has entirely remodeled her transmitter and is now using a 1/2 Thor putting 4 amps into an 80 ft. antenna. The club wishes some of the DX chaps would QSL our Y. L. operator.

6ADA, having completely rebuilt the station at a new location, is now reaching out in his old style.

6MZ recently suffered an attack of acute high voltage and is re-insulating prior to recontinuing with the Sink 1 KW Jefferson.

6AJH has returned home from the hospital but will be bedridden for a while. His station has been remodeled principally through the kindness of Dudley Chambers, 6AHF, and 6AJH will probably be on the air before this is printed. The club hopes that Lester will be given plenty of chance to operate without QRM whenever he is able to touch the key.

A new station is being erected in Coronado by George Remington, using 1/2 Thordarson, Surdam enclosed gap, and say, you fellows in the sand lots, take notice—a sea water ground!

6MZ reports satisfactory progress for DX messages handled in his section. Those stations particularly active being 6FK, AEH, 6ZB, 6KC, 6AKL.

6FK holds the local record for long distance receiving and is also going some on his spark set. Only lack of time prevents him from handling the major portion of the A. R. R. L. traffic.

6EV is never heard from any more. He is our star operator, an old stock exchange Morse man. Those trying to do DX work wish he would come in and personally act as traffic officer every night until our conduct is perfect.

A new C. W. station will shortly be installed by W. W. Dann at 1258 Cypress Ave. No license number has been received to date. 50 watt tubes will be used.

6AHF has built an entirely new plant with a 90 ft. mast and expects to QRM New York shortly.

The village of Bolinas, Calif., according to "World-Wide Wireless," published by the Radio Corporation, has the most wonderful damped wave phone known to the radio art. Most of us have been under the impression that it was necessary to have undamped waves for the operation of telephones; nevertheless, the writer can make an affidavit that the telephone connecting the village of Bolinas and the village of Willow Camp literally operates on the damped wave principle. The two villages are connected by a farmer's line, strung on poles across the shallow bay. When the tide is in and the wind blowing from the southwest, the waves from the waters of the Pacific periodically wash over the telephone wires, and as a result the voices are intermittently cut off. If that isn't damped wave telephony, what is?

Tell them that you saw it in RADIO



STANDARD STRUCTURAL STEEL WIRELESS TOWER

Made of structural Steel. Self-supporting. No Guys to absorb energy.

ERECT IT YOURSELF

Step Bolts provided. Standard Tower 60 feet high and 7 feet square at base.

\$100.00 f. o. b. San Francisco.

Ask your dealer or send for folder.

S. S. HERRICK CO.

Towers, Buildings, Bridges.

Foot of Adeline St. OAKLAND, CAL.

Elements of Radiotelegraphy

By Lieut. E. W. Stone

★

400 PAGES OF DATA ON MANY TYPES OF MODERN RADIO EQUIPMENTS. The demand and popularity of this book prove its superiority.

\$2.50 Postpaid Anywhere

★

RADIO

Pacific Bldg., San Francisco

INDEED
You Should Be A Subscriber

NOTICE

Radio—7XC

The Northwest Radio Service Co., the largest Radio Supply house in the Northwest has moved to

1637 Westlake Avenue Seattle

where a larger stock of up-to-the-minute radio equipment has been received. If you want fast Service, send your order to us. Service is our middle name, and incidentally the corner stone of our success. Remember the new address.

Murdock, DeForest, Radio Corporation, Radisco, A.-P. and other standard lines.

Builders of "PUGET" RADIO PRODUCTS—None Better

10c Charges Your Storage Battery AT HOME WITH AN F-F Booster



So You will never have to give up in disgust when working a distant station. Is it not gratifying to feel Your Filament Battery will always be ready when needed? You know what it's like to have friends call to Listen In & then find your battery dead. The F-F Battery Booster is a rugged Charging Apparatus, un-failing in its ability to deliver service day and night; requiring no skill to operate; charges automatically and operates unattended. Screw Plug in lamp socket, Snap CLIPS on Battery Terminals and watch the gravity come up. AMMETER shows amount of current flowing. Everything Complete in Compact Self-Contained Portable CHARGING UNIT. The F-F BATTERY BOOSTER is a Magnetic Rectifier for 105-125 Volt 60 Cycle A. C. They last a Lifetime. New Models. PRE-WAR PRICES:

- Bantam Type 6 Charges 6 Volt Battery at 6 Amperes..... \$15
- Bantam Type 12 Charges 12 Volt Battery at 5 Amperes..... \$15
- Type 166 Charges 6 Volt Battery at 12 Amperes..... \$24
- Type 1612 Charges 12 Volt Battery at 7 Amperes..... \$24
- Type 1620 Combination Type Charges both 6 and 12 Volt Batteries at 12 and 7 Amperes..... \$36

The Larger Types are recommended for large batteries, or where time is limited. Shipping weights Complete, 12 to 16 Pounds. Send check for Prompt Express Shipment. If via Parcel Post have remittance include Postage & Insurance charges, or order us to ship Type desired C. O. D. Order Now, or Write Immediately for FREE Descriptive Booster & Rotary Bulletin No. 83 & 83-A.

FRANCE MFG. CO. General Offices and Works: CLEVELAND, OHIO, U. S. A. Canadian Rep.: Battery Service & Sales Co., Hamilton, Ontario

"SHRAMCO PRODUCTS"

Amateurs: Send 5c in stamps today for our new Catalog L showing complete line of parts, raw materials and high grade apparatus.

Dealers: Write for our attractive proposition.

THE SHOTTON RADIO MFG. COMPANY, INC.
8 Market St. Albany, N. Y.

KEYSTONE RHEOSTAT



The "Keystone" is one of the finest constructed rheostats on the market, and is made of the best heat resisting and durable material possible to obtain. Neat in appearance, is 2 1/4" diam., 3/4" deep, and 1/4" shaft. All parts are made of brass, and pointer is of heavy brass, nickel plated and polished. Resistance is 6 ohms, 1 1/2 amps. carrying capacity. Can be easily mounted on back of panel by only drilling two holes, also dial can be used, instead of the knob and pointer furnished. Resistance is wound tightly on an insulating strip and can not become loose. Sold on a guarantee of satisfaction or purchase price will be refunded.

PRICE \$1.25

Amateurs and constructors, don't miss sending 5 cents in stamps for our complete set of bulletins on raw materials, machine screws, wire, standard apparatus, audion and amplifying apparatus, and save money and time.

Keystone Radio Company
Greenville, Penn.

Tell them that you saw it in RADIO

JIMMY'S WIRELESS

(As told to the poet)

I've got a wireless set at home.
I saved to beat the band,
And thought that when I had it all
It surely would be grand.

But, dern it! All the family
Just butt in all the time,
Though when I saved to buy the things,
They never helped a dime.

There's Bud; he wants the baseball score.
I find him every noon
Just using up my batteries—
I'll need some new ones soon.

And Sis brings all her friends around
To hear the music play.
When I come home from school I find
Them monkeying every day.

And, after supper Dad comes 'round
And says: "How goes it, Jim?
Here's Jones and Smith to hear some tunes."
And 'course that, too, means him.

They hang onto my head-sets then
The whole two hours long—
The only chance I get to hear
Is when something goes wrong.

And Mamma seems to think I'm mean
Because, of afternoons,
I can't go with her to the church
And have it play some tunes.

I guess she thinks it's somethin' like
A phonograph, by Heck!
But 'cause I don't produce the goods
She jumps right on my neck.

I'll tell the world it's pretty tough
To work and get a set
I never have a chance to use—
I've scarcely heard it yet.

—A. H. HUTCHINSON.

STATIONS HEARD AND WORKED BY 6A0M,

- 1700 SONOMA AVE., BERKELEY, CALIF.
Spark—6ak, 6bm, 6da, 6dp, 6ea, 6eb, (6ef), 6en, 6er, 6fd, 6fh, 6fk, (6gl), (6gp), (6gr), 6gt, 6gx, (6is), (6iv), (6ka), 6kc, 6kl, 6km, 6kp, 6ks, 6kv, (6ky), (6lc), (6mh), 6od, 6oh, 6ol, 6om, (6or), 6it, 6to, 6tv, 6uo, 6vv, 6vz, 6wh, 6aa, 6ak, 6aa, 6aa, 6abm, 6abb, 6abw, (6abx), 6ac, 6ac, 6ad, 6ad, 6ah, 6ai, 6afn, 6afy, 6afz, (6agf), 6agn, 6agp, 6aha, (6ahp), (6ahu), 6ahv, 6aib, 6aif, (6aio), 6ajh, 6akl, 6akw, 6all, 6alp, 6alu, 6am, 6anp, 6arw, 6auh, 6avb, (6avd), 6avv, 6avy, 6b, 6ba, 6ba, 6bz, 6zb, 6zu, 6zx, 6zz, 6zal, 6ah, 6bb, (6bh), 6bj, (6bk), 6br, 6bs, 6bi, (6bf), 6in, (6jw), 6kb, 6ke, 6kh, 6ki, (6kf), 6mu, 6nl, 6nw, 6ot, 6oz, 6tj, 6ya, (6z), 6zk, 6zn, 6zt, 6zu, 6ax, 6pc, 9ed, Can. 9bd.
C. W.—6dp, 6pr, 6abg, 6abz, 6ajh, 6ale, 6alu, (6aoy), 6aoz, 6xab, 6xad, 6xf (cw and music).
Daylight—6bm, (6gr), 6is, 6ka, 6kc, 6kl, 6km, 6mh, 6pr, 6abx (cw and spk), 6acy, 6afy, 6agf, 6aif, 6avb, 6ah, (6bh), 6bk, (6mf).

CALLS HEARD AT 6AIF, BAKERSFIELD, CALIF.

- Spark—5vq, (5za), 5zj, (6aa), 6aa, (6abw), (6abx), 6ac, (6acr), 6acy, 6ada, 6aeh, 6aei, (6aex), 6afn, 6afy, (6agf), (6ah), (6ahp), (6ahv), 6ahy, (6aib), 6aif, (6aio), 6ajr, 6ak, 6akl, 6akt, 6ala, 6all, (6alp), 6alu, 6amk, (6amn), (6ang), 6ani, 6aoa, (6aoe), 6apa, 6ark, 6arw, (6as), 6atq, 6atv, 6au, 6aud, (6avb), (6avv), 6awh, 6bak, 6bar, 6bcj, 6bfe, 6bfx, 6bgl, 6bw, 6cy, 6cz, 6da, 6dm, (6ea), 6eb, (6en), (6ex), (6fh), (6fk), 6gl, 6gp, 6gr, 6gt, 6gz, (6hc), (6ib), 6ik, 6is, 6jc, 6ka, (6kc), 6kp, 6ks, 6ky, 6lc, 6lu, 6mt, 6mo, (6mh), 6ng, (6oc), (6od), 6oh, 6ot, 6pc, 6pj, (6pr), 6pt, (6qr), 6ac, 6aj, 6at, (6ft), (6to), 6tu, 6tv, 6uo, 6vk, (6vx), (6wh), 6wo, 6ws, 6yn, 6zal, (6z), 6za, 6zb, 6ze, 6zu, (6zx), (6zz), (6ba), 6bb, 6bj, 6bk, 6cw, 6fi, 6ft, (6hf), 6ij, 6in, 6iw, (6jd), 6kb, 6ke, 6ky, (6mf), 6mp, 6mu, (6ot), 6tj, 6ya, 6yg, 6zb, 6zo, 6zp, 6zt, 6zu, 6wu, 9yal, Canadian 9ax, Canadian 9bd.
C. W.—(5za) (cw and fone), 6aat, (6abx), (6ale), 6arc-(icw), 6asj, 6asx-(icw), (6aul), 6avy, 6awt, 6awv, 6dr-(icw), 6jd, 6jq, 6jz, 6km, 6oo, 6vv-(cw and fone), 6ws, (6xad), 6za, 6rad, (6zn), 6zf-(cw and icw), (9amb), 9bex, 9dtm, 9dva, 9nx, 9xm, w12, c18, ag1-(fone), and "mc" (Chihuahua, Mexico).

MEYBERG

THE LARGEST RADIO STOCK
ON THE PACIFIC COAST

San Francisco



PROMPT SERVICE FROM
EITHER ADDRESS

Los Angeles

Exceptional Facilities to Serve You

CARRYING an unusually large and complete stock of all the leading radio apparatus, we are in a position to serve you exceptionally well. Write us about our radio items, circuits or radio matters that are of personal interest to you. Any inquiries will be given our careful attention. Descriptive bulletins will be furnished on request in reference to the apparatus we carry. Write today.

Operating the Fairmont Hotel
Radio Station KDN
San Francisco

428 Market Street
San Francisco, Cal.

LEO J. MEYBERG CO.

Send two-cent stamp for NEW Concert Schedule.

Operating Hamburger's
Radio Station KYJ
Los Angeles

950 South Flower Street
Los Angeles, Cal.

Automatic Radio Recorder

*Unparalleled for the automatic recording of market reports,
time signals and all telegraphic data—regardless of speed*

No Limit to
Amplification

Remarkable Elimination
of Q. R. M.

Simple
Fool Proof
Reliable

JUST PLUG IT IN WITH
YOUR PHONES



Price of Relay
Complete with Air Blower
\$125 F. O. B. Palo Alto

Tape Recorder
Complete with
Motor Drive
\$35 F. O. B. Palo Alto
Immediate Deliveries

Licensed Exclusively
For Amateur Use

The Hall Radio Relay

A wonderful addition to the RADIO ART. Manufactured Solely By

KARLOWA RADIO CO., Rock Island, Illinois

Sole Manufacturers of HALL RELAYS

Exclusive Distributor West of Rockies: **J. Edward Jones**
Post Office Box 22—Palo Alto, Calif.

Send 15c for our most complete 55 page radio catalog describing the HALL RELAY and other apparatus

Try REYNOLDS RADIO Service from DENVER

G. W. APPARATUS—TRANSFORMERS	
Acme 200 Watt 350-550 V. mounted...	\$20.00
Acme 200 Watt 350-550 V. unmounted.	18.00
Acme 600 Watt 1000-1500 V. mounted.	33.00
Acme 600 Watt 1000-1500 V. unmounted.	28.00
Acme 150 Watt filament heating mounted.	16.00
Acme 150 Watt filament heating unmounted.	13.00
Acme 75 Watt filament heating unmounted.	9.00
Clapp-Eastham 75 Watt filament heating, with primary rheostat.	12.00
General Radio, modulation.	5.00

CHOKE COILS	
Acme single coil 1.5 Hen. 150 M. A.	4.00
Acme double coil 1.5 Hen. 150 M. A.	6.00
Acme single coil 1.5 Hen. 500 M. A.	6.00
Acme double coil 1.5 Hen. 500 M. A.	8.00

ACCESSORIES	
R. C. Grid Leak U. P. 1718.	1.65
R. C. Grid Leak U. P. 1719.	1.10
R. C. Grid Cond. U. C. 1014, .002 M. F.	2.00
R. C. Condenser U. C. 1015.	5.40
R. C. Filter Cond. U. C. 1635, 1 M. F.	2.00
R. C. Magnetic modulator U. P. 1346.	9.50

PHONES	
Murdock 56-2000 Ohms	5.00
Murdock 56-3000 Ohms	6.00
Baldwin Amplifying, Type C.	12.00

PRICES DO NOT INCLUDE POSTAGE

REYNOLDS RADIO CO., Inc.

VACUUM TUBES	
C. 300 Detector	\$5.00
C. 301 Amplifier	6.50
C. 302 Transmitter 5 Watt	8.00
C. 303 Transmitter 50 Watt	30.00
Moorhead Detector	5.00
Moorhead Amplifier	6.50
Moorhead Transmitter	7.50

SOCKETS	
Victor, fused 1 amp.	1.00
Paragon, nickel plated.	1.00
Remier, moulded	1.50

MOTOR GENERATORS	
Esco. 400 Watt 1000 Volts	165.00
Esco. 100 Watt 500 Volts	65.00
Esco. 40 Watt 350 Volts	48.00
Radico midget	37.50

REGENERATIVE RECEIVERS	
Kennedy short wave 175-600 meters.	80.00
Kennedy Intermediate wave 175-3250 meters	125.00
Kennedy Universal 175-25000 meters.	250.00
Kennedy Amplifiers	\$55.00 & 85.00
Grebe—C. R. 5	80.00
Grebe—C. R. 8	80.00
Grebe—C. R. 9	130.00
Grebe Amplifiers	\$55.00 & 75.00

Mid-West's Largest Wireless Supply House
613 19th ST., DENVER, COLO.

HODEYCOBE MICRAFERRIS BROWN

Continued from page 54

ment on his grandmother, who was in the neighborhood of some 125 years, Chief Ungus and his suite called upon Hodeycobe one afternoon.

"Chief says make grandmother young," grunted the interpreter.

"Tell chief ah am busy today and come later."

"Chief say no. Chief say plenty time now get ready. You do now."

The wrinkled old mother of a decidedly plural progeny stepped forward. She was adorned with wrinkles an inch deep. She was all that age implied—gray, stoop-shouldered, toothless, weightless and nearly clothesless. The skin clung to her bones and her flesh was fast disappearing.

Hodeycobe realized that putting "pep" into this poor unfortunate would be comparatively as easy as shaking hands with Friday through an introduction of Robinson Crewsoe. The moment had arrived whereby he was through. His two partners looked on in profound silence. They, too, felt the end was near.

Hodeycobe's brain, however, was not entirely dumb and he got busy therein. He had the woman step close to the apparatus. They started the old gas engine and the generator wheezed a tiny spark at the touch of the key. After much ceremony he had the woman hold a wire in each hand. One was a ground and the other the power lead.

"Now, lady, stand right quiet like because dis am whut yo' call a major operation. Dis am de wonderful invention of all times. Yo am gwine be young again and do de jazz like de spring chicken."

The interpreter was translating the words to the chief, who seemed greatly interested. Outwardly Hodeycobe was calm, but inwardly directly the opposite.

The current was then shot into the lead she held. Her eyes rolled to the clouds and her mouth came shut so abruptly that her tongue did not have the proper opportunity to escape. It was a cruel trick, but Hodeycobe was in a cruel position. She dropped to the floor, the old generator surprising Hodeycobe as much as anyone. Heavens, what a kick!

"My friends," began Hodeycobe, standing over the form of the electrified female, "she am now in de sleep of youth. If yo' all will kindly migrate from heah and leave us alone ah will be greatly appreciative. Come again tonight."

The chief went out, followed by the party, an implicit believer in the achievements of the great Hodeycobe. They chanted a war song of thanksgiving.

Hodeycobe picked the lady up and laid her behind a screen. He was about to bind and gag her when he thought he noticed an expression on her face that did not bespeak life. He quickly felt of

50 GRID LEAKS FOR \$1.00 "RESISTOHM"

A unique and practical preparation for the Resistance of Grid Leaks and resistance Units

Resistohm—Makes it possible for anyone to make grid leaks, and in various values from 10,000 to 3,000,000 ohms resistance.

Resistohm—Is recognized by operators, both amateur and commercial, to be of correct formula, for the various resistances necessary in order to obtain exact grid biasing.

Resistohm—Appreciated by those who desire the highest efficiency in their detector circuit and in each stage of amplification. Ideal for the grid leakage of the power amplifier, where a low resistance leak may be required.

Resistohm—Will popularize the use of resistance coupled, radio frequency amplifiers, due to the simplicity of resistance variation.

It cannot be stated offhand the proper value for the resistance of the grid leak for any particular set. However, with RESISTOHM the proper value may be quickly arrived at by experiment and the added efficiency realized.

Experts concede that the grid leak is the most practical way of controlling and maintaining the proper potential of the grid.

One bottle of RESISTOHM will furnish enough resistance material to construct numerous grid leaks and carry on many experiments, where a reliable resistance compound is required.

\$1.00 prepaid, United States and Canada

If your dealer cannot supply you, order from us direct.

Dealers—Here is something new, easy to sell, and proposition is good.

PACIFIC RADIO EXCHANGE

439 CALL BLDG., S. F. CAL.

Visit the  Store

in San Francisco

Conveniently located at 24 California St.

It is in charge of an experienced Radio Operator, who will give you helpful advice for all of your radio needs.

SHIPOWNERS' RADIO SERVICE

Incorporated

Home Office, 80 Washington St., New York City



The Detector—SP-1

A New De Forest Line of Receiving Instruments

THE SP SERIES



The Two Step Amplifier—SP-2

The SP Line has been designed for the amateur who appreciates appearance and efficiency—with compactness. All panels are but 7 3/4" high and the widths vary from 4 1/2" in the case of SP-1 to the 8 3/4" of SP-4. We wish to call attention to two features included in the construction of these instruments: Binding posts on the rear of cabinets and filament control jacks.

No longer need the attractiveness of good looking sets be marred by wires criss-crossing across the fronts of panels. Input wires, A battery and B battery leads, tickler connections are all brought to bakelite binding posts set in bakelite insert strips in the back of cabinets. All that projects from the panels of SP instruments are the filament control knobs and the nicked case of the variable grid leak. Unless one has enjoyed the convenience of two-circuit, filament control jacks it is hard to appreciate this feature which saves batteries and constant re-adjustment of rheostats. Only those tubes are lighted which are in use and amplifying transformers not in use are completely disconnected.

Panels are of engraved 3/16" bakelite, the letters being filled in with white that will not chip out or peel off. Hinged tops permit ready access to the interiors for insertion of vacuum tubes and inspection. The SP Line is efficient, de luxe equipment at moderate prices.

PRICES F.O.B. NEW YORK

SP-1	\$18.50
SP-2	\$48.00
SP-3	\$42.00
SP-4	\$65.00



The Detector and One Step—SP-3

De Forest Radio Telephone & Telegraph Co.

1391 Sedgwick Avenue
New York City

Western Distributors

Atlantic-Pacific Radio Supplies Co.

Henry M. Shaw, Pres.
638 Mission St.,
San Francisco, Cal.



The Detector and Two Step—SP-4

\$5 LOUD SPEAKER \$5 24 inch HORN

The latest product in loud speakers is our new adjustable 24 inch horn, made of heavy paper to eliminate metallic sound vibrations. The horn is attached to an adjustable socket, mounted on a mahogany finished stand. Any make of head phone can be attached to the horn by our new adjustable set-screw mechanism and the horn can be turned to face in any desired direction. A bargain at only \$5.00. A three foot green telephone cord supplied free with each instrument.

WRITE FOR COMPLETE INFORMATION AND GET ON OUR MAILING LIST
We Carry Standard Instruments of Many Types

RYAN RADIO CO.

429 BARRETT AVE.

RICHMOND, CALIFORNIA

Tell them that you saw it in RADIO



\$15.50 as shown 200 to 600 meters \$19.50 with all windings in place

J-RAY Unassembled Receiver

SAVE, SAVE, SAVE, on the cost of your receiving outfit by assembling your own. We now offer this complete set of parts, easily assembled in an hour's time, at the exceptionally low price of \$19.50, or if you care to do your own winding, \$15.50. Think of it, fellows, a complete receiving set for \$15.50, and each and every one sold under a money-back-if-not-satisfied basis. This is our contribution towards the lower cost of radio. Set consists of the following:

Stained Oak Cabinet, 18" x 7" x 7", removable top and back.

Polished Formica Panel, 18" x 7" x 3/8", to fit cabinet.

2 Variometers, 4 3/4" square, mahogany wood, complete with winding form.

Variocoupler Secondary Ball, mahogany. Formica Primary Tube, 3 3/4" x 3 3/4".

7 Contact Points, 6 Binding Posts, 1 Switch Lever, 2 Stops.

Set complete with all necessary brass parts, screws, etc., for assembling with directions. Panel drilled, \$0.50 extra.

Complete Receiver, Detector and 1 Step Amplifier, similar to above set but with larger cabinet, ready to assemble, \$29.50, with all windings.

Variometer sets, \$9.75. Comprises Grid and Plate Variometer and Variocoupler, wound and ready for assembling. The best Variometer buy today.

J-RAY MANUFACTURING CO.

2131 De Kalb Street.

St. Louis, Mo.

SOMERVILLE C W CONDENSERS

REALLY DO stand up under 1000 volts. Are tested at 2000 volts, compact, and easily mounted by means of copper lug terminals.

Capacities in Mfd.	.00025 — .001	} 75c Postpaid
	.0005 — .002	

NEW! Somerville Mica Condensers. (mounted between bakelite)

Very Low Power Factor 1.5	.00025 & .0005 Mfd. \$1.00
	.001 & .002 Mfd. \$1.25

ANNOUNCEMENT

Somerville 4" Dial Indicators
Now \$1.75 Postpaid

Free with each pair of type A
BROWN ADJUSTABLE PHONES @ \$18.00
one \$2.50 round Firco Plug!

SOMERVILLE RADIO LABORATORY
Retail Sales Division - Dept. R
176-178 Washington St. Boston, Mass.

COMPLETE CATALOG - 20c

Radio Amateurs of COLORADO,
UTAH, NEBRASKA and WYOMING

Please Remember

DENVER

Has the Largest Wireless Supply Store
in the Middle West

"EVERYTHING IN RADIO SUPPLIES"

We are Distributors of

REMLER, COLIN B. KENNEDY CO.,
DEFOREST RADIO and W. J. MURDOCK
EQUIPMENT and PARTS

Write for our Bulletin and Price List.
We will give prompt Mail Order Service by
Parcel Post or Express, as requested.

Our "REYNARD" Short-Wave Coils are
best on the market—\$2 each.

REYNOLDS RADIO CO., Inc.

613 19th Street, Denver, Col.

her pulse. There was none. She had passed away.

"Well now dat entangles me still moah. Now dey can try me for fust degree murdah. Goshamighty why and which. Wheah shall I do and what shall I go," he chattered inadvertently. She was certainly dead. Not even a flicker of the eyelid.

Under cover of darkness he carried her to a nearby thicket and covered the body with ferns. Carefully he concealed all visible signs and walked slowly back to his hut. He felt sorry for the poor old woman, but she certainly had lived to a point where it was now nothing but suffering. He lay down on the mat which served as a bed and fell into a troubled slumber.

TO the south and east of Zoogoo, some twenty miles distant, is the Isle of Honyok. Here reigns Chief Gugluck, a forceful character. The one thing that was foremost in the life of Gugluck was his daughter, Princetta.

This young lady had heard of Hodeycobe's achievements on Zoogoo from a spy of her own tribe. The menfolks of Honyok had no attraction for her and long since she had given up the idea of matrimony within that group. It must be a great man from a distant country. The spy's narrative of this young man, a captive on Zoogoo, seemed to fit her ideal to perfection.

Early that night she stole quietly through the sleeping village and pushing her catamaran into the water, pointed its nose for a distant speck—Zoogoo Isle. This was certainly brave on her part, as the Gugluck Malays were deadly enemies of the Zoogoo tribe. But Princetta was a daring young beauty and cared not for danger. She had no plans except that when she did get on the island that she would immediately find her man. She had not a doubt but what he would accept her. Never had there been a thing in the world that she wanted but what she did not get.

She arrived early in the morning. Landing beneath a huge palm tree she carefully concealed her canoe and made her way stealthily through the long grass. She soon located the hut of Hodeycobe by the antenna on the trees. Everything was as the spy had said. She made her way to the rear of the hut and crawled under without so much as the crack of a twig. Lying on a mat was Hodeycobe in his troubled slumber. As she was about to awaken him she heard footsteps approaching and slid behind a screen.

It was the committee to see the result of the age experiment.

When the party entered the room their keen eyes darted hither and thither. One of their number awoke Hodeycobe. They had brought with them Hodeycobe's two friends who had been as-

SERVICE-TESTED RADIO EQUIPMENT

We have determined to secure a portion of the radio business on the Pacific Coast and realize that to do so we must offer some inducement to make our efforts successful. Our idea of the reasons that Western amateurs do not purchase from Eastern markets on a larger scale is that we dealers are located too far away from would-be customers. To eliminate objections arising from this handicap we have inaugurated our "SERVICE-TESTED" plan of selling equipment.

Every article which we ship out will be tested thoroughly in our laboratories before it is sent to our customer. There will be no such things as tubes which do not oscillate or "B" batteries which go dead in a short time for the simple reason that any of these articles will be exhaustively tested in ACTUAL SERVICE before the purchaser receives it.

Secondly we will pay all postage charges on orders exceeding \$5.00. This will make our equipment even cheaper than it can be bought on the coast where prices are often higher than listed by the manufacturer. It is needless to mention that our prices are strictly list as can be seen by the following list:

Radio Corporation Products

We are distributors and jobbers for the Radio Corporation of America and always carry a complete stock of their apparatus. We list below their complete line and in addition can supply you with the Radio Corporation C. W. instruction book at 25c per copy.

VACUUM TUBES		KENETRON RECTIFIERS	
Item	List Price	Item	List Price
1 Radiotron (detector) UV-200	\$ 5.00	6 20-watt Kenotron, UV-216	\$ 7.50
2 Radiotron (amplifier) UV-201	6.50	7 150-watt Kenotron, UV-217	24.50
3 Radiotron (5-watt) UV-202	8.00	VACUUM TUBE SOCKETS	
4 Radiotron (50-watt) UV-203	39.00	8 Porcelain Socket (for UV-200, 201, 202, 216) UR-542	1.00
5 Radiotron (250-watt) UV-204	110.00	9 Porcelain Socket (for UV-203 and UV-217) UT-541	2.50
POWER TRANSFORMERS FOR C.W. SETS		10 Bakelite Socket (for UV-200, 201, 202, 216) UP-552	1.50
12 325-watt, UP-1368	25.00	11 Mountings (250-watt tube) UT-501, UT-502	2.00
13 750-watt, UP-1016	35.50	SPECIAL CONDENSERS FOR C.W. SETS	
A-Filament heating Transformer for UV-204, UP-1633		35 Antenna Series Condenser, 7500 V., .0003, .0004, .0005 mfd., UC-1015	5.40
B-Power Transformer for UV-204, UP-1636		36 Plate and Grid Condenser—3000 V., .002 mfd., UC-1014	2.00
C.W. ACCESSORIES		37 Special Condenser—10,000 V., .000025 mfd., UC-1803	5.00
14 Oscillation Transformer UL-1008	11.00	38 Special Condenser—.002 mfd., 6000 V., UC-1806	7.00
15 Magnetic Modulator (1/4 to 1 1/4 amp.) UT-1643	9.50	VACUUM TUBE DETECTOR ACCESSORIES	
16 Magnetic Modulator (1 1/2 to 3 1/2 amp.) UT-1357	12.00	39 Interval Amplifying Transformer, UV-712	7.00
17 Magnetic Modulator (3 1/2 to 5 amp.) UT-1367	17.00	40 Special "A" Battery Potentiometer, PR-536	2.00
18 Filter Reactor (160 mill amp.) UP-1626	11.50	41 Tabular Grid and Plate Condenser	
19 Filter Reactor (300 mill amp.) UP-1627	15.75	.00025 mfd. UC-567	1.20
20 Plate Circuit Reactor, UP-415	6.75	.0005 mfd. UC-568	1.35
21 Filter Condenser 1/2 mfd.—750 V., UC-1631	1.35	.001 mfd. UC-569	1.50
22 Filter Condenser, 1 mfd.—750 V., UC-1632	1.85	.0025 mfd. UC-570	2.00
23 Filter Condenser, 1/2 mfd.—1750 V., UC-1634	1.50	Grid Leaks	
24 Filter Condenser, 1 mfd.—1750 V., UC-1635	2.00	UP-509, .05 megohm	UP-518, .75 megohm
25 Transmitter Grid Leak (5-watt tubes), 5000 ohms UP-1719	1.10	UP-510, .1	UP-519, 1.0
26 Transmitter Grid Leak (50 and 250-watt tubes), 5000 ohms, UP-1718	1.65	UP-511, .15	UP-520, 1.25
27 Antenna Ammeter, 0-2.5 amp., UM-530	6.00	UP-512, .20	UP-521, 1.5
28 Antenna Ammeter, 0-5 amp., UM-533	6.25	UP-513, .25	UP-522, 1.75
29 Sending Key UQ-809	3.00	UP-514, .30	UP-523, 2.00
30 Microphone Transformer UP-414	7.25	UP-515, .40	UP-524, 2.50
31 Filament Rheostat (for UV-200, 201 and 202) PR-535	3.00	UP-516, .50	UP-525, 3.00
32 Filament Rheostat (for UV-203 and 204) PT-537	10.00	UP-517, .60	UP-526, 4.00
33 Rotary Grid Chopper PX-1638	7.25	UP-527, 6.00	each \$0.75
34 Shaft Bushings for 1/4" or 1/2" motor shaft	.20	43 Grid Leak Mounting UX-543	50

Send 15c for our complete literature

ELECTRICAL SPECIALTY COMPANY, 48-50 South Front Street, Columbus, Ohio

Latest Products of the "Signal" Laboratory Told in the New Signal Literature!

Whether like the novice, the Art of Radio is a great "game," or like the experimenter, it is to you the great Business—in either case, you want to keep abreast of developments in apparatus and equipment.

SIGNAL LABORATORIES continue to bring



A popular Signal Product—The new short Wave Tuner, R-37-C Described in the new Bulletin

forth more modern and efficient radio equipment, yet there is no let-up in the demand for earlier popular SIGNAL instruments such as have helped make wireless history.

Therefore, the new SIGNAL Bulletin covers the whole field of Signal Wireless Products—and it is free to you if you use the attached coupon or a post-card.



TEAR OUT AND START THIS COUPON NOW
Signal Electric Manufacturing Co.
 Menominee, Michigan

COUPON

Send me the new SIGNAL WIRELESS BULLETIN

NAME

COMPANY

CITY

STATE

RADIO



**FIRST!
BEST!
100%**

PACENT UNIVERSAL PLUG

This is a radio plug. It fits all standard jacks—and pocketbooks. Of course, no solder is used to make a connection with the Pacent plug. The cord tips are held in such a way that pulling—up to and beyond the breaking of the cord—only tightens the grip. Yet the tips may be released instantly by proper manipulation of the springy strips. A soft, velvety black finish with polished metal parts makes the Pacent plug easy to look at; it is truly beautiful. Rugged construction makes the device good for a lifetime. There is only one Pacent plug and that is approved by the United States Government and used by the foremost amateurs. Don't forget to insist on the original, 100% plug.

From your dealer or direct \$2.00

You should have a copy of our booklet Pacent Radio Essentials.

PACENT ELECTRIC COMPANY, Inc.

Louis G. Pacent, Pres.

Manufacturers and Distributors

150 NASSAU STREET

NEW YORK, N. Y.

Member Radio Section Associated Manufacturers of Electrical Supplies

"FOR IMMEDIATE SHIPMENT"

SOCKETS		"B" BATTERIES	
Murdock	\$1.00	Cyclone—22½ volt (small size)	\$1.00
Paragon	1.00	Cyclone—22½ volt (large size)	2.00
Bemler (moulded bakelite)	1.50	Eveready—22½ volt (large size variable)	3.00
RHEOSTATS		AMPLIFYING TRANSFORMERS	
Bemler	1.00	Rhamstine (mounted)	3.50
Fada	1.00	Acme (mounted)	5.00
DeForest	1.10	Federal (mounted)	7.00
Paragon	1.50	VARIABLE CONDENSERS	
Klosner Vernier	1.50	Chelsea .0008 for panel mounting	4.25
VACUUM TUBES		Chelsea .0011 for panel mounting	4.75
Radiotron U. V. 200 detector	5.00	JACKS	
Radiotron U. V. 201 amplifier	6.50	Federal Single circuit jack85
A-P Electron Relay detector	5.00	Federal Double circuit jack	1.00
A-P Amplifier tube	6.50	Rhamstine Double circuit jack85
FIXED CONDENSERS		PLUGS	
Empire tested grid condenser30	Federal standard plug	2.00
Empire tested phone condenser30	Firth Bull Dog grip plug	2.00
Empire tested grid condenser and leak combined40	Rhamstine plug75
STORAGE BATTERIES		ACCESSORIES	
Marko—6 volt, 40 amp	13.50	Tuska G. W. Inductance	3.75
Marko—6 volt, 80 amp	17.00	Empire Series-Parallel switch85
U. S. Storage—6 volt, 40 amp	10.00	Bemler detector panel	8.00
U. S. Storage—6 volt, 80 amp	13.75	Bemler amplifier panel	6.00
VARIOMETERS AND VARIOCOUPLERS		Electross ball insulators35
Empire variometer	4.50		
Empire variocoupler	5.50		
Tuska moulded variometer	6.25		

Send 10c for Catalog; Money Credited to First Dollar Purchase.

Empire Radio Equipment Co.

Manufacturers and Distributors of Radio Apparatus

271 West 125th Street

New York City

HI-GEE "B" BATTERIES ARE SUPREME

Because they are lowest in price, have a longer life, marvelous recuperation, and unequalled shelf depreciation.

HI-GEE batteries are BUILT especially for us. They are made of the best materials, by accurate workmen. These batteries are absolutely moisture proof.

HI-GEE batteries are made in two grades:

Grade 101, size 2½ x 2 x 3⅞, 22½ volts, list	\$0.90
Grade 101, tapped	1.10
Grade 201, size 2½ x 2 x 3⅞, 22½ volts, list	1.20

Postage paid on all equipment and parts.

HI-GEE Variometers for plate and grid circuits	\$3.60
HI-GEE Variocouplers	3.00
HI-GEE Variocoupler, mounted on copper lined panel, complete with knob, dial and switch	7.50

A postcard will bring our bulletins listing many bargains

HI-GEE RADIO MFG. CO. Box 268-A, MARION, ILL.

Successors to
CITIZEN'S RADIO SUPPLY CO., and HICO WIRELESS SUPPLY CO.

signed to a separate hut. The thing had been planned so that if the experiment failed the three would be together for the final jamberee. No chance for escape.

Knowing full well it was foolhardy to stall further he decided to bluff, and turning toward the back of the hut said:

"Ole lady, if yo' evah done sumthin' foah a fren', do it now. Spirit of de spirits now is yo' time to save a life. Dat life is mine. Come forward to de rescue."

Now the daughter of Chief Gugluck was in a peculiar circumstance. There was nothing for her to do but to come out, and she did.

Hodeycobe staggered.

His two friends suddenly became weak in the knees.

The committee fell upon their knees at the feet of Hodeycobe—scientist par excellence.

Hodeycobe collected himself together in surprisingly double quick time. He arose to the emergency in beautiful style. This was probably the American in him. He did not have the slightest idea how this transposition came about. Anyway, that was the least of his troubles now. He must seize the opportunity.

"Brethren, befoah yo' all stands not a miracle, but a fact in flesh an' bone. Men, yo' is sons of the South Seas. Yo' brains and brawn speak fo' yo' 'telligence."

Here he laid his hand tenderly on the shoulder of Princetta, who winced under the touch of her noble ideal. She was proud of him. He stood so high, so noble, and commanded the attention of his hearers. She was indeed happy. She could not understand what it was all about, but nevertheless it mattered not.

"Heah's de anshuh to yo' great chief. Take dis young lady to him and say foah me that 'heah am yo' grandmothuh transfohmed to sweet sixteen.' It's the old lady whut now ain't."

Princetta now found herself carried to the old chief. This worthy gentleman was nonplussed. He gazed at the girl, trying vainly for a resemblance to his grandmother. He was also thinking of the wonderful achievement of this venerable unknown. He actually displayed outward signs of extreme delectation which was certainly unusual. To bring a smile to the countenance of Chief Ungus was a feat long desired by all. He was absolutely and profoundly satisfied.

BILLY EASTON and Carbolic Acid Johnson, since the apparent accomplishment of their companion, were given more freedom. They wandered hither and thither in the village, but always under close surveillance. They had often vainly tried to get in touch with the young Beauty Princetta. But one day they spied her on the hillside gathering

flowers. They noticed too that she cast longing glances toward Hodeycobe's abode, but she dare not go there, as she had been foiled in the attempt several times. It would never do to let her fall in love with a foreigner.

Now two old heads like Billy and Carbolic were not to believe that this young thing had been older than she now stood. Carbolic took it upon himself to get a little information. An idea had already framed itself in his mind.

"You come see great man?" he asked.

Ah! Her eyes brightened. She straightened and drew a deep breath. Carbolic had hit the nail on the head.

"Why?" she asked in English.

Carbolic was so enthused for the moment that he was almost caught off his guard and would have spoken in a louder tone had not his friend stepped in and cautioned him to be very quiet lest they be heard.

"Good," whispered Carbolic. "Can you catchum a boat foah us tonight? If yo' can get us a boat ah will take you to de great man Hodeycobe."

"Hodeycobe," she said softly, and repeated it over and over again.

"Yes, Hodeycobe, de great man who yo' all like so well." This was another chance and it went home well. Carbolic could see it all now.

Without a word she turned and led them down the hillside and into the dense foliage that surrounded the clearings. Hidden under the spreading branches of a tree was her catamaran.

"What foah yo' ask about that boat?" inquired Billy.

"Just follow yo' daddy, kiddo, and trust to luck. I'se got a plan and if I can get back and carry it out befoah dat old chief eat-em-alive takes a notion he wants to be young again, then I'se win, and we go scot free, boy, scot free. We will go theah in the night and we'se gonna kidnap a baby."

"Baby?"

"Zacly, and we'se gonna bring him heah."

DESTROYER No. 1076 was on foreign duty. She had no special assignment, but was moving along under quarter steam more for the purpose of making a breeze to cool the sweating brows of the crew.

In her wireless room sat First Operator Quigley. Quigley had been hearing the most spooklike signals for two nights. They were getting on his mind so much that he dreamed of them. After one more night of the same experiences, Quigley could stand it no longer. He made a bee-line for the commander's room. Knocking on the door he was told in a pleasant voice to "come in."

Commander Jimmy Goldfield was a young fellow, good looking, energetic, and otherwise. If he could smell adven-

KLOSNER VERNIER RHEOSTAT

Patent

Pending



FOR THE MODERN CRITICAL TUBE

The first and only Vernier rheostat made having but
ONE SINGLE KNOB

for both the rough and fine adjustments

SIMPLE QUICK POSITIVE

Highly finished Condensite base and knob. Phosphor bronze contact springs. All metal parts polished nickel plate. Diameter only 2 1/8 inches.

PRICE ONLY \$1.50

Add Shipping weight one pound.

Get it at your dealer or send direct to us. Sold on a satisfaction or money back guarantee.

Dealers-Jobbers-Manufacturers: Write immediately for attractive proposition.

The following progressive dealers and jobbers handle this new instrument:

Atlantic City, N. J. . . . Paramount Radio Supply Co.
Bethlehem, Pa. . . . Lehigh Radio Co.
Chicago, Ill. . . . Chicago Radio Apparatus Co.
Erie, Pa. . . . Electric Equipment Co.
Ft. Worth, Texas. . . . Prof. Oba R. Garrett.
Kansas City, Mo. . . . Western Radio Co.
New York City . . . American Electro Tech. Appl. Co.
. . . . J. F. Arnold.
. . . . Boscon Radio and Electric Co.
. . . . Continental Radio and Elec. Co.

New York City . . . Dreyfus Sales Corp.
. . . . Empire Radio Equip. Co.
. . . . David Killoch Co.
. . . . Shipowners' Radio Service.
Newark, N. J. . . . L. Funke and Co.
Omaha, Neb. . . . Wolfe Electric Co.
Plainfield, N. J. . . . Paul R. Collier.
Port Arthur, Texas. . . . Port Arthur Radio Laboratory.
Sacramento, Calif. . . . J. C. Hobrecht Co.
Seattle, Wash. . . . Northern Radio and Electric Co.

Klossner Improved Apparatus Co.

2404 Cretona Ave., New York, N. Y.

HEARD AT 6ALL, PASADENA, CALIF. DEC. 21 TO JAN. 4.

5ad(cw), 5if, 5mj, 5of, 5za(sp-k-cw), 6ak, 6dd, 6dp, 6ex, 6fh, 6gf, 6gr, 6gx, 6ka(sp-k-cw), 6kl, 6kp, 6kn, 6nq, 6pr, 6qr, 6sj, 6tf, 6to, 6tu, 6tv, 6uo, 6vm(cw), 6vx, 6za, 6zb(cw), 6zu, 6zx, 6zz, 6ab, 6ak, 6au, 6ax, 6aw, 6ad, 6ah, 6af, 6ag, 6agx, 6aif, 6aio, 6aki, 6alw, 6anf, 6anp, 6atq, 6auc, 6awh, 6baq, 6baz, 6bh, 6mf, 6ti, 6tm, 6xm(cw), 6wd(cw), 6amb(cw), 6ayu(cw), 6dtm(cw), 6dva(cw), 6zaq(sp-k-cw), 6zaq.

HEARD AT 6AWT FROM NOV. 28 TO JAN 5

5za-cw (vy qsa 8 ft. fm cans.), 5zx, 6ea, 6eb, 6gf, 6gt, 6gr, 6gt, 6gx, 6ka-sp-k-cw, 6kl, 6kp, (6ky-sp-k-cw), 6mh, 6od, 6oh, 6qr, 6zu, 6zx, 6zz, 6abg, (6abx-sp-k-cw), 6adl, (6ale-cw), 6alu, (6ahp), (6aib), 6aif, 6aio, 6amk, (6xad-cw), 6zal, 6aw, 6ba, 6bh, 6bk, 6br, 6cw, 6fi, 6gl, 6gc, 6gj, (6hf), 6in, 6iw, 6jd, 6jf, 6jw, 6kj, 6ly, 6ml, 6mp, 6nl, (6nn), 6nj, 6xf-cw voice, buzzer, 6ya, 6yg, 6yl, 6zj, 6zt, 6zu, 6zx, 6ax Canadian, 6bd Canadian, 911-400 cycle spk on around 4:45 a.m. Dec. 11. 9dva-cw very qsa 2 ft. fm cans., qra f pac, cl8-cw.

HEARD AND WORKED BY 6ABW AT ROSEVILLE, CALIF.

4id, 4cb, 5ib, 5za, (6ax), (6avd), (6aib), (6aif), (6aau), 6aeh, (6aio), 6agf, 6agp, (6ahp),

(6ajw), (6aki), (6amn), (6acy), (6adl), 6amk, 6aax, (6bm), (6ba), (6bet), 6baz, 6cu, (6dd), 6ea, 6ex, 6eb, 6en, 6fk, (6iv), 6ia, 6jy, (6kc), (6lc), (6mh), 6ot, 6pr, 6qr, (6tu), (6to), 6tv, 6vx, 6vw, 6xad, 6xac, 6ar, 6zam, 6zn, (6br), (6hb), (6bj), (6bk), (6fi), (6gj), (6hf), 6iy, 6im, (6kb), (6lo), (6mf), (6mu), (6jw), (6nn), 6ot, 6mo, 6pm, (6rn), (6tj), (6ty), 6wa, (6xf) cw phone and music, (6zj), 6zu, 6zv, 6zg, 6agf, 6ag, 6cl, 6uj, 6zn, 6ax, 6bd, 6aja, 6air, 6ayu, 6bbf, 6dva, 6dtm, 6yal, 6blo, 6zaq, 6if. Messages handled in last two weeks, 65.

CALLS HEARD AND WORKED BY 7ZT, PORTLAND, ORE.

(Canadian 5ak), (Canadian 5bi), (Canadian 5fe), (6aa), (6cv), 6dd, (6dp), 6ea, 6en, (6ex), (6fh), (6gr), 6gt, (6gz), 6ky, (6hc), 6hp, 6id, 6ia, (6ka), 6kp, (6ky), 6lc, (6mh), (6to), 6tv, 6pr), (6qr), 6qa, 6to, 6tu, (6uo), (6vx), (6wz), 6zm, 6zt, (6zx), (6abw), 6abx, (6acr), (6acx), 6afn, 6afy, (6agf), (6ahp), (6aib), 6aju, 6alr, 6amk, (6anx), (6ark), 6avv, (6bbr), (6bca), (6zal), (6zxm), (6ba), 6bf, (6bh), (6bk), 6bz, 6ed, (6fi), (6ge), (6hf), 6iw, 6iy, 6jf, (6ke), (6kj), (6km), 6ly, (6mf), 6mo, (6mp), 6mu, 6nj, (6nl), (6nu), 6np, (6tj), 6vg, 6vo, (6xz), 6wa, 6wm, (6yw), 6yz, (6yl), 6ys, (6zh), 6zm, (6zp), (6zu), 6nal, (Canadian 9ax), (Canadian 9bd), C. W.—(Canadian 4eb), 6jd, 6jq, (6ka), (6vm), 6aif, (6ale), 6xad, 6zad, (6zo), (6rn),

Tell them that you saw it in RADIO

C. W. IS THE THING

Suggestions for that 5-Watt Set

A-P Inductances

Pattern 10—No. 12 hard-drawn copper wire. Wound on 5-inch grooved Bakelite Tubing, spaced six turns to the inch; copper tabs every two turns.

Price..... **\$4.50**

From your Dealer or Postpaid in U. S. A.

Pattern 5—No. 12 hard-drawn copper wire. Wound on 4-inch grooved Bakelite Tubing, spaced 8 turns to the inch; copper tabs every two turns.

Price..... **\$4.25**

From your Dealer or Postpaid in U. S. A.



A-P Choppers

Mounted on 1-20th horsepower, 110 volt, 60 cycle Westinghouse Induction Motor. Rotors have either 20 or 30 segments, giving 600 or 900 cycle note. State note desired when ordering. Price, in San Francisco..... **\$27.50**

Shipping weight 14 pounds.



Robbins & Meyers Motor Generators

100 watt, 500 volt, D.C.; 110 volt, 60 cycle, A.C. Price, in San Francisco..... **\$74.75**

Shipping weight 100 pounds.



Jewel Instruments

Pattern 64—Thermo-couple Radiation Meters. 0-2 amps..... **\$12.40**

Pattern 34—0-150 milli-amperes, D.C. Price..... **7.10**

Pattern 74—0-15 volts, A.C..... **8.40**

Pattern 34—0-500 volts, D.C..... **14.25**



Heintz & Kohlmoos, Manufacturers, San Francisco, Cal.

Sole distributors for our apparatus: ATLANTIC-PACIFIC RADIO SUPPLIES CO. San Francisco Henry M. Shaw, President Eastern Office: 5 Kirk Place, Newark, N. J.

MOST MILES PER DOLLAR

With **ATLAS CW** Radio Apparatus

Make your money talk to the tune of 15 miles per dollar

Money back guarantee

1000 Miles		\$70.00	
PT-2 CW trans.	\$11.00	Inductance	\$ 8.00
2 tube sockets	2.00	2 tubes	16.00
1 meter	8.00	1 key	1.00
2 variables	10.00	2 fixed cond's	3.00
1 double choke	5.00	2 switches	2.00
2 rheostats	4.00		
	40.00		30.00
			40.00
Total			\$70.00

Send ten cents for complete catalogue

The American Radio Sales and Service Co.

MANSFIELD, OHIO, U. S. A.

Tell them that you saw it in RADIO

ture his nose led him there. After listening to Quigley's short description of the disturbing signals he thought for a few moments.

"Quigley," he said, "can you trace the sounds?"

"I think so, sir. I have rigged up a temporary rangefinder and have determined the general direction."

"What is it?"

"South by east, sir."

"Good. I'll turn the ship over to you. Give orders up the speaking tube to the pilot and he will follow you. There's nothing like getting to the bottom of this, and we haven't anything else to do."

"**S**AY, for the love of Mike, keep that spalpeen quiet," warned Billy to Carabolic Acid, who had a pop-eyed papoose in tow as they stole along toward Hodeycobe's hut. They had been to the neighboring isle and had kidnapped a kid.

They went along quietly until they reached Hodeycobe's hut. There were voices inside. Peeking through they discovered the owners of these voices. One was Chief Ungus. He had come to be made young. They were just in time. The natives were gesturing with Hodeycobe, who was sweating profusely and sparring for time. The chief would not listen to argument and through his interpreter made it known that he wished this parley closed abruptly and action to begin. Hodeycobe was to make him at least forty years younger. If he wished to take off more than forty years that was optional.

Hodeycobe appeared so nervous that he could scarcely stand. He bade the worthy monarch be seated. This gentleman leaned with his head against the back of the hut.

Carabolic Acid, the man that got his name for his ability to drink home made stimulant, raised a heavy club he had found on the beach. It descended against the spot whence the shadow of the chief's head was protruding. Wham! The chief dropped without even so much as a grunt. The mighty stroke was well aimed.

This performance was not noticed by his body guard, who were so engrossed in examining the queer machinery and the thud of the blow was drowned out by the chug-chug of the wheezing gas engine which Hodeycobe had started for the chief's benefit.

Hodeycobe turned to look at the chief, perhaps having some word for him, and to his amazement beheld the pride of the Zoogoos flat on his muscular back.

About the same time an idea popped into his head. Why not serve the chief as he did the old lady? He quickly turned to the body guard and told them that they must now leave, as the chief was in the "sleep of youth as was the old lady." Without a word they filed out.

By this time their respect for Hodeycobe knew no bounds.

Hardly had the last man of the guard made his exit before his two companions jumped into the hut. They secured ropes and worked like mad to bind the chief securely. He was gagged safely, hurried down a path to the beach, and placed in a cave whose entrance was covered so that prying eyes may not see. Cannibals' eyes are infernally sharp, they had learned.

Rushing back to the hut, Carbolic unwrapped the baby from the blankets and took him inside. Hodeycobe then saw the idea for the first time. He was overcome. Tears streamed down his face. He hugged his companions feverishly.

The child, awakened by the commotion, set up a wolf howling chorus compared to which the ordinary wailings of a hungry civilized baby were as a blissful silence. This aroused the entire village, and with cannibal curiosity, they rushed toward Hodeycobe's hut. A fighting mass of humanity struggled to gain entrance that they may see the latest in reducing age.

Their chief had been transformed. There was no doubt of it. Had they not left him there, and now sitting on the very same chair was a strange infant. The seven picked men, body guard of the monarch, picked up the child and bore him to the tribal meeting grounds beneath the shining stars.

The ceremonies were on.

EARLY the next morning, while the feasting was still in progress, destroyer No. 1076 nosed her way in between the coral bars toward Zoogoo. When a mile off shore the crew was very much surprised to see three men rush to the water's edge, plunge in, and make for the ship with a wickedly speedy stroke. They soon covered the distance.

The natives were too overjoyed to pay attention to their escape.

Captain Goldfield stood on the bridge and watched the proceedings through a glass. They had traced the strange sounds to this rendezvous.

Far back on the island Commander Goldfield caught sight of a solitary figure running like the wind and waving a war club. On the face of the figure was a terrible expression. His whole countenance reminded one strangely of first degree murder.

It was King Ungus.

But that which surprised him most was the form of a girl, rushing to the water's edge. She dove into the surf and made for the destroyer. It was Princetta—erstwhile grandmother apparent—rushing to her lover—Hodeycobe Micraferis Brown.

THE END

We don't

only sell complete sets

but

we also carry a complete line of parts

such as—

PEN BRAND
VARIABLE
CONDENSERS

Remler Sockets

**De Forest
Rheostats**

—and every other thing that is required for the construction of a GOOD Radio Set.

We tell you how to construct your apparatus—how to wire it—and give you expert advice on the most suitable equipment for your individual requirements.



This is the NEW Pen Brand 43 Plate Variable Condenser with binding posts and tension screw. Priced at only \$4.75. Inspect it at our store. You will like it.



GENERAL RADIO Rheostats AND OTHERS IN STOCK



All of the GOOD Sockets are sold by us.



**1230 Polk Street
San Francisco**

**GET
ACQUAINTED**

Visit the radio department of this large and well known Electrical Store. You get real service here—the kind of service that's worth a lot to you.

**DROP IN
TODAY**

**Saco Clad Amplifying
Transformer \$5.00**

Amplification without distortion, or inter tube howling is one of the many advantages derived from equipping your Amplifier with Saco Clads. The price at \$5.00 is right.

We carry a complete stock of receiving apparatus and "C. W." parts.

Our station, KVQ, located on the Sacramento Bee, will be in operation about Jan. 10th. Write for Catalog.



Hobrecht's

1014—6th

Sacramento



RHAMSTINE*

INTRODUCES THE ADAPT-O-PHONE

In the most convincing manner the Rhamstine* Adapt-O-Phone fulfills the demand for a satisfactory loud-speaker at a reasonable price. Reference to the cut will show a standard headset held in position against the special manifold by knurled screws—your own receivers are used—readily inserted or removed. One can quickly understand that the sounds from two receivers of matched tone, are more audible than if but one receiver is used. Herein is a valuable feature of the Adapt-O-Phone. Sounds from the two receivers enter the small end of the horn, are rounded out and amplified in clear undistorted tones.

In addition to its being a most satisfactory loud-speaker, the Adapt-O-Phone is a very attractive unit. The horn is metal, black japanned; the manifold casting heavily plated and polished and is equipped with rubber sleeves to protect the receivers. The base is of wood finished in hand-rubbed mahogany. It stands 20 inches high.

Price Without Receivers \$12.00

Add 25c for Postage and Packing; West of Rocky Mts., 40c.

RHAMSTINE* Plug and Jack



Many thousands of the efficient and attractive Rhamstine* Plug and Jack have been sold. The Jack is of the two-circuit type and automatically places the Amplifying Transformer in the circuit upon removal of the Plug. Both the Plug and Jack are nickel plated and polished. Order yours today.

\$1.50 Per pair—Postage 4c

Manufactured by

J. Thos. Rhamstine*

2152 E. Larned Street

Detroit, Michigan

DESCRIPTION OF C. W. TRANSMISSION SET AT 6AWT

For transmitting one 50 watt Radio-tron power tube is used with 750 or 1300

volts, 60 cycle, a. c. on the plate. The filament is run on a. c. through an Acme 150 watt filament transformer. Radiation varies from 2 amps on 750 volts plate to 3.1 amps on 1300 volts. At

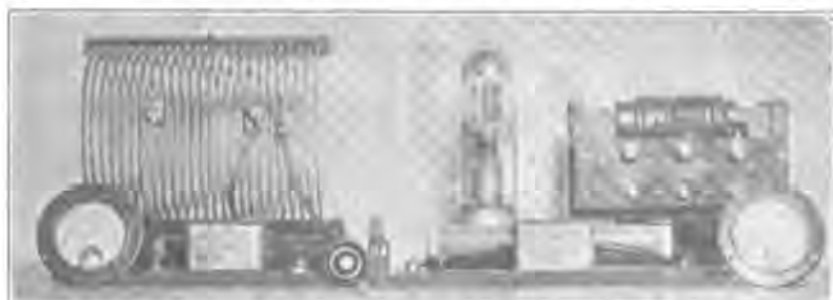

C. W. Transmitting Set at 6AWT

Tell them that you saw it in RADIO

present, due to transformer trouble, the set is run on 750 volts. Radio Corporation apparatus is mostly used. The transmitting aerial is a 4 wire L type, 30 ft. long with a 60 ft. leadin. The aerial is on 16 ft., 10 ft. and 6 ft. spreaders. At the free end it is 60 ft. high. Water pipe system is used for a ground.

The receiving equipment consists of a Grebe CR 8 receiver with a home-made 2 step, using R. C. U. V. 712 transformers. Ordinarily, the first step is used for receiving. A single wire aerial 100 ft. long and 70 ft. high is used.

Until recently a 20 watt C. W. set was used for transmission. With 500 volts d. c. on the plates, the radiation was 1.5 amps. Plate current was furnished by an Esco 125 watt, 500 volts motor generator. For voice, 2 tubes were used as oscillators and 2 as modulator. On voice, radiation was 1 amp. For buzzer and C. W., the four were used as oscillators. C. W. from this set was reported as being received at a distance of 900 miles. Same distance has been easily covered on new C. W. set.

Special Complete Receiving Set



1 pr. Murdock No. 56-2000 ohm phones	\$6.00
100 ft. pure copper aerial wire	.75
2 pr. glass cleat insulators	.10
1 approved ground clamp	.25
1 portable-600 meter receiving set and guaranteed crystal detector	5.00
Total	\$12.50

FOR A SHORT TIME ONLY, \$10.50

We carry a full line of all the best Wireless Apparatus and Parts.

Murdock	Firoo
Acme	Federal
DeForest	Eby
Westinghouse	Brandes
Grebe	Baldwin

SOLID OAK CABINETS

7' x 18'	\$4.00
7' x 12'	\$3.00
7' x 7'	\$2.50

WAXED FINISH

Hinged Cap 50 cents additional

ORDER NOW



DEPT. B-2

BEACON RADIO AND ELECTRIC CO.
246 Greenwich St., New York City.

We Want You

to write us today for full details on our new subscription agency. You can make many extra dollars in your spare time. Write NOW.

RADIO
Pacific Bldg., San Francisco, Cal.

AT LAST!— A Real *DIAL* Rheostat

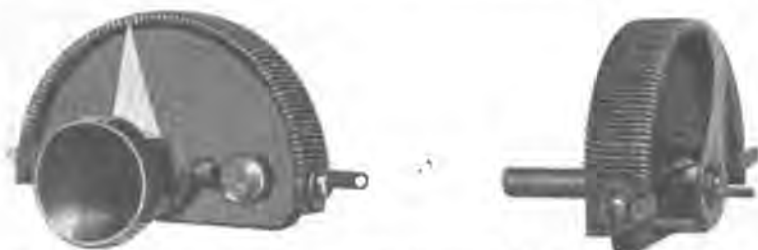

The RADIO SHOP panel mounting rheostat was expressly designed for use with a dial. It has exactly a half turn movement and shuts off filament at zero.

Permits the full range of adjustment to be kept within the scale of dial.

It is sturdily constructed and is the smoothest running filament regulating device ever offered to the field. It will maintain these qualities indefinitely, as it is wound with very large special alloy wire that makes it non-heating when used with standard detector or amplifier tubes. Its resistance is correct to give accurate regulation of potential and will permit of absolutely positive adjustment for maximum sensitiveness.

Only three holes are required for mounting and tinned connection lugs are provided for soldering leads.

The RADIO SHOP half revolution Rheostat postpaid.....\$1.50

(In ordering specify make of dial intended to be used with, also diameter of shaft desired.)

Can also be supplied with knob and pointer as shown, at 25 cents additional.

Dealers and Manufacturers: You can use this Rheostat in your business. Write us if interested.

And Last, But Not Least—Have you ordered your 1922 model of the "RS 1-24" receiver? 100 to 24,000 meters in the one Cabinet, with maximum efficiency on all wavelengths.

THE RADIO SHOP

SAN JOSE

CALIFORNIA

Chelsea Amplifying Transformer No. 50

IMPEDANCE VALUES AT 1000 CYCLES

Primary with Secondary Opening
36,175 ohms

Primary with Secondary Shorted
1,875 ohms

Secondary with Primary Open
1,875,000 ohms

Secondary with Primary Shorted
55,000 ohms



No. 50 Amplifier

AN INSTRUMENT THAT WILL
MAKE YOU PROUD OF YOUR
RADIO STATION

Price as shown, \$4.50; unmounted, \$3.75

Purchase from your dealer
Bulletins sent upon request

Chelsea Radio Co.

150-156 Fifth St.

Chelsea, Mass.



The Bakelite Molded Remler Variometer
Free with 3 Subscriptions

Save
The Most
Offer Ever
the History

Think This Over:

You want the best that money can buy when it comes to purchasing radio apparatus, in order to get maximum results. You also want to read the best publication in print when it comes to radio literature. But these cost money, and here is a plan for getting both at the cost of one.

You should read every word of this advertisement carefully in order to realize its importance—its plan for saving you many dollars in your radio purchases and the remarkable assistance it renders you in getting what you want—at half the regular price.

You can have one of the following

premiums FREE for securing three subscriptions to RADIO: Remler Type 500 Bakelite Molded Variometer; Remler Type 504 Bakelite Molded Variocoupler; Remler Honeycomb Coil Mounting; Pen Brand 43-plate Variable Condenser; Pen Brand 23-plate Variable Condenser.

And all of the above instruments are the very latest in radio perfection. The Remler products are well known and need no introduction. The Pen Brand Variable Condenser is the last word in construction, permanence and beauty. You will be proud to have these instruments in your station.

Subscribe for One Year and Get These

Perhaps it will be difficult—or impossible—for you to secure three subscriptions to RADIO. You may want to subscribe in your own behalf for one year, and we are going to give you choice of one of the following premiums with your own subscription:

Remler 3-inch Bakelite Dial and Knob; Remler Polished Bakelite V.T. Socket; Remler Filament Rheostat;

Pen Brand Grid Condenser; Remler QSA Coil, up to 100 turns; Latest License Quiz Book; Remler Variable Grid Leak; Remler Switch, Knob and Blade.

Some of these premiums retail at \$1.50. Imagine the saving! You get as much as \$3.50 worth of radio usefulness for \$2.00. Isn't this worth while?

SEND \$2.00 FOR YOUR SUBSCRIPTION AND 12c FOR MAILING THE PREMIUM

The Latest Pen Brand VERNIER VARIABLE CONDENSER
FREE WITH TWO SUBSCRIPTIONS
Ideal for C. W. Tuning. Mailing Charges, 15c.

Tell them that you saw it in RADIO

50%
Liberal
Made in
of Radio

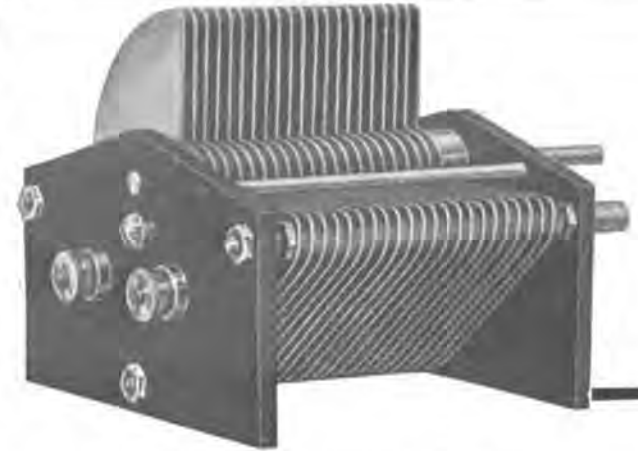

Very Latest Pen Brand Variable Condenser
Free with 3 Subscriptions



TUBES

FREE

Send us three one-year subscriptions to RADIO and you can have one of the following tubes as a premium:

- A.P. Electron Relay Detector Tube.
- A.P. V.T. Amplifier Oscillator Tube.
- Cunningham C-300 Detector Tube.
- Cunningham C-301 Amplifier Tube.

It seems too good to be true, when we tell you that you get a tube that sells for \$6.50 FREE with three subscriptions; but our guarantee protects you. Send \$6.00 for the three subscriptions and 25c for mailing the tube. Surely a remarkable offer. \$12.50 worth of radio usefulness for \$6.25.

POSITIVE

- 1—We positively guarantee all premiums to be exactly as represented.
- 2—Premiums are genuine in every respect, standard and tested.
- 3—All premiums are NEW. No second-hand or rejected apparatus of any kind.
- 4—Premiums are shipped to you directly from the manufacturers in San Francisco.
- 5—Each instrument is thoroughly tested before leaving the plant.

WITH SUCH A SWEEPING GUAR-

GUARANTEE

- 6—Premiums will be shipped by Parcel Post and Vacuum Tubes will be insured.
 - 7—Safe delivery assured. We will replace, free of charge, any premium damaged in transit.
 - 8—Vacuum Tubes are guaranteed to be standard, approved and given the regulation test by the manufacturer before shipment.
 - 9—All orders will be filled without delay.
- ANTEE YOU CAN'T GO WRONG**

You Can't Lose

There are no strings of any kind attached to this remarkable offer. When we tell you that you get a RADIO instrument that sells for \$6.50 FREE with three one-year subscriptions to RADIO, we mean every word we say. You will wonder how we can give you a \$6.50 premium with \$6.00 worth of subscriptions. RIDICULOUS, you will say—but we want you to know that this is a big circulation boosting drive, and we want every reader of RADIO to realize that this offer

means a saving of many dollars to him. We are sacrificing a great deal in order to boost our circulation by many thousands. This offer won't last long, so get busy right now and scout up a few subscriptions. You can send a subscription to your friend—with your compliments. You can get your radio club members to subscribe. There are dozens of radio bugs in your vicinity who should read RADIO.

RADIO speaks for itself as a magazine. This February number is typical of what will be published each month during the year to come. Judging from the past year, next year's issues will be even bigger and better than this. Nowhere can you get more reliable data, better practical articles, or more dependable technical information on what you want to know. Why take the chance of not getting it at the news stand, when a personal subscription will insure your advancement in radio knowledge?

COUPON

RADIO, Pacific Bldg., San Francisco.

Send RADIO for one year to the following:

Name Address

Name Address

Name Address

Enclosed is \$..... for the premium andc for mailing charges.

Premium desired

Send Premium to

Tell them that you saw it in RADIO

Acme

C·W·APPARATUS

Has Stood the Test of Time

EFFICIENT
DURABLE

ATTRACTIVE
CONVENIENT

The First C. W. Apparatus on the Market. Ask Your Dealer, or Us, for
ACME CATALOG describing

C. W. Power Transformers
C. W. Filament Transformers
Modulation Transformers
Choke Coils
C. W. Inductances

Amplifying Transformers
Amplifiers
Detectors
Spark Transformers
Anti-Light Blinkers

ACME APPARATUS CO.

182 MASSACHUSETTS AVENUE
CAMBRIDGE, 39, MASS.

NEW YORK SALES OFFICE : 1270 BROADWAY

Transformers and Radio Engineers and Manufacturers



Amplifying Transformer



C. W. Power Transformer

DO YOU HAVE TO BE SHOWN?

That "Missouri" Service is of the better kind. Real Service. That we actually ship orders a few hours after we receive them, that we have a large and very complete stock of all standard apparatus and parts from which we fill your order, on hand at all times. Therefore "Missouri" is ready to show you. Send us a trial order.

REGENERATIVE RECEIVERS

No. CR-3 Grebe 175-680 Meters Relay Special	\$65.00
No. CR-5 Grebe 175-3,000 Meter Ideal Receiver	80.00
No. CR-8 Grebe 175-1,000 Meters with Tube Control	80.00
No. CR-9 Grebe 175-3,000 Meters with Det. & 2 Stage Amp.	130.00
No. CR-6 Grebe 175-680 Meters with Det. & 2 Stage Amp.	160.00
No. ZRF Clapp-Eastham	38.00
No. RA Westinghouse	65.00

TELEPHONES

No. 56 Murdock 2,000 OHM	5.00
No. 56 Murdock 3,000 OHM	6.00
No. C Baldwins	12.00
No. E Baldwins	13.00
No. F Baldwins	14.00
No. Brandes Superior	8.00

C. W. INDUCTANCES

No. 181 Tuska Cap. Feedback	7.50
No. 182 Tuska Split Filament	10.00
No. 183 Tuska Grid-Tickler	12.50

FILTERS

No. 170 Tuska	16.00
No. UP-1626 Radio Corp.	11.50

HOT WIRE METERS

No. 127 Gen. Radio 1-5-10 Amps	\$7.75
No. 25 Jewel 0-10 Amps	15.00

FIBCO APPARATUS

Saco-Clad Amp. Transformer	5.00
V. T. Sockets Single	1.10
V. T. Sockets Double	2.30
V. T. Sockets Triple	3.50
Vocaloud Stationtype	30.00
Vocaloud Laboratory	25.00
Miget Tuner	15.00
Miget V. T. Control	11.00
Tuner Det. & 2 Stage Amp.	56.00
Bull Dog Plug Flat	2.00
Bull Dog Plug Round	2.50

RHEOSTATS

No. 813 Remler 8 Amp	1.75
No. 810 Remler 4 Ohm	1.00
No. 560 Murdock	1.00
No. 214 Gen. Radio	2.50
No. 25 Paragon	1.50

ROTARY GAPS

No. 443 Murdock	18.50
No. Benwood Bakelite	22.00
No. Benwood Sink With Motor	60.00

"B" BATTERIES

No. 763 Eveready	2.00
No. 766 Eveready	3.00

VACUUM TUBES

No. UV-200 Radiotrons Det.	\$5.00
No. UV-201 Radiotrons Amplifier	6.50
No. UV-202 Radiotrons 5 Watt	8.00
No. UV-203 Radiotrons 50 Watt	30.00
No. UV-204 Radiotrons 250 Watt	110.00

Send us your orders for Radiotrons—our stock is complete.

AMPLIFYING TRANSFORMERS

No. UV-712 Radio Corp.	7.00
No. AMRAD	4.50
No. QO Clapp-Eastham	4.00
No. A-2 Acme	5.00
No. 226W Federal	7.50

INSULATORS AND WIRE

No. 498 Electrode Ball Type	.40
No. 449 Electrode 5-inch	.50
No. 497 Electrode 10-inch	1.00
No. 262 Electrode Leadin	1.25
No. 264 Electrode Leadin	2.50

BRAIDED AEROPLANE ANTENNA

Wire	75c per 100 feet
Bare Copper 80 ft. to the pound	40c per lb.

VT. DETECTORS

No. Y-1 Acme	10.00
No. RORA Grebe Cabinet	8.50

We have a complete stock of standard apparatus. If there is anything that you can not find in the above list just send your order for it at the regular list price and it will be shipped at once to you.

SEND YOUR ORDER IN NOW!

Your Order Will Receive Our Prompt, Careful and Appreciative Attention

Our Motto

WE GIVE ALL WE CAN FOR WHAT WE GET
Instead—OF GETTING ALL WE CAN FOR WHAT WE GIVE

MISSOURI RADIO SUPPLY COMPANY

4623 Maryland Avenue

Dept. G

St. Louis, U. S. A.

NOGO EMITS SOME SHARP BATTLE-WHOOPS

(Translated from the Walsirwinese by David P. Gibbons.)

To Editor RADIO (which sheds free spark-light on Pacific at very nominal cost-price).

DEAREST SIR:—

A few days past ago my Cousin Scratchi returned himself here from sea trip to borderland of hot tamale Mexican country, which are now nearly altogether at peace, account of jazzing of business by bootleg magnets and race-trakkers.

"How are all the little things?" I slang him, after the customer salute.

"You try and see," respond Cousin Scratchi with rye smile, making sleight fishout from stern pocket, "dispenser who sell me this say it has been proved most highly."

"No more proof needed," I refuse thankfully in Volsteady tone of voice, "I appreciate to know what you learned, if any such, about wireless situations while ocean voyaging."

"Oh! quite much indeed," snagger Scratchi; "I have listened tightly to the commercial amateurs on two hundred and thereabove, and the amateur commercials with nervous key-fingers, and also I too discovered out a small few of honorable operators who give thoughtful care to gentlemen at other end."

"But do not all coasty stations of glorious navy behave in suchlike manner?" I rogate.

"I should kiss a submarine!" yip Scratchi with pantagey crackle, "hardly ever so if not at all. Commercial and navy business never mingle up with delicious result and should be separated strongly apart like Sinn Feiners and tan-black Limeys. Also I sniggest that Hon. Harding express free pardon to all nov serving term at those station and furnish up newcomers with correspondence diploma in wireless etiquette or so."

"Where can such most rare teaching be hunted out?" I deploy.

"Teaching of it not rare," Scratchi vibrate sharply, "but practice are. With diaframs to eat operator can obtain many cost-free lessons when KPH are extracting from the ether messages, positions, services and whichnot in steady streams."

"Are he the only one who so do?" I rasp ruffly.

"Oh! indeed no," oscillate Scratchi with disarmament expression, "but he protrudes out like bandaged-up thumb-finger."

"And our fellow-banzais from away-far ancestor land, do they not observe the strictly rules?" I peruse hopefully.

"Truly so," Scratchi make comeback, "since Nippon from here are quite long-ish distance all marus keep nose brightly polished when approaching prohibition limits. Their departure on side of

Continued on page 76

SPIDER WEBS



Cut Shows Front Panel Removed

EXCLUSIVE WESTINGHOUSE AGENTS FOR OUR TERRITORY

WONDERFUL REGENERATIVE SIGNALS

NO MAGNETIC LEAKAGE

\$5.50

Plus 30 cents Postage

New Duplex 1000 Meter Set on Hand

HERROLD LABORATORIES

"Everything for the Amateur"

467 South First Street

San Jose, Calif.

CLASSIFIED ADVERTISING

Advertisements in this section are three cents per word net. Remittances, in the form of currency, money order or stamps, must accompany order.

For Sale—7KR's Navy Standard Receiver \$175 shown in May Radio News. S&R Navy coupler 3800 meters \$11.00, both perfect condition, 528 Market, Portland, Ore.

Vartcoupler, new, completely mounted. Tunes to 800 meters. \$5.50 M. O.—P. P. W. J. Williams, 1118 Sibley St., N. W., Grand Rapids, Michigan.

Trade 25 in. orchestra drum and 13 in. cymbals for two stage amplifier. 475 32nd Ave., San Francisco.

Bargains—Navy Type Coupler 200-3500 meters, Meteor make—reliable, \$10. Murdock 3000 ohm tones, \$4. Electric Fan, one motor 110 volt, \$8. All good shape. Write: Wireless Operator, 919 N. Lawrence, Tacoma, Washington.

Short wave REGENERATIVE RECEIVER, \$20. Detector-2 step amplifier, \$16. Highest grade apparatus. Ralph Haynes, 1236 American Ave., Long Beach, Calif.

For Sale or Exchange—DeForest R. 8. 200 8 Honeycomb coil receiver, tunes from 100 to 25,000 Meters; 2 B. Batteries, \$35. Cash or what I need a short wave receiver. Hyman, 1708 W. 23rd St., Los Angeles, Calif.

Variometers. Hard Maple. Equal to any at any price. Improved design. Money-back guarantee. \$4 postpaid. Rhamstine Sockets, best looking and working socket on the market. \$1 postpaid. LONG RADIO WORKS, Cornelius, Oregon.

ALMOST NEW. 500 Volt, 0-13 AMP. D. C. Generator. Operates at 3400 RPM and requires one ampers at 6 volts for the field. Made by Heints Co. of San Francisco. Just what you need for your C. W. set. Sell for \$25.00. F. O. B. Los Angeles. Write J. B. Dow, care of "Radio," Pacific Bldg., San Francisco.

8ZE Synchronous spark set for sale, consisting of one 45,000 sec. 110 primary United "coffin" transformer, 2KW capacity; one specially made up synchronous gap, using 8 studs at 1800 RPM on 10 in. disk, driven by eight H. P. Crocker-Wheeler synchronous motor, 110 volts 60 cycles, and two special type Dubilier .004 mfd (each) condenser units 45,000 volts. Prices—Transformer, \$65.00; Gap, \$65.00 (new condition); condensers, \$25.00 per section. Sell whole for \$165.00. Terms cash. D. B. McGown, 1247 47th Avenue, San Francisco, Cal.

Ya-Bol Grid condensers, made of excellent material. Only 25c. L. F. Seefred, 343 So. Fremont Ave., Los Angeles, Calif.

BEKUMA YELSBUG—TWO HUNDRED beginners tell how memorized wireless code in thirty minutes to two hours. Booklet, 10 red stamps. Dodge. Box 220, Msmaroneck, N. Y.

RADIO CABINETS—Mahogany or oak finished or unfinished, to your design. Send rough sketch for quotation. Prompt service. Formica cut to size. Radio supplies, parts, etc. Pacific Radio Exchange, 439 Call Bld., San Francisco, Calif.

For Sale—2 K. W. 120 cycle panel type quenched spark transmitter equipped with Kilbourne & Clark gap. Complete with generator; works from D.C. mains. \$250.00. H. P. Sheard, Elk, Wyoming, 72E.

For Sale—Edison Storage Battery, 6 volt 112 amperehour. Good condition. Sell for \$50.00. Sherwood, care Shipowners Radio, 24 California Street, San Francisco.

RECEIVING APPARATA MADE TO ORDER. RADIOMART COMPANY, 1236 American Ave., Long Beach, Calif.

For Sale—Radio Shop R S 1-24 tuner and Proudfoot detector and two stage amplifier for \$120.00. For further particulars send stamped envelope to Robert Browne S. 6, Radio School, Presidio, San Francisco, Calif.

QST de 8VH—One rotary gap for sale. Motor, slow starting 1800 r.p.m., rotary 6 in. in diameter, 18 spark through studs, wooden housing to muffle noise. \$10.00 complete. 1 leyden jar, \$2.00. Want two sections Murdock transmitting condenser and large O. T. H. J. McCoy, 1305 Arch Street, Berkeley, Calif.

THE BEST HONEYCOOMB COILS AT REDUCED PRICES! FRESH STOCK. 25, 50 or 100 turns, 40c; 250 turns, 70c; 500 turns, 90c; 750 turns, \$1.25; 1000 turns, \$1.50; 1200 turns, \$1.85; 1500 turns, \$2.30. MOUNTED, \$1.00 extra. Cotton covered enameled wire, sizes 22, 24, 26, and 28, \$1.50 per pound. Cardboard tubing, three and four inches diameter, 25c a foot. RADIOMART COMPANY, 1236 American Ave., Long Beach, Calif.

Andion Renewals—Any type single stem, tungsten filament detectors repaired for \$2.75; amplifiers as above, \$3; 5 watt power tubes, \$4; VT-1 oxide filaments and to use 20-35 volts "B", \$8.50. Terms cash, or C.O.D. plus charges. Trimount Laboratory, Milford, Mass.

TELEGRAPHY (Morse and Wireless) and Railway Accounting taught thoroughly; big salaries; great opportunities. Oldest, largest school. All expenses low—can earn large part. Catalogue free. DODGE'S INSTITUTE, Haas St., Valparaiso, Indiana.

Tell them that you saw it in RADIO

ANNOUNCEMENT

Our new catalogue No. 22 is just off the press.

Write for your copy today. The supply is limited, so *do it now!*

SERVICE RADIO EQUIPMENT

403 Madison Ave. Toledo, Ohio

SCOPES • DETECTAGRAPH
Detectagraph
AMPLIFYING • RECORDING

AMPLIFY YOUR RADIO SIGNALS WITH Practical Instruments for Commercial and Scientific Purposes

Super-Sensitive Detectagraph Transmitter No. 2, Price \$8.00 complete.

Adjusted Model No. 60 Horn, High Grade Loud Talking Receiver, Cord Plugs and Desk Stand Base, Price \$15.00 complete.

Our New Special Loud Talking Receiver No. 25, Price \$7.50.

Detectagraph Rheostat, especially made for amplifying circuits, Price \$2.00 complete.

Write for our free descriptive new catalog showing our complete Super-Sensitive Hearing and Talking Devices.

G. BOISSONNAULT COMPANY (Inc.)
25 Day St., New York City
Factory: Whitestone, L. I.

You Should See

RADIO TOPICS

In its new Rotograve form

It is the most attractive and interesting Radio Magazine that you have ever seen.

The November number is published in this new modern Artgrave style.

Send 15 cents for a Sample copy.



RADIO TOPICS

4533 N. Sawyer Ave., Chicago, Ill.

STOP! LOOK! and ACT!

V. T.'s AND ACCESSORIES

With each of the listed tubes—Radiotron U.V. 200, \$5.00, and A. P. Moorhead Detector, \$5.00; Radiotron U.V. 201, \$6.50 and A. P. Moorhead Amplifiers, \$6.50—we will supply free of charge your choice of either of these four premiums: Latest Fada Rheostat, \$1.00, No. 810 Remler Bakelite smooth-running Rheostat \$1.00, R. C. of Am. Porcelain V.T. Socket \$1.00, or Murdock V.T. Socket, improved contact type. Either of the Federal single, closed or double circuit jacks, listed respectively at \$0.70, \$0.85 and \$1.00, will be given as premiums with each R. C. of Am. Amplifying Transformer U.V. 712, \$7.00. Fada 5 ampere Nichrome Power Rheostats \$1.35, or R. C. of Am. Porcelain V.T. Socket, supplied free of charge with each \$8.00 U.V. 202 5-watt Radiotron Power Tube for C.W. or Radiophone Transmission. We absolutely guarantee the foregoing apparatus. Only new and high-grade equipment carried in stock. Unsatisfactory goods returned within five days replaced at once. All orders are filled within twelve hours and shipped post paid and insured, thereby saving time and money.

Remember us

The Kehler Radio Laboratories

Dept. P, Abilene, Kansas

Pacific which they own excludedly, however, are horse of different hue."

"Who own ocean hence southly?" I require.

"Harvard and Yale own each one-half," snip Scratchi, "KPH own the other two-third and KFS have strong option on half per cent of what are left."

"How then," I pose with Einstein quirk, "do other stations enter in?"

"Feebly, whenever," buzzes Scratchi, "exceptly during time-sparks and press-hours."

"Then they make press-catching more highly difficult then before?" I moan.

"Some presses might be," rap Scratchi, "but NPG'S spark-press not whatever, because cannot. Operator who do so have devised up very private spacing system which he tick forth with one eye on key-hand and other opticle on clock-hand. Result are very ruinous."

"Who grab up such stutter?" I tap in.

"Only ships which can also purchase hometown daily papers," Scratchi transforms me, "like Admiral Liners, which are painted nice greenish color for easy reference."

"Ships of much courtesy these," I interog with know-something air.

"Oh! indeed yes," rotates he, "and supplied up with most careful-driving skippers,—never guilty of such cheap rudeness as to pass anything while voyaging, unless mightbe a lumbering schooner which are loggerhead with seedy millers and must not arrive before very overdue."

"Do they not also contain operators of high calibrations?" I make connection.

"Who can tell so?" insert my cousin.

"Quite smallish portion of the twelve daily watch-hours are now devote to radio-working, since operator are also expense-biller, freight-chigger and combined purse-clerk under new American style wage-plant."

"Did you receive in any telephone voice-speech while passing from hither to yon and back again?" I resist.

"At all times," Scratchi condenses, "I hear the sweetish voice of Miss Avalon with very central modulations, and enjoy much rich conversations of movie vampers, both he and she. I also joyly raise up Mr. Fairmount speaking, gentleman of graceful impersonality, who donate humerus vocal puff-up to himself and store people while interrupted with classy musical bands and jonmacormix."

"Do you wish to make another such trip-around?" I demand.

"Very soonly," flash Cousin Scratchi. "Hon. dispenser gentleman have biggish shipment coming along and I desire to enjoy fresh supply."

I thank him fluidly and expand to him going-away greets and goodluck wishings.

Same to you, dear Mr. Editor, from
Yours very statically,

HILOLI NOGO.



HERE Is Just What You Have Been Looking For

A real Audion Detector—one that can be attached to your panel in a few minutes. Only two screw holes in panel, both of which are covered when a dial is used on the rheostat, eliminating all unsightly screws.

This new Detector unit occupies less panel space than any other instrument combination on the market, and yet it is absolutely complete.

The instrument assembly consists of an improved type filament rheostat, V.T. socket, mica grid condenser and mica by-pass condenser—all that is needed for a first-class Audion Detector. All of these instruments—each a complete replaceable unit—are assembled on a heavy stamped brass supporting frame, and this frame securely attached to your panel by the two screws above mentioned completes the job. It can be wired into your panel in a jiffy.

Can you imagine anything more complete or compact? Think of it—you can own one of these high grade Detector units for only

\$5.00

This price is only made possible by improved and standardized designs and large quantity production. Each and every piece of this new Detector unit is manufactured in our own factory—the most modern Radio Manufacturing Plant on the Pacific Coast.

Little details are very carefully taken care of in every piece of this Detector unit, the same as is characteristic with all "wireless shop" products. Only the best of materials are used throughout and the unit is fully guaranteed.

This new unit construction is also built into an amplifier which is identical in every respect to the Detector, except that a high-grade amplifying transformer is mounted on the socket base just back of the socket shell. The amplifier unit occupies the same panel space as the Detector unit, and all mounting holes in the panel are the same.

Each unit takes up only 2½ inches of panel space, lengthwise. This means you can get your set into an extremely small space without sacrificing anything. **LOOK AT THESE PANEL SIZES**, which are for sets using "wireless shop units."

Detector	3½" x 6"	Detector and Two Step.....	6" x 9"
Detector and One Step.....	6" x 6"	Detector and Three Step.....	6" x 12"

THE AMPLIFIER UNIT SELLS FOR \$11.00, complete with TRANSFORMER.

This means **YOU CAN BUILD A DETECTOR AND TWO STEP AMPLIFIER FOR \$27.00**, plus the cost of your front panel and case. **AND REMEMBER—IT'S AS GOOD AS THE BEST.**

We can also furnish the front Formica panel, drilled and engraved, for mounting these units, complete with binding posts and special Gorton engraved dial for the rheostat control, as follows:

Panel for Detector only, with Binding Posts and Dial.....	\$ 4.00
Above Panel, fitted with 2-Circuit Jack for Phones.....	5.00
Panel for Detector and One Step Amplifier, with Dial and Jacks	8.00
Panel for Detector and Two Step Amplifier, with Dials and Jacks	11.50
Panel for Detector and Three Step Amplifier, with Dials and Jacks	14.00

These units are all complete, but unwired. Wiring diagram will be furnished with all sets, free of charge. Wire them yourself, and save what any manufacturer would have to charge you for this work. This saving will just about buy your bulbs for the set. Isn't that worth thinking about?

These units are now ready for immediate delivery, but as the demand will be great you should place your order at once. Shipping weight of the Detector unit is one pound and of the Amplifier unit is two pounds. Postal charges and insurance should be included in your remittance.

AND REMEMBER—QUALITY WILL ALWAYS PREDOMINATE WITH

THE WIRELESS SHOP

A. J. EDGCOMB

1262 West Second Street

Los Angeles, Cal.

Tell them that you saw it in RADIO

Honolulu comes to Continental

From far-off Honolulu they send to Continental for prompt, accurate attention to mail orders.

This letter speaks for itself.

You who live much nearer,

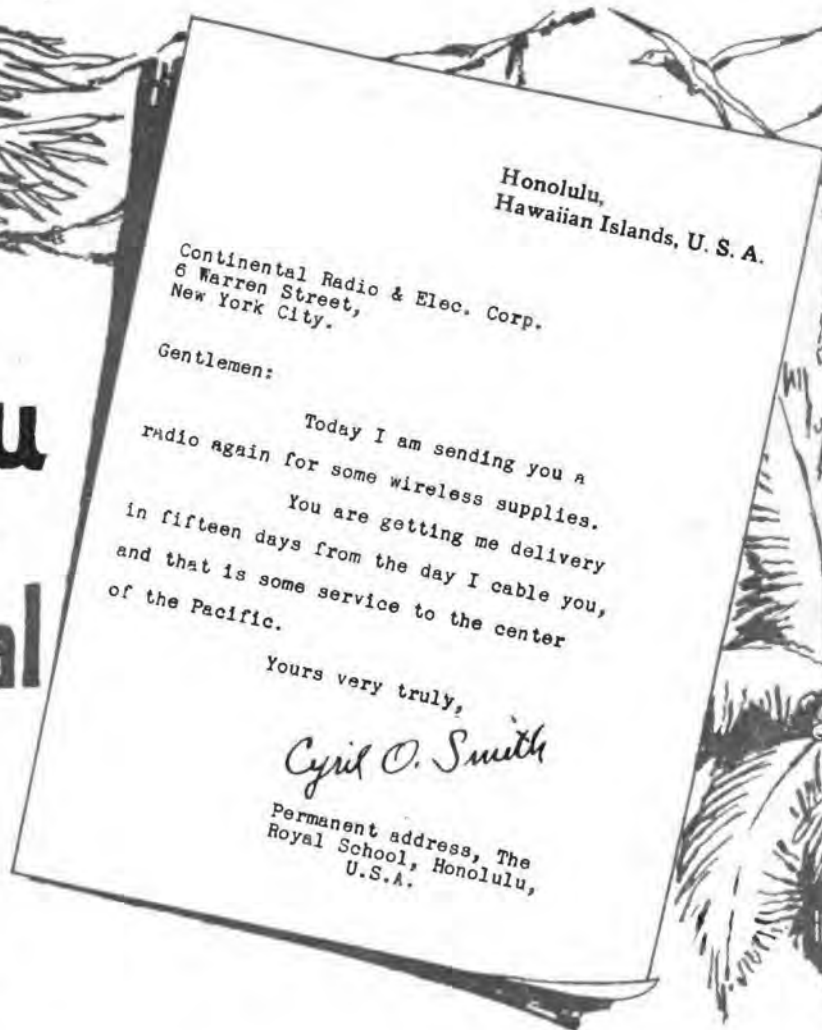

Have You Tried Continental Service?



Send for free leaflets describing Paragon R. A Ten, and the Creco Transformer. Creco 112-page catalog, 25 cents.



HE Wireless Telephone broadcasting is bringing the wonders of wireless daily into thousands of homes that never dreamed of having a radio set before, as well as to advanced amateurs.

We are prepared to supply complete Wireless Telephone receiving outfits as low as \$15.00! And of course we guarantee "Continental Service" to the purchaser to see that he gets perfect satisfaction.

Our comprehensive assortments include: The Marvel Set, \$15.00 complete; the Aeriola Jr. \$25.00; the DeForest Every-man Receiver \$25.00; the Westinghouse R. A. set, \$68.00; the Westinghouse R. C. set, \$130.00; the Paragon R. A. 10 receiver—unexcelled for C. W. reception, \$69.50; and the new Grebe CR9, \$130.00. Orders by mail for any of these sets filled immediately.

CONTINENTAL Radio & Electric Corp.

DEPT. G2

6 WARREN STREET

NEW YORK

ASSEMBLED-BUT NOT WIRED

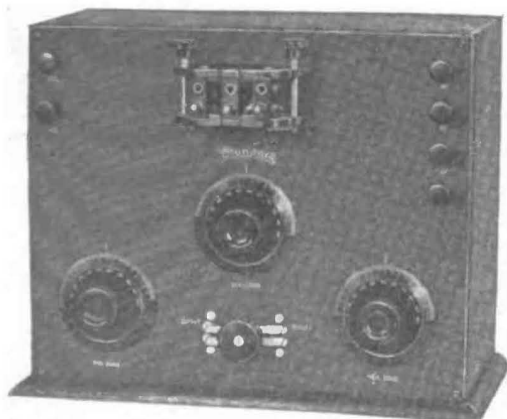

Multiple Wave Tuner—Here you obtain in a single instrument the equipment to receive all classes of signals on all known wave-lengths,—150 to 25,000 meters. It responds to both damped and undamped waves, and is equally efficient for both wireless telephone and telegraph. Minimum number of controls provide extreme simplicity of operation, yet the design renders the tuning especially sensitive and selective. Equipped with DeForest triple-coil mounting and Chelsea condensers. Enclosed in handsome oak cabinet.

Price, completely assembled, F.O.B. New York, \$45.00

Set of 18 DL Coils, to receive all the most used wave-lengths, \$40.00.

Complete set of parts, ready for assembly, \$39.65.

With the addition of a Crystal Detector, the "Standard" Audion tube control for \$12.50, or the Detector and two-step described below, you have a complete receiving station, lacking nothing in range or efficiency.

WIRE YOUR OWN—SAVE MONEY

"Standard" radio instruments—*assembled, but not wired*—solve your problem of getting commercial grade apparatus at prices but little more than the cost of the parts. Here, briefly, is the "Standard" plan:

There are two distinct parts in building complete radio instruments: the actual panel drilling, mounting, etc., which is essentially machine work; and the wiring, which is hand work.

The Standard Assembling Company buys the parts at wholesale prices, and does all the assembling work with the proper machine equipment. This, of course, requires a well-equipped machine shop, not available to the average amateur, and produces a quality of work you could not possibly duplicate.

But the wiring is hand work, and *you* can do it as well as it can be done at the factory. And because it is hand work, it is the most expensive part of the assembly. So right here is where you save the biggest part of the expense. Besides, you probably have your own ideas about wiring.

By buying "Standard" instruments you get the appearance and results of high-grade, correctly assembled apparatus, and at the same time you save all the expensive wiring costs. Only in this way can you secure the combination of machine work where it is necessary, and a price that is only slightly more than a miscellaneous group of parts would cost you. The two instruments shown on this page are excellent examples of the "Standard" plan. Where else could you ever hope to get such handsome, efficient instruments for the prices quoted?

Either of these instruments will be shipped to any part of the United States on receipt of one-third the purchase price. Examine it carefully. Then if you are fully satisfied that it is the best radio purchase you ever made, remit the balance. Otherwise, simply return the instrument and we will refund your money, less carrying charges. Could we make any fairer offer? Then

Take this Opportunity to try the "Standard" Plan at Our Risk.

Detector and Two-Step Amplifier—Your choice of two types, Commercial or Amateur. The commercial type is assembled from the most costly, efficient units available. Radio Corporation UV-712 transformers and General Radio tube receptacles typify the quality thruout. The Amateur type is an exact duplicate, except that transformers and sockets of high efficiency, but lower cost, are used.

Prices, F.O.B. New York:

Commercial type, unwired.....\$55.00

Amateur type, unwired..... 47.00

Here is clear saving of \$10.00 in either case, thru the "Standard" Plan.

Also offered, fully wired, ready-to-operate, at

Commercial type, wired.....\$65.00

Amateur type, wired..... 57.00

Complete set of parts, ready for assembly:

Commercial type.....\$42.00

Amateur type..... 35.00

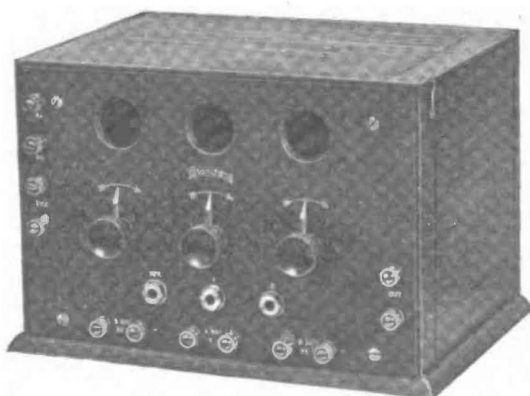

Send 2c stamp for literature describing the complete line of Standard instruments.

STANDARD ASSEMBLING COMPANY

19 Bridge Street, Dept. A, New York

Duplicate the Set Heard Across the Atlantic

Amateur history was made on December 9, when 1-BCG in Greenwich, Conn., was heard in Ardrossan, Scotland—a distance of over 3500 miles.

This amazing feat was performed with four Radiotrons UV-204—one used as a master oscillator, the other three as amplifiers.

There was nothing special about 1-BCG's equipment. His circuit was similar to those described and illustrated in the RCA Catalogue for CW transmission.

You can duplicate the equipment used at 1-BCG for experimental communications at a comparatively small expense.

Look over the RCA Catalogue and Instruction Book. Select the set most suitable for your needs, and then order the required parts from your nearest dealer.



100 Watt Radio Telephone Transmitter

Microphone and Stand.....	\$15.00	Transmitter Grid Leak UP-1718 ..	\$ 1.65	Kenotron Rectifier Tubes UV-217(2)	\$53.00
Jack (\$1), Plug (\$2), Cord (\$1.50) ..	4.50	Transmitter Condensers UC-1015 ..	5.40	Filter Condensers (5) UC-1635	10.00
Oscillation Transformer UL-1008 ..	11.00	Transmitter Condensers (2) UC-1014 ..	4.00	Power Transformer UP-1016	38.50
Magnetic Modulator UT-1367	17.00	Filter Reactor UP-1627	15.75	Incidentals	12.95
Antenna Ammeter UM-533	6.25	Radio Frequency Choke	2.00		
Sending Key UQ-809	3.00	Radiotron Power Tubes UV-203 (2) ..	60.00		
				Approximate total	\$260.00

For complete circuit and details of necessary apparatus to make up this radio telephone set see Fig. 1, page 11, RCA Catalogue, which can be secured from your nearest dealer or by sending 25 cents direct to

SALES DIVISION, Suite 1804

Radio  **Corporation**
of America

233 Broadway, New York City

"I've got it"

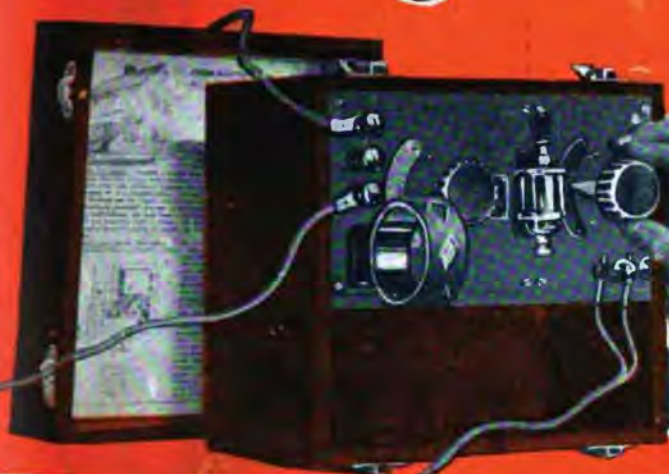

de Forest *Everyman* Radiophone Receiver

The de Forest "Everyman" is the ideal receiving set for homes and for amateur stations for receiving radio music and radio news and for hearing ship and broadcasting stations. Neat, compact, portable, and easily adjusted. To pick up high-power stations simply add inexpensive duolateral coils. "Everyman" set, cased in a handsome walnut finished cabinet with carrying handle, includes enclosed crystal detector, highly selected tuner, telephone set, and duolateral coil plug. The few necessary instructions for operating mounted inside the cover of each set—see photograph above. Price, f.o.b. San Francisco, \$26.50. Ask your dealer for this set by name—the de Forest "Everyman" Radiophone Receiver. If he does not have it, write us direct.

The prices on many de Forest parts have recently been substantially reduced. The popular de Forest reversible filament Rheostat, F-500, has been reduced to \$1.20, the de Forest moulded tube receptacle, R-500, cut to \$1.10. Other new prices are as follows:

LC-100 Triple coil mounting, Reduced to..	\$6.40	Conescu 4" White dial and knob, Reduced to \$	7.9
LC-101 Triple coil mounting with base,		S-100 Series parallel switch with 8 switch	
Reduced to	10.07	points, Reduced to	1.07
LC-200 Coil plug, Reduced to53	S-600 B Battery switch	1.00
LC-400 Triple coil mounting unassembled,		G-100 Variable grid leak64
Reduced to	3.72	S-4 Vario coupler, increased to	5.83
TPR-600 New type coil plug, Reduced to ..	.64	D-101 Crystal detector, increased to	2.91
Conescu 3" White dial and knob, Reduced to	.80	R-400 Inverted tube socket, increased to ..	2.75

If your dealer cannot supply you with de Forest standard equipment and de Forest accessories, write us direct. We distribute, sell and install complete radio equipment for any location or purpose. Our accessory line includes such standard equipment as Magnavox loud-speaking and amplifying apparatus, Westinghouse charging outfits, NAA Galena supplies, etc. We have machinery and special facilities for giving complete expert service both to dealers and to retail purchasers. Write us.

ATLANTIC-PACIFIC RADIO SUPPLIES CO., INC.
638 Mission Street, San Francisco, California
Eastern Office, 5 Kirk Place, Newark, New Jersey
HENRY M. SHAW, PRESIDENT

For the best book on Radio ask your dealer for "Elements of Radiotelegraphy" by Lieut. Ellery W. Stone, U. S. N. Price \$2.50



Radio Dealers

The Atlantic-Pacific Radio Supplies Co., Inc., are sole Western distributors for the de Forest "Everyman" Radiophone Receiver and for the entire de Forest line of complete radio equipment. National distributors for The Moorhead Laboratories, Inc., manufacturers of A-P vacuum tubes, and also sole Western distributors for the following companies and supplies:

Shaw Insulator Co., Moulded Insulation; Diamond State Fibre Co., Condensite-Celoron; Bedmanol Chemical Products Co., Insulating Paints and Varnishes; Pacent Electric Co., Radio Essentials; C. Brandes, Inc., Radio Head Receivers.

No radio stock is complete without these standard lines. We selected these as being the best, the most saleable and the most desirable from all standpoints, among the many brands of radio supplies and materials in the nation at large. We weighed the comparative merits of each line carefully before making a selection, being careful to pick only those which are standard and proved by experience. Write us for wholesale prices and full particulars. Do it now to insure prompt delivery.

This file including all text and images are from scans of a private personal collection and have been scanned for archival and research purposes. This file may be freely distributed, but not sold on ebay or on any commercial sites, catalogs, booths or kiosks, either as reprints or by electronic methods. This file may be downloaded without charge from the Radio Researchers Group website at <http://www.otrr.org/>

Please help in the preservation of old time radio by supporting legitimate organizations who strive to preserve and restore the programs and related information.