

Radio Digest

EVERY WEEK **Illustrated** TEN CENTS

TRADE-MARK

Vol. IV / Copyright, 1923 R. D. P. Co., Inc. CHICAGO, ILL., SATURDAY, JANUARY 27, 1923 No. 3

REPORT "YES" ON LAW

EXPECT VOTE IMMEDIATELY ON RADIO BILL

Committee Makes Unanimous Favorable Report to House of Representatives

Hoover-Denby Fight Ends

Special Action Asked—No Opposition Expected—Amateurs Get Wider Wave Band

(By L. M. Lamm, Special Correspondent)

WASHINGTON.—After months of careful deliberation the merchant marine committee has made a unanimously favorable report to the House of Representatives on the White Radio bill. The report, unavailable for a few days, urges immediate action on the bill on the part of the House. The committee authorized its chairman to ask for a special rule for

RADIO VOICE GOES PAST THICK WALLS

Inventor Talks Through Four Foot Barrier with His New Instrument

NEW YORK.—A demonstration of how Radio can be directed through walls of steel and concrete was given at the Radio Exposition here recently. It was a most remarkable performance. The inventor of the apparatus, Bernays Johnson, stood behind a wall at least four feet thick and directed his voice at will through it.

It is possible, according to Johnson, to place himself and his machine, which needs no aerial or ground, inside the largest steel vault in the country and he will talk to outsiders without the slightest difficulty, metal doors and walls having no deterring effect.

In his experiment Johnson has taken his apparatus 200 feet into a coal mine and talked through the solid walls in a very clear manner. Johnson first made experiments in 1908.

immediate consideration of the bill by the House. If this is allowed, which seems probable, the bill should pass the House shortly after this dispatch has gone to press, according to a statement made by Representative W. H. White of Maine, "father" of the bill.

Bill Smooths Out Difficulties

The bill as reported out on the floor of the house by Chairman W. S. Greene of

Armstrong Sees World Wide Radio Concert

Only Necessary to Increase Power of Transmitters, He Says

BOSTON, MASS.—Sheldon H. Fairbanks, manager of the Boston Radio Show, who has just returned from New York, where he was advisory director of the

THIS RADIO SPEECH WAS A "BLOW UP"

MEDFORD HILLSIDE, MASS.—A "powerful" subject was that of the talk broadcast January 20 from Station WGI here by Arthur La Motte, of the E. I. du Pont de Nemours company. It was full of pep and possibilities and told the farmers what they could do with dynamite.



Here are Sara Southern and James Kirkwood together in a scene from "The Fool," broadcast recently by WJZ, Newark



Sara Southern as the little lame girl in "The Fool," Channing Pollock's new play, which was broadcast from the Times Square Theater, New York, direct from the stage by telephone wires leading to WJZ, the Westinghouse station. This was the first time a play had ever been broadcast direct, although operas had gone on the air from KYW, Chicago, in this fashion, over a year

the merchant marine committee, is identical with the bill introduced by Representative White two weeks ago, which embodied all the changes suggested by the committee. This bill compromises the controversy between the Secretary of Commerce and the war and navy departments which arose relative to the licensing of army and navy Radio operators by the department of commerce.

Among other things the new bill will enlarge the wave length band assigned to amateur transmitting stations.

The bill was changed in this fashion so that it could be favorably reported to the House without amendment.

No Opposition Expected in House

No opposition to the bill is expected in the House.

(Continued on page 2)

American Radio Exposition at the Grand Central Palace, quotes Major Armstrong, the inventor, who was in charge of broadcast reception, as predicting that it would not be long before Radio concerts would be broadcast around the world.

"All that will be necessary," says the Major, "will be to step up the power of the transmitting station, receive it at a central station—say in England—and relay it all over Great Britain." He predicted that broadcasting round the world would come in an amazingly short time, and pointed out the tremendous possibilities for promoting better understanding between the nations.

Million and Half Sets in U. S.

A canvass of the country shows that there are about 1,500,000 Radio sets in homes. It is estimated that Pittsburgh has a set in one home out of every six and that Detroit has between 40,000 and 60,000 sets.

President Has Secret Transmitting Set, Rumor

Harding May Plan to Use Outfit to Address Nation

WASHINGTON.—In the basement of the White House at Washington, President Harding is said to have a Radio transmitting set. Very few people know of this. The fact has been kept secret from most of the very high officials, who are popularly supposed to be "in the know" with current happenings at the United States capital.

The station has never been used. There is considerable speculation as to whether President Harding plans to address the whole nation in the future upon ultra-important questions. The set is said to be powerful enough to enable him to do so.

REPORT "YES" ON LAW

(Continued from page 1)

The agreement reached between Secretary of Commerce Hoover and Secretary Denby and their advisors has altered the bill so that it now carries a clause that army and naval Stations shall not require commercial licenses, that their wave lengths will be assigned by the President, but that when commercial traffic is handled rules and regulations designed to prevent interference with other Radio stations will be observed.

In other words, governmental stations when transmitting other than official matter will use commercial wave lengths and comply with all regulations set down by the Secretary of Commerce.

One feature of the Bill increases the membership of the advisory committee of the Secretary of Commerce from twelve to fifteen, including a representative of the treasury department, another from the shipping board, and an additional member who is not a governmental official.

FLEWELLING CONTEST TWO WEEKS LONGER

OWING to insistent demands from interested Flewelling circuit experimenters, the Flewelling prize contest under the auspices of Radio Digest will be open to contestants two weeks longer. This will make the contest close February 10 instead of January 27th. The prize awards will be announced in the March 3 issue instead of the February 24, to make allowance for the extension. The rules of the contest are given on page 2.

Auto Gets Stuck; Radio to Rescue

Stranded Quartet Uses Home-made Set to Relieve "Sting" of Misfortune

BOSTON, MASS.—A letter has been received by Station WNAC, the Shepard Stores here, from a member of the Salisbury, N. C., Lodge No. 699 of Elks, telling how he heard the concert given by Boston Lodge of Elks on January 3, while on a trip from Salisbury to Lynchburg with his wife and another fellow Elk and wife. The party got stuck in the mud about eleven o'clock at night, ran into a ditch and broke an axle (they have some awful roads in some parts of the south), and five miles from the nearest town.

The Salisbury Elk had a homemade Radio set in the car, so he decided to try for some music to while away the hours until daylight, when they could be able to foot their way to town for help.

Erect Temporary Aerial

They ran a one-wire, 25-foot aerial from a tree to a rail from a fence which they stuck in the mud in front of the car, working all the while in the rain. The highest part was not over eight feet from the ground. Tuning in slowly, they picked up WNAC, just then broadcasting the Elk's entertainment.

"Never did I hear music that sounded so good, far out in the rain and lonely country," continues the writer. "We heard you acknowledge messages from Haverhill, Newburyport, Woburn and many other places. It gave me an idea to send a long distance phone call to Boston. We walked for almost a mile to the nearest house where they had a rural telephone. The exchange operator tried for about an hour and although she got through to Boston, could not get the Shepard Stores, so I imagine you had all gone home."

RADIO RAISES DEBT FROM NEW HOSPITAL

Final Appeal Brings Funds to Finish Construction Bills

LONDON, Ont., Can.—Radio played its part in the opening here recently of the beautiful new Western Ontario War Memorial hospital for sick children. It was the ambition of the directors of the new institution to have it entirely free from liabilities by its opening date, but a few days before the scheduled opening it was discovered that there were still several accounts outstanding which aggregated some few thousands of dollars.

A day was selected when there were to be a number of large public meetings at various smaller Western Ontario centers and arrangements were made with a local broadcasting station and with amateur operators in the towns where the mass meetings were to be held, to broadcast a final appeal for funds. The next morning's mail brought all the additional funds that were required and quite a cash surplus. This was set aside in order to equip a Radio auditorium where the little patients may listen to concerts broadcast from local, Detroit and Toronto stations.

BOOKS

FLEWELLING PRIZE CONTEST RULES

1. Contest is open to all Radiophans, whether or not they are subscribers to Radio Digest, Illustrated. The contest is open now and will close February 10 at midnight. Awards will be announced in the March 3 issue of this publication.
2. The object is to locate and award prizes on a competitive basis for the best Flewelling circuit receiving set entered.
3. Prizes are: First, \$25.00; Second, \$15.00; Third, \$10.00; Fourth to Eighth (five prizes) inclusive, \$5.00 each.
4. In event of a tie, equal prizes will be awarded both contestants.
5. Judges will be the Technical Staff of Radio Digest, Illustrated.
6. To enter the contest send working drawings and diagrams together with an article of from 1,500 to 2,500 words in length describing the making and operation of an actual Flewelling circuit receiving set. The contestant must build this set and test it before entering the contest. The article must tell: (a) how to make the set, (b) how to operate it, (c) helpful suggestions for getting maximum results, (d) actual airline broadcasting station receiving range using only one tube, first employing only an indoor aerial but no ground, second, using a ground but no aerial, and third, if available, using only a loop aerial. Other combinations and notations on the antenna system used will be considered in the award of prizes.
7. In sending material for consideration in the contest, exclusive publication rights are automatically given to Radio Digest, Illustrated. All articles published, but not awarded prizes, will be paid for at regular space rates. Unused manuscripts will be returned to contestants.
8. In deciding the winners of the contest the judges reserve the right to call for any set entered to be sent in for examination and test. Tubes, A and B batteries and phones will not be required in sets sent in for testing.
9. Manuscripts will be judged from the standpoints of neatness, clarity of expression, completeness, and actual tried success of the set described.
10. Originality in the use of various parts of apparatus other than shown by Radio Digest in the Flewelling circuit heretofore, is encouraged and even recommended. See Rule 6, however, for method to be used in determining the range.

Station Hires 7-Year-Old Girl for Vocal Concerts

BELLEFONTAINE, O.—Radio enthusiasts of this city are more than pleased with the word that a resident of the city has been given signal recognition by one of the largest Radio broadcasting station managements in the country. The local dignitary is Miss Clarabelle McDonald, aged seven, daughter of A. L. McDonald,

railroad claim agent, who has been placed under contract by the Crosley Manufacturing company of Cincinnati, and was to give her first number from Station WLW on the night of January 26. Little Miss McDonald, has been singing since she was four years of age.

The committee appointed by the French ministry of posts and telegraphs has recommended that no licenses be required for receiving apparatus.

CONTENTS

Radio Digest, Illustrated, Volume 4, Number 3, published Chicago, Illinois, January 27, 1928. Published weekly by Radio Digest Publishing Company, 123 West Madison Street, Chicago, Illinois. Subscription rates, yearly, Five Dollars; Foreign, Six Dollars; single copies, Ten Cents. Entered as second-class matter April 27, 1922, at the postoffice at Chicago, Illinois, under the Act of March 3, 1879.

"All the Live News of Radio".....	1 to 6
Flewelling Prize Contest Rules.....	2
Receiving Records Contest.....	4
Aerial-A Tube Detector Receiving Set Explanation.....	6
Photo Diagram of Aerial-A Receiving Set.....	7
Radiophone Broadcasting Stations, Part I of the Radiophonist's "Telephone Book".....	8
Multiple Phone Connector; Efficient Single Tube Set; How to Make "Silver Dials".....	9
Editorials; Condensed by Dielectric; Indigest, Humor Column.....	10
A-B-C Lessons for Radio Beginners, Chapter IV, by Arthur G. Mohaupt.....	11
Coil of Wire Tunes Radio Frequency; Honeycomb Coils Used in Reinartz Circuit; Three Other Kinks.....	12
The By-Pass Condenser in the Reflex Circuit, Part III, with Three New Hook-Ups, by H. J. Marx.....	13
R.F. and A.F. Added to Crystal Set, Hook-Up R.D.-7; The Reader's View.....	14
Questions and Answers, Devoted Entirely to the Flewelling Fans' Inquiries.....	15
Radio Illustrated, a Page of Pictures.....	16

Looking Ahead

E. T. Flewelling, Himself, will begin a series of exclusive articles on the circuit bearing his name in the next issue of the Digest. If you are having trouble with your Flewelling "flivver," read what the inventor has to say. It will be sure to help you. Remember Flewelling is writing exclusively for Radio Digest.

Reinartz Questions and Answers will fill page 15 in the next, the February 3, issue. If you want a simple, sensitive and efficient regenerative set, build a Reinartz tuner from Radio Digest's articles on the subject. If you have one but can't get results, read the "Q. and A." page next week.

For the Picture Fans. Ever heard Miss Jessie Koewing of WOR, the first woman announcer in the United States? Or the announcer on the other end of WJAX, Cleveland? They have furnished the Digest with pictures and satisfactory accounts of themselves and will appear on page five next week. Buy the February 3 issue and you can visualize two more mysterious announcers' voices.

How to Construct and Operate a Crystal Detector Receiving Set will be told next issue by Arthur G. Mohaupt in the fifth chapter of his "A-B-C Lessons for Radio Beginners." Many fans stick to the crystal. Every crystal user or beginner should read Mr. Mohaupt's article.

Letson Balliet Was Unfortunally the Victim of a Train Wreck, and hence his long-promised series of beginners' articles has been delayed. But Mr. Balliet will leave the hospital soon. Just when he will be able to resume his work of writing the series is indefinite, but "looking ahead."

Part II of the Radiophone Broadcasting Station Directory will appear in the February 3 or next issue. You would be surprised at the expense and work necessary to keep this feature up-to-the-minute for Radiophan readers of Radio Digest.

Newsstands Don't Always Have One Left

WHEN YOU WANT

Radio Digest

YOU WANT IT!

BE SURE OF YOUR WEEKLY COPY BY SUBSCRIBING NOW

SEND IN THE BLANK TODAY

Publisher, Radio Digest, Illustrated, 123 West Madison St., Chicago, Illinois. 4-3

Please find enclosed check M. O. for Five Dollars (Six, Foreign) for One Year's Subscription to Radio Digest, Illustrated.

Name

Address

City State

"LIFTS" CURRENT FROM CARRIERS

SENDS MESSAGE WITH BORROWED POWER

Cleveland Man Takes Current from WHK with Receiving Set

CLEVELAND, O.—Using a regenerative Copp circuit receiving set, H. S. Scott, of this city, borrowed some current from WHK, the local broadcasting station of the Radiovox Company and sent a message that was received at Independence, Kansas, and Butte, Montana. Station WHK's wave length is 360 meters.

Mr. Scott's set is located at his place of residence, about six hundred feet distant from the Radiovox station which had finished broadcasting, but had not shut off their generator and was still putting out a carrier wave. Mr. Scott tuned his receiving set to the station wave length and by tapping with his finger on the grid terminal of the tube, gave his official, amateur station call, 8BFL, asking to be notified of its reception.

In due time, postal cards were received from amateur stations at Independence, Kansas, and Butte, Montana, stating signals were received QSA (loud).

Mr. Scott was formerly a Radio operator with the Marconi company, and is now in the engineering department of the Ohio Bell Telephone company, at Cleveland. Mr. Scott is in charge of the Radio Engineering class at the Cleveland Y. M. C. A., and is very active in Radio work in this city.

Here's Something New in Revivals

WNAC Broadcasts Noonday and Sunday Sermons of Rev. Masee, Evangelist

By F. N. Hollingsworth

BOSTON, MASS. — Up-to-date revival services are those being conducted at Tremont Temple by Rev. Dr. J. C. Masee, a noted evangelist, whose sermons every noonday as well as Sunday mornings are being broadcast from the Shepard Stores Station WNAC, via a telephone-microphone connection between Tremont Temple and the broadcasting studio.

Dr. Masee says that he has been informed by one of the Radio listeners, a prominent and wealthy business man whose name he refused to give, that the latter had been converted by Dr. Masee's preaching after listening in to it over a Radiophone.

Contributions Mailed In

Numerous letters have also come in from people who stay at home and listen in by Radio to the revival services, and many of them have contrained contributions. One letter was particularly appealing. It was from a crippled boy, who informed Dr. Masee that every day during the services he has been carried to the home of a neighbor to listen in over the Radiophone.

He sent two dollars in his letter, a dollar of it to be devoted, he asked, toward helping some other crippled boy or girl to hear the services by Radio through the kindness of some neighbor who had a set.

To Broadcast "Brimstone Corner"

Arrangements have been made by Station WNAC to broadcast the services from Park Street Church, Boston. This is one of the most famous churches in Boston, located on the corner of Park and Tremont streets. The corner, from the character of the fiery sermons preached in years past, was long known as "Brimstone Corner." On the first and third Sundays in the month, services from Tremont Temple will be broadcast.

With the broadcasting of the services from St. Paul's Cathedral every Sunday morning and Dr. Masee's service at noonday, New England Radiophans and all within reach of WNAC are fortunate. Owing to the severe weather of the past few weeks, many have been prevented from attending church, but have had the services brought to their homes by Radio.

Alabama Farmers Wake Up to Value of Broadcasts

BIRMINGHAM, ALA.—The farmers of Alabama have commenced to make use of Radio. Throughout the state many farmers are availing themselves of the crop summaries and market reports now being broadcast by Station WSY. Recently Roy C. Bishop, secretary of the Alabama Farm Bureau Federation, took advantage of an invitation of the Alabama Power Company's plant in pushing the membership drive of his association. This organization now numbers 7,000 in Alabama, and Mr. Bishop stated that by the use of Radio he expected to more than double the membership within a few weeks.

"WIRED WIRELESS" STANDS GOOD TEST

BROADCASTS TRAVEL OVER ELECTRIC LINES

Apparatus Plugged Into by Light Socket Will Pick up Messages

WASHINGTON.—"Wired wireless" or broadcasting over electric light and power lines—a new means of communication—was successfully demonstrated publicly for the first time at the Bureau of Standards by R. D. Duncan, Jr., of the Signal Corps and consulting engineer of the North American company of New York, and his assistant, I. Isler.

From the substation of the Potomac Electric Power company in Georgetown, the voice of Isler was transmitted over the high voltage lines and received at the Bureau of Standards—a distance of about five miles.

Invention of Major-General Squier
"Wired wireless" is the invention of Maj.-Gen. George O. Squier, chief signal officer of the army. It consists, essentially, of substituting for the transmitting and receiving antennas of Radio stations the electric light wire network of a city.

Instead of the high frequency energy being radiated through space in all directions, as with Radio, it is confined and directed to flow along definite paths from the transmitting station to the various receivers.

System Has Advantages
This new method of broadcasting, it was explained by Mr. Duncan, offers a large number of advantages over the more familiar method of Radio broadcasting. Among the most important is the elimination of a receiving antenna, elimination of fading, static troubles, interference from the signals of Radio transmitting stations and the fact that the receiving apparatus may be plugged into any convenient electric light socket. Due to the absence of radiation from the electric lines, no interference is produced with the commercial Radio traffic or with Radio broadcasting, and for this reason neither government transmitting nor operators' licenses are required.

Conduct Experiments
In cooperation with the Potomac Electric Power Company Mr. Duncan and Mr. Isler have been conducting experiments in this new method of broadcasting for some time, during which the voice has been transmitted over the high voltage lines of the power company from the Georgetown and Tenleytown substations and received at the Bureau of Standards and at different points in Chevy Chase, D. C., and Maryland.

Radio transmitting and receiving apparatus, with a few minor changes, were used in the public demonstration. A 300-watt transmitting set was used.

GOTHAM TURNS RADIO TO "HIGH BROW STUFF"

Arrangements Perfected in University Extension Course

NEW YORK.—While Radio listening in for amusement has for a long time now carried with it an improving public taste in music and art, the first week of a deliberate and openly avowed intent of using the broadcast for "high brow stuff" has just been concluded here. The result has been so satisfactory that the experiment will be continued.

Arrangements thus to establish a university extension course for the people were made between the Society of Radio Artists and Audiences and the Lecture Bureau of the Board of Education, New York, whereby selected lectures broadcast tabloid lectures from Station WHN, Ridgewood, Brooklyn.

Marriage by Radio is declared illegal in New York state.

STRONGEST PLANT TO BE UNDER WAY SOON

MONTREAL, QUE., CAN.—A dispatch from London announces that the Marconi company is going ahead with its previous announced plans to build the highest power Radio station in the world at Vancouver, B. C., and another station at Montreal, in order that messages may be carried readily from London to Australia through Canada. The estimated cost of the Vancouver station is \$2,000,000.

KIDS OF ORPHANAGE JOIN RADIO FAMILY

XENIA, O.—The children of the Old Soldiers' and Sailors' Orphans' home in this city enjoyed a most delightful treat this holiday time when a Radio outfit was presented the home by the Montgomery County Veterans' association. The outfit has been established in the assembly hall in the library and the children of the home and others are enjoying the nightly concerts.

TO SING FOR WORLD VIA WOR



Miss Edith Bennett, the celebrated American born and American trained soprano, who has just been selected from a long list of internationally famous recitalists to sing the world's first America-Europe Radio concert, tentatively scheduled for January 30. Miss Bennett has a voice of rare beauty, power and flexibility. She is also possessed of exquisite artistry and her diction in all languages is almost perfect. Her coming inter-continental musicale will be sung in English, French and Italian. The chairman of special committee of Radio-musical experts that chose Miss Bennett stated that, in his opinion, she was the finest recitalist in existence for broadcasting
Calvin Harris Photo

Oakland, Calif., has an amplifying horn and is thirty-five feet over all. The bell made of 100 feet of spruce one inch thick. has an area of 144 square feet, while the smaller end is the size of a nickel.

ASK CASH TO BUILD POLICE RADIO PLANT

WASHINGTON OFFICIALS ACT FOR ALLOTMENT

Would Enlist Aid of Private Stations in Apprehension of Criminals

By L. M. Lamm

WASHINGTON.—Request for an appropriation to erect a powerful police Radio station here to broadcast information of fugitive criminals will be made within the next few days by Major Daniel Sullivan, superintendent of police, and will meet with the approval of the District commissioners.

Commissioner Rudolph, president of the board of commissioners, declared the proposal "a fine thing." Money to establish such a station is not now available and would have to be obtained through an appropriation by Congress. "If such a proposal comes before the board of commissioners I will vote in favor of it," Commissioner Rudolph said.

The cost of establishing an adequate station and maintaining it is being investigated and will be embodied in the report recommending the move which he will submit to the commissioner in charge of police within the next few days, Major Sullivan said. While he had not yet discussed the plan with the commissioner, Major Sullivan said that he did not doubt approval would be forthcoming, in view of the support given his recommendation for the purchase of tear gas guns in police work.

"I feel sure that the commissioners are as anxious as the police department is to have every aid of modern science available in Washington for detecting and apprehending criminals," Major Sullivan said.

Range to Reach Chicago

Radio experts would be consulted by the police chief relative to the establishment of the station, he said, and the advice of army and navy experts as well as private Radio engineers will be asked. The station contemplated would send its messages at least as far as Chicago.

Washington would be surrounded by a network of Radio stations, under the plan, and every road out of the city would be covered by the system. It is planned to enlist through police officials of surrounding towns and counties, the co-operation of private stations in their territories through which they can be communicated with by the Washington police. Beyond this first ring encircling the city, the net will be extended to other towns and larger cities all over the eastern part of the country, and it is hoped eventually, the entire United States.

CONTRACT HOLDS UP WORK ON NEW PLANT

U. S. Waits to Renew Action on Wheeling Station

WHEELING, W. Va.—The government is ready to put up its new Radio station at Langin Aviation field and will begin the work of removing the old station to the new location just as soon as the contract is signed and received here, according to Captain A. E. Simonin, in charge of the local landing place. The two huge Radio towers have already been erected and within three weeks after the contract is signed the new station can be in operation, Captain Simonin pointed out.

Plans for the new station call for an expenditure of some \$15,000, which will make the Langin field station compare favorably with any other in the country. The new towers are sufficiently high to permit the proper receiving of all messages during any kind of weather. Fog, heretofore, has had considerable to do with the operation on the old station.

A powerful new Radio station is being built near Varberg, Sweden.

THE ANTENNA BROTHERS

Spir L. and Lew P.

Grandpa Is a "Jazz Baby"

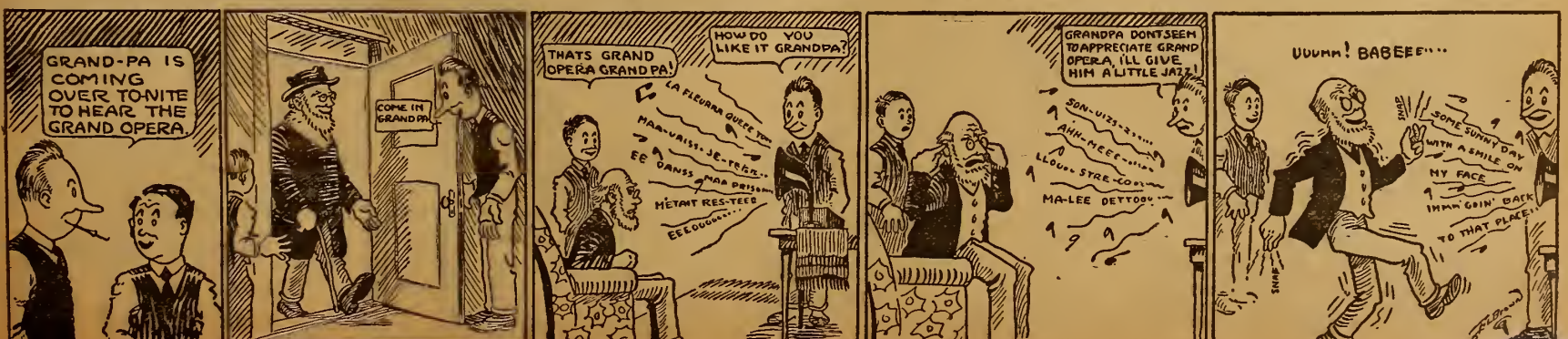

NAA HAS HARD TIME WINNING NOF FANS

REGRET AT PASSING OF ANACOSTIA PLANT

Listeners Encounter Difficulty Tuning Sets on Wave Length of Arlington Station

By Carl H. Buttman

WASHINGTON.—NOF has passed as the government's official broadcasting station, and its big brother, NAA, has come, but there are many fans who hated to see the navy's Anacostia Station go back to its research work. Some find it difficult to get accustomed to NAA at Arlington and to tune it in on 710 meters, the new wave assigned for government broadcasting from Washington.

A hurried survey of the neighboring Radio population indicates how well it liked NOF, but it shows also that some must add a coil to their sets and learn to tune in on longer wave lengths. Out of 83 replies, 61 who have picked up the station since January 3, like the transfer and received the music of the marine and navy bands well enough. Of those who object, 22 prefer NOF and the old 430-meter wave length.

NAA Hears from Fans

Favorable replies to an inquiry were received at Station NAA from New York City, Manchester, N. H., Worcester and Malden, Mass., Wilmington, Del., and Pittston, Pa. Some neighboring fans claimed the broadcasting was too loud, and others too weak. Fort Humphreys, Va., an army station, approves the service as "fine."

It is doubtful if the wave length can be changed to a shorter one, due to the fact that short waves interfere with the regular longer waves used on other sets at NAA for handling official traffic for the government. However, some consolation is found in the fact that the bands are playing at the Marine Barracks in Washington two or three miles away, and a single land line is used for the transmission to the Radio station. This will be improved by the installation of a special line, it is hoped.

Now the musicians perform on Wednesday and Friday nights, in a large barn-like room, too large for the purpose and uncurtained. A sort of transmitting tent is being made, however, which will tend to restrain and concentrate the music for transmission over the line to Arlington, which is certain to improve the concerts.

Want Concerts, Less Politics

Some rather frank expression as to the preference for the concerts was expressed by listeners in who declared that some of the official talks broadcast were a bore. Others complain of a hum and fading, and say NOF was perfect.

Other returns have come to the Public Health Service, which sought to learn how its broadcasts from NAA were received by the Radio public. Out of about 100 replies, over half declared they could not get NAA on the scheduled nights, while thirty-one stated they got the broadcasts "O K." The usual short wave sets were found difficult to tune in on 710 meters but the sets built for longer wave lengths gave less trouble. Generally, the health fans prefer NOF. Sixty out of 80 declared that of four large stations heard regularly they heard NOF best.

It is regretted by the navy that NOF had to be closed, but the work there was experimental and other work must be undertaken. NAA has hardly shaken down to regular work, and experts believe that within a short time improvements in the transmission will be manifest.

Couzens, Pomerene Talk on Air; Harding Notes Read

NEWARK, N. J.—The regular and special program of the annual banquet of the Ohio Society of New York, held in the grand ballroom of the Waldorf-Astoria, was broadcast Saturday night, January 13, from Station WJZ, located here.

The invisible audience heard the address of Speaker Frederick H. Gillette of the National House of Representatives, Senator Atlee Pomerene of Ohio and Senator James Couzens, of Michigan, formerly mayor of Detroit. Ogden Reid, president of the Ohio Society and owner of the New York Tribune, read the message to the society from President Harding, who was unable to attend in person. Mr. Reid, as toastmaster, also introduced the speakers of the evening.

Will Rogers was on the program following the banquet and selections of the Waldorf-Astoria's orchestra and pipe organ and a soloist from Ohio were also broadcast.

The pastor nowadays does not necessarily have to attend his annual donation party. In Spokane, Washington, the ladies of one of the churches gave a reception to the pastor, at which Radio addresses were heard from absent ones.

RECEIVING RECORDS? SEND 'EM IN—

INTEREST doesn't lag a bit in the Receiving Records Contest, although many of the records have been boosted to practically unbeatable distances. New DX aspirants desiring to enter the contest are advised to read the rules given with the records on page 4 of the January 20 issue. The complete list of record holders will appear in the February 10 issue. Watch for this. The new records made last week are as follows:

Station—Miles Away—Who Heard It
 CFCN—1,775, John W. Hale, Houston, Tex.
 CHCC—1,325, Samuel Woodson, Jr., Liberty, Mo.
 CKAC—2,700, A. C. Carter, Juneau, Alaska.
 CKCR—1,225, Samuel Woodson, Jr., Liberty, Mo.
 KDYL—2,075, T. F. Powers, Somerville, Mass.
 KDYS—1,700, M. C. Ridenour, Kingwood, W. Va.
 KFAD—1,250, Cyril Cornwell, Osage, Ia.
 KFN—1,250, Chas. N. Schwab, Grinnell, Ia.
 KFBC—2,125, J. D. Crosby, Stauffer, Pa.
 KFBH—1,450, R. B. Reed, Eureka, Kans.
 KGN—1,875, Fay Allarding, Lake Odessa, Mich.
 KGU—4,650, Eugene Evans, Tippecanoe City, O.
 KJJ—1,575, Chas. N. Schwab, Grinnell, Ia.
 KOP—2,075, T. W. Smith, Watsonville, Calif.
 KPO—2,275, G. Murray, Toronto, Can.
 KWJ—2,125, C. J. Lohman, McDonald, Pa.
 KZM—2,700, Sarkis Kachajian, Worcester, Mass.
 WAAB—1,150, H. K. Cooper, Owego, N. Y.
 WAAP—1,325, W. R. Clark, Bridgeport, Conn.
 WAEP—1,125, F. P. Cerniglia, Tallulah, La.
 WBAX—1,000, Carl Baumeister, Avoca, Ia.
 WCAR—1,750, Sarkis Kachajian, Worcester, Mass.
 WCAK—1,325, Doyle Getter, Arkansas City, Kans.
 WDAS—1,200, Carl Baumeister, Avoca, Ia.
 WGF—1,025, E. McDonald, Valleyfield, Que., Can.
 WGM—2,175, Allan Harvey, Snohomish, Wash.
 WJAE—1,700, A. Moffet, Ottawa, Can.
 WJAX—2,000, Allan Harvey, Snohomish, Wash.
 WKAF—1,025, Wilbur Squier, Detroit, Mich.
 WKY—1,325, T. W. Smith, Watsonville, Calif.
 WLAV—2,000, G. A. Gallagher, Berkeley, Calif.
 WMAF—1,125, Cyril Cornwell, Osage, Ia.
 WNAD—1,500, C. T. Mower, Malden, Mass.
 WOAC—1,600, O. P. Klein, Leduc, Alta.
 WOAI—1,800, O. P. Klein, Leduc, Alta.
 WOAS—1,125, Samuel Woodson, Jr., Liberty, Mo.
 WOZ—1,950, Fred Sheppard, Centralia, Wash.
 WRR—1,225, O. E. Frazier, Watts, Calif.
 WSY—1,950, T. W. Smith, Watsonville, Calif.

Sunday Bible Stories for

Kiddies New WGI Feature

MEDFORD HILLSIDE, MASS.—Among the new features added to the broadcasting program of Station WGI of this city is a series of "Children's Hour" Bible stories on Sundays around five P. M., Eastern time. These are read by "Uncle Billy," with an organ accompaniment by E. Lewis Dunham.

Bankers are beginning to realize the value of Radio publicity, as shown by a recent talk from WGI by P. K. Parker, treasurer of the Lynn Institution for Savings, on "What the Mutual Savings Bank Can Do for You."

The Pacific Coast States have a plan which provides for the closing down of all broadcasting stations at 10 p. m., Pacific time, thereby giving listeners in that vicinity an opportunity to hear concerts from the East.

"GOOGLE-SPARKY" COMICS, GO ON AIR

FANS DRAW CARTOONS BY RADIOED DIRECTIONS

Youngsters in Novel Contest Sketch Pictures on Special "Radio Charts"

LOUISVILLE, Ky.—"Barney Google" and "Spark Plug," famous as racing cartoon characters, have been broadcast by their creator, Billy De Beck. It all happened Tuesday evening, January 10th, at WHAS, the station of the Louisville Courier Journal and Times.

How it happened and the way it was worked was as follows:

The creator of "Spark Plug" was visiting Louisville, and a scheme was worked out by those in charge of WHAS. This was developed by printing in the papers a series of crosslined charts that had two charts, one for drawing "Barney Google," and the other for "Spark Plug." The horizontal lines were indicated by the letters of the alphabet while the verticals were numbered from one to 44, beginning at the left.

The contest was arranged for the youngsters listening in, who pasted the drawing charts on pieces of cardboards. Then as directions for lining the drawings were broadcast by Billy De Beck, contestants proceeded with the drawing, listening in, and following carefully the instructions given. Prizes were awarded for the best drawings turned in by the children.

AMATEURS ADOPT EMERGENCY CALL

Prepare to Aid in Storms; "ASA" Takes Place of "SOS"

HARTFORD, CONN.—Radio amateurs expect to have their stations take the place of practically all other means of communication when the next big blizzard strikes the country, and have adopted a special emergency call of "ASA" which will be used, as is the famous "SOS" call of ships in distress at sea.

A communication to this effect has been received here from N. B. Hood, manager of the Rocky Mountain Division of the American Radio Relay League, who explains that the call is to be used only in case of "dire necessity" and that his office "will do all in its power to protect an amateur who uses this call for humanity's sake in case of storm or disaster."

Radio amateurs have frequently been of great help in an emergency especially of late in Colorado, and Wyoming, when in November, two trains were lost between Denver, Colo., and Casper, Wyo., while the snow drifted 15 feet high. Amateur Station 7Z0 got through a message to 9ANQ, L. V. Wells at Kansas City and it was finally relayed to Omaha.

MYERS TUBES

CHOKES RECEPTACLES ADAPTERS
 Better Discounts, Standard Lines

33 1/3 % DUNGAN RADIO CO.
 Room 64, 68 W. Washington St. Phone Cent. 3377

FIVE OF BIRMINGHAM'S CHURCHES JOIN WSY

Station Broadcasts Sermon from City for First Time

BIRMINGHAM, ALA.—The first broadcast direct from a Birmingham church was made on a recent Sunday evening from the North Highlands Methodist church. The connecting telephone trunk line connected WSY, the Alabama Power Company's station, with the church, and the sermon of the pastor, Dr. W. R. Hendrix, was broadcast. The subject of his sermon was, "The Sunday School Teacher in the Building of a Nation." Besides the sermon a musical program rendered by the choir was broadcast.

There are now five Birmingham churches connected with WSY. These churches are the North Highlands Methodist church, First Methodist, First Baptist, Independent Presbyterian and Southside Baptist.

Patents Procured and Trade-Marks Registered. Advice and terms upon request.

ROBB, ROBB & HILL,
 1417 Hanna Bldg., 956 McLachlan Bldg.,
 Cleveland, O. Washington, D. C.

FOR YOUR RADIO



World BATTERY

Saves you 50% of the usual cost and you get an unconditional **WRITTEN 2 YEAR GUARANTEE**

Best battery buy on the market today. Thousands of satisfied users.

6-Volt 40 Amp.	\$850	6 Volt 60 Amp.	\$1000
6 Volt 80 Amp.	\$1250	6-Volt 100 Amp.	\$1450

Ask about our rubber containers

WORLD BATTERY CO.
 60 E. Roosevelt Rd.—Dept. L.
 CHICAGO, ILLS.

HOW TO MAKE FLEWELLING RECEIVER

COMPLETE

Blue Prints

for the construction of a Flewelling Receiving Unit and two step amplifier.

Full Instructions

FOR ASSEMBLY

Description of apparatus and accessories and details of tuning.

Cabinet Dimensions
 Panel Layout
 List of Parts

Only 50c

Send only money orders—no checks or stamps. Coins at your own risk.

Book Department
RADIO DIGEST
 123 W. Madison Street
 CHICAGO, ILL.



Licensed under
 Armstrong U. S.
 Pat. No. 1113149

A. H. GREBE & CO., Inc.
 Richmond Hill, N. Y.

"THE wise man does not esteem a person more highly because of what he says."

—said Confucius.

The wise radioist is not misled by extravagant claims—he knows that only a Grebe Receiver can come up to his expectations.

Doctor Mfu.



NAVY YARD AND CHAUNCEY ON AIR



The Brooklyn Navy Yard Radio station, NAH, has begun the first of a series of broadcast concerts with prominent opera stars and noted concert musicians. Titto Ruffo of the Metropolitan was first of all the operatic stars to sing there, being heard in the opening concert. In the group, left to right, are Lieut. Com. J. W. Reeves, in charge of station; Rear Admiral C. P. Plunkett, Navy Yard commandant; Titto Ruffo; Enid Grange, piano accompanist. On our right—guess! Chauncey M. Depew himself, as he appeared before the microphone at the recent Radio show in New York. He is nearly 89 years now, so took as his subject, "How to Keep Young." He says to banish worry, forget the past and live in the future.

© Int.

© K. & H.

WSB STARTS NEW RADIO UNIVERSITY

EDUCATORS LECTURE IN NIGHTLY "CLASSES"

Unique Chapter Written in History of Radio as Atlanta Plant Inaugurates "School"

(Special to RADIO DIGEST)

ATLANTA, GA.—Another unique chapter on Radio history has been written by WSB, Radiophone broadcasting station of The Atlanta Journal, in establishing a Radio university which will offer instruction to its invisible listeners from the South's ablest educators.

Atlanta being the key city to education in the South, little difficulty will be encountered in obtaining the services of distinguished instructors who will confine their brief lectures to practical discussions of subjects on which they have specialized.

Lectures to Be Easily Intelligible

WSB's "School of the Air" conducts its classes nightly, except Sunday. The lectures occupy the first quarter-hour of the station's nationally popular 7 to 8 P. M. broadcast, the first regular broadcasting period established in the South. Every phase of education is covered in a manner intelligible to all listeners interested in gaining authoritative knowledge on fundamental matters.

Willis A. Sutton, superintendent of Atlanta's public school system and one of the nation's foremost educators, is dean of the "School of the Air" and has associated with him a distinguished group of men and women of letters, all prominent members of the faculties of Georgia Tech, Emory university, Oglethorpe university, Agnes Scott college, Cox college, the State college of Agriculture, the city's high schools and grammar schools and other educational institutions of Atlanta and the state of Georgia.

Subjects Cover Wide Field

The course of evening lectures is given by the department of science, history, education, economics, engineering, English, home economics, psychology music, and kindred subjects. The speakers briefly discuss some phase of the general topic from a practical standpoint.

The assignment of the fifteen-minute interlude daily to a variation from the routine broadcasting of music and random lectures has drawn favorable responses from all classes of the Atlanta Journal listeners.

New Chief for Capital Club

WASHINGTON.—William A. Parks has been elected to succeed H. H. Lyon as president of the Washington Radio Club at a meeting in the hall of the American Association of Engineers, 1317 New York avenue. Other officers elected were: G. L. Bidwell, vice president; H. A. Snow, secretary-treasurer; H. A. Wadsworth, assistant secretary-treasurer, and B. S. Flather, chief operator. The membership now includes 115 Radio enthusiasts.

WDAP to Chicago Board of Trade

Drake Hotel Station to Carry Voice of Report Speaker Direct from "Pit" Floor

CHICAGO.—WDAP, broadcasting station located on the Drake Hotel, this city, has been purchased by the Chicago Board of Trade, according to Robert M. Dougal, retiring president of that body. Under the new management the far-reaching voice of WDAP will continue to transmit concerts and other entertainment features.

A new arrangement provides for the voice of the reader (in a glass booth on the board floor) to be carried directly by telephone and Radio without relay, so that farmers receiving the report will hear the reader just as he reads the quotations from the blackboard.

Schedule in Use

The schedule now being used by the Board of Trade-Drake plant on all business days is as follows:

9:30 A. M. Central Standard Time—Receipts and shipments, estimated carlots, local weather report, opening futures market: wheat, corn, oats, rye, barley, pork, lard and ribs.

10 A. M.—Futures quotations, live stock receipts and prices.

10:30 A. M.—Futures quotations.

11 A. M.—Futures quotations.

11:30 A. M.—Futures quotations.

12 M.—Futures and cash grain prices.

12:30 P. M.—Futures quotations.

1 P. M.—Futures quotations.

1:20 P. M.—Closing futures quotations and high and low for day, cash grain prices, gross bids for cash grain to arrive.

On Saturdays the closing prices are sent at 12:05 P. M. instead of 1:20 P. M. The visible supply changes are sent when posted.

Concerts and entertainment will be broadcast Tuesday, Thursday and Saturday evenings at 10 P. M., and Sunday evening from 9 to 10 P. M.

All broadcasts are on 360 meters wave length. The station offices, address the Drake Hotel, Chicago, are interested in learning how WDAP is heard during daylight. Hearers are asked to write.

Reroute Italian Waves

WASHINGTON.—Following the recent suspension of direct Radio communication between Italy and the United States and pending the completion of a new high power station near Rome, Radio traffic from Italy to North and South America is being handled via the high power stations of Germany, France, and England. Messages via France or Germany carry a rate of 20 gold centimes less than the cable rate, in the case of full rate telegrams. The same messages via London will be 10 gold centimes less than the cable rate.

Plants Send Same Program at Once

Wires Carry Concert, Broadcast from New York to Boston plant for Transmission

BOSTON, MASS.—WNAC, the Shepard Stores here, and WEA, the broadcasting station of the A. T. & T. company in New York, recently conducted an experiment in simultaneous broadcasting, the first one ever attempted. Over about 300 miles of copper telephone wire the musical program from WEA, which was being broadcast from New York on 400 meters, was conducted to WNAC, and broadcast from there on 360 meters. The telephone line was equipped with filter circuits and repeater amplifiers at intervals, and was carefully tested and adjusted by the telephone engineers to eliminate distortion.

WNAC reported that the sounds came in clearly and without a flaw, and were transmitted as easily as a local program. The numbers included selections by the Hotel Ambassador orchestra; Arthur Wilde, cellist, formerly of the New York Symphony Orchestra; Nathan Glantz, a celebrated saxophonist; Devora Nadworney, contralto; Raymond Freemantle, baritone, and one novelty number, Edward Avis, famous as a bird mimic.

Music Students' Concert Closes Memory Contest

COLUMBUS, O.—Artist pupils of the Grace Hamilton Morrey School of Music, here, rendered all numbers for the third and final program of the Columbus Dispatch's music-Radio memory contest which was broadcast from Station WBAV of the Erner & Hopkins Company January 15. The music for the occasion included all recognized old classics of song, harp, violin and piano, as they have come down to this generation from the hands of the masters of old; the semi-classical ballads and folk songs that have lived persistently in this age of jazz and turbulence, and a few of the newer, modern selections. The pupils put on the program to prove again that the work of old masters and modern classicists is ever a veritable fountain for the music-thirsty multitudes.

Hundreds of contestants heard the concert and are in hopes that their answers will put them in the class of seventeen, to whom will be awarded prizes aggregating \$700.

McMillan Talks for Fans

MEDFORD HILLSIDE, MASS.—Capt. Donald McMillan, Arctic explorer who returned recently from a two-years' exploring trip in the Arctic circle on which he made many important scientific discoveries, broadcast a talk January 18, from Station WGI. His subject was his experience "In The Frozen North."

OPERA, ON TOUR, TO BE HEARD OVER AIR

CHICAGO COMPANY MAY CONTINUE BROADCAST

Management Seeks to Arrange for Direct-from-Theater Service for Radiophans

By Vera Brady Shipman

CHICAGO.—The Chicago Opera Company began its eastern engagement in the Boston Opera House Monday, January 22, opening with Marshall and Raisa in Aida. Efforts have been made to arrange with the eastern broadcasting station to broadcast the operas from the theaters direct. At the time of going to press, Radio Digest had negotiated with the largest stations in the three cities, Boston, Washington and Pittsburgh, and a final decision had not yet been reached.

The operatic schedule in the three cities named includes the best operas on the Chicago company's repertoire.

Probable Schedule Announced

The following was given as the probable schedule by the opera management (with the exception of Puccini operas which are withheld from the air by copyright ruling) any of which operas may be broadcast if eastern stations co-operate with Radio Digest:

Boston: Monday night, Aida; Wednesday matinee, Pagliacci, night, Rigoletto; Thursday night, Love of Three Kings; Friday, The Valkyrie; Saturday night, Il Trovatore. Second week: Monday night, Love of Three Kings; Tuesday night, Parsifal; Wednesday matinee, Snow Maiden; Thursday night, The Valkyrie; Saturday matinee, Carmen, night, Jewels of the Madonna.

One half week in Washington at Poli's Theatre beginning Monday, February 5. Monday night, Aida; Wednesday, night, Snow Maiden.

Last half week at Pittsburgh at the Syria Mosque beginning Thursday, February 8: Thursday night, Jewels of the Madonna; Friday, Aida; Saturday matinee, Carmen, night, Pagliacci.

"U" Prexy Starts College Lecture Course by Radio

INDIANAPOLIS, IND.—A college Radio lecture course was inaugurated here recently when Dr. William L. Bryan, president of Indiana University, delivered an address from the local News-Ayres-Hamilton Radio station, WLK. The subject was, "Why More Boys and Girls Are Going to College."

The Radio course was arranged by the university extension division and Station WLK and consists of educational lectures broadcast Tuesday evening of each week.

The lectures begin at 8:30 P. M., Central time, and are short and phrased in simple language. They are becoming increasingly popular with Radiophans in the central west.

SIMPLE DETECTOR SET EASY TO TUNE

AERIAL-A RECEIVING UNIT HAS FEW CONTROLS

Additional Amplification Stages Can Be Added—Appeal Made in Low Cost and Efficiency

Photo Diagram on Page 7

The standard receiving set illustrated on page seven is an Aerial-A, manufactured by the W. E. Supply and Service Corporation of New York, N. Y. It is one of the simplest that has yet been shown and consists of the detector stage only. Naturally, amplifying stages can be added but its appeal is in the low cost and efficiency of reception. It is provided with a minimum of controls, thus permitting the newest of Radiophans to operate it successfully.

The antenna need not have a total length of more than sixty feet, thus permitting its use in many cases where fans are handicapped for sufficient antenna length.

A well-connected lead to the ground is essential. Good electrical connection should be made to the water pipe or equivalent grounding point, and contact should be made by means of a ground clamp securely bolted to the metal surface, which previously has been scraped clean of all dirt and corrosion.

Description of Connections

All connections are made at the back of the cabinet, the base of which projects about one inch, providing for the location of binding posts.

Starting from the left side the first two are for the phone connections. The third post is for the positive side of the 22½-volt plate or B battery. The center or fourth binding post is for the negative connection of both the plate and also the six-volt filament battery. The positive side of the storage battery is connected to the fifth post. The sixth post provides the connecting point for the ground lead, while the seventh or last post is for the antenna connection.

Tuning Controls

But three tuning controls are necessary, two of which are for the wave length adjustment, and the third for the filament control. This permits adjustment of filament lighting to the point of most efficient operation for the tube used.

The lower tap switch knob regulates the inductance in the antenna circuit by means of the coarser taps in the windings, and should be first adjusted after the filament current has been turned on. This permits the locating of the taps where the reception comes in best.

The finer adjustment of wave length is then affected by means of the upper tap switch, connecting to the finer taps of the primary winding. Because of the

Book Reviews

The Armstrong Super-Regenerative Circuit. By George J. Eltz, Jr., E. E. This is a De Luxe edition of this famous circuit. Profusely illustrated and fully explained. Fifty-two pages. Price, \$1.00.

Radio Receivers for Beginners. By Snodgrass and Camp. Answers the universal question, "How can I receive Radio?" Price, \$1.00.

Home Radio—How to Make It. By A. Hyatt Verrill. This book is particularly adapted for the amateur who desires to know how to make Radiophones. Twelve full page illustrations and diagrams. Price, 75c.

Elements of Radiotelegraphy. By Elery W. Stone. The text was written for the guidance and instruction of Radio students in the communication service of the Navy. It is an instruction book for Radio schools. Price, \$2.50.

Radio for the Amateur. By A. H. Packer and R. R. Haugh. The underlying principles of Radio thoroughly explained in simple language and understandable illustrations. This book will teach you how to construct and operate a receiving set successfully. Price, \$1.50.

Radio Communication. By John Mills. The fundamental principles and methods upon which recent developments are based are emphasized. The vacuum tube is treated in a simple, fundamental and up-to-date manner. Present methods and tendencies of the art are explained in a chapter which is non-mathematical. Price, \$2.00.

Letters of a Radio Engineer to His Son. By John Mills. A series of interesting letters written to a boy. Each letter is full and complete and the most advanced student can skip over some of the letters and get just the information he desires. Price, \$2.00.

The book department of the Radio Digest is prepared to send you any of the books on Radio published, whether listed in our Book Review or not. Let us know what book you want, send us your check and we will see that the book is mailed to you. Postage stamps in payments for books not accepted. Send money order or check. Book Department, Radio Digest Illustrated, 123 W. Madison St., Chicago, Ill.

permissible accuracy of these adjustments no variable condenser is necessary. After these two adjustments have been made, the filament rheostat knob can be readjusted for the best point of operation.

Mischievous youngsters have been having a lot of fun cutting leads and ground wires of Radio sets. This up-to-date variation of the old ringing the doorbells and putting "ticktacks" on the windows is causing much annoyance to the Radiophans.

Radiophan, After Hearing Programs of Nation, Longs for Something New

Arm Chair "Globe Trotting" with Receivers Is Found to Be Delightful Hobby, However, Despite Certainty of Encountering Several Varieties of "Hot Lips" and "Tomorrows"

The Radiophan sits at home comfortably settled in his armchair, with his "Aida" libretto at his elbow and hears every note of Verdi's opera broadcast by KYW of Chicago, while society, elaborately costumed, sits in its boxes, sees and is seen. The Radiophan knows not the divertisement of bright lights, perfume or stunning gowns.

"The first act is over. Kindly stand by for about fifteen minutes."

"This is Station KSD, The St. Louis Post Dispatch." A speech by General Pershing is discovered on the air.

"This is Station WHB, the Sweeny Automobile school, Kansas City, Missouri, the Heart of America."

One travels through the ether waves from Denver to St. Paul. Hundreds of programs are broadcast each evening from all sections of the country.

Programs Much Alike

Programs are nearly all alike. Solos for voice and instruments fraternize with band and orchestra. The youthful soprano from the Kansas City Star sings the same song that the lady from East Pittsburgh sang last Tuesday or the lady from Atlanta will sing next Friday. Violin solos are often hackneyed arrangements.

Why doesn't some enterprising station broadcast a program of DIFFERENT Music instead of the publishers' latest? It may be good for the publishers' business but it is hard on the Radiophan. The listener enjoys classics or songs of sentiment, but the modern programs have too little of these and too much emotional slush.

Opera Stars and Jazz Vie

Many stations broadcast records. Located where good talent is not always available, the enterprising broadcaster realizes that a good record is infinitely bet-

ter than a mediocre soloist. Operatic stars vie with jazz releases. You can count on several brands of "Tomorrows" and two or three "Hot Lips."

The Radiophan is not overly critical. He has not paid for his concert and does not expect too much. Besides, if he doesn't like it he can always tune out without the performer having the slightest idea that he was ever there. If he doesn't like a selection he will probably blame it on the "static" and tune off to something else.

Getting two concerts at once is inconvenient. It is a bit uncanny when listening in on a band number from Fort Worth, "The Eyes of You Keep Smilin' Through" from Newark.

Wandering Back to Youth

A harp solo, "Maiden's Prayer," from the Detroit News brings memories of little girls' first music lessons, pigtails and starched petticoats. As you dream and idly play with the dials, Louisville impudently jumps in with Al Jolson's "Coo-Coo."

Davenport follows with "Where the West Begins." Minneapolis answers as "The Call of the North." Winnipeg, Canada's, "Hello, hello, hello," is easily distinguished.

The clock strikes. You have been globe trotting in your chair, "listening in" (in Radio vernacular) to everywhere. One by one the stations have signed off.

"This is Station WMAQ, the Chicago Daily News," closing chimes of "It's Three o'Clock in the Morning" are followed by "signing off at ten o'clock. Goodnight."

But the air is not sleeping. The Drake Hotel, WDAP, Chicago, broadcasts dance orchestras far into the night.

And somebody, somewhere, is always listening in.

RADIO

Manufacturer Direct to You LOWEST PRICES—HIGHEST QUALITY

Everything guaranteed exactly as represented or money refunded. We pay the postage

Variable Condensers

\$4.50 value, 43 plate	\$1.70
\$3.75 value, 23 plate	\$1.40
\$5.50 value, 23 plate Vernier	\$4.00
\$6.00 value, 43 plate Vernier	\$4.50
\$4.50 value, 11 plate Vernier	\$3.50
\$3.25 value, 11 plate	\$1.25
\$2.50 value, 3 plate	\$1.10

SWITCHLEVERS with large tapered knob	19c	3 Coil HONEYCOMB MOUNTING	\$3.25
BAKELITE SOCKETS or 3-inch dials	28c	2 Coil HONEYCOMB MOUNTING	\$2.45
\$5.50 value, MOLDED VARIOMETER	\$4.40	INDUCTANCE SWITCH with tapered knob	\$1.00
\$5.00 value, MOLDED VARIO COUPLER	\$4.00	Double Blade eliminates use of switch points	
		COMPOSITION DIALS, 2 or 3 inch	22c

SPECIAL JACKS SPECIAL

These are a standard high grade make but we must withhold name of makers account cut in prices.

Single open	32c	Double open	43c
Single closed	38c	Single Fil	46c
Double Fil	50c		

WD 11 BAKELITE SOCKETS	60c	BATTERY HYDROMETERS	40c
WD 11 ADAPTERS	50c	ALL SENSITIVE CRYSTAL	20c

COMPLETE PARTS FOR FLEWELLING CIRCUIT

includes 23 plate condenser, 3 .006 Condensers, 1 Freshman Variable grid leak, 1 panel grid leak, 2 honeycomb coils, a double coil mounting, 2 coil plugs, 8 rubber knob posts, with diagram for construction. Also 1 6x14 Panel.

Outfit Complete for **\$11.95** only

COMPLETE PARTS FOR RHEINARTZ CIRCUIT

Includes 1 7x18 Panel, 1 bakelite socket, 1 high grade vernier rheostat, 11 plate condenser, 1 inductance switch eliminating panel drilling for points, 1 23-plate condenser, 3 fine switch levers, one Rheinartz type coil, 8 rubber knob binding posts, 1 variable grid leak, 25 feet wire for construction, mounting base

board, and diagram, Complete for only **\$10.95**

We emphasize that we positively guarantee all goods purchased from us, and fill your orders same day as received. Lowest Prices, Highest Quality

Manufacturers Outlet Company

MOCO RADIO PRODUCTS 53 West Jackson Blvd., Chicago, Ill.

Radio Receiving Sets

The Aerial-A Tube Detector Unit

As the eighteenth of the series of standard receiving sets, Radio Digest presents the Aerial-A Receiving Set, manufactured by the W. E. Supply and Service Corporation of New York, N. Y. This receiving unit employs the use of a tuned primary circuit, with detector stage only. The circuit is non-regenerative and extremely simple.

Full installation and operation instructions will be found on page six. Although the reader may not possess this particular make of apparatus, it will be well for him to study the diagram and instructions carefully. The points of similarity in standard types of receiving sets will enable the beginner to benefit materially.

VANMUM

W. E. SUPPLY & SERVICE

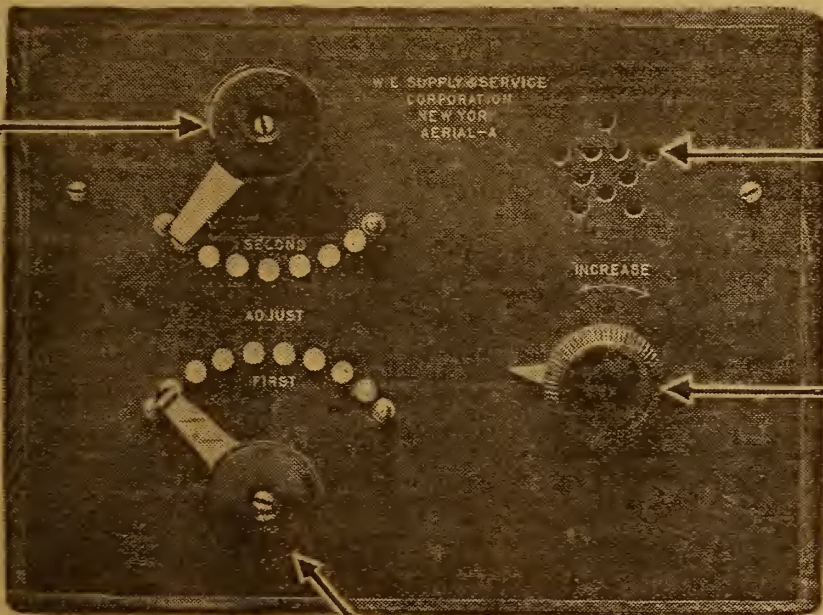

Peepholes to Observe Whether Tubes are Lighted

Knob for Control of Vacuum Tube Filament Current

Tapped Switch for Fine Wave-Length Adjustment.

Tapped Switch for Rough Wave-Length Adjustment.

Rheostat

Vacuum Tube Socket

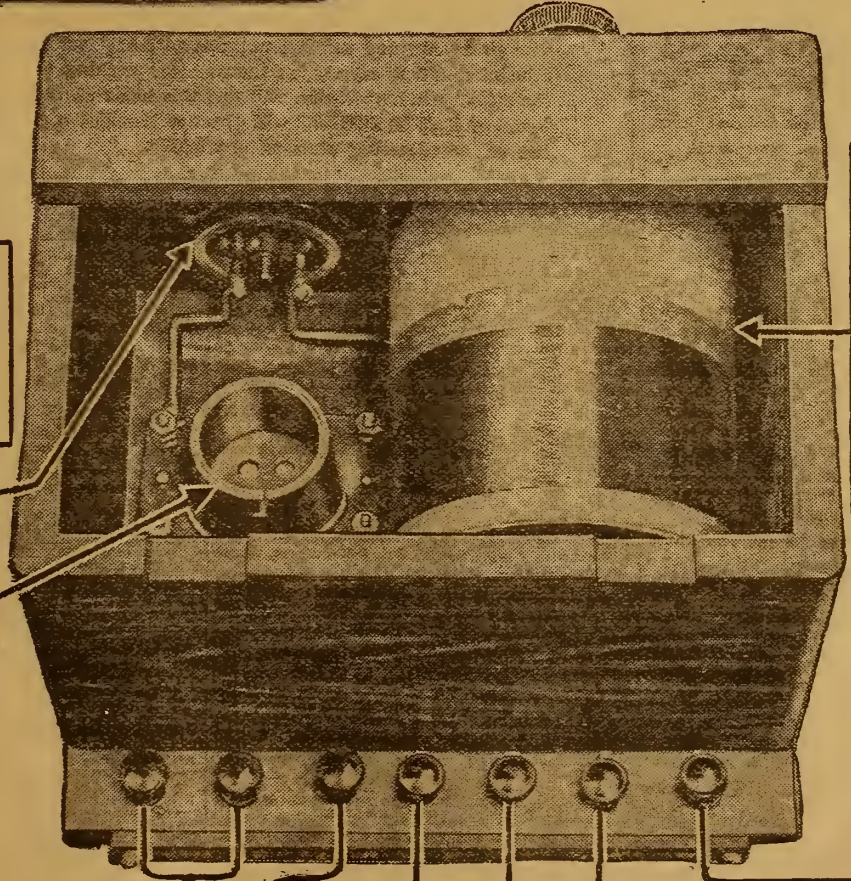

Tapped Primary Coil



Receivers

22 1/2 V. "B" BATT.

6 V. "A" BATTERY

Ground

Radiophone Broadcasting Stations

Corrected Every Week—Part I

AG1, Presidio of San Francisco, Cal. 50 mi. Signal Corps, U. S. A. Sun, 7-9 pm, instruction, Pacific.

AQ6, Canton, O. 425 only, 75 mi. Hdqtrs. 135th F. Artillery, N. G. Wed, Fri, music, Sun, church services, Eastern.

AS6, San Antonio, Tex. 450 only, U. S. Army, Camp Travis, Mon, 7:30-8:30 pm, Thurs, 9:30-10:30 pm, music, Central.

AV7, St. Paul, Minn. Signal Corps, U. S. A.

BE1, Tacoma, Wash. 400 only, Camp Lewis, U. S. Army, Third Signal Company.

CFAC, Calgary, Alta., Can. 430 only, 400 mi. Western Radio Co., Ltd. Daily ex Sun, 3:30-4:30 pm, Daily, 7:45-8:45 pm, Mountain.

CFCA, Toronto, Ont., Can. 400 only, 500 mi. Toronto Star, Daily ex Sun, 12 m, weather; 2:30-3:30 pm, news, music; 5:30-6, news; 8-9, concert, Sun, 8:45-9:45 pm, concert, Eastern.

CFCB, Vancouver, B. C., Can. 440 only, 1,500 mi. Marconi Co. Daily ex Wed, Sun, 3:30-4:30 pm, Daily, 8:30-9:30 pm, reports, news, music, Pacific.

CFCE, Halifax, N. S., Can. 440 only, 150 mi. Marconi Co. Mon, Wed, Sun night, music, entertainment.

CFCF, Montreal, P. Q., Can. 440 only, 1,000 mi. Marconi Co. Daily ex Sun, 1-1:30 pm, Mon, Wed, Fri, 7:30-9 pm, Eastern.

CFCH, Ingoquois Falls, Ont., Can. 400 only, 200 mi. Abitibi Power & Paper Co., Ltd. Daily, 8 pm, weather and stock reports, Experimental station, Eastern.

CFCN, Calgary, Alta., Can. 440 only, 300 mi. W. W. Grant Radio Ltd., Experimental station, Sat, Sun, after 11:30 pm, Mountain.

CFCL, London, Ont., Can. The London Advertiser.

CFCC, Fort Frances, Ont., Can. International Radio Develop. Co.

CFCT, Toronto, Ont., Can. The Bell Telephone Co.

CFVC, Vancouver, B. C., Can. Victor Wentworth Odium.

CHBC, Calgary, Canada, 410 only, 1,000 mi. W. W. Grant Radio Ltd. (Morning Alberta.) Daily, 8:45-10 pm, news, stock quotations, music, Mountain.

CHCA, Vancouver, B. C., Can. Radio Corp. of Vancouver, Ltd.

CHCB, Toronto, Can. Marconi Co.

CHCE, Edmonton, Alta., Can. Can. Westinghouse Co., Ltd.

CHCF, Winnipeg, Man., Can. Radio Corp. of Winnipeg, Ltd.

CHCO, Calgary, Alta., Can. 400 only, 150 mi. Western Radio Co., Ltd. Daily ex Sun, 3:30-4:30 pm, Daily, 7:45-8:45 pm, Mountain.

CHCS, London, Ont., Can. London Radio Shoppe.

CHCX, Montreal, Que., Can. B. L. Silver.

CHCZ, Toronto, Ont., Can. Globe Printing Co.

CHCC, Vancouver, B. C., Can. Can. Westinghouse Co., Ltd.

CHCO, Toronto, Canada, 410 only, 200 mi. Metropolitan Motors Co. Daily ex Sat and Sun, 6:50-8:30 pm, news, concert, Eastern.

CHXC, Ottawa, Ont., Can. 400 only, 50 mi. J. R. Booth, Jr. Mon, Wed, Sat, 8:30-10 pm, music, entertainment, Eastern.

CHY, Montreal, Que., Can. Northern Elec. Co.

CHZ, Montreal, Que., Can. 420 only, 75 mi. Dupuis-Freres, Wed, Fri, 9-10 pm, music, Eastern.

CJCA, Edmonton, Alta., Can. 450 only, 1,000 mi. Edmonton Journal, Ltd. Daily ex Sun, 12 m, reports, concert; 8:30-10 pm, concert, Western.

CJCB, Nelson, B. C., Can. 400 only, 100 mi. James Gordon Bennett, Daily, 8-9 pm, music, news, reports, Pacific.

CJCD, Toronto, Canada, 410 only, 200 mi. T. Eaton Co. Daily ex Sat and Sun, 4-4:30 pm, concert, Sat, 12-12:30 pm, concert, Eastern.

CJCE, Vancouver, B. C., Can. 420 only, 150 mi. Vancouver Sun. Daily ex Sun, 12:30-1:30 pm, 3:30-5, 8-10, music, news, Pacific.

CJCF, Kitchener, Ont., Can. 420 only, 50 mi. The News Record, Ltd., Thurs, 9-11 pm, Eastern.

CJCG, Winnipeg, Canada, 410 only, 1,000 mi. Manitoba Free Press, Daily ex Sun, 10-10:30 am, news; 12-1 pm, reports, Mon, Thurs, 8-10 pm, concert, Tues, 7-8 pm, music, Fri, 5:30-6:45 pm, music, Sun, 8 pm, every other week starting August 20, Central.

CJCH, Toronto, Ont., Can. United Farmers of Ontario.

CJCI, St. John, N. B., Can. 400 only, 75 mi. McLean, Holt & Co., Ltd. Daily, 8-9 pm, music, news, weather, Eastern.

CJCN, Toronto, Ont., Can. Simons, Agnew & Co. Telephone Co.

CJCS, Halifax, N. S., Can. Eastern Telephone & Telegraph Co.

CJCV, Calgary, Alta., Can. Edmund Taylor.

CJCG, London, Ont., Can. 430 only, 800 mi. London Free Press, Daily ex Sun, 12:30-1:30 pm, news, weather, Daily ex Tues, 7-7:45 pm, music, Tues, 7:30-8:30 pm, concert, Eastern.

CJNC, Winnipeg, Man., Can. 400 only, 1,000 mi. Tribune Newspaper Co. Daily ex Sun, 9:30-10 am, 1-2 pm, Mon, 5:30-6:45 pm, Tues, 8-10 pm, Fri, 7-8 pm, Sun, 3-4 pm, Central.

CJSC, Toronto, Ont., Can. Evening Telegram.

CKA, Montreal, Que., Can. 430 only, 1,000 mi. La Presse, Daily ex Sun, 1:30 pm, weather; 1:35-2:30, concert; 4:30-4:55, reports; 5:30-6, dance music, Tues, Thurs, Sat, 7-7:30 pm, bedtime stories; 7:30-8:30, concert; 8:30-9:30, music; 10:30-11:30, dance music, Sun, 4-4:45 pm, 5-6, music, Eastern.

CKB, Winnipeg, Man., Can. T. Eaton Co., Ltd.

CKCD, Vancouver, B. C., Can. 410 only, 150 mi. Vancouver Daily Province, Daily ex Sun, 8:30-9:30 pm, music, entertainment, news, Pacific.

CKCE, Toronto, Ont., Can. Can. Ind. Telephone Co.

CKCF, Regina, Sask., Can. 420 only, 1,500 mi. Leader Pub. Co. Daily ex Sun, 10-10:30 am, news, music; 1:15-2 pm, reports, music, Mon, Wed, Fri, Sat, 7:30-8:15, music, Tues, 7:30-9, concert, Sun, 9 pm, sacred concert, Mountain.

CKCR, St. John, N. B., Can. 400 only, 75 mi. Jones Elec. Radio Co., Ltd. Daily 4-5 pm, concert, reports, Atlantic.

CKCS, Montreal, Que., Can. The Bell Telephone Co.

CKZ, Toronto, Ont., Can. Westinghouse Co., Ltd.

CKKC, Toronto, Ont., Can. Radio Equipment & Supply Co., Ltd.

CKOC, Hamilton, Ont., Can. 410 only, 100 mi. Wertsworth Radio Supply Co., Ltd. Mon, Wed, Fri, 8:30-9:30 pm, concert, Sun, church services, Eastern.

CKQC, London, Ont., Can. 410 only, 50 mi. Radio Supply Co. Mon, Wed, Fri, 7:30-8:30 pm, music, entertainment, Eastern.

CKZC, Winnipeg, Man., Can. Salton Radio Eng. Co.

DD5, Denver, Colo. 412 only, 1,500 mi. Fitzsimmons Gen. Hospital, Mon, Wed, Fri, 8-9 pm, music, Mountain.

DM4, San Antonio, Tex. 1,500 mi. U. S. Army, Kelly Field. No regular schedule.

DM7, San Antonio, Tex. 200 mi. U. S. Army, Brooks Field. No regular schedule.

DN4, Denver, Colo. 340 only, 200 mi. Colorado National Guard, Daily ex Sun, 8:15 pm, weather, news, concert, Thurs, 8:15-9:30 pm, special concert, speech, Mountain.

KDBZ, Bakersfield, Calif. 100 mi. Frank Siefert, Daily ex Sun, 7:30-8:15 pm, reports, music, Sun, sacred program, irregular, Pacific.

KDKA, E. Pittsburgh, Pa. 400 and 485 only, 2,000 mi. Westinghouse Elec. & Mfg. Co. Daily ex Sun, 10-10:15 am, 12:30-1 pm, music; 3:00, sports; 7:00-9, news, features, markets, entertainments; 9-9:55, concert; 9:55-10 pm, time, Sun, 10:45 am, church service; 2:45 pm, Bible story; 3 pm, 7:30, church service, Eastern.

KDN, San Francisco, Calif. 485, 510 also, 500 mi. Leo J. Meyberg Co. Daily, 1-2 pm, 8:30-9, 4:30-5:30, 7-7:15 pm, music, reports, concert, Pacific.

KDWW, New York, N. Y. S. S. America. Home port is New York.

KDFM, Cleveland, O. Westinghouse Elec. & Mfg. Co. KDP, San Diego, Calif. 250 mi. Southern Elec. Co. Daily 7:30-9 pm, news, weather, concert, lecture, Pacific.

KDYL, Salt Lake City, Utah, 485 also, 500 mi. Salt Lake Telegram, Daily ex Sun, 7-8 pm, news, music, entertainment, Mountain.

KDYM, San Diego, Calif. Savoy Theater.

KDYO, San Diego, Calif. Carlson & Simpson.

KDYQ, Portland, Ore. Oregon Inst. of Technology.

KDYS, Great Falls, Mont. 485 also, 1,000 mi. Great Falls Tribune, Daily 12 m weather, time, Mon, Wed, Sat, 8-10 pm, Utah, Sun, 4 pm, church services, Mountain.

KDYW, Salt Lake City, Utah, Cope & Cornwell Co. KDW, Phoenix, Ariz. 100 mi. Smith Hughes & Co. Daily ex Sat, 7-7:30 pm, Mountain.

KDYX, Honolulu, T. H., Hawaii, 500 mi. Honolulu Star-Bulletin Co. Ltd., Daily ex Sun, 12:15-1:15 pm, reports; 6:30-7:30 pm, entertainment, music, talks, Sun, 11 am-12:15 pm, 5-6, church services, 12:00 Meridian.

KDZA, Tucson, Ariz. Arizona Daily Star.

KDZB, Bakersfield, Calif. Frank E. Siefert.

KDZE, Seattle, Wash. 500 mi. The Rhodes Co. Daily ex Sun, 10:30-11 am, 3:30-4:30 pm, news, music, Mon, Fri, 7-8 pm, concert, Wed, 8-9 pm, concert, Pacific.

KDZF, Los Angeles, Calif. Automobile Club of Southern California.

KDZG, San Francisco, Calif. Cyrus Pierce & Co.

KDZH, Fresno, Calif. 485 also, 500 mi. The Herald-Buford Co., Daily ex Sun, 8:15 am, 4-6 pm, news, reports, Daily ex Tues, Fri, 7-8 pm, reports, music, Tues, Fri, 8-9 pm, Pacific.

KDZI, Wenatchee, Wash. Electric Supply Co.

KDZK, Reno, Nev. 50 mi. Nev. Mch. & Elec. Co. Wed, Fri, Sat, Sun, 8-9 pm, music, entertainment, Pacific.

KDZL, Ogden, Utah, Rocky Mountain Radio Corp.

KDZM, Centralia, Wash. 50 mi. Hollingworth Hdw. & Radio Supply Store, Daily ex Sat & Sun, 8-9 pm, music, Pacific.

KDZP, Los Angeles, Calif. Newberry Elec. Corp.

KDZO, Denver, Colo. 500 mi. Wm. D. Pyle, Daily ex Sun, 6:45-7:15 pm, news, 9-10 pm, concert, Mountain.

KDZR, Bellingham, Wash. 200 mi. The Bellingham Pub. Co. Daily ex Sun, 7-8 pm, 8:30-9, music, news, codes, reports, Sun, 7-8 pm, music, Pacific.

KDZT, Seattle, Wash. Seattle Radio Assn.

KDZW, San Francisco, Calif. Claude W. Gerdes.

KDZZ, Everett, Wash. 50 mi. Kinney Bros. & Sep-

ply Co. Mon, Wed, Fri, 8-9 pm, music, Tues, 8-10, sports, Mountain.

KFC, Wallace, Ida. 380 only, 100 mi. Auto Supply Co. Daily, 7:30-8:30, Pacific.

KFCD, Salem, Ore. 100 mi. F. S. Barton, Daily ex Sun, 12-1 pm, 8-9, music, news, Sun, 3-4 pm, church service, Pacific.

KFCF, Walla Walla, Wash. Frank A. Moore.

KFCG, Billings, Mont. 500 mi. Electric Service Station, Inc. Tues, Thurs, Sat, 7:30-9 pm, music, Mountain.

KFCJ, Colorado Springs, Colo. Colorado Springs Radio Co.

KFCL, Los Angeles, Calif. Los Angeles Union Stock Yards.

KFCM, Richmond, Calif. 500 mi. Richmond Radio Shop, Mon, 8-9 pm, music, Sun, 1-2 pm, music, Pacific.

KFCQ, Casper, Wyo. Motor Service Stn.

KFDA, Baker, Ore. Adler's Music Store.

KFDB, San Francisco, Calif. Mercantile Trust Co.

KFDF, Spokane, Wash. 25 mi. E. B. Craney, Daily ex Sat, Sun, 6-7 pm, music, Sat, 8-10 pm, Sun, 4-5 pm, Pacific.

KFDD, Boise, Idaho. St. Michael's Cathedral, Sun, 11-15-12:30 pm, 8-9:15 church services, Mountain.

KFDF, Casper, Wyo. Wyo. Radio Corp.

KFDH, Tucson, Ariz. Univ. of Ariz.

KFDI, Corvallis, Ore. Oregon Agr. College.

KFDL, Denver, Colo. Knight-Cambell Music Co.

KFDS, San Francisco, Calif. John D. McKee.

KFEB, Taft, Calif. City of Taft.

KFEC, Portland, Ore. 25 mi. Meier & Frank Co., Inc. Daily ex Sun, 4-5 pm, music, Thurs, Sat, 9-10 pm, concert, Pacific.

KFED, Polytechnic, Mont. 100 mi. Billings Polytechnic Institute, Mon, 8-9 pm, lectures, Mountain.

KFEJ, Tacoma, Wash. Guy Gresson.

KFEP, Denver, Colo. Radio Equipment Co.

KFFA, San Diego, Calif. Dr. R. C. Shelton.

KFFE, Pendleton, Ore. 100 mi. Eastern Oregon Radio Co., Daily, 7:30-8 pm, music, Pacific.

KFGG, Astoria, Ore. Astoria Budget.

KFGH, Stanford Univ., Calif. 500 mi. 300 and 410 also. Leland Stanford Junior University. No regular schedule.

KFHI, Santa Barbara, Calif. Fallon Company.

KFJ, Los Angeles, Calif. 500 mi. Earle C. Anthony, Inc. Daily ex Sun, 1-1:30 pm, Daily ex Mon & Fri, 7:40-8:20 pm, Tues, Sat, 2-3 pm, Sun, 10:45-11 am, 4-5 pm, 7:40-8:20, Pacific.

KFV, Yakima, Wash. 250 mi. Foster-Bradbury Radio Store, Daily ex Sun, 3-4 pm, Mon, Wed, Fri, 8-9 pm, Pacific.

KFZ, Spokane, Wash. 300 mi. Doerr Mitchell Elec. Co. Tues, Wed, Fri, Sat, 7-8:30 pm, music etc. Pacific.

KGB, Tacoma, Wash. 200 mi. Tacoma Daily Ledger-William A. Mullins Elec. Co. Daily ex Sun, 7-9 pm, Sun, 5-7:30 pm, Entertainment, news, weather, tides, police reports, Pacific.

KGG, Portland, Ore. 500 mi. Hallock & Watson Radio Service, Daily ex Sun, 5-6 pm, music, entertainment, 7:30-8 pm, reports, Sun, 9-10, music, Pacific.

KGN, Portland, Ore. 100 mi. Northwestern Radio Mfg. Co. Irregular schedule.

KGO, Altadena, Calif. 350 only, 300 mi. Altadena Radio Lab. Mon, Wed, Fri, 5:15-6 pm, reports, code lessons, agriograms, Tues, Thurs, 7:40-8:20 pm, concerts, Fri, 7:40-9 pm, concert, Sun, 2-3 pm, church service, Pacific.

KGU, Honolulu, Hawaii, 485 also, 150 mi. The Honolulu Advertiser, Daily, 7:30-9 pm, Tues, Thurs, Sat, special program, 15:00 meridian. (Three hours later than Pacific.)

KGW, Portland, Ore. 400 only, 2,000 mi. Oregonian Pub. Co. Mon, Wed, Fri, 8-9 pm, music, lectures, news, reports, Sun, 7-8 pm, church services, Pacific.

KGY, Lacey, Wash. 50 mi. St. Martins College, Tues, Fri, Sun, 8:30-9:30 pm, news, concert, bedtime story, Pacific.

KHD, Colorado Springs, Colo. 485 also, 50 mi. Daily ex Sun, 8:15 am, weather, Mon, Wed, Fri, 7-7:30 pm, music, lectures, Mountain.

KHL, Los Angeles, Calif. 400 and 485 only, 2,000 mi. Los Angeles Times, Daily ex Sun, 12:30-1:15 pm, 7-7:30, 8-9:30, Sun, 10-11 am, Pacific.

KHQ, Seattle, Wash. Louis Wasmer.

KJI, Sunnyvale, Calif. 500 mi. Radio Shop, Tues, 8:15-9 pm, Fri, 7:30-8:15 pm, Pacific.

KJL, Stockton, Calif. C. O. Gould.

KJR, Seattle, Wash. 200 mi. Northwest Radio Service Co. Daily ex Sun, 8-9 pm, miscellaneous, Pacific.

KJS, Los Angeles, Calif. 100 mi. Bible Inst. of Los Angeles, Tues, Wed, 12-12:30 pm, sacred music, lecture, Sun, 11:30-12:30 pm, sacred music, sermon, Pacific.

KLB, Pasadena, Cal. 300 mi. J. J. Dunn Co. Mon and Fri, 7:30-8:15 pm, concert, Sun, 3-4 pm and 8-9, concert, Pacific.

KLN, Del Monte, Calif. Monterey Elec. Shop, Daily 12-1 pm, weather, markets, news; 7-8 pm, concert, Pacific.

KLP, San Francisco, Calif. 500 mi. Colin B. Kennedy Corp. Mon, 7:30-8:30 pm, Thurs, 8:30-9 pm, Sun, 4-5 pm, Pacific.

KLF, San Francisco, Calif. 300 mi. Warner Bros. Radio Supply Co. Daily, 12-1 pm, Sat, 7:30-8:15 pm, Pacific.

KLX, Oakland, Calif. 500 mi. Oakland Tribune, Daily ex Sun, 7:15-7:30 pm, news, entertainment, Tues,

7:30-8:15 pm, Fri, 8:15-9 pm, and Sun, 3-4 pm, concert, Pacific.

KLZ, Denver, Colo. 200 mi. Reynolds Radio Co. Daily ex Sun, 7:30 pm, news, markets, bedtime story, concert, Thurs, 8-9 pm, concert, Sun, 8-9 pm, church services, Mountain.

KMJ, Fresno, Calif. 200 mi. San Joaquin Lt. & Pr. Corp. Tues, Fri, 7-8 pm, music, Sun, 5-6 pm, music, Pacific.

KMO, Tacoma, Wash. 200 mi. Tacoma Times. (Love Electric Co.) Daily ex Sun, 11-1 pm, 6-7, 9:15-10, concert, news, lecture, Pacific.

KNI, Eureka, Calif. T. W. Smith.

KNJ, Roswell, New Mex. 485 also, 750 mi. Roswell Public Service Co. Daily, 8 pm, news, reports, concerts, Mountain.

KNN, Los Angeles, Calif. 100 mi. Bullock's, Mon, 2:30-3:30 pm, Wed, 2:15-3 pm, Thurs, 4-5 pm, Pacific.

KNT, Aberdeen, Wash. 400 mi. Grays Harbor Radio Co. Daily, 5:30-6 pm, 7:30-8:15, news, concert, Pacific.

KNV, Los Angeles, Calif. Radio Supply Co.

KOB, State College, N. M. 485 also, 500 mi. N. M. College Agr. & Mech. Arts, Daily ex Sun, 11:55-12 m, reports, Mon, Wed, Fri, 7:30-8:30 pm, concert, Mountain.

KOG, Los Angeles, Calif. 300 mi. Western Radio Elec. Co. Daily ex Sun, Wed, 5-5:30 pm, code, news, Mon, Fri, 7:40-8:20 pm, music, Wed, 4:30-5 pm, code, 8:20-9 pm, music, Pacific.

KON, San Diego, Calif. 200 mi. Holzwarner Inc. Daily ex Sun, 4-5 pm and 8:15-9, concert, news, Sun, 10-11 am, 4-5 pm and 8:15-9, church service, Pacific.

KOP, Detroit, Mich. Detroit Police Dept.

KPO, San Francisco, Calif. 300, 600 also, 500 mi. Hale Bros., Inc. Daily ex Sun, 11-12 m, 3:30-4:30 pm, concert, Wed, 7:30-8:15 pm, concert, Sun, 11-12:15 pm, church service, Pacific.

KQI, Berkeley, Calif. Univ. of Calif.

KQJ, Hood River, Ore. 350 only, 50 mi. Hood River News, Daily ex Sat, Sun, 7 pm, news, Tues, Fri, Sun, 8:30-9:30 entertainment, Pacific.

KQV, Pittsburgh, Pa. 300 mi. Doubleday-Hill Elec. Co. Daily ex Sun, 12-12:30 pm, 2:30-3, music, lectures, Mon, Wed, Fri, 10-11 pm, music, entertainment, Eastern.

KQW, San Jose, Calif. 345 also, 500 mi. Chas. D. Herold, Daily ex Sun, 1-1:30 pm, Wed, 8:15-9 pm, concert, Pacific.

KQY, Portland, Ore. 200 mi. Stubbs Elec. Co. Daily, 1-2 pm, 6-7, Pacific.

KRE, Berkeley, Calif. 200 mi. Maxwell Elec. Co. Every other Sat, 8:15-9 pm, Sun, 1-2 pm, 6-7, Pacific.

KSD, St. Louis, Mo. 400 and 485 only, 1,500 mi. St. Louis Post Dispatch, Daily ex Sun, 9:40 am, 10:40, 11:40, 12:40 pm, 1:40, 2:40, 4, 8, Thurs and Sun, silent nights, Mon, Thurs, 11:30 pm, concerts, Central.

KSL, San Francisco, Cal. 50 mi. The Emporium, Daily ex Sun, 10-11 am, concert, news; 2-3 pm, concert, educational talk, Sun, 2-3 pm, concert and educational talk, Pacific.

KSS, Long Beach, Calif. Prest & Dean Radio Co. No regular schedule.

KTW, Seattle, Wash. 500 mi. First Presbyterian Church, Sun, 11-12:30 pm, 3-4:30, 7-9:30, church service, Pacific.

KUO, San Francisco, Calif. 485, 525 also, 1,500 mi. San Fran Examiner, Daily ex Sun, 9-10 am, concert, chat to housewives; 11-12, reports; 3-3:30 pm, lecture, news; 5:30-6:45 pm, concert; 9 am, 12 m, 6:45 pm, weather report, Wed, 3:30 pm, health bulletins, Sun, 9-10 am, concert; 5-6 pm, concert, news, Pacific.

KUS, Los Angeles, Calif. City Dye Works & Laundry Co.

KUY, El Monte, Calif. 500 mi. Coast Radio Co. Daily ex Sun, Sat, 4-4:45 pm, Mon, Thu, 8:20-9 pm, Sat, 3-4 pm, Pacific.

KW, Sacramento, Calif. 300 mi. Sacramento Bee, Daily ex Sun, 6:30-7:30 pm, news, reports, music, Sun, 6-7 pm, reports, music, Pacific.

KWG, Stockton, Cal. 1,500 mi. Portable Wireless Telephone Co. Daily ex Sun, 4-5 pm, news, concert, markets, Tues and Fri, 8-9 pm, concert, Sun, 2-3 pm, concert, Pacific.

KWH, Los Angeles, Calif. 485 also, 250 mi. Examiner, Daily ex Sun, 1:30-1:40 pm, 5:30-6, 6-6:15, 8:20-9, reports, entertainment, Sun, 8:30-9 pm, church service, Pacific.

KXN, Modesto, Calif. Herald Pub. Co.

KXS, Los Angeles, Calif. Braun Corp.

KYI, Bakersfield, Calif. Bakersfield Californian.

KYJ, Los Angeles, Cal. 485 also, 1,000 mi. Leo J. Meyberg Co. (Hamburgers). Daily ex Sun, 4-5 pm, concert, markets, weather, news, Mon, Thurs, Sat, 8-9 pm, same program, Pacific.

KYQ, Honolulu, Hawaii. Electric Shop. No definite schedule.

KYW, Chicago, Ill. 400 and 485 only, 2,000 mi. Westinghouse Elec. & Mfg. Co. Daily ex Sun, 9:25 am, 10, 1:20 pm, 2:15, 2:30, markets; 3 (3:30 ex Mon, Wed, Fri), 4:15, 4:30, 5, news, sports (6:30 Mon, Wed, Fri), 6:15, 6:30, 6:50, bedtime stories; 8-9, music; 9, news, sports; 9:05, special, Sun, 11 am, 3:30 pm, 7, church services, Central.

KYV, San Francisco, Calif. The Radio Telephone Shop, KZG, Seattle, Wash. 100 mi. Public Market & Department Store, Daily ex Sun, 6:45-7:15 pm, music, news, agriograms, Pacific.

KZM, Oakland, Calif. 200 mi. Western Radio Institute (Hotel Oakland), Daily ex Sun, 6:45-7 pm, news, Pacific.

KZN, Salt Lake City, Utah, 485 also, 1,000 mi. Deseret News, Daily ex Sun, 3-4 pm, reports, music, 8-9:30 pm, music, news, bedtime stories etc. Mountain.

KZV, Wenatchee, Wash. Wenatchee Battery & Motor Co.

KZAN, San Francisco, Calif. Atlantic-Pacific Radio Supplies Co.

NAA, Arlington, Va. 710 only, 2,000 mi. Official government broadcasting station. U. S. Navy Dept. Mon, Tues, Thurs, 7:15-7:30 pm, lecture, Mon, Thurs, 6:45-7 pm, lecture, Tues, Thurs, 7:45-8 pm, health lecture, Wed, Fri, 8:30-9:45 pm, band concert, Eastern.

PWX, Havana, Cuba. Cuban Telephone Co.

WAI, Dayton, O. McCook Field, U. S. Army.

WAAB, New Orleans, La. Valdemar Jensen.

WAAP, Wichita, Kan. 500 mi. United Electric Co. Daily ex Sun, 12-12:30 pm, educational program; 10:30 pm, weather, Tues, Fri, 8 pm, entertainment, Central.

WAAJ, Boston, Mass. 50 mi. Eastern Radio Inst. Mon, Wed, Fri, 9-10 pm, music, Eastern.

WAAK, Milwaukee, Wis. 300 mi. Gimbel Bros. Daily ex Sun, 10 am, 11:10, 12:10 pm, 1:25, 3, Daily ex Wed and Sat, 7:15, 7:30 pm, Central.

WAAM, Newark, N. J. 300 mi. I. R. Nelson Co. Daily ex Sun, 11-11:55 am, 3-4 pm, music, Wed, Eastern.

7:30-8 pm, code instruction; 8-9, special program.

WAAN, Columbia, Mo. Univ. of Mo.

WAAP, Wichita, Kan. 500 mi. United Electric Co. Daily ex Sun, 12-12:30 pm, educational program; 10:30 pm, weather, Tues, Fri, 8 pm, entertainment, Central.

WAAQ, Greenwich, Conn. 600 mi. New England Motor Sales Co. Daily ex Sun, 9:30 am-8:30 pm, every half hr, Eastern.

WAAS, Decatur, Ga. Georgia Radio Co.

WAAT, Jersey City, N. J. 70 mi. Jersey Review, Wed, 7-8 pm, concert, lecture, Sun, 7-8, church service, concert, Eastern.

WAAW, Omaha, Neb. 485 also, 500 Omaha Grain Exchange, Daily ex Sun, 11:45, 12:45, 1:45, 1:50, 8 pm, market reports, 8:15-9 pm, music, Central.

Continued—

THE BROADCASTING station directory is the most complete and authentic list of radiophone plants. Letters are being sent various stations every day for information. No other paper or source provides the data given here. The idea is original and a service which RADIO DIGEST has maintained from the start. Every public service broadcasting station is to be found now, not only in the location index, but in the schedule list. The latter, however is divided, one third appearing this week, the second third to appear next week, and the last part, together with the state, city, station index, to appear the week following.

The station schedules, given here, are listed alphabetically by call letters. Following the call is given the city and state, the wave length (PROVIDING a wave length other than 360 meters is used), the miles range of the station, the owner of the station, the schedule of operating hours, and the kind of time used.

The state, city and call list appears with the last third of the station schedules and is merely an index. One wishing to find the calls of the stations in his vicinity, will find this index useful. Three successive issues of RADIO DIGEST will give one the most complete and accurate list of broadcasting stations obtainable.

(NOTE—The second part of the station schedule list will appear next week.)

Multiple Phone Connector

A Simple and Inexpensive Way of Making Connection

Frequently one wishes to use two or more phones on the receiving set. A simple and inexpensive way of making the connection is by means of the arrangement shown in the illustration. Two pieces of sheet brass or copper measuring about 3/4 inch wide and 3 inches long are required. Also, you will need six or more spring connectors taken from old dry cells. If

posts. The phone cord tips are then attached to the spring connectors. If phone condensers are not used or condenser is not equipped with binding posts, the brass strips may be mounted on a piece of bakelite or other panel material, or to the panel itself and connecting wires from the set should then be attached to the brass strips.

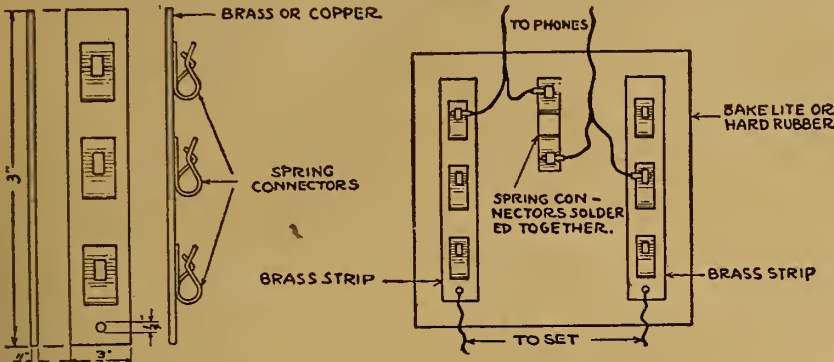

one wishes to use three headsets in multiple, three of the spring connectors are soldered to each of the pieces of brass. If the phone condenser is equipped with binding posts for wire connections, a 1/4 inch hole should be drilled through each of the brass pieces near the lower end, and they may then be attached to the phone condenser by using the regular binding

A simple arrangement for connecting phones in series is shown in the second sketch. Here the brass strips are supported on a piece of bakelite in any desired manner. Additional connectors soldered together in pairs are also required. The sketch shows the method of connecting two phones in series.—P. Starck, Sterling, Ill.

Efficient Single Tube Set

Using the hook-up shown with a single wire aerial 80 feet long and 30 feet above the ground and an ordinary ground I have heard fifty different stations, the most distant ones being KLZ and KEAF at Denver, Colorado. I am using a 23 plate condenser and a vernier condenser in parallel with the primary of the vario coupler, but these are not absolutely necessary,

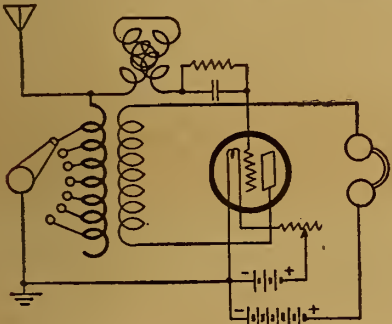

although they make tuning easier. It may appear that the variometer in the grid circuit is not necessary, but I find that without using it, the tube filament must be turned on more brightly to obtain the same results. By using it the life of the tube is lengthened and also the tuning is made easier. When condensers are not used the variometer is absolutely necessary for tuning.

I also found that the plate voltage for the better operation of this set may be found by letting the tube oscillate and then rotate the tickler coil. If a click is heard in the phones, as the tickler is rotated, the voltage is too high. It should be lowered in small steps until the click is eliminated. This will be the best voltage to use. Lower voltage will bring in a weak signal and a high one will be difficult to tune. When the plate voltage is right the set will be easy to tune.

In selecting a detector tube I find that the best one to use may be found by turning the filament rheostat about half way and inserting different tubes, in turn, in the socket. The one which gives the brightest light is invariably the best.

I have obtained better results with this set than any of my friends using a one-tube set, either homemade or otherwise.—John Brown, Youngstown, O.

Antenna Protects House

The antenna will not attract lightning any more than a lightning rod, telephone wire, gutter pipe or tin roof. The antenna, if installed properly, is much less likely to be struck than any other object in the neighborhood. During a thunderstorm the antenna should be grounded, as when it is connected direct to the earth it serves as a medium which permits the static to pass from the air to the ground, as does the lightning rod. There is no risk with a Radio antenna properly installed.

Indoor Aerial Erection

When erecting an indoor aerial, hang up about 100 feet of wire, making the loop as large as possible, with the fewest number of turns. String the wires through the hall and around a room, or they can be given several turns around the ceiling in one room. Connections can be made by

using both ends, or the instrument can be connected to one end and a regular ground connection can be used on the other.—A. A. Vawnut, Chicago, Ill.

How to Make "Silver" Dials

Secure a sheet of stiff brass, cut it to the shape desired with whatever diameter is wished and clean it top and bottom with steel wool until it is bright. Having drilled the shaft and supporting screw holes for the knob, make a solution of sulphuric acid and rain water, using three parts of acid to one of water. Pour the acid into the water slowly, employing a porcelain bowl as container. Dip and wash the disc in this solution. Melt some tinfoil in a clean pan and when the foil has completely melted dip the brass disc in it, allowing it to remain for about fifteen seconds. Place it in a pan of water to cool.

The finish is made by rubbing surfaces with a small piece of clean cloth until the "silver" shines up brightly. The marking may be done with a pen and good ink, or indentations may be stamped in the brass disc before silvering. This treatment may be applied to all the brass work on the set with a resulting neatness in appearance. It would be well to give each part a heavy coat of lacquer or good varnish to prevent tarnishing.—R. U. Batty, Chicago, Ill.

MYERS TUBES

Dealers: Write for Discounts
Hudson-Ross, 123 W. Madison, Chicago

MAGNAVOX Radio

The Reproducer Supreme

THE two sizes of Magnavox meet every requirement—from home gathering to large public audience.

To hookup is simple—no extras or adjustments are required.

R-3 Magnavox Radio
with 14-inch horn (as illustrated)

For homes, offices, amateur stations, etc. . . \$45.00

R-2 Magnavox Radio
with 18-inch horn

For store demonstration, large audiences, dance halls, etc. . . \$85.00

At good dealers everywhere
THE MAGNAVOX CO. New York Office: 370 Seventh Ave.
Oakland, Cal.



R-A-D-I-O

BUY HERE FOR LESS

Radio Supplies purchased here are sold under a positive guarantee of satisfaction. We carry the largest new stock of first quality merchandise.

Complete Parts for Reinartz Circuit

Includes 1 7x18 Formica Panel, 1 Bakelite Socket, 1 Howard Vernier Rheostat, 23 Plate Condenser, 11 Plate Condenser, 3 Switch Levers, 2 Dozen Switch Points, 1 Reinartz Wound Coil, 1 Variable Grid Leak, 8 Binding Posts, 25 Feet Tinned Wire, 1 Base for Coil, 1 Mounting Base Board, and 1 Diagram to Construct This Set. Complete... **\$11.45**

ORIGINAL TYPE "C" BALDWIN UNITS \$4.95

COMPLETE PARTS FOR REG. RECEIVING SETS

This includes 2 Variometers, 1 Coupler, 3 Dials, 1 Rheostat, 1 Cunningham Detector Tube, 1 Bakelite Socket, 1 Mahogany Cabinet, 7x18 Formica Panel, 6 Binding Posts, 1 Switch Lever, 12 Switch Points, 2 Stops and 1 Diagram to construct this set. Set is capable of receiving 1,000 miles if installed with outdoor aerial..... **\$17.95**

VARIABLE CONDENSERS

\$4.30 Value, 43 PLATE, now \$1.75 \$3.10 Value, 5 PLATE, now \$1.25
\$3.70 Value, 23 PLATE, now \$1.45 \$2.70 Value, 3 PLATE, now \$1.15
\$3.30 Value, 11 PLATE, now \$1.35

U. S. A. Signal Corps Aviation Type Western Electric Phones, \$7.95

Each Phone Cap is covered with large soft rubber ear cushions, and an aviation leather helmet goes with each set! These are the only phones to pass the Government specifications for sensitiveness and loudness, the requirements called for in aircraft reception.

COMPLETE PARTS FOR FLEWELLING CIRCUIT

Includes 6x14 Formica Panel, 23 Plate Condenser, 3 Micon .006 Condensers, 1 Freshman Variable Grid Leak, 1 Remler Leak, 2 Coil Mount, 2 Honeycomb Coils, 2 Coil Plugs, 1 Socket, 1 Howard Vernier Rheostat, 8 Binding Posts and 1 Diagram to Wire and Construct This Set. Complete..... **\$12.45**

MAGNAVOX, Loud Speaker, Type R3 \$34.95

VARIOMETERS GENUINE MAHOGANY, \$5 VALUE, NOW **\$1.95**

VARIOCOUPERS, \$4.50 Value, Now **\$1.75**

HONEYCOMB COILS

1,500 Turns.....\$1.50	750 Turns.....\$1.00	75 Turns.....40c
1,250 Turns.....1.50	250 Turns.....75c	50 Turns.....40c
1,000 Turns.....1.25	150 Turns.....60c	35 and 25 Turns.....40c
	100 Turns.....50c	

\$8.50 Guaranteed 3,000 Ohm HEAD PHONES \$3.65

RHEOSTATS.....45c

Sponge Rubber EAR CAPS, Pair.....50c

DIALS, 2, 3 and 3 1/2 in.....25c

THORDARSON AMPLIFYING TRANSFORMERS \$4.50 VALUE, NOW **\$2.95**

GREWOL DETECTORS.....\$1.65

Signal Corps Super Sensitive Microphone Transmitters, **\$2.45**

Solid Copper Aerial Wire, 100 ft. 35c	2-Slide Tuning Coils, at \$1.95	Anti-Capacity Switches \$1.50
Spaghetti Tubing, yard 10c	3-Coil Honeycomb Mountings, with knobs \$4.20	Lightning Switches \$2.65
Cord Tip Plugs 60c	Phone Caps, for mostly all phones 25c	Hydrometers, now at 45c
Lightning Arresters 95c	Signal Corps Hot Wire Ammeters, at \$5.45	Freshman Variable Grid Leaks 95c

FORMICA PANEL 1/8" thick, Square Inch. 1 1/2" BLACK OR BROWN

WE GUARANTEE ALL MERCHANDISE PURCHASED OF US
Mail orders receive immediate attention

BUY HERE FOR LESS

CHICAGO SALVAGE STOCK STORE

509 South State Street, Chicago, Ill.

Radio Digest Illustrated

TRADE-MARK

Published by the Radio Digest Publishing Company, Inc.
123 West Madison Street
Telephone State 4844-4845
Chicago, Illinois

E. C. RAYNER, Publisher
Chas. F. Smisor, Editor Evans E. Plummer, Managing Editor
Harry J. Marx, Technical Editor

Eastern Representative, Jacob Miller, 2126 Broadway, New York
Telephone Columbus 2390

Pacific Coast Representatives
E. J. Wood, 251 Kearny St., San Francisco
Telephone Kearny 1472

H. M. Morris, 417 Western Mutual Life Building, Los Angeles
Telephone 12011



58
PUBLISHED WEEKLY

SUBSCRIPTION RATES

Yearly.....\$5.00 | Foreign.....\$6.00
Single Copies, 10 Cents

Vol. IV Chicago, Saturday, January 27, 1923 No. 3

Receiving Not Affected by Legislation

Owners of Receiving Sets Will Not Be Hampered

NO REGULATIONS are planned for receiving stations by the White-Kellogg bill. The whole bill considered and action taken will be devoted to the transmission of all Radio messages and broadcasts. The status of the amateur and the listener in, established by the present law, is left unchanged, except that the rights of the amateur are extended and additional wave lengths are assigned for his use.

Much is left to the discretion of the head of the Commerce Department, as it is believed that Radio has a fast growing future ahead of it which might be jeopardized if too stringent and detailed regulations were enacted into a law. Regulations believed just and necessary today, might within a space of a few months, prove a handicap to the natural development of Radio. Hence broad powers are planned for the secretary of commerce and his appointed advisory committee of twelve members.

Auto Clubs Direct Tourists

Ether Waves to Direct the Autoist on the Road

AUTOMOBILE clubs in the future will become centers of advice to traveling motorists. They are such aids now, but the future will see them sending out advice as to roads and directions while motorists are speeding along the highways. It will be done by Radio.

One inventor has designed an instrument for the automobile by which the driver can keep on the right track to whatever town he desires to reach by means of a method of Radio signaling. Wires strung along the roads carry the signals which are caught by the instrument on the dashboard while the car travels ahead.

This is only a crude beginning to what automobile manufacturers expect eventually to install in their cars. A Radio receiving and telephone transmitting set, compactly mounted on the right side below the dash, can be made to carry on conversation with the nearest automobile club. From the auto club, in this way, the driver can learn the way to his destination, or make hotel reservations, get aid in the event of a breakdown.

Naval Radio Earnings

Service Rendered Is Valuable and Profitable

RADIO in the navy, taken solely as a business proposition, is a money-maker for the Government. Government traffic handled by Radio stations, other than natural communications, would have cost \$1,080,800 at commercial rates and was less than a third of the traffic handled the preceding year. This amount added to the commercial receipts would have brought the year's business in naval Radio traffic to \$1,708,704 in receipts and savings. When it is considered that the navy in no way competes with commercial stations, but handles messages only where and when commercial stations are not available, the aid rendered in this auxiliary Radio work may be better appreciated.

For the merchant marine alone the naval communication service handled 3,749,483 words during the past year and forwarded press matter to the number of 1,012,279 words.

Will We Have Radio Power?

Wonders of the Future Most Difficult to Conceive

THE mind is hardly able to grasp the wonders of the future that may be accomplished by means of Radio-transmitted power; they are so revolutionary and so stupendous. In no direction does this apply with greater force than in the flights of aircraft, where the safety of the pilot and passengers and the capacity of the craft are so dependent upon a continuous supply of power.

It is within the range of possibility, in fact seems quite feasible, that air-power machinery other than an engine, might make as much as 500 miles an hour with comparative safety. This would make possible a trip through the air from New York to San Francisco between sunrise and sunset, and to intermediate points in a corresponding length of time.

Relieved of the weight of the engine, the plane could be equipped with safety devices, the weight of which now makes these impracticable. Without heavy and costly engines the price of the planes could be reduced to a figure that would make them available for carrying

Condensed

By DIELECTRIC

What marvel in Radio will be forthcoming in the year 1923? Will static be satisfactorily eliminated, thus encouraging the Radiophans to greet summer with a smile? Probably a great many who first knew of the varied entertainment a receiving set would provide, learned to operate one during the fall or winter and when the summer months came, with the unwelcome presence of static, lost considerable enthusiasm. In quite a few instances, I have known men and women to regard Radiophony as something to use and enjoy in those seasons when static was barely apparent, but to discard when sputtering and crashing noises were part of an evening's treat. A real fan fights through everything to gain his end; whether it be to await patiently a lull in the battle of strays in order to catch the station's call letters, or straining every nerve to pick up the faint code letters. I believe static will meet its complete banishment sometime during this year. I also expect to see vast strides in perfecting receiving sets. Let every means be used to further the success of science in each branch of Radio, and every fan actively support all movements tending toward our common good.

Secretary Hoover has a man's size job on his hands in attempting to regulate the multiplicity of details involved in Radio control. It is to be hoped he will receive the loyal support of all factions, for they must necessarily merge their interests in order to reap the full harvest. Strong elements at work with diametrically opposed objections will wreak havoc with what has already been accomplished. We, the Radio public, must not allow any corporate interest, department of government, nor any other agency to lose one iota of gain through lack of co-operation. While Radio is in its infancy is the time for us to permanently secure every advantage for its healthy growth, and this may be done by getting back of Herbert Hoover and upholding him.

If ever a "bug" is happy it is when he can remove every vestige of sneer from the supercilious, nonregenerated human, and it is possible to find such occasionally. The other day I happened to be standing in a stationer's store examining the material which finds its way into the columns of other Radio journals, just to see what some editors let by, and while doing so an acquaintance stopped to inquire if I was "one of those Radio fiends." Now that was a severe blow, for I am careful to apprise the unknowing that Radio is all things to me and without it I am as a tubeless set in a pauper's den. However, it afforded the opportunity to expound a little. He listened in, purchased a copy of RADIO DIGEST, and will soon possess the requisite equipment to classify as "one of those Radio fiends."

While feverishly working to bring in the program of a distant station you may unconsciously spoil the chances of a fellow fan attempting the same thing. When your tube produces interfering oscillations, someone is sure to suffer the consequences. It is said for the new tube invented by H. P. Donle that such interference is impossible when used in a plain circuit. It is to be hoped that this tube may find its way to market, if it does what is claimed for it. Considerable might be said on the subject of tubes, with especial reference to their selling price; also much might be written about the comparison between domestic and foreign manufactured articles.

At this season of the year the farmers are able to find time for some diversion and to devote a part of their leisure to storing up information about various phases of their work. Short courses in agriculture are provided in many of the agricultural colleges throughout the country, whereby the busy farmer may gain the latest knowledge to be had on the subject of animal husbandry, fruit growing, seed selection, etc. It is not possible for many farm owners to attend these courses of only a few months' duration. To them the use of Radio is invaluable. Receiving sets on farms are coming to be as much a regular part of family equipment, as are automobiles. Weather reports; crop reviews; price quotations on farm produce; general business conditions; each of these topics is sure to find attentive listeners among farmers. Some of the State Experiment Stations are now broadcasting lectures by professors of these institutions giving valuable data for use in the coming season's program of planting. Thus does Radio extend its services to the remote homestead, as well as to the crowded apartment.

Broadcasting stations are besieged with words of advice as to the method and matter to be used in satisfying their audiences. It is perhaps impossible to please each listener in on every program, but members of the Radio audiences are requested to write to the stations signifying their preferences, to which heed is given. When numbers in which you are not interested are being broadcast, it is possible to tune in another station where you may find something more to your liking, then turn back when the attractive feature comes along. The advice which I wish to give repeatedly until it is generally adopted is to announce the identity of the broadcasting station immediately following a selection. There are some stations practicing this to the great satisfaction of their audience. Listeners in wish to know to whom they are listening without being required to wait long periods for the announcement.

I had a long paragraph in mind on my pet topic—silent periods—and it looks as though I should have to keep it there for another week at least. Well, it is a chance to practice what I preach: six days of silence!



Shall Dreams Come True?

RADIO INDI-GEST

Friend of Isolation

You stay-at-home folks,
With your comfort and jokes,
Who sit while the North winds blow,
With your wives and your chicks
And your bright, blazing sticks,
Or the cheer of your big stoves glow;
Have you given a thought
To the fellow who's caught
Up North in the drear and the snow?
When the heat of your day
Has at last passed away,
And dimmed is your midsummer sun
When you're near by your fan,
Have you thought of the man



Who camps where the heat waves run;
Have you given a thought
To the one who has naught
Of companionship when day is done?
There is many a chap,
Who lives near a trap
Way up 'neath Aurora's bright glow
Who is chilled to the bone
As he dwells there alone,
But who's thankful he has Radio
Like the one who's hard fate
In the heat isolate,
It's a friend there at hand in the snow.

Ethereally Speaking

A California minister recently broadcast a talk upon



the value of the right atmosphere in home life. The home life, like Radio, often has static in its atmosphere.

It Often Sounds Like Soup

A Western writer poetically describes "great aerials that stretch from towers that pierce the sky." Someone should now immortalize the great artists who fill the "soup-bowl" transmitters that repose in the "sky parlors."

A. B. C. Lessons for Radio Beginners

By Arthur G. Mohaupt

CHAPTER IV

IT IS generally said that Radio messages travel through space in the form of a wave motion, or that certain concerts come in on a 400-meter wave length. Now as to the meaning of all these terms, wave motion, wave length, frequency, etc. Probably it can be explained and made more clear to all if we use the old familiar illustration of water waves as they exist on the surface of a pond or lake.

If a stone is dropped into a pond of still water, the entire surface of the pond at

one complete wave length consisting of a crest and a hollow. The horizontal line OX represents the position of rest, and the distance from this line to the highest or lowest part of a wave is known as the amplitude.

Being acquainted now with the nature of a wave and a wave motion in a medium, we are ready to consider the methods by which Radio messages are carried through space.

A complete Radio communication sys-

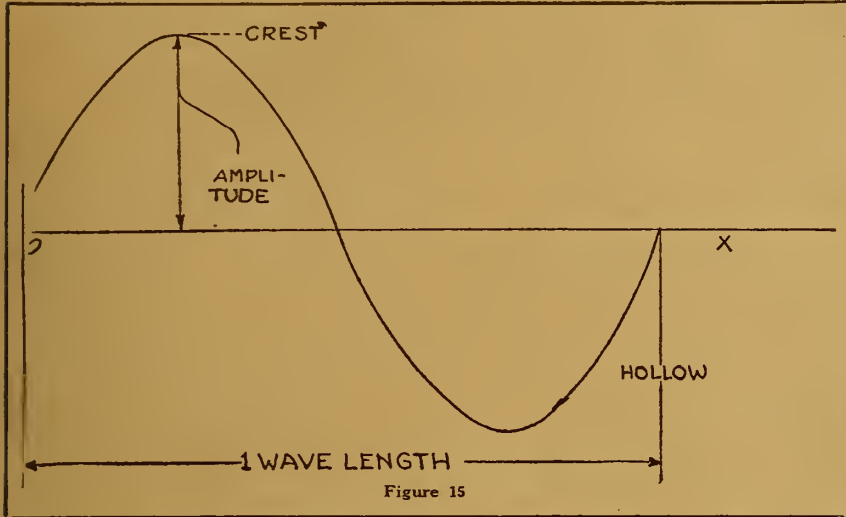

Figure 15

tem becomes disturbed. At the instant the stone strikes the surface, a circular ridge or crest at once forms and expands outward in all directions. Following the crest is a depression or trough in the water. Such a disturbance consisting of a crest and a hollow is called a wave. One important point to remember at this time is that the water does not actually move from the point at which the stone struck the surface, but the disturbance, only, moves outward until it strikes some object or dies out altogether.

Water Is Medium of Transmission

If the stone were tied to a string and pulled up and down so that it struck the water at regular intervals, the entire surface would soon be disturbed with a series of crests and hollows, all starting out at the point at which the stone struck and all spreading outward in all directions. Such a disturbance is called a wave motion, and the water in which the disturbance takes place is called the "medium of transmission."

The rate at which the stone is moved up and down determines the rapidity with which the waves are sent out, or the frequency. The frequency may thus be defined as the number of waves occurring per second. The greater the frequency, the shorter will be each wave; while the less the frequency, the longer will be each wave. Now by the length of a wave, or the wave length, we mean the distance

from one point on a wave to a corresponding point on the next wave. **Height of Wave Is Amplitude** Furthermore, if the stone is raised higher so that it strikes the water with a harder impact, then a more severe disturbance will be caused; that is, the waves will still be of the same length, but the crests will be higher and the troughs deeper. This brings in another new term, namely, amplitude. By the amplitude of a wave or wave motion is meant the maximum distance from the position of rest to highest or lowest point on a wave. The amplitude of a wave, it must be remembered, always depends upon the force or intensity with which the object strikes the medium.

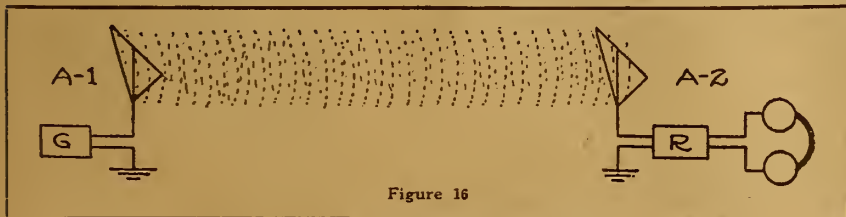

Figure 16

from one point on a wave to a corresponding point on the next wave.

Height of Wave Is Amplitude Furthermore, if the stone is raised higher so that it strikes the water with a harder impact, then a more severe disturbance will be caused; that is, the waves will still be of the same length, but the crests will be higher and the troughs deeper. This brings in another new term, namely, amplitude. By the amplitude of a wave or wave motion is meant the maximum distance from the position of rest to highest or lowest point on a wave. The amplitude of a wave, it must be remembered, always depends upon the force or intensity with which the object strikes the medium.

If a cork is placed on the water at some point, it will be caused to move up and down in exact accordance with the nature of the wave or disturbance that is passing. The cork will not move toward the shore, but will always remain at the same spot and merely move up and down. This shows that the water does not move toward the shore, but that the wave disturbance only moves through it. The cork, however, will in all respects, respond to the wave motion in the water on which it floats.

Thus in Figure 15 we have illustrated

impenetrable. Although no one has as yet in any way come into physical contact with the ether, still for want of a better explanation we will assume that this ether exists and that it is the medium through which Radio messages travel.

Extent of Ether

Various properties or qualities have been assigned to the ether in order to enable us to use it for explaining the various existing conditions. The ether extends throughout all space, even beyond the farthest stars. The ether exists around and through all objects much like water fills a sponge. It cannot be removed from any portion of space, nor can it be pumped out of a container. The ether also offers no opposition to objects moving through it, for the action would be similar to moving a sieve through the air. It is also of an extremely elastic nature, for a disturbance set up at any point in it immediately spreads outward in all directions.

Waves Emanate in All Directions

The Radio sending or transmitting station consists of some form of electromagnetic machinery by means of which a disturbance or wave motion is set up in this medium which we called the ether. These waves emanate or are sent out from the transmitting station by means of a group of parallel stretched wires known as the

transmitting antenna or aerial. These waves represent a certain amount of electrical energy sent out "broadcast" through space. In order that electrical energy can be sent out, through space in the form of a wave motion as was just explained, it is necessary that they be of very high frequency. Consequently, the apparatus in the transmitting station consists of a combination of oscillating circuits by means of which high frequency electric currents are generated, and these high frequency oscillating currents then excite the antenna and cause the electromagnetic waves to be radiated through all space.

Travel 186,000 Miles Per Second

The Radio waves leave the antenna and spread out in the form of expanding spheres all of which have the antenna as a center. They travel through space at the enormous speed of 186,000 miles (300,000,000 meters) per second. In other words, a Radio message would travel approximately eight times around the earth in one second if there were enough energy behind it to keep it going.

In Radio measurements the metric system is very extensively used. In the metric system the unit of length is the meter, which is equivalent to about 39.37 inches. Consequently a speed of 186,000 miles per second, if expressed in the metric system, would be 300,000,000 meters per second. A meter originally was chosen as one-tenth millionth part of the distance between the equator and either pole of the earth.

Waves in Commercial Practice

The waves used in Radio communication range in length from 75 meters (about 244 feet) to 25,000 meters (about 15 1/2 miles). Since Radio waves travel through space at the enormous speed of 300,000,000 meters per second, the above wave lengths represent frequencies ranging from 4,000,000 to 12,000 per second, respectively. The frequency can always be calculated by dividing the speed of propagation (300,000,000 meters per second) by the wave length. If it is desired to calculate the wave length when the frequency is known, it is only necessary to divide the speed by the frequency.

According to Government regulations, all amateur transmitting stations must operate at wave lengths not exceeding 200 meters. This corresponds to a frequency

of about 1,500,000 cycles per second. The shortest wave lengths used in commercial practice are 300 meters, which are the wave lengths used for communicating between ships at sea. Practically all broadcasting in this country at the present time is being done at wave lengths ranging from 360 to 485 meters, the corresponding frequencies being 833,000 and 618,000 oscillations per second. For reliable long distance communication such as trans-oceanic service, longer wave lengths are in general use, ranging from 10,000 to 25,000 meters. These longer wave lengths are more advantageous to use because they are less affected by atmospheric conditions and changes, and hence are more dependable for long distance transmission. Another important item is that when large quantities of power must be handled such as is necessary for long distance transmission, the sending apparatus is less costly with the longer wave lengths than with the shorter wave lengths.

Heat and Light Cut Range

Radio waves in their passage through space are subject to some very peculiar conditions, most of which are as yet not satisfactorily explained. For example, Radio messages can be transmitted over longer distance and with greater ease during the night than during the daytime.

(Continued on page 12)

To Yearly Subscribers Only

Limited Number of

BOUND VOLUME TWO

RADIO DIGEST

Volume Two

13 Numbers

July 15—October 7, 1922

Now Ready for Delivery. Parcel Post Prepaid, Only **\$2.00**

On account of the limited supply, the sale of these bound volumes No. 2 is limited strictly to those readers of the Radio Digest who have subscribed for a year.

TO NEW SUBSCRIBERS

One year subscription to Radio Digest and both bound volumes 1 and 2 **\$7.00**

By subscribing now for one year to the Radio Digest you get both BOUND VOLUMES 1 AND 2, 26 numbers, with one year's subscription for \$7.00.

or either volume 1 or 2, FREE with a year's subscription to Radio Digest **\$5.00**

ALL ORDERS MUST BE SENT DIRECT—No orders on this offer will be accepted, through subscription agencies, news dealers or other sources. Check, money or express orders (no stamps) must accompany all orders.

TEAR HERE—MAIL

Supply Limited—Better Hurry

COUPON

PUBLISHER, RADIO DIGEST ILLUSTRATED, 123 West Madison St., Chicago, Illinois.

I have already subscribed to the Radio Digest for one year, so please reserve me one bound volume Number Two for which I am enclosing check—M. O. for Two Dollars.

Please reserve me Bound Volume Number One and also Number Two and one year's subscription to the Radio Digest, Illustrated, for which I am enclosing check—M. O. for Seven Dollars.

Name

Address

City..... State.....

Coil of Wire Tunes Radio Frequency

Radio Frequency Helps Bring in New Stations

A stage of Radio frequency will bring in new stations that cannot be heard with just a detector and audio amplification. The tuned type of transformer is easy to

WORKSHOP KINKS? EARN A DOLLAR—

THERE are many little kinks worked out at home that would aid your fellow Radio worker if he only knew about them. There are new hook-ups, new ways of making parts and various unique ways of operating sets that are discovered every day. RADIO DIGEST is very much interested in securing such material. Send them in with full details, including stamped envelope so rejected copy may be returned. The work must be entirely original, not copied.

RADIO KINKS DEPARTMENT,
RADIO DIGEST,
123 West Madison St., Chicago, Ill.

construct in the home workshop and gives just as good results when accurately constructed as the core transformer. It is not practical to use more than two stages

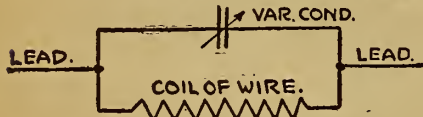

of tuned Radio frequency amplification. The ordinary hard amplifier tubes should be used just like the ones used for audio amplification.

A. B. C. LESSONS

(Continued from page 11)

Some say that certain rays from the sun render certain sections of the air conductive and hence enable it to absorb some of the energy of the Radio waves and thus make them less effective. Furthermore, it is also known that the transmitting range, that is, the distance messages can be sent effectively, also varies from day to day due to the various electrical conditions of the atmosphere.

Another annoyance is that on warm days Radio transmission is often interfered with. This is explained by some as being due to the greater quantities of water vapor present in the air. This vapor is frequently heavily charged with static electricity, which not only attracts and absorbs considerable amounts of energy from the ether, but also seems to collect and accumulate on receiving aerials and produce unpleasant sounds in the telephone receivers. It is said that this is the reason that greater ranges can be covered with the same amount of power during the winter than during the summer months.

A very peculiar condition that exists in many mountainous regions is that Radio waves are reflected from the sides of a high mountain or hill and in this manner cause what is known as an "electrical shadow" on the opposite side. This is similar to the sun shining on one side of a billboard, being reflected, and causing a shadow on the other side. Such conditions often cause the various freak messages that are heard occasionally, for the direct and reflected waves combine and produce the most peculiar results.

An important point to bear in mind is that it isn't always static that is the cause of noise or trouble in a receiving set. There may be a broken or loose connection somewhere, or the antenna may be under the inductive influence of some nearby telephone or power line.

The Receiving Station

The Radio receiving station, we were told, corresponds to the cork that was floating on the water in which the disturbance or wave motion was set up. And as the cork responded in every respect to the nature of the waves that passed it, so the Radio receiving station will be influenced and caused to respond to the Radio waves that pass it.

In order that the receiving station will be influenced by the Radio waves as they pass through space, it must be provided with some form of antenna or aerial to intercept the waves and absorb part of their energy. This receiving antenna may be in the form either of one or more parallel wires stretched out into space, or a spiral or coil of wire commonly known as a loop antenna.

As the advancing Radio waves come upon the receiving antenna, they set up in it by the process of electromagnetic induction electrical oscillations of the same

TWO CIRCUITS USING TUNED COIL

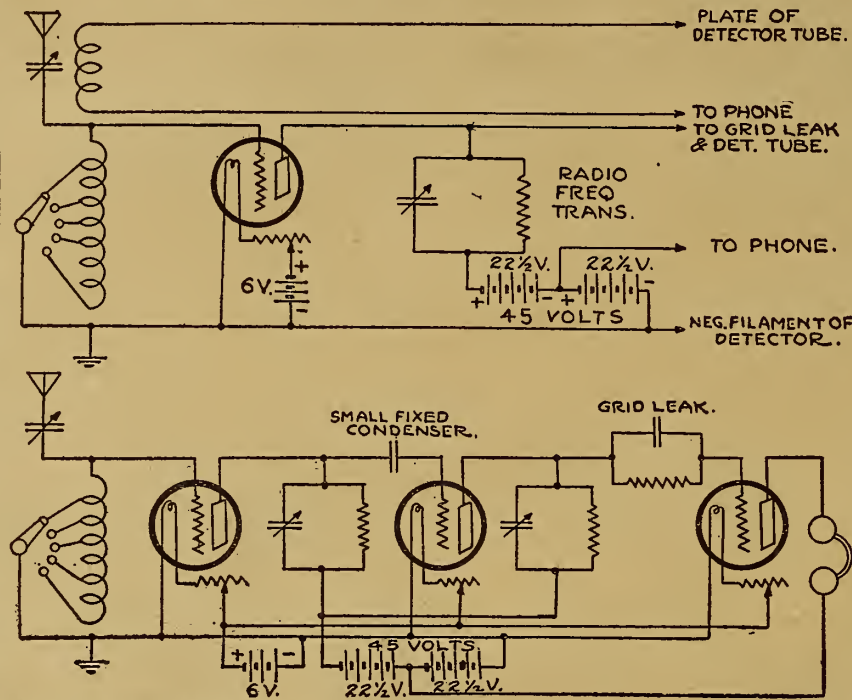

A 23 or 43-plate variable condenser is connected in parallel with a coil of wire wound on a cardboard or fiber tube. This coil consists of about 38 to 40 turns of No. 22 to No. 24 wire on a tube about 3 1/2 inches in diameter.

A diagram is given for connecting the transformer coil with the condenser and also for one and two stages of Radio fre-

quency as connected in the circuit of the Radio set. The transformer is simply connected across the circuit of the tuning coil.

This type of transformer is critical in adjustment which is a great advantage as it eliminates interference. It is easy to construct and gives excellent results.—Charles L. Smith, Jackson, Miss.

frequency. Connected to the receiving antenna is some form of "tuning apparatus" by means of which the antenna can be tuned or adjusted so that it will respond only to a particular wave length and be non-susceptible to waves of other lengths that may be passing through space at the same time.

Receiving Stations Unlimited in Number

It is evident that the number of receiving stations existing within the vicinity of a transmitting or broadcasting station will have but little effect upon the strength of the signals received in any one station, because as the waves advance they will have but very little of their energy intercepted by the receiving antennas.

The electrical oscillations as set up in the receiving antenna, however, are at a very high frequency and far too rapid to affect the human ear and produce the sensation of sound. The receiving station must, therefore, contain additional apparatus for reducing these high frequencies to lower frequencies at which they can be detected as sounds. Furthermore, this reduction in frequency must be accomplished without in any way altering or distorting the incoming oscillations, for otherwise the sounds heard in the receivers will not correspond to those originally sent out at the transmitting station and the received signals would have no meaning. Also, the oscillations are still of an electrical nature and must finally be converted into sounds so that they can be detected by the human ear. This is accomplished by means of telephone receivers, in which we have a sensitive electromagnet that is affected by the electrical oscillations and that in turn moves a diaphragm. This diaphragm by its rapid back and forth motion produces the sounds.

Figure 16 Explanation

In Figure 16 we have illustrated diagrammatically the various parts comprising a complete Radio communication system. G is the electrical generating device in which high frequency electrical oscillations are generated. These high frequency oscillations excite the antenna, A-1, and cause the electromagnetic waves to be radiated into space. As these waves move onward they are intercepted by the antenna A-2 of a receiving station. Electrical oscillations of corresponding nature and frequency are set up in the receiving antenna and these in turn affect the receiving apparatus, R. Here the frequencies are reduced and finally sent through the telephone receivers P H, where the electrical oscillations are changed to sounds that can be detected by the human ear. Although all these processes and transformations may seem rather simple to us now, we must not forget that they represent the results of a great deal of time and effort spent in study and research work by some of the world's keenest investigators.

The human ear can detect sounds only up to certain frequencies, above which

sounds become inaudible. Since the frequencies used for Radio communication are far beyond those which the human ear can be influenced by, they are generally spoken of as Radio frequencies, while frequencies capable of affecting the human ear are known as audio frequencies, the word audio coming from the word audible, capable of being heard. The dividing line is drawn at 10,000. Frequencies below 10,000 per second are known as audio-frequencies, while frequencies above this value are known as Radio frequencies.

Chapter Five

In Chapter Five will be taken up the complete details of construction and operation of a crystal detector receiving set. Since a crystal detector set is readily constructed at little cost, and since it gives excellent results for listening in to nearby stations, no one who wants to enjoy the thrills of Radio can afford to miss Chapter Five, which will appear in next week's issue.

Radio Study Methods

To obtain the best results in Radio, the amateur, to increase his knowledge, should study in the following order: Construction, arrangement operation, function, care and principles of operation.

Helps for Honeycomb Coil Users

Persons using honeycomb coils wish to try out some other kind of coils as an experiment, such as a regenerative set or a single circuit tuner. It is usually necessary to make a lot of bothersome changes in order to make the experiment. If three Remler stationary plugs are secured and plugged in the regular mounting wires may be attached to the external binding posts on these plugs so that any kind of coils may be used.—Hollis Baird, Canada.

The modern rural school is beginning to take up Radio instruction from the more populous centers. In Hawaii a powerful transmitting plant installed by the public department at Honolulu sends out educational subjects to the schools in the rural districts.

Honeycomb Coils Used In Reinartz Circuit

The diagram is of the Reinartz circuit using three duolateral coils and mounting. I have been using this hook-up for some time and have been getting far superior results than with the regular Reinartz circuit. Some features to this hook-up is the fine selectivity in tuning out undesirable stations which are operating on practically the same wave length.

I have picked up stations on the Pacific Coast in the early part of the evenings while the large stations are broadcasting and have had no interference from them. No extra apparatus are required to change over to this hook-up. The diagram is shown with a variable condenser of .0005

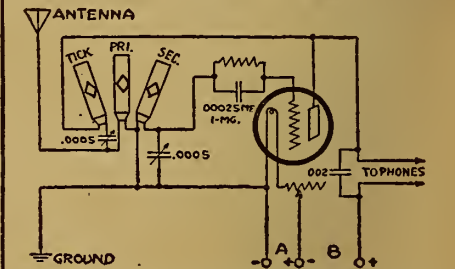

mfd. capacity in the tickler coil. This condenser can be replaced by a fixed condenser of the same capacity.—C. C. Diefenbacher, Memphis, Tenn.

Clamping Fixed Condenser

Those who use the rolled type paper condensers, such as for the grid and phone condensers, may find that considerable noise in their sets will result when the paper comes loose from the tinfoil. This can be easily remedied by placing the con-



denser between two pieces of wood and clamping the whole in a vise, then tying the ends of the wood securely with heavy silk thread. This will keep the paper and tinfoil pressed tightly and prevent the noise from this source.—William A. Nash, Biddeford, Maine.

Phantom Tuner

\$19.75 will bring one of these marvelously sensitive instruments to your address, prepaid. No aerial, ground, loop or radio frequency used. All parts highest quality. Cutlar Hammer, Remler, Dubeller, etc., mounted on genuine bakelite panel. Complete instructions furnished for wiring. No soldering necessary. Have music on strip of lamp cord one hour after set arrives. Our Phantom gets over distance and is practical using detector only. Wind lamp cord in auto top and tune in music while driving. We've done it often. Send stamp for booklet and learn the Phantom story.

VESCO RADIO SHOP, Box D-704, Vacaville, Calif.

FRESHMAN VARIABLE GRID LEAK

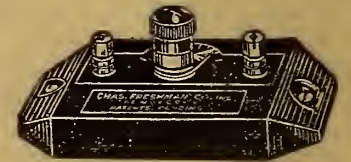

With Micon Condenser \$1.00
Without Condenser 75c

Clarifies Signals, Lowers Filament Current, Increases Battery Life, Eliminates Hissing.

Unbroken range—zero to 5 Megohms; all intermediate points. Fixed capacity, .00025 M. F.

At your dealer's—otherwise send purchase price and you will be supplied without further charge.

Manufactured by
CHAS. FRESHMAN CO., Inc.
97 Beekman Street, New York City

Spirola BETTER LOUD SPEAKER \$3.85 TRUE CABINET TYPE

Not just a common horn built into a cabinet. Beautiful—Compact—THE TONE OF FINE CABINET PHONOGRAPHS. Make your two-step set a HOME ENTERTAINER. All SPIROLAS are of the best construction, with fine, rubbed finishes and are absolutely guaranteed.

SPIROLA DUPLEX—uses any headset. Satin black (DB) finish \$3.85. Oak (DO) or mahogany (DM) finish \$4.85.

SPIROLA SIMPLEX—uses Baldwin or other unit. Black (SB), oak (SO), mahogany (SM) finish, same prices as DUPLEX.

SPIROLA CONCERT—complete with built-in unit and cord. Oak (CO) or mahogany (CM) finish \$12.50.

At dealers or postpaid (C. O. D. if preferred)

L. H. DONNELL MFG. CO., DEPT. D, BOX 70, ANN ARBOR, MICH.

The By-Pass Condenser in the Reflex Circuit

Part III—Reflex Discussion Gives Three New Hook-Ups

By H. J. Marx

THE key to reflex circuits lies in the proper use of by-pass condensers. For this reason the fan should thoroughly understand their functions and the reasons for their use.

Alternating current when passing through a coil or winding of wire encounters a resistance or choking effect, due to the induction from the magnetic field which is created. As the magnetic field is intensified by the introduction of iron cores, this resistance or choking effect is decidedly increased. Direct current however is unaffected, the magnetic field remains constant and unbroken, therefore no induction takes place.

Alternating current will therefore flow through the primary winding of a Radio frequency transformer, which usually has an air core, an iron dust core, or even in some cases a soft iron core of small diameter. This same current however will not pass through the primary winding of an audio frequency transformer, due to the iron core and increased number of turns of very fine wire.

Then again alternating current will pass on through a condenser whereas a direct current will not.

Audio Primary Must be By-Passed

In reflex circuits the current comes through as an alternating current of high frequency. This current in passing through the plate circuits first goes through the primary of the Radio frequency transformer, where it encounters but little resistance to its passage. The next winding through which it must pass is the primary of an audio frequency transformer. As just explained the resistance is too great. In order to overcome this, the primary of the audio frequency transformer is shunted with a fixed condenser through which the audio frequency current is enabled to pass instead of the transformer winding.

Now to follow through what happens after the current has passed through the series of stages the first time. Whether a crystal or tube detector is used, the current has been rectified and is then a pulsating direct current in form, and of much lower frequency. Having been reflected back to the tubes all over again, it passes through the primary winding of the Radio frequency transformer and encounters very little resistance in passing through it. When it gets to the primary of the audio frequency transformer, it goes through the winding instead of the condenser, as was the case before rectification.

Audio Transformer Secondary Effects

The question may be asked why it is that the secondary windings of audio frequency transformers are not always shunted with by-pass condensers. It will be found that the natural capacity of such a winding is usually sufficient to permit the Radio frequency currents to pass through.

There seems to be a wrong impression that this by-pass condenser should be variable and is added for tuning the primary circuits of the various stages to the proper wave lengths.

The variable resistance sometimes added in the plate circuit, is used for stabilizing the various stages through

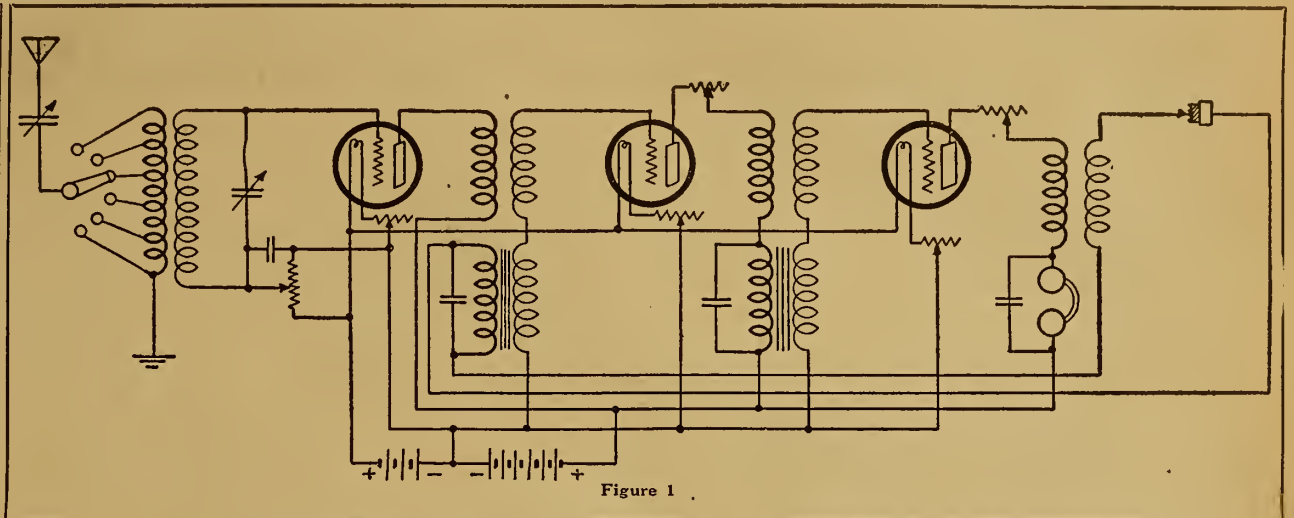

Figure 1

which two different frequency currents are passing.

Hook-Up Figure 1

The Figure 1 three-tube reflex hook-up is very similar to the one published in the first article of this series. Transformer coupling is used throughout, however. Three Radio frequency and two audio frequency are required. A crystal detector is used for rectification of the Radio frequency current. A potentiometer is shunted across the A battery and is

battery. This also acts as a by-pass for Radio frequency currents.

The variable condenser in the primary circuit has a capacity of .001 mfd., while the one shunted across the secondary need not have more than .0005 mfd. All tubes have separate rheostat control.

This circuit will be found selective and simple to operate. The plate voltage should be about 80 volts.

Hook-Up Figure 2

The same type of coupling, with, how-

the antenna is short. A .0005 mfd. variable condenser is used to tune the secondary circuit. The grid potential of all stages except the detector, is controlled by means of a 400-ohm potentiometer connected across the filament or six-volt battery. A .002 mfd. fixed condenser is connected in between the moving lever of the potentiometer and the negative terminal, acting as a by-pass for any stray Radio frequency currents. Fixed condensers of .002 mfd. capacity are shunted

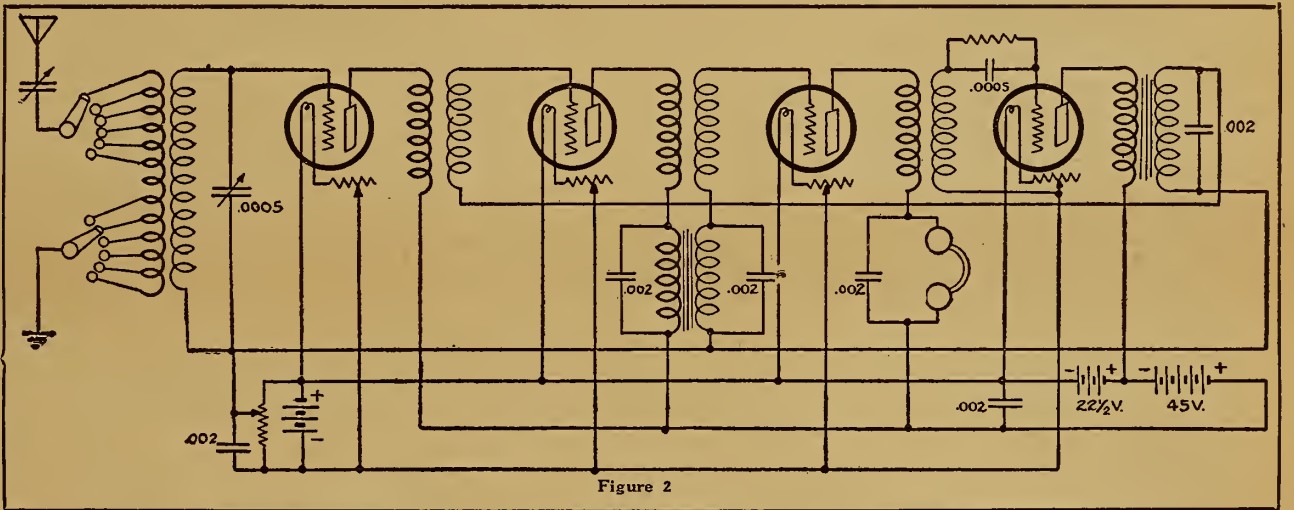

Figure 2

used for controlling the potential of the grid of the first tube.

High variable resistance such as potentiometers (400 to 1,000 ohms or even more) are inserted in series in the plate circuits of the second and third tubes. A .002 mfd. fixed condenser is connected from the moving lever of the potentiometer to the negative side of the filament

ever, a tube detector, is illustrated in Figure 2. This circuit is likewise three stages of Radio frequency, detector and two stages of audio frequency. A variocoupler, with two tap switches for both rough and fine adjustment, is used for the tuning. A .001 mfd. variable condenser is added in series in the antenna circuit although this may be omitted if

across the secondary of the first audio frequency transformer, across both windings of the second audio frequency transformer, across the plate batteries, and also across the phone or output terminals.

In spite of the apparent complex nature of the set, it presents no serious difficulties in tuning. The potentiometer is apt to be rather critical if its resistance isn't high enough. The secondary condenser is also apt to be critical unless a vernier is used. The plate voltage can be increased to as high as 100 in the amplifying stages but it is best to test out for the voltage giving the best results without distortion or mushing of signals. The filament rheostats will have decided effectiveness in selectivity for distant stations. In fact it would be advisable to use a vernier rheostat for the detector tube. The grid leak used in the detector grid circuit might be of the variable type, so that the best grid reaction adjustment can be obtained. This will vary for the different types of detector tubes that may be used.

Hook-Up Figure 3

There is no reason why jacks should not be incorporated in reflex circuits. Although not called for in the Figure 3 illustration, filament control jacks may be substituted. If this is done, both jacks should be connected so that current is furnished to all the tubes when a plug is inserted in either jack.

The last two jacks are for plugging in either the first or second stages of audio frequency. The first jack (double-circuit type) permits the use of a loop aerial, automatically cutting out the variocoupler which would then be unnecessary.

The variable condenser in the primary circuit should have a capacity of .001 mfd. The secondary variable condenser is of the vernier type, having .0005 mfd. capacity.

It will be noticed that only the first stage of Radio frequency uses the potentiometer for grid control. The usual .002 mfd. condensers are used for the by-pass of all Radio frequency currents throughout the circuit. When either jack is in use,

(Continued on page 14)

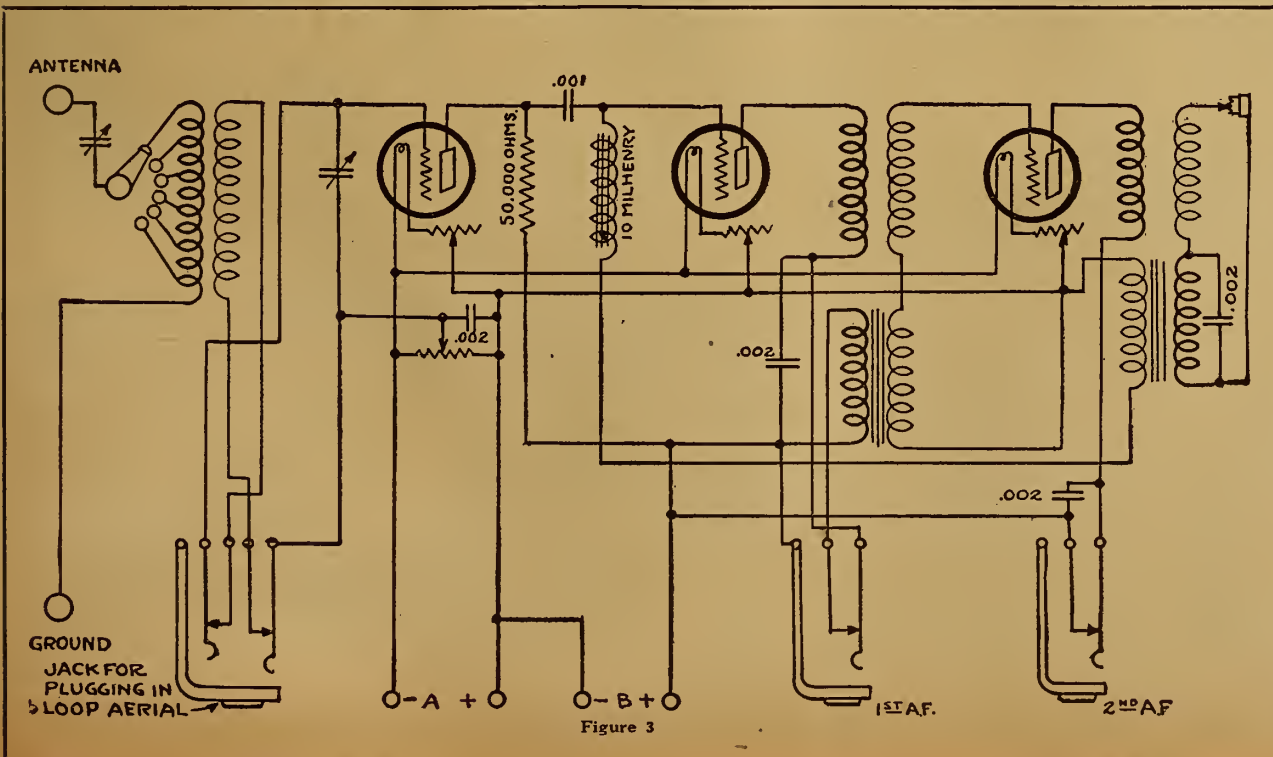
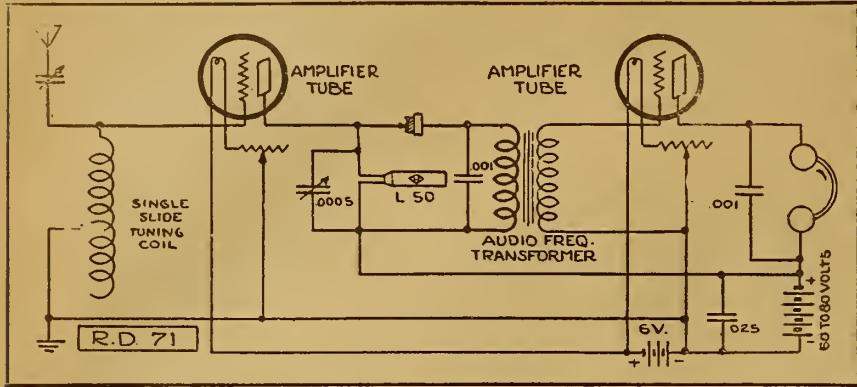

Figure 3

R.F. AND A.F. ON CRYSTAL SET



THIS hook-up was developed to meet the request of a fan who wanted to add Radio and audio frequency to his crystal set. The additional parts required outside of batteries and tubes, are inexpensive and simple.

If necessary (in case of a long antenna) a .001 mfd. variable condenser is added in the antenna lead as shown. A single-slide tuning coil is used for tuning this circuit.

A 50-turn honeycomb coil with a .0005 variable condenser shunted across it permits adjustment of wave length in the coupling between the Radio frequency

amplifier tube and the crystal detector. Any standard audio frequency transformer is used in the coupling between the crystal detector and the audio frequency amplifier tube. The .001 mfd. fixed condenser across the primary of the audio frequency transformer acts as a by-pass of Radio frequency strays that may leak through. In the same manner a .025 mfd. fixed condenser is shunted across the plate battery, which should have a voltage of from 60 to 80.

The controls for tuning have been reduced to a minimum so that the tuning of this circuit will be exceptionally simple.

Cardboard Tubes Are Easily Made at Home

It often happens that the Radiophon wants a cardboard tube of a size not available. I find that it is a simple matter to make them. A bottle, dry cell or any other round object, which is 1/16 or 1/8 inch smaller than the outside diameter of the size desired, is used for the pattern. If these are not at hand a section cut from a limb of a maple tree may be used. The tube is made of layers of paper like kraft paper. The paper is cut to 6 or 7 inches wide and about 5 feet long. Apply paraffin to the object on which you intend to wind the paper and prepare a paste by mixing yellow dextrine with water until you have a smooth paste, roll your paper once around the pattern to keep the paste out, then apply the dextrine on the paper and spread it very thin all over it, then roll the pattern along on the paper. If there is not enough paper in the strip add more and spread on the dextrine.

The paper will not always roll straight, but this will not be detrimental as there will be 2 inches for trimming when the roll is complete. When the desired thickness has been reached leave it on the pattern if possible and place it in an oven to dry. When thoroughly dry trim it with tinner's snips, a razor blade, rasp, sandpaper or anything that you may have available for this purpose. When finished you will have a tube equal to anything you can buy.—Edward Gille, Quincy, Ill.

to the box end and the other to the sliding cover, as shown. The box was then attached to the back of the panel. The tip of the sliding cover was left protruding over the panel at the end. Sliding the cover back and forth provided a means of tuning in the coils. This gives parallel variance rather than angular, and it produces the cheapest mounting that can be procured.—G. E. Lippincott, Philadelphia, Pa.

One Tube Set

The illustration shows a circuit using a detector tube that has given good results. The antenna for this circuit is 10 feet high

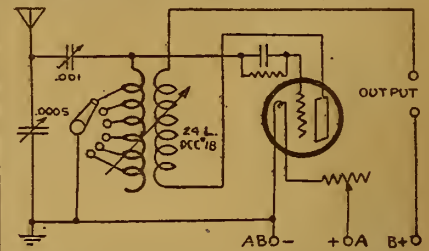

and 25 feet long—one wire. The type of a variocoupler used in this circuit is the one fitted with a rotor set on the upper end of the coil.—Le Roy Dolen, Sapulpa, Okla.

Electrical Terms

Universal electrical terms are easily understood by using a simple water analogy. Volts, or potential, the equivalent to pounds pressure. Amperes, are equivalent to gallons, measuring volume. Watts are the power units, or volts times amperes. Ohms are the resistance unit.

Simple Honeycomb Coil Mounting

The mounting shown in the illustration is original with me, although it is so simple it may have been used many times. In making of the Flewelling circuit I was

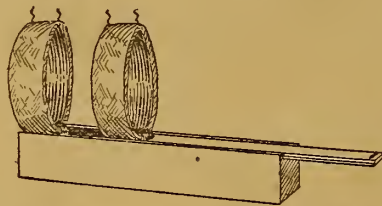

confronted with the problem of mounting the coils in the simplest manner possible, as I have no workshop. I wound two sections of a mailing tube as directed, then cut out a small piece of wood about 1 inch square and about 1/2 inch thick. The piece was covered with tire tape. The block was strapped to the coil.

A small wood box, such as is used for packing fountain pens, made the mounting. One coil was permanently fastened

The Reader's View

Ignorant Radio Dealers

It is unfortunate that so few dealers in Radio apparatus know anything about Radio. In buying my outfit, I visited 18 dealers in a city of 150,000 people. Seventeen of the number had absolutely no idea of the distance range of the apparatus they sell nor could they answer intelligent questions concerning cost of upkeep or relative value of different types of aerials.

One of the number was an amateur and "knew his stuff" and told us truthfully what he knew about Radio sets. He demonstrated fourteen makes for us. We bought a set, with a loud speaker, and it works fine.

I became very much of a fan and bought a smaller set for my own home. I had the same experience in selecting a small set—dealers knew little or nothing about them, and would not let me try them. A dealer was also ignorant of his stuff but let me take a set on 15 days' trial. I found it to be entirely satisfactory. Have heard plainly, clearly and with little interference a total of 62 stations scattered from Cuba to Portland, Ore., and from New York to San Francisco. I know my set.

On December 18 to 23 I was in ——. There is a broadcasting station there and five dealers in Radio apparatus. I spent not less than two hours with each, and they were all unable to get a single out-of-town station satisfactorily on their demonstrating sets. Not only that, but I distinctly heard them advise prospective customers to do things that any "boob" that has owned a set thirty days knows not to do.

I called the dealer to one side and re-monstrated and with his permission made a few changes in his lead-in wire, adjusted plate voltage on his demonstrating set and brought in five distant, out-of-town stations loud and clear through a loud speaker. I am not interested in any way in the sale of Radio apparatus, but at the request of this dealer I looked over four sets that were not giving satisfaction, made necessary changes and adjustments and each of the four sets worked fine on local and distant stations.

Some dealers are preaching the doctrine, "Most any sort of aerial from bed spring, loop, or 50 feet of wire strung around a ceiling will do!" These types of aerials do for local stations, but for distant reception, outside single-wire aerials are so much better with most sets.—S.P.D., Somerville, Tenn., via A. T. & T. Co., New York, N. Y.

Classroom lectures on history are to be broadcast by Radio from the University of Washington.

Radio Tubes Repaired

- UV 200—C 300.....\$3.00
 - UV 201—C 301..... 3.50
 - WD 11—or VT 2..... 4.00
- The right filament and proper vacuum. All tubes guaranteed as good as new. Mark plainly. Pack carefully.

Radio Supply and Repair Co.

125 WEST LAKE STREET
Get our prices on Radio Equipment.

Interference Eliminator

The illustration shows a hook-up in which A represents a single slide tuner which is tuned to the undesired wave length and the tuner on the set is tuned for the desired wave length. The unde-

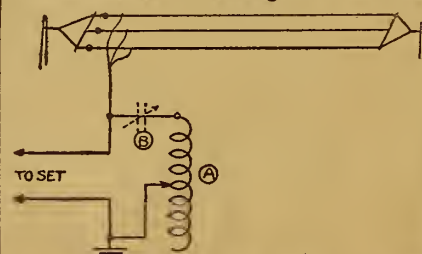

sired wave length passes down the single slide tuner and you have no interference. A variable condenser is shown at B, which when inserted will give better tuning than the one slide coil.—Lester V. Hergman, New York, N. Y.

REFLEX CIRCUITS

(Continued from page 13)

the by-pass condenser is automatically connected across the phones.

The plate battery voltage will run from 60 to 100, depending on the types of tubes that are to be used. These all should be hard amplifying tubes. The 50,000-ohm resistance and the 20-milhenry Radio frequency choke coil are obtainable at the Radio stores.

The second and third tubes can be controlled through one rheostat instead of two, if desired, but the first tube should have an individual rheostat.

In using detector crystals for reflex hook-ups, the same conditions apply as in the normal circuits. For this reason no special characteristics are required other than what is normally expected. Many developments have taken place in the last few months so that a number of the bothersome adjustments have been eliminated.

How to build the Reinhartz Receiver

is told, complete with illustrations and diagrams, in the latest addition to our FREE looseleaf, handbook-catalog now on the press.

Amateurs find the Reinhartz hookup by far the simplest yet designed. In efficiency it rivals the Armstrong and other well-known circuits.

All the parts necessary for building your Reinhartz Receiver are listed in the "Chi-Rad" handbook-catalog—save yourself the trouble of shopping around.

Write for your copy today—ask for "Chi-Rad" Handbook, Edition RR.

Chicago Radio Apparatus Co.

415 So. Dearborn Street
CHICAGO

HUDSON-ROSS

Quality Radio Products
Dealers: Write for Your Discounts
123 W. Madison, CHICAGO

Marked Savings!

- W. D. 11 Tube, \$5.25; W. D. 11 Socket... .50
 - \$3.50 Baldwin R. F. Transformer..... 2.98
 - \$8.00 Baldwin Variocoupler..... 6.50
 - \$6.50 Fisher Variocoupler (large size)... 4.95
 - \$45.00 Magnavox (new type)..... 34.75
 - \$20.00 Baldwin Claraphone..... 16.25
 - Baldwin Phones (type C)..... 9.50
 - \$12.00 Western Electric Phones..... 9.50
 - \$1.00 Freshman Var. Grid. Leak & Cond. .80
 - \$7.00 Federal Audio Transformer..... 5.50
 - 23 P. Var. Condenser \$1.25; 43 P. Var. 1.75
- Prices quoted on other items.

Mail, money order only. Include stamps for postage.
RADIO MAIL SERVICE 146 Grace Street
Jersey City, N. J.

RADIO MAILING LISTS

- 12,000 Radio Dealers, covering U. S. by states Per list \$ 7.50
 - 1,614 Radio Mfrs., covering U. S. by states. Per list 15.00
 - 1,757 Radio Supply Jobbers, covering U. S. by states. Per list 15.00
 - 250 Radio Stations Per list 4.00
 - 257 Mfrs. who make and assemble complete Radio Sets Per list 4.00
 - 25,000 Radio Amateurs & Mfrs. of Radio Stations, Per M 7.50
- Ask for price list covering Canada and England.
Send remittance with order
Trade Circular Addressing Co., 166 W. Adams St., Chicago, Ill.

SPECIAL

Stock Reducing Sale—Limited Supply
All New Merchandise

Terms C. O. D.—First Come, First Served
Immediate Shipment

- Myers Vacuum Tubes..... \$3.35
- Each, net.....
- Myers Adapters..... \$1.20
- Each, net.....
- Myers Audio Frequency Choke..... \$2.35
- Coils, Each, net.....
- Myers Radio Frequency Choke..... \$3.35
- Coils, Each, net.....
- Myers Receptacles..... \$0.70
- Each, net.....
- Mica Fixed Condensers, .25 Mfd..... \$4.05
- Each, net.....
- Mica Fixed Condensers, 2.0 Mfd..... \$1.70
- Each, net.....

HARTMAN RADIO COMPANY

MANSFIELD, OHIO
References—Any bank or banker in Mansfield, Ohio.

DELICATE SOLDERING

Both the manufacturer's and amateur's problem on all fine work is readily solved by the instrument constructed for this particular purpose.



LISTS AT \$6.00

The Post Soldering Iron

Platinum Heating Unit
Interchangeable Tips
(Large and Small)
Universal Current

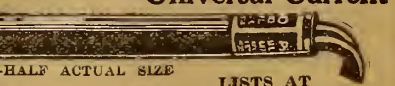

LISTS AT \$6.00

ONE-HALF ACTUAL SIZE
Awarded Certificate of Excellency, N. Y. Evening Mail Radio Institute
From your dealer or write
POST ELECTRIC COMPANY, Dept. 509, 30 E. 42nd St. NEW YORK

Questions and Answers

Devoted Entirely to Flewelling Fans' Inquiries

Flewelling Wave Length Range

(1706) JKG, St. Paul, Minn.
Kindly answer a few questions regarding the Flewelling super-regenerative panel set as shown on page 13 of the December 9 issue.

1. My antenna is a single wire, 100 feet long and 25 feet lead-in. How will this work with the coils mentioned in the circuit?

2. What wave lengths will this circuit cover, with said coils?

3. For panel mounting, can the primary coil be stationary, and the tickler movable?

4. With proper primary and secondary coils, would it be possible to receive the Arlington time signals? If so, what size coils would be needed, and what other changes?

5. Have you anything definite, as to what distance has been heard with this circuit?

A.—1. Your antenna construction is rather long but should be effective with the circuit in question.

2. This circuit should cover from two hundred and fifty to four hundred and fifty meters wave length.

3. Primary coil may be stationary and tickler coil movable.

4. This circuit is not so effective on high wave lengths, and it is doubtful if you would receive Arlington time signals through it.

5. Generally speaking it has a receiving range of up to one thousand miles, although we have had reception reports as high as two thousand miles.

Flewelling for Economy and Range

(1711) HDC, Douglas, Ariz.
I was much interested in your article in the DIGEST, which I read with religious regularity, concerning the Flewelling super-regenerative set for the following reason:

I am a manual training teacher in a town from 500 to 1,000 miles from any good broadcasting stations. I have a homemade Radio-audio set which receives almost everything between here and Portland, Oregon, Davenport, Iowa, Los Angeles, and Houston, Texas. However, complete with tubes and batteries it cost about \$100 and is beyond the means of most of my pupils.

It seems as if this hook-up, used with WD-11 tube, should give distance and volume at little cost.

Do you agree with me?

Can a variable leak, which would be easy for a boy to operate, be made having a fiber base and an india ink line with switch points, variable with switch? If so, how wide a line, how great a radius, and how close should switch points be, and how many of them?

Will this set receive 500 miles (Los Angeles), 700 miles (Salt Lake), 900 miles (Fort Worth) on a loop? If so, what size?

I do not understand how antenna and ground is connected to set. If aerial is used is no ground used?

A.—We are gratified to hear from you with such kindly expression of interest in our publication in general and the Flewelling circuit in particular.

In our opinion this circuit employing WD-11 tube, as suggested, certainly is worthy of experimentation. Use 100 volts on the plate of this tube.

Your idea of variable leak is good.

"ALL-AMERICAN" Amplifying Transformers

Two years of successful use all over the world guarantees permanent satisfaction. Radio and Audio Frequency.
SEND FOR CIRCULARS
RAULAND MANUFACTURING CO.
35 South Dearborn Street Chicago

although we would not trouble with the contact points. Rather make a line 1/4-inch wide and 5 inches long on a piece of fiber with india ink, using a sliding or rotary lever on it.

The suggested range could be accomplished with a loop, as reports confirm this. A 10 to 12-turn loop, 30 inches on a side, will be satisfactory.

For antenna and ground take the two leads which would come from the loop antenna. Usually only one of the two is necessary. Connect to the grid side of the 50-turn coil.

Power Amplifier for Flewelling

(1739) CBS, Toledo, O.

I have a Flewelling super-regenerative panel receiver with single tube as illustrated in your December 2 issue. I have also noted in your December 9th issue, that amplification can be added.

As I have a power amplifier and horn, I am wondering if there is any way I can connect this outfit to the Flewelling. If this can be done, I would appreciate a diagram of the filter circuit that should be used in connection with the outfit so as to eliminate the whistle in the set.

A.—The power amplifier and horn can be used with the Flewelling circuit as suggested. It would be advisable, however, to shunt a variable leak resistance across the two input binding posts of the power amplifier, which are connected to the phone terminals of the Flewelling panel. Use separate B batteries on the power amplifier, although the A battery can be common.

Transformer Connections

(1740) HA, Tampa, Fla.

I am going to try out the "one lung" Flewelling circuit. I notice in your description of the amplifier (audio) for this set you connect one end of transformer secondary to positive side of filament instead of negative side.

Why is this done, or is it immaterial? Nearly all hook-ups connect to negative side. I note also that positive side is specified in Mr. Flewelling's telegram. I note that positive side of A battery is used throughout instead of negative as per usual practice. I do not want to belong to the five per cent who do not get results with this circuit so I am trying to get right before I start.

What effect does a grid condenser of too large capacity have on signal strength?

A.—It is immaterial which method of connecting audio transformer to filament is employed, although it might be well in executing any circuit to follow the details of its originator. A number of hard tubes

will be found to give better results when connected as shown.

A grid condenser having too much capacity will have a choking effect on received signals.

Tin Pan Music

(1737) FW, Detroit, Mich.

I put up a Flewelling circuit and it works fine on WWJ and WCX, which are only one-half mile from me, but when their concert is over and I try for long range I get Atlanta, Kansas City, Newark, Chicago, New York, Minneapolis, Pittsburgh and Schenectady, but the signals are mushy. I can hardly understand them as the music sounds like some one pounding on a tin pan.

I intend rewiring it again and using two steps of audio frequency amplification and also a crystal detector so I can receive WWJ and WCX on the crystal. Would you please send me a diagram of the Flewelling circuit, with a crystal detector and also two stages of audio. I would like to have it drawn so I would have a jack for the crystal, one for the detector and a jack for each step of audio; four jacks in all. I want to use one A battery and two B batteries, 100 volts for Flewelling and 100 volts for audio amplification.

My aerial is in a nest of telephone and high tension power lines, but I have it running at right angles with the power lines. Would this help to make my signals mushy?

A.—Having constructed your antenna at right angles to high tension lines there should be no interference from this source. The mushiness of signals indicates an incorrect value in grid leak. This may be determined and overcome through experimentation. Use the best variable grid leaks you can make or buy.

TELMACO

RADIO SUPPLIES STORES

Prompt Service—Quality Goods—Priced Right
Radio Division

TELEPHONE MAINTENANCE CO.

20 S. Wells St. Franklin 3986
5206 W. Madison, Austin 7041. 1122 E. 47th St

Look for the TELMACO Sign

A crystal detector would not function in the circuit you are employing.

A diagram showing two stages of audio frequency amplification for the Flewelling appears on page thirteen of the December 9 issue. This will be helpful to you.

Kind of Tubes to Use

(1744) GWK, Hope, N. D.

In the December 2 DIGEST, page 13, you give the Flewelling single-tube set saying to use a hard vacuum amplifier tube. Now, on page 13 of December 9 issue you say to use two amplifier vacuum tubes. Then in the reading of it, you say the elimination of the whistling must be accomplished through the detector circuit. Now what I want to know is, do I use three of the same tubes to make a two-stage audio frequency amplifier? Let me know if you use a detector tube and what kind of tube it is.

Could I use a variocoupler in place of the honeycomb coils?

A.—In the Flewelling circuit hard tubes should be used throughout for both detector and amplifier. The employment of a variocoupler instead of honeycomb coils will be entirely practical.

GOVT RADIO STORAGE BATTERIES

All absolutely new Signal Corps Batteries. Edison 3 cell type BB-1 \$4.50; Willard 4 cell type SYR-13 \$4.25; Willard 2 volt 40 A. H. for WD-11 tubes \$4.75; 6 volts Edison \$7.75; Edison B battery elements 4c each.

FLEWELLING .006 CONDENSERS

Bakelite mounted with binding posts. Set of three \$2.90. Variable Grid Condensers .0025 or .0005 max. 45c.

FLEWELLING SPIDER WEB COILS

Easier tuning; clearer signals; green silk wound \$1.75 each.

FLEWELLING VARIABLE GRID LEAKS

Give clearer music, louder signals on any circuit, 75c.

REINARTZ LATEST SPIDER WEB COILS

Double green silk winding on Bakelite spider \$1.95. Choiko coils for Reinartz detector plate circuit \$1.70.

VERNIER FOR VARIABLE CONDENSER

Fits any condenser. Requires no extra space, 95c.

HIGH-POWER AMPLIFYING TRANSFORMERS

Best made. Louder signals. Cannot burn out \$2.95. Jacks, Open circuit .46; Sin. cir. .54; Doub. cir. .62; Plugs .56; 3000 meter long wave couplers \$7.95. We save you money. Tell us what you need. Include Postage With Your Order

QUALITY RADIO SHOP, RICHMOND, IND.



Carter "TU-WAY" Radio Plug

take two head sets and all types cord tip terminals. Price \$1.50. Write for Bulletin on Carter "HOLD-TITE" Jacks and other products.
CARTER RADIO COMPANY, 209 South State Street, CHICAGO

ATWATER KENT

Immediate Delivery
Dealers: Write for Discounts
Hudson-Ross, 123 W. Madison, Chicago

Mounted 3 Circuit Tuner

Exceptional selectivity and sharp tuning, makes the most easily constructed and highest efficiency Set known.

Price without dial
\$6.00
With 3 3/4 Bakelite Dial
\$7.00



Our VARIABLE CONDENSERS, VARIOMETERS, 180 DEGREE VARIOCOUPERS and AMPLIFYING TRANSFORMERS represent maximum workmanship and efficiency at absolute MINIMUM prices.

NEW YORK COIL COMPANY
338 Pearl Street NEW YORK CITY, N. Y.

Wessco

W. E. SUPPLY AND SERVICE CORPORATION
18 MURRAY STREET, New York
2 Blocks South of Chambers, between Broadway and Church St.

OUR PRICES SPEAK LOUDER THAN WORDS
FREE FREE FREE
WITH EVERY \$10.00 AND OVER PURCHASE A \$1.50 22 1/2-VOLT VARIABLE B BATTERY

Mail orders must include postage. TERMS:—Money Orders with Orders—checks not accepted. All Merchandise offered is Standard, Guaranteed, and is of perfect workmanship.

PRICE

Complete

\$35

The Radio Tube Set

AERIAL-A

That Made Good In a Night

INCLUDING PHONES, TUBES, AERIAL and BATTERIES

Better Than The Best

SOCKETS:		PANELS:	
\$1.00 Genuine Bakelite Socket	45c	Guaranteed Genuine Bakelite Panels—7x10,	
\$1.00 Sockets, silk wound	35c	\$1.25; 7x18, \$1.85; 9x10, \$1.60; 5x5, 47c;	
\$1.00 All Moulded V. T. Sockets	25c	3x9, 95c; 6x12, \$1.25; 7x12, \$1.50; 7x9,	
		\$1.15; 12x14, \$3; 7x24	\$ 3.00
DIALS:		\$1.50 Microstats	.85
\$1.00 Genuine Bakelite Dials—3-in., 45c;		Spaghetti, per length	.07 1/2
4-in.	55c	PHONES:	
VARIOCOUPERS:		Special Electric Soldering Iron,	
\$7.00 Guaranteed Genuine Bakelite Pioneer		2 heats	4.95
Variocoupler, silk wound	4.75	20c Bezel	.15
\$4.25 Variocoupler, guaranteed high quality	2.25	\$3.00 Brandes Phones	5.75
\$8.00 Moulded Variocoupler, highest quality	4.50	\$8.00 Dreyfuss Phones	6.00
\$5.00 Shamrock Variocoupler	2.59	\$5.00 Murdoch Phones	3.55
		\$1.00 Freshman Variable Grid Leak	.75
TRANSFORMERS:		WIRE:	
\$5.00 Acme Transformer	3.40	100 ft. coil No. 14, 7-strand pure copper	
\$3.00 Radio Frequency Transformers	1.65	Aerial Wire	.50
\$6.50 Wessco Audio Transformers, highest		Magnet Wire 20 per cent. off list.	
quality guaranteed	3.25	RHEOSTAT:	
VARIOMETERS:		\$1.50 Thordarson Vernier Rheostat	1.10
\$6.50 Pioneer Variometer, Genuine Bakelite		\$1.00 Rheostat	.32
silk wound	4.50	Homecharger De Luxe	13.25
\$6.60 Wessco Variometer, highest quality		Johns-Manville Blk. Com. Tubes, 3-in.	.25
guaranteed	3.25	DETECTORS:	
\$4.50 Variometer, guaranteed high quality	2.40	\$.75 Crystal Detector	.35
\$6.50 Moulded Variometer, highest quality	3.50	\$.40 K. D. Crystal Detector	.18
BATTERIES:		\$1.50 Multi Jack	1.15
\$9.75 Westinghouse Storage B Battery	4.75	\$1.50 Twin Adapter	1.15
\$24.00 A Battery, 100 Amp., 6 V.	16.75	\$1.25 Universal Plug	.75
\$19.00 A Battery, 20 Amp., 6 V.	11.75	BATTERY CHARGERS:	
\$14.50 A Battery, 60 Amp., 6 V.	8.75	\$18.00 Westinghouse Battery Chargers	13.25
\$3.00 Battery, 22 1/2 V. Variable, highest		\$19.50 Westinghouse Battery Chargers for	
quality guaranteed. Large size	1.45	A. & B. Batteries	16.00
\$1.75 B Battery, 22 1/2 V. Variable, highest		70c Open Circuit Jack	.40
quality guaranteed. Small size	.75	85c Double Circuit	.45
CONDENSERS:		75c Battery Hydrometer	.35
\$5.00 23-pl. Variable Condenser	1.85	KNIFE SWITCHES:	
\$5.50 43-pl. Variable Condenser	1.95	Knife Switch S. P. S. T.	.14
3-plate Vernier Variable Condenser	.70	Knife Switch S. P. D. T.	.22
50c Mica Condensers	.25	Knife Switch D. P. D. T.	.35
Thordarson Grid Condenser	.15	Wooden Horn	6.00
Bronze Bus Bar, tinned, ft.	.02	Contact Points	.06

\$25.00 MIRCLE CRYSTAL RECEIVING SET WITH 3000 OHM PHONES, 100 FT. AERIAL, 2 CLEATS AND POR. TUBES, \$7.95

MAGNAVOX—NEW TYPE, NEW CONSTRUCTION, NEW FINISH \$32.50

Radio

Illustrated

Electrical inventions in the last few years have greatly reduced the work about the house and now comes the ether wave machine that fills the air with music and advice about household affairs while the housewife is at the few remaining duties necessary to keep the house in order © K. & H.

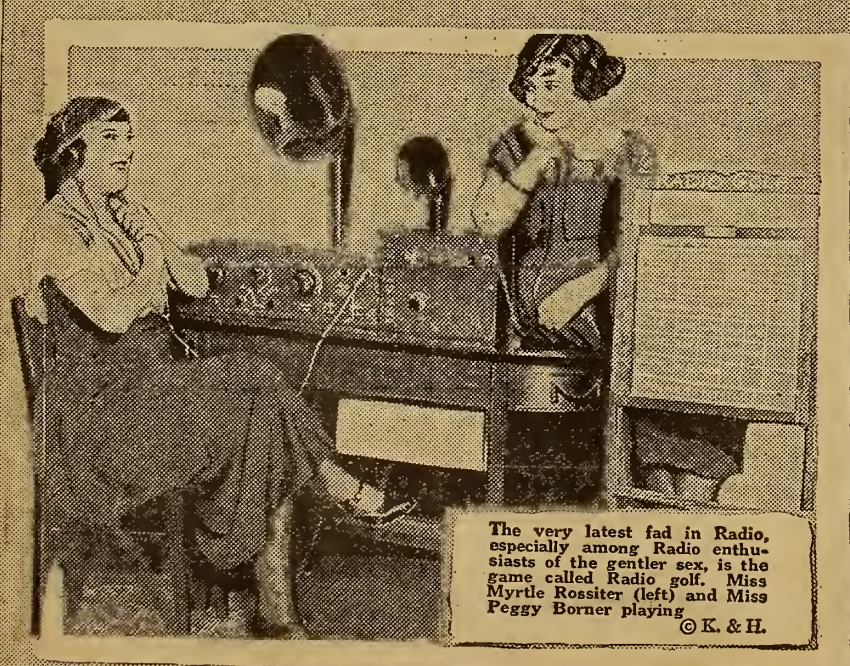

The very latest fad in Radio, especially among Radio enthusiasts of the gentler sex, is the game called Radio golf. Miss Myrtle Rossiter (left) and Miss Peggy Borner playing © K. & H.



The picture is that of William Keating of St. Paul, Minnesota, who has built a small crystal set on which he has succeeded in picking up stations for several hundred miles from the city. Crystal sets, as a rule, are not adaptable to long distances, but young Keating has had unusual luck in picking up such broadcasting stations as St. Louis, Mo., Louisville, Ky., and Davenport, Ia. Keating's hook-up is very simple and similar to those used by most Radio-phans © Int.