

M A R C H 1 9 2 9

# RADIO

# BROADCAST

ENGINEERING

THE LABORATORY

SERVICING



SPECIAL FEATURES IN THIS ISSUE

What Shall a Serviceman Study?

Sensitivity and Fidelity of Grid Leak-Condenser Detection

Measurements on Moving Coil Loud Speakers

For the Serviceman: Circuits of Complete Sets, Collected Tube Data, Technical Helps . . . Also: Sound Movies, What Impedance Means, Centralized Radio, Broadcast Engineering, Automatic Volume Control

T H I R T Y F I V E C E N T S

PUBLISHED BY DORAN & CO., INC. ♦ GARDEN CITY, NEW YORK

# Who Are Your Fellow-Readers of



**D**URING the past several years, we have made exhaustive surveys of our readers to make certain that we were providing the kind of radio magazine that would be most beneficial to you and to the industry. You have written us, praising our efforts; have supported us with your yearly subscriptions, or your regular newsstand purchases; and, coöperating with our Research Division, have told us who you are and what you are doing. In turn we wish to tell you what our surveys revealed:--

84% of RADIO BROADCAST readers are professionally connected with the industry. *IT IS REGULARLY READ AND USED BY* important executives of radio manufacturing companies, by chief engineers in charge of design and production of radio apparatus with a retail value of \$500,000,000 annually. *BY* chief engineers of radio broadcasting stations, by communications engineers who control the far-flung radio links which join nation to nation. *BY* thousands of radio dealers--servicemen who contribute their expert knowledge to sell millions of radio sets, to keep them in working condition, and who use their contact with the consumer to introduce ever better machines and equipment to supplant old sets. *BY* the great numbers of technical men who share the direction of radio retail organizations--those whose expert knowledge directs radio service work on the one hand, and on the

other enables them to choose technically the best in radio merchandise to offer the buying public. *BY* thousands of servicemen who are expanding the uses of radio in new ways, installing receivers and public address systems in schools and elsewhere, etc. *BY* countless engineers and technicians in that newest of the new fields borrowing experience and personnel from radio--the sound motion picture industry.

The remaining 16% of RADIO BROADCAST readers are a vast group of experimenters --those who explore the mysteries of short waves, build all kinds of test apparatus, etc. Among you are countless college students and those who study radio at home, independently, or in organized courses by mail--the coming leaders of the industry.

To all our readers--to the 16% and the 84% --we pledge RADIO BROADCAST in coming months will be better than ever.

Editorially, the services and features which have caused the majority of progressive radio dealers, engineers, executives, servicemen, sales managers and technical leaders of radio to read RADIO BROADCAST --will continue to be offered for *your interest*. RADIO BROADCAST will continue ever abreast or a step ahead of the fastest-growing, most fascinating industry in the world --ever alive, interesting, accurate, and above all, useful.

84% TRADE READERS	
Manufacturers - - - - -	2%
Jobbers, Retailers, and Dealers, Servicemen - - - - -	61%
Engineers - - - - -	21%
TOTAL	84%

**DOUBLEDAY, DORAN & CO., Inc.**

--

**GARDEN CITY, N. Y.**

# "I Found the Short Cut to Success in Radio

*through this amazing home laboratory method!"*

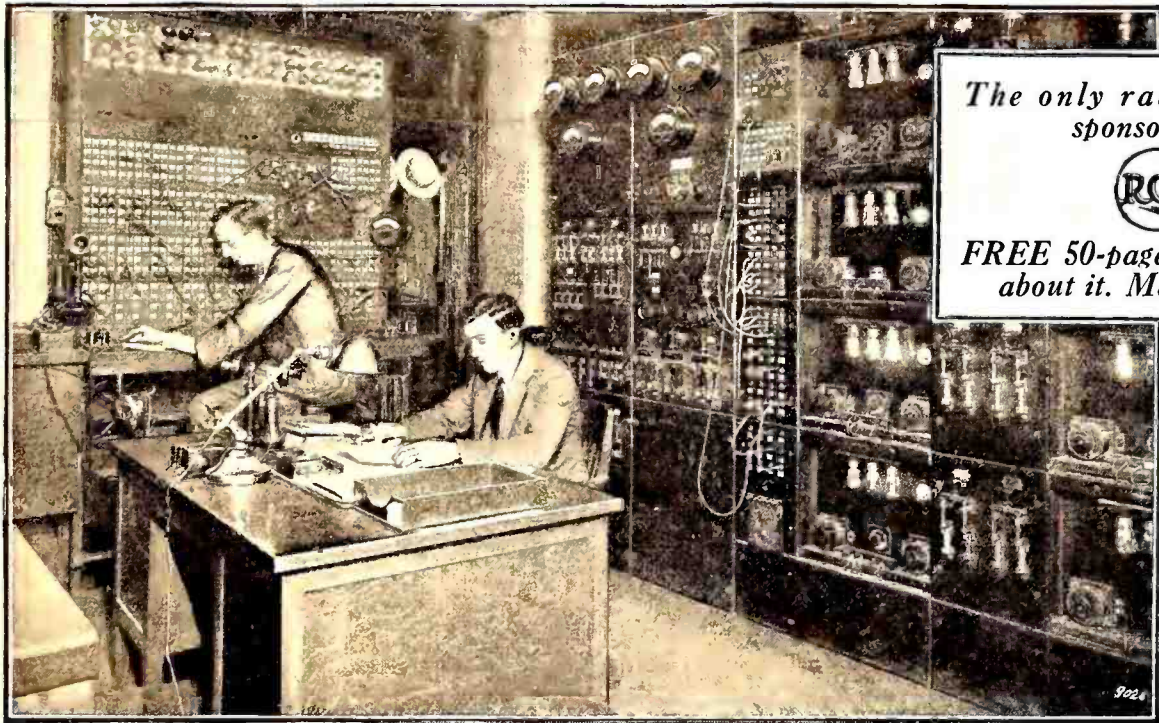

The only radio training  
sponsored by  
  
FREE 50-page book tells all  
about it. Mail Coupon.

*By Frank Halloran*

**I** GOT hungry to get into Radio when I learned about the big money it was bringing my next door neighbor.

He was only twenty-eight years old, but his income was over four times as much as I was getting. He owned a fine car, dressed in expensive clothes, took week-ends off to go hunting and fishing, and was one of the most popular fellows in town.

"Charlie," I asked him one day, "how did you become a radio expert?"

"A cinch," he smiled. "I took it up in my spare time at home."

"What?" I asked in surprise, "you actually took a radio course by mail?"

"No," he shot back. "Not just a mail order course, but the only technical home-laboratory training conducted under the auspices of the Radio Corporation of America! Believe me, this 'big-league' organization not only knows what's what in radio, but it knows how to teach it!"

### *A Great Piece of Luck*

Taking Charlie's advice was the luckiest thing I've ever done. It's bringing me more money in a week than I've often earned in a month!

I never dreamed that learning radio at home was so easy and so fascinating. From

the very first lesson to the last I was thrilled! Each subject was explained in simple word and picture form . . . and written in such an interesting style that I was carried along like a novel!

I didn't know the first thing about radio when I started, yet before many months were over I was able to solve many of the problems which now help me command big money. The lessons took me step by step through trouble-finding and repairing . . . through ship and shore and broadcasting apparatus operation and construction . . . through photoradiograms, television and beam transmission . . . through radio salesmanship, store operation and executive work.

### *Success—In Spare Time!*

I didn't have to give up my regular job. I learned at home during my spare time. And I actually learned by doing! With the course, I received an outlay of the finest standard apparatus with which I was able to build radio circuits and sets of almost every description . . . yet this expensive apparatus cost me absolutely nothing extra!

Even before I had completed the course I was able to earn good money doing odd radio jobs. And it wasn't long after that I was able to give up my regular work and branch out for myself as a full-fledged expert in work that is fun and extremely profitable!

Today, my income is more than doubled . . . and I've only just started! I'm certainly happy that I found this short cut to success!

### *Read This Thrilling FREE Book*

Frank Halloran's wonderful success is just another typical example of the success which the Radio Institute is bringing to hundreds of men everywhere through its wonderful Home-laboratory training . . . the only official radio training based on the inside knowledge of radio developed in the great experimental laboratories of the Radio Corporation of America!

There is an amazing opportunity for you in Radio. Manufacturers, dealers, broadcasting stations, ships . . . all are calling for trained radio experts. The pay is big—the opportunities are limitless—the work is thrilling! Find out all about it. The Institute has prepared an interesting, illustrated booklet telling you all you want to know about this vast industry and about the remarkable home study-course that can fit you for a brilliant radio career. Just mail the coupon below and claim your copy of this valuable booklet . . . it's absolutely free! Radio Institute of America, Dept. R. B. 3, 326 Broadway, New York



Mail this  
coupon

Radio Institute of America  
Dept. R. B. 3, 326 Broadway, New York, N. Y.

Gentlemen: Please send me your FREE 50-page book which tells all about the great opportunities in Radio and about your famous home-laboratory method of guaranteed radio instruction sponsored by the Radio Corporation of America.

Name .....

Address .....

# Hollister<sup>no</sup> 8 = AC

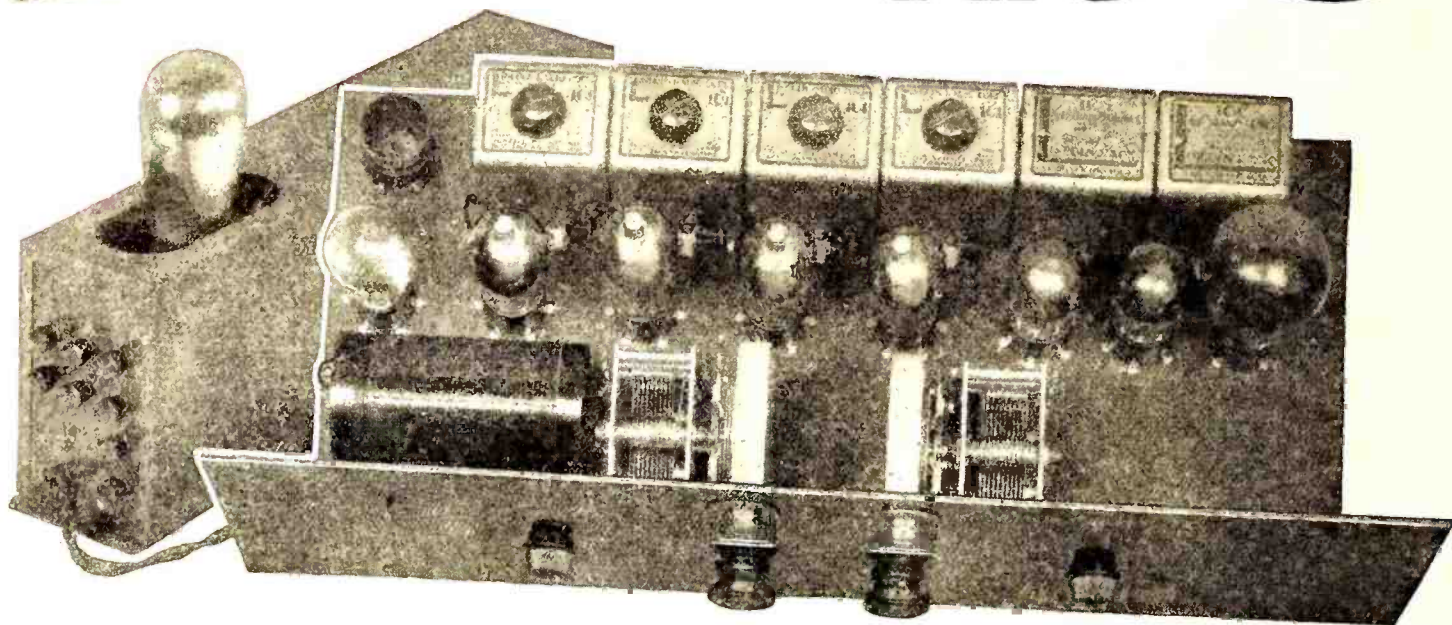

## HERE IT IS!

THE SET YOU HAVE ASKED FOR—WITH ALL THE PROVED PERFORMANCE OF THE LINCOLN 8-80.

Tremendous Power without Oscillation—Tune Where You Will and Station after Station You Never Heard Before Will Crash into Your Home with a Volume You Cannot Get on Local with the Average Receiver

10 K. C. selectivity guaranteed  
 Marvelous tone quality—Clough system of audio  
 Tunable intermediates  
 High sensitivity—2000 miles of ten-inch antenna  
 New highly designed illuminated drum dial and condenser assembly  
 One spot registration  
 Four A. C. screen grid stages—425 volt output

Perfect stability—No squeals or howls  
 Operated complete from small compact unit 3-7/16" x 5-1/4" x 16-1/8" using one 381 type tube only  
 Elegant appearance—finely grained walnut bakelite panel  
 Easy to build

Hollister A. C. 8 Kit Price \$110.00  
 Hollister AB 250 Power Pack 60.00

## LINCOLN 8-80 ONE SPOT SUPER D. C.

PROVEN BY HUNDREDS OF SET BUILDERS TO BE THE MOST POWERFUL RECEIVER ON THE MARKET

5000 miles with loud speaker volume  
 Only one refund asked in seven months' production  
 Operated by two small bone dry rectifiers

Lincoln 8-80 Kit \$92.65  
 Lincoln 110B 43.50

Lincoln Engineering has been endorsed by hundreds of custom set builders. Our big volume of sales is directly due to the wonderful reputation gained through actual performance, and not advertised claims. The Lincoln 8-80 has pioneered the way for better, long distance reception.

From Waukegan, Ill.—comes the report of every frequency logged from 500 KC to 1210 KC, except 880 and 1020 KC.  
 From the Hills of Kentucky—"300 stations logged in one week, 25 being on the West Coast, Mexico and Cuba, and many 50 and 100 watt stations."  
 From Battle Creek, Mich.—"No trouble getting CMC, Havana, while KWKH is on the air and KGO at Oakland while KTIS and Winnepeg are on full blast."

# LINCOLN RADIO CORPORATION

329 SOUTH WOOD ST. — CHICAGO - ILLINOIS.

Authorized Distributors for Lincoln 8-80  
 W. C. BRAUN CO.  
 563 W. Randolph St., Chicago  
 WESTERN RADIO MFG. CO.  
 128 W. Lake St., Chicago  
 ELECTRIC & RADIO SUPPLY  
 22 N. Franklin St., Chicago  
 CHICAGO RADIO APPARATUS  
 415 S. Dearborn, Chicago

LINCOLN RADIO CORP., Dept. B  
 329 South Wood St., Chicago, Ill.

...Send me full information on your products, for custom set builders.

I have never received one of your catalogs.

Name .....

Address .....

Authorized Distributors for Lincoln 8-80  
 KLADAG RADIO LABORATORIES  
 Kline Bldg., Kent, Ohio  
 HENRY L. WALKER CO.  
 27 E. Jefferson, Detroit, Mich.  
 WEDEL CO.  
 520-2nd Ave., Seattle, Wash.  
 SIURE BROS.  
 335 W. Madison St., Chicago

# SM

## Australia to New York— Verified Reception

done—of course—with an S-M Receiver!

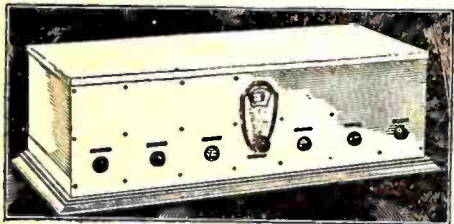

The great Sargent-Rayment 710—aptly termed "The Boss of the Air." Everything the most fastidious listener might want—an ultra-sensitive and knife-edge tuning set, which can, nevertheless, be operated when desired as a real one-dial set—with tone quality unsurpassed even in sets not designed for unusual selectivity. All this at \$130.00 for the KIT, or \$175.00 WIRED—both prices including cabinet!

AUSTRALIA to New York City on 353 meters! Direct verification from Station 2BL in Sydney, New South Wales, to a listener by the Hudson—one of the many thousands who have successfully employed the S-M Sargent-Rayment Seven to break through congested local interference.

We congratulate Mr. Parzelt on this feat of reception, and are happy to be able to supply, to all who desire it, a receiver of such caliber.

Second only to the Sargent-Rayment, and nearly as famous for its distance records—including reception from Japan in many parts of the U. S.—the S-M 720 Screen-Grid Six brings surpassing radio quality within the moderate-priced range. It contains the same matchless S-M Clough-system audio transformers. KIT \$72.50; beautiful metal shielding cabinet extra \$9.25. WIRED complete in cabinet, \$102.00.

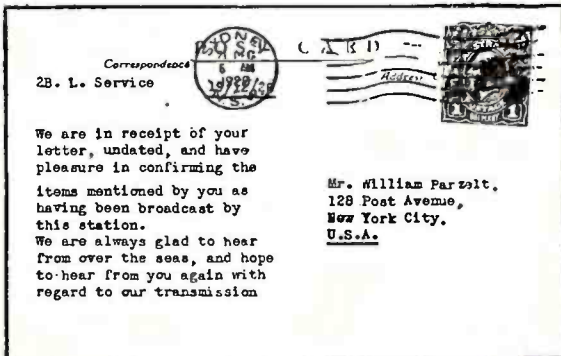

Correspondence  
2B. L. Service

We are in receipt of your letter, undated, and have pleasure in confirming the items mentioned by you as having been broadcast by this station. We are always glad to hear from over the seas, and hope to hear from you again with regard to our transmission

Mr. William Parzelt,  
128 Post Avenue,  
New York City,  
U.S.A.

### Giant-Voiced—Yet Pure-Toned

Never before has such an amplifier as the S-M 690 been available to the setbuilder and service man! It brings within his control installation jobs in theatres, auditoriums, and for all public occasions. The public, thoroughly awakened by the talking-movie, is demanding life-like high-power sound amplification where formerly ears were strained to "catch the high spots."

Find out today about the remarkable things that can be done with an amplifier delivering such tremendous power output as 15,000 milliwatts—from phonograph, microphone, or radio-detector input—with three-point switch on the panel, as well as a knob giving smooth fading control whatever input is being taken.

S-M 690 Amplifier is built on a black crackle-finished heavy aluminum panel 12x21 inches. Uses seven tubes: 1st stage, one '26; 2nd stage, two '27's in push-pull; 3rd stage two '50's in push-pull; two '81 rectifiers. All power from 110-volt A. C. socket. List price, assembled complete less tubes, \$245.

And the S-M 678PD—powerful enough for small theatres and almost any dance hall, yet priced so low as to be ideal for the home also—supplies, by use of the S-M Clough audio system, the full undistorted power of a '50 type tube to any 110-volt D. C. dynamic speaker; supplies field current also. All power taken from 110-volt A. C. light socket. Price WIRED \$73; complete KIT \$65.

Get the new S-M catalog—and begin today to look about you for the opportunities that exist everywhere to make good money by installing S-M amplifiers.

The Radiobuilder, a monthly publication telling the very latest developments of the S-M laboratories, is too valuable for any setbuilder to be without. No. 9 (Jan. 1929) gave full particulars about the new apparatus described above, long before it was available in any other form. Send the coupon for free sample copy, or to enter your subscription if you want it regularly.

If you build professionally, but do not have as yet the S-M Authorized Service Station appointment, ask about it.

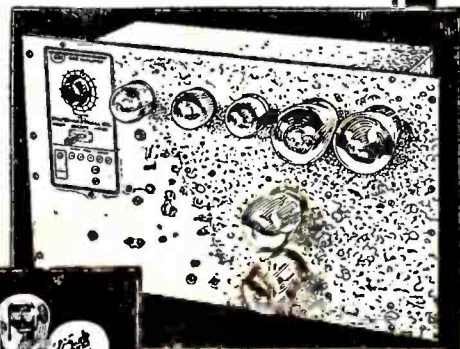

Above  
S M 690

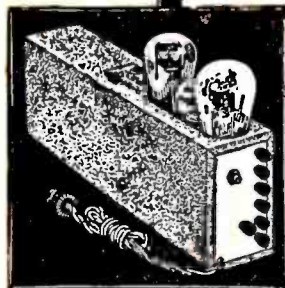

Left  
S-M 678PD

#### Now a Speaker Made as Good as S-M Amplifiers

The S-M Dynamic Speaker, now announced for the first time, establishes still more firmly the superiority of S-M sound amplifying equipment—a speaker supreme in its ability to handle without distortion an amazingly large amount of power. Has the new S-M 229 output transformer built in, with output taps providing proper impedance matching for use with 171, 250, or the new intermediate power tubes, singly or in push-pull. Two types: S-M 850, for 110 volts A. C. (using '80 rectifier tube) \$58.50. S-M 851, for 110 volts D. C., \$48.50.

**SILVER-MARSHALL, Inc.**  
838 West Jackson Blvd., Chicago, U. S. A.

- Silver-Marshall, Inc.  
838 W. Jackson Blvd., Chicago, U. S. A.
- .... Please send me, free, the complete S-M Catalog; also sample copy of The Radiobuilder.
- For enclosed.....in stamps, send me the following:
- .... 50c Next 12 issues of The Radiobuilder
  - .... \$1.00 Next 25 issues of The Radiobuilder
  - .... S-M DATA SHEETS as follows, at 2c each:
    - .... No. 1. 670B, 670ABC Reservoir Power Units
    - .... No. 2. 685 Public Address Unipac
    - .... No. 3. 730, 731, 732 "Round-the-World" Short Wave Sets
    - .... No. 4. 223, 225, 226, 256, 251 Audio Transformers
    - .... No. 5. 720 Screen Grid Six Receiver
    - .... No. 6. "40" Coast-to-Coast" Screen Grid Four
    - .... No. 7. 675ABC High-Voltage Power Supply and 676 Dynamic Speaker Amplifier
    - .... No. 8. Sargent-Rayment Seven
    - .... No. 9. 678PD Phonograph Amplifier

Name.....  
Address.....

# RADIO BROADCAST

WILLIS KINGSLEY WING . . . . Editor  
KEITH HENNEY . . . Director of the Laboratory  
HOWARD E. RHODES . . . Technical Editor  
EDGAR H. FELIX . . . . Contributing Editor

VOL. XIV. NO. 5



ENGINEERING · THE LABORATORY · SERVICING

## Contents for March, 1929

Frontispiece -	<i>De Luxe Radio Service in a Hospital</i>	290
A Multiple-Receiver Antenna System -	<i>V. D. Landon</i>	291
What the Serviceman Should Study	<i>John S. Dunham</i>	294
The March of Radio -	<i>An Editorial Interpretation</i>	296
A Study of Program Possibilities New Radio Service to Aviation		High-Frequency Allocations In the World of Broadcasting
New Automatic Volume Control System	<i>Charles Williamson</i>	299
Strays from the Laboratory - - -	<i>Keith Henney</i>	300
New Trends in Radio Design Two New A. C. Tubes on Way Accuracy of Variable Condensers New Radio Tubes in England Importance of Reducing A. C. Hum		Receiving on 600 meters Selectivity of Browning-Drake Removing Noise in Shielded Re- ceivers League of Nations to Broadcast
An Unusual Organization - - - -	<i>Robert S. Kruse</i>	302
Grid-Leak Grid-Condenser Detection	<i>Frederick Emmons Terman</i>	303
"Radio Broadcast's" Home-Study Sheets - - - -		307
No. 17. Plotting Curves—Part 1		No. 18. Plotting Curves—Part II
A Double-Detection Short-Wave Set	<i>Robert S. Kruse</i>	309
Broadcast Engineering - - - - -	<i>Carl Dreher</i>	311
A Cuban Short-Wave Receiver - -	<i>Frank H. Jones</i>	313
Sound Motion Pictures - - - - -	<i>Carl Dreher</i>	314
Measurements on Dynamic Speakers	<i>Frank C. Jones</i>	316
The Serviceman's Corner - - - - -		319
Importance of Impedance Relations -	<i>C. T. Burke</i>	322
Table of Wavelength Allocations - - - - -		323
Our Readers Suggest - - - - -		324
A Thermionic Milliammeter - - - -	<i>G. F. Lampkin</i>	325
"Radio Broadcast's" Set Data Sheets - - - - -		327
The Majestic Model 70-B Receiver The Federal Type D Receiver		The Crosley Model 704-B Receiver The Crosley Model 705 Receiver
A High-Power Output Tube - - - -	<i>K. S. Weaver</i>	329
In the Radio Marketplace - - - - -		331
Manufacturer's Booklets - - - - -		334
What is a Good Tube? - - - - -		335
"Radio Broadcast's" Laboratory Information Sheets		348
No. 265. Electrifying Battery Sets No. 266. Effect of Room Acoustics No. 267. Power in Broadcast Har- monics No. 268. Mathematics of Tuned Circuits		No. 269. Importance of Bass Notes No. 270. Formulas for Power Out- put No. 271. Tests for Push-Pull Am- plifiers No. 272. Correct Filament Voltages
Book Review - - - - -	<i>Carl Dreher</i>	354
Letters from Readers - - - - -		354
Short-Wave List - - - - -		358
Mexican Broadcasting Stations - - - - -		358

The contents of this magazine is indexed in *The Readers' Guide to Periodical Literature*, which is on file at all public libraries

## . . . among other things

THE issue before you might be called a special tube num-ber. In addition to the series of charts and explanatory curves which accompany them, we present the article by K. S. Weaver of the Westinghouse Lamp Company on the char-acteristics of the 250-type tube, some data in "Strays from the Laboratory" on new English tubes of interest, and a useful article by G. F. Lampkin on the use of a vacuum tube circuit to measure very small values of a.c. with inexpensive apparatus.

WE CALL especial attention to the new section of RADIO BROADCAST, "In the Radio Marketplace." This new news section of the magazine will, as our plans develop, be-come increasingly useful to every reader who is in the radio industry. A new feature, prepared with much the same pur-pose as our famous "Laboratory Data Sheets," appears in the "Marketplace" this month. It is the "Radio Dealers' Notebook" containing complete information every month on one subject of interest to those who serve the public, radio-wise. We welcome suggestions as to how this feature can be broadened to be of increased value. The article by Charles Williamson on page 299 describing an automatic volume control should be of interest to experimenters and to advanced servicemen who may find it possible to install the device on receivers owned by their clients who are interested in owning the latest improvements.

THE April RADIO BROADCAST will contain among many others, an interesting article by Roger Wise on "Charac-teristics of Filament Type Rectifiers," illustrated with many tables and curves; the second article by Prof. Terman on "Detection" will appear, this one being devoted to "power detection"; and, a story by K. W. Jarvis on "Selectivity" —a subject on which much should be said because increased attention is being devoted to it.

MANY radio companies are sending printed matter by mail to radio dealers and radio service organizations, particularly the former. Much of what they send is of prime interest to servicemen and the technical head of the business, who, parenthetically, is often one and the same person. It is an unfortunate fact that as things are, much of this in-formation which servicemen really could use never reaches them. The answer? Well, we would rather the mail be ad-dressed to the serviceman or technician than campaign to change the habits of the dealer who offends.

WILLIS KINGSLEY WING.

TERMS: \$4.00 a year; single copies 35 cents, . . . . All rights reserved. Copyright, 1929, in the United States, Newfoundland, Great Britain, Canada, and other countries by

DOUBLEDAY, DORAN & COMPANY, INC., Garden City, New York

MAGAZINES . . . .  
COUNTRY LIFE, WORLD'S WORK, THE AMERICAN HOME, RADIO BROADCAST, SHORT STORIES, LE PETIT JOURNAL, EL ECO, FRONTIER STORIES, THE AMERICAN SKETCH, WEST.  
BOOK SHOPS (Books of all Publishers) . . . .

NEW YORK: <LORD & TAYLOR, JAMES MCCREERY & COMPANY, PENNSYLVANIA TERMINAL, 166 WEST 32ND ST., 848 MADISON AVE., 51 EAST 44TH STREET, 420, 526, and 819 LEXINGTON AVENUE, GRAND CENTRAL TERMINAL, 10 WALL STREET> CHICAGO: <75 EAST ADAMS STREET> ST. LOUIS: <223 N. 8TH ST. and 4914 MARYLAND AVE.> CLEVELAND: <HIGBEE COMPANY> SPRINGFIELD, MASS: <MEEKINS, PACKARD & WHEAT.

OFFICES . . . .

GARDEN CITY, N. Y. NEW YORK: 244 MADISON AVENUE. BOSTON: PARK SQUARE BUILDING. CHICAGO: PEOPLES GAS BUILDING. SANTA BARBARA, CAL. LONDON: WM. HEINEMANN, LTD. TORONTO: DOUBLEDAY, DORAN & GUNDEY, LTD.

OFFICERS . . . .

F. N. DOUBLEDAY, Chairman of the Board; NELSON DOUBLEDAY, President; S. A. EVERITT, Vice-President; GEORGE H. DORAN, Vice-President; RUSSELL DOUBLEDAY Secretary; JOHN J. HESSIAN, Treasurer; LILLIAN A. COMSTOCK, Ass't Secretary; L. J. McNAUGHTON, Ass't Treasurer . . . .

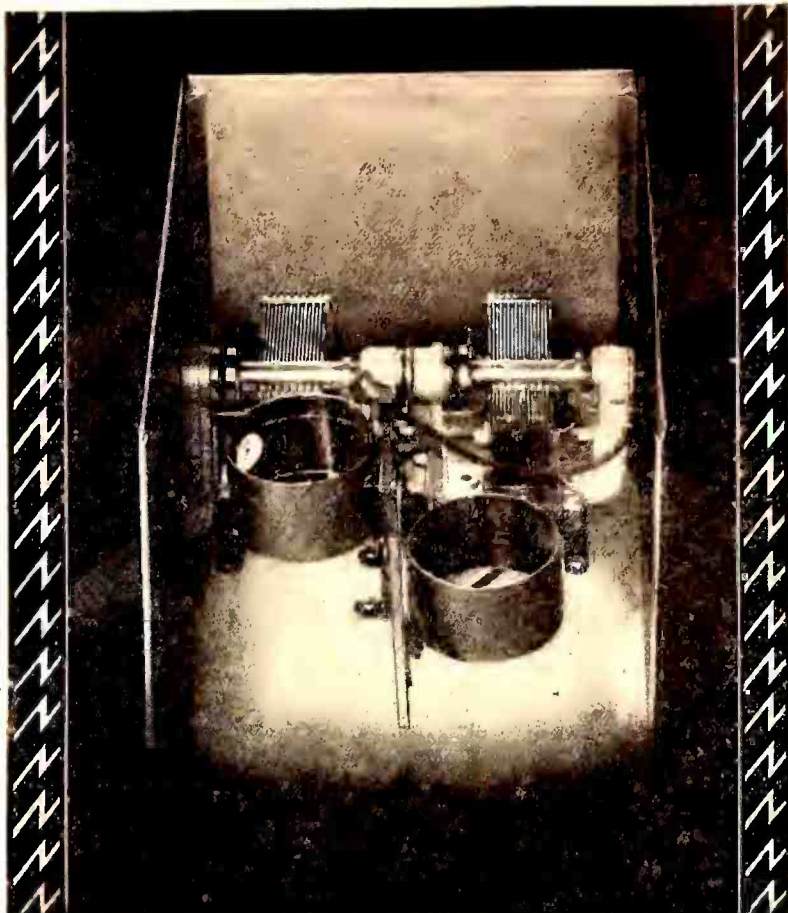

# BAND PASS FILTER

*Effects*  
**FLAT-TOP** tuning  
**10 K.C.** selectivity  
**PERFECT** tone

**T**HE Master Hi-Q 29 is the only circuit permitting the use of shield-grid tubes at their maximum amplifying ability.

So remarkable has been the performance of this receiver that not only are professional men everywhere building it, but the engineers of nearly a score of the foremost radio companies have purchased it either for personal use or for laboratory experiment.

Due to the characteristics of loosely tuned circuits, each of the doubly tuned radio-frequency transformers used in the Hi-Q '29 actually constitutes a "band-pass filter", the effect of which is shown in the graph below. Space does not permit full description of the many advantages thus gained but the informed radioman should quickly grasp the results

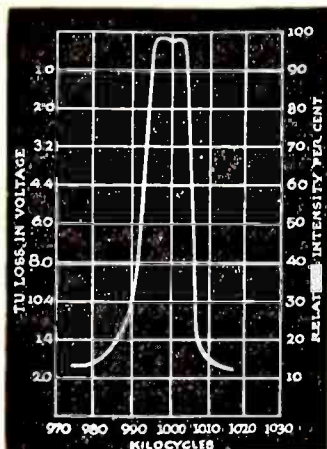

shown in the exclusive Hi-Q "flat-top" response curve.

The sum total of Hi-Q '29 design is a finer degree of both sensitivity and selectivity than has ever been known before with the added advantages of tone quality which experts admit is nothing short of epoch-making.

It will pay you to write for our 80-page illustrated book on Hi-Q "Band-Pass Tuning" and construction details of the four Hi-Q models. Price is 25c. Use the coupon.

# Hi-Q 29

HAMMARLUND-ROBERTS, Inc., 1182A Broadway, New York

Enclosed find 25c for my copy of your book on Hi-Q Band Pass Filter Circuits and full construction details on your four Hi-Q models.

NAME.....

ADDRESS.....

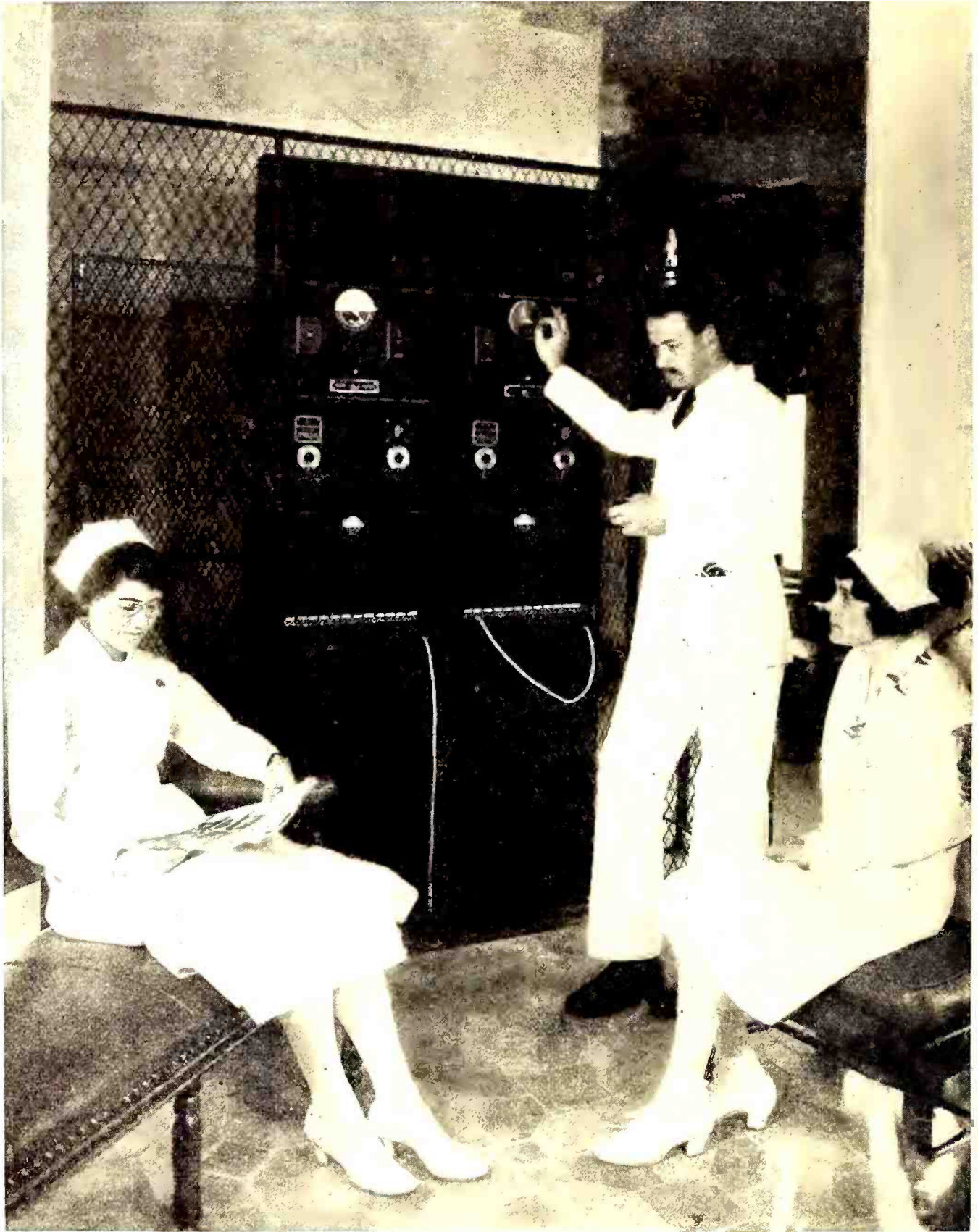

## DE LUXE RADIO SERVICE AVAILABLE IN UP-TO-DATE HOSPITAL

*A centralized two-channel radio program distribution system has been installed in the Knickerbocker Hospital, New York City, by the Radio Corporation of America. Loud-speaker and headphone outlets are located in each of the various wards as well as the rooms occupied by the hospital staff. At any of the outlets the listener has a choice of tuning-in either one of the two programs which are being distributed. This picture shows an operator adjusting the control-panel dials of the new installation.*



## A MULTIPLE-RECEIVER ANTENNA SYSTEM

By V. D. LANDON

Westinghouse Electric & Manufacturing Company

THE nondescript tangle of antennas on the roofs of most large apartment houses is a familiar sight and a frequent source of comment. The opinion most often expressed is that human ingenuity should be able to find a more systematic method of providing the tenants with reception facilities. Nevertheless, no such method previously has made its appearance, the problem being left almost entirely to the devices of the individual tenants.

The result is a maze of wires on the roof which is anything but artistic. It is the "roof jungle" of the modern city. A typical "jungle," which is a sample of what is seen for mile after mile from an elevated train in New York, is shown in Fig. 1.

The "jungle" is not only an eyesore for the landlord, but it results in a great deal of building defacement as well. Nails are driven, holes are bored, and grooves are cut. The ideas as to how it should be done are different with each succeeding tenant. Fig. 2 illustrates the careless way in which many antennas are installed by apartment-house tenants.

In a few instances, this system, or lack of system, has been replaced by a more orderly arrangement supervised or constructed by the building owner. This is usually an improvement from an artistic standpoint, but the radio reception provided is seldom satisfactory for several reasons. The antennas are usually only a few feet above the roof of the buildings and, as practically all modern buildings are of steel framework, which is an excellent ground, the effective height of the antennas is very low. The long lead-in wires, which are usually necessary, have a large capacity to ground which has the effect of partially bypassing what little signal is introduced into the antenna. Although these long lead-in wires do more harm than good in picking up signals, they are very effective in picking up the noise from the various kinds of electrical machinery distributed about the building. Also the close proximity of all these antennas causes a number of undesired effects. If receivers are used that employ tuned input circuits, it will be found that when one receiver is retuned, a change in tuning becomes necessary in the other sets in the building. If some tenants have receivers capable of oscillation, the reception of the others is often interfered with. In addition, each antenna tends to shield the others from the signals.

*This article by Mr. Landon of the Westinghouse Company gives technical data on a system of supplying a large number of radio outlets in an apartment house, from a single antenna located on the roof, each outlet making available to the particular apartment in which it is located a signal comparable in strength to that obtained from a good antenna. One good antenna may be used to supply about 100 outlets. The exact arrangement of the system varies depending upon the number of outlets to be supplied and their arrangement—each installation is to a varying extent a special job.*

—THE EDITOR.

The result of all this is that an overwhelming demand exists for a satisfactory system of distributing radio signals to tenants. The situation is so acute that builders have expressed a willingness to delay their building program if such apparatus would be available at an early date. Many owners report tenants changing apartments in trying to find a location having good reception facilities.

### A New System

THE following describes a system which solves the problem in a manner thoroughly satisfactory to both tenant and owner. The "roof jungle" of antenna wires are replaced by a single antenna of attractive appearance and efficient design. The signals from the common antenna are distributed at radio frequency to each apartment in the building, over conductors which are enclosed in metallic conduit.

Each apartment is equipped with a radio-outlet plate containing antenna and ground terminals. When a radio receiver is connected to these terminals, it will perform in the same manner as though it were connected to a very good isolated antenna. Fig. 5 shows a schematic diagram of an installation.

The received signal causes a radio-

frequency voltage drop across  $R_1$  and this voltage is fed to the grids of the amplifier tubes in the antenna-coupling units. There may be any number of antenna-coupling units up to about ten, used on one antenna. These are located on the roof in the pent house. The radio-frequency transformer,  $T_1$ , in the plate circuit of each of these tubes feeds a transmission line, or distribution riser which leads to several apartments. The coupling tube or "extension unit" in an individual apartment passes the signal on to the individual receiving set through another radio-frequency transformer  $T_2$ .

The unique virtues of this system are:

1. The high signal intensity obtained.
2. The total absence of interaction between receivers.
3. The elimination of the pick-up of interfering electrical noise on the distribution system.
4. The efficient transmission of signals at all frequencies in the broadcast range at the same time.
5. The economy of initial cost and maintenance.
6. Ease of installation.
7. Businesslike arrangement and attractive appearance of the whole system.

A high signal intensity is obtained by the use of a single really good antenna and an efficient distribution system. Interaction between receivers is eliminated by placing a coupling tube in each apartment. Thus a change in the tuning of any receiver does not affect the impedance of the distribution riser in the least. Furthermore, if a receiver oscillates, the generated high-frequency energy does not get past the coupling tube and, hence, does not interfere with the reception of others, except insofar as radiation takes place directly from the coils of one receiver to those of another. Thus interference due to the neighbor's birdies is reduced greatly.

The interference caused by the operation of the various types of electrical machinery about the building is minimized. Of course, that portion of the radiated noise which reaches the antenna high above the roof, will come through. However, the strong electrical fields close to this machinery will not be picked up by the distribution risers. Any voltage induced in the transmission line wire is induced in the enclosing conduit as well and there is no effective input voltage between grid and filament of the coupling tubes from this source. This will of ten mean the difference between good reception and poor reception in buildings where noisy electrical machinery is in use.

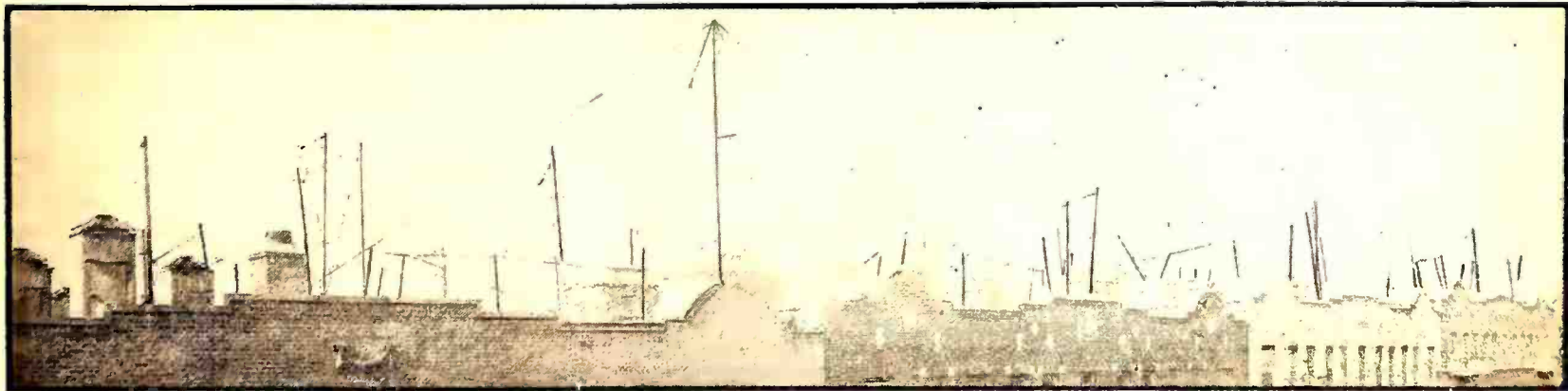

Fig. 1—View of the "roof jungle" of radio antennas in a New York City apartment-house district. The r. f. distribution system described in this article would correct this condition

Principle of System

**E**FFICIENT transmission of signals at all frequencies of the broadcast band simultaneously, is obtained by the use of the principles of the loaded transmission line. The grounded neutral circuit (similar to that of a push-pull amplifier) is necessary to eliminate ground current in the conduit which would prevent proper loading of a single sided line. The radio-frequency transformers are used in the plate circuits of the coupling tubes to match properly the tube impedance to the load.

A feature which is essential to the practicability of the system is the centralization of the B supply for the coupling tubes, since the cost of supplying a separate B-power unit for each tube would be prohibitive. One B supply is used for each antenna-coupling unit and all the extension units tapped off the associated distribution riser. This is better than a single large B supply for the entire system because it makes a more flexible arrangement, better adapted to fitting a wide variety of building sizes.

The arrangement for using the r.f. distribution wires for carrying minus B, and the grounded conduit for carrying plus B, is rather unique and effects a distinct saving in apparatus required. As may be seen in Fig. 5, the grid of the coupling tube is connected directly to the line. The signals are prevented from flowing to the filament by the r.f. choke. The d.c. plate current flowing in the resistor  $R_c$  supplies bias voltage for the grid. The condenser  $C_r$  keeps the filament at ground potential to the signal voltage. The pipe and box are connected to the positive B that is used as the source of B voltage for the plate. The power transformer lights the filament of the tube. If the negative side were grounded and the positive side on the line, as would be more conventional, it would be necessary to add a grid leak and two condensers to each coupling-tube box to obtain equivalent operation.

The economies effected by this method of centralization of B supply, make the cost per apartment of the installation only about the same as the cost of a real good antenna for each apartment.

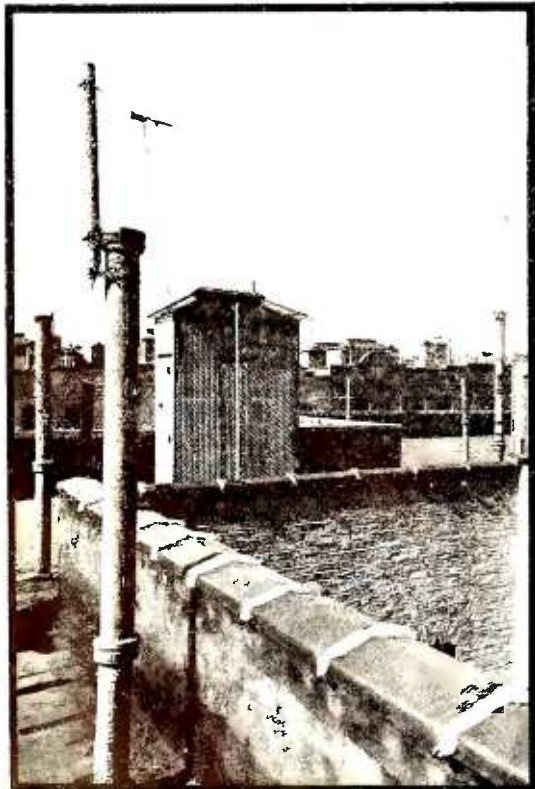

Fig. 2—Each tenant develops a different way to erect an antenna. The above picture shows the careless construction of a typical apartment-house antenna

The entire system is as easily installed and as "fool-proof" as the wiring for the electric lighting circuits. The distribution risers are run in standard half-inch steel conduit (with no appreciable increase in attenuation—to the surprise of many). Where possible, these risers are run vertically from the roof to the ground floor. Any number of coupling tube boxes from one to five may be tapped off on each floor. However, the usual number will be one or two per floor in multi-storied building, since ten coupling tubes is the practical maximum set for one riser. A set of loading coils is inserted in the line on every other floor.

Coupling Boxes Described

**T**HE coupling-tube boxes of both the central and apartment types are sunk into the walls and covered with flush cover

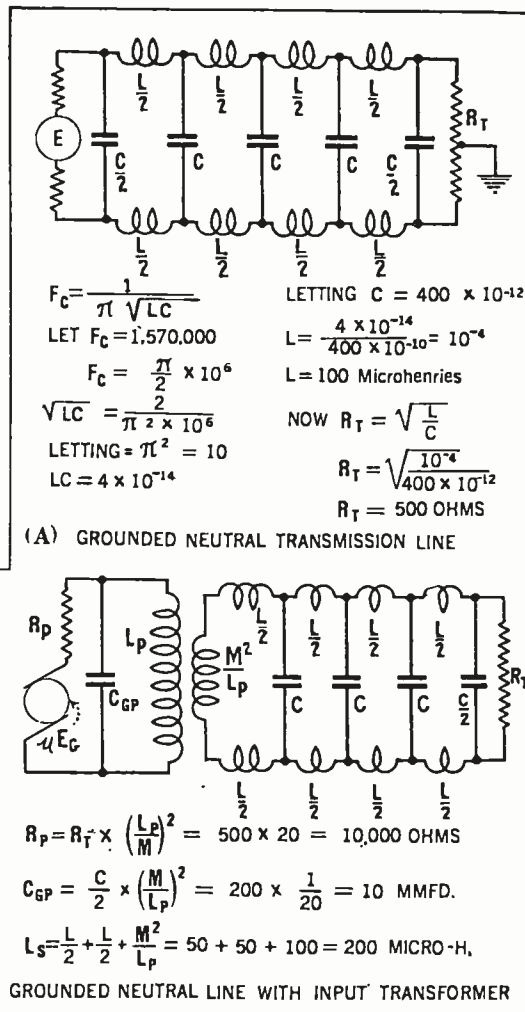
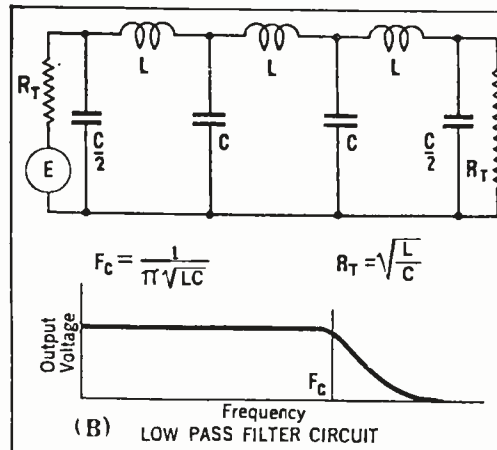

Fig. 3—These circuit diagrams and formulas explain the operation of the apartment-house r. f. distribution system described by the writer

plates. Fig. 1b provides an interior view of a coupling-tube box showing the location of the filament transformer, the tube, and the radio-frequency transformer.

The coils seen just above the filament transformer constitute a set of loading coils for the line. If the coupling-tube box is not in a position where the loading coils are needed, they are omitted. If a set of loading coils is required at a point remote from any coupling-tube box, another type of box is used to mount them separately.

The electrical portion of the coupling-tube box is held in place by two screws. This unit is not inserted in the box until the rest of the installation is complete, thus minimizing the number of damaged units. This assembly is shown in Fig. 4a.

The unit going in the antenna-coupling-tube box is the same except that a slightly different r.f. transformer is used. This is shown in Fig. 4c. The r.f. unit is seen in the top of the box. The bottom of the box contains the B-power unit for one transmission line.

A special outlet plate is installed in each apartment. Antenna and ground pin jacks are provided and also a socket for plugging in a socket-powered receiver. The switch turns off the power on the receiver and on the filament of the coupling tube for that apartment.

The theory of the design and operation of the distribution system is somewhat involved but an attempt will be made to give it in sketchy form. The design is based on the principle of the low-pass filter or loaded transmission line shown in Fig. 3b. The formulas applying to this circuit are:

$$R_T = \sqrt{\frac{L}{C}}$$

$$f_c = \frac{1}{\pi \sqrt{LC}}$$

where  $f_c$  is the cut-off frequency. As shown in the operation curve, higher frequencies than

$f_c$  are attenuated to a degree which increases rapidly as the frequency is increased. Lower frequencies are transmitted with practically no loss. If E volts is applied at a frequency lower than  $f_c$  in series with the first resistor,  $R_t$  (commonly called the generator resistance) then E/2 volts will appear across the terminal resistor  $R_t$ , providing the circuit is so balanced that the two equations are fulfilled.

Fig. 3a shows a grounded neutral circuit. These same formulas apply to a grounded neutral circuit when the inductance used for L is that of the two loading coils of one section of the line in series, and the capacitance used for C is the capacitance of one side of the line to the other side, for a single section between loading coils. The distributed inductance of the wires is negligible in this case as telephone twisted pair is used and there is very little space between wires.

Solving the Formulas

**T**HERE are then a pair of simultaneous equations with four unknowns. Clearly any two of the variables may be fixed at any desired values and the corresponding values of the other two variables are then determined by the two equations.

The easiest value to fix is  $f_c$ . A convenient value for arithmetical simplicity and for practical reasons is:

$$f_c = 1,570,000$$

then  $LC = 4 \times 10^{-14}$

If a convenient value is assigned to L, C, or R, the other two values will then be fixed by the two equations. It is most convenient to have the loading coils a distance apart equal to a multiple of the distance between floors in a building since the coils may then be placed in the coupling-tube boxes and special boxes need not be provided and mounted. A handy distance is every two floors, as will be seen. This length (20 or 22 ft.) of No. 18 telephone twisted pair has a capacity of a little

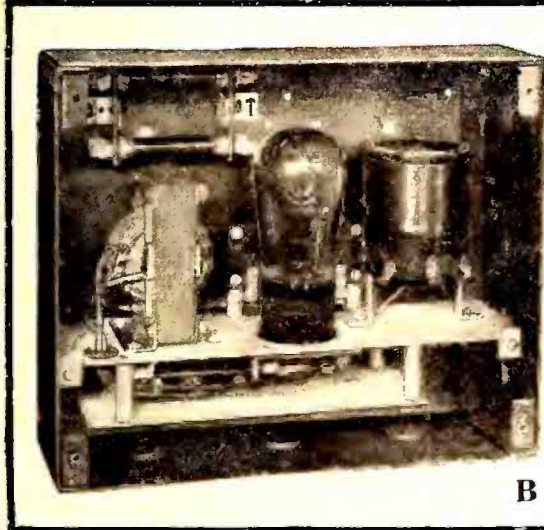
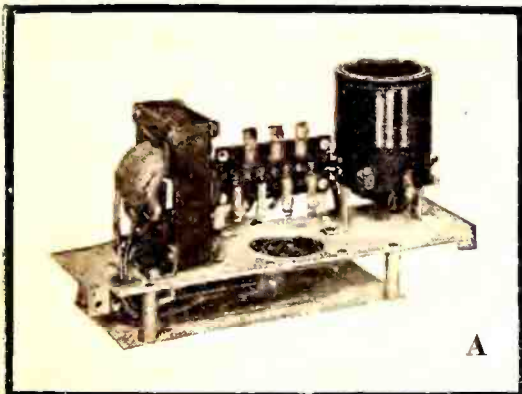

about 2.25. It is designed to match an impedance of about 2000 ohms which seems to be a good average value for the input impedance of the various types of receivers. To make the impedance of the transformer more nearly like that of an antenna, a small series condenser was added.

If a one-volt r.f. potential is applied on the grid of the antenna-coupling tube, and the amplification factor of the tube is nine, we have  $1 \times 9 \times \frac{1}{4} \times \frac{1}{2} \times \frac{1}{2} = \frac{9}{8}$  volt applied to the grids of the apartment-coupling tubes assuming no attenuation. The ratio of the apartment-coupling tube transformer is 2.25

so that  $\frac{1}{2} \times 9 \times \frac{1}{4} \times \frac{1}{2} \times \frac{1}{2}$  or 1 volt is applied to the radio receiver input circuit if its input impedance is 2000 ohms, so as to produce an impedance match. If the impedance is other than 2000 ohms, the input voltage may be greater or smaller but operation has been quite satisfactory with every type of receiver yet tried.

Some time ago a test was made to convince a certain apartment-house owner of the utility of the system. A comparison was made of the sensitivity of a receiver using first, the type of antenna to which he had been limiting his tenants and second the distribution riser to a good antenna 80 ft. long and 30 ft. above the roof. The antenna used for direct connection to the set consisted of about the same length of wire as was used in the antenna on the roof. This wire ran out of a window on the ground floor, up the side of the six-story building and had a ten-foot horizontal section at a height of about 10 ft. above the roof.

The distribution riser delivered more than twenty times the radio-frequency voltage from a local station than the direct-connected antenna provided. This proved that the grounded framework of the building shielded the direct connected antenna very effectively.

The aim of the entire system is to provide signals at each receiver outlet plug which will be the equivalent of what would be obtained if the receiver were located on the roof and had the antenna all to itself.

Since the antenna is to supply such a large number of people, most building owners will find it worth while to put up a really excellent antenna when installing this system. When this is done, the apartment is transformed from an exceedingly poor radio location to one in which reception is exceptionally good.

Fig. 4—Pictures of the apparatus used in an apartment-house r. f. distribution system. A shows the electrical portion of the coupling-tube box, B is an interior view of the coupling-tube box, and C is a view of the antenna-coupling box

over 300 mmfd. Allowing about 50 mmfd. apiece for an average number of coupling tubes (two) gives a line capacity of 400 mmfd. Solving for L: (See Fig. 3A):

$$L = 100 \text{ Microhenries}$$

$$R_t = 500 \text{ ohms}$$

A hundred feet of line having these characteristics is found to transmit signals over the entire broadcast band with a negligible amount of attenuation. The length of each section of the line is not very critical. It may be varied 25 per cent. with no bad effects.

Designing the Transformer

REFERRING to Fig. 3c, a further feature to consider is the design of a suitable transformer to match the plate impedance of the tube (10,000 ohms) to the 500-ohm load. This requires a step-down ratio of the square root of 20 or about 4.5 to 1. Since it is impractical to build a 100 per cent. coupled transformer, the leakage reactance must be used as the loading inductance of the first section of the line. The inductance of the primary must be great enough to make an effective transformation at the lowest frequency of the band.

Two millihenries is found sufficient for the primary. That portion of the secondary which may be considered 100 per cent. coupled to the primary must have an inductance of 0.002 divided by 20 = 100 microhenries. Adding to this the leakage reactance of 100 microhenries gives a transformer with a 2000-micro-henry primary a 200-microhenry secondary, a mutual inductance of 450 microhenries and an effective ratio of transformation of 4.5.

It should be noted that the tube's plate-filament capacity (10 mmfd.) multiplied by the square of the transformation ratio (i.e. 20) supplies the correct terminal capacity for the low-pass filter (i.e. 200 mmfd.).

The design of the output transformer of the apartment-coupling tube is obtained by following a similar line of reasoning. Its ratio is

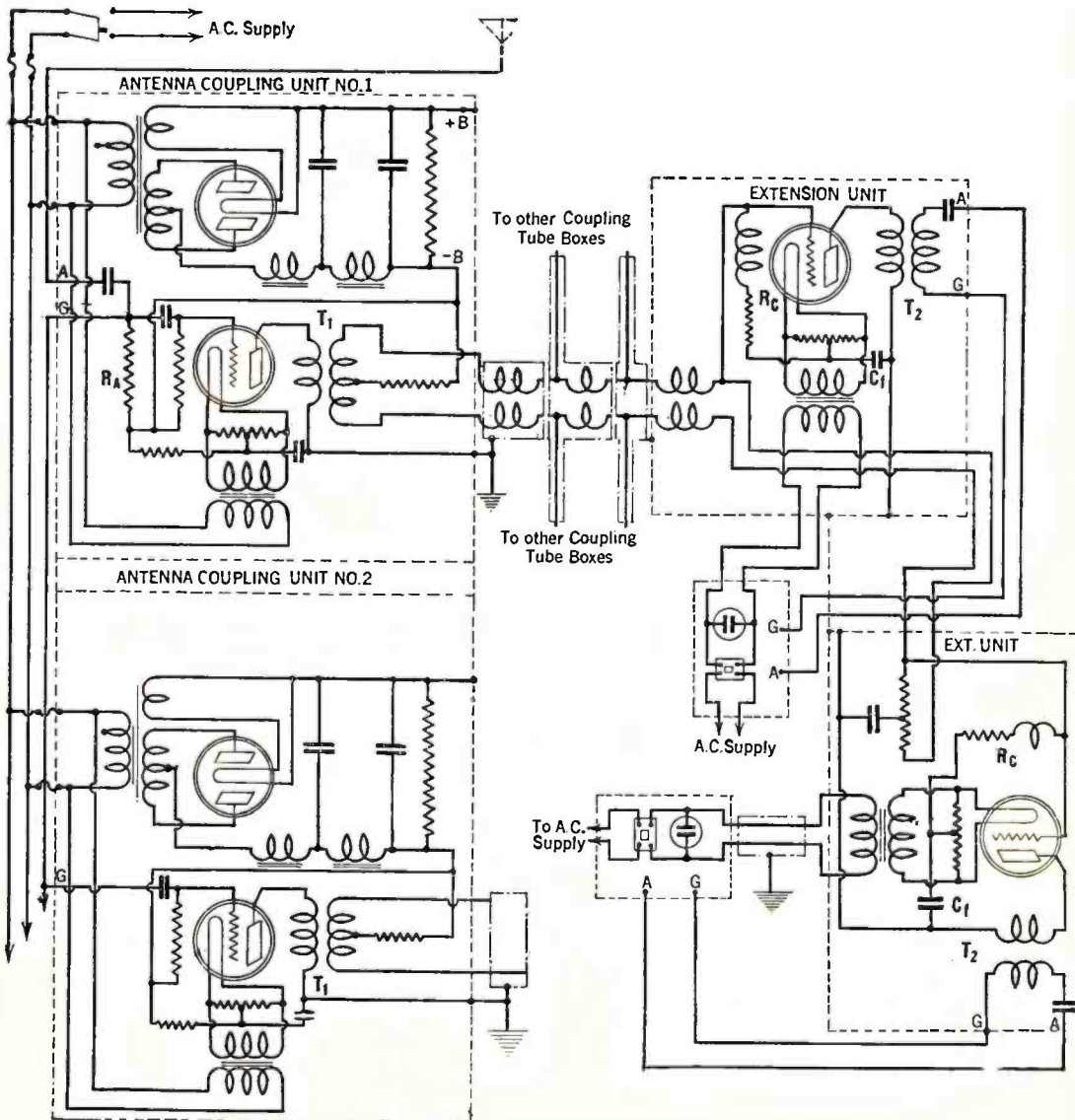

Fig. 5—Schematic wiring diagram of a typical r. f. distribution system of the type designed for apartment house use

# WHAT THE SERVICE MAN SHOULD STUDY

By JOHN S. DUNHAM

QRV Radio Service, Inc.

**B**EFORE we delve into the large subject of methods whereby recalcitrant radio receivers may be induced to play again sweet music, which we shall do in following articles, we might profit by a discussion of the elements of knowledge which the serviceman needs to have if he is to be a really good serviceman instead of just an "expert." There are two definite forms of knowledge the gaining of which the serviceman may pursue, and a definition of what each is, plus what each will do, will give us some basis for deciding their relative importance.

### Service-Manual Knowledge

**L**ET us first consider the man whose radio knowledge is limited to a thorough acquaintance with the kind of service data presented in manufacturers' service manuals. He knows the physical layout of a number of makes and models of receivers. In a particular model, he knows the name of each part and its exact placement, the number of each tube socket, and the types of tubes which correspond to the socket numbers. He knows to which socket prong or to what terminal of which canned up something-or-other "unit" each wire from each numbered terminal lug goes. He knows by heart the fact that, testing with a C battery in series with a high-resistance meter, the proper effect from lug number 2 on the left-hand terminal strip to prong 3 in socket 7 is a full reading of the battery potential on his voltmeter, and that if he does not get such a reading there it will then be necessary to replace the coupling, audio, or power assembly which is catalogue number 3452. He knows in detail exactly which shields, controls, and screws to remove and which wires to unsolder in order to remove that part for replacement, as well as exactly the quickest and easiest way to install the new part.

The man who has that sort of knowledge, all of which can be memorized, like dates in history, from the service manuals put out for dealers and distributors by all reputable manufacturers, can do a number of things with it. Servicing a given model and its associated apparatus, with which he has become familiar by studying the manual and by actual practice on that model, he can find and cure all of the ordinary run of troubles in nearly the minimum of time required. He can also find and cure, from instructions given in the manual, most of the more usual antenna-ground system troubles. If the customer is present, he will give the impression, by the ease and rapidity with which he works, that he is a thoroughly competent, highly trained serviceman. Those things are assets which are unquestionably of great value to every serviceman and every service organization.

But, suppose that this man is called upon to service a receiver, of even the same general type as some of those with which he is intimately familiar, the service manual for which he has been unable to obtain, or having obtained one has not even looked at it. (Servicemen have been known to neglect those things, alas!). Suppose also that the chief engineer employed by the maker of this set has unique (and always superior) ideas of the proper placement of sockets, terminal

strips, wires, and other parts. The serviceman with only the kind of radio knowledge we have described would be completely at sea, and, on that particular job, he would be a total loss to both himself and his organization.

Even taking for granted that a serviceman could obtain all the service manuals for all the models of receivers put on the market by the large number of reputable manufacturers, it is by no means safe to assume that he would be willing to memorize them to the extent necessary if he is to depend upon them as his only source of service information. Neither is it safe to assume that he will never be called upon to service a Ware "T," a Ther-mi-odyne, a deForest, or any one of the four-million sets "designed" and built by an "expert radio engineer" who is always a "personal friend" of the afflicted but innocently enthusiastic customer. The manufactured sets in daily use, the manufacturers of which are no longer extant and for which no service manuals were ever printed, as well as those sets built by individuals, still comprise a very large proportion of the total number of broadcast receivers which are entertaining or annoying—depending largely upon one's degree of musical education—the American nation, and which cannot, therefore, be ignored by servicemen.

### Basic Knowledge

**L**ET us now consider the man who has a broad knowledge of the fundamental theories of tube and circuit operation and thorough understanding from experience of how those theories work out in the few basic kinds of circuits which are in general use, but who has never seen a manufacturer's service manual. Such a man knows approximately what sort of operation to expect from any receiver, because he is familiar with the general results to be expected of that particular type or combination of types of circuit. He knows approximately what voltages and currents to expect at various points. He knows the order of values of resistors, capacities, and inductances used, and something of the degree of overall gain to be expected. He is capable of servicing any make or model of receiver and of solving any problem of cause of trouble as well as the problem of curing any specific trouble found, without having to see the service manual for that particular model of receiver. Because of his general circuit knowledge he can trace out the particular circuit arrangement used, to discover where each part is, and because of his

basic knowledge of operation of circuits he can determine definitely whether each part is functioning properly. If any part is failing to do its job, he does not need service data sheets to tell him how to determine why, or what to do about it.

The man who has that sort of radio training derives from his work a degree of real pleasure, by virtue of his ability to apply *technical knowledge* and *logical thought* to the solution of his service problems, which can never be realized by the man who exercises only his memory of picture diagrams of sockets, terminal lugs, and canned units.

Looked at from the standpoint of service efficiency, however, the work of the man we have just described may not be ideal. Service, to be efficient, must be done thoroughly and it must cope adequately with every problem that arises, no matter how complex, but it must also be done in the shortest possible time. The man who can find and cure any trouble which exists in any radio receiver by reason of his broad technical knowledge, but who is not also familiar with the physical layout of parts and terminals, color codes, and most of the specific data of that nature given in service manuals, is laboring under a *serious* disadvantage. While he is capable of discovering whatever of those details he may require in order to service properly a particular model, it will take him *far more time* to do so on each job than would be required had he studied the manual. And time, in the radio service business, represents money just as fully as it does in most other lines of endeavor. While most of us are repairing radio receivers rather than selling bonds, neckties, or what-have-you because we happen to like it better, there are few of us who are not also under the necessity of deriving from it our daily bread and frequent larger sizes of small shoes.

### Ideal Knowledge

**L**ET us, then, consider the merits of the man who has the kind of memorized knowledge which may be obtained from manufacturers' service manuals, and who also has a broad background of knowledge of the theories underlying the operation of radio receivers in general coupled with extensive practical knowledge of how those theories perform in the types of circuits which are in use.

Such a serviceman can complete the ordinary service job even faster than the man who has only service-manual knowledge, for his additional technical training and experience very often enables him to make a more rapid diagnosis of the trouble, eliminating some of the steps required by the narrowly trained man. He is not stuck by troubles that are unusual, but confidently attacks each job with the unflinching assurance that no matter what the trouble may be, he can discover it, determine its cause, and effectively cure it. Whether he is curing a trouble as simple as the need for replacement of a thoriated-filament tube whose emission has become too low, or a trouble as comparatively elusive as the detuning effect due to imperfect contact, caused by oxidation, between an r.f. stage shield and its base, he makes a very favorable impression on the



*If the customer is present the serviceman will give the impression that he is thoroughly competent.*



*A serviceman may be called upon to repair any one of the four million sets "designed" and built by an "expert radio engineer."*

customer by the rapid, thorough, and confident manner in which he goes about it. He cures all of the troubles in a receiver. For he discovers minor troubles which very often go unnoticed by the narrowly trained man, and when he has finished his work it is rarely necessary to service that set again for a reasonable length of time.

That kind of a serviceman is, so far as his service efficiency goes, the ideal type. If he is working alone, he will be able to make a really adequate living from his work, and he will soon have to employ other servicemen to help him take care of the demand for such unusually good service. If he is an employee, he will help greatly to increase the number of steady customers of his organization, and it follows that his pay will steadily increase and that he will be given larger responsibility as the growth of the business necessitates more executive work.

### Acquiring Knowledge

**H**OW can all this knowledge and experience be acquired? First of all, we must have a strong desire to acquire it in order that we may have the great satisfaction of knowing that our work is really well done and in order that we may attain any real degree of success in the work we have chosen to do. Obviously, the man who relies solely upon the practical experience he can get from actually servicing radio receivers, and does not supplement that with study, will never be a good serviceman. Neither will study alone make a good serviceman. Practice and study must go hand in hand, each supplementing and guiding the other, and proficiency cannot be attained in a few months, but can only be acquired by years of steady interest and effort.

The best source of detailed knowledge of particular models of receiving sets is the manufacturer's service manual or service-data sheets. Most manufacturers have discovered the hopelessness of the task of instilling into the average dealer the fact that it would pay him to give really efficiency service to his customers, something which was discovered by a good many service organizations a number of years ago. Some few of the more progressive manufacturers have awakened to the fact that, because of the attitude of the average dealer toward service, most of the service on their sets is performed by service organizations after the end of the period during which the dealer gives free service. Wanting those service organizations to perform really good service on their sets, they are more than glad to help by furnishing service data on all models upon receipt of requests written on the business letterheads of such concerns. RADIO BROADCAST has been publishing, starting with the June, 1928, issue, circuit diagrams of manufactured receivers together with some of the important data about resistance and capacity constants, and voltage values, which are of considerable aid in the absence of the more complete data usually furnished by the manufacturer.

For the more interesting, and far more important study of the basic principles, there is no single source which is more complete and authoritative than Professor J. H. Morecroft's book, *Principles of Radio Com-*

*munication*. It is published in New York by John Wiley and Sons, Inc., and can be obtained directly from them, or from any good bookshop, at a cost of \$7.50. The price may seem high, but as an investment in the acquiring of knowledge its worth is tremendously greater. A shorter work, which is excellent but which does not have the same wealth of material, is the Army Signal Corps handbook, *Principles Underlying Radio Communication*, written by Dr. J. H. Dellinger of the Bureau of Standards, with the assistance of six other well-known physicists and radio engineers, and one well-known professor of mathematics. It may be obtained, at the ridiculously low cost of one dollar, from the Superintendent of Documents, Government Printing Office, Washington, D. C. The author of this article strongly recommends that those of you who have not read either of these books write immediately to Washington for the latter, and when you have assimilated all of it, then tackle the Morecroft. One other publication which is an invaluable addition to any radio library is the Bureau of Standards Circular No. 74, *Radio Instruments and Measurements*. It may be obtained, for sixty cents, also from the Superintendent of Documents. If your mathematics has become rusty, or if you did not have enough of it in high school, then there is a textbook by George Howe, *Mathematics for the Practical Man*, which assumes only a knowledge of elementary arithmetic and gives you in a very easily understood form exactly what you need for a thorough understanding of Morecroft. It is published by D. Van Nostrand and Co., New York, and costs \$1.50.

While there are a number of current periodicals which contain articles of value, it is the opinion of the author that it is a mistake to attempt to read all of them, and that one good radio magazine is a sufficient supplement to one's study of books. It is also his opinion that RADIO BROADCAST contains a greater amount of material which is of importance to the serviceman than does any other periodical. The "Home Study Sheets," "Laboratory Information Sheets," and "Strays from the Laboratory," which appear monthly, are mines of clearly presented useful information. There also have been, and will continue to be, various technical articles on timely subjects which no radio serviceman can afford to miss if he is to keep step with new developments in the radio art.

### List of Books

[In the preceding paragraphs Mr. Dunham has endeavored to point out the sources where the radio serviceman may obtain accurate information on the phase of radio in which he is interested. If the various books referred to are studied carefully it will be found that they answer practically every requirement. However, the Editor appreciates the fact that the ambitious serviceman will desire to have available a number of reference books and the following fairly inclusive list has been prepared to answer this need. The books named



### Practice and study must go hand in hand

below are what we consider the more important radio publications and the descriptive sentence following each title will help classify the book in the reader's mind.—Editor]

*Radio Instruments and Measurements*. A 315-page book, presenting information regarding the more important instruments and measurements actually used

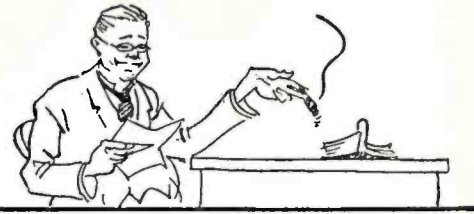

*If he helps to increase the number of steady customers of his organization it follows that his pay will increase steadily and that he will be given larger responsibility*

in radio work. The contents is of interest to all radio engineers. The book is published by the Department of Commerce and is known as Circular No. 74. Obtainable from the Superintendent of Documents, Government Printing Office, Washington, D. C., for sixty cents.

*Principles Underlying Radio Communication*. Another government publication to be recommended. This book is quite an excellent elementary textbook of radio and general electricity and may be easily understood by anyone with a fair knowledge of algebra. Everyone should have it. It is known as Radio Communication Pamphlet No. 40, and the Superintendent of Documents, Government Printing Office, sells it for \$1.00.

*Principles of Radio Communication*, by J. H. Morecroft. This is probably the most complete book on radio engineering. The text deals with all phases of the art of radio communication and the treatment is very complete, the book containing about 1000 pages. John Wiley and Sons, Inc., New York City, Price: \$7.50.

*Thermionic Vacuum Tube*, by H. F. Van Der Bijl. An excellent book setting forth the principles of operation of vacuum tubes. It is a very useful book for any radio engineer. McGraw-Hill Book Co., Inc., New York City. Price: \$3.00.

*Radio Engineering Principles*, by Lauer and Brown. A book less extensive than Morecroft's but excellent for those whose requirements are satisfied with a shorter and less expensive text. It is a very scholarly presentation. McGraw-Hill Book Co., Inc., New York City. Price: \$3.50.

*Radio Frequency Measurements*, by E. B. Moullin. A book dealing with the theory and practice of radio measurements. A handbook for the laboratory and a textbook for advanced students. Many of the measurements are made with the aid of the vacuum tube voltmeter. Published in England but it can be obtained from the J. B. Lippincott Co., in Philadelphia. \$10.00.

*Practical Radio Construction and Repairing*, by Moyer and Wostrel. This book aims to be of service to the amateur constructor and radio serviceman. It is essentially practical in its treatment. McGraw-Hill Book Co., Inc., New York City. Price: \$1.75.

*Practical Radio Telegraphy*, by Arthur R. Nilson and J. L. Horung. A book expressly for radio students preparing to become radio operators. It will also prove useful as a general handbook on the use and care of modern radio transmitting and receiving equipment. McGraw-Hill Book Co., Inc., New York City. Price: \$3.00.

*The Elements of Radio Communication*, by O. F. Brown. This book describes the fundamental principles governing radio communication in simple straightforward language, supplemented by diagrams. The use of mathematical formulas has been reduced to a minimum, although a few algebraical expressions are employed where they are essential. Oxford University Press, New York. Price: \$3.50.

*Principles of Modern Radio Receiving*, by L. Grant Hector. A 305-page book designed to give to the intelligent but non-technically trained man a unified picture of the science of radio and to give some concrete information to the designers, builders and sellers of radio receivers. Burton Publishing Company, Buffalo, N. Y.

*Radio Theory and Operating*, by Mary Texanna Loomis. A complete textbook of 992 pages covering the theory of radio communication. In addition it aims to prepare the student to become a radio operator and make it possible for him to pass the government radio operator's examination. Loomis Publishing Company, Washington, D. C. Price: \$3.50.

*Radio*, by Elmer E. Burns. An excellent course of study on radio for students with high-school preparation in physics and mathematics. It serves as an effective introduction to an advanced text. D. Van Nostrand Co., New York City. Price: \$2.00.

*A Treatise on 25 Testing Units for Servicemen*, by John F. Rider. This book provides much practical data on the servicing of radio receivers. It describes the construction and operation of many useful laboratory instruments. Radio Treatise Company, New York City. Price: \$1.00.

*A Laboratory Treatise on B Battery Eliminator Design and Construction*, by John F. Rider. This book is a worthwhile addition to a library of elementary radio texts. It sets forth the essential principles of the design and operation of B-power units and is of value to servicemen and set-builders. Radio Treatise Company, New York City. Price: \$1.00.

*Radio Broadcast's Data Sheets*. This book consists of 190 short articles giving concise and accurate information in the field of radio and closely allied sciences. The book is full of practical information of value to the radio serviceman, set-builder, and experimenter. Doubleday, Doran and Co., Garden City, N. Y. Price: \$1.00.

*How Radio Receivers Work*, by Walter Van B. Roberts. This book is designed to lay a firm foundation of qualitative but definite ideas that will enable the reader to understand clearly the operation of a radio receiver and to read with benefit the more complete treatments of the subject. RADIO BROADCAST, Garden City, N. Y. Price: \$1.00.

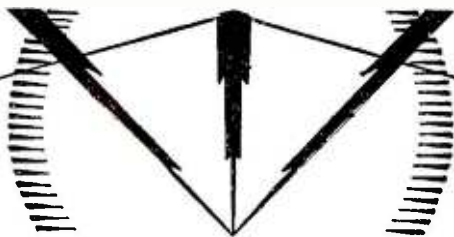

## A Study of Program Possibilities May Open New Radio Markets

THE radio industry is engaged in selling devices for reproducing broadcast programs in the home. Only to the degree that radio entertainment is acceptable to the listening public does its market expand. This season's enormous sales are due as much to general program progress as to increased simplicity of receiver operation and maintenance. Stabilization in receiver design precludes the likelihood of revolutionary sales stimulation because of the appearance of entirely new types of receivers, except through the solution of the many problems retarding the commercialization of visual reception.

For the moment, we dismiss the possibility of television because it is predicated upon considerable technical development and upon the establishment of an entirely new broadcasting structure. We are not in possession of sufficient proof of its reasonably early development as a commercial product to predict whether it will be a vital sales factor within one year, five years, or twenty. The commercial history of the motor car, the airplane, and radio broadcasting itself is illustrative of the long period which may elapse between elementary discovery and general commercial development. As early as 1899, substantial

stock flotations were launched successfully by companies proposing to exploit the radio telephonic and old timers in radio recall entertainment programs heard with crystal sets broadcast as early as 1910, 1912, and 1915. Yet we waited until 1923 before there was a substantial market for home reception.

Assuming that neither visual broadcasting nor radical improvement in the receiver itself are certain to bring about another record-breaking season in the immediate future, we might conclude that we have before us only an era of ordinary, though presumably prosperous, commercial competition, with radio reception as stabilized as the motor car, the typewriter, and the electrical refrigerator. Under those conditions, merchandising skill, service support, and advertising ideas will account for the commercial successes of the future. Indeed, this year's outstanding radio surprise is directly a product of merchandising aggressiveness and a successful appeal to dealer coöperation. Considering that we are far from radio's saturation point and over half the receivers in use are already obsolete, this prospective era of intense commercial competition is by no means a dismal one. The 1928 sales record will probably stand no longer than the end of 1929. There is ample normal demand for radio reception to insure a huge sales volume for many years to come.

The basic commodity of the radio industry, radio programs themselves, however, offer new avenues of public appeal which may uncover unexpectedly large sales fields. Our competent contemporary *Radio Retailing*, re-



The newly appointed Royal Canadian Radio Commission who will investigate broadcasting conditions in the Dominion. From left to right they are; Charles A. Bowman, Donald Manson, Dr. Augustin Frigon, and (seated) Sir John Aird, chairman of the Commission.

cently suggested the idea of a radio set for every office. The present-day program offerings, however, have little more appeal to the average business institution than a kitchen cabinet or a phonograph. A fundamental change in the character of daytime programs is necessary to develop a market for radio reception in the business world. It is one, however, presenting great possibilities if the broadcasting interests possess sufficient initiative to depart from present trends. These possibilities are worthy of the utmost consideration by broadcasting managements because the establishment of specialized audiences at hours now of small commercial value means proportionately increased revenue possibilities.

Certain stations have established daytime audiences of considerable value. While the average standard of programs addressed to the housewife are hopelessly mediocre and fall far short of their mark, nevertheless they have demonstrated the great possibilities of daylight broadcasting. During the day, the major part of these programs is direct advertising of the most flagrant character, restricting response to an indiscriminating though nevertheless large audience. Daytime farm programs have also reached many listeners and great political addresses delivered in daylight hours have been rewarded with adequate response.

### EXAMPLE OF BUSINESS APPEAL

There has not, however, been any conclusive test of appeal to the business man. One requirement which must be met is that he be

served with precisely the information he needs in a few regularly scheduled minutes of each day. An illuminating instance occurred recently in New York demonstrating that radio service to the business man is appreciated. Wmca has been broadcasting a brief news summary and stock market reports regularly in the late afternoon for some years. Under the new allocation, it shares with Wnyc, the municipal station of the City of New York. On one occasion, Wmca relinquished the time devoted to this service, in order that Wnyc might broadcast a glowing description of the accomplishments of the city's administration at the occasion of the opening of a new high school. When the customary time for the stock market quotations came around, Wmca's switchboard was immediately tied up by numerous phone calls from protesting investors and a large number of telegrams and letters, objecting to the suspension of this surprisingly important service, were subsequently received. Unquestionably, by judicious planning, not only can large and valuable audiences be built up for business purposes, but with them, a new market for radio receivers of far-reaching proportions.

During the evening hours, program development may also

broaden radio's appeal. The tendency of the last few years has been principally in the direction of expansion of networks, better pick-up technique, and higher artistic quality. Radio sales have also been greatly stimulated by "great event" programs, such as presidential addresses, political speeches, sporting events, and receptions to public heroes. Unquestionably, we have bigger and better radio programs. This is, however, only normal progress and not any unexpected manifestation of program ingenuity. Departures from the beaten track are few but encouraging.

The continuity program, pioneered four or five years ago in the early Eveready hours under the direction of Paul Stacy, first brought out the possibilities of this field of radio presentation. While Eveready hours stood alone in this field, their successes were national triumphs and their failures appeared to be artistic disasters. Seeking the impossibility of pleasing everyone, Eveready abandoned its brilliant contribution to broadcasting after two seasons of encouraging experiment and rejoined the throng of orchestras with vocal and celebrity programs, only recently returning to a more progressive policy. But such a healthful trend could not be resisted and the continuity is back again in full swing. Nothing has done more to restore it to favor than the outstanding success of WOR's "Main Street Sketches," which have been found sufficiently popular to prove worthy of imitation before every important microphone in the East. The commercial sponsor's demand

for universal appeal has discouraged program pioneering in spite of the fact that radio has scored a much higher percentage of successes with the continuity than its nearest counterpart, the dramatic stage. The continuity has the very important advantage to the commercial broadcaster that it holds its audience's thoughtful attention instead of serving as an almost unidentified background of musical entertainment. We regret that, although the continuity has won a permanent place for itself, most program directors have merely copied the few outstanding successes, despite the infinite variety of original characterization open to writers of continuity scripts.

#### DRAMATIC PROGRAMS

In the field of radio story telling and enactment, a distinctly different field of continuity, the *True Story* hours are the representative success in the field. A higher plane of story structure is conceivable, but, for vividness of presentation and broadness of appeal, they are superior to later imitations.

"Great Moments in History" remain the unquestioned leaders in serious dramatic presentation of the full-time continuity type. But, for pure acoustic artistry, they have been excelled by the N.B.C.'s "Central Park Sketches" and "Interborough Sketches." Their author has caught radio's most illusive quality, vividness of word-picturization. We predict that they will be widely and often unsuccessfully imitated. Though somewhat buried in an obscurity by a maze of conventional orchestral and vocal features, we regard these short dramatic novelties as an important trend because they have a substantial appeal to a distinctive strata of the radio audience, some of which may be hostile to the stereotyped program trend.

Finally, the Damrosch symphonic educational programs offer a new audience appeal, which means that radio tubes will be functioning at hours when they have been accustomed to rest. That is the real test of an expanding radio market, a program appeal which attracts new listeners and increased listening hours. We are not attempting to review program progress from the standpoint of higher general standards but from that of broadened appeal. We expect radio programs to improve because steady progress is necessary to maintain its position in competition with its real competitors, the phonograph, the motion picture, and the motor car. Expansion of radio's market requires more than holding its own against competing forms of entertainment. It must swing into the fold entirely new listening groups or increase the listening hours of its established followers. Creators of new program services make liberal contributions to radio's potential market. The association of program development with the prosperity of manufacturer, jobber, dealer, and radio serviceman is an intimate yet generally unrealized interdependence.

#### A New Radio Service to Aviation

**S**PEAKING at the autumn meeting of the National Academy of Sciences, Dr. E. F. W. Alexanderson described a promising line of research which he has been pursuing, looking toward the development of a means of measuring the height of an airplane above ground. The altimeter, which is conventionally employed, measures barometric pressure and, therefore, gives no indication of height above ground unless the aviator happens to know its exact alti-

tude. Furthermore, the changes in barometric pressure, accompanying changed weather conditions, must be compensated.

The principle of the Alexanderson device is simple. A high-frequency continuous wave is radiated from the plane in flight and the component reflected from the ground is used to heterodyne the frequency generated at the transmitter. When the plane is at a height above ground which is an exact multiple of the transmitting wavelength employed, the reflected signal balances out the radiated signal and the minimum signal is received. As the plane rises through the distance of a wavelength, the signal goes through a complete cyclic change. A graphic record, made on experimental flights, shows that altitudes up to 4000 feet have been determined quite accurately by the method, following exactly simultaneously recorded readings made with an altimeter. The wavelength used was 95 meters and each cycle of the record represents an altitude change of 155 feet.

#### A POSSIBLE DEVELOPMENT

Dr. Alexanderson made several suggestions as to possible lines of development. He proposes the use of two antennas with an oscillator in each, one having a wavelength of ten meters and the other of eleven. The beat frequency of the two oscillations is then detected and observed. The frequency will be of the order of 3,000,000 cycles but the signal intensity will change cyclically as the plane changes in altitude. It will pass through maxima when the echo wave tends to decrease the frequency of the eleven-meter oscillator at the same time that it increases the frequency of the ten-meter oscillator, producing maxima at heights of 25, 75 and 125 meters, corresponding to 80, 240 and 400 feet.

The experience with the new system is naturally limited and, considering the peculiarities of short wave radiations, it is quite possible that ground conditions will cause sufficient variations in the character of the reflected wave to create practical difficulties. It requires a fair amount of equipment aboard the plane and skillful manipulation and, while the duties of the pilot are so manifold, concerned not only with actual piloting but watching of motor indicators, radio communication, and navigation, it is unlikely that so complex a system will have much practical application until it is further simplified. But Dr. Alexanderson has pointed the way to

a fundamental method which shows great promise in solving an important problem in aerial navigation. The trend of development may be in the direction of ground altitude lighthouses which simultaneously radiate two waves of slightly different frequency, operating an automatic altitude indicator aboard the plane. This may be calibrated in feet above ground so that no manipulation will be required on the part of the pilot. The transmitting frequency selected will be such that the pilot can judge with fair accuracy whether he is one, two or three wavelengths above the beacon. For fog use, a signal bell may be helpful in aiding such judgment and, should this be impractical, a triple frequency system may be devised covering the entire range of altitudes without guesswork.

#### High-Frequency Allocations

**T**HE Federal Radio Commission has allocated 551 of the 639 channels between 1500 and 6000 kilocycles, by assigning 308 channels to fixed stations, 148 to mobile, and 95 to government stations. Of the fixed stations, the greatest surprise is offered in the allotment of the Universal Wireless Communications Company of 40 channels, while no additional channels were turned over to the Radio Corporation of America or the Mackay interests. In view of the fact that the Universal Company is an entirely new venture, proposing to compete directly with wire telegraph circuits, this allotment is causing considerable amazement in communication circles. The company is capitalized at \$25,000,000, recruited principally from Buffalo business men. In its directing personnel, as announced, appear no names of executives known to be experienced in traffic management or radio-telegraph technique, although, no doubt, the Commission has been thoroughly satisfied by adequate evidence of sufficient available capital, personnel and technical knowledge or it would certainly not have made such a liberal allotment of valuable channels. This assignment is a distinct departure of the Commission's announced policy of confining high-frequency channel assignment to services which cannot be conducted through non-radio circuits.

Twenty channels are assigned to the press, 73 to marine service, 64 aviation, 5 railroad, 6 portable, including geophysical and police, 138 amateur, 100 visual, 4 experimental, and 70 point to point. Some private communication services granted channels are Ford Motor, Commonwealth Edison, Tropical Radio, Maddux Air Lines, Detroit Edison, Philadelphia Electric, Florida Public Service, Ann Arbor Railroad, Pere Marquette, U. S. Shipping Board, Radiomarine Corporation, Gulf Refining, Humble Oil, Magnolia Petroleum, and Bethlehem Ship, although Ann Arbor and those listed thereafter must also render a general public message service. Armour & Co., Firestone, Good-year Tire, Morris & Co., Sears Roebuck, Universal Pictures, Cudahy Packing, Montgomery Ward, and Victor Talking Machine were denied the channels they requested.

#### In the World of Broadcasting

**M**ERLIN AYLES-WORTH, president of the National Broadcasting Company, in an end-of-the-year statement broadcast through a nation-wide network, announced that the expenditures made through his company for talent in 1928 were \$5,000,000

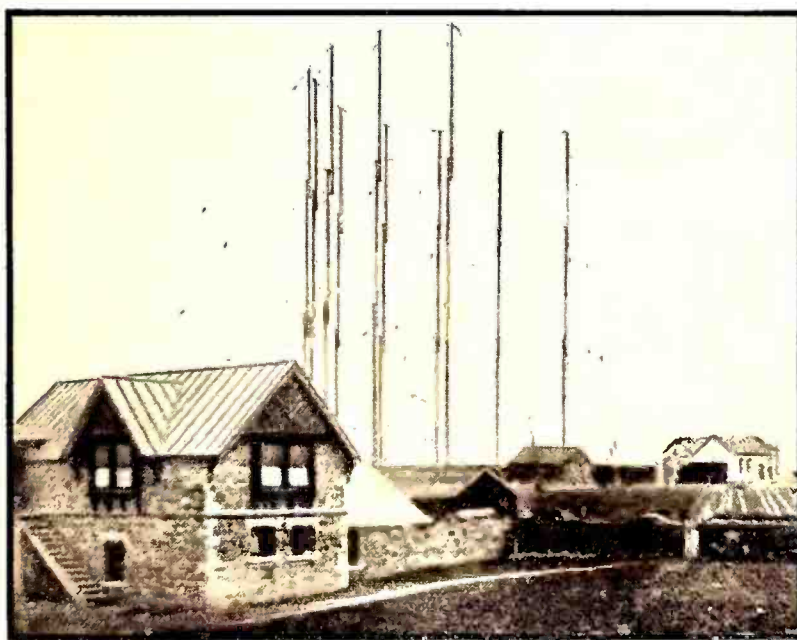

*A reconstructed picture of the half circle of 170-foot masts erected at Poldhu in 1901. This antenna, which consisted of 60 wires in the form of a fan, faced the Atlantic and was used successfully in Marconi's early transatlantic experiments. The transmitter was located in the building in the center of the masts*

and for wire network service, \$2,000,000. If American listeners had paid for their broadcasting service through direct taxation, as do British listeners at their rate of \$250,000 per station per year, American listeners would have paid \$192,000,000 per year or from \$15 to \$25 per set for the maintenance of the 700 stations serving them. The cost of broadcasting is met largely by advertisers who distribute the expense among all classes of listeners and non-listeners. Mr. Aylesworth attempted to show that commercial broadcasting is in no way competitive with newspapers.

**A**PPEALS from decisions of the Federal Radio Commission's decisions have been brought before the Court of Appeals of the District of Columbia by WENR, WCBF, and WLS, and by C. L. Carrell, appearing in behalf of portable stations WKBG, WJBD, and WJBM. The outcome of these cases will determine, in a large measure, whether the Commission has sufficient power to exercise control over the broadcasting situation. Louis G. Caldwell, the Commission's indefatigable chief attorney, has agreed to continue his services through the month of February. If these cases are decided adversely to the Commission, we will enter a new phase in broadcast regulation. Funds will then have to be appropriated, sooner or later, for the confiscation of broadcasting stations so that their number may be reduced to the point that the broadcasting band is no longer overloaded. It will require a long time, however, to put over such a step because neither the broadcasting stations or a majority of the Commission are prepared to face the facts in the matter. Many, like Commissioner Robinson, still favor low-powered broadcasting and heavily overloaded channels thus evading the necessity of reducing the

number of stations on the air. Optimists hope for solution of the congestion problem by development of synchronizing methods, which will eventually enable network programs to be radiated on the same frequency. If commercial broadcasting continues to grow, continuous network broadcasting during the night hours would make it possible to maintain synchronized programs with the network stations assigned to regional channels and preserving cleared channels for network key stations and worthy independents. But until both continuous network broadcasting and practical synchronization are accomplished facts, this solution is still in the future.

**W**NYC has appealed to the courts the decision of the Commission affirming the time sharing order with WMCA. In its brief, filed with the Court of Appeals of the District of Columbia, the city makes much of the point that WNYC is called upon to share time with a commercial station and that the rights of municipal stations are superior to those of commercial stations. Considering that there is no possibility of sharing with any but a commercial station in the metropolitan area and that advertising merchandise is no less useful than advertising the deeds of political incumbents and the gossip of municipal bureaus, this particular plea is based upon apparently unsound foundations. Any superior right which may be established by stations of a political origin over stations operated purely to appeal to the public through their educational and entertainment value would be unfortunate. It is to be hoped that all stations will be compelled to stand upon their service to the public and that no privileged classifications will ever appear in our highly circumscribed broadcasting channels. The most important contribution of WNYC is its

"University of the Air," and its potential service in coöperating in health department propaganda and maintaining law and order. It has not been demonstrated that more than half time is required for these very worthy purposes.

**T**HE Federal Radio Commission announced that after January 1st no visual transmissions of any kind would be permitted in the broadcast band, but it reversed its position before the new order became effective, permitting such transmissions between 1 and 6 A.M. It has, however, dallied so long with this problem that many have become discouraged and the effort to bring about a rapid development of visual broadcasting by experimenter participation has been rendered abortive. Many pioneers have suffered heavy financial losses as a result, which would have been somewhat mitigated by early consideration of the problem. The experimenter, having served his purpose of starting the whole broadcasting structure is thus rudely cast out from a field of activity which showed great promise of a revival of ingenuity and skill in radio reception.

**R**EPRESENTATIVE WALLACE WHITE of Maine has introduced a resolution to extend temporarily the authority of the Federal Radio Commission for another year. If these year to year extensions become habitual, it is quite probable that Congress will ultimately form a communications commission which will have, in addition to the duties of the present Federal Radio Commission, complete regulation over telephone and telegraph systems. Because of its quasi-public nature, the communications business, in common with railroads, suffers from excessive political regulation with the inevitable result that costs of operation are increased proportionately to the political meddling tolerated. Excessive profits in the communications business, and in fact any quasi-public function which is necessarily monopolistic in character, should certainly be regulated so that only a reasonable return is made on the capital invested. As soon, however, as regulation broadens its scope into details of management, it generally works against the public interest. If politicians attempt to rule experts, the results are disastrous and, if experts are substituted for politicians, then the method is wasteful. Had the present commission tackled its problems with greater aggressiveness and expeditiousness, it would now be an appellate body, meeting only on appeals, and regulation would be centered in a bureau of the Department of Commerce, exactly as it was prior to the chaotic conditions brought about in 1926. Congressional meddling is invited by the protraction of the Commission's problems.

**I**N THE first week in January, the Columbia Broadcasting System has augmented its network from 21 stations confined to the northeastern part of the United States, to 47 transmitters reaching from coast to coast. Approximately 100,000 miles of wire, a third of which carry the programs and the balance are monitoring and emergency circuits, are used. Fifty repeater points are involved and in the inaugural broadcast, two-hundred telephone engineers were employed in maintaining wire service.

WABC is now under the management of the United Independent Broadcasters, operators of the Columbia Chain. As soon as the chain's contract with WOR expires in September, WABC will be the source of all Columbia programs. Alterations in the transmitter are contemplated, and removal to a less-populous area has already taken place. WOR plans no chain affiliations after September and will, therefore, become the leading independent station of the metropolitan area, continuing its policy of originating its own features.

—E. H. F.

Schedule of the Best Short-Wave Programs

Station Call Letters	Wave-Length (Meters)	Schedule in Eastern Standard Time							
		Sun.	Mon.	Tues.	Wed.	Thurs.	Fri.	Sat.	
W2XAD Schenectady, N. Y., U. S. A.	19.56	5:30 P.M. to 10:30 P.M.	2:00 P.M. to* 4:00 P.M.  5:00 P.M. to <sup>P</sup> 11:00 P.M.		5:00 P.M. to <sup>P</sup> 11:00 P.M.		2:00 P.M. to* 4:00 P.M.	5:00 P.M. to <sup>P</sup> 11:00 P.M.	
5SW Chelmsford, England	25.53		7:30 A.M. to 8:30 A.M. 2:00 P.M. to 7:00 P.M.	7:30 A.M. to 8:30 A.M. 2:00 P.M. to 7:00 P.M.	7:30 A.M. to 8:30 A.M. 2:00 P.M. to 7:00 P.M.	7:30 A.M. to 8:30 A.M. 2:00 P.M. to 7:00 P.M.	7:30 A.M. to 8:30 A.M. 2:00 P.M. to 7:00 P.M.	7:30 A.M. to 8:30 A.M. 2:00 P.M. to 7:00 P.M.	
W8XK Pittsburgh, Pa., U. S. A.	25.4	11:00 A.M. to 12:00 A.M.  2:00 P.M. to 10:30 P.M.	2:00 P.M. to* 4:00 P.M.  5:00 P.M. to <sup>P</sup> 10:30 P.M.	5:00 P.M. to <sup>P</sup> 10:30 P.M.	5:00 P.M. to <sup>P</sup> 10:30 P.M.	2:00 P.M. to* 4:00 P.M.  5:00 P.M. to <sup>P</sup> 10:30 P.M.	5:00 P.M. to <sup>P</sup> 10:30 P.M.	5:00 P.M. to 11:00 P.M.	
PCJJ Eindhoven, Hol- land	31.2		6:00 P.M. to 9:00 P.M.	6:00 P.M. to 9:00 P.M.		6:00 P.M. to 9:00 P.M.			
W2XAF Schenectady, N. Y., U. S. A.	31.48		5:00 P.M. to <sup>P</sup> 11:00 P.M.	5:00 P.M. to 11:00 P.M.		5:00 P.M. to 12:00 P.M.		6:00 P.M. to 12:00 P.M.	
W2XE Richmond Hill, N. Y., U. S. A.	58.5	7:00 P.M. to 11:00 P.M.	7:00 P.M. to 11:00 P.M.	7:00 P.M. to 11:00 P.M.	7:00 P.M. to 11:00 P.M.	7:00 P.M. to 11:00 P.M.	7:00 P.M. to 11:00 P.M.	7:00 P.M. to 11:00 P.M.	
W8XK Pittsburgh, Pa., U. S. A.	63.5	8:00 P.M. to 10:30 P.M.	2:00 P.M. to* 4:00 P.M.  8:00 P.M. to <sup>P</sup> 10:30 P.M.	8:00 P.M. to <sup>P</sup> 10:30 P.M.	8:00 P.M. to <sup>P</sup> 10:30 P.M.	2:00 P.M. to* 4:00 P.M.  8:00 P.M. to <sup>P</sup> 10:30 P.M.	8:00 P.M. to <sup>P</sup> 10:30 P.M.	8:00 P.M. to 11:00 P.M.	
CJRX Winnipeg, Can- ada	25.6	5:30 P.M. to 10:30 P.M.	5:30 P.M. to 10:30 P.M.	5:30 P.M. to 10:30 P.M.	5:30 P.M. to 10:30 P.M.	5:30 P.M. to 10:30 P.M.	5:30 P.M. to 10:30 P.M.	5:30 P.M. to 10:30 P.M.	

\*—N.B.C. Red Network programs relayed to British Broadcasting Company, England.  
<sup>P</sup>—During 9:00 P.M. 10:30 P.M. period the N.B.C. Red network program comes through all 4 waves. Other periods have separate programs. At 7:00 P.M. you can set your watch by "Big Ben" from London, England.



## Operating Data on a

# NEW AUTOMATIC VOLUME CONTROL SYSTEM

By CHARLES WILLIAMSON

*Department of Physics, Carnegie Institute of Technology*

ALL of us have been annoyed at some time or other by a terrific burst of sound from the loud speaker when, in the course of tuning, we have happened to come across a powerful local station. Sudden loud speaker overloading may also occur with certain types of broadcasting, such as organ music, which exhibits an unusually wide range of volume. In many cases, the voice of the announcer is received at a much higher volume level than that of the music. But the worst case of unexpected sound peaks arises when listening to a distant station that is fading badly. When it comes back, it usually does so with a roar; and static crashes are at their loudest because the sensitivity control has been advanced fully in order to make the program audible when the station fades.

### An Automatic Control

LAST August the writer designed a simple and inexpensive device to cure these troubles. It has been tested on several receivers and in each case the difficulty was corrected almost perfectly.

The addition of the writer's device to any d.c.-operated receiver does not require that the circuit of the set be altered in any way. (When using this device in connection with an a.c.-tube receiver the results may not be entirely satisfactory as an increase in hum may result, particularly when the set uses 226-type tubes—*Editor*.) The device is connected across the loud speaker terminals and is operated by the a.c. voltages appearing across the loud speaker. It functions by reducing the plate voltage on the r.f. tubes automatically as the volume from the loud speaker rises.

Since the device described in this article functions due to the changes in voltage across the loud speaker, it will have the effect of contracting the volume range—in other words it does automatically at the receiving end what the monitoring operator does (or should do) at the broadcasting end. Serious distortion of the signal currents will occur only if the device operates with a time lag so short as to be comparable with one fourth of a cycle at the lowest frequency likely to be handled by the audio system. An examination of the circuit (Fig. 1 diagram A) will show that the time constants of the choke-condenser and resistance-condenser combinations are of the order of 0.1 second or greater.

Dr. Charles Heinroth, the eminent organist, assures me that he would not regard a systematic contraction of the dynamic range as undesirable distortion of his programs. In fact, he thinks it would be better than the hit-or-miss monitoring sometimes met with! Hence I think we can regard this type of automatic volume control as distorting only in a formal sense. Not even a musician can detect it in the receiver's output unless he has an unmonitored output with which to compare it.

Manual adjustment of the plate voltage of an r.f. tube will show that large changes may be made over a certain region without noticeably affecting loud speaker volume. If, as is often the case, the amplification of the r.f. stage under

control is partly regenerative, it will fall off rapidly at first, as oscillation is left behind. After this there will be less change, since the a.c. plate resistance and the mutual conductance of the tube will change slowly with diminishing plate voltage over a certain region. Later, however, they both begin to change faster, and the amplification of the r.f. circuit is reduced rapidly. Thus, in a receiver of this type, this automatic volume control has the advantage that a loud signal throws the receiver out of oscillation instead of into oscillation.

### List of Apparatus

THE parts required for the construction of the volume control described by the writer follow:

- R<sub>1</sub> One high-resistance unit (See Table I for proper value);
- R<sub>2</sub> One rheostat or filament-ballast unit;
- C<sub>1</sub> One fixed condenser, 200-volt, 4-mfd.;
- L<sub>1</sub> One choke coil, 30-henry;
- One tube socket, Ux-type;
- One power tube, 171A-type.

The circuit diagram of the automatic volume control device is shown in diagram A of Fig. 1. This circuit also shows the method of connecting the volume control to a receiver having an output transformer. Diagram B shows the input of the device connected to a receiver having a choke-condenser output circuit. It will be noted that in each of these cases the loud speaker return must be made to the negative 45-volt C-bias terminal rather than to the negative A wire as usual. Diagram C shows the device connected to a receiver using a push-pull output circuit. Two condensers, C<sub>2</sub> and C<sub>3</sub>, are required, as shown.

In all of the above cases, the control tube may be operated from the same A, B, and C supply as the rest of the receiver, and its filament may be heated by a.c. if desired. Also, with all types of receivers the r.f. tubes ob-

tain their plate potential from the "B+R.F." terminal of the volume control unit.

The high-resistance unit, R<sub>1</sub>, should have a value of 50,000 ohms if a plate potential of 180 volts is available, and if there is a negative bias of 4½ volts on the grid of the first r.f. tube. For lower values, either of B or grid bias potentials, the following table shows the proper size resistor to use:

Table I

R.F. Grid Bias (Volts)	Plate Voltage		
	180	160	140
-4½	50,000	40,000	30,000
-3	40,000	30,000	20,000
0	30,000	20,000	10,000

} R<sub>1</sub>  
} Ohms

The values of the resistor R<sub>1</sub> are not especially critical; they are determined by the restriction that the first r.f. tube should not receive more than 90 volts of plate potential. If the r.f. B-plus lead supplies two tubes, the resistances in the above table should be divided by two.

If a variable-resistance unit is used in place of the fixed resistor, it may be set to the best value by placing a high-resistance voltmeter (1000 ohms per volt) across the plate and filament terminals of the first r.f. tube, and adjusting the knob of the variable resistor until the meter reads 90 volts (or whatever other voltage is normally placed on the r.f. tubes). This must be done with the receiver fully turned on, but *not* tuned into any station.

The choke coil, L<sub>1</sub>, used in this device, if not bought as a unit, may be made up of almost anything at hand, since, if only one r.f. tube is controlled, it need not handle more than 5 milliamperes at 90 volts. If a speaker filter is available, it can be used in place of C<sub>1</sub> and L<sub>1</sub>.

With the receiver in operation, there is nothing to suggest the presence of the automatic volume control, except a gratifying absence of speaker overloading. The original volume control on the set, whatever its type, is not interfered with in any way. It might be supposed that the volume-range of the music would be brought to a dead level; such is not the case, however; the range is merely reduced to an extent that the audio system can handle without noticeable distortion. If desired, the amount of such compensation can be regulated by turning down the filament of the control tube; and, of course, the device can be cut out entirely by turning it off. As to the sensitivity of the set, this is in no way impaired; for the full 90-volt potential is available for the r.f. tubes until a signal begins to come in; and it is not materially reduced until the signal becomes loud.

Both calculations and trial indicate that a 112A- or 120-type tube may be used for the control circuit instead of a 171A-type tube with some loss of efficiency. In these cases the negative grid bias for the control tube should be 9 and 22½ volts, respectively. Of course, the r.f. tube or tubes under control may be of any type whatever except the type 226, which hums badly if its plate voltage is changed.

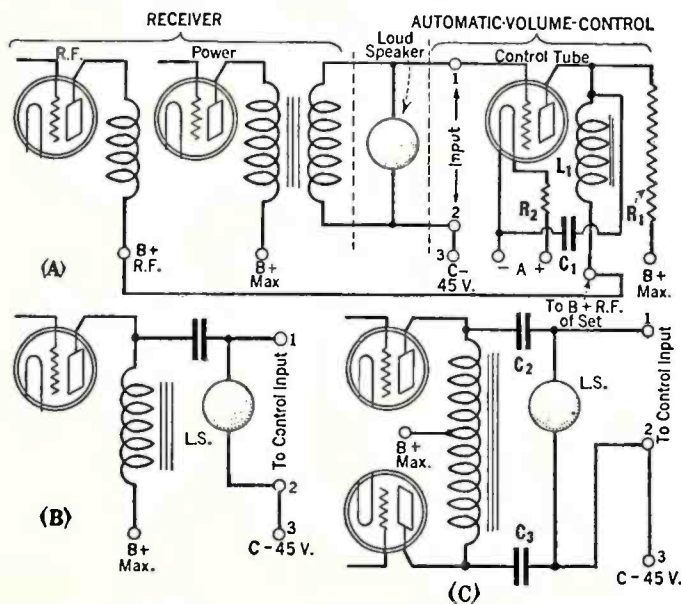
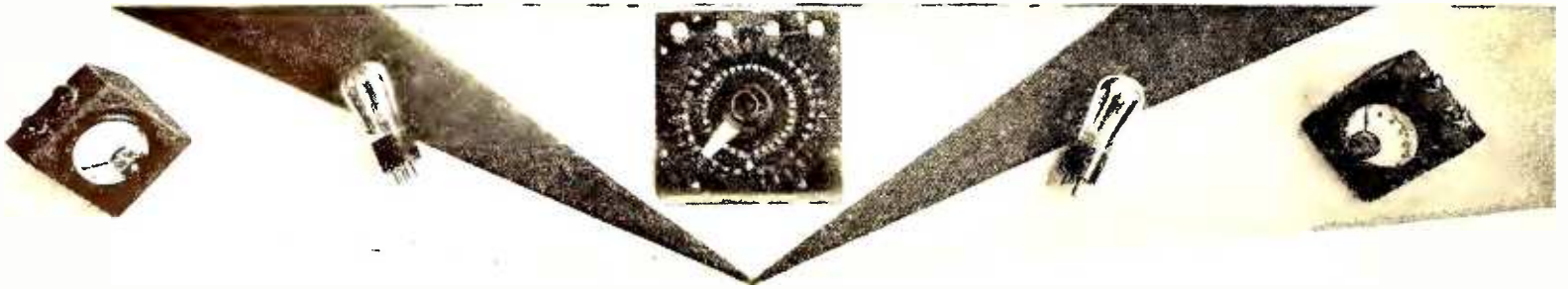

Fig. 1—Diagram A shows the automatic volume control connected with the output transformer of a standard receiver. Diagrams B and C show the input of the device connected with other types of receivers



# STRAYS from THE LABORATORY

## New Trends in Radio Design

IF THE a.c. screen-grid tube is made available before next year's receivers are designed, it is our bet that many of them will find their way into 1930's receivers, just as they have found their way into the best English sets. Over there 39 per cent. of all the types of sets manufactured during 1928 were three-tube sets—and 30 per cent. of the types used r.f. amplification. Screen-grid tubes were used in 80 per cent. of the sets with r.f. amplifiers.

*Data on English receivers:* The above figures are but a part of an interesting analysis which was published in *Wireless World*, November 14, 1928, on the receiver situation in England. The other data show that the five-tube receiver, probably the most popular number of tubes in this country, constituted only 14 per cent. of the several types of receivers made in England during 1928. Seven per cent. of the receiver types employed no r.f. amplification at all, 89 per cent. used a grid leak and condenser type of detector, 70 per cent. used transformer coupling in the a.f. amplifier, and 79 per cent. connected the loud speaker directly into the plate circuit of the last tube.

What will be used in next year's receiver? We have read recently several excellent articles on the use of a screen-grid tube as a detector. These articles described the research of J. R. Nelson, of the Cunningham laboratory, and were published in *Radio Engineering*, October, 1928; *Proceedings, I.R.E.*, June, 1928; and *Lefax* 35, December, 1928.

The great advantage of the C-bias, screen-grid detector lies in its ability to handle a relatively large input r.f. voltage without overloading, and its relatively high output. According to Mr. Nelson, the first stage of audio can be done away with provided we use a screen-grid tube as a detector, and provided the r.f. amplifier supplies from 2.17 to 18.6 times as much amplification as when an ordinary general-purpose tube is used as detector with a two-stage transformer-coupled a.f. amplifier. Now when the 322 detector tube is compared to a 201A tube connected as a grid leak and condenser detector, the amplification of the r.f. end of the receiver must be 18.6 times as much. Of course, a C bias is used with the 322 detector tube. Compared to the use of a 201A as a C-bias detector, the 322 and one stage of audio amplification requires 3.17 times as much voltage amplification from the r.f. amplifier.

If, then, we use screen-grid r.f. amplifiers, say two stages of them, the gain per stage must lie between 1.78 and 4.32 times as much as with present circuits, and if three of them are used, the increased gain per stage must lie between 1.47 and 2.65 for the two cases.

Now it does not seem difficult to design an r.f. amplifier, using screen-grid tubes, that could produce 18.6 times as much amplification as present-day sets, which used with a screen-grid detector, will work directly into a

power tube thereby eliminating one tube. This means an additional voltage gain of about 35 dB to our present-day r.f. amplifiers. We do not consider this impossible—nor are we convinced that it is desirable to substitute r.f. gain for a.f. gain.

One point of importance regarding the use of the screen-grid tube as a detector has not

The following are among the subjects discussed in "Strays" this month:

1. *New Trends in Radio Design*
2. *Two New A.C. Tubes on Way*
3. *Accuracy of Variable Condensers*
4. *New Radio Tubes in England*
5. *Importance of Reducing A.C. Hum*
6. *Receiving on 600 Meters*
7. *Selectivity of Browning Drake*

been discussed—what kind of a frequency characteristic can be obtained with it?

*Selectivity versus sensitivity:* The problem is not to get more amplification into our r.f. amplifiers. We have plenty now. The problem is to increase their selectivity without damaging their fidelity of response. It is our bet that the only reason why people tolerate present-day receivers—and their loud speakers which bring out the low notes—is because of the lack of competition from, and comparison with a really high-quality receiver. One only has to look at the selectivity curves, published in Dr. Hull's article, "Measurements on Broadcast Receivers," in February *RADIO BROADCAST*, or Mr. Jarvis' article in January *RADIO BROADCAST*, to see how few notes above 3000 cycles we are getting, and anyone has to listen but once on any good night in practically any home in the Middle West to long for a more selective receiver.

The only answer is the solution that engineers have suggested time and again, and which the Members of Congress who meddle with radio affairs, do not seem to understand. This answer is to eliminate about

half of the present broadcasting stations. The myth of having 40 cleared channels is amusing indeed to anyone who listens under average conditions. This does not mean listening-in in New York City, or near any great center of broadcasting, but say in Ohio. We had the dubious pleasure of listening-in there during the Christmas week. The receiver was undeniably less selective than many of the two-, three-, and four-stage r.f. amplifiers now on the market, sold as having perfect tone quality.

An hour before sunset in Ohio, we heard stations as far away as Winnepeg, cky, on a four-tube set of the Lab. Circuit type which has been described many times in this magazine. We could tell at once that the practice of putting two large stations, KDKA and WBZ, for example, on adjacent channels is bad. If you live near KDKA it works out fairly well because you can't hear WBZ on the adjacent channel, but if you live equidistant from the two, you can't listen to either of them.

## Two New A.C. Tubes on The Way

IF THERE is anything more interesting than radio gossip, it is speculation on how much of what you hear is true. We are glad to chronicle the gossip regarding two new tubes which—so they say—are soon to appear on the American market. One is an a.c. screen-grid tube of somewhat better characteristics than our present d.c. tube with its fragile and microphonic filament. The tube has a typical heater filament, 2.5 volts and 1.5 amperes. At 180 volts on the plate, a screen-grid potential of 75 volts, and a control-grid bias of minus 1.5 volts, the plate resistance is about 400,000 ohms, its amplification factor about 400, and its mutual conductance about 1000 micromhos. This is considerably better than the d.c. tube with a mutual conductance—which is about all that matters in a tube of this kind—of not much over 300 micromhos. The grid-plate capacity is in the order of 0.01 mmfd., its input capacity about 5 mmfd., and its output capacity about 13 mmfd. The plate current is about 4 mA. and the screen-grid current under normal conditions about 0.3 mA.

The other new tube is a cross between a 171A and a 250, i.e., a tube with about double the power output of the 171A at a maximum plate potential of 250 volts. Many thousands of listeners who overload a single 171 on loud low-note passages, and yet who do not want to overload the house or the neighborhood with the racket from a 250-type tube with 450 volts on the plate, will be pleased with this new tube. Its filament consumes 1.5 amperes at a filament potential of 2.5 volts, and is not of the heater type. Its normal grid bias will be about 50 volts, plate current about 32 mA., amplification factor about 3.5, and power output of 1500 milliwatts.

We have not been able to confirm the rumors that such tubes are going to be announced—but rumors mean that such tubes are in the process of development and that is the im-

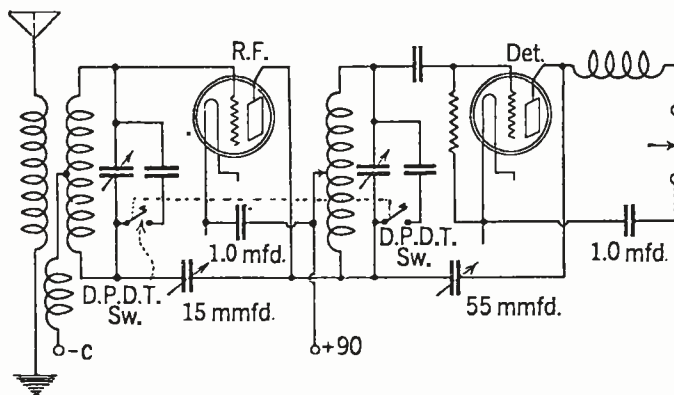

Fig. 1—The diagram of the Lab. Circuit receiver with fixed condensers which increase wavelength range to 800 meters

portant thing. Sooner or later they will appear whether their constants resemble those give above or not.

**Accuracy of Variable Condensers**

LAST month we spoke of the effect on the tuning of a receiver in which one of several ganged condensers was incorrect in its capacity. We have a letter from M. H. Bennett, Electrical Engineer, Scoville Manufacturing Company, which states that an engineering laboratory has determined that on a hundred-degree dial, a discrepancy of 3 mmfd. at 100° is equivalent to detuning one of the condensers by one dial degree, and that such a detuning will cause a reduction in signal strength of about 5 per cent.

Another prominent engineer remarks that the figure of one quarter of one per cent. is too high to be maintained in production—we suspect the question of cost enters here—and that the rest of a radio receiver at the present time cannot be built with such a high degree of accuracy.

**New Radio Tubes in England**

TABLE I gives some data on new Marconi tubes which are available in England, the land of many tubes. Unfortunately all of the data on these tubes are not available, but interest in this country will be directed toward the low filament consumption of some of these samples of foreign economical tubes.

**Importance of Reducing A.C. Hum**

WE HAVE spoken about hum several times. Here is a problem in hum voltages.

Let us suppose the power tube delivers 1000 milliwatts to the loud speaker at the loudest signal to be received, and that the weakest signal will be 40 dB below this value. This is the normal range of broadcasting, 40 dB, corresponding to a power ratio of 10,000 times. Now suppose that at the lowest signal to be heard, the hum output from the loud speaker is not to be objectionable. This means that it ought to be about 20 dB below the signal output. This makes the hum power output 60 dB below 1000 milliwatts, or one microwatt.

If the resistance of the loud speaker to the hum producing voltage is 4000 ohms, the voltage across it is 0.063 volts. Suppose the amplifier is a conventional two-stage transformer-coupled affair using transformers with turns ratio of 3:1 each. The voltage gain of such an amplifier, from resistance output to the primary of the first audio transformer is about 150. The hum voltage across this primary is 0.063 ÷ 150 or about 0.00042 volts or 0.42 millivolts.

All of this indicates that the maximum hum appearing across the first audio transformer must be no greater than 0.42 millivolts—and yet we remember reading somewhere that the hum voltage in the plate circuit of a heater-type detector tube is of the order of several millivolts.

Let us look at the plate-supply device. If the total output potential is about 200 volts, the hum output will be about 50 millivolts. Across the 45-volt tap will be roughly one quarter of this hum voltage or 12 millivolts. For the sake of argument, let us assume that 90 per cent. of this voltage, which is impressed across the plate-filament circuit of the detector finds its way across the primary of the transformer. This means that due to the plate-supply device alone 10.8 millivolts of hum appears across the input. This voltage multiplied by 150 becomes 1.62 volts across the loud speaker. Let us suppose there is already this much there from the use of an a.c. tube detector, or 3.24 volts in all. This amounts to 2.53 milliwatts, or only 26 dB below the maximum output of the amplifier! An assumed hum voltage of 10 millivolts across the 45-volt tap is high because the filter con-

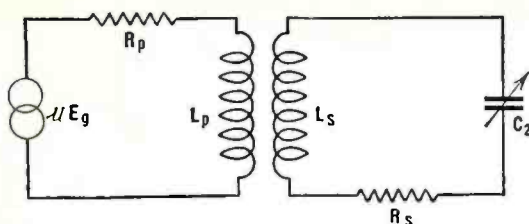

Fig. 2.—Mr. Browning uses this diagram to demonstrate his selectivity formulas

densers across it, and those across the 90-volt tap, get rid of much of the a.c. voltage creating the hum. It is certain, however, that a fairly large capacity should be across the 90- and 45-volt taps. This analysis may account for the fact that many experimenters who have built amplifiers to go down to 120 cycles prefer to use a d.c. tube for a detector and obtain its plate voltage from a 45-volt B battery. And it is surprising how much the low frequencies come up in apparent volume when the a.c. hum is cleaned out of one's receiver, amplifier, power supply, and loud speaker. It is true that so long as the receiver ensemble hums, no signal frequencies lower in pitch than this hum can be heard, and that few signals of the same frequency as the hum can be heard. They must be much louder than the hum—all of which points out some interesting psychological facts. A quiet receiver will always seem to have a much better low-frequency response than one which has a lot of hum in its output.

**Receiving on 600 Meters With Lab. Set**

DURING the *Vestris* disaster we listened-in to the traffic to and from ships in the vicinity of the wreck, and discovered many interesting things about the chaotic condition of the ether during such periods. We used our Lab. Circuit receiver with the addition of two fixed condensers which could be thrown across the tuning condensers. These fixed condensers brought the maximum wavelength that could be received up to nearly 800 meters, and thereby permitted the reception of all of the ship-to-shore traffic on the several channels between 600 and 800 meters. The circuit diagram is given in Fig. 1. The Yaxley switch is a simple double-pole double-throw unit and the condensers had a capacity of 250 mmfd.

**Selectivity in the Browning-Drake Set**

IN SEPTEMBER RADIO BROADCAST, Glenn Browning described some of the engineering behind the 1929 Browning-Drake receiver. This receiver uses somewhat closer coupling between primary and secondary of the interstage r.f. transformer than has been attained heretofore, with the result, according to Mr. Browning, that better selectivity is secured. This statement "closer coupling, better selectivity" bothers many readers, and so we have asked Mr. Browning to explain it. We reproduce some of the mathematics below.

A brief statement of what happens is as follows: for a fixed amount of amplification in a tuned radio-frequency transformer working in conjunction with a given amplifier tube, the selectivity may be increased by advancing the coefficient of coupling and at the same time decreasing the number of turns on the primary so that the amplification remains the same. This is due to the fact that as the

number of turns is decreased and the coupling increased the resistance reflected into the secondary circuit from the primary decreases, and hence the selectivity of the secondary circuit approaches more nearly its selectivity when standing alone and not connected to the plate resistance of the previous tube.

Let  $\eta_p$  and  $\eta_s$  be the ratio of resistance to reactance of primary and secondary circuits and  $\eta_{si}$  be the ratio of resistance to reactance of the secondary when the primary is present. Let  $R_{si}$  be the apparent resistance of secondary when primary is present.

TABLE

$$R_{si} = R_s + \frac{M^2 \omega^2}{Z_p^2} R_p \dots\dots\dots (1)$$

$$\eta_p = \frac{R_p}{L_p \omega}; \eta_s = \frac{R_s}{L_s \omega}; \eta_{si} = \frac{R_{si}}{L_s \omega} \dots\dots\dots (2)$$

$$\eta_{si} = \eta_s + \frac{\tau}{\eta_p} \text{ in general } \dots\dots\dots (3)$$

$$\tau^2 = K \eta_p \eta_s \text{ for a given amount of amplification } \dots\dots\dots (4)$$

Where  $R_s$  = Secondary resistance  
 $R_p$  = Plate resistance of tube  
 $R_{si}$  = Apparent resistance of secondary with primary present  
 $\tau$  = Coefficient of coupling  
 $K$  = Proportionality factor less than 1.

$$\text{Therefore } \eta_{si} = \eta_s + \frac{K \eta_s}{\tau}$$

and as  $\tau$  is increased the selectivity factor of the secondary increases. It is worth noting that if unity coupling prevails and if the proper number of turns are used for maximum amplification,  $K = 1$ , the selectivity of the tuned circuit is halved, as all mathematics and experience dictates.

**Removing Noise in Shielded Receiver**

THE following letter from a reader in Farmington, Michigan, may help others who have shielded receivers. "I would like to pass along a discovery I made regarding the Sargent-Rayment Seven. I had considerable difficulty at first owing to instability in the r.f. stage. At one time it would work perfectly and the next day it would fly into oscillation for no reason at all. I finally found this to be due to poor electrical contact between the partitions and the removable cover. I procured a piece of aluminum 8 inches wide and long enough to cover the r.f. stages and bolted it securely to the partitions. This cured my trouble."

Many experimenters find their receivers do not work after shielding has been added. The trouble lies not with the shielding material of the coils but in the fact that the whole arrangement has not been properly designed. A coil too near a metallic plate will not only lose inductance at an alarming rate but have an astonishing increase in resistance as well.

**League of Nations to Broadcast**

The Secretariat of the League of Nations intends to resume the short-wave broadcast trials which took place in Geneva in May and June of last year. The special purpose of this second series will be to examine the possibility of transmitting speeches from Geneva to the Americas, Japan and Australasia.

The trials will take place in the same technical conditions as those held last year. A studio in the League Secretariat in Geneva will be connected by ordinary telephone cable with the Dutch station of Kootwijk (call letters PCLL) kindly put at the disposal of the League by the Dutch Post Office authorities.

Sixty-minute speeches will be broadcast at 5:00 P.M. (E.S.T.) on 38.8 meters in English, French, and Spanish on March 12, 19, and 26. Thirty minute speeches will also be broadcast in Japanese on March 13, 20, and 27 at 8:40 P. M. on a wavelength of 18.4 meters, and on March 14, 21, and 28 special thirty-minute Australian programs will be broadcast in English at 8:40 P. M. on a wavelength of 18.4 meters.

—KEITH HENNEY

Table I

Type No.	Ef	It	$\mu$	Gm	Rp	Ip	Ep	Eg
DEH 210	2.0	.10	35	700	50000			
DEL 610	6.0	.10	15	2000	7500			
P 625	6.0	.25	6	2300	2400	21.5	160	13
P 625a	6.0	.25	3.7	2300	1600	25	140	18
P 425	4.0	.25	4.5	1950	2300	22	140	14
HL 610	6.0	.10	30	1000	30000			
H 8	.8	.8	40	730	55000			
HL 8	.8	.8	17	1000	17000			
P 8	.8	.8	6	1000	6000			

## AN UNUSUAL ORGANIZATION

By ROBERT S. KRUSE

**A**BOUT seven years ago there was formed in the town of Boonton, N. J., the Radio Frequency Laboratories, Inc., an organization devoted to research—a task that has long been a proudly accepted function of the university.

The first members of the staff were men known to have a permanent interest in the questions "why?" and "how?" Their orders were to get together the necessary apparatus and attack the important problems in radio. I remember clearly the glee with which that prospect was greeted.

That laboratory, with the same frame of mind, is the present Research Division of R. F. L. As its contributions have reached commercial form they have been put into the hands of licensed manufacturers who maintain their contact through an Engineering Division, created for that purpose. Lately there has also been added an Aircraft Radio Laboratory as another major division.

Surprisingly the R. F. L. is not widely known, though it has made fundamental contributions and has for licensees manufacturers whose output is a large share of all that comes to market. Perhaps this is because the contacts have been mainly with the engineers of these organizations, for which R. F. L. is a centralized bureau of research, although working on its original problems as well.

### Accomplishments

**B**ECAUSE of the highly interlocking nature of the research and engineering problems I find it difficult to formulate the work done by these laboratories. However, in the course of various friendly visits made without any such story as this in mind, there has stuck in my recollection some matters that are mentioned in the following paragraphs—the list admittedly being neither complete nor frightfully accurate.

The laboratories developed one of the first neutralized radio receivers, and, incidentally, this was also one of the first single-control sets to be produced.

Methods were developed for determining the sensitivity, selectivity, and fidelity of a radio receiver and these methods have been adopted by the Institute of Radio Engineers as one of the standard methods for measuring a radio receiver's performance.

In collaboration with General Radio, there was developed (and placed on the market by G. R.) a standard signal generator for use in measuring radio receivers.

The Laboratories developed a technique of making sound measurements which made it possible to measure the overall receiver performance from the antenna to the sound wave produced by the loud speaker.

A basic study of detection was made particularly at high signal levels, and detectors were developed which do not produce distortion and which are not subject to overload under normal conditions. These studies applied particularly to 100 per cent. modulated r.f. signals. The use of 100 per cent. modulation is increasing—or perhaps we had better say that there is an increased tendency for transmitting stations to attempt such modulation.

Four-element tubes were designed, constructed,

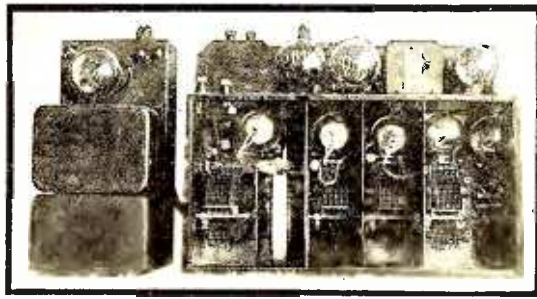

Fig. 1—This compact receiver was developed for use on airplanes with a seven-foot rod antenna

and used in the development of receivers pending the availability of such tubes on the market.

The active research problems are quite beyond such a brief account as this: the designs for the next year's broadcast sets of the licensees are still confidential—though I yearn to write about two features thereof. However, R. F. L. is engaged in another task which may be described. In the commercial progress of aircraft, there has developed a need for a reliable means of guiding an airship—a method that will prove equally reliable during day and night and in all sorts of weather. For this purpose radio beacons have been used but there has existed no receiver for airplane use that would provide the necessary sensitivity and at the same time be able to function without a trailing antenna. The Radio Frequency Laboratories were asked to cooperate with the Department of Commerce in developing a receiver that would do these things.

### The Airplane Receiver

**A**T THE opening of the Aircraft Radio Laboratory on January 9, demonstration flights were made with a new beacon receiver. This receiver uses but five tubes of which the last two are resistance-coupled audio and the first two are of the screen-grid type. It is rather startling to have such a receiver, working with a seven-foot rod antenna, produce a headset signal which, at 30 miles from Hadley Field's beacon station, is far beyond the scale of any ordinary audibility meter and wrecks headsets in short order. With voice modulation at the beacon station, the Wright J-5 motor's roar meekly retreated behind the signal. In I. R. E. language, the set has a sensitivity of 5 microvolts on a 30 per cent. modulated signal. The sets may be used either on the "A & N" beacon system or with the vibrating-reed system. Of these two systems, we will speak but briefly. In both cases there are sent out two beams, diverging slightly and the course lies down the center of the angle.

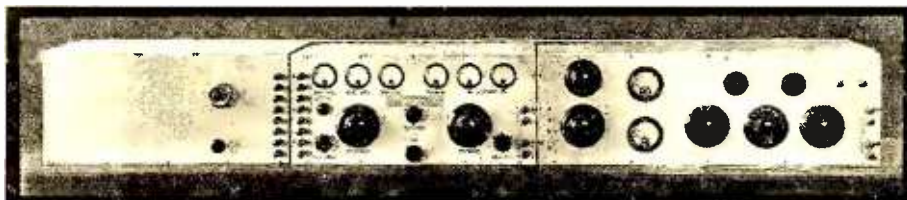

Fig. 2—This apparatus is used in the laboratories of the R. F. L. for measuring the sensitivity of broadcast receiving sets

With the "A & N" system the letter A (· —) is being sent on one beam and the letter N (— ·) is sent on the other beam. The timing is such that if the two beams are being received equally well the two letters interlock to make a steady signal. In the reed system the two beams are modulated at audio frequency, one at 65 cycles and the other at 85 cycles per second. At the receiving end, therefore, the output of the amplifier carried both modulations equally if one is on the course. If the plane falls off course the 65-cycle modulation may be picked up less and the 85-cycle one more (or the reverse) and one reed spreads out more while the other narrows down, thus advising the pilot as to the direction in which he is off. With the receiver mentioned here the system is dependable up to 150 miles, with a normal 2 kw. beacon station and a seven-foot rod antenna on the plane.

### Airplane Height Indicator

**T**HERE is at present being developed by the Aircraft Radio Division of the R. F. L. a height indicator. In its present state of development this device is used to give a series of two or three separate indications (such as the lighting of different colored lamps) each of which corresponds to a definite height above the earth or water over which the plane is being flown. It must be clearly understood that the device is not an altimeter, the device at present used in airships and which tells the pilot the height of his plane above sea level. The R. F. L. height indicator will have no reference to sea level but uses the surface under the plane as the datum point—it is of small interest to a pilot how high he is above sea level when he is flying above a mountain and the tree tops are only 50 feet below.

This new apparatus was first installed in a D. H. plane and successfully operated over land, fresh water, and salt water. A later installation has been made in a radio test plane of the laboratory. The apparatus is in the forward cockpit of the ship and is housed in an aluminum box, the whole weighing about 7 pounds. The antenna is a doublet stretched between wingtips, and lying beneath the wing.

In its present form the device is useful for landing in ground fog, and for landing on smooth water in clear weather. When flying over trees the indicator flickers continually.

Of course, it is felt that aviation radio will become of steadily increasing importance. The Laboratories have acquired an airport. For the hangar we can say that it has better than average accommodations, including garages, living quarters, a shop, an office, and an 80 x 100-foot space for planes, which enter through doors with 18-foot headroom. Amazingly enough the place is heated well. It does not stick in my recollection that I have ever been in an airplane hangar that was not several degrees colder than outdoors.

In another corner of the field is a laboratory containing living quarters, kitchen, lounge and library, bridge measurement room, a transmitting room, transmitting and receiving laboratories, private laboratories, director's conference room, office, and a finely equipped shop.

# GRID-LEAK GRID-CONDENSER DETECTION

By **FREDERICK EMMONS TERMAN**

Stanford University

**D**ETECTION is a subject upon which little real information is available to the radio experimenter. While amplifier circuits are designed with full knowledge of the results that will be obtained under different conditions, the detector is left to chance. Recent investigations have shown that grid-leak grid-condenser detection of weak or moderate-strength signals is determined by a single new tube constant, and that the exact behavior of the detector can be obtained simply by using this new constant. The sensitiveness and distortion resulting with grid-leak detection when strong signals are being received can also be readily analyzed, and it will be shown that a properly operated grid-leak "power" detector is more sensitive and gives less distortion than the usual plate-rectification detector.

A few of the worth-while articles which have considered this subject are as follows:

"A Theoretical and Experimental Investigation of Detection of Small Signals," by E. L. Chaffee and G. H. Browning, *Proc. I. R. E.*, 15, 113; February, 1927.

"The Rectification of Small Radio-Frequency Potential Differences by Means of Triode Valves," by F. M. Colebrook, *Experimental Wireless*, 2, 865; 1925.

"Detection by Grid Rectification with the High-Vacuum Triode," by Stuart Ballantine, *Proc. I. R. E.*, 16, 593; May, 1928.

"Some Principles of Grid-Leak Grid-Condenser Detection," by Frederick Emmons Terman, *Proc. I. R. E.*, Vol. 16, p. 1384, Oct. 1928.

"Detection Characteristics of Three-Element Vacuum Tubes," by Frederick Emmons Terman and Thomas M. Googin, *Proc. I. R. E.*, Vol. 17, Jan. 1929.

## Process of Detection

**D**ETECTION is the name given to the rectification of high-frequency alternating-current voltages in radio receivers. In the grid-leak method of detection, the circuit for which is shown in Fig. 2, the rectification takes place in the grid circuit by making use of the curvature of the grid-current grid-voltage characteristic.

The case of weak signals will be considered first. The grid-leak "power" detector acts very differently, and will be taken up in another article.

The relation between grid voltage and grid current in a typical vacuum tube is given in Fig. 1. It will be noted that there is a small grid current even when the grid is negative with respect to the negative side of the filament. This is the result of the velocity which the electrons have as they leave the filament.

In the absence of a radio signal voltage, the grid assumes a voltage which is the potential of the grid return lead (the lead which completes the circuit from the grid back to the filament) minus the voltage drop due to the grid current flowing through the grid leak. This can be readily seen by examining Fig. 2. This actual grid voltage is the operating grid potential, and gives the point on the grid-voltage grid-current characteristic of Fig. 1 at which the detector operates. The operating grid potential is usually within a fraction of a volt of the negative filament voltage when the grid return lead is connected to the positive side of the filament. A higher

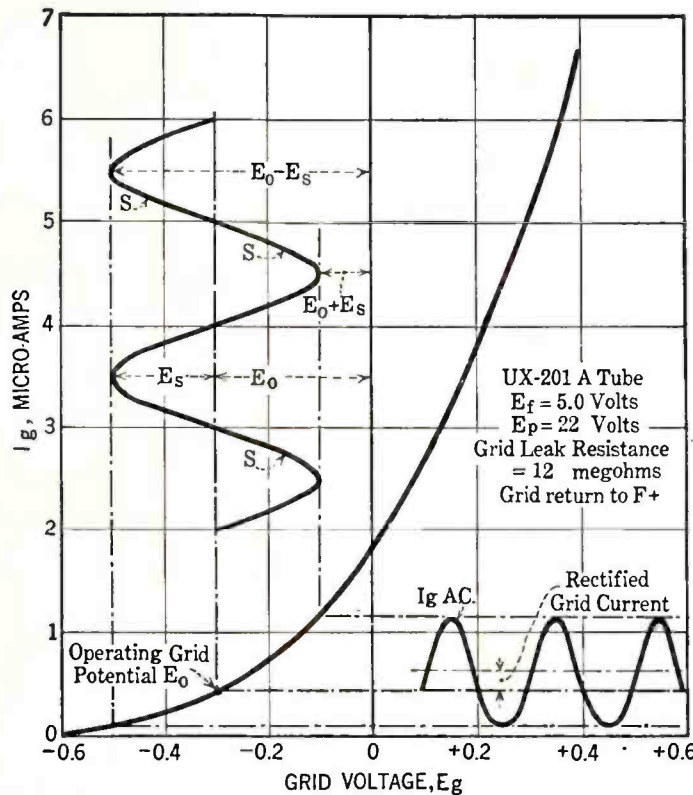

Fig. 1—Grid-current grid-voltage characteristic of a 201A-type tube

resistance grid leak makes the operating grid potential more negative (or less positive), but the grid voltage changes only a volt or so when the grid-leak resistance is varied from  $\frac{1}{2}$  to 10 megohms. The principal function of the grid leak is to fix the operating grid potential at a point on the grid voltage-current characteristic suitable for rectification in the grid circuit.

When a radio-frequency signal, such as developed by the tuned circuit LC of Fig. 2 is applied to the detector grid this voltage is superimposed on the operating grid potential, making the actual grid voltage alter-

nately more and less than the operating grid potential. This is illustrated in Fig. 1 in which  $E_0$  is the operating grid potential,  $E_s$  is the amplitude of signal voltage, and the curve SSS is the variation in actual grid potential when the signal voltage is present.

## Principle of Detection

**T**HE signal makes the instantaneous grid voltage swing alternately from  $E_0 + E_s$  to  $E_0 - E_s$ , as indicated in Fig. 1. This fluctuation in grid voltage causes the grid current to vary, but, due to the curvature of the grid voltage-current characteristic, the grid current increases more during the half cycles when the signal voltage is positive than it decreases during the half cycles when the signal voltage is negative. The net result is a rectified current flowing in the grid circuit produced by the application of the radio-frequency signal voltage to the grid.

Reference to Fig. 1 will make clear how the rectification is accomplished. When the signal is present the instantaneous grid potential varies as indicated by the sine wave SSS. This variation in grid potential causes the grid current,  $I_{g\text{ a.c.}}$ , to vary according to the curve to the right in Fig. 1. The middle dot-dash horizontal line shows the grid current that flows when the grid potential is  $E_0$  (no signal present).

The average grid current that flows when the signal is present is indicated by the light dash line. The difference between these two horizontal lines represents the rectified current flowing in the grid circuit as a result of the application of the signal voltage to the grid.

The amplitude of the rectified grid current depends upon the amplitude of the signal voltage. When the signal is a modulated alternating-current voltage, the rectified grid current varies in amplitude at the frequency of modulation. Thus, when the signal is modulated at 1000 cycles, the rectified grid current pulsates in amplitude at a 1000-cycle rate. In Fig. 3 there is shown the rectified grid current resulting when an unmodulated, a simply modulated, and a complexly modulated wave is rectified in the grid circuit of a detector.

The rectified grid current produced in the manner that has been described by the application of a signal voltage must flow through the impedance offered by the grid-leak grid-condenser combination, and will produce a voltage drop in this impedance. This drop causes the grid potential to become more negative by the amount of the drop, and the change of grid potential thus produced affects the plate circuit by ordinary amplifier action. It is the change of grid potential caused by the rectified grid current flowing through the grid-leak grid-condenser impedance that gives the detection of the signal.

The explanation that has been given of grid-leak detection with weak signals differs considerably from the familiar one in which the function of the grid leak is to let the grid-condenser charge leak off and return to the filament.

*What goes on in a detector circuit is not the easiest thing in the world to understand, but we believe Professor Terman has made the operation of grid-leak grid-condenser detectors as clear as possible. In this article he points out that there are two detector constants that tell the whole story about what a tube will do as a detector, and advocates that tube manufacturers put the values of these constants on tube cartons. We agree. Several other articles on the long-neglected subject of detection are awaiting publication. Some are from Professor Terman and others are from Roger Wise and his former associates at the Cunningham laboratory.*

THE EDITOR.

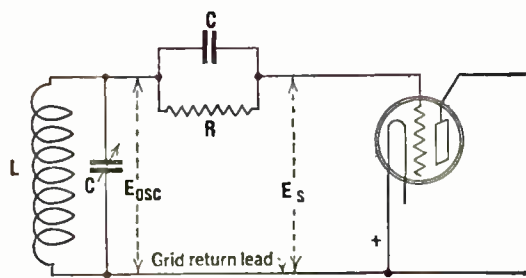

Fig. 2—Circuit for a grid-leak grid-condenser detector

Features of Practical Detection

IT WILL be observed that the grid-leak detector combines two distinct functions. First is the rectification of the signal voltage, and the utilization of the rectified signal current to produce a change of grid potential, and second is the amplification of this change of grid potential in the plate circuit. This latter problem is purely a matter of audio-frequency amplification, and is quite generally understood. The real problem of grid-leak detection is therefore centered around the determination of the change of grid potential by the rectifying process, and the rest of this article will be devoted to a discussion of the factors controlling the rectified grid current, and the voltage drop it produces.

In the analysis of practical detection it is necessary to consider only the audio-frequency components of the rectified grid current. The direct-current component can produce no sound in the loud speaker and so is unimportant.

The sensitiveness of the detector (i.e. the change of grid potential produced by a given input signal voltage) is obviously determined by the effectiveness with which the signal voltage is rectified, and by the amount of opposition which the grid leak-condenser combination offers to the flow of the audio-frequency components of the rectified current. The impedance which the grid leak-condenser combination offers to the rectified grid current depends greatly upon the frequency of this current. At low frequencies, such as 50 cycles, this impedance is very high because the low-frequency current has difficulty in getting through the grid condenser and is accordingly forced through the high resistance of the grid leak. On the other hand, at high audio frequencies, such as 5000 cycles, the grid condenser offers an easy path to the current, practically short-circuiting the grid leak.

The result is that the rectified grid current tends to produce less change of grid potential on the high audio frequencies than on the low notes. This reduction of sensitiveness at the higher audio frequencies can be quite serious, and unless the detector is adjusted properly will lead to very bad quality. Satisfactory reproduction of the high notes requires that the smallest possible grid condenser capacity be used in order to minimize the short-circuiting effect of the grid condenser on the grid leak. If the grid condenser is made too small, however, an appreciable part of the radio-frequency voltage developed by the tuned circuit supplying the grid will be used up in the grid condenser, and the signal voltage,  $E_s$ , actually applied to the grid will be seriously reduced (see Fig. 2). The best value of grid condenser for all standard type tubes is from 0.0001 to 0.00025 mfd. Larger capacities should never be used.

The Equivalent Circuit

FROM the discussion that has been given it is seen that the most important features of the grid-leak detector are the amount of rectified grid current produced by a given signal, and the amount of voltage drop which this rectified current produces in flowing through

the grid leak-condenser combination. Recent investigations, both theoretical and experimental, have shown that the rectified grid current produced by the application of a small radio signal voltage to the detector grid acts exactly as though it were produced by a suitable series of low-frequency generators acting between the grid and filament in series with the grid-filament resistance of the tube.

There is one such generator for each component of the rectified grid current. The most important of these equivalent generators is the one of modulation frequency.

The action that takes place in the grid circuit of a grid-leak detector can be conveniently described in terms of the equivalent grid circuit shown in Fig. 4. Here the rectifying effect of the grid circuit on the radio signal is replaced by the equivalent generators,  $E_r$ , which are considered as producing the rectified grid current in place of the radio signal that actually does. These equivalent generators act in a circuit consisting of the grid leak-condenser combination, RC, in series with the grid-filament tube resistance,  $R_g$ . This grid resistance,  $R_g$ , is analogous in all respects to the plate resistance,  $R_p$ , and is the reciprocal of the slope of the grid voltage-current curve shown in Fig. 1. While the grid resistance in amplifiers is commonly considered as infinite, this is not the case with grid-leak detectors because the detector works with a small but

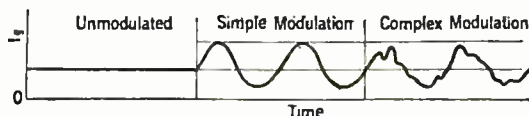

Fig. 3—Rectified current for various kinds of modulation

definite grid current. The grid resistance,  $R_g$ , depends upon the grid, plate, and filament voltages of the tube, and becomes higher as the grid is made more negative. High grid-leak resistances accordingly give a high grid resistance because such leaks give a more negative operating grid potential, while low resistance leaks will fix the operating grid potential where the grid resistance is low.

Tube Capacity

THE capacity  $C_g'$  indicated in Fig. 4 is the input grid-filament tube capacity to audio frequencies. This capacity is larger than the interelectrode capacity by an amount depending upon the plate circuit impedance, and will be in the order of 70 mmfd. with 226, 227, 112A, and 201A tubes when there is a transformer in the plate circuit. The capacity  $C_g'$  is in parallel with the actual grid condenser, C, so that the effective grid condenser capacity is the actual capacity plus  $C_g'$ .

The generators that can be assumed acting between the filament and grid in series with the dynamic grid resistance to produce the rectified grid current have no actual existence. It is merely that the effect of applying a signal voltage to the grid is the same as though these fictitious generators actually were present, and as though they and not the signal voltage were the forces really producing the rectified grid current. The voltage developed by this series of fictitious generators can conveniently be called the rectified grid voltage, and will be represented by the symbol  $E_r$ .

One of the fundamental features of the law of detectors is that the size of the equivalent rectified grid voltage,  $E_r$ , which can be considered as acting to produce the rectified grid current, depends only upon the strength and type of signal and upon the tube characteristics at the operating grid potential. The size of grid condenser and grid leak has no effect on the amplitude of the rectified grid voltage,  $E_r$ , except in so far as the grid-leak resistance affects the operating grid potential.

Part of the rectified voltage,  $E_r$ , in the equiv-

alent grid circuit of Fig. 4 is used up as voltage drop in the grid leak-condenser combination and part is used up across  $R_g$ . The change of grid potential which the rectified grid current produces in flowing through the grid leak and condenser is the grid voltage change which is amplified by the tube in the usual audio-frequency manner. Under ordinary circumstances only the modulation-frequency component of rectified grid voltage,  $E_r$ , need be considered in this process as this component represents the useful output of the detector.

Detector Voltage Constant

THE size of rectified grid voltage,  $E_r$ , used in the equivalent detector circuit of Fig. 4 depends upon the tube characteristics at the operating grid potential and upon the signal voltage. The action of the tube in rectifying the radio-frequency signal voltage can be completely taken into account by a single tube constant called the voltage constant of the grid and represented by the symbol  $V_g$ . The voltage constant,  $V_g$ , is measured in terms of volts and varies between -0.2 and -0.5 volts for nearly all properly adjusted detectors. The voltage constant of the grid depends upon the slope of the grid voltage-current characteristic at the operating point, and upon the way in which this slope varies with grid voltage. Mathematically it is defined by

$$V_g = \frac{2R_g}{\frac{dR_g}{dE_g}}$$

It can be measured by determining the grid resistance at the operating grid voltage, and at grid voltages slightly more and less than the operating voltage.

As has been pointed out, the modulation-frequency component of the rectified grid voltage is the important part. The crest or peak value of this component of  $E_r$  is equal to  $mE_s^2/V_g$  where  $m$  is the degree of modulation, which must lie between 1.00 and zero, and will only reach 1.00 when the music or speech is very loud, and  $E_s$  is the peak amplitude of the signal carrier wave. The crest amplitude is 1.414 times the effective (or r.m.s.) amplitude. It is to be remembered that field strengths, etc., are ordinarily expressed in effective values, while amplifier inputs must be expressed in crest amplitudes because it is the crest amplitude of the sine wave that overloads the amplifier.

Practical Example

AS A simple example, consider the case of a signal modulated 20 per cent, or 0.20 at 1000 cycles, with a carrier crest amplitude of 0.05 volts being applied to a detector grid operated where the voltage constant is -0.25 volts. The crest value of the 1000-cycle component of rectified grid voltage is then  $0.20 \times (0.05)^2 / (-0.25) = -0.002$  volts crest value. The amount of 1000-cycle rectified grid current existing in the grid circuit of the actual detector is the same as the current which this -0.002 volts of 1000 cycles will produce acting in the equivalent grid circuit of Fig. 4. The 1000-cycle voltage drop produced

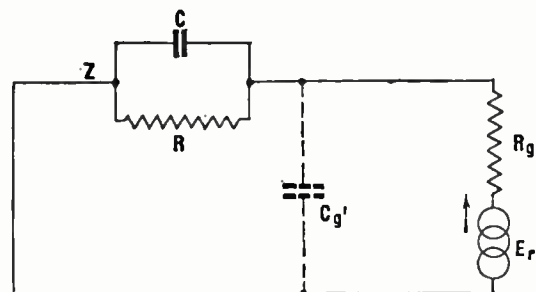

Fig. 4—Equivalent circuit of grid-leak grid-condenser detector

across the grid leak-condenser combination in the equivalent circuit by the action of the  $-0.002$  volts is the amount of 1000-cycle voltage drop in grid potential existing in the actual detector, and is the amount of 1000-cycle voltage which is applied to the input of the audio amplifying system. (This does not mean the voltage applied to the primary of the first audio transformer, for example, but is the audio-frequency voltage impressed on the grid of the detector, which the author considers as the beginning of the audio system. If the  $\mu$  of the detector tube is 8, the maximum voltage across the primary under these conditions would be  $8 \times 0.002$  or 0.016 volts—*Editor*.) The negative sign of the rectified grid voltage is caused by the fact that the voltage constant,  $V_g$ , of the grid is negative, and this merely means that the voltage acts in a direction opposite to that indicated by the arrow in Fig. 4.

It is apparent from a study of Fig. 4 that the fraction of the rectified grid voltage which is usefully used to produce change of grid potential is determined by the ratio of impedance to the rectified grid voltage, which the grid leak-condenser combination offers to the grid-resistance,  $R_g$ . The higher this ratio, the more sensitive will be the detector, but in no case will the change of grid potential ever exceed the rectified grid voltage.

In order that the detector may reproduce the high notes as well as the low notes it is necessary that the impedance of the grid leak-condenser combination at the highest note desired be sufficiently great relative to the grid resistance,  $R_g$ , as to cause most of the rectified grid voltage of this high frequency to be used up as voltage drop across the grid leak and condenser. Then the high notes will be reproduced with full sensitivity and, as the low notes are already as loud as possible, the detector will give good quality output covering the entire audio-frequency range.

The quality of the detector output will be worse for operating points which give a high grid resistance,  $R_g$ , than for conditions which give a low grid resistance. Thus, high-resistance grid leaks give poorer quality than low-resistance ones. With a given size grid condenser, however, the quality is not improved appreciably after the grid resistance gets less than a critical value to be discussed later. The maximum allowable grid resistance,  $R_g$ , is determined by the highest audio frequency to be reproduced at full sensitivity, and by the size of grid condenser. The grid-leak resistance has little effect on the quality at the high notes except as a means of controlling the operating grid potential, and hence of controlling the grid resistance,  $R_g$ , because the rectified grid currents of high audio frequency very largely go through the grid condenser shunting the grid leak.

*Detection Data*

THE most satisfactory way to represent detector characteristics is to plot grid voltage constant,  $V_g$ , as a function of grid

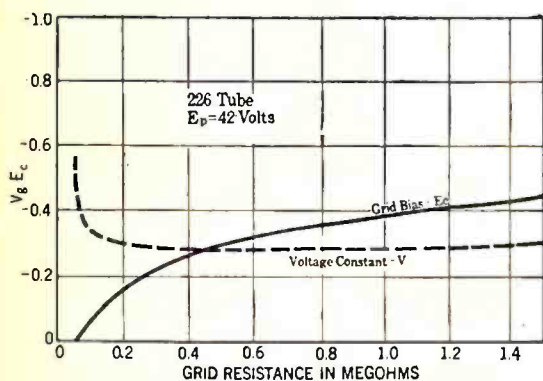

Fig. 5—Rectifying characteristics of a 226-type tube used as a grid-leak grid-condenser detector

resistance,  $R_g$ , at the operating point. Since the sensitiveness of the detector is proportional to the rectified voltage and this in turn is determined by  $V_g$ , while the possible quality is dependent upon  $R_g$ , such a curve can be considered as showing the relation between sensitivity and quality.

A typical relation between the grid voltage constant,  $V_g$ , and grid resistance,  $R_g$ , is shown in Fig. 5. This figure also shows the operating grid potential required to give different values of grid resistance. In examining the  $V_g$ - $R_g$  characteristic it is to be remembered that, since the rectified grid voltage is inversely proportional to  $V_g$ , the sensitiveness is greatest when the grid voltage constant,  $V_g$ , is smallest. In Fig. 5 it is accordingly seen that as the operating grid potential gets more negative, and the grid resistance,  $R_g$ , increases, the sensitivity rapidly increases until  $R_g$  equals about 150,000 to 200,000 ohms. For all grid resistances higher than approximately 150,000 ohms the sensitiveness is greatest when the grid voltage constant,  $V_g$ , is smallest. In Fig. 5 it is accordingly seen that as the operating grid potential gets more negative, and the grid resistance,  $R_g$ , increases, the sensitivity rapidly increases until  $R_g$  equals about 150,000 to 200,000 ohms. For all grid resistances higher than approximately 150,000 ohms the sensitiveness is greatest when the grid voltage constant,  $V_g$ , is smallest.

While Fig. 5 gives the  $V_g$ - $R_g$  characteristic of a particular tube at particular values of

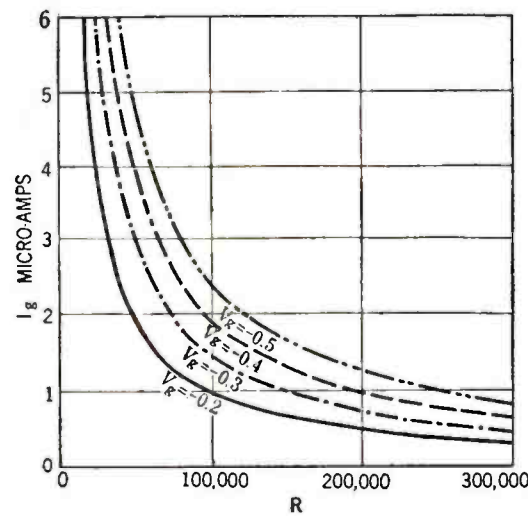

Fig. 6—Grid current as a function of grid resistance and  $V_g$

plate and filament voltages, an investigation in which over 1000 measurements of  $V_g$  were made showed that every tube tested had a  $V_g$ - $R_g$  characteristic similar in shape to Fig. 5. In every case there was the same rapid decrease in  $V_g$  at increasing values of grid resistance and this was followed by the low flat part of the curve at all grid resistances above a critical value.

Not only does every tube have the same type of  $V_g$ - $R_g$  characteristic, but every tube of the same type was found to have substantially the same characteristic for all plate and filament voltages (provided there was sufficient electron emission from the filament). Furthermore using the tube, or even rejuvenating it (in the case of thoriated filaments) had no effect on the  $V_g$ - $R_g$  relation as long as the filament was reasonably active. The only point on which tubes of the same type differ is in the grid voltage required to give a particular value of grid resistance. At high plate and low filament potentials the operating grid voltage must be slightly more positive to obtain a given grid resistance than at low plate and high filament potentials. Even at the same filament and plate conditions different tubes of the same type will sometimes require operating grid voltages differing in extreme cases by as much as 0.5 volts to give the same  $R_g$ .

*Characteristic Curves*

The  $V_g$ - $R_g$  characteristics for standard types of tubes are given in Figs. 8 and 9. These curves are all for a plate voltage of 42

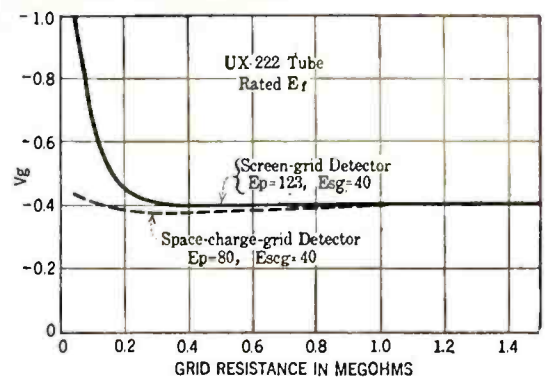

Fig. 7—Detection characteristics of four-clement tubes

and rated filament conditions, but would be substantially unchanged if measured at other plate and filament voltages. The important differences between the various tube types are (a) the value of voltage constant on the flat part of the curve, and (b) the value of grid resistance at which the low flat part of the curve begins. These characteristics are tabulated in Table I. The values in the third column determine the sensitivity of the detector as a rectifier. The tube with the smallest  $V_g$  is the best rectifier, and will produce the greatest change of grid potential with a given signal. The second particular in which different types of tubes differ, i.e., the point at which the flat part of the curve begins, has an important influence in determining the effectiveness with which the high notes may be reproduced. The lower the value of grid resistance at which the low flat part of the  $V_g$ - $R_g$  curve begins, the better the detector.

*Practical Detection*

THE principles and data of the preceding paragraphs will now be applied to the problems involved in selecting detector tubes and adjusting their circuits. In selecting detector tubes it is necessary to remember that the sensitiveness depends upon, first, the maximum change of grid potential obtainable, which is inversely proportional to the value of  $V_g$  over the low flat part as tabulated in Table I, and second, the amplification (produced in the tube) of this change of grid potential. While both the 201A and the 199 have substantially the same  $V_g$ , the 201A tube is a better amplifier because of its higher  $\mu$  and lower  $R_p$  and is, therefore, superior. The 227 tube is a more sensitive detector than the 226 tube because, although they are equally good amplifiers, the 227 tube has a smaller  $V_g$ , and so gives a greater change of grid voltage to amplify. On this basis the 227 heater-type tube is the most sensitive detector, closely followed by the 226 and the 112A types. Other tubes, such as the 201A, 199, 171A, 120, and 12 varieties are distinctly less sensitive, either because of high grid voltage constant or because of low audio-frequency amplification per stage. The 200A gas tube and the 240 high- $\mu$  tube are no better rectifiers than the 201A tube, but as both have a high  $\mu$  they are more sensitive than other detector tubes in resistance-coupled circuits.

*Securing Sensitivity*

IN ORDER to realize the full sensitivity of the detector tube the operating grid potential must be such as to give a grid resistance that is on the low flat part of the  $V_g$ - $R_g$  characteristic. No detector tube should be operated at a grid resistance lower than the value given in the fourth column of Table I. If this rule is violated great loss in sensitivity will result.

Since  $R_g$  is not the same as the grid-leak resistance the next step is the selection of a value for the latter that will give the best operating grid potential. In general, the most

favorable operating point is the one that gives the lowest permissible grid resistance, as indicated in the fourth column of Table I, except that it is best not to operate with  $R_g$  less than 100,000 to 75,000 ohms in ordinary cases because of losses in the grid circuit. The value of grid-leak resistance controls the operating point, as has been explained. The greater the leak resistance, the more will be the voltage drop in the leak, the more negative will this make the actual operating grid potential, and the larger will be  $R_g$ .

The value of grid-leak resistance giving a desired operating grid resistance can be determined exactly by certain obvious measurements, which, however, require apparatus frequently not available, or they can be determined approximately with the aid of Fig. 6, which shows the grid current that will flow when the operating point is on the low, flat part of the  $V_g-R_g$  characteristic, and when the tube's  $V_g$  is on the flat part, and the desired  $R_g$  is known. To select the grid leak in this approximate way one first determines the grid current that will flow at the desired operating grid resistance, using Fig. 6, and then computes the resistance this current would have to flow through to produce a voltage drop equal to the voltage drop in the filament. The resistance thus obtained when used for the grid leak will give the desired grid resistance usually without more than 20 per cent. error for all plate voltages within the usual operating range, and for all tubes of that type. Thus in the case of a 201A tube to be operated at  $R_g = 150,000$  ohms, the grid current as determined from Fig. 6 ( $V_g = -0.47$ ) is approximately 1.57 microampercs and the grid-leak resistance for rated filament potential of 5.0 volts would be  $5/1.57 = 3.2$  megohms. The grid return lead would then be brought back to the positive leg of the filament.

This approximate method can be satisfactorily applied to all tubes except the 200A and the 227. With 227 tubes satisfactory results will be obtained when the grid leak is such as to give a drop of 0.9 volts when the grid current at the desired operating grid resistance is flowing through the leak.

**Grid-Condenser Determination**

AFTER selecting the tube, the proper operating grid resistance, and the grid leak that will give the operating  $R_g$  desired, there remains the determination of the grid condenser. The grid condenser capacity is determined by the highest audio frequency that is to be satisfactorily reproduced, and by the operating grid resistance. The rule is that the reactance of the effective grid condenser capacity (which is the actual grid condenser capacity plus the input grid-filament tube capacity to audio frequencies) at the highest note to be reproduced at least 70 per cent. as well as the low notes must be equal to the grid resistance. Therefore, if  $f$  is this highest frequency and  $C_{eff}$  is the capacity, then

$$C_{eff} = \frac{1}{2 \pi f R_g}$$

The actual grid condenser size is  $C_{eff}$  minus the tube input capacity—about 70 mmfd. for tubes with  $\mu = 9$  and for the other tubes it will be roughly proportional to  $\mu$ .

In the case of the 201A tube considered, if the highest note is to be 5000 cycles, then  $C_{eff} = \frac{1}{2 \pi \times 5000 \times 150,000} = 0.000212$  mfd. As the tube input capacity is about 70 mmfd. a grid condenser capacity of 0.000142 mmfd. will be required. With this capacity notes of 10,000 cycles will be reproduced half as well as the low notes.

In Table I there is tabulated the value of grid-leak resistance which will put the operating grid resistance at approximately the value corresponding to the lowest permissible figure as given in the fourth column of the

action in the control grid of four-element tubes is of exactly the same character as in three-element tubes. Fig. 9 shows the  $V_g-R_g$  characteristic of four-element tubes compared with the 201A tube. The curves for four-element tubes are independent of filament, plate, and auxiliary grid potentials for both space-charge-grid and screen-grid tubes. The only difference between the two connections is that the low flat part of the  $V_g-R_g$  curve extends down to very much lower values of grid resistance in the case of the space-charge-grid tube.

The screen-grid and space-charge-grid tubes can, accordingly, be used very satisfactorily as grid-leak detectors. In particular, the space-charge grid tube combines fair grid rectification with unusual amplifying properties. When arrangements are worked out to satisfactorily utilize the tremendous amplifying properties of the screen-grid tube for audio-frequency amplification grid-leak detection with the screen-grid tube can be used with great success.

**Comparison of Detector Tubes**

THE indications are that the merit of a detector tube as a rectifier depends primarily upon the characteristics of the filament, or the electron emitting cathode, and only secondarily, if at all, upon other features such as the  $\mu$ , electrode voltages, number of elements, power capacity, and the like. The oxide-coated filament is definitely superior to the thoriated-tungsten filament, which, in turn, is better than straight tungsten. At the same time there is some difference between different types of tubes with the same kind of filament material.

In selecting a detector tube the choice depends upon several conditions. If the audio system is resistance coupled the high- $\mu$  240 and 200A tubes are best. When the detector is transformer coupled and is operated by storage battery, the 112A is best, being definitely superior both in amplification and rectification to the 201A which consumes the same filament power. Of the dry-cell filament tubes the obsolescent cx-12 is much more sensitive than the 199. Of the a.c. tubes, the 227 type is the best detector, being better than any of the d.c. or other a.c. tubes.

It is interesting to note that the gas-filled 200A "super-sensitive" detector is no more sensitive than would be a 201A tube built with the same high  $\mu$ . The gas apparently contributes substantially nothing to the 200A tube but an objectionable hiss!

In conclusion it is worth pointing out that the value of the grid-voltage constant,  $V_g$ , over the low flat part of the curve, and the value of grid resistance,  $R_g$ , at which the flat part begins, are tube constants which should be published by tube manufacturers. Both of these quantities are as truly characteristic of a given make and type of tube as is the  $\mu$  and plate resistance. Both detection constants are substantially independent of age, filament, and plate voltages within the operating range of values.

Table I

DETECTION CHARACTERISTICS OF THREE-ELEMENT TUBES

Type	Mu	$V_g$ (volts)	$R_g$ at start of flat part (approximate) (ohms)	Leak resistance to give $R_g$ in column four (megohms)	$C_{eff}$ for 70% reproduction of 5000 cycles (mfd.)
201A	9	-0.47	150,000	3.20	0.000212
200A	20	-0.47	50,000	1.06	0.000636
240	30	-0.17	150,000	3.20	0.000212
199	6	-0.50	125,000	1.50	0.000255
120	3	-0.45	125,000	1.67	0.000255
171A	3	-0.28	200,000	7.2	0.000160
112A	8	-0.26	150,000	5.8	0.000212
226	8	-0.29	150,000	1.6	0.000212
227	8	-0.23	50,000	3.9	0.000636
12	6	-0.27	50,000	4.0	0.000636

Note: Values of  $V_g$  are averages for a number of tubes. Values of  $C_{eff}$  are values for grid resistance as given in fourth column. The actual grid condenser capacity is  $C_{eff}$  minus tube input capacity. Values of  $C_{eff}$  twice the value given in table reproduce 5000 cycles 45 per cent. as well as the low notes instead of 70 per cent. All tubes are RCA or Cunningham.

Table. This table also gives the value of  $C_{eff}$  that reproduces 5000 cycles 70 per cent. as well as the low notes when the grid resistance is the minimum value giving full sensitivity. Values of  $C_{eff}$  twice as big as those given in the table will reproduce 5000 cycles one half as well as the low notes.

In general it is best to use the largest size grid condenser that is consistent with the quality of reproduction desired. Large grid condensers use up less of the radio-frequency signal voltage, as explained in connection with Fig. 2. There is not much to be gained by going to condensers over 0.00025 mfd., however, while capacities much less than 0.0001 mfd. are also to be avoided if possible.

The final decision to be made regarding the detector is the choice of plate voltage. Since the rectifying action in the grid (i.e., the form of the  $E_g-I_g$  curve—Editor) is unaffected by the plate potential, it is desirable to make the plate voltage as high as possible consistent with the safe or allowable plate current. Such a plate potential will give a low plate resistance and hence good amplification. Unusually high plate potentials cannot be used with moderate  $\mu$  tubes, however, because of the high plate current with the grid operating point near zero potential.

Measurements of  $V_g$  of four-element tubes operated as space-charge-grid and screen-grid (222 type) tubes show that the rectifying

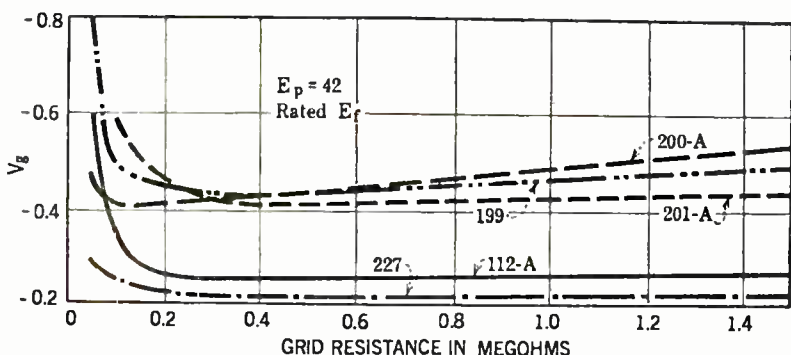

Fig. 8—Detecting characterization of typical tubes

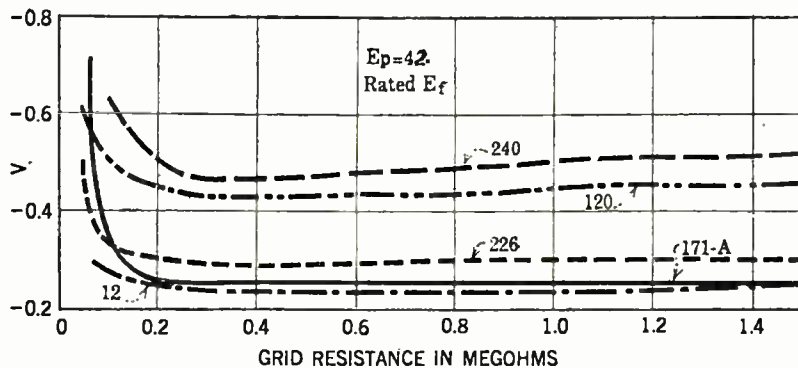

Fig. 9—Detection characteristics of three-element tubes



## PLOTTING CURVES—PART I

ALL experimenters should be able to draw curves, graphs, or plots and to interpret what these pictures mean. Also they should be able to interpret what the curves drawn by other experimenters mean. A note book full of curves is a source of concentrated information of infinite variety. In a few pages it may contain a summary of a month's work in a laboratory, or of many week's work with complex mathematical formulas. It is always a visual picture or representation of some physical, electrical, or mechanical phenomenon. This "Home-Study Sheet" is written in the hope that some of the less apparent facts about curve plotting may be brought to light and that it may encourage more experimenters to keep their data in this convenient form.

To state that a graph is a visual representation of a mathematical expression may not convey

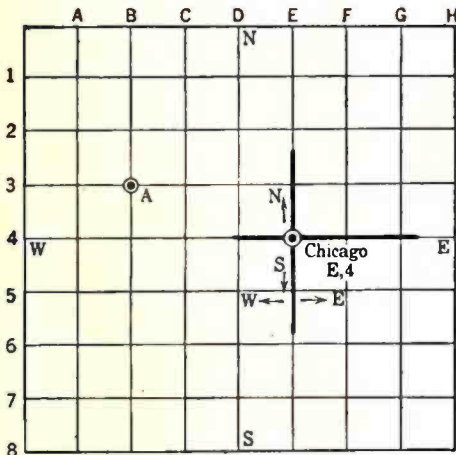

Fig. 1—A map is a form of graph

much to the average experimenter, but such is a fact nevertheless. Every graph or plot or curve may be expressed in the form of a mathematical equation. Some curves, however, are so complex that the expression would be very difficult to figure out. Conversely, every mathematical expression may be plotted in the form of a graph.

A graph is a visual statement that two factors are related to each other in some fashion, either simple or complex. Thus, one factor may increase when the other increases, directly or according to a square or a more complicated law, or it may decrease as the other increases.

A form of graph with which everyone is familiar is a map. We say that a certain town, "A," is so many miles north and so many miles west of Chicago. Anyone with a map could put his finger on such a place at a moment's notice. A map has the essentials of every graph, namely, two coordinates (axes) or directions, north-south and east-west, an origin, in this case Chicago, and a point which we wish to locate with respect to this origin. Fig. 1 shows how we would locate the town of "A." Some maps have the coordinates marked off as shown at the top and down the left side of Fig. 1 and so "A" on such a map would be defined as existing at (B, 3). In this case the origin is at the top left-hand corner of the graph.

Problem 1. Mark on the map a town, "B," which is at (F, 6).

Such a means of locating a point on a map is everyday knowledge.

The next problem is a bit more complex. How would you state that a railroad runs north and south and at a distance of 50 miles from Chicago? Here we must locate not a point on a map but a straight line perpendicular to one axis (coordinate) and parallel to another. A simple expression for such a line, representing a railroad, would be (west 50 miles) signifying that the road ran north and south and was 50 miles west of Chicago at its nearest point.

Problem 2. A road runs south of Chicago through (D, 6) and straight east and west. Mark it on the map.

The next problem would be to describe a road that ran at an angle to the two axes and approached to within 50 miles to Chicago. We could state that it ran through two towns and then give their locations on the map just as we located the point (B, 3) above.

Problem 3. A road runs through (B, 2) and (F, 6.5). Place it on the map. How far south of Chicago is the nearest approach?

A point on a map is located at the intersection of two lines; a line is defined when two points through which it passes are located. The points are always given in certain distances away from vertical and horizontal axes or coordinates.

### Other Types of Graphs

A graph is no different from a map, even though the axes or coordinates may be called X and Y instead of north-south and east-west. Also such high-sounding words as "ordinates" and "abscissa," etc., may be used to express the distance up or down, and right or left, from some point chosen as the origin. In a graph the units of measurements, instead of being miles or feet, may be amperes, dollars, watts, volts, or merely unnamed units.

Generally the origin is at the lower left-hand corner of the graph, although there is no reason why it cannot be somewhere else; for example in plotting the plate current of a vacuum tube against the grid voltage, the vertical axis (representing plate current) is usually near the center of the graph instead of at one corner of it so that both positive and negative values of grid voltage may be represented. Wherever the origin is, to plot the position of a point with respect to the origin, we need only move a certain number of units to the right (or left) and erect a perpendicular line; then move a certain number of units up (or down) and make a horizontal line. Where these two lines cross each other is the position or location of the point.

For example, on Fig. 2 is plotted the point (X=5, Y=5). We find this position by moving 5 units to the right of the origin (where both X and Y are equal to zero). At this point we erect the perpendicular line which contains all points which are 5 units to the right of X=0. Then we draw the line Y=5 and let them cross.

### Equation of a straight line

A point is represented as follows, (X = 5, Y = 5). A straight line is a bit more complex because it goes through two points whose locations must be given. We can get around this complexity by knowing one point through which it goes and the slope of the line, that is the change in its Y units that are caused by a change along its X axis. In general a line is represented by an equation of this form,  $Y = MX + B$ , where M is the slope of the line, and B is the point where it crosses the Y axis. Thus the line  $Y = 2X - 4$  crosses the Y axis 4 units below the X axis and has a slope of 2.

A line parallel to the Y axis is expressed as  $X = \text{so-and-so}$ ; X = 5, for example, because it represents all points 5 units to the right of Y. Similarly a line parallel to the X axis and so many units above it is described in the same manner. For example, a line parallel to the X axis and 5 units above it is represented as  $Y = 5$ .

A line going through the origin, such as OA of Fig. 3, crosses the Y axis at Y = 0 and so B in the equation above equals zero. The formula then becomes simpler,  $Y = MX$  where M is the slope and is actually equal to  $Y/X$ . In Fig. 3 M is equal to  $\frac{3}{6}$  or 0.5 and so the equation of this line becomes  $Y = 0.5X$ .

A line going through points B and C, Fig. 3, crosses the Y axis at Y = 10 and has a slope equal to  $-Y/X$  (because it points in the opposite direction to OA) or  $-\frac{10}{6}$  and so the line becomes  $Y = -\frac{5}{3}X + 10$ .

Problem 4. Locate on Fig. 2 a point (X = 3, Y = 2). Describe in mathematical language the position of the point P on Fig. 2.

Problem 5. Mark off several units in both X and Y directions on a sheet of cross-section paper. Draw out it the following lines,

- (a)  $Y = 3$ , (b)  $X = -1$ , (c)  $Y = 4x + 3$ , (d)  $Y = 3X + 4$ , (e)  $Y = X - 3$ , (f)  $Y = 2X - 3$ .

### Ohm's Law

The equation representing Ohm's law reads,  $I = E/R$ , may be written  $I = (1/R)E$  which looks

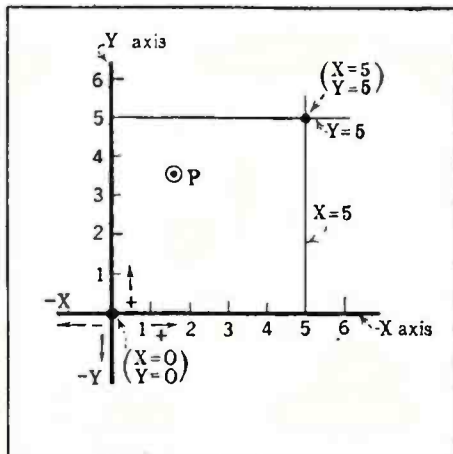

Fig. 2—This drawing illustrates the location of a point on a graph

like the general expression for a straight line through the origin,  $Y = MX$  in which  $M = 1/R$ . Now the reciprocal of the resistance of a circuit, is called its "conductance" and the lower the resistance the greater the conductance. We may write Ohm's law as  $I = KE$  in which K is the conductance and is always equal to  $1 \div R$ . K (or  $1/R$ ) is the slope of the line which expresses the relation between the current and voltage in a circuit.

Problem 6. Assume the resistance of a circuit is 1 ohm, and plot the relation between E and I, making E the X axis and I the Y axis. (Assume various values for E, calculate I when  $R = 1$ , and plot). Then assume several other values to R and plot all on the same sheet of graph paper.

Suppose, however, we have a current of 4 amperes flowing in a circuit having a resistance of 2 ohms. If we add another battery and vary its voltage

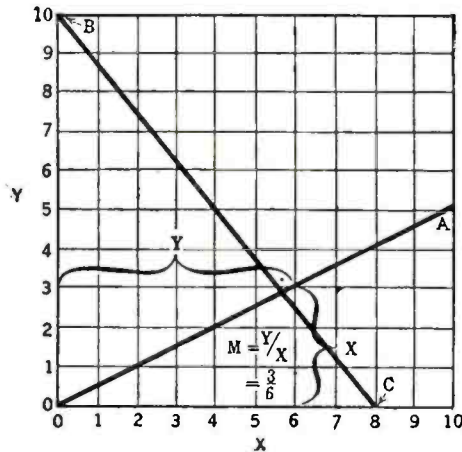

Fig. 3—Drawing shows method of plotting a line on a graph

the current in the circuit will change. How can we express the relation between the total current flowing and the variations in the additional voltages? Let I be equal to the current flowing. Then

$$I = \frac{E}{R} + 4 \text{ or } \frac{1}{R}E + 4 \text{ or } I = \frac{1}{2}E + 4$$

The above formula looks like our general expression,  $Y = MX + B$ . In this case a current of 4 amperes is always flowing; and so when  $E = 0$ ,  $I = 4$  and the line crosses the vertical or current axis at  $I = 4$ . When  $E = 4$  volts,  $I = 4/2 + 4 = 6$  amperes. And so on.

Problem 7. Assume several values for E in the above case and plot the current on cross-section paper. Draw a line through them. Then assume another value of R and replot. Then assume a negative value of E, calculate I and plot. This is equivalent to reversing the battery so that it bucks the battery which is producing the steady current of 4 amperes.

### Units

The appearance of a curve may be changed somewhat by changing the units into which the vertical and horizontal axes are divided. As an example, plot the following data which give the d.c. output voltage of a cx-380 rectifier tube as the load current is changed, and as various a.c. voltages are put on the plate of the tube. There will be three curves for the three plate voltages applied to the tube. First make the vertical divisions, 100, 150, 200, 250 volts, etc. Then make the same divisions, 100, 200, 300, etc. and note how much flatter the curves seem. The slope of these curves is an indication of the "regulation" of the rectifier, that is, how many volts drop is caused by increasing the output current.

Problem 8. The ratio between the voltage and the current at any point on these curves gives the d.c. resistance of the rectifier. The slope of the line, that is the change in voltage divided by the change in current is the a.c. resistance of the rectifier. Calculate the d.c. resistance at each value of output current and plot against current.

### Data for Example

Current output Milliamperes	Volts per plate			Volts output of Rectifier
	300	260	220	
20	375	330	280	}
40	350	300	250	
60	330	280	230	
80	310	260	210	
100	290	240	190	
120	280	230	180	

PLOTTING CURVES—PART II

CURVES may be plotted either from a mathematical formula or equation or from a set of data obtained in a laboratory or from someone who has already done the laboratory work. To plot these curves properly, all one needs is a hard pencil or a ruling pen, some India ink (Higgins' American India ink), a celluloid triangle or rule, a French curve, and some cross-section paper. The latter may be bought from Keuffel and Esser, Deitzgen, Codex, and several other manufacturers, and it comes in many colors, many rulings, and sizes, some of which are punched for loose-leaf note books.

Keuffel and Esser paper No. 359-6 and 355-2R are both convenient and are ruled 10 x 10 to the inch and are punched for standard size note books. Another good paper is Keuffel and Esser No. 359-11 which is ruled 20 x 20 to the inch. Deitzgen No. 340-10 is ruled 10 x 10 and is punched. Codex 2 and 3 cycle logarithmic paper, No. 3135 and 3112, and Keuffel and Esser double logarithmic three cycles, No. 359-120, are useful in plotting frequency characteristics of audio transformers, amplifiers, loud speakers, etc.

Vacuum-Tube Characteristics

The characteristics of a vacuum tube are usually represented on a sheet of graph paper and are called the characteristic curves. Because there are three variable factors involved, plate current, grid voltage, and plate voltage, a complete picture of the tube and its action in a circuit cannot be represented on a single sheet of paper, (which has only two dimensions), but two curves are needed, or better still a three dimension model made of plaster of Paris or wax. Some very beautiful models of this sort are used in the course on vacuum tubes given at Cruft Laboratory, Harvard University, and are part of the equipment of any good radio engineering course. We can get a good idea of what a tube will do by making two curves called the  $E_g-I_p$  and the  $E_p-I_p$  curves. These show what the plate current is at various values of grid and plate voltage. The slopes of these curves are important tube factors.

Problem 1. Plot the data in Table 1, making the vertical axis, the current axis (in mA.). Determine the slope and, remembering that the mutual conductance is the change in amperes divided by change in grid volts, calculate the mutual conductance. The slope of the plate-voltage plate-current curve, using amperes and volts of course, gives the reciprocal of the plate resistance of the tube. The slope of the curve must be divided into 1.0 to get the resistance. Calculate the plate resistance at several points on the curve. Plot the mutual conductance and the plate resistance against grid volts, plate volts, and plate current. In each case assume one of the variable as fixed, e.g., when calculating and plotting the plate resistance assume the grid voltage is some constant value for one set of values, and then assume another value for another set of data.

Table 1

Grid volts = $E_g$	60	80	135	} = $I_p$ mils
0	2.75	4.5	10.25	
-4	.25	1.0	4.75	
-6	0	.25	2.75	
-8	0		1.25	

Correcting Errors of Measurement

A curve which is a visual picture of a given laboratory experiment may be very useful in detecting or

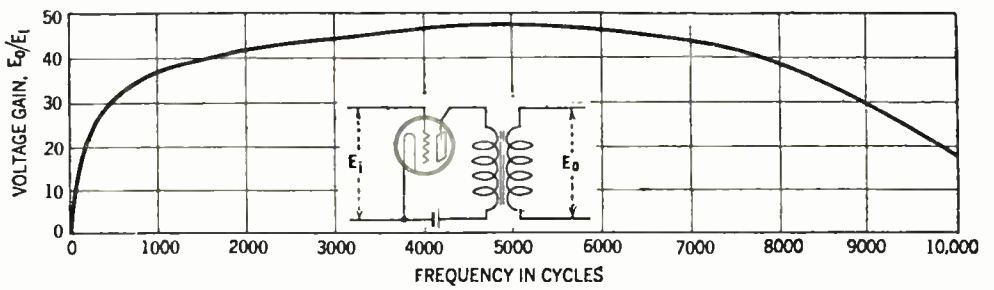

Fig. 1—Frequency characteristics of transformer plotted on cross-section paper

correcting errors in measurement. For example, if we know that the relation between two factors is a straight line, and when we plot the curve, several points seem to be off this line, these points indicate errors in measurement. In calibrating a wavemeter, according to "Home-Study Sheet No. 13," errors may occur, and the only way to tell them is to plot the curve of wavelength squared against capacity, or wavelength against condenser degrees. The first of these curves will be a straight line, and the latter will be a smooth curve. Points off the curve should be considered wrong and must be repeated or disregarded.

Problem 2. Plot the data in Table 2, first, showing the relation between wavelength squared and

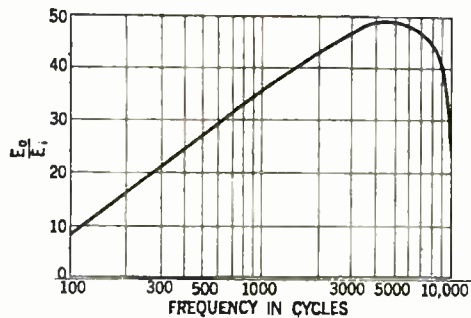

Fig. 2—Frequency characteristics of transformer plotted on logarithmic paper

condenser capacity, and, secondly, the variation of wavelength with condenser degrees. Determine which points are wrong, and indicate what the wavelength should be instead of the values given. If the slope of the straight line, i.e., (wavelength)<sup>2</sup> against capacity is divided by 3.54, the inductance of the circuit will result. Determine the inductance.

Table 2

Wavelength meters	Condenser degrees	Condenser capacity
197.5	15	100 mmfd.
245.	25	150 "
253	35	200 "
300	55	300 "

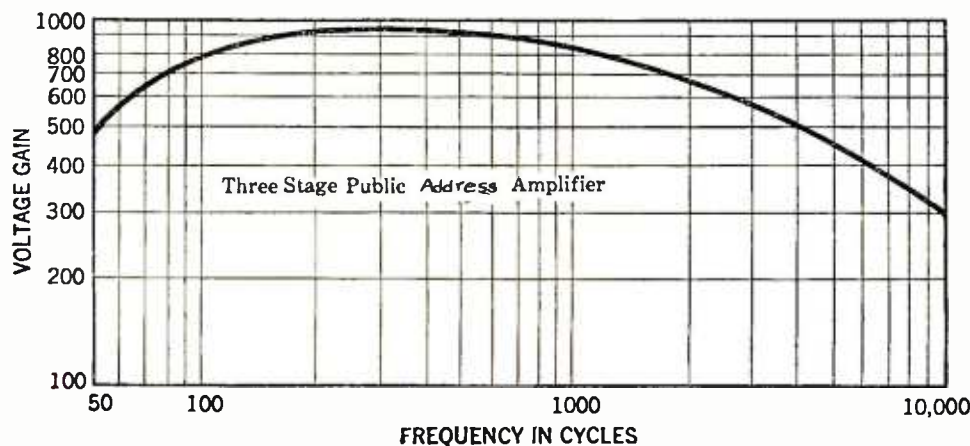

Fig. 3—Power output of an amplifier plotted on Log-Log paper

Amplification-Frequency Characteristics

The frequency characteristics of amplifiers and audio transformers may be plotted directly against frequency. It has now become standard practice to plot amplification against frequency arranged in octaves, so that each change in frequency gets equal attention. For example, the curve of Fig. 1 represents a transformer of the olden days when low-frequency amplification was unthought of. Note what a long flat portion the curve has. Then look at the curve of Fig. 2 in which the same data is presented on logarithmic paper. Here the low frequencies, i.e., from 100 to 1000 cycles are not all cramped into a very small part of the whole horizontal scale but get the same horizontal space as does the range from 1000 to 10,000 cycles—and both of these spaces represent a 10 to 1 change in frequency.

The ear hears according to a logarithmic scale, and so amplifier characteristics are usually plotted against transmission units (nb) of loss or gain with some given frequency as standard. That is, the response at all frequencies is plotted with respect to the response of some intermediate frequency as standard. For example, we may measure the power output of an amplifier obtained at 1000 cycles and then compare the power output of other frequencies to the value at 1000 cycles. Or we may simply plot the power output at all frequencies without regard to any given frequency as standard. One curve gives the characteristic, the other tells us the power output. The characteristic may be obtained from the power output curve by noting from it how much more power is obtained at one frequency than another.

Characteristics of amplifiers should always be plotted with a logarithmic horizontal frequency scale and preferably with a vertical scale either in logarithmic units (nb) or on a logarithmic scale.

Problem 3. Transfer the data given in the curve of Fig. 3 to nb, first calculating the number of nb up or down from 1000 cycles, where the voltage amplification is 850 and secondly plotting the number of nb corresponding to the voltage amplification, e.g., a voltage amplification of 100 corresponds to a nb of 40.

Remembering that the ear can hear with some difficulty changes in power output of 3 nb and cannot hear smaller changes than this, plot the data in Table 3 and determine whether or not the amplifier is a good one. Plot in nb using the power output at 1000 cycles as standard. Will the loss in response at 100 and 5000 cycles be noticeable to the ear?

Table 3

Frequency cycles	Power output milliwatts
60	175
100	350
200	600
400	700
1000	700
2000	700
4000	435
6000	280
8000	105

Summary

A graph is a visual representation of some physical or mathematical law. To plot the curve when the law or equation is known, it is only necessary to assume various values for one of the related factors and to calculate what the other values are. Thus we can plot Ohm's Law by assuming values of voltage and calculating what the current will be at a known resistance. Then voltage and current values are plotted against each other. More complicated relations between two factors give curves which are not straight lines and the mathematical equation or formula is seldom known.

# A DOUBLE-DETECTION SHORT-WAVE SET

By ROBERT S. KRUSE

**I**N THE writer's article published in February RADIO BROADCAST the advantages of double-detection receivers over other short-wave receivers were discussed. In order to facilitate the comparison there was described a species of adapter which may be applied readily to an ordinary detector-audio set, converting it into a double-detection (super-heterodyne) receiver. Since the device employed a heterodyne oscillator two tuning controls were required. This same complication also existed in the two other forms of the circuit which were described, namely a double-detection adapter (to proceed an ordinary broadcast receiver) and an outright short-wave receiver of the double-detection type.

When it is desired to simplify the control and retain the advantages of the tuner, one naturally thinks of combining the tuning controls. The first suggestion is that this may be accomplished by the use of a two-gang condenser after the universal practice employed in broadcast-receiver construction. The solution is not satisfactory, however, since the problem is not the same as the one encountered in the 500-1500-kc. band. The broadcast designer or builder has to make only two coil-condenser combinations work together, but in short-wave work we would be required to make the circuits remain in alignment with four or five sets of coils which are plugged into tuner and heterodyne, respectively. Of course, this can be done, but commercial coils are not matched accurately enough for the purpose since the makers have not anticipated such an arrangement. Indeed, it would be difficult to make them sufficiently alike at a cost approaching the coils now on the market. One may then leave this idea and turn to the alternative, which is to avoid the necessity of tuning two circuits by the process of omitting one of the circuits; patently this involves a transfer of the second circuit's functions to the remaining circuit which must now serve two purposes.

Therefore, we may proceed by investigating the possibility of combining the functions of the oscillator and the first detector in a single tube and a single tuned circuit. The possible difficulties are loss of sensitivity, selectivity and audio quality. The audio quality consideration may be determined more easily by trial than by other means and the reader is asked to accept the rather dogmatic statement that in the arrangement which follows audio quality does not suffer. The selectivity is certainly not improved by the combination of the two circuits, but as it happens the present arrangement is one in which the i.f. amplifier supplies the selectivity and we are not so seriously concerned with that matter.

## *Sensitivity of System*

**W**HEN the question of sensitivity arises one must confess that a definite loss has taken place by reason of the choice of 95 kc. as an intermediate frequency. However, this loss is not serious as the presence of a pair of screen-grid tubes in the complete system produces an overall gain that is materially above that of the system described last month, and is, in fact, above normal requirements. The choice of 95 kc. as an intermediate frequency is due to the desire to avoid any damage to audio quality, while at the same

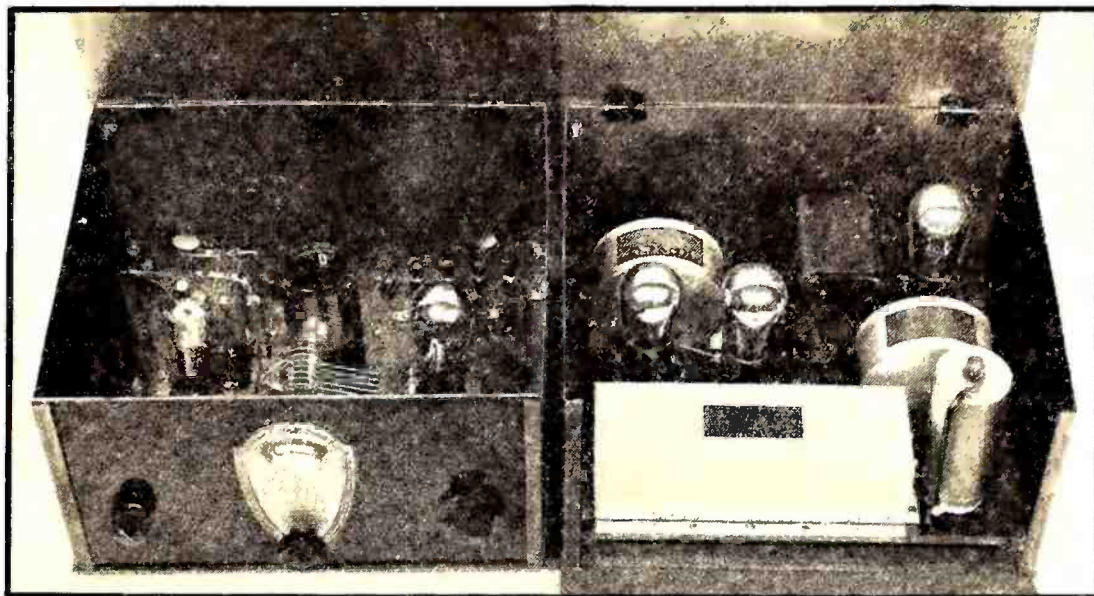

*View of the converted short-wave tuner, i.f. amplifier, and a.f. amplifier.*

time avoiding an excessive amount of detuning of the autodyne detector in process of transferring the signal into the i.f. system. This contrary pair of considerations may require a word of explanation. If audio quality were the only consideration we would choose an intermediate frequency in the vicinity of, perhaps, 1000 kc., thus securing a noiseless amplifier and complete certainty that the harmonics of the oscillating detector would do no damage. This plan was followed in the February article with a separate oscillator (heterodyne). But with an autodyne (combined oscillator and first detector) we cannot use as high an intermediate frequency for we would then be compelled at all times to tune 1000 kc. off the desired signal so as to transfer it to the 1000 kc. amplifier. Such mistuning would, of course, weaken the signal materially whereas the detuning necessary to produce a 100 kc. beat is not fatal. Fortunately this—like the other difficulties—turns out to be an academic, and not a practical, difficulty.

The i.f. system used consists of a pair of Rusco 95 kc. air-core transformers and a Rusco band-pass filter working at 95 kc.

*There are two ways of making a short-wave super-heterodyne, as Mr. Kruse pointed out in February RADIO BROADCAST. One involves turning a short-wave tuner into the frequency changer and one's broadcast receiver into an intermediate-frequency amplifier. In this article he tells how to make a receiver that starts with the antenna and ends with the audio output—and it is a double-detection set of considerable amplification and selectivity. It does not involve playing tricks on one's short- or broadcast-wave receiver.*

—THE EDITOR

The tuner with which the device has been associated in the writer's experiments is made by the National Company and has a wavelength range of 14.5 to 115 meters. At the 115-meter end of the range a 95 kc. beatnote requires nearly 4 per cent. mistuning, which seems rather bad to one accustomed to broadcast work. At the 14.5-meter end the mistuning is about  $\frac{1}{2}$  per cent. Fortunately one is saved by the very thing that suggested the band-pass, namely, the comparative lack of selectivity of a lonesome tuned circuit. In practice the signal obtained is not materially weaker than that obtained with a heterodyne, the rest of the equipment remaining the same. This is, to a considerable degree, accounted for by the fact that the strength of the oscillation was adjusted in all cases to a favorable value by use of the normal controls of the tuner, operating in the normal manner.

Radiation from the autodyne's first detector is prevented by the 222-type tube in the first socket of the receiver.

The circuits, which are shown in Figs. 1, 2, and 3, do not seem to require much explanation. However, some readers may be confused by the band-pass filter, but its purpose may be explained by the simple statement that its business is to pass only the band of frequencies lying between 90 kc. and 100 kc., while stopping lower and higher frequencies. It follows that the only signals to get through the system are those which the autodyne system has transferred into the "pass-band." The purpose of this device is, therefore, to provide the selectivity of the system and to suppress noise as well. Since the Rusco band-pass filter consists of four shunt sections (and the corresponding series parts), it is sufficiently complex to give a good flat top and sharp cut-off, unlike the usual arrays of tuned circuits.

## *Adjustment of Filter*

**O**NE difficulty may arise which has caused several filters to be denounced as "no good." A filter, unless terminating in the proper sort of a load, will produce all sorts of

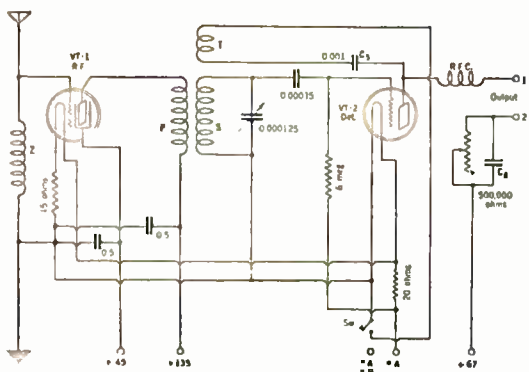

Fig. 1—Complete circuit diagram of the original National short-wave tuner.

weird response effects with bumps of signal coming through where there should be none. If your band-pass filter does not perform properly it is suggested that you shunt a 500,000-ohm Frost resistor across the output, and, by pure cut and try, adjust the terminal conditions so that the desired action is obtained. When the action is correct the signal "snaps" in, stays for a while as the tuning dial of the receiver is turned, and then "snaps" out.

Observe that the output circuit of the National tuner has been altered a bit. This is to permit the 95 kc. output to enter the i.f. system, at the same time permitting the regeneration control to function. The numberings show what has been done, as do the diagrams of Figs. 1 and 2. The r.f. choke has been eliminated,  $C_2$  has been moved, and the wiring has been changed slightly. These changes also improve the control when using the smallest tuner-coil.

Rather than draw the complete schematic diagram it has been considered best to mark various posts of the adapter (Fig. 3), such as "A+," as often as necessary, even though only a single terminal is required in the receiver. Therefore, it should be understood that all binding posts with the same markings on either the set or the adapter are to be connected together.

In the second i.f. stage a 222-type tube is shown. The gain obtained in this way is more than required, but if anyone desires more gain he is welcome to use a 222-type tube in the first i.f. socket as well—providing he can invent a way to match the high plate impedance to the lower impedance of the band-pass filter. This is strictly necessary to secure decent filter action, not to speak of decent gain. On the other hand, it is perfectly practical to use 201A-type tubes in both of the i.f. positions. If this plan is followed the circuits will tend to oscillate and stabilization of some sort must be provided. The simplest thing is the old standby; return the grids to a potentiometer across the A supply and turn the knob to suit. The potentiometer may conveniently have a resistance of 400 ohms and

the grid returns should be bypassed directly to their own filaments with 0.1mfd.

If anyone has available other i.f. transformers they may be used, provided the first contains a primary by-pass condenser. Usually it is of the "tuned" variety and has such a condenser. Frequencies materially above 100 kc. are not to be recommended because of the detuning required, while very low frequencies tend to cause difficulties from noise and damaged quality.

### Concerning A.C. Operation

A RECEIVER akin to the one here described has been operated for some weeks with various portions of the circuit modified to permit the use of a.c. tubes. On the whole the performance has been satisfactory but previous experience with such matters teaches the writer to believe *nothing* about an a.c. job until it has been thoroughly time-tried.

We must not stop without mention of television reception. If the transmission is being made with a 24-hole disc at 15 pictures per second, or a 48-hole disc at  $7\frac{1}{2}$  pictures a second, we have a "basic" frequency of modulation amounting to 360 cycles and a tolerably probable impulse frequency running up toward 9000 cycles. This means that the carrier plus both sidebands will be about 18,000 cycles wide, which is about twice as wide as the "pass" band of the Rusco filter. The set is, therefore, not good for the purpose unless a filter with a wider pass band is used, and even then it does not have much to recommend it since there are easier ways to attack the problem. For this sort of work it is recommended that an entirely different amplifier of the usual "television type" be used which can be done with the greatest ease as the tuner has not been incapacitated in any way. It should be noted that the tuner controls are at all times operated in the same manner whether it be used with the "television" amplifier, the band-pass amplifier or the usual audio amplifier alone.

Since mention has been made of satisfactory gain through the system it may be of interest to run hurriedly through the circuit with this in mind. The first 222-type tube, which is used as a "coupling tube," produces a gain of about 2, the autodyne detector produces a gain that is varied with adjustment and signal strength, the first i.f. tube (201A) produces a gain that is not up to the usual at such frequencies because of its peculiar plate load. The 222-type tube which follows the filter operates with a moderately good plate load and provides most of the gain in the i.f. system, which may be further improved by using a "tuned impedance" at this point, making sure that the condenser between this circuit and the next grid is of very high leakage resistance. The following 201A-type tube, acting as second detector, produces the slight gain which is normal in

that position and this is generally sufficient to cause the signal to overload either this tube or the 112A-type audio tube, although the latter is working under proper conditions. To take care of this condition a Frost high-resistance rheostat has been mounted on the hitherto blank panel of the adapter and has been connected across the secondary of the first 95 kc. transformer. By a minor operation it has been modified so as to open at one end of the scale, thus permitting the removal of the shunt when it is not desired. If no very strong signals are encountered it is better to connect this control across the secondary of the second 95 kc. transformer since then it will have no effect on the detector regeneration.

Another feature of the receiver described by the writer is that the use of the National steel cases and the various part shields results in a complete freedom from the bothersome hand capacity common to short-wave re-

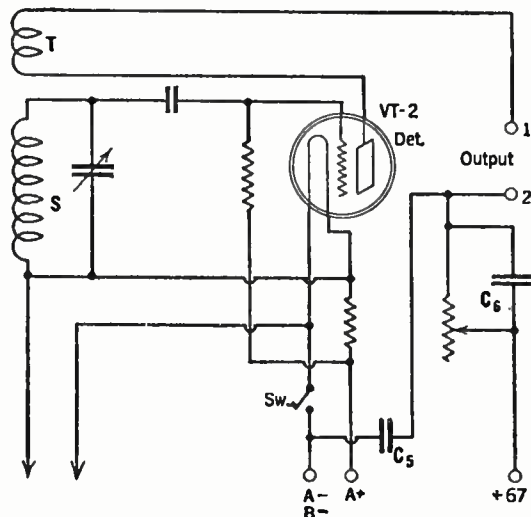

Fig. 2—Changes which must be made in the detector plate circuit of the tuner.

ceivers. To complete this effect the panel of the right-hand (i.f. and a.f.) case was backed by a sheet of aluminum.

### List of Apparatus

THE parts required for the construction of the double-detection short-wave receiver described in this article follow:

- One National screen-grid short-wave tuner;
- One blank panel, aluminum;
- One bakelite basepanel, 9" x 11";
- One Rusco band-pass filter, 95-kc.;
- Two Rusco i.f. transformers, 95-kc.;
- Four tube sockets, ux-type, spring-construction;
- Three Carter resistors, 1-ohm, 2-ohm, and 15-ohm;
- Two Sangamo mica condensers, 0.001-mfd., and 0.0005-mfd.;
- One Durham grid resistor,  $1\frac{1}{2}$ -megohm;
- One Twin-Coupler 222-type shield;
- Clips for grid leak, brass angles for connecting panel and base, machine screws, wire, binding posts, etc.

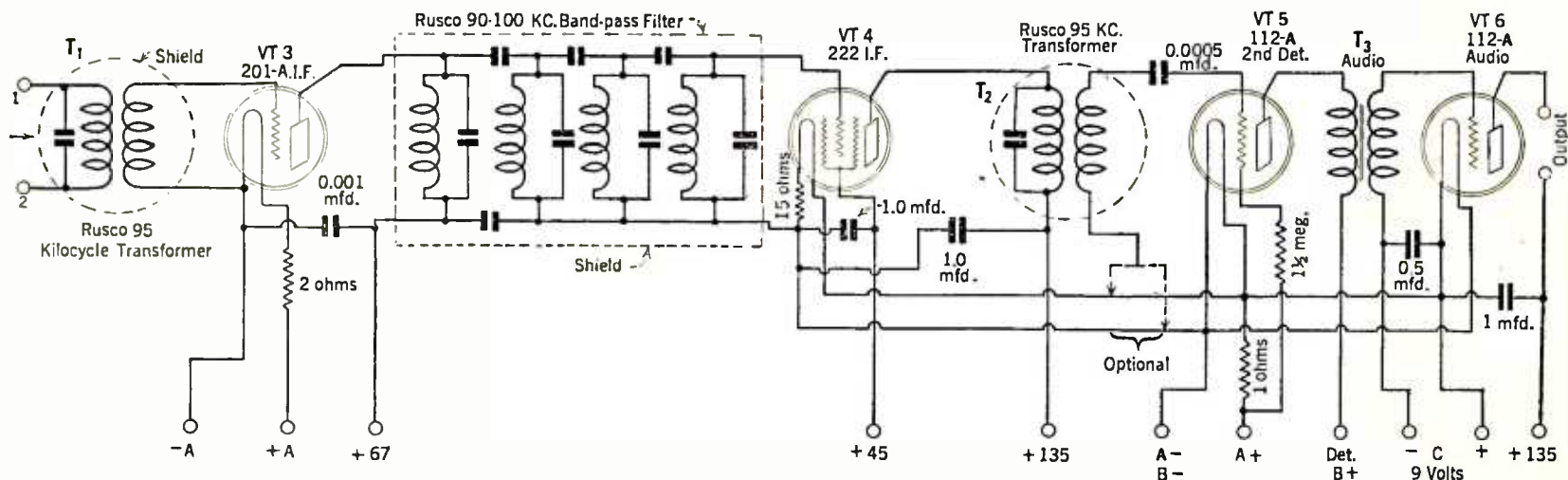

Fig. 3—Circuit of the i.f. and a.f. stages of the short-wave double-detection receiver designed by the writer.

# BROADCAST ENGINEERING

BY CARL DREHER

## Pick-Up Characteristics of Microphones

CONSIDERABLE work is being done in determining the behavior of microphones under various conditions of studio pick-up. While the results will probably not be reported for months or years, the literature already contains some material of practical value for those who are interested in securing the best possible quality of reproduction as well as for laboratory technicians who use microphones in sound-measurement determinations.

B. F. Miessner's article in the September, 1926, RADIO BROADCAST, on "The Importance of Acoustics in Broadcasting" is worth re-reading in this connection. Miessner was concerned in this paper with possible distortion in radio reproduction caused by the directional characteristics of microphones and loud speakers. He concluded that these devices usually vary in directional characteristics with frequency. For horn speakers and flat diaphragms enclosed on one side he secured a polar diagram, reproduced herewith as Fig. 1, which shows a regular falling off in intensity from front to rear at low frequencies, the presence of a minimum at 90-120 degrees at higher frequencies, and a marked beam effect at still higher frequencies. This beam effect was also very noticeable with cone- and baffleboard-type loud speakers, as well as the dynamic units.

Miessner argued that such an effect as that of Fig. 1, secured by measurements on a horn or diaphragm of about 12" diameter, would also be noted in pick-up work with the same device, the action being a reversible one. "It is plainly evident," he wrote, "that if a musical instrument, say a 'cello with low-pitched fundamental and high-pitched overtones, be placed at an angle of 45 degrees to the face,

as it well might in a studio, the fundamental would be received about 75 per cent. as loud as if it were in front of the microphone, while overtones of the order of 5000 cycles would be reduced to less than 10 per cent." He went on to raise the point that a square-law effect might be involved when the directional distortion of the microphone is repeated by the loud speaker. While this is true, quantitatively Miessner's illustration of the 'cello is somewhat misleading under practical conditions, as he himself recognizes, for toward the end of the article he modifies his conclusions as applied to the then standard broadcasting microphone of the Western Electric 373-w double-button carbon type, now superseded by the 387-w. Although this microphone has a closed back, it responds to sounds from the rear because of diffraction around the housing. The facility with which the sound wave bends around the obstruction depends on the wavelength compared to the size of the obstacle. If the microphone housing is small compared to the wavelength, diffraction takes place with little loss in intensity. For higher frequencies, on the other hand, the diaphragm may be in a region of pronounced acoustic shadow, resulting in discrimination against high notes. With an actual microphone diaphragm and housing the ratio of dimensions to wavelength is not as unfavorable as Miessner's curves of Fig. 1 would indicate, and he gives another set of polar diagrams, (Fig. 7 in the original article) here reproduced as Fig. 2, which approximate actual broadcast pick-up conditions. In the latter, it will be noted, the discrimination at 45 degrees against a 5000-cycle tone, compared to a 100-cycle fundamental, is not of the order of 7.5, but only about 2.3.

A simple expedient used by broadcast engineers in order to reduce loss of the high frequencies in picking up music over a wide front, as in the case of an orchestra of good size, is to employ two microphones facing outwards at right angles (Fig. 3) mounted on a single stand a few inches apart. This doubles the angle in which pick-up occurs without serious directional distortion. If this angle is 90 degrees for each transmitter, the two will cover a total of 180 degrees, or all of the space in front of the microphone stand. The outputs of the two microphones are mixed in the usual way (Fig. 4) where the repeating coils have 200-ohm windings to match the impedance of the microphones, and the potentiometers are about 400 ohms each, the combination working into the 200-ohm input of the amplifier. An additional advantage of such a combination lies in the fact that pick-up is not confined to one point in the room and there is less chance of running into any serious acoustic anomalies arising from interference of reflected waves or other effects of the room characteristics. However, a right-angle microphone combination of this type presents no advantage in picking up announcements or other close-talking material.

### THE BEAM EFFECT

The beam effect of projection of high frequencies is well recognized now in human articulation, the output of many musical instruments, and in loud speaker design. Pick-up of ordinary speech with present-day equipment is generally defective when the speaker is not talking directly into the microphone because the high frequencies, which are so important in the interpretation of speech, issue in a beam in the direction in which the

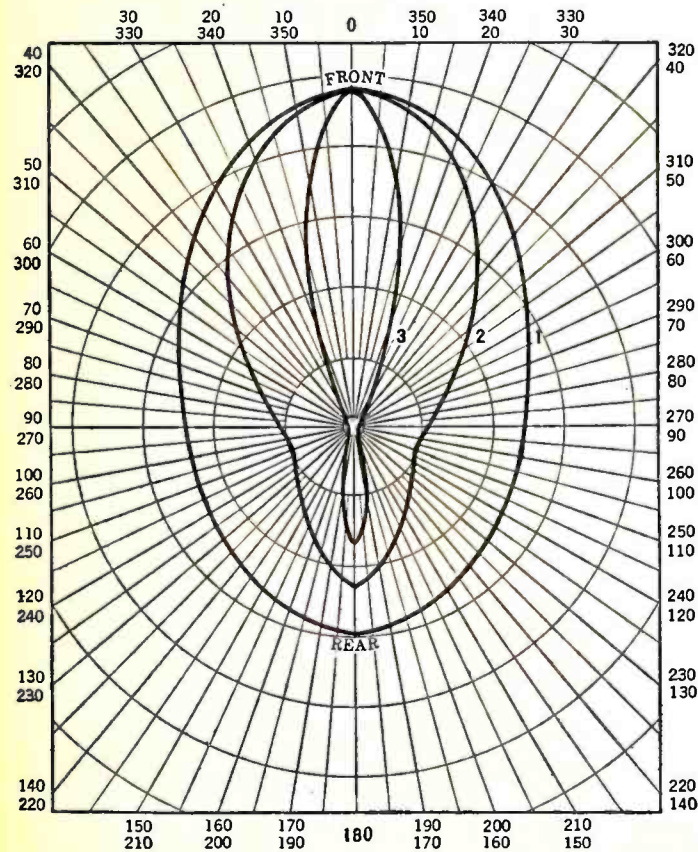
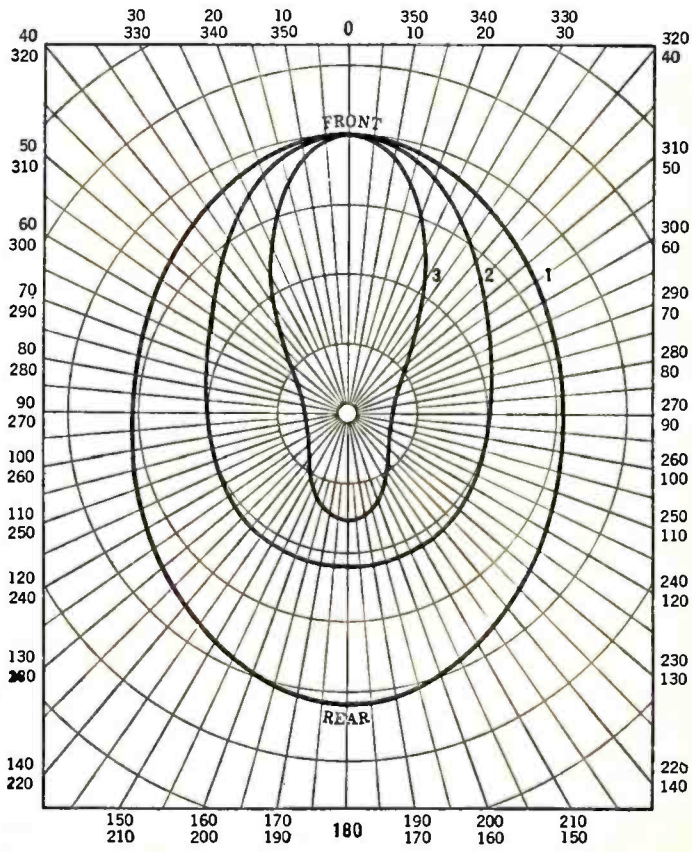

Fig. 1 — (left) Polar curves showing directional characteristics of horns and flat diaphragms enclosed on one side at frequencies of (1) 100, (2) 1000, and (3) 5000 cycles

Fig. 2 — (right) Approximate directional characteristics for broadcast microphones at standard test frequencies of 100, 1000, and 5000 cycles, respectively



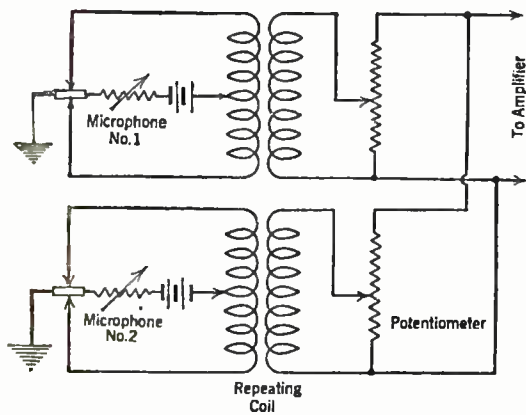

Fig. 4—Circuit used for mixing the output of two microphones

speaker is looking. Likewise, in listening to a loud speaker from a position well to one side of the orifice, one gets the bass with almost full volume, but the 3000-5000-cycle range is partly lost. The same effect is observed in listening to a loud speaker in another room—considerable sound comes through the intervening corridor, but intelligibility is poor because the high frequencies, probably deficient to begin with, do not bend around corners as well as the longer waves. Transmission of high frequencies is always a delicate job, and constant precautions are necessary to retain them. A cone loud speaker designed with a certain kind of paper, for example, loses the high frequencies first of all when a heavier grade of paper is substituted. The high notes are lost before the low ones in transmission along a telephone line. Directionally, likewise, discrimination is usually against the upper frequency range.

MICROPHONES IN LAB. WORK

Microphones, useful to the broadcast engineer as a means of sound pick-up, also serve as measuring instruments in the laboratory. The condenser transmitter is the form most used for this purpose, its construction and mode of operation being favorable to constancy of characteristics over long periods, while a carbon microphone, obviously, cannot be depended upon to the same extent. Stuart Ballantine has recently reported in part on his work on "The Effect of Reflection by the Microphone in Sound Measurements," in the December, 1928, *Physical Review*. The article, which appears in slightly abridged form in the same month's issue of the *I.R.E. Proceedings*, is of more interest to laboratory technicians than to broadcast operating engineers, but should not be entirely ignored by those of the latter who want to be known as up-to-date workers.

The condenser transmitter is used in acoustic work to measure sounds which, after it picks them up and converts the energy into corresponding electrical variations, are amplified and operate a recording system, such as a vacuum-tube voltmeter and galvanometer. Fig. 5, for example, shows the use of such a system in measuring loud-speaker characteristics.

The only trouble with this scheme is that the condenser transmitter is so large that it tends to distort the sound field which it is supposed to measure. It is as if, in measuring the flow of a stream, we introduced an object so large that it changed the velocity and direction of the current. There is one method of acoustic measurement which does not suffer from this defect, or does so, at least, to a lesser degree. This is the Rayleigh disc, which is affected by the velocity component of the sound wave, while the condenser microphone is a pressure-operated device. The usual form of the disc is a thin, light, elliptical piece of mica, suspended at the end of the long axis by a fine fibre, and silvered on one side to reflect a beam of light. Under the impact of a sound

wave the disc, which is only about half an inch long, is deflected. The angle of deflection is measured by means of the light lever and gives an indication of the acoustic forces at work. A condenser transmitter, being a relatively cumbersome implement, requires some correction for its own effect on the forces it measures, and what Ballantine has set out to do in the article cited is to assess the correction required at different frequencies.

If the waves are long they bend around the microphone (diffraction) with little influence by the obstruction on the field, but short waves are reflected with a consequent increase in the apparent value of the pressure before the diaphragm. A tightly stretched diaphragm of infinite extent would reflect all sound waves perfectly and the indicated pressure would be double the pressure which would prevail were the microphone out of the way. The microphone is large enough to act as such an obstruction for short sound waves. The problem then is to evaluate the extent to which the microphone raises the instantaneous sound pressure at various frequencies.

Ballantine goes about this with a simple but ingenious procedure. He mounts his condenser transmitter with its first stage of amplification in a spherical "hullet," with the diaphragm sensibly in the surface of the sphere. The diffraction of sound by a spherical obstacle is a classical problem, soluble by intricate but known methods. Ballantine has performed the calculations and drawn his results in the form of a curve showing the ratio of the indicated pressure to the pressure in the undisturbed field (microphone removed) at various frequencies. With a sphere six inches in diameter, he finds that this ratio is unity at 100 cycles (no correction required), about 1.25 at 500 cycles, 1.56 at 1000 cycles, 1.77 at 2000 cycles, up to nearly 2.0 at 10,000 cycles. He has also determined the curve for a 12-inch spherical mounting. The results may be applied experimentally to the more usual forms of microphone mountings, which are not amenable to calculation. Ballantine

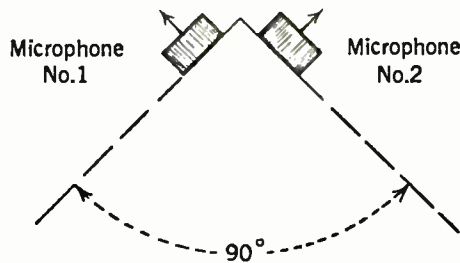

Fig. 3—Microphones mounted at right angles double the angle in which pick-up occurs

has this work under way. When the correction curves for practical mountings are published, more accurate determinations of sound pressures by the use of ordinary condenser microphones will be possible.

Correction After a Decade

MY OPINION of engineers, I being one of them, is that they are valuable members of society. But I must admit that sometimes they are all wrong.

In the summary of the paper by Bailey, Dean, and Wintringham on "The Receiving System for Long-Wave Transatlantic Radio Telephony," presented before the Institute of Radio Engineers, I find a calculation of the effect of a receiving location in Maine (for reception of British transatlantic telephone signals) and wave antenna arrays instead of a simple antenna. "If the receiving were to be accomplished near New York using a loop antenna," it reads, "we would have to increase the power of the British transmitting station 20,000 times to obtain the same signal-to-noise ratio."

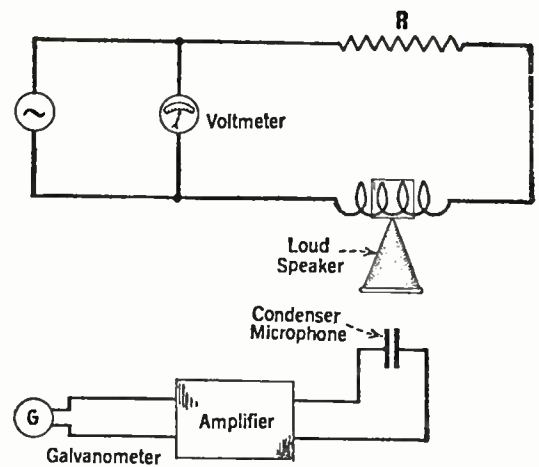

Fig. 5—System for measuring loud-speaker characteristics

Ten years ago I was working on static elimination in company with a first-rate radio engineer. His record since then has borne out that classification. What I recollect distinctly is that as we were walking home one day he said, "After all, the way to lick static is to use more power at the transmitter."

Two million kilowatts, say?

Safety for the Broadcasters

COMMENTING on an article in *RADIO BROADCAST* about the electrocution of one of the engineers at Davenport, Mr. Saul Bloch offers the following idea as a means of preventing such fatalities in broadcast stations:

"In setting up a transmitter why not build the following type of moving platform next to those parts of the apparatus which carry high tension currents?"

- "1. The platform should be located in such a manner that when anybody wishes to approach the high tension wires he will have to stand on the platform in order to be within reach of the wires;
- "2. The platform should be set on some sort of device which would permit it to drop slightly below its normal level when the man steps on it;
- "3. The platform should be so connected in the circuit that when it moves down with the weight of the man the high tension circuit would be automatically broken."

"To an engineer," adds Mr. Bloch, "this may not be feasible and may even be considered as an invention of Ruhe Goldberg's, but it is being offered in all sincerity."

While I do not consider this idea practicable I certainly feel that it deserves discussion, if only to keep the subject before the men who take the risks. My opinion remains as I have frequently stated it before—that there is no mechanical substitute, in working with high tension currents, for unremitting awareness of danger on the part of the operators and the caution that should result therefrom. A disconnect scheme like that proposed by Mr. Bloch could not be depended on to function infallibly. Automatic shut-down devices actuated by push-buttons and operating through relays sometimes fail to act. An open-circuiting platform would entail the same jeopardy. There are times, also, when the operator wants to get close to the set, while it is in operation, in order to observe a tube or some other part of the equipment. If he knows that the 10,000 volts are ready to jump on him he is as safe a foot from the conductors as ten feet away. The stuff will not leap at him; he has to get within an eighth of an inch before anything can happen. In the vast majority of cases where men have been killed or injured it has been because they forget that the current was on.

## A CUBAN SHORT-WAVE RECEIVER

By FRANK H. JONES

WITH modern receiving equipment the radio fan in the United States finds it enjoyable to sit at home of an evening and listen to a musical program which is reproduced practically without distortion or electrical interference. However, the inhabitants of the tropics, and Cuba in particular, are not accustomed to this privilege. Owing to the prevalence of extremely strong static discharges, quality reception of American stations in the 200 to 500 meter wave band is a farce during most of the year. It is only during the middle of winter—from December 15 to February 15—that it is possible to derive any degree of pleasure from listening-in to programs originating in the United States.

Of course, most radio fans in Cuba are able to obtain good reception from their local station, FWX, which is located in the middle of the island, and they can always pick-up the signals of 6kw without difficulty. But these two stations do not transmit programs of the quality which the large American chains provide. Therefore, the only way open to the radio fan in the tropics to receive quality programs is to intercept the signals of the various short-wave stations which in many cases transmit the same program which is sent out on broadcast wavelengths, but even this method is not entirely satisfactory due to the extreme fading which seems to affect all high-frequency transmissions.

The writer has developed a duplex short-wave receiver which offers a practical solution to the tropical radio fan's problem. An abbreviated schematic diagram of circuit will be found in Fig. 1 on this page, and a description of the electrical features of the circuit is given in this article. However, before entering into a technical discussion, the value of the various high-frequency signals which may be received will be given further consideration.

### Programs Available

THE writer, who is located in Tuinucu, Cuba, has been able to receive with satisfactory volume the signals of seven short-wave stations which transmit high-quality broadcast programs. These stations are: w2XAF, Schenectady, N. Y., on 31.48 meters; w2XAD, Schenectady, N. Y., on 19.56 meters; 5sw, Chelmsford, England, on 25.53 meters; w8XK, Pittsburgh, Pa., on 25.4 or 63.5 meters; CJRX, Winnepeg, Canada, on 25.6 meters; PCJJ, Eindhoven, Holland, on 31.2 meters; and Columbia's new station, w2XE, Richmond Hill, N. Y., on 58.5 meters. Of the above listed stations w8XK, w2XAD, and w2XAF usually transmit the programs of WEAf or WJZ, the NBC's Red and Blue network programs, while station w2XE sends out the programs of the Columbia chain. So, if one can receive these stations well, he is listening to the real pick of radio programs. A table giving the operating schedule of these stations will be found on page 298 of this issue.

In his endeavor to receive short-wave programs, the first serious problem encountered by the writer was that of fading, and the periods of fading were found to be much more frequent than on the long wavelengths. Also,

it was discovered, that fading periods differ on different wave bands. This fact prompted the design of the receiver described in this article; it was thought that if the same program could be received on two different wavelengths with two different detectors, and the outputs of the two detectors feeding into the

picked-up with the other detector, and the outputs of the two detectors, each of which bring the same program, are mixed in the audio amplifier. The result is a very satisfactory signal from the loud speaker.

There are several interesting features of the system described above. First, the loud-speaker volume is doubled as the audio components of the signals of the two detectors are added. Secondly, there is no increase in distortion as the signal from England arrives at practically the same time as the one from Schenectady—the time difference is only  $\frac{3}{10000}$  second and this cannot be detected by the human ear. Thirdly, either one of two antennas, or both, may be used to pick-up the signals, and by switching from one to the other, or using one antenna for one detector and the other antenna for the other circuit, it is possible to find a combination which provides minimum static and interference. Of course, the two antennas should be erected at right angles to each other.

### Explanation of Circuit

RETURNING to the diagram of the detector circuits it will be noticed that the two detectors, X and Y, are isolated from each other and from the audio unit by r.f. choke coils and aluminum shielding. The next most interesting feature is the cam switch which governs the manner in which the detectors are connected with the double primary input transformer (Samson type Y interstage push-pull) of the amplifier. With the switch in the X position, only the X detector feeds its half of the primary of the transformer, with the switch in the Y position, the Y detector is connected with the other half of the primary of the transformer, and with the switch in the mid position both detector circuits feed into the double primary simultaneously.

The use of a double primary transformer is not absolutely essential to the success of the writer's system, but it provides most satisfactory results. In place of the double-primary transformer, it is possible to use an ordinary interstage transformer (not push-pull) by connecting the plate terminals of the two detector tubes to the "P" terminal of the transformer, and the positive B supply to the "B+" terminal of the transformer. An interstage push-pull transformer with three primary terminals instead of four (Samson make them) may also be used; in this case the plate of one detector is connected with one "P" terminal of the transformer, the plate terminal of the second detector is connected with the other "P" terminal, and the positive of the B supply is fed to the "B+" terminal of the transformer. However, the circuit shown seems to be less susceptible to low-frequency noises such as 60-cycle hum.

It is not necessary to give specific information regarding the other details of the receiver as they are more or less standard. The two detector circuits are identical, and may be similar to those used in your pet short-wave set. Following the input transformer, the a.f. amplifier is standard. The writer built the best possible amplifier as he wished to obtain good fidelity and this proved very much worth while.

*The unique short-wave receiving circuit described on this page will be of interest to radio experimenters living in the tropics where static on broadcast wavelengths is severe during most of the year. Mr. Jones points out that the same high-quality programs may be received with fidelity on short wavelengths. On these waves static is not as noticeable and fading may be overcome by mixing the signals of two stations which transmit the same program. A table on page 298 of this issue gives the operating hours and wavelengths of seven high-powered short-wave broadcasters which transmit chain programs. The hours during which two or more stations broadcast the same program are also indicated.*

—THE EDITOR

same audio amplifier, the fading periods of the two short-wave signals bearing the same program would tend to cancel out, leaving a more or less constant signal for the loud speaker to reproduce.

It is interesting to note the way in which this principle may be employed to advantage by the radio listener. By listening-in on short wavelengths for an evening it will be found that frequently several stations transmit the same chain program simultaneously.

For example, w2XAD, on 19.56 meters, transmits WEAf's program to 5sw where it is rebroadcast on 25.53 meters for British listeners. Therefore, the 19.56-meter signal is received with one detector, the 25.53-meter signal is

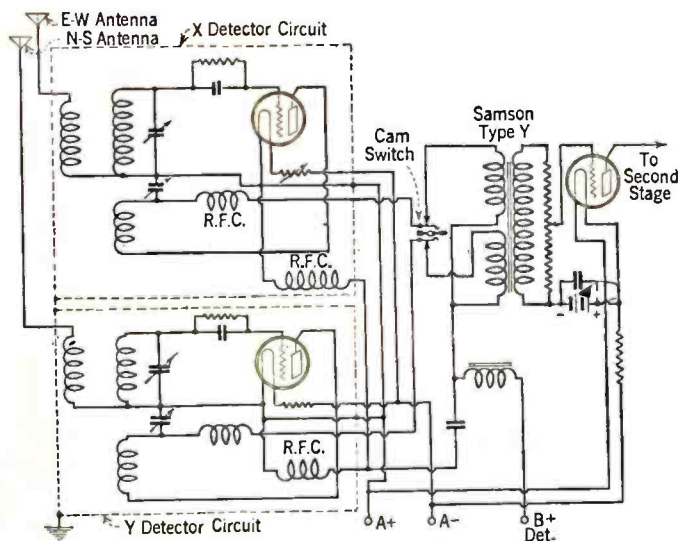

Fig. 1—Circuit diagram of the author's system for duplex reception of short-wave programs

## The Projection of Motion Pictures

**N**O ONE will learn, from a reading of this article, how to operate a motion-picture projector, and, if he did, it would be of little avail professionally in most localities unless, at the same time, the reader in question secured admission to the projectionists' union. The purpose of the article is the less ambitious one of explaining the principles involved in motion-picture projection, as part of a description of the most elementary sort of the mechanism in which those principles are embodied. A good many of the technical people working in movie studios, especially those on the sound end, know little about projection, just as most of the projectionists have only vague ideas about the camera and sound-recorder side of the business. This is unfortunate, since the studio and the theatre are closely tied together through the film itself, and the introduction of sound has raised the technical requirements all around.

The operating aspects of projection are set forth at length in several handbooks. The ones which have been used in the preparation of the present discussion are:

Richardson: *Handbook of Projection* in two volumes. Chalmers Publishing Co., 516 Fifth Avenue, New York, N. Y. 960 pages.  
Cameron: *Motion Picture Projection*. Cameron Publishing Co., Manhattan Beach, N. Y. 1272 pages.

### PATH OF LIGHT

The elements of a motion-picture projection system are shown in Fig. 3. Except for the element of motion, these are basically the same as those of a magic lantern or stereopticon; a source of light, a transparent picture, and a lens system for throwing an enlarged image of the picture on a screen. A motion-picture projector is, in fact, simply an optical lantern equipped with means for moving a succession of pictures across the projected light to produce an illusion of motion.

In a theatre the source of light is generally an arc lamp fed from a direct-current source. Where less light is required a large incandescent lamp may be used. This is simpler and cleaner, but the intensity of the light available is limited. The source of light is housed in a sheet metal box, the *lamp-house*, which must be properly ventilated to carry off heat as rapidly as possible. Normally a flue is provided to carry away the gases of the arc. In back of the source of light there may be a reflector. The positive pole of the current supply is connected with the upper carbon, which may be cored. The crater of the arc thus forms on the upper carbon. As it is necessary to keep the arc on the optical axis of the train of lenses following, a small motor controller is usually installed to feed the carbons forward. The lengthening of the arc automatically actuates the motor through a solenoid. In an average theatre the arc will consume about 25 amperes at 110 volts. In very large houses 100-ampere arcs are found. A knife switch on the projector controls the current supply to the light.

A system of two or three large lenses concentrates the light of the arc on the film and the objective lens on the other side which forms the image on the screen. This may be in the form of two lenses with their plane surfaces outward and convex surfaces facing each other, as shown in Fig. 3. The combination is a *condenser*. The lens next to the source

*The sound motion picture industry is moving with such rapidity that even those in that field—as is Mr. Dreher, who writes regularly on the subject for RADIO BROADCAST—have trouble in keeping abreast of developments. It is the purpose of these regular contributions to survey some of the highlights in the technical branches of sound picture work with the purpose of providing accurate technical information for those working in the field, for practising broadcasters whose daily work is perilously close to sound movies, and for all others who are interested.*

—THE EDITOR

of light is called the *collector*; the lens nearest the objective is called the *converging lens*.

The lamp-house also contains a door, usually placed in front of the condenser, which may be used to intercept the light before it can reach the film. Generally this is operated manually by means of a handle. The term "douser" applied to it is self-explanatory.

The whole lamp-house is set on the back of the projector.

### SAFETY DEVICES

The next element in the schematic arrangement of Fig. 1 is the *automatic fire shutter*.

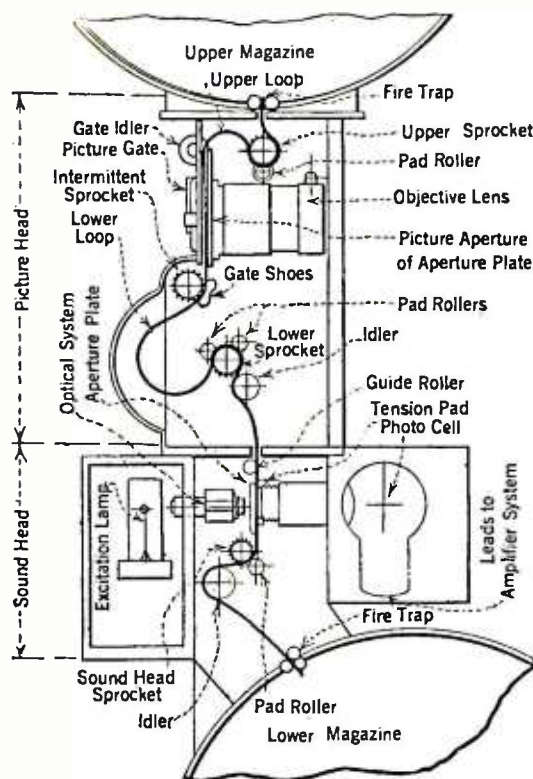

Fig. 1—Schematic diagram of mechanism in a standard motion-picture projector with sound adjunct

The heat of the light source in a theatre motion-picture projector is so intense that if the film stops moving it will catch fire. The operator may extinguish his arc in time to avoid this, but to prevent reliance being placed on a human element a centrifugally operated shutter is placed ahead of the film. At normal speeds this is kept open by the action of a governor, but as soon as the speed drops to a point where there is danger of ignition the shutter drops. The speed at which the shutter operates may be around 40 feet per minute, the normal silent projection speed being from 60 to 120 feet per minute, while sound pictures run at 90 feet per minute.

The film itself passes through the projector with the pictures upside down and the emulsion side toward the source of light. In the standard size it is 1 3/8" wide and 5 mils thick. Both margins are perforated so that the film may be dragged along by means of toothed wheels called *sprockets*. There are 64 perforations per foot, or four to a picture on either side, 16 pictures to the foot being standard. The base of the film is made from cotton soaked in a mixture of nitric and sulphuric acids to render it soluble, forming pyroxyline or nitro-cellulose. This is dissolved in a mixture of camphor, alcohol, and other materials, forming a viscous "dope," which is spread and dried on large drums with much complicated processing and finally cut up into strips of celluloid coated on one side with the light-sensitive emulsion of silver bromide in gelatine. The emulsion of *negative stock*, used in cameras, is more sensitive and less contrasty than that of *positive stock*, from which prints are made. Sound records, incidentally, are better made on positive stock.

The mechanism for taking the film through the projector will be considered in more detail later.

The light which passes through the film is brought to a focus in the *objective or projection lens*, where the rays cross so that the image is seen on the screen right side up. The projection lens generally consists of a system of four lenses, the two near the film forming a duplex lens, while the other two are cemented together to make a compound lens with the surface of greatest convexity toward the screen.

A rotating *shutter* completes the assembly. In Fig. 3 this is shown in front of the objective lens in an edgewise view. In this form it is a segmented disc with two or three blades to intercept the light. Other designs are possible, as well as other positions; the light may be interrupted before it reaches the film, and this has the advantage of reducing the heating of the film. The need for a shutter arises from the fact that the motion of the film is intermittent and it is desirable to allow the light to reach the screen only while the film is standing still before the lens. As is well known, the illusion of motion is secured through the psycho-physiological phenomenon of persistence of vision, sixteen pictures a second, or preferably more, blending into an optical impression of continuous motion. But if the light is not interrupted while the film is being moved, white streaks will appear on the screen owing to the sensitiveness of the eye to white objects in motion against a dark background. Hence a shutter is provided and timed to cut off the light during the intervals when the



successive pictures are being jerked into place. This periodic light interrupter has an auxiliary function, which is, by means of an added blade or two, to break up the stationary periods of projection and thus to eliminate flicker. These functions will be considered quantitatively later.

The *throw* or *projection distance* is measured, as shown in Fig. 3, from the objective lens to the screen, along the *axis of projection*, which is a straight line passing through the center of the photograph, the center of the screen image, and approximately through the center of the source of light. All the elements of the optical train, when in proper adjustment, are centered on the axis of projection.

MECHANICAL DESIGN

Fig. 1 gives a view of the projector mechanism from the right side, where all adjustments are made, and where the projectionist stands during operation. The film to be projected is placed in a length of 1000 or 2000 feet on a reel in the *upper magazine*, the beginning being on the outside of the roll, with several feet of *leader* before the action of the subject begins. The film issues through an opening or *valve* in the magazine and passes through a *fire trap*, an arrangement of rollers to smother a fire inside the head and prevent it from reaching the film inside the magazine.

The film is dragged out of the magazine by the *upper sprocket*, which is driven through gears on the other side of the head with uniform angular velocity. A *pad roller* presses the film against the sprocket by spring action. A short loop of film is then left, and the film passes through the gate, which consists on one side of a flat plate with an aperture against which the celluloid is held in a plane so that it is possible to get an accurate focus on it. The standard size of the aperture through which the light passes is, for silent film, 0.906" by 0.6795"; when there is a sound track on the film the picture aperture must be correspondingly reduced in its long dimension. The pressure which keeps the film flat against the aperture plate is supplied by small metal bars called *tension shoes*, which are backed by *tension springs*. These also exercise braking force on the moving film, of which more will be said later. The position of the projection lens opposite the picture aperture is clear from Fig. 1.

The *intermittent sprocket* controls the motion of the film just below the gate. The film is pressed against it by means of a curved shoe, or a pad roller may be used as in the case of the other sprockets. The driving member of the intermittent mechanism is a circular cam, which actuates a "star," the motion of which is imparted to the intermittent sprocket. The design may be such that for a 360-degree movement of the driving member the sprocket goes through a 90 degree arc. It moves, then, one-quarter of the total time, corresponding to a 3:1 time ratio of stationary to moving time. If projection is at the rate of 90 feet per minute, corresponding to 24 pictures per second, the intermittent must move 24 times per second also, and while it is moving it must drag the film through the gate three times as fast as the continuously moving sprockets above and below the intermittent pass the film along. Between the lower sprocket and the intermittent there is a loop of film, longer than that between the intermittent and the upper sprocket. Through these loops the jerky motion of the film in the gate is made independent of the continuous motion elsewhere. There must be sufficient slack at these points so that when the film is jerked down through the gate the section between the upper sprocket and the gate will not be pulled taut, and, similarly, when the film is at rest in the gate the continuous motion of the lower sprocket must not tighten the film between the intermittent and lower sprockets. Both loops, while the projector is running, vibrate at a frequency equal to the number of pic-

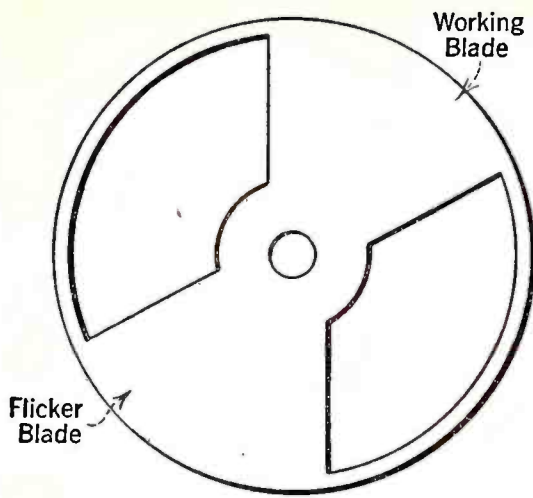

REVOLVING SHUTTER

Fig. 2—Drawing shows type of shutter used for motion-picture projection

tures per second, owing to the periodic lengthening and shortening of the section of film in each loop. The regular alternation of rest and rapid movement of film in the projection mechanism, with slower, continuous motion above and below, is the design basis of the commercial intermittent type of motion-picture projector.

Mention was made above of the fact that the tension shoes in the gate exercise a braking action on the moving film. If the braking pressure is insufficient the film tends to "overshoot"—it does not stop, that is, at the instant that the motion of the intermittent sprocket ceases, but is carried on slightly by the momentum. This defect manifests itself by a tendency for the picture to move up on the screen. The tension must be set so that this will not occur at the highest speed at which the projector is run. The effect of too much tension, on the other hand, is rapid wear on the intermittent mechanism, the teeth of the intermittent sprocket, and the film itself.

OPERATION OF SHUTTER

Now that the action of the intermittent has been described the operation of the shutter may be analyzed in greater detail. Fig. 2 presents a view of a segmental disc type of rotating shutter, viewed from a point in front of the projector. The shutter in this case has two blades. One of these, usually slightly the broader, is known as the *working, cutting, obscuring, main, master, or travel blade*, which has the function of intercepting the light dur-

ing the movement of the film across the picture aperture. The necessity for this has already been discussed. The second blade, known as the *intercepting or flicker blade*, interrupts the light during the rest or projection period and thus reduces or eliminates flicker by increasing the number of pictures per second thrown on the screen. Flicker is the visible alternation of light and darkness. It is visible when it is not sufficiently rapid. Sixteen pictures per second is enough to produce an illusion of motion, but not enough to overcome consciousness of the alternation of light and darkness. The addition of a second blade to the shutter increases the alternations to 32 per second, making the flicker less annoying. Higher projection speed obviously tends to decrease flicker by increasing the number of pictures per second and the periodicity of the light fluctuation. The frequency required for comfortable vision depends on the brightness of the screen, which is dependent on the intensity of the light source and the type of reflecting surface used in the screen. With a very bright screen a three-blade shutter (two flicker blades) may be preferable to the two-blade type. At 24 pictures per second (90 feet per minute), which is standard for sound pictures, the three-blade shutter gives 72 flashes of light on the screen each second, with intervening periods of darkness. This is sufficient to reduce flicker to a negligible point under normal conditions of bright lighting and high screen reflection.

The shutter must be timed (set in phase) so that the obscuring blade cuts off the light while the film is moving. This is taken care of approximately by a preliminary setting of the shutter so that it covers the projection lens almost all the time that the intermittent is moving. The residual light, called "travel ghost," which gets through under this condition and manifests itself as a series of white streaks in the picture, may be eliminated by a secondary adjustment which is provided on standard projectors.

It is standard practice to thread the projector in frame, that is, to insert the film so that one of the pictures coincides exactly with the aperture and appears in the proper position on the screen. In some machines a framing device is provided, consisting of a small incandescent bulb which is lighted during the threading process so that the projectionist may view the film in the aperture through a small door. Misframing results in parts of two pictures appearing on the screen at the same time, the frame line between them being in the aperture instead of coinciding with its upper or lower edge. This may be corrected by means of an adjustment while the machine is running. Even if the picture is properly framed at the beginning of the reel, a badly made splice may throw it out of frame.

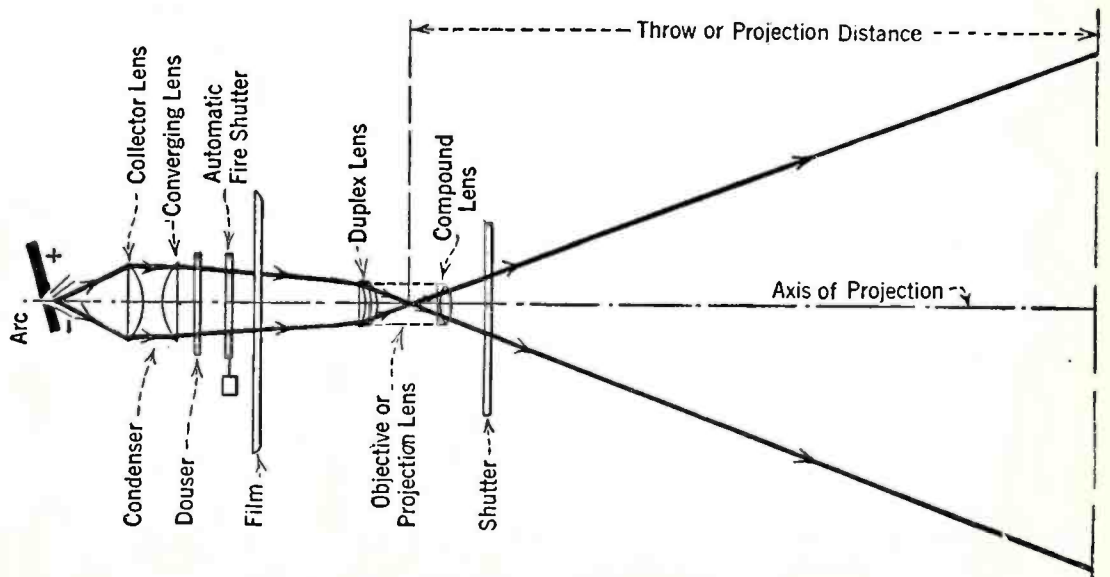

Fig. 3—Path of light in motion-picture projection

## MEASUREMENTS ON DYNAMIC SPEAKERS

By FRANK C. JONES

**T**HERE are two general types of loud speakers in use at present for radio reproduction. These are the electro-magnetic drive and electrodynamic drive cone loud speakers. The latter is the most recent and will be considered in the following discussion because it gives a much wider frequency response than do other types.

The usual dynamic loud speaker consists of a moving-coil system and some form of magnetic field. The moving coil is attached to a small cone which acts as a diaphragm to set the surrounding air into motion. This coil moves back and forth in the magnetic field and the amplitude and frequency of motion depends upon the audio signal currents through the coil. The cone usually has two supports, one near the moving coil in the form of a fibre or aluminum spider frame, and the other at the front edge of the cone in the form of a thin leather ring. These two supports allow the cone to vibrate freely in a plunger motion back and forth.

The magnetic field generally consists of a field winding, an iron core, and a shell-return magnetic path. The power used by the field varies from 2.5 up to 20 watts for different types. Most of the magnetic field flux is used up in the air gap across the moving coil since this gap is fairly large. At least 0.010 inch clearance is allowed on each side of the coil and the coil itself is from  $\frac{1}{32}$  to  $\frac{1}{16}$  inch thick.

### The Dynamic Unit

**T**HE dynamic loud speaker is really a very complex machine when an attempt is made to analyze it electrically. At first sight, it appears that it functions in a simple fashion, i.e., the diaphragm is actuated by the moving coil which in turn moves in accordance with the audio-frequency currents flowing through it. This is true within certain limits but the question arises as to how much distortion is introduced for currents of different frequencies.

It is assumed ordinarily that a dynamic loud speaker is inertia controlled, that is, its diaphragm acts as a plunger. Then, for simple harmonic motion where the driving force alternates between  $+F$  and  $-F$  dynes, the amplitude can be expressed as

$$x = \frac{F}{\omega^2 M}$$

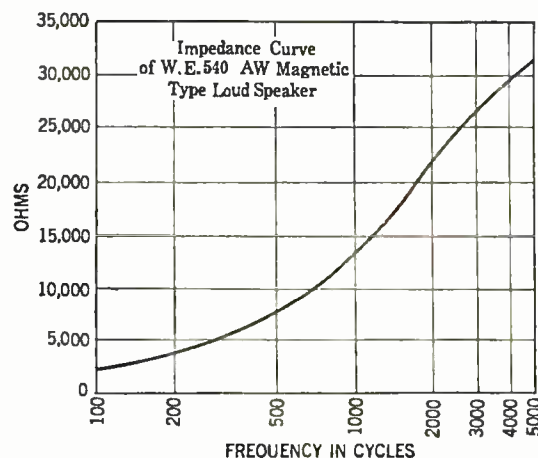

**Fig. 1—Impedance curve of a standard magnetic-type loud speaker**

*At the present time a good moving-coil loud speaker in a three-foot-square baffleboard operated from a good amplifier provides fidelity par excellence. Mr. Jones, an independent investigator living in California, gives us some actual data on well-known speakers in this article, data which should appeal to anyone interested in "quality." The effect of cabinet resonance, the directional effects of dynamic speakers, and the use of filters are discussed and illustrated graphically. Incidentally, an article on the electrostatic loud speaker is being prepared for an early issue.*

—THE EDITOR.

Where  
 $x$  = amplitude  
 $F$  = force in dynes (due to current in moving coil in the magnetic field)  
 $\omega = 2\pi$  times the frequency  
 $M$  = Mass of moving element in grams.

This equation shows that the amplitude varies inversely as the square of the applied audio frequency. According to Raleigh, *Theory of Sound*, the power radiated from one side of a large diaphragm is

$$P = \frac{1}{2} \rho V S \omega^2 x^2$$

and in the case of a small diaphragm

$$P = \frac{\rho S^2 \omega^4 x^2}{2\beta V}$$

$P$  = power in ergs  
 $V$  = velocity of sound  
 $\omega = 2\pi f$   
 $x$  = amplitude of motion  
 $\beta$  = solid angle of radiation  
 $S$  = diaphragm area.  
 $\rho$  = density of air  
 $f$  = frequency in cycles

By large and small diaphragms are meant those whose outside diameters are larger and smaller, respectively, than the wavelengths of sound expressed in physical measure. These two equations show, therefore, that for a small diaphragm, the amplitude must vary inversely as the square of the frequency for constant sound output. For a large diaphragm the amplitude must vary inversely as the frequency.

For high audio frequencies, the wavelength becomes small enough to have the equation for the large diaphragm hold true, i.e., the amplitude varies inversely as the first power of the frequency. This means that the power output in sound will be so small at the high frequencies that the lower frequencies will be overemphasized. This occurs in some models of dynamic loud speakers, and may be made worse by cabinet resonance.

### Operation at High Frequencies

**T**HE two formulas are true for inertia-controlled diaphragms in which the whole diaphragm moves as a unit. This actually holds true for low frequencies with a small cone such as is used in a dynamic loud speaker. The cone shape gives the diaphragm very

good rigidity. However, for higher frequencies, this does not hold true since the apex vibrates separately and flexural waves are radiated out to the edge of the cone. This is liable to cause standing waves along the diaphragm for the higher frequencies due to reflected waves from the edge of the cone. This occurs at certain frequencies and is quite apparent in the response curves for some loud speakers.

Because at high frequencies the loud speaker cannot be considered as inertia controlled there usually results a large increase of sound output for the higher frequencies. The combination of the two effects, inertia control and wave-motion control, generally causes a peak at about 3000 cycles per second for most commercial forms of these loud speakers. Beyond that point the plunger action or inertia control output drops off so rapidly that it is negligible and practically all of the sound output comes from the wave-motion action.

The motional resistance and impedance curves of the action of the moving coil and diaphragm also show that the output would be very small for the higher frequencies if it were not for this wave-motion action. Fig. 3 shows some impedance curves of two varieties of dynamic loud speakers. In both cases the moving coil has an appreciable inductance so its reactance increases rapidly for the higher frequencies. This reactive component is of very little use and serves to give a poor impedance match to the power tube. An example of the impedance of a magnetic type of loud speaker is shown in Fig. 1.

### Motional Resistance Measurements

**T**HE moving coil should consist theoretically only of a pure resistance, and the motional resistance portion of this would represent the useful part towards work done. This motional resistance is due to the acoustical load on the diaphragm and so is related to the useful sound output. It is possible to measure the motional resistance for all frequencies by means of an impedance bridge. First a resistance curve is taken with the cone free to vibrate and moving with an amplitude about equal to that obtained for normal sound output. Then the cone must be blocked securely, a very difficult job to do completely, and a second resistance curve made. The difference of values of these two curves gives a third curve of the motional resistance. These curves are interesting because they indicate the load

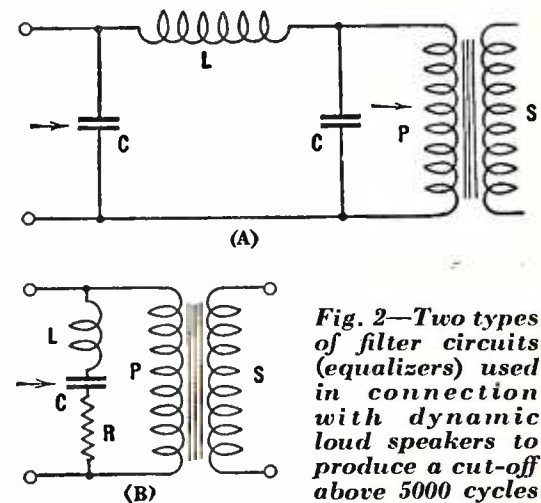

**Fig. 2—Two types of filter circuits (equalizers) used in connection with dynamic loud speakers to produce a cut-off above 5000 cycles**

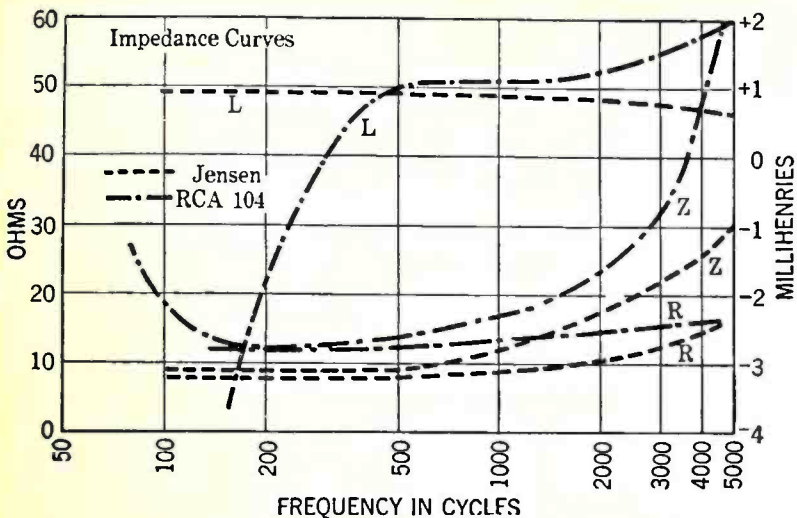

Fig. 3—Impedance curves of two popular dynamic loud speakers.

weight of the system are changed. Heavier paper causes an energy loss due to the added weight. It also affects the higher frequency due to increase of stiffness. The size of the cone also affects the frequency response due to the acoustic impedance which the air offers. Another effect is the directional properties at high frequencies due to the megaphone effect of the cone. The cone shaped diaphragm is not ideal but its advantages overshadow its shortcomings in present-day design.

That it is possible to overcome the usual

peak at about 3000 to 4000 cycles by proper design was shown in a test on a new model Jensen speaker. This curve is shown and as can be seen the shift from plunger action to wave motion is gradual enough so that the response is nearly uniform. This was done by using a larger cone diaphragm which changes the weight and stiffness. Using a larger diaphragm means a good low-frequency response since for the same amplitude of motion there is of course a much greater amount of air set in motion. Conversely, for the same sound output the larger diaphragm does not have to move as far, which simplifies construction somewhat.

For low frequencies, 30 to 100 cycles per second, the amplitude of motion for good sound output is quite great. A motion of  $\frac{1}{4}$  to  $\frac{3}{8}$  inch is not uncommon. Such great motion causes crystallization of the rear spider support with breakage of these springs in time. With the larger diaphragm the motion is much less so the tendency to break is greatly lessened.

Baffles for the Dynamic

THE subject of baffles is difficult to handle since it must consider the effect of cabinet resonances, circulating air currents, standing-wave effects, and acoustics of rooms.

A source of sound emits waves of a spherical or hemispherical shape and these vibrations of air travel out to all parts of the room. Reflection and resonant effects take place, though generally the reflection properties are of major importance. The sound waves are reflected more or less from anything which they strike. If the walls and floor have drapes and rugs, the amount of absorption is,

of course, much greater than in a bare room. Therefore, the reverberation is less, that is, the echo effect is small and so a note or tone of any frequency dies out more rapidly. The definition of music is also much clearer in such a room, and within certain limits, much more pleasant.

Another effect of excessive reverberation is the creation of standing waves of sound. In this case the reflected waves are of sufficient amplitude, and of proper phase for some frequencies, to cause points of maximum and minimum sound. This is easily noticed on organ music which is generally sustained long enough to allow a person to move a few inches or a few feet during some particular note. The presence of maximum and minimum areas of sound for some frequencies is quite pronounced in many rooms.

Reasons for Baffle

A DYNAMIC loud speaker with its small diaphragm will not produce tones of low frequencies unless a baffle of some sort is provided. The baffle should provide a path through the air such that the shortest distance from one side of the cone to the other is at least one quarter the wavelength of the lowest frequency desired. This does not prevent interference of the two sources of sound waves at the edges and near the baffle but it does stop the air circulation sufficiently to allow the loud speaker to reproduce the low tones. Considering the velocity of sound in air to be about 1100 feet per second, a baffle for tones as low as 75 cycles per second can be calculated easily.

$$\frac{1}{4} \times \frac{1100}{75} = 3\frac{2}{3} \text{ feet} = \text{diameter of baffle}$$

This, of course, can be in the form of a square  $3\frac{2}{3}$  feet on a side. Thus to reproduce actually a tone of 30 cycles a baffle 9 feet square would be necessary. The wall or ceiling of the room may be used for the purpose when such a baffle is desired.

If frequencies below the "cut-off" of the baffle are impressed on the loud speaker, the resulting tone is made up mostly of higher harmonics. Tests by ear apparently show quite a bit of the fundamental tone but this is nearly all due to the modulating property of the human ear, since it combines the harmonics in a manner similar to the first detector or "mixer" tube in a super-heterodyne receiver. For example, if the ear hears two tones one of 120 and one of 180 cycles, there is apparently a strong 60-cycle tone present, which, of course, is not apparent to electrical recording systems. Fortunately very little music is transmitted below 80 to 100 cycles per second so a baffle of 3 feet effective length is sufficient for present-day needs.

When a flat baffle is used there are no

impedance which is offered to the power tube. Some dynamic loud speakers have a large motional reactance which becomes negative for some low frequencies with an abrupt peak at the natural resonant period of the moving coil and cone system. Usually this occurs at such a low frequency, from 20 to 70 cycles, per second, that it is not noticeable on radio reproduction.

Filter Systems

PRESENT-DAY models of dynamic loud speakers usually have some form of filter or equalizer as an integral part of them. The impedance of the moving coil is quite low, from 4 to 12 ohms for low frequencies, so a step-down transformer is used to obtain better undistorted power output from the power tube. In all cases the filter is connected across the primary or high-impedance side of the transformer. These filters or equalizers cut off above certain frequencies or cause a power loss at some frequencies.

The most general type of filter consists of a simple "Pi" section filter consisting of two 0.01- to 0.02-mfd. condensers and a 100- to 200-millihenry inductance as shown in Fig. 2A. This form of filter cuts off the frequencies above its natural resonant frequency and has practically no effect on the lower frequencies. It is called a low-pass filter because it cuts off above about 4000 cycles per second. Contrary to manufacturers' statements, these do not cut-off at about 5000 cycles, but all makes tested began to cut-off at about 3500 cycles. A 4000-cycle cut-off is very difficult to notice as far as speech is concerned but some of the brilliance is lost, especially for music.

Another form of filter or equalizer (diagram B of Fig. 2) consists of a resistance, inductance and capacitance in series connected across the primary of the step-down transformer. At the resonant frequency of this circuit the attenuation is greatest. By proportionating the values in this equalizer the "dip" may be made sharp or broad and deep or shallow to remove a resonant peak in the loud speaker output. This form of equalizer may be used to remove the peak mentioned before where the wave motion and plunger motion combine to cause an increased sound output. This peak and its removal by the last named method is shown in response curve A of Fig. 5.

The series-resonant filter is used in the Jensen dynamic loud speaker while the "Pi" filter is used generally on the Magnavox, Rola, and other popular makes of dynamic loud speakers.

By properly designing the shape and weight of the moving system it should be possible to eliminate equalizers and filters. A shallow cone, with an opening greater than 90°, will cause the wave motion to become effective at a lower frequency unless the stiffness and

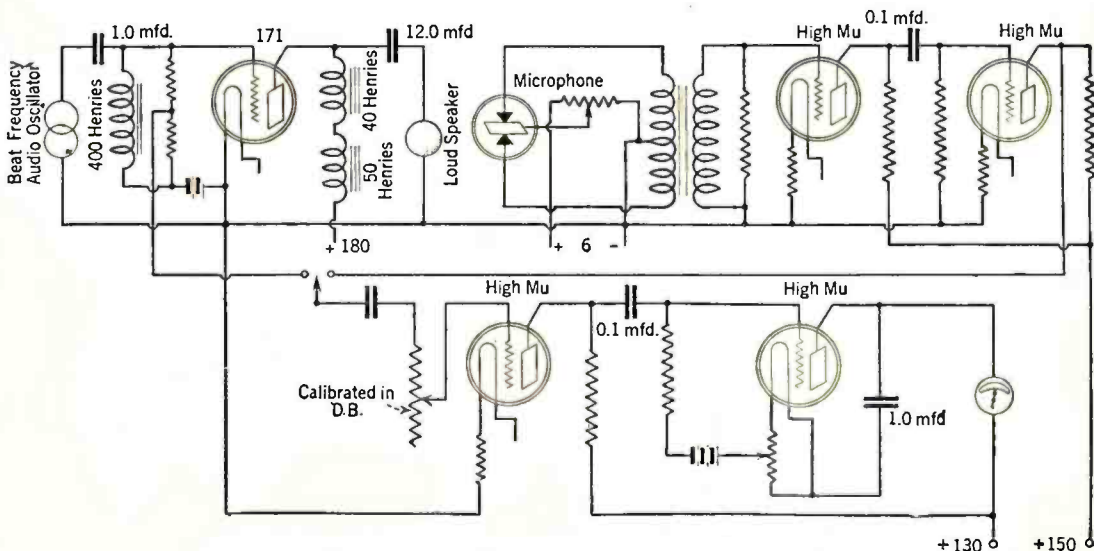

Fig. 4—The circuit used by the writer for measuring the characteristics of dynamic-type loud speakers.

resonant effects but as soon as the sides are bent around, as in a cabinet, had resonance occurs. Part of this resonance is due to the sides vibrating and part due to the natural period of the cavity. Making the cabinet of heavy wood helps reduce the resonating effect due to the sides vibrating. That this effect of cabinet resonance is very bad can be shown experimentally. The effect on music and speech is to change the quality greatly. It becomes booming in nature because the resonance is generally at low frequencies, and, in addition, the air chamber attenuates the high frequencies.

Response Measurements

MEASUREMENTS were made by means of a W. E. 387w transmitter and calibrated amplifiers over the audio-frequency band in an effort to learn something about cabinet resonance. The circuit arrangement used is shown in Fig. 4 in which a special beat-frequency audio oscillator was used as a source of sound. This audio oscillator had a range of from less than 30 cycles up to about 15,000 cycles and was, of course, continuously variable. Particular care was taken to minimize standing waves of sound in the room. The most practical method is to have the "mike" less than a foot from the loud speaker so that the direct sound wave is much stronger than the reflected waves.

Numerous response curves were run with the "mike" in different locations. Some trouble was had from room resonance and re-

flecting surfaces since either the loud speaker or the "mike" had to be moved for the different runs. Even with these effects it is quite evident that cabinet resonance is pronounced as shown in curve B of Fig. 5. A larger cabinet generally has a lower resonant period, but because of audio amplifier deficiencies, it may not be very noticeable.

Padding the inside of the cabinet with felt does not help much since felt is not an efficient absorbing material for low frequencies. Therefore, felt padding may attenuate the high frequencies more and tend to make the quality even more drummy in character. Felt padding helps occasionally in damping the sides to prevent vibration. Lining the cabinets with acoustic celotex or some such material should help greatly. Mounting the entire loud speaker unit in thick felt seems to remove the cabinet resonance but this cuts down the sound output nearly half. Only the front can emit sound in this case so a larger power tube is necessary to prevent overloading in the audio amplifier for the same sound output.

Effect of Small Cabinets

THE harmful effect of small cabinets on the higher frequencies is shown vividly in the curves c of Fig. 5. The solid curve was taken with the microphone about 15 centimeters in front of the loud speaker, the dotted curve was taken with the microphone at the same distance to the rear and the dot-dash curve was made with the microphone on one side. The dot-dash curve shows the effect of

cabinet resonance since the "mike" was near one of the vibrating surfaces. The sudden drop at low frequencies is probably due to interference of sound waves emitted from the back and front of the loud speaker.

The dotted curve d of Fig. 5 shows the effects of cabinet resonance and the attenuation of the high frequencies. Evidently the cabinet cavity acts like a condenser in absorbing more energy on the higher frequencies. It is like a horn loud speaker in which there is a large air cavity between the diaphragm and the throat of the horn. It is quite a well-known fact that such a cavity attenuates the high frequencies greatly. If the air chamber or cavity is large enough with respect to the diaphragm, such as with a console cabinet, this attenuation of the high frequencies is of much less importance. If a small cabinet must be used, drilling a few large holes in the sides should help reduce both cabinet resonance and high-frequency attenuation. These holes would prevent the small cabinet from acting as a horn, but the effective haffle size would be diminished somewhat so the very low notes would be down a little in level.

Large cabinets such as those used to completely house the radio receiver may reduce the resonance to a minimum by using a screen back for the cabinet and by not having any shelves inside of the cabinet. The use of a couple of strips of acoustic material, such as type BB Celotex, fastened to the sides or sides and top inside of the cabinet should make this form of cabinet practically as good as a flat baffle.

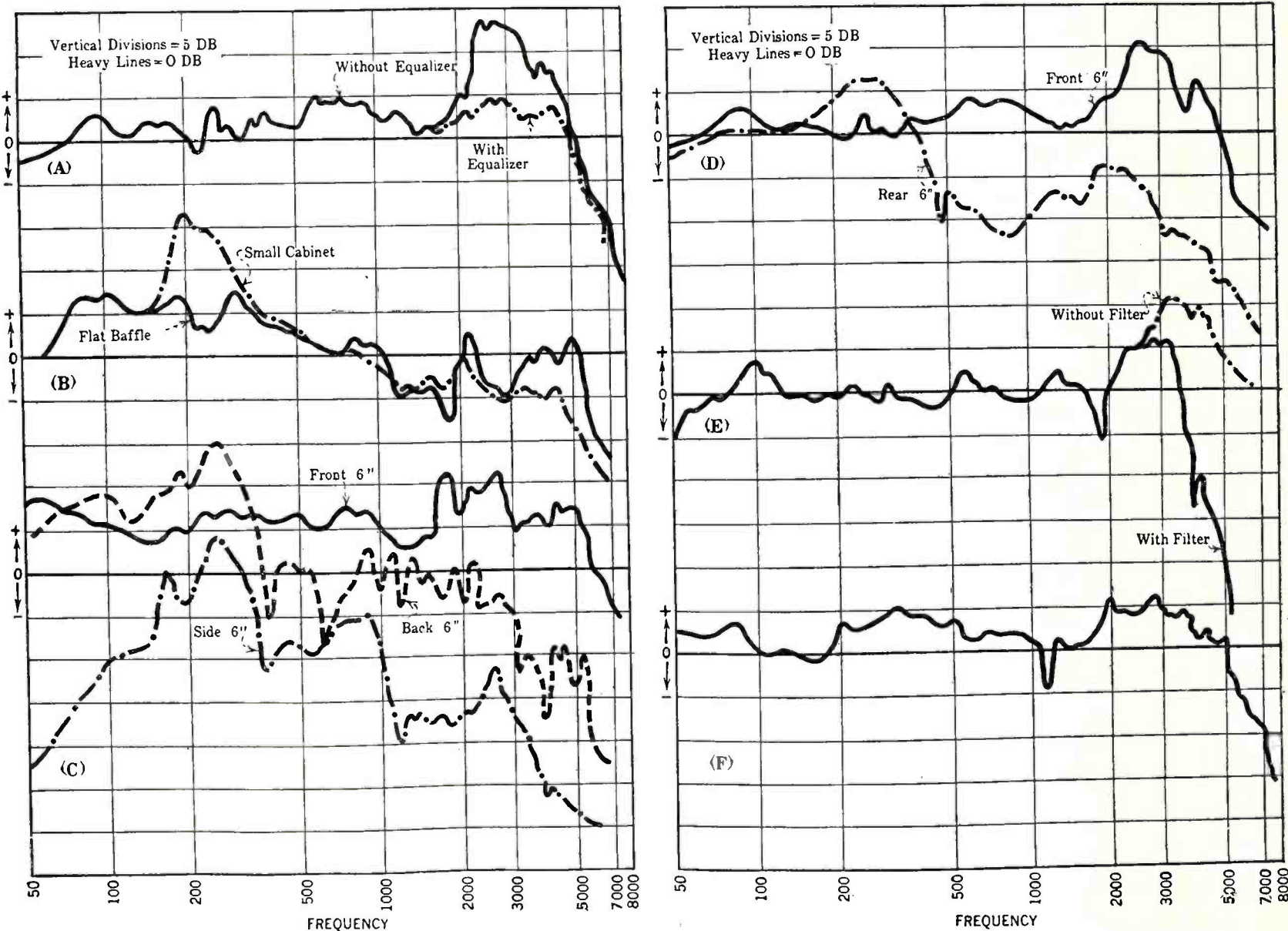

Fig. 5—Response curves of several dynamic-type loud speakers measured under different conditions. Curve A, Jensen loud speaker; curve B, Jensen loud speaker with different baffles (measured five feet in front of loud speaker); curves C, dynamic loud speaker in a small cabinet; curve D, small-cabinet-type dynamic loud speaker; curve E, Magnavox dynamic loud speaker; curve F, Jensen loud speaker with large cone and no filter or equalizer.



## THE SERVICEMAN'S CORNER

### **R**ADIO Interference from House Plumbing:

Two extraordinary but similar cases of radio interference have come to my attention. Although both conditions arose in the operation of short-wave receivers, the trouble may be affecting ordinary receivers, and telling of the experiences here may enable others to clear up an obscure source of trouble. In the first instance, a microphonic trouble developed in the receiver. The noise was terrible. The effect was suggestive of a loose connection. Sometimes a violent rapping on the set produced little effect, while placing an object on a distant table produced an explosion. Every connection from antenna to ground on a cold-water pipe was thoroughly overhauled. The trouble would reappear after each discovery and removal of its supposed cause. Matters reached a desperate state. As a final test, the set was put in operation and a 40-foot extension cord attached to the head set. The set was in the dining room and the floors of the dining room and kitchen were explored by rapping with a stick from point to point, like a blind man and the resulting static was carefully studied. A lone point on the floor, remote from the set, was found to be the most "sensitive." The extension was then carried through the floor to the cellar and the exploring transferred to the pipes hung from the floor overhead. Some were quite sensitive but they were not coupled with the ground connection.

The trouble was quite by chance traced to the metal stopper of a laundry tub. This stopper fitted loosely in the drain outlet and was attached by a brass chain to the cold water faucet. This proved to be a most sensitive microphone affected by vibrations conveyed to it from pipes hung overhead. It acted as a variable short circuit in the pipe ground system, changing the electrical constants of the system. Pulling out the plug and hanging it over the side entirely cleared this vexing interference.

Later an annoying but less overwhelming noise was traced to a variable contact between two pipes in the cellar that crossed each other. A little wedge of wood placed between them remedied this trouble. Probably many similar cases of interference exist which have not been traced down. This is particularly likely to be true of those who are now acquiring short-wave receivers. If trouble from loose connections cannot be found in wires in the attic, it is time to be suspicious of pipes in the cellar!

—C. A. BRIGGS,  
Washington, D. C.

A simple method of determining if a noisy receiver is suffering from the trouble described by Mr. Briggs is to run fifty feet of wire almost anywhere, and use this as a counterpoise in place of the ground. Also, a simple cure might be a permanent counterpoise or six feet of iron pipe driven into the earth.

With this issue of RADIO BROADCAST, "The Serviceman's Corner" stretches into its natural stride. The purpose of this department is to publish everything and anything of genuine interest to the radio serviceman that can be briefly and thoroughly covered. Subjects justifying longer treatment will be covered in complete articles elsewhere in RADIO BROADCAST. Contributions, payable at our usual rate, will be welcome from engineers, manufacturers, servicemen, and dealers who have been intimately associated with any of these problems.

It is requested that the contributor write us on his professional stationery, enclosing with his letter copies of his business cards and business literature if any.

—THE EDITOR.

**Servicing Magnavox Receivers:** William K. Aughenbaugh, of Altoona, Pa., has run across several Magnavox receivers that would not function when the original tubes were replaced with R. C. A. or Cunningham tubes. The difficulty, he points out, can be remedied by short circuiting the coil of wire that will be found under the cardboard at the bottom of the set—near the front panel. Also the pin on the volume-control rheostat should be removed or bent so that the rheostat can be adjusted to the full "on" position if necessary.

**Finding tube-locations:** I was recently called on to install a new a.c. set. Not finding any installation instructions or data on proper location of tubes, I hit upon a useful method of locating the proper socket for the proper tube.

No mistake can be made about the 280 or the v-227, especially since the latter has five prongs. The set in question required four 226's, one 227, two 171's and one 280. Putting a 226 in a 171 socket won't do the 226 any good. I took a 171 and put it into the first socket next to the 227. I was sure about the location of the 227. Not seeing the filament light, I assumed it to be a 226 socket. In this way, by trying all the other sockets, I found which were the 226 sockets and which the 171.

FRED BERKLEY, Astoria, Long Island.

**Polarity Incorrectly Stamped:** I just serviced a Radiola No. 20. The owner of this set was using a 22.5-volt B battery as a C battery, connected correctly. I tested the set as usual. It would receive only locals, and these not at all well. Closer inspection, with a voltmeter, showed that the C battery was incorrectly stamped, the stamping being reversed for positive and negative. This is the second time in my eight years of servicing sets that this same thing has come to my attention.

GEORGE A. HARTMANN, Howell, Indiana.

Terminal reversal has also happened within the experience of the editor. A check of the socket and tube connections with the usual plug-in testing outfit would show this up as a very high plate current through the tube having the reversed grid bias.

**Servicing Cheap Receivers:** L. R. Arnold, of the Richards Radio Company, Providence, R. I. comments on the difficulties of servicing inexpensive receivers. These are often characterized by fairly good reception on local stations, but are insensitive to distant stations and stations covered by the upper section of the tuning dial.

These receivers can often be improved, as far as sensitivity is concerned, by running all r.f. tubes, with the exception of the first, from 135 volts through a bypassed variable resistor, using the additional knob as a sensitivity and volume control.

**A Portable Receiver To Check General Conditions:** The Kolster Radio Company provides its dealers with a portable demonstration set possessing several points of interest that recommend similar outfits for the serviceman. The complete apparatus is pictured in Fig. 1, and consists of two carrying cases, one holding the receiver, tubes and power supply, and the other the loud speaker. A portable receiver of somewhat similar design is of inestimable value to the serviceman in solving the more general problems of poor reception. The inability of a receiver being serviced to receive certain stations can be checked against a standard receiver, the characteristics of which are well known to the serviceman, to determine whether it is the location or the receiver that is at fault.

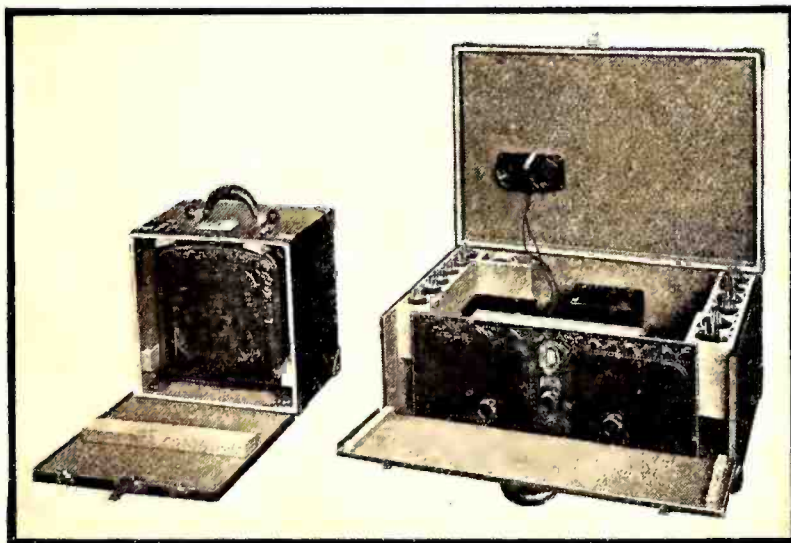

Fig. 1—Portable radio receiving apparatus that suggests a useful adjunct to the serviceman's equipment for determining general receiving conditions

An outfit of this sort proved itself worth while to the department editor in the case of a batteryless installation in a d.c. district of New York City. Noisy reception in this particular apartment removed radio from the entertainment class. However, by using a portable receiver, operating entirely from independent battery sources, it was easily ascertained that the pickup was conductive through the lines. The receiver was rewired for battery reception (a desperate remedy) and has been giving satisfactory service ever since.

*An Unusual Problem:* The following incident came to my attention while servicing an Atwater-Kent battery receiver equipped with an A-power unit, and perhaps a little information about it might help a brother service man.

The set was playing along nicely when I arrived, but a moment later the thing stopped dead. After about 30 seconds the set gradually began to play and soon was up to its full volume. As nothing like this had happened before installing the power unit, of course, this was blamed. A careful check of both the A- and B-power unit circuits failed to reveal anything. A wire from the power rheostat in the A-power circuit seemed to be a little loose, but installing a new power rheostat didn't remedy the trouble.

By carefully questioning the owner of the set I discovered that some time before a very similar trouble had developed in the set when it was operating from batteries. The music had died down but hadn't stopped entirely and by working the filament switch the full volume of the set could be brought back. This led to the inspection of the filament switch. Sure enough there was the trouble. This is how I doped it out. The filament switch with a slight jar or other disturbance would cause a poor connection in the filament circuit. This, in turn, would cause the voltage in the A-power unit to rise due to the reduced load. The condenser in this particular unit (a Hartford with an electrolytic condenser and Tungar full-wave rectifier) would blow as soon as 8 volts or more was pushed into it. It took the condenser perhaps three seconds to heal and the remainder of the thirty seconds to charge up again. After repairing the switch this trouble disappeared entirely.

ALTON R. BOWEN, Pleasantville, N. J.

*All In a Day's Work:* Here are two difficult problems which I solved more or less by chance. The trouble was similar in each case and may aid in solving related troubles found by brother servicemen.

The first, a Freed Eisemann model 57, had been working very satisfactorily. One day on turning it on it was found to have lost its volume even on local stations. On checking it with an analyzer, the amplifier and power potentials were found to be considerably less than normal. In checking the power pack I found it o. k. I turned the set upside down and turned it on and noticed a minute curl of smoke as I pulled the wire running from the plate of the power tube to the jack. On closer inspection, I found the insulation of this wire was leaking and, as it was cabled with a ground wire, it practically caused a short circuit. When these wires were separated and the plate wire replaced (as it was burned badly) the set acted normally again.

The other was a Fada battery model which had lost its pick-up and even locals tuned broadly with no great kick. This set checked perfect. When I had it out, however, I noticed that where two wires went through the metal parts of the frame circles of corrosion had formed. By replacing these wires with new insulation where possible and by entire new wires in places where this was impossible, and rebalancing the set, normal reception was obtained.

In both these cases the wire involved was covered with a material similar to black cotton and impregnated with wax. It is not so good!

GEORGE W. BROWN, South Boston, Mass.

*The D. C. Problem:* Supplementing your editor's remarks about the portable receiver and artificial "static" in d.c. districts, Arthur R. Gerling, of Kellogg and Bertine, New York, writes:

During my eight years of selling and servicing radio receivers in the wealthiest d.c. district in the United States, I have acquired a knowledge of what the *élite* want in the way of radio entertainment and reception, and also

## Radio Service

### For Particular People

❧

Now is a good time to have the Radio looked over, tested, and put into first-class condition.

A radio receiver is a very delicate piece of apparatus and no matter how well constructed should have attention from time to time to maintain it in order for best results.

Often a little work of this kind will make a marked improvement in quality of reception.

Batteries, Eliminators, Tubes, Aerial should all be in proper order.

We are technically trained for this work, have the most modern tools, testing outfits, and appliances for performing this work in a workmanlike manner, at reasonable prices. A postcard or telephone call will receive prompt attention.

*Endorsed by*  
National Radio Institute,  
Washington, D. C.

WILLIAM V. LOWE  
Box No. 387 Tel. 3527-M  
Fitchburg, Mass.

*Fig. 2—A neat specimen of radio service-sales literature that brings returns for William V. Lowe, of Fitchburg, Mass.*

the bug-a-boos that sometimes prevent us from giving them just what they want.

These folks whom I have chosen to call the *élite* would be quite satisfied—for the most part—with just the same kind of reception that their chauffeurs get out in the Bronx (where a.c. current is supplied). In many cases even this is denied them—why? First, because they are burdened with d.c. current with its many disadvantages known to all servicemen. Second, the management of the apartment houses in which they dwell often have stringent rules regarding the erection of antennas, and usually forbid them entirely—quite a reasonable attitude. Third, the numerous d.c. motors always found in large apartments—elevators, refrigerators, exhaust fans, water pumps with their armatures spitting fire and interference with every revolution. These are a few of the things that the serviceman has to think about when installing the present-day d.c. set, plus the natural loathing of the "madame" to have wires stretched here and yon about her drawing room, boudoir—or what have you.

The several sets now being put out by leading manufacturers are successful in only a comparatively small percentage of cases, and these very often because of the industry of the serviceman making the installation as regards filtering motors—known to interfere—putting filter banks in the d.c. line—experimenting with antennas, etc.

Is the manufacturer really interested in helping to solve this d.c. problem by putting out a set that will cut down d.c. interference to a minimum, or must the serviceman continue to rub along as best he can under the circumstances?

My answer to the d.c. question is: A super-heterodyne using a loop—disappearing when not in use—201A-type tubes—d.c. operated—console cabinet with a self-contained dynamic loud speaker. Price range \$350.00 to \$500.00. What is your answer? Solve it and the residents along Park Avenue will forever be in your debt.

[By the way, the portable used by the editor was exactly this].

*Neat Connections with Bell Wire:* It is possible to use ordinary bell or annunciator wire for hook-up and for external wiring purposes without having the work marred, as far as appearance is concerned, by frayed ends.

If first the outer cover is unwound as far back as desired, then the inner covering, which is wound in the opposite direction, is unwound to the same point, and the two loose ends tied together and clipped short, there will never be any ragged ends hanging loose.

J. H. BOND, Dallas, Texas.

*Testing Audio-Frequency Transformers:* When going on service jobs I always carry a carbon microphone button with me, which can be shunted across the primary of the first audio transformer in series with a six-volt battery. If, on speaking into it, the voice comes through well, the audio channel can be eliminated as the source of trouble.

BERNARD J. CANNON, Pittsburgh, Pa.

[Another simple way of accomplishing the same test is to connect a loud speaker across the grid leak of the detector tube, and speak against the diaphragm. The unit from an old horn-type loud speaker may be included conveniently in the service kit for this purpose. It is, as Mr. Cannon suggests, the simplest test for the audio channel—*Editor*].

*Defective Transformers:* The usual tests for an open primary will not locate a microphonic transformer winding, which is the cause of a great deal of trouble down here in Florida. I have run across several cases of transformer trouble that tested o.k. with a battery and milliammeter, but were defective in operation, due, probably, to the dampness of climate. When suspecting trouble of this nature, I connect a 4.5-volt C battery across the primary of the transformer and a pair of telephone receivers across the secondary. A defective primary will generally show up, as a loud scratching, after a few seconds. The effect, of course, is stepped up by the transformer.

C. WASHBURN, JR., Jacksonville, Fla.

*Noise in the volume control:* Here is a suggestion for remedying a difficulty which has turned up in some instances. If a set had not been used for some time and the weather has been damp, slight oxidation may occur at the point of the volume-control contacts. A condition of this kind will cause some noise when the volume control is adjusted. *Fada Sales* points out that, although such a condition may not always be apparent, it is easily fixed by moving the contact arm back and forth until the slight oxide coating has worn away.

*Watch for bad contacts:* Two simple sources of improper contact which may cause trouble are worth mentioning. Receivers equipped with loop antennas connecting to the receiver through a plug and jack arrangement may develop noise due to dirty contacts. This trouble is quickly stopped by rubbing the plug with a bit of fine sandpaper. Contact prongs in the house-lighting plug circuit connecting the receiver to a convenience outlet may become slightly bent so that the contact in the outlet is not tight. Noise resulting from

this cause is removed by bending the prongs to assure a tight contact.

*The Case of the Broken Vase:* "A telephoned service call" writes D. F. Greer, Coatesville, Pennsylvania, "informed me that while the set tuned properly, it lacked volume. I assumed that it was probably a case of poor tubes, open transformer, or similar ailment. On testing the set, antenna and ground were o.k. and routine tests showed no opens, no shorts, tubes good, plate and filament voltages correct, proper C voltages, and still the set did not deliver a "kick." A new speaker was substituted with no change. I was on the point of removing the set to my shop for a bench test when I accidentally discovered the difficulty. In testing the B power unit, I had clipped the negative lead of the meter on the negative post and the positive lead at the time lay in my left hand. I gazed disgustedly at the set and toyed abstractedly with the extension cord of the loud speaker. There was a deflection in the voltmeter (the cord had been tested for continuity), and at the same time a tingling sensation in my hand. Then the truth dawned. The loud speaker was being shunted by moisture in the cord. I could not understand what caused the dampness until one of the maids confessed she had knocked over a vase containing cut flowers and the water had seeped into the cord. This experience illustrated to me the value of a high-resistance voltmeter.

*Antenno-Ground, connections:* While there are several devices made for the purpose of bringing the antenna and ground wires into the house, the use of an ordinary convenience receptacle makes a neat job and one which is uniform with other receptacles and wiring in the house. I have found that the owners of higher-priced sets prefer this manner of entrance rather than the use of window strips and manufactured receptacles. A porcelain tube is used through the brickwork to insulate the antenna lead-in. The wires are then pulled through the knock-out in the rear of the receptacle and the ends clamped under the screws inside the box. A length of double-conductor and receptacle plug then connects the set to the outlet. Be sure to cut the hole in the baseboard to fit the box and not the outlet plate. Fig. 4 shows this method.

—D. L. LOVE, Greensboro, N. C.

Items of Interest

CONTRIBUTIONS on the routine of servicing, the general equipment, and tools employed are piling in on the service

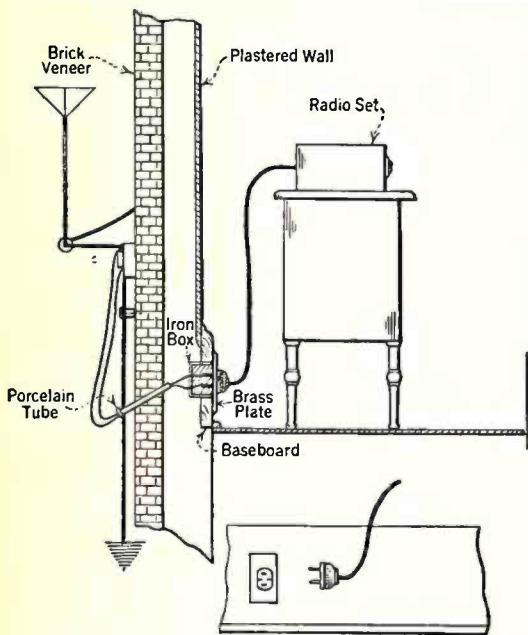

Fig. 4—A neat method for bringing antenna and ground wires in the house

editor's desk in response to our recent request for such material. Just what we are going to do with this—outside of the fact that it will be used—we don't know. It is possible that the material will prove of sufficient interest and length to justify a separate article—or perhaps we shall make a symposium of the various contributions—or, again perhaps, we shall pick the best points of all contributions and give them to you as a digest.

At any rate we are still open for suggestions on the routine of servicing and the simplest, yet complete, equipment with which to do it.

FRANCIS H. ENGEL, Radiotron Engine r. with the R. C. A., sends along the following suggestions in reference to tests on rectifiers and power tubes suspected of suffering from old age:

(1) The loss of emission in a rectifier tube (which is the usual cause of failure) is quite often accompanied by an increase in alternating-current hum. The most practical and simplest method of determining whether or not the rectifier tube is defective is to remove the tube in question and substitute in its place a new tube of known good quality.

(2) The average life of the 281-type rectifier is greatly in excess of 1000 hours when operated under maximum rated conditions. Individual tubes may fall short of this figure but the large majority of them will exceed it.

(3) Regarding a test for defective output tubes the same scheme as outlined above for the rectifier tube would seem best.

Many servicemen have written us asking for suggestions as to the best book available on the background of radio theory. We don't know any such book because each inquirer wants a book with some special emphasis to suit his particular needs. Most of our correspondents want a book on radio circuits, particularly dealing with receiving circuits, which does not devote major attention to the general theory of electrical circuits. There is such a book, indeed there are several. How Radio Receivers Work, by Wolter Van B. Roberts and published by RADIO BROADCAST, Garden City, N. Y. at \$1 net contains precisely the simple, clear analysis that is so welcome when it is found. Other useful books are listed on page 295 of this issue.

(4) Another test which a serviceman should make when looking for trouble in the rectifier unit of a receiving set is to test for d.c. voltage across the output terminals of the filter and voltage divider. Knowing, from experience, the normal value he can readily tell by his meter reading whether or not the rectifier tube is performing satisfactorily.

*Literature That Sells Service:* The radio service business, for the greater part, concerns a commodity that sells itself. When a radio set actually goes wrong, the average person turns to the serviceman and it requires no salesmanship to convince him that his set needs repairing. But sales literature—circulars and cards describing the advantages of some particular serviceman or company—can go a long way toward building up a profitable service business.

Such literature acts in several ways. It reminds the radio owner that it is foolish to wait until his set actually goes bad,—until he misses entertaining programs—before calling in the serviceman. It also impresses on his mind the name and address of a reliable serviceman available in case of trouble. Thirdly it may call his attention to subtle difficulties existing in his set of which he was only vaguely aware.

Fig. 2 shows a card circulated by William V. Lowe, Certified Radiotrician, of Fitchburg,

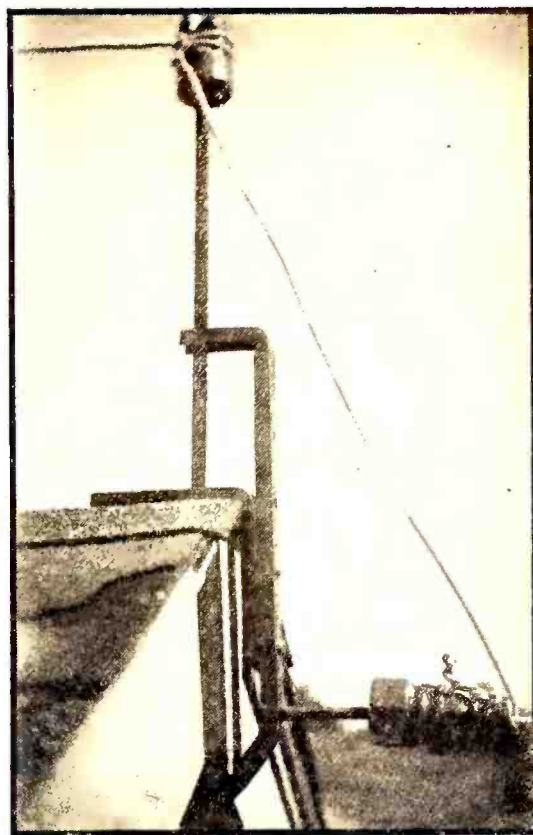

Fig. 3—A simple antenna clamp which is easy to install.

Mass., that gives a good idea of what can be done in the way of progressive servicing.

The possibilities of drumming up trade in this manner are enormous. Special circulars could be prepared, prior to important broadcasts, suggesting the inspection services of an expert at a special price. The average set owner should be educated into having his equipment examined at regular intervals—in the same way that the intelligent man goes to his dentist. Stock circulars can be prepared for distribution in the late summer suggesting that now is the time to have receivers gone over thoroughly in preparation for the coming radio season.

Good radio service sales literature might turn the summertime into a profitable radio season.

"The Serviceman's Corner" is particularly interested in circulars, letterhead and cards of this nature, and will pay a special price for those reproduced.

Arthur Rogers, New York City serviceman, has been building up sales on electric phonograph pick-ups by following up his old customers. He circularizes the owners of receivers he made several years back, adding to this list all recent service jobs on old equipment. He suggests modernizing these receivers by the installation of power amplifier apparatus and new speakers. The phonograph pickup naturally follows.

"The Serviceman's Corner" pays for live sales tips.

What should the serviceman charge? What is an equitable price for an inspection?—for an hour's work? How should the serviceman figure his charges? Should the profit on parts lessen his charges for time? "The Serviceman's Corner" will welcome an exchange of ideas on this subject.

An antenna clamp which makes installation quick, and much neater than is often possible has been brought out by the F. G. Manufacturing Company, 1117 Peoples Bank Building, Indianapolis, Indiana. This clamp requires no nails or braces to affix it to the roof, or chimney. A sample has been examined in the Laboratory and found very satisfactory. The picture, Fig. 3, shows how the device looks.

# IMPORTANCE OF IMPEDANCE RELATION

By C. T. BURKE

Engineering Department, General Radio Company

IT IS recorded that a lecturer on sanitation, speaking in a portion of the country which shall from motives of policy, be nameless, upon reaching the inevitable question period was somewhat taken aback by the query "What's sanitation?" Lest the writer find himself in a similar predicament he hastens to define impedance, which he is going to endeavor to explain briefly in this article. The first part of this article is devoted to the general subject of impedance and the latter part of the article to its application to audio transformers.

Impedance is that quality in an electrical circuit which impedes or limits the flow of current, and determines the value of the current that flows when a given pressure (voltage) is applied against the obstruction. It should not be necessary to point out that, if we are connecting an electrically operated device in a circuit, the impedance of the device is of the utmost importance, since it regulates the amount of current which is delivered to it from the source. A device of very great impedance approaches an open circuit in effect, that is, little current flows from the generator to the load. On the other hand, if a short circuit (very low impedance) is placed across the generator, all the available voltage will be used up in forcing the large current through the internal impedance of the generator.

The power supplied to the load depends neither on current nor voltage alone; it is proportional to the product of current and voltage, that is, power equals volts times amperes. Fig. 3 shows the variation of current, voltage, and power for a source of 5000 ohms impedance (for example, a tube with a plate impedance of 5000 ohms, such as a 210 or 112A) and generating 100 volts, as the load impedance is varied. The current is at maximum when the output or load resistance is zero under which conditions the current is equal to the voltage, 100, divided by 5000 ohms which gives 20 milliamperes. The voltage available across the load is equal to

$$\text{Voltage across the load} = 100 \text{ volts times } \frac{\text{Resistance of load}}{\text{Resistance of load plus internal resistance of generator (5000 ohms)}}$$

The voltage across the load, therefore, rises as the load impedance is increased and will be at maximum when the load impedance is infinitely high. The power in the load, however, rises to a maximum where the load is 5000 ohms, or equal to the source impedance. This relation is always true; that is, the maximum transfer of energy occurs when the source

(generator) impedance and the load impedance are equal. This is a universal rule applying to batteries, rotary generators, and converters, as well as to vacuum tubes.

*We are pleased to present this article by Mr. Burke in which he endeavors to clear up some misconceptions regarding impedance, especially as it affects the operation of audio transformers. Impedance is a characteristic possessed by every unit used in a receiver and few things in radio are more important than a clear understanding of what impedance is and how it affects the operation of various devices.*

—THE EDITOR.

## Conditions in Tube Circuits

IN COMMUNICATION circuits, the impedance of the circuit elements is often necessarily high, so that the current flow even under short circuit will not cause damage. Under these circumstances, with vacuum tubes it is possible to realize the theoretical maximum output of the device, obtained when the load impedance equals the generator impedance, and the so-called "matching" of impedances becomes important. That is, in connecting two circuits or devices together, it becomes important to have the impedance of the circuit in which the power originates (the source) equal to the impedance of the load (or "sink"). For a concrete example, a power tube of 5000 ohms impedance will deliver maximum power to a load of 5000 ohms impedance.

The importance of exact matching of impedance has undoubtedly been over-emphasized. In the power curve of Fig. 3 it will be noted that, while the maximum power to the load occurs with a load resistance of 5000 ohms, the load resistance can vary from 2600 to 10,900 ohms, a range of about 4 to 1, with only ten per cent. reduction in load power. Owing to a peculiarity in the behavior of vacuum tubes, the maximum undistorted output will be delivered to a load of twice the impedance of the tube, i. e., 10,000 ohms for a 5000-ohm tube, and in designing a circuit this relation is usually aimed at.

The impedance of a device is determined generally by certain considerations in its design which cannot be altered conveniently to obtain the optimum impedance relation when the device is worked out of a source of a certain impedance. The remedy for this situation is fortunately quite simple, involving only the use of the so-called impedance adjusting transformer. The remainder of this article is devoted to a discussion of this important device.

## Impedance Adjustment

IT WILL be remembered that impedance was defined as the opposition which a circuit offered to the flow of current, in other words the factor which determines the flow of current from a source of definite voltage and

internal impedance. If, then, a load impedance may be so affected as to cause the same current to flow in from the source as would another impedance, it is, so far as the source is concerned, equivalent to the latter impedance. If the load impedance is less than the source impedance there are two methods of increasing it, by means of a series impedance, and by means of a transformer. The series impedance method does not generally accomplish the desired result. Under the conditions in which we are principally interested, i. e., a vacuum tube feeding a loud speaker, the series impedance is not effective. While the "matching" thus accomplished does increase the power output of the tube, it does not increase the input to the load, since the added power is dissipated in the extra series resistance. Similar reasoning will dispose of the suggestion of the use of a parallel impedance to reduce the load impedance. There is left as a possible means of impedance adjustment, the transformer.

The action of a transformer is to step-up or -down an alternating current or voltage. Since the transformer is not a source of power, the power must be the same on both sides except for the losses in the instrument. Power being proportional to the product of current and voltage, this product must be the same on both sides of the transformer, i. e. the current is stepped-up in the same ratio as the voltage is stepped-down, and vice versa. This ratio of transformation is the ratio of turns in the two windings (approximately).

Consider the loaded transformer of Fig. 1. The definition of impedance may be stated

$$\text{algebraically as: } Z = \frac{E}{I}, \text{ i. e.,}$$

$$\text{impedance} = \frac{\text{voltage}}{\text{current}}$$

Then if  $Z_{i.e.}$  is the equivalent impedance of the transformer and load (the impedance which would permit the same current to flow as flows with the loaded transformer):

$$Z_{i.e.} = \frac{E_1}{I_1} = \frac{NE_1}{I_2} = \frac{NE_1 Z_L}{E_2} = N^2 Z_L$$

where  
 $Z_{i.e.}$  — equivalent impedance of load from primary of transformer  
 $N$  — turns ratio =  $E_1/E_2$   
 $E_1$  — voltage across primary  
 $I_1$  — primary current  
 $I_2$  — secondary current  
 $E_2$  — secondary voltage  
 $Z_L$  — load impedance

That is, the equivalent impedance of a transformer of a turns ratio of  $N$ , loaded with

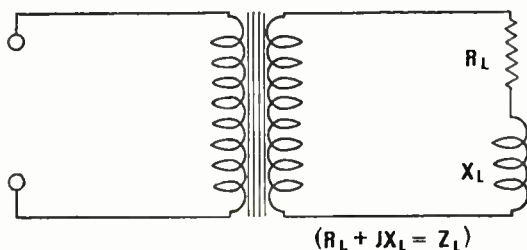

Fig. 1—Diagram of a transformer with load.

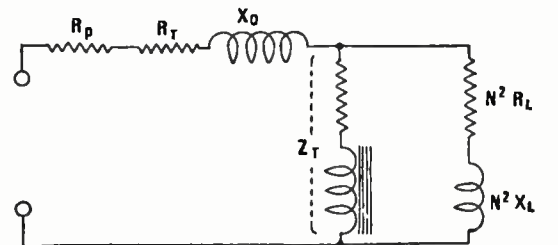

Fig. 2—Equivalent circuit of the loaded transformer. The circuit of Fig. 1 may be replaced by this series-parallel network



an impedance  $Z_L$ , is  $N$  squared times  $Z_L$ , or the effect of the transformer is to multiply the load impedance by the square of the turns ratio which may be a fraction or an integer depending upon whether the high or the low side of the transformer is loaded.

In the foregoing discussion, the turns ratio of the transformer is assumed to be the only transformer characteristic entering the relation. This ideal condition does not actually exist and, in designing or selecting an impedance adjusting transformer, other factors must be considered. There are, of course, the power losses which invariably accompany the passage of power through a conversation. These, however, are small in a well-designed transformer. Most important, however, is the impedance of the transformer itself.

In discussions of impedance-adjusting transformers, the statement is often made that the primary impedance of the transformer should equal the impedance of the source, and its secondary impedance equal that of the load. At best this is a careless statement. The effective impedance of the loaded transformer is determined by the

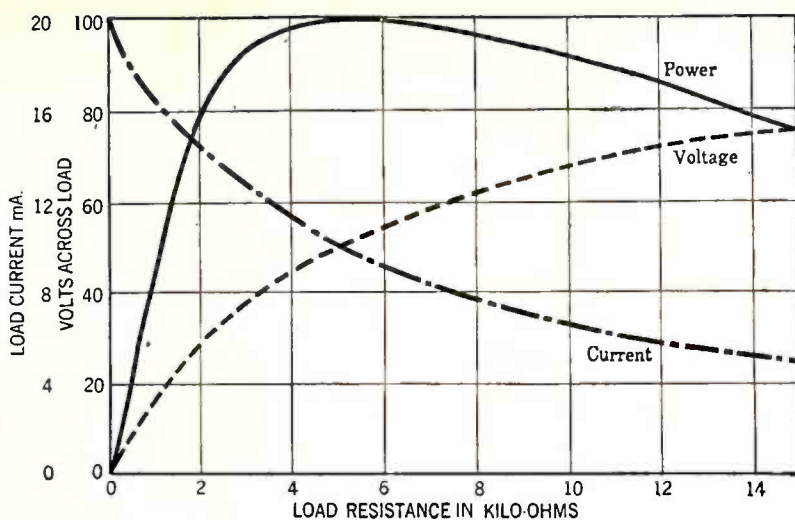

Fig. 3—Variation of voltage, current, and power as the load is varied. Values were computed on the basis of a 5000-ohm tube impedance and a resistance load

impedance of the load over the frequency range for which good efficiency is maintained. The complete equivalent circuit of the loaded transformer is shown in Fig. 2.

The series impedance,  $R_t$  and  $X_o$ , repre-

sents the loss in voltage due to transfer losses and leakage reactance. The shunt impedance,  $Z_i$ , is equivalent to the primary open circuit impedance of the transformer, to which one would expect the term transformer impedance to apply. This impedance has no definite value unless a frequency is specified, i. e., it varies with frequency. The fact that this impedance was ignored in the original discussion gives the clue to its proper value—it must be so high as to take no appreciable current from the source. The useful frequency range of the transformer is the range of frequencies over which this impedance is high enough to prevent appreciable current flow through it. At any frequency at which the transformer is useful, this impedance must be, not equal to, but several times the impedance of the source.

An impedance-adjusting transformer should have a turns ratio equal to the square root of the ratio of the impedances to be coupled. The input impedance of the transformer with the secondary open circuited should be several times that of the source at all frequencies in the range to be covered.

## Table of Wavelength Allocations

The following table gives the wavelength allocations which were adapted by the International Radiotelegraph Conference at Washington, D. C. The data show the type of service permitted in wavelength bands

between 5 and 30,000 meters (60,000 and 10 kilocycles per second). This radio allocation plan, of course, is used in all civilized countries of the world, as it was adopted at an international conference.

Frequencies in kilocycles per second (kc/s)	Approximate wavelengths in meters	Services	Frequencies in kilocycles per second (kc/s)	Approximate wavelengths in meters	Services
10- 100	30,000-3,000	Fixed services.	550- 1,300 <sup>4</sup>	545- 230 <sup>4</sup>	Broadcasting.
100- 110	3,000-2,725	Fixed services and mobile services.	1,300- 1,500	230- 200	(a) Broadcasting.
110- 125	2,725-2,400	Mobile services.			(b) Maritime mobile services, waves of 1365
125- 150 <sup>1</sup>	2,400-2,000 <sup>1</sup>	Maritime mobile services open to public correspondence exclusively.			kc/s (220m) exclusively.
150- 160	2,000-1,875	Mobile services.	1,500- 1,715	200- 175	Mobile services.
		(a) Broadcasting.	1,715- 2,000	175- 150	{ Mobile services.
		(b) Fixed services.			{ Fixed services.
		(c) Mobile services.	2,000- 2,250	150- 133	{ Amateurs.
		The conditions for use of this band are subject to the following regional arrangements:	2,250- 2,750	133- 109	{ Mobile services and fixed services.
		All regions where broadcasting stations now exist working on frequencies below 300 kc/s (above 1000m).	2,750- 2,850	109- 105	{ Mobile services.
160- 194	1,875-1,550	Other regions { Fixed services.	2,850- 3,500	105- 85	{ Fixed services.
		{ Mobile services.			{ Mobile services and fixed services.
		Regional arrangements will respect the rights of other regions in this band.	3,500- 4,000	85- 75	{ Mobile services.
		(a) Mobile services.			{ Fixed services.
		(b) Fixed services.	4,000- 5,500	75- 54	{ Amateurs.
		(c) Broadcasting.	5,500- 5,700	54- 52.7	{ Mobile services and fixed services.
		The conditions for use of this band are subject to the following regional arrangements:	5,700- 6,000	52.7- 50	{ Mobile services.
		(a) Air mobile service exclusively.	6,000- 6,150	50- 48.8	{ Fixed services.
		(b) Air fixed services exclusively.	6,150- 6,675	48.8- 45	{ Broadcasting.
		(c) Within the band 250-285 kc/s (1200-1050m). Fixed service not open to public correspondence.	6,675- 7,000	45-42.8	{ Mobile services.
194- 285	1,550-1,050	Europe { (d) Broadcasting within the band 194-224 kc/s (1550-1340m).	7,000- 7,300	42.8-41	{ Fixed services.
		(a) Mobile services except commercial ship stations.	7,300- 8,200	41-36.6	{ Amateurs.
		(b) Fixed air services exclusively.	8,200- 8,550	36.6-35.1	{ Fixed services.
		(c) Fixed services not open to public correspondence.	8,550- 8,900	35.1-33.7	{ Mobile services.
			8,900- 9,500	33.7-31.6	{ Mobile services and fixed services.
			9,500- 9,600	31.6-31.2	{ Broadcasting.
			9,600- 11,000	31.2-27.3	{ Fixed services.
			11,000- 11,400	27.3-26.3	{ Mobile services.
			11,400- 11,700	26.3-25.6	{ Fixed services.
			11,700- 11,900	25.6-25.2	{ Broadcasting.
			11,900- 12,300	25.2-24.4	{ Fixed services.
			12,300- 12,825	24.4-23.4	{ Mobile services.
			12,825- 13,350	23.4-22.4	{ Mobile services and fixed services.
			13,350- 14,000	22.4-21.4	{ Fixed services.
			14,000- 14,400	21.4-20.8	{ Amateurs.
			14,400- 15,100	20.8-19.85	{ Fixed services.
			15,100- 15,350	19.85-19.55	{ Broadcasting.
			15,350- 16,400	19.55-18.3	{ Fixed services.
285- 315	1,050- 950	Radio beacons.	16,400- 17,100	18.3-17.5	{ Mobile services.
315- 350 <sup>2</sup>	950- 850 <sup>2</sup>	Air mobile services exclusively.	17,100- 17,750	17.5-16.9	{ Mobile services and fixed services.
350- 360	850- 830	Mobile services not open to public correspondence.	17,750- 17,800	16.9-16.85	{ Broadcasting.
360- 390	830- 770	(a) Radio compass service.	17,800- 21,450	16.85-14	{ Fixed services.
		(b) Mobile services, on condition that they do not interfere with radio compass service.	21,450- 21,550	14-13.9	{ Broadcasting.
390- 460	770- 650	Mobile services.	21,550- 22,300	13.9-13.45	{ Mobile services.
460- 485	650- 620	Mobile services (except damped waves and radiotelephony).	22,300- 23,000	13.45-13.1	{ Mobile services and fixed services.
			23,000- 28,000	13.1-10.7	{ Not reserved.
485- 515 <sup>3</sup>	620- 580 <sup>3</sup>	Mobile services (distress, call, etc.).	28,000- 30,000	10.7-10	{ Amateurs and experimental.
515- 550	580- 545	Mobile services not open to public correspondence (except damped waves and radiotelephony).	30,000- 56,000	10-5.35	{ Not reserved.
			56,000- 60,000	5.35-5	{ Amateurs and experimental.
			Above 60,000	Below 5	{ Not reserved.

<sup>1</sup>The wave of 143 kc/s (2,100m) is the calling wave for mobile stations using long continuous waves.

<sup>2</sup>The wave of 333 kc/s (900m) is the international calling wave for air services.

<sup>3</sup>The wave of 500 kc/s (600m) is the international calling and distress wave. It may be used for other purposes on condition that it will not interfere with call signals and distress signals.

<sup>4</sup>Mobile services may use the band 550 to 1,300 kc/s (545-230m) on condition that this will not cause interference with the services of a country which uses this band exclusively for broadcasting.

NOTE.—It is recognized that short waves (frequencies from 6,000 to 23,000 kc/s approximately—wavelengths from 50 to 13m approximately) are very efficient for long distance communications. It is recommended that as a general rule this band of waves be reserved for this purpose, in services between fixed points.

# our readers suggest . .

## Reducing Static

A SIMPLE and effective way to reduce heavy static crashes and other interference such as howls from radiating receivers to the signal level has been tried out by the writer on a number of receivers with gratifying results.

A neon glow lamp, such as is sold by electrical-supply houses for use as pilot lights on 110-volt lines, is the "magic lamp" which effectively reduces static to ineffectual "plunks," and cuts the ear-splitting howl of radiating receivers to a less offensive squeal that does not rise in volume above that of the incoming signal.

The neon glow lamp, known as T14 and rated at  $\frac{1}{6}$  watt, costs 60 cents. It has a screw base, containing a resistance compound which prevents excessive current flow when used on standard light circuits. Carefully cut this screw base off with tin snips and remove the resistance compound, being cautious not to break the delicate bulb or the fine lead-in wire. Solder No. 30 copper wires to the leads. Bend a piece of light metal around the glass bulb so as to form a mold for a base. Drop in hot sealing wax or rosin. This will harden into a base which will protect the tube and the delicate terminals.

The "static-spiller" is now ready to be connected in shunt with the loud speaker as suggested in Fig. 1.

The signal volume should be adjusted to suit the average requirements. At this volume setting the neon tube will not light at all, or only at rare intervals. When static is received if the surge is equal or smaller in amplitude than the incoming signals it will pass through unaffected by the neon tube, but it will be fairly innocuous. The crashing static that makes radio reception impossible is greater in volume than the received signal and therefore "spills over" through the shunting neon tube. When bad static is being received the crashes are visible each time they occur, the tube flashing brightly.

When the squeal of a blooper comes through the tube lights, holding the squeal down to the level of the received signal.

R. F. STARZL, Le Mars, Ia.

### STAFF COMMENT

Mr. Starzl's idea should be reasonably effective in many cases. It is *not* a static eliminator. It is merely a device that has a limiting effect on volume. If the device is set to operate above a certain arbitrary signal level, the effect of any disturbance above this limit will be reduced.

It will be desirable to adjust the neon-lamp circuit so that it spills over at the correct

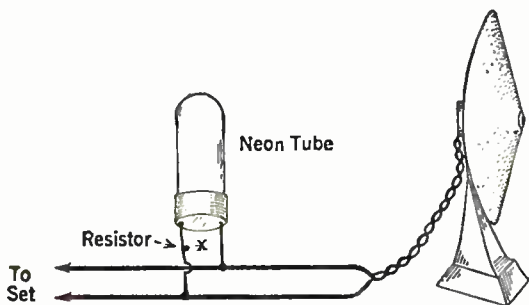

Fig. 1—A neon tube connected as shown above is an effective static reducer

This department of RADIO BROADCAST is utilized each month for the presentation of miscellaneous short radio articles which are received from readers. These abbreviated manuscripts describe "kinks," radio short cuts, and economies that the experimenter runs across from time to time and that can be made clear in a concise exposition. Although some of these notes have been submitted by engineers and professional writers, the editors particularly solicit contributions from the average reader. All material accepted, including photographs, will be paid for on publication at our usual rates with extra consideration for particularly meritorious ideas

—THE EDITOR.

intensity. If it spills over at too low a volume a variable resistor, such as a universal range Clarostat, should be placed in series with it.

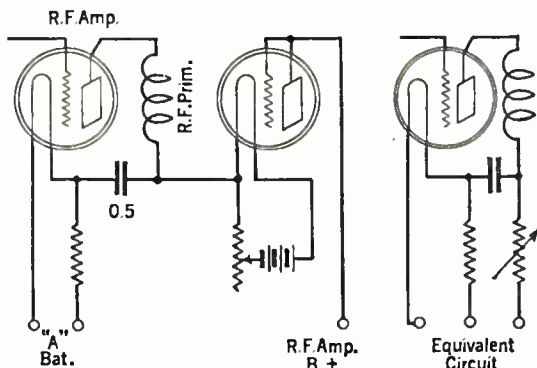

Fig. 2—The vacuum-tube circuit shown above is an excellent variable-range high resistor

## A Variable-Range High Resistor

THE vacuum tube can be used as a variable high-range resistor for a variety of radio purposes, by taking advantage of the fact that its internal resistance varies with the filament emission. With plate and grid elements of the tube connected together, either filament leg may be used as one terminal of the resistor, and the common grid-plate connection as the other. The filament is controlled by a rheostat, which, in turn, varies the resistance of the plate-filament circuit. Using a 199-type tube a resistance range of from about 3000 ohms to infinity can be secured. The actual lower limit will vary with the voltage applied across the device.

The principal advantage of this arrangement is that it provides a silent, velvet variation in resistance. It may be used most successfully as a regeneration or oscillation control in receiving circuits, as suggested in Fig. 2. The use of a 199-type tube is recommended because, in many instances, it will be necessary to use a separate filament-lighting source. The resistor, of course, is operable only in d.c. circuits (such as the plate circuit of a receiver), and the plus side of the line must be connected to the plate-grid terminal.

RALPH VAN KEUREN, Beloit, Michigan.

## A Good Coil Cement

AN EXCELLENT dope for coating solenoid coils, and for giving the necessary rigidity to spiderwebs and other self-supporting coils, may be made by dissolving one ounce of paraffin in one pint of high-test gasoline. This solution may also be used as a substitute for boiling in paraffin in almost any radio impregnation job.

S. W. OLDERSHAW, Waterbury, Conn.

## Ghostly At Least

I HAVE found that my radio set can be enjoyed by everyone in the house by means of a very simple device. I attached a long cord to my loud speaker, and passed it through the same hole that I use to bring my battery wires up from the cellar. Then I place my loud speaker directly in front of the opening where cold air is taken into the hot-air furnace. When I turn on my radio set, the pipes from the furnace serve as carriers, transmitting the music into all rooms of the house. Oftentimes a guest is quite mystified to hear this perfectly transmitted music coming out of the register.

JACQUE LONGAKER, Buffalo, N. Y.

### STAFF COMMENT

The idea is novel—useful to an extent, and replete with humorous possibilities. But we should hesitate to second our contributor's characterization of the reproduction as "perfectly transmitted." Hot-air heating pipes hardly have the acoustic properties of an ideal loud speaker.

## An Economical Voltage Divider

THE 2 candle-power 110-volt carbon lamps, purchasable at almost any five and ten cent store for ten cents, make excellent resistor units for radio purposes. Each lamp has a resistance of about 2000 ohms.

I have found them particularly applicable to the requirements of a voltage divider in power-supply units. A power source having a maximum potential of 180 volts will require from six to eight lamps for a "bleeder" arrangement. These may be mounted easily by placing them in holes, one inch in diameter, drilled in thin wood or a bakelite strip. After the lamps have been mounted they are connected in series by soldering directly to the screw bases. Employing eight lamps, any voltages between 0 and 180 may be had in 22.5 volt steps. A typical arrangement is suggested in Fig. 3. As usual, each voltage tap should be bypassed to B negative.

C. H. GALBRAITH, Boston, Mass.

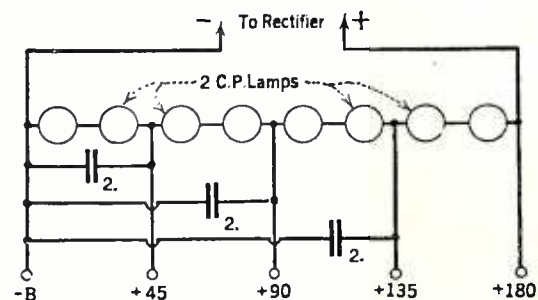

Fig. 3—A simple inexpensive voltage divider for a B power-supply unit.

# A HOME-MADE THERMIONIC MILLIAMMETER

By G. F. LAMPKIN

IT IS more than ordinarily difficult for the radio worker to measure alternating currents around or below 25 milliamperes. A necessity for determination of currents in this range usually leads to a contemplation of vacuum thermo-couples and d.c. microammeters. Full-scale ranges of 100 milliamperes can be had rather reasonably in self-contained thermogalvanometers; but because of the current-squared crowding of the scale, readings below 25 milliamperes cannot be reliably taken.

It is useful, then, to know that a vacuum tube can be fitted up rather simply to measure alternating currents from some 5 milliamperes upwards. A 199-type tube, a one-milliamper d.c. meter, and a 30-henry choke are the chief accessories necessary to measure currents in the above mentioned range. In the range from 35 milliamperes to as high as desired only the tube, d.c. meter, and appropriate shunts are needed.

Calibration of a home-made meter usually necessitates the use of a standard meter for the same kind and range of current. In this case, however, only a 0-100 d.c. milliammeter is required, and it can be improvised from the 0-1 meter if necessary.

## Design of Meter

THE principle utilized in the thermionic meter is the change in emission current of a tube due to change in filament-heating current. Fig. 1 is the circuit diagram. The 0-100 milliamper meter is not a permanent part of the set-up, but is used only to obtain the initial filament-current, plate-current characteristic. Fig. 2 shows this curve for a typical 199-type tube. Appreciable emission is not had until some 35 milliamperes flow in the filament. It is evident 5 or 10 milliamperes of a.c. alone would have no effect whatsoever in producing emission current.

The scheme, then, to measure alternating currents in this lower range is to pass an initial d.c. through the filament, and on this current superimpose the a.c. which is to be measured. The a.c. alternately adds to and subtracts from the steady filament current. If the temperature of the filament could instantaneously follow these current fluctuations, the plate current would swing up and down the emission-current curve of Fig. 2. However, because of heat capacity, thermal lag, frequency of fluctuations, and such, the temperature of the filament cannot follow the heating-current fluctuations. What happens is that the temperature takes up a new value dependent on the new root-mean-square value of the heating current. The average value of the current, of course, does not change—but the average value plays no part in determining the filament temperature. The r.m.s. value of

the steady initial current is simply its d.c. value. The new r.m.s. value caused by the combination of the a.c. with the d.c. can be calculated by:

$$I_{r.m.s.} = \sqrt{(I_{d.c.})^2 + (I_{a.c.})^2}$$

This change in heating value of the filament current is evidenced by a change in the d.c. plate current. By suitable calibrations, and

*The author of this article, who is no stranger to the readers of RADIO BROADCAST, has used the meter described to measure the overall frequency characteristics of receivers, the currents into loud speakers, the a.c. in power-supply chokes whose inductance was being measured, and, as he says, once one has an instrument that will measure accurately small values of a.c., many other uses will be found for it. It is much less expensive than a combination thermo-couple and microammeter—and repairs are less costly, too.*

—THE EDITOR

fortunately by calculations, the magnitude of the superimposed a.c. can be determined from plate-current readings.

In the set-up of Fig. 1 the 30-henry choke is necessary to insure that the a.c. takes its intended path through the tube's filament. The filament battery has a low a.c. resistance, and were it not for the choke it would bypass the larger part of the a.c. The usual d.c. resistance value of a 30-henry choke is approximately 300 ohms, which makes necessary a filament battery of 22½ volts. The filament battery should be of the heavy-duty B type, for it must supply a current of 40 or 50 milliamperes. A 400-ohm rheostat or potentiometer is used for filament control. The filament battery could be made to serve also as a B battery, by returning the anode connection to the positive terminal. However, the comparatively heavy load which the battery must supply tends to cause a rather rapid drop in voltage; and, although the battery remains entirely suitable for A supply, the changed plate voltage leads to inaccurate results. For this reason, another battery is used to supply the plate voltage. One additional battery, a 4½-volt unit which supplies bucking-out current for the plate meter, is also used.

When obtaining the emission characteristic of Fig. 2, readings are taken up to one milliamper plate current, the full-scale range of the meter. Then a 50-ohm rheostat, which is connected across the plate meter, is adjusted until the deflection is exactly half its original value. This will require a shunt of approximately 39 ohms on a Jewell meter. Readings up to 2 milliamperes are taken, because the curve in this region is necessary for calculating calibration points.

The sensitivity of the thermionic meter depends on what part of the tube's filament-current, plate-current characteristic is worked. It

may be seen that a given change in r.m.s. filament current at a low initial current, say 38 mA., will produce only a fraction of the plate-current change that would be caused at a higher initial current 60 mA., for example. The resistance in the circuit diagram of Fig. 1 through which bucking-out current is fed to the plate meter is fixed. The only control is the 400-ohm filament rheostat.

The procedure in using the meter is to close the battery switch and adjust the filament rheostat until the plate meter reads zero. This will happen when the emission current equals the bucking-out current supplied through the 4½-volt battery and fixed resistor.

Thus the size of the fixed resistor automatically determines what initial emission current must flow and accordingly what part of the filament-plate current characteristic is to be used. If the value of the fixed resistor is low, the bucking-out current will be large. To produce an equally large emission current a high initial filament current will be necessary, and the resultant sensitivity of the meter to a.c. will be good. However, extreme values of initial filament and emission current are detrimental to the tube's life and the accuracy of calibration and so should be avoided.

The calibration curves of Fig. 3 were made by measuring the superimposed 60-cycle current on the tube's filament, and taking the corresponding plate-current readings. With a 2500-ohm resistor in the bucking-out circuit, the initial plate current, which was required to equal the bucking-out current, was 1.6 milliamperes; and the superimposed a.c., which gave a one-milliamper plate current range, was 3 to 18 milliamperes. Greater sensitivities can be had by working higher on the emission curve, i.e., with smaller values of bucking-out resistance, but such is not advisable. A 10,000-ohm fixed resistor and an initial plate current of 0.4 milliamperes gave a range of 6 to 23 milliamperes a.c. (curve 2 of Fig. 3). With the bucking-out circuit opened, and the plate current adjusted to an initial current of 0.02 milliamperes, the a.c. maximum was 35 milliamperes (curve 1.). The calibration on the latter range departs much farther from the linear than does the one for 6-23 milliamperes. The lower range calibration works over a more restricted and a straighter part of the emission characteristic, so that it does not show the sharp bend present in the 15-35 milliamper curve.

It is important to note that there must not exist a d.c. path in the circuit which carries the to-be-measured a.c. A d.c. path would draw current from the filament battery of the tube and disarrange the zero setting. In



Parts required for construction of a 35-m.A. thermionic milliammeter

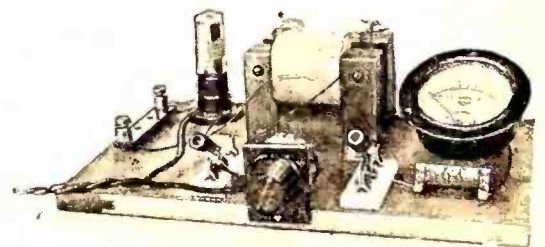

View of the author's thermionic milliammeter set-up

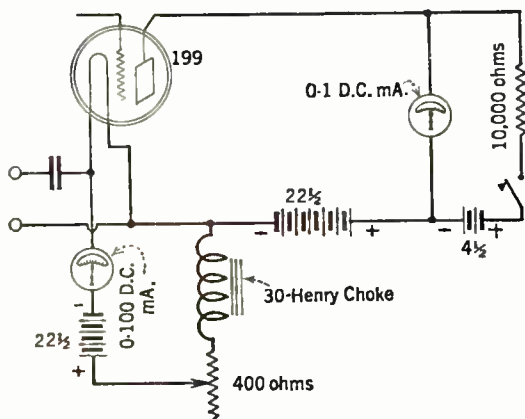

Fig. 1—Schematic circuit of thermionic milliammeter

such cases it would be necessary to insert a condenser in the a.c. leads to the tube. The size of the condenser is determined by the impedance which it is permissible to insert in the circuit carrying the a.c. The resistance of the thermionic meter alone to the a.c. is approximately 50 ohms.

Calibration by Calculation

THE check between calculated and calibrated points agrees within 3 per cent. and this shows that it is not necessary to have 20- or 40-milliamper a.c. meters at hand to calibrate the thermionic meter. From the known data as to initial filament-current and emission characteristic it is perfectly feasible to get good calibrations by computation. The procedure followed for the 6-23 milliamper curve (curve 2 Fig. 3) was first to measure the bucking-out current through the 10,000-ohm resistor. This was 0.4 milliamperes. From the emission curve of Fig. 2, 0.4 milliamperes corresponds to 46 milliamperes, the initial filament current. This is  $I_{d.c.}$  in the formula above. Then values of superimposed  $I_{a.c.}$  were assumed—say 7, 10, 14, etc. milliamperes—and the resulting r.m.s. values figured. For instance, for 10 milliamperes of assumed a.c.,

$$I_{r.m.s.} = \sqrt{(16)^2 + (10)^2} = \sqrt{2116 + 100} = 47.1 \text{ mA.}$$

Going back to the emission curve, 47.1 milliamperes in the filament gives 0.52 milliamperes plate current. Although 0.4 milliamperes already flow in the plate circuit, the meter reads only .12 mA. because of the bucking-out current. Thus the meter reading of 0.12 milliamperes corresponds to 10 milliamperes of superimposed a.c. In the case of the 15-35 milliamper curve (curve 1, Fig. 3) there was no bucking-out current. The initial plate current of 0.02 milliamperes meant a filament current of 36 milliamperes. The combination with an assumed value of 33 milliamperes a.c. gives:

$$I_{r.m.s.} = \sqrt{(36)^2 + (33)^2} = \sqrt{1296 + 1089} = 48.8 \text{ mA.}$$

The plate current for 48.8 milliamperes filament current is 0.75 milliamperes. Thus when the plate meter reads 0.75 mA., 33 mA., a.c. flows through the filament.

Both the filament battery and the bucking-out battery circuits on the meter set-up can be opened, and a.c. alone used to heat the filament—in which case currents from 35 milliamperes up can be measured. If lower current ranges are not necessary, the thermionic meter becomes simplicity itself. The raw materials required are only the tube, the one-milliamper meter, and a 22 1/2-volt B battery. There are no restrictions as to d.c. path in the circuit in which current is measured. The wave shape of the current is immaterial—on any sort of wave the meter reads the r.m.s. value. Shunts may be used to extend the range indefinitely upward. The fact that a

filament-current change of only 35 to 50 milliamperes gives full-scale change on the plate meter is both an advantage and a disadvantage. The limited a.c. range allows an open and easily read scale so that currents can be determined accurately. It also means, however, that an inconvenient number of shunts must be used to give overlapping ranges.

A possible alternative is to connect the grid of the tube to one side of the filament. By doing this the rate of increase of plate current with filament current is cut down, and a range of approximately 35 to 60 milliamperes results. In other words, the minimum readable current is 58 per cent. of full-scale value as compared with 70 per cent. when the grid is tied to plate. However, this alternative method makes the plate current dependent in a greater measure on the plate voltage, so that changes in plate voltage damage the accuracy more than in the case of grid-plate connection.

In Fig. 4 are given sample calibrations for the tube (grid connected to plate) when carrying a.c. alone, with and without shunts. These calibrations may be made with either d.c. or a.c. and then be used to measure any sort of a current.

[Editor's Note: Mr. Lampkin has indicated but briefly the uses to which such an instrument as he describes can be put. Anyone who has worked in the laboratory where small

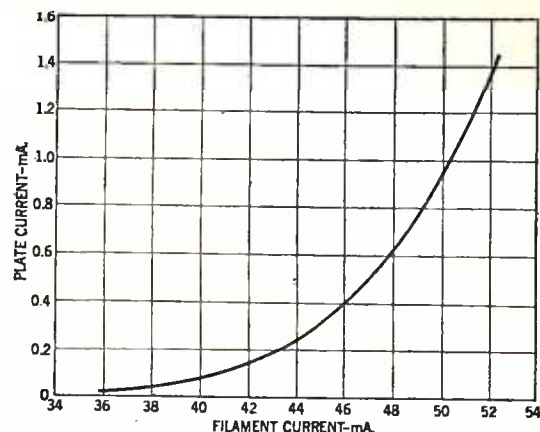

Fig. 2—Filament-current, plate-current characteristics of 199-type tube with 22 1/2 volts on plate and grid

a.c. potentials must be measured, either at low or high frequencies, will appreciate the advantages of this combination of tube and d.c. meter.

As an example, let us try to measure the impedance offered to a 60-cycle current by a 30-henry choke coil. There are various methods, all of which are more or less complex. This impedance, however, is largely inductive reactance, and, if we knew the current through the coil at a given a.c. potential across it, this reactance could be calculated. From this calculation would come the value of inductance and impedance in which we are interested. At 30 henries, and with an a.c. potential of 110 volts, the current through the coil will be about 10 milliamperes. Now a thermo-couple that will measure currents of this value costs about \$25 and requires a sensitive d.c. microammeter in order to read the rectified current. This meter will cost not less than \$35 and probably will amount to \$100. Therefore, in order to measure this small current of 5 to 10 milliamperes, equipment worth over \$100 is required.

The device described by Mr. Lampkin will measure this current easily and at much less cost than by the use of a thermo-couple and indicating meter. It is only necessary to put an initial current through the filament of the tube and then to add the current going through the choke. The differential of filament current will cause a differential in plate current which can be read on an inexpensive d.c. meter. After the tube and meter are calibrated, or when the values of plate current corresponding to certain values of filament current have been calculated, the meter is immediately useful. The change in plate current caused by the change in filament current can be obtained from a curve similar to those given on this page.

Other uses for the device have been indicated in the box on the preceding page. In all of the cases where a.c. and d.c. both flow through the device under measurement, care must be taken to prevent the d.c. current from flowing into the tube filament. This is a simple matter and requires only a large fixed condenser through which the a.c. will pass but which offers a very high opposition to the flow of d.c.

This milliammeter is one that can be built and operated by any home experimenter or any laboratory worker. The requirements are simple, a d.c. meter reading about one milliamper, a 60-milliamper filament tube, and a little patience at calculating what plate current will be read when a given a.c. current is added to the filament current.

As the author points out the resistance of the voltmeter to the a.c. currents which it is designed to measure is of the order of 50 ohms. The effect of this resistance on the circuit in which this a.c. currents flow must be taken into account, but in general such an addition will not upset the circuit condition.]

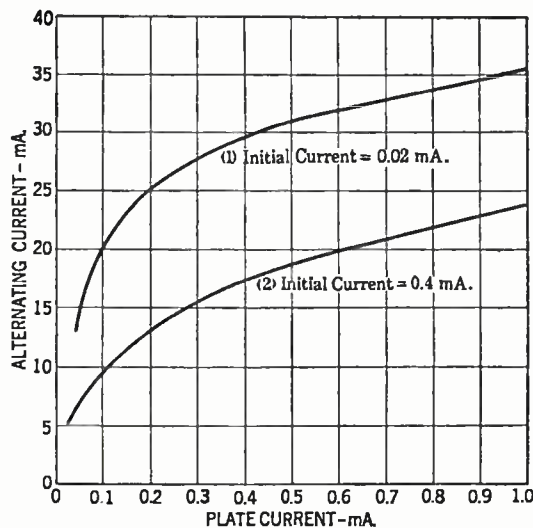

Fig. 3—Calibration curves of thermionic milliammeter

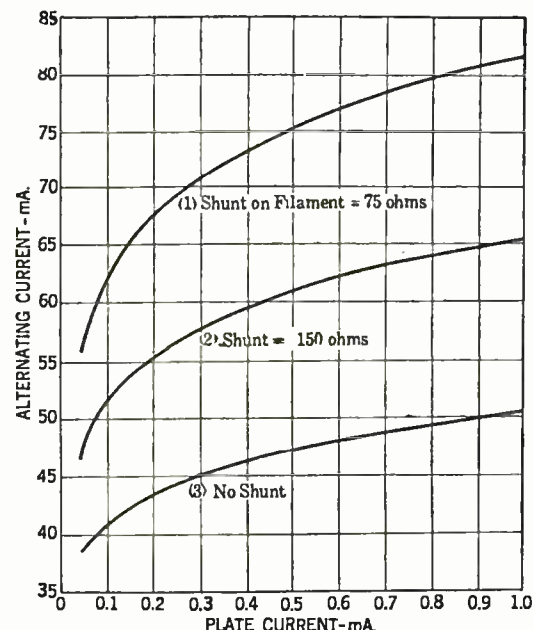
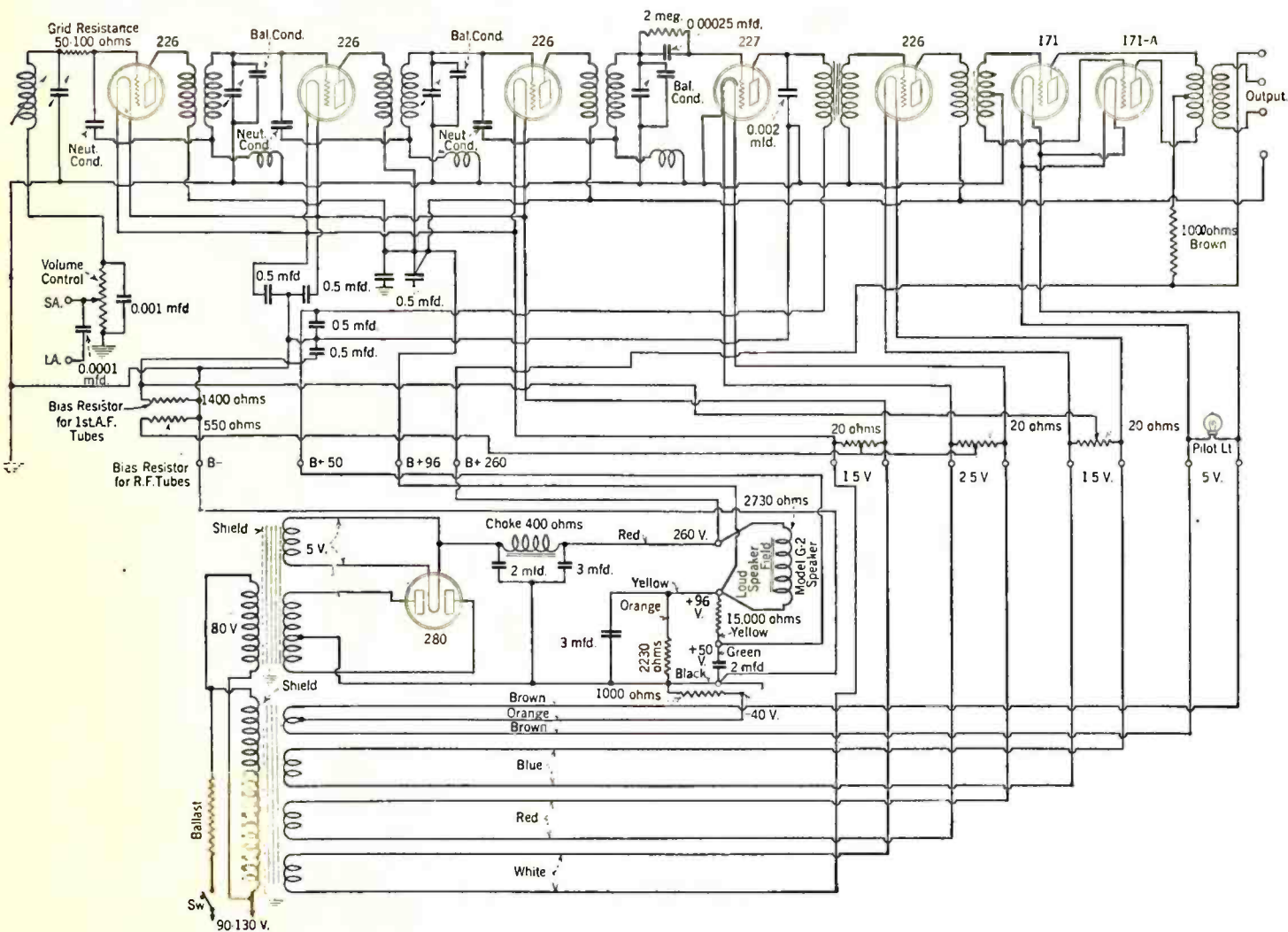

Fig. 4—Calibration curves of thermionic milliammeter with two values of filament shunts.

THE MAJESTIC MODEL 70-B RECEIVER

This seven-tube Majestic receiver consists of a three-stage tuned radio-frequency amplifier, a detector and a two-stage transformer-coupled audio-frequency amplifier, the output circuit of which is push-pull using

two 171A-type tubes. The power unit supplies A, B, and C potentials to the set and also provides field current for a Majestic model G-2 dynamic loud speaker.



THE FEDERAL TYPE D (60 CYCLE) RECEIVER

This interesting receiver manufactured by the Federal Radio Corporation uses four 201A- and one 171A-type tubes in a series filament circuit, the necessary current being furnished by a Raytheon BA-type

rectifier. It should be noted that the filament circuits of the r.f. amplifier tubes contain r.f. choke coils to prevent common coupling in the filament supply.

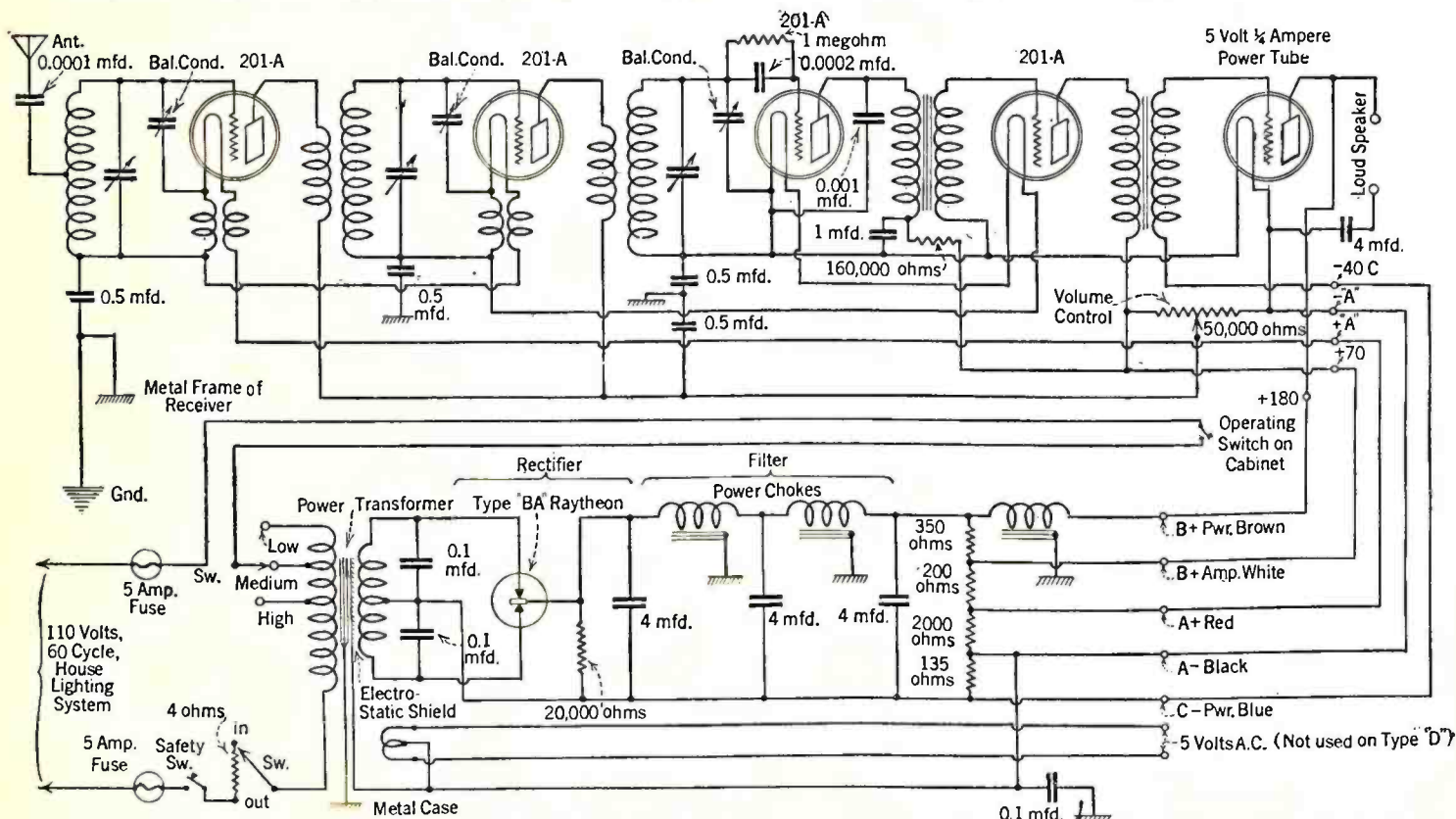

The data which was given in the description of the receiver in previous "Set Data Sheets" has been lettered on the above diagram.

THE CROSLY MODEL 704-B RECEIVER

This popular model in the Crosley line is a complete a.c. set. The Hazeltine neutrodyne circuit is used in the r.f. amplifier to prevent oscillation. The circuit of the power supply is designed to furnish field

current to a Crosley Dynacone loud speaker although any type of loud speaker may be used with the set. The output circuit is push-pull.

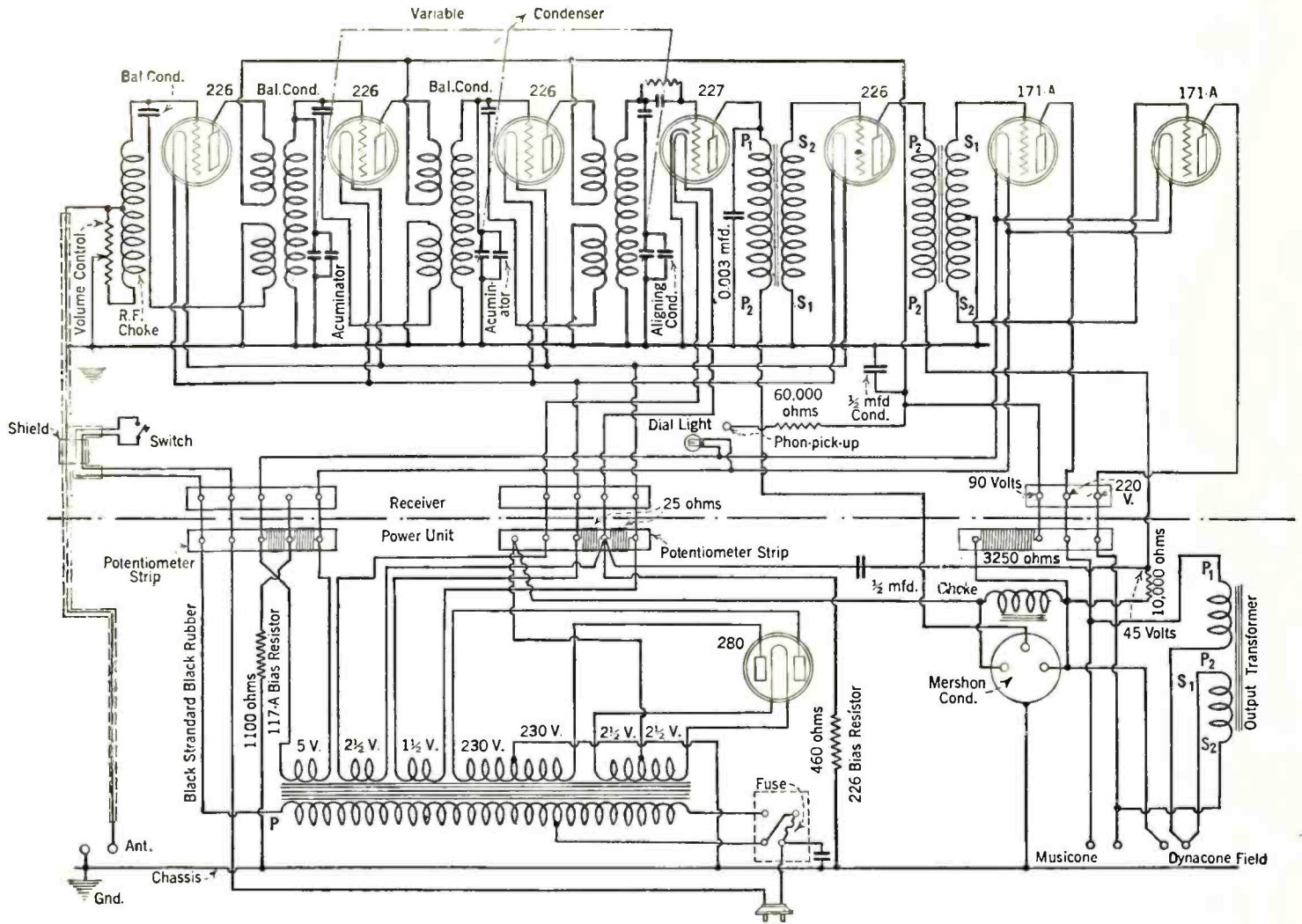

THE CROSLY MODEL 705 RECEIVER

This light-socket-operated receiver is designed for use in districts where the only power supply available is 110 volts d.c. The set uses five 201A- and three 171A-type tubes in a series-filament circuit. The

two push-pull 171A-type tubes in the output are supplied with about 90 volts so the available a.f. output is 100 milliwatts per tube giving a total of 300 milliwatts.

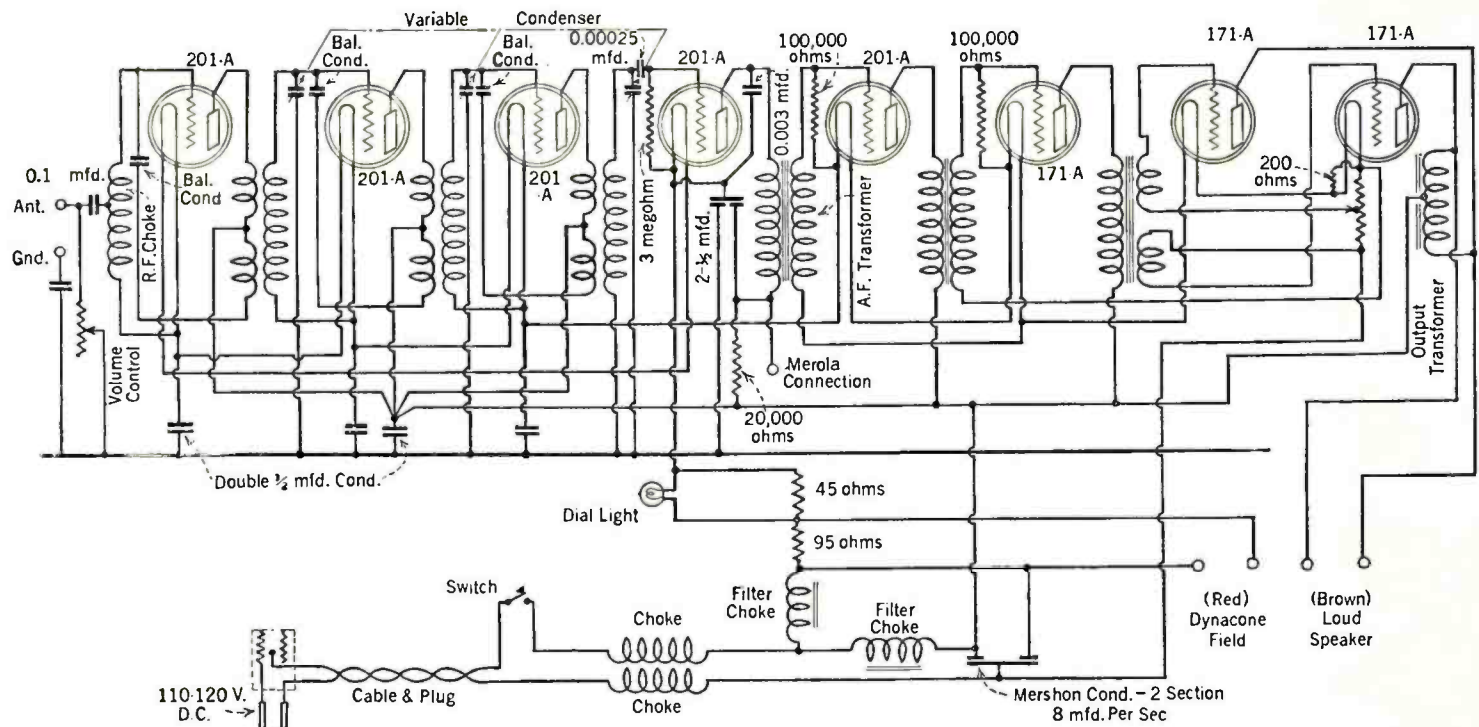

The data which was given in the description of the receiver in previous "Set Data Sheets" has been lettered on the above diagrams

# A HIGH-POWER OUTPUT TUBE—THE 250

By K. S. WEAVER

Westinghouse Lamp Company

THE 250-type power tube was developed to fill a definite place in the field of radio reception, that of a tube which would deliver a large output to a loud speaker without appreciable distortion and with a grid swing or input signal strength readily obtainable with available apparatus.

The tube as finally developed has been found to meet this requirement well. A filament of the coated type is used which insures an ample electron emission with a moderate filament power consumption. The plate resistance is inherently low, a plate voltage of only 450 being required for full power output.

The general characteristics of the tube were determined according to its intended use as a power amplifier. Consequently it is not well adapted for use as an oscillator or voltage amplifier. The use of a coated filament together with the low amplification factor, which were found to be very desirable features, are not ideal from the standpoint of oscillator tube design, although the tube can be used as an oscillator in certain cases.

Before going into the details of the development of the 250 it may be of interest to consider some of the factors which have made the production of tubes of high power output desirable.

A very few years ago about the only kind of loud speaker in general use was of the horn type operated by a vibrating metallic diaphragm. The characteristics of this type of loud speaker were such as to accentuate greatly the higher frequencies and to suppress the lower frequencies. Recent developments, however have made it possible to reproduce frequencies well below 100 cycles with practically normal relative intensity.

A general idea of the relatively large amount of power that the output tube must handle in order to reproduce the lower frequencies adequately may be secured by examination of a curve in the paper "An Analysis of the Voice-Frequency Range" by I. B. Crandall and B.

MacKenzie, *Bell System Technical Journal*, July, 1922. This curve shows in a striking way that in normal speech the power associated with the low frequencies is enormously greater than that associated with the high frequencies.

The same general relation may be observed readily by the use of an oscillograph or a milliammeter inserted in the output circuit of a receiving set. Low notes at intensities which are not particularly striking to the ear are seen to have amplitudes many times greater than those of the higher notes. This effect is evident whether speech, vocal music, or instrumental music is being studied.

A little thought will show that the use of tubes designed for low power output in sets equipped with transformers which pass the low notes will, unless the output of the set be very much reduced, result not only in bad distortion of the low notes, but also in many cases the complete obliteration of the high notes.

Table I shows the power output, grid swing and other characteristics of the tubes which have been developed from time to time in order to meet the growing demand for a larger power output.

## Analysis of Various Types

OF THE tubes listed the 199- and 201A-types are general purpose tubes, the others were designed primarily as output tubes. The 112A, however, while distinctly an output tube, has a high amplification constant which makes it useful as a voltage amplifier and detector as well. The 210 also has a fairly high amplification constant which facilitates its operation as an oscillator; but as a power output tube, although the plate voltage is high, the grid swing is only 35 volts and the power output is low compared with that of the 250.

The power output of the 250 is about ninety times as great as the output of the 201A which originally was used as the output tube of most storage-battery-operated sets at the time when the horn-type loud speaker was common.

Most people readily appreciate the advantages of increased volume when it has been demonstrated that this can be obtained without distortion.

With the relatively poor fidelity of reception that was formerly obtained, people having a well-developed sense of musical harmony, generally preferred to use low volume due to their unconscious objection to the distortion at full volume. In many cases it was contended that the music was too loud although it was the distortion accompanying high volume which was the real source of the objection. With the best equipment now available most people, after becoming accustomed to the fact that good volume may be obtained without distortion, prefer to have their sets adjusted for a more normal volume.

## Development of the 250

AT THE time work was started on the development of this tube it was decided to limit the plate potential to 450 volts; and in order to keep the physical dimensions within limits that would permit the use of the standard UX base the plate was limited to a size which was estimated to be able to dissi-

pate 25 watts without an unduly high temperature rise; the blackening of the plate makes a larger heat dissipation possible, due to the resulting increase in thermal emissivity. It was further estimated that with one stage of audio-frequency voltage amplification, using equipment now available, a grid swing of 80 volts peak could be obtained.

With these factors fixed as a starting point, several tubes were made up having amplification constants ranging from 2.5 to 8.3.

A set of static characteristic curves was then taken for each tube and from these was calculated the maximum undistorted power output that could be obtained, using in each case the optimum value of load impedance and grid bias. The plate current in all cases was limited to 55 milliamperes, the value corresponding to a heat dissipation of 25 watts. The maximum second-harmonic distortion permitted in these calculations was five per cent., a value which has been assumed generally to be inappreciable in effect on reproduction.

The methods of calculating the maximum power output from a set of static characteristic curves have been described in detail by others ("Design of Non-Distorting Power Amplifiers" by E. W. Kellogg, *Proceedings A.I.E.E.*, Feb., 1925, and "Output Characteristics of Amplifier Tubes" by J. C. Warner and A. V. Loughren, *Proceedings I.R.E.*, Dec., 1926); a brief outline of the procedure will be sufficient here.

For a moderate plate voltage at which the heat loss at the plate is below the maximum allowable, the best load impedance is equal to twice the tube impedance. That this is true has been shown theoretically by W. J. Brown ("Symposium on Loud Speakers," *Proceedings of London Physical Society*, 36, Part III, April, 1924) and was verified experimentally by Hanna, Sutherland, and Upp preceding their development of the 250.

An actual determination of the proper load impedance and grid bias for maximum power

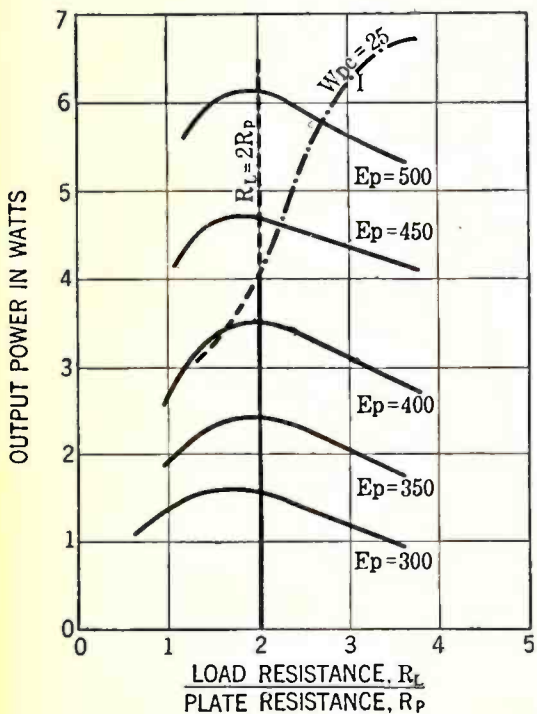

Fig. 1

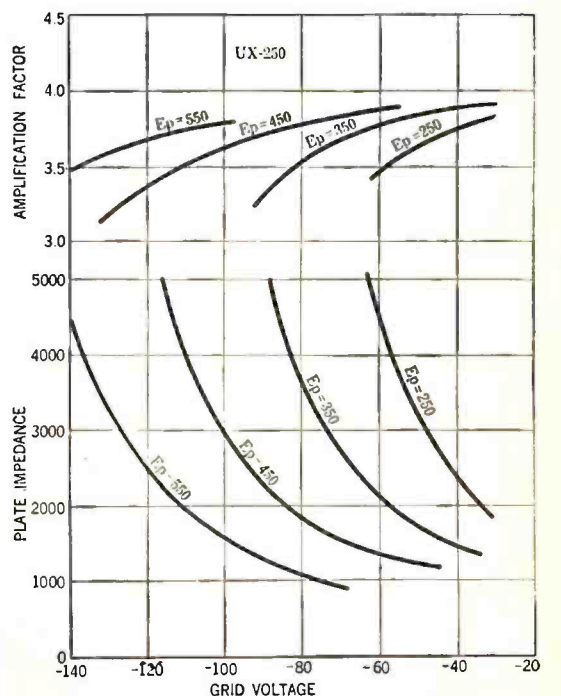

Fig. 2

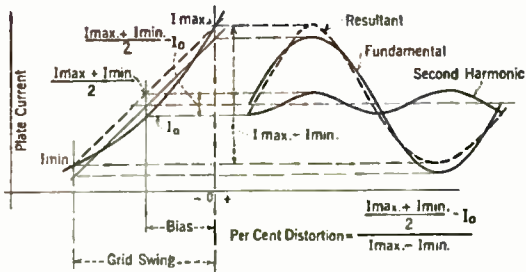

Fig. 3

output at a given plate voltage involves a considerable amount of cutting and trying, due in part to the fact that the tube resistance varies with plate current. The most straightforward procedure is probably that of taking points on the plate-current curves, at the desired plate voltage, corresponding to several values of plate current and determining for each the load impedance that will give the maximum power output without excessive distortion, Fig. 6.

The power output in watts for any dynamic curve is given by:

$$W = \frac{(I_{max} - I_{min}) (E_p max - E_p min)}{8}$$

The minimum plate current is that where the negative grid swing is equal to the fixed grid bias.

When this has been done it will be found that the ratio of the load resistance to the plate resistance,  $R_L/R_p$  becomes less as the plate current is increased or the grid bias is decreased; and that the maximum power output is obtained at a point where the ratio is equal to approximately two.

If, however, the plate current at this point is greater than the maximum allowable, the output corresponding to the maximum plate current must be used, the load impedance being in this case greater than twice the tube impedance.

Fig. 3 illustrates one step in the procedure, that of determining the second-harmonic distortion due to the curvature of the dynamic characteristic. The formula used is—Dis-

tortion equals  $\frac{\frac{1}{2} (I_{max} + I_{min}) - I_0}{I_{max} - I_{min}}$

and gives the amplitude of the second harmonic component as a decimal of the amplitude of the fundamental.

Fig. 1 shows the relation between the power output obtainable at various plate voltages and the load impedance. The curve marked  $W_{dc} = 25$  shows the limiting values as determined by a plate dissipation of 25 watts. This curve also shows that when the plate current becomes the limiting factor, a load resistance greater than twice the tube impedance should be used. For example, at  $E_p = 500$  the load resistance should be 2.8.

In Fig. 4 are summarized the results of the work done on the tubes of different amplification constants. Curve 1 shows how the maximum undistorted power output varies with amplification constant, the dotted portion indicating how the output would increase if the plate dissipation were not a limiting condition. Curve 2 shows the corresponding grid swing required in peak volts.

It will be seen that the grid swing required to operate the tube at full output becomes rapidly greater as the amplification constant decreases. Also it will be noted that the power output reaches a maximum and then decreases. Both of these conditions are due to the fact that at low values of amplification constant the grid becomes less effective in controlling the electron flow to the plate. This results in an excessive curvature of the plate-current characteristic which gives a correspondingly limited working range when the maximum distortion permitted is fixed at a low value.

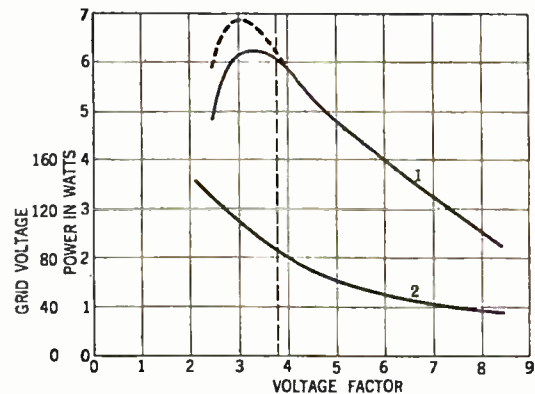

Fig. 4

Fig. 5 shows the relation between maximum undistorted power output and plate voltage. Over a limited range the power output may be taken as proportional to the square of the plate voltage.

Figs. 2 and 7 show the static characteristic curves.

The dotted curves of Fig. 7 correspond to a filament voltage of 7. The maximum undistorted power output is in this case 4.27 watts, a grid swing of 78 volts being required. It will be seen that there is little loss in maximum power output or in sensitivity when the tube is so operated, and it is, in fact, frequently preferable to operate the tube slightly below normal filament voltage in order to protect it from over voltage due to line fluctuations when, as is usually the case, it is operated on alternating current. Careful control of filament voltage will help materially in securing satisfactory operation and long life.

The inter-electrode capacities are: from grid-to-plate 9 mmfd., from grid-to-filament 7 mmfd., and from filament-to-plate 5 mmfd.

### Operation of the 250

THE 250, requiring for full power output a grid swing of 80 volts, has been designed to be operated from a detector followed by one stage of audio-frequency amplification.

By the use of a high plate voltage on the detector, and the plate-current method of detection the intermediate stage of audio-frequency amplification may be omitted. This will tend to improve the quality, due to the elimination of one audio transformer, as well as to the improved detector action when plate-current detection is used. This, of course, will require rather high radio-frequency amplification preceding the detector. The power supply for use with an amplifier employing a 250-type output tube should use two 281-type half-wave rectifier tubes in a full-wave circuit.

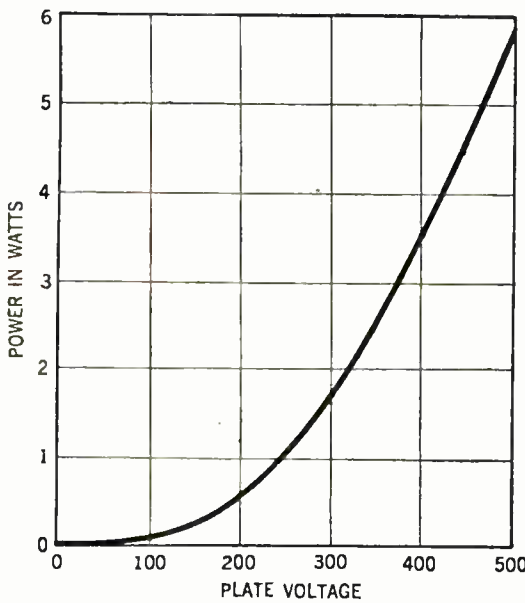
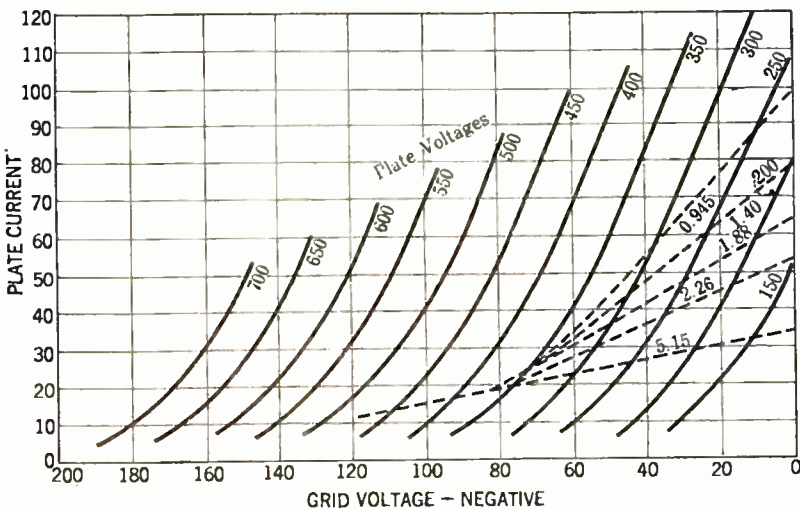

Fig. 5

Table I—Power Output of Various Tubes

TYPE TUBE	$E_p$	$E_g^*$	MU	$R_p$	FILAMENT	OUTPUT MILLIWATTS
199	90	-4.5	6.6	15,500	(Thoriated)	7.6
	90	-7.15		18,000	(Tungsten)	17.5
120	135	-22.5	3.3	6600	(Tungsten)	105.
201A	90	-4.5	8.0	11,000	(Tungsten)	14.
	135	-9.0		10,000		55.
112A	180	-13.5	8.0	4700	Coated	275.
171A	135	-27.	3.0	2200	Coated	330.
	180	-40.5		2000		720
210	125	-35.0	7.5	5100	(Thoriated)	1550
					(Tungsten)	
250	350	-58.5	3.8	1900	Coated	2450
250	300	-67.5		1800		3500
250	450	-80.0		1800		4600

\*To negative end of filament.



Above: Fig. 6 Right: Fig. 7

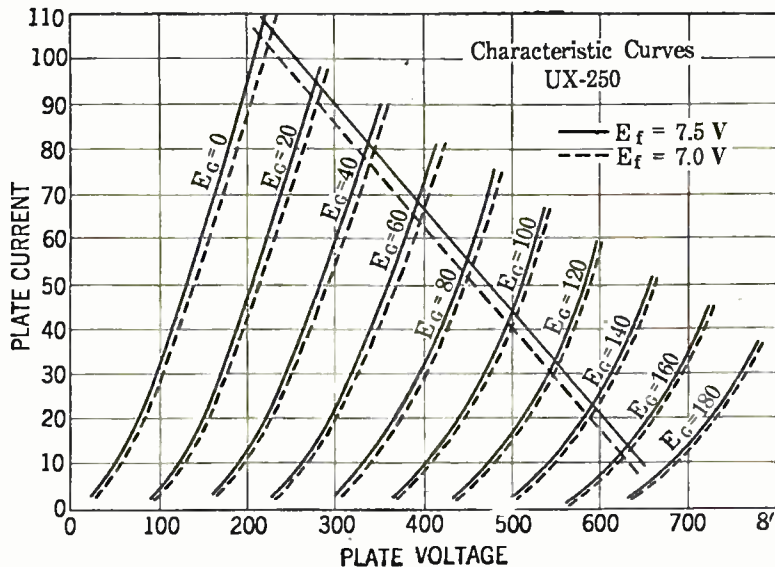



# IN THE RADIO MARKETPLACE

News, Useful Data, and Information on the Offerings of the Manufacturer

## Two New Tubes

AT LEAST two new tubes will be released during 1929; one is a new power tube which will (according to information given by Philco to their jobbers, at a recent meeting in Philadelphia which we attended) be made available sometime during the first quarter of the year and the other is an a.c. screen-grid tube which will be released sometime during the second quarter. Probably one or both of these tubes will be used in some of the sets that manufacturers will bring out in the fall. Further data regarding these two tubes will be found on page 300 in "Strays from the Laboratory."

## Freshman Price Reduction

ON JANUARY 17, the Chas. Freshman Company announced a price reduction on all cabinet models of the Freshman line. The new list prices of the various models are as follows: Q-16, \$99. QD-16, \$129. N-12, \$149. N-17 \$195. These prices do not include tubes.

## How to Sell Battery Sets

SALES suggestions of wide use to those interested in the market for battery-operated receivers have been made by the National Carbon Company, makers of batteries and receiving sets. A survey made under their direction developed the fact that there are more than 10,000,000 homes in the United States that are not wired for electricity and cannot use a.c. sets. Of this astounding number, very few are not potential customers for radio sets.

Many dealers have allowed this large market to escape their notice because of the justified popularity of the a.c. set. The National Carbon Company have formulated a plan to help dealers sell this large market. The principal points in their plan are:

1. The dealer is asked to ascertain from his local chamber of commerce, bank, or other authority, the approximate limits of his trading area.

2. He is asked next to consult either the United States census or county maps for the approximate population of his trading area.

3. Dealer then divides this total population by 4.3, which will give him the approximate number of families. This will be the total potential market for both a.c. and battery-operated sets.

4. Following that, he ascertains from his electric light and power company how many of these homes are wired. (This is, the number of residential meters in his area.)

5. Dealer subtracts the number of wired homes from the total number of families and he has the approximate number of homes which cannot use a.c. radio sets. This represents his market for the modern battery-operated set.

It is suggested that dealers order their stock of a.c. and battery-operated sets accordingly.

Some interesting information turned up as a result of the survey. Washington, D. C., is regarded as one of the most urban communities in the country. A large part of the District of Columbia is built up as a city. Yet there are no fewer than 28,300 homes in the District unwired for electricity and potential markets for battery sets. Ohio has 342,000 unwired homes; Kentucky 418,700; Pennsyl-

In this section of RADIO BROADCAST is grouped a great deal of information of value to the dealer and serviceman, to the professional set-builder, and to the many others who find themselves doing one thing or another in the radio industry. This month we present a compact but complete report on a popular receiver for home and custom set-building, tabulated data in an interesting and useful form for the dealer and serviceman and a great deal of other carefully selected miscellaneous information of definite interest. A careful reading of these pages will help you to keep abreast of what is going on.

—THE EDITOR.

vania 852,500; North Carolina 514,900. The total for the entire United States is 10,559,510. In many states it is estimated that the battery market is 70 per cent. of the total.

## Roger Wise With Majestic

ROGER M. WISE, for many years chief engineer of E. T. Cunningham, Inc., has left that organization and joined the Grigshy-Grunow Company of Chicago, manufacturers of Majestic radio sets and loud speakers. A tube manufacturing division, it is said, will be added to the other manufacturing activities of Grigshy-Grunow.

## New Receivers Announced by Fada

RECENTLY Fada announced several new receivers containing such features as push-pull amplification and dynamic loud speakers in the console models. The new Fada 16 is an eight-tube set using five 227-type tubes,

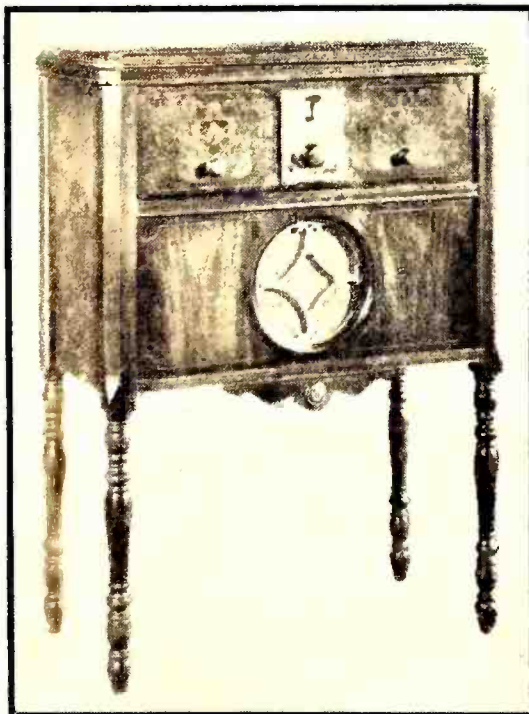

The eight-tube Philco console model receiver—one of their new line

● march, 1929 . . . page 331 ●

two 171A-type tubes, and a 280-type rectifier tube. The circuit consists of three stages of tuned r.f., detector and two-stage audio amplifier, the last stage being push-pull. Fada 32 uses the same circuit and tubes as the 16, but differs in the fact that it is housed in a console with a built-in dynamic loud speaker. The Fada 18 is a d.c.-operated set designed to fulfil the needs of those living in districts supplied with direct current. This set uses five 112A tubes and two 171A tubes in a circuit similar to the model 16. Other items in the Fada line are the model 72 radio-phonograph combination, the model 4 magnetic speaker, the models 14 and 15 dynamic loud speakers.

## Federal Series-Filament Sets

THE models F-10 and F-11 Federal Orthosonic receivers are designed for either a.c. or d.c. operation and they use ordinary  $\frac{1}{2}$ -ampere tubes in a series-filament circuit, all the necessary A, B, and C potentials being supplied by a Raytheon BA-type rectifier. The four r.f. stages and the first audio stage employ 201A-type tubes. The detector is a 112A-type tube and the power stage uses a 171A-type tube. The order of the tubes in the series-filament arrangement is first r.f., second r.f., third r.f., fourth r.f., detector, and finally second a.f. The set is completely shielded and carefully neutralized. If the set is to be supplied from d.c., i.e., a storage battery and a B-power unit, it is simply necessary that the tube filaments be connected in parallel instead of in series.

## New Philco Console Receiver

THE New Philco line for 1929 features a console set selling at the low price of \$157. The set is entirely a.c. operated and contains eight tubes including a rectifier. Into the console is built a dynamic-type loud speaker. There are two other models in this line, the Highboy selling for \$275, without tubes, and the Lowboy selling for \$215. All of these sets use the same circuit, consisting of a neutralized tuned r.f. amplifier followed by a two-stage audio amplifier with push-pull in the output. The Philco Company feel that these sets will require a minimum of servicing but have nevertheless arranged the design of the set so that all connections may be reached easily so that any servicing which may be necessary can be done quickly and efficiently.

## Polymet to Make Coils

THE Polymet Manufacturing Company of New York has announced the purchase of the Coilton Electric Manufacturing Company of Easton, Pa. Polymet is now in a position to supply filter blocks, condensers and resistances, and, with these added facilities, coils for power transformer, audio transformers, moving-coil loud speakers, power packs, etc., are being manufactured.

## Jensen Auditorium Loud Speaker

AN auditorium-type dynamic loud speaker is being manufactured by the Jensen Radio Manufacturing Company. This loud speaker will be made in three models differing only in the method of field excitation. The a.c. model will have a field coil with a resistance of 2250 ohms and it will consume a current of 90 mA. at a potential of approximately

F-1



200 volts; the field current will be supplied by a full-wave rectifier system using the 280-type rectifier tube. The 220 d.c. model has the same field as the a.c. model but it is intended that the field will be supplied from 220-volt d.c. service mains—in this model a transformer and rectifier are of course unnecessary. The type 110 d.c. model is to be supplied from 110-volt d.c. mains. The field resistance is about 600 ohms and the field current, therefore, is about 180 mA. It should be noted that the power consumed by the field in each case is about 20 watts. The cone has a diameter of 12 inches.

*A Super-heterodyne Kit Set—The Tyrman "80"*

ALL radio receivers in use to-day fall into one of two broad classes, that group in which the signal is amplified at the frequency at which it is received and a second group in which the signal is amplified at some fre-

*The new Majestic model 71 is a completely shielded seven-tube receiver. The cabinet is of "post-colonial" design and the built-in loud speaker is a dynamic type*

quency other than that at which it is received. In the first class are the tuned r.f. sets and in the second class fall all the super-heterodyne sets. Fancy names have been attached to individual makes of receivers in both classes, but in principle and general design they remain essentially the same.

Here we describe a super-heterodyne that has been designed to utilize to best advantage the fundamental characteristics of this type of circuit, and secondly, which has been designed to take full advantage of the a.c. screen-grid tube to obtain the greatest sensitivity consistent with satisfactory selectivity and fidelity.

The Tyrman Imperial "80" employs a first detector, oscillator, and three stages of intermediate-frequency amplification using a.c. screen-grid tubes and operating at a frequency of 480 kc. The i.f. amplifier is followed by the second detector and a two-stage transformer-coupled a.f. amplifier. The power tube is a type 250 which is part of the B supply. Interchangeable coils are provided so that the set may be used for both broadcast and short-wave reception.

In the design of the i.f. amplifier a very complete set-up of laboratory instruments and equipment was necessary to measure accurately the efficiency of the a.c. screen-grid tubes at frequencies of about 500 kilocycles. The efficiency of the screen-grid tube operating as an impedance-coupled amplifier was the basis of comparison as to gain per stage while the characteristics of a band-pass filter was the goal for selectivity.

The actual gain of an impedance-coupled screen-grid amplifier is in the order of 36—a satisfactory figure—but the width of the bottom of the curve is too broad for good selectivity.

In order to obtain the maximum efficiency from a screen-grid tube it was found necessary to tune the plate circuit with a low-loss coil and condenser combination. An interesting thing was noticed with regard to the relative amplification obtainable from a screen-grid tube with various LC ratios. A one-inch diameter coil form was used with a variable condenser. The first measurements were made with approximately .0005 mfd. of capacity tuning the one-inch diameter coil. Only enough turns of wire were used to have sufficient inductance to tune to 500 kilocycles.

With a coil of 140 turns of No. 30 enamel wire on a one-inch diameter form tuned with .0005-mfd. capacity, a gain per stage of only fifteen was obtained. A coil of 325 turns of No. 34 enamel wire was tuned with a few micromicrofarads to the same frequency and a gain of thirty-six to forty was obtained. This data was the basis of all further work on Tyrman intermediates.

Finally experimental work was begun upon tuned primary and secondary circuits. The first results were discouraging because of the general characteristics of coupled tuned circuits which produce double-peaked curves. This led to the measurement of loosely coupled tuned circuits. It was found that by just barely coupling the two circuits a result as shown in the curve insert (A) of Fig. 1. could be obtained. Then by carefully designing the LC ratio of both the primary and secondary circuits an actual amplification in the order of twenty-five to thirty per stage was possible.

To improve the selectivity of the first-detector circuit regeneration was employed. Some of the r.f. currents in the plate circuit of the first detector were fed back to the lower end of the antenna coil by a small semi-fixed condenser, C<sub>1</sub>, which is adjustable from the top of the set by a screw driver. Once set it should not be necessary to readjust it unless antenna or tubes are changed.

BIASING RESISTOR

In designing the rest of the circuit, provision was made for obtaining grid-bias voltage for

*The Radio Dealer's Note Book—No. 1 Interference Filters*

ACCURATE summaries of useful information are constantly of value to those radio folk who deal with the public. This sheet, the first of many such on various subjects to follow, sets down collected information on interference-prevention devices. The dealer or serviceman can remove this part of the page for his notebook or he can have it photostated in any number of copies.

The electrical noises from oil burners, battery chargers, heating pads, sign flashers, vacuum cleaners, dental motors, electric thermostats, sparking brushes on motors, etc., can be amplified and detected by a modern sensitive radio receiver almost as well as it can amplify and detect the signals from broadcasting stations. The latter is a desirable program, the former is certainly undesirable. As receivers have become more sensitive the problem of eliminating interference due to electrical appliances has become a pressing question of constantly increasing importance.

If general electrical interference cannot be eliminated by attaching some gadget to the receiver—the interference must be eliminated at the source. Fortunately, however, there are now available a large variety of devices designed for use at the source of interference and their installation is a simple problem.

We have listed in the table all the interfer-

ence devices on which we have data available at this time. From the table some idea of the wide variety of devices available can be obtained but it is not possible here to point out the many uses to which they can be put, or the manner in which some of the manufacturers have arranged the devices so that they can be installed easily and quickly.

The problem of installing interference preventors is the job of the dealer and serviceman and data on these devices should be in the hands of all those who do servicing. As a service to readers, the Editors have arranged that servicemen may receive complete information on all the devices listed in the table by simply writing to the Service Department of RADIO BROADCAST and requesting the data on interference devices. We would suggest that in all cases a card or letterhead be enclosed with the request to identify the writer as a serviceman or dealer.

Manufacturer	Type No.	Price	Line Voltage*	Wattage Rating
Potter Mfg. Co.	103-03	\$ 2.25	110	
	104-04	3.00	110	
	105-05	3.75	110	
	303-03	3.00	220	
	304-04	3.50	220	
	305-05	6.50	220	
Dubilier Condenser Corp.	1	5.00	220	
	2	7.50	220	
Tobe Deutschmann Co.	Junior	3.50	110	500
	11	10.00	110	1000
	22	15.00	220	2000
	23		220 3 phase	2000
	55	20.00	550	
	56	25.00	550 3 phase	
	60	20.00	600 d.c.	
	110	15.00	110	400
	131	20.00	110	1000
	132	25.00	110	2000
	133	30.00	110	3000
	134	35.00	110	4000
	135	40.00	110	5000
	221	20.00	220	1000
Dongan Electric Mfg. Co.	D-207	7.50	110	
	D-215	5.00	110	
Acrovox Wireless Corp.	IN-24	6.50	125	
	IN-44	9.00	220	
Therm-A-Trol Mfg. Co.		3.00	110	
Advance Electric Co.	Claroceptor	7.50	110	

\*Line voltages are a.c. unless otherwise specified.

each tube. The use of heater-type tubes permitted the employment of individual grid-bias resistors which were connected between the cathodes and ground.

The volume control had to be independent of frequency and should not detune the set or spoil fidelity. The best place for such a control is before the second detector and by experiment it was decided the best method was to increase the grid bias on two of the screen-grid tubes by varying the biasing resistor,  $R_1$ , connected between the cathode and ground. This resistor had to be so designed as to be able to give a small amount of bias at its minimum-resistance position and the value of resistance had to increase at a uniform rate until maximum resistance was attained in order to get sufficient grid bias at minimum-volume position or maximum-resistance position. It was found that when the grid bias upon a 222-type or screen-grid tube was  $1\frac{1}{2}$  volts the amplification was greatest, and, as the grid bias was further increased or decreased, the amplification began to decrease. The volume control was, therefore, designed to have a value of minimum resistance which kept the grid bias on the two intermediate-frequency screen-grid tubes at about  $1\frac{1}{2}$  volts—the best value.

THE AUDIO SYSTEM

The audio of the Tyrman "80" was designed especially for the 227-type tube and the frequency characteristic of the audio amplifier is sufficiently wide to give the utmost in fidelity in conjunction with the 250 power amplifier and a good loud speaker.

Bypass condensers are an essential part of the Tyrman "80." It was found necessary to bypass individually each of the bias resistors. This tended to eliminate the possibility of coupling through a common grid circuit. A filter block consisting of six 1-mfd. condensers is provided for bypassing the 150- and 50-volt B supplies and for bypassing the audio circuit.

It was found necessary to incorporate a special filter, consisting of a resistance and a capacity, in the first audio circuit. Without this filter it was found that at times instantaneous huge drains imposed upon the

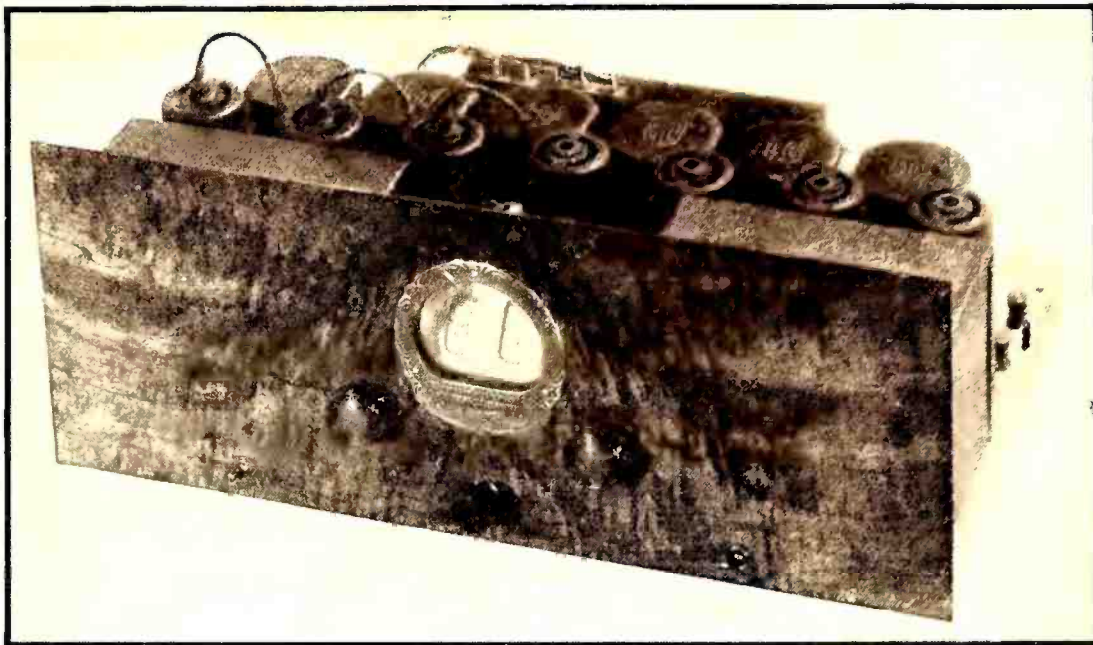

Front view of the Tyrman Imperial "80" receiver

power pack by the 250 tube (due to overloading) caused plate modulation of the detector circuit and resulted in "motorboating."

POWER PACK

The power pack for the Tyrman "80" was designed with three ideas in mind, first, low hum, secondly, plenty of available output, thirdly reliability. The power pack has a transformer which can be overloaded one-hundred per cent. without causing serious trouble. Normally, it operates at a temperature far below the normal temperature at which transformers of this type are usually operated. The voltages delivered by the secondaries are such that line voltage can vary from 100 to 130 without causing trouble with the set or the tubes. The filament or heater potential is set at 2.1 volts and, although the tubes will operate at 1.9 volts and also at 2.3 volts, this point was found to be the most desirable for average conditions.

In order to obtain the amount of current necessary for good regulation and for operating the dynamic-speaker field directly from the power pack, it was necessary to use two 281-type rectifying tubes but this was more than compensated in the increased reliability of the power pack. The Tyrman "80" power pack can be used to energize any 100-volt dynamic-speaker field which does not require more than 45 milliamperes.

The mechanical or chassis design of the Tyrman "80" makes it a pleasure to wire the set because no wiring is necessary above the subpanel. The fact that all of the grid circuits are returned directly to ground eliminates a great number of wires in the set and also prevents the possibility of interstage feed-back due to parallel wiring.

The parts for this receiver are sold only in kit form by the Tyrman Electric Company. The total cost of a complete set of parts for the receiver and power supply is \$199.50.

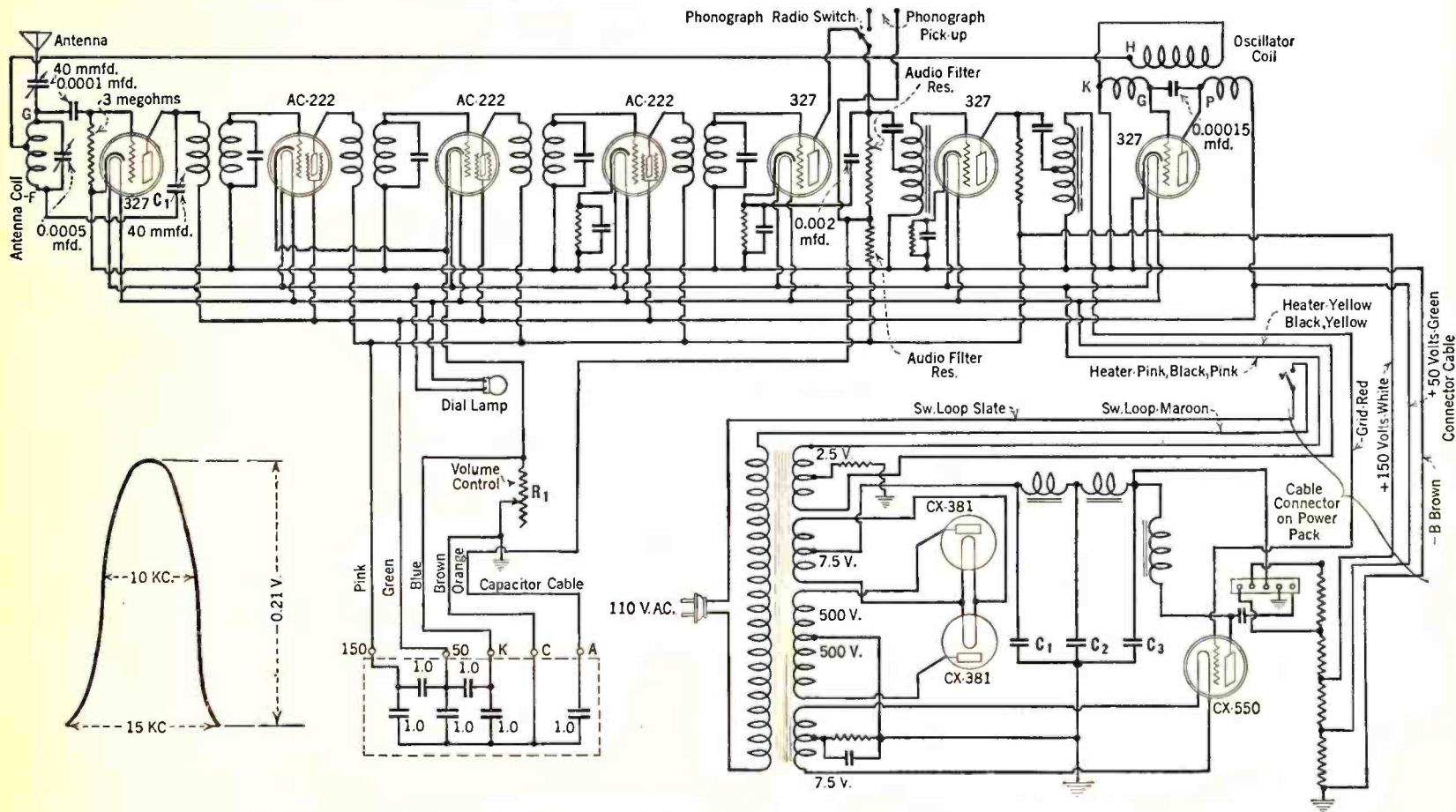

Fig. 1—Complete schematic diagram of the Tyrman Imperial "80" super-heterodyne receiver. Insert A: frequency characteristic of i.f. amplifier stage.

# MANUFACTURERS' BOOKLETS

A Varied List of Books Pertaining to Radio and Allied Subjects Obtainable Free With the Accompanying Coupon

1. FILAMENT CONTROL—Problems of filament supply, voltage regulation, effect on various circuits, and circuit diagrams of popular kits. RANIAL COMPANY.
5. CARBORUNDUM IN RADIO—Pertinent data on crystal detectors with hook-ups, and information on the use of resistors. THE CARBORUNDUM COMPANY.
12. DISTORTION AND WHAT CAUSES IT—Hook-ups of resistance-coupled amplifiers with standard circuits. ALLEN-BRADLEY COMPANY.
17. BAKELITE—A description of various uses of bakelite in radio, its manufacture, and its properties. BAKELITE CORPORATION.
22. A PRIMER OF ELECTRICITY—Fundamentals of electricity with reference to the application of dry cells to radio. Constructional data on buzzers, automatic switches, alarms, etc. NATIONAL CARBON COMPANY.
23. AUTOMATIC RELAY CONNECTIONS—A data sheet showing how a relay may be used to control A and B circuits. YAXLEY MANUFACTURING COMPANY.
30. TUBE CHARACTERISTICS—A data sheet giving constants of tubes. C. E. MANUFACTURING COMPANY.
32. METERS FOR RADIO—A book of meters used in radio, with diagrams. BURTON-ROGERS COMPANY.
33. SWITCHBOARD AND PORTABLE METERS—A booklet giving dimensions, specifications, and shunts used with various meters. BURTON-ROGERS COMPANY.
37. WHY RADIO IS BETTER WITH BATTERY POWER—What dry-cell battery to use; their application to radio, wiring diagrams. NATIONAL CARBON COMPANY.
46. AUDIO-FREQUENCY CHOKES—A pamphlet showing positions in the circuit where audio-frequency chokes may be used. SAMSON ELECTRIC COMPANY.
47. RADIO-FREQUENCY CHOKES—Circuit diagrams illustrating the use of chokes to keep out r. f. currents from definite points. SAMSON ELECTRIC COMPANY.
48. TRANSFORMER AND IMPEDANCE DATA—Tables giving the mechanical and electrical characteristics of transformers and impedances, together with a short description of their use. SAMSON ELECTRIC COMPANY.
53. TUBE REACTIVATOR—Information on the care of vacuum tubes, with notes on reactivation. THE STENLING MANUFACTURING COMPANY.
56. VARIABLE CONDENSERS—A bulletin giving an analysis of various condensers together with their characteristics. GENERAL RADIO COMPANY.
57. FILTER DATA—Facts about the filtering of d. c. supplied by means of motor-generator outfits used with transmitters. ELECTRIC SPECIALTY COMPANY.
58. HOW TO SELECT A RECEIVER—A common-sense booklet describing what a radio set is, and what you should expect from it, in language that anyone can understand. DAY-FAN ELECTRIC COMPANY.
67. WEATHER FOR RADIO—A very interesting booklet on the relationship between weather and radio reception, with maps and data on forecasting the probable results. TAYLOR INSTRUMENT COMPANIES.
69. VACUUM TUBES—A booklet giving the characteristics of the various tube types with a short description of where they may be used in the circuit; list of American and Canadian broadcast stations. RADIO CORPORATION OF AMERICA.
72. PLATE SUPPLY SYSTEMS. Technical information on audio and power systems. Bulletins dealing with two-stage transformer amplifier systems, two-stage push-pull, three-stage push-pull, parallel push-pull, and other audio amplifier, plate, and filament supply systems. AMERICAN TRANSFORMER COMPANY.
73. RADIO SIMPLIFIED—A non-technical booklet giving pertinent data on various radio subjects. Of especial interest to the beginner and set owner. CROSLY RADIO CORPORATION.
76. RADIO INSTRUMENTS—A description of various meters used in radio and electrical circuits together with a short discussion of their uses. JEWELL ELECTRICAL INSTRUMENT COMPANY.
78. ELECTRICAL TROUBLES—A pamphlet describing the use of electrical testing instruments in automotive work combined with a description of the cadmium test for storage batteries. Of interest to the owner of storage batteries. BURTON ROGERS COMPANY.
81. BETTER TUNING—A booklet giving much general information on radio reception with specific illustrations. Primarily for non-technical set-builders. BREMER-TULLY MANUFACTURING COMPANY.
88. SUPER-HETERODYNE CONSTRUCTION—A booklet giving full instructions, together with a blue print and necessary data, for building an eight-tube receiver. THE GEORGE W. WALKER COMPANY.
89. SHORT-WAVE TRANSMITTING EQUIPMENT. Data and wiring diagrams on construction of all popular short-wave transmitters, operating instructions, keying, antennas; information and wiring diagrams on receiving apparatus; data on variety of apparatus used in high-frequency work. RADIO ENGINEERING LABORATORIES.
90. IMPEDANCE AMPLIFICATION—The theory and practice of a special type of dual-impedance audio amplification. ALDEN MANUFACTURING COMPANY.
95. Resistance Data—Successive bulletins regarding the use of resistors in various parts of the radio circuit. INTERNATIONAL RESISTANCE COMPANY.
98. COPPER SHIELDING—A booklet giving information on the use of shielding in radio receivers, with notes and diagrams showing how it may be applied practically. Of special interest to the home constructor. THE COPPER AND BRASS RESEARCH ASSOCIATION.
99. RADIO CONVENIENCE OUTLETS—A folder giving diagrams and specifications for installing loud speakers in various locations at some distance from the receiving

- set, also antenna, ground and battery connections. YAXLEY MANUFACTURING COMPANY.
101. USING CHOKES—A folder with circuit diagrams of the more popular circuits showing where choke coils may be placed to produce better results. SAMSON ELECTRIC COMPANY.
  102. RADIO POWER BULLETINS—Circuit diagrams, theory constants, and trouble-shooting hints for units employing the BI or B rectifier tubes. RAYTHEON MANUFACTURING COMPANY.
  104. OSCILLATION CONTROL WITH THE "PHASATROL"—Circuit diagrams, details for connection in circuit, and specific operating suggestions for using the "Phasatrol" as a balancing device to control oscillation. ELECTRAD, INCORPORATED.

120. THE RESEARCH WORKER—A monthly bulletin of interest to the engineer and home builder. Each issue contains special articles on radio design and construction with special emphasis on resistors and condensers. AEROVOX WIRELESS CORPORATION.
123. B SUPPLY DEVICES—Circuit diagrams, characteristics, and list of parts for nationally known power supply units. ELECTRAD, INC.
124. POWER AMPLIFIER AND B SUPPLY—A booklet giving several circuit arrangements and constructional information and a combined B supply and push-pull audio amplifier, the latter using 210-type tubes. THORDARSON ELECTRIC MFG. CO.
125. A. C. TUBE OPERATION—A small but complete booklet describing a method of filament supply for a.c. tubes. THORDARSON ELECTRIC MFG. CO.
126. MICROMETRIC RESISTANCE—How to use resistances for: sensitivity control; oscillation control; volume control; regeneration control; tone control; detector plate voltage control; resistance and impedance coupling; loud speaker control, etc. CLAROSTAT MFG. CO.
129. TONE—Some model audio hook-ups, with an explanation of the proper use of transformers and chokes. SANGAMO ELECTRIC CO.
130. SCREEN-GRID AUDIO AMPLIFICATION—Diagrams and constructional details for remodeling old audio amplifiers for operation with screen-grid tubes. THORDARSON ELECTRIC MFG. CO.
131. THE MERSHON CONDENSER—An illustrated booklet giving the theory and uses of the electrolytic condenser. AMRAD CORPORATION.
132. THE NATIONAL SCREEN-GRID SHORT-WAVE RECEIVER—Constructional and operating data, with diagrams and photographs. JAMES MILLEN.
133. THE NATIONAL SHIELD-GRID FIVE—A circuit diagram with constructional and operating notes on this receiver. JAMES MILLEN.
134. REMLER SERVICE BULLETINS—A regular service for professional set-builders, giving constructional data, and hints on marketing. GRAY & DANIELSON MFG. CO.
135. THE RADIOBUILDER—A periodic bulletin giving advance information, constructional and operating data on S-M products. SILVER-MARSHALL, INC.
136. SILVER MARSHALL DATA SHEETS—These data sheets cover all problems of construction and operation of Silver-Marshall products. SILVER-MARSHALL, INC.
139. POWER UNIT DESIGN—Periodical data sheets on power unit problems, design, and construction. RAYTHEON MFG. CO.
140. POWER UNIT PROBLEMS—Resistance problems in power units, with informative tables and circuit diagrams. ELECTRAD, INC.
141. AUDIO AND POWER UNITS—Illustrated descriptions of power amplifiers and power supplies, with circuit diagrams. THORDARSON ELECTRIC MFG. CO.
142. USE OF VOLUME AND VOLTAGE CONTROLS. A complete booklet with data on useful apparatus and circuits for application in receiving, power, amateur transmitter, and phonograph pick-up circuits. CENTRAL RADIO LABORATORIES.
143. RADIO THEORY. Simplified explanation of radio phenomena with reference to the vacuum tube, and data on various tubes. DEFORREST RADIO COMPANY.
144. LOW FILAMENT VOLTAGE A. C. TUNES. Data on characteristics and operation of four types of a.c. tubes. ARCTURUS RADIO TUBE COMPANY.
145. AUDIO UNITS. Circuits and data on transformers and impedances for use in audio amplifier plate and output impedances and special apparatus for use with dynamic speakers. SANGAMO ELECTRIC COMPANY.
146. RECEIVER CIRCUIT DATA. Circuits for use in resistances in receivers, and in power units with descriptions of other apparatus. H. H. FROST, INC.
147. SUPER-HETERODYNE CONSTRUCTION. Construction and operation of a nine-tube screen-grid super-heterodyne. SET BUILDERS' SUPPLY COMPANY.
151. THE SECRET OF THE SUPER. Constructional and operation data on the Licolb 8-80 One-Spot Super. LINCOLN RADIO CORPORATION.
152. POWER SUPPLY ESSENTIALS. Circuits and data on power-supply devices, and descriptions of power apparatus. POLYMET MANUFACTURING COMPANY.
153. THE EVERREADY FIDELITY CURVE. An analysis of the frequency range of musical instruments and the human voice which shows how these tones are reproduced by a receiver with an audio range of 60 to 5000 cycles. NATIONAL CARBON COMPANY.
154. AMPLIFIER AND POWER SUPPLY CONSTRUCTION MANUAL. A booklet giving descriptions, circuit diagrams, and lists of parts of several popular amplifier and power supply circuits. ACME WIRE COMPANY.
155. THE CUSTOM SET-BUILDER—A four-page monthly bulletin containing information of interest to servicemen and custom set-builders. CLARK AND TILSON, INC.
156. PHOTO-ELECTRIC CELLS—A booklet describing the applications, theory and characteristics of photo-electric cells. THE G-M LABORATORIES, INC.
157. USES OF ELECTRICAL METERS—Set of blueprints showing correct use of meters in laboratory and testing circuits. WESTON ELECTRICAL INSTRUMENT CORPORATION.
158. THE TRUVOLT DIVIDER. A circular describing ten popular power-pack circuits. Circuits, lists of parts, and pictures are also included. ELECTRAD, INC.
159. RADIO COURSE OF INSTRUCTION. A series of five lessons designed to teach boys the principles of radio design and construction. JUNIOR RADIO GUILD.

## Two Books of Interest to Readers of Radio Broadcast

Radio Broadcast Laboratory Information Sheets (Nos. 1-190)

### How Radio Receivers Work

By Walter Van B. Roberts

Ask any newsdealer for *Radio Broadcast Data Sheets* or both books may be obtained by writing to RADIO BROADCAST, Garden City, N. Y.

Price \$1.00 each

105. RECEIVING AND TRANSMITTING CIRCUITS. Construction booklet with data on 25 receivers and transmitters together with discussion of low losses in receiver tuning circuits. AERO PRODUCTS COMPANY.
108. VACUUM TUBES—Operating characteristics of an a.c. tube with curves and circuit diagram for connection in converting various receivers to a.c. operation with a four-prong a.c. tube. ARCTURUS RADIO TUBE COMPANY.
112. HEAVY-DUTY RESISTORS—Circuit calculations and data on receiving and transmitting resistances for a variety of uses, diagrams for popular power supply circuits, d.c. resistors for battery charging use. WARD LEONARD ELECTRIC COMPANY.
113. CONE LOUD SPEAKERS—Technical and practical information on electro-dynamic and permanent-magnet type cone loud speakers. THE MAGNAVOX COMPANY.
114. TUBE ADAPTERS—Concise information concerning simplified methods of including various power tubes in existing receivers. ALDEN MANUFACTURING COMPANY.
115. WHAT SET SHALL I BUILD?—Descriptive matter, with illustrations, of fourteen popular receivers for the set-builder. HERBERT H. FROST, INCORPORATED.
118. RADIO INSTRUMENTS, CIRCULAR "J"—A descriptive manual on the use of measuring instruments for every radio circuit requirement. A complete listing of models for transmitters, receivers, set servicing, and power unit control. WESTON ELECTRICAL INSTRUMENT CORPORATION.

In sending the coupon below, make sure that your name and address are included and are plainly written. Also make sure that the listing of booklets from which you choose is that of the latest issue of the magazine, as *Radio Broadcast* cannot guarantee the delivery of booklets not listed in its current issue.

### USE THIS BOOKLET COUPON

RADIO BROADCAST SERVICE DEPARTMENT  
RADIO BROADCAST, Garden City, N. Y.

Please send me (at no expense) the following booklets indicated by numbers in the published list above:

.....  
 Name.....  
 Address.....  
 (Number) (Street)  
 (City) (State)

### ORDER BY NUMBER ONLY

Note: RADIO BROADCAST assumes no liability for delivery of booklets. All requests are forwarded promptly to manufacturers who mail booklets direct to you. This coupon filled out must accompany every request.  
R. B. 3-29

# WHAT IS A

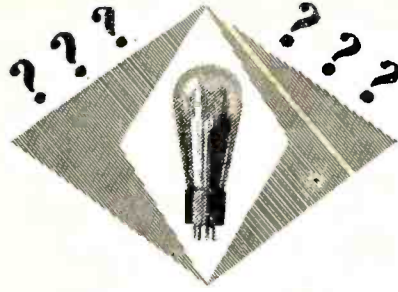

# GOOD TUBE

**T**HREE years ago a series of articles was published in RADIO BROADCAST as a result of a serious investigation of the characteristics of the radio vacuum tubes then on the market. Nearly one hundred tube manufacturers sent samples of their products to the Laboratory to be tested. Many of these manufacturers have since demonstrated the fact that they had no business in the tube market—their names are forgotten. At that time, radio listeners and dealers did not have the means of finding out the characteristics of the tubes, and probably knew little about what the characteristics meant if they had been able to obtain them. No one knew how long a tube was supposed to last, least of all the ultimate user. Then the market for radio receivers was rising rapidly, but was still small. And so the data collected in the Laboratory and published in this magazine not only gave the possible users an idea of how to judge good tubes, but how to use them intelligently, and—if they desired—simple methods of measuring their characteristics as well.

To-day the picture is different. There are perhaps a dozen reputable manufacturers of tubes for receivers and power apparatus—and yet the market for tubes has increased to a degree never dreamed of by the forefathers of radio. The tubes made by these manufacturers are more uniform in their characteristics, have longer lives, and look and act more like their brothers from other factories. The tube business is “shaking down;” it is becoming more a matter of engineering and less of cut-and-try. The names of tube manufacturers we still see on tube cartons are the names of people who have learned by experience how to make a good tube.

Now the question is, “What is a good tube?”

The data presented in the following pages is an attempt to answer that question. It is presented for the benefit of radio dealers and servicemen whose responsibility to the users of tubes is great. These men are in intimate contact with radio listeners and must daily answer the question, “What tube do you recommend?” The data should be interesting to the ultimate user of the tube too, for he ought to know what to expect and when his expectations have or have not been realized. The more the serviceman-dealer knows about the tubes he sells, the better he can satisfy the demands of the user who wants long life more than he wants a cheap price.

The data are in a form so that they can be clipped from the magazine and filed in a note book. We suggest each sheet be mounted on a heavier sheet in the notebook. This information represents the latest obtainable data on the best-known tube manufacturers and until something startling occurs in the tube business, something entirely unforeseen, the data presented here will be representative of what these better known manufacturers are building into their tubes.

Answering the question “What is a good tube” involves two factors, the electrical characteristics of the tube and the factor of economics. How long will the tube last?

The characteristics of general- and special-purpose tubes have undergone no radical changes in a year or more. Whether or not this is fortunate, we are not prepared to state. It is true that every reputable manufacturer who is interested in his future is doing his best to build good tubes, tubes whose characteristics are good when the user purchases them, and good for a long time afterward. The uniformity in the characteristics, as shown by comparing the data in the following pages, was not true three years ago. Then there was a wide disparity between the characteristics of one tube as compared with a similar type made in another plant. Now a 201A-type tube is a 201A-type tube no matter who makes it.

## Standard Tube Types are Similar

**D**IFFERENCES among the products of the tube manufacturers are differences of construction, differences of material, differences of packing for shipment, etc. The electrical characteristics are much the same no matter what the name of the tube. But the differences in mechanical construction, in puniping, and in the choice of materials used are the differences that determine life, the second criterion by which one may judge a good tube.

The first factor, the electrical characteristics of tubes, involves the manufacturer alone. The second involves both the manufacturer and the user. The best of tubes will blow up if the proper wires of the receiver are crossed, or if a screw driver in the experimenter's or engineer's laboratory or in the serviceman's shop falls into the power supply by accident. The best tube will have short life if its filament or plate is overloaded with voltage. The electrons which make the radio wheels go round are tireless workers, but their supply is limited. The best tube will suffer with fatigue if it is forced to work under conditions for which it was not designed.

Generally speaking, tubes from one of the manufacturers represented in the following pages should last as long as from any other,

and, although there may have been a time when manufacturers deplored the fact that their tubes lasted too long, it is true now that every manufacturer must make his tubes as good as is possible. Competition takes care of that.

And yet all the responsibility for long tube life does not rest with the manufacturer. The serviceman who recommends the tube, the dealer who sells it, and the user who employs it must share this responsibility. The dealer-serviceman's share is particularly great for it is he who knows whether or not the set-owner is operating the tubes of his set at voltages recommended by the manufacturer. It is he who must tell the user not to raise the filament and plate voltages until the last “ounce” of signal strength or “DX” is extracted from his radio.

## Importance of Correct Voltage

**A** TUBE manufacturer is much more familiar with his product than anyone else can be, and when the tube manufacturer sets the voltage limits which his tubes can stand, the user has no right to assume a new set ratings for himself and to expect the manufacturer to replace tubes which seem to have premature failure of emission. In other words, if the correct filament or heater voltage of a certain tube is 2.5 volts, the experimenter should not use 3.0 volts nor should he use 2.0 volts and expect long healthy tube life.

Let us consider the case of a power tube, a full-wave filament rectifier, for example. It seems natural to suppose that it will last much longer if we don't overload the filament and such is true. But let us reduce the voltage across the filament, burn it at a lower temperature, and see what happens. All tubes lose emission as they get old. Rectifier tubes have a certain lower emission limit beyond which they cannot hope to keep up with the drain of electrons imposed not only by the receiver, but by the filter and voltage divider as well. Once the tube emission falls below this figure, the voltages supplied to a receiver begin to fall, a.c. hum begins to come up—because the wave-form of the rectified current is no longer halves of sine waves, but has a flat-topped form, hard to filter—and the regulation goes bad because of the increase in effective resistance of the rectifier and hence of the plate-voltage supply system.

When such a tube is operated below its rated temperature the supply of electrons is not as great as when the temperature is raised. This means that the useful life of the tube is decreased, because the lower limit in emission is reached sooner. The tube is still good, and probably would continue to supply plenty of voltage if its temperature were increased—but the only safe and economical method is to supply the heating voltage that the tube needs throughout its life.

How can the user tell a good tube from a bad one? He must first of all buy a tube whose name is known to him. It is safe to state that a purchaser of tubes gets exactly what he pays for, and if he wants freedom from replacement worries, he should purchase a tube whose name is one he is sure of, one that is nationally advertised and sold, and backed by a manufacturer who has a reputation for making good products out of glass, nickel, and electrons.

A purchaser cannot tell by looking at a tube whether it is good or not. He must rely either on the tube maker's reputation or upon the advice of his dealer or serviceman. It is certain that the latter must not trick the former into buying “just as good” products on the supposition that they can get away with it. A dealer who has a monopoly on the radio sales in his community might sell the tubes that cost the least and had the shortest life, but he could be sure that someone would soon furnish his customers with better tubes—even at a higher price, and that his short-sighted policy would get its merited result.

There is a practice in “gyp town” of showing a prospective customer how good a tube is by stepping on a foot switch which boosts the plate voltage while the tube is being tested. Of course, the plate current will be high, and the customer thinks he is receiving a high-emission product. The chances are he is getting somebody's shrinkage.

The answer is to buy tubes from well-known dealers, who safeguard their customers as well as themselves. If tubes get weak, as indicated on a reputable dealer's or service organization's tester, within a short time, look at the name. In the majority of cases it is one you never heard of.

From the dealer's standpoint, the rules for successful tube sales are but three—1. Sell only well-known tubes, 2. Insist that your serviceman install these tubes so that the voltage will be correct, 3. Make sure that the purchaser operates the tubes according to the conditions the manufacturer recommends.

From the user's standpoint, there are three rules, 1. Buy a well-known tube, 2. Buy it from a well-known dealer, 3. Operate the tube at correct voltages.



# Cunningham RADIO TUBES

STANDARD SINCE 1915

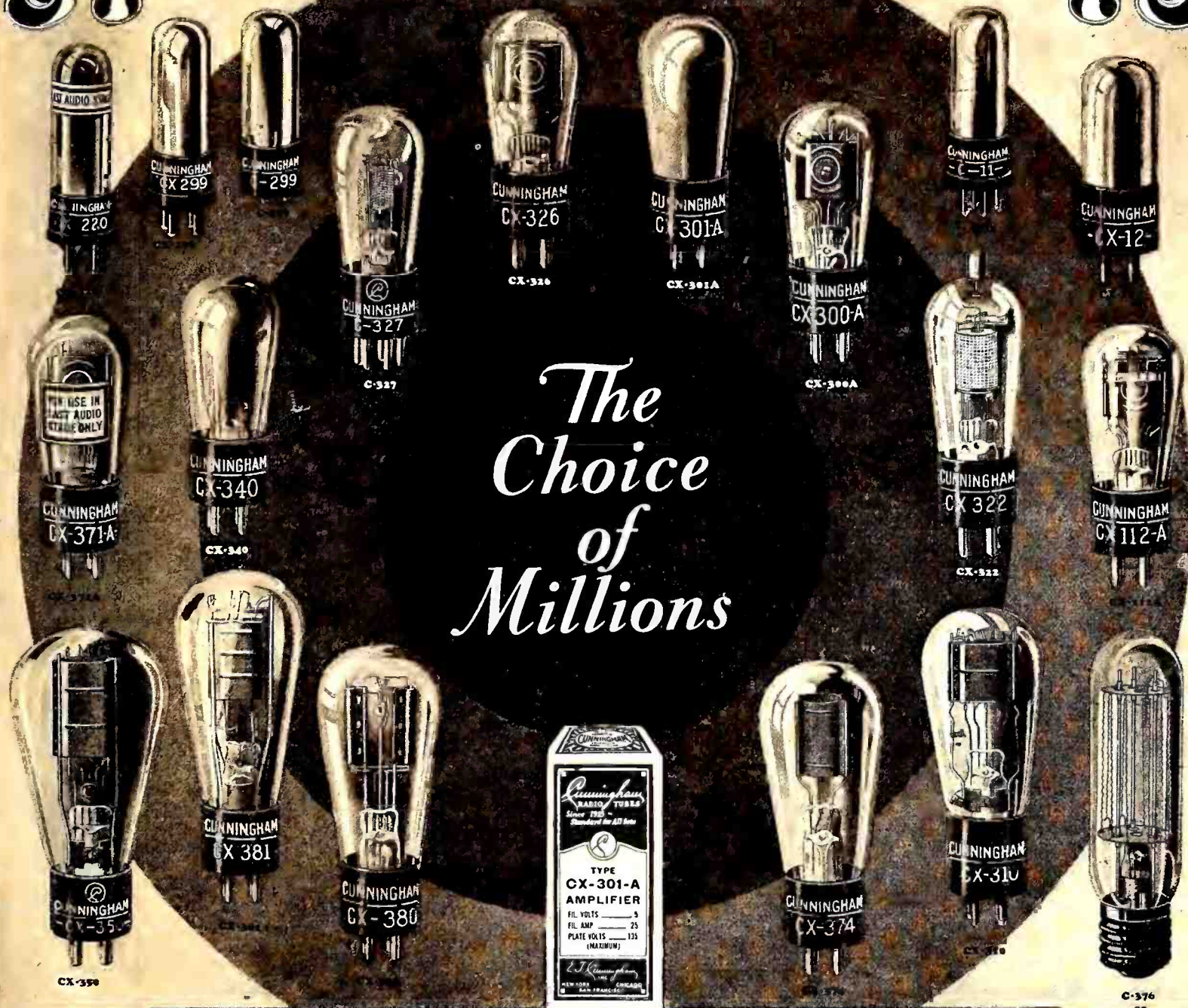

*The  
Choice  
of  
Millions*

**What greater Endorsement  
than Public Approval  
Since 1915**

Don't use Old Tubes with New Ones  
use New *Cunningham* tubes throughout

# RADIO BROADCAST'S TUBE DATA CHARTS — II SYLVANIA PRODUCTS COMPANY

THE users of vacuum tubes have a right to expect two things from the manufacturer of the tubes: first the proper characteristics at the start of their life, and secondly a long life. Life tests were made in RADIO BROADCAST'S Laboratory on several makes of tubes. The life tests consisted of running the filaments of the tubes from a.c. and putting 100 volts d.c. from a generator on the plate with the grid left free. At the end of each hundred hours each tube was taken off test and its plate resistance and amplification factor measured on a tube bridge. The amplification-factor measurement gave an indication of any change in the internal arrangement of the tube elements, the test of the plate resistance indicated whether or not the emission of the filament was falling off.

It is a fact that Sylvania tubes not only had the correct characteristics at the start of such a life test and held them throughout the test, but the majority of the tubes tested actually decreased slightly in plate resistance, and thereby had a some-

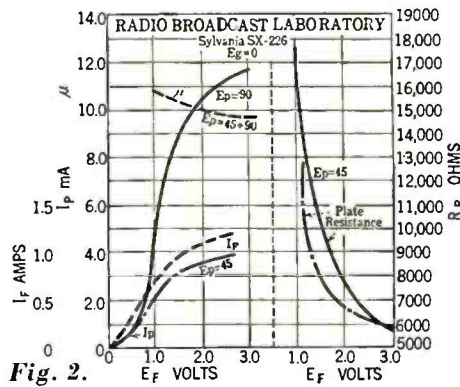

Fig. 2.

on the Sylvania eighth-ampere general-purpose tubes, the SX-201B tubes, prove them to have as good or better characteristics than the average quarter-ampere tube of the 201A-type.

Some characteristic curves of Sylvania a.c. tubes of the heater and filament types are shown in Figs. 1 and 2. These data are plotted against heater volts  $E_h$ , for the SY-227 tube and against filament volts,  $E_f$ , for the SX-226 tube. They show the utility of running these tubes at voltages beyond their normal rating, and prove that voltages slightly under rated values will produce practically identical characteristics. For example, the plate resistance (Fig. 1) of the SY-227 at a plate potential of 90 volts with a zero grid bias is approximately 10,000 ohms when using a heater potential of 2.25 volts; with the same grid and plate voltages the plate resistance is about 8500 ohms at normal heater temperature.

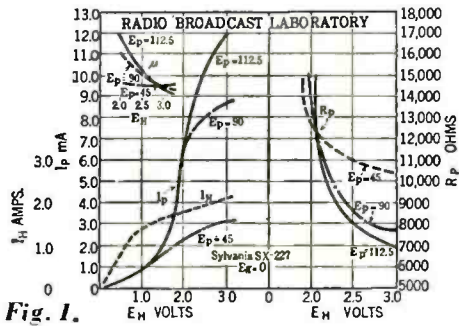

Fig. 1.

what higher mutual conductance at the end of 1000 hours than they did at the start of the test. In other words the tubes improved. The curve in Fig. 3 shows the average tube of the lot. Its starting resistance was 12,700 ohms, and at the end of 1500 hours when the test was discontinued the resistance had decreased to 12,000 ohms or about 6 per cent.

The Sylvania Company makes 19 types of tubes, including two special detectors, the SX-200A and the SX-200B. The latter is an eighth-ampere special detector tube. Both are caesium vapor tubes, and get special care in manufacture and test. With each special detector tube is packed a certificate which guarantees "greater distance receiving range and more volume in the reception of weak signals than any other tubes."

Characteristic curves made in the Laboratory

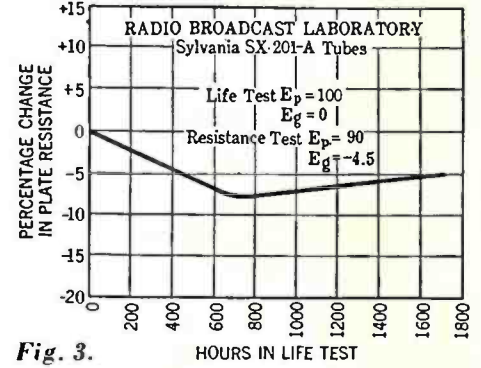

Fig. 3.

## AVERAGE CHARACTERISTICS OF SYLVANIA RADIO TUBES

TYPE	USE	BASE	HEIGHT (Max)	DIAM. (Max)	FILAMENT			PLATE VOLTS		PLATE mA.	GRID VOLTS	PLATE RESISTANCE (OHMS)	AMPLIFICATION FACTOR	MUTUAL CONDUCTANCE MICROMHOS
					SUPPLY SOURCE	VOLTS	AMPS.	DETECTOR	AMPLIFIER					
SX-201-A	Detector Amplifier	X	4 1/16"	1 13/16"	Storage 6 V.	5.0	0.25	20-45	45-135	1.0 to 3.0	0 to 9.0	11,000	8.5	725
SX-201-B	Detector Amplifier	X	4 1/16"	1 13/16"	Storage 6 V.	5.0	0.125	20-45	45-135	1.0 to 3.0	0 to 9.0	11,000	8.5	725
SX-200-A	Detector	X	4 1/16"	1 13/16"	Storage 6 V.	5.0	0.25	20-45	-----	Detector 1.0-1.5	-----	30,000	20.0	680
SX-200-B	Detector	X	4 1/16"	1 13/16"	Storage 6 V.	5.0	0.125	20-45	-----	Detector 1.0-1.5	-----	30,000	20.0	680
SX-112-A	Semi-Power Amplifier	X	4 1/16"	1 13/16"	Storage 6 V. A.C. 5 V.	5.0	0.25	-----	90-180	5.5 to 13.0	6.0 to 12.0	5,500	8.0	1500
SX-171	Power Amplifier	X	4 1/16"	1 13/16"	Storage 6 V. A.C. 5 V.	5.0	0.50	-----	90-180	10.0 to 20.0	16.5 to 40.5	2,200	3.0	1400
SX-171-A	Power Amplifier	X	4 1/16"	1 13/16"	Storage 6 V. A.C. 5 V.	5.0	0.25	-----	90-180	10.0 to 20.0	16.5 to 40.5	2,200	3.0	1400
SX-240	Det. Amp. Res. Coupling	X	4 1/16"	1 13/16"	Storage 6 V.	5.0	0.25	135-180	135-180	0.1 to 0.3	1.5 to 4.5	150,000	30	200
SX-199	Detector Amplifier	X	4 3/8"	1 3/16"	Dry Cells 4.5 V. Storage 4 V.	3.3	0.06	20-45	45-135	1.0 to 3.2	0 to 10.0	15,500	6.6	425
SV-199	Detector Amplifier	V	3 1/2"	1 1/16"	Dry Cells 4.5 V. Storage 4 V.	3.3	0.06	20-45	45-135	1.0 to 3.2	0 to 10.0	15,500	6.6	425
SX-120	Power Amplifier	X	4 3/8"	1 3/16"	Dry Cells 4.5 V. Storage 4 V.	3.3	0.125	-----	135	6.5	22.5	6,300	3.3	525
SX-226	Amplifier	X	4 1/16"	1 13/16"	A.C. 1.5 V.	1.5	1.05	-----	90-180	3.5 to 7.5	4.5 to 15	7,400	8.2	1100
SY-227	Detector	Y	4 1/16"	1 13/16"	A.C. 2.5 V.	2.5	1.75	20-90	90-180	3.0 to 7.5	6.0 to 13.5	10,000	8.2	900
SX-222	Amplifier	X	5 3/8"	1 13/16"	Dry Cells 4.5 V. Storage 4-6 V.	3.3	0.132	-----	135-180	1.5	1.5	850,400	300	350
SY-222 A.C.	Amplifier	Y	5 3/8"	1 13/16"	A.C. 2.5 V.	2.5	1.75	-----	135-180	5.0	1.5	200,000	150	650
SX-210	Power Amp. Oscillator	X	6 1/4"	2 7/16"	A.C. 7.5 V.	7.5	1.25	-----	250-425	10 to 18	18-35	5,000	8.0	1600
SX-250	Power Amp. Oscillator	X	6 1/4"	2 1/16"	A.C. 7.5 V.	7.5	1.25	-----	250-450	28-55	45-84	1,800	3.8	2100
Model	Use	Base	Height (Max)	Diam. (Max)	Filament			Plate		Notes: Where only one set of characteristics is given these apply to the mean or most used values of plate and grid voltages. Bases will be designated by the following letters, according to their styles: X = Standard Push Type, Four Long Prongs. V = Old Navy Type Four Short Prongs Y = Push Type, Five Long Prongs				
					Supply Source	Volts	Amps.	Max A.C. Volts	Max D.C. mA.					
SX-281	Half-Wave Rectifier	X	6 1/4"	2 7/16"	A.C. 7.5 V.	7.5	1.25	750	110					
SX-280	Full-Wave Rectifier	X	5 3/8"	2 3/16"	A.C. 5 V.	5.0	2.0	300 per Plate	125 Both Plates					





# EC RADIO TUBES

**A** few of the many popular types included in the **EC** line.



AC-22



N-27  
<227>



J-71-A  
<171-A>



L-50  
<250>



M-26  
<226>



AX  
<201A>

**EC** Tubes are recommended for their exquisite tone quality and long life.

# Improving the Radio Dealer's Service to the Public - - -

**B**Y MAKING available for public use (usually in advance of other tube manufacturers) each new development in the tube industry, CeCo has won the hearty endorsement of thousands of radio pioneers. This carries with it a great responsibility.

For this reason—the public looks for more than *the usual* from CeCo. A superior performance is expected—demanded. Accordingly, each CeCo tube **MUST** be as painstakingly fashioned, tested and re-tested as though it were the sole output of the factory.

We pledge our continued support to this policy, as well as to the policy of experimentation and research to improve constantly the performance of radio tubes.

Write today for the interesting CeCo story:

*Don't miss the CeCo Couriers entertaining program every Monday evening at 8:30 Eastern time (7:30 Central time) over the Columbia Broadcasting System.*

**CECO** Manufacturing Co., Inc.  
Providence Rhode Island

**CECO Radio Tubes**  
*are used by millions.*

# Why Raytheon Tubes are "HEALTHY"

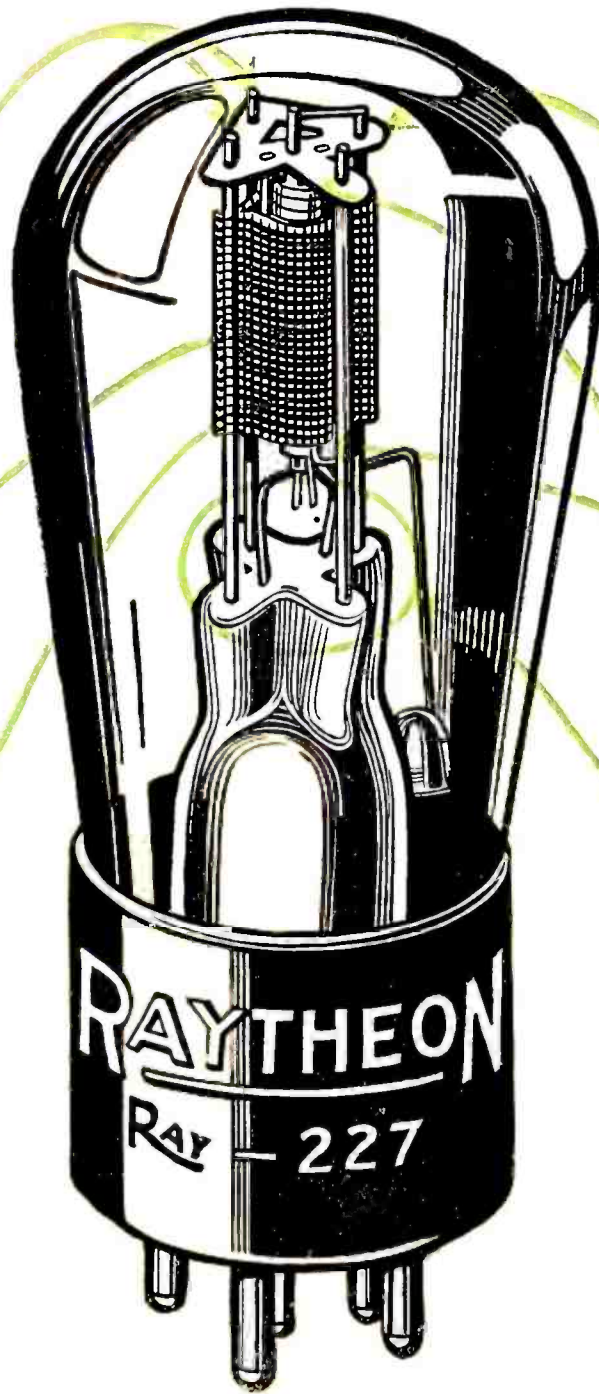

**FIXED SUPPORTS**

*Top and Bottom*

Give extreme rigidity. Hold elements in place. Doubly strengthen grid and plate.

**HEATER FILAMENT**

Extra heavy. Touches no insulation. Insures long life.

**OXIDE COATED CATHODE**

New process gives high emission at low temperature.

**MICA TOP**

Anchors and spaces elements. Microphonic noises impossible.

**INSULATING SPACERS**

Hold heater filament rigidly in place without touching

**4-PILLAR CONSTRUCTION**

Anchors elements top and bottom. They can't move to change tube characteristics

Ray  
227

**THE RAYTHEON TYPE**

(Spacing Insulators not in contact with filament)

Heats up quickly—absorbs expansion—position of filament rigidly fixed—long life

**FLOATING FILAMENT TYPE**

(No Spacing Insulator)

Quick heating—but heater often touches Cathode causing burn-out or HUM. Position of filament not rigidly fixed

**COVERED FILAMENT TYPE**

(Spacing Insulator in contact with full length of filament)

Slow heating—but insulation wears out filament. Short life

The performance and life of a radio tube are largely governed by the maintenance of the pre-determined fixed position of the elements to each other. When the elements (*filament, grid and plate*) are shifted—due to weak mechanical construction or vibration in shipment—the life of the tube is frequently shortened by as much as 75%.

Unlike any and all other radio tubes, the relative positions of all the elements are permanently maintained in Raytheon tubes and the fragility has been conquered and eliminated. Raytheon tubes cost you no more and by longer life, they should reduce your maintenance cost by one-half. And—most important of all—their performance never varies.

**Raytheon**  
LONG LIFE RADIO TUBES

RAYTHEON MANUFACTURING COMPANY, Cambridge, Mass.

# RADIO BROADCAST'S TUBE DATA CHARTS — III RAYTHEON MANUFACTURING COMPANY

IN THE opinion of the Laboratory, one of the single most important steps toward bringing radio reception to its present point of near perfection is to be credited to the Raytheon Company's gaseous rectifier tube which was the first really satisfactory tube useful in supplying d.c. voltages from an a.c. source—and which is to be found to-day in thousands of plate voltage supply units as well as in equipment supplying A, B, and C voltages.

The "Raytheon tube," by which everyone means the 125-milliamperer rectifier tube, came at an opportune time. The tubes used ranged from

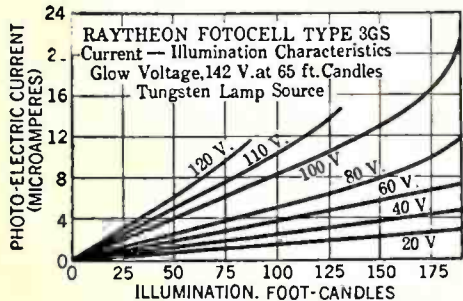

an overworked 201A-type tube with its grid and plate connected together, to some few special two-element filament-type tubes, none of which was able to stand up under the heavy demand for electrons in plate voltage supply devices. The Raytheon tube stood up—and so "B eliminators" became successful adjuncts to modern radio receivers.

When television began to interest development engineers, there was an immediate demand for photo-electric cells. These are glass bulbs, not unlike radio receiver tubes, into which a light can be directed. When this light falls upon the sensitive electrode, it liberates electrons which are attracted

toward a positive plate, and so a light beam can release an electric current from a local B battery. The strength of this current should be proportional to the light falling on the sensitive plate, the tube should not be microphonic, should be of low electrical capacity, should have a high order of sensitivity—that is, the current released from the local battery must be as high as possible with a given amount of incident light—and must be stable in operation.

The experience accumulated in the Raytheon laboratories since 1920 in the purification and study of rare gases made possible the development of such photo-electric cells. A graph gives the characteristic of the type 3GS Foto-Cell.

There is also a demand for a tube which has opposite characteristics from the Foto-Cell, that is, a tube which will give off light when excited by an electrical input. This light should vary in direct proportion to the strength of the incoming signal. The tube must be uniform in illumination, low in power consumption, and as brilliant as possible. Such a cell is the Raytheon Kino-Lamp. Under full-voltage conditions it supplies 10 candlepower of illumination which can be easily and positively controlled by television signals.

## High Power Rectifiers

For years the "S" tube was the stand-by of the amateur. The passing of the "S" tube was a regrettable incident—but now the Raytheon Company has a new rectifier that has characteristics as shown on this page. This looks like an ideal tube for the amateur and anyone who wants a source of high voltage d.c. secured from the a.c. lamp socket. The curves show that the tube has a low internal resistance which indicates that very little power will be lost in the tube.

Low internal power losses, good regulation characteristics, high efficiency, and high output voltages are the advantages of this new Raytheon product known as the Ray-S tube. It can be used wherever high current at high voltage is desired. For example, at an input r.m.s. potential of 2500 volts, a current

of 200 milliamperes can be supplied at a d.c. voltage of 2860, which represents a power of 570 watts.

## Receiving Tubes

The Raytheon Company has recently begun the manufacture of receiving tubes of the types indi-

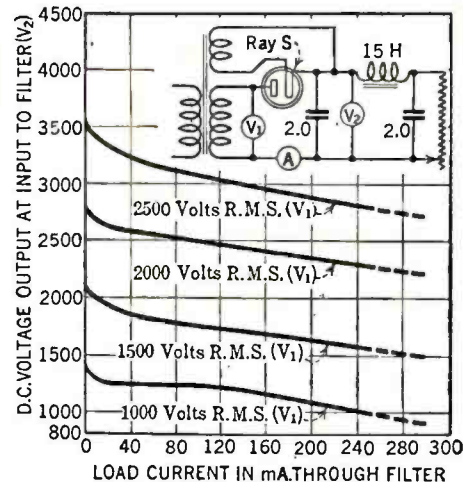

cated in the chart. All of these tubes have been tested in the Laboratory and were found to check the characteristics described by the manufacturer. They are distinct in their method of construction, and their design will permit the building of usable and practical tubes of types now considered only theoretical. The rugged construction also assures the consumer of receiving the tubes with the same matched characteristics as are achieved in the factory.

## AVERAGE CHARACTERISTICS OF RAYTHEON TUBES

TYPE	USE	FILAMENT VOLTS	FILAMENT AMPERES	BASE	MAXIMUM HEIGHT	MAXIMUM DIAMETER	DETECTION				PLATE CURRENT (mA)	AMPLIFICATION FACTOR	PLATE RESISTANCE (OHMS)	MUTUAL CONDUCTANCE (MICROHMS)	MAXIMUM UNDISTORTED OUTPUT (MILLIWATTS)	
							B VOLTAGE (VOLTS)	GRID LEAK (MEG OHMS)								
RAY X-112-A	D.C. Detector	5.0	0.25	4-Prong Standard	4 1/16"	1 13/16"	45	—	2-5	—	—	5.5	8.0	5300	1500	—
RAY-227	A.C. Detector	2.5	1.75	5-Prong Standard	4 1/16"	1 13/16"	45	—	2-5	—	—	5.0	9.0	8500	1050	—
AMPLIFICATION																
							B VOLTAGE (VOLTS)	C BIAS VOLTAGE		BIAS RESISTOR						
								FILAMENT ON D.C.	FILAMENT ON A.C.	FILAMENT ON D.C.	FILAMENT ON A.C.					
RAY X-226	A.C. Amplifier	1.5	1.05	4-Prong Standard	4 1/16"	1 13/16"	90 135 180	—	6.0 9.0 13.5	—	1700 1500 1800	3.5 6.0 7.5	8.2 8.2 8.2	9400 7400 7000	875 1100 1170	20 70 60
RAY-227	A.C. Amplifier	2.5	1.75	5-Prong Standard	4 1/16"	1 13/16"	90 135 180	—	6.0 9.0 13.5	—	2000 1800 2250	3.0 5.0 6.0	9.0 9.0 9.0	10,000 9000 9000	900 1000 1000	20 65 140
RAY X-171-A	A.C. or D.C. Power Amplifier	5.0	0.25	4-Prong Standard	4 1/16"	1 13/16"	90 135 180	16.5 27.0 40.5	19.0 29.5 43.0	1700 1700 2000	1900 1900 2150	10.0 16.0 20.0	3.0 3.0 3.0	2500 2200 2000	1200 1360 1500	130 330 700
RAY X-112-A	A.C. or D.C. Power Amplifier	5.0	0.25	4-Prong Standard	4 1/16"	1 13/16"	90 135 180	4.5 9.0 13.5	7.0 11.5 16.0	800 1300 1350	1300 1650 1600	5.5 7.0 10.0	8.0 8.0 8.0	5300 5000 4700	1500 1600 1700	30 120 300
RAY X-245	A.C. or D.C. Power Amplifier	2.5	1.5	4-Prong Standard	5 5/8"	2 3/16"	150 200 250	—	27.0 38.0 50.0	—	1200 1400 1500	23.0 27.0 32.0	3.5 3.5 3.5	2200 2050 2000	1600 1700 1750	400 900 1600
RAY X-210	A.C. or D.C. Power Amplifier	7.5	1.25	4-Prong Standard	5 5/8"	2 3/16"	250 350 425	18.0 27.0 35.0	22.0 31.0 39.0	1500 1700 1750	1800 1950 1950	12.0 16.0 20.0	8.0 8.0 8.0	5600 5150 5000	1330 1550 1600	340 925 1540
RAY X-250	A.C. Power Amplifier	7.5	1.25	4-Prong Standard	6 1/4"	2 11/16"	250 350 450	—	45.0 63.0 84.0	—	1600 1400 1500	28.0 45.0 55.0	3.8 3.8 3.8	2100 1900 1800	1800 2000 2100	900 2300 4600
RAY A.C.22	A.C. Screen-Grid Amplifier	2.5	1.75	5-Prong Standard	5 3/8"	1 13/16"	180	—	1.5	—	Screen Grid Volts 75	3	400	500,000	800	—

## AVERAGE CHARACTERISTICS OF RAYTHEON RECTIFIERS

TYPE	USE	FILAMENT VOLTS	FILAMENT AMP.	BASE	LENGTH	DIAMETER	MAX. A.C. PER PLATE (VOLTS)	MAX. OUTPUT AMPERES
BH	Full Wave	—	—	4-Prong Standard	4 1/2"	1 13/16"	350	0.125
BA	Full Wave	—	—	4-Prong Standard	6"	2 7/16"	350	0.350
RAY X-280	Full Wave	5.0	2.0	4-Prong Standard	5 5/8"	2 3/16"	350	0.125
RAY X-281	Half Wave	7.5	1.25	4-Prong Standard	6 1/4"	2 7/16"	700	0.085
RAY X-866	Half Wave	2.5	5.0	4-Prong Standard	5 7/8"	2 3/16"	2000	0.250
RAY-S	Half Wave	5.0	5.0	Mogul Screw	8 1/2"	2 1/16"	3000	0.300

## AVERAGE CHARACTERISTICS OF RAYTHEON KINO-LAMP

TYPE	USE	BASE	MAXIMUM HEIGHT	MAXIMUM DIA.	STARTING VOLTAGE	OPERATING VOLTAGE	OPERATING CIRCUIT (mA)	CANDLE POWER PER mA.	SURFACE BRIGHTNESS LAMBERTS PER m <sup>2</sup>
Kino-Lamp	Television	4-Prong Std	6 1/2"	2 1/16"	210	150	10 To 80	0.14	0.03

## AVERAGE CHARACTERISTICS OF RAYTHEON FOTO-CELLS

TYPE	USE	BASE	MAXIMUM HEIGHT	MAXIMUM DIA.	APERTURE	LUMENS PER FOOT CANDLE	SENSITIVITY MICRO-AMPS PER FT. CANDLE	GLOW VOLTS 65 ft. Candles
3 GSS	Television	—	2 1/2"	1 1/16"	1/2" x 1"	0.003	0.03	130
3 VS	Television	4-Prong Std.	6 3/8"	2 7/8"	2" Dia.	0.022	0.04	—
3 GS	Television	4-Prong Std.	6 3/8"	2 7/8"	2" Dia.	0.022	0.15	150
3 VL	Television	—	12"	2 1/8"	1 1/2" x 8"	0.082	0.10	—
3 GL	Television	—	12"	2 1/8"	1 1/2" x 8"	0.082	0.35	150
3 GLL	Television	—	15"	3 5/8"	2 1/2" x 10"	0.170	0.75	150

# Unquestionably~

## the Most Complete Radio Testing Apparatus Ever Devised

**T**HE SUPREME is sweeping the country by storm. Radiotricians and engineers everywhere are amazed at its performance, and its already long list of users are enthusiastically proclaiming its superiority. Truly an amazing instrument; it makes every test that can be made by all other testing devices combined and many that heretofore have not been available in any service instrument.

### Complete, Handy Carrying Case

The case containing the instrument was designed after careful study by practical radiotricians of many years' experience in radio service. Its arrangement is most complete and convenient—a proper place for every tool, accessory, part, and material that a service man might need; even a swinging tube shelf that affords absolute protection to tubes. A complete set of tools, from electric soldering iron to screw driver, is furnished, and of course, all necessary adapters and accessories. Everything the service man requires—all in one case. And still, due to ingenious design, this case is only 18 x 10½ x 7 in., and weighs complete only 25 lbs.

### Send No Money

The SUPREME must sell itself to you on sheer merit and performance. We are willing to place it in your hands for actual use in your service work, and allow you to be the sole judge of its value. Fill out and sign the following request for six-day trial.

### 6 Day Trial

Date.....

SUPREME INSTRUMENTS CORPORATION  
318 Supreme Building  
Greenwood, Miss.

Please ship me one Model 400A SUPREME.

Upon delivery of the instrument, I will deposit with the express agent either the cash price of \$124.65 or \$38.50 cash and 10 trade acceptances (instalment notes) for \$10 each, due monthly, at my option, subject to the following conditions:

It is agreed that the deposit made with the express agent shall be retained by him for six days. If within that time, after testing the instrument I am not entirely satisfied, I have the privilege of returning the instrument to the express agent in good condition, with the seal unbroken (see note below) and all tools and parts intact. Upon such return and upon the prepayment of return express charges, the deposit I have made with the express agent will be promptly returned to me.

Signed.....  
Firm name.....  
Address.....  
City..... State.....

Please send three or more trade references, including at least one bank, with this coupon.

NOTE:—The seal on the panel of the instrument covers the master screw in the assembly. It is never necessary to disturb this, and it does not in any way prevent or restrict the use of the instrument. Factory guarantee ceases with disturbance of seal.

### Three Weston Meters

Mounted in Bakelite cases.

- 1 Voltmeter, three scales of 0/10/100/600, 1000 ohms per volt.
- 1 Milliammeter, of 125 mils and 2½ amps.
- 1 A. C. Voltmeter, three large scales of 0/3/15/150.

All instruments are manufactured for 110 volts and 60 cycles. Instruments for other voltages or frequencies can be furnished special at slight increase in price.

### Prices and Terms

Under our time payment plan, the Model 400A SUPREME can be bought for \$38.50 cash and 10 trade acceptances (instalment notes) for \$10 each, due monthly. Cash price, if preferred, \$124.65. All prices are net and do not carry dealers' discounts.

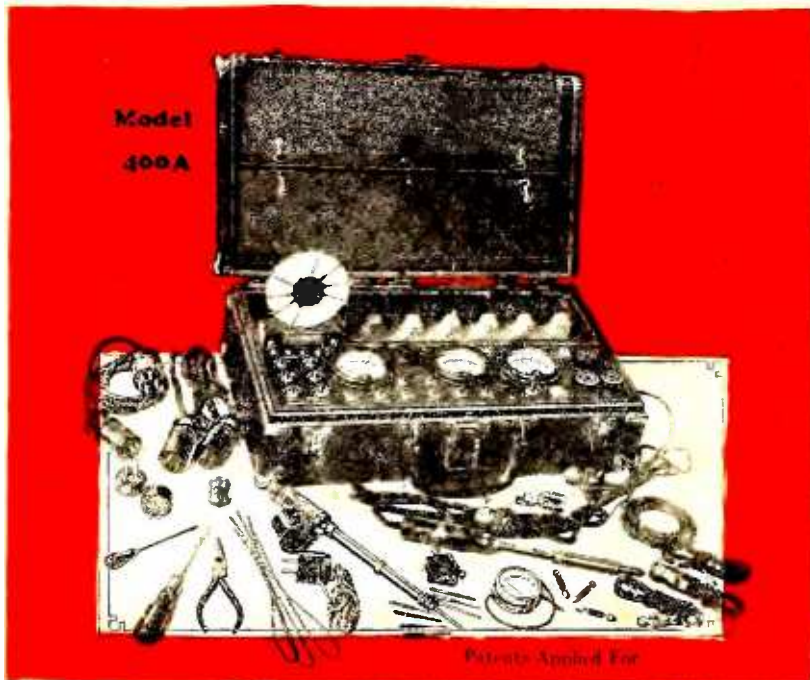

*conceivable*

## Makes every test on any Radio Set-

You have waited long and patiently for an instrument such as the SUPREME. It is now here—at your command for greater accuracy and thoroughness, bigger profits and satisfied customers.

Tubes, power units, loads, breakdowns, voltages, all instantly analyzed, peaking condensers, also modulated radiator. Everything you have ever hoped for is there, all contained in one compact instrument.

The only self-rectifying oscillation tester in existence.

The exact working conditions of any tube from 1½ to 15 volts, including screen grid, heater type, and rectifier tubes, are shown by meter readings; the only service instrument that shows output of rectifier tubes on meter.

The oscillation tests from alternating current are made possible by the exclusive self-rectifying SUPREME Power Plant. Every radio engineer and service man will appreciate this feature.

The SUPREME radiator sends out a modulated wave. Simply plug into A. C. line. No more wasting valuable time on broadcast stations; always at your service and finer adjustment assured.

Condensers can be balanced or synchronized—not by the former tedious methods—but with both meter reading and audible click. Easy and much more accurate.

All continuity tests can be made from socket on either A. C. or D. C. sets, with independent cathode readings.

The SUPREME heavy duty rejuvenator provides scientific method of rejuvenation of any thoriated filament tube. Will reactivate up to 12 tubes at one time without removal from set. Push a plug—the SUPREME does the rest.

The SUPREME will give direct reading of amplifying power of tubes and will show actual working condition of all tubes.

The SUPREME will play radios with open transformers and will give condenser, choke coil output and capacity output on radios not wired for that purpose.

Access is provided to all apparatus through pin-jacks. Will test condensers for breakdown. Contains various fixed condensers from .001 to 2 mfd., a 30 ohm rheostat, a 500,000 ohm variable resistance, and an audio transformer, for instant use and various combinations.

It will give plate and filament voltage readings with or without load; will test voltage and current of all radios, including those using tubes such as 210 and 250. It will give grid circuit readings up to 100 volts; plate voltage readings up to 600 volts; will test output of trickle chargers, or any output up to 2½ amps.

Why wait longer? Share in the satisfaction and added profits that come with SUPREME ownership.

## The Sign of Efficient Radio Service



Radio Owners: Look for this emblem in your radio shop or on the button worn or card carried by your service man. It is your guarantee of dependable service.

# SUPREME

## Radio Diagonometer

# RADIO BROADCAST'S TUBE DATA CHARTS — IV CeCo MANUFACTURING COMPANY

THE chart on this page gives the characteristics of the entire CeCo line of tubes. A glance will show that the line is complete, and that the constants are such as experience and engineering has dictated to be the best for the tubes serving the purposes for which they were made. In addition to tubes whose names and uses everyone knows, there are several others on this list that will need some explanation. For example, type G is a high- $\mu$  tube useful for resistance- and impedance-coupled amplifiers. Owing to its rather low plate resistance, 25,000 ohms at a plate potential of 60 volts and at zero grid bias, the tube will make a good detector. In addition to this tube, CeCo manufactures a special detector, type H, which has a somewhat lower  $\mu$  and a lower plate resistance than type G. Both of these tubes have a fairly high mutual conductance.

Type K is a special radio-frequency amplifier tube, with an amplification factor of 12.5 and a plate resistance of 11,000 ohms. Under normal operating conditions, viz, 90 volts on the plate and a negative bias of about one volt, the mutual con-

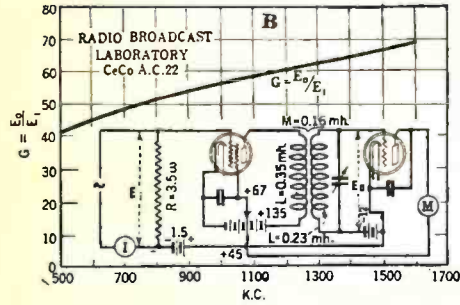

ductance is equal or better than the average general-purpose tube, and naturally enough, a somewhat greater amplification at high frequencies results.

Type L 15 is a new power tube, as is Type L45. At the time of compiling these data, only experimental tubes were available, and it is not thought wise to include data on these tubes. Suffice to say, the CeCo organization is awake to the necessity of power tubes fitting into the picture somewhere

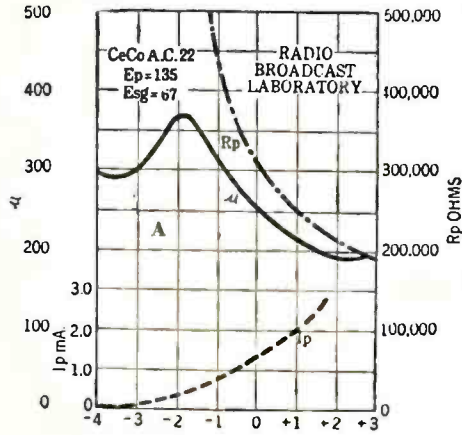

between the present 171 and the much more powerful tube, the 250 type.

Despite the interest in the screen-grid tube, little has been done with it in commercial receivers, chiefly because it required a source of d.c. current for its filament. The chart below shows the characteristics of the CeCo a.c. screen-grid tube, the A.C. 22. It is a standard heater-type tube, namely, one requiring 2.5 volts and 1.75 amperes, and because of this construction it does not suffer from many of the faults of the d.c. screen-grid tube. It is not microphonic, its filament (cathode) is sturdy and it has copious emission of electrons. Its plate resistance is 450,000 ohms and its mutual conductance over 700 micromhos under normal operating conditions, i.e., 135 volts on the plate, 67.5 on the screen grid, and a negative bias of 1.5 volts on the control grid.

Fig. A gives the essential characteristics of the tube plotted with reference to the control-grid bias.

To see what the tube would do as a radio-frequency amplifier, the data in Fig. B and Fig. C were taken in the Laboratory. The circuit diagram is given on Fig. B and shows a resistance input of 3.5 ohms, a transformer coupling the A.C. 22 to a standard

heater-type tube operating as a C-bias or plate-rectification detector, and a microammeter in the plate circuit of the detector which acts as a vacuum-tube voltmeter.

The voltage ratio,  $E_o/E_i$ , varies from about 40 at low broadcast frequencies to about 70 at 1500 kc. This means that an input voltage of 0.1 volt, after passing through the screen-grid tube and its coupling transformer, became 4.0 volts on the input to the detector at 500 kc. and 7.0 volts at 1500 kc.

Fig. C gives an idea of the selectivity of a single stage as illustrated in Fig. B. The primary of the transformer had an inductance of 350 microhenries, the secondary an inductance of 235 microhenries and the mutual inductance between them was about 160 microhenries, giving a coefficient of coupling of about 0.56. The secondary had a diameter of about 2 inches and was space wound so that its

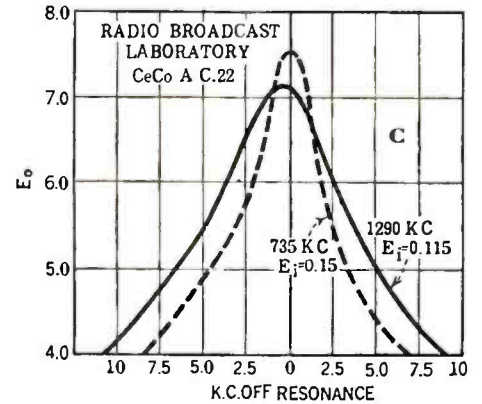

resistance was quite low. The input resistance of the detector was high since it was an overbiased tube. As Fig. C shows, the selectivity of such a single stage varies at the two frequencies used. At 1290 kc. the selectivity is such that a 5000-cycle note would suffer a loss of about 3.5 db while at 735 kc. the loss would be 4.4 db.

## TEST CHARACTERISTICS OF CECO TUBES

MODEL NO	CORRESPONDING TYPE	USE	A BATTERY VOLTS	FILAMENT VOLTS	FILAMENT AMPERES	DETECTOR PLATE VOLTS	AMP. MAX. PLATE VOLTS	GRID BIAS	TEST DATA AVERAGE					MU	NOTES
									PLATE VOLTS	GRID VOLTS	PLATE CURRENT (mA.)	PLATE RESISTANCE (OHMS)	MUTUAL CONDUCTANCE (MICROMHOS)		
A	OIA	Detector Amplifier	6.0	5.0	0.25	45	135	0.5-9.0	90	4.5	3.1	9500	900	8.5	General Purpose
OIB	201 B	Detector Amplifier	6.0	5.0	0.125	45	135	0.5-9.0	90	4.5	3.1	9500	900	8.5	" "
B-BX-C	199	Detector Amplifier	4.5	3.0	0.06	45	90	0.5-6.0	90	4.5	2.8	16,000	400	6.4	General Pur.3 Types of Bases
RF 22	222	R.F. Amplifier	4.5	3.3	0.132	---	180	-1.5/+45	135	-1.5/+45	----	600,000	666	400	Special Circuits for 4 Element Tubes
AC 22	222	R.F. Amplifier	---	2.5	1.75 A.C.	---	180	-1.5/+75	180	-1.5/+75	4.0	400,000	1,050	420	
E	120	Power Amplifier	4.5	3.0	0.12	---	135	15.0-22.5	90	16.5	4.0	7,500	440	3.3	Last A.F. Stage
F	112	Power Amplifier	6.0	5.0	0.50	45	180	4.5-12.0	90	4.5	4.8	5,000	1,600	8.0	" " "
F 12A	112A	Power Amplifier	6.0	5.0	0.25	45	180	4.5-12.0	90	4.5	4.8	5,000	1,600	8.0	" " "
G	240	Hi Mu	6.0	5.0	0.25	90	180	0.5-5.0	60	0	0.8	25,000	800	20	Res. and Impedance Amplifiers
H	---	Detector	6.0	5.0	0.25	67-90	---	1.5-4.5	80	0	3.0	14,000	1,030	14.4	Hard Detector
J 71	171	Output	6.0	5.0	0.50	----	180	16.0-45	90	16.5	9.0	2,500	1,200	3.0	Last A.F. Stage
J 71 A	171A	Output	6.0	5.0	0.25	----	180	16.0-45	90	16.5	9.0	2,500	1,200	3.0	" " "
K	---	R.F.	6.0	5.0	0.25	45-90	135	0.5-3.0	80	0	4.8	11,000	1,130	12.5	Radio Frequency Amplifier
L 10	210	Power Amplifier	8.0	7.5	1.25	----	425	12.0-35.0	180	12.0	7.0	7,000	1,100	7.8	Power Stage
L 15	-----	Power Amplifier	6.0	5.0	1.0	----	180	15.0	180	15.0	15.0	3,750	2,000	7.5	" "
L 45	---	Power Amplifier	---	2.5	1.5 A.C.	----	250	-33 to 50	250	-50	32	1,900	1,845	3.5	" "
L 50	250	Power Amplifier	8.0	7.5	1.25	----	450	45-84	250	45	28	2,100	1,800	3.8	" "
M-26	226	A.C. Amplifier	----	1.5	1.05 A.C.	----	135	6.0-16.5	90	6.0	3.7	9,400	875	8.2	A.C. on Filament
N-27	227	A.C. Detector	----	2.5	1.75 A.C.	45	135	6.0-13.5	90	6.0	3.0	11,300	725	8.2	Separate Heater A.C.
R-80	280	Rectifier	----	5.0	2.0	----	350	----	----	----	125	----	----	----	
R-81	281	Rectifier	----	7.5	1.25	----	750	----	----	----	110	----	----	----	

# The Radio Broadcast LABORATORY INFORMATION SHEETS

THE aim of the Radio Broadcast Laboratory Information Sheets is to present, in a convenient form, concise and accurate information in the field of radio and closely allied sciences. It is not the purpose of the Sheets to include only new information, but to present practical data, whether new or old, that may be of value to the experimenter, engineer or serviceman. In order to make the Sheets easier to refer to, they are arranged so that they may be cut from the magazine and preserved, either in a blank book or on 4" x 6" filing cards. The cards should be arranged in numerical order.

Since they began, in June, 1926, the popularity of the Information Sheets has increased so greatly that it has been decided to reprint the first one hundred and ninety of them (June, 1926-May, 1928) in a single substantially bound volume. This volume, "Radio Broadcast's Data Sheets", may now be bought on the newsstands, or from the Circulation Department, Doubleday, Doran & Company, Inc., Garden City, New York, for \$1.00. Inside each volume is a credit coupon which is worth \$1.00 toward the subscription price of this magazine. In other words, a year's subscription to RADIO BROADCAST, accompanied by this \$1.00 credit coupon, gives you RADIO BROADCAST for one year for \$3.00, instead of the usual subscription price of \$4.00.

—THE EDITOR.

BYRD ANTARCTIC EXPEDITION

Aug. 21, 1928.

Address Here  
Suite 340  
Baltimore Hotel  
New York

International Resistance Company,  
422 S. 4th 20th Street,  
Philadelphia, Pa.

Gentlemen:  
You will be interested to know that we are choosing your resistors for test bench purposes to all receivers to be carried on the Expedition which will be about thirty in number. Our choice is prompted by the necessity of extreme dependability under adverse operating conditions and freedom from arcing tube noises which your resistors have shown in sensitive high frequency receivers such as will be employed by the Expedition.

Yours very truly,

Byrd Antarctic Expedition  
Malcolm P. Hanson  
Chief Radio Engineer

1076 023



On the Byrd Antarctic Expedition Only DURHAMS are Used!—another tribute to the DURHAM Metallized principle!—another tribute to the extreme care with which DURHAM Resistors, Powerohms and Suppressors are made!—another tribute to DURHAM accuracy and utter dependability!—read the above letter from Chief Radio Engineer Malcolm P. Hanson of the Byrd Antarctic Expedition. In effect he says, "We are using DURHAMS exclusively because past experience has taught us that they can be relied upon for perfect performance under even the most adverse conditions." DURHAM Resistances are available for every practical resistance purpose in radio and television work from 250 ohms to 100 Megohms and in ratings for all limited power purposes. Used in leading radio laboratories, endorsed by leading engineers and sold by leading jobbers and dealers. Descriptive literature on the entire line of DURHAM products will be gladly sent upon request.

**DURHAM**  
METALLIZED  
**RESISTORS & POWEROHMS**

INTERNATIONAL RESISTANCE CO.  
2006 Chestnut Street, Philadelphia, Pa.

No. 265

RADIO BROADCAST Laboratory Information Sheet

March, 1929

## Electrifying Battery-Operated Sets

IT IS much easier and generally more satisfactory to change a battery-operated receiver over to complete a.c. operation by the use of an A-power unit than by rewiring the set for a.c. tubes; in both cases a source of B and C voltages is, of course, necessary. The use of an A-power unit to permit light-socket operation may be accomplished without rewiring the set, and, if the unit is a good one, one can be sure that the operation of the set from the A-power unit will be essentially the same as when it was run from the storage battery.

An A-power unit is somewhat similar to a B-power unit, both of them consisting of a transformer, rectifier, and filter system. The A unit differs from the B unit simply in the rectifier and filter system which must be capable of supplying two or three amperes instead of a few milliamperes.

The circuit of a typical A-power unit is given on this sheet. The transformer, T, supplies a.c. voltage to the rectifier, R, which feeds pulsating d.c. to the filter system where the ripple is removed so that the current leaving the output terminals of the filter system is practically pure d.c.

The arrangement of the chokes and condensers in the filter system varies in different units. In some cases both the chokes are placed in the same side of the line and three condensers are frequently used instead of two.

The transformer, T, is generally provided with taps on the secondary, as we have indicated, so that the output of the system may be corrected for different current drains. The greater the output current required from the unit, the higher must be the voltage impressed across the rectifier.

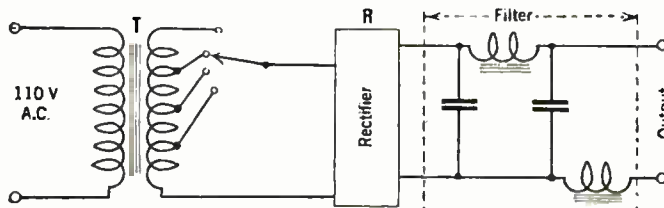

No. 266

RADIO BROADCAST Laboratory Information Sheet

March, 1929

## Effect of Room Acoustics

MR. IRVING WOLFF, of the Technical and Test Department of R. C. A., remarks in an article on loud-speaker measurements (*Proc. I. R. E.*, December, 1928) that,

"We are sometimes annoyed after having conducted listening tests on a loud speaker, and having reached the conclusion that it is pretty good, to find it unsatisfactory when moved to a different room or even a different position in the same room. It is, therefore, very important when taking loud-speaker curves to consider the question of room acoustics and loud-speaker position.

"Some of the factors which may be expected to have a pretty big effect are:

- Room absorption characteristics
- Room resonances
- Position of loud speaker in room
- Position of listener with respect to loud speaker.
- High frequencies are radiated in a beam. If high response is wanted the speaker should, therefore, be pointed and placed so as to cover as large a portion of the audience as possible. Placing the loud speaker

in a corner or in any kind of a cavity will usually have a big effect on the response. The space between the back of the loud speaker and wall or other obstruction will act as a resonant chamber whose vibrations will be excited by the vibrations of the rear side of the loud speaker diaphragm. It is impossible to say whether this effect will be pleasing or otherwise. It will depend on the unadulterated response characteristic and whether the resonance is of such frequency as to supply a region which is lacking.

"Under present broadcasting conditions where the range of frequencies transmitted is cut off pretty sharply at 5000 cycles or below, tube overloading on a loud speaker which reproduces real high frequencies show up as a roughness, rasp, and very often as a sound which resembles a paper rattle. This is caused by the generation of harmonics and combination tones. These added notes show up particularly badly when they are produced at the higher frequencies, as there is no true transmitted sound of the same frequency to act as a mask."

Note: The serial number of Lab. Sheet No. 256, "Power Output" in the January issue was duplicated accidentally in the February issue by a Lab. Sheet, "Three Types of Graphs," bearing the same number. In order to correct their records, readers may assign the number 264 to the sheet entitled "Three Types of Graphs."





**PLUG** in a Falck Claroceptor between wall socket and radio set and eliminate "static" from motors, street cars, telephones and electrical appliances. This new improvement by a pioneer radio parts manufacturer grounds and thus blocks out line interference noise and radio frequency disturbances. *Also improves selectivity and distance.* Requires no changes in set. Measures just 3½ x 5½ x 2½ inches. Thousands now all over America use the Claroceptor for clearer A. C. reception. Get one right away—at radio parts dealers. Write for descriptive folder.

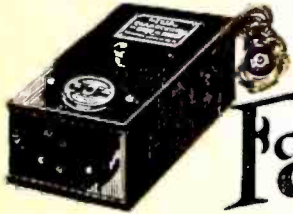

\$7.50 complete with cord and plug

**Falck**

**CLAROCEPTOR**

Built by ADVANCE ELECTRIC CO.  
1260 W. Second St. Los Angeles, Calif.  
JOBBERs and DEALERS, GET OUR PROPOSITION

**Jenkins & Adair  
Microphone Mixing Panel  
TYPE 3-B**



For Broadcasting, Electrical Recording, and Power Speaker Systems

THE 3-B Mixing Panel is designed to accommodate almost any combination of pickup circuits up to a total of six. Any three of these may be made to pass through the three Compound Mixing Controls at the same time, and instantaneous switching is available for the remaining circuits.

The incoming circuits may consist of condenser transmitters, carbon microphones, telephone lines or low impedance phonograph pickup devices, in practically any combination. When a single input circuit of extremely low level is encountered, the positions not in use may be cut entirely out of the system, thus causing no loss whatever to the weak incoming signal.

The panel is 5/16 black sanded Bakelite, 19 in. wide and 12½ in. high. Detailed information and circuit is shown in bulletin No. 7, which we will be glad to mail to you. The net price in the U. S. A. and Canada is \$275.00, F. O. B. Chicago.

J. E. JENKINS & S. E. ADAIR, Engineers  
1500 N. Dearborn Parkway,  
Chicago, U. S. A.

Send for our bulletins on Broadcasting Equipment

*Perform that  
"adenoid  
operation"  
on your set*

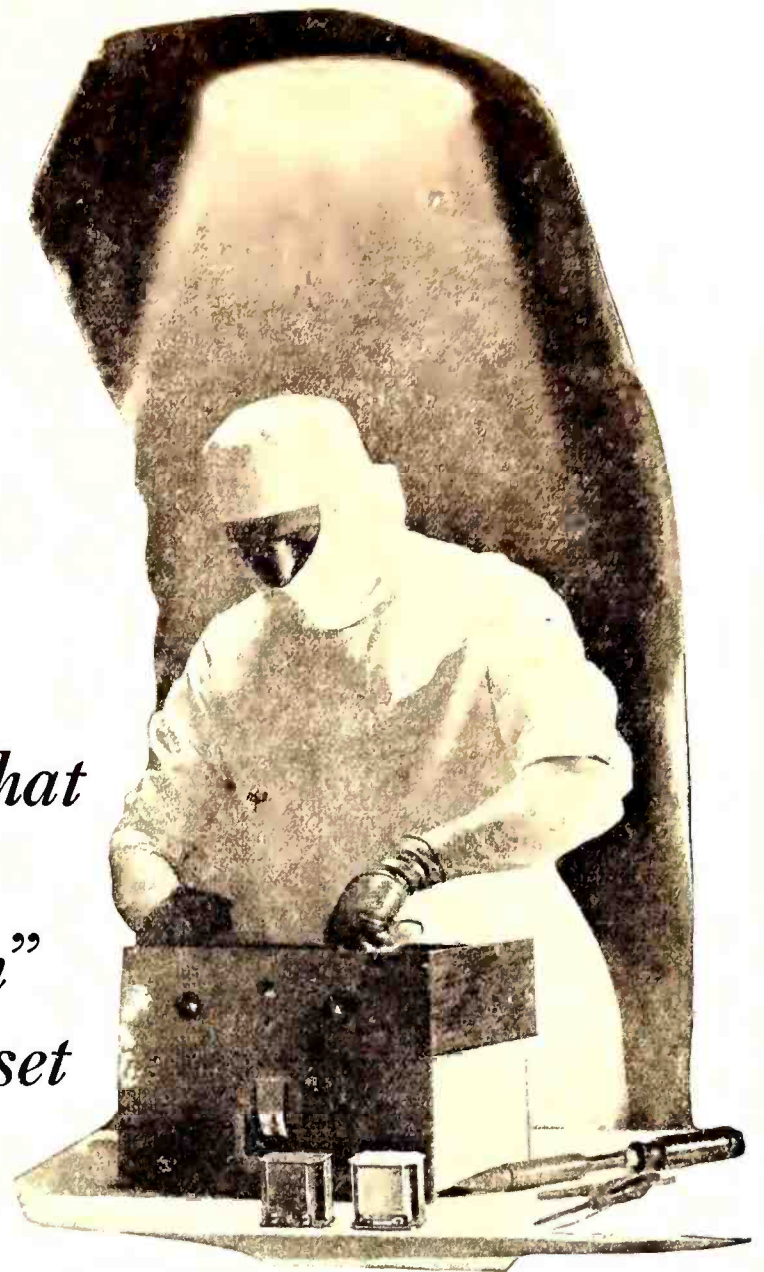

TAKE out the "adenoids", those inferior transformers which make your set sound as if it were afflicted with a bad case of adenoids... Then put in their place, the standard of excellence in Audio Transformers—AmerTran DeLuxe.

Ever hear a child talk before and after an adenoid operation? Well, if you have, you will appreciate the difference AmerTran transformers will make in any set.



AmerTran DeLuxe—1st stage turn ratio, 3. 2nd stage turn ratio, 4. Price each \$10.00.

AmerTran products are built exclusively for the purpose of achieving realism in tone. It cannot be done cheaply, or haphazardly. AmerTran's 30 odd radio products all play their definite part in producing the finest tone known to radio.

Why not perform that "adenoid operation" today? See your dealer or write to us. Ask for Bulletin No. 1084.

**AMERTRAN**

AMERICAN TRANSFORMER COMPANY  
Builders of Transformers for more than 29 years  
72 Emmet St. Newark, N. J.

Power in Broadcast Harmonics

A BROADCASTING station is assigned to a definite frequency by the Federal Radio Commission. In the operation of the station it is essential that the major part of the radiation take place within 500 cycles of this assigned frequency. Since, however, for reasons of economy, the oscillators at the transmitter are generally overloaded rather than underloaded, it is always found that they generate, beside the fundamental frequency, a considerable amount of energy at harmonic frequencies. A transmitter operating on a frequency of 500 kilocycles will generate energy at 1000 kilocycles so that the program could be heard on both of the channels—and, of course, it is probable that the 1000-kilocycle wave would produce interference with a station assigned to that frequency. Some method must, therefore, be used to suppress the harmonics since, if they are permitted to get into the antenna, they will cause interference in other broadcasting channels. The greatest interference is caused in the channel corresponding to a frequency twice that on which the station is authorized to operate. In the August, 1928 *Bell Laboratories Record* the following interesting remarks were published relative to the suppression of harmonics from one of the experimental stations operated by the Bell Telephone Laboratories:

"In this respect, as in many others, 3XN, the latest broadcasting development of our Laboratories, marks a new level of attainment. The transmitter has a power input into the antenna system of 50 kilowatts for the carrier wave alone, and the instantaneous peak power during the broadcasting of a program may reach 200 kilowatts. And yet with all that power in the carrier wave, the amount of the second harmonic allowed to escape would not light the tiniest incandescent lamp made. To be exact, it is less than 0.005 watt and represents about one-ten-millionth of the power of the carrier wave.

"Ordinarily, a purity (lack of harmonics) of 80 to 95 per cent. can be readily and cheaply attained. To carry this to 99 per cent. costs considerably more and to carry it to 99.9 per cent. many times as much. The extent to which the purification is carried out is now left largely to the designers of the radio transmitter, and they look upon it as an economic balance between the job that they would like to do and the cost of the equipment that can be justified. The more powerful the broadcasting transmitter, the more important becomes the problem of attenuating its harmonics, and the greater the care which must be bestowed upon its harmonic filters."

Mathematics of the Tuned Circuit

THE tuned circuit and its characteristics are important. Therefore, in this sheet are presented a few of the mathematical expressions concerning such circuits.

The current (I) flowing around a circuit consisting of a coil and a condenser connected in series may be determined by the following formula:

$$I = \frac{E_i}{\sqrt{R^2 + (\omega L - \frac{1}{\omega c})^2}} \quad (1)$$

where

- I = current in amperes
- E<sub>i</sub> = voltage induced in the circuit
- R = resistance of circuit
- L = inductance of coil in henries
- c = capacity of condenser in farads
- ω = 2 π times the frequency in cycles

At resonance ωL equals  $\frac{1}{\omega c}$  and equation (1) is therefore reduced to

$$I = \frac{E}{R} \quad (2)$$

At resonance the energy stored in the condenser is

$$\frac{cE_i^2}{2} \quad (3)$$

where E<sub>g</sub> is the voltage across the condenser. The energy in the coil is

$$\frac{LI^2}{2} \quad (4)$$

and if the resistance is small in comparison with ωL then the energy is equal in both cases and

$$I = E_g \sqrt{\frac{c}{L}} \quad (5)$$

whence

$$E_g = I \sqrt{\frac{L}{c}} \quad (6)$$

The last equation indicates that the voltage, E<sub>g</sub>, across either the coil or the condenser is proportional to the ratio of L to c.

The gain of a tuned circuit may be defined as the voltage, E<sub>g</sub>, generated across the circuit divided by the voltage, E<sub>i</sub>, induced in the circuit.

$$E_g = I\omega L \quad (7)$$

and combining equation (2) with (7) and solving for the gain, we have

$$\text{Gain} = \frac{E_g}{E_i} = \frac{\omega L}{R} \quad (8)$$

Importance of Bass Notes

SUPPOSE that a certain note on the piano is sounded in the studio of a broadcasting station and the characteristic of the radio circuit is such that the fundamental frequency of the tone is not transmitted but all the harmonics are. Even though the frequency of the fundamental never even reaches the loud speaker, if all the harmonics are reproduced we will be able to tell what note was sounded. It is a peculiar characteristic of the human ear that to a considerable extent it can, in some manner, supply to our consciousness many of the fundamental frequencies which are not reproduced by an ordinary radio system.

The fact that the ear is capable of supplying missing fundamental frequencies under some conditions does not mean that it is not worth while to design the radio system so that it is capable of reproducing them. The results would be much better if the fundamental were transmitted—this may be proved

easily by playing the same note on the piano. The difference would be quite noticeable as the true note would sound much richer and be somewhat lower in pitch. The qualities which the note lacked when the fundamental was eliminated would be quite evident and the advantages, of designing a radio system to transmit the fundamentals of all the audio frequencies, of obvious value.

Since there is a large group of instruments in an orchestra—the trombone, cello, double bass, bassoon, drums, etc.—which sound many notes that are low in frequency, say below 150 cycles, it would seem that just as these instruments are essential in an orchestra to give correct balance, so the reproduction of the fundamental frequencies of their notes is essential for good quality. Imagine a symphony orchestra with all of these instruments lacking! However, it is usually unnecessary to reproduce notes below 60 cycles.



Individual Instruction Cards  
for testing  
Factory-Built Radio Sets  
An Added Service of the  
WESTON MODEL 537  
A.C. and D.C. Radio Set Tester

THESE Instruction Cards, by covering the specific testing requirements of individual receivers, make the Model 537 a still more useful test set for the service man.

They save the service man's time by giving a complete outline of procedure for testing the principal makes of factory-built sets and, in addition, give the socket voltages and tube plate current for every stage throughout the set, as well as the comparative grid test on the various tubes.

The Model 537 is designed to meet the service requirements of every type and kind of radio receiver. Its use, however, is reduced to still greater simplicity when testing any particular make of set in conjunction with its individual instruction card.

Write to us and we will be pleased to acquaint you with full particulars. Or, better still, address your inquiry to your radio jobber, supply house or our nearest representative—and ask for a demonstration.

**WESTON ELECTRICAL INSTRUMENT CORP.**  
604 Frelinghuysen Avenue  
NEWARK, N. J.



# CROSLEY

announces:

3  
optional  
colors

Mandarin Red  
Nanking Green  
Manchu Black



Attach to  
antenna  
and add tubes

The AC Electric  
Gemchest

\$ 99.99

To radio's great *value* Crosley now adds **STYLE**. To perfection of radio reception Crosley introduces **FASHION**. Chinese Chippendale is the motif. Three popular, smart, stylish colors afford your trade a splendid choice. Mandarin Red, Nanking Green and Manchu Black. All gold trimmed.

The size of this chest is stylishly right. Not too big. Just enough color to complete the furnishing of any room.

In it is built the famous Crosley AC Electric **GEMBOX** and the Crosley dynamic type power speaker **DYNACONE**.

The same cabinet with the Crosley 8 tube **SHOWBOX** built in sells for \$114. Prices quoted do not include tubes.

Radio excellence! Decorative smartness! Color harmony! See other side of this announcement for complete line.

# CROSLEY

*announces:*

## Price Correction

After the black printing on this sheet, analysis of manufacturing costs made it possible to reduce prices on the Crosley Gemchest and Showchest described on the reverse side of this sheet. The price on each model has been reduced \$5.00.

NEW PRICES  
GEMCHEST

**\$94**

SHOWCHEST

**\$109**



The New

8 tube JEWELBOX

**\$105**

Power detector, tuned antenna circuit, UY-227 tubes in all sockets except output and rectifying.

*"The finest radio money can buy."*

Power detector makes use of plate rectification instead of grid rectification as commonly used in radio. Result: *over-loading prevented* and tone improved.

Tuned antenna circuit creates selectivity and sensitivity to a degree of quality never before attained.

By use of UY-227 type tubes, except in output, filtering of circuits is improved.

Add to these features other improvements such as NEW volume control, improved audio system, full voltage supply, no power pack trouble and genuine neutrodyne balancing.

Sell this great value—be in radio *profitably* in 1929.

Write us for address of nearest Crosley jobber.

CROSLEY

8 Tube

SHOWBOX

**\$80**

This famous, finely balanced neutrodyne receiver—sensitive and selective to a marked degree is also available in a new black wrinkle finish brushed with white gold as well as the popular brown and gold finish.

Features of the SHOWBOX are FULL VOLTAGE on audio plates—perfected MERSHON Electrolytic condenser in power pack which will *not* break down—push-pull amplification — modern illuminated dial and many others found in sets at twice its price.

Crosley dynamic type power DYNACONE \$25



CROSLEY

Line for 1929

Strongest in the

Industry

Lowest priced FIRST CLASS AC electric radio on the market—The GEMBOX at \$65. Unusually sensitive and selective. Genuine neutrodyne and operates power speaker.

Crosley battery type sets are same superior neutrodyne circuits as found in Crosley AC Electric sets.

6 tube BANDBOX—operates power speaker—\$55.

5 tube Dry Cell BANDBOX, Jr., for places where battery recharging is impossible—operates loud speaker—\$35.

THE CROSLEY RADIO CORPORATION, CINCINNATI, OHIO  
Powel Crosley, Jr., Pres.

Montana, Wyoming, Colorado, New Mexico and West prices slightly higher.  
Prices quoted are without tubes

# AEROVOX BUILT BETTER CONDENSERS AND RESISTORS

## Eliminate Man-Made Static

Radio listeners all over the country are finding welcome relief from the innumerable line noises caused by motors, elevators, refrigerators, oil burners, bells and other electrical appliances by using Aerovox Interference Filters. These units are also effective in preventing disturbances from electrical appliances from being applied to the electric lines. Detailed information will be sent gladly on request.

A COMPLETE CATALOG with illustrations and detailed descriptions may be obtained free of charge on request.



The Aerovox Research Worker is a monthly publication that

will keep you abreast of the latest radio developments. Your name will be put on the mailing list free of charge on request.

**AEROVOX WIRELESS CORP.**  
76 1/2 Washington St., Bklyn., N. Y.  
**PRODUCTS THAT ENDURE**

# Both BYRD and WILKINS Choose HAMMARLUND Condensers

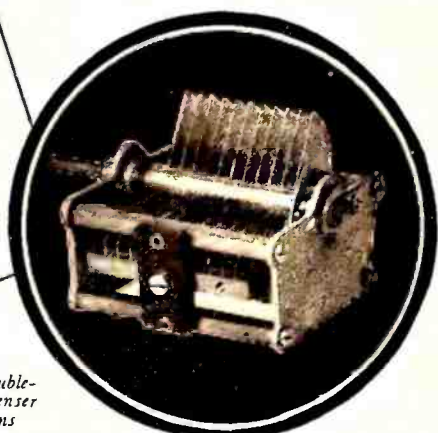
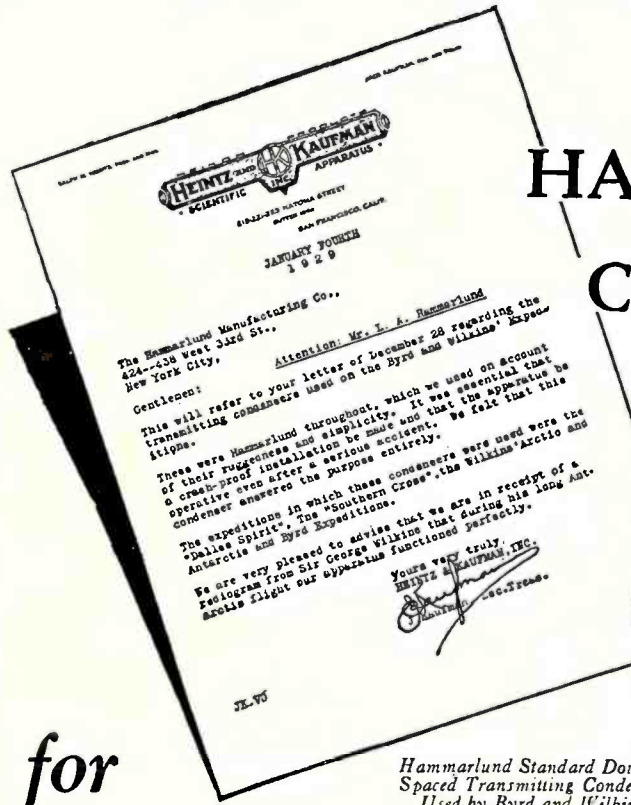

Hammarlund Standard Double-Spaced Transmitting Condenser Used by Byrd and Wilkins

for

## "Ruggedness and Simplicity"

"THE WORLD'S most southerly radio station works perfectly," states Carl Petersen, Radio Operator of the Byrd Antarctic Expedition, according to The New York Times.

Heintz and Kaufman, the builders of the Byrd and Wilkins' radio equipment, as well as that for the record-breaking aeroplane "Southern Cross", selected Hammarlund condensers "on account of their ruggedness and simplicity"—crashproof qualities—not easily made inoperative in case of accident.

Every radio product of Hammarlund make—condensers, coils, chokes, drum dials—has the unfailing virtues of endurance and superior performance which make them the first choice of experts the world over.

Write Dept. RB3 for Descriptive Literature

**HAMMARLUND MANUFACTURING CO.**  
424-438 W. 33rd Street New York, N. Y.

For Better Radio  
**Hammarlund**  
PRECISION  
PRODUCTS

# Potter Condensers



THE selection of leading manufacturers for the finest radio receivers. Insure the operation of your radio set or power amplifier with Potter condensers, which are known for

their Quality — Uniformity — Long Life—Economy.

- T-2900 Condenser Block for the single 250 type tube amplifier..... \$20.00
- T-2950 Condenser for the push-pull 250 type tube amplifier..... \$22.50
- T-2098 Condenser Block for single 210 type tube amplifier..... \$20.00
- T-280-171 Condenser Block for power pack with 280 type tube rectifier. \$18.00

### Potter Interference Eliminator

Enjoy radio broadcast programs normally spoiled by interference from oil burner, ice machine motors, fans, violet rays, vacuum cleaners, etc.

Remedy: connect 104-04 Interference Eliminator to the line circuit at the point where interfering device is connected.

Price \$3.00



**The Potter Co.**  
North Chicago, Illinois  
A National Organization at Your Service

**CORWICO**  
*Braidite*  
HOOK-UP WIRE  
"THE BRAID SLIDES BACK"  
At All Dealers

- 25 Feet Stranded ..... 35c
- 25 Feet Solid ..... 30c
- Red, Green, Yellow, Blue, Black

FREE Send us the name and address of your dealer and we will send you a sample package of Braidite FREE. Include 10c for postage.

**CORNISH WIRE CO.**  
38 Church Street New York City

Wire Your Home With  
**YAXLEY**  
Radio Convenience Outlets

FOR every radio need, in brushed brass or Bakelite. Fit standard electrical switch or outlet box. Single plates and in gang in many combinations.

- No. 135—For Loud Speaker ..... \$1.00
- No. 136—For Aerial and Ground ..... 1.00
- No. 137—For Battery Connections ..... 2.50
- No. 138—For A C Connections ..... 1.00

(Bakelite, 25c additional per plate)

At Your Jobber's

**YAXLEY MFG. CO.**  
Dept. B, 9 So. Clinton St., Chicago, Ill.

# Improves Radio Reception and Increases Life of Tubes

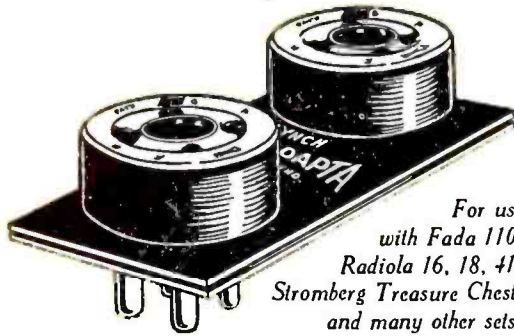

For use with Fada 110, Radiola 16, 18, 41, Stromberg Treasure Chest, and many other sets.

## LYNCH TUBADAPTA

eliminates the blasts and unnatural noises of full volume reception. Output of receiver is practically doubled, with absolutely no distortion. A simple means is provided for using.

### 2 Tubes in Parallel

in last audio socket. This reduces the impedance in the power stage, resulting in much better reproduction of the ordinarily "hard-to-get" low notes.

The Lynch Tubadapta can be installed by anyone in ONE minute, and retails for only \$2.50. If your dealer cannot supply you, let us know, and we will tell you where to get it.

### Other LYNCH Products



- Metalized Resistors.** Dependable, permanently accurate, noiseless.
- Leak-Proof Mountings.** Single or double, of genuine Bakelite.
- Grid Suppressors,** for radio frequency circuits to stop oscillation and improve reception without broadening tuning.
- Filament Equalizers.** Used in filament circuits to keep the filaments at their best operating points.

It will pay to send for 40-Page Free Booklet, "Resistance, The 'Control Valve' of Radio."

**ARTHUR H. LYNCH, Inc.**  
1775 Broadway (at 57th St.) New York

### Manufacturers of QUALITY RADIO PRODUCTS

No. 270

RADIO BROADCAST Laboratory Information Sheet

March, 1929

### Formulas for Power Output

THE undistorted power output of a tube is defined as the maximum power which can be supplied to a load without introducing more than five per cent. distortion due to the curvation of the tube's characteristic. It has been determined that the maximum amount of undistorted power is obtained from any given tube when the load resistance equals twice the plate resistance of the tube. The power output can be computed from the formulas

$$P = \frac{2 (uE_{gr})^2}{9 R_p} 10^3 \quad (1)$$

when

- P = power in milliwatts
- u = amplification constant
- E<sub>gr</sub> = r.m.s. value of signal voltage on the grid
- R<sub>p</sub> = plate resistance

If peak values of a.c. voltage on the grid are used instead of r.m.s. then the formula is:

$$P = \frac{(uE_{gp})^2}{9 R_p} 10^3 \quad (2)$$

when E<sub>gp</sub> = peak value of signal voltage on the grid.

Both of these formulas are calculated for the condition that the load is twice the plate resistance — the condition for maximum undistorted output.

These general formulas can be simplified if applied specifically to the various power tubes in use, and the table on this sheet gives these simplified formulas. For example, the power output of a 112A is equal to 2.86 times the square of the r.m.s. value of the a.c. voltage on the grid of the tube.

The column R<sub>p</sub> indicates the plate resistance used in calculating the simplified formulas.

Type of Tube	R <sub>p</sub>	Power in Milliwatts	
		R. M. S.	Peak
171A	2000	E <sub>g</sub> <sup>2</sup>	0.5 E <sub>g</sub> <sup>2</sup>
112A	5000	2.86 E <sub>g</sub> <sup>2</sup>	1.43 E <sub>g</sub> <sup>2</sup>
210	5000	2.86 E <sub>g</sub> <sup>2</sup>	1.43 E <sub>g</sub> <sup>2</sup>
250	1800	1.78 E <sub>g</sub> <sup>2</sup>	0.89 E <sub>g</sub> <sup>2</sup>

No. 271

RADIO BROADCAST Laboratory Information Sheet

March, 1929

### Test for a Faulty Push-Pull Amplifier

SEVERAL letters have been received recently by the Laboratory relative to the operation of push-pull amplifiers. Evidently some servicemen, quite capable of servicing any ordinary type of amplifier, are frequently unable to repair the push-pull amplifier that does not give good quality but which is wired correctly, uses good apparatus, and employs tubes that take normal plate current. The trouble is generally due to oscillations in the push-pull amplifier but to detect these oscillations it is necessary to apply to the push-pull amplifier a somewhat unusual test.

The test which is necessary to detect the oscillations

consists of placing a meter in the C minus lead to the push-pull stages to determine if there is any grid current. The location of the meter is shown in sketch A. Under normal conditions there will be zero current in the grid circuit but if the circuit is oscillating several milliamperes may flow in the grid circuit. If such a test indicates that an amplifier is oscillating, then one or both of the following remedies must be applied.

The first thing to do is to connect a 50,000-ohm resistor in the common C-minus lead at the point indicated as "A" in sketch B; this resistance should not be bypassed with a condenser. The fidelity will not be affected in any manner by the inclusion of this resistor in the circuit but it is practically always effective in suppressing the oscillations.

In some cases a second change may have to be made to suppress completely the oscillations. If the resistance is not entirely effective, a choke coil, such as might be used in a B-power unit, may be connected at point "C" in sketch B. A choke coil must be used here instead of a resistance because of the loss in plate voltage which would be produced by a resistance.

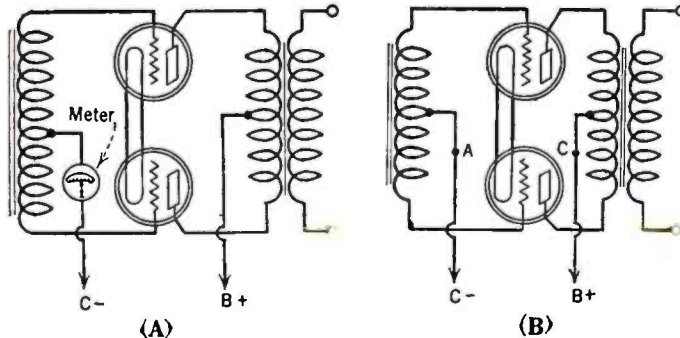

No. 272

RADIO BROADCAST Laboratory Information Sheet

March, 1929

### Importance of Correct Filament Voltages

THIS Laboratory Sheet supplies additional information on the subject covered in Sheet No. 254 published in the January issue. The latter sheet suggested the use of somewhat lower than rated voltage on the filaments of 226- and 227-type a.c. tubes. The information which follows from R. M. Wise, Chief Engineer of E. T. Cunningham, Inc., points out that the use of lower than rated voltages is not to be recommended generally.

"In using new tubes, and particularly with certain tube types, very satisfactory operation will be obtained at considerably reduced voltages. However, we find that reduction of the voltage below a certain point has little beneficial effect on tube life, and in some cases may shorten it due to the fact that the coated filament at times loses its activity when operated at very low temperatures.

"As an example, we find that average new c-327 tubes will give excellent performance below 2.0 volts, yet the emission life of the cathode at this temperature is not as satisfactory as is the case when it is operated at, or near, rated voltage.

"The c-327 heater voltage rating has been chosen with all of these factors in view, and, while for detector service we find it advisable for a time to recommend 2.25 volts, this recommendation has

never been extended to the operation of the tube as an amplifier. As an amplifier we consider the preferred operating range to be from 2.4 to 2.6 volts, while as a matter of fact it will show satisfactory operation over a wider range of voltages. This recommendation has also been extended to include tubes used for detector service.

"It is particularly important to operate power and rectifier tubes within a range of + or - 5 per cent. from the rated value. Several instances of unsatisfactory operation of type cx-350 have been traced to operation at 6 volts. In each case satisfactory operation was obtained as soon as the filament potential was raised to 7.5 volts.

"It is true that there is not much change in characteristics when the tubes are operated somewhat below rated voltage. This holds for new tubes, but the question of maintaining uniform emission throughout the life of the tube is an important factor, and, as previously mentioned, this is best realized by operating the tube close to rated voltages. There is added advantage that when so operated a moderate change in emission will not affect operation, due to operation on or below the knee of the saturation curve, while if operated at reduced voltages a similar change in emission will result in impaired performance."

*"Almost as Good as a  
VICTOREEN"*

*The Greatest Compliment That  
Can Be Paid Any Radio Receiver*

The selectivity, sensitivity, tone quality and reliability of a Victoreen is positively unsurpassed by any "production" receiver on the market.



**Victoreen Parts Are The  
Standard of Quality**

There is no real substitute for them, and for what they do. Victoreen developments are continually in advance of the times, yet they never are offered to the public until the most exhaustive tests have proved their merit.

The heart of the new Super Heterodyne circuit is the Victoreen Super Transformer, vastly improved for 1929, tuned and matched to a precision of 1/3 of one per cent. In addition, the circuit itself contains improvements far ahead of its time.

**Complete Kits Available  
Either A. C. or D. C.**

*Blue Prints and Assembly Instructions Are  
FREE. State whether You Wish A. C. or D. C.*

**THE GEO. W. WALKER  
COMPANY**

*Merchandisers of Victoreen  
Radio Products*

2825 Chester Avenue Cleveland, Ohio

**FROST**



**FROST VOLUME  
CONTROL**



**FROST APPROVED  
A. C. SWITCH**

Gives complete, stepless and wonderfully smooth control of volume and oscillation. Wearproof roller contact arm, Bakelite case and dust cover. \$2.00 and \$2.25.

Single hole mount 110 volt A.C. Snap Switch. Tested to 250 volts, 3 amps. Underwriters' approved. 75c.



**FROST GEM  
RHEOSTATS**

Made to deliver a service that is not usually expected from little rheostats like these. Mighty good little rheostats, taking up little space and supplied either plain or with D.C. switch. Easy to solder to. Plain, 75c. With switch, \$1.00.



**FROST BAKELITE  
RHEOSTATS WITH  
D. C. SWITCH**

Cleverly mounted German silver D.C. battery switch is firmly attached to Bakelite panel on back of rheostat, affording quick on and off control of filament current. 2 to 75 ohms. \$1.35.

**HERBERT H. FROST, INC.**

Main Office and Factory: ELKHART, IND.  
Chicago San Francisco

**RADIO**



**There Are No Short Cuts To Quality**

IF YOU demand from Radio the beautiful natural reproduction now possible with modern power tubes and the proper Parts then you must buy or build a Receiver properly designed from the very finest Parts. There is no short cut—Quality demands the finest—in

engineering, materials and workmanship. Dongan Parts—acknowledged as the Standard of Quality—have always been built to give superlative results. You can be confident that a set properly built with Dongan Parts will give you the best that Radio can offer.



No. 7568  
\$13.50

**For Use with  
UX 250 Tubes**

- No. 7568 Transformer for full wave rectification using 2 UX 281 tubes to supply B and C power to receiver and power for 2 UX 250 tubes. \$13.50
- No. 8529 Transformer similar to No. 7568 with the addition of 2 low voltage windings, one for 226 tubes and the other for 227 tubes so that you can build a power amplifier for either radio receiver or phonograph pick-up. \$17.50
- No. 6551 Double Choke, for use with above transformers. \$15.00
- D-600 Power Amplifier Condenser Unit. \$16.50
- D-307 A Condenser Block, used in connection with D-600. \$10.00
- No. 1177 Straight power Amplifier Output Transformer. \$12.00
- No. 1176 Same as No. 1177 but of Push Pull type. \$12.00

Please Mail Item Checked C. O. D.  
Please send Detailed Information.  
Send 20c for copy of Duston AC Manual.

Name .....

Address .....

City..... State.....

**DONGAN ELECTRIC MFG. CO.**  
2991-3001 Franklin Street  
Detroit

**Dongan  
Parts  
are Standard  
in many  
Famous  
Receivers**

**TRANSFORMERS of MERIT for FIFTEEN YEARS**

**SAVE  
\$2.00**

**RADIO BROADCAST  
Garden City, N. Y.**

Gentlemen: Please enter my subscription to RADIO BROADCAST for two full years at the special rate of \$6.00—saving me \$2.00 on the regular subscription price.

(If you are already a subscriber your subscription will be extended for two full years from date of expiration.)

Name .....

Address .....

City..... State.....

No order can be accepted unless the classification to which you belong is checked below.

- Manufacturer  Technician  Engineer
- Radio Dealer  Service Man  Set Builder

(Other Occupation).....

**MAIL  
TODAY**

# BOOK REVIEWS

## Whatever You Want to Know

about RADIO—principles, methods, apparatus—you will find instantly in

# THE RADIO MANUAL

A Complete Course in Radio Operation In a Single Volume



A Handbook for Students Amateurs Operators Inspectors

For the first time an entire course of training in one book—the most complete and up-to-date work on radio. Developed simply and clearly from the elementary stage right through all phases of principles, practise, and apparatus so that a beginner with no knowledge of electricity

may get all the needs either for amateur operation or to qualify for a government license as operator or inspector.

### Prepared by Official Examining Officer

The author, **G. E. Sterling**, is Radio Inspector and Examining Officer, Radio Division, U. S. Dept. of Commerce. The book has been edited in detail by **Robert S. Kruse** for five years, Technical Editor of QST, the Magazine of the Radio Relay League. Many other experts assisted them.

**16 Chapters Cover:** Elementary Electricity and Magnetism; Motors and Generators; Storage Batteries and Charging Circuits; The Vacuum Tube; Circuits Employed in Vacuum Tube Transmitters; Modulating Systems; Wavemeters; Piezo-Electric Oscillators; Wave Traps; Marine Vacuum Tube Transmitters; Radio Broadcasting Equipment; Arc Transmitters; Spark Transmitters; Commercial Radio Receivers; Radio Beacons and Direction Finders; Radio Laws and Regulations; Handling and Abstracting Traffic.

**New Information** never before available such as a complete description of the Western Electric 5 Kilowatt Broadcasting Transmitter; description and circuit diagram of Western Electric Superheterodyne Radio Receiving Outfit type 6004-C; Navy Standard 2-Kilowatt Spark Transmitter; etc., etc. Every detail up to the minute.

### Free Examination

"The Radio Manual" has just been published. Nearly 700 pages. Profusely illustrated. Bound in Flexible Fabrikoid. The coupon brings the volume for free examination. If you do not agree that it is the best Radio book you have seen, return it and owe nothing. If you keep it, send the price of \$6.00 within ten days.

### Order on This Coupon

**D. Van Nostrand Co., Inc.,**  
6 Warren St., New York

Send me THE RADIO MANUAL for examination. Within ten days after receipt I will either return the volume or send you \$6.00, the price in full.

(Radio Broadcast 3-29)

Name.....  
St. & No. ....  
City and State.....

**PRACTICAL TELEVISION** By E. T. Larner, with a Foreword by John L. Baird. D. Van Nostrand Co., New York, 1928. 175 pages, \$3.75.

This book, as one of the earliest texts on television, is a volume of some importance, although, judging by the price in comparison with the number of pages, the publishers do not anticipate any considerable circulation for it.

In his Foreword Mr. Baird asks, "Where better can we seek for truth than in scientific research? Sport, Business, Art, Music, and all the other avenues into which man directs his energies, are tainted with commercialism, self-interest, passion, and emotion." It is painful, beside such iridescent idealism, to be forced to quote the irresponsible ballyhoo of Captain Oliver George Hutchinson, Managing Director of Baird International Television, Ltd., who is engaged in promoting Mr. Baird. Said Captain Hutchinson on a recent visit to the United States:

"I am happy to say that no longer is the 'Television' in a state of experimentation. John L. Baird, the inventor, has perfected the instrument, so that it can no longer be said to be in a visionary state. It now reproduces, in the minutest detail, the features and the actions of a human being on a glass disc which can be a part of one's radio set at little cost.

"A month ago Mr. Baird went a step further, a step which brings nearer the possibility of seeing actions at the time they are actually taking place, sent from a distance in their natural colors with their natural lighting—green fields, blue sky, sunset, even the varied colors and movements of the English Derby scene. In other words actual vision in color has been transmitted. This, combined with the transmission of scenes in daylight, will mark the greatest advance toward seeing from afar in their natural state without any artificial lighting, scenes and people as they exist."

Thus, the duly authorized spokesman of Mr. Baird. "No longer in a state of experimentation!" "Perfected!" "Reproduces in the minutest detail!" Any one who knows the theory and practical status of present-day television, including Mr. Baird's brand, will tell you that it is in a highly experimental state, far from perfection, and that it reproduces only objects of limited size, moving slowly if at all, and with details missing. Mr. R. P. Clarkson, in his television articles in RADIO BROADCAST (July and August, 1928) depicts the present field of television much more accurately.

Aside from a tendency to act as one more of Mr. Baird's press agents, Mr. Larner has written an informative book. After an introductory chapter he proceeds with a historical discussion, in which he states truly that the name of the early inventors in the field is legion. He mentions Caselli, Bain, Bakewell, Vavin, Fribourg, the ubiquitous Edison, Milmault, Willoughby Smith, Senlezq, Grabam Bell, Arynson, Perry, Kerr, Middleton, Connolly, McTighe, Hick, Carey, Bidwell, Knudsen, De Bernouchi, Ruhmer, Rignoux, Fournier, Szepepanik, Rosing, Campbell Swinton, Korn, Poulsen, M. J. Martin, the Bell Telephone Laboratories, Thorne Baker, Ranger, Marconi's Wireless Telegraph Company, Ltd., The Radio Corporation of America, Belin, Hollweck, Dauvillier, von Mihaly, Jenkins, Alexanderson, and Baird. Larner himself is an engineer of the British Post Office, but, save in the case of Baird, he seems to have little pro-British bias in his historical résumé.

The chapter on "Photo-Electricity and the Photo-Electric Cell" will interest sound-movie technicians as well as experimenters in the field of television. There is a reasonably comprehensive discussion of the vacuum and gas-filled types, with descriptions and curves

of the British General Electric Company's potassium and potassium-argon cells, the Cambridge Instrument Company's potassium-helium cell, a somewhat inadequate treatment of methods of coupling photo-electric cells to amplifying systems, and a brief description of the three- and four-electrode type of photo-cell in which the transition from the photo-electric device to the input of the amplifier is affected internally in a single tube.

Reviewing television research in the form of specific attempts, Larner outlines two general solutions: (1) Imitating the construction of the eye by using a large number of selenium cells, forming a mosaic of the scene; and (2) Using one cell only and causing the illuminated elemental areas of the scene to fall in rapid succession on this cell. The first attempts followed method (1) and failure was due to the lag of the cells and the complication of multiplying cells, controls, and wires. By the second general method partial success was attained by a considerable number of the investigators. Among others Jenkins's prismatic disc, the Moore glow lamp, and Alexanderson's 1927 seven-channel apparatus are mentioned. Following this chapter there is one on cathode-ray devices and another on optical aspects ("Images and their Formation"). Chapter VIII is entirely devoted to the Baird televisor. The three-disc transmitter and Baird's other devices are clearly diagrammed. The last two chapters of the book include a discussion of television technique.

This book has the virtues and defects of any premature treatment of a scientific problem. Although the major principles of television are old, it is only recently that methods and apparatus have been refined to a point where a restricted success could be achieved. Mr. Larner has written his account while methods are still everywhere in flux and before any authentic commercial solution is in sight. He deserves credit as a pioneer in the literature, but of necessity his work is incomplete, and to a large extent lacking in perspective and impartiality.

CARL DREHER.

## Letters from Readers

### Service Men Disagree

**D**URING the last few months considerable space has been devoted in the pages of RADIO BROADCAST to articles of interest to radio servicemen; notable among these was the series of experiences in radio servicing which were recounted by Mr. Alcorn, a practicing serviceman. Considerable interest in material of this nature has been manifest in recent letters which have been received from readers. Although much of the correspondence has been very liberal in its praise, other letters have contained constructive criticism which is also appreciated.

In the following paragraph are excerpts from a letter written by the president of QRV Radio Service, Inc., one of the oldest and largest service organizations in New York City. Although the views expressed in this letter do not coincide with those of Mr. Alcorn, the arguments are very interesting.

#### To the Editor:

We are roused from our literary lethargy by a driving desire to comment on the service article by Mr. Alcorn, appearing in November RADIO BROADCAST. We strongly disagree with the author's opinion that the cost of manufactured set analyzers is prohibitive. We believe that, if a service organization is to function to the optimum efficiency, its servicemen in the field must be equipped

(Continued on page 356)



## For the New Tubes!



**NATIONAL**  
Single-Dial Tuning-Unit  
No. 222-A  
for A. C. Sets

### For the new R. C. A.—A. C. Shield-Grid Tube

This improved NATIONAL Tuning Unit embodies matched condensers for better single control, and coils designed for use with this wonderful new A. C. Tube.

### For the new R. C. A. Power Tube

A special NATIONAL A-B-Power No. 7180-A furnishes the 250 volts for plate and 50 volts bias—required for best operation of this latest power-tube.

The NATIONAL A-100 Velvetone Audio-Transformer is designed to work into the same new tube.

Send for Bulletin 130, 150-R.B.

**NATIONAL**  
RADIO PRODUCTS  
National Co., Inc., Malden, Mass.

## POLYMET smashes the neck of the bottle



Remember how coils held up 1928 radio production? No more of that, for now—

### POLYMET MAKES COILS!

The high Quality, quick Service, and absolute Dependability, long associated with Polymet Condensers and Resistances are now carried into the coil industry. Polymet has the answer to every coil problem—Polycoils. Blue prints of your coil requirements are especially solicited.

POLYMET MANUFACTURING CORP.  
597 Broadway New York City  
**POLYMET PRODUCTS**

## "You Can Forget the Condensers—If They Are DUBILIER'S"

Specially designed for Thordarson Power Packs Type 574 for use with the Rathenon BH tubes or the Elkon Metallic EBH rectifier.

Type 575 for use with 210 type tubes and 281 rectifier tubes.

Type 1152 for use with 210 and 250 type tubes and 281 rectifier tubes.

Type 1120 for use with 280 type rectifier tubes or the Elkon E-80 metallic rectifier.

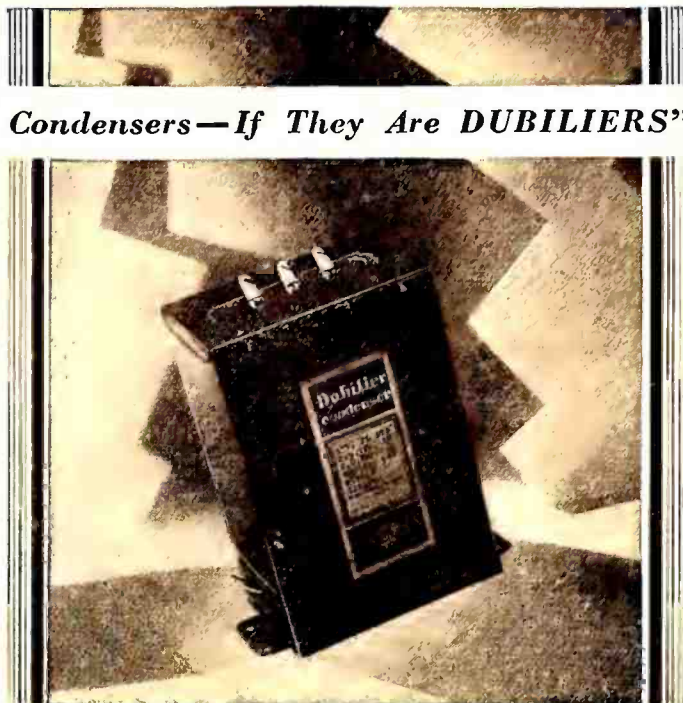

*There  
is*

## No Substitute for Quality!

No amount of lurid claims by nimble-penned advertising writers will take the place of quality in the final analysis—the operation in your power supply.

Ever since the advent of Radio, Dubilier has been the manufacturers' standard—and the set builders' stand-by. Built in every Dubilier Condenser is a factor of safety which is *your* safeguard for years of service without failure.

### DUBILIER LIGHT

### SOCKET AERIAL

—“A Moulded Bakelite Product”

Bring in programs with a minimum of interference. Do away with the unsightly and trouble causing outside aerial and lightning arrestor. Simply attach to the set and plug into the nearest light socket. Uses no current. Sold by all good dealers. Price \$1.50.



# Dubilier

## CONDENSER CORPORATION

10 East 43rd Street, New York City

Address  
Dept. 34



for free  
catalog

Reg. U.S. Pat. Off.

### Helpful Technical Information

A regular feature of RADIO BROADCAST is the series of Laboratory Information Sheets, which cover a wide range of information of immediate value to every radio worker, presented in a form making it easy to preserve them. To insure your having every issue, send your check for \$4.00 for one year's subscription, to

Subscription Department, Doubleday, Doran & Co., Inc.  
Garden City, N. Y.

### CUSTOM SET BUILDERS

Browning-Drake has an interesting and unusual proposition. Take advantage of the fact that more Browning-Drakes are built than any other. Write today.

**BROWNING-DRAKE CORP.**  
Cambridge Massachusetts

## Prevents Current Wobble

\$1.10 with mounting  
(in U. S. A.) at all  
dealers.

Install Amperite for every tube and smooth out "A" current wobble that ruins reception. Amperite adjusts itself to the exact need of each tube. A type for every tube—A. C. or D. C.

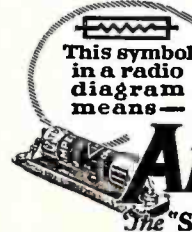

This symbol  
in a radio  
diagram  
means—

**Radiall Company**  
10 FRANKLIN ST., NEW YORK  
FREE—"Amperite Blue Book"  
of modern circuits and  
valuable construction data.  
Write Dept RB3.

**AMPERITE**  
REG. U.S. PAT. OFF.  
The "SELF-ADJUSTING" Rheostat

Letters from Readers

(Continued from page 354)

with the most complete time-conserving testing apparatus obtainable, within the limits of practical portability. We believe that a good set analyzer, or diagnoser—as we prefer to call them—when carried by an intelligent experienced radio serviceman who is thoroughly familiar with the uses to which such a device may be put, will pay for itself within six months, by reason of increased efficiency in locating trouble exactly, in saving of time, and also in the very beneficial psychological effect on the customer.

As one concrete example of the value of a good-diagnoser, in rebuttal of Mr. Alcorn's statement to the contrary, a really well-designed one will accurately show an open r.f. grid suppressor, as well as other open circuits in the r.f. portion of a receiver.

JOHN S. DUNHAM, New York City.

A copy of these paragraphs of Mr. Dunham's letter was forwarded to Mr. Alcorn, and the following reply has been received to the opinion expressed above:

To the Editor:

I have read with interest the comment received from Mr. Dunham on my November article. I disagree with your correspondent, because the costly elaborate test equipment is prohibitive to the small radio dealer who has only two or three servicemen. Of course, if an organization is as large as your correspondent's seems to be, judging from his letter, the cost of testing equipment is not as important, especially if servicing constitutes the entire activity of the business. On the other hand, the small dealer finds that an outlay of about seventy-five dollars for the portable test equipment of each serviceman is considerable, unless his financial condition is much better than the average.

B. B. ALCORN, Kew Gardens, N. Y.

No. 32 Tinned Hair Wire

SINCE the publication of the article "From Milliammeter to Multimeter" in June RADIO BROADCAST a number of readers have asked where the wire specified for the shunts may be obtained. The author of the article has come to our aid in answering this question.

To the Editor:

The No. 32 tinned hair wire, specified in the article "From Milliammeter to Multimeter," consists of an annealed steel base on which a coating of tin has been applied. It should be obtainable at any good hardware store. The Pickering Hardware Company, Fifth and Main streets, Cincinnati, Ohio, can furnish the wire on five-cent spools. One spool is more than sufficient to make the shunts described.

G. F. LAMPKIN, Cincinnati, Ohio.

Our Policy Appreciated

A QUESTION always open to debate is whether a radio publication is justified in mentioning in its columns the trade names of manufactured parts. It is our opinion that readers derive the greatest benefit from articles when complete information is given, but all magazines do not agree on this point. A letter from South Africa shows the foreign reader's reaction to our policy.

To the Editor:

I wish to express my appreciation of the fact that you always mention the name of the manufacturer when describing a circuit in your magazine. This is particularly desirable from the viewpoint of readers in foreign lands. As you may easily understand, it often takes months to secure apparatus from the United States, and when trade names are not included in an article the time required to secure

(Continued on page 358)



**NOW—**  
**IT'S**  
**ADJUSTABLE**

**CARBORUNDUM DETECTOR**

TURN of the pressure screw gives you perfect tone balance. Then, position is fixed by adjusting lock nut, so that pressure remains permanently sensitive. Just another improvement to further insure the Perfect Tone Quality you always get with the Carborundum Detector—and tone quality is everything. Recommended by noted radio-circuit designers.

DEALER OR DIRECT—\$1.50 IN U. S. A.  
Send for Free Book "Carborundum in Radio" D-2

The Carborundum Company, Niagara Falls, N. Y.  
Canadian Carborundum Co., Ltd., Niagara Falls, Ont.

Carborundum is the Registered Trade Mark of The Carborundum Company for its Silicon Carbide and is its exclusive property

**ROBERT S. KRUSE**  
*Consultant and Technical Writer*

103 Meadowbrook Road, West Hartford, Conn.  
Telephone Hartford 45327

BROADCASTING FROM THE INSIDE

EVERY month in RADIO BROADCAST appears the departments "As the Broadcaster Sees It," written by Carl Dreher, one of the best known broadcast engineers in the country. Alive with humor, news, apt and searching comment, Mr. Dreher's writings have become one of the most popular features of radio writing anywhere. Are you reading it? Subscribe by the year and make sure of not missing a single issue. Mail your check for \$4.00 to Subscription Department, Doubleday, Doran & Co., Inc., Garden City, N. Y.

**A Saving of**  
**\$1.50**

NOW you can have both RADIO BROADCAST and RADIO sent to your address at a special price. \$5.00 for both of these nationally recognized authorities. Your subscription to RADIO costs you only \$1.00 for a full year if you accept this offer immediately.

**\$5<sup>00</sup> FOR BOTH**

IF you are already a subscriber to either or both magazines you can extend your subscription for another year at this special price.

Send coupon and \$5.00 NOW

RADIO BROADCAST  
Doubleday, Doran & Co., Inc.  
Garden City, N. Y.  
Here is \$5.00. Send RADIO BROADCAST and RADIO for 1 full year.

Name.....  
Street & No.....  
City.....  
State.....

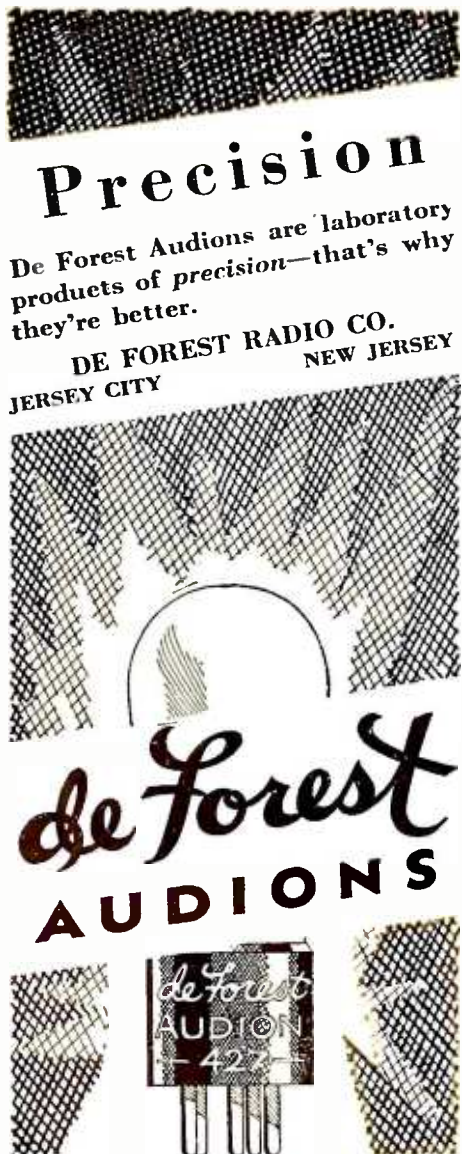

**Precision**

De Forest Audions are laboratory products of precision—that's why they're better.

DE FOREST RADIO CO.  
NEW JERSEY  
JERSEY CITY

**de Forest**  
**AUDIIONS**

**SCREWDRIVER  
RESISTANCE**

**Don't Guess**

at resistance values! You can't fool electricity. Instead, use a **DUPLEX CLAROSTAT**, with its double-barreled resistances, instantly adjustable to any values by means of an ordinary screwdriver. Neat. Compact. Practical. Inexpensive. Foolproof. Just the thing for plate and grid-bias voltages for any set. And don't forget



**There's a Clarostat for Every Purpose**

No matter what your resistance problems, no matter what circuit, tubes, power, line voltage and so on, there's a **CLAROSTAT** of proper size, range and type for the job. WRITE for literature regarding the **CLAROSTAT** line. Better still, send 25 cents in stamps or coin for "The Gateway to Better Radio"—the best investment in radio happiness.

**CLAROSTAT MFG. CO., Inc.**  
Specialists in Radio Aids  
284 N. 6th St., Brooklyn, N.Y.

**MUTUAL CONDUCTANCE METER**

Tubes are the heart of radio. Engineers, Service Men, Laboratory Workers must know how good their tubes are. Tube measuring equipment for either the determination of a single tube constant, mutual conductance, or for the most extensive examination of tube characteristics has been designed by the General Radio Company.



To test a number of tubes of the same type, the Mutual Conductance Meter—Type 443 is sufficient to cull the bad tubes from the good. This Bridge has a single dial calibrated directly in Micromhos with an accuracy of adjustment that is greater than the average uniformity of production tubes. This margin of accuracy is the user's guarantee that after the Mutual Conductance bridge has discovered the secret of the tube, the story is told. This bridge is now used for production tests in tube plants, by dealers who want to protect themselves and insure their customers will get wide awake tubes, and by service men—everywhere, in fact, where a quick tube test is desired.

**Type 443 Mutual Conductance Meter . . . . Price \$55.00.**

The Mutual Conductance Meter is but one item in an extensive line of laboratory apparatus, including decade resistance boxes, wave and frequency meters, crystal control apparatus, inductance, resistance and capacity standards, attenuation networks, and high quality audio frequency amplifying and power equipment.

**GENERAL RADIO COMPANY**

30 State Street  
274 Brannan Street

Cambridge, Massachusetts  
San Francisco, California

600 pages—300 illustrations



**Everything you want  
to know about  
RADIO**

Every branch of radio knowledge is covered in this complete 5-volume Radio Library. For everybody in the radio field—mechanics, operators, inspectors, service men, salesmen, owners of radio stores. Written by such experts as Harry F. Dart, E. E., Member, Institute of Radio Engineers; C. H. Vose, B. S. in E. E., of the Radio Engineering Dept. of the General Electric Co.; W. H. Freedman, E. E., Fellow, American Institute of Electrical Engineers, and other prominent Radio Engineers. Gives you the whole science of radio in clear, understandable English, illustrated with nearly 300 pictures and diagrams. Handsomely bound, pocket-size volumes, stamped in gold. Includes Picture Transmission and Reception. Worth many times its moderate cost. Send the coupon with \$7.50 in check or money-order.

*Money back if not satisfied.*

International Correspondence Schools  
Dept. 8298-F, Scranton, Pa.

I am enclosing \$7.50 for which please send me your five-volume RADIO LIBRARY. It is understood that I may return the books in five days and you will refund my money if I am not satisfied.

Name.....  
Address.....



CHECK . .  
. CHECK .  
. . CHECK

*through a barrage of inspections*

**E**xamined at every step . . . checked at every operation and tested at frequent intervals . . . that is the lot of each and every ARCTURUS A-C Tube . . . interminably "on trial."

Not a tube escapes. It must measure up to the most rigid standards set by our engineers. Standards that have spelled suc-

cess for ARCTURUS A-C users . . . that have made ARCTURUS Tubes the basis by which other tubes are judged.

The engineering attainments in ARCTURUS A-C Tubes are sound reasons why critical engineers and manufacturers demand these Long-Life blue tubes.



ENGINEERING FACTS HAVE A UTILITY SIGNIFICANCE TO THE BROADCAST LISTENER



ARCTURUS RADIO CO. NEWARK, N.J.  
**ARCTURUS**  
A-C LONG LIFE TUBES

# WATCH Jensen in 1929

Every radio authority knows what Peter L. Jensen did in 1927 and 1928. His perfection of the dynamic speaker assured the qualities in a radio reproducer which the perfection in audio circuits demanded. His reproducers served as the pattern for the entire radio industry.

And now watch Jensen in 1929!

The new Jensen Auditorium Speaker has already been announced. It is designed to operate with all types of amplifiers from the smallest with one tube to the largest with push-pull stages employing type 250 tubes.

And in sensitivity, in brilliance and separation of tones, in its ability to reproduce tremendous volume, this speaker is unmatched by any other reproducer ever made.

Write today for literature and technical data.

## JENSEN RADIO MFG. COMPANY

338 N. Kedzie Ave., Chicago, Ill.  
212 Ninth St., Oakland, Calif.

JENSEN PATENTS ALLOWED AND PENDING

Also Licensed under Lektophone and Magnavox Patents

### NEW LOW JENSEN PRICES

Type	Unit	Cabinet	Console
D4-6 volt			
D4 AC-110 volt A.C.	\$35.00	\$55.00	\$70.00
D5-90 to 180 volt D.C.	45.00	65.00	80.00
	35.00	55.00	70.00
Jensen Auditorium Speaker			
DA4-110 volt D. C.		\$55.00	
DA5-220 volt D. C.		55.00	
DA5 AC-110 volt A. C.		70.00	
Cabinet and Console Models and Prices to be announced shortly.			

# the 1929 Jensen DYNAMIC SPEAKERS

## Letters from Readers

(Continued from page 356)

apparatus is doubled, due to the necessity of first writing the publication for the trade names of the parts required.

B. STRUTT MAJOR,  
Johannesburg, South Africa.

## Short Wave Stations

MANY radio listeners equipped with short-wave receivers are anxious to pick up the signals of experimental telephone stations operating on frequencies within the range of their set. In this connection RADIO BROADCAST has endeavored to prepare a schedule of short-wave transmissions, but it has been found that the hours of operation of these stations is varied from day to day. The list which is printed below contains as much accurate data as it is possible to publish at the present time. The principal stations of the world, which may be heard regularly in this country with a simple short-wave receiver, are listed in the order of their assigned wavelengths.

Call Letters	Location	Wave-Length
PCLL	Kootwijk, Holland	18.4
W2XAD	Schenectady	19.56
WOWO	Fort Wayne	22.8
W2XAB	New York	24.0
W8XK	Pittsburgh	25.4
5SW	Chelmsford, England	25.5
CJRX	Winnipeg, Canada	25.6
2FC	Sydney, Australia	28.5
2ME	Sydney, Australia	28.5
W2XAL	New York	30.91
PCJJ	Eindhoven, Holland	31.2
W2XAF	Schenectady	31.48
JB	Johannesburg, S. Africa	32.0
3LO	Melbourne, Australia	32.0
W2XAI	Newark	43.0
WBZ	Springfield	50.0
WLW	Cincinnati	52.02
WTFE	Mt. Vernon, Va.	56.0
AJG	Nauen, Germany	56.7
W2XE	Richmond Hill	58.5
GC	Paris, France	60.0
3XL	Bound Brook	60.0
W9XU	Council Bluffs	61.06
KDKA	Pittsburgh	63.5
W6XAR	San Francisco	65.0
W2XBA	Newark	65.18
WBZ	Springfield	70.0

## Mexican Short-Wave Stations

The following is a new list of radio-telephone stations in Mexico which has just been received from Mr. L. Lujan, Consul of Mexico.

### RADIO BROADCASTING STATIONS IN MEXICO\*

Owner	Call letters	Power Watts
Raul Azcarraga, Mexico, D. F.	CYL	500
"El Buen Tono," Mexico, D. F.	CYB	500
C stulo Llamas, Mazatlan, Sin.	CYR	500
Pablo Langarica, Mexico, D. F.	CYX	500
Roberto Reyes, Monterrey, N. L.	CYM	200
F. Zorrilla, Oaxaca, Oax.	CYF	100
Partido Socialista del Sureste, Merida, Yuc.	CYY	105
Efrain R. Gomez, Mexico, D. F.	CYS	250
Miguel S. Castro, Mexico, D. F.	CYH	105
Martinez y Zetina, Mexico, D. F.	CYO	101
Secretaria de Educacion Publica, Mexico, D. F.	CZE	500

\*All stations are licensed to operate on wavelengths between 350 and 550 meters.

### EXPERIMENTAL MEXICAN RADIO STATIONS\*

Owner	Call letters	Power Watts
Constantino Taruava, Monterrey, N. L.	24-A	20
Rodolfo Krause, Tampico, Tamps.	26-B	20
Licco Fuente, Saltillo, Coah	23-A	100

\*Experimental stations are licensed to operate on wavelengths between 100 and 250 meters.

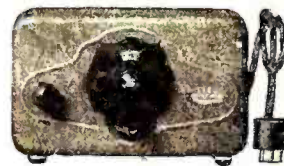

NEW!

## "AERO-CALL" SHORTWAVE CONVERTER

SHIELDED - FILTERED

Factory-Built, Ready to Plug Into Your Present Radio Set

The Aero 1929 Converter is a compact factory-built short-wave adapter equipped with special short-wave coils. It is designed for both A. C. and D. C. sets. Operates perfectly on A. C. or D. C. sets without motorboating, by an auxiliary filter system control. It can be plugged into any regular radio set. This amazing radio instrument now makes it possible for you to reach 'round the world—England, Germany, Holland, Australia, Panama, Java and many foreign countries are some that are tuned in regularly on short-wave. Permits you to enjoy international programs and many others from coast-to-coast that your regular receiver cannot get. What a thrill it is to plug this into a tube socket on your regular set and instantly be in another world! No change or wiring required. All complete, ready to operate, tubes and coils hidden, no apparatus in sight, except the neat, golden-brown, compact metal cabinet in crackle finish. Size, 9x5 1/2 x 2 1/2 in.

The only converter we know of that really works on all sets. Two models—A. C. and D. C. Write for Catalog and literature, or send \$25.00 and name of your dealer.

Model A, without tube, for A. C. sets } \$25  
Model D, without tube, for D. C. sets }

At leading dealers' and jobbers'

## AERO PRODUCTS INCORPORATED

4611 E. Ravenswood Ave. Dept. 239  
CHICAGO, ILL.

SAVE  
\$2.00

RADIO BROADCAST  
Garden City, N. Y.  
Gentlemen: Please enter my subscription to RADIO BROADCAST for two full years at the special rate of \$6.00—saving me \$2.00 on the regular subscription price.  
(If you are already a subscriber your subscription will be extended for two full years from date of expiration.)

Name .....

Address .....

No order can be accepted unless the classification to which you belong is checked below.

Radio Manufacturing  
 Sales Executive  
 Engineering Executive  
 Service Engineer  
 Engineer

Radio Retailing  
 Owner Radio Store  
 Manager Radio Dept.  
 Other Outlet

Radio Wholesaling  
 Sales Executive  
 Serviceman

Radio Servicing  
 For Dealer Organizations  
 Independent

(Other Radio Connections)

MAIL TODAY