

F E B R U A R Y 1 9 2 9

RADIO

BROADCAST

ENGINEERING ● THE LABORATORY ● SERVICING



SPECIAL FEATURES IN THIS ISSUE

Overall Measurements on Broadcast Receivers
Television Experiments in the Amateur Frequency Bands
The Business Side of Radio Service Work

And for the Engineer: Sound Movies, Double Push-Pull Audio Amplifiers, Broadcasting, Filtering in Audio Amplifiers . . . For the Service Man: Troubles in Power Supplies, Circuits of Complete Sets

T H I R T Y F I V E C E N T S

PUBLISHED BY DORAN & CO., INC. ♦ GARDEN CITY, NEW YORK

Great Features
Tell You Why

6000

RADIO-TRICIANS

Are Offering
These

NEW HI-Q RECEIVERS

NO man can use the title "RADIO-TRICIAN" unless he can qualify as a radio expert. So when we tell you that 6000 authorized "RADIO-TRICIANS" throughout the country are building the new Hi-Q 29 Receivers you must agree that these receivers MUST have outstanding qualities.

The biggest advance of the year in radio design is the "Band Pass Filter"—a system which effects absolute FLAT TOP *square cut-off* TUNING with positive 10 K. C. selectivity. This is the big feature of Master Hi-Q 29 Receivers. No other set in the world has it to our knowledge. It eliminates "cross talk" even in crowded areas which

*Custom-Built to
Any Pocketbook!*

have many powerful stations and gives a Super-sensitivity and Super-selectivity which assures coast-to-coast reception. Further than this, it produces a quality of tone which we have never heard equalled in any receiver!

For 1929 there are FOUR Models of Hi-Q Receivers—for battery or A. C. operation. All are the joint creation of ten of America's leading parts manufacturers. All are stage-shielded and built on steel chasses from only the finest parts available in the radio industry.

You should own one of these wonderful receivers. Build it yourself or have it built for you by your local RADIO-TRICIAN.

1. 10 K. C. SELECTIVITY
2. ABSOLUTE FLAT-TOP Square Cut-off TUNING
3. SCREEN-GRID TUBES
4. STAGE-SHIELDED STEEL CHASSIS
5. CONCEALED WIRING
6. SIMPLIFIED OPERATION
7. NATURAL REPRODUCTION
8. COAST-TO-COAST RECEPTION

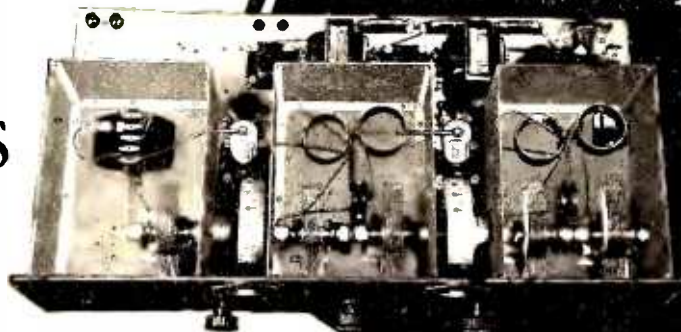

4
MODELS
for Battery or
A. C. Operation

Write For
This New
80-page
Construction
Manual



The biggest and most complete book of its kind ever published. Tells how to build the 4 new Hi-Q Receivers. Photos and diagrams illustrate every detail. Covers power amplifiers, tube and battery combinations, antennae, installation, short-wave adapters, house wiring and a wealth of other data on the custom-built Hi-Q. Price 25 cents including postage.

HAMMARLUND-ROBERTS, Inc. 1182-CBROADWAY NEW YORK CITY

Associate Manufacturers



Pick the RADIO JOB you want and fill it in only 9 months!



Radio Operator
\$90 to \$200 per month
with all expenses paid



Broadcast Operator
\$1,800 to \$4,800 a year



Radio Inspector
\$2,000 to \$4,500 a year

By means of this "Big-League" home-training sponsored
by Radio Corporation of America

Send for FREE
BOOK about Radio.

WHY struggle along on less than \$45 a week? Why wait years for success that can be yours in only 9 months?

As a result of a marvelous new kind of home-study training in Radio, hundreds of men are today leading straight for financial independence! Radio pays from \$2,000 to \$25,000 a year. The work is thrilling . . . the hours are short. Vacations with pay . . . opportunities for seeing the world . . . adventure galore!

Prepare at Home with this Big Laboratory Outfit

Get the "How" as well as the "Why" of Radio—with this expert training! Only an hour or so a day in spare time is all you need! As part of your course, you receive absolutely free of extra charge—a magnificent outlay of apparatus. With this outfit you learn to build fine sets and solve the problems that bring big pay.

*Training Sponsored by
Radio Corporation of America*

Our graduates are in big demand everywhere. They enjoy greater success because they're posted right-up-to-the-minute in *everything* in Radio. Radio's progress each year is measured by the accomplishment of the great engineers at work in the research laboratories of Radio Corporation of America. This Radio organization sets the standards for the industry, and stands back of every lesson in the course.

Money Back if Not Satisfied

The lessons prepare you for success in all phases of Radio—manufacturing, servicing, selling, ship and shore broadcasting, Television, Photoradiodiagrams and Radio equipment. A signed agreement backed by RCA assures you of complete satisfaction upon completion of the training—or your money will be promptly refunded.

Read This Thrilling Free Book

It gives you the real "dope" about Radio and describes in detail the famous training that has enabled us to place thousands of our students in fine positions, usually from 3 to 10 days after graduation. It may mean the turning point in your life. It tells in 50 fascinating pages and photos all about Radio's brilliant opportunities for adventure and success. Mail the coupon now—the book is absolutely free!

RADIO INSTITUTE
OF AMERICA
Dept. R.B.-2
326 Broadway New York



Radio Institute of America
Dept. RB-2
326 Broadway, New York, N. Y.

Gentlemen: Please send me your big FREE 50-page book which tells about the brilliant opportunities in Radio and about your famous laboratory-method of guaranteed radio instruction at home.

Name.....

Address.....

SM

The Peer of All Theatre or Stadium Sound Amplifiers

Now Offered to the Public for the First Time

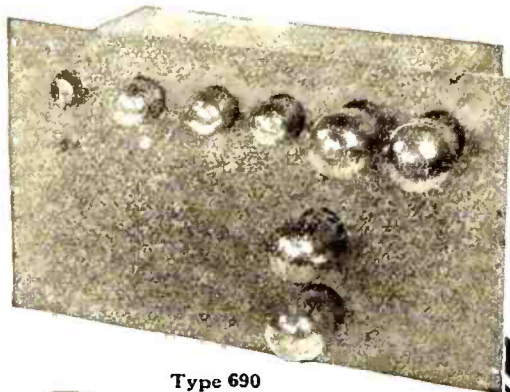

Type 690

EVER since the revolutionary improvement in tone quality created by the Clough audio system when first demonstrated to the trade last June, the S-M laboratories have been working day and night to make this discovery available for the largest theatres, auditoriums, football stadiums, and such assemblages at a low cost.

As the culmination of these labors, S-M takes the greatest pride in announcing the 690 Super-Power Amplifier. Three stages—two of them push-pull—microphone, radio, or single or double record input—two 250 type tubes in the last push-pull stage giving 15,000 to 16,000 milliwatts output, with uniformly high tone quality down to 50 cycles such as only S-M Clough Audio Transformers can produce—the same quality that is drawing crowds into S-M-equipped movie theatres throughout the United States.

With such a unit available completely wired at \$245 list price, less tubes—knowing as you do the tremendous present demand for sound amplifiers of the highest grade—can you as a setbuilder or service man afford to neglect the installation opportunities which this new S-M amplifier offers you?

For the Smaller Theatre, or the Home—

The new 2-stage S-M 678PD Phonograph Amplifier is priced so low that, while particularly adapted for dance halls and small theaters, it is ideal for the home also. Used with any 110 volt D.C. dynamic speaker, it takes input from any magnetic phonograph pickup, or from the detector tube of a broadcast or short-wave receiver, and, by means of its S-M Clough-system audio transformers, supplies to the speaker undistorted the full power output of its 250-type tube. Tubes required are: 1—226, 1—280, 1—250 type. All input power is taken from the 110 volt A.C. house-lighting mains. Price (less tubes), WIRED, \$73.00; complete KIT, \$65.00.

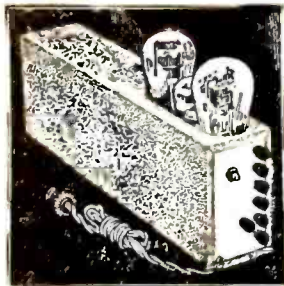

Type 678D

Or you can get 250-tube power right in your present set by inserting a 250 tube (with an adapter) in the last socket of the set, and using the S-M 675ABC Power Supply. Presto!—the 675 supplies all ABC power to the new power tube (without a single change to the set) and replaces all B batteries or other B eliminators as well. (It will also supply A and C power to A.C. tubes).

Add a 675 to your set and you have all the advantages of the fine, full sonorous tone the super-power tubes bring—tone you find only in \$300.00 to \$500.00 factory-built sets—yet you can add it to your set for \$54.00 plus two tubes!

The 675ABC power supply is priced at only \$54.00 for the kit, or \$58.00 fully wired with adapter.

These New S-M Transformers Make It Possible

Built on the Clough System, with curves flat from below 50 cycles to well above 5000—these transformers give to "push-pull" a new and really startling significance. And their prices, like their quality, are unbeatable!

257 Push-Pull Input Transformer, to operate from one amplifier tube into two 171A, 210, or 250 tubes. Price, \$7.00
227 Push-Pull Interstage Transformer, to feed from two 112A, 226, or 227 tubes into two 112A, 226, 227 or 171A, 210 or 250 tubes.....\$8.00
258 Tapped Output Impedance, to feed from two 171A tubes into any standard speakers.....\$5.00

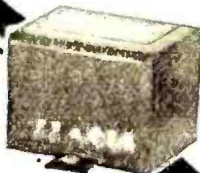

Type 257

Get 250
Tone Quality
in Your Present
Receiver



Type 227

248 Universal Output Choke, to feed out of two 210 or 250 tubes into one to six or more standard speakers; provided with several impedance-matching taps. It will handle over 20 watts without core saturation. Open-mounted..\$7.00
228 (248 in case like 227).....\$8.00



Type 248

Remember—S-M guarantees these push-pull transformers to have a finer frequency characteristic than any and all competitive types—bar none.

Are you getting *The Radiobuilder* regularly? No. 9 (Jan. 1929) describes these new push-pull transformers, and the 690 Amplifier, as well as the new (and different!) S-M Dynamic Speakers. No. 7 (Nov. 1928) described in detail, with complete circuits, a 750-volt rectifying system. Sample copies may be had without charge as long as they last; use the coupon.

If you build professionally, by all means ask for information on the S-M Authorized Service Station proposition; its money-making opportunities are greater than ever.

SILVER-MARSHALL, Inc.
838 West Jackson Blvd., Chicago, U. S. A.

Silver-Marshall, Inc.
838 W. Jackson Blvd., Chicago, U. S. A.
...Please send me, free, the complete S-M Catalog; also sample copy of *The Radiobuilder*.
For enclosed.....in stamps, send me the following:
... 50c Next 12 issues of *The Radiobuilder*
... \$1.00 Next 25 issues of *The Radiobuilder*
S-M DATA SHEETS as follows, at 2c each:
... No. 1. 670B, 670ABC Reservoir Power Units
... No. 2. 685 Public Address Unipac
... No. 3. 730, 731, 732 "Round-the-World" Short Wave Sets
... No. 4. 223, 225, 226, 256, 251 Audio Transformers
... No. 5. 720 Screen Grid Six Receiver
... No. 6. 740 "Coast-to-Coast" Screen Grid Four
... No. 7. 675ABC High-Voltage Power Supply and 676 Dynamic Speaker Amplifier
... No. 8. Sargent-Rayment Seven
... No. 9. 678PD Phonograph Amplifier

.....Name
.....Address

SM

**On Top of the World—
S-M Screen Grid Six
and Sargent-Rayment Seven**

Get these Record-Breaking Kits from W. C. Braun Co.

(All testimonials here quoted were entirely unsolicited)

"Just to say that I have one of your 720 Screen-Grid Six's with 670B power unit . . . Picked up Japan, 1:00 A. M.—came in strong—four stations in Chicago and everything up and down the coast . . ."

—F. A. Forbes, Oakland, Calif.

"Think of the thrill of getting your dinner concert from KFI on a 6-tube receiver away up here in Northern Wisconsin . . . At the end of the dial twisting session I had 28 stations over 1000 miles away, from 21 states and 3 provinces of Canada, and WKAQ, Porto Rico . . ."

—Clinton B. DeSoto, Withee, Wis.

"I am writing to tell you about the results I am getting from the 720 Screen-Grid Six. I have brought in stations from New York to Japan with good volume on the speaker and the tone quality is very natural . . . The following are some of the stations I have received: JOIK, Sapporo, Japan, WHAM, Rochester, N. Y. . . . I had two other Japanese and some other foreign stations, but I haven't the call letters yet. WLW, WGN, KWKH come in good almost every night."

—Alonzo Henderson, Mossy Rock, Washington.

"I am having great success with the 720 and 740 sets. Only today, I received 3 orders for 720s and one for a 730. In all my experience of building kits for fans, I have never had the feeling of really giving value till I took up your line. I think it is the best that money can buy in its class and my long list of satisfied customers surely is the proof that their sets are wonderful."

—Howard Brett, New York City.

"Last night picked up Halifax, Nova Scotia with such volume that I had to turn the volume control half off. We then proceeded to pick distance to the satisfaction of the prospect . . . I got his order then and there."

—L. Frank Miller, Brooklyn, N. Y.

The plain cold facts are simple. The Silver-Marshall 720 is a six-tube r.f. set using three screen-grid tubes, a detector, and two stages of S-M Clough audio amplification. It's an all-metal, shielded assembly, just like the finest ready-made sets, with its own attractive two tone brown metal shielding cabinet, its antique brass escutcheon plate with two dials, volume knob, and a small selectivity knob. Yet this set with its three stages of screen grid r.f. amplification, and its audio system that money can't buy in a ready-made set, costs you but \$72.50 for the S-M packed kit, or \$102.00 for an S-M custom-built wired receiver, complete with cabinet.

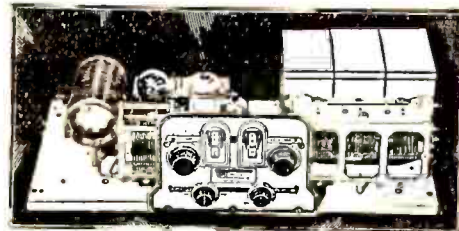
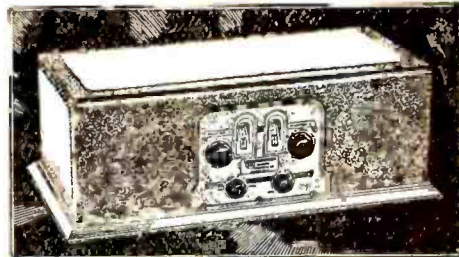

"Boss of the Air"—Doubt It?—Read These:

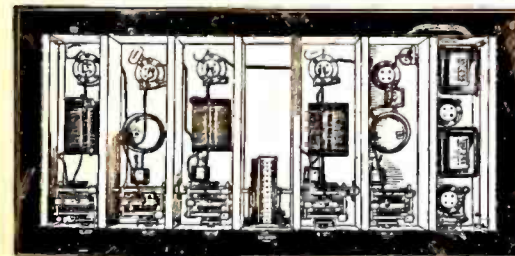
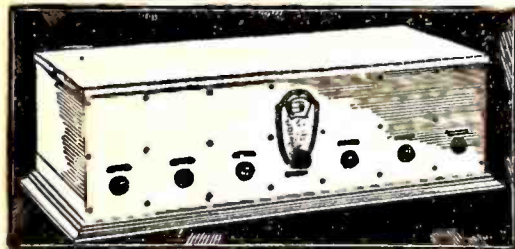

The Sargent-Rayment Seven is the first and only set to offer four stages of screen-grid tuned r.f. amplification, and the unsurpassed tone quality of the S-M Clough audio system—the first and only set to give one-dial control, yet at the same time individual stage trimmers that mean the last drop of sensitivity when you want it. And its seven tubes, with 171, 210, or 250 power tube, give fine tone or hair-splitting selectivity, super-distance or local programs with thrilling quality. Shipped from stock: KIT \$130.00—or FACTORY-WIRED \$175.00. Both complete with handsome satin aluminum shielding cabinet.

THE MUNICIPAL COURT OF CHICAGO

Samuel H. Trude, Judge

"I am very much pleased with the custom-built 710 Sargent-Rayment receiver. . . which I have been using in connection with a cone-type loud speaker at the South Shore Country Club, Chicago.

"This is a remarkably good receiver for all kinds of radio reception. I have found that distant broadcasting stations can be tuned in on all wave channels over the entire broadcasting band—one and only one at a time with the single tuning drum."

—Samuel H. Trude

"It may interest you to know that the first station I tuned in was KOA (1500 miles away) and that last Saturday morning from 3 to 4 A.M. we listened to three stations in Japan—JOAK, JOGK, and JOAH."

—Walter A. Reeves, Seattle, Wash.

"Some time ago I bought a 710 Sargent-Rayment set from Mr. Toolan of Lansing, Michigan. . . It has marvelous tone, volume, sensitiveness, and selectivity. I am right across the street from WTAM and can tune them out. . . in a few points."

—J. W. Carvey, Cleveland, Ohio.

"I have just finished building one of your 710 Sargent-Rayment kits. I am delighted with its performance. It is the only set that I know of that will bring in stations here in the day time. . . It does it with good volume."

—Claude H. Matthews, Roswell, N. M.

"The most I can say is—it was worth waiting for—the Sargent-Rayment 710. The most wonderful set I ever had anything to do with—goes together beautifully and makes a handsome job in its silvery-white finish."

—The Radio Shoppe, H. O. Hornbake, South Brownsville, Pa.

OFFICIAL WHOLESALE DISTRIBUTORS FOR S-M PRODUCTS

As official wholesale distributors for the products of the Silver-Marshall laboratories, W. C. Braun Co., Wholesale Radio Headquarters, offers you this big line of radio merchandise with the assurance that your orders will be filled on the very day they are received. Our plant is located very close to the Silver-Marshall factories and we can give you service on your orders impossible to secure anywhere else. Order your favorite S-M parts, kits and supplies here. You'll save time and money.

In addition to the complete Silver-Marshall line, we offer you a complete line of everything in the radio field—sets, radio furniture, tubes, power units, portable receivers, dynamic and other speakers, parts and kits for all popular circuits advertised in the leading radio publications, short wave and television

supplies, short wave transmitters, radiophones, public address systems, novelties, etc.

Special departments include auto tires and tubes, auto accessories, electrical goods, lighting fixtures, wiring material, household appliances, stoves, vacuum cleaners, washing machines, camping equipment, sporting goods, golf and baseball supplies, outing clothing and thousands of everyday necessities.

Our centralized location insures fast service to customers in all parts of the country.

Thousands of choice bargains are shown in the big 1929 Braun Catalog. If you haven't a copy, send for it at once. It is free—mail the handy coupon now.

W. C. BRAUN COMPANY
Pioneers in Radio
528 W. Randolph St.
CHICAGO
ILLINOIS

W. C. BRAUN CO.,
528 W. Randolph St., Chicago

Dear Sirs: I am not receiving the W. C. Braun Co. Catalog regularly. Please put my name on your mailing list of set-builders and dealers, giving me the prices and information on S-M parts and other merchandise. My letterhead is attached.

Name.....
St. & No.....
City.....State.....

RADIO BROADCAST

WILLIS KINGSLEY WING Editor
 KEITH HENNEY Director of the Laboratory
 HOWARD E. RHODES Technical Editor
 EDGAR H. FELIX Contributing Editor



VOL. XIV. NO. 4

ENGINEERING · THE LABORATORY · SERVICING

Contents for February, 1929

Frontispiece - -	<i>Life Test Racks for Vacuum Tubes</i>	226
A Figure in Radio Progress - - -	<i>Edgar H. Felix</i>	227
Measurements on Broadcast Receivers -	<i>L. M. Hull</i>	230
The March of Radio -	<i>An Editorial Interpretation</i>	233
The Davis-Dill Publicity Barrage Fitting Receivers to New Allocations Aircraft Radio With the Broadcasting Stations	Progress in Long- and Short-Wave Radio News of the Radio Industry Decisions of the Courts	
The Business Side of Radio Servicing	<i>John S. Dunham</i>	236
Strays from the Laboratory - - -	<i>Keith Henney</i>	239
Power, Efficiency and Energy Power of Station Harmonics Three New Pamphlets Available Importance of Tube Voltages Impedance of Standard Loud Speakers	A Test for Screen-Grid Tubes Duration of Engineering Jobs How Useful Is a tube? Accuracy of Variable Condensers New High-Voltage Rectifier Tube New Regulation of the Commission	
An Efficient Push-Pull A. F. System	<i>Kendall Clough</i>	241
Sound Motion Pictures - - - - -	<i>Carl Dreher</i>	244
Broadcast Engineering - - - - -	<i>Carl Dreher</i>	246
Transmitting Amateur Television -	<i>Boyd Phelps</i>	247
Are Filters Needed in A. F. Amplifiers?	<i>Keith Henney</i>	250
Book Reviews - - - - -	<i>Carl Dreher</i>	252
"Radio Broadcast's" Home Study Sheets - - - -		253
No. 15. The Transmission Unit	No. 16. Experiments with a Wave-meter	
The Serviceman's Corner - - - - -		255
An Economical Battery-Operated Receiver	<i>Howard E. Rhodes</i>	257
Volume Control Systems - - - - -		259
"Our Readers Suggest—" - - - - -		260
A Short-Wave Super-Heterodyne	<i>Robert S. Kruse</i>	262
Trouble Shooting in the Power Unit	<i>B. B. Alcorn</i>	264
"Radio Broadcast's" Service Data Sheets - - - -		265
No. 17. The Philco Electric Receivers	No. 18. The Browning-Drake Receiver	
In The Radio Marketplace - - - - -		267
The Remler "29" Super-Heterodyne	The Junior Model "Hi-Q 29"	
Manufacturers' Booklets - - - - -		270
"Radio Broadcast's" Laboratory Information Sheets		272
No. 256. Three Types of Graphs No. 257. Heater Connections for A. C. Tubes No. 258. An Analysis of Filter Circuits No. 259. Filter Circuit Characteristics	No. 260. Voltage Gain in R. C. Amplifiers No. 261. Where A. C. Hum Originates No. 262. Advantages of Dual Push-Pull No. 263. Wavelength - Kilocycle Chart	

The contents of this magazine is indexed in *The Reader's Guide to Periodical Literature*, which is on file at all public libraries

. . . among other things

THE unit heretofore employed by engineers to express power ratio—the TU—has been superseded by another which means the same thing, but has a more logical name. The new unit is the Bel and the decibel, abbreviated DB, expresses exactly the same numerical relations at its predecessor, the TU, did. All references in this magazine from this issue on will employ the new term. For those who wish to refresh their memory on the point—and the whole question of the transmission unit—Home Study Sheet No. 15 on page 253 of this issue furnishes an unusually complete review.

THE present issue contains a vast deal of interesting and useful information. In especial, Kendall Clough's article should prove of importance to those who are trying to solve audio problems requiring the use of an amplifier furnishing a large amount of undistorted power for such uses as public-address systems, etc. The article by Keith Henney on page 250 discussing the value of complete filtering in audio amplifiers is thoroughly practical and the conclusions are supported by careful measurements. The second appearance of Carl Dreher's department devoted to sound motion pictures contains information invaluable to those working in the field. And those who have followed Mr. Dreher's "As the Broadcaster Sees it" will recognize the same material under its new heading "Broadcast Engineering," a title which more properly describes his regular contributions.

THE present issue differs in appearance from those which preceded it. The changes in the text pages make for increased readability. The cover, of which we are very proud, was designed in New York by A. R. Tobias, one of the best known and ablest of present-day designers. The typography of the text pages was done by W. B. Dutcher of the Art Department of Doubleday Doran & Company.

RADIO dealers and servicemen are writing us in great numbers with the most enthusiastic praise for the sections of this magazine written especially to help them. Our plans for the coming months include many articles which no serviceman or dealer can afford to miss. Of especial interest is the article by John S. Dunham on page 237 of this issue on the business problems of service work. The March number will be a special tube issue with a wealth of information in a very useful form. In addition are special articles on an ingenious r.f. distribution system for apartment houses, Prof. Terman of Stanford University on "Detection," K. S. Weaver of Westinghouse on the UX-250, Frank Jones on "Dynamic Loud Speaker Measurements," C. T. Burke on a "Discussion of Impedance," an interesting circuit for automatic volume control, and our special departments, packed full of useful information.

WILLIS KINGSLEY WING.

TERMS: \$4.00 a year; single copies 35 cents, All rights reserved. Copyright, 1929, in the United States, Newfoundland, Great Britain, Canada, and other countries by

DOUBLEDAY, DORAN & COMPANY, INC., Garden City, New York

MAGAZINES
 COUNTRY LIFE, WORLD'S WORK, THE AMERICAN HOME, RADIO BROADCAST, SHORT STORIES, LE PETIT JOURNAL, EL ECO, FRONTIER STORIES, THE AMERICAN SKETCH, WEST.
 BOOK SHOPS (Books of all Publishers)

NEW YORK: <LORD & TAYLOR, JAMES MCCREFFRY & COMPANY, PENNSYLVANIA TERMINAL, 166 WEST 32ND ST., 818 MADISON AVE., 51 EAST 44TH STREET, 420, 526, and 819 LEXINGTON AVENUE, GRAND CENTRAL TERMINAL, 38 WALL STREET> CHICAGO: <75 EAST ADAMS STREET> ST. LOUIS: <223 N. 8TH ST and 4914 MARYLAND AVE.> KANSAS CITY: <920 GRAND AVE. and 206 WEST 47TH ST.> CLEVELAND: <HIGBEE COMPANY> SPRINGFIELD, MASS: <MEEKINS, PACKARD & WHEAT.

OFFICES

GARDEN CITY, N. Y. NEW YORK: 244 MADISON AVENUE. BOSTON: PARK SQUARE BUILDING. CHICAGO: PEOPLES GAS BUILDING. SANTA BARBARA, CAL. LONDON: WM. HEINEMANN, LTD. TORONTO: DOUBLEDAY, DORAN & GUNDEY, LTD.

OFFICERS

F. N. DOUBLEDAY, Chairman of the Board; NELSON DOUBLEDAY, President; S. A. EVERITT, Vice-President; GEORGE H. DORAN, Vice-President; RUSSELL DOUBLEDAY, Secretary; JOHN J. HESSIAN, Treasurer; LILLIAN A. COMSTOCK, Asst'l Secretary; L. J. MCNAUGHTON, Asst'l Treasurer

W K F I

**IN A
STEEL BANK BUILDING
ON A
10 FT. ANTENNA
WITH
TREMENDOUS VOLUME!**

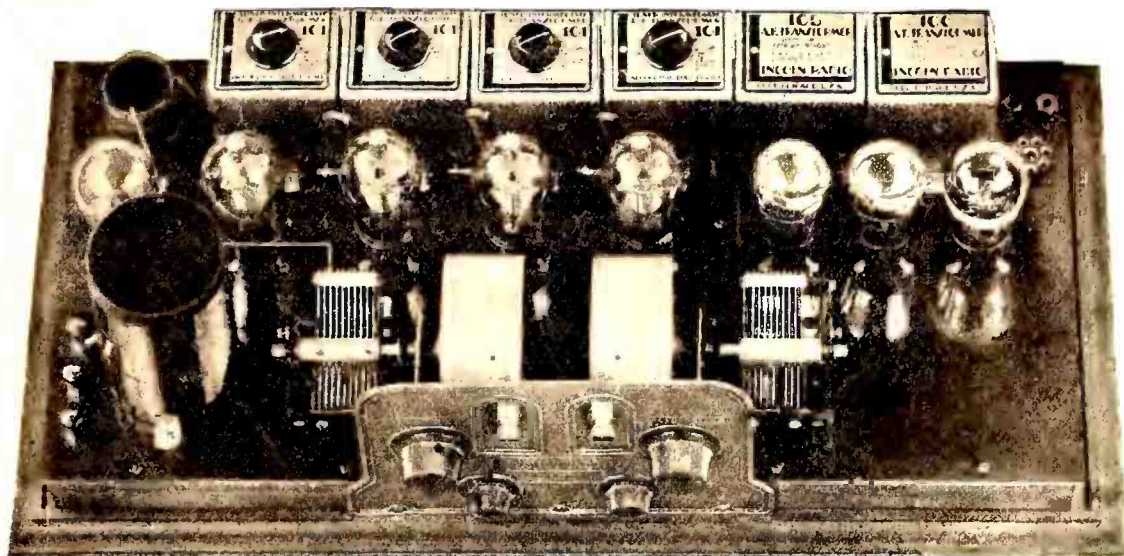

That's the performance of the Lincoln 8-80 in the heart of Chicago

SET BUILDERS REPORT

Telegram Nov. 28th—"JAPANESE STATIONS RECEIVED ON LINCOLN SUPER JOAK, JOIK, JOBK." TOKYO, JAPAN; SAPPORO, JAPAN; OSAKA, JAPAN; BROUGHT IN THROUGH THE MANY STATIONS AROUND 300 METERS.

"SIX PACIFIC COAST STATIONS WITHOUT ANTENNA OR GROUND."—From Illinois.

"After using it several days I can truthfully say that it is the first set that I ever heard or owned that performs as per the advertisements of the manufacturers, in fact, if possible, it is a little better than advertised."

"Being an ardent DX fan and having constructed and used practically all of the standard supers and tuned radio frequency outfits and having personally constructed and experimented with intermediate super transformers and equipment, I find the Lincoln 8-80 the best answer to all DX requirements. Only an experienced set builder can fully appreciate what it means to have solved for him such problems as having a proper means of matching an intermediate transformer to any tube's individual characteristics. Tone quality, simplicity of operation, the ease with which outside stations can be brought in and the fact that the price is within range of all, make this the first set that I feel I could conscientiously recommend to everybody."

"75 stations logged before the new allocation of stations from a Chicago Hotel where 75 other receivers could not get out." Practically every Lincoln 8-80 owner reports this wonderful reception.

NOT A SINGLE BUILDER HAS ASKED FOR HIS MONEY BACK OR WISHED TO RETURN HIS LINCOLN 8-80.

A WORD TO THE CUSTOM SET BUILDERS

You can out-demonstrate, out-perform any competitive equipment in your territory. You can pull in station after station in every degree of the dial with perfect tone quality of your local station. All this without a squeal, and only using a small part of your available power, and at a price without competition. You can convince your customer in one short demonstration.

The price of complete kit for the Lincoln 8-80 is \$92.65.

Due to the new principles involved every 8-80 works exactly alike, and you can get the same results as our finest laboratory model.

If you want an evening full of straight-from-the-shoulder super-heterodyne dope written by an engineer who has played with every super going in the last few years, send 25 cents for William H. Hollister's "Secret of the Super" using the coupon below.

LINCOLN ENGINEERING SERVICE ON STANDARD KITS

Order to-day for immediate shipment any of the following Lincoln-Guaranteed complete kits:

Sargent-Rayment Seven (S-M 710) kit . . . \$120.00	Tyrman 80-super—less power pack . . . \$134.50
S-M 720 Screen Grid Six . . . 72.50	Tyrman 72 receiver kit . . . 98.50
S-M 720 Screen Grid Six—factory wired . . . 102.00	Tyrman 72AC, with power pack . . . 153.50
1929 Laboratory Superheterodyne . . . 95.70	H. F. L. Isotone 10-tube super . . . 195.00

LINCOLN RADIO CORPORATION
329 SOUTH WOOD ST. - CHICAGO - ILLINOIS.

Authorized Distributors for Lincoln 8-80

WESTERN RADIO MFG. CO.
128 W. Lake St., Chicago
WALTER ROWAN CO.
833 Washington St., Chicago
ELECTRIC & RADIO SUPPLY
22 N. Franklin St., Chicago
RADIO SUPPLY COMPANY
912 Broadway, Los Angeles

LINCOLN RADIO CORP., Dept. B
329 South Wood St., Chicago, Ill.

.....Send me your big free catalog, listing a complete line of 1929 kits for custom building.

.....Enclosed find 25c. for which send me William H. Hollister's new book, "The Secret of the Super."

Name

Address

Authorized Distributors for Lincoln 8-80

KLADAG RADIO LABORATORIES
Kline Bldg., Kent, Ohio
WHOLESALE RADIO SERVICE
6 Church St., New York City
CHICAGO RADIO APPARATUS
415 S. Dearborn St., Chicago
HORACE HILLS
200 Davis St., San Francisco, Calif.



LIFE TEST FOR ALL TYPES OF RADIO VACUUM TUBES

In the Van Cortlandt Park Laboratories of the Radio Corporation of America there are facilities for testing 18,000 tubes simultaneously. The power required to furnish the plate current for these tubes is 400 kilowatts and the power used in heating the filaments is 240 kilowatts! So great is the heat dissipated by the tubes under test that a special ventilating system is necessary. The above picture shows a section of the racks in which the tubes are tested.

A FIGURE IN RADIO PROGRESS

By EDGAR H. FELIX

NO ONE is quoted more frequently by the press on radio subjects than Dr. Alfred N. Goldsmith. Newspaper men ask his views because he is always ready with accurate information and considered opinion. He has a succinct and vivid power of expression, readily quotable, and easily understood by the layman. Through the continuous contact which Dr. Goldsmith maintains as Chief Broadcast Engineer of the Radio Corporation of America with the research and development work conducted at many important radio laboratories in this country and abroad, he has first-hand information on the significance of almost every new development in the radio field.

In more technical circles, Dr. Goldsmith is recognized as an authority in every phase of radio research. His fund of knowledge is literally enormous. He is not a specialist in a single branch of radio science; his forte is coordination so that each step in technical progress may be used most effectively in commercial service and be welcomed as new and improved products for introduction to the public.

When an engineer desires to know if, how, when, and by whom any phase of radio engineering, however remote, has been investigated, he may pursue one or two courses. He may consult all the host of technical periodicals published all over the world and communicate with the heads of research departments of electrical concerns in the United States and abroad, or he may ask Dr. Goldsmith. The second method is the more efficient.

This facility for knowing the facts is the product of a lifetime devoted to the acquisition of detailed and complete information. First an honor student at the College of the City of New York, then lecturer, and finally professor at his Alma Mater, consulting expert on radio matters, Director of the Communicating Engineering Laboratories, then Chief Broadcast Engineer of the Radio Corporation, and, now, added to those duties, Chairman of the Board of Consulting Engineers of the National Broadcasting Company, and Vice-President in Charge of Engineering and Production of the RCA Photophone Corporation—this is, in brief, the career of Dr. Goldsmith. A few weeks ago the title of Vice-President of the Radio Corporation of America was conferred upon him. His profession has given him its highest honor, the presidency of the Institute of Radio Engineers. Since its beginnings, Dr. Goldsmith has been a prime mover in making the Institute the recognized international technical organization of the radio field. He has edited its *Proceedings* and has earned them their well-merited reputation of the most comprehensive and complete technical journal devoted to a specialized field.

Dr. Goldsmith's injection into radio was as well ordered a process as his later pursuit of the art. During his college work, physics attracted him and physics led him to mathe-

atics, the unfailing guide of the physicist. In electricity, he found the ideal confluence of physics and mathematics for, in no phase of all-embracing physics, are the laws of mathematics so dutifully and systematically applicable.

Having, by so logical a process, devoted

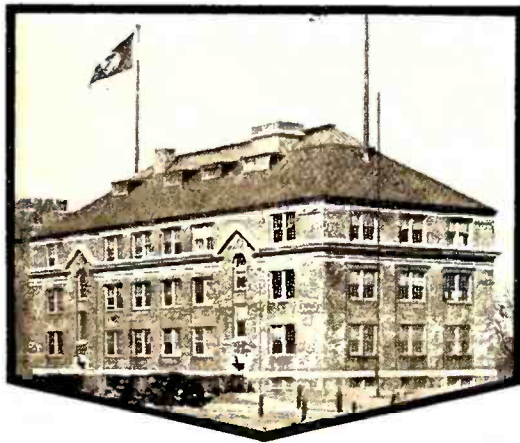

The Van Cortlandt Park Laboratories of the Radio Corporation of America which Dr. Alfred N. Goldsmith directs

himself to radio, the young student at once set himself a definite goal of achievement. Following the established practice of the mathematician, he set forth a theorem as the goal of his efforts. As he expressed that theorem to me, it was "To make possible the appearance of an individual, or any number of individuals, both in their vocal and visual embodiment, instantaneously, through any terrestrial distance by the agency of radio." In the crude state of the radio art, when that objective was set up, it was a rather ambitious conception. To-day, we no longer discuss the correctness of the theorem; it is only a matter of a reasonably short time before the proof of its correctness will be a practical demonstrated fact. That this conception of the possibilities of radio was his from the time Dr. Goldsmith dedicated himself to radio, is borne out by the singleness of purpose with which he has devoted himself to it and how intimately he has been associated with its attainment.

Goldsmith graduated from the College of the City of New York in 1907, and in 1911, won his Ph. D. from Columbia. His scholastic career was brilliant; he captured numerous prizes and honors but, unlike most exceptional students, he never lost his delightful sense of humor. Indeed, it has stood him in good stead during the many trials which have beset the growth of radio.

A log of Dr. Goldsmith's experimental work is a history of the progress of radio. He did not, like most students, acquaint himself with the experiments of Heinrich Hertz by dutifully reading his physics book. He actually performed most of Hertz's recorded experiments in the college laboratory with

physical duplicates of that great investigator's equipment. In the same manner, he has, step by step, submitted every important experiment and development in radio having promise of commercial application, to critical test in his laboratory.

Was College Instructor

AFTER his graduation, Dr. Goldsmith remained instructor at the College of the City of New York, at first using a small room for experimental purposes, which later grew to become a series of laboratories for extensive engineering and research study. To-day, Dr. Goldsmith still has a laboratory which he directs, a large well-equipped five-story building at the southern end of Van Cortlandt Park in New York City. New radio devices are tested and passed for approval in these laboratories before they go into production. Thereafter, a percentage of the output is tested with every kind of measuring instrument, in order to assure uniformity.

As a part of Dr. Goldsmith's work as technical advisor of the National Broadcasting Company, the receiving apparatus for the rebroadcasting of programs from Great Britain is being developed in his laboratory. While going through the building with him, I heard 5sw of Chelmsford, England, coming through with loud-speaker volume from a special super-heterodyne. The principal problem awaiting solution, or rather awaiting final development, is that of a special receiving system, including an automatic fading compensator, so as to assure a constant signal.

It is not essential to rehearse all the details of Dr. Goldsmith's technical achievements. I need mention only two incidents in that extensive career to confirm his devotion to his theorem—to make possible the instantaneous appearance, both visual and vocal, through any terrestrial distance by the agency of radio.

As early as 1915, when the first vacuum tubes capable of radiating any appreciable power were available, Dr. Goldsmith began broadcasting from the College of the City of New York. Station 2XX, with 1500 watts in the antenna, having as its audience a handful of amateur experimenters, broadcast unblushingly to all the states of the Union. So definite was the Doctor's conception of a broadcasting service in 1915, that he invariably dedicated his programs to the entertainment of listeners over this extensive territory by carefully reading the entire list of states as a part of the preliminary announcement.

This procedure, as we view it to-day, may appear to have been almost impertinent, were not the range which this meagre power covered fully appreciated. One purpose of the rather lengthy announcement was to enable listeners to tune and to adjust their all too delicate receivers before the program began. But a second justification for the announce-



Dr. Alfred N. Goldsmith manipulating a special remote-control amplifier for broadcast transmission

ment was the fact that 2XN's programs were actually reaching a large part of the country. One of its regular listeners was Dr. A. Hoyt Taylor, then at the University of North Dakota at Grand Forks, N. D., and now in charge of the Naval Communication Laboratories near Washington.

First Remote-Control Station

ANOTHER distinction which this early broadcasting station possessed is that it was the scene of the first experiments in remote-control broadcasting. As a convenience, Dr. Goldsmith arranged an outlet for the telephone circuit so that he could call the college from his home on lower Fifth Avenue, have the telephone receiver at the college connected with the broadcasting transmitter, and thus broadcast from uptown on Morningside Heights, while listening to his own voice returning by radio. In the pressure of work, Dr. Goldsmith evidently had not read his contract with the telephone company and presumably the company was in ignorance of these early experiments.

Thus identified with the first remote-control broadcasting and the first long-range broadcasting, it is interesting to observe that Dr. Goldsmith also took part in the first public demonstration of radio picture reception, broadcast from a general broadcasting station and received in his home. There had been previous instances of picture broadcasting from WJY, WGY, and WOR but, in connection with none of these, was the reception publicly conducted. Out of the original experiments in remote-control radio telephony has grown a nationwide, wire-interconnected, broadcasting system, operated under the technical supervision of Dr. Goldsmith. Thus, the first prophecy of his conception of radio service, namely the vocal appearance, is now transferable instantaneously through any terrestrial distance. He now awaits accomplishment of the second and the progress made is a matter of public record.

There have been some recent additions to Dr. Goldsmith's laboratory building and, on my most recent visit, he offered to show me the new facilities. But he first paused for a moment in the reception room to find a

waiting friend to accompany us. The friend proved to be a bright-eyed youngster of twelve, who strode with us in silent amazement through the upper floors of the laboratory. Here an entire floor of new testing equipment had been installed to measure the operating characteristics and life of alternating-current tubes which are now being manufactured in large quantities. There are facilities for testing 18,000 tubes simultaneously and the power required to furnish the plate current for these tests is 400 kilowatts! The power used in heating the filaments of these tubes is 240 kilowatts. So great is the heat dissipated by the tubes under test that a special ventilating system is necessary which pumps a complete renewal of air into the test room every three minutes.

Other Testing Equipment

ALTHOUGH many specialized lines of radio and acoustic research and development are carried on at this laboratory, the greater part of its facilities are devoted to exacting testing of the Radio Corporation's commercial products. A percentage of the output of all the factories contributing to the RCA line is sent here for test. Under the most elaborate and systematized scrutiny, the constants and life of tens of thousands of vacuum tubes annually are determined and the uniformity of their performance maintained. Receiving sets are likewise tested for every factor which determines their ultimate reliability and service to the user. One amazing device automatically plots an audio-frequency response curve and writes an infallible record of its fidelity of reproduction without the influence of human judgment. Extensive original work in circuit design and reproducer development is also conducted under Dr. Goldsmith's direction.

The theory, design, and operation of both receiver test equipment and vacuum-tube production testing was described in the November, 1928, *Proceedings*, Institute of Radio Engineers, in papers entitled "Quantitative Methods Used in Tests of Broadcast Receiving Sets" and "Vacuum Tube Production Tests," both by A. F. Van Dyck and F. H. Engel of the Technical and Test Department of the Radio Corporation of America.

Walking through this laboratory and listening to Dr. Goldsmith's explanation of the purpose of the major experiments taking place, accompanied by the young enthusiast, reminded me of a day, some fifteen years ago, when I, at about the same age, had walked through Dr. Goldsmith's laboratory at the College of the City of New York. Indeed, it was that visit which confirmed my conviction that radio would always be both my work and my hobby. But it is no peculiar distinction to have been wedded to the radio art by Dr. Goldsmith.

In Dr. Goldsmith's office are many mementoes of his career, ranging from autographed photographs from Marconi, Steinmetz, and Einstein to a significant radio emblem from the sculptor Edward Field Sanford, Jr., made for Dr. Goldsmith. But none of these seems closer to him than a bronze plaque, given him by the five students of the first radio engineering course which he conducted at the College of the City of New York. One of the names I noticed was that of J. D. R. Freed, now President of the Freed-Eisemann Company, another Carl Dreher, until recently staff engineer of the National Broadcasting Company, now Chief Engineer of RCA Photophone

Company and well known to all readers of RADIO BROADCAST, J. Marsten and H. Kayser, both well-known radio engineers. In succeeding years, without counting the thousands of men who studied radio while the College of the City of New York became a training ground for Signal Corps radio men with Dr. Goldsmith in charge of instruction, many have definitely started on a radio career through Dr. Goldsmith's influence.

The Youngster's Reaction

WHETHER the youngster who accompanied us will become a radio engineer as a result of this visit, I am hardly qualified to state. During most of the time we went through the laboratories, his eyes bulged in uncomprehending astonishment, much as mine, in 1912, had bulged at the sight of a three-stage, audio-frequency amplifier. It was the largest collection of tubes which I had ever seen at any one place at one time. When phones were connected in the output of this magnificent equipment, I heard, for the first time, the tinkling signals of European and mid-Pacific stations. The youngster of 1928 was more impressed by a demonstration of three power speakers with large baffles, reproducing simultaneously and with amazing volume, a Moran and Mack record. Astonishment soon gave way to laughter at the witticisms of the comedians.

The period from 1918 to the present day has witnessed not only amazingly rapid technical progress in the radio art but a great increase in the ramifications of the radio industry. When I first visited Dr. Goldsmith in 1912, radio communication in the United States was controlled by the British-owned Marconi Wireless Telegraph Company. Shortly after the War, the Radio Corporation of America was formed to take over its ship-to-shore business and to build up a world-wide trans-oceanic communication system. The Corporation's activities were limited strictly to radio-

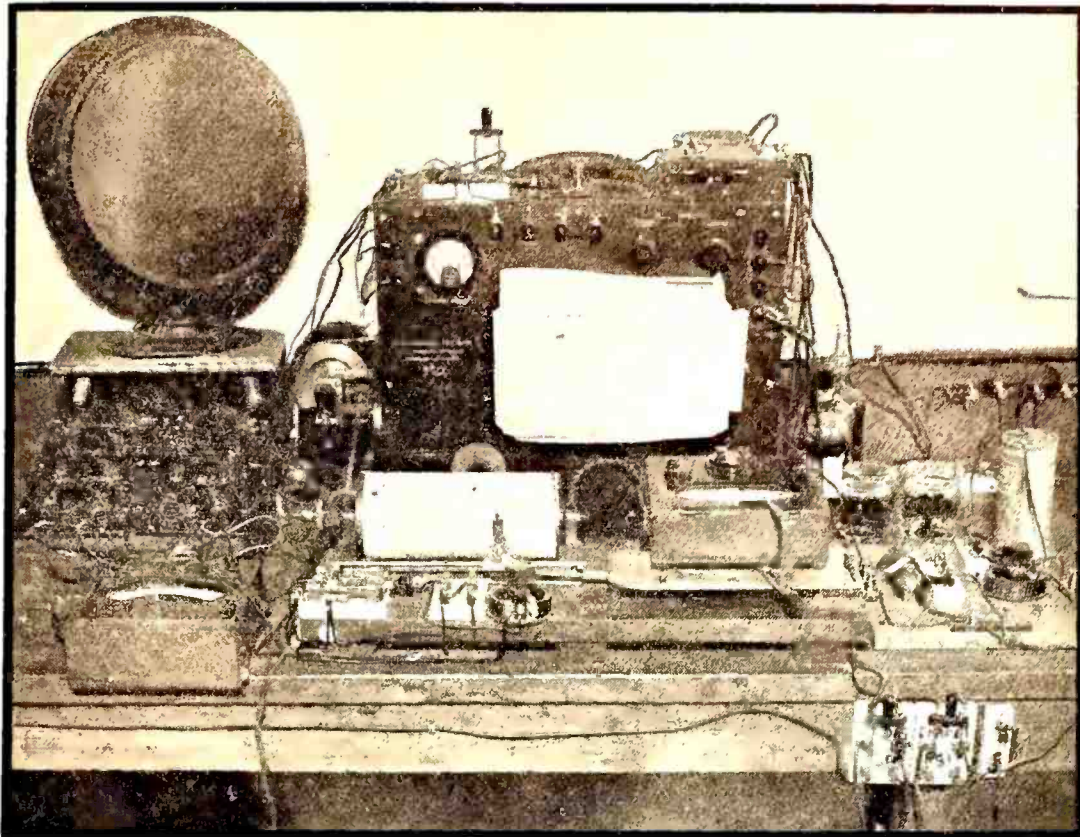

This audio-frequency oscillator is used in the Van Cortlandt Park Laboratories for acoustic measurement work

alliances with chains of vaudeville and motion picture theatres, it is establishing its own outlets for the sound films which it is to produce. Radio transmission of pictures, both across the ocean and to various points in the United States, is slowly developing and is likely to lead ultimately to home television. But, in spite of these broadening activities, radio broadcasting remains, for the time at least, still a field of paramount interest.

One of the cardinal principles to which Dr. Goldsmith is committed is the use of high power in broadcast transmission. He believes that we now have a disproportionate system, launching only moderate power into the ether and requiring, in turn, excessive sensitivity and amplification in the receiver to secure a satisfactory volume in reproduction. As a penalty for this unbalance, the receiving equipment responds to every kind of electrical disturbance, even though minute. But, no matter how great the power of the broadcasting station, it cannot hope to overcome every kind of power interference.

"Radio is a comparatively young art and it has not yet had time to influence the electrical industry as a whole," said Dr. Goldsmith. "Within ten years, the manufacture of electrical equipment which causes undue disturbance to radio reception of signals of reasonable strength will be barred, not by legislation, but as an obviously necessary measure in the interests of public convenience, just as the muffler has become a part of every automobile. It is quite possible to design elevator motors, cash registers, bell-ringing equipment, electric refrigerators, and any kind of machine involving the making and breaking of electric circuits so that it will cause little fluctuation or disturbance in the power system of which it is a part. It will require time to accomplish these things, but unquestionably it will be done. With greater power in broadcasting and greater amplification in the receiver, necessitating a smaller pick-up device, the annoyance of static has been reduced to a point where it may be

considered negligible. The next to go will be excessive man-made electrical interference with normal signals."

Picture Broadcasting

WITH respect to the broadcasting of pictures, Dr. Goldsmith feels that the possibility of amateur participation in picture experiments should be encouraged, but that apparatus so far developed is not sufficiently simple and reliable to appeal to any but the experienced set-builder and experimenter.

"While I believe experiment should always be encouraged and the participation of amateurs in practical picture reception will hasten the day that the apparatus will be of a form suited to general sale, I do not believe the public should be deprived of entertainment by the broadcasting of pictures for the benefit of a few experimenters. Picture broadcasting, when conducted for experimental purposes through broadcasting stations, should be primarily confined to such hours that the average listener does not use his radio. This consideration confines most experimental picture broadcasting to the early morning hours. It should remain thus restricted until substantial audiences are built up, a possibility only when practical and foolproof apparatus is available. It may then be necessary to transfer picture transmission to other and more suitable wave bands."

This observation reveals the underlying foundation of Dr. Goldsmith's attitude toward the public. Zealous as he is to encourage picture broadcasting, he does not believe it should be permitted to interfere with regular entertainment until it is ready, by reason of low cost and reliability, for general public consumption. And likewise, every new development of the laboratory, however promising in its experimental stages, must stand the test of public service before it is truly a practical device. Bridging the gap from the laboratory to the public is the problem to which Dr. Goldsmith has so ably devoted himself.



Special bridge used in the Van Cortlandt Park Laboratories for measuring the electrical characteristics of radio vacuum tubes

telegraph communication. Its successful activities in this field have been largely overshadowed by the business incidental to radio broadcasting. More recently, it has entered the talking motion-picture field and it is rapidly acquiring motion-picture studios. By

MEASUREMENTS ON BROADCAST RECEIVERS

By L. M. HULL

Formerly, Engineering Department, General Radio Co.

THE general subject of overall measurements on any kind of a radio set is one about which engineers do a great deal of talking but not much writing. Thus, the literature of the subject is in a rather unsatisfactory state, although the technique of providing small measured radio-frequency voltages at definitely localized points is quite generally understood, and is now being employed extensively for the standardization of broadcast receivers, even in laboratories which do not profess to be centers of research.

Most laboratory measurements on a radio receiver are based upon the assumption that the action of a wave field upon an exposed antenna, in building up a high-frequency voltage across a receiver input impedance at the base, may be simulated so far as the receiver is concerned by a locally generated signal which is fed into the receiver through a local impedance having reactive constants equivalent to those of the antenna. For example, the effective height of an antenna is any length in meters which makes a conventional formula give the right numerical result. But on many occasions in this cruel competitive age the design engineer is forced into the embarrassing responsibility of deciding whether receiver A will give more service per dollar than receiver B, without having the leisure or the facilities for operating both A and B in a hundred different localities on a hundred different antennas. The problem of making a laboratory measurement from which valid generalizations can be derived is then of vital importance which cannot be resolved by definition.

The practice of measuring a receiving set by assuming an "equivalent" local or dummy

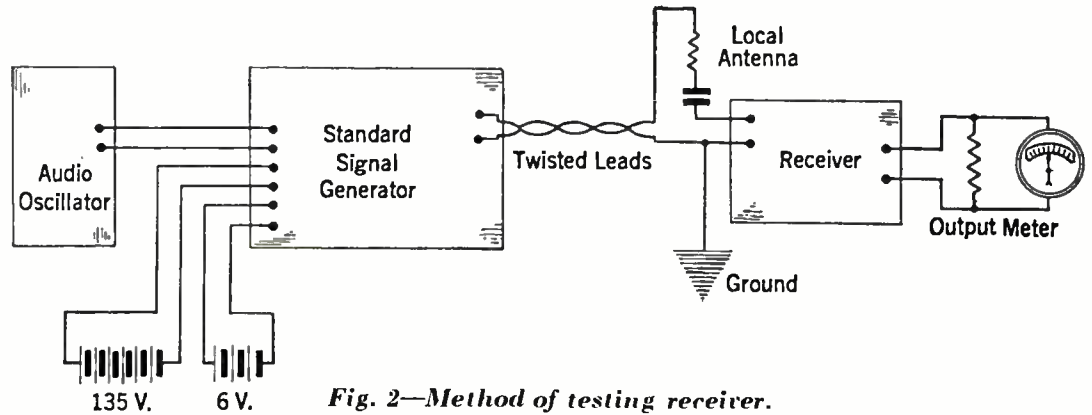

Fig. 2—Method of testing receiver.

antenna and impressing a voltage in series with it would seem to be justified by theory. This

This article by Dr. Hull, formerly of the Engineering Staff of the General Radio Company, treats of a subject that has been hotly discussed pro and con by engineers ever since there were any broadcast receivers. How to measure accurately the overall gain of radio sets has been a serious problem and the device which Dr. Hull describes here is, as far as we know, the first of its type to be generally available. Some of the material in this article was presented by Dr. Hull in a paper delivered before the Radio Club of America.
—THE EDITOR.

theoretical argument, as outlined, is not new. It was recently summarized by Colebrook

(*Experimental Wireless and the Wireless Engineer*, p. 567, Nov., 1927) and objections to it may be answered by two kinds of experimental evidence as follows:

Experimental Evidence

FIRST, if an antenna excited by a wave field is series-tuned to some frequency lower than its fundamental, and various resistances are inserted at the base (enough to vary the current at the base over a wide range) a linear relation will be obtained between current and resistance, indicating that the voltage due to the wave field acts like a constant voltage in series with some impedance, which is substantially independent of the current, at least over certain ranges. Second, if a tuned receiver input circuit is compared with a pure resistance on an antenna excited by a wave at frequencies below the fundamental, and then compared at the same frequency excited by a local generator through an impedance equal to the antenna impedance as measured at the base, the relative factors of merit will be the same for each form of measurement.

Thus it may be concluded that the use of a local signal in measuring antenna-operated receivers is partially justified by the theory I have outlined, and is better justified by experience.

A primary necessity for such measurements is a local signal generator of such a form that a known minute radio-frequency voltage may be produced between two particular terminals and nowhere else. With this available we can forsake the pernicious practice of measuring the individual amplifier stages, detectors and what not, independently, and multiplying the results together to arrive at the performance of the set. I do not question the value of the piecemeal measurements; they constitute essential steps in the design. But what we are now concerned with is an appraisal of the final result.

There are two schools of thought with regard to the design of refined local sources. One advocates the inductive-coupler method, in which a measured current is passed through an exposed coil and the small test voltage is picked up on a second coil having a small calculated mutual inductance with the first. A

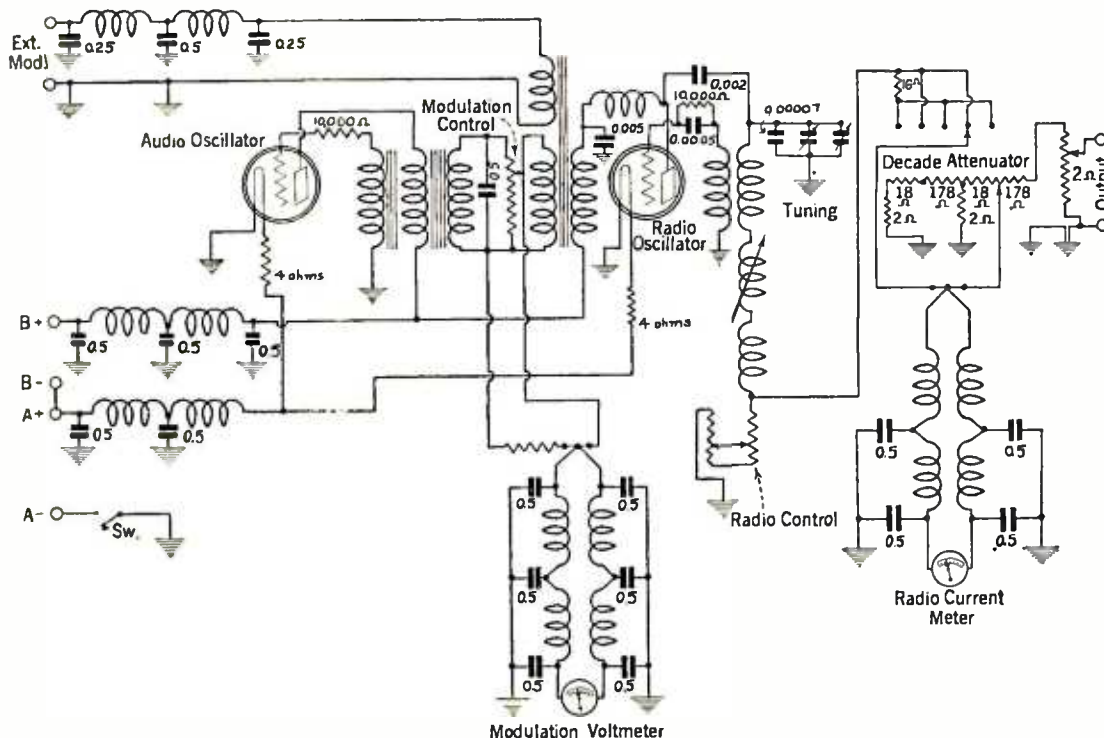

Fig. 1—Schematic diagram of standard signal generator.

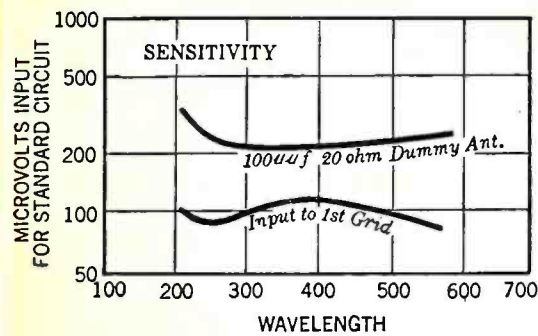

Fig. 3

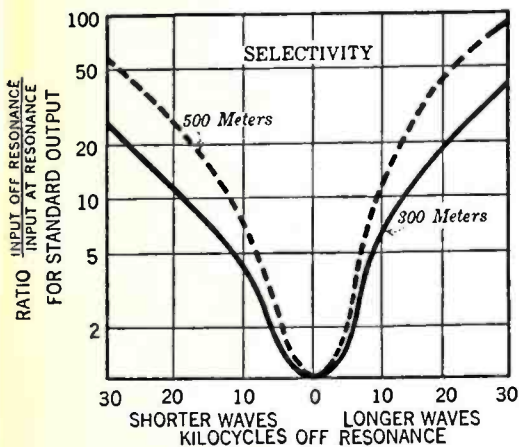

Fig. 4

(4) The whole outfit to be reproducible by ordinary skilled shop labor.

A diagram of the circuits employed is shown on Fig. 1. A single audio oscillator tube is provided within the apparatus, for modulation at a fixed frequency of about 400 cycles. This is the frequency normally used for the most common sensitivity and selectivity measurements. This oscillator includes the tube shown at the left of the drawing and the iron-core transformer tuned by a fixed condenser. This transformer feeds a modulation transformer through a resistance voltage divider marked "Modulation Control." The audio voltage is impressed by the modulation transformer through a one-to-one ratio upon

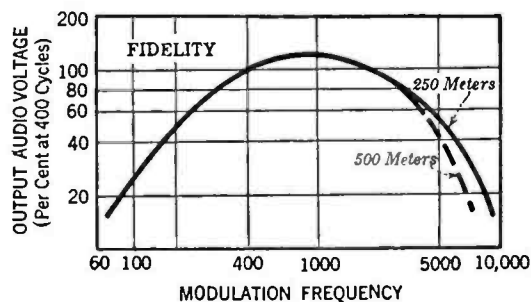

Fig. 5

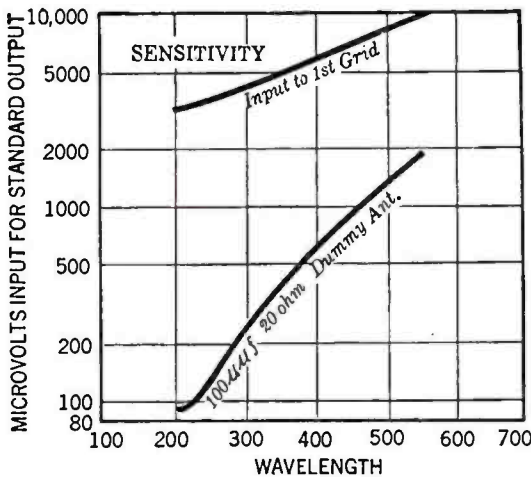

Fig. 6

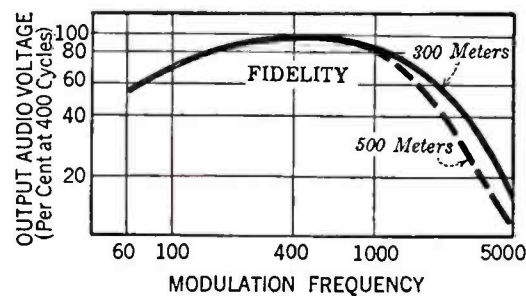

Fig. 7

the plate circuit of the radio oscillator tube, and is measured by a thermal voltmeter comprising a resistance, a thirty-ohm thermocouple, and a panel-mounting d.c. galvanometer shown at the lower part of the figure. A low pass permits the use of an unshielded external audio oscillator which may be positioned anywhere with respect to the signal generator and the receiver under test, and which may be connected to the signal generator through unshielded leads. The radio oscillator tube has a "parallel feed" plate circuit consisting of the secondary of the modulation transformer and a radio-frequency choke coil in series with the positive B battery terminal and the plate. The tuned circuit of the radio oscillator consists of a "vario-coupler" inductance which is connected by a metal belt to the variable tuning condenser, both being

operated by a tuning dial on the front panel. A small variable condenser is provided in shunt with the main condenser for fine tuning adjustments. The tuned circuit is closed through an attenuator, which is bypassed to ground by a non-inductive variable resistance marked "Radio Control." This resistance thus furnishes a means for adjusting the modulated radio-frequency current flowing into the attenuator. The current which passes into the attenuator is measured on a four-ohm thermo-couple connected through a twin two-section filter into a panel-type d.c. galvanometer which is exposed on the front panel of the outfit. The output end of the attenuator terminates in a two-ohm non-inductive slide-wire which is connected to the output terminals on the front panel. This slidewire consists of a short piece of No. 38 manganin wire stretched over a copper return path with an insulation strip 0.01 inch thick between them.

Fig. 10, is an external view of the outfit. The various instruments and controls will be recognized from the description previously given. The external dimensions are 17 x 15 x 12 inches.

Fig. 2 shows a conventional method of connecting the signal generator through a local or dummy antenna to a receiver under test. For the sake of completeness an external audio oscillator is shown. The receiver may be positioned at any convenient point near the source and twisted leads a foot or so in length do not introduce an appreciable error since the impedance at the generator end is never more

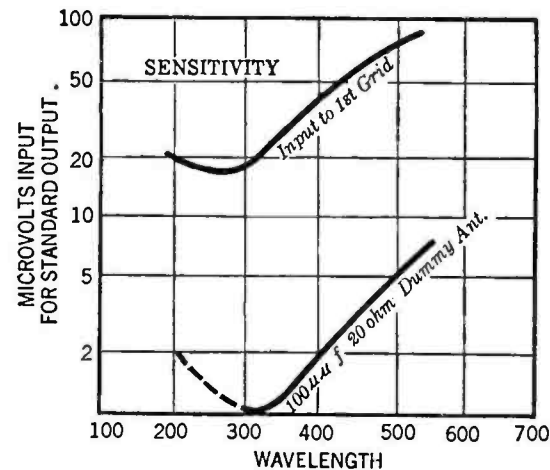

Fig. 8

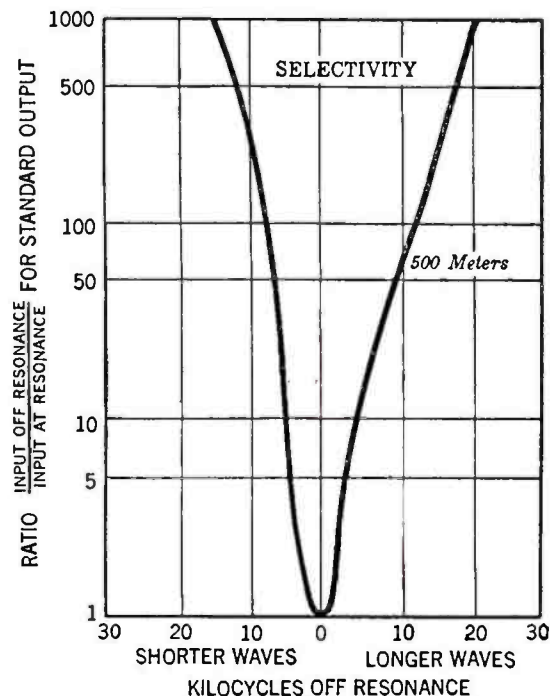

Fig. 9

typical design has been described by Rodwin and Smith. (*Proc., I.R.E., Feb. 1928, p. 155*). It is open to certain objections as to both convenience and accuracy. The current in the generator coil must be varied over a wide range, necessitating either a series of thermal meters or a radio-current transformer, and the mutual inductance between the coils may be modified by different amounts at different frequencies, by adjacent shields, or other conductors. On the other hand, the method has the advantage of impressing a field directly upon the loop designed for use with a receiver under test, instead of impressing a voltage in series with the loop, from which the equivalent field must be calculated.

In accordance with the second method, the test voltage is developed across a small known resistance which terminates a resistance attenuation network fed by a measured radio current. This method presents the general advantage of allowing all current-carrying impedances to be buried in shields, exposing only a single terminal which is above the shield by the amount of the test voltage. It allows a rating which is directly expressible in field strengths for normal signal in the case of an antenna-operated receiver.

An outfit which I think is interesting in that it is moderately portable and yields results comparable in accuracy with more bulky equipment, is the one which I am about to describe.

A Standard Signal Generator

THIS outfit was developed to fulfil four conditions:

- (1) A portable source equipped for use with external, unshielded batteries.
- (2) A range of output voltages from one microvolt up, with sufficient shielding to prevent the induction by stray fields of voltages in any adjacent tuned circuit comparable with the output voltage.
- (3) An accuracy well within the consistency of measurements with highly stable receivers.

than two ohms. The error in any ratio on the slidewire or decade attenuator is not greater than 3 per cent. at any frequency above 1500 kc.; (2) The error in the absolute value of the voltage between the generator terminals is not greater than 4 per cent. at any frequency and is probably much less for potentials above 10 microvolts.

The accepted practice in measuring and rating receivers is to impress the known voltage from the generator in series with the local antenna circuit and the input terminals of the receiver. The output of the receiver is equipped with a resistance load appropriate to the power tube or tubes which terminate the audio amplifier. A "normal signal" is specified for all receivers, usually 50 milliwatts. All measurements are referred to the radio-frequency voltage, with a specified percentage modulation and a specified antenna, which will produce normal signal in the output load of the receiver. With an output load of 2000 ohms, for example, normal signal corresponds to about 14 volts which is a reasonable loud-speaker voltage. A simple "output meter" is required for all such measurements. It may be a vacuum-tube voltmeter or a thermal meter. Furthermore, sensitivity measurements are usually made with a modulation frequency of 100 cycles and 30 per cent. modulation.

General Shielding

THE radio- and audio-oscillator circuits are mounted in a heavy copper box with a removable lid. This main internal shield is fitted to a metal sub-panel, which is attached by metal studs to the outside panel, also of metal. The outside panel is screwed tightly to a copper-lined cabinet and forms with it the outside shield. The various filters are each distributed, part inside the internal shield and part between the internal and external shield. All controls are brought through both shields to the front panel on *insulated* shafts. Metal shafts are undesirable because they frequently make rubbing contacts with one or both shields and produce unexpected and disturbing phenomena.

All battery lines, the external modulation lines, and the lines to the two d.c. meters pass through filters. These particular filters were evolved from a number of different laboratory outfits and finally reduced to the minimum amount of inductance and capacity which maintain the insulated terminals at negligible radio-frequency potentials above the external shield. The coils in all the filter sections consist of bobbins wound with No. 20 wire to an inductance of about 400 microhenries, and each mounted in an individual copper shielding cell. All the capacities in the battery and instrument lines are 0.5 mfd. The end capacities on the modulation filter are 0.25 mfd., making this line an impedance of about 30 ohms throughout the audio-frequency band, as looked at from the external modulation terminals. The modulation transformer winding, which is fed through this line, is correspondingly a low-voltage winding.

The resistance attenuator is built of small non-inductive units in which no wire larger than No. 38 manganin is employed. It will be noted that no single resistance unit is larger than 178 ohms. This permits the use of the reversed-loop form of winding which

experience has shown to be more reliable as a radio-frequency voltage-drop resistance at 1500 kc. than the so-called bifilar or parallel-strand winding. Capacity effects in the reversed-loop winding would be important, even with wire as small as No. 38, if high resistances were employed. Suitable methods of using radio-frequency slidewire in radio gain-measuring outfits have already been developed and an adaptation of the older technique is employed. Voltage ratios of over 10 to 1 may easily be obtained on a wire not over one inch long. Thus, by the use of the slidewire to provide the necessary continuous variation, steps of 10 to 1 may be employed on the attenuator and a single value of current may be employed for all values of test voltage from the highest to the lowest, which is a great advantage from the standpoint of convenience.

By using the slidewire, then, we are enabled to employ a decade attenuator having only five steps. Using the values of resistance shown the attenuation ratios are as follows: 10,000 to 1, 1,000 to 1, 100 to 1, 10 to 1, and 1 to 1. The slidewire is normally provided with a calibrated scale of 20 divisions. Thus, with the current through the radio current meter adjusted to a fixed value of 50 milliamperes and the attenuator at the last point on the left, a radio potential of one microvolt is impressed between the output terminals with the slidewire on its first scale division, and 10 microvolts with the slidewire at maximum. The slidewire scale is correspondingly multiplied in microvolts output at other points on the attenuator. The current may also be operated at twice the foregoing value without forcing the meter off scale, which provides a maximum output voltage of 200,000 microvolts.

The sliding-contact switch shown above the decade attenuator in the diagram of Fig. 1 is simply a device for throwing a fixed resistance of approximately 16 ohms in series with the attenuator on alternate points in order to keep the total resistance in the radio-frequency circuit constant and prevent current variations as the attenuator is shifted. This compensating resistance is controlled by a separate switch mounted on the same shaft with the attenuator switch because it and its associated leads must be carefully shielded from the right-hand or low-voltage portion of the attenuator. The shielding of this attenuator is a delicate and rather complicated

matter, brought about by the fact that for convenience we elected to start with large radio-frequency currents.

Actual Receiver Performance

THE next few illustrations show some receiver performance curves made with an outfit of the character described above. These were merely picked at random as illustrative of the general types of information yielded by these measurements, and are by no means intended as a complete study of any one receiver. All these curves were taken with a local antenna of 20 ohms resistance and 100 mmfd. capacity. This does not affect the selectivity and fidelity appreciably but for a study of sensitivity, various antenna combinations should be employed.

Figs. 3, 4, and 5 show the sensitivity, selectivity and fidelity of a receiver which has two tuned radio-frequency stages, stabilized by grid suppressors with a third radio-frequency tube at the input fed by an untuned antenna circuit—six tubes in all, with three tuned circuits. It is not very sensitive with a small antenna, owing to the voltage loss in the untuned input circuit. This is shown by the lower curve which was taken for comparison with the antenna circuit cut out (Fig. 3).

Fig. 6 shows the sensitivity of a big-grade five-tube set containing two well-balanced radio stages and a good audio amplifier. It is shown to bring out the effect of using a high turns ratio in the radio transformers in order to obtain selectivity in a non-regenerative set having only three tuned circuits. Fig. 7 shows the excellent low-frequency fidelity resulting from the use of heavy audio transformers. The big-frequency part of the curve indicates that the designer might profitably have decreased the losses in the audio transformers in view of the amount of side-band cutting present in the radio amplifier.

Fig. 8 is an example of extreme and mostly undesirable sensitivity. This receiver has four tuned, balanced radio stages with five tuned circuits. At 300 meters, one microvolt in an antenna of 100 micro-microfarads capacity produces normal signal. The decrease in sensitivity below 300 meters is due to the fact that the gang condenser was not properly aligned. Fig. 9 shows the razor-like selectivity effect of five tuned circuits and also the effects of some accidental regeneration.

I am indebted to Mr. Malcolm Ferris of the Radio Frequency Laboratories for selecting these curves for me from his files.

The study of overall performance curves is fascinating because it offers endless opportunity for interpretation. I have by no means discussed all the measurements which can profitably be made on broadcast receivers even after their design is completed. But I do not wish to minimize the importance of constant listening to receivers and manipulation of them on actual reception of broadcast signals. I believe that an experimenter can best employ his facilities by making constant comparisons and correlations between the overall performance curves of any receiver and his reasoned impressions of its behaviour in actual signal reception. By such a procedure a mature and valuable experience in the interpretation of overall characteristics can be obtained without which they are apt to be nothing but scraps of paper.

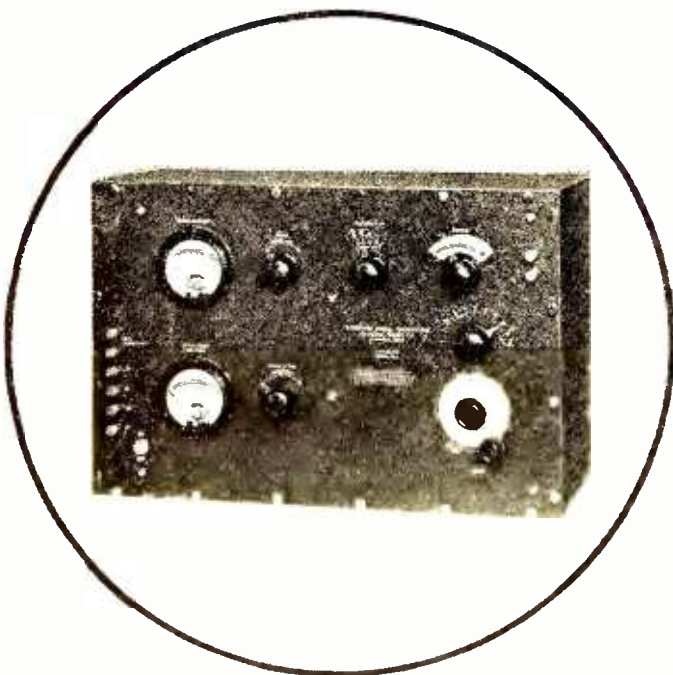
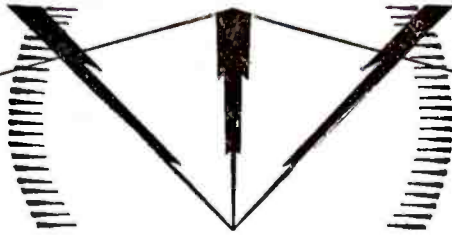

Fig. 10—External view of signal generator.



The Davis-Dill Publicity Barrage Begins

OPEN season for obscure Congressmen to focus public attention upon themselves by shooting holes in the unfortunate broadcast structure is again upon us. The first to seize upon this tried method of limelight winning were the familiar figures of Senator C. C. Dill and Representative E. L. Davis.

The theme of their 1928 short-session song hit is that the power of broadcast stations should be limited to 10,000 watts. "These high-powered stations," says Senator Dill, "dominate the dials of most receiving sets within a radius of 150 to 200 miles of the transmitter using immense power. Since the Commission will not protect the public, Congress is the only body that can do so. The people for whom Congress passed radio legislation are entitled to conditions under which they may listen to stations other than those of immense power. In practice, it is found that these high-powered stations cannot be separated by kilocycles."

Our listening post is so located that the effect of high-powered transmission may be observed under the most ideal conditions. Within twenty miles are WJZ and WFAF and 110 miles to the North is WGY. Utilizing a receiver costing less than \$150, we heard, between sundown and 11 P.M. during the first ten days of the new allocation, while each of these "dominating" high-powered stations were broadcasting, WCAU, WWVA, WHAM, WFBR, WRVA, WPG, WBT, WTAM, KYW, WHO, WBZ, KDKA, WCFL, CKCW, CFRB, WFIW, WCSH, WMAK, WLS, WENR, KWKH, CJCG, KOA, WHAS, WCCO, KTHS, WNC, WJR, WGN, WLW, WPTF, WMAW, WSM, WGBF, WTMJ, WIP, and WFI, each with intelligible loud-speaker volume. The local stations are not included in the list. Over half of these out-of-town stations were reproduced with sufficiently good quality to be comparable to locals. The entire spectrum of low- and high-powered local stations is spread adequately so that none interferes with another. There is not the slightest support for the Senator's statement that stations over 25,000 watts cause any greater trouble than 500- and 1000-watt stations at equal distances.

It is a well-known experience that, when power increases are first put into effect, poorly designed receivers in the immediate vicinity show up their inadequate selectivity. After a few weeks of operation, ancient receivers are replaced, excessively long antennas are reduced to more reasonable proportions and wave traps are installed at locations within four or five miles of such stations. These alterations are necessary, whether the new station is 5000 or 100,000 watts. Levelling the power to 10,000 watts does not eliminate the need for these reasonable modifications, nor does it increase by an iota the number of stations which may be loaded upon our broadcast channels without heterodyning. On the other hand, power curtailment reduces service to listeners in remote areas and increases the

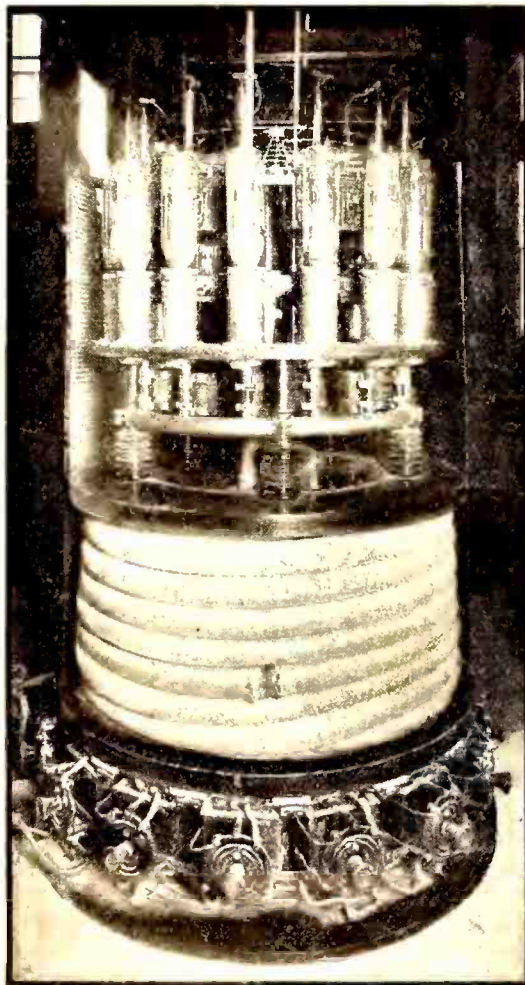

Circular bank of 15 water-cooled power-amplifier tubes used for transatlantic telephony. This unit has an output of 200 kw.

disturbing effect of interfering atmospheric and electrical noise upon reproduced programs tuned-in by both urban and rural listeners.

PUBLIC PREFERENCE

The public prefers the loudest station which offers an acceptable program. The higher the signal level, the less sensitive and less expensive the receiver required to reproduce it. As the signal level is reduced, the musical quality of reception is proportionately injured regardless of amplification power. Restricting broadcasting to low power deprives the rural listener of any real broadcasting service and, even with a most expensive receiver, whatever programs he is able to tune-in from low-powered stations are marred by excessive tube noise, static and electrical interference.

It was only with the advent of high-powered broadcasting that radio was lifted from a curiosity to a musical instrument. The senator is setting out to destroy the musical value of radio for all except those within the shadow of broadcasting stations. The greatest damage which would be wrought by the adoption of his proposed measure would be the farmer and

the rural listener who finds radio an almost essential enhancement to his happiness. He usually is equipped with a less expensive receiver and will resent the loss of the only stations which give him a good loud-speaker signal.

The Senator's effusion is inspired by the fact that it enables him to make spectacular attacks upon the great electrical interests. Defending the weak against the strong makes good newspaper copy, even though, in the case of broadcasting, its prospective effect is to weaken radio signals and curtail broadcasting service. It is inevitable that the great electrical and radio interests should be the only ones willing to build great stations because small fry can neither afford to erect such stations nor to pay the immense cost of operation and maintenance involved. Hence, discrediting high power has that delightful anti-monopoly flavor which is so effective with the gallery and the press. In the last analysis, the listener is the one who would pay, were the Senator successful in forcing his proposal into law, by being compelled to buy a more expensive receiver and by the reduced quality of reception which the weakened signal would give him.

Senator Dill's bill to authorize a salary of \$10,000 a year to the chief counsel of the Federal Radio Commission is a most constructive measure and we are pleased to commend his stand in this matter.

BROADCASTERS AS UTILITIES

Representative Huddleston of Alabama wishes to class broadcasting stations as public utilities because they wield great public influence. The principal effect of such classification would be to take from program directors the right to select entertainment and educational features according to the desires of the listening audience. According to public utility principles, whoever has the price of broadcasting would be entitled to the service of the microphone. Facilities must be provided to meet whatever demands the public makes for them. Considering that there is no way of increasing the number of broadcasting stations to the thousands necessary so that all who wish could broadcast, the proposal is no more unreasonable than requiring the President of the United States to take all persons of voting age for a joy ride in his limousine on the Fourth of July. Newspapers and motion pictures also have great public interest and they might, on the same plea Mr. Huddleston makes for public utility regulation of broadcasting, be compelled by Congress to publish all news and propaganda items submitted to them and to film all politicians at whatever cost they render such service to anyone.

We hope that the trade associations of the radio industry will profit from the painful lesson which they should have learned last year, when the destructive Davis Amendment was slipped over while the industry associations slept. Since the general public

does not know what it is all about until after legislation is passed and the politicians playing with radio legislation do not intelligently protect the interests of the listener, it is highly essential that definite steps be taken by the radio industry to defend the threatened ether channels. Legislation tending to reduce broadcasting service should be vigorously opposed lest politicians, in their zeal for publicity, destroy the structure which has been so painfully built up.

Fitting Receivers to the New Allocations

IF THE new allocation structure survives the attack of self-seeking broadcasters and meddling politicians, it is likely to form the foundation upon which all future allocations will be based. A month's observation, under the new conditions brought about by the allocation, reveals an entirely new broadcasting world. In general, leading stations are now no longer marred by heterodyne whistles, with the consequence that their clarity of reproduction is greatly improved. On the other hand, in most localities, the number of points on the dial that near-by local stations are found has been reduced. This is the case particularly in the congested districts of New York and Chicago. In the wide gaps between the local stations, the listener with the moderate priced set is now served with good quality by stations several hundred miles distant. With a highly sensitive receiver, he can hear distant programs during the early evening hours as reliably as after midnight prior to the reallocation.

These new reception conditions make those characteristics of receiver performance, paramount in the embryo days of broadcasting, once more of great value. For the last two or three years, we have been concerned principally with improved convenience in maintenance, secured by powering receivers directly from the light socket, and better tone quality, made doubly desirable by the availability of high-powered, high-quality transmissions. Although progress in these directions is by no means halted, it now becomes increasingly desirable to encourage greater sensitiveness and better selectivity. Both these objectives were once attained by using regenerative receivers, the selectivity and sensitivity of which increase proportionately to the amount of regeneration employed. Fortunately, the regenerative receiver is no longer with us because a slight move of the dial, when it is in



RADIOGRAM

The New York Times.

"All the News That's Fit to Print"

RADIO STATION
TIMES SQUARE, NEW YORK



NO. 1111
ADDRESS
DATE

S.S.
C132 WFAT. Eleanor Bolling November 22, 1928

TO

Radio Broadcast,
New York City.

NOV 23 1928

Please mail to catch S. S. Makura, leaving San Francisco, November 28th, May, October and November issues Radio Broadcast, address Byrd Antarctic Expedition, care Tapley, Dunedin, New Zealand. We are not leaving Dunedin for the ice barrier until arrival this mail about December 20th.

Malcolm Hanson.

Mr. Wing
Pls airmail these to Frisco
Meinholtz, Times

This radiogram, signed by Lieut. Hanson, radio head of the Byrd Antarctic Expedition, shows that the explorers plan to keep abreast of the times on radio subjects by reading Radio Broadcast

its most efficient operating condition, converts it into a transmitting station. But, even with several stages of tuned radio frequency, the best we can hope to do is to equal the selectivity obtainable with well-designed regenerative receivers. However, we cannot rely, in this day and age, upon regeneration. Regeneration sharpens tuning to the point that discrimination of audio as well as radio frequencies is obtained, so that either low or high tones are lost. This militates against the quality of reproduction, a characteristic no longer tolerated by the discriminating listener.

We must, therefore, find new means of securing the degree of selectivity which has now become desirable and useful without sacrificing tone quality. This may be attained by the band-pass filter systems, admitting full energy of a ten-kilocycle channel band but

discriminating sharply against any signals outside the desired channel. As progress is made in improving selectivity, the permissible power of broadcasting stations will increase greatly and consequently the listener may ultimately expect satisfactory programs on every dial position of his receiver. Furthermore, the number of stations which give him a clean signal, rising above local electrical noise and atmospheric disturbance, will increase in proportion to the power of the transmitting station. Forward looking manufacturers will take advantage of the opportunity which the new allocation brings by departing from stereotyped designs and producing receivers possessing new standards of selectivity and sensitivity.

Aircraft Radio

IN HIS annual report, Major General George S. Gibbs, Chief Signal Officer of the Army, announces the development of a new, double-voltage, direct-engine-driven generator, replacing the wind-driven dynamotor, hitherto used for powering transmitters and receivers. The motor-driven power source can be used while the plane is on the ground and is considerably more reliable than the wind-driven type. One of the principal problems with wind-driven generators was the requirement that automatic, self-regulating propellers, which compensated the variations in speed of the ship, are required to insure reasonably constant voltages.

THE Bureau of Standards is improving its radio direction beacon by making it unidirectional. This will not only increase the beacon signal strength in the desired direction, but reduce the possibility of interference. A combination of vertical antenna with the two crossed coil antenna is used.

Schedule of Broadcast Television Transmissions

Call Letters	Location	Wave-length	No. of Holes in Disc	Speed of Disc (R. P. M.)	No. of Pictures Per Second	Schedule of Transmissions E. S. T.*
w2xaf	Schenectady, N. Y.	31.5	24	1260	21	Tuesday 1:30 P. M. Sunday 11:15-11:45 P. M. Tuesday, Thursday, Friday 1:30-2:00 P. M. Monday, Wednesday, Friday 8-9 P. M. 5-10 minute periods every hour station is on air 10 to 11 A. M. Daily except Sunday Probably 11:30-12 P. M. Daily Irregular
w2xad	Schenectady, N. Y.	19.6	24	1260	21	
w3xx	Washington, D. C.	16.7	48	900	15	9:30 P. M. Daily
wrny	New York City	326	48	450	7.5	
w2xal	New York City	32	48	450	7.5	Irregular 1:30 to 2:30 A. M.
w9xaa (wcfb)	Chicago, Ill.	61	48	900	15	
wmaq	Chicago, Ill.	447.5	45	900	15	
w4xa (wrec)	Memphis, Tenn.		24	900	15	
w1xay (wlex)	Lexington, Mass.	62	48	900	15	
w2xau	Beacon, N. Y.					
w8xav	Pittsburgh, Pa.	63.5	60	900	15	
w6xc	Los Angeles, Calif.	66	36	1080	18	

*As this issue goes to press the status of television on broadcast wavelengths is unsettled. The Commission has invited all interested parties to attend a meeting to discuss the advisability of allowing visual broadcasting within the band from 500 to 1500 kc. Also, the Commission has limited television transmission in this band to between the hours of 12 midnight and 6 a. m.

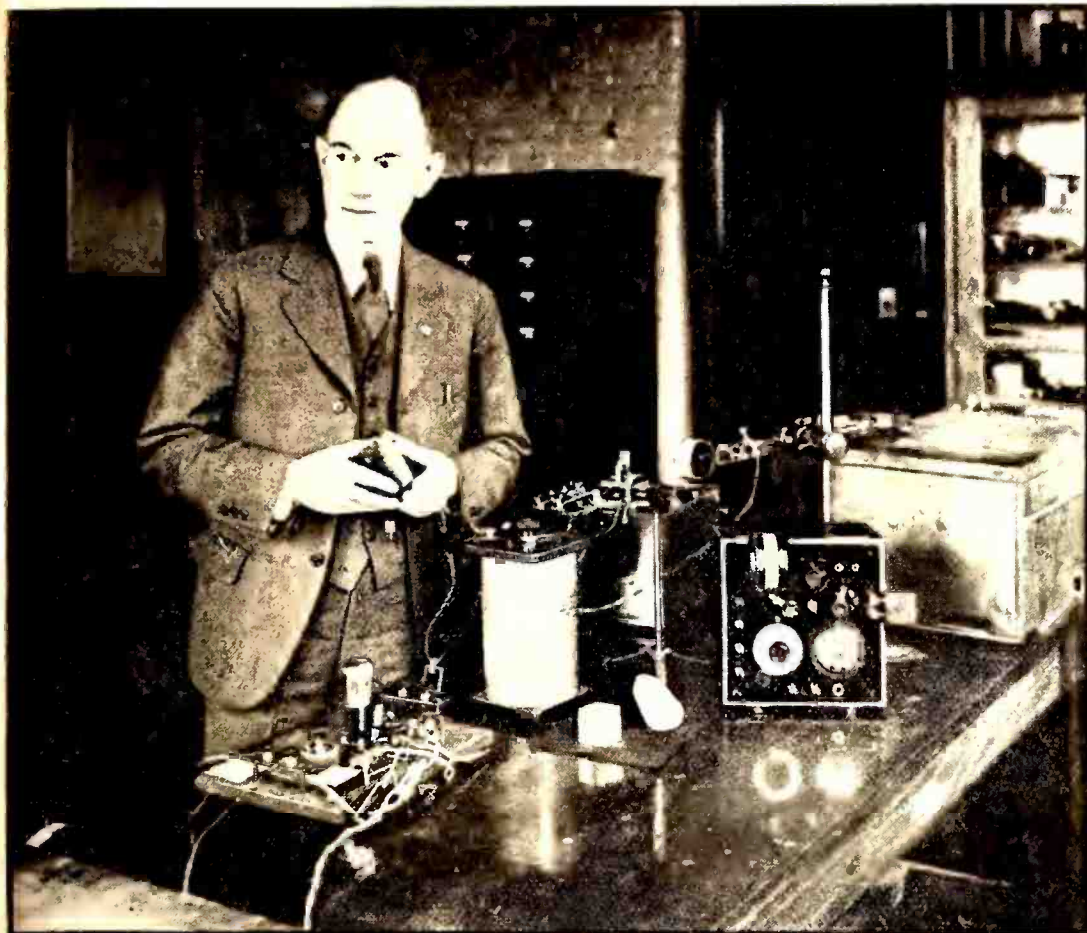

Dr. Walter G. Cady, head of the Department of Physics at Wesleyan University, has been awarded by the I. R. E. the 1928 Morris Liebmann Memorial prize for the year's outstanding accomplishment in radio

perior service to the listeners. It would not be difficult, were municipal and state stations held superior to commercial stations, to completely dominate the dials with municipal, political, chamber of commerce, and state university broadcasting stations. Many of these, no doubt, serve a useful purpose, but they are very far from representing a substantial part of the listener's service.

THE Department of Commerce has ordered special radio receivers, equipped with accurate means of measuring frequencies, to check broadcasting stations. No matter how perfectly allocation is worked out, if stations do not adhere closely to their assigned frequencies, serious heterodynes are bound to result. Some of the deviations of channel assignments are sufficiently great to be observable with an ordinary commercial receiver, if the owner takes the time to plot a dial setting-frequency curve. Captain Guy Hill, the Federal Radio Commission's engineer in charge of broadcasting, reported, among others, deviations of WKBQ, 25,400 cycles high; WNJ, 18,000 cycles low; WEVD, 8900 cycles high; WAFD, 73,200 cycles low, and WSDU 20,100 cycles high. Such extraordinary deviations are adequate evidence of total technical incompetence, sufficient to warrant cancellation of stations' licenses. With the imperfection of even the best kind of crystal control, moderate and occasional deviations are not entirely avoidable, but some of the deviations noted amount to from two to five degrees on the ordinary radio receiver dial and only the most moderate technical skill is required to avoid them.

THE Federal Radio Commission's decision to revoke the 1000-watt construction permit granted WIL, after KWK had successfully prosecuted a hearing for full time on the 1350-kc. channel which WIL expected to share with it, is illustrative of the precarious character of the broadcasting business. Construction permits should not be granted on terms which involve curtailing the power or time of established stations without first obtaining a waiver from the stations involved. While we have little sympathy for anyone who constructs a broadcasting station in an area already receiving adequate service, we feel that those having the courage to invest in new broadcasting facilities should at least be given every reasonable protection. WIL will not even have the satisfaction of offering an opening program with its new 1000-watt transmitter, the construction of which was entered upon only after a proper permit had been obtained from the Commission.

ACCORDING to press reports of the evidence of Hugo Gernsback, appearing on behalf of his station, WRNY, before the Commission, the Edison Hour has cost the New York Edison Company as much as \$20,000 in a single week. This is the highest cost for talent ever reported for a single feature of that character. The Edison Orchestra is not at all unusual and it is amazing to learn that this feature costs twenty times the average of similar features of equal program merit.

Progress in Short- and Long-Wave Radio

A COMPREHENSIVE report concerning high-frequency allocations, prepared for the Federal Radio Commission by T. A. M. Craven, emphasizes the importance of accurate maintenance of assigned frequen-

THE latest edition of the annual list of amateur radio stations in the United States includes the call letters, names, and addresses of the operators of 16,928 amateur transmitting stations. W. D. Terrell, chief of the Radio Division of the Department of Commerce, reports that 2983 applicants for commercial operators' licenses and 5687 for amateur licenses were given examinations during the current year.

With the Broadcasting Stations

HARRY BELLOWES, Manager of WCCO, Minneapolis, has announced his desire to utilize only those network programs he selects from the offerings of the N. B. C. and Columbia systems. While such freedom of choice is desirable from the standpoint of the local station manager, the widespread adoption of this attitude would make the economic position of the purveyors of wire-syndicated programs unstable. Wire networks cannot be conducted economically unless a reasonable number of hours are used by all the stations served. Furthermore, the commercial broadcasters, who make chain broadcasting possible, are not justified in excessively high talent cost unless a considerable number of stations distribute the programs.

Nevertheless, Mr. Bellows is pointing the way to a trend which will ultimately gain headway. With the improvement in recording musical programs upon films and records, we may eventually see a lessened use of the wire method of distributing programs. If this trend is ever carried to the point that wire distribution of programs becomes uneconomic, however, it would be a great loss to broadcasting in that permanently set-up, nationwide networks could no longer be maintained. Then great broadcasting events, such as presidential speeches and sporting events,

could no longer be broadcast on a nationwide scale simultaneously with their occurrence. Hence, this trend is acceptable only to the point that it does not affect the stability of wire-syndicated program service.

FOR the purpose of record, we present the following figures from the St. Louis Post-Dispatch, summarizing the now-forgotten, radio presidential campaign:

Time used in nationwide hook-ups, 50 hours to a side.

Stations broadcasting Smith's acceptance speech, 115, a record number.

Stations broadcasting Hoover's acceptance speech, 107.

Average price an hour, about \$7500

Democratic appropriation for radio, \$600,000; spent nearly \$650,000.

Republican appropriation for radio, \$100,000; believed to have spent practically as much as the Democrats.

Total radio expenditures of both parties, including local spot broadcasting, estimated at \$2,000,000.

Replies from listeners: Democratic, 250,000 letters, 10,000 telegrams, \$600,000 in cash contributions. Republican, 100,000 letters and heavy contributions.

Compare this with the very limited use of broadcasting in the previous campaign, amounting to forty or fifty thousand dollars for each party.

CONGRESSMAN EMMANUEL CELLER, appearing for WNYC in its efforts to replace WMCA, which shares its 570-kc. channel, stated that WNYC being a municipal station, operated by a government body, has superior rights over a commercial station. Were such a principle recognized, it would be unfortunate because municipal or state operation does not by any means insure su-

cies. The standard used should have an accuracy of 0.025 per cent., although 0.005 per cent. is within the range of practical possibility. He recommends that no licenses be granted to any who do not demonstrate that they can maintain their assigned frequencies within 0.05 per cent.

A FEATURE of the *Vestris* disaster which has escaped general attention was the discovery that the American steamer *Montoso* was hardly 25 miles from the sinking ship but, being unequipped with radio, did not hear of the disaster until its arrival in Boston several days later. The *Montoso*, having less than the minimum number of passengers or crew required to make radio equipment compulsory, cannot be criticized for its failure to be so equipped. Nor would it be justifiable to increase the requirements so that thousands of small steamers, most of which do not venture into seas where they are likely to be of value in saving life, are required to maintain radio service. It would be possible, however, to design receiving equipment which is automatic and which would require no personnel to operate. When a characteristic distress signal is received, such a device can actuate an alarm bell and also automatically place in service a signal-recording device, huilt upon the principles of a picture recorder. Then, by reference to a code book, the message could be interpreted by any person, however unskilled in the radio art. Such equipment would not be excessively expensive either in installation or maintenance and could be required upon all ships above a thousand tons which travel more than fifty miles on the high seas.

[News of the Radio Industry

THE Radio Corporation of America has voted to form a separate communication company as a step toward the ultimate sale of its communications interests either to the International Telephone & Telegraph Company or the Western Union. It is necessary that the White Act be amended to make such a sale possible but, in view of the precedent set in England, where legislation was passed to permit merger of cable, telegraph and radio communications interests, there is considerable hope that Congress will relax its hostile attitude toward the R. C. A. sufficiently to pass such an amendment. David Sarnoff has been promoted to the title of Executive Vice-President of the Radio

Corporation of America. Dr. Alfred N. Goldsmith becomes Vice President and Chief Broadcast Engineer, Manton Davis, Vice-President and General Attorney, and Elmer Bueher, Executive Vice-President of R. C. A. Photophone. Hiram S. Brown has been elected President of Radio-Keith-Orpheum. He was formerly President of the United States Leather Corporation.

THE Jenkins Television Corporation, a subsidiary of the deForest Company, has been formed with a capitalization of ten million dollars. Two and a half million dollars' worth of the stock is offered the public. C. Francis Jenkins is Vice President in charge of engineering. Presumably the short-wave shadowgraph reproducer will be marketed by the company. The subject of transmissions is taken from silhouette films and the reproduction is enlarged by means of lenses and mirrors to about six by six inches. From what we have seen of Jenkins' apparatus, it has considerable curiosity value, but great strides must be made in detail and shading before it can be said to have entertainment value. Mr. Jenkins' long experience in television research makes progressive improvement certain, but how long it will take before the unsolved problems of channel conservation, necessary to television of educational and entertainment value, will be solved is still more a guess than a prediction.

THE Traffic Committee of the Radio Manufacturers' Association has presented detailed demands for reduced and equitable freight rates applying to radio receivers, before the Joint Classification Committee of the principal railroads. Bond P. Geddes, Executive Vice-President, and W. J. M. Lahl, Manager of the R. M. A. Traffic Bureau, appeared for the R. M. A. on this question, which is of vital interest to the radio industry.

THE Department of Commerce reports the value of radio output in 1927 at \$191,848,665, an increase of 8.4 per cent. over 1925. The production of tube type sets fell 19.1 per cent. in number but rose 0.7 per cent. in value. Socket power devices constituted 13.4 per cent. of the total value of radio apparatus manufactured during the year.

PIERRE BOUCHERON, for many years advertising manager of R. C. A., has been placed in charge of the new R. C. A. southern district sales office at Atlanta.

KOLSTER RADIO CORPORATION has closed contracts with Wired Radio, Inc., a subsidiary of the North American Company, effecting a patent interchange arrangement and requiring that one-third of Wired Radio's requirements be manufactured by Kolster at cost plus 25 per cent. basis.

Decisions of the Courts

IN AN opinion handed down by Judge John C. Knox of the Federal District Court for the Southern District of New York, Dubilier patent 1,497,095 and Horton patent 1,572,604, held by the Dubilier Condenser Company, were held invalid and, therefore, not infringed by the Aerovox Wireless Corporation.

THE Federal District Court of New Jersey upheld R. C. A., G. E., and A. T. & T. in their joint action against the Shamrock Manufacturing Company. The defendant unsuccessfully held that the parties in the suit represented misjoinder of action.

THE Hazeltine Corporation won a decision over Atwater Kent in the Brooklyn Federal Court. Atwater Kent contended that, because of earlier patents granted Alexander-son, under which they are licensed, they did not infringe the Hazeltine patents. Judge Grover M. Moscovitz enjoined Atwater Kent from further infringement and ordered an accounting. An appeal has been entered.

THE Supreme Court of the United States declined to review the injunction issued by the Federal District Court for Delaware, restraining the R. C. A. from enforcing Clause 9 of its license to receiver manufacturers, to which objection was brought by a group of vacuum tube manufacturers.
E. H. F.

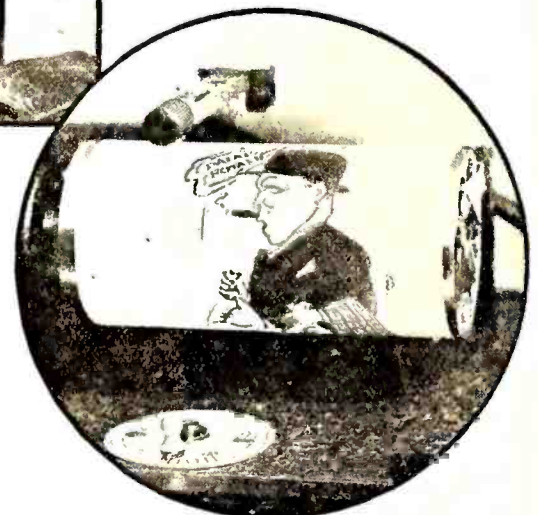
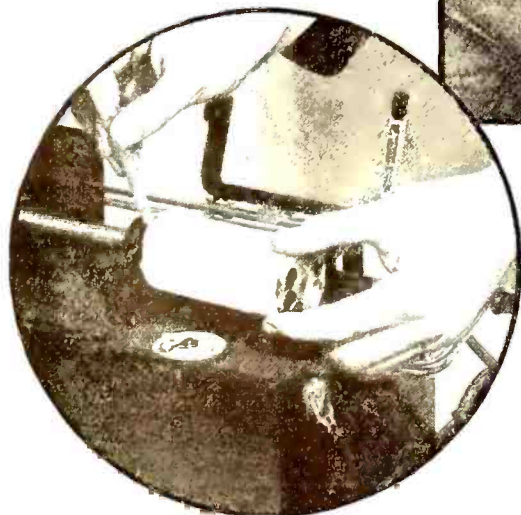

These pictures show the Fultograph apparatus which is used by the British Broadcasting Company for the broadcasting of pictures. (above) The apparatus being set in motion at Station 2LO, (left) adjusting the paper to the receiving cylinder, and (right) a cartoon as it is received on the cylinder

E-1

THE BUSINESS SIDE OF RADIO SERVICING

By JOHN S. DUNHAM

QRV Radio Service, Inc.

THE ensuing article, which has been permitted, by the Grace of God and lack of penetration of the Editor—no matter what he may be saying about it from his hox seat on the right—to appear in this august (or February) publication, does not contain one word of technical problems, but rather of general service questions which we believe are both outstanding and common to most of us who are in the service game. You may, therefore, with entire propriety—and very little loss—omit reading it and wait for the more or less technical problems which we hope to vigorously attack in following articles.

In order to discuss any subject intelligently it is first necessary to know what that subject embraces, to effect an orderly division of its phases, and then to discuss each phase separately. If we are talking about our own problems as servicemen, then it will help clarify the situation to classify not only our problems but also to divide up into groups the different kinds of servicemen. We believe that servicemen may be divided into three general classifications, into which fall at least 90 per cent. of all the men in the country who are doing any sort of radio service work.

The first, and we believe the largest, class is composed of those who are working alone in their own residence neighborhood, and devoting either all of their time or only a part of it to servicing broadcast receivers. This class comes from the amateur ranks, professional set-builders, high school and home experimenters, commercial and Navy radio operators, electricians, radio "institutes," and many other sources. A large number of them, like Topsy in Uncle Tom's Cabin, "just grewed."

The second class is composed of those who are working as servicemen for service organizations, or in the service departments of radio dealers. The vast majority of such men has been recruited from the ranks of those who first started working for themselves around the neighborhood, although some of them are from as many different sources as is the first class itself.

The third class is made up of those who are the employers of other servicemen, either as executives of their own service or sales-service organizations or as heads of service departments. This third class, which is largely responsible for the beginnings of general organization in the service field, has grown up from

both of the other classifications. The author, who has done various kinds of radio work since 1912, including amateur, commercial, and Navy operating, has been successively in each of the three classifications of servicemen since KDKA started broadcasting.

Every serviceman is a potential employer or director of other servicemen. Most em-

While the radio serviceman is eager for every scrap of technical information he can get to help him in his daily problems, technical information, unfortunately, is not all he needs. There are business problems to be faced and woe unto him who neglects them, for, even if he be technically beyond reproach, if his business methods are not sound anyone can forecast the result. Mr. Dunham, the writer of this article, is head of the QRV Radio Service in New York and writes from long experience. His article will be interesting to every man doing service work
—THE EDITOR.

ployers and directors have been servicemen. Those few who have not are indeed unfortunate. The problems of the man who is an employee are also those of the other two classes. The man who is working alone has a great many problems and responsibilities which his brother, who is an employee, does not have to share, but his problems are shared by the third and smallest class, the employers, who, besides all the troubles of all other servicemen, have thrust upon them enough additional problems to keep them awake nights. In this article we shall treat of those problems which are confined chiefly to the lone serviceman and the employer, but in which, we think, every ambitious service employee is also interested.

Policies of Procedure

NO SERVICE concern, whether it be composed of one man or of fifty men, can operate at optimum efficiency unless definite policies of procedure in all its activities have been clearly formulated and are rigorously followed. Changes of policy are, of course, necessary in any business with changing conditions, but when new policies are formed they must be carefully formed and steadfastly followed.

The first outstanding question of policy which must be answered definitely is: Shall we perform service only for the individual radio owner; shall we do only contract work—service for department stores and other radio dealers who do not desire to maintain their own service force; or shall we take all the work we can get of both individual and contract work? The advantages of dealing with

the individual, over those of dealing with the store, are manifold. The average individual is more concerned about how efficient the service is than he is about how much it costs. He does not want to pay more than he has to but he is willing to expend whatever may be necessary in order to have his radio properly taken care of. The average store, on the other hand, while having a strong desire to satisfy its customers, wants primarily the cheapest service it can get. While they also want good service, they will not pay a reasonable price for good service. It is a strange, but nevertheless an actual fact, that it is seemingly impossible to convince the average merchandising man in a department store or the average radio dealer how much more economical it is and how much more it means in customer satisfaction to pay a labor charge of \$2.50, for example, to have the troubles in a particular radio completely cured by a thoroughly competent serviceman in one call than it is to pay \$1.00 per call for the three or four calls which are so often necessary when the work is being handled by incompetent poorly trained servicemen. In that respect, then, the advantage in favor of the individual is that he may be charged for labor at a rate which permits good service and a decent profit, both of which are impossible in contract work.

Another Difference

THE next important difference is that batteries, tubes, replacement parts, accessories, and other apparatus may be sold to the individual whereas none of those sources of income may be sold to the store, which is an obvious advantage in favor of the individual trade. The gross income which is normally obtained from dealing directly with the individual, as an average per call, is actually from two to four times greater than that which is obtained from contract work. While the overhead and the investment must be greater for individual work when computed per call, they are actually less when computed per dollar of gross income. In other words, if with a total investment of \$1000.00 a serviceman could do a maximum annual contract business of \$3000.00, then with the same investment he could do at least \$5000.00 worth of individual business and at the same time keep his percentage of overhead expense approximately the same. The real advantage is that,

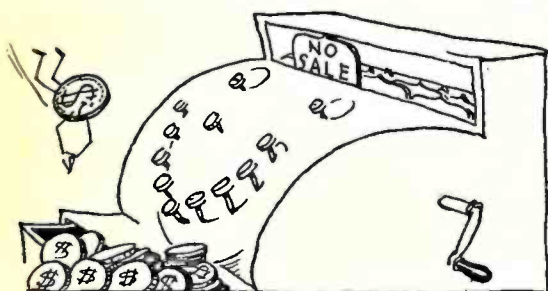

No-charge calls help to increase business.

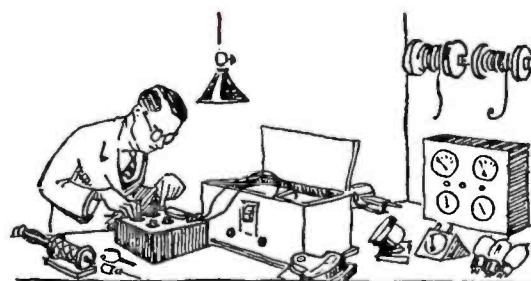

Every service organization should be well equipped.

while in the first case a net profit of 5 per cent. on \$3000.00 represents an actual gain of 15 per cent. on the investment of \$1000.00, the same percentage of gain on a \$5000.00 gross means a gain of 25 per cent. on the investment.

Another important difference between these two classes of service work is the difference of stability. If a serviceman is relying upon one store or even half a dozen stores for all or most of his income, and the one store, or two or three of the half dozen stores, should suddenly decide to farm out their service work to a competitor, who offered to do the same work cheaper, the business of the man who had been doing that work would be totally, or at the very least, badly crippled. On the other hand, if the serviceman is depending upon a comparatively large number of individuals, the loss of a few of them, while unfortunate, cannot ruin his business, a point which is extremely important and cannot be emphasized too strongly.

The only important advantage contract work has over individual work is that it may be built up with much greater rapidity. The acquisition by a serviceman of one radio store may give him that store's work for perhaps 500 individuals, whereas it may take him a year or more to build up a steady individual clientele of that number.

Sales vs. Service

THE next problem is that of how much relative emphasis to place upon service and upon sales. Shall we devote all of our energy to increasing the efficiency of our service, making only such sales as are necessary adjuncts to proper, complete service; shall we divide our energy equally between service and sales; or shall we devote the major portion of our energy to making sales, using service only as a gateway for sales and as a method of keeping in touch with the customers to whom we have made sales?

It seems to be a popular belief among servicemen that a greater percentage of profit may be had from selling tubes, batteries and apparatus, including parts, accessories, and complete sets, than may be had from the sale of service itself. That this belief, while popular, is a misconception, has been amply proven by the records of the organization of which the author is a member. The greatest gross profit which the average service concern can make from sales of whatever radio supplies may be sold, as an average of all of them over a period of a year, is about 35 per cent. and we believe that only a very small proportion of the service concerns in this country even closely approach that as an actual figure, if their accounting is properly done. An average gross profit of 40 per cent. on labor, however, is a practical possibility for the average service concern, and because that percentage of profit is not limited by fixed dealer discounts, 40 per cent. can be, and is, exceeded in actual practice. Other things being equal, there is, then, a decided advantage in keeping the income from service as large a proportion of the total income as possible.

It would be an ideal condition if one could do only service work and eliminate selling, but that condition cannot be attained. Even with no sales effort, the sales of those things which necessarily go with service will be large. In the author's organization, to give a concrete example, despite the facts that receiving sets are not sold at all and that no emphasis is placed on energy expended in attempting

to sell parts or accessories, the actual gross sales to individual customers of tubes, batteries, replacement parts, accessories such as trickle chargers and relays, with an occasional good loud speaker, total *more* than the gross sales of service alone to those customers. So that every service concern, regardless of size, is a sales concern to a very considerable extent, whether or not they desire to be, which leads us to the germane observation that a service concern *can* devote its entire effort

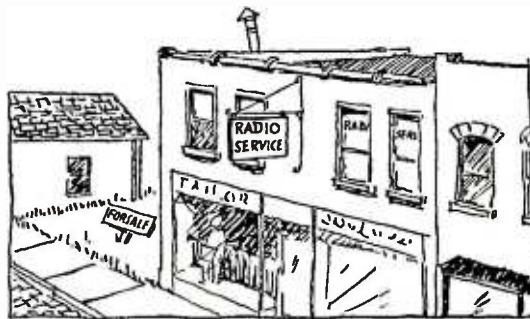

Service organizations may be located on the second floor in low-rent districts.

to the improvement of the efficiency of its service and still derive a very large proportion of its income from sales.

Large and Small Cities

WE BELIEVE that, in all of the larger cities of the country, the serviceman can obtain a larger number of steady customers within a given area, and build up a more permanent, profitable business by developing the most efficient service possible and letting the sales take care of themselves, than he can by dividing his energy between service and sales effort. One great advantage of this policy in large cities is that, with sales effort in the background, a location on a prominent street or even a ground floor location on any street, with its attendant high rent, is not at all necessary, thus permitting a much lower overhead expense than would otherwise be the case.

In smaller cities and towns, where the possible number of individual customers is not so great, the amount of income which must be derived per year from each customer is necessarily greater in order that a sufficient total income may be had. We believe that condition exists in fewer places than is the general belief among servicemen, but if it actually is the case, then it becomes necessary to devote more energy to sales, even to the extent of selling complete sets in order to avoid losing customers who would otherwise purchase them elsewhere and then have the service performed by the dealer from whom the set was bought.

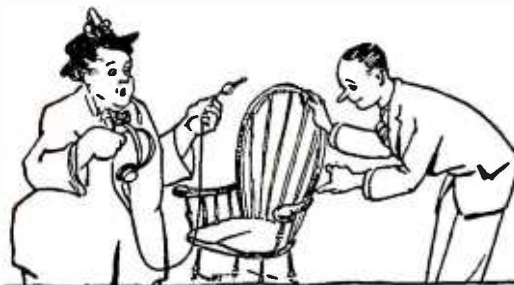

The serviceman should be courteous first, last, and always.

No-Charge Calls

ONE other major problem which we shall discuss briefly is the question of just how far we shall go to satisfy our customers. Shall we keep our percentage of no-charge calls down to the absolute minimum by making only those which are necessary in order to collect money due us on a previous call; shall we make without question as many free calls as each customer would like without making any attempt to limit the percentage of such calls; or shall we adopt a middle course somewhere between those two extremes? The basic consideration is the well-known fact that a thoroughly satisfied customer means—in the vast majority of cases—not only a permanent customer but also the best possible advertising medium which exists. All organizations that have achieved a large and permanent success, no matter what they are selling, have done so because, first of all, they have satisfied each individual customer better than most of their competitors in the same field. Many highly successful concerns, especially in the retail field, have gone so far as to adopt the policy that "the customer is always right." That policy can be applied very advantageously in our own field of radio service, and we believe it needs to be applied more generally than it has been. It is fairly obvious that if, by making a no-charge call in order to satisfy a customer, we succeed in keeping him as a regular customer where he otherwise would go to some one of our competitors, we have then made an entirely justifiable sales expenditure, for by that free call we have secured future profitable business, from the customer himself and also from those friends of his to whom he will mention his satisfaction.

On the other hand, we cannot afford to give, such a large percentage of free calls that our profit on chargeable calls will be eaten up by them. If, however, we find that we are giving too many free calls, the remedy for that condition is not to limit the number of free calls we will make, but to make our service so efficient and so pleasing to our customers that we will not need to make many free calls in order to give satisfactory service. The efficiency of the serviceman in the field, providing he is properly equipped, can be, and should be, kept over 95 per cent. In other words, the no-charge calls necessitated by the failure of a serviceman to cure properly the troubles in a radio, or by his failure to take with him the type and number of tubes and batteries or other supplies he may require need not exceed 5 per cent. of the total number of calls made. The percentage of no-charge calls of that nature made by the author's organization during the twelve months ending November 30th, 1928, was under 3 per cent. The exact figure was 2.68 per cent.

The percentage of no-charge calls made for other reasons, as a matter of policy to keep the good will of customers, automatically will remain low so long as the service efficiency is high and customers are handled fairly, courteously and with a real desire to serve them to the utmost of our ability. The total percentage of no-charge calls made, from all causes, should not exceed 15 per cent. and can be kept, as a matter of actual record in practice, under 10 per cent. Every service concern, even if it consists of only one man, should keep an accurate classified record of the no-charge calls made, to be tabulated monthly and analyzed along the lines which are suggested in this article.

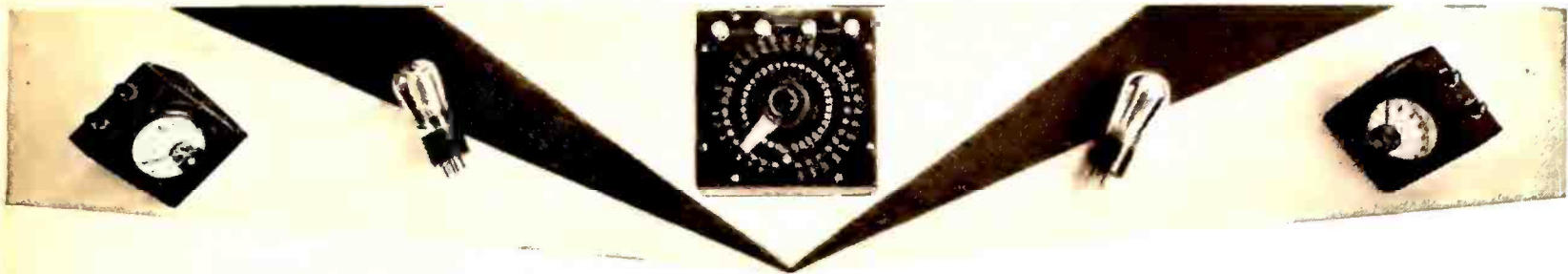

STRAYS *from* THE LABORATORY

Regarding Power, Efficiency and Energy

MANY people, engineers included, speak indiscriminately of power, energy, and efficiency.

These words are technical terms and do not mean the same thing. Energy is the *ability to work*—whether that energy is being used or not. There are two kinds of energy, kinetic energy—the energy due to motion—and potential energy—the energy due to position. A bullet traveling at a high rate of speed hits a target. The target is heated and damaged. When the bullet hits, it gives up its kinetic energy. A ball on top a flag pole has potential energy, because if it falls it can do a lot of work—or damage, depending upon the way you look at it.

Power is the *rate of doing work*. It requires the same amount of energy or work to raise a ton of coal one foot into the air whether it is done all at once by means of a steam shovel, or whether it is scooped into one's furnace a pound at a time. The difference is in the time required. The steam shovel is more powerful.

Efficiency is the *ratio between the useful work accomplished and the total amount of work expended* in getting a task done. An efficient man is not the one who gets the most work done, but the man who gets done whatever he is at with the least expenditure of effort.

As this is written a release is received from the General Electric Company which refers to a "powerful" optical system. What can a "powerful" optical system be? Is it one that consumes considerable power? Or does it have a high "resolving power"? This is but one example of the loose way in which one of these terms is used.

Let us consider a tube, such as a 171, feeding power into a load, a resistance, for example. The power in the plate circuit of that tube is used up in two ways, part of it on the plate of the tube, and part of it in the load. The sum of these two powers represents the total amount of power in the plate circuit.

Now, the conditions for maximum power output from the tube, and for maximum

efficiency are not the same. That is, if we vary the load resistance, R , a value will be reached, which is numerically equal to R_p , the plate resistance of the tube, when the maximum power output will be delivered to the load. But the efficiency at this point will be only 50 per cent.; that is, as much a.c. power goes up in heat on the plate of the tube as appears in useful power in the load. If the load resistance

The following are among the subjects discussed in "Strays" this month:

1. Power, Efficiency and Energy
2. Power of Station Harmonics
3. New Pamphlets Available.
4. Importance of Tube Voltages
5. Impedance of Loud Speakers
6. A Test for 222-type Tubes
7. Duration of Engineering Jobs
8. How Useful is a Tube?
9. Accuracy of Variable Condensers
10. New Power Rectifying Tube

is increased the power output goes down, the efficiency comes up. The curves in Figs. 1 and 2 illustrate this point. A 171 tube is assumed to be working into various load resistances and the power output and efficiency are plotted against this value of resistance.

Let us suppose we have a dynamo rated at 10 kilowatts. At maximum power output, half of this power, 5 kw. must be expended in the resistance of the generator winding—and as C. T. Burke would say, it is time to call out the fire department. To secure maximum power output it is necessary that the resistance of the apparatus to which the generator is attached shall have the same resistance as the generator.

Power of Station Harmonics

MANY fans who tune-in to short-wave broadcasting have listened to some more or less bad music which later is identified as a harmonic radiation from one of the broadcast-frequency-hand transmitters. An operator in the laboratory of *Citizen's Radio Call Book* (Chicago) recently picked up the sixth harmonic of station WHAM (Rochester N. Y.) on a Silver-Marshall short-wave receiver. In this connection the following statement regarding the experimental transmitter at Whippany, N. J., 3XN, published in the *Bell Laboratories Record*, August, 1928, may be interesting:

"The transmitter has a power input into the antenna system of 50 kilowatts for the carrier wave alone, and the instantaneous peak power during the broadcasting of a program may reach 200 kilowatts. That is enough power to meet the lighting requirements of a village of over one hundred houses, and yet with all that power in the carrier wave,

the amount of second harmonic allowed to escape would not light the tiniest incandescent lamp made. To be exact, it is less than .005 watt and represents about one-ten-millionth of the power of the carrier wave."

Three New Pamphlets Available

THE following pamphlets and publications have been received and will be found of interest to every experimenter and radio engineer.

1. *Design of Tuned Reed Course Indicators for Aircraft Radiobeacon*, by F. W. Dunmore, Research Paper No. 28, Bureau of Standards, price 5 cents.

2. *Methods for the Derivation and Expansion of Formulas for the Mutual Inductance of Coaxial Circles and for the Inductance of Single-layer Solenoids*, by Frederick W. Grover, Bureau of Standards, Research Paper No. 16, price 10 cents.

3. *Radio Acoustic Position Finding*, special publication of the Department of Commerce No. 146, price 20 cents.

All of the above papers may be obtained from the Superintendent of Documents, Government Printing Office, Washington, D. C.

Another interesting publication is the October, 1928, *Congressional Digest* which contains considerable material on the problems of radio reallocation. It includes articles by the Radio Commissioners whose names are seen frequently in print, a glossary of radio terms, and the new schedule of broadcasting stations, their powers, frequencies, locations, etc. It costs 50 cents.

Rated Voltages. Should Be Applied to Tubes

WE have spoken several times of the futility of running tubes at values of plate voltage or C bias not recommended by the manufacturer. It is true that initial performance obtained from a

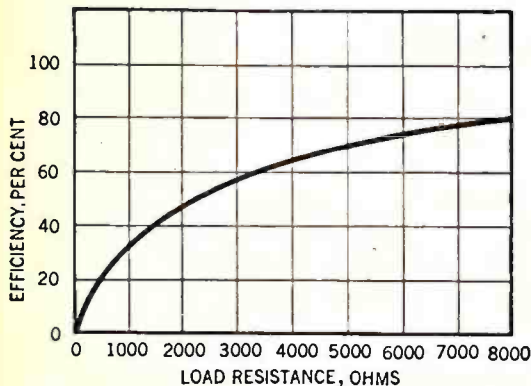

Fig. 1—Efficiency of 171-type tube versus load resistance.

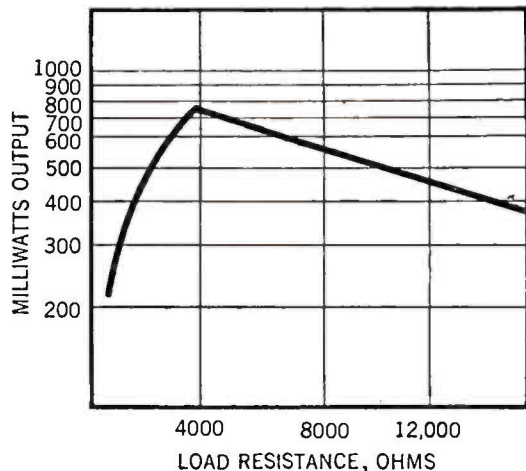

Fig. 2—Undistorted output of 171-type tube versus load resistance.

screen-grid tube by putting 180 volts on the plate and 1.0 volt C bias on its control grid may be somewhat startling and beyond the expectations of the hopeful user, but it is true, too, that he should have no come-back on the manufacturer when his tube fails prematurely.

Servicemen will do a favor for both the tube manufacturer and the user of tubes if they will insist on proper voltage values. A tube that gives fine initial performance and then fails long before its expected 1000 hours are obtained cannot but make the user skeptical of other products of the same tube manufacturer.

Within the last year we have had two manuscripts in the office in which the writers advised the use of values of plate voltage and C bias on screen-grid tubes that would limit their life to several months instead of a year or more. In one case the values of voltage were so excessive that the filament actually changed its brilliancy when the plate voltage was turned on.

Impedance of Standard Loud Speakers

MANY readers have inquired about the impedance of loud speakers. On this page is a curve made on the W.E. 540-AW loud speaker made by Frank C. Jones, of California, who has written several articles for RADIO BROADCAST. It shows that this loud speaker, long the standard laboratory loud speaker, has an impedance of 4000 ohms at 100 cycles, 13,050 ohms at 1000 cycles, etc. Here, too, is the impedance curve on the R.C.A. 104-A loud speaker—a moving-coil loud speaker.

A Test for Screen-Grid r.f. Tubes

A READER asks how to check his cx-322 tubes. The Cunningham engineering department states that a good emission test is to tie the grid, screen grid, and plate together and to apply 50 volts to these elements. Next, place 3.3 volts across the filament and measure the plate current. If the current is above 12 mA. the tube is good. Has every engineer, every serviceman, and every laboratorician a copy of the *Cunningham Tube Data Book*? It has in it just this kind of data.

How Long Will the Engineers' Job Last?

RADIO engineers often wonder how long it will be before their jobs are jobs of the past, with the progress now being made toward perfection. As an example let us look at the curves in Fig. 5 which are taken from *The Wireless Magazine* (England) of July 1928. They show the progress that has been made in the Columbia (English) phonograph records and reproducers since 1920. What will the engineers do next? There is no object in extending the frequency scale? Will they invent some new frequencies? Our suggestion is to drag out into the open

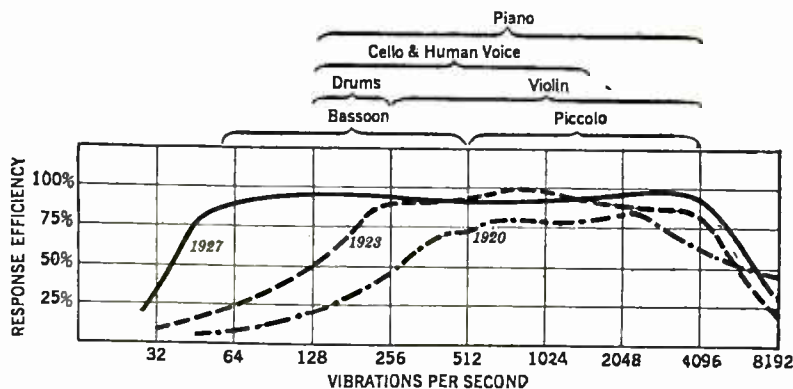

Fig. 5—Frequency characteristics of old- and new-type phonographs.

this year's manufactured receivers use tubes of this type. Is it possible that receiver manufacturers are waiting until the kit people have developed circuits to the point where set manufacturers can use them without any development cost?

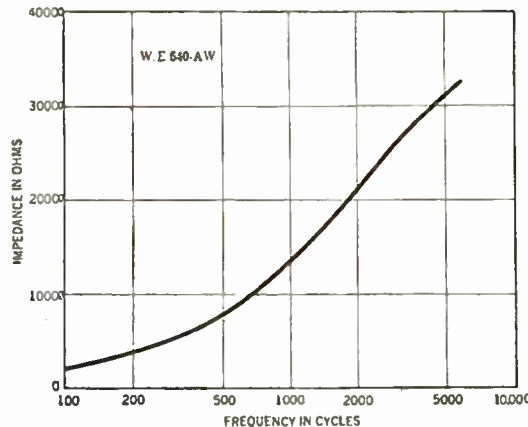

Fig. 4—Impedance curve of W.E. 540-AW loud speaker

those machines which will play for an hour or so without the bother of shifting records.

How Useful is a Tube?

Arcturus Radio Company. In a statement made recently Mr. Lewis suggests that a vacuum tube's usefulness has, in the past,

increased with the square of the number of its elements. Thus the addition of the grid to Fleming's original two-element tube increased the tube's utility four times, then the isolated cathode, the heater, made possible the operation of tubes from raw a.c., and finally the word of Schottky and Hull in putting the second grid in the tube has again increased the value of the tube. Mr. Lewis believes that the a.c. screen-grid tube is the most satisfactory tube in the world.

We would agree with this belief except that no one seems to know how to make use of the tube's evident possibilities. Note that few of

Accuracy of Variable Condensers

THE Hammarlund Manufacturing Company states that individual units of a Hammarlund three-gang condenser are accurate to within one quarter of one per cent. It is interesting to see what difference a discrepancy of this amount from the rated capacity will make in a tuned circuit. Suppose one condenser of the three is one quarter of one per cent. higher in capacity than the other two. By now many cycles at 1500 kc. will the circuit which this condenser tunes be out of resonance?

The capacity of the condenser compared with the others is $C \times 1.0025$ and the frequency to which this circuit tunes, compared with the resonant frequency of the other circuits will be one half of one per cent. lower, or at 1500 kc., the circuit will actually tune to $1500 - 7.5 = 1492.5$ kc. This is probably more accurate than commercial coils can be made—and so The Hammarlund Manufacturing Company has something to talk about in the accuracy of their production condensers.

New High Voltage Rectifier Tube

THE Raytheon company have announced a new rectifier, apparently a modern "S" tube whose demise was regretted by every transmitting amateur. This new tube will rectify 300 milliamperes of current at 3000 volts, and the voltage drop is only 10 or 12 volts. This is a lot of power as anyone who multiplies $I = .3$ by $E = 3000$ will find out. (It amounts to about one kilowatt). We are hoping to get some of these tubes in the Laboratory for our short-wave transmitters, w2cy and w2ej. Incidentally, the Raytheon Company plans to manufacture all types of receiving and amplifying tubes of the filament type.

New Regulation of Radio Commission

GENERAL Order No. 55 of the Federal Radio Commission contains this paragraph, "No license shall be granted to any applicant for a fixed station, coastal station, or aeronautical station who is unable to satisfy the Commission that he can maintain the assigned station frequency with an accuracy of 99.05 per cent. or better at all times."

At 6000 kc. this amounts to 3000 cycles. How is the applicant to satisfy the Commission on this point?—KEITH HENNEY.

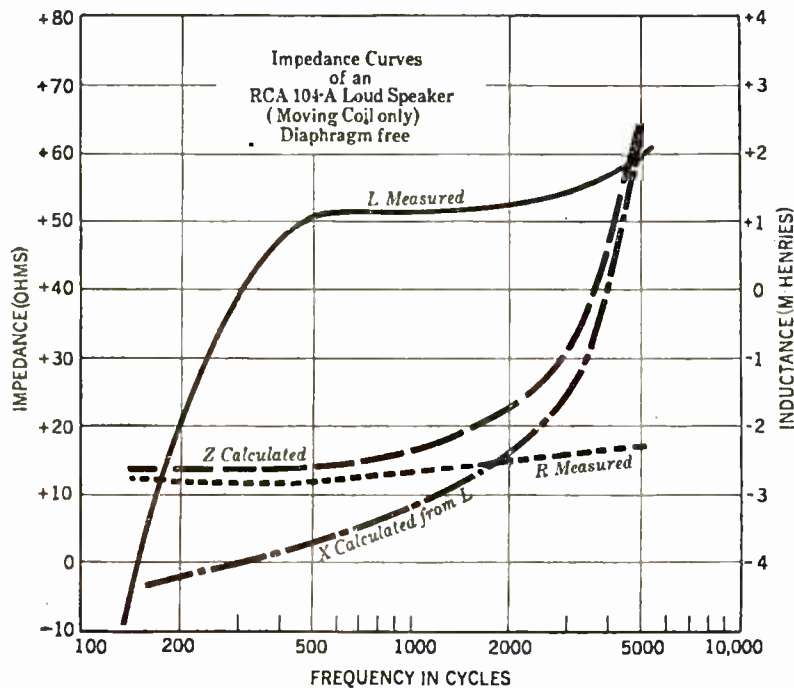

Fig. 3—Characteristic Curves of R.C.A. 104A loud speaker

AN EFFICIENT PUSH-PULL A. F. SYSTEM

By **KENDALL CLOUGH**

Engineering Dept., Silver-Marshall, Inc.

THE common concept of the advantage of push-pull amplification seems to be the possibility of providing an undistorted output greater than that which would be available from a single tube in the power stage. As a matter of fact, the available output from the push-pull stage is somewhat greater than is available from the same two tubes used in simple parallel relationship. The manner in which the signal impressed on the grid circuit of the push-pull arrangement is amplified in the plate circuit, while the harmonics generated (distortion) within the push-pull circuit cancel out in the plate circuit, has been so well discussed in texts on vacuum tubes (*Thermonic Vacuum Tubes* by Van der Bijl, page 261) that it would be superfluous to go over the matter here.

The writer has completed recently several designs of push-pull amplifiers using tuned transformers and it is felt that some expression of the performance of the combination of these two principles will be of interest to the readers of these columns.

Analysis of Circuit

TURNING to Fig. 3 we have two power tubes connected in push-pull to a divided choke coil. This coil may be the primary of either a transformer or an auto-transformer. In the use of the latter, however, resides several advantages of the push-pull system from a design standpoint. It is apparent that, when two well-matched tubes are used (passing the same plate current), the ends of the winding A and A', are at substantially the same d.c. potential. For this reason the speaker can be connected across these points without any danger of damaging current flowing through the speaker winding. This eliminates the expense of the blocking condenser which is ordinarily used with plate chokes. In the same way the two points, B and B', are at the same potential when placed equally distant from the center and may be used for speaker connection when a step-down ratio is desired for operation of low-impedance speakers. In addition, the simultaneous use of all or a portion of the winding as both primary and secondary results in a closer magnetic coupling between the tube and speaker circuits, with consequent improvement in efficiency and frequency

characteristic. A further result is the economy of window area for the copper in the iron core. This results in either more liberal size of copper wire in a given lamination or a greater reduction in the overall size of the device than would result with the use of two separate windings.

We are grateful to Kendall Clough for explaining, in an engineering manner, the advantages of using more than one stage of push-pull in audio amplifiers. Several engineers have advocated such an unorthodox amplifier, but few seemed to have any good reason for it. In this article Mr. Clough states that there are distinct advantages and explains what they are. The amplifier he sent to prove his contentions made the entire Laboratory Staff discontented with their own personal equipment—which was not double push-pull!
—THE EDITOR.

In considering the more intimate details of the design, theory indicates that the inductance of the choke should be large compared with the impedance of the tubes out of which it operates. Of the four tubes available for power use, the 112, 210, 171 and 250, the first two are of about 5000 ohms impedance and the latter two of 2000 ohms. The 112-type tube has never enjoyed much favor because of its limited output, while the 210 is not as commonly used at present, probably because it requires as high a plate voltage for its operation as the larger and more capable 250-type tube. For these reasons only the 171 and the 250 will be considered. Fortunately, these are the two low-impedance tubes of the group which simplifies the problem of attaining a sufficiently high impedance for good operation at the low frequencies. Calculation and measurements indicated that a total inductance of 32 henries would be sufficient with a 4000-ohm output circuit (the plate impedances of the two tubes are in series) to give very good response at the low frequencies with several speakers that were at hand.

Another advantage inherent in the push-pull circuit made this value of inductance

rather simple of attainment. In the ordinary single choke or transformer the iron is subjected to a continuous magnetizing force due to the direct current flowing through the winding to the plate. In order to prevent this force from magnetizing the core to or near the point of saturation, it is necessary to place a good size air gap in the magnetic circuit. This, in turn, increases the reluctance of the magnetic circuit making it necessary to use a much larger core (in order to secure the necessary inductance) than would be necessary if this magnetizing force did not exist. Even when the adequate inductance is attained in this manner, the core is subjected to a considerable magnetizing force, causing the signal to operate on an asymmetrical magnetization curve which is as distinctly undesirable in an output transformer as in an interstage device. This type of distortion was pointed out in the author's previous article (July, 1928, RADIO BROADCAST) on the subject of audio amplifiers.

Advantage of Circuit

IT WILL be seen in Fig. 3 that, although the two halves of the choke are wound in the same direction, the plate currents flow in opposite directions to the plates; hence the magnetizing forces in the core, due to the two halves of the winding, cancel, and the resulting force in zero. [It will be noted that the author has indicated the direction of current as passing from plate to filament, thereby conforming to the convention that currents always travel from the point of positive potential to the point of negative potential. The actual electronic flow is of course in the opposite direction. *Editor.*] It should not be inferred, as many designers seem to have done, that this permits dispensing with the air gap altogether, although it does permit a smaller air gap, resulting in more economical use of the iron in securing the requisite inductance. A small air gap must be included in order that the original value of inductance, measured at small values of audio-frequency current, may be maintained at high signal levels.

Before proceeding with the design features of the input transformer that is to supply the two voltages, Cg, these voltages

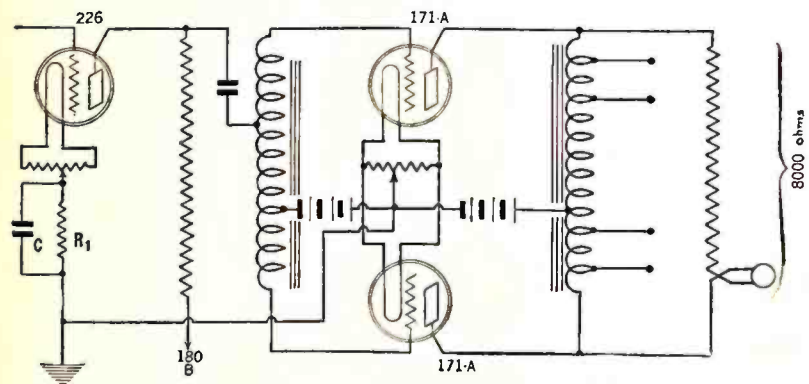

Fig. 1

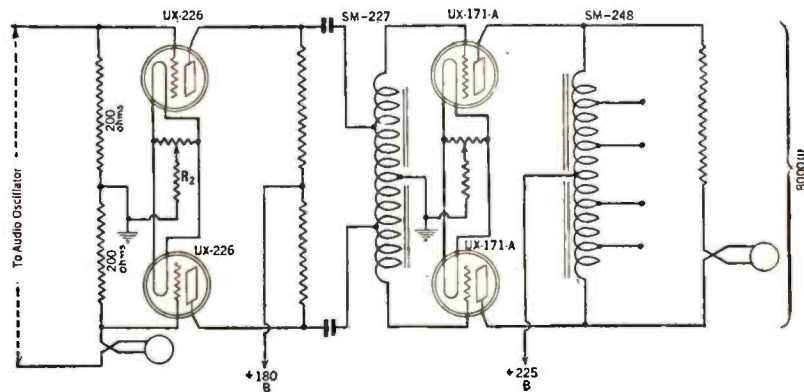

Fig. 2

were supplied from an oscillator as shown in Fig. 4, and the performance of the tube and output transformer circuit were examined for undistorted output at 500 cycles. The input voltage to the stage, as determined by the reading of the meter, M_1 , and the equal resistors, R_1 , was increased in small steps and the output power at each step computed as the product of the 8000-ohm resistor, R_2 , and the square of the current through it. In this way the output in watts per volt input squared could be computed, and plotted as shown in Fig. 5. This curve was taken with two UX171A tubes operating with 180 volts on the plates, and the choke of Fig. 4. It will be noted that the output available before the gain falls appreciably is about two watts. The manufacturer's tables give an output of 0.7 watt for this tube which would permit of 1.4 watts output with the two tubes operated in simple parallel arrangement. The difference, 0.6 watt, in output is due to the push-pull arrangement. As a matter of fact, the ear does not notice the distortion until the output per volt squared has dropped about 2 DB, allowing the operation of this stage to 2.8 watts output. This output is sufficient to operate a dynamic loud speaker with sufficient undistorted volume for the home and for small halls and has the advantage over a 250 tube of employing low voltages that are available easily at low cost. Where larger outputs are required the 250 tubes will and can be used with the same choke.

The performance of this single stage with 250-type tubes was measured in the same way as the previous combination of 171's and the results are plotted in the curve of Fig. 6-A. It will be seen that this arrangement is suitable for operation where about 12 watts are required for coverage of considerable area. The impossibility of its operation for home use at full volume is indicated in the fact that none of the smaller dynamics on the market

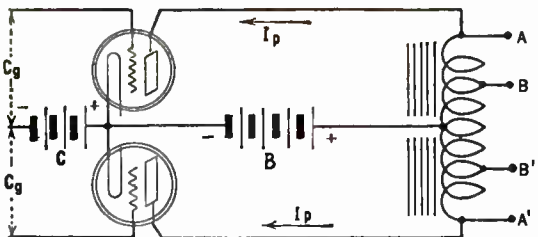

Fig. 3

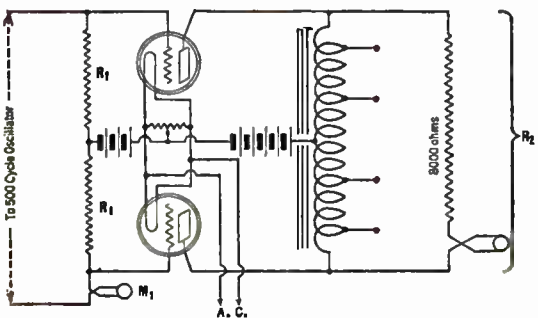

Fig. 4

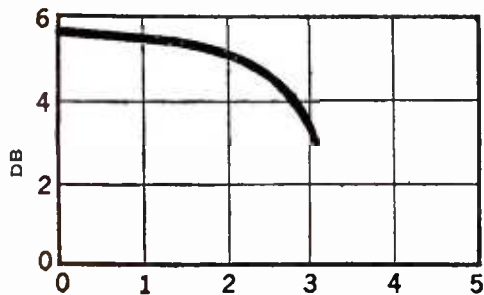

Fig. 5

will stand this output without rattling badly on the high frequencies.

Attention is called to the fact that both of the curves discussed were made with an 8000-ohm resistor in the output circuit. It has been shown many times that maximum undistorted volume (not maximum volume) is realized from a tube circuit when it is operating into a resistance of double its own plate resistance. The condition for maximum volume, neglecting distortion, is satisfied when the output resistance is equal to the tube's resistance. In order to illustrate the latter condition, the curve of Fig. 6-B was prepared using a 4000-ohm resistor in the output circuit. It will be seen that while the gain is somewhat greater than in curve A, the bend indicating distortion occurs at a much lower level. This illustrates a common malady in power amplifiers. In order to secure high volume the temptation is to operate the tubes into a low-impedance output circuit when properly the amplification should be increased in the preceding stages. As seen in the curves of Fig. 6, the volume is increased by this means, but the

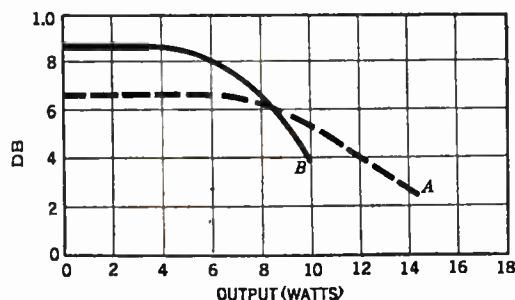

Fig. 6

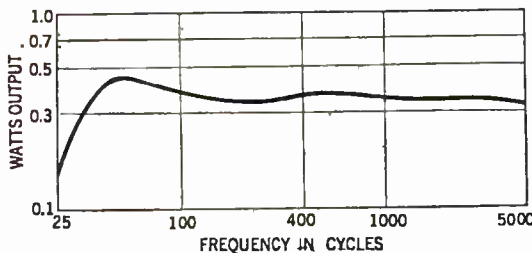

Fig. 7

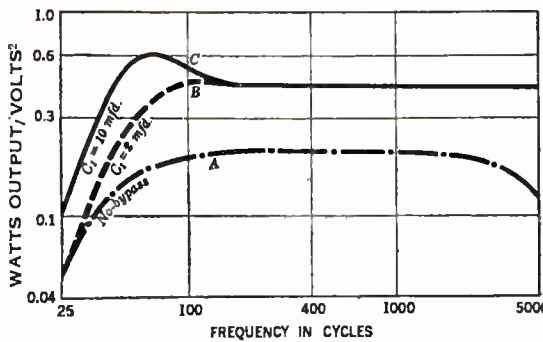

Fig. 8

undistorted output available is actually reduced.

In view of the fact that many loud speakers do not have sufficiently high impedances to permit operation under conditions similar to those of Curve A if the loud speakers are connected to the plate terminals of the power tubes (terminals A and A', Fig. 3), two other sets of taps have been directly provided on the choke for the loud speaker connection. These provide two available step-down ratios the use of which permit a low-impedance speaker to present the proper impedance to the tubes for attainment of the greatest possible undistorted power. The actual ratios available are 1:1, 1:0.73, and 1:0.48. The first of these will be used when the low-frequency impedance of the speaker is 8000 ohms or greater;

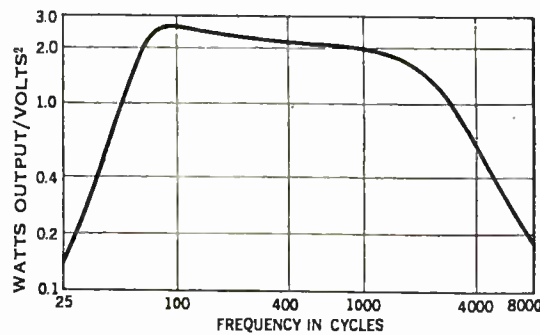

Fig. 9

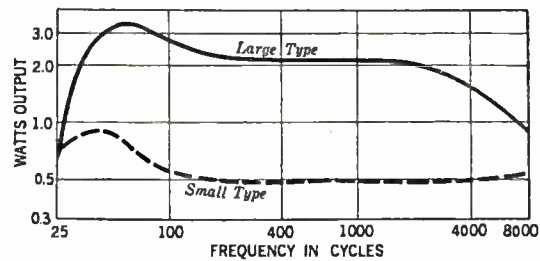

Fig. 10

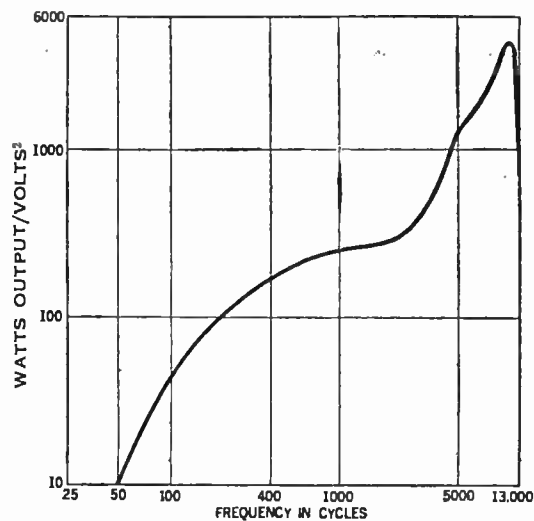

Fig. 11

the second for speakers of 4000 ohms or less, while the third tap is useful where several speakers are to be operated in parallel. Where the impedance of the speaker is not known, the best connection can be determined by trial by connecting a milliammeter in the plate supply lead and operating with that ratio which allows the greatest volume with a minimum of variation in the plate current.

A Further Advantage

A FURTHER advantage of the push-pull circuit was noted during this work. This was the possibility of obtaining the plate voltage from the output of the rectifier tubes as shown in Fig. 12 without the use of a filter other than the 4-6-mfd. condenser from the center of the choke to ground. This is of particular advantage in the operation of 250-type tubes for the size of the smoothing chokes is reduced to that necessary for handling the small currents of the preceding stages. In addition, the voltage divider can be inserted at the input, the filter as shown allowing the safe use of lower voltage condensers for the remainder of the filter, which is a distinct economy. It was found that with this arrangement the best of dynamic speakers with large baffle could be operated without objectionable hum from the power supply. In the same way the hum from the filament circuit was observed to be negligible. Changing the plate supply to batteries, temporarily, it was found that there was no increase in hum when the lead to the center tap of the filament resistor was

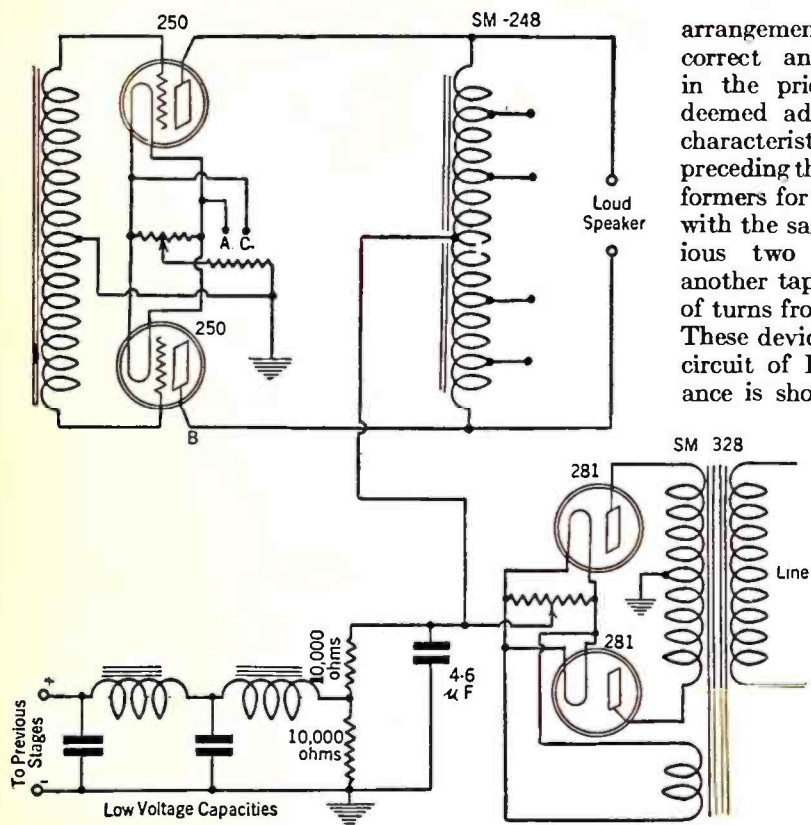

Fig. 12

returned to one side of the filament terminal. Every appearance was that this was a rather ideal power stage, and attention was turned to interstage transformers for its operation.

Two interstage devices were designed. The smaller of the two has an effective ratio of 1.8 when operating out of a 226-type tube. Characteristics on this unit are shown in Fig. 7, and the circuit used to make the measurements is given in Fig. 1. When this curve was taken a C battery was used for grid bias rather than the resistor R_1 of Fig. 1. When the resistor was used, as is the ordinary practice, an inferior characteristic was obtained as shown in the curves of Fig. 8. The lower curve, A, shows the characteristic obtained when no bypass was used across the biasing resistor. Curve B indicates the operation with the usual bypass of 2 mfd. Not until this was increased to 10 mfd. did the operation approach the original curve of Fig. 6. The inferior performance without a large bypass is due to the signal current in the plate circuit setting up a voltage drop across the resistor, R_1 , which is in opposite phase to the input voltage thus reducing the amplification. Curve B Fig. 8 indicates that a 2-mfd. capacity has a sufficiently low reactance to prevent this at the higher frequencies, while the low frequency amplification is still impaired.

The larger device has a ratio of 3.6 and its characteristic is shown in the curve of Fig. 9. It will be noted that a very definite high-frequency cut-off has been introduced due to the higher ratio and larger physical size of the windings. This is not at all undesirable, particularly for operation with phonograph records where a scratch filter is ordinarily inserted to accomplish the same thing. It should be noted that all of these curves were taken with the output circuit and the power tubes as in the circuit shown in Fig. 1.

Elimination of Harmonics

MOST advocates of the push-pull amplifier have dwelt at length upon the elimination of harmonics in the output stage and allowed distortion of that character in previous stages to go unmentioned. The push-pull

arrangement of the output does not correct any distortion appearing in the prior stages, and it was deemed advisable to measure the characteristics of a push-pull stage preceding the power stage. The transformers for this purpose were made with the same windings as the previous two mentioned, but with another tap placed on equal number of turns from the center. See Fig. 2. These devices were measured in the circuit of Fig. 2 and the performance is shown in Fig. 10. The improved amplification on the low frequencies is due to the larger ratio of primary inductance to tube impedance. In changing from single to push-pull operation, the effective resistance of the plate circuit has been doubled (two tubes in series), while the total primary consists of twice as many turns and hence four times the inductance. (The inductance is substantially proportional to the square of the number of turns.)

As a definite advantage of the operation of this circuit, it is interesting to note that when the bias resistor, R_2 Fig. 2, was shunted by a 10-mfd. condenser, no measurable change in the characteristic occurred at any frequency, indicating that the degenerative effect of this resistor in the single tube arrangement had been completely eliminated by means of the push-pull feature.

As an example of the effect of small bypasses across C-bias resistors, the curve of Fig. 11 has been prepared. This curve was taken on a three-stage amplifier having two 250-type tubes in the output circuit. The interstage transformers when measured individually with batteries had very good characteristics due to the use of nickel-alloy in the cores.

It will be noted in the curve, however, that due to the degenerative effect of inadequately bypassed C-bias resistors, the bass frequencies are almost entirely suppressed. In such cases as this it would be true economy to add two tubes to make the outfit push-pull all the way through and eliminate the bypasses entirely.

At the conclusion of the experiments on push-pull amplification, a complete phonograph amplifier was built up with the small transformers described in the above. The circuit of this amplifier is shown in the diagram of Fig. 13. It would be quite safe to say that the operation of a good dynamic loud speaker or an amplifier of this gain would be next to hopeless with single-circuit amplification due to the difficulty in eliminating the hum from the filament and plate circuits to a sufficient extent to insure a pleasant effect on the listener. It was found in the construction of this amplifier that, when the power supply was put in a separate sheet steel case from that which housed the amplifier, to prevent induction from the power supply to the transformers, the hum due to the filament circuit could be balanced out with the greatest ease and that the hum under the best conditions was so weak that it could not be heard more than two feet from a large baffle on which a dynamic loud speaker was mounted. The true significance of this statement will be appreciated by noting on the curves the high amplification produced at hum frequencies.

In the writer's previous article on tuned audio amplification, it was stated that the employment of the circuit advocated by him for interstage transformers eliminated the generation of even harmonics due to the asymmetrical magnetization characteristic of the iron when employed in circuits which allow the plate current of the tube to flow in the primary of the transformer. Obviously, no claim could be made for the elimination of the odd harmonics by the writer's method of connection. It will be obvious to those acquainted with the theory of push-pull amplification that these harmonics will be eliminated by the use of the circuit and that the combination of the two effects will practically assure freedom from wave form distortion.

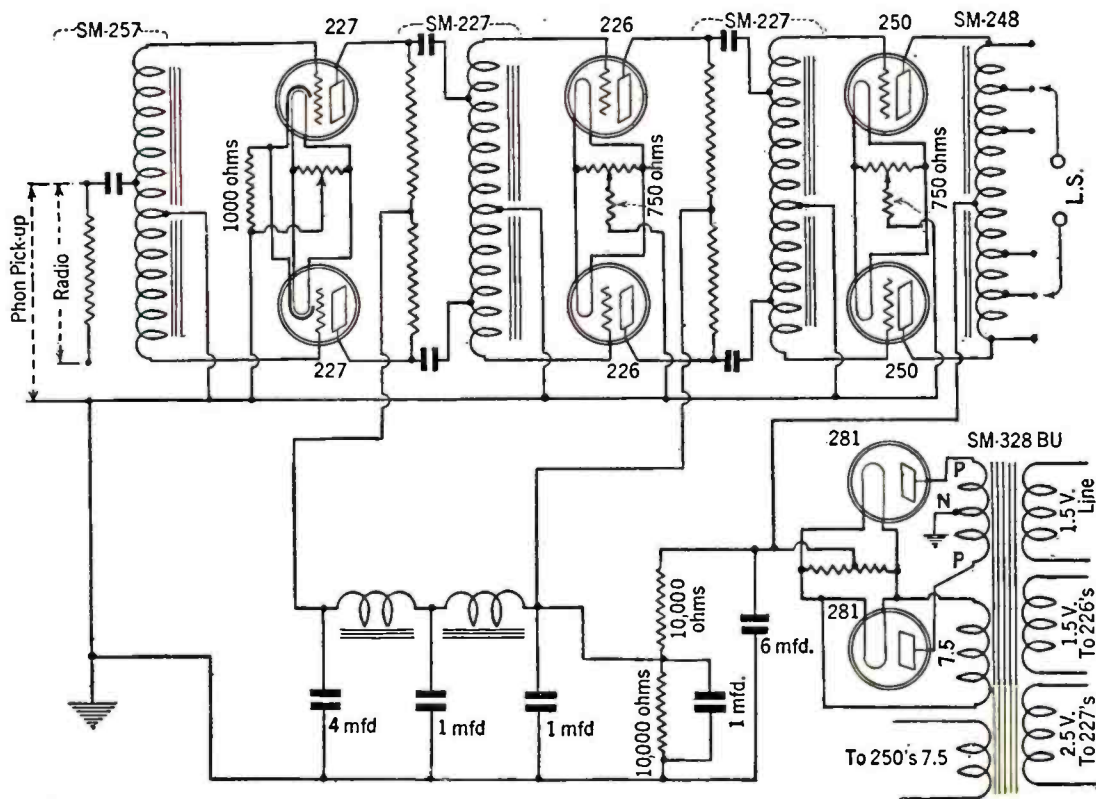

Fig. 13

SOUND MOTION PICTURES

TECHNICAL DATA

BY CARL DREHER

Further Data on Photo-Cell Characteristics

THE construction and general theory of operation of photo-electric cells has been discussed in a previous article (November, 1928, RADIO BROADCAST). The fundamental importance of the device makes it advisable to consider its properties further, however, and in more quantitative terms than formerly.

Dr. Herhert E. Ives in his paper "The Alkali Metal Photo-electric Cell," *Bell System Technical Journal*, April, 1926, gives curves showing the behavior of cells used in picture transmission. The characteristics here reproduced as Fig. 1 show the voltage-current relationship for vacuum cells with a small centrally placed anode within a concentric spherical cathode. That is, the positively charged plate or collecting member is placed within, and about at the center, of a considerably larger sphere, the inside of which is coated with the emitting material, and the cell contains no gas. The anode receiving a positive charge with respect to the cathode, the current for a given illumination increases with the voltage between the electrodes, at first rapidly, then more slowly, until a saturation point is reached. The shape of the curve depends somewhat on the wavelength of the light falling on the cell; at longer wavelengths the electrons given off by the cathode move more slowly and are collected more quickly by the anode. Now if a small quantity of gas is introduced into the cell, the curve changes remarkably, to the shape shown in Fig. 2. The wavelength of the incident light still plays a part, but now instead of saturating, so that increasing the voltage beyond a certain point no longer effects an increase in the space current, the cell has a critical potential at which the gas breaks down. With the addition of the gas (very little is introduced—a fraction of a millimeter of mercury being the pressure) the cell becomes more sensitive, and also somewhat more liable to variations in production and damage in use. The electrons liberated by the cathode collide with mole-

cules of gas, producing ionization phenomena which increase the current. In both vacuum- and gas-type cells, if the voltage is held constant and the illumination is changed, a linear relationship between illumination and current

This is the second of a series of articles dealing with sound motion pictures. RADIO BROADCAST was first and alone in its field to provide intelligent and authoritative articles on the engineering aspects of broadcasting and we are happy to be first now with authoritative articles on sound movies. The latter field is so close to broadcast engineering that it is proving of absorbing interest to almost everyone in radio. Pages in this magazine will regularly be devoted to this subject

—THE EDITOR.

is found, provided some structural precautions are taken. If the window of the cell, through which the light enters, is made too large, it is likely to become charged and to cause a curved illumination-current characteristic.

Fig. 3, also taken from Ives, shows the current-voltage relationship in microamperes and volts for a potassium cell used in picture transmission, the illumination being 100 meter candles from a tungsten lamp, with an aperture area in the cell of 1.5 sq. cm. The luminous flux reaching the cathode is given as 0.015 lumen. The meaning of these photometric terms may as well be explained before the discussion is continued.

The *Handbook of Chemistry and Physics*, compiled by C. D. Hodgman and N. A. Lange, published by the Chemical Rubber Company at Cleveland, and now in its thirteenth edition, is useful in this connection. The principal definitions required are given on pages 1004-1005. Since light is radiated in all directions, we must first consider some solid geometry. The surface of a sphere of radius r is given by $4\pi r^2$. The unit of solid angle, called the *steradian*, is the angle which encloses a surface on a sphere equivalent to the square of the radius, that is, the total area divided by 4π . The *total luminous flux* from a light source is the total visible energy emitted in unit time. The unit, called the *lumen*, is the flux emitted in a unit solid angle as defined above, from a point source of one candle intensity. It follows that the total emission of one candle equals 4π lumens. *Luminous intensity* or *candle power* is the property of a source of emitting luminous flux; it is measured by the flux emitted per unit solid angle. The unit is the *international candle*, which is approximately the intensity of a standard English sperm candle (there are more constant and precise standards). *Illumination* on a surface is measured by the luminous flux

incident on a unit of that area. The common units are the *lux*, one lumen per square meter, and the lumen per square foot. At unit distance from a point source of unit intensity the illumination is unity, hence such units of illumination as the *meter candle* (lux) and the *foot candle* (one lumen per square foot).

In slightly less technical language, we may summarize the above by saying that a light source emits luminous flux, measured in lumens, that the intensity of the source in candle power is measured by the flux or flow in a unit solid angle, and that the illumination is a matter of flux per unit area, and depends on the intensity of the source and the distance from it of the surface.

Applying these ideas to the cell cited by Dr. Ives, we note that the illumination given is 100 meter candles. This might come from a source having an intensity of 100 candles placed one meter from the cell. Such a source evidently emits 400π lumens over a sphere with a surface, at a distance of a meter, of $4\pi(1)^2$ square meters, or 4π square meters, or $40,000\pi$ square centimeters. We are also told that the area of the window of the cell is 1.5 square centimeters. Hence the flux in lumens reaching the interior of the cell will equal

$$\frac{400\pi \times 1.5}{40000\pi} = 0.015 \text{ lumens}$$

This checks the figure given in the paper. If the calculation is not clear, the reader is referred to Fig. 4, which is not taken from Dr. Ives' paper, but has been added to clarify the present discussion. If the units are consistent, the flux entering the cell may be obtained by multiplying the illumination by the area of the window.

Current-voltages characteristics for another type of photo-cell are shown in Fig. 5. For convenience this cell, which is also of the gas-filled type, will be referred to as Cell No. 2. The window in this case is larger (about 8 square centimeters as compared to 1.5 square

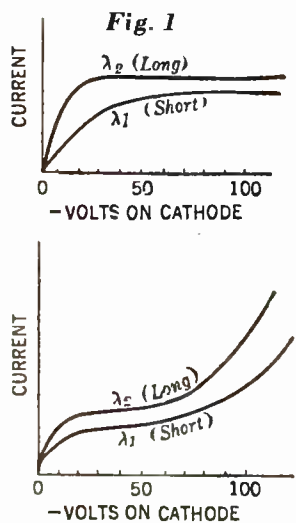

Fig. 1

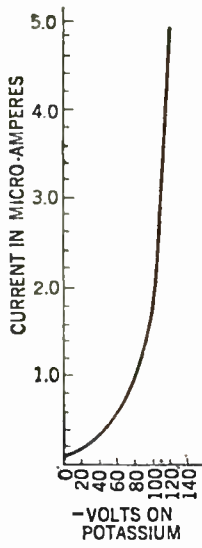

Fig. 3

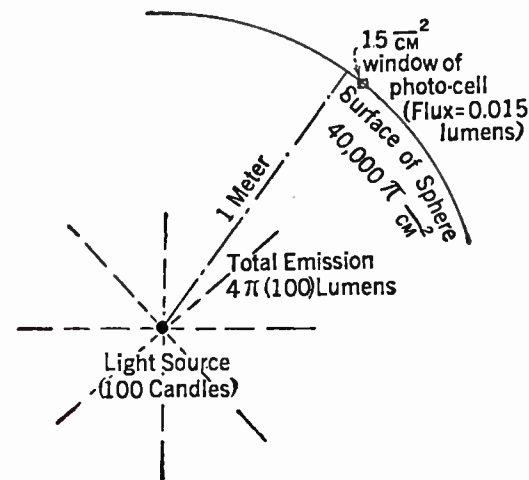

Fig. 4

centimeters for the cell shown by Ives) and the pick-up of light flux is greater. Four anode voltage-current characteristics are drawn in Fig. 5; these cover the range from 0.05 lumen, to 0.5 lumen.

If, now, we take this family of curves and, with a fixed anode voltage, such as the cell would have in practice, find the currents corresponding to various illuminations, we secure the rectilinear graph of Fig. 6, which shows that within this range the photo-cell current is directly proportional to the light falling on the cell. The voltage in this case is 70. The slope of the line is a measure of the sensitivity of the cell under the conditions then existing. A steeper curve would show greater sensitivity. The cell under discussion, with a voltage of 70 between the cathode and the anode, has a sensitivity of about 10 microamperes per lumen. The sensitivity of photo-cells is normally expressed in terms of microamperes per lumen, the amount of light used in the measurement being of the order which the cell will receive in use—a value of 0.1 lumen would be about right for Cell No. 2.

As explained in the previous article on photo-cell circuits, the cell may be coupled to the associated vacuum-tube amplifier in any of the usual ways, as through a resistance or transformer. If a coupling resistance of 2 megohms is assumed, as in Fig. 7, an instructive calculation of the practical efficiency of the cell, the ratio, that is, of the electrical energy output to the light energy input, may be carried out. Light is known to have a mechanical equivalent, in the region of maximum visibility, of about 1.5 milliwatts per lumen. The sensitivity of the cell described above (No. 2) is about 10 microamperes per lumen in the circuit of Fig. 7. Assuming an input of 1 lumen, or 0.0015 watt, the electrical output energy is that corresponding to 10 microamperes through 2 megohms, which, by the application of I^2R , is found to be 0.0002 watt. The electrical light efficiency of the cell is then 0.0002 divided by 0.0015, or about 13 per cent. This demonstration, however, may be more interesting than rigorous.

Testing This and That

IN THE old days, when tubes did not oscillate as readily as they do now when you want them to the experimenter would frequently touch the grid terminal with his finger to find out whether the circuit was functioning or not. A dull thud in the phones as the finger was applied to the grid and again when it was removed indicated that oscillations were present. This is one of those simple tests which make laboratory work and trouble shooting less arduous, and it is still used in work on receiving sets. Of course, it is not applicable to transmitters, where the grid bias is often dangerously high.

Somewhat later, in broadcast stations, the operators would tap the microphones at the beginning of a transmitting period and listen to the noise in the monitoring speakers for a check on the air. Of course speech input to the microphone gave a better test along the line to the modulators, but one could not put it out on the air without attracting attention whereas the taps would mean nothing except to the insiders.

Now the finger method is used for test purposes in still another application. In sound-movie systems it is necessary to test the apparatus before each performance, in addition

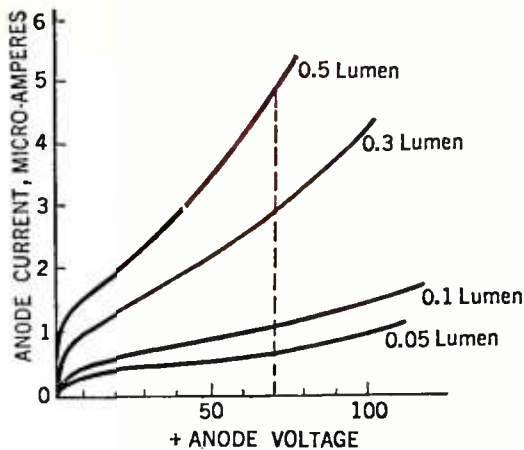

Fig. 5

to the usual meter checks, by some simple audio method which will only take a few seconds. Where disc reproduction is used this is accomplished by tapping the needle of the phonograph pick-up gently, with all the amplifiers on and the projection room speaker going, but the house speakers, preferably, cut off. The tapping, amplified, is heard in the speaker if everything is o.k. The proper loudness with the normal gain setting is soon learned. If the sound is taken off the film the finger method is equally useful, although the application is somewhat modified. Before film is put in the machine, but with the exciting lamp in the sound head and all the vacuum tubes lighted, the finger is moved up and down through the beam of light where it enters the photo-cell. As it shuts off the light and lets it through again characteristic clicks are heard in the speaker. The indication in that case is that there is nothing radically wrong between the film and the speakers. Of course if the test is made with the house speakers as

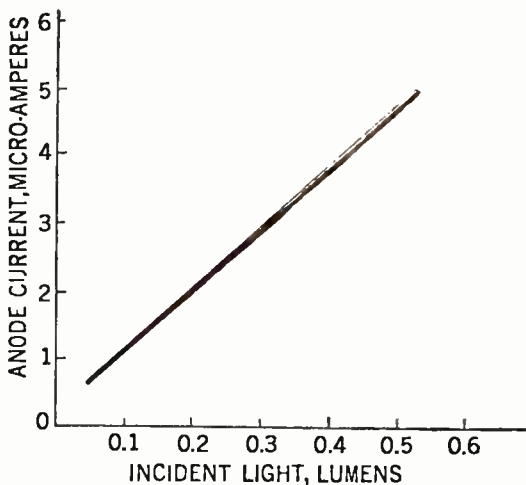

Fig. 6—This curve shows the light-current characteristics of gas-filled photo-electric cell No. 2. The diagrams below show methods of connecting a photo-cell with an amplifier

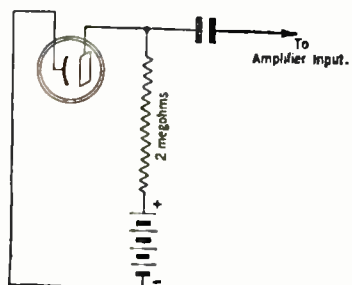

Fig. 7

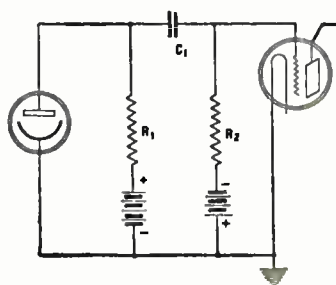

Fig. 8

well the security is even greater, but the volume should be kept down.

When there is more time and scientific means are available, sound-movie machines are tested with special discs or films supplying tone at constant frequency and amplitude. Some of these provide a number of frequencies within the band which the system is expected to transmit. The overall frequency characteristic, as well as any periodic irregularities, such as flutter in the tones, caused by the gear system—a defect to which some film sound reproducers are liable—may thus be checked. The method corresponds to tone tests on a broadcast wire channel or amplifier system, except that the tone is supplied optically or mechanically instead of with an oscillating tube. But for everyday use nothing beats the finger tests.

Photo-Cell Connections

FIG. 3 on page 33 of November RADIO BROADCAST, showing the connection of a photo-cell to the first stage of an amplifier through a resistive coupling, is somewhat awkwardly drawn, and Fig. 8 in the present issue gives a more orthodox and complete picture. The circuit is the same, it will be noted, as a standard resistance-coupled amplifier. The polarizing voltage reaches the photo-cell anode through the resistance R_1 , across which the audio voltage is taken off. C_1 is a blocking condenser to confine the transfer to this audio variation. R_2 is a leak for the first three-element tube, with the C-battery at its base. R_2 is usually several times as large as R_1 , which may be of the order of 2 megohms.

Philology in the Movies

D. R. DE FOREST, who got off the famous sneer about Græco-Schenectady designations when the terms "pliotron" and "kenotron" were first offered to the world, should have something to say about the present crop of names for sound devices in the movies. Leaving out the past nomenclature, in which the mortality is rather heavy as the promoters go back to playing the horses, the following synthetics were discovered in a cursory search of two moving picture trade papers:

Phototone, Orchestraphone, Orchestrola, Duotone, Electrograph, Duplex-o-phone, Dramaphone, Cortellaphone, Bristolphone, Sonoratone, Phonofilm, RCA Photophone, Movietone, Vitaphone, Vocafilm, Synchraphone, Theatrephone, Moviephone, Tonefilm, Biophone, Cinephone.

This leaves out the foreign legion as well as a considerable number of American devices which were not advertising in those issues. A few are big, synchronized outfits, but most of them are theatre photographs intended for use in the smaller houses as an unsynchronized accompaniment to the pictures—simply a twin turntable, switches, a volume control, amplifier, and a cone loud speaker or two.

After extended calculation, in which I consulted the works of Poincaré, Bertrand Russell, Lobatchevski, and Weierstrass, I find that 1.363×10^{18} possible combinations of *phone*, *tone*, and *film* with various other words in the English language remain on tap, so that no alarm need be felt by those interested in the continuance of this educational activity.

BROADCAST ENGINEERING

BY CARL DREHER

Pertinent Information on Broadcast Monitoring

BROADCAST monitoring generally consists in putting some sort of loud speaker in a control room and leaving the rest in the hands of an ex-wireless operator who has got tired of going to sea. This gives sufficiently satisfactory results in some cases, but as the programs get bigger and costlier, corresponding to a similar progression in the advertisers who pay for them, and as receiving sets improve and field strengths go up, judgment of what leaves the station becomes more critical. Some of the scientific aspects of the problem are worth considering.

Two papers by Irving Wolff and Abraham Ringel, primarily on the subject of loud speakers, should be read by the up-to-date broadcaster in this connection. These articles ("Loud Speaker Testing Methods," *Proceedings I. R. E.*, Vol. 15, No. 5, May, 1927, and "Sound Measurements and Loud Speaker Characteristics," *Proceedings I. R. E.*, Vol. 16, No. 12, Dec., 1928.) throw considerable light on problems of sound reproduction in general.

One possible defect in acoustic judgment, which is not mentioned by these authors, is that of anomalies in hearing. Naturally anyone who has anything to do with judging the output of a broadcasting station should have normal ears, with adequate response within the usual frequency limits of human audition. I mention this because I am told that at one station the technical staff has an unhappy time with a very elderly orchestra leader whose ears have become insensitive to high notes. He comes out into the control room and listens to the orchestra, with an assistant conducting, and insists on getting a better balance in the higher octaves. Nobody wants to tell him that the trouble is in his own head, and he remains an unsolved problem.

Monitoring should be done in a quiet room with average acoustic properties. Noise from motors or other sources is very objectionable. It leads to auditory fatigue and carelessness, and may mask defects in transmission. The best plan is to put the gain control into a small, acoustically treated room within sight of the studio through a double glass window and well isolated acoustically, with a good loud speaker near the operator, and a musician to advise him. The room should be free from unusual resonances and the period of reverberation should be low. Wolff and Ringel point out this pertinent fact: "A person who has been in a room, which is not average, for a rather long time, becomes accustomed to it, and is no longer struck by its acoustic peculiarities." A monitoring chamber about 12 by 9 by 8 feet, with a hard floor, but the walls and ceiling lined with material absorbing about 25 per cent. at 512 cycles and free from extraordinary absorption at any frequency, is a good compromise. Such a room will have a period of 0.4 second and will not show the striking resonance effects of small rooms finished in hard plaster and not treated for acoustic improvement.

SELECTION OF LOUD SPEAKER

The differences between loud speakers are such that the selection of one for a monitoring room is a moot problem. The old born types, with their single high-resonance peaks and a rapid fall to nothing on either side, may be left out of consideration. One solution is to use a moving-iron loud speaker and a moving-coil type, or several moving-coil speakers in different sized baffles, and to set up the orchestra and the performers on a basis of compromise between them. A more practical procedure is to select one speaker which is fairly typical for the period and to judge on the basis of its output. It should be a good loud speaker in the interest of the progress of the art generally, and because it is hopeless to try to adapt transmission to the defects of all kinds of receivers in the homes of listeners. Ringel and Wolff found, in this connection, that "the loud speaker which has the best looking characteristic (most free from peaks) will, in spite of the defects of existing broadcasting transmitters and receivers, generally sound best when tried on radio."

Where conditions favor it, radio monitoring as a supplement to audio is desirable. When a relatively noise-free signal is available from the air a good radio receiver to which the loud speaker can be switched from the audio amplifier output of the station should be provided. If there were enough difference it would be worth while to simulate radio transmission during rehearsals by modulating a baby transmitter with the same characteristics as the radio plant of the station.

On important programs the preparation of a cue sheet is worth while. This may include the gain settings for various portions of the program, as determined during rehearsals.

ANOTHER SYSTEM

It is quite possible that more elaborate methods of broadcast monitoring will be developed in the future as standards of performance rise. The sound movies may be pointing the way in this field. Some of the large producers have gone to the trouble of placing the microphone mixing and gain controls on a "bridge" or platform in one corner of a room about fifty feet on a side, otherwise empty except for a few men and pieces of apparatus, and with monitoring loud speakers of the theatre projection type, operating at theatre volume, in the diagonal corner. The speakers are about 70 feet from the operators. The room is acoustically treated and gives a good imitation of theatre conditions during the recording. There is nothing else in the place; this volume of 125,000 cubic feet is entirely turned over to the monitoring staff. The actual recording on film or disc takes place elsewhere, and the studio where the action is photographed and picked up acoustically is on the other side of a sound-

proof wall, although it is within sight through double windows. Interphone connections are of course provided between the separate units. This scheme may not improve the quality of the product enough to justify the expense; if a cheaper system will give almost equally good results, it will naturally prevail. It is, however, a bold attempt to fit the means to the end, and the attitude, if not the mechanism, is worthy of imitation.

The Truth is Mighty and Must Prevail

THE lament is frequently raised that once an error is spread abroad it is impossible for the truth to catch up with it. This is a sad fact, even in engineering circles. Specialization adds to the confusion. The highly skilled technicians in some little corner of applied science can't be fooled when it comes to their own specialty, but they take more or less on hearsay material from other fields, and thus they learn many things which are not so.

The fallacy about remedying defective acoustics in auditoriums by the use of stretched cords and wires is known to all acoustic engineers. Its absurdity was first exposed by Wallace Clement Sabine. It can be shown theoretically that the scheme cannot work, and practice bears out the theory. When it seems to work the usual reason is that a large audience has been crowded into the hall, and the resulting increase in acoustic absorption has partially remedied the trouble. To an acoustic engineer, or any university student in the physics of sound, or to broadcasters who know the elements of their business, all this is well known, but among other learned men the romantic device of stretching wires for acoustic correction still holds its own. I present in evidence an excerpt from the discussion on Prof. F. R. Watson's "Acoustics of Motion Picture Theatres," taken from the *Transactions of the Society of Motion Picture Engineers*, Vol. XI, No. 32, 1927, p. 650:

MR. S.: You probably remember when the Century Theatre in New York was opened. The acoustics made it almost impossible to give a play, so they intermeshed the ceiling with fine wire and it made a great improvement.

MR. R.: I should like to add that I know a case in Chicago where a plain wall building gave a bad echo. They stretched wires across the hall and kept adding them until they broke up the echo.

MR. C.: I believe that is a common method. I know the Denver Auditorium suffered that way and the cross wires corrected the effect, but of course they are unsightly.

MR. WATSON (*communicated*): Wires in an auditorium are practically useless. If an auditorium with wires has good acoustics, this must be due to other features—carpet, upholstered seats, or other absorbers. The Denver Civic Auditorium, for example, had a considerable amount of absorbent installed.

TRANSMITTING AMATEUR TELEVISION

By **BOYD PHELPS**

A GREAT deal of credit for the development of short waves has been given to the amateurs but only a handful of their large numbers did any degree of pioneering, as Mr. Kruse has pointed out in previous articles in this magazine. Jenkins, Maxim, the Secretary of the Navy, and a host of others are looking to the amateurs for the development of television. Television, however, has been with us for some time but somehow the amateurs, like proverbial mules, have been backward about coming forward in the field. A few experimenters have set up receiving apparatus to satisfy their curiosity, but transmitting seems to be considered out of the question.

Knowing that amateurs like particularly hard problems, the Federal Radio Commission took the recommendations verbatim of a group of amateurs interested primarily in two-way telegraphic-code communication and assigned the worst and least usable of amateur channels to amateurs for television purposes. The 5.00 to 5.35 meter (60 to 56 megacycle) band is highly experimental with only spasmodic distant reception and the lone two-way contact of the writer and former 2Nz to its credit. It is suspected of being a daylight wave for very long distances under certain conditions, or rather a whole flock of conditions, but little is known of this band for telegraphy, let alone television.

The remaining legal amateur television band, which is from 150 to 175 meters (2,000-1715 kc.), is practically deserted because most amateurs wish to take advantage of the much better carrying power of the shorter waves over great distances on low power. The inability to erect a large enough antenna in the average back yard to permit efficient sub-fundamental operation constitutes a serious disadvantage to some. Also, the band is largely occupied by illegal but never-the-less present harmonics of practically every broadcasting station from one to a thousand miles distant. Other conditions such as static and distance to power ratios are not unlike the so-called "graveyard" broadcast waves around 200 meters. In other words, amateur television must not be expected to cover every continent with a few watts of power for it will take considerable power and good conditions to cover a few hundred miles.

Before any of us drift too far apart we ought to think of some standardization of the many optional methods of producing and reproducing the images so that we may all use the



A victim posing in front of Phelps' televisior

same type of receiver for many transmitting stations. As receiving does not require learning the code and taking a license examination it is quite probable that the non-transmitting experimenters "looking-in" will outnumber the television transmitters many times over, and it is for these that standardization should be especially helpful, so that it will not be necessary to use different discs, different speeds, different arrangement of holes, and

different directions of scanning to receive each transmitter.

Rules of Standardization

TO START things along the same path, let us adopt some simple rules of standardization, based on how the resultant signals must be "unscrambled" at the receiver. The first rule I propose is to make all transmitters such that the receiving disc holes will scan the image from left to right and the spiral more slowly progress from top to bottom, *exactly as we read a printed page*. Random design of a trans-

The pictures below show three induction motors which have been converted for synchronous operation

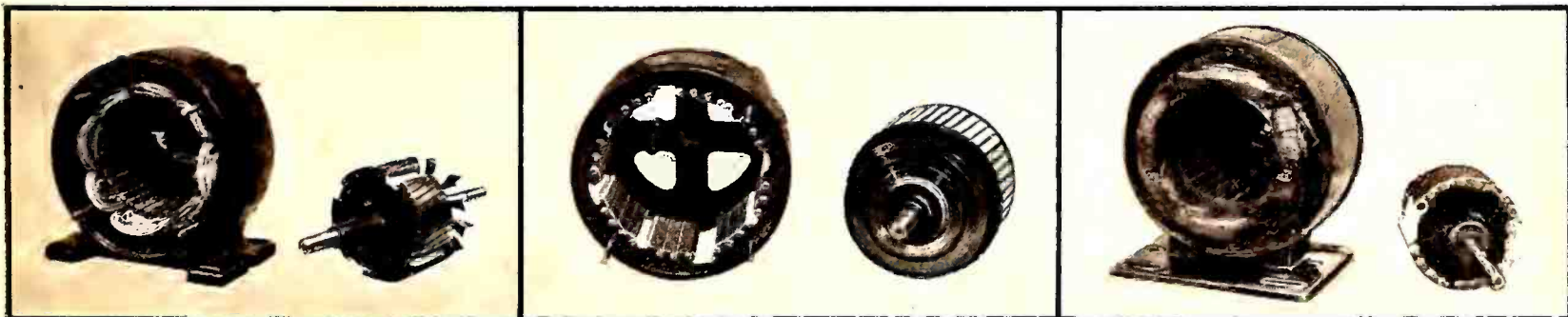

mitter, however, may cause the "lefts" and "rights" to be reversed, or the picture upside down, or both.

We next need to standardize the speed of the disc, a speed of 450 r.p.m. or $7\frac{1}{2}$ pictures per second is very slow, causes a bad flicker, and requires a synchronous motor with a large number of poles. One broadcasting station uses this speed, mainly to keep its modulated frequencies within 5 kc. required limits, and one uses a speed of 1200 r.p.m. or 20 pictures per second, but the majority use a speed of 900 r.p.m. or 15 pictures per second, which seems a wise choice from many standpoints and might as well be ours.

The easiest way to secure very constant speed is by the use of a synchronous motor. Such a motor may be made by the amateur without much trouble or expense by cutting out eight slots in an 875 r.p.m. squirrel-cage motor of about $\frac{1}{4}$ h.p. The illustrations show several types of non-synchronous motors that have been slotted and rewound to run synchronously at 900 or 1800 r.p.m. In some cases the rotor is slotted and in some cases the stator gets divided up, depending upon which has the copper-bar squirrel-cage construction. There seems to be no data as to how much metal should be cut away. The writer has varied the width of the cut from 10 to 30 per cent. with little effect. The 1750 r.p.m. motor shown at the right was slotted at two places and assembled; it runs synchronously at 1800, although it should have four slots for more power at synchronous speed. Similarly one 1725 motor illustrated on the left was rewound to have eight poles of the same total number of turns as before on four poles but only four slotted places instead of eight and it runs nicely at 900 r.p.m. synchronously on the transmitter. The other motor illustrated in this group shows the 900 r.p.m. "sink" motor used at w2BUO for reception. With all of these motors the power is about 40 per cent. of its former rating which is adequate for television purposes if a $\frac{1}{4}$ h.p. motor frame is employed and a small direct-mounted disc is used. With too great a load the motor gets out of step and throbs or "hunts" with grunting noises at the rate of two or three per second. A small type G-10

neon lamp held behind the scanning disc will show four black bars moving towards or away from the center if the motor is not running synchronously, otherwise the bars appear to stand stationary. If more power is desired, or if the motor does not keep in step, a winding may be put in the slots cut out and fed with direct current. Each pole so wound should be wound in the opposite direction so as to produce alternate north and south poles and greatly increase the power delivered before falling back out of step.

The Remaining Question

THE remaining question to be decided is the number of holes we are to use in the disc and this may not be so easily settled. Scanning discs of 24, 30, 48, and 60 holes are now in use among the broadcasters and experimental stations of the big laboratories, but the tendency is to standardize on 48 holes. The greater the number of holes in the disc the finer grained the picture will be and the better detail it will show, but the difficulties in realization mount up rapidly as the number of holes is increased. For the same size picture, the 48-hole disc will have holes of half the diameter of the 24-hole disc, and these holes will let through only one-quarter the amount of already weak light that the larger holes pass. Therefore, expensive and very sensitive photo-electric cells are necessary for a 48-hole transmitter; intense illumination, unusual amplifier shielding, and supply filtering also add to the difficulties immensely as compared to 24-hole systems. Mr. Kruse points out that the optics with 24 holes is far simpler and I am inclined to agree that with so many new problems for the experimenter in this new field that the 24-hole disc should be the standard for a while. Possibly later we may tackle 48 holes, but by that time the broadcasters may develop some new agreement which we may use as a standard. Decently recognizable faces can be obtained with 24-hole discs and many other factors and misadjustments may easily produce worse quality with 48-hole systems, especially when considering the number of things that can go wrong. Then, to do justice to 48-hole discs the efficiency and amplification through a total of eight to eighteen stages must be uniform up to about 50,000 cycles whereas with a 24-hole disc picture quality crosswise equal to that vertically may be had without going above 9000 cycles, and even 5000 cycles as the upper limit does not give an entirely hopeless result. This makes possible the use of iron-core audio transformers with their immense gain over the usual resistance-coupled stages.

While not wishing to appear dogmatic in proposing the above rules, I believe the beginner will find them helpful as much is to be learned and will be learned in developing 24-hole television to a high degree. A possible future transition respecting an increase in holes does not mean throwing away equipment and starting in all over again. The experience gained with 24-hole television will result in a saving in time, tools, material and temper. None of the recommendations

above will hamper future development for a long time. They permit either of the two basic methods of scanning and great latitude for individual ingenuity along many lines, and best of all they promote coöperation and close friendship amongst experimenters. In the old 200-meter spark days amateur conventions were meeting places for acquaintances made over the air and nightly maintained to get together. Nowadays the appeal of great DX so easily gotten with low power, together with the fact short waves skip over much of one's own state so that the closest friends over the air are the farthest away, conventions have not increased in interest as they otherwise might. As a result conventions are used for one amateur to boastfully acclaim how many foreign countries he communicated with the evening before or to display his choice cards reporting his signals as "loudest in America,"—an often used expression. Television on 150-175 meters may bring back the good old days, not the crashing spark, but the fellowship, which is easily half of the game.

Late Wednesday afternoon November 28, 1928, the writer transmitted his first television schedule to Werner Olpe, w2BUO, about two miles away, and Robert S. Kruse, w1OA, West Hartford, Conn., about a hundred miles distant. Mr. Kruse did not have his scanning disc finished at the time so he was only able to report on the signal strength, fading, interference, etc., but Mr. Olpe succeeded in reproducing the images excellently before his whole family. Easily recognizable shadowgraphs were produced and the hammer used to tack up some test charts was recognized and described. Incidentally, it was not realized that the hammer was in the field of vision at the transmitter—pulling down the shades is soon not going to be sufficient in the modern home. On subsequent tests a few days later Mr. Kruse got fleeting glimpses of moving images under combinations of most all the difficulties mentioned at the first of this article,—fading, low signal level and broadcast harmonics. One broadcast harmonic was so bad that a transmitter retune was necessary.

The First Amateur Television

AFTER the manner of proclaiming world champions in various new athletic classifications in which they have not yet contested, and consequently are unbeaten, the writer follows suit in calling the above the first amateur television.

A sufficiently detailed description of the transmitter to permit it being copied by the layman would take considerable space. Some parts of the construction would not be ethical or convenient to try to copy as parts on hand were used wherever possible. However, some idea of the equipment necessary may be gained from a description of what was used for these tests although the apparatus is almost daily "subject to change without notice."

To start with, two 500-watt Mazda bulbs with tin reflectors produce the light source, flood-lighting the subject or victim at close range, not unlike a doctor's baking lamp in action. A few sittings and one should be immune from rheumatism of the face for at least 200 years! Plug-in victims with plenty of spares and an ashpit beneath might be just the ticket. Because of this and because the writer's experiments have been largely one-man affairs, test charts and drawings have been substituted, one devilish horned figure being particularly able to stand the heat is



A view of Phelps short-wave transmitter

dubbed the "Spirit of Television." Charts with various checkerboard meshes give amplifier characteristics at a glance but a cross or plus sign is usually used as a preliminary test to facilitate synchronizing receivers.

The optical system continues through either a lens from an old post-card projection lantern or a reading glass, the latter being preferable as it has a somewhat shorter focus. With this lens the image is projected directly on the transmitting scanning disc upside down and with its lefts and rights reversed. Therefore, it is projected on the bottom of the disc which scans in a counter clockwise direction with the spiral progressing upward or inward to conform with the rules given for standardizing television receiver disc scanning. While the 1½ inches square surface at the bottom edge of the disc acts like a projection curtain, somewhere in the picture area there is a hole moving across this projected image and letting light through to the light-sensitive photo-electric cell mounted directly behind, that is, when the hole is in a part of the picture that is bright. For every turn of the disc each part of the image is analyzed by the scan holes and the resistance of the photo-electric cell is varied in accordance with the intensity of light reaching it.

The Scanning Disc

THE scanning disc used for the receiver is the same as for the transmitter except that holes are drilled with a size 40 drill in the transmitter disc and a size 44 drill for the receiver. The disc may be made from a flat brass plate 0.05" or more thick, or of somewhat thicker aluminum. From the center of the brass plate a 6-inch radius circle is drawn and sub-divided into 24 equal parts from which points lines are scratched to the center. Starting about ⅜ inch in from the edge of the one-foot diameter circle a scratch is made on each radius line ⅙ inch nearer the center for each radius line until the 24 radii have been scratched. The points located in this manner determine the positions of the holes of the spiral. In order to increase the initial electrical signal energy above the noise level a considerable degree of overlap in the track of adjacent holes seems permissible in the transmitter disc, but the same overlap in a receiving disc would give a streaked picture, hence the different drill sizes. The holes in the disc shown in the picture are nearly a tenth of an inch in diameter, and a gain equivalent to considerable amplification is the result.

While silhouettes are comparatively easy to transmit because the intense light shining directly into

the photo cell, working with reflected rays, from the face at a distance, the light is so weak in its indirect reflected path as to produce only a very minute current in the cell. The signal in the first few stages of amplification may be easily buried under noises such as filament emission, vibration from the scanning motor, noisy B, C, or A batteries or connections, stray feedbacks, audio regeneration, a.c. induction, noisy grid leaks, plate resistors or grid blocking condensers, etc. Too much emphasis can not be put on using good parts in the first few stages at the same time obtaining a rapid gain in signal level above stray pick-up noise. In order to gain this end one of the first amplifiers built by the writer for this purpose used transformer coupling in the first two stages and between the cell and first tube input, but in spite of considerable shielding enough a.c. was induced from the motor into the windings of the transformers to spoil the pictures. Therefore, resistance coupling was resorted to and finally the advantages of the screen-grid tube were used in a resistance-coupled amplifier with surprising improvement. A theoretical voltage amplification of sixty per stage is obtained, which compares well with transformer coupling, and better quality results. The disadvantages of stray induction coupling, even with only moderate shielding, are done away with and the only new difficulty introduced seems to be that only small signal potentials can be handled by this type of tube because the maximum grid swing is only about a volt and a half. However, for amplifying the very weak photo cell currents up to a moderate workable volume where one can be sure of their existence, the screen-grid tube seems admirably well fitted. Two stages are shown in the diagram although three have been used where the reflected light intensity was unusually weak. However, when three stages are used considerable isolation of battery circuits and shielding is necessary in order to realize anywhere near maximum gain. Indeed, even with the diagram shown, considerable juggling was necessary to get rid of assorted howls and squeals. In this connection it must be remembered in placing and shielding the amplifier that the resistance-coupled stages may pick up, amplify, and overload on radio frequency from the transmitter. Also, it should be mentioned that there seems to be a scarcity



A close-up view of the transmitting scanner and television amplifier

of amplifying transformers that will handle heavy plate current and volume (such as between a 7½-watt amplifier and a 50-watt modulator) with good response up to 9000 cycles.

Transmitting Circuits

IN THE matter of oscillatory circuits, any of them work but those that shift wave with different plate voltages should be avoided as they do this in modulation. Consideration should also be given the degree of cutting off of the side bands farthest from the carrier, representing the best image detail, by sharp tuning in amplifier stages as well as degree of modulation efficiency. The diagram on this page shows the complete transmitting circuit used by the writer in his experiments with amateur television.

The television experimenter will at times, no doubt, lose patience with his results, or lack of results, and may even tend towards profanity. The Bible is often a great soother of sorrow and the television experimenter has not been forgotten therein and may get comfort from Hahakkuk II, 3, which reads, "For the vision is yet for an appointed time, but at the end it shall speak, and not lie; though it tarry, wait for it; because it will surely come."

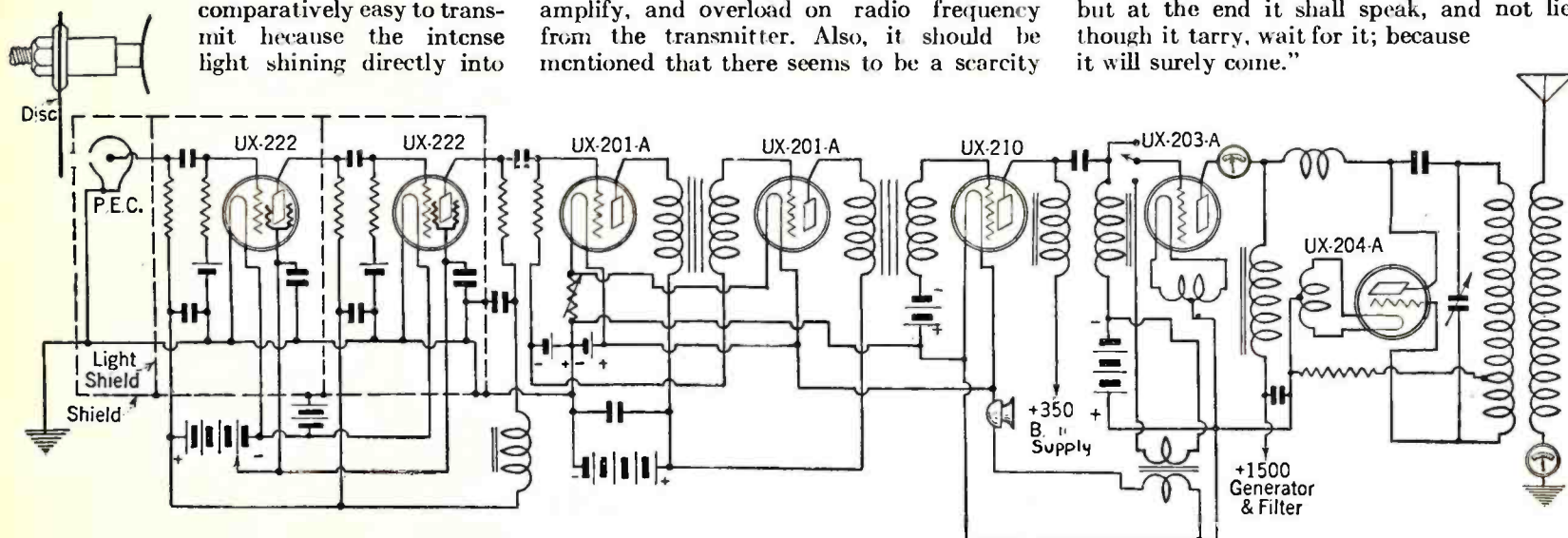

A complete schematic diagram of the apparatus used in the amateur television experiments

ARE FILTERS NEEDED IN A. F. AMPLIFIERS?

By KEITH HENNEY

Director of the Laboratory

OSTENSIBLY, a two-stage transformer-coupled audio amplifier is a perfectly simple assembly of apparatus for the set-builder to put together and operate. All that it is necessary to do is to mount the transformers, sockets, binding posts, and C-bias resistors, if a.c. operated, on a base-board, and wire them up. But, is it as simple as this? Suppose you have the manufacturers' curve on a single transformer, giving its frequency characteristic, have you any assurance that the complete amplifier will have such a curve, or will it have additional humps and hollows in it, and will it tend to sing at some high frequency, or will it "motorboat" if you try to run it on a none-too-good B supply?

For years George Crom of Amertran has been trying to educate experimenters up to the point where they will "filter" their amplifiers. The use of such filters keeps the a.c. where it belongs, and prevents it from roaming through the B-supply unit where it would become mixed with a.c. from other circuits. According to Mr. Crom, the characteristic of a two-stage amplifier will be that of a single stage squared provided—and only provided—it is well filtered. Just what does this mean?

The circuit of a well-filtered Amertran DeLuxe amplifier is shown in Fig. 3 and a picture of the unit will be found in Fig. 4. A list of parts used in constructing it in the Laboratory will be found at the end of this article. To determine the value of Mr. Crom's suggestions regarding filtering, we took this amplifier into the Laboratory and measured its characteristic by putting constant voltages on the input through 12,000 ohms—to simulate the detector out of which it ordinarily works—at various frequencies, and measuring the current into a non-inductive output resistor of 4000 ohms. According to tube experts, the greatest amount of undistorted power output from a 2000-ohm tube (cx-301A) will be secured when the load into which it works is equal to 4000 ohms, and while the loud speaker into which the amplifier works will not have a constant impedance equal to 4000 ohms at all frequencies, we cannot hope to simulate it

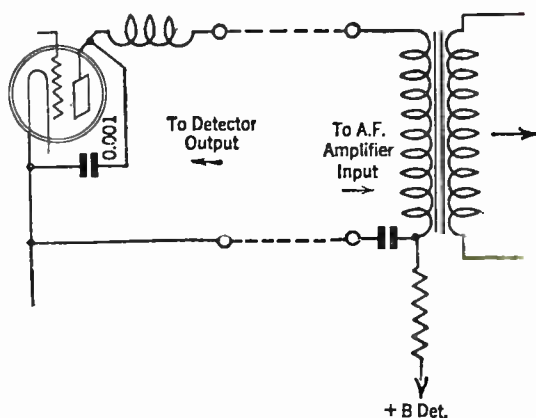

Fig. 1—When filtering is employed in the detector plate circuit, two wires are needed to connect the detector with the amplifier input

George Crom of the Amertran Company has maintained for a long time—he first stated his position in an article in RADIO BROADCAST for October, 1925—that audio amplifiers and their filter circuits could not be considered separately. It is fair to say that his thoughts have not been as generally appreciated as they might have been. We went into our Laboratory and this interesting article, with accurate and quantitative data is the result. It all means simply this: it is not enough to build your amplifier from the best of units, you must also use proper filtering. From the information given here, everyone can go over his own amplifier and apply the suggestions given. With audio amplifiers and reproducers now covering a really satisfactory scope, real fidelity can be attained, where it was not possible several years ago. This article is the first to give, we believe, any considerable quantitative data on this important subject.

—THE EDITOR.

better than this. If the amplifier itself has a good characteristic when operated into a resistance load of the proper value, the problem is then up to the loud speaker designers to make a unit that will give equal results.

In these tests we were not concerned with overall amplification nor with the power output, but for simplicity of measurement we calibrated our output current meter—a Weston thermocouple—in dB (TV) up and down from 5 mA. which, into 4000 ohms, is equal to an output of 100 milliwatts.

How Tests Were Made

THE source of tones was a beat-frequency oscillator which would function down to 60 cycles easily; its output was impressed across 10,000 ohms and 500 ohms in series, and the voltage drop across the 500 ohms (General Radio resistance box) was impressed on the amplifier. The B supply was a Majestic power unit which used a gaseous rectifier tube, and which had been found to have an output impedance representative of all such devices. To obtain plate potentials lower than 180 volts—which was applied to the 171 tube—we used resistors of 25,000 and 50,000 ohms, respectively, at R_4 and R_1 . Since 12,000 ohms is much lower than the d.c. resistance of a detector, we placed only 22.5 volts on this tube so the current through the primary of the first DeLuxe transformer was about 1.0 milliamper. The 227 tube (a deForest) was supplied with 90 volts on the plate and about 5 volts on the grid. The 171 tube (a Raytheon) had 180 and 40.5 volts on its plate and grid, respectively.

To prevent any of the a.c. in the primary of the first transformer from entering into the B supply we placed a 1.0-mfd. condenser, C_1 , as shown which provided a low-impedance path as compared with the 50,000-ohm resistor. The grid circuit of the first tube was filtered by means of a high series resistance, R_1 , and a low-reactance condenser, C_2 . A.C. voltages appearing across the 2000-ohm resistor, R_3 , were not able to enter the grid circuit, first because of the high resistance in series with it and secondly because the lower end of the audio transformer secondary is practically short circuited to the filament, so far as a.c. is concerned, by the condenser C_2 .

Similarly, a.c. currents in the 227 tube circuit were kept out of the B supply by filtering the plate circuit of the first audio tube by means of the condenser C_3 and the resistor R_4 . This means that the a.c. voltages across R_3 were very small. The grid circuit of the power tube was filtered in the same manner as the 227, and to keep the a.c. currents of the last tube from wandering around through the B supply the loud speaker was connected directly to the center-tap of the filament of the 171. All the a.c. currents that entered the B supply from the last tube, were those which passed through the choke L_4 , and these were very small as compared with the currents going through the loud speaker. That was the purpose of the choke, to keep the a.c. currents going through the loud speaker and not through the choke. The purpose of the condenser, C_6 , was to keep the d.c. flowing through the choke, and not through the loud speaker.

The above paragraphs describe how our apparatus was arranged. Now what happened when we placed tones on the input, and measured them in the output? The amplifier was flat from 100 to 8000 cycles (curve A, Fig. 5), it went down about 1.0 dB at 60 cycles, and up about 8.6 dB at 10,000 cycles where the capacity across the secondary resonated with

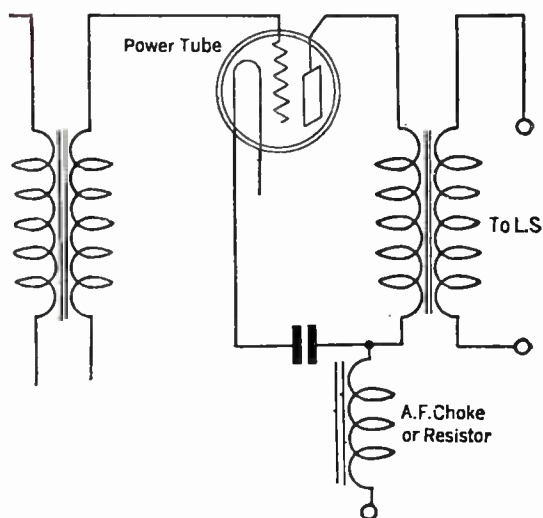

Fig. 2—When an output transformer is employed the filter system illustrated above should be used in the plate circuit of the power tube

the transformer leakage reactance. Since the transformers employed high-permeability cores (about five times the permeability of silicon steel cores) the leakage reactance was low, and the resonant frequency was high—well above the usual range of frequencies transmitted by broadcast stations. This is a very good characteristic.

After completing this test there were a number of experiments which we had to perform. "How much filtering can we remove before the characteristic goes bad?" "Or will it go bad?" These were questions which we had to answer. First, we removed R_1 , and connected the 22.5 volts directly from the B supply to the lower end of the primary of T_1 . This left 1.0 mfd. across the 22.5-volt tap. At 60 cycles (C) of Fig. 5 the amplifier went down 6.6 dB from its 1000-cycle level, and the entire amplifier was down 1.0 dB. Why?

Those who read the "Armchair Engineer" (March, 1928, RADIO BROADCAST) will remember we calculated the amount of a.c. current that flowed through a 40-henry choke (which is a good big choke) when the loud speaker was connected as in this test. This a.c. current, although small, flows through the B supply, sets up an a.c. voltage there, and part of this voltage appears across the 22.5-volt tap. This voltage is fed into the input of the amplifier and, of course, is amplified. Since the amplifier was now down at 60 cycles, it means that the transformers were so "poled" that this a.c. voltage impressed on the input from the B supply, returned to the 4000-ohm output resistor out of phase with the original voltage, and hence was subtracted from it.

It is worth while, then, to filter the detector. In this case, despite the 1.0-mfd. condenser across the 22.5-volt tap, the amplifier was down, indicating that this capacity (which has a reactance of 2650 ohms at 60 cycles) was too small to give any bypassing effect. When the resistor, R_1 , of 50,000 ohms, was in the circuit, however, the condenser was relatively much more effective and kept these a.c. voltages from entering the primary of the first a.f. transformer.

Other Experiments

IN THE next experiment we increased the a.c. current through the B supply by connecting the output resistor directly across output choke, thereby reducing its impedance to approximately 4000 ohms and increasing the a.c. through the B supply by the amount that previously went directly to the filament. Now

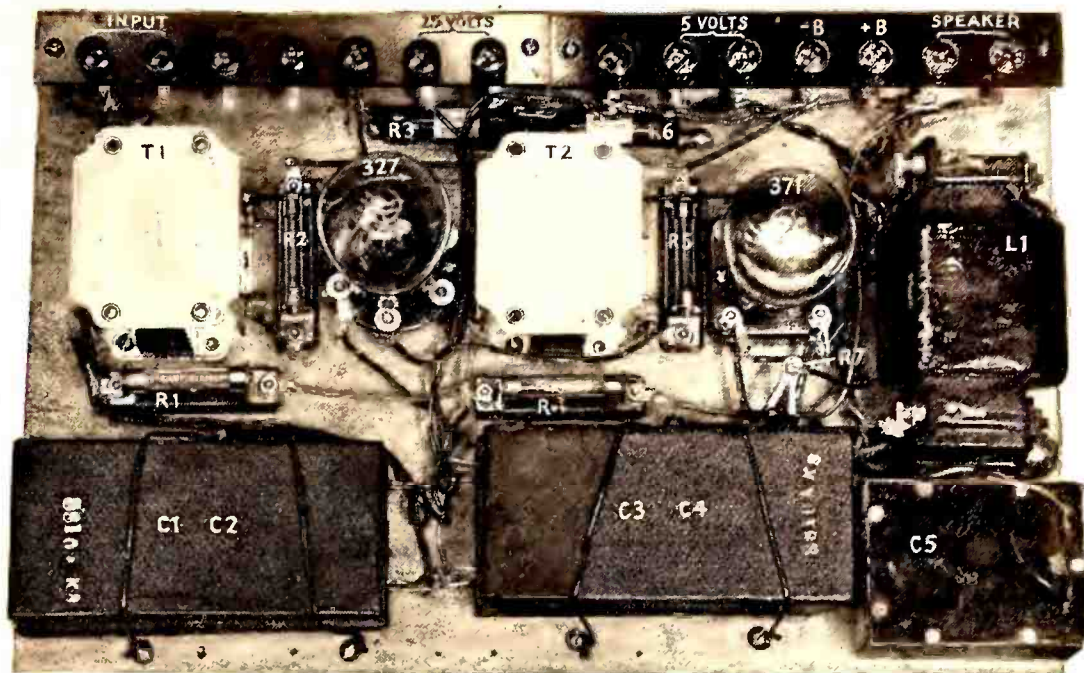

Fig. 4—Top view of completed amplifier shows exact arrangement of apparatus on baseboard

the amplifier (D) in Fig. 5 was down 14.8 dB at 60 cycles, and down 7.0 dB at 1000 cycles. Placing 8 mfd. across the Majestic unit increased the 60-cycle response to 12.8 dB—a gain of 2 dB—but this was not worth while. Since this is analogous to operating the amplifier with an output transformer, it is absolutely essential that the detector supply be well filtered and as near (physically) the first a.f. transformer as possible. This necessitates two wires from the detector to the amplifier as in Fig. 1.

Filtering the 22.5-volt circuit (the detector plate-voltage supply), as in Fig. 1, and removing all filtering from the first a.f. tube, provided a good characteristic, almost as good as with the filtering in the circuit.

Taking out all the filtering, even the by-pass condensers across the C-bias resistors, gives the characteristic shown at (B) in the curve. With this arrangement the amplifier suffered badly at both low and high frequencies. Placing the loud speaker across the choke and removing all filtering gave the characteristic at (E)—which in our estimation is pretty terrible. Replacing the condenser across the C bias to the last tube increased the 1000-cycle response to normal but improved the 60- and 100-cycle response only 4 dB, showing that this capacity is far too small to do much good compared

with the 2000-ohm resistor which it bypasses. In other words, at low frequencies its reactance is too great to be of much good as a bypassing agent. It is only when the circuit beyond this condenser (toward the B supply) is increased in impedance (one-half megohm, R_5) that the condenser gets in its good licks.

Now with all the filtering in place, a 1000-ohm resistor placed in the B-supply lead caused no change in the characteristic at either low or high frequencies, proving that if the amplifier is properly constructed, it is independent of the source of plate or grid voltages.

Conclusive Proof

HERE, then, is conclusive proof that Mr. Crom is correct. The audio amplifier must be filtered if the good characteristic of a single transformer is to be preserved when a two-stage affair is constructed. Here is an amplifier operating entirely from a.c., that gives a flat frequency characteristic from 100 to 8000 cycles and a power output of roughly 100 milliwatts for an input r.m.s. signal of 0.1 volt, or to put it another way, an amplifier that requires an input r.m.s. signal of 0.31 volts to produce a one-watt output. This is true providing the 171-type tube with a μ of 3 is used and providing it works into twice its own internal plate resistance. It is a beautiful amplifier, since it has not only a good characteristic but plenty of overall gain as well.

Now how much of this filtering is necessary? So far as this particular amplifier and particular B supply are concerned, we can do away with the filtering in the grid and plate circuits of the first audio tube—but it is highly questionable whether such an economy would be a true saving. The filtering in the detector plate lead and the shunt condenser and series resistance in the grid circuit of the power tube are both absolutely essential. But so far as a general amplifier and a general B supply are concerned, we need every bit of filtering there is in this present assembly of apparatus as shown in Fig. 3.

While it is true that the ear will not detect differences of perhaps 10 dB at the two extremes of the audio band, it is not safe to say that we can eliminate such filtering as is only effective in bringing up these frequencies. If, by accident, one of the transformer primaries

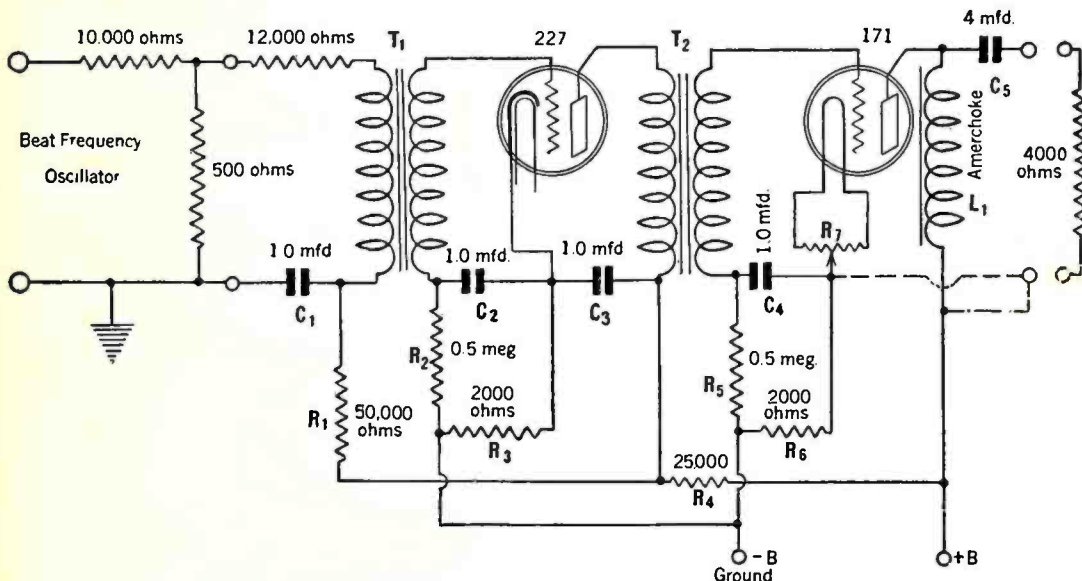

Fig. 3—Schematic diagram of a well-filtered two-stage transformer-coupled a.f. amplifier

had been poled differently, the chances are that the entire amplifier would sing at some frequency with the removal of any part of the filtering. The only safe way to get a good characteristic out of good transformers is completely to isolate all a.c. circuits. The best place to do this, physically, is in the amplifier itself, for with this arrangement the amplifier circuit is entirely independent of the B supply.

It will be noted that the series filter resistor must pass the plate current required for the tubes on the side furthest from the plate supply unit. Thus, in the circuit diagram, Fig. 3, the 50,000-ohm resistor must be able to carry the plate current of the detector or about 2 mA, and the 25,000-ohm resistor must pass not only the plate current of the first a.f. tube, or about 3 mA., but the current taken by the detector as well, or about 5 mA. in all. The resistors should be able to handle at least one watt.

The series resistors in the grid circuit do not handle any steady current at all since there should be no current flowing in this part of the circuit. Mr. Crom, however, states that these resistors should be able to handle considerable current which is taken by the charging of the shunt condensers. It is his

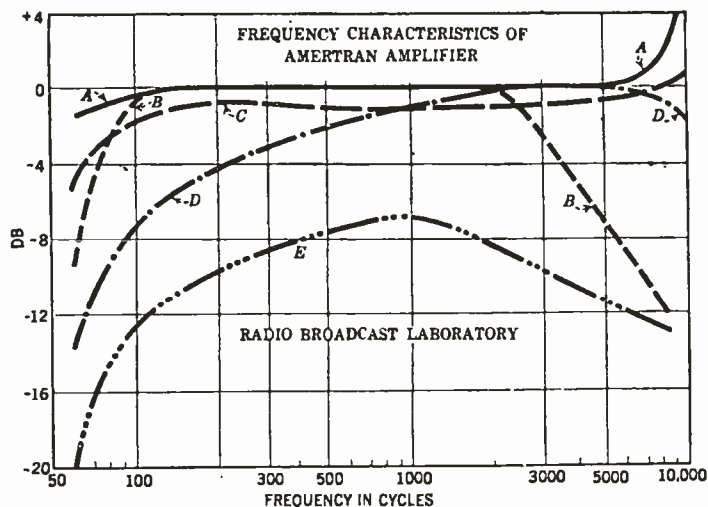

Fig. 5—These curves show the frequency response characteristics of the amplifier with various filter combinations

experience that small grid leak type resistors frequently go bad in this kind of filter circuit within a few months after the apparatus is put into use, probably due to the momentary high currents passed through them. Noisy resistors, of course, should always be avoided as a never ending source of embarrassment and bother.

The voltages which the condensers must handle are not very great, and ordinary 150-

or 200-volt units of the paper-dielectric type will prove satisfactory. If the tubes are taken from their sockets while the power is turned on, however, the full voltage output of the plate supply unit will be impressed on the condensers, and if such conditions ever exist, it is well to use condensers that will stand up under the added strain. Although the filter condenser in the plate circuit of the first a.f. tube is required to stand up under a voltage of not much over 90 volts with the tube in the socket, if the tube does not draw plate current, or is taken from its socket, the voltage across the condenser may rise to the full 180 volts supplied to the power tube.

List of Parts

THE list of parts indicates what was actually used in the Laboratory. Equivalent apparatus may be used, of course. The complete list follows:

- C₁, C₂, C₃, C₄—Faradon condensers, 1-mfd., type WS3810-A;
- C₅ Acme condenser, 4-mfd., Series A;
- L₁ Amerchoke, type 874;
- R₁ Durham Powerohm resistor, 50,000-ohm;
- R₂ Daven Hi-duty Glastor resistor, 0.5-megohms;
- R₃ Aerovox Pyrohm resistor, 2000-ohm; type 992;
- R₄ Durham Powerohm resistor, 25,000-ohm;
- R₅ Daven Hi-duty Glastor resistor, 0.5-megohm;
- R₆ Aerovox Pyrohm resistor, 2000-ohm; type 992;
- R₇ Electrad center-tapped resistor, 20-ohm;
- T₁, T₂ Amertran DeLuxe Transformers;
- Fourteen Eby Binding Posts.



BOOK REVIEWS



THE B. B. C. HANDBOOK, 1929. The British Broadcasting Corporation. Published in September, 1928. 480 pages, including advertising.

The British Broadcasting Company's Handbook, issued for the second time, illustrates an underlying difference between the British and American forms of broadcasting. In the United States the large broadcasting chains content themselves with getting what newspaper publicity they can, and satisfying their listeners and advertisers. In its Handbook, which of course is also a publicity medium, the B. B. C. assumes the rôle of a British institution, somewhat on the order of the House of Lords, the Royal Institute, and the Church of England.

In the advertisements which are included with the text we note that the British radio manufacturers, like their American prototypes, build perfect radio sets which will, however, be less than perfect when the next model comes out.

The articles cover a wide range. There are recapitulations of important programs and a discussion of program plans for the future. Sports, the opera, educational material, and orchestral broadcasts receive considerable space. There are miscellaneous articles indirectly connected with broadcasting, such as the one on "Bands, Orchestras, and Instruments." Artists who have broadcast extensively give their views on the best technique. The listeners are even told how to listen. The drama and religious broadcasting are not neglected. The press, poetry, and copyright limitations are other miscellaneous heads picked out at random from the text. Like the radio itself, the Handbook evidently aims to present

a number of things of interest to its variegated group of patrons.

The "Technical Section" contains a summary of progress in transmitter design, in which low-power transmitter modulation is favored, although not enthusiastically. The radiation pattern of the Daventry station is shown. There is quite an informative article on broadcast acoustics, including a disclosure of the "artificial echo" scheme. The output of the microphone amplifier is split, one channel going directly to the transmitter, while the other, through a re-inforcing amplifier, actuates a loud speaker in an echo room with bare walls and a consequently high period of reverberation. The sounds emitted by the loud speaker are picked up by a microphone in the room, and mixed with the straight studio output in any desired proportion. The method is an ingenious one and should give good results in selected cases where the distortion involved in repeating through a loud speaker is not objectionable.

The article on microphones discloses the fact that in the British stations the moving-coil type of microphone which was standard at one time has been largely superseded by a carbon transmitter apparently of the Reisz type, in which the sound affects a layer of carbon granules through a rubber membrane, and by American condenser transmitters. Considerable material on receiver problems also appears in the technical section of the Handbook.

The illustrations are interesting and some of them refute the idea which has proved so useful in American vaudeville shows, that the British generically lack a sense of humor.

CARL DREHER

RADIO, By Elmer E. Burns, D. Van Nostrand Co., New York, 1928, 255 pages, price \$2.00.

The sub-title of Radio is "A Study of First Principles"; it is intended for "Schools, Evening Classes, and Home Study." The author is an instructor in physics in the Chicago high schools. The treatment, probably as a result, is more thorough in setting forth the theoretical basis of the art than most elementary books, and there is correspondingly less "How to Make" material. Graphs are used liberally but there is some application of simple mathematics, and here and there a vector diagram. At the same time Mr. Burns' text never becomes abstract or merely verbal. His first chapter, in fact, plunges abruptly into "Simple Receiving Circuits," without the preliminary wooing of the principles of electricity to which we have become accustomed. However, the author then retraces his steps, starting with electric batteries, and going through electric circuits and Ohm's Law, electron tubes, alternating currents, detectors and amplifiers, fundamentals of receiving circuits, oscillators and transmitting circuits, and radio measurements. In an appendix some of the common mathematical relations are brought together, and there are lists of graphic, mathematical, and code symbols. An index is provided.

Radio—"First Principles" provides an excellent course of study for students with high-school preparation in physics and mathematics. It might serve as an effective introduction to an advanced text like Morecroft's, for, in its restricted sphere, it shows some of the same care in preparation and choice of material.

CARL DREHER.

Radio Broadcast's Home-Study Sheets

The Transmission Unit

WHEN comparing the voltage amplification or the power output of two or more amplifiers, it is convenient to use a unit of comparison that bears some relation to the sensitivity of the ear. For example, the difference in volume output between a full orchestra playing very loud and playing very softly is about one million times. And yet to the ear the difference is only about 60 times; that is, between these two extremes in level, there are about 60 steps which the ear can detect by which the volume may be increased.

As another example, one amplifier may deliver 600 milliwatts of power into a loud speaker while another is capable of turning out one watt, or 1000 milliwatts. Off hand one would say that the second is a great deal better, but is it? Of two amplifiers having voltage gains of 50 and 60, the second is better, of course, but if it costs a great deal more, is it worth it? As a matter of fact the differences between these two amplifiers would be scarcely audible to the average ear.

A convenient unit of comparison has been known as the Transmission Unit of Loss or Gain, and is now called the Decibel, abbreviated to db. It has been called the ru, for want of a better name, up to the present time. The db is one tenth of the internationally used unit, the Bel, named in honor of Dr. Alexander Graham Bell, the inventor of the telephone. The transmission unit of loss or gain was originated in the telephone industry which deals almost exclusively with differences in volume in which the ear plays a part, and so such a unit, which had some connection with the manner in which the ear hears, was necessary.

The db is defined as "Ten times the common logarithm of the ratio between any two powers."

$$NDB = 10 \log_{10} P_1/P_2 \dots \dots (1)$$

in which N is the number of db by which the two powers P₁ and P₂ differ. The db is such a unit that the trained ear can just distinguish the differences between two powers which differ by one db, or one unit of loss or gain.

The table below gives some easily remembered values of db and the corresponding power and voltage or current ratios.

NDB	APPROX. POWER RATIO	APPROX. VOLTAGE OR CURRENT RATIO
3	2.0	1.4
4	2.5	1.58
6	4.0	2.00
7	5.0	2.24
9	8.0	2.8
10	10	3.16
20	100	10.0
23	200	14.0
30	1000	31.6

The second advantage in the use of such a unit, which is a logarithmic unit, will be apparent in glancing at the above table. Every time the power is doubled, we add 3 db, and every time the power is multiplied by 10, we add 10 db. Thus a ratio of 2 gives 3 db, a ratio of 4 gives 6 db, a ratio of 8 gives 9 db, etc. All power ratios between 100 and 1000 are included between 20 and 30 db. DB are to be added when power ratios are multiplied, and subtracted when power ratios are divided. Thus, if one amplifier has a gain of 25 and is to be used after another similar amplifier, the total voltage gain is 25² or 625, which is awkward. But if the gain of each amplifier is 25 db, the total gain is 50 db.

In other words the db is a compressed unit, and neglects differences of power the ear cannot detect. Thus, when an engineer speaks of the superior power output of his amplifier as compared with another, one must be careful to translate the power ratios into db before taking him too seriously.

Example: Let us consider an amplifier that is capable of turning out 100 milliwatts of power. By how much must we increase its output before the ear can just tell the difference?

Solution: A table of db, or a logarithm table, tells us that 1.0 db corresponds to a power ratio of 1.25. Thus the power output to which 100 milliwatts must be increased before the difference is audible to the ear is,

$$\begin{aligned} \text{db} &= 1.0 \text{ when } P_1/P_2 = 1.25 \\ \text{or } P_1/100 &= 1.25 \\ \text{or } P_1 &= 125 \end{aligned}$$

and so the power output must be increased to 125 milliwatts before the ear can tell the difference.

Strictly speaking, the unit of loss or gain deals with power ratios only, but with a little juggling of our mathematics we can use it to express ratios

of current or voltage. It is only necessary to convert these voltages and resistances to powers, get the ratio and convert to db, or to use the following formula when voltage ratios are involved:

$$NDB = 20 \log \frac{E_1/\sqrt{R_1}}{E_2/\sqrt{R_2}} \dots \dots (2)$$

or (when current ratios are involved)

$$NDB = 20 \log \frac{(I_1)^2 R_1}{(I_2)^2 R_2} = 20 \log \frac{I_1 \sqrt{R_1}}{I_2 \sqrt{R_2}} \dots \dots (2)$$

in which the factor 20 appears because of the fact that the voltages in the above equation are squared. (When you square a number, you double its logarithm.) If the impedances into which two currents flow, or across which two voltages appear, are equal, the expression for db becomes,

$$NDB = 20 \log \frac{E_1}{E_2} \text{ or } 20 \log \frac{I_1}{I_2} \dots \dots (3)$$

How to Use DB

To convert power ratios to db look up the logarithm of the ratio and multiply it by ten. To convert current or voltage ratios to db, look up the logarithm and, if the impedances are equal, multiply this logarithm by 20. If the impedances are not equal, use formula (2). When looking up logarithms, remember that all numbers up to 10 have logs between 0 and 1, all numbers between 10 and 100 have logs between 1.0 and 2.0, all numbers between 100 and 1000 have logs between 2.0 and 3.0, etc. In other words the first figure of the log of all numbers between 100 and 1000 will be 2 and the next number tells us exactly where, between 100 and 1000, the number is. Thus, the power gain corresponding to 100 is 20 db and corresponding to 200 is 23 db—adding 3 db every time the power is doubled—and for 400 is 26 db.

When converting db to power ratios, follow this example. What is the power ratio corresponding to 18 db? Dividing by 10 gives 1.8. The figure 1 tells us that the number lies somewhere between 10 and 100, and the figure 0.8, when looked up in a log table, is the log of 6.32. The ratio is, then, 63.2. If it were 28 db the figure 2 indicates that the number lies between 100 and 1000 and the "antilog" of 0.8 is 6.32 so the ratio is 632.

Example: An amplifier has one volt applied to its input resistance of 10,000 ohms. Across its output resistance of 4000 ohms appears a potential of 40 volts. What is the power gain in db, the voltage gain in db, and the voltage gain expressed as a ratio?

Would it be worth while to increase the amplification so that 50 volts appeared across the output? Solution:

$$\text{Power input} = P_i = \frac{(E_i)^2}{R_i} = \frac{1^2}{10000} = 10^{-4} \text{ watts}$$

$$\text{Power output} = P_o = \frac{(E_o)^2}{R_o} = \frac{40^2}{4000} = \frac{1600}{4000} = 0.4 \text{ watts}$$

$$\text{Power ratio} = \frac{P_o}{P_i} = \frac{0.4}{10^{-4}} = .4 \times 10^4 = 4000$$

Power gain = 10 log 4000 = 36 db (because the log of 4 is 0.6 and because the first figure of the logs of all numbers between 1000 and 10,000 is 3 and the power gain in db is 10 times the log of 4000)

$$\text{Voltage gain} = 36 \text{ db} = 20 \log \frac{E_o/\sqrt{R_o}}{E_i/\sqrt{R_i}}$$

$$\log \frac{E_o/\sqrt{R_o}}{E_i/\sqrt{R_i}} = \frac{36}{20} = 1.8$$

Voltage gain = 63

If E_o becomes 50, gain (between E_o = 50 and E_o = 40) = 20 log $\frac{50}{40}$ = 2.0 db. And so the difference between an output voltage of 50 and one of 40 would be hardly worth any trouble to get it. The solution to this example is characteristic of all such problems.

The easiest way to learn to use the db chart in Fig. 1 is to look along the horizontal axis for the db corresponding to a power ratio of 100 which is along the right vertical axis. This we know is 20 db. A power gain ratio of 20 corresponds to 13 db. A voltage gain ratio of 6 corresponds to 15.6 db. A power loss ratio of 0.2 corresponds to 7 db, a voltage loss ratio of 0.06 corresponds to 24.5 db, etc.

Problems

Problem 1. What in db corresponds to a voltage ratio of 100? Power ratio of 100? What voltage ratio corresponds to 100? What power ratio?

Problem 2. A current of 0.006 amperes flows through a resistance of 1000 ohms. A switch reduces this current to 1.0 milliampere. How much is the current reduced in db?

Problem 3. An amplifier has a normal output of 1 watt. A switch is provided so that its output can be reduced in 5 db steps. What is the output in watts when it is reduced by 5, 10, 20, and 25 db?

Problem 4. A radio receiver has a voltage gain in its radio-frequency amplifier of 50 db. Express this in voltage ratio, and in power amplification provided that the same impedance closes the input and output of the amplifier.

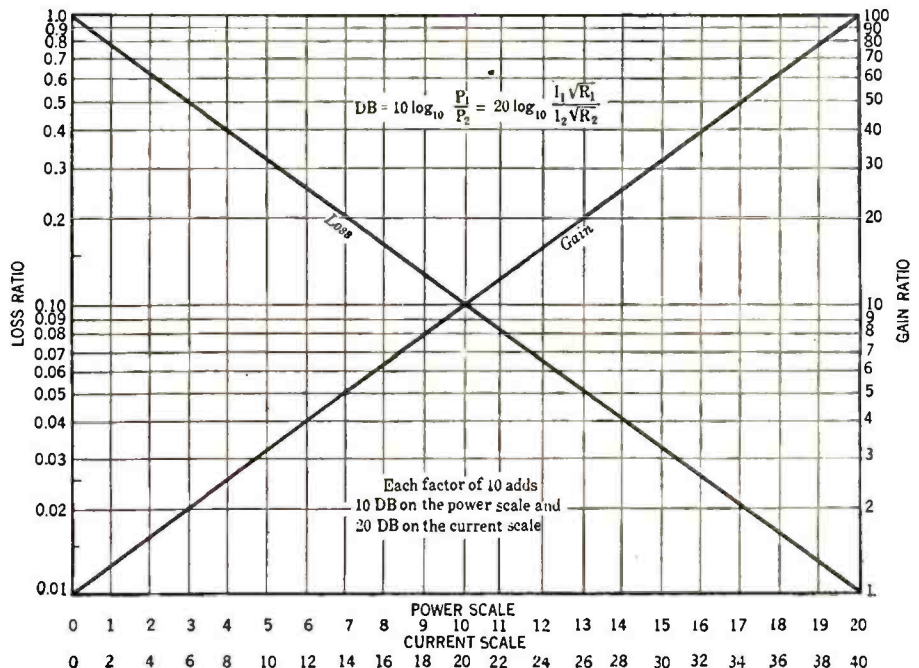

Fig. 1—Chart of transmission units (DB)

Radio Broadcast's Home-Study Sheets

Experiments With a Wavemeter

METHODS of calibrating a wavemeter were discussed in Home-Study Sheet No. 13. If the experimenter provides himself with a heterodyne wavemeter, that is an oscillating vacuum tube with a grid-current meter and a series of coils and a tuning condenser, he has, in his own laboratory, the most important item of equipment for a whole series of interesting, instructive, and useful experiments. The heterodyne wavemeter can be avoided if an oscillating detector is used with a pair of telephones in its plate circuit according to Fig. 1. The circuit will have to be calibrated, but this can be accomplished as indicated in Home-Study Sheet No. 13. With this system, instead of using a grid-current meter to indicate resonance with another circuit, a click in the telephones serves the same purpose.

Properties of Coils and Condensers

A. Wind up on a form approximately 2.0 inches in diameter about 60 turns of rather large insulated wire, say about No. 20, so that the distributed capacity will be large. Connect the ends of the coil across a variable condenser whose capacity at several settings is known—a calibrated condenser, in other words. A 500-mmfd. condenser will have about the maximum capacity needed. Starting at the maximum condenser capacity, "click," the coil-condenser combination into the oscillating detector, or into the heterodyne wavemeter. Note down the wavelength or frequency, and then change the setting of the variable condenser and get a new wavelength or frequency setting. Continue until three or four points have been secured, for example, if a 500-mmfd. condenser is used, get the wavelength at 500, 400, 300, 200, and 100 mmfd.

Make a table, as in Table 1, showing the condenser capacity, the wavelength, and the wavelength squared. Plot, as in Fig. 2, the wavelength squared against capacity. A straight line should result, because of the equation,

$$(\text{wavelength})^2 = 3.54 \times L \times C$$

where L = microhenries
C = mmfd.

This equation states that the wavelength squared is proportional to the capacity. The "proportionality factor," that is, the factor which connects the wavelength squared and the capacity is L, the inductance.

The slope of the line divided by 3.54 then, is the value of L, that is,

$$L = \frac{1}{3.54} \times \frac{(\text{wavelength})^2}{\text{capacity}}$$

It will be noted that the line crosses the vertical axis (the wavelength-squared axis) at some distance above the zero point. In other words, if there were no additional capacity present, except what the coil inherently possesses, the wavelength squared would be given by this value. This point on the curve gives us the natural wavelength of the coil, determined by its inductance and its distributed capacity.

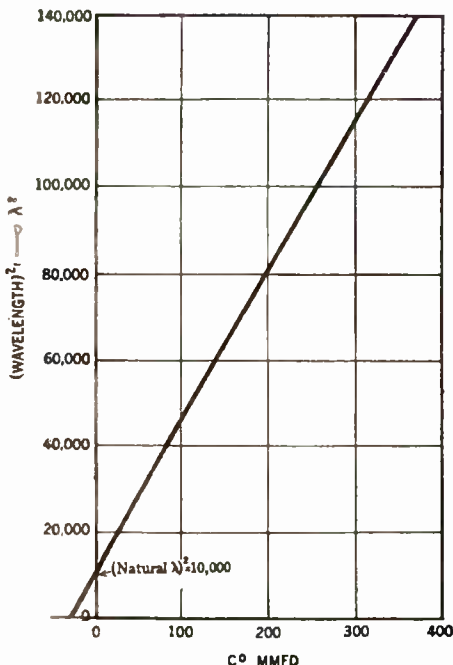

Fig. 2

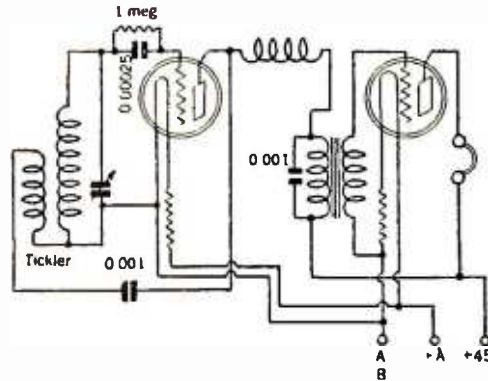

Fig. 1

distributed capacity. To check this value, remove the condenser and click the coil alone into the wavemeter.

The point where the line crosses the capacity axis gives us a value for the distributed capacity of the coil. This value when multiplied by the proper value of L gives us the LC product which, when fitted into the formula above, gives us the natural wavelength of the coil.

Thus one experiment not only gives us the inductance of a coil, but its distributed capacity and its natural wavelength as well. The greater the distributed capacity of the coil, the more accurately it can be measured by this method.

As a check on this method of determining the inductance of a coil, calculate the inductance from the following formula,

$$L = \frac{d^2 N^2}{9d + 10b}$$

where d is the diameter in inches
N is the number of turns
b is the length of winding in inches

Measuring Capacity

B. The product of L and C in a circuit determines the wavelength or the frequency to which that circuit will tune. When the circuit is near by a source of energy of this frequency, the circuit begins to absorb energy and a large current will flow in the coil and the condenser. This phenomenon is the basis of all tuning in radio circuits, and has been described in Home-Study Sheets 11 and 12. It can be used for measuring purposes as well as for receiving radio signals as the following experiment will prove.

Connect a condenser whose capacity is known across a coil so that the combination will "click" into the range of frequencies over which the wavemeter or oscillating detector will cover. Adjust the circuit to resonance. Connect across the condenser a capacity whose value is unknown but which is desired. Adjust the variable standard capacity until resonance is again obtained. What has happened?

We have increased the total capacity in the circuit by adding the unknown condenser to the standard. We must, therefore, reduce the setting of the standard until the total capacity in the circuit is as it was before.

For example, if the condenser were set at 400 mmfd. when resonance occurred without the unknown capacity, and at 320 mmfd. with the capacity, the difference, 400 - 320, or 80 mmfd., gives the capacity of the unknown.

Such a method enables the experimenter to disregard the capacity of the coil and of the leads since they are in the circuit at all times and do not affect the difference of capacity produced by adding another condenser to the circuit.

If a large condenser is to be measured, it may be necessary to put it in series with the standard condenser to obtain resonance. The experimenter must remember that when two condensers are put in parallel the resultant capacity is the sum of the individual capacities—this is the basis of the experiment just described; but that when two condensers are put in series, the resultant capacity is the product of the individual capacities divided by the sum, or the resultant capacity, C_0 , of adding C_1 in series with C_2 is

$$C_0 = \frac{C_1 \times C_2}{C_1 + C_2} \text{ or } \frac{1}{C_0} = \frac{1}{C_1} + \frac{1}{C_2}$$

If the capacities of small paper or mica condensers are measured by these methods, i.e., determining their capacity at high frequencies, some strange results will occur. The capacities will differ rather widely from the rated values. Air condensers will

give true readings, however. The variation in capacity at different frequencies seems to be a kind of electronic disturbance in the dielectric at high frequencies so that the dielectric constant is not what it is at low frequencies. Such discrepancies are not important where the units are used as bypass condensers but when they are to be used for tuning circuits, one cannot rely on their markings. The experimenter should make a list of the rated capacities, the measured capacities, and the percentage accurate of a series of small fixed condensers.

Measuring Antenna Capacity

C. Connect a coil in series with the antenna and ground and "click" into the wavemeter or the detector. Then remove the antenna and ground wires and connect across the coil a variable condenser whose capacity is known, or can be obtained. Tune the condenser until resonance is obtained. Then the capacity of the condenser is the same as the capacity of the antenna.

Measuring Antenna Inductance

D. Connect a known inductance in series with the antenna and ground and measure the wavelength of the system. Then connect another inductance, different in value from the first, and get a new value of wavelength. Then the two wavelengths are related as below:

$$(\text{wavelength})_1 = 1.884 \sqrt{(L + L_a) C_a} = \lambda_1$$

$$(\text{wavelength})_2 = 1.884 \sqrt{(L + L_b) C_a} = \lambda_2$$

where L_a = antenna inductance
 C_a = antenna capacity

Eliminating C_a from these two equations, gives

$$L_a = \frac{L_1 \lambda_2^2 - L_2 \lambda_1^2}{\lambda_1^2 - \lambda_2^2}$$

Problems

1. Two condensers whose capacities are 400 mmfd. and 500 mmfd., respectively, are across two inductances. Both combinations tune to the same frequency. What is the ratio of inductances? If the inductance across the 400-mmfd condenser is 300 microhenries, what is the inductance across the other?

2. What is the inductance of the coil used in the experiment which produced Fig. 2? What is its distributed capacity? What is its natural wavelength?

3. If the wavelength of a circuit varies as the square root of the capacity, what must be done to the capacity in a circuit to double the wavelength? If the wavelength varies as the square root of the inductance, and if the inductance varies as the square of the number of turns, how is the wavelength related to the number of turns on a coil? That is, if a coil has 30 turns and tunes to 300 meters, how many turns are necessary to tune to 600 meters?

4. A coil to tune over the broadcast band has 75 turns. It is used with a 0.00035-mfd. condenser. How many turns, approximately, will be needed if the condenser is 0.0005 mfd.?

5. A coil-condenser combination tunes to 450 kc. when the capacity is 600 mmfd. When an unknown condenser is placed in series with the condenser, the circuit tunes to 600 kc. What is the value of the unknown capacity?

6. An antenna tunes to 300 meters when 200 microhenries are in series with it, and to 400 meters when the inductance is increased to 300 microhenries. What is the inductance of the antenna? Remembering that the antenna inductance is in series with the "loading" inductance, and that the total inductance in the circuit can be calculated by adding the individual inductances, what is the capacity of the antenna? What is its natural wavelength?

7. An antenna has a natural wavelength of 400 meters and a capacity of 0.0003 mfd. How would you reduce the natural wavelength to 200 meters?

8. The LC product of a coil and condenser to tune to 220 meters is 0.01362 mfd. If the distributed capacity of the coil to be used plus the minimum capacity of the variable condenser amounts to 50 mmfd. what is the necessary inductance? What will be the tuning range if the maximum capacity of the condenser is 0.00035 mfd.?

Table I

C_0 MMFD	WAVELENGTH	(WAVELENGTH) ²
100	212	45000
200	283	80000
300	340	115000
350	364	132000

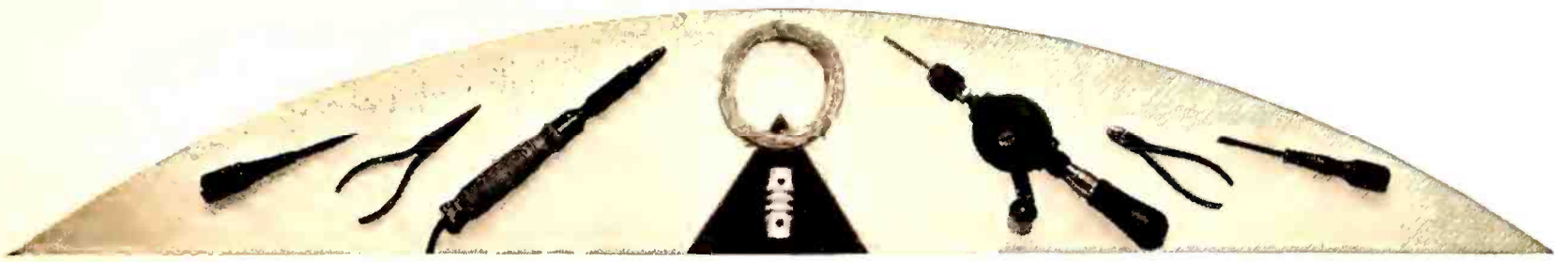

THE SERVICEMAN'S CORNER

SERVICEMEN have not been slow to write us of their unqualified approval of "The Serviceman's Corner." And what is more, they have sent us a great number of excellent contributions, many of which appear in the paragraphs below. We welcome contributions, all of which, if accepted, will be paid for at space rates.

Melvin L. Shook, of Shook & Jones, Akron, Ohio, writes that a large proportion of their service calls are on old sets. "So far, our experience on the a.c. sets has largely been the replacement of tubes. One of our greatest difficulties is in securing circuit diagrams of standard receivers which we are called upon to service. It eliminates a lot of work when you have the diagram with the constants to go by. As practising servicemen we are constantly called upon to service all types of sets. Consequently, we greatly appreciate your 'Service Data Sheets on Manufactured Receivers.'"

It is doubtless true that a large amount of service work is not done by the dealer from whom the set was purchased. Service organizations and individuals doing service work will be wise to collect systematically all the data on all types of sets which turns up from any reliable source.

How to Tell Failing Rectifier Tubes: Failure of the rectifier tube is best indicated by a decrease in the plate voltage supplied to all tubes in the receiver. It may be distinguished from failure in the last audio tube by comparing the voltage readings obtained on the remaining tubes with the plate voltage reading on the power tube. When the rectifier tube is at fault, all readings will be low; when the power tube has failed, all readings will be high. E. T. Cunningham Inc., inform us that the average life of the CX-381 is 1000 hours or more when the transformer voltage does not exceed 700 volts and the plate current is limited to 85 mA. maximum. Tubes of this type operated from transformers not made recently may be operating out of 750 volts, with a resulting lessening of tube life. Another important precaution is operating the filament at its rated voltage. The tolerance here is not greater than plus or minus 5 per cent. (see RADIO BROADCAST for January, 1929, page 181.)

Replacing a Fixed Condenser in A. K. Sets: "I have had considerable difficulty in procuring a condenser of proper physical dimension to replace the fixed by-pass condenser in Atwater Kent sets," writes G. A. Thurling of Springfield, Massachusetts. "This condenser breaks down, shorting the B-power circuit and making reception very weak, or altogether impossible.

"The fixed condenser used in a Ford ignition spark coil makes an excellent substitute. Discarded Ford coils may be purchased for

These pages mark the third appearance of our special section for the practising serviceman. To say that this department has been enthusiastically received would be putting it mildly. Scarcely any innovation in RADIO BROADCAST in the last five years has attracted so much favorable comment. We are welcoming carefully considered contributions which, if accepted, will be paid for at our regular rates. A number of contributions describing set testers have been received and we are not at present interested in others unless they are designs of great originality and especial merit. Contributions are especially desired which describe the solution of especially baffling problems encountered which service manuals do not cover and similar items calculated to be of the widest interest to others working in the field. Typewrite your contributions and address them to the Editor, Serviceman's Corner, RADIO BROADCAST, Garden City, New York.

—THE EDITOR.

as little as twenty-five cents at most Ford service stations. This condenser fits snugly in place of the usual condenser in Atwater Kent models."

Testing a.c. plate voltage: Servicemen testing the plate voltage on tubes operated from a.c. often make the mistake of placing their voltmeters across the B supply just as they would in a d.c.-operated amplifier, for example. This does not give the true plate voltage, but the plate plus the grid voltage. In order to read the true plate voltage of an a.c.-operated tube, especially where the tube gets its C bias by the plate-current drop through a resistor, the meter must be con-

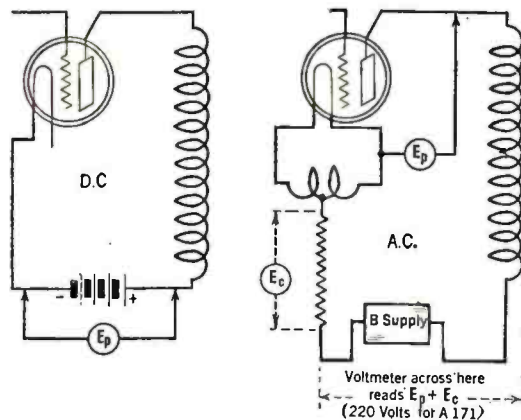

Fig. 1—These diagrams show how to measure accurately the plate and grid voltages in a.c.-operated receivers

nected between the plate terminal of the tube's socket and the filament terminal of this tube. It does not matter which of the two filament terminals is used. See Fig. 1.

Increasing Response on the Longer Wavelengths: My contribution is on the subject of boosting volume on the long-wave end of the dial on sets employing a resistor across the grid and ground as an untuned coupler for preventing the length of the antenna used from affecting the gang control of the radio-frequency stages following. Such sets as the Aero Seven, Graybar 310, R. C. A. Models 16, 17, 18, Knight 6-7, Monroe 8-9, and many others can be improved with this simple kink. Take any solenoid coil such as is used to cover the broadcast band in conjunction with a 0.00035-mfd. condenser and connect one end of the coil to the antenna post of the set and the other end to the ground post. Coils having a diameter greater than two inches seemed to work best. Some old Lorentz wound coils out of an ancient Freshman Masterpiece set worked excellently. The primary coil was ignored, but care was taken that the ends did not short. The results were not so good on two Atwater-Kent sets the coils were tried on, probably because A.K. uses a choke instead of a resistor across the antenna and ground. The most effect of the coil in all cases was on the long waves, just where most one-dial sets need a little more energy.

—J. P. KENNEDY, South Bend, Indiana.

Interference Elimination: In one locality a great deal of motor noise was picked up by a Radiola 18 and it was found that by removing the ground the trouble was reduced to such an extent that it was not objectionable, while in another case with the same type of receiver the trouble seemed to be due to a faulty ground. When a wire was shunted across the water meter the interference practically vanished and the volume picked up at least 50 per cent.

—K. R. TANTLINGER, Cumberland, Md.

Trouble in a Radiola 17: Operation would be normal for about twenty minutes then a tremendous noise would drown out the signal. This noise would continue and then normal operation would obtain. Tubes were tested and proved in good condition, but as an additional precaution were tested in another set. Routine tests for continuity were made, showing proper results. The trouble was finally remedied by replacing the grid condenser. The condenser after removal was tested for a short circuit with 250 volts, but it showed no current passage. As I was unable to disassemble it without injury, I do not know what the trouble was. [The test made would indicate a short circuit, but not an "open." It is just possible that the mica grid condenser in question had an open cir-

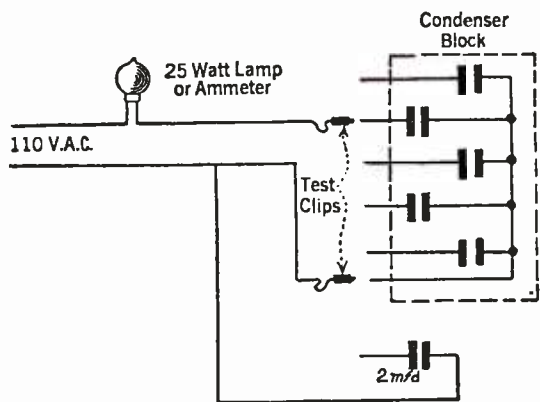

Fig. 2—Method of determining approximate capacities of various units in a condenser block.

cuit which could not be shown by 250-volt test.—Editor.]

—W. C. ROEMER, New Haven, Connecticut

Testing Condensers: Several days ago in building up a power amplifier. I tore down an old power unit in order to salvage the condensers. I lost track of the various leads on the condenser bank and was faced with the problem of finding a quick and easy method of determining the common ground and the various capacity leads. I finally hit upon this scheme: The two leads from the 110-volt a.c. main are connected in series with a 15- or 25-watt lamp and the condenser to be tested. See Fig. 2. Since a.c. is employed, some current will flow. The amount which flows depends on the capacity of the condenser. The glow of each section was compared with the glow using a standard 2-mfd. condenser. In this way I could determine not only the ground lead or common lead, but also the approximate capacity of each section. If an a.c. ammeter is available, a much more accurate check can be made. For an ordinary condenser bank, however, the lamp method is quite satisfactory.

—KARL F. OERLEIN, Philadelphia, Pa.

Common A.C. Receiver Troubles: The simple chart below lists some of the most frequently encountered troubles in a.c. receivers. The chart is not exhaustive by any means, but may suggest to others ways of organizing service information which they have or may gather in the course of their work. The use of this chart in conjunction with a good set tester, such as Jewell, Weston, Supreme, will enable the serviceman to locate quickly the defective part or condition.

Symptoms:	For causes refer below to:
No Filament Voltage	No. 1
No Grid Voltage	No. 2
No Plate Voltage	No. 3, 4, 5, 6, 7
Voltage with little or no current in Plate Circuit	No. 8, 9
Excessive Plate Current	No. 10

Causes:

- 1—Loose terminals, poor soldering, open or shorted power transformer winding.
- 2—Open grid suppressor, open divider resistor, open a.f. or r.f. transformer secondary.
- 3—Open divider resistor.
- 4—Open r.f. primary.
- 5—Open a.f. primary.
- 6—Shorted by-pass or filter condensers.
- 7—High-resistance connections, open leads, or loose terminals.
- 8—Low-emission tube.
- 9—Defective socket, dirty contacts.
- 10—Open a.f. or r.f. grid circuit, no bias, excessive plate voltage, defective tubes.

CARLTON W. CROTEAU, Mount Carmel, Conn.

Shooting Trouble on Atwater Kent No. 20: Having made many service calls on Atwater Kent model 20 sets, two main sources of

trouble stand out: blown out by-pass condensers, and blown resistors. To test properly for these troubles, a regular set tester is desirable, but if none is available, a high-resistance voltmeter (1000 ohms per volt) should be used. Test the plate voltage on each of the r.f. sockets. If there is no plate voltage, remove the set from its cabinet and make a circuit tester from a high-resistance voltmeter. See Fig. 3. If the condenser passes a steady voltage, it should be replaced. To test the resistors, the set must be removed from the cabinet and tested with the meter arrangement suggested. My experience has shown that in nine out of every ten service calls on this set these two tests made in this way will locate the trouble.—F. D. MITCHELL, Collingdale, Pennsylvania.

Hum in Moving-Coil Loud Speakers: "I have had two a.c. Peerless dynamic speakers which hummed badly, due apparently to feedback on the 8-volt a.c. links," writes L. A. Moss of Los Angeles, California. "A 4000-mfd. dry 'A' condenser stopped it, so that there is now no hum at all. Fig. 4 shows the method of connection. [The suggestion is excellent, but the reason for the hum is not correct. Hum in a.c.-operated moving-coil

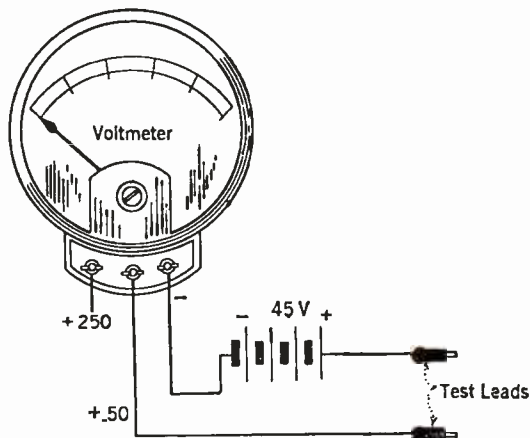

Fig. 3—A high-resistance voltmeter and battery provide an efficient circuit tester

speakers is due to the fact that the rectifiers employed do not supply pure d.c., but a pulsating direct current. Placing a condenser across the field cuts out much of the ripple and the field is therefore supplied with current more nearly pure d.c.—Editor.]

Items of Interest

MANY servicemen are called upon to remedy interference due to oil burners, mechanical refrigerators, leaky power lines, door bells or the neighbor's pet dog. We have answered many requests from men in the field as to what printed matter is available on the solution of interference problems. These are the references:

"Suppressing Radio Interference," by A. T. Lawton RADIO BROADCAST, September, November, 1927; January and March, 1928. 35 cents each. Circuits and methods for solving every kind of interference problem. Order copies from subscription department, Doubleday Doran & Co., Inc., Garden City, New York.

Radio Interference Problems, a bulletin. National Electric Light Ass'n., 420 Lexington avenue, New York City, 60 cents each.

Radio Interference, Casey. Distributed by Radio Manufacturers Ass'n, 32 West Randolph Street, Chicago, Price 25 cents.

The information from each of these sources does not differ greatly. In our opinion, the RADIO BROADCAST articles by Lawton are the most complete, with the National Electric

Light Association pamphlet a close second. The RMA pamphlet is also good.

The bound volume of RADIO BROADCAST's Laboratory Data Sheets contains a great deal of useful information for radio servicemen. Many have written us ordering extra copies for use in the field, and, even though the book has been on sale for little more than a month, thousands of orders have been filled from servicemen. If your newsdealer does not have the Sheets orders can be sent directly to the Circulation Department, Doubleday Doran & Co., Inc., Garden City. Price, one dollar.

In a recent article in this magazine by B. B. Alcorn, the use of test prods was discussed. While made-up prods can be had, Mr. Alcorn advises that those he used were made in his shop. He bought fibre tubing with an inside diameter about the size of the average pin jack. The Weston Electric Instrument Company, Newark, N. J., supply with some of their meters a long-pointed prong. Extra prongs can be had from Weston. These were slipped inside the tubing and flexible leads soldered to the far end. And so you have perfectly satisfactory prods which are really invaluable for service work in the field or on the shop bench.

The Tobe Deutschmann Company, Canton, Massachusetts, have been supplying for some time devices for interference reduction and elimination. Mr. Deutschmann writes that in addition to the apparatus they have for sale, the engineering department of the company is glad to lend its aid in helping to solve immediate interference problems which present themselves. Inquiries should be sent direct to Mr. Deutschmann at Canton.

Tobe Deutschmann now make the following devices for interference work: radio interference filter No. 1 (large capacity condensers connecting across the supply line), filterette No. 22 (metal box containing fuses, condensers, etc.), filterette No. 31 (for sign flashers).

A dealer in Manhattan, Kansas, the Kolster Radio Company informs us, got good radio reception where it seemed almost impossible in a downtown building. A motion-picture theatre wanted to receive a particular broadcast and reproduce it in the auditorium through Kolster moving-coil reproducers. A special telephone line was secured, connecting the theatre and the home of G. W. Livingston, the local Kolster representative. A Kolster K-20 set was installed and its output transmitted over the telephone line to the theatre where the reproducers were connected. This bit of initiative brought credit to the dealer, the set, the theatre, and unquestionably made some set sales.

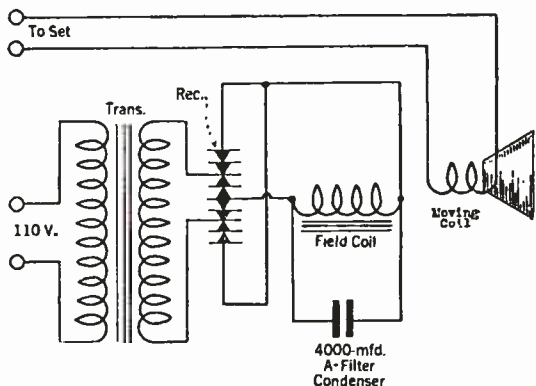

Fig. 4—Hum in a.c.-operated dynamic loud speakers may be reduced by use of a 4000-mfd "A" condenser.

AN ECONOMICAL BATTERY-OPERATED SET

By HOWARD E. RHODES

Technical Editor

AN INEXPENSIVE receiver with a plate-current consumption low enough to permit economical operation from dry-cell batteries should appeal to those living in districts so remote from power lines that light-socket-operated receivers cannot be used. Those who would like to build this type of receiver also require that it provide good quality, sensitive, and selective enough for ordinary reception, and that it cost not more than about \$40, exclusive of tubes, batteries and loud speaker.

Such a set has been built up in RADIO BROADCAST'S Laboratory and is illustrated and described in this article. The feature, which more than anything else contributes to the low current consumption of the receiver, is the resistance-coupled audio amplifier, since the plate current drawn by the high- μ tubes is not more than about 0.2 milliamperes per tube. The power tube is a 112A and the r.f. amplifier and detector tubes are 201A's. The plate-current consumption of the entire receiver is 10 milliamperes, and with this load the three heavy-duty B batteries required for the operation of the set should have a life of about 500 hours, the equivalent to about a year's operation if the set is used a couple of hours each day. The total drain of 10 milliamperes required for the operation of the set is divided between the various tubes as indicated below.

TUBE	PLATE CURRENT
201A r.f. amplifier	2.0 mA.
201A detector	0.5 mA.
240 first a.f. amplifier	0.2 mA.
240 second a.f. amplifier	0.2 mA.
112A power tube	7.0 mA.
Total	9.9 mA.

The circuit diagram of the receiver is given in Fig. 1. The set consists of a stage of tuned radio-frequency amplification, a regen-

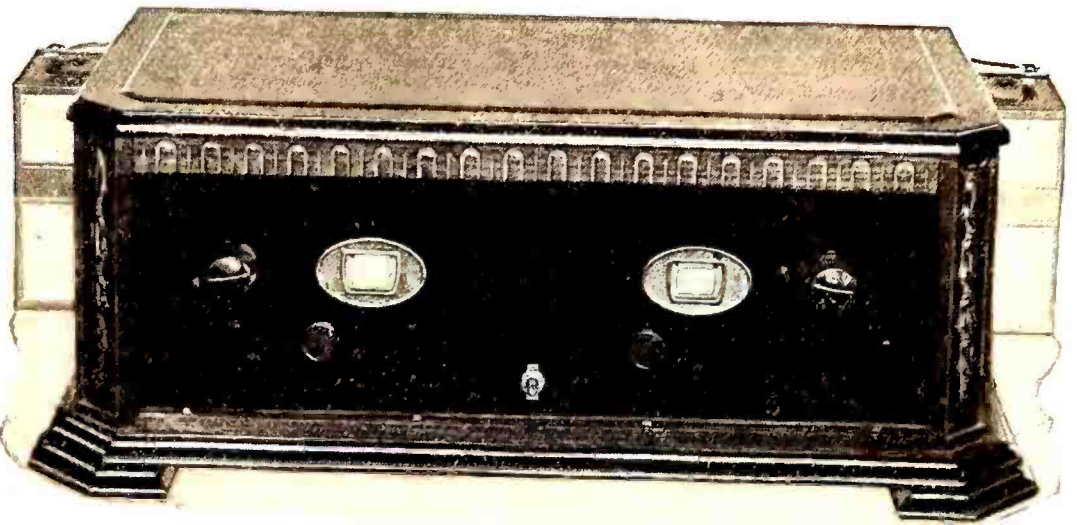

View of receiver installed in an attractive walnut cabinet

erative detector, and a three-stage resistance-coupled amplifier. The two tuning condensers are C_1 and C_2 , and C_4 is the neutralizing con-

denser. Regeneration is controlled by the tickler coil, L_5 . Coil specifications, which will enable those who so desire to build their own coils, are given in Fig. 2.

The circuit of the resistance-coupled amplifier is perhaps somewhat unusual. Such amplifiers frequently have a tendency to "motorboat" and to prevent this filter circuits have been placed in the plate circuits of the detector tube and the first- and second-audio tubes of this receiver. In the detector plate circuit the filter consists of C_7 and R_3 , in the first audio-amplifier circuit the filter is C_8 and R_3 , and in the second amplifier circuit, C_9 and R_3 comprise the filter. In these filter systems, the condensers C_7 , C_8 , and C_9 provide low-impedance paths directly from the plate circuits to the filaments, so that all the currents flow through these condensers, rather than through the resistors R_3 and into the B batteries where they might cause common coupling which would result in oscillations or "motorboating." These filter systems will prove especially advantageous when the B batteries become old and their resistance increases as this tends ordinarily to produce "motorboating." In the Laboratory it was found possible to place a resistor of 1000 ohms in series with the negative B lead before the amplifier began to "motorboat." This value of resistance would correspond to a resistance of about 333 ohms per battery and when the resistance reaches this value the batteries have long since passed the end of their useful life.

The plate resistors, R_1 , used in the amplifier each have a value of 250,000 ohms and the grid resistors, R_2 , all have a value of 2 meg-ohms. The coupling condensers, C_6 , have a value of 0.005 mfd. These values of resistance and capacity yield a satisfactory frequency response. However, those who feel that the decrease in response at 60 cycles is too great may improve the response at this frequency by using larger coupling condensers.

When a detector is followed by a resistance-coupled amplifier it is quite important that

This receiver, which has more to recommend it than neat appearance, should interest those who are unable to use the power lines as a source of A and B potential. The A potential must be supplied from a storage battery, and with this design it is really economical to operate this outfit from B batteries. The total current consumption is not more than 10 mA. With average use this means that a set of B batteries should last about a year. The cost of the essential parts does not exceed \$40 which should make this set even more interesting!

—THE EDITOR.

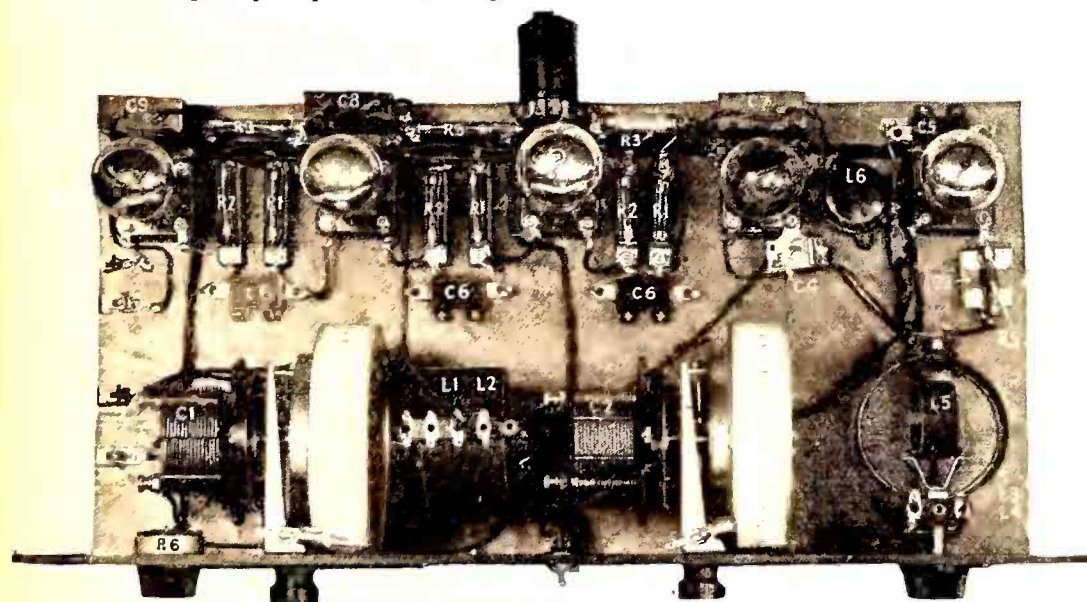

Top view shows arrangement of parts on baseboard

none of the r.f. currents in the plate circuit of the detector tube are permitted to pass into the audio amplifier. For this reason there is included in the plate circuit of the detector the r.f. choke coil, L_6 , and the small 0.0002-mfd. by-pass condenser, C_5 . These two units comprise a filter system which causes the r.f. currents to pass directly back to the filament of the detector tube but which does not prevent any of the audio-frequency currents from passing into the audio amplifier.

The receiver contains two tuned circuits, L_2C_1 and L_4C_2 . Were it not for the fact that regeneration was incorporated in the detector these two tuned circuits would not give sufficient selectivity. By means of the regeneration control, however, it is possible, when necessary, to bring up the selectivity to a point where satisfactory discrimination between different stations is obtained readily. The various taps are placed on the antenna coil, L_1 , so that when the set is first placed in operation reception may be checked with the antenna connected to the different taps and the lead can be soldered finally to that tap giving the most satisfactory combination of sensitivity and selectivity. The volume control consists of a variable resistor, R_6 , connected in the filament circuit of the r.f. tube.

Output Arrangement

THIS receiver has been operated in the Laboratory with a 112A-type output tube feeding into a good moving-coil loud speaker, and excellent quality was obtained at moderate volume. If more volume is desired a 171A-type tube may be used with 135 volts on the plate and a 27-volt C bias. Under these conditions the latter tube will deliver about 330 milliwatts of undistorted power as compared with about 120 milliwatts which is obtained from a 112A tube with 135 volts on the plate and a C bias of minus 9 volts. The only disadvantage of using a 171A-type tube rather than a 112A is the increased plate current drain which will raise the total load on the B batteries from 10 mA. with a 112A-type tube to 19 mA. with a 171A-type tube. With the latter tube the batteries will, therefore, have a life of about 250 hours. We feel that in most cases the 112A-type tube will prove satisfactory although, if sufficient volume is to be supplied for dancing, for example, then it will probably be necessary to make use of a 171A-type tube.

In operating this set in the Laboratory it

was interesting to note how clearly defined is the overloading point of the resistance-coupled amplifier. When using transformer-coupled amplifiers a certain small amount of overloading may exist on peaks without experiencing serious distortion, but with a resistance-coupled amplifier even slight overloading tends to make the tubes block so that reception is practically ruined. All this simply

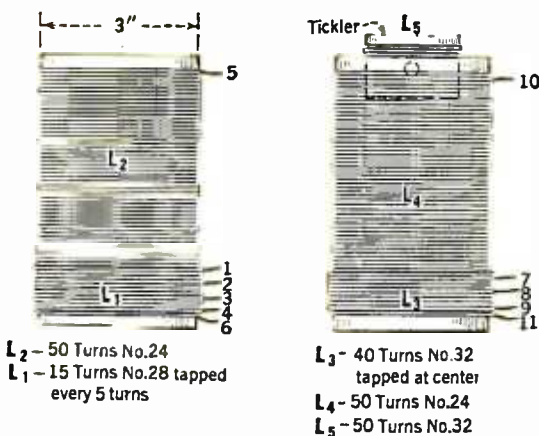

Fig. 2—Coil Specifications for battery set

means that in operating the set the volume control must be kept at a point low enough to prevent overloading. Incidentally, the plate and grid voltages supplied to the first and second audio tubes are such that these tubes will not overload if called upon to supply a peak potential of about 50 volts to the grid of the power tube. It follows, therefore, that the amplifier has more capacity than necessary to supply either a 112A- or a 171A-type tube, since the latter tube (with a C bias of 27 volts) doesn't require a peak potential of more than 27 volts on its grid.

The model of this receiver which was constructed is illustrated in the various pictures. The baseboard is 10 inches deep and 20 inches long and the panel is 7 inches high and 21 inches long so the set will fit in any of the standard cabinets which are generally 21 inches long and about 12 inches deep. The various parts which make up the set are lettered on the circuit diagram, Fig. 1, to correspond with the lettering in the pictures and in the list of parts. With these data it will not be difficult to locate the various units on

the baseboard and to lay out the panel. The drilling templates supplied with the Remler drum dials are used in locating the various holes on the panel. The volume-control rheostat, R_6 , the on-and-off switch, and the regeneration control may be placed as indicated in the pictures. In starting the construction of the receiver, the coils and condensers should be placed on the baseboard first, their corresponding position relative to the panel determined, and the latter drilled as indicated above. The various sockets, resistor mounts, and condensers are then mounted on the baseboard. The cable connector is located along the rear edge of the baseboard.

The tuning of this receiver should not be difficult. To tune in a station regeneration should be increased until the detector circuit oscillates, the carrier wave should be tuned-in by locating a heterodyne squeal, and then the first condenser may be tuned to resonance. Maximum selectivity will be obtained when considerable regeneration is used in the detector circuit; therefore, in those locations where great selectivity is required it is advisable to operate the set with some regeneration, reducing the volume if necessary by means of the volume control.

Parts Required

THE parts used in the model illustrated in this article are named below. Other parts electrically equivalent may, of course, be substituted if desired. The complete list follows:

- C_1, C_2 Two Remler condensers, 0.0005-mfd.;
- C_3 One Polymet grid condenser, 0.00015-mfd.;
- C_4 One Hammarlund neutralizing condenser;
- C_5 One Frost fixed condenser, 0.0002-mfd.;
- C_6 Three Frost fixed condensers, 0.005-mfd.;
- C_7, C_8, C_9 Three Polymet by-pass condensers, 1-mfd.;
- L_1, L_2 One Hammarlund antenna coil.;
- L_3, L_4, L_5 One Hammarlund r.f. choke, type R.F.C. 250.;
- R_1 Three Daven Glastors, 0.25-megohm.;
- R_2 Three Daven Glastors, 2-megohm.;
- R_3 Three Daven Glastors, 0.1-megohm.;
- R_4 One Frost fixed resistance, 0.8-ohm.;
- R_5 One Daven Glastor, 2-megohm.;
- R_6 One Yaxley filament rheostat, 15-ohm.;
- S One Frost Filament switch.;
- Five Frost sockets.;
- One Frost cable, type 780.;
- One Frost cable connector, type 781.;
- One coil Frost hook-up wire.;
- One Micarta panel, 7 x 21-inch.;
- One Baseboard, 10 x 20-inch.;
- Two Remler drum dials, type 40.;
- Four Farnestock clips.

The total cost of the parts listed above is not more than \$40.00.

The following accessories are required:

- Two 201A-type tubes.;
- Two 240-type tubes.;
- One 112A-type tube.;
- Three Eveready heavy-duty B batteries.;
- Two Eveready C batteries, 4½-volt.;
- One Storage battery, 6-volt.;
- One Loud speaker.

The set described in the preceding paragraphs was constructed as a result of requests from many readers for data on a receiver that might be operated economically from B batteries. Those who desire such a receiver but who, perhaps, do not want to go to the trouble of constructing one will be interested in the Eveready receiver. This set contains six tubes, is single controlled, and uses 240-type high- μ tubes throughout, except in the power stage where a 112A- or a 171A-type tube is recommended. This Eveready receiver contains three stages of r.f. amplification and shielded, the detector is followed by a resistance-coupled amplifier. The set lists at \$85, without tubes or batteries.

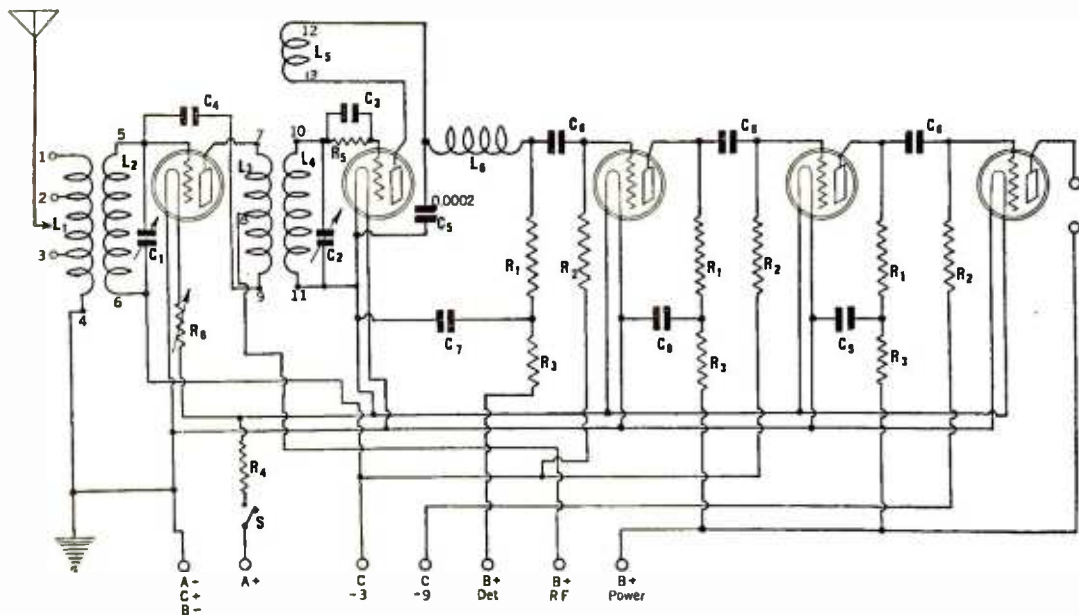

Fig 1—Complete schematic diagram of the low current consuming receiver developed in the Laboratory

VOLUME CONTROL SYSTEMS

THE modern radio receiver has three controls on the panel—the tuning dial, the on-and-off switch, and the volume control. The electrical position of the first two controls is fixed—the on-and-off switch always is connected in the power circuit and the tuning dial always controls to the tuning condensers. The volume control, however, may be located at many different points in the circuit.

From the standpoint of volume control a radio receiver might be divided into two main sections. In one section we place all the apparatus between the antenna and the input to the detector and the other section includes the circuits from the output of the detector to the loud speaker. Let us consider first the former section and determine at what points a volume control might be located.

The First Section

THE first section mentioned above, consisting of that apparatus between the antenna and the input to the detector, is actually the r.f. amplifier and so discussion now centers around where the volume control might be located in such an amplifier. In Fig. 1 we show seven diagrams of different parts of an r.f. amplifier system and each drawing indicates a different location for the volume control. Diagram A shows the volume-control resistor connected between antenna and ground. Sketch B shows the volume control connected across the primary of one of the r.f. transformers, in C the volume control is connected in series with the ground lead, and in D it is across the secondary of an r.f. transformer. In E the volume control is across the secondary of the r.f. transformer feeding the detector tube, and in F the volume control is a rheostat in the filament circuit. Diagram G shows a variable resistor, R, in series with the plate circuit of an r.f. tube and this provides another method of controlling volume. The characteristics of these various arrangements are briefly given below.

Arrangement A: This control is used in many receivers and is considered quite satisfactory. Its one disadvantage is that when the control is adjusted to a point where its resistance is quite small (to obtain a low output from the loud speaker)

the shunting effect of this resistor may lower the selectivity of the first r.f. transformer. Since, however, the volume is cut down when listening to powerful local stations, selectivity is not especially important and this is not a serious drawback. This volume control arrangement may be considered satisfactory.

Arrangement B: This arrangement is practically the same as A except that the resistor is connected across the primary of one of the interstage r.f. transformers. This control may also be considered satisfactory.

Arrangement C: With the volume-control resistor connected in series with the antenna-ground circuit, as in this arrangement, minimum volume is obtained when the volume control has a maximum value of resistance. This control will not tend to decrease the selectivity, but in many cases it has the disadvantage of making it impossible to bring the volume to absolute zero.

Arrangement D: Connecting a resistor across the secondary of a tuned circuit is

essentially similar to connecting a smaller low-value resistor across the primary, as was done in arrangement A, and both controls have essentially the same characteristics.

Arrangement E: The input circuit to a leak-condenser-type detector tube is generally of much lower resistance than that of a tube used as an r.f. amplifier; for this reason the selectivity of the tuned detector grid circuit is lower than the r.f. stages. Therefore, a volume control may be connected across this tuned circuit without materially impairing the selectivity of the receiver.

Arrangement F: A rheostat in the filament circuits of the r.f. tubes has long been a standard type of volume control in battery-operated sets. However, it cannot be used with a.c. receivers, since it is not practical to control the volume by varying the filament currents of a.c. tubes. With the 226-type tubes varying the filament current would tend to increase the hum and in the case of the 227-type tube the electron emission from the cathode does not follow instantaneously the variations in current through the heater.

Arrangement G: This type of volume control, consisting of a resistor in series with the B supply to the r.f. tubes, has been used very satisfactorily in battery-operated sets but cannot be considered a good control for receivers operated from a B-power unit. As the resistance is increased to reduce the volume the current drain of the r.f. tubes also decreases and, as a result, the voltage on the other tubes in the receiver is increased.

In summary we would classify arrangements A, B, D, and E as satisfactory volume controls for any receiver, arrangements A and E being, in general, preferable. F is a satisfactory control for a battery-operated set. C and G are unsatisfactory.

The Second Section

VOLUME controls in any part of the circuit following the detector are generally unsatisfactory, for they do not prevent overloading of the detector tube when receiving strong local signals and detector overloading can produce serious distortion. A safe rule is always to locate the volume control at some point in the r.f. amplifier.

In Table I we have listed resistors made by various manufacturers which can be used satisfactorily as volume controls.

Table I

ARRANGEMENT	RESISTANCE REQUIRED	MANUFACTURERS
A	5000 ohms	Carter type TP-5M, Frost type 1897
B	10,000 ohms	Carter type TP-10M, Frost type 1898
D	100,000 ohms	Bradleyohm type E, Carter type 11, Centralab type 100M, Frost type 1891, Clarostat Universal type, Electrad Tonatrol
E	100,000 ohms	Bradleyohm type E, Carter type 11, Centralab type 100M, Frost type 1891, Clarostat Universal type, Electrad Tonatrol
F	15 ohms	Carter type IR-15, Frost type 1815, Yaxley type 515, Clarostat Universal type, Electrad Tonatrol

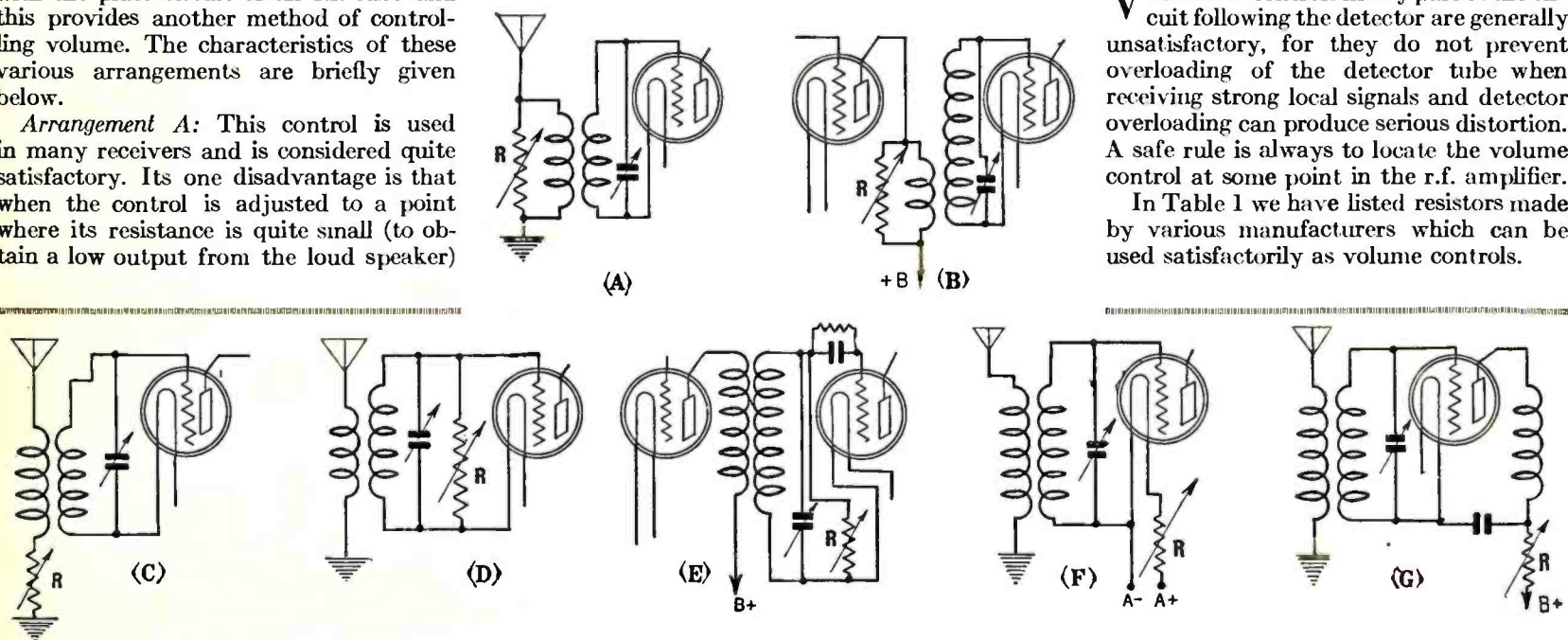

Fig. 1.—The volume of a radio receiver may be controlled in many different ways. The above diagrams illustrate seven different systems which are used frequently

our readers suggest . .

Uses for Damaged Meters

THE writer recently had on hand two Weston model 425 thermo-ammeters, reading up to 1.5 amperes, that had been used as antenna ammeters. Accidental overloads destroyed the thermo-junction but left the galvanometer movements undamaged. Test showed that the movement gave a full-scale deflection with a current of about 2 milliamps. The meters were accordingly taken apart, the thermo-junctions discarded, and the leads from the moving coils attached to the external connecting posts of the meters. One of the meters was then employed as the grid-current meter in the modulated oscillator described in June, 1924, RADIO BROADCAST, a nichrome shunt of about ten ohms being connected across the meter to provide a little damping. Otherwise the meter would be working practically on open circuit, and the needle would oscillate freely owing to the absence of electromagnetic damping, making the observation of readings difficult.

The remaining meter was used as resonance indicator in an absorption wavemeter for transmitting work, the circuit of which is shown in Fig. 2. A "low-loss" coil and condenser form the tuned circuit. The meter in series with a carborundum crystal, is tapped across about one-eighth of the coil. Carborundum is used for two important reasons: it is robust, holding its adjustment indefinitely, and not being liable to burn out on accidental overload; and it usually has a high resistance of the order of thousands of ohms, so that it does not unduly damp the tuned circuit, which would make the point of maximum response very broad and indefinite. For the same reason, the crystal and meter are shunted across only a small portion of the tuned circuit, and in practice the instrument tunes so sharply, especially on the shorter waves, as to make a slow-motion control necessary for comfortable working. It is quite sensitive, giving a good deflection at 80 meters when excited by the modulated oscillator at a distance of a foot. A shunt of ten ohms or so, wound on a match-stick with fine nichrome wire, is needed to steady up the needle, the best value for which should be found experimentally.

A picture of the instrument is shown in Fig. 1. The writer used a crystal of carborundum set in solder in a cup, with a steel phonograph needle attached to a stiff spring as the "cat-whisker" (use plenty of pressure), but no doubt the commercial carborundum detector cartridge would be quite satisfactory. The connections to the meter may have to be reversed to get the polarity right. No attempt was made to calibrate this instrument in wavelengths, in view of the possibility of a fresh point in the crystal being needed occasionally which might affect the calibration. The point of maximum response to the transmitter is found, and the actual wavelength is then obtained by removing the instrument without disturbing its setting, and coupling it to a modulated oscillator, which

This department of RADIO BROADCAST is utilized each month for the presentation of miscellaneous short radio articles which are received from readers. These abbreviated manuscripts describe "kinks," radio short cuts, and economies that the experimenter runs across from time to time and that can be made clear in a concise exposition. Although some of these notes have been submitted by engineers and professional writers, the editors particularly solicit contributions from the average reader. All material accepted, including photographs, will be paid for on publication at our usual rates with extra consideration for particularly meritorious ideas

—THE EDITOR.

has been carefully calibrated, and is kept as a standard wavemeter.

F. G. CANNINE, Melbourne, Australia.

High-Frequency Tuning

I HAVE read in RADIO BROADCAST numerous excellent articles on short-wave reception and transmission. In most receivers the tuning condensers specified are usually of 0.00014 mfd. capacity, or thereabouts. For easy tuning, especially on the very short wavelengths, a small capacity condenser is to be preferred. In my receiver I use a 50-mmf. General Radio midget condenser cut down to 4 plates (about 12 mmfd.), and I find this sufficient for all bands from 18 meters up to above 85. A hair-splitting vernier isn't necessary, and with an ordinary 4-1 vernier the tuning is not in the least critical.

HARRY F. WASHBURN, Jr., New York City.



Fig. 1—External view of home-made wavemeter. The resonance indicator is a d.c. milliammeter.

A Handy Connector

OFTEN the experimenter finds it desirable to connect several pairs of headphones in series, or to make other temporary connections. It usually takes considerable time to connect the phone tips, and I have hit upon a plan which greatly simplifies the process.

I carefully removed the clips from several discarded B batteries and placed them in my tool box. Whenever it is necessary to connect two phone cords or wires all that is necessary to make a tight connection is to insert the tips into the clip from opposite sides, and the connection is tight until you are ready to release it.

IRMEI N. BROWN, McAfee, Ky.

Increasing Charging Rates

A TUNGAR or Rectigon two-ampere charger can be made to charge up to three amperes simply by removing the outer cover or shield. This metal shield around the transformer absorbs considerable energy, particularly the old-type cast-iron cover on the Rectigon.

To give the battery a quicker charge, simply remove the cover.

R. B. BARROWS, Portland, Me.

STAFF COMMENT

The same applies to six-ampere chargers. The charging rate may be still further increased (apparently without damage to the tube) by remounting the elements of the charger on a wooden base. This will also eliminate most of the noise associated with many commercial types of tube rectifiers.

Home Broadcasting

HERE is a surprisingly simple and inexpensive way of converting your present radio set into a speech amplifier or public-address system. Such an outfit is not only amusing for use in the home hut has many valuable applications for special events, large gatherings, etc.

A single open-circuit jack is wired across the grid and negative filament terminals of the detector tube socket, into which the leads from the microphone transformer are plugged. In this way the detector tube functions as the additional stage of audio-frequency amplification desirable for best results with a microphone.

The microphone in this case is a standard telephone transmitter and the transformer is a Jefferson No. 1603 bellringing transformer. The 110-volt primary leads from the transformer are connected to a regulation loud-speaker plug and inserted into the jack connected to the grid circuit of the detector tubes. The telephone transmitter, with 3 standard dry-cell batteries in series, is connected across the two outside binding posts on the transformer (the terminals of the 18-volt secondary winding).

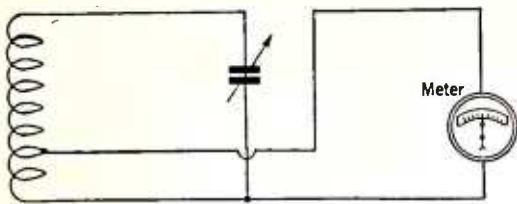

Fig. 2—Circuit diagram of absorption wavemeter

This arrangement will be found to have excellent voice-frequency characteristics and the output will be very lifelike and natural, depending of course upon the quality of your audio amplifier. As the microphone is very sensitive it must be placed some distance from the loud speaker, preferably in another room if used indoors, to prevent mechanical feedback and squealing. A volume control in the audio amplifier will be found helpful in controlling the output as well as any tendency to squeal due to proximity of microphone and loud speaker.

T. F. McDONOUGH, Los Angeles, Cal.

STAFF COMMENT

Mr. McDonough is perhaps a little tolerant of the quality in the arrangement he describes—which by the way, works nicely. However, the standard telephone microphone, aside from being the property of the Bell Telephone Company, is hardly partial to the frequency requirements of good loud-speaker speech reproduction. Much better quality will be secured by plugging the winding of a horn-type loud speaker into the jack provided in the detector circuit—without a transformer of any kind. The loud speaker is used as the microphone. You may speak into the horn, or the horn can be removed and a small mouth-piece substituted. No batteries are used. The loud-speaker unit functions as a magnetic microphone, and will output excellent quality.

A Simple Wire Shield

“Our Readers Suggest—” for last November contains a contribution on reducing hum in a.c. sets by running the a.c. leads in grounded BX cable. Another and perhaps easier way of securing the same results, is to wrap the leads in “talking tape,” and grounding as usual.

“Talking tape” is the familiar indoor antenna tape.

H. CRANSTON JONES, Brooklyn, N. Y.

A Simple Lightning Arrester

AN EFFICIENT lightning arrester may be made from old phonograph needles. Obtain a small piece of bakelite and mount on it two strips of brass copper or other metal. The strips may be held in place by two terminals, as shown in Fig. 3. The phonograph needles are soldered on to each strip, towards

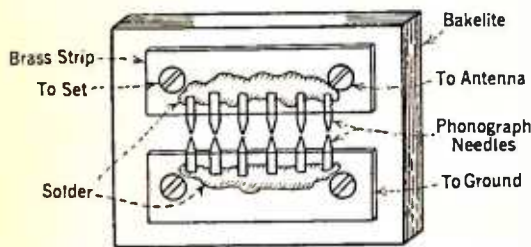

Fig. 3—Old phonograph needles may be used in the construction of a practicable lightning arrester.

each other, with a gap of $\frac{1}{16}$ " between them. The leads from the antenna and the ground are connected to the terminals on the strip. A heavy discharge of lightning will jump the gap and will not injure the receiver.

EDWARD PIRANIAN, Philadelphia, Pa.

An Emergency Output Circuit

A SIMPLE emergency repair of a set in which the primary of the output transformer had burned out was accomplished as illustrated in Fig. 4. The secondary of the transformer was connected as a choke coil and the loud speaker fed through a 2-mfd. condenser. The primary was left unconnected.

Break connections at points marked “X” and make the new connections indicated by dotted lines.

As the repair was an emergency one, and some doubt was felt about the particular condenser at hand standing up under the voltage applied to the last audio tube, the return from the loud speaker was connected to the B-plus side of the choke, so that the

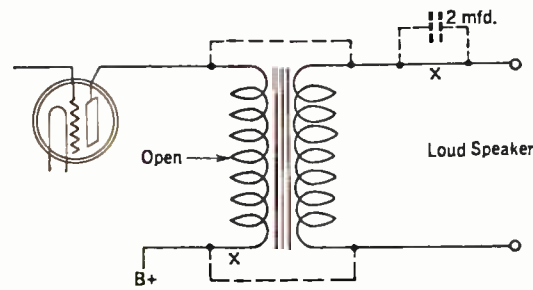

Fig. 4—Diagram shows method of using burnt-out transformer as an output choke.

B supply would not be short-circuited if the condenser did blow.

If a condenser of proper voltage rating is used, the return may be connected to the negative filament or to the center-tap connection of the filament transformer secondary if the tube is lighted from a.c.

JOHN O'DONNELL, The Bronx, N. Y. C.

STAFF COMMENT

This department receives more suggestions on output arrangements than on any other phase of receiving technique. The editor considers that this is indicative of unusual interest in the subject, and so will continue to publish the majority of such contributions, even with the possibility of an occasional duplication.

High-Resistance Voltmeter

THE high-resistance voltmeter is second only to output devices in contributions to this department. The following suggestion is submitted by D. J. VALENTINE, of Bangor, Me.

The average radio fan or set-builder seldom can afford the price of a high-resistance voltmeter, although there are many occasions where the use of such an instrument is practically a necessity. For best results the B voltage applied to the plate circuits from a power-supply system should be adjusted carefully with a high-resistance meter, instead of by guess work, as the average fan must do. The voltmeter described below was made by the writer at a cost of less than \$10.00, and it

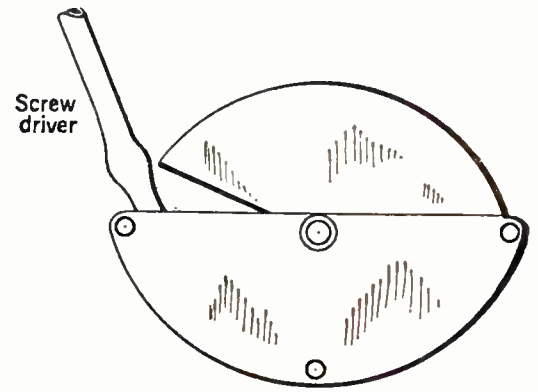

Fig. 5—Bending the plates at the right-hand side of the condenser affects tuning on both long and short waves, while bending them at the left-hand side will affect only the long waves.

has a resistance of 1000 ohms per volt, which means that only 1 mA. is drawn for full-scale deflection. The parts were mounted on a small piece of rubber panel, with the necessary binding posts, and the whole enclosed in a cigar box which was covered with artificial leather.

The meter is a milliammeter with a range of 0-1 milliampere and the resistors are Daven “Davohms” of 200,000 and 500,000 ohms. The resistors are guaranteed accurate within plus or minus 1 per cent. By throwing the single-pole, double-throw switch (such as a Yaxley Antenna Switch No. 11), either the 200,000-ohm unit or both units are thrown in series with the meter (Fig. 6), and the range becomes 0-200 or 0-700 volts accordingly. Of course, other values of resistances may be used, and the range of the instrument extended to 1000 volts or more. The accuracy depends on the accuracy of the meter and of the resistors. If desired it may be calibrated with a standard although the one built by the writer proved to give sufficiently true readings for all ordinary uses.

STAFF COMMENT

The voltage will always equal the reading on the meter divided by 1000 times the resistance in series with it.

Balancing Gang Condensers

THERE are many instances, particularly in factory receiver construction, where trimmers are not provided to compensate tuning discrepancies in tandem-tuned circuits. The proper adjustment of such circuits may be effected by inserting a screw driver between the plates, close to where they are attached to the frame, and prying one stator plate nearer to an adjacent rotor, thus raising the capacity of the section without materially altering the tuning characteristic (an advantage over the trimmer system). It is also possible, by means of this method, to compensate tuning on the long wavelengths without affecting tuning on the short wavelengths, as suggested in the drawing of Fig. 5.

A. T. LEQUEAR, Erie, Pa.

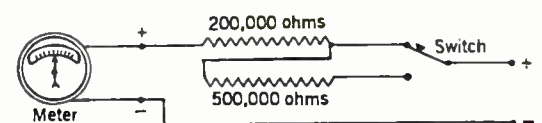

Fig. 6—Circuit of home-made high-resistance voltmeter.

A SHORT-WAVE SUPER-HETERODYNE

By ROBERT S. KRUSE

IT WILL be recalled that Armstrong's form of double-detection receiver was devised to meet an emergency. The French army owned a large number of long-wave amplifiers but desired short-wave amplification. Depending on the gullibility of the amplifiers, Armstrong devised a converter which would connect in the antenna circuit, hastily turning short-wave signals into long-wave signals and passing them on to the amplifier. The amplifier trustingly accepted them as genuine long-wave signals and amplified them into something of presumable military value. In the enthusiasm of the moment, one assumes, there was invented the name "super-heterodyne" which has itself been amplified into something of unmistakable commercial value.

This bit of radio history naturally brings double-detection to mind whenever one has a short-wave amplification problem on hand. In the broadcast band the problem no longer exists, other means of seemingly equal merit being universally known and somewhat less universally available. In the region below 150 meters, and in fact to some degree between 150 and 200 meters, the problem of satisfactory amplification is still present and one is somewhat amazed that the double-detection receiver does not have a larger foothold.

The situation is probably historical. Until very recently the sub-200 meter region was almost wholly telegraphic; even the radiophone experimenters used the key to supplement their microphones. The commercial men who worked in the region were all message handlers. Naturally, therefore, the receivers were suited to telegraphic reception and for that purpose the double-detection principle has no alarming advantage between 25 and 200 meters; one can do nearly as well with a simple oscillating detector and audio amplifier.

As soon as telephony and television invaded the shorter waves the story became different. The oscillating detector became merely regenerative and in that act lost most

Given a short-wave receiver of the conventional regenerative detector type, how can it be improved? Mr. Kruse turns it into a double-detection receiver, which is the "high hat" way of saying super-heterodyne. He adds a frequency changer, and an amplifier working at the frequency to which the desired signal is changed. This amplifier may be specially built or it may be one's broadcast frequency receiver used as an amplifier, second detector, and audio amplifier. Mr. Kruse has another article on this double-detection business in the office, and it will appear in a forthcoming issue of RADIO BROADCAST.

—THE EDITOR.

One may turn to tuned r.f. stages, using the 222-type tube, but for several reasons this is not as simple as tuned r.f. in the 200-550 meter region. The best of these reasons is that one is trying to cover the huge territory between 14 and 200 meters and this is equivalent to 20,000 kilocycles! It is a troublesome task to cause a set of plug-in coils with gang tuning to "run together" with the cramped scales that result. One must either drop down to a single r.f. stage and two controls or else convert the signals to some more normal wavelength where they will be more amenable to amplification. The second scheme makes necessary the use of a double-detection system.

In this article the writer describes a double-detection (super-heterodyne) receiver. It is made by adding a heating oscillator to an already existent short-wave receiver. The beat frequencies from this oscillator and receiver are amplified at a lower frequency, detected again, and then amplified.

The Detector-audio Adapter

THE particular kit shown in the illustrations is chain-store distributed and, therefore, an excellent subject for manipulation since additional parts may be obtained easily. It happens also that the coils used are especially suited to the adaptation, although a "dodge" to make others perform similarly is also given.

Referring to Fig. 1 we have the normal diagram of the set which is, for some mysterious, reason called the "Wasp"! It employs the usual regenerative detector, VT₁, plus two stages of audio. Regeneration is controlled by means of a variable bypass condenser, C₂. The tickler, T, and primary, P, are on the same plug-in form with the tuned secondary, S.

of its sensitivity and all of its selectivity. The result is a receiver as primitive in principle (though not in circuit) as the infamous "single circuit" of a few years ago.

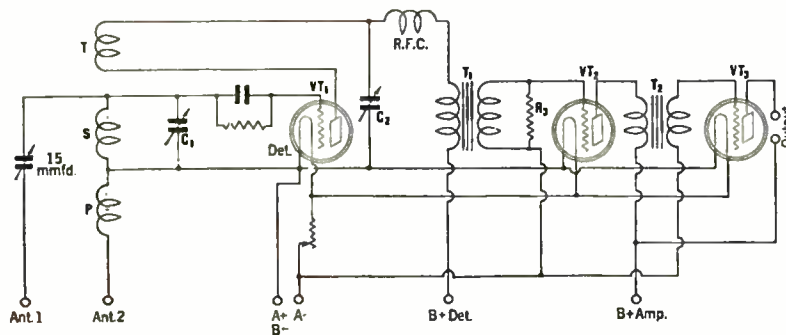

Fig. 1—The normal circuit of the "Wasp" receiver

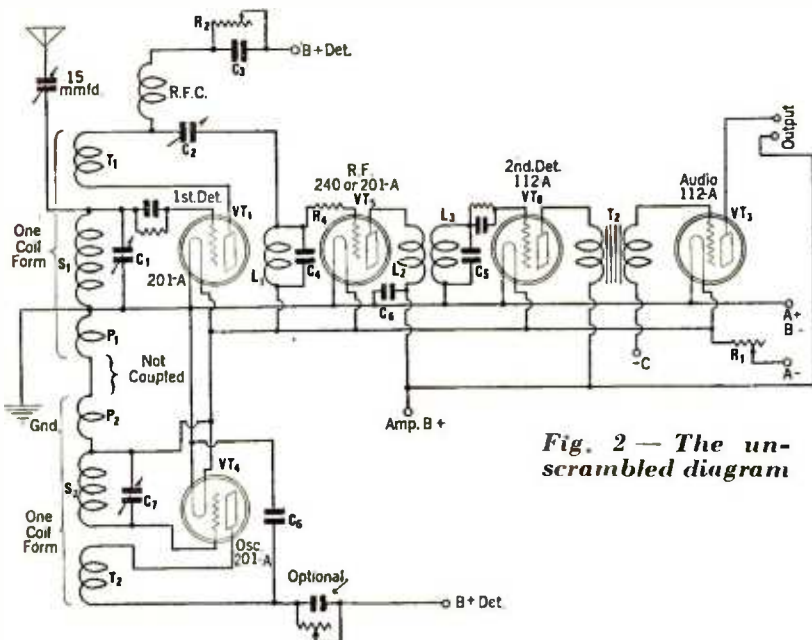

Fig. 2—The unscrambled diagram

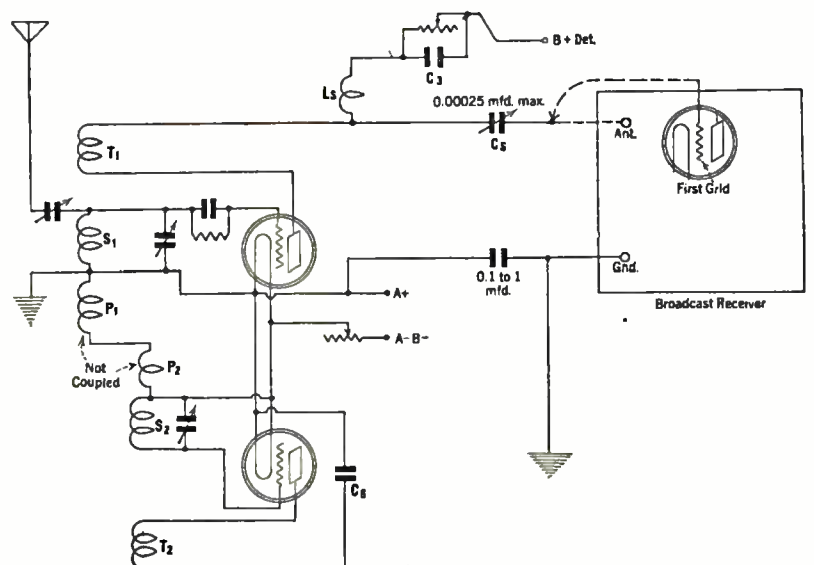
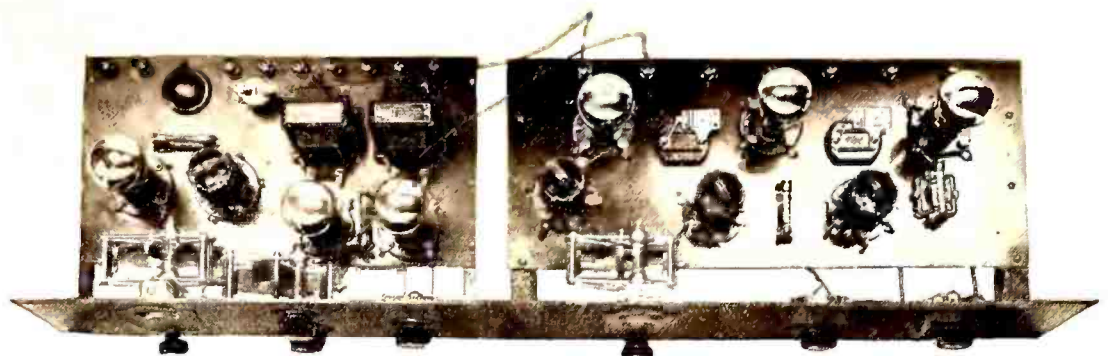

Fig. 3—How the broadcast set is connected with the detector-oscillator

In Fig. 4 we have the circuit converted into a double-detection affair by the addition of an oscillator, VT₄, one stage of r.f., VT₅, and a second detector, VT₆. In the unscrambled diagram of Fig. 2 T₁, S₁, and P₁ are the coils on the plug-in form feeding the first detector. The coil P₁ was originally intended for use in the antenna circuit, as in Fig. 1, but an alternative method of antenna coupling has been provided through terminal A₁ and the 15-mmfd. condenser. This alternative method is used in the set when adapted, the coil P₁ acting as an oscillator pick-up in conjunction with the extra coil P₂ on the oscillator plug-in coil form. Such an arrangement has the advantage that as the coils are changed the pick-up coils change with them and the pick-up from the oscillator remains more uniform than is the case with a set-and-leave arrangement. This is a considerable advantage when going over so wide a range as these tuners cover. It will be seen that P₁ and P₂ in series with the filament leads form an untuned "link" transfer circuit. The rotor of the regeneration-control condenser, C₂, is disconnected from the filament and through a clipcord is run to the top of the tuned circuit L₁C₄ which feeds the r.f. tube, VT₅. (See Fig. 4). This tube may be a 201A, 240 or 222 without causing any change in the system up to this point. The clipcord should be reasonably short and kept tolerably clear of things. Since the condenser C₂ is now a sort of coupling control between the first detector, VT₁, and the circuit L₁C₄ it cannot be used to control detector regeneration. This regeneration is too valuable to lose, and it is accordingly suggested that C₂ be set rather high and oscillation in VT₁ controlled by the addition of the 500,000-ohm Frost rheostat, R₂, with a 0.1-mfd. shunt condenser, C₃. This is not essential and one can get along very nicely without these devices by simply reducing C₂, which may in fact be a "postage-stamp" mica condenser. The first audio transformer primary has been disconnected and the wires connected together, also the first a.f. tube, VT₂, has been removed from the socket.

The oscillator is tuned by the condenser C₇, which is a duplicate of C₁. The condenser C₆ is merely a bypass and may have a capacity of 0.001 mfd. If it happens that the oscillator tends to squeal (audio-frequency blocking) it may be necessary to introduce at X a combination of rheostat and condenser like that shown at R₂ and C₃. The description above is general rather than applying to the particular unit shown in the illustrations. Having put the converted short-wave signal into the tuned circuit L₁C₄ we naturally



Top view of "Wasp" receiver and amplifier

would like to know something of that circuit. L₁ is a common broadcast r.f. coil shunted by a fixed condenser which tunes the circuit to a point above the broadcast band; 0.0005 mfd. is a convenient capacity obtainable in the small "postage-stamp" mica condensers. The output of the r.f. tube is fed into transformer coil L₂, L₃. The latter is another ordinary broadcast tuner coil shunted by a .0005-mfd. mica condenser. Since the condensers

usual primary found on the coil will serve. A 240-type tube will call for about double the number of turns used by the 201A, while the 222 tube should have a winding with a number of turns equal to about 1/2 the number of L₂. The 222-type tube will require a tube-shield and on the whole it is less painful to use the 240 or the 201A. If this tube desires to oscillate use an ordinary "grid suppressor" at R₄. Two stages may be used as they are not much more troublesome when worked in this manner. Obviously these two stages, the second detector and the audio system may all be found in the broadcast receiver with which the unit it used. Diagrams differ so greatly in these that the reader will find it safer to devise his own diagram of connection rather than to rely on Fig. 3 which may overlook some of the possible causes of trouble when used on a strange receiver. The points to remember are simply that the output of the first detector is to be applied either to the antenna post or to the grid of the tube in the first tuned circuit in the r.f. system of the receiver, at the same time making sure that the detector plate voltage does not get into the input to the receiver. A stopping condenser, C₅, of adjustable nature and a choke, L₅, will do the trick. The choke must, of course, be good over the broadcast range as well as the range in

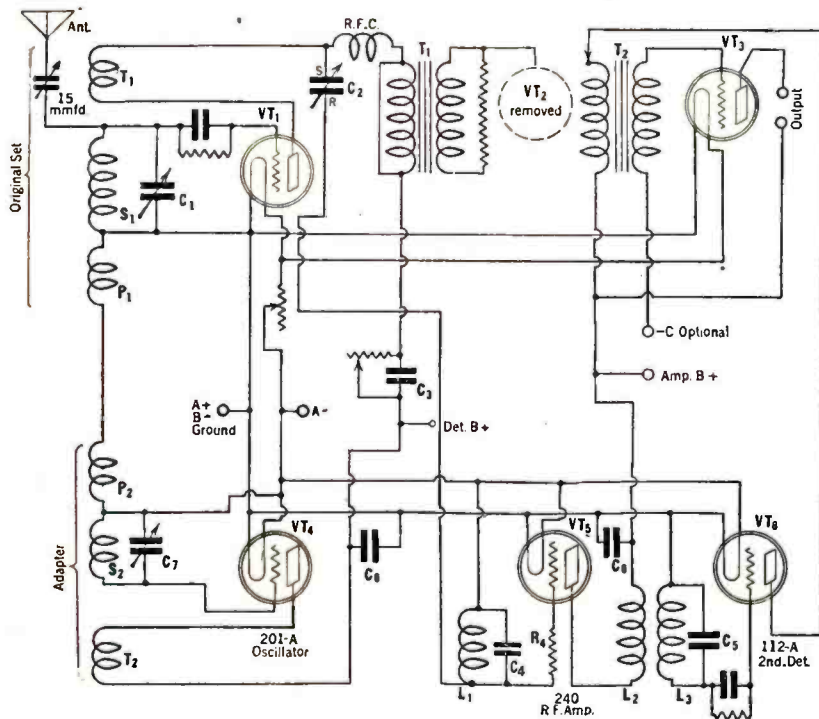

Fig. 4—Method of connecting amplifier and oscillator to receiver

C₅ and C₄ will not have exactly the same capacity one of them must be shunted by a midget condenser of some sort that can be adjusted while the set is in operation. Any one of the various "screwdriver" condensers on the market will do, provided the range is adequate. It is, of course, possible to use regular tuning condensers at C₄ and C₅ or to use condensers of the mica-compression type with capacities high enough to make sure of resonance at some point. This whole thing can be done much more easily than it can be described.

The winding L₂ depends on the tube used ahead of it. If a 201A-type tube is used the

which the short-wave tuner is to work. The chokes furnished with short-wave tuners usually fulfil this requirement.

A list of the apparatus used by the writer in the construction of his short-wave superheterodyne receiver is given below. However, the experimenter may substitute electrically equivalent parts, if desired. The complete list follows:

- One Pilot "Wasp" tuner;
- Two Frost resistors, 500,000-ohm;
- One tuning condenser, 140-mmfd.;
- One vernier dial;
- One tube socket, ux-type (for oscillator coil);
- Two tube sockets ux-type (for coils L₁ and L₂₋₃);
- Three tube sockets, ux-type;
- One extra set of Pilot "Wasp" coils (Two coils of a kind are used in the set and oscillator, respectively, while the 200-500 meter coil of each set is used for L₁ and L₂₋₃. The tickler serves as L₂);
- One grid leak, 1.5-megohm;
- One grid condenser, 0.00025-mfd.;
- One grid suppressor, 300-ohm (R₄);
- Assorted by-pass condensers, 0.001-mfd. and larger (C₆);
- Combination of fixed and adjustable condensers with maximum capacity of 0.0005 mfd. in each case. In the writer's set C₄ is a Sangamo unit and C₅ is a Sangamo unit plus an XL adjustable condenser);
- One panel, 7" x 10" or 7" x 14";
- One baseboard;
- Two brackets;
- Binding posts, wire, solder, usual small hardware, etc.

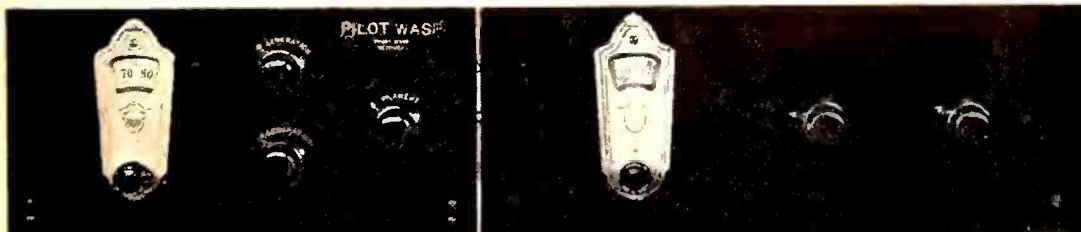

Front view of "Wasp" receiver and amplifier

TROUBLE SHOOTING IN THE POWER UNIT

By B. B. ALCORN

IN THE first three installments of this series of articles discussing the problems encountered in the servicing of radio receivers, the writer devoted considerable space in describing the symptoms, methods of detection, and rectification of troubles experienced with the usual types of factory- and home-made sets, and also accessories such as tubes, batteries, cable connectors, etc. However, similar difficulties which are found in power-supply units as yet have not received their share of consideration. This month, therefore, the eccentricities of power devices are the chief subject of discussion.

In the repair of the receiving set proper, the three most frequent causes of trouble, in the order of their importance, are open circuits, short circuits, and defective parts, respectively. On the other hand, the chief cause of breakdown in power-supply circuits are short circuits, although defective parts and open circuits are also major considerations.

Concrete Examples

IN ORDER to provide concrete examples of the problems encountered in the servicing of power units, a few of the writer's most recent experiences will be recounted. The first concerns an unusual short circuit which was found in the Radiola 104 loud speaker. In the power supply of this unit the usual trouble is shorted filter condensers, and this condition is manifest by the plates of the 216B-type rectifier tubes becoming red hot, due to the heating effect of the extra current which passes as a result of the short circuit. In the case under discussion, however, the plates of the rectifier tubes did not overheat, although the power unit was inoperative. In this instance, in performing the manufacturer's continuity test, it was found that sparks could be drawn from all parts of the chassis when the power was turned on. The trouble was located finally in the secondary winding of the power transformer which had become grounded to the chassis, thus shorting the rectifier tubes out of the circuit. The only possible repair was substituting a new transformer.

Very often owners of Radiola 28 receivers and 104 loud speakers complain that one or all of the tubes of the set have burnt out. Fortunately, the serviceman usually finds that this is not true. With this combination of receiver and power unit the tubes of the set are heated with current obtained from the B-supply circuit of the power unit. Therefore, when the tubes of the set fail to light it is often indicative of the fact that the emission of one or both of the 216B-type rectifier tubes has decreased. When this trouble develops it is necessary to replace the rectifier tube or tubes in order to bring the B current back to normal.

A peculiar but not uncommon complaint was brought to our attention by the owner of a recent model Atwater Kent electric receiver. It was explained that the set functioned perfectly except for sharp snaps which were heard every once in a while and which *did not* seem to issue from the loud speaker. On his first visit the noise did not occur and the serviceman was forced to report that the set seemed to be in perfect condition. The second evening the noise was more in evidence, and, when the serviceman arrived in response to a call, he was able to satisfy himself that such a condition did exist, but it was necessary to remove the set to the shop in order to locate the trouble. In a 500-volt d.c. test it was found that the snaps were caused by temporary breakdowns in the dielectric of one of the filter condensers, thus permitting an occasional internal discharge.

Sometimes it is possible to "service" a receiver via the telephone and an excellent illustration of this concerns a receiver operated with a Balkite A-power unit. It was explained that, although the set would operate satisfactorily when pulled away from the wall, the tubes would not light when the cabinet was in its usual position against the wall. We told the owner to add water to the cell of the A-power unit and then report on the operation of the set. In this case our guess was correct; the electrolyte in the rectifier cell was so low that it did not touch the electrode unless the front legs of the radio cabinet were raised by the rug when the cabinet was moved away from the wall.

A Stromberg Carlson power unit which would go off and on alternately while the power was turned on proved to be another baffling problem for us to solve. In this case a small break in the filament of one of the 2-ampere Tungar rectifier tubes was the cause of the trouble. The expansion and contraction

of the filament, which operates at a fairly high temperature, explained the peculiar performance of the power unit.

Home-Made Repairs

WHEN a receiver ceases to function an over-ambitious set-owner often endeavors to effect a repair before soliciting the aid of a serviceman. An amusing incident of this nature recently came to our attention, and, as usual, the repair attempted by the owner was unsuccessful. The serviceman, who was assigned to the job of eliminating the bad distortion which the set had developed, found the set in perfect condition and discovered that the distortion was caused by too much voltage on the plate of the detector tube. Therefore, the B-supply unit, which was a Philco socket power device, was examined for defects. As soon as the lid was removed the trouble became apparent; the cartridge resistor in the plate circuit of the detector tube was wrapped carefully with tin foil, thus preventing its operation as a voltage reducer. The owner explained that it had burnt out and he tried to repair the "fuse" by wrapping it with tin foil in a manner which he has found effective with automobile fuses. For some reason or other tin foil seems to be considered a universal remedy by set owners.

Corrections

IN NOVEMBER RADIO BROADCAST the writer described an experience in servicing a Radiola 18 which may have been misleading; it was stated that an open circuit in an r.f. transformer manifests all the symptoms of a short. Frankly, we did not take time to ascertain a possible explanation for the seemingly impossible condition, but, after discussing the problem with others in the service field, it has been decided that a short must have been caused by the open ends of the offending r.f. transformer. In this case the repair of the open circuit would have remedied the short.

An error also occurred in the December article of this series which we wish to correct. In a paragraph describing trouble encountered with a deForest reflex receiver, the statement was made that "this particular short manifests itself as an open circuit, and, when the set was tested with a set-checker the results indicated a burnt-out transformer. However, further tests showed that the transformer was perfect, the trouble being caused by shorted condenser in shunt with the winding of the transformer." This statement is incorrect as a check of the records indicates that the set-checker showed a "dead" short. We regret this error as it has confused a number of servicemen who have followed these articles.

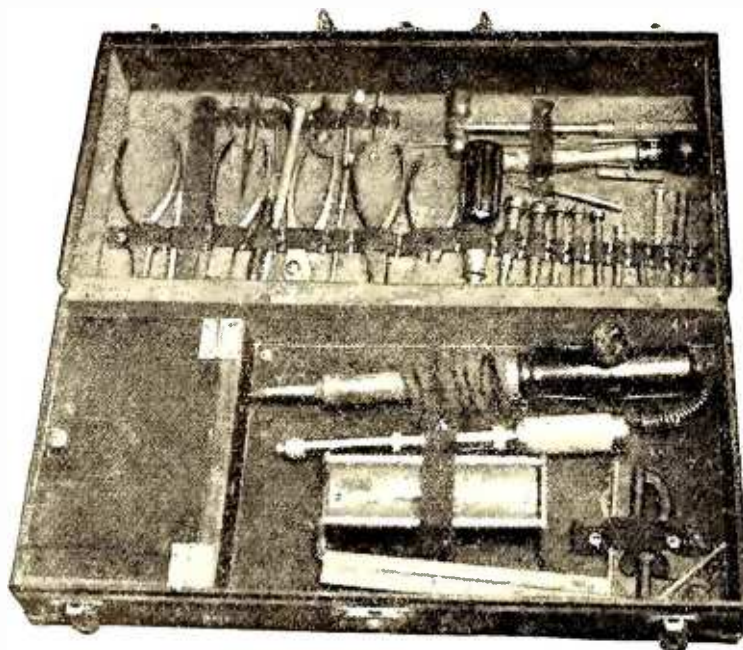

A typical serviceman's tool kit

Radio Broadcast's Service Data Sheets

The Philco Electric Radio Receivers, Series 5

THE Philco receivers are available in several different models but all of them use the same fundamental circuit consisting of three stages of tuned and neutralized radio-frequency amplification followed by a detector and a two-stage audio amplifier. There are six tubes in the receiver; four type 226, one type 227, and one type 171A. The receiver can be obtained in several table models or in cabinets. One model is a combination electric phonograph and radio.

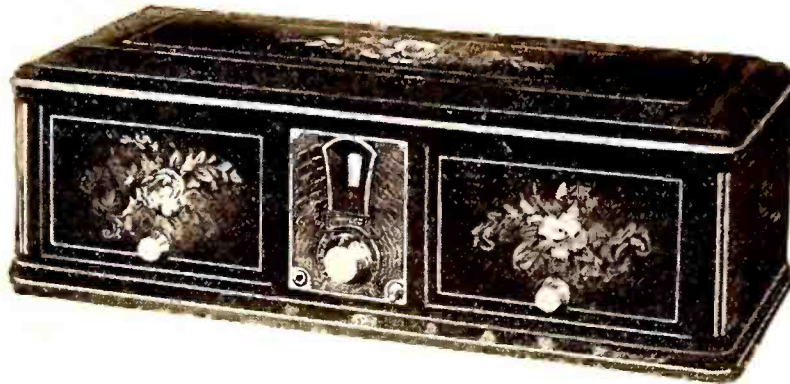

Philco set in colored cabinet

Technical Discussion

1. TUNING SYSTEM

Four main tuning condensers are used in the receiver. They are C_1 , C_2 , C_3 and C_4 . The latter three condensers have connected across them small compensating condensers, C_5 , C_6 , and C_7 , which provide a method of compensating slight differences in the circuit capacities, thus bringing all the tuned circuits into exact electrical alignment. Across the first tuning condenser, C_1 , is connected the small condenser, C_8 , which is called the "range control." This range-control condenser serves normally to tune the first circuit to exact resonance but it also has a second function. A small spring contact on the condenser C_8 serves to ground the grid of the first tube when the condenser is rotated to the extreme left. Under such conditions the gain of the receiver is reduced to a point which is quite satisfactory for average local reception. Each r.f. stage is neutralized by the Hazeltine method, the neutralizing condensers being C_9 , C_{10} and C_{11} .

2. DETECTOR AND AUDIO SYSTEM

A grid-leak-condenser-type detector is used followed by a two-stage transformer-coupled a.f. amplifier. The grid leak is R_1 and the grid condenser is C_{12} . In the plate circuit of the detector tube is connected the small by-pass condenser, C_{13} , with a capacity of 0.001 mfd. T_1 is the first audio transformer and T_2 is the second-stage audio transformer. J_1 is a jack into which a phonograph pick-up unit may be connected. When a phonograph pick-up unit is being used the volume control of the receiver should be turned off and the volume regulated

by means of the control supplied with the pick-up device. The power tube is a 171A and in its plate circuit are connected the output filter choke coil, L_1 , and the condenser C_{14} with a capacity of 0.5 mfd. This filter system functions to keep out of the loud speaker the d.c. currents in the plate circuit.

3. VOLUME CONTROL

The volume-control resistor, R_2 , is connected between antenna and ground. The movable arm on this resistor is connected to one end of the primary of the first r.f. transformer.

4. FILAMENT CIRCUITS

The 226-type r.f. amplifiers and the first audio amplifier tube are supplied with approximately 1.5 volts from the secondary S_1 on the power transformer, T , the 227-type detector tube is supplied with 2.5 volts from S_2 , and the 171A power tube supplied with 5 volts from S_3 . In order to permit an accurate hum balance to be obtained, adjustable potentiometers, R_3 and R_4 , are connected across secondaries S_1 and S_2 , respectively, and these resistors are adjusted at the factory to a point of minimum hum at the output. The condensers, C_{15} and C_{16} , which are connected between each side of S_1 and ground, serve to bypass the r.f.

currents which would otherwise have to flow through the resistor, R_2 .

5. PLATE CIRCUITS

The detector tube is supplied with about 35 volts, the r.f. and first a.f. tubes with approximately 90 volts, and the 171A-type power tube with 135 volts. The plate current for each 226-type tube is approximately 3.5 to 4 milliamperes. The 227-type tube draws about 1.5 milliamperes and the power tube requires about 15 milliamperes. The plate circuits of the r.f. tubes are filtered by the by-pass condensers C_{17} , C_{18} , and C_{19} and the resistors R_5 , R_6 , and R_7 . The by-pass condensers each have a capacity of 0.1 mfd.

6. GRID CIRCUITS

Grid bias for the various tubes is obtained across the resistor R_8 . The C bias on the 226-type tube is approximately 6 volts, and approximately 28 volts is placed on the grid of the 171A power tube. There is no bias on the detector tube. This C-bias resistor is by-passed by an 0.1-mfd. condenser, C_{20} .

7. POWER SUPPLY

The power supply is contained within the receiver cabinet. It consists of a power transformer, T , tapped for various line voltages and containing five secondary windings. S_1 , S_2 , and S_3 supply filament current for the tubes in the receiver, S_4 supplies filament current for the rectifier tube which is a type 280, and the secondary S_5 supplies plate voltage. The filter system consists of the filter condenser C_{21} , C_{22} and C_{23} and the choke coils L_2 and L_3 . The condenser C_{21} has a capacity of 2 mfd., C_{22} has a capacity of 3 mfd., and C_{23} has a capacity of 4 mfd. The by-pass condensers, C_{24} and C_{25} , each have a capacity of 1 mfd. The power supply and filter system are designed for operation on 50- to 60-cycle a. c., but power equipment can be supplied for operation on 25- to 40-cycle power systems.

The small condenser C_{26} is connected between one side of the a. c. line to a terminal on the receiver marked "Loc" meaning local. For local reception satisfactory results can be obtained by connecting the "Loc" terminal to the "Ant" terminal and when this is done the power lines are used as an antenna.

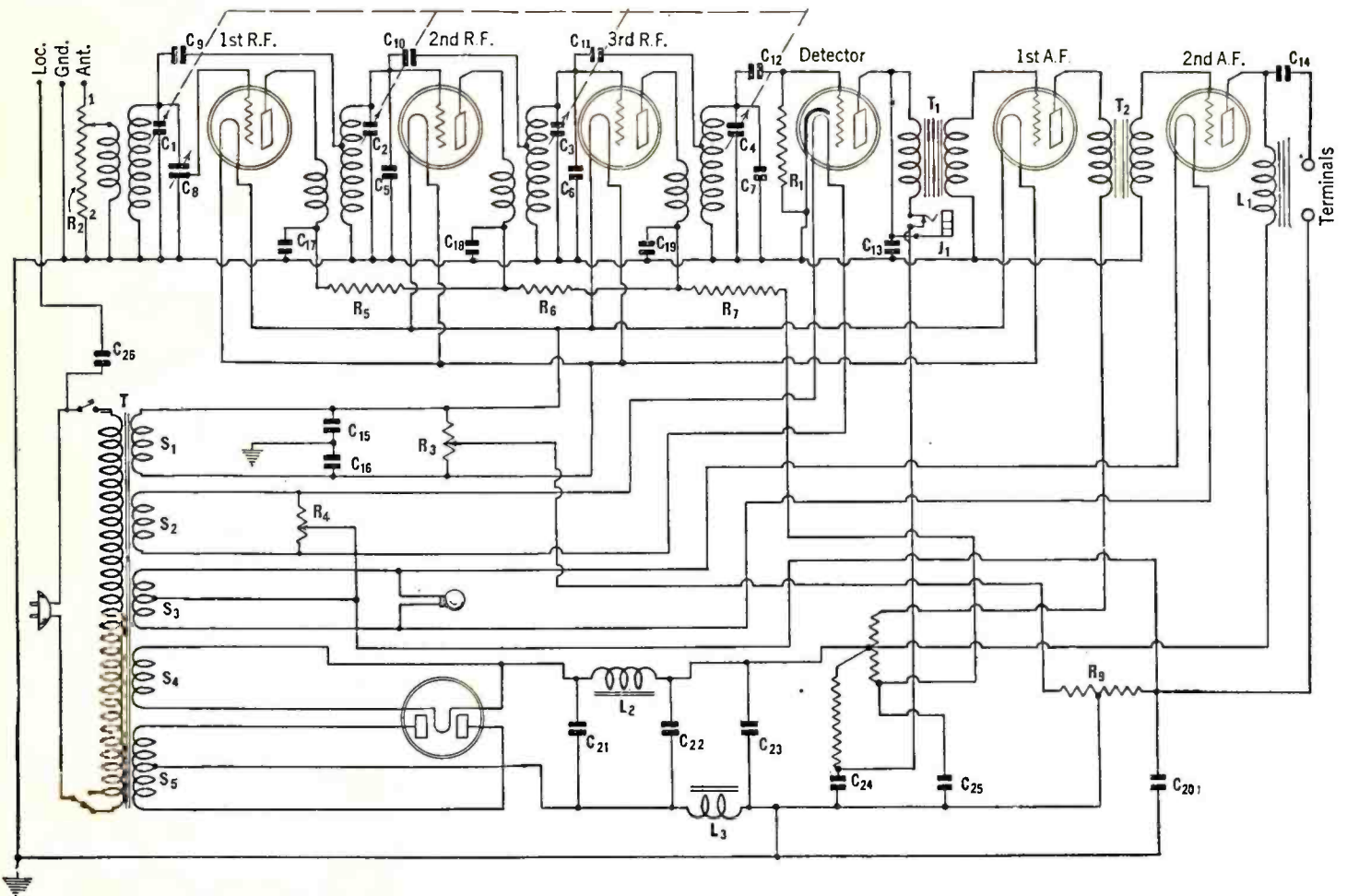

Circuit diagram of receiver and power unit

Radio Broadcast's Service Data Sheets

Browning-Drake Receiver Models 34, 36, and 38

THE Browning-Drake Model 34 receiver is a completely self-contained table-model a.c. set designed for 105-120 volt 50-60 cycle current. In a console cabinet with a dynamic or air-chrome speaker the receiver is known as Model 36D or 36A, and in a hightboy console it is listed as Model 38.

A noteworthy feature is the symmetrical mechanical construction, all power equipment forming an integral part of the chassis, which is of aluminum and which is perfectly balanced in all dimensions. The seven tubes and rectifier are all mounted along the rear of the chassis, adjacent to the shielding partitions, and form the basis for the description "Eight-in-Line" applied to this receiver in advertising.

The amplifier tubes are all of the 226 type, with the exception of the last stage, which is a 171A. The detector is of the 227 type. A 280-type full-wave rectifier is used.

The coils are at right angles to each other and are mounted on a bakelite strip beneath the base. The variable condensers are ganged and operated by a knob controlling a large drum. A special mechanism prevents slack, the two driving cylinders being joined by a phosphor bronze spring and connected to the drum by a beaded chain. Even illumination is provided by a miniature lamp in back of the scale, which rotates behind a recessed escutcheon plate. The cabinet work of the 1929 models is confined almost entirely to walnut with Duco finish.

Technical Discussion

1. THE R.F. TUNING SYSTEM

The antenna stage of the receiver is of the untuned type with a 1000-ohm variable resistor, R_1 , connected between the grid and filament of the first tube. This unit is controlled from the front panel and constitutes the volume control. The second and third radio-frequency stages and detector are tuned through a single dial. Perfect alignment is secured through the use of small compensating condensers, C_3 , C_4 , and C_5 , across the main tuning condensers, C_1 , C_2 , and C_3 . The compensating condensers are accurately set at the factory and are not accessible in the cabinet models.

2. THE DETECTOR AND AUDIO SYSTEM

The audio amplifier employs a three-stage resistance-coupled circuit. Type 226 tubes in the

first two stages and a type 171A tube is employed in the output stage. Grid detection is used in the Model 34 receiver. The leak, R_2 , has a resistance of 8 megohms and the condenser, C_6 , has a capacity of 0.00005 mfd. In the audio amplifier, plate resistors, R_3 , of 100,000 ohms are used, while the grid resistors are 500,000 ohms, R_4 , for the first stage and 100,000 ohms, R_5 , for the second and third stages. The coupling condensers, C_7 , in the amplifier have a capacity of 0.1 mfd.

3. FILAMENT CIRCUITS

The filament supply system consists of five separate windings on the power transformer, T. The supply, S_1 , for the 280-type rectifier is center tapped on the winding. The 1.5-volt winding, S_2 , for the first two audio amplifier tubes, the 5.0-volt supply, S_3 , for the power amplifier, the 2.3-volt filament winding, S_4 , for the detector, and the 1.5-volt r.f. filament supply, S_6 , are shunted with resistors to get the center point. Through the use of separate windings, for the r.f. and a.f. tubes, tendency toward hum is reduced greatly. Each of the windings, S_1 , S_2 , S_3 , and S_4 , is provided with a 60-ohm center-tapped resistor, R_6 , accurate to less than 0.5 per cent. Inasmuch as leads are short and the windings are separate, the use of such accurate center-tap connections helps greatly in the elimination of hum. The 1.5-volt radio-frequency supply is bypassed at the sockets by one 0.1 mfd. condenser, C_8 , on each side of the filament. This prevents common coupling in the center-tapped resistor and aids in the elimination of 60- or 120-cycle modulation of the incoming signal.

4. PLATE CIRCUITS

The plates of the radio-frequency tubes are supplied with 140 volts d.c. from the power supply and draw a plate current approximately from ten to twelve milliamperes. The detector plate is supplied with 20 volts and the current drawn in this circuit is one milliamperere. The audio amplifier tube plates are furnished from the 200-volt source in the power supply. The voltage drop in their respective plate resistors reduces the plate voltage on the first audio tube to 60 volts and that on the second amplifier to approximately 75 volts. The plate current in each case is between 1.5 and 2.0 milliamperes depending upon the tube. The full voltage of the supply, 220 volts, is impressed on the power

amplifier plate. The actual voltage across the tube is less than this value, however, by the amount of the grid-bias voltage as is indicated later. The plate current in the power amplifier tube is 20 milliamperes.

5. GRID CIRCUITS

The radio-frequency amplifier grids are connected to ground or to the chassis frame through their respective r.f. transformer secondaries. The r.f. bias is applied between the filaments and ground and is secured by the IR drop through a 1000-ohm resistor, R_7 . The negative bias thus applied to the r.f. grids is from ten to twelve volts. The detector grid is operated at cathode potential, no biasing being required for grid detection. The audio amplifier tube grids carry a negative bias of from 4 to 5 volts furnished by the IR drop across the 500-ohm resistor R_8 . The power amplifier grid is biased in the same manner, the plate current to the tube passing through a 2000-ohm resistor, R_9 , in the filament circuit. This resistor is a part of the voltage divider and is bypassed with a 1.0-mfd. condenser, C_9 . The value of this bias voltage is approximately 40.5 volts.

6. THE POWER SUPPLY

The power supply contains a power transformer, T, a 30-henry filter choke, L, a triple-section Mershon filter condenser, C_{10} , and a voltage divider, R_{10} . The power transformer has a single primary winding, a high-voltage secondary, S_1 , having 300 volts on each side of the center tap, a 5-volt center-tapped winding, S_2 , for the rectifier, two separate 1.5-volt windings, S_3 and S_4 , for the a.f. and r.f. amplifiers, a 5-volt winding, S_5 , for the power amplifier, and a 2.3-volt winding, S_6 , for the detector. The 2.3-volt winding supplies the dial light as well as the detector. Full-wave rectification with a 280-type tube is employed. The output of the rectifier is passed through the 30-henry choke with 8 mfd. on each side. This filtered d.c. is then carried to the voltage divider where taps are taken off for the 140-volt supply to the radio-frequency plates and 45 volts for the detector heater. The 140-volt tap is bypassed with the remaining 8-mfd. section of the Mershon condenser. The power transformer choke, and filter condenser are all operated well under their normal rating so that excellent filtering and freedom from trouble are assured.

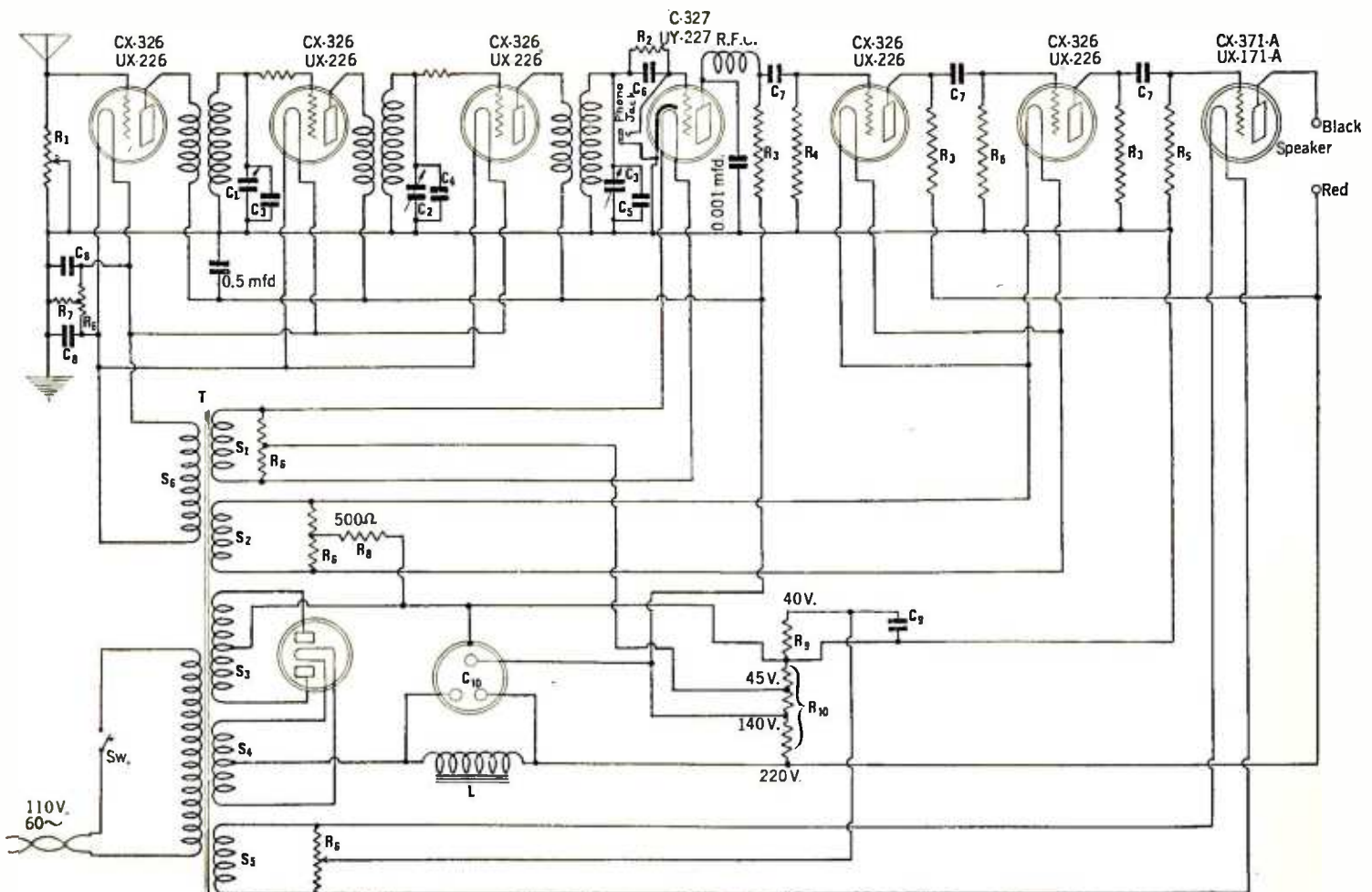

Circuit Diagram of Receiver and Power Unit.

IN THE RADIO MARKETPLACE

News, Useful Data, and Information on the Offerings of the Manufacturer

The Remler "29" Super-Heterodyne Receiver

THE Remler "29" is a super-heterodyne receiver intended for use with a short antenna which may be of either the inside or outside variety. The receiver incorporates a stage of screen-grid radio-frequency amplification followed by a regenerative first detector, an oscillator, three stages of transformer-coupled, screen-grid, intermediate-frequency amplification functioning at a frequency of 115 kilocycles, a second detector, and a suitable audio amplifier. The circuit diagram is given in Fig. 1.

The major function of the radio-frequency stage preceding the first detector is to increase the selectivity. The screen-grid tube is used in this stage of radio-frequency amplification because of its inherent stability of operation.

The intermediate amplifier of the "29" employs three tubes of the screen-grid type. Although the screen-grid tube is theoretically capable of providing a gain of 40 or 50 per stage, in no case has such gain been obtained in practice and the necessary degree of selectivity maintained. However, both the gain and the selectivity of the screen-grid intermediate amplifier are far greater than could be obtained from an amplifier employing tubes of the 201A type even if excessive regeneration were used. The gain per stage has, however, purposely been held down somewhat in order to eliminate excessive tube background noise and to maintain the degree of selectivity deemed necessary under present day conditions.

Tubes of the 201A type are used for the oscillator and for the first and second detectors. Both detectors are of the leak-condenser type. The regeneration employed in the first detector circuit is obtained by inductively coupling the plate and grid circuits of the tube by means of a third winding or tickler coil, L_1 . The degree of regeneration is controlled from the panel by means of a

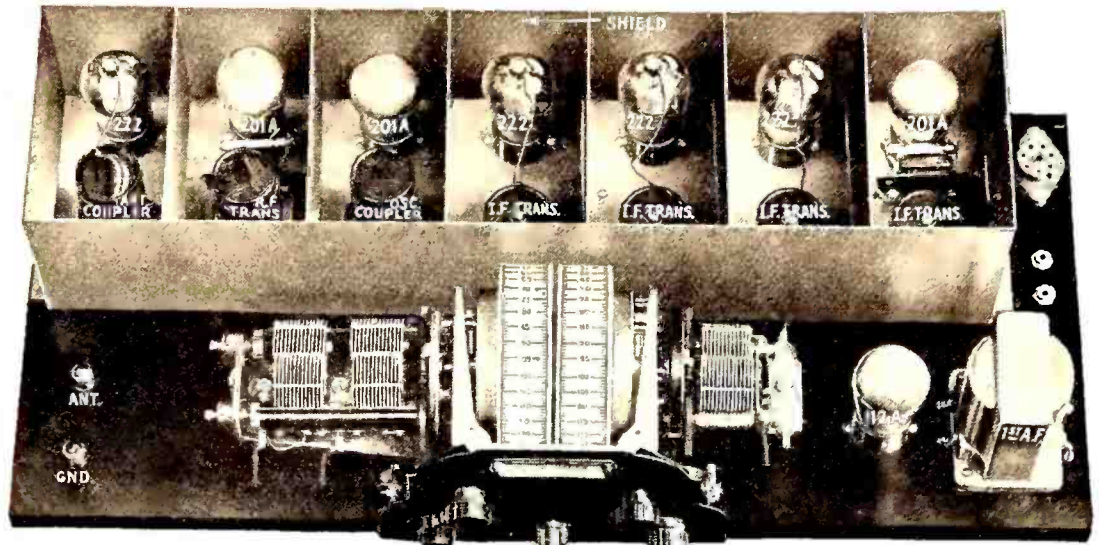

Chassis view of receiver with shield covers removed

This section of RADIO BROADCAST is devoted to describing the uses of apparatus on the market. In this category fall kits from which receivers and power units may be assembled, descriptions of the uses of parts and accessories which may be announced by manufacturers, and practical information of value to the serviceman, custom set builder and experimenter—all of whom are interested in keeping abreast of what is going on. This month, the excellent kit receivers of Remler and Hammarlund-Roberts are described.

—THE EDITOR.

2000-ohm variable resistor, R_1 , which is shunted across the tickler coil. Maximum regeneration is used only for the reception of distant stations for which a slight sacrifice

in quality of reproduction is permissible. For high-quality local and semi-distant reception the regeneration control should be retarded.

The heart of the Remler "29" is the No. 712 screen-grid selector-amplifier. This unit incorporates within a single heavy copper case the radio-frequency and intermediate-frequency amplifier tubes, the transformers, the oscillator and the two detectors. Each individual circuit is, in turn, fully shielded. Such shielding of the individual stages is necessary because of the high gain obtained per stage. The amplifier unit is completely wired at the factory and colored leads extend from it for connection to the panel controls, the tuning condensers, the audio components, and the battery cable terminal block. The intermediate transformers are peaked at the factory and vernier adjustments are provided so that differences in tubes or misalignment due to rough handling during shipment may be compensated by the builder of the set.

FOUNDATION UNIT

Custom set-builders have in the past occasionally run into trouble due to the improper location of radio-frequency components and wiring. In the design of the Remler "29" great care has been exercised to make the construction such that these difficulties can not arise. All component parts of the "29" are to be mounted by the builder on a pressed-steel chassis which is included in the No. 752 foundation kit. In addition to those parts mounted directly on it, it supports a pressed-steel panel to which are fastened those instruments controlled from the panel. The instrument panel, the escutcheon plate, and all necessary binding posts, phone-tip jacks, brackets, insulating washers, control knobs, screws and nuts are packed with the foundation kit.

There are two major tuning controls which operate, respectively, the Remler Type 632 two-in-line condenser, C_1 and C_2 , controlling the radio-frequency amplifier and first detector circuits, and the Remler Type 638 condenser, C_3 , controlling the oscillator circuit. A

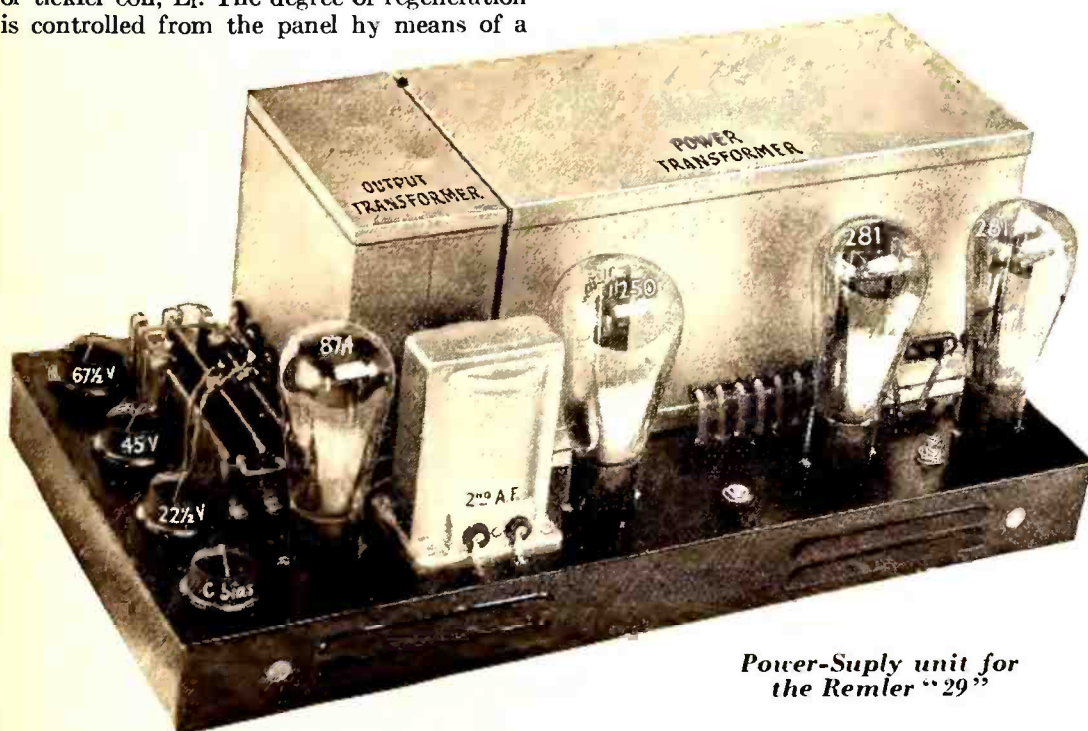

Power-Supply unit for the Remler "29"

The Six-Tube, Screen-Grid, Junior Model "Hi-Q 29"

THE "Hi-Q 29" Junior Model has been tested in the Laboratory and was found to be an efficient receiver; that is, it is sensitive, selective, and will bring in stations with good fidelity. In a single evening the receiver brought us a number of out-of-town stations in addition to the old stand-by's such as KDKA and WGY. It has 20-kc. selectivity and this makes it possible here in New York to receive WLW when WOR is on the air. WOR was audible in the background, but the frequency separation of these two stations is only 10 kc. It had more r. f. gain than could be used in this particular locality. The cost of parts, \$54.60, brings it within the reach of nearly everyone.

The circuit diagram of the d.c.-operated Junior model is shown in Fig. 1. Two screen-grid tubes are used in the radio-frequency amplifier, and the first, which is untuned, is coupled to the antenna-ground input system through a 3000-ohm variable resistor which serves as the volume control. The receiver is a true single-controlled set, although it employs two sharply tuned circuits.

The plate circuit of the first screen-grid tube looks into a specially designed transformer which has several primary taps, so the experimenter can choose the one that provides the best selectivity. The primaries are small and wound of many turns of fine wire.

Following the first untuned antenna stage are two carefully tuned stages, the second r.f. amplifier and the detector. The voltage gain in the antenna stage is not high, but contrary to many such untuned stages using low- μ tubes (of the 201A type) it provides some voltage gain. The second stage, of course, has a high voltage gain and the detector input, being tuned, adds its bit to the overall radio-frequency amplification of the receiver. The coils are typical Hammarlund spaced winding solenoids of a good shape.

C-BIAS DETECTOR

The detector, which is a 201A-type tube, is used in a C-battery circuit because of the greater input voltage handling ability and somewhat greater freedom from high audio-frequency loss. Following this tube is a three-stage resistance-coupled audio amplifier, the

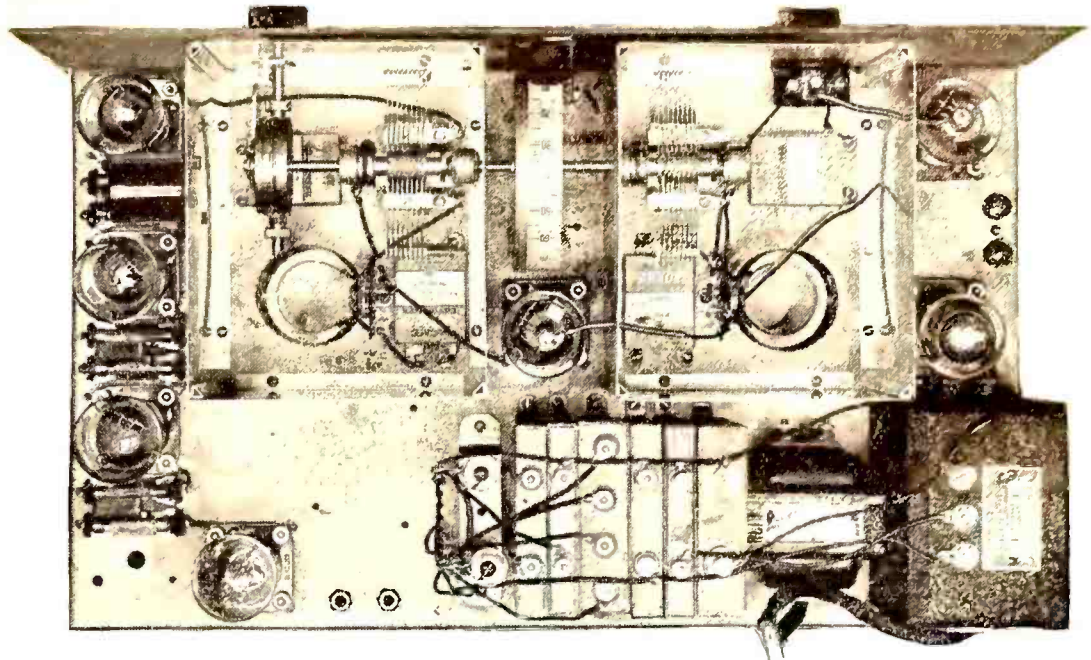

Chassis view of the Junior "Hi-Q 29" A. C. Receiver

first tube being a 240, or hi- μ type, the second a 201A and the final tube a 171A.

The screen-grid tubes are placed outside the shielding boxes which enclose the tuning components. The control-grid leads are shielded, and thus there is little danger of unwanted feed back from one stage to another. The filtering in the r.f. amplifier consists of 5000-ohm resistors in the plate circuit of each tube and 0.5-mfd. by-pass condensers connected from the low-potential side of each primary to the filament of the tube in question. The advantage of such filtering has been pointed out many times in this magazine; its purpose is to keep the r.f. plate currents out of the B supply and to prevent them from becoming mixed with similar currents of another stage.

Bias for the screen-grid tubes is obtained by connecting the low-potential end of the grid input circuit to the battery end of a filament resistor. The correct plate voltage for this value of C bias is obtained through the 5000-filter resistor—the voltage drop across this resistor is small since the normal plate current of the tube is only about one milliamper. Such a grid bias lengthens the life of the tubes appreciably. Bias for the

resistance-coupled amplifier tubes is obtained externally as is that for the detector.

A choke coil has been placed in the plate circuit of the detector to prevent r.f. voltages from overloading the resistance-coupled amplifier. In addition a condenser is placed across the input to the amplifier so that the detector will be provided with a low-impedance output (to r.f. currents) with consequent better detection.

All in all, the Junior "Hi-Q 29" is a six-tube receiver, using screen-grid tubes at their best, i.e., well shielded and well filtered, a C-battery detector, a resistance-coupled amplifier provided with values of resistance and capacity that will permit the amplification of all frequencies from below 100 to well over 5000 cycles, and a power tube designed to deliver at least 350 milliwatts of power to an average speaker. Because of the suggested plate voltage on the 171A, 135 volts, an output device is not necessary from the standpoint of protecting the loud speaker, although there is plenty of room for it on the baseboard of the receiver.

LIST OF PARTS

The picture gives a good idea of the internal appearance of the receiver, and the list of parts below indicates the discrimination with which its designers picked out the components. There is an a.c. model of the same general circuit employing Arcturus tubes. The list price of the latter is \$104.20, and the receiver as put together is a completely self-contained tuner, amplifier and power supply.

The complete list of parts follows:

- C₁, C₂ Two Hammarlund Midline condensers, 0.00035-mfd., type ML-17;
- C₃ One Sangamo fixed condenser, 0.001-mfd;
- C₄, C₅, C₆, C₇ Four Parvot by-pass condensers, 0.5-mfd.;
- L₁ One Hammarlund r.f. choke coil, type RFC-85;
- R₁ One Carter tapered volume control, 3000-ohm, type TP-3M;
- R₂, R₃ Two Durham Metalized resistors, 0.25-megohm;
- R₄ One Durham Metalized resistor 0.1-megohm;
- R₅, R₆ One Durham Powerohm, 100,000-ohm, 1-watt;
- R₇ One Durham Powerohm, 50,000-ohm, 1-watt;
- T₁, T₂ Two Hammarlund r.f. transformer, type SGT-17;
- Sw One Carter battery switch, type 2;
- One Hammarlund drum dial, knob-controlled;
- Six Benjamin sockets, type 9010;
- Two Yaxley phone-tip jacks, type 422;
- One Yaxley cable connector, type 660;
- One Hi-Q 29 Junior foundation unit containing panel, shields, chassis, coupling condensers, resistor units, resistor clips, binding posts, shafts, wire, screws, etc.

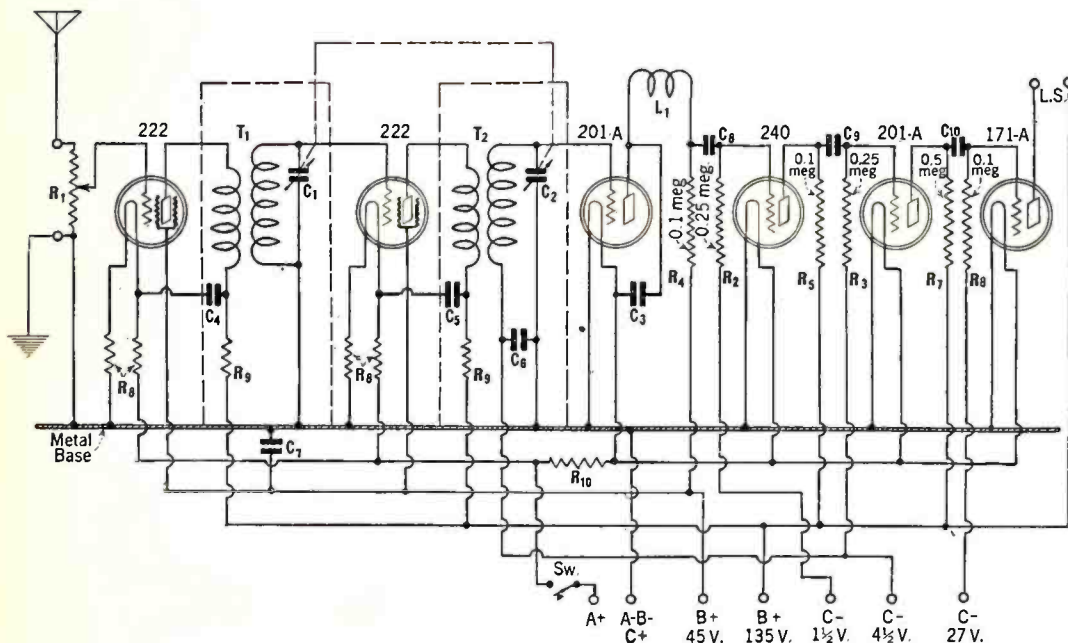

Fig. 1—Schematic diagram of the Junior Model "Hi-Q 29"

MANUFACTURERS' BOOKLETS

A Varied List of Books Pertaining to Radio and Allied Subjects Obtainable Free With the Accompanying Coupon

READERS may obtain any of the booklets listed below by using the coupon printed on this page. Order by number only.

1. FILAMENT CONTROL—Problems of filament supply, voltage regulation, effect on various circuits, and circuit diagrams of popular kits. RADIAL COMPANY.
5. CARBORUNDUM IN RADIO—Pertinent data on crystal detectors with hook-ups, and information on the use of resistors. THE CARBORUNDUM COMPANY.
12. DISTORTION AND WHAT CAUSES IT—Hook-ups of resistance-coupled amplifiers with standard circuits. ALLEN-BRADLEY COMPANY.
15. B-ELIMINATOR AND POWER AMPLIFIER—Instructions for assembly and operation using Raytheon tube. GENERAL RADIO COMPANY.
- 15a. B-ELIMINATOR AND POWER AMPLIFIER—Instructions for assembly and operation using an R. C. A. rectifier. GENERAL RADIO COMPANY.
17. BAKELITE—A description of various uses of bakelite in radio, its manufacture, and its properties. BAKELITE CORPORATION.
22. A PRIMER OF ELECTRICITY—Fundamentals of electricity with reference to the application of dry cells to radio. Constructional data on buzzers, automatic switches, alarms, etc. NATIONAL CARBON COMPANY.
23. AUTOMATIC RELAY CONNECTIONS—A data sheet showing how a relay may be used to control A and B circuits. YAXLEY MANUFACTURING COMPANY.
30. TUBE CHARACTERISTICS—A data sheet giving constants of tubes. C. E. MANUFACTURING COMPANY.
32. METERS FOR RADIO—A book of meters used in radio, with diagrams. BURTON-ROGERS COMPANY.
33. SWITCHBOARD AND PORTABLE METERS—A booklet giving dimensions, specifications, and shunts used with various meters. BURTON-ROGERS COMPANY.
37. WHY RADIO IS BETTER WITH BATTERY POWER—What dry-cell battery to use; their application to radio, wiring diagrams. NATIONAL CARBON COMPANY.
46. AUDIO-FREQUENCY CHOKES—A pamphlet showing positions in the circuit where audio-frequency chokes may be used. SAMSON ELECTRIC COMPANY.
47. RADIO-FREQUENCY CHOKES—Circuit diagrams illustrating the use of chokes to keep out r. f. currents from definite points. SAMSON ELECTRIC COMPANY.
48. TRANSFORMER AND IMPEDANCE DATA—Tables giving the mechanical and electrical characteristics of transformers and impedances, together with a short description of their use. SAMSON ELECTRIC COMPANY.
53. TUBE REACTIVATOR—Information on the care of vacuum tubes, with notes on reactivation. THE STERLING MANUFACTURING COMPANY.
56. VARIABLE CONDENSERS—A bulletin giving an analysis of various condensers together with their characteristics. GENERAL RADIO COMPANY.
57. FILTER DATA—Facts about the filtering of d. c. supplied by means of motor-generator outfits used with transmitters. ELECTRIC SPECIALTY COMPANY.
58. HOW TO SELECT A RECEIVER—A common-sense booklet describing what a radio set is, and what you should expect from it, in language that anyone can understand. DAY-FAN ELECTRIC COMPANY.
67. WEATHER FOR RADIO—A very interesting booklet on the relationship between weather and radio reception, with maps and data on forecasting the probable results. TAYLOR INSTRUMENT COMPANIES.
69. VACUUM TUBES—A booklet giving the characteristics of the various tube types with a short description of where they may be used in the circuit; list of American and Canadian broadcast stations. RADIO CORPORATION OF AMERICA.
72. PLATE SUPPLY SYSTEMS. Technical information on audio and power systems. Bulletins dealing with two-stage transformer amplifier systems, two-stage push-pull, three-stage push-pull, parallel push-pull, and other audio amplifier, plate, and filament supply systems. AMERICAN TRANSFORMER COMPANY.
73. RADIO SIMPLIFIED—A non-technical booklet giving pertinent data on various radio subjects. Of especial interest to the beginner and set owner. CROSLLEY RADIO CORPORATION.
76. RADIO INSTRUMENTS—A description of various meters used in radio and electrical circuits together with a short discussion of their uses. JEWELL ELECTRICAL INSTRUMENT COMPANY.
78. ELECTRICAL TROUBLES—A pamphlet describing the use of electrical testing instruments in automotive work combined with a description of the cadmium test for storage batteries. Of interest to the owner of storage batteries. BURTON ROGERS COMPANY.
81. BETTER TUNING—A booklet giving much general information on radio reception with specific illustrations. Primarily for non-technical set-builders. BREMER-TULLY MANUFACTURING COMPANY.
84. FIVE-TUBE EQUAMATIC—Panel layout, circuit diagrams, and instructions for building a five-tube receiver, together with data on the operation of tuned radio-frequency transformers of special design. KARAS ELECTRIC COMPANY.
88. SUPER-HETERODYNE CONSTRUCTION—A booklet giving full instructions, together with a blue print and necessary data, for building an eight-tube receiver. THE GEORGE W. WALKER COMPANY.
89. SHORT-WAVE TRANSMITTING EQUIPMENT. Data and wiring diagrams on construction of all popular short-wave transmitters, operating instructions, keying, antennas; information and wiring diagrams on receiving apparatus; data on variety of apparatus used in high-frequency work. RADIO ENGINEERING LABORATORIES.
90. IMPEDANCE AMPLIFICATION—The theory and practice of a special type of dual-impedance audio amplification. ALDEN MANUFACTURING COMPANY.

95. Resistance Data—Successive bulletins regarding the use of resistors in various parts of the radio circuit. INTERNATIONAL RESISTANCE COMPANY.
98. COPPER SHIELDING—A booklet giving information on the use of shielding in radio receivers, with notes and diagrams showing how it may be applied practically. Of special interest to the home constructor. THE COPPER AND BRASS RESEARCH ASSOCIATION.
99. RADIO CONVENIENCE OUTLETS—A folder giving diagrams and specifications for installing loud speakers in various locations at some distance from the receiving set, also antenna, ground and battery connections. YAXLEY MANUFACTURING COMPANY.

On this page are listed radio manufacturers' booklets which may prove of interest to readers of RADIO BROADCAST. The list is revised each month and a constant effort is made to keep it as accurate as possible. In all cases the booklets listed have been selected because of the valuable information which they contain. Among the new booklets of interest to experimenter are the following: 139, 143, 144, 145, 154, 156, and 157.

—THE EDITOR.

101. USING CHOKES—A folder with circuit diagrams of the more popular circuits showing where choke coils may be placed to produce better results. SAMSON ELECTRIC COMPANY.
102. RADIO POWER BULLETINS—Circuit diagrams, theory constants, and trouble-shooting hints for units employing the BH or B rectifier tubes. RAYTHEON MANUFACTURING COMPANY.
104. OSCILLATION CONTROL WITH THE "PHASATROL"—Circuit diagrams, details for connection in circuit, and specific operating suggestions for using the "Phasatrol" as a balancing device to control oscillation. ELECTRAD, INCORPORATED.
105. RECEIVING AND TRANSMITTING CIRCUITS. Construction booklet with data on 25 receivers and transmitters together with discussion of low losses in receiver tuning circuits. AERO PRODUCTS COMPANY.
108. VACUUM TUBES—Operating characteristics of an a.c. tube with curves and circuit diagram for connection in converting various receivers to a.c. operation with a four-prong a.c. tube. ARCTURUS RADIO COMPANY.
112. HEAVY-DUTY RESISTORS—Circuit calculations and data on receiving and transmitting resistances for a variety of uses, diagrams for popular power supply circuits, d.c. resistors for battery charging use. WARD LEONARD ELECTRIC COMPANY.
113. CONE LOUD SPEAKERS—Technical and practical information on electro-dynamic and permanent-magnet type cone loud speakers. THE MAGNAVON COMPANY.

In sending the coupon below, make sure that your name and address are included and are plainly written. Also make sure that the listing of booklets from which you choose is that of the latest issue of the magazine, as Radio Broadcast cannot guarantee the delivery of booklets not listed in its current issue.

USE THIS BOOKLET COUPON

RADIO BROADCAST SERVICE DEPARTMENT
RADIO BROADCAST, Garden City, N. Y.

Please send me (at no expense) the following booklets indicated by numbers in the published list above:

.....
.....
.....
.....
.....
.....
Name.....
Address.....
(Number) (Street)
.....
(City) (State)

ORDER BY NUMBER ONLY

This coupon must accompany every request.
R B 2-29

114. TUBE ADAPTERS—Concise information concerning simplified methods of including various power tubes in existing receivers. ALDEN MANUFACTURING COMPANY.
115. WHAT SET SHALL I BUILD?—Descriptive matter, with illustrations, of fourteen popular receivers for the set-builder. HERBERT H. FROST, INCORPORATED.
118. RADIO INSTRUMENTS, CIRCULAR "J"—A descriptive manual on the use of measuring instruments for every radio circuit requirement. A complete listing of models for transmitters, receivers, set servicing, and power unit control. WESTON ELECTRICAL INSTRUMENT CORPORATION.
120. THE RESEARCH WORKER—A monthly bulletin of interest to the engineer and home builder. Each issue contains special articles on radio design and construction with special emphasis on resistors and condensers. AEROVOX WIRELESS CORPORATION.
121. FILTER CONDENSERS—Some practical points on the manufacture and use of filter condensers. The difference between inductive and non-inductive condensers. POLYMET MFG. CO.
123. B SUPPLY DEVICES—Circuit diagrams, characteristics, and list of parts for nationally known power supply units. ELECTRAD, INC.
124. POWER AMPLIFIER AND B SUPPLY—A booklet giving several circuit arrangements and constructional information and a combined B supply and push-pull audio amplifier, the latter using 210-type tubes. THORNDARSON ELECTRIC MFG. CO.
125. A. C. TUBE OPERATION—A small but complete booklet describing a method of filament supply for a.c. tubes. THORNDARSON ELECTRIC MFG. CO.
126. MICROMETRIC RESISTANCE—How to use resistances for: sensitivity control; oscillation control; volume control; regeneration control; tone control; detector plate voltage control; resistance and impedance coupling; loud speaker control, etc. CLARONAT MFG. CO.
129. TONE—Some model audio hook-ups, with an explanation of the proper use of transformers and chokes. SANGAMO ELECTRIC CO.
130. SCREEN-GRID AUDIO AMPLIFICATION—Diagrams and constructional details for remodeling old audio amplifiers for operation with screen-grid tubes. THORNDARSON ELECTRIC MFG. CO.
131. THE MERSHON CONDENSER—An illustrated booklet giving the theory and uses of the electrolytic condenser. AMRAD CORPORATION.
132. THE NATIONAL SCREEN-GRID SHORT-WAVE RECEIVER—Constructional and operating data, with diagrams and photographs. JAMES MILLEN.
133. THE NATIONAL SHIELD-GRID FIVE—A circuit diagram with constructional and operating notes on this receiver. JAMES MILLEN.
134. REMLER SERVICE BULLETINS—A regular service for professional set-builders, giving constructional data, and hints on marketing. GRAY & DANIELSON MFG. CO.
135. THE RADIOBUILDER—A periodic bulletin giving advance information, constructional and operating data on S-M products. SILVER-MARSHALL, INC.
136. SILVER MARSHALL DATA SHEETS—These data sheets cover all problems of construction and operation on Silver-Marshall products. SILVER-MARSHALL, INC.
139. POWER UNIT DESIGN—Periodical data sheets on power unit problems, design, and construction. RAYTHEON MFG. CO.
140. POWER UNIT PROBLEMS—Resistance problems in power units, with informative tables and circuit diagrams. ELECTRAD, INC.
141. AUDIO AND POWER UNITS—Illustrated descriptions of power amplifiers and power supplies, with circuit diagrams. THORNDARSON ELECTRIC MFG. CO.
142. USE OF VOLUME AND VOLTAGE CONTROLS. A complete booklet with data on useful apparatus and circuits for application in receiving, power, amateur transmitter, and phonograph pick-up circuits. CENTRAL RADIO LABORATORIES.
143. RADIO THEORY. Simplified explanation of radio phenomena with reference to the vacuum tube, and data on various tubes. DEFORREST RADIO COMPANY.
144. LOW FILAMENT VOLTAGE A. C. TUBES. Data on characteristics and operation of four types of a.c. tubes. ARCTURUS RADIO COMPANY.
145. AUDIO UNITS. Circuits and data on transformers and impedances for use in audio amplifier plate and output impedances and special apparatus for use with dynamic speakers. SANGAMO ELECTRIC COMPANY.
146. RECEIVER CIRCUIT DATA. Circuits for using resistances in receivers, and in power units with descriptions of other apparatus. H. H. FROST, INC.
147. SUPER-HETERODYNE CONSTRUCTION. Construction and operation of a nine-tube screen-grid super-heterodyne. SET BUILDERS' SUPPLY COMPANY.
151. THE SECRET OF THE SUPER. Constructional and operation data on the Lincoln 8-80 One-Spot Super. LINCOLN RADIO CORPORATION.
152. POWER SUPPLY ESSENTIALS. Circuits and data on power-supply devices, and descriptions of power apparatus. POLYMET MANUFACTURING COMPANY.
153. WHAT THE EVERREADY FIDELITY CURVE MEANS TO RADIO RECEPTION. An analysis of the frequency range of musical instruments and the human voice which shows how these tones are reproduced by a receiver with an audio range of 60 to 5000 cycles. NATIONAL CARBON COMPANY.
154. AMPLIFIER AND POWER SUPPLY CONSTRUCTION MANUAL. A booklet giving descriptions, circuit diagrams, and lists of parts of several popular amplifier and power supply circuits. ACME WIRE COMPANY.
155. THE CUSTOM SET-BUILDER—A four-page monthly bulletin containing information of interest to servicemen and custom set-builders. CLARK AND TILSON, INC.
156. PHOTO-ELECTRIC CELLS—A booklet describing the applications, theory and characteristics of photo-electric cells. THE G-M LABORATORIES, INC.
157. USES OF ELECTRICAL METERS—Set of blueprints showing correct use of meters in laboratory and testing circuits. WESTON ELECTRICAL INSTRUMENT CORPORATION.

**164
PAGES
of RADIO
VALUES**

A NEW CATALOG JUST OFF THE PRESS

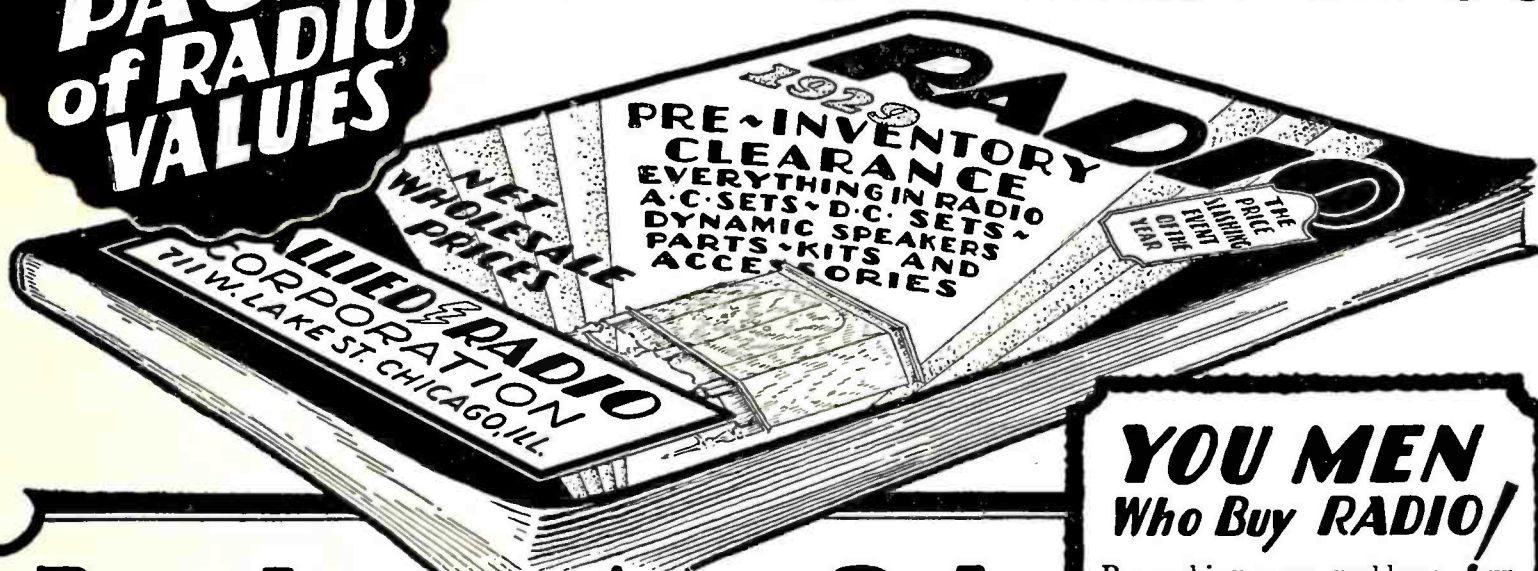

Pre-Inventory Sale

A PRE-INVENTORY SALE featuring some of the most drastic price reductions of the season. Our tremendous stocks must be **reduced**. Prices have been cut to the bone. Everything in our large stocks of radio merchandise is included. You will marvel at the remarkable values. Now is the time to buy. A new large catalog, featuring these remarkable values is now ready. Every radio enthusiast—every dealer—every set builder should send for this new catalog—quoting **lowest wholesale prices on everything** in radio.

YOU MEN Who Buy RADIO!

By making your problems our problems, we know the service you require—and to render you such service the entire Allied organization is dedicated—to give you the service you have a right to expect. Tremendous stocks, remarkable values and a real desire to serve, all combine to make Allied your ideal source of supply.

SET BUILDERS!

Set Builders, Amateurs and so called "Hams" will delight in the *unusual variety*—and **remarkable values** that are offered in standard kits and parts. Tremendous stocks—**real organization**—prompt shipping service all combine to make Allied your ideal source of supply.

RADIO DEALERS!

The live radio dealer—the man who keeps pace with the rapid advance of radio will find much of **real interest** in the Allied Catalog. New A-C Sets, D-C Sets, Dynamic and Magnetic Speakers, television equipment, in fact **everything** that an impatient radio public is demanding.

Lowest Wholesale Prices

Allied Service will prove a revelation to you in what radio service can really be. Allied Executives backed by years of training in radio are practical men. They know radio. Their vast experience has built up around them an organization trained to serve. Months of effort have built up here a tremendous reserve of stock that makes for prompt shipments; and this stock is new stock comprising the seasons pick of such prominent manufacturers as Silver-Marshall, Tyrman, Aero, Hammerlund-Roberts, etc.

You Profit When You Buy Right

Buying right is half the battle. From the small set builder to the large dealer, your success depends upon gauging the public pulse of radio and in **buying right**. Everything that is new in radio—the items the radio public is now demanding are here, ready for your call. Write now—the catalog is **free** for the asking.

Write for Catalog Now

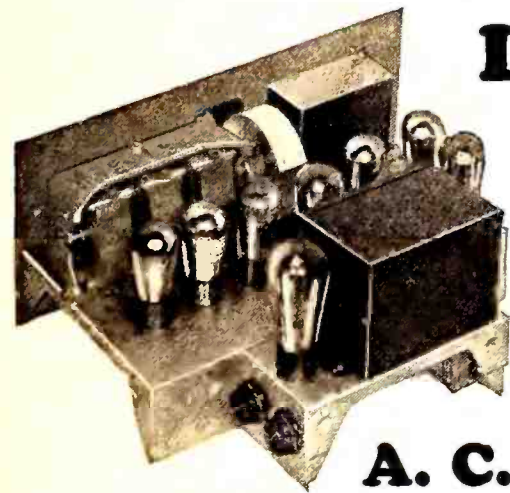

A. C.

ELECTRIC SETS

Allied offers you a new—complete line of A-C Receivers, available in either chassis form or in a wide variety of beautiful console models. Prices range from \$32.95 to \$199.00. Dollar for dollar they stand out as one of the season's leading receivers. Engineered to unusual perfection they offer you features found only in the highest priced sets.

Allied Radio CORPORATION

711 W. LAKE ST. Dept. A-5 CHICAGO, ILL.

CLARITY



*Noted for the
Bell-Like Clarity
of their Tone*

CECO's exquisite tone quality is not accidental. It is the result of deliberate effort in design, a higher quality of materials and special and exclusive processes which are employed in the rugged construction of these beautifully toned, long-lasting tubes. Sold everywhere.

Have you heard CeCo's delightfully entertaining radio program over the entire Columbia Broadcasting Chain of 20 cities—every Monday evening, 8:30 Eastern time, 7:30 Central time?

CeCo Mfg. Co., Inc. • Providence, R. I.

CECO

Radio Tubes

FOR EVERY RADIO NEED

The Radio Broadcast LABORATORY INFORMATION SHEETS

THE aim of the Radio Broadcast Laboratory Information Sheets is to present, in a convenient form, concise and accurate information in the field of radio and closely allied sciences. It is not the purpose of the Sheets to include only new information, but to present practical data, whether new or old, that may be of value to the experimenter, engineer or serviceman. In order to make the Sheets easier to refer to, they are arranged so that they may be cut from the magazine and preserved, either in a blank book or on 4" x 6" filing cards. The cards should be arranged in numerical order.

Since they began, in June, 1926, the popularity of the Information Sheets has increased so greatly that it has been decided to reprint the first one hundred and ninety of them (June, 1926-May, 1928) in a single substantially bound volume. This volume, "Radio Broadcast's Data Sheets", may now be bought on the newsstands, or from the Circulation Department, Doubleday, Doran & Company, Inc., Garden City, New York, for \$1.00. Inside each volume is a credit coupon which is worth \$1.00 toward the subscription price of this magazine. In other words, a year's subscription to RADIO BROADCAST, accompanied by this \$1.00 credit coupon, gives you RADIO BROADCAST for one year for \$3.00, instead of the usual subscription price of \$4.00.

—THE EDITOR.

No. 256

RADIO BROADCAST Laboratory Information Sheet

February, 1929

Three Types of Graphs

IF WE have before us a job of plotting a curve of an a.f. amplifier to show how the voltage gain varies with frequency, we must decide just how the curve is to be plotted. Curves may be plotted on several types of cross-section paper which will be illustrated in a future Laboratory Sheet. The problem is this, should we plot the curve on ordinary cross-section paper or on log or log-log paper, and should we plot frequency against dB or against voltage output.

The essential purpose of a curve is to enable one to obtain a visual idea of the characteristics of the amplifier. Since the purpose of an a.f. amplifier is to amplify currents which will finally be converted into sound, it is preferable to plot the curve to such a scale that its final shape indicates as nearly as possible the variations in response as they would be audible to the ear.

Now it has been determined that the ear hears variations in intensity in accordance with a logarithmic function. For this reason, if we are to plot fre-

quency against output voltage, it is advisable to plot the curve on log-log paper so that the variations will be indicated on the curve in their relative importance as heard by the ear.

If we desire to plot frequency against dB then the curve should be plotted on log paper. In such a case we would find that the shape of the resultant curve was the same as that of the preceding curve plotted on log-log paper, for in converting from voltage to dB we take into consideration the logarithmic function.

In all cases the frequency scale should be plotted on a log scale so that each octave in the scale takes up an equal amount of space. Take a piece of cross-section paper with a log scale on it and measure the distance in inches between 10 cycles and 100 cycles, a change in frequency of 10 to 1. Then measure the distance between 100 and 1000 and between 1000 and 10,000. The distances are all equal and equal sections of the curve therefore receive an equal amount of space.

No. 257

RADIO BROADCAST Laboratory Information Sheet

February, 1929

Heater Connections for A. C. Tubes

AN EXAMINATION of the circuits of various a.c. receivers using one or more 227-type tubes shows several different ways the heaters of these tubes may be connected into the circuit.

In sketch A we show the heater of the tube quite independent of the remainder of the circuit. In sketch B the center tap of a resistor connected across the heater is grounded and in sketch C the center tap of the resistor connected across the heater is connected to the plus 45-volt terminal. Of these three arrangements the one most commonly used is B in which the heater is grounded, since such an arrangement gives satisfactory oper-

ation in most cases. It is generally unwise to arrange the circuit as indicated at A, since the heater under such conditions is more or less floating and is liable to introduce hum into some part of the circuit.

The reason for the use of the arrangement shown at C is somewhat complicated. When the heater of the tube becomes hot it, of course, emits some electrons and it is possible for some of these electrons to enter the plate circuit. Since the heater is operated on a.c. the emission from it is not uniform and, therefore, a hum will be produced if any appreciable number of electrons are drawn from the heater.

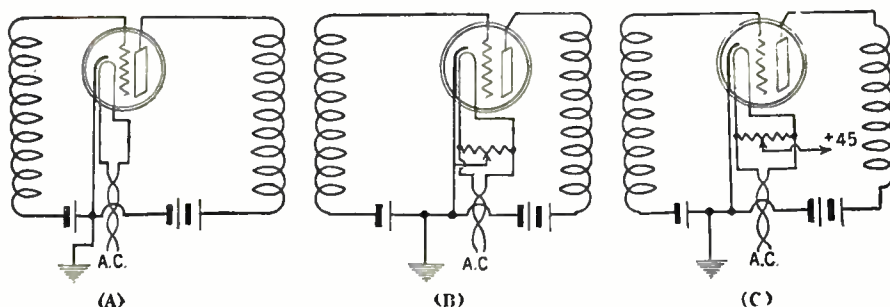



**5000 Hours
Instead of 1000!**

When your fragile 1000 hour rectifier tube in your "B" Eliminator "blows", don't put another just like it in the socket—be modern—get one of the husky, solid, all dry 5000 hour Elkon EBH rectifiers from your dealer and forget your rectifying troubles for 5000 hours, at least.

The new Elkon EBH replaces all BH type rectifiers—no changes in wiring—simply take out the trouble-causing gas tube and plug in the smooth, powerful, trouble-free Elkon—that's all there is to it.

Other Elkon Replacement Rectifiers, too

Ask your dealer about the new dry Elkon rectifier which replaces the wet jar Philcatron type A and type AA in all Philco power units—trickle chargers, "A" Eliminators and A combinations. For the Philco "A" Eliminator equipped with Elkon rectifiers, use the Elkon M-16 for replacement. Eleven "A" Eliminators have used the M-16—be sure you get the M-16 in the red, black and yellow box. The Elkon V-4 is used for 6 makes of trickle chargers, and the Elkon is the only authorized replacement rectifier for the Balkite Power Units, types N, K and J.

ELKON, INC.

Division of P. R. Mallory & Co.
350 Madison Ave., New York

ELKON, Inc., Dept. E-32
350 Madison Avenue, New York City
Kindly send me complete information on Elkon Radio Products.

Name..... Address.....



Elkon rectifiers are tested with receiving sets

Raytheon Kino-Lamp

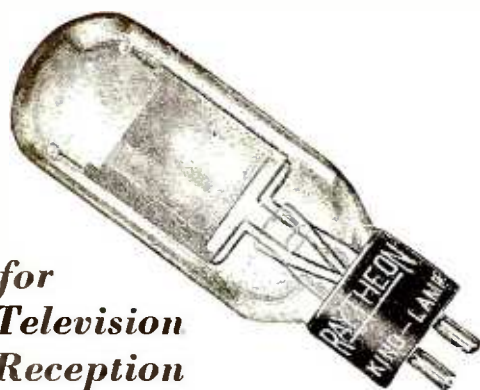

for
Television
Reception

This lamp is made in numerous types and styles, which provide suitable light sources and light-sensitive relays for all systems.

List Price, \$7.50

Raytheon Foto-Cell



for
Television
Sending

This is an extra-sensitive broadcasting tube, supplied in either hard vacuum or gas-filled types, and in two sizes of each.

Information and prices on application

Raytheon BH LONG LIFE RECTIFYING TUBE



for
"B" Power
Eliminators

Over a hundred different makes of "B" Eliminators require this tube, and take no other. There are millions of them in daily, satisfaction-giving use.

List Price, \$4.50

Write for further information on any of this equipment

RAYTHEON MFG. CO.
CAMBRIDGE, MASS.

No. 258

RADIO BROADCAST Laboratory Information Sheet

February, 1929

An Analysis of Filter Circuits

ON LABORATORY Sheet No. 259 are given a circuit diagram and set of curves showing the output voltage from a typical full-wave rectifier using two 281-type tubes. These curves will prove helpful in determining what voltage is necessary across the power transformer to deliver a given voltage to the filter system. The curves show the output of the rectifier with transformer voltages ranging from 550 volts per plate up to 700 volts per plate.

Two sets of curves are given, one set being obtained with the standard filter system indicated in the circuit diagram and the other with a special circuit recommended by the E. T. Cunningham, Inc. The solid curves show the voltages with a standard filter system and the dotted curves show the voltage with a special filter system. In determining the latter curves the first filter condenser, C_1 , was omitted.

When using the standard type of filter system the load on the tube is quite heavy and the peak value of current, which the rectifiers are called upon to supply under full-load conditions, reaches values as

high as 310 milliamperes, although the average current drawn from the filter system is only 125 milliamperes; the filament must be capable of supplying the maximum value of current, i.e. 310 milliamperes. With the first condenser, C_1 , removed from the filter system the voltage output for a given transformer voltage decreases considerably, as indicated by the curve, but with this condenser removed the tube operates under much more satisfactory conditions. The peak value of current used in such a circuit is only 140 milliamperes when the load current is 125 milliamperes. In other words the peak current has been reduced from 310 milliamperes to only 140. This reduction increases the life of the filament, and a tube having a total emission of 150 milliamperes will still give satisfactory operation in the special filter circuit although it would not function satisfactorily in an ordinary filter circuit where the plate current reaches values up to 310 milliamperes. It is recommended that this special filter system be used wherever possible.

No. 259

RADIO BROADCAST Laboratory Information Sheet

February, 1929

Filter Circuit Characteristics

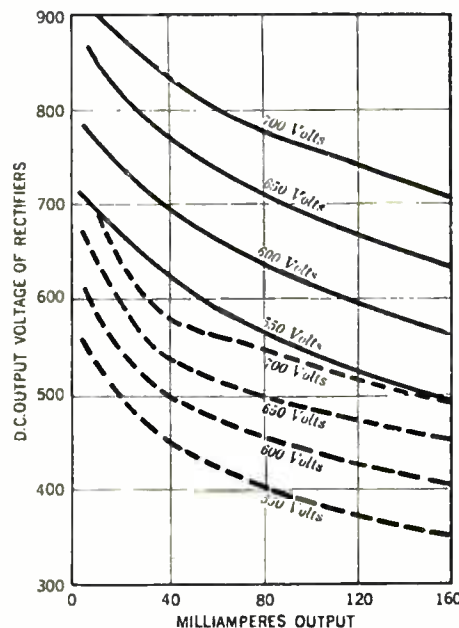
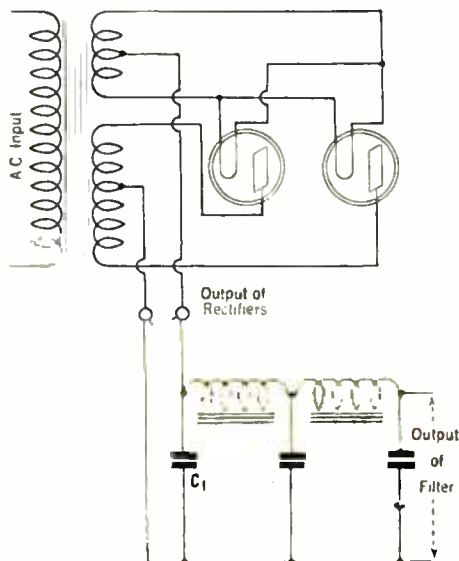

No. 260

RADIO BROADCAST Laboratory Information Sheet

February, 1929

Voltage Gain in Resistance-Coupled Amplifiers

LABORATORY Information Sheets Nos. 242, 243, 219, and 250, discussed resistance-coupled amplifiers; the latter two sheets gave the circuit diagram and a list of parts for the construction of a good amplifier of this type. In this sheet further data is given regarding resistance-coupled amplifiers in comparison with other types.

The overall voltage gain in a resistance-coupled amplifier is generally much greater than that of a transformer-coupled amplifier. For example, a standard two-stage transformer-coupled affair has a voltage gain of about 100 from the input to the grid of the power tube. The usual three-stage resistance-coupled amplifier using high- μ tubes has a gain of about 400 from the input to the power tube's grid. This additional gain is not always an advantage. If such an amplifier is used in a receiver operated entirely from batteries this high gain will simply have the effect of increasing the loudness of the signals, but if such an amplifier is used in a receiver operated from a B-power unit it is probable that the hum output will be much greater than it

would be if a two-stage transformer-coupled amplifier were substituted for it. This is due to the fact that, as pointed out in Laboratory Sheet No. 261, the hum voltage developed across the loud speaker is a direct function of the overall gain of the amplifier and the amount of hum introduced into the detector circuit. Since the amplifiers have a ratio of about 4:1 in gain, the hum voltage developed when using the resistance-coupled amplifier will be about four times as great, assuming that all other conditions remain the same.

For these reasons it frequently is advisable to construct the resistance-coupled amplifier with somewhat lower gain. For example, if instead of using two 240 tubes we use one 201A and one 240 then the overall gain will be about 150 which is a very satisfactory value.

For some reason the resistance-coupled amplifier has not found wide use in manufactured or home-constructed receivers although when properly designed it is certainly capable of giving results as good as any other type of amplifier.



Thrilling Tone Purity
Radio's Richest Voice



We have now been using Thordarson transformers for some four years, which should be proof conclusive that we think them capable of maintaining the high quality of Sparton Radio Receivers, which we so jealously guard.

W. Sparks

President-General Manager
The Sparks-Withington Company

THE manufacturers of the world's finest receivers realize the important relationship between the choice of transformers (power supply and audio) and the performance of their instruments. Almost universally they have turned to Thordarson as the source of their transformers.

In Thordarson Power Supply Transformers they have found an efficiency of design, an abundance of power and a constancy of performance that makes their power unit free from service calls; and in Thordarson Audio Transformers a fidelity of reproduction that renders their receivers musical instruments of the highest caliber.

The purchaser and builder of radio receivers who seeks the ultimate in performance will insist on Thordarson Radio Transformers.

THORDARSON ELECTRIC MFG. CO
Transformer Specialists Since 1895
Huron, Kingsbury and Larrabee Streets
Chicago, Illinois

THORDARSON
RADIO
TRANSFORMERS

Supreme in Musical Performance



"Isn't it about time, Dad, you eliminated the adenoids?"

ANY set with inferior transformers has adenoids. Why not have your set give you what it is capable of—its a mighty simple thing to eliminate the adenoids from your set — and to substitute true tones as given by AmerTran radio products.



AmerTran ABC Hi-Power Box—500 volts DC plate voltage, current up to 110 ma. AC filament current for all tubes for any set. Adjustable bias voltages for all tubes. Price, east of Rockies—less tubes—\$95.00



Complete 2 stage audio amplifier First stage AmerTran DeLuxe for UX 227 AC and second stage AmerTran Push-Pull for two 171 or two 210 Power Tubes. Price, east of Rockies—less tubes—\$60.00.

No matter what your set is you have yet to hear the music as it is broadcast from the studio with all of the overtones and shadings from the lowest stop on the organ to the piercing note of the piccolo.

AmerTran audio systems will give you every tone broadcast—just as it is broadcast from the studio. A pair of DeLuxe transformers, or the superb power amplifier (push-pull for 210 tubes) and the ABC Hi-Power Box. No matter what AmerTran audio system you choose, your set will be free from adenoids. See your dealer or write to us.

AMERTRAN

AMERICAN TRANSFORMER COMPANY
Builders of Transformers for more than 29 years
71 Emmet St. Newark, N. J.



Safeguard Your A. C. Installation

SATISFACTORY and economical operation of A. C. receivers is contingent upon maintaining close regulation of operating voltages, by means of suitable A. C. measuring instruments. This is necessary because of the wide fluctuation in the potential of secondary lines furnishing current to house lighting circuits.

Set manufacturers, dealers and electric light and power companies everywhere are cooperating to the end that voltage regulation, both on supply lines and in connection with voltage control equipment of the receivers themselves, may be effected for the better operating service of all set owners. For this reason, as well as for other testing requirements outlined in the following, all purchasers of A. C. receivers are urged to provide themselves with an instrument such as is shown in the illustration—known as the Weston Model 528 A. C. Voltmeter, range 150/8/4 volts.

When you find that there is an excessive in-put voltage, it follows that there is too high a voltage on the filament which shortens the operating life of the rectifying tubes. The Model 528 Voltmeter therefore checks the line supply voltage at all times and indicates when adjustments should be made to manually operated line voltage regulators between the power supply and the power transformer.

This voltmeter also indicates when the line voltage is over-rated, thus enabling the operator to make an adjustment in the set for the higher line voltage so that normal life can be obtained from his tubes.

The Model 528 is also made as Ammeters which are especially useful in checking the total load of the A. C. Set—in conformity with set manufacturers' instructions. The determination of A. C. filament flow in A. C. tube filament circuits is easily obtained by means of this instrument.

Write for your copy of Circular J fully describing the Weston Radio Line.

Weston Electrical Instrument Corporation
604 Frelinghuysen Ave.,
Newark, N. J.

WESTON
RADIO
INSTRUMENTS

No. 261

RADIO BROADCAST Laboratory Information Sheet February, 1929

Where A. C. Hum Originates

THE amount of a.c. hum audible in a loud speaker connected to a radio receiver depends upon various factors. With a given installation, however, the hum depends to the greatest degree upon the amount of a.c. ripple introduced into the plate circuit of the detector tube. This hum voltage may come from the B-power unit or from a.c. tubes, and in a.c. sets some hum is, of course, obtained from both of these sources.

It is important to realize the importance of any hum in the detector circuit. Consider an ordinary transformer-coupled amplifier using, say, a 3 to 1 ratio transformer between the detector and first a.f. tube, and assume that the first a.f. amplifier tube has a mu of 8. Between the plate circuit of the detector tube and primary winding of second a.f. transformer the gain is, therefore, 24. It follows from this calculation that, if a given amount of hum is obtained from a loud speaker when there is a certain hum voltage in the plate circuit of the first a.f. tube, that the same amount of hum will be obtained with only one-twentyfourth as much hum voltage in the plate circuit of the detector tube. For these reasons it generally is found that ampli-

fiers which are noisy under normal operation are generally quiet if the output of the detector tube is short circuited—a definite indication that the major part of the hum arises in the detector circuit.

Let us consider a concrete example. Suppose that we have a two-stage a.f. amplifier with 3 to 1 transformers, the first audio tube having a mu of 8 and the power amplifier having a mu of 3 and that the load resistance in the output is equivalent to 4000 ohms. Assume that a hum potential of 0.1 volts is existent in the plate circuits of the detector tube and also the first audio amplifier. The hum voltage from the plate circuit of the first a.f. amplifier circuit will produce a hum potential of 0.6 volts across the 4000-ohm load resistance. The hum voltage in the detector circuit will produce 14.4 volts in the load circuit. Even assuming that these two voltages are 180 degrees out of phase so that they oppose each other the voltage in the load circuit would be 13.8 volts. It follows from these figures that practically all the hum in the output will come from the detector circuit. The importance of proper design in the detector circuit to eliminate any small hum voltages cannot be overemphasized.

No. 262

RADIO BROADCAST Laboratory Information Sheet February, 1929

Advantages of Dual Push Pull

HIGH-GAIN a.c.-operated power amplifiers, designed particularly for use in public-address systems, frequently make use of two 250-type tubes in push pull in the output. If these tubes are operated at their rated voltage in order to obtain the maximum amount of undistorted power a total value of peak signal voltage across the secondary of the push-pull transformer feeding these tubes must be about 160 volts. Assuming that this transformer has a ratio of 3 to 1, the voltage across its primary must be 160 divided by 3, or approximately 53 volts. If the tube feeding this transformer has a mu of 8 then the voltage on its grid must be about 7 volts, and, in order to prevent the possibility of overloading, the grid bias should, therefore, be twice this value plus about 10 per cent. or 15 volts. We might consider using a 226-type tube to feed the push-pull stage, but the maximum rated voltage of this tube is 180 volts with a corresponding grid bias of 13.5 volts which, from the figures given above, is not sufficient.

It is for this reason that we find many of the power amplifiers designed for public-address work consisting of two push-pull stages, the power output

stage being fed by a preceding push-pull stage using 227- or 226-type tubes. Through the use of the push-pull arrangement we are able to handle voltages somewhat greater than twice that which can be handled by a single tube. These tubes in push-pull can then handle without difficulty the voltages required to load up two 250-type tubes in push-pull. It follows obviously, from these figures, that any power amplifier using 250-type tubes in push-pull must be preceded by a push-pull stage if maximum output is desired, since a single 226- or 227-type tube will be badly overloaded when called upon to supply the necessary voltages. The above discussion, of course, does not consider the possibility of using a small power tube in the circuit preceding the push-pull stage.

If we assume that we can obtain from the detector circuit about 0.3 volt and that 160 volts are required on the grids of the power tubes, it follows that the gain in the amplifier must be about 530 (160 divided by 0.3). The gain of an ordinary amplifier, is about 100 and, consequently, when using 250's in push-pull it is essential that a three-stage audio amplifier be used.

No. 263

RADIO BROADCAST Laboratory Information Sheet February, 1929

Wavelength-Kilocycle Chart

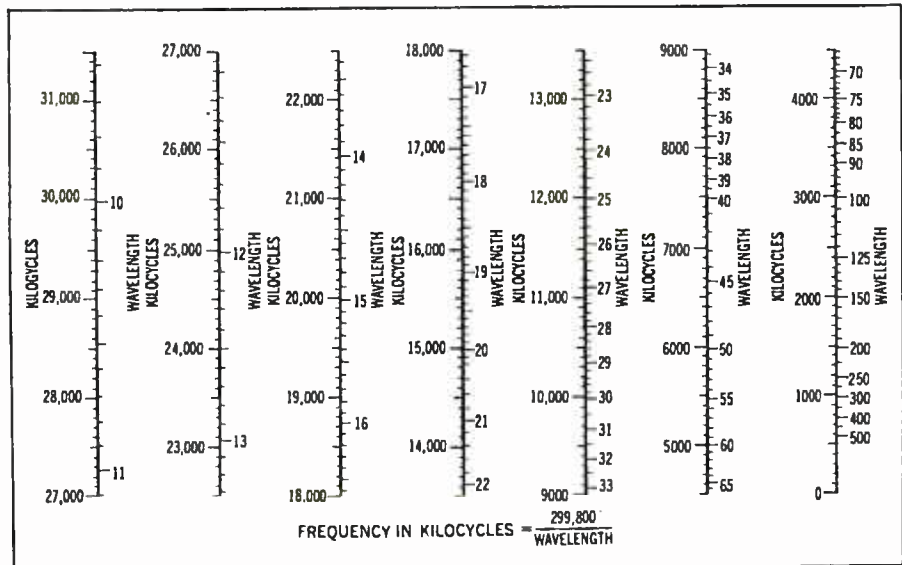



**Born in
1923**

and still going strong!

SIX years ago Remler developed and applied the Twin-Rotor principle to radio condensers. Since 1923 refinements have been added, two and three gang models have been introduced, but there has been no change in basic design, no departure from the Twin-Rotor principle which has won increasing recognition from year to year.

This Remler Condenser set new standards of perfection in tuning. During these six years of Remler leadership, every other condenser on the market has been radically changed in design. Yet to-day the Twin-Rotor continues to hold its place of definite dominance in the Condenser field.

You will not find them in factory-built receivers, because set manufacturers work strictly on a cost basis and will not pay the extra price of a high quality product. But wherever set-builders gather, whenever performance counts more than price, there you will find that the famous Twin-Rotor is valued at its true worth—is considered the World's Best Condenser.

Write us for complete information on the full line of Remler Condensers in various capacities and types.

REMLER

Division of

GRAY & DANIELSON MFG. CO.

260 First Street San Francisco, Calif.

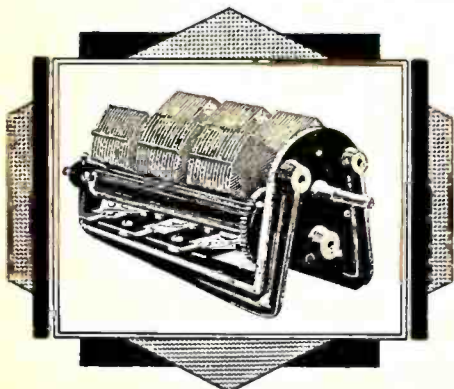

**Now...4 or 6 Volts
with the
Improved
Knapp
"A" POWER**



Operates on 105 to 120 volts, 50 to 60 cycles.

- 10 Improvements**
1. Two taps for 4 or 6 volts operation.
 2. Larger filter system.
 3. Three Elkon Dry Condensers instead of two.
 4. Improved Choke Coils.
 5. Pendant Switch, Controlling "A" Power, "B" Eliminator and Set.
 6. Dial for Regulating Voltage.
 7. Celeron Front Panel.
 8. Baked Finish.
 9. Heavier Gauge Metal Cover.
 10. Die Cast Base Plate instead of wood.

**The only "A" Power
Suitable for all Sets**

*— Irrespective of number of tubes — including
SuperHets, Short Wave and Television receivers*

THE new Knapp "A" Power is designed for the most exacting service — super-hets, short wave and television receivers included. I knew that if it would perform satisfactorily with these receivers that there could be no question as to its efficiency on ordinary broadcast signals. The three Elkon dry condensers, the improved choke coils and the special Elkon dry rectifier make the difference between ordinary and Knapp performance.

No Change in Price

Even with these wonderful and costly improvements, there has been no advance in price—due to the tremendous volume going thru my plant. Remember that the Knapp is the fastest selling "A" Power on the market.



David W. Knapp, Pres.

KNAPP ELECTRIC, Inc.
—Division of P. R. Mallory & Co., Inc.—
350 Madison Ave., New York City

See your dealer today

Go to your dealer today. Most of the good ones carry the Knapp in stock. Do not accept a substitute—because only in the Knapp will you get full satisfaction as typified by the famous Knapp "A" Power. If your dealer cannot supply you send the coupon.

Mr. David W. Knapp, Pres.,
Knapp Electric, Inc., Dept. K-23
350 Madison Ave., N. Y. C.
Send me complete information on the Knapp
"A" Power.

Here's the Answer

to every question about the principles, methods, or apparatus of radio transmitting and receiving.

THE RADIO MANUAL

A Complete Course in Radio Operation In a Single Volume



A Handbook for Students Amateurs Operators Inspectors

For the first time an entire course of training in one book—the most complete and up-to-date work on radio. Developed simply and clearly from the elementary stage right through all phases of principles, practise, and apparatus so that a beginner with no knowledge of electricity

may get all he needs either for amateur operation or to qualify for a government license as operator or inspector.

Prepared by Official Examining Officer

The author, **G. E. Sterling**, is Radio Inspector and Examining Officer, Radio Division, U. S. Dept. of Commerce. The book has been edited in detail by **Robert S. Kruse** for five years Technical Editor of QST., the Magazine of the Radio Relay League. Many other experts assisted them.

16 Chapters Cover: Elementary Electricity and Magnetism; Motors and Generators; Storage Batteries and Charging Circuits; The Vacuum Tube; Circuits Employed in Vacuum Tube Transmitters; Modulating Systems; Wavemeters; Piezo-Electric Oscillators; Wave Traps; Marine Vacuum Tube Transmitters; Radio Broadcasting Equipment; Arc Transmitters; Spark Transmitters; Commercial Radio Receivers; Radio Beacons and Direction Finders; Radio Laws and Regulations; Handling and Abstracting Traffic.

New Information never before available such as a complete description of the Western Electric 5 Kilowatt Broadcasting Transmitter; description and circuit diagram of Western Electric Superheterodyne Radio Receiving Outfit type 6004-C; Navy Standard 2-Kilowatt Spark Transmitter; etc., etc. Every detail up to the minute.

Free Examination

"The Radio Manual" has just been published. Nearly 700 pages. Profusely illustrated. Bound in Flexible Fabrikoid. The coupon brings the volume for free examination. If you do not agree that it is the best Radio book you have seen, return it and owe nothing. If you keep it, send the price of \$6.00 within ten days.

Order on This Coupon

D. Van Nostrand Co., Inc.,
8 Warren St., New York

Send me THE RADIO MANUAL for examination. Within ten days after receipt I will either return the volume or send you \$6.00, the price in full.

(Radio Broadcast 2-29)

Name.....

St. & No.

City and State.....

1000 Hours!

The dealer who recommends De Forest Audions, the perfected radio tubes, offers you 1000 hours of matchless radio entertainment.

DE FOREST RADIO CO.
NEW JERSEY
JERSEY CITY

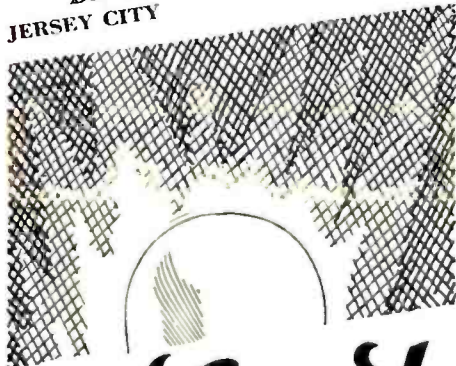

de Forest AUDIONS



AEROVOX

BUILT BETTER
CONDENSERS AND RESISTORS

False Economy Is Costly

Nothing is likely to prove as costly as a cheaply made, over-rated condenser or resistor.

Whether you are a manufacturer, professional set builder or experimenter, you cannot afford the high cost of a cheap condenser or resistor.

Aerovox condensers and resistors are conservatively rated and thoroughly tested. They are not the most expensive, nor the cheapest but they are the best that can be had at any price.

A COMPLETE CATALOG with illustrations and detailed descriptions may be obtained free of charge on request.



The Aerovox Research Worker is a monthly publication that will keep you abreast of the latest radio developments. Your name will be put on the mailing list free of charge on request.

AEROVOX WIRELESS CORP.

76 1/2 Washington St., Bklyn., N. Y.
PRODUCTS THAT ENDURE

CORWICO

Braidite

HOOK-UP WIRE
"THE BRAID SLIDES BACK"

FREE SAMPLE

Send us the name and address of your dealer and we will send you a sample package of Braidite FREE. Include 10c for Postage. We do this because we want you to get acquainted with Braidite and prove to yourself its many exclusive features. Send for your sample NOW.

CORWICO Braidite

CORNISH WIRE CO. NEW YORK

At All Dealers

25 Feet Stranded 35c

25 Feet Solid 30c

Red-Green Yellow Blue-Black

CORNISH WIRE Co
30 Church Street New York City

Jenkins & Adair

Microphone Mixing Panel

TYPE 3-B

For Broadcasting, Electrical Recording, and Power Speaker Systems

THE 3-B Mixing Panel is designed to accommodate almost any combination of pickup circuits up to a total of six. Any three of these may be made to pass through the three Compound Mixing Controls at the same time, and instantaneous switching is available for the remaining circuits.

The incoming circuits may consist of condenser transmitters, carbon microphones, telephone lines or low impedance phonograph pickup devices, in practically any combination. When a single input circuit of extremely low level is encountered, the positions not in use may be cut entirely out of the system, thus causing no loss whatever to the weak incoming signal.

The panel is 5/16 black sanded Bakelite, 19 in. wide and 12 1/2 in. high. Detailed information and circuit is shown in bulletin No. 7, which we will be glad to mail to you. The net price in the U. S. A. and Canada is \$275.00, F. O. B. Chicago.

J. E. JENKINS & S. E. ADAIR, Engineers
1500 N. Dearborn Parkway,
Chicago, U. S. A.
Send for our bulletins on Broadcasting Equipment

"Standard of the World"

A fitting title for

VICTOREEN

Super Receivers

Down thru the years, from the very beginning of Radio, Victoreen has kept ahead of its time. Developments from the Victoreen Laboratories are constantly **ADVANCE** announcements of radical improvements in radio reception.

The New Victoreen Circuit for 1929 eclipses all past achievements. It combines unparalleled sensitivity, selectivity and tone quality.



Perfected A. C. Operation

Until you have heard and used a 1929 A. C. Victoreen you cannot realize what a wonderful receiver it is. Stations that you have never heard before, together with all the old favorites, are at your instant command.

The heart of this master circuit is the Victoreen Super Transformer, vastly improved for 1929, tuned and matched to a precision of $\frac{1}{3}$ of one per cent. In addition, the Victoreen Circuit itself contains improvements far ahead of its time.

Complete Kits Available

Either A. C. or D. C.

Write us for complete information regarding the latest Victoreen developments.

Blue Prints and Assembly instructions are **FREE**. State whether you wish A. C. or D. C.

Victoreen Power Amplifier and "B" Supply

for Best Results from Any Receiver

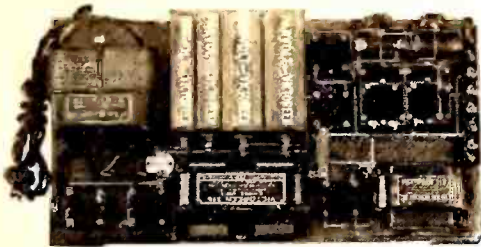

Supplies 45, 90, 180 and 450 volts, using a UX 210 or 250 in the last stage. Contains two voltage regulator tubes so that the 90 and 180 volt taps are supplied with a constant volt potential. It is the last word in "B" Supply. For the most satisfactory results you must have it.

FREE BLUE PRINTS, with list of parts and complete assembly instructions, will be sent upon request.

The George W. Walker Company
Merchandisers of Victoreen Radio Products
2825 Chester Ave., Cleveland, Ohio

Victoreen

Quality Radio Parts

The Remarkable Efficiency of HAMMARLUND PARTS Is Exemplified in the New JUNIOR "HiQ-29" RECEIVER

IT'S THERE—this receiver. With everything you can ask—beauty, tone, selectivity, volume. **PERFORMANCE** plus—that's what the new Hammarlund-Roberts Junior "HiQ-29" will give you.

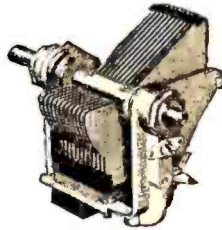

MIDLINE CONDENSER

The coils, condensers, chokes, shields, drum dial and foundation unit are of Hammarlund design and manufacture—a guarantee of **QUALITY** you can rely on.



R. F. CHOKE COIL

You can build the Junior "HiQ" yourself easily or have a professional do the work at a very reasonable cost. Two models—either for house current or battery operation. Your dealer has all parts.



ILLUMINATED DRUM DIAL

Send 25c for "HiQ-29" Construction Manual. It tells the whole wonderful "HiQ" story.

HAMMARLUND MFG. CO.

424-438 W. 33rd St. New York



SHIELD GRID COIL

For Better Radio
Hammarlund
PRECISION
PRODUCTS

Before Buying

Any "A" Eliminators

Write me about the discount card which enables you to purchase the new and improved **Knapp "A" Power Kit** at a liberal discount.

The most complete "A" Power Kit ever offered—Address for details of plan—

David W. Knapp, Pres.

Knapp Electric, Inc., Room 414B
350 Madison Ave., New York City

ROBERT S. KRUSE

Consultant and Technical Writer

103 Meadowbrook Road, West Hartford, Conn.

Telephone Hartford 45327

Modern Tube Control A.C. or D.C.

AMPERITE self-adjusting Control of tube temperature insures best results from modern radio receivers. Tone, sensitivity, volume—all are improved by **AMPERITE**. \$1.10 with mounting (in U.S.A.) at all dealers.

Radiall Company
30 FRANKLIN ST., NEW YORK

This symbol in a radio diagram means—

FREE—Amperite Blue Book of modern circuits and valuable construction data. Write Dept. H. B. 2.

AMPERITE
REG. U. S. PAT. OFF.
The "SELF-ADJUSTING" Rheostat

Quality
with Volume
never possible
before



The Jensen AUDITORIUM SPEAKER

DYNAMIC, OF COURSE!

Here is a new dynamic speaker by Peter L. Jensen which again sets the standard of reproduction, just as his first dynamic cone did in 1927.

It is called the Jensen Auditorium Speaker, and brings to you a quality, a brilliance and a volume of reproduction never attained before.

For use in auditorium or theatre this new all-purpose speaker should be operated from the largest amplifier. For home use it is just as efficient when operated from one type 171 amplifier tube.

Three models are available; one for field operation from 110 Volt DC; one for 220 Volt DC; one for 110 Volt AC. The latter type, illustrated above, requires a full wave rectifier tube, type 280 or 380. Approximately 18 watts are required to excite the field. The cone is 11 inches in diameter.

Write to us, or let your dealer demonstrate.

JENSEN RADIO MFG. COMPANY
338 N. Kedzie Ave., CHICAGO, ILL.
212 Ninth Street, OAKLAND, CAL.

*Jensen Patents Allowed and Pending—Licensed under
Leakophone and Magnavox Patents*

Jensen

AUDITORIUM SPEAKER



TONE QUALITY

Now the Carborundum Detector is adjustable. A turn of the pressure screw gives you perfect balance—gives you perfect tone. The detector then remains fixed and permanently sensitive, by tightening the lock nut.

Tone Quality is everything in radio; here is another improvement that further assures it. Recommended by noted radio-circuit designers.

DEALER OR DIRECT, \$1.50 IN U. S. A.

Send for Free Book "Carborundum in Radio"—D-2

THE CARBORUNDUM CO., NIAGARA FALLS, N. Y.
Canadian Carborundum Co., Ltd., Niagara Falls, Ont.

Carborundum is the Registered Trade Mark of The Carborundum Company for its Silicon Carbide and is its exclusive property.

CARBORUNDUM

REG. U. S. PAT. OFF.

DETECTOR



Write
for
this
Discount
Card
NOW!



*It will enable you to purchase the
New and Improved*

KNAPP "A" POWER KIT
at a liberal discount

The new Knapp "A" is the finest and most complete kit ever offered. It is the only "A" Power adaptable to Short Wave—Super Heterodyne and Television reception.

Take advantage of the wonderful offer today—write

David W. Knapp, Pres.

Knapp Electric, Inc.

Division of P. R. Mallory & Co., Inc.

Room 414B, 350 Madison Ave., N. Y. City

**GET MY
DISCOUNT CARD!**

**Before buying a
KNAPP "A" POWER KIT**
Absolutely dry—Magically
silent—the finest "A" Power
adaptable to Short Wave,
Super-Heterodyne and Tele-
vision reception.

**WITH THE
10 NEW IMPROVEMENTS**
Write me today for details of this
money saving plan and get your dis-
count card. Address

DAVID W. KNAPP, Pres.
Knapp Electric, Inc.

Division of P. R. Mallory & Co., Inc.
Room 414B, 350 Madison Ave., N. Y. C.

Send for **WESTERN RADIO**

new 1929 Catalog

DEALERS AND SET BUILDERS

The NEW 1929 catalog is crammed full of the FINEST, NEWEST, Nationally known A. C. sets, consoles, cabinets, dynamic speakers, kits, eliminators and accessories at LOWEST PRICES. Largest stock of radio parts, Prompt delivery. *No delay.*

Write for our FREE catalog

WESTERN RADIO MANUFACTURING CO.
128 W. Lake St. Dept. RB-2 Chicago

FREE



The Big Friendly Radio House

Potter Condensers

Quality, Long Life



THE selection of leading manufacturers for the finest radio receivers. Insure the operation of your radio set or power amplifier with Potter condensers.

Potter T-2900 Condenser Block for the single 250 type tube amplifier—\$20.00.

Potter T-2950 Condenser Block for the push-pull 250 type tube amplifier—\$22.50.

Potter T-2098 Condenser Block for the single 210 type tube amplifier—\$20.00.

Potter SM-673 Condenser Block for Silver Marshall Power Amplifier and Power Supply units—\$20.00.

Potter 105-05 Interference Eliminator for oil burner and ice machine motors—\$3.75.

The Potter Co.

North Chicago, Illinois

A National Organization at Your Service



The Vital Point

Since any radio, old or new, is only just as good as the tubes in its

sockets, it is clear how vital a point perfectly balanced tubes are.

The brand of radio tube is just as important as the "make" of the set.

Insist on

Cunningham RADIO TUBES

for clear

reception

QUALITY LONGAN PRODUCTS



No. 7568

\$13.50



Dongan Electric Mfg. Co.

Name

Street

City..... State.....

TRANSFORMERS of MERIT for FIFTEEN YEARS

For Power Amplification Select from Successful Parts of the 1928-'29 Season

It is so easy now to re-build your set for power amplification that there is little excuse for anyone not having the full-throated, inspiring natural tones and volume of up-to-the-minute radio. The Approved Dongan Power Amplifier Parts listed here are the choice offerings of the current season—are in use now in tens of thousands of sets throughout America.

For Use with U X 250 Tubes

- No. 7568—Transformer for full wave rectification using 2 UX 281 tubes to supply B and C power to receiver and power for 2 UX 250 tubes.....\$13.50
- No. 8529—Transformer similar to No. 7568 with the addition of 2 low voltage windings, one for 226 tubes and the other for 227 tubes so that you can build a power amplifier for either radio receiver or phonograph pick-up.....\$16.50
- No. 6551—Double Choke, for use with above transformers.....\$15.00
- D-600—Power Amplifier Condenser Unit.....\$16.50
- D-307—A Condenser Block, used in connection with D-600.....\$10.00
- No. 1177—Straight Power Amplifier Output Transformer.....\$12.00
- No. 1176—Same as No. 1177 but of Push Pull type.....\$12.00

Check items you are interested in and return with coupon—complete information sent to you at once. You can secure immediate delivery of any item by inclosing check or money order.

Custom Set Builders

Your trade will get the best from sets built up with these parts. Discounts quoted on request.

DONGAN ELECTRIC MFG. CO.
2991-3001 Franklin Street
Detroit

TYPE 587-B Power Speaker Filter

The Type 587-B Speaker Filter is intended for use in the output of such power tubes as the 250 type, where the plate current is large, but the tube impedance is so low that no adjustment of impedance is needed. The Type 587-B Speaker Filter is suitable for use following impedances of 2000 to 10,000 ohms. The speaker is thoroughly insulated from the high voltage by means of 4-MF. condensers in each speaker lead.

GENERAL RADIO CO.

Bulletin No. 931-B will be sent on request

30 State Street, Cambridge, Mass.
274 Brannan St., San Francisco, Calif.



Type 587-B Power Speaker Filter. Price \$9.00

2000 HOURS OF SUPER TUBE SERVICE

THAT'S what you can expect from the Arcturus No. 127 A-C Detector—the tube that is famous for long life.

...acts in 7 seconds...increases volume...and gives better as well as longer service. With Arcturus Tubes programs come in clear—free from annoying hum and distortion.

To get the best reception from your A-C set, use Arcturus blue Tubes. Your dealer will show you Arcturus superiority—you will instantly realize that Arcturus are better tubes in every way. Interesting folder, B1 upon request. Arcturus Radio Company, 220 Elizabeth Avenue, Newark, N. J.



Arcturus No. 127
A-C Detector

ARCTURUS A-C LONG LIFE TUBES

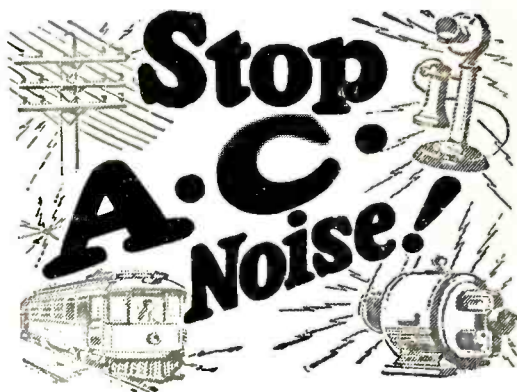

DON'T let the "static" that comes in over the house lighting system from motors, street cars, telephones and electrical appliances mar your radio programs with blare, squeal, fry and scratch!

Plug in a Falck Claroceptor between wall socket and set and have clearer A.C. reception. A wonderful new improvement by a pioneer radio equipment manufacturer. Grounds and thus blocks out line interference noise and radio frequency disturbances. Also improves selectivity and distance. Requires no changes in set. Measures just 3½x5½x2½ inches. Tested, proved. Praised by thousands. Get one right away—at radio parts dealers. Write for descriptive folder.

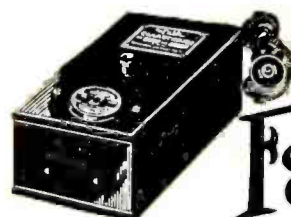

\$7.50 complete with cord and plug

Falck CLAROCEPTOR

Built by ADVANCE ELECTRIC CO.
1260 W. Second St. Los Angeles, Calif.
JOBBERs and DEALERS, GET OUR PROPOSITION

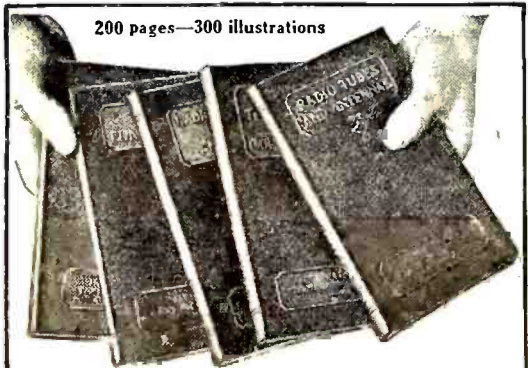

200 pages—300 illustrations

Everything you want to know about
RADIO

Every branch of radio knowledge is covered in this complete 5-volume Radio Library. For everybody in the radio field—mechanics, operators, inspectors, service men, salesmen, owners of radio stores. Written by such experts as Harry F. Dart, E. E., Member, Institute of Radio Engineers; C. H. Vose, B. S. in E. E., of the Radio Engineering Dept. of the General Electric Co.; W. H. Freedman, E. E., Fellow, American Institute of Electrical Engineers, and other prominent Radio Engineers. Gives you the whole science of radio in clear, understandable English, illustrated with nearly 300 pictures and diagrams. Handsomely bound, pocket-size volumes, stamped in gold. Includes Picture Transmission and Reception. Worth many times its moderate cost. Send the coupon with \$7.50 in check or money-order.

Money back if not satisfied.

International Correspondence Schools
Dept. 8298-F, Scranton, Pa.

I am enclosing \$7.50 for which please send me your five-volume RADIO LIBRARY. It is understood that I may return the books in five days and you will refund my money if I am not satisfied.

Name.....

Address.....

BALANCE!

Good radio, like a good watch, is a question of proper balance. And precise resistance provides that balance.

Whether it is line voltage, plate voltage regeneration or grid bias, you can always obtain the proper balance by means of a Clarostat, because—

There's a Clarostat for Every Purpose

From grid leak to power applications, from a few ohms to ten megohms, from the compact requirements of a volume control to the sturdy requirements of a television motor control, your requirements are instantly met by the proper type of Clarostat.

Ask your dealer or write us for information. Better still, send a quarter for "The Gateway to Better Radio"—20,000 words and 88 pictures of real radio dope.

CLAROSTAT MFG. CO., Inc.
Specialists in Radio Aids
284 N. 6th St., Brooklyn, N.Y.

Before Buying any "A" Eliminator

Get my authorized Discount Card and complete description of the finest "A" Power Kit ever offered.

DAVID W. KNAPP, Pres.

Knapp Electric, Inc.

Division of P. R. Mallory & Co., Inc.

Room 414B, 350 Madison Ave., N. Y. C.

Radio HEADQUARTERS

The newest radio wrinkles—A-C, grid tube, short wave, television, dynamic speakers, newest tubes and circuits—anything and everything in radio—are now ready for you at Barawik's. With elections, football, National broadcasting, Roxy and other big doings filling the air, thousands of newcomers will take to radio this year as never before. Business will be good—Set builders will make money. You can clean up big by Buying from Barawik—the oldest, biggest, most reliable radio house in the world. Let us prove it. Send now for the Big Book—all ready for you—free. Get the latest radio information and lowest prices.



BARAWIK CO.

122-C CANAL STA.
CHICAGO, U. S. A.

This Big Book Sent to You Free

FREE BOOK

Name.....

Address.....

City.....

LAYING THE CORNERSTONE OF QUALITY

Polymet condensers and resistances for Radio and Television are carefully made, carefully tested, and accurately rated—is it any wonder they are the choice of 2/3 of the R. C. A. licensed manufacturers?

Send for the Polymet Catalogue

POLYMET MANUFACTURING CORP.
597 Broadway New York City



POLYMET PRODUCTS

"You Can Forget the Condensers—If They Are DUBILIERS"

Specially designed for Thordarson Power Packs Type 574 for use with the Ratham BH tubes or the Elkon Metallic EBII rectifier.

Type 575 for use with 210 type tubes and 281 rectifier tubes.

Type 1152 for use with 210 and 250 type tubes and 281 rectifier tubes.

Type 1120 for use with 280 type rectifier tubes or the Elkon E-80 metallic rectifier.

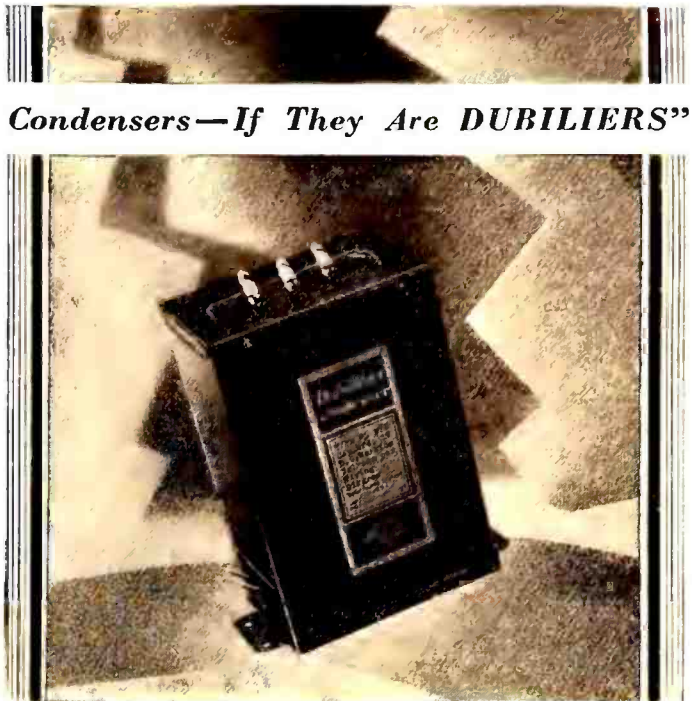

There is

No Substitute for Quality!

No amount of lurid claims by nimble-penned advertising writers will take the place of quality in the final analysis—the operation in your power supply.

Ever since the advent of Radio, Dubilier has been the manufacturers' standard—and the set builders' stand-by. Built in every Dubilier Condenser is a factor of safety which is your safeguard for years of service without failure.

DUBILIER LIGHT SOCKET AERIAL
—*"A Moulded Bakelite Product"*

Bring in programs with a minimum of interference. Do away with the unsightly and trouble causing outside aerial and lightning arrestor. Simply attach to the set and plug into the nearest light socket. Uses no current. Sold by all good dealers. Price \$1.50.



Dubilier

CONDENSER CORPORATION

10 East 43rd Street, New York City

Address Dept.



for free catalog

SET BUILDERS write for Discount Card

Enabling you to purchase the new and Improved Knapp "A" Power Kit at big discount—Write for full particulars.

DAVID W. KNAPP, Pres.
Knapp Electric, Inc.

Division of P. R. Mallory & Co. Inc.

Room 414B, 350 Madison Ave., N. Y. C.

NEWS to Set Builders

BARAWIK CO., 122B Canal Sta. CHICAGO, U. S. A.

LATEST RADIO GUIDE

Barawik offers set builders bigger bargains—bigger opportunities to make money this season. New sets, new kit ideas, all the leading parts, dynamic speakers, supplies, etc. Lowest rock-bottom prices. Bigger stocks, quicker service. Send for Big Bargain Book today—free.

YAXLEY

APPROVED RADIO PRODUCTS

RADIO CONVENIENCE OUTLETS
CABLE CONNECTOR PLUGS
RHEOSTATS POTENTIOMETERS
JACKS SWITCHES RESISTANCE UNITS

For greater convenience in receiver operation and dependability in set construction make up your list of parts and accessories from the New Yaxley Catalog. FREE. Send for it today.



YAXLEY MFG. CO.
Dept. B-9 So. Clinton St., Chicago, Ill.

GET THIS BIG GREEN BOOK NOW!

New!
AERO KITS 1929!

The Big Green Book gives the very latest details on Aero Coils and Kits, Short Wave Radio, newest broadcast radio receivers, short wave converters, telephone transmitters, coil kits, adapters and a host of new wrinkles for 1929.

24 Different New Kits Shown for 1929

The kits everyone is talking about are fully described in the new 1929 Aero Green Book—Aero 7-29, Aerodyne 6-29, Chronophase, Metropolitan, Trio, International, Standard, Radiophone—in Shield Grid, A. C. and D. C. models. Be sure to send for your copy of this 25c Big Green Book—worth \$25.00 to anyone who wants to keep up with the latest radio wrinkles.

Mail coupon for your copy today—NOW!

AERO PRODUCTS
INCORPORATED
4611 E. Ravenswood Ave., Dept. 229
CHICAGO, ILL.

MAIL THIS COUPON NOW
AERO PRODUCTS, INC. Dept. 229
4611 E. Ravenswood Ave., Chicago, Ill.

Send me your Big Aero Green Book, 25c, giving the latest information on What's New in radio, short wave, etc.

Name _____

St. and No. _____

City _____ State _____

Aero Short Wave Gets Everything in the Air

England Every day—

Australia on Thursdays—

Holland on Fridays

**VELVET
Socket-B
power for
your Radio**



**list price
less tube
\$26.50**

A REALLY FINE PRODUCT AT A POPULAR PRICE

VELVET . SILENT . HUM . FREE . OUTPUT
FOOL . PROOF . SAFETY . VOLTAGE . ADJUSTMENTS
USING . THE . SAME . RECTIFIER . TUBE . AS . THE
HIGHEST . PRICED . A . C . SETS . THE . UX . 280
RUNS . SETS . UP . TO . SIX . TUBES . AND . GIVES
FULL . 180 . VOLTS . FOR . 171 . POWER . TUBE

Licensed under RCA Patents

**NATIONAL
VELVET-B**

SEND FOR BULLETIN NO. 132 R. B.

NATIONAL CO. INC.

ESTABLISHED 1914
W. A. READY, PRES.

MALDEN, MASSACHUSETTS

● february, 1929 . . . page 284 ●

www.americanradiohistory.com