

RADIO BROADCAST



CONTENTS

A Band-Pass Filter in a New Kit Set

The Status of Experimental Television Now

A One-Spot Screen-Grid Super With R-F-Amplifier

Kruse Describes a Short-Wave Transmitter

Home Experiments for the Radio Beginner

How the Talking Movies Work

35 Cents

Doubleday, Doran & Company, Inc.
Garden City, New York

OCT-1928

ONLY
\$99 for this **PACKARD**
SUPER 8—\$250 A.C.
ELECTRIC RADIO SET !

Direct From Our Factory

Today's greatest radio! A truly sensational offer! The Eight-tube PACKARD A. C. Electric Radio — a regular \$250 set—shipped to any home in the U. S. at direct from factory price of only \$99. And to prove our claims we will ship this set to your home on

**\$5000.00
 CASH BOND
 to Back Our
 GUARANTEE**



The PACKARD Engineers

have invented this most unusual, powerful SUPER-Eight Tube Radio. Astonishing volume and tone quality. Remarkable selectivity and long-distance reception. Leading radio engineers unanimously agree that there is no better radio made — regardless of price.

Let us prove this by shipping a set to your home on 30 days' trial. Examine the set from A to Z. Let the most exacting critics pass on its merits. And if, after the 30 day trial period, you are convinced that the Packard Eight-tube Electric is fully the equal of any console radio set selling up to \$250—then, and only then, need you decide to keep it at our factory price of only \$99—otherwise, return it.

This marvelous set combines every new scientific development in receiving sets—possessing beauty, refinement, durability. Gets everything on the air from coast to coast—from Mexico into Canada, loudly, clearly, and distinctly. Only one dial to tune in all stations.

You Save the Jobbers', Dealers' and Salesmen's Profits

The PACKARD Radio is shipped direct from our factory. All the in-between profits are deducted from the price of the set and instead of paying \$250 you pay only \$99. Quantity production, economy in selling, and only a small profit for the manufacturer makes this astounding offer possible..

**MAIL COUPON NOW FOR
 30 days' free trial offer**

Don't miss this opportunity. Mail coupon at once for complete information about the PACKARD A. C.—8 TUBE ELECTRIC RADIO and our liberal 30 days' free trial offer. No obligation on your part. Our \$5,000.00 cash bond backs up our guarantee.

PACKARD RADIO CO.
 2323 Milwaukee Ave. Dept. 530 Chicago, Ill.

WORLD'S GREATEST RADIO
Genuine Walnut Console Cabinet

Eight powerful A. C. tubes and one genuine full-wave rectifying tube—nine tubes in all. Supreme quality throughout. Simple to operate. Connect the plug to electric socket and turn switch. Only one dial to tune. One hundred per cent electric. Handsome walnut cabinet—two-tone genuine DUCO finish. Metal trimming finished in old gold. Marvellous built-in, powerful speaker. Size of cabinet is 54 inches high, 27 inches wide.

**Packard Radios are also
 made for BATTERY OPERATION
 PRICED AS LOW AS \$53**

Packard Radio Company
 2323 Milwaukee Ave., Dept. 530 Chicago, Ill.

I am interested in Packard Radios and your \$5,000.00 Bonded 30 days' free trial offer and guarantee. Send full details.

Name

Address

City State

The Lincoln 8-80 Steps Out the Year Round

4 SCREEN GRID TUBES

ONE SPOT

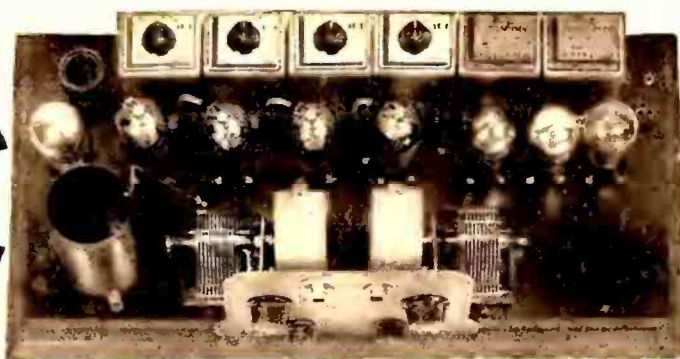

TUNABLE I.F. STAGES

NEW AUDIO

Selectivity Plus Marvelous Tone Quality High Amplification Without Distortion

JUST another super? Decidedly not! The Lincoln 8-80 is not even similar to any super heretofore offered. We challenge the whole world of radio engineers to point out any one receiver incorporating the many advantages and new principles unique to the 8-80. IT IS NEW and different from the antenna hinding post to the loudspeaker tip jacks—a new screen-grid first detector, a radically different three-stage, screen-grid intermediate-frequency amplifier and a revolutionary audio system. Yet it is remarkably simple, more beautiful and goes together easier than any other set you've ever seen. It stands alone, a radically new triumph of engineering based on sound common sense.

The remarkable new Lincoln screen-grid, intermediate-frequency amplifier is the secret of the astonishing performance of the 8-80. Gone are the well-meant but clumsy methods of the past—complicated shielding "laboratory matched" transformers that are never matched when the set is finished, matched sets of tubes, and all of the heretofore "necessary evils" from which you tried in vain to obtain real reception.

Lincoln has substituted in their place *tunable I. F. stages*, screen-grid tubes, and a minimum of scientifically designed shielding that is a component of the parts, far more effective yet scarcely noticed.

After you have built the Lincoln 8-80 you turn four little knobs on the intermediate transformers, just as you would tune an ordinary T. R. F. set and in a few seconds you have overcome the greatest fault in super construction. You actually peak the transformers yourself to the point where they operate at greatest efficiency for you, not in a laboratory test outfit, but right in your own set you compensate entirely for every difference in wiring and tube characteristics—impossible with other transformers. Though perfectly matched, the shielding is so well designed that with correct voltage the 8-80 cannot oscillate and will not squeal or howl—perfectly stable operation. All this means that now for the first time, you can build a receiver that will start right out bringing in distant stations, one after another, 10 K.C. apart, with no squeals and no interference and yet retain all of the side hands for perfect tone quality.

Not only in selectivity and quiet operation is the Lincoln 8-80 supreme. Its new audio transformer, utilizing the revo-

lutionary Clough System to the fullest extent, gives it infinitely better tone, far more volume and less distortion than any other type of transformer can possibly provide. The effective transformation ratio per stage—exclusive of tube gain—averages 1.4 to 1, 50% greater than that of any other and more expensive transformers, and with all this—true reproduction, fidelity of tone, and positively uncanny realism.

Even in appearance, the 8-80 is far ahead of any factory-built receiver at anywhere near its price. The beautiful Lincoln 112 two-tone metal shielding cabinet (\$9.25 additional) houses the completed receiver and at the same time provides 100% perfect shielding.

It is ALL of these features that make the 8-80 the sweetest super you've ever tuned. And that is positively what it is! In the Lincoln offices in a reinforced steel and concrete building—the most difficult type for radio reception—the 8-80 consistently brings in stations 2000 miles distant at night, and 400 miles in daylight! And this is done in Chicago, through a barrage of thirty or more high-power local stations and with only a 15 foot *inside* antenna. Nashville, Pittsburgh, Shreveport, Atlantic City, Dallas, New York City, all come like locals, and most of them with no antenna at all—only a ground connection. Stations from all points of the compass will fill your log night after night.

The price of the complete kit for the 8-80 is \$92.65. And the set you build from it will give these same results, for every set built tunes easily and positively to peak efficiency, thanks to the new principle of William H. Hollister—an old-timer in the game who demonstrated "wireless" to college professors before Marconi first bridged the Atlantic. And all his experience, ranging over a quarter of a century, has gone into the 8-80. IT OUGHT to be some set—AND IT IS!

LINCOLN GUARANTEES THAT THE 8-80 WILL GIVE BETTER RESULTS THAN ANY OTHER EIGHT-TUBE SUPER YOU CAN BUILD.

If you want an evening full of straight-from-the-shoulder super-heterodyne dope written by an engineer who has played with every super going in the last few years, send 25 cents for William H. Hollister's "Secret of the Super" using coupon below.

Have you seen the new Lincoln power supplies? There are two: one for B voltage only and one for A, B, and C voltage for AC tubes. Each one comes in a beautiful brown crystalline steel shielding case. B current of 50 to 60 m.a.—plenty for any ten-tube set—at 180 to 200 volts, with 22½, 90 and 135 available—also 22-90 variable, Type 110B lists at \$43.50, type 110ABC at \$46.00. They're fully guaranteed, and are described in detail in the big catalog which the coupon below will bring you.

LINCOLN ENGINEERING SERVICE ON STANDARD KITS

DO **YOU** KNOW THAT

you can buy the really finer standard kits—those that have come up to the rigid standards of performance set by the Lincoln Laboratories at standard prices, and at standard discounts if you are a professional setbuilder or dealer? The Lincoln Engineering Service means a lot—you are assured not only of same-day shipment, but you have the double assurance of factory inspection, plus Lincoln inspection—and Lincoln offers you only complete kits that exhaustive tests have proved to be right—and then fully guarantees each to you.

Order to-day for immediate shipment any of the following Lincoln-Guaranteed complete kits:

Sargent-Rayment Seven (S-M 710) kit . . .	\$120.00	Tyrman 80—super—less power pack	\$131.50
S-M 720 Screen Grid Six	72.50	Tyrman 72 receiver kit	98.50
S-M 720 Screen Grid Six—factory wired	102.00	Tyrman 72AC, with power pack	153.50
1929 Laboratory Superheterodyne	95.70	Scott World's Record 9-tube S. G. super	138.10
		H. F. L. Isotone 10-tube super	195.00

LINCOLN RADIO CORPORATION 329 SOUTH WOOD ST. - CHICAGO - ILLINOIS.

Setbuilder agents are wanted in every community. We have a most interesting plan which you will find highly profitable. Write for complete details, or use the coupon.

LINCOLN RADIO CORP., 329 South Wood St., Chicago, Ill.
 Send me your big free catalog, listing a complete line of 1929 kits for custom building.
 Let me have details of your agency plan.
 Enclose find 25c, for which send me William H. Hollister's new book, "The Secret of the Super."

Name

Address

Authorized Distributors for Lincoln 8-80
WESTERN RADIO MFG. CO.
 128 W. Lake St. Chicago, Illinois
W. C. BRAUN COMPANY
 564 W. Randolph St. Chicago, Illinois
WALTER ROWAN COMPANY
 833 W. Washington St. Chicago, Illinois

SM

IF YOU DON'T LIKE THE BRUTAL TRUTH

—better not read this page!

Silver-Marshall unconditionally guarantees the new S-M Clough system audio transformers to give greater amplification, much finer tone, and far less distortion than any standard transformers made by any other American transformer manufacturer.

Contrast this straight-from-the-shoulder guarantee with the advertising phrases used by other manufacturers—not one dares offer the guarantee that S-M has given for two consecutive years—ever since the first 220 transformers were produced. And with impartial comparative tests S-M engineers have been demonstrating to thousands that the new 223, 225, 226, 255, and 256 transformers are far superior to any and all other makes.

Naturally, not all fans have been able to attend S-M demonstrations at the R.M.A. Trade Show and in the larger cities. It is perhaps hard for you, satisfied as you may be with the audio equipment you have been using, to believe that any transformers can be as far ahead of all other types as are the new S-M's. So we can only say to you: "Buy a pair of 225 and 226's, or a pair of 255 and 256's; hook them up and test them. Then, if you're not satisfied that they are better than anything you've ever heard, return them to the factory for full credit." The fan unwilling to accept such an offer and who says, "The old stuff I'm using satisfies me" must simply be a man opposed to progress, content to stand still, and it is not to him that S-M appeals. But the open-minded and progressive fan, ever seeking something better and finer, will find in the new S-M transformers a quality of reproduction beyond his fondest expectations.

Take the case of the manufacturer of America's most expensive high-class sets, seeking the best possible audio amplification for an ultra-fine receiver. After testing all standard high grade transformers, this manufacturer's engineering staff went on record with the statement that S-M's large and small transformers are the finest of all transformers they had ever tested over a period of fifteen years! Or consider the case of the chief engineer of the largest independent manufacturer of theatre and auditorium amplifying systems, a man who has tested and analyzed all standard audio transformers—and finally selected the new S-M audios as the most perfect known audio system. Men who know, not guess, all acknowledge the supremacy of S-M audio transformers.

This is a strong statement to make, but we back it up with a guarantee such as no other manufacturer has ever offered for audio transformer equipment.

We dislike to tread upon the sensitive toes of other transformer manufacturers, but we know what the new S-M audios will do. And so do these other manufacturers! One of them recently approached us. "Look here," he said in substance, "we're both making audio transformers. Let's be friendly. We're not going to say anything about hysteretic distortion in our advertising, and we wish you wouldn't make an issue of it." But S-M is neither to be cajoled nor threatened. For the first time in the history of commercial audio transformer design, Silver-Marshall has eliminated hysteretic distortion, and the new S-M transformers give a sharpness and definition to bass and treble alike such as has never been known before.

Do you remember when transformer "curves" used to climb "way up in the air"? Maybe you've noticed that most manufacturers are now advertising audio transformers with a high frequency cut-off. Two years ago S-M was first to introduce this feature. At first scoffed at by other manufacturers, it was eventually adopted by practically all! Two years ago S-M also introduced the first really large models of audio transformers—a feature which more and more competing manufacturers have copied of late. And in the new Clough system under which the 223, 225, 226, 255 and 256 transformers are made S-M has again introduced revolutionary improvements just two years ahead. When you buy S-M audio transformers, you're getting the best—S-M unconditionally guarantees this to you in a straight-from-the-shoulder way that no other manufacturers have ever dared to adopt. No matter what audio transformers you have or are using, S-M guarantees you better results with the new 223, 225, 226, 255 and 256 models.

For the finest possible tone, the new S-M 225 first stage and 226 second stage types at \$9.00 each are utterly unequalled. Their two stage curve is shown at E, with its rising bass characteristics and 5,000 cycle anti-hiss cut-off. The two smaller types, S-M 255 first stage and 256 second stage, are unconditionally guaranteed finer than all other types on the market, and give the curve D—see how much better they are than three sets of standard competitive eight and ten dollar types, shown at A, B, and C under the same operating conditions.

Other outstanding values in new S-M kits, parts, and accessories are illustrated and described on the pages that follow. Several of our cooperating distributors who recognize S-M quality and S-M leadership join us in presenting the 1929 S-M line.

SILVER-MARSHALL, Inc.

838 W. JACKSON BOULEVARD. CHICAGO, U. S. A.

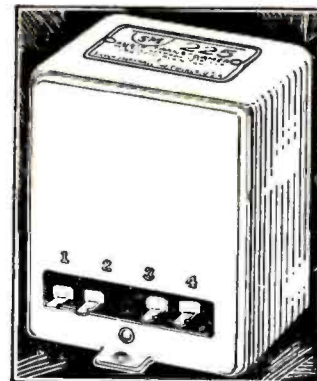
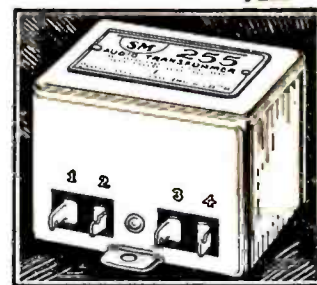

At the S-M factory there is always in operation a comparison amplifier. If you're in Chicago, ask to have your favorite transformers compared against the new S-M's—then they'll be your favorites. Remember—all other transformers give hysteretic distortion—only the new S-M's are free from it.

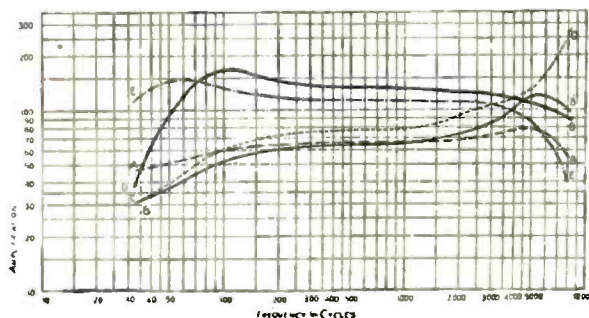

SILVER-MARSHALL, INC.
838 W. Jackson Blvd., Chicago, Ill.

-Send Complete Catalog—FREE, with sample copy of "The Radiobuilder."
-Send information about the S-M Authorized Service Station franchise.
-Enclosed is 10c for five selected S-M constructional Data Sheets on new products.
-Enclosed is 50c for the next twelve issues of "The Radiobuilder" (or \$1.00 for the next twenty-five issues).

.....Name
.....Address

SM

*What Is This Year's
Greatest Value?*
THE 720 Screen Grid Six!

OF ALL the radio sets the S-M Laboratories have ever tested, of all the sets that have borne the S-M endorsement in the last four years—yes, of all these and more—we believe the new 720 Screen Grid Six to be the finest all-around set of them all.

That's a man-sized recommendation. And you can bet it's some set when S-M gets squarely behind it and tells you that you'll find the biggest radio value to-day in this new Screen Grid Six. This is as it should be, for the new receiver is a simplified and improved design of the Shielded Grid Six that took the country by storm this past winter and spring—the only receiver that anyone ever dared to offer with an unqualified guarantee of absolute satisfaction or your money back! And now S-M tells you that the new Screen Grid Six is an even better set!

It's the kind of a set you can build in an evening, with its pierced metal chassis and positive fitting assembly. And the thrills begin when you put it on the air. Station after station will come in with local volume, you'll really find positive 10 K.C. selectivity; and tone—well, like those who have tested it already, you just won't be able to help sitting back and telling the world "Baby, that's a radio set." Three stages of tuned, shielded screen-grid R.F. amplification, a detector, and two stages of the new S-M audio transformers that have taken the country by storm—two vernier drum dials in a beautiful antique brass control escutcheon, individually copper-shielded R.F. circuits, a rigid die-cast gang condenser—look these features over and you'll realize why the 720 cuts through the toughest interference regularly—why it gives 10 K.C., selectivity and almost unbeatable DX.

Remember that S-M backs the 720 to the limit—assures you that you can't get more actual radio at twice the cost. And—S-M passes on to you right now the production savings of a big season, and prices the 720 kit at only \$72.50 complete, or \$102.00 custom-built with cabinet. For the kit, the new metal shielding cabinet is \$9.25 additional.

Better get your order in now—720's are hard to get, so great is the demand.

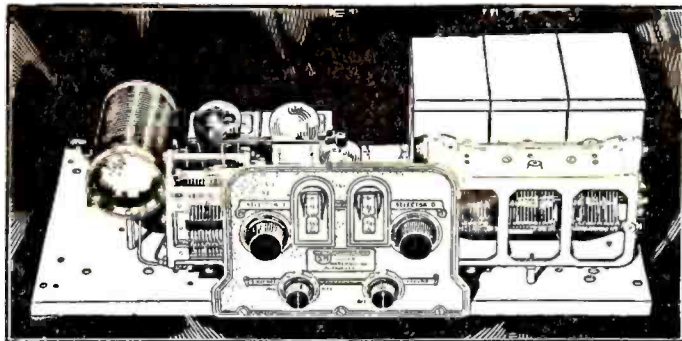

Did you ever see as much actual screen grid radio value for only \$72.50?

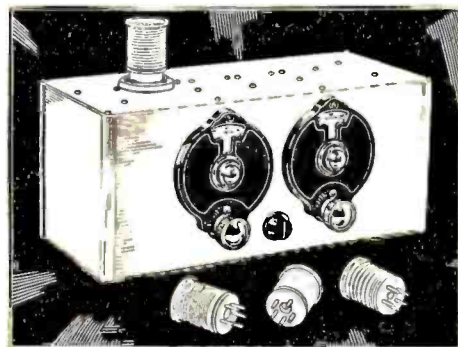

Here are the trimmest short wave sets ever—the new "Round-the-World" kits.

Tune Over the "Thrill Band" with an S-M Short Wave Set

HAVE you had your taste of the "thrill band"—the wavelength band from 17 to 200 meters? Down on these low waves are the foreign broadcasters—English 5SW with Colonial programs—Dutch, French, German and other rebroadcast programs. Down there you can hear KDKA, WGY, and WLW programs when static blankets out their regular waves. And television—the low wave band is its busy nursery. You can hear amateurs in almost every country, all in an evening—if you have an S-M "Round-the-World" short wave set. S-M "Round-the-World" kits build up into such neat, trim, snappy receivers—with screen grid R.F. amplification, and one dial tuning—that you just can't help getting the thrill of your life as you tune one.

The "Round-the-World Four" is a complete four-tube regenerative (non-radiating short wave receiver kit with aluminum shielding cabinet. It has one screen grid R.F. stage, a regenerative, non-radiating detector, and two high-gain Clough audio stages. It tunes from 17.4 to 204 meters with four plug-in coils, and can bring in five continents in an evening. The kit is \$51.00, complete with cabinet, coils, and full instructions—ready for immediate shipment.

The 731 "Round-the-World" Adapter is the two-tube, R.F. amplifier and detector, less the two stage A.F. amplifier of the above set. With an adapter plug, it converts any set to long-distance short wave reception. Price, complete with cabinet and four coils (17.4 to 204 meters) \$36.00. The 732 "Round-the-World" Essential Kit contains the two tuning and tickler condensers, the four plug-in coils, coil socket, and three R.F. chokes, with full instructions for building a one, two, three or four tube short wave set. It costs but \$16.50 complete.

Choose any one of the three kits you prefer, and step out into the "thrill band!"



New 5-prong plug-in coils, for short and broadcast waves. Wound on forms of threaded, moulded bakelite.

Besides the sets and kits above described, we can make prompt shipment from stock of all S-M products, including the 710 Sargent-Rayment Kit; 740 and 740 AC Coast-to-Coast Kits; S-M Unipacs and Power Supplies, Audio Transformers and other parts. Best discounts quoted to the trade. Fill out and mail at once the coupon at the right, and get our big new catalog, FREE.

WHOLESALE RADIO SERVICE CO.
6 Church Street, New York, N. Y.

Wholesale Radio Service Co.
6 Church St., New York, N. Y.

Please send at once your new free catalog listing S-M and many other highest-quality radio kits, parts and supplies, as advertised in Oct. "Radio Broadcast."

Name

Street No.

Town



SM

RADIO'S FINEST PRECISION RECEIVER

"The Sargent-Rayment Seven"

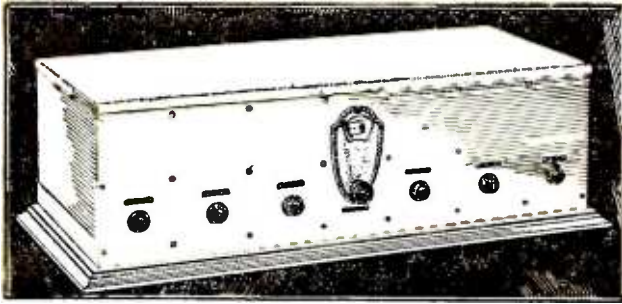

A STATION tuned in for every ten kilocycles—a hundred stations heard in one summer evening, in the heart of Chicago interference—that is the performance record of the 710 Sargent-Rayment Seven—latest masterpiece of these inventors of a unique receiver system of past popularity.

The 710 Sargent-Rayment Seven is a precision laboratory radio receiver for the veteran fan. It has been designed throughout as such. It is like a battleship stripped for action, shorn of every piece of surplus gear. The thick aluminum shielding and chassis, finished in satin silver and trimmed by black instrument name plates with white engraving gives to the appearance a beauty and dignity in keeping with the set's fine performance. Electrically, the receiver consists of five sharply tuned circuits in a four-stage screen grid R.F. amplifier, all tuned by a single illuminated drum, and provided with individual verniers. One knob turns the set on and off—another controls volume from zero to

maximum. There are no other controls. Following the R.F. amplifier are the detector and the A.F. amplifiers, using the new S-M 255 and 256 audio transformers which provide unequalled tone quality and high volume in a perfect circuit balance with the 251 tone filter which is included. Each circuit is individually shielded, bypassed, and isolated from all others. The set goes together simply and positively, with clear direct wiring. It is a joy to build, so workmanlike is its design and layout.

To the fan who appreciates and values really fine performance, in a truly precision receiver of great individuality and distinction, we unhesitatingly recommend the 710 Sargent-Rayment Seven. The kit for this receiver, approved by the designers and exclusively manufactured by Silver-Marshall, Inc., is priced at \$130.00 complete with cabinet and walnut finish moulding.

Note: All our customers will be supplied as rapidly as possible with the Approved Sargent-Rayment kit, but since speed of production is necessarily limited by the extreme precision required in every part of this unique receiver, orders should be placed at once by those desiring to be early on the ground with the Sargeant-Rayment Seven.

740 COAST-TO-COAST FOUR

TO the thousands of fans for whom the four-tube, R.F. amplifier, regenerative detector and two-stage audio amplifier is the time-tested standard of receiver comparison, the new Coast-to-Coast Four offers the finest performance yet attained with this remarkable circuit. A screen grid R.F. amplifier stage, immeasurably finer coils than ever before, the new Clough high-gain audio system, and an all-metal assembly, make the "740" the biggest \$51.00 worth of radio set you've ever listened to.

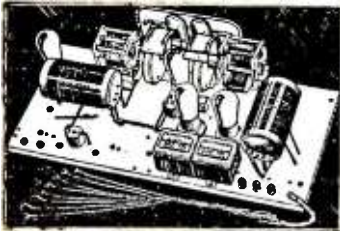

Through summer static, the Coast-to-Coast Four plays on the speaker New York, Florida, Texas, and California stations, cutting through local Chicago interference only 10 or 20 K.C. away. Its tone quality is such as only S-M transformers can provide. Housed, like the 720 Six, in the new S-M 700 table-model metal shielding cabinet, it harmonizes beautifully with any home furnishings.

Despite this demonstrated superiority, in every respect, over all other sets in its price class, the 740 complete kit costs but \$51.00; or the 740AC kit, \$53.00 complete. The 700 cabinet is \$9.25 additional.

We go emphatically on record that no matter what set you build or buy, the 740 Coast-to-Coast Four is the best dollar for dollar value you can find around fifty dollars. It goes together easily and simply, performs with a vengeance, and for the professional setbuilder provides a low-priced set that will outdemonstrate ready-made sets at twice its price.

S-M 676 Dynamic Speaker Amplifier

This is a single stage power amplifier especially for use as a third stage, after any radio set, to boost volume and tone to give extra fine results with standard dynamic loud speakers. It uses one UX281 rectifier and one UX250 super-power amplifier, and has binding posts for receiver output connections, loud-speaker cord tips, and also for the dynamic speaker field. The 675 Amplifier operates any dynamic speakers having a 90 to 120 volt DC field, to which it supplies necessary power. Added to any set equipped with a dynamic speaker, it will provide a marvelous improvement in tone and volume. Price, 676 WIRED, \$55.00; or 676 in KIT form, \$49.00.

Western Radio Mfg. Co.

"The Big Friendly Radio House"

128 West Lake Street Chicago, Illinois

MEDIUM AND HIGH VOLTAGE POWER SUPPLIES

B and ABC Power Units for Radio Sets

S-M 670B Reservoir Power Unit has five different B voltages, of 22, 90, 135, and 180 volts fixed, and one variable voltage ranging from 22 to 90 volts. It will deliver up to 60 M.A. to operate any standard receiver, and is specifically recommended for S-M receivers. Type 670ABC is the same unit with 1½, 2½, and 5 volt A.C. filament supply added, and is a complete ABC power plant for an A.C. tube equipped receiver. Both use one UX280 rectifier. Price, 670B, WIRED, \$43.50, or in kit form \$40.50. Price 670ABC power supply WIRED, \$46.00, or, in kit form, \$43.00.

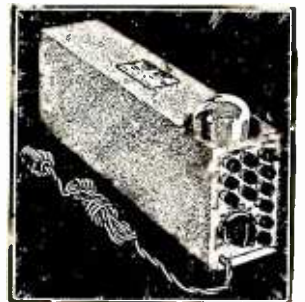

675ABC High Voltage Power Unit

S-M 675 power unit is a high voltage power supply delivering 450 volts maximum. It is provided with an adapter which allows a UX210 or UX250 super-power tube to be used in the last stage of any receiver at all, to which the 675ABC supplies 22 fixed, 22 to 90 variable, and 90, 135, and 450 volts B power, as well as A and C power for the power tube, and 1½ and 2½ volts A.C. for A.C. tube filaments if used. It is the biggest power unit value ever offered, and costs but \$58.00 WIRED, or \$54.00 in kit form, less one UX281 rectifier tube.

Full Line of S-M Products

We carry every kit or part mentioned in this section. Prompt service is assured. Maximum discounts to dealers. Send the coupon now.

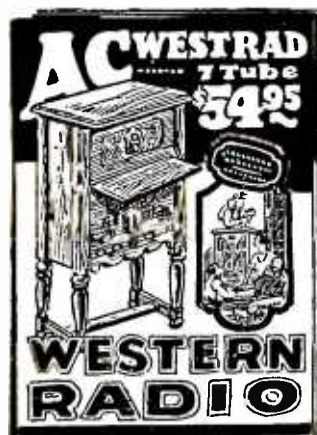

WESTERN RADIO MFG. CO.
128 W. Lake St., Dept. SB-10
Chicago, Ill.

Please send at once your new FREE catalogue listing S-M parts and kits as well as many other highest-quality radio products.

..... Name
..... Address
..... City
..... State

SM

**Nine Tubes
(6 Screen Grid)**

—and What CAN'T They DO!

The 1929 Laboratory "Super"

THREE stages of screen grid radio-frequency amplification, a screen grid first detector, two stages of 65kc. intermediate screen grid I.F. amplification, and a super-powered second detector—all copper shielded—working into an audio stage using the new Clough system—no wonder the 1929 Laboratory receiver spins rings around the best of superheterodynes!

And all of this tremendous amplification, with selectivity that makes stations literally snap in and snap out, is controlled by two vernier drum dials, and a "volume" and a "sensitivity" knob. No wonder it's easy to bring in stations from Maine to Florida, Texas, California, and Canada all in one evening. No wonder a log of a hundred stations can be piled up with this ultra-selective, extraordinarily sensitive screen-grid super that has out-performed every other superheterodyne tested against it!

For the fan who wants real "super" results without squeals and station repeats clogging up his dials, the Laboratory Super is the set. Just imagine a super that can be tuned from one end of the dials to the other right in Chicago without a single local station repeating, and yet be able to use a 65 kc. intermediate frequency with all the tremendous amplification this frequency, plus screen-grid tubes, gives. No wonder the new Laboratory Receiver is the set you've been looking for—a set so sensitive that you can out-demonstrate any other super with it at any time at all. And it has the ultra-fine tone

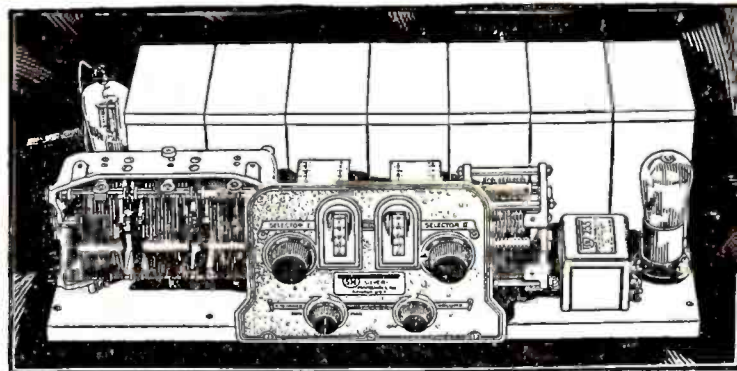

that can be gotten only from the new S-M audio transformers and a stage of external light socket, push-pull 210 or 250 Unipac amplification, the highest powered, finest toned amplification that money can buy!

If you've built lots of supers, and know what real results are, this set will give you a new thrill for distance, selectivity, tone.

Despite its absolutely startling performance, the parts, mostly of S-M manufacture with all that this implies, cost but \$95.20 complete, less Unipac amplifier which is not absolutely essential. And the overwhelmingly superior results the Laboratory Super will give, no matter what you compare it with, make it outstandingly the finest superheterodyne money can buy.

UNIPAC POWER AMPLIFIERS

Single Stage Unipac Amplifier

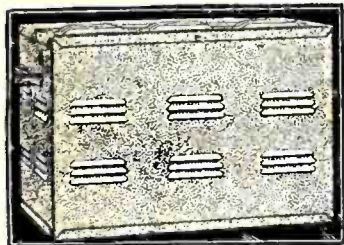

Either of two S-M single stage power amplifiers replaces B batteries on any receiver and adds a stage of super-power amplification. Type 681-210, the most powerful amplifier made for home use, employs 2-UX210 or UX250 power tubes in push-pull, two UX281 rectifiers, and a UX874 regulator tube. It supplies 45, 90, and 135 volts B to the radio receiver. A lower-powered unit is the 681-250, using only one UX210 or UX250 amplifier tube, but identical with the 681-210 in other respects. Price, 681-210 WIRED push-pull Unipac \$102.00; or 681-210 KIT, \$87.00. Both are ideal for the Laboratory super. Price 681-250 WIRED Unipac, \$96.50; or 681-250 KIT, \$81.50.

lator tube. It supplies 45, 90, and 135 volts B to the radio receiver. A lower-powered unit is the 681-250, using only one UX210 or UX250 amplifier tube, but identical with the 681-210 in other respects. Price, 681-210 WIRED push-pull Unipac \$102.00; or 681-210 KIT, \$87.00. Both are ideal for the Laboratory super. Price 681-250 WIRED Unipac, \$96.50; or 681-250 KIT, \$81.50.

Two Stage Unipac Amplifier

Two complete two stage super-power Unipac Amplifiers, for amplification of radio set detector output or phonograph record pickup are the finest and most powerful of their types. S-M 682-210 uses one UX226 first stage tube, two UX210 or UX250 super-power tubes in a push-pull second stage, two UX281 rectifiers, and a UX874 regulator tube. It supplies two stages of power amplification and 45, 90, and 135 volts B power for a receiver, and A.C. filament power too. Type 681-250 is the same Unipac except that it uses only one UX210 or UX250 tube in the last stage. 682-210 WIRED push-pull Unipac lists at \$117.00; or 682-210 KIT at \$102.00. The 682-250 WIRED Unipac lists at \$111.50; or 682-250 KIT at \$96.50 ready to assemble.

Fill Out the Coupon and Mail It to Us

SETBUILDERS SUPPLY CO.

Romberg Bldg., Madison and Market Sts.

CHICAGO

ILLINOIS

Public Address Unipac

For coverage of crowds of 1,000 to 10,000 people, indoors or outdoors, with one to twelve loud-speakers, the 685 Public Address Unipac is the only light-socket amplifier now available. It uses one UY227, one UX226, one UX250, and two UX281 rectifiers in three stages for microphone, radio, or record pick-up amplification. It is the ideal self-contained, portable or permanent amplifier for conventions, theatres, churches, etc. Prices: 685 WIRED Unipac, \$160.00; or 685 KIT, ready to assemble, \$125.00.



We carry a complete line of S-M Parts and Kits, including all the big new headliners for immediate shipment; 720 Screen Grid Six Kit, \$72.50; 720 Custom-Built Receiver, \$102.00; 710 Sargent-Rayment Kit, \$130.00; 740 Coast-to-Coast Four Kit, \$51.00; 730 Round-the-World Four Kit, \$51.00; Complete Parts for 9-tube 1929 Laboratory Receiver \$95.20. All can be shipped at once. Also the new Unipacs, power supplies, audio transformers, and other parts. Our new catalog will be a revelation to you—use the coupon and get it now! LIBERAL DISCOUNTS TO THE TRADE.

SETBUILDERS SUPPLY CO., Dept. 19-2
Romberg Bldg., Madison and Market Sts.
Chicago, Ill.

Send me at once, free, your new catalog listing S-M and other radio parts, cabinets, consoles, and accessories of highest quality.

Name.....

Address.....

Town..... State.....

SM

720 "Screen Grid Six" Kits 710 "Sargent-Rayment Seven" 1929 "Laboratory Super" Parts

ALL new S-M kits and parts are winners! We have one of the largest stocks in the world of S-M apparatus—as well as of all other lines known to the set building trade. Send for our free catalog showing wholesale prices on all the latest parts, kits and A C sets.

Allied Radio Corporation is the headquarters for high quality radio equipment. Ask us for data sheets on "Round the World" short wave kits, S-M Unipacs, and other popular circuits in which S-M parts are specified.

ALLIED RADIO CORPORATION • 711 W. Lake St., Chicago, Ill.

SM

Sargent-Rayment 7

1929 Laboratory Parts.

Complete parts for these famous receivers now in stock. Get our special prices to Professional Set Builders and Dealers.

TELEVISION!

Write for our very latest literature on TELEVISION. The newest developments as shown in our catalog will surprise you.

Our 1929 Catalog!

All the latest developments including Television, described in our NEW FREE 1929 Catalog, just completed. Lowest prices on all new nationally advertised kits, sets, accessories, cabinets, etc. Get the BEST in RADIO—AT THE BIGGEST SAVING. Complete stock carried. No delays. Write for catalog TO-DAY.

Walter Rowan Co.

Dept. 102 833 Washington Blvd.
Chicago, Ill.

Improved Reception

Marvelous tone quality from the lowest to the highest note when your Power Amplifier is equipped with a Potter Condenser Block.

No. T2900
where
one 250
Type
Power
Tube
is used
\$20.00



No. T2950
where
two 250
Type
Power
Tubes
are used
\$22.50

Highly Efficient—Long Life

The Choice of Leading
Radio Engineers

Ask your dealer for full information

POTTER MFG. CO.
North Chicago, Illinois



Whether you want purer tone or clearer DX, you will get it with Quality Televocals. All standard types. Ask for them at your dealers.

Televocal Corporation
Televocal Building
Dept. B-3, 588 12th Street
West New York, N. J.

Televocal

Quality Tubes

This is a good time to subscribe for

RADIO BROADCAST

Through your dealer or direct, by the year only \$4.00

DOUBLEDAY, DORAN & CO., INC. GARDEN CITY, N. Y.

RADIO FUSE

PREVENTS DAMAGED TUBES, COILS,
BATTERIES AND ELIMINATORS.



OAK PARK MFG CO BOX 324 OAK PARK, ILL. FUSES 10¢

HOOK-UP BOOK FREE

Improve your reception with
CARBORUNDUM
Stabilizing Detector Units,
Grid Leaks and Resistors
THE CARBORUNDUM COMPANY
DEPT. D-2, NIAGARA FALLS, N. Y.



BOOKS by TELEGRAPH

to and from

Doubleday Doran Book Shop in
New York Cleveland Kansas City Springfield St. Louis



Do You Run Your Radio—or Does It Run You?
Do you control your loud speaker volume to fit the occasion—from soft, mellow musical background to loud, sharp, fascinating and attention-arresting entertaining? "The GATEWAY TO BETTER RADIO" tells how to make the radio do your bidding, how to avoid distortion, deals with a hundred and one things. 25c a copy and worth it many times over. From your dealer or direct from CLARONAT MFG. CO., Inc.
Specialists in Variable Resistors
285-7 N. Sixth St., Brooklyn, N. Y.

ROBERT S. KRUSE
Consultant and Technical Writer

103 Meadowbrook Road, West Hartford, Conn.
Telephone Hartford 45327

SM

Official Wholesale Distributors

QUICK

Get your Silver-Marshall Parts from W. C. Braun Company

We are wholesale distributors for all Silver-Marshall products, shown and catalogued on the four pages in the Silver-Marshall section of this issue of Radio Broadcast. Also complete parts for set builders of the 720 Screen Grid Six Receiver. A complete stock of parts is on hand for immediate shipments to fill dealers' requirements anywhere.

Everything in Radio

We carry the largest and most carefully selected line of radio

goods in the country—the lines of the leading manufacturers of sets, parts, kits and accessories.

Mail orders given special attention. We are fully equipped to serve dealers on mail orders promptly and efficiently. Our new dealers' catalog lists over 4000 items in radio, electrical goods, sporting goods, auto supplies and allied lines that keep the dealers' business humming twelve months of the year. Write for free copy of this catalog on your letterhead and learn about our successful dealer plan.

W.C. BRAUN COMPANY *Pioneers in Radio* 581 W. Randolph St. **CHICAGO** ILLINOIS

SM

Get it of Us!

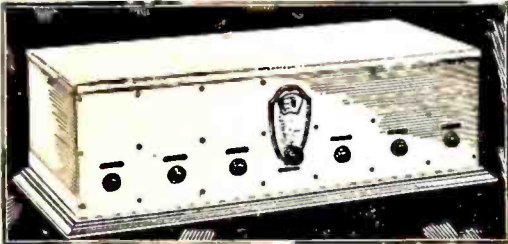

10 KC Selectivity

OUR stock is complete—we have the new S-M 720 Screen Grid Six and other S-M Kits—as well as all other quality parts and accessories on the market. 24-hour service.

Send us your orders for the "Fastest Service West of the Rockies"—you'll be a regular customer from then on. Get acquainted with "The Radio Parts Jobbers" of the Northwest.

SET BUILDERS: Write for our catalog and discount sheets. Maximum discounts to all dealers.

WEDEL COMPANY

Established 1888
520 Second Avenue
Seattle, Washington

SM

IT'S HERE!

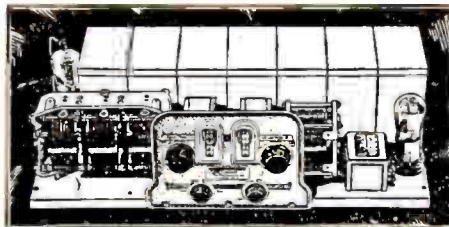

FOR QUICK, prompt service on Silver-Marshall and other standard parts lines, write us.

We ship the same day order is received.

Dealers and Set-Builders write for our New Big Catalog just off the press—it's free.

Maximum Discounts.

KEYSTONE RADIO CO.

111 N. 4th Street
Philadelphia, Pa.

SM

Hammarlund
Roberts
Custom-Built
Radio

Hammarlund Hi-Q 29
Authorized Official Distributors
Silver-Marshall Kit Headquarters
National Television

WE are ready to ship all parts specified in this publication, as well as those parts called for in other leading radio papers. Tie up with a house that is amply financed to carry a complete and varied stock of merchandise. Royal-Eastern has been in business since 1897—31 years—and we are known to have the fastest shipping facilities in New York. Send for our new 1929 trade catalog. There is a copy for you. It is chock full of all the latest radio and television developments, as well as kindred electrical lines. We feature only nationally advertised merchandise. All kits are in stock—Send your order to-day—Prompt shipment is assured. We know you will like our service!

Royal-Eastern Elec. Supply Co.
16 West 22nd St., New York City.

Why not subscribe to *Radio Broadcast*? By the year only \$4.00; or two years, \$6.00, saving \$2.40. Send direct to Doubleday, Doran & Company, Inc., Garden City, New York.

Write Doubleday, Doran & Company, Inc., Garden City, Long Island, for a list of their

**NATURE
BOOKS**

SM

—for performance
GRAYMORE
for Service!

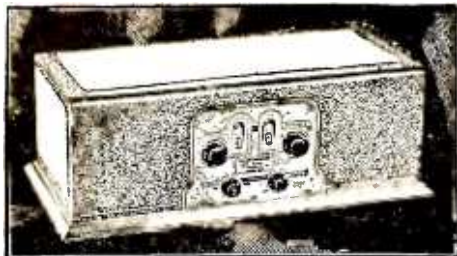

720 SCREEN GRID SIX

Here is a set which, in appearance alone, is worthy to stand with factory products selling at several times the price. But look further into the Screen Grid Six—examine the four tuned circuits—the new high-selectivity S-M 140 antenna coil—the rigid diecast gang condenser—the screen grid r. f. stages individually shielded in neat copper cans—and finally the marvelous new audio transformers. Then you will have some idea of the 720's overwhelming superiority in actual reception.

When we get hold of a set carrying the S-M guarantee, and are able to offer it at a list price of only \$72.50 for the complete kit (the 700 cabinet is \$9.25 extra)—or the entire set custom-built in this cabinet and tested in the S-M laboratories at \$102.00—then we say it's a bargain. Order yours now!

GRAYMORE ships promptly, from stock, not only the 720 and 710 kits or wired sets above described, but all other S-M products—including the 730 "Round-the-World" Short-Wave Four; the 740 "Coast-to-Coast" Four for either DC or AC tubes; the Unipac Power Amplifiers including the new 685 Public Address Unipac; Medium and High Voltage Power Supplies; the new Clough System Audio Transformers, and many others. Send for our catalog showing S-M and other prominent lines of high-grade radio products. Discounts to Dealers.

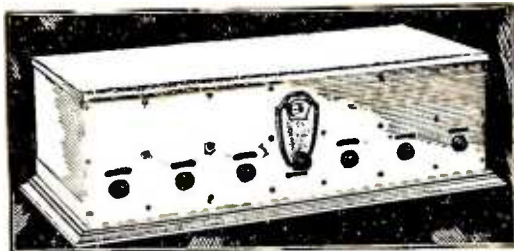

710 SARGENT-RAYMENT SEVEN

A station tuned in for every ten kilocycles—a hundred stations heard in one evening—that is the performance record of the 710 Sargent-Rayment Seven—latest masterpiece of the inventors of the "Infradyne." The 710 is a precision laboratory instrument for the veteran fan. The thick aluminum shielding and chassis give beauty of a strikingly appropriate type. Other features responsible for this unusual performance include five sharply tuned circuits in a four-stage screen grid r. f. amplifier, all tuned by a single illuminated drum, and provided with individual verniers. Each circuit is individually shielded, bypassed, and isolated from all others. New S-M transformers insure unbeatable tone quality.

The approved 710 Sargent-Rayment kit is priced at \$130.00; with cabinet wired complete, \$175.00

GRAYMORE RADIO CORPORATION

142 Liberty Street, New York City

Please send your catalog and best trade discounts on S-M and other leading lines of radio merchandise.

Name.....

Address.....

GRAYMORE RADIO CORPORATION

142 Liberty Street

New York City

THE MIRACLE OF THE RADIO WORLD!

Newest Guaranteed 7-Tube 1-Dial Console Set—Worth \$200

BUY DIRECT

1929 MODEL



ALL ELECTRIC RADIO

30 DAYS' FREE TRIAL!

A Wonder Bargain!

Buy direct from factory. \$200 VALUE

Outperforms sets selling at 2 and 3 times our low price. Includes console shown, made of combination walnut; A. C. electric set, all tubes, built-in magnetic speaker and aerial equipment,



Only \$79.85

COMPLETE Nothing Else to Buy

Powerful Reception—Amazing Tone!

Remember—30 days free trial. You be the judge! Worth \$200 and looks it! Only one dial to tune—illuminated! Marvelous mellow tone. Selective and gets distance easily. The radio sensation for quality, price and performance. Mail coupon today for our big, money-saving Free Catalog, before you buy any radio or accessories!

Battery Sets

Our low factory prices on the complete line of Diamond Electric and battery operated radios shown in catalog will amaze you!

Our New FREE Catalog—Just Published—Shows You How To SAVE HALF!

Diamond Radio Company

Dept. 220 - 820 S. Clinton St., Chicago, Ill.

MAIL THIS COUPON TODAY!

Diamond Radio Company, Dept. 220 820 S. Clinton St., Chicago, Ill.

Please send me your Free Catalog of Diamond radios and details of your 30 Day FREE Trial offer

Name.....

Address.....

City.....State.....

AT LAST! JEEMS SUPER TROUBLE SHOOTER

the easy method for locating trouble in your superheterodyne. This handy chart, comprising 16 symptoms, 130 possible causes, is highly recommended by professional set builders as a valuable asset in the work shop. ACCURATE, SURE, COMPLETE, PRACTICAL. By mail 50c.

ROBERTS RADIO SERVICE

CAXTON BLDG.

CHICAGO, ILLINOIS.

'Round the World With New Karas Short Wave Receiver

Enjoy the thrills of hearing stations thousands of miles away. Karas engineers have developed short wave equipment to highest point. Easy to build. Easy to tune with Karas Micrometric dials. 63 to 1 ratio. Uses Karas condensers built like a fine watch. Karas coils and audios—standard of the world. Send to-day for complete information and construction blue print. Free.

KARAS ELECTRIC COMPANY

4033K1 N. Rockwell Street, Chicago

Name.....

St. and No.....

City and State.....

4033K1

Aerovox Condensers and Resistors have been firmly established as *The Specified Products* by the more discriminating manufacturers.

Write for the Research Worker, a free monthly publication that will keep you abreast of Radio's latest developments.



NA-ALD
TRADE MARK
MADE IN U.S.A.

No. 502.

ELECTRIC PICKUP

Price \$5.00

Here is an improved type of Electric Pickup for electrically reproducing music from phonograph records through radio sets or power amplifiers. Fits A.C. or D.C. sets with UX or UV sockets. Comes complete ready to work and is sold with a money back guarantee.

Na-Ald also makes a complete line of sockets, adapters and power amplifiers. Write for complete catalog.

Alden Manufacturing Company
Brockton Massachusetts

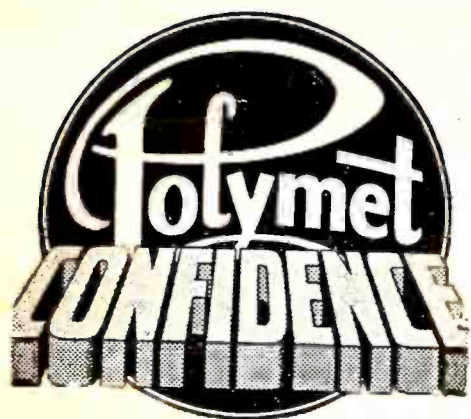

Confidence in Polymet quality. Confidence in Polymet service. Confidence in Polymet dependability.

Confidence in Polymet to produce the best in every electric set essential led to the adoption of Polymet by two-thirds of the R. C. A. licensed radio manufacturers.

It's the "little bit more" put into Polymet Products that brings the results which inspire this Confidence.

We don't ask your confidence 'til we've won it.

Send for our new catalogue showing the complete line of Polymet electric set essentials.

POLYMET MANUFACTURING CORP. 597 Broadway, New York City

POLYMET PRODUCTS



Prompt Deliveries on all new S-Y Kits and Parts

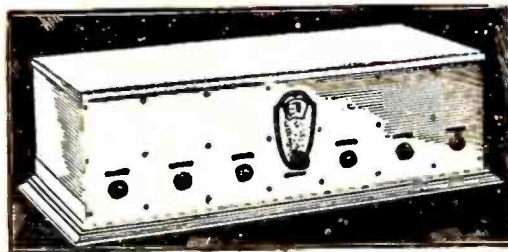

The S-M line-up for 1929 is unbeatable. Greatest values are offered the set-builder.

SEND for Hammer's Catalog and dealer discounts. For years we have specialized in furnishing set-builders with the fastest selling equipment at rock bottom prices.

Let us show you what Hammer Service really means.

We have in stock the S-M 710 "Sargent-Rayments"; 720 "Screen Grid Sixes"; 730 "Round the World" Kits; 740 "Coast to Coast" Fours; S-M Unipacs, power supplies and all parts, also all other leading lines at maximum discounts.

S. HAMMER RADIO CO.

142 Liberty Street

New York, N. Y.

Out-Selling All Other Kits!

Sargent-Rayment Screen Grid Seven

Designed by the Inventors of the Infradyne

Manufactured by Silver-Marshall, Inc.

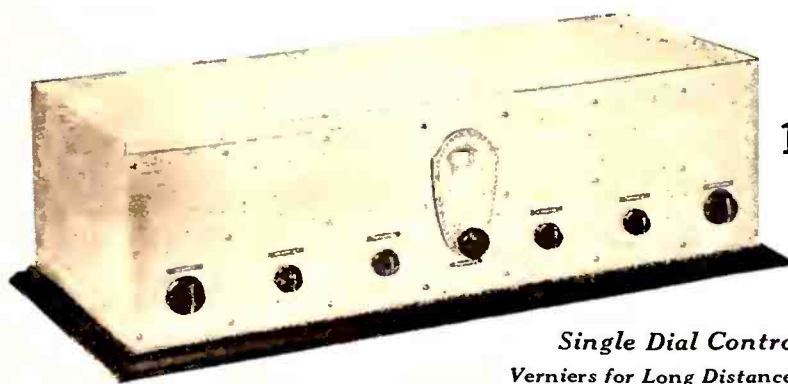

Single Dial Control Verniers for Long Distance Tuning

A Real "DX" Getter with 10 KC Selectivity

Supplied in two finishes, grained aluminum and crackle crystalline. The crackle crystalline finish is known as our De Luxe Model and is put out only by us.

A Station for Every Dial Degree

That is the average performance of the Sargent-Rayment Seven over the entire dial. Under average conditions 100 stations per night can be heard with it.

The Sargent-Rayment Seven has an amplifier composed of four screen-grid tubes. There is no regeneration. No "grid suppressors" or other counteracting devices are used to stop oscillation, the oscillation is fundamentally eliminated in the circuit design thus allowing every bit of tube amplification to be retained for useful work. Under these conditions are we unreasonable when we claim that this receiver has more power, more sensitivity and more selectivity than anything else ever offered for sale? Watch the DX records go to smash this winter!

WRITE FOR FREE BOOKLET

Save your own time and get better results by buying this kit already built up, wired, and tested, ready to operate. Look over the prices listed below and see if it will pay you to build one. Every set fully guaranteed.

Grained Aluminum Model, kit \$130.00, built-up \$150.00. Brown, crackle crystalline model, kit \$140.00, built-up \$160.00. Except for the finish, the models are identical in every respect.

Form with fields for Name, Address, City and State, Name of Jobber, and a note about AIR MAIL.



**GET BOTH
AND
SAVE
\$1.95**

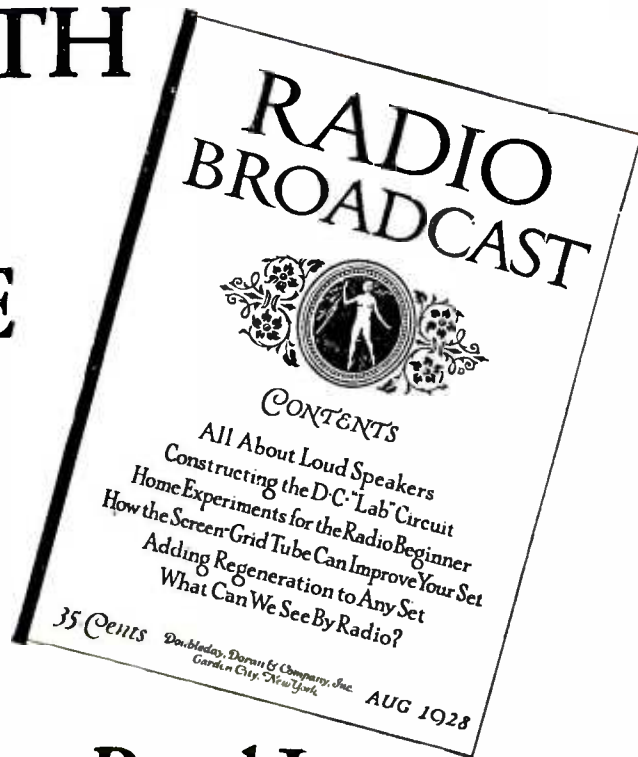

This Offer is Good—Read It

The Citizens Radio Call Book and Radio Broadcast offer you a combined subscription rate whereby you can now get both of these magazines at a saving of \$1.95. Radio Broadcast and Citizens Radio Call Book are today the two best buys in radio magazines. The combination covers every field of radio. The Citizens Radio Call Book contains live radio information together with a complete list of all broadcasting stations, schedules and wave-lengths. The construction articles, circuit diagrams and detailed information on all popular circuits is of the utmost value to the home constructors, professional set builders and radio service men.

Radio Broadcast supplements the Call Book by giving you each month throughout the year a complete review of the whole radio situation. Radio Broadcast contains the news and interpretations of current radio events as well as exclusive special articles by the foremost radio engineers of today. The combination of Radio Broadcast and Citizens Radio Call Book can not be equalled from the standpoint of radio theory and practical data on every known phase of radio.

Send \$4.25 For Both and Save \$1.95

These radio magazines if purchased at any newsstands would cost you a total of \$6.20 a year. (4.20 for 12 issues of Radio Broadcast and \$2.00 for 4 issues of Citizens Radio Call Book). By subscribing to both in combination you save \$1.95 over the newsstand price of both magazines. If you are a subscriber to Radio Broadcast or to Citizens Radio Call Book you can still take advantage of this low combination rate of \$4.25. We will extend your subscription for one year. Don't miss this opportunity!

Send \$4.25 Today

Mail Coupon Now

Radio Broadcast, Garden City, N.Y.

Enclosed is \$4.25 for which please send the next twelve issues of Radio Broadcast and also one full year's subscription to Citizen's Radio Call Book (4 issues).

NAME

ADDRESS

I am a subscriber to Please extend my subscription one year.

Decorative and Efficient Dynamics



Showing the fireplace and wall picture speakers.

Advance Fireplace Co., Detroit

HERE'S the newest thing in dynamic speakers—an attractive fireplace screen or handsome picture speaker — that you can easily build yourself. Either will be a worthwhile addition to your home, and you have a thoroughly dependable dynamic unit, the latest thing in radio, as well.

The fireplace baffle board comes in gum wood, walnut or mahogany, or unfinished for you to do in any color to match any decorative plan. It is sent knocked down and is

easily assembled. When assembled it is 30 inches high and 36 inches wide.

The picture speaker comes in several beautifully oil painted designs on velvet or will be painted to your own design at no extra cost. Including frame the size is 24 x 34 inches. A six-inch magnetic speaking unit of standard make is used.

Color! Tone!

Everyone is using color in their homes now. With either our fireplace or picture speakers you can have color that will harmonize with your home color scheme.

And our speaking units will give you a richness, a clarity of tone you usually associate with speakers much higher in price. Get our prices today.

Enjoy your radio to the fullest this winter with these splendid and decorative speakers. We furnish everything. Write to-day for our remarkably low prices.

BRYDEN PRODUCTS, Inc.

2559 Bellevue Ave.

Detroit, Mich.

RADIO BROADCAST

OCTOBER, 1928

WILLIS KINGSLEY WING, Editor
 KEITH HENNEY, Director of the Laboratory
 EDGAR H. FELIX, Contributing Editor

Vol. XIII. No. 6

CONTENTS

Cover Design	From a Design by Harvey Hopkins Dunn	
Frontispiece	Where Radio Progress Begins	330
Television—Its Progress To-day	Howard E. Rhodes	331
A Nine-Tube Screen-Grid Super	Robert Burnham	334
The March of Radio	An Editorial Interpretation	337
The Low-Power Stations Plead Their Case Regulations for Television and Picture Transmission		
The "Hi-Q 29"—A Receiver with a Band-pass R.F. Amplifier	Here and There	
	D. K. Oram	341
A Short-Wave Transmitter for 1929	Robert S. Kruse	344
"Strays" from the Laboratory	Keith Henney	347
Two Interesting Patents Radio as a Scapegoat A Screen-Grid Mystery Mortality Among the A.C. Tubes		
Engineers as Salesmen Testing for Soft Tubes Short-Wave Reception The Remler A.F. Amplifying System		
A Two-Tube A.C. Screen-Grid Tuner	James Millen	349
As the Broadcaster Sees It	Carl Dreher	352
Sound Motion Pictures Lord Rayleigh on Sound		
The Sargent-Rayment Seven Receiver	Howard Barclay	354
"Radio Broadcast's" Home Study Sheets		357
Nos. 7 and 8. Alternating Current		
The 222 Tube as an R.F. Amplifier (Part II)	Glenn H. Browning	359
Book Review	Carl Dreher	360
Coupling Methods for the R.F. Amplifier	Bert E. Smith	361
"Our Readers Suggest—"		364
A Power Unit Voltage Divider Obtaining Screen-Grid Bias Testing for Soft Tubes Matching Condensers and Coils in Tandem Tuned Circuits An Amplifier Kink		
Dynamic Speaker Field Supplied from B-Power Unit A Simple Audio Channel Equalizer A.C. Tube to Reduce Microphonics An Antenna Booster for Loop An Output Filter Without a Condenser		
The "Vivetone 29" Receiver	R. F. Goodwin	366
"Radio Broadcast's" Service Data Sheets on Manufactured Receivers		369
No. 9. The Bosch Model 28 Receiver No. 10. The Splitdorf "Inherently Electric" Receiver		
Practical 5-Meter Hints	Robert S. Kruse	371
New Apparatus	Useful Information on New Products	372
Radio Helps in the Coast Survey	D. L. Parkhurst	374
Manufacturers' Booklets		376
"Radio Broadcast's" Laboratory Information Sheets		378
No. 225. Calculating Grid Bias for A. C. Tubes No. 226. Grid Bias Circuits for A.C. Tubes No. 227. The Audio Transformer No. 228. The Dynamic Loud Speaker		
No. 229. The Telephone Transmission Unit No. 230. Filters No. 231. Impedance-Coupled Amplifiers No. 232. The Voltmeter		
Photo Broadcasting in England	William J. Brittain	384
Letters from Readers		386

The contents of this magazine is indexed in *The Readers' Guide to Periodical Literature*, which is on file at all public libraries.

AMONG OTHER THINGS. . .

READERS who did not see our announcement in this space last month with respect to the change in our publication date and who failed to see our October issue when they expected may be somewhat confused. Effective with this number, RADIO BROADCAST is on sale at all good newsstands on the first of the month. That is easy enough to remember.

THE issue before you now contains an unusually wide range of material, and in the descriptions of receivers offered the constructor in kit form for the present season, is especially complete. Our November issue promises a story on present trends in radio progress, a description of a new audio amplifier system, two articles on television, the first of a series of practical articles on radio service for men actually facing the music, and a variety of constructional articles. These are in addition to our popular departments which will run as usual.

A FEW of our readers who carefully classify the contents of each issue feel that each article should be classified according to the Dewey decimal system when published. At one time our excellent British contemporary, *Experimental Wireless*, classified their articles this way, but has since discontinued the practice. RADIO BROADCAST is quite willing to serve its readers, but we feel that this classification would appeal to all too few. The editor would be glad to hear from those who favor the scheme—and from those who prefer the *status quo*.

AND here we group many miscellaneous matters; read them, but remember, you were warned! . . . The complete set of "R. B. Lab. Data Sheets" in book form—No. 1-190—is now available at \$1 per copy from the Circulation Department of this company. . . . We shall soon start a special department, along lines similar to "Our Readers Suggest—" to be made up of practical contributions from radio service men and professional set builders. Quite a few interesting contributions are already in the office and readers who desire to submit any ideas that seems to them worth while passing on are invited to do so. The same general rules hold for these contributions as for the "Readers Suggest" department. . . . How many readers are interested in the problems of series-filament connection for a.c. operation? We should like to hear from readers who have done some work along this line, or from those who would like an article devoted to the subject. . . . In the past few weeks, our mail has contained a number of simple questions about radio which we are thinking of answering in a short article composed simply of the questions and their answers. We invite the submission of short and particularly troublesome questions which readers would like to see treated in this way. . . . A radio house in Sao Paulo, Brazil, informs us that they are expanding and desire exclusive American agencies for radio apparatus in Brazil. Manufacturers who wish to get in touch with this house may write the editor. . . . Our request in the August "Strays" for methods of testing for hard and soft tubes has brought two answers. One may be found in this number on page 348, in the "Strays" department, and the other on page 364 in the department "Our Readers Suggest—"

TWO of the writers in this issue who have investigated the use of the screen-grid tube with various kinds of coils, arrive at conclusions which are different—but most interesting. The stories concerned are by Bert Smith and Glenn Browning. —WILLIS KINGSLEY WING.

DOUBLEDAY, DORAN & COMPANY, INC., Garden City, New York

MAGAZINES
 COUNTRY LIFE
 WORLD'S WORK
 THE AMERICAN HOME
 RADIO BROADCAST
 SHORT STORIES
 EDUCATIONAL REVIEW
 LE PETIT JOURNAL
 EL ECO
 FRONTIER STORIES
 WEST
 THE AMERICAN SKETCH

BOOK SHOPS (Books of all Publishers)
 NEW YORK: { LORD & TAYLOR; JAMES McCREERY & COMPANY
 PENNSYLVANIA TERMINAL AND 166 WEST 32ND ST.
 848 MADISON AVE. AND 51 EAST 44TH STREET
 420 AND 526 AND 819 LEXINGTON AVENUE
 GRAND CENTRAL TERMINAL AND 38 WALL STREET
 CHICAGO: 75 EAST ADAMS STREET
 ST. LOUIS: 223 N. 8TH ST. AND 4914 MARYLAND AVE.
 KANSAS CITY: 920 GRAND AVE. AND 206 WEST 47TH ST.
 CLEVELAND: HIGBEE COMPANY
 SPRINGFIELD, MASS: MEEKINS, PACKARD & WHEAT

OFFICES
 GARDEN CITY, N. Y.
 NEW YORK: 244 MADISON AVENUE
 BOSTON: PARK SQUARE BUILDING
 CHICAGO: PEOPLES GAS BUILDING
 SANTA BARBARA, CAL.
 LONDON: WM. HEINEMANN, LTD.
 TORONTO: DOUBLEDAY, DORAN & GUNDY, LTD.

OFFICERS
 F. N. DOUBLEDAY, Chairman of the Board
 NELSON DOUBLEDAY, President
 GEORGE H. DORAN, Vice-President
 S. A. EVERITT, Vice-President
 RUSSELL DOUBLEDAY, Secretary
 JOHN J. HESSIAN, Treasurer
 LILLIAN A. COMSTOCK, Asst't Secretary
 L. J. McNAUGHTON, Asst't Treasurer

Copyright, 1928, in the United States, Newfoundland, Great Britain, Canada, and other countries by Doubleday, Doran & Company, Inc. All rights reserved.
 TERMS: \$4.00 a year; single copies 35 cents.

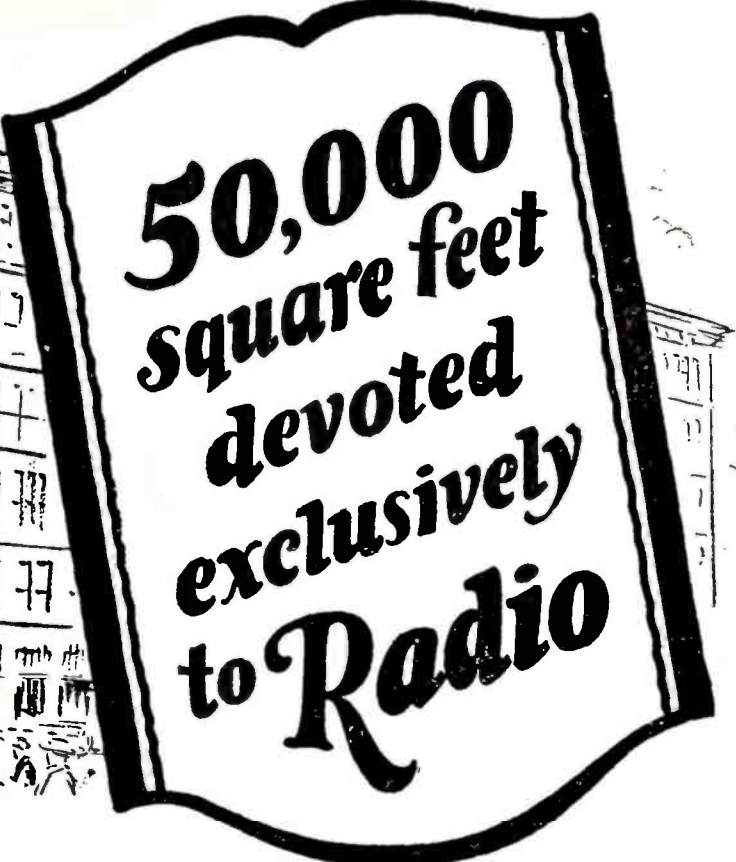

Lowest Wholesale Prices

Set Builders

Set Builders and experimenters will welcome an association here where tremendous stocks of practically all of the nationally advertised lines are carried—coupled with an organization trained to serve. Immediate shipments are assured. Silver-Marshall—Hammarlund—Roberts—Aero—Tyrman and practically all of the latest kits and parts are available. Your orders, large or small, will be handled with a promptness and dispatch that should prove a revelation to you in Radio Service.

Dealers

Dealers who line up with Allied Service will never disappoint their trade on deliveries. Our immense stocks in Sets, Parts, Kits and Accessories enable you to render real service to your trade. Immediate shipments insure rapid turn-over—eliminating the necessity of carrying large stocks on hand—and this along with lowest market prices will prove an ideal connection for the live dealer.

Allied Radio Corporation is composed of a large corps of trained men who have had years and years of experience in radio. They know how to get results. Their great fund of experience is now available for your benefit. They know the newest improvements, the up-to-the-minute demands of the trade and are ready to give you personal, helpful service.

50,000 FEET OF RADIO

50,000 square feet of floor space in a large modern building is devoted exclusively to radio. Floor after floor is filled with a tremendous stock of every variety that is exceptionally complete in kits, parts and sets of every description. Here are found the latest improved designs and styles in radio equipment.

NEW A. C. SETS AND KITS

New A. C. sets priced as low as \$35.45. Also a wonderful array of beautiful consoles ranging in price from as low as \$12 up to \$200. A complete assortment of the famous Silver-Marshall parts and kits—in stock ready for your call. Practically all of the nationally advertised lines in parts and kits are available here for immediate shipment. New A. C. Sets, Power Dynamic Speakers—all the latest and newest in Radio is here at prices that actually defy competition.

LOWEST WHOLESALE PRICES

Tremendous sales volume coupled with a rapid turnover to the thousands of radio dealers throughout the country who have come to depend on Allied Service enables us to go into the open market and buy for cash—at tremendous savings—and these savings are passed right on to you in the way of better merchandise and lower prices.

IMMEDIATE SHIPMENTS

The Allied organization is trained to service. Real team work from executives and department managers to stock clerks and office boys—all animated by a desire to serve—to make Allied service Radio's most dependable service.

Send for Large, Free, New, Illustrated Catalog "A-1"

Allied Radio CORPORATION

Wholesale Radio Distributors

711 West Lake Street Dept. A-1 Chicago, Illinois

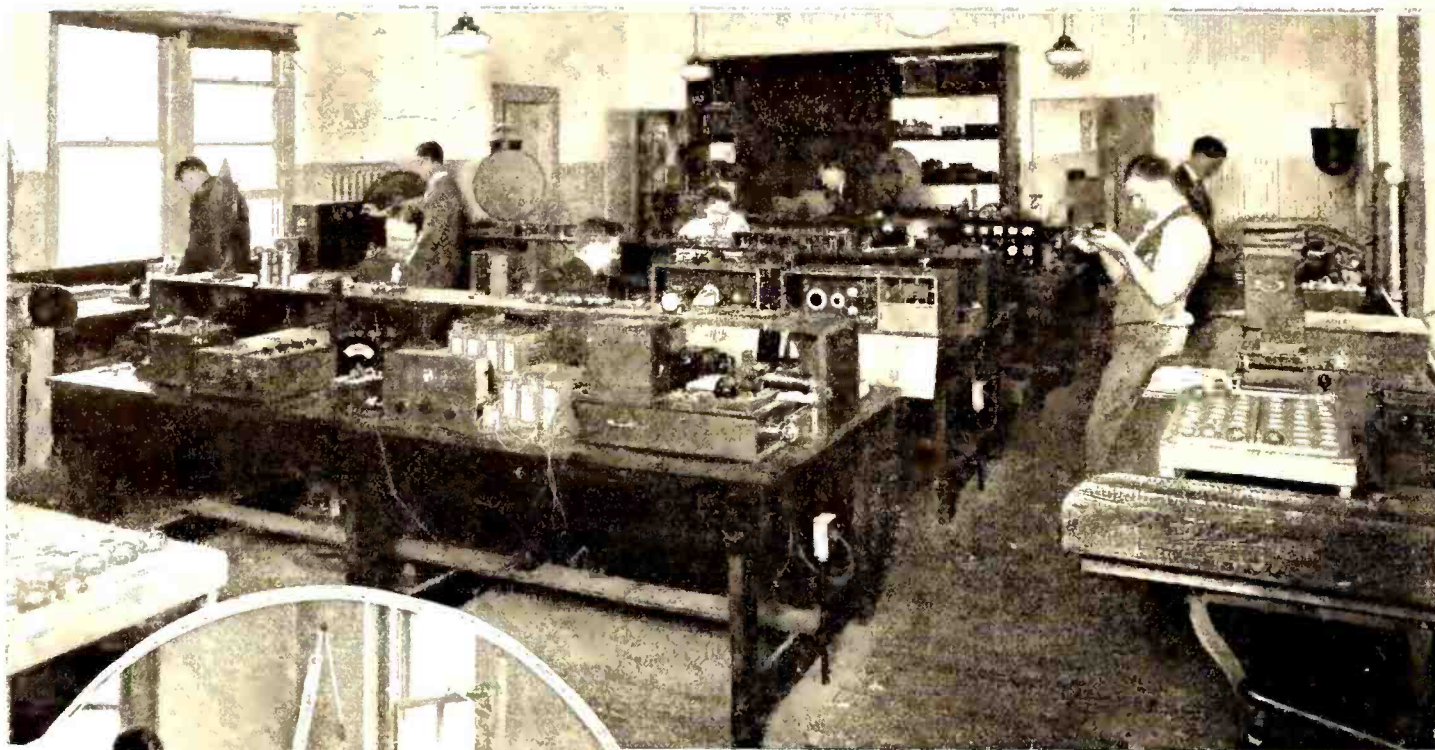

A Modern Radio Laboratory

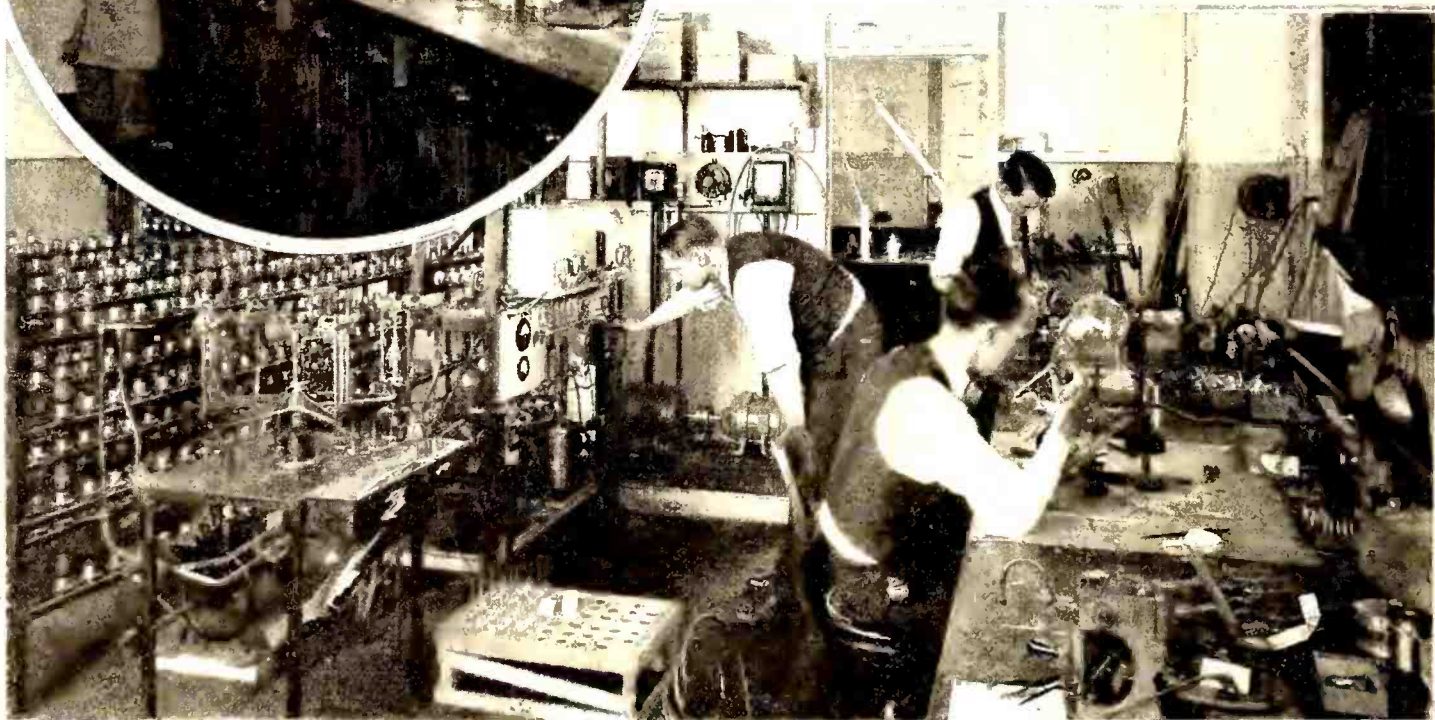

Where Radio Progress Begins

These views in the laboratory of the Arcturus Radio Company give a graphic picture of the organized experimentation that goes on before a technical advance is announced to the radio public. At the top is the testing room, where every characteristic of a radio receiver or vacuum tube may be accurately measured. Precision condensers, oscillators, resistance and inductance standards, and gain measuring equipment fill this experimenters' paradise. The circle inset shows a corner of the chemical laboratory, where experiments are carried on with the gases and metals that make up a vacuum tube. At the bottom is a complete tube factory in miniature, where the engineers can build any tube they want at a moment's notice. The man at the left is bending over a vacuum tube pump for exhausting experimental tubes. At the extreme left are racks in which tubes are given life tests. Such scenes as this may be duplicated in the laboratory of any wide-awake radio manufacturer.



A RADIO MOVIE DEMONSTRATION

Dr. Frank Conrad, Assistant Chief Engineer of the Westinghouse Electric and Manufacturing Company, with the transmitting apparatus with which he recently demonstrated the radio transmission of moving pictures. At the right is the light source; next to it are the scanning disc and focusing lenses; at the left are the film reels and (in the cylindrical can) the photoelectric cell

Television—Its Progress To-day

By HOWARD E. RHODES

Radio Broadcast Laboratory

LIKE the search of the ancient philosophers for the elixir of life, television has been for years an inspiring dream of man. Although its first fruits in experimental demonstrations have been shown only in the past few years, the principles on which these demonstrations have been built have been work of several generations of scientific endeavor. The scanning disc, for example, which is an essential part of all the systems being utilized in this country to-day, is the invention of Nipkow, and dates back to 1884. To a considerable extent the problems which it was necessary to solve to make the recent demonstrations possible have been associated with the applications of already known principles, but the future development of the art will be the result of research—the systematic pursuit of knowledge—or the result of some new television tool, and it seems likely, to the writer, that such is necessary to make television really practical.

Enough has already been done in television, however, to excite the interest of everyone. Some stations are now on the air with television, and some are getting ready to go on, so that dyed-in-the-wool experimenters will find it hard to resist the temptation to set up apparatus to receive the broadcasts—even though their quality and program interest is negligible. For the benefit of these experimenters, and also for those interested only in the thrill of "looking in," we here report the progress of television in this country to date. The questions that immediately pop into one's mind—how good are the results, what stations are transmitting, how much does the receiving apparatus cost—are answered as fully as possible. In order that

the article might be written with a background of experience, the past few weeks have been spent collecting data and personally seeing several demonstrations.

TELEVISION DEMONSTRATIONS

THE first television demonstration seen by the writer which showed promise of being applicable to home use was the demonstration by Dr. E. F. W. Alexanderson at the Schenectady

IN THE July and August issues this magazine published two articles by Mr. R. P. Clarkson which set forth quite clearly the fundamental problems associated with television. By no stretch of the imagination could Mr. Clarkson be considered optimistic in his outlook, and by some he is probably considered decidedly pessimistic in regard to the present methods of approach to the problems of television. It should be realized, however, that Mr. Clarkson was writing from the point of view of one who wished to bring this science from its air-castle fancies back to terra firma. The present article has a different purpose. It is the result of a careful survey—in many cases, by personal visits—of the stations now broadcasting, or about to broadcast television, and its aim is to give the reader information on who is doing the work, how it is being done, and what results have so far been accomplished.

—THE EDITOR.

plant of the General Electric Company. This company through three of its stations is now transmitting television signals in accordance with the schedule given in Table 1. The receiver in this demonstration consisted of a scanning disc with a neon tube back of it, the disc being turned by a motor and manually synchronized by varying the resistance of a rheostat.

Essentially similar apparatus was used for part of the American Telephone & Telegraph Company's demonstration, with the difference that synchronization in the latter case was accomplished by means of synchronous motors—a more scientific method of holding the receiver in step with the transmitter, but also much more expensive. To the Telephone Company television constitutes a method of communication complementary to the telephone, and its interest is to develop a system giving quality reproduction. Therefore it cannot consider any system in which synchronization is not positive and automatic. In the same classification fall the more recent tests of this company in which actual outdoor events were televised. The apparatus used was entirely beyond the scope of the experimenter. The experimenter must depend upon other sources for television signals—and who knows but that some interesting results might come from his work. Even the greatest are sometimes caught napping!

More recently we saw a demonstration at the laboratory of the Daven Company, which has employed Mr. P. H. Kober, a former associate of Doctor Alexanderson, to develop television apparatus for them. In the Daven laboratory, a complete television transmitter and receiver have been constructed, similar in operation and results, so far as the writer can see, to that demonstrated at the General Electric Laboratories. Synchronization of the receiver with the transmitter is accomplished by means of a rheostat in series with the motor, across which a push-button switch is placed. The resistor is adjusted so that the motor tends to turn at slightly below the correct speed; pressing the

TABLE I: WHO IS ON THE AIR WITH TELEVISION SIGNALS

Call Letters	Location	Wave-length Meters	No. of Holes in Disc	Speed of Disk. (R. P. M.)	No. of Pictures Per Second	Schedule of Transmissions (E. S. T.)
WGY	Schenectady, N. Y.	379	24	1260	21	Sunday, 10:15-10:30 P. M. Tuesday, Thursday, Friday, 1:30-2:00 P. M.
2XAF	Schenectady, N. Y.	31.4	24	1260	21	
2XAD	Schenectady, N. Y.	22	24	1260	21	
3XK	Washington, D. C.	46.7	48	900	15	Monday, Wednesday, Friday, 8-9 P. M.
WRNY	New York City	326	48	450	7.5	5-10 minute periods every hour station is on air
2XAL	New York City	32	48	450	7.5	
9XAA (WCFL)	Chicago, Ill.	61	48	900	15	10 to 11 A. M. Daily except Sunday
WMAC	Chicago, Ill.	447.5	45	900	15	Probably 11:30-12 P. M. Daily
4XA (WREC)	Memphis, Tenn.		24	900	15	Irregular
1XAY (WLEX)	Lexington, Mass.	62	48	900	15	9:30 P. M. Daily
8XAV	Pittsburgh, Pa.	62.5	60	960	16	Irregular

button short-circuits the resistor so that the motor tends to revolve slightly above the correct speed. Successful synchronizing then becomes a matter of getting the knack of pressing and releasing the button at such intervals as to hold the disc at exactly the correct speed. And this is no small job! More anon about synchronizing. As will be pointed out, Jenkins, in our opinion, has a better method.

At the Daven Company's laboratory a pretty young lady was asked to sit in front of the television transmitter located in one corner of the room while the rest of us moved over to the opposite corner where the television receiver was located, the transmitter and receiver being connected electrically by wire. The young lady smiled, winked, smoked a cigarette (these moderns!) and we saw it all in the receiver. The color of the received image is pink—the characteristic glow of a neon lamp. As we recall it, the size of the picture appeared to be about 3" by 3".

On August 21, this company held a public demonstration in connection with station WOR. A demonstration for the public, interested in practical television, and with little or no interest in experimental television, had to be arranged in the form of a show. In this instance puppets were used, as in Punch and Judy, since they are small and their entire movements can readily be reproduced in a small space. The experimenter doesn't care very much about what is sent, being interested in how good the results are, but this demonstration possibly gives us some idea of the technique that will be developed for the first television programs.

A journey to Washington, D. C., to the private laboratory of C. Francis Jenkins, provided one of the most enjoyable days of the investigation. On July 2 Jenkins began the broadcasting of radio movies—i. e., transmitting from a strip of motion picture film—from his experimental short-wave station, 3XK, going on the air every Monday, Wednesday, and Friday night. He has gotten the coöperation of many experimenters, and up to the present his pictures have been received as far west as Chicago and north as far as Boston.

Jenkins demonstrated two different types of television receivers. One of these uses a drum type scanning disc, which has the advantage that it can be made much smaller in size than a flat scanning disc designed to give the same size picture. The drum disc which we saw consisted of a cylinder about 7" in diameter and about 4" long, with 48 small scanning holes punched in its peripheral wall and arranged in the form of a four turn helical. A neon light

source containing four small plates each about $\frac{1}{8}$ " square is located in the center, and quartz rods extend from each hole in the wall to the neon tube. This drum with its 48 quartz rods cannot be cheaply made and for the first television experiments a flat scanning disc will prove satisfactory and more economical. We therefore leave a more complete description of it for a later date. Jenkins also had in operation a receiver using an ordinary flat scanning disc from which satisfactory reception could be obtained. This receiver, a picture of which appears in this page, used a small 48-hole scanning disc, the source of light being a small G. E. neon lamp. This lamp gives a picture probably not more than about $\frac{3}{4}$ " high and about $\frac{1}{2}$ " wide—quite small.

The method of synchronizing is interesting and we found it quite easy to hold the picture stationary. The arrangement used is indicated in Fig. 1. The scanning disc, D, is mounted on a shaft which revolves in the bearing, B. The motor, M, is mounted on a block of wood at a small angle to the disc as indicated, and the mounting block fitted with a slider, fitting into a groove on the baseboard. The screw, S, enables the operator to move the motor to the left or right, parallel to the disc. The end of the motor shaft is fitted with two flanges, F, about $2\frac{1}{2}$ " in diameter with a rubber disc, R, clamped between them. This rubber disc may be made by cutting a $2\frac{1}{2}$ " or 3" diameter disc from an old automobile inner tube. The motor is so located that the rubber disc bears against the scanning disc at a point about 3" from the center of the scanning disc. The motor which may be any type, a.c. or d.c., is connected to the line without the use of a resistor

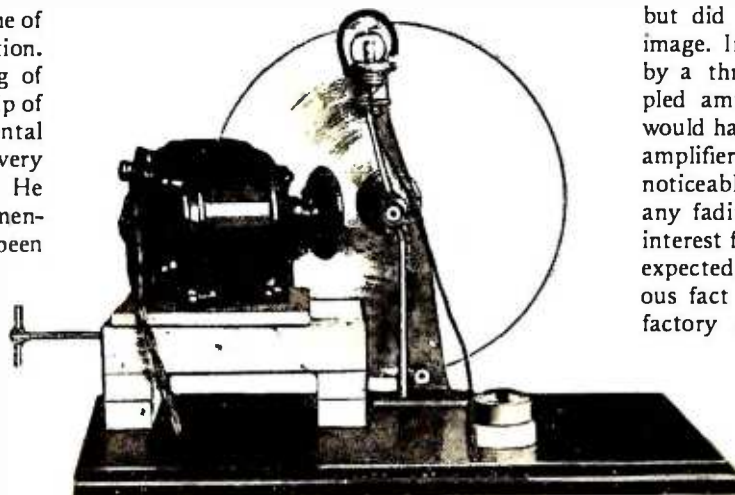

JENKINS' SCANNING APPARATUS

This rear view of Jenkins' receiving apparatus shows the scanning disc, neon lamp, and driving motor. The screw at the left varies the speed of the disc by moving the friction drive motor along its surface.

and the speed of the disc is adjusted by turning the screw, S, thereby moving the motor assembly further away from or nearer to the center of the scanning disc. With this arrangement the motor runs constantly at normal speed; at least, it runs much more uniformly than when synchronizing by means of a resistor in the motor circuit—the method mentioned previously. We recommend that those who decide to do some television experimenting, start off with this method—although since we are experimenting everyone has a perfect right to try any and every method he can think of to obtain easy synchronizing.

Jenkins at present transmits silhouettes, although he expects soon to transmit ordinary pictures. Silhouettes were used at first so as to keep the side band frequencies within a limit of about plus or minus 5000 cycles. The short-wave channels now being licensed for experimental television are 100 kc. wide, and in a band of this width it is possible to transmit the wide band of frequencies essential for transmitting high quality half-tone pictures. To date, Jenkins has always sent out the same program—a little girl bouncing a ball. In reception the girl and the ball will show up black, silhouetted against the pink background of the neon glow.

A trip was made to Boston a few days later and at this point we succeeded in receiving 3XK, Jenkins' station, and getting recognizable images on a television receiver constructed by James Millen. Static marred reception considerably, but apparently had less effect on television reception than on ordinary broadcast reception which was very poor at the time. At this time we used a large 2' disc made by the National Company and a Raytheon Kino-Lamp, from which combination can be obtained pictures about $1\frac{1}{2}$ " square.

This test at Mr. Millen's home was made on a Friday between the hours of 8 and 9 P. M. E. S. T. during one of Jenkins' regular transmission periods. Static was very bad, and during the latter half of the demonstration there was thunder and lightning. In spite of this, plus considerable fading, what we considered fairly good results were obtained. The transmission started off with an announcement in both code and phone telling what the program consisted of, after which the actual transmission began. The incoming signals contained components of all the frequencies in the audio band, but the characteristic note in the loud speaker seemed to be about 2000 cycles, probably because the ear is most sensitive to this frequency.

At various times during the hour, especially during those moments when the signal was strong, the silhouettes of our little girl with the bouncing ball could be easily recognized. The static produced a lot of black spots and lines on the picture but did not prevent one from recognizing the image. In this test a short-wave tuner followed by a three-stage high-quality transformer-coupled amplifier was used. Theoretically, results would have been better with a resistance-coupled amplifier but the improvement would not be noticeable unless good strong signals without any fading were being received. This test is of interest for it gives one some idea of what can be expected, and it also indicates the perhaps obvious fact that television reception will be satisfactory at any point at which a good loud-speaker signal can be received.

While at Boston we had hoped to see a demonstration from the local station, WLEX, which has obtained a short-wave television license as indicated in Table 1, but the new 500-watt short-wave transmitter was not yet ready. Before this article is published WLEX will probably be on the air with regular programs.

Station WRNY of New York has installed a television transmitter and are transmitting programs through their regular broadcasting station and their short-wave station, as indicated in Table 1.

According to a recent release from the Westinghouse Electric and Manufacturing Company, the experimenter will soon be able to look to the station this company operates for programs of radio movies—it will be noted from Table 1 that this company has obtained an experimental license. A demonstration of radio movies was held in Pittsburgh on August 8th—a demonstration which we, unfortunately, did not see. The system used was in one respect at least, unusual: a mercury arc lamp, magnetically controlled by the incoming signals, we understand, was used in place of the neon tube, the advantage being that much more light can be obtained from the arc than can be obtained from the neon tube so that brighter images are possible. The neon tube doesn't give any too much light. On the other hand, it seems likely that the arc will be more expensive than the neon tube.

Incidentally, the statement in the Westinghouse release to the effect that the demonstration held August 8th, 1928, "was the world's first demonstration of radio movies and possibly the most astounding of the many advances in the science of radio announced in the past year," is rather surprising since, as mentioned previously,

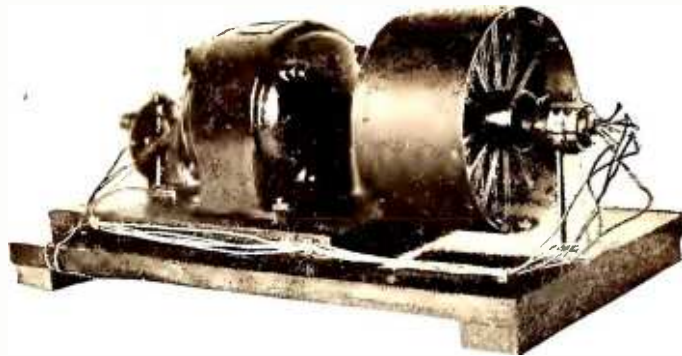

JENKINS' SCANNING DRUM

This view of the scanning drum shows clearly the quartz rods extending from the holes in the surface of the drum to the neon lamps in the center. The wire connections to the four-element neon lamps are seen at the right

tube. As a basis of comparison we might say that the signals should preferably be strong enough to load up a 171A tube with 180 volts on the plate and a 40-volt C bias. If a transformer-coupled amplifier is used, three stages instead of two may be necessary unless the signals are good and loud. A three-stage resistance-coupled amplifier is preferable, however, especially as quality improves. An amplifier of this type properly constructed will pass the higher frequencies which would be cut off by a transformer-coupled amplifier.

The cost of a television receiver disc neon lamp and motor will vary, depending upon the parts used. Forty or fifty dollars should cover it in all cases. Table 2 shows the companies which are at present manufacturing apparatus for use in television reception.

Complete details for the construction and operation of a television receiver are not given here, but will be the subject of a future article. In these pages we have aimed merely to make clear for the readers of this magazine the present status of experimental television.

CONCLUSIONS

IN RESULTS, none of the demonstrations which we have seen, possibly with the exception of those by the American Telephone and Telegraph Company, first held on April 7, 1927, produces pictures which hold one's interest for any length of time. The present appeal of the art is not one of receiving good pictures, but is to do at home—all by oneself—what is demonstrated in the laboratories of a large corporation with the aid of a thousand engineers, and a million dollars worth of apparatus. When one sees such a demonstration, its greatest appeal—of doing it oneself—is lost, and there remains nothing but comparatively poor reception of the image of a person, made pink-faced because of the characteristic glow of the neon tube in the receiver.

Television, then, is still the province of the experimenter, the man who likes to do his own pioneering. And to the experimenter it should be among the most fascinating of all the fields

of modern scientific advance—because its possibilities are so vast, its perfection so tenuously in the future, and its technique so amenable to new ideas and new ways of doing things. And what does the experimenter, the scientific enthusiast, get out of it? To the world at large, perhaps, pep and a hearty laugh are the attributes of the stock promoter, a fish-tail handshake and absent-mindedness the concomitants of the scientific outlook. Such views, however, must be held by persons who have never been on the inside. The scientist and experimenter get as much fun out of peeping through a spectrometer (a device for measuring the energy associated with a spectrum) as does the baseball fan when he catches the ball that Babe Ruth knocks into the

stands. They merely get their joy out of life in different ways. C. Francis Jenkins is a shining example in the field of television of the man who is carried on by the sheer joy of being on the inside of a great development. He is sixty years old, and has been working some twenty-five years on photo broadcasting, television and a host of other things, yet he still retains an enthusiasm which seems to charge his whole staff. Jenkins' attitude, that of getting a thrill out of working with something new, and putting together stuff that frequently utilizes some gadgets from the junk box, is that of a born experimenter. Do you want to experiment with television? Then answer this question: Can you get a kick from twisting dials and rheostats for a couple of hours to get finally some fleeting, perhaps hardly recognizable image in the viewing window of a scanning disc? Or do you have to see the previously mentioned Babe Ruth knock a homer to get a thrill?

Although the cases aren't exactly synonymous, think of the thrill Galileo got out of looking through his glass—the first telescope. As a young lad, Galileo used to watch the candelabrum in the cathedral swing slowly to and fro; he timed its motion by the pulse beat in his wrist, and thought of using such a device for the measurement of time. In later life he invented the telescope, and with it saw thousands of stars never before seen by man. In 1610 he wrote to Kepler:

"Oh, my dear Kepler, how I wish that we could have one hearty laugh together! Here, at Padua, is the principal professor of philosophy, whom I have repeatedly and urgently requested to look at the moon and planets through my glass, which he pertinaciously refuses to do. Why are you not here? What shouts of laughter we should have at this glorious folly! And to hear the professor of philosophy at Pisa laboring before the Grand Duke with logical arguments, as if with magical incantations to charm the new planets of the sky." Some joy is surely to be derived from doing what hasn't been done a thousand times before.

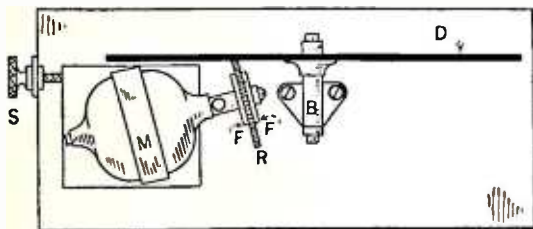

FIG. 1. HOW JENKINS CONTROLS THE DISC SPEED

Jenkins has been transmitting radio movies ever since July 2nd. Furthermore, in the May, 1927, issue of the *Bell Laboratories Record* we read, among other statements, that during research in television, "a strip of motion picture film was projected from a standard machine upon a photoelectric cell. The moving picture of this film was then re-created for an observer by receiving equipment involving a suitable neon tube and a scanning disc." But whether first or last the Westinghouse tests are of interest to experimenters as another possible source of television signals.

APPARATUS FOR RECEPTION

TABLE 1 sums up the situation with as complete a list as could be obtained of those who expect to transmit television signals. The table also gives the data one must have in order to receive the programs. In this connection the important facts are the number of holes required in the scanning disc and the speed of the disc. The column headed number of pictures per second is equal to the speed of the disc in r.p.m. divided by 60. The table shows, among other things, lack of cooperation for as many as five different scanning discs (or one scanning disc with five sets of holes: 24, 36, 45, 48, and 60) would be required to receive all of the stations.

A complete television receiver consists of a tuner, which may be any ordinary broadcast band or short-wave set depending upon whether the signals to be received are being transmitted on the broadcast or short-wave bands. Strong signals are required for the operation of the neon

TABLE II: WHO IS MAKING TELEVISION APPARATUS

Name of Manufacturer	Apparatus
Daven Corp.	Motors, scanning discs (either 24, 36, or 48, holes), neon tubes, rheostats for controlling motor speed, completely assembled resistance-coupled amplifiers. Complete kit for about \$45.00
Insuline Corp. of America	Complete kit listing for \$52.50, containing scanning disc with either 24, 36 or 48 holes, motor and control apparatus, magnifying lenses (to make the picture appear larger), hardware
National Co.	48-hole scanning disc. Price: \$15.00
Raytheon Mfg. Co.	Kino Lamp. A neon lamp with 1½" plates for use in television receivers. Price: \$12.50
Interstate Electric Co.	Type M2V Baldor television motor. Price: \$23.00

A Nine-Tube Screen-Grid Super

By ROBERT BURNHAM

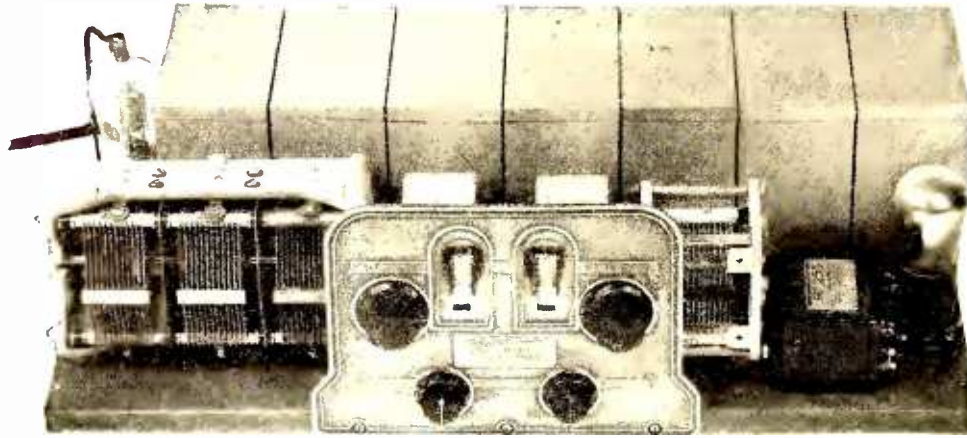

FIG. 1. THE RECEIVER WITHOUT THE CABINET

Compact construction makes this nine-tube super-heterodyne occupy a smaller space than most receivers of the same number of tubes. All the tubes except the antenna input and audio tubes are housed in the shield cans in the rear.

WITH the steady increase in the number of broadcasting stations operating in the frequency band of 550 to 1500 kc. that has taken place in the last several years, the efficacy of the super-heterodyne system of reception has gradually dwindled, for the characteristics of the typical super are such that the effective selectivity of the oscillator dial is practically halved due to the basic principle of the system. This and the accompanying fact that the average super-heterodyne, besides repeating stations at two or more points on one of the two tuning dials, will bring in a multiplicity of heterodyne squeals, has militated against the advantages of this system, such as the high amplification possible, until to-day it is quite safe to say that a good 6-tube screen-grid t.r.f. receiver will outdistance an ordinary 7 or 8-tube super-heterodyne in the matter of actual distance reception, primarily due to the greater effective selectivity rather than to the greater sensitivity of a t.r.f. set. The usual method of obviating repeat points upon a super-heterodyne is to use an intermediate frequency so high that the separation upon the antenna tuning dial of two stations which may be heterodyned by a single given oscillator adjustment is so great that the repeat point is either beyond the required oscillator range (for the majority of signals) or so far separated as to impose no undue selectivity requirement upon the antenna circuit. This system in a measure vitiates the principal advantage of the super-heterodyne which is the higher amplification, obtainable at low radio frequencies, than may be had at such high intermediate frequencies as are encountered in the r.f. amplifier of a t.r.f. set or as are necessary in the i.f. amplifier of a successful one-spot super. This factor makes some one-spot super-heterodynes actually inferior to a good t.r.f. set of two less tubes!

Bearing in mind that a low intermediate frequency is necessary to realize the full amplification possibilities of the super-heterodyne system and that the frequency changing feature of the super-heterodyne must in no way be relied upon to provide adequate selectivity under present broadcast conditions, the receiver pictured and

described herewith was developed. As it has been developed, this receiver does not depend upon the selectivity usually obtained in the intermediate-frequency amplifier at the expense of tone quality, or upon the apparent selectivity resulting from the frequency changing action. To provide a high degree of selectivity, the input to the first detector has instead been designed to provide in itself practically all of the selectivity required for this rather unusually sensitive set. This end is attained through the use of a 3-stage radio-frequency amplifier, tuned by a 3-gang condenser to any desired wavelength. This amplifier is sufficiently selective in itself to provide effective

MANY of us have probably operated a super-heterodyne which would tune-in a single powerful local station at four and sometimes six or more points on the dial. This condition is due to two factors: (a) insufficient selectivity in the tuned circuits preceding the first detector, and (b) the generation of harmonics by the oscillator. There are two methods of overcoming these difficulties. One of these methods is to raise the frequency at which the intermediate amplifier is designed to operate to a value such that the second point (and the harmonics) of the oscillator cannot, for practically all dial settings, beat with any station except the one desired to produce the proper frequency to be amplified by the intermediate amplifier. This method was used in the receiver described by Mr. W. H. Hollister in the September issue.

The second method of making fool-proof the operation of a super, uses one or more stages of ordinary r.f. amplification ahead of the first detector, so that practically all the required selectivity (as well as some gain) is obtained in this amplifier; the intermediate amplifier then functions to amplify greatly the signal without being also called upon to supply all of the necessary selectivity. The receiver described in this article employs this second method.

—THE EDITOR.

selectivity and at the same time a high degree of r.f. amplification. By this means the super-heterodyne system has been freed of any drawback resulting from oscillator dial repeat points attendant upon the use of the low intermediate frequency necessary to provide really high amplification; and at the same time the disturbing

effect of heterodyne squeals has been practically done away with, even when the receiver is operated in such congested centers as New York and Chicago.

THE DESIGN OF THE RECEIVER

IN FIGURE 1, the receiver is seen with the cabinet removed. The set has been designed to be enclosed in a console or table cabinet to suit the builder's fancy, though it is particularly adapted to the new S-M metal cabinet which adds to the effectiveness of the shielding in the set. Figure 4 shows the details of the receiver assembly with the copper stage shields which enclose all r.f. circuits removed, and with all parts labeled as in the parts list. In Figure 2 is the schematic circuit diagram of the receiver, while Figure 3 shows the set with tubes in place but shields removed.

The receiver consists essentially of a three-stage broadcast band t.r.f. amplifier employing three screen-grid tubes and a screen-grid first detector. Coupled into the screen lead of the first detector is the oscillator, which is of conventional type. Following the first detector is the two-stage 65-kc. intermediate amplifier and the second detector. All of these circuits are individually shielded in small copper cans with removable sides and tops for easy access. Following the second detector is a single stage of audio amplification utilizing the new Clough system. The receiver is intended to operate with an external power amplifier in order to provide a high degree of tone quality. Because of the desirability of a 210 or 250 type output tube to prevent overloading it has been thought best to omit this last stage tube from the receiver assembly. Despite the apparent complication of the r.f. amplifiers involved, the control of the receiver is simplicity itself, for the 3-gang t.r.f. amplifier condenser is controlled by the left-hand drum dial of Figure 1, while the oscillator condenser is controlled by the right-hand dial. Sensitivity of the t.r.f. amplifier is controlled by the small knob at the lower left of the control panel escutcheon, R₁. This adjustment takes the form of a potentiometer which varies the screen-grid potential of the

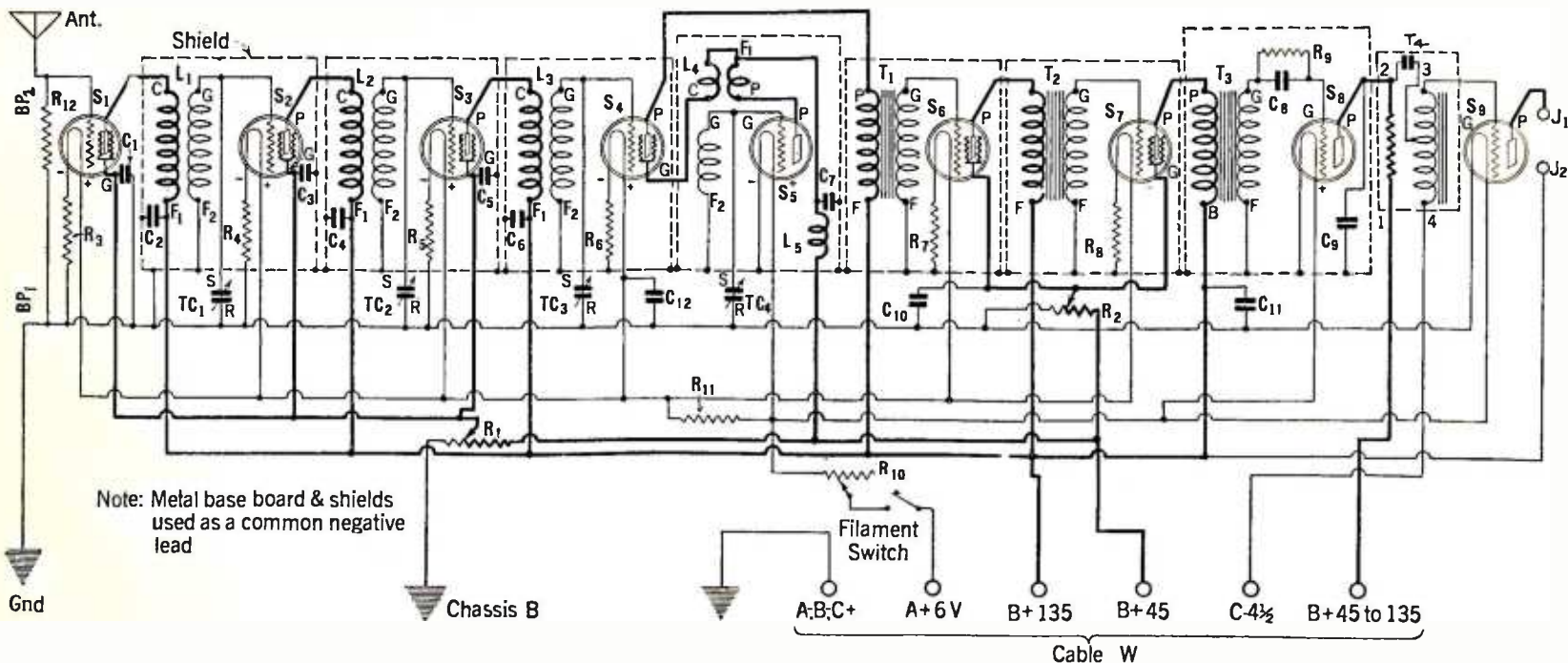

FIG. 2. THE SCHEMATIC DIAGRAM

tubes. A similar potentiometer, R_2 , at the lower right of the control panel escutcheon carries an on-off switch attachment and serves to vary the screen potential of the two intermediate amplifiers. The r.f. amplifier employed is very similar to that found in the 6-tube receiver described upon pages 281-283 of the September issue of RADIO BROADCAST, except that in this super-heterodyne a dummy input tube is utilized to simplify tuning (since there is amplification and sensitivity to spare) and a screen-grid first detector is employed. The 222 tube is used here for a number of reasons, among them the fact that the effective selectivity of the first detector circuit is somewhat greater than would be the case were a 201A to be used with the same circuit arrangement.

The receiver is mounted upon a steel chassis $21\frac{7}{8}$ " long, $9\frac{1}{8}$ " wide, and $\frac{5}{8}$ " deep. At the left end (as in Fig. 4) is the first r.f. tube. Its grid circuit is connected across an antenna resistance, R_{12} , attached beneath the chassis to ground and antenna binding posts BP_1 and BP_2 . This tube feeds the two tuned r.f. amplifier stages utilizing tubes S_2 and S_3 , while S_3 feeds the detector stage including tube S_4 . The three tuned circuits are identical and employ r.f. transformers having secondaries consisting of $98\frac{1}{2}$ turns of No. 29 enameled wire wound upon a threaded bakelite tube in a space $1\frac{1}{2}$ " in diameter and $1\frac{1}{2}$ " long. These secondaries are tuned by sections TC_1, TC_2, TC_3 of the 0.00035-mfd. die-cast gang condenser (each section is equipped with an individual trimmer). The r.f. transformer primaries are wound with 35 turns No. 38 wire upon a $1\frac{1}{4}$ " tube placed at the filament end of the secondary. Individual 10-ohm filament resistors are used for each of the first four screen-grid tubes and the screen-grid and plate circuits are bypassed by $\frac{1}{2}$ -mfd. condensers to provide very short r.f. paths and thus prevent disturbing interstage coupling. In preliminary tests it has been found that

if the plate lead of the detector tube, S_4 , is removed from the P post of the first intermediate-frequency transformer and instead is connected to post No. 2 of the first-stage audio transformer, that the t.r.f. receiver resulting will provide very satisfactory distance reception over a range of several hundred to one thousand miles or more, and selectivity which in itself is considerably greater than that obtained from many ready-made receivers. This arrangement may be resorted to for preliminary testing of the receiver. (While a screen-grid detector tube would not work into an ordinary audio transformer at all satisfactorily, the characteristics of the Clough audio system are such that a screen-grid detector may feed directly into a transformer of this type with a quite satisfactory resultant frequency characteristic.)

The oscillator coil, L_4 , has a grid winding equivalent to the r.f. transformer secondaries and in addition a coupling coil consisting of 35 turns of No. 34 d.c.c. wire on a $1\frac{1}{4}$ " tube and a tickler coil wound in a slot at the bottom of the form consisting of 35 turns of No. 34 d.s.c. wire. The grid winding of the oscillator is shunted by the 0.00035-mfd. condenser, TC_4 , controlled by drum dial D_2 . A small r.f. choke coil, L_5 , is placed directly under the oscillator coil base with its axis at a right angle to the axis of the oscillator

coil. (The oscillator and t.r.f. coils are wound upon moulded S-M plug-in forms which fit any standard 5-prong tube socket.)

In working upon the intermediate amplifier, a number of different transformer designs were evolved and tested, and in the course of this work the possibilities of standard i.f. transformers now on the market were investigated. The S-M 210 transformers which are normally broadband iron core types were found to give excellent results with screen-grid tubes and due to their comparatively small primaries, functioned as rather sharply tuned transformers, giving an amplification of 65 per stage at 65 kc. and a band width of about 10 kc. at forty per cent. of maximum amplification—a quite satisfactory characteristic for an intermediate amplifier.

The intermediate amplifier tubes are S_6 and S_7 , the second detector S_8 , and the three i.f. transformers are T_1, T_2, T_3 . The second detector employs a grid condenser and leak for rectification, while the first detector has really no means provided to effect rectification. While this may seem peculiar, it was observed in operating tests that due to the effect of the impressed oscillator voltage, very satisfactory detection was obtained even though none of the usual precautions were employed in the circuit to insure it. This being the case, it was thought best to take advantage of this propitious condition and discard the usual adjuncts to rectification, such as grid condenser and leak or C battery, which seemed only likely to add complications without any resulting gain to the receiver.

In actual operation this 9-tube super-heterodyne operating into a power amplifier stage has allowed reception of weak out-of-town stations within 10 kc. of any Chicago local station when the receiver was operated in residential districts. In comparative tests against other receivers, it was found that this super-heterodyne would in every case show a considerably higher noise level

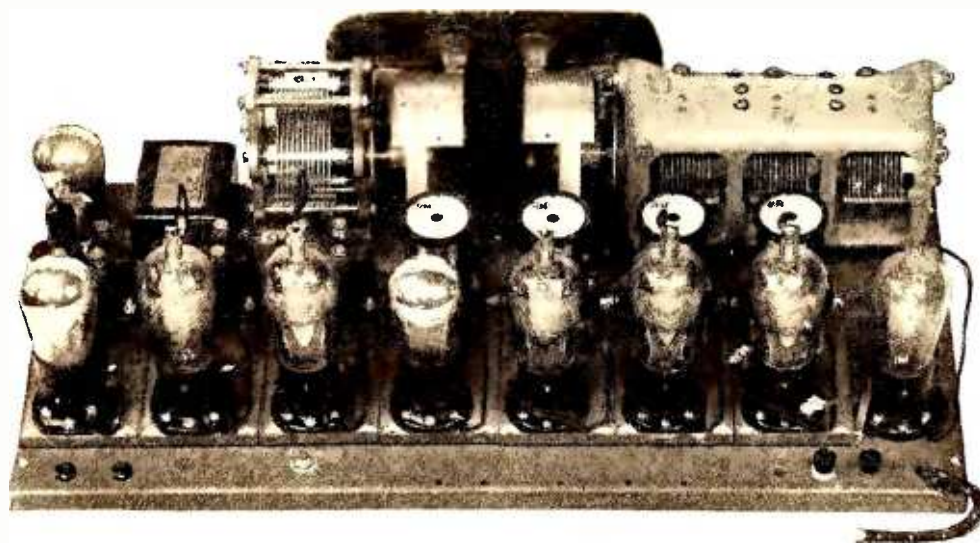

FIG. 3. WITH THE SHIELDS REMOVED

Screen-grid tubes are used in the three r.f. stages, the first detector stage, and the two i.f. stages. A CX-301A tube is used for an oscillator, and 112A tubes in the second detector and first audio sockets.

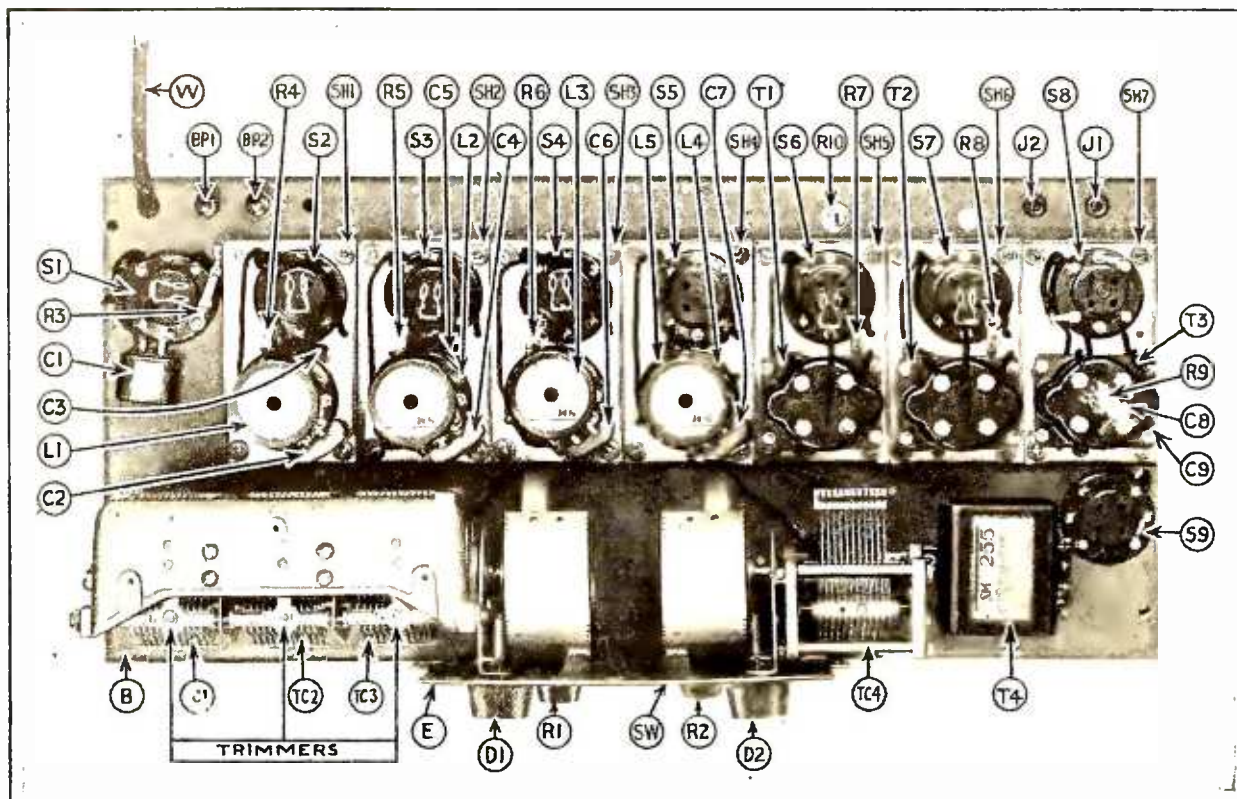

FIG. 4. THE RECEIVER SEEN FROM ABOVE

when adjusted to maximum sensitivity. This condition was thought to indicate a very satisfactory degree of sensitivity indeed—a value so high that it could not be utilized in the warm, summer weather due to the high noise level. During preliminary tests small 50 and 100-watt stations 1000 or more miles away were received with loud speaker volume, and the more powerful stations on the Atlantic and Pacific coasts, and in fact in all parts of the country, were received with excellent volume whenever the noise level was low enough to let these stations be separated from the noise.

CONSTRUCTION AND OPERATION

THE construction of the receiver itself is quite simple. The parts employed in the model described herewith are listed at the end of this article, the listings being accompanied by the designating letters seen in the various illustrations and in the circuit diagram. Despite the apparent complexity of the circuit, the receiver is very simple to put together for it is built up upon a very ingenious pierced steel chassis which is available in the open market. On this chassis, which incidentally is suited to the mounting of a number of different types of receivers, all necessary wiring and mounting holes are pierced so that to assemble the set it becomes necessary merely to put the various parts in the different stage shields as seen in the photographs and then to bolt these stage pans to the chassis itself, along with a few other parts. The wiring is quite easily handled, as all leads are short and direct and the use of the metal chassis as the A minus, B minus and C plus common circuit return eliminates a large number of connecting wires. The only parts mounted beneath the chassis are the three 1-mfd. bypass condensers, C_{10} , C_{11} , C_{12} , the antenna resistance, R_{12} , and the rheostat, R_{10} , (the adjusting screw of which is visible in Figure 4). The connecting cable used simplifies the battery connection to the receiver and eliminates the multiplicity of binding posts ordinarily used for this purpose.

The testing and operation of the receiver is most simple, it being necessary after it has been assembled, wired, and checked, merely to connect

the necessary A and C batteries (or light-socket power units) to the battery cable and then to connect the proper leads of the cable to the B-voltage binding posts of a single-stage power amplifier and B supply. (The receiver may not be operated satisfactorily from dry B batteries, since the current drain on the 45-volt circuit is approximately 30 milliamperes—though the total current drain of the whole receiver is only 40 mA.) A good standard B-power supply should be used for the set if a power amplifier is not employed, though the latter is distinctly desirable since it is never wise in the interests of good tone quality to operate a loud speaker directly out of a single audio stage following a detector tube. Nevertheless, this may be done for test purposes and until the builder can afford an amplifier, for the receiver will give very good loud speaker volume without the use of a power output stage (which should preferably be a 210 or 250 push-pull stage).

In operation, stations are tuned in upon the Selector I and Selector II dials, and volume and stability is adjusted by means of the two small knobs on potentiometers R_1 and R_2 , the set is turned off by turning R_2 to the *off* position. The stations will be received at only one point upon the left-hand dial and at two points upon the right-hand dial. This condition, however, is no disadvantage, for the selectivity of the r.f. amplifier is so great that there is never any possibility of two stations, for which a single oscillator setting will serve, coming through the receiver at one time—the short-wave t.r.f. amplifier absolutely prevents this usual source of super difficulty. This receiver cannot be operated at maximum amplification adjustments except in locations having a most unusually low noise level and under the best of weather conditions, for the sensitivity of the receiver is such that in ordinary residential districts noises not heard on most receivers can be brought in with ear-splitting volume; and of course many weak stations ordinarily not heard come in with them. This, however, is no disadvantage, for by turning down the gain controls of the receiver local programs can be received with quietness, freedom from interference, and satisfying tone quality obtainable from few other radio sets.

LIST OF PARTS

THE substitution of electrically and mechanically equivalent parts may be made in the list below, at the builder's choice. The apparatus in kit form, with all the necessary hardware, is obtainable from several mail order houses, at about \$96.00 list price.

- B—1 S-M 701 universal pierced chassis
 - BP₁, BP₂—2 moulded binding posts, consisting of $\frac{3}{8}$ " screw, nut, and moulded top
 - C₁ to C₇—7 $\frac{1}{4}$ -mfd. midget bypass condensers
 - C₈—1 0.00015-mfd. grid condenser with clips
 - C₉—1 0.002-mfd. bypass condenser
 - C₁₀, C₁₁, C₁₂—3 1-mfd. bypass condensers
 - D₁—1 S-M 806L (left) vernier drum dial
 - D₂—1 S-M 806R (right) vernier drum dial
 - E—1 S-M 809 dual control escutcheon
 - J₁, J₂—2 Yaxley 420 insulated tip jacks
 - L₁, L₂, L₃—3 S.M. 132B plug-in r.f. transformers
 - L₄—1 S.M. 132C plug-in oscillator
 - L₅—1 S-M 275 choke
 - R₁, R₂—2 Yaxley 3000-ohm midget potentiometers, type 53000
 - R₃ to R₈—6 Carter RU10 10-ohm resistors
 - R₉—1 2-megohm grid leak
 - R₁₀—1 Carter A3 3-ohm sub-base rheostat
 - R₁₁—1 Carter H $\frac{1}{2}$ 2-ohm resistor
 - R₁₂—1 Durham 150,000-ohm resistor
 - S₁ to S₈—8 S-M 511 tube sockets
 - S₉—1 Naald 481XS cushioned tube socket
 - SH₁ to SH₇—7 S-M 638 copper stage shields
 - SW—1 Yaxley 500 switch attachment
 - T₁, T₂, T₃—3 S-M 210 long-wave transformers
 - T₄—1 S-M 255 first-stage a.f. transformer
 - TC₁, TC₂, TC₃—1 S-M 323 3-gang condenser, 0.00035-mfd. in each section
 - TC₄—1 S-M 320R 0.00035-mfd. Universal condenser
 - 4 S-M 512 5-prong tube sockets
 - 1 S-M 708 10-lead, 5-foot connection cable
 - 2 S-M 818 hook-up wire (25 ft. to carton)
 - 1 Set Hardware (furnished by Set Builders Supply Co.)
- To make the set operative, the following accessories are necessary:
- 6 CX-322 tubes
 - 2 CX-112A tubes
 - 1 CX-301A tube
 - Power amplifier (210 or 250 push-pull preferable)
 - B-power unit (135 volts maximum)
 - Source of A and C voltage

THE MARCH OF RADIO

NEWS AND INTERPRETATION OF CURRENT RADIO EVENTS

The Low-Power Stations Plead Their Case

AT THE recent series of hearings before the Federal Radio Commission, a hundred stations attempted to show cause why they should be allowed to continue in operation. The evidence proved to be a most comprehensive presentation of the case of the smaller broadcasting station. So eloquently did some of the owners of the condemned stations present their story that many a hard hearted enemy of broadcasting congestion felt that means must be devised to take care of as many worthy local stations as possible. Not only must the rights of listeners to good reception be considered but also that of communities to broadcast.

The whole question is: To what degree shall good reception for the greatest number and the widest areas be sacrificed to the self-imposed wish of a minority of communities to broadcast? No one would oppose extension of broadcasting facilities to any community, however small, did not such a policy inevitably restrict enjoyable listening to that limited number within the high grade service area of a local station. But even disregarding the listener's rights entirely, how many of the insatiable host of radio advertising stations, most of them parading before the commission as altruistic local service stations, could be accommodated were the entire broadcasting band devoted to their exclusive use?

In spite of the obvious local sentiment for the continuance of some of these community stations, the statement remains unrefuted that no great number of them can be taken care of without making high-power broadcasting impossible. From the engineering standpoint, the capacity of the ether is strictly limited to a definite number of stations of a given power per channel, separated by a definite minimum distance. As early as March 24, 1927, a member of the staff of RADIO BROADCAST presented to the Federal Radio Commission a comprehensive plan for broadcast station allocation which definitely appraised the station capacity of the broadcast band and provided for equitable distribution of channels by areas. The plan proposed that the United States be divided into areas 500 miles square, and laid out a definite quota of high-power, regional and local stations of various powers which could be accommodated for simultaneous operation in each area. It pointed out that the Commission's first task was to appraise the capacity of our 89 broadcast channels and then allot their facilities equally to specific areas. Only now is the Commission beginning to do all of these things.

With respect to local service stations, the plan pointed out that 50-watt stations, providing "high grade" service for three miles and "satisfactory" rural service for 22.5 miles, were adequate to meet the requirements of local communities broadcasting for the benefit of a particular city and its environs and would make it possible to provide such facilities for the great-

est possible number of cities. Several stations of that power can be assigned to the same channel, if separated by a minimum of 500 miles. Were all of our 89 channels assigned to this service exclusively, there would be a maximum of 1157 local service stations. The maximum area receiving satisfactory service would be 1,839,630 square miles, or approximately half the area of the

United States. Assuming equal geographic spacing, there would be a carrier on every dial setting of the receiver, but a program of satisfactory strength could be received in half the area of the country on but one dial setting. *The other half of the country would have no "satisfactory" service whatever.* No allotment would be made to higher powers on this basis, so that the listener, tiring of his one local station, could not take advantage of high grade regional stations. The other extreme which could be adopted would be to give virtually no consideration to the rights of communities by assigning all channels to super-power stations endowed with exclusive channels. This would provide a maximum of 89 stations of 50,000 or 100,000 watts. A station of 50,000-watt power has a "high grade" service range of 90 miles and a "satisfactory" service range of 360 miles. The total area receiving "satisfactory" service coverage from 89 such stations would be 36,236,350 square miles. Therefore, were these stations spaced equidistantly, there would be twelve 50,000-watt stations within 360 miles of every point in the United States. The high-grade service coverage would be 13,747,830 square miles. In other words, the listener would have a choice of four stations within high grade service range and twelve within satisfactory service range, no matter where he was located. With 1157 50-watt stations, only 8099 square miles of the United States would have high grade service.

Any plan of allocation is a compromise between these extremes. Either few communities will have radio as a medium of expression, while the listener, no matter where he is located, will have a considerable choice of powerful stations, or else many communities will have opportunity to place themselves on the air for local service while the actual area getting high grade service would be significantly reduced.

The table on this page, taken from *Using Radio in Sales Promotion*, gives the average number of stations per channel, their minimum separation and their service ranges and areas. The average of one and a half stations per channel of 5000 watts is based on the fact that two stations of such power may be placed at diagonal extremes of the United States, while in any other location the 5000-watt station must have an exclusive channel. The table also shows that there is no gain in frequency space by reducing the maximum power from 100,000 to 10,000 watts, or any other such figure, as is often suggested, because a 10,000-watt station takes as much ether space as a 100,000-watt station.

The most important argument against the high-power station is that the total number of radio broadcasting stations in the United States is reduced in proportion to the number of high-power stations permitted. A few large stations naturally tend toward the centralization of broadcasting in a few organizations, because high-power stations are unprofitable unless they draw upon the finest possible program sources and the most fruitful revenue producing programs. The other extreme is in the establishment of many community stations of low power and necessarily of low program merit.

It is our opinion that the low-power station should be encouraged in sparsely populated sections where there is no reasonably good service from high grade stations, but that in populous areas, with many independent broadcasting sta-

Station Power in Watts	No. in U. S. per Channel	Separation in Miles (min.)	Range Miles		Area Served Sq. Miles	
			High Grade	Satisfactory	High Grade	Satisfactory
50	13	500	3	22.5	7	1590
500	3	1250	10	65	314	13,273
5000	1.5	3000	30	160	2827	80,427
50,000 or over	1	6000	90	360	154,470	407,150



JUST BEFORE MAKING RADIO HISTORY

At Signal Hill, Newfoundland, Senatore Marconi, in the center, Mr. G. S. Kemp (left) and Mr. P. Paget (right) are pictured with a basket containing a balloon that they hope will carry an antenna on which to receive radio signals from Poldhu, England, Time: December, 1901. The balloon was carried away in a gale, but a kite was used, and the historic letter "S" came through from England—the first transatlantic radio signal ever received.

tions, the standard should be reasonably high. Radio, after all, is not for the benefit of the broadcasting station management or owner, but for the listener. To the average listener it represents a greater sacrifice to restrict the range of regional and national stations, a real program loss to immense areas, than to lose the chamber of commerce and the local glee club program, indifferently released by an inadequately financed and low-power local broadcasting station.

The evidence brought before the Commission in behalf of the local stations was almost entirely drummed up by the station managers themselves and tended to produce an exaggerated conception of their local service, not always shared by the listeners. The large, loyal followings and the program merit of the high grade, high-power stations is axiomatic and has never required substantiation in the form of affidavits by politicians. Let us place the right of the listener to hear above that of the politician to shout.

SPECIFIC EVIDENCE FOR THE SMALL STATION

MOST of the evidence brought before the Commission was in the form of impassioned speeches by station owners, supported by local politicians. Senator Curtis of Kansas, for instance, swore out an affidavit in behalf of WGL of New York City, a station notorious for consistently wretched quality of transmission and mediocrity of programs. The one occasion on which it really attracted attention to itself was when it proposed to broadcast the mutterings and shriekings of the inmates of an insane asylum. With such examples as these, the Commission undoubtedly discounted greatly any evidence put into the record by politicians whose objective was obviously to win local sentiment rather than to help broadcasting.

Some stations were able to show specialized local service of considerable merit. It is for just such stations that we urge a limited number of local service channels. The fact that good local stations are supported by local advertising accounts is to their credit, in that it assures their economic independence and the fact that, in the opinion of advertisers at least, they have substantial audiences.

In the most unfortunate plight were those stations charged with excessive frequency deviation. Some of these were able to show that they employed the utmost diligence in checking their frequencies against crystal oscillators purchased from companies of the highest repute. Because the crystals were inaccurately calibrated or because months were mysteriously required for their delivery to the station, these stations had no means whatever of maintaining themselves upon their assigned frequencies. Their difficulties were further complicated by the fact that, at the higher frequencies, stations are assigned with closer geographic spacing and the effects of deviation are more disastrous as the frequency increases. In so many instances were the sta-

tion's troubles laid at the doors of incompetent crystal grinding that alarmists were ready to charge that a conspiracy was on foot to destroy smaller stations by supplying them with inaccurately calibrated crystals.

Without an accurately calibrated crystal, it is impossible to maintain a station on its frequency. Only by diligent observation and constant checking against an accurate crystal can a station maintain its correct position in the broadcasting spectrum at all. Occasional deviation is unavoidable; consistent deviation inexcusable. The present standard of 500 cycle maximum deviation is reasonable, but license revocation for a few violations is entirely too drastic a measure in the present state of the art. Suppliers of crystals, in a position to grind them to the accurate requirements of broadcasting, are few in number. Instead of accepting the responsibility attendant upon that position and giving the substantial aid they might to the conscientious broadcasters, these few suppliers allow months to pass between the acceptance and filling of an order and are not above blaming the Government's measures, rather than the defects of the crystal, when a crystal is found to be off frequency.

Regulations for Television and Picture Transmission

CONSIDERING the rapid spread of picture broadcasting from coast to coast and the known intention of a great many additional broadcasting stations to undertake television and the broadcasting of radio pictures-

this fall, the Commission's announced intention to apply regulation to this new form of program is a matter of general interest to the broadcast listener and the management of broadcasting stations.

There are two classes of image transmission to consider: (1) those systems involving the use of the conventional radio telephone broadcasting equipment, capable of radiation upon the standard broadcast channel without infringing upon neighboring channels; and (2) those using new methods of transmission and attempting the radiation of an excessive number of image impressions so that they radiate signals audible on neighboring channels.

Before regular audiences are established for the latter type, which appears to include every attempt at television transmission so far made, regulatory orders should be issued which definitely limit all transmission in the broadcast band to a maximum channel width allowable without interference with neighboring channels. The Commission would be placed in a most embarrassing position if it found broadcasting disrupted by television signals, after thousands of listeners had equipped themselves with scanning discs and neon tubes in the attempt to receive these signals as television images. There should be no attempt to throttle the development of television, but traffic evils in the ether cannot be safely disregarded. The Commission is fully empowered by the Radio Act to "regulate the kind of apparatus used with respect to its external effects and the purity and sharpness of the emissions from each station and from the apparatus therein." It may therefore require that transmissions in the broadcast band be kept within definite 10-kilocycle limitations. Certain television transmissions in the broadcast band can now be heard twenty, thirty and even fifty kilocycles above and below the channel assigned to the station radiating them.

As for picture transmissions, however, which do not involve any new character of signal with respect to "external effects and purity and sharpness of emissions," the Commission's jurisdiction is limited to their bearing upon public convenience and necessity. Picture transmissions made with the conventional radio telephone broadcasting stations are purely matters of program. They are for a special class of broadcast listener whose radio receiver has a picture-making attachment, but these listeners are no more a special class than are owners of farms for whom special farm programs are radiated, or foreign language groups which are often favored by special programs of no interest to any other listeners.

The Commission is distinctly barred from regulating radio programs. It is doubtful whether the Commission may prescribe that a station shall not serve those of the radio audience desiring to receive pictures except within certain limited hours, any more than it may restrict the time devoted to philosophical lectures, jazz music

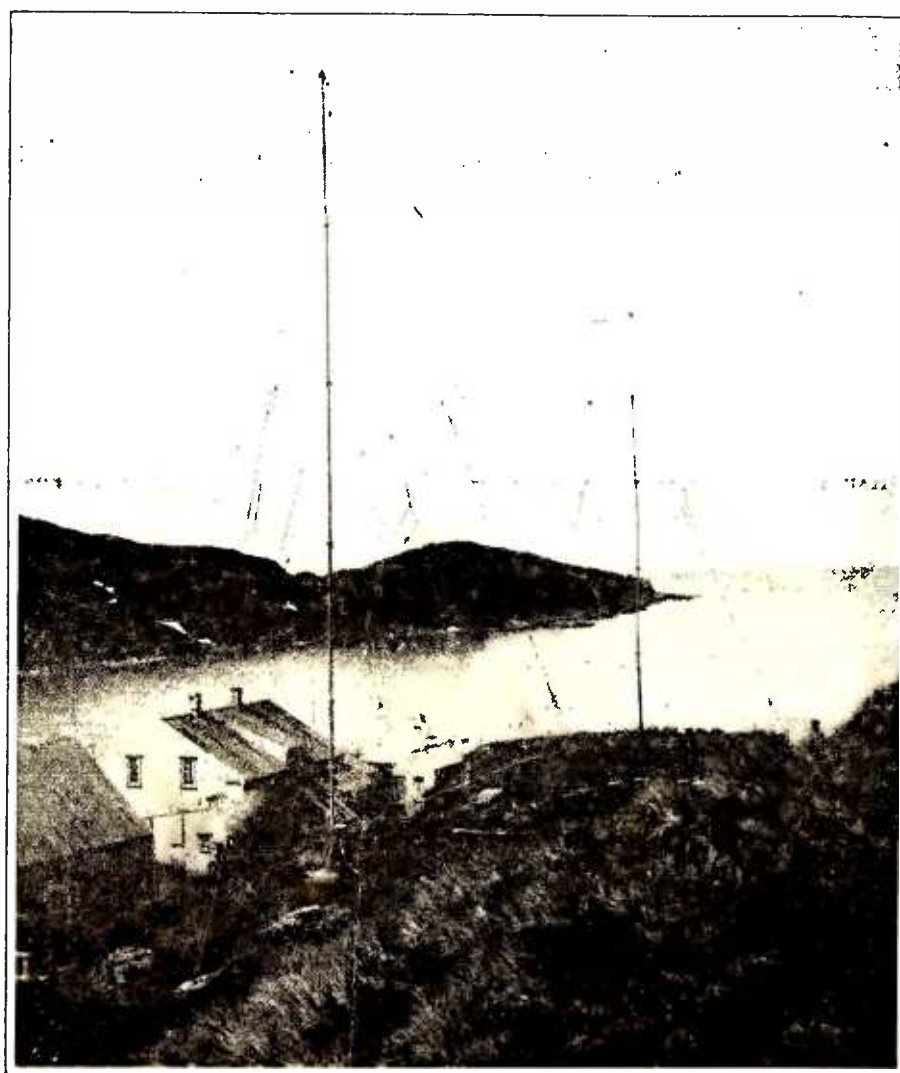

THE MOST SOUTHERLY STATION

Until Commander Byrd gets to work in the far south, this station at Prince Olaf Harbor, South Georgia, will have the honor of being the most southerly of radio-telegraph stations. It employs a 500-watt Marconi telephone-telegraph transmitter, and it is used to control the movements of whalers in antarctic waters. This photograph was taken in the summer, when for a short time the snow partially disappears and a few plants may be seen.

or direct advertising. Picture broadcasting is a general service of pictures into the home. For the present, this is a service principally to experimenters and pioneers—the same class which initiated the broadcast boom in 1920—and it is unfair to pass special regulations restricting the service to that growing group.

However, in one sense, the desired objective of the Commission to restrict picture signals to hours such that the public, seeking musical entertainment, shall not be too frequently disturbed by picture signals, has already been attained. Ninety per cent. of all picture transmissions take place during daylight hours when the stations involved have heretofore been customarily silent. No program director is prepared to force picture signals upon an audience predominantly interested in tone reception, especially between the hours of eight and eleven in the evening, and the maximum weekly schedule of the stations now broadcasting pictures through out the United States involves less than twenty minutes of actual picture signal per week. This is certainly not too great a concession to the experimenter who looks forward to the day that illustrated radio programs will be received in every broadcast listener's home. In spite of the doubtful validity of a regulation applying program restrictions, there is really no opposition to the Commission's proposed course in limiting the number of picture transmissions permissible.

Here and There

THE Army Air Corps, according to F. Trubee Davison, Assistant Secretary of War for Air, will install radio beacons at Mitchel Field, N. Y., San Francisco, Cal., San Antonio, Texas, Uniontown, Pa., Dayton, Ohio, and Washington, D. C. Experiments prove that the range of these beacons may be extended up to 2000 miles, if required.

CHIEF Radio Supervisor W. D. Terrell has issued an order to amateur and experimental stations, effective October 1, that they use the intermediate "w," if located in continental United States, and "k," if in our territories or insular possessions, in accordance with the plan adopted by the International Radio Telegraph Convention.

A STUDIO is being installed in the new administration building of the Board of Education of Pittsburgh, Pa., in order that educational programs may originate there for radiation by KDKA. Practically every school in Pittsburgh has been equipped with a receiving set and, at specified times, lessons on a particular subject will be broadcast to all pupils of all schools of a certain grade. Educational work of this nature has been carried on in England for several years. More than 4000 schools in London and Daventry are equipped to receive programs radiated through the British Broadcasting network.

Another experiment along educational lines was conducted for a period of six weeks last season by WEEI of Boston, and will soon be resumed on a more elaborate scale. From one to one-thirty o'clock on Tuesday and Thursday afternoons, the students of the S. A. Day Junior High School of Newtonville held classes in the assembly hall before the loud speaker. The success of the project was so marked that many schools were equipped with radio receivers during the summer. The subjects taught last season were French, poetry, music, science, history, and geology.



HOW IT'S DONE IN JAPAN

Nipponese broadcasters use Western apparatus (in this case a Marconi 10-kilowatt transmitter), but they manage to create the atmosphere of a Japanese print even in so mechanistic a background as this. The photograph shows the modulator and amplifier panels of Station JOBK at Osaka, one of Japan's leading broadcasting stations.

CONTRIBUTIONS ranging from fifty cents to two dollars were received by Tex Rickard as expressions of thanks from members of the radio audience for making possible the broadcasting of the Tunney-Heeney fight. Rickard, upon receipt of these donations, expressed the opinion that they were evidence that the broadcasting companies have been receiving something good for practically nothing for a long time. His contract with the N. B. C. soon expires and the probabilities are that Rickard's peace conferences will not be broadcast for some time to come. Eventually, however, a commercial sponsor will probably be found for them.

THE Columbia Broadcasting System has concluded arrangements with Station WABC, operated for some years by A. H. Grebe & Company, to become its alternate New York key station on the evenings that WOR is not available. Columbia chain programs have thereby become nightly affairs. WOR has also relinquished Sunday afternoons and evenings in favor of WABC.

ADVERTISERS are spending from ten to twelve million dollars yearly in presenting good will programs through radio, according to Frank A. Arnold of the National Broadcasting Company. This, it seems to us, is greatly underestimated, since it does not take into account the money spent on local stations for advertising announcements.

THE number of stations deleted from the list of broadcasters as a direct result of the notification to show cause, served on 164 stations, amounted to but 36. All but 57 of the cited stations appeared at the hearings with witnesses and affidavits, and 21 stations filed affidavits by mail.

CAPTAIN S. C. HOOPER has been made Director of Naval Communications to succeed Rear Admiral Craven, who has been made commandant of the naval training station

at Great Lakes, Ill. Captain Hooper has been temporarily assigned to the Federal Radio Commission as short-wave expert.

A LIST of frequency assignments for special services on short waves was announced by Captain Hooper, just prior to his appointment as Director of Naval Communications. Six channels were reserved for communication between airplane and ground stations; five channels for communication between ships, ship-to-ship and coastal stations by radio telephony; one channel for police departments; three marine calling frequencies; two groups of frequencies comprising eleven channels for experimental purposes; five for geo-physical purposes; six for railway communication between engine and caboose; four for scientific expeditions and yachts, in addition to their usual calling frequencies; three for portable stations and twenty for power line control. This latter generous allocation should certainly satisfy the power companies.

APPEARING before the Federal Radio Commission on May 14, 1928, to request a great number of 100-kilocycle width channels for television purposes, Dr. Alfred N. Goldsmith of the Radio Corporation of America stated: "Radio television is at a stage where it is prepared to leave the seclusion of the research laboratory and to enter into the daily affairs and uses of men. Intensive development work of an experimental nature has already been carried on and transmission of television material is at hand through confidential experiments and transmissions carried on at Schenectady, Pittsburgh, and New York. In other words, television is not a vague and remote project, but, while still experimental, is an imminent and plausible possibility."

After pointing out that uninformed television broadcasters would transmit an endless series of unsatisfactory pictures which would benefit only oculists in the proportion that they would ruin the eyesight of the public, Dr. Goldsmith continued: "In the interests of saving both the

vision and the television of the public, only an experienced and responsible organization, such as the Radio Corporation of America, should be granted license to broadcast television material, for only such organizations can be depended upon to uphold high ideals of service." If these statements are universally accepted, all but the R. C. A. will quit the television field.

AMONG the suggestions made for increasing the number of local communities which may be represented in the ether by broadcasting effusions, came one from Senator Edwards of New Jersey to the effect that 25 channels be set aside for stations of 5000 watts power or more, leaving 52 channels for 500-watt stations and 12 channels for stations of 250 watts power shared with Canada. The average number of 500-watt stations which can be accommodated on a single channel is not higher than three, although there is a theoretical maximum of six, so that the Senator's plan provides for about 150 500-watt stations and for from 25 to 50 stations of greater power. The seemingly liberal plan therefore represents an even more drastic cut than that proposed by the engineers.

IN THE appointment of Louis G. Caldwell of Chicago as Chief Counsel for the Federal Radio Commission, and Dr. J. H. Dellinger, former Chief of the Radio Division of the Bureau of Standards, as Chief Engineer, the Commission has recruited to its ranks two of the most eminent and competent men in their respective lines. Caldwell, who is in no way related to his namesake, the Commissioner for the first district, has made a most exhaustive study of radio law and has represented important broadcasting interests. Dr. Dellinger's reputation as a scientist requires no rehearsal to any radio enthusiast. He has been a public servant for many years and, unlike most of those few qualified to act in an advisory capacity on technical matters to the Commission, has no former association which might be deemed a disqualification by radical persons.

THE Bell Telephone Laboratories demonstrated, on July 12, a new photoelectric cell which is considerably more sensitive than any similar device so far shown publicly. The original television transmitter and receiver, demonstrated over a year ago, were used in the newer demonstration, and by application of the more sensitive photoelectric cell, a full size figure in motion was successfully televised. The new cell greatly increases the range of vision of the eye of television and places even greater emphasis on the still unsolved problem of conserving the frequency or channel space required to transmit a television image of sufficient detail to have real entertainment value.

A NEW Japanese broadcasting station has been opened at Kumamoto of 10 kilowatts power, operating on 380 meters. The call letters are JOGK.

OUR commercial attaché in London reports that an American radio receiver, having five tubes, delivered at London at a cost of forty-five dollars, must then pay royalties of fifteen dollars to the Marconi Wire-

less Telegraph Company. These royalties tend to curtail American radio exports to England. American exports in 1926 to that country amounted to \$55,375 in sets and \$34,089 in tubes.

IMPROVEMENT in the naval communications system is indicated by the fact that the average time of messages between the Pacific Coast and the Philippines has been reduced to one hour and fourteen minutes in May, 1928, as compared with seven hours and five minutes, the average obtaining in June, 1926.

THE Radio Communications Board of the Philippines decided to issue licenses only to short-wave telegraph stations for remote districts where the services thereby established will not compete with that offered by the Bureau of Posts. Seven stations will soon be placed in operation by that body.

RECOGNITION of radio broadcasting as an agency for political propoganda has been accorded by the major political parties through the appointment of Joseph Israel II as radio director for the Democratic National Committee and O. P. Gascoigne to a similar office for the Republican National Committee.

BEGINNING with a single installation in June, 1925, the Lighthouse Service now has in operation twenty radio beacons along the shores of the Great Lakes. In fair weather, these stations transmit signals four times daily for a half hour, permitting the taking of compass readings. During heavy weather, they maintain a continuous compass service.

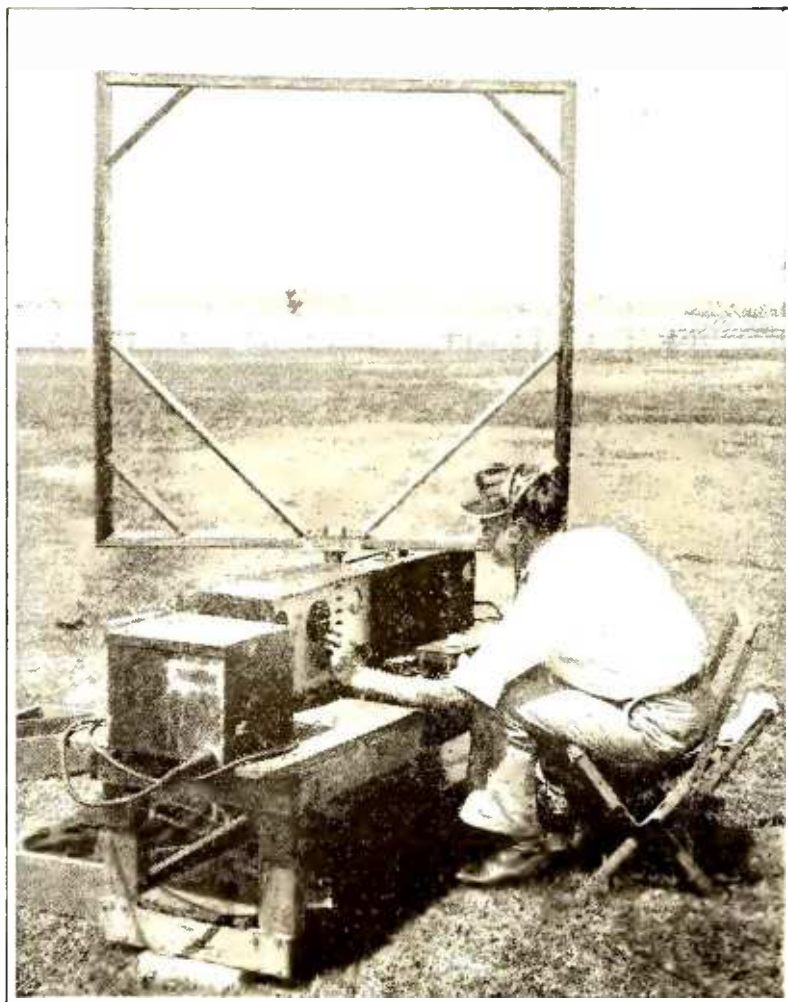

WHAT'S DOING ON THE POTOMAC

This open-air laboratory is part of the Bureau of Standards equipment for testing the field strengths of broadcast transmissions, in an effort to help in unraveling the present station allocation muddle. The transmitter is two miles to the south, across the Potomac near Washington, and the engineer is making a record of the field strength of various broadcasts.

A COMPANY has been formed in Sidney to take over the control of two local broadcasting stations which were suffering from lack of program variety and tendency to duplicate features. This is the first step in merging all Class A stations in a single system. It is said that only the state-controlled station at Queensland will remain outside the pale, if the plan of the new company is successful.

THE International News Service expects to exchange press reports with Europe from a station to be located at 59th Street in New York City. Reception will be conducted at Leafields, where re-transmission to all parts of Europe is possible. The United Press will not attempt to use radio in competition with existing communication systems, but will utilize its station at Garden City for expeditions, important broadcasts and similar special services.

AT A meeting of the International Circulation Managers Association, it was brought out that radio summaries of news features helped newspaper circulation, but that radio has cut the sales of extras on important scheduled events, such as prizefights and baseball games.

ONE million shares of Baird Television, Ltd., at five shillings a share, were subscribed to by the English public recently. These shares have risen in value upon circulation of a rumor that the American rights to Baird Television had been purchased. This public support of the issue appears surprising in the absence of any regular broadcasting of television images, and in the face of the hostile attitude of the British trade press, which issued an unanswered challenge to Baird to make a public demonstration of television by radio, posting a prize of five thousand dollars.

A Delaware charter has been filed by the American Baird Television Corporation with a capital stock of a million shares of no par value. No doubt the public will soon be invited to participate in this enterprise, possibly in advance of any demonstration of Baird equipment.

LICENSED broadcast listeners in Germany on April 1, 1928, totaled 2,234,732, as compared with but 2000 on January 1, 1924. The license fee paid by these numerous listeners amounts to fifty cents a month each and the government budget for the support of the nine broadcasting stations maintained in that country amounts to \$12,500,000.

THE British Broadcasting Corporation showed a total income of \$4,508,130 for 1927, of which about four million was from licenses and the balance from publications and other sources. Of this revenue, \$2,438,640 was spent for program material. The system was on the air during the year for a total of 68,000 hours. There were 20 hours of break-down. The number of listeners amounted to 2,395,174, an increase of 217,000 over the previous year. Apparently, the numbers of listeners in England and Germany are about equal, but three times as much money was spent in serving the German system as the British.

—E. H. F.



*The Master
Hi-Q Receiver
in Its Cabinet*

The "Hi-Q 29"—A Receiver with a Band-pass R. F. Amplifier

By D. K. ORAM

Hammarlund Mfg. Co.

IN THE design of a modern broadcast receiver it is conceded that quality of reproduction and selectivity are of prime importance. Also, in most cases, a high degree of radio-frequency amplification is a distinct asset, if it can be secured without loss of stability and without affecting the preceding qualifications. A high-gain r.f. amplifier preceding the detector tube increases the sensitivity of the receiver as a whole. Great sensitivity is highly desirable from two standpoints. First, it enables the set owner to receive programs from very distant stations when he feels so inclined, and second, it makes possible quite satisfactory reception from local and moderately distant stations on a very short indoor antenna even in unfavorable locations.

Unfortunately, these three prime requisites of a fine receiver, quality of reproduction, selectivity, and sensitivity, are by no means independent of each other. For example, the modern high-quality audio transformers now available make possible the construction of a practically perfect audio amplifying system. If a power tube is used in the last stage of such an amplifier and its output fed into one of the better type speakers, the audio amplifying and reproducing system leaves little to be desired. However, this system can only amplify and reproduce what is fed into it by the detector tube, which in turn receives the signal from the radio-frequency amplifier. Hence it is evident that even a perfect audio system cannot provide a high quality output from the loud speaker if distortion is introduced in the r.f. amplifier due, let us say, to excessively sharp tuning, technically known as "side band cutting."

In the same way selectivity and sensitivity are incompatible. One of the reasons for this condition is not generally understood, and is even more seldom taken into consideration. The average receiver owner or experimenter bases his judgment almost entirely on the "apparent" selectivity. This is quite natural, in view of the fact that the actual selectivity of a receiver can only be determined by a series of very careful measurements. The apparent selectivity of the

OLD timers in the radio game who remember the difficulty in getting a lot of current into the antenna without the double humped resonance curves which usually resulted from their efforts may be shocked to learn that a use has been found for such broadly tuned circuits. Since Dr. F. K. Vreeland gave his paper on band selector circuits before the I. R. E. we have been waiting for the receiver that would put into practice such ideas, which consist briefly in making use of the "flat top" tuning effect of closely coupled tuned circuits or of the "staggering effect" of several circuits tuned to slightly different frequencies.

The present Master Hi-Q receivers employ two band-pass filters—that is, two circuits tuned to the same frequency and coupled together, with the result that the resonance curve is very flat over a range of frequencies controlled by the constants of the circuit and with very steep sides, so that unwanted stations have more than usual difficulty in making their presence heard.—THE EDITOR.



ordinary radio set decreases as its sensitivity increases. Therefore, of two receivers having exactly similar "actual" selectivity and one having, say, three times the sensitivity of the other, the set having the higher sensitivity (or amplification) will invariably seem broader or less selective. This principle is very clearly shown in Fig. 1. Curve A is the response curve of the less sensitive receiver when tuned to 600 kc. Assuming that no 600-kc. station is on the air at the time no sound will be heard from the loud speaker, as the sensitivity of the set is not great enough to bring the 580-kc. station (which is assumed to be on the air at the time) above audibility. Curve B represents the response characteristic of the more sensitive receiver, and under the above mentioned conditions the 580-kc. station will now be heard, since the increased amplification of the more sensitive receiver is sufficient to bring the signals above audibility. Thus it is quite easy to understand why the more sensitive of the two sets will appear to be

less selective, although in reality one is equally as selective as the other.

THE ADVANTAGE OF THE SCREEN-GRID TUBE

THE new 222 type screen-grid tube with its high amplification factor and extremely low plate to grid capacity would at first glance seem to be ideal for use in r. f. amplifiers. The manufacturers of these tubes state that a voltage step-up of forty or more per stage is obtainable at broadcast frequencies. In addition the plate-to-grid capacity is said to be of the order of one-fortieth of a micromicrofarad or about one-four hundredth as great as that between the plate and grid of the 201A type tube. Therefore the appearance of the screen-grid tube, with a capacity so small that neutralization is unnecessary, was welcomed by set designers, and many circuits using them made their appearance. Many of these sets did have enormous amplification, making possible quite satisfactory reception on very short antennas. The selectivity of these sets, however, left much to be desired—so much so that the tube acquired the reputation of causing broad tuning.

In planning the set to be described the natural advantages of the screen-grid tube were carefully considered, and the various methods of overcoming the apparent disadvantages were also investigated. Two stages of r. f. amplification were decided upon as sufficient, as they could reasonably be expected to produce an overall voltage gain of more than one thousand. In order to achieve a high degree of selectivity with this amount of amplification some special form of tuning is necessary. The conventional antenna coupler and two interstage t. r. f. transformers were found to be wholly inadequate in the matter of selectivity, although the amplification was good. The tuned plate-impedance coupling condenser and grid leak arrangement specified by the manufacturers of the tube was passed up for the same reason. Calculation showed that it was quite feasible to tune both the grid and plate circuits of these screen-grid tubes. This is one of the marked advantages of this type of tube, since an attempt to tune both grid and

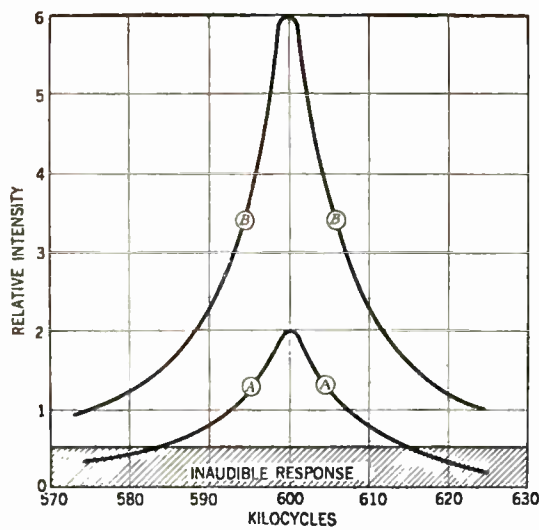

FIG. 1

plate circuits of an ordinary amplifier tube invariably results in uncontrollable self-oscillation. When both grid and plate circuits are tuned a two stage r.f. amplifier has a total of five tuned circuits, including the grid circuit of the first tube. This increased number of tuned circuits would naturally provide a marked increase in selectivity. In fact the scheme looked so good on paper that an experimental receiver was constructed embodying these ideas. The circuit diagram of the experimental model was substantially the same as that of the finished receiver shown in Fig. 5. On test, this model performed in a truly remarkable manner, greatly exceeding expectations. The r. f. gain was very good—enough to bring in many distant stations, including one on the Pacific Coast. The selectivity was such that more than a dozen distant stations were received while the local stations were operating. This test was made last May using a 75-foot antenna located in midtown New York.

THE COUPLING TRANSFORMERS

THE remarkable performance of this receiver can best be understood by consideration of the principles involved in its design. The inter-stage r.f. transformers are quite unique, in that they consist of two exactly similar coils. One constitutes the primary of the transformer and is connected in the plate circuit of the preceding tube, and the other coil acts as the secondary and is connected to the grid of the following tube. Each coil is tuned to resonance with the desired signal by means of a 0.00035-mfd. variable condenser. Due to the rather unusual mounting arrangement the mutual inductance or coupling between primary and secondary is very small. However, this does not mean that the energy transfer from primary to secondary is inefficient. On the contrary, when two tuned circuits are coupled to each other, the maximum secondary voltage is obtained when the relation $(2\pi f)^2 M^2 = R_1 R_2$ is satisfied, where f is the frequency to which both circuits are tuned, M is the mutual inductance in henrys, and R_1 and R_2 are the effective radio-frequency resistances of the primary and secondary, respectively. In the case of the coils used in the receiver under discussion the maximum secondary voltage is obtained with a coupling coefficient of the order of one per cent. The physical arrangement of the coils, as shown in Fig. 3, was chosen because it seemed the simplest way to secure such loose mechanical coupling while still keeping the coils close together, thus conserving space.

Due to the inherent characteristics of loosely coupled tuned circuits each of these doubly tuned r.f. transformers really constitutes a band pass filter. This is quite clearly shown in Fig. 2. In this figure is shown the tuning characteristic of one of these double-tuned loosely coupled transformers. The dotted line represents the response curve of one tuned circuit alone, and the solid line that of both circuits properly coupled. It will be noticed that the dotted curve of the single circuit is a typical resonance curve; very sharp on the top at exact resonance and sloping gradually toward zero as the frequency is increased or decreased. On the other hand the solid curve of the double circuit is quite broad and almost flat on the top over about seven kilocycles, but slopes more steeply on the sides and the response approaches zero much more rapidly above and below the resonant frequency. These curves in Fig. 2 are based on actual measurements of one of the new r.f. transformers used in the Hammarlund-Roberts "Hi-Q 29."

While one of these double-tuned r.f. transformers provides an unusual degree of selectivity, the use of two such stages in cascade results in a vast improvement. As an illustration note that the response of an interfering signal at 20 kc. below resonance on the solid curve of Fig. 2 is but 9 per cent. or about $\frac{1}{11}$ of the response at the frequency for which the set is tuned.

This is for one stage only. After going through the second stage, however, the intensity of this interfering signal will have been reduced to $\frac{1}{60}$ per cent., or about $\frac{1}{125}$. At the same time the addition of the second stage does not materially affect the shape of the top of the re-

sponse curve. The top of the curve remains substantially the same as shown in Fig. 2; the sides become much steeper and the response approaches the zero line at a much more rapid rate.

[These percentages, when reduced to losses in τU , give interesting figures. At 20 kc. off resonance, for example, the discrimination of a single resonant circuit—using Mr. Oram's percentages—is 14 τU , while the doubly tuned circuit gives an additional 8 τU or a total loss of 22 τU . When these signals are passed through an additional doubly tuned circuit this becomes 44 τU , and if the antenna stage has a discrimination of 10 τU at 20 kc. the total selectivity factor becomes 54 τU , which is the difference between signals from two stations at an equal distance from the receiver but differing in power by a ratio of 250,000.—THE EDITOR]

The width and flatness of the top of the solid curve shown in Fig. 2 has an important bearing on the quality of the received speech and music. This is due to the fact that broadcast stations do not transmit on a single frequency, but rather on a band of frequencies. The width of the side bands varies somewhat, depending on the transmitter adjustments and also on the type of program being broadcast. They are, however, generally conceded to be about five kilocycles wide for high quality transmission. It is

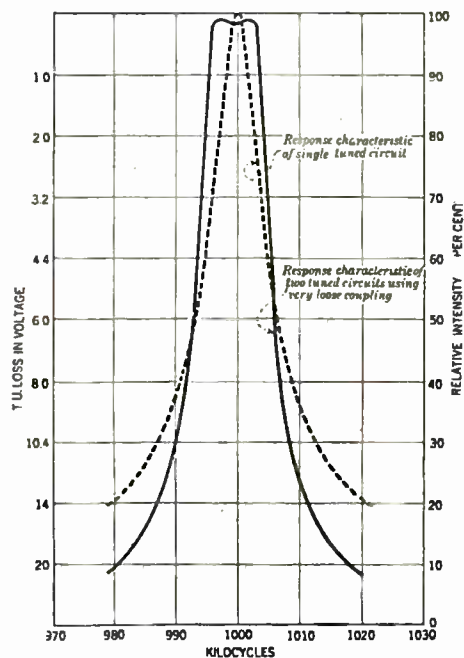

FIG. 2

therefore apparent that the receiver should be capable of amplifying a band of frequencies with substantial uniformity if the program is to be received faithfully. Hence the desirability of the wide flat top on the overall response curve of a high-grade receiver. When the top of the response curve is sharp instead of flat all the frequencies in the band are not amplified equally. Consequently certain of these frequencies reach the detector much stronger than others with the result that even the most perfect a.f. amplifier and loud speaker will be unable to reproduce the program with its original quality.

The two double-tuned r.f. transformers used in the Hammarlund-Roberts Hi-Q 29 necessitate the use of four variable condensers—one to tune each of the four coils. Since all four of the tuned circuits are identical these four variable condensers are rotated by a common shaft actuated by a new model drum dial having a smooth positive drive without backlash. The tuned input circuit to the grid of the first screen-grid tube, often referred to as the antenna coupler, is of the conventional type having a tapped primary making it adaptable to different length antennas. The variable condenser tuning this antenna coupler is on a separate shaft and has a separate drum dial, thus enabling this circuit to be tuned to exact resonance with the received signal.

OTHER DESIGN FEATURES

THE volume control is quite out of the ordinary and is made possible only by the characteristics of the screen-grid tubes. It consists of a

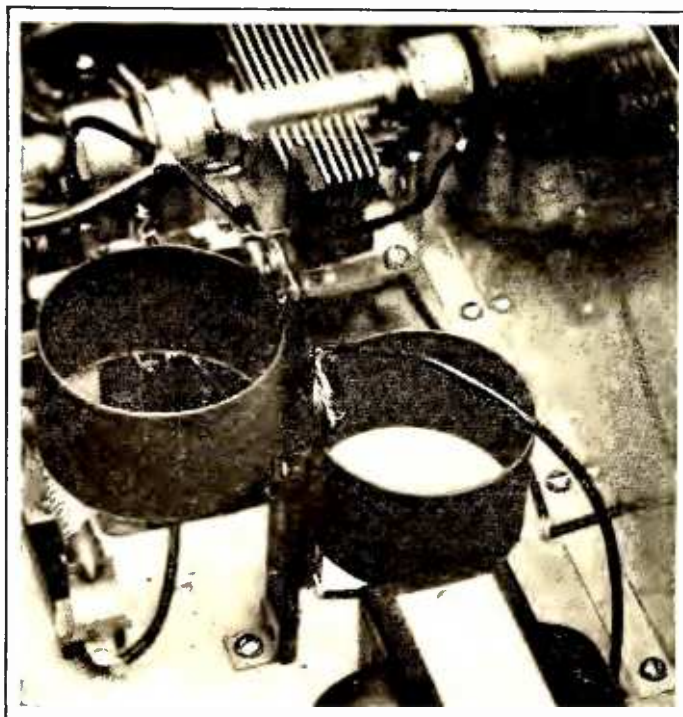

FIG. 3. AN R. F. COIL

Both primary and secondary of this interesting transformer are $1\frac{3}{8}$ " in diameter and $1\frac{1}{8}$ " long, wound with silk covered wire, about 80 turns of No. 28 wire being used. The detector input coil has a tap at about the twentieth turn from the grid end, as indicated in Fig. 5.

100,000-ohm potentiometer, R_1 , connected across the 45-volt B supply. The center tap of this potentiometer provides a variable voltage which is impressed on the screen grids of the two r.f. amplifier tubes. The amplification obtainable from these tubes varies within wide limits as the voltage on the screen grids is varied, being at maximum around 45 volts and dropping rapidly as the screen-grid potential is reduced. This provides a very smooth control of volume within wide limits without affecting quality or tuning in the slightest degree.

While the screen-grid tubes have a very low value of capacity between plate and grid, thus almost entirely obviating the tendency to feedback through the tubes themselves, this advantage is nullified if feedback occurs in other parts of the receiver. Taking this into consideration, every effort has been made to isolate all circuits in which coupling might result in instability. The negative bias for the grids of the r.f. tubes is secured by the drop across individual 10-ohm resistors, R_6 and R_8 in series with the negative leg of each screen-grid tube filament. Since the screen grids of both these tubes are biased by the 100,000-ohm potentiometer, R_1 , 5000-ohm isolating resistors, R_{10} and R_{11} , are inserted in the lead to each of the screen grids, which are in turn bypassed by means of separate 0.5-mfd. bypass condensers, C_8 and C_{10} . The plate circuits of these tubes are likewise isolated by individual filters consisting of separate radio-frequency choke coils, L_1 and L_2 , and bypass condensers, C_9 and C_{11} . In addition to the above mentioned precautions the entire r. f. end of the receiver is thoroughly shielded. Each stage is entirely enclosed in a snug fitting aluminum box which is securely fastened to the metal chassis. The screen-grid tubes are so located that the leads to the control grids are as short as possible and well removed from the plate leads, which are also very short. By placing these tubes between the cans as shown in Fig. 4 the can sides are used also as tube shields, effectively preventing coupling between the tube elements and other parts of the circuit. This arrangement provides the minimum coupling between output and input circuits, which is extremely important.

The audio amplifier is of the conventional type consisting of two stages transformer coupled. The a.f. transformers, T_1 and T_2 , have a very flat frequency characteristic over the usual a. f. range. An r.f. choke coil is placed between the plate of the detector tube and the first a.f. transformer to prevent any stray r. f. voltages from getting into the a. f. amplifier. A 171 type tube is recommended for use in

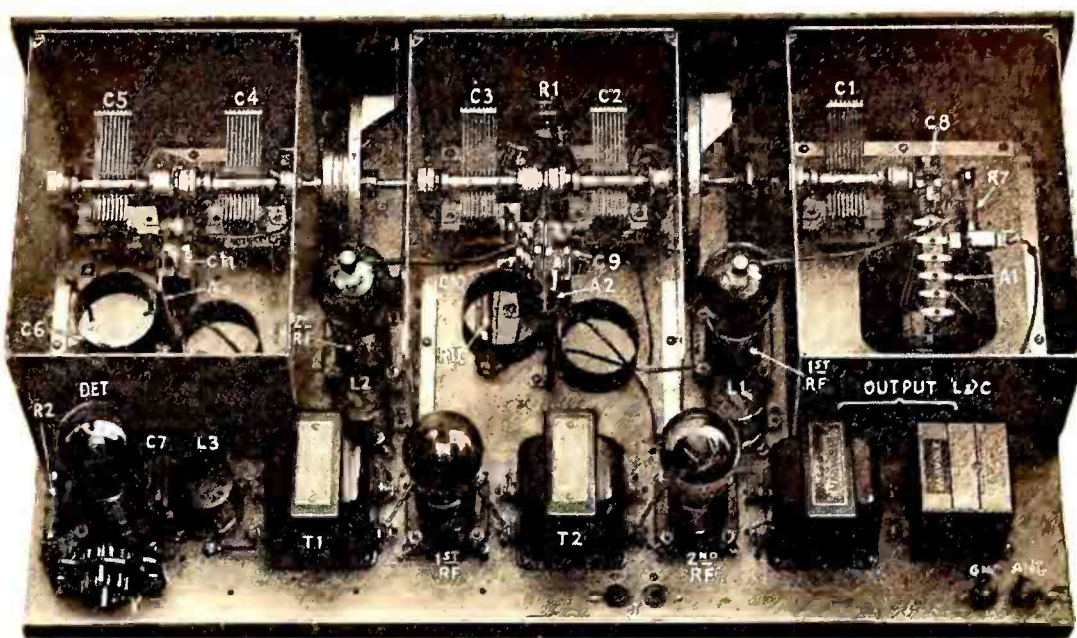

FIG. 4. HOW THE INSTRUMENTS ARE MOUNTED

the last stage, although other types may be used if suitable A, B and C voltages are available.

A. C. OPERATION

ALTHOUGH the above description is based on the battery operated model, a complete all electric model has been developed. Arcurus a.c. screen-grid tubes are used and some slight changes in wiring are required. Otherwise the operating characteristics and set performance of the a.c. and d.c. models are identical. Constructional data on the a.c. model may be obtained from the kit manufacturers, or through RADIO BROADCAST. Fig. 4 is a top view of the a.c. set, which is similar in general appearance to the d.c. model.

LIST OF PARTS

THE parts used in the d.c. laboratory model of the Master Model "Hi-Q 29" receiver are listed below. The coil data is given in Fig. 3 in case it is desired to make these at home. All the other parts are of standard design, and substitution of other makes of equivalent parts may be made.

A_1, A_2, A_3 —1 Hammarlund coil set, No. HQ-29
 C_1 to C_5 —5 Hammarlund midline condensers, 0.00035 mfd., No. ML-17
 C_6 —1 Sangamo fixed mica condenser, 0.00025 mfd.

- C_7 —1 Sangamo fixed mica condenser, 0.001 mfd.
 - C_8 to C_{11} —4 Parvult bypass condensers, 0.5 mfd., series 200
 - J—1 Pair Yaxley insulated phone tip jacks, No. 422
 - L_1, L_2, L_3 —3 Hammarlund radio-frequency chokes, No. RFC-85
 - R_1 —1 Carter "Hi-Pot" potentiometer with switch, 100,000 ohms, No. 11-S
 - R_2 —1 Durham Metallized resistor, 2 megohms
 - R_3, R_4, R_5 —3 Amperites, No. 1-A
 - R_6, R_7, R_8, R_9 —4 fixed filament resistors, 10 ohms (included in foundation unit)
 - R_{10}, R_{11} —2 fixed resistors, 5000 ohms (included in foundation unit)
 - T_1, T_2 —2 Thordarson audio transformers, No. R-300
 - Y—1 Yaxley Cable Connector and Cable, No. 660
 - 2 Hammarlund knob-control drum dials (walnut), No. SDW
 - 5 Benjamin Cle-Ra-Tone sockets, No. 9040
 - 2 Eby engraved binding posts
 - 1 "Hi-Q 29 Master" foundation unit (panel, shields, chassis, shafts, binding post strips, clips, fixed resistance units $R_6, R_7, R_8, R_9, R_{10}$ and R_{11} , resistor mounts, and all special hardware required to complete receiver.)
- To place the set in operation the following apparatus is necessary.
- 2 CX-322 tubes
 - 2 CX-301A tubes
 - 1 CX-371A tube
 - Source of A, B, and C voltage (6 volts A, 45, 90, 135 volts B, $4\frac{1}{2}$ and 27 volts C)

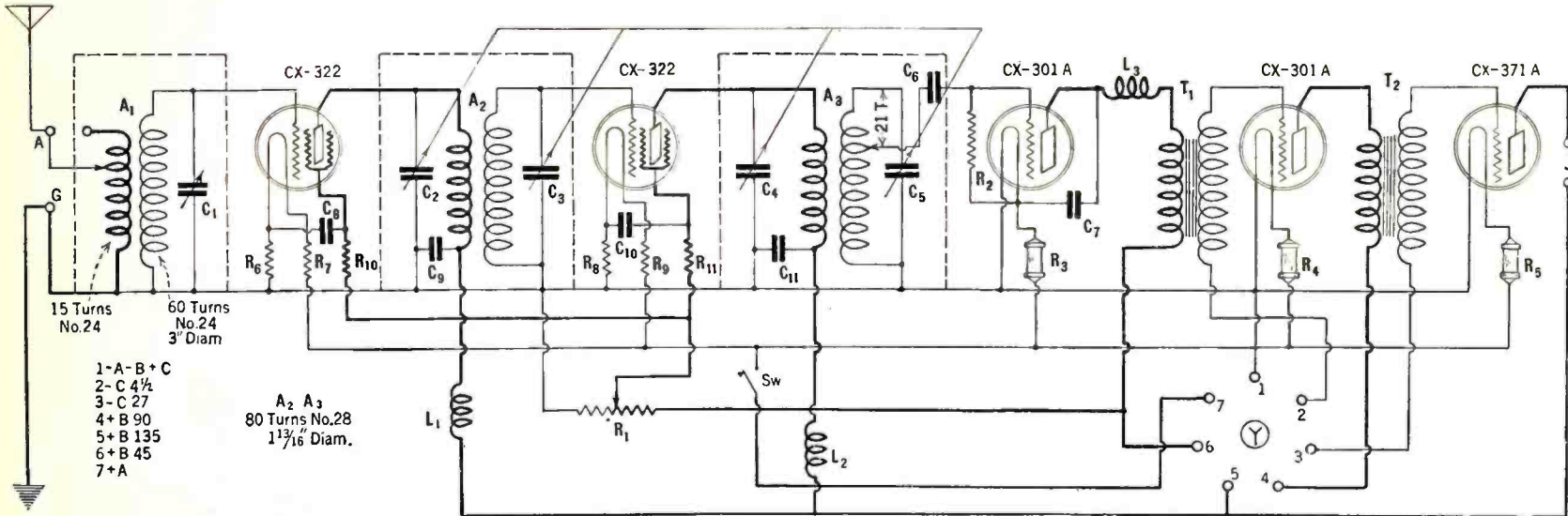
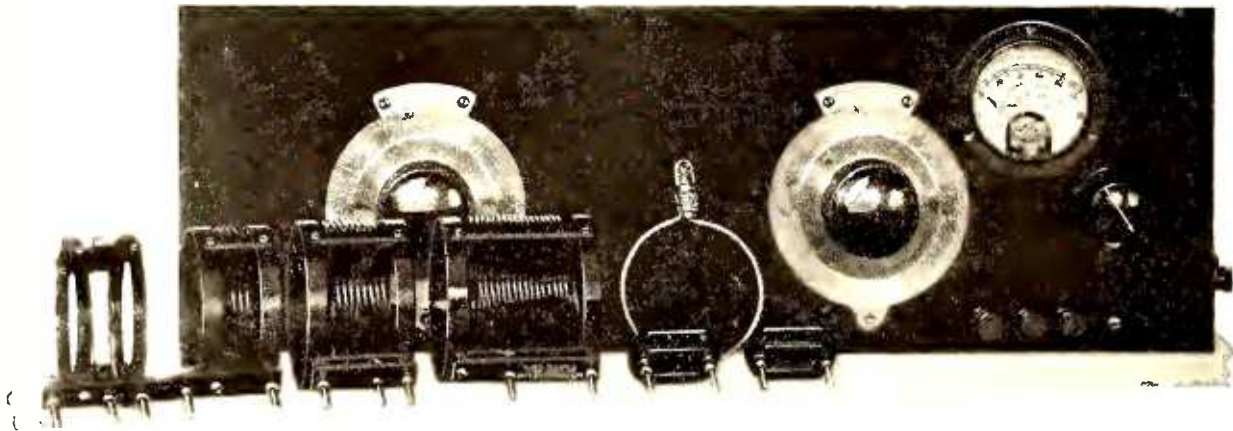

FIG. 5. THE CIRCUIT OF THE "HI-Q 29"

A Short-Wave Transmitter for 1929

By ROBERT S. KRUSE



THE COMPLETED TRANSMITTER

The transmitter is shown here with one set of plug-in coils and condensers (except the 10-meter coils, which are shown in Fig. 2) and with the small loop-and-lamp used testing the oscillator and amplifier circuit.

AMATEURS are a curious lot—years ago they should and could have had just such a 1920 transmitter as Mr. Kruse describes in this article, a transmitter that stays on the wavelength to which it is set, one which delivers a good note, and in which vagaries of antenna height or power supply are prevented from affecting the frequency of transmitted signals. The transmitter is an oscillator-amplifier set-up that can be put on the air “as is” or that can be used with an external r.f. amplifier employing bigger tubes. Or, as a later article will describe, the present apparatus can be modulated by voice and thereby provide rapid communication over medium distances.

—THE EDITOR.

MY GOOD friend H. B. Richmond once said that it is good practice to discount warnings of radio troubles by 90 per cent. in most cases but by 100 per cent. if a complete disaster is announced.

The rule has worked well for four years. It happens that during those four years I have probably written or edited as many stories about American short-wave radio as anyone. For both reasons I have the utmost confidence in applying Mr. Richmond’s entire 100 per cent. discount to the present predictions of the calamities that are to befall amateur radio transmission when the bands are narrowed on January 1, 1929.

There is absolutely nothing to these dangers except state of mind. No legal lightning will strike the transmitting antenna; no one will be arrested for owning a microphone; no startling new apparatus will be needed.

A set not good enough for 1929 was certainly never good enough for 1928; therefore, the set to be described is no more of one year than of the other. Furthermore it is in no way revolutionary except in being so laid out as to permit the use of all of the “practical” bands. Incredible as it may seem, such sets seem not yet to have been built, although their design involves nothing new.

THE “PRACTICAL” BANDS

IT IS necessary at the beginning to gain some understanding of the importance of breaking away from the vicious habit of “choosing a wavelength” or a pair of wavelengths, building a

transmitter for them, and then settling down until removed by force. The active experimenter is not quite as guilty of this practice as the more stationary “message handler.” Unfortunately the beginner is very likely to hear the latter (who is constantly on the air) and to follow him into the unhappy scramble on 40 and 80 meters. As a result howling bedlam exists in those bands and its occupants are sure they cannot spare even one kilocycle from either band, whereas 1929 will cut the 40-meter band from 1000 to 300 kilocycles.

The present situation in the amateur bands, with respect to wavelength allocations, is summed up in Table I, on this page.

Analyzing this table, it seems at first that the available space has been reduced from 15,000 kc. to 7485 kc., and the amateur deprived of half his territory. However, of the 15,000 kc. available to the amateur in 1928, the bands actually used were only 4000 kc., and this includes the almost uninhabited 150–200 meter band. The wavelengths below 10 meters were vacant—some 11,000 kc. of ether space. Now for 1929 the available space on the 10, 20, 40, 80, and 180 meter bands amounts to 3485 kc., and this does not include some 4000 kc. on the 5-meter band which is crying for development.

We see at once that the saddest possible way of looking at the thing is that we will drop from 4000 to 3485 kilocycles. Somehow that outlook fails to depress me. It seems as if the beginner will find quite as much room as before, while the present station owner has but to bring his equip-

ment up to the requirements of a year ago in order to be perfectly ready for 1929.

PRELIMINARIES

THE discussion and the table will have made clear that we should have a set and an antenna capable of operating at a variety of wavelengths. Having set the transmitter squarely on one of those wavelengths we are ready to begin telephone or telegraph transmission with the certainty of reaching someone.

The beginning of the whole business is this ability to set to a known wavelength with a transmitter which will thereafter stay on that wavelength. Since we propose to work in 5 and possibly 6 bands it would be very expensive, complex and time-consuming to do this thing with crystal control, nor is that necessary if a suitable wavemeter is permanently stationed alongside the transmitter.

It is perfectly possible to build a suitable wavemeter, but it is a difficult job even for the experienced experimenter who is assisted by calibration from a quartz crystal or else some new standard frequency schedules from our good friends of the Gold Medal Station wcco-9xl-9wi. It is much more satisfactory to purchase an “amateur band wavemeter.”

While the wavemeter is coming we have time to explain to the newcomer in transmitting what is required in the way of licenses. Two licenses are required, both being issued by the Federal Radio Commission through the various Supervisors of Radio under Mr. W. D. Terrell, Chief of the Radio Division of the Department of Commerce. The first license to be obtained is the amateur operator’s license. One should accordingly write to the Supervisor of Radio for the particular district in which one lives and request information as to the manner of obtaining the operator’s license.

The papers received in reply will explain how the operator’s license is obtained and at that or a future time one is advised as to the station license which will state the station call and also the wavelengths at which it may operate. None of the examinations are hard, nor need any fear be felt with regard to the test on code reception, since the necessary skill can be acquired at odd times by listening to short-wave stations and ships with a plug-in coil receiver. If there is any hurry the thing can be done more rapidly by a

TABLE I
AMATEUR CHANNEL ALLOTMENTS

1928		1929	
Width in kc.	Wavelength in meters	Width in kc.	Wavelength in meters
500*	150—200	285†	175—200
500*	75—85.7	500†	75—85.7
1000*	37.5—42.8	300†	41.1—42.8
2000*	18.7—21.4	400†	20.8—21.4
2000	9.99—10.7	2000†	10.0—10.7
8000	4.69—5.35	4000	5.0—5.4
1000	0.7477—0.7496		Below 5 not reserved
4000 kc. used now		3485 kc. practical	

*Bands used in 1928.

†Bands practicable in 1929.

week or ten days of tutoring with an operator and a buzzer. It is well if the tutor is very steady, and rather undesirable if he is fast, or thinks he is.

THE QUESTION OF POWER SUPPLY

HAVING done with rumors and law we may now get down to radio. There is space in this article neither for the fundamentals of transmission nor for a technical display of equations and curves, and the reader may therefore assume the evil preliminaries to have been completed before his arrival. The circuit of the transmitter is shown in Fig. 1, and is a simple variation of the Colpitts oscillator which permits placing fairly large capacity across each of the tube capacities whose variations ordinarily cause wavelength changes. Even with such a circuit the greatest steadiness is not obtained unless it is protected from the variations of the antenna system and from changes in filament and plate voltage. The antenna variations can be kept from the oscillator (to a very large degree) by interposing a stage of neutralized r.f. amplification; our set accordingly consists of a receiving tube used as an oscillator with a somewhat larger tube acting as amplifier. That idea is, of course, very far from new and has during the last few years been carried out in many forms.

To avoid the effects of voltage variation, the use of the oxide filament type of tube represented by the UX-112, or the UX-201A tube with the thoriated filament, is recommended. Both of these tubes can stand slight variations in filament voltage without much effect on frequency. These are used where storage battery filament supply is used for the oscillator, which is, of course, desirable for the greatest steadiness. Since a storage battery is more or less of a nuisance one may wish to use alternating current filament supply. A wide variety of tubes have been tried on a.c. supply by the author, and *very much* the best, when both steadiness and life are considered, have been the Arcturus Type 28 and Type 30. Please understand that I am not criticizing other small tubes, which are doubtless perfectly good for their normal purposes.

The oscillator plate supply is obtained from a 180-volt battery of dry cells, which can be of the size represented by the Burgess type 2308, or of the larger size. This practice was first hauled out of the laboratory and into transmission practice by Mr. Willis Hoffman of the Burgess Laboratories. (NOTE: A special heavy-duty 108-volt unit cataloged PL-5728 has just been put on the market by Burgess for this purpose.) By providing a very steady oscillator these devices start the whole set off in the right direction.

THE CIRCUIT LAYOUT

THE oscillator may be a 201A, 112, 112A, Arcturus Type 28, or even 226 tube. The amplifier may be a 112, 171, 210, 250, or Arcturus Type 30 tube. Consequently rheostats have been omitted entirely in the diagram and discussions and are to be supplied externally or else built in when the builder has found his pet tube combination. The set as it stands is meant for a 201A, 112, or Arcturus Type 28 tube in the oscillator socket and a 112, 171, or Arcturus Type 30 tube in the amplifier socket. It has, however, been run with a 112 in the first socket and a 210 or 250 tube in the second socket. The operation was satisfactory, but the stopping condenser, C₅ in Fig. 1, in the amplifier plate circuit becomes rather warm at voltages above 300. For regular operation with the 210 or 250 as amplifiers it should be replaced by a Sangamo 1000-volt type. With these changes the amplifier plate voltage may be carried as high

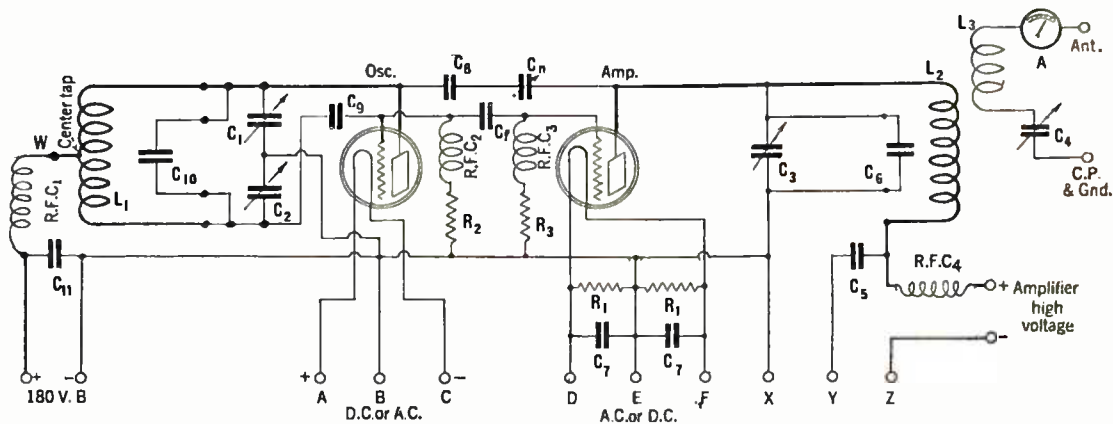

FIG. 1. THE SCHEMATIC DIAGRAM

as 600, provided that a similar change is made in the plug-in loading condensers for the amplifier.

It will be noticed from the photograph at the beginning of this article that the panel shows three peculiarities which may as well be explained now. The antenna meter is a Weston thermo-galvanometer of the well-known model 425 which gives full scale reading with a current of 115 milliamperes. The antenna current is ordinarily much larger and the meter is then shunted by a short piece of wire whose length is found by trial (starting with a very short wire). When working with very short waves in the harmonic manner explained later the current is sometimes very small, but nevertheless the shunt should be in place until one is satisfied that it may be removed without damage to the meter. Secondly, it will be noticed that the antenna tuning condenser, below and to the right of the meter, has no dial. This is my personal preference to which the reader is not bound, though I prophesy he will find a dial worthless. Finally we have the three binding posts which have to do with three methods of keying, of which more later.

Since it is impossible to guess just what sort of a scale the prospective builder desires he is given the opportunity of pleasing himself by so arranging matters that both the coils and the fixed loading condensers are readily exchanged or removed. Thus any one of the coils may be used with or without a loading condenser and additional coils can be manufactured at will on homemade forms or by cutting sections from the 10-turns-per-inch Hammarlund "stovepipe" coils

and equipping them with the same General Radio spring plugs with which those shown are furnished. The coils to be used in the oscillator are center-tapped, the center-tap being brought to a third spring plug for which a socket is added in the oscillator coil mounting. To permit all coils to be used in any position an extra hole is drilled in the amplifier coil mounting to accommodate this plug.

Table 2 shows how all the standard bands can be reached with a set of Aero transmitting coils plus a pair of single-turn copper strip coils such as are shown in Fig. 2 for the 10 meter band. The coils illustrated are about 3 1/2" in diameter. They are made of strip about 3/32" thick and 3/8" wide. All the bands are well spread out on the dial and will be quite O. K. for 1929, especially as the dials can be read to one part in 1000.

On the 10-meter band it is advantageous to use heavy wire or strip in the tuned circuits, not to reduce resistance but to have less inductance in the leads and therefore a bit more in the coil.

It will be noticed that no arrangement has been made for changing the amount of power fed from the oscillator to the amplifier except by making changes in the size of the feed condenser, C_f. Taps on the coil L₁ are a nuisance and are therefore avoided. This does not mean that C_f should be tinkered with after the right adjustment for a given amplifier tube has been found. On the contrary it should be left severely alone thereafter since changes in it will shift the wavelength calibration, which is not serious but rather confusing. C_f may be a small variable condenser but this is not recommended for the reason just mentioned; if a change is really needed the screw terminals of the Sangamo condenser always permit it. A capacity of 50 or 100 mmfd. will meet all needs. For the 210 as amplifier the larger capacity is recommended.

OPERATION

FOR its normal operation the set needs only one meter which is placed in the antenna circuit. One must admit that it would be somewhat more convenient to operate the set during the first few days if at least one more meter were available. However, the receiving set will serve the same purpose, though a bit less conveniently.

Everything being assembled and the filaments lighting satisfactorily, one should begin by removing the amplifier tube and making sure that the oscillator tube does really oscillate. This can be done by listening with the receiving set and tuning either the transmitter or the receiver slowly. They should not be too close together nor should the antenna be connected to either one. If the signal is not found in this way a milliammeter or a pair of phones may be put into the plate supply lead at the point marked W in Fig. 1 and the tuning process repeated. At resonance a click in the phones or a jump of the



THE GENERAL RADIO WAVEMETER

The wavemeter has coils to cover all the amateur wave bands. The small U-shaped coil in the box is for the 5-meter band

meter will be encountered. The phones are to be preferred since with them the observer can recognize the familiar sound occasioned by an oscillating tube. Do not leave the phones in the plate circuit long, even with a 201A, and do not use them at all with larger tubes. Fortunately, such oscillators usually work promptly. If any doubt remains it may be removed with a very simple device consisting of a small flashlamp or a panel light to the terminals of which is soldered a single turn of wire about 3" in diameter. This is hung on the end of the oscillator coil, L₁, and will usually

light promptly unless the lamp is too large or too closely coupled to the coil, L₁. If no light can be obtained with any of the various coils in place everything should be gone over carefully and as a final resort a different grid leak may be tried.

Since the r.f. amplifier is very much like those used in reception it has the same troublesome habit of wanting to go into oscillation.

To make sure of this point one removes the lamp-and-loop from L₁ and hangs it on the end of L₂, after which the oscillator is started but the amplifier plate supply is left off, although it is best to light the amplifier filament. By careful tuning of C₃ it should be possible to cause the lamp to light in the new position. Since the absence of plate supply for the amplifier prevents amplification it is clear that the power is being fed through from the oscillator by capacity effect between the plate and grid of the amplifier tube. This can be neutralized by adjustment of C_n until the lamp is out. The adjustment must be made without bringing the hand near C_n, which calls for some sort of a wooden screwdriver whittled from a dowel or the like. The lamp will probably go out over quite a wide range of C_n. The condenser should accordingly be set in the middle of this space. It is best to repeat the adjustment with several coils and with different settings of C₁, C₂ and C₃ to obtain the best average adjustment.

A SIMPLE ANTENNA SYSTEM

HAVING an oscillator and amplifier in operation, one is ready for the antenna. There is a general belief that to work on five or six wavebands it is necessary to have as many different antennas. Fortunately this is not correct, and a single antenna system of normal dimensions will give a good account of itself on 5, 10, 20, 40, 80 and 180 meters.

An antenna system can be made to oscillate electrically at a variety of frequencies without the necessity of changing its length each time. Thus if we desire to work at 40 meters we need not have an antenna which is "just made" for that wavelength, but can just as well use one which tunes to 120 meters naturally. The third harmonic of this wavelength is 40 meters on which we desire to work.

This is exactly what is to be used with this set—a regular broadcast receiving antenna about 100 feet long from the end of the lead-in to the tip end of antenna. In addition a 75-foot counterpoise will be necessary and a good ground connection. When on the 180-meter band the antenna and counterpoise wires are connected together at the point of connection to the antenna

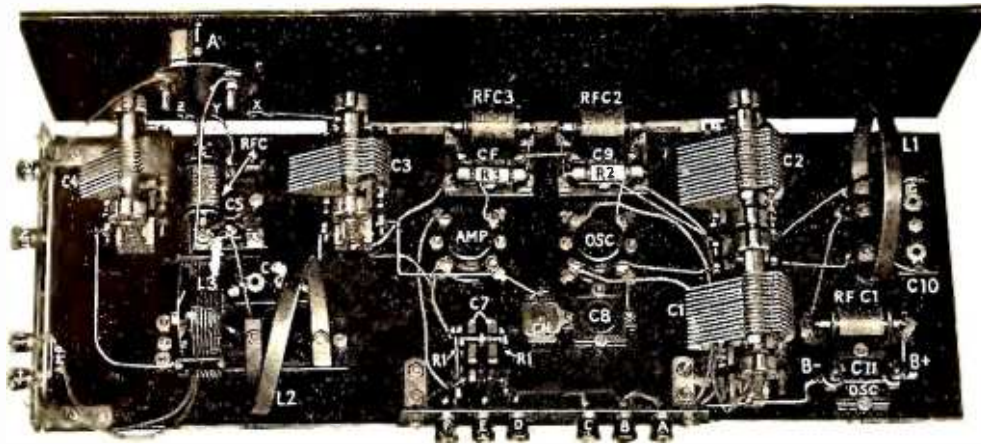

FIG. 2. THE LAYOUT OF PARTS

The coils, L₁ and L₂, are the special coils used for covering the 10-meter band. They are described in the text. Only the plug-in mounts for the oscillator and amplifier loading condensers, C₁₀ and C₆ are shown in this picture

coil L₃, and a ground is attached to the ground post. In addition a small loading coil may be necessary. On the other amateur bands the ground is not used and the counterpoise is attached to the ground post, the antenna to its proper post, and the loading coil not used at all.

The antenna should be 20 feet or more above ground and may be as high as 60 feet. The counterpoise wire should be not closer than 6 feet to ground or any other solid material.

The practical method of getting the transmitter on the air is to tune the oscillator to the desired wavelength by means of the wavemeter, then to tune the amplifier to that same wavelength, as shown by the best response of the wavemeter when placed at that end of the set, and finally to adjust the antenna tuning system so that current shows on the antenna meter.

The movable antenna coil, L₃, is not a device for obtaining the largest possible antenna current, which, as a matter of fact, does not give as good performance as does a slightly smaller antenna current. A rough general rule is to start with the coil L₃ at about 45 degrees and after the largest possible antenna current is obtained by adjustment of the various tuning condensers this coil may be tilted back to a position giving about 80 per cent. of the largest current.

No rule is good in transmitter adjustment until one has checked the result by listening with an oscillating receiver. This should be done without a receiving antenna, and the receiver should not be in the same room with the transmitter. In most cases it will be found that it is preferable to detune the antenna slightly, rather than to secure the 20 per cent. drop entirely by tilting of L₃. An adjustment that is satisfactory on a fair day may not answer through wind and rain. On the first bad day the whole series of adjustments should be checked.

In order to make precise adjustment and reading practical the set is given dials which not only have a smooth slow-motion mechanism (generally miscalled a "vernier") but in addition have a true vernier scale which permits reading to one tenth of one division of the dial scale.

TABLE 2

Band (Meters)	Osc. Coil	Amp. Coil
10	1 turn special	1 turn special
20	3 turn standard	3 turn standard
40	3 turn standard +C	3 turn standard +C
40	8 turn standard	8 turn standard
80	8 turn standard +C	8 turn standard +C
180	16 turn standard +C	17 turn standard +C

C = 0.00025-mfd. plug-in condenser.

MICROPHONE AND KEY

FOR several years there has been a rather tiresome controversy as to the desirability of the microphone and voice against the key and code. It is somewhat hard to see why a controversy is necessary, since both schemes have advantages and disadvantages which every man should be free to weigh for himself. Briefly the phone is rapid but has a relatively short reliable range, whereas the key makes up for its slowness by a very materially greater range and a superior ability to work through interference and static.

This at once suggests the use of phone on those waves which are most reliable over limited distances and the use of the key for longer distance work. There is, however, no reason for being arbitrary about it and I personally feel that an unfairness was committed in recommending the removal of phone from the 20-meter band and its restriction to the top pair of bands, which in effect restricts it to local and semi-local work.

It will be seen that the various factors interlock so that unavoidably one must consider the question of modulation as a whole, including both the key method and the voice method. This will be done in a future article. For the present, however, the transmitter can be put on the air by strapping X and Y (Fig. 1) and keying between them and Z or by strapping Y and Z and keying between them and X. Short key leads are advisable.

LIST OF PARTS

The parts used in the model of the transmitter illustrated are as follows:

- A—1 Antenna meter. Any 0-1 ampere type or Weston model 425 thermo-galvanometer with shunts
- C₁, C₂—2 National Equitune condensers, 0.00025 mfd., ganged on same shaft
- C₃, C₄—2 National Equitune condensers, 0.00025 mfd.
- C₅—1 Bypass condenser, 0.01 mfd. (see text, p. 345.)
- C₆—1 Sangamo mica loading condenser equipped with General Radio spring plugs, 0.00025 mfd.
- C₇—2 Filament bypass condensers, 0.006 mfd.
- C₈—1 Fixed condenser, 0.005 mfd.
- C₉—1 Oscillator grid condenser, 0.0002 mfd.
- C₁₀—1 Sangamo oscillator loading condenser, 0.00025 mfd. See note on C₆.
- C₁₁—1 B-battery bypass condenser, 0.01 mfd.
- C_f—1 Feed condenser, 0.0001 mfd.
- C_n—1 Hammarlund neutralizing condenser
- L₁, L₂—1 Set of plug-in coils as described in Table 2.
- L₃—1 Aero hinged antenna coil
- R₁—2 Carter center-tap resistors, 15 ohms
- R₂, R₃—2 Tobe Veritas grid leaks, 7500 ohms
- RFC₁, RFC₂, RFC₃, RFC₄—4 National type 90 Universal chokes
- ABC—Oscillator filament supply posts
For d.c. connect B & C
For a.c. leave B blank, connect A to D and C to F
- DEF—Amplifier filament supply posts
- XYZ—Control posts. Use for phone and telegraphy
- 2 National Vernier dials
- 2 General Radio sockets, type 349
- Composition front panel, 7" x 21"
- Composition base board, 8" x 21"

The tubes which may be used and the power supply are discussed in the text.

Two Interesting Patents

TWO American patents which should interest technical readers are quoted and illustrated in *Radio* (Berlin) for July, 1928. The first (No. 693,646) is shown in Fig. 1, slightly redrawn, and was issued to Fritz W. Falck of Los Angeles. It is composed of a system to prevent distortion due to core saturation in an audio amplifier. The idea is to use two transformers as shown and to divide the load so that either transformer will be adequate to "separately handle the current without distortion."

The second patent (No. 148,975) given mention in the July issue of *Radio* (Berlin) has been granted to a well known worker in radio fields, Dr. Lewis M. Hull, and consists of a two-grid tube circuit, the second grid being used in connection with an external inductance to impress upon the second grid "a compensating voltage of proper phase and amplitude to oppose feedback currents flowing through the capacities of the tube between anode and control grid."

The diagram in Fig. 1 illustrates Doctor Hull's scheme. It has been seen many times within the last year in foreign periodicals, which have done considerably more with multi-grid tubes than has been done in the United States. Technicians will see the purpose of the extra grid and the coupling coil—to do away with the necessity of neutralizing the grid-plate capacity of the tube.

Such a circuit cannot be used with our screen-grid tubes since they have been designed with an entirely different purpose in mind, i. e., to decrease the inherent grid-plate capacity to such a low figure that danger from unwanted oscillations is minimized.

Radio as a Scapegoat

IT HAS become necessary for the Royal Meteorological Office to answer the many people of England who feel

that broadcasting has something to do with weather. The prevalence of bad weather in England has been laid to the influence of the radio signals which of course cover that land, and in spite of the loud "no" which the Royal Meteorological Office answers to such ideas, it is probable that people will go on blaming the radio for everything that seems out of season or out of keeping with their plans and pleasures.

It is difficult for people to believe that radio is something that falls under the laws of nature, just as automobiles or flat irons do. Not a week passes by but what some doctor, or lawyer, or teacher, who ought to know better, approaches us with some argument like this: "Now, I don't know anything technically about radio, but wouldn't this be a good idea?" and then he launches forth on some impossible or already old scheme. The fact that the laws of transmission and reception are well known, and that methods of attaching coils, condensers and tubes together are already printed in books, never causes the would-be radio inventors a moment's pause. And when some engineer tells them that their scheme is not worth wasting time on, they always feel he is liable to steal the idea and hasten for this reason to find another and less trained ear for their schemes.

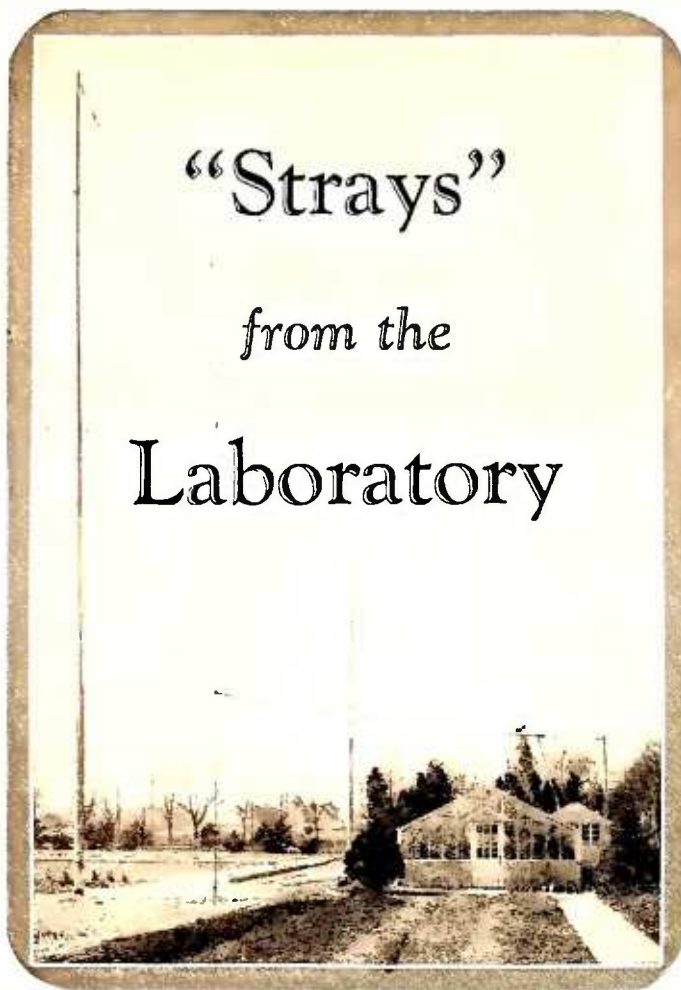

**"Strays"
from the
Laboratory**

A Screen-Grid Mystery

SERVICE men often run into strange and interesting problems. Suppose you were called out to look at a screen-grid tube receiver which seemed pretty "dead" although all of the tubes burned with normal brilliancy, voltages were correct, there were no opens or shorts, etc? Would you finally trace the trouble to lacquer on the small metal cap on top of one of the screen-grid tubes and to which a wire should normally have made an electrical connection? A case of this sort came to our attention recently; once the lacquer was scraped off and proper electrical connection made, the receiver, needless to state, came to life.

Mortality Among the A. C. Tubes

THE rapidity with which such tubes as the 171's burn out when their filaments are operated from a.c. may give a clue to the real reason why a.c. tubes seem to be shorter lived than battery tubes. The fault is not with the tubes, it lies with poor power line regulation. At times the line voltage is high, and naturally the filament voltage is high. Some tubes decrease in life by 50 per cent. when the voltage across the filament increases ten per cent.

Mr. A. O. Viereck, of Springfield, Mass., states

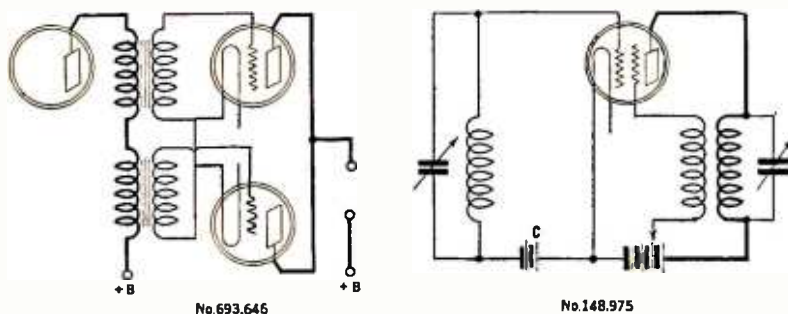

FIG. 1

that 171 tubes lasted less than 100 hours for him until he hit upon the plan of placing a resistance in series with the filament, and turning it so that the filament was just bright enough to prevent distortion. At the time of writing the letter his 171 "still was going strong," although it had been in use for over two months.

A still better remedy, of course, is to put a resistance in the 110-volt line which feeds the receiver. This may be set so that the voltage to the power equipment is below the point where too frequent tube replacement becomes necessary due to overloaded filaments.

Few people realize that considerable power must be dissipated within the tube and that overloading its filament or plate circuits is vastly more important, economically, than overloading its grid with a.c. voltages. A ten per cent. increase in line voltage produces a 20 per cent. increase in power used up in the filament and an equal increase in power required by the plate circuit. The filament must bear the brunt of all this increase, and unfortunately it does not have the margin of safety that is found in a machine rated in kilowatts.

Engineers as Salesmen

NOT long ago we read with considerable interest the statement of the head of a well

known eastern university that the average salary of the graduates of this institution of the class, let us say, of 1910, is kept down to a rather low figure by the salaries of men now engaged in teaching, those in government service and those who are engineers.

It is only too true that engineering as a profession does not pay so well as selling bonds, or real estate, or selling anything, for that matter. However, it is encouraging to note from time to time the increasing appreciation for the work of the engineer and the laboratorician. The following statement comes from a vice-president of one of the largest banking institutions in New York City and is quoted from *Science*, April 27, 1928:

"When any New York banker is called upon to finance any corporation or business, especially one based directly or indirectly upon scientific pursuits, the first investigation made is in regard to the attitude of the institution toward the advancement of scientific knowledge. If there is maintained a scientific laboratory with a generous regard for the advances in pure science, the security is, to that extent, considered good. But if no attempt is being made to keep up with, or a little in advance of, the developments in science, then no considerable loan will be risked upon such a venture. Permanent business success is too intimately linked with scientific attainment to make any other attitude safe."

We chatted recently with the executive of a radio company whose name is everywhere a synonym for quality, for honest dealing and for the genial friendliness of its personnel. This organization is making changes in its methods of merchandising which will practically eliminate its present selling organization—the non-technical salesmen, who as far as salaries go rate much higher, in general, than engineers.

"We have found," stated this executive, "that our best salesmen are our engineers. They know

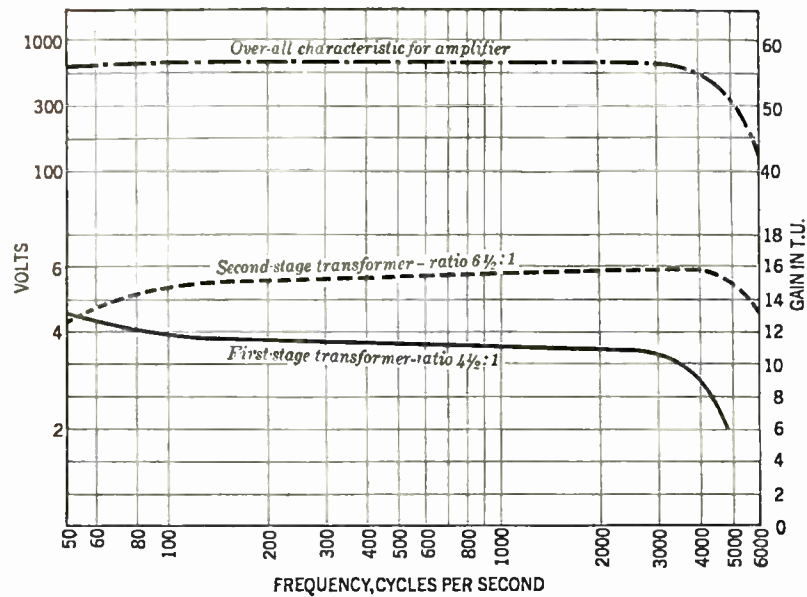

FIG. 2. FREQUENCY CHARACTERISTIC OF THE REMLER AUDIO SYSTEM

what they are talking about, what the organization they are "selling" needs; they can get into laboratories where no salesman would get even a pleasant look. They talk on equal terms with the chief engineer or director of research of the greatest organizations. Not one of our engineers goes out in the field who does not return with an armful of orders."

The Arcturus Radio company has recently decided to employ graduate engineers in their sales department. Mr. L. P. Naylor, Sales Manager, says:

"We need them on the road quite as much as in the lab. A. C. tubes are in a way a highly technical development—as well as something new. Reactionary dealers often bring up specious arguments against their use which can be answered authoritatively only by an engineer. And besides, the logical mind of the technically trained man is psychologically well grounded for sound salesmanship."

And so it looks as though the engineer may come into his own after all. Our idea of a good way for a young man to divide his time in college is to spend about three years in engineering school and three years in business school. He could then get a job selling bonds for the technical apparatus he, as an engineer, has designed.

We gloat over Mr. Naylor's final words, "the logical mind of the technically trained man is psychologically well grounded, etc." They may help to tide us over those bad moments when our classmate of the class of so-and-so, who sells real estate, invites us for a ride in the park in his new Packard.

Testing for Soft Tubes

The following quotation from a letter from Professor Frederick Emmons Terman, of Stanford University, relates to our recent request for methods of testing for soft tubes:

Tubes which contain gas, popularly called soft tubes, can be detected with the circuit shown in Fig. 3. The test is made by touching lead *a* to the grid lead as shown, thus short-circuiting the grid leak. If a click is produced in the phones the tube is soft. Absence of a click indicates a hard tube.

The test described is based on the fact that, in gaseous tubes there is some ionization produced in the tube even at low and moderate plate potentials. The ionization is caused by electrons striking the gas molecules and breaking them in pieces, some of which are positive (ions) and some negative (electrons). The positive ions are attracted by the negative grid, causing a grid

current to flow through the grid leak. Short-circuiting the grid leak alters the grid potential by eliminating the voltage drop of the grid current in the grid leak, thus causing a change of plate current, and a click in the phones. When there is no gas in the tube, no positive ions are produced, and as electrons will not flow to the negative grid, there is no grid current, no voltage drop in the grid leak due to grid current, and hence no click in the phones on shorting the leak.

In carrying out the test a leak of at least a megohm should be used. It is also desirable to use a rather negative C battery, such as three or more volts. Soft tubes, such as the 200A, will draw a considerable electron current at grid voltages of one or two negative, and upon increasing the C bias the grid current goes through zero and changes direction, being positive ion current beyond about 2½ volts. To make certain a suspected tube is soft, it is desirable to test it at two grid voltages to insure that the reversal point of zero grid current is avoided.

With 45 volts on the plate and minus 3 volts on the grid, a 201A tube gives substantially no click, while a 200A tube, which contains much more gas, produces quite a thump.

Short-Wave Reception

OUR ONLY comment to this letter lifted from *World Radio* (England) is that Mr. Bell either has a magnificent DX receiver or a grand location.

I should like to report on short-wave reception in America. As everyone knows, short waves are no good over short distances. Consequently, reception of U. S. stations is poor. To tabulate:—

- United States.*
- 2XAF: Very fine in daylight; hardly audible at night.
- 2XAD: Always poor, especially at night.
- 8XP: Very fine in daytime.
- 8XK: Excellent on some nights.
- 8XAL: Excellent on some nights.
- 2XAL: Good only in daytime.
- Australia.*
- 2ME: Excellent with loud speaker strength 5:30-8:30 A. M. E. S. T., relayed 5sw recently; 5 sw coming 20,000 miles.
- Java.*
- ANH: Good volume, 7-8 A. M.
- Holland.*
- PCJJ and PCLL: Always received with a strong signal, almost any hour.
- England.*
- 5sw on 24 meters relaying 5xx. I have left this till the last for I want to write at some length about it. 5sw as received in this part of America is simply phenomenal. Using (0-V-2) every evening I can easily run the loud speaker 5-7 P. M. E. S. T. 5sw at 5 P. M. is as strong a signal as WEAFF, 50 kw. (200 miles east), 492 m. 5sw 7:30-8:30 A. M. is received with good headphone strength. But from 2-7 P. M.

(when England is in darkness and America in daylight) 5sw is as regular and dependable as many of our U. S. stations. One would think we were in the British Isles.

Big Ben is an old friend. We have been in the Savoy Hotel, Carlton Hotel, Ambassador Club, New Princess Restaurant, Hotel Cecil, and other places.

Some of the best programs are the organ recitals from Bishopsgate and Southwark Cathedral and the National Symphony concerts.

Now a word about the medium wavelengths. 2LO is the most consistent. Spain is next. I will tell about one night (January 21) which was a fine night for European reception:—(These stations were on according to *World Radio*). (After 5:30 P. M. E. S. T., dark here):—

303 meters Nurnberg	Drowned out by WGR.
306 "	Fair dance music.
312 "	Carrier wave.
326 "	Drowned out by WPCH.
345 "	Very fine.
353 "	Fair.
361 "	Very fine — dance music.
375 "	Fair.
380 "	Stuttgart Good.
385 "	2ZY Good.
396 "	Hamburg Drowned out by WPAP.
405 "	5SC Drowned out by WLIT.
428 "	Frankfurt Good.
470 "	Langenberg. Under WRC.
492 "	5GB Under WEAFF.

It is unfortunate that WRC and WEAFF are always on, making reception of these last two impossible.

RAYMOND M. BELL.
55 Wilson Street, Carlisle, Pennsylvania

The Remler A. F. Amplifying System

IN ENGLAND the argument as to whether the parts of a radio system should each be perfected or whether the whole system should have a "flat characteristic" has assumed much greater proportions than any such discussion in this country. This is due, no doubt, to the fact that few radio manufacturers prepare a complete tuner, or amplifier, or other assembly of radio equipment, but have been more interested in selling a part such as an audio transformer or a coil.

The curves in Fig. 2 represent the frequency characteristic of the new Remler audio-frequency amplifying system—about which we shall have an article in the near future. It is composed of two stages, as usual, each of which distorts somewhat. When combined, however, the defects of one stage are taken care of by the other so that a very good characteristic results. The advantage of such "matching" of one unit to another lies in the greater over-all amplification that can be secured. For example it is not possible to build at reasonable cost a 6.5 to 1 audio transformer that will not fall off in voltage step-up at low frequencies. When added to another stage which rises at the low end the result is as shown.

The average gain of a two-stage audio system using high grade parts is about 50 TU. This curve shows that the Remler amplifier has a gain of 57 TU or a difference of voltage step-up of from 300 to approximately 710.

—KEITH HENNEY

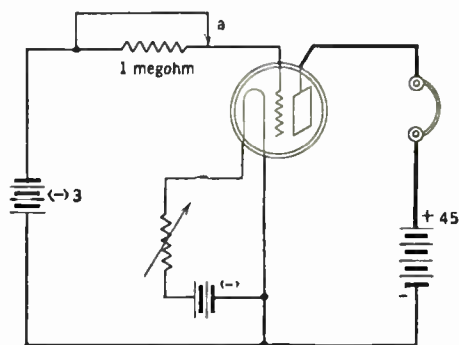
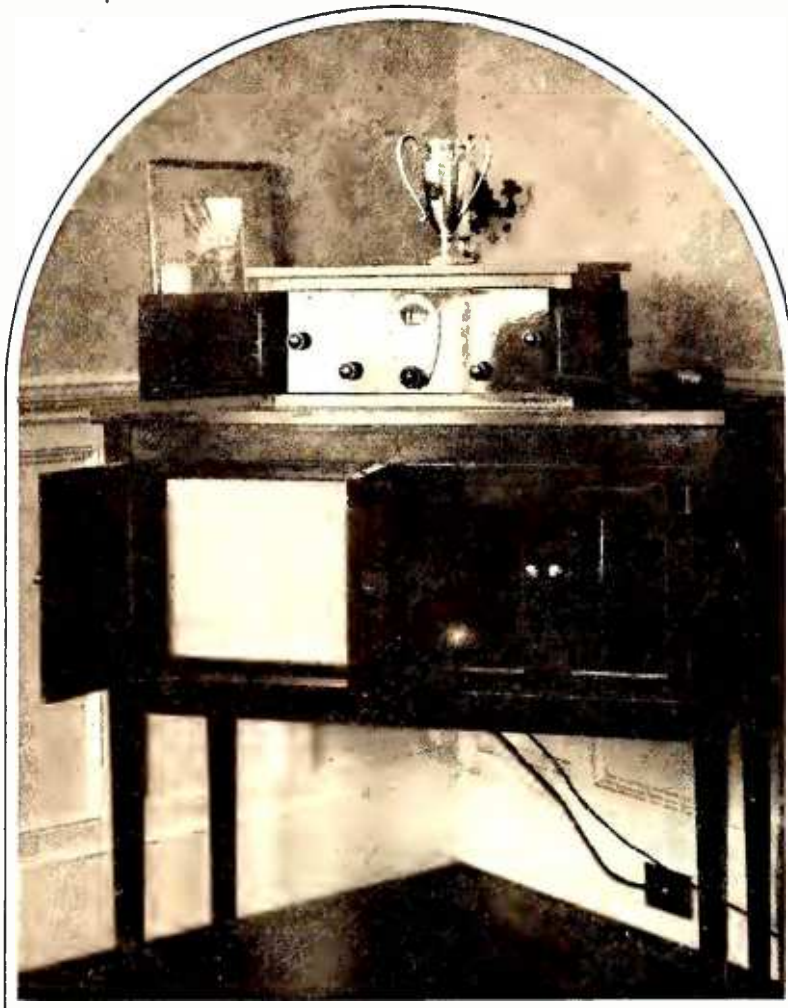

FIG. 3. A CIRCUIT FOR TESTING HARD AND SOFT TUBES

A Two-Tube A. C. Screen-Grid Tuner

At The Left:
The Author's Installation



By JAMES MILLEN

OF MANY different receivers described during the past few months in the various radio publications, one that has obtained unusual popularity is the National Screen-Grid Five, an article on which appeared in the May issue of RADIO BROADCAST (pages 20-22).

With the advent of the a. c. screen-grid tube, it now becomes possible to redesign this receiver for complete a. c. operation without sacrificing any of the meritorious points of the d. c. model.

In redesigning the set for a. c. operation it was found desirable to divide it into three separate units—the tuner, the amplifier, and the power supply. Such a division was made for two reasons—improved performance and convenience.

Satisfactory performance requires that the a. c. "hum" be reduced to an extremely low value, possible when the position of the power box relative to both the tuner and the audio amplifier can be adjusted. Such an arrangement is also convenient, as it permits the tuner being mounted in a small cabinet and placed on a small table, while the rest of the apparatus is located in some out-of-the-way closet, bookcase or chest. Or again, the tuner may be placed in the upper part of a small console cabinet with the amplifier and power box in the lower or "battery" compartment.

Another advantage of the separate unit arrangement is the simplicity of construction for the person who wants a set capable of quality performance and yet does not want to become involved in the construction of a power amplifier. All that is necessary for such a person to do is assemble and wire the 2-tube tuner, which, due to the design, is most simple, and then connect up a standard ready built amplifier, power box, and speaker.

But in the end what really counts is the performance of the receiver. Everyone is interested in tone quality. The city dweller is also vitally interested in selectivity, which in this tuner is such that it enabled the author in a recent test at the Hotel Stevens in Chicago to get any of the local stations without interference even from KYW, which is only a block or so away. In congested areas like Chicago and New York the reader should not, however, expect distant station reception through the locals. Some experimenters may get a few dx stations while the locals are on, but those who don't should not be disappointed. In smaller cities such as Boston, however, no trouble is had in breaking through the locals. With careful tuning the writer can tune out the local WJAC and bring in WJZ only 10 kc. above at almost any time.

THIS article gives the construction of an a. c. model of a screen-grid tuner, a d. c. model of which was described in the May, 1928, issue of RADIO BROADCAST. Mr. Millen, in this article, describes the use of this tuner in conjunction with a completely a. c. operated transformer-coupled audio amplifier using type 250 tubes in push-pull. It is interesting to note that the author recommends the use of about 300 volts on the plates of the 250 tubes so as to make possible the use of a less costly power supply than would be required if 500 volts were to be supplied to each of the tubes. 250 tubes in push-pull with 300 volts on the plate can supply to the loud speaker about 4 watts, which is more than sufficient for any ordinary installation.

—THE EDITOR.

WPG, WGY, WEA, four or five of the Chicago stations and any number of others are received with fair regularity.

THE TUNER

THE 2-tube tuner described in this article is quite similar to the model described in the May issue of RADIO BROADCAST, with the difference that this set is for complete a. c. operation whereas the former model was for battery operation. This set consists of a regenerative detector preceded by a stage of r. f. amplification using a CeCo a. c. screen-grid tube. The detector is a type 227 tube. The two tuning condensers, C_1 and C_2 in Fig. 1, are ganged together to a common drum dial and variations in the first tuned circuit, due to the effect of the antenna circuit,

are compensated by means of the antenna trimmer, which is a small movable winding, L_2 , mounted inside the secondary, L_1 . Those who want to may of course construct the set using two separate dials, making it a dual control receiver, in which case the antenna trimmer will be unnecessary.

The screen-grid tube is coupled to the detector circuit by means of an r. f. transformer especially designed for the circuit, the primary, L_3 , consisting of 55 turns of No. 38 wire, slot wound and located at the filament end of the secondary, L_4 . The latter coil is made of 90 turns of No. 28 wire on a tube 2" in diameter. The tickler, L_5 , has 22 turns on a movable form located at the grid end of the secondary. The antenna coil, L_1 , has 65 turns of No. 28 wire on a 2" tube; the coil L_2 contains 12 turns.

To prevent instability due to coupling in the plate supply the B plus lead to the plate of the screen-grid tube is bypassed to the cathode by a 1-mfd. condenser, C_4 , and voltage for the screen grid is fed to the tube through an r. f. choke coil, L_6 ; this circuit is also bypassed to the cathode by condenser C_3 , which has a capacity of 1.0 mfd. To prevent hum the heaters of the two tubes are grounded by the connection between ground and the 25-ohm center-tapped resistor, R_3 .

In assembling the tuner first mount all the parts on the sub-panel as indicated in Fig. 1 and 2. The coils, tuning condensers and drum dial are all obtained as a single unit mounted on an aluminum girder frame and can be simply screwed fast to the sub-panel. The two choke coils, L_6 and L_7 , are mounted in clip holders. As indicated in the Fig. 1 the sub-panel is supported at the rear end on two small brass pillars so as to leave space under the sub-panel for the location of the bypass condensers and the several other pieces of apparatus and to permit most of the wiring to be done under the panel where it does not affect the appearance of the completed set.

In mounting the apparatus and wiring the receiver, frequent reference should be made to circuit diagram, Fig. 3, and Figs. 1 and 2. Any type of hook-up wire or bus bar may be used. For the receiver illustrated in this article bus bar was used. The wiring is a simple, straightforward job and no difficulties will be experienced if care is exercised in the construction of the set.

As the a. c. 222 tube is of the 2.25-volt heater type, similar to the type 227 detector tube, one heater voltage is required. This same voltage can be used for lighting the dial light, small dial lights with 2.5 volt filaments now being obtain-

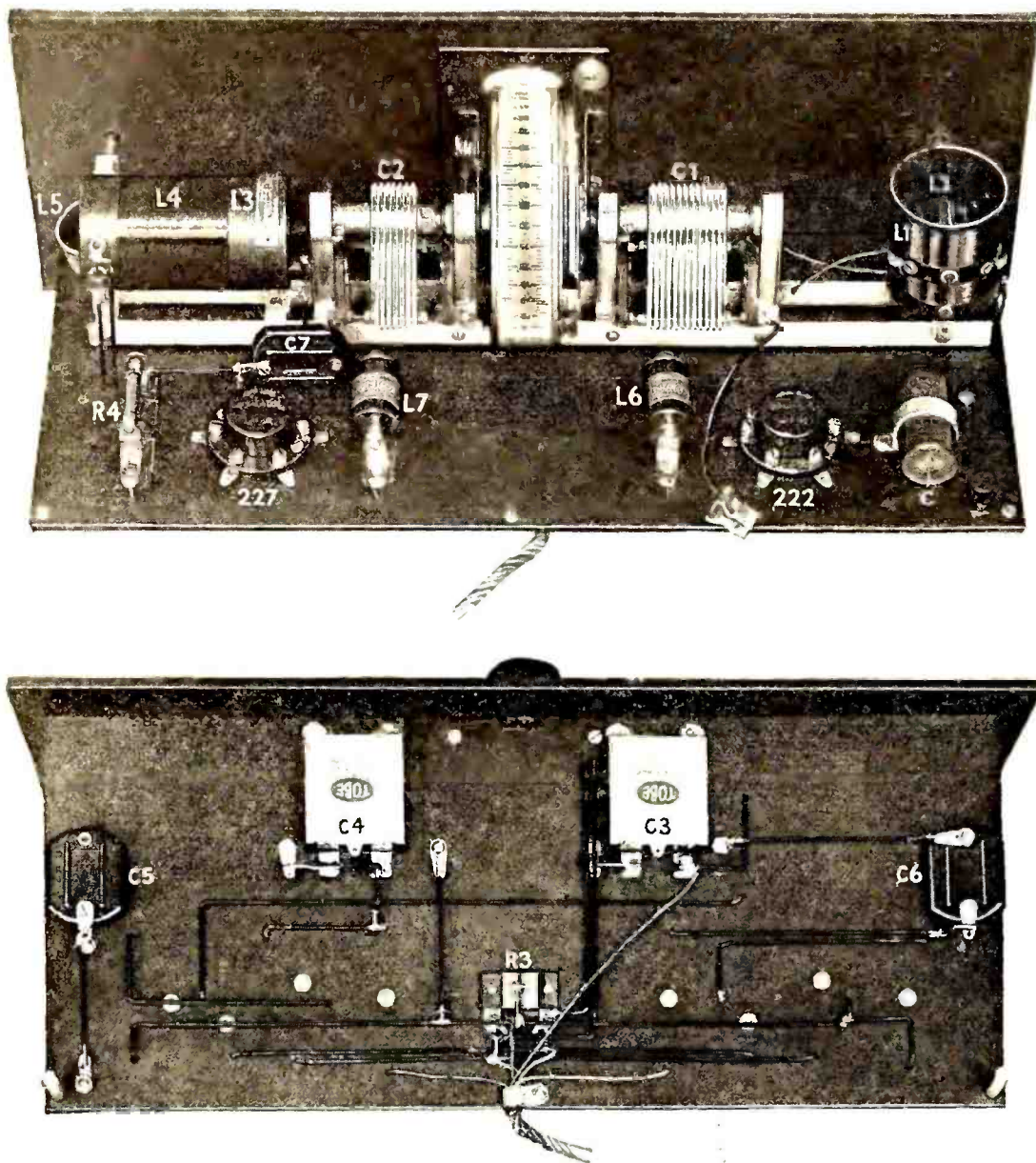

FIG. 1. TOP AND BOTTOM VIEWS OF THE TUNER

able from the manufacturer of the dial. It will be noted that a single 1½-volt flashlight cell is used to obtain bias for the control grid of the type 222 tube. While it is possible to obtain this voltage by means of resistors and a condenser it

was felt that the additional expense of this arrangement was not warranted.

The practice of locating the volume control at the end of an extension cord rather than on the panel proper is becoming quite general, but

whether the actual control is located on the panel or at the end of an extension cord does not affect the type of control which is recommended for use with this receiver. The volume control consists of R_1 and R_2 in Fig. 3, an arrangement for varying the positive bias on the screen grid of the type 222 tube. R_1 has a value of 1000 ohms and R_2 a value of 5000 ohms.

THE AUDIO AMPLIFIER

ANY good audio amplifier may be used with the screen-grid tuner as just described. The writer uses the push-pull amplifier illustrated in Fig. 4. This amplifier uses the new National Veritone audio transformers which have cores of a special nickel-steel alloy, for by the use of such a core material it becomes possible to reduce very materially the bulk of the transformer and at the same time to improve its frequency characteristic.

It will be noted from the Fig. 4 that four sockets are provided in this amplifier. The additional socket is of the UX type and is connected in parallel with the UY socket in the first stage. Therefore, when the amplifier is used with a tuner employing d. c. tubes, a type 112A tube may be used in the first stage in place of the 227.

The C-biasing resistors located in the amplifier base are of such values as to provide automatically the proper C bias to either the type 210 or 250 power tubes, regardless of the plate voltage used. Where high volume is desired and the use of high plate voltage is not objectionable, then it is recommended that a pair of type 210 tubes be used in the power stage. For home use, however, far more than sufficient volume is obtainable when using 250 type tubes at about 300 volts. It is not necessary to use 500 volts on the plates, for with 300 volts as delivered by the power box shown in Fig. 5, it will not be possible to overload the tubes at normal volume levels. The power output will be about 4 watts. One of the great advantages of push-pull amplification, in addition to improved tone quality as the result of the reduction of harmonic distortion, is the fact that a relatively low plate voltage suffices to give a large undistorted power output.

If more than one speaker is to be operated at one time, regardless of the type of amplifier

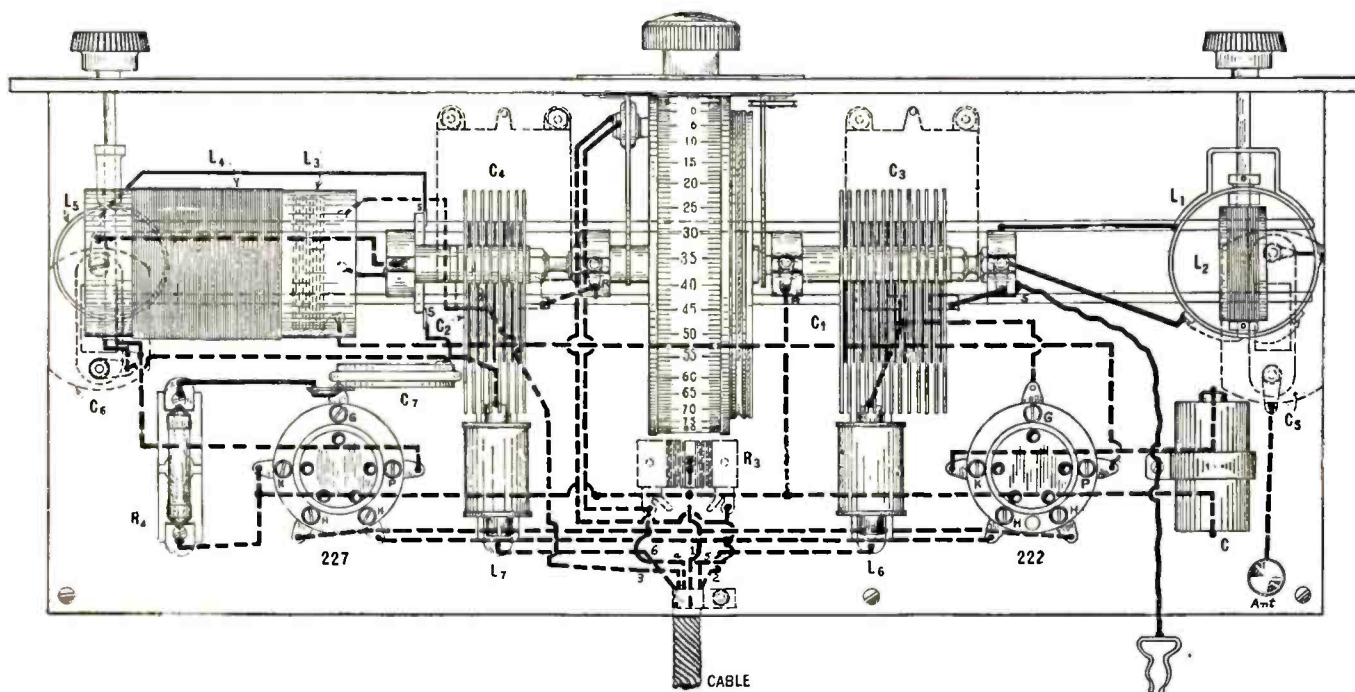

FIG. 2. THE PICTURE WIRING DIAGRAM

This diagram corresponds with the circuit diagram, Fig. 3, with the exception that the volume control resistors, R_1 and R_2 are not shown, since, as indicated in the text, some constructors may want to locate this control at the end of a flexible lead.

being used, it is most important that they all be connected so that they work together, i. e., in phase with one another. Such a relation is obtained by reversing the leads to those loud speakers which are out of phase.

THE POWER SUPPLY

AS HAS already been pointed out, the reason for separating the amplifier and power supply is to reduce the a. c. hum to the lowest possible value. A hum level hardly noticeable with the ordinary cone loud speaker will be quite objectionable with a dynamic cone.

In the author's opinion, a power unit capable of delivering 500 volts to the plates of a pair of 250 tubes is unnecessary, as well as quite costly; for the 4-watt output which two 250 tubes in push-pull will deliver with 300 volts on their plates is ample for all home installations.

The National power box, shown in Fig. 5, uses a single type 280 full wave rectifier, and the output of the unit is about 300 volts at a current drain of 100 milliamperes. Each B voltage is adjustable by means of the small levers which control the position of moving contacts on a wire wound output potentiometer. In addition, a. c. filament voltages of 1.5, 2.25, and 7.5 are provided. The filament windings are supplied by a separate transformer completely shielded from the high-voltage B transformer. A safety switch is provided which shuts off the power whenever the cover is raised sufficiently to expose the terminals.

NOTES ON OPERATION

IN HOOKING up the various apparatus, the power box should be located at least two feet—preferably a little farther—from either the set or the amplifier, and should be moved around until the position of minimum hum is obtained.

A good ground connection must also be made to the B minus terminal on the power unit. The a. c. supply cord should be kept well away from any other leads and especially from the input side of the audio amplifier. If the a. c. type of dynamic speaker is used, it also should be placed as far as possible from the audio amplifier and tuner in order to prevent the picking up of stray leakage flux from the field supply transformer and rectifier.

Under no condition should one of the special shields now on the market be used over the a. c. 222 tubes, as such shields prevent proper heat radiation and will ruin the tube in a very short time.

Very excellent performance from the tuner may readily be obtained with a short wire connected directly to the control grid of the type 222 tube (the cap on top of the tube) as an antenna. In fact, such an antenna is to be recommended for use wherever extreme selectivity is desired. Where the set is not located very close to any broadcasting stations, however, a 20' or 25' indoor antenna may be used. Such an antenna should be connected directly to the tap on the antenna coil. Where the conventional 50' to 60' outdoor antenna is to be used, the series antenna condenser, C_5 , must be employed as in Fig. 3. Such an antenna will be found of considerable aid in increasing the range and volume output of the receiver on distant stations in any location where local interference, power leaks, and other sources of noise are not bothersome.

When the receiver is first put into operation, the antenna trimmer should be set in mid-position, the set screws on

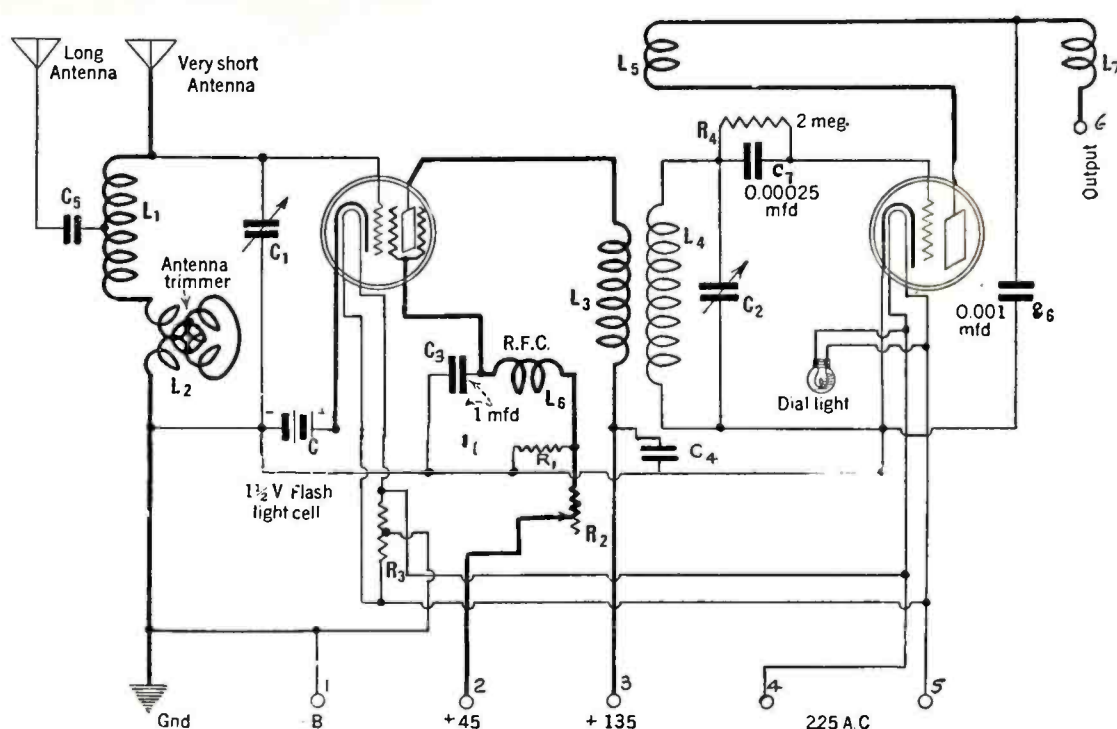

FIG. 3. THE SCHEMATIC DIAGRAM

the tuning condensers loosened, and then some local station should be carefully tuned-in by moving by hand the two tuning condensers separately. This process is necessary in order to get the two circuits in step. The set screws are then tightened, and any slight variations on other stations may be compensated by means of the trimmer. If the two circuits are not properly lined up, broad tuning and lack of sensitivity are certain to result.

In tuning for distant stations, the use of re-

generation in the detector circuit will be found of great assistance. As a result of the use of the screen-grid tube in the r. f. stage, the set will not radiate and the detector may, if desired, be permitted to oscillate, in which case stations may be picked up by their carrier waves, without annoying the neighbors.

In order to obtain smooth regeneration it is advisable to try several different values of grid leaks and also different values of detector plate voltage.

LIST OF PARTS

THE list of parts given in this article indicate those used in the model illustrated. A substitution of other equivalent parts is possible.

- C_1, C_2, L_1 to L_5 —1 National tuning unit, No. 222.
- L_6, L_7 —2 National r. f. chokes, No. 90, with mounts
- C_3, C_4 —2 Tobe bypass condensers, 1 mfd.
- C_5 —1 Sangamo fixed condenser, 0.0001 mfd.
- C_6 —1 Sangamo fixed condenser, 0.001 mfd.
- C_7 —1 Sangamo fixed condenser, 0.00025 mfd.
- R_1 —1 fixed resistor, 1000 ohms
- R_2 —1 variable resistor, 5000 ohms
- R_3 —1 General Radio center-tapped resistor, 60 ohms
- R_4 —1 grid leak, with mount, 2 megohms
- 2 General Radio 5-prong sockets
- 1 Westinghouse Micarta front panel, 7" x 18"
- 1 Westinghouse Micarta sub-panel, 7" x 17"
- 1 1 1/2-volt flashlight battery
- 1 Ceco a. c. 222 tube
- 1 Ceco N 27 tube
- 1 2 1/2-volt dial lamp

To make the set operative, an A power supply of 2.25 volts a. c., a B supply of 180 volts, and an audio amplifier and loud speaker, are necessary. In the hook-up described, a National push-pull power amplifier was used, with a dynamic cone, and the A and B power was supplied by a National Power Box, No. 250AB. The power amplifier uses 2 Ceco L50 tubes and 1 Ceco N 27 tube, and the power box 1 Ceco R80 tube.

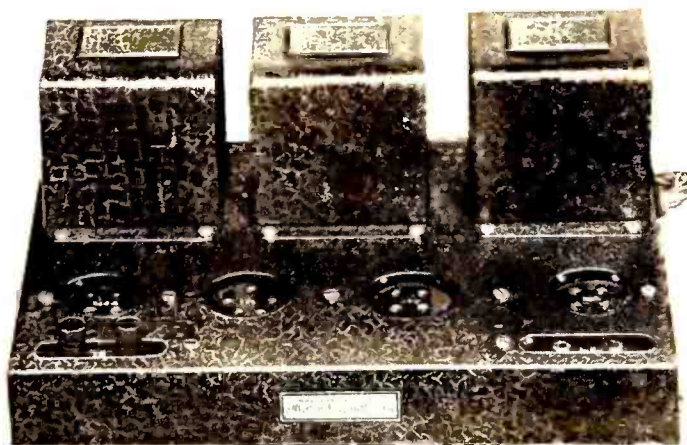

FIG. 4. THE NATIONAL POWER AMPLIFIER

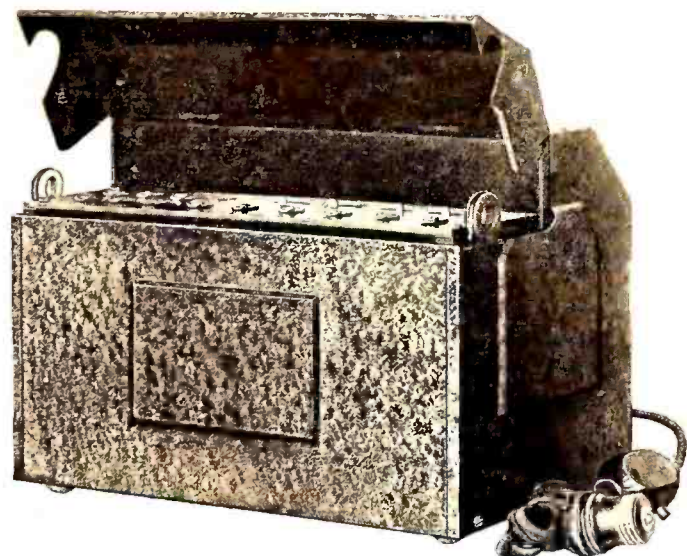

FIG. 5. THE NATIONAL POWER BOX

AS THE BROADCASTER SEES IT

BY CARL DREHER

Sound Motion Pictures

THIS department began enlightening the world in the March, 1925, issue of RADIO BROADCAST. At that time broadcasting was full of uncertainties and worries, with all its statesmen trembling for its commercial future, and their constituents ready to drink shoe polish every night. The present stability of the broadcasting business cannot be ascribed to the publication of this department, which now amounts to a total of 170,000 words, or the length of two novels, with several *Saturday Evening Post* stories left over. But neither can any man say that our writings have interfered with the development of the field.

Without misgivings, therefore, we now present some general discussions in branches of technology allied to broadcasting. This is in line with our previous policy of not confining our subjects to broadcasting proper. We have ranged over considerable portions of the radio telegraphic art, wire telephony, television, and public address work. In other words, we have gone wherever the vacuum tube went, and that is pretty far. But then, the broadcaster who aims to know only his own business is likely to find that he does not know even that which he thinks he knows—another application of the Parable of the Talents.

At this time the application of sound effects to the movies is undergoing rapid development. This article is not a contribution to the engineering of the subject, which, naturally, contains its own intricacies. It is intended merely to give a semi-technical, general picture of what is going on.

The commercial methods of synchronizing sound and motion pictures utilize two basic methods of recording and reproducing the sound: phonograph records, and photography or other marking on the film. In either case what has been done is substantially the addition of a public address system, properly synchronized, and actuated by a sound record instead of a microphone, to the moving picture equipment, in the reproducing process; while in the recording job we add the audio portion of a broadcasting equipment to the motion picture camera, precautions being taken similarly to keep the two in step.

The phonographic method is simple but does not provide absolute synchronization, since the film and disc remain separate entities throughout and synchronization depends on the coupling affected between them. Photographic methods of recording the sound on the picture film give more assurance in this regard, but entail modifications in the picture in order to make room for the sound record. This is, however, a perfectly feasible device in practice.

In all sound picture recording where microphones are used in the moving picture studio they must be placed out of range of the camera, or, if they are within the picture field, they must be hidden or camouflaged so that they will not appear in the picture. In some news reel work the microphone is allowed to show in the picture, but this is a special case. Fig. 1 shows how a talking or vocal record of a performance may be made simultaneously with the picture. The microphone is placed just above the field taken in by the camera, but close enough

to the performer to pick up the sound effectively. The output of the microphone is faithfully amplified in all its essential frequencies, just as in broadcast practice, through as many stages as are required to get a few watts of audio energy, and with the usual precautions against overloading.

If phonograph disc recording is employed the resulting audio energy is used to cut the record. The fundamental practice does not differ from electric phonograph recording as described in various technical publications during the last few years. The discs are larger, 16"-20" sizes being used in place of the usual commercial 10"-12" records. During recording the wax is usually viewed through a microscope in order to control the excursion of the stylus, which must vibrate through an amplitude sufficient to over-ride noise in the low portions of the music, without cutting into the adjacent groove during loud passages. An audio monitoring check is of course used at the same time. A common driving motor for the camera and the turntable on which the wax is mounted may be employed. By means of gears such a machine, running at a constant speed of, usually, 1200 r. p. m., may be made to take the film through at a standard speed of 90 feet per minute, while the turntable revolves at 33 r. p. m. By means of electromagnetic governing methods the speed of the motor may be kept very constant. If it is desired to separate the sound and picture recorders individual motors may be used; these usually operate on 3-phase alternating current and are of the synchronous type, especially designed for the purpose. In the reproducer a common drive is always used for the camera and phonograph turntable. In one commercial form an ingeniously designed motor generator operating on 60-cycle, 3-phase, 110- or 220-volt a. c., with the speed controlled through a small 720-cycle generator on the same shaft, furnishes the driving power for the reproducer.

In sound film phonograph work recording is generally done starting from the inside of the record. The space at the center permits a better start to be made, and the higher peripheral speed on the outside is an advantage in the handling of the loud passages which usually come at the end of a number. The records are plainly marked for start and finish. The start is made with the driving power off, the needle set at the beginning of an inside spiral on the disc, and the starting frame on the film similarly in the aperture of the motion picture projector. At least two projectors are provided in the theatre for continuous operation. The amplifier portion may or may not be in duplicate also. In the larger houses dupli-

cate amplifier equipment is naturally provided, whatever system of sound reproduction is installed.

When the sound record is photographed on the film the picture must make room for it, as shown in two sound film strips reproduced in Fig. 2. The sound track is only about one tenth of an inch wide, and in a standard film width of 1.3779 inch (35 millimeters) it is not difficult to accommodate the sound as well as the visual record. In Fig. 2 the sound tracks appear next to the left hand lines of sprocket holes. The picture frames may be allowed to retain the same ratio of length to height, in which case they must be optically reduced in printing, or, in the photography, a little strip may be sliced off one side, the height remaining the same.

The picture and sound may be recorded on the film in one operation, but this entails the complication of forcing the camera men and the audio recording men to work in close proximity. Usually it is preferable to place the camera in a sound-proof booth (when required) and to locate the sound recorder in another booth where a monitoring speaker may be kept in operation. The two machines are run by synchronous motors as previously explained, the starting point on each film being indicated by a light marker. Separate sound and picture negatives are thus produced; these are combined photographically and positive prints containing both records, properly synchronized, may thus be turned out.

There are two principal methods of recording the sound by means of light modulation. One is known as the variable density method; the resulting record consists of lines of different degrees of darkness the full width of the sound track, the record being made by admitting light to the film with an intensity proportional at each instant to the loudness of the sound. Or, alternatively, the sound record may be of the variable amplitude type, in which the whole width of the sound track is occupied only by the loudest sounds recorded, and vibrations of lesser amplitude are recorded in correspondingly narrower zigzags. Both these forms of marking are shown in Fig. 2. The latter form of marking is similar to an oscillogram, and is, in fact, made by means of a galvanometer on the order of an oscillograph. The number of bands in the variable density record, and the number of peaks in the variable width method, in a given distance along the film, is of course proportional to the frequency.

The method of recording (Fig. 3) is as follows: The film is run through the recorder at the standard speed of 90 feet per minute. The microphones pick up the sound, which is amplified in the usual manner. If a variable density record is to be made the output of the amplifier varies the intensity of a special glow lamp, the light from which is permitted to reach the film through a slit less than the width of the sound track (100 mils) and under a mil wide. In the case of the variable width record the audio currents cause the element of an oscillographic galvanometer to vibrate. A minute mirror mounted on the element reflects light from a constant source onto the film in such a way that the

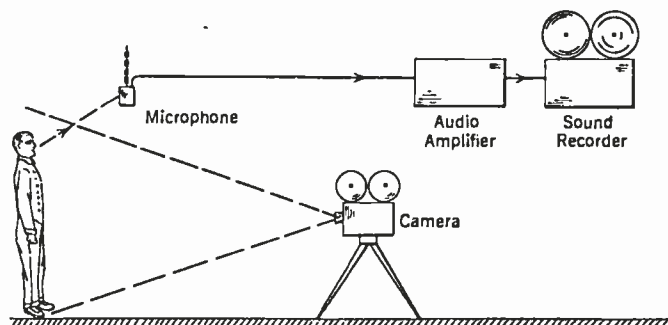

FIG. 1

width of the exposure corresponds in loudness to the sound input to the system. The exposure is also made through a narrow slit.

In reproduction (Fig. 4) the film is run through the projector at the same speed. If the speed in the projector is higher than standard, the reproduced notes will be sharp; if lower, flat. A constant source of light shines through a narrow slit similar to that found in the recorder onto the sound track of the film. A photo-electric cell receives the light passing through the sound track. The light it receives through the film at each instant depends on the density of the record at that point, or its width, depending on which method of recording is used. In either case the output of the photo-electric cell should be proportional to the original intensity of the sound. The current output of the cell is only a fraction of a microampere, but two or three stages of audio amplification bring it up a level where it can be handled by amplifiers of the usual broadcast type, followed by an output stage the size of which depends on the amount of volume required.

In one type the output stage, in large houses, utilizes four tubes in push-pull parallel, each having an oscillator rating of 50 watts; the total power delivered to the plates is about 200 watts, so it may be conjectured that 30-40 watts of undistorted audio energy are delivered to the loud speakers. The power stage is preceded by six stages of audio amplification. The usual gain controls, meter panels, etc., are on the panels.

The speakers are mounted above, behind, or



FIG. 2. TWO "TALKIE" FILM STRIPS

The two talking movie film strips, reproduced above in exact size, show how the sound record is photographed on the film. In the film at the left the sound is recorded as a zigzag line at the left of the film. In the strip at the right, the sound track at the left of the film is made up of bands of varying degrees of darkness extending the full width of the sound track

which Alexander Graham Bell demonstrated his invention of the electric telephone before the British Association of Science. The work on which the book is based was largely finished, therefore, before the invention of the telephone. Yet telephone engineers refer to it frequently, and no one can write a book on acoustics or vibrating systems without leaning hard on Rayleigh.

In a second edition which appeared in 1894 a chapter on "Electrical Vibrations" appeared among other additions. This marked the transition of the treatment of audio vibrations from the mechanical to the electrical aspects. But almost all the electrical theorems, however generalized and intricate, are found in the differential equations of Rayleigh's investigation of mechanical vibrating systems. Rayleigh perhaps never saw anything like a wave filter or an artificial line, but his grasp of the general meaning of oscillation was such that his analyses required only a little adaptation to be useful in dealing with such devices.

This unity of the acoustic past and present is manifested in some of Fletcher's sentences, as when he writes, "It is strikingly difficult to transmit energy of vibration from air to steel, or vice versa, for the amount which crosses the junction is only 0.00001 of that which arrives at it. In other words, a transmission loss (sometimes called a reflection loss) at a junction between air and steel is about 50 TU." Rayleigh expressed in TU tells us why a tuning fork makes as little noise as it does, even though it vibrates vigorously; fundamentally it is because air and steel are such different substances. The same loss occurs when we try to transmit oscillating electrical energy from one circuit to another with widely different constants.

Another interesting point brought out by Fletcher is Rayleigh's evident regard for the work of Heaviside, to which he frequently refers in the 1894 edition. Six years before the invention of the loading coil, Rayleigh discussed attenuation and distortion along lines, saying, "The cable formula . . . is an example . . . where waves of high frequency are attenuated out of proportion to waves of low frequency. It appears from Heaviside's calculations that the distortion is lessened by even a moderate inductance." This also appeared to Professor Pupin. Rayleigh goes on: "The effectiveness of the line requires that neither the attenuation nor the distortion ex-

ceed certain limits, which, however, it is hard to lay down precisely. A considerable amount of distortion is consistent with the intelligibility of speech, much that is imperfectly rendered being supplied by the imagination of the hearer." For this the telephone companies can still thank God.

Rayleigh also pointed out, in Fletcher's words, "the definite limitations of a horn radiating sounds having wavelengths larger than the opening of the horn." And, while we are admiring Sabine as he deserves, let us not forget the following paragraph which Fletcher has quoted from Rayleigh:

In connection with the acoustics of public buildings there are many points which still remain obscure. It is important to bear in mind that the loss of sound in a single reflection at a smooth wall is very small, whether the wall be plane or curved. In order to prevent reverberation it may often be necessary to introduce carpets or hangings to absorb the sound. In some cases the presence of an audience is found sufficient to produce the desired effect.

In the absence of all deadening material the prolongation of sound may be very considerable, of which perhaps the most striking example is that afforded by the Baptistery at Pisa, where the notes of the common chord sung consecutively may be heard ringing on together for many seconds. According to Henry it is important to prevent the repeated reflection of sound backwards and forwards along the length of a hall intended for public speaking, which may be accomplished by suitably placed oblique surfaces. In this way the number of reflections in a given time is increased, and the undue prolongation of sound is checked.

Rayleigh also deduced from the equations for the transmission of sound through air of uneven temperature that in the usual auditorium, where the air is warmer at higher points, sound will be refracted upward and consequently a speaker will be heard better by listeners above than below him.

As the viscosity of the air is small, sound waves do not decline rapidly in amplitude. The loss is greatest for the higher frequencies. A sound having a wavelength of one centimeter loses two thirds of its initial amplitude in traveling through 88 meters, while a graver sound, with a wavelength of 10 centimeters, suffers the same attenuation in traversing 8800 meters. The attenuation is proportional to the square root of the frequency.

"It is frequently stated," says Fletcher, ending his review, which contains more substance than many an original paper, "that when a treatise on a scientific subject has become 10 or 15 years old, it is ready for the cellar or the garret, its obsolescence being due to the rapid advances which science is making. This book on 'The Theory of Sound' is certainly an exception. It is now more than 50 years old and it will continue to be used for a good many years."

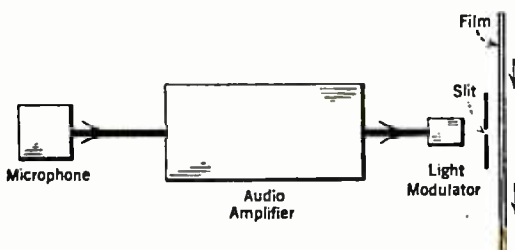

FIG. 3.

on the sides of the motion picture screen. In some cases they are made to "fly" with the screen, i. e., the speakers are attached to the screen and may be pulled up with it into the scenery loft. Or the speakers may be pushed around on trucks backstage. The proper number, location, and orientation of speakers depends on the power of the outfit and the acoustic characteristics of the house.

Lord Rayleigh on Sound

IN THE May, 1928, issue of the I. R. E. *Proceedings* there is a review of Lord Rayleigh's treatise on the "Theory of Sound." The book has recently been issued in a revised edition, two volumes, 494 pages, by Macmillan in London. The I. R. E. review is by Harvey Fletcher of the Bell Telephone Laboratories. My comments are a review of a review, but there is enough substance and inspiration in Rayleigh's classic work on sound to stand that attenuation.

Few broadcasters have the physical background to appreciate Rayleigh's book equation by equation, but one has only to page it to realize that one holds the record of a great piece of work by a great physicist. Dr. Fletcher points out that "The Theory of Sound" has been the standard text on the subject for the last 50 years. The first edition appeared in 1877, the year in

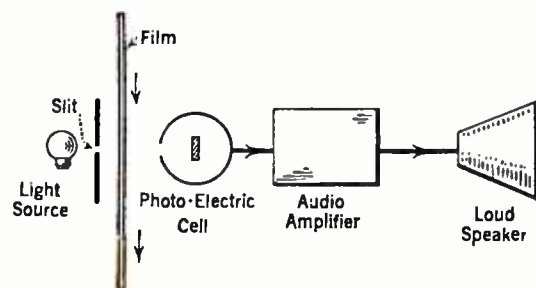
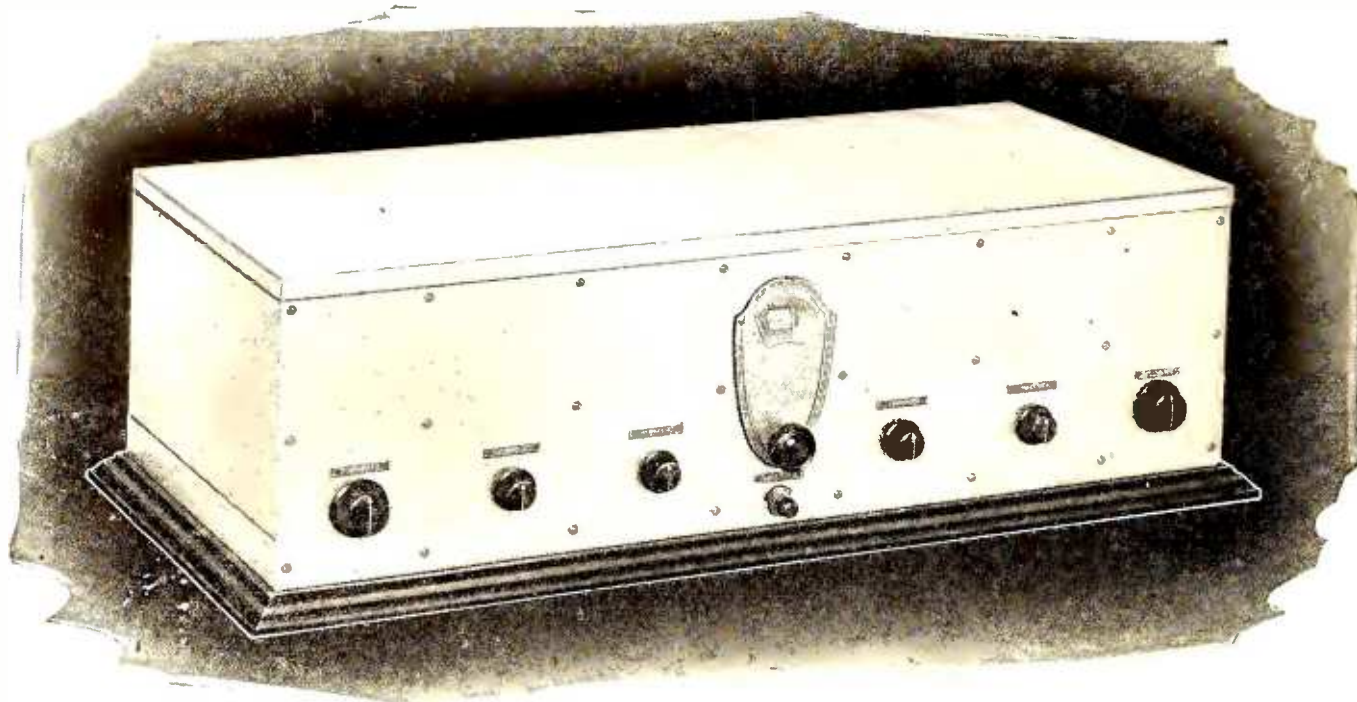

FIG. 4



A RECEIVER OF STRIKING APPEARANCE

The Sargent-Rayment receiver, with its aluminum cabinet and panel mounted upon a walnut base moulding, and black control knobs, presents an unusual and rather modern appearance which is perhaps more in keeping with the electrical age which it typifies than the more conventional wooden cabinets. The gang condenser control is in the center, and the volume control at the right; the other five knobs control the individual trimming condensers for balancing exactly the r. f. stages

The Sargent-Rayment Seven Receiver

By HOWARD BARCLAY

THE receiver described in this article is striking in that it departs successfully from many of the generally accepted tenets of home-built receiver design, and approaches the standards set by the higher priced factory-built sets costing up into the hundreds of dollars. It was developed by Messrs. Sargent and Rayment, the inventors of the Infradyne circuit which created considerable interest several years ago, and it embodies four individually shielded stages of t.r.f. amplification, a detector, and two audio stages of the Clough design. As it has several unusual features it is felt that a description of the salient engineering points of the design will be of interest to readers.

From the photographs and diagram it is seen that the receiver consists of an aluminum shielding assembly which serves the dual purpose of a cabinet for the entire receiver, and individual stage shielding for the different circuits of the set. This cabinet is made up of a pierced aluminum chassis, with the edges turned down, to which are fastened a number of smaller formed pans which serve as partitions, thus dividing the inside of the cabinet off into seven separate and distinct compartments. The assembly is completed by the front and back panels, which are bolted to the chassis and to all eight partitions, and finally by an aluminum cover, the edges of which are turned over to provide tight lap joints when the cover is placed on the receiver assembly. All of the metal work is of 7/64" aluminum, which provides most satisfactory electrical shielding. The complete shielding assembly alone uses nearly fourteen pounds of aluminum; the size is 27 $\frac{1}{8}$ " long, 12 $\frac{1}{8}$ " wide, and 8 $\frac{1}{8}$ " high. In the picture on this page the receiver assembly is shown mounted upon a walnut base moulding which trims up the ap-

pearance so that the set would not look out of place in the average living room. The aluminum assembly is finished in attractive satin silver.

Examination of the different illustrations and the circuit diagram in Fig. 1 shows that the amplification progresses from the antenna tuning circuit in the extreme left compartment of the aluminum shielding cabinet, through the four stages of tuned r.f. amplification to the detector in the sixth compartment. Four screen-

grid tubes are used in the r.f. stages, and a 201A, or preferably a 112A, for detector. In the extreme right compartment is housed the 2-stage audio amplifier and output transformer with the volume control. The center compartment of the receiver is left vacant except for the drum control dial which turns all five of the tuning condensers. All stage compartments are 12" deep, 6 $\frac{3}{4}$ " high, and 4 $\frac{1}{8}$ " wide.

PERFORMANCE

IN TESTS conducted upon different models of the Sargent-Rayment receiver during the period of its development, rather surprising results were obtained. On the West Coast, where the average receiver capable of giving adequate selectivity for other locations generally falls down quite badly, due to a number of peculiar local conditions, the Sargent-Rayment Seven has given positive 10-kc. selectivity—that is, it will separate distant stations ten kilocycles away from local broadcasters. As a specific instance, 10-kc. separation was obtained on either side of KGO in Oakland, Cal., and in the same location KRLD of Dallas was brought in between KF1 and KFRC. This is very exceptional operation in this locality. Such selectivity seems to leave little to be desired, for the receiver will go down to the noise level and bring in on the loud speaker any station sufficiently louder than atmospheric noises to be distinguished from it. To many radio fans this statement does not mean very much because upon the less sensitive receiver it is seldom indeed that the noise level observed is ever so loud as to drown out signals. This is not true of the Sargent-Rayment, for a simple turn of the volume control knob will increase its sensitivity to a point where weak atmospheric noises come in with a roar under conditions which would

THE names Sargent and Rayment are probably familiar to many of our readers as the designers of the Infradyne, a receiver which has been described by our contemporary, *Radio, on the Pacific Coast*. The receiver described in this article is of the tuned radio-frequency type, employing four stages of r.f. amplification with type 222 tubes. The audio amplifier contains two transformer coupled stages.

Although all the tuning condensers are controlled from a single dial, the set cannot truly be considered a single control receiver, for to obtain the maximum possible results the designers have placed small midget condensers across each tuned circuit. This, we feel, is a good idea, for it means that each circuit can be definitely adjusted to exact resonance. To put together a receiver containing this number of r.f. stages and have each stage in exact resonance with all the others throughout the entire broadcast band would necessitate exceedingly accurate coil and condenser matching.

—THE EDITOR.

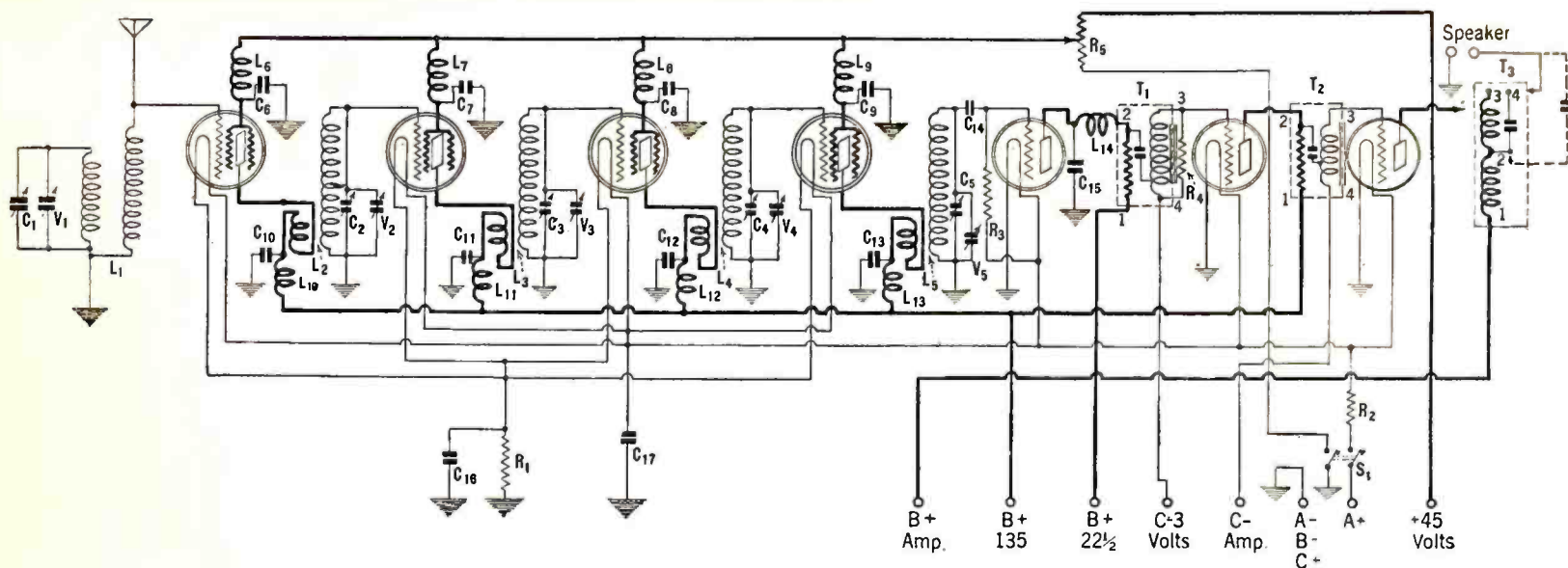

FIG. 1. THE SCHEMATIC WIRING DIAGRAM

If a 112A or 210 tube is used in the power stage, the plate lead of the power stage should be connected to terminal 3 of the output device, T₃; if a 171A or 250 tube is used, to terminal 2. Also note that if 180 volts or less is used with a 112A or 171A tube in the last stage, the speaker should be connected to terminal 4 of T₃ as indicated in solid lines. If more than 180 volts is used—as with a 210 or 250 tube—the speaker must be connected through a 600-volt 2.0-mfd. condenser to terminal 2, as indicated by the dotted lines

ordinarily be quiet for other receivers. Models of the receiver brought to Chicago and tested under the trying conditions produced by twenty or more local stations in simultaneous operation, have brought in as many as one hundred broadcast stations in a single evening's tuning. One receiver was tuned over the broadcast band, beginning at 550 kc. and going up the frequency scale. As rapidly as the dial could be turned and the verniers trimmed for maximum signal strength, new stations could be logged. When the evening was over, it was found that a station had been logged for every transmission channel, beginning at 550 kilocycles and going on up to over 1200 kilocycles before any gaps were found (channels upon which no station could be heard). This in itself is a remarkable record, and one which indicates the high degree of amplification that may be had in a carefully designed tuned radio-frequency receiver taking full advantage of the possibilities of screen-grid tubes and adequate shielding.

CIRCUIT DESIGN

ALL of the four r.f. stages consist of essentially similar tuning coils and tuning condensers associated with screen-grid amplifier tubes and the necessary bypass condensers and choke coils to insure absolute isolation of the various amplifier circuits. Each stage embodies an r.f. transformer with the secondary wound of 72 turns of No. 25 plain enameled wire on a threaded bakelite tube 2½" in diameter, the winding occupying a space 2¼" inches long. The turns are spaced 32 turns per inch. The r.f. resistance characteristics of this coil are most excellent. To each of the interstage r.f. transformer secondaries is coupled a primary consisting of 25 turns of No. 28 d.c.c. wire, wound upon a 2¼" diameter bakelite tube, fitting inside the secondary at the filament end.

Upon close observation, the antenna coupling coil, L₁ in Fig. 2, will be found to differ slightly from the interstage coupling transformers in the succeeding r.f. stages. This coil is of the tuned

rejector type, having a primary winding of 20 turns of No. 28 d.c.c. wire with the turns spaced ⅛" apart on a tube 2¼" in diameter. This winding is common to the antenna circuit and the grid circuit of the first r.f. tube. Surrounding this coil, and coupled closely to it, is a second coil which is similar to the secondary windings in the succeeding stages. This coil is tuned by the first or extreme left-hand tuning condenser and serves to reject effectively undesired signals, without having its tuning greatly affected by various sizes of antenna.

Examining a typical r.f. stage, it is seen to consist of the r.f. transformer; the 0.00035-mfd. tuning condenser with its associated 0.000025-mfd. midget vernier condenser; a tube socket for the screen-grid amplifier tube; two ¼-mfd. bypass condensers, and two radio-frequency choke coils. Each amplifier circuit is complete in its own shielded compartment, and the only leads carrying r.f. current running from stage to stage are the plate leads. One of the ¼-mfd.

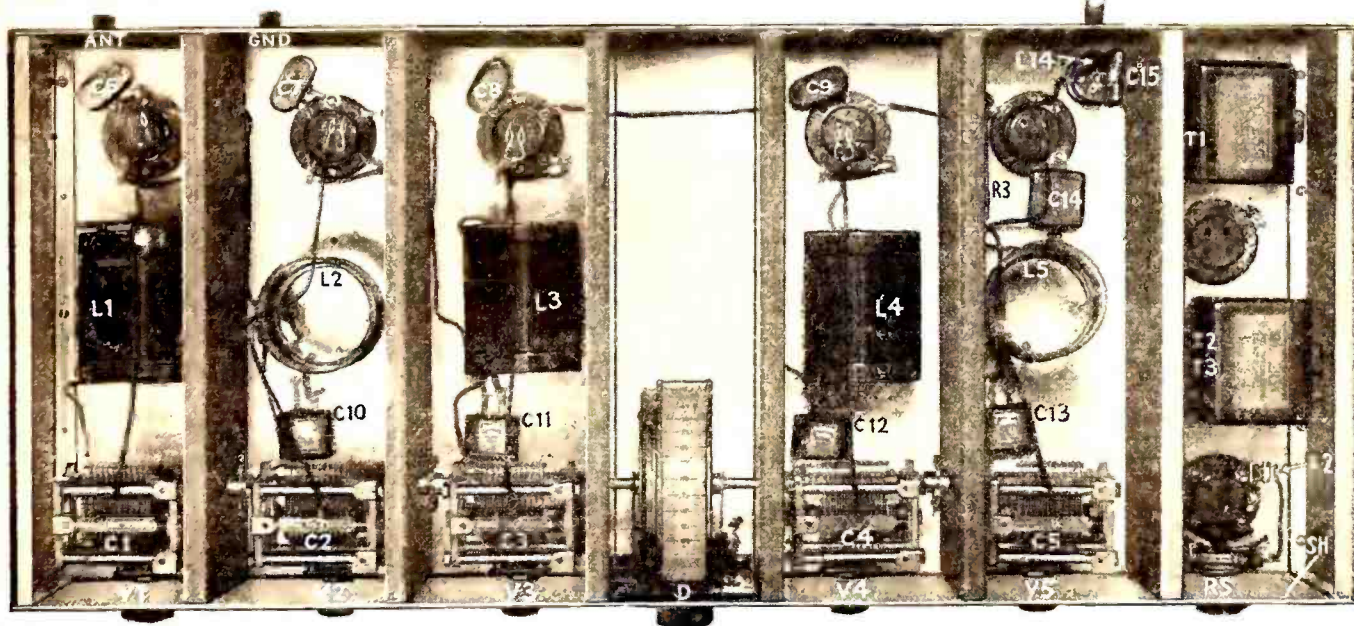

FIG. 2. WITH THE TOP REMOVED

From left to right are the four r.f. stages, the detector stage, and the two-stage audio amplifier housed in one compartment. In this compartment the second-stage audio transformer, T₂, is mounted on top of the output transformer, T₃. The five trimming condensers, V₁, V₂, V₃, V₄, and V₅, are mounted just under their respective tuning condensers. The mounting of the remainder of the parts above the sub-panel is clearly shown in this picture

condensers is connected from the screen-grid to the grounded shield, and one from the B plus side of the r.f. transformer primary to the grounded shield. Electrical isolation is further insured by the use of two r.f. choke coils, one connected in the screen-grid lead and one in the plate lead of each r.f. amplifier stage. These chokes are placed on the under side of the chassis. An additional r.f. choke is used in the detector plate circuit to prevent any r.f. currents from straying into the audio amplifier.

With all of these precautions, the receiver is remarkably stable; however, it is capable of being made to oscillate when desirable. A detailed analysis of the functioning of the screen-grid tubes as r.f. amplifiers indicates that even though the plate-to-grid capacity of the screen-grid tube has been reduced to an almost negligible value, this value is still high enough to allow oscillation if sufficiently good circuits are used with the tube. As very good circuits have here been employed to provide as high amplification and selectivity as is possible, the volume control has been combined with a stability control so that the r.f. amplifier stages may be operated at peak efficiency at every wavelength, regardless of oscillation tendency.

Measured amplification curves of the different stages show repeater voltage gains varying from 17 at 550 meters to 30 at 200 meters, these comparatively low values having been selected in order that the full merit of the tuned circuit might be taken advantage of to obtain the selectivity required by modern broadcasting conditions. The rising characteristic of the r.f. amplifier at short wavelengths is compensated by the tuned antenna input circuit, which has an opposite characteristic in that it shows greatest voltage step-up at 550 meters with a decreasing step-up at shorter wavelengths.

The five tuning condensers, C_1 , C_2 , C_3 , C_4 , and C_5 , are all connected together, and are operated by a single drum control dial, this connection being effected by means of the floating removable shafts, and flexible couplings arranged to link the condensers. The receiver can be tuned over the entire broadcast band with the single tuning drum, no difficulty being experienced in ganging, due to the high accuracy of the double spaced condensers employed. It was felt desirable, however, to equip each stage with individual tuning verniers, V_1 , V_2 , V_3 , V_4 , and V_5 , so that there would be absolutely no question in the

mind of the operator that his receiver could always be tuned to absolute peak efficiency on any and all wavelengths in the broadcast band.

NOTES ON CONSTRUCTION

THE construction of the receiver is quite simple, for there is available for it the complete shielding assembly, fully pierced, and requiring only the insertion of some 88 $\frac{5}{8}$ screws with their nuts and lockwashers, to put it together. The use of this large number of screws to hold the shielding together is the result of an interesting fact discovered during the development of the set. At first an endeavor was made to use the simple and attractive corner-post type of assembly, attaching these posts to the chassis and slipping the partitions, ends, front and back panels into the slots of these corner posts. The result was a very attractive mechanical job, but of very poor electrical characteristics, for the electrical joints provided between the partitions and the chassis (and for that matter between the partitions and the corner posts) were of such a variable nature as to change the entire performance of the receiver. It was necessary merely to strike the shielding with the palm of one hand to change the electrical contact between the different portions of the shielding, thereby altering their shielding effects on the circuits. From these results it was found that it would be necessary to use lap-joints and thick aluminum and to insure positive contact at many points, which accounts for the use of nine fastening screws to each partition.

The parts, and accessories, used in the Sargent-Rayment Seven are listed at the end of this article, and being of standard manufacture, may all be procured upon the open market, including the especially prepared aluminum cabinet assembly. The coils may be wound at home from the data given in the text. The assembly of the receiver is quite simple, involving only the mounting of the parts upon the pierced chassis with machine screws, wiring them up, and finally, the attachment of partitions and front and back panels with the 88 machine screws previously mentioned. The wiring of the set is surprisingly simple for a receiver of this type, as may be seen from a study of the two pictures in Fig. 2 and Fig. 3. The schematic wiring diagram in Fig. 1 also shows the simplicity of the wiring.

LIST OF PARTS

In the list below the substitution of equivalent parts may be made at the builder's choice.

- C_1 to C_5 —5 S-M variable condensers, 0.00035 mfd., type 320-R
- C_6 to C_{13} —8 Polymet Bypass condensers, 0.25 mfd.
- C_{14} —1 Polymet Grid condenser, 0.00015 mfd.
- C_{15} —1 Polymet Bypass condenser, 0.002 mfd.
- C_{16} , C_{17} —2 Potter Bypass condensers, 1.0 mfd.
- D—1 National Velvet vernier dial, type F, with illuminator
- L_1 —1 S-M antenna coil, type 141
- L_2 , L_3 , L_4 , L_5 —S-M r.f. transformers, type 142
- L_6 to L_{14} —9 S-M r.f. chokes, type 275
- R_1 —1 Carter resistor, 3 ohms, type H-3
- R_2 —1 Carter resistor, 1.0 ohm, type H-1
- R_3 —1 Grid leak, 2 megohms
- R_4 —1 Durham resistor, 150,000 ohms, with leads
- R_5 —1 Yaxley Junior potentiometer, 3000 ohms, type 53000-P
- S_1 —1 Yaxley Junior switch, double circuit (d.p.s.t.), type 740
- SH—1 S-M aluminum shielding cabinet with control legends, type 705
- T_1 —1 S-M first-stage audio transformer, type 255
- T_2 —1 S-M second-stage audio transformer, type 256
- T_3 —1 S-M output transformer, type 251
- V_1 to V_5 —5 S-M midget condensers, 0.000025 mfd., type 340
- 1 S-M walnut finish base moulding, type 706
- 1 S-M 10-lead battery cable, type 708
- 2 cartons S-M hook-up wire, type 818
- 7 S-M tube sockets, type 511
- 2 Yaxley insulated tip jacks, type 420
- 1 set hardware (obtainable from manufacturer)
- The accessories necessary to make the set operative are as follows:
 - 4 CX-322 r.f. tubes
 - 1 CX-301A or, preferably, CX-112A detector tube
 - 1 CX-112A first a.f. tube
 - 1 CX-371A power tube
 - 1 6-volt storage A battery or A-power unit
 - 4 45-volt heavy-duty B batteries or a B-power unit (180 volts), such as the S-M 670-B Reservoir Power unit
 - 1 40½-volt C battery
 - 1 4½-volt C battery

If it is desired to use a CX-350 type power tube in place of the 371 in the last stage, a high-power A-B-C supply, such as the S-M 675 ABC Hivolt Power supply, should be used. In this case only the 4½-volt C battery is necessary, and a 2-mfd., 600-volt condenser must be placed between the speaker and terminal 2 of the output transformer, T_3 , (see Fig. 1.)

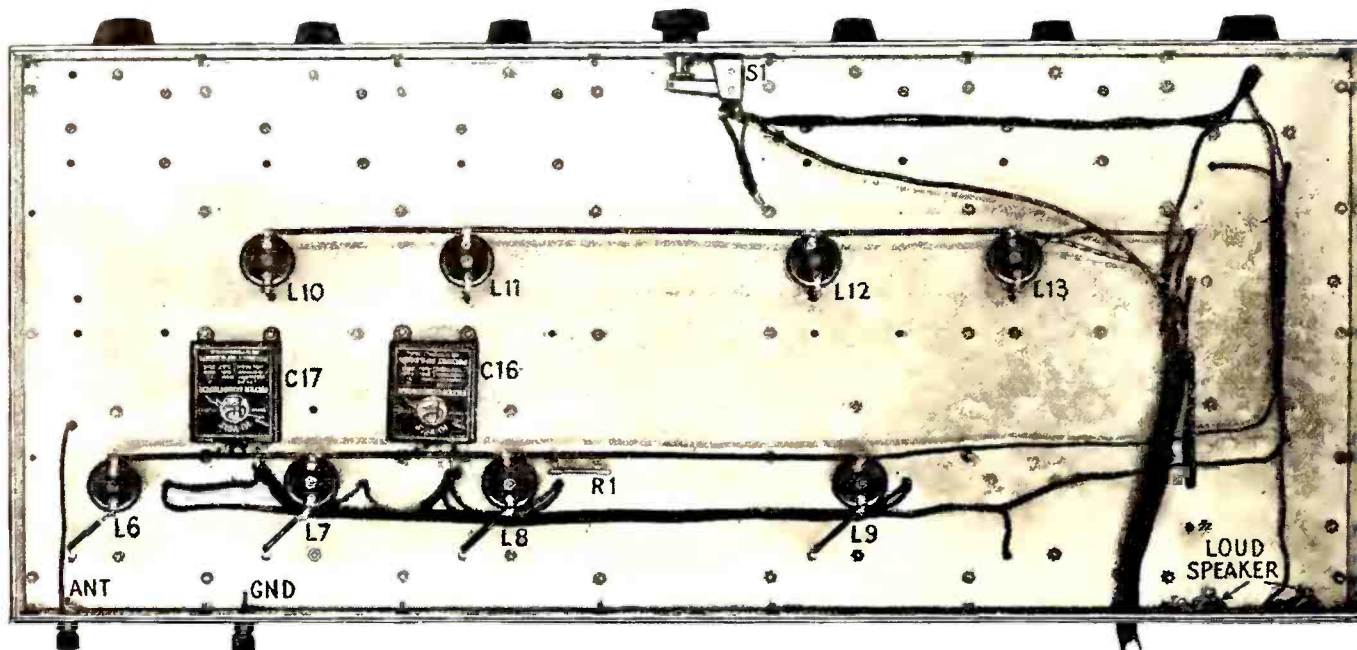

FIG. 3. THE UNDER SIDE

This view gives an idea of the simplicity of the wiring of the receiver, resulting from the use of the metal chassis as the A minus circuit return. The mounting of the condensers and chokes on the under side of the chassis is also clearly shown

Alternating Current

Part I

AN ALTERNATING current is one in which the magnitude and direction of flow of the current are continually changing. A direct current flows steadily in a given direction and at a more or less constant magnitude. The laws governing direct current phenomena and apparatus and the associated circuits are fairly simple; Ohm's Law will enable the experimenter to solve nearly all d.c. problems he runs into. The laws of a.c. circuits, on the other hand, are more complex—but for this very reason provide more enjoyment for the experimenter and those who like to solve problems.

Home Study Sheet No. 3 shows how Ohm's Law is to be applied to some radio problems; this Sheet gives the fundamental facts about alternating currents.

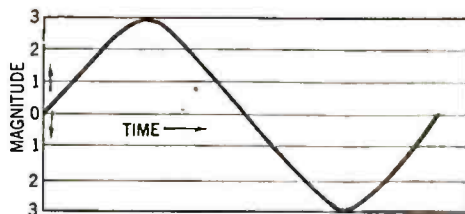

FIG. 1

DEFINITIONS

At regular intervals the direction of flow of an alternating current reverses, and therefore its variations in magnitude are as follows: the voltage starts at zero, rises to a maximum in one direction, decreases to zero, changes its direction, increases to a new maximum and then falls to zero, after which the **CYCLE** is repeated. Figure 1 is a representation of a single cycle of a.c. voltage. Such a picture is called a **SINE WAVE**. The number of times a second this cycle is repeated is called the **FREQUENCY**; the time required for one cycle is the **PERIOD**.

House lighting currents are usually of 60 cycles although in some localities 25-cycle and 133-cycle circuits exist. So slowly do the alternations take place on a 25-cycle circuit that lights burning from them seem to flicker, although people who have never seen lights operated from circuits of higher frequency seem not to notice the unsteadiness of their own illumination. Audio-frequency currents have frequencies ranging from as low as the ear can hear, about 32 cycles per second, to as high as we can hear, about 15,000 cycles per second. Radio circuits have frequencies ranging from about 10,000 cycles to as high as 30,000,000 cycles. Long-wave transoceanic communication takes place on the lower radio frequencies, broadcast transmissions on frequencies between 550,000 and 1,500,000 cycles, short-wave communication from 1,500,000 to 30,000,000 cycles. A kilocycle is one thousand cycles.

PLOTTING AN A. C. CURRENT

To show graphically what happens when an alternating current flows, let us look at Fig. 2 which consists of a circle in which is a rotating arm attached to the center and touching the circumference—a rotating radius. Suppose the circle moves to the right—carrying with it the rotating arm—at a constant speed such that it moves the distance of its diameter in the time it takes the rotating arm to make one complete rotation in a counter-clockwise direction. Suppose a piece of chalk is attached to the end of the arm touching the circle. What sort of figure would it trace out as the two motions referred to take place? It would be a wavy form exactly like the alternating current curve in Fig. 1. The arm represents (mechanically) the rotating armature of an a.c. generator; the movement of the circle to the right represents the passage of time. The curve is a graphic representation of the changing values of an alternating current.

PHASE

Since a complete circle has 360 degrees, we may speak of the position of the arm in terms of the number of degrees it has rotated within the circle. When it is perpendicular to its starting position it has traversed one quarter of 360 degrees or 90 degrees; when it is parallel but pointing in the opposite direction, it has gone through 180 degrees, or one **ALTER-NATION**, and so on. These various positions of the rotating arm are called its **PHASES**. Thus we speak of the 90-degree phase, and so on.

Since the magnitude of the voltage in an a.c. circuit is continually changing, it becomes expedient to have a means of knowing what the voltage is at any particular instant. At 0 degrees it is zero, at 90 degrees it is maximum, at 180 degrees it is zero again, at 270 degrees it is maximum, but in the opposite direction, and at 360 degrees the cycle is completed, and the voltage is again zero.

A.C.—INSTANTANEOUS VALUE

The **INSTANTANEOUS** value of an a.c. voltage or current is always referred to with regard to the maximum value. That is, if we multiply the maximum value by some factor which connects it and the phase, we shall have the instantaneous value.

A measure of the instantaneous value is the vertical height of the end of the rotating arm above the horizontal axis. The vertical height is measured by the length of the line dropped perpendicularly from the end of the arm to the horizontal axis; it is known as the **vertical component**. Now let us remove the vertical arm and its accessory lines from its circle and make what is known as a vector diagram at the 45-degree phase. In Fig. 3 let us label the arm, **E** (maximum voltage), the vertical component **e** (instantaneous voltage), and the angle which represents the phase, ϕ . Now if we divide the vertical component by the length of the arm, that is,

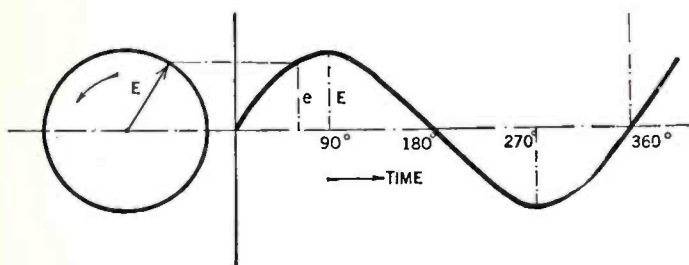

FIG. 2

e/E , we shall have a ratio which is defined mathematically as the **SINE** of the angle, usually written $\sin \phi$. This is the factor which connects the length of the arm and the vertical component.

$$\text{Thus } \sin \phi = e/E \text{ or } e = E \sin \phi$$

The numerical values of the sines of a number of angles are given in Table 1, and with their use we have a means of calculating the instantaneous values of a voltage provided we know the maximum value and the phase angle in degrees. At 90 degrees the vertical component is equal to the arm **E** and so the instantaneous value of the voltage at this phase is the maximum value. Can you prove this mathematically, using the data in Table 1?

EFFECTIVE OR R.M.S. VALUE

Since an alternating current is reversing at a rapid rate, the needle and mechanism of an ordinary d.c. meter would indicate only an average value which would be zero. Some other means must therefore be provided for comparing an a.c. current with a d.c. current.

We say, therefore, that an a.c. current is equal to a given d.c. current when they produce the same heating effect, and this value of the a.c. current is called its **EFFECTIVE** value. It is equal to the maximum value divided by the square root of 2, or

$$I_{\text{eff.}} = \frac{I_{\text{max.}}}{\sqrt{2}} = I \times .707$$

and

$$E_{\text{eff.}} = \frac{E_{\text{max.}}}{\sqrt{2}} = E \times .707$$

Since the heating effect of a current is proportional to the square of the current, we may obtain the effective or heating value over a complete cycle of alternating current by taking the average of the squares of several instantaneous values of current and extracting the square root. This value of current is then the square root of the average or mean squares of a number of values of current. This is abbreviated to "root mean square" or r.m.s., which is another term for effective value. In this expression "mean" and "average" have the same meaning.

The maximum or "peak" value of an a.c. voltage is used in determining the C bias necessary for an amplifier; the r.m.s. value is used in all power problems. It may be obtained by dividing the maximum value by 1.4 or by multiplying the maximum value by 0.707. Meters for use on a.c. circuits indicate the effective or r.m.s. values. The form of the wave in well regulated a.c. power circuits is nearly a true sine wave, that is, one in which the relation between the length of the rotating arm (the maximum value **E** or **I**) and the vertical component (the instantaneous value **e** or **i**) is the sine of the angle between the arm and the horizontal axis. If the a.c. current is not a true sine wave these relations do not hold.

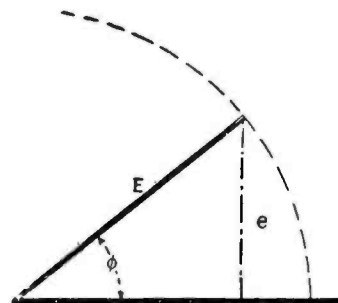

FIG. 3

PROBLEMS

- Express in kilocycles the values of frequency given in paragraph four of this Study Sheet.
- Assume that the maximum value of an alternating current is 10 amperes. On cross section paper plot its instantaneous values through one complete cycle by using the data in Table 1.
- The effective value of an a.c. voltage is 110 volts. What is the maximum value?
- What is the effective value of current in a circuit in which the maximum value of current is 10 amperes?
- The maximum value of a certain current is 10 amperes. What is the phase when the instantaneous value is 5 amperes?
- In a certain circuit the effective value of the voltage is 15 volts. What is the instantaneous value of the voltage at the 45 degree phase?
- Check the relation between maximum and r.m.s. values by getting the square root of the average squares of several currents as plotted in Problem 2.
- If power in watts is equal to $(I_{\text{r.m.s.}})^2 \times R$, what is the power used up in heating a resistance of 10 ohms when the peak voltage is 10?
- Express by means of a vector diagram and in a formula the voltage in a circuit at phase 45 when the maximum value is 20.
- Tell all you can about what the equation, $e = 10 \sin 30^\circ$, means.

TABLE 1

Angle in Degrees	Sine
0	0.0
30	0.5
45	0.7
90	1.0
120	0.87
180	0.0
270	-1.0
360	0.0

Alternating Current

Part II

IF THE experimenter wishes to know the difference between a.c. and d.c. circuits, let him try to measure the current flowing through a 30-henry choke when placed across the 90-volt tap of his plate supply unit, and then when placed across the 110-volt a.c. line. Evidently the choke has a much different effect on an a.c. line than it does on a d.c. line. What is this difference?

Let him, too, try to measure the current through a 1-mfd. bypass condenser when placed across this 90-volt tap, and across the 60-cycle line. Here again we see the difference between d.c. and a.c.

The choke—another name for an inductance—passes much less current on 60 cycles than it does on d.c.; the condenser passes none at all on d.c. and an appreciable amount on 60 cycles.

INDUCTIVE REACTANCE

The opposition to the flow of a.c. currents offered by a coil of wire is proportional to its **INDUCTANCE**, the property of a coil which tends to prevent any change in the flow of current. If one could measure the rate at which the current flows into a choke coil and the rate at which it flows into the same length of wire stretched out straight, he would see that the final value of the current was attained much later when flowing into the coil. The same fact would be observed were the current flowing out of the coil or straight wire. The spark which takes place when the connection from a battery to an iron core choke is broken is evidence that the current tends to keep on flowing even after the connection is broken.

How does an inductance tend to prevent changes in current?

Such a tendency is the result of several fundamental electrical phenomena. In the first place, when current begins to flow into a coil, lines of force from each turn of wire extend themselves out from the coil to form what is called the magnetic field of the coil. In the second place, whenever a line of force cuts across a conductor, or vice versa, a voltage is induced in that conductor. Thus, when the many lines of force thread their way through the coil of wire, each turn of wire is cut by the lines of force from the other turns, so that a voltage is built up across the terminals of the coil. Now the third fundamental fact is that the voltage, which is called the "induced" voltage, is in such a direction that it tends to prevent any increase or decrease of current in the coil.

We have the following phenomena then to explain the effect of inductance on changes of current: current flows into the coil causing lines of force to cut the individual turns of the coil; this in turn induces a voltage in the coil which has such a polarity that the increase in original current flowing into the coil is retarded.

When the connection is broken the opposite effect takes place; that is, the induced voltage tends to prevent the decrease of current with the result that its existence is prolonged. This voltage, then, must be in the same direction as the voltage tending to force current into the coil, so that across the ends of the coil, or the break in the circuit, a large voltage is built up. This voltage consists of the original impressed voltage from a battery, for example, plus the induced voltage. This explains the spark which takes place and the rather severe shock which may be felt from even small unpressed voltages and a small coil.

It is important to note that it is only when the current in the coil is changing—increasing or decreasing—that the lines of force in the magnetic field change. And it is only the *changes* in the lines of force that give rise to induced voltages; hence the retarding effect of an inductance occurs only when the current flowing changes.

Since an alternating current is continually changing, increasing in value, reversing its direction of flow, decreasing in value, etc., the opposition which inductance offers to its flow is considerable.

The opposition which an inductance offers to the flow of alternating currents is measured in ohms just as resistance is, and its technical term is **REACTANCE**. The reactance of a coil depends upon the frequency of the current and the inductance of the coil, and is numerically equal to 6.28 times the inductance in henries times the frequency in cycles. The abbreviation and formula for inductive reactance are

$$X_L = 6.28 \times f \times L$$

Thus, doubling the frequency doubles the reactance in ohms, so does doubling the inductance at the same frequency.

Since the current into an inductance does not rise to its maximum value instantly, there is a lag between the times of maximum voltage and maximum current. The maximum current is not reached in a pure inductance (no resistance) until the voltage has gone through 90° of its cycle. The current in an inductive circuit, therefore, is said to **LAG** behind the voltage. This is illustrated in Fig. 1, in which the maximum values of the current and the voltage are 90° apart. It is also shown in the vector diagram Fig. 2 which represents two arms rotating at the same speed

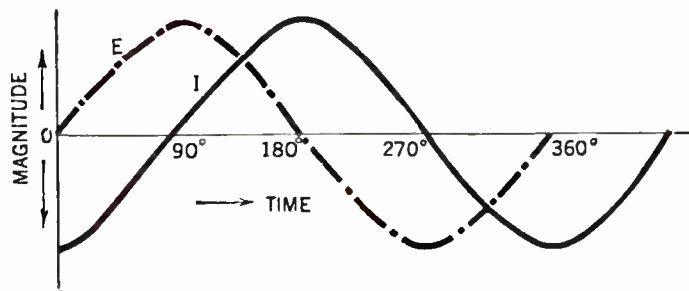

FIG. 1

but 90° or one fourth of a cycle apart.

Since the maximum values of the current and voltage are 90° apart, we must take this fact into recognition when we desire to know the instantaneous values of the current. If the voltage is at the 150° phase, the current is 90° behind it or at its own 60° phase. This difference of 90° is called the **ANGLE OF LAG**, or the **PHASE ANGLE** between the voltage and the current. The instantaneous value of the current is expressed by

$$i = I \sin (\phi - 90^\circ)$$

EXAMPLE. What is the instantaneous current at the 150° phase in an inductive circuit in which the maximum current is 10 amperes?

$$\begin{aligned} i &= 10 \sin (150^\circ - 90^\circ) \\ &= 10 \sin 60^\circ \\ &= 10 \times .87 = 8.7 \text{ amperes.} \end{aligned}$$

Figure 3 is the vector diagram illustrating this problem. It is drawn to scale so that the various lengths of line represent the various values of current and voltage.

CURRENT IN INDUCTIVE CIRCUITS

Just as the current in a resistance circuit is expressed by Ohm's law, whether it is d.c. or a.c., so is the current in an inductive a.c. circuit expressed by a similar formula.

$$I = \frac{E}{X_L} = \frac{E}{6.28 \times f \times L}$$

and if the voltage is effective, or maximum, or instantaneous, the current will be effective, maximum, or instantaneous.

PROBLEMS

1. Plot the reactance of a coil of 0.1 henry as the frequency is increased from 100 to 10,000 cycles, and then from 10 to 1000 kilocycles. What would the reactance be if the inductance were 1 millihenry? One henry?

2. A coil has the following dimensions: length of winding, 2 inches; diameter, 3 inches; number of turns, 65. What is its reactance to a current of 750 kilocycles? What current would flow through it if the voltage (effective) were 10? (See Home Study Sheet No. 2, July RADIO BROADCAST.)

3. Make a vector diagram for the following condition and solve by means of the formula above. The instantaneous voltage at the 135° phase is 5 volts; what is the instantaneous current if the effective current is 5 amperes? The circuit is inductive.

4. How much inductance must be placed in a 110-volt (effective) circuit at 60 cycles to limit the current to 1 ampere? At 6000 cycles?

5. The maximum value of the voltage in an inductive circuit is 140, the maximum current is 10 amperes. At what phase is the instantaneous current equal to 7 amperes? What is the instantaneous value of the voltage? What inductance must be added to reduce the maximum current to 7 amperes if it is a 133-cycle circuit? What will be the effective current then?

6. Can you explain why a 25-cycle transformer is larger, heavier, and more expensive than one built for 60 cycles? What would be the result of placing a 60-cycle transformer on a 500-cycle circuit? What would happen if a 500-cycle transformer were placed on a 60-cycle circuit?

7. Suppose you couple a loud speaker to an output tube by means of a choke and a condenser. The output a.c. voltage at 1000 cycles is 50; this appears across the choke which has an inductance of 30 henrys. What a.c. current flows through the choke? If the condenser offers no impedance to the flow of current at this frequency, and if the loud speaker which is, then, shunted across the choke, has an impedance of 4000 ohms, how much a.c. current flows through it? Suppose the power into the loud speaker is equal to the current squared multiplied by the impedance of the speaker. What power is going into the speaker? Suppose 2 per cent. of this electrical power is turned into sound energy by the speaker. How many watts of sound output power comes from the speaker? How many micro-watts?

8. Draw the diagram of a two-stage audio amplifier using 3-1 transformers working out of a detector tube which has an impedance of 20,000 ohms, the power or second stage working out of a tube with an impedance of 12,000 ohms and a mu of 8. These plate impedances are in series with the impedance of the primary of the following audio transformer. Suppose across the first audio primary is 0.5 volt at 100 cycles. The transformer primaries have effective inductances of 100 henrys. Figure the a.c. current in the plate circuit of the detector and the first audio tubes. (Combine the tube and transformer impedance by adding them.)

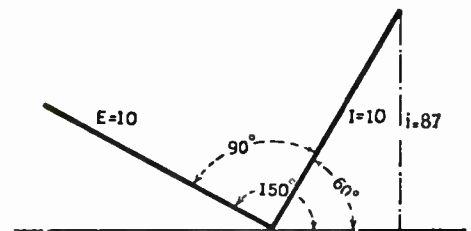

FIG. 3

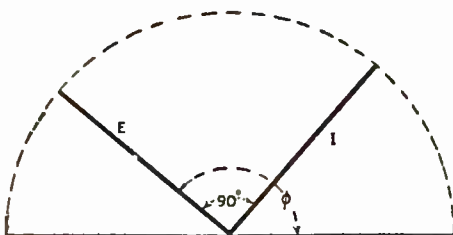

FIG. 2

The 222 Tube as an R. F. Amplifier

Part II

By GLENN H. BROWNING

IN THIS, the second article from Mr. Browning's notebook on the 222 tube, the author discusses two common methods of coupling a screen-grid tube to a detector or to a following amplifier. The equations by which Mr. Browning arrived at his conclusions should be interesting to the mathematically inclined; the results of those equations and the laboratory data will be interesting to anyone who likes to keep up to date in radio.

—THE EDITOR.



IN THE article on page 252 of September RADIO BROADCAST the characteristics of d.c. and a.c. types of screen-grid tubes were discussed and their performance in untuned amplifiers was also considered. It is the object of this article to treat of two types of tuned radio-frequency amplifiers, one the common radio-frequency transformer where a primary and secondary winding is used, and the other the auto-transformer usually termed tuned impedance.

The function of a tuned radio-frequency amplifier is not only to amplify incoming signals but also to give the desired amount of selectivity. There is also the question of the tendency of the preceding circuits to oscillate, which is very important with tubes which have a great deal of

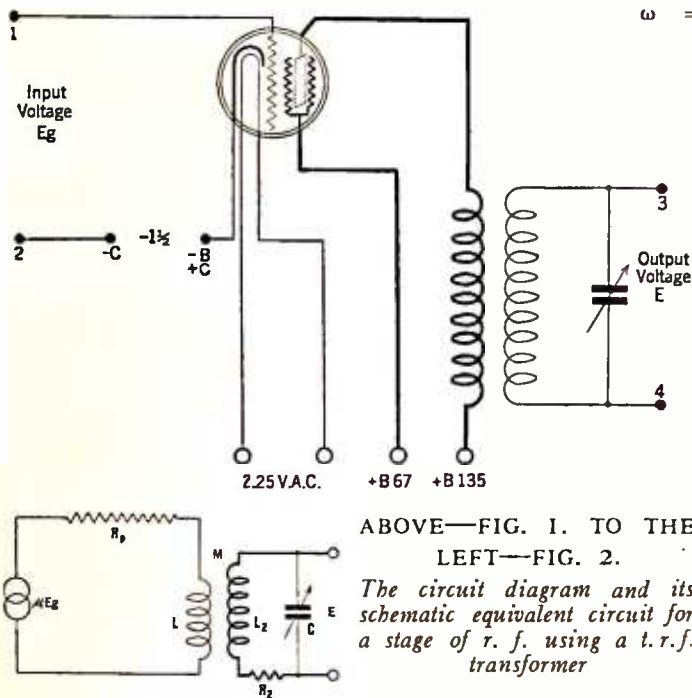

ABOVE—FIG. 1. TO THE LEFT—FIG. 2.

The circuit diagram and its schematic equivalent circuit for a stage of r. f. using a t. r. f. transformer

capacity between grid and plate. This effect, however, is minimized with the screen-grid tube, and consequently will not be dealt with at length here.

To determine the design of an r.f. transformer for the screen-grid tube the mathematics for a one-stage amplifier such as shown in Fig. 1 should be examined and the voltage amplification, i. e., output voltage, E, divided by input, E_g , calculated. As far as alternating current is con-

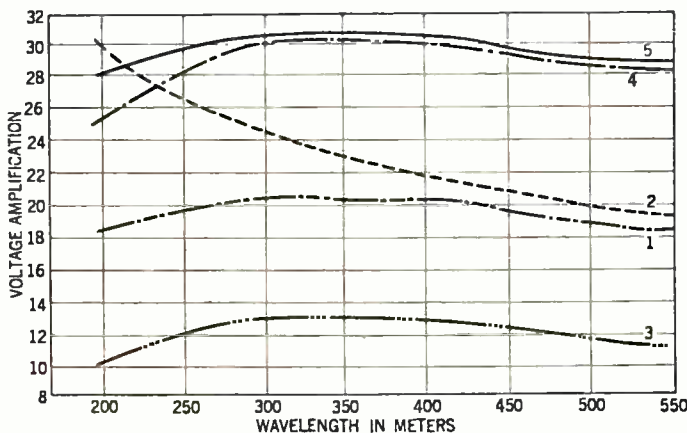

FIG. 3

Theoretical and actual voltage amplification curves over the broadcast band for the types of r. f. coupling discussed in this article

cerned Fig. 1 reduces to Fig. 2, where a voltage of μE_g is applied in series with the plate resistance, R_p , and the primary of the transformer. Analyzing this circuit and making certain simplifications the voltage amplification is

$$\frac{E}{E_g} = \frac{\mu \tau \sqrt{L_2/L_1}}{\tau^2 + \eta_1 \eta_2} \quad (1)$$

- Where μ = amplification factor of the tube
- τ = coefficient of coupling between primary and secondary
- L_2 = Secondary inductance in henrys
- L_1 = Primary inductances in henrys
- η_1 = $R_p/L_1 \omega$
- η_2 = $R_2/L_2 \omega$
- ω = 2π frequency

It will be readily seen by equation 1 that there is a relation between η_1 , η_2 and τ that will make the amplification a maximum. This relation is

$$\tau^2 = \eta_1 \eta_2 \quad (2)$$

for maximum voltage amplification.

The amplification obtained by the transformer and tube when this relation is satisfied is

$$\frac{E}{E_g} = \frac{\mu \sqrt{L_2/L_1}}{2 \sqrt{\eta_1 \eta_2}} \quad (3)$$

From this analysis it may be seen that L_2 should be as large as possible consistent with tuning down to the lowest wavelength desired. L_1 should be as small as possible consistent with satisfying the relation $\tau^2 = \eta_1 \eta_2$.

It should be noted that when L_1 is small that η_1 is large and consequently the coupling must be increased. Thus it is advantageous to

make the coupling large consistent with keeping the capacity between the primary and the secondary windings small, as this capacity between the two circuits has the effect of introducing a voltage in the secondary circuit somewhat out of phase with the voltage induced by the magnetic coupling.

With the ordinary 199, 201A, 226, and 227 type tubes, the plate resistance is sufficiently low so that all the above relations may be satisfied, and

maximum gain may be obtained. (See *Proceedings of Institute of Radio Engineers*, December, 1926.)

However, with the screen-grid tube the plate resistance is between 400,000 and 700,000 ohms so that η_1 is very large and the relation $\tau^2 = \eta_1 \eta_2$ can never be satisfied. Of course the primary inductance of the r.f.t. may be increased up to the point where the distributed capacity of the winding itself tunes the primary to some frequency in the wavelength band. η_2 is made as small as possible but can never be reduced below a value of about 0.003 except with regeneration. Therefore, it is essential in the design of a transformer for the screen-grid tube to make the coupling very large. This problem was attacked by the

writer some months ago and by careful design the coefficient of coupling was increased from its usual value of about 0.5 to 0.91. This factor depends upon the geometrical relation between primary and secondary in such a way that the shorter the secondary winding with the primary in a given position the larger τ becomes. The coils which showed a τ of .91 were wound on a 2" form and had a winding length of $\frac{9}{16}$ ". The primary was slot wound and placed $\frac{1}{4}$ " from the low potential end.

With these coils in the one-stage amplifier the circuit of which is shown in Fig. 1, and using a CeCo a.c. 22 tube, an amplification of about 20

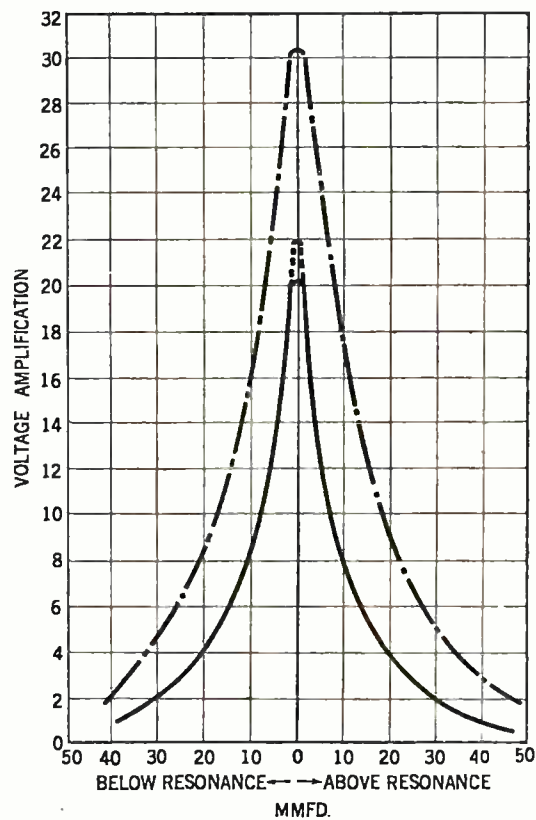

FIG. 4

The solid curve is the actual resonance curve of the transformer shown in Fig. 1 and 2 at 400 meters. The dotted peak is the portion of the calculated curve which does not coincide with the actual curve. The dot-dash curve is the resonance curve of the tuned impedance shown in Figs. 5 and 6

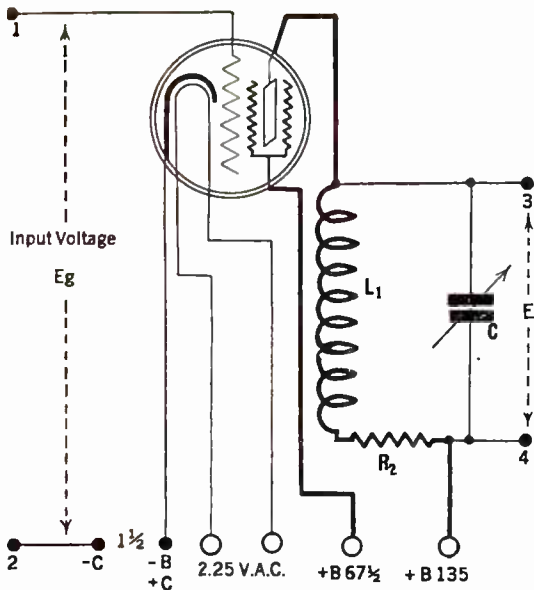

FIG. 5

The circuit of a stage of tuned impedance r. f. amplification using a screen-grid tube

per stage could be obtained. The method of measuring this gain was to put in a signal from an r.f. oscillator of 0.1 volt, as measured on a Rawson Thermal Multimeter, and to measure the voltage developed across points 3 and 4 by means of a vacuum tube voltmeter. The results are shown in Fig. 3. In curve 1 voltage amplification is plotted against wavelength. The theoretical amplification as calculated from equation 1 is shown by curve 2. The discrepancy between measured values and calculated ones is probably due to the capacity between primary and secondary windings of the r.f.t., as the effect of any

capacity would be more pronounced on the short than on the long wavelengths.

As a matter of comparison the amplification of a 201A tube used in conjunction with a well-designed transformer is shown by curve 3. Not only does the screen-grid tube with the transformer described above give more amplification per stage, but furthermore a number of stages may be used without neutralization, whereas with the 201A, careful neutralization is necessary.

Before considering the amplification given by a tuned impedance, let us consider the selectivity obtained with the transformer and the Ceco a.c. 22 tube. The selectivity depends primarily upon the resistance, R_2 , inherent in the coil and condenser in the secondary circuit. However, this resistance is increased due to the effect of the primary. Instead of considering the resistance

itself let us consider $\frac{R}{L\omega}$ which is nearly constant

over the wave band and gives directly the sharpness of tuning of the circuit. The smaller this factor the sharper the circuit tunes.

For a given amount of amplification the selectivity of the radio-frequency transformer as a whole depends upon the coefficient of coupling, so that when it is increased to obtain amplification the selectivity of the transformer is also increased.

The solid curve in Fig. 4 shows the resonance curve of the transformer at 400 meters where amplification is plotted against capacity of the tuning condenser above and below resonance. The calculated curve falls for the most part on the

measured curve except that the theoretical curve is slightly higher as shown by the dotted line.

Let us now consider the amplification and selectivity of the screen-grid tube using tuned impedance as shown in Fig. 5, with the equivalent circuit Fig. 6. In this case the gain is given by

$$\frac{E}{E_g} = \frac{R_2}{\tau_2^2 R_p + R_2} \quad (4)$$

so that the smaller the resistance in the secondary circuit and the smaller τ_2 the larger the amplification. Fig. 3, curve 4, shows the amplification measured while using a 2" coil. The calculated curve, 5, in this case is quite close to the measured values, 4. However, the apparent selectivity of the tuned impedance amplifier as shown by the dot-dash curve in Fig. 4, is not as good as in the case of the transformer. There seems also to be another disadvantage in using tuned impedance which is due to the tendency of the circuits to oscillate when using only two stages. The writer has been able to build with careful shielding a two-stage r.f. amplifier using the transformers described without the slightest tendency to oscillate. Regeneration on the detector was possible with the result that tremendous signal strength and fine selectivity were obtained, while with tuned impedance considerably more care was necessary to get two stages to be stable, and even then it seemed as if the signal strength were no greater than with the transformers plus regeneration, while the selectivity of the two systems was not to be compared.

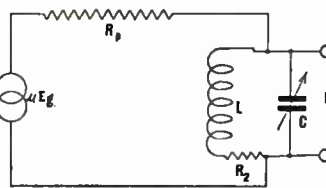

FIG. 6

The equivalent schematic circuit of Fig. 5

Book Review

By CARL DREHER

WIRELESS DIRECTION FINDING AND DIRECTIONAL RECEPTION. By R. Keen. Iliffe & Sons, Ltd., London. 490 pages. 1927. 21s.

THE statement that a given work is indispensable to those interested in the subject is a much misused cliché of technical book-reviewing, but in the case of Keen's "Wireless Direction Finding and Directional Reception" it is merely the literal truth. This book was first published in 1922 under the title of "Direction and Position Finding by Wireless." In the second edition the title was changed to include directional aerial systems, which had in the meantime assumed importance. Keen's work is an important contribution to the specialized literature of radio. It is a serious technical job and not intended for those to whom radio is a plaything. The mathematics is fairly simple, but the vectorial and diagrammatic treatment is very thorough and obviously designed for the attention of engineers and engineering students.

After an introduction, which includes an impartial historical treatment of the subject, directional transmission and reception are discussed. The wave antenna of Beverage, Rice, and Kellogg is described at the end of Chapter 2. The third chapter is devoted to "Frame Aerial

Reception." This is discussed in detail, such topics as "Elimination of Vertical" (the antenna effect of a loop, which plays a part in reception) being treated. The theory of practical systems of this type is comprehensively stated and the chapter closes with a discussion of "Fallacies in Heart-Shape Circuits," this being a study of difficulties found in cardioid-reception circuits using a combination of loop and antenna pick-up. The following chapter describes the characteristics of rotating loop installations of the following types: Radio Communication Company, Ltd., Soci t  Fran aise Radio-El ctrique, Gesellschaft f r Drahtlose Telegraphie (Telefunken), Siemens Brothers and Company, Ltd., U. S. Bureau of Standards, Washington, Marconi's Wireless Telegraph Co., Ltd., Radio Corporation of America, and the Federal Telegraph Company. The descriptions are quite extensive and well illustrated with diagrams and photographs. Chapter 5 is devoted to an analysis of the Bellini-Tosi system, which uses large fixed loops for directive transmission and reception. Another chapter goes into the theory and practice of map drawing. The radio engineer will have his hands full with such terms as "The Gnomonic Graticule," "The Retro-Azimuthal Chart," "The Orthomorphic Cylindrical Projection";

in this chapter and the one following, on "Position Finding and Wireless Navigation," he will have it brought home to him that radio direction finding is as much a branch of geography and navigation as of wireless communication.

Chapter 9, on "Night Effect and Other Freak Phenomena" is of general interest to students of the vagaries of radio transmission. In the following two chapters the discussion returns to types and characteristics of apparatus on shore and afloat. Theory, testing, calibration, and operation are considered in turn. Chapter 12 tells about "The Aircraft D. F. Installation"; it is as complete as possible, but in his preface the author says that this chapter "is still necessarily very curtailed. Although there has been much activity in this direction, there are few concrete designs of aircraft D. F. available for inclusion here." For this state of affairs the difficulties encountered in such installations, as well as the indifference of many airmen, are responsible.

Two more practical chapters, on "Fault Clearing and Maintenance," and "Notes on Field and Nautical Astronomy" complete the work. A bibliography of 374 references and an index are included. If anything material on the subject has been omitted it has escaped the present reviewer.

Coupling Methods for the R. F. Amplifier

By BERT E. SMITH

Aero Products, Inc.

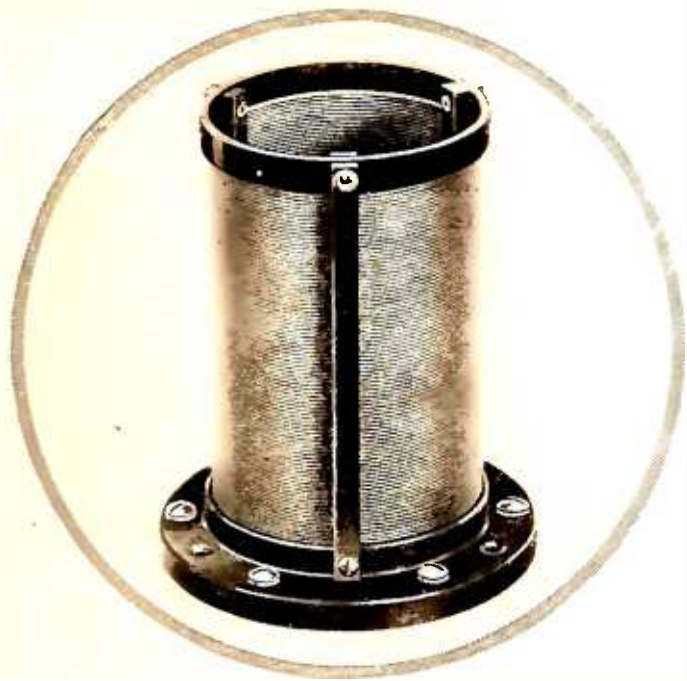

One of the Coils Tested

WHEN the screen-grid tube was first introduced it was heralded by many as a panacea for all the ills associated with r. f. amplifiers. That such is not the case is becoming more and more evident. The tube undoubtedly is valuable, but just what can be expected of it can be determined only from the data obtained from carefully done laboratory investigations. In this article is presented some such data indicating the comparative gain and selectivity that can be obtained from the tube when it is used with different types of r. f. transformers.—THE EDITOR.

FOR several years the development of radio-frequency amplification has been practically dormant, with little, if anything, new in sight at the present time. Recent improvements have been confined to the sonic end of the receiver, with the result that radio has been lifted from a fad to an art, but the old thrill of "distance" has passed! No longer do eager commuters rush for the morning train to brag about the dx of the night before, and no longer do "Radio Widows" get divorces because their husbands desert them to spend the nights with the radio set and the thin elusive signals from a transmitter three or four thousand miles away.

For, strangely, in spite of the fact that receivers now average six or seven tubes where they used to have perhaps three, and broadcasters use ten or a hundred times their former power, it is harder and harder to get distant stations.

Many theories have been advanced to explain this, but in the final analysis, it becomes increasingly evident that the truth must be that in the rush for selectivity and quality, designers have lost sight of sensitivity. The science of radio-frequency amplification has seen retrogression rather than progress. Nothing of any real value has been introduced since the Hazeltine neutrodyne system several years back, and even that, insofar as the principle of neutralization by external capacitive reactance is concerned, was only a variant of the earlier Rice system.

In the years immediately following the introduction of the neutrodyne, many schemes have been advanced purporting to produce the full theoretical amplification of the tube and transformer, or to enable the tubes to be stabilized without any loss of efficiency, but all have proven impractical, and 100 per cent. efficient radio-frequency amplification continues to be a vainly sought chimera. A surprising number of manufacturers have returned to the oldest method of stabilizing known—potentiometer grid control. Some are cutting down the plate voltage applied to the tubes. Some use variable leaks across the tuning condenser, broadening the tuning and losing all the well known advantages of low-loss coil and condenser construction. Practically every manufactured receiver to-day on the market employs one of the

"losser" systems which were so violently, although justly, condemned a few years ago!

Small wonder, then, that receivers do not reach out for distance now as then!

That there is still a call for sets which will bring in distant stations was distinctly evidenced by the sudden rush when the screen-grid tube was announced, and it is decidedly unfortunate that this tube was heralded by so much misleading publicity, which led builders to expect much that has proven impossible. Many of the leading publications carried editorial matter describing the great amplification obtainable from a tube which would not oscillate, and even the largest tube manufacturers and best engineers in the country allowed statements to appear such as "a voltage amplification of 200 per stage is obtainable, but at broadcast frequencies the resonant impedance is lower reducing the amplification by 25 per cent. of this value."

It may be possible to get such gain from the tube in laboratory apparatus, constructed by competent engineers, and under ideal conditions, but performance of this kind cannot by any means be secured from the ordinary broadcast receiver. It has become extremely doubtful, in the writer's opinion, whether the tube in ordinary use in tuned radio-frequency receivers operating at frequencies of 500 kilocycles and higher can produce great deal better all around results than the 201A type tube which has been standard for so long a time.

With all these facts firmly in mind, an investigation was recently undertaken with the object of determining two things: First, whether some existing method of stabilization could not be so modified as to give really passable results by permitting r.f. amplifiers to be built without the intentional introduction of losses except as

desired for a volume control; and secondly, whether this amplification might be obtained within appreciable limits of selectivity, regardless of the type of tube used. However, all the tests described below utilized the 222 type of tube. No new ground was gone over, and nothing was developed which did not bear out previous empirical design, but there had been so much theoretical data published, and so little of the results of actual quantitative tests, that it seemed that figures obtained through concrete experimentation might be at least refreshing.

Prior to commencing any actual work, certain limits were laid down as essential if the results were to be of any value in designing a receiver which could be constructed by the kit builder. First, standard apparatus, obtainable by anyone, must be employed. Second, the need for any complicated balancing, by means of expensively accurate apparatus after construction, must be avoided if possible. Thirdly, the use of shielding, while not barred, was considered undesirable as introducing superfluous expense and trouble. Last, no involved or critical adjustments of any kind were allowable, as a receiver must be infallibly sure to give good results if the connections are properly made, in the hands of the most inexperienced operator.

THE TEST OF COUPLING METHODS

THE first actual operation was the determination of the method of coupling tubes, and the optimum values to be used in the coupling device. For this the set-up shown in Figure 1 was utilized originally, but since the conditions in the grid circuit of the amplifier tube were not identical with those which would be encountered in actual practice, it was found advisable to add a second stage, coupled to the grid of the test stage tube by a special radio-frequency transformer having an absolutely flat amplification-against-frequency characteristic. The use of this stage allowed the test stage to be adjusted to operate in a manner exactly identical with its performance in an actual receiver, permitting oscillation to take place in the same way and at the same point. The output of a modulated oscillator, variable in frequency over the broadcast spectrum, was led through an adjustable attenuator to the grid of the first amplifier tube,

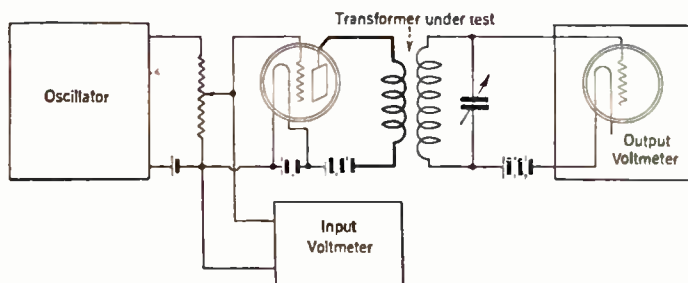

FIG. 1

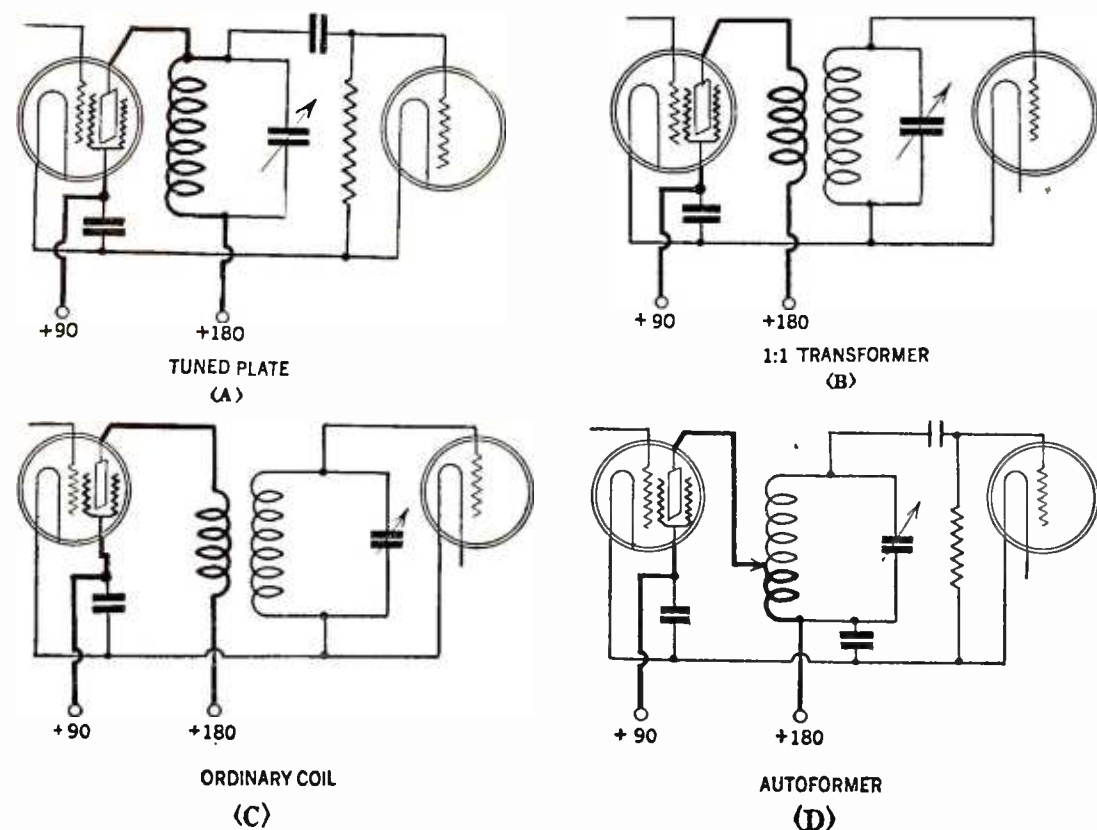

FIG. 2

also actuating a very sensitive vacuum tube voltmeter. By this means the input signal could be kept constant regardless of frequency variation. The output of the coil under test was led to a second vacuum tube voltmeter whose input characteristics were similar to those of a typical detector circuit. A second transformer, having the same flat amplification-against-frequency characteristic already mentioned, was used as a standard of comparison for plotting figures of merit on all couplers used.

This test was given to coils of sixteen types, as many of each type being tried as were deemed necessary to determine their worth. Inasmuch as the reproduction of all these curves here would only lead to confusion, due to their number, and would serve no particularly useful purpose, we will show the results obtained in those most usual types which had a bearing on the final result. However, as a matter of information, it may perhaps be advisable to outline roughly the types involved and the major reason for their abandonment.

All coils were of the general type illustrated in the photograph on page 361, having 77 turns of wire in the secondary circuit, air-spaced to conform to an approach to the ideal shape factor and supported by a skeleton bakelite frame, so that the insulation losses are kept at a minimum figure. The self-inductance of the secondary alone was 167.4 microhenries and the radio-frequency resistance of the coil in series with a Cardwell condenser varied from 3.85 ohms at 550 meters to 9.6 ohms at 200 meters. These figures are meaningless in direct relation to almost all of the actually tested coils, as the introduction of a primary coil, or the use of a portion of the secondary coil for coupling, have a decided effect on both the inductance and the high-frequency resistance of the secondary.

Among the types tested were:

1. A tuned impedance, directly from plate and grid to ground. Fig. 2-A.
2. An auto transformer, in which a portion of the secondary is used as primary, the low potential ends being common. Fig. 2-D.

3. A transformer in which the primary and secondary are coupled by a bypass condenser at the low potential ends, the direction of the winding being continuous from plate to grid, and the coil being tuned from plate to grid, as in the R. B. Lab. circuit and Betts circuit adaptations.

4. A primary wound to take up a length of $1\frac{1}{2}$ " inside the secondary. Fig. 2-B.

5. A primary wound to take up $\frac{1}{2}$ ", placed inside and in the center of the secondary.

6. A primary wound to take up $\frac{1}{2}$ ", placed inside and opposite the low potential end of the secondary. Fig. 2-C.

7. A primary wound with a length of $\frac{1}{8}$ ", placed in both positions above described.

8. A primary wound in a $\frac{1}{8}$ " slot, coupled adjustably to the secondary.

9. A primary wound on the same diameter as, and at an adjustable distance from, the secondary.

10. A tuned primary with adjustable coupling to the secondary.

Each was tested with a varying number of

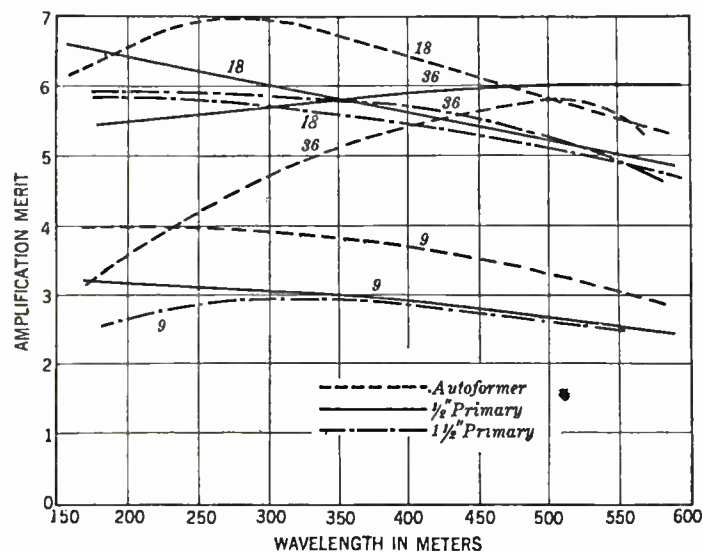

FIG. 3

The numbers on the curves refer to the number of turns used in the primaries of the coils that were tested

primary turns, and where possible, with varying degrees of coupling, as well as with primary windings in both directions in the first few tested. Empirical analysis previous to the test had led us to believe that where capacitive coupling existed between the plate circuit of the preceding tube and the grid circuit of the following tube, the voltage in the secondary due to this coupling would be in quadrature with that generated by the inductive coupling when the winding was continuous in direction from plate to grid, and hence would reduce the amplification obtainable, although probably flattening the curves somewhat due to the change in relative energy transfer by capacity and inductance at varying frequency. This was borne out in the first few curves, and since the object of the test was to secure the highest possible amplification throughout, the balance of the tests was made entirely with the windings in opposite directions.

RESULTS

IN FIG. 3 curves of amplification are shown on three windings in types 2, 4 and 6, and will be discussed at more length later. Type 1, illustrated in Fig. 2-A, generally advocated for use with the screen-grid tube, showed no greater amplification than several other types, and was pronouncedly poor in selectivity. Type 3 gave beautifully flat curves, but the amplification was low, as only a portion of the built up voltage was impressed across the grid and filament of the following tube, and the selectivity was rather poor. Types 7 and 8 appeared desirable from some angles for particular purposes, but in general were not considered as useful as the standard types. Due probably to the large distributed capacity of this type of winding, decided resonance peaks were obtained which varied in their amplitude with the degree of coupling and number of turns used. When a coupling was adjusted to the optimum degree where only three peaks were observed in the broadcast spectrum and a merit figure of $4\frac{1}{2}$ to $5\frac{1}{2}$ was obtained, the selectivity was very poor, and when either coupling or self-inductance was so adjusted as to allow appreciable selectivity, variations in amplification as high as 50 per cent. were unavoidable. It seems therefore evident that this type of winding is not as a rule desirable. Type 10 gave extremely good results, but was impractical for use in receivers because each stage would require three controls, two for tuning and one for coupling, each of which required adjustment for every frequency change.

Types 4 and 6 are very commonly used, and hence we have selected them for detailed presentation in connection with type 2, which was finally adopted as best. Type 4, illustrated in Fig. 2-B and generally advocated for use with the screen-grid tube when the tuned impedance arrangement is not employed, is shown on the chart of Fig. 3 in dot-dash lines, and it will be noted that after the number of turns increases to a certain point, no further increase in amplification is obtained, and hence the 1:1 ratio which has been recommended is not only unnecessary, but undesirable, since the selectivity, poor at all times with this type of construction, is very bad when more than eighteen turns are used.

Type 6, illustrated in Fig. 2-C, is the type most commonly used at the present time and the results indicate that if conventional circuits are to be employed, it is considerably superior to any of the others tried. It is at least as good in amplification as the widespread primary, with

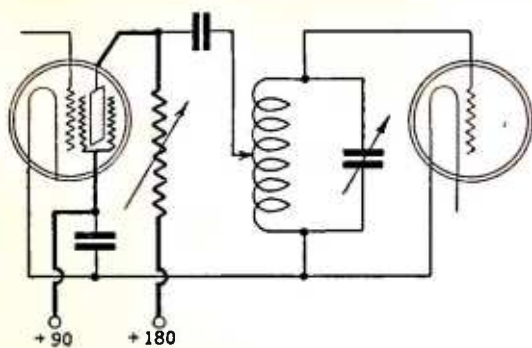

FIG. 4

a considerably improved selectivity factor. It will be noted in Fig. 3 that a variation in the number of turns results in a change of the point where maximum amplification is secured, and hence in a multistage cascade amplifier where selectivity in one or two stages may be sacrificed, comparatively uniform amplification can be secured over the whole band by adjusting the number of turns in the primary of each transformer.

Results obtained from type 2, illustrated in Fig. 2-D, are of extreme interest. In this type of coil a varying portion of the secondary acts as primary, with the primary and secondary currents in this portion of the coil in quadrature. The inductive coupling for the same number of turns in the primary is much greater in this type of coil, hence a comparatively high plate circuit impedance is built up with a relatively small number of turns, with consequent greater overall amplification. It will be noted in Fig. 3 that when many turns are used as primary, the amplification on the shorter wavelengths is reduced, because the portion of the coil in which the currents are in quadrature is appreciable and hence the voltage at the grid of the following tube is lower. This can be put to good use in a multistage amplifier to secure substantially uniform amplification over the whole spectrum. The selectivity of this arrangement compares very favorably with all of the types tested, and is pronouncedly superior to both the more or less commonly used types directly compared.

In the selectivity curves shown in Fig. 6, a selectivity factor of 50 is fair, 55 is good, and 60 is an extremely desirable value. At 350 meters this selectivity figure can be obtained with the autotransformer circuit with an amplification figure of merit of 5.7, whereas with the $\frac{1}{2}$ " primary corresponding selectivity is secured with an amplification of only 3.6, or about 65 per cent. In this particular instance the superiority of the autotransformer type is very outstanding.

As shown in Fig. 2-D the autotransformer circuit is not very practical due to the high potential (d.c.) of the tuning condenser. The circuit of Fig. 4 retains the advantages of the coil construction while eliminating this drawback.

OSCILLATION CONTROL

UP TO this point no mention has been made of oscillation. Depending upon the tube used and the constants of the circuit, this was frequently encountered, even with the screen-grid tube, unless some means were taken to prevent it. In this connection, it must be borne in mind, in analyzing the results obtained, that they only hold good in a circuit carefully adjusted in such a way that oscillations cannot take place.

A review of various methods of stabilization indicated that the best results were probably ob-

tained by shifting the phase angle of the currents in various stages, by a method somewhat similar to that illustrated in Figure 4. Here in the plate circuit, we have one branch consisting of resistance only and another of capacity and inductance in series, the latter value depending upon where the tap is placed on the tuning coil.

By varying the resistance, it is possible to change the angle by which the current leads the voltage in any one stage, and in this way control the tendency towards oscillation. Unfortunately, however, when resistances of the proper value to give us adequate control of the phase angle are employed, it will be found that any variation of the resistor varies the plate voltage applied to the tube and may seriously affect the amplification obtainable. In order to avoid this, the circuit shown in Fig. 5 was finally adopted. The r.f. choke, L_2 , having a comparatively low d.c. resistance, was shunted around the resistance, maintaining a maximum static value of plate voltage at the tube, while offering a very high impedance to radio-frequency currents. The resistance, R_1 , can now be varied without affecting the static value of the plate voltage and will be found to serve very nicely as an oscillation

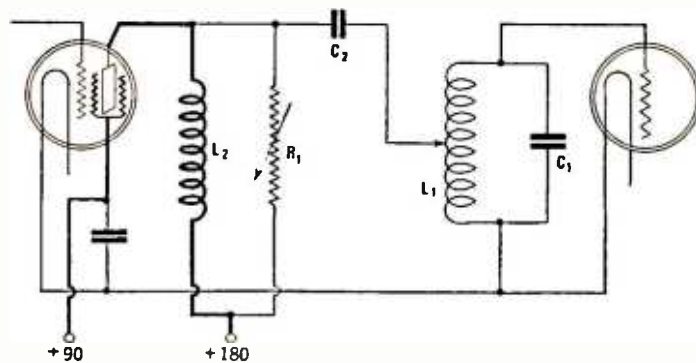

FIG. 5

control; and if it can be reduced to a low value, so as to effectively short circuit C_2 , it can also be employed as a volume control for the receiver.

In a circuit containing two stages of r.f. amplification, it will rarely be found necessary to employ more than one such resistance, as sufficient adjustment can be obtained to avoid oscillation while still maintaining a satisfactory value of overall amplification. Maximum results, regardless of the type of tube used, can be obtained by varying the proportion of L_1 which is used in the plate circuit of the preceding tube. Little trouble was experienced from inductive coupling between coils, provided a distance of at least 6" was between coil centers. Fig. 7 shows the coupling between two secondaries of the type used, having parallel axes.

Shielding always introduces certain losses in the coil, and also complicates the mechanical construction of the receiver. It will be seen from the curve in Fig 7 that the necessity of shielding is mitigated as far as inter-stage coupling effects go, while the diameter of the coil is so small that direct pick-up from local stations is reduced to a minimum.

In the interest of compactness, a trial was made of another method of mounting the coils where three or more tuned circuits existed. The coils were mounted comparatively close to each other but in such positions that their fields were

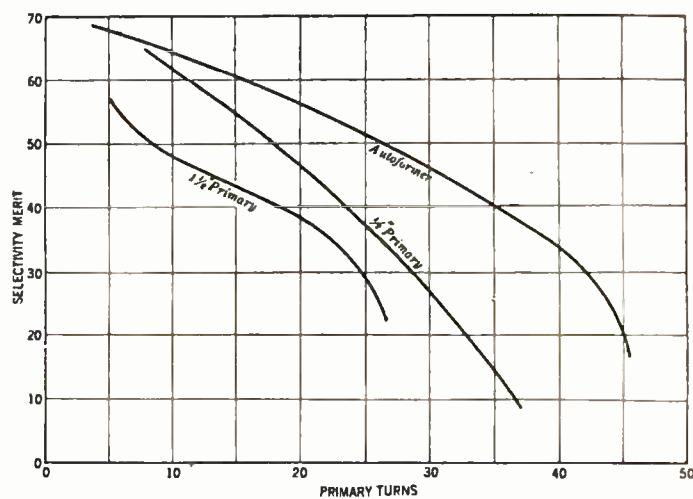

FIG. 6

opposed. It will be recalled that this "sacred angle" construction was used in practically all of the earlier neutrodynes. While placing the inductances at such an angle that the magnetic fields of several coils intermingle the least, gives some relief against unwanted coupling of this type, at the same time the coupling due to the capacity then existing between coils vitiates the most of the benefit theoretically secured.

When the coils were placed sufficiently close to secure any advantage from compactness, capacity coupling was encountered to such an extent as to destroy completely any possible advantage to be gained from this method of mounting. In addition, the length of grid leads required was in excess of a passable figure, and consequently the scheme was abandoned.

The next portion of this article will describe the construction of a receiver using two stages of tuned radio-frequency amplification with screen-grid tubes employing the "Chronophase" system whose final evolution is pictured in Fig. 5. The particular receiver in question has fully justified the long period of experimentation preceding its actual construction and will be found both in sensitivity and selectivity to be superior to most receivers with one or two additional stages of radio-frequency amplification. On a 25-foot antenna located on the shore of Lake Michigan, in the heart of the most congested mass of broadcasting stations in the world, it has been possible to cut through locals and secure good loud speaker reception of stations a thousand miles distant.

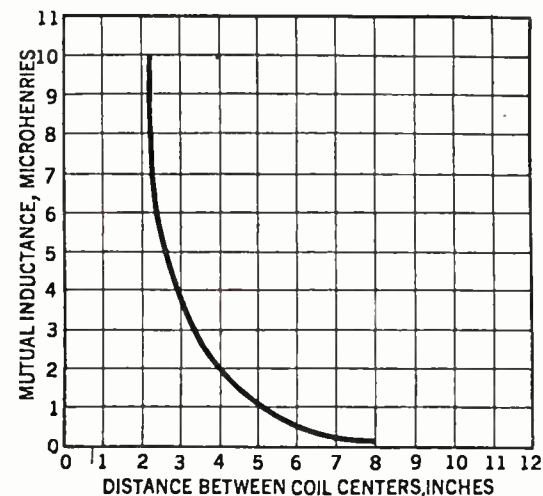

FIG. 7

“Our Readers Suggest—”

OUR Readers Suggest” is a clearing bouse for short radio articles. There are many interesting ideas germane to the science of radio transmission and reception that can be made clear in a concise exposition, and it is to these abbreviated notes that this department is dedicated. While some of these contributions are from the pens of professional writers and engineers, we particularly solicit short manuscripts from the average reader describing the various “kinks,” radio short cuts, and economies that be necessarily runs across from time to time. A glance over this “Our Readers Suggest” will indicate the material that is acceptable.

Photographs are especially desirable and will be paid for. Material accepted will be paid for on publication at our usual rates with extra consideration for particularly meritorious ideas.

—THE EDITOR.

A Power Unit Voltage Divider.

THIS department has published, from time to time, contributions describing various home constructed voltage divider systems and other devices for the improvement of power units designed prior to those incorporating more modern apparatus. Several of these arrangements have provided for C-bias potentials.

The circuit of a compact voltage divider unit, recently placed in the market by Electrad, is shown in Fig. 1. The various resistors incorporated in the unit are all variable, providing for any desired seven positive and negative potentials within the limits of the power supply output.

The “Truvolt” divider may be incorporated in the output circuit of a new power unit or used to provide special potentials from a ready-built supply unit.

Noisy reception can often be traced to disintegrating resistors in the voltage distribution system of a power supply device, a difficulty that is readily eliminated by substituting the Electrad divider unit for the original resistor system. The old resistors should be removed and the divider connected between the points of the highest potential, i.e., between the highest B voltage post and B negative or the highest C bias terminal, if such is provided on the power unit, Terminal 1 on the divider is connected to the high voltage side of the line, and Terminal 7 to the low voltage side.

Each potential secured from the divider should be bypassed with a 1.0-mfd. condenser to the post used as B negative, as suggested by the dotted lines in Fig. 1, which shows the terminal arrangement for the potentials generally required. However, the divider can be connected to the receiver in many ways to secure practically any voltage distribution.

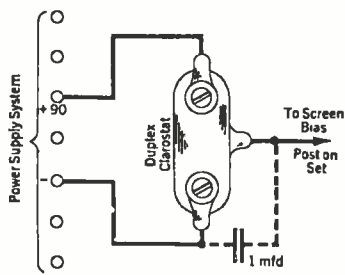

FIG. 1
The circuit arrangement of the Truvolt divider. This unit can be used for the rejuvenation of old power supply sets as well as in the construction of modern designs

with a 1.0-mfd. condenser, indicated in dotted lines in Fig. 2.

A. R. COATES, New York City.

Testing for Soft Tubes

IT IS the general custom to test for a “soft” tube by operating it under an excessive plate potential. The blue haze, caused by ionization, is an indication that the tube is soft. Unfortunately, a test of this nature often changes the characteristics of the tube, occasionally lessening the efficiency of what otherwise would be a good detector.

A perfectly safe test, more compatible with the tenets of laboratory procedure, may be effected with a small spark coil, such as that employed in the Ford, Model T, ignition system. If one of the secondary terminals is not already wired to the primary (as is the case with the Ford coil), make this connection, using a couple of dry cells

FIG. 2
A simple way of obtaining the correct positive bias for the screen grid on a screen-grid tube. This bias varies with circuit, tube and available control grid bias

Obtaining Screen-Grid Bias

FOR the most efficient operation of screen-grid receivers a positive bias on the screen grid is required. Few power units designed prior to the introduction of the 222 tube provide the proper screen voltage. By means of a Duplex Clarostat, connected as a potentiometer between the negative and plus 90 volt posts on my power supply set, I am able to secure the best biasing potential. The circuit is simple and is shown in Fig. 2. Both adjustment screws should be given about two and a half turns up (from a tight adjustment) and then the lower screw adjusted until signals are amplified most efficiently. The bias potential should be bypassed

to energize the primary. Take the tube in hand, covering the glass as much as possible, and touch any of the terminals to the high tension lead from the coil, watching the while for glow. No sign of ionization indicates a hard tube—or one full of air. In this latter case, of course, the filament would burn out when connected across the usual battery circuit.

A pale greenish glow, close to the inside surface of the glass, indicates about the right amount of gas for a good detecting tube. If the glow is purple, and is confined to a small area directly around the plate and filament, the probability is that there is too much gas for efficient detecting action.

ALFRED A. GHIRARDI, Stapleton, N. Y.

Matching Condensers and Coils in Tandem Tuned Circuits

WHILE the general procedure for matching isolated coils and condensers is fairly well understood, I have never read anything on the process involved in matching coils and condensers already connected in a receiving circuit. The following system will be of value to the experimenter who desires to match an r.f. tuning combination more closely than can be done by the trial and error method on a station.

The method employs an oscillator with a meter in the plate circuit to indicate resonance. It is not essential to know the wavelength to which the oscillator is tuned, as long as it is within the broadcast band. Fig. 3 shows a circuit that can be employed as an oscillator.

The number of turns of wire wound on a $3\frac{1}{2}$ " winding form is indicated on the diagram. The size of wire is not important.

The additional materials are about three feet of rubber covered wire and a small clip facilitating a temporary connection to the grid side of the circuit being tuned. Cut the wire in half and twist two ends of it together for about one inch, making a small condenser. One of the two remaining ends is soldered to the clip and the other to the grid terminal of the oscillating tube.

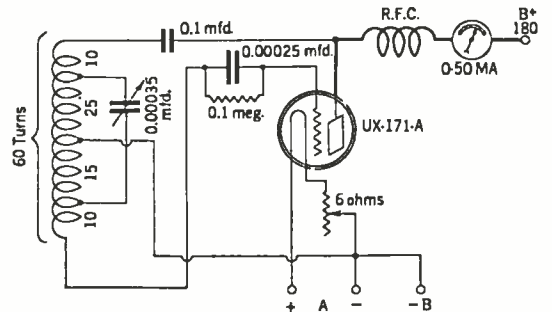

FIG. 3
An easily constructed oscillator for use in matching circuits in single control receivers, and other purposes. Any one of the several oscillators previously described in RADIO BROADCAST may be used

The procedure is as follows: Have the condenser sections of the combination to be matched half way out. (If the condensers are to be matched with the aid of trimmers, the trimmers also should be at half maximum capacity.) Start the oscillator and snap the clip to the grid side of one of the condensers. Tune the oscillator to resonance, which will be indicated by a maximum dip on the meter. If the dip is too broad, reduce the capacity of the twisted rubber-covered wire—by cutting down the overlap—until a sharp dip is obtained.

Snap the clip on the next condenser, and adjust this to resonance (without touching the oscillator adjustment) either by use of the trimmer, or by tapping the plates into place. At maximum deflection the two stages are in resonance with each other. The procedure is the same for additional circuits.

JOHN BENEDICT, Maspeth, L. I.

An Amplifier Kink

HAVING an occasion to revamp an old set for a friend of mine, I used the audio-frequency arrangement shown in Fig. 5. The Thordarson 3½:1 transformers, originally supplied with the set, were merely rewired to conform with the diagram.

The tone quality was considerably improved, particularly on the lower register. I effected still further improvement by the use of 112A tubes in the detector and first audio sockets.

EDWIN M. WRIGHT, Phila., Pa.

ohm resistor (a Pilot Resistograd) adds the low notes to taste.

H. D. HATCH, Wollaston, Mass.

STAFF COMMENT

MR. HATCH'S idea should prove most effective in eliminating the "boom" experienced with many cone and airplane cloth speakers.

A. C. Tube to Reduce Microphonics

MANY battery-operated receivers, the operation of which is characterized by excessive microphonic disturbances, can be improved by the substitution of a UX-227 a.c. tube in the detector socket with the proper filament resistor to permit its operation from a 6-volt battery.

Previous to making the suggested change, enjoyable reception from the writer's battery-operated set was practically impossible. Footsteps in the room, or the passage of a truck in the street, was sufficient to set up ringing microphonics in the loud speaker.

Appreciating the fact that the rigidity of cathode structure in a.c. detector tubes tends to reduce the vibratory motion responsible for microphonics, I replaced the UX socket in my receiver with a 5-prong socket, wiring a 6-ohm rheostat in series with the filament circuit. The cathode is connected to the positive filament terminal on the socket—that is, "C" and

plus "F" are strapped together. A UX-227 tube can now be used as a detector. If the time lag—30 to 40 seconds—is objectionable, an Arcturus type 127 tube can be used instead. This latter tube "comes up" in about seven seconds.

STAFF COMMENT

THE Editor of this department has done considerable experimenting with the use of heater type tubes in airplane receivers, where they are very effective in the reduction of microphonics.

If the reader does not care to change the socket in his receiver, an Arcturus type 171 tube can be plugged into the detector socket, without making any changes in the receiver at all. No additional rheostat is required for this 5-volt tube.

An Antenna Booster For Loop

I HAVE a loop-operated set which is badly shielded by surrounding walls. To correct this I am using an outside antenna inductively coupled to the loop by means of a coil. The coil is placed inside the loop and connected to the outside antenna and to the ground.

I am using a 3" coil with 50 turns of No. 20 wire. I find that by tapping this coil in four places, that is, every ten turns, the reception is greatly improved over the entire range of wavelengths. That is, on short waves the 10-turn tap is just right while on long waves 40 turns or 50 turns is about right, with proportionate taps in between.

WILLIAM D. ESCH, Cherryvale, Kans.

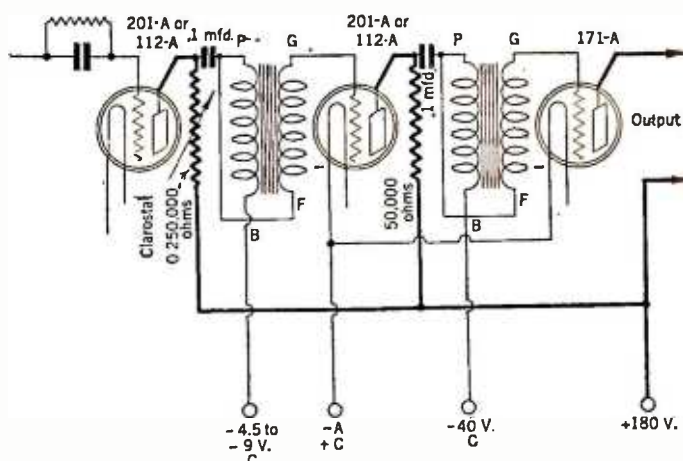

FIG. 5

Rearranging an old amplifier in accord with this circuit will give fine quality even with poor amplifying transformers

STAFF COMMENT

AN ARRANGEMENT practically identical with Mr. Esch's suggestion was described in this department for December, 1927, and January, 1928. A commercial coupling coil for this purpose is made by the Jenkins Radio Company of Davenport, Iowa.

An Output Filter Without a Condenser

A VERY effective output device for use with the average receiver may be made with the use of a choke only (the condenser being omitted) providing the characteristics of power tube and speaker are known so that the proper choke may be employed.

In a receiver constructed by the writer, a 171 type tube was used in conjunction with an R. C. A. 100 speaker, which is comparable in characteristics to most cone reproducers. A condenser of sufficient capacity not being available, the speaker was connected in parallel with a 25-henry choke as shown in Fig. 6-A. The equivalent circuit, based on a frequency of 100 cycles, is shown in Fig. 6-B. At this frequency the impedances are, approximately: tube—2000 ohms, choke—15,700 ohms, and speaker—2000 ohms. The d.c. resistance of the choke is 600 ohms and that of the speaker is 1800 ohms.

It will readily be seen that the speaker, being of relatively low impedance, will take about 90 per cent. of the a.c. current, but due to its high resistance, compared to that of the choke, will allow but one third of the d.c. current to pass. This will be in the neighborhood of 6 milliamperes, which is not objectionable. The resistance of the plate circuit is considerably lower than that of the actual output device, and hence the voltage drop will be smaller.

The quality of reproduction, using this combination, was found to be excellent.

GLENN R. TAFT, Ticonderoga, N. Y.

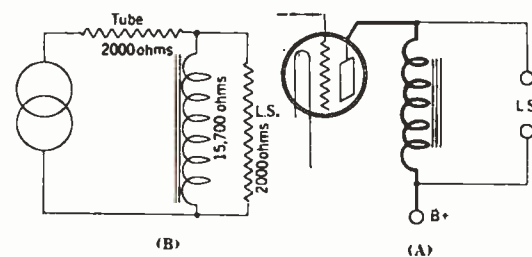

FIG. 6

An output device using a choke coil without the conventional condenser. The wiring circuit is shown at A, and at B is the equivalent schematic circuit

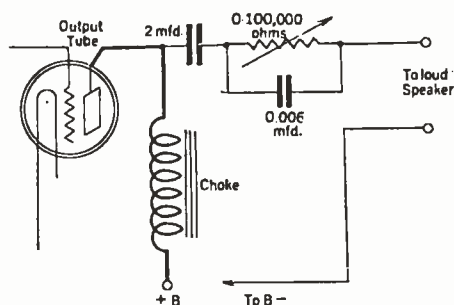

FIG. 4

A simple equalizing arrangement that controls the reproduction of low notes. This device will eliminate the "boom" in many modern speaker-amplifier combinations

STAFF COMMENT
THE arrangement suggested by Mr. Wright emphasizes the low notes. Reproduction of the higher notes can be enhanced by the substitution of a 30-henry choke for the 50,000-ohm resistor in the plate circuit of the first audio tube.

Dynamic Speaker Field Supplied from B-Power Unit

IT IS possible to excite the windings of several of the d.c. type of dynamic loud speakers from the plate current to a receiver operated from a line power supply source. It is merely necessary to connect the excitation windings of the loud speaker between the choke coil nearest the output of the socket power unit and the maximum voltage post. The connection is broken and the circuit recompleted through the windings, care being observed to connect the positive loud-speaker post to the choke coil. The current drain to the receiver should be in the neighborhood of 100 milliamperes. This, however, is generally the case where a dynamic speaker is justified.

A. V. SVENDSEN, New Zealand.

A Simple Audio Channel Equalizer

I HAVE found several sets in which the combination of a good audio channel and a good speaker gives an overemphasis to the low notes. I find that the addition to the usual choke output device suggested diagrammatically in Fig. 4, is most effective in controlling the amount of low-frequency reproduction.

The 0.006-mfd. condenser bypasses the high frequencies anyway, and varying the 100,000-

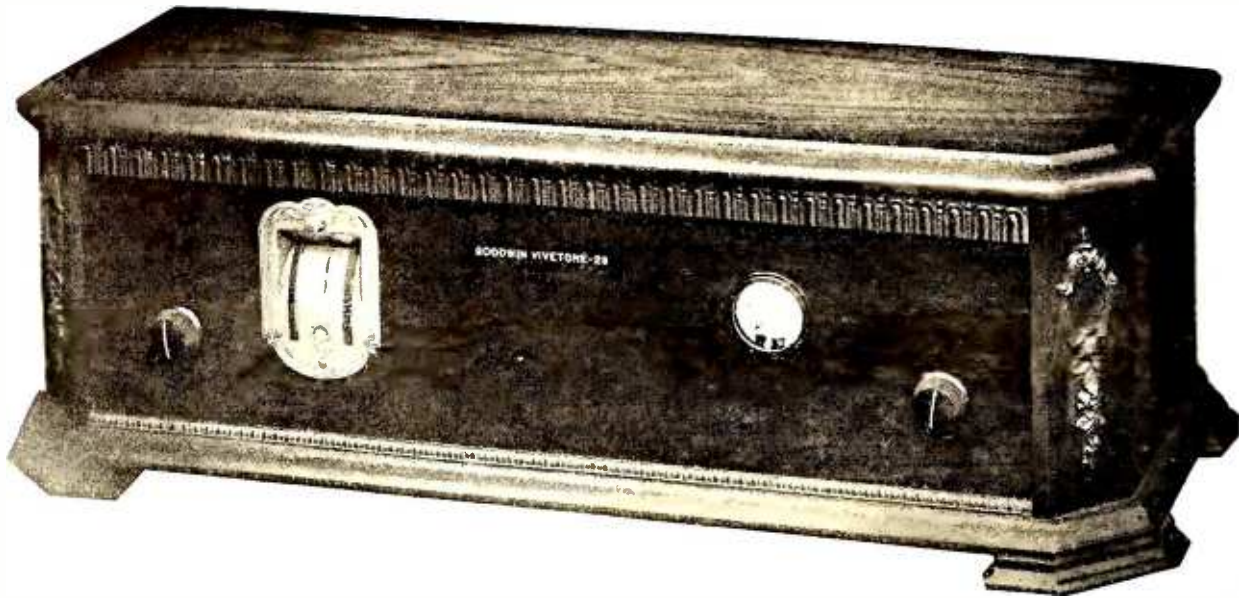

The Receiver Combines Simplicity and Beauty

The "Vivetone 29" Receiver

By R. F. GOODWIN

THE receiver which Mr. Goodwin describes in this article is a t.r.f. set which performed in the Laboratory in a fashion to indicate that its designer is not prone to exaggeration. There are several novel features; one is an automatic regeneration control, consisting of a resistor which changes its value as the set is tuned, thus adjusting the C bias on the r.f. tubes and keeping them from oscillating at any dial setting. Another is an a.c. voltmeter which is mounted on the panel so that the operator can tell at all times the voltages across his tubes. If the constructor builds one of the amplifier-power supply units the author has developed, he will have in it a regulating device which will enable him to keep this voltage at its proper value regardless of line voltage fluctuations.

—THE EDITOR.



SENSITIVITY, selectivity, quality of reproduction, beauty in appearance, and simplicity of operation—these are the five paramount requisites of a modern receiver. Every discriminating radio constructor or enthusiast must consider each of these features separately and in connection with each other when he decides what receiver to build, buy, or operate. Some of these features are often secured at a sacrifice of others; as in other phases of life one cannot get something for nothing.

The "Vivetone 29" is a receiver in which the effort has been made to incorporate all these features to as high a degree as possible without too great a compromise. In other words, it embodies a circuit that has considerable radio-frequency gain, that is simple to operate—there are only two controls—and yet is sufficiently selective to cope with modern broadcasting conditions. More will be said about the sensitivity and selectivity later when the writer describes his own success with the receiver in a location which is none too good for dx reception. It is enough to state now that the selectivity is sufficient to enable one to tune through many local stations with a minimum of interference,

and that the sensitivity is such that distant stations can be picked up with a great deal of ease.

DESIGN FEATURES

THE fact that the set contains three stages of r. f. amplification, each separately shielded and constructed of the best "low loss" apparatus now on the market, may account to the technical reader for the set's gain. With the addition of the detector input, which is tuned, the receiver has four tuned circuits, each working with a minimum of regeneration so that the order of selectivity is rather high.

There are two novel features, one of which has not been seen heretofore so far as the writer is aware, and the other—an a. c. voltmeter on the panel—is omitted from the vast majority of otherwise well designed sets. The novel feature which impresses the writer most is a simple but effective method of automatically controlling the regeneration in the r. f. stages. This is done by automatically varying the bias of the grids of the r. f. tubes as the set is tuned to various frequencies.

It is well known that all t.r.f. receivers tend to oscillate badly on the high frequencies (shorter wavelengths) and that many such receivers have included in their mechanism a resistor which changes the plate voltage, or C bias, of the r. f. tubes so that actual oscillation does not take place. Such devices are always manually operated, so that at each setting of the tuning condensers it becomes necessary to adjust the regeneration control—often labelled a volume control—to the point of best operation.

In this receiver all such adjustments are made automatically by attaching a 2000-ohm variable resistance, PP-2000 in Fig. 2 and 3, to the shaft of the tuning condensers. It is so adjusted that as the tuning condensers are varied the bias is reduced at the lower frequencies and increased at the higher frequencies. This has the same effect as changing the plate voltages to these tubes, but in the writer's experience is a neater method of accomplishing the same result, i. e., the maintenance of greater stability as a whole.

In addition to the automatically changing resistance, another resistance is shunted across

the bias adjuster for fine adjustments. This resistance, PP-5000, is located on the panel so that manual regulation may be had when desired. It must be understood that it is not necessary to change the setting of this resistance at all for ordinary operation, but when one is dx hunting he often needs just that small additional control which "brings 'em in."

On the panel is an a. c. voltmeter which, after the receiver has been placed in operation, is permanently connected across the heater element of the detector tube. It shows the voltage across that tube at all times, and since this tube in common with all the others is fed from a filament supply transformer the meter's indication tells what the general voltage conditions are. The writer has developed a series of power units for this receiver in which are incorporated voltage regulating devices. It is a simple matter, then, to keep the voltages across the filaments and heaters of the tubes at the proper value at all times.

If the receiver is operated with another power device in which there is no provision for voltage adjustments, the operator may obtain such regulation by placing a power resistor in series with his power transformer primary.

AUDIO AND POWER UNITS

THE "Vivetone 29" receiver proper does not incorporate an audio amplifier, since the writer does not believe that an audio amplifier should be built in the same cabinet with the r.f. portion if the size of the set is to be kept within attractive proportions. Keeping it separate from the tuning elements of the receiver not only gives the builder a choice of audio equipment, but also permits him to have more room for the disposition of his r.f. apparatus. Space in this part of the receiver is most important when one is interested in sensitivity and selectivity.

The writer has developed two power amplifier units that can be constructed for the "Vivetone 29." One of these uses a CX-310 tube in the last stage with a Thordarson 210 power pack. This unit will be described in a later issue. Each of these units incorporates a complete audio amplifier and A-B-C-power supply. The home con-

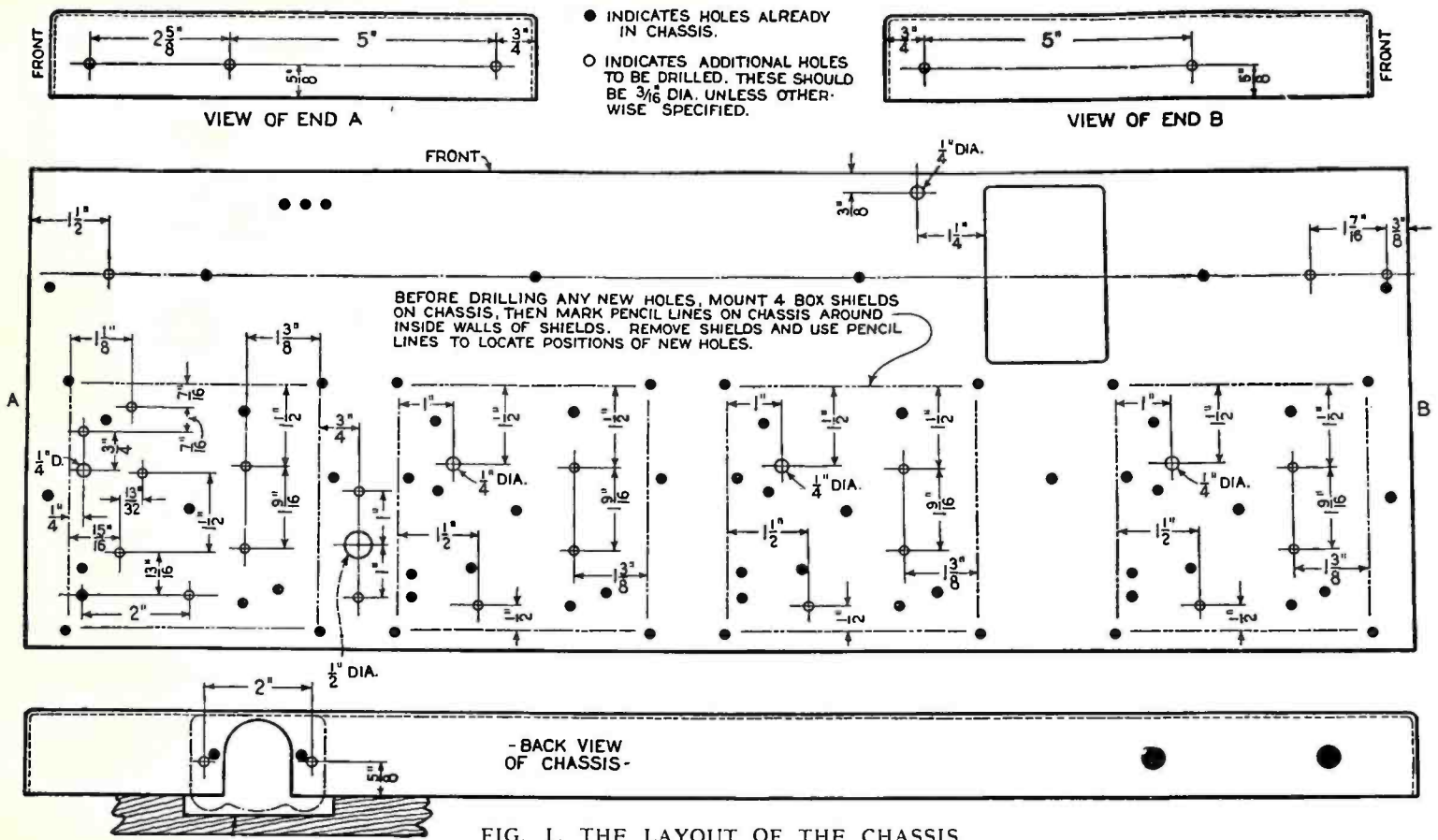

FIG. 1. THE LAYOUT OF THE CHASSIS

structor or custom set builder may choose the power supply unit that suits his pocketbook, or may pick out the one which gives the greatest amount of output power at audio frequencies. The quality of reproduction that is obtainable from the receiver with either of these units or with any good amplifier and power equipment is comparable with the best receivers on the market to-day.

The tuning equipment illustrated and described here can be used, of course, with any amplifier. The output of the detector may easily be placed on an amplifier of any number of stages or of any type of coupling devices. With the advent of the newer power tubes, the constructor is advised to go in for the best he can afford, since a receiver made of the best apparatus now purchaseable should be able to stand up in comparison with the receivers to be designed and built for several years to come. In other words the best possible receiver and power equipment is, in the long run, the most economical. Unlike the automobile, it does not depreciate at a very rapid rate.

The receiver is battery-less. It is entirely electrified with either of the power units the writer has built or with any power apparatus which operates from a light socket. This is accomplished by the use of 326 and 327 a.c. tubes.

CONSTRUCTION

PROBABLY the most novel part of the receiver so far as the home constructor is concerned, is that all the parts in it are standard and can be purchased at most dependable radio dealers.

The sub-base and box shields are standard products of the Aluminum Company of America

and most of the holes required for mounting the parts to this sub-base have been punched in during the manufacturing process. The few additional small holes required can easily be made with the aid of a small hand drill which is most generally part of the radio technician's tool kit. Fig. 1 shows exactly where to drill these holes.

The construction of the receiver is simplicity itself, and is clearly shown in the schematic and picture wiring diagrams in Figs. 2, 3 and 4 and the panel layout in Fig. 1. Resistor PP-2000, whose variable arm is attached to the gang condenser shaft, is mounted on a brass bracket $2\frac{1}{16}$ " high and $\frac{3}{8}$ " wide screwed to the chassis. Each of the r. f. coils, 9072, is mounted by means of two $\frac{6}{32}$ " round head machine screws $1\frac{1}{2}$ " long, being thus raised above the chassis. Full-sized drawings and additional constructional notes on the receiver and power unit number one and number two may be obtained from the writer. To cover the cost and postage they are priced at \$1.00.

It will be noted that the circuit diagram calls for grid suppressors of 400, 500, and 600 ohms for the three radio-frequency amplifiers. Decreasing the values of these resistances increases the amplification. For example, a good combination would be 300 ohms in the first stage, 400 in the second, and 500 ohms in the third. They may, however, be decreased to as low as 200, 300 and 300 for the three stages respectively. This, of course, is to be determined only by the one who is constructing the receiver, since some like to tune in stations without experiencing regeneration, while others like the "swish" of a slightly regenerative set as they go through a carrier signal.

THE CABINET

THE writer's receiver is housed in a Corbett cabinet $7\frac{1}{2}$ " x $26\frac{1}{2}$ " x $10\frac{1}{2}$ " deep. The cabinet had to be prepared for its reception by cutting out holes for the cable plug and the antenna and ground connections. To have the chassis of the receiver fit snugly in the cabinet it was necessary to remove a small portion of the wood at both the front and back corners. These cabinets, however, may be secured from the Corbett people with such alterations already made.

If the constructor is careful his efforts will be rewarded with a magnificent receiver. The set can be placed on a table or in one of the special cabinets which houses the power supply apparatus in the bottom.

A model of this receiver has been in operation at the writer's laboratory for several months and its performance has given considerable satisfaction. The laboratory is located not over a half mile from

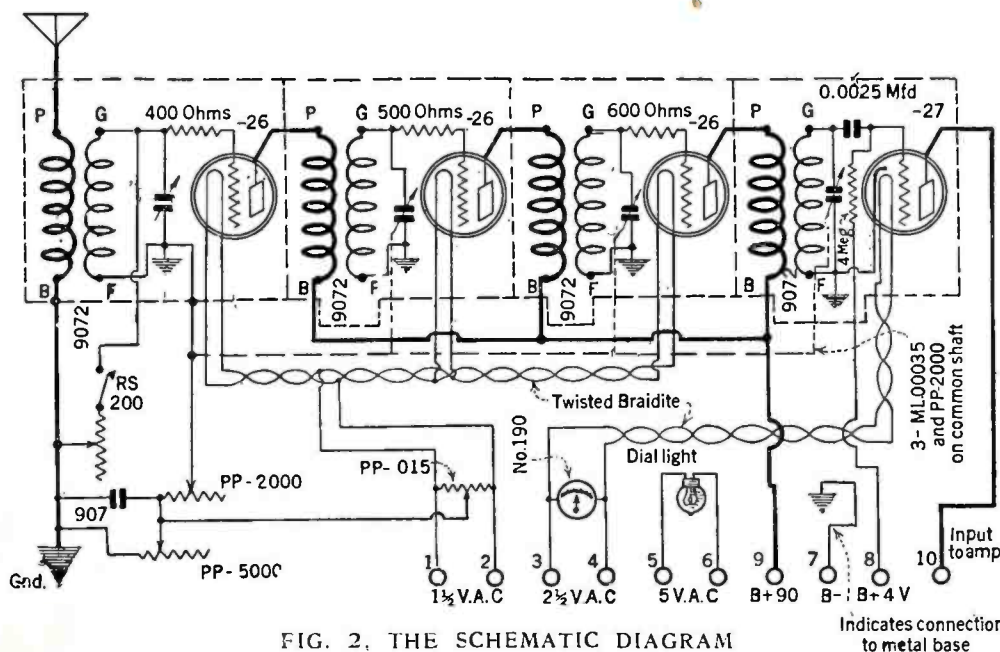

FIG. 2. THE SCHEMATIC DIAGRAM

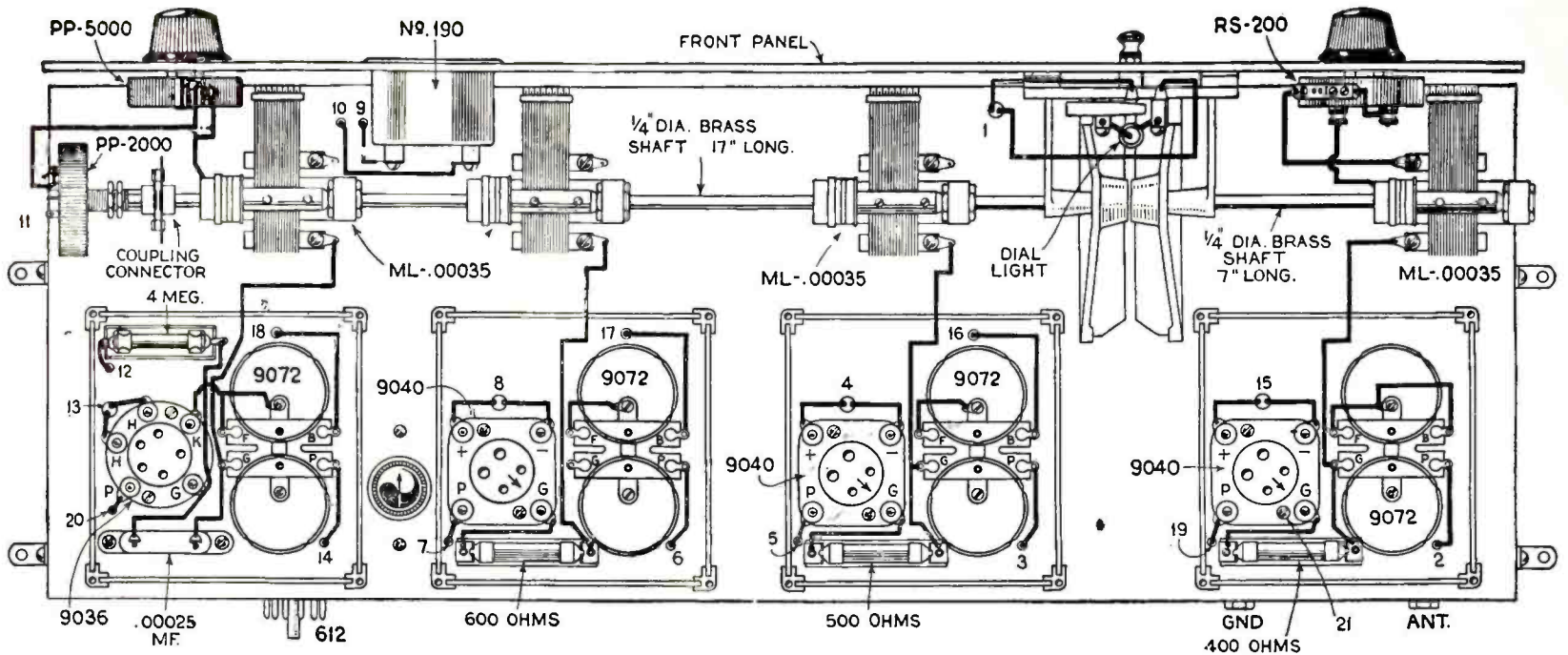

FIG. 3. INSTRUMENTS AND WIRING ABOVE THE CHASSIS

With the rotor plates of the condensers fully meshed, the position of the variable arm of resistor PP-2000, when viewed from the left end of the chassis in this diagram, should be two thirds of the way up towards the vertical on the left hand side. The coded holes in the chassis correspond to the numbers in Fig. 4.

three New Jersey stations, WOR, WAAT, and WKBO. In this location we are able to tune WEBB and WMBB in Chicago, KDKA, and several other stations within a radius of 1000 miles. On several occasions, shortly after midnight, we have listened to programs broadcast by KFI and KHJ, Los Angeles, on a loud speaker. The Chicago stations were often mistaken for local broadcasters.

All in all, the "Vivetone 29" is a receiver which is not difficult to build or operate, and which is sufficiently selective to cope with the present broadcasting situation and, with sufficient sensitivity to amplify weak signals up to the point where they can be enjoyed.

LIST OF PARTS

AS NOTED above, all the parts used in this receiver are of standard design, and may be replaced by equivalent parts of manufacturers

other than those mentioned below. The type numbers of the parts listed below correspond with the lettering on the diagrams.

- 4 Hammarlund variable condensers, 0.00035 mfd., type ML-00035
- 1 Dubilier condenser, 1.0 mfd., No. 907
- 1 Dubilier moulded micadon condenser, 0.00025 mfd.
- 1 Hammarlund illuminated drum dial
- 1 Pair Yaxley phone tip jacks
- 1 Centralab potentiometer, 5000 ohms, type PP-5000
- 1 Centralab potentiometer, 2000 ohms, type PP-2000
- 1 Centralab potentiometer, 15 ohms, type PP-015
- 1 Centralab switch-type Radiohm, 200,000 ohms, type RS-200
- 3 Daven grid stabilizers, 400, 500 and 600 ohms, respectively
- 1 Dubilier Metaleak, with mount, 4 megohms
- 4 Aluminum Junior box shields

- 4 Benjamin Lekeless Transformers, No. 9072
- 1 Hammarlund coupling connector
- 1 Jewell voltmeter, 0-3 volts a.c., No. 190
- 1 Aluminum shielded chassis, "Vivetone 29"
- 1 Yaxley 12-wire cable connector and plug, No. 612

- 3 Benjamin 4-prong sockets, No. 9040
- 1 Benjamin 5-prong socket, No. 9036
- 1 Micarta front panel, 7" x 26"
- 1 Corbett cabinet, 7" x 26" x 10" deep
- 1 roll solid Braidite wire
- 1 roll flexible Braidite wire
- 3 CX-326 tubes
- 1 CX-327 tube

To make the set operative either of the Vivetone A-B-C-power-pack amplifier units, or the following accessories, are necessary:

- Audio amplifier of good design
- Filament transformer to supply 1 1/2, 2 1/2 and 5 volts a.c.
- Source of B power (90 and 45 volts)
- C battery (-4 1/2 volts)

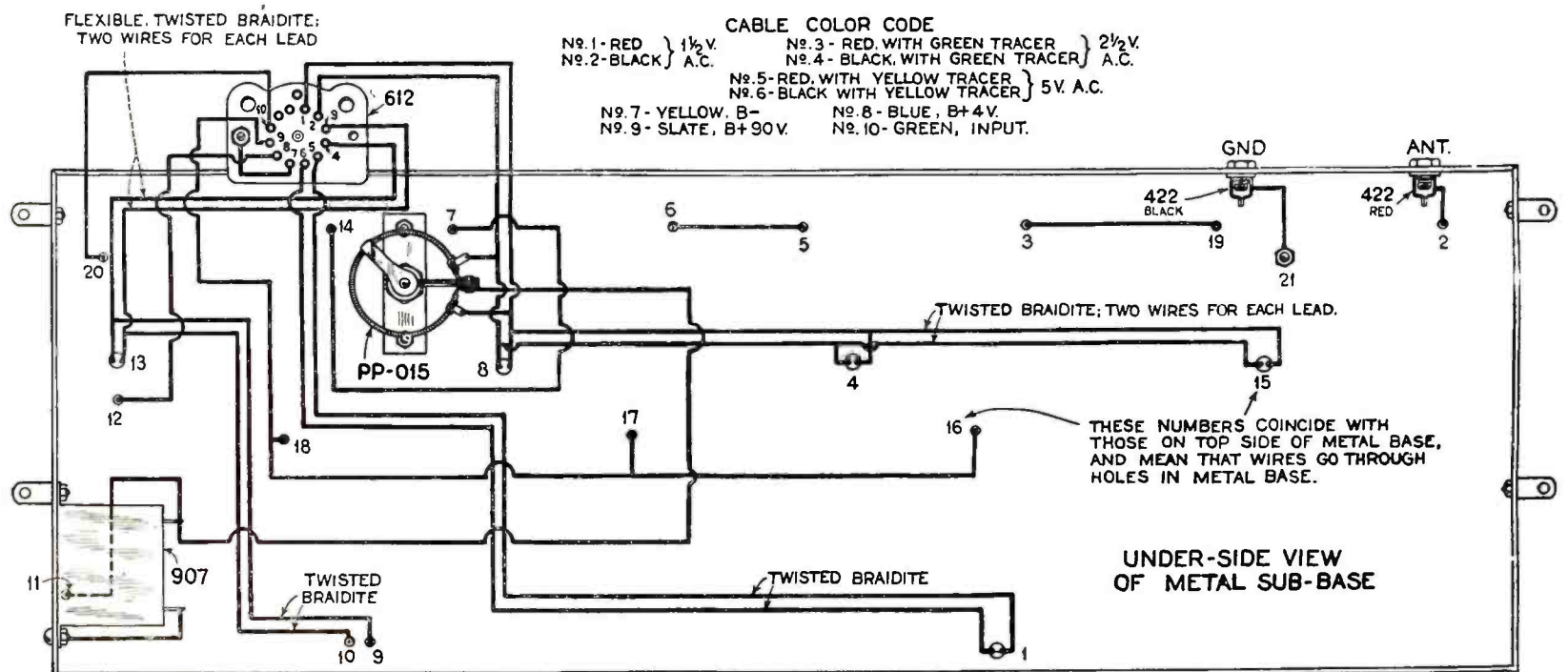

FIG. 4. THE UNDER SIDE OF THE CHASSIS

The potentiometer, PP-015, is insulated from the chassis, and its shaft should not touch the aluminum. Care should also be taken in mounting the cable plug receptacle that its position is such that none of the pins will touch the aluminum chassis.

No. 9.

RADIO BROADCAST'S Service Data Sheets on Manufactured Receivers

October, 1928.

The Bosch Model 28 Receiver

THIS is a seven-tube receiver employing three stages of tuned radio-frequency amplification, a detector and a two-stage transformer-coupled audio amplifier, the second stage of which is push-pull. Type 226 tubes are used in the r.f. and first a.f. stages, a type 227 tube in the detector stage and two 171A type tubes in the push-pull stage, and a type 280 rectifier in the B-power unit. The four tuning condensers are ganged to a single panel control—an illuminated drum dial. The additional controls on the front panel are a volume control and a "clarifier," which is actually a variometer with a pretty name. It tunes the antenna circuit to resonance. The volume control is a high-resistance potentiometer R_1 .

This receiver is designed for operation on 60-cycle a.c. lighting circuits at voltages from 100 to 130 volts, a tapped transformer primary serving to adjust the receiver for correct operation on any voltage between these two limits. A plug is used to connect to that particular tap on the transformer which gives best results. Moving the plug to the right (to the "115" or "125" socket) decreases the voltage on the tubes. It will, therefore, prolong the life of the radio tubes to operate the receiver with the switch plug in a position as far to the right as is consistent with satisfactory reception. For example, if the maximum line voltage measured is 115 volts, try the switch plug not only in the "115" socket, but also in the "125" socket as well. If the latter gives good results it will be of decided advantage to use this position, as it will increase the useful life of the tubes and reduce to a minimum the danger of burning out tubes. Do not, therefore, move the switch plug to the left in an effort to secure louder reception.

Model 28 is housed in a table mounting cabinet. Models 28A and 28B are console types. All models have self-contained power units.

TECHNICAL DISCUSSION

1. Operation

The receiver is operated by three controls. The main tuning control serves to turn all the tuning condensers and tune in any desired station. The control is graduated into 100 divisions and after a station has been recorded, it can always be picked up at the same reading of the dial. Changes in the length of the antenna will not affect the station logging. The Clarifier is actually a variometer across

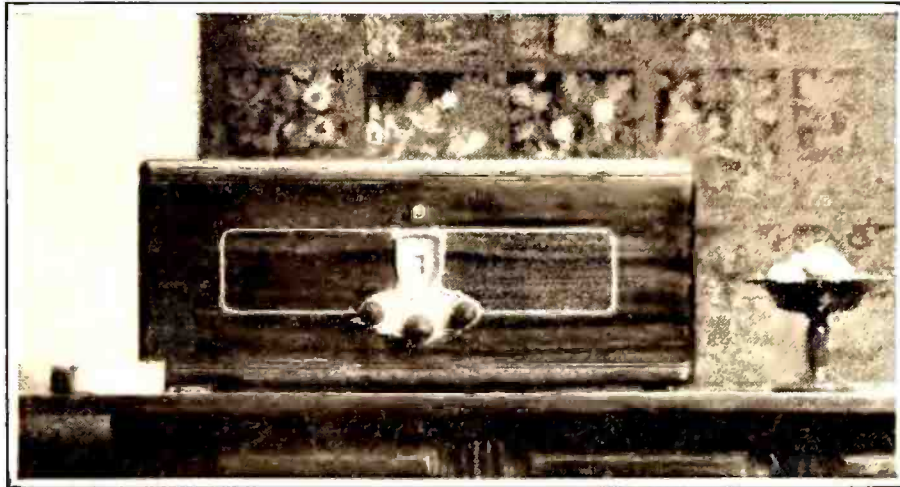

CABINET MODEL 28

the antenna and ground and is an auxiliary tuning device which brings this circuit of the receiver to the point of exact resonance. After tuning in a station with the main dial, the Clarifier should be adjusted to the point of maximum volume. The volume control adjusts the volume to any desired level.

2. Tuning System.

The r.f. amplifier consists essentially of three stages of tuned and neutralized amplification, with a variometer across the input circuit to permit the accurate tuning of this circuit to resonance. The circuits are all matched at the factory by means of the small condensers, C_1 and C_2 , connected across the second and third tuning condensers. The sensitivity and selectivity of the set is improved distinctly by the use of the variometer in the input circuit.

3. Detector and Audio System.

Grid leak and condenser detection is used and a type 227 tube is used as the detector. The audio stages are transformer coupled, the second stage being push-pull. The push-pull amplifier with 171A type tubes can deliver all the volume required for home use, without any distortion due to overloading. The detector is supplied with 40-50 volts, the first a.f. amplifier with about 100 volts plate potential and a C bias of 7 volts. The push-pull tubes receive about 150 volts and a C bias of 35 volts. The push-pull tubes feed into the output transformer, T_1 , the loud speaker being connected to its secondary terminals.

4. Volume Control

This control consists of a high resistance potentiometer, R_1 , connected across the input to the first r.f. tube. In this position it functions to regulate the signal energy entering the r.f. amplifier and therefore prevents tube overloading.

5. Filament Circuits.

The filament leads to the various tubes are twisted pairs of wires connecting between the transformer and the various tube sockets. The type 226 r.f. tube filaments are supplied with approximately 1.4 volts, the 227 type detector with about 2.4 volts, the first a.f. tube—a type 226—with 1.4 volts, and the power tubes with 5 volts. Resistances, R_2 , R_3 , and R_4 , are connected across the various filament circuits for hum balance.

6. Plate Circuits.

The plates of the r.f. tubes in this receiver are supplied with approximately 100 volts and the grids with 7 volts. The detector is supplied with the same voltage as the r.f. tube, but this voltage is reduced to about 50 by the resistance, R_5 , in series with the plate circuit. The first a.f. tube has 100 volts on the plate and 7 volts on the grid. The power tube receives about 130 volts and the grid bias is about 35 volts. The filament circuits of the r.f. tubes are bypassed to ground by C_3 and C_4 , each with a value of 0.5 mfd. The plate circuits are bypassed by the 1.0-mfd. condenser, C_5 ; the detector bypass condenser, C_6 , also has a capacity of 1.0 mfd. R_6 reduces the maximum voltage to 100.

7. Grid Circuits

Grid biases for the various tubes are obtained by connecting resistors between the center tap of the filament circuits and B minus, which corresponds to ground. Seven volts for the r.f. and first a.f. tubes is supplied by R_7 and 35 volts approximately for the grid of the power tube is obtained from R_8 . There is zero bias on the grid of the detector.

8. Power Supply.

The transformer, T_2 , in the power supply unit supplies low voltage to the filaments of all the tubes and the dial light and also high voltage to the rectifier system, which uses a type 280 tube in a full-wave system. A single section filter is used consisting of C_6 , L and C_7 . The maximum output voltage from the filter is supplied to the output audio stage. The primary of the power transformer is tapped to permit the operation of the receiver on line voltage from 100 to 130 volts.

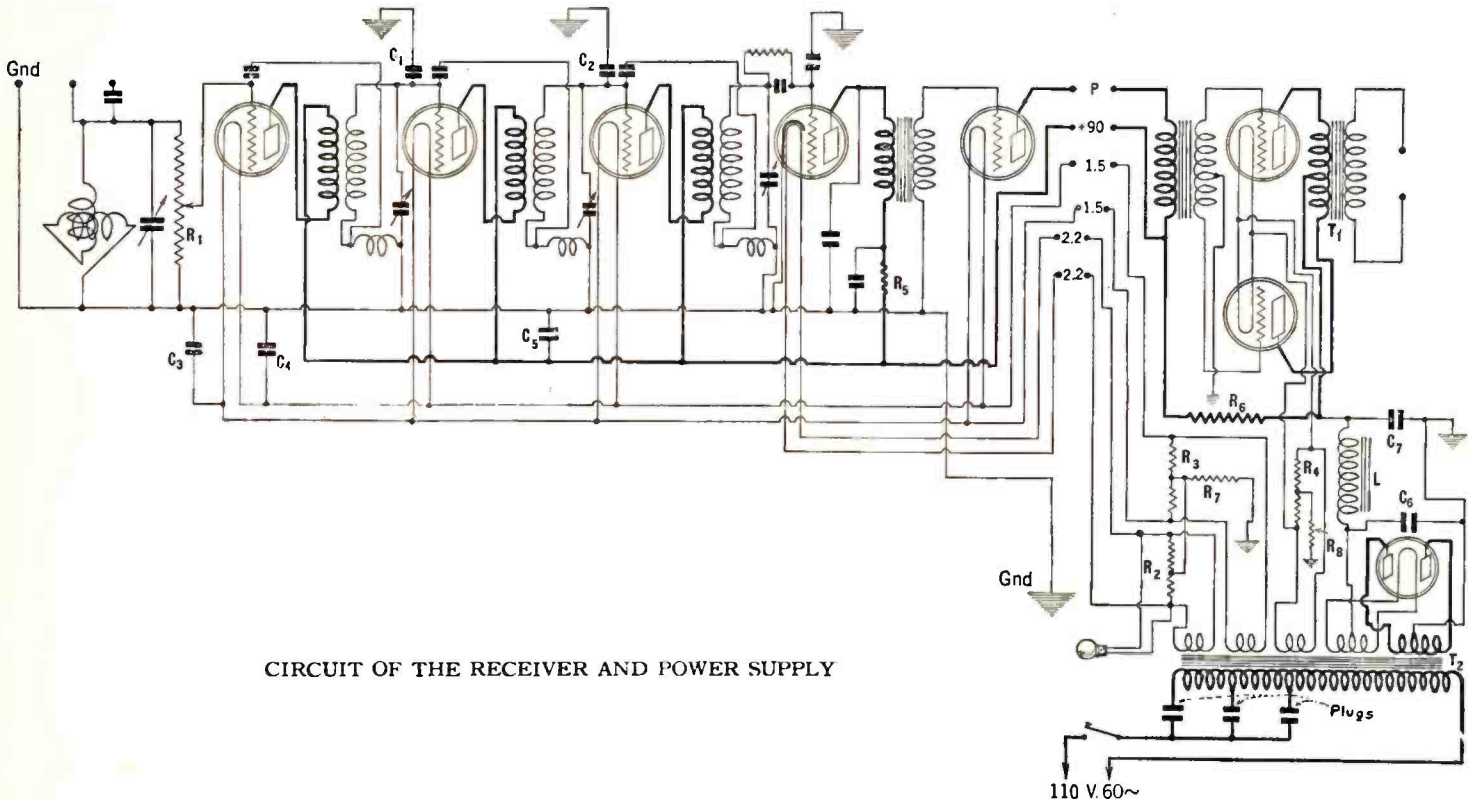

CIRCUIT OF THE RECEIVER AND POWER SUPPLY

The Splitdorf "Inherently Electric" Receiver

THIS sheet is devoted to a discussion of a six-tube, completely self-contained electric receiver. It employs a.c. tubes, is single controlled and consists of three stages of r.f., a detector and two stages of transformer-coupled audio amplification. It is designed for operation from a 110-volt, 60-cycle light socket. Type 226 tubes are used in the r.f. amplifier and in the first a.f. stage. The detector is a type 227 tube and the output tube is a type 171A. The antenna circuit is arranged with several taps to adapt the operation of the set to short, medium and long antennas.

TECHNICAL DISCUSSION

1. Tuning System.

The tuning system comprises four r.f. transformers and tuning condensers consisting of L_1 and C_1 , L_2 and C_1 , L_3 and C_1 , and L_7 and C_1 . A single-gang assembly contains all four tuning condensers, each section of which has a capacity of 0.00035 mfd. The antenna is connected to A_1 , A_2 , or A_3 , depending upon whether it is short, or medium length, or long. The small variable inductor forming part of L_1 is in the circuit so that the effect of the antenna on the first tuned circuit may be compensated and this circuit brought into exact resonance at all wavelengths.

This receiver is not neutralized but is stabilized by grid resistors, R_1 , R_2 , and R_3 , each with a value of 600 ohms. This method of oscillation control is used in many receivers and is quite effective.

2. Detector and Audio System

The grid-leak-condenser type detector employed in this receiver uses a 0.00025-mfd. grid condenser, C_2 , in conjunction with a 2-megohm grid leak, R_4 . The detector is a type 227 tube and its output is fed into a two-stage transformer-coupled audio amplifier. The output of the detector circuit is bypassed by C_4 with a capacity of 0.0001 mfd. The first stage audio transformer, T_1 , has connected across its secondary a small fixed condenser, C_5 , of 0.00025 mfd., probably to prevent singing in the a.f. amplifier at high frequencies. The output of T_1 supplies signal voltage to the grid of V_5 , a 226 type a.c. tube. The loud speaker is isolated from the plate circuit of the power tube by a choke-condenser combination consisting of choke coil X_2 and condenser C_{11} ; this condenser has a capacity of 1.0 mfd.



A NEW SPLITDORF MODEL

This beautifully housed receiver is the new Splitdorf Abbey Senior. It incorporates many new features not found in the older Splitdorf circuit described in this Sheet. It uses six tubes, one of them a 250 type, and is equipped with a phonograph jack and a novel "sensitivity-selectivity" switch.

3. Volume Control.

A 500,000-ohm variable resistance, R_4 , is connected across the input to the detector in this receiver and functions as the volume control. The input circuit of a grid leak and condenser type detector is generally quite low and as a result the tuned circuit preceding it has poor selectivity. It is therefore a good idea to place the volume control at this point, for at this point in the circuit it cannot affect the selectivity of the receiver to any marked degree. Since the control is ahead of the detector it is possible to regulate the volume to prevent overloading of the detector tube.

4. Filament Circuits.

Filament current for the various tubes in the

receiver is supplied by the power transformer, T_3 . Secondary winding S_1 supplies 1.5 volts to the 226 type tubes, secondary S_2 supplies 2.5 volts for the heater of the detector tube and secondary S_3 supplies 5.0 volts for the power tube. S_4 also supplies current for the dial light. All the filament circuit leads are twisted to prevent hum, and 30-ohm potentiometers, R_6 and R_7 , are connected across the secondaries, S_1 and S_2 , to make it possible to obtain a very accurate hum balance.

5. Plate Circuits.

The output tube, V_6 , of the audio amplifier is supplied with the maximum voltage from the power supply unit—180 volts. All the r.f. tubes and the first a.f. tube receive 110 volts and the detector is supplied with 45 volts. The plate circuits of the r.f. tubes are bypassed in the set with condenser C_2 , whose capacity is 0.5 mfd. The detector plate supply bypass condenser is C_8 , located in the power unit. Its value is 1.0 mfd.

6. Grid Circuits.

The output tube of the set has a bias on the grid of 40 volts, supplied by sections of the resistor, R_8 , in the power unit. The bypass across this resistor, C_{10} , has a value of 1.0 mfd. Section d of the resistor supplies bias for the first a.f. and all the r.f. tubes. This bias voltage is 7.5 volts and the bias resistor is bypassed by the 2.0-mfd. condenser, C_9 . The tone quality would be very poor, due to loss of the low frequencies, if these bypass condensers, C_9 and C_{10} , were not included in the circuit across the C bias resistances.

7. The Power Supply.

The A-B-C supply for this receiver consists of the power transformer, T_3 , the rectifier, V_7 , which is a type 280 tube, the filter system and the voltage dividing resistor, R_8 . This resistor has a total value of 13,200 ohms divided as follows: section a , 2500 ohms; section b , 5400 ohms; section c , 4500 ohms; section d , 150 ohms; section e , 650 ohms. The filter circuit consists of the filter choke coil, X_1 , and the two filter condensers, C_6 , with a value of 4.0 mfd., and C_7 with a value of 6.0 mfd. The primary of the transformer is fused at F and the entire receiver is turned on and off by the switch, Sw .

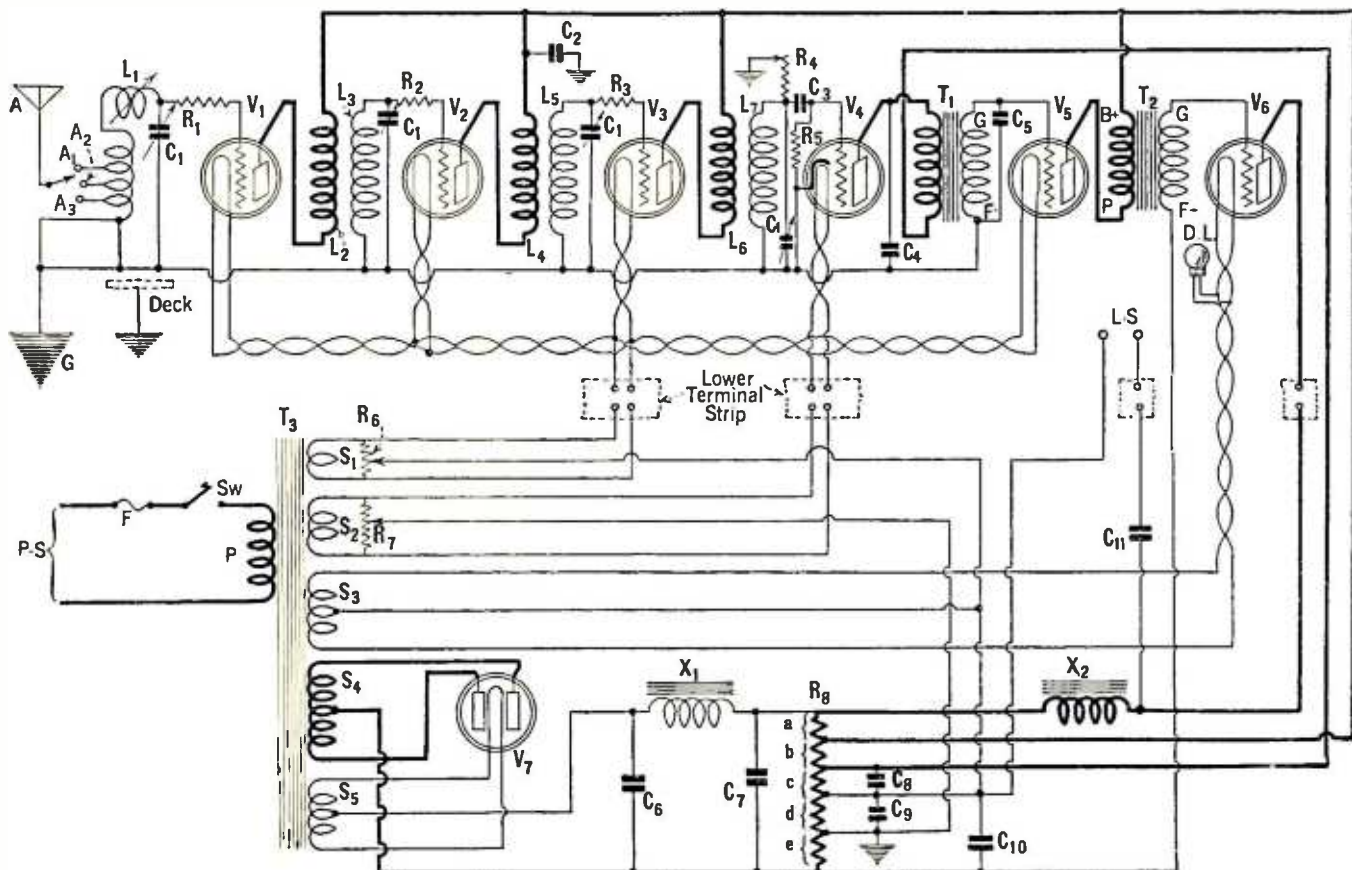

RECEIVER AND POWER SUPPLY CIRCUIT

Practical 5-Meter Hints

By ROBERT S. KRUSE

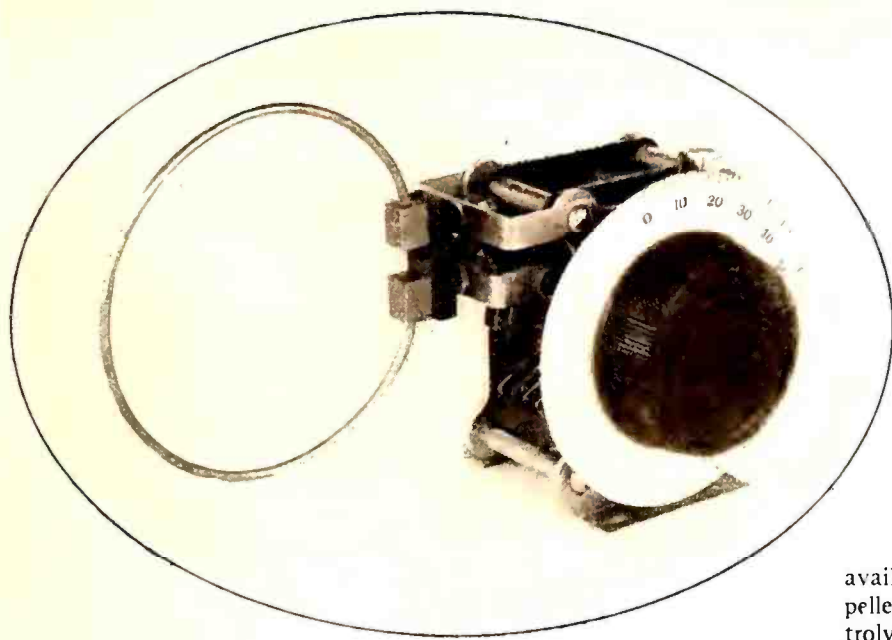

THE 5-METER WAVEMETER

IN THE preceding stories the very attractive possibilities of the 5-meter band have been discussed. There will be added here a few time-saving hints.

Very early it became evident that the average experimenter did not make a satisfactory job of building and calibrating a 5-meter wavemeter. At the writer's suggestion the General Radio Co. developed the very rugged little meter shown on this page, which remains the only one on the market, although the band-covering

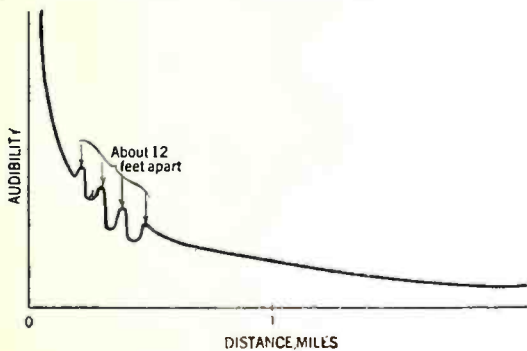

FIG. 1. "WEST PEAKS"

meter of the same firm also has a 5-meter coil. The meter here shown is most convenient when mounted on a short wooden or bakelite panel, although the hand-capacity effects are small because of a good C/L proportion.

In the previous articles the plate and filament supply were not mentioned. It is best to use alternating filament supply, but one should *not* use the center-tap of a transformer secondary. It is far more satisfactory to use a double 100-ohm resistor or a 200-ohm potentiometer. The latter has the advantage of permitting one to find exactly the right point. Either method permits one to use any toy transformer or even a bell-ringing transformer.

The plate supply may be raw a.c. as a starter, as was suggested, but had better be rectified. The filter should *not* have a condenser next to the rectifier tube. First should come a choke of 1-5 henrys inductance, then a 2.0-mfd. condenser, then a choke of 10-100 henrys and finally another condenser, as large as convenient, shunted by a resistance of 25,000-100,000 ohms. The reasons for this type of filter are good but too lengthy to mention here.

Although the UX-852 tube is excellent for the 5-meter band, no proper rectifier for it is

available. One is compelled to use electrolytic rectification, or else a too-large kenotron, mercury arc or d.c. generator.

A new gas tube may be available soon. When the set is taken into the field one must of course have some sort of automatic key at the station to keep making signals. A suitable one is shown herewith. It consists of the motor of a 16" electric fan, a standard Boston Gear Works worm gear and a cam in the edge of which are milled code letters as desired. A bakelite cam worked out with a file is just as good. The edge of the cam bears on a brass strip screwed under the knob of an ordinary telegraph key which controls the transmitter. Parenthetically, it is best to key the set by the method shown in Fig. 2—for reasons good but lengthy.

Having the key going one gets into the field with the receiver and is then uncertain whether things are proceeding well. The appearance of the following effects is normal and reassuring.

AUTOMOTIVE EFFECTS

BEFORE one is long afield the automobile injects itself into the picture. Its ignition noises are rather troublesome, although this is lessening as the Model T Fords and their spark coils diminish in number. After a little practice one can distinguish the type of motor and its condition to a considerable degree by listening with a 5-meter receiver as a car passes. Cars with monthly service programs have vastly the best average performance as regards the steadiness of their 5-meter signals.

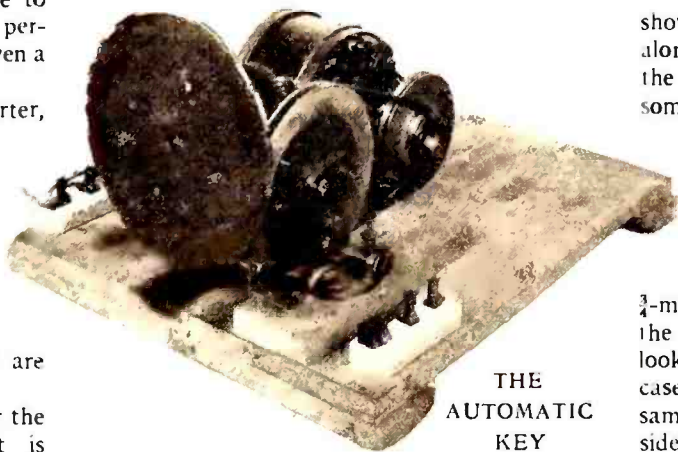

THE AUTOMATIC KEY

THIS short article contains some operating data which Mr. Kruse did not cover in his article on 5-meter transmission and reception in the September issue of RADIO BROADCAST. Several "freak" transmission effects on the 5-meter band are also explained.

—THE EDITOR.

If one is near the road another effect will be observed: each passing car detunes the received signal a trifle. This statement is made general, though we must admit lack of evidence against the Rolls Royce, which did not come along that road. It was possible to tune the station out, and then bring it back by interposing a suitable automobile. "Suitable" means any type of about the right size and body structure; a Buick and a Nash are interchangeable for the purpose, whereas a Franklin and a Stutz are not! The gist of the difference lies in the difference between the wood-and-aluminum body of the "Benjamin" as compared with the fabric-covered

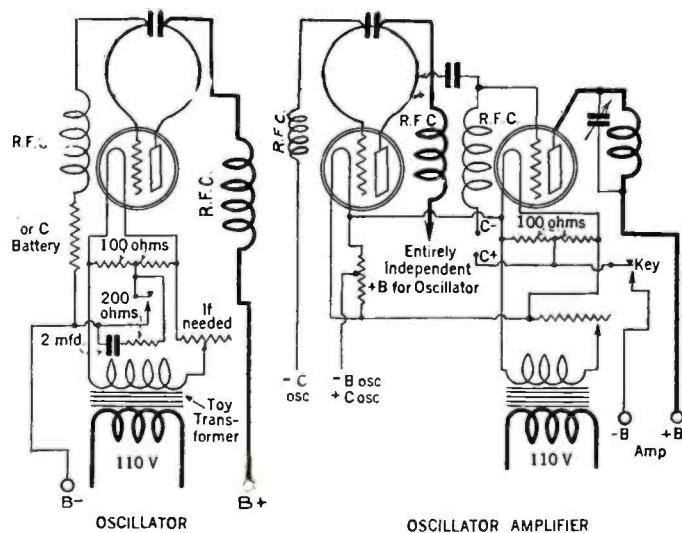

FIG. 2. THE KEYING DIAGRAM

Stutz body, and the only possible value of the stunt is to suggest the importance of small absorption effects at 5 meters.

"WEST'S PEAKS"

TO C. H. West of 2CSM we are indebted for first calling attention to the curious effect shown in Figure 1. He noticed that in driving along a road there appeared to be "humps" in the signals at 12-foot intervals when one was some $\frac{1}{3}$ or $\frac{1}{4}$ mile from the station. Subsequent observations produced the same effect at various stations, the spacing between peaks remaining reasonably constant, though sometimes the peaks are entirely absent at a particular station. The same thing has since been observed at $\frac{3}{4}$ -meter wavelength with all the dimensions of the picture about one seventh as large. It looks like an interference pattern, but in most cases appears to be stationary and of much the same proportions regardless of the things alongside the road at that place.

New Apparatus

PRODUCTS of radio manufacturers whether new or old are always interesting to our readers. These pages, a feature of RADIO BROADCAST, explain and illustrate products which have been selected for publication because of their special interest to our readers. This information is prepared by the Technical Staff and is in a form which we believe will be most useful. We have, wherever possible, suggested special uses for the device mentioned. It is of course not possible to include all the information about each device which is available. Each description bears a serial number and if you desire additional information direct from the manufacturer concerned, please address a letter to the Service Department, RADIO BROADCAST, Garden City, New York, referring to the serial numbers of the devices which interest you, and we shall see that your request is promptly handled.—THE EDITOR.

Shielded Wire Prevents Stray Coupling

X60

Device: SHIELDED HOOK-UP WIRE. This hook-up wire is a rubber-covered No. 18 with an additional braid of metal over the rubber insulation. When this metal braid is grounded it forms an effective shield around the wire. The metal braid is sufficiently flexible so that the wire may be readily bent into any desired form. It has all the conveniences of a flexible hook-up wire with the additional advantage that it is shielded. It is available in rolls of 100 feet. **Manufacturer:** Belden Manufacturing Company. **Price:** \$3.50 per 100' roll.

Application: In constructing high gain r.f. amplifiers, especially those using type 222 screen-grid tubes, it is absolutely essential that no coupling of any sort exist between the input and output circuits of the tube. Frequently it is possible that the comparatively short leads connecting one tube to the next will produce sufficient capacitive coupling to some other part of the circuit to cause the amplifier to oscillate.

Coupling of this type can be eliminated by the use of shielded wire. The circuit diagram in Fig. 2 indicates at what point in the circuit of a stage of r. f. amplification it might be wise to use shielded conductor.

For Smoother Volume Control

X61

Device: VARIABLE HIGH RESISTANCES. For volume control. Many of us when operating a volume control have noticed that frequently the volume does not vary uniformly as the control is turned. Turning the control a given distance at a certain point will produce a given change in volume and then turning it twice as far will produce a very much greater change in volume. It would be desirable to make use of a volume control resistor of a characteristic such that the changes in volume were more nearly proportional to the movements of the control.

Resistances of this type have been designed to give uniform variation of volume and can be

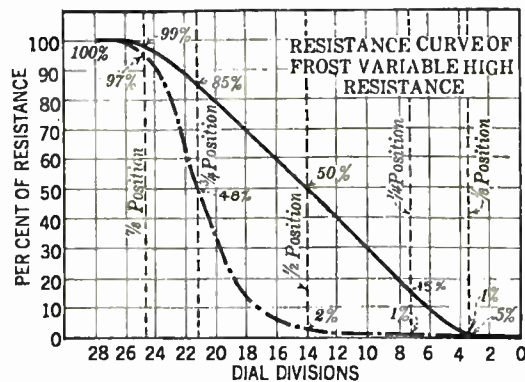

FIG. 1

obtained in sizes ranging from 2000 to 10,000 ohms. The curves of such resistances are given in Fig. 1. The solid curve indicates that of an ordinary resistance in which the variation in the resistance is directly proportional to the dial setting. The dot-dash curve is that of the new type resistance. It will be seen that the resistance does not vary directly with the dial setting but varies slowly at first and then more rapidly, which results in smoother volume control.

The catalog numbers and prices of these new type resistances are given below.

No. 1896, 2000 ohms—\$2.25

No. 1897, 5000 ohms—2.25

No. 1898, 10,000 ohms—2.25

Manufacturer: Herbert H. Frost, Inc.

Application: As indicated above these units are designed for use as volume controls in radio receivers, and because of their special characteristics have certain advantages over other types of resistances. All of these resistors are made with three terminals, like a potentiometer, and can be used as a potentiometer type of control or, if desired, by connecting to the center terminal and one of the outside terminals, the unit can be used as a two terminal resistor. The direction of rotation of the knob to decrease or increase the resistance will depend upon which outside terminal is connected.

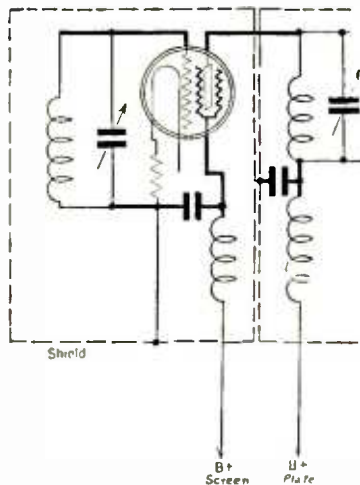
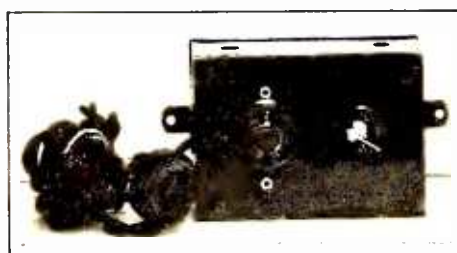

FIG. 2

A Safeguard for A. C. Tubes

X62

Device: CENTRALAB RADIO CONTROL BOX. This is a device designed for use in conjunction with light-socket operated receivers. It consists of a small metal box in which is placed a variable resistance. The power lead on the box is plugged into the light socket and then the power lead from the receiver is plugged into the receptacle on the box. This places the variable resistance in



CENTRALAB CONTROL BOX

series with the line. If the line voltage is excessive, i. e., greater than that on which the set is designed to operate, the control on the box can be adjusted so that part or all of the resistance is in series with the line and the excess voltage will then be absorbed.

Manufacturer: Central Radio Laboratories. **Price:** \$3.00.

Application: Excessive line voltages have evidently caused considerable trouble with a.c. operated receivers. If a.c. tubes, or any tubes for that matter, are subjected to excessive filament voltage, their life is materially shortened. Excessive line voltage supplies excessive filament voltages to tubes in a set, and it is essential, therefore, that some device be used to permit compensation for line voltages greater than about 110, the voltage on which most receivers are designed to operate. A device of this sort, of course, requires manual control if the line voltage varies during the day and night. Also there is no means of determining when the voltage applied to the set is 110. Probably the best method of operation, therefore, is to gradually increase the resistance (which reduces the voltage applied to the receiver) until an effect on reception is noted and then to decrease slightly the resistance.

Devices can be obtained which will automatically regulate the line voltage so that the receiver is always supplied with exactly 110 volts. Such devices are expensive, costing perhaps five times as much as this device. For a simple unit that will permit longer life from a.c. tubes the power control box is to be recommended.

A Complete Push-Pull Amplifier

X63

Device: PUSH-PULL AMPLIFIER, MODEL P-P-2. A complete single-stage push-pull amplifier designed for the use of two 171 type tubes. This device does not contain any power supply, but must be operated in conjunction with batteries or A and B power units. **Manufactured by** HAROLD POWER, INC. **Price:** \$38.00, with tubes. **Application:** This amplifier is designed for use in conjunction with a radio receiver in those cases where more power output is desired than can be obtained without distortion from the power tube incorporated in the receiver. This amplifier can deliver at least 1400 milliwatts of power without overloading—about ten times as much as can be obtained, for example, from a 112A type tube.

A Plug Which Can't Be Broken

X64

Device: SOFT RUBBER PLUG. Ruggedly constructed of solid soft rubber. Shaped to form a convenient grip for the fingers when pushing it in or pulling it out of a socket. Only sold attached to Belden cords which come in 10-, 20-, and 50-foot lengths. **Manufactured by** the BELDEN MANUFACTURING COMPANY. **Price:** \$2.75.

Application: This plug can be thrown around, dropped, or stepped on without fear of breaking it. Judging from the number of ordinary hard rubber plugs that have been broken in RADIO BROADCAST Laboratory we venture a guess that we ought to have about 600 of these!

A 30-Henry Choke for Filter Circuits

X65

Device: SAMSON FILTER CHOKE COIL, TYPE 312. A choke coil designed for use in the filter circuits

of B-power units. It is capable of carrying direct currents up to and somewhat in excess of 120 milliamperes. At 120 mA. its inductance is 30 henrys. The d.c. resistance of the choke is, approximately 290 ohms. *Manufacturer:* Samson Electric Manufacturing Company. *Price:* \$12.00. *Application:* The choke coil is applicable to various filter circuits in which it is necessary that the circuit handle currents of about 120 mA. If the value of current does not reach values higher than about 80 mA, then the Samson choke type 380 (\$11.00) may be used; for currents not in excess of 30 mA, the type 30 (\$5.00) is satisfactory.



SAMSON CHOKE

The low-resistance characteristic of these choke coils makes them very satisfactory for use in filter systems, for with low-resistance circuits the voltage regulation of the power unit will be better than with high-resistance circuits; the resistance of the filter choke coils should be low enough so as not to have any great effect on the regulation of the system. These requirements are fulfilled very satisfactorily by Samson chokes.

Radio-Frequency Choke Coils

X66

Device: RADIO-FREQUENCY CHOKE COILS. Two types are available.

Code No. RFC-85, with an inductance of 85 millihenrys, a distributed capacity of 3 mmfds. and a resistance of 215 ohms. *Price:* \$2.00.

Code No. RFC-250, with an inductance of 250 millihenrys, a distributed capacity of 2 mmfds. and a resistance of 420 ohms. *Price:* \$2.25

Manufacturer: HAMMARLUND MANUFACTURING COMPANY.

Application: These r.f. chokes are for use in the r.f. B-plus leads and in the detector plate lead to keep the r.f. currents out of the plate supply unit and out of the audio amplifier. Although two types are available it is likely that in broadcast receivers the cheaper 85-millihenry choke may be satisfactorily used in all cases. The impedance of these coils at broadcast frequencies will be determined by the distributed capacity of the coil. At 1500 kc. the impedance of the 85-millihenry coil will be about 30,000 ohms and the impedance of the 250 millihenry coil about 45,000 ohms. The 85-millihenry coil, however, will give at broadcast frequencies a sufficiently high impedance so that satisfactory filtering action can be obtained. It is interesting that the coil with the higher inductance has less distributed capacity than the smaller coil.

R. f. choke coils of this type can also be used in constructing an intermediate-frequency amplifier for a super-heterodyne. An example of such a use can be seen by referring to the article by L. T. Goldsmith in the May, 1928, issue describing the construction of a super-heterodyne.

A Neon Lamp for Television

X67

Device: KINO LAMP. A neon tube designed for use in television receiving apparatus. The tube measures about 6½" high and about 2" in diameter and is fitted with a ux type base so that it can be plugged into a standard tube socket. The a.c. resistance of the tube is about 1200 ohms and the current through the tube should not exceed about 20 milliamperes d.c. This corresponds roughly to about 200 volts across the tube. The three circuit diagrams in Fig. 4 show circuits in which the tube may be used in television receivers. All three circuits are quite satisfactory, circuit A probably being the simplest in construction and operation.

Manufacturer: Raytheon Manufacturing Company. *Price:* \$12.50.

Application: The principal use for this tube is in the output circuits of television receivers, although it may be used in any place where a gas discharge tube is required, and probably other applications for it will suggest themselves to our readers. Since the plate of the tube is about 1½" square the received television picture will be of the same size. A word of caution—never overload the tube. Don't put it across a d.c. source of voltage without a current limiting resistance in series with it. Keep the current as low as possible, for the lower the current used, the longer the life of the tube will be.

An A.C. Screen-Grid Tube

X68

Device: A.C. SCREEN-GRID TUBE, TYPE A.C. 22. The tube is of the same general construction as d.c. screen-grid tubes with the exception that the electron emitting member has a heater similar to that used in type 227 tubes. The heater requires 2.5 volts to operate it. This tube may therefore be connected in parallel with 227 type tubes, since they also require 2.5 volts. The a.c. 22 tube fits into a standard 5-prong socket. *Manufacturer:* CeCo Manufacturing Company. *Price,* \$8.00.

Application: This tube is for use in the construction of a.c. operated receivers requiring the use of a screen-grid tube. The connections of a single r.f. stage using this tube are given in Fig. 3.

Filter and Bypass Condensers

X69

Device: ACME PARVOLT CONDENSERS. These condensers are available in all standard capacities and voltage ratings. Both bypass condensers designed for comparatively low voltage and filter condensers designed for 200, 400, 600, 800, 1000, and 1500 volts can be ob-



ACME CONDENSERS

tained. The condensers are tested and fully meet the standards of the R. M. A. Complete block condensers can also be obtained designed for use in the various types of well-known power units, such as the Samson, Amertran, Silver-Marshall, Thor-danor, etc.

Manufacturer: Acme Wire Company. *Prices:* Vary depending upon capacity and voltage rating of the condensers.

Application: These condensers are designed to fulfill every need for condensers in radio receivers and power units. The condensers are equipped with mounting feet and screw terminals.

Loud Speaker Extension Cords

X70

Device: LOUD SPEAKER EXTENSION CORD. A 50-foot extension cord equipped with pin terminals on each end. Supplied with a bakelite connector for easy connection between the extension cord and the loud speaker. The cord consists of two rubber insulated wires covered with a brown cotton braid. *Manufacturer:* BELDEN MANUFACTURING COMPANY. *Price:* \$2.25

Application: This extension cord will prove useful in cases where the loud speaker is to be operated at a point distant from the radio receiver. In the good old summer time the loud speaker might be placed outside on the lawn, under a shady chestnut tree. To control the volume, use can be made of a variable resistor such as a Table Type Clarostat (mentioned in this department in the May issue) connected across the loud speaker terminals.

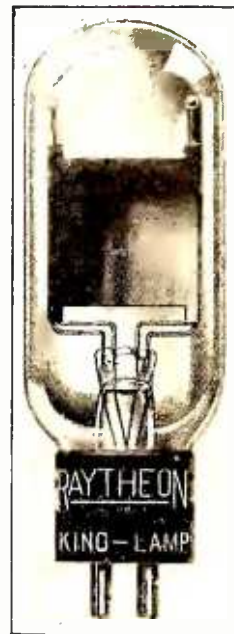

FOR TELEVISION

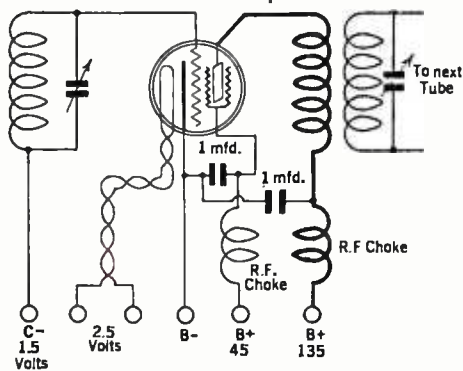

FIG. 3



THE A. C. 22 TUBE

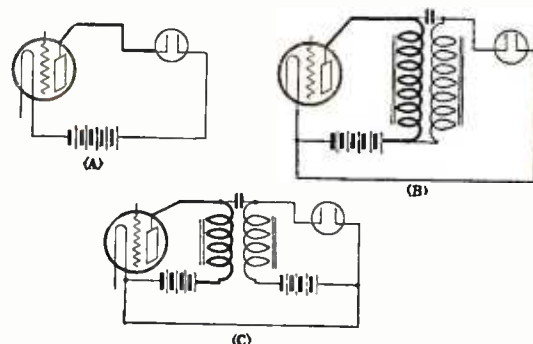
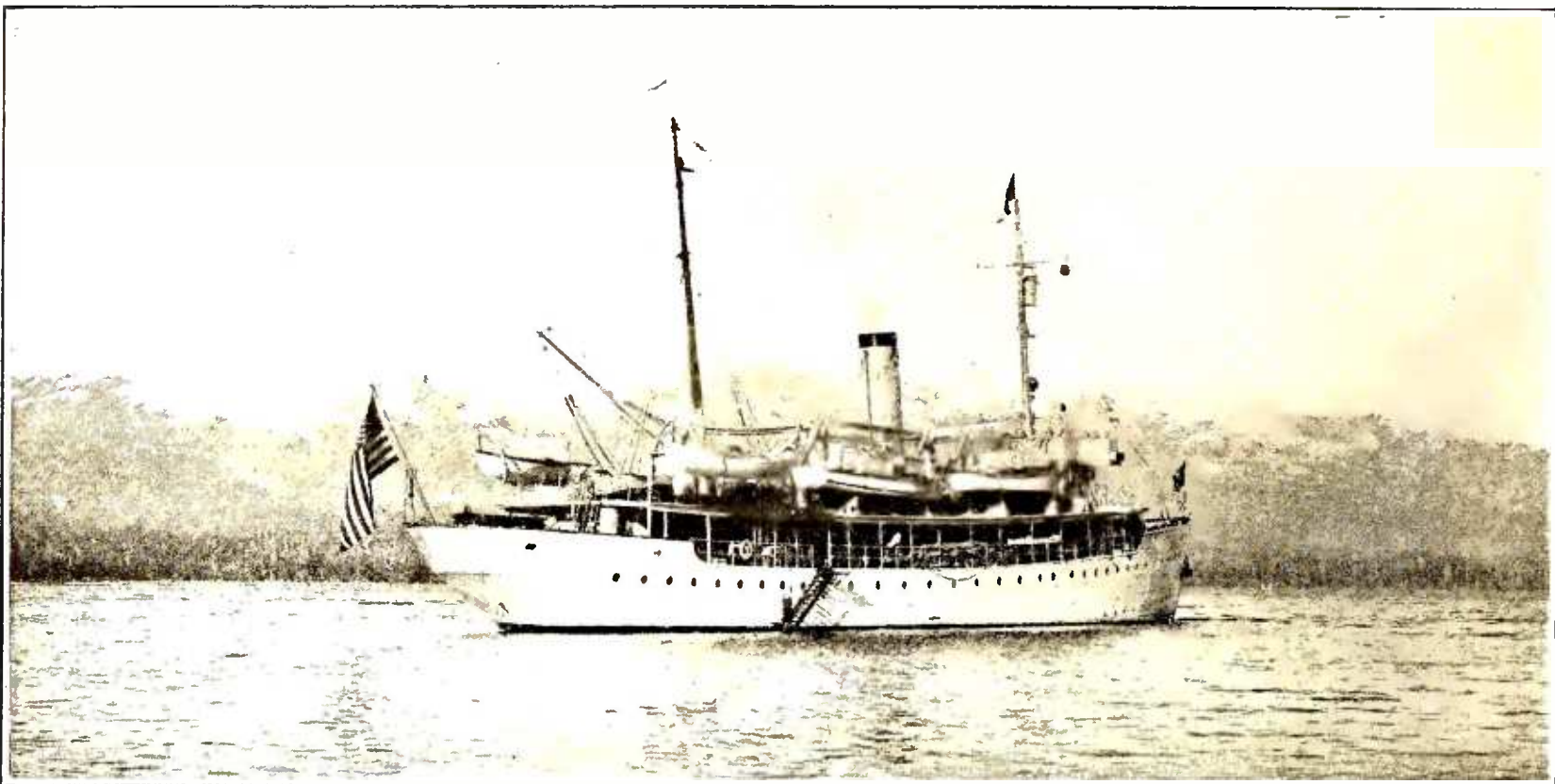

FIG. 4



THE U. S. COAST AND GEODETIC SURVEY SHIP SURVEYOR

Radio Helps in the Coast Survey

By D. L. PARKHURST

Chief, Instrument Division, U. S. Coast and Geodetic Survey

THE method of acoustic range finding described by Mr. Parkhurst seems to have several advantages over the radio beacon system, when used for short distances over uniform masses of fairly deep water. The actual distance of the ship from shore stations is measured by the time taken for sound waves to pass through the water from ship to shore, whereas in the beacon system only the bearings of shore stations may be determined. Furthermore, the acoustic system is entirely automatic, the time of the signals being mechanically recorded on the chronograph tape aboard the ship. With the beacon system there is always a possible error due to the operator. On the other hand, the acoustic method has proved itself useful only over short distances (200 miles at the most), and through water that is uniform in temperature and not broken up by shoals. These advantages indicate that it might have great usefulness as a guide to ships at the entrances of harbors.

—THE EDITOR.



THE use of radio for direction and range finding has made great strides in the past few years, especially in the development of directive beacons for sea and air navigation. The U. S. Coast and Geodetic Survey has recently developed another interesting method of range finding, which makes use of both sound and radio waves. In making depth measurements off the coast it is frequently necessary for the Survey ships to be out of sight of land, so that ordinary triangulation methods of accurately locating the position of the ship cannot be used. In such cases the position of the ship is deter-

mined by a method known as acoustic range finding, in which the distance of the ship from shore is measured by the velocity of sound waves through water, the recording being effected by means of radio.

When the surveying ship has made a depth measurement, or sounding, a bomb containing a

pound or so of high explosive, such as TNT, is dropped overboard and exploded twenty or more feet beneath the surface. The sound produced is picked up by a submerged microphone, or hydrophone, located on the ship, and the impulse transmitted through a three-stage audio amplifier to the pen-actuating magnet of a chronograph, making a mark on a paper recording strip. The sound of the explosion also travels through the water in all directions, and is picked up by hydrophones anchored in approximately fifty feet of water at two or three known points on the shore. Insulated cable connects these hydrophones to a three-stage amplifier at each shore station. The amplified signal actuates a relay which sends a flash from a simple 140-meter low-power radio transmitter. The radio signal is picked up by a tuned receiver on board the ship, and amplified, and this current also actuates the chronograph pen beforementioned.

The paper strip, or tape, has been moving at a uniform rate during the time between the bomb explosion and the reception of the radio flash, and consequently the space between the two pen marks is an index of the elapsed time.

Accurate measurements have determined that the velocity of sound through sea water is approximately 4920 feet per second, varying somewhat with the water temperature. For example, if the elapsed time is 60 seconds, the ship is consequently 295,200 feet, or 55 10/11 miles, from the shore station.

The information is not complete if only one shore station is in operation, as the ship may be anywhere on a circle whose radius equals the time multiplied by the velocity of sound in water; consequently, two or more stations are used and the crossing point of the arcs for each station in-

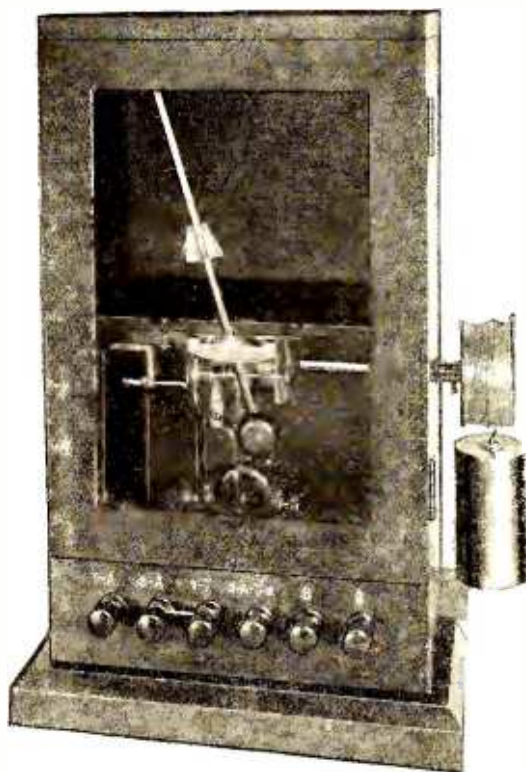

FIG. 1. ONE OF THE AUTOMATIC TRANSMITTING KEYS

dicates the ship's position. Fig. 3 illustrates this graphically. An automatic signaling device is attached to the transmitter of each shore station so that it sends out a characteristic signal and may be readily identified.

HOW THE SYSTEM OPERATES

IN GREATER detail, the operation of the apparatus is as follows:

The bomb, a tin can or cast-iron container, is filled with loose TNT, and just before firing a No. 8 blasting cap, with a length of Bickford powder train blasting fuse crimped to it, is inserted, the joint being sealed with wax or other plastic. The fuse is anchored so that the cap will not pull out.

At the proper moment, after a sounding has been completed, the fuse is lighted and the bomb thrown overboard. When the explosion occurs, the sound excites the carbon grain button in the ship's hydrophone, which is located in a small tank of water attached to the outer skin of the vessel. The ensuing current is amplified in a three-stage audio amplifier using two 201A and one 171 tubes and 6 to 1 transformers. The amplified current passes through the coils of a pen-operating magnet on a chronograph. The chronograph, shown in Fig. 2, is of a commercial type, having two pens, and is driven by a 6-volt, storage battery shunt motor.

Such a motor will run at practically constant speed, as the load is very light. In fact it is only necessary that the speed be constant during the first and last seconds.

The timing device consists of a high grade marine chronometer fitted with a circuit breaking device which operates each second, causing the second chronograph pen to make a mark on the record strip, which is standard $\frac{3}{4}$ -inch stock ticker tape. Fig. 2 shows at the bottom the type of record made on this tape.

After the record of the explosion has been made by means of the ship's hydrophone, the tape continues to pass through the chronograph, each second being marked upon it by the chronometer. The sound from the bomb travels through the water to the hydrophones of the shore station. These are sometimes anchored as much as two miles offshore, depending upon the character of the sea bottom, as it has been found that the system does not operate so well unless the hydrophones are at least 50 feet below the surface. Submarine cable, armored where wave action may cause chafing, connects the hydrophones to the shore station apparatus.

The energy from the hydrophones is amplified in a three-stage amplifier, which is very similar to that used aboard ship, and the current actuates an 800-ohm relay which completes a circuit through a 140-meter transmitter, sending out a radio flash. At the same time this relay sets an automatic telegraph key in operation which sends out three additional, equally timed flashes from the transmitter. No two keys have the same timing, so that each station may be identified by its characteristic markings on the chronograph tape. The automatic keys, one of which shown in Fig. 1, are made up with an ordinary musician's metronome as a time element, having the spring removed and weight drive substituted for it. A standard pony relay is mounted directly beneath it with a finger attached to its armature which engages

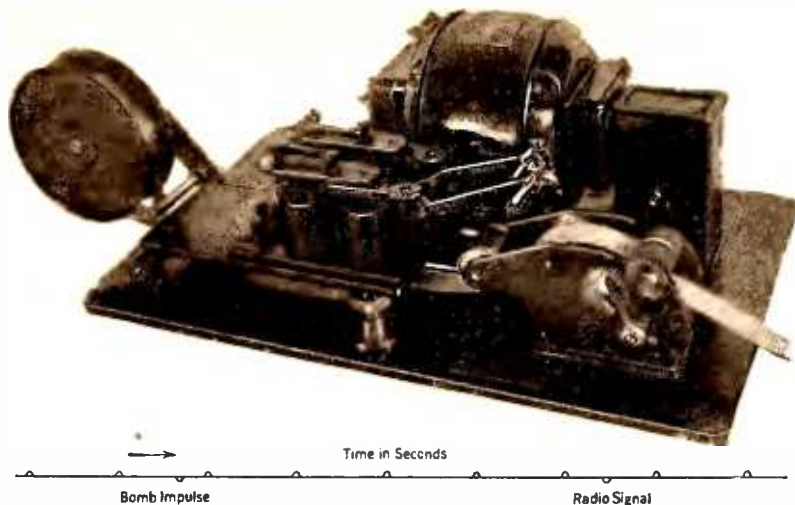

FIG. 2. THE RECORDING CHRONOGRAPH

Two pens can be seen poised above the tape in the chronograph. The relay operating one of the pens is actuated by the chronometer; the other relay is operated by the signals from the hydrophone and the short-wave receiver on the ship. The type of record made is indicated below the photograph.

with a similar finger on the pendulum of the metronome when it is in the off position. The impulse from the bomb pulls the armature over, releasing the metronome mechanism, and a suitable system of contacts acting on a notched wheel attached to the time shaft opens and closes circuits in such a manner that the armature is held over during one complete revolution of the time shaft and at the same time sends out three flashes through the radio transmitter. When one revolution has been made the armature is released and the metronome stops.

The transmitter is a single UX-210 tube instrument designed to transmit at 140 meters. It is sufficiently powerful to transmit through approximately two hundred miles.

The initial and the three identifying flashes from the shore transmitter are picked up on the ship by a standard make of short-wave radio receiver. This receiver contains a detector tube and two stages of audio amplification, and additional amplification is secured by connecting this receiver to the three-stage amplifier previously described. The panel of this amplifier is fitted with a double throw switch, by means of which either the hydrophone or the radio receiver may be connected to it. As soon as the explosion has occurred and has been recorded, this switch is thrown over, disconnecting the hydrophone and

connecting the radio receiver ready for the impulse from the shore station to be recorded. The amplified radio signal actuates the second chronograph pen previously referred to, making a mark upon the tape.

RESULTS

THE tape now contains a line punctuated at one side with the one second marks recorded by the chronometer. The other side of this line is punctuated with the impulse from the hydrophone and also those from the several shore stations with their characteristic identification marks. The time elapsed between the bomb explosion and the radio reception may be readily determined by counting the number of second marks and by measuring the fractions at each end. Multiplying this figure by the velocity of sound through sea water gives the distances from the ship to the several shore stations. As

the geographic positions of these stations are already known, arcs of the proper radii are struck from each and their intersections indicate the ship's position. Ample accurate results for the type of work have been obtained by this means.

This system possesses certain difficulties of operation in some localities. Experience has shown that the apparatus works better where the bottom falls rapidly away from the shore and where the water is cold and of fairly even temperature. Shoals also seem to present difficulties in the transmission of sound through water. The exact influence of each of these factors has not been fully determined, but active investigation is being carried on. On the Atlantic Coast of the United States, where the continental shelf extends for a good many miles offshore, and also where the water is comparatively warm, considerable difficulty has been experienced in getting the apparatus to work satisfactorily over any great distance. On the other hand, on the West coast, where these conditions do not obtain, excellent results have been achieved over a distance of about two hundred miles.

The system has such attractive possibilities for the location of positions at sea rapidly and economically, that development work will be rapidly carried on in an effort to perfect its use under all conditions.

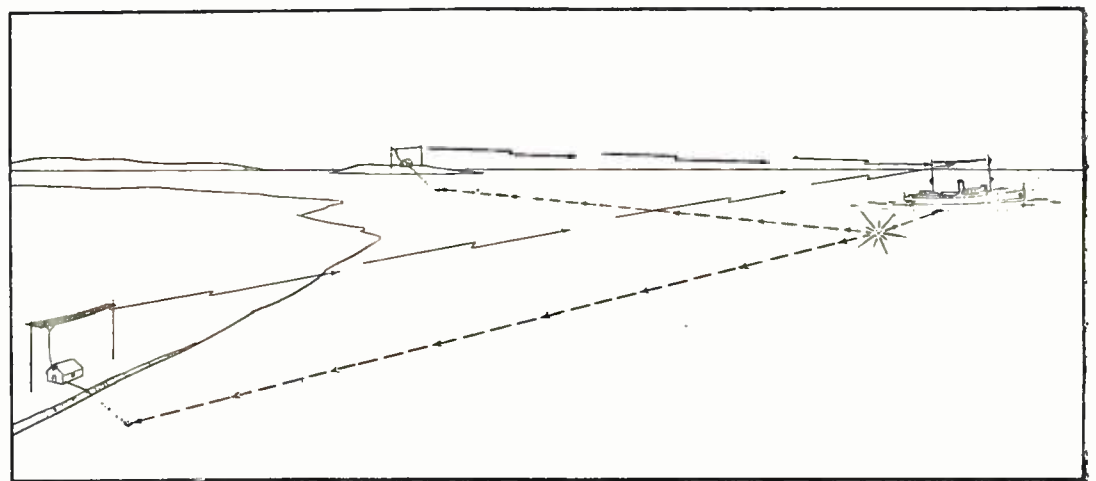

FIG. 3. THE ACOUSTIC RANGE FINDING METHOD

The bomb exploded under water by the ship produces sound waves that are picked up by the hydrophones of the two shore stations, causing the two shore stations to transmit radio signals. These are picked up by the ship, and the elapsed time between explosion and signals gives the data for the calculation of the distance of the ship from the two shore stations. Thus its position can be located.

Manufacturers' Booklets

A Varied List of Books Pertaining to Radio and Allied Subjects Obtainable Free With the Accompanying Coupon

READERS may obtain any of the booklets listed below by using the coupon printed on this page. Order by number only.

1. FILAMENT CONTROL—Problems of filament supply, voltage regulation, and effect on various circuits. 1928 revised booklet, with circuit diagrams of popular kits. RADIALL COMPANY.
5. CARBORUNDUM IN RADIO—A book giving pertinent data on the crystal as used for detection, with hook-ups, and a section giving information on the use of resistors. THE CARBORUNDUM COMPANY.
9. VOLUME CONTROL—A leaflet showing circuits for distortionless control of volume. CENTRAL RADIO LABORATORIES.
10. VARIABLE RESISTANCE—As used in various circuits. CENTRAL RADIO LABORATORIES.
12. DISTORTION AND WHAT CAUSES IT—Hook-ups of resistance-coupled amplifiers with standard circuits. ALLEN-BRADLEY COMPANY.
15. B-ELIMINATOR AND POWER AMPLIFIER—Instructions for assembly and operation using Raytheon tube. GENERAL RADIO COMPANY.
- 15a. B-ELIMINATOR AND POWER AMPLIFIER—Instructions for assembly and operation using an R. C. A. rectifier. GENERAL RADIO COMPANY.
17. BAKELITE—A description of various uses of bakelite in radio, its manufacture, and its properties. BAKELITE CORPORATION.
22. A PRIMER OF ELECTRICITY—Fundamentals of electricity with special reference to the application of dry cells to radio and other uses. Constructional data on buzzers, automatic switches, alarms, etc. NATIONAL CARBON COMPANY.
23. AUTOMATIC RELAY CONNECTIONS—A data sheet showing how a relay may be used to control A and B circuits. YAKLEY MANUFACTURING COMPANY.
26. DRY CELLS FOR TRANSMITTERS—Actual tests given, well illustrated with curves showing exactly what may be expected of this type of B power. BURGESS BATTERY COMPANY.
30. TUBE CHARACTERISTICS—A data sheet giving constants of tubes. C. F. MANUFACTURING COMPANY.
32. METERS FOR RADIO—A catalogue of meters used in radio, with diagrams. BURTON-ROGERS COMPANY.
33. SWITCHBOARD AND PORTABLE METERS—A booklet giving dimensions, specifications, and shunts used with various meters. BURTON-ROGERS COMPANY.
36. CHARGING A AND B BATTERIES—Various ways of connecting up batteries for charging purposes. WESTINGHOUSE UNION BATTERY COMPANY.
37. WHY RADIO IS BETTER WITH BATTERY POWER—Advice on what dry cell battery to use; their application to radio, with wiring diagrams. NATIONAL CARBON COMPANY.
46. AUDIO-FREQUENCY CHOKES—A pamphlet showing positions in the circuit where audio-frequency chokes may be used. SAMSON ELECTRIC COMPANY.
47. RADIO-FREQUENCY CHOKES—Circuit diagrams illustrating the use of chokes to keep out radio-frequency currents from definite points. SAMSON ELECTRIC COMPANY.
48. TRANSFORMER AND IMPEDANCE DATA—Tables giving the mechanical and electrical characteristics of transformers and impedances, together with a short description of their use in the circuit. SAMSON ELECTRIC COMPANY.
53. TUBE REACTIVATOR—Information on the care of vacuum tubes, with notes on how and when they should be reactivated. THE STERLING MANUFACTURING COMPANY.
56. VARIABLE CONDENSERS—A bulletin giving an analysis of various condensers together with their characteristics. GENERAL RADIO COMPANY.
57. FILTER DATA—Facts about the filtering of direct current supplied by means of motor-generator outfits used with transmitters. ELECTRIC SPECIALTY COMPANY.
58. HOW TO SELECT A RECEIVER—A common-sense booklet describing what a radio set is, and what you should expect from it, in language that anyone can understand. DAY-FAN ELECTRIC COMPANY.
67. WEATHER FOR RADIO—A very interesting booklet on the relationship between weather and radio reception, with maps and data on forecasting the probable results. TAYLOR INSTRUMENT COMPANIES.
69. VACUUM TUBES—A booklet giving the characteristics of the various tube types with a short description of where they may be used in the circuit. RADIO CORPORATION OF AMERICA.
70. IMPROVING THE AUDIO AMPLIFIER—Data on the characteristics of audio transformers, with a circuit diagram showing where chokes, resistors, and condensers can be used. AMERICAN TRANSFORMER COMPANY.
72. PLATE SUPPLY SYSTEM—A wiring diagram and layout plan for a plate supply system to be used with a power amplifier. Complete directions for wiring are given. AMERTRAN SALES COMPANY.
73. RADIO SIMPLIFIED—A non-technical booklet giving pertinent data on various radio subjects. Of especial interest to the beginner and set owner. CROSLY CORPORATION.
76. RADIO INSTRUMENTS—A description of various meters used in radio and electrical circuits together with a short discussion of their uses. JEWELL ELECTRICAL INSTRUMENT COMPANY.

78. ELECTRICAL TROUBLES—A pamphlet describing the use of electrical testing instruments in automotive work combined with a description of the cadmium test for storage batteries. Of interest to the owner of storage batteries. BURTON ROGERS COMPANY.
81. BETTER TUNING—A booklet giving much general information on the subject of radio reception with specific illustrations. Primarily for the non-technical home constructor. BREMER-TULLY MANUFACTURING COMPANY.
84. FIVE-TUBE EQUAMATIC—Panel layout, circuit diagrams, and instructions for building a five-tube receiver, together with data on the operation of tuned radio-frequency transformers of special design. KARAS ELECTRIC COMPANY.
85. FILTER—Data on a high-capacity electrolytic condenser used in filter circuits in connection with A socket power supply units, are given in a pamphlet. THE ABOX COMPANY.
87. TUBE TESTER—A complete description of how to build and how to operate a tube tester. BURTON-ROGERS COMPANY.

Radio Broadcast
Laboratory Information Sheets
(Nos. 1-190)
in
BOUND VOLUMES

Ask any news dealer for "Radio Broadcast Data Sheets" or write direct to the Circulation Department, Doubleday, Doran & Co., Inc. See page 378 for further details. Price \$1.00

88. SUPER-HETERODYNE CONSTRUCTION—A booklet giving full instructions, together with a blue print and necessary data, for building an eight-tube receiver. THE GEORGE W. WALKER COMPANY.
89. SHORT-WAVE TRANSMITTER—Data and blue prints are given on the construction of a short-wave transmitter, together with operating instructions, methods of keying, and other pertinent data. RADIO ENGINEERING LABORATORIES.
90. IMPEDANCE AMPLIFICATION—The theory and practice of a special type of dual-impedance audio amplification are given. ALDEN MANUFACTURING COMPANY.
92. RESISTORS FOR A. C. OPERATED RECEIVERS—A booklet giving circuit suggestions for building a.c. operated receivers, together with a diagram of the circuit used with the new 400-milliamperer rectifier tube. CARTER RADIO COMPANY.
95. Resistance Data—Successive bulletins regarding the use of resistors in various parts of the radio circuit. INTERNATIONAL RESISTANCE COMPANY.
96. VACUUM TUBE TESTING—A booklet giving pertinent data on how to test vacuum tubes with special reference to a tube testing unit. JEWELL ELECTRICAL INSTRUMENT COMPANY.

In sending the coupon below, make sure that your name and address are included and are plainly written. Also make sure that the listing of booklets from which you choose is that of the latest issue of the magazine, as Radio Broadcast cannot guarantee the delivery of booklets not listed in its current issue.

USE THIS BOOKLET COUPON

RADIO BROADCAST SERVICE DEPARTMENT
RADIO BROADCAST, Garden City, N. Y.

Please send me (at no expense) the following booklets indicated by numbers in the published list above:

.....
.....
.....

Name..... (Number) (Street)

Address..... (City) (State)

.....
.....

ORDER BY NUMBER ONLY

This coupon must accompany every request. R B 9-28

98. COPPER SHIELDING—A booklet giving information on the use of shielding in radio receivers, with notes and diagrams showing how it may be applied practically. Of special interest to the home constructor. THE COPPER AND BRASS RESEARCH ASSOCIATION.
99. RADIO CONVENIENCE OUTLETS—A folder giving diagrams and specifications for installing loud speakers in various locations at some distance from the receiving set. YAKLEY MANUFACTURING COMPANY.
101. USING CHOKES—A folder with circuit diagrams of the more popular circuits showing where choke coils may be placed to produce better results. SAMSON ELECTRIC COMPANY.
102. RADIO POWER BULLETINS—Circuit diagrams, theory constants, and trouble-shooting hints for units employing the BH or B rectifier tubes. RAYTHEON MANUFACTURING COMPANY.
104. OSCILLATION CONTROL WITH THE "PHASATROL"—Circuit diagrams, details for connection in circuit, and specific operating suggestions for using the "Phasatrol" as a balancing device to control oscillation. ELECTRAD, INCORPORATED.
105. COILS—Excellent data on a radio-frequency coil with constructional information on six broadcast receivers, two short-wave receivers, and several transmitting circuits. AERO PRODUCTS COMPANY.
108. VACUUM TUBES—Operating characteristics of an a.c. tube with curves and circuit diagram for connection in converting various receivers to a.c. operation with a four-prong a.c. tube. ARCTURUS RADIO COMPANY.
110. RECEIVER CONSTRUCTION—Circuit diagram and constructional information for building a five-tube set using restricted field coils. BODINE ELECTRIC COMPANY.
111. STORAGE BATTERY CARE—Booklet describing the care and operation of the storage battery in the home. MARKO STORAGE BATTERY COMPANY.
112. HEAVY-DUTY RESISTORS—Circuit calculations and data on receiving and transmitting resistances for a variety of uses, diagrams for popular power supply circuits, d.c. resistors for battery charging use. WARD LEONARD ELECTRIC COMPANY.
113. CONE LOUD SPEAKERS—Technical and practical information on electro-dynamic and permanent magnet type cone loud speakers. THE MAGNAVOX COMPANY.
114. TUBE ADAPTERS—Concise information concerning simplified methods of including various power tubes in existing receivers. ALDEN MANUFACTURING COMPANY.
115. WHAT SET SHALL I BUILD?—Descriptive matter, with illustrations, of fourteen popular receivers for the home constructor. HERBERT H. FROST, INCORPORATED.
116. USING A B POWER UNIT—A comprehensive booklet detailing the use of a B power unit. Tables of voltages—both B and C—are shown. There is a chapter on trouble-shooting. MODERN ELECTRIC MFG. CO.
118. RADIO INSTRUMENTS. CIRCULAR "J"—A descriptive manual on the use of measuring instruments for every radio circuit requirement. A complete listing of models for transmitters, receivers, set servicing, and power unit control. WESTON ELECTRICAL INSTRUMENT CORPORATION.
120. THE RESEARCH WORKER—A monthly bulletin of interest to the home constructor. A typical feature article describes the construction of a special audio amplifier—AEROVOX WIRELESS CORPORATION.
121. FILTER CONDENSERS—Some practical points on the manufacture and use of filter condensers. The difference between inductive and non-inductive condensers. POLYMET MFG. CORP.
123. B SUPPLY DEVICES—Circuit diagrams, characteristics, and list of parts for nationally known power supply units. ELECTRAD, INC.
124. POWER AMPLIFIER AND B SUPPLY—A booklet giving several circuit arrangements and constructional information and a combined B supply and push-pull audio amplifier, the latter using 210 type tubes. THORDARSON ELECTRIC MFG. CO.
125. A. C. TUBE OPERATION—A small but complete booklet describing a method of filament supply for a.c. tubes. THORDARSON ELECTRIC MFG. CO.
126. MICROMETRIC RESISTANCE—How to use resistances for: Sensitivity control; oscillation control; volume control; regeneration control; tone control; detector plate voltage control; resistance and impedance coupling; loud speaker control, etc. CLAROSTAT MFG. CO.
129. TONE—Some model audio hook-ups, with an explanation of the proper use of transformers and chokes. SANGAMO ELECTRIC CO.
130. SCREEN-GRID AUDIO AMPLIFICATION—Diagrams and constructional details for remodeling old audio amplifiers for operation with screen-grid tubes. THORDARSON ELECTRIC MFG. CO.
131. THE MERSHON CONDENSER—Two illustrated booklets giving the theory and uses of the electrolytic condenser. AMRAD CORPORATION.
132. THE NATIONAL SCREEN-GRID SHORT-WAVE RECEIVER—Constructional and operating data, with diagrams and photographs. JAMES MILLEN.
133. THE NATIONAL SHIELD-GRID FIVE—A circuit diagram with constructional and operating notes on this receiver. JAMES MILLEN.
134. REMLER SERVICE BULLETINS—A regular service for the professional set builder, giving constructional data, blueprints, and hints on marketing. GRAY & DANIELSON MFG. CO.
135. THE RADIOBUILDER—A periodic bulletin giving advance information, constructional and operating data on S-M products. SILVER-MARSHALL, INC.
136. SILVER MARSHALL DATA SHEETS—These data sheets cover all problems of construction and operation on Silver-Marshall products. SILVER-MARSHALL, Inc.
139. POWER UNIT DESIGN—Periodical data sheets on power unit problems, design, and construction. RAYTHEON MFG. CO.
140. POWER UNIT PROBLEMS—Resistance problems in power units, with informative tables and circuit diagrams. ELECTRAD, INC.
141. AUDIO AND POWER UNITS—Illustrated descriptions of power amplifiers and power supplies, with circuit diagrams. THORDARSON ELECTRIC MFG. CO.

A NEW NOTE IN AUDIO AMPLIFICATION

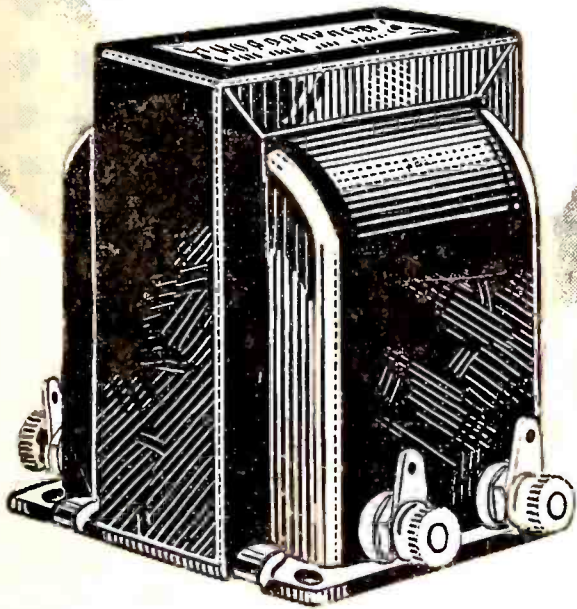

THORDARSON R-300 AUDIO TRANSFORMER

SUPREME in musical performance, the new Thordarson R-300 Audio Transformer brings a greater realism to radio reproduction. Introducing a new core material, "DX-Metal" (a product of the Thordarson Laboratory), the amplification range has been extended still further into the lower register, so that even the deepest tones now may be reproduced with amazing fidelity.

The amplification curve of this transformer is practically a straight line from 30 cycles to 8,000 cycles. A high frequency cut-off is provided at 8,000 cycles to confine the amplification to useful frequencies only, and to eliminate undesirable scratch that may reach the audio transformer.

When you hear the R-300 you will appreciate the popularity of Thordarson transformers among the leading receiving set manufacturers. The R-300 retails for \$8.00.

THORDARSON ELECTRIC MANUFACTURING CO.
Transformer Specialists Since 1895
WORLD'S OLDEST AND LARGEST EXCLUSIVE TRANSFORMER MAKERS
Huron and Kingsbury Streets — Chicago, Ill. U.S.A.

Power Supply Transformers

These transformers supply full wave rectifiers using two UX-281 tubes, for power amplifiers using either 210 or 250 types power amplifying tubes as follows: T-2098 for two 210 power tubes, \$20.00; T-2900 for single 250 power tube, \$20.00; T-2950 for two 250 tubes, \$29.50.



Double Choke Units

Consist of two 30 henry chokes in one case. T-2099 for use with power supply transformer T-2098, \$14; T-3099 for use with transformer T-2900, \$16; T-3100 for use with transformer T-2950, \$18.



Power Compacts

A very efficient and compact form of power supply unit. Power transformer and filter chokes all in one case. Type R-171 for Raytheon rectifier and 171 type power tube, \$15.00; Type R-210 for UX-281 rectifier and 210 power tube, \$20.00; Type R-280 for UX-280 rectifier and 171 power tube, \$17.00.



Speaker Coupling Transformers

A complete line of transformers to couple either single or push-pull 171, 210 or 250 power tubes into either high impedance or dynamic speakers. Prices from \$6.00 to \$12.00.

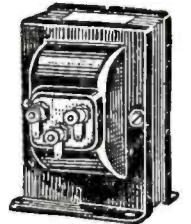

Screen Grid Audio Coupler

The Thordarson Z-Coupler T-2909 is a special impedance unit designed to couple a screen grid tube in the audio amplifier into a power tube. Produces excellent base note reproduction and amplification vastly in excess of ordinary systems. Price, \$12.00.



THORDARSON ELECTRIC MFG. CO.
500 W. Huron St., Chicago, Ill. 3583-J

Gentlemen: Please send me your constructional booklets on your power amplifiers. I am especially interested in amplifiers using.....tubes.

Name.....

Street and No.....

Town.....State.....

Raytheon Kino-Lamp



TWO PIONEER TELEVISION ACCESSORIES

The Raytheon Laboratories invite correspondence from both engineers and amateurs in regard to these two accessories now in successful operation.

Raytheon Kino-Lamp is the first television-reception tube developed to work on all systems.

Raytheon Foto-Cell, an extra sensitive broadcasting tube, is supplied in either hard vacuum or gas-filled types.

RAYTHEON MFG. CO.

Kendall Square Bldg., Cambridge, Mass.



Raytheon Foto-Cell

The Radio Broadcast LABORATORY INFORMATION SHEETS

THE aim of the Radio Broadcast Laboratory Information Sheets is to present, in a convenient form, concise and accurate information in the field of radio and closely allied sciences. It is not the purpose of the Sheets to include only new information, but to present practical data, whether new or old, that may be of value to the experimenter, set builder or service man. In order to make the Sheets easier to refer to, they are arranged so that they may be cut from the magazine and preserved, either in a blank book or on 4" x 6" filing cards. The cards should be arranged in numerical order.

Since they began, in June, 1926, the popularity of the Information Sheets has increased so greatly that it has been decided to reprint the first one hundred and ninety of them (June, 1926-May, 1928) in a single substantially bound volume. This volume, "Radio Broadcast's Data Sheets" may now be bought on the newsstands, or from the Circulation Department, Doubleday, Doran & Company, Inc., Garden City, New York, for \$1.00. Inside each volume is a credit coupon which is worth \$1.00 toward the subscription price of this magazine. In other words, a year's subscription to RADIO BROADCAST, accompanied by this \$1.00 credit coupon, gives you RADIO BROADCAST for one year for \$3.00, instead of the usual subscription price of \$4.00.

—THE EDITOR.

No. 225

RADIO BROADCAST Laboratory Information Sheet

October, 1928

Calculating Grid Bias for A.C. Tubes

CORRECT RESISTANCE VALUES

IN ALL a.c. receivers, grid bias for the various tubes is obtained by connecting resistances of the correct value at the correct point in the circuit. The calculation of the value of the resistance and its placement in the circuit have been the subject of quite a few letters written to the Technical Information Service and we have therefore devoted this Laboratory Sheet to the subject. The circuit diagrams of six combinations are given on Laboratory Sheet No. 226.

If these diagrams are examined one important point will be noted, which is that the resistance, R, which supplies C bias to the tube, is always connected between the center of the filament, or the cathode in the case of heater type tubes, and negative B. The resistance is placed in this position in relation to the circuit no matter what tube or combination of tubes is used. With the resistor in this position the plate current of the tube must go through it in order to reach the filament, or cathode, and therefore the voltage drop across the resistance is equal to the plate current times the resistance in ohms. To calculate the value of resistance, we must therefore know the value of grid bias that we desire

to obtain and also the plate current flowing through the resistance. For example, in diagram A we have indicated a 226 type tube. By reference to any table of tube characteristics we can determine that the 226 type tube with 90 volts on the plate requires a grid bias of 6 volts and the plate current is 3.5 milliamperes. R is found by dividing the grid voltage required, 6, by the plate current in amperes, 0.0035, which gives a value of 1700 ohms as the required value of resistance.

In diagram C, a 171 tube is used, forty volts of grid bias are required if the plate voltage is 180 volts. The plate current under such conditions is 20 milliamperes, and 40 divided by 0.02 amperes gives 2000 ohms as the value of resistance required for C bias.

If a circuit utilizes more than one tube of the same type for which we require the same value of grid bias, the circuit is arranged as indicated at E, in which case the plate current of both of the tubes flows through resistance R. If the plate voltage on the 227 type tube is 90, the plate current is 3.7 milliamperes and the required grid bias is 6 volts. The grid bias resistance is then equal to 6 divided by 7.4 (the total current of the two tubes) which gives 800 ohms as the correct value for R.

No. 226

RADIO BROADCAST Laboratory Information Sheet

October, 1928

Grid Bias Circuits for A.C. Tubes

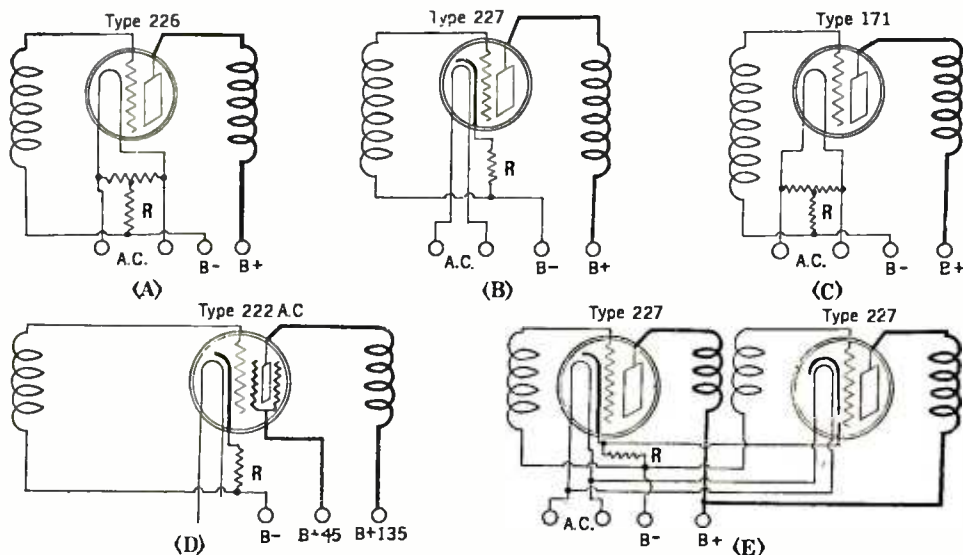

4 NEW HI-Q RECEIVERS

Custom-built To Any Pocketbook!

AGAIN Hammerlund-Roberts opens the radio season with advancements in construction and performance that will be marveled at throughout the entire radio world.

This year, instead of merely one outstanding Custom-built receiver as in past years, we announce **FOUR** wonderful instruments—the result of the combined engineering efforts of the foremost parts manufacturers in America. **FOUR** brand-new models—a Junior D.C., a Junior A.C., a Master D.C. and a Master A.C. that establish a totally new standard in radio design.

The new Master Hi-Q typifies the marvelous efficiency of the entire line of 1929 Hi-Q's. A five-tube stage-shielded receiver that is built upon a solid steel chassis. Only the very finest parts in the industry are used, including the new screen-grid tube. Circuit is a new development with a **BAND-PASS FILTER**, which effects absolute **FLAT-TOP square cut-off TUNING** for the first time to our knowledge in radio history. **FLAT-TOP TUNING** with 10 K.C. selectivity! "Cross-talk" is impossible with this set, for the reason that it is impossible to receive more than one station at a time, even in large cities where many powerful stations are broadcasting!

**10 K.C. SELECTIVITY...ABSOLUTE FLAT TOP TUNING
COAST-TO-COAST RECEPTION...NEW TONE QUALITY
SCREEN-GRID TUBES . . . SHIELDED STEEL CHASSIS
CONCEALED WIRING...SIMPLIFIED CONSTRUCTION**

This peak achievement of Hi-Q design is a real "coast-to-coast" instrument. Stations don't merely "swish" in as with

even the best of receivers. They absolutely "CLICK" in—sharp, clear, definite. No hum, no buzz, no oscillation—nothing but the pure, natural, clear-as-crystal signal exactly as it is delivered to the microphone.

There is nothing like this new Hi-Q Receiver available anywhere in any circuit at any price. Wonderful sensitivity. Wonderful selectivity. And tone quality that simply cannot be described.

The other three new Hi-Q 29 Receivers have similar qualities—each the fullest value available in the radio world—each a finer instrument than any ready-built receiver selling at \$50 to \$100 more money.

*Send Now for This New
80-Page
Construction Manual*

Biggest and most complete book ever published. Tells how to build the 4 new Hi-Q Receivers. Photos and diagrams illustrate every detail. Covers power amplifiers, tube and battery combinations, antennae, installation, short-wave adapters, house wiring and a wealth of other data on custom-built radio. Price 25c.

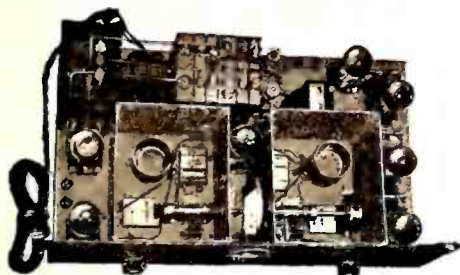

JUNIOR A. C. HI-Q 29

A screen-grid, shielded receiver made with the finest parts available. Extremely selective, sensitive, tone quality unsurpassed, simplified construction.

Junior Hi-Q 29 complete without cabinet, \$54.35. Junior A. C. Hi-Q 29 complete without cabinet, \$103.95.



Any Hi-Q Model, whether in this delightful console or one of the Hi-Q Cabinets, makes a pleasing, decorative adjunct to the finest interior.

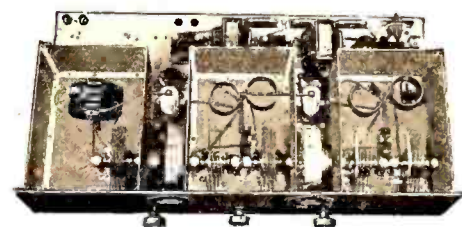

MASTER HI-Q 29

The outstanding feature of this set is the Hi-Q Band-pass Filter, which actually effects FLAT-TOP TUNING within a 10 K. C. band. Also screen-grid tubes, completely shielded, concealed wiring. Master Hi-Q 29 complete without cabinet, \$99.50. Master A. C. Hi-Q 29 complete without cabinet, \$151.80.

HAMMARLUND-ROBERTS, INC., 1182-A Broadway, New York

Associate Manufacturers



For the A. C. Set Builder

The name "WESTON" on any meter you select is the highest guarantee of long life and dependable service with the lowest cost of instrument upkeep. The following three models are recommended for those having professional or technical interest in radio set construction—builders, transmitting and repairmen and all others who demand the best obtainable operating performance.

Model 301
D. C. Milli-ammeter



3 1/4" diam.
Also Model 506
2" diam.

Use of Milliammeter in the Plate Circuit

For checking plate current and plate and grid battery conditions. Low B and C battery voltages determined by direction of fluctuation of the pointer when strong signals are received. Placed in the B-battery lead this instrument checks the set as a whole, or it checks any one radio or audio stage when placed in the plate circuit of that stage—Price, \$8.00.

Model 489



1000 ohms per volt

D. C. Portable voltmeter—1000 ohms per volt resistance guaranteed. For checking output of Battery eliminators. Also made in lower resistance models for general D. C. testing service—Price \$13.50 to \$28.00.

Triple Range A. C. Voltmeter

150/8/4 volts. A compact, light-weight, portable instrument with red and black mottled bakelite case for testing A. C. supply and tube voltages of socket power A. C. receivers. Also made as double-range voltmeters up to 600 volts, and as single-range ammeters and milliammeters—Price, \$13.50 to \$18.50.

Model 528
3 Range



150/8/4 volts

Weston Electrical Instrument Corporation
604 Frelinghuysen Ave.,
Newark, N. J

WESTON
RADIO
INSTRUMENTS

No. 227

RADIO BROADCAST Laboratory Information Sheet

October, 1928

The Audio Transformer

THE EFFECT OF ITS INDUCTANCE

THE diagram on this sheet indicates at A a single stage of audio-frequency amplification; B is the equivalent circuit, in which E_g is the signal voltage in the plate circuit, L_a is the leakage reactance of the transformer, L is the inductance, and C is the distributed capacity of the secondary and the tube input capacity, transferred to the primary. R_p is the plate resistance of the tube. Let us study this circuit to see what happens at various frequencies. The treatment given below is not exact but is approximately correct.

At low frequencies the reactance of C in comparison with L is very large and the reactance of L is very large in comparison with that of L_a . Therefore at low frequencies the voltage in the plate circuit divides between L and R_p . The voltages across these two parts of the circuit are 90 degrees out of phase and the percentage of the total voltage that appears across L depends upon the ratio of the re-

actance of L to the resistance of R_p , and varies as indicated in the second column in the table, column 1 being the ratio of the reactance of L to the resistance, R_p .

Now suppose that we desire to work the transformer out of a 201A-type tube with an R_p of about 11,000 ohms and that at 60 cycles we want to utilize at least 70 per cent. of the total voltage. Then, from the table we will have to make X_L , reactance of the coil L at 60 cycles, equal to the resistance of the tube. Therefore:

$$\begin{aligned} X_L &= 11,000 \\ 2\pi fL &= 11,000 \\ 6.28 \times 60 \times L &= 11,000 \\ L &= 30 \text{ henries} \end{aligned}$$

We might look at the problem in another way. Suppose we desire a transformer with a voltage drop at 60 cycles of not more than 1 TU. When a circuit is 1 TU down in voltage, the actual voltage loss is

about 11 per cent., leaving 89 per cent. This corresponds to a ratio of X_L over R_p of 2. Therefore, from the table the reactance of L at 60 cycles must be twice the resistance of the tube or 22,000 ohms.

$$\begin{aligned} 2\pi fL &= 22,000 \\ L &= 59 \text{ henries} \end{aligned}$$

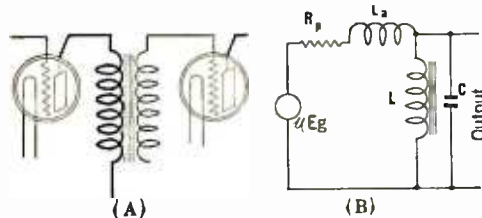

TABLE

$\frac{X_L}{R}$	Percentage of total voltage across L
4.0	97
2.0	89
1.0	71
0.5	44.6
0.3	28.7

No. 228

RADIO BROADCAST Laboratory Information Sheet

October, 1928

The Dynamic Loud Speakers

THE FIELD MAGNET

THE dynamic-type loud speaker depends for its operation on the production of a very strong magnetic field in the air-gap in which the moving coil is placed. This air-gap is indicated in the sketch on this sheet. The useful magnetic flux is that indicated by the light solid lines flowing directly across the gap, and the leakage flux—that part of the magnetic field which serves no useful purpose—is indicated by the dot-dash lines.

The flux which any given amount of magnetic material, such as iron or steel, can handle efficiently is definitely limited by saturation. When the iron is saturated its resistance—reluctance is the technical term—to the flow of magnetic lines through it increases and then the leakage flux increases. The flux will tend to take that path which has the lowest

reluctance. To prevent leakage the pole pieces are frequently shaped in some peculiar manner, such as indicated at B, in order that the actual air-gap will be a very much lower reluctance path for the flux than any other path. The leakage flux in sketch A does not have to travel a path much longer than the actual air-gap, i.e., the two paths have about the same reluctance. In the pole shape indicated at B the flux path outside the air-gap is much longer than the path through the air-gap. The latter arrangement therefore tends to reduce the leakage flux.

Assuming that the iron does not saturate, the flux in the air-gap will increase very rapidly as the size of the gap is decreased, and in practice the gap is always made as small as possible, leaving just sufficient room for the coil to move without any danger of its striking the pole pieces.

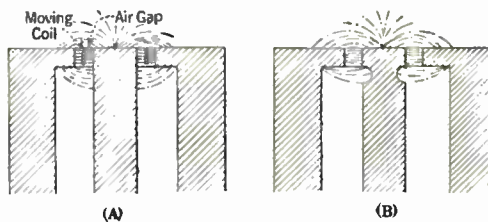

No. 229

RADIO BROADCAST Laboratory Information Sheet

October, 1928

The Telephone Transmission Unit

No. of TU	Power Ratio		No. of TU	Power Ratio		No. of TU	Power Ratio		No. of TU	Power Ratio	
	Gain	Loss		Gain	Loss		Gain	Loss		Gain	Loss
0.1	1.023	.977	2.7	1.862	.537	5.3	3.39	.295	7.9	6.17	.162
0.2	1.047	.955	2.8	1.906	.525	5.4	3.47	.288	8.0	6.31	.158
0.3	1.072	.933	2.9	1.950	.513	5.5	3.55	.282	8.1	6.45	.155
0.4	1.096	.912	3.0	1.995	.501	5.6	3.63	.275	8.2	6.61	.151
0.5	1.122	.891	3.1	2.04	.490	5.7	3.72	.269	8.3	6.76	.148
0.6	1.148	.871	3.2	2.09	.479	5.8	3.80	.263	8.4	6.92	.144
0.7	1.175	.851	3.3	2.14	.468	5.9	3.89	.257	8.5	7.08	.141
0.8	1.202	.832	3.4	2.19	.457	6.0	3.98	.251	8.6	7.24	.138
0.9	1.230	.813	3.5	2.24	.447	6.1	4.07	.245	8.7	7.41	.135
1.0	1.259	.794	3.6	2.29	.437	6.2	4.17	.240	8.8	7.59	.132
1.1	1.288	.776	3.7	2.34	.427	6.3	4.27	.234	8.9	7.76	.129
1.2	1.318	.759	3.8	2.40	.417	6.4	4.37	.229	9.0	7.94	.126
1.3	1.349	.741	3.9	2.45	.407	6.5	4.47	.224	9.1	8.13	.123
1.4	1.380	.724	4.0	2.51	.398	6.6	4.57	.219	9.2	8.32	.120
1.5	1.413	.708	4.1	2.57	.389	6.7	4.68	.214	9.3	8.51	.118
1.6	1.445	.692	4.2	2.63	.380	6.8	4.79	.209	9.4	8.71	.115
1.7	1.479	.676	4.3	2.69	.372	6.9	4.90	.204	9.5	8.91	.112
1.8	1.514	.661	4.4	2.75	.363	7.0	5.01	.200	9.6	9.12	.110
1.9	1.549	.645	4.5	2.82	.355	7.1	5.13	.195	9.7	9.33	.107
2.0	1.585	.631	4.6	2.88	.347	7.2	5.25	.191	9.8	9.55	.105
2.1	1.622	.617	4.7	2.95	.339	7.3	5.37	.186	9.9	9.77	.102
2.2	1.660	.603	4.8	3.02	.331	7.4	5.50	.182	10.0	10.00	.100
2.3	1.698	.589	4.9	3.09	.324	7.5	5.62	.178	20.0	100	.01
2.4	1.738	.575	5.0	3.16	.316	7.6	5.75	.174	30.0	1,000	.001
2.5	1.778	.562	5.1	3.24	.309	7.7	5.89	.170	40.0	10,000	.0001
2.6	1.820	.550	5.2	3.31	.302	7.8	6.03	.166	50.0	100,000	.00001

Another huge achievement by FROST-RADIO

...a complete line of these famous radio parts

Frost-Radio has scored another of its characteristic achievements in bringing out a number of new items to supplement its already famous line of parts. Frost now offers the finest and most complete line of radio parts of any manufacturer in the

field. Whether you build sets for yourself or for others you will find in this great line practically all of the vital and important parts you require. Your favorite dealer can supply you. Why not get in touch with him today?

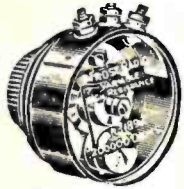

Frost-Radio Variable High Resistances

Offer marvelous control of volume and oscillation. Roller contact arm is practically frictionless. Bakelite case and dust cover. Supplied in a wide range of resistances. \$2.00 and \$2.25.

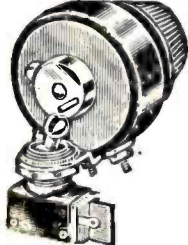

Equipped With Approved AC Switch

Underwriters' approved AC snap switch fitted to our Variable High Resistance makes ideal combination. Switch is tested to carry 250 volts at 3 amperes. \$2.75 and \$3.00.



Frost-Radio Variable High Resistance with DC Switch

Another combination of the Frost Variable High Resistance with quick-operating switch having positive "off" position, for use only with battery operated sets. Switch has sterling silver contacts, with German silver springs, and Bakelite insulation is used. \$2.35.



Frost Gem Variable High Resistance

Identical with our larger Resistance Units except in size. The Gem is housed in Bakelite case measuring 1 1/2 x 1/2 in., thus saving much space back of panel. \$2.25 and \$2.50.



Frost-Radio Gem Rheostats

Mighty good little rheostats, built to give long service and stand the gaff. Take up but little space, are single hole mounting and are easy to solder to. Supplied plain or with DC switch, the latter offering a remarkable combination at minimum cost, as it combines both rheostat and switch. Plain type, 75c. With switch, \$1.00.



Frost-Radio Bakelite Rheostats

The original aircooled Bakelite rheostat with one-piece moulded frame and resistance wire wound on threaded flexible Bakelite strip. Supplied in a wide range of resistances, \$1.00. Potentiometers, \$1.25 to \$2.50.



Frost-Radio Bakelite Rheostat with Switch

Battery operated sets find wonderful service in these Frost Rheostats with switch mounted on Bakelite panel. Switch has positive "off" position, and springs are German silver with sterling silver contacts, 2 to 75 ohms, \$1.35.



Frost-Radio AC Snap Switch

Approved, single hole mount AC switch 3 amp., 250 v., 75c.



Frost-Radio Hum Balancer

Ideal for smoothing the ripple out of AC current. Easy to regulate with screw driver by means of slot-headed shaft, \$1.00.



Frost-Radio Bakelite Cable Plug

A remarkable achievement in an all-Bakelite Cable Plug. Terminals are spun into sockets and cannot work loose even when overheated in soldering. Color code molded into Bakelite. Plug is equipped with 5-ft. seven wire braid covered cable with best rubber insulation on individual wires. Plug and cord only, \$2.25. Baseboard or sub-panel socket, 75c.



Frost-Radio Moulded Mica Condensers

Finely made and extremely accurate. Guaranteed to within 10%. Unaffected by moisture or climatic changes. Molded Bakelite, with finest quality mica dielectric. Neat, small, easy to attach either to metal subpanel or by means of soldering lugs, 45c to 90c.

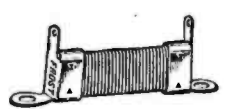

Frost-Radio Fixed Resistances

Windings are on die cut flexible Bakelite strip, with firmly staked terminals, .4 to 1000 ohms. Also as center tapped resistances to provide grid return in AC sets, 6 to 64 ohms, 15c to 50c.

FROST-RADIO UNIVERSAL RESISTANCE KIT

Consists of four 2000 ohm potentiometers, three 2000 ohm fixed resistors and one 1500 ohm fixed resistor. Supplies voltages 0 to 30, 30 to 50, 50 to 70, 90, 135, and 180. Resistors fitted with sliding connections. Complete kit (not illustrated), \$9.00.

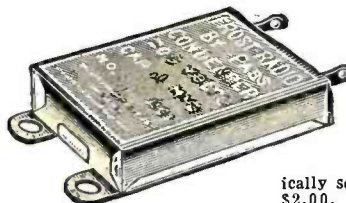

Frost-Radio By-Pass Condensers

Accurate capacities and conservative voltage ratings distinguish these new Frost Condensers. Built of best materials, thoroughly seasoned, vacuum impregnated and hermetically sealed. .1 to 2 mfd. 80c to \$2.00.

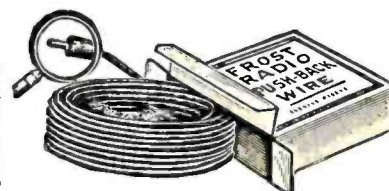

Frost-Radio Hook-Up Wire

Simply push back the braid for soldering, and slide it back over the soldered joint. No. 18 double cotton covered, impregnated wire. 50 ft. roll, 80c.

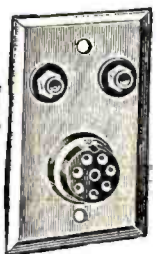

Frost-Radio 210 Blocking Condensers

Built to give super-service, with conservative voltage ratings. Every item of material used in their construction is the very best obtainable. Enclosed in hermetically sealed cases of gold-bronze lacquered metal, with tinned terminals. The best Blocking Condensers money can buy. \$18.00.



Frost-Radio Heavy Duty Filter Condensers

Like our Blocking Condensers, Frost Filter Condensers are a quality product, made of the finest linen paper and highest grade foil. Conservatively rated. Will give long service. .5 to 2 mfd. \$1.40 to \$7.00.

"WORTH MANY TIMES 10c TO ANYONE WHO IS INTERESTED IN RADIO"—Send for this 16-page book today.

Those who have sent for the new Frost Data Book tell us it is worth many times the dime asked for postage and mailing. It contains a vast amount of valuable information—tells also about the complete Frost-Radio line—YOU should have a copy. Fill out and mail coupon today.

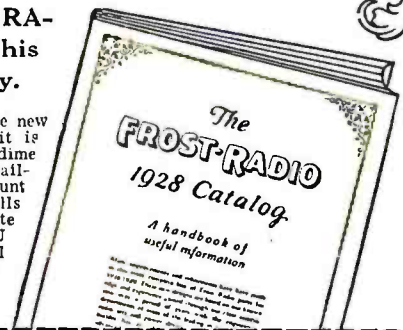

HERBERT H. FROST, Inc. RB10
160 No. La Salle Street, Chicago

Send me your new Frost Data Book, containing not only valuable radio information, but also facts about your new line. I enclose 10c.

(Are you a professional set builder?.....)

Name

Street Address

City State

HERBERT H. FROST, INC.
Main Office and Factory: **ELKHART, IND.**
New York City CHICAGO San Francisco

?

Do You Read the TECHNICAL JOURNAL of the RADIO INDUSTRY

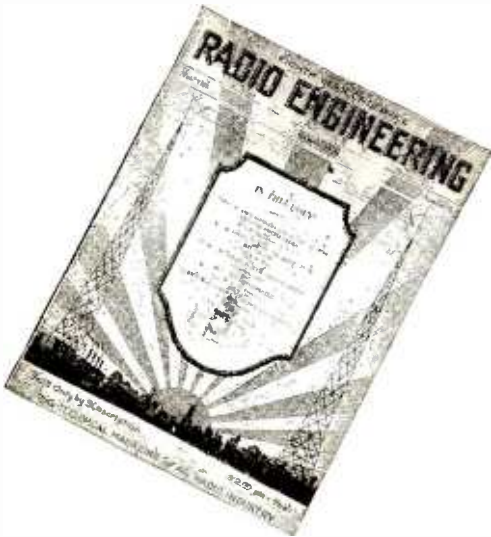

Editor—M. L. Muhleman
Associate Editors—John F. Rider and Austin C. Lescarboura
Managing Editor—G. C. B. Rowe

Radio Engineering has been published for eight years for the engineers, technicians, manufacturers and dealers of the radio field.

It covers, in some forty text pages each month, the latest developments in manufacturing and engineering, design, production, etc. It includes valuable material on construction, testing and servicing.

In the "Commercial Developments" section, *Radio Engineering* deals with television, moving picture transmission, aeroplane and train communication, speech amplifying systems, etc.

Contributors and authors include the leading engineers in the electrical and radio field.

**Radio Engineering is
NOT
sold on newsstands**

*If you are not already a subscriber,
use coupon below.*

RADIO ENGINEERING, Inc.
 52 Vanderbilt Ave., New York, N. Y.

Enclosed find { \$2.00 for 1 year } sub-
 { \$3.00 for 2 years } scrip-
 tion to *Radio Engineering*.

Enclosed find twenty cents (20c) for which
 send sample copy of *Radio Engineering*.

(PLEASE PRINT NAME AND ADDRESS)

Name.....
 Address.....
 City.....
 State.....

Please check classification.

Manufacturer Dealer
 Engineer Technician

Anything else.....

No. 230

RADIO BROADCAST Laboratory Information Sheet

October, 1928

Filters

HOW THE VARIOUS TYPES DIFFER
IN TELEPHONE and radio circuits various types of filters are used and in this Laboratory Sheet we will indicate how the several types differ.

First let us define a filter. We might say that a filter is a circuit arrangement that will separate direct current from alternating current or vice versa or a circuit that will separate alternating currents of one or a group of frequencies from alternating currents of a different frequency or group of frequencies.

Filters can be divided into three general classes: (A) low pass filters; (B) high pass filters; (C) band pass filters.

Low pass filters. A low pass filter is designed to pass all the low frequencies below a certain cut-off frequency and to oppose the passage of frequencies above the cut-off frequency. The frequency characteristic curve of an ideal low pass filter is given in sketch A. The r.f. choke coil used in the plate circuit of a detector tube functions as a low pass filter, since it permits audio frequencies to pass into the audio amplifier but excludes from the amplifier the high carrier frequencies.

High pass filters. Sketch B gives a frequency characteristic of an ideal high pass filter and it will be noted that it has the opposite effect to a low pass filter in that it permits the passage of high frequencies and obstructs the flow of low frequencies. The r.f. chokes and condensers used in the plate circuits of an r.f. amplifier are an example of a high pass filter, functioning to pass the high frequencies directly to the filament, thereby keeping them out of the plate supply, but obstructing the passage to the filament of the d.c. plate current (which can be considered a current of 0 frequency).

Band pass filters. This type of filter permits the passage of a band of frequencies and excludes all those frequencies below or above this band. A very common type of band pass filter is used in radio receivers—the tuned circuit. When a coil-condenser

combination is tuned to a given broadcasting station it permits the passage of that band of frequencies associated with that broadcasting station and excludes to a more or less greater degree frequencies either lower or greater than that of the station we are trying to receive. The ideal curve of a band pass filter is indicated in sketch C.

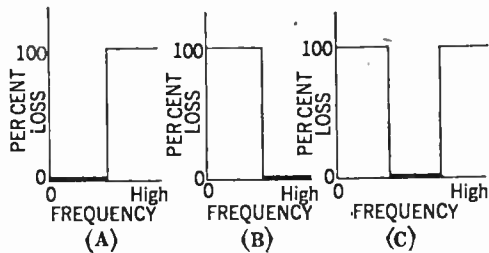

No. 231

RADIO BROADCAST Laboratory Information Sheet

October, 1928

Impedance-Coupled Amplifiers

THE EFFECT OF THE SIZE OF THE INDUCTANCE

IN CONNECTION with impedance-coupled audio amplifiers, the statement is frequently made that the coupling inductances should have as large an inductance as possible, creating the impression thereby that the larger the inductance the better the results. Such is not the case. First, let us examine the effect of the inductance at low frequencies.

The curve on this sheet indicates how the amplification from a stage of impedance-coupled audio

varies with the inductance in henries of the coupling coil, L. This curve is calculated for a frequency of 60 cycles, assuming that this is the lowest frequency which we desire to amplify uniformly. It is assumed that the tube has a plate impedance of 30,000 ohms and a μ of 20, and that the coupling condenser, C, and the grid resistance, R, are of such values as not to affect the amplification. If 100 per cent. amplification were obtained, the gain would be 20, and with an infinitely high inductance this gain might be realized at low frequencies. With practical values of inductance, however, the gain is less than this and varies with the inductance as indicated by this curve.

The value of the coupling inductance should be the smallest value that will give satisfactory gain at the lowest frequency to be amplified, which we have assumed in this case to be 60 cycles. At medium frequencies the amplification obtained from a circuit of this sort is approximately equal to the amplification constant of the tube and we might assume as a reasonable figure that the amplification at 60 cycles shall not be less than 75 per cent. of the amplification obtained at medium audio frequencies. 75 per cent. of 20 is 15, the value therefore of the gain at 60 cycles. This corresponds to an inductance of 100 henries.

If a value of inductance much greater than this is used to obtain more amplification at low frequencies, it will be found that the high frequencies begin to fall off due to the shunting effects of the tube and coupling coil capacities. Amplifier curves with various values of coupling impedance will be given and explained in a future Laboratory Sheet.

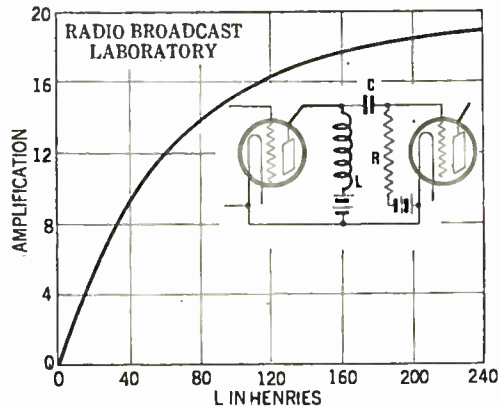

No. 232

RADIO BROADCAST Laboratory Information Sheet

October, 1928

The Voltmeter

HOW IT WORKS

IN PRECEDING Laboratory Sheets, Nos. 205, 214 and 222 we explained the construction of the galvanometer and the ammeter and indicated how they differed. The voltmeter is quite similar to these two instruments, differing in only one important respect to be explained below.

A voltmeter is used obviously to measure voltage. We desire to measure this voltage using as little power as possible, for if the instrument itself requires any great amount of power it is liable to affect the voltage reading of units such as batteries or B-power units which are designed to deliver only a small amount of power.

To measure the voltage of some source of potential we might take a very low reading ammeter, one having a maximum scale reading of perhaps 0.01 amperes, place it in series with a known high resistance and then connect it across the source of potential. The ammeter would read the current that flowed and then by Ohm's law, which states that the voltage is equal to the current times the resistance, we could calculate the value of the voltage.

In a voltmeter this high resistance is permanently connected inside of the instrument and the scale

is calibrated to read volts instead of amperes. In other words we might say that the instrument solves Ohm's law for us and makes it unnecessary to calculate the IR drop every time we wish to measure a voltage.

Ammeters and voltmeters may in general be distinguished in one other way other than the fact that they are marked "volts" or "amperes" on the scale of the instrument. It will generally be found that ammeters have fairly large terminals and they are generally of metal. Voltmeters have small terminals and they are always of the insulated type. Ammeters are equipped with metal terminals because no damage results to the instrument or the circuit in which it is connected if the terminals are accidentally short-circuited; ammeters are always connected in series with a circuit and have a very low resistance, so that shorting them affects the circuit very little. Voltmeters, on the other hand, are always connected across the source of potential, and if the voltmeter terminals are accidentally short-circuited then the source of potential is short-circuited. A short-circuit may not be a serious thing when measuring a B battery, but may cause damage if it occurs when measuring the voltage at a light socket or when measuring the output voltage of a large generator.

PEP UP YOUR SET!



Replace your Balkite Acid Jar with the Authorized Solid, Dry ELKON Replacement Unit. . . Get away from Acids, Water, Corrosion, Trouble. . .



BUY ELKON—The Authorized Replacement Unit
 Throw away the acid jar! No more fuss, mess, trouble. Simply re-
 move the Acid Jar and snap in the Elkon Replacement Unit—
 Solid—dry—self healing—no attention or adjustments, and for-
 get it for 5000 hours.
 The Elkon Replacement Units and those made by the Fan-
 steel Products Company containing the Elkon Dry Rectifier
 are the only ones authorized for replacing the acid jars in
 Balkite Power Units.
 With the Elkon Self-Healing Replacement Rectifiers, your
 type K will charge at the rate of .8 ampere, type N at the
 rate of 1 ampere. The charging rate of type J the large char-
 ger, is raised 20%. Increased efficiency, too! Why not see
 your dealer today!

ELKON, INC.
 Port Chester, N. Y.
 Division of P. R. Mallory & Co., Inc.



This is just one of the many reasons why Elkon Replacement Units are authorized by Fansteel—A accurate, careful testing of every Rectifier.



Perhaps you need a New Elkon Rectifier

If your set hasn't the same pep and kick it did when you first installed your "A" Eliminator, you need a new Rectifier in the "A" Eliminator. And you are lucky if you have a Majestic, Webster, Knapp, Fada, Sentinel, Metro and many others for then you can slip the old rectifier off, and put in a new Elkon Replacement Rectifier in less time than it takes to read this. And the old eliminator is as good as it ever was! Buy one today from your dealer.

If your trickle charger isn't keeping the battery up as well as it did when you bought it—buy a set of Elkon replacement rectifiers and it will be as good as it ever was. Elkon Type V-4 replacement Units can be placed in Acme, Elkon, National, Cleveland, Precision, Bernard. Today's a mighty good time to pep up the old charger—see your dealer.

Radio Department,
 Elkon, Inc., Port Chester, N. Y.
 290 Fox Island Road.
 Send me complete information on Elkon Radio Products.
 Name _____ Address _____



The Nerve Center of Your Radio

BECAUSE Cunningham Radio Tubes carry the true tone and reproduce pure harmony, they are rightly called the nerve center of your radio.

Tubes that have had long, constant use should be replaced with *new*, correct Cunningham Tubes to enable you to enjoy modern broadcast reception.

*Never use old tubes
with new ones—use
new tubes throughout*

E. T. CUNNINGHAM
Inc.

New York
Chicago
San Francisco

Cunningham
RADIO TUBES



AUSTRIA'S PRESIDENT SIGNS A "FULTOGRAPH"

Dr. Siepel, President of Austria, is at the left, signing a photograph of himself transmitted by radio by the method perfected by Captain Otho Fulton (in the center, with his hand on the table). Captain Fulton developed his apparatus, the "Fultograph", in Vienna; the British Broadcasting Company is now considering its adoption.

Photo Broadcasting in England

By WILLIAM J. BRITTAIN

REGULAR broadcasting of pictures is promised for Great Britain by October. The British Broadcasting Corporation is now considering the adoption of the "Fultograph," the apparatus of Captain Otho Fulton, an Englishman who has been experimenting in Vienna for three years.

Captain Fulton gave me a demonstration of his apparatus when I met him in Vienna. The photograph to be transmitted is printed on a copper foil coated with sensitized fish glue. Exposure to light makes part of the glue surface insoluble. Washing removes the soluble parts, which have not been exposed to light, and a half-tone picture in glue is left.

The foil is then placed on the transmitting machine. All you can see is a box containing a small clockwork motor, and at the side a cylinder which can move slowly round, like the one on Edison's first phonograph. The foil is wrapped round the cylinder, which is then set going. Over the foil a metal needle passes.

When the needle is touching a part of the bare foil a current passes and is transmitted. When it touches a part where the glue is, the glue acts as an insulator, and no current passes.

In receiving the picture broadcasts a one-tube set is sufficient for distances within a mile of the broadcasting station; for greater distances a receiver of two or more tubes is necessary.

You can hardly tell the receiving set from that at the transmitting end. Round the brass cylinder a piece of paper dipped in chemicals, and still damp, is placed. A platinum needle passes over it, and when current is being sent out at the transmitting end a current passes between the needle and the cylinder, and the paper is stained brown through the action of the current on the sensitized paper. Thus the picture is traced out.

In his early experiments, Captain Fulton told me, he synchronized reception and transmission

by means of a pendulum device devised by himself and Mr. T. Thorne Baker, of London, with whom he formerly collaborated. Both receiving and transmitting instruments were fitted with a long pendulum which made an electric contact at every beat of $1\frac{1}{2}$ seconds and released the cylinders for a new revolution.

With this method it was found that unless there was absolute stability, the picture was ruined; so now Captain Fulton has devised a series of relays giving him electro-magnetic synchronization. This enabled him in a test to take his apparatus on a ten-day steamboat trip along the Danube and receive pictures from his laboratory in Vienna during the entire trip.

The fact that the glue on the copper foil is easily scratched calls for some remedy. One is to "burn in" the picture; another, used by Thorne Baker, is to roll the glue picture between polished steel, so that the picture sinks into the metal, like a picturesque commutator.

For the chemicals in which the semi-absorbent paper is dipped, several mixtures are used. One is a potassium iodide and starch solution, which gives a coloration with the passage of a current of less than two milliamperes; and another solution, used in the Jenkins laboratories, contains ammonium nitrate, ammonium chloride, and potassium ferrocyanide.

"All the time I have tried to simplify radio picture apparatus for the man at home," Captain Fulton told me. "I consider my latest apparatus is as simple as a cart: a cart has only the wheels and the body, and if you take either away it isn't a cart any more. My assistants and I have worked hard and now we have made a home set to be sold to the public for about seventy-five dollars. They have already been adopted in Vienna."

The pictures are $4\frac{1}{2}$ inches by $3\frac{1}{2}$ inches, and those I saw received were as distinct as hurriedly produced newspaper photographs.

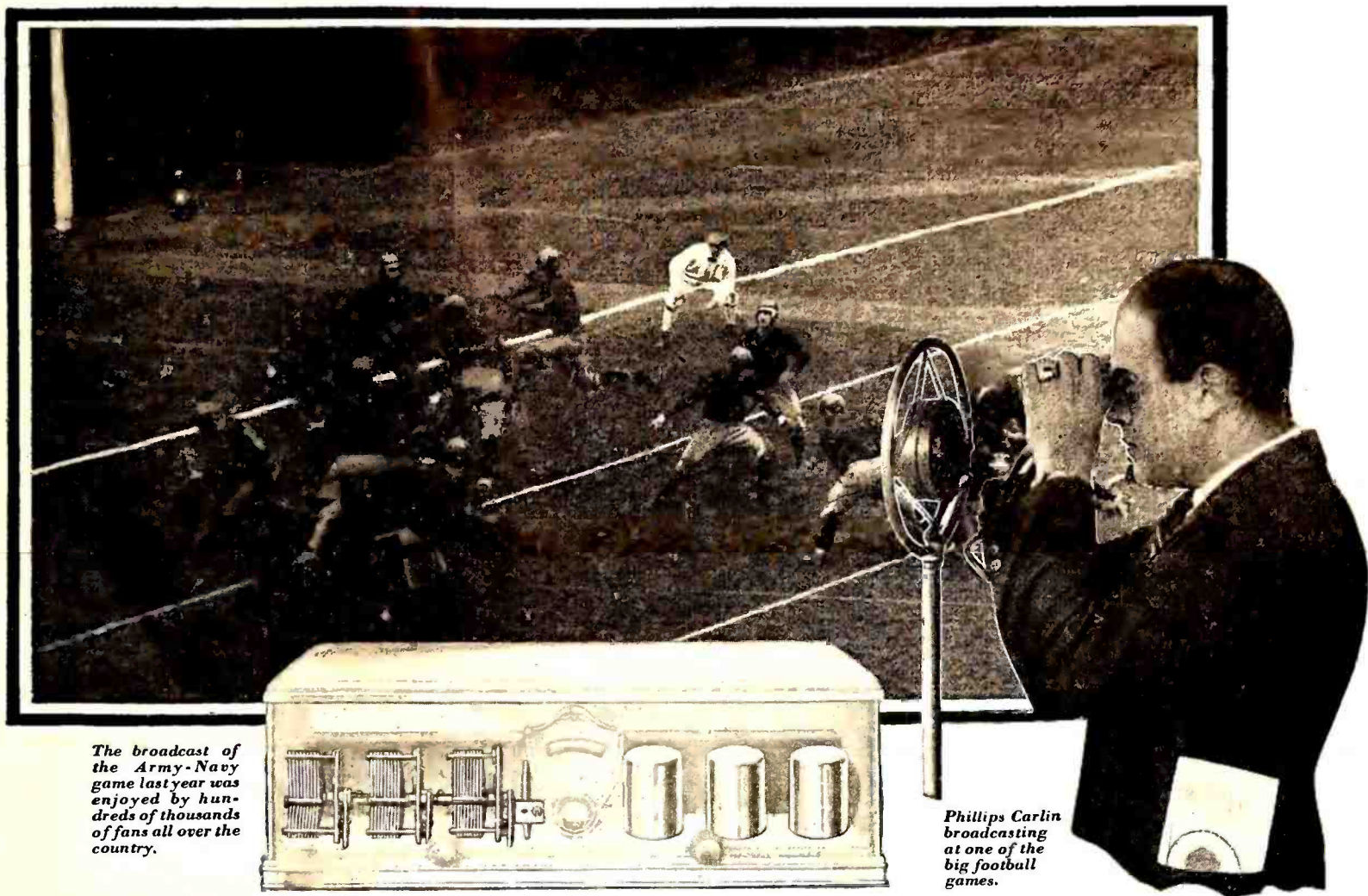

The broadcast of the Army-Navy game last year was enjoyed by hundreds of thousands of fans all over the country.

Phillips Carlin broadcasting at one of the big football games.

The Big Game Comes Over~ BETTER~CLEARER

MILLIONS of enthusiastic football fans are listening this fall to the play by play broadcasts of America's greatest games. They are experiencing almost as keen enjoyment as if they were sitting in the stands. The voice of the announcer comes to them clearly and distinctly because their receiving sets are Aluminum equipped.

Leading radio manufacturers are using Aluminum extensively for shielding, for condenser blades and frames, for chasses, sub-panels, front panels and for many other parts—because Aluminum so ideally meets the varied conditions that radio design presents.

It combines remarkable shielding properties, high electrical conductivity, great strength and extreme lightness.

Examine the set you contemplate buying. If it is Aluminum equipped you may rest assured that the manufacturer has done everything in his power to give you the finest possible reception.

And if you are building a receiving set use Aluminum for finest results.

We will gladly send you the booklet, "Aluminum For Radio," which explains the varied radio uses to which Aluminum is adapted.

ALUMINUM COMPANY OF AMERICA

ALUMINUM IN EVERY COMMERCIAL FORM

2464 Oliver Building
Pittsburgh, Pa.



Offices in 19 Principal
American Cities

ALUMINUM

The mark of Quality in Radio



Easy to build . . . unequalled performance . . . at a price you will be glad to pay

Marvelously Realistic Reproduction . . . Remler Audio System . . . Perfect Control of Volume from Maximum to a Whisper.

Simple to Operate . . . Expert Results for Every Member of the Family.

All the Selectivity that Could be Desired . . . Clean-Cut Separation of Stations on Adjacent Channels.

Superheterodyne Sensitivity . . . Shield-Grid Amplification.

Stable Operation . . . Completely Shielded Throughout.

Easy to build . . . Can be Assembled, Wired and Put into Operation in One Evening. No Special Knowledge or Experience Necessary.

Most of the Wiring Completed and the Circuits Balanced at the Factory . . . Only a Few Wires to be Installed by the Builder in Accordance with Color Code.

Eliminator or Battery Operated.

Combined Power Amplifier and Plate Supply . . . CX 350 (UX 250) Power Tube . . . Full Wave Rectification . . . B Voltage Regulation Provided for.

Steel Chassis Amplifier Construction . . . Compact and Rigid.

Power Transformer Primary Tapped for Different Line Voltages.



REMLER POWER AMPLIFIER

The story of the "29," what it is and what it does, is complete in Bulletin No. 17. Sign the coupon for your free copy.

Remler Division, Gray & Danielson Mfg. Co.
260 First Street, San Francisco, California.

Gentlemen: Please send me:
 All the "dope" on the "29".
 Bulletin service for professional set builders.

Name _____

Address _____

City _____ State _____

Do you build and sell sets? _____

Letters from Readers

The Last Word

WHAT appears to be the final answer to the questions that arose over the meaning of Greenwich Mean and Greenwich Civil Time, as used in the list of short-wave stations in the May issue, has come from Captain C. S. Freeman, U. S. N., Superintendent of the U. S. Naval Observatory. The necessary corrections for the errors which occurred in the original list appeared in this column in the August issue, but we appended a request for information as to whether there was any recognized system of time computation which used a day starting at noon. Captain Freeman answers:

To the Editor:

There is no longer any time in use by which the day is reckoned as beginning at noon. That kind of day was called the astronomical day, and was used principally by astronomers, navigators, and persons engaged in longitude determinations. In making their computations, the above mentioned persons used data from the national ephemerides (astronomical ephemerides). Beginning in 1925, all the national ephemerides discontinued the use of the astronomical day, and all users of these publications changed accordingly.

It would have been better probably if the term "Mean Time" had not been continued in use in referring to the day beginning at midnight. However, its use has not been due to confusion in the minds of the users, since among them are the astronomers and time authorities of Europe, who undoubtedly understand the significance of the terms involved.

The matter may be summed up as follows: Greenwich Mean Time (G. M. T.) and Greenwich Civil Time (G. C. T.) refer to the same system of time computation, the first being the European designation and the second the American designation. This system of computation begins its day at midnight (0 hours) in the longitude of Greenwich, England. No system in use to-day begins the day at noon.

Volunteer Proof Readers

IT SEEMS that our embarrassment in the September issue over the presence of errors in these pages has inspired several readers, ambitious for the position of million-dollar proof reader, to point out several other mistakes in the September number. However, since each of the two correspondents quoted below points out only one error, and fails to find the error noted by the other, the lucrative position in the proof room remains vacant, and the firm is still holding on to the million dollars.

To the Editor:

After reading the article in the September RADIO BROADCAST on page 308 in regard to mistakes, I hardly have the heart to write you about a glaring error on page 253 of the same number. But really, your contributors, compositors and proof readers should know the difference between "flaunting" and "flouting." It seems rather strange, but almost every time I have seen the word "flaunting" used recently, especially in the daily press, the writer has actually meant "flouting." "Flaunting the constitution, (or the 18th amendment)" seems to be a favorite phrase with the newspaper writers.

I would suggest to the editor of every newspaper and magazine that a little notice be put up in the office to the effect that the words "flaunting" and "flouting" had better not be used at all. Then there will be no confusion between them.

B. R. WHITE, New York City

(Continued on page 388)

BENJAMIN

Cle-Ra-Tone Radio Sockets



Specially Designed
for

A. C. Detector Tubes

Spring supported, shock absorbing. The tube holding element "floats" on perfectly balanced springs. Reduces microphonic disturbances, tends to lengthen life of tube and lessens the possibility of short-circuiting closely spaced tube elements.

Y-Type, Green Top, for 5 Prong A C Tubes: for mounting on top of panel, \$1.00; for direct attachment to panel, 75c.

Red Top, for Standard UX Type Tubes: For mounting on top of panel, 75c.; for direct attachment to panel, 50c.

Shelf Supporting Brackets

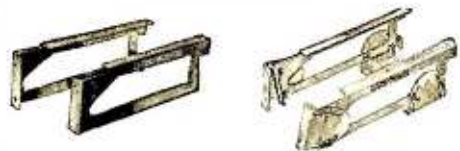

A decided advantage for the neat and substantial construction of the set. Use when panel and subpanel are assembled to make one complete removable unit. The Adjustable Brackets permit panels to be mounted vertically or at any desired angle.

No. 8629—Rigid—70c. per pair
No. 9029—Adjustable—\$1.25 per pair

At all Radio and Electrical
Dealers and Jobbers

Benjamin Electric Mfg. Co.

120-128 S. Sangamon Street
Chicago

New York
247 W. 17th St.

San Francisco
448 Bryant St.



Majestic Music—Martial Volume From Your Present Radio Set

PAC2,
Price without
tubes \$175.00

equal to the coronation music of Rheims Cathedral, can be obtained by adding a Samson PAC2 which will also eliminate all A, B and C batteries with their attendant care and replacement.

Rich bass notes, remarkable clarity and a volume which can be controlled from a whisper to 7 watts—sufficient undistorted power to operate 12 to 16 loud speakers or 500 to 700 headsets.

Samson PAC2 Amplifiers are designed to meet AIEE Standards and Underwriter's Requirements. Nothing is left to chance—even the filter condensers are built to our own rigid specifications. Compensation is provided for 105 to 120 volt, 50-60 cycle current. External voltages are provided for 45, 90 and 135B, $-4\frac{1}{2}C$ and raw AC current for two 227's and five 226's tubes. An 874 regulator tube is used to maintain B voltages. When used in conjunction with tuning units PAC2 Amplifiers are ideal for supplying music or instruction to schools, hospitals, apartments, clubs, etc.

Send for folder R. B. on Samson Amplifiers

Samson Electric Co.



Factories at Canton and Watertown, Massachusetts

Main Office:
Canton, Mass.

Manufacturers
Since 1882



Push-Pull Power Stage for Dynamic Speakers

For best results, every dynamic type speaker should be preceded by a push-pull amplifier. This is particularly true because they reproduce frequencies as low as 30 cycles and the attendant hum from raw AC on the filaments of power tubes is greatly pronounced unless filtered out by a push-pull amplifier.

The AmerTran completely wired push-pull power stage has been specially designed for dynamic speakers. Consists of type 151 input and

output transformers (200 for working out of 210 type tubes or type 362 for 171 type tubes). Both the 200 and the 362 have the secondary designed for connecting directly to the moving coil of the speakers. Completely wired with sockets and resistances. Also available for cone type speakers and for both 210 and 171 tubes.

Licensed under patents owned or controlled by RCA and may be bought with tubes.

Price complete (without tubes) \$36.00
(slightly higher west of Rocky Mountains)

Write us for hook-up of this remarkable instrument.
AMERICAN TRANSFORMER COMPANY
Transformer Builders for more than 28 years
283 Emmet Street, Newark, N. J.

Letters from Readers

(Continued from page 386)

To the Editor:

In a spirit more of sorrow than of censure, I am writing to call your attention to what appears to be a grave discrepancy in a certain paragraph notice contained in the copy headed "Here and There" on page 255 of your September issue. And to think that said discrepancy should occur in the same issue in which the little article "Our Mistake" unfolds its shameful tale, is enough to make any lover of RADIO BROADCAST break down and weep. However, you evidently said your "prayer to the radio gods" with little or no faith, for, lo, the "letters are already commencing to come in". Which "ain't no way to pray"!

Now don't think for one moment that I discovered above mentioned error—for I didn't; I am chronically near-sighted and sadly afflicted with "neglectitis" when it comes to details—how I loathe the word! But one of our Argus-eyed announcers (he's lots of other things around here, too) sorrowfully pointed it out to me—"and to think it's in our dear ole RADIO BROADCAST too," he sobbed. And so, I hurried straightway to my typewriter and decided to call your attention to it *immediately*, thinking maybe you might wire that Mencken man that you'd found his "million-dollar-a-year proof reader", as that salary would come in right handy.

On Page 255 in September issue, you will note, in black and white, that the "cost of broadcasting the Republican National Convention through 42 stations amounted to \$77,000, or a little over a dollar a *minute*." And right there we've got you! You mean *seconds*, of course. For had the Grand Old Party been on the air 72,000 *minutes* as you say, it would have been some convention, as it would have broadcast 1200 hours or 50 days. Beats the Democratic 1924 record by about 4 weeks solid.

GENE BROWN, (Station WBAL)
Baltimore, Md.

Furthermore, we ourselves have also discovered a few typographical peditilloes, which we are not going to mention for the reason that we want to keep our job.

Java on the Air

FROM George E. Morcroft, Pittsburg, Pa., comes this interesting news of the new radiotelephone service between Holland and Java:

To the Editor:

In your September issue (page 256) I noted a little news excerpt in which you told of the opening of a high-frequency radiotelephone system between Holland and Java, but you were unable to give details "as the dispatch from abroad was garbled."

If you are interested in further information as to these stations I would like to say that the Dutch station involved is PCLL at Kootwijk, Holland, on a frequency of 16,300 kc. with a power input of 32 kilowatts. I have often received this station and have had reception confirmed. The Java end is taken care of by two transmitters which are modulated at the same time, according to a letter I have just received from the Chief of the Radio Laboratory at Bandoeng, Java, confirming my reception of one of these stations, ANH. The two transmitters are ANH, at Malabar, Java, on a wavelength of 17.0 meters, and ANE at Bandoeng, Java, on 15.93 meters. The letter from Java also contains the information that music is broadcast several days a week from ANE on a wavelength of 15.93 meters from 1300 G. C. T. to 1750 G. C. T. (8 A. M.—12:50 P. M.—Eastern Standard Time). The telephone communications are carried on on Tuesdays and Thursdays from 1500 G. C. T.—1700 G. C. T. (10 A. M.—12 noon E. S. T.). PCLL at Kootwijk, Holland, also

(Continued on page 390)

ACTS

in **7** Seconds

—against 30 seconds to a minute for other tubes...Arcturus 127 A-C Detector Tube—quickest acting, longest-lasting...Proved by test to have useful life far in excess of 1,000 hours...For quicker action, better tone, longer tube life—put an Arcturus A-C Long Life Tube in every socket..."Get Action with Arcturus Tubes—quicker, better."

ARCTURUS RADIO COMPANY
255 Sherman Avenue Newark, New Jersey

ARCTURUS

EBY

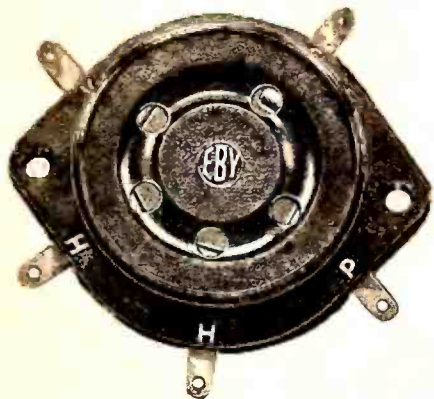

Top view showing built-in guide for tube prongs



Bottom view without base showing contacts

SOCKETS

Eby Sockets have

1. Good looks that will improve the appearance of any set.
2. Grooved tops to guide tube prongs.
3. New and improved prongs providing long, tight spring contact. High current carrying capacity and low interelectrode capacity. Ideal for use with A. C. tubes.

List price UX type 40 cents
UY type 50 cents



BINDING POSTS

Eby Binding Posts are all that binding posts could be.

Completely insulated with non-removable tops engraved in popular markings.

TIP JACKS

Eby Tip Jacks have countersunk tops so that the pin can't wobble. Equipped with red and black Bakelite washers for insulating from metal panels. List price 25 cents per pair.



The H. H. EBY MFG. CO., Inc.
4710 Stenton Ave. Philadelphia, Pa.

The New Knapp "A" Power Kit

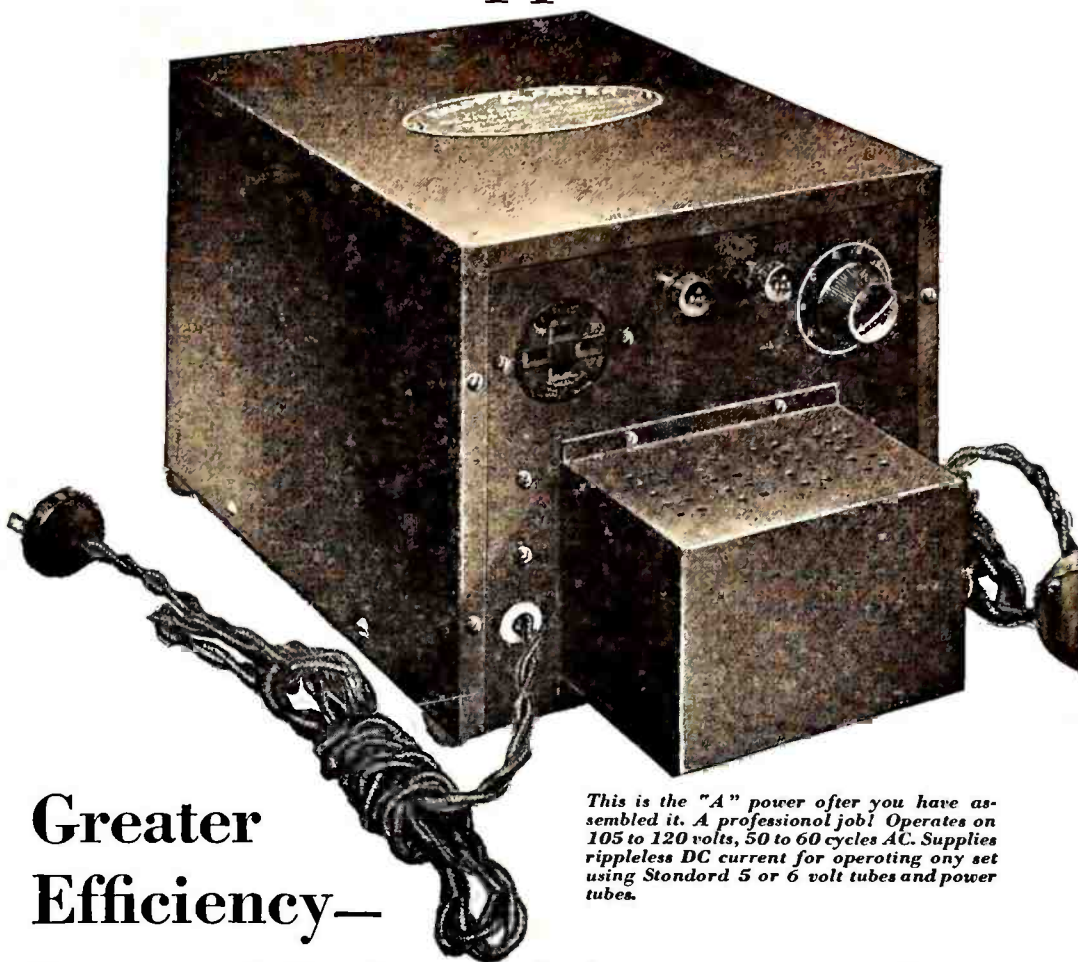

This is the "A" power after you have assembled it. A professional job! Operates on 105 to 120 volts, 50 to 60 cycles AC. Supplies rippleless DC current for operating any set using Standard 5 or 6 volt tubes and power tubes.

Greater Efficiency—

Improved Design and Appearance—Lower Price—Money-making Plan for Set-Builders

Your radio fans who made my "A" power the largest selling "A" power last spring have made it possible for me to offer the finest "A" Power ever developed—in Kit form—even more complete than before. Study the illustrations—read the improvements—and you will wonder how I was able to reduce the price. You are the answer. I sold 5 times as many "A" Powers as I expected to—and this season I am counting on you to help me again by buying even more.

The 8 Improvements

1. Larger Filter System—3 Elkon Condensers instead of 2. Ideal for Super Hets and Short Wave Sets.
2. Improved Choke Coils
3. Pendant Switch Controlling "A", "B" Eliminator & Set
4. Dial for regulating voltage
5. Celeron Front Panel
6. Baked finish
7. Heavier gauge metal cover
8. Die Cast Base Plate instead of wood

COMPLETE KIT—EASILY ASSEMBLED

Like my Kit last year, the New Knapp Kit is a tooled job—the parts seem to fall into place. Every hole is drilled—all that it is necessary for you to do is to put the screws and nuts in place and connect a few wires. Everything is supplied. Nothing for you to buy extra. The fool-proof instruction sheet makes it easy for anyone to assemble.

THE SET-BUILDER TAKEN CARE OF

You set-builders played with me (as the saying goes) and I am going to continue to play with you. My engineers have designed an "A" Power which is well-nigh perfect—my production men, based on tremendously large quantities have cut their cost, so that I can keep faith with you by reducing the cost. And regardless of what the established trademay think about it—I am going to continue to give you the maximum discounts. The coupon will bring you the full details of both the new "A" Power and the special discounts to set-builders. David W. Knapp, Pres.



KNAPP ELECTRIC, Inc., Port Chester, N. Y.
—Div. P. R. Mallory & Co., Inc.—

Mr. David W. Knapp, President,
KNAPP ELECTRIC, Inc.,
334 Fox Island Road, Port Chester, N. Y.
Kindly send me complete information on the
Knapp "A" Power and your special discounts for
Set-Builders.
Name _____
Address _____

How is your SHORT-WAVE Reception? Let HAMMARLUND Improve it!

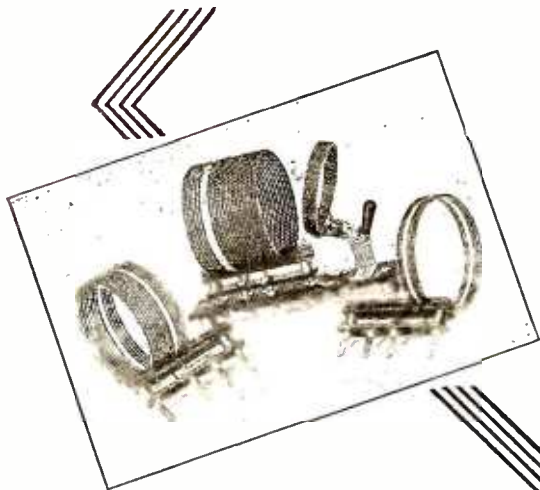

Short-Wave PLUG-IN COILS

Wound with a definite space between turns, wire anchored and supported by a thin film of strong, efficient dielectric material.

Distributed capacity and resistance are minimum. Widely-spaced plug-in terminals. Adjustable primary held in position by friction.

The Standard 3-coil set (illustrated) covers the 15-107 meter range with a .00014 mfd. Condenser. Other coils available for from 8 to 215 meters.

Short-Wave CONDENSERS "Midline" or "S. F. L."

Hammarlund Short-Wave Condensers are far-famed among fans and engineers alike.

Accurate capacity ratings; smooth-turning rotor with full-floating, removable shaft; cone bearings; soldered brass plates, permanently aligned with tie-bars; sturdy die-cast frame; Bakelite dielectric; large phosphor-bronze pigtail; friction adjustment.

Available in .0001, .00014 and .00025 capacities.

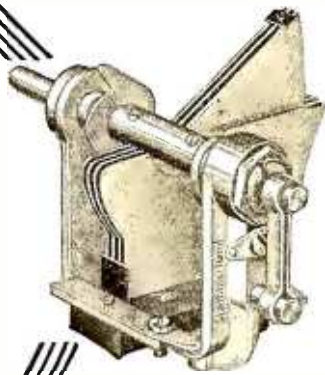

Radio-Frequency CHOKE COILS

A specially developed method of winding and impregnating assures minimum distributed capacity. High impedance.

No pronounced period. Current-carrying capacity, 60 milliamperes.

Two sizes—85 and 320 millihenries.



Send 10c.
for the

HAMMARLUND SHORT-WAVE MANUAL

Brimful of
Useful Data

HAMMARLUND MFG. CO.
424-438 W. 33rd Street
New York, N. Y.

For Better Radio
Hammarlund
PRECISION
PRODUCTS

Letters from Readers

(Continued from page 388)

transmits musical programs 1300 G. C. T.—1650 G. C. T. (8 A. M.—11:50 A. M. E. S. T.) on Wednesdays.

Another Kruse Fan

IN THE September number we spoke of the enthusiasm accompanying the addition of Robert S. Kruse to our list of authors. It hasn't stopped yet. To prove this we quote from a letter from Alphy L. Blais (VE-2AC—VE-2AS), Thetford Mines, P. Q.

To the Editor:

When R. S. Kruse signed off from *QST*, I thought he was lost to the amateur world. It was a great and comforting surprise to meet him with the R. B. gang—still keeping on the same "amateur spirit." Gosh, I'm glad he's with us again—and that 5-meter band has got me in a trance. Give us more and more of it. R. S. K. has a way all his own to make one understand, and nobody can go wrong when following his instructions.

The radio work done here at VE-2AC, VE-2AS (O. R. S. of A.R.R.L.) is mostly amateur traffic handling on 20 and 40 meters. The 10-meter band is tackled with little results due to heavy local QRM.

I believe it would be very useful for us if R.B. were to give us an article on a frequency meter for the amateur bands. With the new laws coming in 1929 our old equipment goes kerplunk. Kruse is familiar with our wants and can give us a hand.

In 1923 I wrote to RADIO BROADCAST saying how good a magazine it was. In 1924 and 1925 also, especially commenting on Keith Henney and his "Home Lab." articles, unsurpassed so far. In 1926 and 1927 I wrote again giving you a cheer, and in 1928 it would take a book to write my praise. RADIO BROADCAST has reached a point where everything in it needs praise and no knocking. With *QST* you are the perfect magazine. Your advertising policy is very fine, and I side with you—no trash, only quality.

Wired Wireless

WIRED wireless is up for discussion again. On page 10 of our May issue we discussed editorially the probable place of wired wireless programs with respect to "space" or radio broadcasting of programs. Wired wireless has its place, but we feel that it does not yet offer serious competition to radio broadcasting. In St. Paul, Minnesota, as in several other communities in the Middle West, wired wireless programs are being offered commercially. The letter below is from a St. Paul resident whose name is omitted for obvious reasons.

To the Editors:

The St. Paul wired wireless system is comprised of a central receiving station where the programs are picked up on a well-designed receiver and then put over the land wires to the subscriber's home at high amplification. The subscriber has nothing but a speaker in his home, with some sort of resistance volume control.

The operator at the central station either picks the programs off the air, or, in the absence of suitable programs, puts on a little Orthophonic music for the subscribers—rather a limited service for \$5.00 monthly! However, I am of the opinion that the A. T. & T. may furnish the St. Paul wired wireless concern with the blue and red networks of the N. B. C.

In talking over the wired wireless situation with fellow members of the radio trade, I have run into the argument of what will the advertiser do if wired wireless should predominate over the radio. In my opinion, the advertiser would be assured of a more regular audience than he is at

(Continued on page 392)

Fahnestock Clips

RADIO'S GREATEST CONVENIENCE

Used by Manufacturers of Standard Sets and Parts
—and by Manufacturers of High Grade Wet and Dry Batteries.

ALL GENUINE FAHNESTOCK CLIPS

bear our imprint on the thumb
piece of the clip.

WORLD'S LARGEST MAKER OF CLIP TERMINALS
48 different sizes and styles to meet all requirements.

Send for Catalog and Samples

FAHNESTOCK ELECTRIC CO.

L. I. City

New York

RADIO FANS, a one-year's subscription to Radio Broadcast will cost you four dollars, two years six dollars. Consider this expenditure as being a necessary investment on your part for the future development of your own knowledge of Radio.

Wholesale Prices

Everything in Radio kits, parts, accessories, sets. Improved designs and styles. Big selection at worthwhile saving. Immediate service; personal attention. Send for complete, illustrated Catalog "A-1." Wholesale prices.

**Allied Radio
CORPORATION**
711 W. LAKE STREET, CHICAGO

LONGER LIFE



WHEN you install a set of CeCo Tubes in your radio, you immediately notice the greater clarity of reproduction—the increased sensitivity and the better volume.

But your greatest satisfaction will come with their longer operating life—making CeCo the most economical tubes to buy, and worthy of their slogan “they cost no more, but last longer”. This is made possible partly by the exclusive method of evacuation.

To avoid disappointing results, make sure each socket is equipped with CeCo tubes. Whether for battery or A. C. operation. There's a CeCo for every radio need—including “special purpose” tubes that are not obtainable elsewhere. They are sold by leading dealers everywhere.

Tune in Monday Evenings to the nearest of the 18 Columbia Broadcasting stations and hear the musical program of the CeCo Couriers—8 P. M. Eastern time, 7 P. M. Central time.

CeCo MANUFACTURING Co., Inc.
PROVIDENCE, R. I.

TONE



Push-pull Transformers with impedances to match power tubes and dynamic speakers

Type “BX” Input Transformer has extremely high primary inductance. Secondary accurately divided.

Price, each.....\$6.50

Type “GX-210” Output Transformer. Especially designed for push-pull amplifier using UX-210 or CX-310 tubes. Secondary connects directly to moving coil of dynamic speaker.

Price, each.....\$6.50

Type “HX-171” Output Transformer. Same as above except impedance matches UX-171, CX-371, or UX-250, CX-350 tubes.

Price, each.....\$6.50

Free circular giving audio hook-up and complete information on request

SANGAMO ELECTRIC COMPANY

Springfield

Illinois



Lost in the Arctic — But Tuned-In on Pittsburgh, Pa.

The Viglieri Group of Gen. Nobile's ill-fated expedition was lost on an ice-floe in the Arctic, but listened nightly to the news flashes and concerts from Pittsburgh and other American and European broadcasting stations. And day by day it sent out a call for help which was heard and as we know, answered before it was too late.

New wonders of science become accepted facts in our lives in such rapid succession that the wonder soon wears off.

The first messages from ship to shore and shore to ship were indeed miracles. Here was a degree of safety never found before in all the centuries of seafaring. When the channels of the ether

were filled with music and the spoken word, ready to be chosen and enjoyed by any owner of a simple broadcast receiving set, here was a greater miracle.

A greater miracle still has been the development in the use of short waves. These have circled the globe and made possible the messages that saved the lives and reason of the lost Italians.

A Short-Wave Receiving Set will make you able to hear easily radio broadcasts from all over the world. More and more stations here and in Europe, Australia and New Zealand are putting their programs on the short-waves. New marvels are waiting for you and your friends.

NATIONAL COMPANY INC. has developed new and better equipment for the simple construction of non-radiating short-wave receiving sets employing the 4 electrode 222 Tube. This equipment is described in our Bulletin No. 131-B. Write us for it today.

NATIONAL RADIO PRODUCTS

NATIONAL CO. INC. W. A. READY, PRESIDENT MALDEN, MASS

4TH EDITION

Just Off Press

"RADIO THEORY and OPERATING"

by Mary Texanna Loomis

The standard radio text and reference book of America. Nearly 900 pages, over 700 illustrations, flexible binding.

PRICE \$3.50—Postage Paid

For sale by hundreds of bookdealers throughout America and many foreign countries. Or may be purchased direct from the publishers. Send check or money order to

LOOMIS PUBLISHING COMPANY
Dept. 10 Washington, D. C.

Why not subscribe to Radio Broadcast? By the year only \$4.00; or two years \$6.00, saving \$2.40. Send direct to Doubleday, Doran & Co., Inc., Garden City, New York.

Wholesale Prices

Tremendous stock and sales volume, with rapid turn-over to the thousands of radio dealers we serve enable us to make you worthwhile savings at lowest wholesale prices. Write for latest, new illustrated Catalog "A-1"

**Allied Radio
CORPORATION**
711 W. LAKE STREET, CHICAGO

Letters from Readers

(Continued from page 390)

present able to get by radio with its weather and interference problems to contend with. Say that the subscriber had a choice of two national programs over his wired wireless installation, as is possible in one Minneapolis hotel, the chances are he would be more apt to be listening during weather that is ordinarily bad in radio, yet would not affect the telephone lines carrying his wired wireless programs to his home.

Radio can be greater than wired wireless could ever dream of, but its broadcasters must be progressive and not allow two or three chains to corner the entertainment features of the country. Because of a lack of power and talent on the part of Midwest broadcasters, we here must look to the chains and if it is the chains we must look to very long, the fickle public can be quickly won over to the possibilities of the telephone companies bringing these programs into their homes, free of static, interference, squeals, etc. To show you just why this would be so easy to bring about I give you a little idea of what the listener in these cities is up against.

Chicago, while close to us, is not heard regularly nor well enough, as a rule, to be termed consistent entertainment. Neither are Michigan broadcasters. Omaha and Des Moines, as a rule, come in like locals day or night but now devote most of their time to the red and blue chains of the N. B. C. With but few exceptions, our two best broadcasters spend their efforts toward rebroadcasting the chain programs. I have heard it said time and time again by the ardent radio fan that 95 per cent. of his listening time is devoted to listening to the chain features.

The recent action of Congress in really cutting down super-broadcasting has played into the hands of the big interests, who will some day attempt to put this wired wireless idea across, for unless we can have a sufficient number of super-broadcasters to cover the country, the advertisers will boycott the independent radio stations and in turn we face a loss of talent by these broadcasters for lack of financial support to put on their own broadcasting. The very life of the radio industry depends on a sufficient number of high-powered radio stations that can be heard consistently and with a greater variety of programs than is now possible for the average radio fan to obtain.

The radio industry should feel alarmed at the wired wireless situation before it becomes too late.

American Interference Patrols

THAT the big light and power companies of this country are as anxious as the radio fan to remove the nuisance of man-made interference is evidenced by this letter from the Union Electric Light and Power Company, of Saint Louis:

To the Editor:

Our attention was first attracted to RADIO BROADCAST by its articles on radio interference, and in particular, the series of articles of Mr. A. T. Lawton. It was to receive this series of articles that our subscription was entered.

Our company has been quite interested and active since 1924 in locating and removing all sources of interference for which it is responsible. It has been somewhat discouraging at times when this service, rendered voluntarily, has been taken advantage of by many listeners and some dealers, who have blamed all their troubles on "leaky transformers." In most cases we have found this situation was caused by ignorance of the nature and source of interference. Many of the early articles on interference in magazines and newspapers strengthened this erroneous impression by the incorrect or misleading statements contained in them.

Such articles as those by Mr. Lawton are not only doing much to correct this misconception, but are also of great assistance to those who are earnestly trying to trace and eliminate interference. We hope to see more such articles.

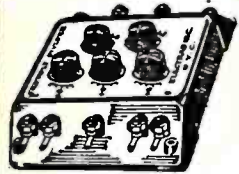

U. S. Patent 1676869
and Patents Pending

Voltage
Separation
—the Secret
of Perfect
Eliminators

TRUVOLT DIVIDER

NOW! Electrad makes better eliminators possible with the TRUVOLT Divider. It separates output voltage so that you always get the right voltage in the right place. Saves complicated calculations, difficult wiring and the use of voltage regulator tubes. Simple—compact—easy to use.

List Price \$12.50

Electrad Specializes in a Full Line of Resistance Controls for all Radio Purposes, Including Television.

Write for Free Circuit Data and Description of TRUVOLT DIVIDER.

Dept. MA-10, 175 Varick St.
New York

ELECTRAD

LOGIC

RADIO communication is here to stay—

VARIABLE or other condensers are essential component parts of most installations—

CARDWELL CONDENSERS are built to stay with radio and to last for the life of your installation—

WHY putter?

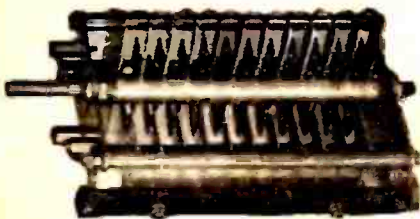

Scores of special condensers may be found in course of construction at any time in the Cardwell Factory, engineered and designed for the foremost constructors of commercial transmitters and broadcasting stations. The regular CARDWELL line includes, as heretofore, the condensers most widely used and in demand.

What is your problem?

"There is a CARDWELL for every tube and purpose."

- High Voltage Transmitting Condensers
- Transmitting Condensers for Medium and Low Power
- Air Dielectric Fixed Condensers
- Receiving Condensers

LITERATURE UPON REQUEST

THE ALLEN D. CARDWELL
MFG. CORPN.

81 PROSPECT ST., BROOKLYN, N. Y.

Goodwin "VIVETONE 29"

Truly a Standard of Efficiency
for A-C Operation

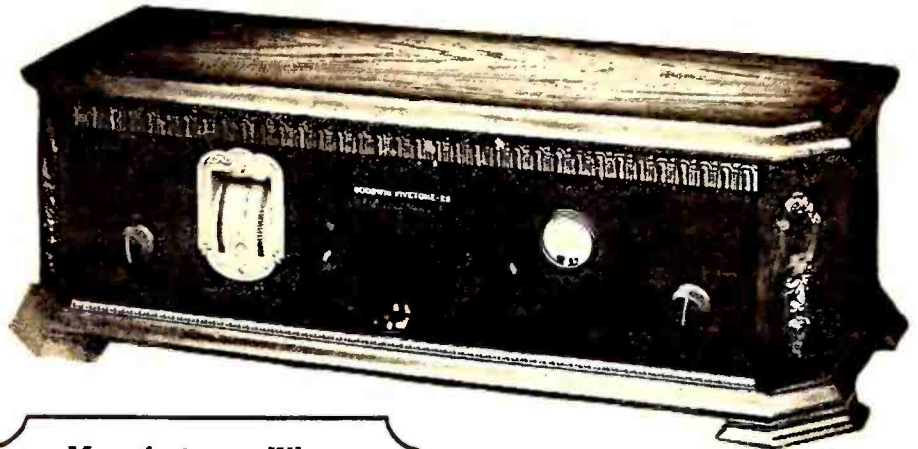

Manufacturers Whose
Standard Parts Are Used
in the "VIVETONE 29"



"BRAIDITE" HOOK-UP
WIRE



For Better Radio
Hammarlund
PRECISION
PRODUCTS



THORDARSON

Centralab

YAXLEY

WARD-LEONARD

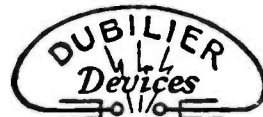

Reg. U.S. Pat. Off.

DAVEN

DRILLED AND ENGRAVED
WALNUT MICARTA PANELS
FOR THE "VIVETONE 29"
ARE AVAILABLE

HERE is a receiver that embodies to the highest degree those five features of paramount importance, namely—Sensitivity, Selectivity, Quality Reproduction, Beauty of Appearance and Simplicity of Construction with resulting Ease of Operation. In measuring up to these five necessary requirements the Goodwin "Vivetone 29" is truly a standard of efficiency.

All the parts used in the "Vivetone 29" are made by radio's most reliable and reputable manufacturers. Each part sets the standard in its line and is recognized as such by radio's leading engineers. The use of these quality parts in the "Vivetone 29" insures long and satisfactory service.

The constructor and commercial set builder can purchase all the parts used in the "Vivetone 29" from any dependable dealer.

BLUE PRINTS FOR THE "VIVETONE 29"

Send today for the four complete full sized constructional blue prints incorporating every detail for the construction of the "Vivetone 29." Enclose \$1.00 to cover cost of mailing and the actual cost of the blue prints.

Goodwin Radio Research Lab.
167 Glenwood Ave. Jersey City, N. J.

New!
A Speaker Extension Cord that Lies Flat on the Floor Under the Rug!

Put your set and loudspeaker anywhere. Place them as far apart as you wish. Then connect them with the wonderful Belden Extension Floor Cord. It lies flat under the rug. Out of the way—no wiring—no fuss. Get one at your dealer, now!



Belden Mfg. Company
 2312-A S. Western Avenue
 Chicago

Belden

CORWICO
Braidite
 HOOK-UP WIRE
 "THE BRAID SLIDES BACK"

Cuts Wiring Time in Half

Shove back the insulation, solder the connection and the braid slides back into place, leaving no exposed sections of bare wire. Braidite is the quickest and easiest working hook-up wire made.

Safe as insulated wire and as convenient as bare wire. You cannot scorch or burn Braidite with a soldering iron. Use Braidite in the next set you build.

At All Dealers

- 25 Feet Stranded 35c
- 25 Feet Solid 30c
- Red, Green, Yellow, Blue, Black.

FREE Send us the name and address of your dealer and we will send you a sample package of Braidite FREE. Include 10c for Postage.

CORNISH WIRE CO.
 38 Church Street New York City



TROUBLE?

If your set or power pack refuses to work, or you want to improve the quality of reception or increase selectivity—

If you want to modernize and electrify your present receiver—

Let US help you solve your difficulty

For example: It will cost you only from \$5.00 to \$10.00 for the repair service consisting of testing the receiver, tracing the trouble and then repairing it. The set will then be shipped to you in perfect operating condition and guaranteed.

For further details address
SILVER RADIO LABORATORIES
 2114 Mapes Ave. New York, N. Y.

Build a Daven Television Receiver

Complete Essential Kit, \$60.00

THE first complete Kit. Furnished with either T-24, T-36 or T-48 Scanning Disk, Motor, Bushing, Rheostat, Daven Television Tube, 3 Complete Stages of Daven Television Amplification and Instructions for Building.

Daven Television Receiver, Complete, including Television Tube—\$100.00 Less amplifier Tubes.



DAVEN TELEVISION APPARATUS

Daven Television Scanning Disks	Each
24 T-24.....	\$ 5.00
36 T-36.....	7.50
48 T-48.....	10.00
Comb. Disc with 24, 36 and 48 Apertures T-468.	15.00
Daven Tele. Amp. T-3.....	12.50
Daven Spec. Telev. Amp. T-4 for 2 Hi Mu Tubes and 2 power Tubes 171, 210, 250 Types.....	17.50
Daven Telev. Neon Lamp, 20 to 80 Milliamperes Striking Voltage 100 Plate 1 1/2" x 1 1/2".....	12.50
Daven Telev. Motor.....	27.50
Daven Bushing to fit 1/4", 1/8" and 3/16" Motor Shafts	1.00
Daven Bushing for 48 Aperture disc.....	3.50
Daven Rheostat.....	3.50
Daven Telev. Photo Elect. Cell 1 3/4" Bulb.....	20.00
Daven Telev. Photo Elect. Cell 3/4" Bulb.....	37.50
Daven Television Couplers.	
1st Stage No. 421X D-421XX	
2nd Stage No. 422X D-422XX	
3rd Stage No. 423X D-423XX	
x Glastors are used for Grid and Plate resistors	2.15
xx Super Davohms in Plate and Glastors in Grid	4.65
Daven AC 71 for output tubes in series with Television Lamp.....	3.50
Daven AC 10 (for brighter illumination).....	9.00
Daven Mu 20 Hi Mu Tubes for Amp. Stages.....	2.25
Daven Mu 6 Power Tube.....	3.50

Send 2c stamp for new Television Booklet

THE DAVEN CORPORATION
 Amplification Specialists

190 Summit Street Newark, N. J.



\$2.00 Insures Your A.C. Tubes

The Vitrohm 507-109 Unit costs \$2.00. Installed on your radio set, it lengthens a. c. tube life by automatically lowering filament voltage.

Attached in a moment—Nothing combustible—Nothing to wear out—Does not get excessively hot.

It consists of a Vitrohm Resistor mounted within a perforated metal cage, a plug, and a receptacle.

Write for free information on this and other Ward Leonard Radio Products.

WARD LEONARD MOUNT VERNON ELECTRIC CO. NEW YORK

For Greater Utility
and Enjoyment
of Radio

YAXLEY
APPROVED RADIO PRODUCTS



Wire Your
Home for
Radio

Yaxley
Radio Convenience
Outlets

Enjoy your radio programs in any room in the house. Put the batteries in any out-of-the-way place. Bring aerial and ground connections to most convenient point. These outlets fit any standard switch box. Full instructions with each outlet.

- No. 135—For Loud Speaker Connections.....\$1.00
 - No. 136—For Aerial and Ground Connections..... 1.00
 - No. 134—For Several Loud Speaker Connections..... 2.50
 - No. 132—12 Conductor—For Power Pack Connections..... 3.00
 - No. 137—7 Conductor—For Battery Connections..... 2.50
 - No. 138—For AC Connections..... 1.00
- Also furnished in two and three plate gang combinations

WITH BAKELITE PLATES

Now furnished with a rich satin brown Bakelite plate, with beautiful markings to harmonize, at 25 cents extra.

Cable Connector Plug

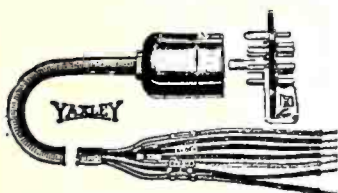

Complete as illustrated with 5-foot cable and cable markers. Mounting plate mounts on base panel by means of bracket. Bakelite construction; positive spring contacts; no loosening of pins or springs in soldering. You

cannot put the Cable Connector Plug together improperly. All terminals and cable ends plainly marked.

- No. 660—Complete.....\$3.00

Junior Rheostats and Potentiometers



Small in size—1 7/8" diameter—yet have exceedingly fine adjustment. Contact arm rides smoothly on resistance strip. Extra heavy metal base and an expanded metal retaining cup help dissipate heat, retarding overheating. Mount in 7/8" panel hole.

- Junior Rheostats, with knob, ratings up to 400 ohms.....\$0.75
- No. 51000—1000 ohms..... 1.00
- Junior Potentiometers, with knob, ratings up to 400 ohms..... 1.00
- 1000, 2000 and 3000 ohm sizes..... 1.25

Colored Phone Tip Jacks

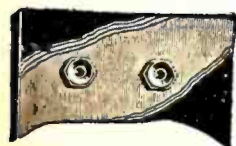

Have distinctive colored caps, red for positive side of loud speaker and black for negative side. Cap is of Bakelite. Take standard Phone Tips. Phone tips nest all the way in Jack, making excellent spring contact.

Lessens danger of shorts. For Bakelite or metal panels.

- No. 422—Insulated Colored Phone Tip Jacks Per Pair.....\$0.25

At Your Dealers

YAXLEY MFG. CO.

Dept. B, 9 S. Clinton Street
CHICAGO, ILLINOIS

*Increased Amplification
Improved Quality
with this new valve*



**Harold P. Donle's
Latest Achievement**

THE inventor of the famous Sodian Detector valve brings out this DA2 6-volt amplifying valve which can be used in any type D. C. set with no changes.

Amplification for both audio and radio frequency are greatly increased, and the quality of your set vastly improved.

Those that have tried these valves are enthusiastic about them.

Full size illustration of the DA2 amplifying valve. Price \$3.00 each.

Here is what some of them say:

"We seem to obtain far greater volume and clarity."

"Really, it is the most marvelous valve I have ever come in contact with."

"I have tried two of these tubes in my regular tuned radio frequency broadcast receiver, and I am delighted with the increase in volume and distance obtained."

"Received the four tubes ordered, to-day. Must say that they even exceed all my expectations."

"It is a pleasure to report that the three tubes I received from you Saturday have increased the sensitivity of my Hammarlund-Roberts Hi-Q to a considerable degree. I also tried one in the R. F. stage of a Brown-ing-Drake and there too, the gain was considerable."

"Excellent for low wave sets"

If your dealer has not yet received his stock, mail orders will be promptly filled upon receipt of check.

The Donle Electrical Products Corporation
MERIDEN, CONNECTICUT



TRANSFORMER AND "A" FILTER

Tobe TransAformer consists of a step down transformer and a 3 ampere rectifier unit completely assembled in one unit. Fits neatly on top of a Tobe "A" Filter as shown. No wiring required, just plug into the house supply.

The Tobe "A" Filter and the Tobe TransAformer make a good, complete A Supply.

The same Tobe "A" Filter attached to any good two ampere charger such as a Tungar, Rectigon or even a good Electrollic charger, will make a complete A Supply.

- Tobe "A" Filter \$18.00
- Tobe TransAformer \$15.00
- Tobe A Supply includes Tobe "A" Filter and Tobe TransAformer, completely wired and assembled. 8 tube capacity 33.00



TOBE DEUTSCHMANN CO.

Canton, Massachusetts

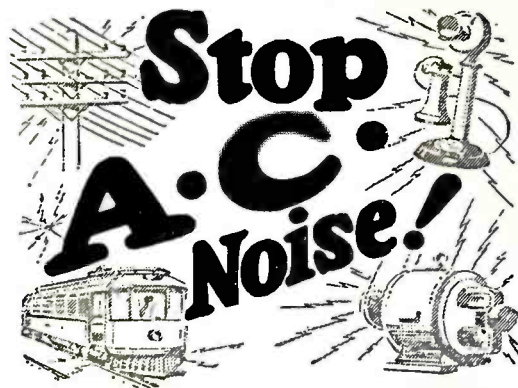

DON'T let the "static" that comes in over the house lighting system from motors, street cars, telephones and electrical appliances mar your radio programs with blare, squeal, fry and scratch! Plug in a Falck Claroceptor between wall socket and set and have clearer A.C. reception. A wonderful new improvement by a pioneer radio equipment manufacturer. Grounds and thus blocks out line interference noise and radio frequency disturbances. Also improves selectivity and distance. Requires no changes in set. Measures just 3 1/2 x 5 1/2 x 2 1/2 inches. Tested, proved. Praised by thousands. Get one right away—at radio parts dealers. Write for descriptive folder.



\$7.50 complete with cord and plug

Falck CLAROCEPTOR

Built by **ADVANCE ELECTRIC CO.**
1260 W. Second St. Los Angeles, Calif.
JOBBERs and DEALERs, GET OUR PROPOSITION



Your Tubes STEADY AS THE STARS When AMPERITE-Controlled

Don't let "A" battery current fluctuations spoil your radio reception or ruin your tubes. Install Amperites and automatically keep the filament temperature constant according to tube rating. Entirely unlike fixed resistors. With AMPERITE control tubes last longer and your set sounds better. Panel arrangement improved and wiring simplified. Tuning is easier and volume is increased. A type for every tube—battery or A. C.

\$1.10, with mounting (in U. S. A.) at all dealers. **Radiall Company** 50 FRANKLIN ST., NEW YORK



FREE "Amperite Blue Book" of latest circuits and construction data. Write Dept. RB 10

AMPERITE The "SELF-ADJUSTING" Rheostat

Send For New Radio Book - - It's Free

New hook-ups. This book shows how to make short wave receivers and short wave adapters. How to use the new screen grid tube in D. C. and A. C. circuits. How to build power amplifiers, ABC eliminators. Up-to-the-minute information on all new radio developments. It's free. Send for copy to-day.

KARAS ELECTRIC COMPANY
4033K2 N. Rockwell Street, Chicago

Name

St. and No.

City and State

4033K2

RADIO PANELS

BAKELITE—HARD RUBBER

Cut, drilled and engraved to order. Send rough sketch for estimate. Our complete Catalog on Panels, Tubes and Rods—all of genuine Bakelite or Hard Rubber—mailed on request.

STARRETT MFG. CO.
521 S. Green Street Chicago, Ill.

Be an EXPERT RADIO OPERATOR



MIDGET TELEPLEX

JUST LIKE HAVING AN EXPERT OPERATOR IN YOUR HOME

Only \$3.50

Good pay, travel, excitement, adventure. This wonderful instrument will teach you to read the code like an expert in half the usual time. Reproduces actual sending of expert operators. Sends messages, radiograms, newspaper matter, etc.—regular code traffic anywhere, anytime and at any speed. All you have to do is listen. Easy and fascinating. Strong, waxed tape-records carry complete code instructions. Just what you need for home practice. You'll be amazed when you hear it.

Satisfaction Guaranteed.—Send only \$2.50 for MIDGET TELEPLEX with lessons, or \$5.50 for complete set with high-frequency key and buzzer. Satisfaction guaranteed. Send Today.

TELEPLEX COMPANY
72 Cortlandt St., NEW YORK CITY

This is a good time to subscribe for RADIO BROADCAST Through your dealer or direct, by the year only \$4.00
DOUBLEDAY, DORAN & COMPANY, Inc., Garden City, N. Y.

Send for WESTERN RADIO

New 1929 Catalog

DEALERS AND SET BUILDERS

The NEW 1929 catalog is crammed full of the FINEST, NEWEST, Nationally known A. C. sets, consoles, cabinets, dynamic speakers, kits, eliminators and accessories at LOWEST PRICES. Largest stock of radio parts. Prompt delivery. No delay.

Write for our FREE catalog

WESTERN RADIO MANUFACTURING CO.
128 W. Lake St. Dept. RB-10 Chicago

The Big Friendly Radio House



SET BUILDERS

Write us for new illustrated Catalog "A-1" containing all the new and popular kits in radio. Our tremendous stock enables us to give you immediate service on all radio supplies at wholesale prices.

Allied Radio CORPORATION
711 W. LAKE STREET, CHICAGO

**THE FINEST
BROWNING-DRAKE
ASSEMBLY
EVER DESIGNED**

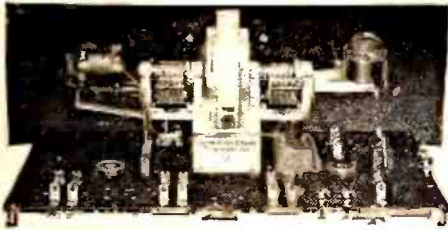

The new A. C. Shield Grid Browning-Drake assembly is a combination of all the most modern and advanced ideas of receiver construction. The famous Kit has been designed this summer by Professor Browning for assembly with shield grid tubes, both A. C. and D. C. For the first time this well-known circuit has been reduced to single control, while the tickler feedback control is retained for the exceptional sensitivity for which it is noted.

Complete parts list at only \$59.45, the lowest list price yet reached by a kit assembly of the highest quality. Full constructional details including full scale picture wiring diagram may be obtained free on request.

We have some territory open for exclusive distributors and authorized dealers handling factory-built Browning-Drake receivers. Write for our proposition on this line which brings both profit and prestige.

BROWNING - DRAKE CORP.
Cambridge, Mass.

BROWNING-DRAKE
RADIO



**New and Improved Power Amplifier
TRANSFORMER
for use with
U-X 250 TUBES**

This newest Dongan Transformer is designed for full wave rectification using two UX 281 tubes to supply B and C power to receiver and power for two UX 250 Tubes.

There are two low voltage windings, one for 226 tubes and the other for 227 tubes so that you can build a power amplifier for either the radio receiver or for phonograph pick-up.

With No. 8529 Transformer use one No. 6551 double choke in filter circuit. Approximate D. C. output from filter, 525 V 130 mls. Secondary voltages 650-650V, 170 mls., 7½ V 2½ amp. C.T. 7½ V, 2½ amp. C.T. 2½ V 1¼ A. C. T. 1½ V 4.2 A.



No. 8529—\$16.50

Approved Parts for UX-250 Tubes

- No. 6551 Double Choke. May be used where current does not exceed 250 mls. \$15.00
- No. D-600 Power Amplifier Condenser Unit has been designed for use with the CX 281 rectifier tubes, and CX 210 or 250 power tubes. Having a working voltage of 1000 volts and mounted, in crystal lacquered steel cases, they will be found unsurpassed for reliability and stability. Unit contains sections of 2-2-4 Mfd. \$16.50
- No. D-307 contains condensers of 4-2-1-1 Mfd. sections with a working voltage of 400 volts for use in connection with D-600 \$10.00
- No. 1177 A splendid straight power amplifier output transformer designed for use with UX 250 P. A. Tube \$12.00
- No. 1176 Similar to No. 1177 but the Push Pull Type. \$12.00

Set Manufacturers and Custom Set Builders

You are cordially requested to take advantage of Dongan's very complete engineering facilities. All approved parts are in production now. Prompt attention will be given to any special design in which you are interested.

DONGAN ELECTRIC MANUFACTURING CO.

2991-3001 Franklin Street
Detroit



This is a good time to subscribe for
RADIO BROADCAST
Through your dealer or direct, by the year only \$4.00
DOUBLEDAY, DORAN & CO., Inc. GARDEN CITY, N. Y.

**50,000 FEET
OF RADIO**

50,000 square feet of floor space in a large, modern building devoted exclusively to radio. Tremendous stock of latest kits, parts and sets in improved designs and styles **at wholesale prices.** Write for Catalog "A."

**Allied Radio
CORPORATION—
711 W. LAKE STREET, CHICAGO**

\$75 to \$125 Weekly
**Charging Batteries
Starts You**

Let me show you how to make big money right from the start. I've prepared a **FREE** book explaining all details. First week's profit pays for all equipment. You can get all the battery charging business in your community with my Service Station Charger—it's years ahead of ordinary chargers—handles 50% to 70% more batteries. I explain everything—start you in a business of your own and put you on the way to big money. Write for **FREE BOOK.**
**C. F. HOLMES, Chief Engineer, Dept. R B
Independent Electric Works
5116 Ravenswood Ave. Chicago, Ill.**

FREE BOOK—Just Out

PUSH-PULL TRANSFORMERS FOR POWER AND REALISM



Type 541-A
Input Transformer
Price \$15.00

The advantages of connecting two tubes in a push-pull circuit are already firmly established. The new General Radio Type 541 Push-Pull Transformers consist of one input and two output types for either magnetic or dynamic reproducers.



Type 541-C
Output Transformer
(For Dynamic Speaker)
Price \$10.00

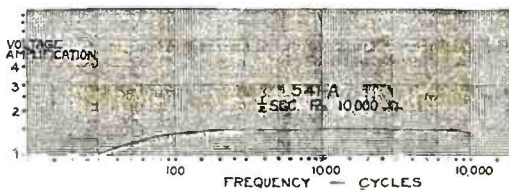

Bulletin No. 930 with direct to consumer prices will be sent on request.

GENERAL RADIO CO.

30 STATE ST.
CAMBRIDGE, MASS.
274 BRANNAN ST.
SAN FRANCISCO, CALIF.

Improves any set.
Easy to install.



Neat, compact, durable.
Moderate in price.



"The Perfect Contact Radio Ground"

Patent Applied For

PER-CON MFG. CO.

Richmond, Indiana



TRANSFORMER AND A FILTER

Tobe TransAformer consists of a step down transformer and a 3 ampere rectifier unit completely assembled in one unit. Fits neatly on top of a Tobe "A" Filter as shown. No wiring required, just plug into the house supply.

The Tobe "A" Filter and the Tobe TransAformer make a good, complete A Supply.

The same Tobe "A" Filter attached to any good two ampere charger such as a Tungar, Rectigon or even a good Electrollic charger, will make a complete A Supply.

- Tobe "A" Filter \$18.00
- Tobe TransAformer \$15.00
- Tobe A Supply includes Tobe "A" Filter and Tobe TransAformer, completely wired and assembled. 8 tube capacity 33.00



TOBE DEUTSCHMANN CO.

Canton, Massachusetts

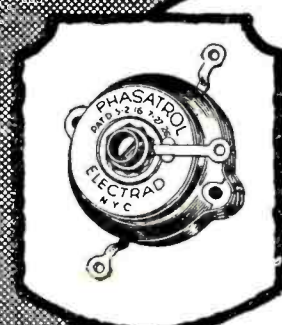

Licensed by Rider Radio Corporation Patented 5-2-'16; 7-27-'26. Pats. Pending

Curb Oscillations!

PHASATROL

Reg. U. S. Pat. Off.

A True Balancing Device for Radio Frequency Amplifiers

Rid your set of the R. F. oscillation nuisance by installing a Phasatrol in each stage of R. F. amplification. They dampen the circuit and absorb surplus energy, thus neutralizing oscillations. By adjusting it to the desired value, it is possible to cure even the most obstinate R. F. amplifier stage from the oscillation habit. Price \$2.75 each.

Electrad specializes in a full line of Controls for all Radio Purposes, including Television.

Write for Free Hook-Up Circulars

Dept. M-10, 175 Varick Street
New York

ELECTRAD

Jenkins & Adair Condenser Transmitter

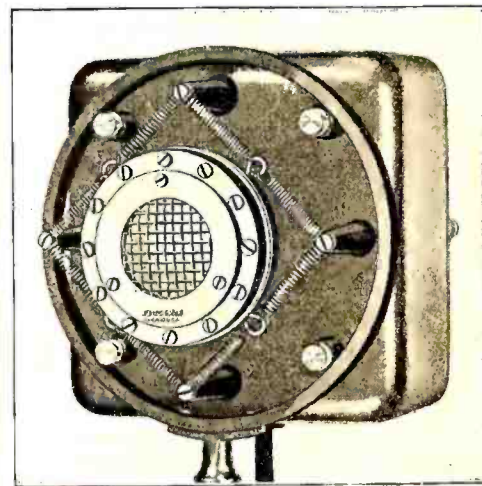

For Broadcasting, Phonograph Recording, and Power Speaker Systems

THIS transmitter is a small condenser which varies its capacity at voice frequency, and is coupled direct into a single stage of amplification, contained in the cast aluminum case. The output, reduced to 200 ohms, couples to the usual input amplifier. The complete transmitter may be mounted on the regulation microphone stand. It operates on 180 v. B and 6 or 12 v. A battery.

This transmitter contains no carbon, and is entirely free from background noise. Its yearly upkeep is practically nothing. It is extremely rugged, and will withstand hard usage.

Price, complete with 20 ft. shielded cable, \$225.00 F.O.B. Chicago.

J. E. JENKINS & S. E. ADAIR, Engineers
1500 N. Dearborn Parkway,
Chicago, U. S. A.

Send for our bulletins on Broadcasting Equipment

**Latest
GREATEST
RADIO CATALOG
and GUIDE**

THE BARAWIK CO. has, all these years, been famous for its variety of radio supplies, which it offers at money-saving prices. Newest dynamic speakers, "B" eliminators, socket power equipment, A-C harness, fine cabinets and furniture, amplifiers, latest amateur equipment, tubes, batteries; in fact, anything you can ask for is here, ready to ship, at a saving in price. Quality merchandise, selected goods by reliable makers—just what you want—at big discounts.

Your Savings are Tremendous

Ask any of the quarter million Barawik customers why they trade here, and they'll tell you that, quality considered, our prices can't be beat. That's something to think about! Quality comes first—new, fresh, good reliable merchandise, but the price always means a tremendous saving, nevertheless. Get our catalog and prove this to yourself. Don't spend a nickel until you see our offerings first.

You need this great radio bargain book as never before—Mail the coupon now—**TODAY.**



FREE

Barawik Co. 1210 Canal Sta. CHICAGO, U. S. A.

Mail this coupon for FREE Bargain Book.

Name _____
Address _____



**FERRANTI
Audio Frequency
Transformers**



are specified for the
SKYSCRAPER

Principal parts for the SKYSCRAPER including aluminum base, three shields and front panel correctly drilled, one Ferranti Audio frequency Transformer Type A-F 5, one A-F 5C and one O-P 8C for magnetic type speakers or O-P 4C for dynamic cone speakers and three special radio frequency coils. Complete instructions for building with necessary photographs and drawings. List price \$95.00. Instructions only, net price \$1.00.

Send 15c in coin for copy of the 1929 Ferranti Year Book

FERRANTI, INC.

130 W. 42nd St. New York, N. Y.
FERRANTI, Ltd. FERRANTI
Hollinwood ELECTRIC, Ltd.
England Toronto, Canada

**Pound wise —
but Penny foolish!**

GETTING the old, familiar adage turned around, but it applies to those radio fans who try to save a few pennies on their condenser blocks. Building a socket-power device is an expensive proposition — and the condensers are the most vital parts in them.



Type PL-574, specially designed for Thordarson R-171 Power Compact, Ratheon BH Gas type Rectifier or Elkon EBH Metallic Rectifier.
Price \$16.50

Cheap, undersized condensers may look pretty in the can — but the huskiness — the factor of safety isn't there.

You can bet on Dubiliers — true, you'll pay more for them — but they'll do more and last longer.

**DUBILIER
LIGHT SOCKET
AERIAL**



**Yes sir, it works on your
Set — or Money Refunded**

No need to be troubled with an outdoor antenna or lightning arrestors any more — simply plug in the Dubilier Light Socket Aerial — clear reception, less static and interference and plenty of volume. No current consumed. All good dealers sell it on a 5 day money-back guarantee. If your dealer is out of stock write to us.

Free Catalog for radiofans, simply write



Dubilier

CONDENSER CORPORATION

4377 Bronx Blvd.

New York

**Beginning Sept. 15
How to Make
YOUR OWN RADIOVISOR**

By C. Francis Jenkins

THE new invention you have been reading about! Here is a wonderfully interesting and constructive series telling you how to be a pioneer in the field of Radiovision. All instructions are given simply and clearly with diagrams. Read these weekly articles and be first with a Radiovisor in your home.

Especially written for

Science News-Letter
2179 B St. Washington, D. C.

Introductory Offer—13 weeks, \$1



**SILENCER
SOCKET**



For anyone building short wave or regular sets, using sensitive detector or screen grid tubes, the Na-Ald 481-XS socket is recommended. This silencer socket prevents microphonic noises and preserves the life of these delicate tubes. Recommended in circuits elsewhere in this magazine.

Na-Ald makes a socket for every purpose, as well as more than thirty different adapters. Write for new catalog just off the press.

Alden Manufacturing Company
Brockton, Massachusetts

CROSLEY

DYNACONE



A simple explanation of the new, amazing power dynamic speaker that has swept the radio market at \$25

The dynamic principle of radio speakers means **POWER**—combined with the finest attainable **QUALITY**.

Dynamic speakers get their **POWER** by the use of an *electromagnetic field*. Translated from Engineering into English this means that the permanent field

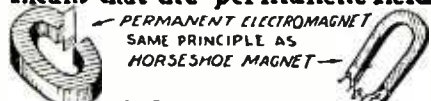

magnet of the average radio speaker is replaced by a powerful electromagnet.

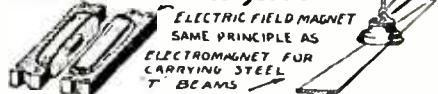

Comparing the possible **POWER** of electromagnets and permanent magnets is like comparing a magneto to a dynamo.

The magneto uses permanent field magnets. It will serve admirably as a shocking machine but cannot light a single lamp bulb.

The dynamo uses electro magnets. Even a moderate sized dynamo will run the lights of an entire village.



Heretofore, the use of

dynamic speakers was limited to a comparative few who could afford them because they required a separate battery to supply the current for their electromagnet coils.

DYNACONE eliminates the battery — and utilizes current direct from the set to operate its field coils.

A continuous direct current is always flowing in the plate circuit of the power output tube of the radio set.

Upon this direct current is superimposed the fluctuations of the signal.

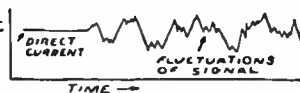

It has been customary to keep the direct current out of the loudspeaker because so strong a current would tend to *paralyze* the speaker by pulling its armature over against the field magnet.



To get rid of this strong direct current, a transformer,

or a condenser is used, which allows only the signal fluctuations to

enter the speaker armature. **DYNACONE** uses the latter method for keeping the direct current out of its armature but makes use of this very current, which other speakers throw away, for energizing its field electromagnets.

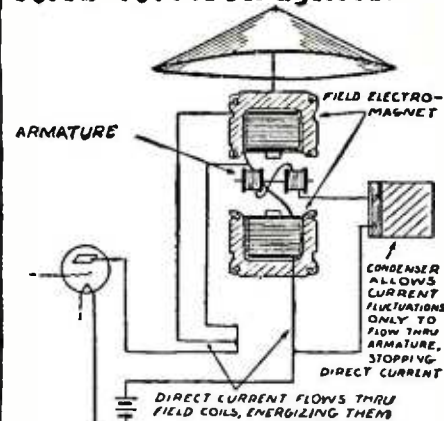

By thus ingeniously utilizing energy heretofore thrown away, **DYNACONE** achieves **POWER** and **QUALITY** only attainable with the dynamic principle, without any special batteries or other apparatus. It is simply connected directly in the output circuit of any set using a 171 type power tube operating at 180 volts on the plate.*

* If the set has an output transformer, this is disconnected by the dealer when **DYNACONE** is installed.

The above description applies to the Type E **DYNACONE**. The Type F **DYNACONE**, which has four connections to the set, takes its direct current from ahead of the output transformer instead of using a condenser to effect its separation from the voice current which actuates the armature.

THE CROSLEY RADIO CORPORATION

DEPARTMENT 20

Cincinnati, Ohio

Powel Crosley, Jr., Pres.

Montana, Wyoming, Colorado, New Mexico and West prices slightly higher