

March
1926



35
CENTS



RADIO BROADCAST



F.J. Edgars.

MAKING APPARATUS FOR THE
HOME LABORATORY

APPLYING "MULTIPLE REGENERATION"
TO POPULAR RECEIVING CIRCUITS

How to Make an All-Purpose Coil Winder
Forecasting Radio Reception from the Weather

Doubleday, Page & Co., Garden City, New York

Cunningham

RADIO TUBES

Since 1915—
Standard for all Sets

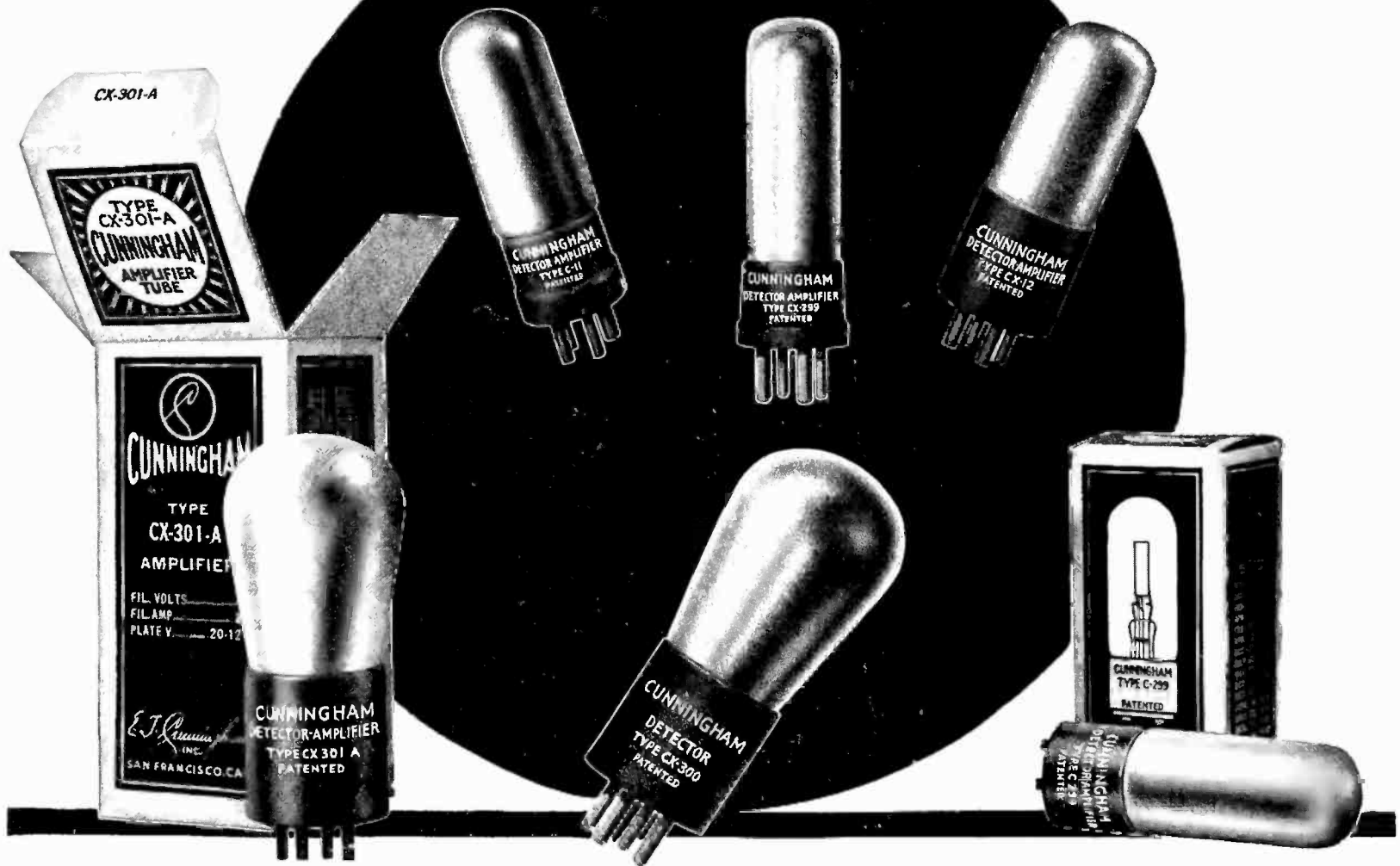

PROVEN DEPENDABLE

In millions of homes where Radio is Entertainment; in thousands of homes where Radio is a Hobby, and in thousands of laboratories where Radio is a serious matter for Research—Cunningham Radio Tubes have proven dependable.

The familiar Orange and Blue Carton is famous the world over as representative of quality in reception plus rugged endurance.

Since 1915--Standard for All Sets



Types C- & CX--

E.J. Cunningham Inc.

NEW YORK

CHICAGO

SAN FRANCISCO

★ Tested and approved by RADIO BROADCAST ★

www.americanradiohistory.com

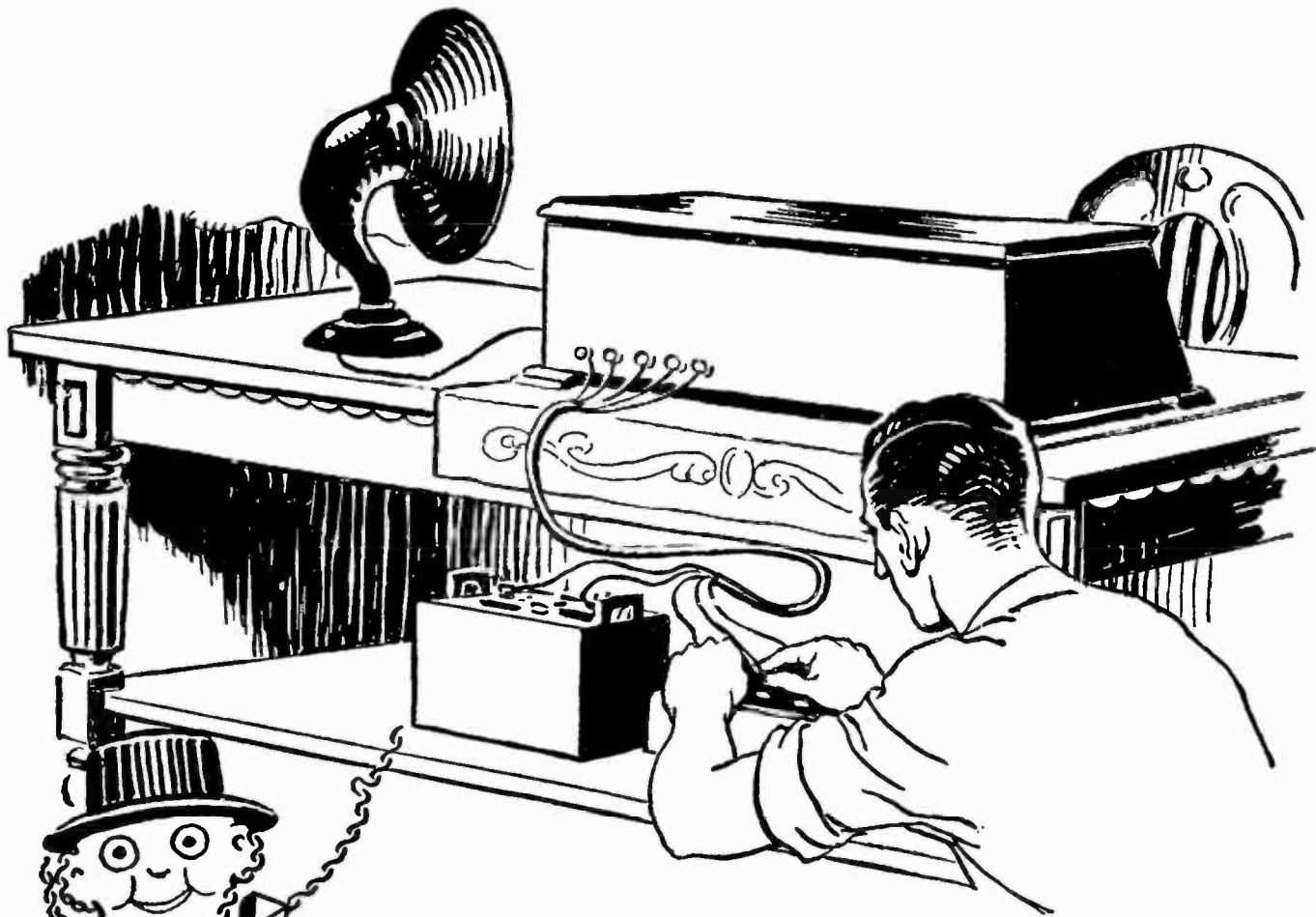

Easy to trace circuits with a Belden Battery Cord

A BELDEN Radio Battery Cord has five flexible rubber-covered cotton-insulated conductors, each identified by a separate color marking. There is no danger of short-circuits between A and B-batteries that are so costly in tubes.

Another thing! The Belden Radio Battery Cord takes the place of the messy tangle of wires usually found between a radio set and the batteries. It makes a neat, compact installation that greatly improves the appearance of any set.

One burned out tube will pay for many Belden Radio Battery Cords. Why not get your cord, now?

Look for the Belden Striped Carton

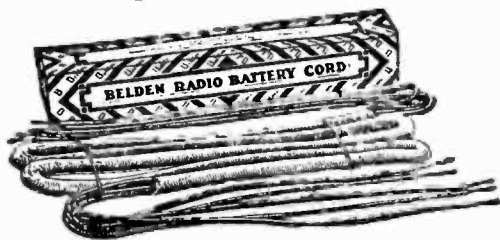

Mail the Coupon for Free Illustrated Booklet

BELDEN MANUFACTURING CO.
 2312K South Western Ave., Chicago

Please send me your booklet entitled "Helpful Hints for Radio Fans."

Name.....

Address.....

Belden



Health and happiness through radio

Each morning, young and old everywhere are adding to their store of health by doing the setting-up exercises broadcasted from many stations. Each evening radio adds to their pleasure and happiness through the dance programs.



In developing receiving sets that make the benefits of radio broadcast reception practical for everyone, radio engineers have found Bakelite to be superior for a great variety of radio parts—particularly those that are vital to clear reception and true tonal quality.



Bakelite is the preferred material for panels, dials, knobs, condensers, tube sockets and tube bases, plugs, rheostats and for other radio de-

vices including speakers. In fact, 95% of radio set and parts manufacturers use Bakelite as they have found that its permanently high insulation value, its strength, its lasting color and finish, its immunity to injury through exposure to heat or moisture, make it superior for radio use.



It is always best to make sure that the radio set or parts that you buy are Bakelite insulated.

Write for Booklet 29

BAKELITE CORPORATION
247 Park Avenue, New York, N. Y.
Chicago Office: 636 West 22nd St.
BAKELITE CORPORATION of CANADA, Ltd.
163 Dufferin Street, Toronto, Ontario, Canada



BAKELITE

REGISTERED U. S. PAT. OFF.



THE MATERIAL OF A THOUSAND USES

"The registered Trade Mark and Symbol shown above may be used only on products made from materials manufactured by Bakelite Corporation. Under the capital 'B' is the numerical sign for infinity, or unlimited quantity. It symbolizes the infinite number of present and future uses of Bakelite Corporation's products."

★ Tested and approved by RADIO BROADCAST ★

One Tuning Control ~ Calibrated in Meters!

THIS has been accomplished in the Ferguson Model "Eight" without the slightest sacrifice in the efficiency for which Ferguson Receivers have long been famous.

After choosing your program from the evening newspaper, simply turn up its wavelength on the indicator and in comes your station, clear and true!

Three stages of perfectly matched audio enable you to enjoy full loud speaker volume on even the distant stations.

Go to your Authorized Ferguson Dealer and examine the super-craftsmanship of a Ferguson, noting the graceful dignity of the cabinet. Then, hear a comparative demonstration—experience the unrivaled ease of operation—the true tone fidelity—and you will know why the Ferguson has been universally acknowledged to be "The Gold Standard of Radio Receivers."

J. B. FERGUSON, INC.
41 East 42nd Street • New York, N. Y.

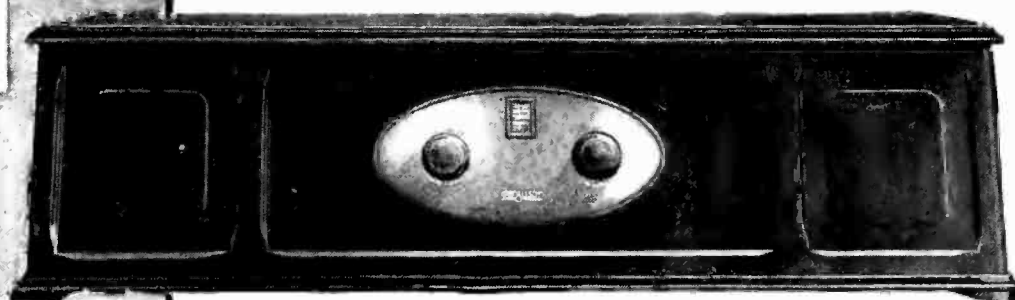
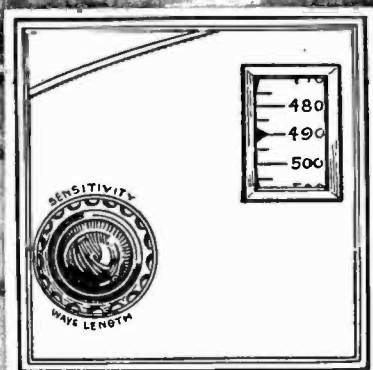

Ferguson

J. B. INCORPORATED

The Gold Standard of Radio Receivers

Brigham



Distortionless Amplification

In impedance coupled Amplifiers (which evenly amplify all the notes in the musical scale) as well as in most of the latest developments in audio amplification, fixed condensers and grid leaks are essential elements of the hook-up.

Unless the accuracy and reliability of these parts are above question, the results from the unit will prove disappointing.

The set-builder who uses *Dubilier By-Pass Condensers* and the silent *Dubilier Metaleak* in constructing this unit, works with the assurance that comes from the use of parts whose performance has been tested and guaranteed by the best known manufacturer of condensers in the world.

Dubilier

CONDENSER AND RADIO CORPORATION



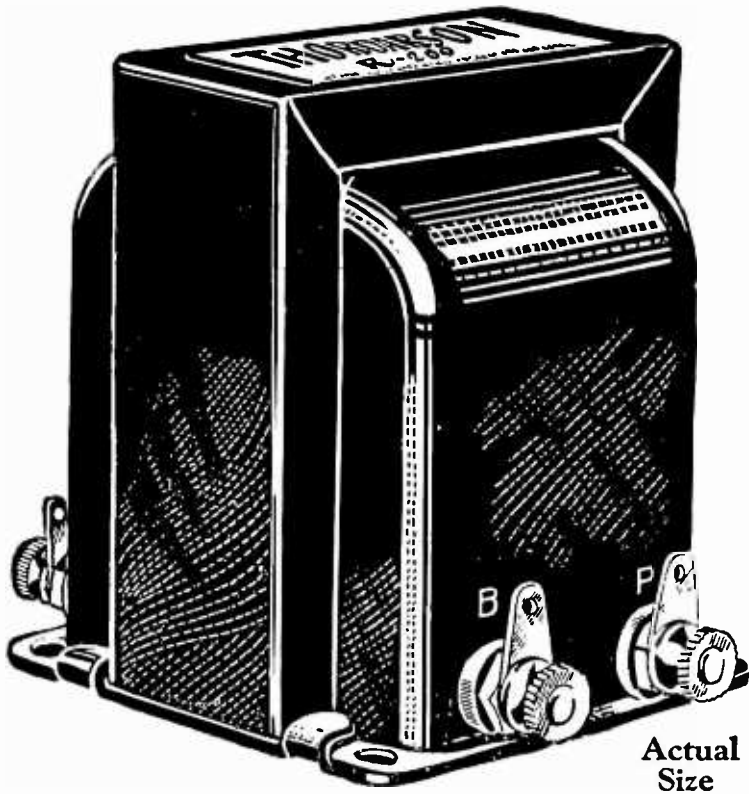

Actual Size

Here is the New
THORDARSON
R-200

used in the
Silver-Cockaday
Single Control
Receiver

described in Popular Radio, March

Price \$8 each

A Big New Audio Frequency Transformer—Guaranteed by Thordarson

THIS big new Thordarson R-200 contains a super-size layer-wound square coil. The much larger magnetic circuit, so provided, minimizes core losses (a leading cause of distortion in powerful receivers). If your present transformers distort voices and instruments when you desire full volume, if they blur the low notes, if they are lacking in genuine musical quality, replace them with a pair of these big new Thordarson R-200's. Ideally adapted for all two-stage amplifiers.

If dealer is not yet supplied, order from us. Write for fully descriptive literature.

Other Thordarson Transformers

Autoformers (All Frequency Amplifiers), \$5 each. Regular Super Audio Frequency Transformers in either sub-panel or top mounting type: 2-1, \$5; 3½-1, \$4; 6-1, \$4.50. Power Amplifying Transformers, \$13 the pair. Interstage Power Ampli-

fyng Transformers, \$8. For Raytheon B-eliminators: R-195 Transformer, \$7; R-196 Choke, \$5. All Thordarson products are unconditionally guaranteed. Shipped direct upon receipt of price, if dealer cannot supply.



THORDARSON ELECTRIC MANUFACTURING CO.
Transformer specialists since 1895
WORLD'S OLDEST AND LARGEST EXCLUSIVE TRANSFORMER MAKERS
Chicago, U.S.A.

Let the Pure Tones Through

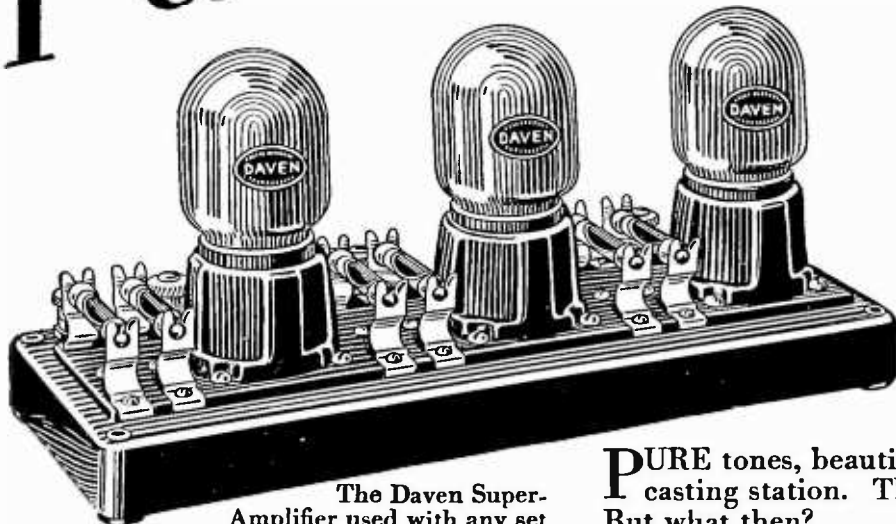

The Daven Super-Amplifier used with any set or circuit carries through the full, clear tones of the broadcasting station programs. If you prefer to assemble the Amplifier, obtain the Daven 3-stage Kit, which includes all parts except sockets.

Make Your Old Set A 1926 Model!

PURE tones, beautifully clear and full, go out from the broadcasting station. They reach your detector still pure and clear. But what then?

From the detector your amplifying apparatus operates. Distortion arises unless you take advantage of a method of amplifying that far-sighted manufacturers and thousands of set builders are now adopting—Resistance Coupled Amplification. Resistance Coupling is not new, *but Resistance Coupling with real volume amplification is new.* It is the most approved method of letting pure tones through.



The new Daven Special Coupling Condenser Type "A", for Resistance Coupled Amplification, sold separately and also included in all Daven Amplifiers, Kits and Resisto-Couplers. For greater volume and better quality.

The Daven Super-Amplifier costs little. It is easily and conveniently installed in any set made. Buy it complete to save hook-up labor. For those preferring to assemble, the Daven 3-stage Kit gives all the necessary parts except sockets. You will join hundreds of others who have written to thank us for the improvement Daven has given.

Write us today for The Resistor Manual, an authoritative book on Resistance Coupled Amplification, 25c at good dealers, 30c by mail.

DAVEN PRODUCTS ARE SOLD ONLY BY GOOD DEALERS

"The Sine of Merit"

DAVEN RADIO CORPORATION

Resistor Specialists



Newark

Reg. U. S. Pat. Off.

New Jersey



The new Daven High MU Tube Type MU-20, used with the Daven Super-Amplifier, gives 50% more volume—6 volt, ¼ ampere. A Daven Power Tube Type MU-6 in the last or output stage helps any set regardless of the method of amplification—6 volt, ½ ampere.



THE RESISTOR MANUAL is the handbook of Resistance Coupled Amplification. At your dealer's 25c. By mail postpaid 30c.

CLIP THIS COUPON

DAVEN RADIO CORPORATION
154 Summit Street, Newark, New Jersey
Please send me the following on Resistance Coupled Amplification:
Check One

- Resistor Manual. 30c is enclosed.
- Complete Catalog (free).

Name.....

Address.....

For Dealers: Send your letterhead and we will have our nearest distributor communicate with you.

THE BIG LITTLE THINGS OF RADIO



SC

SM Low Loss Inductances

All-bakelite Low Loss Interchangeable Coils for 50-550 meters. These new coils may be used as oscillators, antenna adapters and R F transformers in standard circuits. Price of all types. Each\$2.50
Sockets for any size coils. Each.\$1.00



SM VERNIER DIALS

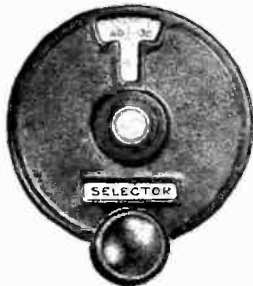

The SM Type 801 Vernier Dials are of all bakelite construction. Zero to 100—clockwise — counter-clockwise or 360 degrees (for Remler Condensers) in a single type. In appearance and operation the SM is the finest vernier dial on the market. Price each. .\$.250

The new Type 316 .00035 Mfd. condensers are furnished with permanent finish brass plates supported in a die cast U-shaped frame carrying front and rear adjustable cone bearings. Designed so any number may be placed one behind the other and permanently locked in any position to be controlled by a single dial. Price \$5.75

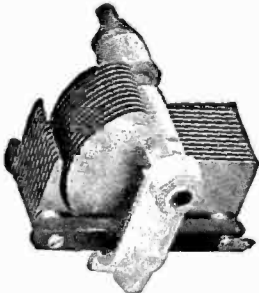

Type 340 Compensating Condenser. .000025 Mfd. supplied with brass plates for single hole panel or base mounting, complete with knob. \$1.50



Type 510 All Bakelite Socket for UX tubes. Springs of phosphor bronze—retain tension indefinitely make contact with full length of tube pins.....50c

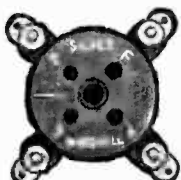

Have you read the description of the S C Receiver in the March issue of Popular Radio Magazine? There is an unusual story behind it—a story of two men, McMurdo Silver and Laurence M. Cockaday, enlisting the aid of seven unexcelled engineering organizations—the pick of the industry—for an unusual purpose. Not to find the answer to a problem, for the answer is the Ideal Receiver—but to devise ways and means of duplicating ideal requirements day-in-day-out—of duplicating in actual practice, theoretically-perfect operation.

They did it! With the S C Receiver. In a single stroke they combined single control . . . unlimited wavelength range . . . tuned radio frequency amplification . . . regeneration . . . unequalled quality of reproduction and a simplicity of assembly positively astounding. "THE KEY TO THE S C RECEIVER" tells the whole amazing story. Send 25c for this booklet to-day.

THE SILVER "SIX"

This amazing receiver has everything that makes for perfect reception. Thousands of builders report its startling performance—enthusiasm over its marvelous selectivity and sensitivity—marvel at its extraordinary volume. You will find Mr. Silver's description of the "Six" very interesting. Send for it today.

Anyone can build the "Six" and obtain marvelous results

Type 600 KIT includes all parts necessary to build the "Six" \$53.00

Type 610 KIT essentials only, including 3 condensers, 3 inductances and 3 inductance sockets \$27.75

THE IMPROVED RAYTHEON-THORDARSON B-ELIMINATOR

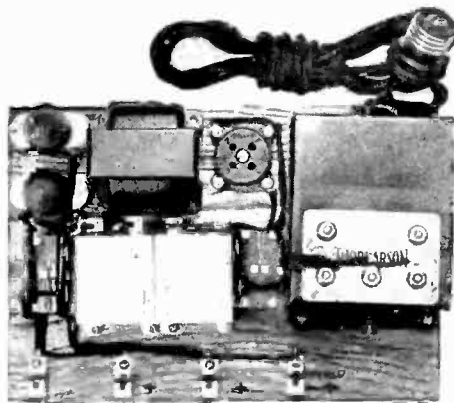

The SM Type 650 Kit includes Thordarson transformer, choke, Tobe condensers, genuine Raytheon tube, Bradleyohms and all necessary parts. Price \$34.00.

This eliminator will deliver from 20 to 200 volts at three different, adjustable voltages with maximum current of 50 milliamperes—more than enough for the largest receiver. Send for Assembly Instruction by McMurdo Silver..... 10c

SEND FOR CIRCULARS ON SM PRODUCTS

SEE THEM AT YOUR DEALERS

SILVER-MARSHALL, Inc.

103 S. WABASH AVE., CHICAGO



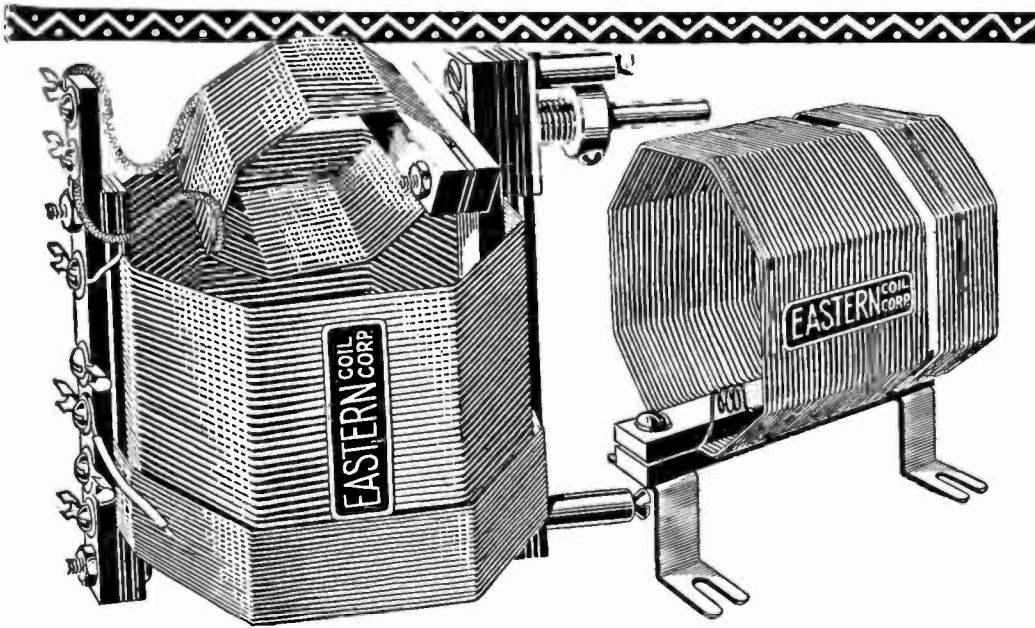

EASTERN KNOCKOUT COILS (TYPE R)

Specified
by
RADIO
BROADCAST
for the
"Aristocrat"
Set

for the EASTERN KNOCKOUT CIRCUIT, the original unreflexed ROBERTS, (four tubes), and the Radio Broadcast "Aristocrat," the single control unreflexed Roberts, resistance coupled, using five tubes.

These sets represent the famous *Roberts* circuit at perfection—the most efficient, simplified, and non-critical developments.

Price, \$8.50 per set.

EASTERN COILS are now ready for the new
Radio Broadcast

U N I V E R S A L

four tube circuit, which will enable fans to get the best possible results from this popular new set.

Type U-V Coils.....\$4.50 per set

The use of the marvelously efficient *Eastern Pickle Bottle Coils* in any circuit guarantees perfect performance. You will be amazed at the natural reproduction, increased selectivity, volume, and long distance range.

No celluloid or collodion binders on wires.

- Eastern Pickle Bottle Coils** may also be had for the following popular and leading circuits—
- "EASTERN CLASSIC" circuit, the latest achievement in non-regenerative, efficient tuned R. F. reception—makes the ideal five-tube set. Hook-up free on request.
 - EASTERN CLASSIC COILS (Type EA, for use with .0005 condensers), set of 3.....\$6.00
 - EASTERN CLASSIC COILS (Type EB, for use with .00035 condensers), set of 3.....\$6.00
 - BROWNING-DRAKE (Type B-D).....\$8.00
 - THREE CIRCUIT (Type 3 C).....\$6.00
 - M. B. SLEEPER RX-1.....\$6.00
 - DX SUPERDYNE (Type S).....\$8.00
- At your dealers or direct postpaid

EASTERN COIL CORPORATION

22 Warren Street

Dept. R. B.

New York

Why not subscribe to *Radio Broadcast*? By the year only \$4.00; or two years \$6.00, saving \$2.40. Send direct to Doubleday, Page & Company, Garden City, New York.

FIXED RESISTORS
Micamold
REG. FIXED CONDENSERS

"Made of Mica and Moulded in Genuine Bakelite."

With Micamold Resistors and Condensers you need no clips or mounts—just solder direct to the terminals, thus eliminating point or loose contact and accidental dislodgment of the units. Micamold Products are moulded in genuine Bakelite and guaranteed within 5% of calibrations and constant in value. They are noiseless, moisture-proof and indestructible.

At all good Radio Stores.

MICAMOLD RADIO CORP.
Flushing & Porter Aves.
BROOKLYN, N. Y. ★



MOULDED UNDER PRESSURE OF 50 TONS

JEWELL

NEW 15-C

JEWELL RADIO CATALOG IS JUST OFF THE PRESS, SEVERAL NEW RADIO INSTRUMENTS ARE SHOWN IN IT.

Write ★

Jewell Electrical Instrument Co.
1650 Walnut St. - Chicago
"26 Years Making Good Instruments"



"It gets that last mile"

The AIRGAP SOCKET

FOR MAXIMUM RESULTS

Install AIRGAPS. They prevent closed circuits, absorption of current, inter-coupling of circuits, feedback and undesirable capacity. THEY MAKE ANY CIRCUIT more stable and sharpen tuning, resulting in purer and clearer tones with more volume particularly on distant stations.

At all dealers 75c each

AIRGAP PRODUCTS CO. MFR.
188 N. J. R. Rd. Ave.
Newark, N. J.

SEE THAT GAP! ★



Radio Battery Chargers

Best by Test ★

\$8⁵⁰ minus bulb

east of Rockies

Your dealer can get it for you

THE ACME ELECTRIC & MFG. CO.
1410 Hamilton Avenue Cleveland, O.

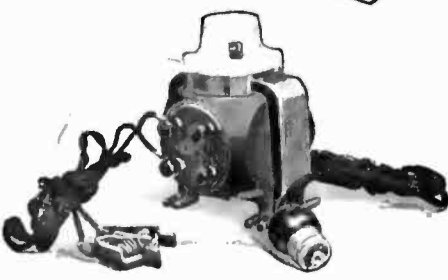



Oh boy

KESTER
Rosin Core
Radio SOLDER
Sure is Safe and Simple

Approved by
Radio Engineers
A Genuine Solder

CHICAGO SOLDER COMPANY
4222 Wrightwood Ave., Chicago, U. S. A.

Originators and
World's Largest Manufacturers of
Self Fluxing Solder

**YOUR DEALER
CAN SUPPLY YOU**

22½ Volt
un-acid
everlasting
rechargeable
"B"
Storage Battery

\$2.95
includes
chemical



45 volts \$5.25, 90
volts \$10.00, 112½
volts \$12.50, 135
volts \$14.75, 157½
volts \$18.80.

Truly the biggest buy today. Easily charged on any current including 32 volt systems. Any special detector plate voltage had. Tested and approved by leading authorities such as Popular Radio laboratories. Over 3 years sold on a non-red tape 30 day trial offer with complete refund if not thoroughly satisfied. Further guaranteed 2 years. Knock-down kits at greater savings. Complete "Hawley" "B" Battery Charger \$2.75. Sample call 35c. Order direct—send no money—simply pay the expressman cost on delivery. Or write for my free literature, testimonials and guarantee. Same day shipments.

B. Hawley Smith, 312 Washington Ave., Danbury, Conn.

Speed RADIO TUBES



SUPREME
IN
PERFORMANCE

The one outstanding Tube
in radio betterment.



TYPE
201-A

No station too distant for "SPEED"
Tubes. They bring in voice and
music as broadcasted.

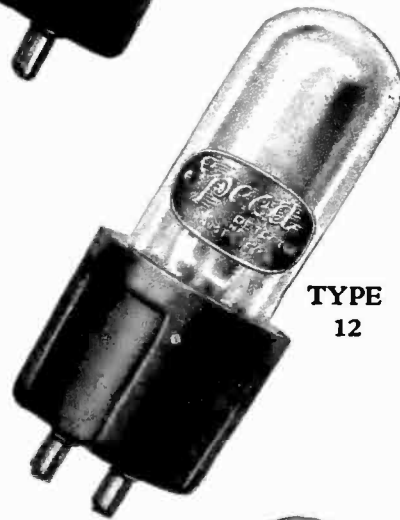

TYPE
12

The latest charted tests from Radio
Broadcast Laboratories prove
"SPEED" Tubes are superior in
quality and performance. Send for
a copy.

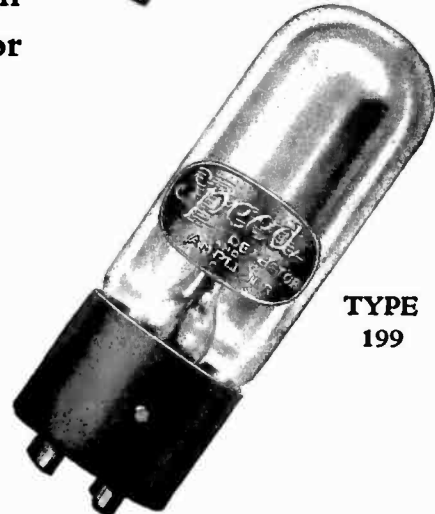

TYPE
199

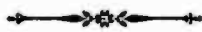

CABLE SUPPLY CO.
INCORPORATED

Sales Offices

907 Broadway, New York City

RADIO BROADCAST

ARTHUR H. LYNCH, Editor
 WILLIS K. WING, Associate Editor
 JOHN B. BRENNAN, Technical Editor

MARCH, 1926
 Vol. VIII, No. 5

CONTENTS

Cover Design	· From a Painting by Fred J. Edgars	
Frontispiece	· · A Majestic English Radio Tower	546
A Man and His Hobby	· · · · E. E. Horine	547
The March of Radio	· · · · J. H. Morecroft	552
Can We Forecast Radio Reception from the Weather?	· · · · J. C. Jensen	558
What Multiple Regeneration Can Do For Your Tuned R. F. Amplifier	· · · · V. D. Landon	563
As the Broadcaster Sees It	· · · Carl Dreher	568
	Drawings by F. F. Stratford	
Standards for the Home Laboratory	· Keith Henney	573
The Listeners' Point of View	· · John Wallace	577
An All-Purpose Coil Winder	· Edward Thatcher	582
The First Report on the International Tests	Willis K. Wing	588
Super-Heterodyne Construction	· Harold C. Weber	589
The Grid—Questions and Answers	· · · · ·	594
	Variable Voltage from a "B" Substitute A Loop R. F. Receiver Making Grid Leaks Operating Characteristics of the New Tubes Charging Storage Batteries from D. C.	
"Now, I Have Found"	· · · · ·	600
	How to Make Balloon Coils An Audio Bypass Method Improved Loud Speaker Reproduction A Low Loss Coil One Use for a Bypass Condenser	
A New Way to Make Money in Radio	· · · · ·	
	D. C. Wilkerson	606
A Key to Recent Radio Articles	· E. G. Shalkhauser	608
What Our Readers Write	· · · · ·	618

BEHIND EDITORIAL SCENES

THE present number of RADIO BROADCAST was prepared and edited during the week of the International Radio Broadcast Tests, but in spite of the disorganization of office personnel and the conventional magazine routine, we feel that a very interesting lot of radio material has been assembled. E. E. Horine, who wrote, "A Man and His Hobby" which is the leading article, is known to many radio men as assistant radio manager of the National Carbon Company. Professor Morecroft, in his comments about the Naval Radio Service, has stirred up considerable discussion, with rather vocal partisans on each side. In attempting to take a neutral position, we have been accused of attempting to accomplish all sorts of dire ends. But as Professor Morecroft has stated, the only purpose has been to indicate what seemed to us to be the facts and to try to discover how conditions may be remedied.

RADIO'S relation to weather conditions has been discussed ever since the coherer days of the art, but we doubt if any more important or complete information has been presented than Mr. Jensen gives in his article, "Can We Forecast Radio Reception from the Weather?" By carefully studying the maps and curves in the article, experimentally inclined radio folk have opened to them a most interesting field for investigation. And Mr. Landon's article on multiple regeneration is also a frankly experimental presentation of a subject which has very large possibilities and we expect many interesting reports from home constructors who put some of Mr. Landon's suggestions to practical tests. The long-awaited third article in the series for the home constructor who wants to go further in radio than set building appears on page 573, and if the letters addressed to Mr. Henney, the author of the series and director of our Laboratory are any indication, those to follow are also eagerly awaited. That interest is not hard to explain, for the series is packed full of material of the utmost help to the radio-ambitious.

FROM our correspondence from the increasing number of experimenters interested in short wave transmitting and receiving, it would appear that RADIO BROADCAST'S \$500 prize contest for the design of an efficient short wave receiver was attracting a great deal of interest. Our amateur contemporary, QST, devoted a page to announcing the contest in its February issue. For those who have not seen particulars of the contest, full information may be had by writing to the Director of the Laboratory, RADIO BROADCAST, or on page 444 of this magazine for February.

IN THE April RADIO BROADCAST, we can promise another one of Keith Henney's absorbing and informative articles on tubes. There will also be a distinctly helpful article on various means of filament control, prepared by John B. Brennan, Technical Editor of this magazine. There will be a review of the International Radio Broadcast Tests which will be of interest to nearly every radio listener who has a receiver more elaborate than a crystal set.—W. K. W.

Doubleday, Page & Co.
MAGAZINES
 COUNTRY LIFE
 WORLD'S WORK
 GARDEN & HOME BUILDER
 RADIO BROADCAST
 SHORT STORIES
 EDUCATIONAL REVIEW
 LE PETIT JOURNAL
 EL ECO
 THE FRONTIER
 WEST

Doubleday, Page & Co.
BOOK SHOPS
 NEW YORK: { LORD & TAYLOR BOOK SHOP
 PENNSYLVANIA TERMINAL (2 Shops)
 38 WALL ST. AND 166 WEST 32ND ST.
 GRAND CENTRAL TERMINAL
 ST. LOUIS: { 223 NORTH 8TH STREET
 4914 MARYLAND AVENUE
 KANSAS CITY: { 920 GRAND AVENUE
 306 WEST 47TH STREET
 CLEVELAND: HIGBEE CO.
 SPRINGFIELD, MASS.: MEEKINS, PACKARD & WHEAT

Doubleday, Page & Co.
OFFICES
 GARDEN CITY, N. Y.
 NEW YORK: 285 MADISON AVENUE
 BOSTON: TREMONT BUILDING
 CHICAGO: PEOPLES GAS BUILDING
 SANTA BARBARA, CAL.
 LONDON: WM. HEINEMANN LTD.
 TORONTO: OXFORD UNIVERSITY PRESS

Doubleday, Page & Co.
OFFICERS
 F. N. DOUBLEDAY, President
 A. W. PAGE, Vice-President
 NELSON DOUBLEDAY, Vice-President
 RUSSELL DOUBLEDAY, Secretary
 S. A. EVERITT, Treasurer
 JOHN J. HESSIAN, Asst. Treasurer

DOUBLEDAY, PAGE & COMPANY, Garden City, New York

Copyright, 1926, in the United States, Newfoundland, Great Britain, Canada, and other countries by Doubleday, Page & Company. All rights reserved.
 TERMS: \$4.00 a year; single copies 35 cents.

who tests your tubes?

WHO makes the vacuum tubes you use? is one important question. Who tests them? is another.

The same great research laboratories that developed the Mazda lamp have developed the Radiotron. The five great factories that manufacture the Mazda lamp, manufacture the Radiotron. And the same genius and the same scrupulous accuracy are behind the test methods developed for the RCA test laboratories.

You would not think of putting into your lighting socket today, anything but a Mazda lamp. Why put into your radio socket, anything but an RCA Radiotron—backed by the same skill, the same engineering and manufacturing resources?

A Radiotron is far more difficult to make than an electric lamp. It demands accuracy to the hundredth of an inch. It demands ten million times rarer exhaustion of the air from the tube. And to guard against error in the turning out of hundreds of thousands of Radiotrons—to insure the high standards of uniform perfection that have made famous the names of RCA, General Electric and Westinghouse, the RCA test laboratories have developed tests delicately exact. When you buy a vacuum tube—know who made and tested it. Look for the RCA mark and the name Radiotron on the base.

RADIO CORPORATION OF AMERICA
CHICAGO NEW YORK SAN FRANCISCO



RCA Radiotron

MADE BY THE MAKERS OF RADIOLAS

★ Tested and approved by RADIO BROADCAST ★

Leadership

LEADERSHIP attained and maintained can be accomplished only through rendering a service in a better way than any other individual or organization. *The* RADIO DEALER, pioneer radio trade publication attained leadership by delivering results to its advertisers, by providing an efficient medium through which manufacturers and others could reach the distributors and retailers of its industry. That leadership has been maintained by constant and successful effort to give better service and to extend the influence of the publication among those who represent real buying power.

The RADIO DEALER consistently carries a greater volume of advertising than *all* other radio trade publications combined. An analysis of the December RADIO DEALER shows that 174 advertisers carried space in *The* RADIO DEALER exclusively, having no space whatever in other competitive publications. These 174 advertisers, or over 73 per cent, relied upon *The* RADIO DEALER exclusively to get their announcements and sales messages across to the distributing and retail trade.

Highly significant as these figures are as to the supremacy of *The* RADIO DEALER as a profitable advertising medium, no effort will be spared to increase the value and to extend the influence of *The* RADIO DEALER, so that in 1926 we may serve all who support the publication still better.

RADIO DEALER
PUBLISHING CO.
(Inc.)

10 East 39th Street
New York, N. Y.

CARRY YOUR ANNOUNCE-
MENTS AND SALES MESSAGES
TO THE DISTRIBUTING AND
RETAIL TRADE IN—

The
RADIO DEALER

The Radio Trade Journal for the Radio Business Man



ONLY the best panel material is good enough for the "Universal." In signifying its approval of Insuline for this circuit, Radio Broadcast Laboratories accord it a tribute that speaks volumes.

Insuline is made specially for radio—to meet its exacting requirements! It has greater dielectric strength than any other panel material. It is moisture-resistant and moisture-repellent. It does not warp or crack. Its beautiful high-lustre surface remains unimpaired throughout the years. Add the perfections of an Insuline Panel to the perfections of the "Universal" and you have a set that represents the last word in efficiency.

Insuline Panel for the "Universal," beautifully engraved in a combination of white and gold and drilled ready to set up; Black, \$3.50; Mahogany, \$4.00; "Frieze" finish, \$4.00. We also furnish a special Sub Panel for the "Universal" in Insuline, 7x17x3/16", mounted with 4 sockets to take the new UX and old UV tubes. Price \$3.50. Insuline Panels, drilled and engraved for all popular circuits, including the following, can be obtained from all good radio dealers.

Hammarlund Roberts
Radio Broadcast Aristocrat
Radio Broadcast Universal
Citizen's Radio Call Book 45 Kilo-
Cycle 9-Tube Super Het.
B.-T. Counterphase, 5 and 6 Tube
Browning-Drake

B.-T. Nameless
Cockaday 7 Tube Super Het.
Roberts Knockout
Freshman Type TRF
Ambassador
Eastern Classic
The New Yorker

If your dealer can't supply you write us direct. Don't take a substitute for Insuline. Insuline sub-panels completely drilled and mounted with Metal Sockets for both UV and UX tubes are available for all of the above circuits. Insulating brackets for sub-panel mounting to replace the old metal brackets. Made of 1/2" Genuine Bakelite size 2" x 6 1/2" with drilled and tapped holes for mounting to sub-panel and front panel. No electrical losses.

List Price, \$1.25 per pair.

Write for free booklet and price lists

INSULATING COMPANY OF AMERICA, INC.
(Radio Panel & Parts Corp.)

Insuline Building 59 Warren Street
NEW YORK CITY

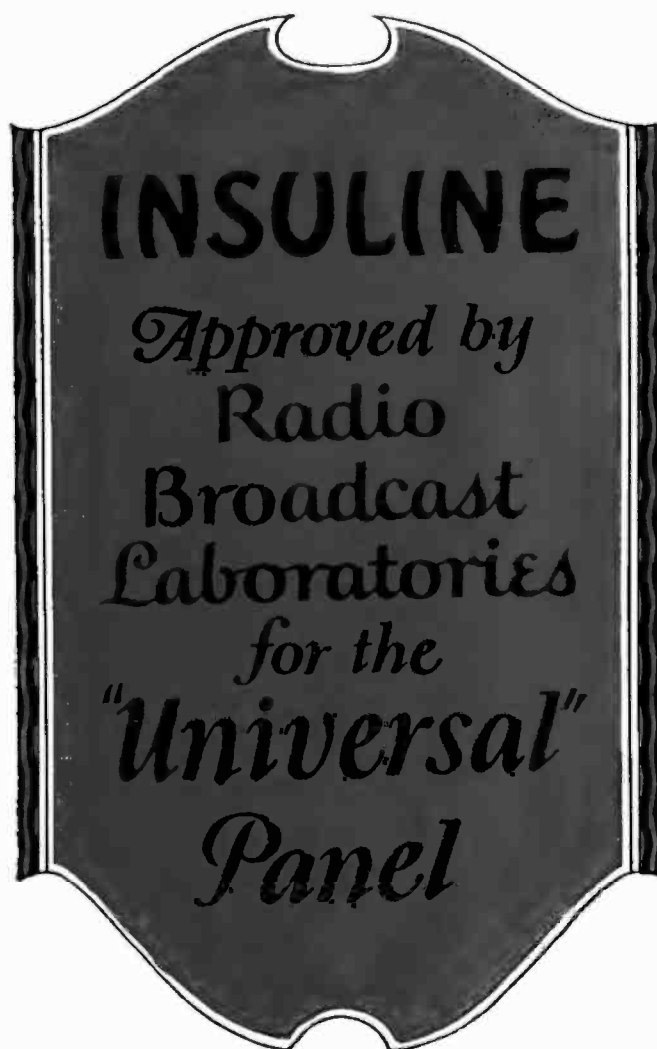

INSULINE—THE PANEL FOR BETTER-BUILT SETS

★ Tested and approved by RADIO BROADCAST ★



THE RADIO BROADCAST

UNIVERSAL

FOUR TUBE RECEIVER

A Masterpiece



Exemplifying All the Refinements of Modern Receiver Design

The Radio Broadcast "UNIVERSAL" has been designed by Arthur H. Lynch to include every popular improvement of receiver design that is practicable for home construction.

The experiences and skill of Radio Engineers, Radio Editors, and amateur set-builders throughout the United States are summarized in this receiver.

While the circuit itself is not new in principle it is slightly different in its application, and embodies the latest refinements of the radio art.

Build

★

The RADIO BROADCAST

UNIVERSAL

FOUR TUBE RECEIVER

Behind the Panels

★ Tested and approved by RADIO BROADCAST ★

The RADIO BROADCAST

UNIVERSAL

FOUR TUBE RECEIVER



in Radio Technique

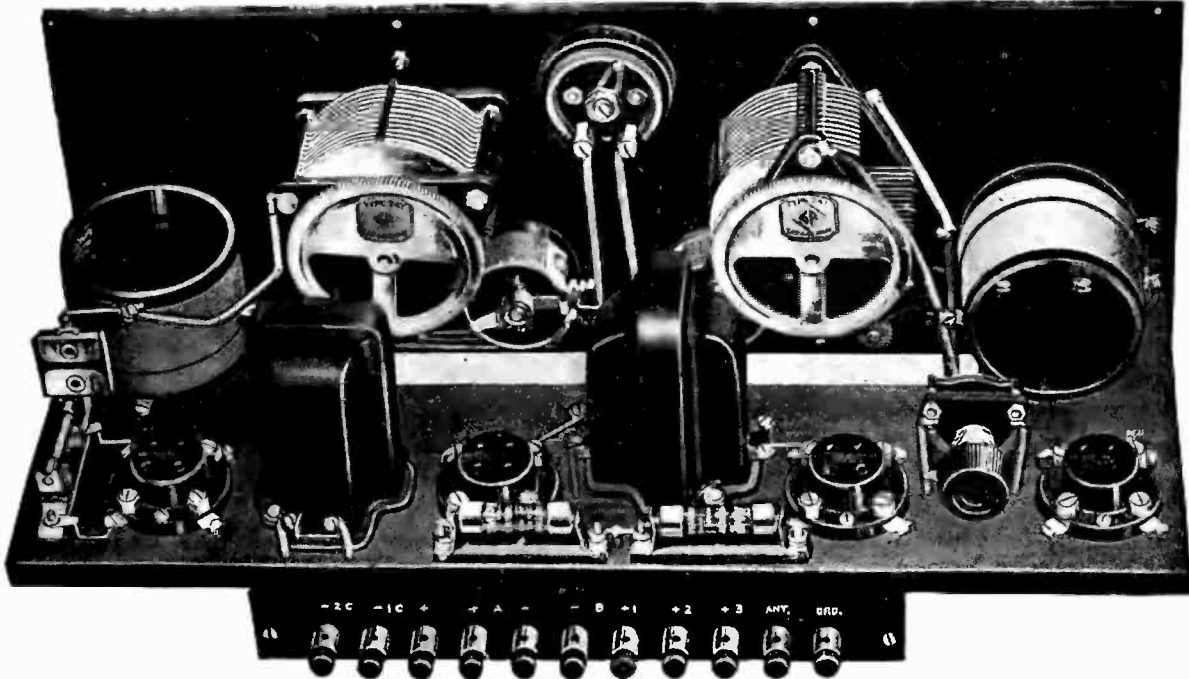

From a standpoint of performance, simplicity, and economy of construction and operation, the "UNIVERSAL" is unrivalled.

To the set-builder who expects real results from his set we give our assurance that he will get them from a properly built "UNIVERSAL."

Free to Set-Builders

Ask your local dealer for free booklet containing diagrams, templates, list of parts, and complete instructions for building the "UNIVERSAL." If he is unable to supply the necessary information and instruments, write to Dept. "UNIVERSAL," General Radio Co., Cambridge 39, Mass.



with

GENERAL RADIO

INSTRUMENTS

of Better Built Sets

★ Tested and approved by RADIO BROADCAST ★

Speed RADIO TUBES

The Choice of
those who demand
**QUALITY
PERFORMANCE**

"SPEED" TUBES get all the notes,—even the deepest bass reproduced with clarity.

"SPEED" TUBES have successfully met the rigid tests of the best laboratories.

"SPEED" TUBES are sold by a large number of wide awake dealers. If you cannot find them in your town, write us.

Sold with a **Worthwhile Guarantee**

DEALERS AND JOBBERS

An exclusive franchise on "SPEED" TUBES is valuable. A few territories are still available. Write for details.

**Cable Supply
Company**

INCORPORATED

Sales Offices

907 BROADWAY
NEW YORK



TYPE
201-A

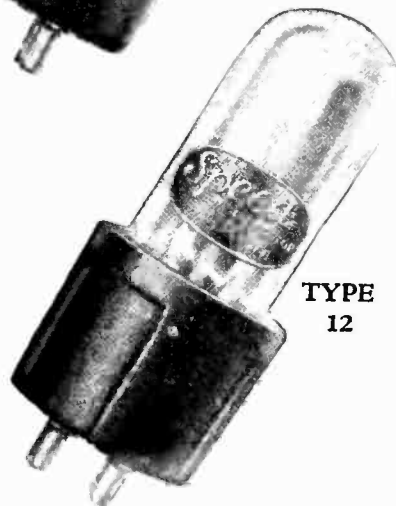

TYPE
12

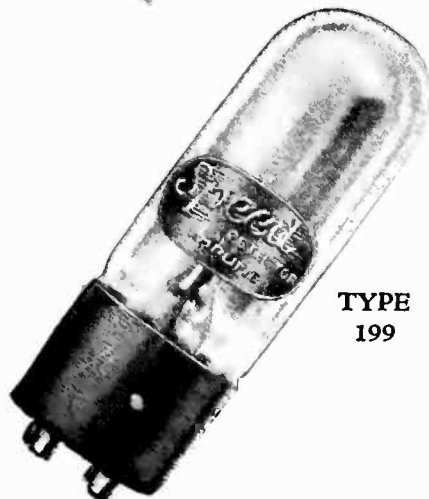

TYPE
199

To Help You Get Better Radio Reception

A New Radio Club to Study the Weather

YOU are invited to join a newly organized club to study the relations between radio reception and the weather. There are no dues and no assessments. This new organization is the Storm-O-Guide Club. All readers of RADIO BROADCAST are eligible.

A thousand charter members in all parts of the country are wanted to help in a nation-wide semi-scientific study to determine the effect of weather conditions on radio reception.

It is hoped that through thousands of individual observations, the study of these individual observations when assembled at Club Headquarters and the free exchange of ideas among its members, the underlying causes for atmospheric interference with good reception will be discovered.

Everybody interested in radio will find the study of weather a fascinating hobby—a hobby that will undoubtedly lead to better all-round radio reception as well as being a material aid in getting greater distance.

Preliminary observations have indicated that when radio signals cross regions of different atmospheric pressure DX reception is better than when the signals parallel pressure lines. Whether or not more extensive and thorough investigation will prove the correctness of this preliminary observation is one of the scores of questions that can be settled only by the active, intelligent co-operation of radio fans throughout the country.

STORM-O-GUIDE CLUB

BELOW you will find an Application for Membership in the Storm-O-Guide Club. If you wish to be a Charter Member of this new club fill in and mail the application blank today. Remember there are no dues and no assessments. Joining the club puts you under absolutely no obligations. The Storm-O-Guide Club is purely a co-operative organization for promoting better radio reception. You are invited to

Join To-day!

Application for Membership in the STORM-O-GUIDE Club

Secretary, Storm-O-Guide Club,
Taylor Instrument Companies,
125 Ames St., Rochester, N. Y.

PLEASE enter my name as a Charter Member in the Storm-O-Guide Club. I have filled in below the information asked for. This application is made on the understanding that there will be no dues or assessments and that I am placed under absolutely no obligations.

Signed

Address

Name of Sect.....

Circuit..... No. of Tubes.....

Announcing RADIO CENTER

FOR the first time in the history of the industry, radio manufacturers can now enjoy year-round demonstration and sales facilities of unequalled attractiveness in the heart of the world's greatest radio market—New York City.

Sound-proof booths of special construction—a location where unusual clarity of reception can be had from any of the well-known broadcasting stations—every facility for the efficient transaction of business—conference rooms—a radio laboratory—these are but a few of the unique advantages provided at Radio Center.

Occupying two floors of more than twenty thousand square feet in the famous Bush Building, 42nd Street, Radio Center is superbly situated for all-round accessibility—and its patrons enjoy the unequalled Bush Terminal Distribution service.

Radio Center is the big move of the year—directed by men of wide experience in successful co-operative merchandising, and backed by ample financial strength.

The demand for space is already large—the time to investigate is NOW—call in person if you possibly can — write, or better still, wire for a copy of the Radio Center Book.

RADIO CENTER, INC.

S. Herbert Mapes, President



BUSH BUILDING

130 West Forty-Second Street

New York City

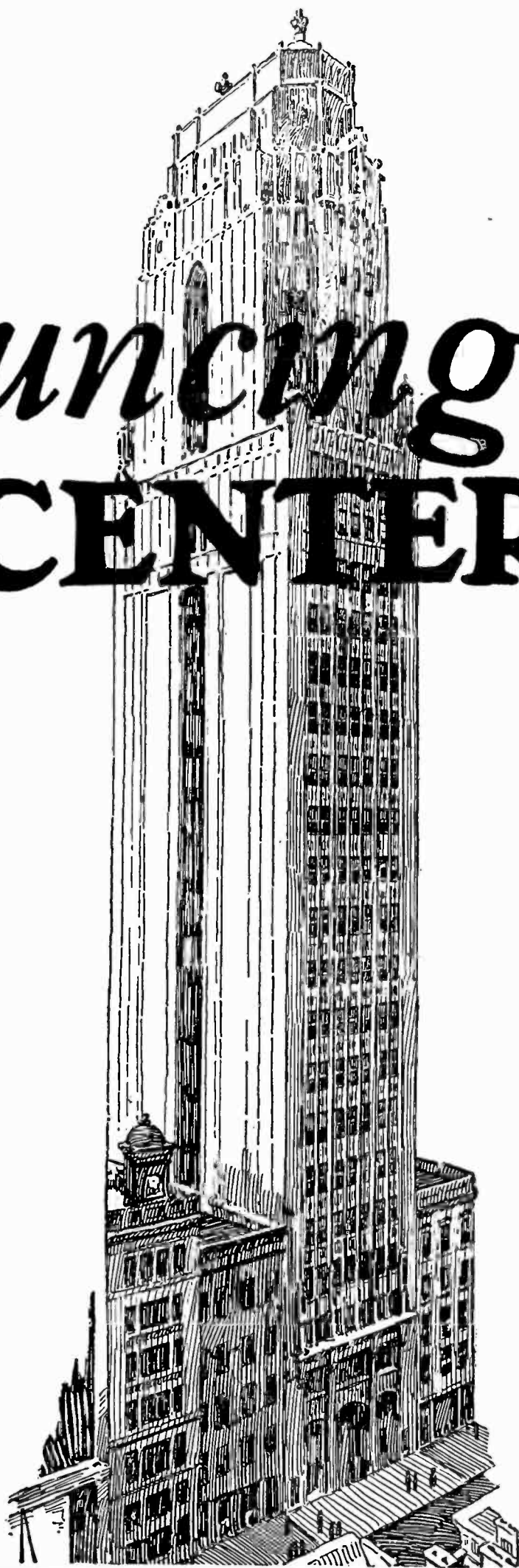

A Scientific Instrument House of International reputation offers for the first time direct to the public an improved S.L.F. Variable Air Dielectric Condenser

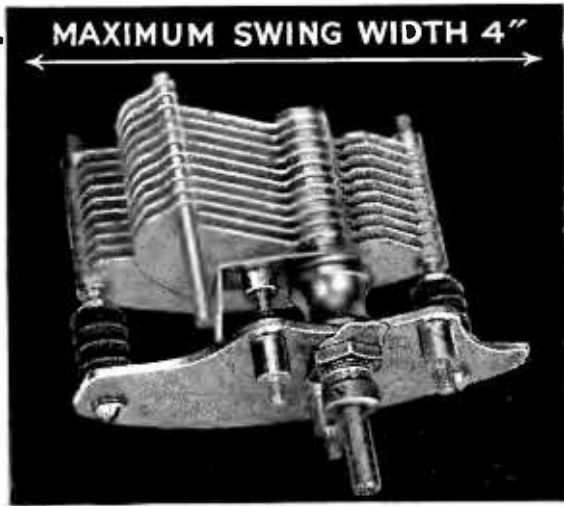

★

Made of the best materials obtainable, the highest grade of aluminum and the best grade of brass. Besides the materials used, the workmanship is that of instrument makers rather than ordinary mechanics and several features of decided merit are embodied in this Condenser, among them being the improved calibration curve.

The S. L. F. Condenser that takes no more room than old types

The popular "straight-line frequency" calibration gives too rapid a capacity variation near maximum capacity to permit convenient tuning for the longer-wave-lengths. This will be appreciated by radio fans, who appreciate the nicely balanced compromise, such as has been obtained by equal spacing of broadcasting stations and equal facilities of tuning over the entire frequency band. Its compactness is appreciated, due to the fact that most of

the present-day "straight-line frequency condensers" have narrow, pointed rotor plates of small area, which require a large number of plates and give rise to an extravagant rotor sweep, so as seriously to crowd the other parts of the set. In our Condenser the eccentric semi-circular plates, which gives the improved calibration curve, has a substantial area and only a moderate sweep.

Special Features

- Low Minimum Capacity, reaching down to 200 meters. Negligible Losses.
- Individually fitted bearings, allowing no side or end play.
- Highly developed crimping process insures good bonding between plates.
- All plates centered, due to rigid assembly and inspection tests.
- General sturdiness of construction and clean workmanship.
- Our enormous production for set manufacturers enables us to make this extremely fine price offer to the public.
- Sold only on a cash with order basis, money returned if you are not more than satisfied that they are exactly what you want and equalled electrically or mechanically.

Price, \$2.75 each Set of three, \$8.00

Sent by paid parcel post anywhere in U. S. A.

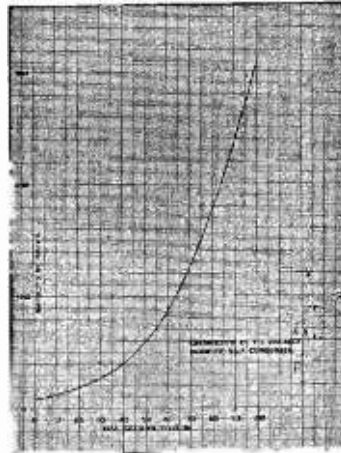

THOMPSON-LEVERING COMPANY—Radio Division

353-357 NORTH 57th STREET

PHILADELPHIA, PENNA.

TRADE MARK REGISTERED

every reader of this magazine needs

G.I. Static Reductor

TRADE MARK

★



Practically eliminates normal static—reduces excessive static to a minimum. Eliminates necessity of outside aerial with any set—makes a squealing receiver absolutely non-reradiating—increases selectivity—improves tone quality.

Elevates an inexpensive receiving set to the dignity and quality of a high-priced receiver.

Enables a good set to bring in far-distant stations with a full, clear, smooth tone not before dreamed possible.

Ask your dealer—or send purchase price direct and you will be supplied.

Price, \$28.50.

GENERAL INSTRUMENT CORPORATION

423 Broome St., New York City

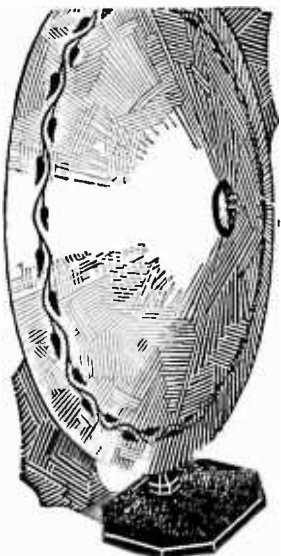

Make Your Own Cone Loud Speaker and Save \$25⁰⁰

(All Parts Supplied)

Why pay \$35 for a cone loud speaker when you can easily assemble a splendid super-sensitive one at home with the complete parts we send you—and save \$25?

We include a special complete cone unit, blueprint and simplified directions for assembling. You can easily set up this wonderful speaker in a few interesting hours. Large size, stands eighteen inches high, complete in every detail. Not only unmatched for beauty but reproduces both music and voice with faultless accuracy. Yet the cost is amazingly low—only \$10 for the most approved form of speaker known. You make this big saving because we save the cost of assembling and packing and you save all jobbers' and dealers' profits.

SEND NO MONEY

Simply send name and address and the complete outfit will be sent you by return mail. When postman brings package deposit with him only \$10.00 in full payment. If you aren't more than delighted—if you are not absolutely convinced that you have a cone speaker equally as fine as any \$35 cone sold—simply return the parts within ten days and your money will be instantly refunded. Never before has a better radio bargain been offered. You would pay at least \$35 for a cone speaker of equal quality anywhere. Act at once. Write NOW!

SCIENTIFIC RADIO LABORATORIES 254 West 34th Street, Dep't 23, New York City

★ Tested and approved by RADIO BROADCAST ★

The New McCullough A-C RADIO TUBE

*It Operates off the House Electric Current, Eliminating the "A" Battery
It Assures Longer Life, because of the Ruggedness of the McCullough Giant Cathode
It Produces Greater Electron Emission, Better Quality of Reception—and
Volume of Signal without Distortion*

IN the set equipped with McCullough A-C Tubes is found a new pride in radio possession; the satisfaction of having radio in its newest and most logical development and the assurance of obtaining the very best results of which any set is capable.

The bother of the "A" battery, its periodic refilling and recharging, diminishing current supply, etc., has always been the "fly in the ointment" of the listener's pleasure. Now this nuisance is eliminated, the house electric current

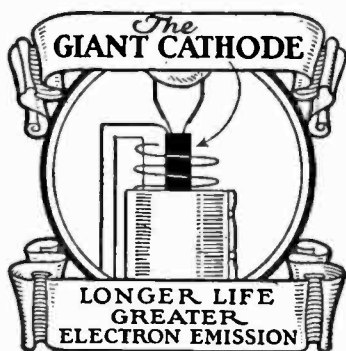

taking its place through the new A-C Tube, being stepped down from the 110 line voltage by a small transformer. Once the new tubes are installed, and the transformer connections made, the set is operated as simply as snapping on the light of a reading lamp.

However, the new tube goes far beyond looking after the mere comfort and convenience of the set owner. When the broadcast program comes pouring in—local or distant—and *quality of reception* is the thing uppermost in the listener's mind, then it is that the new McCullough A-C Tube performs in a manner that establishes a new standard of supremacy of radio performance.

The Rugged Giant Cathode

The sturdy, rugged giant Cathode, the dominating McCullough feature, which takes the place of the fragile filament of the ordinary vacuum tube, is responsible for this marked new efficiency. Its multiplied capabilities are directly derived from the larger electron emitting surface, creating an electron emission immeasurably in excess of the capabilities of the frail element it displaces.

This greater electron emission, with its resultant lower impedance, produces a new standard of signal strength in the vital sense of greater volume of sound in true natural tone. To the longer straight portion of the new tube's characteristic curves is attributed a new tone quality distinctly defined. The rugged construction of the Cathode prevents vibration and all microphonic distortion and noise.



Prompt Deliveries Assured—

The vast manufacturing and great technical facilities of the *Kellogg Switchboard & Supply Co., of Chicago*, are now back of the new tube, assuring uniformity of quality and adequate production.

\$6—List Price

Radio Set Manufacturers and Jobbers of radio tubes are urged to get in line with this important development.

McCullough Sales Co.

Distributors McCullough A-C Tubes

20 Grand Ave., Brooklyn, N. Y.

25 W. BROADWAY, NEW YORK

533 WABASH AVENUE, CHICAGO

963 LIBERTY AVENUE - PITTSBURGH, PA.

for the ARISTOCRAT

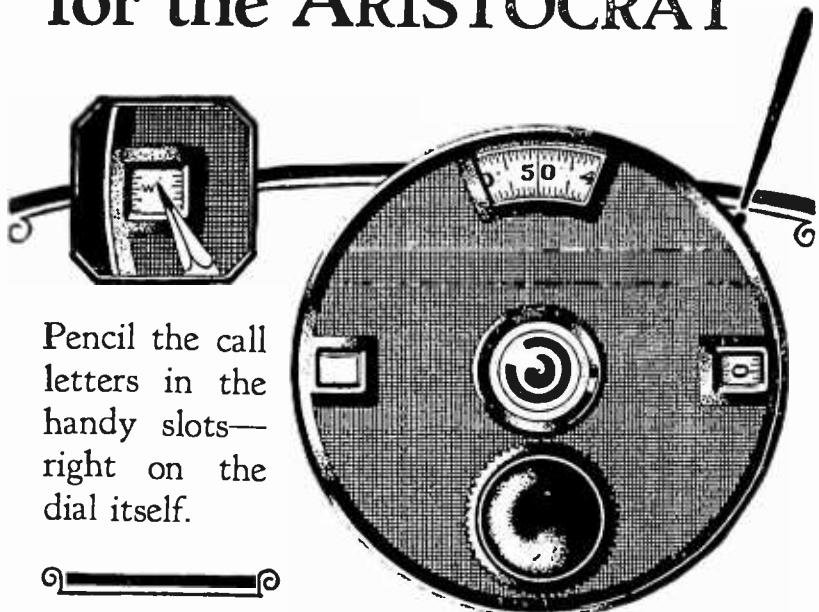

Pencil the call letters in the handy slots—right on the dial itself.

Searching dial-action

The Aristocrat—designed for new-day conditions—naturally has MAR-CO dials—the tuning controls designed for new-day needs,

For MAR-CO dials provide the smooth, precision tuning-action today's congestion demands. They search each degree with hairline fineness—they respond instantly to your slightest touch—and patented friction drive banishes forever, all suggestion of backlash or "play".

Each MAR-CO dial is moulded in flashing black Bakelite, to avoid all losses experienced with metal dials. A set of MAR-CO dials adds both distinction and precision—to the Aristocrat you build, or to the set you already own.

All dealers have them. In nickel-plate, \$2.50. In gold-plate, \$3.00. Provided with scales reading 0 to 100, or 100 to 0, as preferred. Martin Copeland Company, Providence, R. I. Branch offices in New York, Chicago, Boston, and San Francisco.



Hairtrigger
response

Micrometerlike
accuracy

MAR-CO DIALS



The 1926 model tuning control



Dealers!

Here's the

**Book To Go By
When You Go To Buy**

It contains a complete display of the newest and latest in radio sets, kits, parts, equipment and apparatus. All standard, nationally advertised and "in demand" products illustrated and quoted.

SERVICE & SATISFACTION

We are the largest wholesale distributors of radio products east of the Mississippi and we are serving dealers and builders in every state in the union. We carry a complete stock insuring immediate shipment.

Distributors: SILVER MARSHALL SIX

All parts as listed below are available in convenient kit form, packed in an attractive orange display carton. The Type 600 Kit includes all necessary parts to build the SIX complete, using

only a screwdriver, pliers and soldering iron. This circuit has been prominently featured by several leading "fan" publications and is enjoying a permanent, widespread demand.

S-M Silver SIX Kit contains these parts:

3 S-M 311 .00035 SLF Condensers.....	\$5.75	List
3 4" Nauid Molded Dials.....	.75	"
3 S-M Coil Sockets (each).....	1.00	"
2 S-M 112A Inductances (each).....	2.50	"
1 S-M 110A Inductance.....	2.50	"
6 S-M 510 Sockets.....	.50	"

T O - D A Y !

Write for Price List and Dealer's Discount
N O W !

COMPLETE PARTS FOR THESE CIRCUITS IN STOCK	HAMMARLUND-ROBERTS COCKADAY'S LC-26 RECEIVER RAYTHEON PLATE SUPPLY UNIT COCKADAY'S RECTIFIER BROADCAST UNIVERSAL	DEALERS: Write for complete information, price list and discounts
--	--	---

WHOLESALE RADIO SERVICE CO.
6 Church St. RB 226 New York City

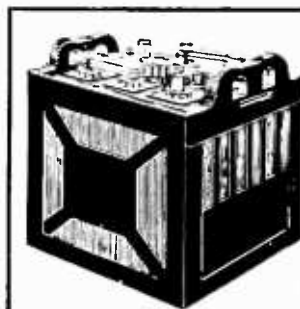

**CHICAGO
Radio
BATTERIES
Auto**

Solid One Piece
RUBBER CONTAINERS

GUARANTEED FOR 2 YEARS

FAMOUS for unexcelled quality, guaranteed long-lived service and unvarying dependability.

Chicago Batteries offer the Radio fan an "A" Power that is backed by years of experience and master workmanship with the finest materials available. Endorsed and approved by leading Radio and Automotive authorities. Chicago Batteries in their new non-leak, solid rubber cases represent an amazing value at lowest cost.

PRICES

Solid Rubber Case RADIO Batteries	
6 volts, 100 Amps.....	\$ 8.79
6 volts, 120 Amps.....	10.79
6 volts, 140 Amps.....	13.50

GUARANTEED 2 YEARS

Solid Rubber Case Auto Batteries	
6 volts, 11 plates.....	\$ 8.79
6 volts, 13 plates.....	10.79
12 volts, 7 plates.....	13.50

SAVE MONEY—ORDER DIRECT

Buy Chicago Batteries direct from the manufacturer. Batteries you order will be shipped the same day. Express C O D or 5% discount cash with order.

CHICAGO BATTERY CO.

1206 Peoria St.

Chicago, Ill.

RADIO 'RITHMETIC

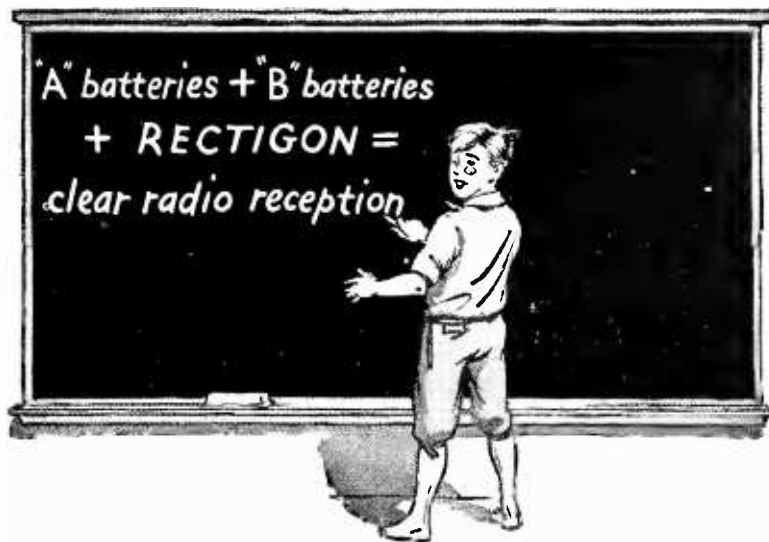

Multiply distance by adding a *RECTIGON*

A SIMPLE solution for so big a result! Want band music? Try KDKA. Jazz? Theatricals? Maybe you'll find it at WBZ, KYW or KFKX. What your local stations won't provide can be obtained easily from somewhere else.

How well you receive radio entertainment depends upon the condition of your batteries —and that's up to you. With a Westinghouse

Rectigon on the job both your "A" and "B" batteries can be kept fully alive to the greatest possibilities of your set.

And it's easy as can be. Just snap on the leads and turn on the current. There's no muss or fuss; no acids; no chemicals, and no noise. The Rectigon more than pays for itself within a short time.

WESTINGHOUSE ELECTRIC & MANUFACTURING COMPANY

SOUTH BEND, INDIANA

The Westinghouse Rectigon Battery Charger



No storage-battery radio is complete without a **RECTIGON.**



© 1926,
W. E. & M. Co.

Westinghouse manufactures, also, a complete line of Micarta radio panels, Micarta tubes and instruments.

★ Tested and approved by RADIO BROADCAST ★

www.americanradiohistory.com

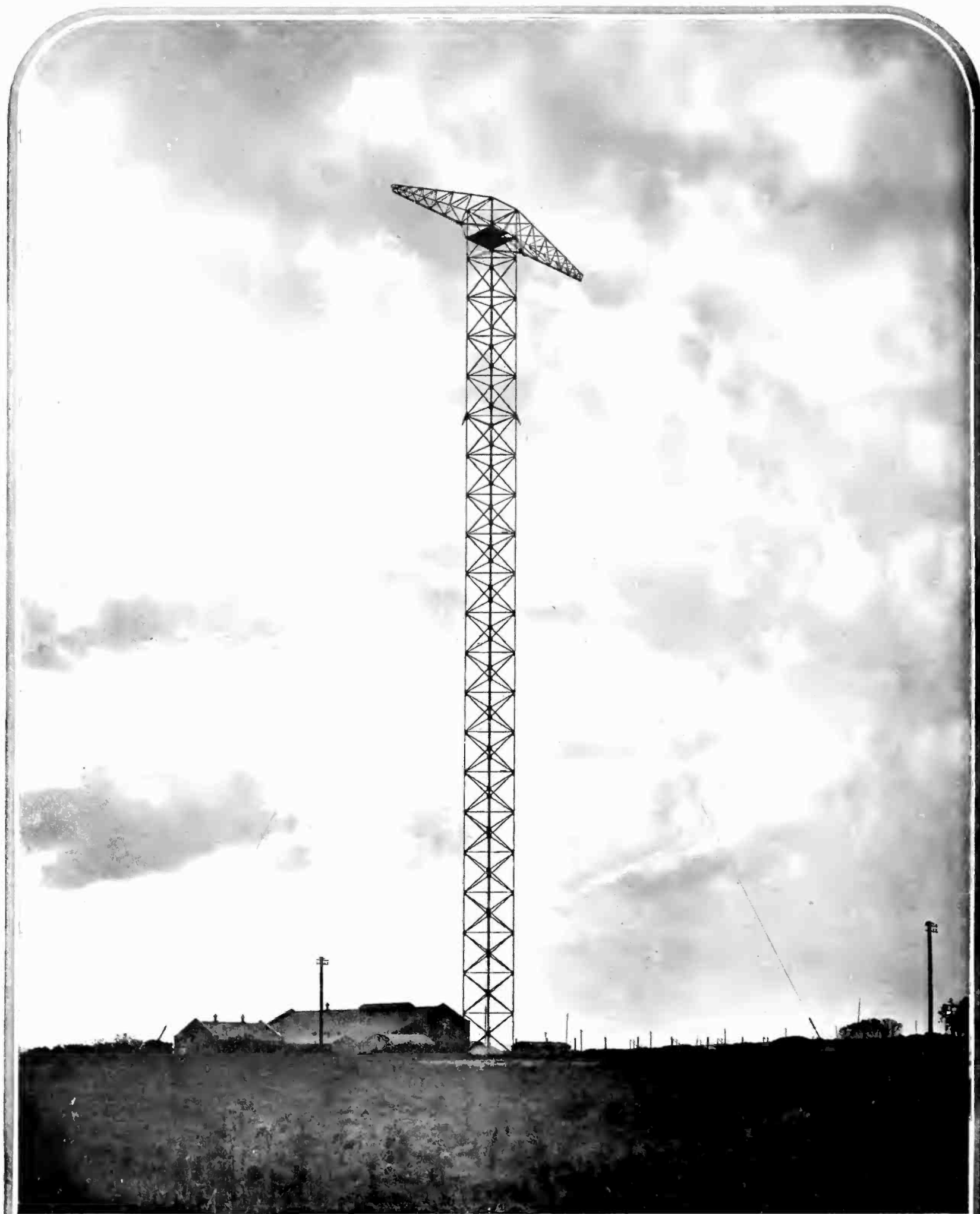

WHERE ENGLISH MESSAGES LEAVE FOR THE UNITED STATES

One of the majestic towers of one of the new beam stations of the British Marconi Company. The station is located in Dorchester, Dorsetshire and was chiefly erected to communicate with stations on the east coast of the United States. Tests with the new equipment have been progressing for some time

RADIO BROADCAST

VOLUME VIII



NUMBER 5

MARCH, 1926

A Man and His Hobby

The Story of One Man's Experiences With Short Wave Code Transmitters on Low Power—The Philosophy of the Radio Amateur—How Australia Was Reached From British Columbia With Batteries and a Receiving Tube as a Transmitter

By E. E. HORINE

A NEW and thrilling experience is in store for the dyed-in-the-wool broadcast listener when he first tunes-in on the shorter wavelengths set aside for the use of the amateur. Around about 7500 kc. (40 meters), the air is literally full of signals of all kinds, day and night, summer and winter. It's all code down there. No grand opera stars singing in heavenly voices; no prominent speakers wagging the silver tongue; no jazz. Only a succession of queer sounding dots and dashes, in all manner of tones and pitches, from low guttural growls to high-pitched, clear, chirping notes. Some of them sound as if they might have originated next door, while others create the impression of having come across thousands of miles of ocean and land; and the chances are they have, for it is an everyday occurrence for amateurs of different nations, on opposite sides of the world, to converse with each other. The field of amateur radio is the dx fan's paradise, and therein lies a part of the fascination of the game.

Listening-in on the amateur bands stirs the imagination and arouses the curiosity. There seem to be thousands of these amateurs at work, bombarding the ether with their messages, clamoring away, trying to engage some one's attention perhaps thousands of miles distant. Who are these amateurs? What kind of

folk are they? What do they talk about? What keeps them so everlastingly at it?

The best way to answer these perfectly natural questions is to recount the story of what one amateur has done. Clair Foster, or to give him his correct entitlements, Colonel Clair Foster, 6 HM, Carmel, California, is more or less a newcomer to the ranks of amateur radio. He calls himself a greenhorn, but there are those who will take emphatic issue with him on this score. Two years ago, he knew nothing about amateur radio. He had constructed a few broadcast receivers and was beginning to yearn for new worlds to

conquer, when he met John Reinartz. And that meeting was the beginning of a new life for Colonel Foster.

His first and natural objection was he couldn't read code, but this was pooh-pooed, laughed at, ridiculed. Anybody can learn the code; a little study, a little practice, and you are ready to stand the examination for a transmitting license. Age is no barrier, nor is sex, for there are many girl amateurs, YL's in "ham" language

Foster says the small time and study he devoted to learning the code was the best investment he ever made. It has been the means of opening up for him a new field of activity; it has brought him a host of new friends, many of them on the other side of the world, with whom he is on terms of closest intimacy, yet whom he has never seen, and probably never will see. It has drawn him into an international fraternity guided by a self-imposed code of ethics that comes closer to being a literal application of the golden rule than anything else on this earth. It has afforded him the most pleasant hours of his life, and turned him into a youth again, bubbling over with enthusiasm.

HATS OFF TO THE FIVE WATTERS

HIS station at Carmel, California, 6 HM, uses a 250-watt tube, and with it he has "worked" fellow amateurs in the Philippines, Japan, Australia, and other



LOOKING TOWARD AUSTRALIA

From the little shack of Col. Clair Foster's radio cabin near Port Alberni, B. C. The mountain is called Mount Arrowsmith, and did not seem to block the modest radio signals from the battery-operated, 5-watt, short wave transmitter installed here by Colonel Foster and operated under the call C9CK. The story tells how a simple transmitter was built and communication established all the way across the Pacific with amateur radio men in Australia

countries. But he feels that reaching out to great distances with high power isn't so remarkable. It's the fellow who does it with low power that deserves credit for real achievement, and this "most miles per gallon" idea is now coming in for a great deal of attention on the part of the amateur. Commenting on this phase of radio transmission, Foster says,

After working a number of distant stations that were using very low power, my hat came off to the chaps who could put out such clear and steady signals with 5 watters—and even 201-A receiving tubes. Every one I bumped into I boned for his dope, and I have collected through their courtesy quite a bunch of it. I see no especial credit coming to the fellow who busts out with the big tubes. Of course it is satisfying to have a wallop so that when you answer a CQ (general call) you are the fellow the other chap almost surely hears; but the big field for the practical use of radio can't be opened up with the use of big, expensive equipment. Only a small proportion of those who will become interested in transmission can afford the heavy outlay.

The big tubes themselves are expensive, and they require a rather costly array of auxiliary apparatus for their operation—a high voltage motor generator, or a system of rectifiers and filters to convert the commercial alternating current into as close an approximation of the pure direct current of batteries as possible. But with the small tubes, the installation cost of a complete transmitter becomes ridiculously low. The transmitter itself can be built for much less than the cost of a good broadcast

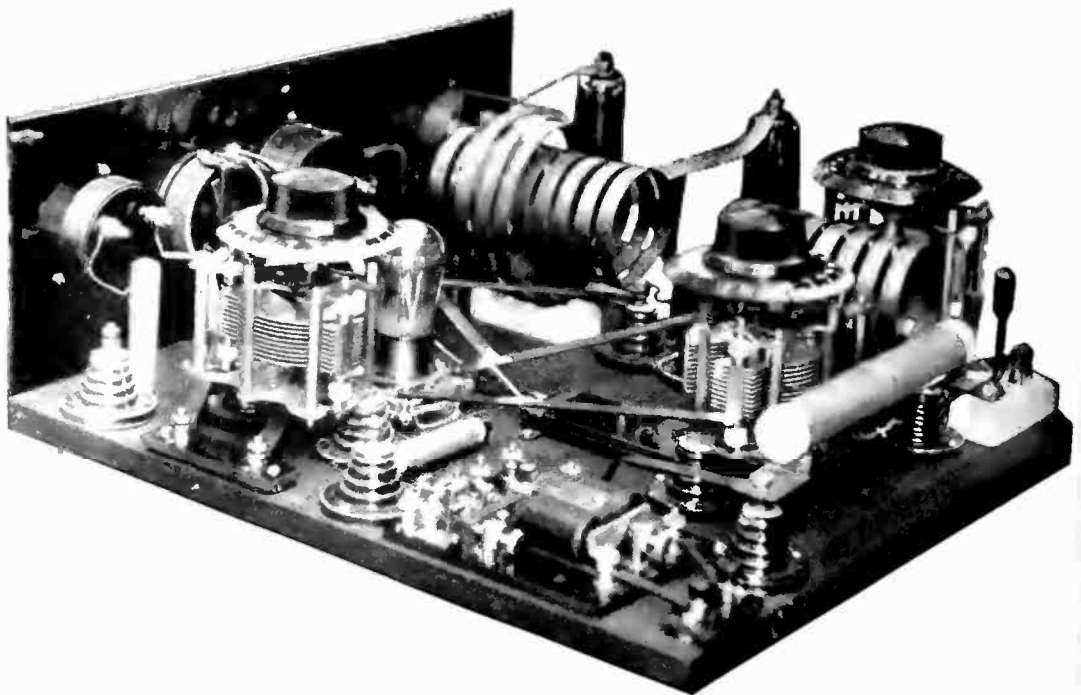

THE TRANSMITTER THAT TALKED TO SOUTH AUSTRALIA

The photograph was taken before the coils were changed. The most notable feature of the outfit is the careful placement of the parts which certainly had much to do with the extraordinary results produced by the arrangement

receiver, and it can be operated successfully and reliably from B batteries.

Foster's low power transmitter, 9 CK, was designed and built in California, but was operated all summer at a point on Vancouver Island, about 125 miles north of Victoria. The outstanding characteristic of this transmitter is the careful and painstaking workmanship expended on its

construction. There is nothing ragged or loose about it. Every part fits perfectly in its appointed position, and the coils, as can be seen, are made of heavy copper strips, with nothing touching the turns. They are supported by their own rigidity, and the whole transmitter is just about as low loss as it is possible to build such a set. This careful attention to small details is largely responsible for the fine work done by this transmitter.

The shack was located on the shore of a lake surrounded by snow capped mountains over which or through which the signals from the little transmitter had to pass to get anywhere. It is a wild, rugged country, remote from civilization, and naturally no electric power available for any purpose. There is only one way to get power in that country, and that is to carry it along in the form of batteries.

But that wasn't the real, fundamental reason for deciding to run his low power transmitter with B batteries. If the weak signals put out by such apparatus are to get anywhere, it is essential for the note emitted to have a high, penetrating sound, otherwise it can't be read at considerable distances, and batteries are ideally suited to impart to the transmitter a tone that is not only penetrating, but steady and free from swinging.

In connection with the use of B batteries for power supply for transmitters, Colonel Foster said, in one of his earlier letters written before leaving Carmel for Vancouver Island,

Along this line, most of us on 15,000 kc. (20 meters) have been using 250-watt tubes. But 9 DFH has the steadiest signals I hear, and he is using a lonely 5-watter (about the size of an ordinary receiving tube) with less than 20 watts input. And recently, I worked 4 BL, in Lakeland, Florida, who was coming in here fine through heavy static disturbance, using a 201-A

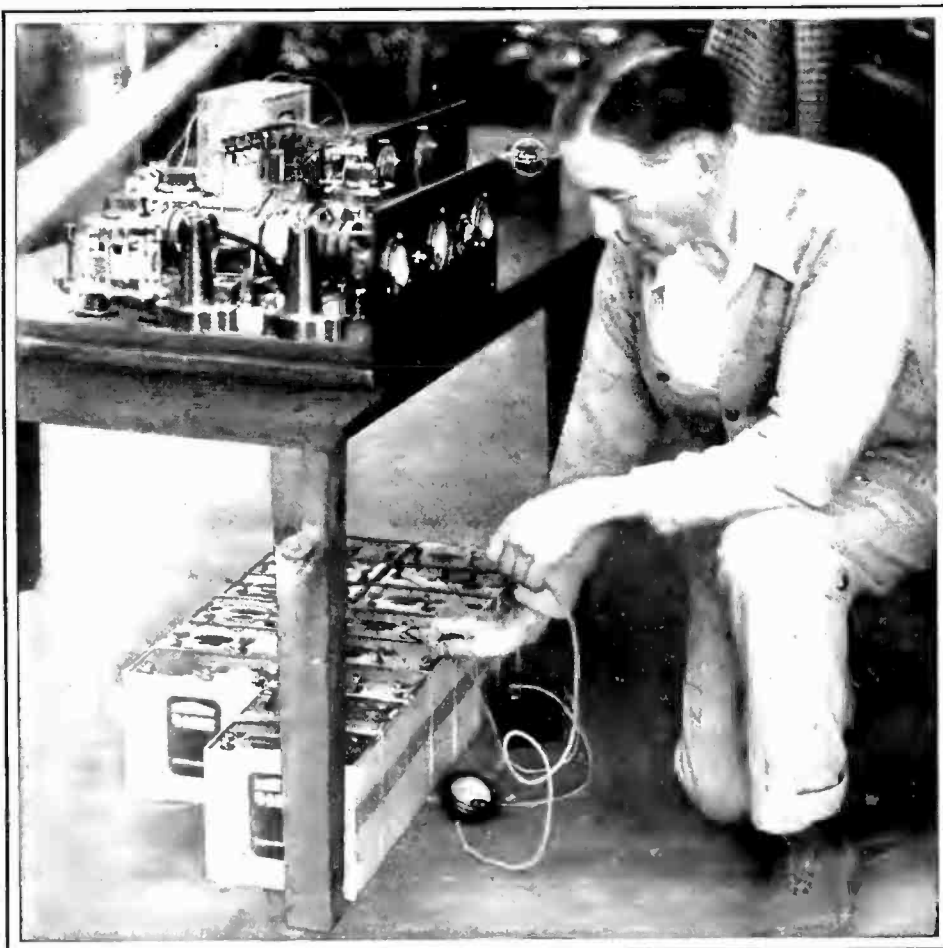

THE COMPLETE OUTFIT AT C9CK

The transmitter, receiver, "power plant," and operator—Colonel Clair Foster himself. Note the wavemeter on the right top of the table

with an Australian station from Vancouver Island, using a 201-A receiving tube, is a notable achievement, but not a record. Other amateurs have surpassed this performance, and while naturally elated at his success, Colonel Foster was conscious that there was danger of his lapsing into the role of the joyous ham experiencing a major thrill instead of maintaining the attitude of a cold-blooded observer; for after all this might prove to be freak transmission. To settle this point, he and 5 BG arranged a daily schedule, the idea being, that if they could repeat the performance day after day, it would establish beyond any doubt that there was nothing freakish about it. The maintaining of that schedule is one of the outstanding points of amateur radio history, for they kept it up for fourteen days without a break, through all kinds of interference from other stations and static, under conditions not considered favorable for transmission and reception. And the daily schedule was finally discontinued, not because communication became impossible, but because they had demonstrated conclusively that reliable two-way communication could be established and maintained with extremely small power.

THE AMATEUR: CURIOUS MIXTURE

AMATEUR call letters consist of a numeral followed by two or more letters. This was all very well for a while, but of late, international communication has become such an everyday occurrence, that it has become necessary to adopt some means of separating the nations of the earth! It is customary to precede the regular call letters with an initial, designating the country in which the station is located. For example: U 6 HM is station 6 HM in the United States. C 9 CK is in Canada; A stands for Australia, Z for New Zealand, etc. This old earth of ours is rapidly getting too small to hold the amateur!

The fourteen day schedule with Kauper reveals the many-sided nature of the ham. He is interested in his work, and takes it seriously, but not too seriously. He is human, just like the rest of us, and enjoys a joke as well as anybody. In fact, the amateurs have coined a word which is used to indicate the appreciation of a joke, or to call attention to what is considered a joke. Like most of the words in ham language, it is short, for it must be remembered that all communications are spelled out, letter by letter, and short words are at a premium. This particular word is "Hi."

Freely translated, it means, "That's a hot one! Consider me laughing. Ha! Ha!" Or, in case the sender interjects a "Hi" into a sentence, it means, "That's a joke—you are supposed to laugh now."

They have a lot of fun, these hams, in the pursuit of their labors. There is no formality about them. Everybody is OM—old man. Log sheets of amateur stations fairly bristle with OM's and other abbreviations which are as useful and effective as they are curious. Here is the way it goes. This is A 2 TM talking to C 9 CK at 6:15 A.M. August 13.

Only last part OM—missed QRA (your location) again OM—say OM, send V's after call till I get you best then QRA please—think about record for low power OM—congratulations OM, very fine business—want get your QRA OM please try again.

Six "old mans" in one short message! That's ham language.

The intimate side of the relations between amateurs is revealed in this message from Foster, commenting on his intercourse with Kauper, A 5 BG.

Our times are, of course, widely apart. Kauper takes in an evening movie show, then goes to his "shack" as every ham fondly terms his little sanctum, the privacy of which must never be invaded by the uninitiated without special invitation—to listen for C 9 CK. Day before yesterday he asked "Just what is your time now," and added "Ours is 11:25 P.M., August 27th". I replied, "5:55 A.M., August 28th." Next time he came back he said "Thanks for time. Hi."

Such conversations flashed back and forth across the vast expanse of the Pacific bring out many intimate touches like that. The daily habit of going to the movies; the fact that Kauper is married and that his wife sometimes objects to his sitting at the key so late at night; and many others. And all this with a man more than nine thousand miles away, but who, thanks to radio, is also your next door neighbor. That's the kind of associations formed by amateurs. No wonder the ranks are filling up with newcomers.

One of the first things Colonel Foster told Kauper was that his little transmitter was being run by B batteries, such as are used for reception, because that was one of the unusual features of the installation. Kauper appreciated the significance of the use of batteries, and made frequent comments on it. Several times, when the going got too hard for him he said "Can read, but can't you stick a few more B batteries on her?" One day, when the signals arriving in South Australia were exceptionally loud and clear, Kauper said "Say OM, you must own a couple of B battery companies, Hi."

This kind of thing kept up for two solid weeks. The original plan was to keep the schedule for only one week, but the going was so good that they hung on for another week. Colonel Foster is convinced they could have kept it up indefinitely. Even after the schedule was completed, he and Kauper chatted back and forth every now and then, apparently enjoying the freedom from their self-imposed task.

TRANSMITTER COST VERY LOW

IT IS hard to realize that this vast distance was bridged with a little transmitter that any one with a little knowledge of the subject can build at a total outlay of not to exceed \$50.00. That's the wonderful part of it. This low power, long distance transmitting is not a rich man's game—it is within the practical reach of all. And in the amateur ranks, there is room for all. They welcome the new comer with open arms, and go to unbelievable lengths to help him get started right.

Colonel Foster, like all hams, has his facetious moments. Commenting on the performance of the 201-A tube in his transmitter, he said:

In all fairness I should make the confession that this particular 201-A tube is not an ordinary 201-A. It was especially prepared for this job. It spent eighteen months as an oscillator in a broadcast super; then it worked for a while as a detector in a receiver built solely for very short waves. In this way it gained a lot of experience as an oscillator so of course it knew its business when it entered the transmitting field.

Colonel Foster is thoroughly convinced of the value of using B batteries with low power transmitters. In his enthusiasm over this form of power supply, he is doing all he can to get other amateurs to duplicate his apparatus, batteries and all, for he is convinced that with any other kind of power supply he

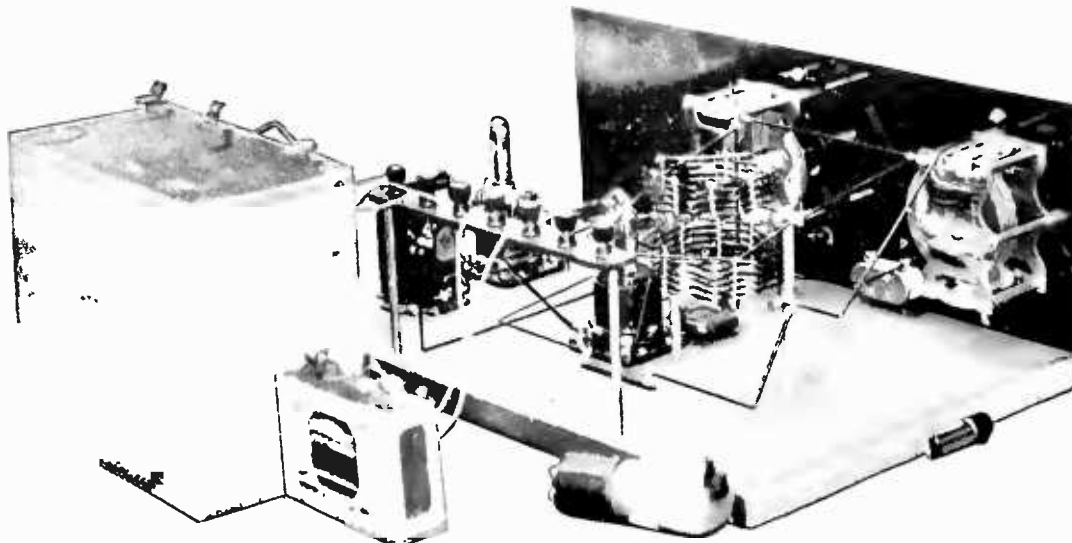

THE SHORT WAVE RECEIVER

Which is not much larger than a B battery. A receiving 201A tube, used as a transmitter is on the table, near a "peanut" tube used in the receiver

would never have made the fine record of keeping a two weeks daily schedule with Kauper, away down yonder on the under side of the world.

Writing about his plans for the winter at Carmel, he said:

"I'm going to keep on using dry cell B batteries for this work even if I have to give up a hundred dollars apiece for them"

That was written after five months grilling had only partially exhausted the B batteries he took with him to Vancouver. They are now reposing in a warehouse in Port Alberni, waiting for next summer's work.

He takes none of the credit of his accomplishment to himself but distributes it impartially between the batteries and the amateurs who helped him out—typical of the generous spirit of hamdom. His letters are full of praise for Kauper and the way he hung on through the schedule. He goes on to say of his Australian friend:

"Am simply lost in admiration of that chap. Just think of the courage displayed in asking for a report that of necessity must be more or less complicated, and knowing that it must come back to him in a thin, high, bird-like note that must take a mighty fine pair of ears to hear at that distance. Only one thing in his favor—C9 CK's note is absolutely steady. It has been so reported all over the map. This is due partly to the set and the way it is adjusted, but more to the fact that both filament and plate supply are from batteries."

And again:

Kauper is a wonderful chap. It is obvious that he is keenly alive to the fact that in keeping this daily schedule under actual working conditions Australian amateur station 5 BG and Canadian amateur station 9 CK are helping to make radio history.

Once, after recounting in detail all the messages flashed back and forth across the Pacific in one of their scheduled communications, Colonel Foster burst out with:

"There's a game boy for you! That's the kind of stuff that has sent the amateurs ahead so fast in this new and marvelous short-wave field that the commercial interests, professionals, and high-brows can only plod along behind in the dust and pick up what the amateurs let drop."

And that's a typical amateur attitude too. But pardonable.

Enthusiastic as he is over past amateur performances, Colonel Foster is even more enthusiastic over the future possibilities. And the more amateurs there are testing

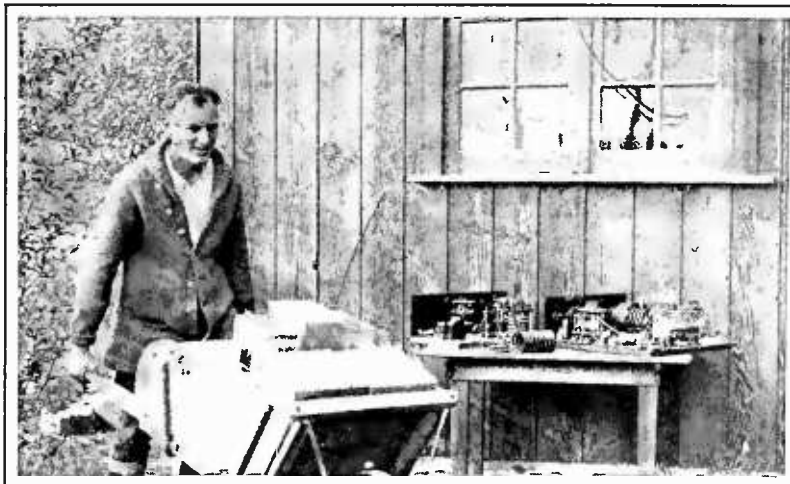

BREAKING CAMP AT 9CK

As Harry Lyman started away from the radio shack, he remarked, "Well, here goes C9CK's famous QSB", Which meant C9CK's high, penetrating, flute-like note

away and experimenting with new things, the sooner his dream will come true. It isn't an expensive game—quite the reverse, especially in the short-wave, low power field. And in the opinion of many, that is the field where the greatest radio progress is to be made in the next few years. The ease with which one can embark on this fascinating, thrilling enterprise of radio transmission will doubtless be responsible for hosts of new recruits into the amateur fraternity.

Colonel Foster's comments on the future

of amateur radio are timely and pertinent.

"I feel that in these experiences of mine there is really a big story. You know me well enough to know that I don't mean big because I did it. It is big because the infant art of radio did it, and is continuing to do it. It is big because of the far-reaching possibilities it discloses for the human good. Not theorizing as to the probability of long distance communication with extremely low power, but proving the practicability of it by doing it day after day. Unlike the automobile, heralded as the greatest promoter of human progress, radio can never be used to the great advancement of the bank robber, gunman, and bootlegger.

And just look at the future possibilities, certainties of this inexpensive low power stuff as a promotor of peace among the peoples of the earth. Why, with all the warm friendships that are being born every day among the radio amateurs of one country with those of another, it will soon be all a politician's life is worth to say, "Let's start something." Just fancy some big stuffed shirt's telling me to go out and fight young Kauper!

And that, mind you, was written by a reserve officer.

Since the completion of the summer's adventure on Vancouver Island and the termination of correspondence regarding it, Colonel Foster has paid us a visit here in the East. He is as sunny, as breezy, as enthusiastic in person as one would imagine him to be from his letters. A most pleasant, human and companionable man.

He has retired from active participation in all business and is pursuing the radio transmission game as a hobby. Unlike many hobbies, his is useful, not only to himself, but to others. And he is not a one-sided man, as are many hobby riders. He can discourse entertainingly on any subject proposed, for he has led an active life, full of many and varied experiences. He has a wealth of good stories, and he tells them with a merry twinkle in his eye that belies his years.

He has worked hard, borne heavy responsibilities, achieved much; and now, after a useful and successful business career he is really enjoying life—thanks to radio. Colonel Foster represents just one type of man to whom amateur radio has appealed and lifted to a higher plane of enjoyment of life, and what it has done for him, it will do for any one, young or old, who seriously takes up this new and fascinating game.

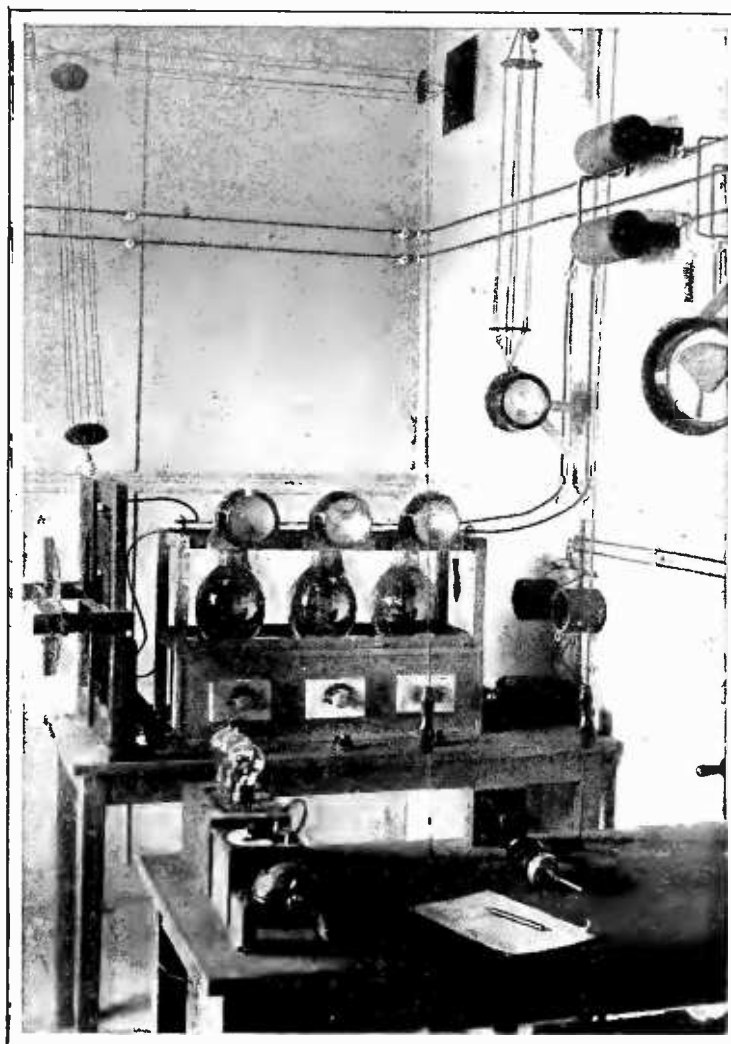

A 500-WATT AMATEUR STATION

Owned by *La T. S. F. Moderne*, a French radio magazine. This might almost be dubbed a superpower station when compared to the "midget" transmitter used so successfully by Colonel Foster



THE MARCH OF RADIO

By *J. J. Morecroft*

Past President, Institute of Radio Engineers

Additional Opinions About the Naval Radio Service

OUR comments regarding the Naval Radio Service in the December RADIO BROADCAST brought forth some letters from our readers which deserve presentation with at least as much emphasis as that used in giving our own ideas. Elsewhere in this issue there is printed a communication from Mr. H. A. Halcomb, who was in the radio service at the time when our destroyer squadron went aground on the California coast. He enjoys the distinction of "knowing" that radio was not at fault in this accident, as his log was used in the investigation. Evidently then Mr. Halcomb knows that the radio bearings received by the fleet were correct—and still the fleet ran aground! Does this mean that the radio bearings were considered of so little importance by the navigating officer that he preferred to cruise by dead reckoning? Had the radio compass service proved of so little reliability in the past that a navigator at that time preferred to depend upon his judgment of the effects of currents, winds, etc., rather than plot his position on a chart in accordance with the radio signal? If so (and we can see no other way to recon-

cile the event with Mr. Halcomb's statements), hadn't radio failed to function properly, to lead up to such a catastrophe? The spirit in which our comments were made was a friendly one, and not one of cynical criticism. We were attempting to answer the question—is radio doing as much for our Navy as it is capable? If not, conditions should be changed either by increasing the reliability and utility of the radio service or in educating the personnel properly to appreciate its worth.

Another letter taking us to task for the article comes from Mr. C. J. Pannill, vice-president of the Independent Wireless Telegraph Company. Mr. Pannill says:

An article of this kind may do the Naval Communication Service considerable harm, and it is only fair to ask that Professor Morecroft get in touch with the proper authorities in the Navy Department and set the public right through the publication in RADIO BROADCAST of a correction to his article mentioned. My idea in taking this matter up with you is due to my particular interest in the Naval Communication Service, since I had a good deal to do with laying the foundations of the service during the time I served in the Navy.

Now it is just possible that pointing out the way in which radio has not proved it-

self may do the Naval Communication Service more good than could be accomplished by the method suggested by Mr. Pannill. If misstatements were made, we shall be the first to apologize and retract them, but in spite of some of Mr. Pannill's remarks, it is not evident that our criticisms were in error. The circumstance which brought forth our comments was the dismal failure of radio communication in the *PN-9 No. 1* near-disaster. Referring to the U. S. S. *Honda* affair and the *PN-9 No. 1* failures, Mr. Pannill says that "they are not chargeable to any one branch of the Navy or its organization. These failures may have been the fault of the Navy but the reasons assigned were not sound and were evidently written without adequate knowledge of the facts."

It so happens that as Mr. Pannill's letter came to hand, we were reading further evidence on the *PN-9 No. 1* inquiry and found that "Lt. Byron J. Connell, pilot of the *PN-9 No. 1* said that he was satisfied the *PN-9 No. 1* failed to locate the *Aroostook*, the last of the station boats on the Hawaiian flight, because the radio bearings received were in error. The plane followed the bearings given and landed in the sea to remain there for nine days." In the same hearing, Commander Rodgers said that the

The photograph in the heading above shows one view of the 20-kw. vacuum tube transmitter at the Naval station, NAA, at Arlington Virginia. Note the water-cooled tube. (© Harris & Ewing)

failure to reach the *Aroostook* was "due to confusion of radio bearings and possibly an error in navigation."

In contradistinction to the two letters mentioned above, attempting to "soft pedal" radio's performance in the two instances named, the Navy itself sent us a most courteous inquiry for suggestions as to what constructive criticism we could offer.

As Mr. Halcomb says, it is easy to sit back and criticize what others have done but how to do better? Well, in the interest of radio progress, we insist again that the *PN-9 No. 1* should have had an emergency radio outfit. Too much weight? Then leave one of the men at home and make the rest of the crew work a little harder. Better have eight overworked men arrive at their destination than nine men somewhat less fatigued drifting helplessly toward Japan.

Unless one has looked at a map of the Pacific in the vicinity of this near-disaster he cannot realize how closely this crew came to perishing. It is almost an accident that they happened to drift into an island. Had the direction of wind changed a little they would probably have drifted clear into the Pacific—forever.

Shouldn't there have been some radio outfit aboard which would keep them in touch with their supply ship when they were forced down? It is doubtful if any sensible man to-day would differ with us.

If such a flight as that to Hawaii is so close to the impossible that even the added weight of an emergency radio outfit would spell failure then it should not be attempted. The Navy is not supplied with so many capable airmen that it can afford to take again chances as it took in that flight. Those responsible for such projects as was attempted by the *PN-9 No. 1* will never be told by their junior officers that the chances of success are too slim to make the scheme worth while—our officers are not of that mind. It remains, therefore, for some rank outsider, such as ourselves, to venture the statement that possibly things should have been done differently.

The Progress of Radio in 1925

PROBABLY the one event standing out more than any other during the year 1925 in so far as the interests of the general listener are concerned, was the spirit in which the questions arising at the National Radio Conference were settled. While the conference could not give Secretary Hoover any power to act, it brought to him so strongly the sentiment of the country on certain of radio's problems that he has been able to act since then with the assurance that the radio public was behind him. It is notable that for some weeks now, not a single broadcast license has been issued. It is hoped that this condition will continue.

All questions arising in the broadcasting realm, said the radio conferees, must be settled in the interests of the broadcast listeners and the establishment of this

policy for the guidance of future radio executives will prove to be a real boon to all of us. Any sensitive set to-day gives heterodyne notes in many of the radio channels which are supposed to be without interference and this situation can be remedied only by keeping constantly in mind the policy that the interest of the listener, rather than that of the broadcaster, must prevail. Many of our present stations must soon be eliminated, and this event was certainly predicted by the spirit of the radio conference.

The great attempt being made to furnish the public with a satisfactory battery eliminator is perhaps the next outstanding feature of the radio season just passed. Not yet successful enough to call the problem solved, yet near enough to make us believe that the real solution is at hand, the work of those radio engineers engaged on this problem is probably of more present significance to the broadcast listeners than any other. Of course, as the battery interests maintain, there are many places where 110 volts a. c. cannot furnish power for the radio outfit because there are many houses which do not have it. The number of such homes is rapidly diminishing so that it may truthfully be said that the battery eliminator (for both A and B supplies) is awaited to-day by millions of listeners.

The remarkable popularity of the straight line frequency condenser shows that there was a real demand for such a piece of apparatus. First introduced about two years ago, it has, during the past year, shown itself so valuable that the old semi-circular plate condenser has today a limited sale. The innovation of this specially formed con-

denser, spreading out the stations on the lower part of the dial, was a decided help to the broadcast listeners.

The use of the piezo-electric crystal as a frequency stabilizer will soon be looked back upon as one of the milestones in the improvement of radio transmission. With the present spacing of stations on the frequency scale, some standardization scheme is absolutely necessary and the curiously acting bits of quartz crystal which serve to make a small tube oscillate at an exact and constant frequency, are accomplishing this purpose admirably. Rochelle salt is about one hundred times as active a crystal as is quartz and would probably serve the purpose even better if it were not so fragile, and soluble in water. Piezo-electrically a wonderful material, it is mechanically so inferior to the durable and constant quartz, that the latter will undoubtedly soon be fixing the frequency of all our important broadcasting stations.

Picture transmission by radio secured a large amount of attention during the past year, but so far has become commercially important over only one or two channels. It is sure to develop into a service of immense importance (with the possibility of doing away altogether with our dash and dot communication system) but much development work remains to be done before that is accomplished.

The quality of reception in the average receiving set was much improved during the past year. Great improvements were made in the characteristics of tubes to operate with loud speakers, by the research engineers of the General Electric Company, and several fundamental and important

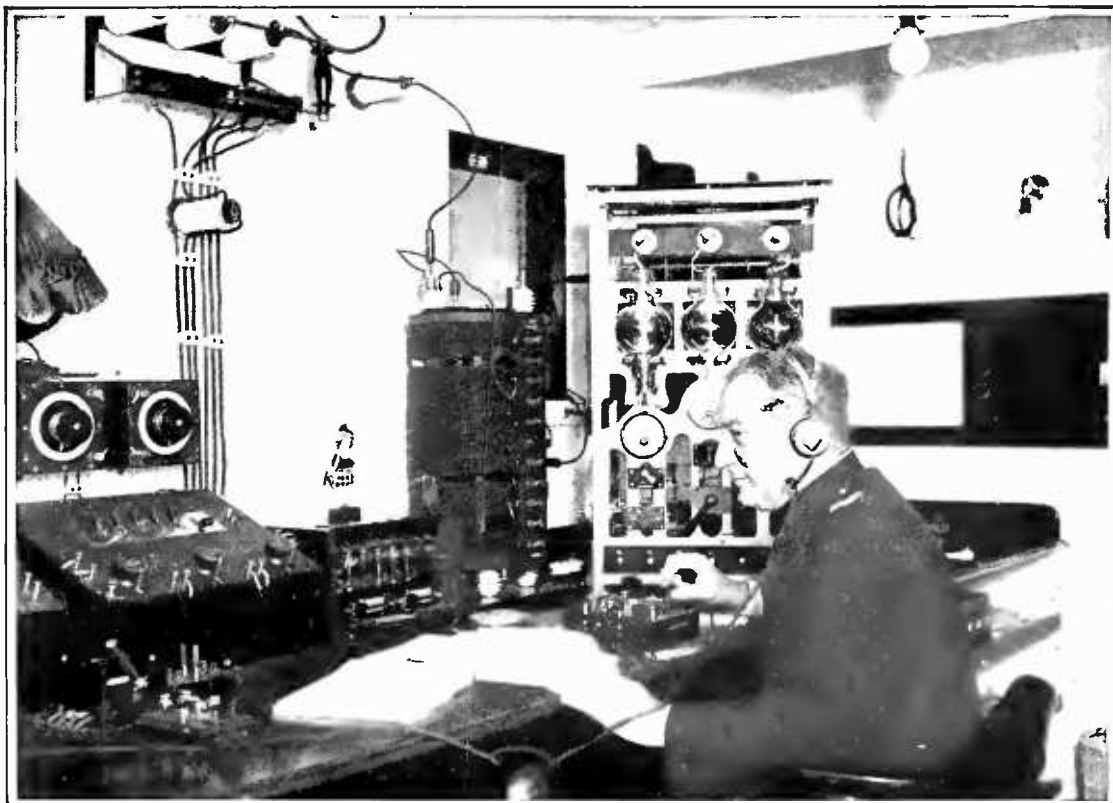

A CORNER IN THE RADIO CABIN OF A NEW ITALIAN LINER

The *Conte Biancamano*, which is said to be the largest liner flying the Italian flag. The installation is quite modern. A 500-watt tube transmitter for telegraphy can be seen in the right hand corner. Note the position of the transmitting key, just a few inches from the edge of the operating table. This position would be almost an impossible one for an American operator, as practically all of the operators trained here use a sending motion which rests the entire arm on the table

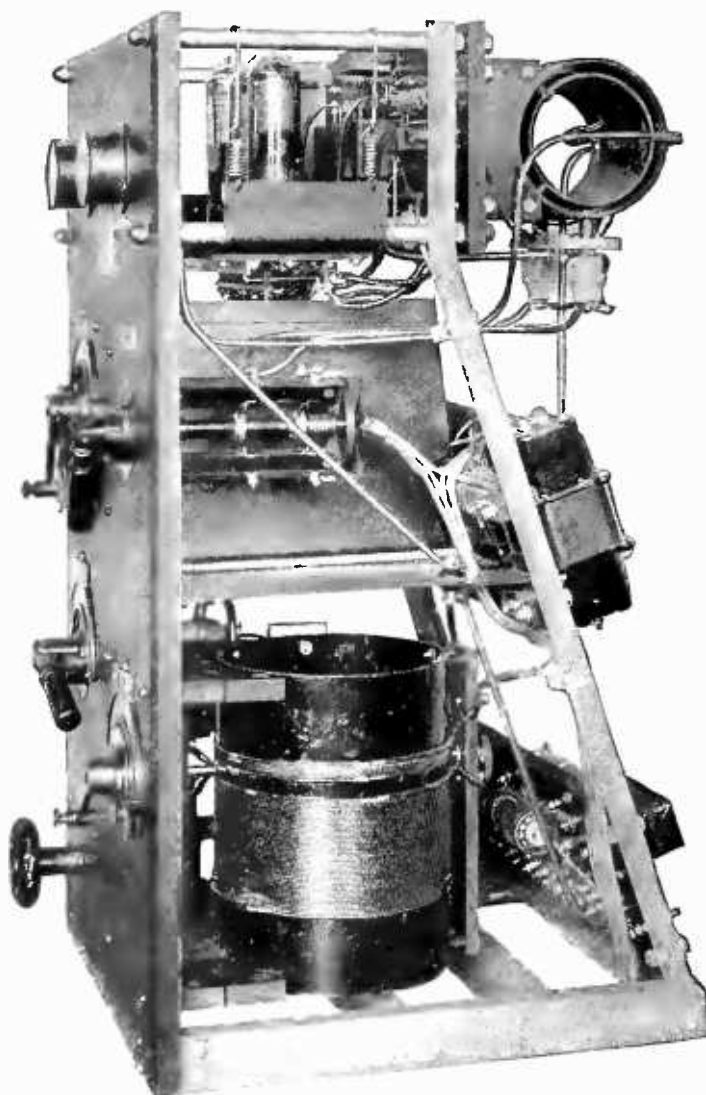

ONE OF THE RADIO DEVELOPMENTS OF 1925

A beautifully compact vacuum tube commercial transmitter with a power of two hundred watts. This outfit has a wavelength range of 600 to 900 meters and is especially designed for radio telegraphy aboard ships

studies of the characteristics of loud speakers themselves were reported to our engineering societies. To some extent keeping pace with the improved quality of reception of the average receiving set, the programs themselves may in general be considered as somewhat better than last year. Most notable among the year's accomplishments in this direction is the series of Atwater-Kent Musical Hours. Not less pleasing, even if less important, are several series of concerts by certain of our well-known trios and ensembles. The "Dinner-Hour" music is a real treat for the average suburbanite, who gets the benefit of good music with his meals without the disadvantage of a cover charge. As one turns from station to station, however, at about eleven o'clock in the evening, he is impressed with the concentration of jazz. It is hard to believe that there really is a demand for the concoctions the average dance orchestra sends out over the midnight radio channels.

With the advent of two 50-kilowatt stations, wcy and wjz, the era of international broadcasting seems ready to start. The rebroadcasts which have occurred to date, of programs flung across the Atlantic, haven't been worth while except as a "stunt." But by raising the signal strength ten times or more, the static disturbance

may become comparatively unimportant. In general, these high powers have not caused as much disturbance as had been anticipated; those close by (within a few miles) have no doubt been well deluged with the energy of these powerful stations, but by using proper traps to bypass most of their signals, much of the present trouble will disappear. A proper policy for a super-power station to adopt would be to start operation on very low power and gradually to increase the radiation, taking perhaps three months to grow to their normal rated strength. This method of procedure would do away with much of the complaint as the near-by listeners would gradually become accustomed to methods and apparatus for eliminating these powerful signals.

The feeling against the regenerative receiver has steadily grown until the listener is almost ashamed today to acknowledge the ownership of such a set. The man known to operate such a receiver is at once blamed by his neighbors for all the howls they hear and the continued cultivation of this attitude, by those owning non-radiating receivers, will do much to hasten the demise of this undesired member of the receiver family.

A most remarkable study of wave interference and signal distortion was reported during the past winter and it seemed to the writer that Bown, Martin, and Potter, the research engineers responsible for this work, were laying out for themselves a unique problem on which they will probably work alone. It is likely that these engineers will do this work so well that the field becomes theirs and we shall look entirely to them for explanations of transmission phenomena.

In the patent situation, the granting of the high vacuum invention to Langmuir stands out as the one event of the year. Continued and expensive litigation along other lines points out the entire inadequacy of our present patent scheme. It seems nowadays that the granting of a patent has scarcely more significance than a license to sue others. The overworked staff of our Patent Office is so loaded up that frequently five years or more are required for a patent to be issued. Secretary Hoover may be able to arrange some new method of procedure so that much of the wrangling, which now takes place before a court after the patent is issued, might be heard before the patent is granted, so that the patent is really of some value to the inventor; at present it is worth practically nothing unless he is backed by some powerful corporation.

The year has seen a growing appreciation of the value of scientific research—not the research having as its goal a new receiving set, or more economical triode, but research in the realm of pure science, the kind undertaken to determine the truths of an unsolved problem. Not only has the work of the pure scientist received increasing recognition, but from the highest sources, words of appreciation have been showered upon him.

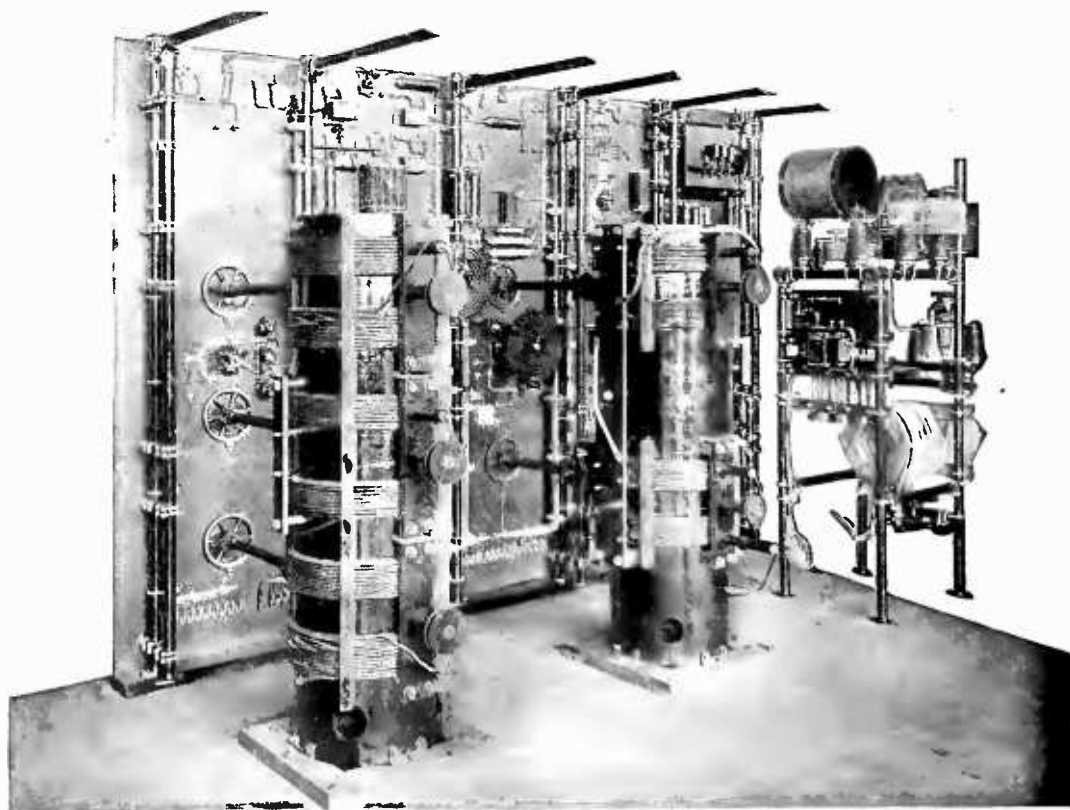

THE CONTROL PANEL OF A FORTY-KW. TUBE TRANSMITTER

Built by the General Electric Company for use in the station at Kahuku, Hawaii. This transmitter when installed will continue the radio link now in force between Hawaii and California. Another similar radio station competes with the cables to Japan and links Hawaii with Tokio

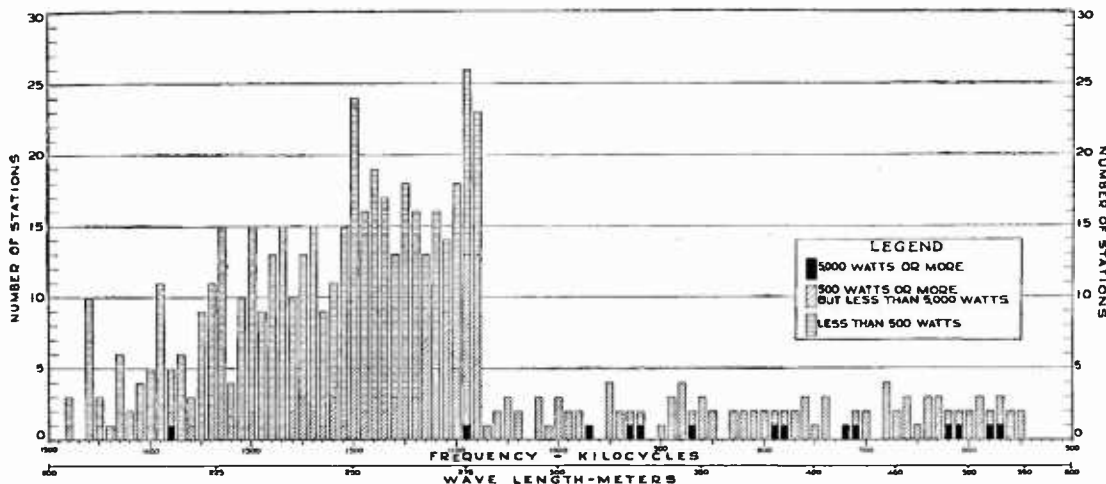

THE DISTRIBUTION OF BROADCASTING STATIONS IN THE UNITED STATES

On the first of November, 1925. This chart was officially compiled for the Department of Commerce. Note how comparatively few stations there are operating with a power of more than 5 kilowatts. Since the Fourth National Radio Conference, the number of stations has not increased. There are now 536 broadcast stations to supply aërial provender for the estimated four and a half million radio receivers

In a recent talk before the Society of Mechanical Engineers, Secretary Hoover expressed the opinion that Michael Faraday's discoveries were of such value as to "perform for us in one day more service than the whole banking community does in a year." Yet Faraday never received more than five hundred dollars a year, whereas the bank executive to-day never feels himself overpaid with a \$50,000 salary. Yet even now so little do we appreciate men with the Faraday point of view, that we spend for research and pure science only one tenth of what we spend for cosmetics. For every dollar the scientist spends to discover the truth, the women of the land spend ten to conceal it. But when such men as Mr. Hoover bring their influence to back up research in pure science then we are well started to fill the position in the world's scientific progress which our country is evidently destined to occupy.

A Note on the Langmuir Patent

A SHORT time ago we made a comment on the "high vacuum patent" which was issued to Langmuir, expressing our idea that Langmuir had not invented anything and that the issuance of the patent was a mistake on the part of the Patent Office. We are in receipt of a letter from Mr. F. S. McCullough, who has been associated with vacuum tube manufacture for many years, in which he agrees heartily with the ideas we expressed. This tube engineer has some old DeForest audions in his possession, he says, which show a higher vacuum than do the present Radio Corporation tubes. As long as facts such as these can be certified to by reputable engineers it is incomprehensible that the Court should sustain the Langmuir patent.

More Millions for Radio

IT SEEMS that some ambitious attorneys have persuaded R. A. Fessenden (well-known for his submarine signalling apparatus and patents on the radio heterodyne principle) that he has been grossly

swindled by some sort of monopolistic control in the radio industry and that by due legal process he might collect as damages \$60,000,000. It is very interesting to a college professor, with his rather modest income, to see how some of these radio inventors do juggle with millions. Their smallest unit of money seems to be about \$100,000, and to judge from the rumors extant, some of them have collected many units.

Fessenden really has been a very prolific worker in the radio field, one of his ideas, for example, being covered by the heterodyne patent. To hear a high-frequency current it must be combined with another current of nearly the same frequency, to produce beats. The first alternator of the type now credited to Alexanderson was built by Fessenden. He now claims that eight of the principal concerns dealing in radio have conspired to do him out of his just rewards and have not offered him a fair value for his invention. The attorneys' claims sound rather flimsy to us, but possibly the men who drew them up feel that there is some chance of collecting a little money for their client.

Who Invented the New Photo-Electric Cell?

IN THE same mail that brought criticism of our naval radio article came a letter from Mr. T. H. Nakken, criticizing our comments on the photo-electric cell which accomplished such remarkable effects at the recent electrical show. The new type of photo-electric cell was shown by Mr.

Zworykin, of the research staff of the Westinghouse Company. That company claimed the invention was theirs. Mr. Nakken informs us, however, that he patented this device several years ago and that full publication was made in England and France three years ago. "This," according to Mr. Nakken, "made it comparatively easy for the Westinghouse Company to invent the device."

So, with the aim of being fair, we cannot do less than publish Mr. Nakken's claim to this novel piece of apparatus. His patent in the United States was issued about a year ago, but was filed over five years ago. It may be that Mr. Zworykin has added something to Nakken's ideas, but on such a controversial point we can hardly enter in these columns.

Broadcast Listeners Organize

IN THE Middle West, the broadcast listeners have found it to their advantage to organize in order to improve the conditions under which they receive their programs. One such organization, the Broadcast Listeners Association of Indianapolis, reports an extensive program with the purpose of eliminating interference of all sorts. After only a short existence, the membership list has expanded to twelve hundred and the activities become quite diversified. The small membership fee proves sufficient to carry on what paid work appears necessary; certain trouble locating apparatus has been purchased and is regularly used by some of the members in finding out the reasons for poor reception.

According to a report recently released, meetings are held regularly, at which radio engineers generally give talks on interfer-



RADIO PRINCIPLES AT WORK IN THE POWER HOUSE
The so-called "storm detector" used in the power house of the Brooklyn Edison Company at Gold Street. The principle of the device is merely a simple application of the detection of static charges, which is ingeniously employed to ring a bell. With a warning of approaching storms, the power companies can prepare for the increased load that the darkness will cause

ence causes and their prevention; from three hundred to five hundred people have attended these meetings. A campaign against the single-circuit regenerative receiver is being constantly waged, while for those who still prefer to use this type of receiver, an educational series of talks on the proper and legitimate use of regeneration has been carried out.

A remarkable degree of coöperation has been secured from the public utility companies in Indianapolis and vicinity. A typical letter, from the superintendent of the Indianapolis Street Railway Company says: "This company stands ready to cooperate with the Broadcast Listeners Association at all times and will remedy any condition of its tracks or cars that might interfere with radio reception. We have already cleared up several bad spots that have been complained of by radio users." The telephone company and the electric power companies have similarly expressed their desire to remedy conditions which are pointed out by the Listeners Association as being detrimental to good radioreception. This association, it appears, is accomplishing a really valuable work for the listeners in Indiana.

The Month In Radio

THE annual report of the Chief Signal Officer brings to light the fact that the army is now regularly using radio channels to carry on its routine business. A net of radio stations all over the country has been built up, the network comprising twelve major stations and sixty auxiliary ones. About eight hundred messages are handled each day over this network. In requesting more appropriation for development, General Saltzman states that if the communication which was effected through his radio chain had been handled by commercial channels it would have cost the government \$156,000. It is just possible that it actually cost the government more than that if the proper charges were made, but even so the radio chain is a valuable asset to our country, one that the Army should have available for emergencies in any case, even though it could show no saving at all.

FEW of us know enough about automobiles to care thoroughly for them ourselves; we depend largely upon the service man for inspection or repairs. Without the country-wide service of this character it is sure the automobile industry would not have grown as it has.

Now, in a lesser degree probably, the radio receiving sets of our country need the service man. But few of the listeners know the functions of the different parts of a set, but they would like to know that they are functioning properly. The "radio service man" is due to arrive. A group of repair and maintenance men, thoroughly familiar

with all ordinary types of receivers, could build up quite a clientele in almost any sizable town, we imagine. They must know the different sets and what they are capable of and how to remedy faults. It seems as though quite a lucrative business might be built up along this line and we expect to see someone do it.

As is frequently mentioned, the way of the inventor is long and tedious and he never knows whether his idea is safely his own or not. A case in point has to do with the modulation of the output of a vacuum tube oscillator. This scheme is used in every broadcasting station today. In spite of its universal application, no patent has yet been granted. White, of the General Electric Company, Hartley of the Bell Laboratories, and De Forest have been in a three-cornered argument for about eight years. After going through the normal Patent Office routine, the case went to the Examiner of Interferences, who gave De Forest priority. The Board of Examiners in Chief was then appealed to by White and Hartley and this board reversed the interference examiners' verdict and gave the idea to Hartley. Then De Forest and White appealed the case to the United States Court of Appeals and only now have the arguments before this court just been completed.

Even an older matter apparently still has to be settled. The Court of Appeals of the District of Columbia has just reversed a ruling of the Patent Office on Lévy vs. Armstrong, so that now Lévy is permitted to go ahead with interference proceedings against Armstrong, to whom the regenerative patent has already been issued. And in this same line it still remains to be settled, apparently, whether Armstrong or De Forest is entitled to the oscillating audion patent.

EACH year the work of the Bureau of Standards is inspected and reported upon by a Visiting Committee, made up of men not connected in any way with the Bureau but all of whom are closely in touch with the needs of our country as regards development and research. After commenting upon the great value to our country shown by the results of the Bureau workers (the report states that the automobile industry is saving \$155,000,000 a year as a result of Bureau studies) the committee emphasizes the great value of basic research—the kind that has no immediate apparent application.

It is the opinion of the committee that the Bureau work should tend in this direction more than it has done in the past. It is pointed out that private research laboratories are generally forced to work on certain questions having to do with special problems of the industry maintaining them and that these laboratories are not generally free to publish their researches. The Bureau of Standards, on the other hand, is maintained by the government for the good of all industries and so can most suitably attack those apparently unremunerative



A. ATWATER KENT

Philadelphia; Radio Manufacturer

"Improved programs, I believe, will feature 1926 broadcasting to an even greater extent than was true in 1925. As a result of the Sunday night programs by world famous artists, that I was fortunate enough to arrange, I have found that the American public likes good music. They will get more of it during the coming year. Perhaps the two greatest fields for the development of radio in 1926, however, are its use on the farm and in education. Steps recently taken by Secretary Jardine to further radio service to farmers will prove of far reaching importance. The time will come when every schoolroom—city and country alike—will have a radio receiving set to supplement the work of the teacher in the class room. The new year will bring a big advance toward that condition."

problems out of the results of which industry generally reaps rich rewards.

THE past year's report of the Commissioner of Lighthouses, just received, indicates the gradually increasing importance of radio signalling to the protection of ships approaching our shores. The very first paragraph, which is a long one, deals only with the new radio installations. There are now thirteen radio fog signal stations under his direction, one of them, installed on Lake Huron during the past year, being the first of its kind to be tried out on the Great Lakes. Equipment for fifteen additional stations (all outfits of the vacuum tube type) is ordered, six for the Great Lakes, one for the Maine coast, and the rest for the Pacific. We note that one of these is for Point Arguello, the scene of the Naval destroyer catastrophe. Certain improvements in synchronizing the signals from adjacent stations have been carried out and the fog signal station on Nantucket Light has been operated during the past year for fifteen minutes out of every hour to test the efficiency of the station in giving long-distance bearings for the incoming ships. No comments are made as to whether this service has been of appreciable value.

Important as we may think the radio fog signalling to be, it is actually a very small



GEN. CHARLES MCK. SALTZMAN

Washington; Chief Signal Officer
United States Army

"While the technical advance in radio broadcasting apparatus for transmission and reception during the year 1925 has been confined largely to improvement in programs and wider dissemination of those programs as a result of the use of greater power and linked up stations, there has been much development in other fields of the art, principally in long distance telegraphic communication. The most outstanding advance in this branch of radio communication has been in the development of the short wave bands, where it has been demonstrated that on certain frequencies, with an insignificant amount of power and at small cost, communication has been conducted over greater distances that had hitherto been considered only possible of accomplishment with the extremely high power, long wave stations. I predict that in the coming year we shall see many improvements and novelties in the broadcasting activities. In the commercial field and as a result of the short wave developments, we may look for some revolutionary advances in radio communication and correspondingly increased use of radio for international correspondence."

part of the total activity of this government department. For 1926 out of a total appropriation of \$9,700,000, only \$16,000 is allowed for radio fog signals. Of a total of 1207 fog signals, fog horns, submarine bells, whistling buoys, bell buoys, etc., only thirteen of them are radio stations.

The fog signal on the Ambrose Channel Lightship is a tube transmitter which has been operated close to the metropolitan district since April, 1924; the report comments on the fact that no complaint of interference has ever been lodged against this station. Had a spark transmitter been used, the government would have heard from a great many broadcast listeners, no doubt.

WE GENERALLY like to print reasonably accurate statements in these columns, but it seems that one slipped in a few issues back which hasn't the stamp of

dependability. Mr. William Dubilier, who makes a rather good living from mica condensers, was quoted as saying that in America the radio industry has grown so rapidly that it is now equal to the automobile industry.

Mr. Sarnoff estimates the past year's radio business as \$350,000,000, and he would not be inclined to understate the matter. *Motor Magazine* tells us that there was an increase in car registration in our country of 2,132,758 last year. So by combining Mr. Dubilier's statement and Mr. Sarnoff's estimate with the above figure we find that the average price of the new automobiles purchased last year was \$164.30! We must conclude that Mr. Dubilier's statement was open to question.

A PUBLICATION of the Bureau of the Census, dealing with the Farm Census of New Hampshire, gives the total farms reported as 19,895, of which only 2,366 had radio outfits. Evidently there is still plenty of market for good receiving sets.

Interesting Things
Said Interestingly

ALMA GLUCK (New York; former opera singer and still well known on the concert stage): "Since the time a single record netted me sufficient to buy a private house on Park Avenue, receipts from royalties have fallen off precipitously, and all because of radio. The radio is a nuisance. They are perfectly darn foolish things to have around, and, besides the squawks, most of what one hears over the radio is terrible."

HUGH S. Pocock (London, England; editor of *Wireless World*):

"Wireless is still a new industry, and the design of apparatus associated with broadcast reception is passing through a stage of evolution. The steady development which is going on is not entirely the outcome of invention, but is more probably due to the stabilizing of an industry and the establishment of an improved manufacturing organization. It may be said that the manufacturer and the wireless enthusiast have rivalled each other in an endeavor to construct equipments possessing good selectivity, an extensive receiving range, with easy manipulation and the elimination of distortion. It must be admitted that a peculiar position has existed where prospective purchasers would exercise caution and seek advice before selecting a receiving set, and exhibit a hesitancy that would indicate a lack of confidence in the manufacturer. The exhibition this year indicates

that a change has come about and that the wireless trade is now taking a lead. It is now possible to select a broadcast receiving set built to a design that will not be rapidly superseded and with which the user will remain satisfied in spite of his technical interest in receiver design."

J. J. WALSH (Dublin, Ireland; Minister of Posts and Telegraphs):

"The science and practice of agriculture and horticulture will hold a prominent place in the items comprising the programs of our broadcasting stations, and it will be sedulously seen to that everything that wireless broadcasting can do will be done to inform and instruct the farming classes and to keep them in touch with current agricultural research.

Market reports, seasonable lectures, weather forecasts, etc., will be regular features of the programs.

Our news service we propose to make second to none, and how much this will be appreciated by our country people will be understood when it is remembered that they are insatiable gluttons for news. Their salutations are invariably followed by '*Bhfuil aon sceul agat?*' ('Have you any news?')

REV. DR. S. EDWARD YOUNG (New York; in a sermon delivered at the Bedford Presbyterian Church, Brooklyn):

"We should encourage broadcasting stations and broadcasters to refrain, as far as possible, from conflicting with the usual hours of church worship. Since nothing can really take the place of the assembling of God's people in God's house, the time of their assemblage ought to be protected from needless rivalry or distraction. To be commended is a great broadcasting station for not starting its tremendous entertainment at night until after the sanctuaries have closed.

DR. JOHN J. TIGERT (Washington; United States Commissioner of Education):

"The benefits of hearing the best music are so great that I have always favored making it available to the greatest number of persons possible. Arrangement of programs such as the Atwater Kent series marks the attainment of an important milestone in this direction, because it will make a vastly greater number of Americans acquainted with the best music and the best musicians.

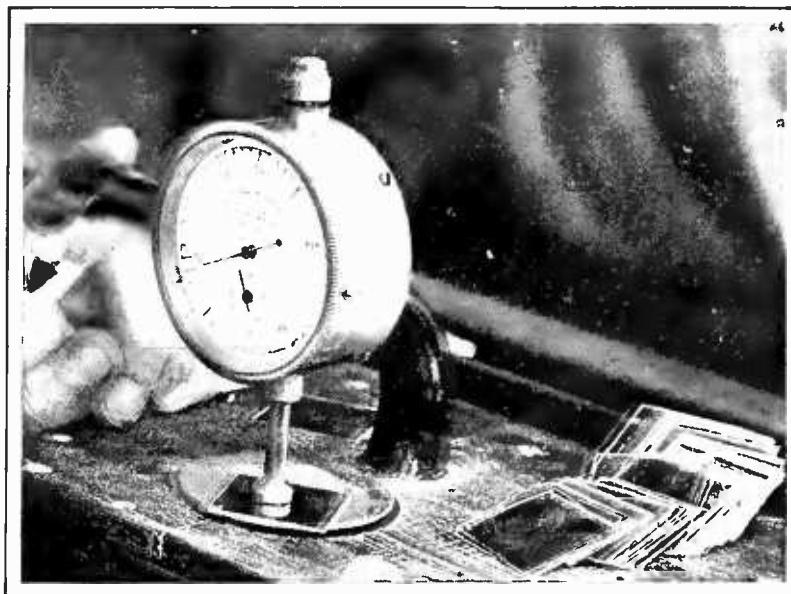

IN THE MANUFACTURE OF FIXED CONDENSERS
The mica must be accurate in thickness. One degree on the large-scale micrometer in the photograph equals one one-thousandth of an inch

Can We Forecast Radio Reception From the Weather?

The Results of Many Experiments Seem to Show That Weather Conditions Influence Radio Reception—Some Rules for the Amateur Radio-Weather Forecaster

By J. C. JENSEN

Nebraska Wesleyan University

MARK TWAIN is credited with the remark that although everyone talks about the weather, no one does anything about it. Thirty years ago when bicycle riding was all the rage among the young people, many a joy ride of twenty miles over country roads was suddenly turned into a weary tramp through the mud when an unfriendly thunderstorm got into action in mid-afternoon. Not long ago the newspapers carried accounts of automobile tourists who were marooned on the top of Pike's Peak by an early snowstorm, and of the loss of our famous dirigible, the *Shenandoah*, in an Ohio windstorm. It would be unreasonable to expect that radio, the latest "indoor sport," should be an exception and escape without any handicaps resulting from weather conditions. Radio reception has the advantage, however, that when J. Pluvius makes its use impracticable, the operator suffers no further inconvenience than the necessity of turning to the trusty phonograph or the piano for his entertainment.

The variations in radio reception may be grouped under three heads:

CAN I forecast radio reception as the weather is forecast?" Since the publication of Professor Van Cleef's "Do Weather Conditions Influence Radio?" we have received many inquiries worded like that sentence. Many amateurs who now have radio receivers are anxious to extend their hobby, but still to maintain a distinct radio tinge to their experiments. The investigation of how radio conditions are influenced by the weather can be done with no other equipment than a good radio set and the United States Weather Bureau daily weather map. The map is printed by most newspapers or one can be put on the mailing list of the nearest Weather Bureau office for a small sum. Neither Mr. Van Cleef, or Mr. Jensen would care to say that radio conditions, that is, the strength of signals, amount of static, and the probabilities of fading can definitely be forecast. Mr. Jensen in this highly interesting article does say, however, that, knowing national weather conditions, it is possible to tell pretty definitely and accurately what conditions will be. The author will of course be glad to hear from readers who find interesting facts about the vagaries of the weather, and Mr. F. M. Herrick of the Taylor Instrument Companies, Rochester, New York, would similarly like to hear from experimenters.—THE EDITOR.

RESULTS OBTAINED BY OTHER EXPERIMENTERS

ATTEMPTS to explain the variations in radio receiving conditions have been made constantly since the very beginnings of wireless transmission, but the tremendous increase in the number of persons owning receiving apparatus since the advent of broadcasting has resulted in a much more general interest in all problems affecting clearness and regularity of reception. Space will permit the mention of only a few of the most important of these experiments.

1. Irregularities in signal strength which persist for hours or even days at a time, resulting in clear reception from a given station on one evening and faint or inaudible response on the next. Such fluctuations are spoken of as changes in audibility.
2. Sharp, noisy, crackling sounds are called "Static."
3. A short period variation in signal intensity, the usual interval from one point of high audibility to the next being from three to five minutes. This is called "fading."

While we may not be able to "do anything about it," our purpose in what follows is to connect these three phenomena up with weather conditions.

Dr. L. W. Austin of the United States Bureau of Standards has been engaged for several years in recording the signal strength of high-power, long-wave commercial stations such as Nauen in Germany and LaFayette in France. His reports show that transmitting conditions are more favorable at night than in the daytime and in winter than in summer. The amount of static disturbance varies greatly from day to day and is worst in the summer months. During the years 1920 and 1921, the American Radio Relay League in cooperation with the Bureau of Standards conducted an extensive series of investigations in which amateurs used their receiving sets to determine the audibility of signals under various weather conditions. They found that stronger signals were obtained when the radio waves from transmitter to receiver pass parallel to the isobars than when they move at right angles to them. [An isobar is an imaginary line connecting or marking places on the earth's surface where the barometric height, reduced to the sea level, is the same at a given time for a certain period.] It was found that stormy weather at the transmitting station does not affect the range or strength of the signals and that an area of clear weather connecting both stations results in less fading. Cloudy weather at the receiving station resulted in much more static than did clear weather. Our British cousins have recently completed a similar investigation and report conclusions in general agreement with those already given. They also found that the nature of the earth's

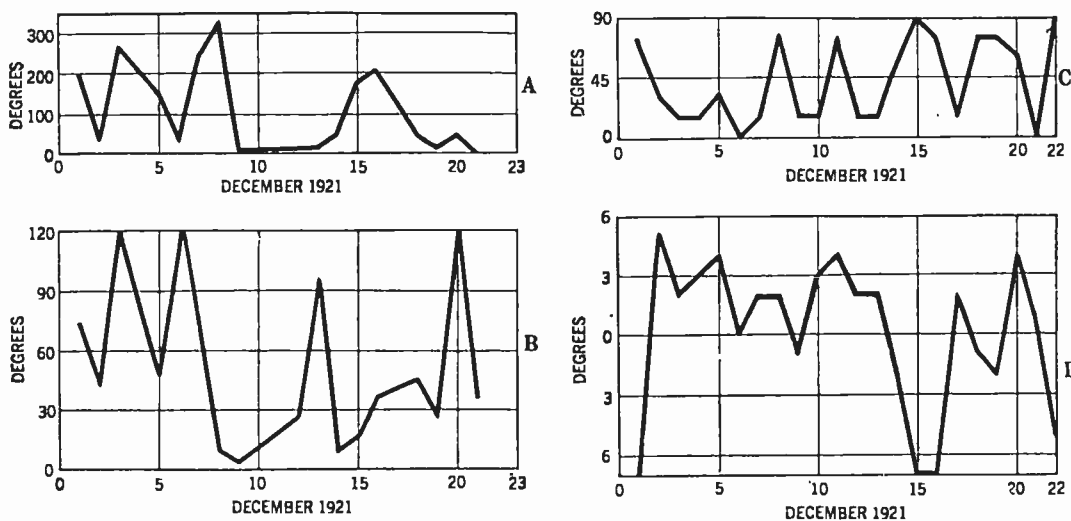

FIG. 1

Measurements of signal intensity variations of station NAA, the Naval station at Arlington, Virginia. Curve B shows the variations from night to night, during the first twenty one days of December in 1921. Note that, in B, on December 3rd, NAA's signals were 120 turns audible, while they were only four times audible on the 9th. Curve A indicates the static audibility for the same nights

FIG. 2

Signal intensity variations of NAA (operating on 113.1 kc., 2650 meters) for the month of April, 1922. Curve A shows the static audibility and B the signal variations. The maximum signal audibility for this month, as compared with December referred to in Fig. 1 is thirty. In December, the maximum was more than 300, while the static peak record here is 750 (Curve A), more than twice the December maximum. Curve A is static intensity. Curve B is audibility. In Curve B, Fig. 2, maximum audibility is 30 while in Fig. 1 Curve B, the maximum audibility is 120. Curve C, here and in Figs. 2 shows the angles made with the isobars of Fig. 3 and 4, by a ruler connecting Arlington, Virginia and Lincoln, Nebraska, on the map. Curves D (Figs. 1 and 2) give the number of isobars cut by the radio waves in passing between transmitter and receiver

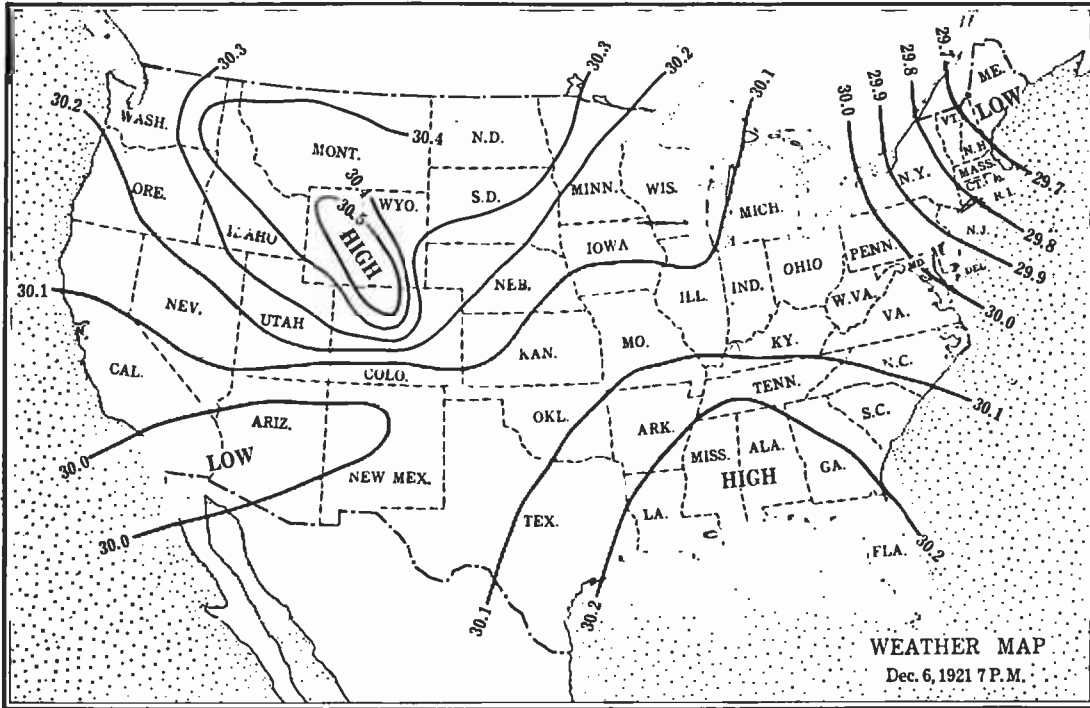
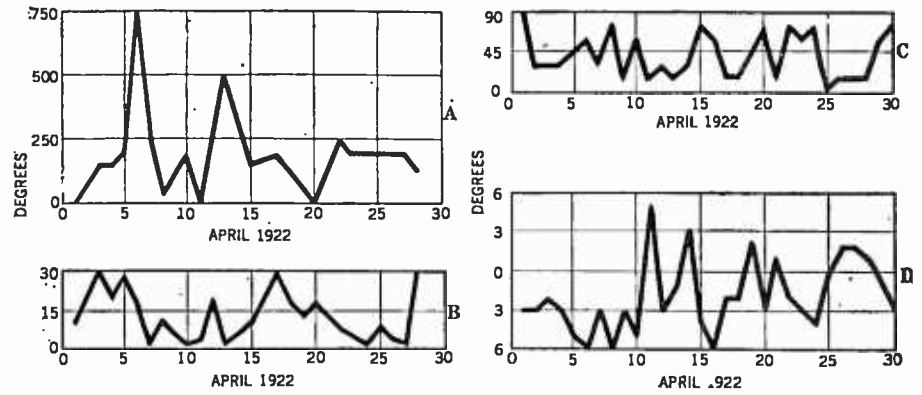

FIG. 3

The United States Weather Bureau map for one of the days covered by the curves in Fig. 1. Mr. Jensen explains the coincidence and relation of reception conditions with weather conditions in the article

surface in a given region influenced the strength of signals, water and mineral deposits being more favorable to good reception than sandy soil and rock. They further maintain that some signal variations attributed to fading are in reality caused by the antenna swinging in the wind and throwing the receiver out of tune.

Early in 1924, Dr. G. W. Pickard published an article on signal fading which presented the first satisfactory method by which the actual signal strength of radio carrier waves may be recorded. The curves obtained with his apparatus show rapid fluctuations in the carrier wave, the time between peaks and the amount of change varying from night to night. The same type of apparatus was used by Doctor Pickard and others in obtaining data concerning the effects of the eclipse of last January on radio signals. The results show a sharp rise in signal strength as the moon's shadow passed over the observer, conditions quickly returning to those normal for daylight work after the eclipse had passed. Further records made at sunset by a considerable number of observers during the summer of 1925, by the use of Pickard's method, show rapid fluctuations in the signal strength just after sunset, conditions becoming steadier and the

signals reaching night intensities about thirty minutes later.

One of the most interesting and widely discussed articles dealing with radio and the weather was that of Professor Van

Cleef in RADIO BROADCAST for May, 1925. This writer combined the observations of the lay observer of radio programmes with the technical training in weather lore of the climatologist and claims to have found a number of specific relationships between radio reception and weather conditions. The most important of these are that strong signals occur when transmission is at right angles to the isobars, or lines joining points of equal barometric pressure; signals are weaker, and fading is worse, when radio waves pass parallel to the isobars, and reception is weaker when transmission crosses from one pressure area to another. Before discussing these points in detail, let us turn to some recent experiments in the writer's laboratory.

RESULTS OF ACTUAL RADIO MEASUREMENTS

AMONG the most accurate and extensive records of signal strengths yet made are those by Mr. M. P. Brunig, a graduate student in the radio laboratory at Nebraska Wesleyan University, three years ago. The audibility of the time signals from NAA, together with that of static, was measured daily over a period of several months. A local oscillator gave a standard tone whose intensity could be measured by means of a thermocouple and a galvanometer. This tone was then used to measure the sensitivity of the ear

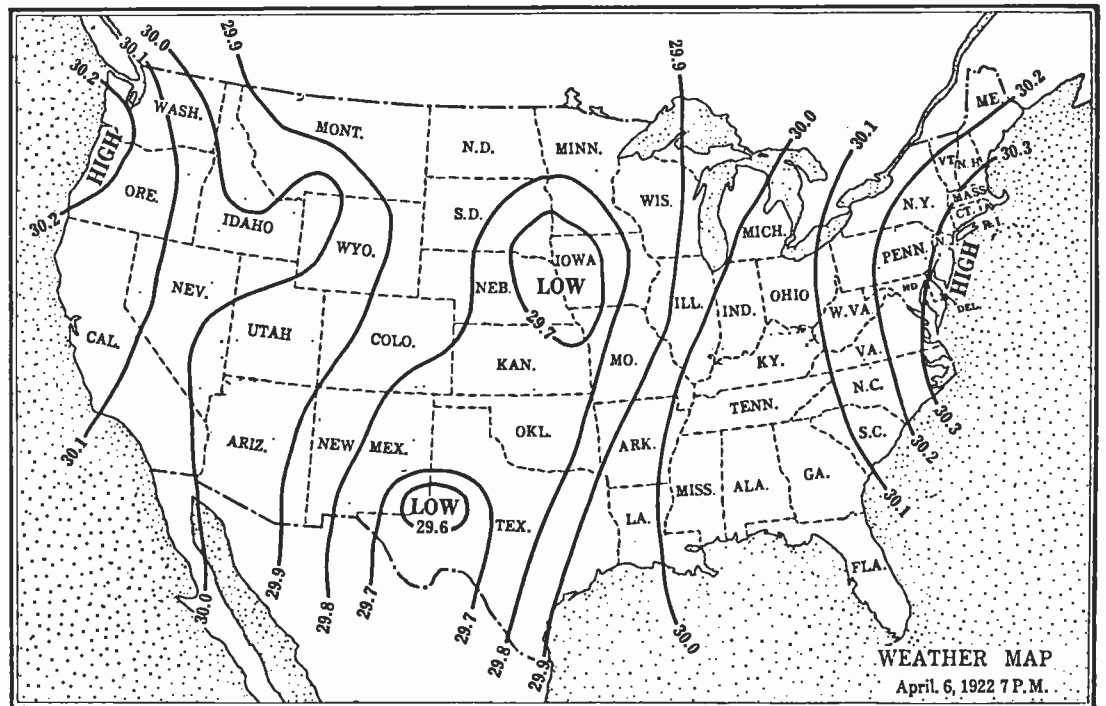

FIG. 4

Another Weather Map for the period covered in the curves of Fig. 2

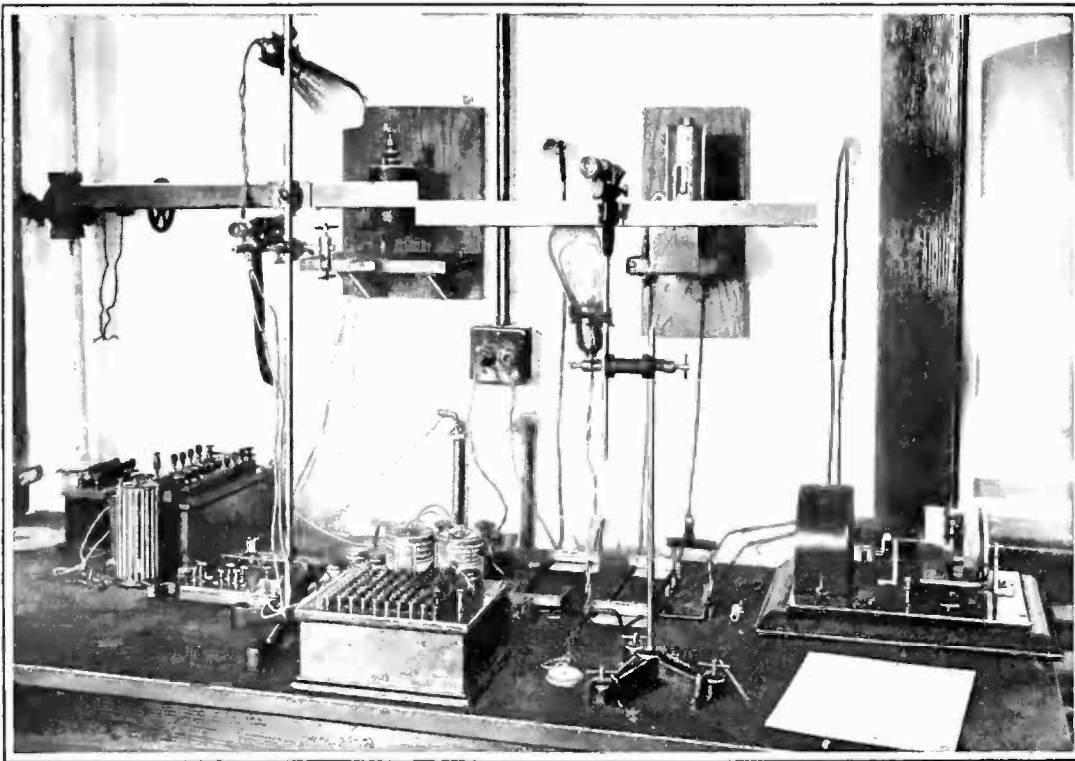

FIG. 5

The apparatus used to make the observations detailed in this article. The signals are received on a six-tube super-heterodyne. In the plate circuit of the second detector is inserted a fifth intermediate-frequency transformer. A head set is shunted across a .002-mfd. fixed condenser in series with the primary of this transformer. Shunted around this condenser is a sensitive wall-galvanometer (seen on the right side of the wall). In series with the secondary are a crystal detector and another .002-mfd. condenser. The field strength of broadcasters is accurately recorded with the galvanometer. The battery and resistance box in the foreground are used in neutralizing the small plate current of the UV-199 tube which has more recently replaced the crystal as a detector. To the right of the resistance box is a recording rain gauge and on the wall to the left of the galvanometer is a Compton electrometer, both of which are used for meteorological research

of the observer and to standardize the adjustments of the receiving set. A simple vacuum tube receiver with the necessary voltmeters and ammeters to check on batteries and filament current, and an audibility meter, completed the outfit. The original report on this research was

published in the *Monthly Weather Review* for December, 1922, but since the appearance of Professor Van Cleef's article we have gone over all the original observations together with the corresponding weather maps in order to study the relations of the weather conditions between transmitter

and receiver, and the observed signal strength. Curve B of Fig. 1 shows the remarkable variation in signal intensity from night to night, the data covering the first twenty-one days of December, 1921. Signals from NAA were 120 times audible on December 3rd, 6th, and 20th, while they were only four times audible on the 9th and eight times on the 14th. Curve A indicates the static audibility for the same nights and it is very evident that heavy static does not necessarily accompany weak signals, for on the evening of December 3rd, static was 260 times audible yet the signals were very loud. Ordinarily, however, strong and frequent crashes of static coincided with weak signals. Curves A and B of Fig. 2 give similar data for April, 1922. The maximum signal audibility for that month was thirty as compared with 120 for December, while the static peak record was 750, or more than twice the December maximum.

Many newspapers at present reproduce the daily weather map, so that if there is any simple relation between the directions of the isobars and radio receiving conditions, a few moments' study of the map should be sufficient for determining the radio probabilities for the evening. In Figs. 3 and 4 are shown two typical weather maps, chosen from the periods covered by the curves of Figs. 1 and 2. On December 6th, 1921, clear, fair weather prevailed all the way from the high barometer area in Colorado to the Atlantic coast. The entire distance from eastern Nebraska to Arlington, Virginia, lies between the two isobars marked 30.1 inches. Conditions on April 6th, 1922, were entirely different, with a storm area over Nebraska and Iowa and a high barometer region in the eastern states. A radio signal from Arlington to

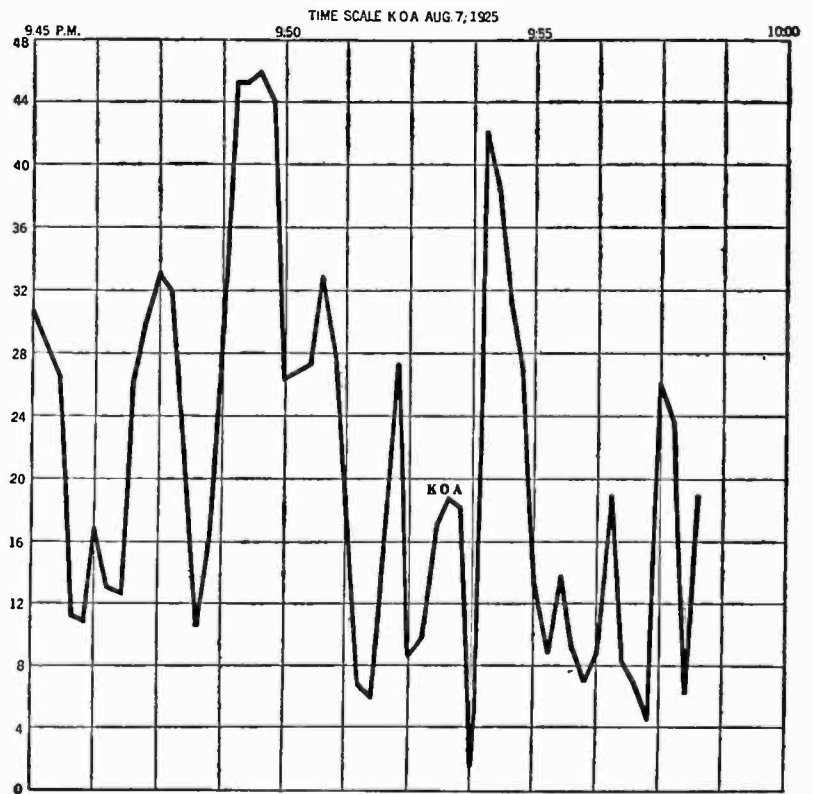
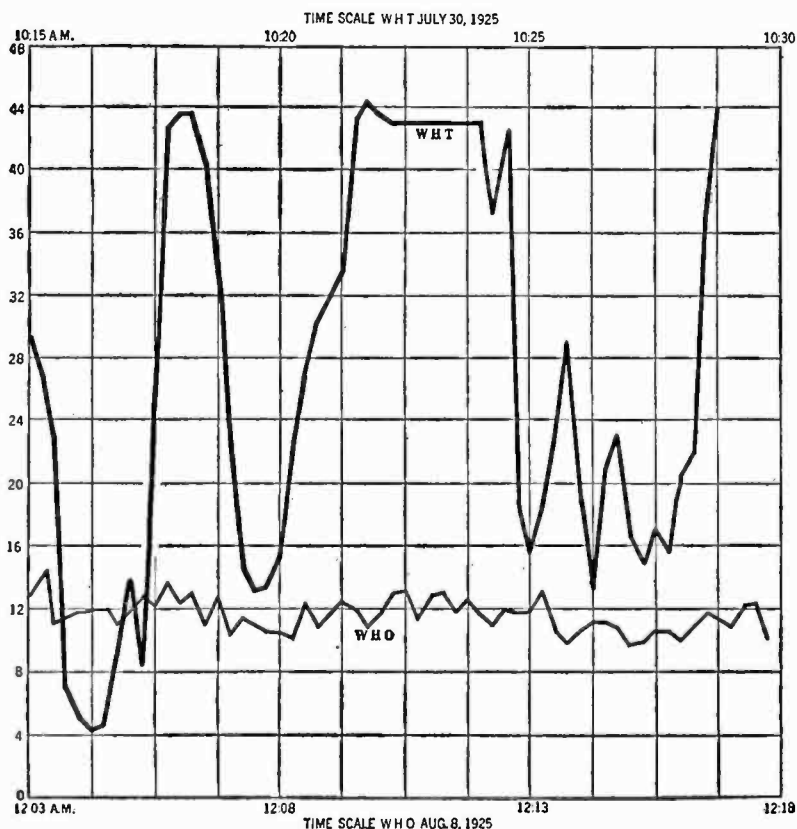

FIG. 6

Several representative curves on different stations, taken from a great many made by Mr. Jensen. Audibility is plotted on the left

University Place, Nebraska, must cross six isobars, pressures dropping from 30.3 to 29.7 inches. Curves C of Figs. 1 and 2 show the angles made with the isobars by a ruler connecting Arlington, Virginia, and Lincoln, Nebraska, on the map. On December 6th, this angle was 0° while on April 6th it was about seventy-five degrees. Curves D give the number of isobars cut by the radio waves in passing between transmitter and receiver, distances above the zero line indicating that the pressure was higher at the receiving end so that the waves must travel "uphill." From these studies, our data shows that *the highest audibilities are obtained when a ridge of high pressure extends from the sending station to the receiver.* Good results may also be expected when the waves travel at right angles to the isobars, provided they do not need to pass over an intervening low and up again. Poorest signals result from passing diagonally across the isobars or through a storm area. While these general rules apply to a majority of our records, it must be clearly understood that they are not infallible, and other controlling forces doubtless should be taken into account.

MEASUREMENTS OF STATIC

THE current in a lightning discharge is of the order of 5000 to 10,000 amperes, hence it is not surprising to find that electric waves produced by these crashes may travel for hundreds of miles. Measurements made in our laboratory show that an antenna or other insulated conductor may become charged to potentials of more than 5000 volts when a stormcloud is overhead and our sensitive apparatus records the smaller charges even before the thunderstorm itself is visible on the western horizon. In the northern hemisphere, thunderstorms are most common in the southeast part of a low area. These conditions prevailed in eastern Nebraska in the map of Fig. 4, and attention has already been called to the very high static audibility for that day. In high winds, and especially with drifting snow, the air often becomes electrified by wind friction, causing an antenna wire to take on a charge sufficient to cause sparks to jump across a lightning arrester to ground. Under such conditions the writer has known charges to accumulate of sufficient magnitude to be heard all over a large room as they jumped across an antenna condenser. The worst thing about these and other forms of static discharges is that the waves produced by them are scattered over a large number of wavelengths so that they are not easily tuned-out.

WHEN SIGNALS FADE

WHILE almost everyone who has used a radio receiver to any extent has noted the gradual variations in the loudness of program, special apparatus is required to measure

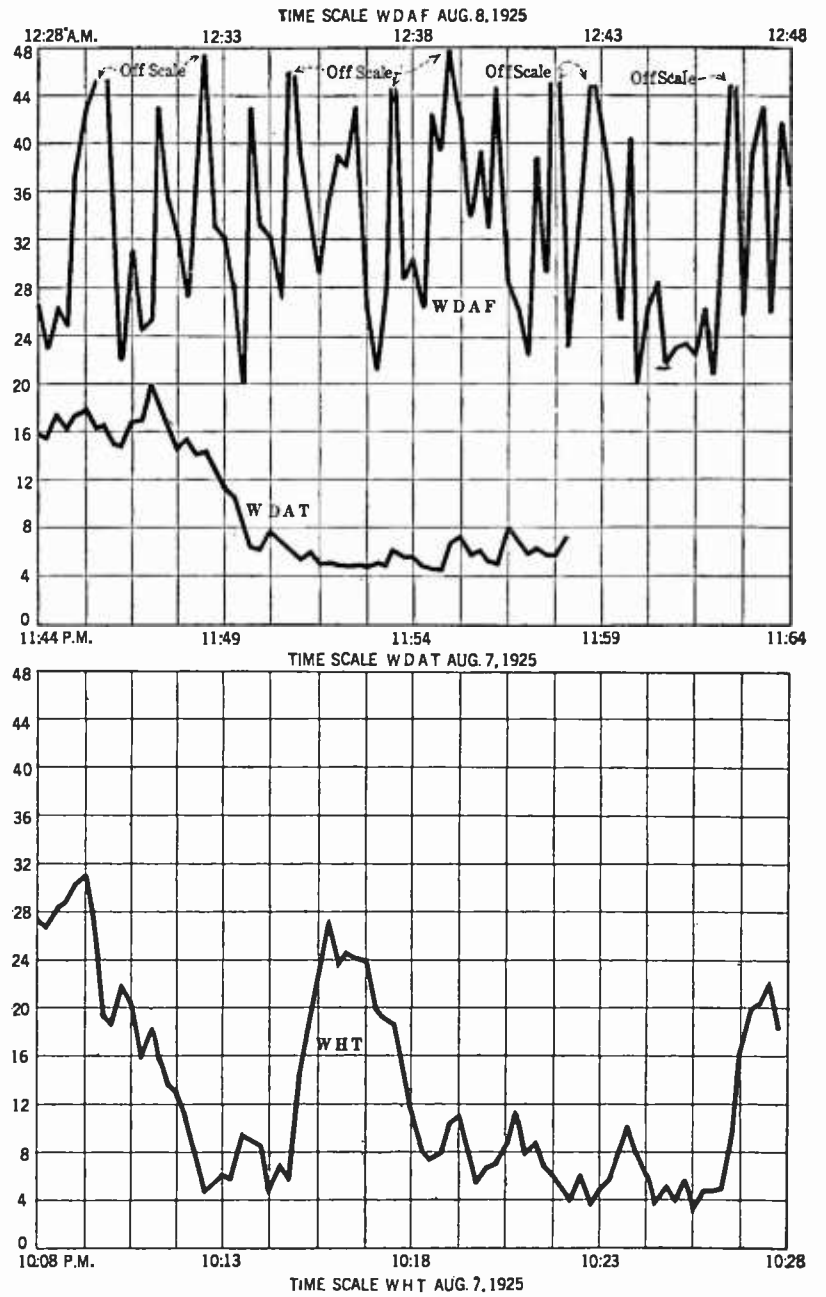

FIG. 7

Time scale plotted against audibility on several stations on the night of August 7, 1925. The Weather Map below, (Fig. 8), shows the general conditions prevailing at 7 P. M. the same day

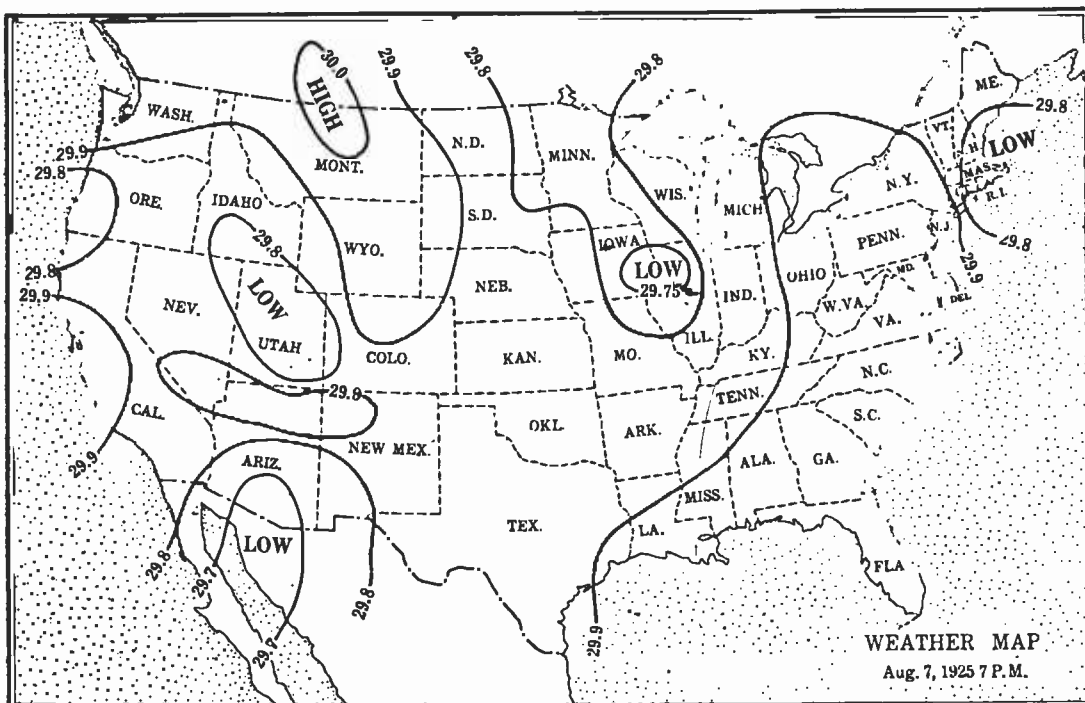

FIG. 8

the actual changes in signal strength. The ear is not a reliable measuring instrument and tone impressions cannot readily be kept in mind for several minutes for comparison. Another difficulty lies in the fact that different parts of a musical program may vary considerably in loudness because of the character of the selections themselves, a change which has no relation whatever to true fading. The apparatus in use for making signal fading records in the radio laboratory of Nebraska Wesleyan University consists of a six-tube super-heterodyne receiver with vernier dials for tuning, and ammeters in the filament circuits. In the plate-circuit of the second detector is placed a fifth intermediate frequency transformer. A telephone head-set is shunted across a .002-mfd. condenser in series with the primary of this transformer, for use as a pilot in tuning and in following programs which are being recorded. In series with the secondary are a crystal detector and another .002-mfd. condenser. Shunted around this condenser is a sensitive wall galvano-

meter as shown in Fig. 5. More recently we have replaced the crystal detector with a UV-199 tube and have also built up an automatic recording device somewhat similar to the Shaw Recorder used in Doctor Pickard's experiments. With this equipment, galvanometer deflections are proportional to the strength of the carrier wave and are not at all affected by the music or voice modulations heard by the radio listener.

In Figs. 6, 7, and 8, are shown a few typical records, chosen from the large number now on file. Three of the four curves in Fig. 6 are daylight graphs and give conclusive evidence that transmission is much more steady in the daytime than at night. The weather map for May 16 shows a marked storm area in the region of Lake Erie, with clear and settled weather over the great central plains. This accounts for the remarkably regular curve from WDAF at Kansas City. From WCCO at Minneapolis, on the other hand, some effects of the storm to the east are noticeable. The night record for WCX at Detroit is unusually regular, being obtained with a "high" in northern Minnesota, a "low" in Tennessee, and the intervening isobars running almost exactly parallel between University Place and Detroit.

Reference to the time scales on Figs. 7 and 8 will show that these records were all made on the evening of August 7, with the exception of that for WHT on July 30th. The midnight curve for WDAF contains the most rapid and violent changes of our entire series to date. While the period between peaks is commonly from four to six minutes, these are only ninety seconds apart, and continue the cadence with great regularity. This becomes all the more noticeable when contrasted with the records of WDAT at Chicago and WHO at Des Moines taken just a few minutes before. The graphs for WHT at Chicago and KOA at Denver, taken earlier in the evening, are typical mid-summer curves. The meteorological map for the evening of August 7th is reproduced in Fig. 9. The weather was hot and sultry, with no well-defined storm area in the plains region, a condition classed as "unsettled" by the meteorologist.

CONCLUSIONS

A DISCUSSION of the application of the data presented above to the Heaviside theory of radio transmission would be beyond the scope of this article. So far as it is possible to formulate an opinion based on actual observations, the

Eccles-Larmor theory which requires a refracting upper layer rather than an ionized, reflecting surface, agrees more nearly with the facts. There is strong evidence for definite relationships between weather conditions and radio reception although other factors, such as the earth's magnetic field, probably also play a part. The general conclusions supported by the data presented may be summarized as follows:

1. Signal strength will be greatest with settled weather conditions and transmission parallel with the isobars. (Fig. 3).
2. Good reception may also occur at right angles to the isobars unless a storm center intervenes between sending and receiving stations.
3. Static is most noticeable as a storm area approaches, the crashing noises being audible for several hundred miles; and the hissing noises prevailing only in the immediate vicinity of a "low."
4. Fading is much less troublesome in daylight than at night.
5. Fading is much more noticeable in unsettled weather than when transmission is parallel with the isobars along the ridge of a "high."

With these rules as a general guide, a radio forecast has been sent out daily at 4:30 P. M. from station WCXJ, since October 1st, 1925. While encouraging reports have been received, the project is yet in the experimental stage.

EDITOR'S NOTE

THE conclusions reached by Mr. Van Cleef, in his article, "Do Weather Conditions Influence Radio?" in the May, 1925, RADIO BROADCAST are reprinted below, so that experimenters can compare the findings of the two investigators. Mr. Van Cleef reached his conclusions from his observations without a great deal

of study of the radio theories advanced for variation in radio receiving conditions. Mr. Jensen has proceeded from the point of view of the radio investigator. Mr. Van Cleef's first point is in direct opposition to that of Mr. Jensen as he claims strongest transmission at right angles to the isobars. Mr. Jensen has found that loudest signals are to be heard in territories parallel with the isobars, along the ridge of a "high", with no difference in pressure between transmitting and receiving stations. This conclusion is also opposed to Mr. Van Cleef's second rule. With respect to fading, Mr. Jensen thinks that the worst fading is found with a "flat" barometer or large "low" area, while the third rule of Mr. Van Cleef assumes most fading on a ridge or parallel with the isobars.

1. If a line connecting the receiving station with the broadcasting station crosses the intervening isobars at right angles, reception is at its best.
2. The steeper the isobaric gradient (that is, the closer the isobars to each other) the stronger the reception.
3. The more nearly the transmitted waves approach parallelism with the isobars, the weaker the reception. Under these conditions, fading occurs.
4. Reception in a Low pressure area tends to be somewhat weaker than in a High of corresponding intensity.
5. Reception is weaker when the transmitted waves cross from one pressure area into another than when they travel only within one area.
6. The strength of reception for any station is a factor of both its location within a pressure area and its position with respect to the broadcasting station.
7. "Bad weather" does not affect reception, excepting as it may be the index of an unfavorable pressure distribution.
8. Reception can be as good in "bad weather" as in good weather if the pressure distribution is right.
9. Temperature does not influence reception, excepting as it may be the index of pressure distribution as follows:—
 - (a) Reception is better in winter than in summer because the cyclones and anticyclones are more intense in the winter period.
 - (b) Reception is better when temperatures are low than when high, because low temperatures usually indicate intensive High pressure areas, that is, areas with steep isobaric gradients.
 - (c) Low temperatures accompanying poorly defined High pressure areas make reception poor.
10. Shallow or flat pressure areas result in much static-noise in the receiver.

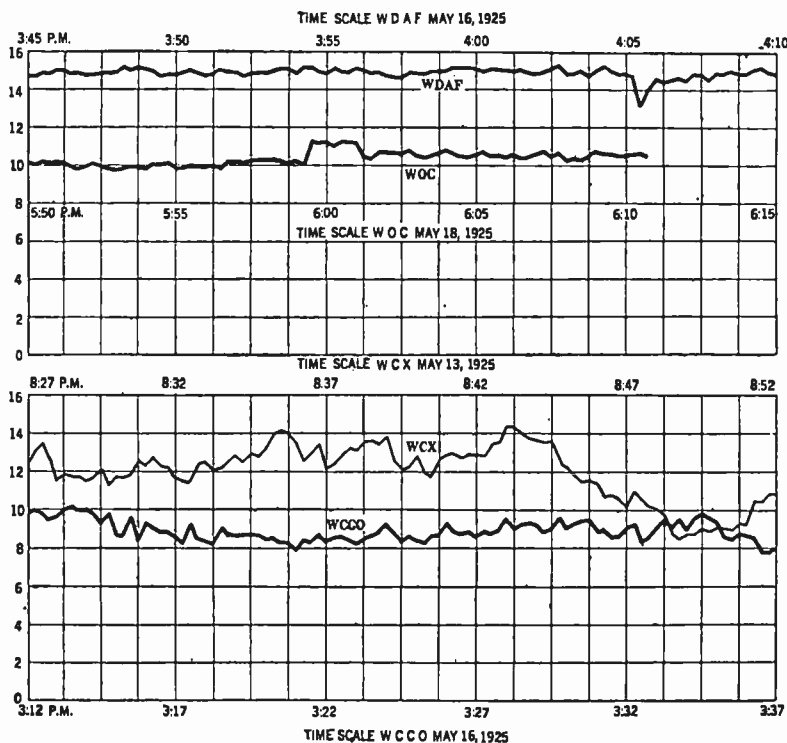

FIG. 9
Some remarkable records of daylight reception during the spring of last year

What Multiple Regeneration Can Do for Your Tuned R. F. Amplifier

Suggestions for Experimenting with and Applying Multiple Regeneration to a Great Variety of Circuits with a Consequent Large Gain in Sensitivity—Details of the Circuit and Operating Suggestions

By V. D. LANDON

Radio Engineering Department, Westinghouse Electric and Manufacturing Company

A GREAT deal of experiment has been spent in an effort to obtain the full amplification of regeneration twice or more times in the same amplifier. The average experimenter does not obtain the desired result, though the reason for failure is somewhat puzzling unless considerable study is made of the subject.

Take for example the well known Roberts Knockout Receiver. This circuit (with one stage of audio added) is shown in Fig. 5. If a station fifty to one hundred miles distant is tuned-in with this receiver, using zero tickler adjustment, a comparatively weak signal results while a 500- to 1000-mile station is usually inaudibly weak. Nevertheless when the tickler is advanced to the critical point, the gain in signal is sufficient to bring in stations well over one thousand miles distant and with full loud speaker volume. Only on poor nights or on very weak stations is difficulty found in obtaining sufficient volume for satisfactory reception.

On such occasions, however, imagine the thrill of having another tickler control capable of boosting the signal again by the same ratio! It was with this in mind that a great many experimenters tried the effect of unbalancing the neutralizing condenser in an effort to regenerate the antenna as well as the detector circuit. Also many have tried various schemes of feeding energy from the de-

EXPERIMENTERS in radio have tried for a long time to secure the undoubted advantages in sensitivity that multiple regeneration would give, but always there have been very serious practical obstacles in the way. This article, by Mr. Landon, who is an experimental engineer with the Westinghouse Electric & Manufacturing Company, at present attached to their offices in Springfield, Massachusetts, is in no sense a construction article. The basic principles of the system are outlined by the author, and they can be applied by the constructor to the particular receiver which he may have. The number of receivers employing tuned radio frequency amplifiers now in use in this country must be much more than five hundred thousand and the Landon method is applicable to all of them—it will add considerably to their sensitivity. The importance of the experimental field opened up by this article can scarcely be overestimated.—THE EDITOR.

tector back into the antenna circuit by inductive coupling. One such scheme was suggested by the technical staff in the April, 1925, RADIO BROADCAST.

Many of those who experimented along these lines thought they had achieved the desired result when they tried the set because it becomes very critical. An

adjustment of the tickler or the balancing condenser or of either tuning condenser, upsets the adjustment of one or more of the other three controls. However, a more critical receiver does not mean a more sensitive one. If a comparison is made between two sets using the circuit of Fig. 5, one of which is well balanced while the other has a variable neutralizing condenser, it will be found that there is very little difference in the sensitivity of the two sets. This is found to

be the case in any circuit in which an attempt is made to regenerate the antenna circuit by means of some form of coupling to a regenerated detector. Briefly the reason is this:

When energy is fed back through the tube capacity so as partly to regenerate the antenna, the tickler setting for critical regeneration is reduced, offsetting the gain in the antenna.

In other words, if the two circuits are somewhat coupled, both may be partly regenerated, but both may not be completely regenerated, since the system as a whole starts oscillating before this point is reached.

Before attempting the true solution of the problem, let us reduce the Roberts circuit of Fig. 5 to the equivalent four-tube circuit. This is shown in Fig. 2. Theoretically, the only difference between Fig. 5 and Fig. 2 is that in Fig. 5 the first tube does the work of the first and third tubes of Fig. 2. In practice,



FIG. 1

By employing the Bremer-Tully three-coil unit, all the windings for the dual regenerator system are very simply provided. The rotor coil, pointed out in this illustration, is used as the radio frequency tickler coil while the adjustable coil and fixed coil are used as antenna and secondary windings respectively. The receiver pictured here was hastily assembled to conform with the principles of construction laid down by Mr. Landon in his article. It consisted of three tubes, namely, regenerator, radio-frequency amplifier, and detector. The coil unit shown at the left constitutes the detector secondary, tickler and r.f. plate circuit coil. The former and latter are both wound on the vertical coil form while the tickler is variable and is shown in a diagonal position

RADIO BROADCAST Photograph

the circuit of Fig. 5 can be made equal to that of Fig. 2 only after considerable experiment. In presenting the multiple regeneration circuits, the circuit of Fig. 2 is used as a starting point because it is not subject to certain troubles which a reflex set may develop.

THE BEST WAY TO ATTAIN INCREASED SENSITIVITY

THE solution of the problem is in regenerating each tuned circuit, all the while keeping the coupling between them to zero. Such a circuit is shown in Fig. 3. It will be found with this receiver that the advantage gained by using two ticklers instead of one depends a great deal on the completeness of neutralization. The more exact the neutralization the greater the gain in signal.

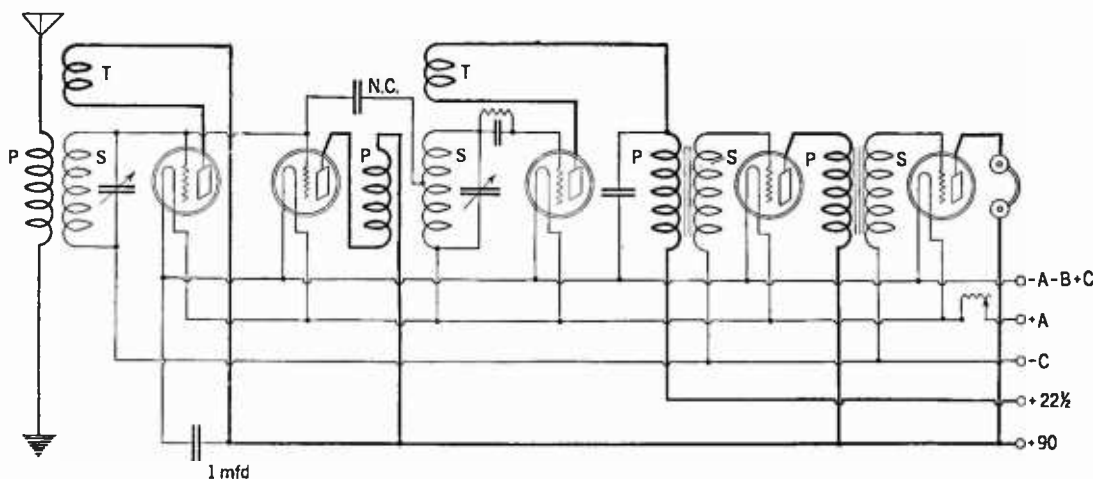

FIG. 3
The Browning-Drake with regeneration added to the radio-frequency amplifier circuit

Notice that the change from the circuit of Fig. 2 is very slight. Another tube, and a small coil were added. A means of varying the coupling of the coil to the antenna circuit must be provided. The grid circuit of the new tube is the same as that of the first tube, that is, the two grids are tied together. However the plate circuit of the new tube is separate. It consists of the new coil which is used as a tickler.

Another method of controlling antenna regeneration is to use a fixed tickler with a variable resistor in series. A bypass condenser must be provided to bypass r.f. currents around the resistor. When the resistance is all "in", the voltage applied to the plate of the tube is insufficient for oscillation to occur. When the re-

sistance is gradually cut out, the point of critical regeneration is approached until finally oscillation occurs. When the set is properly constructed it should be possible to start or stop oscillation at any wavelength with this resistor. There are several good resistors for this purpose on the market, which have a range of 10,000 to 100,000 ohms such as the Royalty, Bradley, Centralab, and Clarostat.

It is also possible to control the antenna tickler by any of the commonly used methods. A coil having the same value as the secondary coil may be substituted for the variable resistor and a variable condenser shunted around this coil for tickler control. Or the tickler lead may go directly to the B battery terminal with a separate (vernier) rheostat on the first tube for regeneration control. In this latter case the tube filament brilliancy is turned down to the point just below the point of oscillation. This is a very simple and effective system.

For ordinary reception, the first tube may be left out of the socket, the set being used like the standard Roberts Circuit. However, when a signal is found which cannot be brought up to the desired volume,

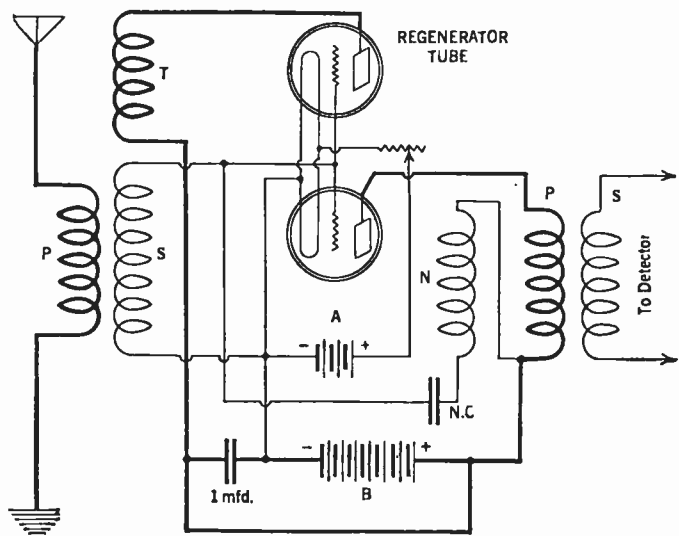

FIG. 4

Here are shown the important parts of the usual radio frequency circuit to which has been added the extra tube whose grid is paralleled with that of the first tube and whose plate return is made through a coil coupled inductively to the first secondary and thence back to the B battery. Notice that in all the circuit diagrams accompanying this article a 1-mfd. condenser connects from the plus B to the minus A lines

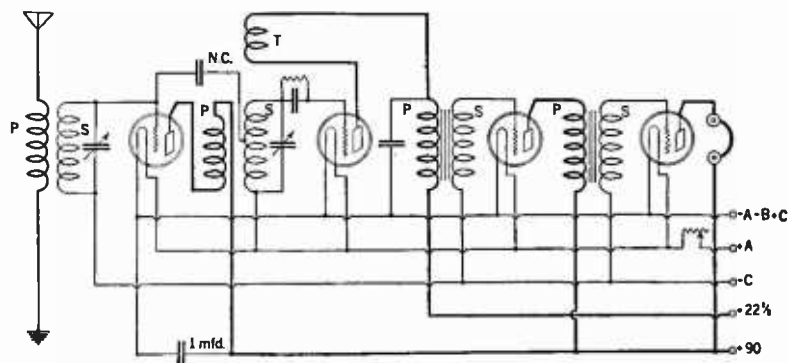

FIG. 2
This is the Browning-Drake circuit, familiar to readers of RADIO BROADCAST as one having excellent tuning qualities

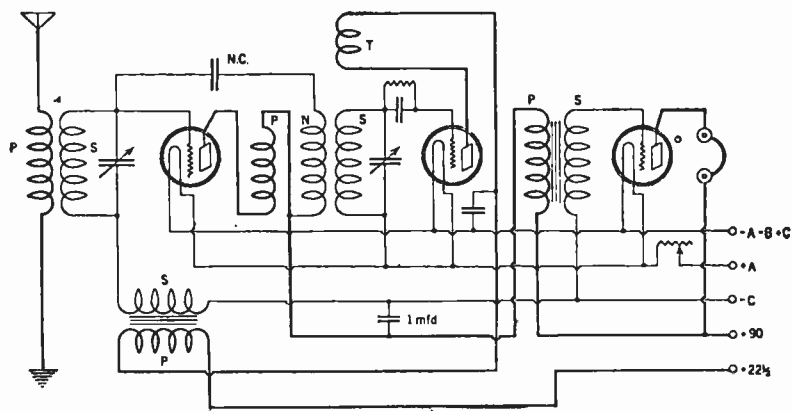

FIG. 5

The regular three-tube Roberts receiver consisting of one stage of tuned, neutralized, radio frequency amplification, a regenerative detector whose output is reflexed back to the first tube and then followed by a straight audio stage

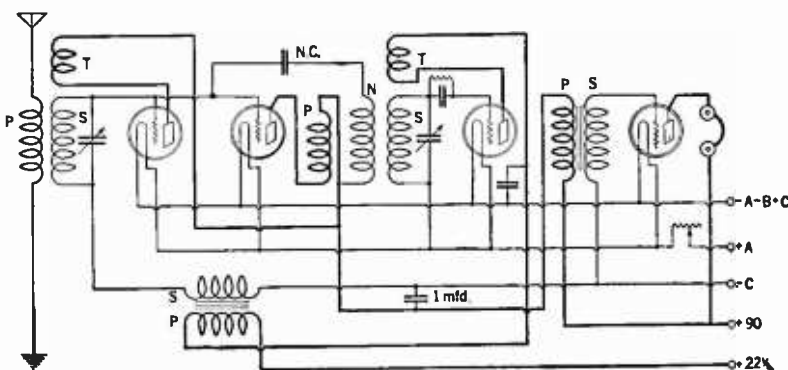

FIG. 6

The Landon system of r.f. regeneration added to the reflexed Roberts circuit. In the article, this is used as a basis for a discussion of the merits of dual regeneration

a great gain in signal is to be had by inserting the tube and adjusting the antenna tickler to the critical point which is just below the oscillating point.

It is also very easy to provide a filament switch to cut in the tube when it is needed, but for those who are not so particular about the filament current used, it is perfectly practical to leave all five tubes lighted whenever the set is in operation. The extra tube will have no effect on the circuit as long as the antenna tickler is set at zero, and of course, this control should not be used until necessary, since the receiver will radiate when the antenna circuit is caused to oscillate. There is no point in

Facts About the Circuit System

Material required for regenerator stage:

One socket, one tube, one tickler coil, a rheostat and filament switch.

Values of parts employed in the Circuit:

No definite values are stipulated as it is desirable for the builder to select for himself the size of tuning coil and condenser he wishes to cover the frequency range in which he is interested. The bypass condenser across the primary of the first audio stage should be .001 mfd. For the tuning coils, the ratio of primary to secondary should be 1 to 4 for the antenna circuit and 1 to 3 for the detector. The tickler coil should have $\frac{1}{2}$ the number of turns of the secondary coil to which it is coupled.

Operation:

When first tuning for a station, keep the regenerator tube unlighted. When the distant station is tuned-in and it is desired to increase sensitivity, turn on the filament switch of the regenerator tube and slowly advance the coupling between the regenerator tickler and the antenna secondary coil. Do not attempt to regenerate up to or beyond the oscillation point which manifests itself by a raucous squeal. Always employ the regenerator as a reserve of sensitivity and power.

Important points to remember:

A large bypass condenser, such as a 1-mfd. should connect from the B battery terminal of the new tickler coil direct to the minus A; the secondary coils for r. f. stage and detector should be placed at exact right angles to each other.

get down to the much discussed static level except on unusually quiet nights. In other words, those broadcasting stations whose signal intensity is higher, or stronger than the static intensity—otherwise termed static level, have a very fair chance of being tuned-in with the aid of the extra

advancing the antenna tickler to the oscillating point since it makes the receiver inoperative as far as the reception of ungarbled, undistorted reception is concerned and, furthermore, interference is caused with neighboring receivers which should be avoided at all costs.

The extra control simply provides the operator with a reserve of power in case of need. With this type of set it is possible to

control. Those below the static level have not this possibility. Briefly, a receiver employing this regeneration system has all the sensitivity for which there is any use.

THIS SYSTEM HAS WIDE APPLICATION

OF COURSE the main idea of Fig. 3 can be applied to practically all circuits employing tuned radio frequency

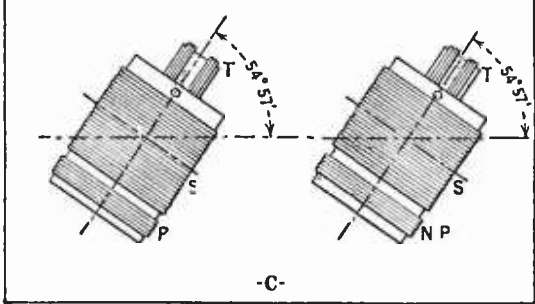
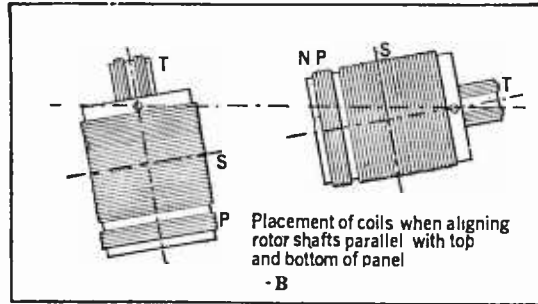
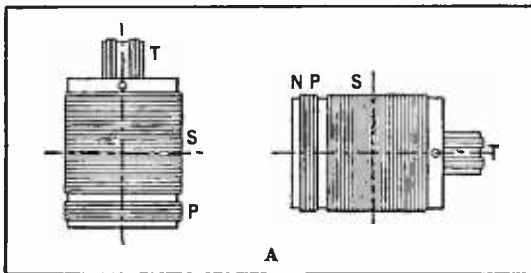
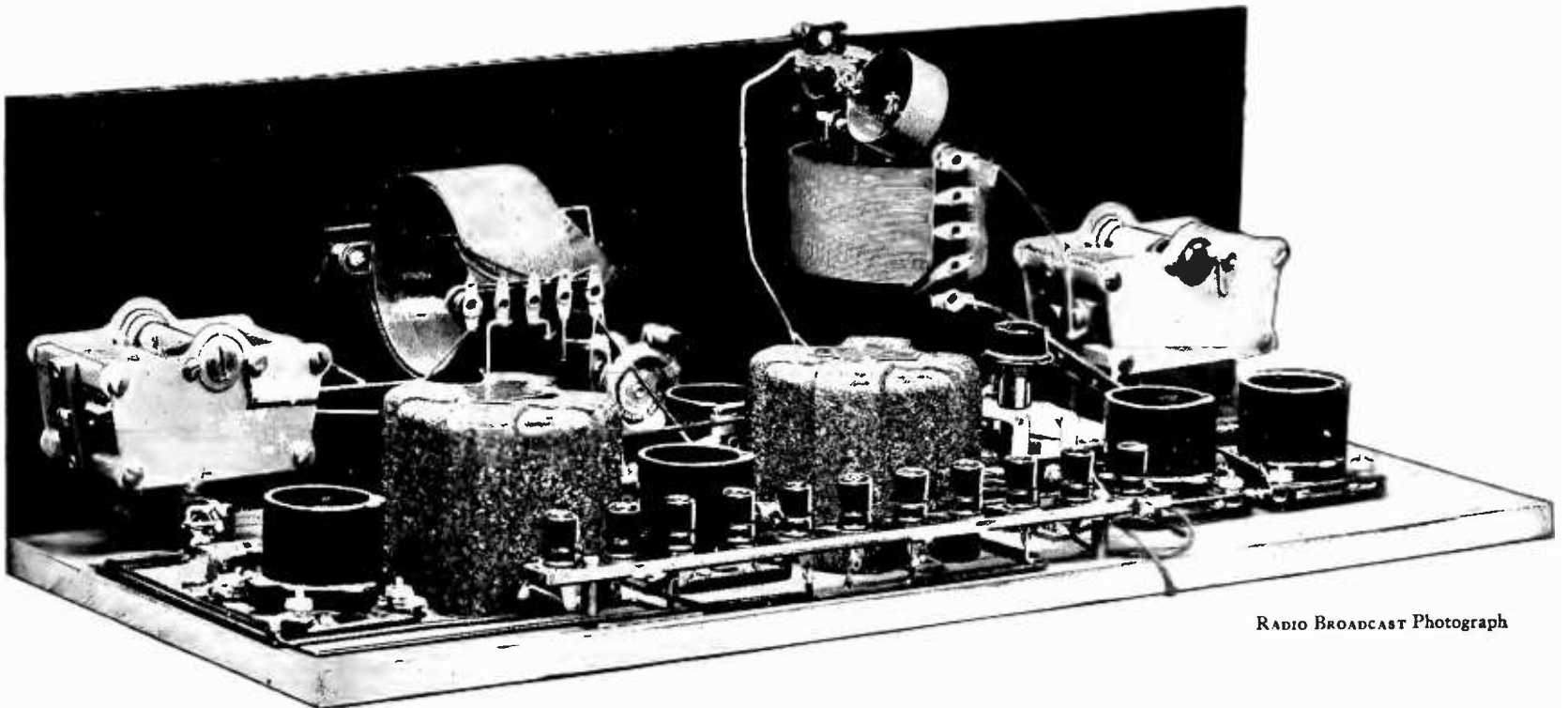

FIG. 7

To obtain satisfactory neutralization of the radio frequency amplifier, it is first necessary to de-couple the tuning coil units to prevent any undesirable feedback or inter-coupling effects which are not helpful. Here are shown several ways of placing the coils to obtain the desired effect. In A, the secondary coil axes are at right angles to each other; in B the condition prevails excepting that the two coil units have been shifted so that the rotor coil mounting holes in the panel are on a straight line parallel with the top and bottom edge of the panel. This is only where uniformity and symmetry of panel layout is desired. In C the angle of coil placement, 54°—57' made prominent in most neodynes is shown. Here it is desirable to have the coil centers placed not less than 6 inches apart



RADIO BROADCAST Photograph

FIG. 8

The rear view of a receiver employing dual regeneration constructed solely for experimenting. Note that the secondary coils of each tuning unit have their axes at right angles to each other. This is an absolute necessity where a positive neutralization of the radio-frequency amplifier is to be obtained

amplification. For the lovers of reflex, Fig. 6 is given. Notice that the first two tubes act in parallel at both radio and audio frequency. This circuit could easily be made from the Roberts Circuit as the only changes necessary are the addition of a tube and the tickler coil. Then there are the thousands of neutrodyne receivers to which this system is admirably adapted.

Fig. 9 shows a two-stage tuned r.f. amplifier in which regeneration can be obtained in two places. The neutralization of the first stage is variable so that the antenna can be regenerated by capacity feedback. The detector circuit is regenerated by means of a tickler as usual. There is coupling between the first two circuits, but the coupling between the detector and the other two circuits must be kept as near zero as possible.

Fig. 11 shows a two-stage amplifier in which regeneration occurs in three places. In view of the foregoing, the diagram is self explanatory.

In practice, the circuit of Fig. 11 would be extremely hard to balance accurately enough to operate satisfactorily. By using separate batteries on each stage and by separating them by several feet, it could probably be done, though the sensitivity would be greater than is ever necessary, except perhaps for long distance daylight reception. Probably, the most practical circuit employing multiple regeneration is that of Fig. 3.

It is not the purpose of this article to give exact constructional details for this set. Individual constructors will have their own ideas as to what the panel layout should be, since each will incorporate different varieties of apparatus. However, it will be necessary to keep in mind certain points, if the set is to work properly.

The coils must be low loss for good results. The lower the resistance the greater

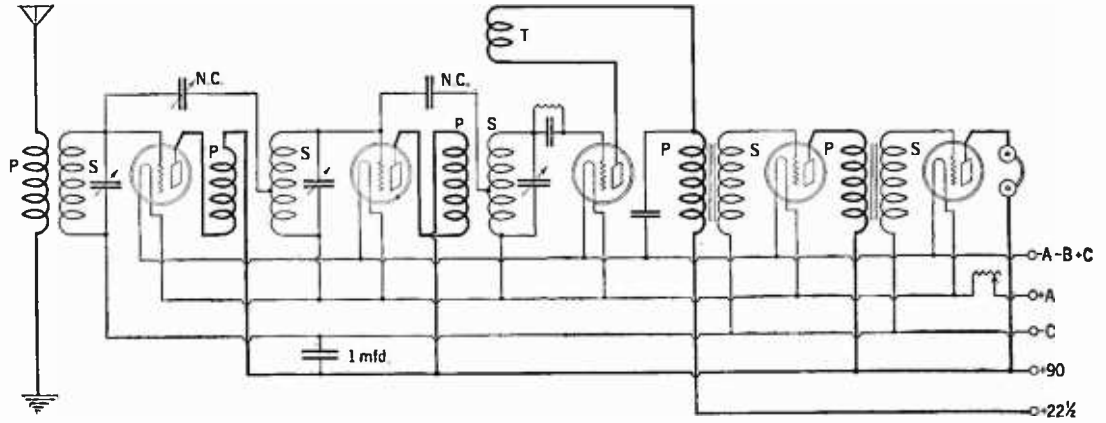

FIG. 9

The standard neutrodyne circuit employing a regenerative detector. To this circuit may be added the radio-frequency amplifier regeneration system shown in Fig. 4

the sensitivity, even when full regeneration is employed. The effect of resistance in the grid circuit of a regenerated system is thoroughly discussed in December, 1925, *Proceedings of the I. R. E.* "An Analysis of Regenerative Amplification" by the writer and K. W. Jarvis.

The two grid coils may be any of the well known low loss designs, so long as the broadcast range can be covered with the variable condensers used. The following may help in choosing the type of winding.

CHARACTERISTICS OF THE BEST COILS

THE Lorenz or basket weave coil has fallen into disrepute among the exponents of low loss lately. Nevertheless it is about as good a coil as can be made in a given small volume. In general, however, coils wound on tubing are better because they are larger. The chief losses in the Lorenz type of winding are due to eddy currents in the wire itself caused by the magnetic flux from adjacent turns. This loss is reduced to a minimum by using large diameter coils and a spaced winding. The larger the volume which is to be oc-

cupied by a coil the larger the wire that may be used with advantage. Number 24 wire (B & S Gauge) is about right for a coil three inches in diameter. No. 16 wire is better if the coil diameter is in the neighborhood of six inches.

The effect of the average type of tubing in the field of the coil is negligible in dry weather or immediately after a coil is thoroughly baked. However, the resistance of a coil may be multiplied by three or four in wet weather if proper precautions are not taken to keep the moisture out. The coil may be made moisture proof by treating it with a good coil varnish such as Sterling Copal varnish. The coil should be baked dry, then dipped in the varnish and baked again. Painting the outside of the coil with varnish is not sufficient, since moisture will be absorbed by the inner surface of the tubing. Of course collodion will do the trick but it is rather expensive. Celluloid sheets dissolved in acetone to a consistency of shellac or varnish also is effective as a coil binder.

All coils, such as primary windings and ticklers, which are not a part of the tuned circuit, should be wound with very fine wire such as No. 35 d.c.c. The resistance of these coils in themselves is not important, but if large wire is used in them the resistance of the tuned circuit to which they are coupled is increased, and this causes a reduction in efficiency.

It is well to remember that this article does not deal specifically with the construction of a receiver but rather explains the application of a regeneration control system to existing receivers.

The ratio of primary to secondary winding should be about 1 to 4 in the antenna circuit and about 1 to 3 in the detector circuit. Each tickler coil should have about 3/4 the number of turns of the grid coils. Remember that it is necessary to neutralize the coupling between the tuned circuits almost perfectly if any gain is to be noticed from multiple regeneration. This means extreme care to place the coils at right angles or as shown in Fig. 7 in order to prevent inductive coupling. It will be noticed also that any metal in the field of either coil may distort the field so as to cause coupling even when the coils are at right angles. Adjustment of the capacity balance (neutralization)

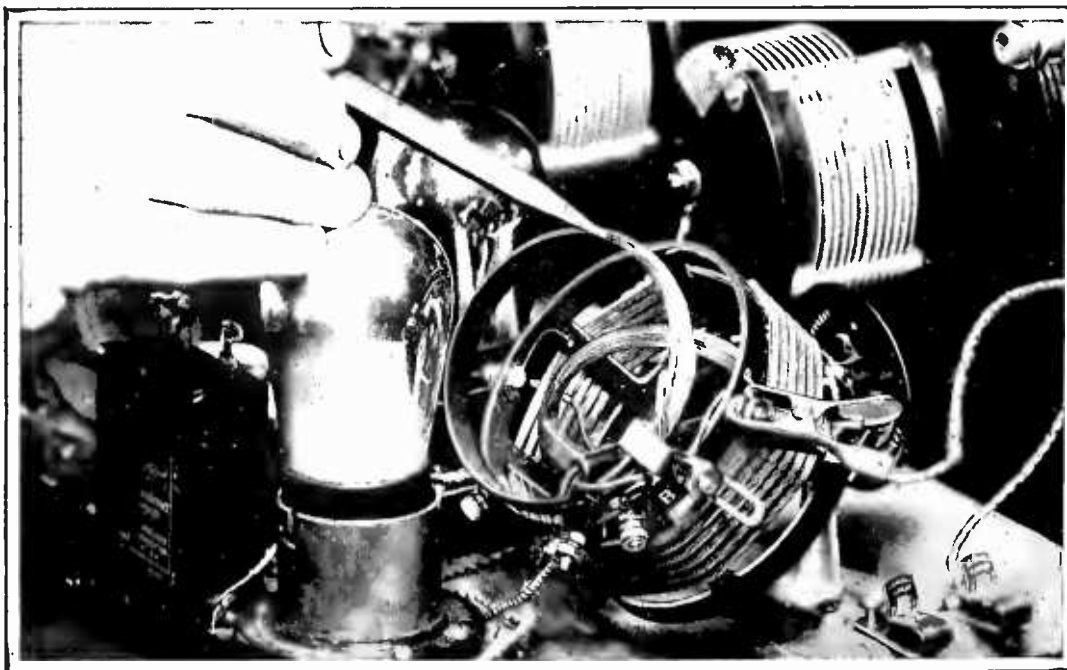

RADIO BROADCAST Photograph

FIG. 10

The pencil points to an adjustable antenna coil which aids greatly in obtaining the correct coupling between antenna primary and secondary circuit of the radio-frequency amplifier. The additional tube, which functions in the dual regenerator part of the circuit, is located directly behind the Bremer-Tully coil unit

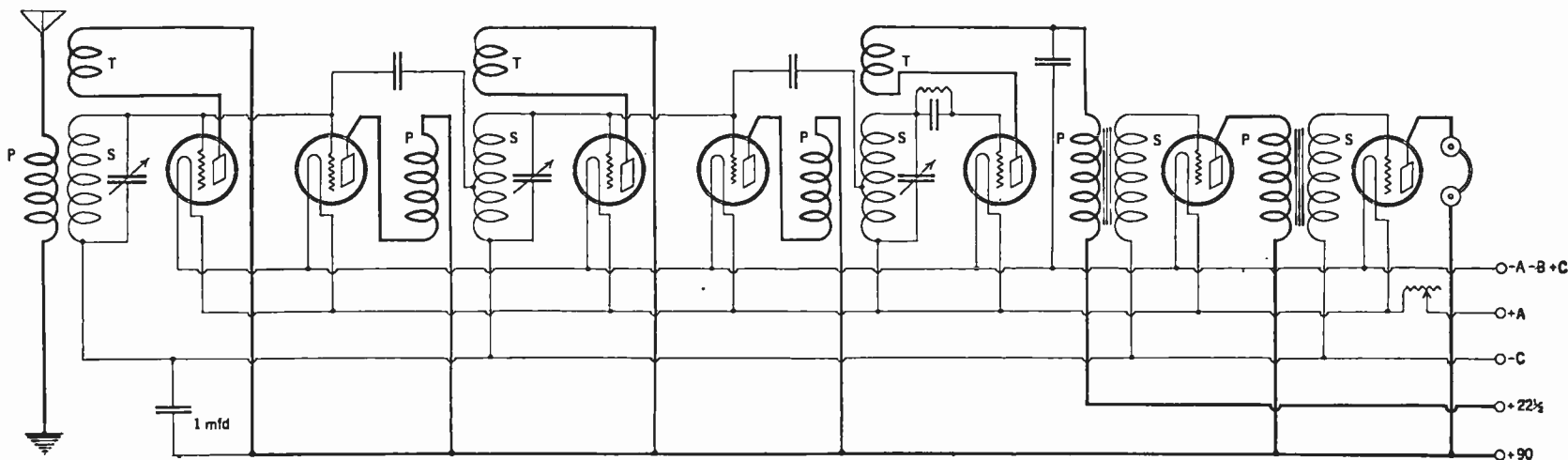

FIG. 11

Three ticklers for two r. f. stages and the detector. An hypothetical case of applying the Landon regeneration system to the neutrodyne receiver. It is unlikely that in this instance much will be gained by its use because of the extremely critical tuning which will result. Two ticklers, one for the second r. f. stage, and one for the detector, would be the more practical application of the Landon regeneration system.

should need no explanation. Let it suffice to say that the adjustment should be made as accurately as possible.

But for those who are incorporating this system in a new construction, it is assumed that neutralization has not been obtained, therefore the following memorandum on neutralization will be helpful.

Maintaining zero coupling between the first secondary and the radio frequency tickler coil, the detector tickler is advanced to cause regeneration in that circuit. Previous to this, the receiver should be tuned to some station which responds at the half-way point on the tuning dials. The squeal produced should not be made too loud. Rotate the antenna-secondary tuning condenser over a small arc. If the pitch of the squeal varies, then the set is not properly neutralized. The capacity of the neutralizing condenser employed in the circuit should be varied a little at a time until the pitch of the squeal does not vary. Then the receiver may be considered neutralized. The constructor should not confuse squeal intensity with squeal pitch.

BEST APPLICATION OF THESE EXPERIMENTAL SUGGESTIONS

A NOTICEABLE gain in selectivity will be obtained if no part of the set is grounded except one end of the antenna coil as shown in all the circuits printed with this article. This is especially effective if all battery leads are kept short.

Of course all the usual precautions should be taken. To avoid apparatus of poor design, buy only well known makes of apparatus when purchasing such items as sockets, rheostats, grid leak, variable condensers, transformers, tubes, etc.

To aid in neutralization, keep all grid and plate connectors as short as possible. Run the leads to the neutralizing condenser in as short a line as possible. Do not omit any of the bypass condensers shown. Those shunted across the primary of an audio transformer should have a capacity of about .001 mfd. The condenser across the B battery should be about 1 mfd.

To avoid bad joints and leakage losses, use rosin core or soft wire solder in wiring the set. All battery leads should be cabled if they are close together for a considerable distance in a set. This will avoid closed loops.

It should be kept in mind that all the multiple regeneration circuits shown in this article are capable of oscillating into the antenna. This is true of any r.f. circuit employing a means for neutralization and where the neutralization is not perfect. Care should be taken not to cause such oscillation at any time, since interference to neighboring receivers is the inevitable result. This is readily accomplished if the receiver is tuned as follows, which is the easiest and most natural method.

Leave the antenna tickler at zero or nearly so, and operate the set in exactly the same way that a Roberts Knockout Receiver is operated. Occasionally a signal will be found which is too weak to be brought to the required volume by this method. The antenna tickler should then be brought up to the critical point, after the other controls are properly adjusted. If oscillation should occur, it will be immediately apparent to the operator who should back off the control at once.

The circuit of Fig. 3 is especially recommended to home builders as it is the simplest and most practical of the circuits shown. It is believed that any one who completes it will be well pleased as it is a wonderful performer.



RADIO BROADCAST Photograph

FIG. 12

Adjustment of the neutralizing condenser is an important procedure in the correct operation of this receiver. John B. Brennan, Technical Editor of RADIO BROADCAST, is shown here making this adjustment in RADIO BROADCAST Laboratory

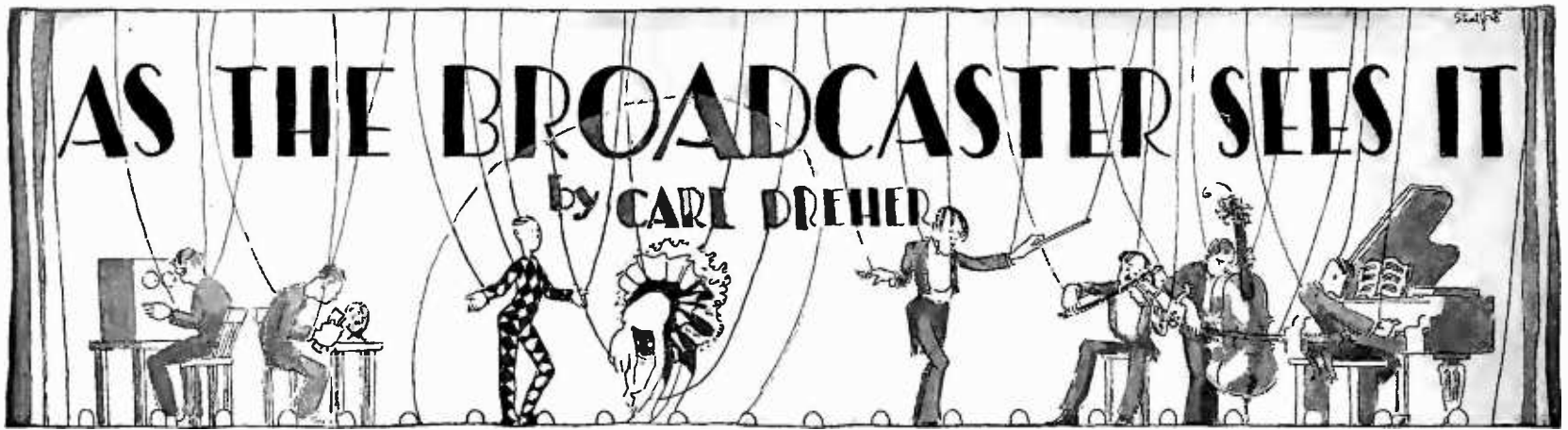

Drawings by Franklyn F. Stratford

Putting the Listener Under the Microscope

SOME years ago, in a moment of despair, I proposed the establishment of a broadcasting station to be operated for the pleasure of the engineers alone, in vacuum, so to speak. In this way the cares of the program directors, engineers, announcers, artists and other functionaries would be marvellously reduced. They would be kinder to their wives and children, and suicides and murders would be less among them. The ceaseless tension of the broadcasting business would be relieved, and professional broadcasters would become as carefree as shepherds on pleasant summer afternoons. I can see them going around playing joyfully on little pipes, the operators fraternizing with the announcers, all hands looking ten years younger, gaining weight, and enjoying life. And all through the elimination of the listeners. The method I suggested was to run the station without an antenna. Thus no one would have to worry about what went out, nor how it sounded, because no one would listen to it but the station staff, and they wouldn't give a continental.

This is a dream with which I please myself once in a while. For, in the hard world of reality, the listeners crack the whip over me and all my colleagues in the various divisions of the broadcasting business. They make and break us. Please them we must, or we don't eat—unless we give it up altogether and become garbage collectors and hosiery salesmen once more. One should give prolonged consideration to fauna of such importance to one's welfare. Therefore we shall devote a portion of this department, without further delay, to a discussion of the listener, testing his reactions to various acids and alkalis, purifying and educating him, and giving him praise where due, but nowhere else.

In the course of business I recently had occasion to make a journey with a United States Supervisor of Radio, a gentleman who is a philosopher as well as an administrator. During our talk he commented on the remarkable contrast between the perfectly supine reaction of many citizens to the avoidable evils of existence, and the fearful how-dy-do immediately raised when something goes wrong on the radio. An automobilist will sit almost motionless at the ferry landing for four hours, on Labor Day or some other holiday, waiting his turn to get on the boat, with scarcely a murmur. If he lives in a big city, he will submit himself and his womenfolk to the most inordinate crowding in their daily journeys about the town, without batting an eyelash. He allows himself to be robbed by hatcheck boys, abused by the traffic

cop when his car slides two inches over the line, and to be told by conventional imbeciles that he must not wear his straw hat after September 15th. None of these injuries is inevitable. Wharves, bridges, and subways may be built to accommodate peak loads, a posse of public-spirited citizens could lynch a hatcheck boy and duck one of the over-eloquent traffic directors, and the bitter-enders among the straw hat wearers could free themselves by marching to the Polo Grounds in a body on September 25th and shooting down the first hoodlum who threw a pop bottle at them. My remedies are a trifle radical, and all the readers of this law-abiding periodical will not agree with them, but there can be no debate about the underlying thesis. In all these situations, and a multitude more, the people stand for anything. But not in radio! Just let some foreign freighter open up on 450 meters during a concert, and twenty irate listeners sit down and write a letter to Secretary Hoover. The more moderate ones get after the Supervisor, but there are always some for whom nothing less than the Secretary will do. The Secretary must suppress the amateurs, brush the cobwebs off an ill-managed station's carrier, stop XXX from air advertising, and torpedo the Jugo-Slovakian merchant marine. He must do these things right away, or Richard Roe and John Doe will rise agin the government.

Here is an actual instance. A large broadcasting station was set up at a point 30 miles from New York, the location having been determined by careful tests and calculations. New York has a lot of suburbs, and inevitably some of them were and are (for neither the towns nor the station have been moved) much nearer the transmitter than that. When the station started testing, after only a day one gentleman, a lawyer, sat down and wrote a long petition to Secretary Hoover. He is quite a prominent lawyer and writing 1200 words must have cost him a neat sum in time and energy. It seems he had an *eleven-tube* neutrodyne, which, as he was a lawyer and had made it himself, was absolutely perfect, and with the near-by station going he could not hear one in Chicago which he had to hear, or die, so there was nothing left but to write the Secretary. As a matter of fact, in about half the time he spent in dictating that epistle he could have rigged up a wave trap which would have solved his problem. The company which put up the station knew that a wave trap would take it out in all the near-by towns when it wasn't wanted.

I do not mean that all the listeners are chronic kickers. Most of them are amiable and appreciative souls, or else the martyrs at the broadcasting end of the circuits would all have eaten rat poison by this time. For instance, in the case mentioned above, after a brief period of testing, some 1500 letters were received, of which thirty-eight were protests—some of them justified by special circumstances—while the remainder were favorable and most of them full of enthusiastic praise.

Listeners who desire to help the broadcasting stations to which they write should keep in mind the necessity for being definite in their statements and, if the matter is a technical one, critical in their observations. Some listeners are too prone to imagine things. A while ago one of the stations for whose operation I am responsible technically developed hiccoughs a few hours before an exceedingly important program was scheduled to go on. The cause was obscure, and, supported by the other heroes on the technical staff, I started to wrestle with the thingamajigs and doodaddles. With the kind permission of the local Federal official, we put the carrier on during a two-hour blank period and let an orchestra rehearsal go out. Everything—power, radiation, modulation—remained as usual in the past year and a half, and the only irregularity was an intermittent growl down in the bass. While we were sweating and swearing and tearing things apart, a listener called on the telephone. "I wish to report on your test," he announced excitedly. I didn't want any report, but as the most polite and speedy way of getting rid of him I asked what he had found. "Your station sounds just as usual," he declared after some irrelevancies, "but the wave is *terribly broad!*" Restraining an impulse to reply, "So's your old man!" I thanked our informant and got away, having lost several minutes when I needed them as a squirrel needs acorns during a severe February.

On the other hand, several of our listening customers render us occasional valuable aid with all the precision of observation and expression of trained engineers, although one of them is a physician and others are in similarly detached professions. Out of a spirit of pure helpfulness, they write extensive reports full of valuable technical data. The same thing is true on the program end. Every program manager has a circle of listening friends whose judgment and criticism are important factors in determining the nature of the material he uses. "Applause mail" is necessarily one of the guide-

posts in program work. Letters from people who know definitely what they want and don't want, and why, are always carefully read. It is not always possible to answer them individually; if the volume of mail is great, a system of form answers is the only way to avoid running into prohibitive expense, although even then some of the letters must receive special attention.

The more pretentious the writer, the less the value of his letter, as a general rule. Recently I received a report on signal strength from one well-wisher who printed "Radiotrician" under his name. There was not the slightest sign of an address on the letter, and all it told me was that someone in the United States heard us satisfactorily. And in the letter he asked for an answer, and he is probably riled because he failed to get one!

The listeners have their foibles, just as the broadcasters have theirs. And it is hard to please all the people all the time. In fact, as I have had occasion to argue in this place before, to attempt to do so leads directly to stultification. And some members of the audience will always prove unreasonable. All that is true, but in the last analysis the progress of broadcasting is accelerated by the pressure exerted by unsatisfied patrons. The power level is being raised because people object to getting their music mixed with the electrical racket of the vicinity. The programs are improving because people will no longer listen to feeble stuff, and because they want entertainment as good as that of the best theatres and concerts. Not everybody can keep up with the procession. Well, if some of the stations fall by the wayside, the event is proof, in each case, that there is no place for that station. So let the tomahawks fly, and the devil take the hindmost; the time may yet come when Mr. Hoover will be able to separate stations by so many kilocycles that the "dyne" squeals will be lost in the upper reaches of audibility, and for that and other blessings we shall have to thank, in part, the listener-die-hards.

A Jazz Lover Lifts His Voice

COMMUNICATION from a defender of jazz harmony, Mr. Bernard Kelly of Pueblo, Colorado:

SIR:

You are about to solve a great problem for me. I am one of "Those things" that like their jazz straight, and in these times when radio broadcasters are simply drenching the nation with the polluted stuff, I can't seem to bag it. I thought that I might be trying to operate my set without aerial and ground, but this does not seem reasonable, as I can get any number of salon orchestras, coloratura sopranos, and players of Bach and Wagner. Perhaps atmospheric conditions here are so educated as to shut out the barbaric jazz and give asylum to the classics which nobody else can find. Need I add that I was desolated until I read your December article.

Apropos of your statement: "If you want Jazz issuing from your loud speaker, there are certain wavelengths in every locality where you can get it at any time." I am enclosing herewith a little blank of my own arrangement, together with a stamped, addressed envelope, whereon you, being a good sport, will inscribe these various stations. I use a Roberts Knock-out set. Let this guide you in your choice, and remember, I'm very choosy about my jazz. I would have been satisfied to get it on the headphones, but your added promise of loud speaker volume greatly pleases me, and in return for this favor, I'll give you a tip. KOA of Denver is one of those stations where they specialize in uplift. They have there some very palatable violinists and pianists, together with an array of songsters who have never heard of Irving Berlin. Moreover, they have just begun to give Spanish lessons. Here indeed is a safe refuge from Jazz. I await your reply most impatiently.

The blank to which Mr. Kelly refers is prepared with, as can be seen, diabolical ingenuity and thoroughness; its general lay-out will appear from the sample which I am magnanimous enough to print above:

WHERE TO GET JAZZ WHEN YOU WANT IT

Compiled by Carl Dreher

HOURS
Mountain Time

Day	7 P.M.	8 P.M.	9 P.M.	10 P.M.	11 P.M.	12 P.M.
SUNDAY						
MONDAY						

If Mr. Kelly was "desolated" before the appearance of my article "In Defence of Broadcasting" in the December number, by the dearth of jazz on the Colorado steppes, he was in no worse case than I am at this moment. I am not merely desolated, but prostrated, and there is nothing more terrible than to be desolated and prostrated at the same time. In fact, the coincidence of these two acute malaises is so rare and dangerous that I may be able to make some money by exhibiting myself before the annual meeting of the American Medical Association (if they have one), or by travelling with an old-fashioned medicine show (if any still exist). The last time I was so sad was twelve years ago, when my first audion bulb gave up the ghost after two hours of use, leaving me bankrupt and heartbroken. My present grief flows from two sources: first, from hearing Mr. Kelly cry "Jazz! Jazz!" when there is no jazz, and secondly, because I am unable to make good on the sentence which Mr. Kelly has plucked out of my article. It appears that there is a neighborhood where jazz is not always on tap for those who crave its charms. Well, that's certainly too bad. Mr. Kelly might try some suasion on Mr. Talbot, the program man at KOA. If all else fails, he can move to New York, a town which spouts hot jazz as Old Faithful spouts hot water. Above 360 meters one gets it now and then; below 360 meters jazz runs riot. Incidentally, in common with the Hon. Gilbert Seldes, I have no objection to the stuff in limited quantities and



"THEN TWENTY IRATE LISTENERS WRITE A LETTER TO SECRETARY HOOVER."

when it is well done. I would rather listen to a good jazz band than a rotten soloist; there are even times when I'd rather listen to a good jazz band in preference to a good soloist or classical orchestra, depending on my mood. For example, when I write out my income tax check, once a year, I like to listen to jazz; it cheers me up. The only reason I took Mr. Nathan up on this question is that he seemed to think that radio music is practically all jazz, a conclusion with which my battered ears did not agree. And now along comes Mr. Kelly, roasting me by implication, because there isn't enough jazz! I give it up!

Technical Routine in Broadcasting Stations

3. Monitoring

THE word "monitor" is one of the contributions of wire telephone practice to broadcasting. Its technical meaning is to listen to what is going over a circuit for the purpose of making indicated adjustments. The principal one of these adjustments, in broadcasting, is the regulation of the amplification, or "gain," as the telephone people call it.

Skillful broadcast monitoring is an art in itself. The necessity for it arises through the fact that radio transmitters cannot be built, at the present stage, to accommodate the extreme ratios in volume of many musical performances. The energy emitted by a symphony orchestra, going full blast, with the conductor sweating like a stevedore and all hands sawing, thumping, and blowing to the maximum capacity of their instruments, is in the ratio of about 100,000:1 to a few of the pieces playing *pianissimo*. This does

not faze musicians a bit, but it gives an engineer the willies. The power ratio of machines—the ratio of the maximum power which the machine can handle effectively, to the minimum, is as a rule quite low, probably not more than 10. One cannot build a machine which will have the power of a locomotive, when that is required, and which in the next second can be used to crack nuts efficiently. If it is a good nut cracker, it will not be an adequate locomotive, and if it is a good locomotive it will be lamentably wasteful as a nut cracker. This is from the standpoint of the engineer as a manipulator of energy—raw horsepower. But a broadcast transmitter is not a mere engine. It is a combination of musical instrument and machine. So a compromise becomes necessary. The energy ratio remains large, say of the order 1,000:1, but even so it is only one tenth of one per cent. of the original. The reproduction is not perfectly natural, but it sounds better than it would if the 1,000,000:1 ratio were the basis of operation. In that case the low portions would drop below the noise level, with the result that portions of the performance would be lost altogether. By ironing out the peaks and faint passages to this extent the ultimate quality of reproduction is at its best.

This 1000:1 reduction in ratio is accomplished manually. Of course, in many types of music the actual original ratio is much lower than a million to one, and in that case the reduction should be correspondingly modified, the object of the competent control engineer always being to leave the original alone just as far as the load characteristics and noise level of the broadcasting medium will permit. There are, in general, two types of incompetent control operators. The first is careless; he "lets it ride." Some-

times he lets the level drop so that no one on the outside hears it, and at other times he allows overloading and distortion to mar the performance. The announcements are too high or too low with respect to the music. They should be slightly above the average value of the music, say 60 per cent. amplitude. The second type of undesirable control operation is the over-cautious method, whereby the modulation is ironed out to such a degree that most of the contrast is lost. This fellow constantly pulls down the gain when the music is loud, for fear that it will overload, and brings up the *pianissimo* passages so that the listeners will be sure to hear them. He can't do much to a jazz band, but heaven help the station which lets him loose on a symphony orchestra. A good gain regulator is like a good fighter; he always has something in reserve. He is unlike a fighter in this: he seldom moves fast. Jerky manipulation of the amplification handle is out of order. The movement should be smooth; the only abrupt changes in the music should be those which the composer wrote into it. Of course the whole thing can be gauged better by one who knows the piece being played. He can look ahead and give a more finished performance than the man who has no idea of what is coming next. The gain control should not be moved except when

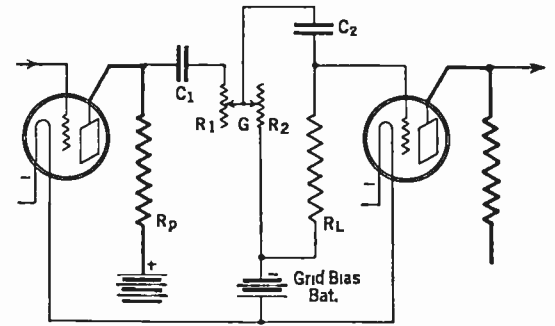

FIG. 1
A "Gain" control in a field control set

necessary, and then its movement should never be neglected; the competent control operator knows which is when.

On field events, the control should be in the hands of the field technician, he being on the ground and in a better position to judge than the man at the station end of the line. The station engineer sets his gain control once and for all, theoretically, moving it after that only to correct errors on the part of the field man. On studio events the job devolves on the station control operator, necessarily. As a rule, less monitoring is required in the studio, for very large orchestras, organs, choruses, etc., are encountered more in the field.

The usual form of gain control is a potentiometer arrangement carrying only audio fre-

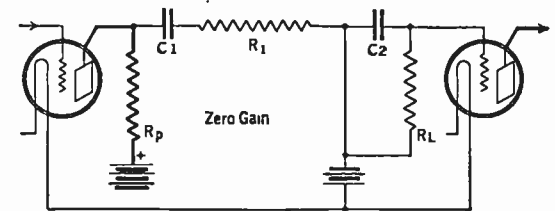
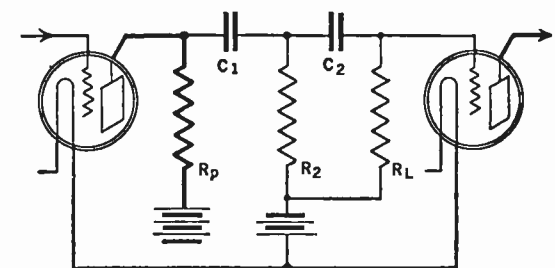

FIG. 2

quency and isolated by means of condensers from any d.c. circuits whose variation would give rise to noise. Fig. 1 shows such an arrangement between stages of a resistance-coupled amplifier. Rp is the resistance in the plate of the first tube, C1 a condenser of the order of 0.5 mfd. separating the gain control and following tube from this plate circuit, G is the gain control, which is so arranged that as one resistance R1 is cut in, the other resistance, R2, is correspondingly reduced, C2 is the second isolating condenser, of the same magnitude as C1, RL is the grid leak of the following tube. Fig. 2 illustrates how, with the contact in one extreme position, C2 has one side short-circuited to the filament of the second tube, while the resistance R1 is in series between the tubes, practically blocking the transfer of audio voltages. In Fig. 3, the reverse condition obtains, R1 being all out, while the total drop of R2 is available to pass on audio fluctuations to the second triode. This gain control is noiseless, unless the sliding contacts are so bad that they open momentarily,



Maximum Gain
FIG. 3



HE CRIES "JAZZ, JAZZ," WHEN THERE IS NO JAZZ

breaking the connection between the tubes between which the gain control functions.

The crude gain control which is sometimes seen in small stations—a means of cutting down filament voltage on one of the audio amplifiers, is bad because as the emission of the tube drops the impedance rises, resulting in the loss of low frequencies in most cases, as well as other anomalies.

Memoirs of a Radio Engineer

X

IN THE January issue it was related how the Federal legislation of 1912 started to bring order out of chaos in the radio world. The job was not a small one, and now, thirteen years later, it is not yet completed. For as fast as one patch of chaos was ironed out in one place, another, such as broadcasting, bobbed up somewhere else, to keep the authorities busy. That the law was provided with teeth was demonstrated very shortly. A young man who, after the passage of the act providing for station and operator's licenses, had continued to transmit without either, on a wavelength that happened to suit him, was haled to court and fined. This was in 1913, and the incident received considerable publicity. The law had gone into effect December 23, 1912, and by that date about five hundred of the twelve hundred amateurs in New York City had applied for their papers. Those who continued to operate were warned by W. D. Terrell, now Chief Supervisor of Radio, with headquarters in Washington, but then in charge of the New York district. "These amateurs," said Mr. Terrell, "who make it a practice to interfere with business communication, are nearly all known to us. There may be a very few whose whereabouts we have not yet found out, but in a short time, thanks to the efforts of commercial stations and of the vast majority of amateurs, who realize that the delinquencies of these few may call for laws still more strict,

we will run them all down." And indeed, after a half year or so, the only unlicensed amateurs left were little fellows with spark coils of limited range; practically all the big fellows had submitted.

I had no transmitting station worth the name, but by this time I was fairly adept at copying and was filling my log book with such entries as the following:

- Sept. 10, 1912. 2.27P. Ward liner *Havana*, WH, talking to NY. Distance, 251 miles.
- Jan. 11, 1913. 8.00P. MAA, White Star *Carmania*, working MSE.
- Jan. 20, 1913. 2.23P. SS *Moltke*, DDM, working MSE. Good sig.
- Mar. 1, 1913. 5.15P. KKK, SS *El Occidente*, calling MSE. Comes in well with low tone. Wanted to know if MSE knew where SS *Comus* was.

MSE was the Seagate land station, later WSE, a famous transmitter in its day. It had a 3-kw transmitter with rotary gap.

My log book also contains numerous messages copied from ships and the few land stations around town. Besides WSE, the principal transmitters in the New York district at this time were FNK, the Bush Terminal station of the National Electric Signalling Co., and TWT, operated by the Atlantic Communication Company at 111 Broadway. The latter two had beautiful notes around 1000 cycles, which they maintained with remarkable purity of tone for weeks at a time. Their flute-like whistles enraptured all the amateurs, half of whom would cheerfully have killed a man for a 500-cycle alternator and a quenched gap.

"Wireless telephony" was not unknown, but it was as yet no more than a curiosity. The principal hope of its proponents was that it might supplant wireless telegraphy; its application in broadcasting apparently occurred to no one, as yet. The following report in the *New York Times* shows how radio telephony was regarded toward the end of 1912:

VOICES HEARD BY WIRELESS

Marconi Operator Picks Up Conversation 150 Miles Away

SAN FRANCISCO, Dec. 18.—A demonstration that wireless methods may be used for transmission of the human voice was made on the recent trip of the Pacific Mail liner *San Jose*, which reached here to-day from Panama. Last Monday, while off the Lower California coast, C. H. Kessler, the ship's Marconi operator, distinctly heard conversation while he was taking a wireless message. The conversation was a test of wireless telephones between Catalina Island and the mainland of California, and was carried on 150 miles from Kessler.

At noon, when R. H. Shimek relieved Kessler, he also heard scraps of conversation, as well as music from a phonograph. As several passengers were around the wireless room he gave them individual receivers, and they heard ragtime music distinctly, and even danced around the deck to the tunes. The Captain was called in and heard the music.

This experience was said to be the first of the kind ever recorded, and it suggests that the wireless at sea may yet be handled like the telephone, which would be a great economy in time of transmission, especially in the case of vessels in port.

Antique stuff! Even the words—"wireless," "ragtime," are out of date. And the speculation in the last paragraph was on the wrong track. By far the best way to communicate with vessels in port is by the simple expedient of hauling a telephone cable aboard and hooking up the ship to the nearest exchange. The big ocean liners all have telephone switchboards, and when



“ . . . THE ENERGY EMITTED BY AN ORCHESTRA GOING FULL BLAST. . . . ”

they are at their piers you call up the various extensions just as you call up the local delicatessen dealer or the town dog-catcher. And when they are at sea, the radio telegraph provides a faster and more reliable service than telephony can give. The code cuts through static and interference where telephony would only yield a jumble. Even now only a few ships carry radio telephone transmitters, and they are considered a luxury, although presumably the time will come when the great liners will carry extremely powerful radio telephone sets providing a ship-to-shore service linked up with the land telephone. But the wireless phone did not have to await this development before it could come into its kingdom. Broadcasting supplied that.

Broad Waves and Sharp

ONCE an error has taken firm root the only thing to do is to wait a few centuries until it is forgotten, for you will certainly not get rid of it in any quicker way. Thus, probably a majority of the population still believe that blondes are treacherous, that no one with brown eyes can ever become a great man, that touching a toad will cause warts, and that Aaron Burr was a villain while Alexander Hamilton was an angel. There is no law against believing what one pleases, even though it is wrong. This is likewise true of the almost universal belief among radio listeners and newspaper critics that in some mysterious way the engineers of a broadcast station can sharpen its wave, as if it were a pencil which can be whittled down with a jack knife. Everybody believes it, although it isn't so. It is true of a spark station emitting a decadent wave train, and that is no doubt the origin of this radio superstition. But given a broadcasting station of P meter-amperes modulating a continuous wave of a certain radio frequency Y, modulated at audio frequency X with per cent. modulation Z, the only factors influencing the broadness of tuning in reception are (1) The signal strength at the point in question, and (2) The kilocycles admittance of the receiving set at the said frequency Y. In other words, when people talk of a broadcasting station as having a "broad" or "sharp" wave in the abstract they are emitting nonsense. It becomes sense only when a particular receiving location with known signal strength from the station in question, and the tuning characteristics of the receiving set, are definitely specified. When a listener declares that a certain broadcasting station has a "broad" wave, it usually means that he gets a very strong signal from that station, or that he has a badly designed receiving set, or both. If he says that the wave is "sharp" the conclusion is that the signal is relatively weak, or that the receiver tunes sharply, or both. Assuming the power of the station as fixed, it has no control over either condition.

The Lingo of Radio

Onomatopoeia

THIS disagreeable looking Greek word is applied to those terms which through their sound imitate the thing described. There are a few such words in radio, most of them not of radio origin, however. "Buzzer," for example, and "howling," "squealing," for uncontrolled

audio frequency oscillation, as of an amplifier. The older telephone term for this phenomenon, "singing," has not broken into radio to any extent.

The only original radio names which exhibit the tendency toward sound imitation in word formation appear to be the words describing certain kinds of strays: "Clicks," "crashes," and "grinders." "Clicks" are the short sharp impulses, "crashes" are somewhat longer and more bothersome; "grinders" are still longer and may consist of a succession of shorter impulses.

Imported Words: Foreign Influences.

Except from the English, American radio is indebted very little to foreign languages for its radio terminology. The only instance I can recall offhand of a word borrowed outright is the German "litzendraht" for stranded high frequency conductor, and this has been modified into "litz."

It is interesting, however, to note how widely British and American radio terminology differ. The divergence, of course, is by no means confined to radio. Again, a Britisher talks of "ordinary" and "preference" stock, where an American says "common" and "preferred." The following is a comparison of a few British and American radio terms:

BRITISH	AMERICAN
Anode, plate	Plate
Ebonite	Hard rubber
Gear	Apparatus
Components	Parts
Maker	Manufacturer
Factor	Jobber
Earth	Ground
Basket coils	Spiderweb coils
Pile winding	Bank winding
Valve	Bulb, tube
Reaction	Regeneration
X's, atmospherics	Static
Note magnifier	Audio amplifier
Accumulator	Storage battery
Frame aerial	Loop
Jigger	Oscillation
	transformer spiral
	helix
Anode (of a tube)	Plate
Low frequency (l.f.)	Audiofrequency(a.f.)



"A YOUNG MAN WAS HALED TO COURT"

High frequency (h.f.)
Terminal
Telegraphist

Radio frequency (r.f.)
Binding post
Operator

The curious term "listen-in," incidentally, appears to be of English origin. Why the "in" was added is as much of a mystery as the appearance of the same preposition in the British slang phrase, "do him in"—"kill him." Whatever its origin, it has led to some horrible compounds, like "listeners-in," which is about as far as one could go if one sat down to invent the most awkward phrase possible.

Why do we speak of an air-core transformer? The case is really one of the absence of a core, and we might better call it a "coreless transformer" or an "air transformer." Of course air is something—witness the trouble we take to get it out of our electron tubes, but is it solid enough for a core? However, we all talk of it in that way.

Why "variometer" to denote a continuously variable inductance? The instrument does not measure anything, so the "meter" part of the name is out of place, and the "vario" is too vague to mean anything. In a less aggravated form, "potentiometer" has the same or similar faults.

The only thing that can be said in favor of the terms "A," "B," and "C," batteries, for plate filament, and grid bias, respectively, is that they are brief. Such arbitrary designations are very puzzling to beginners. These terms, incidentally, date back to the invention of the three-electrode tube.

Of late years, some effort has been made to achieve uniformity in the use of suffixes in speaking of the common electrical properties. On this basis it is not correct to speak of "resistance" coupling in an amplifier; one should say "resistive" coupling. An "inductor" is the physical object or coil possessing the property of "inductance"; its effect is "inductive." Likewise "resistor," "resistance," and "resistive"; "capacity," "capacitance," and "capacitive." However, no one will be arrested for using the wrong suffix.

Proper Names

THE Alexanderson alternator, the Poulsen arc, the Heaviside layer, are instances where the name of a man of original ideas has become attached to a machine or theory. The common electrical units, also commemorate the names of great scientists, as the *farad* (Michael Faraday), the *ampere* (after André Marie Ampère), the *volt* from (Count Alessandro Volta), and the *henry* (Joseph Henry—an American physicist, incidentally). Then there is poor Pierre Vernier, who died in 1637 after inventing an attachment for indicating accurately parts of divisions in linear measurements, and never conceived of a radio set—and his name is applied to the fine adjustment of variable condensers three centuries later!

Radio terms derived from the various older engineering arts are too numerous to mention. Such words as "decrement," "eddy currents," "secondary," "primary," etc., are of old standing in electrical science. The various prefixes which denote magnitude, such as "meg" (one million); "kilo" (one thousand); "milli" (one-thousandth); "micro" (one millionth); and their combinations, are all in general scientific use and not peculiar to radio.

Standards for the Home Laboratory

How the Home Experimenter Can Build and Use the Necessary Standards of Inductance, Capacity, and Resistance—Essential Tools for All Kinds of Experiments—More Suggestion for the Ambitious Home Experimenter

By KEITH HENNEY

Director, Radio Broadcast Laboratory

THERE are two stages in the life of any experimenter whether he be inclined toward chemical, mechanical, or electrical pursuits. The first stage may be represented by the desire to do something of an experimental nature, it matters little what, as long as something happens. The second may be marked by the experimenter's desire to know what has happened, if anything, and how much of it has happened. Any one can hook a condenser across the antenna and ground of a receiver and note what happens. Any one can attach a coil across that condenser and have a wave trap. But after a few preliminary bouts with a tricky device of this nature, the experimenter will probably plot a curve of the thing, showing what happens to certain frequencies when the condenser is varied.

This business of wanting to know what happens, and how much, when the condenser is tuned, signalizes the entrance of the radio experimenter into the second stage of his career. Lord Kelvin, one of the world's greatest experimental and mathematical scientists, is credited with saying that any research enters upon a scientific basis when actual figures are put down on paper, when the experimenter knows how much, and when, and begins to get some idea of "why."

Just as building radio receiving sets palls on most any one after the dozenth is completed, so will endless and aimless experimenting get to be stale sport unless there is something to look forward to.

The staff of RADIO BROADCAST Laboratory has prepared a number of experiments for those who are interested in the more serious side of

radio research, and the essential apparatus will be described from time to time. The first article of this series, in the September RADIO BROADCAST, described a simple vacuum tube oscillator for the home experimenter that in the Laboratory has proved to be of endless service. It consists of a radio-frequency oscillator, a miniature broadcast station in fact, which is modulated with an audible tone. The uses of this oscillator were described in the December magazine. The

capacity, and resistance, and for practically all of his work he uses these quantities in varying proportions and in various relations to each other. He winds a coil and finds that it will tune to a certain frequency band with a .0005-mfd. condenser. He may feel that tuning is broad. He knows then that there is resistance in the coil, too much resistance perhaps. But he wants to know how much, how to reduce it, and what is the practical limit of reducing resistance.

In other words, he wants to know "how much?"

To do exact or even approximate work, the research engineer and the home experimenter alike must know to a certain degree of precision the constants of the apparatus with which he works. To know that one's apparatus is correct to within a certain per cent. is to know that one's results will be valuable to that extent. Accurately designed equipment, carefully calibrated, inspires a degree of confidence in the worker that will be one of his best assets.

In any well equipped Laboratory, the question "how much?" is answered in one of several ways. The simplest method and the one most often employed is a comparison of the apparatus under

test with some high grade standard. For instance, one builds a coil. He wishes to know its inductance and perhaps its resistance. By a complicated series of experiments he may arrive at both of these values, but by a simple comparison with a coil already measured he may arrive at the answer in a short time.

Among the first acquisitions to a home laboratory, then, are standards of inductance, capacity, and resistance with which all unknown coils, condensers, and resistances may be compared.

MORE than one satiated home constructor has written us that this series of articles by Mr. Henney, the director of our Laboratory, has caused them to renew their subscription to RADIO BROADCAST and to take a new interest in the technical side of radio. Dust that has collected on soldering iron and pliers is shaken off, and unused parts in the miscellaneous pile of odds and ends owned by every constructor worthy of the name are assuming a new value. There are many among the amateur radio folk who have the feeling that if they could just learn a bit more about what could be called the laboratory fundamentals of radio, they would be able to make considerable progress in the art, and perhaps even make a discovery of some importance. We believe that these articles, of which this is the third, will be of great value to these inquisitive souls. Those two valuable Government radio books, Bulletin No. 74 of the Bureau of Standards, and Principles Underlying Radio Communication, published by the Army Signal Corps are used as bases in the present article. Every radio enthusiast who really wants to learn more about the art should own these volumes, which can be had from the Government Printing Office.—THE EDITOR.

present article will deal more with the uses of this device and mention a few lines of experiment along which the home constructor should work.

WHAT ARE THE ELEMENTS OF RADIO?

THE apparatus used in radio consists largely of two simple elements, inductance and capacity, that is, coils and condensers. Each of these components of oscillating circuits has resistance, so the experimenter has to deal with three important electrical quantities, inductance,

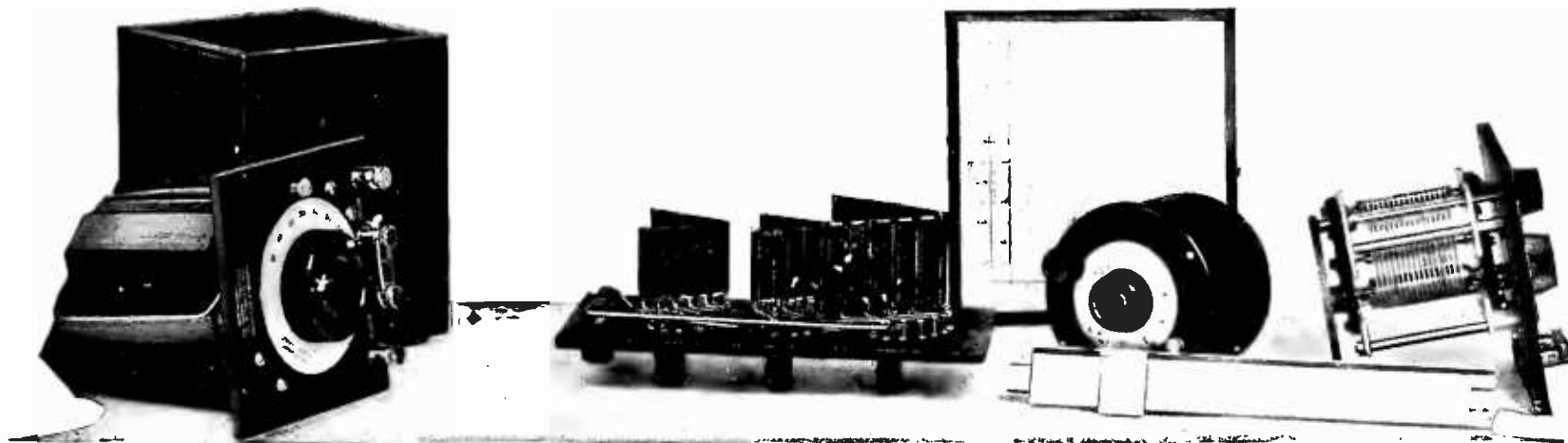
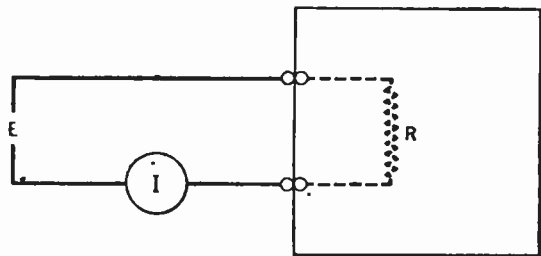

FIG. 1

RADIO BROADCAST Photograph

Some of RADIO BROADCAST Laboratory's standard apparatus. Note the peculiar construction of the "inner works" of the resistance box. The other apparatus is a standard variable condenser and a variometer which is used as a standard of inductance. An idea of the size of the equipment may be judged from the ever-useful slide rule which is just 10 inches long



Power = $(I)^2 \times R$

FIG. 2

This represents a source of direct current energy feeding a load which is in the box. If the ammeter is not accurate, the amount of power used cannot be correctly computed

These standards must be carefully made and accurately measured. Fortunately, the construction of a coil is sufficiently simple that anyone can do it, and thanks to the work of the Bureau of Standards physicists, the home worker can calculate its inductance with sufficient accuracy for all ordinary work. Fortunately, too, he may construct a standard of capacity, or at small outlay he may purchase a variable condenser equipped with a dial calibrated in micro-microfarads, such as the General Radio No. 247.

The importance of knowing the accuracy of one's equipment may be illustrated by the following experiment. Fig. 2 represents a source of direct current feeding a certain "load" which is in the box. We desire to know how much power in watts it required. Knowing the resistance of the box and having an ammeter in the circuit, it is a simple matter to compute the power for

power = (current)² × resistance

where power will be in watts provided the current is in amperes and the resistance is in ohms. If the resistance is one ohm and our ammeter says that ten amperes are flowing, we get from our formula $(10)^2 \times 1 = 100$ watts. But if our ammeter reads ten per cent. too low, in other words it is only 90 per cent. correct, 11 amperes will actually be flowing and the power will be 121 watts, an error of twenty one per cent.

Or suppose that we want to design an inductance that will tune to 1000 kilocycles (300 meters) with a condenser of .00025 mfd. capacity. At this frequency, the product of the capacity in microfarads and the inductance in microhenries is .025331, so that the inductance value must be 101.32 microhenries. If we design such a coil and our measurements show that it has this value when it is actually ten per cent. greater, that is, 111.45 microhenries, the frequency will be about 950 kilocycles (315 meters). These values come from the relation between frequency, inductance, and capacity.

$F = \frac{1}{1.884} \sqrt{LC}$

Such errors are discouraging to any worker, and to one who wishes to make accurate experiments or apparatus, they are hopeless.

Examples of some of RADIO BROADCAST's standards of inductance, capacity, and resistance are shown in Fig. 1. They are made by the General Radio Company. Similar apparatus may be obtained from Leeds and Northrup, the Cambridge Instrument Company, and others. The list numbers and prices for the General Radio Equipment are given below:

Resistance Box, Type 102-K	.1-, 1-, 10-, 100-ohm units	\$47.00
Capacity	Type 239-F .001 mfd.	19.00
	Type 247-F .0005 mfd.	5.50
Inductance	Type 107-G 100 to 6000 microhenries	24.00

A standard fixed capacity is a good addition to any laboratory and may be constructed of metal plates with air dielectric. Neglecting minor corrections, the capacity of such a condenser may be calculated by the following formulae

$C_{mmf} = \frac{.0885S}{T}$ Where S is the area of one plate in sq. cms. Where T is the distance apart of the plates in cm.

$C_{mmf} = \frac{.225S}{T}$ Where S is as above in square inches Where T is as above in inches

If some other insulator than air separates the plates, such as mica, or glass, the formula will not hold, and the home constructor is not advised to stray from the use of air in his standard condenser. It has the advantage that it is of constant "dielectric" value. Its use makes it possible to calculate the capacity fairly accurately, and like all apparatus supplied by nature, it is free. As an example, two square plates 10 cm. on a side, separated by one mm. of dry air will have a capacity of 88.5 mmf. as shown below

$C_{mmf} = .0885 \times 10 \times 10$

$C_{mmf} = 88.5$

A good variable condenser may be any of the commercial types. The General Radio Type 247 is specially valuable if provided with a calibrated dial. The standard should have a capacity of about .0005 to .001 microfarad, should not be equipped with a stop so that the plates may be rotated through a full revolution without bringing up against a metal pillar with a thud sufficient to move the plates on the shaft. This would invariably spoil the calibration of the instrument. It should be of the old fashioned straight line capacity variety since the curve of such a condenser will be a straight line as is shown in Fig. 3 which is the calibration of the Laboratory's standard.

The ordinary small bypass condensers are not at all suited for laboratory standards. They have been known to depart as much as 50 per cent. from their rated capacity and are not independent of external conditions such as moisture and temperature. Sangamo fixed condensers, however, have been found to be within 10 per cent. of their rated capacity and are usually within 5 per cent. It is probable that manufacturers of similar condensers will furnish ones of measured capacities at slightly increased cost. Variables with calibration curves may also be

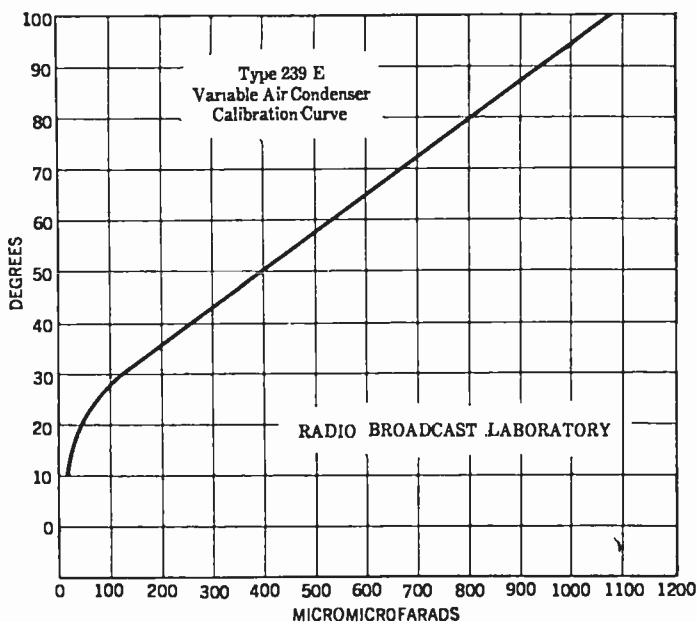
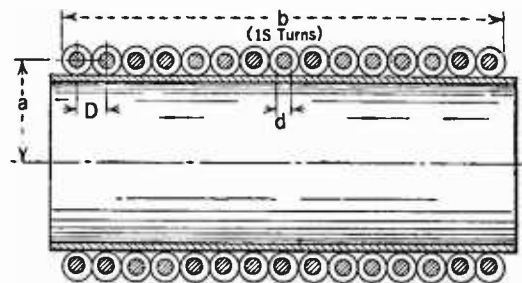

FIG. 3

A calibration curve of the standard condenser shown in Fig. 1. It is of the "straight line capacity" type and is an excellent standard



DATA	N = 15	b = ND = 15 × 1.1 = 16.5
	d = .4 cm	2a = diam. = 24.4
	D = 1.1 cm	b = length = 16.5 = 1.48
	a = diam. of tubing + d = 12.2	K for 1.48 = 0.598
		L = 48 microhenries

FIG. 4

Essential dimensions for a coil whose inductance will be 48 microhenries. The dimensions are those that are to be fitted into the formula given in the text

obtained from well-known manufacturers, or they may be sent to RADIO BROADCAST's Laboratory where they will be calibrated at a nominal cost.

INDUCTANCE STANDARDS MADE AT HOME

THE construction of an inductance standard should present no difficulties to the experienced home constructor. He should procure a coil form, bakelite, hard rubber, glass, cardboard soaked in paraffine, or some other insulating material, wind it full of No. 18 d.c.c. wire, attach the ends of the wire to small binding posts at the ends of the tubing, and calculate the resultant inductance. Fig. 4 shows the essential dimensions of an inductance in centimeters and gives the values to fit into the inductance formula below, which may be found in the Bureau of Standards Circular No. 74, and the Signal Corps Book, Principles Underlying Radio Communication

L in microhenries = $\frac{.0395A^2 N^2 K}{C}$

The method of applying the data to the formula is shown below. The constants are taken from Fig. 4.

$L = \frac{.0395 \times (12.2)^2 \times (15)^2 \times .598}{16.5} = 48$ microhenries

These values may be found on Page 386 of the Signal Corps Book already mentioned and a drawing of such a coil is shown there too. As another example a single layer coil on a five-inch form 11 inches long and having a total of 150 turns will have an inductance of a little over one millihenry. This is too large for ordinary radio measurements over the broadcast band of frequencies, since the coils ordinarily used have an inductance of from .1 to .5 millihenries, or 100 to 500 microhenries.

The factor K in the above formula varies as shown below. The inductance may be more accurately calculated if the coil is somewhat longer than its diameter. Attention is also called to the coil inductance chart published in RADIO BROADCAST, May, 1925, Page 46.

DIAMETER LENGTH	K	DIAMETER LENGTH	K	DIAMETER LENGTH	K
.10	.959	1.25	.638	3.00	.439
.25	.902	1.50	.595	3.50	.394
.50	.818	1.75	.558	4.00	.365
.80	.735	2.00	.526	5.00	.320
1.00	.688	2.50	.472	6.00	.285
				8.00	.237

After the coil is wound it should be given a coat of collodion, a performance that will cause many eyebrows to lift. Collodion, so it is said, increases both capacity and resistance of a coil. This is true, but for a standard of inductance one must have a coil that once calibrated will not

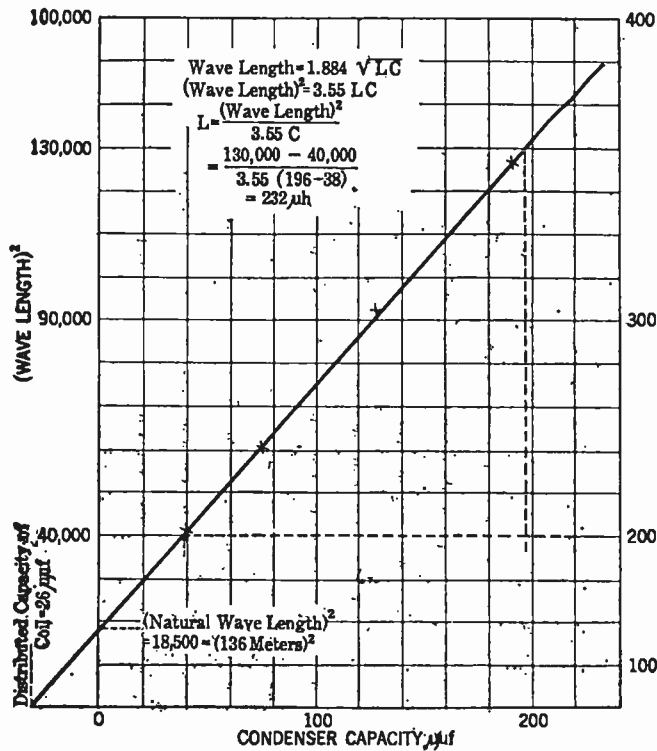

FIG. 5

An interesting experiment that any one with a calibrated condenser and a source of radio frequency voltage—an oscillator, or signals from broadcasting stations—can perform. This curve was made from data on a rather poor coil, poor in that its distributed capacity is higher than is desirable

vary. A coil whose wire is firmly held together and to the form and made moisture proof will have fairly fixed constants. The fact that its resistance and capacity are somewhat greater than desirable for a tuning coil need not bother us at all since it is only to be used as a means of comparing inductances.

INDUCTANCE-CAPACITY EXPERIMENTS

HERE is an interesting experiment that any one can perform provided he has a calibrated condenser, a coil, a source of oscillations variable over a certain range of frequencies, and a simple receiver. The source of oscillations may be broadcasting stations whose frequencies are known, or the radio part of the modulated oscillator; the receiver can be anything that oscillates, from a single-circuit blooper to the detector circuit of a Roberts, a Browning-Drake, or any similar receiver.

The coil is shunted by the condenser and tuned to various frequencies. To tell when it is tuned, the inductance should be brought near the tuning coil of the receiver. When the coil-condenser

unit is accurately tuned to the incoming frequency to which the receiver is already in resonance, a sharp click will be heard in the telephones indicating that enough energy has been subtracted from the oscillating detector by the tuned circuit actually to stop oscillations. A different frequency is then chosen and a new point determined. After several of these points have been found, a curve is made, plotting the wavelength squared against the shunt capacity as shown in Fig. 5. This should result in a straight line which is really a picture of the formula,

$$\frac{(\text{wavelength})^2}{(L \times C)} = 3.55$$

The chart in Fig. 5 shows the method of ascertaining the inductance of the coil, its natural wavelength, and its distributed capacity. This experiment does not give accurate results, but it will give the home constructor several hours of enjoyment. He will find that some coils will have large distributed capacity—which is bad—and that when this capacity is

large that the coil will not tune to the higher frequencies (lower wavelengths). He will be able to compare the value of inductance determined in this manner with that calculated from the formula already given. He will begin to see how coils and condensers perform when they are in a receiver.

The data for Fig. 5 is as follows:

Cmmf	FREQUENCY	WAVELENGTH	(WAVELENGTH) ²
75	1,224 KC.	245	60,000
125	985	305	93,000
190	845	355	126,000
250	736	407	166,000
325	674	452	205,000
380	605	495	245,000

L from curve = 232 mh.
" as measured on bridge = 210 mh.

Now that descriptions of both capacity and inductance standards have been given, and it is assumed that the home constructor has added such apparatus to his laboratory, it is necessary to have some method by which they can be used to measure other unknown coils and condensers.

The simplest method is by the use of a slide wire bridge as shown in Fig. 6. It consists of a straight piece of wire of uniform thickness, preferably of one of the high resistance alloys such as manganin, advance, nichrome, or similar wires and about two feet of No. 24 will make a very good bridge.

The exact resistance is immaterial, although it should be as high as is consistent with mechanical strength. Too fine a wire will not last, and too large a wire will not have sufficient resistance. No. 24 seems to be a fair compromise. A scale divided in some convenient manner is fixed below the wire so that the ratio between A and B may be easily read.

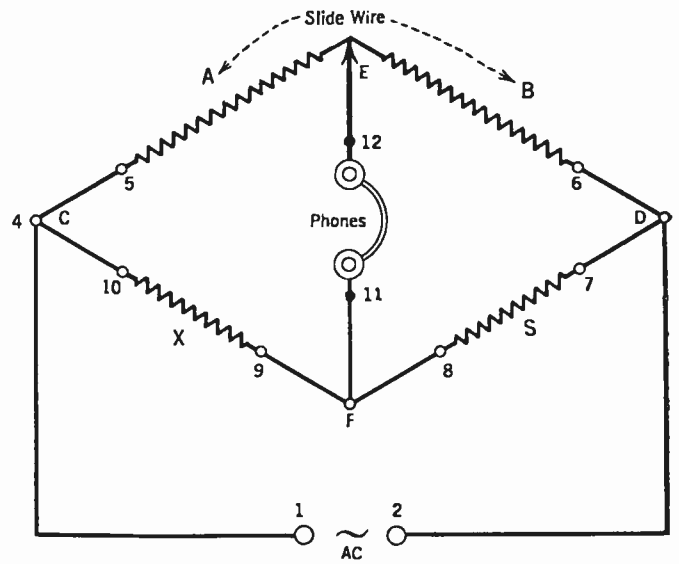

FIG. 7

The principle of the slide wire bridge. When no sound is heard in the telephones, there is a simple ratio which exists between the various "arms" of the bridge so that the unknown may be calculated

Binding posts are provided so that telephones, the a. c. voltage, and the standard and unknown inductances, or other apparatus, may be attached. Extra binding posts should be provided so that fixed known resistances may be added to the two arms of the bridge to increase its usefulness as indicated later.

The principle of the bridge is shown in Fig. 7. Here are four arms, A, B, X, and S. These arms may be resistances, capacities, or inductances, or they may be combinations of these three variable quantities. Usually, and as in this case, A and B are pure resistances with a variable tap X represents the unknown being measured, S is the standard.

An alternating voltage is placed across the bridge as shown in Fig. 7 and a pair of telephones

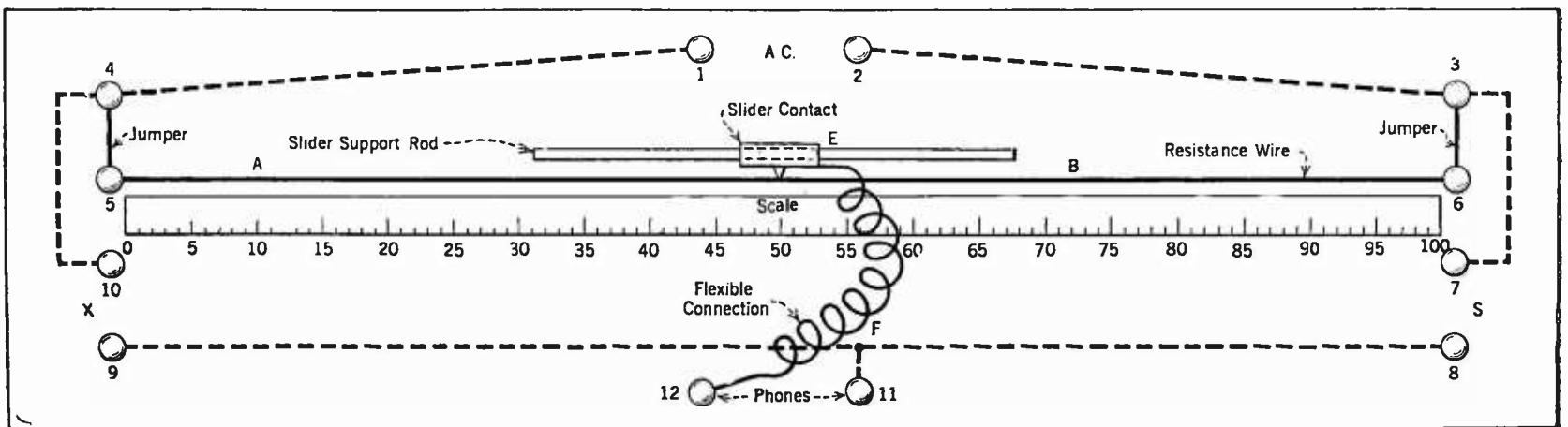

FIG. 6

A simple slide wire bridge by means of which comparisons may be made between unknown capacities, resistances or inductances and laboratory standards. In a home or commercial laboratory such a device is extremely useful

are used to indicate a balance. The a. c. voltage may be supplied by a buzzer, or better by a vacuum tube oscillator, such as the audio part of the modulated oscillator already mentioned.

In practice, the unknown is placed at X, the standard at S, and the variable slider moved along the slide wire until the sound in the phones is balanced out. At this point the voltages at the points C and D are equal (no voltage difference across the receivers) and the following relations hold:

$$\begin{aligned} (1) I_1 A &= I_2 X \\ (2) I_1 B &= I_2 S \\ (3) \text{ Divide (1) by (2)} \\ \frac{A}{B} &= \frac{X}{S} \end{aligned}$$

The result is that the same ratio between X and S exists that holds for A and B, and this latter may be easily read from the graduated scale below the slider. For resistance and inductance it means that X may be found by substituting in the above equation and for capacity the inverse relation is the true one. That is, for capacity:

$$\frac{A}{B} = \frac{S}{X}$$

For example let us suppose that we have placed our standard inductance at S and an unknown at X and that when no sound is heard in the phones, or a minimum sound, the slider lies at 40. Then A=40, B=60 and

$$\frac{40}{60} = \frac{X}{500} = 334 \text{ microhenries}$$

provided the standard is known to be 500 microhenries. If we were measuring capacity and the standard S was equal to .001 when the slider read 40 and 60 for the arms A and B the ratio would be

$$\frac{40}{60} = \frac{.001}{X} = .0015 \text{ microfarads}$$

MAKING RESISTANCE STANDARDS

THE construction of high frequency resistance standards presents a more difficult problem to the average constructor. Such resistances should have neither capacity nor inductance, and that's the trouble. They should also be independent of the current passing through them; in other words their resistance should not vary as they warm up.

For high frequencies there is no resistance unit that will be better than a single straight wire as short as possible. It has negligible inductance at ordinary frequencies. Until the construction of such units are described in RADIO BROADCAST the reader is referred to the Bureau of Standards *Circular No. 74*, sixty cents, or to an article by John M. Clayton in the October, 1925, *QST*.

Mr. Clayton uses maganin wire, B & S gauge No. 38 to 44, and for resistances from .1 to 30 ohms, the wire will be one quarter to 2½ inches long. The ends are soldered, with a minimum of solder, to heavy copper wires and the resistance part of the unit sealed into small glass tubing so that it will be protected. After these units are constructed, they must be measured on some sort of bridge and that is where the average home constructor will have the greatest

difficulty—for he must have a standard resistance to begin with.

The process of making such a set of resistance units will be described soon, and at the same time the proper procedure to have them measured will be outlined.

With the modulated oscillator, inductance and capacity standards, and the simple slide wire bridge the home experimenter can do many interesting things. He may investigate the distributed capacity of coils, he may neutralize his receiver which may be built from coils whose constants are known and whose tuning range may be calculated in advance. He may measure the inductance and capacity of home made or manufactured material. When he buys a bypass condenser he may actually find out what its capacity is, and many will be his surprises.

Throughout his investigations, the home experimenter should keep a careful notebook. Everything should be put down that seems to have any significance at all. The worker can never tell when his data may be useful in the future. It may save him considerable time to be able to turn to page so-and-so in his note book and find an exact calibration of this condenser, or variable inductance, or the frequencies a certain combination of coil and condenser will tune, or the capacities of certain fixed condensers that are about the laboratory. And if unexplainable happenings take place, let the experimenter put down as nearly as possible what he believes is taking place, circuit diagrams, the constants of all apparatus—perhaps at some future time such data may be useful in patent cases. One can never tell in these busy days of radio invention.

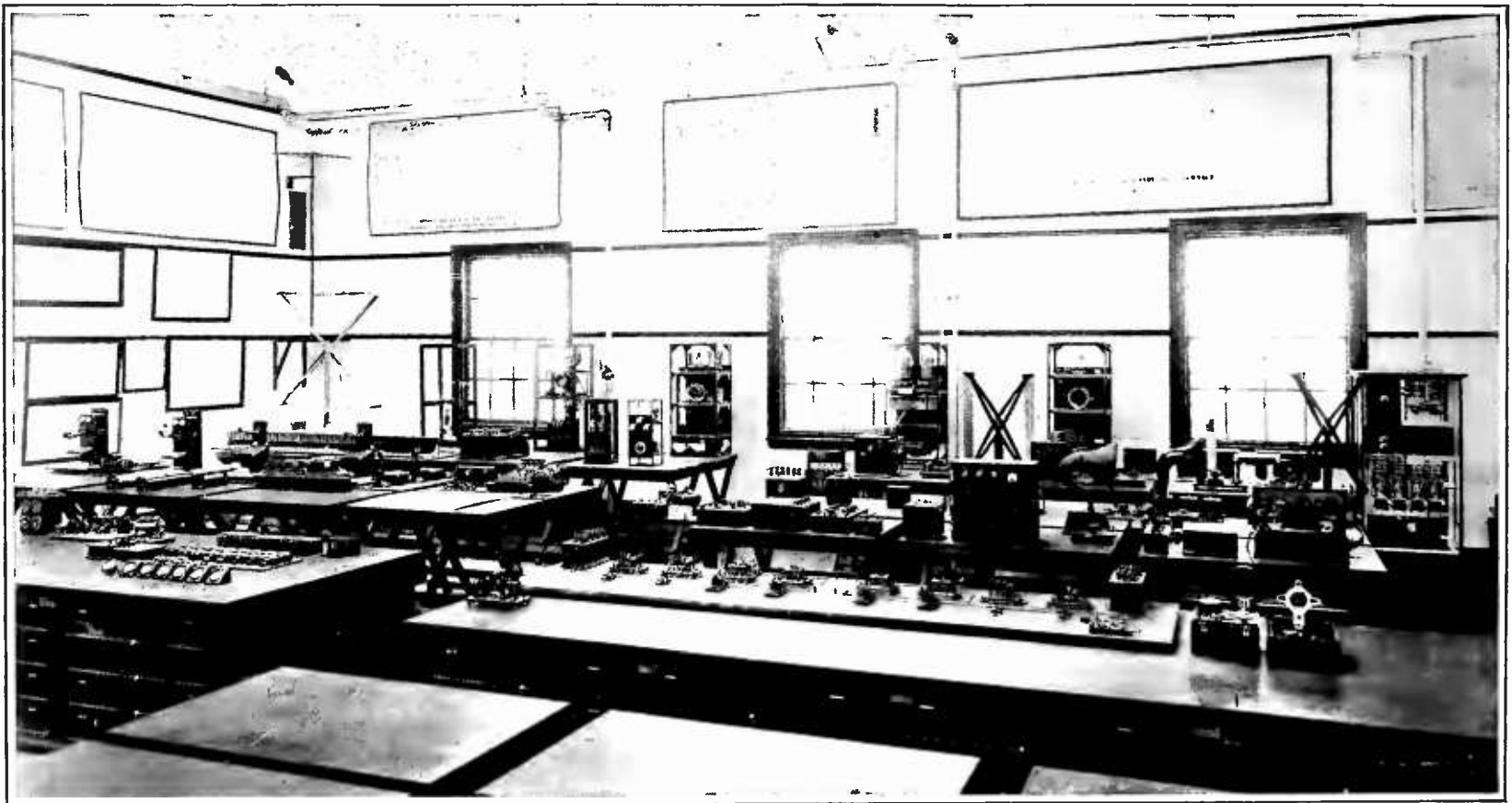

A WELL EQUIPPED RADIO LABORATORY

A view in the electrical engineering laboratory of Rennselaer Polytechnic Institute at Troy, New York. The home experimenter can never hope to attain an expensively equipped laboratory with all the various instruments found in such laboratories as Marcellus Hartley at Columbia and Cruft at Harvard and in other Universities. But much of the equipment can be made, and not very expensively at that, by the constructor in his own laboratory. As much constructional material of that sort as possible has been and will be described in this series of articles



The Listeners' Point of View

Conducted by John Wallace

Wanted: A Radio Shakespeare!

FROM Mr. Edgar H. Felix of New York City we have received the following pregnant theme, upon which he has invited us to improvise variations:

"One of the problems which vex radio program managers is the discovery of suitable text for dramatic recitations. More frequently than not, the broadcast listener finds the efforts of would-be dramatic artists a program of confusion because so much that is essential is either missing or requires the bolstering of tedious announcement. One outstanding exception is found in the prolific works of Shakespeare, which offer a repertoire to meet the needs of every conceivable kind of dramatic talent.

"Shakespeare contended with the very problems which make broadcasting performances fail. He, too, was practically limited to the sense of hearing in his presentations, because stage lighting and scenery were not developed in his day. A few uncertain candles, which hardly served to guide the almost unseen actors to their position on the stage, were the only sources of illumination. There was no scenery; colored drapes indicated the surroundings; green a field, blue a sea, and so forth.

"Appreciating these handicaps, Shakespeare always worked into the actor's lines all the essential information which makes an aural rendition both understandable and enjoyable. There is a wealth of description which performs the function now served by stage setting, scenery, and illumination, and which permits of complete appreciation through the medium of the microphone."

By way of checking up on Mr. Felix's very interesting point, we picked up a volume of Shakespeare—it happened to be *Hamlet*—and found

in the first ten lines examined a demonstration of the truth of Mr. Felix's suggestion: "Shakespeare always worked into the actor's lines all essential information."

HAMLET

ACT ONE SCENE ONE

Elsinore. A Platform before the Castle

Francisco at his post. Enter to him Bernardo.

Bernardo. Who's there?

Francisco. Nay, answer me: stand and unfold yourself.

Bernardo. Long live the king!

Francisco. Bernardo?

Bernardo. He.

Francisco. You come most carefully upon your hour.

Bernardo. 'Tis now struck twelve; get thee to bed, Francisco.

Francisco. For this relief much thanks: 'tis bitter cold, and I am sick at heart.

Bernardo. Have you had a quiet guard?

Francisco. Not a mouse stirring.

This play was probably first presented in broad daylight, in a circular, roofless building (as this sort of theater preceded the walled in, candle-lit type). Doubtless

a hot noon-day sun was beating down on the actors while they recited their lines. Probably there was no scenery. Yet all necessary information was conveyed to the audience of London citizenry, and not in an obvious and uncomfortable manner. First they were told the names of the characters. Secondly they were informed that it was twelve o'clock at night. Thirdly they learned that it was bitter cold. And fourthly, that the death-like silence of midnight prevailed (though probably the theatre was echoing with the noise of boisterous late comers).

Mr. Felix's immediate point, and a well taken one, is that Shakespeare be drawn on more frequently for dramatic recitations. As a matter of record this has occasionally been done. We have happened on a couple of instances. The "To be or not to be" soliloquy was recited by Basil Sydney, the star of *Hamlet—In Modern Dress* over some time ago. This station also presented a group of readings, by whom we've forgotten, from *The Taming of the Shrew* and *Macbeth*. Station KOA had a program in which one John Connery portrayed the various characters in the grave-digger scene from *Hamlet*.

However, even at best, it seems unlikely that recitations will ever make an astounding success with radio audiences. The most potent idea suggested by the above letter, we think, is that all aspiring radio-playwrights be required to read and assimilate in their entirety each and every one of Shakespeare's dramas.

For the radio play has, to date, proved to be an utter and complete wash-out. Of the many we have heard we know of no one we would call a complete success. Several were fair. The large majority were terrible. Once we thought we had



THIS

Gentle reader, is not the culinary staff of WGY broadcasting recipes for home brew but the Players of said station putting over a one-act play called "Danger" and having to do with lovers buried in a coal mine

a good one: it had held us breathless, spell-bound, and so forth, for fully ten minutes—but just then a shooting occurred and we spent the rest of the play trying to figure out who in thunder had been killed.

Now if recollection immediately rushes to your mind of some radio play which you heard and thought was a wow, we plead guilty to an occasional absence from the loud speaker and protest that that must have been one we slipped up on. Dwelling upon those we have heard, we are unable to decide whether, as an average, the plays or the actors were worse. We're inclined to hand the palm to the latter.

But in fairness to the radio Thespians it should be observed that theirs is a more difficult task than that of their brethren on the visible boards. The stage actor is assisted by props, costume, action, gesture, and makeup. If all these accessories are of high standard, his cerebral and vocal deficiencies may be partly overlooked, or at least not seem quite so glaring.

Not so of the radio actor. His ability to put over his part is exclusively dependent upon his ability correctly to understand and interpret his lines and upon his natural vocal endowment. We advance this point, not because we think it to be an obscure one, in the ferreting out of which we have exhibited great acumen, but because, obvious as it is, it does not seem to have occurred to radio play producers. Their radio players are made up, for the most part, of second rate hams who would in no wise add to the glory of a third-rate stock company.

As a matter of fact, nothing short of an all-star cast culled from the headliners of the legitimate stage would be able to put across a flawless radio play, so difficult is the chore. Such a cast we may not expect; but at least we may ask the station directors to come a little closer to it. High school dramatics may be endured while we are waiting for little Oswald to go up for his diploma, but they are likely to be tuned-out when they come via radio.

When, occasionally, we have heard a genuinely competent and experienced troupe of players perform, they have almost invariably been weighted down by some impossible stage piece that defied their most valiant efforts to transmogrify it into a radio-piece.

Drama is one of the most difficult of all forms of writing, and, perversely, of all forms of writing the most easy to criticize. Easy to criticize because we need rely on no objective standards or canons of judgment; our personal reaction is the final criterion. We may

know nothing at all of the craft of acting, yet we are justly entitled to pass on acting. If the actor succeeds in creating the illusion of reality (or of unreality, as the case may be) we declare him to be a good actor. If he creates no illusion but simply remains an "actor" we call him a bad actor. Simple!

So we feel encouraged to state dogmatically that we have never heard a radio play worth two bent pins and war tax. For we don't recall having ever been completely absorbed in, or carried away by one. We have never experienced any difficulty in getting "back to earth" after listening to a radio play; to us at least, every radio play has remained just a "radio play" from start to finish. The reason for their unsuccess has been stated so often it has become banal: "Radio is an entirely new medium and requires an entirely new and distinct type of play." Yet, in spite of the frequent reiteration little has been done about it.

Now comes news of a new radio play contest, and our hope perks up. Perhaps something may come of it. Station WLS, of Chicago, and the Drama League of America are its joint sponsors. It is press agented as the first radio play contest in the world, which is not entirely correct. The General Electric Company opened a similar contest in 1923 which continued about six months, closing on December 31 of that year. In this contest a \$500. prize was offered for the best play, and ten additional prizes were given for manuscripts thought to be satisfactory for radio presentation. WGBS, New York, conducted one last year, and several others of purely local import have been held. But at any rate the WLS contest is a pretentious undertaking and should bring interesting results.

The prizes are sizable if not munificent; first award is \$500. And the judges are George Arliss, Augustus Thomas, and James O'Donnell Bennett. Doubtless by the time this appears in print, the prizes

will have been long awarded and the plays will have been aërially presented. But the rules governing the contest may be still of interest and we quote some of them, as outlined by George Junkin, field secretary of the Drama League:

Radio will not allow any sly stage business. Glances, asides and business with props cannot be put over, to the radio audience. Entrances and exits must in some way be told in the action of the play. Just as the movies brought about the new drama and a new way of presenting it, so will radio. Sounds will be the principal vehicle. Bells of all sorts, church, dinner, telephone, house and others can be used to advantage. Rain, storms, musical backgrounds, horse, airplanes, automobiles, all have sounds which can be duplicated and will lend life to the words and action of the radio play.

Any play submitted must be original and not have been printed.

Original one-act plays, eighteen to twenty-five minutes in length.

Few characters—maximum, five principals.

Accompany action with appropriate sounds.

Farce, comedy, drama, melodrama, tragedy and mystery plays.

Plays must be clean, wholesome material.

Plays should not have material which would be objectionable to any sect or nationality.

Write plays as though they were to be produced for the blind.

Everything necessary in the action must be made plain.

With due appreciation of Mr. Junkin's suggestions, we hope that too many contestants will not go in for the clanging bells, galloping hoofs, and wailing wind effects. Little gain can come from such-like trickery. In the final analysis it's the words, words, words that count. Just as the radio actor has to have a better command of his voice and inflection than the legitimate actor, so the radio playwright has to have a better command of the President's English. With neither scenery nor action to fill in his gaps of thought he is up against a problem even harder than Shakespeare had to face. So it would seem that the radio playwright

who would do his job in the best possible manner will need to possess slightly more ability than Shakespeare. Here's hoping such a man comes to light!

Dinner Orchestras: Excellent Radio Features

ONE of the pleasant features of radio is the dinner orchestra. As radio standards go, the dinner orchestras occupy a lofty position on their respective programs. This is particularly true of some of the smaller stations. Located, as they often are, in towns where there is a decided dearth of



CYRIL MAUDE

The famous English stage star, familiar to many theatergoers who saw him in "Are'n't We All?" and "These Charming People," shown here listening to an American radio receiver in use in his apartment in New York. Mr. Maude has, so far, ventured no authoritative opinions on a comparison of English and American broadcasting



FREDERICK STOCK

Conductor of the Chicago Symphony Orchestra, which was heard some time ago through WMAQ of that city

available talent (and where there should never have been a radio station) the best broadcast material available is often the orchestra at the local hospice. In larger cities the membership of these bands often includes recruits from first rate symphony orchestras.

It is safe to guess that some hundred thousands of our citizenry dine nightly to radio music. And if a careful job of tuning has been done, and a mild pianissimo applied, these radio strains wafting in from the front parlor, add considerably to the relish of home cooked victuals—to say nothing of the delightful possibility of an occasional healthy obligatto of static, under cover of which one may really enjoy one's soup or celery.

Among the dinner bands we have listened to, we give the KDKA Little Symphony Orchestra a class A position. This is one of the few stations that, itself, supplies the orchestra. Next comes to mind the Commodore Hotel concerts from WJZ and the Waldorf Astoria Rose Room orchestra heard through WEAJ. Close to the top of the list come the Drake Concert Ensemble and the Blackstone String Quintette heard through WLJB (or WGN). These two orchestras are picked up so as to alternate numbers.

The Brown Palace String Orchestra at Denver, offered by KOA is very good. KGO relays the dinner music of a caravansary called Roberts-at-the-Beach, which comes in a bit later than our customary dining hour. From Detroit comes Jules Klein's Hotel Statler Orchestra, via WWJ. WSM, at Nashville, offers Francis Craig's Hermitage Hotel orchestra on alternate nights and KGW at Portland, Oregon, presents a first rate trio from six to seven.

Will Broadcast Stations Ever Specialize?

ONE of the planks in the platform of this polite if not pertinent purveyor of program piffle is that radio stations be constrained to specialize.

Specialization will eventually overtake the radio industry just as surely as it has the magazine business, and every other entertainment dispensary. At some future date we shall rant on at great length in these pages in an attempt to prove this point, which, since it is transparently obvious, should not be too much of a chore. For the present we shall be content to record joyfully the advent of two stations whose announced policy is to specialize.

WBAL at Baltimore, operated by the Consolidated Gas Electric Light and Power company of that city, broadcast the following manifesto on its opening night:

In its desire to be known as the radio station of good music rather than merely "another station of the air," WBAL hopes to attain an enviable distinction. If this station gives Baltimore a reputation for broadcasting good music, well performed, in a distinctive manner, it will serve the city better than if it tried to compete with the general run of stations by doing exactly what they do.

WBAL has a definite weekly program schedule: Sunday night, Twilight music (whatever that is!) Monday, Concert night; Tuesday, Ensemble night; Wednesday, silent; Thursday, Concert night; Friday, Novelty night; and Saturday, silent.

A slightly different policy is that announced by WHAP, New York:

The intention of the founders has been to establish an institution through which high ideals and standards can be expressed in the fields of education, musical art, and good citizenship. In matters of current opinion and in civic and social questions, WHAP will depart from the neutral and passive attitude generally maintained by broadcasting stations, as it has definite convictions, which will be expressed on the air.

Believing that those who favor jazz music and vaudeville songs are already receiving an ample volume of this material from other stations, WHAP will not broadcast any music of this type. Without making its musical programs at all heavy or academic, WHAP plans to arrange radio concerts that will have artistic merit, as well as entertainment value. Education is also to have a prominent place on the program, and several courses of half-hour talks are to be given by noted university lecturers. American history, English literature, and other subjects will be treated.

Of course we don't want all stations to specialize thusly, in highbrow manner—let it be in any manner they chose, as long as it is specialization. For this reason we are inclined to regret the passing of WTAS at Elgin, Illinois.

WTAS, catering to "Willie, Tommie, Annie, and Sammy" was frankly a lowbrow station—and proud of it. WTAS had thousands of devoted and enslaved listeners. If you didn't particularly snap for its offerings (nor did we) you doubtless carefully memorized its dial markings and learned to trip lightly past them. Meanwhile, your next door neighbor sought them out and enjoyed his fill of peppy pieces and flip announcing. So no harm was done.



MADAME TAMAKI MIURA

Japanese Soprano and well-known and praised interpreter of "Butterfly" who was heard in recital recently from WEBH, Chicago. We can't say who the evil genius who butted into the picture, is, but of one thing we are moderately certain. He is not an announcer

Consistency in Programs

DEAR! O DEAR! The way of the reformer is hard! Possibly a couple of our gentle readers will recall that we towered to heights of what we considered to be righteous wrath in these columns last month in a diatribe against the "hodge-podge" program that jumps from one offering to another quicker than a nervous flee in a litter of pups.

And what was our reward? No sooner had we laid down our flaming pen than we were slapped in the face by the following notice in a local (Chicago), journal:

Symbolic of the variety which has marked the daily broadcasts of WBCN since its inception, the twenty-four-hour program which will mark the first anniversary of the station, will include a creditable representation of practically every kind of talent on the air to-day. Everything from a whistler to a brass band will be offered.

There is great variety, as among the acts booked are a brass band, two dance orchestras, pipe organist, male vocal octet, male vocal quartet, mixed vocal quartet, male vocal and instrumental quartet, three female vocal duos, two male vocal duos, a saxophone trio, a banjo trio, violin duo, harmonica duo, guitar duo, mandolin-guitar duo, four violin soloists, a cellist, a bagpiper, pianologist, musical reader, monologist, two dramatic readers, four speakers, an operatic soprano, an operatic tenor, three classical piano soloists, a blind tenor, three jazz piano soloists a trombonist, one harmonica soloist, three piano-accordionists, two mandolin soloists, one "song and patter" duo, a Scotch harmony duo, a mixed harmony duo, a Scotch soloist, a French barytone, an English soprano, seven other sopranos, a Swedish tenor, fourteen other tenors, a dialect singer, a negro barytone, two blues singers, a children's entertainer, two whistlers, two xylophone soloists, a basso, three classical barytones, two contraltos, one popular barytone, a girl barytone, harmonica-guitar player, eleven song writers, a barn dance fiddler and a tipple-player.

Stories By Air

COSMO HAMILTON, the scrivener, read a specially composed radio novel over wjz recently, and since, regularly at 8 p.m. each Saturday evening, accompanied by sundry and droll remarks on the possibilities of the new medium. On the first night, he said in part:

My radio novel idea, which is not the condensation of an already written full-length novel, but of one written newly for the radio, which must take no longer than fifteen minutes to read, anticipates the time when, very shortly, the few people who still buy novels—and they are very few—will have joined the vast majority who look and listen but are physically and mentally unable to stop.

But equally entertaining was F. P. A's comment the following morning in "The Conning Tower" of the New York *World* which we cannot refrain from quoting:

Mr. Cosmo Hamilton, having said that the radio would put the spoken drama out of business, advances a parasang and predicts that the radio will make unnecessary the written novel. Novels, Mr. Hamilton forecasts, will be broadcast. And a jolly idea, too. Perhaps in a day or two we shall revise, for radio audiences, some novel or other. It would have been a glorious thing to do in the old days. There is a scene in *Ivanhoe*, for example, that goes something like this:

"My grandsire drew a good bow at Hastings."

"The foul fiend on thy grandsire and all his generation! In the clout! In the clout! A Hubert forever!"

The radio audience would listen in on this:

"Hello, folks! This is Walt Scott, from WEA, broadcasting. Well, here we are in Sherwood Forest. The boys are having a contest in archery.

There they are, folks, all lined up. Now, let's see. Well, Sir Reginald steps up and starts boasting.

"My grandpa was a curly wolf at this game," he says. 'He won a cup at Hastings Field.'

"So's your old man!" cried they all.

"And now, folks, while they're shooting, Miss Elsie O'Brien, who takes the part of Rebecca in the novel, will sing, 'I've an Eye for Ivanhoe.' If you like this little lady, folks, send a postal to her in care of the Waverley Length Radio Corporation, Newark, New Jersey. The Waverley Length Radio Corporation, Newark, New Jersey."

A Leader Explodes

WE ARE in receipt of the following letter addressed to our worthy predecessor in this department:

PUEBLO, COLORADO

MR. KINGSLEY WELLES,
Editor, "Listeners' Point of View"

SIR:

The only thing that avoided a conflagration in the local post office last night was the fact that I had the mental and moral strength to contain my wrath over a period of hours before putting it on paper.

It's all about Jazz. It seems to me that you and most of your fraternity of critics are wearing yourselves down to mere shadows over an evil which does not exist. Much as it may astound you to know it, there are those of us who prefer jazz to the more profound type of program, and oddly enough, our radio sets cost just as much to run as do those of the listeners who like the classics. Yet where is all this Jazz coming from? Out here in the great open spaces, I twirled the dials of our Roberts Knockout one night last week (it was not Sunday) and brought in fifteen stations without a single Jazz orchestra among them. I got sermons and speeches;

sopranos and bassos; cornetists, pianists, and violinists; organs, bands, long-winded announcers, and a pain in the neck. Conditions must be a lot different in New York.

It has come to the point where a person who wishes to listen to a jazz concert must wait around until ten or eleven o'clock before his wish can be fulfilled, and even then he may be disappointed. In fact, you mention a station in New York which forbids dance orchestras the air until ten-thirty. Fine! And now, let us close the air to sopranos of the coloratura variety, and to Hungarian Rhapsodies from ten-thirty on. Apropos of this discussion, I have sent a stamped, addressed envelope to Carl Dreher, who says in part: "If you want jazz issuing from your loud speaker, there are certain wavelengths in every locality where you can get it at any time." I confidently expect Mr. Dreher to solve my problem for me, with the added assurance of loud speaker volume.

For your information, may I state that KOA of Denver seems to fulfill your ideal of a broadcasting station? Twice a week for short periods they have genteel dance orchestras on the air. I pass them by rather hurriedly for the "Packard Six" of KFJ which is unashamedly a dance orchestra. Incidentally, I always set my dials for KFJ on Sunday night and turn on the juice afterward. They always have a program of lighter numbers for those who do not wish to go to sleep with their headphones on.

Very truly yours,

BERNARD KELLY.

If we may be permitted to rally to the defense of Mr. Welles (and incidentally to our own, as one of the "fraternity of critics" indicated above) we will hazard the guess that Mr. Welles never desired to bring conditions to such a sorry pass as Mr. Kelly seems to have found them.

On our own behalf, we sympathize entirely with Mr. Kelly's point of view the while rejoicing that he has found jazz so difficult to find. Rather too little jazz than the vast too much that prevailed until recently. With the demand for jazz bands and artists slightly greater than the supply the quality was bound to suffer. When jazz is good it is very, very good; but when it is bad it is horrid.

Broadcast Miscellany

THE broadcasting of the autumn's football games was, by all odds, the best piece of work done by radio during the last half year. The broadcasting of basketball, hockey, and such-like games, that has been prevalent during the last few months has proved to be an unmitigated fizzle. The success of a sporting event broadcast is dependent on the listeners' ability to visualize the progress of the contest. If it is a tax on one's optics intelligently to follow the plays of a fast hockey match, it is a considerably greater strain on the mind's eye to turn the same trick. Football is fundamentally adapted to broadcasting: the game is essentially a spectacle—a series of clear cut and well defined pictures. Basketball is far from picturesque. It is all action. And the



JULES KLEIN'S HOTEL STATLER ORCHESTRA

Which plays dinner and noon-day music from wwj in Detroit. Left to right, standing: Eric Ernst, Raymond Epstein, Erick Wyle, Benjamin Culp; seated: Jules Klein, and Frank Hancock

action is too rapid to be delineated by the radio reporter with any degree of interest. We are no better able to picture the progress of the game than we are when we read a newspaper report of it.

NOT a bad idea, wor's, of celebrating a writer's birthday with a program of his brain children. On Rudyard Kipling's birth anniversary, December 30, this station broadcast a program made up of readings of his best known verse with orchestral accompaniment, and several solo renditions of poems which have been set to music. There was also a speech by Mr. Russell Doubleday, one of the members of the firm which is his American publisher. The excellent Eveready Hour over the WEA chain, on the following Tuesday, prepared as usual by Mr. Paul Stacey also reminded listeners throughout the eastern United States of Kipling's greatness.

KSD, at St. Louis, has a Thursday afternoon feature that may or may not be of interest to club women. Not being one we can't say. At any rate, the Wednesday (!) Club of St. Louis, throws its meetings open to the ladies at large every Thursday from 4 to 5 o'clock (P.M.). The program is known as the "Women's Hour." Among the subjects so far treated at its sessions are: "The Newest Things in Dramatics" and "Home Hygiene and Public Health."

THE Atwater-Kent concert programs through WEA and its chain of some fifteen stations continue to be about the best thing on the radio bill of fare. Not the least factor in their success is the fact that the series has continued so long now, and so regularly, that ninety per cent. of all listeners know its day and hour by memory and can thus plan their Sunday evenings to listen-in if they desire. The occasional almost equally excellent program from many another station is all too often lost in the shuffle.

DURING the period from January 1 to November 30 (1925), WEA was on the air almost 2800 hours; the Plant Department or technical delays caused by unavoidable equipment trouble in this time totalling slightly in excess of five hours; the studio delays or time lost between program presentations, 12 hours and the delays occasioned by sos calls from vessels in distress 17 hours.

WE DON'T want to boast about the receptive qualities of our receiver, but we are here to state that we have listened to broadcasts of the New York Philharmonic Orchestra, from wjz, out here in the wilds of Illinois, from which we have derived almost as much pleasure as from our seat in Orchestra Hall, which, to us, seems saying quite a bit for radio. And it needs kind words!

OLIVER M. SAYLER'S "Footlight and Lamplight" talks over WGBS are worth attention. Mr. Sayler relates current gossip of the stage, and reviews, in a brief and entertaining manner, recent books. The talks are on Thursday evenings at 8:30 P.M. Eastern time.

IT WAS WHAS (Louisville) we think—though we tuned-out so fast we might have got its letters wrong—that jangled our nerves like bells out of tune the other night by stating that it was "radio-casting."

CHICAGO programs are evincing a slight improvement. WJAZ has an excellent program of music Thursday nights from 10 to 12. Efforts to make some arrangement whereby the productions of the Chicago Civic Opera company could be broadcast have so far been unsuccessful. The broadcasting of opera involves a myriad complications. To mention only two of them: many artist's contracts prohibit broadcasting and some opera's copyrights prohibit broadcasting.

THE Cincinnati Symphony Orchestra is on the air once a month during a series of twenty community radio concerts being broadcast in the name of the community of Cincinnati through WSAI. Fritz Reiner is conductor of this orchestra. Its engagement was in response to a popular demand among listeners throughout the country, nearly 3000 letters having been received after its first concert urging repetitions.

NOT an habitual peruser of the comic sections, and likewise by no means a faithful listener-in on the "kiddie" (Ouch!) programs, we found ourself, nevertheless, completely absorbed in Uncle Walt's (WGN) broadcast of the comics on a recent Sunday morning. Stumbling accidentally on this program, we picked up the funny paper, as instructed by the speaker, sat ourself down, and didn't get up until he had finished reading all eight pages!

BUT, withal, from Chicago comes the high-spot in programs since last writing. The Chicago Symphony Orchestra, which has never before consented to broadcast its concerts at last agreed to furnish a two-hour program, which was picked up by WMAQ for the opening program of its new 1000-watt apparatus.

The concert was one of a regular series conducted by Frederick Stock. As a musical offering it was the equal of anything that has yet been tendered us by radio. Of course there was the inevitable muffling of some of the instruments, especially during loud passages—but on the whole a good job for non-studio broadcasting. To date no promise has been made of further concerts.

THIS year of grace 1926 was ushered in by the ringing of Liberty Bell at the stroke of midnight on New Year's eve. Station WIP broadcast the historic gong at the conclusion of an official ceremony inaugurating Philadelphia's Sesquicentennial year.



THE KGW DINNER CONCERT TRIO

Who are heard nightly from station KGW of the Portland *Oregonian*. The personnel and instrumentation reading from left to right: Gladys Johnson, cellist; Julius Walter, pianist; Abe Bercovitz, violinist. They are presented through the courtesy of Olds, Wortman & King, of Portland

An All Purpose Coil Winder

How to Make and Use a Simple Coil Winder for Solenoid and Lorenz Type Coils Together With Useful Inductance Tables



RADIO BROADCAST Photograph

By EDWARD THATCHER

AS LONG as radio constructors assemble sets, there will be those who want to make the coils they use in the set with their own hands. There are, of course, plenty who have no desire to wind their own coils any more than they care to make an audio transformer or wind a set of bobbins for head telephones. So many of our readers write in for information on how to wind this or that sort of coil that the information contained here should be of wide interest. Practically every common type of coil can be made with this simple device, from the simple solenoid to the more complex diamond and basketweave types. The inclusion of an ingenious turn-counter makes the device of great practical value. Many examples of Mr. Thatcher's work in other, non-radio, lines, have appeared in The Ladies' Home Journal and other publications. He is especially known for his excellent amateur ship models.—THE EDITOR.

old discarded auto speedometer, which may be purchased for about a dollar at most auto junk yards. Perhaps a search of the home garage may result in finding one. A bicycle cyclometer may also be used, if a few slight alterations are made. Fig. 2 shows such a cyclometer mounted. This one cost 85 cents at a mail order house. The various forms used with the simple machine are shown in Figs. 4, 5, 6, 7, 8, and in the top illustration on this page. These will be described in detail later on. It might be well to mention here that these same forms may be found very convenient for hand winding if you do not care to make the machine.

In Fig. 3 may be seen the coil winder and counter unassembled. The hook J, is exactly similar to the one used to make the handle I.

It should be understood that the dimensions given for the coil winder and counter may be made to suit individual needs, those given being found convenient for most of the coils which have come to the writer's attention.

The frame is made from soft pine wood taken from a packing box. A saw, plane, drills, and a hammer, are the only tools necessary for this part of the work. All the parts should be very carefully marked out and squared up before cutting them out.



MOST of us who tinker with radio know the bother of keeping count of the turns of wire on a coil as it is being wound, or of counting the turns after the coil is finished, particularly with such coils as the basketweave type or other coils of a similar nature.

With the simple coil winder and counter shown in Fig. 1, and some simple forms which are easy to make, you may wind practically any type of continuously wound coil very easily, and enjoy a smoke at the same time if you care to. You may stop winding to light your pipe and resume operations sure that the turns will be counted correctly, and if you should accidentally wind on too many turns, you may easily unwind them. The counter will always show the number of turns on the coil.

This coil winder and counter is in the form of a very simple lathe, the counter being nothing more than part of an

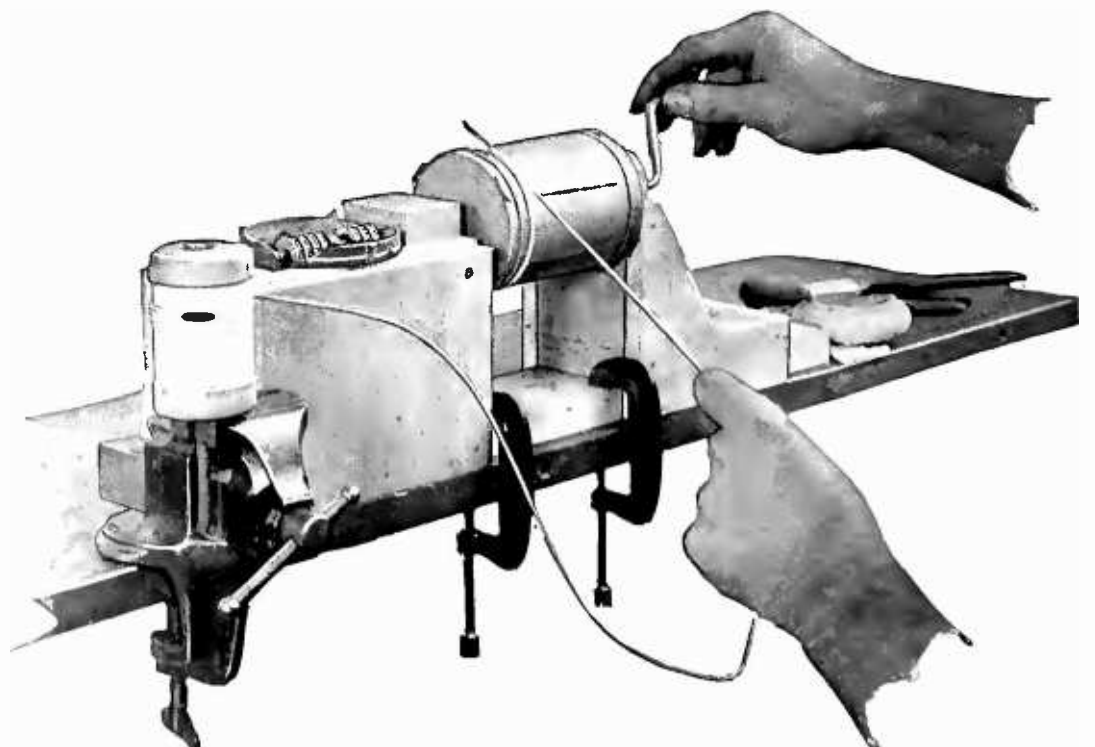

RADIO BROADCAST Photograph

FIG. 1

The inexpensive, easily made coil winder and counter is illustrated "in action" here. With the aid of this device high grade coils are within the reach of all home-constructors and experimenters

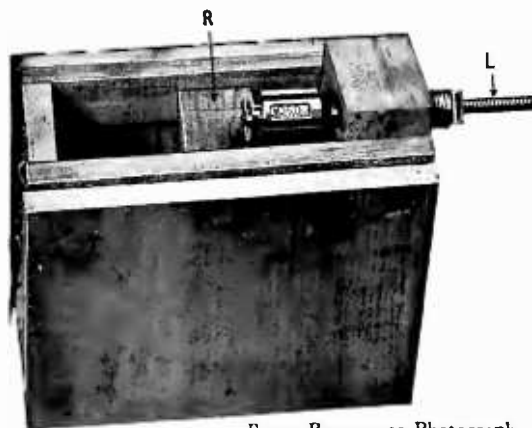

RADIO BROADCAST Photograph

FIG. 2

A cyclometer type of turn-counter which may be satisfactorily used. Your local hardware or bicycle store can supply you with a similar one

In Fig. 3, A is the baseboard or bed of the winder. This is $\frac{3}{4}$ inch thick, $2\frac{5}{8}$ inches wide, and 18 inches long. B-B are two pieces which are used to support the counter. Each piece is $\frac{7}{16}$ inch thick ($\frac{3}{8}$ or $\frac{1}{2}$ inch will do as well), $4\frac{1}{2}$ inches high, and 6 inches long. These pieces are glued, nailed, or screwed to one end of the baseboard.

C is the base of the sliding tailstock, and is $\frac{3}{4}$ inch thick, $2\frac{1}{8}$ inches wide, and $5\frac{1}{4}$ inches long. A slot G $\frac{1}{4}$ inch wide and $3\frac{1}{2}$ inches long is centered in this base. The screw F passes through the slot G into the baseboard A, and is tightened up to hold the tailstock in position. The two pieces E-E are made of wood $\frac{7}{8}$ or $\frac{3}{4}$ inch thick, and each piece is $5\frac{1}{4}$ inches long. Each of these pieces is sawn out to make room for turning the handle I, a coping or compass saw being used for this purpose. These two pieces, E-E, are glued and either nailed or screwed to pieces D and C, the end of piece D resting on top of piece C.

Piece D is $\frac{3}{4}$ inch thick, $2\frac{1}{8}$ inches wide, and $4\frac{1}{4}$ inches high. In this piece is drilled the hole H, into which the handle may be pushed and allowed to turn easily. The position for this hole is best found by sliding the tailstock along the bed until the end of the stovebolt used to make the counter shaft, rests against D, when the counter is mounted in position between the pieces B-B.

The handle I is made of a common screwhook. This is 4 inches in length and made of stock about $\frac{1}{4}$ inch in diameter, a common size obtainable at most hardware and 10-cent stores. To transform the screwhook into a screw handle, place it upright in the vise jaws, the hook end uppermost, with the bend just

above the top of the jaws. Use a monkey-wrench to grasp the hook and bend it out roughly into the shape of a handle. The handle is then removed from the vise and straightened up a bit by hammering on some sort of an anvil, such as the bottom of an old flat iron, taking care not to injure the screw thread.

The screw end of the hook will be found rather blunt. This may be much improved for our purposes if the threads are filed down so that they barely show at the point, tapering up gradually to the full thread at the end, next to the handle, so that the thread is much like the threaded end of a polishing spindle. A tapered screw of this kind will enter the wood more easily, and the further it is screwed in the tighter it will hold.

THE COUNTER DEVICE

NOW for the counting head M. It is quite easy to remove the counting device from a common speedometer.

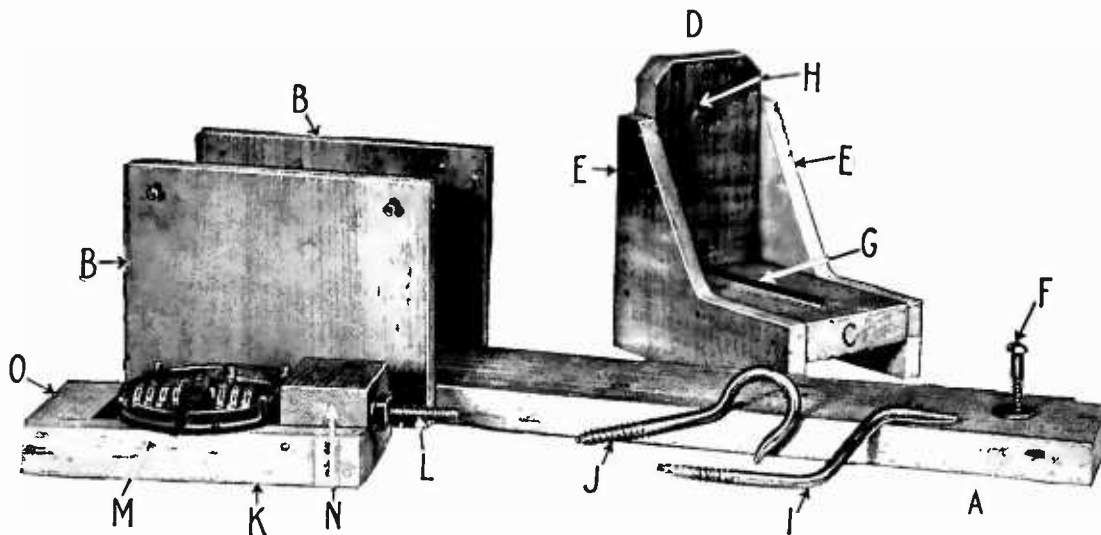

RADIO BROADCAST Photograph

FIG. 3

The coil winder partly assembled. Box wood, screw hooks, screws and a turn-counter are the requirements for the construction of this handy laboratory apparatus. The lettered parts are for identification with the Material List and refer directly to the description of the preparation of the material in the text

Pry off the glass cover and you will usually find that the counter may be removed by taking out a screw or two, when it may be lifted out and separated from the speed indicator. The counter probably registers a number of miles and these may be set back on the "trip" by the device found in most indicators. The total mileage however, must be turned backward if you wish it to register 0000. Unless you wish to wind coils of more than 99 turns, the total mileage indicator may be disregarded. However, it may be turned back after the counter is mounted in its frame by attaching a hand drill to it and turning it backward, or fastening the counter shaft to the chuck of a lathe head and running

it backward this way. Then you will have a counter which will register up to 9999, quite enough for most experimenters. The trip and season counters are usually connected by a simple clutch arrangement, which may be thrown in or out as you like. In the counter shown in Fig. 10, the set device is not made use of, it being a simple matter to turn the counter backward to 000 after the coil is wound and before the form is removed.

The counter M, Fig. 10, is supported by a simple wooden frame which is made as follows. There are two pieces like K, each piece being $\frac{1}{2}$ inch thick, $\frac{3}{4}$ inch wide, and 6 inches long. These two pieces are fastened together at the head end by a block of wood N, $1\frac{1}{2}$ inches thick or high, $1\frac{3}{4}$ inches wide, and $1\frac{1}{2}$ inches long. The block is glued and nailed, or screwed, to the side pieces. Through this block is drilled a hole to accommodate the stove bolt L, which should turn easily in this hole, the head of the stovebolt connecting with the end of the counter shaft, as will be described later. The exact position of this hole may best be found by experimenting with the counter resting in position, so that the hole through N is exactly in line with the center of the shaft of the counter.

The piece O is $\frac{3}{4}$ inch thick, $1\frac{3}{4}$ inches wide, and $1\frac{1}{4}$ inches long. It should be understood that the dimensions of all the pieces may be changed to accommodate any particular type of speedometer you may have. If a cyclometer is used follow Fig. 2.

Now look at Fig. 11. The stovebolt L is $\frac{1}{4}$ inch in diameter and 3 inches long. This should be provided with two nuts and one or more washers. The end of the counter shaft P, on the counter M, is filed to a flat shape like the end of a screw driver, care being taken to have the wedge-like end exactly in the center of the counter

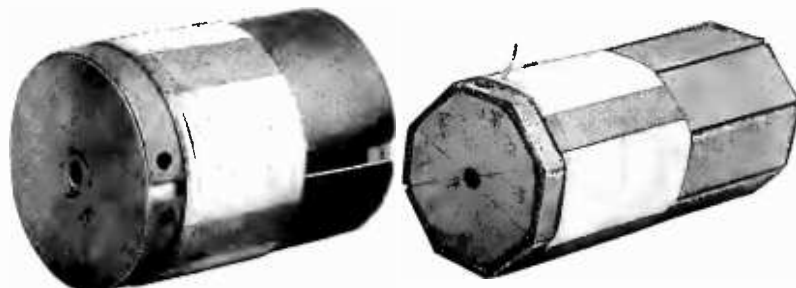

RADIO BROADCAST Photograph

FIG. 4

Here are the cylindrical and pickle-bottle coil forms with a very good example of coil binding utilizing gummed paper. Note that just below the center hole in the end piece of each coil form is situated the pin which engages in the nut on the turn-counter shaft

shaft, as this is to slip easily in the slot in the head of the stove-bolt, so that the latter may turn the counter as it is turned around by the coil form, which in turn is turned by the handle. A small hole is drilled in one corner of the nut on the stove-bolt as shown at Q, with a twist drill about $\frac{1}{8}$ inch in diameter. A pin or brad driven in the end of each coil form fits in this hole to prevent the coil form from turning on the shaft without turning the counter, thereby causing a wrong count.

When you have the counting head ready to assemble, slip the stovebolt through the hole in N, place a washer on the threaded end, and then screw on the nut with the hole Q in it until it is fixed very tightly on the end of the thread, taking care, of course, that the stovebolt turns easily without undue play. The counter M should then be mounted on its wooden frame and screwed to it, so that every time the stovebolt makes one revolution the counter will register. Remember that the red figures on the counter are tenths and the black figures on the wheel next to the red figures will count one for every turn of the shaft.

ADJUSTING A CYCLOMETER

A CYCLOMETER also makes a very good counter. It will have to be tinkered with a bit, however, before it will count one for every turn of the shaft. The cyclometer shown in Fig. 2 was treated as follows. The disk-like end opposite the star wheel was removed by placing the points of a small pair of round nosed pliers in the two holes found in this end, and unscrewing it. Inside this disk were several washers which were removed and left out. On the end of the star wheel shaft thus exposed, will be found a small brass disk. To this disk is attached a small pinion which engages a ring or internal gear attached to the first row of figures. The pinion should be soldered fast to the disk which is on the end of the star wheel shaft. It will then be locked in the ring gear turning this with the star wheel shaft, one turn, one count. Care must be taken with this soldering, and only a small amount of flux and solder are necessary.

Two small holes about $\frac{1}{8}$ inch in diameter are then drilled about $\frac{1}{4}$ inch apart and equidistant from the star wheel shaft, these holes being drilled in the disk attached to the end of the shaft, to which the pinion was soldered.

A "U" shaped piece was then bent out of a piece of thin steel wire taken from a paper fastener, the points of the "U" being $\frac{1}{4}$ inch apart. The U shaped piece is then soldered in the center of the slot in the head of the stovebolt L, Fig. 2. The ends of this soldered piece of wire engage the two



RADIO BROADCAST Photograph

FIG. 5

End pieces, coil form, and screws are all that is required to make up the cylindrical form for the sample of solenoid coil shown at the right. The wood strip indicated at A is employed as a backbone for the coil form

holes drilled in the disk at the end of the star wheel shaft. The whole should be a rather loose fit to prevent binding.

To solder steel to steel you may find that your regular soldering flux used for bus bar work will not work very well. "Killed" acid is best for this purpose. This is made of muriatic acid in which as much pure zinc as possible is dissolved. To make this flux pour a small quantity of muriatic acid in an old cup. Set this cup in a pan of

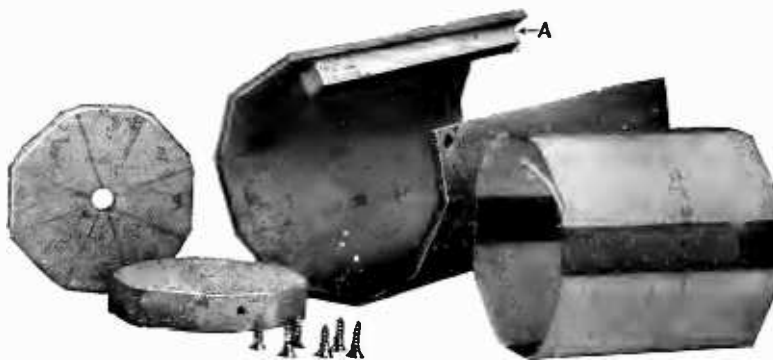

RADIO BROADCAST Photograph

FIG. 6

Here are the parts for the pickle-bottle coil form. Low loss coils of this type of winding may easily and speedily be wound for use in the many Roberts and other circuits described in past issues of RADIO BROADCAST

water to keep it cool, taking care that no water gets in the acid. Cut up a number of pieces of pure zinc (the zinc covers of old B or A battery dry cells are excellent), and put a small quantity of the zinc clippings in at a time and add to them from time to time until no more zinc will dissolve. Allow the acid to stand for a time, strain through muslin, and it is ready to use. The parts to be soldered are painted with it. Never use this flux for

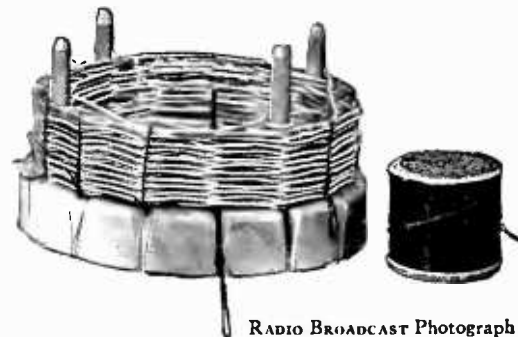

RADIO BROADCAST Photograph

FIG. 7

The Lorenz or basketweave coil is more difficult to wind, but when finished, is one that any experimenter would be proud to use in his receiver. Substantial, well-wound coils do much to insure proper operation of one's receiver. The spool of thread also shown above is for binding the coil turns together

radio or electrical work as it is very corrosive for such work. It is well to coat the solder which you are using with this flux. The flux will be found excellent for steel, iron, copper, brass, etc., when these metals are not used for carrying electric currents. The cyclometer is held to its frame by screwing the lug attached to it to the block R, Fig. 2.

COLLAPSIBLE COIL FORMS

FIGURE 1 shows the coil winder and counter in use, starting to make a low loss self-supporting solenoid coil.

The spool of wire is held by a large nail which is placed between the vise jaws, the head of the nail being tapped with a hammer until the coil of wire may be turned with just the right amount of tension.

The form used to make a solenoid coil of low loss design is shown in Fig. 5. This particular coil is of 50 turns wound over a 3-inch form. The form is partially collapsed to remove the coil when it is finished. The form may be reassembled and used over again as many times as it is desired. The outer or cylindrical part of the form shown is made out of a section cut from an ice cream container which was originally $3\frac{1}{2}$ inches in diameter. The two wooden disks used as the ends of the form are cut to such a diameter so that when the cardboard covering is put in place over these wooden disks, the outer diameter of the

whole form is 3 inches. As the thickness of the cardboard is $\frac{3}{8}$ inch, it will readily be seen that the diameter of the wooden ends is $2\frac{1}{8}$ inches.

The section cut from the ice cream container is planned so that when it is screwed to the wooden ends there will be a space of from $\frac{1}{8}$ to $\frac{1}{4}$ inch left open between the ends, on the side, as shown in Fig. 4. Directly underneath the edges are glued narrow strips of wood about $\frac{1}{4}$ inch square, as at A, Fig. 6. These strips of wood support the pasteboard which might otherwise be drawn in by the tension of the wire when winding a coil. These two strips should be placed in such a manner that the edges of the form may be easily pushed inward when the coil is wound and the wooden ends removed, to allow for the removal of the finished coil.

Forms for coils of practically any diameter may be made up in this manner, using such cylindrical forms as oatmeal boxes, mailing tubes, and the like.

Figs. 4 and 6 show the form used to make the pickle-bottle type of coil. Like the cylindrical form the pickle-bottle form may be used any number of times. The pasteboard used to make this form was approximately $\frac{1}{8}$ inch thick (strawboard

taken from the sides of a packing carton). The wooden ends are then 2 inches in diameter across the flats. A pattern should first be made for these wooden ends, which are cut from soft pine about $\frac{3}{8}$ inch thick. The outside of the form is made in one piece divided into eight equal parts, each dividing line being scored on the out-

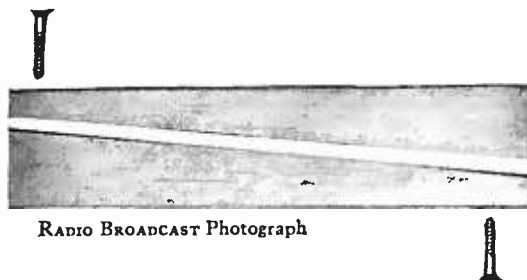

FIG. 8

When this double-wedge rectangular form is mounted in the coil winder, it is possible to wind a long strip of coil with a square cross-section, so that it may be bent into a circular form, thereby making up the much discussed toroid coil. On page 600 of this issue, Mr. John L. Lee shows in detail the constructional steps in making up such a coil

side with a sharp knife to allow the pasteboard to fold down sharply over each angle of the wooden ends to which it is screwed. A strip about $\frac{1}{8}$ inch wide is cut off one end to prevent the edges interfering when the form is collapsed, and a strip of wood A, is glued and tacked to one or both edges at the end of the form as shown in Fig. 6. The piece (or pieces) A are just long enough to fit between the wooden ends when these are in place. The corners formed by the angles on the outer edges of these wooden forms are cut off slightly to allow for the bends in the pasteboard.

A $\frac{1}{4}$ -inch hole is drilled in one of the wooden ends, this end being slipped over the threaded end of the stovebolt connected to the counter. A short brad is driven in this end and the head of it cut off so that it may be pushed into the hole drilled in one corner of the nut which is screwed on the stovebolt. By changing the diameter, or rather, building a similar form of any desired diameter, pickle-bottle coils may be wound as called for.

When a simple solenoid coil is to be wound, and the form is to be left inside, circular pieces of wood are sawed out to fit inside of each form and these are held with screws while the coil is being wound. Holes are of course drilled in each disk, one hole to fit over the stovebolt and

in the second disk a suitable hole is drilled into which the screw end of the handle is inserted.

WINDING A LOW LOSS SOLENOID COIL

THE coil forms shown in Figs. 4 and 5 are mounted in the winding machine as shown in Fig. 1. Four strips of gummed tape are held, gummed side up, to the form with rubber bands. The handle is shown firmly screwed into one end of the form so that it may be turned against the tension likely to be put on the wire, without slipping.

Fig. 1 also shows how the winding is started. A pin is pushed through the side of the pasteboard form where it is desired to start the winding, and the end of the wire wrapped once or twice around this pin to hold it.

The gummed side of each strip of tape is moistened with water before the winding is started. After this, the winding may be proceeded with, and if everything is right, it should go very rapidly. The speed and

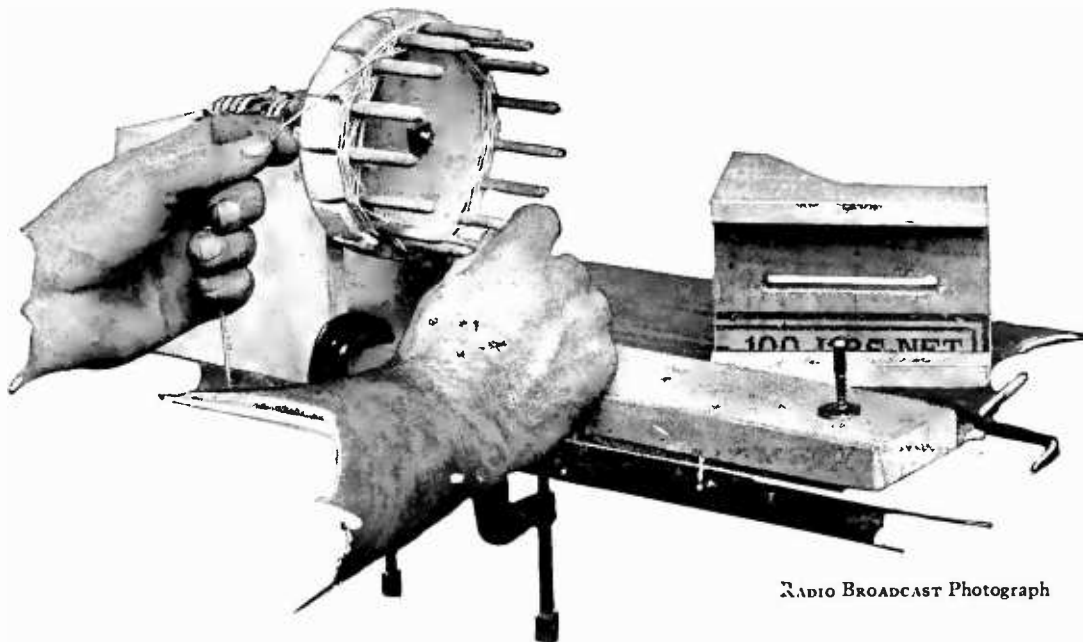

FIG. 9

"Spiderweb coil forms may be mounted in the same way as the basket-weave coil form shown here," says Mr. Thatcher. The sliding tailstock is removed when such coils are wound

accuracy with which coils may be wound on this simple machine with an occasional glance at the counter, will be only too apparent.

When the required number of turns are wound on, stick another pin through the coil form to wrap the wire on at the end of the winding while the paper tape is pasted about the coil.

Moisten the ends of the gummed paper tape which extends beyond the winding, first removing the elastic bands and proceed to fold the ends of the moistened tape over the winding, pressing each strip firmly in place.

Taps may be made in coils of this kind by lifting up a short loop of wire at the

MATERIAL LIST FOR COIL WINDER

PART	PART LETTER	DIMENSIONS	NUMBER REQUIRED
Baseboard	A	$\frac{3}{4}$ " x $2\frac{1}{2}$ " x 18"	1
Counter Supports	B	$\frac{1}{2}$ " x $4\frac{1}{2}$ " x 6"	2
Tail Stock Base Support	C	$\frac{1}{2}$ " x $2\frac{1}{2}$ " x $5\frac{1}{2}$ "	1
Tail Stock Face	D	$\frac{1}{2}$ " x $2\frac{1}{2}$ " x $4\frac{1}{2}$ "	1
Tail Stock Sides	E	$\frac{1}{8}$ " x $5\frac{1}{2}$ " shaped as shown	2
Tail Stock Screw	F	1" x No. 6 Wood Screw	1
Tail Stock Slot	G	$\frac{1}{2}$ " x $3\frac{1}{2}$ "	1
Handle Hole	H	$\frac{1}{2}$ "	1
Handle	I	$\frac{1}{2}$ " x 4"	1
Counter Base Sides	K	$\frac{1}{2}$ " x 1" x 6"	2
Stove Bolt	L	$\frac{1}{2}$ " x 3"	1
Turn Counter	M		1
Counter Head Block	N	$1\frac{1}{2}$ " x $1\frac{1}{2}$ " x $1\frac{1}{2}$ "	1
Counter End Block	O	$\frac{3}{4}$ " x $1\frac{1}{2}$ " x $1\frac{1}{2}$ "	1

No dimensions are given for coil forms as the constructor must use his own judgment in selecting the forms for the coils he wishes to wind.

desired turn, twisting it, and then going on with the winding. Another winding, such as a primary, may be wound over the first coil, after this is wound, and the tape stuck to it as usual, by wrapping a single layer of Empire tape or even gummed tape, about the first coil and then winding the second coil on this, this second coil being held together with strips of gummed tape as the first one was, the form being left in place until both coils are wound on and the gummed tape is dry. To remove the form, the screws are taken out, after the handle is unscrewed, and the coil removed from the counter head. Then the wooden ends are removed, and the pasteboard form is pressed in at the joint until the coil may be easily slipped off.

WINDING BASKETWEAVE AND DIAMONDWEAVE COILS

THE form for winding a basketweave coil is shown in Fig. 9 mounted on the counter shaft. The extra nut provided with the stovebolt is used to hold it in place, a pin in the

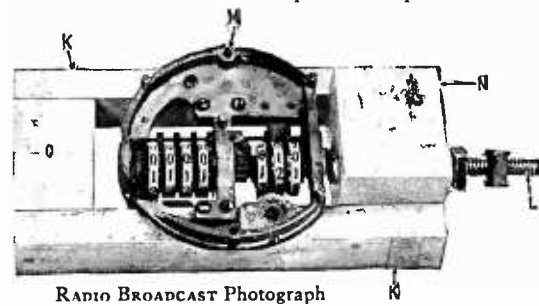

FIG. 10

Another use for the automobile speedometer—only here it tells you how far you've gone and not how fast. However, with practice, the home constructor becomes quite efficient in making the coil turns lay side by side at an exceeding high speed. For an explanation of the lettered parts, the constructor should refer to the text

SPIDERWEB COIL				
SIZE WIRE	NUMBER OF SPOKES	NUMBER OF TURNS	INSIDE DIAMETER	FREQUENCY RANGE
No. 24 d.s.c.	15	52	1 1/4 in.	1764-500 k.c. (170-600 meters)
No. 20 d.c.c.	17	46	2 in. (no form)	2540-565 k.c. (118-529 meters)
No. 24 d.c.c.	11	50	1 1/4 in. " "	2630-565 k.c. (114-529 meters)

BASKETWEAVE				
SIZE WIRE	NUMBER OF SPOKES	NUMBER OF TURNS	INSIDE DIAMETER	FREQUENCY RANGE
No. 18 Enamel d.c.c.	13	58	2 1/2" between peg centers	2361-500 kc. (127-600 meters)
No. 18 d.c.c.	14	60	4 1/2" between peg centers	2290-550 kc. (113-545 meters)
No. 24 d.s.c.	15	64	2 1/2" between peg centers	2054-495 kc. (146-605 meters)

DIAMONDWEAVE				
SIZE WIRE	NUMBER OF SPOKES	NUMBER OF TURNS	INSIDE DIAMETER	FREQUENCY RANGE
No. 26 d.s.c.	15	57	2 1/4 inches	2040-495 kc. (147-605 meters)
No. 20 d.c.c.	21	36	2 1/2 inches	2650-694 kc. (113-432 meters)
No. 24 d.c.c.	15	44	2 3/4 inches	1764-560 kc. (170-535 meters)

pictures to show up better, but plain uncolored cotton string is usually recommended for this purpose.

On the right of the top illustration on page 582 will be noticed a form for winding a diamondweave coil. Grooves are shown in the face of the central part of this form. After the wire is wound on the form, the flexible needle is used to thread the string up through the winding as each peg is removed.

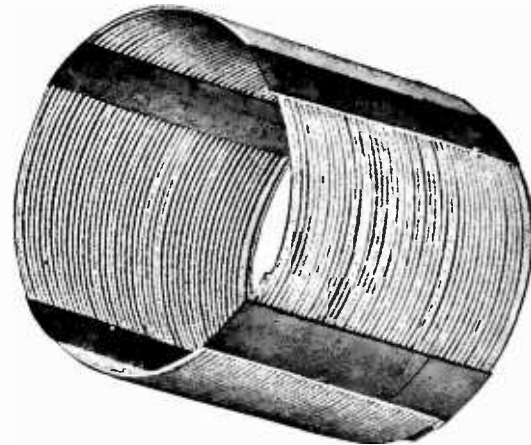

RADIO BROADCAST Photograph

FIG. 12

For the experimenter who desires the last word in low loss, Mr. Thatcher offers this space wound coil, which he wound on his indispensable coil winder. A thread is wound with the wire, separating turn from turn. When the coil is completed and fastened together, the thread is removed

DATA ON SPECIMEN COILS

THE data in the table shown elsewhere on this page will serve as a guide to those constructors wishing to wind coils for

other side engaging the hole in the first nut. Spiderweb coil forms may be mounted in the same way, except that a common pin may be pushed through the form, and through the hole in the nut, before the second nut is screwed in place.

It will be noticed that opposite every peg in the form shown in Figs. 7 and 9 is a deep groove, the top of which extends into the hole for the peg.

These grooves are made by first making a cut with a saw and then enlarging this with a three cornered file or a sharp knife.

The reason for these cuts is as follows: After the winding is finished, a flexible needle, about 3 inches long is used with string to sew the coil together as each peg is removed.

The flexible needle is made of a piece of copper wire about No. 20 gauge, bare or enamel covered, it being doubled to form a loop at one end. The other end, or ends, are held together by a drop of solder which is rounded over with emery cloth to remove any sharpness. The needle thus made, being very soft and flexible, may be bent to a suitable shape to be passed into the slot in the side of the form and up through the top of the winding, after each peg is removed. Black thread is used in the

use in tuned circuits. In the first test to determine the correct number of coil turns, a .0005-mfd. variable condenser was employed.

From the table it will be noted that for each type of coil the wire size, number of spokes, number of turns, and coil diameter is different for each three examples, yet the frequency spectrum (wavelength range) does not differ greatly.

With a .00035-mfd. variable condenser, the secondary sizes for the above types of coils will take not more than 80 turns. Usually 77 is correct. The correct value varies slightly with changes in coil diameter and wire size. If the tuned circuit is found to tune to frequencies below the range desired, then remove a turn at a time until the lowest frequency (longest wave) you wish to tune to is tuned-in somewhere near the high end of the condenser scale, usually between 90 and 100.

The primary and tickler coils for use with these secondaries should have about one third the number of turns as the secondaries. For a tuned radio-frequency amplifier circuit, employing no neutralization system, it will be well to reduce the primary turns to from six to ten, otherwise oscillation in each stage will be uncontrollable.

It will be observed that the number of turns for a coil, tuned with a .0005-mfd. condenser, is approximately 60, and conforms to a certain degree with the Inductance chart prepared by Mr. Homer Davis on page 587.

With this coil winder it is also very easy to make up such coils as are shown in Fig. 12, which represents the

latest design in space wound solenoids. An ordinary cylindrical form can be used, such as is shown in Fig. 5. A piece of heavy thread is wound in parallel with the wire so that all the turns are separated, and when the coil is finally completed, the thread separator is removed leaving a space wound solenoid very well adapted for use in tuned radio frequency circuits. Adhesive tape is employed to keep the coil together. By referring to Fig. 12 it will be clearly seen how the tape is arranged.

In order to obtain the same inductance, a coil of this type will require a few more turns than are necessary for a solenoid that is not space wound. Because of its low loss features and low distributed capacity, due to the spacing between turns, the wavelength range of this coil is, in general, somewhat greater than that obtained with an unspaced winding.

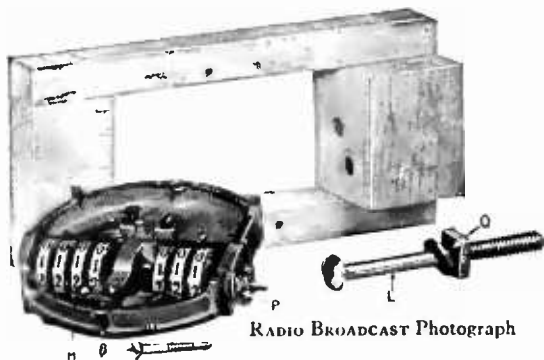

RADIO BROADCAST Photograph

FIG. 11

An unassembled view of the turn counter and support frame. With care, the shaft P should be filed so that it engages the slot in the head of the bolt L, on which the coil for m is mounted

KIND OF INSULATION							
B. & S. GAUGE	DCC	SCC	DSC	SSC	ENAMEL	AND SCC	AND SSC
14	13 7	14.6	14 7	15 0	15 2	14 2	14 7
15	15 0	16.2	16.4	17 0	17 0	15 8	16 5
16	16 7	18 0	18 2	19.0	18.7	17 6	18 4
17	18.5	20 0	20 0	21.2	21 4	19 5	20 5
18	19.6	22 3	22.3	23 6	24 0	21 7	22 9
19	22 5	25 0	25 2	27 0	27 2	24 2	25 8
20	24 5	27 5	27 5	29 5	30 1	26 5	28 4
21	27 5	30 8	30 8	32 8	33 6	29 6	31 5
22	30 0	34 0	34 0	36 6	37 7	32 7	35 0
23	32 7	37 5	37 5	40 7	42 3	36 1	39 0
24	35 5	41 5	41 5	45 3	47 2	39 7	43 1
25	38 5	45 7	45 7	50 3	52.9	43 7	47 9
26	41 8	50 2	50 2	55 7	59 0	47 8	52 8
27	45 0	55 0	55 0	61 7	65 8	52 1	58 1
28	48 5	60 0	60.0	68 3	73 9	57 0	64 4
29	52 0	65 5	65 5	75 4	82.2	61 9	70 6
30	55 5	71 3	71 3	83 1	92 3	67 4	77.9
31	60 0	77 3	77 3	91 6	103 0	72 8	85 3
32	62 7	83 7	83 7	101 0	116 0	79 1	93 9
33	66 3	90 3	90 3	110 0	130.0	85 6	103 0
34	70 0	97 0	97 0	120 0	145 0	91 7	112 0
35	73.4	104 0	104 0	131 0	164 0	98 8	123 0
36	77 0	111 0	111 0	143 0	182 0	105 0	133 0
37	80.3	126 0	126 0	155 0	206 0	113 0	146 0
38	83.5	133 0	133 0	168 0	235 0	120 0	157 0
39	89 7	140 0	140 0	181 0	261 0	128 0	172 0

FIG 13

This table, giving the number of turns per inch of various kinds of wire, is to be used in conjunction with the capacity-inductance data table printed on the following page

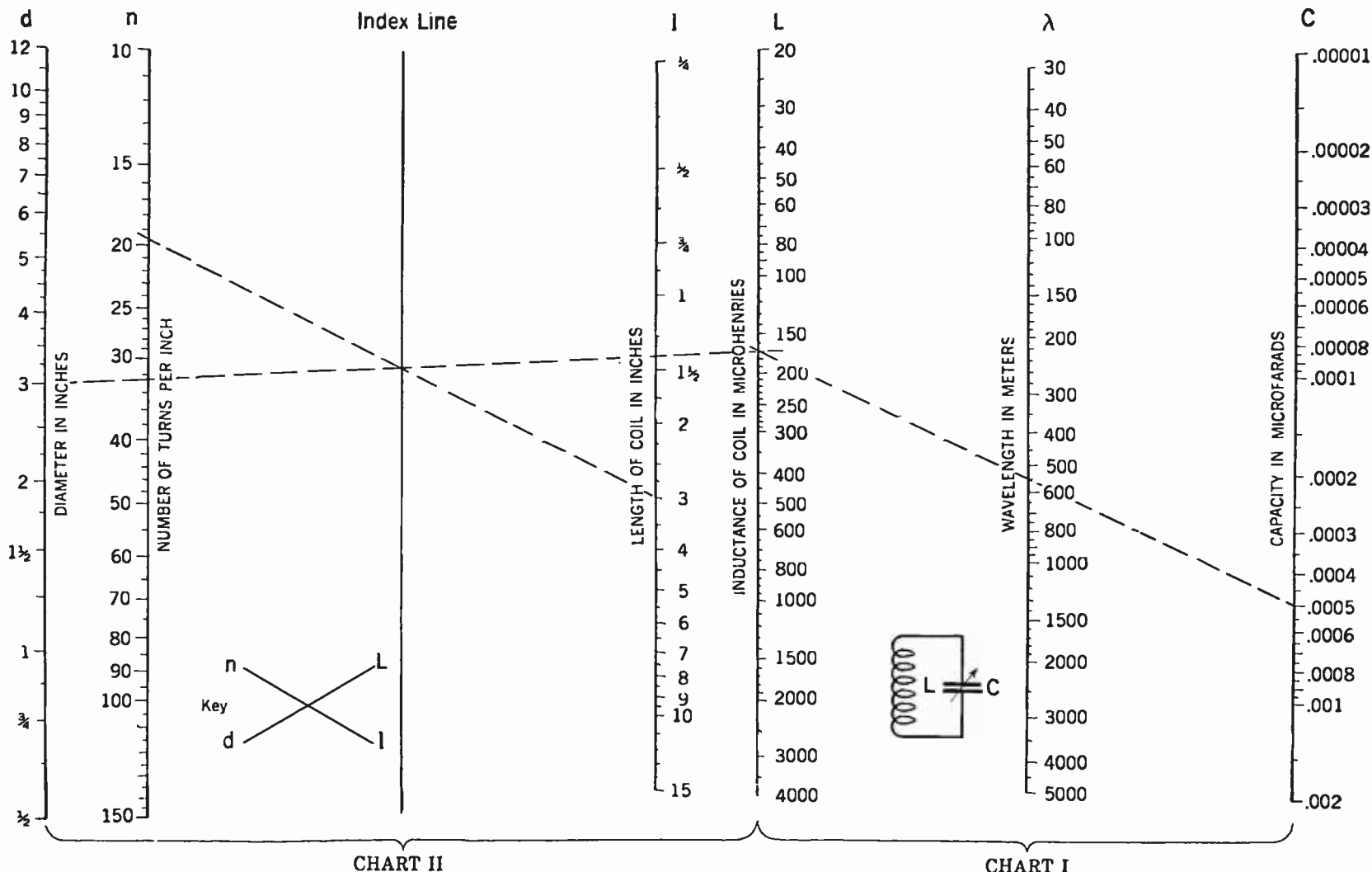

CHART II
Connect three known values as per key, and read fourth at point of intersection.
Example: If $L=170$ mh., $d=3''$ and $n=196$, then $l=3''$

CHART I
Connect two known values and read third at point of intersection.
Example: If $\lambda = 550$ m. and $C=.0005$ mfd then $L 170$ mh

COIL DATA CHART

With the aid of this chart, a ruler, and pencil, the experimenter can very simply determine the approximate specifications for a solenoid coil to cover a definite frequency spectrum (wavelength range) with any condenser on hand. Full information for its use was contained in an article by Mr. Homer Davis, on page 46 of the May, 1925, issue of RADIO BROADCAST.

Briefly, the chart is used in the following manner:

Suppose the constructor has a .0005-mfd. variable condenser and he wishes to cover a tuning range whose extremes are 545 kc. and 1500 kc. (550 to 200 meters). Therefore, he must wind a coil so that, with the condenser plates entirely meshed, the tuned circuit, comprising coil and condenser, will respond to 545 kc. (550 meters). The problem is to first determine the inductance value in microhenries. By connecting together with a ruler and pencil the values of capacity (.0005 mfd.) on column C and the wavelength extreme (550 meters) on column λ (wavelength), and continuing this line so that it intersects column L, a value of L (inductance) is denoted.

Now, knowing the size of wire he is to use, the constructor looks for the number of turns to the inch for that particular size of wire as indicated on the wire table, Fig. 13, and then spots this position on column "n" above. If No. 18 d.c.c. is to be used, the number of turns per inch will be 19.6. Then he, knowing the diameter of the coil he is to wind, draws a line from the diameter figure point on column "d" to the inductance value in microhenries on column L, determined previously. This latter line between d and L intersects the index line. Now from the spotting on column n (19.6 if 18 d.c.c. be employed), a line is drawn to pass through the point of intersection on the index line continuing on to the column L, thereby indicating the approximate length in inches of the coil to be wound. Knowing this value, then L times n equals the number of turns for the complete coil.

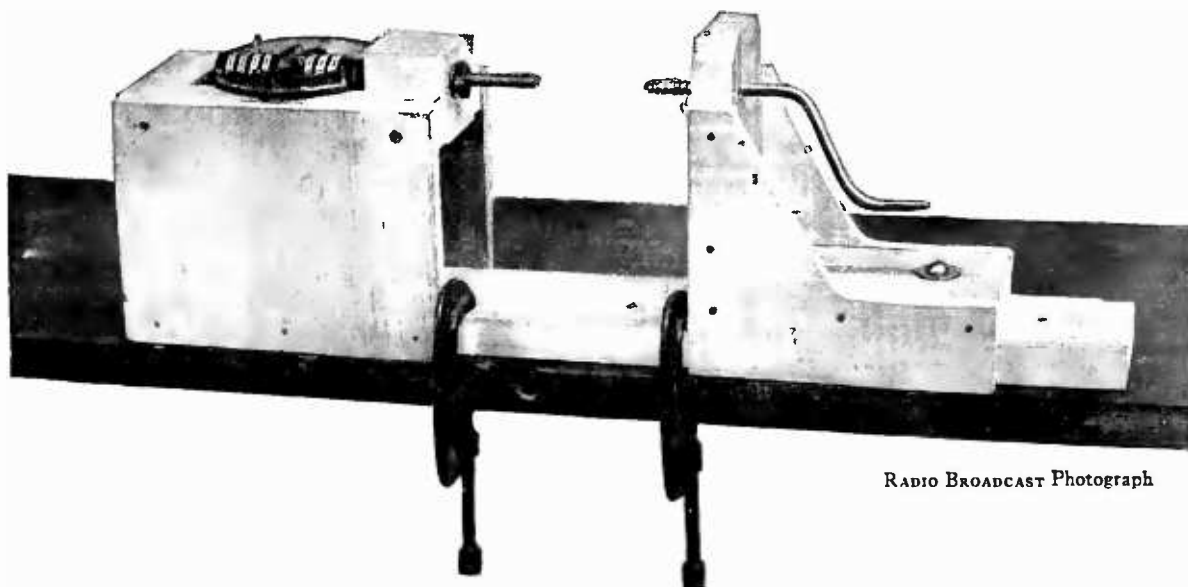

RADIO BROADCAST Photograph

THE ASSEMBLED WINDER

Clamped to the bench and ready for work. By comparing this picture with the illustration Fig. 1, which shows the winder in operation, it will be plainly understood how the solenoid form—and other forms too for that matter—are fixed to the winder

The First Report on the International Tests

By WILLIS K. WING

SEVERAL days before the Third International Radio Broadcast Tests are completed, it is a difficult matter to prepare anything more than what the newspapers refer to as a "bulletin" on the general success or failure of the most elaborate of the international broadcasting efforts which have yet taken place. A story on the results of the Tests will appear in RADIO BROADCAST for April, after sufficient time has elapsed for the thousands and thousands of reports to be sifted and verified. Now, with a desk loaded with telegrams and detailed reports of reception of foreign stations contained in letters, covering reception for the first few nights of the Tests, it is not possible to present all the facts. Most of the news of immediate interest to radio listeners has been furnished them already through their newspapers and in that field a monthly magazine cannot hope to compete.

But at International Test headquarters here in Garden City we have the reports of eager listeners who carefully tuned to the foreign wavelengths, and praises be to their radio souls, lots of them heard the coveted distant stations!

In brief, the first three nights of the Tests were very poor for receiving, at least on the East coast of the United States and in the Middle West. On the first two nights, reception was moderately good north and south and indifferently good east and west—the most important directions to the great body of American listeners. There were few indeed who reported reception of the English stations on Sunday, January 24th and of the Continentals on Monday, the day following. And, to top it off, and not to make excuses, but rather to state a sad fact, the oscillating receiver reared its electrical head and made reception well-nigh impossible for many listeners whose receiving equipment was efficient and sensitive enough to have a good chance of hearing the foreign broadcasts. If ever the genuine menace of the radiating receiver was demonstrated, it was demonstrated during these Tests.

On Tuesday night, the 26th, American listeners were more successful, and Cardiff and Aberdeen were reported in a considerable number of localities. Mail from the Middle and far West has not yet reached Garden City, so it is not possible to say at this time how successful listeners in those parts of the United States were in hearing English and Continental broadcasts on that night.

But on Wednesday night, the 27th, in the Eastern part of the United States, weather conditions had greatly improved and reception from the Middle European stations seemed to be much better, many verified reports being received on Hamburg and Prague, as well as on Madrid. The South American stations, too, seemed to come in better than before and the three Buenos Aires stations and the faithful Oax at Lima, Peru succeeded in

reaching a considerable number of listeners.

During the first three nights of the international experiment, there were storms at sea, as a number of SOS calls gave evidence that ships on the Atlantic were having their own troubles—far more serious than the uncertain reception American listeners had to face. The confirmation programs from many of the Continental broadcasters which were forwarded to Garden City by Dwight K. Tripp, the representative of RADIO BROADCAST in Paris, by

courier on the S. S. *Leviathan* were held up two days by a delay of that length in the arrival of the ship, due to the heavy weather on the Atlantic.

Of dramatic happenings, there were many, and it is hoped they can be chronicled in the April number of this magazine. There is the story of the experiences of those of the staff who took a broadcast receiver out to a thinly populated corner of Long Island, far from telephone or telegraph and connected with headquarters only by a battery-operated short wave transmitter and receiver, but that will have to wait.

In England, early cablegrams from Percy W. Harris, editorial manager of Radio Press, the English organization appointed by RADIO BROADCAST in charge of the Tests there, indicate that our fellow British enthusiasts were not highly successful in receiving American broadcasts during the first two days of the transmissions. There has not so far been time for reports more complete than that. Receiving conditions in England seemed to be exceptionally poor during the early part of the Test week.

Reports of reception of the foreign broadcasts, which are coming in to the offices of RADIO BROADCAST by mail and telegraph are being answered as promptly and completely as possible and an official card of verification is being sent to those fortunate enough to have heard any or all of the foreign stations. Those who have not yet sent in their report are urged to mail it in and to make it as complete, but as brief, as possible.

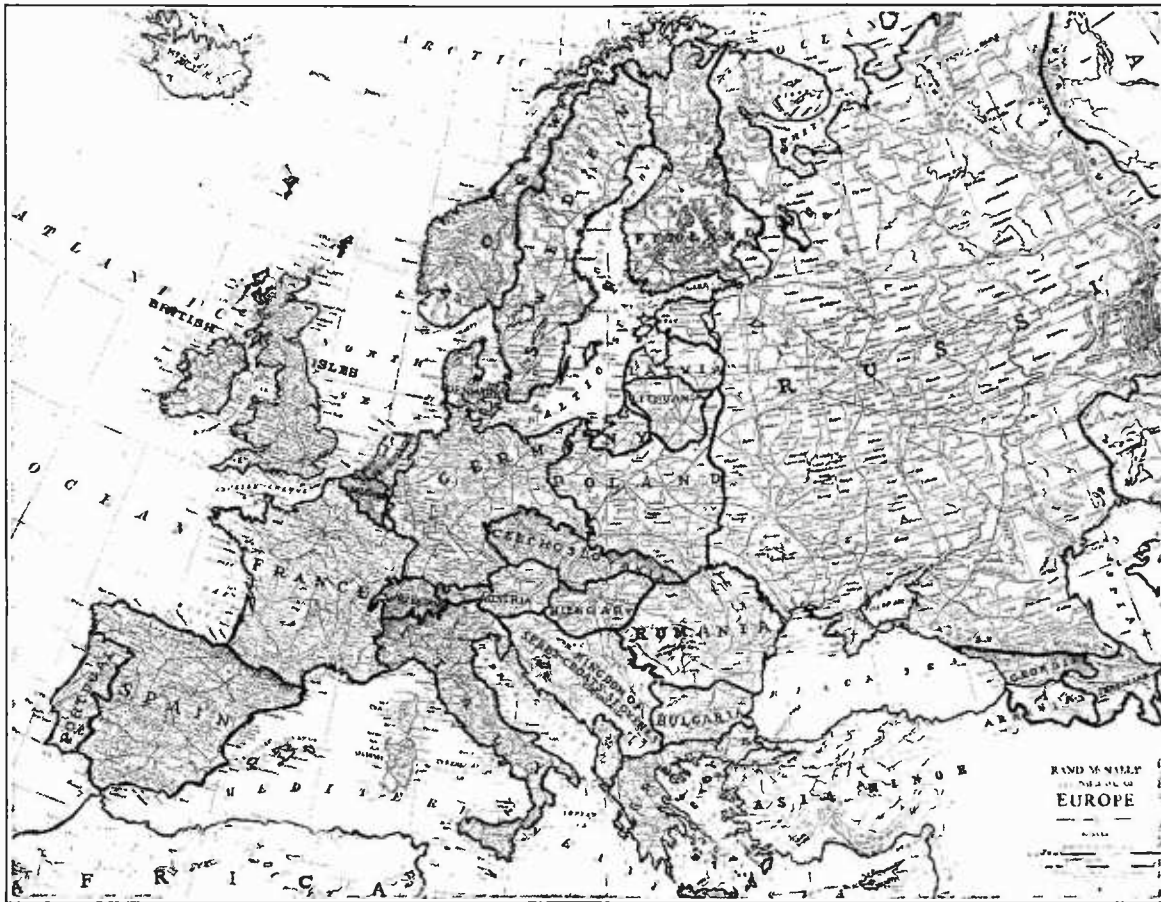

© Rand, McNally

Super-Heterodyne Construction

In Which the Various Sections of a Super-Heterodyne Are Described in Turn—Timely Hints and Constructional Data are Given for the Benefit of Those Contemplating the Construction of Such a Receiver

By HAROLD C. WEBER

A GREAT DEAL of misunderstanding seems to exist at present in regard to just what advantage the super-heterodyne type of receiver has over other circuits. In the opinion of the writer a Roberts receiver properly constructed gives all the selectivity, and by the addition of two stages of audio frequency amplification, all the volume one could desire. It is remarkably free from distortion, and if one lives in a locality where a good outdoor antenna can be erected, there is some doubt in the author's mind as to whether the super-heterodyne will produce results any more satisfactory than those obtainable by the more simple Roberts circuit. The big advantage obtained by the use of the super-heterodyne circuit is its ability to work on a small loop and, in so doing, produce just as good results as can be obtained by other sets with the aid of an outdoor antenna. From this it can be seen that the super-heterodyne finds its greatest use in thickly populated sections where it is difficult to erect a satisfactory outdoor antenna. The builder of a super-heterodyne may expect to obtain the same results on an eighteen- or twenty-inch loop with his super-heterodyne that

he has been obtaining in the same location with an outdoor antenna on either a good neutrodyne, for example, or a Roberts set. If he lives on the Atlantic Coast, and has been unable to receive Pacific Coast stations with his Roberts or neutrodyne set, it is doubtful whether he will be able to do any better with a super-heterodyne working on a loop. Attempts to make the super work on a large outdoor antenna are for the most part unsatisfactory, due to its great sensitivity. The weakest winter static noises resembled in volume a heavy thunder-

storm, after passing through the set. Of course, working the super-heterodyne on an outdoor antenna has the further disadvantage that considerable annoyance will be caused to one's neighbors unless a buffer or blocking tube is used in front of the first detector.

The discussion will now be turned to the various component parts of the super-heterodyne, and as each section is discussed, various experimental results which have been obtained will be pointed out.

THE FIRST DETECTOR

THE first detector circuit of the beat type receiver is really little different from any other detector circuit, and it is

has tried both schemes and believes that there is nothing to be gained by the use of the bias battery. In all of the sets he has constructed results obtained with the grid leak and the grid condenser fully equal those obtained with a C battery. The use of regeneration on the first detector tube will be found helpful. This is most easily accomplished by the use of a split loop, as pointed out in Mr. Silver's article in the July, 1925, RADIO BROADCAST. It is not necessary to use the midget variable condenser as he suggested. One may wind the loop with bare copper wire, and then place the center tap on that point of the loop where the first detector just refuses to oscillate. In place of the

midget condenser a .00025-mfd. fixed condenser may then be used. If the loop contains about fourteen turns of wire, it will be found that the best point for the mid tap is approximately four turns away from that end of the loop which is connected to the grid return, or ten turns away from that side of the loop connected to the grid.

One point seems to have been overlooked in this first detector circuit by a great many constructors; that is, the necessity for providing a low resistance path for the high-

frequency oscillations in the plate circuit of the first detector. No one would think of constructing a single-tube regenerative set without the use of a proper phone bypass condenser, and yet a great many super-heterodyne constructors neglect to use a bypass condenser at the same point in their super. This bypass condenser need not be larger than about .00015 to .00025 mfd. and, in fact, if the split-loop method is used, the condenser which must be included in the circuit will serve the double purpose of providing regenerative feed-

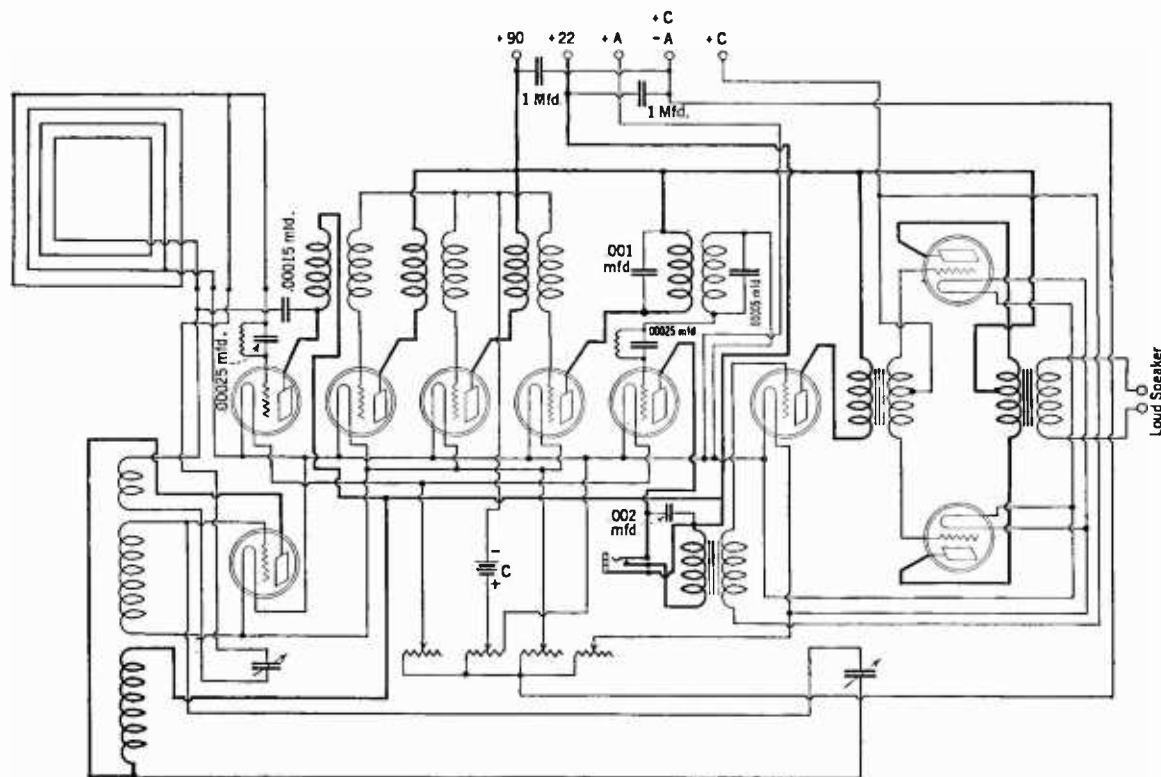

CIRCUIT DIAGRAM OF THE AUTHOR'S RECEIVER

A nine-tube super-heterodyne. The only controls appearing on the panel are the two condenser dials, three rheostat knobs, a potentiometer control, and a single jack for headphone use. The loud speaker is put in operation by merely pulling out the phone plug and turning on the audio rheostat

imperative that if one wishes to obtain satisfactory results the same care be exercised in building this part of the set as would be exercised in the construction of any good low loss one-tube receiver. This means that the condenser used for tuning the loop must be a good one. Its capacity should not be more than .0005-mfd., and it should be equipped with a smooth-acting vernier dial. Considerable discussion has been raised as to whether this first detector circuit should be operated with a grid leak and a grid condenser or with a C battery. The author

back and a low-resistance path for the high-frequency currents. The detector circuit must be coupled to the oscillator in some manner, and this can be done by coupling on to the plate circuit of the detector or to the grid circuit. Personally, the author feels that slightly better results are obtained by grid-circuit coupling than by plate-circuit coupling. The pickup coil may be placed either on the grid side of the loop or on the grid return side. The most satisfactory place for this coil seems to be between the grid return and that point where the tuning condenser connects to the loop. The coupling coil is shown connected in this position in Fig. 1.

Here again authors seem to differ as to the proper number of turns to be used for coupling. Anything from one turn to six turns seems to work satisfactorily on the broadcast wavelengths. Results obtained using from about six to thirty-five turns seem to be somewhat less satisfactory. Satisfactory operation is again obtained by the use of anywhere from thirty-five to fifty turns on the coupling coil. This may mean that the detector circuit can be coupled to the oscillator circuit either capacitively or inductively. Evidently, the transfer of energy is mostly by induction with the low number of turns in the coupling coil, and perhaps mostly by capacity when a large number of turns is used. It does seem, however, that there is a range from approximately six to twenty-five or thirty turns where results are inferior to those obtained either above or below this figure. Incidentally, there appears to be little actual advantage gained in making the coupling coil movable.

THE OSCILLATOR

THE oscillator is an extremely important part of any super-heterodyne. The author has found the Hartley oscillator circuit to be the most satisfactory. If a

30-kc. (10,000-meter) wave is used on the intermediate amplifier, a suitable construction for the coils in this circuit is two twenty-seven turn coils wound with No. 22 or 24 double silk-covered wire on a thin bakelite or cardboard tube, approximately $2\frac{3}{4}$ inches in diameter. Both coils are wound in the same direction. The proper method of connecting these coils in the oscillator circuit is shown in Fig. 2, and the coupling coil in the first detector circuit should be placed at the grid coil end of the oscillator coil unit rather than at the plate coil end.

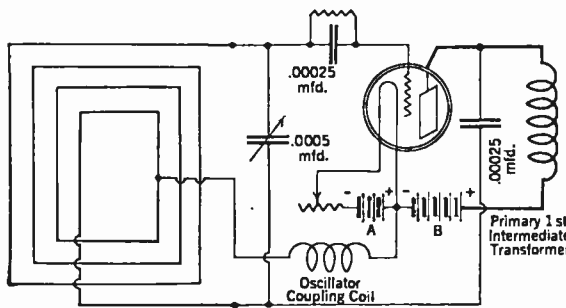

FIG. 1

Serious difficulty will no doubt be experienced with harmonics if one attempts to use more than twenty-five or thirty volts on the oscillator tube. Perfectly satisfactory results can be obtained with ten or twelve volts on the oscillator tube using 201-A type tubes. If the coupling coil of the first detector is coupled too closely to the oscillator circuit, some difficulty may occur, due to the fact that the oscillator will stop functioning whenever the first detector is tuned to approximately the same wavelength as the oscillator. This difficulty is easily overcome by loosening the coupling between the detector and oscillator circuits.

Too much care cannot be exercised in the selection of a suitable tube for use in the oscillator. This is one of the most critical tubes in the whole set, and several should be tried in this position until one is found

that functions satisfactorily. No station should be heard at more than two points on the oscillator dial in a properly constructed super-heterodyne. Most stations, even powerful locals four or five miles away, can be completely tuned out by a movement of less than one degree on the oscillator dial if the set is working properly. The same sharpness of tuning holds for the first detector circuit, if proper care is used in its construction, and low-loss parts are used throughout.

INTERMEDIATE FREQUENCY AMPLIFIER

SO MUCH has been said about intermediate-frequency amplifiers in various articles that the author really hesitates to add anything. A long discussion has been waged as to the relative merits of the air-core transformer versus the iron-core. It is usually admitted that it is much easier to amplify at a frequency of thirty kilocycles than at the higher frequencies to which most air-core transformers are tuned. Most iron-core transformers have their peak at about thirty kilocycles (10,000 meters), whereas the air-core transformers work at a very much higher frequency (shorter wavelength). This means among other things that, in general, more grid bias can be applied to an intermediate-frequency amplifier, using iron-core transformers, than to one using air-core transformers. Of course, increasing the grid bias decreases the B battery consumption, and when one is using anywhere from six to nine tubes, B battery current becomes an item of major importance. Offsetting this gain obtained by the use of iron-core transformers rather than air-core ones is the fact that unless the iron-core instrument is carefully designed, there is a great tendency for it to amplify at audio frequency, and therefore to be very noisy. If one uses the higher grade types of iron-core transformers now available, no difficulty will be experienced with noises from the intermediate-frequency amplifier.

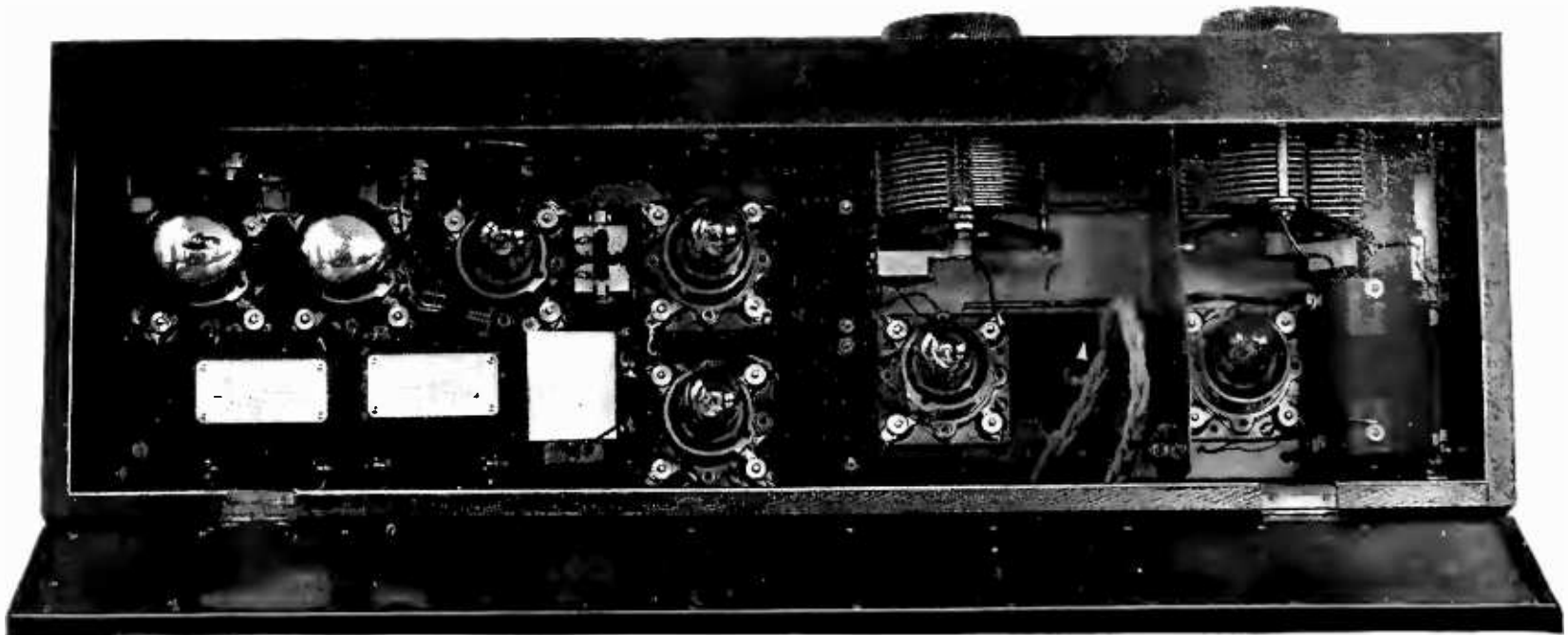

RADIO BROADCAST Photograph

A SEVEN-TUBE SUPER-HETERODYNE

Note the copper shield between the first and second tube units (at the right)

If the set is properly constructed, the intermediate-frequency amplifier often can be run with the potentiometer arm completely over to the negative side, and it will be found that often a few volts of C battery can be added to this circuit.

It is claimed that, unless the set is very thoroughly shielded, ten thousand meter transformers will be likely to pick up long-wave code signals. It is felt that most of the trouble experienced by the users of ten-thousand meter transformers in this respect is due to the fact that their leads have been made too long. The best plan at the present time seems to be to mount the long wave transformers, if they are of the iron core type, directly under the tubes to which they are to be connected, and then, if trouble is still experienced, to try grounding the metal casings with which most long-wave transformers are now protected. In fact, grounding the casings of these transformers is usually found advantageous in any case.

The question of tuned input versus tuned output for the intermediate-frequency amplifier has long been a debated point. It has been argued that tuned output does offer some advantage in that a sharply tuned transformer will not pass any audio frequency which may be picked up by the first transformer in the train. This tends to cut out noise in the set. The author has tried both tuned input and output on the same set, and has come to the conclusion that, with the better makes of long-wave, iron-cored radio-frequency transformers now on the market, little trouble will be experienced from transformer noises in any case. There is one advantage that the tuned input circuit does have over the output circuit. It will be remembered that reference was made to the bypass condenser which is quite necessary across the primary circuit terminals of the first long-wave transformer in the first detector circuit. Placing a bypass condenser at this point is not very helpful to the amplifying action of the transformer, providing it is an iron-core instrument; but if a tuned air-core transformer is used at this point, the fixed condenser necessary across its primary terminals serves the purpose of a bypass for the high-frequency oscillations as well as serving as a means of tuning for the transformer. From this point of view it might be argued that tuned input does have some advantage over tuned output. Of course, if one is using a split-loop method

for obtaining regeneration this advantage does not appear, and under these considerations it is doubtful whether either a tuned input or a tuned output offers any advantages. Surely any good iron-core transformer, when used in a properly constructed super-heterodyne, will give all the selec-

fixed condenser across the primary of this instrument, and approximately a .00025 mfd. fixed condenser across the secondary. Inasmuch as many small fixed condensers vary somewhat, it may be necessary to try several before satisfactory results are obtained. If access can be had to a wave-

meter tuning as high as 30 kc. (10,000 meters) of course one can design his transformer so that it will exactly match the peak on the iron-core transformers which are to work with it. A good intermediate-frequency amplifier will usually give all the amplification necessary with two stages, and it is very doubtful whether one should ever use more than three stages.

THE SECOND DETECTOR AND AUDIO AMPLIFIER

THE second detector usually gives very little trouble in any set. Rather a low value grid leak seems to work best in this

circuit, usually about two to four megohms and, of course, the phone bypass condenser should not be omitted. Here again experiment will show the best value for this condenser. Usually a condenser with a capacity of from .001 mfd. to .006 mfd. will be found most suitable, preference being given to the low values.

A good super-heterodyne will give all the volume that one could desire for headphone use without any audio amplifier, even when receiving distant stations on the loop. For loud-speaker operation one, and possibly two stages of audio frequency amplification may be added. Here again the use of good transformers cannot be over emphasized. If the constructor is willing to pay a high price for one of the new type high ratio audio-frequency transformers now on the market, all well and good; otherwise he will probably obtain the most satisfactory results by not attempting to use a transformer having a ratio of more than 3 or 3½ to 1. Some of the newer transformers mentioned above will amplify in a very satisfactory manner even though they do have ratios of 5 or 6 to 1. Such a transformer cannot, however, be constructed cheaply due to the fact that it requires a heavy core and an exceedingly large number of turns on its secondary. Unless the set is to be used in a large room or hall, one good stage of audio-frequency amplification will usually give enough volume for satisfactory loud-speaker operation. If a second stage is desired, it had best be either of the power type using some such tube as the UV-202 or the Western Electric 216-A, or perhaps,



RADIO BROADCAST Photograph

A COPPER LINED CABINET

Shielding will prevent body capacity effects and also prevent the coils, transformers, etc., picking up the transmitted waves thus impairing the efficiency

tivity in tuning that could be desired, especially if the first detector is made regenerative. For those who are interested in experimenting with tuned input and output circuits, the following specifications will be found useful in constructing an air-core transformer having a peak at about 31 kc. (9600 meters); primary, 750 turns No. 30 d. s. c. wire, random wound on a form having a central opening ¾ of an inch in diameter and 1/16 of an inch wide. Secondary, two 800-turn coils connected in series and wound with d. s. c. wire on the same

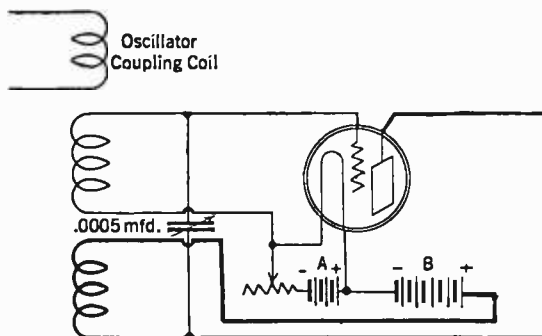

FIG. 2

form as the primary was wound on. The two secondary coils are to be placed one on either side of the primary coil. If these coils are wound on a suitable collapsible form, they can be lightly doped with collodion and made self-supporting, thus doing away with any supporting form. In this way some slight increase in efficiency can be had over coils wound on solid forms. It will be necessary to shunt a .001 mfd.

the push-pull construction which has been quite popular during the last year or two.

The second stage of audio-frequency amplification handles exceedingly heavy currents, especially on local signals, and any ordinary receiving tube will become so overloaded that bad distortion will occur. Some discussion has been raised as to the necessity for a filter before the audio-frequency amplifier to keep the intermediate-frequency currents from entering it. It is doubtful whether such a filter will be found necessary if careful construction work is done. The use of large bypass condensers (.5 to 1.0 mfd.) across both the amplifier and detector sections of the B battery, will aid in keeping these currents out of the audio circuits.

GENERAL CONSIDERATIONS

IF ONE is going to the expense of building a super-heterodyne, the author would by all means advise the use of storage battery tubes, except in those cases where a portable set is desired, or where the charging of storage batteries is a great inconvenience. The B battery current drawn by a super-heterodyne, although it is large, need not be excessive. The author's own set, using nine 6V-2 tubes, draws but eight to ten milliamperes of B battery current and from 1 1/2 to 1 3/4 amperes on the A battery side, by actual measurement. If more than twenty milliamperes are drawn in the B battery circuit by a super-heterodyne using

Considerable care must be exercised in the selection of tubes for the intermediate-frequency amplifier, and it may be necessary to try several different arrangements of tubes in the set before a really satisfactory arrangement is found. The operation of the whole set may be ruined by one faulty tube anywhere before the second detector.

A great many times it will be found that the loop does not have much directional effect and that it can very often be built inside a cabinet housing the set with practically no loss in signal strength. This is true with the author's own set, and such a construction does much toward improving the appearance of the set and protecting the loop and its connections from dirt and injury.

A comparison of the results obtained by the author using his set, with those results obtained using other sets in exactly the same location, may be of interest. The set is located in one of the suburbs of Boston. Several years ago a three-tube set, employing the three-circuit tuner, was used in the same place with a three-wire indoor antenna about thirty-five feet long and twenty-five feet high. New York stations could be heard on the loud speaker regularly, and Chicago stations occasionally. About two years ago a five-tube neutrodyne set was installed. This employed three stages

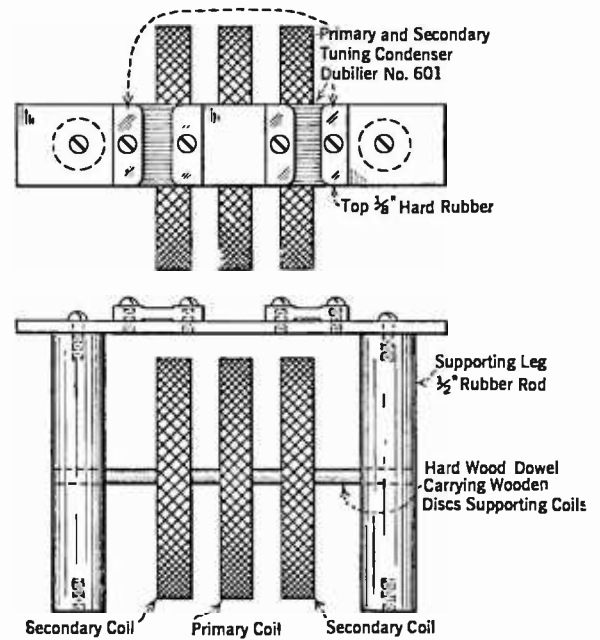

FIG. 3

A sketch of the author's 9600-meter tuned output transformer drawn approximately to scale

push-pull, gives consistent loud speaker operation on Chicago stations and fairly consistent loud speaker operation on Cuba and the Texas stations. London's 2 LO was heard on the loop twice during last year's transatlantic tests, once on the loud speaker.

The author does not feel, however, that the present super-heterodyne, working on its built-in loop, is any more effective as a distance getter than was the previous neutrodyne set working on the thirty-five foot indoor antenna. Of course there is the advantage that the present set has but two tuning controls.

Whether or not the super-heterodyne is enough better than the other good circuits known to-day to justify the extra expense demanded in its construction and operation, is still a debatable question.

In conclusion let it be repeated that it is impossible to overestimate the undesirability of operating the super-heterodyne on an outside antenna. Even when a loop is employed it is possible to interfere with other receivers in the same building. For successful operation the type of receiver depends on the fact that it is a miniature transmitter, and as such, will cause considerable interference if coupled to an outside antenna.

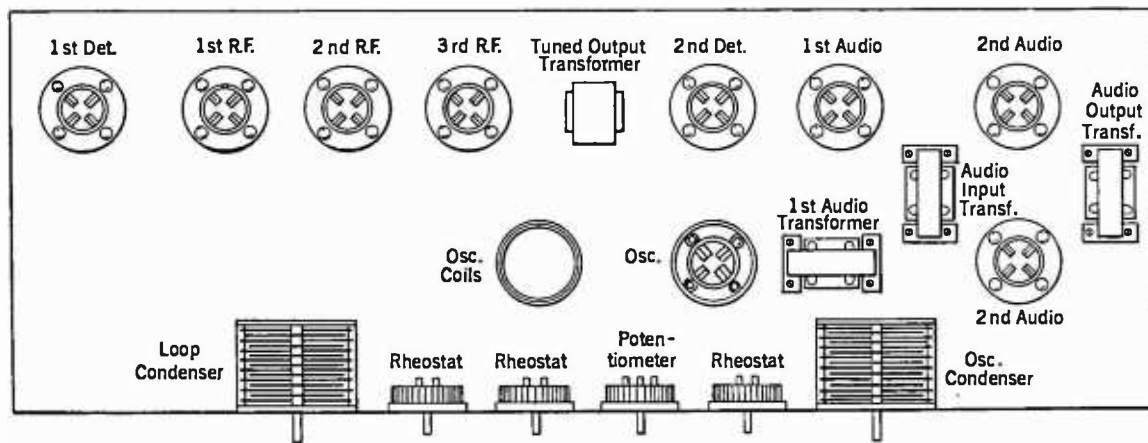

LAYOUT DIAGRAM

Of the essential parts of a nine-tube superheterodyne using two stages of audio, the second stage being push-pull. Note the position of the oscillator tube, coils, and condenser, as far away from the first detector as possible. The long wave transformers are mounted under the three radio frequency tubes feeding into them, and are not shown in this sketch

iron-core transformers, it is probable that there is something wrong somewhere in the set.

Any voltage from 45 to 90 is suitable for use on the intermediate-frequency tubes. For best results, one should not use more than 20 to 30 volts on the detectors.

In order to use as few rheostats as possible, the two detectors may be operated from one rheostat, the three intermediate amplifiers from a second, the oscillator perhaps from a third, while the audio amplifiers may well be run through fixed resistance units rather than from a rheostat.

of neutralized radio-frequency amplification and two stages of audio-frequency amplification, one of the latter being reflexed through one of the radio tubes. Loud speaker operation on the Chicago stations was possible, using the same antenna as outlined above; fairly consistent loud-speaker signals on stations as far south as Cuba and Texas were obtained. The present set, a nine-tube super-heterodyne, using three stages of intermediate-frequency 30-kc. amplification and two stages of audio-frequency amplification, the second stage being

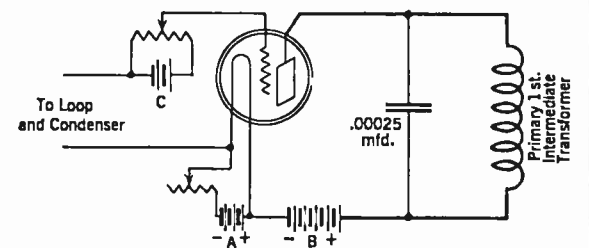

THE C BATTERY CONNECTIONS

On the first detector tube to obtain grid bias. The potentiometer used here must be a high resistance one of about 1800 ohms. The high frequency bypass condenser may be seen directly across the first transformer primary. This is the method of connecting the condenser when regeneration is not used on the first detector

The Newest Achievements of POWEL CROSLEY JR.

Industrialist—Pioneer Radio Builder—Master of Mass Production

Four Entirely New 4- and 5-tube Radio Sets—Also the Crescendon

Never before has Crosley engineering and manufacturing genius been so brilliantly demonstrated as in this group of new Crosley sets.

Here, at prices so low as to be literally revolutionary, are three 5-tube sets and one 4-tube set—entirely new in principle, design, circuit, and appearance—entirely unique in the results they give on distant and local stations—entirely unprecedented in the values they now introduce.

On two of these sets is offered the Crescendon, a new and exclusive Crosley feature—an extra volume control by which average incoming signals can be built up or modified in a manner nothing short of amazing. Introduced on the new 4-29 and 5-38, the Crescendon principle makes its first appearance in the low price field, its use having hitherto been restricted to one set costing several times as much.

Particular emphasis is directed to the new Crosley RFL receiving sets that utilize an entirely new and patented circuit which provides true cascade amplification and closely approaches the theoretical maximum of efficiency per tube. Non-oscillating at any frequency and absolutely non-radiating, the RFL Crosleys are specifically recommended for use in congested areas and for satisfactory performance in the hands of inexperienced operators.

In addition to their truly marvelous selectivity, sensitivity, and purity of tone, these new Crosleys have been given a new order of beauty that cannot help but win the highest admiration.

We do more than urge you to go to the nearest Crosley dealer for a demonstration! We ask you to go prepared for the most startling revelation in radio ever announced in the entire history of the industry—and predict that your expectations will be more than satisfied!

Crosley manufactures radio receiving sets which are licensed under Armstrong U. S. Patent No. 1,113,149, or under patent applications of Radio Frequency Laboratories, Inc.



THE CROSLEY RADIO CORPORATION, CINCINNATI, OHIO

Owning and Operating WLW first remote control super-power broadcasting station in America



The Crosley 4-tube—4-29

in which the Crescendon is equivalent to one or more additional tubes of tuned radio frequency amplification . . . \$29



The Crosley 5-tube—5-38

All the volume, selectivity, sensitivity and purity of tone available in the best 5-tube set—plus the Crescendon . . . \$38



The Crosley 5-tube—RFL-60

A set so marvelous in performance that its appearance on the market is bound to create a new standard of comparison . . . \$60



The Crosley 5-tube—RFL-75

For simplicity and speed in tuning, fidelity of tone, and decorative beauty—it stands unchallenged at twice the price . . . \$75

West of the Rocky Mountains all prices as published are 10% higher

CROSLEY · RADIO

B E T T E R · C O S T S L E S S

★ Tested and approved by RADIO BROADCAST ★

ASK . . ANY . . RADIO . . ENGINEER



An every-night adventure of Burgess Radio Batteries

ONE of the reasons why you should always buy Burgess Radio Batteries is that the batteries used by air-mail pilots—battleships—explorers—and the majority of recognized radio engineers—are evolved in the Burgess Laboratories and manufactured in the Burgess factory.

These batteries are identical with the batteries sold by your dealer and thousands of other good dealers everywhere.

BURGESS BATTERY COMPANY

GENERAL SALES OFFICE: CHICAGO

Canadian Factories and Offices:
Niagara Falls and Winnipeg



THE GRID

A Department Devoted to Solving the Problems of our Readers

QUERIES ANSWERED

1. HOW MAY I OBTAIN A VARIABLE VOLTAGE SUPPLY FROM MY B BATTERY ELIMINATOR FOR THE PLATES OF MY RADIO FREQUENCY AMPLIFIER TUBES?
R. A. W.—New York City.
2. WILL YOU PUBLISH A SIMPLE CIRCUIT DIAGRAM FOR A LOOP R. F. RECEIVER?
F. M.—Cape May, New Jersey.
3. WHAT IS THE BEST WAY OF MAKING MY OWN GRID LEAKS FOR EXPERIMENTAL PURPOSES?
M. L. H.—Bay Shore, Long Island.
4. WHAT ARE THE OPERATING CHARACTERISTICS OF THE NEW TUBES?
C. A. B.—Little Rock, Arkansas.
5. I HAVE D. C. IN MY HOME. HOW MAY I CHARGE MY STORAGE BATTERY?
L. P.—New York City.

SEPARATE R. F. TUBE VOLTAGE FROM B BATTERY ELIMINATORS

MOST B battery eliminators are so constructed that only two distinct voltage values are obtainable, a variable one for the detector tube and a fixed figure for the audio amplifier. When a receiver employing radio frequency amplification is used, it is therefore necessary to apply the same potential to the r.f. tubes as is applied to either the detector or audio plates. It is often advisable to use an intermediate value for the r.f. tubes, however, and this may be accomplished by the addition of a suitable resistance in series with a second lead from the positive high voltage tap of the instrument.

It is a very simple matter to make this addition to the circuit, and it is possible to obtain the variable resistance on the market. In most instances one having an approximately correct

obtain the desired voltage regulation. As an instance; if it is desired to regulate the voltage on the r.f. tubes from 65 to 100 volts, then the maximum resistance value is obtained by applying the formula:

$$R = \frac{E - E_1}{I}$$

Here $E_1 = 65$, $E = 100$, and $I =$ current in amperes per r.f. tube. If no C battery is used in the radio-frequency amplifier then the plate current per tube will be about 5 milliamperes, so where the receiver consists of two r.f. stages the total is 10 milliamperes or .01 amperes. Substituting values for the formula we get—

$$R = \frac{100 - 65}{.01}$$

$$R = \frac{35}{.01} = 3500 \text{ ohms}$$

Where a C battery is employed, the current is

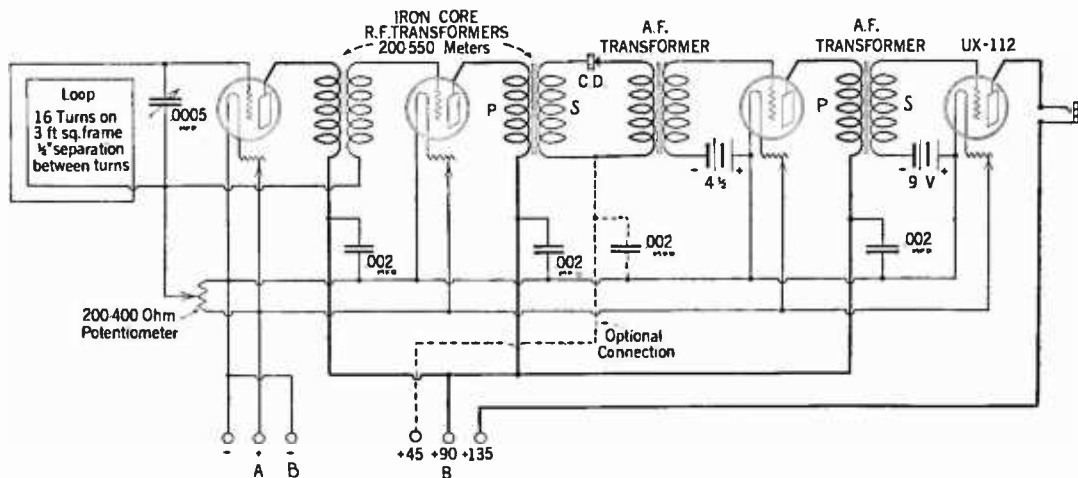

FIG. 2

range will have to be selected. For instance, if it is found that one having a maximum of 4000 ohms is necessary, one rated at 5000 ohms will be just as satisfactory.

The user can very simply determine for himself the value of the resistance necessary to

reduced by a third or a half, and if the experimenter has a milliammeter he can determine in an instant the actual drain per tube by inserting the meter in each tube's plate circuit.

The connections of this additional resistance in the B supply circuit are shown in Fig. 1.

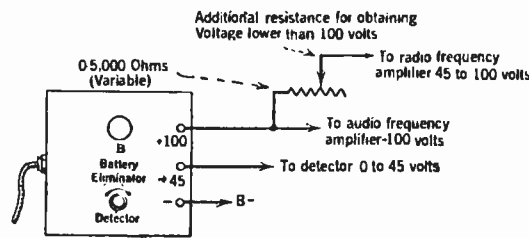

FIG. 1

ONE DIAL LOOP RECEIVER

A VERY simply constructed one dial receiver, employing two stages of un-tuned radio frequency amplification, a crystal detector, and two stages of audio frequency amplification, is shown in Fig. 2.

To prevent the radio frequency stages from oscillating continuously, a potentiometer of 200 to 400 ohms is shunted across the A battery

*Unfailing
radio power
from the*
LIGHT SOCKET



with

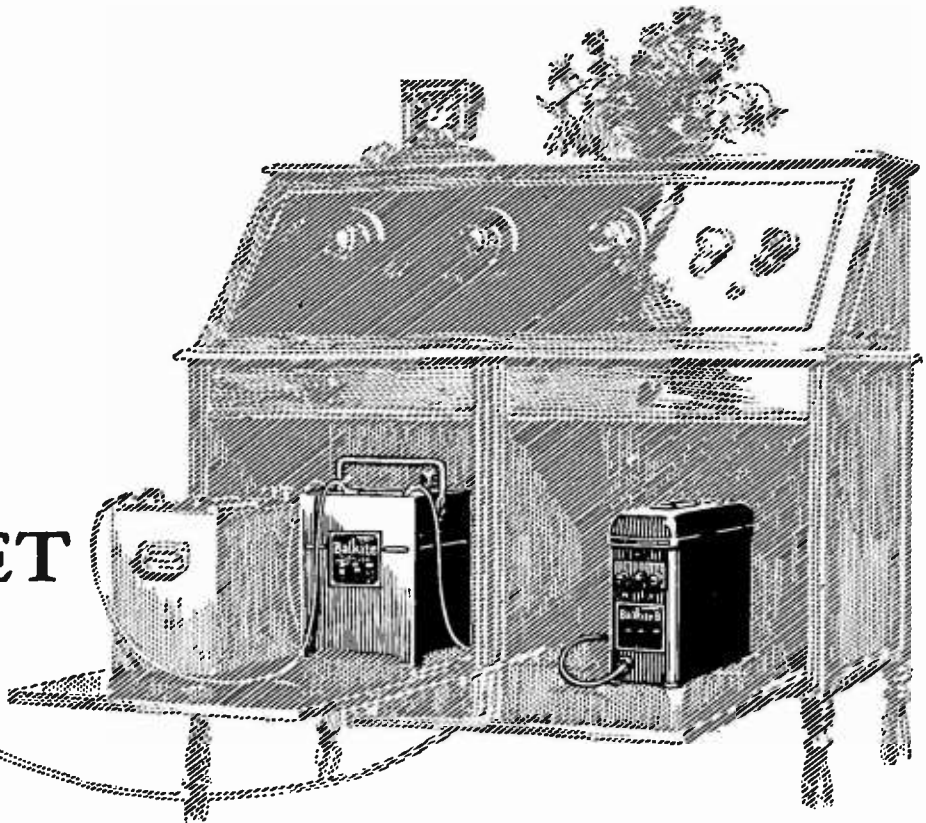

Balkite Radio Power Units

Balkite Radio Power Units give unfailing, uniform current for both circuits from the light socket. One very popular Balkite installation, especially for heavy duty sets where reserve "A" power is required is with the Balkite Battery Charger and Balkite "B." Here the noiseless, high-rate Balkite Battery Charger is ideal. If your battery should be low, you merely turn on the charger and operate the set. Balkite "B" eliminates "B" batteries entirely and supplies plate current from the light socket.

Balkite light socket equipment

Another very popular Balkite installation is with the Balkite Trickle Charger and Balkite "B." The Balkite Trickle Charger converts your "A" battery into an automatic "A" power unit that provides "A" current from the light socket, so that both circuits operate from the lighting circuit. This installation enables you to convert your present receiver into a light socket set.

Noiseless — No bulbs — Permanent

All Balkite Radio Power Units are permanent pieces of equipment, entirely noiseless, have no bulbs, nothing to break, replace or get out of order. Their current consumption is very low. All operate from 110-120 volt AC current, with models for 50, 60 and other cycles. *All are tested and listed as standard by the Underwriters' Laboratories.*

[The Balkite Railway Signal Rectifier is now standard equipment on over 50 leading American and Canadian Railroads]

FAN STEEL
Balkite ★
Radio Power Units



Balkite Trickle Charger

Converts any 6-volt "A" battery of 30 ampere hours capacity or more into an automatic "A" power unit that furnishes "A" current from the light socket. With 4-volt and smaller 6-volt batteries may be used either as an intermittent charger or a trickle charger. \$10. West of Rockies, \$10.50. In Canada, \$15.



Balkite Battery Charger

The popular rapid charger for 6-volt "A" batteries. Noiseless. Can be used during operation. Special model for 25-40 cycles. \$19.50. West of Rockies, \$20. In Canada, \$27.50.



Balkite "B"

Eliminates "B" batteries and supplies plate current from the light socket. For sets of 6 tubes and less. \$35. In Canada, \$49.50.

Balkite "B" II

Supplies plate current from the light socket. Will serve any standard set. Especially adapted to sets of 6 tubes or more. \$55. In Canada, \$75.

MANUFACTURED BY FANSTEEL PRODUCTS COMPANY, INC., NORTH CHICAGO, ILLINOIS

SOLE LICENSEES IN THE UNITED KINGDOM: MESSRS. RADIO ACCESSORIES LTD. 9-13 HYTHE RD., WELLESDEN, LONDON, N. W. 10

★ Tested and approved by RADIO BROADCAST ★

www.americanradiohistory.com

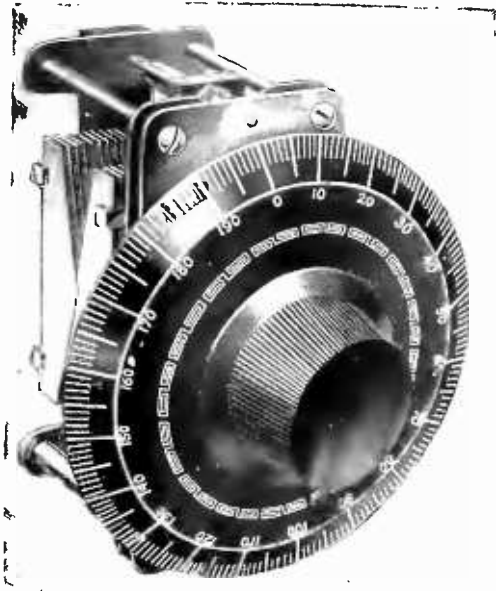

Greater Station Spread With 360° Dial

NEW Wade vernier dial, finished in beautiful black lacquer is a vital factor in the Wade tuning efficiency—Spread stations over the entire 360° circumference and gives twice the space between stations for close tuning as rotor plate types of straight line frequency condensers using 180° dials. No more bunching of stations, none of the annoyance of overlapping stations.

By actual test the Wade condenser gives the lowest minimum capacity and wider tuning range. Covers the whole broadcast range and down below 200 meters.

No Body Capacity Effects

A separately grounded frame insulated from both sets of plates shields the condenser from all body capacity effects—an important feature, exclusively in Wade Condensers.

WADE TUNING UNIT

Including Condenser and Dial

The Wade Tuning Unit consists of a Wade Condenser geared to a four-inch 360 degree vernier dial of 16 to 1 ratio. Finest possible control with no backlash. Prices below are for the complete unit.

- Capacity .000125 mfd.....\$6.00
- Capacity .00025 mfd..... 6.25
- Capacity .00035 mfd..... 6.35
- Capacity .0005 mfd..... 6.50

At your dealers, otherwise send purchase price and you will be supplied postpaid.

Jobbers and dealers write for further information and opportunities in your locality.

The Viking Tool and Machine Company, Inc.
 745-A 65th Street Brooklyn, N. Y.



leads. The return side of the secondary of the first r.f. amplifying transformer and the lower side of the loop are connected to the central arm of this potentiometer. It is recommended that a power tube, such as the UX-112, be employed in the last audio stage. This will insure quality reproduction providing a C battery of the proper value is employed, to bias its grid. The use of a C battery in the first audio stage will be found helpful also, and should be included, although its value will not be as high as for the second stage.

Any type of loop capable of being tuned to the broadcast band of frequencies is suitable

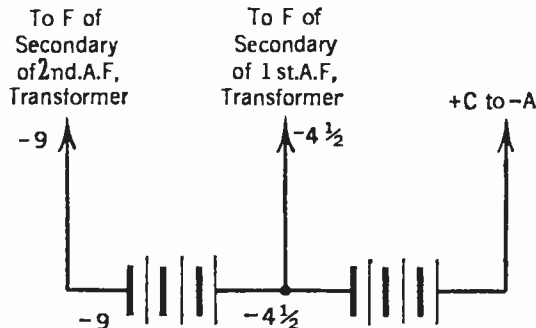

FIG. 3

but for those who wish to make their own, it is suggested that a box frame, three feet square and ten inches wide, and having 16 turns of No. 18 bell wire wound thereon, separated 1/2 inch apart, be employed.

Values for the various parts are indicated in Fig. 2 while Fig. 3 shows how two 4 1/2-volt C batteries, connected in series, may be used to furnish grid bias for both audio amplifier stages.

MAKING YOUR OWN GRID LEAKS

THE true experimenter always desires to make as much of his own apparatus as is possible. Grid leaks are important in maintaining the proper standard of reception and not always is it possible for the experimenter to secure a grid leak of the value which will produce these results.

With the aid of drawing ink and a business

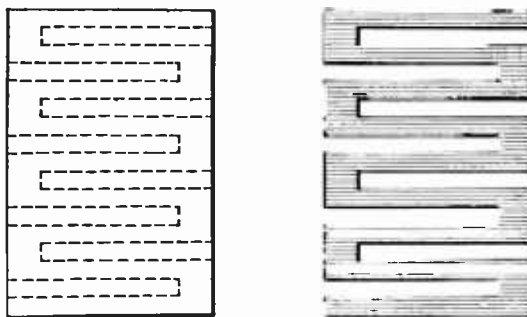

FIG. 4

calling card, it is possible to make grid leaks of various values.

One side of the card is completely covered with the ink and then by cutting into the sides with a pair of scissors as shown in Fig 4, it is possible to vary the value of leak by removing the sections cut into.

Grid leaks of this type should be thoroughly dried before using, as the value of the leak will vary with different degrees of temperature and moisture.

Paper clips make satisfactory connections to the ends of the inked paper.

NEW TUBES AND THEIR CHARACTERISTICS

ONLY recently the new line of radio tubes has been added to the fast-growing accumulation of apparatus from which the constructor may make his choice in building high quality receivers. More and more atten-

tion is being centered upon the production of units designed to be employed in receiver installations where quality is the goal.

A BATTERY SUPPLY	FILAMENT TERMINAL VOLTS	B BATTERY (AMPLIFIER)	GRID BIAS	NORMAL PLATE CURRENT
FOR THE UX-112 THE REQUIREMENTS ARE:				
6	5	157.0	10.5	7.9
6	5	135.0	9.0	5.8
6	5	112.5	7.5	2.5
6	5	90.0	6.0	2.4
FOR THE UX-120 THE REQUIREMENTS ARE:				
4.5	3	135	22.5	6.5

The new tubes offer to the constructor the means for operating his receiver at the efficiency at which it should be operated. However, there are certain requirements that must be observed in the use of these tubes.

Those that interest the constructor most are the power tubes, UX-112 for 6-volt source, and the UX-120 for 4 1/2-volt source. Each must be supplied with its correct grid and plate voltage or else there is no advantage in their use. The requirements are shown in the accompanying table which appears at the top of this column.

HOW TO CHARGE STORAGE BATTERIES FROM D. C.

THE charging of storage batteries which serve to supply the energy for the filaments of radio tubes is a problem which has engaged the attention of many engineers who are seeking to make this work easy for the man at home.

In many places only alternating current is obtainable for charging purposes and, where this is the case, some rectifying devices must be employed to change the current in the lighting mains from alternating to direct current. Where a simple rectifier is used the resultant rectified current is not purely a constant direct current but is more correctly termed a pulsating direct current.

A glance at A in Fig. 5 shows how this occurs. The alternation or cycle of current in an alternating current line assumes a definite form starting at a zero or neutral line. It then rises to a positive value afterward decreasing to the neutral again. This constitutes a half cycle. Now it continues below the neutral line toward the negative in the same fashion as it went positive. Therefore, it is observed that the cycle consists of two wave forms, one positive, the other negative in potential.

The rectifier is so designed and operated as to exclude the negative half of the alternation, permitting only the positive half to pass. This results in a series of pulsations of a positive nature which, if visible, would look like those shown in B. It is these periodic raps or pulsations which enter the battery on charge, causing a chemical change in the nature of the plates of which the battery is composed, so that it resumes its original charged state.

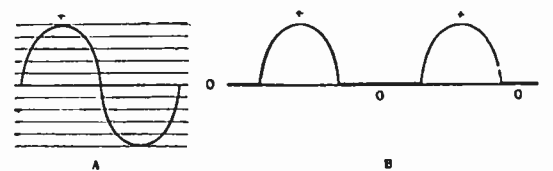
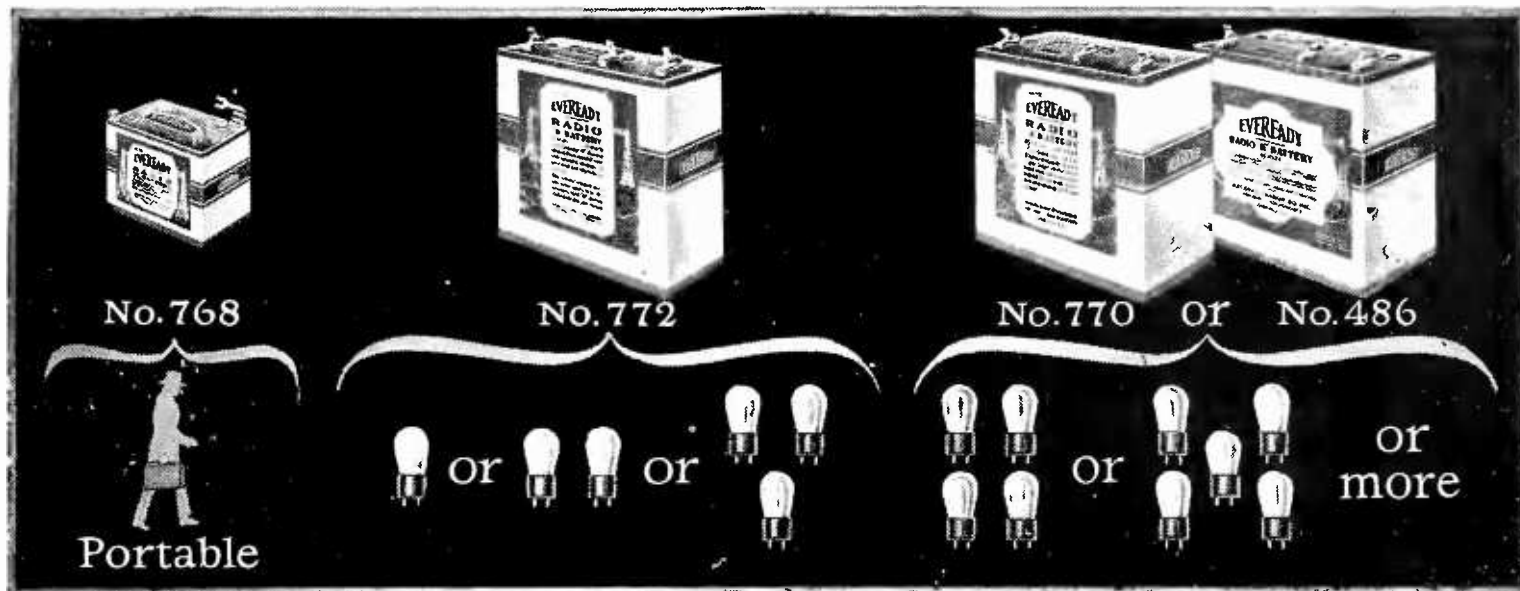

FIG. 5

This chemical change within the battery must be accomplished slowly, that is, at a low ampere-hour rate, otherwise the compound pressed into the plates of the battery will disintegrate and fall to the bottom of the cell, thus causing short-circuits from plate to plate.

Where the charging current is direct current a different procedure must be employed. Here

Perhaps you, too, can cut your "B" battery costs in half. Just follow the chart. It gives you the secret of "B" battery economy.



THOUSANDS of people have made the discovery that Eveready "B" Batteries, when used in the proper size and with a "C" battery*, are the most economical, reliable and satisfactory source of radio current.

On sets of one to three tubes, Eveready "B" Battery No. 772, used with a "C" battery, will last a year or longer, usually longer. On sets of four and five tubes either of the larger Heavy Duty Eveready Batteries No. 770 or No. 486, used with a "C" battery*, will last eight months or more.

These figures are based on the average use of receivers, which a country-wide survey has shown to be two hours daily throughout the year. If you listen longer, of course, your batteries will have a somewhat

shorter life, and if you listen less, they will last just that much longer.

Here is the secret of "B" battery satisfaction and economy:

With sets of from 1 to 3 tubes, use Eveready No. 772.

With sets of 4 or more tubes, use either of the Heavy Duty Batteries, No. 770, or the even longer-lived Eveready Layerbilt No. 486.

Use a "C" battery on all but single tube sets.

Evereadys give you their remarkable service to the full when they are correctly matched in capacity to the demands made upon them by your receiver. It is wasteful to buy batteries that are too small. Follow the chart.

In addition to the batteries

illustrated, which fit practically all of the receivers in use, we also make a number of other types for special purposes. There is an Eveready Radio Battery for every radio use. To learn more about the entire Eveready line, write for the booklet, "Choosing and Using the Right Radio Batteries," which we will be glad to send you on request. This booklet also tells about the proper battery equipment for use with the new power tubes. There is an Eveready dealer nearby.

Manufactured and guaranteed by
NATIONAL CARBON CO., INC.
 New York San Francisco
 Canadian National Carbon Co., Limited
 Toronto, Ontario

Tuesday night means Eveready Hour—9 P. M., Eastern Standard Time, through the following stations:

- | | |
|------------------|--------------------|
| WEAF—New York | WSAI—Cincinnati |
| WJAR—Providence | WEAR—Cleveland |
| WEEL—Boston | WWJ—Detroit |
| WTAG—Worcester | WGN—Chicago |
| WFI—Philadelphia | WOC—Davenport |
| WGR—Buffalo | WCCO { Minneapolis |
| WCAE—Pittsburgh | WCCO { St. Paul |
| | KSD—St. Louis |

KGO—San Francisco, 8 P. M. Pacific Coast Time

EVEREADY
Radio Batteries
—they last longer

*NOTE: In addition to the increased life which an Eveready "C" Battery gives to your "B" batteries, it will add a quality of reception unobtainable without it.

“and even the distant stations now come in loud and clear”

A UX Power Tube will increase volume and clarity in YOUR set, too!

REWIRING UNNECESSARY

NOTE: The UX-120 tube has been designed to increase volume and clarity in all dry battery sets. The UX-112 tube has been designed to increase volume and clarity in storage battery sets. To make it easy for you to secure the great benefits of the UX tubes without rewiring your set, a complete line of Na-Ald Adapters and Connectoralds have been manufactured. Months of service have proved their efficiency. Below are given three very efficient and easily made applications of the new power tubes. For complete details covering all possible applications of the new tubes mail coupon at bottom of ad.



No. 920 Connectorald

How to improve sets equipped with UV-199 tubes

To increase volume and clarity in sets using UV-199 tubes, use the UX-120 tube in the last stage. Easily fitted to the UV-199 socket with a Na-Ald No. 920 Connectorald which also provides cables for attaching necessary extra 45 volts B battery and 22½ volts C battery required for the UX tube. Price, \$1.25.

How to switch to dry batteries without sacrificing volume or quality

The combination of a UX-120 tube for the last stage with UX-199 tubes in the other sockets provides, with dry cells, results previously obtained only with storage batteries. Fit UX-120 tube to the UV-201A Socket with Na-Ald Connectorald No. 120. Cables provided for attaching extra B and C batteries. Fit UX-199 tubes in all other sockets with Na-Ald No. 419-X Adapters. Price, No. 120 Connectorald, \$1.25; No. 419-X Adapter, 35c.



No. 120 Connectorald



No. 419-X Adapter

How to improve storage battery sets

Volume and clarity can be increased in storage battery sets by using the UX-112 tube in the last stage. Easily fitted to the UV-201A socket by means of the Na-Ald No. 112 Connectorald which provides cables for attaching necessary extra B and C batteries. Price, \$1.25. Mail coupon below for complete adapter information covering use of new tubes in all sets.

ALDEN MANUFACTURING COMPANY
Dept. B 16 Springfield, Mass.
All Na-Ald Sockets, Dials and Adapters are protected by patents. Many patents Pending



ALDEN MFG. CO.,
Dept. B16, Springfield, Mass.
Please send me complete information on how to increase volume and clarity in any set by the use of the new tubes.

Name.....
Address.....
City..... State.....

the current is already direct so there is no need to rectify. However, it usually is higher in voltage than is desirable, and if a battery were connected to it directly, the low resistance of the battery would cause high current to be passed through it. This is equivalent to a rapid high charge which, as explained previously, causes disintegration of the plates of which the battery is composed. Therefore, when employing d.c., it behooves us to regulate the current flowing through the battery on charge so that this breaking up does not occur.

If the resistance of the battery could be increased, then less current would flow in the circuit. Of course, it's not possible to increase the battery resistance, but an external resistance can be added to the circuit which will accomplish the desired result.

By the use of a simple formula, it is possible to calculate the resistance necessary to charge the battery at a predetermined rate. In this formula, $W = I \times E$, the E represents the d.c. line voltage, usually 110 volts, and I represents the

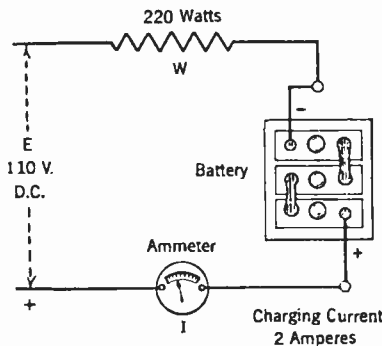

FIG. 7

rate of charge in amperes at which we wish to charge the battery. Let us suppose that we wish this rate to be 2 amperes. Then $I = 2$, and W represents watts, the unknown. If we could determine this value of W, then we could make use of the many home electric appliances, such as electric light bulbs, toasters, irons, heaters, etc., to charge the battery. Usually the manufacturers of such devices have a nameplate fastened to the apparatus which, among other things, tells its line voltage and watts value.

By applying the formula we find that $W = 2 \times 110 = 220$ watts. From this we see that, if in the charging circuit we employ a device rated at 220 watts, the battery will be charged at the rate of 2 amperes. Batteries are rated in capacity, that is, their ampere-hour capacity. Theoretically, if a 100 ampere-hour battery be discharged at the rate of 2 amperes, it will last for 50 hours of use. In recharging this battery to its former state of usefulness, it is necessary to charge it for 50 hours at 2 amperes or 25 hours at 4 amperes or 100 hours at 1 ampere, etc.

Coming back to the use of formulas, if we wished to determine the actual resistance of the device necessary to charge the battery at 2 amperes, the formula $R = \frac{E}{I}$ would be employed. By substituting values we see that $R = \frac{110}{2} = 55$ ohms. To check back our first formula, $W = I \times E$, there is another one, $W = I^2 \times R$, which will prove that the resistance of a 220 watt device is 55 ohms when used on a 110 volt d.c. line.

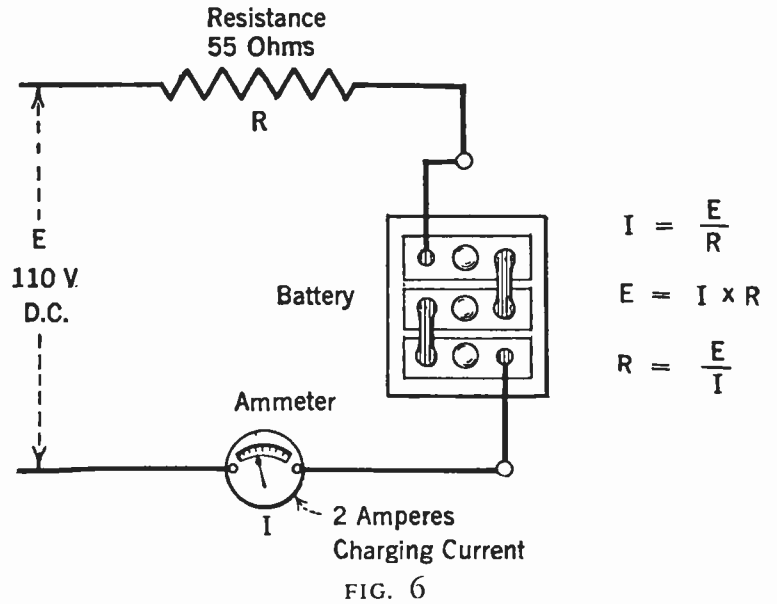

FIG. 6

Substituting values, $W = 2^2 \times 55$, or $W = 4 \times 55 = 220$ watts.

Often the experimenter will know his line voltage and the wattage of a piece of electric apparatus. By using the formulas above and transposing symbols, it is possible to determine the rate of charge of a battery circuit when that apparatus is included in the circuit as part of the charging medium. The variations or transpositions of the first formula $W = I \times E$ are, $E = \frac{W}{I}$ and $I = \frac{W}{E}$. It is the last one that we can apply in the last case described, $I = \frac{W}{E}$ or $I = \frac{220}{110} = 2$ amperes. If $W = 600$, then $I = \frac{600}{110} = 5.45$ amperes. These explanations will become more apparent from an observation of the circuits in Figs. 6. and 7.

In a great many homes there is employed a local lighting system, such as the farm lighting affairs. They consist mainly of a bank of storage batteries totalling 32 volts, with a direct current generator, the latter being used to charge them. Often it is not practicable to move the radic storage battery to the location of the generator and batteries, and it is more convenient to charge the battery from a light outlet. By inserting a resistance in series with the 32-volt line, the 6-volt battery may easily be charged. Applying the above formula to determine the resistance necessary to charge at the rate of 2 amperes $R = \frac{E}{I}$ or, $R = \frac{32}{2} = 16$ ohms. Where the value of a resistance is known, say 8 ohms, and it is desired to determine the rate of charge when using that resistance, then $I = \frac{E}{R}$, or $I = \frac{32}{8} = 4$ amperes.

GRID INQUIRY BLANK

Editor, The Grid
RADIO BROADCAST
Garden City, New York

DEAR SIR:

Please give me the fullest information on the attached questions. I enclose a stamped envelope.

I am a subscriber to RADIO BROADCAST and therefore will receive answers to my queries free of charge.

I am not a subscriber and enclose \$1 to cover cost of answers.

NAME.....

ADDRESS.....

G. M.

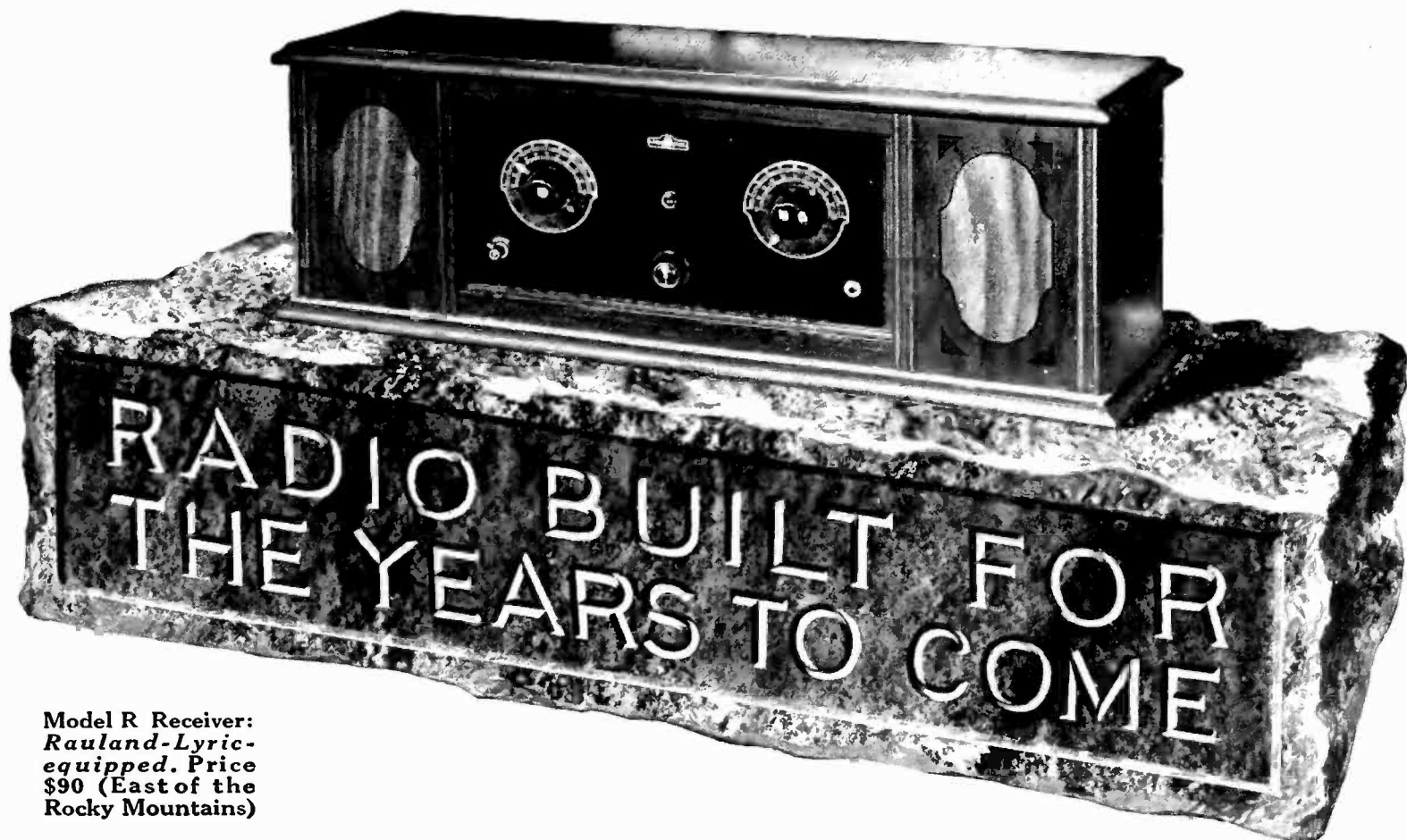

Model R Receiver:
Rauland-Lyric-
equipped. Price
\$90 (East of the
Rocky Mountains)

Beauty and Permanence

Listeners Marvel—

at the wealth of enjoyment awaiting but a touch of the fingers.

Women Are Delighted—

with the tasteful stateliness of the Model R cabinet, as much as with the neatness of its battery accommodations.

Engineers Voice Approval—

of the rigid spot-welded steel chassis, protecting from damage every part of a set that stands as a notable example of the *completely manufactured* rather than the merely *assembled* radio receiver.

Service Men Commend—

the thoroughness with which every part has been made proof against the interruption of its service, so far as human ingenuity can devise.

Dealers Are Enthusiastic—

over the excitement created everywhere by this unique receiver and the uniform satisfaction felt by its users.

Buy "Solid Value" in Your Radio

The leading wholesaler of radio apparatus in your community has probably been, for years, an ALL-AMERICAN Authorized Distributor. ALL-AMERICAN Guaranteed Radio Products are being shown everywhere by responsible and reliable dealers.

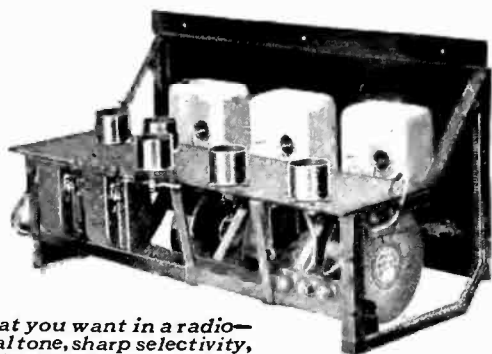
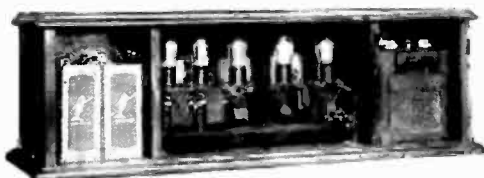

All that you want in a radio—
natural tone, sharp selectivity,
straight-line-frequency tuning
(360°) unaffected by position
of the fingers, extreme
sensitiveness, permanence.

ALL-AMERICAN RADIO CORPORATION, E. N. Rauland, Pres., 4213 Belmont Ave., Chicago, U. S. A.

between
RMA

OWNING AND OPERATING STATION WENR—266 METERS

ALL-AMERICAN

Pioneers in the Radio Industry

★ Tested and approved by RADIO BROADCAST ★

www.americanradiohistory.com

-TEAR OUT-

Radio Institute of America
328 Broadway, New York City

Please send me full information about your Home Study Course of radio instruction.

I am interested in the complete course, including code instruction, which qualifies for the U. S. Gov't Commercial or Amateur Radio License.

I am interested in the technical course for radio dealers, jobbers and salesmen.

Name

Address

A Shortage of Trained Radio Men!

We can't supply trained radio operators to the shipping companies fast enough! Atlantic, Pacific—Gulf and Lakes—our graduates are sought everywhere.

You can't get better radio training than that offered by Radio Institute of America. Courses planned and supervised by RCA secure you your 1st Class Commercial Radio Operator's License. And an immediate position awaits every graduate.

Moreover you can study at home in spare time.

The coupon will bring you complete information.

RADIO INSTITUTE OF AMERICA

Formerly Marconi Institute
Established in 1909

328 Broadway, New York City

"NOW, I HAVE FOUND . . ."

A Department for the Exchange of Ideas and Suggestions of Value to the Radio Constructor and Operator

CONTRIBUTIONS to this department are welcome and those used will be paid for at the usual rates, that is, from two to ten dollars each. A prize of twenty-five dollars is given for the best idea used during each three-month period. The prizewinner for the last period was announced in the February RADIO BROADCAST. Manuscripts intended for this department should not exceed about three hundred words in length, and should be typewritten. Little consideration can be given to manuscripts not typewritten. Envelopes should be addressed to this department, RADIO BROADCAST, Garden City, New York.

HOW TO MAKE BALLOON COILS

BALLOON coils are often seen in many of the latest circuits, but no instructions are given for making them, thus depriving the experimenter of most of the real pleasure of building his own set.

They can be easily made, however. First of all secure a round stick about an inch in diameter and ten inches long, for a winding form. When using one coil within a larger coil (primary and secondary), one form will need to be larger by about a quarter inch, or more, in diameter. Saw a slot about seven inches long in the form and make a wedge as shown in A, Fig. 1, to hold it open while winding the coil. Wrap this form with paper to prevent the insulation of the wire sticking to it when the cement is applied. A tack is employed to hold the paper and is left protruding from the wood so that the beginning of the wire may be fastened to it when the next procedure, that of winding the coil, is started. A second tack is used to hold the other end of the coil when the latter has been completely wound. The size of wire and number of turns can be taken from a manufactured coil, or found by trial. To hold the wires together while bending the coil around the core, the use of collodion, or better still, a solution of acetone and celluloid, is recommended. When thoroughly dry, the coil can be taken off by removing the wedge and closing the slot. A round piece of wood will do for a core for a small coil, or a piece of bakelite tubing for a larger one. Make the core any convenient length. The diameter of the core may be found by cutting a strip of paper the length of the winding and making the core of such size that the paper will not quite meet. Remove the paper from outside of coil and place on the core as shown in B, Fig. 1. A waxed thread should be run through to secure the coil to the core; then carefully

bend the coil around the core and secure with the thread. Space the free coils as evenly as the job requires. A thread around the core on the outside of the coil as shown in C, will help to hold the individual turns steady. When these coils are to be used one inside the other, secure the larger coil to the core but do not space the wires at the joint. The small coil can be slipped in the larger one. A narrow strip of paper is used to space the coils as shown in section in C. Now secure the smaller coil with thread and space the coils as desired.

JOHN L. LEE,
Washington, D. C.

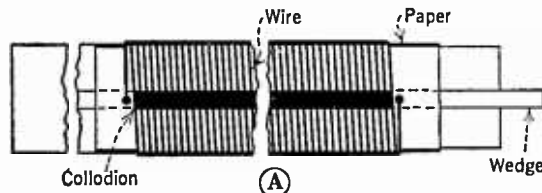

A GOOD AUDIO BYPASS METHOD

FROM a constructor's point of view may I register a point in connection with Mr. Millen's power amplifier as published in the November, 1925, RADIO BROADCAST. I have reference to the use of a resistance as a means of securing the negative grid bias, as is best illustrated in his Fig. 9.

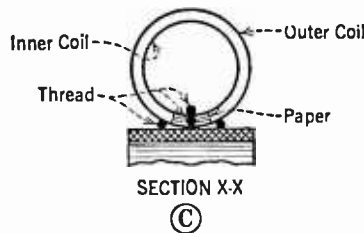
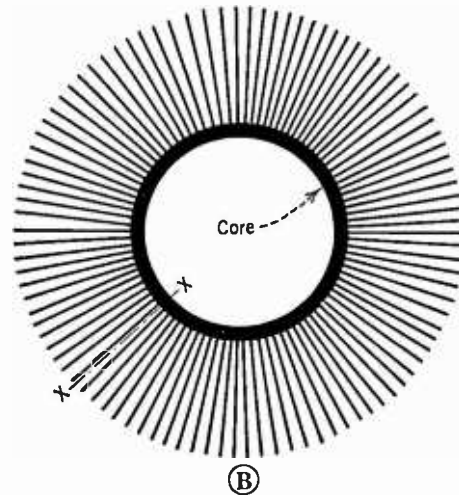
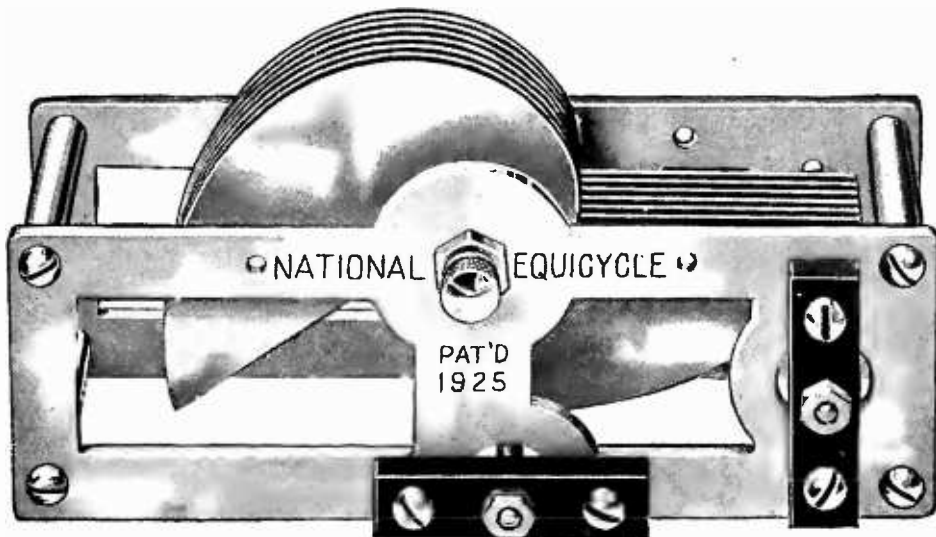

FIG. 1

Let us suppose that a milliammeter in the plate circuit of the power tube registers 10 milliamperes, and let us suppose that the audio frequency fluctuations range from 5 milliamperes to 15 milliamperes. The voltage drop across R₃ is proportional to the value of the plate current, since the entire plate current must pass through R₃ in order to reach the filament. The voltage drop, therefore, not only varies in the ratio of 1:3 during the audio frequency cycle but unfortunately this variation is—as one might say—"180 degrees out of phase" with the grid current fluctuations. When the grid has reached its most positive potential, the negative grid bias is then at a maximum, because the plate current is at a maximum, and when the grid has reached its most negative potential, the negative grid bias is then at a minimum because the plate current is at a minimum. The effect, therefore, is to reduce the amplitude of the grid circuit fluctuations, and con-

The *New* NATIONAL EQUICYCLE Condenser

The latest development in straight line frequency control as applied to NATIONAL Condenser design. Increases range of rotation from 180° to 270°, permitting more precise adjustment and sharper separation of stations, and accomplishes this WITHOUT GEARS, CAMS, OR LEVERS.



(Patented February 10, 1925)

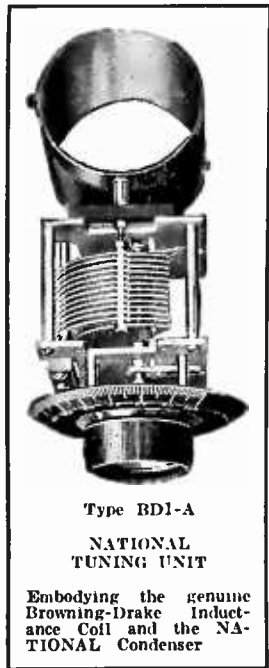

Type BD1-A
NATIONAL TUNING UNIT

Embodying the genuine Browning-Drake Inductance Coil and the NATIONAL Condenser

It changes a mob into an orderly procession

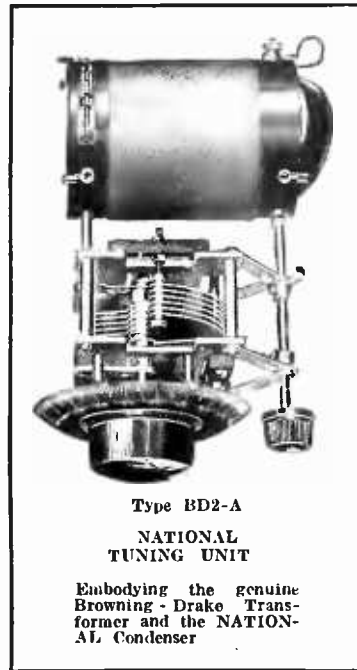

Type BD2-A
NATIONAL TUNING UNIT

Embodying the genuine Browning-Drake Transformer and the NATIONAL Condenser

and lengthens the line of march!

Tests Conducted at Harvard University, by Prof. Field, give characteristics of the new Equicycle Condenser as indicated by the following graph:

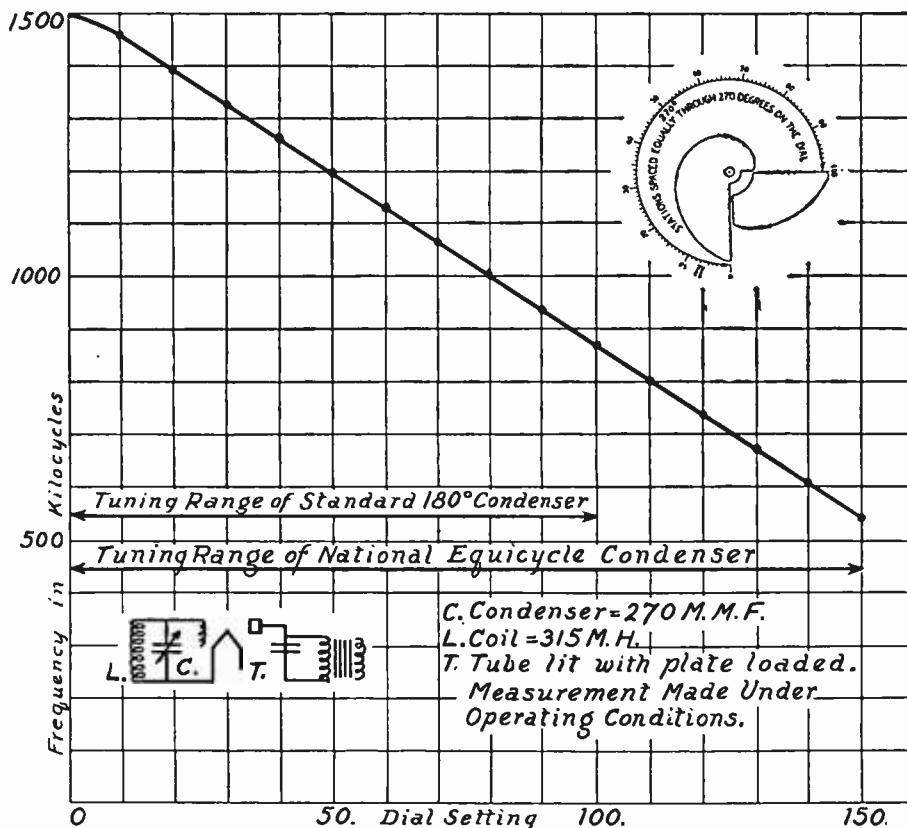

—The novel shape of the plates spaces the station groups at equal intervals of 10 kilocycles (as specified by the U. S. Department of Commerce) in a true straight frequency line.

—The same electrical efficiency and mechanical ruggedness that have always characterized NATIONAL DX Condensers have been embodied in the *new* NATIONAL EQUICYCLE Condenser.

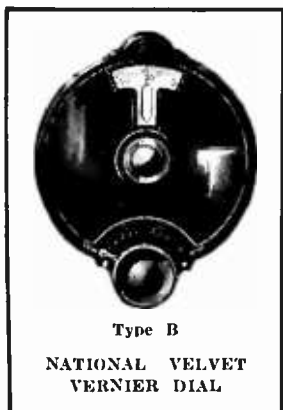

Type B
NATIONAL VELVET VERNIER DIAL

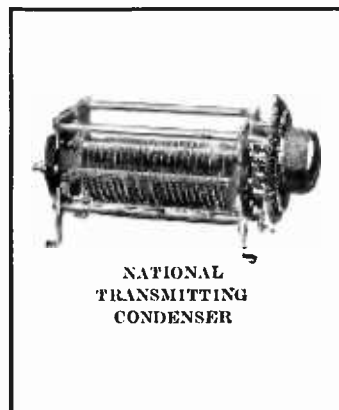

NATIONAL TRANSMITTING CONDENSER

Get the Genuine. Insist upon NATIONAL COMPANY'S RADIO Products. Your dealer appreciates your patronage and will gladly get them for you. Write for Bulletin III-RB

NATIONAL COMPANY, Inc.

W. A. READY, PRESIDENT

110 Brookline St.

Cambridge, Mass.

★ Tested and approved by RADIO BROADCAST ★

Protects

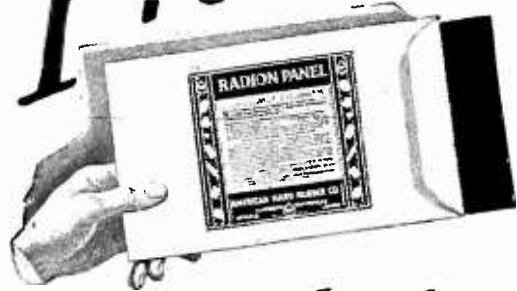

against leaks and losses

THE UTMOST possible protection against leaks and losses in the circuit is afforded by Radion—*The Supreme Insulation*.

Radion Panels reduce surface leakage and dielectric absorption to a minimum. Their beautiful surface finish adds to the attractiveness of any set. Radion Dials match their beauty of finish and help to get close tuning. Radion Sockets reduce capacity effects.

Radio dealers have the complete line of Radion low-loss parts. Manufacturers will find it to their interest to write us for prices on moulded parts. Send for catalog.

FREE Booklet, "Building Your Own Set" mailed on request.

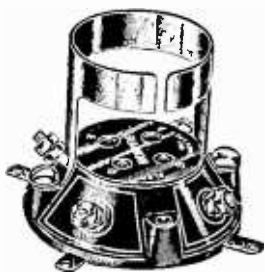

No. 2 Radion Socket for new UX tubes, with collar adapter for old type tubes. No. 4 same as No. 2, without collar adapter, for new UX tubes exclusively

AMERICAN HARD RUBBER COMPANY
Dept. C-15
11 Mercer St.
New York City
Chicago Office:
Conway Building
Pacific Coast Agent:
Goodyear Rubber Co.
San Francisco
Portland

RADION

The Supreme Insulation

Made to order exclusively for radio purposes

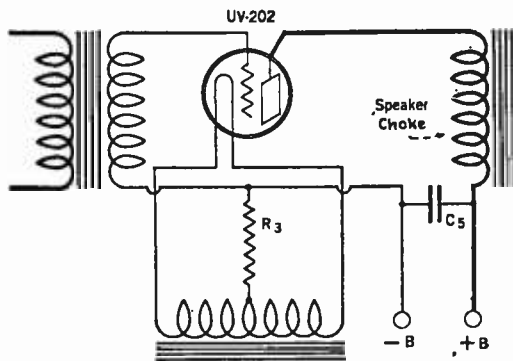

FIG. 2

sequently the amplification. It amounts in fact to a reversed feedback.

The audio frequency bypass condenser, C5, of his Fig. 4, if transferred to Fig. 9 for simplicity of illustration, would appear as in accompanying Fig. 2. In this position C5 does not overcome the objections noted as the entire plate current (both d.c. and a.c. components) must still pass through R3.

I wish to suggest that C5 be placed as in Fig. 3 shown herewith. It is evident that in this position only the average plate current (i.e. the d.c. component) will pass through R3, and a fairly constant grid bias will be obtained throughout the entire audio frequency cycle which will neither add to, nor subtract from, the grid current fluctuations. The a.c. component of the

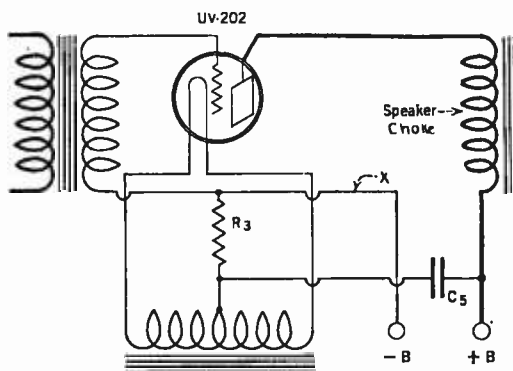

FIG. 3

plate current is now supplied by C5, or "bypassed" if one wishes to think of it in that way.

With the change in position of C5, if now a 20-henry 25-milliamper choke is introduced at X, the combination becomes as good as a dry cell C battery.

JEROME KIDDER, M.D.
Salina, Kansas.

HOW TO OBTAIN IMPROVED LOUD SPEAKER REPRODUCTION

THE ideal radio set of to-day is, no doubt, the one constructed with a view of securing the highest possible acoustic perfection of reproduction. Sources of distortion in a multi-tube set are galore, and it takes expert knowledge to build one that can be depended upon to bring in the favorite broadcast programs day after day with an unflinching quality of reproduction.

Every component that goes to make up your receiver installation may in a way, be considered as a distortion device. Let us consider the present day loud speakers, ignoring entirely for the moment all distortion that may be due to resonance and similar phenomena. Those built along electro-magnetic lines employ the ordinary

telephone type diaphragm and an electro-magnet. On these speakers the magnetic stress placed upon the diaphragm by the non-modulated component of the plate current is the cause of a certain drag or excessive inertia that is productive of distortion.

On electro-dynamic loud speakers, distortion is partially due to the great load that the low impedance moving coils place upon the tube with the output of which they are connected in series.

Any overloaded loud speaker will produce distorted reproduction.

To improve the quality of reproduction by improving the operation of the loud speaker used in conjunction with a set,

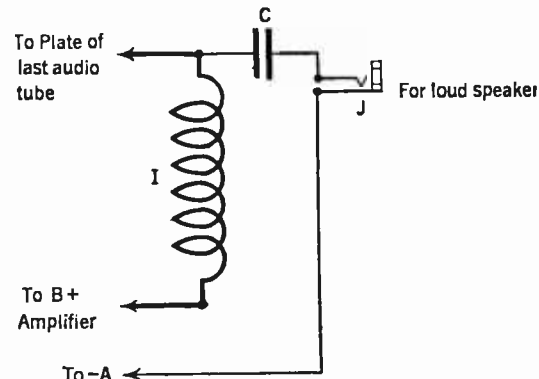

FIG. 4

it is generally recommended to employ some sort of a shunt plate feed for the loud speaker in such a manner that only the modulated component of the plate current be permitted to flow through the loud speaker coil windings.

Fig. 4 shows the conventional arrangement of such a plate shunt feed, where I is usually the secondary of an audio transformer or an impedance of similar characteristics, C a 1-to 4- mfd. blocking condenser, and J an open circuit output jack.

The writer has found that practically identical acoustical improvement can be had by an arrangement as shown in Fig. 5, where R is a grid leak of approximately 50,000 ohms, C a 1- to 2-mfd. condenser, and J the output jack.

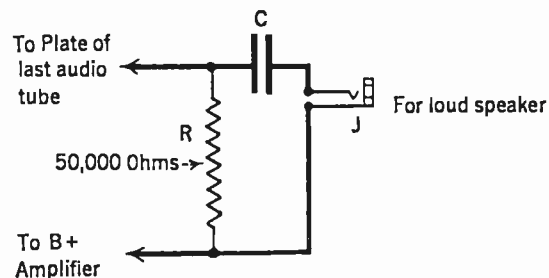

FIG. 5

This arrangement was found quite as effective in reducing loud speaker distortion as is the one shown in Fig. 4. It has a tendency to stabilize the audio amplifying system which is especially apparent when high plate voltages are employed.

It can be built into any set as it takes up very little space, and it does not cost nearly as much as the impedance shunt-plate feed that is the more commonly used.

BORIS S. NAIMARK,
New York City.

A LOW LOSS COIL

THE following method describes the making of a low loss solenoid coil which is quite rigid and can be removed with ease from the coil form.

COILS

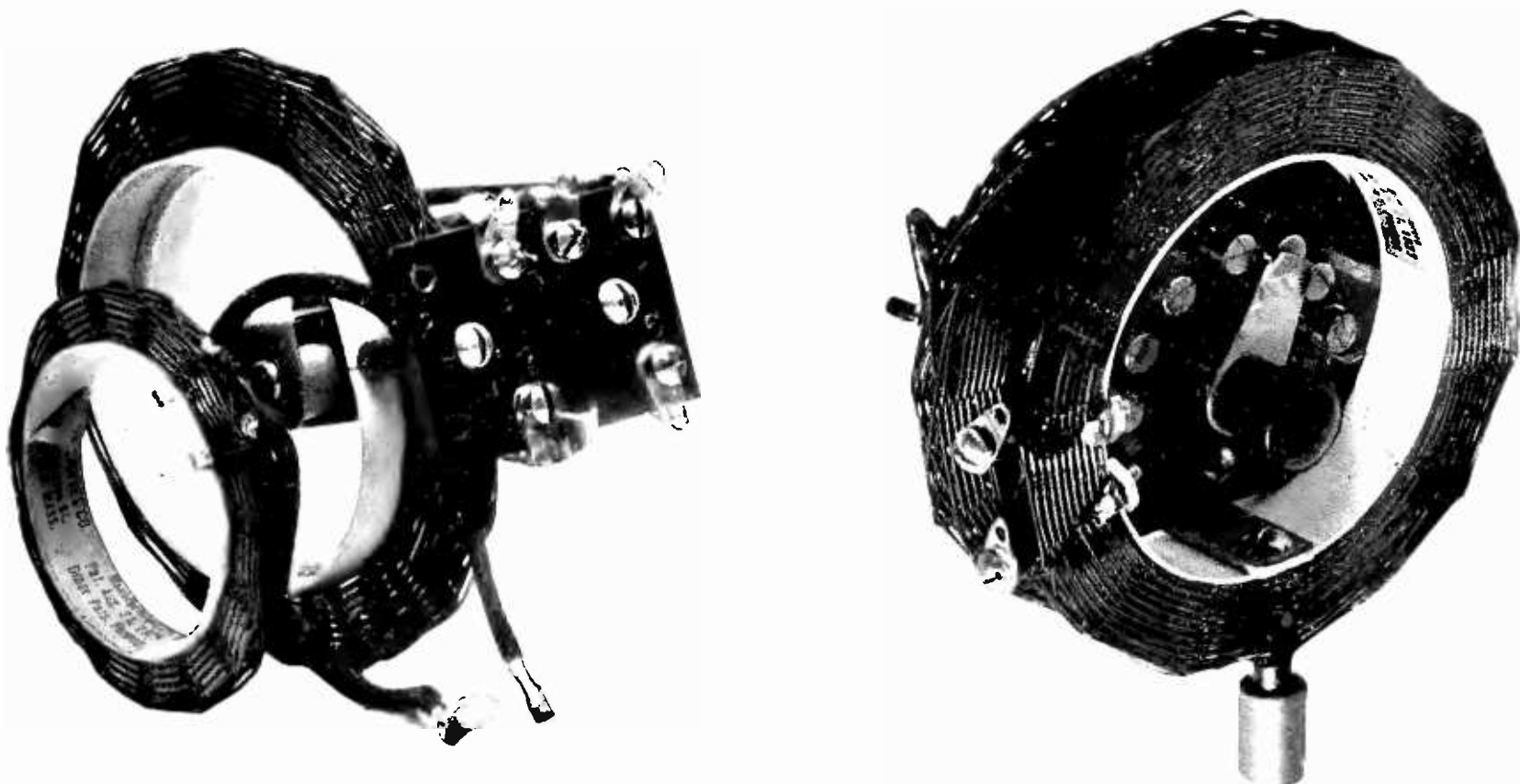

by SICKLES

developed exclusively for the Aristocrat

THE F. W. Sickles Co. felt strongly that a receiver so advanced in design as the "Aristocrat" deserved coils just as advanced in order to give to the home constructor the inherent benefits of this receiver.

As a consequence Mr. Sickles, who is the developer of the proved "Diamond Weave" principle in coils and who is chief engineer of the F. W. Sickles Co., set to work. The result of his engineering ability backed by thorough-going and practical research, is being enthusiastically welcomed by laboratories everywhere in America. The "Aristocrat" Coil by Sickles is based upon scientific facts, not wishes nor fancies. And these facts were determined by an exhaustive and conclusive series of tests upon highly sensitive and calibrated electrical instruments.

The "Aristocrat" Coil is unquestionably the best coil ever produced by Sickles.

Write for Radio Broadcast's Five Foot Diagrams.



THE F. W. SICKLES CO.

132 Union Street, Springfield, Mass.

★ Tested and approved by RADIO BROADCAST ★

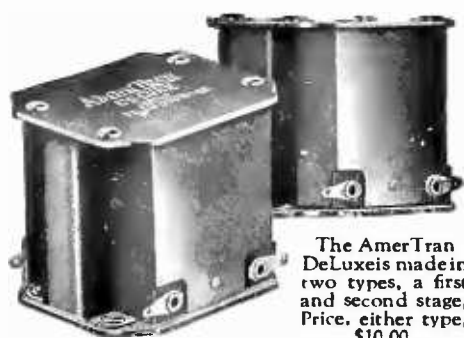

The AmerTran DeLux is made in two types, a first and second stage. Price, either type, \$10.00.

A New Standard of Excellence in Audio Amplification

The realism of this new audio transformer is outstanding. Realism of this kind results from the uniform amplification of the fundamental tones of the lower register. The AmerTran DeLux makes possible the natural reproduction of not only the Overtones, but all of the transmitted Fundamental tones.



AmerTran Power Transformer type PF-45, Price \$15.00, type PF-52, Price \$18.00.

The AmerChoke type 854 is a choke coil or impedance coil of general utility. Price \$6.00.



A Good Audio Amplifier

Requires enough plate and grid bias voltage on its tubes to prevent them from being overloaded by the signal voltage.

The AmerTran PF-45 or PF-52 with the half wave high voltage rectifying tubes now available and suitable condensers and resistances—together with three AmerChokes Type 854 will furnish these proper voltages. This combination will give real quality loudspeaker volume. AmerTran Power Transformers also supply A. C. filament current for the last audio tube.

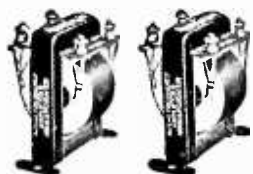

AmerTran Audio Transformers type AF6 (turn Ratio 5) and AF7 (turn ratio 3 1/2) are the leaders in their class. Price, either type, \$5.00.

Write for booklet describing these and other AmerTran Products—with recommendations on their use. It's free on request. All prices are F. O. B. Newark, N. J.

AMERICAN TRANSFORMER CO.
178 Emmet Street, Newark, N. J.
"Transformer builders for over twenty-five years"
Sold Only at Authorized AmerTran Dealers.

To make the coil form, a wooden block is turned down to a hollow cylinder 2 1/2 inches in diameter and 4 1/2 inches long. See Fig. 6. Then two plugs and two rings are made, one ring and plug for each end of the tube. The diagram shows the constructional data for these. Now two grooves are cut lengthwise on opposite sides of the tube, and a saw cut is made halfway between the grooves on one side. This completes the coil form.

The four bakelite strips, shown in the illustration, are heated until they can be slightly curved, as shown in Fig. 7, and are then allowed to cool. By curving the strips the middle turns of the coil are

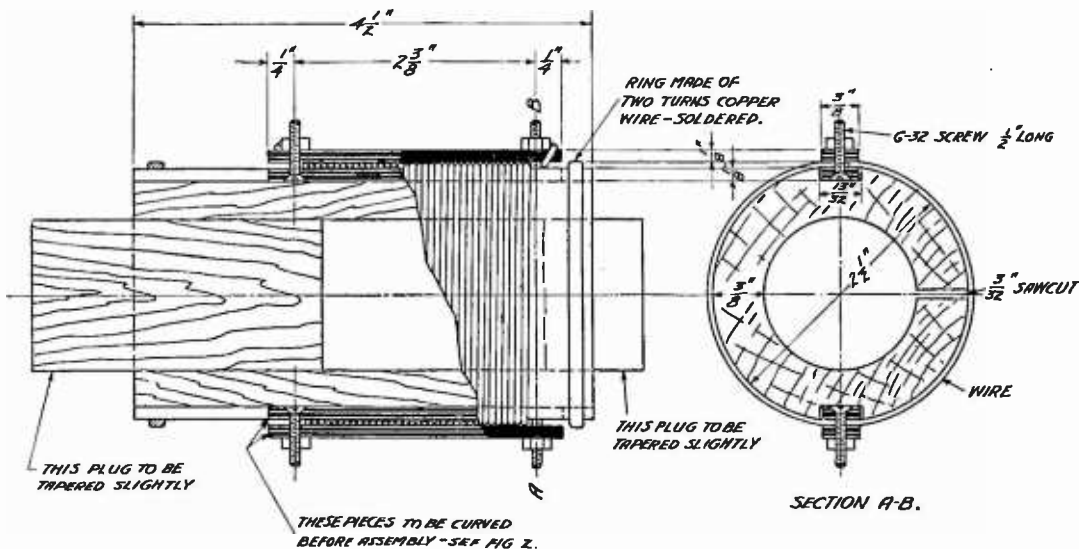

FIG. 6

held fast. The strips are, of course, equal in width to the grooves mentioned above.

Before starting to wind the coil, the two copper-wire rings are put on the form ends and the plugs inserted. Then two of the bakelite strips, with their screws, are placed in the grooves and the curve taken out by binding with string at the middle. The beginning of the wire is bent around one of the screws, which are used for terminal posts, and the winding proceeded with in the usual manner, care being taken to keep the bakelite pieces straight. When finished, bend the wire around the other screw and then fasten down the other two bakelite strips on top of the wire. A little binder can be used to cement the wire to the strips.

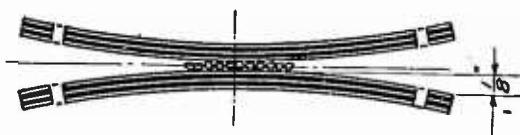

FIG. 7

To slip the coil off, remove plugs and rings and compress the tube.

The experimenter can, by lengthening the bakelite strips and using the same size wire, wind a primary coil at one end of the tube. If smaller wire is used, the outside strips will have to be in two pieces. Also a fixed or movable tickler could be mounted at the other end of the coil.

EVERETT FREELAND,
Dowagiac, Michigan.

ONE USE FOR A BYPASS CONDENSER

IT IS noticeable that in a large number of radio receivers, commercial or home made, the quality of tone is not as good as it should be. In some receivers there is a distinct hiss or a high shrill whistle which comes in continuously with the music or speech. This whistle or hiss is caused by some slight feedback between the tubes, and seems to indicate that there is some oscillation in the audio frequency end which should not be there. To the critical listener this is very objectionable. It may often be effectively stopped, without

affecting the volume of the receiver, by placing a small mica type bypass condenser in the proper place. The condenser should be placed across the plate and plus filament of the last, or in other words, the output tube. Its value should not be less than .005 mfd. but it may be found on trial that

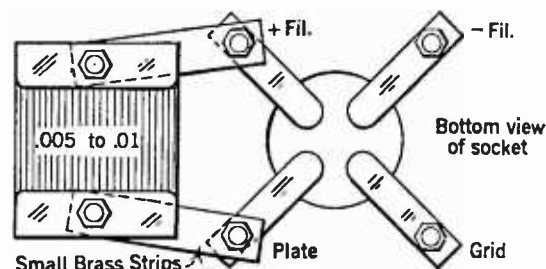

FIG. 8

this should be increased to .01 mfd. A convenient way of mounting the condenser is given in the sketch Fig. 8, which shows the underneath part of the socket and contact springs. A small brass strip about one inch long, with a hole near each end, can be bolted direct to the condenser and to the bolt holding the socket spring. This idea was tried out on a manufactured set of the lower priced kind, and the results were so much improved that such a condenser is being placed on every set of this type that is sold. Placing a condenser across the speaker posts of the receiver was not found to produce the same results as the volume was reduced to some extent, and the tone changed.

K. B. HUMPHREY,
Brooklyn, New York.



CARDWELL CONDENSERS

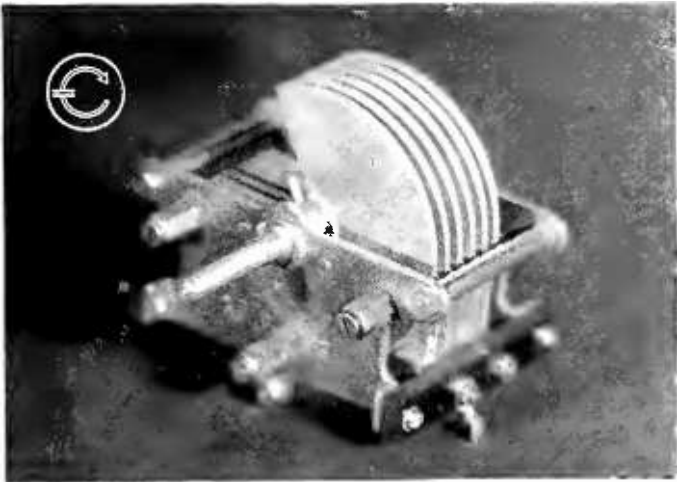

MR. ARTHUR H. LYNCH approved the new Type E taper plate Cardwell as the ideal for use in the "Aristocrat" and other receivers as soon as he saw and tested it.

The new taper plate Type E Cardwell is the logical answer to the demand for a straight frequency tuning curve. Semi-circular plates, far heavier than ever used before, assure permanent calibration, and it will mount entirely behind a four-inch dial. Its depth back of the panel is less than three inches.

The price for the .0005 mfd. size is \$5.00. Other sizes are priced proportionately.



Write for illustrated catalogue
If your dealer can't supply you, order
direct from us

The Allen D. Cardwell Mfg. Corp.
81 Prospect Street Brooklyn, N. Y.



"THE STANDARD OF COMPARISON"

★ Tested and approved by RADIO BROADCAST ★



ARBORPHONE A New Conception of Good Radio

NO MATTER what experience you have had with radio you've a new thrill coming when you listen to Arborphone performance the first time.

Clear reception—even on D X work—is the outstanding quality that endears Arborphone to thousands of owners all over this country. Your Arborphone makes a radio concert something to enjoy with unmarred enthusiasm.

Mother, sister or any member of the family can get plenty of stations on the Arborphone. An expert isn't required to operate this remarkably simplified receiver. Another point—this artistic set is incased in a gracefully designed cabinet, a masterpiece of the woodworker's art.

By all means buy no set before trying out the Arborphone at your dealer's. No value in radio to equal it. Let us send you a copy of our new and interesting radio book.

\$55⁰⁰

Dealers

The sales plan back of this wonderful set assures you a splendid year 'round business. Ask for details—by mail or wire.

\$60.00 in Rocky Mt. and Pacific Coast States.

MACHINE SPECIALTY CO.
321 S. Main St. Ann Arbor, Michigan

"All you could Ask of a Radio"

RADIO FANS, a one-year's subscription to Radio Broadcast will cost you four dollars, two years six dollars. Consider this expenditure as being a necessary investment on your part for the future development of your own knowledge of Radio.

Big FREE RADIO
Catalog & Guide

PARTS, HOOK-UPS, SETS and KITS

Send now for this valuable FREE book. Full of advanced hook-ups, parts and kits. A real guide. Shows factory built sets and the new ideas in radio. Send at once. No charge. No obligation. Please include name of radio fan.

BARAWIK CO.
102-109 S. Canal St., Chicago

A New Way to Make Money in Radio

As Long as New Apartment Houses Are Being Erected, There Will Be Plenty of Opportunity for the Go-Ahead Man

By D. C. WILKERSON

AS WITH the swing of the pendulum, the first impressions which labeled radio with the yellow-golden streak as a bonanza for quick wealth, seem to have changed of late.

Hundreds of fly-by-night radio enterprises are going permanently out of business, and perhaps their disgusted proprietors have spread the story that "radio is a lemon." At any rate, although many attractions are offered to young men to take up radio and kindred subjects by the large corporations, most of whom spend real money to train these neophytes, the 1925 crop of college graduates has not leaped into the arms of these welcoming agencies.

Regardless of false impressions blabbed about

nections inside? You can bet your new loud speaker they would.

Now then, who has enough initiative to organize and broach the proposition of making such installations for the building operations company? It would not require much investment in the way of tools and equipment, while copper wire, insulators, screws, spreaders, masts, and the like, can be obtained anywhere. You could make a deal with your local hardware store to supply you at a discount.

Armed with a ladder, some roof "stickers," and some gumption, a couple of bright active fellows could "clean up" in the home town on a job like this. Old clothes, a flock of screw drivers, and a smile or two, would make valuable adjuncts.

Why not try it some of you fans who want to capitalize your hard-earned knowledge of radio?

Again, another market for your knowledge presents itself. It is becoming quite the thing for multiple installations to be rigged up for hotels and apartment houses. Here is a field.

Some jack plates for wall plugs, wiring connecting to a central distribution point where the elevator operator, or telephone girl, keeps tuned-in to some program or other, is not a difficult job.

Inexpensive loud speakers, with plug in each suite, complete the panorama. Some of the finest hotels and apartment houses in the country are being built with these radio conveniences installed.

The work must be done by somebody, and it might as well be you.

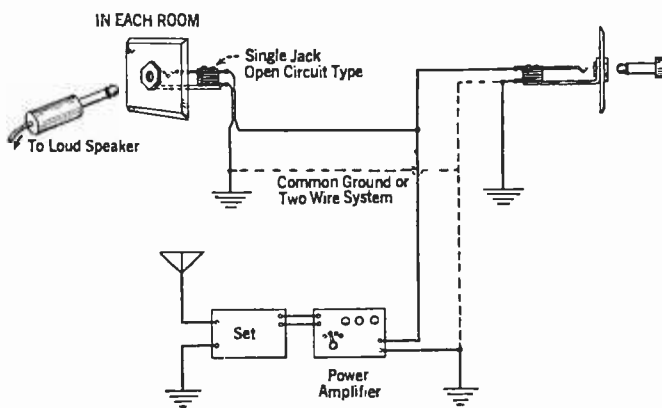

CENTRAL DISTRIBUTION PLAN

A series of jacks, one in each hotel room or apartment living room, may be connected in parallel to the output of a central receiver kept in tune by the telephone operator. A separate ground for each jack is often advisable, it being as near to the jack as possible

hither, thither, and yon, by those who may be soured on radio, the radio art is yet a sound and promising field for men, young or middle-aged, or even old. Its possibilities are so tremendous that one can scarcely grasp them. A field for radio not generally realized will be discussed here.

Have you ever stopped to consider how radio in real estate is a genuine asset? Only last month one realty firm of note advertised that their new subdivision of houses was in an excellent location for radio, in other words, out of the dead spot zones.

Now then, how many new houses are being built by companies of large operating facilities in your neighborhood? Perhaps ten, fifty, a hundred, or maybe a thousand, depending upon where you live.

Would these houses sell more readily if they were equipped with antenna and ground, and convenient con-

STURDY ERECTION A PRIME FACTOR

AND here is another stunt. How about these tanglefoot rooftops which entrap the wary burglar or zealous fireman with equal facility? More rigid fire regulations will surely

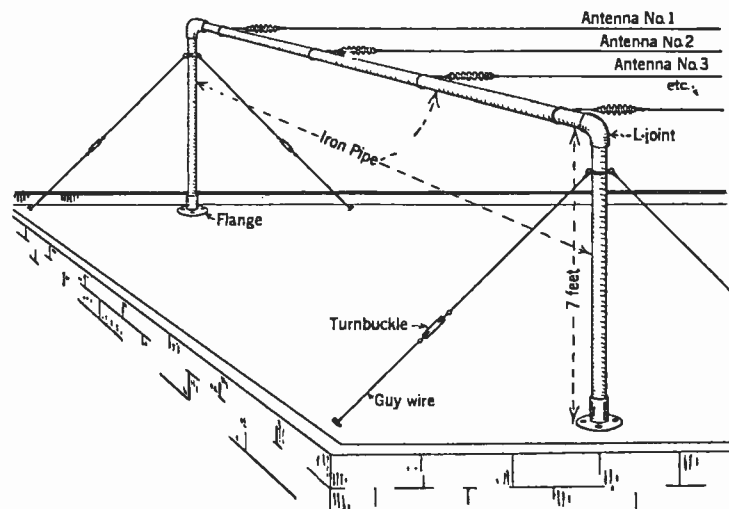

A NEAT MULTIPLE ANTENNA ARRANGEMENT

By the use of iron piping supports, several antennas may be supported without fear of disaster during heavy storms

★ Tested and approved by RADIO BROADCAST ★

Send for this New Hookup

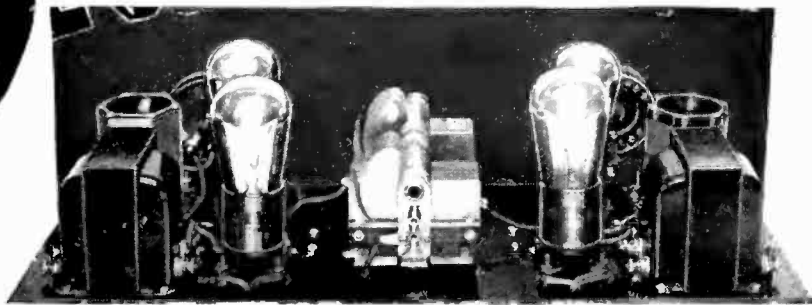

Four Tube Receiver

Here is the outstanding radio receiver development of the season, in which is combined the genius of two of the most successful and distinguished radio engineers, assisted by the engineering and laboratory staffs of seven prominent radio manufacturers. Here is a receiver for the home builder that will represent for several seasons to come a far greater value than any other design available. Send for the book. Read how to obtain the following

Startling New Features

SINGLE CONTROL—But one tuning or station selector control.

SELECTIVITY—In a residential district of New York City, within a few hundred yards of powerful stations, thirty-five stations were heard between 9 and 10 p. m. on the loud-speaker. KFI, in Los Angeles, was heard with ample volume to fill two rooms. Tests in Chicago brought in either coast with ample speaker volume, and indicated that a consistent range of 1,000 to 2,500 miles might be expected.

QUALITY—Two new-type Thordarson power amplifying transformers possessing a substantially flat frequency characteristic over the range of 40 to 6,000 cycles, give a quality of reproduction so perfect that comparison by the best trained human ear with other types of amplifiers will not reveal any superior type.

VOLUME—In all cases the volume will exceed that obtainable from other four-tube receivers, and in practically all cases equal or exceed that obtainable from standard five and six-tube receivers.

UNLIMITED WAVELENGTH RANGE—Through the use of interchangeable coils, the wave-length range is practically unlimited.

WIRING AND ASSEMBLY—All wiring is carried in a special harness. Since each wire is exactly the right length, and has a special color, it is impossible to go wrong in wiring. No soldering is needed unless preferred by the builder. Only a screwdriver and a pair of pliers necessary to assemble this set in less than two hours.

Over-all design, rugged and solid. Adapted to practically any standard cabinet, any standard tube, any battery or eliminator source of supply, outdoor antenna or loop. While the parts are the best that the leading laboratories of the country afford, the set can be built at an extremely low cost. Full description of the receiver will be published in the March issue of Popular Radio.

Get the hand book at your nearest Radio Dealer or clip the coupon and send with 25 cents TO-DAY. Address

**The S-C Merchandising
Committee**

106 S. Wabash Ave.
Chicago



**The S-C
Merchandising
Committee:**

106 S. Wabash Avenue · Chicago

Gentlemen: Please find enclosed 25c. for which send me hand book of the new S-C Receiver.

No choicer group of radio products has ever been embodied in a single radio receiver. Not only are these manufacturers nationally known and accepted as the leaders in radio design and construction, but they have developed for the S-C receiver many new features which will create a new standard in reception throughout the radio world.

Represented Manufacturers:

Belden Mfg. Co.
S-C Wiring Harness

Central Radio Laboratories
Centralab Resistance

Polymet Mfg. Corporation
Fixed Condensers, Leak
and Leak Clips

Silver-Marshall, Inc.
Variable Condensers, Coil Sockets,
Coils, Tube Sockets, Vernier Dial,
Mounting Brackets

Thordarson Electric Mfg. Co.
Equiformer Audio
Transformers

Poster & Co.
Drilled and Processed Front Panel
and Drilled Sub-Panel

Yaxley Mfg. Co.
Rheostat, Jacks, Switch

Name _____

Address _____

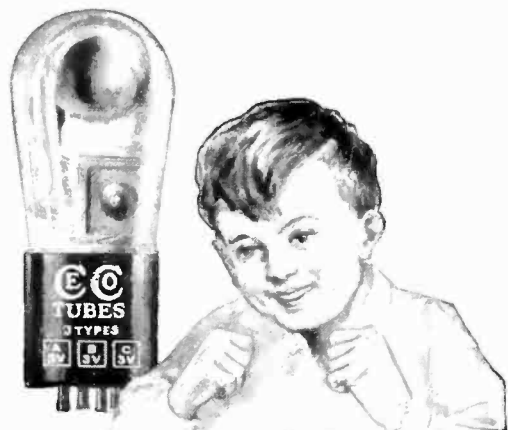

-it's in the Tube

A receiving set is no better than its tubes.

With other parts and connections *right* a set may be as good as its tubes—no set can be better.

That's why you want CECO Tubes. They stand up and deliver. With them your set works at its maximum. Clarity of tone, rich volume, long life—CECO has them all to a superlative degree.

Our charted tests (results confirmed by laboratories of national reputation) PROVE CECO TUBE SUPERIORITY—whether used as detectors, audio or radio frequency amplifiers.

CECO Tubes make a Good Receiver BETTER. Try them and you'll BUY them always—for results.

Now Ready! CECO Tubes with new type Long PRONG BASES. Also, Power Amplifier Tubes, E (Dry Cell Type), F (Storage Battery), for last stage of Audio Frequency.

Dealers write giving jobber's name.

C. E. Mfg. Co., Inc.

702 Eddy Street, Providence, R. I.

CECO TUBES

REMEMBER! WHEN BUILDING THE ROBERTS',

KNOCK-OUT AND ARISTOCRAT

receivers that CLAROTUNERS are easier to mount, easier to hook-up, and that a more even approach to the point of MAXIMUM AMPLIFICATION is effected with CLAROTUNERS.

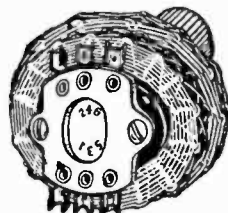

DO YOU KNOW

that CLAROSTAT is the perfect variable resistor, having a greater range and a greater carrying capacity than any other, and that it is the only logical resistor for the UNIVERSAL receiver?



Send Stamp for Hook-ups

American Mechanical Labs., Inc.

285 North Sixth Street

Brooklyn, New York

A KEY TO RECENT RADIO ARTICLES

By E. G. SHALKHAUSER

THIS is the fifth installment of references to articles which have appeared recently in various radio periodicals. Each separate reference should be cut out and pasted on cards for filing, or pasted in a scrap book either alphabetically or numerically. An outline of the Dewey Decimal System (employed here) appeared in the November and January RADIO BROADCAST, and will be reprinted in an early number.



R382. INDUCTORS. COILS.
QST. Dec. 1925, pp. 9-12.
"Toroids," F. J. Marco. Toroids.

Through the increased use of radio frequency amplification, coils have been designed which are said to give greater selectivity than is the case with common solenoid coils. The toroid coil is an outgrowth of some of these newer developments. It has practically no external field. Considerable theoretical and practical data accumulated by the author, is presented. The advantage of this new coil lies in the lessening of interstage magnetic coupling. It does not nullify interstage oscillations in r. f. amplification.

R582. TRANSMISSION OF PHOTOGRAPHS. PHOTOGRAPH TRANSMISSION.
QST. Dec. 1925, pp. 12-17.
"Practical Picture Transmission," T. P. Dewhurst.

The Jenkins Laboratories have two picture transmission machines available for amateur use, the "Midget" and the "Junior." Both of these instruments are pictured and described in detail. Certain facts regarding the use of the apparatus and method of operating it are considered. Circuit diagrams are shown and explained.

R386. FILTERS. FILTERS.
QST. Dec. 1925, pp. 24-26.
"Amateur Filter Problems," F. S. Dellenbaugh.

A summary of problems pertaining to low-pass filters from 25 cycles a. c. to commutator ripples in generators, is given. A full page of design data covering construction of induction coils with carrying capacity of .05-.5 amperes, is included. The "brute force" and "intelligence" method of filtering are discussed, and diagrams shown. Tests of filter action using telephone induction coil and headphones are diagrammatically included.

R357. FREQUENCY CHANGERS. FREQUENCY CHANGERS.
QST. Dec. 1925, pp. 29-30.
"Frequency Doubling in Vacuum Tubes," T. T. Greenwood.

A method whereby the ordinary three-electrode tube may be used to double the output frequency in a circuit, is described. Use is made of the decrease of grid current for either increase or decrease of plate potential. Diagrams illustrate the points under consideration.

R374. DETECTORS, CRYSTAL. CRYSTAL.
QST. Dec. 1925, pp. 31-32.
"The New Carborundum Detector," M. L. Hartmann and J. R. Meagher. Carborundum.

A fixed crystal detector for broadcast receivers is described. Carborundum is used since this crystal is superior to any others, considering electrical stability and permanence. It has been developed to a point, according to the author, where its use may be an asset to modern receiving sets. The commercial product is shown and circuit diagram given.

R402. SHORT WAVES. SHORT-WAVE TRANSMISSION.
Proc. I. R. E. Dec. 1925, pp. 677-683.
"An Investigation of Transmission on the Higher Radio Frequencies," A. Hoyt Taylor.

A preliminary range chart has been constructed for telegraphic communication, 5 kw. in the antenna, at various frequencies. The conclusions upon which the range chart is based are derived from experiments made by the Naval Research Laboratory, from experiments made by amateurs, and from such data as the Laboratory has had access to from commercial and Government sources at home and abroad.

An attempt has been made to indicate in a general way the advantages and disadvantages of high frequency telegraphic transmission. Various critical regions are pointed out where new phenomena make their appearance; (1) region between 2000 and 3000 kcs. (2) region around 6000 kcs. (3) developments at higher frequencies of uncertain ranges.

The development of a missing region to extensive areas is shown to take place with a frequency rise to 20,000 kcs. The chart also attempts to indicate, in a general way, the region of uncertain communication and the regions where further exploration is urgently needed. It is quite evident that the range data is far from complete and that many individual cases will be found in contradiction to the chart, but it does represent a general average of the situation as it presents itself to the engineers in the Naval Service.

R115. DIRECTIONAL PROPERTIES. DIRECTIONAL RECEIVERS.
Proc. I. R. E. Dec. 1925, pp. 685-707.
"A New Directional Receiving System," H. T. Friis.

The paper discusses methods of combining the signal currents from the different antennas in a directional receiving system, and a detailed description is given of a system by which all phase and amplitude adjustments are performed upon the beating current inputs of a double detection receiver. The theoretically derived shape of the directional characteristic of a two-loop system has been verified by experiments, and data on reduction of static for such a system are given. Photographs and diagrams are shown of all the apparatus used.

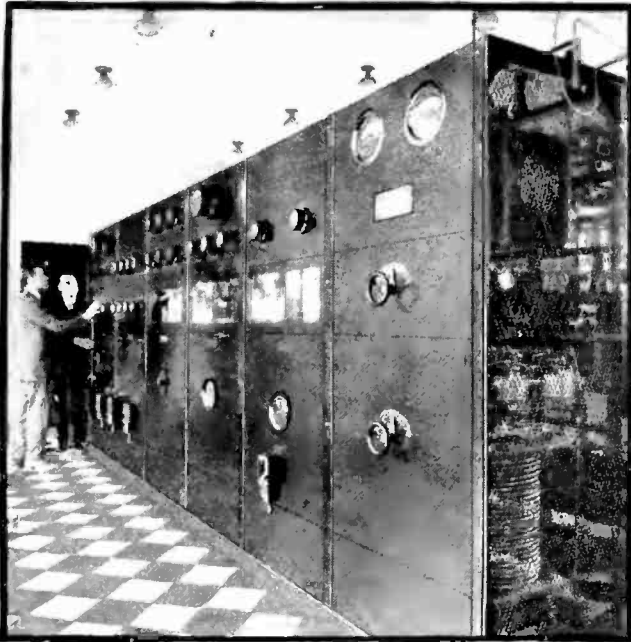

**\$50. to \$250 a week
IN WORK THAT IS
ALMOST ROMANCE**

Be a Radio Expert



Get into the great new Big-Pay Industry—Radio. If you're earning a penny less than \$50 a week, **clip coupon now.** Send for **AMAZING FREE BOOK.** Be a Radio Expert and draw down big money for the easiest and most fascinating work in the world. Positions everywhere. Thoroughly-trained men are in big demand. Need for Radio Experts in every community. Short hours. **BIG PAY.** Free book gives all the facts. Astonishing opportunities—thousands of them! Every day N. R. I. trained men are taking good places in the Radio field. Free book tells all about their success. Send for it now!

Learn Quickly and Easily AT HOME

Master Radio Engineers will show you how to qualify quickly and easily at home, for Radio's fine jobs. We **guarantee** to train you successfully. Lack of experience no drawback—common schooling all you need. Our tested, clear methods make it easy for you. Send coupon now for free proof.

Instruments Given with Course

All instruments shown here and many others given to students for practice work while learning. Receiving sets, from simplest kind to thousand mile receiver. An **UNEQUALLED OFFER.** Many other big features for limited time only

Famous Training That "Pays for Itself"

Spare-time earnings are easy in Radio. Increase your income almost from the start through practical knowledge we give you. This is the famous **practical** training that **pays its own way.**



Get
this
Amaz-
ing Book

Most amazing book on Radio ever written—full, interesting facts about this great field and how we prepare you and help you start. You can do what others have done. **GET THIS BOOK.**

SEND COUPON

Send coupon to-day for special limited offer, including all instruments—you'll get full particulars by return mail.

National Radio Institute

Dept. CU5, Washington, D. C.

You get
all of
these

MAIL THIS NOW

NATIONAL RADIO INSTITUTE

Dept. CU5

Washington, D. C.

Without obligating me in any way, send me your free book, "Rich Rewards in Radio," and all information about your practical, home-study Radio course.

Name.....Age.....

Address.....

Town.....State.....



Operates WMAQ

"Accepted a position with Chicago Daily News—Station WMAQ. My income practically doubled thanks to your fine course."

KEITH KIMBALL, Chicago.



Gets Big Job

"Just been made Sales Manager of this Radio concern—a big raise in pay. Regret I did not take course sooner."

R. E. JONES, Bay City.



LARGEST RADIO SCHOOL IN THE WORLD

ORIGINATORS OF RADIO HOME-STUDY TRAINING

New "AMSCO" Products

*The choice of
Leading Radio Engineers*

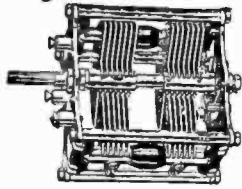

AMSCO SIAMESE CONDENSERS

Used by William H. Preiss in his "Straight 8" Receiver, R. E. Lacault in his "Ultra-dyne," L. M. Cockaday in his "L. C. 26" Receiver, and specified by Lester L. Jones for single control receivers.

It Clicks into Contact

AMSCO UNIVERSAL SOCKET



All standard UX and CX radio tubes snap in with a click that assures positive contact.

Patented Amsco construction fully enclosed in genuine Bakelite. One hole mounting. They save space



DE LUXE MODEL AMSCO VERNIER DIALS

Now finished in gold, silver, and jet. Free acting—forward or backward, fast or slow, without momentum or backlash. Gives finesse to fingers.

FOR STRAIGHT-LINE AMPLIFICATION

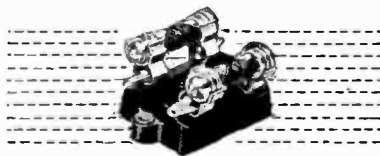

AMSCO RESISTANCE COUPLERS

The perfected instruments for straight-line amplification. All frequencies within the voice and music ranges, from the highest treble to the lowest bass, are augmented equally, giving true tone reproduction without distortion.

Investigate Amsco Resistance Couplers, Grid Gates and Resistors.



AMSCO PRODUCTS, INC.
Broome & Lafayette Sts., New York

Make your set a Super-Het

THE circuit described in Radio Broadcast for June and August will change any set into a super-heterodyne. It is particularly applicable to five-tube neutrodyne and tuned RF sets. It changes these two circuits into super-heterodynes as good as most, and considerably better in some respects than any super-heterodyne circuit ever devised.

Stations come in at but one point on the oscillator dial. There is mathematically no possibility of harmonics. Full scale blue prints with reprint of article \$1.00.

Eastern Coil antenna coupler	\$6.00
O'Connor oscillator coupler	4.75
Special fixed condenser60
Complete parts including panel, drilled and engraved, special formica bushings, screws, and wire, blue prints and reprint.....	37.50



A. O'CONNOR & COMPANY

Super-Heterodyne Headquarters Since 1923

9702 Euclid Avenue Cleveland, Ohio

R140. CIRCUITS. CIRCUITS,
Transmitting.
Radio. Dec. 1925, pp. 26 ff.
"How to Identify the Transmitting Circuits," Lieut. J. B. Dow, U. S. N.
An oscillating tube circuit is used for transmitting purposes. Six basic circuits, the Meissner, Coupled plate, Coupled grid, Hartley, Modified Hartley, and Colpitts, are listed by the author, together with diagrams and a general discussion. Other circuits, such as the grid condenser and leak system, are considered modifications of the fundamental ones. Some of the modifications are taken up and diagrams shown.

R343. ELECTRON TUBE RECEIVING SET. RECEIVER,
LC-26.
Popular Radio. Dec. 1925, pp. 495-511.
"LC-26 Receiver," L. M. Cockaday.
A receiver considered by the author as the best one yet constructed, and available in parts for the radio experimenter, is described. It is a five-tube resistance-coupled set. Front, rear, and side views, including wiring diagram and list of parts, are shown. All details pertaining to the set are carefully presented.

R381. CONOENSERS CONOENSER
LOSSES
Popular Radio. Dec. 1925, pp. 521-525.
"Condensers," S. Harris.
The question of losses in condensers is a difficult problem in radio engineering, but one should have some idea about high frequency resistances in condensers. The radio experimenter will have no difficulty in understanding some of the effects due to eddy currents, dielectric losses, etc., the author believes. A simple method of measuring such losses in condensers is presented by the writer.

R550. BROAOCASTING. INSTRUMENTS,
Placing of
Popular Radio. Dec. 1925, pp. 526-532.
"The Oboe in 4-D," T. L. Bayard.
The location of each instrument in group radio transmission, orchestra or band, before the studio microphone, is a problem which has been studied at some length and solved to some extent by engineers of station KDKA at Pittsburgh. Charts and explanations furnish the reader with considerable detailed information.

R582. TRANSMISSION OF PHOTOGRAPHS PHOTOGRAPHIC
TRANSMISSION.
Popular Radio. Dec. 1925, pp. 540-544.
"Pictures by Telephone or Radio," E. H. Hansen.
A new method of transmitting pictures by radio, called the "Phono-Photo" method, is described. Fundamental data on present types of systems developed, are reviewed and compared with the system presented by the author. A photo-electric cell is required, actual pictures being transmitted over the ordinary telephone lines in a remarkable short time.

R261. ELECTRON TUBE VOLTMETERS. VOLTMETERS,
Vacuum Tube.
Popular Radio. Dec. 1925, pp. 552-555.
"A Vacuum Tube as a Voltmeter," L. M. Cockaday.
A three-electrode vacuum tube is used as a voltmeter to cover a considerably greater range than the voltmeter in common use, since it can be applied to either d. c. or a. c., from a fraction of a volt to several hundred volts. An explanation of its uses, and the method of applying it, is given in detail. Circuit diagram and apparatus assembled, is shown.

R382. INDUCTORS. INDUCTANCE
VALUES.
Popular Radio. Dec. 1925, pp. 559-561.
"The Relative Merit of Some Types of Inductance," B. B. Minnium.
The author presents a careful analysis of several types of inductance coils, mainly pertaining to the method of winding them, and makes a comparison of their relative L-R values. Some conspicuous results are obtained, which should be considered carefully before deciding which coils are the best. A graph shows the L-R ratio and the wavelength plotted for six types of windings. The torus coil appears to be far the poorest coil investigated.

R364. CRYSTAL DETECTORS. CRYSTALS.
Popular Radio. Dec. 1925, pp. 575-576.
"Do Impurities Improve Crystal Detectors?,"
Doctor Wherry, of the Bureau of Chemistry, presents one of the most complete lists of crystal detector minerals and their composition, which has ever been published. It appears that crystals with some impurities are better for high frequency detecting purposes than the pure minerals, although there are some exceptions.

R342.7. AUDIO-FREQUENCY AMPLIFIERS. AMPLIFICATION
Audio-Frequency
RADIO BROADCAST. Jan. 1926, pp. 313-316.
"Additional Notes on the Model 1926 Receiver," E. R. Pfaff.
The author describes an improved audio amplifying unit to be used with the McMurdo Silver receiver (described in Nov., 1925, *RADIO BROADCAST*) using transformer, resistance, or choke-coil coupled amplifiers. In using increased plate voltages for power tubes, it is frequently necessary to use a shunt method of horn connection for good results. Resistance coupling, with its advantages and precautions to be observed, is reviewed at length.

R402. SHORT WAVES. SHORT-WAVE
TRANSMITTER.
RADIO BROADCAST. Jan. 1926, pp. 321-325.
"A Universal Short-Wave Transmitter," N. Hagemann.
The construction of a high frequency telegraph transmitter, using receiving parts, is described. The circuit shown is capable of steady oscillations even when plate or filament current should vary somewhat. Complete instructions, wiring diagrams, and photographs are given.

R343. ELECTRON TUBE RECEIVING SETS. RECEIVER,
Universal.
RADIO BROADCAST. Jan. 1926, pp. 331-336.
"Radio Broadcast's Universal Receiver," A. H. Lynch.
The article starts with a general review of the radio parts situation at the present time and proceeds to give a detailed account of several good receivers which may be built by the home constructor. The "Universal," an exceptionally efficient four-tube receiver, using one r. f. stage, tuned and neutralized, a regenerative detector, and good audio stages, is described. Photographs serving to illustrate the general layout of instruments.

Every Radio Fan should have this book
JUST OUT—514 PAGES



Compiled by
HARRY F. DART, E.E.
Formerly with the Western Electric Co., and U. S. Army Instructor of Radio.
Technically edited by
F. H. Doane

NO MORE need you turn from book to book, hoping to find what you want. It is all here, in 514 pages crammed full of every possible radio detail. Written in plain language, by engineers for laymen. 100,000 sold.

IT EXPLAINS: Electrical terms and circuits, antennas, batteries, generators and motors, electron (vacuum) tubes, many receiving hook-ups, radio and audio frequency amplification, broadcast and commercial transmitters and receivers, super-regeneration, codes, etc.

Send \$1 today and get this 514-page I. C. S. Radio Handbook—the biggest value in radio today.

International Correspondence Schools
Box 8299-E, Scranton, Penna.

I enclose One Dollar. Please send me—post-paid—the 514-page I. C. S. Radio Handbook. It is understood that if I am not entirely satisfied I may return this book within five days and you will refund my money.

Name.....

Address.....

Check here and enclose \$1.50 if you wish the edition bound in Leatheroid.



You can play the scale in an hour and play Jazz in a week on the

Buescher Saxophone

We give 3 free lessons with each new instrument. They start you. Teach yourself. It's great fun practicing because you learn so quickly. Even though you have failed with some other instrument, you can learn the Buescher Saxophone. And it will make you the most popular person in your set. 6 days' free trial in your own home, any instrument. No obligation. Easy terms if you decide to buy. Send now for beautiful free literature. A postal brings liberal proposition. Address:



Buescher Band Instrument Co. (3)
1220 Buescher Block Elkhart, Indiana

Hoyt Radio Rotary Meter

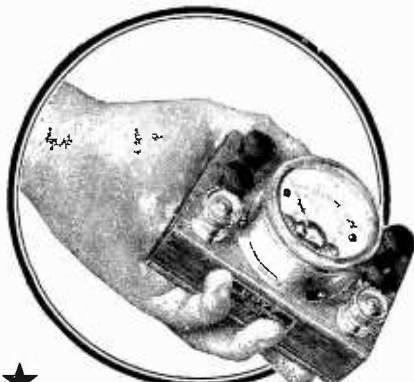

Price \$24

This unique meter will do all testing necessary on Radio receiving sets, tubes, batteries and battery eliminators. It furnishes the experimenter and Radio dealer with a single instrument with 5 different ranges, reading from as low as 1/4 milliamperes or 1.8 volt to 7.5 milliamperes or 150 volts. Operation is simple and accident-proof.

BURTON-ROGERS CO.
26 Brighton Ave. Boston, Mass.

RADIO PEP
B-BATTERY ELIMINATOR
NO TUBES NO HUM



Buy no more B-batteries!

USE the unlimited supply of cheap, dependable electricity right at hand in your household lighting circuit.

This can be done with *permanent* satisfaction with **RADIO PEP**.

RADIO PEP is the **FIRST** eliminator to completely solve the problem, as it is the only one made with **EIGHT PERFECTED ELECTROLYTIC CELLS**, replacing tubes and doing away with all the familiar tube troubles.

Two or four cells *overloaded* will not give **PERMANENCE** and **POWER**—the outstanding characteristics of **RADIO PEP**.

135 VOLTS are called for by the modern sets and tubes; here you get it year after year without weakening.

For 110-125 volts, 60-cycle alternating current.

Send for particulars and name of our nearest dealer. Price \$38.
Money back guarantee.

★ **PEP MFG. CO., Inc.**
33 West 42nd Street

New York



ACME WIRE RADIO PRODUCTS

Celatsite Wire

Celatsite is a tinned copper bus bar wire with a *non-inflammable* "spaghetti" insulation in five colors. Supplied in 30 inch lengths.



Flexible Varnished "Spaghetti"

A perfect insulation tube for all danger points in set wiring. Costs little more and is worth a lot more than the cheaper substitutes offered. Black, yellow, red, green, brown, for wires No. 10 to No. 18. 30 inch lengths.

Celatsite Battery Cable

For connecting A and B Batteries (or current supply) to radio set. Silk braid covering 5 flexible Celatsite wires—5 feet long—a different color for each terminal. Prevents messy wiring and "blown" tubes. Adds greatly to the appearance of your set.



Enameled Antenna Stranded

The best outdoor antenna you can put up. 7 strands of enameled copper wire; maximum surface for reception. Enameling prevents corrosion and consequent weak signals. 100, 150 or 200 foot coils, boxed.

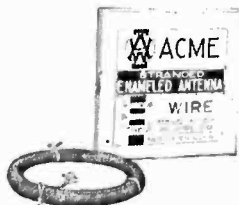

Loop Antenna Wire

You can make a good loop with Acme wire made of 65 strands of fine copper wire, green silk covered. Flexible; non-stretching, neat.

Flexible Celatsite Wire

Flexible stranded wire for "point to point" and sub-panel wiring—latest method of wiring sets. 5 colors, black, yellow, green, red and brown, one for each circuit. 25 ft. coils.



Send for Folder

THE ACME WIRE CO., Dept. B
New Haven, Conn. ★

This is a good time to subscribe for

RADIO BROADCAST

Through your dealer or direct, by the year only \$4.00

Doubleday, Page & Company

Garden City, New York

WHOLESALE

EXCLUSIVELY

LUDWIG HOMMEL & CO

929 PENN AVENUE

PITTSBURGH, PA.

**SATISFIED DEALERS
BECAUSE**

WE HELP THEM ~

Catalog 466~B is free to Dealers

R450. BROADCASTING. STATION, *Radio News*. Dec. 1925, pp. 798 ff. *Broadcasting*.
"What Happens In the Broadcast Station," A. P. Peck.
A fundamental description of the operation of a modern broadcasting station, including the principles of sound vibrations, the purpose of the microphone, the operation of the transmitting tubes, the method of modulating high frequency currents, and the equipment of the rooms housing the broadcasting station.

R142.3. INDUCTIVE COUPLING. COUPLING. *Radio News*. Dec. 1925, pp. 800 ff.
"Coupling—Tight or Loose?," S. Harris.
In this article, the first of a series, is presented a mathematical treatise on the question of coupling between coils. Actual measurements, made with different coils, are shown graphically, with constants of the coils given. Only concentric coils are considered, variations being made in diameter of coils, number of turns, and position of primary with respect to secondary (whether in center or to one end). The effect of the antenna constants, when considered with coil coupling, is another important factor.

R402. SHORT WAVES. TRANSMITTER, *Radio News*. Dec. 1925, pp. 803 ff. *Short-Wave*.
"The Baby Transmitter," W. B. Schulte.
A complete description of a low power transmitter using UV-199 tube, and operating at high frequencies (7500 kc.), is given. The modified Colpitts oscillator used, was developed at the Burgess Laboratories. Ordinary dry batteries furnish the plate and filament supply. The circuit diagrams show clearly how this set can be constructed.

R334. FOUR-ELECTRODE TUBES. ELECTRON TUBES, *Radio News*. Dec. 1925, pp. 804 ff. *Four-electrode*.
"Multiple Grid Vacuum Tubes and Their Advantages," T. H. Nakken.
The author presents an analysis and working principle of a two-grid tube, giving its advantages and theory of operation. One grid is connected directly to part of the B battery voltage in order to neutralize the space charge within the tube. The other grid performs its regular functions as in three-electrode tubes. It is said that capacity effects between grid and plate may be prevented by this unique arrangement of grids. As a power tube, this device has many possibilities.

R402. SHORT WAVES. TRANSMITTER, *Radio News*. Dec. 1925, pp. 807 ff. *Five-Meter*.
"Five-Meter Transmission," R. E. Kolo.
The construction of a transmitter and receiver operating on 50,000 kc. (5 meters) and the arrangement of Lecher wires to measure these high frequency currents, is given. The University of Illinois experimental station worked out the apparatus design. Data on construction and operation is given in detail.

R381. CONDENSERS. CONDENSERS, *Radio News*. Dec. 1925, pp. 808 ff. *Electrolytic*.
"Electrolytic Condensers," I. A. Smith and J. Millen.
A description of the much talked of electrolytic condensers, is presented. Tables give relation of capacity to voltage formation values and the critical voltages for aluminum anodes with various electrolytes. Construction of such condensers for transmitting and receiving purposes, and proper sized choke coils to be used for good results, is part of the information given to enable the constructor to build his own.

R375. DETECTORS; RECTIFIERS; ELIMINATORS, *Radio*. Dec. 1925, pp. 15 ff. *MISCELLANEOUS*.
"The A B C Battery Eliminator," G. M. Best.
The construction of an eliminator to replace the A, B, and C batteries, thus operating the radio receiver from the regular 110 volt a. c. power circuit, is described. Any set using up to and including eight tubes, may connect to this eliminator. Some changes in wiring are necessary in the set. A list of complete parts are given and diagrams shown. The construction of the eliminator is not difficult, and is considered quiet in operation. Rewiring diagrams for the Browning-Drake and also an eight-tube super-heterodyne, are given.

R073. TRAINING OF OPERATORS. EXAMINATIONS, *Radio*. Dec. 1925, pp. 22 ff. *Government*.
"Passing Your Next Radio Examination," C. W. Rados.
Complete information is presented concerning the license examinations for amateur and commercial operators. These examinations are conducted by the Department of Commerce and may be taken at any one of the district offices. A code test comes first, followed by an examination in theory and laws of radio communication. A sample code test is also included in this very complete article.

R443. ELECTRON TUBE RECEIVING SET. RECEIVER, *Radio*. Dec. 1925, pp. 25 ff. *Browning-Drake*.
"The Single Control Browning-Drake Receiver," H. A. Nickerson.
A method of converting the Browning-Drake circuit to single control is described, using two condensers mounted on one shaft. This circuit is well adapted to such an arrangement, writes the author. The principle of operation, with the change suggested, is considered at some length. Other changes to be made are also given consideration.

R143. DAMPING; DECREMENT. DAMPING, *Radio*. Dec. 1925, pp. 29 ff.
"Damping," L. R. Felder.
A fundamental and simple explanation of the question of "damping," also called "decrement," is given. "Damping" is found in all radio circuits, since they all have more or less resistance. It will increase broadness of resonance as explained and indicated graphically. This problem must therefore be considered in the design and efficiency of all radio apparatus.

R242. REACTANCE-VARIATION METHOD. COIL MEASUREMENTS, *Radio*. Dec. 1925, pp. 31.
"A Standard of Coil Comparison," G. F. Lampkin.
The author makes a plea for expressing in some standard way the meaning of coil efficiency. He suggests that the ratio of L-R be used, and gives his reasons, explaining this ratio of reactance to resistance at some length.

CHELSEA *Super-Five*

\$50



EVERYwhere— Winning New Friends

THAT'S exactly what the new Chelsea Super-Five is doing because it offers supreme performance at a popular price. Each Super-Five is housed in a beautiful mahogany-finish cabinet with graceful sloping panel and large over-size dials for easy tuning. Dust-proof, fool-proof inside panel to protect the "vitals." Hand soldered connections. Rugged bus-wiring throughout. Convenient cord leads for making all connections.

See these Chelsea features at
Your Dealers. Write Us
for Folders.



CHELSEA RADIO COMPANY
CHELSEA, MASS.

This is a good time to subscribe for

RADIO BROADCAST

Through your dealer or direct, by the year only \$4.00

DOUBLEDAY, PAGE & CO. GARDEN CITY, NEW YORK

MORE PROFITS for the PROFESSIONAL SET BUILDER

WE have an unusually interesting proposition to make to the man who is now building (or has the ability to build) radio receiving sets for resale.

This is a real opportunity. Write today for full information.

Gearhart-Schlueter Radio Corp.
716 Voorman Ave. Fresno, California

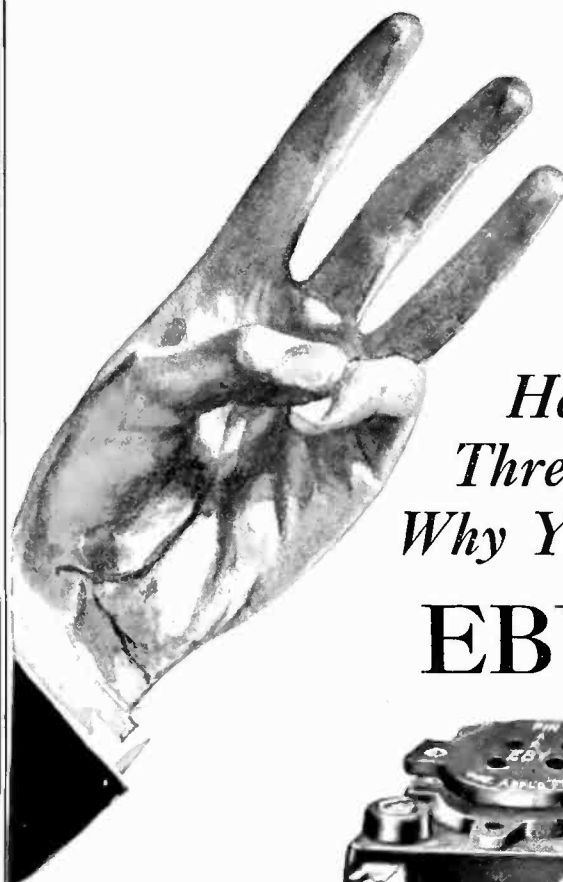

Here Are
Three Good Reasons
Why You Should Use

EBY



SPRING SOCKETS

- 1** A three point wiping contact that insures a positive contact at all times regardless of the size of the prong or amount of solder on the prong tip.
- 2** Its ingenious design permits the tube to "float" when in service. This feature reduces microphonic noises to a minimum and prevents tube damage.
- 3** All the advantages of interchangeability of the new UX, CX, and UV tubes for 6oc. Don't take chances on twenty loose connections in a five-tube set. Use the new EBY positive contact sockets for better reception.

If your dealer can't supply you
write to us sending his name.

H. H. EBY MANUFACTURING CO.
4710 Stenton Ave., Philadelphia



This is the EBY Binding Post that is standard equipment on eight out of ten of the radio receivers made in America—your dealer has all of the 27 different markings.

★ Tested and approved by RADIO BROADCAST ★



The Magic Dial

\$2.50

AS AMAZING AS A STROKE OF MAGIC!



Variable condensers that are not straight line frequency, tune as if they were, if you install

Bruno MAGIC DIALS

If your dealer can't supply you, order direct. \$2.50.

As if at the touch of a wondrous wand, stations otherwise crowded together—are evenly separated. Uncrowd the air with the Magic Dial! Genuine moulded Bakelite with fluted columns of Arabian inlay, \$2.50

“SLO-MOSHEN” VERNIER DIAL, \$2.00

Powertone Electric Co.

(Subsidiary of Bruno Radio Corp.)

Dept. P 223 Fulton St. N. Y. City



This is a good time to subscribe for

RADIO BROADCAST

Through your dealer or direct by the year, only \$4.00

DOUBLEDAY, PAGE & CO.

GARDEN CITY, NEW YORK



RADIO WIRES

We manufacture all types.

- Round braided antenna wires
- Flat braided antenna wires
- Round stranded antenna wires

- TRADE MARK REG.
- Above types in copper—tinned copper—enameled copper—tinned bronze.
- Loop wires in silk or cotton covered.
- Litz wires.
- Enameled wires.

- Antenna supporting springs.
- Cotton and silk covered wires for set wiring.

Write us for descriptive catalogue.

ROSS WIRE COMPANY

69 Bath St., Providence, R. I.



★ Tested and approved by RADIO BROADCAST ★

R134.4. REGENERATIVE ACTION. REGENERATIVE
Proc. I. R. E. Dec. 1925, pp. 709-753. AMPLIFICATION
“An Analysis of Regenerative Amplification,” V. D.
Landon and K. W. Jarvis.

This paper shows some of the defects of present theories regarding regeneration, and presents a new method of analysis based on the idea of a power balance. It is shown that a signal voltage does not supply power to a regenerated circuit, but merely prevents certain losses from occurring. This upsets the balance between power input from the tickler and power lost in the circuit, so that oscillation occurs. The amplification obtainable in this way has a definite limit, the limit being caused by variations in the plate and grid impedances of the vacuum tube, as the amplitude of the grid voltage increases. The rate of variation of these impedances as the grid voltage increases, depends on the tube and on the direct voltage used.

The use of a grid leak and condenser decreases the voltage amplification, by increasing the rate of change of the plate-filament impedance. In general, however, increased detecting efficiency more than makes up for the difference when audio frequency output is considered. The effect of resistance in the grid circuit is to decrease the amplification by increasing the effect of the impedance variations.

The best turn ratio to use in a regenerated transformer is the same ratio that should be used in a non-regenerated transformer. The amplification obtainable increases rapidly as the strength of an applied signal is decreased. Although the inductance-capacity ratio does not affect the amplification obtained on an a. c. wave train, this ratio does affect the amplitude of the audio output when a modulated signal is being amplified. If a low L-C ratio is used, high notes will be lost when a weak signal is being received with full regeneration.

Regenerative amplification also occurs when a tube is in a condition of self-oscillation, providing the strength of the local oscillation is weak. A regenerated circuit amplifies non-resonant frequencies to a certain extent, the amount depending on the value of the reactance that would be needed to tune the circuit to the non-resonant frequency.

R382.5. OSCILLATION TRANSFORMERS. INDUCTANCES,
Proc. I. R. E. Dec. 1925, pp. 755-766. *Air-Core.*
“Designs and Efficiencies of Large Air-Core Inductances,”
W. W. Brown and J. E. Love.

Representative designs of large air-core antenna tuning inductances suitable for outdoor and indoor service, are described. The latest improved designs are described in greater detail and compared with earlier designs on a basis of efficiency and kilovolt-ampere capacity. Formulas are given for calculating the ohmic and eddy current conductor power factor of coils using finely stranded, separately insulated, strands. In graphical form are shown the variations of ohmic and eddy current power factor with frequency, with four different conductors wound in a given arrangement to given dimensions. Also the variation of the sum of ohmic and eddy current power factors, with frequencies for a representative conductor on various diameters, are given. These values were calculated by the formulas given, and indicate very high efficiencies for the latest types of coils.

R342.6. RADIO-FREQUENCY AMPLIFIERS. TRANSFORMERS,
Proc. I. R. E. Dec. 1925, pp. 767-779. *Radio-Frequency.*
“An Efficient Tuned Radio-Frequency Transformer,”
F. H. Drake and G. H. Browning.

A mathematical discussion of a new type of r. f. amplifying transformer is given, which, it is claimed, is capable of giving greater amplification per stage than other transformers now used. Circuit diagrams and charts are shown verifying the theoretical work done.

R610. EQUIPMENT; STATION DESCRIPTION. STATION,
Radio News. Dec. 1925, pp. 770 ff. *Broadcasting.*
“Britain's New Superpower Broadcasting Station,” A.
Dinsdale.

Great Britain's largest broadcasting station, located at Daventry, is described. Several photographs show interior and exterior arrangements. The present rated power output is 25 kw., although up to 60 kw. can be used in the future. The circuit design, oscillator, amplifier, modulator, and sub-modulator, are discussed separately. The tubes are water-cooled, the system employed being taken up in detail. The station frequency is 187 kc. (1600 meters), call letters 5 xx.

R113.1. FADING. FADING.
Radio News. Dec. 1925, pp. 772 ff.
“The Nature, Cause, and Reduction of Fading,” G. W.
Pickard.

Mr. Pickard discusses the inconstancy of the space circuit, giving a very exhaustive and complete study of the probable causes of fading. His explanations are supplemented by charts and data taken over long periods of time. From his observations it appears that the Kennedy-Heaviside layer theory does not explain day and night and seasonal variations, but the cause must be found elsewhere. A system of multipoint antennas for receiver, transmitter, or both, is proposed to improve conditions.

R130. ELECTRON TUBES. TUBES,
Radio News. Dec. 1925, pp. 786 ff. *Cold-Cathode.*
“Cold-Cathode Gas-Filled Discharge Tubes,” C. B.
Bazzoni.

Some fundamental principles pertaining to electron discharges through vacua, are presented. The Crookes dark space and the Faraday dark space in partially exhausted tubes, are two of the interesting phenomena explained at some length.

R350. GENERATING APPARATUS; TRANSMITTING SETS. TRANSMITTERS,
Radio News. Dec. 1925, pp. 790 ff. *Radio Telephone.*
“Transatlantic Radio Telephony,” G. C. B. Rowe.

According to information in this article, the Western Electric Company will announce transatlantic radio telephone service on a commercial basis shortly. A new system of transmission, known as the single side-band eliminated carrier, is used. This system is described and illustrated. A special system of reception is necessary, a local oscillator being employed in order to properly detect the signals. The advantages of this new system are discussed at some length.

Goodrich Silvertown

The Radio Panel Supreme!

- 1 Easier to drill and machine.
- 2 Better color, lasting lustre.
- 3 Lower free sulphur—no discoloration.
- 4 Higher softening point—no warping.

Goodrich V. T. Sockets Spaghetti Tubing
 Radiophone Ear Cushions
 ★ Battery Mats
 Hard Rubber Tubes for Coils

The B. F. Goodrich Rubber Company
 Established 1870 Akron, Ohio



\$2.25

Selected As The Best Variable Resistor

By the Raytheon Manufacturing Company and others, because it has no equal for voltage control in "B" Battery Eliminators.

A RANGE FROM ALMOST ZERO TO 5,000,000 OHMS and A CARRYING CAPACITY OF 200 milliamperes, ten times greater than that of any other variable resistor.

Consequently, in B Battery Eliminators, where so much depends upon a proper voltage control, its freedom from noise, the necessity of its carrying capacity and staying put when once adjusted—is where the CLAROSTAT is SUPERIOR.

If your dealer cannot supply you, write direct ★

American Mechanical Laboratories, Inc.
 285-287 North Sixth Street, Brooklyn, N. Y.
 Special types for "A" and "B" Battery Eliminators available for Manufacturers.

SANGAMO Mica Condensers in intermediate sizes



IMPROVE
TONE
RANGE
AND
VOLUME

IT is accuracy, not luck, that makes one receiver sweeter and more powerful than another that is almost its twin. Especially condenser accuracy, for the closer you come to absolute accuracy at these critical parts, the more wonderful your receiver will be. The cost of accurate condensers is small—the effect is immense.

Now you can get Sangamo Mica Condensers in capacities in between the usual stock sizes, so you can build with greater accuracy than ever before. They are guaranteed to be accurate and they always stay accurate, being solidly molded in bakelite. Neither heat, cold, moisture, pressure nor acid fumes will affect their capacity, because bakelite seals the delicate parts against all outside influences.

Capacities in microfarads and prices

0.00004	}	0.001	} 50c.
0.00005		0.0012	
0.00006		0.0015	
0.00007		0.00175	
0.00008		0.002	
0.0001		0.0025	
0.00012		0.003	
0.00015		0.0035	
0.000175		0.004	
0.0002		0.005	
0.00025	0.006	85c.	
0.0003	0.007	90c.	
0.00035	0.0075	95c.	
0.0004	0.008	\$1.00	
0.0005	0.01	1.15	
0.0006	0.012	1.20	
0.0007	0.015	1.25	
0.0008			

With Resistor clips, 10c. extra

Also Sangamo By-Pass Condensers ★
 1/10 mfd. 8c. 1/2 mfd. 90c.
 1/4 mfd. 8c. 1 mfd. \$1.25

Sangamo Electric Company
 6332-1 Springfield, Illinois

RADIO DIVISION, 50 Church Street, New York

SALES OFFICES—PRINCIPAL CITIES

For Canada—Sangamo Electric Co. of Canada, Ltd. Toronto.
 For Europe—British Sangamo Co., Ponders End, Middlesex, Eng.
 For Far East—Ashida Engineering Co., Osaka, Japan.



The Best in the World

No Batteries

are required even to operate the most powerful 10-tube receiver pictured above, if you use the new laboratory type

Model A Power Unit

One Customer Telegraphs:

“Receiver assembled, performing like a thoroughbred.”

The Amateur or Experimenter with his ultra-modern high-powered receiver is years ahead of Commercial Radio.

It is significant that unsolicited testimonials are constantly being received from even the far corners of the earth, where Norden-Hauck Engineers have furnished the finest radio apparatus known to the art today.

Quotations gladly furnished on radio parts and apparatus having non-infringing uses.

Write for Literature



NORDEN-HAUCK, Inc.

Engineers

1617 Chestnut Street, Philadelphia, Pa.

demand a changing of this bad condition. Who is going to be the bright fellow to straighten it out at a profit to himself?

A survey of most apartment-house roofs in the country will show what has to be done. Far beyond the unsightliness of these trap-maze, antenna-ridden roofs, it is not pleasant to have to duck and dodge such affairs when bent on getting a breath of fresh air.

There are two ways to get this thing ironed out. Dr. A. Hoyt Taylor has invented a multiple-tap antenna from which as many as a hundred sets can be connected. Why not apply this principle to rigging up apartment house roofs in a more workmanlike manner?

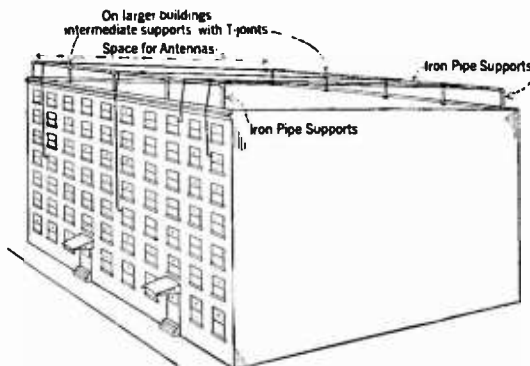

A STOUT ANTENNA SYSTEM

In which the possibility of a tangled mass of collapsed antennas is greatly mitigated. Nowadays the average apartment house rooftop is “enhanced” by a multiplicity of awkwardly arranged antennas in all stages of confusion

Or again, the use of a solid spreader at either end of a roof made of iron pipe and joints, properly braced, and carrying a whole gang of antennas at a safe height above the roof, is easy to set up.

Who is going to get this business? It is there, waiting for somebody. Big or little; a crowd of young men interested in radio should have no trouble in making their knowledge pay them big dividends.

Here are some sketches to show you just how to solve such problems. It is essential that radio encourage young men, all men, in fact, to get into the game and use their knowledge for the advancement of the craft. There is always a scarcity of men who know their business, especially in radio.

There are more men versed in the bread-and-butter knowledge of radio, of a type fitted to perform the work outlined here, than in almost every other industry. You men who read this publication must know quite a bit about radio.

Put your knowledge to work. It means money to you; it means experience, and new minds, and more willing hands to do the work that radio needs to have done.

DEMAND FOR RADIOS INCREASES IN CZECHOSLOVAKIA

FOLLOWING a severe depression in the radio business during the summer months in Czechoslovakia, things are now beginning to look up again, and the last few winter months have seen quite a strong demand for radio equipment. It is extremely difficult to obtain accurate figures of the total number of receiving sets now in use, but two reliable sources estimate this figure to approximate 20,000, of which 8000 are located in the city of Prague, where is a 5000 watt broadcasting station. At present there are forty-nine manufacturers of radio equipment in Czechoslovakia, but they do little business, most of the apparatus there being of foreign manufacture.

Why not subscribe to *Radio Broadcast*? By the year only \$4.00; or two years, \$6.00, saving \$2.40. Send direct to Doubleday, Page & Company Garden City, New York.



Burns Speaker with Concert Unit

The Heart of the Speaker

Large size and scientific construction of the Concert Unit gives the remarkable tone values which combined with the special amplifying properties of the BURNS horn produce remarkable results.

Burns horn is of distinctive design with pyralin flare in several handsome finishes.



Manufacturers

American Electric Company

State and 64th Streets, Chicago, U. S. A.

★ Tested and approved by RADIO BROADCAST ★

**NEW PROFITS
for RADIO DEALERS**



The B & R 5 Battery Charger will charge 5 Radio "A" batteries at once. Built for 110 volts, no power line needed. Plug it in on any lamp socket and set it to work. It pays for itself in two to three months.

Price, \$60 with bulb.

Send for our Charger booklet.

BURTON & ROGERS MFG. CO.
755 Boylston St. Boston, Mass.

LATEST "COAST TO COAST" FULLY GUARANTEED

**RADIO'S-10 DAYS FREE TRIAL
SAVE 1/3 TO 1/2**

Users everywhere report Miraco Radios get programs coast to coast on loud speaker; outperform sets three times as costly. Many hear foreign countries. Radio's most amazing values in unconditionally guaranteed, factory-built long distance sets—let testimony of users convince you.

MIRACO RADIO GETS 'EM COAST TO COAST
Powerful New Multi-tube Miraco gets long distance on loud speaker. Set, ONLY \$27.35 retail
FREE! Literature on latest improved 1 to 5 tube models, new low prices, testimony of users and SPECIAL OFFER. Write: **MIDWEST RADIO CORP'N**
Pioneer Builders of Sets
406-W E. 8th St. Cincinnati, O.

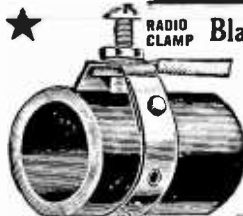

Blackburn Ground Clamps

Telephone companies using MILLIONS. Adjustable—fits any size pipe. Requires no pipe cleaning—screw bores through rust and scale. Send 12 cents for sample and postage. Blackburn Specialty Company 1960 E. 66th St. Cleveland, O.

"A Better Condenser"



The TOBE DEUTSCHMANN High-Voltage By-Pass Condenser in its silvered, shielded metal case is designed for all usual by-pass work in radio receiving-sets, and for construction of "B" eliminators of the Raytheon and other types.

0.10 Mfd.. \$0.60c.	0.5 Mfd.. \$0.75
0.25 Mfd.. \$0.70c.	1.0 Mfd.. \$0.90
2.0 Mfd.. \$1.75	

We announce a new TOBE High-Voltage Filter Condenser for strictly filter uses, for power amplifiers and other high-tension work up to 750 volts. Each of these is individually tested and stamped with date of test. Accuracy is guaranteed to within 5% of rating. Put up in heavy metal cases and recommended for precision work. Prices are the same as our former list on filter condensers.

The new TOBE "B" BLOCK is out, for "B" eliminator construction, with one 8 Mfd., two 2 Mfd., and two 1 Mfd. condensers in one case. Saves \$2.50 over cost of separate units,—saves space,—saves wiring.

Send for free eliminator diagrams

TOBE DEUTSCHMANN CO.
Cornhill, Boston, Mass.

COMO

**VARIABLE-RATIO
AUDIO-TRANSFORMER**

4 to 1 - 6 to 1 - 8 to 1
all in one transformer

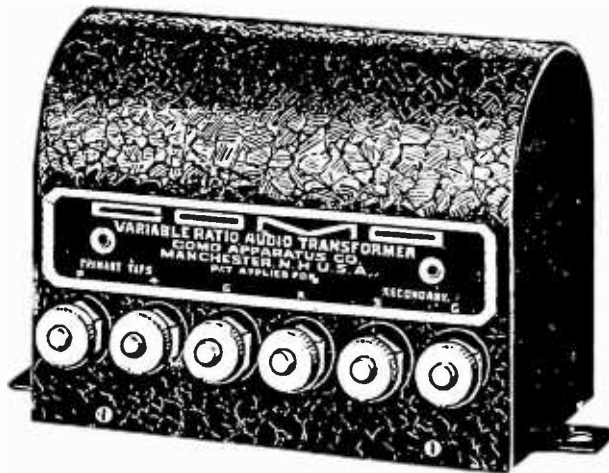

With this new Como Variable Ratio Transformer the set builder may secure for each stage of audio amplification the exact ratio best suited to the purpose. He may match more closely the primary impedance of the transformer with the plate impedance of his tubes, with a choice of 6 different values.

Built by a pioneer in radio manufacturing, this new Como product will reproduce music and speech with lifelike faithfulness.

In the familiar Como round-top, shielded metal case, at your dealers.

PRICE, \$6⁰⁰

Send for descriptive pamphlet R

COMO APPARATUS COMPANY, INC.

Kelley Street

Manchester, N. H.

This is a good time to subscribe for

RADIO BROADCAST

Through your dealer or direct, by the year only \$4.00

DOUBLEDAY, PAGE & CO.

GARDEN CITY, NEW YORK

ARE YOU THE MAN

to be first in your town to sell and demonstrate POWEROLA, the famous 5-tube, no battery ELECTRIC LIGHT SOCKET RADIO RECEIVER (not an attachment), universal for D. C. or A.C. (100-115 v. 40-60 cycle,) three now sold and demonstrated by THE NEW YORK EDISON CO., public utility companies and radio, electric and music dealers everywhere. Absolutely dependable, fully guaranteed, powerful, practical, perfect in performance. Tested and indorsed by Popular Radio, Radio Broadcast, Radio News, all leading authorities and engineers of your local electric light company.



**Are You the Man Who Sees Opportunities Ahead for Real Money Making?
YOU, TOO, CAN MAKE POWEROLA**

Send \$1.00 for wiring diagrams showing parts used and how to make any set or circuit (1 to 8 tubes) operate satisfactorily without A, B or C batteries, from A. C. or D. C. This is the newest and greatest proposition in radio.

Write for literature, terms and prices at once

THE POWEROLA RADIO CORP., 1845 BROADWAY, NEW YORK CITY

★ Tested and approved by RADIO BROADCAST ★

AMPLION

Product of
38 Years'
Experience



For Better Radio Reproduction

"I have listened to many loud speakers, but never to any music which can compare with that reproduced by the Amplion. The sound is clear, sweet and well modulated. It brings in clearly instruments in bands and orchestras that were lost in other speakers. Through my Amplion I enjoy my radio to a degree I had never thought possible."

You will be as appreciative as this gentleman, once you hear your set through an Amplion. Creation of the originators and oldest makers of loud speaking devices—Alfred Graham & Co., London, England—The Amplion leads in popularity throughout the world.

Enjoy an Amplion demonstration at your dealer's. Six models, including phonograph units, equipped with cords and panel plugs, \$12 up. Write for the

★ "Amplion Pedigree."

**THE AMPLION CORPORATION
OF AMERICA**
Suite L, 280 Madison Ave., New York City
Chicago Branch: 27-29 N. Morgan St.
Burndept of Canada, Ltd., Toronto

WHAT OUR READERS WRITE

Naval Radio

PROFESSOR MORECROFT'S comments on the Naval Radio Service in the December RADIO BROADCAST created quite a considerable amount of interest. This especially interesting letter from a gentleman apparently in an excellent position to criticize, should be read in conjunction with Professor Morecroft's remarks elsewhere in this number.

Editor, RADIO BROADCAST,
Doubleday, Page & Company,
Garden City, New York.

SIR:
After a long month of waiting for your December issue to reach the Coast, I was successful in obtaining a copy today.

After reading Prof. J. H. Morecroft's article about the Naval Radio Service I decided that an answer to a few of his statements and questions was in order.

Just a year ago on the 22nd of this month, I was discharged from the Naval Radio Service. At the time of the *Honda* disaster I was on the U. S. S. *Sumner*, No. 333, 12th Squadron of the Pacific Destroyer Force. My log was used at the hearing which was held at North Island and I know it was through no fault of radio that the disaster occurred. If Mr. Morecroft had looked this matter up more carefully before his writing, he would not have made such a statement.

As for the California-Hawaii flight Mr. Morecroft states: "According to the planes commander, a perfect landing on the ocean was made and nothing happened to interfere with the radio apparatus performing as it was intended to do. Why didn't it perform?" The generators for the radio are wind driven therefore a plane must do her working before landing. Also the transmitting antenna is reeled in before landing. It is a known fact that these planes could not carry the extra weight necessary to transmit while on the water. Of course we all have some ideas of 'How it should have been done' but put yourself in their position and you will see it different. All possible space was needed for fuel, etc., and fuel is heavy—so are batteries, or other equipment necessary for transmission while a plane is down.

Very truly yours,
H. A. HALCOMB.
San Diego, California.

Standardization of Radio Parts

THE need for universal standardization of radio parts is still very general, but much progress in this matter has been made since the inception of broadcasting. The subject was revived in a recent letter to this office, and we would like the comment of our readers on this matter.

ASSOCIATED MANUFACTURERS OF ELECTRICAL SUPPLIES, CHICAGO, ILLINOIS

Editor, RADIO BROADCAST,
Doubleday, Page & Company,
Garden City, New York.

SIR:
Every one in the radio industry realizes that standardization of radio parts and sets is necessary to bring about a more stabilized condition. The A. M. E. S., which has brought about the



FREE!

12-Cell — 24-Volt Storage 'B' Battery

Positively given free with each purchase of a WORLD "A" Storage Battery. You must send this ad with your order. WORLD Batteries are famous for their guaranteed quality and service. Backed by years of successful manufacture and thousands of satisfied users. Equipped with Solid Rubber Case, an insurance against acid and leakage. You save 50 per cent and get a

★

2-Year Guaranteed

Bond in Writing WORLD Battery owners tell their friends. That's our best proof of performance. Send your order in today.

Solid Rubber Case Radio Batteries

6-Volt, 100-Amperes	\$11.25
6-Volt, 120-Amperes	13.25
6-Volt, 140-Amperes	14.00

Solid Rubber Case Auto Batteries

6-Volt, 11-Plate	\$11.25
6-Volt, 13-Plate	13.25
12-Volt, 7-Plate	16.00

Send No Money Just state battery wanted and we will ship day order is received, by Express C. O. D. subject to your examination on arrival. **FREE "B" Battery** included. **Extra Offer:** 5 per cent discount for cash in full with order. Buy now and get a guaranteed battery at 50 per cent saving to you.

WORLD BATTERY COMPANY
1219 So. Wabash Ave., Dept. 24 CHICAGO, ILL.

World

STORAGE BATTERIES

Set your Radio Dials at 210 meters for the new 100 watt World Storage Battery Station, WSBG, Chicago. Watch for announcements.

KDKA • WFAF • WGN • WJS • KHJ • KGO • KFAF • WJY • KOP

RADIO AGENTS WANTED

You Can Now Earn a
5 Tube Demonstrator FREE!



In addition to \$25 to \$100 a week, part or full time. Everyone a prospect. Complete line standard sets and accessories, \$5 to \$90. Write today for illustrated catalog and exclusive selling plan for live dealers and community agents. 20TH CENTURY RADIO CO., 1045 Coca Cola Bldg., Kansas City, Mo.

Wonderful Volume with Clearness AMPL-TONE



\$3.00 ★

Phonograph makers have spent years perfecting the acoustic properties of their phonographs. Use an AMPL-TONE Unit and make a real Loud Speaker in an instant or use it in your horn and get better results.

After all, speakers are as good as their unit. We make a real unit at a real price. Money gladly returned if you are not entirely satisfied.

The UNION FABRIC CO.
DERBY, CONN.

Makers of the Excellent French AMPL-TONE Headset

Please send me an AMPL-TONE Unit for which I enclose \$3.00.

Name.....

Address.....

State.....

Laboratory Product



CRESCENT LAVITE RESISTANCES

for Distortionless Amplification.

Used in 50 big broadcasting stations. 12,000, 48,000, 50,000 and 100,000 ohms. For distortionless amplification. Order a Crescent today at \$1.50. Special sizes made to order. Discounts to dealers.

Crescent Radio Supply Co. 11-3 Liberty St., Jamaica, N. Y.

RADIO RENCH

Five strong little wrenches and a handy screw driver fitting every nut and bolt on your radio. All held together by a patented device so none will be lost, but easily directed for use.



15¢

Niagara Metal Stamping Corp
Dept. 502, Niagara Falls, N. Y.

Folder Free

PREMAX

THE ARISTOCRAT

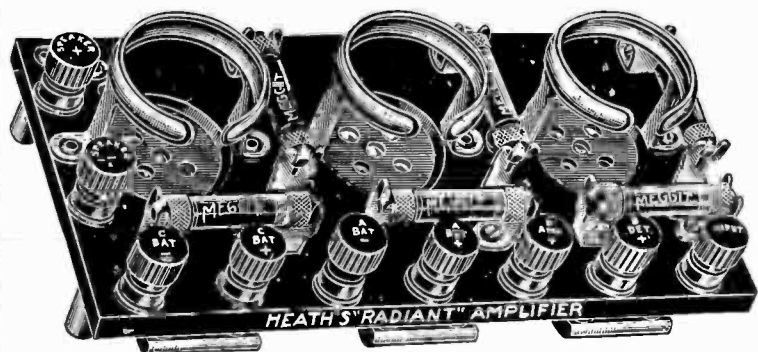

HEATH RESISTANCE COUPLED AMPLIFIER

Used in Radio Broadcast's Latest Set

Resistance Coupled Amplification has improved radio reception and simplified set construction. For these reasons Radio Broadcast used resistance coupling in the design of their new Aristocrat Receiver. In this wonder set Radio Broadcast recommends the use of Heath's 3-Stage Resistance Coupled Amplifier. The well known quality and performance of Heath's compact, 3-stage unit makes it particularly suitable for any set where full volume and unusual quality are desired.

Write for Literature



Heath Radio and Electric Mfg. Co.

206-210 First Street

Newark, N. J.

BUS BAR WIRE

Use **COOK'S**

We make a superior wire of pure copper



Every piece of Cook Bus Bar Wire is now plainly stamped "COOK'S"—your protection against substitutes.

It is finished square or round, properly tinned and correctly tempered for radio use.

Furnished in standard lengths of 2 feet.

EDWARD N. COOK PLATE CO.

70 Ship Street

Providence, R. I.

Representatives

A. ALLEN SMITH
304 E. Fourth St., Los Angeles, Cal.

MR. W. I. OTIS
Rialto Building, San Francisco, Cal.

WOOD & LANE CO.
915 Olive Street, St. Louis, Mo.

HARRY J. CAFFREY
51 East 42nd St., New York, N. Y.

Complete list of GUARANTEED PARTS FOR Silver - Marshall Model 1926

"MODERN BROADCAST 6-TUBE RECEIVER"

When building this receiver be sure you use only the parts specified and you will have the satisfaction of possessing the finest receiver yet developed.

- 3—S-M 311 .00035 S. L. F. Condensers
- 3—4 in. Kurz Krasch Moulded Dials
- 3—S-M 515 Coil Sockets
- 2—S-M 112A Inductances
- 1—S-M 110A Inductance
- 6—S-M 510 Sockets
- 2—Carter 6-ohm imp. Rheostats
- 1—Central Laboratory 500,000 ohm Modulator
- 3—Daven Resistance couplers complete
- 1—Carter 101 Jack
- 1—Carter 102A Jack
- 1—Carter On-off Switch
- 1—.002 M. F. Condenser
- 2—Dubilier .5 M. F. By-pass Condensers
- 1—7 x 24 Drilled, Sanded and Engraved Bakelite Panel
- 1—7 x 23 Oak Base Board, Bus-bar, Screws, Lugs, etc.
- 1—Belden 5-lead color cable

Complete Parts **\$49.50**
as Specified, Only . .
Wired and Ready to Use \$8. Extra

EXTRAS

Daven MU-20 Tubes	\$ 4.00
Daven MU-6 Power Tube	5.00
Western Electric 540-A.W. Cone Speaker	27.50

All parts carried for Every SILVER-MARSHALL CIRCUIT

WE ALSO CARRY ALL THE PARTS FOR THE

HAMMARLUND ROBERTS-RECEIVER

Endorsed by Ten Leading Radio Engineers

Engineers of the leading manufacturers who make these parts endorse the operation of the Hammarlund-Roberts Receiver only when it is constructed with these specified units which the designers have found to coordinate most efficiently with one another.

Order from this list and we guarantee you prompt delivery.

Unit No. 1.	2 Rauland-Lyric Transformers at \$9.00	\$18.00
Unit No. 3.	2 Hammarlund .0005 mfd. Model "C" or S. L. F. Condensers at 5.00	10.00
Unit No. 2.	1 Hammarlund "Midget" Condenser 5 plate, 16 mmfd. at 1.80	1.80
Unit No. 4.	1 Set Hammarlund-Roberts Coils at 7.50	7.50
Unit No. 5.	2 Na-ald "Super DeLuxe" 4 in. Bakelite at .75	1.50
Unit No. 6.	5 Na-ald "DeLuxe" Sockets at .75	3.75
Unit No. 7.	1 Na-ald K3844—1 3/4 in. Dial at .20	.20
Unit No. 10.	1 Carter 25-ohm "Imp" Rheostat at 1.00	1.00
Unit No. 11.	1 Carter Single Circuit No. 101 "Hold-Tite" Jack at .70	.70
Unit No. 12.	1 Carter "Imp" Battery Switch at .65	.65
Unit No. 16.	1 Durham Metallized Resistor at .40	.40
Unit No. 8.	4 Amperites No. 1-A at 1.10	4.40
Unit No. 13.	1 Dubilier Type 640-G .00025 mfd. Grid Condenser at .50	.50
Unit No. 14.	1 Dubilier Type 640 .002 mfd. Fixed Condenser at .45	.45
Unit No. 15.	1 Dubilier Type 640 .006 mfd. Fixed Condenser at .80	.80
Unit No. 9.	5 Prs. Union Phone Tip Jacks, per pair at .25	1.25
Unit No. 17.	1 Hammarlund-Roberts Foundation Unit (contains engraved bakelite-Westinghouse Micarta panel, drilled bakelite sub-panel metal brackets and wire at 7.90	7.90

Complete Parts as specified **\$57.50**
Hammarlund De Luxe Cabinet \$12.
Wired and Ready to Use \$10. Extra

General Radio UNIVERSAL RECEIVER

This is the simplified 4-tube circuit described in detail in the January issue of this magazine. Diagrams and complete instructions furnished with each complete set of parts.

Complete Parts **\$38.50**

Mail orders shipped same day received

HEINS & BOLET
46 PARK PLACE. NEW YORK

**for
radio
aerials
—COPPER
wire**

COPPER combines
the essential
qualities of—

**resistance to cor-
rosion,
tensile strength,
high conductivity.**



**COPPER & BRASS
RESEARCH ASSOCIATION**

25 Broadway, New York

Order your copy of *Radio Broadcast* from your news dealer or radio store. Make sure that he reserves a copy for you each month. If your favorite radio store does not stock the magazine write us giving name of radio dealer and address.

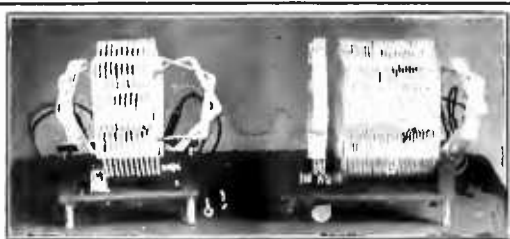

LOW LOSS

Tuners and Coils for all circuits

3 Circuit Amateur and Broadcast tuners\$7.00
Radio Frequency Transformers (each).....\$2.00
Coils to order. Write for literature.

Davenport Radio Laboratories ★
1711 W. Locust Street Davenport, Iowa

standards in the electric light and power field, have created a Radio Section to standardize radio sets and parts.

The Radio Section so far has made wonderful progress in radio standards, but before going further, it is considered advisable to get as much information as possible as to what should be standardized. Some of the things we have in mind that should be standardized at once are as follows:

1. Should Rheostats, Condensers, etc., be of the one-hole mounting type, or mounted by means of screws?

2. Should Dials and Condensers be so designed that when the dial is turned to the right the numbers on the dial increase, or should the numbers increase when the dial is turned to the left?

It seems to us that inasmuch as rheostats turn from left to right, that the other controls should turn in the same direction. There are many sets and condensers on the market on which the dials turn from right to left. It would seem that if this could be standardized it would be a step in the right direction.

3. Should all Dials and Knobs have the same size Holes, and if so, what size do you recommend?

4. How far should Condenser Shafts project through the panel?

There seems to be no standard length of condenser shaft, which results in much annoyance, due to the fact that dials do not fit properly.

The Radio Section has already standardized such items as Cords, Cord-tips, Plugs, Jacks, Rheostat Shafts, Standard Color Code for wiring sets, etc.

What other specifications, in your opinion, should be standardized?

Your recommendations will be beneficial and we will greatly appreciate any assistance or suggestions you care to give.

Very truly yours,
A. J. CARTER.

Chairman, Parts Committee Radio Section.

A Letter from Chicago's "Miss Radio"

BEFORE the commencement of the recently concluded International Tests, RADIO BROADCAST appointed listening posts all over the country so that the fullest possible data could be collected on this subject after the Tests were completed. One of our letters was sent to Chicago's "Miss Radio," and here is her reply.

Editor, RADIO BROADCAST,
Doubleday, Page & Company,
Garden City, New York.

Sir:

I would like very much to be appointed as an official listening post for the International Radio Broadcast Tests. I have a certificate of reception awarded to me last year for the successful reception of programs as broadcast from 2 LO and FPTT, Paris.

I am using an Atwater Kent-10, an Atwater Kent-20, and an Apex Super-Five. I have three different antennas; (1) 140 feet long, south to north; (2) 100 feet long, east to west; (3) 50 feet long, north to south. I have logged 264 different broadcasting stations, and am still going strong. The Atwater Kent-10 was my first set, and was bought in March, 1924.

I was awarded second prize in the "Radio Diana" contest conducted by the Radio World's Fair in New York City, and was awarded first prize in the "Miss Radio" contest at the Chicago Radio Show. I hope to have a five-watt short-wave transmitter going soon.

Very truly yours,
FLOSSIE E. ERICKSON,
Bloomington, Illinois.

NEW MODEL "T" CABINET

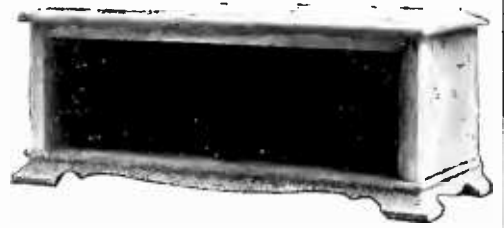

Sizes in stock. Have piano hinge, and are full 8" and 10" deep inside.

Size	Mahogany Finish	Mahogany or Walnut	Size	Mahogany Finish	Mahogany or Walnut
7x18-8	\$8.55	\$9.50	7x13-10	\$10.20	\$11.55
7x21-8	9.30	11.50	7x21-10	10.90	13.25
7x24-8	10.10	12.60	7x24-10	11.70	14.65
7x26-8	10.70	13.35	7x26-10	12.65	15.80
7x28-8	11.80	14.70	7x28-10	13.00	16.20
7x30-8	12.75	15.85	7x30-10	13.30	16.65

HAMMARLUND ROBERTS CABINET

With piano hinge, sloping panel, and fancy line grooves.
Mahogany or Walnut.....\$14.00
Mahogany Finish..... 11.50

BROADCAST UNIVERSAL AND ARISTOCRAT CABINETS

Model T design, with slots and drilling to specifications
Mahogany or Walnut.....\$11.00
Mahogany Finish..... 9.00

Shipping charges prepaid

"CORBETT'S CABINETS" have been preferred for several years by quality set builders and are unquestionably superior in design and finish. They are backed by our guarantee to please you. Carefully hand-rubbed piano finish. Well packed for shipment.

WRITE FOR CATALOG showing attractive models for all sizes of radio cabinets, consoles and tables.

Jobbers and Dealers write for discounts. ★

CORBETT CABINET MFG. COMPANY
St. Marys Pennsylvania



**NO MORE LOOSE CONNECTIONS
X-L PUSH POST**

A Binding Post that really does excel, looks, action, service and convenience. Push it down—insert wire—cannot jar loose from vibration. No screwing or danger of shearing off wires. Furnished attractively plated with soldering lug and necessary markings.

Price Each, 15 Cents

X-L RADIO LABORATORIES
2424 Lincoln Ave. CHICAGO

Why not subscribe to *Radio Broadcast*? By the year only \$4.00; or two years, \$6.00, saving \$2.40. Send direct to Doubleday, Page & Company, Garden City, New York.

FOR CLEAR, QUIET "B" POWER



RADIO Storage "B" Battery

12 Cells 24 Volts Lasts Indefinitely—Pays for Itself
Economy and performance unheard of before. Recharged at a negligible cost. Delivers unflinching power that is clear, pure and quiet. Approved and listed as Standard by leading Radio Authorities, including Pop. Radio Laboratories, Pop. Sci. Inst., Standards, Radio News Lab., Lafax, Inc., and other important institutions. Equipped with heavy glass jars. Heavy rugged plates. Order yours today!
SEND NO MONEY Just state number of batteries wanted and we will ship day order is received. Extra offer: 4 batteries in series (96 volts), \$10.00. Pay exp. even after examining batteries. 5 per cent discount for cash with order. Mail your order now!

WORLD BATTERY COMPANY
1219 So. Wabash Ave., Dept. 78 Chicago, Ill.
Makers of the Famous World Radio "A" Storage Battery
Prices: 6-volt, 100 Amp. \$11.25; 120 Amp. \$15.25; 160 Amp. \$16.00.
All equipped with Solid Rubber Case.

World STORAGE BATTERIES
Set your Radio Dials at 210 meters for the new 1000 watt World Storage Battery Station, WSBG, Chicago. Watch for announcements.
WOKA WFAF WGN WJS KRJ KGO KFAT WVAZ

MYERS TUBES



Get Out of the Fog

Myers Tubes make an instantaneous improvement in the clarity, volume, distance and quality of reception from any Radio Set.

The Tube is the Voice of the Circuit

MYERS Tubes are real Radio Tubes—not modified incandescent lamps. They are made by pioneer Radio Tube designers, for Radio purposes exclusively. Compact, precisely correct, free from dead spaces and clumsy dimensions. Finest performance, finest appearance.

Special internal geometry gives highest mutual conductance and largest factor of amplification, resulting in maximum performance when used in either transformer, impedance or resistance coupled circuits.

Unbreakable in normal use, Double-end electrode supports. Absolutely non-microphonic. Perfectly uniform. No matching necessary.

Marvelous Clarity

Internationally preferred by amateurs and experts. Made with standard four prong base, or double-end, in Types Myers 01A, Myers 01X, Myers 99, Myers 99X.

List price, any type \$2.50.

Fully protected by patents pending and issued in the United States and Foreign Countries.

At Your Dealers

Myers Radio Tube Corporation
Cleveland, Ohio



RADIO FANS, a one-year's subscription to Radio Broadcast will cost you four dollars, two years six dollars. Consider this expenditure as being a necessary investment on your part for the future development of your own knowledge of Radio.

RADIO CATALOG

DEALERS!

Send for our big new live Catalog. Contains hundreds of standard nationally advertised sets, kits and parts. Use your letterhead

Western Radio Co.
134-136 W. Lake St. Chicago, Ill.

New! Tone and Volume Control

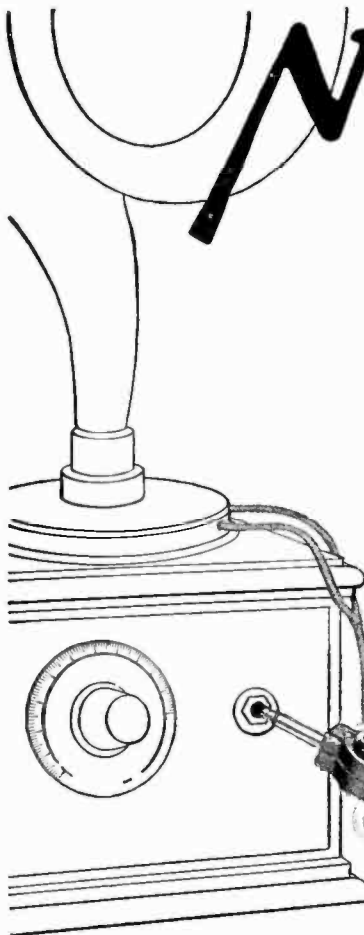

The new **CENTRALAB MODULATOR PLUG** gives any degree of tone volume from a whisper to maximum, by the simple turn of a knob. Great for smoothing out powerful local stations, and for lessening static interference.

Centralab Modulator Plug can be attached in a moment. No tools necessary. It replaces your present phone plug.

Retails at \$2.50 at your dealer's, or direct from us

Central Radio Laboratories

22 Keefe Ave.

Milwaukee, Wis.



A Two Year Subscription Saves You Two Dollars

It saves you the bother of renewing next year.

It is the most economical way to subscribe. You simply write six dollars instead of four when sending your check or money order. Try it for two years. Form the habit!

RADIO BROADCAST

Garden City, N. Y.

ALL STATIONS EVENLY DISTRIBUTED OVER ENTIRE SCALE

**N
O
W**

Complete Separation of Low Wave Stations

Perfectly accomplished with Tune-Rite, the straight line frequency dial. A marvel in scientific construction, it instantly converts any set to straight line frequency. Bring your present set up-to-date by replacing your old dials with Tune-Rite. Beautiful in appearance. Easily mounted without drilling.

Price, \$3.50

Write for instructions

Radiall Company
Dept. T.R.B.-2, 50 Franklin St., N.Y.

TUNE-RITE
The Straight Line Frequency Dial
Made by the makers of Amperite, the Self-Adjusting Rheostat

Today - in every good set!

A turn of the Tuning Dial—that's all!

And presto! The AMPERITE self-adjusting rheostat control does the rest. Tones so clear, voices so distinct, volume so good, you simply are amazed. Tubes deliver as never before when under these seemingly magical influence of AMPERITE individual control. No guessing. Less wiring. Permits of any type or combination of tubes. Specified in all popular construction sets. Price, \$1.10.

There is an AMPERITE for every tube

Write for free hook-ups

Radiall Company
Dept. R.B.-3, 50 Franklin St., N. Y. City

AMPERITE
REG. U.S. PAT. OFF.
The "SELF-ADJUSTING" Rheostat

★ Tested and approved by RADIO BROADCAST ★

The MOLLIFORMER "B" UNIT REPLACES "B" BATTERIES

Now In Its Second Successful Year
No Hum—No Acids—No Tubes

MODEL F W 4

This is the completely assembled MOLLIFORMER "B" UNIT designed especially for 5 or 6 tube receivers requiring no more than 100 volts on the amplifiers. The MOLLIFORMER employs improved electrolytic full wave rectifier. Low in cost and exceptionally low in operation.

PRICE

MODEL F W 4. Completely assembled. \$24.50

BUILD IT YOURSELF

You can build your own MOLLIFORMER "B" Unit in less than an hour and save money. The Kits listed below include all the essential parts necessary to assemble the unit complete.

Complete Kit Model F W 4—60 cycle A-C. \$17.00

Complete Kit Model F W 8—60 cycle A-C. 22.50

25 and 40 cycle transformers \$2.00 additional

Kits include Rectifiers

Parts sold separately if desired

DEALERS—write for discounts ★

C. E. JACOBS, Sole Mfr.
2804 N. Kedzie Ave. Chicago



ALMOST TOO GOOD TO BE TRUE X-L VARIO DENSERS

INSTALL THEM IN YOUR SET AND LEAVE THEM SPEAK FOR THEMSELVES

Endorsed and Used by the Foremost Radio Engineers

MODEL N—Capacity range 1.8 to 20 micro-microfarads, for balance in Roberts two tube, Browning-Drake, McMurdo Silver's 1-tube set, Neutrodyne and tuned radio frequency circuits. Price, \$1.00

MODEL G—For the Cockaday circuit, filter and intermediate frequency tuning in super-heterodyne and positive grid bias in all sets.

G-1—.00002 to .0001 Mf. G-10—.0003 to .001 Mf. G-5—.0001 to .0005 Mf.

Price each with Grid Leak Clips \$1.50

X-L RADIO LABORATORIES 2424 Lincoln Avenue, CHICAGO

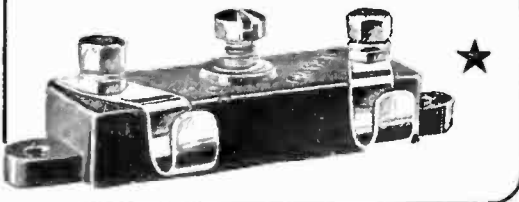

KORACH

Tuned Loop
Multiple Switch
Board Tuner
Directional
Base Compass for
Logging
Collapsible

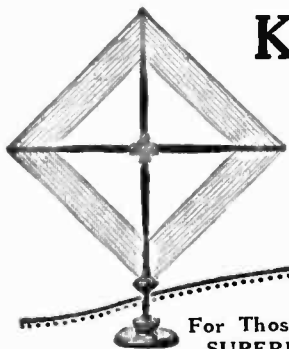

For Those Who Demand
SUPERIOR RESULTS

Leads the march towards perfect radio reception under all conditions. Not merely a "loop" but an ingenious arrangement of mechanical skill designed for superior results. L. M. Cockaday, using this loop, reached out across the Atlantic to audibly hear many trans-continental stations. Selectivity Plus Distance

unheard of with common loop aorials. The Korach excels on all sets designed for loop reception. Priced at \$12.50, and for sale by all good dealers. Full particulars sent for 2c stamp and name of local dealer.

KORACH RADIO CO.
20 E. Jackson Blvd., Dept. 8, Chicago, Ill.
Dealers and Jobbers: Write today for attractive proposition.

The Korach Junior
A modification of
the "Senior" but possess-
ing all its important features—\$10.00.

"Using the Radio Broadcast Aristocrat I successfully tuned in, on Sunday night, Jan. 24th, to the program being broadcast from station 6BM, Bournemouth, England."

THIS IS the gist of a report received at the offices of RADIO BROADCAST from Mr. H. L. Palmer of Rockville Centre, New York.

The Roberts type of receivers, of which the Aristocrat is the latest and most modern development, have consistently figured in the reception of long distance programs. Last year the Roberts Knockout Reflex did the trick and now it is the Aristocrat that comes to the fore as a receiver of merit and accomplishment.

RADIO BROADCAST's specially prepared blue-prints show you how to build two types of the Aristocrat Receiver.

A stage of tuned neutralized radio frequency amplification, a regenerative detector and three stages of resistance coupled audio amplification insure sensitivity, selectivity and excellent tone quality and volume.

One dollar, sent to RADIO BROADCAST's Book Department brings these full-sized blue-prints with instruction book direct to you.

Write to RADIO BROADCAST's Book Department, Doubleday, Page & Company, Garden City, N. Y.

RADIO BROADCAST,
Garden City, N. Y.

Enclosed find one dollar for which send me Radio Broadcast Aristocrat Blue-Prints.

R. B. M.

★ Tested and approved by RADIO BROADCAST ★



**A New and Finer
Quality of Reception**

**Raytheon
Tube B-Eliminator**

using



B-Power Units



TRANSFORMERS
509 Full Wave
\$7.00 List
Also—Transformers and Chokes for R. C. A. and Cunningham Tubes.



CHOKES
514 20 henry
\$5.00 List
Raytheon Tubes
\$6.00 List

Thousands of fans who have built their own B-Eliminators, using Raytheon tubes and Dongan Transformers and Chokes, have found an almost unbelievable improvement in reception. Smooth, uninterrupted plate supply perfects the quality of all signals and greatly clears up and gives added strength to D X work—the ideal equipment for the International Tests.

Dongan B-Power Units are essential parts to the construction of this remarkable new Eliminator. Complete instructions make it easy to build your own. Tubes and Dongan parts at most good dealers. For interesting details write for information at once.

Manufacturers

For B-Eliminator and Receiving Set manufacturers, Dongan offers a complete line of B-Power Units, Audio Transformers, A. C. Tube Step-Down Transformers and Voltmeters. Information or engineering cooperation at your request.

★ Check or money orders filled at once—build your own and enjoy consistent, quiet and economical radio.

Dongan Electric Manufacturing Co.
2991-3001 Franklin Street Detroit, Mich.



FROST-FONES **Highly Sensitive to Weak Signals**

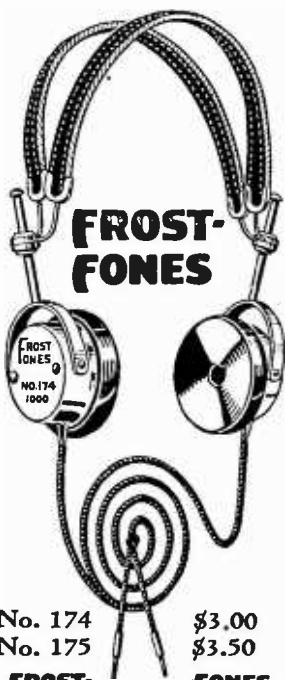

To get any real enjoyment out of DX work you must use a good pair of head fones, which are designed specifically to pick up weak signals. Due to our extreme care in winding coils, lapping shells, grinding magnets and testing and measuring **FROST-FONES** they are about twice as sensitive to weak signals as most other head fones. We could not be more particular about **FROST-FONE** quality if we built them to sell for ten dollars. Our huge production insures low prices and our rigid inspection guarantees high quality. Your dealer right in your neighborhood stocks **FROST-FONES**. Order from him today.

No. 174 \$3.00
No. 175 \$3.50
FROST-FONES

HERBERT H. FROST, Inc.
314 West Superior Street Chicago, Illinois
NEW YORK KANSAS CITY LOS ANGELES
Export Office: 314 West Superior Street, Chicago

LEARN THE CODE AT HOME with the OMNIGRAPH

"Just Listen—The Omnigraph will do the teaching"



THE OMNIGRAPH Automatic Transmitter will teach you both the Wireless and Morse Codes—right in your own home—quickly, easily and inexpensively. Connected with Buzzer, Buzzer and Phone or to Sounder, it will send you unlimited messages, at any speed, from 5 to 50 words a minute.

THE OMNIGRAPH is not an experiment. For more than 15 years, it has been sold all over the world with a money back guarantee. The OMNIGRAPH is used by several Depts. of the U. S. Govt.—in fact the Dept. of Commerce uses the OMNIGRAPH to test all applicants applying for a Radio license. The OMNIGRAPH has been successfully adopted by the leading Universities, Colleges and Radio Schools.

Send for FREE Catalogue describing three models. DO IT TO-DAY.

THE OMNIGRAPH MFG. CO., 13K Hudson St., New York City
If you own a Radio Phone set and don't know the code—you are missing most of the fun

RADIO PANELS

OF GENUINE BAKELITE

Cut, drilled and engraved to order. Send rough sketch for estimate. Our New Catalog on Panels, Tubes and Rods—all of genuine Bakelite—mailed on request.

STARRETT MFG. CO. ★
521 S. Green Street Chicago, Ill.

Thorola Receivers and Speakers ★
Must Outperform

Reichmann Company, 1752-39 W. 74th St., Chicago



Short Leads Made Possible!

SHORT LEADS—which improve so much the efficiency of any set—are made possible through the use of sub-panels mounted on

GARFIELD NON-METALLIC BRACKETS

They offer to the radio builder brackets without any of the disadvantages of metal construction but with all of its strength. Made of RADION—the supreme insulation—wires can touch, run through or near them without danger of short circuits and without creating distributed capacities. Tested for structural strength under a pressure of 2000 lbs. Condensers and coils retain original, designed values in the field and S. L. F. Condensers remain straight line frequency. They will also greatly improve the appearance of your set.

\$1.25 a pair at your dealer's—or we will send them direct

★ **GARFIELD RADIO MFG. CORP.**
64 Vesey Street, Dept. A, New York

Send for Latest RADIO CATALOG and GUIDE



Sets—Parts—Kits
Radio's Newest
You need this big FREE book. A practical guide to success in set building. Gives advanced hook-ups. Shows all newest parts and kits, built up sets ready for use, battery eliminators, radio's newest creations. Write for Copy Free, also send name of radio fan. Send to-day.
BARAWIK CO.
102-109 S. Canal St., Chicago

INDEX TO ADVERTISERS

IN THIS ISSUE

A

Acme Electric & Mfg. Co., The536
Acme Wire Co., The612
Airgap Radio Products Co.536
Alden Mfg. Co.598
All-American Radio Corp.599
Allen-Bradley 3rd cover
American Electric Co.616
American Hard Rubber Co., The602
American Mech. Lab.608-615
American Transformer Co.604
Amplion Corp.618
Amsco Products Co.610

B

Bakelite Corp.530
Barawik Co., The606-623
Belden Mfg. Co.529
Blackburn Specialty Co.617
Buescher Band Inst. Co.611
Burgess Battery Co.594
Burton-Rogers Co.611-617

C

C. E. Mfg. Co.608
Cable Supply Co., Inc.537-544
Cardwell, Allen D.605
Central Radio Lab.621
Chelsea Radio Co.613
Chicago Battery Co.544D
Chicago Solder Co.537
Como Apparatus Co.617
Cook Plate Co., Edward N.619
Copper & Brass Research Ass'n.620
Corbett Cabinet Mfg. Co.620
Crescent Radio Supply Co.618
Crosley Radio Corp.593
Cunningham Co., E. T.2nd cover

D

Daven Radio Corp.534
Davenport Radio Lab.620
Deutschmann Co., Tobe617
Dongan Electric Mfg. Co.623
Dubilier Con. & Radio Corp.532

E

Eastern Coil Co.536
Eby Mfg. Co., H. H.613

F

Fansteel Products Co.595
Ferguson, Inc., J. B.531
Frost Co., Herbert E.623

G

Garfield Radio Corp.623
Gearhart-Schlueter613
General Instrument Co.544B
General Radio Co.542-543
Goodrich Co., B. F.615

H

Hammerlund Mfg. Co.4th cover
Heath Radio & Elec. Mfg. Co.619
Heins & Bolet619
Hommel Co., Ludwig612

I

Insulating Co. of America541
International Corres. School611

J

Jacobs, C. E.622
Jewell Electrical Inst. Co.536

K

Korach Radio Co.622

L

Lynn Radio Co.544

M

Machine Specialty Co.606
Martin-Copeland Co.544D
Micamold Radio Corp.536
Midwest Radio Corp.617
Myers Radio Tube Corp.621
McCullough Sales Co.544C

N

National Carbon Co.597
National Co.601
National Radio Inst.609
Niagara Metal Stamp Corp.618
Norden-Hauck616

O

O'Connor Co., A.610
Omnigraph Co., The623

P

Pep Mfg. Co.611
Powerola Radio Co., The617
Powertone Radio Co.614

R

Radiall Co.621
Radio Center, Inc.544A
Radio Corp. of America539
Radio Dealer540
Radio Inst. of America600
Reichmann Co.623
Ross Wire Co.614

S

S-C Merchandising Committee, The...607
Sangamo Electric Co.615
Scientific Radio Lab.544B
Sickless Co., The F. W.603
Silver-Marshall535
Smith, B. H.537
Starrett Mfg. Co.623

T

Taylor Instrument Co.544
Thompson Levering Co.544B
Thordarson Elcet. Mfg. Co.533
Twentieth Century Radio Co.618

U

Union Fabric Co., The618

V

Viking Tool & Machine Co.596

W

Western Radio Mfg. Co.621
Westinghouse Electric & Mfg. Co....545
Wholesale Radio Service Co.544D
World Battery Co.618-620

X

X-L Radio Laboratories620-622

Make Your Radio Set More Efficient With Allen-Bradley Radio Devices

IT matters not whether you are building a receiver or own a factory-built set, in either case you can make your set more efficient by using Allen-Bradley Radio Devices in many parts of the receiver. In addition to the various devices for filament control, grid leak and potentiometer control, there also are the Bradley-switch and the Bradleyner which are easily installed. The one-hole mounting makes installation quick and easy.

TO bring your set up-to-date, replace your old condensers with Bradleydensers and thereby enjoy the selectivity of straight-line-frequency tuning. The condenser is extremely compact and will not interfere with any other parts on your panel. Don't forget the Bradley-Amplifier for perfect audio amplification. This efficient amplifier is a complete unit ready for immediate use in your set. Try Allen-Bradley Devices tonight and hear the difference!

*Insist on Allen-Bradley Products
Sold In Distinctive Checkered Cartons*



Bradleystat
PERFECT FILAMENT CONTROL



Bradleyleak
THE PERFECT GRID LEAK

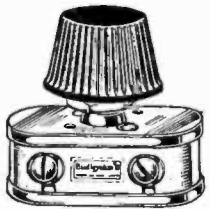

Bradleyohn
PERFECT VARIABLE RESISTOR

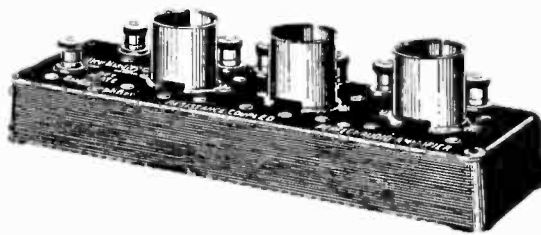

Bradley-Amplifier
Resistance-Coupled
PERFECT AUDIO AMPLIFIER

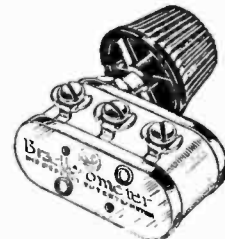

Bradleyometer
THE PERFECT POTENTIOMETER



Bradleyswitch
PERFECT BATTERY SWITCH



Bradleyunit
Amplifier Resistors

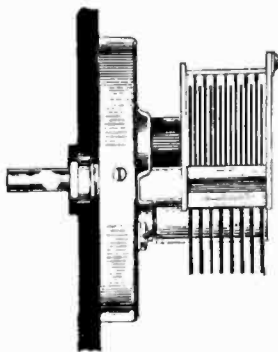

Bradleydenser
PERFECT S.L.F. CONDENSER



Bradleyunit
PERFECT FIXED RESISTOR

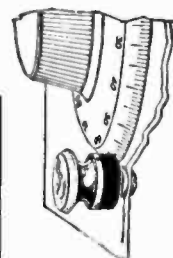

Bradleyner
PERFECT VERNIER KNOB



Allen-Bradley Company,
278 Greenfield Ave., Milwaukee, Wis.

Please send me, immediately, your latest literature describing the entire Allen-Bradley line.

Name.....

Address.....

.....

★ Tested and approved by RADIO BROADCAST ★

HAMMARLUND

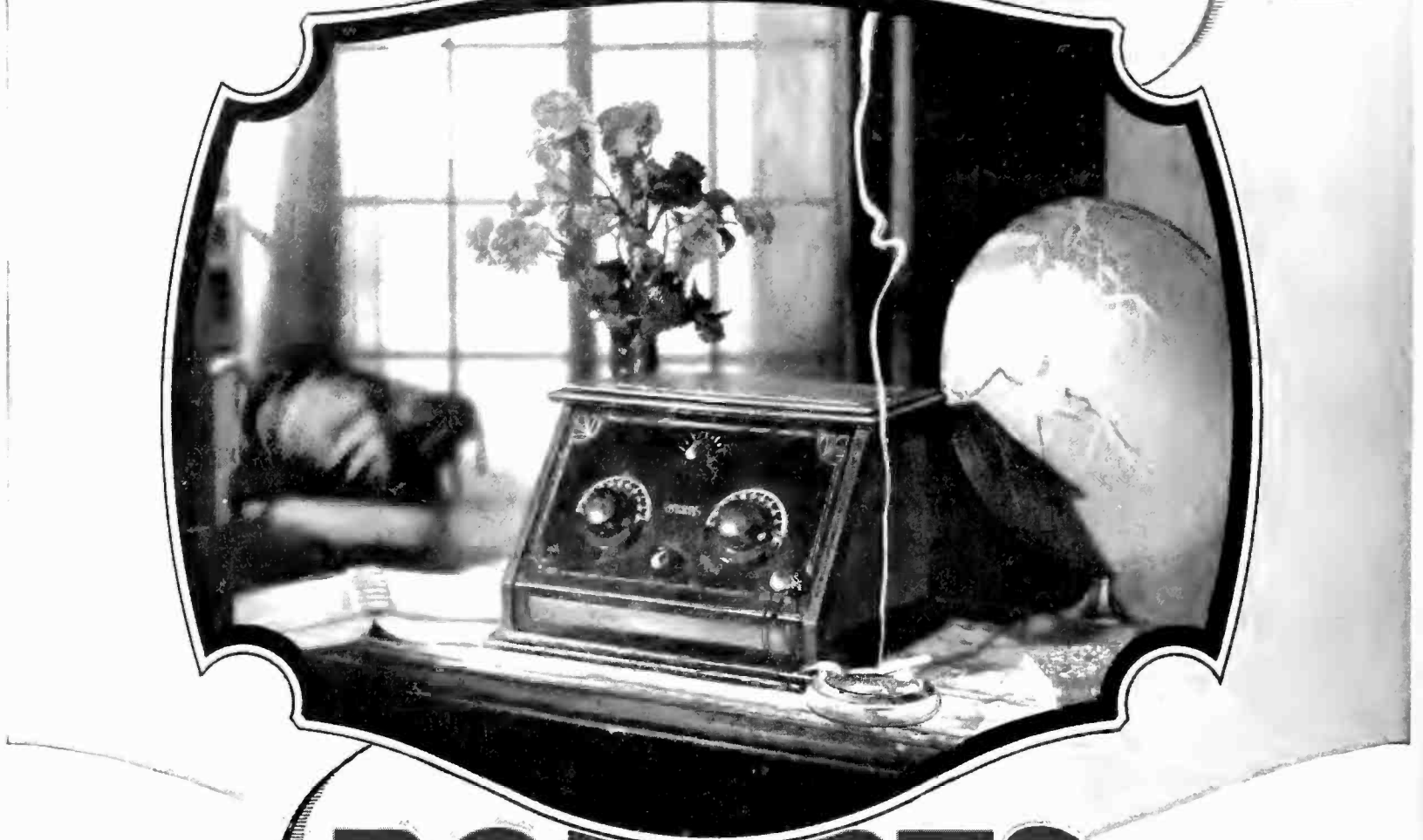

ROBERTS

As long as human ingenuity progresses, there will never be an "ultimate" radio receiver. But of one thing you may be sure—that for a long time to come, there will not be evolved a more efficient circuit arrangement than is employed in the new Hammarlund-Roberts Receiver.

Ten leading radio engineers, each an expert in the design of some particular unit, devised the Hammarlund-Roberts Receiver as their composite ideal. The result of this co-ordination of ideas is a receiver which, although operating on only five tubes, possesses the sensitivity of any standard eight-tube receiver, plus a high degree of selectivity which insures reception of distant signals without interference from strong local stations.

HAMMARLUND MFG. CO.

Tuning is simplicity itself. The volume and tone quality are exceptional, the receiver being designed to operate on the new cone type of speaker.

And best of all, without any previous experience, you can construct it yourself, from the finest parts known to radio, and with results worthy of any professional builder.

The cost, \$60.80 (cabinet extra) is only about one-third of the price of any factory-built receiver of equal quality.

Your dealer sells the famous Hammarlund parts pictured below, and can supply you with all the other parts specified in the "How to Build" book, which will be mailed to you on receipt of 25 cents.

424-438 W. 33rd St., NEW YORK

For Better Radio
Hammarlund
PRECISION
PRODUCTS

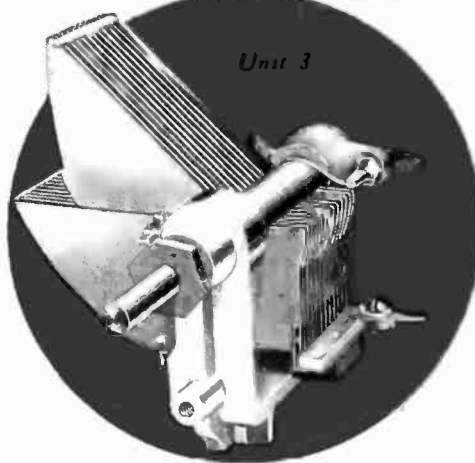

Unit 3

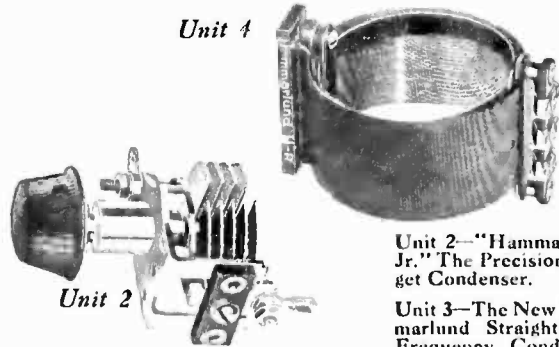

Unit 4

Unit 2

Unit 2—"Hammarlund, Jr." The Precision Mid-get Condenser.

Unit 3—The New Hammarlund Straight-Line Frequency Condenser.

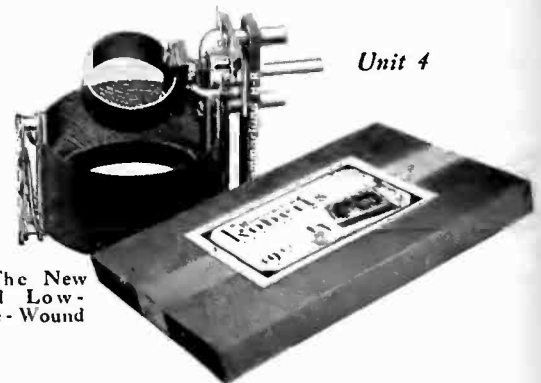

Unit 4

Unit 4—The New Hammarlund Low-Loss Space-Wound Coils.

Send 25 cents for illustrated book, giving complete instructions for assembling, wiring and operating the Hammarlund-Roberts Receiver.

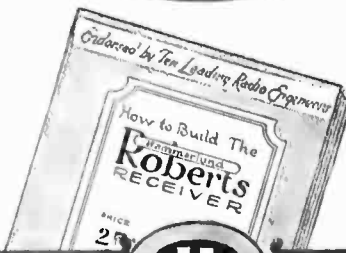

The Foundation Unit contains all special parts needed to build the Hammarlund-Roberts Receiver, including drilled and engraved panels, brackets, wire, screws, etc.



★ Tested and approved by RADIO BROADCAST ★