

MAY 1925

# RADIO BROADCAST

35 CENTS



**How to Build a Two-Stage Radio-Frequency Amplifier**

**THE MARCH OF RADIO**

**A New Method of Transmitting Pictures by Wire or Radio**

DOUBLEDAY, PAGE & COMPANY

GARDEN CITY, NEW YORK



## Two Strikes Three Balls!

The pitcher has completed that slow, leisurely, tantalizing wind-up. That long, lithe, million dollar arm has flashed back. A moment . . . and the ball, a white, hissing streak, is catapulting toward the catcher's waiting mitt. And the winning or losing of a World Series depends on whether or not the batter has his eye on the ball.

A Cunningham Tube always has its eye on the ball. It stands ready to transmute an electrical impulse, traveling at a speed which would make the speed of a baseball seem a snail's pace, into music, a President's message—what you will.

Since 1915---

*Standard for All Sets*

Types C-301A: C-299: C-300: C-11: C-12, In the orange and blue carton.

Price \$3.00 each



**Cunningham** ★  
**RADIO TUBES**

Home Office:  
182 Second St.,  
SAN FRANCISCO

*E. J. Cunningham Inc.*

NEW YORK  
CHICAGO

Patent Notice: Cunningham tubes are covered by patents dated 2-18-08, 2-18-12, 12-30-13, 10-23-17, 10-23-17 and others issued and pending.

★ Tested and approved by RADIO BROADCAST ★

EBL24040



*Specify  
Belden*

## Ask the Belden dealer about loops

Are you planning to make a loop for your radio receiver? Then go to the nearest Belden Radio Dealer and examine a spool of Belden Loop Wire. Notice its construction for efficiency. It is made of 60 strands of bare copper twisted with 5 strands of half hard phosphor bronze. The phosphor bronze wires provide strength and make Belden Loop Wire non-sagging and non-stretching. It is just the wire you need for folding loops. The insulation matches the loop frame in color. Get ready for summer radio by making your loop aerial, now! Send for our booklet, "Helpful Hints for Radio Fans." Use the coupon.



### *Belden Loop Wire*

It is merchandised on 100 ft. spools, packed five spools in one Belden orange-and-black striped carton. Leading dealers and jobbers carry Belden Radio Products.

★  
**Belden**

Manufacturing Company  
2312A So. Western Ave.  
CHICAGO, U. S. A.  
*Manufacturers of Electrical Wire  
Products Since 1902*

Belden Manufacturing Company,  
2312A So. Western Ave., Chicago

Please send me by return mail your booklet, "Helpful Hints for Radio Fans."

Name \_\_\_\_\_

Address \_\_\_\_\_

★ Tested and approved by RADIO BROADCAST ★

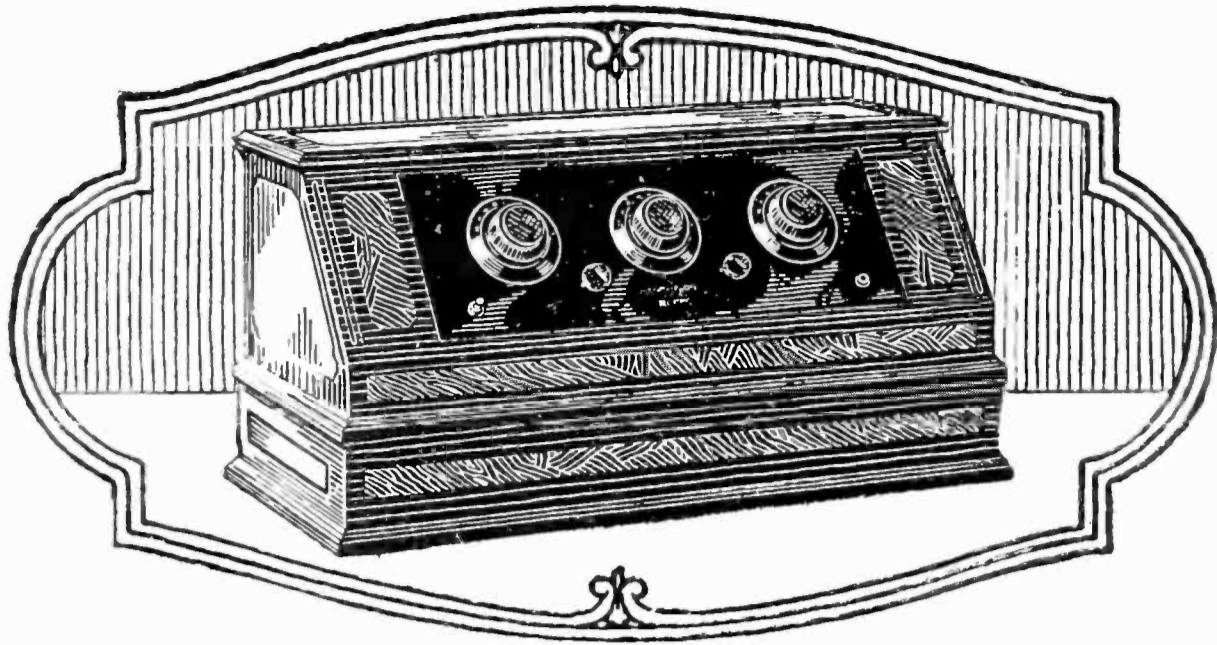

# *Distinguished for its Musical Excellence!*

Refinements had to come before radio could make its true appeal on the basis of musical excellence.

This was the view of the Thompson engineers, who, with fifteen years' experience in manufacturing wireless equipment to their credit, set their ample resources to the task of producing a radio receiver which should be not "just a radio," but a musical instrument.

On every hand the Thompson Neutrodyne is acknowledged as the maestro of radio, a truly fine musical instrument by every standard. The recognition accorded the Thompson is due to Thompson Tone.

Tone that is versatile in its handling of every sensitive shade of music. Tone that falls pleasantly upon the ear of the most orthodox music-lover. Tone that does not and cannot offend the sensibilities of the most critical listener. Thompson Tone!

## SIX TUBES GIVE DISTANCE WITH VOLUME

An unique transformer (an exclusive Thompson engineering feat) permits the use of six tubes in the Thompson Neutrodyne — an achievement heretofore confined to the experimental laboratory. Distant programs that come in faintly (if at all!) on ordinary receiving sets are delivered with the volume and brilliance of nearby broadcasts on the 6-tube Thompson.

## THREE SETS FROM WHICH TO CHOOSE

The 6-tube Thompson Concert Grand, illustrated above, retails at \$180. This is unquestionably the finest thing in radio today at any price. There is also the 5-tube Thompson Parlor Grand which retails at \$145. Thompson quality throughout, but with one tube less than the Concert Grand. Then there is the 5-tube Thompson Grandette which retails at \$125. This differs from the Parlor Grand chiefly in size and cabinet work.

R. E. Thompson Mfg. Co., 30 Church St., N. Y.

# THOMPSON RADIO ★

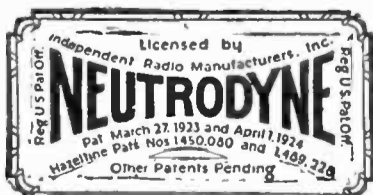

Prices slightly higher West  
of the Rocky Mountains

### *The Thompson Speaker*

The Thompson Speaker contains over-size magnet and coils, amplifying armature, diaphragm in scientific cone shape. The volume regulator enables adjustment for varying strength of near and far stations. Uses no battery current. For supremely natural home radio — The Thompson Speaker — Retail at \$28.



★ Tested and approved by RADIO BROADCAST ★

# Earn \$50 to \$200 a Week in RADIO

**You can! Hundreds of ambitious men are already earning thousands of dollars in this wonderful new industry—you, too, can get your share. Mail coupon below for Free Book which describes fully the amazing money making opportunities in Radio and tells how YOU can earn from \$5,000 to over \$10,000 a year.**

**T**HE astounding growth of Radio has created thousands of big money opportunities. Millions of dollars were spent during the past year on Radio, and thousands of young men are needed right now to meet the ever increasing demand of work.

Men are needed to build, sell, and install Radio sets—to design, test, repair—as Radio engineers and executives—as operators at land stations and on ships traveling the world over—as operators at the hundreds of broadcasting stations. And these are just a few of the wonderful opportunities.

## Easy to Learn Radio at Home in Spare Time

No matter if you know *nothing* about Radio now, you can quickly become a Radio Expert, by our marvelous new method of practical instruction—instruction which includes all the material for building the latest up-to-date Radio apparatus:

Scores of young men who have taken our course are already earning from \$75 to \$200 a week. Merle Wetzel of Chicago Heights, Ill., advanced from lineman to Radio Engineer, increasing his salary 100% *even while taking our course!* Emmett Welch, right after finishing his training started earning \$300 a month and expenses. Another graduate is now an operator of a broadcasting station-PWX of Havana, Cuba, and earns \$250 a month. Still another graduate, only 16 years is averaging \$70 a week in a Radio store.



The National Radio Institute is America's Pioneer Radio Home Study School—established in 1914. Our course is the absolutely complete one now being offered which qualifies for a government first class commercial license. It gets you the *bigger* paying jobs in Radio.

## Send for FREE BOOK

Learn more about this tremendous new field and its remarkable opportunities. Learn how you can quickly become a Radio Expert and make big money in Radio.

We have just prepared a new 32-page booklet which gives a thorough outline of the field of Radio—and describes our amazing practical training in detail. This Free Book, "Rich Rewards in Radio," will be sent to you without the slightest obligation. Mail coupon for it *now!*

For a short time we are offering a reduced rate to those who enroll at once. Act promptly and save money. National Radio Institute, Dept. 31GB, Washington, D. C.



## Wonderful Opportunities

Hardly a week goes by without our receiving urgent calls for our graduates. "We need the services of a competent Radio Engineer" — "We want men with executive ability in addition to Radio knowledge to become our local managers" — "We require the services of several resident demonstrators"—these are just a few small indications of the great variety of opportunities open to our graduates.

Take advantage of our practical training and the unusual conditions in Radio to step into a big paying position in this wonderful new field. Radio offers you more money than you probably ever dreamed possible — fascinating easy work—a chance to travel and see the world if you care to or to take any one of the many Radio positions all around you at home. And Radio offers you a glorious future!

### PAY INCREASES OVER \$100 A MONTH



I am averaging anywhere from \$75 to \$150 a month more than I was making before enrolling with you. I would not consider \$10,000 too much for the course.

(Signed) A. N. Long,  
Greensburg, Pa.

### DOUBLES SALARY

I can very easily make double the amount of money now than before I enrolled with you. Your course has benefited me approximately \$3,000 over and above what I would have earned had I not taken it.



T. Winder,  
Grand Junction, Colo.

### NATIONAL RADIO INSTITUTE Dept. 31 GB Washington, D. C.

Please send me without the slightest obligation your Free Book, "Rich Rewards in Radio," and full details of your special Free Employment Service. Please write plainly.

Name ..... Age .....

Address .....

City ..... State .....

# Music Master Success



**Music Master**

Resonant Wood Insures  
Natural Tone Quality



Model VI, 14" wood bell \$30

Model VII, 21" wood bell \$35

Connect Music Master in place of  
headphones. No batteries. No ad-  
justments.

Prices of all models slightly  
higher in Canada



Model VIII, Mahogany Cabinet  
with "full-floating" wood \$35  
bell . . . . .

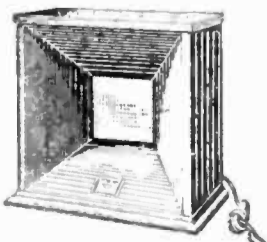

Model V, wood bell, Metal  
Cabinet, Mahogany finish \$18

—Its True Significance

THE advent of Music Master sounded the death knell of the mere "loud speaker", transformed the radio receiving set into a musical instrument and made possible the wonderful stellar program now the feature of nation-wide broadcasting.

Music Master does more than reproduce—it interprets, it re-creates. Imitated but never equaled, it remains the *supreme musical instrument of radio*—and there IS no substitute.

**MUSIC MASTER—the Ultimate of Artistic Radio Re-Creation**

Music Master's precision instrument is the acme of scientific perfection. Music Master's tone chamber of heavy cast aluminum is a marvelous mold of sound without distortion. Music Master's amplifying bell of resonant wood gives to every sound its full, vibrant qualities and natural characteristics.

Music Master's manufacturers pledge unreserved and unconditional protection to every purchaser. Back of your dealer stands the Music Master Corporation to guarantee its products *direct* to anyone, anywhere, at any time.

## Music Master Corporation

Makers and Distributors of High-Grade Radio Apparatus  
Tenth and Cherry Streets, Philadelphia  
Chicago Pittsburgh  
Canadian Factory: Kitchener, Ontario

★ Tested and approved by RADIO BROADCAST ★



## Newport Selectivity Opens for You The Treasure Box of Broadcasting!

Into the Treasure Box of Broadcasting are daily poured treasures that fade the "King's Ransom" into insignificance, treasures that make even the connoisseur breathless.

Into this Treasure Box goes daily the most priceless accomplishment of civilization which for want of a better name is called genius. Comes a mighty spender who scoops with a lavish hand out of the inexhaustible reservoir of human thought all the jewels of art, of science, of industry and dumps them into this Treasure Box. All the rarest pearls that it has taken over ten thousand years of mental groping to find are in it. Even the wealth of the world passes through it every twenty-four hours. All the secrets, all the beauty, all the mellowness of Time are locked within it.

Yet, the mere twist of a Newport dial, makes all these treasures yours. More than that! The Newport dial will bring this Treasure Box into your living room and open it for you. You may keep it all or take your choice.

★ *Newport Radio Corp.*  
 —————  
*250 West 54th Street,*  
*New York City*

*The Newport is a Good Receiver Built in a Piece of Fine Furniture*

★ Tested and approved by RADIO BROADCAST ★



# AFTER ALL

*Here is the answer:*

**T**HE Neutrodyne is the largest selling type of Radio Receiver, and the Freed-Eisemann is the largest selling Neutrodyne.

*There is a very good reason!*

*Freed-  
Eisemann*



FREED-EISEMANN RADIO CORPORATION  
Manhattan Bridge Plaza, Brooklyn, N. Y.

★ Tested and approved by RADIO BROADCAST ★





**“I selected it for its  
high insulating qualities  
It cuts down the losses in the circuit”**

**T**HOSE were the exact words of a prize-winner in a radio set-building prize contest, when asked why he used a Radion Panel. Like thousands of others, he had found by experience that there is nothing quite like Radion for real results.

Our engineers developed Radion Panels *especially to order* for radio. Losses from surface leakage and dielectric absorption are exceptionally low. And low losses mean clearer reception, more volume and more distance.

*Easy to Work—moisture proof—resists warping*

RADION is easy to cut, drill and saw. You need not have the slight-

est fear of chipping. Radion resists warping. It's strong. It's moisture proof. It comes in eighteen stock sizes and two kinds, black and mahogany.

Radiodealers have the exact size you want. The use of Radion by the manufacturers of ready-built sets is almost invariably a sign of general good quality in that set.

*Send for booklet  
“Building Your Own Set”*

OUR new booklet, “Building Your Own Set,” giving wiring diagrams, front and rear views, showing new set with slanting panel, sets with the new Radion built-in horn, lists of parts and directions for building the most popular circuits—mailed for ten cents.

**AMERICAN HARD RUBBER COMPANY**

Dept. C5, 11 Mercer St., New York City

Chicago Office: Conway Building.

Pacific Coast Agent: Goodyear Rubber Co., San Francisco, Portland

**RADION**

*The Supreme Insulation*

**PANELS**

*Dials, Sockets, Binding Post Panels, etc.*



AMERICAN HARD RUBBER COMPANY  
Dept. C5, 11 Mercer St., New York City

Please send me your new booklet, “Building Your Own Set,” for which I enclose 10 cents (stamps or coin.)

Name.....

Address.....

★ Tested and approved by RADIO BROADCAST ★

**1- Better color**  
*- lasting luster*



**2- Lower free sulphur**  
*- no discoloration*

*Triple your satisfaction by using Goodrich Radio Panels*

**3- Higher softening point**  
*- no warping*

**L**OW dielectric losses in the panel increase selectivity and range. Any good hard rubber panels are lower in dielectric losses than panels made from other materials.

We stake our reputation built up over a period of fifty-five years that Goodrich Hard Rubber Panels are absolutely satisfactory in every way and distinctly superior to other hard rubber panels in the three important respects listed above.

For maximum selectivity and widest range, use:

*Goodrich Hard Rubber Radio Panels . . . Goodrich V. T. Sockets . . Goodrich Variometers Unwound . . Radiophone Ear Cushions . . . . Spaghetti Tubing . . . . Battery Mats*

THE B. F. GOODRICH RUBBER COMPANY    Established 1870    Akron, Ohio

**Goodrich**  
**RUBBER *Radio Products***

*"Best in the Long Run"*

★ Tested and approved by RADIO BROADCAST ★

*"This Is WWJ"*

Radio with the Detroit News is a tradition—a tradition based upon more than a quarter of a century of experimental work inaugurated by the late James E. Scripps, founder of the News itself. The News began broadcasting away back in September 1920. Today Radio the world over, admires WWJ for the clear, even, mechanical perfection of its message. And the Detroit News Orchestra is everywhere an accepted standard of sound, musical excellence. Hear it, at its very best, through The Superspeaker.

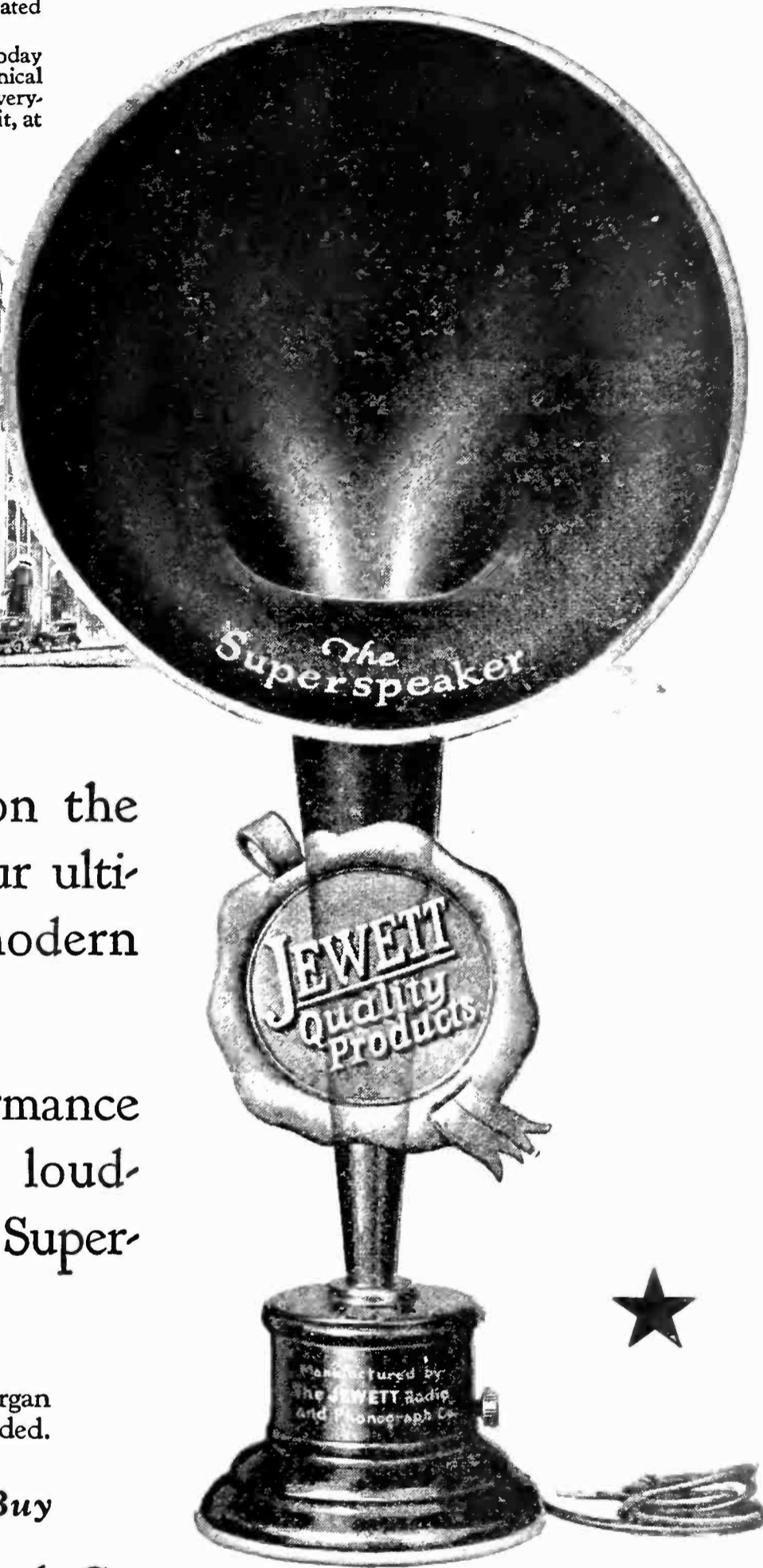
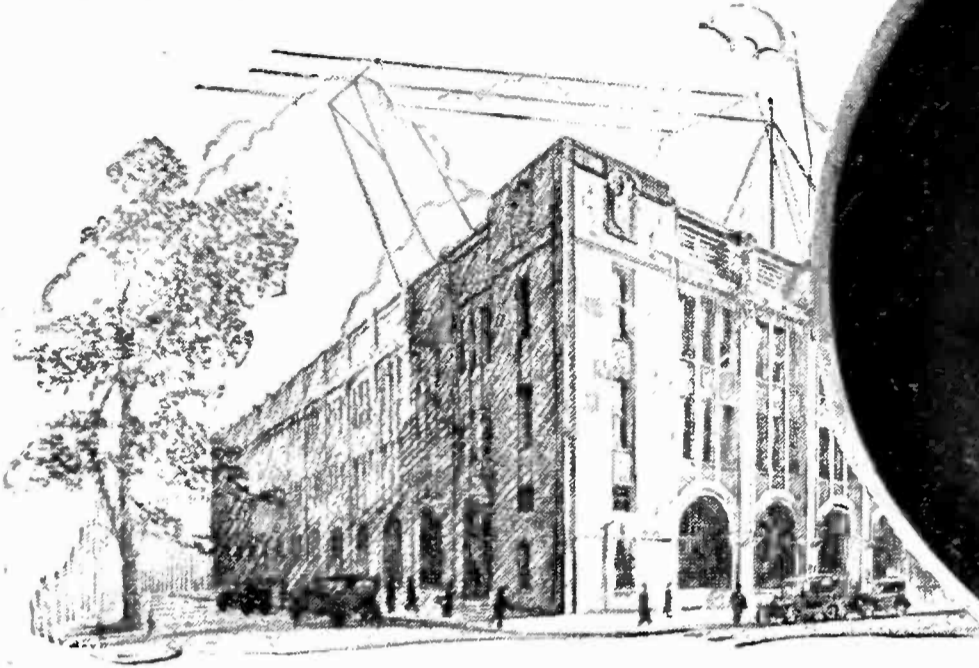

**"COAST to Coast on the Loudspeaker"** is your ultimate hope from a modern Radio Set.

But this is 100% performance and needs the 100% loudspeaker—The Jewett Superspeaker, nothing less!

The throat is as straight as an organ pipe. No extra batteries are needed.

*Compare It—You'll Buy*

Jewett Radio & Phonograph Co.  
5672 Telegraph Road Pontiac, Michigan

*The*  
**Superspeaker**  
*Trademark Registered*

★ Tested and approved by RADIO BROADCAST ★

# DUPLExX CONDENSERS

## DUPLExX STANDARD



"None other so good."  
Conforms to Bureau of Standards specifications for lowest losses and best electrical characteristics. Skeleton metal end-plates and automatic take-up for bearing wear are among its features. Absolute satisfaction guaranteed!

## DUPLExX JUNIOR



Lacks some of the costly refinements of DUPLEX Standard, but is "the best value for the price." Die cast rotor, milled stator posts, and other features usually found only in highest priced condensers. Electrical and mechanical perfection guaranteed.

## In Matched Sets For Uniform Dial Settings

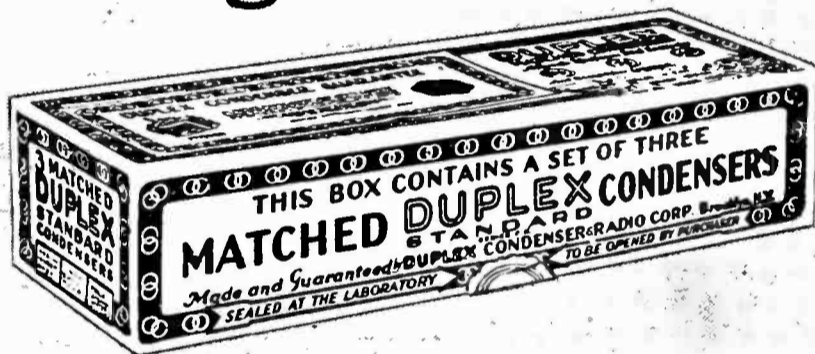

This most recent **DUPLExX** achievement — **DUPLExX Standard** condensers, specially tested, matched and guaranteed to have identical capacity curves, packed in sealed kits of three — has been enthusiastically welcomed everywhere by radio set builders, both professional and amateur. It is the *only* kit that affords uniform dial settings for Neutrodynes and all other tuned radio frequency circuits. There is only *one* number to log — not three — when you use a **DUPLExX Matched KIT**.

*Instructive literature sent on request*

## DUPLExX CONDENSER & RADIO CORP.

46 Flatbush Avenue Extension, Brooklyn, N. Y.

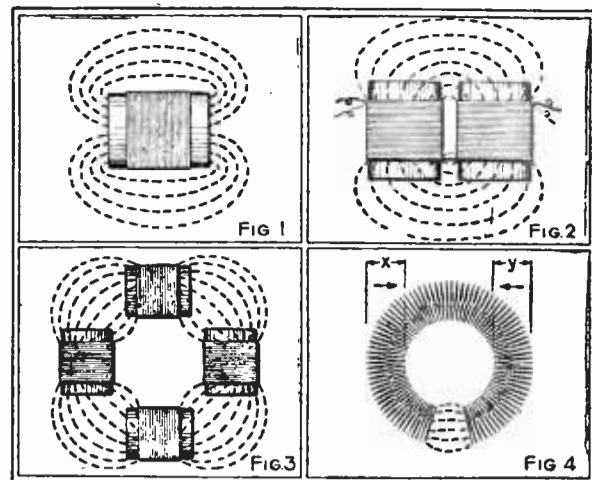
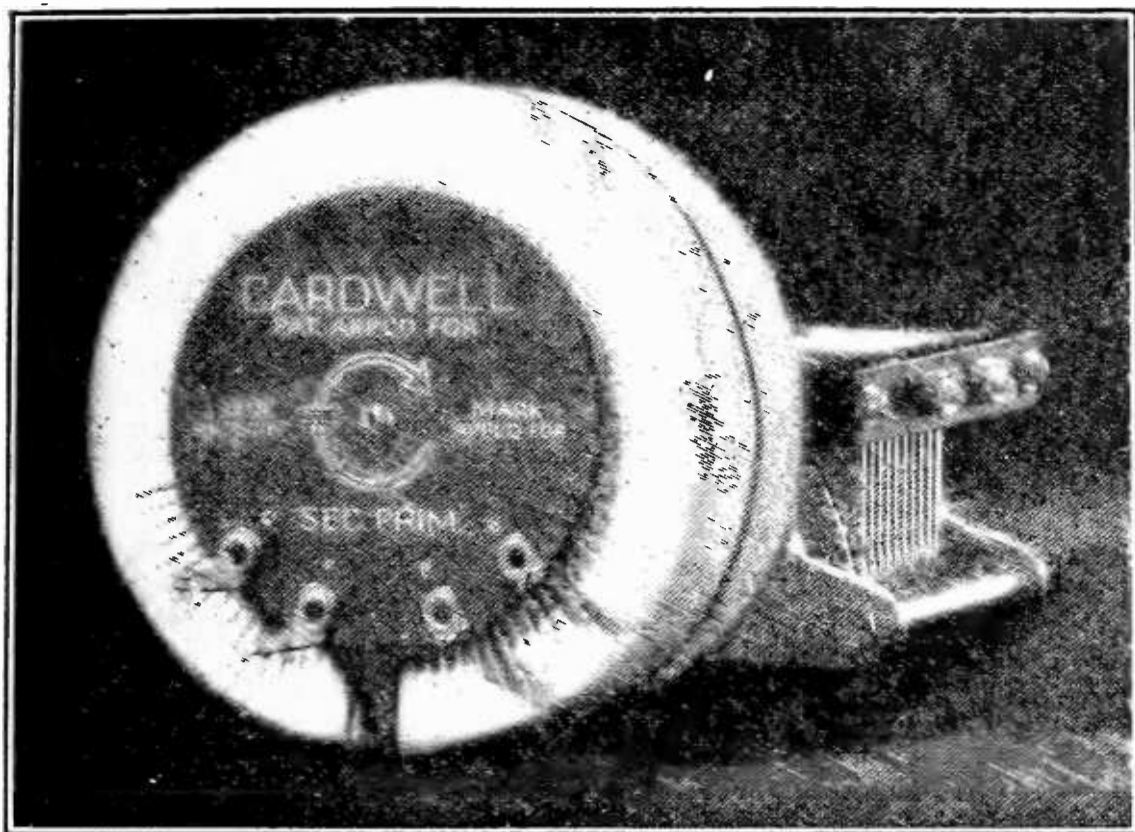

General Theory of the Toro-Tran

Figure 1 shows how the field of the ordinary coil extends into space and increases losses due to stray field. Figure 2 shows a "double series" winding, which restricts the field somewhat. Figure 3 shows a "four series" winding and the field almost enclosed. In Figure 4 (the Toro-Tran) the field is entirely enclosed and the losses due to stray fields are eliminated. Note that a stray signal passing through the coil at "X"—not introduced from the aerial or the tube—is balanced out at "Y" by the reversed polarity of the winding. This rejects undesirable signals, while the concentrated internal field builds up the tuned signal. Hence maximum distance and selectivity.

# —and now the TORO-TRAN!

CARDWELL, whose pioneer "low-loss" condenser established new standards of radio efficiency, is now introducing the Toro-Tran\*—the ideal *balanced* coupling inductance for all radio frequency work.

\*TRADE MARK  
Registry applied for

The Toro-Tran eliminates signal energy picked up by ordinary coils from nearby stations. It eliminates magnetic feed-back in multi-stage radio frequency circuits, thus removing the most active factor in causing howling and distortion, and thereby increasing selectivity and distance. It rejects almost entirely the interference effects caused by electrical power

machinery, elevators, door-bells, arc stations, etc.

The Toro-Tran winding confines the field to the inside of the coil, a small area, and thus avoids one of the greatest causes of loss known to radio receivers—that of stray magnetic fields, which result in the absorption of signal energy and reduce the efficiency of the receiver tremendously.

### Note these unusual advantages in assembly and operation

- |   |  |   |
|---|--|---|
| <p>1. Compactness. The coils do not require spacing or angular mounting. They occupy less space than your condensers.</p> <p>2. Permit exact nullification for tube and stray capacity without guesswork or tedious testing.</p> <p>3. Closed magnetic field eliminates magnetic feed-back in tuned radio frequency amplifiers.</p> | <p>4. Low distributed capacity, due to air spacing of each winding and to low voltage-drop per turn of small diameter wire.</p> <p>5. Maximum coupling and high ratio of voltage increase due to concentrated field with zero leakage.</p> <p>6. Absence of all supporting insulation in the field of the coil. This is one of</p> | <p>the greatest loss factors in the ordinary circuit and is not remedied by "skeleton" or so-called "low-loss" windings.</p> <p>7. Ease of neutralizing oscillation due to tube capacity by means of rotating control, which anyone can "balance."</p> <p>8. Low capacity between primary and secondary, affording maximum transfer of energy to succeeding grid circuit.</p> |
|---|--|---|

The Toro-Tran has a lower "circuit resistance" (i.e., effective resistance as assembled in a set and not as isolated in the laboratory for theoretical measurements) than any inter-stage tuned transformer made and has a correspondingly higher amplification factor, its ratio exceeding ten.

To appreciate the many remarkable advantages of the Toro-Tran, write for our two free booklets: "The Torodyne Circuit" and "The Most Interesting Radio Frequency Transformer Ever Invented."

Toro-Trans are ready to mount in any tuned radio frequency circuit. Replace your ordinary coils

with Toro-Trans. You will be astonished with the results. Most .00035 mfd. variable condensers will tune them, but by using Cardwell Condensers you get maximum efficiency.

Order from your dealer or direct

CARDWELL TORO-TRAN WITH BALANCING POTENTIODON.....	\$ 4.00
Cardwell .00035 Condenser for tuning.....	4.75
Cardwell .00035 Vernier Condenser.....	6.25
Cardwell .00035 Dual Condenser (two-in-one).....	8.00
Cardwell .00035 Triple Condenser (three-in-one)....	12.00
Cardwell Audio-Trans (compound audio transformers)	10.00

The Allen D. Cardwell Manufacturing Corp.  
81 Prospect Street, Brooklyn, N. Y.

★ Tested and approved by RADIO BROADCAST ★

"By merit raised to an eminence"—Mi ton

# NATIONAL Velvet Vernier Condensers and Dials

are used by Lieutenant Frederick H. Schnell

(Traffic Manager, American Radio Relay League) for communication with amateurs on wave lengths from 20 to 125 meters from the Pacific Fleet during the cruise to Australia and return.

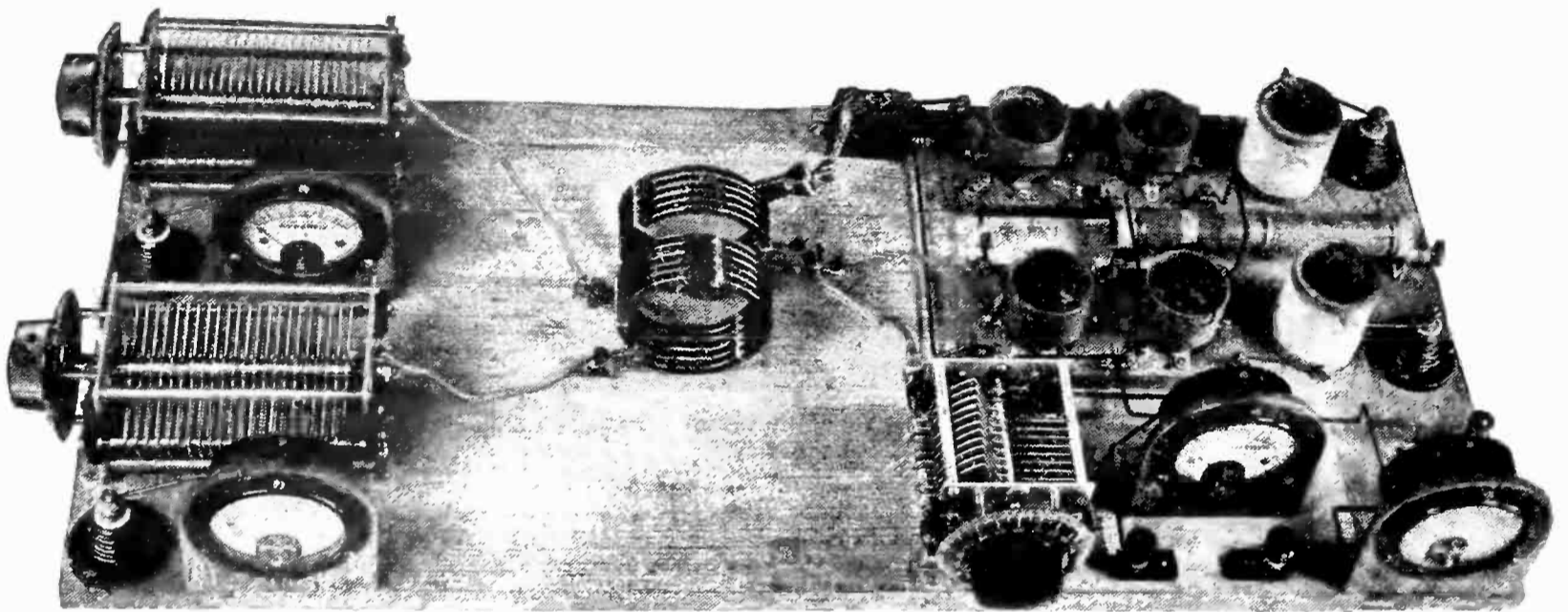

LIEUT. SCHNELL'S TRANSMITTER USING THREE NATIONAL CONDENSERS

In recognition of his splendid achievements in short-wave experiments, Mr. Schnell was invited to join the Pacific Fleet and was commissioned a lieutenant.

For his short-wave transmitter he has chosen NATIONAL Condensers with NATIONAL Velvet Vernier Dials.

NATIONALS won this high honor only after the severest tests, one of which was the application of 6,000 volts A. C. at 40 meters *without a breakdown*. That tells the triumphant truth of the merit of NATIONAL Condensers. What further proof of their efficiency and dependability could you ask?

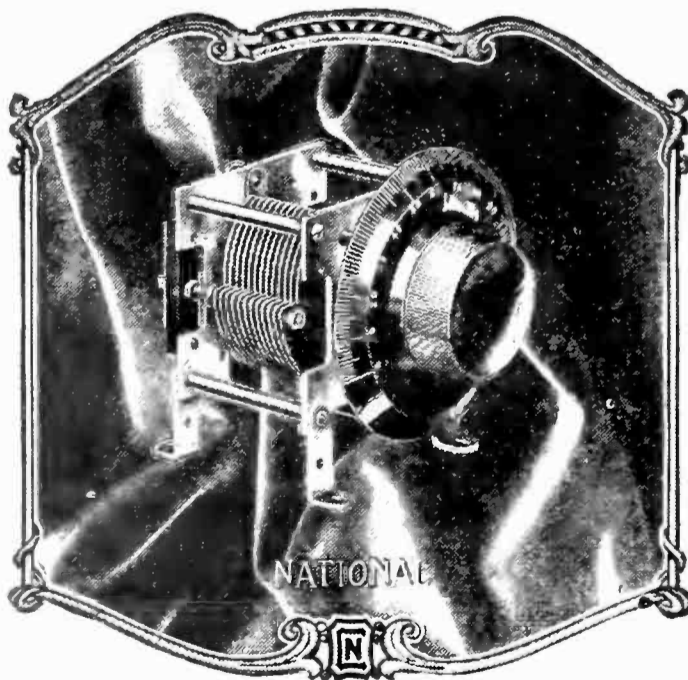

If your dealer is not yet stocked with NATIONALS, send us his name. We will see that you are supplied. Here are the prices:

#### Transmitting Condensers (complete with Dial)

.00025 (23 plates) \$11.00;  
.00046 (43 plates) \$16.00.

#### Receiving Condensers (complete with Dial)

3<sup>3</sup>/<sub>8</sub>" Bakelite Dial, Capacity-maximum-MF .001—\$7.25;  
.0005—\$6.25; .00035—\$6.00  
.00025—\$5.75. 4" Bakelite Dial, Capacity-maximum-MF .001—\$7.50; .0005—\$6.50; .00035—\$6.25;  
.00025—\$6.00.



## NATIONAL COMPANY, Inc.

110 Brookline Street

Cambridge, Massachusetts

Sole Licensees for the manufacture of the National Regenerator under the Browning-Drake Patents

★ Tested and approved by RADIO BROADCAST ★

# Silver-Marshall, Inc.

## RADIO EQUIPMENT

### SILVER CIRCUIT DESIGNS



McMurdo Silver  
Assoc. I. R. E.

**T**HERE is authority back of Silver Circuit Designs. . . . They are the result of years of research and experimentation with hundreds of models, all supervised by McMurdo Silver, Assoc. I. R. E., who is unsurpassed in Radio Design work. . . . Silver Circuit Designs have been approved by the "WHO'S WHO" of Radio. . . . These designs represent new and direct routes to better results rather than makeshift changes in old methods.

Sets built according to Silver Circuit Designs have outperformed every promise made for them. Successful builders all over the country report consistent coast to coast loudspeaker reception. In regular, routine reception these sets surpass the record performances of every other receiver.

Silver Circuits are the most efficient that can be designed. Even inexperienced builders can realize to the greatest extent the advantages derived from the numerous improvements they embody. They are Circuits that Engineer and Novice alike can follow, each with the assurance of obtaining the same perfect results.

**THE SILVER SUPER**—The 7-Tube Wonder Set—Uses standard tubes, either dry cell or storage battery. Wave length range 200 to 570 meters. Range, approximately 500 to 5,000 miles with loud speaker volume on a small loop. Embodies the highest refinements known in Receiver Design. Blueprints and Complete Building Instructions, 25c.

**THE SILVER 4-TUBE RECEIVER**—Will do everything on a 70-foot antenna that a Silver Super will do on a Loop, and that is coast to coast loudspeaker reception. Secures the very limit of performance with 4 tubes. Construction so simple that even the most inexperienced builder can assemble the set in a few hours, and secure perfect results.

**THE S-M DISTORTIONLESS AMPLIFIER** assures perfect tone quality. Can be assembled as a complete unit on a standard panel and plugged into your set, or the amplifier unit alone can be installed in any set, factory or home built, in place of any transformer-coupled amplifier. Costs no more than a two-stage transformer-coupled amplifier. Tube and socket expense balanced by low cost of resistances. Send 10c for Mr. Silver's pamphlet—"A DISTORTIONLESS AMPLIFIER."



**Books by McMURDO SILVER, Assoc. I.R.E.**

"THE PORTABLE SUPER-HETERODYNE" explains the theory, design, construction, and operation of the portable super. It is the most complete and authentic treatise of its kind ever printed. Contains drawings, photos, diagrams, and complete building instructions. Order your copy now. Price, 50c.

"THE FOUR-TUBE KNOCKOUT RECEIVER" describes Mr. Silver's latest circuit, in detail. Explains how four tubes secure Super-Heterodyne results. In addition to Photos, Diagrams, and complete building instructions it contains much valuable data on low loss inductances. You will find it mighty interesting. Price, 25c.

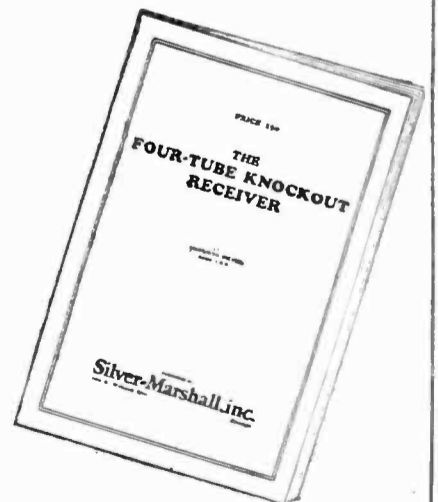

★ **FREE** "THE WHY OF SILVER CIRCUITS"  
Send For It To-day

Eastern Distributor:  
Twentieth Century Radio Corp.  
102 Flatbush Ave., BROOKLYN, N. Y.

**SILVER-MARSHALL, Inc.**  
103 S. Wabash Ave., CHICAGO, ILL.

★ Tested and approved by RADIO BROADCAST ★



# Radio at its Finest ~ Now Within Your Reach



*This is Not a Kit!*

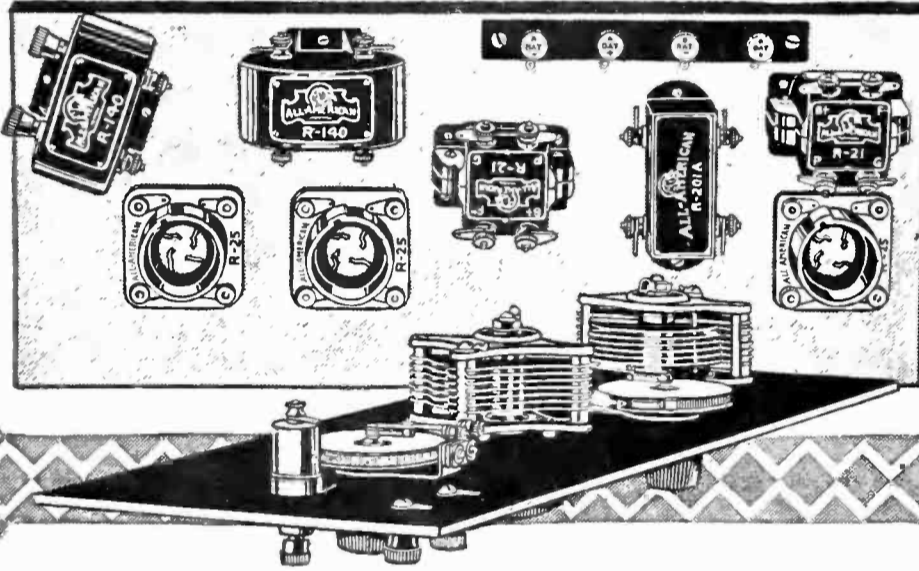

## Semi-Finished—Factory-Mounted ★

**Y**OU buy this set with the ALL-AMERICAN parts properly mounted on the panel and baseboard. Without knowledge of blueprints, circuits or names of radio parts, you can wire up an ALL-AMAX SENIOR in *one delightful evening* and know that it is right. This completely mounted highly efficient three-tube set costs you no more than you would pay for a kit of parts. Price, \$42.

Ten cents will bring you the new Radio Key Book, and upon request we will include, free, a complete wiring blueprint of either ALL-AMAX SENIOR or ALL-AMAX JUNIOR.

**ALL-AMERICAN RADIO CORP.**  
E. N. Rauland, President  
2652 Coyne Street, Chicago

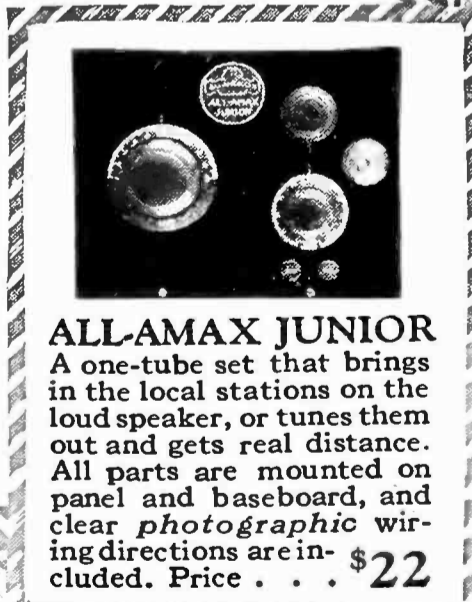

**ALL-AMAX JUNIOR**  
A one-tube set that brings in the local stations on the loud speaker, or tunes them out and gets real distance. All parts are mounted on panel and baseboard, and clear *photographic* wiring directions are included. Price . . . \$22

**WIN AN ALL-AMAX RECEIVER**  
At your favorite Radio Store

Ask them about the great ALL-AMERICAN Slogan Contest

You can win a set by submitting a SLOGAN

Everybody can enter. It costs nothing

# ALL-AMERICAN

★ Tested and approved by RADIO BROADCAST ★



# Another Famous TOWER

Equal to the BEST  
regardless of price



# Tower

Scientific

## LOUD-SPEAKER

### \$8.50

Surely a Wonderful TOWER TRIUMPH

Unquestionably the greatest Loud Speaker Value ever offered, giving the quality and volume to be found in the most expensive speakers, but priced within the reach of all.

The many features include magnets that lift 2 lbs. 10 oz., diaphragm of specially constructed material, perfect non-vibrating fibre horn, finished in beautiful golden bronze with 10" bell.



Tower's Scientific Phones are tested and approved by Government licensed Radio Operators, thus guaranteeing uniform tone, quality and accuracy.

On sale at all good dealers  
from coast to coast.



The Woolworth Bldg., New York City, is the tallest office building in the world being 792 feet high, containing 60 stories, and having an estimated weight of 206,000,000 lbs.

**THE TOWER MFG. CORP.**  
98 Brookline Ave. Dept. I Boston, Mass.

## Worlds Greatest Loud Speaker Value

★ Tested and approved by RADIO BROADCAST ★

# Radio Broadcast

WILLIS K. WING  
ASSOCIATE EDITOR

ARTHUR H. LYNCH  
EDITOR

JOHN B. BRENNAN  
TECHNICAL EDITOR

MAY, 1925

COVER - - - - -	<i>From a Painting by Henry J. Peck</i>	
WHERE PHOTOGRAPHS WERE SENT BY RADIO—IN 1922 - - -	<i>Frontispiece</i>	
A NEW METHOD OF TRANSMITTING PICTURES BY WIRE OR RADIO	<i>Charles C. Henry</i>	18
HOW THE GOVERNMENT IS REGULATING RADIO BROADCASTING	<i>R. S. McBride</i>	29
THE DISTANCE FIEND - - - - -	<i>A. H. Folwell</i>	35
THE MARCH OF RADIO - - - - -	<i>J. H. Morecroft</i>	36
HOW TO DESIGN RADIO COILS - - - - -	<i>Homer S. Davis</i>	46
HOW TO BUILD A TWO-STAGE RADIO-FREQUENCY AMPLIFIER	<i>John B. Brennan</i>	49
THE LISTENERS' POINT OF VIEW - - - - -	<i>Jennie Irene Mix</i>	62
IN THE R. B. LAB. - - - - -		68
How to Record Radio Signals		
Shooting Trouble		
Building Your Own Lab		
AS THE BROADCASTER SEES IT - - - - -	<i>Carl Dreber</i>	74
ON OUR BIRTHDAY - - - - -	<i>Arthur H. Lynch</i>	82
NEW FASHIONS IN RADIO PROGRAMS - - - - -	<i>James C. Young</i>	83
DO WEATHER CONDITIONS AFFECT RADIO? - - - - -	<i>Eugene Van Cleef</i>	90
CALIFORNIA ON THE LOUD SPEAKER - - - - -	<i>Cartoon by W. R. Bradford</i>	94
THE MEANING OF THE STAR - - - - -		95
HOW TO SOLDER - - - - -	<i>W. F. Crosby</i>	96
LATEST ALTERATIONS IN BROADCAST WAVELENGTHS - - - - -		99
THE REVELATIONS OF ENOCH - - - - -	<i>W. R. Bradford</i>	100
"NOW I HAVE FOUND . . ."		102
THE GRID - - - - -		106
Connecting Volt- and Milliammeters in Receivers		
How to Add a Stage of Radio Frequency to a Regenerative Set		
College Correspondence Radio Courses		
Straight Audio, Push-Pull, and Resistance-Coupled Amplification Added to the Roberts		
Knockout		
Identifying the Markings of Audio Transformers		
Additional Notes on the Roberts Circuit		
NEW EQUIPMENT - - - - -		114
AMONG OUR AUTHORS - - - - -		116

Copyright, 1925, in the United States, Newfoundland, Great Britain, Canada, and other countries by Doubleday, Page & Co.  
All rights reserved. TERMS: \$4.00 a year; single copies 35 cents.

F. N. DOUBLEDAY, *President*  
ARTHUR W. PAGE, *Vice-President*

NELSON DOUBLEDAY, *Vice-President*  
RUSSELL DOUBLEDAY, *Secretary*

S. A. EVERITT, *Treasurer*  
JOHN J. HESSIAN, *Ass't. Treasurer*

*Doubleday, Page & Co.*  
MAGAZINES

WORLD'S WORK  
COUNTRY LIFE  
GARDEN MAGAZINE & HOME BUILDER  
RADIO BROADCAST  
SHORT STORIES  
EDUCATIONAL REVIEW  
LE PETIT JOURNAL  
EL ECO  
THE FRONTIER

*Doubleday, Page & Co.*  
BOOK SHOPS

NEW YORK: LORD & TAYLOR BOOK SHOP  
PENNSYLVANIA TERMINAL ARCADE  
LONG ISLAND TERMINAL ARCADE  
AND 38 WALL ST.  
ST. LOUIS: 223 NORTH 8TH STREET  
4914 MARYLAND AVENUE  
KANSAS CITY: 920 GRAND AVENUE  
TOLEDO: LASALLE & KOCH  
CLEVELAND: HIGBEE CO.  
NEWARK: 34 PARK PLACE  
SPRINGFIELD, MASS., MEEKINS, PACKARD & WHEAT

*Doubleday, Page & Co.*  
OFFICES

GARDEN CITY, NEW YORK  
NEW YORK: 120 WEST 32ND STREET  
BOSTON: PARK SQUARE BUILDING  
CHICAGO: PEOPLES GAS BUILDING  
SANTA BARBARA, CALIFORNIA  
LONDON: WM. HEINEMANN, LTD.  
TORONTO: OXFORD UNIVERSITY PRESS

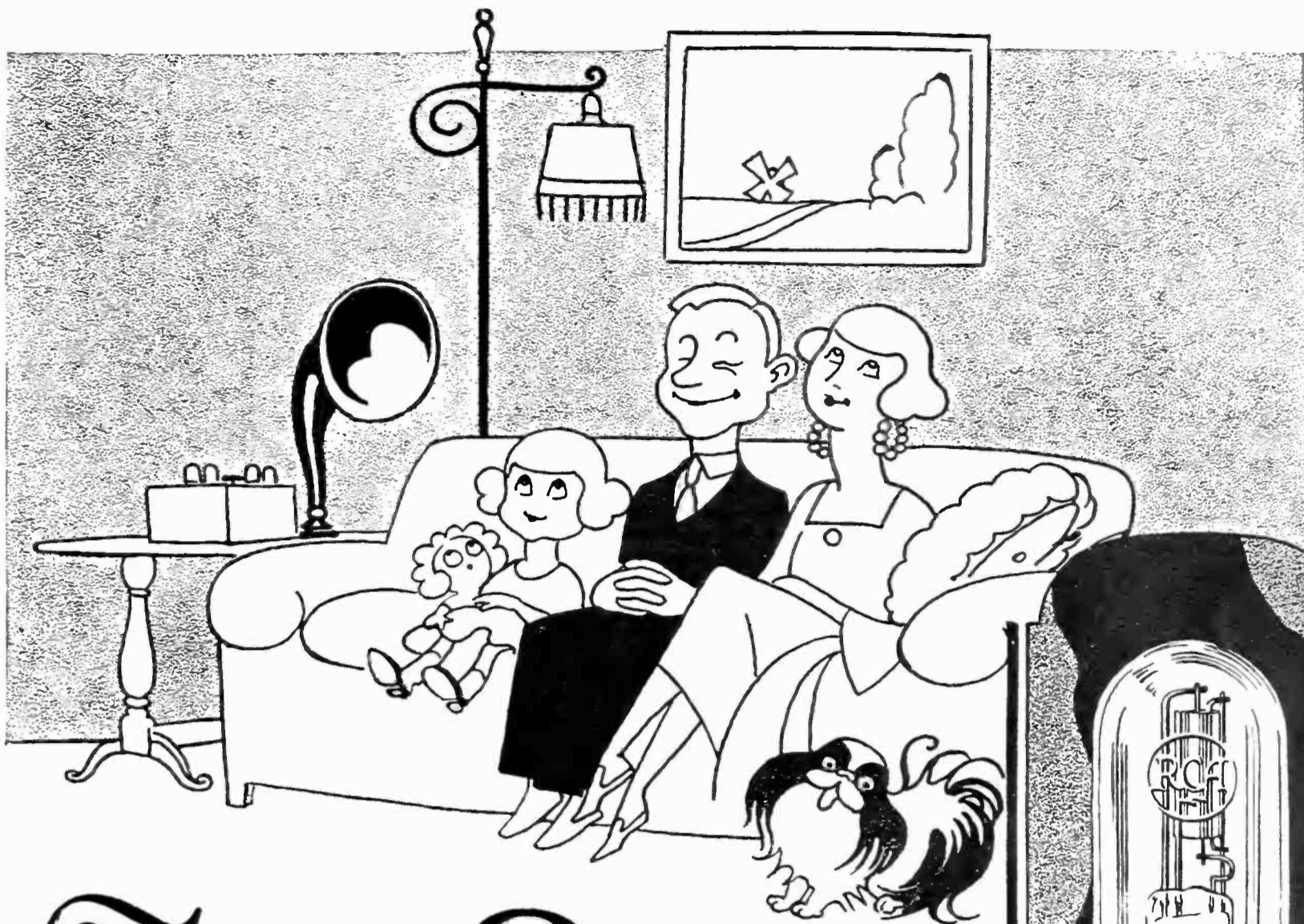

# There's Quality in everything

**I**N everything from a binding post to a vacuum tube, there is quality. But quality counts most in the vacuum tube. A radio set can be built for distance, for clear tone, for volume. But to get the best out of any hookup—you want to fit it with genuine Radiotrons.

No matter what type of set you have—or what type of circuit you are buying tubes for—ask for Radiotrons by name—and make sure you get the genuine by looking on the tube for the word Radiotron and the RCA mark. Quality counts!

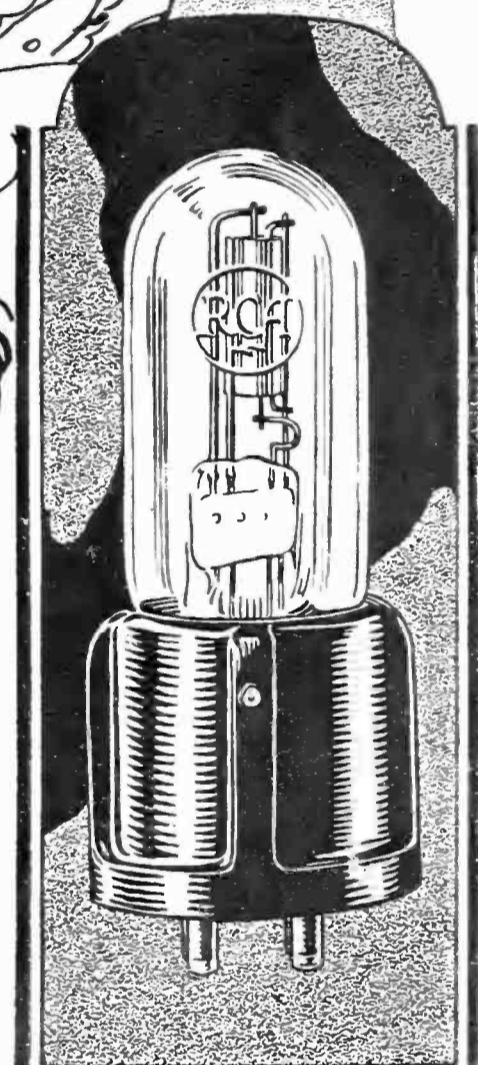

NOW \$**3<sup>00</sup>**

WD-11      WD-12      UV-200  
UV-199           UV-201A

Radiotrons with these model numbers are only genuine when they bear the name Radiotron and the RCA mark.

Radio Corporation of America

Sales Offices: Suite 35

10 So. La Salle Street  
Chicago, Illinois



28 Geary Street  
San Francisco

233 Broadway  
New York



This symbol of  
quality is your  
protection

# Radiotron

REG. U. S. PAT. OFF.

★ Tested and approved by RADIO BROADCAST ★



representing those used for power work have been made in various places, but usually the inductance, being very small, has been neglected. In the study of transient phenomena the presence of both capacity and inductance is necessary to support the wave front. Therefore the study of artificial lines with correct distributed constants is being taken up and a cable will be constructed by the students as soon as a method of design has been worked out.

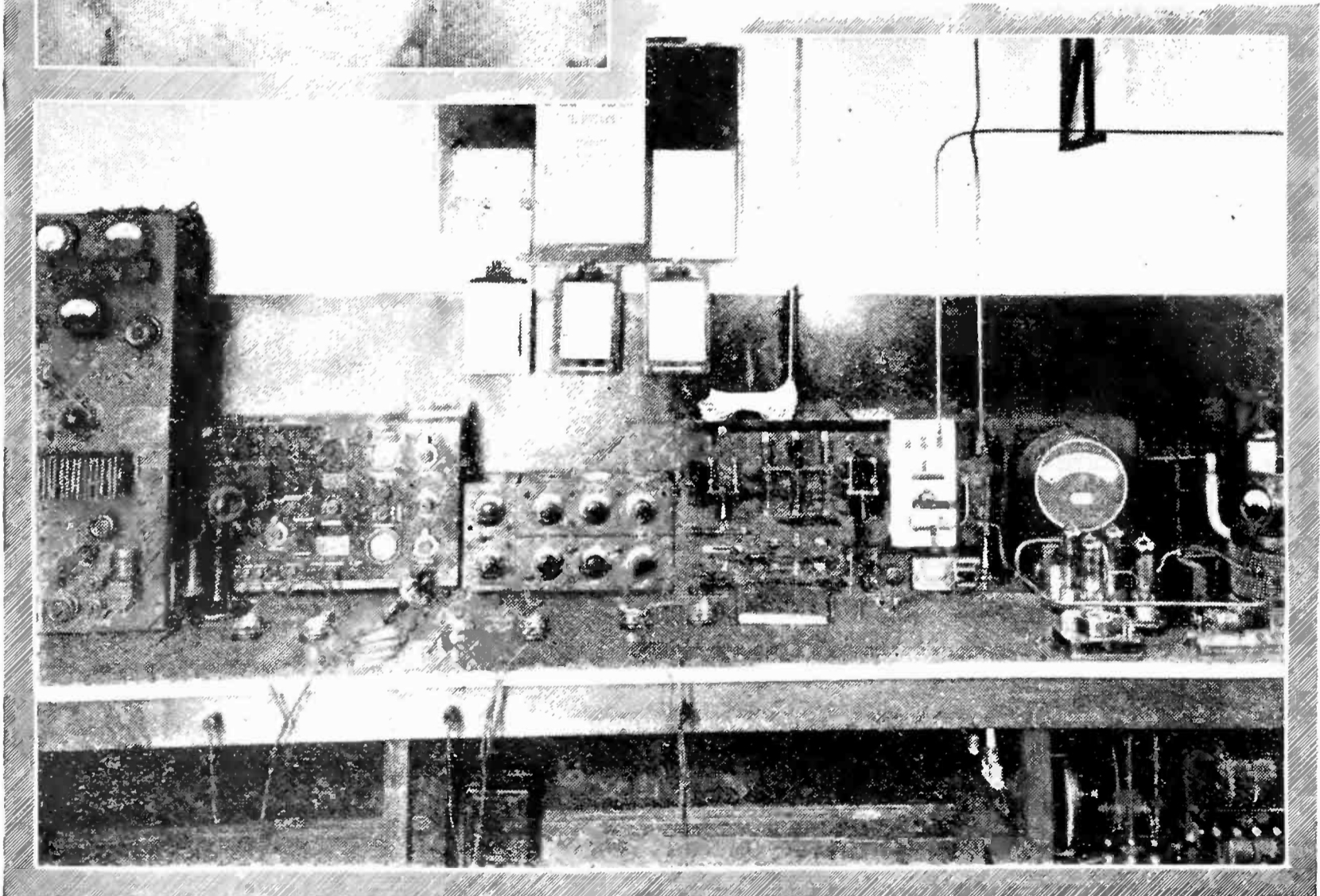

#### WHERE PHOTOGRAPHS WERE SENT BY RADIO—IN 1922

The lower cut shows a corner of the experimental station 1xm at the Massachusetts Institute of Technology at Cambridge, Massachusetts, where Dr. W. R. Hainsworth and Austin C. Cooley developed a method of picture transmission, which in its present form shows many points of superiority over existing systems. The upper photograph on the right is a bit of typewritten text transmitted by the system, in February, 1923, at a speed of sixty words per minute. The top left-hand picture was one of the first to be sent by Doctor Hainsworth in 1922. The article on page 19 explains the origin and present development of Mr. Cooley's methods which are an outgrowth of this early work

# RADIO BROADCAST

Vol. 7, No. 1



May, 1925

## *A New Method of Transmitting Pictures by Wire or Radio*

*A Review of Existing Methods of Sending Photographs—Details of the Cooley System Never Before Published—An Efficient and Very Fast Transmitter Whose Applications are Many and Important*

By CHARLES C. HENRY

IMAGINE, a hundred messengers delivering photographic reproductions of business letters, photographs, printed matter, legal papers, social correspondence, and innumerable forms of communication received from distant points by a single instrument. The instrument that will accomplish this is already known to many as a phototelegraphic receiver. Few even of those who have followed the recent developments in phototelegraphy appreciate the huge commercial and economic importance it will have in the near future.

Most of us read with interest the accounts of the transmitting of photographs across the Atlantic and admired the engineering achievement of reproducing them with such fidelity here in America. In hundreds of magazines and papers, copies of the received pictures of President Coolidge, Secretary Hughes, the Prince of Wales, and others were prominently displayed.

The whole world has heard about the transmission of the 1924 Republican Presidential Convention pictures by the American Telephone and Telegraph Company. The quality

of the pictures received in New York from Cleveland compare favorably with the average newspaper picture.

The *Chicago Tribune*, the *New York Daily News*, and the *Los Angeles Times* have been tied together for several months with the Marvin Ferree system of phototelegraphy operating over leased telegraph lines. Pictures are exchanged daily between these prominent newspapers and appear in their columns beside other news pictures. There is no noticeable difference in quality between the two. The trade name "Telepix" is attached to all of these telegraphed photos.

Not long ago, C. Francis Jenkins, of Washington, D. C., conducted radio phototransmission experiments between Anacostia, Maryland, and Medford Hillside, Massachusetts. His received pictures were badly mutilated by commercial radio telegraph traffic because of the particular wavelength used; but with better radio facilities at his command, it is likely that his test pictures would have been quite successful.

Edouard Bélin is at present in New York engaged in the intensely interesting experiment

of attempting to receive radio photographs from a Paris station. The St. Louis *Post-Dispatch* and the New York *World* have closely followed and supported his work for many years. Using his system, these two newspapers transmitted pictures with great success last December between St. Louis and New York City.

Those engaged in this work of phototelegraphy are racing with each other in their attempts to build up the first strong commercial foundation. It seems evident that the commercial field will be limited to one or two systems. It is quite possible that the ultimate system will be made up of contributions by the many scientists now engaged in the work.

Millions of dollars have been spent for the development of phototelegraphy by those who appreciate its adaptability to handling communications of all kinds, whether it be photographs, drawings, script, or printed

### Thirty-Seven Seconds for a Picture

The Cooley system, described in Mr. Henry's article, is capable of transmitting a five-by-seven-inch half-tone photograph or a line drawing over a perfect wire line in thirty-seven seconds. There are other methods in present use which send photographs by radio and by wire, but the time consumed is from four to fifteen minutes. Speeding up the transmission involves very great technical problems. Notable among these are the systems of the Radio Corporation, the American Telephone and Telegraph Company, Marvin Ferree, Edouard Bélin, and C. Francis Jenkins. RADIO BROADCAST is proud to present this story of Mr. Cooley's achievements, particularly because much of the development work was done in its own Laboratory.

Every sign points toward the early perfection of a commercially practicable system of phototelegraphy whose aid and influence in industry will be incalculable. RADIO BROADCAST believes the technical attainments of Mr. Cooley's system are of the greatest importance. Every reader who is interested in general scientific progress and all those engaged in developing radio and wire communication will read of what has been done with the deepest interest.—THE EDITOR

matter. The speed at which typewritten messages may be transmitted over such a system is so great that one set of apparatus could handle all the messages going between New York and Boston, which are now being transmitted over thirteen lines of automatic printing telegraph. The adaptation of phototelegraphy to transoceanic radio communication will not only speed up the service but will tend greatly to reduce the unfortunate effect that static now has. In the present system, letters forming the words are coded into dots and dashes and sent very rapidly. A bad crash of static will completely destroy one or more words. Such a crash of static

would only mar portions of letters from different words if the message were transmitted by phototelegraphy. To meet the keen competition of the cables, transoceanic radio companies must adapt some system that will insure reliability and at the same



MOUNT RAINIER, IN WASHINGTON

Transmitted by the Cooley system. Much of the recent development work on this system which was started in Cambridge, Massachusetts, in 1922, was done in the Laboratory of RADIO BROADCAST at Garden City

time increase the capacities of their present stations.

#### HOW PICTURES SOUND

**I**F YOU should ever listen to radio signals that are serving to transmit photographs, you will hear a buzz of constant pitch but of varying intensity. The variations in intensity seem to repeat every second, or probably oftener, but each repetition will be slightly different from the previous buzz. Each impulse, that goes to make up the buzz, represents the light coming from a tiny area on the picture being transmitted. Every one knows that newspaper prints are made up of thousands of tiny dots. In light places on the pictures, these dots are very small. The dark portions are made up of dots so large they form together to make a solid black mass. When transmitting any photograph, a dot is sent with each electrical impulse, but these impulses occur so rapidly that they appear as a buzz when one hears them on the radio. Rows of dots are sent in rapid succession; this explains the repetition of the signal intensities at short intervals. It is not necessary to split the photograph up into tiny dots before transmitting, for this is automatically done by the

electrical apparatus in the photograph transmitter.

At the receiving station, the electrical impulses are transferred on a suitable paper back into dots and these dots are arranged exactly as they are on the original picture. To do this, both transmitting and receiving apparatus must operate at exactly the same speed, that is to say, they must be synchronized. The technical problems involved in synchronizing have been some of the most important of the many difficult ones in developing the transmitting apparatus.

A picture that is to be transmitted across the Atlantic by the Radio Corporation of America's system, or from one city to another over the Bell System lines, is first printed on a transparent film. This process is rather simple and does not require much time. Nevertheless, such a procedure would involve undesirable complications for constant and regular commercial service. Both the Telepix and Bélin systems call for especial types of negatives peculiar to the transmitting methods employed. The making of such negatives requires a little more time than do the prints used on the Radio Corporation and American Telephone and Telegraph Company

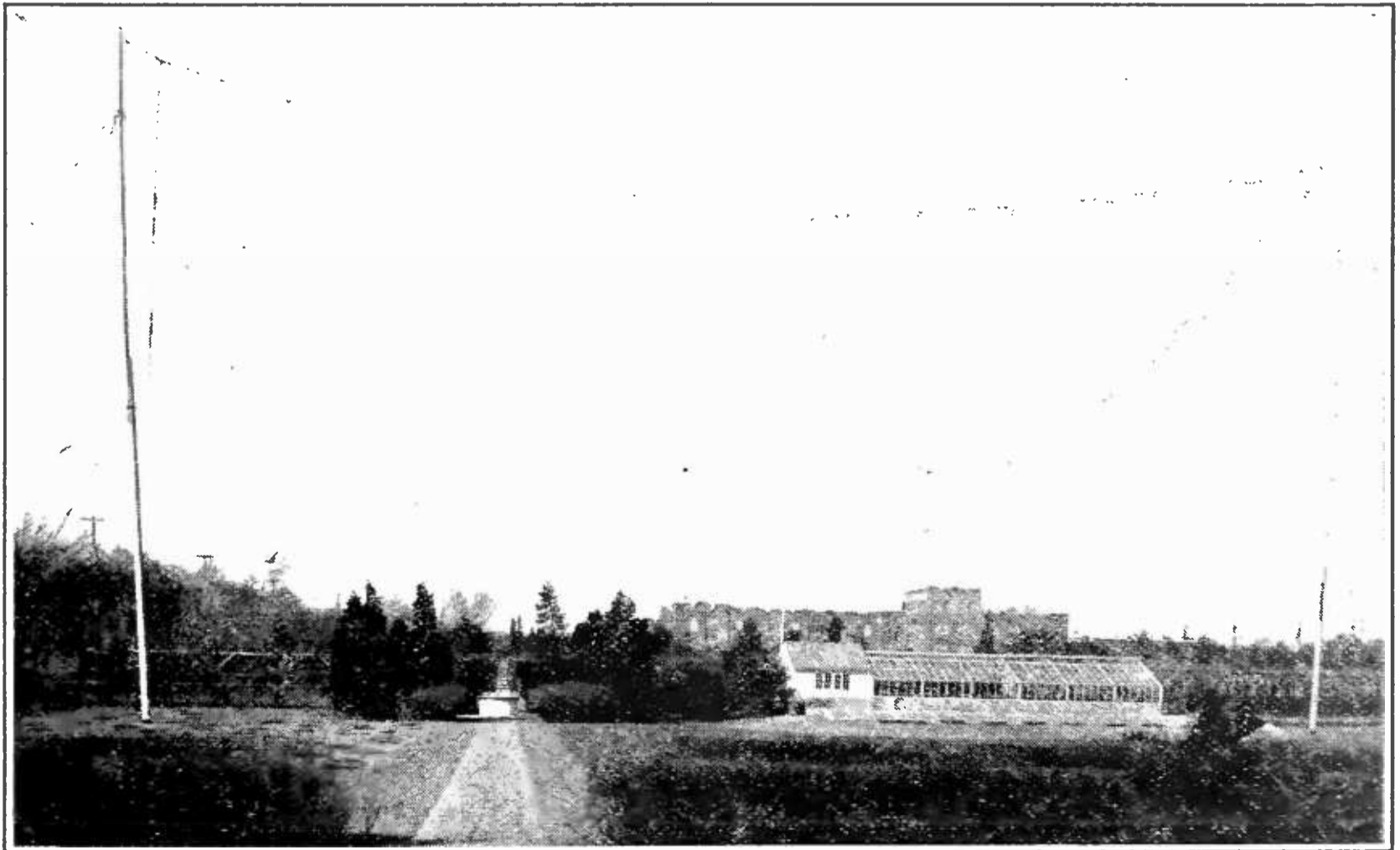

RADIO BROADCAST Photograph

#### THE RADIO BROADCAST LABORATORY

Showing the antenna and counterpoise system. Two masts eighty-five feet high support the two cage antennas. The longer antenna has a spread of 154 feet. The laboratory where Mr. Cooley did much of the development work on his photograph transmission system is located in the white cabin between the two masts. The buildings of Doubleday, Page & Company are in the background



## BEFORE—AND AFTER

The original and a radio transmitted version of a photograph sent during the early experiments of the Cooley-Hainsworth system. The picture on the right was sent with fifty dots to the inch. Average newspaper halftones have sixty-five dots to the inch (this magazine's halftones have 110 dots to the inch)

HON. R. B. HOWELL,  
WASHINGTON, D.C.

OCTOBER 1, 1924,

DEAR SENATOR HOWELL:— MAY I CALL YOUR ATTENTION TO A NEW METHOD OF COMMUNICATION, THE RADIO PHOTO LETTER. IT RETAINS THE AUTHENTIC CHARACTER OF AN AUTOGRAPH LETTER WHILE DELIVERING IT AT THE SPEED OF RADIO. IT IS THE BEGINNING OF THE PRACTICAL APPLICATION OF MY TEN YEARS DEVELOPMENT OF A RADIO SERVICE TO THE EYE, WHERE HERETOFORE RADIO HAS BEEN DEVELOPED ONLY AS A SERVICE TO THE EAR. ISN'T IT ABOUT TIME THE GOVERNMENT BEGAN CONSIDERING A MORE RAPID COMMUNICATION SERVICE TO BUSINESS? PHOTO COPIES OF LETTERS ARE ADMISSIBLE IN COURT. PHOTO COPIES OF BUSINESS LETTERS DELIVERED BY RADIO (AT THE SPEED OF LIGHT) WOULD BE JUST AS AUTHENTIC AND BINDING WHILE SPEEDING UP COMMERCE ENORMOUSLY. COMMERCE LIKE AN ARMY, CAN GO FORWARD NO FASTER THAN ITS MEANS OF COMMUNICATION. A MORE RAPID MEANS OF INTERCOURSE AS A NEW TOOL FOR SPEEDING UP BUSINESS, AND SHOULD CORRESPONDINGLY INCREASE OUR NATIONAL WEALTH.

*C. Francis Jenkins*

## A REAL RADIO LETTER

Sent by the inventor of the system, C. Francis Jenkins, from Anacostia, Maryland, to Washington by radio last October. The Jenkins system has some points in common with the development of Mr. Cooley, but in essence, the Cooley system operates along other and entirely new lines. The radio photoletter may in a few years be an accepted part of our industrial system

systems. A good commercial system of phototelegraphy should be able to transmit, without further preparation, any photograph or message printed on ordinary photograph paper.

## THE MECHANICS OF PHOTOGRAPH SENDING

SOME systems transmit the signals in dots and dashes instead of dots of intensity corresponding to the portion of the picture being transmitted. The dashes represent dark places in the pictures and the dots make up the light areas. This system is readily adapted to operation on telegraph circuits or radio telegraph stations. The cost of these



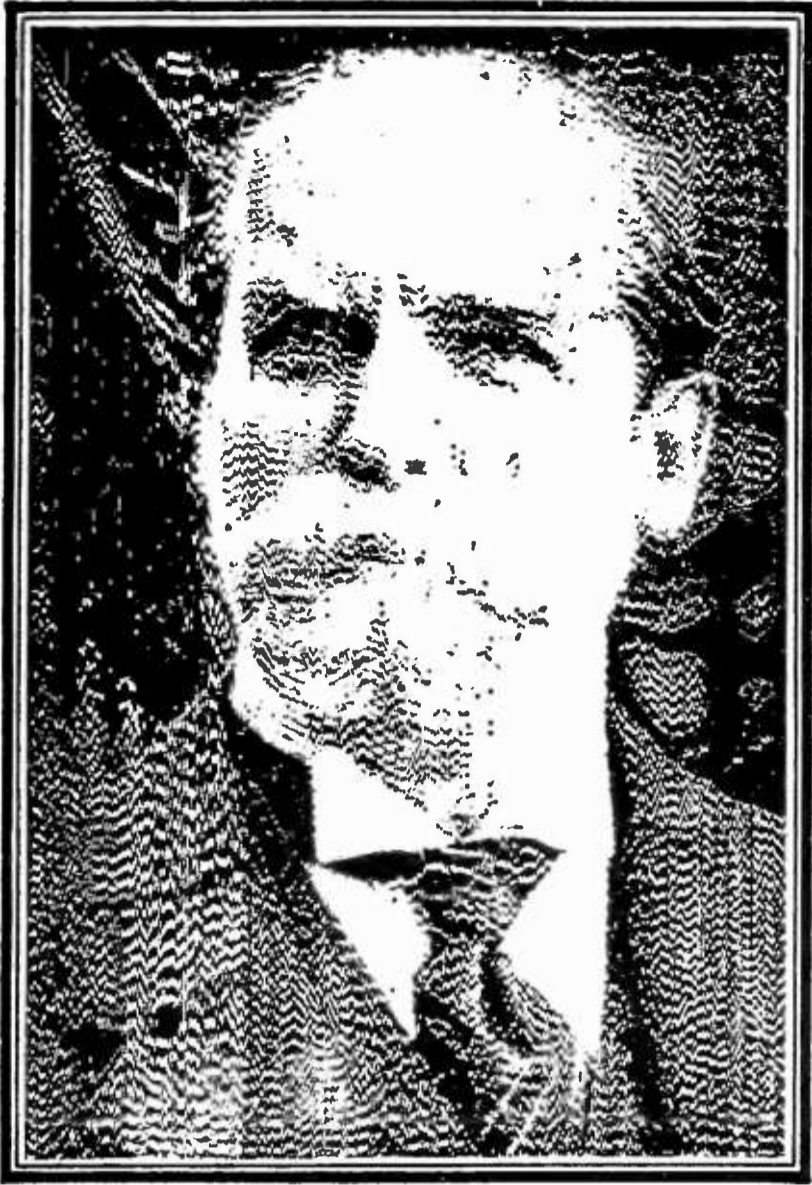

CHARLES EVANS HUGHES

Former Secretary of State, whose photograph was sent across the Atlantic by the Ranger-Radio Corporation of America "photoradiogram" system. The Ranger method, while used in this instance on a high power, long wavelength radio circuit, can be used on a wire line equally well

communication channels is much lower than the ones required for the dot system as used by the American Telephone and Telegraph Company, Jenkins, Bélin, and others. The Radio Corporation sent pictures across the Atlantic in twenty minutes by the dot-dash method. An hour or more is required to transmit a Telepix picture over a telegraph wire, but these pictures are larger and contain more detail than those handled by the Radio Corporation. The American Telephone and Telegraph Company have transmitted pictures of considerable detail in four or five minutes, but special wires were required. The cost of the communication channels used is an important factor that will determine the commercial value of any system. In some cases the high cost may be offset by the great capacity of the apparatus operating over the channel.

When a system of phototelegraphy goes into commercial use, there will probably be separate rates for printed matter and photo-

graphs. This is because the adjustments of the apparatus can remain fixed when handling black and white subjects while the transmitting of a photograph would require special attention so that the tones and shades may be properly reproduced at the receiving station. A picture having little contrast and printed on sepia paper would require adjustments of the apparatus entirely different from one having contrast and printed on a glossy paper.

## THE STORY OF THE COOLEY SYSTEM

THE Cooley system, which has never been made public, incorporates more contributions to the art than does that of any other inventor. This development is an outgrowth of

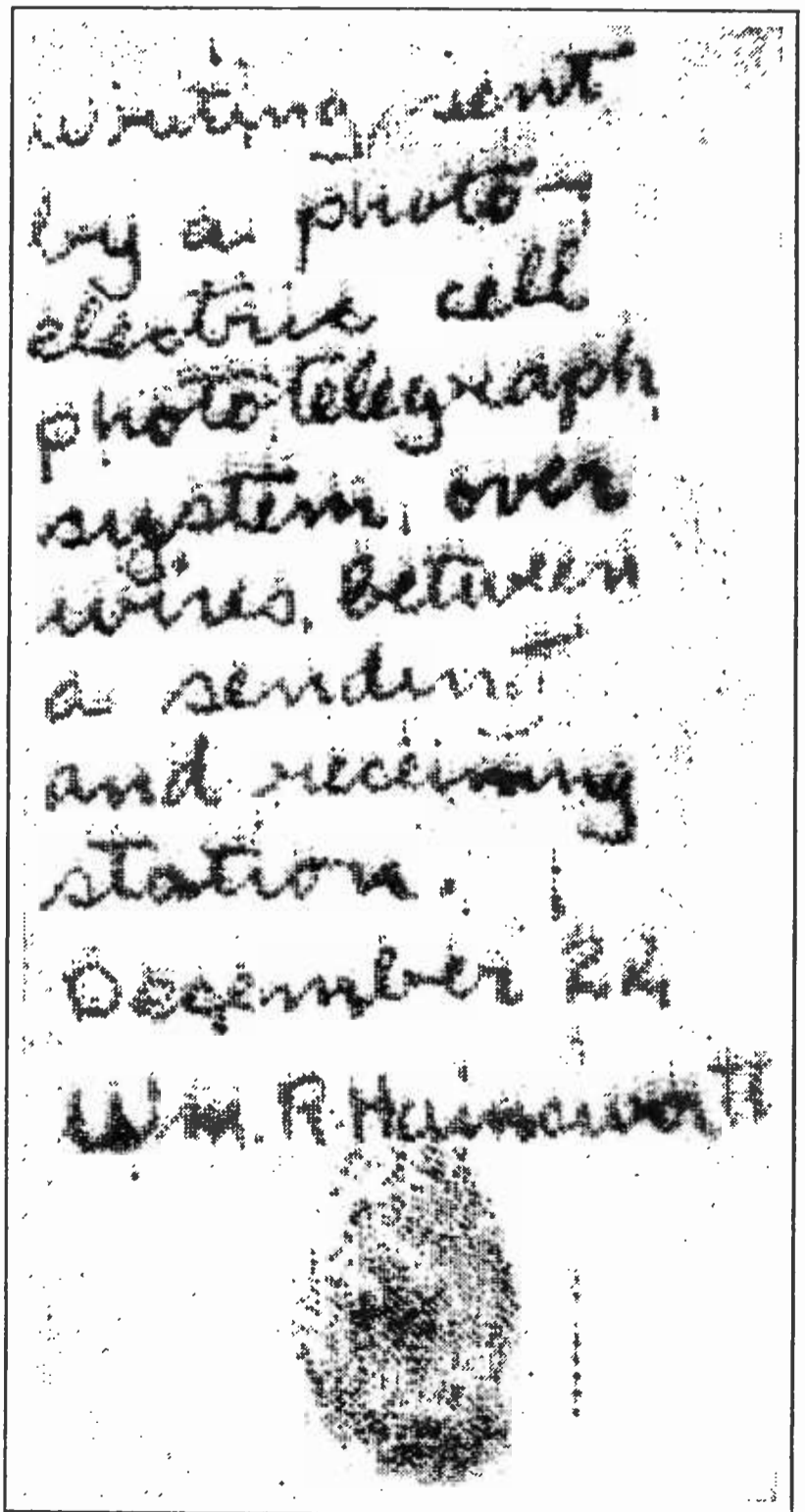

## VERITABLE "RADIO WRITING"

A sample of writing of Doctor Hainsworth, one of the inventors of the Cooley-Hainsworth phototelegraph transmitting system. This was sent experimentally in Cambridge in 1922

work begun by Dr. William R. Hainsworth at the Massachusetts Institute of Technology, Cambridge, Massachusetts, in November, 1921. From that time until March, 1923, the investigation centered on the use of methods paralleling very closely those made public by the American Telephone and Telegraph Company last summer. Austin G. Cooley, then a student at the Massachusetts Institute of Technology, joined Dr. Hainsworth in the fall of 1922 for the purpose of assisting in the application of radio to the equipment which was being operated satisfactorily in the laboratory.

Having become convinced that this system was too unreliable, that it was definitely limited in speed, and that it was encumbered

with so many obstacles in the way of its future acceptance as anything but an elaborate laboratory toy, in the spring of 1923 they decided to abandon their ideas and to start out along entirely different lines of research.

C. E. Tucker, a well known authority on electrical communication; Prof. F. S. Dellenbaugh, a prominent electrical engineer; Dr. F. G. Keys, director of the Physical Chemistry Department at the Institute; Captain Clayton and Sergeant Truax, both of the United States Army Signal Corps, were a few of the members of the faculty of the Massachusetts Institute of Technology who took an active interest in the Cooley-Hainsworth development work and furnished valuable assistance in securing

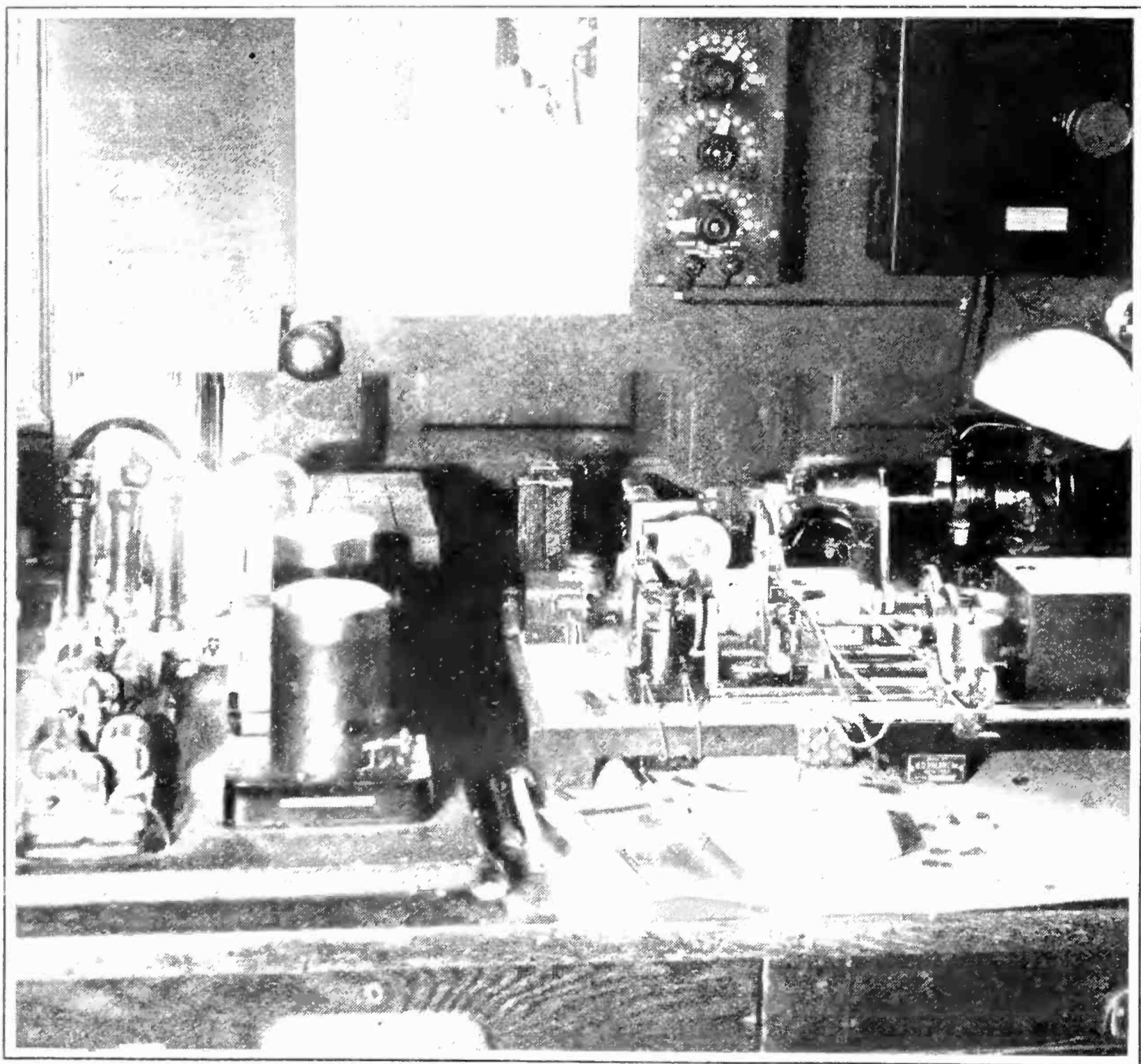

RECEIVING APPARATUS OF THE RANGER SYSTEM

Used by the Radio Corporation of America. The picture is printed on the small revolving drum in the foreground which is driven by the motor directly behind it. Exact synchronism between the motor of the transmitting and receiving apparatus is an essential of all photographic sending systems. The first public demonstration of this system took place during the week of December 1, 1924, between New York and London

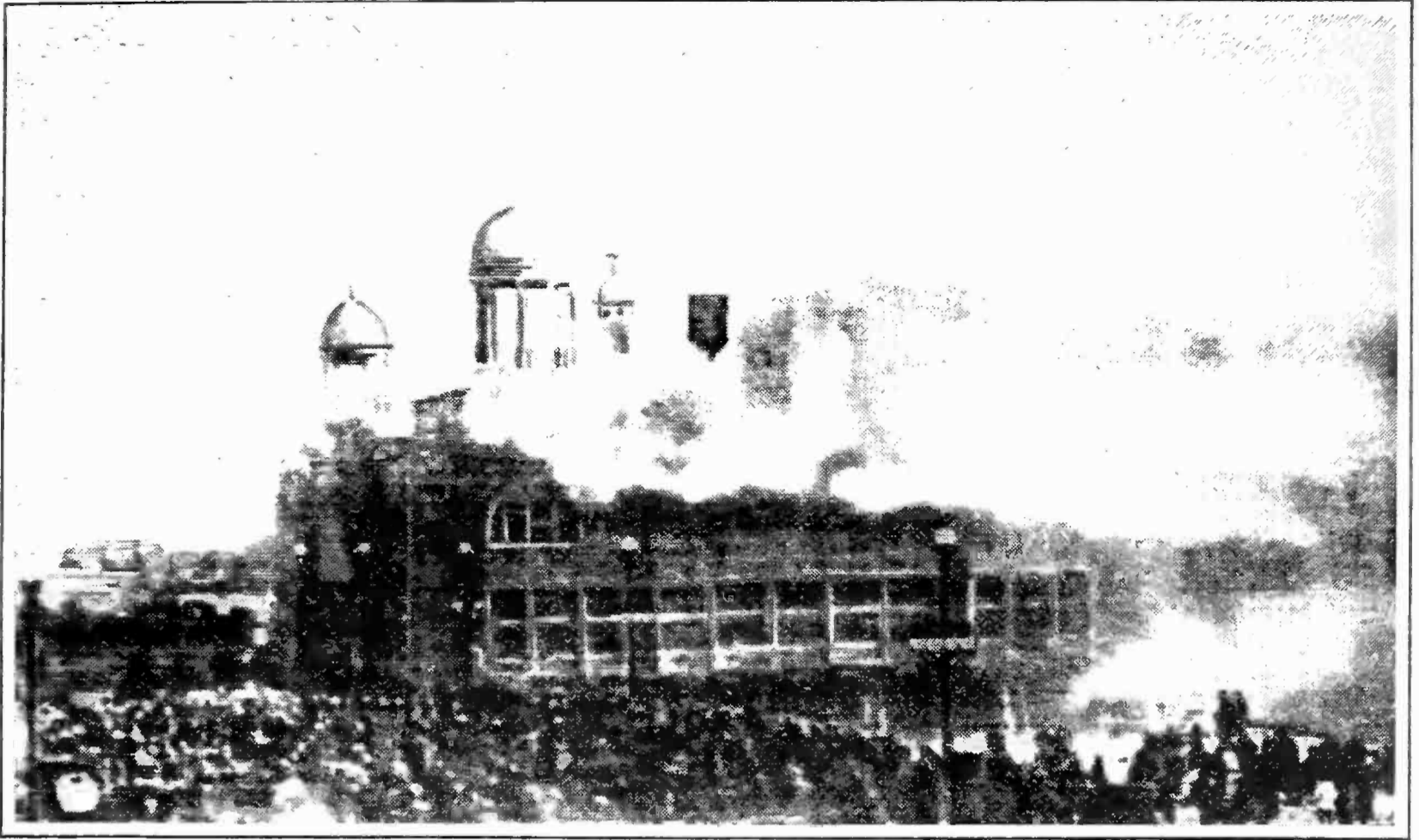

#### A TELEPIX PHOTOGRAPH

Which was sent between New York and Chicago. The photograph was retouched after it was received. A comparison between this and the original below shows that considerable detail was lost in the transmitting process. A picture of this type is one of the most difficult to transmit

the necessary apparatus and instruments. Dr. Jacob Kunz of the University of Illinois had contributed materially to the work by

placing at their disposal his newly developed photoelectric cell.

Many of the radio fans in the vicinity of

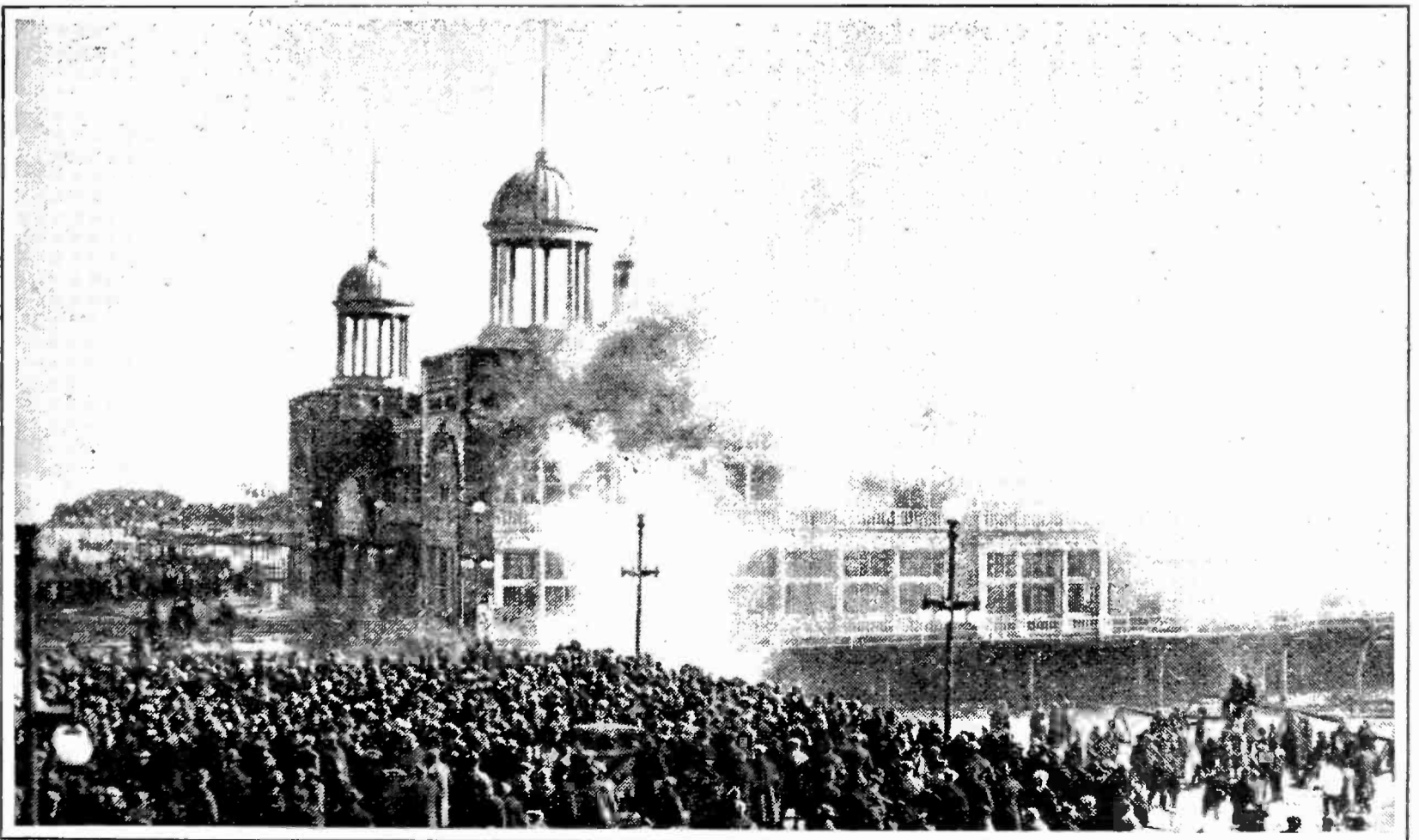

#### AN ORIGINAL PHOTOGRAPH

The telegraph version is shown above

Boston will recall hearing mysterious buzzes accompanied by clicks occurring at intervals of a little more than a second apart on a 200 meter radio wave during the month of December, 1922. Many inquiries were answered by explaining that "special tests on radio control were being conducted." Probably no one had the slightest conception that pictures were being sent over the air. It was from the experimental radio station 1XM, located at the Institute, that the pictures were transmitted. They were received in Dr. Hainsworth's laboratory, not far distant. The quality of the received pictures was poor, but the work must be given considerable credit, for it was probably the first time that the synchronizing of the receiver with the transmitter was accomplished by radio.

The development work on the phototelegraphic system was conducted in Dr. Hainsworth's laboratory and radio station 1XM where Mr. Cooley spent most of his time. In the summer of 1923, the first tests on the new system designed by Mr. Cooley were made in this radio "shack." It is seldom that apparatus of new and unusual design meets its builder's expectations. Mr. Cooley was prepared to be disappointed. But on the contrary, unusual and encouraging results were obtained.

With the aid of a colleague, Mr. R. A. Cunningham, Mr. Cooley rushed along the construction work on a complete set of apparatus to be used for demonstration purposes. Dr. Hainsworth left Boston during the summer of 1923 to take up some other work in Seattle. Since that time he has not been able to take an active part in the development of the phototelegraphy system for which he is responsible.

#### AT THE RADIO BROADCAST LABORATORY

WHEN Arthur H. Lynch, editor of this magazine, was asked to assist in obtaining laboratory space for the development of the Cooley phototelegraphic work, he was quick to realize its possibilities. Without the slightest hesitation he freely offered the facilities of the RADIO BROADCAST Laboratory for the test of Cooley's ideas. Accordingly, night and day, and with this precious equipment constantly under the eyes of watchmen, Cooley pursued his tests of a high speed phototransmission device for reproducing at distant points photographs having all the shades necessary to make up a perfect picture.

It was not until after the International

Radio Broadcast Tests in December, 1924, that the various units of the new Cooley phototelegraphic system had been properly coördinated and it was possible to send pictures of satisfactory quality in the RADIO BROADCAST Laboratory. Arrangements were made to loop the picture signals through two local telephone exchanges and to return them to the Laboratory, where both transmission and reception might be watched by the operators. The transmitter was connected to a telegraph line which terminated at the RADIO BROADCAST office. At this point, the signals were acoustically transferred to a telephone which was connected to the private branch exchange of Doubleday, Page & Company. This private branch exchange was in turn connected to the Garden City telephone exchange, where the usual telephone connections were set up for the wire which serves the Laboratory telephone.

#### SUCCESS ON THE FIRST TEST

IN THIRTY minutes ten pictures were transmitted. The apparatus was readily synchronized within ten seconds before the reception of each picture began. The pictures transmitted were taken from magazines and rotogravure sections of newspapers. In the receiving apparatus, the pictures were printed out on an inexpensive photographic paper that required developing and fixing before the image could be seen. The thirty minutes mentioned included the time required for this work. The quality of the received pictures was fair, in spite of a defective device in the transmitter. This device was the photoelectric cell, a necessary part of the equipment. Air had leaked into it and caused its action to be sluggish. A new one is now being built by Dr. Kunz, especially designed to meet the high speed requirements in this system of phototelegraphy.

The limitations of the Cooley system are unknown. It is probable that a commercial type model, which can handle four hundred messages an hour, will be constructed within the next year. Compare this with the present machine-printing telegraph, which averages about fifty messages an hour.

Using the Cooley design, the transmitter or receiver is neither bulky nor expensive to construct. In a commercial embodiment planned for an early date, a portable transmitter will be built for the use of newspaper photographers. It will be necessary only to connect the machine to the electric light socket, get the newspaper office by telephone, and place

the negative, still wet from the developing solution (if utmost speed is desired) in the machine, and, in the course of a minute or two, transmit it to the photographer's headquarters. And, wonderful though it may seem, the photographer may send it to be received as either a negative or a positive. He may also send a print or even a clipping from a magazine or newspaper and have the replica in the hands of the editor within a few minutes after completing his telephone connection. Since this work may be done acoustically, there is no need of any electrical connection between the photo-transmitter and the telephone.

#### ONE PICTURE—EVERY HALF MINUTE

MR. COOLEY has not lost sight of the fact that 1200 impulses per second is about the maximum number that can be transmitted over a commercial telephone line. This limits the speed of transmission to about seventeen square inches per minute if the picture is to be printed out with sixty-five dots per inch, this being standard for newspaper prints. The speed might be increased through the use of high quality transmission lines such as are used for carrying programs from a studio

to a broadcast station. In such lines the circuits are so arranged that frequencies up to 4000 cycles per second are passed. At the 4000 impulse rate, only thirty-seven seconds would be required to send a five-by-seven-inch picture.

Before this copy of RADIO BROADCAST reaches the reader, it is confidentially expected that the necessary alterations in the present model will be made, so that the most detailed photograph with all its half-tone shadings can be transmitted over any telephone or radio circuit that is capable of transmitting intelligible speech. There is every hope for the early detailed announcement of this phototelegraphic system that is fundamentally new and novel in its transmission and receiving methods.

The quality of the photographs transmitted by this system can be made especially good for magazine use. By increasing the speed of transmission, photographs can be sent at a greater speed, for use in newspapers. In its final form, the apparatus will be extremely simple, relatively inexpensive, and equally adaptable for line or radio transmission.

In connection with this work, a very important new use of the vacuum tube has been discovered and a very plausible theory has



THE ORIGINAL—AND THE TELEGRAPHED PHOTOGRAPH

Sent from New York to Chicago by the "Telepix" system now in use by the *Chicago Tribune* and the *New York Daily News*. The cut on the right is a print of the wired picture after it had been slightly retouched. At present, wired photography is decidedly expensive and too slow for general commercial use

been formulated for its operation. Still another use of the vacuum tube has been developed to an extent which shows excellent



promise. It is now thought that it can be included in the design of a new and novel receiving circuit which will be a great improvement in the sensitivity as compared to present-day receivers. Many patents are now pending for the various inventions which have been made in connection with the Cooley system. As rapidly as the patent work permits, RADIO BROADCAST will disclose the technical developments that are made as the work progresses.

There has been much discussion in recent years about the theories of the German scientist Einstein and his theory of the relativity of time and space. In a very definite and striking way, the radio transmission of photographs illustrates the contentions of that famous scientist, although certainly not in the way he intended.

This new art has reached the stage where commercial telephone, telegraph, and radio companies must recognize it as an ally or prepare to meet its competition. The constant barrier of distance is again about to be dealt a blow as deadly as that delivered by the general utilization of the locomotive, automobile, airplane, the telegraph, and radio. Since time is the only important measure of geographical space, phototelegraphy bids fair appreciably to shrink the magnitude of our world.

#### CALVIN COOLIDGE

President of the United States. This photograph was also sent across the Atlantic by the Ranger system. The dots and lines which go to make the picture can be clearly seen.

**C**OMPLETE instructions on how to build the Roberts four-tube Knockout receiver so that it can be fitted into any phonograph cabinet will appear in an early number of RADIO BROADCAST. It is now possible to buy manufactured sets which can be used in a phonograph cabinet, but thus far, no information has yet appeared which is of any help to the home builder. The mechanical details of the receiver are especially well worked out and the panel can be used with any type of cabinet phonograph now on the market.

# How the Government Is Regulating Radio Broadcasting

The "Interest of the Listener" Is the Final Test of Regulation—The Present Situation and Future Possibilities—An Interview with Judge Davis of the Department of Commerce

BY R. S. McBRIDE

**I**NCREASING service to the listener," is the only proper basis for radio regulation and development in the opinion of Herbert Hoover, Secretary of Commerce. But it is a long way from this generalization to the practical working out of a Government policy. So RADIO BROADCAST has undertaken to study the departmental policy as to the control of broadcasting to see just what this statement really means. For this purpose, an interview was secured with Judge Stephen B. Davis, Solicitor of the Department of Commerce, with results that are most gratifying from the point of view of the listener. There is no doubt that the radio audience is assured of every protection and aid which the skilled agents of the Government can offer and that fair and helpful service will be given to any broadcasting development that has real merit.

GARDENING FOR JACK OF THE BEAN STALK

**O**NE can well imagine the troubles which a gardener would have had caring for the yard of Jack of bean-stalk fame. But such a gardener would have had no more trouble in pruning the bean stalk to shapely form than does the Department of Commerce in directing the

growth of the radio broadcasting business. In this, as in the fairy tale, not even the sky is the limit, so it seems.

Four years ago—or August, 1921, to be exact—the first broadcasting was begun. To-day the Department lists nearly 600 broadcasting stations in operation or under construction.

These must be guided and safeguarded if the real interest of the industry, which means the wishes of the general public of listeners, is to be adequately protected. And with ether space so much at a premium to-day, the task is not an easy one.

In view of the continued rapid growth of broadcasting, many have foreseen a constantly increasing confusion in the air, which would be helpful to no one and harmful to all. Anticipating this situation the Department was asked, "How much worse must things get before they can begin to improve again?" Or putting it another way, "How much more

broadcasting interference must the public tolerate before it will rise up and demand rigid regulation and complete elimination of the interfering stations?"

These questions were addressed to Judge Davis, who is really acting as first officer of

## The Wavelength's the Thing

Everyone who knows the pleasant pressure of head phones or who is often attentive to a loud speaker has discovered that the ether paths are becoming more crowded every day. The average radio listener—if there is such a person—has probably wondered how the Government is dealing with the serious problem of distributing the broadcast wavelengths, which, when one considers the number of applicants for the comparatively few available, are few enough. There has been a deal of excited speculation on what would happen if a number of so-called super-power stations were licensed—speculation, it may be said, with only an indifferent knowledge of the facts. Mr. McBride has gone to headquarters for his information and we think he has presented very well the attitude of the Department of Commerce. The Department is charged with administering the Radio Act under the very difficult changing conditions of radio. That radio progress has not been greatly hindered by hasty and ill-considered legislation is due to the many good and capable friends of radio who have used their influence honestly and well in Washington.—THE EDITOR

the good ship *Radio*. The answer which he makes is most encouraging. He says, "Conditions will not be allowed to get any worse. They are far too bad already." Pressed further on this matter, Judge Davis stated that there are no more wavelengths available for broadcasting in the Class B wavelength area. Practically, this is an announcement to all newcomers in the broadcasting field that they will not be permitted to crowd in and add confusion between 280 and 550 meters. And to the broadcast listeners, as to all other well wishers of radio, this is the most welcome news of many months past.

#### FIXED CONDITIONS TO-DAY CHANGE TO-MORROW

**B**UT in stating this conclusion, Judge Davis repeatedly emphasized that no plan of the Department can be regarded as permanently fixed. Radio itself is changing; the Department's plans must keep pace or become a handicap. It is clearly the purpose of the Department to prevent any such unfortunate result. For to-day, however, it is safe to conclude that the Department intends to protect the listener's interest by limiting the number of stations which can work within the so-called Class B range. To-morrow some new scheme may develop which will permit granting of more Class B licenses on these wavelengths, but radio science to-day does not apparently hold forth this possibility.

Already in this Class B range, the average broadcast listener has a choice of several programs at ordinary broadcasting hours. But the Department is not content with this, for it seems to be well demonstrated that with a gradual advance in power at the stations in different parts of the country, the number of unquestionably good programs from which the great body of radio listeners may choose can be increased up to eight or ten. If so, many different stations can be made regularly available to each of us. There will then be ample opportunity for choice between grand opera, jazz, oratory, and educational productions. The Department is working toward this goal, cautiously, to be sure, but with every confidence that it is entirely practicable.

#### SAFE-GUARDING SMALL STATIONS

**C**LASS B stations with power of from 500 to 2000 watts now afford the most reliable broadcasting service over a considerable area. But the Department still regards the small local stations of great importance to the communities that they serve. Secretary

Hoover, commenting on this situation at the recent radio conference, said:

I know the importance of these smaller stations to the communities they serve. I know that there are millions of crystal sets and small tube sets whose owners are practically compelled to-day to rely upon the stations at their doors and are getting good service from them. These are the people I have in mind and the ones I primarily want to serve, for the owner of the multi-tube set, reaching out for an indefinite number of miles, is pretty well able to look out for himself. I want to see the little fellow get something more than he has now.

From this statement it is evident that any plan for improving the service from the powerful Class B group is not going to involve serious hazards for local use of low-power stations that fit properly into the general scheme of things.

The Department, Judge Davis emphasizes, still regards the small set, even the crystal set, as the most important unit for consideration in planning broadcast regulations.

#### THE SUPER-POWER BUG-A-BOO

**T**HE recent suggestion of Mr. David Sarnoff that one or two very powerful stations using perhaps 50,000 watts should be erected to serve the entire country aroused a storm of protest. Much of the objection came from misunderstanding. Some came from propaganda spread abroad by small-station broadcasters who feared the results of such a development. The Department was quick to answer these objections with the announcement that no alarming or radical changes are being contemplated.

Thus far, Judge Davis explains, only two stations have advanced as far as 2000 watts and only eight or ten are using as much as 1500 watts. This advance has been made in steps of 500 watts and each forward step is closely watched by the Department.

The object of these advances is two-fold: First, an *increase in the dependability* of radio, from the listener's point of view, over the ordinary range of regular reception. Second, an *extension of the effective range* so that the rural districts of the country will be adequately served and afforded some choice of program wherever that is possible. The first of these advantages means regular loud speaker service from stations that now are simply passable contributors to the family enjoyment when head phones are used. The second advantage means widening of the possible field of service without creation of any new stations, new interference, or new expenses.

The useful range of a broadcasting station,



the Department emphasizes, is the area within which signal strength is sufficiently greater than static or other interference that the program is regularly audible at all times during broadcasting periods. Broadcast stations with inadequate power are about as useful as an ordinary telephone beside a pneumatic riveter. We know the message desired is coming through the instrument, but it does us no good. Until we find out how to quiet

In the early days the Department decided that a spacing between stations of ten kilocycles was as close as could properly be used without interference. In other words, they permitted each station to take a seat ten kilocycles wide. Now all the seats are taken and each man must hold his overcoat on his lap and put his hat under his own seat. Naturally it seems a bit more crowded; but, as the Department officials clearly explained, it

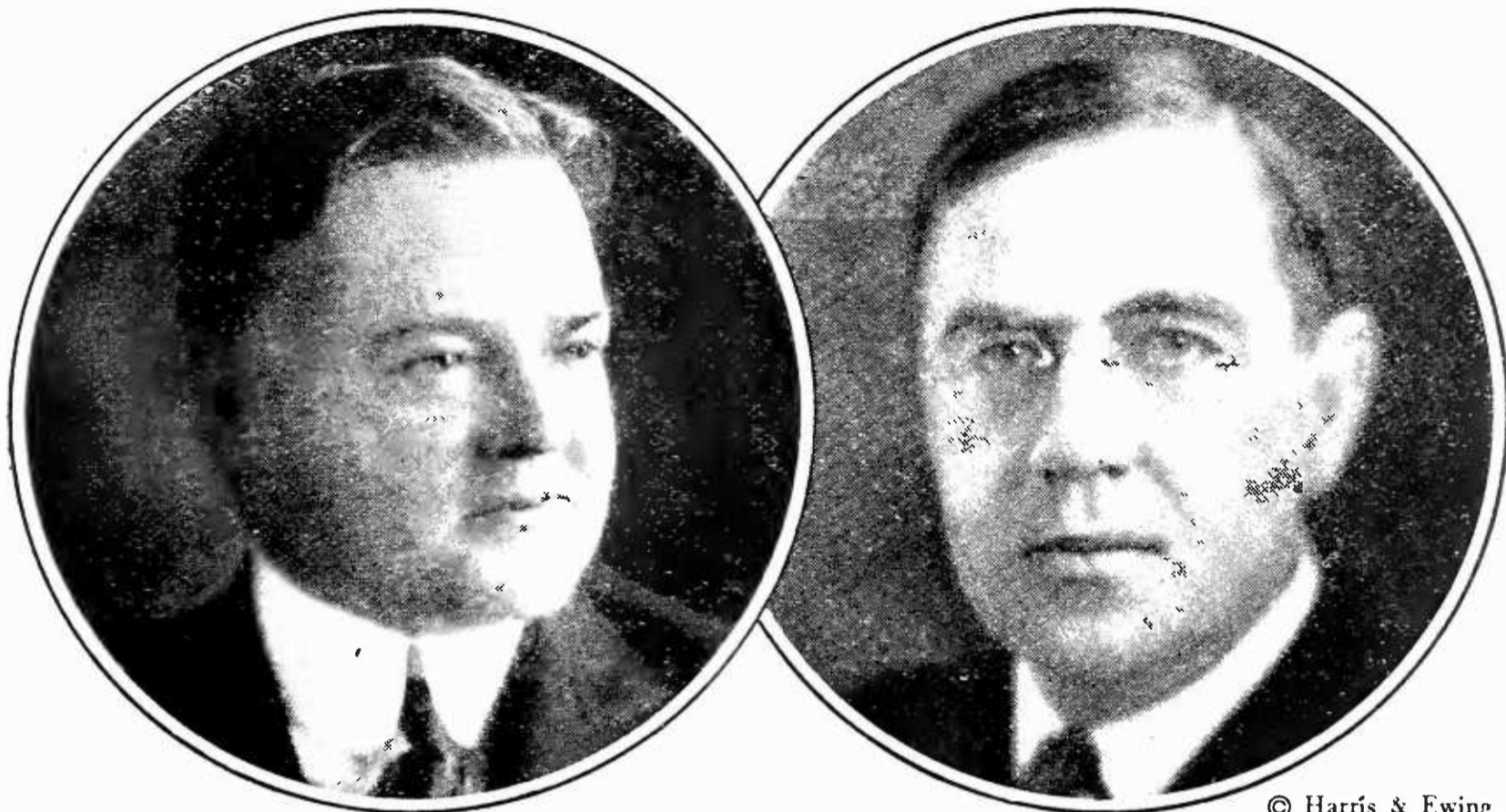

© Harris &amp; Ewing

#### HERBERT HOOVER AND JUDGE STEPHEN B. DAVIS

Captains of the good ship *Radio*. As Secretary of Commerce, Mr. Hoover for the last four years has had to face some very difficult administrative problems, for radio communication has greatly altered during that time. Broadcasting was merely a commercial experiment in 1921. Compare the radio situation when Mr. Hoover took office, with conditions on the fourth of March, 1925, when the whole country was "hooked up" by wire and radio and enabled to hear the inaugural ceremonies in Washington. Judge Davis, as the solicitor for the Department, has been in direct touch with radio affairs and it is known that his opinions are very similar to those of Mr. Hoover's

the riveter of static we have no choice but to increase the power of the station so that we can hear it despite this interference.

#### IS BROADCAST CROWDING ONLY APPARENT?

**I**F WE go to the movies in the early afternoon there is usually plenty of room so that we can put our hat and overcoat in a vacant seat beside us and sit with comfort any place in the theater that we may choose. So it was in radio broadcasting a few years ago. All of the newcomers found plenty of room. They were given wavelengths that allowed all the freedom for careless operation that the crudities of early apparatus made inevitable. But to-day the broadcast territory is as badly crowded as the movies when the town's favorite star is showing in her newest film.

is simply that all the assignments possible are now made, not that there is any closer assignment authorized to-day than heretofore.

The Department undertook a series of experiments during the middle of the winter to see whether a closer spacing was not feasible. In other words, they tried to make each radio seat a few inches narrower. On attempting a seven-kilocycle spacing in this experiment, came the answer very clearly. The Department admitted that the answer was very definitely "No!"

Secretary Hoover has announced this finding in unmistakable language. He says, "The recent experiment of the Department in attempting to increase the number of wavelengths by decreasing the difference to seven kilocycles proved unsuccessful with the present

development of instruments." And, further on in a recent official statement, the Secretary stated that "it is absolutely necessary to maintain a wide kilocycle separation between stations so close together (geographically). Otherwise they will destroy each other." And as the Department well recognizes, they will destroy the listener's patience and interest even more promptly.

#### THE SURVIVAL OF THE FITTEST

**E**VOLUTIONISTS explain that the advance from animal to man occurred by the survival and development of the fittest form of life. In radio, a similar evolution to the high-class station which all can anticipate for the future is now in progress. When one station makes great improvements, the neighboring stations have three choices:

1. They may keep up by making similar improvement.
2. They may confess inferiority by continuing on the old superseded basis.
3. They may go out of business.

The history of radio indicates that alternatives 1 and 3 are about the only possible ones. Judge Davis made this point very clear by a large radio map which hangs on his office wall. On that map blue pins show the Class B stations, green pins the Class A, and black pins the stations that have been, but are no more. At almost every point where blue pins appear they are surrounded by the black markers of discontinued stations, stations which could not stand the pace and therefore quit rather than confess permanent inferiority.

The Department is wondering whether this is not a necessary and logical course to be followed. That station which is most progressive and gives the best service, judged always from the standpoint of the listener, will succeed. The neighboring stations which cannot do so well are not long in learning that their effort and expenditure is producing no advantageous result. It is well from all points of view, even their own, that they should go out of business; fortunately they do.

#### CONCENTRATION WITHOUT MONOPOLY

**T**HE Class B stations, which now afford the widest and most dependable class of service, offer the most serious problem in interference. Any DX fan in the center of the country can safely boast that his set will reach from Orono, Maine, to Los Angeles, and from Winnipeg to Cuba, but his boast is true only when he speaks of Class B stations, for those of Class A rarely have sufficient power to be heard more than occasionally beyond a hundred miles.

In the Class B range there are built or building more than 100 stations, with only forty-seven wavelengths to be distributed among them. So now, on the average, there is less than one wavelength for each two stations, which means that many Class B stations must divide their time of operation. This division of time has led to much difficulty; but the Department, for the present at least, is allowing the problem to solve itself.

#### UNCLE SAM: HOTEL CLERK

**T**HE Department in radio takes much the same attitude as the room clerk at a popular hotel. As evening approaches all of the rooms are engaged, yet there are numerous



DAVID SARNOFF

Vice-president and general manager of the Radio Corporation of America. At the third annual radio conference in Washington which met at the call of Secretary of Commerce Hoover in October, 1924, Mr. Sarnoff suggested that the way to solve some of the broadcasting problems would be to license several very high-powered stations of the order of fifty kilowatts which, located in various parts of the nation, would give dependable broadcast service over a large area. A high-powered broadcast station has recently been erected by the British Broadcasting Company in England

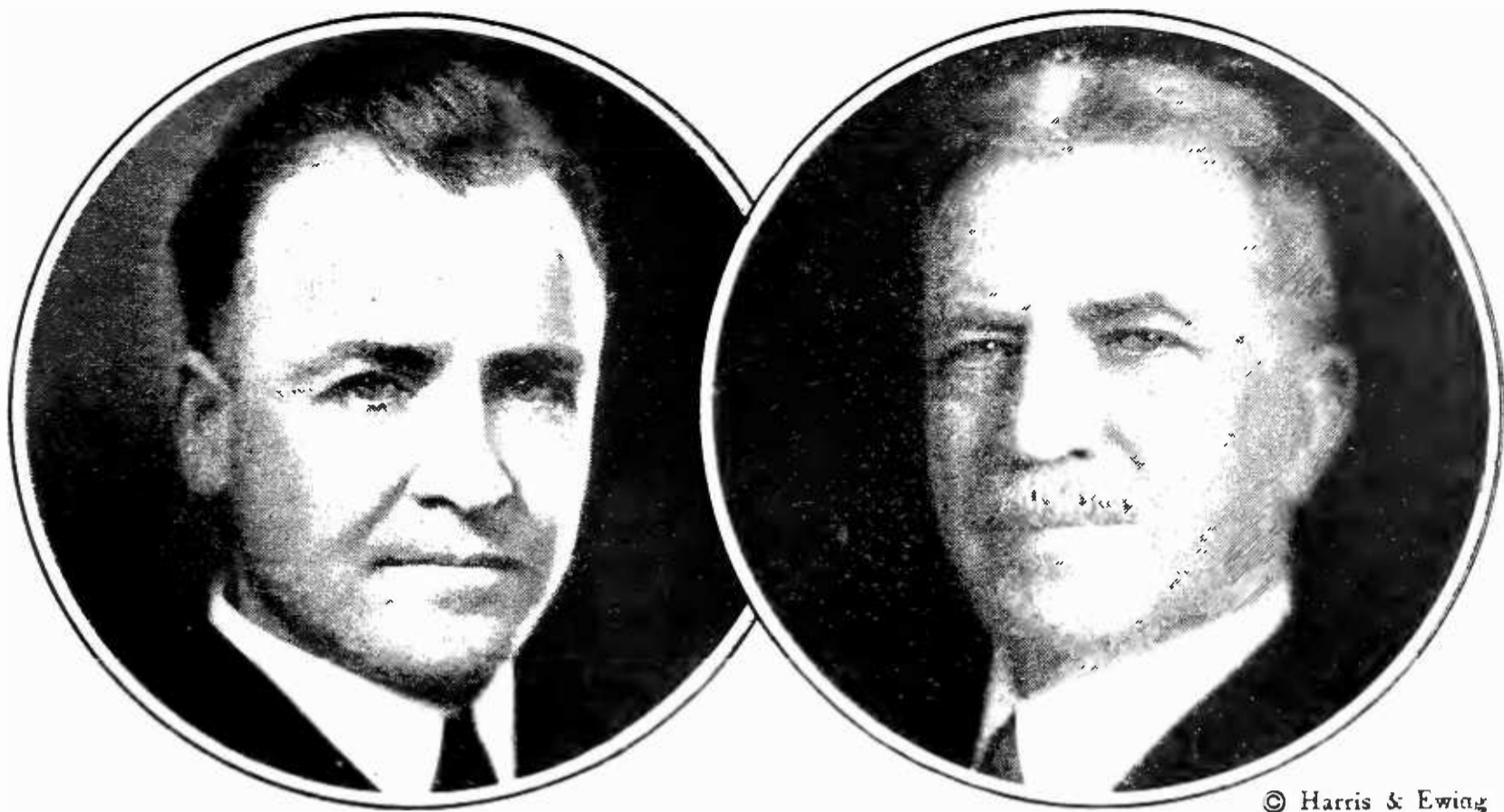

© Harris &amp; Ewing

## DR. J. H. DELLINGER AND D. B. CARSON

Dr. Dellinger is head of the radio laboratory of the Bureau of Standards, which, being a division of the Department of Commerce, works closely with the Radio Service. D. B. Carson is Commissioner of Navigation and is the general supervisory head of the Radio Service

demands for accommodations still to be met. In the radio Class B hotel, it is sun-down and all of the wavelengths are assigned. What does Uncle Sam, the radio room clerk, do? Just what the hotel clerk would do under the same circumstances.

The newcomer arrives and wishes accommodations. If he has a friend who will share with him his room, or Class B wavelength, the clerk welcomes him and makes this room assignment. He is glad to have each double bed filled with two paying guests. If a third friend arrives and the first two are willing to have a cot placed in the room, all are happy and are all accommodated. But if the late-comer does not find such a friend to accommodate him, obviously the clerk will not turn out one of his regular patrons to make room for the newcomer, nor will he insist that the earlier arrival share his bed, or wavelength.

Uncle Sam, in planning wavelength assignments in the Class B wavelength range, takes the same stand. As the Secretary of Commerce puts it, "The Department cannot give what it has not got." And it is perfectly clear that there are no Class B wavelengths left. Hence one can properly read between the lines of the Department's recent statement that *there will be no further assignment of Class B wavelengths* for the present or the near future. Nor will the Department willingly destroy the value of present wavelength assignments by

demanding that they be shared with late-comers.

## "S. R. O." AT THE BOX OFFICE

LET us go back again to the theater for comparison with the radio station. The early-comers, or those who bought tickets in advance, fill all the seats, yet there is a long line at the box office despite the sign "Standing Room Only." Uncle Sam, with no radio seats in the Class B orchestra, has hung out his "S. R. O." sign, too. But he will, in fact under the law he must, grant licenses and assign wavelengths. He does this by a ticket of admission which entitles the new broadcaster to work only in the Class A range, 205 to 280 meters. In this range he is not comfortably seated as a member of the radio broadcasting party. He finds himself standing behind the back seats, jostled by other late-comers, and seeing the performance at great disadvantage. But he is simply paying the penalty as a late-comer.

If some of the present Class B stations discontinue service or cease to give service adequate from the public point of view, their licenses, which are renewable every 90 days, will doubtless not be renewed for comfortable third-row aisle seats. In fact, Uncle Sam, just as the theater management, reserves the right to withdraw the admission ticket at any time. Hence a disorderly station, like a dis-

orderly spectator, will promptly find himself outside. As one leaves, another may be seated. The place he gets depends upon the appropriateness of location, service proposed, and wavelength thus made available.

#### THE CINCINNATI "ROW"

RECENTLY, a controversy over division of broadcasting time in Cincinnati was not promptly settled by the local Class B stations, two of which for several nights broadcast simultaneously on the same wavelength. The Department officials were asked in this and in one other similar case, "What are you going to do about it?" The answer was very simple, "Nothing."

If two stations insist on killing themselves and each other, the Department is perfectly willing that they should do so but it will not allow this situation to interfere with public service. Two such disorderly patrons of the radio hotel will be permitted to settle their

controversy outside. The wavelength which they should have agreed to share peaceably will very promptly be given to someone else who will use it in the public interest.

Only one or two such examples will be ample to demonstrate to broadcasters that the public interest must be served. On no other basis can the radio broadcaster exist. On no other basis will he be permitted to retain his Class B license.

#### POLICING IS NOT CENSORSHIP

THE Department properly is insisting that each station maintain a certain technical standard of service and that it stay properly on its own wavelength. But the Department is equally emphatic that this is policing, not censorship.

Judge Davis explains that neither he nor any one else in the Department is willing to assume that they know enough to determine on behalf of the public what may and what



#### WHERE AMERICAN RADIO ACTIVITIES ARE CONTROLLED

The Department of Commerce building in Washington. Here, in the Bureau of Navigation, Radio Service offices, the administrative lines run to the entire nation. The Department controls every amateur operator with a transmitting station and every commercial ship and shore station, as well as the very host of broadcasters. The radio inspection staff and the appropriation supplied them has never been large enough so that the inspection duties could be adequately done

may not be broadcast. Whether such a station provides jazz or education, whether it runs from six o'clock to midnight, or from midnight to noon, is not defined or regulated in any way. The public is the judge, and the public makes its wishes known in no uncertain manner to the broadcast station which does or does not serve its needs or whims.

But providing all this power over the stations for the listener is not an easy matter, and at times the Department does not get undivided encouragement and support from the public. One difficulty which has been raised by the effort to protect the Class B wavelengths against undue crowding is the vigorous protest of some listeners that they cannot separate accurately all of the stations in the Class A group, the band from 205 to 280 meters. Naturally they cannot; and as crowding in that band becomes worse, the difficulty will be greater. But this crowding is in the public interest. It means that nine tenths of the useful wavelength area is reasonably safeguarded by suitable spacing between wavelengths and only one tenth is crowded. As the listener understands the great advantage of this, the Department hopes that it may gain even greater support for this idea. Certainly from the point of

view of the public, nine-tenths of the radio loaf is better than none.

ALMOST since 1912 when the Department of Commerce was charged with the enforcement of the radio laws, and certainly since the advent of broadcasting, they have struggled along as best they could, making Herculean efforts to accomplish their tasks with the pitifully small staff and Congressional appropriation granted them. The radio affairs of the country are supervised from nine district offices. If each radio inspector had an equal territory, that would give each one five and one third states to look after. And in some district offices, an inspector and one or two assistants are expected to do all the work.

The recommendations of the radio conference, called in October, 1924, by Secretary of Commerce Hoover, were the consensus of the "best minds" of radio who were gathered there. It is generally agreed that the reason the changes suggested were not put in force was because the Department was so crippled in available funds and in personnel that any additional undertakings on their part were absolutely out of the question.—THE EDITOR.

## THE DISTANCE FIEND

**H**E WAS a distance fiend,  
A loather of anything near.  
Though WOLF had a singer of opera fame,  
And WOW a soprano of national name,  
He passed them both up for a Kansas quartet  
A thousand miles off and hence "harder to get."  
New York was too easy to hear.  
He was a distance fiend.

He was a distance fiend,  
His radio ruling his life.  
When he and his family went to the play,  
He'd take them to Yonkers instead of Broadway.  
The show being over, he'd blow to a bite  
In far Staten Island, that very same night.  
God pities his daughter and wife,  
He was a distance fiend.

He was a distance fiend.  
Alas, but he died one day.  
Saint Peter obligingly asked would he tell  
His choice of a residence—Heaven or Hell?  
He replied, with a show of consistency fine:  
"Good sir, you have hit on a hobby of mine.  
Which place is the farthest away?"  
He was a distance fiend.

—A. H. FOLWELL, in *The New Yorker*

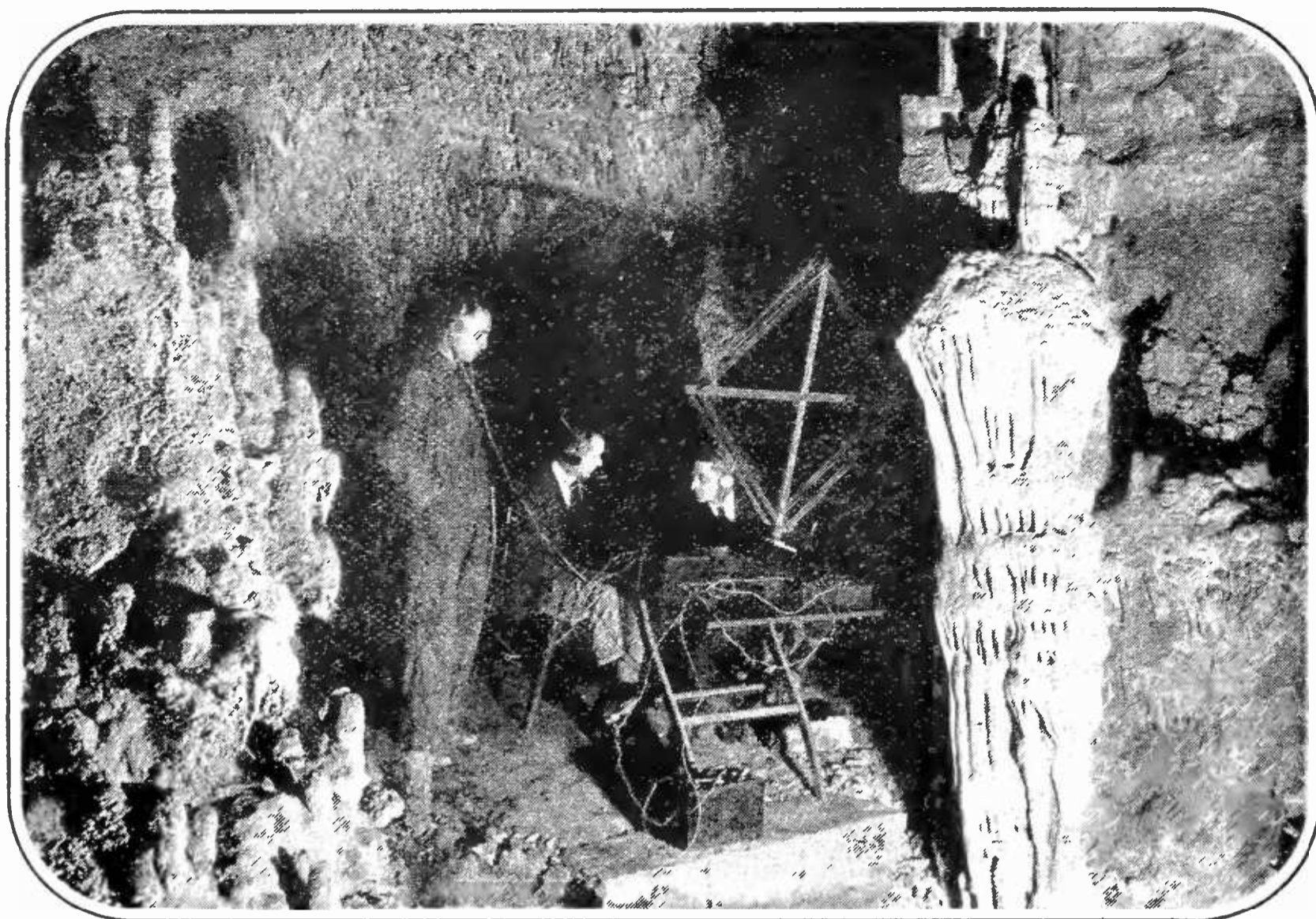

#### RADIO IN A VIRGINIA CAVE

Endless Caverns at Newmarket, Virginia. Experiments with radio reception have been tried in many unusual locations from coal mines to bank vaults, but it is doubtful if any radio equipment has been located in more picturesque surroundings

## THE MARCH OF RADIO

BY

*J. J. Morecroft*

Past President, Institute of Radio Engineers

### What Does the New Allocation of Broadcast Wavelengths Mean?

**J**UST why the Department of Commerce reallocated many broadcast wavelengths is not evident. "The Department of Commerce has been engaged for some time in an attempt to divide the ether more efficiently than has been the case hitherto," was the announcement from Washington. Here are some examples of the new assignments: WEAJ 491.5 meters, instead of 492, WGBS 315.6 instead of 316, WJY 405.2 instead

of 405, WHN 361.2 instead of 360, etc. These changes are so insignificant that just what is gained is not at all evident. Certainly no new channels have been created by such diminutive shifts from former wavelengths. The changes are so small that unless very careful observation was made before and after the change, the average listener would not realize that any change had been made. If for example, WJY tuned at 30 on a condenser dial before,

it will now tune at 30.03, but such a shift is much less than the width of one of the division marks on the dial. Most of the changes in the other well known stations are of equal insignificance insofar as the average listener is concerned.

### The First Presidential Radio Inaugural

**G**REATER and greater become the radio audiences which are invited to attend the country's important events. When President Coolidge took the oath of office on March 4, the whole country was enabled to listen-in, and we must add, his speeches generally make very good listening. At least 21 stations participated in the broadcasting network, extending from Boston to San Francisco, and from St. Paul to Atlanta. This was the Telephone Company group and in addition, WRC, WJZ, and WGY of the Radio Corporation were tied in by their own wires.

It must give President Coolidge increased courage (if such were necessary) to reaffirm his stand for safeguarding the country's funds—this idea of realizing that he can talk directly to probably 15,000,000 of his countrymen.

We hope that soon Congress will be forced to broadcast its activities. Verbose senators may have their activities somewhat rationalized and sobered if they realize that secret chamber procedure is no longer available to them. Not very many

of them would care to vote in the affirmative to increase their own salaries immediately after the president had outlined his economy program—that is, they wouldn't care to if they knew that a few million of their constituents were listening carefully to their words.

### What Membership in the Institute of Radio Engineers Means

**F**REQUENTLY we get inquiries about the status of some radio writer who signs himself "radio engineer" or some such title, or declares his status by giving membership in this or that society. It is perhaps pertinent to explain the significance of membership in the Institute of Radio Engineers. Insofar as we know, this is the only bona fide association of radio engineers in existence.

In its membership of about 2500, three grades are recognized, and the ranking of a member in one or the other of these grades gives a very trustworthy estimate of the man's standing in the radio profession.

Anyone of mature age who is actively interested in radio may become an Associate member of the Institute. The applicant has certain formalities to go through, such as filling out a regular membership blank giving his training, business, references, etc., but no difficult conditions are imposed to hinder him from becoming an associate member.

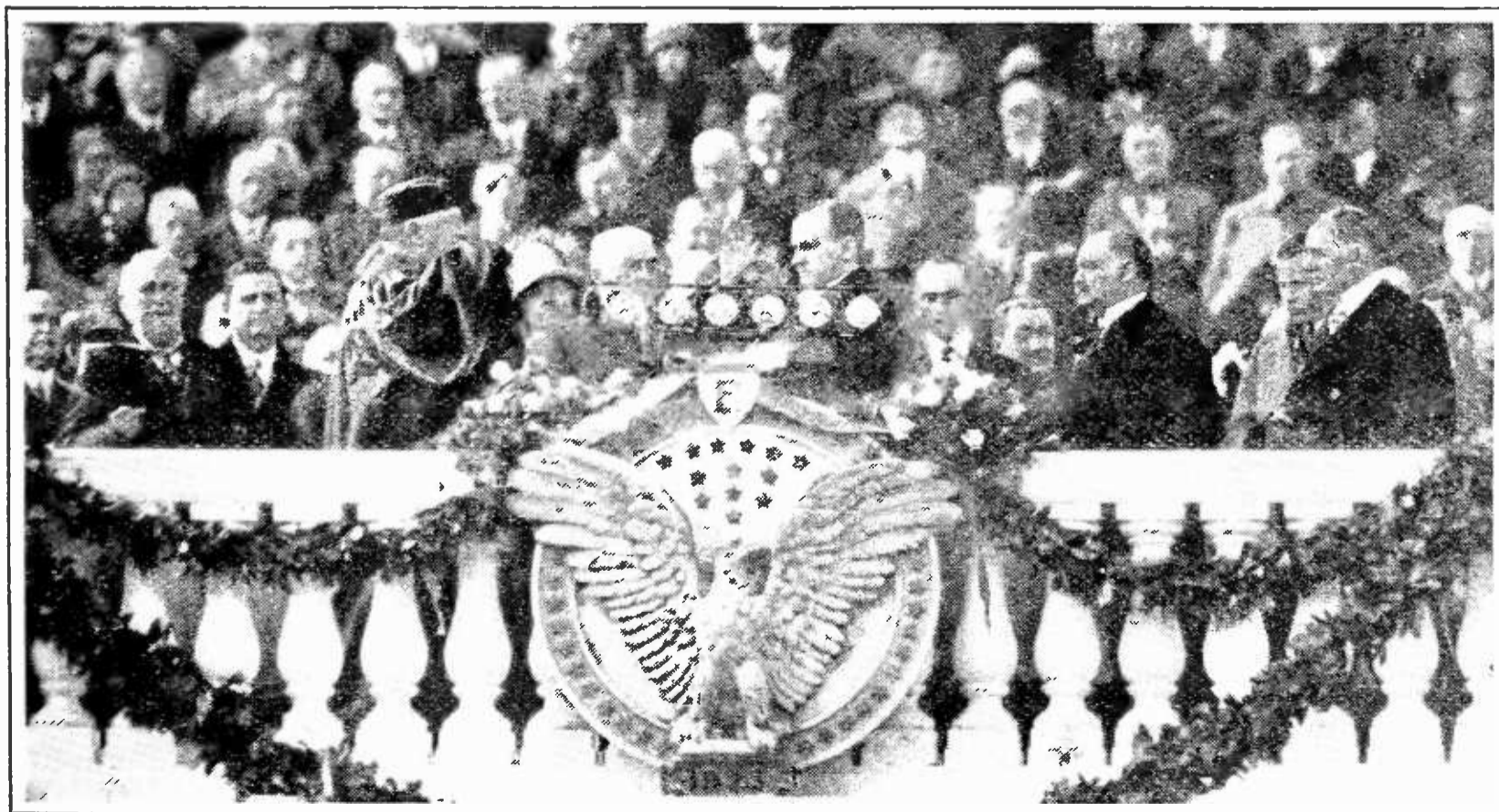

THE FIRST RADIO INAUGURATION

President Calvin Coolidge, taking the oath of office from Chief Justice William Howard Taft, of the United States Supreme Court. March 4, 1925, was the first time in American history that an ex-president administered the oath of office to an incoming president. The twenty-four stations which broadcast the ceremonies practically linked up the entire nation

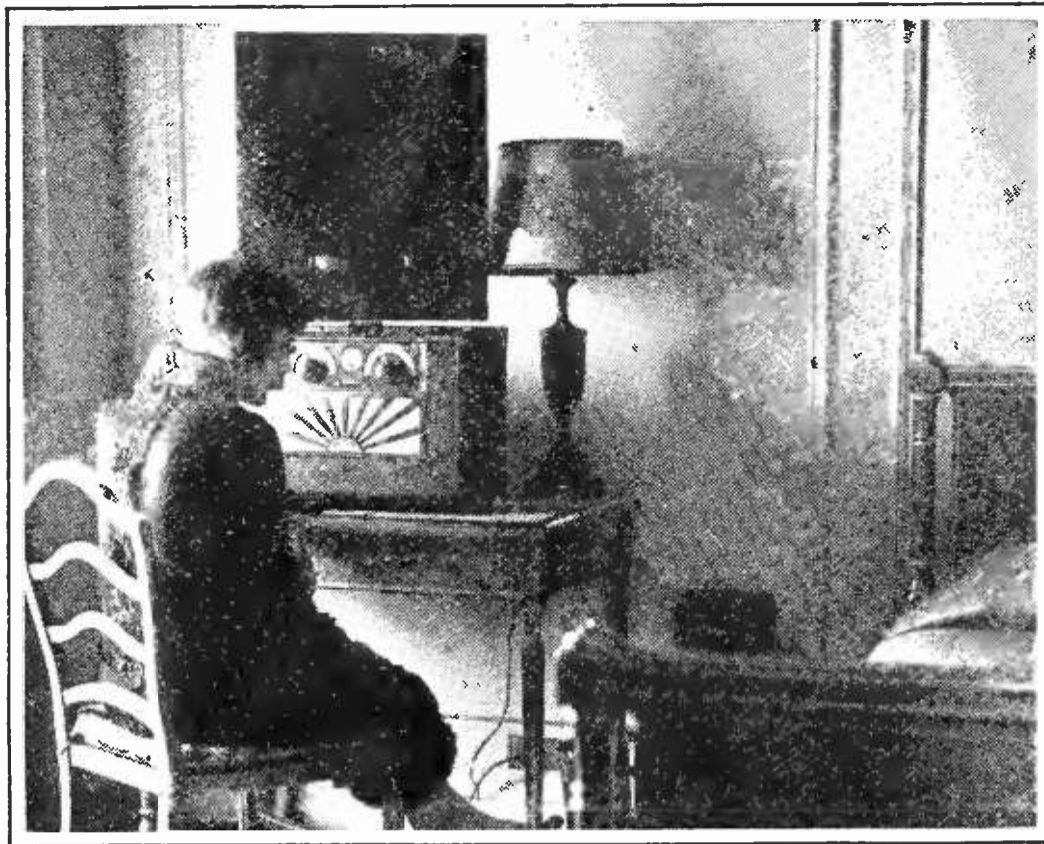

ENGAGING A HOTEL ROOM AND RADIO

Is now possible at the Drake Hotel in Chicago, the Roosevelt in New York, and the Benjamin Franklin in Philadelphia. A portable set is installed in the room of the guest ordering it. Having an individual receiver allows the guest to select his own radio entertainment. In some large apartment houses, hotels, and hospitals a central receiver has been installed and the output is then wired to the various rooms. The disadvantage is that but one program can be heard at a time and little or no selection is offered the guest

The rank as Associate I. R. E. does not carry with it any certification by the Institute that the member is or is not a capable radio engineer.

To become a member of the Institute (Member, I. R. E.) a man must submit to the Board of Direction a record of his radio achievements. This record is carefully scrutinized by men who know the radio field well. Membership is given only if the man's record shows him to be a capable engineer of sufficient ability to carry out any ordinary radio project. Possibly one quarter of the total membership of the Institute have the rank of member and in this group will be found practically all those engineers who are responsible for modern radio development.

The Institute has for its highest grade of membership that of Fellow. This rank is bestowed only upon those few engineers who have proved themselves leaders in the radio field. Probably less than one twentieth of the total membership has been given this highest rank.

### Radio a la Carte

**T**HE Hotel Roosevelt, New York among others has installed a novel radio service. Instead of putting a receiving station on the roof and installing wires to the guest's room as has been done in some of the larger

apartment houses in New York, the management of the Roosevelt has decided that the guests could be better served by putting actual radio sets in the rooms. To start the experiment, a dozen portable receivers with self-contained loop antennas have been purchased and are at the call of any guest. Presumably the management will see that the sets are maintained in good condition, and the guest has merely to ask for radio service, and a receiving set will be dispatched to his room at once and he may tune-in on any station he desires.

### Broadcast Licenses Should Be Granted Only on Petition

**A**S CHURCHES, hotels, Elks, Klansmen, and apparently everyone else, scramble for broadcasting licenses, and get them, the question must occur

to any one with common sense, where is it all leading to and why should the practice be kept up? What policy controls the Department of Commerce in issuing licenses? Or has it no policy? Is the real situation the same as the apparent one—that any one can get a broadcasting license who applies for it?

Apparently feeling that he owed the public some comment on the rapidly congesting condition of the radio channels, which is accumulating under his direct supervision, Mr. Hoover recently issued a long statement on the radio situation parts of which we quote:

There are at present 563 broadcasting stations in operation, or under construction. The most difficult problem in radio regulation and development is the distribution of wavelengths in such a way as to prevent interference between stations. There are in all 86 different wavelengths available, if we keep the stations 10 kilocycles apart and stagger the assignment of wavelengths geographically so as to prevent overlap in the area of effective reception.

The recent experiment of the Department in attempting to increase the number of channels by decreasing the difference to 7 kilocycles proved unsuccessful with the present development of radio receiving apparatus.

All through the lengthy document we searched to see if Mr. Hoover did not expect some time to lessen his license-issuing activities. There is no mention of it. It looks as



though the Secretary thought he had no discretionary power in withholding permission from the new stations, or else that he greatly feared to use it, but that conclusion scarcely seems justified in view of the personality of the present Secretary.

According to one of the writers in the *New York Times*:

There is difficulty in seeing just what excuse there is for granting the broadcasting privilege to one applicant and denying it to others equally reputable. Nevertheless a justification for drawing the line somewhere on mere numbers of grantees must be found if radio is to progress toward the realization of its possibilities, or if it even is to retain those which it now demonstrates.

Some time soon Mr. Hoover will have to say "No, I cannot see that the interests of the radio listener will be served by granting you a license, so I must decline to issue one to your anticipated station." It seems as though someone is missing the real idea of radio's possible progress. The issuance of a license should not depend upon either precedent, favor, standing of the applicant, fear of embarrassment, or any other item of this nature. As many of our correspondents continually point out, the question Mr. Hoover has to ask himself is, Do the listeners want this proposed station? If they don't want the station then the license should not be granted.

We venture to suggest that a new applicant be obliged to accompany his request for a license by a petition, signed by at least 100,000 people who live within, say 50 miles of the site of the proposed station. The number of required petitioners should depend upon the locality—around Chicago and New York it might well be 1,000,000, and in sparsely settled country, possibly

50,000 or less. This procedure would decide the question just as it should be decided—in the interest of the radio listener.

### Will the British Receiver License System Fail?

WE HAVE mentioned once or twice that if this government should ever decide to take over radio broadcasting and should attempt to maintain the service by collecting revenue from the listeners in the form of a tax or license, it would require a tremendous force of collectors with hundreds of thousands of warrants, to make the collections good. We think that the broadcast listener does not want to be licensed, and if the good American public does not want to pay a license fee, it probably won't. The nation has been told to stop drinking intoxicating liquor for some years now, but hasn't yet agreed to submit to a ban on what is still regarded by many as a "legitimate," even though unconstitutional, privilege.

There are several countries where license fees from the listeners are depended upon for maintaining broadcast service, among them, England. We can safely say that the Eng-

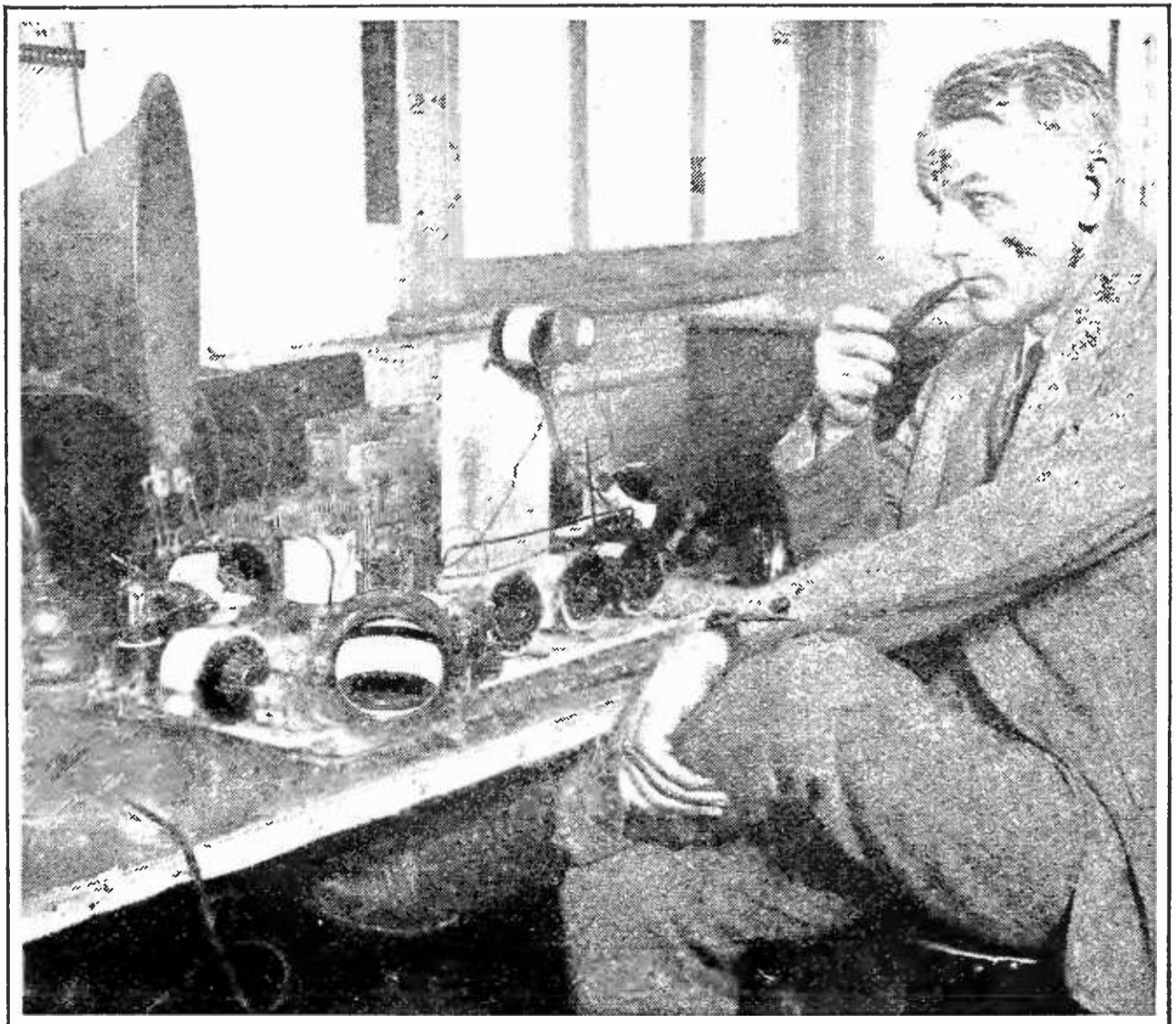

ROY A. WEAGANT

Chief Engineer of the De Forest Radio Company, at work on a receiver circuit in his laboratory

lishman is a more law-abiding citizen than we are. The Post Office authorities, who have the task of supervising British radio, estimate, says a news dispatch, that there are 2,500,000 pirates, who have listening sets but who have not paid the government fee. A bill is urged to permit drastic punishment for these ether robbers. Twelve months' imprisonment or \$500 fine has been suggested. Even should such a measure be enacted, trouble would still be encountered because before entering a man's house a warrant is required, and the promiscuous issuance of search warrants would certainly arouse a tremendous antagonism in a land where every man's cottage is supposedly still regarded as his castle.

If there really are 2,500,000 radio pirates in England, it doesn't augur well for the license system of control. If these reports are accurate, it looks as if the license system in England is doomed to fail in the very near future.

### Radio Quality Will Count

AS WE glance through the radio advertisements each month, it is only too plain that many radio firms, like Kipling's ships, "pass in the night." Many a man who knew nothing whatever of the radio

game, was persuaded by some overenthusiastic adviser that "mints of money" were to be gleaned from the radio public. All one had to do was to get something which sounded like radio and then spend lots of money on advertising. After that it was to be nothing but a matter of counting profits. These inexperienced radio adventurers are the ones who come and go—but few of them last to enjoy the confidence of the radio public.

As these bargain-apparatus firms start up with apparently a tremendous price slash over the older and more conservative firms dealing in the same line of goods, it must frequently seem to these manufacturers that their sales are due for a slump. But they don't slump and if the quality is maintained high, they won't. New as radio is, people already realize that the apparatus with a name behind it is probably worth more than the nameless waifs with which the irresponsible store has its shelves loaded. A reliable firm name means much in the paint, steel, or tool business. Conservative radio firms, whether they manufacture panels, binding posts, condensers, or what not, will soon start to reap the benefit of their reputation. It probably won't be very long before the radio public learns to buy "by the name" rather than "by the price."

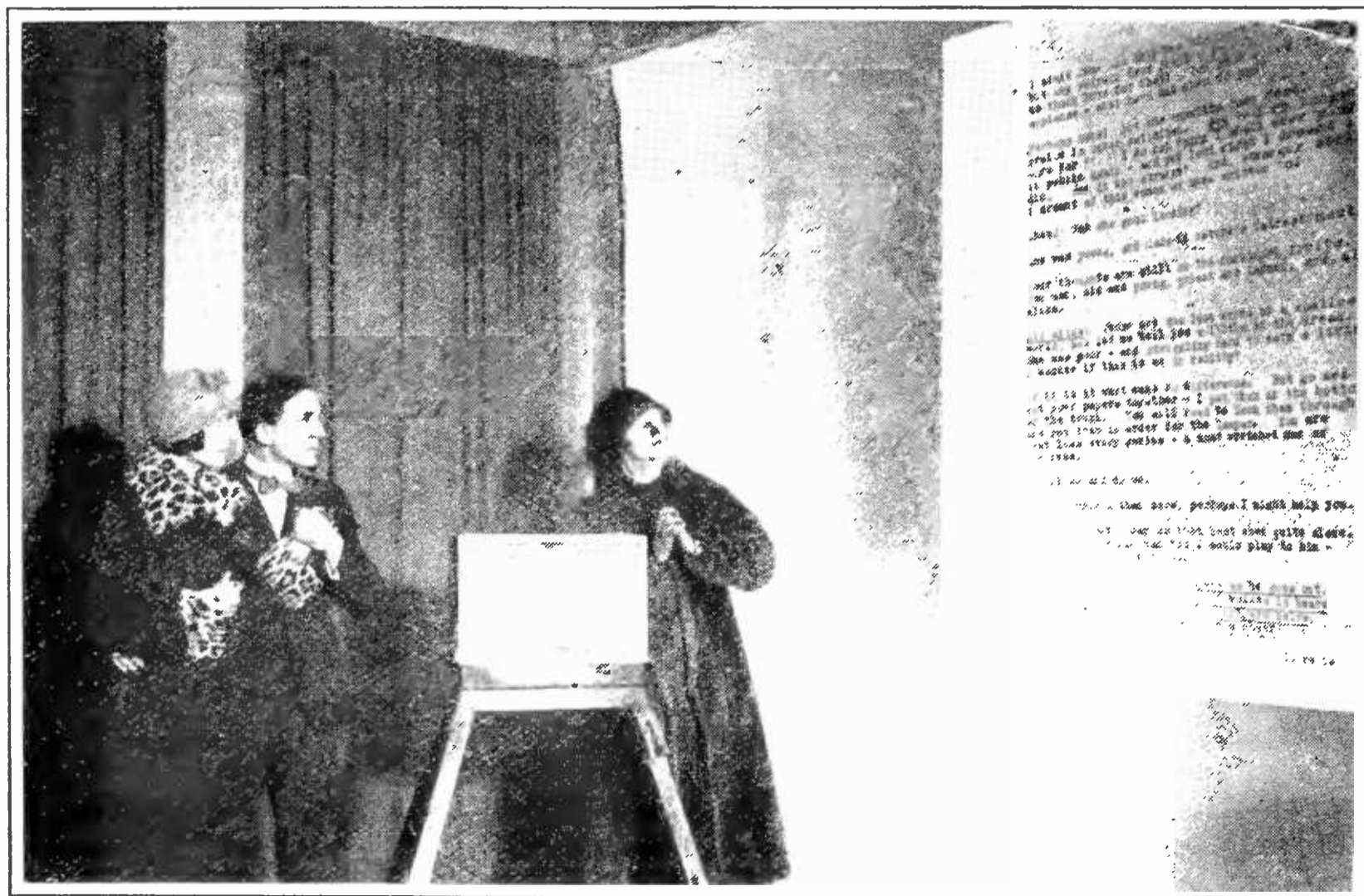

THE WRITING ON THE WALL

During the presentation of a radio play in an English broadcasting studio. The typewritten pages of the manuscript were projected on a screen on the studio wall where all could see it. The microphone, English style, is enclosed in the rectangular box in the center

## Vacuum Tubes in Another Legal Tangle

JUST before the De Forest audition patent expired, the attorneys for his company brought about an action which had a startling effect upon the Radio Corporation subsidiaries. In the United States District Court at Wilmington, Delaware, Judge Hugh M. Morris, granted an injunction which stopped the Radio Corporation's sale of tubes manufactured by the Westinghouse Lamp Works. The case involved nothing of direct interest to the radio listener. It seemed merely to be a legal squabble.

When one stops to think of it, the legal profession seems to be the most inbred union in existence. You have to be a lawyer to make a law, and you have to be a lawyer to prove that someone else is breaking a law. Furthermore, one can't become a lawyer unless the rest of the union wants him, because the lawyers write the entrance examination for the union. One set of lawyers draws up a legal document to permit a lamp company to manufacture vacuum tubes and another lawyer hails them into court to show that their law was bad. It appears that the De Forest agreement which would permit the Westinghouse Electric and Manufacturing Company to manufacture tubes would not permit the Westinghouse Lamps Works to do so, even though it is acknowledged by all that the Lamp Company is simply that part of the Westinghouse Company which had the facilities for making tubes. The Manufacturing Company is equipped for making motors and all kinds of electrical machinery, but not for turning out delicate lamps and vacuum tubes, and so naturally turned its

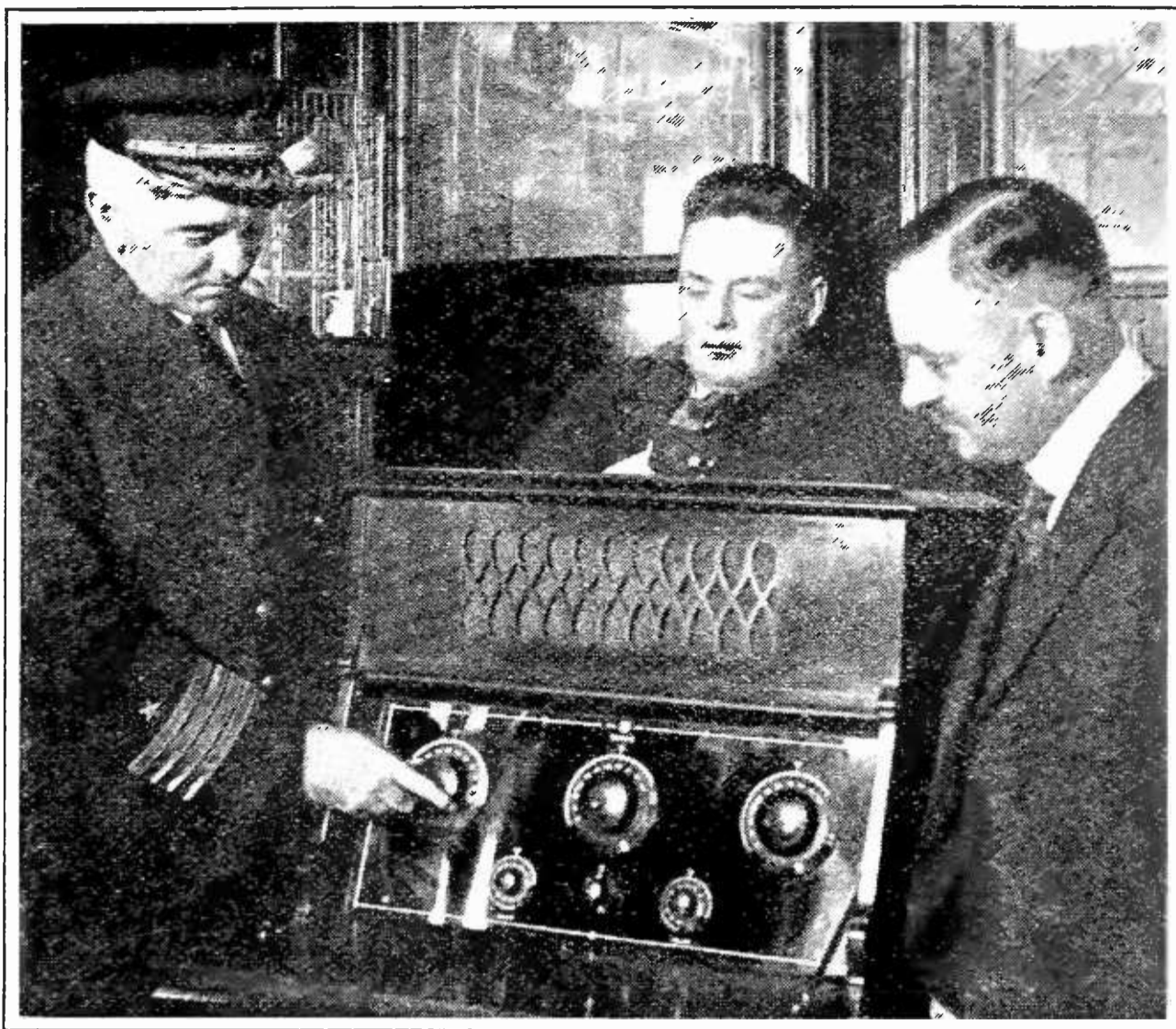

ABOARD THE S.S. "GEORGE WASHINGTON"

Captain Cunningham has a broadcast receiver which he uses in the time he can spare from his nautical duties. Captain Cunningham was navigator of the U. S. A. T. *Leviathan* during the War. From left to right, Captain Cunningham, W. J. Roche, and T. H. Rossbottom

tube activities over to the lamp division. Judge Morris ruled that even though the parent company had the right to manufacture tubes, the Lamp Company had no such right and all the tubes it had wrongfully manufactured must be confiscated and held.

So the lawyers go, one getting a company into trouble, so that another can get it out. It looks as though in this case the attorneys for the De Forest Company have been a little bit shrewder than those of the Radio Corporation.

## Radio Dispute in Cincinnati

THE ever increasing number of broadcasting licenses issued by the Department of Commerce is practically certain to bring trouble in a short time, in ever increasing amounts. Some method of equitably limiting the number of stations must be found by the Department. It is their job and they might just as well tackle it now.

A strange instance of the Department's inactivity took place in Cincinnati. Two stations in that city had been granted licenses to operate on the same wavelength. After much squabbling as to the proper division of

time, they finally did operate on the same wavelength—at the same time! It was reported from Washington that the Department of Commerce had been repeatedly asked to step in and settle this impossible situation but had declined on the ground that to set such a precedent would get the Department hopelessly enmeshed in a maze of disagreements between stations.

One might well ask the Department how it did expect such disputes to be settled. It is a strange idea of privilege and duty which consents to the issuance of broadcasting licenses to any who want them and then when trouble comes to the listening public as a result of the excessive number of stations, to turn one's back and let someone else settle the trouble—trouble directly due to the Department's freedom with its licenses. Who, we may well ask, does Mr. Hoover think will step in to straighten out such troubles between the various stations, if his department thinks the task too onerous?

### Making Radio Transmission Surer

**I**N A recent talk before the American Institute of Electrical Engineers, Mr. Alexander-son, chief consulting engineer of the Radio Corporation, gave a general description of their network of channels which is being

rapidly extended over the earth. After outlining general troubles and difficulties which an engineering audience could well appreciate, the speaker went more into detail to show how the Radio Corporation was continually working to increase the certainty of communication over their radio links. He spoke of the remarkable wave antennas used at Riverhead, over which signals from all the stations in Europe are received. Although static has not been annihilated by the R. C. A. engineers, this reception scheme of theirs ensures communication unless there is a severe local thunderstorm. To obviate the possibility of such a storm interfering with transatlantic channels, another receiving antenna has been fitted up in Maine, so that either can now be used, depending upon where the atmospheric disturbance is least.

He spoke of new features in short wave transmission, a so-called high-angle beam. If one could rely upon his rather scanty description, it appears that he thinks it may be possible to send short wave energy from one place to another by some kind of beam system which is directed high up in the air, to come down at a desired spot by reflecting from the earth's upper conducting atmosphere. This story reads more like a poet's dream than like an engineer's narrative, so don't give it too much credence as yet.

It may be possible to send beams of energy high up into the sky and so around the Heaviside layer, but it is more likely that such an effect will be found in England than here. America has done practically nothing with directed beam transmission, but Marconi and Round seem to be progressing continually along just these lines.

If directed beams sent high into the air actually get much farther than those sent along the earth's surface they would probably have found out and reported it to us long ago.

### The Day of Good Music

**V**ERY recently a most welcome announcement was made by Mr. John A. Holman, broadcasting manager of



LAYING A ROGERS UNDERGROUND ANTENNA

At Hyattsville, Maryland. Dr. J. Harris Rogers is nearest the camera. The Rogers system has been developing experimentally for some time and has been watched by officials of the War and Navy Departments

station WEAJ. The public's demand for jazz has greatly decreased, he asserts, as evidenced by the letters received from the station's listeners. Of the many thousands of listeners who now write in, by far the most want good music, he says; and thanks be, say we, that the managers are waking up to the fact that the whining, croaking, saxophone with its associated agony-producing pieces of barbarism, are due for the discard, as far as the radio listener is concerned.

Mr. Holman evidently thinks there has been a change of appreciation on the part of the listeners, but we doubt this very much. The letters no doubt indicate such to be the fact, but it seems more likely that the admirer of jazz would write enthusiastic letters to the broadcaster more often than a lover of Chopin and Mozart. The appreciator of jazz is the one who makes the most noise, just as a dozen wild American-Irish would make enough noise against such a speaker as Mr. Lloyd George to drown out the approbation of the remaining 2000 in the audience. This has probably been the case with the radio audience—those who wanted good music are the quiet type who suffered much and long before remonstrating against the finally unbearable monotonies of much of the modern jazz.

### What the Radio Corporation Did in 1924

SEVERAL points in the annual report of President Harbord of the Radio Corporation for the year 1924 demand comment. We think it is only fair to give the Radio Corporation credit for being the first to inaugurate broadcast concerts by well-known phonograph recording artists. The idea, which was later taken up by the American

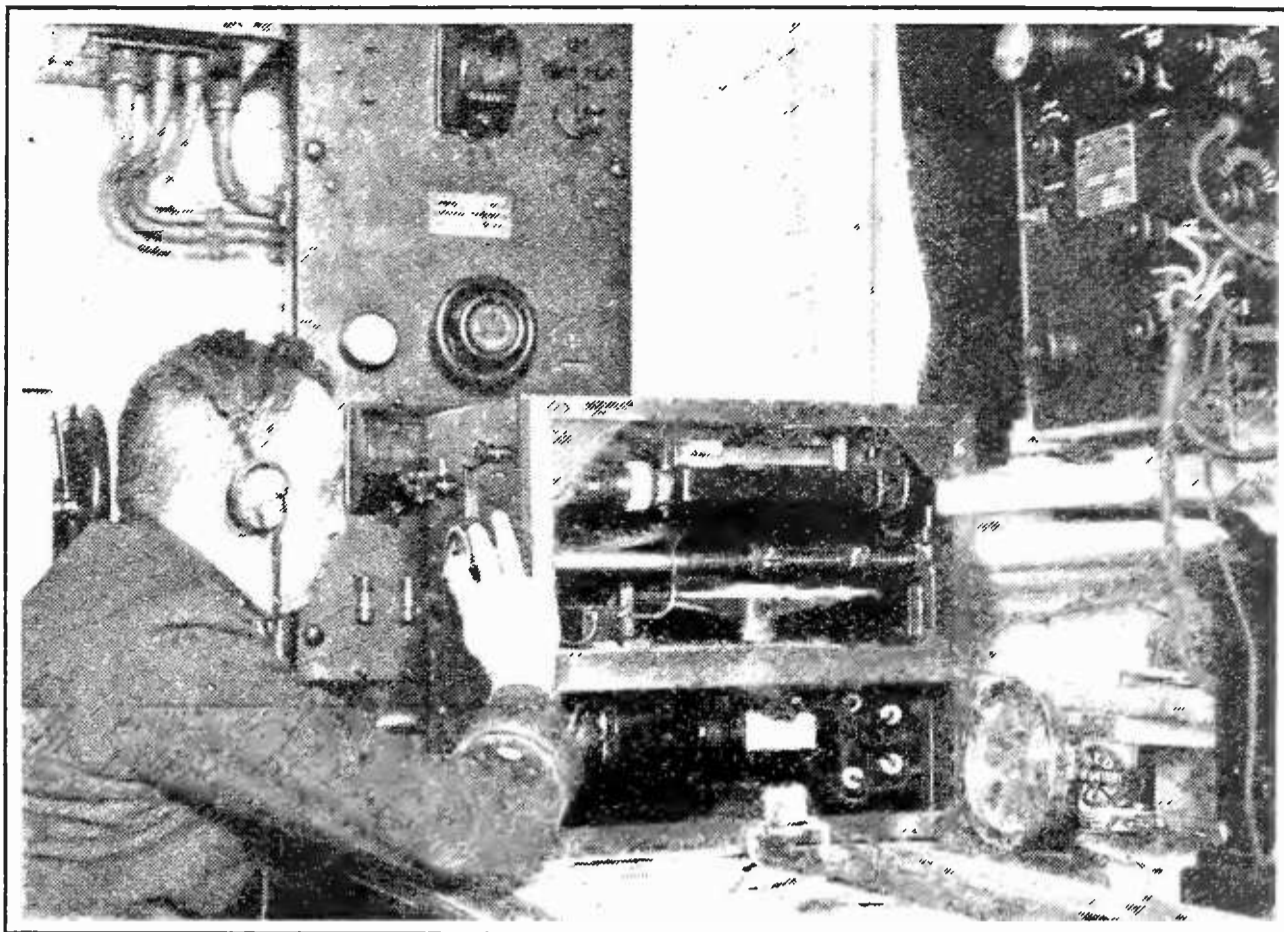

### CHARTING THE DEPTH OF THE PACIFIC OCEAN

With the sonic depth finder, a new application of well-known radio principles. The apparatus projects a vibration which follows through the water to the ocean bed; it is then reflected back. The elapsed time is measured from which the depth of water can be calculated. Lieut. Clore of the U. S. S. *Pioneer* is shown in the radio cabin of his vessel operating the depth finder

Telephone and Telegraph Company with much success, originated in an agreement between the Radio Corporation and the Brunswick-Balke-Collender Company. This innovation in broadcasting programs was an inspiration, and it is a pleasure to record our appreciation of its inception.

In speaking of the value of the radio business, General Harbord made the interesting statement that for every dollar spent on musical instruments of all kinds, phonographs, pianos, and organs, seventy-five cents was spent on radio. Radio business was about three-quarters that of the entire jewelry business of the United States.

In transoceanic traffic, radio carried between twenty and thirty per cent. of European traffic, and fifty per cent. of the trans-pacific messages. Apparently the proportion of radio to cable messages is not changing very rapidly, as it is our recollection that about the same proportion existed during the previous year.

### Radio Raises Cable Earnings

INSTEAD of taking business away from the transoceanic cables, the development of radio appears actually to have put money into the coffers of the cable companies, according to a statement of Clarence H. Mackay. Mr. Mackay says that the Commercial Cable



E. F. W. ALEXANDERSON

Schenectady; Chief Consulting Engineer,  
Radio Corporation of America

*"There is a large and growing group of amateurs who pursue radio for the love of the art. The art to them is not the performance in the studio but the technical art of radio itself. Radio has enjoyed a greater following of amateurs than any other branch of engineering, and it is the thought of these amateurs that moulds the future. They are one step closer to reality than the imaginative writers, like Kipling and Jules Verne, who give us glimpses of the future long before they can be realized. The amateur likes to anticipate what advances in the art may reasonably be expected within the next decade"*

Company had handled more business over its cables in 1924 than during any previous year of the company's existence.

The changing economic situation in Europe was reflected in a growing demand for cable service, and as for radio's encroachment on the cable's territory, Mr. Mackay says "on the contrary, the radio has actually stimulated the use of electrical communication between the continents, and of the new business so created, the cables are really getting more than their proportionate share."

### Mr. Sarnoff As An Optimist

SEVERAL times during the last decade the press has chronicled that someone had laid low Demon Static and that hereafter, by the application of some heaven-born device, radio was to be freed of troublesome atmospheric disturbances. Too well now, we know that these were all illusions.

But now Mr. Sarnoff, General Manager of

the R. C. A., strikes an entirely different note when mentioning static. At a recent dinner he ventures the opinion that static, after all, is not an unmixed evil.

I often wonder, whether the same minds saw the limitations of radio telephony because of the lack of secrecy, and now see a limitation of radio because of static, might not be disappointed to wake up some morning in the future to find that the static, which is all-pervading, represents a great and free gift of nature to man, who may yet learn to harness that energy, get it from the air, and make it do a great work for man.

Not seeing through the same rosy-hued glasses as does the speaker on this occasion, we venture that the man who gets static out of the air, no matter what he does with it after he removed it from the radio realm, will already have done a great work for man.

Incidentally, Franklin with his kite did show us exactly how to do this thing quite some years ago, didn't he?

### Interesting Things Interestingly Said

DR. WILLIS R. WHITNEY (Schenectady; director of research for the General Electric Company): "We are building a \$150,000 laboratory to be devoted to research in the field of directional radio and short wavelengths. Our experimenters have obtained results on wavelengths on less than fifty meters. We can't yet explain why such waves travel as far as they do, with relatively weak impulses behind them, or why they should have passed, unaffected, through the belt of darkness produced by the eclipse, while the longer wavelengths were either accelerated or deflected."

We can look for the transmission of power by radio if we are satisfied to use 99 per cent. of our power in transmitting the other one per cent. It is a matter of cost. So long as it is cheaper to send power over wires, there is no incentive to send it over the air. The ordinary radio transmitter sends power through the air, though in relatively small quantities. It may be more economical to send power through the air for operating a powerhouse switch than to send a man to do it."

THE REV. FATHER JOHN HANDLY (Society of the Paulist Fathers, New York): "The thing that impressed me along the lines of my daily work in collecting money for the new Paulist League broadcasting station was the fact that our Divine Lord was describing a scene very familiar to me in the parable of the Sower and the Seed, because I was reared on a stony briar-choked farm down in Tennessee. . . . There are many who are doubtful about the value of radio as a means of teaching reli-

gion. I want to call their attention to this point—that our Lord thought it worth while to broadcast the Word of God in spite of the fact that some of the seed fell by the wayside. . . . He thought it worth while because he hoped some would fall on good ground and bring forth fruit.”

**WILLIAM A. FISCHER** (Boston; in a recent paper read before the Music Teachers' National Association in St. Louis): “Radio listeners in this country are tax free and have been trained to expect a startling variety of entertainment for nothing, while broadcasters have been, and still are, placing their dependence on performers and speakers who give their services without pay in their eagerness for publicity. Thus a vicious circle has been started. Until artists worth paying for are regularly engaged, radio concerts, with exceptions, will continue to be merely a source of advertising to immature performers who, instead of helping the public to enjoy good music, often cast opprobrium on it by their inadequate and inarticulate performances.”

**ROBERT L. COX** (New York; second vice-president, Metropolitan Life Insurance Company, speaking of the Company's plans for broadcasting setting-up exercises through WEAJ, WJAR, and WEEI): “While radio itself is no experiment, the use of it for teaching health is still in the developmental stage. We are going to give the radio audience what they want in this respect, but we don't propose stopping with the letters. We have other means of finding out what people want. . . . Through our agents, we shall be able to make a house-to-house canvass and learn what the radio fans think, not only of our health messages and exercises, but of radio programs in general.”

**ROBERT H. RANGER** (New York; engineer, Radio Corporation of America; in charge of development work of the Radio Corporation system of transmission of photographs by radio): “For eighty years a thousand or more investigators and certainly millions of dollars have been concerned in the attempt to transmit pictures successfully at a distance. Economics enters into the problem as much as mechanical and electrical design. In the photoradiograms transmitted across the Atlantic in December, we narrowed them down to a kind of sketchy, shorthand form, because of the economic factors of time, power, and cost, all of which are highly important in picture transmission. . . . The response accorded photoradiograms, which was far greater than those of us who have been concentrating on prosaic long-distance wireless telegraph communication ever expected, has greatly encouraged us in our efforts to refine and improve the transmitted picture.”

**RUDOLPH H. WURLITZER** (New York; manufacturer of musical instruments): “Our company believes that radio will develop the musical taste of the people of the United States more rapidly than if radio had not existed. We regard our sales, totalling \$14,782,576 during a nine-



MARTIN P. RICE

Schenectady; Director of Broadcasting,  
General Electric Company

*“The Department of Commerce is now embarrassed by the number of broadcasting stations desired in comparison to the number of wavelengths available. A reallocation of wavelengths is now in progress in the hope of improving conditions for the radio listener. It would be highly desirable to provide an exclusive wavelength for each station operating with sufficient power to reach across the continent and having programs of national interest. Such a plan would increase materially the reliability of long distance broadcast reception and the increased range would stimulate the large stations to strive for the best in programs. Progress along these lines would not restrict the development of the strictly local stations designed to reflect the community life of their own districts. Such stations, operating on another band of wavelengths, have their own function and they may, on occasion, be tied into the general or national group by means of wire lines or radio rebroadcasting”*

months' period when radio was mounting in popularity, as compared with \$13,653,809 during the same period in 1923, as significant. It is estimated that more than thirty million people in this country play some musical instrument. When such a large population of players have their natural human interest in music stimulated by the radio programs, an increased demand for musical instruments is not at all surprising.”

**THIS ADVERTISEMENT** is a “tabloid History of American Civilization; a capsule critique of the Higher Learner in these U. S. A.; it appeared in the Shreveport *Journal*,” comments F.P.A. in the New York *World*. The advertisement:

ONE SET HARVARD CLASSICS, 51 Books,  
new, for Radio Receiving Set. Box 634,  
*Journal*.

# How to Design Radio Coils

A Simple Non-Mathematical Method Which  
Can Be Applied by Any Radio Constructor

BY HOMER S. DAVIS

ONE of the most frequent problems confronting the amateur radio builder is the design of the inductance coils of a new receiver. Often the size of tubing or kind of wire specified by the designer is unobtainable, or one may prefer to re-design a coil to conform to the principles of low-loss design. "Cut and try" methods are crude at best, and if the amateur has some means of easily computing the inductance of a coil, he can save both time and expense by its use.

The solenoid, or single-layer winding, is a common form of coil, and it is rather generally agreed to be the most efficient for a given value of inductance. But although the simplest to design, the formula for a solenoid is rather difficult to use unless one is quite familiar with mathematics. Fortunately, there are several methods of representing formulas graphically, and of these, the alignment chart is probably the easiest to use, and therefore offers the best solution to our difficulties. A pencil and a ruler are all that are required to use these charts.

A discussion of the manner in which they were worked out is given below for the benefit of any who may care to follow it through, although it is not in any way essential to the use of the charts. The reader may skip entirely over this discussion if he so desires.

The formula for the inductance of a single-layer solenoid is:

$$L = .02507d^2n^2lK$$

where  $L$  represents the inductance in mi-

crohenries,  $d$  the diameter in inches,  $n$  the number of turns per inch,  $l$  the length of the solenoid in inches, and  $K$  the shape factor. The latter depends upon the ratio of the diameter to the length, and its value may be obtained from tables in the Bureau of Standards Bulletin No. 74 and elsewhere. Thus it is not especially difficult to solve for the inductance of a coil when  $d$ ,  $n$ , and  $l$  are known. But the factor  $K$  causes no end of trouble when we try to use the formula in the reverse direction, solving for  $l$ , since  $K$  is then an unknown also. Cut and try methods must be resorted to. We can express  $K$  in a formula in terms of  $d$  and  $l$ , but the relationship is not simple. However, in most cases, the value of the ratio  $\frac{d}{l}$  lies between  $\frac{1}{2}$  and 2, and between these limits we may express  $K$  as approximately:  $K = 0.674 \left(\frac{d}{l}\right)^{-0.293}$

Substituting this in the first formula, we have:

$$L = .0169n^2d^{1.707}l^{1.293}$$

and  $K$  has been eliminated. It is now possible to solve for any one value when the three others are known. It is still a formidable looking equation, but it may be charted with ease. It is hardly necessary to explain here how the charts are constructed, but suffice it to say that they are based upon the same theory as the slide rule, which was described in the "R. B. Lab." department of the January 1925 number of RADIO BROADCAST.

## A Coil Calculator

Is what the chart which accompanies this article of Mr. Davis's, really is. Any number of constructors who tried to build a radio set from directions have been stopped short by their inability to secure a certain size coil and had no way of calculating its size, except by mathematics. And mathematics, to many of the radio constructing gentry, is not a desirable part of the picture. Many of the advanced radio calculations lead one directly into the calculus. Those who wish nothing more than a good rule-of-thumb will find the chart will allow them to build coils to the specifications of the various construction articles, will allow them to build a coil to attain a certain wavelength range with a condenser of given size, and by reversing the process, it is possible to find out what size condenser should be used with a given coil to attain a known wavelength. The chart and the wire table should be of great help to the builder of sets.—THE EDITOR



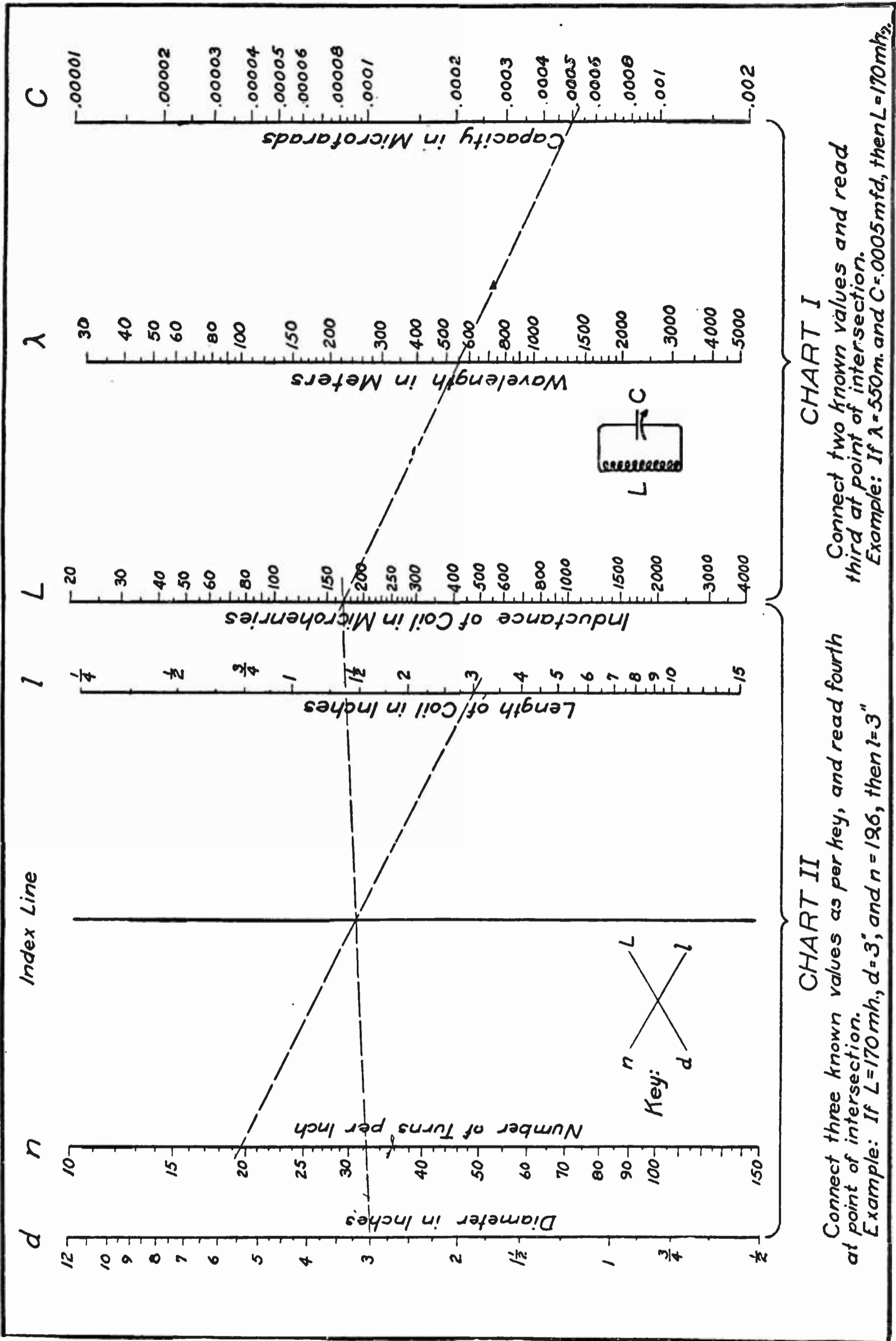

FIG. 1

The formula from which Chart 1 was constructed is

$$\lambda = 1884\sqrt{LC}$$

where  $\lambda$  represents the wavelength in meters, L the inductance in microhenries, and C the capacity of the tuning condenser in microfarads.

Referring to Fig. 1, it is seen that the two charts have been placed side by side, with the L-scale in common. As an example of the use of these charts, let us say that we wish our tuned circuit to reach a maximum wavelength of 550 meters, and that we plan to use a .0005 mfd. variable condenser tubing three inches in diameter, and No. 18 d. c. c. wire. With a pencil and ruler we draw a line from .0005 on the C-scale through 550 on the  $\lambda$ -scale, until it intersects the L-scale, reading 170 mh., as the required inductance of our coil. Another line is drawn from L = 170 to d = 3.

Referring to the copper wire table, Fig. 2, we find that No. 18 d. c. c. wire can be wound 19.6 turns to the inch, so we draw a third line from this value on the n-scale, through the intersection of the second line and the index line, until it intersects the l-scale. This shows us that the coil should be wound to a length of three inches, and the product of n and l gives 59 as the number of turns required.

The chart may be worked in the reverse direction in exactly the same manner, always making sure that the correct pairs of scales are connected together.

The amateur builder will find many uses for these charts. In addition to their value in designing inductances for a new receiver, they may be used to redesign a coil for different sizes of tubing, wire, or tuning condenser than originally specified.

KIND OF INSULATION							
B. & S. GAUGE	DCC	SCC	DSC	SSC	ENAMEL	ENAMEL	
						AND SCC	AND SSC
14	13.7	14.6	14.7	15.0	15.2	14.2	14.7
15	15.0	16.2	16.4	17.0	17.0	15.8	16.5
16	16.7	18.0	18.2	19.0	18.7	17.6	18.4
17	18.5	20.0	20.0	21.2	21.4	19.5	20.5
18	19.6	22.3	22.3	23.6	24.0	21.7	22.9
19	22.5	25.0	25.2	27.0	27.2	24.2	25.8
20	24.5	27.5	27.5	29.5	30.1	26.5	28.4
21	27.5	30.8	30.8	32.8	33.6	29.6	31.5
22	30.0	34.0	34.0	36.6	37.7	32.7	35.0
23	32.7	37.5	37.5	40.7	42.3	36.1	39.0
24	35.5	41.5	41.5	45.3	47.2	39.7	43.1
25	38.5	45.7	45.7	50.3	52.9	43.7	47.9
26	41.8	50.2	50.2	55.7	59.0	47.8	52.8
27	45.0	55.0	55.0	61.7	65.8	52.1	58.1
28	48.5	60.0	60.0	68.3	73.9	57.0	64.4
29	52.0	65.5	65.5	75.4	82.2	61.9	70.6
30	55.5	71.3	71.3	83.1	92.3	67.4	77.9
31	60.0	77.3	77.3	91.6	103.0	72.8	85.3
32	62.7	83.7	83.7	101.0	116.0	79.1	93.9
33	66.3	90.3	90.3	110.0	130.0	85.6	103.0
34	70.0	97.0	97.0	120.0	145.0	91.7	112.0
35	73.4	104.0	104.0	131.0	164.0	98.8	123.0
36	77.0	111.0	111.0	143.0	182.0	105.0	133.0
37	80.3	126.0	126.0	155.0	206.0	113.0	146.0
38	83.5	133.0	133.0	168.0	235.0	120.0	157.0
39	89.7	140.0	140.0	181.0	261.0	128.0	172.0

FIG. 2  
Wire turns per linear inch

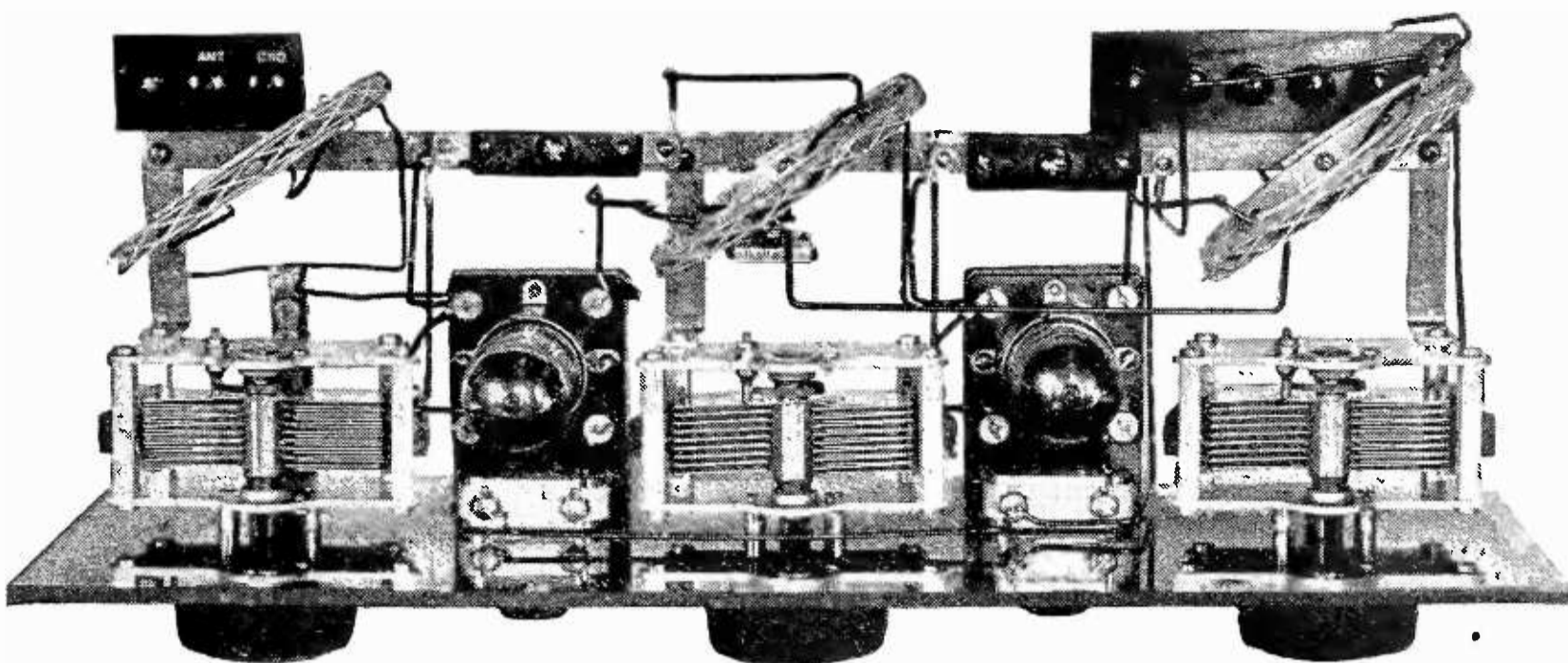

RADIO BROADCAST Photograph

### OVER THE TOP

A layout view showing the actual scarcity of wiring. The angle of placement of the coils is clearly indicated

# How to Build a Two-Stage Radio-Frequency Amplifier

BY JOHN B. BRENNAN

THE amplifier described in this article incorporates some new and desirable ideas in construction. Leads have been reduced to the shortest possible length, the famous Roberts system of double-wound coils has been used for the neutralization of each stage, and the especially efficient diamond weave coils employed for the transformers. This unit is simply a radio-frequency amplifier which can be connected to any detector. A later article will describe a detector and audio-frequency amplifier which may be used with it. In these days of high power broadcast stations, the selectivity gained by the use of radio frequency amplification is especially desirable. By completely neutralizing both stages of this amplifier, the full gain from each tube is secured. The simplicity of design and the ease of construction of this unit, in addition to its important feature of non-radiation, should appeal to every constructor.—THE EDITOR

**B**EFORE dealing with the construction of a radio-frequency amplifier it is well to understand just what radio frequency energy is and how it may be amplified.

The signal radiated by a broadcast station is composed of many electromagnetic vibrations or alternations. Due to many causes, such as the power of the transmitting station, absorption losses, location of the receiver, etc., these impulses which are collected by the receiving antenna may be too feeble to actuate the detector tube. When this is the case,

little or no rectification in the detector tube takes place, making it impossible for the signal to be heard. To state the case simply, the detector tube performs the function of rectifying and making audible the very high or radio frequencies which cannot be sensed by the ear. This tube, so to speak, transforms or lowers the radio-frequency currents to an audible or audio-frequency current.

The vacuum tube can function as an amplifier (or repeater,) and it is possible to strengthen the amplitude of the very feeble received signal from the antenna, by means of

a radio-frequency amplifier, before it reaches the detector.

Contrary to the general belief, the original signal potential is not passed along and amplified in these successive stages of radio-frequency amplification. The action in these units is more on the order of a trigger releasing device. To understand this, the action of an amplifier must be observed.

THE TRIGGER ACTION OF THE TUBE

WHEN a signal is applied to the grid of an amplifying tube, the electronic emission from the filament is interrupted in its path to the plate because the grid acts as a shutter or trigger device. By means of a local source of potential (the B battery), the variation in signal frequency is faithfully reproduced in the plate circuit of the tube in the form of a varying, direct current potential many times greater in strength than the original signal applied to the grid of the tube.

In other words, the vacuum tube has repeated and amplified the incoming signal without changing any of its characteristics.

We have so far traced the action in this circuit to the plate circuit of the first tube.

A typical two-stage radio-frequency amplifier with detector and one-stage audio amplifier is shown in Fig. 1.

Now in this plate circuit is contained the primary coil P2 of the radio-frequency coupling unit. This unit, consisting of the primary and a secondary which is connected to the input of the next tube, performs the function of inductively coupling one tube circuit to the next so that the signal received by the antenna may be repeated at a greater ampli-

Mu, OR AMPLIFICATION FACTOR OF TUBE

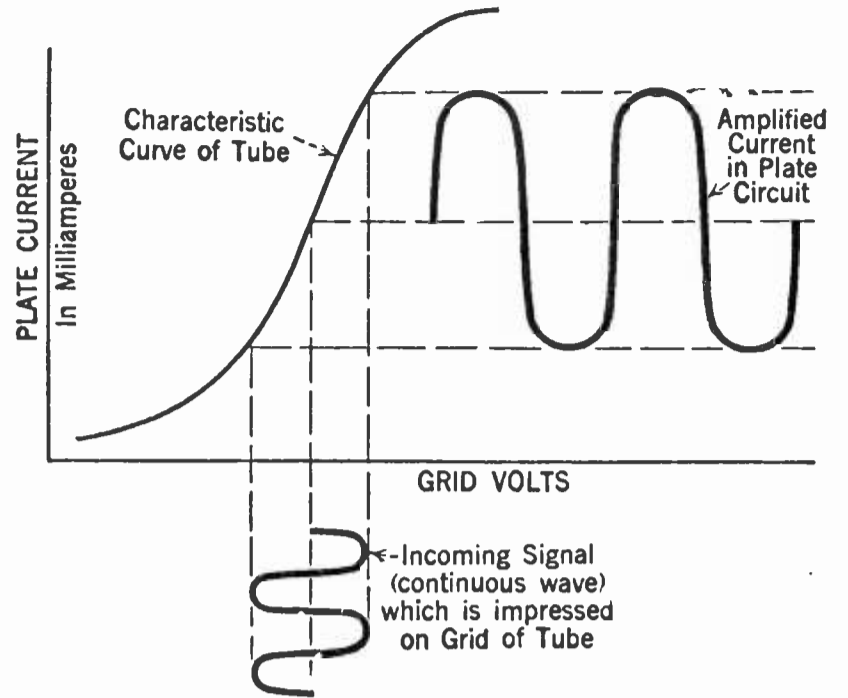

FIG. 2

How a tube amplifies, graphically shown. This only takes into consideration the amplification factor of the tube. Actually, the amplification is greater, due to the step-up value of the r. f. coupler unit

tude in each successive stage. In this instance, the unit is a radio-frequency transformer.

When the variation of current takes place in the first plate circuit, coinciding with the variation of frequency of the received signal, an electro-magnetic field is set up in and about the plate coil, the intensity of which varies with the variation of the plate energy. This varying magnetic field induces in the secondary of the transformer, which is the grid coil of the next tube, a magnified voltage corresponding exactly to that to be found in the preceding plate circuit. (The direction in which the current flows in the two coils is

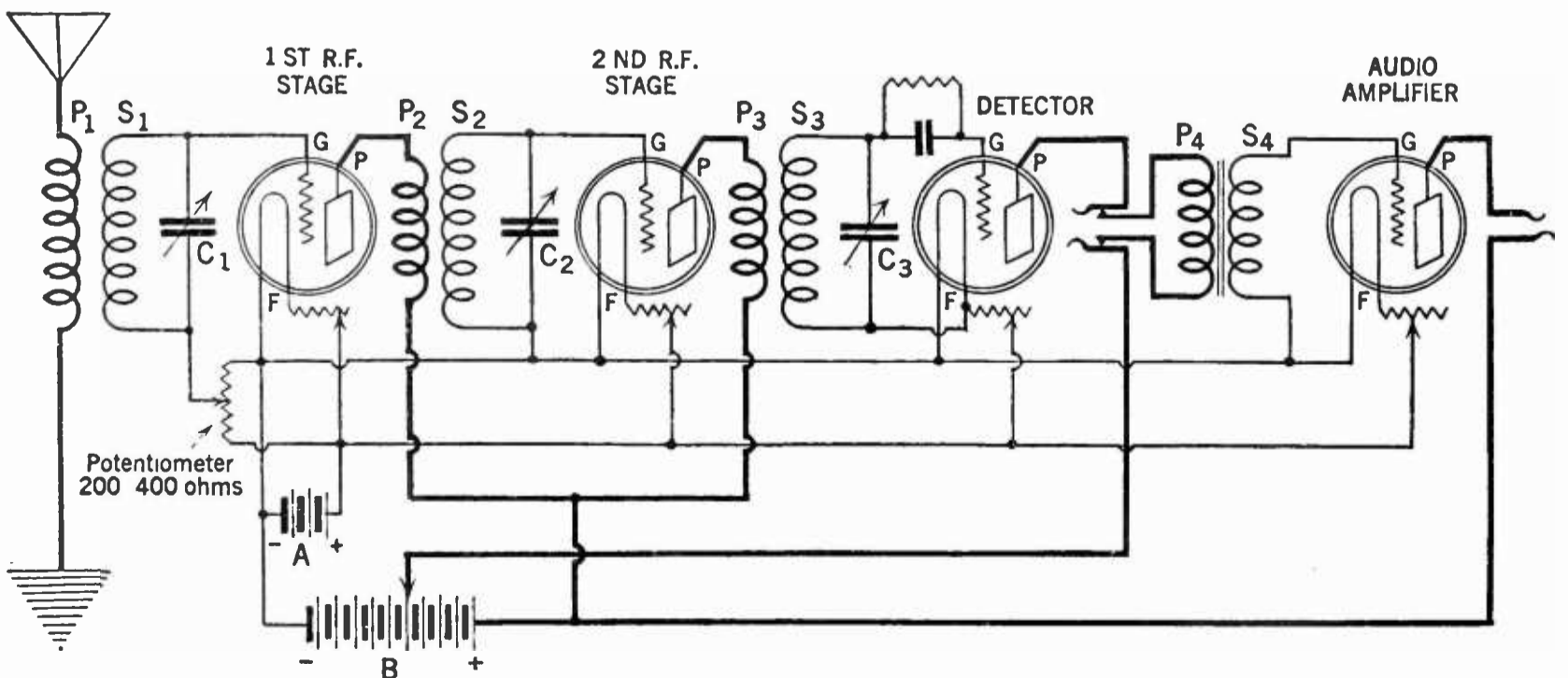

FIG. 1

A typical radio-frequency amplifier circuit. Oscillation control is obtained by the potentiometer

opposite, but, for our present study, that fact makes no difference.)

Then, of course, the magnified signal is applied to the grid of this second tube and the entire tube action is repeated again, and so on for each successive stage. See Figs. 2 and 3.

The variable condensers C<sub>1-2-3</sub> shunted across the various secondaries are employed to tune the circuits to the wavelength of the received signal. For this reason the unit P<sub>2</sub>, S<sub>2</sub> and C<sub>2</sub> in combination, is called a tuned radio-frequency transformer. We may sum up then by saying that in action, a radio-frequency amplifier will magnify the feeble antenna vibrations which ordinarily would not be strong enough to actuate the detector tube.

While radio-frequency amplifiers do, to a certain degree, increase the volume of a receiver, their main function is to amplify feeble radio energy which comes from great distances. This is the way in which a radio-frequency amplifier will increase the receiving range of a radio receiver. Such an amplifier will not, as a rule, increase the volume of signals which are already strong enough to be heard well.

#### THE DESIGN OF AN AMPLIFIER

**T**O PASS the action of amplification from one tube to another, called cascading, some coupling means, which was previously explained, must be employed.

Several methods for coupling have been devised, such as untuned transformer-coupled, tuned impedance-coupled, and tuned transformer coupled. The names indicate the method employed to induce energy from the plate circuit of one tube to the grid of the next. Amplifiers employing tuned radio-

frequency transformers have been generally accepted as the most satisfactory and they are embodied in the amplifier to be described here. The satisfactory operation of the set depends to a great extent upon the correct design of the radio-frequency coupling-unit.

The ratio of transformation is important. In some cases a 1 to 1 ratio is employed, but in the majority of cases the radio-frequency coupler has a step-up ratio of its own. For instance the primary or plate coil will be wound with ten turns of wire while the secondary coil will have sixty turns. This is a 6 to 1 ratio between secondary and primary respectively. The shape and size of the coils also have their good and bad effects on the successful operation of the receiver. The meaning of this ratio must not be misunderstood. Actually, when the number of turns on the primary nearly equal one half of the secondary, the voltage step-up is greatest but the neutralization becomes increasingly difficult with the increase in size of the primary winding.

When the amplifier employs coupling units of large physical dimensions there is danger of a feedback action between these several coupling units. This undesirable feedback is due to the magnetic fields of the coils becoming interlinked and interfering with each other. This danger is also present even when small coils are used, if they are placed too close together. The difficulty is overcome by turning the coils at such angles to each other that the coupling effects between the coils of the transformers themselves are minimized.

There are other methods of bringing this result about. In some amplifiers we find metal shielding which prevents feedback. Changing the angle of the coils is a simple

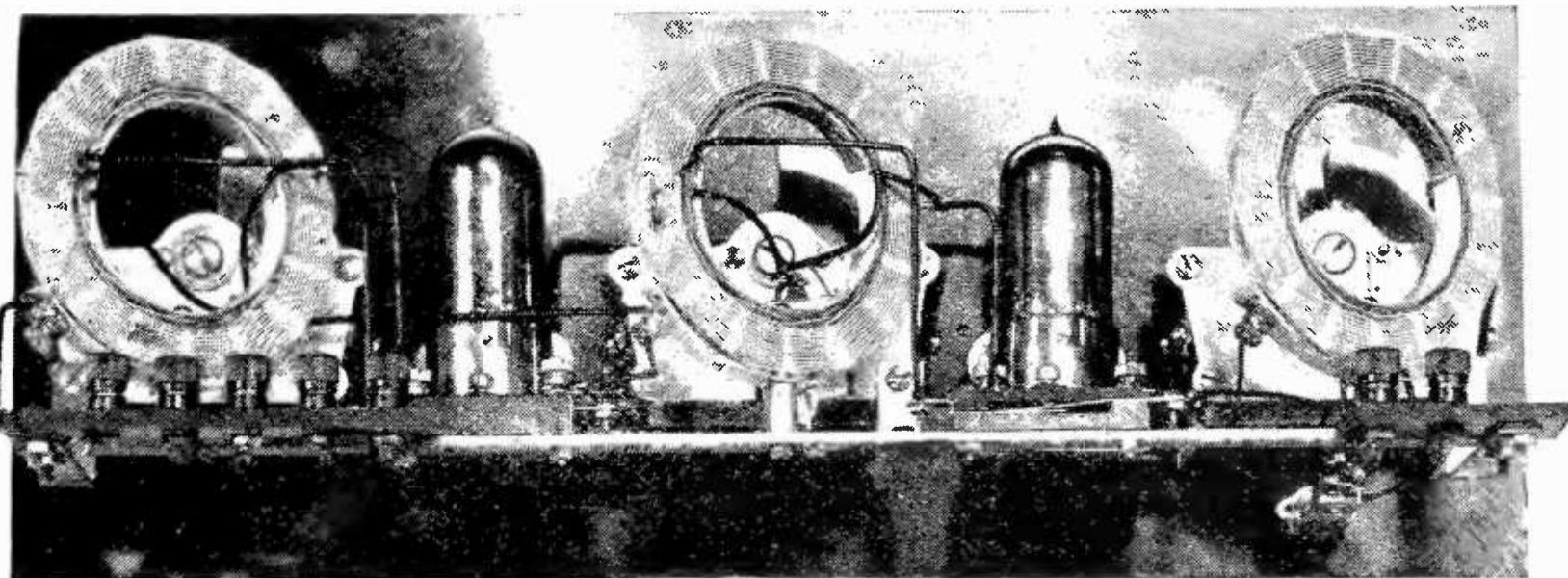

RADIO BROADCAST Photograph

#### BEHIND THE WORKS

A general view of the distribution of the parts. The Bradleystats are situated behind the tube sockets

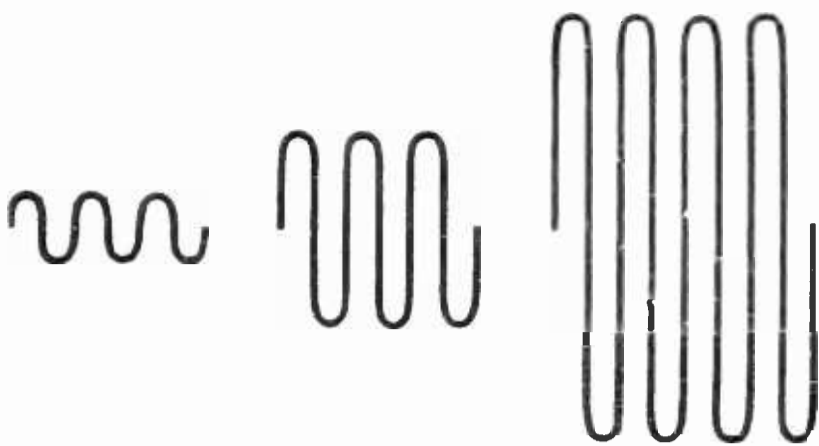

SHOWING GRAPHICALLY,  
THE AMPLIFICATION IN SUCCESSIVE STAGES

FIG. 3

A graph showing the successive amplification in a cascade amplifier

effective method. It is necessary to wind the several transformers as nearly alike as possible so that when the secondaries are shunted by condensers of a like capacity the wavelength range will be the same for each stage. The dials will then read the same.

#### OSCILLATION; FEED-BACK NEUTRALIZATION

VACUUM tubes, when connected to the usual grid and plate coils may be made to generate an oscillation whose frequency depends largely upon the inductance of the grid coil and capacity of the condenser shunting it. See Fig. 4.

It is a well-known fact that, if a circuit embodying these characteristics were utilized, a miniature radio transmitter would result. This would be not only uncomfortable for the user himself because of the many-toned squeals set up, but an amplifier of this sort would also seriously affect neighboring receiving installations because it would act as a transmitter, producing squeals in every receiver within range. This property is usually termed the radiation characteristic of an amplifier.

Some means of balancing out these squeals must be provided. Lossers, compensators, traps, and reverse feed-back are sometimes employed but they are, as a rule, not as stable as the arrangement proposed here. A very fine form of this neutralizing system has been brought out by Hazeltine and Roberts. In their system, any tendency to oscillate is completely neutralized or balanced out by the neutralizing condenser and the proper placing of the coils, all exerting a force on the grid of the tube equal and opposite to that set up by the action of the inter-capacity coupling of the tube as well as the inter-coil coupling of the radio-frequency transformers. An explanation in detail of this theory by Mr. W. Van B. Roberts, appeared in the April, 1924, and

was repeated in the January, 1925, RADIO BROADCAST.

Wiring also presents a problem to be solved by a careful and well planned procedure. Grid and plate leads should be as short as possible and should not be parallel to each other. There should not be any inductive loops in the filament circuit. In fact, the filament circuit should be finished first. Then the other connections to it may be made as short as possible.

Soldering is an important consideration and should not be overlooked. Too much solder is just as bad as too little. Keep your iron evenly hot and clean all the time. Don't use a great quantity of soldering paste and use a good grade of solder. While it seems strange that such mechanical considerations should enter into a discussion of the design of radio-frequency amplifiers, its worth may be realized when it is considered that a poor soldering job will completely offset the finest design and assembly, and render the amplifier practically inoperative.

#### HOW MANY STAGES?

NOW the number of stages of radio-frequency amplification that may be successfully employed is limited by the human element. Two stages of radio-frequency amplification have become accepted as the maximum number that may be advantageously operated. More than this usually lowers the operating efficiency of the receiver. Multi-stage radio-frequency amplifiers have made their appearance on the radio-market. These types are usually controlled by a gear arrangement actuating the several condensers, but due to electrical and mechanical difficulties, have not become very popular.

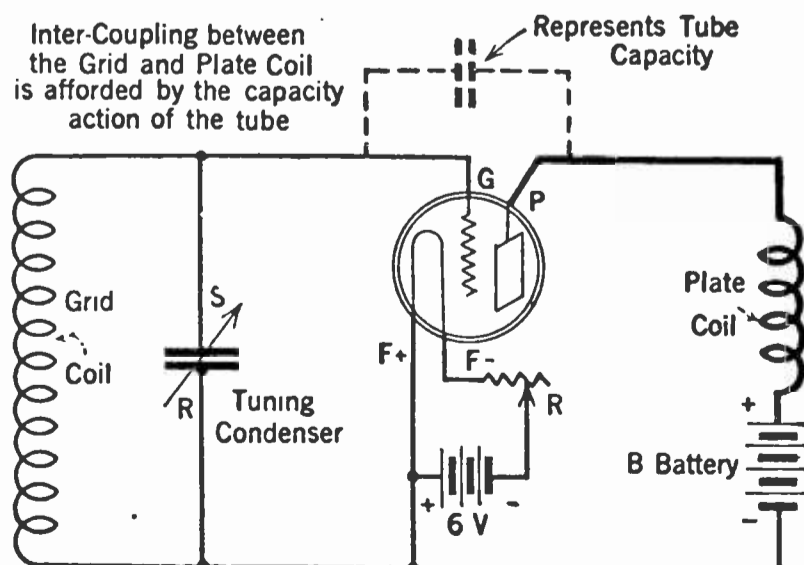

FIG. 4

A circuit capable of oscillating—thereby becoming a miniature transmitter when coupled to an antenna

RADIO-FREQUENCY TRANSFORMER DESIGN

THE style of winding of a radio-frequency coupler offers an interesting field for study. Spiderweb and diamond weave styles have lately come to the forefront of radio design because of the mechanical and electrical advantage they present and the ease with which they may be made and mounted. The same value of inductance can be provided in a concentrated spiderweb or diamond weave form which, if constructed as an ordinary single-layer coil would require a much larger space. Also, with these new inductances, the distributed capacity of the coil has been materially lowered which increases the overall efficiency of the unit. When the winding is concentrated, the magnetic field set up by the currents travelling through the coil is similarly concentrated and does not feed over into adjacent coil units.

Engineers have made electrostatic coupling a special study. Full reports of their findings are not yet available. However, the few bare facts such as separation of parts, concentration of coil winding, and simplicity of wiring serve to guide us toward correct constructional design. The circuit of the radio-frequency amplifier described here is shown in Fig. 5. This amplifier may be used with any type of detector and audio-frequency amplifier now available. In a future number of RADIO BROADCAST we shall describe a detector and

amplifier unit especially designed for use with this radio-frequency amplifier.

This circuit consists of three tuned circuits. The output of the last circuit connects to the input of the detector tube to be used. The antenna and ground are connected to the primary of the first circuit.

As may be seen by the several photographs accompanying this article, all the parts are mounted upon the panel and a baseboard is eliminated. As far as possible, the ideas brought out in this discussion have been incorporated in the amplifier unit described here.

CONSTRUCTION OF THE UNIT

TO MAKE the amplifier in accordance with these instructions, it is well to procure the parts as listed. *Other parts of similar design and quality may be used with equally good results.* The use of UV-201-A or DV-2 tubes is recommended but others such as 1½ and 3 volt tubes may be satisfactorily employed.

The coils used were made up by the F. W. Sickles Co. of Springfield, Mass., from specifications supplied. For those who wish to wind their own, the coil data is included in the following pages.

THE PANEL

IN LOCATING the holes to be drilled in the panel, it is well to lay off the dimensions on the rear of the panel. Otherwise the

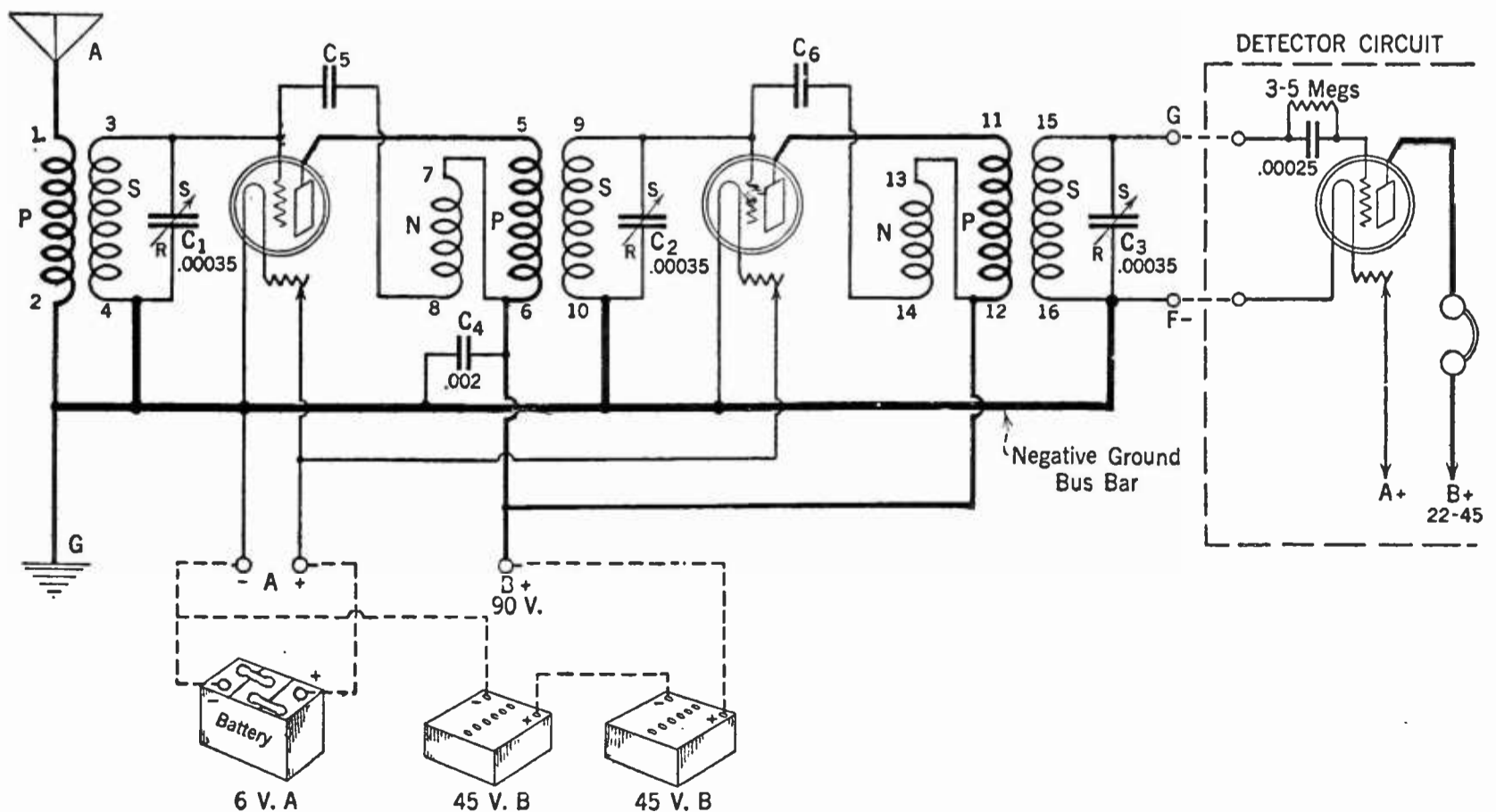

FIG. 5

The schematic circuit diagram of the amplifier whose construction is described. The heavy line indicates the brass bus bar strip connections

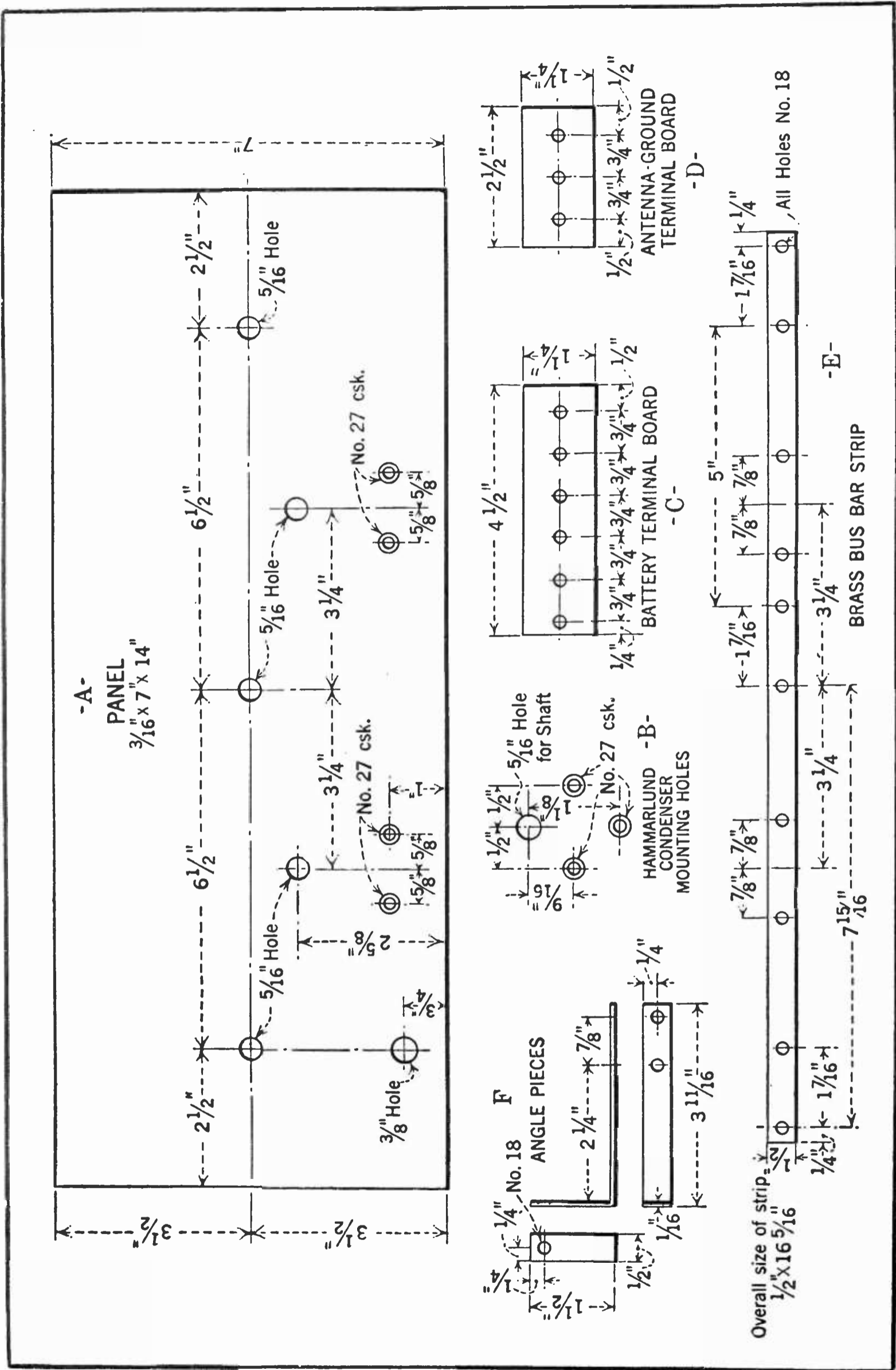
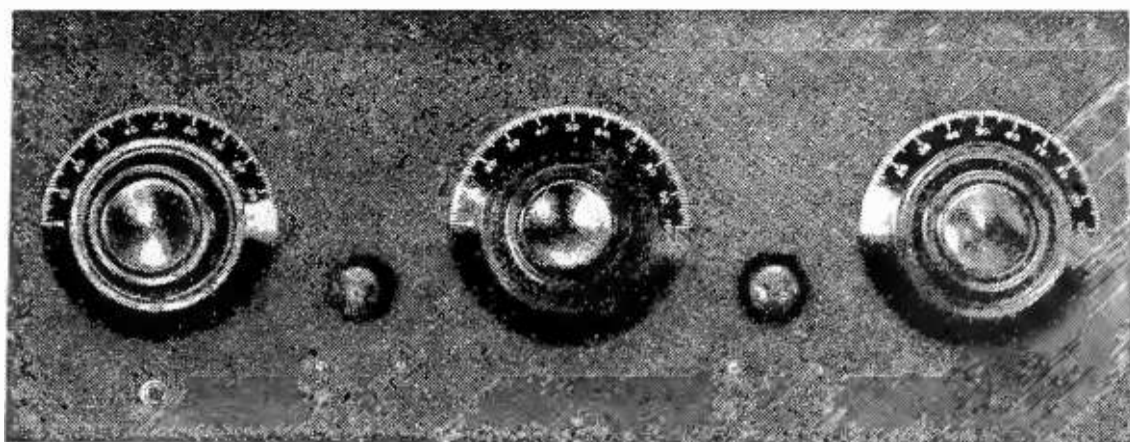

FIG. 6

A. The panel layout, front view. In actual practise it is better to transfer the dimensions to the back of the panel to prevent deep scriber lines. B shows the mounting holes for the condensers and C-D the binding post terminal layout. In E the details for drilling the brass bus bar are shown



scriber lines, if marked on the front, would be visible and unsightly unless removed by a graining process. Some builders will wish to provide a grained surface on the front of the panel. Graining may be accomplished by rubbing the panel along its length, with a straight motion, with No. 0 emery cloth. This is continued until all the glossy marks on the panel have been removed.



RADIO BROADCAST Photograph

A SYMMETRICAL PANEL ARRANGEMENT

The jack in the lower left is for plugging-in a loop. Vernier dials may be substituted for those shown

The graining process usually takes place after all the holes are drilled. The panel is then polished with an oiled cloth.

In drilling the holes it is well to drill all of them first, with a No. 28 drill and then enlarge to the required size with the correct size drill. This procedure affords a more accurately drilled panel than if all the holes were directly drilled with the required size drills in the beginning. By referring to the panel layout in Fig. 6A it will be observed which holes are to be countersunk. This layout should be thoroughly understood before actual construction is begun.

In a similar manner of layout, the binding post strips and brass mounting bus-bar strip are prepared and drilled. See Fig. 6 C, D, E, and F.

WINDING THE COILS

THE type of coil used here is termed the diamond weave. To wind these coils it is necessary to have a cylindrical wooden form (a rolling pin of the required size will do) 2 3/8 inches in diameter. Around the circum-

ference of this cylinder, at approximately 1/2 inch intervals are driven brass or wooden pins 3/16 inch in diameter 1 1/4 inches long. The coil winding form is illustrated in the sketch Fig. A. No. 22 d.c.c. wire is used throughout the windings.

The antenna coupler has only a primary and secondary. The other two coil units have a

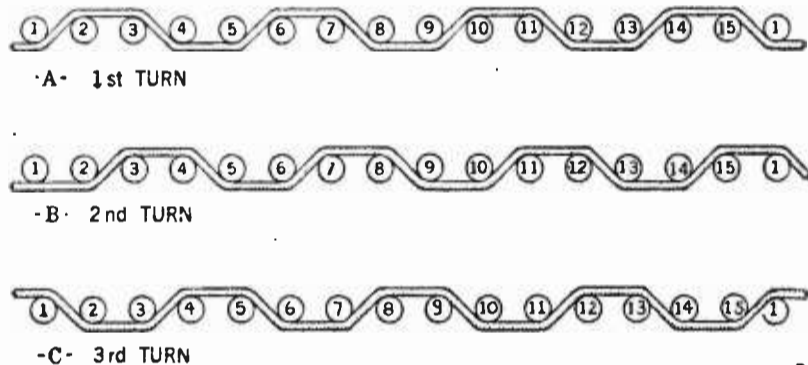

FIG. 8

Shows the first three turns in their relative positions to the spokes in producing a successive overlap resulting in the diamond weave coil

double-wound primary, constituting the N-P coils, and a secondary (S), as illustrated in Fig. 5.

The weave of the coil is produced as outlined in Figs. 7B and 8A-B-C. The first three turn positions are illustrated and will serve to indicate the progressive overlap of each additional layer of the winding. Success in this winding is all in the start. The beginning of the wire, allowing for a six inch lead, is fastened at the pin 1. From there it is brought diagonally to 2. From around the outside of 2 and 3 it diagonally crosses to 4. Here it again goes around the outside of 4, and 5, and so on. It will be observed from this that the winding style is continued over two and under two spokes.

Due to the odd number of spokes, the successive layers progress or stagger themselves. This permits a winding which makes the position of each layer wound different from

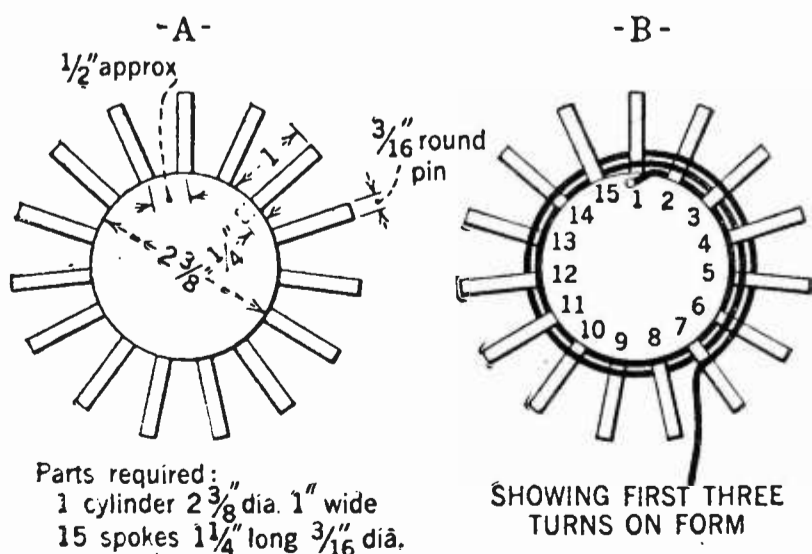

FIG. 7

A. is a coil form for winding the diamond weaves. B. How the weave is produced. Under two, then over two, is the rule

adjacent layers. So the diamond weave is produced.

For the second and third radio-frequency couplers, the primaries must be double-wound to provide the neutralizing winding which is connected to the grid of the tube through the neutralizing condenser. In winding the double primary it is well to have two spools of wire, one preferably colored so as to facilitate identity of connections.

Six and one half turns of the pair of wires are wound for the primaries of the second and third couplers. This ratio was selected after tests were conducted where 12 and 18 turn primaries were employed.

The antenna primary consists of a single wire wound for six and a half turns.

After the primaries are wound, the secondaries are wound directly over them for forty-five turns in the same fashion and in the same direction as the primary. The inside lead or beginning of the secondary is started several spokes away from the end of the primary so that the leads are not too close together in the finished coil.

The coil may be painted with a solution as a binder which has been prepared by dissolving celluloid in acetone, or other "dope" of this nature. The best coils are made without dope and their turns are held in place by lacing made of ordinary grocer's white cord.

To remove the coil from the form, withdraw all the spokes and then slide the coil off, taking care to prevent it from coming loose. Fig. 9 shows how to insert the mounting screw so that the coil may be fastened to the brass bus bar running the entire length of the receiver.

The outside turn of the secondary connects to this screw. The brass bus bar constitutes

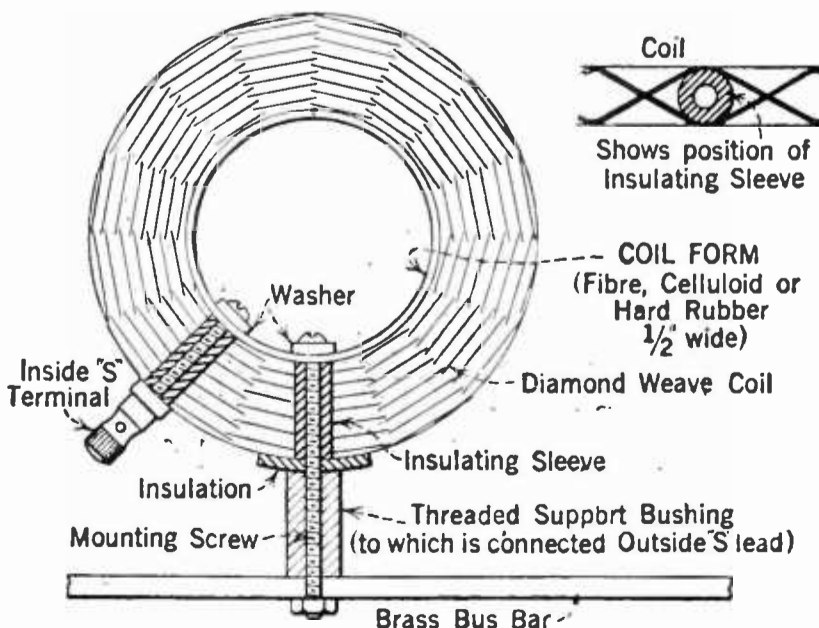
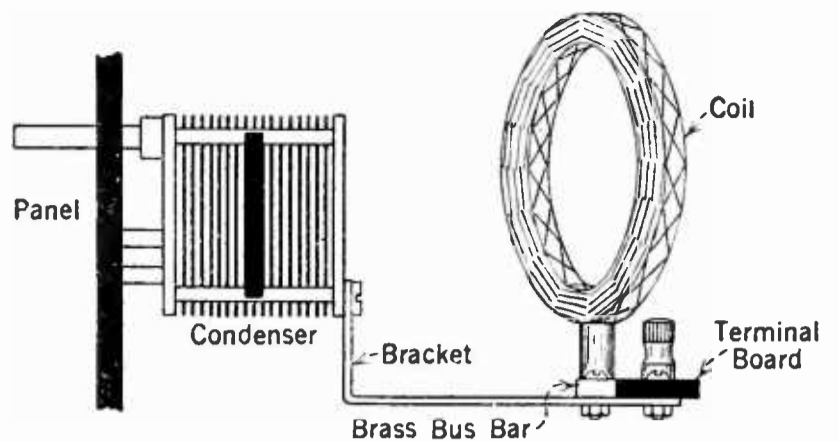

FIG. 9

How the coil is mounted on the brass bus bar strip



METHOD OF ASSEMBLY OF CONDENSER, ANGLE BRACKET, COIL AND TERMINAL BOARD

FIG. 10

All the parts are sustained by means of the panel and angle brackets

the negative or grounded line of the entire circuit.

As may be seen from this sketch, the  $\frac{6}{32}$  mounting screw is securely fastened to the coil by means of washers and nuts. If it is obtainable, a piece of bakelite or fibre tubing  $\frac{3}{16}$  inch in diameter may be slipped over the mounting screw to insulate it from the coil winding. The narrow strip of hard rubber or celluloid used as a coil form and inserted after it is wound is also fastened underneath the head of the screw and washer.

The coil support may be a larger-diametered piece of tubing or a brass rod may be turned down if the machinery is available. But as little metal as possible should be used in the direct field of the coils.

#### ASSEMBLY

WITH the panel drilled, the coils wound, and all the other material on hand, the job of assembly may now be started.

First the sockets, then the rheostats and finally the condensers are mounted on the panel. It is well to state here that the assembly directions as outlined only hold good for the material as listed. When other parts are used, the builder must employ his own ingenuity in producing an arrangement as nearly like that described as possible.

Looking at the back of the panel, the lower right screw of the right and center condensers holding the end plate of the condensers to its frame is removed. Also the lower screw of the left condenser is removed.

Brass angle brackets  $3\frac{1}{8} \times 1\frac{1}{2}$  inches  $\times \frac{1}{2}$  inch are fastened, as shown in Fig. 10, to the condensers at the places where these screws have just been removed, by replacing the screws securing the brackets at the same time. It is absolutely essential that these screws be

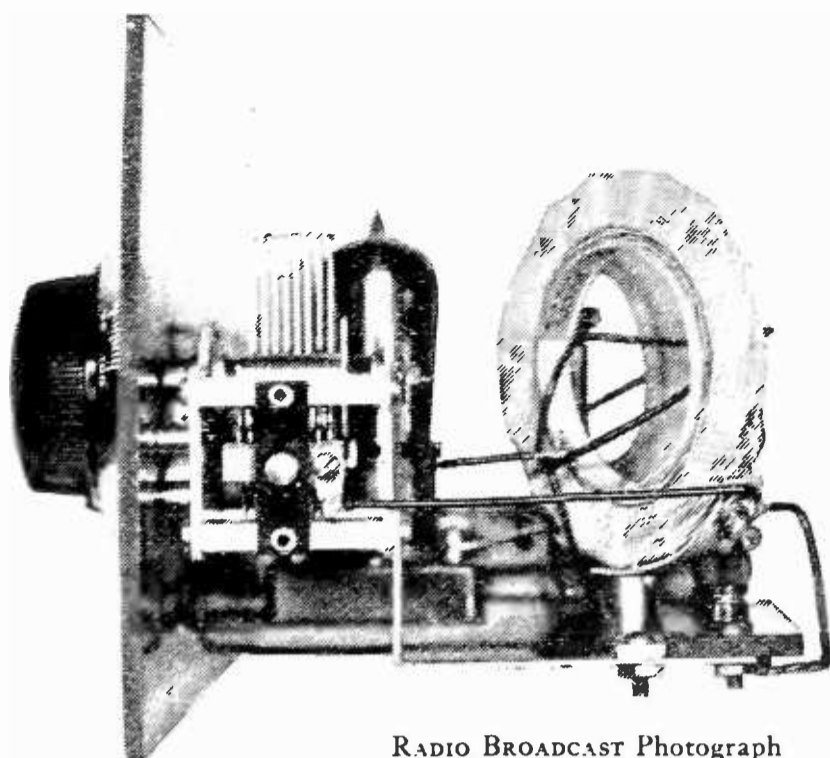

RADIO BROADCAST Photograph

#### A VIEW OF THE ANGLE BRACKET FROM THE RIGHT SIDE

exceptionally tight, but not tight enough to turn off the heads, so that a positive electrical connection between the condenser and plate, angle bracket, and bus-bar strip is assured.

Fig. 10 also shows how the binding post terminal strip is mounted on the bracket. Connections to the binding posts are made on the under side, and the wires are soldered to lugs fastened to the posts.

Fig. 13 shows the angle at which the coils are placed when mounted upon the bus bar strip.

#### WIRING

**D**UE to the placement of the parts, the grid and plate leads are comparatively short and well separated. In fact the only long leads in the circuit are the filament supply connections.

All connections should be soldered. Lugs may be used at socket and condenser terminals to facilitate the soldering job and this also permits the terminal nuts to be tightly fastened down on the lugs before the soldering is begun. Suitable wrenches for this work are now on the market. The wiring plan is shown in Fig. 11. The schematic circuit diagram is Fig. 5.

The jack shown in the lower left hand corner of the panel photograph is used for plugging-in the loop to the first tube circuit. This jack performs the function of automatically disconnecting the first secondary coil from the tuning condenser and replacing it with the loop. See Fig. 14.

The inside lead to this secondary connects to the blade of the jack marked No. 2. The

outside lead connects to the brass bus bar negative line through the metal screw and support bushing. The third and fourth blades of the jack also connect to the negative bus bar. Blade No. 1 connects to the stator plates of the condenser. These points are made clear in Fig. 14.

The connections to the coils are as follows:

The antenna connects to the inside of the primary, the outside to the ground. The inside of the secondaries connect to their respective grid socket terminals, the outside leads being connected to the negative side of the filament line. The mounting screw is utilized and another screw terminal provided as shown in Fig. 9 for the secondary leads. The primary leads merely project out of the coil.

For the double-wound primaries, the inside lead of one of the pair of wires connects to the plate of the preceding tube. The outside end of the other coil connects to the grid through the neutralizing condenser. The remaining two leads are connected together and are brought to the positive B battery terminal.

A .002 mfd. fixed condenser is connected from the B terminal to the minus A terminal. A detector circuit (to which, of course, may be added several stages of audio-frequency amplification) is connected to the r. f. amplifier as shown in Fig. 5. for test purposes.

#### OPERATING THE AMPLIFIER

**A**SSUMING that UV-201-A's are used throughout (although any standard type of tube may be substituted) the 6 volt filament

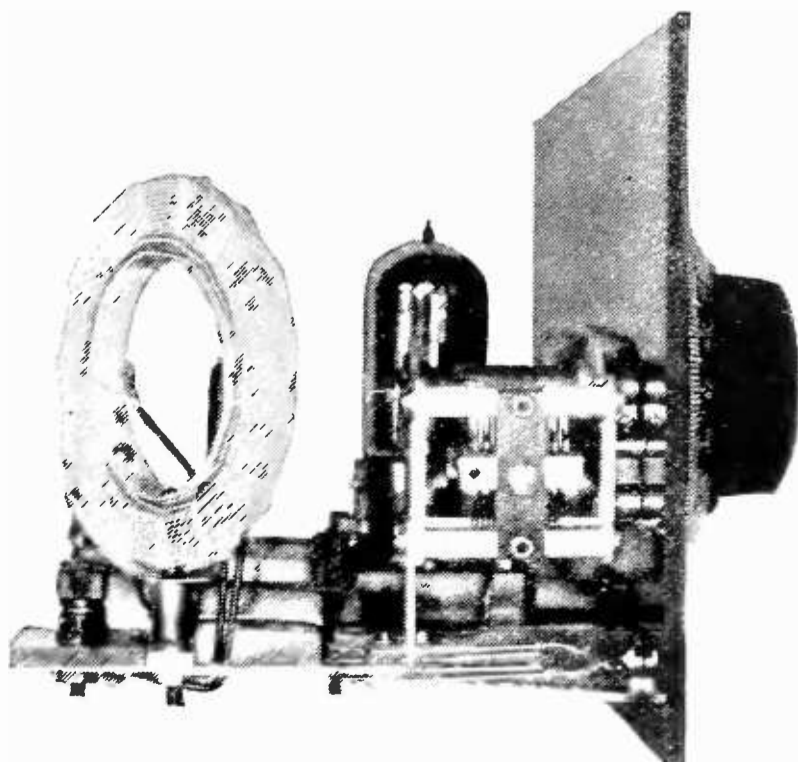

RADIO BROADCAST Photograph

#### LEFT SIDE OF THE AMPLIFIER

The bracket supporting the bus bar, coil, and binding post terminal board is clearly shown, and the jack mounting as well

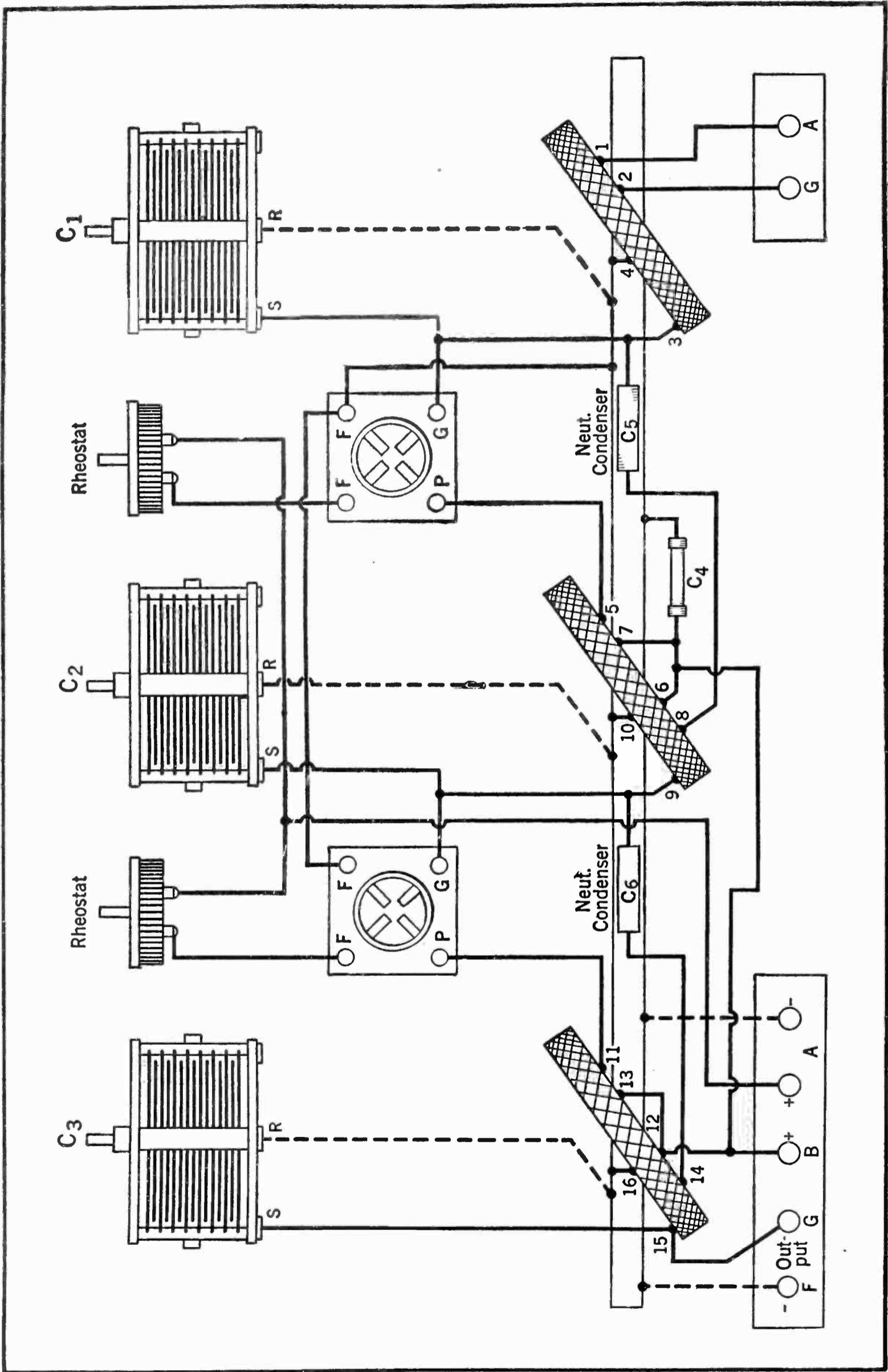
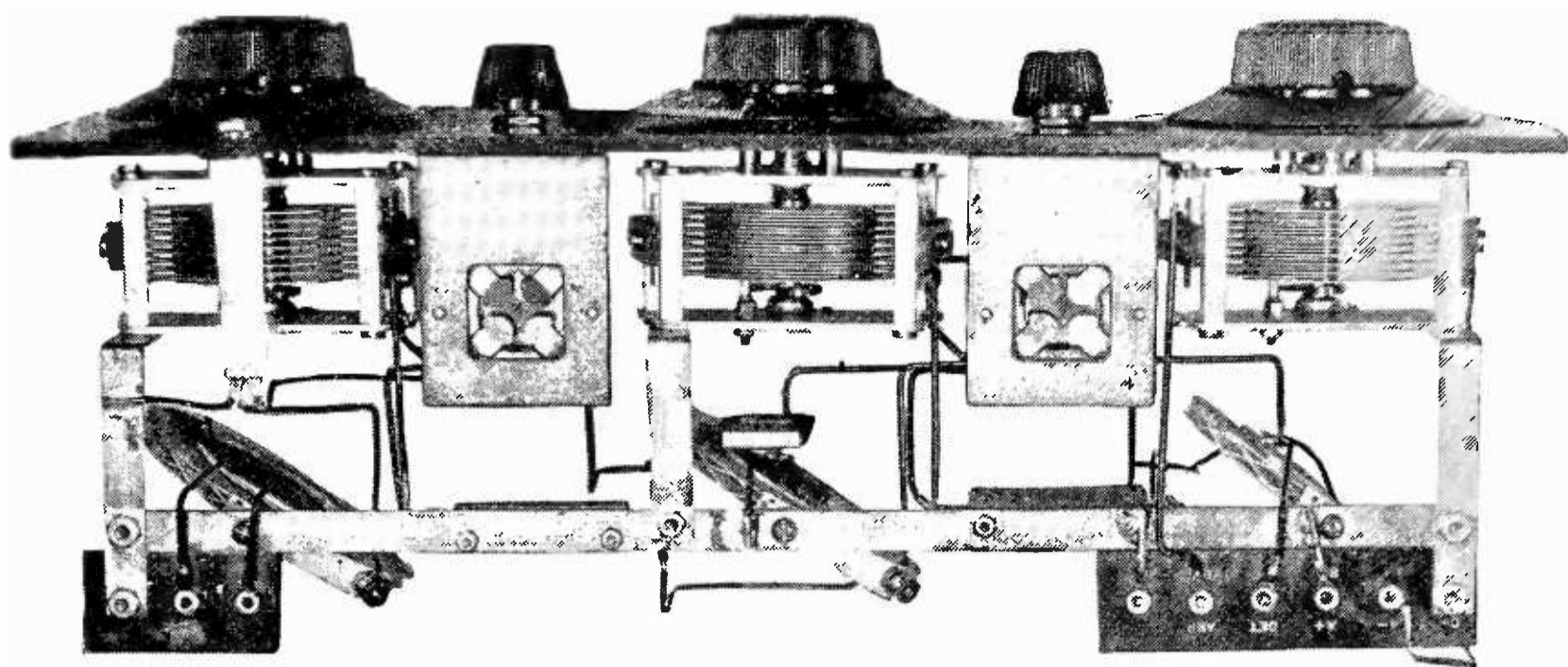

FIG. 11  
An actual wiring layout of the amplifier. The various coil terminals are numbered and correspond to those shown in Fig. 5



RADIO BROADCAST Photograph

LOOKING UP FROM UNDER

The function of the bus bar as part of the circuit and as a supporting member is clear. The sockets are of the panel mounting type

battery is connected to the battery posts on the terminal board at the left of the amplifier (looking at the rear). From right to left, these posts are designated as follows:—negative filament, positive filament, positive B battery, grid output, negative filament output.

The posts on the right terminal strip are:—antenna and ground, from right to left. The B battery post is connected to the 90 volt terminal of the B battery. The other connections are made as shown in Fig. 5.

With the aid of the wavelength curve shown in Fig. 12, the approximate position of the dials may be ascertained for a desired wavelength

setting. Due to differences in winding the coils and wiring, this curve will not be accurate for every amplifier of this type which may be constructed.

It will be observed that the antenna coupler condenser will tune rather broadly in comparison to the other two.

The method of tuning the amplifier would be to set the antenna condenser dial at the desired setting, referring to the curve and then slowly rotate the other two simultaneously through a small arc at approximately the same setting. When the sharpest point has been obtained, retune the antenna condenser dial for a final setting.

LIST OF PARTS USED,

1 Panel 7 x 14 x $\frac{3}{16}$ inches . . . . .	@	\$1.00	\$ 1.00
3 Hammarlund Variable Condensers .00037 mfd. . . . .	@	4.75	14.25
2 Federal Panel Mounting Sockets . . . . .	@	1.20	2.40
2 Bradleystats . . . . .	@	1.85	3.70
3 Sickles Coil units . . . . .			
2 X-L Vario-densers . . . . .	@	1.00	2.00
3 Na-ald Super De-Luxe Dials . . . . .	@	1.00	3.00
Brass strip . . . . .			.50
Mounting screws—wire, etc. . . . .			.50
1 Double-circuit Carter Jack . . . . .			1.00
			<hr/>
			\$28.35

When the coils are home-made the supplies necessary for their winding are as follows:—

- $\frac{1}{2}$  lb. No. 22 d.c.c. wire
- Bakelite or metal bushing supports
- Washers
- Insulation strip, fibre, celluloid, etc.
- Screws and nuts

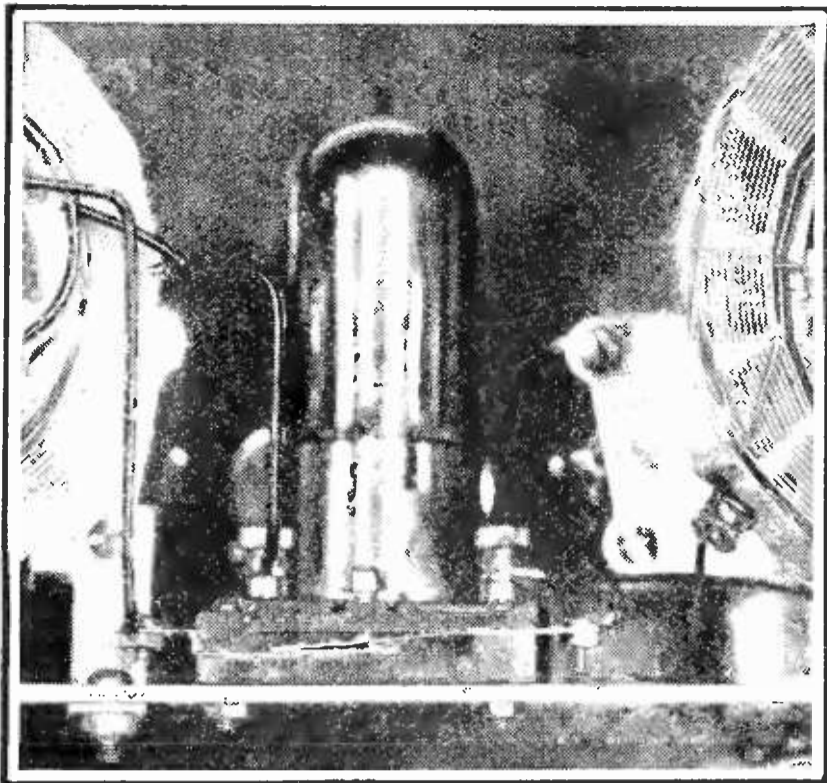

RADIO BROADCAST Photograph

#### A DETAILED VIEW OF THE NEUTRALIZER

Part of this condenser is cut away. The turning of the screw, top center, varies the capacity

#### NEUTRALIZING THE AMPLIFIER

ON THE lower wavelengths it will be observed that the amplifier will go into oscillation more easily than on the higher wavelengths.

Now, by turning the adjusting screw of the neutralizing condenser, up and down, a point may be reached where the self oscillation is entirely eliminated or perhaps only feebly present. This oscillation is recognized in the form of a squeal whose pitch varies. The detailed method of neutralization was fully described in "Notes on the Robert Circuit," in the January, 1925, RADIO BROADCAST.

It is well to apply the neutralization process at several wavelengths, noting the position of the tubing for each change, so that an average may be struck. If the amplifier works properly, no great difference in the several neutralizer settings will be noted.

Since this circuit, is not reflected it is quite satisfactory to employ the standard neutrodyne method of neutralization. Briefly explained, that is as follows: A station is tuned-in, preferably a distant one, so that the signal is not as loud as a local. Then the first tube is removed from the socket, and one filament prong is covered with a slip of paper or spaghetti tubing, so as to insulate it when replaced in the socket. Now after inserting in the socket (the filament will not light) the station previously tuned-in may be heard faintly. Carefully retune for maximum signal strength, which will not be as loud as when the

tube was lighted. Then adjust the neutralizing condenser until the signal almost, or perhaps actually disappears. This tube is then completely neutralized and the same process may be applied to the next tube. As each tube is neutralized, the filament prong insulation is removed.

With the condensers and coils used, as described, the amplifier will cover a wavelength range varying from 230 to 600 meters for the entire broadcast band.

#### WHAT TO EXPECT FROM THE AMPLIFIER

THE author does not attempt to set a distance limit on reception of a set using this amplifier when connected to a detector circuit. The radio public has educated itself to the point where it takes with a grain of salt the highly imaginative claims of sometimes over-enthusiastic set designers about the distance range of their receivers.

It is not our desire to put a limit on the reception qualities of this amplifier. Rather let us say that it will equal any two stage radio-frequency amplifier we have ever tested

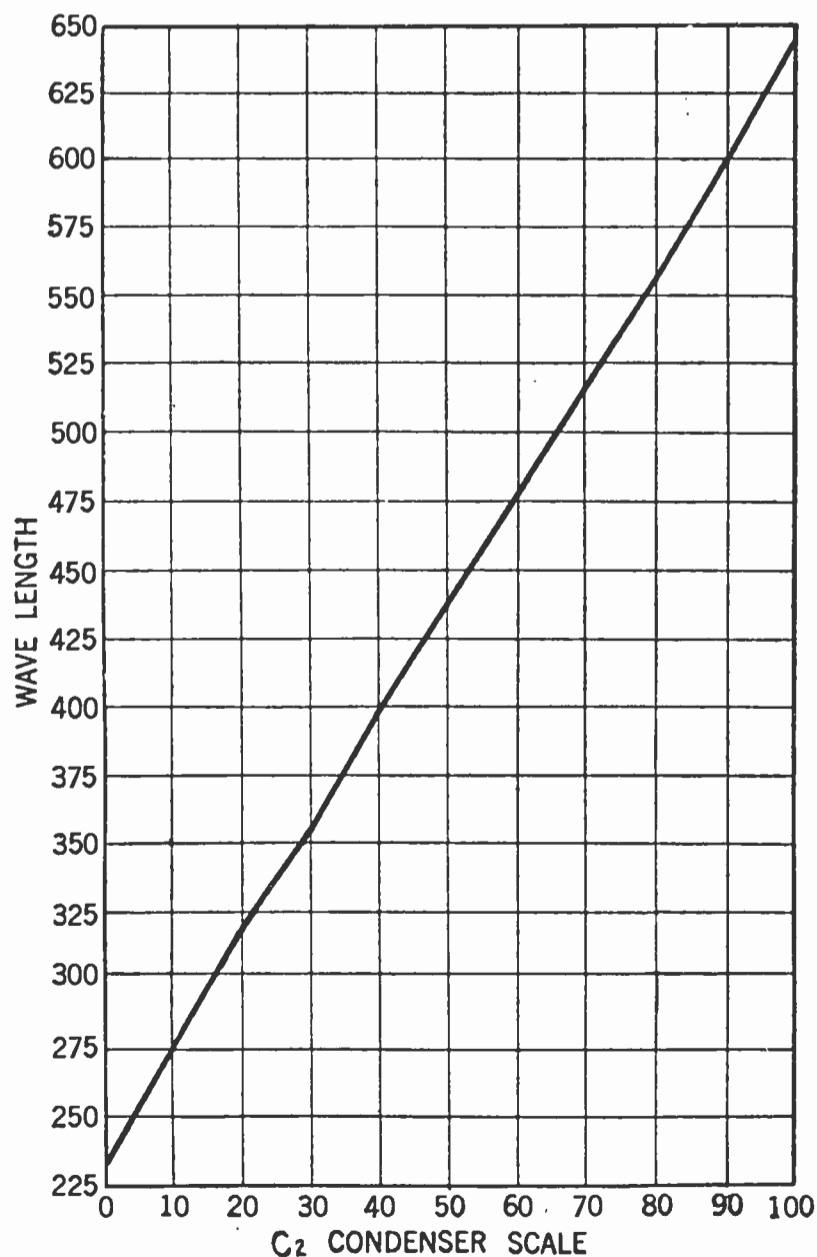

FIG. 12

A wavelength chart which may be used as an aid in locating stations

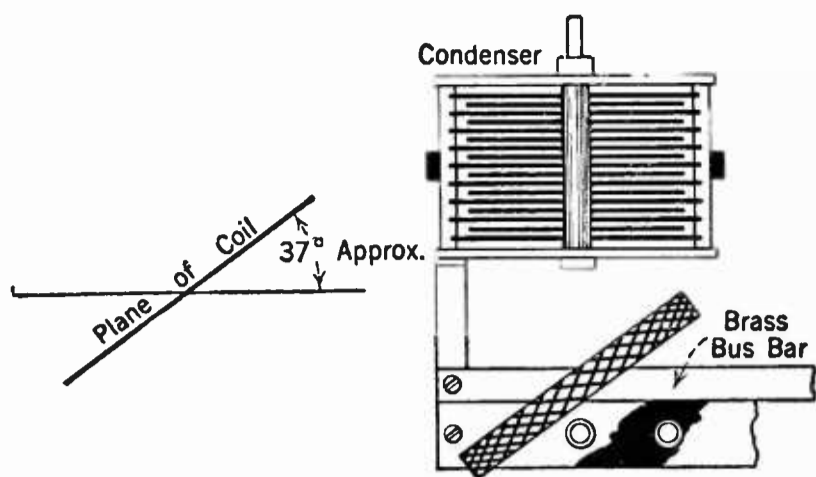

FIG. 13

To obtain complete neutralization, the coils should be turned at an angle to the bus bar as shown here. The value is approximate. Actual test will determine the correct placement

—and we've surely tested more than a few.

This radio frequency amplifier is especially adaptable for use with a loop.

In a future article the construction of a detector amplifier unit will be described which, while it may be used with any tuner, is especially intended for use with the radio-frequency amplifier described here.

General Additional Notes

THE use of a loop with this amplifier will naturally reduce the strength of received signals and therefore not a great deal of distance work will be accomplished when the loop is used.

However, for sharpness of tuning, and quality of reception, the results when a frame antenna is used are difficult to equal where local stations are being received. Loop reception on locals is desirable where tone quality and clarity are prime factors. The placement of the loop near the antenna-ground wires (which may be connected together)

loosely couple it to the antenna circuit which increases the volume but may effect the quality of reception because this connection will cause some static to be received when any is receivable.

The tuning of the first condenser when a loop is used will depend largely upon the number of turns of wire wound on the loop.

For all practical purposes, a standard pancake loop 30 inches square, wound with 16 turns of wire spaced  $\frac{3}{8}$  of an inch apart will suffice covering the entire broadcast wavelength band.

If variable plate neutralizing condensers are used, some other means for mounting them on the brass bus bar strip must be arranged. It is not advisable to mount them on the panel unless such an arrangement permits of the use of very short leads. The adjustment of this neutralizer is very rarely changed, so that for all practical purposes, the back-of-panel mounting will prove quite satisfactory.

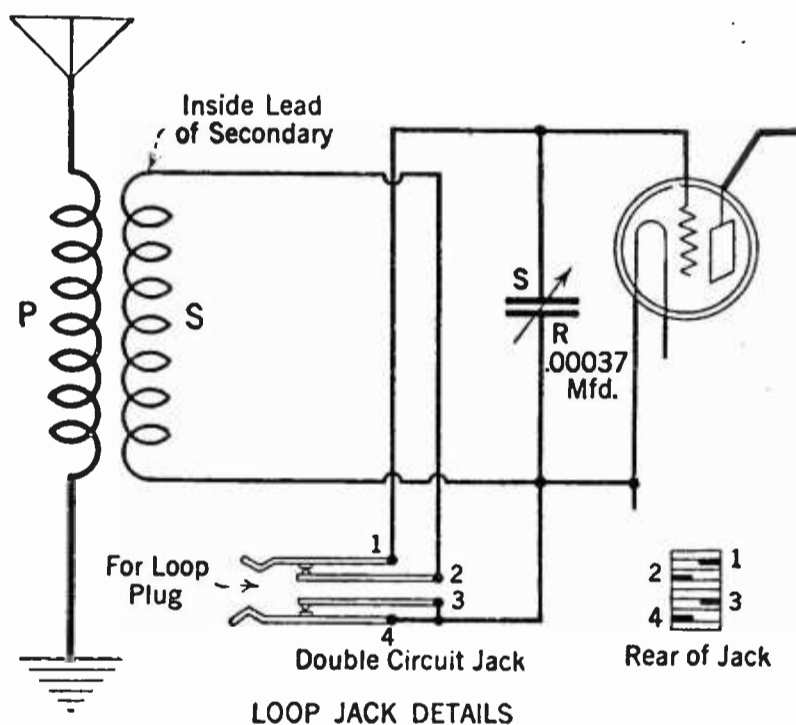

FIG. 14

When a jack is incorporated for the use of a loop, the circuit must be altered so that the antenna coupler may be automatically thrown in the circuit when the loop is not being used

*THE material appearing in this magazine is fully protected by copyright, and editors of periodicals are advised that unauthorized publication of circuit diagrams, technical descriptions, and parts or the whole of articles, without due permission and credit, is an infraction of the law. Those who wish to reprint material appearing in these pages are asked to communicate with the editor.*



## Good National Radio Programs Prove "What the Public Wants"

THE linking of a sufficient number of stations to carry to uncounted listeners the WEAF programs of outstanding musical quality will do more to bring about a reform in the general character of all radio music than any other attempt that has yet been made with such an end in view. Not that the powers that rule WEAF had this in mind when establishing this wide connection through the country. Quite the contrary. With those officials it is wholly a matter of business, as all who are familiar with the firms who are putting these programs on the air through WEAF well know. But one could scarcely ask the American Telephone and Telegraph Company to give this well-nigh priceless opportunity to the public for nothing. So, as the intricate question "Who is to Pay for Broadcasting?" apparently remains as far from being answered as ever, we may well be thankful that we have this present development which makes possible the hearing of real artists at stated times, instead of, as before, being almost always nationally swamped by mediocrity or worse.

Lovers of good music now glory in the opportunity to hear it through their receiving sets on those nights when such music is specially featured. And we are confident that hundreds of thousands who have until now

always referred to such people as "highbrows" or "poseurs," are going to go over to these very ranks when they find through experience that love of good music is no more a pose than is the preference of living in a neighborhood where the surroundings are beautiful to the eye rather than in one where ash and garbage cans predominate.

It might seem, after all, as if the best way to cure the public of a desire for the undesirable is to surfeit it with the undesirable. After having heard announced, "The orchestra will now play, 'Dirty Face,'" about one hundred thousand

times, they may welcome hearing that the Victor Talking Machine Company orchestra will play the "Ballet Music from 'Faust.'" Especially will they welcome the announcement after they hear this music a sufficient number of times to become familiar with it. You see, we are taking it for granted that



JOSEPH KNECHT

Without whom the Waldorf Astoria would almost have to go out of business, or so it seems. He has long been conductor of this hotel's Concert Orchestra. Their Sunday evening programs, broadcast by WJZ, are prime favorites with radio listeners





ANNA PINTO

The youthful harpist who has been heard frequently during the season from wjz, is now "off the air" until fall, having gone on a well-deserved vacation

those who have been reveling in "Dirty Face" over the radio lack acquaintance with this ballet music which is probably as well known as any music of its kind ever written.

The much-discussed question of having a few very high-powered stations in this country that would ultimately control all the broadcasting has met with violent opposition from the hundreds of stations conducted for the purpose of advertising the products of the business firms operating them. The majority of these stations are far below any commendable standard so far as their programs and the manner in which they are presented are concerned. Will this new development in radio, which is bringing the best in radio music to far distant points, in time put these stations out of business? There would be nothing lost and a good deal gained for the public were this to come to pass.

Does it not look as if this linking of stations is but another way of having the broadcasting within the power of the few? Be this as it may, developments along the right line are coming so rapidly that all who have deplored the quality of radio programs in this country are beginning to grow optimistic. Whether the methods used to bring about this change will be permanent, no one can say. But of one thing we may be absolutely assured. Radio music having had this upward trend, can never again sink to the low level that has so widely obtained.

Of great interest are the statistics given by John A. Holman, broadcasting manager of the American Telephone and Telegraph Company relative to his opinions of the change in the musical taste of radio listeners during the past two years. In January, 1923, approximately seventy-five per cent. of radio fans favored jazz. In the same month of 1924 this percentage fell to thirty five and in

January of this year to five per cent. These figures tell their own story.

Among the fine programs regularly featured through W E A F are those given by the Atwater Kent Company. Have you noticed that the singers of the quartet heard in these programs are never announced by name? That should be qualified by saying that we have never heard them so announced. "The tenor of the Atwater Kent Quartet will now be heard in the solo, "On-



PROFESSOR MARSHALL S. BROWN

Dean of the faculties of New York University, who has delivered interesting weekly lectures on American history from station wjz, New York

away, Awake, Beloved!" And when you hear him sing you know that he is not an amateur looking for publicity through the microphone; indeed if he were, he would insist on having his name announced, "before and after." We are quite willing to hazard the guess that this quartet is made up of paid professionals—and admirable ones at that—who do not want their names sent out as "radio artists," a position that can be understood considering the present chaotic conditions prevailing in broadcasting. If this guess is a wrong one, we stand ready to be corrected.

Are not the phonograph companies, as long as they broadcast programs made up from titles almost entirely taken from the titles of records made by each artist presented, in danger of a repetition that will be tiresome? Here is a tip for the Victor authorities. Have all your baritones avoid "La Paloma" for a time!

### Great Artists Are Coming to Radio

**U**NDER no circumstances will I ever permit an artist under my management to be heard by radio. Were such a thing to happen without my consent, I would consider it ground for cancellation of contract and take immediate steps to bring that about."

Many managers of musical artists have said this to the present writer. And one and all are now permitting, evidently gladly, the most famous people under their management to be heard over the microphone. Nor are these hearings confined to the programs of the phonograph companies, but go so far as to include appearances at public concerts. We do not know that, to date, any complete public recital by any artist has been broadcast, but where the program is a mixed one, various artists appearing, a portion at least of each artist's contribution to the whole is given to the radio public. It all but goes to prove that we must either keep up with the procession or drop out of it altogether.

**D**OES hearing the phonograph programs stimulate your desire to take advantage of the opportunity when it

offers of hearing and *seeing* these same artists in concert? We are of the belief that, with the majority of people, hearing an artist in a few numbers would arouse the desire to hear him in an entire concert if possible.

### What Happened at WTAM

**I**N THE March number of this magazine, the statement was made in "The Listeners' Point of View" that on Christmas Eve, "Silent Night, Holy Night," was jazzed from station WTAM, Cleveland. The statement carried the explanation that the present writer did not hear this sacrilege and hotly denied it when first given the information, but that this information came from a sufficient number of sources to seem to prove it true. It appeared at the time all the more inexcusable considering the standard maintained by WTAM which is conducted by the Willard Storage Battery Company.

It is with pleasure, therefore, that we



ROSELINE GREENE

Leading woman of the WGY Players, who is but eighteen years old, and a junior in the New York State College for Teachers, where she is taking the classical course. Her entire professional dramatic experience has been gained under Edward H. Smith, the director of the WGY Players

publish a denial of this statement received in a letter from Mr. S. E. Baldwin, in charge of broadcasting at WTAM:

So far as we know, the only time this particular piece of music has been sung or played over station WTAM was on the night of December 24, 1924—Christmas Eve. On that particular program it was played or sung some five times, being first sung by the Cleveland Music School Settlement, under the leadership of Alice Shaw Duggan.

The second time it was sung by the Old Stone Church Quartet, composed of Mrs. Robert J. Kelly, Alice Shaw Duggan, Harold Branch, and Fred S. True. This quartet is probably the best known church quartet in the city of Cleveland.

It was then sung by Miss Marie Similink, one of the leading contraltos of Cleveland. Later in the evening it was again sung by Doris Stadden Kaser, and at midnight played by trumpeters of the Cleveland Concert Band in conjunction with chimes from the Old Stone Church.

The writer was either present or listened by radio to the entire concert; he is perfectly familiar with the music, and to the best of his knowledge, nothing of the kind of which you accuse us occurred on the night of December 24th.

Isn't it rather unjust to publish statements of this kind without first taking them up with the supposed offender? There is a possibility that sometime you may be wrong.

Frankly acknowledged. Probably a number of people heard more than one station at once at that hour, the leading fault of radio at present. At any rate, there is a moral in this. Never say it was so unless you heard it yourself.

**A**BE MARTIN says: "So far I ain't noticed that any romances hev cum from th' publishing of radio photographs."

## Shall Broadcast Music Be Explained?

**I**T WOULD be well if all the musical explanations now preceding the numbers presented on the Victor and Atwater Kent programs were completely done away with until they can be presented as they should. Some of us even go so far as to believe they should never be attempted under any circumstances. As matters now stand, they are compiled evidently from the studio dictionary by someone who knows nothing of the subject. They are put into type and then read by the announcer.

When Toti Del Monte sang "Caro Nome" from "Rigoletto," the attempt to explain what the song meant was wholly futile. For that matter, you can go to any of these early Verdi operas and never completely know what the story is about. How, then, can Gilda's infatuation for the dissolute Duke be explained?

Then there was De Luca's singing of "Largo al factotum" from

Rossini's "Barber of Seville." We defy anyone who has been to see this opera one hundred times to tell the plot offhand. There was no attempt to tell the plot when De Luca gave his superlative rendition of this number, but there were some jumbled comments about his fame in the rôle of "Rigoletto," and then something about the rôle of the barber, "Figaro," in the Rossini opera.

If something must have been said, why not let it go with saying that "Largo al factotum" is one of the most famous comic songs in all operatic literature, and that De Luca is unexcelled among living baritones in its interpretation?



MAGDELINE BRARD

A very artistic French pianist, who, although scarcely out of her 'teens, commands the admiration of connoisseurs in both this and her native country. She was recently heard through station WEAJ



LOLA SUMMERS

Ingenue of the WGY Players. She has been associated with this radio dramatic company since their first production

### How Classical Music Should Be Played

**W**E ARE much interested in learning the outcome of the suit for \$10,000 damages filed by Francis E. Woodward, a music teacher of Spokane, against the leader of an orchestra in that city, the allegation being that the rendition by the orchestra of the classical compositions of the old masters is such that, "the public has received a perverted idea of classical music, insofar that children may no longer desire a musical education."

The jazzing of the classics is the greatest outrage perpetrated by jazz orchestras. Mr. Woodward assuredly had the courage of his convictions in entering this suit. A pity he could not have filed it against the city instead of an individual. Where the classics are seldom heard in their original form in public performance, the influence of these mutilations would be much more far-reaching than in Chicago or New York, let us say. Would that Mr. Woodward might win ten times ten thousand dollars!

### The Fame of Georges Bizet

**I**F GEORGES BIZET, composer of "Carmen," and of the "L'Arlésienne Suite" so frequently heard over the radio from the better class stations could know that his name, through the means of broadcasting, is now familiar to practically the entire American public, well, imagination fails to measure his astonishment. After meeting with little but failure throughout his short life, he died

at the age of thirty-nine, a few days after his "Carmen", now judged by many as the one perfect opera ever written, was first produced. Three years before this he had been commissioned to write incidental music to Alphonse Daudet's three-act play, "L'Arlésienne." The play was withdrawn after fifteen performances. Of the twenty-seven musical numbers written for this drama, Bizet chose various ones and from them made a suite for concert use, and this was successful. The music, as all who have heard it know, is exquisite. It has all the elegance and finesse of the French school, and in the "Adagietto" carries the theme of sadness with such art that it becomes beauty rather than sorrow.

But Bizet did not confine himself to the French school by any means when he wrote "Carmen." Here is a Spanish story translated by a Frenchman into Spanish atmosphere with music that, while although it is not of Spanish origin, sounds as if it were. But it speaks of admiration of Wagner, even more.

June 3, 1925, will mark the fiftieth anniversary of Bizet's death. After all, that is not so very long to have become established as world famous, when, in dying, success, to say nothing of fame, seemed a myth.



JOHN A. HOLMAN

Director of Broadcasting for the American Telephone and Telegraph Company. He has made a careful study of the preferences of radio listeners, judging from the letters written to the various stations controlled by his company, and recently announced that public preference was swinging from jazz to classical music

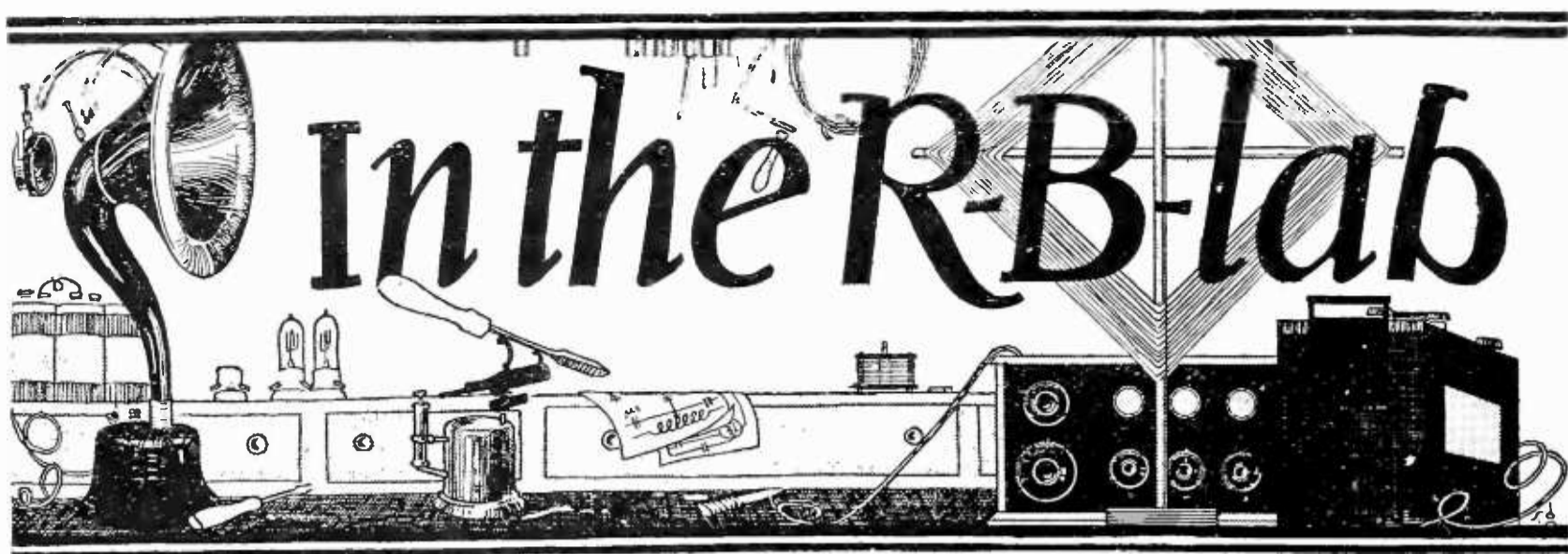

## How to Record Radio Signals

**T**HERE are many occasions when it is desirable to make records of wireless reception. Figs. 1, 2, and 3 illustrate a system of recording that is comparatively simple and yet quite effective. The apparatus described was installed as a check on fading phenomena during the total eclipse of the sun on January 24th, 1925.

The apparatus consists of three primary parts, the tuner — which may be any convenient set — the amplifier, and the recording dictaphones. Two stages of amplification are sufficient, although three steps of resistance-coupled intensification with volume control were used in this laboratory. It is advisable to have some volume regulation in order to lower the maximum intensity below the blasting point of the recording diaphragms.

Standard office dictaphones were prepared by affixing telephone receivers to the throats of the speaking tubes. The soft rubber fixtures intended for adapting head sets to horns, are convenient for the purpose. Two dictaphones are not required but were employed in the RADIO BROADCAST tests to insure an unbroken record.

The machines should be located at least five feet from the receiver and more if convenient, to eliminate motor induction. Grounding the frames of the machines will also reduce interference from this source.

It is generally desirable to monitor recording on a loud speaker. This is most easily

accomplished by connecting the telephone receivers (clamped to the recording instruments) in series with the loud speaker. A shunt variable resistance, 200 to 5000 ohms, across the phones, provides the recommended volume adjustment, without greatly affecting the loud speaker. If more convenient, any other satisfactory form of speaker unit may be substituted for the phones.

In recording fading, it is advisable to keep the receiver oscillating and record the beat note or squeal of the distant stations. In addition to

the greater intensity and sensitivity of this arrangement, signal variations will be much more noticeable due to the fact that the sound will vary approximately as the square of the signal variations.

### OTHER USES

**A**SIDE from the recording of fading

and swinging, this apparatus may be put to many other interesting and useful purposes.

It will immediately suggest itself for recording programs of special or historical interest, such as the inaugural address of the President of the United States. Reception is affected in the manner described, except, of course, that no beat note is produced.

### LEARNING CODE

**D**ICTAPHONES have been used for some time in the reception of high speed (80 to 100 words per minute) radio telegraph code signals. For transcription, the machine is

### *In the R. B. Lab. This Month*

*A Complete Article—Radio Recording with a variety of applications, such as tracing oscillating receiver interference, learning the radio code, and others.*

*Shooting Trouble—How we go about it. This article is the first of a series that will help the reader to solve difficulties in his receiver systematically and swiftly.*

*Notes on Wiring Your Own Lab.*

slowed down considerably, and the messages typed off at perhaps twenty words a minute. Speed reduction presents an excellent system for learning the code — an acquisition which many broadcast enthusiasts are attempting. It is merely necessary to speed the machine slightly and record any six hundred meter commercial station, or two hundred meter amateur station, and copy the sending of the operator at the desired reduction. The machine is tireless and will give you any number of repetitions.

#### TRACING CODE INTERFERENCE

**A**LL types of interference can be logged on the machines and later identified by an expert, as amateur interference or commercial code, arc-lights, leaky pole transformers, etc. *It is only when the type of interference has been determined* that it is possible for the radio inspector to take steps to eliminate it.

Systematic logging of all kinds of interference for later identification by an expert radio telegraph code operator would go far toward clearing up the air.

An identified "bloop" made to listen to

his own mush, recorded on a neighboring receiver, may be thoroughly impressed with the iniquity of his action.

#### REPRODUCING

**T**HERE are two convenient ways of reproducing the radio records. The first, and perhaps more satisfactory method, is to employ the standard dictaphone transcribing machine, listening in the customary manner through the rubber tubing. The second, and more spectacular system, is to reproduce electrically, amplifying the sound and outputting it to a loud speaker. This method is illustrated in Figs. 2 and 3.

The arrangement as suggested in the diagram consists of three parts, the microphone for picking up the sound, the amplifier, and the talker. This apparatus may readily be a simple re-arrangement of the equipment employed for recording. The microphone (of the magnetic type) is conveniently the telephone receiver or loud speaker unit clamped to the throat of the dictaphone adjusted for reproducing, but connected to the input instead of the output of the amplifier. The loud speaker

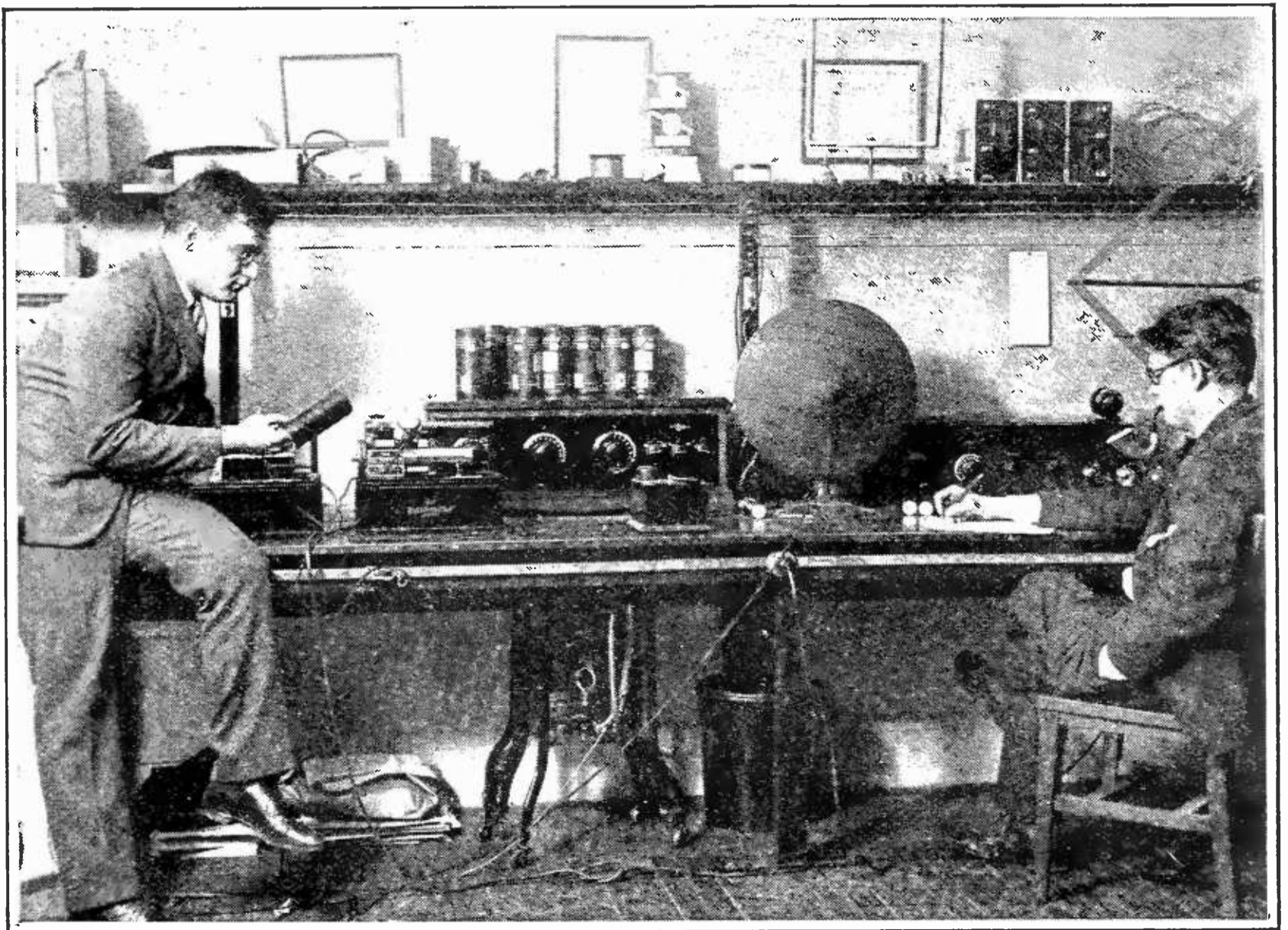

FIG. 1

Making fading records in The R. B. Lab. Beat-note fluctuations are monitored on the loud speaker and permanently recorded on the dictaphones

remains in the plate circuit of the last tube.

When recording and then reproducing in this fashion, it is most important that the amplifier, which is really used twice, be free from audible distortion. With the interposition of the several mediums, it is inevitable that quality will be lost, and every effort must be made to reproduce faithfully. Unless the experimenter is very sure of the results produced by his amplifier, resistance coupling is recommended. In the photographs, a three-stage resistance-coupled amplifier was employed for recording, and a two-stage transformer-coupled amplifier for reproducing.

The reproducing system can be readily applied to any phonograph arrangement where great volume or electrical transmission is desired. It is only necessary to place the microphone where it will intercept the sound waves at a point of fair concentration. A magnetic microphone of the type described is preferable to the ordinary carbon grain variety.

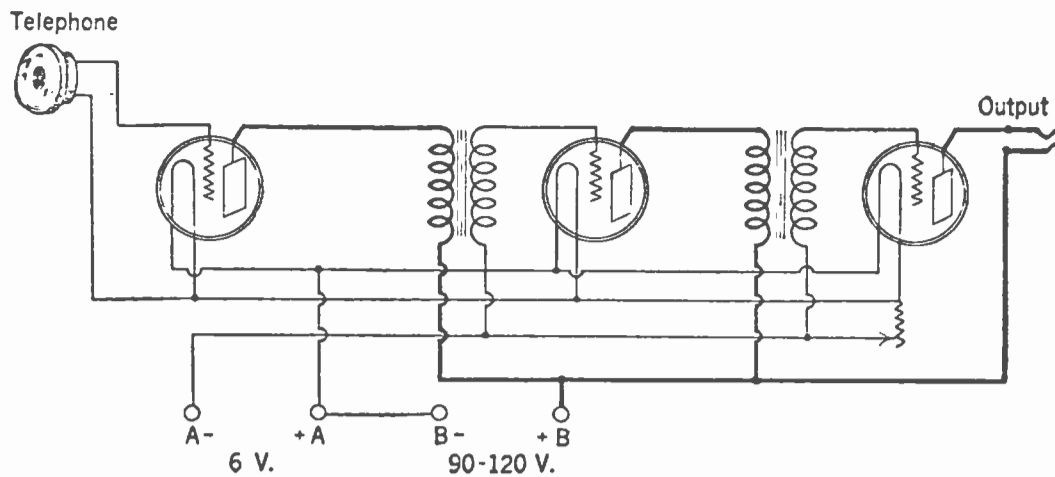

FIG. 3

The circuit diagram for the amplified reproduction of audio records. This system may be employed for the amplification and transmission of phonograph music

### SHOOTING TROUBLE

EVERY laboratory, and every radio experimenter for that matter, must be prepared for the innumerable difficulties that beset the way of radio experiment. This laboratory has its full share of them; in fact it is part of its business. Shooting trouble may be simplified and thereby made more swift and efficient, by following a certain logical procedure. A doctor does not treat his patients in a haphazard manner. He does not tap them on the chest when they have a tooth-

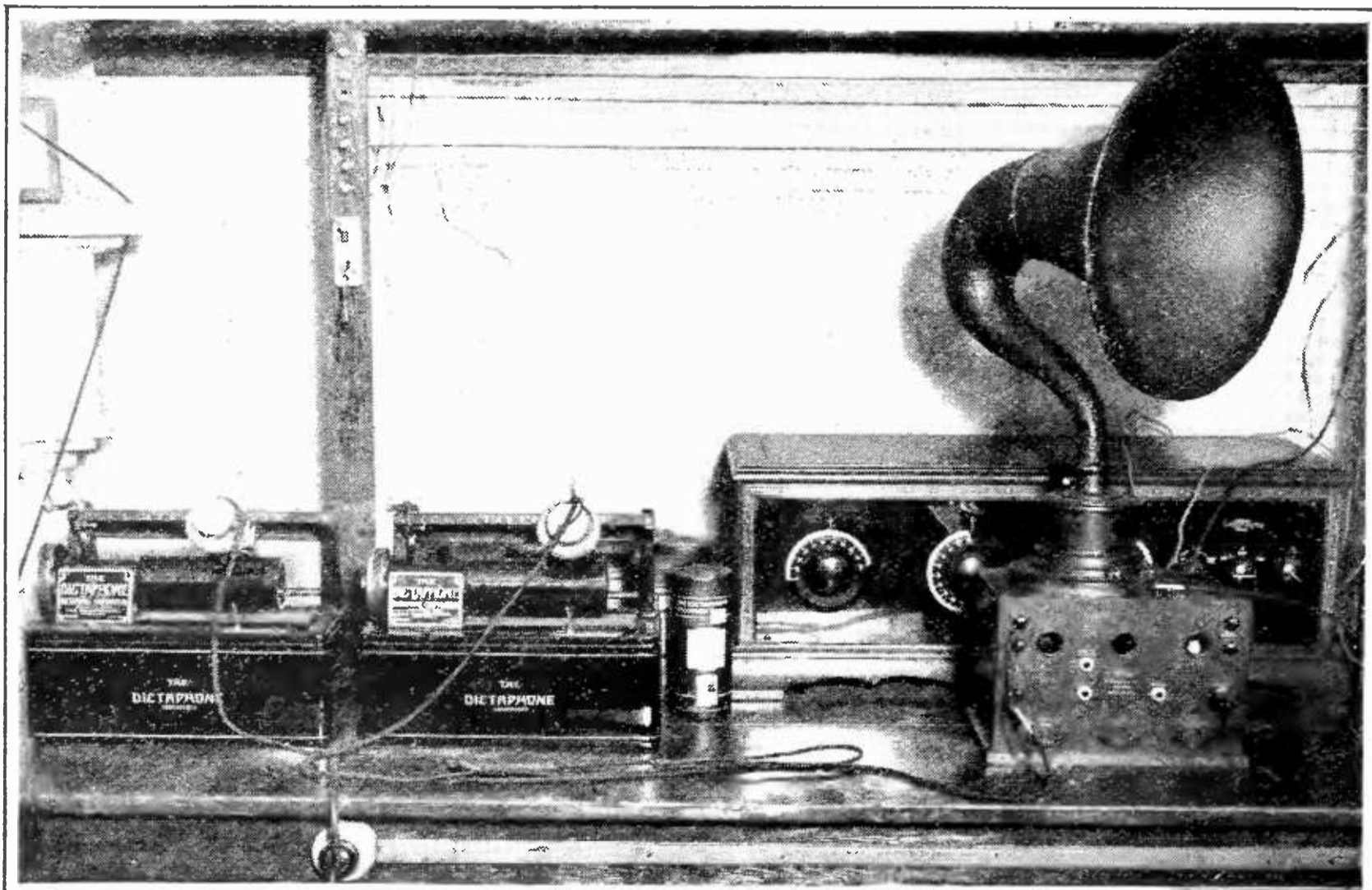

FIG. 2

The amplifying arrangement for reproducing the records on the loud speaker. The telephone receivers or loud speakers employed for recording may be used as pick-up microphones in reproducing



ache, but rather he observes the symptoms and through a sequence of thought and experiment establishes just what and where the trouble is. Likewise in radio a few consistent observations, even by the most unexpert member of the family, will often solve the difficulty without calling in an expert.

There are three types of radio difficulties:

Absolute Inoperation  
 Poor Operation  
 Noises

These are general headings and they cover a multitude of the conventional radio sins. In this article we shall begin to treat the first group, not because it is the most prevalent (which is doubtful) but because its treatment is the more definite and simple.

#### THE SET WON'T WORK

PERHAPS the receiver is turned on in the usual manner but nothing happens. The receivers or loud speaker is dead, and the twisting of dials futile. The first thing to be done is to locate the trouble. The second

task—to be treated next month—is to apply the remedy associated with that particular trouble.

*Test No. 1*—Turn off the bulbs, listening for a click in the phones or speaker. No click indicates a break somewhere in some battery circuit. When there is no click, we proceed to

*Test No. 2*—Inspect the bulbs. If they light, the filament circuit is O. K. A very dim, partial light (which however, should give a faint click in Test No. 1) suggests a low A battery. One or more bulbs may be “blown”. If the bulbs do not light we try

*Test No. 3*—Make a momentary “short” of the binding posts on the set generally marked A-plus and A-minus, with a pair of scissors or any other metal object that is convenient. A spark indicates trouble in the set itself—filament wiring, burnt-out rheostats, loose socket prongs, filament control jack, or an inoperative switch. No spark shows that the trouble is on the battery side—in the leads to the battery, in the battery terminals, or a dead battery.

If Test No. 2 finds the bulbs normally

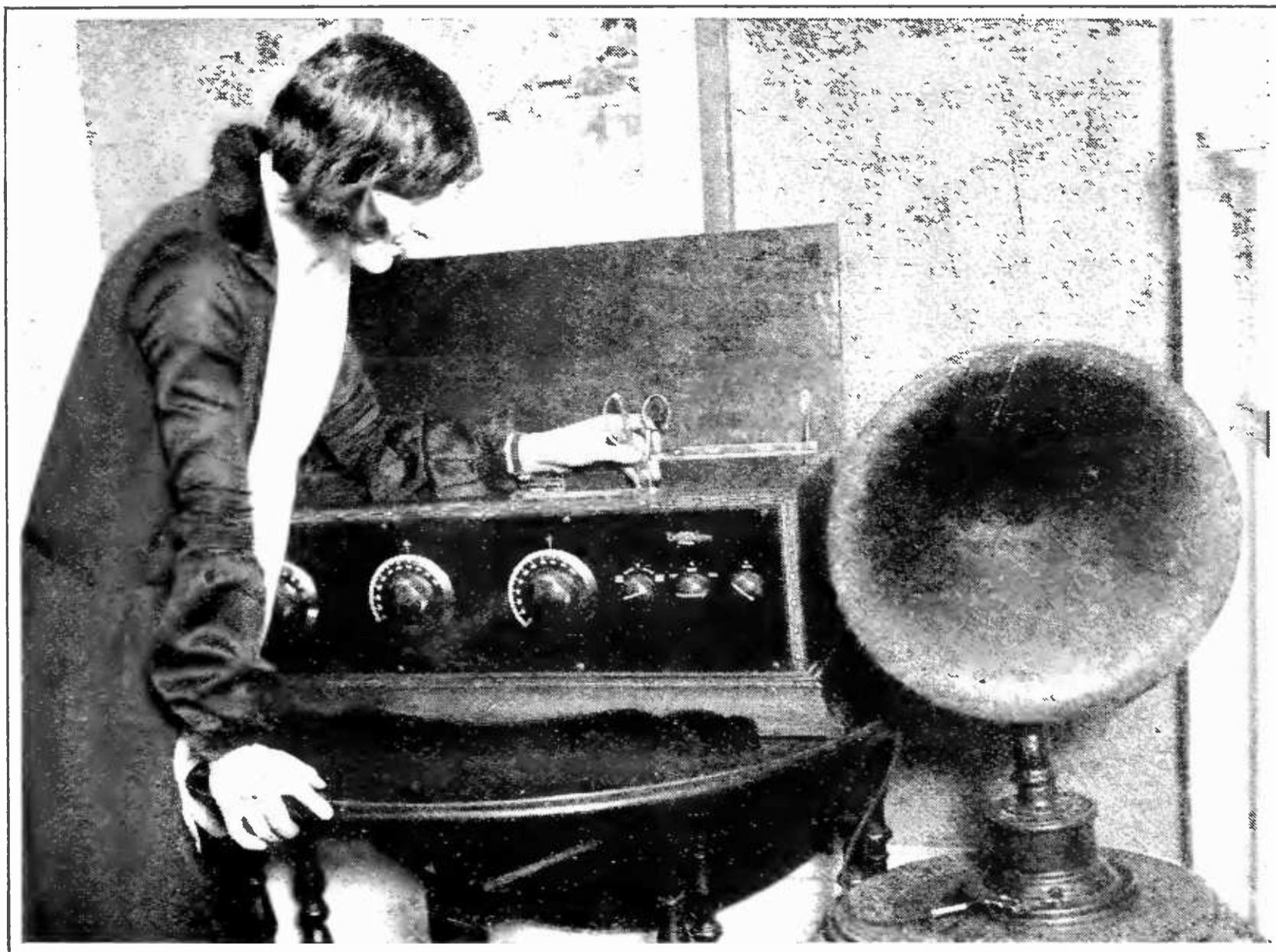

FIG. 4

“There is no spark, Harry, You’d better take a look at those battery leads”. There are many simple tests that almost any one can make which will show up the more common radio ailments, and suggest a way to remedy the difficulty without calling in an expert



FIG. 5

If the bulbs light, pull the plug out, listening for a click in the loud speaker or phones. When these simple tests do not actually show you the way out of your difficulty, a description of the results will be of very great benefit to the Grid Department, or to your local expert in helping you out

lighted, the plate circuit in the last tube is, probably open. This may be additionally ascertained by

*Test No. 4.*—Pull the phone plug in and out, listening for a click. Change from phones to loud speaker and repeat the test. This will place the difficulty in either the output instrument or within the set. If one pair of telephones give a click in response, it is evident that the difficulty lies in the other. If the trouble is in the receiver proper, and neither phones or speaker work, try

*Test No. 5.*—Place another tube in the last socket and repeat Test No. 4. No response absolves the tube, placing the blame on an open B battery circuit, with the probability that the phones and speaker are in good condition.

*Test No. 6.*—This should be in the form of a momentary short, or, better, a voltmeter test across the B battery posts on the set. If current is indicated, this shows the trouble is within the set; the current from the battery has succeeded in traveling as far as the binding posts. No deflection on the voltmeter or spark, if the voltmeter is not used, locates the difficulty on the battery side.

If tests No. 1 or No. 4 show that there is a plate circuit, that the batteries are O. K., the next test on non-regenerative sets (neutrodynes and stabilized radio frequency) is

*Test No. 7.*—It is then possible that there are no receivable stations on, which means that they are off schedule or shut down by an SOS. More than one fan has decimated his set during the enforced silence accompanying a distress call at sea. Have someone ring your doorbell, or turn on and off your electric light, respectively while you listen for a rough buzz or clicks in the receivers or loud speaker. These will indicate that in all probability everything is O. K., or that the trouble is in the antenna or ground connections. No results or results below normal, suggest the radio frequency circuit is the source of difficulty.

*Test No. 8.*—With regenerative receivers, those employing detector feed-back and potentiometer or similarly controlled radio frequency circuits, this test will probably precede test No. 7. Turn up the regenerative or "volume" control. The usual oscillations, "plops", or squeal, show that the regenerative detector and audio frequency tubes are O. K. The operator will then proceed to Test No.

7. Negative results from Test No. 8 show a fault in the regenerative tube or tubes or in any of the audio stages except the last, which Tests 1 and 4 proved O. K.

*Test No. 9*—Tap the bulbs with a pencil, moving progressively toward the antenna connection. This generally means from right to left: second audio, first audio, detector, etc. No ring will be heard in the loud speaker when the faulty tube or stage is reached.

*Test No. 10*—Changing tubes will almost always eliminate or define the bulbs as the source of difficulty.

*Try all these tests when your set is working, immediately when the trouble is discovered if possible, in order to acquaint yourself with the response you may expect from a working receiver.*

### BUILDING YOUR OWN LAB

**W**IRE your lab. with an eye for convenience in testing and operating more than one receiver in different parts of the laboratory. The arrangement developed in the R. B. LAB can be enlarged or reduced to suit individual convenience.

Filament and plate batteries are centrally located with charging apparatus, and are wired to the benches using colored wire, often called "code wire."

Six outlets are desirable, which provide for the connections to as many receivers or test apparatus. Seven wires are used. Two differently colored heavy stranded wires carry the A battery current. Four No. 18 annunciator wires of variegated hues, provide plus B battery from  $22\frac{1}{2}$  to 140 volts. The negative B is connected to positive A on the battery table. The seventh wire connects to an outside antenna which may be disconnected by a switch at each of the six outlets.

One hundred and ten volt lines are run in metal moulding along the edges of the benches with similar outlets. The moulding itself affords the ground. The moulding should be installed according to underwriter's requirements, who, however, have no jurisdiction over the other wiring.

If desired, fuses, switches, and meters (volt, ampere and milli-ampere), can be installed at the battery table. Several photographs taken in the Lab. depict the utility of this arrangement.

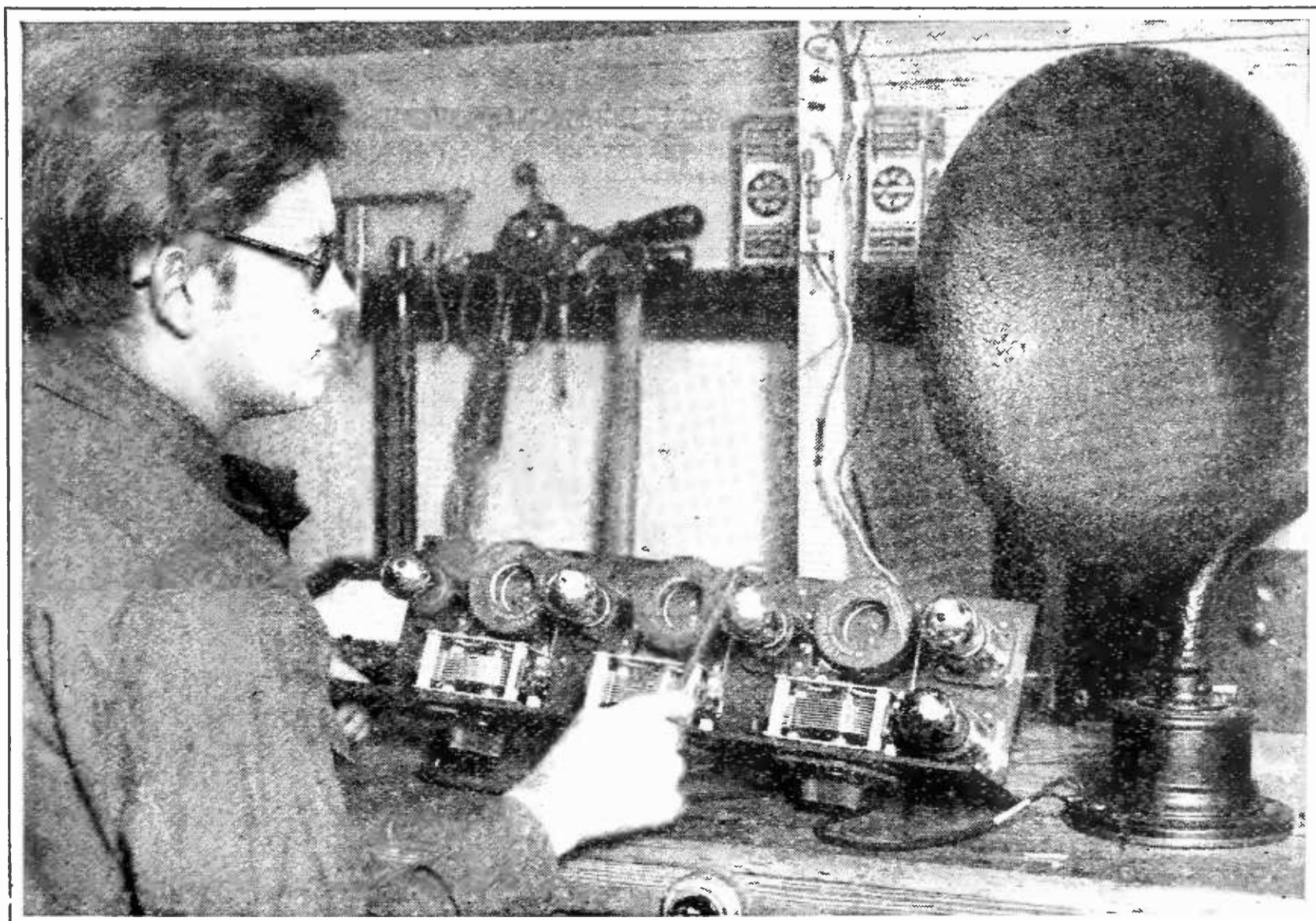

FIG. 6

Tap the bulbs and listen for the usual ring. A ring from any of the r. f. or detector tubes shows that the audio amplifier is O. K.

# as the broadcaster sees it

by Carl Dreher



*Drawings by Franklyn F. Stratford*

## How Much Power is "Super-Power"?

**H**OW big must a broadcasting station be to claim attention as a "super-power" outfit? Estimates appear to vary. The owners and publicity representatives of the 5-kw transmitters now being put into operation in various sections of the country like to refer to them as super-power equipment. But if 5 kw is super-power, what would 50 kw be? We had better be careful, or we shall run out of awe-inspiring prefixes. It is certain that Mr. David Sarnoff, who is responsible for the idea and for the spreading abroad of the term, had a considerably greater magnitude in mind than 5 kw.

However that may be, it is a fact that the power rating of present-day broadcasting stations is trifling compared to that of the great transoceanic and transcontinental radio telegraph installations. One of these immense transmitters is described in a paper by Dr. Cornelius J. DeGroot in the December, 1924, number of the Proceedings of the Institute of Radio Engineers, "The High-Power Station at Malabar, Java." This station connects the Dutch East Indies directly with Holland, arc transmitters being used in the main. At the present time 2,400 kw is the power supply to the arcs, whereby 1,200 kw are fed to the antenna, as compared to 0.5 kw in the antenna of a standard Class B broadcasting station. 1,200 kilowatts! Ten years ago all the man-made radio frequency energy in the world probably did not amount to 1,200 kw. Dr. DeGroot is not satisfied, however. He assures us that when he gets another motor generator from the General Electric Company he will be able to supply 3,200 kw to his arcs, obtaining about 1,600 kw in the antenna. This will

put the station on a 20-hour-a-day basis of communication over its 7,500-mile circuit, which is in excess of the traffic requirements.

But, simply regarded as power, 1,200 or 1,600 kw are not figures to arouse respect among power engineers. In a good-sized power plant, such as one of those which supply energy for the subways of New York City, the wattmeter reads in the neighborhood of 100,000 kilowatts on normal load, and this load fluctuates 5,000 up and down. The mere variation in the load carried by such a plant is far greater than the maximum output of the largest radio station in existence.

The comparison is instructive, and chastening to the pride of the radio engineer, but at bottom it really does not mean much, for the commodities are not in the same class. Raw electric energy is one thing, and modulated radio energy—especially that voice or musically modulated—is quite another. Moreover, this difference between simplicity and complexity is only the first of a number of unlikenesses. There is a difference in reception, for one thing. The subway train or the electric toaster takes power from the line and uses it up. Radio receiving sets, in general, amplify, sometimes very greatly, the quantity of energy which they pick up. A super-heterodyne in robust form may possess a voltage-amplifying capacity of from 5,000 to 10,000 times, according to Mr. Armstrong (from 25 to 100 million times energy amplification), and no doubt many receivers of more plebeian types have an energy amplification of millions of times (energy amplification is the square of voltage or current amplification). It should be noted that this development of receiving amplifiers

has been necessitated by the great attenuation involved in radio transmission, the losses in the intervening medium being far greater than those of an electric power transmission network.

But the principal distinction lies in the extraordinarily small amount of energy required to satisfy the human ear. "The speech energy output of the normal voice has been found to be at the rate of about 125 ergs per second. If we could have a million persons talking steadily and convert the energy of the voice vibrations into heat, they would have to talk for an hour and a half to produce enough heat to make a cup of tea. This merely serves to illustrate that in terms of power or energy human speech is exceedingly weak. Furthermore, most of this energy is carried by the vowel sounds. At the upper and lower limits of audition it takes about a hundred million times as much energy to enable one to hear as it does in the range of 1,000 to 5,000 cycles, where the ear is most sensitive. At all frequencies, the energy required is small, and in the most favorable region the minimum audible tone corresponds to a pressure change per square centimeter of about 0.001 of a dyne. This pressure is roughly equivalent to the weight of a section of a human hair about one thousandth of an inch long (about one third as long as its diameter)." (R. L. Jones: "The Nature of Language." *Journal A. I. E. E.*, April, 1924.)

Thus a public address system or a moderate-powered broadcasting transmitter may, as has been pointed out, contain more speech energy than all the inhabitants of the globe yelling with all their might and main at the same instant—if they could be persuaded to cooperate to this extent, which I doubt. It is for this reason, basically, that wireless stations are not, relatively speaking, powerful. They need not be as powerful as agencies which light homes or transport freight or press trousers, because these actions require infinitely more energy than

speech and hearing, and it is in hearing that radio communication usually terminates. That is why super-power in electrical engineering—the section-wide coordination and integration of power generating facilities—deals with magnitudes enormously greater than the super-power projects of radio broadcasting. The latter, however, assume imposing proportions as soon as we compare them with the energy levels of unaided speech or the general run of sounds found in nature.

Since writing the above I have come across two newspaper articles bearing on this subject. One of them is a publicity release by Mr. J. D. R. Freed, also pointing out that "super-power" is a term too loosely and inflatedly used in radio at the present time. Mr. Freed compares the power of a large broadcasting station like WEAJ, with 2 kilowatts in the antenna, with the 665 kilowatts consumed by a ten-car subway train (presumably this is starting energy). An electric sign on Broadway consumes 263 kilowatts. The average broadcasting station of to-day puts into the antenna only about as much power as one needs to light a six-room flat. Mr. Freed's idea of super-power is from 1000 to 10,000 kw for an international program distribution. In other words, he would go up to and above the level of the Malabar transmitter of Dr. DeGroot. The only question we raise at this point is: Who is going to put up the money? Also, in his comparison of power magnitudes, Mr. Freed does not discuss the bearing of the relatively minute energy required by electro-acoustic devices, on the problem of radio power.

However, Mr. Freed is an engineer and what he says is sound and pertinent. At the opposite extreme is a publicity release by a radio and phonograph company which is about to enter the broadcasting field with a "station of tremendous power. It is said that it will have a range of from 15,000 to 20,000 miles." And what is going to be

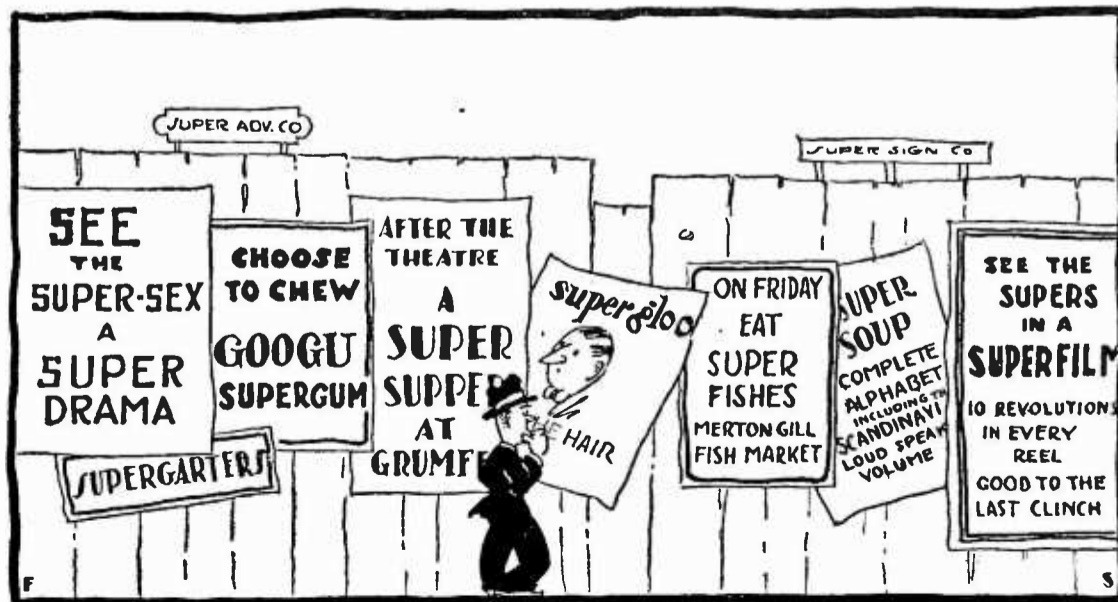

what does "super" mean?

the power of this colossus? Answer: 5 kw. You may breathe again.

Moreover, the engineer of the company informs the world that this new station will "influence profoundly broadcasting in daylight." This gives the impression, to the lay reader, that the daylight range of a 5 kw transmitter must be somewhat comparable with the night range of the present order of figure 0.5 kw sets. This belief is entirely erroneous.

Messrs. H. W. Nichols and Lloyd Espenschied, two prominent radio and telephone engineers, investigated this subject some years ago, in the course of a larger work which occupied them at that time, and reported their results in a scientific paper. (Nichols and Espenschied: "Radio Extension of the Telephone System to Ships at Sea," *Proc. I. R. E.*, Vol. XI, No. 3, June, 1923.) They made actual measurements. It was found that in order to equal during daylight the freak ranges secured by radio telephone stations on broadcasting wavelengths (then 360 and 400 meters) during the most favorable times at night, about 10,000 times as much power would be required. A 0.5 kilowatt station would have to raise its power to 5000 kilowatts!

But what's a little multiplier like 1000 to a publicity representative and radio engineer, model 1925? Less than nothing, for these gentry never heard of Nichols and Espenschied and Alexanderson and Wien and Braun and Armstrong and Latour and DeForest and the few hundred other earnest engineers whose exclusive creation radio broadcasting is. And, if they have heard of them, they care no

more for scientifically derived data than the Long Island fanatics who recently awaited the end of the world.

### Artistic Stands for the Microphone

THE design of microphone stands, at the present time, is far too conventional. They are tame, unimaginative things wrought of bronze pipes or one-time respectable parlor lamps. This has a depressing effect on the whole broadcasting art, for the general public gets its ideas of radio largely from the myriads of pictures showing the great, and the aspirants to greatness, posed before a microphone stand in the attitude of talking to 10,000,000 fellow citizens—even when the station power is about 10 watts. What an opportunity is neglected here! The future belongs to the genius who will express himself through radio microphone stands, fitting them to special situations, somewhat as follows:

A ravishing silver-plated girl in attractive déshabillé for lecturers on literary censorship, denouncers of the younger generation and petting parties, etc.

For Mayor John F. Hylan of New York City, a bust of Gen. John F. O'Ryan, his opponent in the local traction controversy. General O'Ryan could hold the microphone in his teeth.

A foaming stein or champagne bottle for prohibitionists.

At woc, the learned chiropractors might talk to a mound of issues of the *Journal of the American Medical Association*, the microphone surmounting the same.

For Messrs. Arthur Lynch, Willis K. Wing, and Zeh Bouck, the desperate crusaders for a squealless ether, what could be more appropriate than a gigantic diagram of a single-circuit regenerator, rampant, with the microphone suspended from the oscillations?

The ramifications of the idea are obvious. Its inspirational properties are unlimited. We leave its execution to philanthropists and artists.

### Note on Announcing

A COMMITTEE has recently been occupied, in New York City, with the task of raising the standards of announcing. Various conclusions as to rate, pitch, inflections, and other characteristics were reached and duly published.

A most praiseworthy work. But the committee omitted consideration of one funda-



we need artistic microphones

mental fault with which nine announcers out of ten are afflicted: they talk too much.

## How and Why Stations Heterodyne One Another

**T**HE problem of heterodyne interference between broadcasting stations has the same origin as the rush hour jam in a large city: too many people are in the same place at the same time.

Class B stations are supposed to be spaced ten kilocycles apart, with an effort being made to reduce the separation to  $7\frac{1}{2}$  cycles, in order to create additional channels for new stations. These are theoretical separations, conditioned on all the stations keeping their exact assigned frequency. Unfortunately, they vary. When they get a few thousand cycles apart, all the listeners within range of both hear a beat-note, a continuous melancholy whistle, varying slightly in pitch from minute to minute, and well calculated to drive sensitive persons crazy—although, through the psychological phenomenon of auditory fatigue, some people get used to the beat and hardly hear it after a time, unless it is very loud.

As a matter of fact, any two—or any number of stations, for that matter—have a beat note in any receiver capable of picking up their waves. If they are 10 kilocycles apart, they have a beat note of 10 kilocycles, or 10,000 cycles, which is over twice as high as the highest note on a piano. This pitch is too high to pass effectively through the audio-amplifying circuits of a receiver, and what little does get through is suppressed by the loud speaker and the human ear, neither of which is designed to respond ardently to such an acute note. In short, nothing is heard. But as the two stations, through the deviation of one or the other, or both, from its or their assigned frequency, approach each other, the beat note between them passes into the band of audible and essential frequencies to which the acoustic apparatus of the receiver and listener responds. The resulting interference may be anything from a very shrill whistle up around 4000 cycles, scarcely audible to one not listening for it, down to an angry recurrent growl on either side of zero-beats, if the two stations happen to be right on the same wavelength. Or, it may be a loud, continuous whistle of medium musical pitch. Loudness depends on the strength of the electric fields of the two interfering stations at the heterodyning location; pitch depends on



### running down station interference

their respective frequencies and the variations therein. The ultimate result is telephone and telegraph calls from irate listeners.

Unfortunately, a station which is too weak to produce a workable signal in a given neighborhood, is perfectly capable of giving rise to heterodyne interference with stations supplying a powerful signal to the locality on which it depends for program service. This is one of the inherent traits of heterodyne amplification, the same which enables an oscillating receiver to hold a very audible beat-note with a distant station, while, in the non-oscillating condition, the modulation of the station in question is inaudible—a characteristic which is therefore responsible for the reprehensible use of beat reception by users of radiating receivers. Great is heterodyne amplification, and, like many other great things, it is also capable of causing a deal of mischief.

The result is that in, say, New York City, you may be listening to one of the local stations five or ten miles distant, employing enough amplification to get a comfortable signal; and although in that condition your set could not possibly hear a Chicago broadcaster of the same power, when that Chicago station climbs on to your New York station's wavelength, you get a beat-note of perhaps a quarter the intensity of the local station's signal. (Living in New York, and being responsible for the technical operation of any of the local broadcasters, I naturally assume, and stand ready to prove it with wavemeters and firearms, that the Chicago station is at

fault.) But if the New York broadcaster then takes his carrier off the air, and you let your receiver alone, there is silence. You have to bring up your amplification in order to hear Chicago.

This has an important bearing on the problem of running down heterodyne interference when it does occur. The only receiver which can be safely used in such work is one which has a volume control independent of the frequency adjustments. If the tuning and intensity controls are electrically interlinked, I should say that the receiver is worthless for detective equipment.

If you are near one of the heterodyning transmitters, you are not likely to be able to identify the more distant one unless Number 1 takes his carrier off the air. If the interference is serious, and the transmission of the station is properly monitored from a point outside the studio, this is likely to be done. The engineers are waking up to the fact that they can best solve their station-interference problems by direct action, by exchange of telegrams between the broadcasters involved, as soon as the trouble starts. The telegraph companies are generally willing to give priority to such messages. It is preferable to take the carrier off the air for a few minutes, for the purpose of identifying the interfering station, and to send him a telegram explaining the situation, rather than to suffer the condition to continue and to allow the program to be hashed up, in greater or less degree, for the entire evening.

It is customary, when shutting down for this purpose, to take the listeners into one's confidence and to solicit their aid, for, with the great natural variations in receiving conditions, quite possibly some outsider will be able to do the job better than the one or two members of the station personnel engaged in chasing down the trouble. The purpose of this article is to give listeners some data which will make their testimony reliable in this regard.

The rules of the game may be summarized as follows:

1. When the announcement goes out, tune your set precisely to the wavelength of the local broadcaster who complains of the interference. This can usually be done in the few remaining seconds of transmission.

2. If you are receiving on a loud speaker, change to head telephones; your chances with the phones are obviously better.

3. When the carrier goes off the air, bring up your *volume* control till the interfering station is readable. *Don't touch the frequency controls.*

4. If you are able, under these conditions, to

make a positive identification, and you feel inclined to do that much for the cause, dispatch a telegram to the party of the first part who has gone off the air. The next best thing is to write a letter.

5. If the intensity and wavelength (frequency) controls of your set are not perfectly free from interaction, or if you are not confident that your set tunes very sharply, you can be of greatest service by staying out of the controversy. Your testimony will only confuse the issue.

Of course, if you have a set accurately calibrated in kilocycles, it may be permissible to try to determine the actual frequencies of the stations involved, but with ordinary equipment one is not justified in testifying that Station Number 2 was actually on the wavelength of Station Number 1 unless the frequency-determining elements of the receiver remained unchanged. Even this, of course, is only a beginning, for Station Number 1 may have been off his wave. Once it has been established, however, which stations have been involved, it is usually possible to clear up the situation for the time being, and the accurate calibration of their frequency indicators must be left to the Federal radio supervisors.

The necessity of instructing the listeners in the above procedure, if they are to be of service in these situations, was brought home to me by a recent incident. I was listening at my home when one of the stations in which I am interested developed heterodyne interference early in the evening. Program complications made it inadvisable to interrupt the service later, so I telephoned immediately and had the carrier taken off the air for four minutes. Before these instructions could be carried out the interfering station shifted his wavelength, and the beat-note ceased. It was too late to cancel the order, and the carrier went off. I listened on the chance that the distant station might come in again during the four-minute period of observation, but heard nothing except two extremely distant transmitters heterodyning each other, and a spark station in the English Channel. As soon as the carrier went back on the air, Dr. Alfred N. Goldsmith telephoned me to say that he also had heard nothing to indicate that any one was on our wavelength, and that on his specially calibrated super-heterodyne both of the out-of-town stations which occasionally clash with us were on their assigned frequencies. Dr. Goldsmith is the chief broadcast engineer of the largest radio company in the world, and has been making precision measurements in radio for about fifteen years, so that what he says must be accepted as *ex*



*cathedra*. But a considerable number of listeners notified the station that X and Y, the two transmitters with which we sometimes have difficulty, were on our wavelength. We know that at this particular time X and Y were innocent. Clearly our well-meaning informants were wrong in their conclusions.

As long as only two stations heterodyne each other, there is hope, but in the not infrequent case where three transmitters are involved, one can do little but sit back and stand the gaff. Generally, when one carrier is taken off the air, the remaining two beat with each other to such a degree that the announcements of neither can be understood. The only thing that a broadcaster in this situation could do would be to shift his own wavelength and get clear of them both. But that is reprehensible, for if individuals start taking the law or the wavelength into their own hands in this way, the present difficulties of ether congestion will become aggravated to the point of chaos. Such a remedy is worse, in the long run, than the disease. Communication and coöperation between broadcasters should all be in the direction of keeping every one on his assigned frequency. If the stations will only stay put, we shall be able to say, as far as beat interference is concerned, "The rest is silence."

### Who is Which in Radio— Colonel Combust

ON OUR recent trip abroad we carried letters of introduction to Colonel Combust, the Chief Signal Officer of the unmatched Euphratean army. We had considerable difficulty catching up with Colonel Combust, for the Euphratean forces were just then retreating before the matchless Kustanian army, a war having sprung up between the two monarchies over a chorus girl. Finally the officer was located, standing up to his mustache in a river, and waving his sword to encourage the brave Euphrateans who were swimming around him. Delivering our letters through an orderly, we hove to in our rowboat, waiting for a statement.

"We shall deceive the enemy," cried the gallant colonel, "for the code our signal corps operators send is absolutely unrecognizable, even by ourselves. Therefore the cursed Kustanians will be unable to discover our designs, our arms will triumph, and the lovely chorus girl Tina will be restored to the Euphratean "Follies," from which she was wantonly kidnapped by the King of Kustania, that insolent pig!"

As the valiant colonel swung his sword close to our nose during this denunciation, we rowed several boat-lengths upstream before asking:

"Has the King of Kustania no chorus girls in his own dominions?"

"He has," explained the colonel, "but his taste in that line is exotic, like that of a DX hunter, who praises the stations of every country but his own."

"Are you, then, afflicted with broadcasting stations, sir?" we inquired.

"Yes, indeed," answered Colonel Combust, "and I predict with confidence that, after we have defeated the enemy in this present war over Tina, the next war between Euphratea and Kustania will be brought about by the broadcasting stations."

"What!" we cried. "We understood that broadcasting was to lead to universal peace, the hearts of the Mongolians, Californians, and Esthonians being softened by mutual listening to bedtime stories, lectures on the dog-collar industry, and reports on measurements of the losses in No-Loss variable condensers. Nay, more, we had worked out a plan whereby all international disputes were to be settled, not by citizens shedding each other's blood, but by the announcers of the several countries being allowed and incited to talk each other to death. Thus an orderly and beneficial process would be substituted for barbarous warfare. What could be sweeter than to have the announcers die for their countries, while other citizens continue to hug their girls—"

"Whose girls—the announcers'?" interrupted the colonel with great interest.

"Announcers have no girls," we exclaimed impatiently. "The conjugal tie cannot long unite two such verbose entities as a woman and an announcer, and girls, realizing this

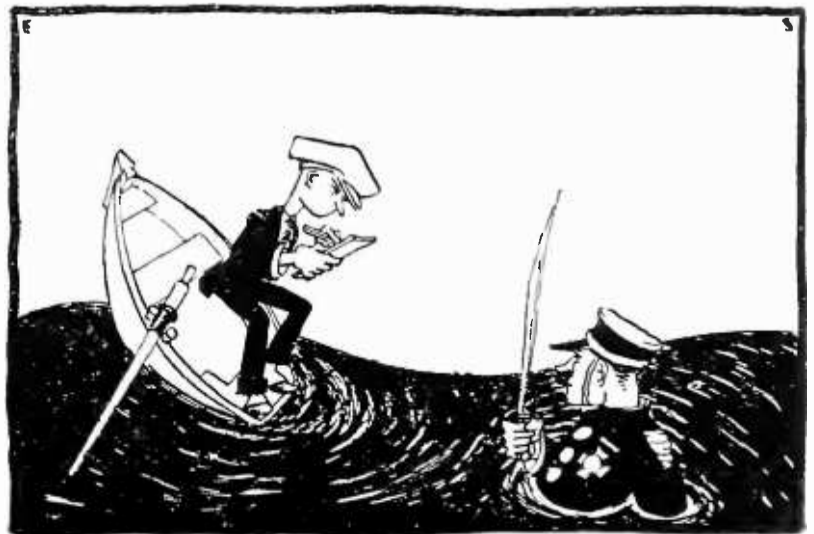

*the boat oscillated like a blooper*

fact, do not waste their time on the gentlemen of this trade."

"Nature is wonderful," agreed the doughty officer.

"As we were saying," we continued, "the announcers will perish, but respectable realtors, cheese-brokers, and clothing dealers will continue to drink chocolate sodas and to roll the bones. No longer will war ravage and impoverish countries. Such, at least, was my plan and expectation. And now you, Colonel, tell me that the great nations of Euphratea and Kustania are on the brink of another war—when they finish the present one—over a question of broadcasting stations! Oh, Colonel——"

Such was our agitation that we stood up in the rowboat.

"Sit down," called the officer. "You are rocking the boat."

Indeed, the boat was oscillating like the single-circuit receiver owned by the janitor's little boy. We sat down.

"Nothing could be more natural," Colonel Combust asserted. "The Euphratean engineers having erected a 3-kilowatt station, immediately the greasy Kustanians proceeded to put up one of 10 kilowatts. Is not that a *casus belli*? Shall we hesitate to defend our national honor?"

"But, sir," we assured him, "does any one doubt that three Euphratian kilowatts are worth ten Kustanian kilowatts?"

"Absolutely," cried the Colonel. "But you should hear the modulation. It is an atrocity. The whole world should make war on a country which permits such distortions in the ether."

"Don't say that, Colonel! On that basis, will not the League of Nations attack Newark, New Jersey, and stab it in the lower wavelengths?"

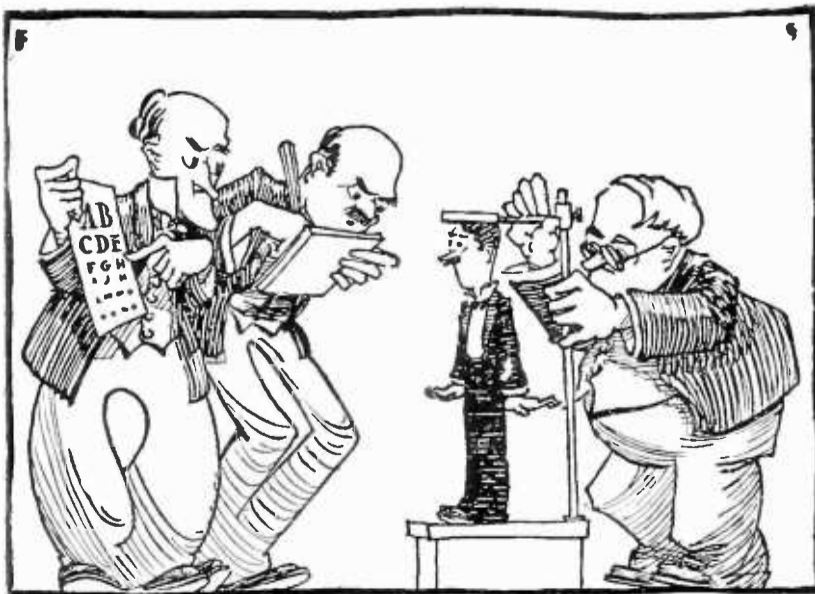

committees are judging announcers

"Why not?" inquired Colonel Combust, undisturbed, as ever, at the prospect of another war. "The surrounding marshes will be eternally grateful to any power which delivers them from some of those Class A coffee-grinder broadcasters."

"Besides," he continued, reverting to his favorite subject of the disputes between Euphratea and its hostile neighbor, "why should Kustania have a broadcasting station at all? The miserable Kustanian goatherds have no more valid use for such an apparatus than a football player has for a *brassière*."

"Are they deaf and dumb, then?" we asked.

"No," answered our informant, "although it would be a blessing if they were. You should hear their so-called broadcasting. What uncouth speech! What asinine arguments! What unadulterated drivel! Music such as little children make on their drums and fish-horns on Christmas! It is indescribable. One must hear it. But, as you seem a well-meaning and moral young man, I pray that you may be preserved from such an ordeal."

"Colonel, you speak exactly like one broadcaster about another in the same town—in my country. They refer to each other, reciprocally, in such sweet terms. But this is a conflict which we cannot resolve at the present time. So tell me, Colonel, would it not be possible for you to issue forth from this river and have dinner with me in that town I see on the horizon?"

"It would be bad tactics," answered the immersed officer, regretfully. "We have strategically placed our superb army in this river because the despicable Kustanians have 60,000 more men than we. But, such is their fear of being washed, that they will not venture near a body of water of this size. Thus by remaining in the river we are carrying the war to a glorious conclusion."

"The sensation of hunger," writes the physiologist Cannon, ". . . may take imperious control of human actions." A journalist is human. Hunger forced us to take leave of the heroic Colonel Combust and the other brave Euphrateans. When we had rowed about fifty feet towards the shore the Colonel hailed us.

"Sir, will you grant me a great favor?" he called. "Bring me back a ham sandwich and a water-proof radio receiver."

"Why the radio receiver?" we asked. "Would you not rather have two ham sandwiches?"

"No," answered the valiant soldier pite-

ously, "my feet are cold, and I would warm them by listening to the strains of 'Red Hot Mamma' broadcast nightly by 500 American stations."

Unfortunately, when we returned the river had frozen over from shore to shore, and no sign remained of the great-hearted colonel and his army. Furthermore, the Kustanians beat us up to within an inch of our lives for affording assistance to the enemy. We are proud, therefore, to present to our readers this last interview with Colonel Combust. *Requiescat in pace*—which, translated, means, May he freeze in peace.

### Why Should Radio Appeal Only to the Auditory Sense?

THE quotation with which we are now about to grace this crude and materialistic department is ladled out from the daily sugarwater offering of a metropolitan radio critic:

Deferring to the guest of honor's habitual aversion to radio, broadcasting forces had tactfully concealed the microphone among masses of flowers. Their sweet odor was infused into the words of the speakers, which transmitted with unusual clarity in spite of the blossomy screen.

A sweet odor was infused into the words of the speakers, ladies and gentlemen. Observe that honeyed figure of speech.

However, this is not the time to make my confessions in full. What I started out to develop was a speculation on the relation of radio to the various senses of a human being, as suggested by the above quotation. Is it conceivable that odors will ever actually be transmitted by radio? It certainly is. In radio telephony we start with a microphone, which changes sound waves to electrical impulses; the rest is easy. In the photo-radiogram processes which have recently been demonstrated, we allow light to impinge on a photoelectric cell, the light waves are transformed into electrical fluctuations, and photographs are sent over the ocean. Anything that can be translated into electrical energy can be transmitted by radio. Hence why not smells? The sense of smell involves the chemical action of vapors, essences, gases, or finely divided particles brought into contact with special organs of sense, the olfactory nerves. All we have to do is to invent an olfactory-electric cell, containing suitable chemical reagents, which will generate proportionate and appropriate electrical impulses

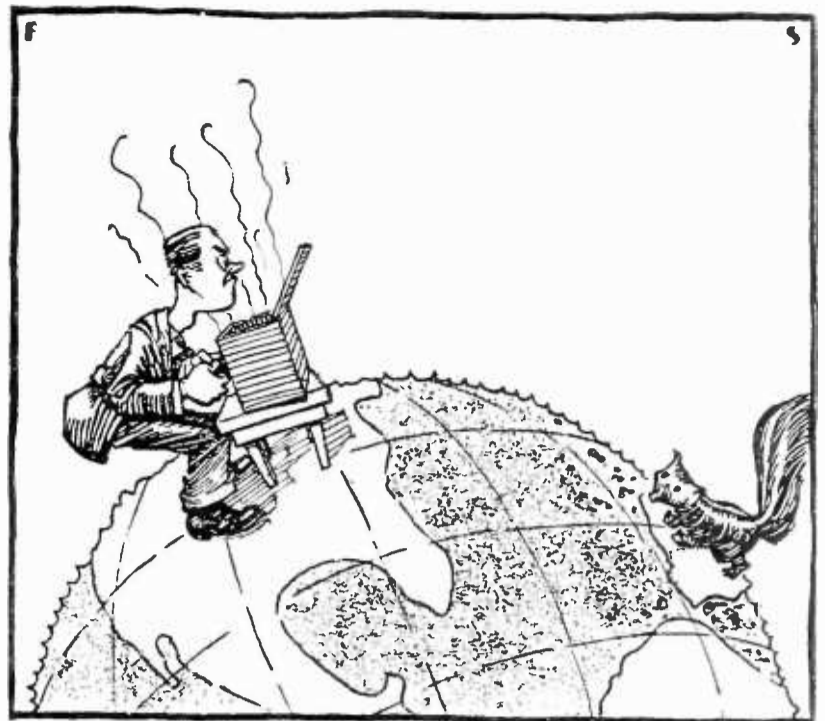

### smelling a civet cat across the world

when exposed to vapors, essences, gases, or finely divided particles suspended in air; and the rest is a cinch. When that dingus is invented—and anything can be developed if the Board of Directors will appropriate enough money—we shall be able to smell a civet cat or a piece of *fromage de brie* across the world. Oh, but that will be a glad day!

When will it dawn? No one who has given due heed to the human mania for invention can doubt that it will arrive. But when? Not immediately. For those who insist on figures, I am glad to estimate that its chances of arriving within the present century are only 314 in 1,000,000,000,000,000,000,000,000. Our readers will recognize this proportion immediately as being of about the same order of magnitude as the probability of M. Leon Trotzky voyaging to the United States to address Congress and to become a master of boy scouts.

The second portion of this learned treatise occurred to me while I was engaged in some research work of a medical nature. It appears that when a man dies the senses usually fail in the following order: smell and taste, sight, touch, and hearing. The significance of this to broadcast listeners is obvious. In the physiological turmoil of dissolution, when the individual is no longer responsive to odors, tastes, spectacles, and contacts, he can still harken to his favorite broadcasting station. He can hear that, more or less, until he blows up entirely. There is an assurance which should destroy the fear of death! If any patron of broadcasting wishes, in gratitude, to send me a check for \$10,000, my address may be obtained from the Editors.

# ON OUR BIRTHDAY

WITH this number, RADIO BROADCAST is three years old and we are going to take this opportunity of climbing to the house top and shouting about ourselves. During the remainder of the year, we will be modest and hide our light under a bushel, but on our birthday we should have a bit more latitude.

We feel that we are doing the job that we set out to do pretty well. If this presumption is unwarranted, we invite you to tell us wherein we have failed in order that we may not appear to fail again. Our job is not an easy one and we're human just like you, and we not only can, but sometimes do make mistakes. As a rule our mistakes are brought home to us in no uncertain terms, but there may be a few we've made that you haven't told us about.

DURING the last three years we have been plugging along with ideals, which, for a while, seemed like the pot of gold at the rainbow's end. These ideals are approaching nearer to actuality all the time. Our first and perhaps most important ideal from your point of view is a desire to present to our readers the best technical information that research makes available. It is with considerable pride that we recall having published the first article on a transformer-coupled superheterodyne, and another article describing various important experiments with the "super." It is significant to note that literally hundreds of "supers" have been described by other publications and that we find our first set for home construction is just about as good as any of the newer types—with the single exception of the Hanscom super-heterodyne, and that receiver saw the light of day in our own pages.

There are other circuits we have described in the magazine during our short three years of publication. The Knockout series of receivers have been tremendously well received by readers of the magazine in practically every part of the world, and if the letters which you, the reader, write us, can be accepted as any indication, that series is becoming increasingly popular. And these receivers are popular, we feel, because they fill a very definite

want among radio constructors. Our criterion is "Such a receiver and circuit must be reliable and technically sound. It must be helpful and useful to the radio constructor." These requirements, we feel, our construction articles have fulfilled.

And while we're on the subject of circuits, it is in order to say a word about our attitude toward "trick circuits." We never have and never will publish any construction articles on trick circuits. Our ideal is the publication of one extremely good "how to make it" article a month. If it employs a new, but good circuit—such as the two-tube superheterodyne we have up our sleeves for next month—so much the better. If on the other hand, no really new circuit is found, a more satisfactory arrangement of an old but good one is, as a rule, of real value. In March of last year we published an article entitled "The Truth About Trick Circuits." One gentleman whose circuit was rather severely criticized in the article brought suit against us in court for \$100,000 damages. Fortunately for you and for us, the jury decided in our favor. We shall continue our policy of telling the truth, even when it hurts.

AS A parting shot, we cannot resist mentioning the International Radio Broadcast Tests which were conducted by us for the second time last November. To you we owe a vote of thanks for your cooperation in making them a success. And they were more successful than anything of the kind ever attempted. From last year's experience we have learned much which will make our work of preparation for next fall much more effective.

Everything considered, we have had a fairly good and profitable time together during our short friendship, and our plans for the immediate future will, we trust, meet with your entire approval. As an example of some of our plans, we are glad to announce that we are going to add eight pages of text beginning with the June magazine. We greatly appreciate your friendly support and trust that our efforts in the future will warrant its continuance.

Arthur H. Szyrch.

# New Fashions in Radio Programs

How the Present Trend of Radio Advertising Is Improving the Quality of Broadcast Programs—A New and More Intelligent Rôle for the Announcer—What the “Balanced Performance” Means to the Radio Listener

By JAMES C. YOUNG

ANYBODY who has listened-in on the radio knows that weary feeling which sometimes steals upon the heart when the announcer reaches the next number. As for the announcer, he is a man worthy of kindly thoughts. He must go through 365 nights in the year, announcing anything up to a dozen numbers every night. And he must endeavor to introduce each one in an original way.

Some announcers are businesslike and crisp. They stick to their subject. Others affect the grand manner and cultivate theatrical inflections of the voice. Some others—alas!—turn to humor. That is the most painful method in the end. But whatever the method, the announcer has one of the hardest jobs in the radio business. He strives to make himself interesting every evening, and he must attempt the thing with the same old tools. We know in advance, every trick that he can play yet we must listen and hope for the best. Only a brave man would apply for the job. There should be a certain award in paradise for every announcer.

Of all the announcers known to the radio public, the noted “Roxie” has gained the surest hold on popular favor. His methods are distinctly personal and highly successful. He is the leading man of his own program and probably known

to a larger number of followers than any other personality associated with radio.

Interesting things happened when the man higher up at WEA F undertook to edit “Roxie’s” little monologues. For some time WEA F has believed that the endless repetition of announcements was trying on radio nerves. And WEA F suspected that “Roxie’s” monologues were somewhat trying as well. Therefore the blue pencil went into his talk about the old folk back home and the condition of Aunt Matilda’s health.

On one eventful Sunday night several months ago “Roxie” out-did the most stilted introduction known to radio. A host of followers listened and wondered and became

amazed. What was the matter with “Roxie”? Next day the papers told them. He had been edited. Immediately an almost unanimous protest poured in upon WEA F, the greatest expression of opinion ever drawn from a radio audience. There was plenty of static in that protest. It spluttered a good deal, demanding that the editorial frown be removed from “Roxie’s” copy. And WEA F relented, without even putting an ear to the ground. Such is the public estimate of one announcer who has caught the popular favor. But he is almost alone among a multitude. For some time it has been evident that radio must

## So This Is Advertising!

For some time, radio listeners in the eastern and central parts of the United States have listened faithfully every Tuesday night at nine to the entertainment given during what was called the Eveready Hour. These programs have differed from the usual run of radio entertainment, for they have been presented as a complete unit. And they have been well done. The idea of making a radio program follow one plan or idea for several hours at a time is not new—WGY and others have used it in the radio play, and WJZ made some sporadic efforts along this line with their “Spanish Night” and others. Radio broadcasting is nothing more or less than good showmanship, and as Mr. Young points out, we cannot expect the announcer to do constant marvels with an old bag of tricks. The step in broadcast programs which the author describes so interestingly is a real forward and important one, we believe. One frequently hears the fear expressed that broadcast programs will eventually turn into nothing but constant and very insidious advertising, but it is our opinion that the natural adjustment of things will prevent the overloading of the air with advertising that is objectionable.—THE EDITOR

evolve a better method of presentation for its programs.

It was this kind of reasoning that led to one of the distinct innovations in radio, a dramatic program presenting music and theme in a form of continuity which holds many possibilities. When radio was new somebody perceived the need of a cue to what the programs meant, and that brought in the announcer, of whom great things were required. He has met the task well, but the continuous program, built in dramatic sequence, will make his work considerably easier for himself and the listener.

Instead of bobbing up every ten minutes, like those in a class, he can make one announcement in an hour and try to do it in a humanly interesting fashion. No tricks are required, just a plain statement of what should be a few pertinent facts. Then the continuing theme must keep alive the interest created, constantly reminding the listener of the general trend, but steadily developing the performance as it is done in the theater, on the screen—everywhere the drama has an influence. This, in fact, is the true radio drama and not a hybrid adaptation such as the reading of a play. Radio has developed every means of expression peculiar to itself and it is thoroughly reasonable to suppose that its own kind of drama will be the next step in evolution.

That stage is now opening before us, if we may believe the evidence furnished by one successful broadcaster, responsible for the performance known to a national radio audience as the *Eveready Hour*. Promptly at nine o'clock each Tuesday night the entertainers in this group take over the air as controlled by WEAJ in New York. For the next hour, some millions of Americans are entertained in a way distinctly new to radio. WEAJ transmits the program to ten other stations, WFI, WCAE, WGR, WEEL, WEAR, WCCO, WWJ, WOC, WSAI, and WJAR. And for sixty intensive minutes an invisible audience equal to the population of many nations may enjoy a real radio drama.

#### SOMETHING GOOD DOING EVERY MINUTE

**H**OW is the thing done? The answer to that question goes back a little way. The first attempt grew from an acute sense of the elements lacking in a typical program, which too often has reached the point where the old minstrel show wound up. No matter how clever Mr. Bones might be, it was not possible for him to continue longer than he did.

And the announcer in a large measure corresponds to Mr. Bones. He is supposed to say something clever whenever the show lags.

The Armistice Day program of last year for the *Eveready Hour* was a notable example of what can be done to brighten a radio performance. The announcer made known in an easy, conversational way that his listeners were to think of themselves as the men inside "a sleeping stretch of tents, thousands of men at their rest. The sun has just risen; the guard has raised the flag and our slumbers are broken by reveille, 'Oh, How I Hate to Get Up in the Morning.'"

Here was a bit of rapid fire psychology at its quickest. The listener instinctively handed over his imagination to the entertainers and let them do with it just about as they pleased. This quality of imagination accounts for a fair half of the success which attends any program. And this is the way the entertainers proceeded, a quick succession of voices:

Sergeant: "Fall in! 'Ten-shun! Right Dress! Front—Count off."

Then the other voices came into play in a way familiar to a large number of listeners: "1—2—3—4. . . . 1—2—3—4". . . . Sir, the company is formed."

Any man ever in the army, or whoever had a friend in the ranks, or who even knew anything about the war, must be beguiled by that kind of introduction. Then the Captain speaks:

"Sergeant, after mess march the company to the Y hut. There will not be any drill this morning. The *Eveready* entertainers have come to camp and they will put on a show this morning. That's all, sergeant."

This was getting over the difficult business of introduction in a way to please and charm and not once to jar the senses. Next came the assembled voices in the supposed Y hut, evoking memories of 1917, when the world seemed as if it might be going to pot. After a period of singing, the announcer speaks again, but he has become a monologist by this time and we feel friendly toward him instead of wishing that he would get through once and for all and keep quiet. This is what he says:

"We've come to the day when tin hats have been issued and the boys are laying bets that they will sail soon. They win. We're on the transport. There isn't much noise permitted as the big hulk creeps out of Hoboken in the blackness of early morning, but many of the uniformed passengers feel like singing." And they do sing, just about what-

ever they like—"Good Bye, Broadway," "Over There," and "'Till We Meet Again."

If a listener could resist a tug at the heart when that last song died out he would be a strange sort of American. But it has not been recorded that anybody failed to keep spiritual company with the transport on its eventful way. Then comes France: danger, war, and death. At the end, "Flanders Fields" is declaimed to music, and taps sounded.

#### UNITY AND INTEREST FOR THE PERFORMANCE

THAT is an excellent example of the continuous dramatic performance by radio. It is the same kind of vehicle that once was used to carry along the old variety show when it began to emerge from a number of disjointed acts, which afterward became vaudeville. Although vaudeville is a reversion, in a measure, it is a performance requiring no interpretation by announcement. Even the boy who used to come out and change the signs has disappeared, and now an electrical device supplies the information that the next act will be the performing seals.

Although radio has not offered us the seals as yet—at least, not under that description—there is a wide field of development possible by the adoption of the continuous theme. The idea was not wholly original with the group of entertainers who have scored so

successfully by this means, but they at least have utilized it with more definitely successful results than any other group. Therefore they must receive recognition for their efforts, along with the men in charge.

There is virtually no limitation on what may be done with the dramatic theme by radio. Another of the Eveready Hours was devoted to a performance described as the Age of Man program. This choice arose from the wish to present a program of old songs in a new way, attempting to escape from the boresome device of an announcer with trembling voice who talked about the days down on the farm. That sort of introduction is particularly bad when the announcer speaks about a farm with all the intimate acquaintance of a native New Yorker. In this case the introduction was managed to the accompaniment of a piano and violin playing a lullaby, which swiftly developed into "Rock-a-Bye, Baby."

#### CLEVER THEATRICAL MECHANICS

IT IS not an easy matter to prepare the mind of a radio audience in something like two minutes for such a song as "Rock-a-Bye, Baby." Everybody in America has heard that lullaby so often at all stages of life, that it must be particularly well rendered to hold the attention. It cannot be literally thrown at an audience, as so many songs are tossed



#### MEMBERS OF THE RADIO ENTERTAINERS

Grouped during a typical Eveready Hour. They are: Left to right, seated: Charles Harrison, tenor; Beulah Young, soprano; Rose Bryant, contralto; Wilfred Glenn, baritone; all of the Eveready Mixed Quartet; standing beside Mr. Harrison, Graham McNamee, announcer; standing behind Mr. Harrison, A. J. Klein, noted African hunter; standing to Mr. Glenn's right Edward Berge, pianist; Alex Hackel, violinist, and Jacque de Pool, cellist, of the Eveready Trio. Others are chorus singers selected from the New York Oratorio Society and extra orchestral players

through the ether. "Rock-a-Bye, Baby" requires gentle treatment and a sympathetic mood.

Well, this particular evening of old songs was pronounced one of the biggest things done in radio entertaining for months. A response from far and near showed that the program landed in the psychological center of the public favor. This program progressed from its opening number with such music as Brahm's "Cradle Song," gradually advancing through the songs of boyhood, youth, and the courting age. Then the songs went on to the succeeding stages of life and what obviously must be the last—Home, Sweet Home.

Still another successful program was made up of sea songs, a class of musical composition especially suited for radio because of the long lilt to the melodies, which seem to slip onto the ethereal waves with a genius all their own. A departure still further

afield brought before the microphone one Martin Christiansen, able seaman turned taxi driver. And the announcer made known that Christiansen literally was going to tell "the story of his life." Of course, he did not express the matter just that way. Instead, he explained that some time before, Christiansen was sitting on the box of his cab in New York, reading a morning paper, when he chanced to see in the news that William Beebe was homeward bound from the Galapagos Islands, one of the lost places of the Pacific.

Christiansen read that item and rushed down to the dock so that he might greet the only man he had ever heard about who knew

those islands. Christiansen was on the dock when the explorer arrived and the story he told Beebe afterward constituted a rattling good chapter in the explorer's book about those islands. All of that explanation was packed into a few sentences by the announcer, who then turned over the air to Christiansen, and let him speak for himself. He was the sort of man fully capable of that effort and proceeded along this line:

SOMETHING DECIDEDLY NEW

WELL, I suppose the story begins when I signed up with the bark *Alexander*, down on the other side of the world. That was at Newcastle, New South Wales, in Australia. The *Alexander* was loaded with a cargo of coal bound eastward across the Pacific for Panama. She carried a captain, mate, cook, and sixteen of us men."

Now almost every boy in the world has wanted to be a sailor and practically every girl

has feared that her first sweetheart would run away, as he threatened, because she refused his manly hand. The appeal of the sea is universal. It is probable that no other class of fiction ever written is read by so many people. If Christiansen's introduction of his story had appeared upon the printed page, instinctively we would have moved a little closer to the light and have settled down for an evening's joy.

That is what happened with the radio audience. Who can imagine a man telling us about sailing on a trip like that, without every poor landlubber lending eager ear? Christiansen was better than a passable story teller. He went on in this strain:



RED CHRISTIANSEN

The "sea-going" taxi driver of New York whose adventures in the lost islands of the Pacific were seized upon as material for one presentation of a new type of radio program



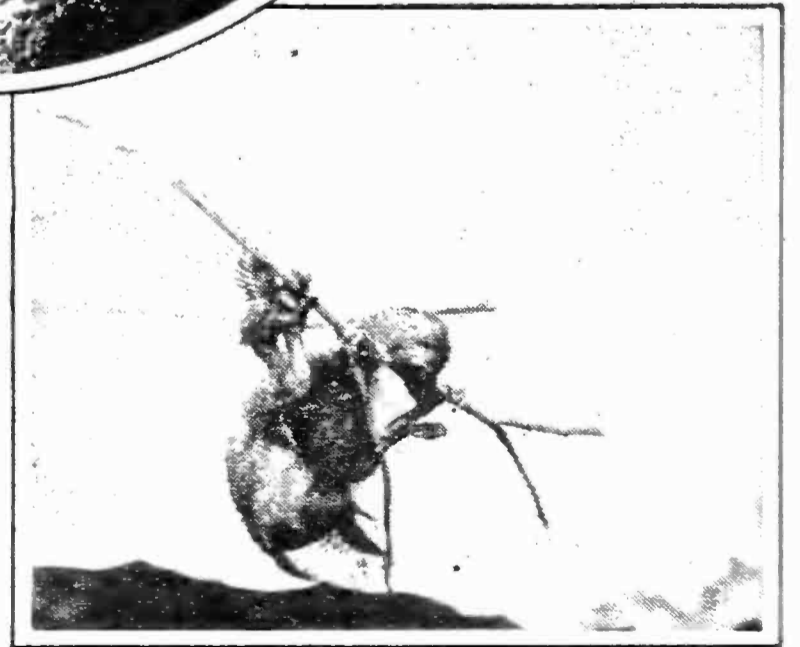
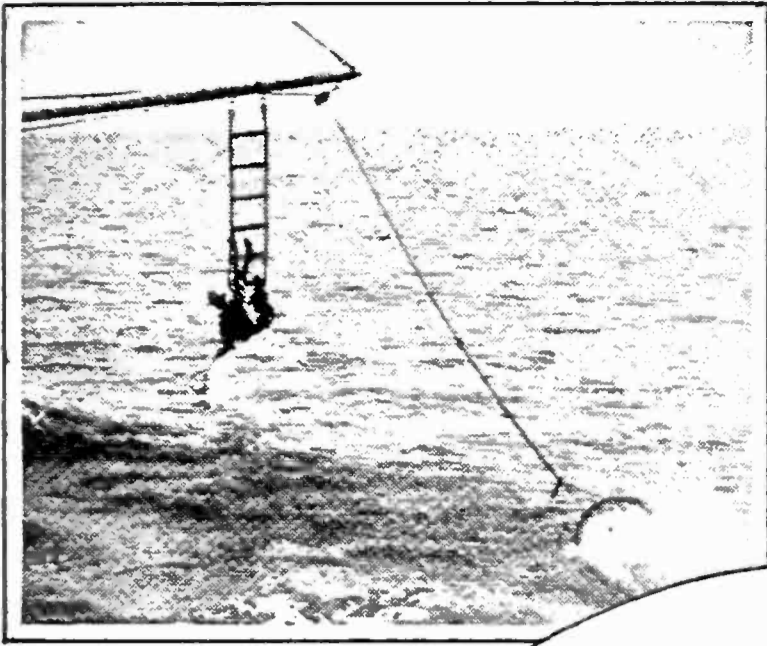

### SCENES IN THE GALAPAGOS ISLANDS

Often called the lost islands of the Pacific, which William Beebe, the noted explorer and scientist, investigated some years ago. A taxi driver in New York, who had been a sailor shipwrecked on the islands appeared on a radio program and described his experiences there. Broadcasting programs of a high order are tending toward better unity and the "Explorer's Night Program" in which Mr. Christiansen took part from WEAJ and connected stations was one of this new type. The center cut shows a giant marine lizard which exists only in the Galapagos Islands. It lives in the sea and is about five feet long. The upper left picture shows specimens from the sea being gathered from the yard-arm of the exploring ship. The upper right photograph shows a huge boa constrictor caught near the Islands. The lower left picture is of a giant marine lizard feeding in the surf. The lower right shows a Hoatzin fledgling, the missing link between the lizard and the bird

"I had been living in a sailor's boarding house, run by Nellie Simonds. The day we shipped, Nellie rowed out in the bay and brought some refreshments along as a parting gift. I don't mind telling you that her brand of refreshments made a bigger hit with us than the stuff we had to drink before we got through that voyage. As the tug took hold and started off, we sang to her and she sang back. It was a happy send-off."

That immediately opened the way for the quartette to sing one of those good-bye songs, and the quartette performed in fine fettle. Then Christiansen went on again. Before he stopped talking, there was hardly a radio ear in some thousands of miles that was not aquiver with his story about those forsaken islands and the things that happened there. It was such a yarn as Stevenson would have

liked to spin. A listener could experience for himself all the heartache, thirst, and peril that went into the sailor's adventures. In the end, it was pleasant to know that he had adopted the comparatively easy and safe pursuit of driving a New York taxicab, although many men of a less eventful past might call that high adventure.

The Christiansen story was a new endeavor in many ways, and received wide recognition from the press.

#### THIS IS ADVERTISING

WHO would ever undertake, let us say, to link the yarn of a sailor's adventures with advertising? And the Eveready Hour entertainers, of course, represent the idea of selling by publicity. Here is a development so broad that the possibilities cannot be even



#### EXCELLENT CLASSICAL MUSIC

Is given during the Eveready Hour by the Mixed Quartette, which consists of Wilfred Glenn (left), baritone; Rose Bryant, contralto; Beulah Young, soprano; Charles Harrison, tenor, Tom Grisselle. During the specially arranged hour of entertainment, given each week by this organization, each is a complete entity. The program by this group and others of the organization is part of a completely balanced program which has been well received by the listeners

estimated. We may conceive of a new expedition to the pole so that the explorer shall describe to us how comfortable he was in some particular brand of knit underwear, while he drank a special blend of tea and munched upon a soda cracker of national reputation.

Whatever are the developments in store for us, the established fact is that a sailor's tale of perilous deeds in far places makes mighty interesting material for a radio program. This is a far step from the day not long past when the only kind of discourse known to radio was the sort which dealt with the advisability of accumulating enough for old age by smoking one cigar less every day. Nobody will fall out with the wisdom of that discourse, but it hardly was entertainment. There has been no perceptible diminution in the consumption of cigars nor any appreciable gain in the total of savings from the thousands of such lectures forced upon the ear of the nation.

But if we know the human heart at all, we cannot doubt that Christiansen's yarn will be talked about around uncounted firesides for many months. It was the kind of tale to make everybody huddle closer to the hickory log—or even the radiator—and bless their stars that those islands with the terrible name are so far away. By association, those who heard the story at first hand will long think of it as a part of the *Eveready Hour* program. And the programs just as inevitably are associated with national advertising of the wares behind them.

Such considerations lead naturally to the oft discussed problem of where advertising legitimately stops—or begins—in radio broadcasting. Whatever the ethics of the case, it is beyond dispute that radio advertising has increased greatly within recent months. It is in a fair way to equal the power of the accepted advertising in newspapers and magazines. So far it usually has taken the indirect form. But the appeal is none the less direct; we may be assured by the large number of concerns turning to this method.

At a moment when the country is enjoying a broad prosperity, radio advertising would seem to have entered upon a period of development that will surpass anything ever known. The experiences of the automobile industry and the movies are being repeated anew. All of these considerations may or may not interest the radio user. What he seems to care about principally is the quality of entertainment offered for his amusement. Certainly that quality grows better every day and the element of originality introduced by the entertainers in question, under the immediate direction of Paul F. Stacy, suggests a means of enlivening the radio program for the benefit of everybody.

The day evidently is not far removed when the typical radio program will cease being its present jumble of odds and ends put together on the general pattern of Joseph's coat. We may expect a balanced performance, to use a theatrical term, and it is not improbable that an entire evening's entertainment will be presented by the medium outlined. It should be possible to arrange such a program so as to encompass a wide variety and still preserve the theme of continuity. A theatrical setting of the kind suggested on the transport and the canteen would be easily adaptable to lengthy performances. One of the first dramatic principles holds that the continuity of time, place, and action best assures command of attention.

Whether this development be great or small, the radio audience of America at least may be thankful to the *Eveready Hour* entertainers for introducing a device to help out the hard working announcer. Poor fellow, he has labored nobly, turning phrases around, trying to be humorous and grave, and otherwise experimenting with the tools in his kit. Although there may be nothing distinctly new beneath the sun, it is certain that the continuous dramatic theme for radio programs is a decidedly fresh and pleasant departure "on the air."

---

**G**UGLIELMO MARCONI has written an article for *RADIO BROADCAST* which will appear in an early number. He writes of his recent experiments, in England, at sea, and aboard his yacht, with radio transmission by his famous "beam system". Signor Marconi firmly believes that beam transmission of radio energy on very short wavelengths is a general development that is now upon us. This article is the first that Signor Marconi has published in America describing what he believes is a revolution in radio transmission.

# Do Weather Conditions Influence Radio?

A New Theory, Advanced by a Climatologist, Tending to Prove That Atmospheric "Highs" and "Lows" and Other Weather Phenomena Affect Receiving Conditions

BY EUGENE VAN CLEEF

Ohio State University

IT IS certainly not uncommon to hear radio enthusiasts say, "I couldn't get much last night, too much static," or "Bad night last night, couldn't get a thing from the west and just a few eastern stations," or again, "Can't expect results to-night, too rainy."

Correct as the reports may be as far as actual poor reception is concerned, the diagnoses are not always true. This is because the average person is unacquainted with the mechanics of the circulation of the atmosphere. He knows that the weather changes, but does not appreciate fully the direction of these changes and the part which atmospheric pressure plays in our daily weather.

Weather, of course, is local at any given time. One could well say that weather travels, and the weather which a given city west of us has to-day, may be the kind of weather we shall have within the next twenty-four to thirty-six hours. This suggests that a certain brand of weather is not universal at a given time of day or night, but that there may be a radical difference in the state of the weather at the broadcasting station and that where the receiving instrument is located.

The weather in the United States changes

because of the influence of shifting atmospheric pressure areas known technically as Cyclones and Anti-Cyclones. In the cyclone, the air in general blows spirally inward, upward, and in counter-clockwise fashion. In the anti-cyclone, the air blows spirally downward,

outward, and in a clockwise direction. In neither pressure area is the movement violent. The diameters of the storms may be anywhere from 400 to 1500 miles. These pressure areas are not always symmetrical in form and consequently their diameters may vary along a dozen different radii.

These storms travel across the United States in a general easterly direction, entering the United States either from the southwest, west, or northwest and leaving by way of the Atlantic coast, but most often by the St. Lawrence river valley. In the autumn months, September to November, hurricanes and violent cyclones, may enter

the United States from the southeast in the vicinity of Florida, penetrate at times as far as the Galveston coast of the Gulf of Mexico, and then following the customary paths across the eastern half of the country. The hurricane is the exception and not the rule.

## Talk—Minus Facts

THOSE interested in radio have for years tried to find out the factors which influence the radiation and reception of radio waves. There have been a number of theories adduced to explain the sometimes peculiar variation of the signals. Probably best known of such theories is the Heaviside layer theory, which, very briefly, assumes that the various ionized layers of the upper atmosphere refract, absorb, or aid the waves in their passage. RADIO BROADCAST does not assume responsibility for Mr. Van Cleef's conclusions that weather conditions definitely affect radio conditions, but we should like to observe that his findings seem to fit in very well with what actually is the case. It is quite possible that atmospheric conditions have a definite and yet unexplained relation to the variations in the Heaviside layer. It may be, too, that the findings of this experimenter can be put with the conclusions of other experimenters and relations between phenomena as yet unknown may be seen. At least, the author has done a genuinely good piece of work. Those who have similar access to national weather information should be very much interested in continuing and checking these conclusions.—THE EDITOR

THE IMPORTANCE OF LOW AND HIGH PRESSURE AREAS

CYCLONES and anti-cyclones pass across the country approximately every three to four days, varying in frequency with the season of the year. They always occur alternately. Two high pressure areas (anti-cyclones) or two low pressure areas (cyclones) never succeed each other. "Lows" and "Highs," as they are named on the weather map, always alternate. Meteorologists have studied the variety of weather associated with these pressure centers, and through the agency of the United States Weather Bureau, the forecasting of the passing weather has attained a fair degree of accuracy.

In general, it may be said, that cloudy, rainy, or snowy weather and moderate to high temperatures are the accompaniment of Lows, while clear and cool to very cold weather accompanies Highs. There are exceptions to both of these assertions, but they are not many. Now, a striking feature of these pressure areas lies in the variation of their respective intensities as revealed by the arrangement of their *Isobars*. An isobar is a

line which passes through all points having the same atmospheric pressure, i.e., through all points where the barometer reads the same. The isobars tend toward a concentric arrangement. In an ideal pressure center they would be absolutely concentric. Irregularities in their course may be due to many reasons, such as temperature differences, variations in moisture content of the air, topography, and so on.

DO WEATHER CONDITIONS INFLUENCE RADIO RECEPTION?

IT OCCURRED to the writer when he heard statements referring to the weather and radio reception, such as are quoted at the beginning of this discussion, that their logic was frequently faulty. It seemed that with broadcasting and receiving stations oftentimes 500 to 1000 miles apart, the local weather conditions at the receiving station could not have much influence on reception, unless the same conditions prevailed over all the country between the two stations. Such uniformity in weather is not common. Therefore, to ascribe poor receptivity to the local weather could not be an accurate analysis. Furthermore, it was true that occasionally

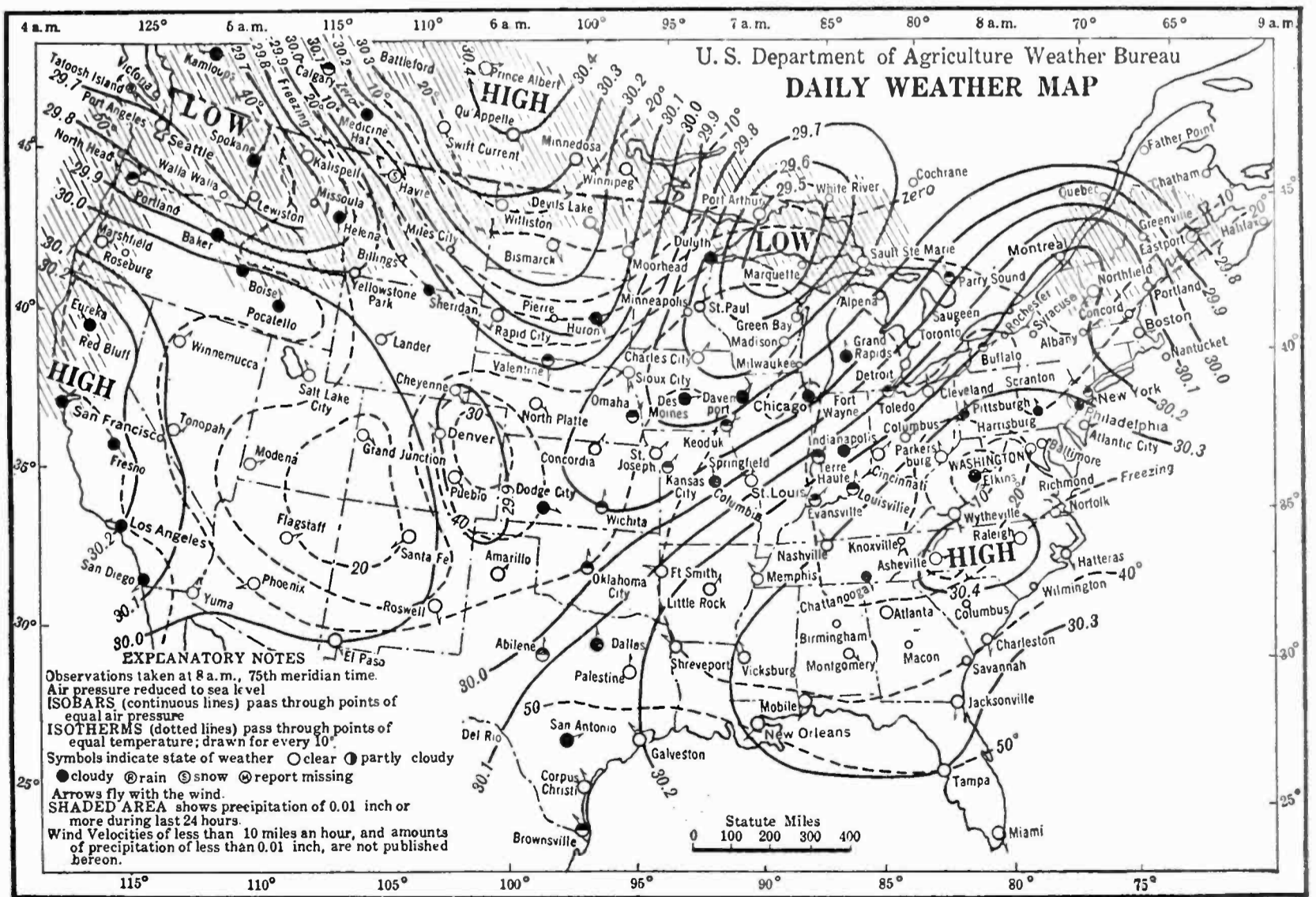

A TYPICAL WEATHER MAP OF THE UNITED STATES

Which shows clearly the alternating "Highs" and "Lows." According to the theory advanced by the author, radio reception in a low pressure area tends to be somewhat weaker than in a high pressure zone of corresponding intensity

when the weather was "bad," reception was good, although the association of the two facts at such times was entirely overlooked. It seems to be a common trait among most of us to analyze and criticise rather thoroughly when things go wrong but to take matters for granted when we are enjoying results which seem to us to be wholly normal.

The situation just noted led to an investigation, which has thus far revealed some striking conclusions. It seems that since broadcasting involves the transmission of electromagnetic waves, a wave motion transverse in type, there might be a definite relation between such transmission and the circulation of air in High and Low pressures. Observations were made to determine whether any such relationship might exist, or whether there could be a relation between the strength and clarity of reception, and the arrangement of isobars.

#### NEW THEORIES FOR RADIO CONDITIONS

A FIVE-tube neutrodyne set was used, with an outside antenna about 125 feet long, and about 30 feet from the ground. The

direction of the antenna was almost exactly northeast-southwest. The observations follow:—

1. If a line connecting the receiving station with the broadcasting station crosses the intervening isobars at right angles, reception is at its best.
2. The steeper the isobaric gradient (that is, the closer the isobars to each other) the stronger the reception.
3. The more nearly the transmitted waves approach parallelism with the isobars, the weaker the reception. Under these conditions, fading occurs.
4. Reception in a Low pressure area tends to be somewhat weaker than in a High of corresponding intensity.
5. Reception is weaker when the transmitted waves cross from one pressure area into another than when they travel only within one area.
6. The strength of reception for any station is a factor of both its location within a pressure area and its position with respect to the broadcasting station.
7. "Bad weather" does not affect reception, excepting as it may be the index of an unfavorable pressure distribution.

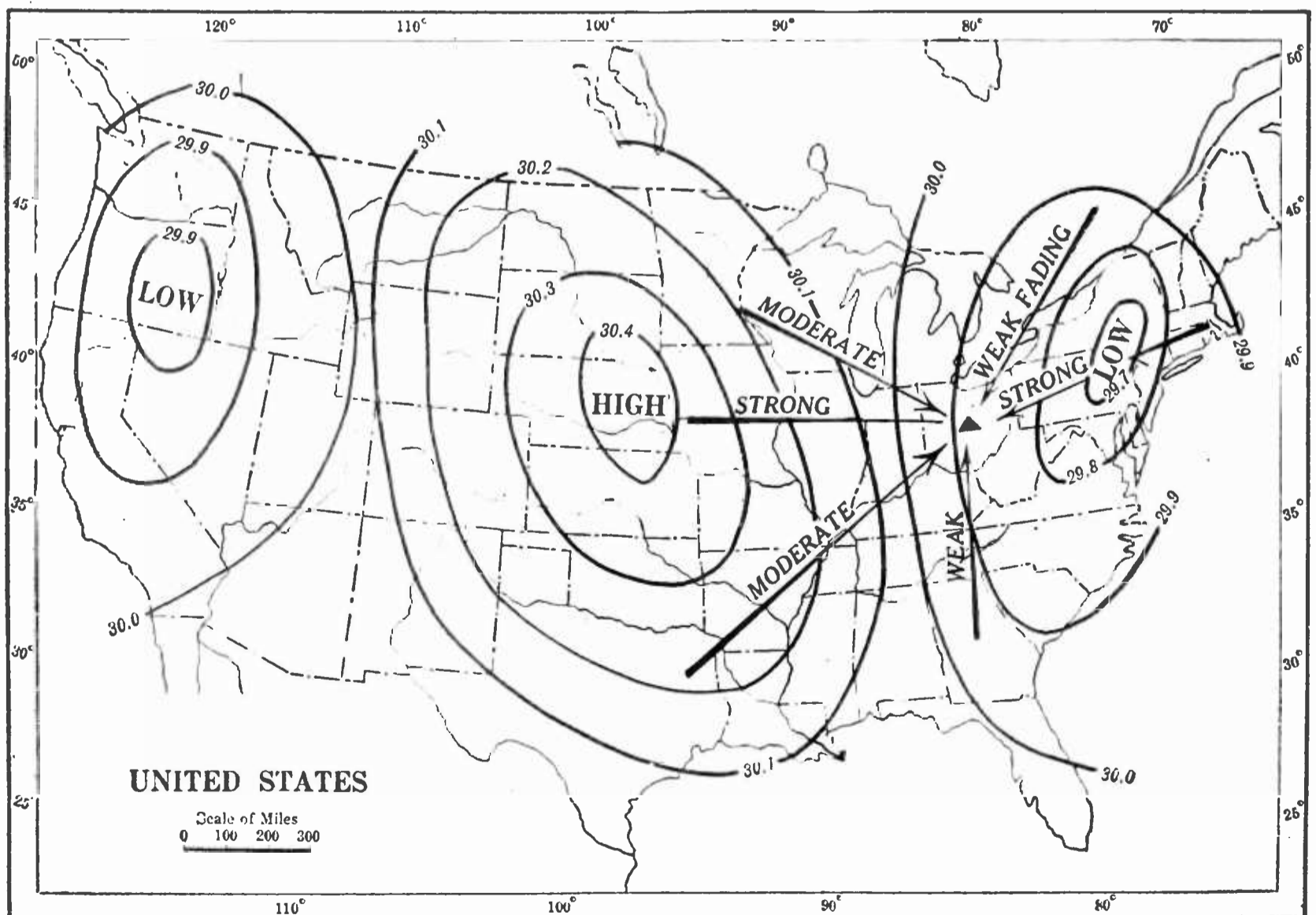

AN IDEAL WEATHER MAP

Drawn to show the relation of the strength and clarity of reception to the angle between the direction of transmission and the isobars. An isobar is a line which passes through all points whose barometric pressure is the same. The arrows on the map indicate the direction from which broadcast signals were received during one of the tests made at the author's station in Columbus, Ohio

8. Reception can be as good in "bad weather" as in good weather if the pressure distribution is right.
9. Temperature does not influence reception, excepting as it may be the index of pressure distribution as follows:—
  - (a) Reception is better in winter than in summer because the cyclones and anti-cyclones are more intense in the winter period.
  - (b) Reception is better when temperatures are low than when high, because low temperatures usually indicate intensive High pressure areas, that is, areas with steep isobaric gradients.
  - (c) Low temperatures accompanying poorly defined High pressure areas make reception poor.
10. Shallow or flat pressure areas result in much static-noise in the receiver.

#### HOW CONDITIONS CAN BE FORECAST

WITH the above observations well defined, the question which quite naturally arises is, Can the strength and clarity of reception be forecast? The answer is, "Yes!" It can be forecast with the same degree of accuracy as the weather, but hardly with any greater degree. Forecasting the weather depends upon a knowledge of the movements of cyclones and anti-cyclones and their peculiarities in various seasons of the year. Forecasting radio reception, assuming no interference

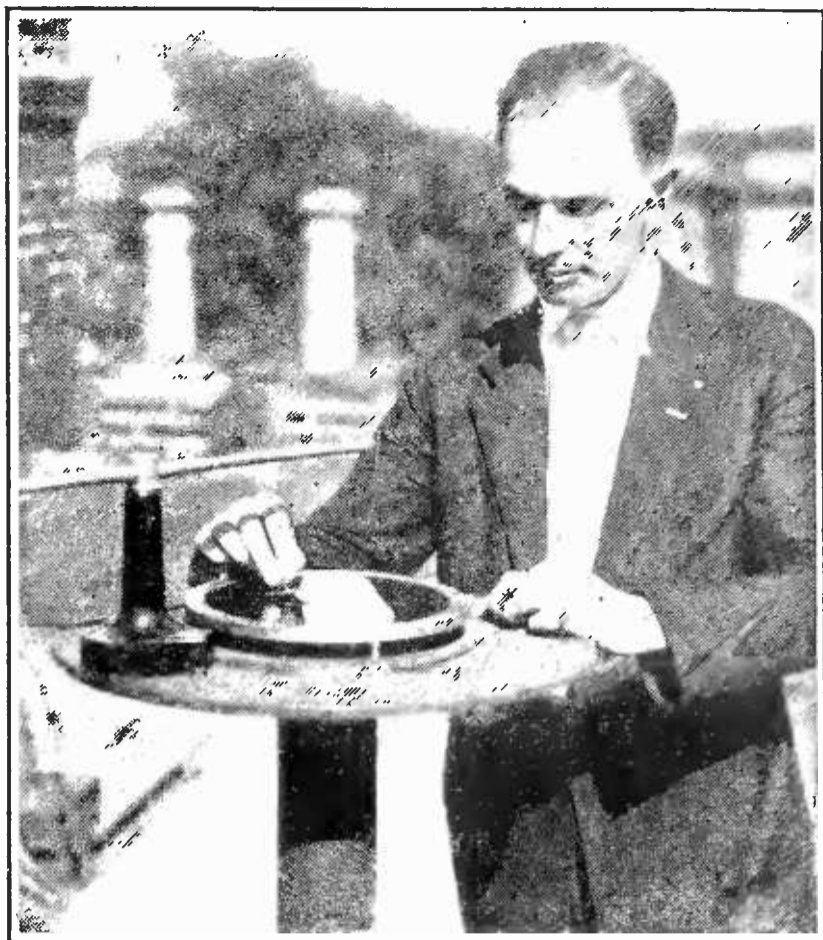

© Underwood & Underwood

#### THE NETHOSCOPE

Used by the Weather Bureau to aid in predicting the weather. Simplified, the apparatus is a black mirror and is used to determine the direction and velocity of clouds

by regenerative sets or the like, is dependent likewise upon a knowledge of the movements of the same pressure areas. However it involves not the forecast-

ing of the probable state of the weather at the station concerned, but only the prognostication of the arrangement of the isobars between the respective receiving and broadcasting stations, and the probable steepness of the isobaric gradients.

By such forecasts, much may be saved to the people. One may know the futility of trying to get certain stations on given nights and save power, time and nervous energy. Sets may not be blamed for poor service when pressure conditions are the cause; and broadcasters may not be criticised for failure to speak plainly or loudly enough, or in general because of lack of efficiency,

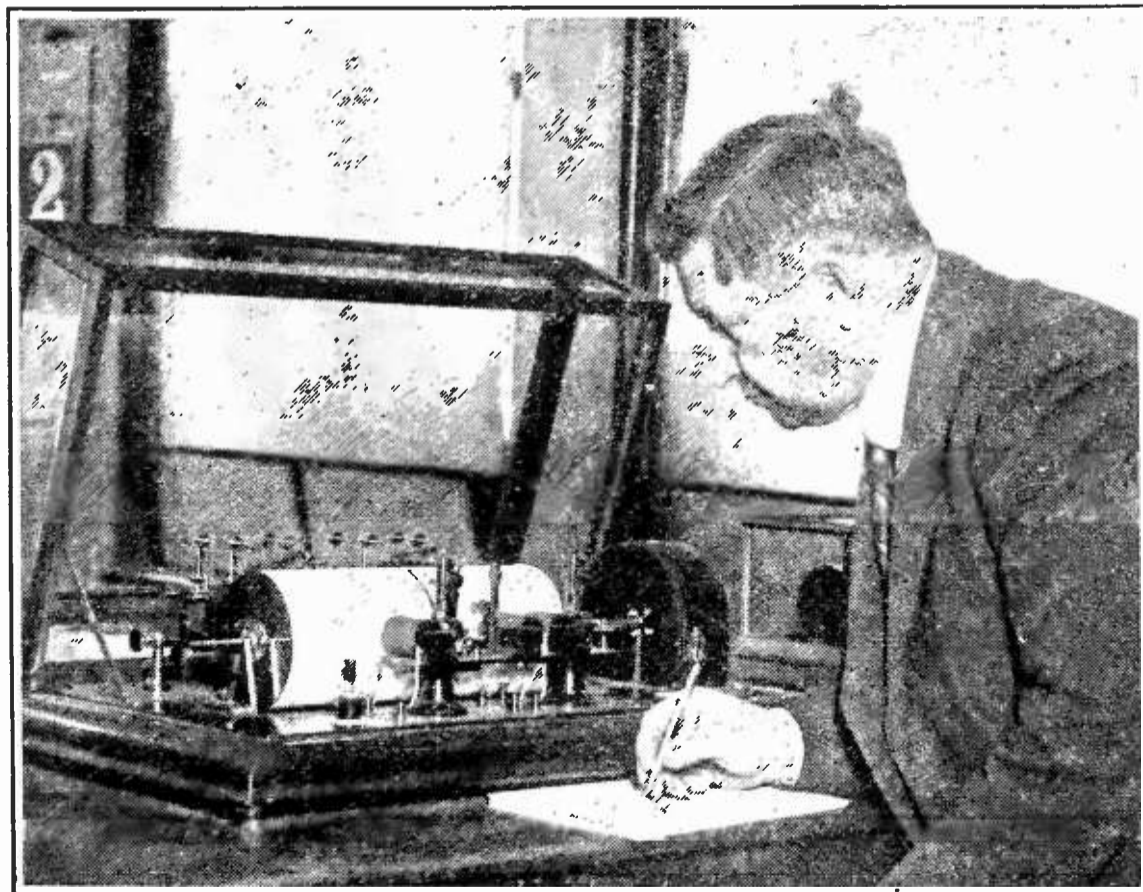

© Underwood & Underwood

#### WEATHER FORECASTING APPARATUS

According to the results of the experiments of the author, when weather conditions are accurately known and compared with radio transmission and reception phenomena, it is probable that much may be discovered about the mysteries of freak radio signals. The device shown in the photograph records the direction and velocity of the wind

when as a matter of fact they are performing properly and well.

Another phase to this problem, not yet worked out, involves the relation between the power required to send the waves and a possible adjustment with respect to the atmospheric pressure. We know there is some relation to sunshine, for during the

daytime one can not receive over great distances, unless the sky is clouded the entire distance. So there may be a correspondence between the wave motion itself and the air pressure, which if learned, would reduce the amount of power required for wave transmission and perhaps in still other ways wholly revolutionize broadcasting.



OBSERVATIONS ON THE RADIO LIFE: NO. 2  
*California on the loud speaker*



# The Meaning of the ★

**P** RIMARILY the star of approval, which appears in RADIO BROADCAST advertising, means "Approved by Radio Broadcast Laboratory." Although this certification means a great deal to those advertisers whose copy bears this mark of approval, it does not necessarily discriminate against the copy not so marked.

In placing this sign of approval in our advertising pages, several issues are considered. It is far from humanly possible for us to test each item advertised by every manufacturer and still do the great amount of development work which has proved so valuable to our readers. Where we have sufficient knowledge of a manufacturer's products and his business standing, we place our Star on his copy with the assurance that, if the customer is not satisfied, the manufacturer will refund his money. In case a manufacturer develops a questionable device we always request that samples be submitted for our inspection. Advertisers with whose products we are not thoroughly familiar are required to submit samples before receiving the Star.

The meaning of the Star however, is not thus limited, for, added to the approval, which is advantageous to the manufacturers, we are not overlooking the prospective customers. A reader seeing the Star should not necessarily draw the inference that here is a product better than any other. It does, however, mean to the reader that he will either get satisfaction or his money back. In placing the Star in advertising, we are assuring the reader of our confidence in these manufacturers. The omission of the Star indicates that we have not had the opportunity to become thoroughly familiar with the products advertised. The fact that advertising appears in our pages at all indicates that we consider it reliable.

In placing our approval on apparatus submitted for test we have no intention of causing friction by unfair discrimination. Our approval does not in any way indicate that we assume that the products of those advertisers are perfect. What it does mean is that the manufacturer has satisfactorily met the claims he is making for such apparatus and that he supports his claims with a "money-back" guarantee. In passing on the apparatus in this manner, we must necessarily take its selling price into consideration and so the Star is an assurance that one will get full value on his investment.

"Approved by Radio Broadcast Laboratory" gives the purchaser assurance that he is buying the product of a reliable manufacturer and that he can in this way feel certain of getting reasonably satisfactory results. Its purpose is to boost the legitimate and honest manufacturer. It is our intention to extend our present plans to the point where RADIO BROADCAST will carry no advertising where the apparatus has not actually been tested in our laboratory.

# How to Solder

By WILLIAM F. CROSBY

**T**O THE uninitiated, the art of soldering appears to be something which only the most expert workman can do. It appears to be a talent which the novice can hope to acquire only with years of practise. It may be an art, but it is an easy art, and one which even some of the most in-expert of our radio builders have conquered, to the great improvement of the sets they build.

There is just one fundamental rule in successful soldering, and that is cleanliness. This does not necessarily mean that the man doing the work must have on a clean collar and his hands must be manicured; but it does mean that he must see that the soldering iron has a clean collar of solder and that the surfaces to be soldered are manicured.

Seriously, though, soldering is easy, once the importance of having everything clean is realized. Solder will positively not stick to a surface which is oily or corroded. If one part is clean and the other dirty, the solder will stick to the clean surface but not to the dirty. If you do not believe this just try it and see. Fully half of those who have trouble with soldering because the surfaces will not stick, or the solder drops off, have not realized that a clean surface is the first essential.

The next step is the consideration of the soldering iron itself. Many constructors are using gas heated irons with varying degrees of success, but once let a man use an electric soldering iron and he will never make further use of the gas range. These irons may be secured in many sizes and shapes and some of them have interchangeable points. With this type of iron it is possible to secure a fine point for small work, a curved point for the inaccessible places or a blunt, heavy point for the work which is more in the open. The writer is of the opinion that the fine pointed iron is the best for all around radio work. It is satisfactory for coarse soldering and also for the finer work and if a little care is exercised in wiring the set, there is no reason why every connection cannot be reached. Of course the inside wires should be placed first and the work carried on so that the outermost wires come last.

## "TINNING" THE IRON

**G**ENERALLY a new soldering iron is not "tinned." In other words the surface is coppery all over and, in passing, it might be just as well to point out that soldering "irons" are not iron at all but "copper," for it seems to conduct and hold the heat better.

Now suppose we want to "tin" a new iron. The first thing to do, of course, is to get it hot, not red hot, and not cherry red either. Usually a good test is to have a small can of soldering paste handy and dip the point of the iron in this from time to time. When the iron is sufficiently hot, the paste will sputter in a good lively fashion and after a little experience you will be able to tell at just what point the soldering is easiest.

Assuming that the iron is properly heated the next step is to plunge the end briefly into the can of soldering paste. Before this is entirely burned off, solder should be applied to the end of the iron and then rubbed over the point with a soft rag. It is surprising to observe the ease with which this is made to adhere, provided, of course, the point is clean. The whole end of the iron should be treated in this manner until it is tinned completely. Make sure that the rag is doubled back and forth several times so that

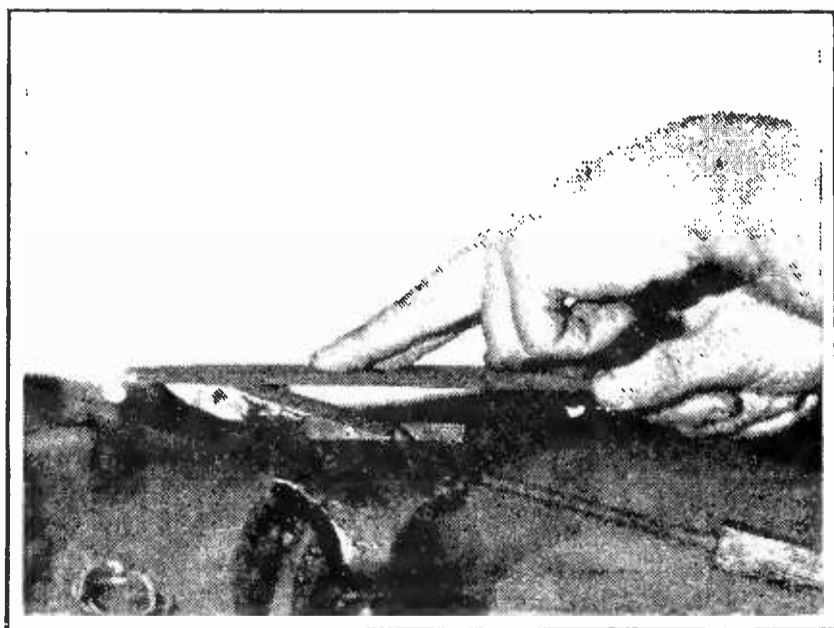

RADIO BROADCAST Photograph

FIG. 1

The soldering iron should always be shinely clean. The burned coating which collects on the working surface of a gas iron can be removed with a flat file as shown in the photograph. When using the file, the solderer should push it away from him and lift the file from the surface on the return motion



RADIO BROADCAST Photograph

FIG. 2

Rubbing the working top of the iron on a piece of sal ammoniac removes the oxide coating and prepares it for tinning. The iron must be quite hot and the surface of the sal ammoniac must be clean

your hand will not come into contact with the hot iron. This rag should be kept handy at all times and when doing extensive soldering, the point should be wiped clean occasionally. It may also be necessary to re-tin the point if the iron has become too hot at any time. When this is done, it is first necessary to scrape the point with a file so that the shiny copper is again exposed. The rest of the procedure is then followed as outlined before.



RADIO BROADCAST Photograph

FIG. 3

Applying the strip solder to the cleaned tip of the iron. The solder should quickly take to the iron after it has been properly cleaned

## WHAT SOLDER TO USE

THERE are many different kinds of solder on the market, but it is generally conceded among radio men that good resin core solder is the best for all around work. This is excellent if used with a small amount of soldering paste and you can make up a joint which will last for years.

Acid core solder is completely out of place as far as radio is concerned. The acid will attack the copper and cause quick corrosion with consequent noise in the set. Of course plain wire solder is excellent, but it will be necessary to use a little more paste with it.

The paste consists of a resinous material of a pasty consistency which helps to make the solder stick by acting as a cleaning agent.

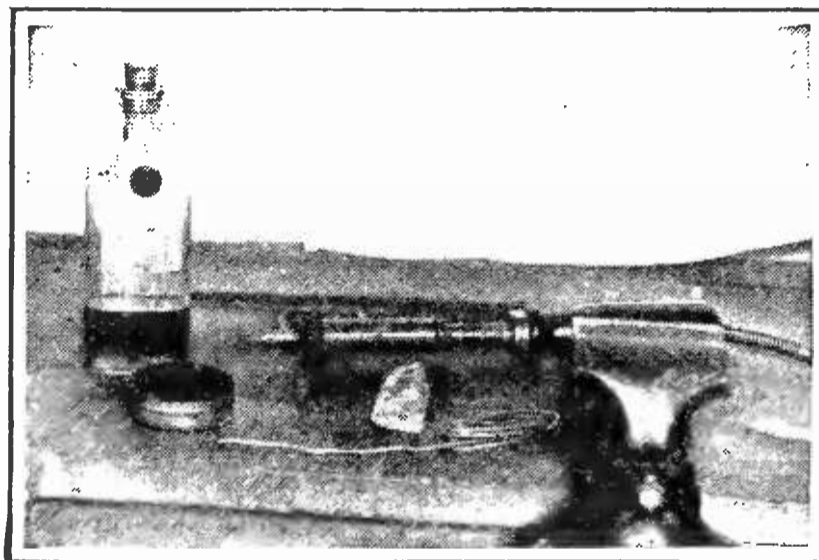

RADIO BROADCAST Photograph

FIG. 4

A good soldering outfit. From left to right: liquid soldering flux, paste flux, flat nose pliers, electric iron, sal ammoniac, and strip solder

There are many forms of this material some of which are liquid in form. It is never advisable to use too much of any of these materials, because all of them will cause trouble if applied in this manner.

The customary thing is to have a match handy, and with this dip out just a tiny bit of the paste and apply it to both surfaces to be soldered. A little solder is then applied to the end of the hot iron, the two surfaces placed together, and the solder applied. Make sure that the surfaces are held tightly together until the solder has had a chance to cool. This is a matter of seconds only and before the joint becomes entirely cold, wipe it off with the rag used for cleaning the iron. This wiping off will remove surplus soldering paste or flux and prevent possible corrosion of the joint.

Remember that a tiny drop of the solder



RADIO BROADCAST Photograph

FIG. 5

Wiping the iron to keep it bright. A clean iron means good work. Any old cloth may be used to wipe the iron

will do the work better than a big crystal-like lump. The solder should be hot enough to flow evenly almost like water. The surface of a correctly soldered joint should be smooth with only enough solder to hold the joint together. Wiping it off as suggested, will do much to improve the appearance.

#### A PRACTICAL EXAMPLE OF A SOLDERING PROBLEM

**L**ET us actually solder a joint. We will make a connection between a new piece of bus bar and an old soldering lug on a variable condenser. This condenser happens to be mounted on a panel in the usual manner.

The first thing to do is to place the iron on to heat, either by plugging it in on the electric light socket or by placing it over the gas flame in the kitchen. While the iron is heating we get the rag, wire solder, and paste handy and then proceed to clean off the surfaces. The lug on the condenser is badly corroded and it will never hold solder. A small file or a bit of emery paper will help us here and the lug is soon shiny. It is also advisable to touch up the bus bar a little despite the fact that it is new. The grease on the hands will sometimes cause failure in a connection of this kind, especially if the wire has been handled a lot. A light scraping with a knife is sufficient to clean the bus bar.

The wire is now bent into place so that it touches the soldering lug on the condenser.

If possible, arrange this in such a way that the wire rests in place by itself. This makes matters easier and takes the strain from the connection. Since solder, like water will not run up hill, it will be far easier to make this connection if we tilt the whole set forward so that the lug on the condenser is on top.

When the soldering iron is sufficiently hot, it is dipped for an instant in the paste. A bit of this paste is applied with the match to the bus bar and the lug. Next take the solder and hold it so that a small drop adheres to the surface of the iron. Apply the iron to the joint then and allow the solder to flow in smoothly around the wire and the lug. It is not necessary to cover the wire entirely as long as it is held securely. Put the iron back to heat, and by this time the joint should be hardened sufficiently to hold. The next step is to wipe it off with the rag. An excellent joint results.

#### GENERAL ADVICE TO THE SOLDERER

**R**EMEMBER that the solder is in a liquid form and if you handle the iron too quickly it will drop off and possibly burn you or your clothing. Remember also that copper and brass are good conductors of heat and if you handle the parts just soldered too soon, you may get a bad burn. Brass binding posts particularly, have a way of staying hot for a long time and some of the fixed condensers are veritable furnaces for holding the heat. In fact due to this alone, it is far better to make a connection through a fixed condenser with a small machine screw rather than soldering the

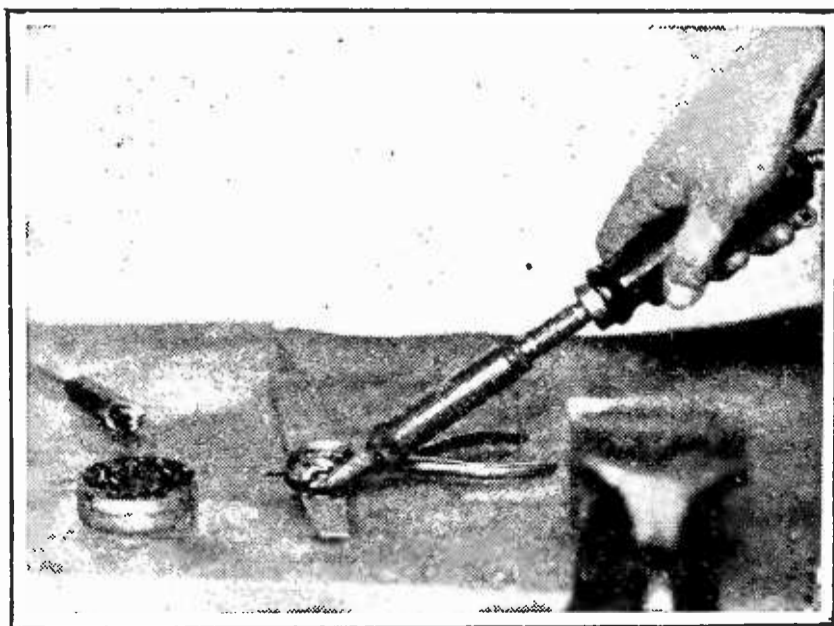

RADIO BROADCAST Photograph

FIG. 6

Re-tinning the iron. A small can cover containing a portion of melted solder and paste flux may be employed for periodically re-tinning the iron. The flux cleans the soldering iron surface so that the solder in the can cover will adhere to it

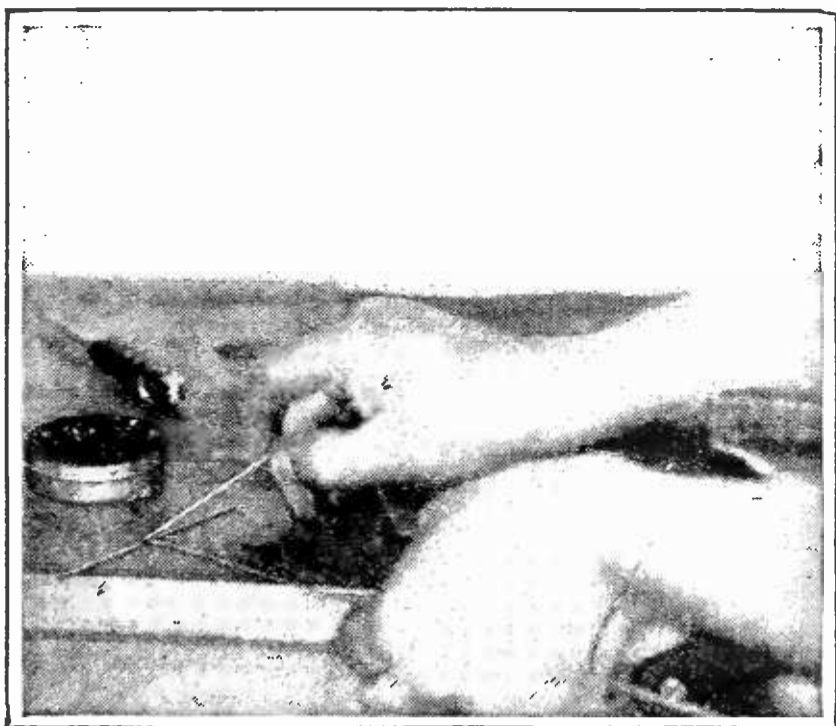

RADIO BROADCAST Photograph

FIG. 7

How to prepare a joint for soldering. A bit of flux is applied, with the aid of a stick or scrap piece of bus bar, to the joint to be soldered. This flux cleanses both wires so that the solder will stick to them

wire to it. Many fixed condensers have actually been short circuited by the soldering process.

Do not think that because every joint is soldered, the set cannot have a loose connection, because this happens far too often. Sometimes too much paste applied to a joint will cause a layer of this material to harden in between the two surfaces. Naturally such a condition will make the set very noisy. In another case the writer found a set in which a soldered connection had completely parted due

to the fact that the wires had been under too much tension when soldered. This joint had pulled apart during the set owner's absence, and it was only after several evenings of frantic effort that the trouble was finally located in one of the most inaccessible parts of the set.

To sum up the whole art of soldering, the "artist" must remember just two things. Keep the soldering iron clean and the surfaces *clean*. This is the whole secret of the thing.

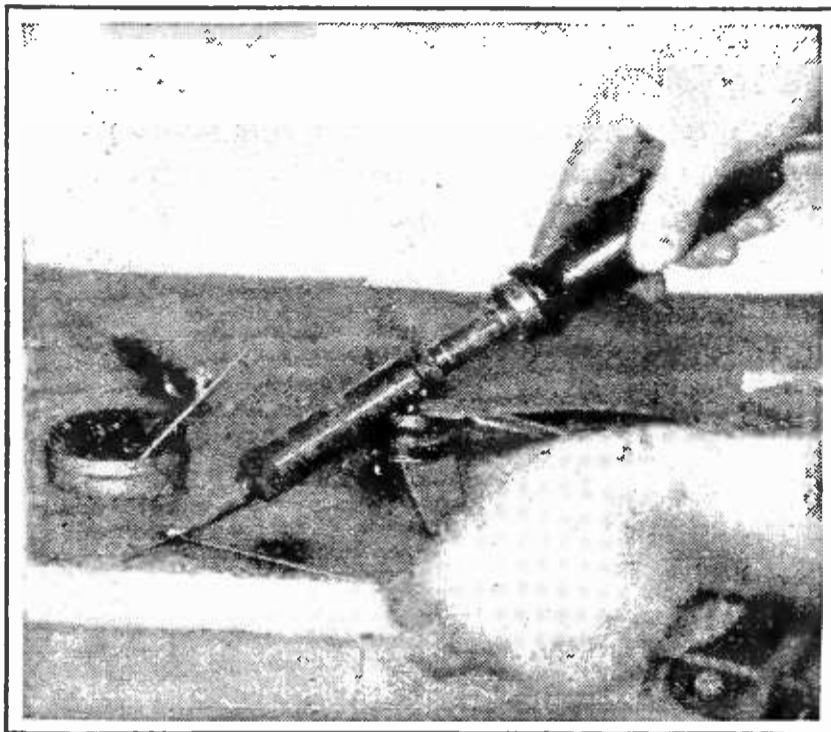

RADIO BROADCAST Photograph

FIG. 8

The iron should be held firmly on the joint to be soldered, touching both pieces so that when they become heated, the solder on the tip of the iron will flow evenly over the point. Additional solder may be fed from the strip solder wire or it may be "picked up" from the can cover



## Latest Alterations in Broadcasting Wavelengths

COMPLETING the list of Class B broadcasting stations whose wavelengths have been reallocated by the Radio Service, Department of Commerce, the following Pacific Coast stations received new wavelength assignments:

KNX	Los Angeles, Calif.	336.9 meters
KFAE	Pullman, Wash.	348.6
KGO	Oakland, Calif.	361.2
KFOA	Seattle, Wash.	384.4
KHJ	Los Angeles, Calif.	405.2
KPO	San Francisco, Calif.	420.3
KFI	Los Angeles, Calif.	468.5
KGW	Portland, Ore.	491.5
KIX	Oakland, Calif.	508.2

Wavelengths assigned to points where broadcasting stations are to be erected were:

Corvallis, Ore., 280.2 meters, Los Angeles, 293.9, Phoenix, Ariz., 299.8, Seattle, Wash., 305.9, Pasadena, Cal., 315.6; Salt Lake City, 333.1; Missoula, Mont., 394.5, and Seattle, 454.3.

It was recently announced in a news dispatch from Washington that the Radio Service was considering readjusting the entire wavelength assignments now in force with Class B stations. This would be done in order to give each station a separation of fifteen kilocycles instead of ten, as is now the case. It is not now known when that reassignment will take place.

# The Revelations of Enoch

The Short-Wave Doodlebug—Pocket Humor and Radio Philosophy Uttered by a New Electro-Optical Discovery

BY W. R. BRADFORD

**I**N THE baseboard that runs around the floor of my studio, and radio lab. is a hole made by a mouse at some earlier time. The hole at present is occupied by a Doodlebug, who holds forth there, in bachelor quarters. I had gone to quite some pains in making friends with this little fellow, and at last succeeded to the point where he would poke his head from the hole and look me over carefully with his beady, black little eyes.

As we became better acquainted, I began to take liberties. One day I held forth a finger for his inspection, and the little cuss mounted my finger, whereupon, I lifted him to my desk, where reposed a Knockout Roberts set. The Doodlebug gazed at the set and began to show interest.

I made a little ladder and placed it against the panel. The Doodlebug climbed the ladder! After a careful inspection of the set, he turned and waved his antenna in a peculiar, jerky manner. Getting no response, he repeated this several times. Suddenly I discovered he was wigwagging me, in the International code!

"Make a short wave set," said the Doodlebug: "I want to talk to you!"

"What wavelength shall I make it?" I wigwagged back.

"Make it one half of one per cent." said the Doodlebug.

Alas! My lab contained no equipment to comply with this Volsteadian requirement: "Talk with me in wigwag," I signalled: "Later on I shall make a set."

The Doodlebug pulled down his vest, metaphorically speaking, and wigwagged the following:

## NEW RADIO PHILOSOPHY

**R**ADIO is nothing new to me. I was born with it, as all of the insect family are. Few of the insects have vocal cords, so we de-

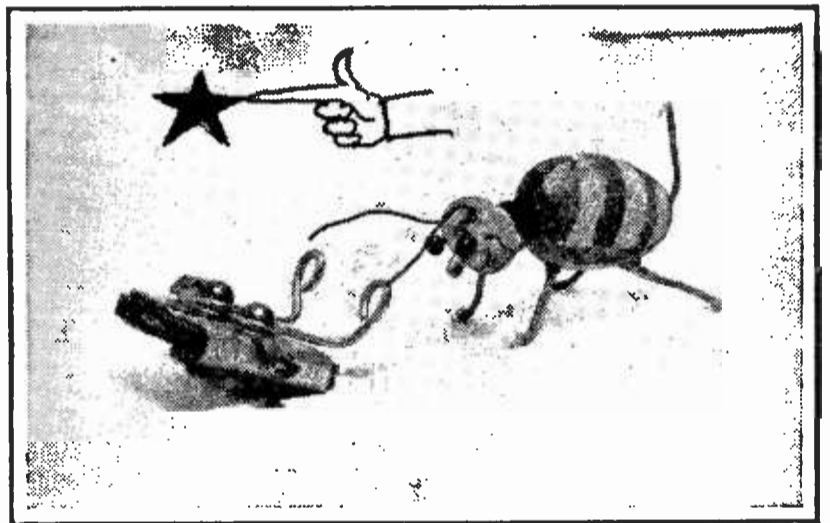

ENOCH TESTING A GRID CONDENSER

And putting the hall mark of approval on it

pend on radio for our communication. No, we have no understanding of the sign language, such as your mutes use, though our different postures and actions indicate our feelings and desires, in a more or less crude manner. But our main means of communication is by radio. Our waves are similar to those you use, but very much shorter. Man may some day be able to communicate with us when he understands our units of measurement, which are minute, compared to your methods.

"We do not receive and send by your methods. What you would call nerves, are all arranged for, in our antenna, our segmented organs of sensation. You depend on sound. We feel vibrations. Though these vibrations are minute, we can receive and send them a considerable distance—as much as two hundred feet. No, we are not bothered with

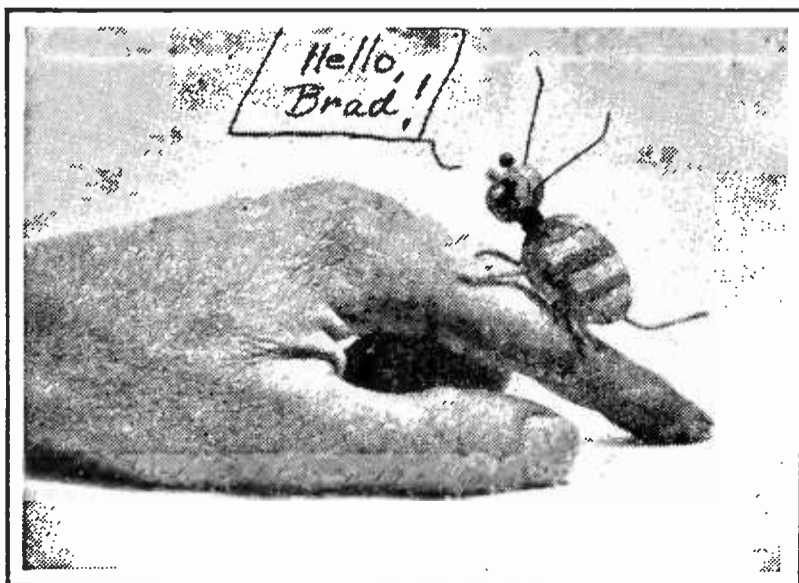

"THE LITTLE CUSS MOUNTED MY FINGER . . ."

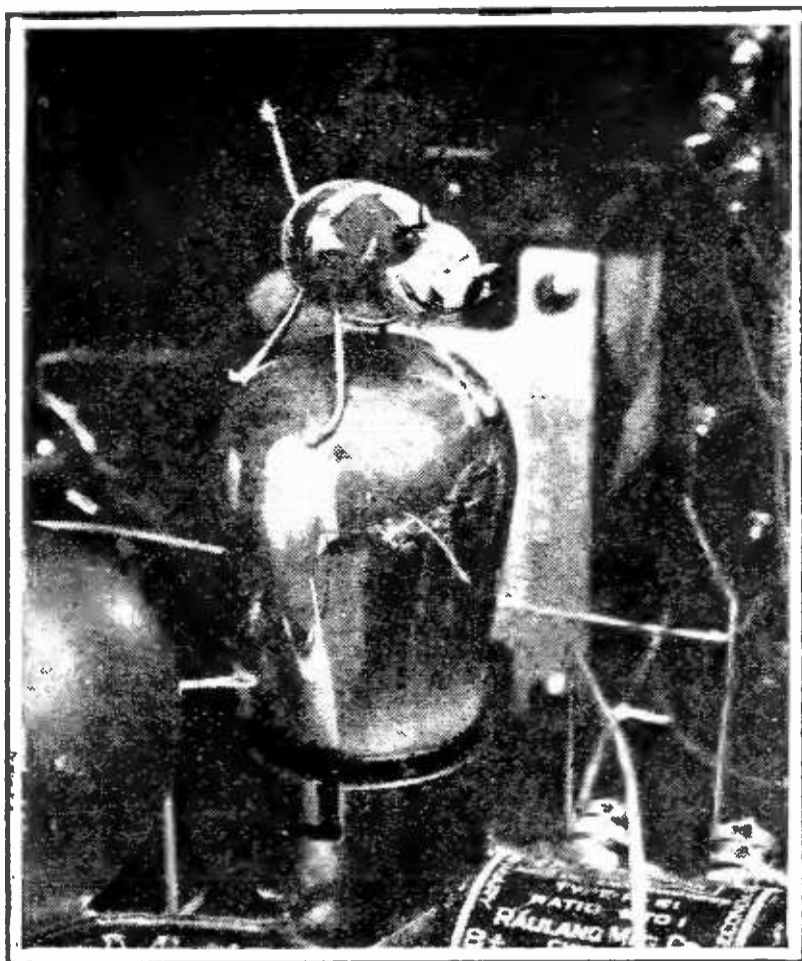

IT'S A WISE BUG

That knows its own receiver. Enoch, the confidential radio bug, is photographed in a moment of his marked preference for the Roberts Knockout set

static, or extraneous interference. We have no 'squeal hounds' to make our radio a thing to swear at. There is no 'best circuit' with us. Each one of us is his own super-heterodyne, so to speak. Thus, much valuable time is saved, which would otherwise be wasted in endless wrangling over 'low loss apparatus,' and such flubdub!"

(Did you ever hear the likes of that? The very kernel of good, sound radio sense!)

The Doodlebug continued: "Maybe you doubt me? Well, the ignorant ever condemn that which they do not understand."

(Get that? That little jasper has read Rochefoucauld's *Maxims*, I betchuh!)

The Doodlebug waved on: "An ant finds an open sugar bowl. He is not like a human—greedy, and wanting all for himself. No. He is one of God's creatures who share with others—at least, with their own kind. Does he waste valuable time running wildly around, shouting: 'Oi, yoi, yoi! Come and get a mouthful of sugar'? No. He broadcasts the news with his own little station—his nerves, and his antenna. Each ant's sensory apparatus, his antenna, is tuned to the same wavelength, which never varies. All the ants

within range of his broadcast come and tune into the feast—until one of you humans turn loose with a howitzer loaded with insect powder."

(So that was the way ants learned of sugar banquets! Come to think of it, it must be so. One time an ant crawled down my back—and took his broadcasting station with him. Inside of two minutes, a string of ants had begun to crawl up my trouser leg! I'll wager the explorer ant got lonesome, and broadcast for company!)

Just then Mrs. Betterhalf called: "The furnace needs attention!" Quick as a flash the Doodlebug ran down the ladder and made for his hole in the baseboard.

Bachelor Doodlebug? Such actions denote fear of the feminine, and indicate that this little rascal at some time had some unpleasant matrimonial mélange. (I fear the plot is going to thicken somewhere.)

His actions brought to mind those of a comic character of mine, so I named him Enoch. Enoch, you remember was afraid of his wife.

I shall make a short-wave set. The shorter the better, evidently. Then in our next interview we may learn more about short-wave radio—and other things. We shall see.

(As Enoch hurried to his hole, I pot-shotted him with my faithful camera. Doesn't it make a nice little tail piece, for a story finish? Thanks. I thought you'd like it.)

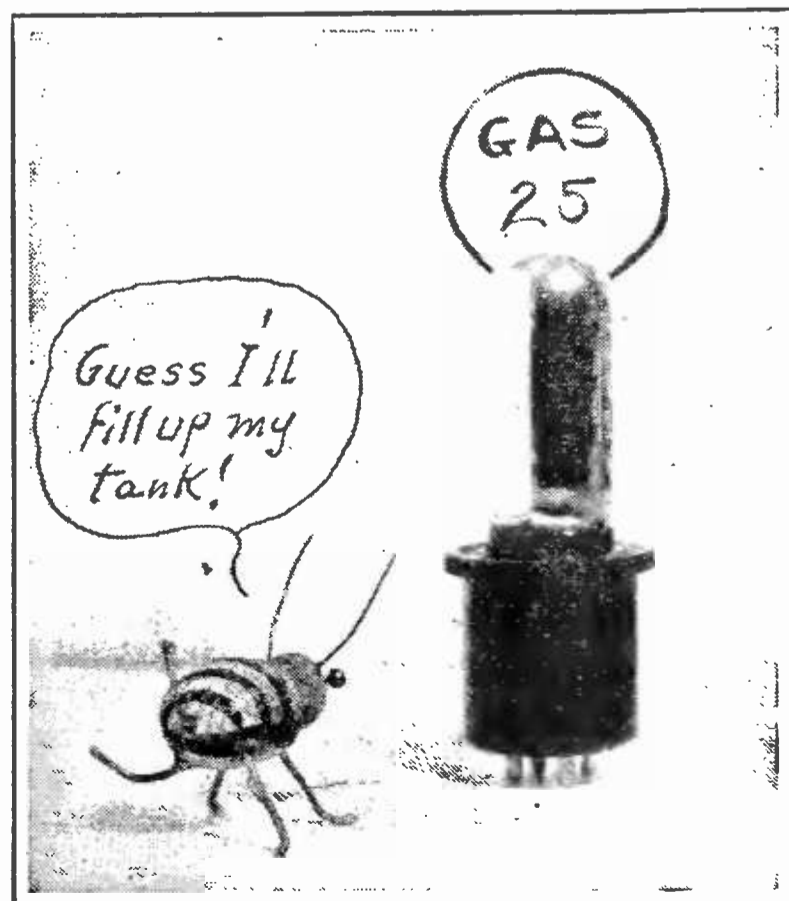

# “NOW, I HAVE FOUND . . .”

A Department Where Readers Can Exchange Ideas  
and Suggestions of Value to the Radio Constructor and Operator

## ALTERNATING CURRENT AS A SOURCE OF FILAMENT SUPPLY

RECENTLY I have been experimenting with alternating current as a means of heating the filaments of vacuum tubes. The idea is, of course, an old one, but for some reason has never been put into practice to any great extent. Alternating current cannot be used satisfactorily to heat a detector tube filament. This article will be confined to a discussion of the use of alternating current in amplifiers.

With the advent of the dry cell tube our troubles concerning filament supply would seem to be ended. However, these small tubes are so designed that they are unable to handle much power and hence are not very satisfactory as audio-frequency amplifiers, especially in the second stage. For tubes requiring more than .25 ampere filament current, dry cells are uneconomical.

The difficulty to be overcome when alternating current is used, is the hum which is produced in two ways:

1. If the grid return be connected to either end of the filament, then the grid potential becomes alternately positive and negative with respect to the midpoint of the filament. If it were possible to connect the grid return to the midpoint of the filament, then, of course, its potential would not change. This cannot be done but a trick may be employed which by means of a potentiometer, as shown in Fig. 1, the same results may be produced. Here we see that the midpoint of the potentiometer remains at constant potential, namely, the same potential as the filament midpoint. Hence, by adjusting the potentiometer we can make the grid return remain at this same potential. This simple adjustment is easily made and the hum reduced to a very small quantity.

2. The temperature of the filaments does not remain constant, but changes continually from a maximum value to a minimum value as the current through the filament passes through its cycle.—zero, positive maximum, zero, negative maximum, zero. See Fig. 2.

For the usual house lighting supply, the frequency is 60 cycles per second. The filament temperature, therefore, reaches its max-

imum and minimum temperatures 120 times per second. This produces an audible hum in the phones at a frequency of 120 vibrations per second. It is interesting to check this value against the tone of B below middle on a properly tuned piano. If middle C is 256 vibrations per second, then B, an octave below, is about 123 vibrations per second. By listening to the hum produced in the phones when the potentiometer arm is properly adjusted for constant grid potential, and comparing this hum to B below middle C, we cannot detect the three cycles difference.

If the potentiometer arm be moved so that the grid return is connected to one end of the filament, instead of midway between its two ends, then the grid potential varies with respect to the filament at the rate of 60 cycles per second. This, of course, causes a 60 cycle hum in the phones in the plate circuit. If we actually move the potentiometer arm away from its mid position and at the same time listen in the phones, we hear the 120 cycle hum gradually become lost in the 60 cycle hum, as the latter increases in amplitude the further we move the potentiometer arm from its midpoint.

Well, all this theory sounds very fine, but what good is it? In answer to this I shall describe briefly a single-stage audio-frequency amplifier which I have constructed employing the potentiometer feature as outlined, and find entirely satisfactory from every standpoint. The quality of reproduction is good, the volume is ample, and there is *no* noticeable a. c. hum. The loud speaker which I am using is merely a fibre megaphone about 2 feet long with a wye victrola headset connector soldered to it, and a pair of Western Electric phones. The quality of reproduction is better than many loud speakers now on the market.

Now for the amplifier itself. The apparatus required:

- An audio-frequency amplifying transformer.
- Rheostat, tubes, socket.
- Potentiometer (200 ohms or more).

The apparatus is assembled in a manner similar to the usual audio-frequency amplifier. The rheostat *must* be placed between the



potentiometer and the a. c. supply as shown. See Fig. 3.

I am using this amplifier in conjunction with a one-tube reflex set. This tube is a UV-199, and its filament supply consists of three dry cells in series. The proper negative grid bias for the audio amplifier tube may be obtained either from a separate C battery, or, by connecting the A battery of the first tube so that it acts as C battery for the second. This is shown in Fig. 3.

The value of C battery which will give undistorted amplification depends upon the type of tube used and also upon the plate voltage. For 200 and 300 tubes, use about 1.5 volts. For 201-A and 301-A tubes use 1.5 volts for a plate voltage of 40 volts, and 4.5 volts for a plate voltage of 90 volts.

The a. c. supply for filament must of course be transformed from 110 volts to a lower value. This is most economically done by means of a toy transformer which can be purchased for a couple of dollars. The secondary voltage may be from 5 to 10 volts. Most storage battery tubes are designed to operate at a filament voltage of 5 volts. I am using a UV-200 tube, consuming a filament current of 1 ampere. The secondary of my transformer gives me 5 volts. The type of rheostat used depends upon the tube. In this circuit, a 6 ohm rheostat is used.

In order to find out the resistance of the rheostat necessary, first determine the normal filament voltage and current of your tube and the secondary voltage of your transformer. Subtract the filament voltage from the transformer voltage and divide by the current. This gives the value of normal resistance in series with filament. The rheostat should, to allow for discrepancies, have a somewhat higher resistance than this computed value, say 25 per cent. For example:

Given

Filament voltage—5 volts.

Filament current— $\frac{1}{4}$  ampere.

Transformer secondary voltage—8 volts.

$8 - 5$  volts = 3 volts.

$3 \div \frac{1}{4} = 12$  ohms.

Adding 25 per cent. we get 15 ohms as the resistance of the rheostat. It can be seen from the above that any value of transformer voltage may be used provided the rheostat resistance is properly computed.

I use only one stage of amplification on my set because the resulting volume of signal is quite sufficient. However, there is no reason why two stages cannot be used, employing a common potentiometer and filament rheostat. The rheostat as determined for one stage may also be used for two stages.

Of course, the filament transformer may be constructed without much trouble, but its specifications will not be given here.

The audio amplifier using a storage battery may readily be converted to use a. c. merely by the addition of the potentiometer. The total initial cost of the a. c. amplifier is less than the usual method and its upkeep is less. Another point of some importance is the fact that tube filaments have a longer life when heated with a. c. than when d. c. is used.—J. B. CLOTHIER, JR., Lansdowne, Pennsylvania.

### A SCREW STARTER

WHEN constructing radiosets it is often difficult to hold the screws so that they may be put in some nearly inaccessible place. An efficient device may be made by slotting a piece of quarter-inch brass rod about six inches long, with a hack saw, for about a half inch. In this slot two phosphor bronze strips about an inch and a quarter long are inserted and soldered in. The tips are then filed so that they will be thin enough to insert in the slots of small screws. They are then sprung so that their natural position is with the ends about an eighth of an inch apart. When these tips are pressed together and placed in the slot in the screw, and then re-

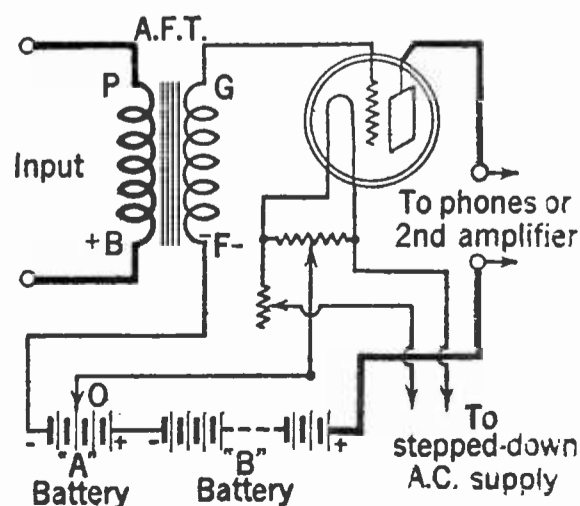
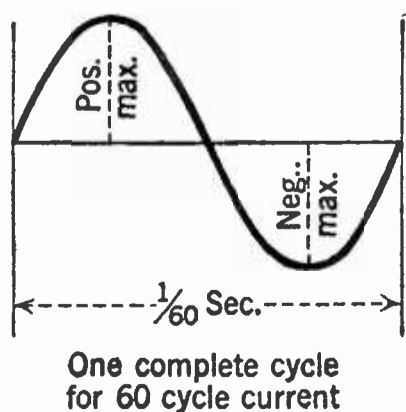
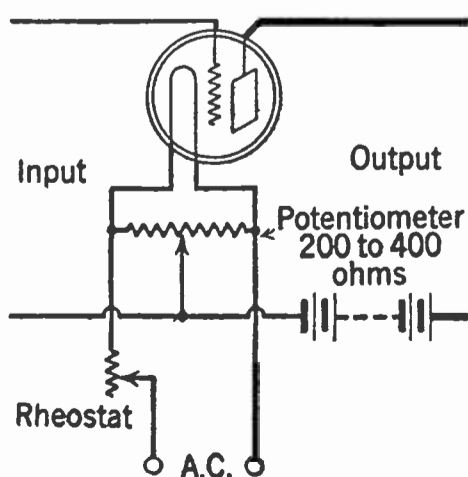

FIGS. 1, 2, AND 3

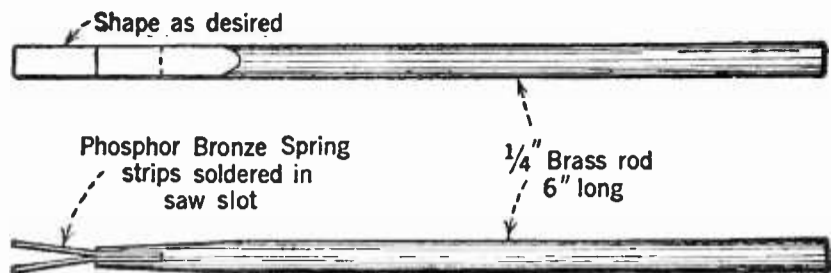

FIG. 4

leased, they will hold the screw securely until it has been started, and then it can be released by simply pulling. The sketch, Fig. 4, shows the details.

### A CONVENIENT MOUNTING STRIP

A VERY practical method of installing a receiver is to bring all battery leads up through the top of the operating table, to binding posts mounted on a strip of bakelite which is fastened to the table top. Fig. 5 shows the details. This not only provides an exceptionally neat installation by keeping all wires and batteries out of the way, but will be found very advantageous whenever it is necessary to change from one receiver to another, or to test out any receiving set. The A battery and B battery posts are not connected in any way, due to the individual requirements of the various circuits, but these connections can be bridged across from one post to another, if such connections are not taken care of in the wiring of the receiver itself.

Short pieces of wire are run from the posts on the mounting strip, to the posts at the rear of the receiver, and when taking off one receiving set to try another, it is merely necessary to loosen the binding posts on the table, allowing the connecting wires to remain attached to the receiving set, and they will then be in proper position for re-connecting.

This method of bringing antenna, ground, and battery leads to a receiving set will immediately find favor with all experimenters who ever have occasion to disconnect one receiver to test out another circuit.—HARRY W. GILLIAM, Big Stone Gap, Virginia.

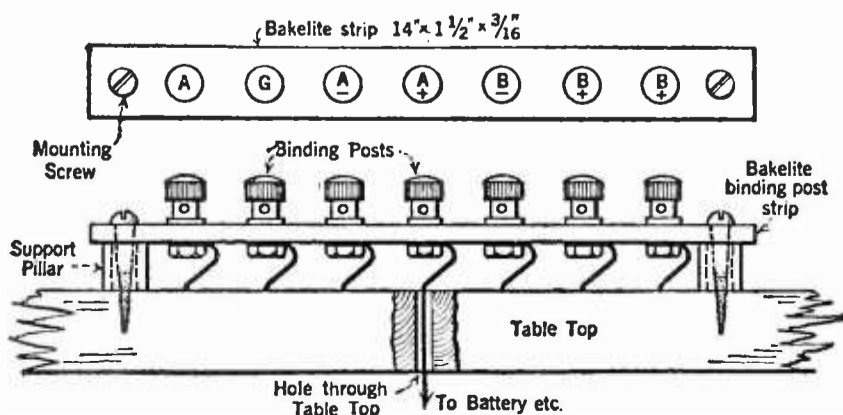

FIG. 5

### A GOOD FILTER CONDENSER

NO DOUBT many readers were very much interested in the B battery from the lamp socket, as described by Mr. Le Bel in the September, 1924, RADIO BROADCAST. Perhaps they may also be interested in the following description of an electrolytic condenser for use in such an outfit.

The condensers built by the writer and used in this outfit were made as described below and as illustrated by the sketch, Fig. 6. Each condenser required one large mouthed glass jar, a hard rubber or wooden top, an aluminum sheet, a quarter inch diameter steel rod and an electrolyte of ammonium phosphate in pure water. The aluminum sheets used were four inches wide by five feet long and one sixty-fourth inch thick. A small tab or ear was left on each for making a connection. The sheets were rolled into a spiral as shown. The steel rod is for making contact with the solution.

After the parts are assembled and the solution poured into the glass jars, the plates must be formed by passing a current through the condensers. This may be done by connecting a 100 watt lamp in series with them and plugging the circuit into a lamp socket. It takes a long time to form the plates but it can be done with a little patience. When the

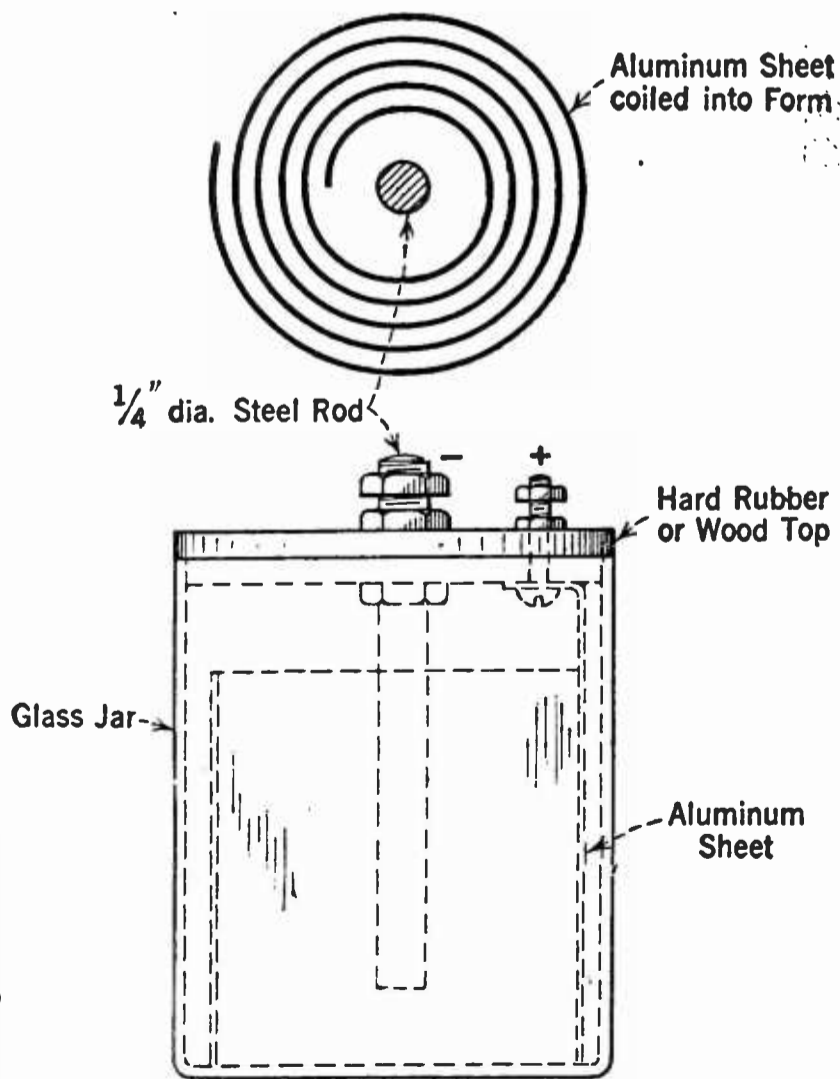

FIG. 6

forming is advanced far enough a good spark should occur when the condenser is short circuited after a charge.

A pair of these is now working very well in a lamp socket B battery outfit. The residual hum is small enough to be negligible and it seems to become less with use. This outfit is supplying the plate potential for a Roberts Knockout circuit in very satisfactory fashion.  
—C. E. SEIFERT, Cincinnati, Ohio.

### MAKING YOUR OWN CABINET

**T**HE average amateur makes a very poor job of his cabinet, which spoils the appearance of an otherwise good receiver. The following is a description of how to make it look like a factory job with a piano finish, without the use of a lot of clamps.

It is possible even to use an old walnut sewing machine top for the wood. The general specifications are outlined in Fig. 7.

The joint at "a" is glued, but clamps are not required to hold it. It is sawed as in "b." First use a marking gauge, place a back on the line to keep the saw straight, or use a mitre

box if one is available. Next use a chisel on the end to cut it out.

Then bore three holes in each side piece for round headed brass screws as at "a," place the back of the case in a check and mark the holes through; but when drilling allow a little draught to draw pieces up tight, as in C.

This will bring the pieces up tight when glue and screws are applied so that the joint will not show. The bottom moulding is in two pieces. The top bead is a strip  $\frac{1}{4} \times 1\frac{1}{4}$  inches with outside edge rounded and corner mitred shown at "b."

The base "c" is moulded with two chisels: one is a core box gouge, and the other a plain flat chisel. This is quite easy to do. When finished, scrape and sandpaper. The top bead "b" is then glued to the base "c."

After the case is together, get a bottle of white shellac and a small sponge. Apply three coats with the sponge, one right after the other as soon as dry. Allow about twenty minutes between coats. Then have a small piece of cotton batting tied up in a piece of woolen rag, wet this in alcohol and rub all over the case well. Now go all over the case with a piece

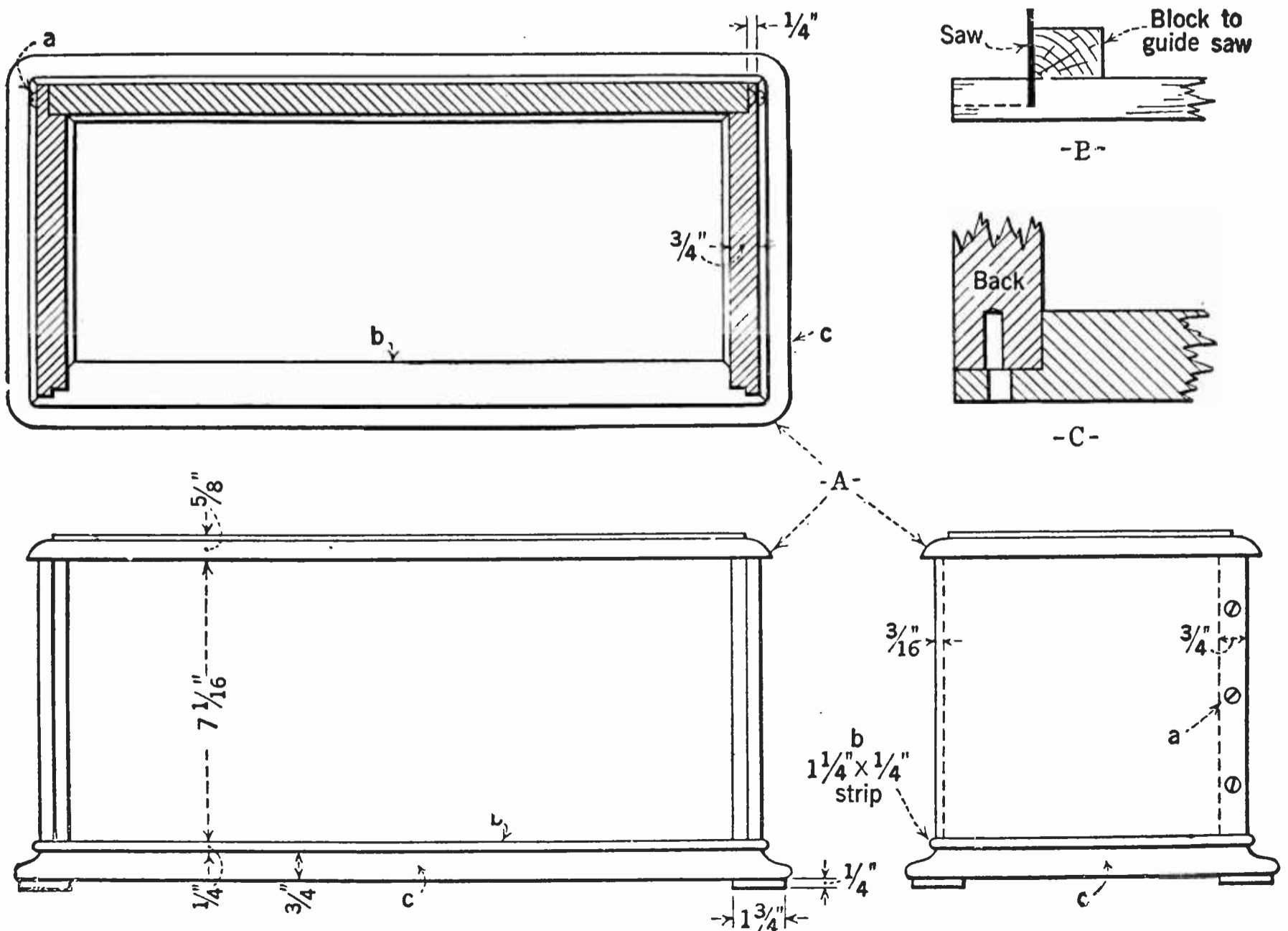

FIG. 7

of tallow, then dust on rotten stone from a woolen bag and rub well with the heel of the hand and a clean rag. The more you rub the better the finish. Try it and see; the finish will look like a piano, provided the wood is smooth when you start.—WELSFORD A. WEST, Hopewell, Nova Scotia.

### A TICKLER KINK FOR THE ROBERTS

**A**FTER trying every conceivable way of working the tickler for my Roberts set, I have devised the scheme shown in Fig. 8. I have found it more satisfactory mechanically and electrically than the factory-made apparatus.

This arrangement cost me thirty cents (not including coils). It is made from the hardware of a 180° coupler bought at a five and ten cent store.

As will be seen, the tickler coil is brought

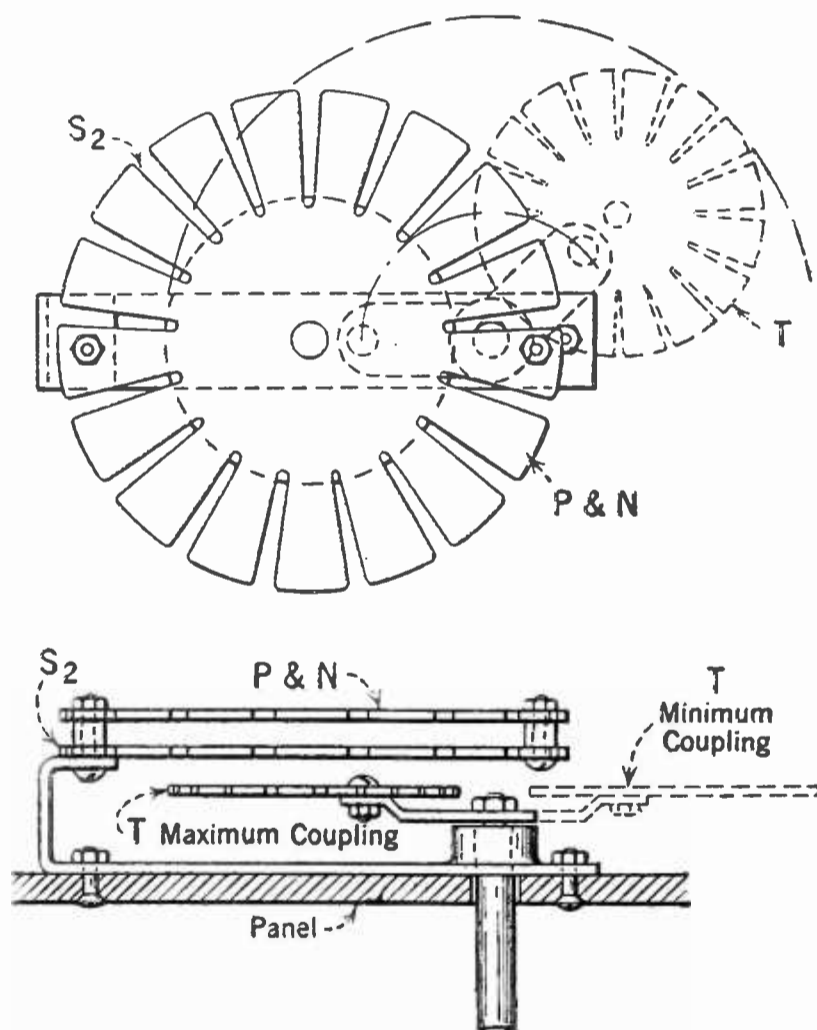

FIG. 8

into the field of the  $S_2$  coil very gradually by turning the dial.

Another feature is the small amount of space required behind the panel; it is about  $2\frac{1}{2}$  inches.

The coils are wound on standard forms, the T coil being cut smaller than the others.—J. BELL, Ottawa, Canada.

### WHEN WORKING BAKELITE

**T**O SQUARE up the edges of bakelite, a common wood plane may be used if it is set rather finely.

An excellent and rather unusual finish may be given bakelite by inserting in the chuck of a drill press, a piece of wood about  $\frac{3}{4}$  inch in diameter, and bringing this down on the surface of the bakelite so that the circles produced will overlap slightly. The finish is similar to that given the armor plate of safes, and when done evenly, gives a very pretty effect. It is best to practice on the wrong side of the piece or on a scrap piece until the knack is acquired.—CARL PENTHER, Oakland, California.

### DULL FINISH FOR PANELS

**T**HE instructions usually given for removing the gloss finish from bakelite, formica, or condensite panels, are to rub them down with No. 0 sandpaper and oil. However, in practice I have found that a very smooth yet dull finish, with no scratches, is more easily obtained by rubbing the panel down with No. 00 steel wool, dry. Oil may be used with the steel wool, or applied afterward, but is not at all necessary. The direction of rubbing should be back and forth, lengthwise with the panel. After the panel is rubbed down in this way, it is very easy to mark locations on it with a sharp lead pencil, when laying it off preparatory to drilling.—HARRY W. GILLIAM, Big Stone Gap, Virginia.

**F**OR a long time, RADIO BROADCAST has felt the need of an outlet for the many excellent ideas dealing with various features of radio construction which reach our office. If you have an idea about a valuable and useful new circuit, some new device, a construction or operating suggestion, we should like to have it. Payment of from two to ten dollars will be made for every idea accepted. The description should be limited to three hundred words and typewritten. Accompanying sketches, drawings, and circuit diagrams should be as plain as possible. We do not want simple, obvious suggestions. Material to be acceptable for this department must offer something of definite value to the constructor. Mere novelty is not desired. Address your manuscripts to this department, RADIO BROADCAST, Garden City, New York.



*See Important Special Announcement on Page 112*

## QUERIES ANSWERED

HOW MAY I USE A VOLTMETER AND MILLIAMMETER IN A RADIOLA SUPER-HETERODYNE CIRCUIT?

C. J. M.—Pittsburgh, Pennsylvania.

I WISH TO ADD A STAGE OF R. F. AMPLIFICATION TO MY REGENERATIVE RECEIVER. HOW SHALL I DO IT?

W. D. M.—Worcester, Massachusetts.

WHERE MAY I OBTAIN A COLLEGE CORRESPONDENCE COURSE IN RADIO?

L. G. B.—Wilkes-Barre, Pennsylvania.

WILL YOU PUBLISH A CIRCUIT DIAGRAM SHOWING

### METERS AND B BATTERIES

HERE again we discuss the specific problem of the use and aid of meters in the B battery circuit of a Radiola super-heterodyne to determine the state of life of these batteries.

A milliammeter (0—100 milliamperes scale) when placed in the circuits as shown in Fig. 1, A-B-C and D registers the drain upon the B batteries in milliamperes. This meter itself does not consume any of the energy as it is of low resistance. It may be permanently included in the circuit.

The full B battery drain will be indicated when the meter is connected in the terminal as in D, because this is the common return lead of the battery for both 45 and 90 volt terminals. In C only the 45 volt drain would be indicated, and in B only the amplifier drain would be manifest.

The voltmeter (with a scale reading from 0 to 150 volts) is used to indicate the state of voltage of the B battery. When voltage tests are made, the terminal leads of the meter should only be momentarily touched to the B battery.

The resistance of a voltmeter is such that a leakage path would be provided for the B battery current, and would soon discharge the battery, making it inoperative. Therefore it is not well to connect the voltmeter permanently across the B battery terminals. A switch may be provided which will connect it in the circuit for momentary readings.

The milliammeter and voltmeter afford all definite check on the life and condition of the B batteries and should be included in all installations, especially where many tubes are employed.

HOW TO USE STRAIGHT AUDIO, PUSH-PULL, OR RESISTANCE-COUPLED AMPLIFICATION WITH THE TWO-TUBE ROBERTS CIRCUIT?

K. H.—Burlington, Vermont.

I HAVE BECOME CONFUSED WITH THE MARKINGS ON AUDIO-FREQUENCY TRANSFORMERS. WILL YOU EXPLAIN THE PROPER MARKINGS AND CONNECTIONS?

B. W. E.—Roanoke, Virginia.

HAVE YOU ANY OTHER ADDITIONAL NOTES ON THE ROBERTS CIRCUIT?

C. T. S.—El Paso, Texas.

### ADDING R. F. AMPLIFICATION TO REGENERATIVE RECEIVERS

A METHOD for adding radio frequency amplification to a regenerative receiver was discussed in the March, and May, 1924, RADIO BROADCAST, but as these issues are out of stock at Doubleday, Page & Co., the subject will be briefly treated here.

The problem to be considered in an addition of this kind is to construct an amplifier which will not radiate of itself into the antenna or pass along the oscillations of the regenerating detector.

The coupler T-1, in Fig. 2, is of the standard type, a primary with a secondary of about 50 turns shunted by a .0005 mfd. variable condenser. The primary may be variably coupled to the secondary. A tube socket, rheostat, .002 mfd. fixed condenser and 200 ohm resistance is all that is otherwise necessary.

The primary of the regenerative receiver serves as the plate coil of the amplifier. Radiation is prevented by the use of the 200 ohm resistance, which may be termed a lossy, in series with the high voltage lead of the B battery supply.

Fig. 3 shows the Roberts form of amplifier which is highly recommended. Here, the plate coil of the amplifier must be specially wound with a pair of wires. The inside lead of one coil connects to the grid of the tube through a neutralizing condenser, and the outside lead of the other coil connects to the plate. The remaining two leads are connected together and thence connected to the high voltage B battery lead. The antenna coupler is of the standard type.

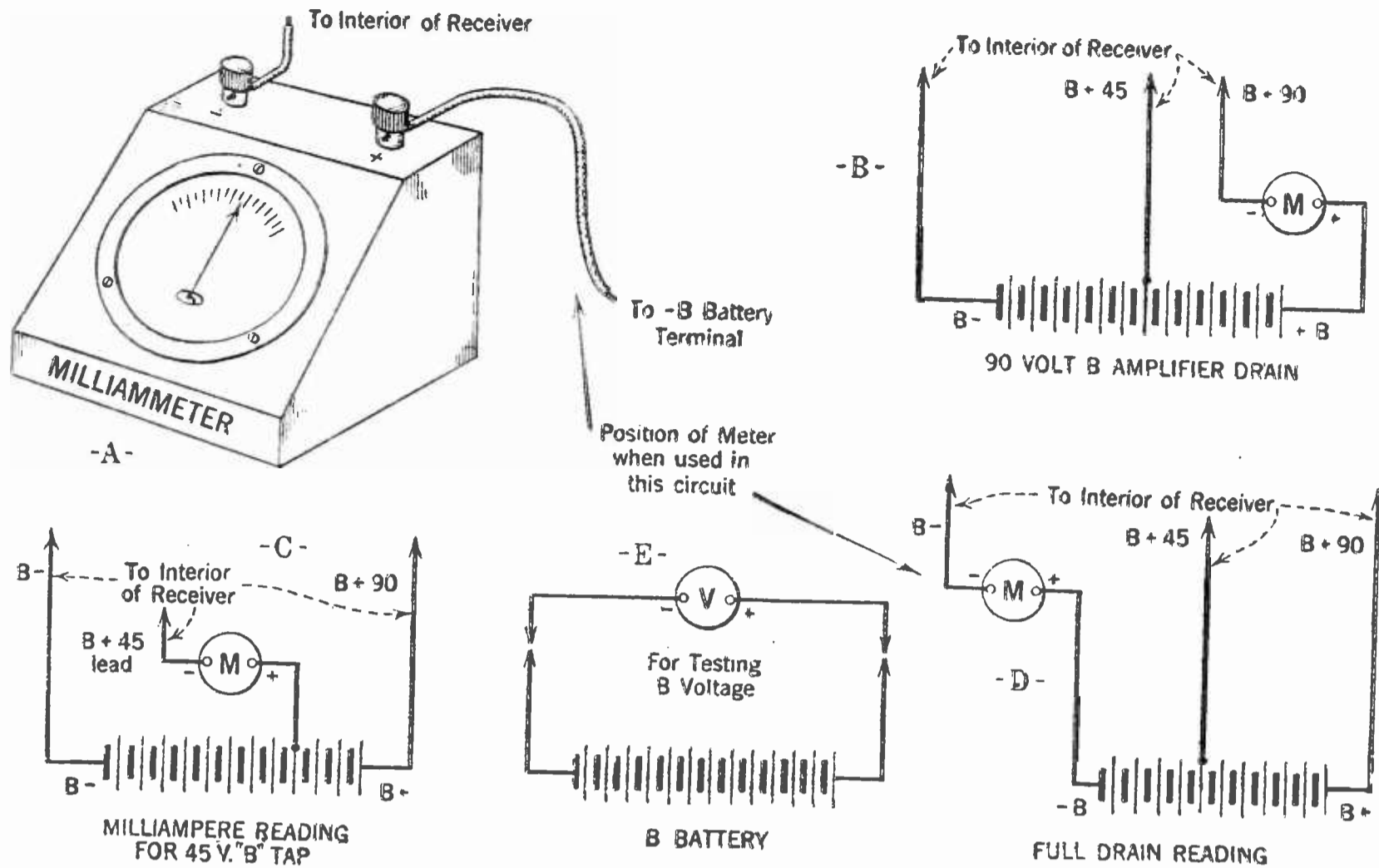

FIG. 1

COLLEGE RADIO CORRESPONDENCE COURSES

INTENDING in no way to discriminate, this department can advise that for those wishing to further their radio studies the course as outlined by the prospectus of the Department of Engineering of the Pennsylvania State College, State College, Pennsylvania, is especially interesting.

Two courses are provided, one, elementary, covering the principles of radio electricity—how telephone, crystal, and vacuum tube sets work—amplification, etc.—working drawings for eight typical receivers—discussions on topics such as static, directional effects, radio-photography, test methods, etc. This course is of ten assignments and costs \$10.00.

The advanced course is also in ten assignments and the price is \$15.00. It applies to technical men and amateurs, desiring the mathematical treatment of the subject, together with the electrical theory involved. It covers elementary electricity, radio circuits, electromagnetic waves, damped wave transmission, the electron tube, apparatus for reception, the tube as a generator, radio telephony, etc.

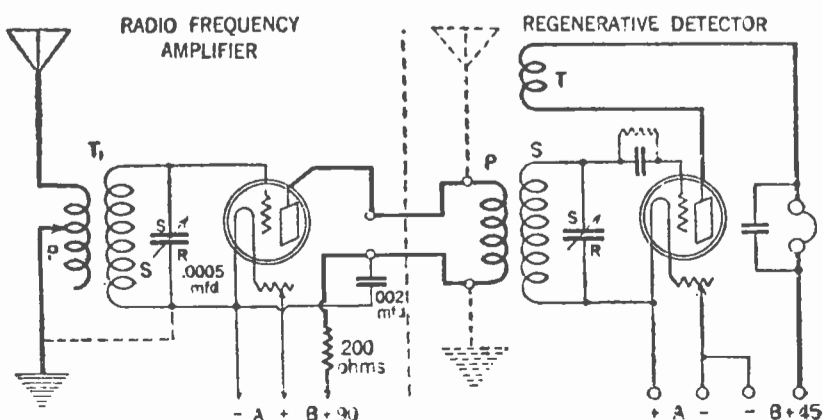

FIG. 2

AUDIO AMPLIFIER CIRCUITS FOR THE ROBERTS RECEIVER

IT IS to be remembered that the original two-tube Roberts circuit already contains one stage of audio-frequency amplification in the reflexed first tube. Now, in the addition of amplifiers the following has been determined:

1. The standard straight stage of audio usually

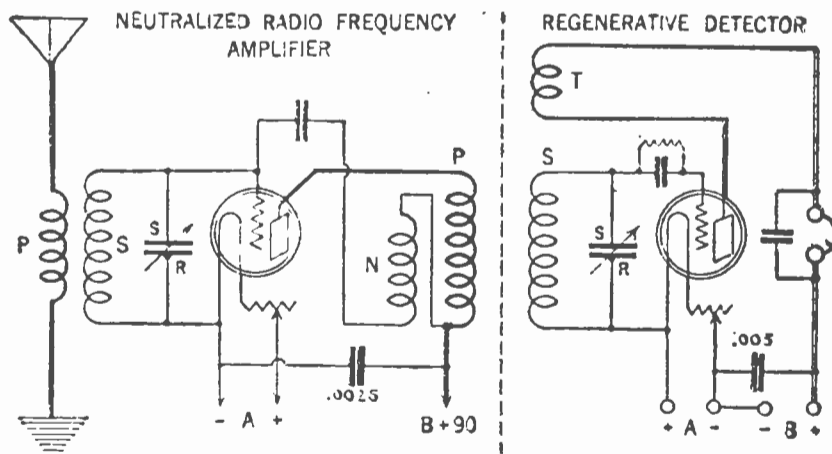

FIG. 3

overloads and causes distortion unless the transformer secondary is shunted by a variable resistance of a value of 10,000 to 100,000 ohms. The full amplification factor of the stage is not realized because of the inclusion of this "losser".

2. The push-pull amplifier is admirably suited for controlling the output of the two-tube receiver and will furnish plenty of volume. However, as is the case with all audio-frequency transformers, the quality of reproduction is slightly affected because the amplification characteristic of the transformer favors some band of frequencies over others.

3. The resistance-coupled amplifier will not pro-

# Facts! not Fancies!

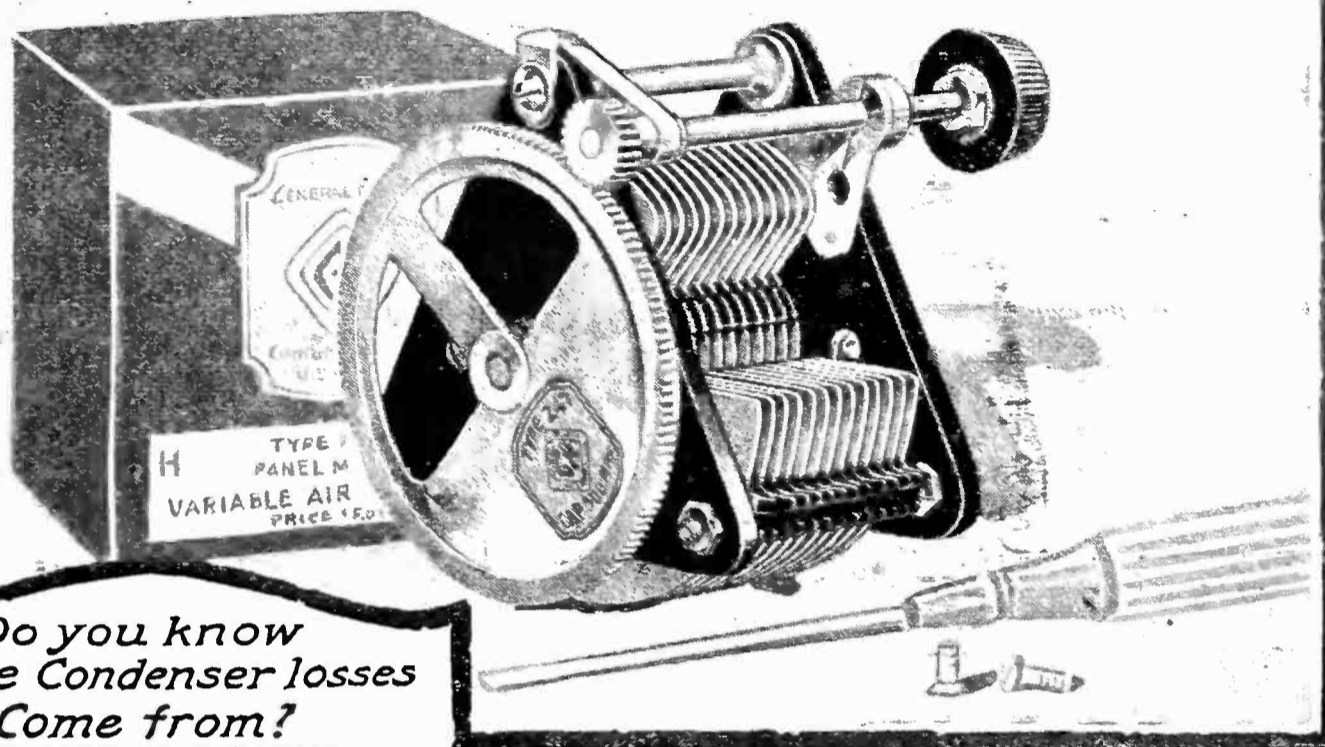

*Do you know where Condenser losses Come from?*

**R**ESISTANCE LOSSES are the losses which most seriously affect the efficiency of a condenser when at working radio frequencies. They arise from poor contacts between plates and from poor bearing contacts. Soldered plates and positive contact spring bearings reduce these losses to a minimum.

Eddy current losses occur in metal end plates and the condenser plates themselves. While not so serious as resistance losses, they increase with the frequency, and therefore should be kept as low as possible.

Dielectric losses are due to absorption of energy by the insulating material. Inasmuch as they vary inversely as the frequency, they have less effect upon the efficiency of a condenser at radio frequencies than any other set of losses. The use of metal end plates in short-wave reception to eliminate dielectric losses is never justified, because they introduce greater losses than well-designed end plates of good dielectric.

The design of General Radio Condensers is based on scientific facts and principles, not on style and fancies.

Specially shaped plates always in perfect alignment give the uniform wave-length variation which permits extremely sharp tuning.

Rotor plates are counterbalanced to make possible accurate dial settings.

In 1915 the General Radio Company introduced to this country the first Low Loss Condenser, and ever since has been the leader in condenser design.

Lower Losses and Lower Prices make General Radio Condensers the outstanding values of condenser design.

*Licensed for multiple tuning under Hogan Patent No. 1,014,002*

Type 247-H, with geared Vernier Capacity, 500 MMF. Price **\$5<sup>00</sup>**

Type 247-F, without Vernier Capacity, 500 MMF. Price **\$3<sup>25</sup>**

**GENERAL RADIO CO.**  
CAMBRIDGE, MASS.

★ **GENERAL RADIO** ★  
Quality Parts

duce as much volume as the push-pull amplifier but will be faultless in quality when properly adjusted. In all three types of amplifiers, the input connects to the two central blades of the double circuit jack.

The diagram, Fig. 4, is self-explanatory.

AUDIO TRANSFORMER MARKINGS

THE designations of binding post markings on audio-frequency transformers have become standardized to a great extent, but there are still some that do not follow general practice.

In Fig. 5, the binding post marks coincide with

2 TUBE ROBERTSCIRCUIT

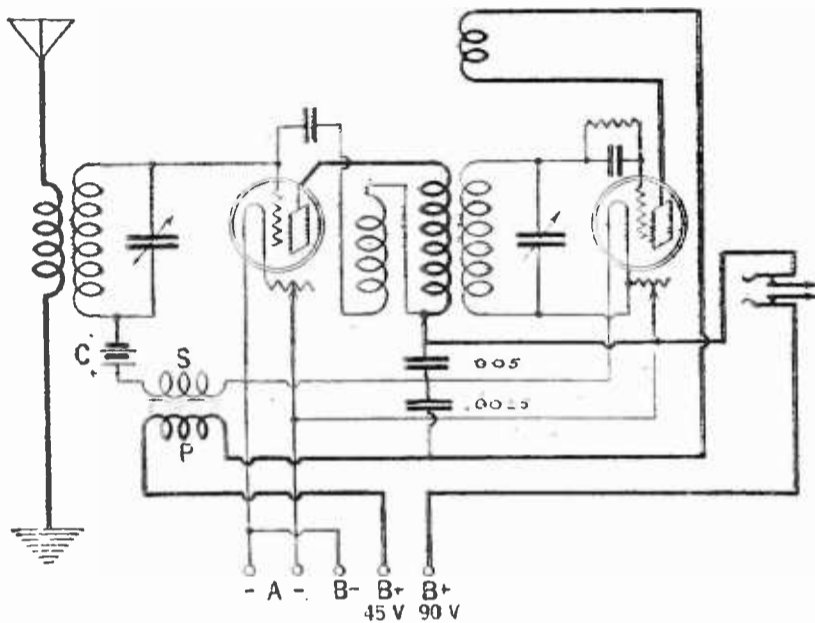

FIG. 4

the markings as applied to circuit diagrams. Fig 6 shows how the marks appear when the primary posts are turned the other way around. The outside lead of the secondary is the point of high potential in the secondary circuit and usually connects to the grid. Standard practice has it that the outside of the primary should then go to the plate. However, be sure to have the grid connected to its proper post, then if results are not as expected it is well to try reversing the leads to the primary of the transformer. This is especially important in reflex circuits such as the Roberts.

NOTES ON THE ROBERTS CIRCUIT

THOSE who used Sickles coils in the Roberts circuit may have found that it was not possible to tune to the lower wavelengths. This is especially true of the first lot of Sickles coils manufactured. The condition may be remedied in two ways:

1. Change the connection of the return side of the secondary to the negative side of the A battery line instead of the positive, as is commonly shown in the circuit diagrams.
2. Remove five or six turns from the NP and tickler coils.

When removing turns from the tickler coil simply unwind them from the outside of the coil. When removing turns from the NP coils, unsolder the outside ends of both the green and white wires, and unwind both of them together until you have taken

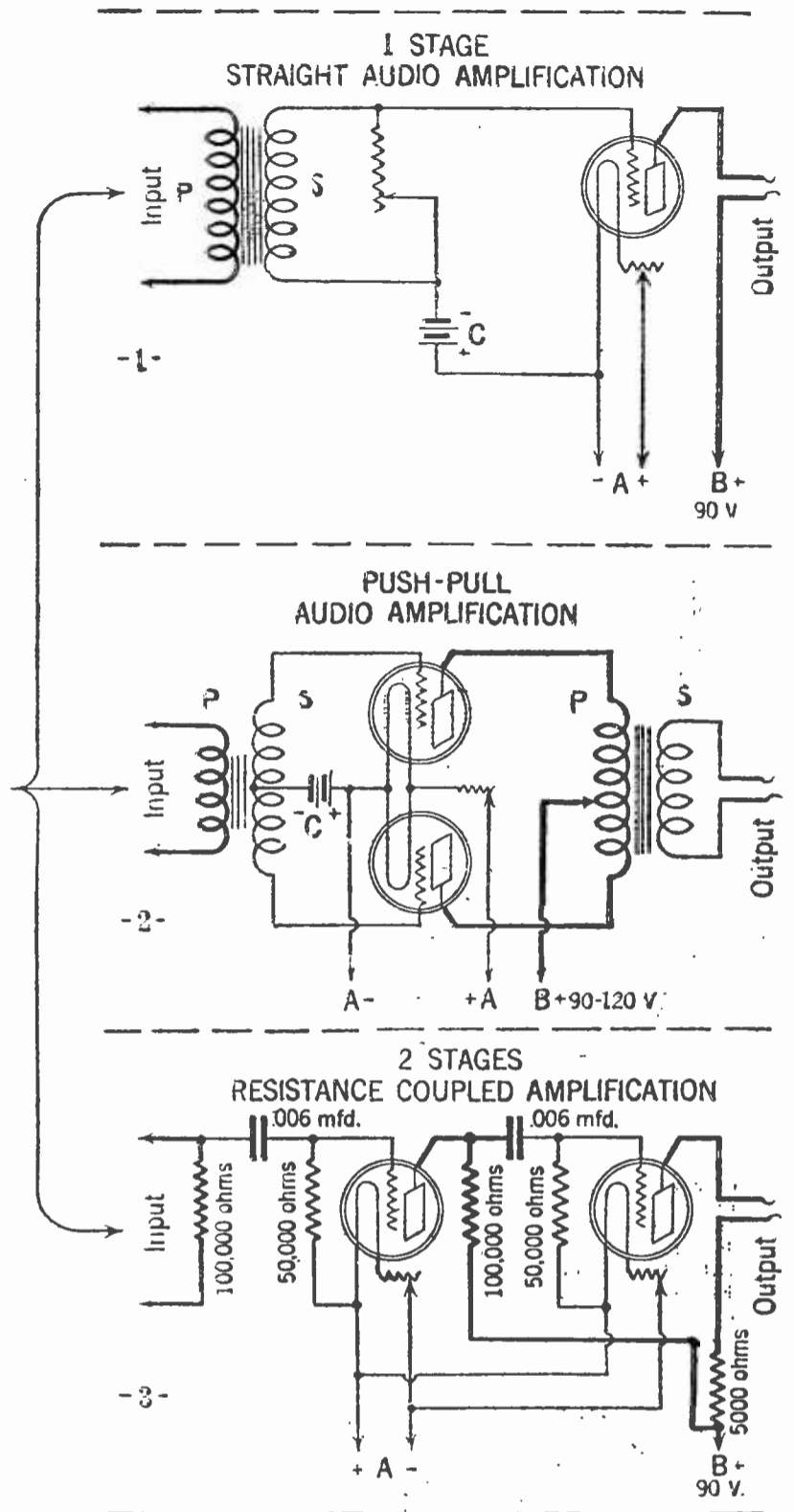

Top view of Audio Frequency Transformer

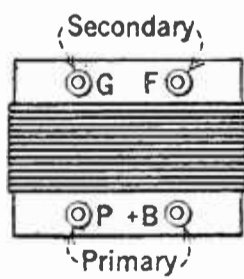
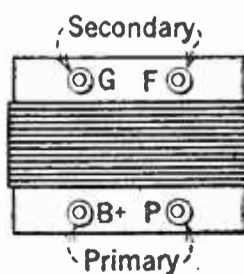
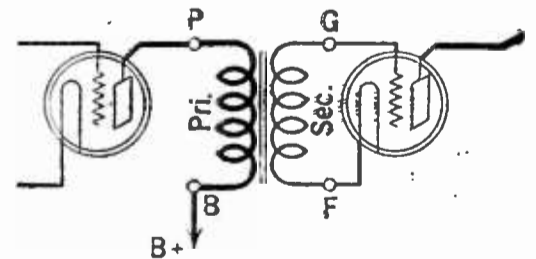

FIG. 5



Top view of Audio Frequency Transformer

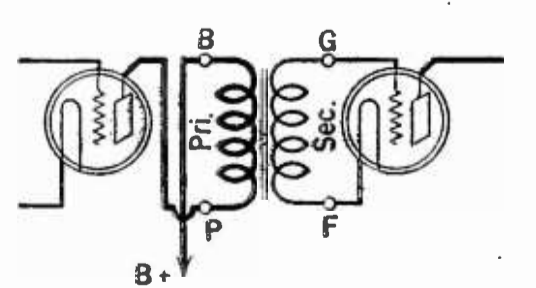

FIG. 6

off six turns, then connect the green and white wire exactly as they were connected before.

This will make your set operate perfectly down to



# Lacault Scores Again!

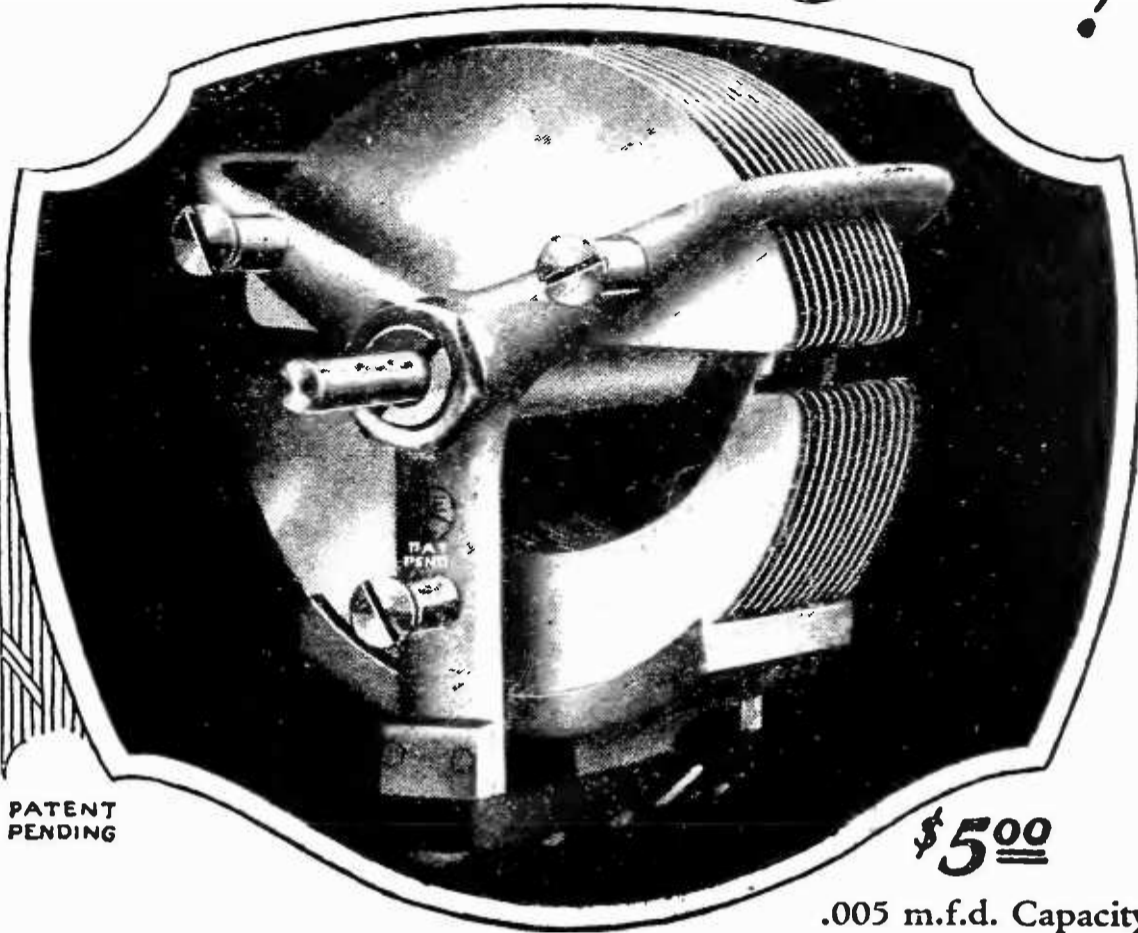

PATENT  
PENDING

**\$5<sup>00</sup>**

.005 m.f.d. Capacity

The new Ultra-Lowloss condenser is the latest radio improved device designed by R. E. Lacault, formerly Associate Editor of Radio News, the originator of Ultradyne Receivers and now Chief Engineer of Phenix Radio Corporation.

## ULTRA-LOWLOSS CONDENSER

LIKE every Lacault development, this new Ultra-Lowloss Condenser represents the pinnacle of ultra efficiency—overcomes losses usually experienced in other condensers.

Special design and cut of stator plates produces a straight line frequency curve, separates the stations of various wave lengths evenly over the dial range, making close tuning positive and easy.

With one station of known frequency located on the dial, other stations separated by the same number of kilocycles are the same number of degrees apart on the dial.

In the Lacault Ultra-Lowloss Condenser losses are reduced to a minimum by use of only one small strip of insulation, by the small amount of high resistance metal in the field and frame, and by a special monoblock mounting of fixed and movable plates.

At your dealer's, otherwise send purchase price and you will be supplied postpaid.



**ULTRA-VERNIER  
TUNING CONTROL**

Simplifies radio tuning. Pencil-record a station on the dial—thereafter, simply turn the finder to your pencil mark to get that station instantly. Easy—quick to mount. Eliminates fumbling, guessing. Furnished clockwise or anti-clockwise in gold or silver finish. Gear ratio 20 to 1.  
Silver \$2.50      Gold \$3.50

Design of lowloss coils furnished free with each condenser for amateur and broadcast frequencies showing which will function most efficiently with the condenser.



This seal on a radio product is your assurance of satisfaction and guarantee of Lacault design.

### To Manufacturers Who Wish to Improve Their Sets

The Ultra-Lowloss Condenser offers manufacturers the opportunity to greatly improve the present operation of their receiving sets.

Mr. Lacault will gladly consult with any manufacturer regarding the application of this condenser to his circuit for obtaining efficiency.

**PHENIX RADIO CORPORATION, 116-C East 25th St., New York**

★ Tested and approved by RADIO BROADCAST ★

one hundred and eighty meters and will not in any way weaken the received strength of the long wavelength stations. If for any reason you cannot get regeneration at five hundred and fifty meters increase the detector plate voltage.

When mounting the Sickles coils in the four-tube Roberts layout, the planes of the coils are practically opposite to that arrangement employing the Nazeley spiderwebs. The builder must exercise his own ingenuity in the proper placement of his coils so that they will not hinder the action of the variable condensers and he must make sure that the action of the tickler coil be not restricted.

The antenna coupler may be mounted directly on the panel slightly below the switch blade. This brings the tap leads quite close to the switch points. It also allows ready adjustment of the coupling between the primary and secondary.

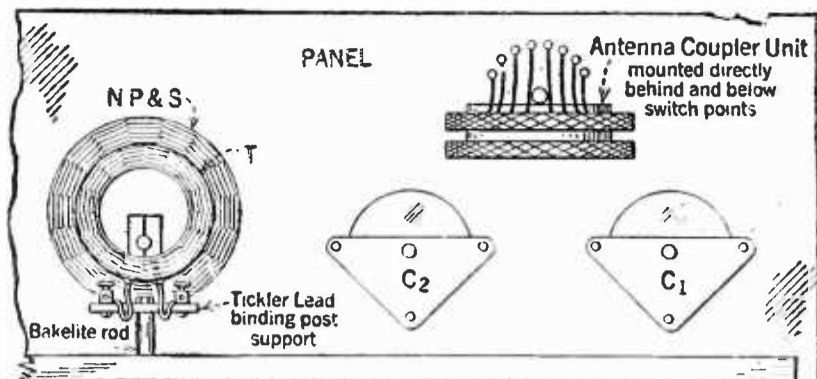

FIG. 7

The arrangement is as shown in Fig. 7 and permits of short leads to both switch points and variable condenser. A binding post strip may be mounted directly behind the tickler coil to accommodate the flexible leads from the tickler and the bus bar connections to it.

## IMPORTANT ANNOUNCEMENT

**T**HOUSANDS of you are writing the Grid for technical advice every month. The expense of framing a complete and exhaustive reply to each letter is very high. The editors have decided that the benefit of the questions and answers service will continue to be extended to regular subscribers, but that non-subscribers, from April 15 on, will be charged a fee of \$1 for each letter of inquiry which they send to our technical department. Very frequently, our technical information service proves of definite money value to you who write us, for we are often able by a sentence or two of explanation, to put you on the right path before you have made a perhaps expensive mistake.

The occasional reader of RADIO BROADCAST will be charged a fee of \$1 for complete reply to his questions, and the regular subscriber can continue to take advantage of the service as before. In that way, the non-subscriber will help share the cost of the technical staff whose service he gets. Every letter receives the benefit of the experience of the editor and the technical staff and every correspondent may be sure that his questions will receive careful consideration and reply.

When writing to the Grid, please use the blank printed below.

### GRID INQUIRY BLANK

Editor, The Grid,  
RADIO BROADCAST,  
Garden City, New York.

Dear Sir,

Attached please find a sheet containing questions upon which kindly give me fullest possible information. I enclose stamped return envelope.

(Check the proper square)

- I am a subscriber to RADIO BROADCAST. Information is to be supplied to me free of charge.
- I am not a subscriber. I enclose \$1 to cover costs of a letter answering my questions.

My name is \_\_\_\_\_

My address is \_\_\_\_\_

# The two outstanding parts in radio!

Give low losses and amplification without distortion to any set

**Q**UANTITY and distance are what a radio set must give. To insure Quality, amplification without distortion is essential. And to insure Distance, low losses are essential. That is radio in a nutshell.

People in whose sets Acme Transformers are used, are sure of hearing concerts "loud and clear" so a whole roomful of people can enjoy them.

The Acme A-2 Audio Amplifying Transformer is the part that gives quality. It is the result of 5 years of research and experimenting. It gives amplification without distortion to any set. Whether you have a neutrodyne, super-heterodyne, regenerative or reflex, the addition of the Acme A-2 will make it better.

To get the thrill of hearing distant stations loud and clear, your set must have low losses, for it is low losses that give sharp tuning to cut through the locals, and it is low losses that allow the little energy in your antenna to come to the amplifier undiminished. That's what the Acme condenser will do for any set. And it will do it for years because the ends can't warp, the bearings can't stick and the dust can't get in and drive up the losses several hundred per cent.

The Acme Reflex (trade mark) owes its success and its continued popularity to these two outstanding parts in the radio industry, for low losses and amplification go hand in hand.

Use these two parts in the set you build. Insist on them in the set you buy.

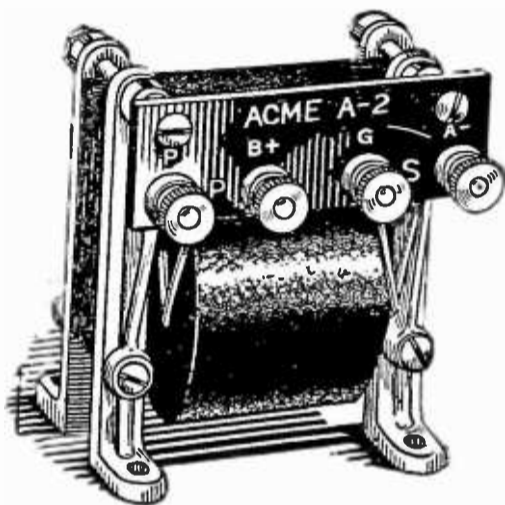

Acme A-2 Audio Frequency Amplifying Transformer

Send 10 cents for 40-page book, "Amplification without Distortion"

**W**E HAVE prepared a 40-page book called "Amplification without Distortion." It contains 19 valuable wiring diagrams. In clear non-technical language it discusses such subjects as, Radio Essentials and Set-building. How to make a loop; Audio frequency amplifying apparatus and circuits; Instructions for constructing and operating Reflex ampli-

fiers; How to operate Reflex receivers; Antenna tuning circuits for Reflex sets; "D" Coil added to Acme four tube reflex; "D" coil tuned R. F. and Reflex diagrams; and several more besides. It will help you build a set or make your present set better. Send us 10 cents with coupon below and we will mail you a copy at once.

**ACME APPARATUS COMPANY**  
Transformer and Radio Engineers and Manufacturers  
Dept. F4, Cambridge, Mass.

**SEND THIS COUPON**

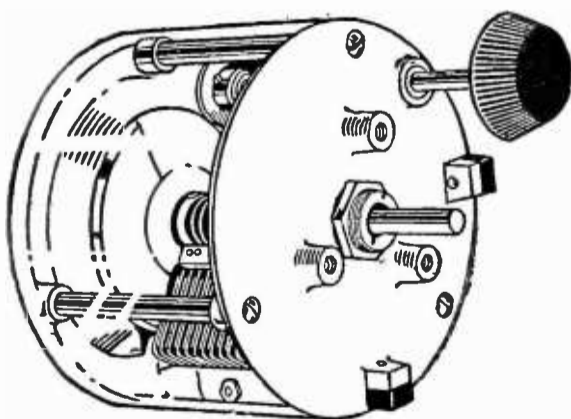

Acme Low-Loss Condenser

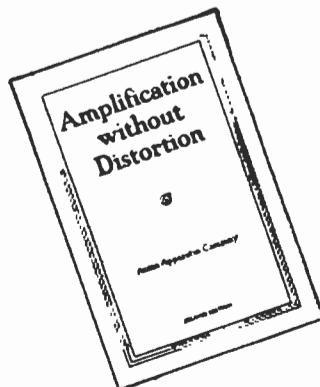

<p><b>ACME APPARATUS COMPANY</b> Dept. F4, Cambridge, Mass. Gentlemen:— I am enclosing 10 cents (U. S. stamps or coin) for a copy of your book "Amplification without distortion."</p>	
<p>Name .....</p>	
<p>Street.....</p>	
<p>City..... State.....</p>	



# ACME ~for amplification

★ Tested and approved by RADIO BROADCAST ★

# New Equipment

## THE ANDREWS PADDLEWHEEL COIL

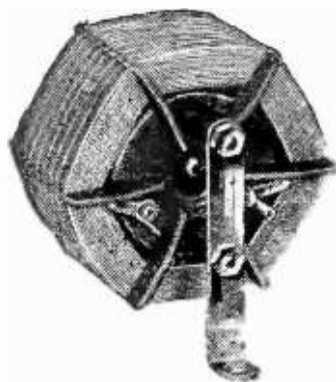

A well made inductance designed to give a higher ratio of inductance to resistance. The several groups of spiral windings are space insulated from each other without the use of any adhesives or dope. Tuned with a .00025 mfd. condenser, this R. F. transformer inductance has a range from 200 to 600 meters. Made by Radio Units Inc., Maywood, Illinois. Price \$3.00

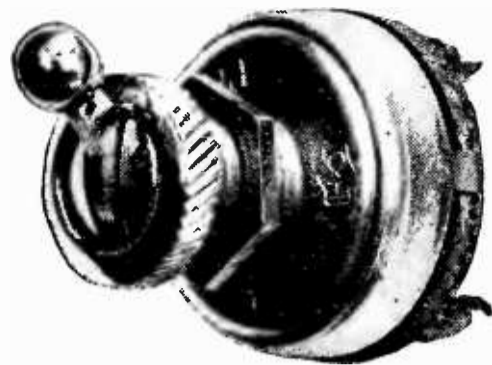

## TOGGLE BATTERY SWITCH

A new battery switch designed for use in the radio receiver. It is neat in appearance with a polished nickel finish and has large make-and-break contact surfaces. The wide spacing of the terminals permits ease in making connections. It is easily mounted on the panel with only one hole required. Made by The Cutler-Hammer Mfg. Co., Milwaukee, Wisconsin

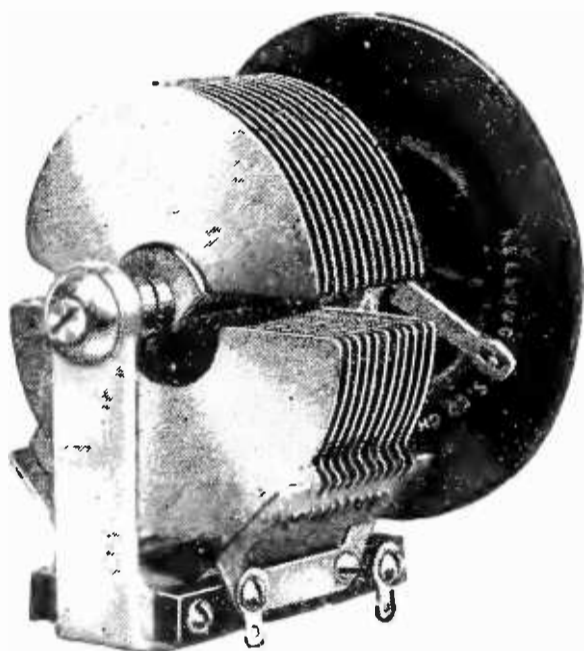

## KELLOGG CONDENSER

A low loss variable condenser with a heavy brass frame containing a minimum amount of metal. Direct three-point contact with the rotor assures positive connection. A special Kellogg dial in conjunction with the vernier attachment makes for very fine tuning adjustment. Made by the Kellogg Switchboard and Supply Co., Adams and Aberdeen Sts., Chicago, Illinois

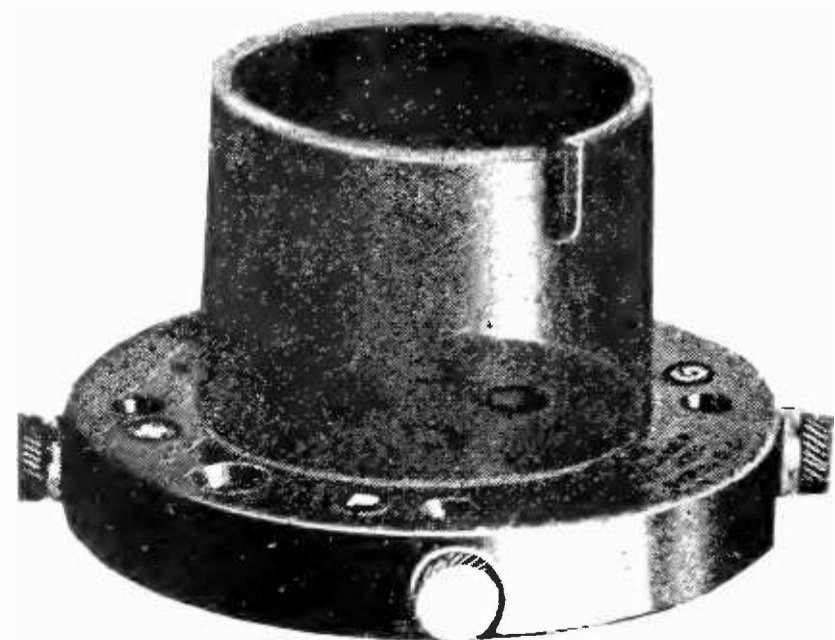

## "BALLGRIP" SOCKET

A molded bakelite socket of unusual design. Contact with the tube prongs is obtained through a ball socket arrangement molded into the base of the unit. The construction is such as to eliminate the possibility of internal short circuiting. Made by Quality Molded Products, Inc., 1 Exchange Place, Jersey City, New Jersey. Price \$1.25

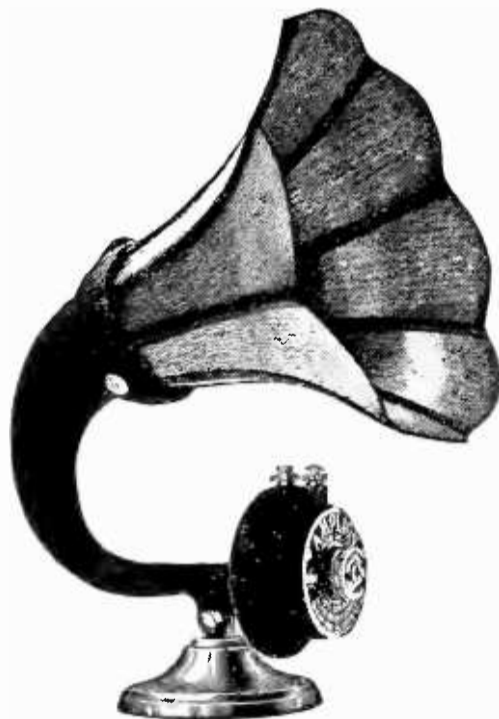

## AMPLION LOUD SPEAKER

This speaker is designed to give great sensitivity and naturalness of tone. The Amplion "Floating Diaphragm," kept from contact with metal by rubber gaskets, rests on a narrow ledge in the case, lightly held there by a spring ring with enough pressure to prevent "chatter" when extreme volume is desired. Another feature of the Amplion is the use of rubber insulation between the several sections of the horn to eliminate any ring or resonance. Made by The Amplion Corporation of America, 280 Madison Ave., New York City

# Only specialists can make *good* fixed condensers

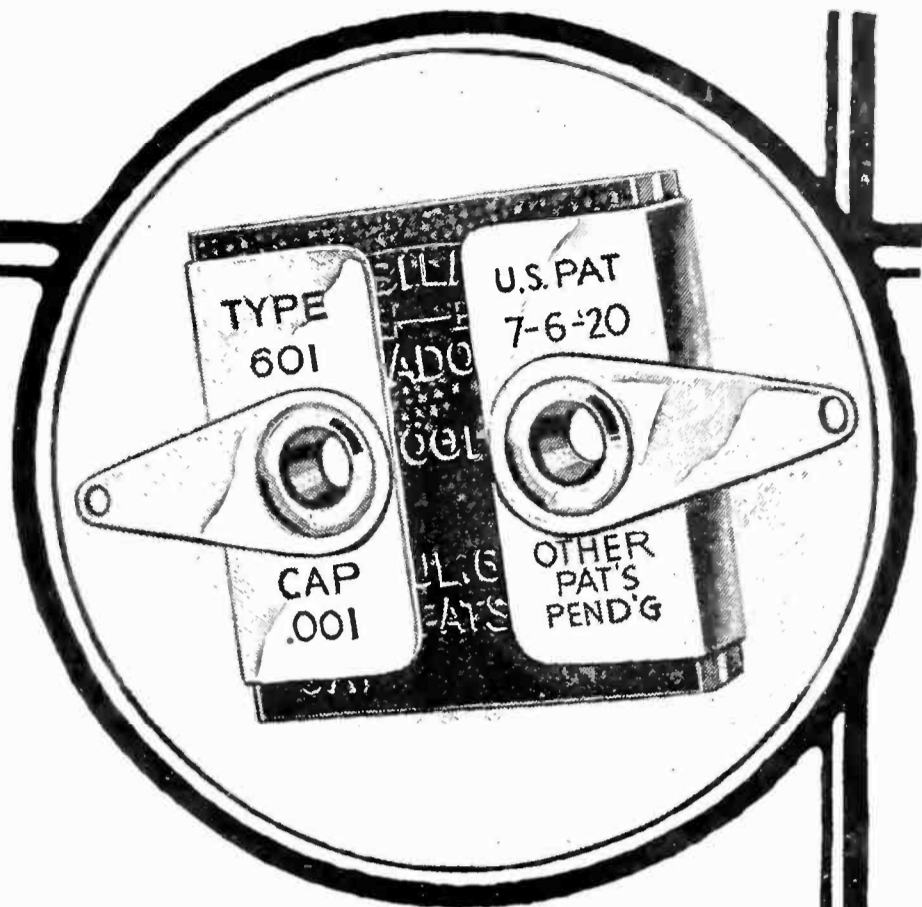

**T**HE small fixed condensers in your radio set are there to help you get clear reception. If these little condensers are not made *most accurately* the quality of reception you get—even though your set may be excellent in all other respects—will be greatly impaired.

You will find that nearly all sets made—in fact over 90% of them—are equipped with Dubilier Micadons. This is the name by which all Dubilier fixed condensers are known.

Be sure your set—whether you buy it or build it—is equipped with Micadons. They are made by *specialists*.

# Dubilier

**CONDENSER AND RADIO CORPORATION**

# Among Our Authors

**C**HARLES C. HENRY, the author of "A New Method of Transmitting Pictures by Wire or Radio" has had a variegated radio history. He studied electrical engineering at



C. C. HENRY

Massachusetts Institute of Technology, was an instructor at the Harvard Naval Radio School during the war, and later was radio compass expert for the Navy when compass stations were installed on the Atlantic Coast. He is now radio engineer for the Sonora Phonograph Company.

**R**S. McBRIDE is a resident of Washington who for many years has been close to the current of affairs there. As far as we know, his interview with Judge Davis is the first complete and official statement made by Department of Commerce officials outlining their policy on American radio affairs.

**J**OHAN B. BRENNAN is technical editor of **RADIO BROADCAST**. In addition to his experimental work in the Laboratory, he is kept decidedly occupied answering the tremendous quantities of mail which reach his busy Grid Department. The other day he was chuckling at high frequency over the letter of a correspondent who prayed to know what was wrong with his "radiant frequency alpinist."

**Z**EH BOUCK has bombarded his associates on the staff and others of his friends with triumphant and perhaps boasting postal cards, showing scenes at Nassau. He has just returned to New York again to resume his radio duties.

**J**AMES C. YOUNG, who is a well known special writer, in the past few months has made many trips on Coast Guard cutters to find out the facts about rum running. A number of his articles have appeared in the *New York Times* and the *World's Work* about



W. F. CROSBY

his interesting discoveries in this "industry." Another article by Mr. Young will appear in an early **RADIO BROADCAST** which will tell some interesting facts about how radio is being used by American newspapers.

**E**UGENE VAN CLEEF is Professor of Geography at Ohio State University at Columbus. He is a specialist in Climatology and in 1918 served under Col. E. M. House as expert to prepare information for use at the Versailles Conference. It seems to us that Mr. Van Cleef has discussed a highly interesting subject in "Do Weather Conditions Influence Radio?" We hope, in later numbers of this magazine, to have his and other investigators' opinions in the theory of radio transmission discussed at some length.



EUGENE VAN CLEEF

**I**BEGAN radio about 1908," writes W. F. Crosby, "with a coherer and spark coil transmitter. I was able to send about 100 feet with that advanced equipment! Later, when I installed a 'modern' carborundum detector and potentiometer, I heard Colon, Panama, from New York which gave me a thrill from which I have never quite recovered." Mr. Crosby spends much of his time experimenting in his laboratory at Mt. Vernon, New York.

**W**. R. BRADFORD, one of the radio oracles of the *Philadelphia North American*, is a cartoonist and an amateur photographer whose work is very well known. The radio doodlebug was discovered by his sharp-lensed camera. Mr. Bradford promises that he has some interesting stories to tell about the adventures of this strange electrical insect.

**I**N SUCCEEDING numbers, **RADIO BROADCAST** will print articles quite as interesting and as helpful as those which have received such favorable comment in recent months. The official manuscript drawer is fairly bursting with good things in store for our readers. One of these is an exclusive article by Marconi himself which we expect will be greeted with great interest.

*Prest-O-Lite*

**RADIO CHART**

Voltage of Tubes	No. of Tubes	Type of Tubes (see foot-note)	Total Rated Ampere Drain	Recommended Prest-O-Lite "A" Batteries		
				Order by following Types	Days between Charging	
5-Volt Tubes  C-300 and UV-200 are interchangeable  C-301A, DV-2 and UV-201A are interchangeable	1	UV-200	1	69 WHR OR 67 WHR	22 16	
	2	UV-201A	1/2	67 WHR	33	
	2	1 UV-200 1 UV-201A	1 1/4	611 WHR OR 69 WHR	22 17	
	3	UV-201A	3/4	69 WHR OR 67 WHR	29 22	
	3	1 UV-200 2 UV-201A	1 1/2	611 RHR OR 69 WHR	21 14	
	4	UV-201A	1	69 WHR OR 67 WHR	22 16	
	4	1 UV-200 3 UV-201A	1 3/4	613 RHR OR 611 WHR	22 15	
	5	UV-201A	1 1/4	611 WHR OR 69 WHR	22 17	
	5	1 UV-200 4 UV-201A	2	613 RHR OR 611 WHR	19 13	
	5	UV-201A	1 1/2	611 RHR OR 69 WHR	21 14	
	8	UV-201A	2	69 KPR OR 67 KPR	21 15	
	For sets using current at a rate higher than 2 amperes.			2 1/4	69 KRL OR 67 KPR	22 13
				2 1/2	69 KRL OR 69 KPR	19 16

Copyright, 1925  
The Prest-O-Lite Co., Inc.

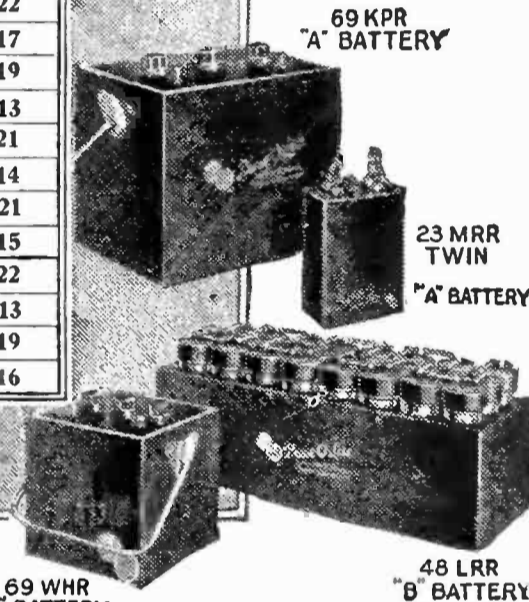

**How to fit storage batteries to your set**

IT PAYS to buy wisely—to select batteries that bring out the best in your set and are of the right capacity to give fine reception at charging intervals best suited to your convenience.

The new Prest-O-Lite Radio Chart tells you how to select such batteries. The part of the master chart shown here covers "A" Batteries for 5-volt tube sets. Use either of the two sizes recommended for your set, depending on the days of service you wish between chargings (based on the average use of your set of three hours a day). You will find the larger capacity battery more desirable unless facilities are provided for frequent and easy recharging. For "B" Batteries, and "A" Batteries for peanut tubes, see the complete chart at your dealer's.

Special structure plates, high porosity separators and scientific internal construction make Prest-O-Lite Batteries dependable sources of the even, unvarying current absolutely necessary for volume, clarity and distance.

Prest-O-Lite Batteries are made to give long, faithful service. They're easy to recharge—and offer you truly remarkable savings. Though standard in every respect, they are priced as low as \$4.75 and up. See them at your dealer's—or write for "How to fit a storage battery to your set—and how to charge it."

THE PREST-O-LITE CO., Inc.  
INDIANAPOLIS, IND.  
New York San Francisco  
In Canada: Prest-O-Lite Company of Canada, Ltd.  
Toronto, Ont.



★ Tested and approved by RADIO BROADCAST ★

# BURGESS RADIO BATTERIES

## Quality at *Every* Price

Cabinet or table space many times determine the size and type of radio batteries selected by the user.

Burgess manufactures a battery for every radio circuit and tube. Your choice of any one of many types involves no sacrifice of economy or service hours. The value and quality of Burgess Radio Batteries are constant—your satisfaction assured.

### Ask Any Radio Engineer

Write to 225 Burgess Engineering Building, Madison, Wisconsin, for the Burgess Radio Compass. It is amusing, unusual and useful.



One of several sizes of Vertical 'B' Batteries.

Burgess 'C' Batteries improve reception economically.

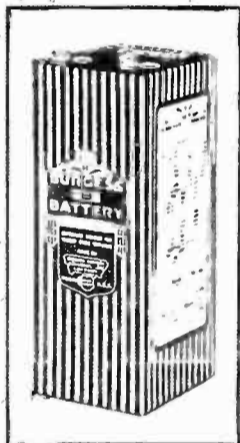

Standard Burgess Radio No. 6 'A' Battery. "Over Twice the Life."

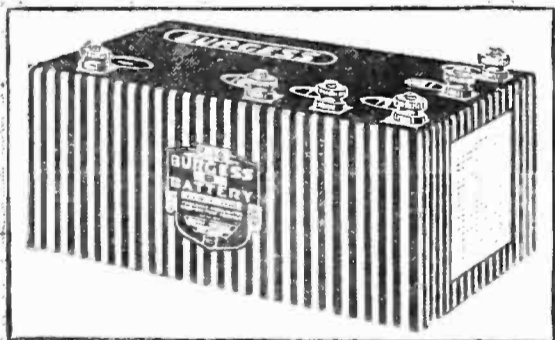

Burgess block shape 'B' Batteries are made in numerous types and voltages.

## BURGESS BATTERY COMPANY

Engineers DRY BATTERIES Manufacturers  
Flashlight • Radio • Ignition • Telephone  
General Sales Office: Harris Trust Bldg., Chicago  
Laboratories and Works: Madison, Wisc.

In Canada. Niagara Falls and Winnipeg

## For Push-Pull Take No Chances! Use "Como Duplex"

The World's standard for Push-Pull amplification. Como Duplex Transformers are being specified continually by practically all leading Radio Editors and Authors of Radio subjects. This is because they know that the user will get results. Why not take their advice?

The new form of assembly takes up less room in your set.



Price \$12.50 per pair

COMO APPARATUS CORPORATION  
Manchester New Hampshire



## BRANSTON RADIO

Save \$75. to \$200.

Build Your  
Own  
Reflexed  
Super  
Heterodyne



Get Maximum  
Selectivity,  
"Local"  
Volume on  
distant  
stations,  
Wonderful  
Tone

### Use Branston Kit No. R-199

Contains 8 matched super transformers, tested and guaranteed. Make 7 tubes do the work of 10. \$35.00. **Branston Accessory Kit No. R-199-A** contains panel, base, and correct jacks, condensers, rheostats, switch, (assembled) and sockets, square bus bar, spaghetti, grid leaks, etc., to complete the set. \$50.00. (Be sure to state whether you intend using 199 or 201-A tubes.)

Your dealer has Branston Kits or can get them for you. If not, write us direct.

CHAS. A. BRANSTON, Inc.  
813 Main St. Buffalo, N. Y.

Manufacturers of Branston Violet Ray  
High Frequency Generators

In Canada—Chas. A. Branston, Ltd., Toronto, Ont.



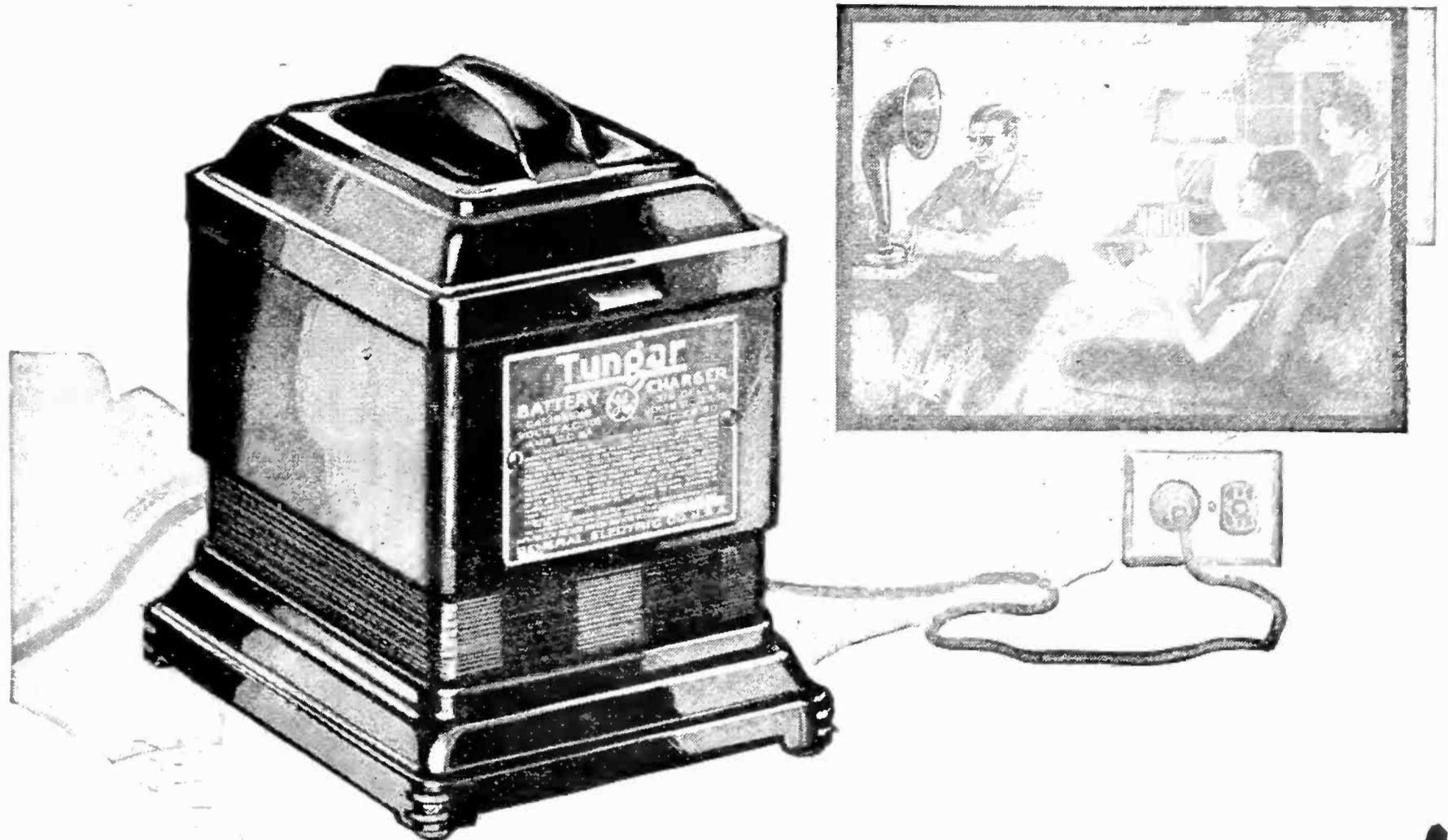

# KEEP reception clear!

Keep it clear. Keep it loud—with all the volume your set should have. Keep the battery at top notch—fully charged—peppy.

The Tungar charges your storage battery overnight while you sleep—and at a cost of hardly more than five cents. It's easy! Just two clips—and a plug for the house current. Or you can make a permanent connection, and just throw a switch. Keep your set at its best all the time—with a Tungar.



The Tungar is a G-E product, developed in the great Research Laboratories of General Electric.

The New Model Tungar charges Radio A and B storage batteries, and auto batteries. Two ampere size (East of the Rockies) . . . \$18.00

A Tungar is also available in five ampere size, design unchanged (East of the Rockies) . \$28.00

60 cycles—110 volts

# Tungar

REG. U.S.

PAT. OFF.

## BATTERY CHARGER



*Tungar—a registered trademark—is found only on the genuine. Look for it on the name plate.*

Merchandise Division

General Electric Company, Bridgeport, Conn.

# GENERAL ELECTRIC

★ Tested and approved by RADIO BROADCAST ★

# BARKELEW

## Screw Grip DONT SOLDER Cord Tips!

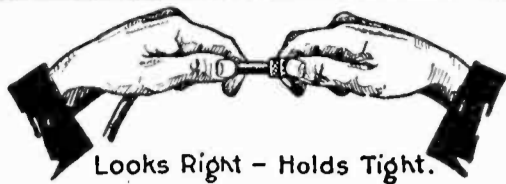

Looks Right - Holds Tight.

Any of our Standard Tips shown below will run on the same Universal Sleeve.



No 630 PRICE 5¢



No 631 PRICE 5¢



No 632 PRICE 5¢

A CORD TIP that requires no solder, no wrapping of the insulation and no tools other than a pen knife and a small screw driver. Anyone can attach it quickly and have a factory finish.

The internal thread of the Universal Sleeve "A" draws inside all loose ends of insulation.

The Wood screw "B" inserts in the wire core of the cord until the head seats (see B-2) making an excellent electrical contact. This screw also wedges the cord out into the internal thread of "A" making a firm mechanical joint.

All parts are of brass, nickel plated.

See our Bulletin No. 36 at your Dealers. If he hasn't his copy, we have one for him.

The Barkeley Electric Mfg. Co.  
Middletown, Ohio, U. S. A.

NEW YORK, 157 Chambers St.  
BOSTON, 31 Bedford St.  
WASHINGTON, D. C., Mills Bldg.

CHICAGO, 15 S. Clinton St.  
DENVER, Denham Bldg.  
MINNEAPOLIS, 1017 Lumber Ex.

SEATTLE, 1041 Sixth Ave. S.  
SAN FRANCISCO, 75 Fremont St.  
LOS ANGELES, 443 S. San Pedro St.

TORONTO, Geo. R. Archdeacon, No. 7 Crang Ave.

JUST A MINUTE!

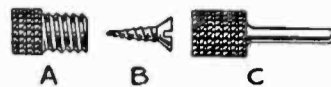

A B C  
PAT. PENDING

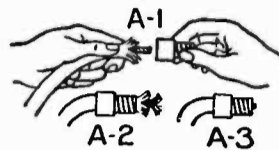

The Universal Sleeve "A" has an internal thread. Screw it on end of wire.

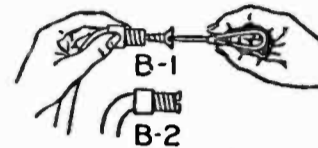

Expose 1/16" of bare wire. Insert wood screw "B" locking wire to sleeve.

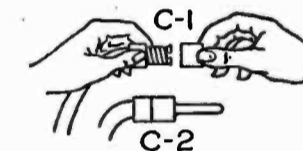

Screw on any of our standard Screw Grip Tips shown at left.

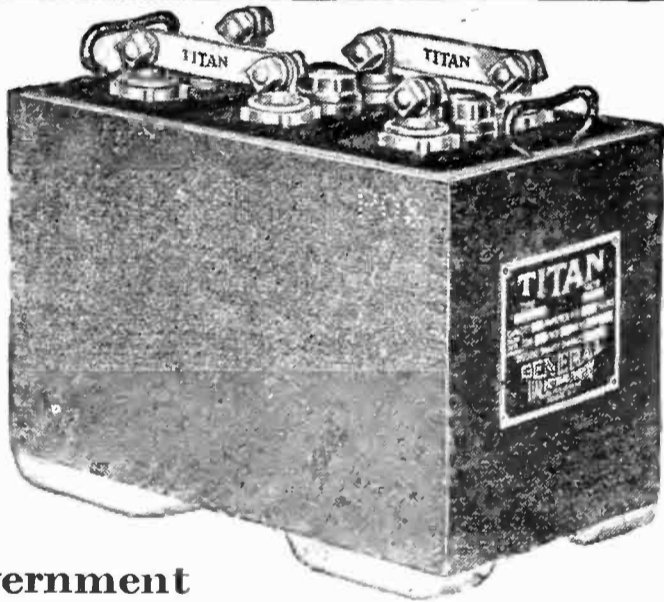

The U. S. Government Endorses Titan "A" Batteries!

After conducting all kinds of tests of the most rigid and careful nature over a period of years, (tests which were necessarily competitive), the U. S. Government has endorsed the Titan "A" Battery by ordering 1,700 of them. This signal endorsement, considering that there are hundreds of battery manufacturers, has come because the U. S. Government gets from 5 to 8 years dependable service from the Titan "A" Battery and because these batteries were found to be superior in quality.

The Titan is a 6 Volt "A" Battery with bolted connections across 3 cells (2 Volts per cell). This is a decided advantage in that it enables you to easily and quickly adapt your battery voltage to your tubes. Bolted connections remove the ordinary difficulties of repair and keep the expense at a minimum. The extra heavy plates in the Titan "A" Battery insure over 5 years dependable service. The Titan is especially suited for DX.

Assembled in hard wood case, mahogany finished, and mounted on porcelain skids, it presents an appearance that is highly attractive.

Designs with burned connections as low as \$12.00 for 110 ampere hour capacity.

Carefully packed. Shipped anywhere. Ready to use.

Write for circular on Titan 48 Volt 6000 M.A.H. "B" Battery.

GENERAL LEAD BATTERIES CO.  
Chapel St. & Lister Ave. Newark, N. J.

Jobbers and Dealers: Write for Merchandising Information

## The TWIN-AUD



List Price \$9.50

AT ALL GOOD DEALERS

PEERLESS RADIO CORPORATION  
Newton Lower Falls Boston, Mass.

IS IN THE SET YOU SHOULD BUY

Because of its two audio transformers combined in one unit it compels any loud speaker to give the maximum in volume and clearness of reproduction.

"No library complete without Kipling complete"

## FORMICA RADIO PANELS TUBES AND RODS

WRITE TO-DAY for your copy of our new catalog listing and pricing 3384 different sizes and kinds of Formica Radio Panels, 126 different sizes of Formica Tubes, and 21 different sizes of Formica Rods.

DRILLING—ENGRAVING

Lowest prices consistent with good work.

STARRETT MFG. CO.  
521 S. Green St. - Chicago, Ill.

★ Tested and approved by RADIO BROADCAST ★

# The Finer Side of Radio

## A Song That Reached Home

A great baritone sang  
with uncommon fervor to  
his enraptured listeners

The melody seemed to string  
a golden chain of words  
for some responsive heart

It reached ten times a  
million hearts

For as the music faded into  
silence the singer said  
**GOOD NIGHT, MOTHER!**

And then we knew that song  
had gone straight and true  
to someone somewhere in  
that vast invisible audience

Someone whose tear-dimmed  
eye  
saw not the wonderful singer  
but a little boy whose  
tousled  
head lay on her breast

And in that spell of mother  
love which makes millions  
kin

All those listening hearts  
"tuned in" to one heart

A heart that must have felt  
the magic of ten million  
prayers unified in one  
"God bless her!"

*Our Bristol Loud Speaker had given us all the rich tonal quality of the singer's voice, its natural sweetness, its pathos. It had been a wonderful evening*



### FIVE MODELS

The Cabinet shown here is of beautifully finished mahogany, 17 x 10 x 10½. It has a full-floating wooden horn with long expansion chamber and a high-grade electro-magnetic tone reproducer. Price \$30.00 Horn types from \$12.50 to \$25.00. (Send for Bulletin AH-3022)

Ask your dealer to demonstrate them on the Bristol Comparophon.

# BRISTOL TRADE MARK AUDIOPHONE REG. U.S. PAT. OFFICE Loud Speaker

THE BRISTOL COMPANY, Waterbury, Conn.



★ Tested and approved by RADIO BROADCAST ★



Hear Grand  
Opera Singers,  
Dance Music, etc.

**\$78**

Within the comforts of your home you may now listen to gems from Grand Opera, charming dance music, favorite home songs and hymns as clearly as if the artists were in your room. Until you have heard the Resas Tone-A-Dyne, nothing we can say will convince you how marvelous is this five-tube Receiver.

Once a station is located, it always comes in at the same point. J. F. Davidson, Rutherford, N. J., heard seventy stations in two weeks on his Resas Tone-A-Dyne, including stations in Montreal, Nebraska and Georgia.

Operates on indoor or outdoor antenna. Large size. Handsome appearance. A truly remarkable set that is unexcelled at twice the price.

*Ask Your Dealer to Give  
You a Demonstration.*



**RESAS, Inc., New York City**  
112 Chambers St. New York

## Specializing KNOCK-OUT ROBERTS KITS

A service you may avail yourself of when buying a kit for this wonder circuit. We have specialized in this circuit—knowing it to be the best set that we have seen in our sixteen years of wide radio experience.

We have built a number of these sets for the editor of this magazine using the parts from our kits and have hundreds of satisfied users throughout the country. These kits are composed of the highest grade of apparatus, each part being tested in our laboratory. This is our guarantee to you.

"Knock-out" Two-Tube Roberts . . \$39.00  
"Knock-out" Three-Tube Roberts . . 46.00  
"Knock-out" Four-Tube Roberts . . 59.00  
*A Construction Book with Each Kit*

Your order is carefully packed and delivered to your door. You may remit with order or pay your postman.

*Experimental—Testing—Research—Service*

**RADIO RESEARCH LABORATORIES**  
SCHNEIDER-HORNEIJ

*Associate Members, Institute of Radio Engineers* ★

154 Nassau St.

New York City

## BROWNLIE VERNIER DETECTOR

PATENT PENDING

FOR REFLEX OR CRYSTAL SETS

Best  
Reflex  
Crystal  
Detector

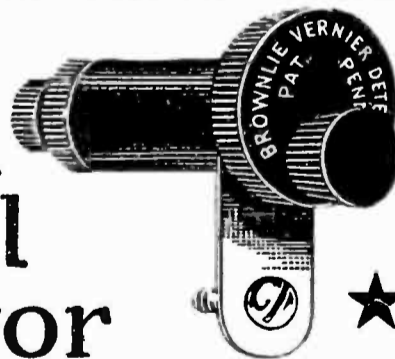

Says the **Acme Apparatus Co.**

No longer does the whisker scratch the crystal, or is the sensitiveness killed by heavy spring pressure—the Vernier Regulator takes care of that. It will surprise you to know how sensitive Crystal Detectors are when correctly made.

For Panel or Base Mounting  
including Crystal. Guaranteed **\$2.00**

At your dealers, otherwise send purchase price and you will be supplied postpaid.

**ROLAND BROWNLIE & COMPANY**  
20-24 Saunders Street Medford, Mass.

★ Tested and approved by RADIO BROADCAST ★

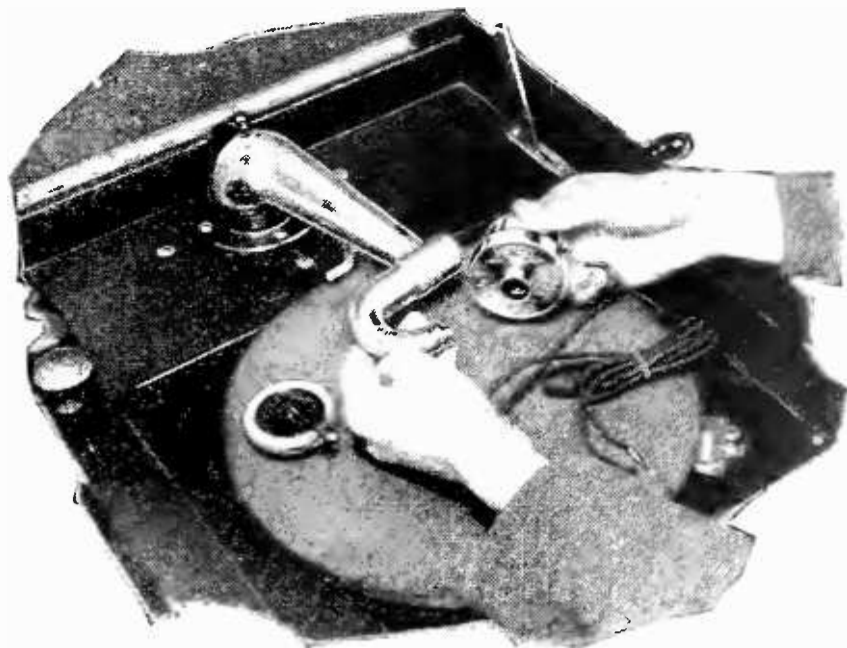

# From Phonograph to Radio in a Jiffy—

Phonographic reproduction is justly famous for its accuracy and tone. But your own Phonograph will excell its best prior performance when you connect it with your Radio set by a Jewett Vemco Unit.

Slips on or off in a Jiffy—no tools needed.

A Phonograph one minute, a Radio loudspeaker the next.

But be sure the unit is a Vemco—the leader of all Radio-Phonographic equipment!

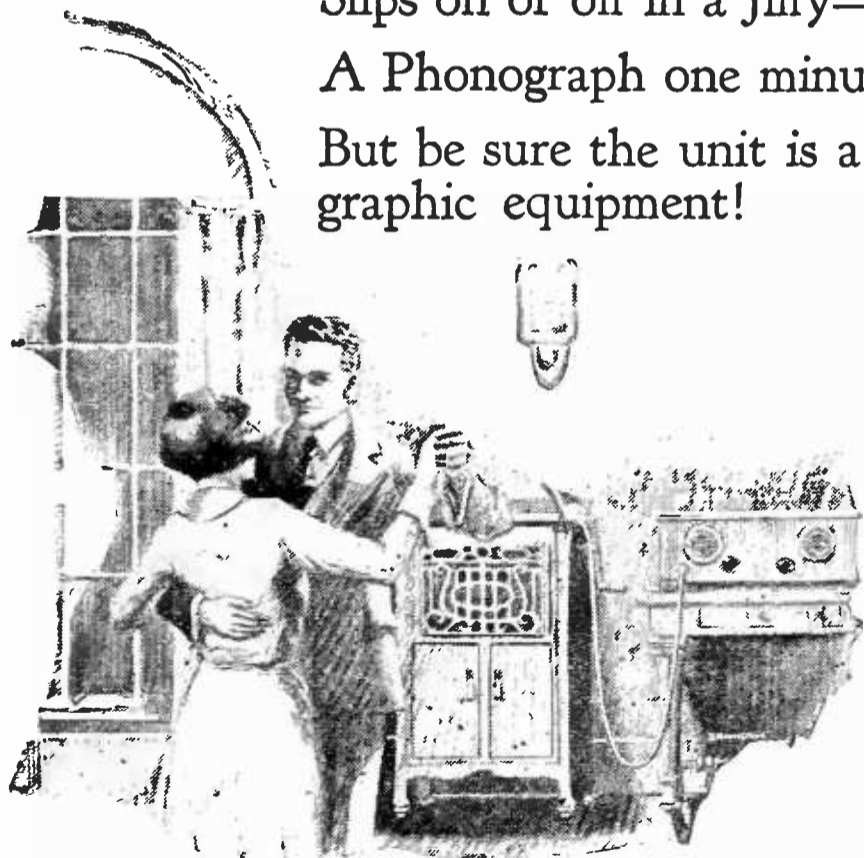

The same reproducer we use in the world-famous Superspeaker—Adjustable for volume control—A real musical instrument built by experienced musical instrument people—Standard model fits Victrola tone arm—simple adapters for other phonographs.

‘THERE IS NO SUBSTITUTE FOR THE BEST’

JEWETT RADIO &  
PHONOGRAPH COMPANY  
5672 Telegraph Road · Pontiac, Mich.

# The Jewett Vemco Unit ★

★ Tested and approved by RADIO BROADCAST ★

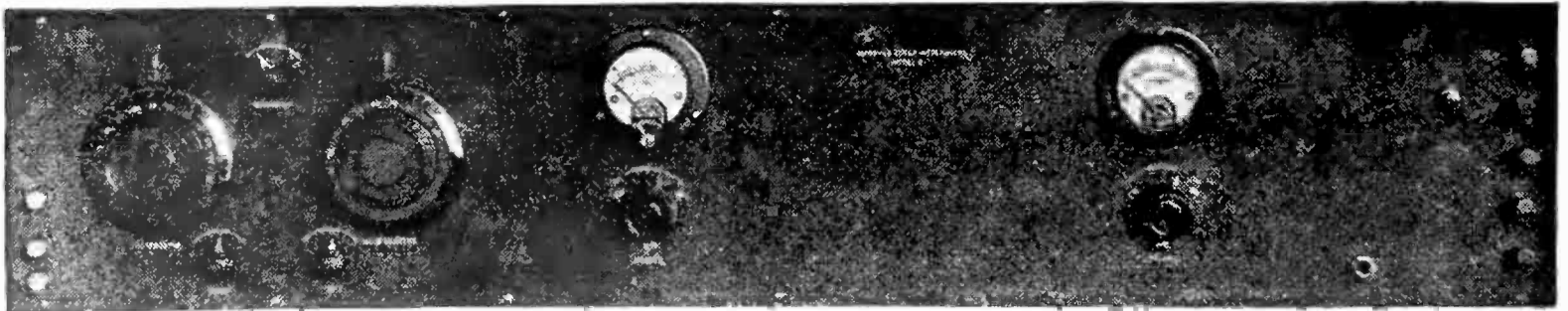

**Super-Power 6-Tube  
Pliodyne 6**

The famous new Golden Leutz Model. Range 1,500 to 3,000 miles. Two stages radio frequency; detector and three stages audio frequency amplification. Solid mahogany cabinet. Finest materials throughout. Guaranteed mechanically and electrically perfect. Completely constructed, without accessories, \$60

**For any Circuit**

Prompt shipment can be made on tested, standard apparatus of the following manufacture:

- |                   |           |
|-------------------|-----------|
| E. I. S., Inc.    |           |
| General Radio     |           |
| Ultradyn          | Willard   |
| Sangamo Electric  |           |
| Benjamin Electric |           |
| Allen Cardwell    |           |
| Dubilier          | Formica   |
| Weston            | Magnavox  |
| Jewell            | Amer Tram |
| Western Electric  |           |
| Radio Corporation |           |
| Music Master      | Acme      |
| Cutler Hammer     | Frost     |
| Federal           | Kellogg   |

**Super-Heterodyne C-7**

*Model C-7, the Long Distance Concert Receiver  
With a Telephone Range of 3,000 Miles*

**F**EW of the so-called new "circuits" or modifications of standards approach the C-7 in efficiency—for long range, for high audibility, for selectivity. Experimenters' Information Service design. *Seven tubes give the result of ten* because this model allows signals to be regenerated and heterodyned through radio frequency amplifier.

E. I. S. Model . . . All material we furnish is endorsed and recommended by the designers. ★

Using the finest apparatus and building to Naval standards, Model C-7 has a telephone range of 3,000 miles.

**Norden-Hauck Price List Saves You Money**

**Free Information—Write for descriptive matter and price list. Our service is as near as your mail box.** **Full Stock on Hand—We carry complete stocks of laboratory tested apparatus for immediate shipment.**

**NORDEN, HAUCK, INC.** 1617 Chestnut St., Philadelphia *Engineers . Office and Laboratories*

**Now**  
**EBY**  
**BINDING**  
**POSTS**  
are  
★ **15¢**  
—In 25  
Different  
Markings

**GILFILLAN NEUTRODYNE**  
**SETS — KITS — PARTS**  
Made in our three Radio factories with years of Radio experience behind them.  
*Send for Literature*  
**GILFILLAN BROS. INC.** ★  
1815 W. 16th St., Los Angeles, Calif.  
**KANSAS CITY**      **NEW YORK**  
2525 W. Penn Way      225 W. 57th St.

**Move Your Loud Speaker  
Wherever You Want Music!**

Go to your favorite radio shop and ask for a PREMIER 20-foot Extension Cord. No loss in volume. A big gain in convenience and radio enjoyment. **\$1.75**

*Complete with plug,*  
Made by CRESCENT BRAID CO. Inc., Providence, Rhode Island

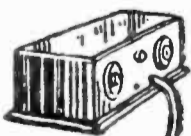

*Premier 20 foot*  
**Extension Cord**

**Superior—as its name implies**



★ Tested and approved by RADIO BROADCAST ★

# MARWOL

BABY GRAND

## FIVE TUBE TUNED RADIO FREQUENCY

*Three-fold Beauty*

The beauty of the Marwol Baby Grand is threefold—beauty of reception, beauty of appearance . . . and with these, the beauty of remarkably low cost.

Here is a splendid, little, sturdy, all-round set that contains the highly successful Marwol Circuit of the Model A-1, only more compactly—therefore offers the same extraordinary selectivity and range, with ease of operation, that makes the Marwol to-day's best radio buy for the money!

A light compact receiver easily convertible into an ideal portable set for summer use. West of the Rocky Mountains, \$45.00



Marwol 5 tube Tuned Radio Frequency Model A-1  
\$60.00

\$**40**<sup>00</sup>

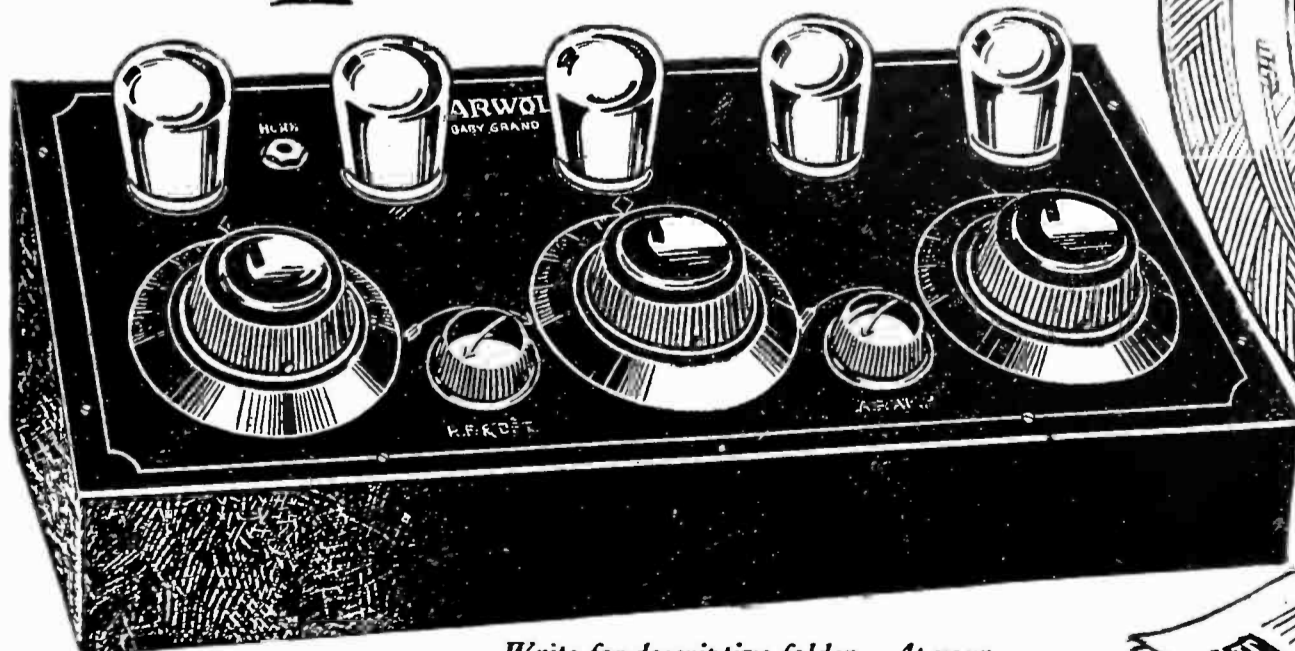

*Write for descriptive folder. At your dealers—otherwise send purchase price and you will be supplied postpaid.*

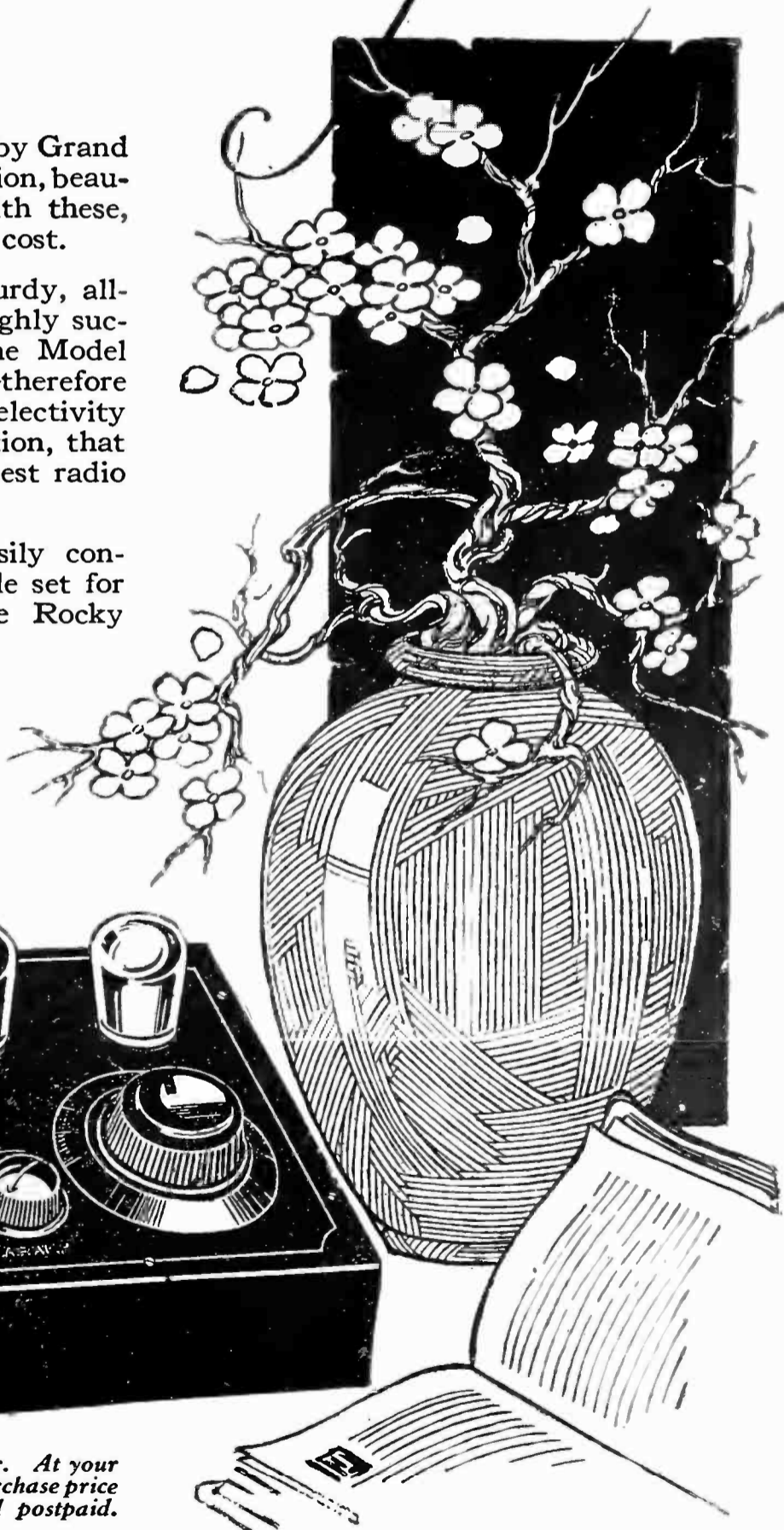

MARWOL RADIO CORP., 85-G Mercer Street, New York

★ Tested and approved by RADIO BROADCAST ★

For Better Radio  
**Hammarlund**  
 PRECISION  
**CONDENSER**

Copyright March 17, 1925

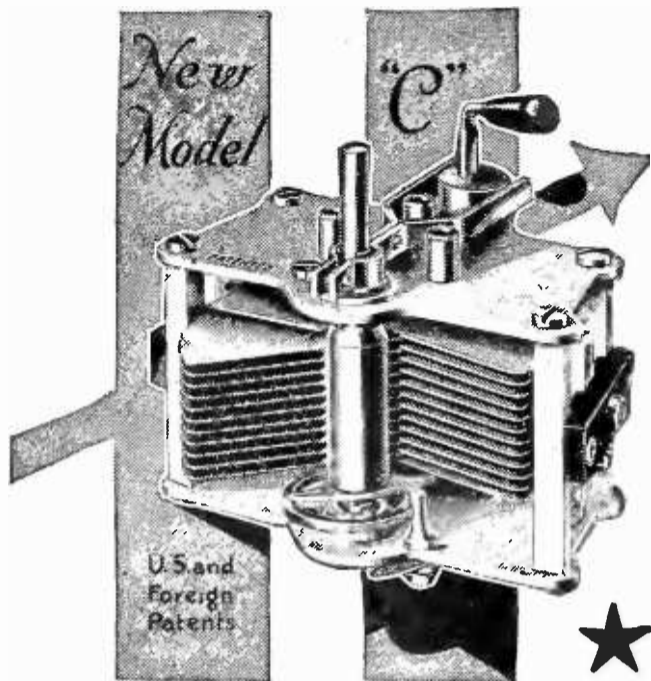

THE more you know about the technical requirements of radio, the more you appreciate the technical refinements of the Hammarlund New Model "C" Condenser.

It is an instrument of laboratory precision sold at a popular price by the better radio dealers. All capacities; plain and vernier.

Use Hammarlund Condensers in the receiver you build. Look for Hammarlund Condensers in the receiver you buy.

HAMMARLUND MANUFACTURING CO.  
 424-438 West 33rd Street, New York

**9 points of superiority**

- |  |  |
|--|--|
| <p><b>1</b>—Soldered brass plates, chemically treated against corrosion; perfect alignment.</p> <p><b>2</b>—Stator plates specially shaped for easy tuning of low waves.</p> <p><b>3</b>—Adjustable ball-bearing rotor shaft, grounded through metal end-plates.</p> <p><b>4</b>—Soldered clock spring pigtail, with automatic stop.</p> | <p><b>5</b>—Minimum dielectric; losses too small to be measured.</p> <p><b>6</b>—Rugged, compact construction; cannot warp.</p> <p><b>7</b>—Micrometer cam-vernier moves all plates; knob or lever control; no backlash.</p> <p><b>8</b>—Takes any size dial.</p> <p><b>9</b>—The product of 14 years' experience, making precision instruments.</p> |
|--|--|

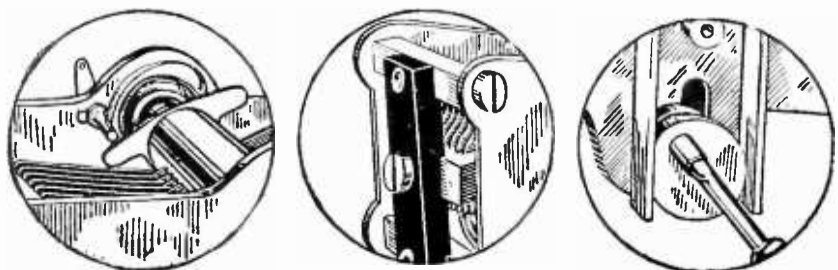

**This NEW**  
 ★ **Super Horn**  
 Brings Magic Clearness to Radio

The new Kellogg *Symphony* Reproducer is a new-type horn recently developed by our experts—based on the magnetic diaphragm principle.

It brings to radio a marvelous tone-quality, a beauty you have never heard before. Attaches to any set and can be adjusted for the particular "volume" requirements of the set.

At all radio dealers. Ask for it by name. See it, hear it—compare!

KELLOGG SWITCHBOARD & SUPPLY CO.  
 Chicago Illinois

**KELLOGG *Symphony* Reproducer** Price \$20.

With every Kellogg Radio part, The Use is the Test

**Building**  
**Better Service** ♀  
 into **RADIO PARTS**

Aside from recognized radio uses in which no other metals can be substituted, COPPER and its alloys help you to make good radio sets *better* sets.

For instance, binding posts are superior posts, and battery nuts give best service and satisfaction when made of dependable free-cutting BRASS rod. And—

★ their speedier production makes labor costs lower.

**COPPER & BRASS**  
 RESEARCH ASSOCIATION  
 25 Broadway, New York

★ Tested and approved by RADIO BROADCAST ★



# Make More Money by Building Radio Sets with **INSULINE**



Ready Drilled and  
Engraved Panels

★ for  
All  
Popular  
Circuits

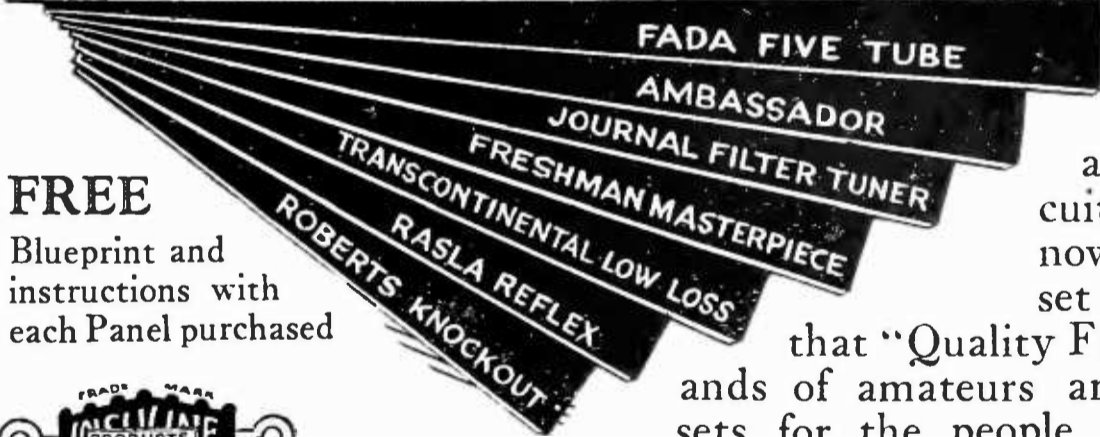
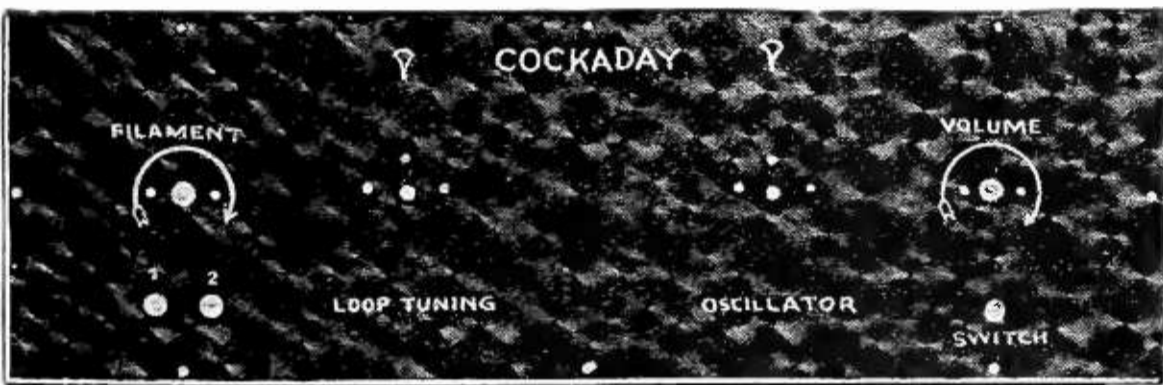

**FREE**  
Blueprint and  
instructions with  
each Panel purchased



We stock ready drilled  
and engraved panels for  
all popular and demanded cir-  
cuits. With these panels it is  
now possible for every amateur  
set builder to give his product

that "Quality Factory Made Look." Thou-  
sands of amateurs are now engaged in building  
sets for the people in their community. And  
making real money, too.

**Enter this new well-paid field on your full or spare time**

As an amateur you are qualified to build a better and more efficient set than most people. Get around to your neighbors for their orders and build these sets with Insuline Panels. It's lots easier than you think. If your work requires an odd size panel we can cut and drill it to your individual requirements at a slight additional cost. Don't lose any more time. Get busy to-day. If your dealer can't supply you, send in his name with your order and we will supply you direct.

**Radio Panel and Parts Corp.**  
59 Warren Street (Insuline Bldg.) New York City

★ Tested and approved by RADIO BROADCAST ★

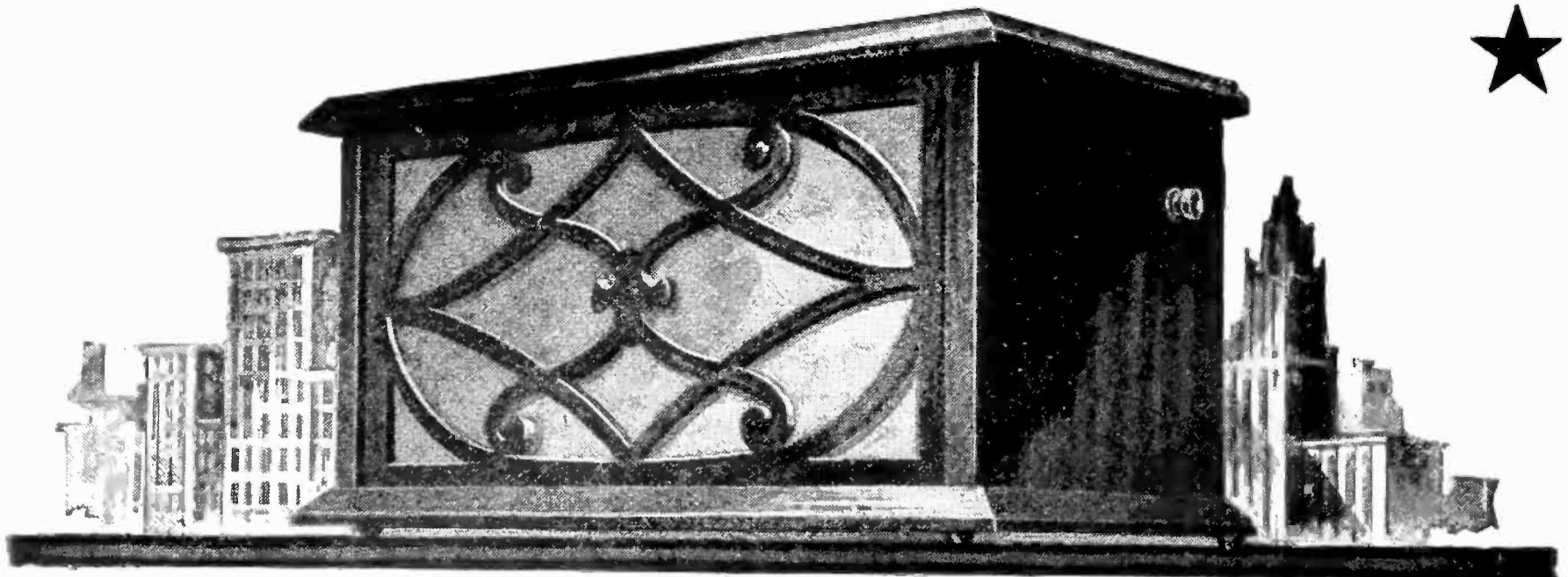

# Bel-Canto—The Biggest Thing in Radio!

No matter what instrument you purchase—violin or piano or loud speaker, the first essential is tone quality—next volume—then design. It will pay you to hear a BEL-CANTO.

### THE ONLY PATENTED CABINET SPEAKER

The BEL-CANTO has exceptional volume and a mellow brilliant tone quality. Our secret is a flexible reed tone chamber, an exclusive BEL-CANTO feature. The BEL-CANTO Cabinet Loud Speaker is a real musical instrument—a truly "beautiful singer." Workmanship is of the best—solid wood throughout—beautifully finished.

**Price only \$17.50**, a fraction of its comparative cost  
*Your dealer can get it for you, or we will ship prepaid on receipt of price*

**JOBBERs**—Write us today about out-of-town territory

*West of Rockies—Prices are \$18.00, \$15.50, \$10.50*

**BEL-CANTO RADIO AND TELEPHONE EQUIPMENT CO., Incorporated**  
872 Broadway, New York City



Gooseneck Fibre Horn with Adjustable Unit, \$15.00



The original Bel-Canto Fibre Horn with Adjustable Unit, \$10.00

## -the Panel SUPER Fine

No other material known possesses the many combined advantages for radio paneling as does Dilecto. It has every endorsement of dealer and manufacturer, because it is practically indestructible.

**The Continental Fibre Co.**  
Factory: Newark, Delaware

NEW YORK, 270 Madison Ave.  
CHICAGO, Wrigley Building  
PITTSBURGH, Farmers Bank Building  
SAN FRANCISCO, 75 Fremont St.  
LOS ANGELES, 307 S. Hill St.  
SEATTLE, 1041 Sixth Ave., So.

★ Look for the Red Stripe

Offices and agents throughout the world

# Dilecto

## DURHAM Grid Leaks

Used by Eagle, Howard, Thompson, Zenith and others. Fit all sets. Sold on guarantee.

**50¢** Metallized Fixed Leaks  
18 sizes; under 1/4 meg., 75c; over 1/4 meg., 50c.

Glass Sealed Variable Leaks  
3 sizes fit all sets; 75c each for 1/10, 5 and 10 megs. . . . . **75¢**

At dealers or postpaid ★

**DURHAM & COMPANY, Inc.**  
1936 Market Street · Philadelphia, Pa.

## Passed By Underwriters

The Jewell lightning arrester has passed all underwriters tests for both indoor and outdoor installation.

Sold by leading radio dealers everywhere.

★ Price \$1.10

**Jewell Electrical Instrument Co.**  
1650 Walnut St. · Chicago

★ Tested and approved by RADIO BROADCAST ★



Then you will say:  
 “This has the distinction of genius”

IN EVERY industry there is some product that is incredibly fine—whose perfection beggars the comparison of price.

In radio, it is Rola. Not a “loud speaker” or “reproducer”—but a “Re-creator.” It actually *re-creates* every note, every shade of voice and instrument, as faithfully as a polished mirror reflects an image.

Rola was built with a full appreciation of the important part that a reproducing device plays in radio. With the knowledge that the finest set can be no better than its loud speaker. Price, you will agree, is of little moment when you consider the many advantages to be gained by actually *re-creating* the beautiful radio programs.

There are many excellent loud speakers—just as there are many excellent musicians. But the subtle distinction that we recognize as genius in some musicians is easy to recognize in the performance of Rola.

Rola’s tone quality, its volume even—is self-adjusting . . . the mood of the musician himself. A wonderful new method of re-creation automatically eliminates the distortion of overloaded tubes—just as it amplifies the weakest sounds from your set.

A watch-like precision of manufacture assures you a lifetime of service. You will never care to replace your Rola—and that, in itself, makes it the wisest of investments.

When you hear a Rola—and we suggest that you hear it before you buy any loud speaker . . . you will appreciate that with it comes the same satisfaction that you experience in owning a thoroughbred horse—a grand piano of some master make . . . or anything that is unmistakably the finest of its kind. At the better radio stores. Price, complete with 14-inch horn and cord, \$36.00. Phonograph unit with adapter, \$22.50.

A product of the Rola Company, 4250 Hollis Street, Oakland, California. Marketed nationally through Baker-Smith Company, Inc., Head Office, Call Building, San Francisco, California. Branch offices in principal cities.

**Rola** ★  
 RE ★ CREATOR

Free Booklet-mail coupon below

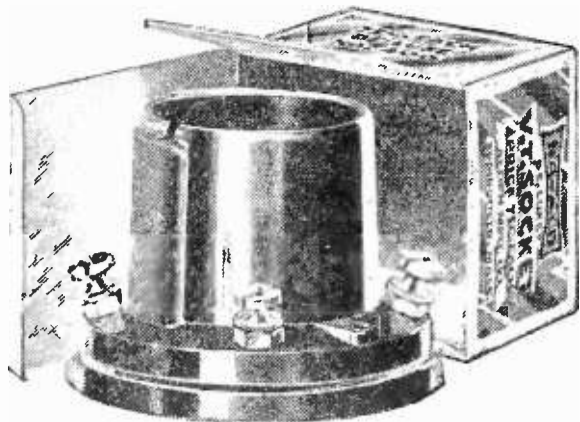

## Clearer Reception this easy way

**T**HE important thing is to have clean, perfect contact between tubes and sockets. Otherwise disturbing noises will continue.

You can always have clean, perfect contact by using Na-Ald Sockets—the *only* sockets with these 3 essential features:

- (1) **Lowest losses.** Laboratory tests proved that of 13 best known makes Na-Ald Sockets were the *only* ones having losses lower than a good low loss condenser.
- (2) **Low capacity.** The same test showed that Na-Ald has the lowest capacity of any socket—very essential for short wave length reception.
- (3) **Positive side-scraping** contact (not just side pressure) that cleans corrosion from tube terminals.

Use Na-Ald Sockets in the set you build or buy, if not already installed by the manufacturer. De Luxe 75c; others, 35c. and 50c.

**ALDEN MANUFACTURING COMPANY**  
Also makers of the famous Na-Ald Dials  
Dept. B-6 Springfield, Mass.

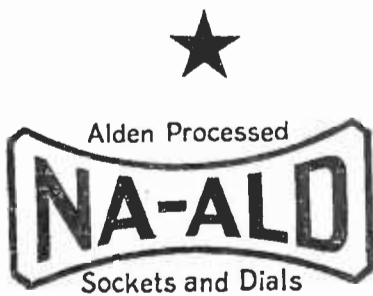

ALDEN MANUFACTURING COMPANY  
Dept. B-6, Springfield, Mass.  
Please send free copy of booklet, "What to Build," showing tested and selected circuits.

Name.....  
Address.....  
City..... State.....

## for super-fine tuning

**MAJOR TUNER** will end those "interference blues." A set built with the **MAJOR TUNER** gets only one station at a time—the one you want to get and no other.

**MAJOR TUNER** is the most advanced form of three circuit Low-Loss tuner. It is packed with complete picture wiring diagrams and full instructions.

If your dealer cannot supply you, write us **\$4**

**BEL-TONE RADIO CO.**  
161 Jamaica Ave., Brooklyn, N. Y.



## ARROW BATTERY SLASHES Prices TO CONSUMERS

Prices Smashed!  
Quality Not Sacrificed

Here is real battery quality, guaranteed to you, at prices that will astound the entire battery-buying public. Order direct from factory. Put the Dealer's Profit in your own pocket. You actually save much more than half, and so that you can be convinced of true quality and performance, we give a **Written Two-Year Guarantee**

Here is your protection! Noneed to take a chance. Our battery is right—and the price is the lowest ever made. Convince yourself. Read the prices!

- Special 2-Volt Radio Storage Battery, \$3.75
- Special 4-Volt Radio Storage Battery, 6.00
- 6-Volt, 60 Amp. Radio Storage Battery, 7.00
- 6-Volt, 80 Amp. Radio Storage Battery, 8.00
- 6-Volt, 100 Amp. Radio Storage Battery, 9.50
- 6-Volt, 120 Amp. Radio Storage Battery, 11.50
- 6-Volt, 140 Amp. Radio Storage Battery, 13.00

We ask for no deposit. Simply send name and address and style wanted. Battery will be shipped the day we receive your order Express C. O. D., subject to your examination on arrival. Our guarantee accompanies each battery. We allow 5% discount for cash in full with order. You cannot lose! Act quick. Send your order today—NOW.

**Arrow Battery Co.**  
1215 South Wabash Ave.  
Dept. 10 Chicago, Ill.



★ Tested and approved by RADIO BROADCAST ★

# ★ Ferguson

## *New and Startling in Results and Improvements*

**“YEARS AHEAD.”** Here is a receiver that will still be new in principle when others are forgotten.

**HEIR TO ALL THAT IS IN THE AIR** this new product of the FERGUSON laboratories truly establishes a real standard in high class receivers for those who demand efficiency and quality beyond the ordinary. We challenge *any* receiver to get equal distance and give as good selectivity under similar conditions.

**NERVE CENTER OF THE ETHER.** Without regeneration or radiation, the sensitivity, is so great, it is like a thing alive. You get all the stations that are on the air and you can tune them in to loud speaker volume. No disappointments.

**AMAZING RESERVE POWER.** Gives that satisfying sense of having power to overcome all reception difficulties. Enables you to reach out beyond the ordinary confines of reception. Uses anything from a 15 ft. indoor to a 200 ft. outdoor aerial. This makes it very easy to instal and frees one from the usual aerial troubles.

**MAKES AIR YIELD ITS SECRETS.** Almost as sensitive to distant as local stations. As the two tuning dials are turned, signals come in close together and yet can be separated easily with the new vernier dials. Direction of aerial seems to make no difference. The volume control, and the ability to switch in 4, 5, or 6 tubes gives all the volume average loud speaker will take, irrespective of distance.

Our dealer distribution is strictly limited to those of the highest class, and each dealer is protected as to territory. From such we welcome requests for demonstration and full details. Likewise buyers who are interested in radio of a new and higher type.

### *Illustrated Catalog on Request*

It is a fact that the FERGUSON was the only radio receiver demonstrated at the March New York Show. The receiving aerial on the roof of the Hotel Pennsylvania was right under and within 150 feet of the Gimbel sending aerial, and yet it was proved that other stations came in well and without interference. This, we believe, is the best proof of our claim for selectivity almost beyond any requirements.

### **J. B. FERGUSON, Inc.**

*Manufacturers of High Class Radio Receivers*

Executive offices and showrooms: 41 E. 42nd St., New York  
Metropolitan Distributor: THE RANCE CORP.



**Ferguson Six—Console Model**

Complete with special builtin loud speaker, with Amplion unit, compartments for "A" and "B" batteries and battery charger. Cabinet work the finest, genuine walnut, finished in latest high light style. Plenty of room for books and radio literature. Top panel drops down when receiver is in operation, providing a handy desk arrangement.

Price, \$290

Batteries, tubes, and charger extra

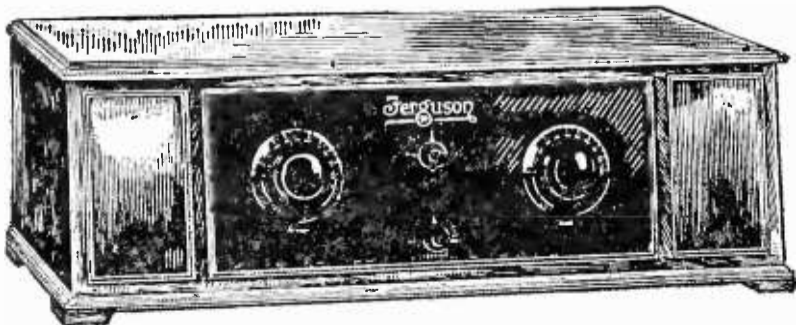

**Ferguson Six—Cabinet Model**

Employs two stages of balanced tuned radio frequency oscillating detector (equal to regeneration for added volume but without radiation or effect on tuning); three stages of perfectly matched audio frequency. De Luxe high light walnut or mahogany cabinet with separate compartments for "B" batteries.

Price, \$180

Tubes and batteries extra

Cash in—  
Crash in!

This is a profit-making invitation

FEDERAL has determined to lead in radio just as it has led in the electrical field for over a quarter century.

This means money profit for every radio jobber and dealer who ride in on the wave of buying Federal is creating. Don't hesitate. Federal has the money, ability, and experience to set its own place in the market—and it has set positive leadership as its rightful place. The Federal franchise will become increasingly valuable and more exclusive as Federal presses toward its goal. Get in now if you want to lead with Federal.

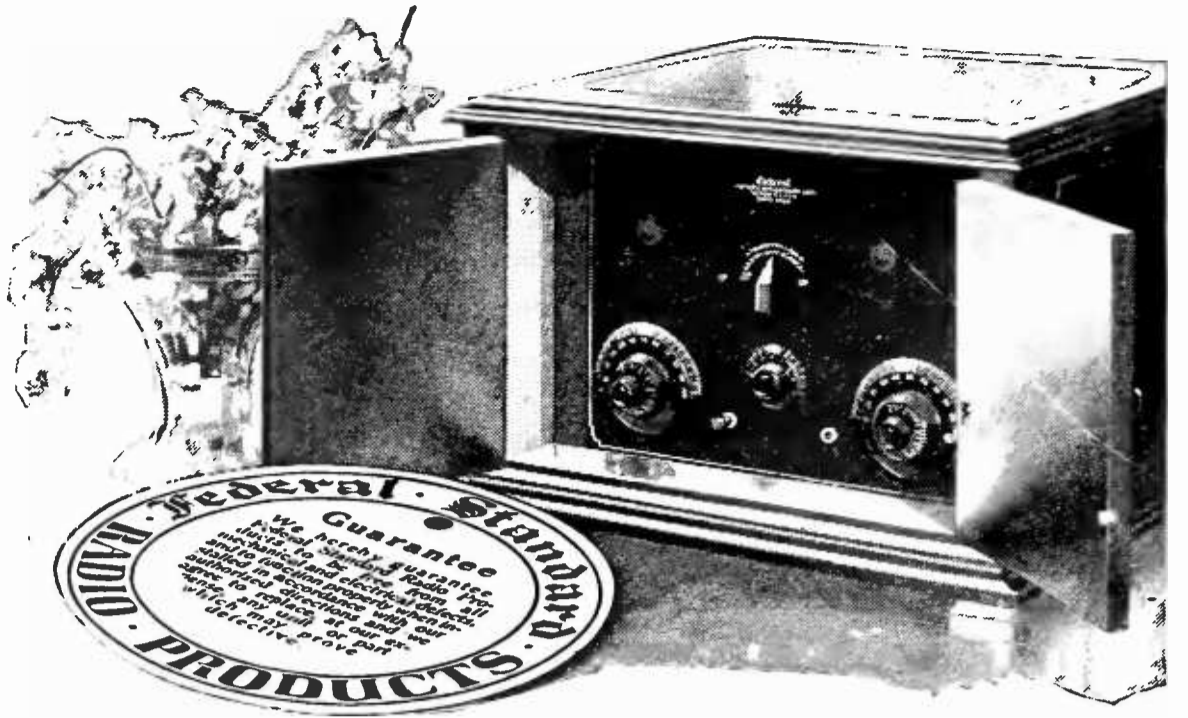

Write Federal for further information. Learn all about the new Federal equipment. Learn what stands behind the new Federal guarantee. Learn how the new Federal overcomes service expense. Learn the exceptional advantages offered by the new Federal's enclosed amplifying unit—and ball bearing suspension. Learn what sales points these advantages give you in your demonstrations. Learn what the new Federal gives in distance range, in selectivity and absolute tonal purity. Write us to-day for all facts—if you want radio leadership in your community.

 ★  
**Federal**  
Standard RADIO Products

FEDERAL TELEPHONE MFG. CORP.  
Buffalo, N. Y.

THE SILENT  
**FRANCE**  
MULTI-DUTY  
SUPER-CHARGER

**Knows No Equal!**

In superior performance, freedom from trouble, convenience, and quietness the France Super-Charger knows no equal.

Up to 120 volts of "B" battery can be charged IN SERIES without the fuss and trouble of wire changing. It also economically charges "A" or "C" batteries at a 5 to 7 ampere rate, tapering as battery is charged.

Price of Super-Charger, \$22.00; West of Rockies, \$23.00; Canadian prices furnished upon request. Write us for name of nearest dealer, also literature describing and illustrating the France Super-Charger.

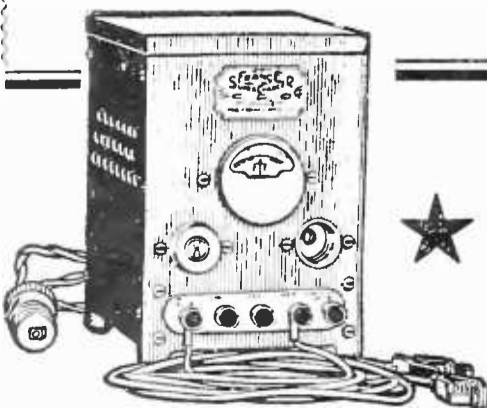

★  
**THE  
FRANCE  
MFG. CO.**

10327 Berea Road  
Cleveland, Ohio

Crescent Lavite Resistances Absolutely Non-Inductive

12,000  
48,000  
50,000  
100,000 } Ohms



List  
\$1.50

★  
Special resistance to order. When better resistances are made Crescent will make them. CRESCENT RADIO SUPPLY CO., 5 LIBERTY ST., JAMAICA, N. Y.

**NEW IDEAS WANTED**

Well known Radio Manufacturer whose products are nationally advertised and sold everywhere wants new Radio device to sell. Will pay outright or royalty for idea or invention which is really new and salable. Address:

Mr. R. F. DEVINE  
116 West 32nd St. Room 1101 New York, N. Y.

**FAHNESTOCK CLIPS**

The Perfect Radio Connectors—Are Used



★  
Reg. U. S. Patent Office

By manufacturers of standard sets and parts and makers of wet Battery, and exclusive on Eveready Dry Batteries. Their Sure Patented Grip is recognized universally by enthusiastic users.

FAHNESTOCK ELECTRIC CO. Long Island City



The new Sangamo Mica Condenser, actual size; accuracy guaranteed within 10 per cent. of marked capacity, and guaranteed to sustain that accuracy. Solidly molded in smooth brown bakelite, this condenser sets a new standard of neat compactness.

Announcing

## an accurate fixed condenser of Sangamo Quality



High accuracy, sustained in service, has been inseparably identified with the name Sangamo for over a quarter of a century. It has won world-wide renown for Sangamo Meters. Linked with a reputation for accuracy too great to be jeopardized by the least deviation from its high standards, the name "Sangamo" is synonymous with success.



FIXED condensers are important units in a radio receiver, and should be carefully chosen for *sustained accuracy*. A poorly made fixed condenser varies with every temperature and humidity change. In reflex and other circuits where capacity is a critical factor, accuracy in the fixed condenser may make the great difference between a set that performs perfectly, and one that is as uncertain as the weather.

Sangamo Mica Fixed Condensers are guaranteed to be accurate to within 10 per cent. under all temperature and humidity conditions. Neither the intense heat of soldering, nor the dampness of the rainy season will impair the accuracy of these condensers. Even at the seashore where the salt air creeps in to change the capacity of exposed condensers, the accuracy of the Sangamo is not affected in the least.

Sangamo Condensers are made in all standard capacities, and sold at very reasonable prices. Also supplied with grid leak clips.

★ Sangamo Electric Company  
Springfield, Illinois

1310-2

RADIO DIVISION, 50 Church Street, New York • Offices in all Principal Cities

★ Tested and approved by RADIO BROADCAST ★

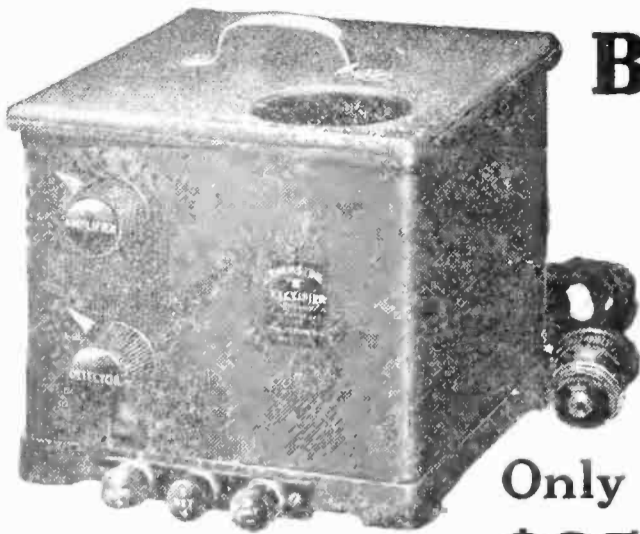

# Better than "B" Batteries

You'll get finer music, better reproduction and more enjoyment from your radio set when the Rhamstine\* "B" RECTIFIER is used instead of batteries. Two controls, one for the Detector and one for the Amplifiers makes it possible for you to feed just the right voltage to get the best results, The Rhamstine\* "B" RECTIFIER plugs into your electric light socket, has no hum, no acid, is easy to operate and furnishes the cheapest electric current obtainable. Cannot burn out any tubes.

RHAMSTINE

Only  
**\$25**

## "B" RECTIFIER

**Send No Money**



Mail the coupon to-day, pay on delivery and try the Rhamstine\* "B" RECTIFIER on your own set under any and all conditions. Try it for five days and if it doesn't do everything claimed for it—if it is not more than satisfactory—if you are not more than pleased with it, return it and Rhamstine\* will refund your money gladly. This is the same hard and fast guarantee under which thousands of Needlephones have been sold. Mail the coupon to-day.

**Dealers Note.** This is the lowest priced, completely assembled source of B current on the market. Write for dealer proposition before someone else gets it.

**J. THOMAS RHAMSTINE\*** 5  
506 E. Woodbridge St., Detroit, Mich.  
Send me your "B" RECTIFIER by express C.O.D. subject to inspection, at \$25. It is distinctly understood that if I am not entirely satisfied, I will return it within 5 days and receive a refund of the full purchase price.

Mail this  
Coupon  
To-day

Name.....

Address.....

**J. THOS. RHAMSTINE\***  
**Detroit Michigan**

## Celerundum - Rectifiers

DELIVER NATURAL TONE QUALITY

For  
Reflex  
Sets



For  
Crystal  
Sets

"The Crystal With a Soul"  
Reg. U. S. Patent Office

**"DE-TEX-IT" COMPLETE**  
**\$1.25**

A Perfect Fixed Detector  
Best for Reflex and Crystal Sets

More  
Power

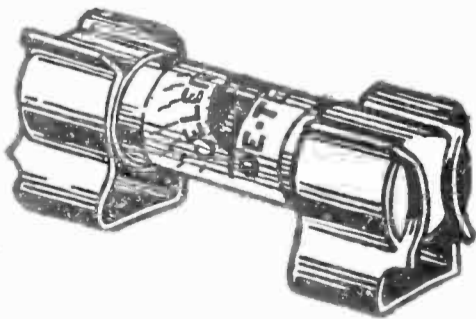

Greater  
Volume



Celerundum Crystals  
Selective Contact  
Catswhisker Troubles Eliminated  
Supersensitive Long Distance  
WILL NOT BURN OUT. Price 50 cts.  
(With Contact Spring.)



**Celerundum Radio Products Co.**  
70-78 Woodbine Street Wollaston, Mass.

## HEATH



CONDENSERS

For Real Radio Reception

Write for Literature

HEATH RADIO & ELECTRIC MFG. CO.  
206 First St., Newark, N. J.

## HERCULES



AERIAL MAST

20 Ft. Mast.....\$10  
40 Ft. Mast..... 25  
60 Ft. Mast..... 45



All steel construction. Complete with guy wires and masthead pulley. We pay the freight.

S. W. HULL & CO., Dept. F-6  
2048 E. 79th St. Cleveland, O.

Write for  
Literature  
and  
**FREE**  
Blueprint



## FROST-RADIO MUSSETTE

Phonograph Attachment

CONVERTS your present phonograph into loud speaker. Pure, clear tone, and faithful reproduction of voice and music insured. Order from your dealer.



List price, complete with cord as shown.....**\$5.50**



**HERBERT H. FROST, Inc.**  
314-324 WEST SUPERIOR STREET, CHICAGO  
NEW YORK CITY CLEVELAND KANSAS CITY LOS ANGELES



# NEW



## VERNIER WITHOUT LOSSES

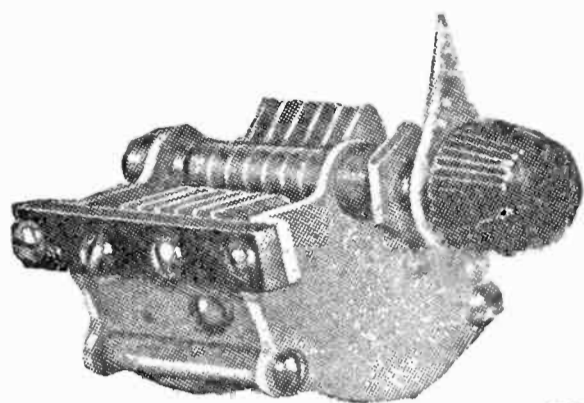

Actual Size  
Actual Price

**\$1.50**



A PERFECT VERNIER makes for perfect reception. "Continental" has made that possible with the new *Junior*—a miniature low loss condenser of advanced design and precision workmanship. Shunted across the standard condenser it makes the perfect vernier, with none of the faults of friction attachments or geared dials. Long Distance Stations come sailing through local broadcast with increased volume and amazing clarity.

### CONTINENTAL

**LOW LOSS**  
JUNIOR CONDENSER

*If your dealer can't supply you write us direct*

## GARDINER & HEPBURN, INC.

611 Widener Building

PHILADELPHIA, PA.

# Low-Loss "Supercoils" Fully Adjustable For All Circuits

"RADIO BROADCAST'S 'KNOCKOUT'"  
Walter Van B. Roberts' Circuit

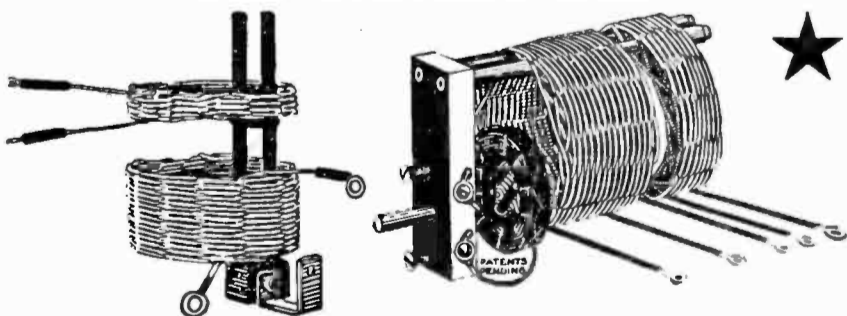

**Per Set, 5 coils in 2 mountings \$8.00**

At your dealers or direct \$8.00 plus P. P.

Combining Radio Frequency, Regeneration and Reflex.

Endorsed by Mr. Arthur H. Lynch, Editor, Radio Broadcast.

Basket weave windings. Large, duplex insulated wire. Adjustable couplings. Minimum dielectric.

Sent p. p.—C. O. D.—\$8.00—plus postage.

**PERFECTION RADIO MFG. CO.**  
Office 319-1520 Chestnut St. Philadelphia, U. S. A

## S. HAMMER RADIO COMPANY 305 Atkins Ave. Brooklyn, N. Y.

Compare our offer! Complete parts for the  
"KNOCKOUT" 4-TUBE ROBERTS RECEIVER

- |   |   |
|---|---|
| 1 7 x 21 Drilled and Engraved Panel                                 | 1 Eveready C Battery                                      |
| 1 Set of Eastern Authorized Pickle-Bottle Coils                     | 1 Box of assorted screws, nuts, washers, lugs, etc.       |
| 1 Dubilier .00025 Grid-Condenser with grid leak mounts              | 1 Baseboard   |
| 1 Dubilier Mica Condenser .0025 mfd.                                | 2 Gen. Ins. Low Loss grounded rotor Condensers .0005 Cap. |
| 1 Fada type Neutralizing Cond.                                      | 1 Daven or Electrad 2 meg. leak                           |
| 4 Amsco Double contact spring sockets                               | 1 Dubilier Mica Condenser .005 mfd.                       |
| 1 Precise 5-1 ratio audio transformer                               | 3 Amsco 20 ohm rheostats                                  |
| 1 Doz. Switch Points and Stops                                      | 2 Como or Modern push-pull transformers                   |
| 1 Drilled and Engraved Binding Post panel                           | 1 Amsco inductance switch                                 |
| 1 Patent Closed Circuit Jack  | 3 Univernier New Type Dials                               |
| 1 Set of Radio Broadcast Blue Prints and Book of Instructions       | 7 Unmovable Binding Posts                                 |
| Free with Each Order 1 Genuine Bakelite Panel Drilled and Engraved. | 1 Patent Open Circuit Jack                                |
| Our Kit Price .....   | 8 Feet of high grade cambric tubing                       |
|   | 30 Feet of tinned bus wire                                |

**\$39.50**

Complete Exact Specified Parts for  
ROBERTS NEW 6-TUBE SET  
Including 1 FREE Genuine Bakelite Panel drilled and engraved. Our Kit Price .....

**\$61.50**

Genuine Complete Parts For  
RASLA FOUR-TUBE REFLEX RECEIVER  
FREE Genuine Bakelite panel drilled and engraved. Our Kit Price .....

**\$41.50**

*We Specialize in Cockaday Kits  
Write for complete descriptive circular of our kits before buying elsewhere*

Transportation Prepaid. One third must accompany all C. O. D. Orders. Not insured unless insurance charges included.

★ Tested and approved by RADIO BROADCAST ★

# ROBERTS



(TRADE MARK)

## The Wonder Circuit of the Year

RADIO BROADCAST SAYS: "The Greatest Receiver for Home Construction we have ever seen."

### STRONG WORDS THESE—BUT JUSTIFIED

We make the ONLY COILS Bearing the Official Endorsement of WALTER VAN B. ROBERTS, E.E., Ph.D.

Real low loss, Silk wire wound on Celoron Bakelite forms, with mechanically perfect mountings.

Packed with neutralizer and Building Instructions for the two tube set by Mr. Roberts.

Avoid disappointment, insist on the Genuine.

**\$ 8<sup>00</sup>**

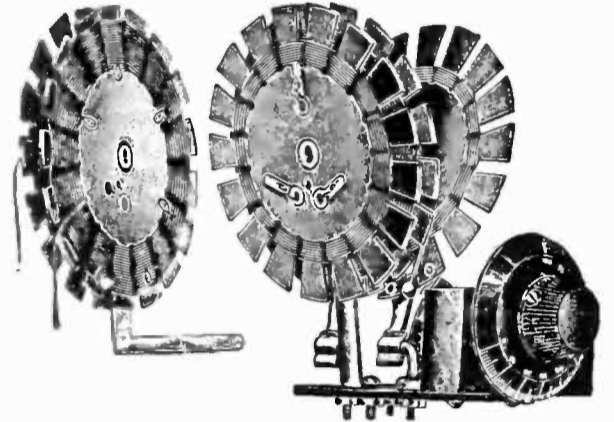

NAZELEY ROBERTS UNITS

## J. NAZELEY CO.

571 Hudson St.

Sole Manufacturers

NEW YORK

WITH better and more powerful broadcasting—

and with a sensitive, responsive Telomonic III receiver—

the fascination of radio continues this year, regardless of the calendar.

Write to Danziger-Jones, Inc., Dept. B, 25 Waverly Place, New York for booklet, "The KIT of a thousand Possibilities."

*Telos Radio*

DANZIGER-JONES, Inc. 25 Waverly Place, NEW YORK



## ALL SHOT

That's the common expression of dry cell "B" batteries. Purchase the economy way and enjoy clearer reception, and greater

volume. Put together an everlasting "HAWLEY" rechargeable "B" storage battery. Nickle-iron alkaline type. No former experience or soldering necessary. Put up in both assembled and knock-down types. The knock-down units contain all actual material for building battery and are put up in 90 volts at \$8.95; 100 volts at \$9.95; 120 volts at \$11.60; 135 volts at \$12.75; 150 volts at \$13.90; 200 volts at \$17.50. Guaranteed for 2 years with a 30 day trial offer of complete satisfaction or return of your money without any ifs nor ands. Complete sample cell 35c prepaid. 8 page illustrated folder of instructions showing simple putting together, making charger and charging free with all orders. Complete manufactured "B" battery charger \$2.75. Order direct or write for my literature, guarantee, and testimonials. Same day shipments. Address

B. F. SMITH

31 Washington Ave.

Danbury, Conn.

## Best for Reflex

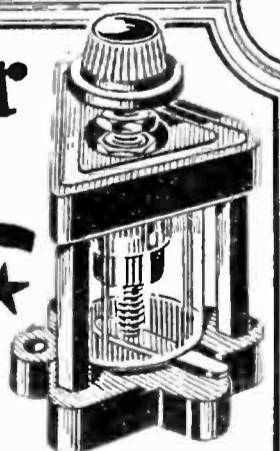

### and Crystal Sets ★ FRESHMAN

Double Adjustable Crystal Detector

No more searching for the sensitive spot. —Merely turn the knob as you would a dial.

For base or panel mounting, complete with Freshman Super - Crystal

**\$1.50**

At your dealer's, otherwise send purchase price and you will be supplied postpaid.

CHAS. FRESHMAN CO., Inc. 106-7th Avenue, New York

★ Tested and approved by RADIO BROADCAST ★

# SUPORTENA

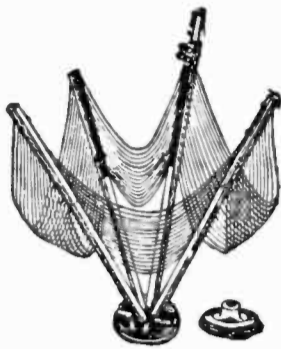
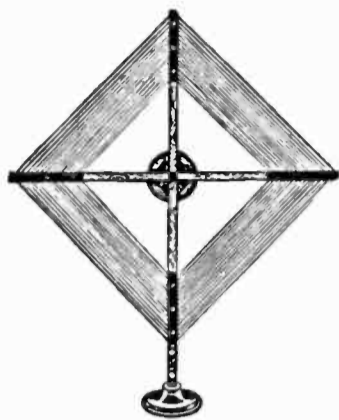

\$9.00



Patent Applied for

The final word in  
**FOLDING LOOPS**

The Slider permits Tapping  
at every one of the  
**16 Turns!!**

**ANY TUBE SET NOW MADE PORTABLE**

Twelve different hookups showing how to use it, with  
different types of receivers.



*Perfected by Radio's Master Loop Craftsmen.*

571 HUDSON ST. **J. NAZELEY CO.** NEW YORK



\$3.50  
COD

**RADIO Storage "B" Battery**  
*Lasts Indefinitely—Pays for Itself*

12 Cells  
24 Volts  
Economy and performance unheard of before. Recharged at a negligible cost. Approved and listed as Standard by leading Radio Authorities, including Pop. Radio Laboratories, Pop. Sci. Inst. Standards, Radio News Lab., Lefax, Inc. and other important institutions. Equipped with *Solid Rubber Case*, an insurance against acid and leakage. Extra heavy glass jars. Heavy rugged plates. Order yours today!

**SEND NO MONEY** Just state number of batteries wanted and we will ship day order is received. **Extra Offer:** 4 batteries in series (96 volts), \$13. Pay expressman after examining batteries. 5 per cent discount for cash with order. Mail your order now!

**WORLD BATTERY COMPANY**  
1219 So. Wabash Ave., Dept. 78, Chicago, Ill.  
*Makers of the Famous World Radio "A" Storage Battery*  
Prices: 6-volt, 100 Amp. \$12.50; 120 Amp. \$14.50; 140 Amp. \$16.00.  
All equipped with Solid Rubber Base.

**World FOR STORAGE BATTERIES RADIO**



KDKA - WFAF - WGN - WJS - KHJ - KGO - KFAF - WJY - KOP

## BLUEBIRD Radio Tubes

Distinctly New and Efficient.

A quality tube at a moderate price, made possible by our direct sales plan. "Bluebird" is sensitive and powerful—produces clear volume.

BAKELITE BASE

- Type 200.....5 Volts, 1 Ampere Detector Tube.
- Type 201A.....5 Volts, .25 Ampere Amplifier and Detector.
- Type 199.....3-4 Volts, .06 Ampere Amplifier and Detector.
- Type 199A.....3/4 Volts, .06 Ampere With Standard Base.
- Type 12.....1 1/2 Volts, .25 Ampere Platinum Filament. Amplifier and Detector. **\$2.00**
- All Standard Types—
- Type 202, 5 Watt Transmitter \$3

ALL TUBES GUARANTEED

to work in Radio Frequency. Especially adapted for Neutrodyne, Reflex, and Super-Heterodyne Sets. When Ordering Mention Type.

**BLUEBIRD TUBE CO.**  
200 Broadway Dept. B. New York City



Shipped Parcel Post C. D. D.

## The FRENCH BINDERS

Good books with artistic binding

COUNTRY LIFE PRESS

GARDEN CITY, N.Y.

## LEARN THE CODE AT HOME with the OMNIGRAPH

"Just Listen—The Omnigraph will do the teaching"

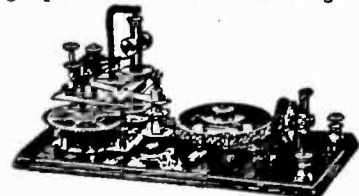

THE OMNIGRAPH Automatic Transmitter will teach you both the Wireless and Morse Codes—right in your own home—quickly, easily and inexpensively. Connected with Buzzer, Buzzer and Phone or to Sounder, it will send you unlimited messages at any speed, from 5 to 50 words a minute.

THE OMNIGRAPH is not an experiment. For more than 15 years, it has been sold all over the world with a money back guarantee. The OMNIGRAPH is used by several Depts. of the U. S. Govt.—in fact, the Dept. of Commerce uses the OMNIGRAPH to test all applicants applying for a Radio license. The OMNIGRAPH has been successfully adopted by the leading Universities, Colleges and Radio Schools.

Send for FREE Catalogue describing three models. DO IT TO-DAY.

★ **THE OMNIGRAPH MFG. CO., 16K Hudson St., New York City**

*If you own a Radio Phone set and don't know the code—you are missing most of the fun*

★ Tested and approved by RADIO BROADCAST ★

# ATTENTION SET MANUFACTURERS

Our special "Selector" variable condenser with self-balanced coils attached is the equipment you have been waiting for—at a price you can afford to pay.

To enable you to successfully manufacture a five tube, popular priced radio receiver consisting of two stages of tuned radio frequency, detector and two stages audio, combining selectivity, volume, true tone, distant reception and simplicity.

OUR "SELECTOR" LOW LOSS GROUNDED ROTOR VARIABLE CONDENSER "THE MANUFACTURERS SPECIAL" answers the demand for a ruggedly constructed efficient instrument at an exceptionally low price.

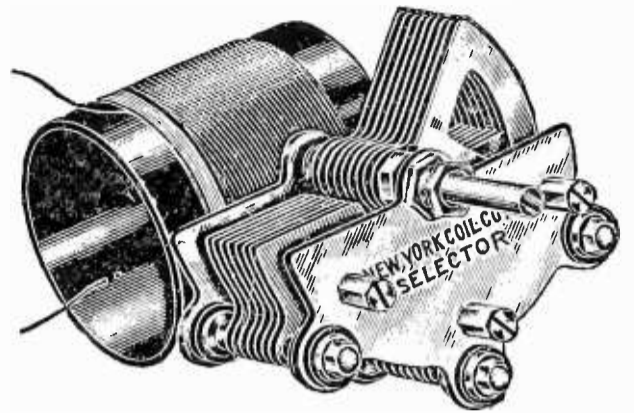

Get manufacturers price and descriptive literature  
**List Price \$2.75 .0005 (23 plate) — \$2.50 .00035 (17 plate)**

**NEW YORK PRECISION MICA FIXED CONDENSERS—CHOICE OF LEADING MANUFACTURERS AND RADIO ENGINEERS.**

**All Capacities. Price 35c. to 75c.**

**NEW YORK COIL COMPANY**

338 Pearl Street

New York City, N. Y.

Pacific Coast — Marshank Sales Co., 926 Insurance Exchange Building, Los Angeles, Calif., also San Francisco, Portland

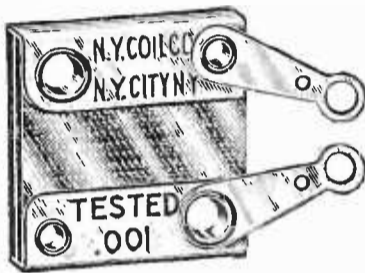

**Obsolete**

Take the **"GUESS"** Out of Tube Control **\$ 1.10** **★**  
*With* **Everywhere**

AMPERITE—the Self-Adjusting rheostat, takes care of tube current better than any expert operator could regulate it. No more hand rheostats or filament meters necessary. Brings the most out of each individual tube automatically. Simplifies wiring, doubles tube life, lowers set cost. Approved by all leading laboratories. Used in every popular construction circuit.

**RADIALL COMPANY**  
 Dept. R.B.-6, 50 Franklin St., New York City

Write for **FREE** Hook-ups

**AMPERITE**  
 REG. U. S. PAT. OFF.  
*"means right amperes"*

*Let the non-directional*  
**Thor Speaker Lamp**  
 [Patents Pending]

bring in your Radio programs and furnish light at the same time. Many models—many styles—parchment or any color silk shades.

Table lamp models \$35.

*At your dealers—or delivered.*

**★ THOR Radio Division**  
 of the Golden Gate Brass Manufacturing Co.  
 1239-1243 Sutter St., San Francisco, Cal. (125)

**Standard Radio**  
**PARTS and SETS**  
**AT WHOLESALE**

Specializing in shipments to dealers and individuals carrying on a radio business as a side line.

*Write for attractive discount list*

**Radio Dealers' Purchasing Co.**  
 30 Church Street, New York, N. Y.

**ACH TUNING INSTRUMENT**  
Using Expensive WORM GEAR

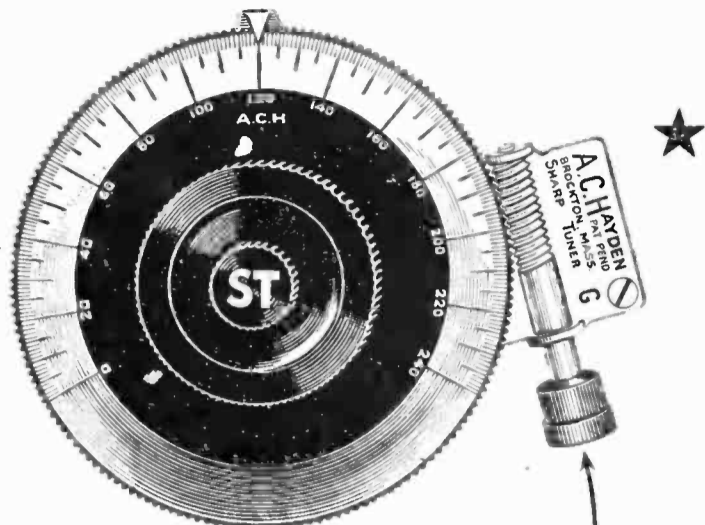

Why the A.C.H. is different

3 in. DIAL → A.C.H. → (156-t0-1)

4 in. DIAL → A.C.H. → (215-t0-1)

Price 3-inch size.....\$2.50 Price 4-inch size.....\$5.00  
Regular fitting 5/16 shaft. 1/4 and 3/16.....5c each extra

The expensive worm gear is a type of gear in a class by itself. Ask for the

**WORM GEAR**

*A new way to spell*

**SELECTIVITY—WORM GEAR**

A WORM GEAR HAS NO SUBSTITUTE OR OTHER NAME

*Mail orders—prepaid U.S.A.—if not at dealers*

**A. C. HAYDEN RADIO & RESEARCH CO.**  
BROCKTON, MASS., U. S. A.

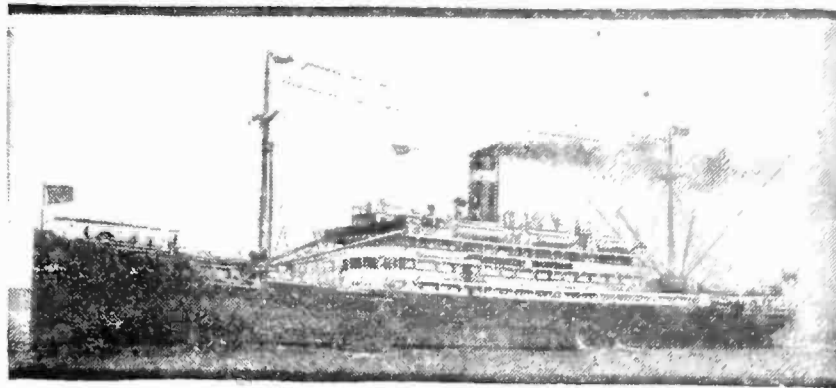

*S. S. Santa Teresa of the Grace Line. The Radio operators are graduates of the Radio Institute of America.*

**Radio —**  
**the career for you!**

Sailing on ocean steamers—with good pay and excellent quarters — at liberty whenever the ship is in port—big opportunity for advancement—all these help to make radio operating a lucrative and highly respected profession.

*Thorough Training Essential  
for Success*

Only skilled men can succeed in radio. But with the course of instruction offered by the Radio Institute of America, success depends only on your own application to study. Have you perseverance? Then follow the footsteps of 7,000 successful Radio Institute graduates.

*Study Radio In Spare Time*

Even though employed at present you can qualify for your U. S. Govt. Commercial Radio License in a few months of home study. Radio Institute is conducted by the Radio Corporation of America, assuring you of a thorough up-to-date Home Study Course. Mail the coupon now for more information.

**Radio Institute of America**

*(formerly Marconi Institute)*

Established in 1909

328 Broadway, New York City

CUT HERE

RADIO INSTITUTE OF AMERICA  
328 Broadway, New York City

Please send me full information about your Home Study Course of radio instruction.

- I am interested in the complete course including code.
- I am interested in the technical course without code.

Name.....

Address .....

**Actual Performance**  
**Is the real test**  
**Of any Condenser.**

**Judged**  
**On this basis**  
**The RATHBUN**  
**Is the equal**  
**Of any — and**  
**At any price.**

**There is**  
**No Better Value.**

RATHBUN MANUFACTURING CO., Inc.  
Jamestown New York



★ Tested and approved by RADIO BROADCAST ★

# Hommel Refers all Inquiries for Radio Apparatus to his Local Dealers

We advertise nationally and locally and get many consumers' inquiries. These are turned over to our dealers. We have many letters from dealers thanking us for the sales that resulted.

Our central location, prominence, extremely attractive display room and show window bring consumers into our store. These, too, we refer to our dealers.



# Hommel never Retailis !

He wholesales only—he will not compete with his dealers. This means he gives his dealers material even when it is scarce because he will not sell it over a retail counter. He is noted for prompt shipments, gives liberal discounts and plays fair at all times.

BUY FROM HOMMEL AND GET THE INQUIRIES.

Send for Hommel's Encyclopedia of Radio Apparatus 266-B

**LUDWIG HOMMEL & CO**

929 Penn. Ave.

Pittsburgh, Penna.

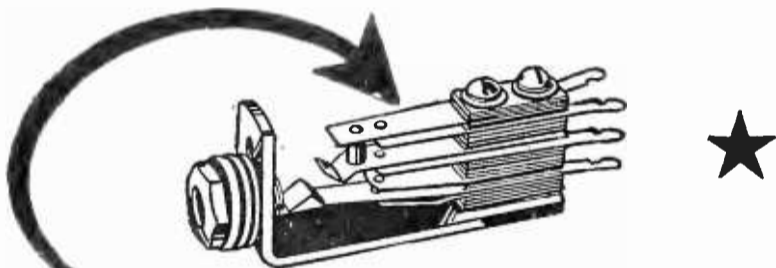

## The spring's the thing!

Don't underestimate the importance of good jacks.

Don't buy jacks because they're cheap. Over 25 leading set manufacturers use only Pacent Jacks. They have that most important essential—*fine springs* that keep the tension constant and the contact perfect.

Write for catalog of complete Pacent Line

PACENT ELECTRIC COMPANY, Inc.  
91 Seventh Avenue, New York City

Washington  
Minneapolis  
Boston  
San Francisco  
Chicago  
Birmingham

**Pacent**  
RADIO ESSENTIALS

Philadelphia  
St. Louis  
Buffalo  
Jacksonville  
Detroit

Canadian Licensees: R. H. White Radio Co., Hamilton, Ont.

**DON'T IMPROVISE - PACENTIZE**

## Burns The Perfect Reproducer

Tone loud and pleasing  
Handsome material and design

Black—\$22.50 Shell—\$25.00

AMERICAN ELECTRIC COMPANY  
State & 64th Sts. Chicago



## RADIO LOUD SPEAKING FACTORY GUARANTEED SET



only \$29.50

AGENTS DEALERS WRITE

SEND FOR testimony of users and SPECIAL OFFER. MIDWEST RADIO CORP'N Pioneer Builders of Sets 406-S, E. 8th St., Cincinnati, O.

MIRACO GETS'EM COAST to COAST

## Protects Radio Tubes



You can protect tubes against destruction from short circuits for a few cents by installing the "Gem" Radio Fuse. Then when there's a "short," the fuse blows and the tubes aren't injured. Easily installed. Sent postpaid for 60c with fuse block for attaching, if not at your dealers. Write for booklet.

CHICAGO FUSE MFG. CO.

1505 West 15th St., Chicago, Illinois

## "GEM" RADIO FUSE

★ Tested and approved by RADIO BROADCAST ★

# THE SUPERUNIT

*Type A*  
For standard  
base tubes

*Type B*  
For 199  
and 299's

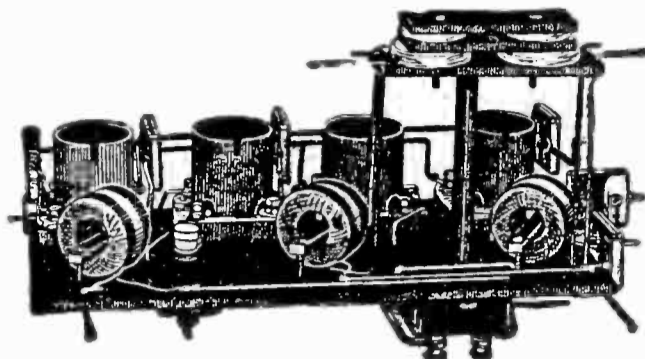

With  
complete  
instructions  
and wiring  
diagram  
\$37.50

A tested four tube assembly with an unusual reception range. By adding tuning condensers and audio frequency stages you can build a six tube set that will cover the continent on the loud speaker.

The Type B Superunit is particularly adapted for portable sets.

We guarantee that the "B" battery current for a six tube set using the Superunit will not exceed ten milliamperes, and the set can be operated on a "B" battery eliminator.

**For \$75** we supply all the parts with drilled panel and base. Two styles, straight panel or sloping panel.

Loops for the set, \$8.50.

**ALLAN T. HANSCOM**

**Woonsocket, R. I.**

## The New CHELSEA

**FIVE-TUBE RECEIVER—**

For distance and volume it's superb. Finished in rich mahogany with bakelite panel, it compares favorably with the highest priced receiver manufactured. A real 5-tube receiver that's positively easy to tune and operate. *See and hear one to-day!*

**PRICE**  
\$**50.00**

West of  
Rocky  
Mountains  
\$60.00

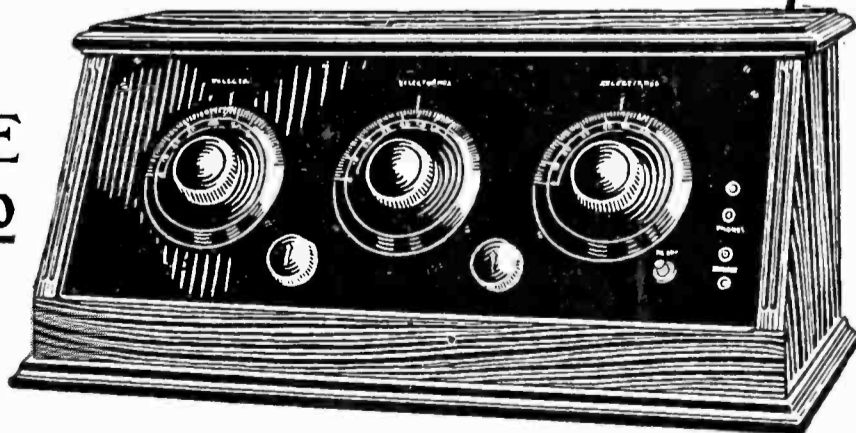

*Write to-day for illustrated circulars*

**CHELSEA RADIO COMPANY**  
179 SPRUCE STREET ~ CHELSEA, MASS.

Chicago  
St. Louis  
Seattle

Denver  
Los Angeles

San Francisco  
Cleveland

### SUPER FIVE

The Ultimate  
of  
**SELECTIVITY**

Manufactured by one of the oldest established radio companies in America. The new CHELSEA is by far the lowest priced *quality* set on the market.

For the best tone quality you **MUST** use a CHELSEA.

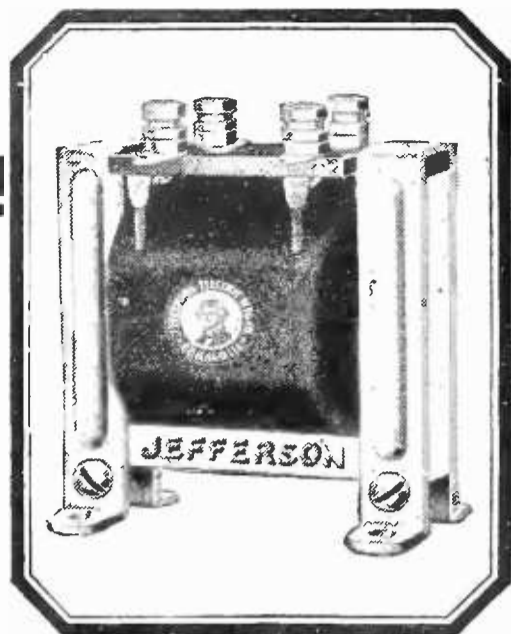

# Reliability

THAT trait of thoroughness which merits confidence is always met with high regard. For there is deep satisfaction in knowing that the task in hand is being done as well as it is possible to do it.

This appreciation for reliability has established the leadership enjoyed by Jefferson Transformers. Sheer quality and performance have won the favor of unbiased radio authorities the world over.

Full, rounded amplification over the entire musical range—a constant delight to radio listeners. Such splendid performance is the result of 20 years specialization in the manufacture of transformers. Replace the transformers now in your set with genuine Jeffersons and see how your set will improve.

**Jefferson Electric Mfg. Co.**  
501 S. Green St. Chicago, Ill.

Manufacturers of:

- |   |                                     |
|---|-------------------------------------|
| RADIO TRANSFORMERS                        | AUTO TRANSFORMERS                   |
| BELL RINGING TRANSFORMERS                 | TESTING INSTRUMENTS                 |
| SIGN LIGHTING TRANSFORMERS                | TOY TRANSFORMERS                    |
| AUTOMOBILE IGNITION COILS                 | FURNACE AND OIL BURNER TRANSFORMERS |
| JUMP SPARK — MAKE AND BREAK COILS         | OIL BURNER IGNITION COIL            |
| SPECIAL HIGH AND LOW VOLTAGE TRANSFORMERS |                                     |

**Finer Selectivity**  
Equip your receiving set with Apex Vernier Dials. They will greatly increase the efficiency of any set. Make tuning positive—bring in distant stations. Your dealer has them. If not, send \$2.00 for Royal Brass Finish—\$2.50 for Satin Silver Finish, or \$3.50 for DeLuxe Gold Plated (24k).

**APEX SUPER 5**  
This highly efficient tuned radio frequency receiver is most advanced in design and construction. An instrument that meets every critical expectation of the radio enthusiast.

Housed in a highly finished walnut cabinet, complete with Jones Multi-plug Battery Cable. All settings highly gold plated. Sells for \$95 complete excepting accessories.

At All Good Dealers  
**APEX ELEC. MFG. CO.**  
1410 W. 59th St. Chicago  
Dept. 504

## Music As You Like It, Voice As You Must Have It

To Be Had Only From An ALL-Wood Speaker

There is a real reason for the noticeably superior tone quality of Madera Clear-speakers. They are made of compressed wood throughout; the bell, the tone chamber and even the base. This substance responds to and amplifies a wider band of sound variations than any other. You, therefore, get natural reproduction from Madera Clear-speaker because none of the notes are missing. Music as you like it and voice as you must have it.

Go to your dealer and have him demonstrate Madera No. 807. Compare the result obtained from any other speaker at any price. A word or two from this wonder instrument will convince you.

**COMPRESSED WOOD CORPORATION**  
Formerly American Art Mache Company  
357 W. Austin Ave. Chicago

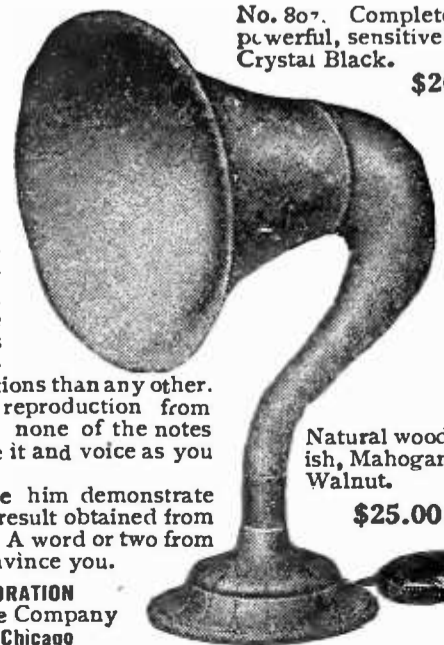

No. 807. Complete with powerful, sensitive Unit. Crystal Black. \$20.00

Natural wood finish, Mahogany or Walnut.

\$25.00



# Physicist Tests B-T Condensers

G. M. Wilcox, Professor of Physics at Armour Institute of Technology, recently conducted tests on B-T Condensers taken from stock. The test included a comparison of readings obtained by interchanging a B-T Condenser with their "laboratory standard" in a circuit through which a current was passed at radio frequency.

The results show that B-T Condensers have less resistance than the *laboratory standard*. Part of Professor Wilcox's letter is reproduced below:

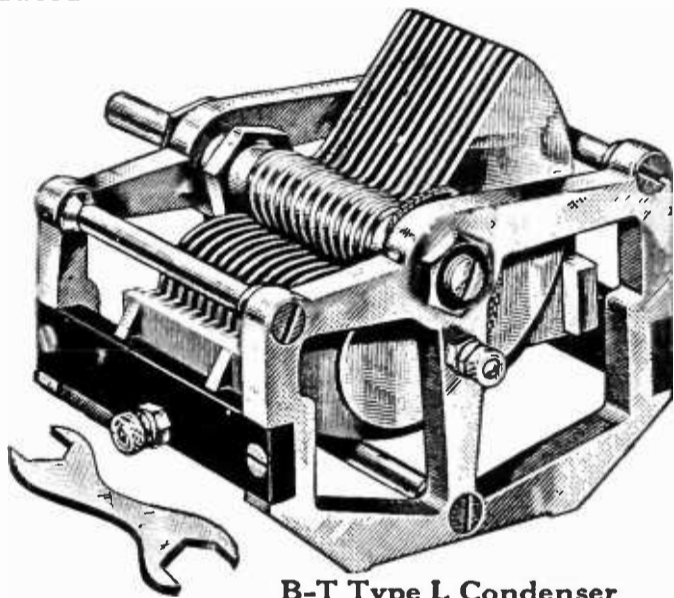

B-T Type L Condenser  
Clockwise Reading



Chicago, Illinois,  
February 27, 1925.

"When Bremer-Tully Condensers were in the circuit, the current was from 1 to 2% greater than that obtained with the Laboratory Standard. It was necessary to introduce about 0.1 ohm in the circuit to bring the current down to the same value as that obtained with the "standard." The *equivalent resistance* of B-T Condensers is therefore less than that of the standard by approximately 0.1 ohm."

## "Better Tuning"

The 7th edition of "Better Tuning" is ready,—48 pages of hook-ups, helps, and information valuable to all radio fans, including section on B-T "Nameless." At all high-grade dealers or by mail on receipt of 10 cents.

Pioneers of "Better Tuning"

**BREMER-TULLY MFG. CO.**  
532 S. Canal St. Chicago

# Takes the MYSTERY out of RADIO!

100,000 SOLD  
514 PAGES



Compiled by  
**HARRY F. HART**  
E.E.  
Formerly with the  
Western Electric  
Co., and U. S.  
Army Instructor  
of Radio.  
Technically  
Edited by  
**F. H. DOANE**

BE A RADIO expert—it's easy for the 100,000 who own this compact, complete Radio Handbook. Written in good, plain understandable language. Crammed full of facts, every one useful and important. Explains how receivers and transmitters work, how to build and operate them. Whatever you or your friends want to know, it's here. Will save you many times its small cost.

**TELLS ALL ABOUT:** Electrical terms and circuits, antennas, batteries, generators and motors, electron (vacuum) tubes, most receiving hook-ups, radio and audio frequency amplification, broadcast and commercial transmitters and receivers, super-regeneration, codes, license rules. Many other features.

Nothing else like it. Make this extraordinary book your radio library—just this one little giant is all you need. Everything in one index, under one cover, in one book for one dollar. The biggest dollar's worth in radio to-day. Combines the knowledge of many expensive works. Buy this and save the difference.

Just mail the coupon with a dollar bill and your name and address, and we will send you this 514-page I. C. S. Radio Handbook by return mail. Note the other good books listed below and the low prices.

### INTERNATIONAL CORRESPONDENCE SCHOOLS Box 8298 -D, Scranton, Penna.

I enclose \$....., for which send me, post-paid, the Handbooks marked X, at \$1 each. It is understood that if I am not entirely satisfied I may return them within five days and you will refund my money.

**RADIO HANDBOOK, 514 pages, \$1**

- ( ) Automobile Handbook, 354 pages - - - - \$1
- ( ) Electrical Handbook, 414 pages - - - - \$1
- ( ) Chemistry Handbook, 348 pages - - - - \$1
- ( ) Pharmacy Handbook, 324 pages - - - - \$1
- ( ) Traffic Man's Handbook, 386 pages - - - - \$1
- ( ) Building Trades Handbook, 409 pages - - - - \$1
- ( ) Machine Shop Handbook, 335 pages - - - - \$1
- ( ) Salesman's Handbook, 352 pages - - - - \$1
- ( ) Advertising Handbook, 445 pages - - - - \$1
- ( ) Bookkeeper's Handbook, 302 pages - - - - \$1
- ( ) Civil Engineer's Handbook, 411 pages - - - - \$1
- ( ) Steam Engineer's Handbook, 298 pages - - - - \$1

Name .....

Address .....

Enclose \$1.50 for each book if you want the Leatheroid binding. All of the above books can be had in this binding except the Traffic Handbook and the Building Trades Handbook.



## Do You Hear Each Instrument Distinctly?

With the unique design of Rauland-Lyric comes a peculiar excellence. There is brought before you, as a noted critic remarked, "the very personality of each artist," as he explores the resources of his instrument. Such a quality, indeed, as to render insignificant, in any radio set, the added cost of Rauland-Lyric Amplification.

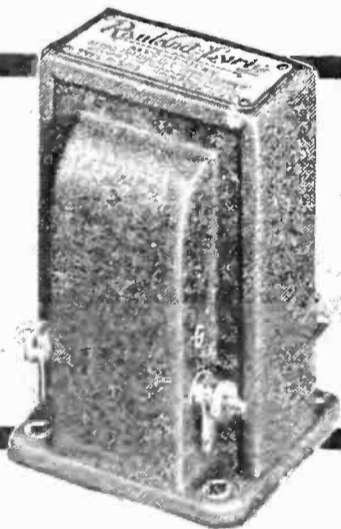

Rauland-Lyric is a laboratory-grade audio transformer designed especially for music lovers. The price is nine dollars. Descriptive circular with amplification curve will be mailed on request. All-American Radio Corporation, 2652 Coyne St., Chicago.

**Rauland-Lyric**  
AN

★ **ALL-AMERICAN**  
TRADE MARK  
**TRANSFORMER**

The Choice of Noted Music Critics

## Send for FREE Bulletin 94

Whether you plan to build or to buy a receiving set, it will pay you to know something about the "insides" of radio. This booklet gives you the "inside dope" on some of the recent inventions embodying the latest ideas of radio engineers.

In this bulletin is full information about the

**Premier "HEGEHOG" Audio Transformer**  
Ratios 1 to 3, 1 to 4, and 1 to 5, \$3.50  
Ratio 1 to 10 \$4.50



This light weight audio transformer has earned a place in the very front rank for its remarkable volume and pure, natural tone. It is 100% self-shielded against foreign noises.

Its small size is a surprise to everyone. It cuts the space requirements for audio transformers in two. This is a big advantage in portables and makes it ideal for neat and compact wiring.

FREE HOOKUP DIAGRAMS also sent on request. All popular types. Address

**PREMIER ELECTRIC COMPANY**  
3812 Ravenswood Avenue Chicago

## PREMIER Quality Radio Parts

Read RUDYARD KIPLING'S Books

For sale everywhere

Doubleday, Page & Co

## Keep your Radio set Clean!

You must have a NODUST to keep your set working its best! Each stroke of a NODUST forces a blast of compressed air into all the hard-to-get-at places and cleans out every speck of dust and dirt in a jiffy.

If your dealer has not received his NODUSTS yet, we will send you one on receipt of \$1.00. Satisfaction guaranteed.

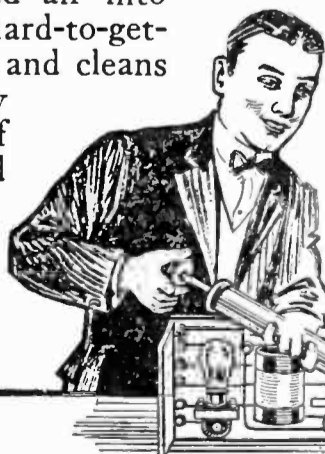

**PEIFFER & CO.**  
86 Liberty Street  
Newark, N. J.

**Can You Beat This for QUALITY?**

**ROBERTS  
KNOCK-OUT  
PARTS**

The maker's reputation is staked on every part. MORISON Service backs their reputation. You can not get a finer Roberts outfit. Buy a complete kit from MORISON and save money.

**Parts for 2 Tube Roberts**

1 Set Sickles Coils No. 18	\$ 8.00
2 Hammarlund .0005 Mfd. Var. Con. @ \$5.00	10.00
1 Karas Harmonic Audio Transformer	7.00
2 Benjamin Standard Sockets (vibrationless)	2.00
2 Amsco 20 Ohm Rheostats @ \$1.25	2.50
1 MARCO Neutralizing Condenser	1.25
3 4" E. Z. Toon Dials @ \$2.25	6.75
1 Carter Jack Switch No. 2	1.00
1 Federal Single Circuit Jack No. 1421	.60
1 Amsco Switch Lever with 7 Points, 2 Stops	.40
1 Dubilier 601 G Fixed Con. .00025	.45
1 Dubilier 601 Fixed Cond. .002	.40
1 Dubilier 601 Fixed Cond. .005	.60
1 Daven 2 Meg. Grid Leak	.50
1 7" x 21" Radion Panel	2.65
1 Eby Mounted Binding Post Strip	1.25
1 Doz. Lengths Bus Bar	.25
Screws and Lugs	.50

Complete with Blue Print, \$41.50

**Parts for 2 Stage Resistance Coupled Amplifier**

2 Daven Resisto Coupler Mountings, No. 41 @ \$1.00	\$2.00
2 Daven .1 Meg. Resistors @ .75	1.50
1 Daven .5 Meg. Resistor	.50
1 Daven .25 Meg. Resistor	.50
2 Dubilier 601 Fixed Cond. .006 @ .75	1.50
2 Amperites No. 1A with Mtgs. @ 1.10	2.20
2 Benjamin Standard Sockets (vibrationless)	2.00
1 Federal Single Jack	.60
1 Carter Switch No. 2	1.00
6 Eby. Binding Posts @ .15	.90
1 7" x 10" Radion Panel	1.25
Screws and Lugs	.50

Complete with Blue Print, \$13.00

Try Us for any Radio Parts you cannot get

C.O.D. MAIL ORDERS  
WILL BE  
SHIPPED PROMPTLY  
WHOLESALE—RETAIL

**MORISON**  
Electrical Supply Co., Inc.  
15 E. 40th St., New York City

**EARN**

**\$3,000 to \$10,000  
a Year as Radio Expert**

Enter fast growing radio field, thousands of big pay jobs waiting for you. U. S. Gov't., Steamships, R. R.'s., Corporations eagerly seek Radio trained men. Advancement rapid, earn from \$3,000 to \$9,000 yearly.

**Pleasant Home Study In**

**RADIO**



A. G. MOHAUPT

**Prepare for Big Pay in Spare Time**

My reputation as Radio Engineer and instructor insures you complete, speedy success, at home in spare time; earn while you learn. I make you expert in radio designing, building, repairing and operating and teach you only practical "inside" dope. You quickly complete my course and a few pleasant hours prepare you to step into Big Pay. No experience required.



**FREE  
1000 Mile  
Radio Outfit**

This set, when completed, has a range of over 1000 miles. I give it free with my course. I give you practical training by having you work on this set. The knowledge you gain is not mere book knowledge but is usable, practical experience.

When you have finished my course, you can sell this set at a price that will pay the cost of the course. For a short time only, by my special plan, I will give a tube radio set in handsome cabinet to men, absolutely **FREE**. Send at once for my **FREE** wonder-book of inside Radio "dope." Act quickly.



**MAIL COUPON**

A. G. MOHAUPT, Radio Engineer,  
Radio Association of America,  
4513 Ravenswood Ave., Dept. B.5 Chicago  
Please send me details of your Home Study Course—also your Free "Radio Facts" and information on how I can get a FREE 1000-mile Radio Set.

Name.....  
Address.....  
City.....State.....

**NO MORE "B"  
BATTERIES**

"Before you buy any parts for a B Current Supply Unit read what Phil Fay has to say about them in the March issue. Then send for full particulars on the Molliformer B Unit. It more than fulfills the conditions laid down in that timely article."

**Model F W 8 has variable detector and amplifier taps. Plenty of voltage for any radio set.**

Uses no expensive rectifier Tubes. Operates on 110 V. 60 cycle A. C. and costs less than 1/10c per hour for current. Kit of necessary parts, \$22.50 including rectifier..... **22**

Send for free folder with wiring diagram

**C. E. JACOBS**  
2804 N. Kedzie Ave. Chicago

DEALERS WANTED. Write for discounts.

# Coto

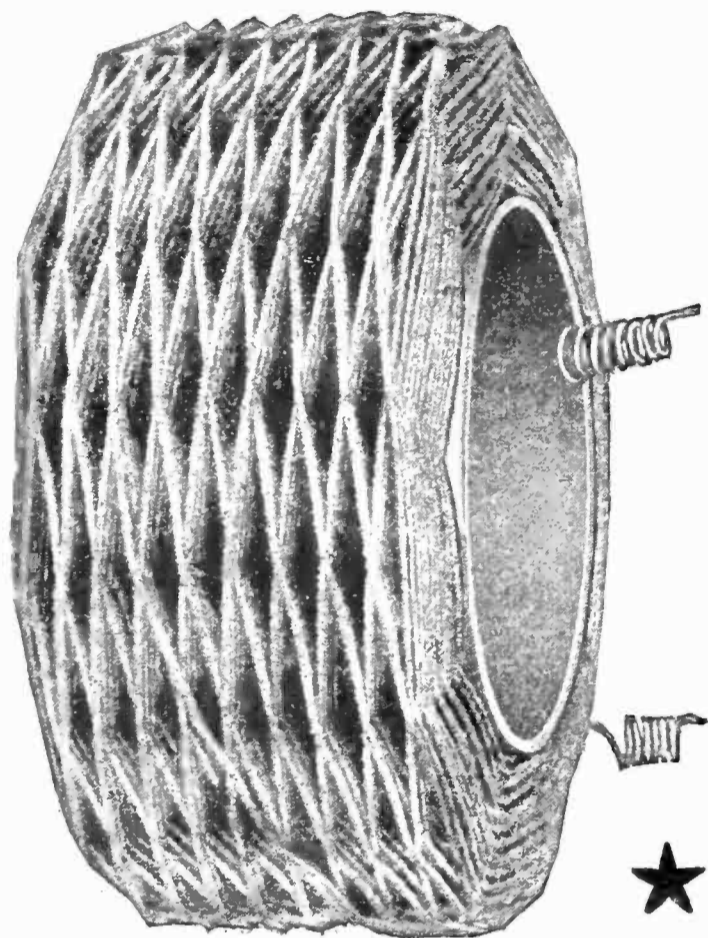

1. Accurately wound Coils of maximum durability
2. Dependable deliveries
3. Prices commensurate with quality of product

For the manufacturer who prefers his coils produced by commercial winders, the Coto Coil Co. is prepared to render an exceptional service. Our long experience in this field and our equipment of "Universal" coilwinding machinery, enables us to make prompt shipment of wire windings either simple or complicated in construction. Requests for quotations and samples will have the prompt and careful attention of our engineers.

**COTO COIL CO.**

87 Willard Ave. Providence, R. I.



**Solid Rubber Case**

## You Save 50%

World 6-Volt Storage Batteries are famous for their guaranteed quality and service. Backed by years of Successful Manufacture and Thousands of Satisfied Users. You save 50% and get a

**2-Year Guarantee Bond In Writing**

World Battery owners "tell their friends." That's our best proof of performance. Send your order in today.

<b>RADIO BATTERIES</b>	
6-Volt, 100-Amperes . . . . .	\$12.25
6-Volt, 120-Amperes . . . . .	14.25
6-Volt, 140-Amperes . . . . .	15.00
<b>AUTO BATTERIES</b>	
6-Volt, 11-Plate . . . . .	\$12.25
6-Volt, 13-Plate . . . . .	14.25
12-Volt, 7-Plate . . . . .	17.00

**SEND NO MONEY**

Just state battery wanted and we will ship day order is received, by Express C. O. D., subject to your examination on arrival.

**Extra Offer:** 5% discount for cash in full with order. Buy now and get a guaranteed battery at 50% saving to you.

**WORLD BATTERY COMPANY**  
1219 S. Wabash Ave., Dept. 24 Chicago, Ill.

**World**

Approved and Listed as Standard by Leading Authorities including Radio News Laboratories, Popular Science Institute of Standards, Popular Radio Laboratories, Radio Broadcast Laboratories and Lefax, Inc.

**Solid Rubber Container**

Now Standard equipment on all World Storage Batteries. No more leakage or breakage of jars or rotting of box.

## The FRENCH BINDERS

*An artistic binding will make a rare gift for your best friend—your book.*

Country Life Press—Garden City, N. Y.

## Tuning the World



**FREE** ★

Ask your dealer or send us four cents in stamps for circuit diagrams in which this remarkable coil can be used.

# UNCLE SAM

## Master Tuning COIL

Uncle Sam Elec. Co. 219 E. 6th St., Plainfield, N.J.

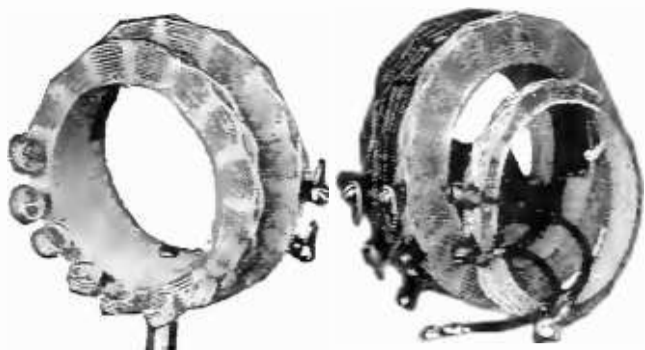

Coils for Roberts Circuit No. 18  
Price \$8.00 a set

# SICKLES DIAMOND-WEAVE COILS

Patented Aug. 21, 1923

*For Craig, Roberts and Hoyt Circuits*

Sickles Coils were chosen by Albert G. Craig in designing his remarkable new Reflex Receiver using the new Sodian detector, and are specified by him for this circuit in the February issue of Popular Radio. This coil set, No. 20, is priced at \$4.50.

For the very popular Roberts Circuit the Sickles Coil Set No. 18 (\$8.00) is standard equipment. Unit No. 1 has primary and secondary coils. Unit No. 2 has primary, secondary, neutralizing coil and tickler. Broad variation in coupling adjustments is provided for. Tickler is provided with 180 degree dial control.

Coils for the Hoyt Circuit at \$10.00 a set, for the Knockout Reflex Circuit at \$4.00 a pair, the Tuned Radio Frequency coil at \$2.00 each and the Acme Reflex circuit at \$4.50 a set are among the standard Sickles coils. We manufacture special coils also for manufacturers' requirements.

**An entirely new system of  
Radio Reception**

*Sickles Diamond Weave Coils have been specified for use in the Hoyt System of Signal Augmentation, by the inventor, Francis R. Hoyt. We have a limited number of blue printed copies of Mr. Hoyt's original laboratory notes on this new system of radio reception, together with nine circuit sketches, which will be sent free to you upon receipt of this coupon and four cents for postage.*

The F. W. Sickles Co.  
335 Worthington St., Springfield, Mass.  
Please send information of Hoyt System.

Name .....

Address .....

*Send for descriptive catalogue*

★ **The F. W. Sickles Co.**  
335 Worthington Street  
SPRINGFIELD, MASS.

# RADIO

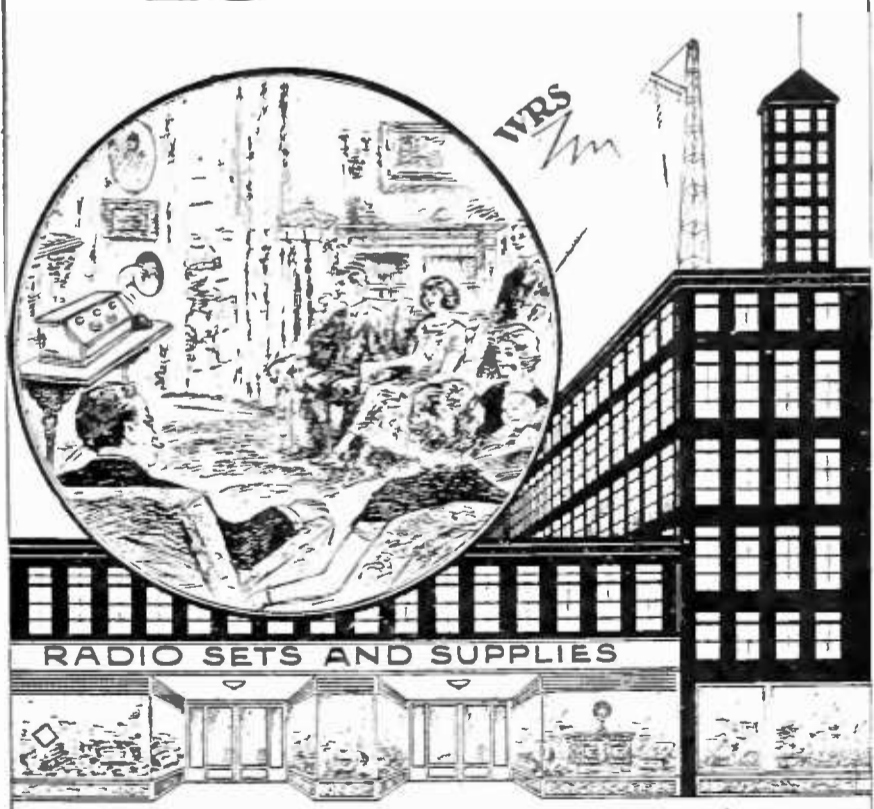

**WHOLESALE RADIO SERVICE CO**  
9 CHURCH STREET — NEW YORK

Write **FREE** 80 PAGE  
for Our **CATALOG**

REMEMBER W R S SELLS DIRECT

TO YOU BY MAIL AT **LOWEST PRICES**

No other catalog includes such a complete assortment of **KNOCK-DOWN** Sets and Circuits.

*Cockaday Super-Het, Ultradyne, Cockaday DX, Roberts Knock-Out, Neutrodyne, Superdyne, Pressley Super-Het, Rasla.*

and many others. A complete list of over 800 Broadcasting stations, trouble shooting chart and much matter of general interest to every radio fan is included.

We specialize in Radio Broadcast Circuits

*Write us for the circuit you wish to build*

**WHOLESALE RADIO SERVICE CO., 9 Church St., New York City**

★ Tested and approved by RADIO BROADCAST ★

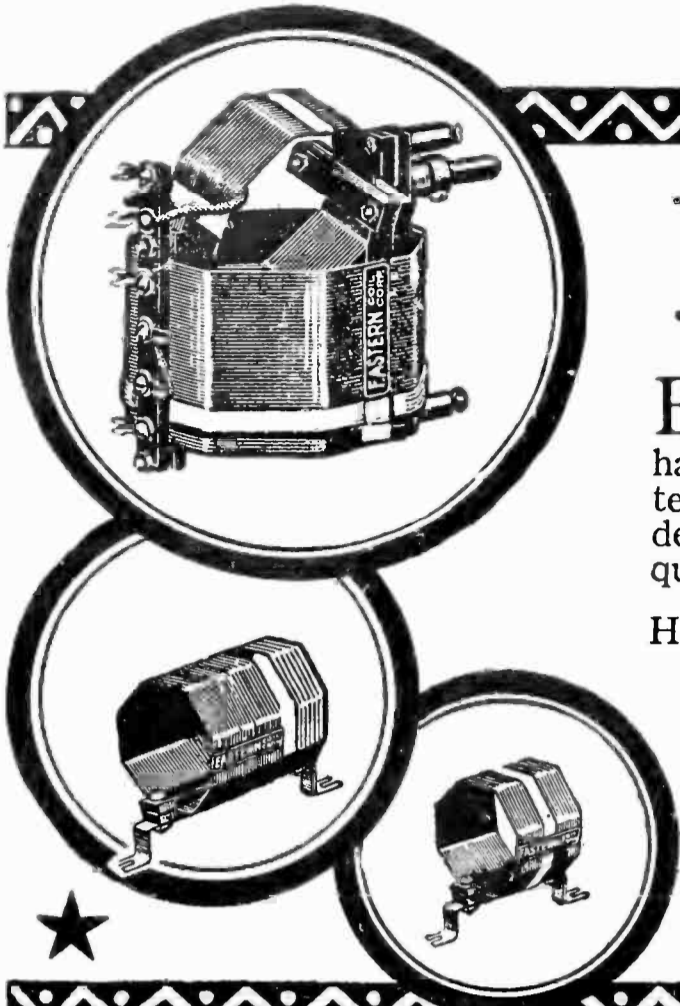

# EASTERN

**E**ASTERN Pickle Bottle Coils are creating a sensation in New York for the Radio Broadcast Roberts Circuit! They have the highest inductance of any low loss coils, which guarantees greatest *volume* and *distance* reception, and their perfect design assures maximum *sensitivity*, *selectivity* and finest tone quality. Endorsed by RADIO BROADCAST.

Hook-up and full size panel layout with material arrangement FREE with each set of coils. Easy to follow. \$8.50 per set.

Also designed for perfect performance in the DX Superdyne, (\$8.00 per set), Three Circuit (\$6.00), and for tuned R. F. for .0005 or .00035 condensers (\$2.00 per coil).

*At your dealers or direct, postpaid.*

**EASTERN COIL CORPORATION**  
22 Warren Street Dept. R.B. New York

## *pickle bottle* COILS

**NO AERIAL**  
**NO LOOP**

**THE Antennaphone**  
REPLACES THE AERIAL

IMPROVES RECEPTION

Easy to install. Not attached to but merely placed under the telephone. Sold with a money-back guarantee. At your dealer or sent by mail upon receipt of One Dollar.

**ANTENNAPHONE CO.**  
90 West St. New York City

*The New*

**MU-RAD RECEIVER**  
MA-20

*The Last Word in Radio* ★

*Write for Literature*

MU-RAD LABORATORIES, Inc., 801 Fifth Ave., Asbury Park, N. J.

### JUDGMENT OF THE STORM

By Roy Mason

A novel written from the photoplay of Ethel Styles Middleton which has been produced by the Palmer Photoplay Corporation. \$1.50.

Doubleday, Page & Co., Garden City, N. Y.

### *The Andrews* **Deresnadyne** ★

**RADIO RECEIVING SET**  
*combines* tone quality and selectivity with distance and volume  
De Luxe Model \$165 without accessories. Write for literature  
**ANDREWS RADIO CO.** 327 S. La Salle St., Chicago

### **fits Grid Leak** **any mounting**

**FRESHMAN PLUNGER**  
TYPE VARIABLE GRID LEAK

was designed especially for the non-technical set owner who can replace in an instant the fixed grid leak with this new, efficient cartridge type Variable Grid Leak, without requiring the change of a single wire. ★

*At your dealer or by mail postpaid. Write for free catalogue.*

**65c**

240 W. 40th St., New York

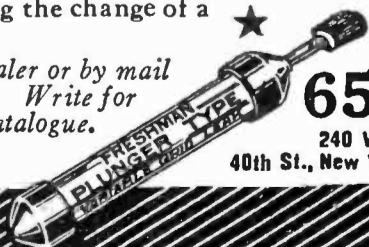

### **VESCO SMILES AT MILES**

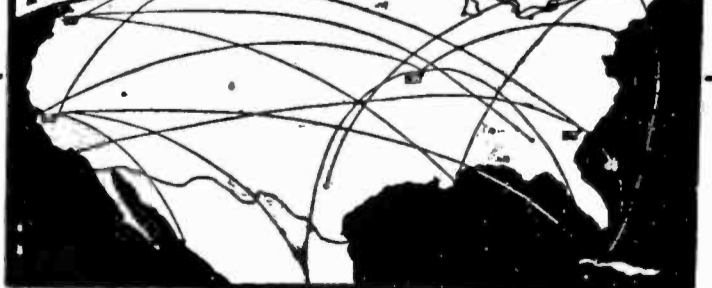

#### **ON ONE TUBE**

**BIG FREE BOOKLET** tells the story. California users of **CROSS COUNTRY CIRCUIT** hear Atlantic Coast, Canada, Cuba, Mexico, and Hawaii. Atlantic Coast users hear England to California. Our new plan makes this set easiest and cheapest to build. One hour puts in operation. One tuning control. No soldering. Any Novice can do it. **BIG BOOKLET FREE** or complete instructions for 25c stamps or coin.  
**VESCO RADIO CO.** Box RB-117 Oakland, California

★ Tested and approved by RADIO BROADCAST ★

? ? ? ? ? ? ? ?

**Y**OU are planning to build a radio receiver and you want to know what kind to make. Shall it be a one-tube reflex, or a four-tube ultra-sensitive tuned and neutralized radio-frequency receiver using regeneration and push-pull amplification? The book which will satisfy the needs of every radio constructor, RADIO BROADCAST'S **KNOCK-OUT RECEIVERS**, contains instructions on how to build these—in fact it tells how to make eight separate receivers.

There is no better group of receivers from which to pick the type to build than those contained in RADIO BROADCAST'S **KNOCK-OUT RECEIVERS** because they have been designed by experts to fit the need of the broadcast listener. All of them can be built from standard parts.

Complete information is contained in the book (which has one hundred pages), for building these receivers, but no blue prints can be sold with it. Well known radio authors like Walter Van B. Roberts, Zeh Bouck, Kenneth Harkness, John B. Brennan, and others have written the descriptions. This book is now being printed and deliveries will be made at once. It will be sent to any address on receipt of \$1.00.

-----  
**DOUBLEDAY, PAGE & COMPANY,**  
 GARDEN CITY, NEW YORK

Please find enclosed \$1.00 for RADIO BROADCAST'S **KNOCK-OUT RECEIVERS** to be sent to

.....  
 NAME

.....  
 RBM ADDRESS

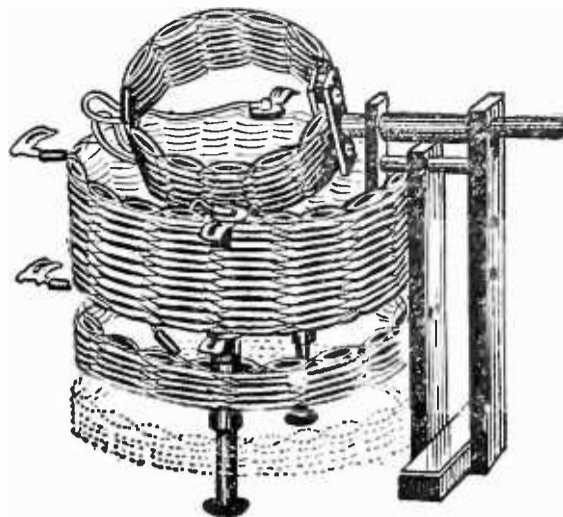

Reg. U. S. Patent Office

**For Sensitivity—  
 Selectivity—  
 Distance**

**Transcontinental Low Loss Tuner**

You love to labor—then make the most of it. To just build a radio set is not sufficient—the receiver you labor on should be the best.

Many radio fans using the Transcontinental Low Loss Tuner report having heard European Stations during the International Test Week. These remarkable 3-circuit tuners can be purchased at any good Radio Store.

**List Price, \$7.00**

*Jobbers and distributors wanted*

**TRANSCONTINENTAL SALES CO.**

241 Market St.

Newark, N. J.

**RUDYARD KIPLING**



**C** The finest of all gifts—a complete set of Kipling. (In cloth or leather.

**AT ALL BOOK STORES**

**NOW \$3.50 C.O.D.**

**THE RABAT SENIOR**  
 4200 MIL. AMPS. CAPACITY

Direct from factory to you

**For a Limited Time Only**

You can purchase for \$3.50 a 12 cell 24 volt RABAT SENIOR battery. Saving \$6.10 thru direct buying. 24 cell 48 volt size \$7.00

Rabat Senior batteries are neat, powerful, noiseless. Separate clear glass cells and patented rubber cork with heavy duty plates 3/16" x 1" x 2 1/2" with staggered ribbed grid form the backbone of this sturdy battery. Shipped completely charged ready to use. Order now, save \$6.10

**Rabat Super Charger \$3.00 c. o. d.**  
 Specially designed to satisfactorily recharge any storage "B" battery. Shipped complete ready to use, including lamp socket, attachment plug and cord. You save \$1.80 by ordering direct.

Send No Money but order today. After examining and approving these batteries pay Expressman the small c. o. d. charges. RABATS are guaranteed two years.

**THE RADIO RABAT COMPANY**  
 1757 ST. CLAIR AVENUE CLEVELAND, OHIO

★ Tested and approved by RADIO BROADCAST ★

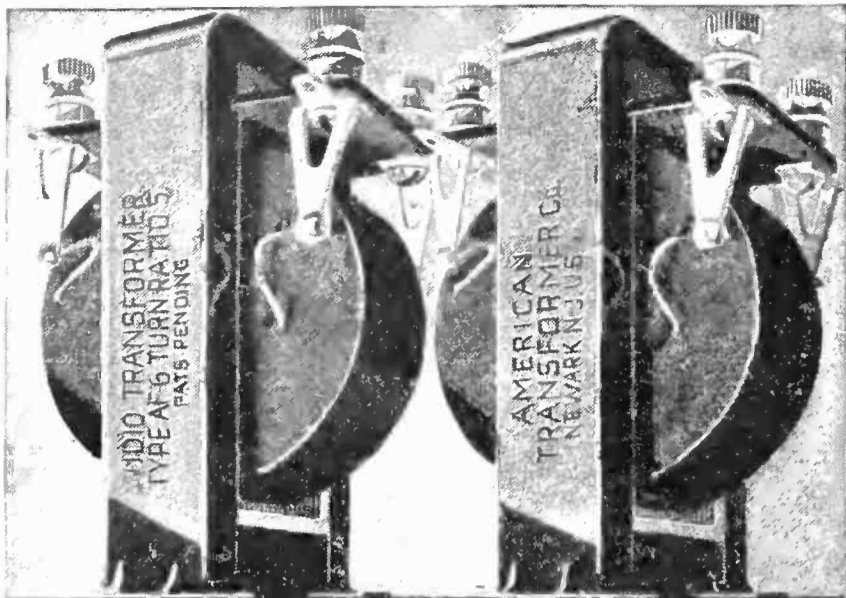

## Build or Rebuild with AmerTrans

**O**NE of the reasons why AmerTrans are preferred for fine sets is their strong, even amplification. They are made to be used by the pair as smooth working twin transformers.

AmerTrans amplify extreme tones with naturalness and uniformity. They are high in quality, produce great volume and can always be depended on to deliver the utmost in audio amplification.

AmerTran is made in two types, one of quality—AF6, ratio 5:1 and AF7, ratio 3½:1. Price either model, \$7.00 at your dealer's. ★

*Buy them by the Pair!*

**AMERICAN TRANSFORMER  
COMPANY**

181 Emmet St., Newark, N. J.  
"Transformer builders for over 24 years"

### A new System of Radio Reception!

Francis R. Hoyt, inventor of the *Hoyt System of Signal Augmentation* has specified AmerTrans for use in this new system. We have a limited number of Blue Printed copies of Mr. Hoyt's original laboratory notes on this new system of radio reception, together with nine circuit sketches, which will be sent free to you upon receipt of this coupon and 4 cents for postage.

NAME \_\_\_\_\_

ADDRESS \_\_\_\_\_

**AMERTRAN**  
TRADE MARK REG. U.S. PAT. OFF.

## Bringing Distant Stations Closer

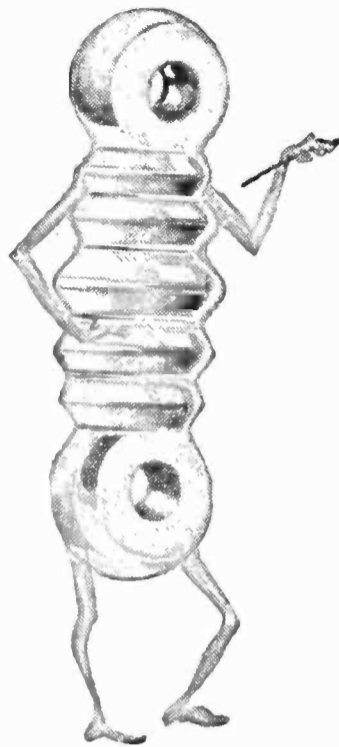

Nearby stations thunder in because the antenna gathers in an ample supply of energy.

Distant stations lose energy on their way to your set. Conserving these faint signals through perfect insulation of your antenna is just like moving your set toward a station.

PYREX all-weather insulators improve reception by cutting down antenna leakage.

PYREX is the trademark of a special composition possessing distinctive electrical characteristics. It is not an ordinary glass.

PYREX Broadcast Insulators retail for 45 cents.

*Insist on obtaining PYREX* ★

**CORNING GLASS WORKS**

*Industrial and Equipment Div.*

Corning

New York

**PYREX**  
**INSULATORS**

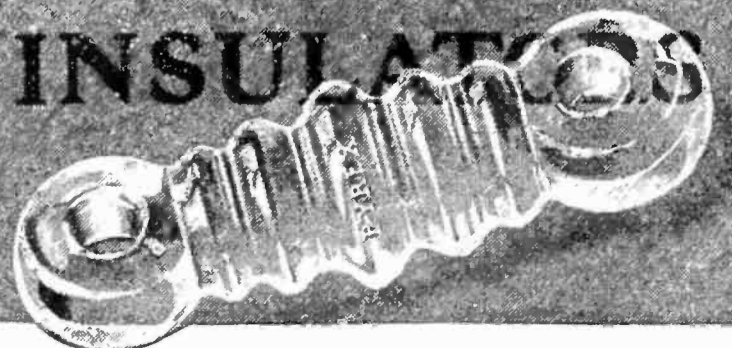

★ Tested and approved by RADIO BROADCAST ★



*Mayolian*  
NEW YORK

## A B-Battery Supply for A.C. or D.C. That Can Be Built at Home!

The **Mayolian B-Battery Supply** is a practical, guaranteed B-Battery supply that is simple to construct, that is inexpensive to operate, and that is highly efficient. The **Mayolian** can be assembled and working in 45 or 50 minutes. To construct the **Mayolian B-Battery Supply** requires only:

**1 Mayolian Input Transformer, \$8.00**  
**Type No. 601**

**1 Mayolian Filter Unit, \$21.00**  
**Type No. 602**

2 Standard Sockets. 1 Resistance.

Nothing else is required to build the **Mayolian**.

1. The **Mayolian** operates on either A. C. or D. C. with equal efficiency.
2. The **Mayolian** delivers 180 volts on open circuit when A. C. is employed.
3. The **Mayolian** has a Detector Variation of from 0 to 80 volts.
4. The **Mayolian** operates either 200 or 201-A tubes as detectors with equal efficiency.
5. The **Mayolian** delivers 50 milliamperes on closed circuit.
6. Your tubes cannot be burned out when a **Mayolian B-Battery Supply** is used.
7. The **Mayolian** is a new filter circuit that chokes the "hum" out of both sides of the line.
8. The **Mayolian** may be assembled in your cabinet. It requires no more space than your B batteries.

Write for **Mr. Mayo's** descriptive and construction booklet.

*Orders shipped anywhere. Remit with order or pay your Postman on delivery. Money refunded if not satisfactory*

**Easy to Construct—Practical—Efficient—Economical**

**M A Y O L I A N**

**R A D I O C O R P O R A T I O N**

**1991 Broadway New York City**

**Eastern Factory Representative: 20th CENTURY RADIO CORP.**  
**102 Flatbush Ave. Brooklyn, New York**

★ Tested and approved by RADIO BROADCAST ★

# HOW TO MAKE

## The Radio Broadcast Knockout Four-Tube Roberts Receiver

is completely described in

### Radio Broadcast's blue-prints with 16 page instruction booklet

Here are just a few reports received from constructors who have used our booklet and blue-prints:

I enthusiastically endorse everything good said of the Roberts. It's a whiz.—Mr. J. W. Wons, 1116 Edson Avenue, Johnstown, Pennsylvania.

The purpose of this letter is to report results on the remarkably efficient Roberts Knockout receiver. This is the second one I have built, both of which contain the most efficient hookup of the kind that I have ever seen. I can best explain what I think of the Roberts by saying that I also have a very good nine-tube super-heterodyne which has been idle ever since I built the wonderful Roberts. Mr. Roberts and your magazine deserve credit and thanks of the public for presenting them with such a remarkably efficient set.—Mr. I. T. Suggs, 618 Humbolt Avenue, St. Paul, Minnesota.

Stations received on two-tube Roberts—for one month:—  
KRE, KLS, KZM, KLX, KGO, KPO, KUO, KFRC, KFUQ, KFNV, KFNZ, KFUU, KFUS, KWG, KFQV, KDZB, KFON, KNX, KFI, KHJ, KJS, KFSG, KFQG, KFWB, KPPC, KGW, KFOA, KFAE, KFCF, KJR, KFQW, KFAU, KDYL, KFPT, KOA, KFKX, KFRU, KOB, KLZ, KYW, KDKA, WOAW, WDAF, WBAP, WFAA, WCC, WHAA, WEBH, WQJ, WWJ, WLW, WHB, WOS, WJZ, WCAI, WCBD, WTAS, WHO, WTAM, WGY, WGR, WCX, WCCO, WMC, WSAI, CFCT, CKCD, CNRC, CFCN, CKCX, CFAC.—Mr. Allan Browne, 1525 Milva St., Berkeley, California.

Interference, caused by radiating receivers, is an unnecessary evil and can be eliminated. That is one of the chief reasons why we have consistently advocated the construction of our RADIO BROADCAST Knockout Four-Tube Receiver. For distance and quality reception we offer to you a receiver combining the advantageous features of 1—non-radiation by means of neutralized radio-frequency amplification; 2—push-pull audio-frequency amplification; 3—reflexing; and 4—regeneration. All in four tubes! Our blue-prints with complete instruction booklet show you how to construct it. The coupon below and a dollar brings them to you.

*DEALERS! We have a most attractive proposition for you. Will you let us aid you in selling stock parts for this Receiver? Make sales that stay sold.*

-----  
DOUBLEDAY, PAGE & CO.  
Garden City, New York

Enclosed find my dollar for the blue-prints and sixteen-page Instruction Book for building RADIO BROADCAST's Four-Tube Knockout. It is understood that my dollar will be returned if the material sent me does not come up to my expectations.

Name.....

Address.....

# Fit for a King

Britain's greatest engineers in designing receiving equipment for his Majesty, KING GEORGE V. chose Resistance Coupled Amplification. None other would do.

## The DAVEN RESISTANCE COUPLED SUPER AMPLIFIER

will give to your favorite tuner, that finesse in quality amplification desired for the Chambers of Buckingham Palace. With Resistance Coupling over tones and under tones are amplified alike, therefore distortionless. The most delicate shadings in musical compositions, either with instruments or the voice, are reproduced with a faithfulness not obtainable with any other method of amplification. The DAVEN SUPER AMPLIFIER is truly a revelation and certainly the last word for distortionless amplification. It costs less to install than other methods of amplification and adds greatly to the life of your "B" Batteries.

Your Dealer will be glad to show you this SUPER AMPLIFIER, which can be attached to your favorite tuner in less than fifteen minutes. The base and sockets are in one piece and of molded Bakelite. Resistors and condensers of correct capacity inserted, and the completely assembled unit fully tested before being packed.



### DAVEN RESISTANCE COUPLED KITS

These kits are put up in three or four stages and brings perfection of amplification to those who would rather build than buy a completely assembled Resistance Coupled Amplifier. Complete instructions enclosed with each kit so that no difficulty should be experienced in their assembly.

Secure from your Dealer the "RESISTOR MANUAL," our complete handbook on Resistance Coupled Amplification. Price 25c. Post-paid 35c.

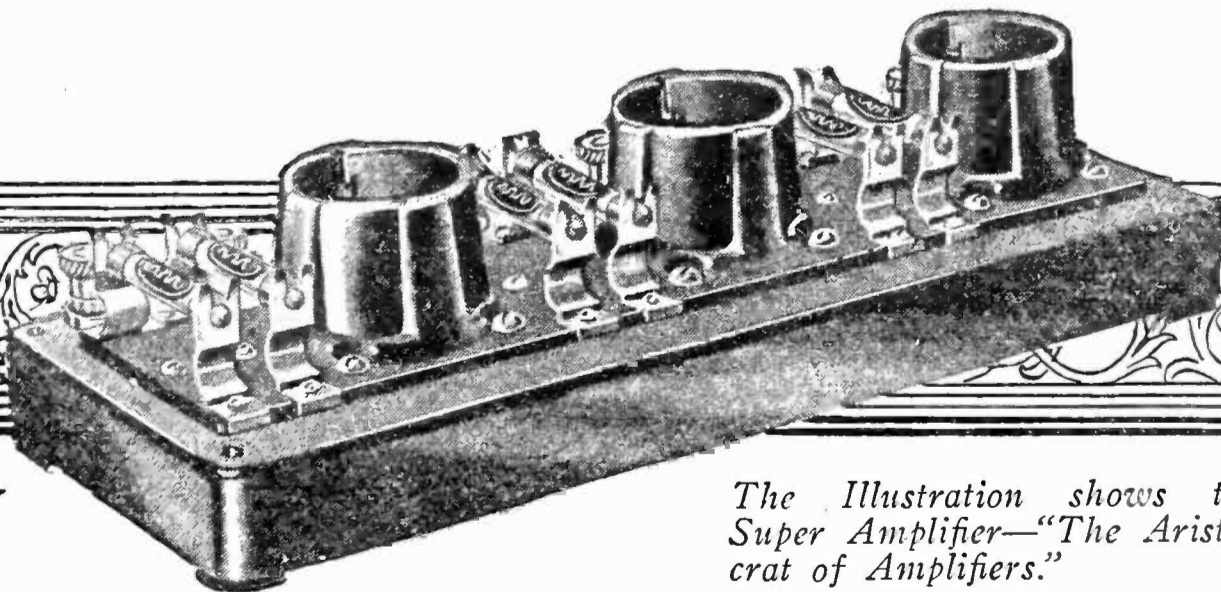

The Illustration shows the Super Amplifier—"The Aristocrat of Amplifiers."

# DAVEN RADIO CORPORATION

"Resistor Specialists"

Newark,

DAVEN RADIO

New Jersey

★ Tested and approved by RADIO BROADCAST ★

# INDEX OF ADVERTISERS

## IN THIS ISSUE

### A

Acme Apparatus Co., The.....	113
Alden Mfg. Co.....	130
Allen Bradley Co.....	156
American Electric Co.....	140
American Hard Rubber Co.....	7
American Transformer Co.....	150
Andrews Radio Co.....	148
Antennaphone Co., The.....	148
Apex Electric Co.....	142
Arrow Battery Co.....	130

### B

Barkeley Elec. Mfg. Co.....	120
Belden Mfg. Co.....	1
Bel Tone Radio Co.....	130
Bel Canto Mfg. Co.....	128
Bluebird Tube Co.....	137
Branston Co., Chas. A.....	118
Bremer-Tully Mfg. Co.....	143
Bristol Company, The.....	121
Brownlie & Company, Roland.....	122
Burgess Battery Co.....	118

### C

Cardwell Mfg. Co. Allen D.....	11
Celerundum Products, The.....	134
Chelsea Radio Co.....	141
Chicago Fuse Co.....	140
Como Apparatus Co., The.....	118
Compressed Wood Corp.....	142
Continental Fibre Co., The.....	128
Copper & Brass Research Ass'n.....	126
Corning Glass Works.....	150
Crescent Braid Co., Inc.....	124
Crescent Radio Supply Co.....	132
Crosley Radio Corp.....	Fourth Cover
Cunningham Co., E. T.....	Second Cover

### D

Danziger-Jones Co.....	136
Daven Radio Co.....	153
Doubleday, Page & Co.....	149-152
Dubilier Condenser & Radio Corp.....	115
Duplex Engine Governor Co.....	10
Durham & Co.....	128

### E

Eastern Coil Corp.....	148
Eby Mfg. Co. The H. H.....	124
Electrad, Inc.....	132

### F

Fahnstock Electric Co.....	132
Federal Tel & Elect. Co.....	132
Ferguson Inc., J. B.....	131
France Mfg. Co.....	132
Freshman Co., Chas.....	136-148
Freed Eiseman.....	6
Frost, Inc., Herbert H.....	134

### G

General Electric Co.....	119
Gardiner & Hepburn.....	135
General Lead Batteries Co.....	120
General Radio Co.....	109
Gilfillan Bros.....	124
Goodrich Rubber Co.....	8

### H

Hammer Radio, S.....	135
Hammarlund Mfg. Co.....	126
Hanscom, Allan T.....	141
Hayden Radio & Research Co. A. C.....	139
Heath Radio.....	134
Hommel & Co. Ludwig.....	140
Hull & Co., S. W.....	134

### I

International Corres. School.....	143
-----------------------------------	-----

### J

Jefferson Electric Co.....	142
Jewett Radio & Phonograph Co.....	9-123
Jewell Elec. Inst. Co.....	128
Jacobs, C. E.....	145

### K

Kellogg Switchboard & Supply Co.....	126
Konkle, James H.....	146

### M

Marwol Radio Corp.....	125
Mayolian Radio Corp.....	151
Midwest Radio Co.....	140
Morison Elec. Supply Co.....	145
Mu Rad Lab.....	148
Music Master Corp.....	4
Mydar Radio Co.....	Third Cover

### N

National Carbon Co.....	155
National Company.....	12
National Radio Inst.....	3
Nazeley Co., J.....	136-137
Newport Radio Inc.....	5
New York Coil Co.....	138
Norden-Hauck & Co.....	124

### O

Omnigraph Mfg. Co., The.....	137
------------------------------	-----

### P

Pacent Electric Co.....	140
Peerless Radio Corp.....	120
Peiffer & Co.....	144
Perfection Radio Mfg. Co.....	135
Phenix Radio Corp.....	111
Premier Electric Co.....	144
Prest-O-Lite Company, Inc.....	117

### R

Radiall Co.....	138
Radio Association of America.....	145
Radio Corp. of America.....	17
Radio Dealer's Purchasing Co.....	138
Radio Inst. of America.....	139
Radio Panel & Parts Corp.....	127
Radio Rabat Co.....	149
Radio Research Lab.....	122
Rathbun Electric Co.....	139
Rauland Mfg. Co.....	14-144
Resas, Inc.....	122
Rhamstine J. Thos. Co.....	134
Rola Co.....	129

### S

Sangamo Electric Co.....	133
Silver-Marshall Inc.....	13
Sickles Co., F. W.....	147
Smith, B. H.....	136
Starrett Mfg. Co.....	120

### T

Thompson Mfg. Co., R. E.....	2
Thor Radio Department.....	138
Tower Mfg. Co.....	15
Transcontinental Sales Co.....	149

### U

Uncle Sam Electric Co.....	146
Universal Winding Co.....	146

### V

Vesco Radio Company.....	148
--------------------------	-----

### W

Wholesale Radio Service.....	147
World Battery Co.....	137-146

**EVEREADY HOUR**  
**EVERYTUESDAY AT 9 P. M.**  
*(Eastern Standard Time)*

For real radio enjoyment tune in the "Eveready Group." Broadcast through stations—

WEAF New York	WCAE	Pittsburgh
WJAR Providence	WGR	Buffalo
WEEI Boston	WOC	Davenport
WEAR Cleveland	WCCO	Minneapolis
WWJ Detroit		
WFI Philadelphia	WSAI	Cincinnati

*The proven  
 Dry Cell for all  
 Dry Cell  
 Radio Tubes*

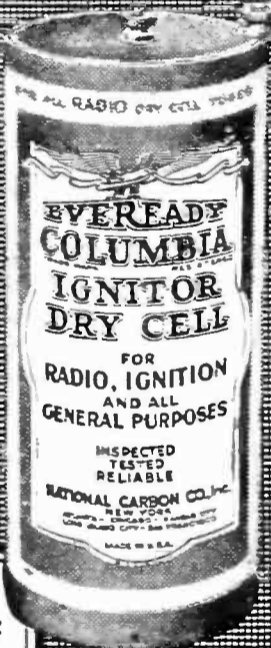

Eveready Columbia Ignitor Dry Cell "A" Battery for all Dry Cell Tubes 1½ volts

# Recommend good batteries

IN AN effort to reduce the first cost of a radio set, a newcomer in radio often buys inferior batteries. You know such "saving" is really wasteful. Tell your friends who are about to buy receivers that the best batteries obtainable will prove to be the most economical. Tell them to buy Eveready Radio Batteries—they last longer and, because they are greatly superior, they give complete satisfaction.

*Manufactured and guaranteed by*  
**NATIONAL CARBON COMPANY, Inc.**  
 New York San Francisco  
 Canadian National Carbon Co., Limited, Toronto, Ont.

# EVEREADY Radio Batteries

*-they last longer*



No. 770  
 45-volt  
 Extra  
 Large  
 Vertical  
 Price  
 \$4.75  
 For use  
 on multi-  
 tube sets



No. 767  
 45-volt  
 Large  
 Horizontal  
 Price  
 \$3.75  
 With  
 variable  
 taps

★ Tested and approved by RADIO BROADCAST ★

# The Allen Bradley Line of Perfect Radio Devices

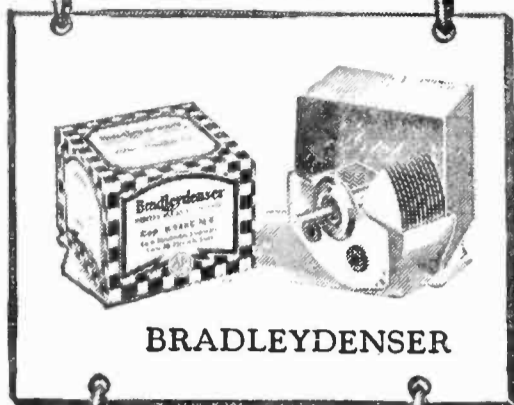

BRADLEYDENSER



BRADLEYSTAT

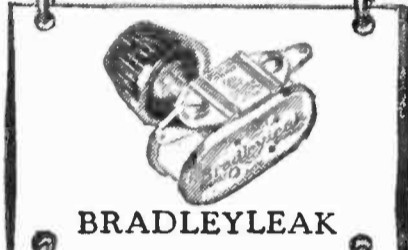

BRADLEYLEAK

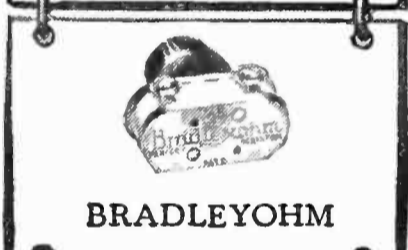

BRADLEYOHM

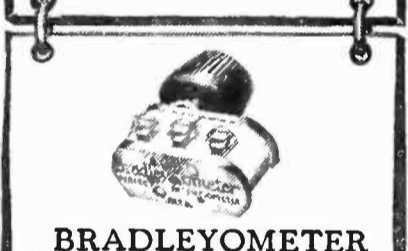

BRADLEYOMETER

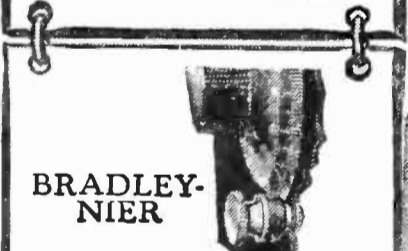

BRADLEY-NIER



BRADLEYSWITCH



## A distinctive series of radio units for set builders who seek superlative results

EVERY amateur yearns for perfection in his radio receiver. Better quality, greater volume, and closer selectivity are the requirements of discriminating radio enthusiasts, and the circuits which meet these requirements are inevitable favorites.

The experienced set builder has learned the value of fine radio parts, and he knows the important part they play in getting maximum results from a selective circuit. Hence, it is not strange that the Allen-Bradley line has gained increasing popularity with the introduction of the super-selective hook-ups. In fact, for stepless, noiseless, perfect control, Allen-Bradley Radio Devices have no peers. Your set will be a better set if you use them. Let us send you an illustrated folder about the Allen-Bradley line.

### Allen-Bradley Co.



Electric Controlling Apparatus

278 Greenfield Ave., Milwaukee, Wis.

*Manufacturers of graphite disc rheostats for over twenty years*

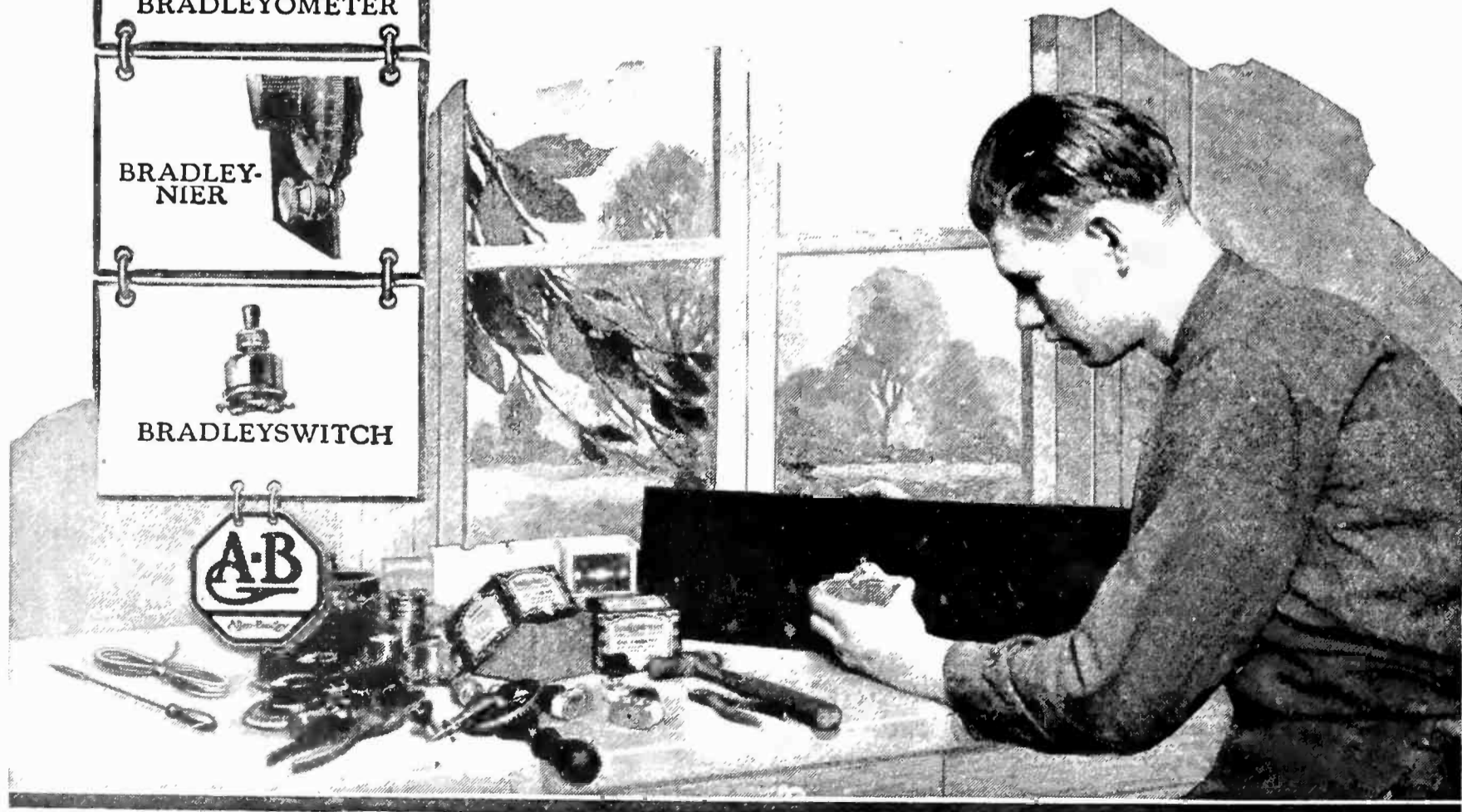

★ Tested and approved by RADIO BROADCAST ★