

More About the One-Tube Reflex

RADIO
BROADCAST
JANUARY 1924

Full Account of the Transatlantic Tests

A Two-Stage Amplifier
For Your Receiver

“If You Like Them, Let
Them Know It”

What You Should Know About
Antennas and Grounds

A Simplified
Super-Heterodyne

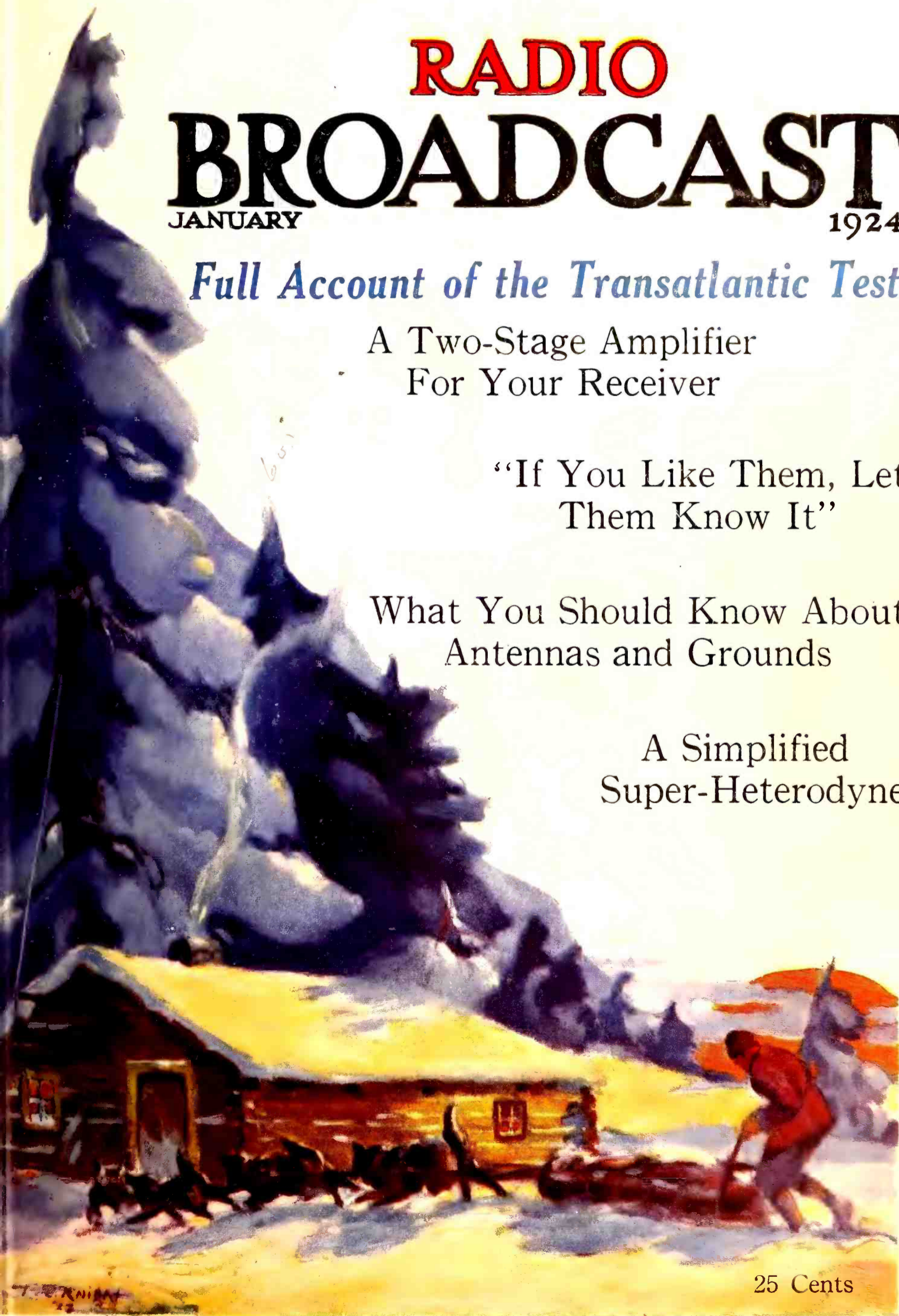

25 Cents



Cunningham

RADIO TUBES

The Heart of Your Receiving Set

IN the case of all living things the heart is the most vital organ. Weaken, injure or destroy the heart and life is accordingly weakened, endangered or destroyed.

In a radio receiving set the tube is analogous to the heart. Remove it entirely and the set will cease to function. Use an inferior tube and the results will be inefficient and generally not pleasing to listen to.

In living things a perfect heart does not always insure a healthy body, but on the other hand it is indispensable. The same is true of the radio receiving set. It may be perfect in every detail but unless the best tubes are used the results will not be perfect.

Cunningham Radio Tubes were developed in the great Research Laboratories of the General Elec-

tric Co., and are now being made in that company's modern and mammoth factories under the supervision of highly skilled engineers.

Better tubes are not attainable. There is a model specially adapted to every set, every circuit and every socket used to-day. Every radio dealer can supply you with Cunningham tubes. Buy them for replacements. Insist that they be included when purchasing a new set—and you will know that your receiving set has a perfect heart.

The care and operation of each model of Receiving Tube is fully explained in our new 40-page "Radio Tube Data Book." Copies may be obtained by sending ten cents to our San Francisco office.

Patent Notice: *Cunningham tubes are covered by patents dated 11-7-05, 1-15-07, 2-18-08, and others issued and pending. Licensed for amateur, experimental and entertainment use in radio communication. Any other use will be an infringement.*

Cunningham Radio Tubes

| | |
|---|-------|
| C-301A—6 Volts ¼ amp. Amplifier | *6.50 |
| C-299—3 Volts .06 amp. Dry Battery Det. and Amp. | 6.50 |
| C-300—6 Volts Gas Content Detector | 5.00 |
| C-11—1.1 Volts .25 amp. Dry Battery Det. and Amp. Special Base... | 6.50 |
| C-12—Similar to C-11 with standard base... | 6.50 |

E. J. Cunningham Inc.

Home Office:
182 Second Street
San Francisco, Cal.

154 West Lake Street
Chicago, Illinois

30 Church Street
New York City, N. Y.

★ Tested and approved by RADIO BROADCAST ★

SOLID COMFORT Comes With The Use Of The

TRADE MARK
AUDIOPHONE

REG. U. S. PAT. OFFICE

because nothing is lost from the original broadcasting.

Not only is it easily possible to distinguish the words of the speaker, but also the minute gradations in pitch, timbre and quality of overtones which distinguish individual voices.

The Audiophone is complete and self-contained—needs no separate battery or other accessories—goes to you ready for use on connecting to your receiving set. It will prove a source of lasting pride and pleasure.

Audiophone Sr., Price \$32.50
Audiophone Jr., Price 22.50



BRISTOL ONE STAGE POWER AMPLIFIER



If greater volume is desired, over what you already obtain, use the Bristol One Stage Power Amplifier. No C Battery required..... **Price \$25.00**

Write for Bulletin and address of the nearest dealer handling our instruments.

THE BRISTOL COMPANY
Waterbury Conn.

★ Tested and approved by RADIO BROADCAST ★

Radio Broadcast

ARTHUR H. LYNCH, EDITOR

JANUARY, 1924

| | | | |
|---|-----------|----------------------------------|-----|
| DAVID LLOYD GEORGE MAKING HIS FAREWELL SPEECH BY RADIO | - - | <i>Frontispiece</i> | |
| THE MARCH OF RADIO | - - - - - | | 183 |
| WHAT RADIO MEANS AT A ROCKY MOUNTAIN RANCH | - - - - | <i>Ashley C. Dixon</i> | 192 |
| THE CHOICE OF A RECEIVING TUBE | - - - - - | <i>B. S. Havens</i> | 195 |
| LISTENING-IN IN MAMMOTH CAVE | - - - - - | <i>Fred G. Harlow</i> | 197 |
| WHAT YOU SHOULD KNOW ABOUT ANTENNAS AND GROUNDS | | <i>R. H. G. Mathews</i> | 201 |
| WHEN THE PRISON BAND GOES ON AT WOS | - - - - - | <i>J. M. Witten</i> | 205 |
| THE ARISTOCRACY OF RADIO RECEIVERS | - - - - - | | 207 |
| A SIMPLIFIED SUPER-HETERODYNE | - - - - - | <i>A. J. Haynes</i> | 210 |
| VARIOUS CIRCUITS AND WHAT THEY MEAN | | | |
| Part II. What Inductance Is and How It's Used | - - - - | <i>Zeb Bouck</i> | 217 |
| MAKING RADIO ATTRACTIVE TO WOMEN | - - - - - | <i>Lewis Wood</i> | 221 |
| HOW TO NEUTRALIZE THE NEUTRODYNE | - - - - - | <i>Kimball Houton Stark</i> | 223 |
| MUSIC DEALERS: LOGICAL SALESMEN OF RADIO SETS | - - - - - | <i>T. M. Pletcher</i> | 226 |
| WHAT OUR READERS WRITE US | - - - - - | | 230 |
| HOW GERMANS USE RADIO AT AUTO RACES | - - - - - | | 233 |
| WHAT RADIO MEANS TO ME | - - - - - | <i>W. Francis Goodreau</i> | 234 |
| IN THE R. B. LAB | - - - - - | | 236 |
| Improving the One-Tube Reflex Set | | The Daniell Cell as an A Battery | |
| The One-Tube Reflex with a Ballantine Variotransformer | | Building Your Own Laboratory | |
| A "Super" Wave-Changer from a Three-Circuit Regenerative Receiver | | | |
| ALONE AMONG THOUSANDS | - - - - - | | 245 |
| IF YOU LIKE THEM, LET THEM KNOW IT | - - - - - | <i>Myra May</i> | 246 |
| A TWO-STAGE AMPLIFIER FOR YOUR RECEIVER | - - - - - | <i>Carl Goudy</i> | 250 |
| THE GRID | - - - - - | | 260 |
| Adding Audio Amplification to the One-Tube Reflex | | | |
| ADDITIONAL BROADCASTING STATIONS IN THE UNITED STATES | - - - - - | | 262 |
| NEW EQUIPMENT | - - - - - | | 264 |
| AMONG OUR AUTHORS | - - - - - | | 266 |

Copyright, 1923, by Doubleday, Page & Co. All rights reserved
TERMS: \$3.00 a year; single copies 25 cents

F. N. DOUBLEDAY, Pres.

RUSSELL DOUBLEDAY, Sec'y.

ARTHUR W. PAGE, Vice-Pres.

S. A. EVERITT, Treas.

NELSON DOUBLEDAY, Vice-Pres.

JOHN J. HESSIAN, Asst. Treas.

DOUBLEDAY, PAGE & CO.

THE WORLD'S WORK

COUNTRY LIFE

THE GARDEN MAGAZINE

SHORT STORIES

EDUCATIONAL REVIEW

CHICAGO: People's Gas Bldg.

GARDEN CITY, N. Y.

NEW YORK: 120 W. 32nd Street

BOSTON: Tremont Bldg.

LOS ANGELES: Van Nuys Bldg.

Clear as Your Headphones

CALL in the crowd, now. Everyone can listen in with as much joy as one man at the headphones. Here is a loudspeaker with a reproducing range so wide that it gets all the tones—the high notes—and the low ones—with all their overtones and partials—full and rich. With a horn so perfect that it causes no distortion—adds no vibration of its own. And a one-finger adjustment that controls the volume, at your pleasure. Everything—music, speech, sports news—*clear for the crowd!* No more one-man radio sets. Everybody gets it—all!



This symbol of quality is your protection.

Radiola Loudspeaker
Model U. Z.—1320
Price \$36.50



Radio Corporation of America

Sales Offices: Dept. 31

753 Broadway, New York

10 So. La Salle St., Chicago, Ill.

433 California St., San Francisco, Cal.

Radiola

LOUDSPEAKER

★ Tested and approved by RADIO BROADCAST ★

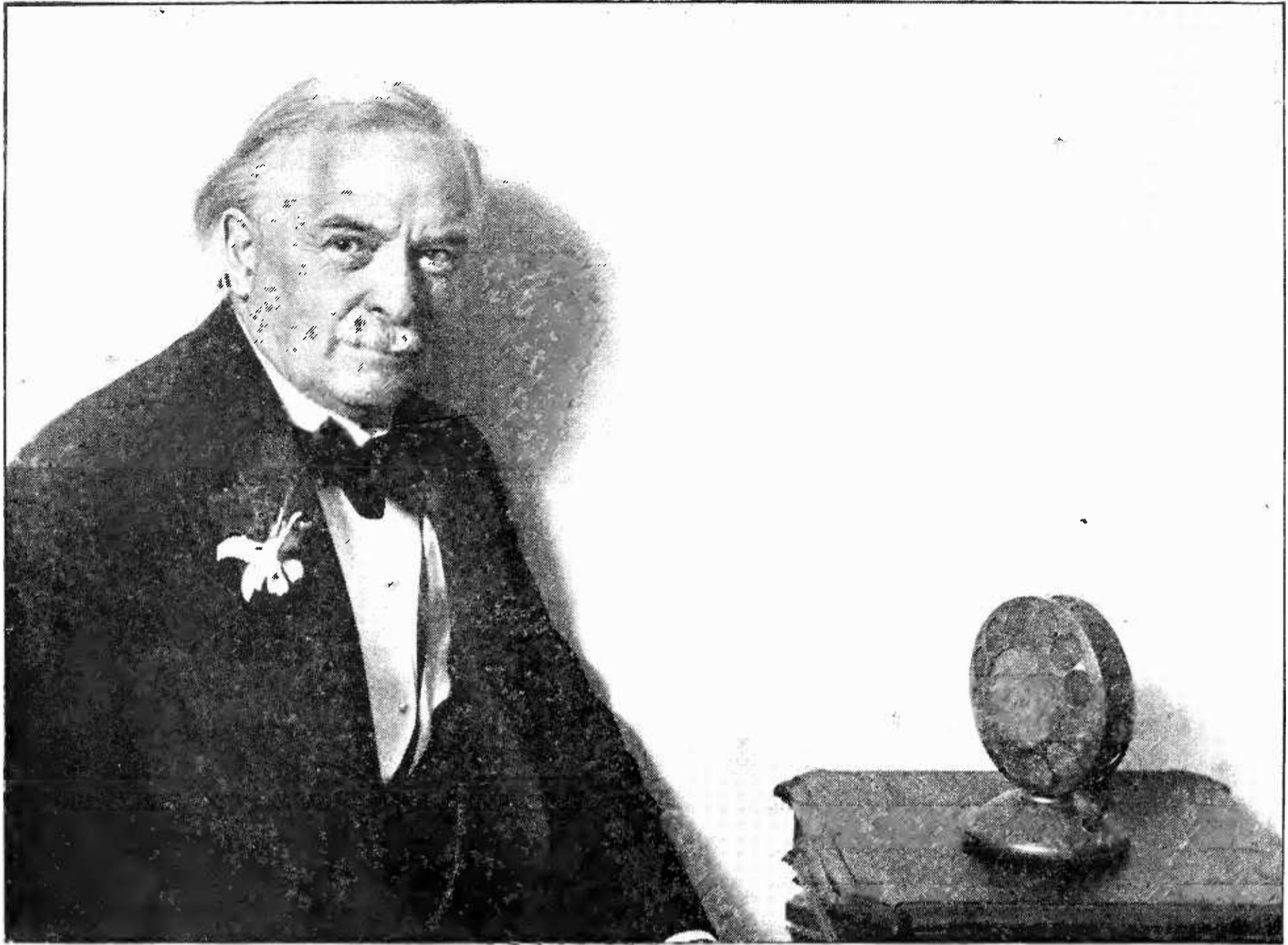

“THOSE WHO MAKE WAR, WHETHER THEY ARE INDIVIDUALS OR NATIONS, CANNOT ESCAPE RESPONSIBILITY FOR THE PEACE. . . .

“But if you here, this mighty people, if our people throughout the British Empire, resolutely, firmly, courageously, without flinching, carry out the message, then I have no fear but that humanity will climb to higher altitudes of nobility, of security, of happiness, than it has ever yet known.”

—*DAVID LLOYD GEORGE,*

In his last address to the American people on Friday evening, November 2nd at the Metropolitan Opera House, New York. Hundreds of thousands heard the speech, broadcasted through WEAFF's faithful microphone

The Transatlantic Broadcasting Tests and What They Prove

How the Tests Originated, How They Progressed, and What Went on at RADIO BROADCAST'S Receiving Station in Garden City

EXCERPT FROM MR. OWEN D. YOUNG'S SPEECH, TRANSMITTED THROUGH WGY, WHICH OPENED THE AMERICAN TRANSATLANTIC TESTS

Friends and neighbors of Europe and America, I greet you from station WGY in behalf of the radio enthusiasts of America and in the name of RADIO BROADCAST, under whose inspiration and direction these transatlantic tests are being carried out.

First, let me send to the engineers of the world the congratulations of the technical concerns of America. Your efforts have made possible these first steps in international communication, which, in the end, will make all the world one neighborhood. We shall have understanding in place of misunderstanding. We shall have relationship of neighbors in place of the relationship of strangers. Men who talk with each other daily, with the object of better understanding, do not fight. Let these international conversations go on. Let the work of the engineers go on.

Next, let me say a word about the radio amateurs of the world, for they are engineers in the making. The greatest asset of any new art is, to have the youth of the world interested in its development and confident of its future. The greatest inventions have been made by men under thirty. Hundreds of thousands of young men in this country are interested in and at work on radio. Future inventive genius of the world is preparing to add its great contributions. Radio is to-day the debtor of many young men, once amateurs, now great inventors. The amateurs of to-day will be the inventors and engineers of to-morrow; not only from the great research laboratories, but from that little spare room in the attic and that old work bench in the cellar will come new and great discoveries. Let the work of the amateurs go on.

Peace can come through voluntary disarmament only when, and to the extent that, we substitute instruments of international communication for instruments of international destruction. Engineers develop instrumentalities. They are not responsible for their use. Whether instruments shall be used for peace or war depends not upon the engineer, but upon the public opinion of the peoples of the world, and informed public opinion rests upon adequate communication.

The coöperation of the scientists and engineers of all nations to render a service to all peoples sets an example for the politicians and diplomatists of the world. Will the politicians follow that example?

ON SUNDAY night, November 25th, a stage was set such as the world had never known before.

This stage was built of rock and earth and ocean, with the moon and stars as spot-light and border-lights, and with a good part of the entire English-speaking world as audience.

For the first time in history, the man-in-the-street in England and his brother layman in the United States were enabled to listen to each other's voices.

And when the clocks of the Eastern and Middle-Western sections of this country struck ten, and farther west, nine, thousands of receiving sets were tuned

to the wavelengths of the eight stations of the British Broadcasting Company which transmitted to American listeners as the first step in the seven-day international broadcasting tests arranged by RADIO BROADCAST, in conjunction with the *Wireless World* and *Radio Review* (London). Aiding these two publications were the resources of the

RADIOGRAM
WORLD WIDE WIRELESS

CONTINENT TO CONTINENT SHORE TO SHIP SHIP TO SHIP

Via RCA RADIO CORPORATION OF AMERICA Via RCA

FORM NO. 117
RECEIVED AT 64 BROAD STREET, NEW YORK, NY. M. DATE 1923 NOV 27 PM 12 39

MPMUU R535 LONDON 31
RADIO BROADCAST
DOUBLEPAGE NYK

AMERICAN BROADCASTING HEARD THROUGHOUT COUNTRY BEST WGY NATIONAL ANTHEM SPEECHES LYNCH YOUNG ALSO WHAZ KDKA WMAF KSD WOR WGR WBAH WQAR FULL REPORTS EXPECTED TOMORROW

RADIOGRAM

CONFIRMATION COPY
11878

TELEPHONE: BROAD 6100 To secure prompt action on inquiries, this original RADIOGRAM should be presented at the office of the Radio Corporation. In telephone inquiries quote the number preceding the place of origin

SHOWING HOW WELL ENGLAND HEARD US



OWEN D. YOUNG

Chairman of the Boards of Directors of the General Electric Company and the Radio Corporation of America. Mr. Young opened the transatlantic broadcasting from this side

British Broadcasting Company and of our National Association of Broadcasters, besides the many American stations which signified by telegram to RADIO BROADCAST their eagerness to cooperate in these great scientific tests. International broadcasting on a large scale had never before been tried, and broadcast listeners throughout America were at the highest pitch of excitement to know whether or not *their* sets could pick up the faint signals from abroad.

The English listeners were no less enthusiastic, although the difference in time brought the beginning of their tests literally to "Three O'Clock in the Morning." Small wonder then, that this familiar music-hall piece found a significant place on many of the British programs.

HOW THE TESTS ORIGINATED

UPON his return from a trip to England a few months ago, during which he made a detailed study of radio broadcasting there, Mr. F. N. Doubleday, President of Doubleday, Page & Company, made the suggestion at one

of the weekly meetings of the editors of his magazines that it would be extremely interesting, and stimulating both to the progress of radio and to international friendship, were it possible for RADIO BROADCAST to arrange a program of broadcasting from this country to England.

After a rather extended discussion, the suggestion was made that two-way broadcasting, instead of one-way tests, be attempted. A working plan was outlined by this magazine and submitted to Hugh S. Pocock, Editor of the *Wireless World and Radio Review* of London. Mr. Pocock brought the proposal to the attention of the British Broadcasting Company and an agreement was made between that company's chief engineer, Captain E. P. Eckersley, and the two radio magazines, to carry out the plan.

Mr. Pocock and Captain Eckersley arranged all the details in England and immediate steps were taken to secure the cooperation of those interested in radio in this country. Inasmuch as National Radio Week would come at a time when atmospheric conditions would be favorable, it was decided to hold the tests as a feature of the National Radio Week program.

Newspapers all over the country were quick to appreciate the importance of this international program and were most generous with their space. In New York, for instance, the Associated Press, the United Press, and the International News Service spread abroad over their wire lines daily stories relating the details as they developed.

WHO WAS TO SPEAK FOR AMERICA?

NATURALLY, when it came to inviting speakers to broadcast messages to England from this country, our first thought was of the President. And we visited the White House in an effort to have Mr. Coolidge address the people of America and England simultaneously. Mark Sullivan, of Washington, the internationally known writer on politics, acted as RADIO BROADCAST's representative at the Capitol. Unfortunately, there was not time enough to arrange the diplomatic details necessary for an arrangement, entirely unprecedented, of this kind.

Similar diplomatic obstacles prevented the Prince of Wales and Prime Minister Baldwin of Great Britain from speaking. As the most influential single man in the radio field in the United States, we looked to Owen D. Young,

Chairman of the Boards of Directors of the General Electric Company and the Radio Corporation of America, to open the international program for America. Through Mr. Stuart Crocker, assistant to Mr. Young, we learned that Mr. Young would be glad to aid our program in any way he could.

When we brought our plans to Major-General James G. Harbord, President of the Radio Corporation, he, too, was quick to lend his generous aid.

The romance of this attempt at international communication appealed very strongly to Mr. Henry Ford. Every American knows that Mr. Ford is credited with making the impossible possible in the automobile industry, and he was so much in sympathy with this first attempt at linking nations by voice that he agreed to address the people of England and America through his own station at Dearborn, Michigan—WWI. In securing Mr. Henry Ford's cooperation, we were greatly aided by Mr. Samuel Crowther, Mr. Ford's biographer.

One of the most important addresses made during these tests was that of Charles Evans Hughes, Secretary of State, on Friday night, November 30th, in Philadelphia, before the American Academy of Political and Social Science, and broadcasted by WDAR in that city.

Although we have held our presses until the last minute in order to give our readers as detailed a report as possible, the programs from the English broadcasters have not come through in full. Each American broadcaster had full charge of arranging his own transatlantic program.

However, Governor Hyde of Missouri spoke for fifteen minutes from KSD in St. Louis, and British Vice-Consul Hyde and Mr. Frank Conrad, Chief Engineer of the Westinghouse Electric and Manufacturing Company, made addresses from the Pittsburgh *Post* studio which were put on the air by KDKA.

On the nights of the American transmission, the most powerful broadcasting stations on this



"THE FIRST NIGHT"

Scene: RADIO BROADCAST laboratory, Garden City, L. I., where two super-heterodynes and a six-stage tuned radio-frequency receiver occupied the attention of (left to right): George J. Eltz, Jr., George Toohill, A. J. Haynes, Paul F. Godley, C. L. Farrand, and the editor of this magazine

side of the Atlantic were invited to send special programs from ten to ten thirty, Eastern Standard time. And every broadcast listener knows how many of these stations prepared excellent programs and put them on the air.

The day following each of the American transmissions, the British Broadcasting Company and the *Wireless World* advised RADIO BROADCAST by radiogram of the American stations which were heard best in England. Shortly before the final two-way test, we chose the American stations to send the final program to England from these reports of good reception in England.

The list of American broadcasters sending on the first three American test nights would be excessively long. But the stations selected for the two-way communication on the last night were: WGY, WOR, KSD, WGR, WTAM, WOC, WSAI, WHAZ, WJAZ, and WGI.

In concluding the American participation in these international tests, Major-General James G. Harbord, President of the Radio Corporation of America, spoke to the people of England for five minutes over a special telephone wire from New York city through WGY in Schenectady.

Burton J. Hendrick, Associate Editor of *The World's Work* and biographer of the late Walter Hines Page, addressed the people of the British Isles through WOR in Newark.

COÖPERATION BY AMATEURS, COMMERCIAL STATIONS AND BROADCASTERS

WITHOUT the help of amateur and ship and shore operator, broadcaster, and radio executive, the tests would have failed utterly. And what help they gave! RADIO BROADCAST has always maintained that the radio amateur is ever willing to assist in any activity contributing to the development of the art. Of this, no greater proof could be had than the fact that

during the entire week not a single complaint against amateur interference was made.

Because the wavelengths of some of the broadcasting stations are very close to those used for ship-to-shore commercial traffic, interference with radio programs is sometimes experienced. Unfortunately, this is at present a matter quite beyond the control of either ship or shore stations. Five minutes before the first transmission from England began,

we communicated with the Marine Superintendent of the Radio Corporation and requested that he send a service message to his ships asking them to remain silent for the half-hour period of the tests, except in case of an emergency. Our request was complied with and interference from this source during the week was practically negligible. A similar request, made to Mr. C. J. Pannill, President of the Independent Wireless Telegraph Company, received the same courteous attention.

Our most serious problem was to secure the coöperation of the broadcasters themselves. With approximately six hundred broadcasting stations in the country, this seemed an almost hopeless task.

Mr. Eugene F. McDonald, Jr., President of the National Association of Broadcasters, and Mr. Paul B. Klugh, the Association's executive chairman, were apprised of the campaign and their help was enlisted. The National Association took it upon itself to secure the coöperation of all the broadcasters numbered among its members. Almost before the sun went down on the day the Association decided to coöperate, the announcers of some of the best broadcasting stations in the country were telling their radio listeners of the great experiment to come.

Our attempts to keep the American broadcasters silent on the first two nights of the



MARTIN P. RICE

Director of Broadcasting of the General Electric Company, whose whole-hearted coöperation went a long way toward making the tests successful

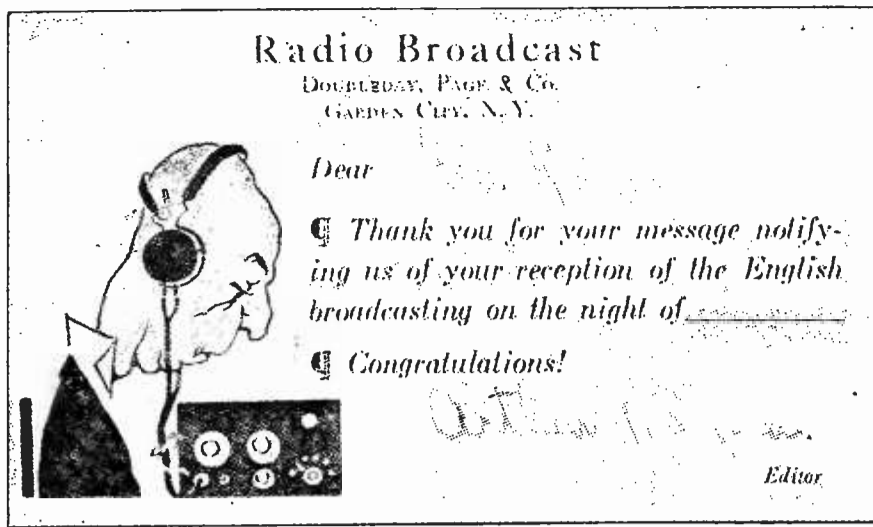

CARDS LIKE THIS WENT TO ALL WHO REPORTED HEARING ENGLAND

English transmission were only partially successful. We appealed to the President of the National Association of Broadcasters to communicate with all his member stations by telegraph. He advised them to broadcast an announcement requesting listeners-in to communicate with other stations in their vicinity asking them to remain silent during these eventful half-hours. That night, at our own laboratory, we heard this message flung out over the country. The result was almost absolute silence on the last and most important night of the tests. Could a more convincing demonstration be had of the effectiveness of radio broadcasting in reaching every section of the country?

Having to act on such short notice was a great hardship on most of the directors of the broadcasting stations. Most of them had complete programs arranged, many of which had already been published in the newspapers. Thanksgiving night was a particularly difficult one to handle. Many special features had been arranged. But these men sacrificed the interest of their individual stations for the greater interest. They deserve the highest praise for their coöperation and resourcefulness in making these eleventh-hour shifts in their programs.

In order that both sides of the broad Atlantic might know exactly how the tests were faring at all times, it was necessary to have a rapid means of inter-communi-

cation. The voice tests were pure experiment. But transocean radio telegraphy was not. So the well-established radio telegraph came to help out the infant radio telephone. General Harbord put the transatlantic service at our command and a direct wire was installed between the Broad Street Radio Central office in New York and RADIO BROADCAST laboratory at Garden City. The British Broadcasting Company and Marconi House, London, were connected by a similiar wire so that not an unnecessary second was lost in communication between the two countries. As an instance of the effectiveness of this circuit, during the tests from England on the first night, we were receiving speech which we believed was from London but which we could not understand. A request that a piano be played was winged over the radio telegraph circuit across the Atlantic. Just three minutes later a pianist in London was playing, and we were listening to the music in Garden City in common with hundreds of others whose reports have reached us by telegraph and mail from as far west as Davenport, Iowa.

Any visitor to the RADIO BROADCAST offices during the test week would have been as deeply impressed as were the editors with the phenomenal interest shown by listeners-in in every corner of the nation. Telegrams, letters, post cards and a host of local and long distance telephone calls, poured into the office night and day, each with their story of English reception.

MAJOR-GENERAL HARBORD
President of the Radio Corporation
of America, who, with his great
organization, helped to make the
tests possible

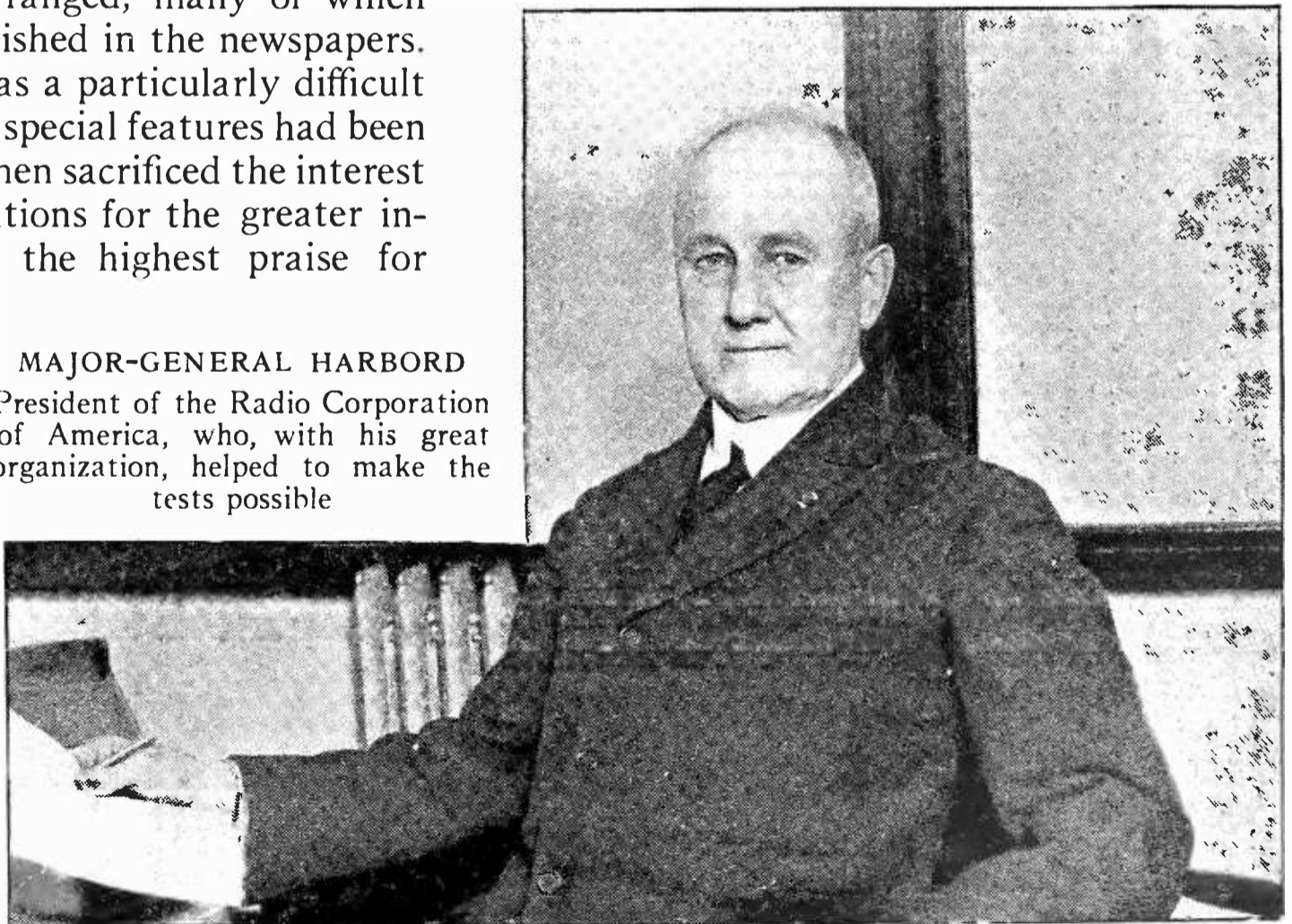

The broadcast listener was alert, capable, and extremely willing to do his bit, even to the extent of considerable expenditure for telegrams and long distance phone calls. For instance, one youth in Connecticut had a telegram in our office ten minutes after a British program had finished, reporting his reception of it.

In order to facilitate communication of this character, Commercial Vice-President C. A. Comstock of the Postal Telegraph-Cable company agreed to use every facility of his company, through careful instructions to his district office managers, to hasten the delivery of messages from listeners-in in various sections of the country to the Garden City laboratory.

SPECIAL RECEIVING STATIONS

ALTHOUGH every effort was made to have the receiving station in RADIO BROADCAST laboratory the finest possible, we wished to enlist the best radio aid in this

section of the country in receiving England. On the first night of the test, in RADIO BROADCAST's Laboratory, Paul F. Godley (best known to American fans through his successful reception of American amateur signals, in Scotland, in November, 1921) and C. L. Farrand (Mr. Godley's associate), operated a specially constructed tuned radio-frequency amplifier receiver employing a three-foot loop antenna. George J. Eltz, Jr., manager of the radio department of the Manhattan Electric Supply Company, used a nine-tube super-heterodyne which he constructed especially for the test. A. J. Haynes, Vice-President of the Haynes-Griffin Radio Service, Inc., operated a seven-tube super-heterodyne, which was also constructed for these tests. All of these receivers picked up English signals.

On the last night of the tests, Frank M. Squire, Chief Engineer of the De Forest Radio Telegraph and Telephone Company, picked up England on a six-tube reflex receiver.

Located outside of New York and communicating with our laboratory, were Dr. Walter van B. Roberts, of the Palmer Physical Laboratory, Princeton University, with a super-heterodyne of his own design. Dr. L. M. Hull of the Radio Frequency Laboratories at Boonton, N. J., operated a six-stage tuned radio-frequency receiver. Engineers of the General Electric Company moved a receiving station from Schenectady to a point outside the city in order to get better signals. Besides these, Mr. Frank Conrad, Chief Engineer of the Westinghouse Electric and Manufacturing Company, listened-in at Pittsburgh, Pa. Several of the students at Rensselaer Polytechnic Institute at Troy, N. Y., used a 12-tube super-heterodyne of the resistance-coupled type.

Operators at most of the broadcasting stations kept us advised of the results they obtained. At Station CFAC, Calgary, Alberta, operators used a ten-tube super-heterodyne. Operators at WOC, Davenport, Iowa, WOR, Newark, N. J., and KSD, St. Louis, also advised us of their success.

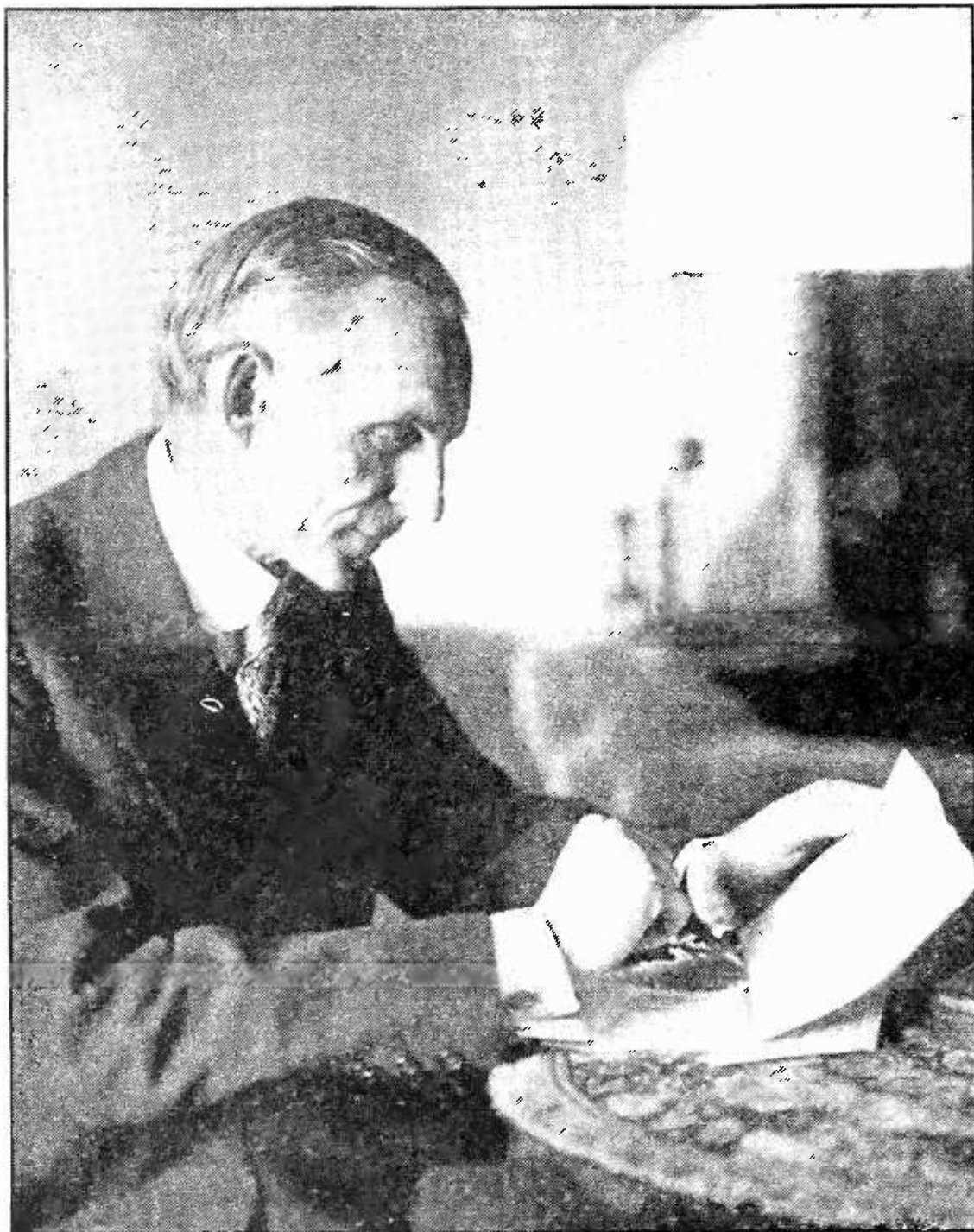

HENRY FORD

Who spoke to England from his own station, WWI, at Dearborn, Michigan, on November 30th. Mr. Ford had never made a radio address before

DIFFICULTIES AND ADVANTAGES IN ENGLAND

THE difficulties in arranging this test were not only electrical, but physical. It is well-known that radio signals cover much greater distances at night than during daylight hours. For this reason, it was thought advisable to run the tests during a period when complete darkness prevailed between the English stations and the United States and Canada. From 10 to 10:30 P. M. Eastern Standard time, the period chosen for these tests, is 7 to 7:30 P. M. on the West Coast and from 3 to 3:30 A. M. in England.

Picture the problem of the British Broadcasting Company. They had eight stations, joined by land wire to the central offices in London. They had large staffs to maintain, during these extra hours. An additional force of experts was required at their central office to handle the mass of detail incident to keeping the whole eight stations running smoothly. Besides, the strain on the operators and managers was considerable. Not only had they to broadcast during their usual hours, but each night for a week the entire crew was kept up until at least four every morning with American transmission and reception.

Besides this, the telephone exchanges leading into the Broadcasting Company's offices were positively clogged with calls after and during their tests. There was also an enormous influx of mail from British listeners.

There were, however, four distinct advantages that British listeners had over those in America. All the British stations were under single control. There was, then, no interference from other broadcasting stations in England. Oscillating receivers, which proved a serious source of interference in cities in the United States, are prohibited by law in England. Furthermore, the American stations used a great deal more power to transmit than the English. And finally, the arrangement of programs offered slight difficulty to the English also, since all the stations were controlled at one office.



SENATORE GUGLIELMO MARCONI

At 3 A.M., London Time, November 28th, he addressed the American listeners-in through the eight stations connected by land lines to the central office in London

It would seem that it must be a notable event indeed which would keep Guglielmo Marconi, whose speech was recorded in this country, up until three o'clock in the morning. Senatore Marconi, in his radio address, mentioned this significant fact: it was just twenty-two years ago in December that the experiment took place wherein he received from Poldhu, England, that eagerly awaited letter "S" at St. Johns, Newfoundland.

A WRECK OF PLANS AVERTED

ONE of the most serious situations we had to deal with presented itself on Thanksgiving morning. The tests conducted from England the night before had been quite unsatisfactory, due to the failure of many of the American broadcasting stations to shut down, together with unfavorable atmospheric con-

ditions on this side. The British Broadcasting Company then decided to conduct no more tests until the last night. Before their radiogram to this effect was received, we had telegraphed all over the country requesting broadcasters to maintain the silence periods on the last two remaining nights of the tests. The prospect of reception from the other side seemed excellent. Then came this startling message from England: *Reception still good no more tests until attempt at two way communication December first as per program—British Broadcasting Company.*

At twelve o'clock, we sent a message to both the British Broadcasting Company and the *Wireless World*, stating that we had secured much better cooperation and that listeners-in throughout America were waiting for them to transmit. After waiting two hours for a reply, we asked Mr. W. A. Winterbottom, Traffic Manager of the Radio Corporation to send a service message to the traffic manager in England exhorting him to get in communication with Captain Eckersley of the British Broadcasting company, or Mr. Pocock of the *Wireless World* by telephone. Within another hour, we had received this reply: *Doublepage New York — London 363 Bournemouth 385 metres 3 to 330 AM GMT—British Broadcasting Company.* A deep sigh of relief then was breathed. Service of this kind almost surpasses belief.

The space available does not permit us to detail the story of receiving England on all the test nights, but perhaps the account of the first night of receiving from England will interest thousands of other listeners in all sections of the land.

After spending a day installing the receiving sets and making preliminary tests, three complete receivers at our laboratory were ready to listen-in for the English broadcasts. RADIO BROADCAST'S new laboratory was rushed to completion for the tests, but the electric light installation had not been completed. Mr. Godley and Mr. Farrand operated their receiver in a room opening off the laboratory, aided by the glow of a kerosene lamp. Beside them, operating the land wire between RADIO BROADCAST and Radio Central, Broad Street, New York, was

Willis K. Wing, of the RADIO BROADCAST staff. Behind them, in the semi-darkness, representatives of most of the New York newspapers and news services as well as foreign correspondents of English papers were gathered, eagerly awaiting the first faint British voice. At one side were the press photographers with camera and flashlight gun. Two of the most interested spectators in the laboratory were Mr. F. N. Doubleday, and Nelson Doubleday—both ardent radio enthusiasts.

In the laboratory itself sat Mr. Eltz and Mr. Haynes at their respective sets. For a half hour before the test period, the visitors were entertained by music picked up from all over this country as the operators tuned-in to get their bearings on the wavelengths and dial setting on which they would be most likely to pick up the English stations.

“HELLO, AMERICA!”

IMAGINE yourself with us in the new “shack” that night. It is five minutes to ten. The first stroke of the time signals from Arlington booms in on the loud

speakers. As each second brings the start of the test nearer, you feel the tension increase. You hear the long dash. It is just ten. Now. . . Loud speakers are abandoned for headphones. The faint click of a filament rheostat seems as loud as a shot. Fifteen minutes pass. The only stations heard are those Americans which unwittingly continued to broadcast. No word is said, but the waiting newspaper men detect an occasional frown on the faces of the tense operators which tells plainer than words that so far, there's “nothing doing.”

Now the operators bend over their receivers and manipulate their dials most delicately. Speech is heard, but they cannot understand it. They are asked to hold their receivers to the same wavelengths, while a radiogram is sent to London asking for piano solos. Three minutes pass. Faint but clear come the notes of the piano playing in distant London. The operators catch the now famous: “Hello, America” and the newspaper men leave hastily to telephone to New York. Success! In another minute—literally—RADIO BROADCAST'S congratulatory radiogram is in London.



EUGENE F. McDONALD, JR.
President of the National Association of Broadcasters, who helped to keep American stations off the air during the British transmitting periods

WHAT THESE TESTS PROVE

INTERNATIONAL broadcasting is now no longer an idle dream, but a fact. Now we can expect its rapid development. These developments may not make it possible for the owner of an average receiver to listen-in on London at will. It may first be necessary to abandon our present system of direct broadcasting for some form of re-broadcasting. By this plan, the waves from stations operating in England, or even other countries, would be picked up by sensitive receivers here, amplified and sent out by any of the stations we now hear.

Before this kind of international broadcasting can be realized, there are many technical difficulties which must be overcome. But by this arrangement, it would be possible, as Marconi himself has already suggested, for the owner of a modest crystal set,

over here, to receive speech and music from Europe.

If we are not content to postpone international voice communication until this re-broadcasting system has been completed, these tests have absolutely proved that broadcasting stations of higher power than those used in Great Britain are essential. For American stations of more than average power experienced little difficulty, in general, in reaching England, whereas the English stations operating with comparatively low power did exceedingly well to be heard in this country at all.

Heretofore, the need for high-power transmitters has not been felt in England, due to the fact that their stations have been designed to serve a territory much smaller than ours.

A better apportionment of wavelengths is an unquestioned necessity to overcome the

(Continued on page 195)

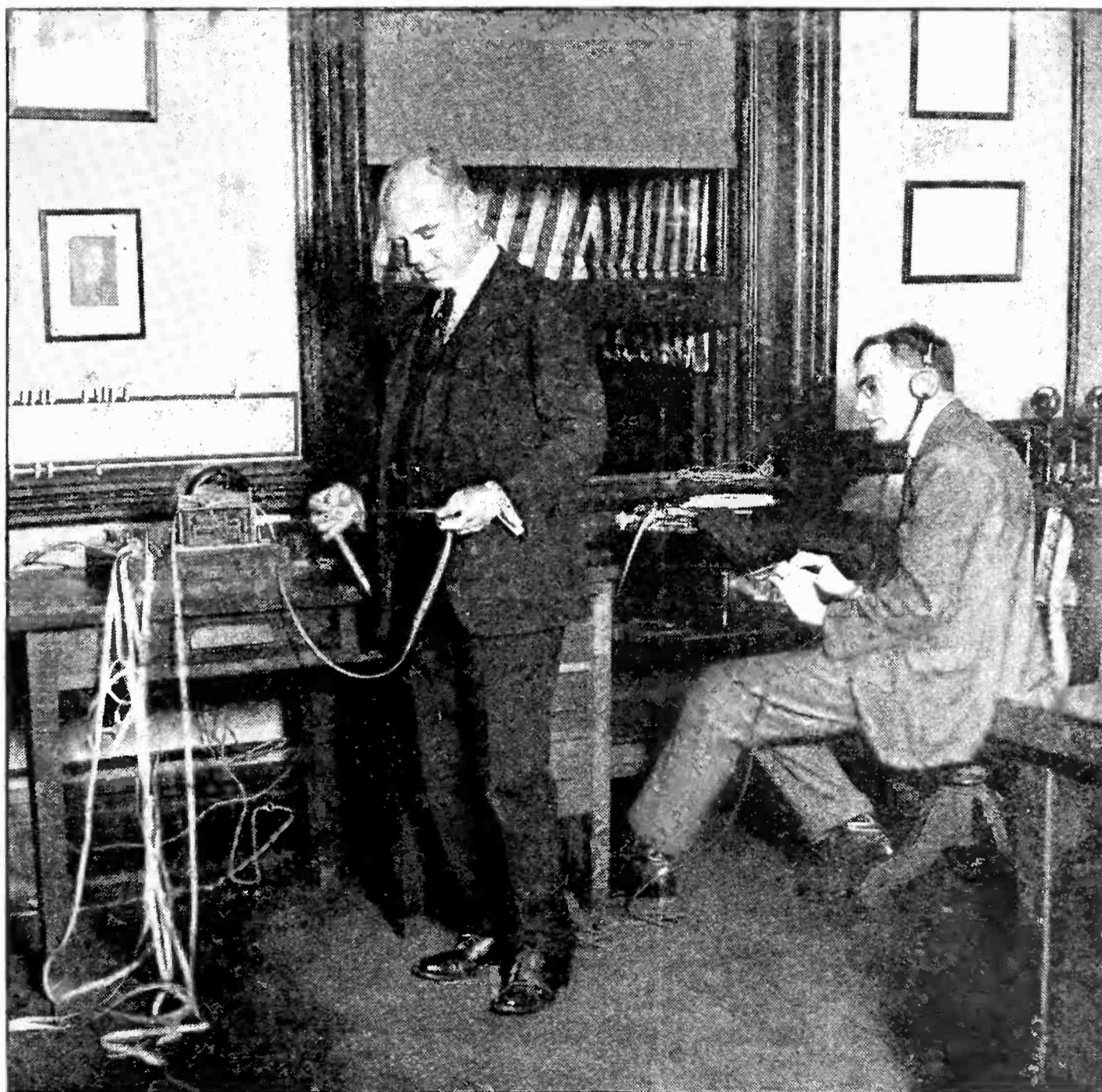

AT RADIO CENTRAL, NEW YORK

W. A. Winterbottom, Traffic Manager of the Radio Corporation, looking over the tape used on the Wheatstone transmitter in sending messages to England directly from the RADIO BROADCAST laboratory, notifying the British broadcasters of their success in reaching America



THE HOUSE THAT RADIO MADE

A view of the Dixon ranch at Stevensville, Montana, taken Thanksgiving Day, 1922. In the spring of 1922, the house was radio-less. Now it contains broadcasting station KFSR and amateur stations 7IT and 7ACP

What Radio Means at a Rocky Mountain Ranch

A Story of the Remarkable Change that Twelve Months Brought in a Remote Home in Montana

By ASHLEY C. DIXON

FAR out in western Montana, under the shadow of the mighty Bitter Root Mountains, lies a little valley some ten miles wide near its center and about seventy-five miles long. Similar in many respects to dozens of other ranching valleys of the great northwest, it might well be the scene of any of the present-day stories which have such an appeal to the Eastern reader: stories of cattle, of irrigation, or of the "Winning of the West."

Such spots are always described as smiling with the goodness of nature. The air is warm and dry. The sun always shines, and the hardships of city life are unknown.

In part this is true. But there is another

side to the changing seasons which mark the cycle of the sun's passage to the winter solstice. The summer is comparatively short. Autumn comes early in September, and following close upon the light frosts comes the Rocky Mountain winter. Then nature shows her other side, and for months the fields and ranch houses lie under a mantle of snow. The soft music of the summer breeze is replaced by the roar of the northeast wind bearing its burden of fine stinging snow. Roads drift feet deep in hard-packed ice particles. Cattle band together for mutual warmth and protection, seeking the shelter of the cotton-wood clump on the creek bottom.

To the Bitter Root Valley came an Eastern

family about thirteen years ago, just as thousands of others have come to trade the hardships and comforts of Eastern city life for the entirely different hardships and comforts of the West. The ranch home with its large room and its big open fireplace, took the place of the city house. Alfalfa, fruit, and livestock replaced the office desk, and the rumble of the streets and clang of the trolley were forgotten.

There were compensations to make up for everything left behind save one thing alone. No one who enjoys concerts, opera, or addresses by the leading minds of the nation can ever find a substitute for the pleasure they give. While living in a great city such forms of entertainment are taken as a matter of course. One does not realize what they really mean till they are not to be had. And winter is the season of music.

We, the above-mentioned family, put in eleven long mountain winters. The days are short in the northwest country, and night comes in what used to be considered mid-afternoon. There were books to be read, cards and other games, and the phonograph. No physical comforts were lacking around the evening fire, but something was lacking, a part of the old life was gone with nothing to take its place. Then came radio!

A year ago last May we began to hear of the wonders of the radio receiver, and how one could light certain lamps contained in a box, after properly hooking the box up to a wire out-

Has This Happened Yet to You?

Says Mr. Dixon: "In September, 1922, we lighted our first tube. To-day the son is a licensed commercial radio operator, and the writer holds an amateur license. Each has his own transmitting set with which communication is had every night with other amateurs in the western half of the United States."

side the house, turn a few dials, and listen to music. Wonderful! We had never seen such a box, nor did we know whether the lights in it were arc lamps or just the ordinary household electric lights. But no matter what the type or kind, if they would bring the outside world to us over the mountains and through the miles of snow covered pines, we wanted some of these Aladdin's Lamps of radio.

Advice was sought, but very difficult to get.



FIFTEEN MONTHS AGO THIS ROOM CONTAINED NOTHING
More technical than a $\frac{1}{4}$ -KW sewing machine.

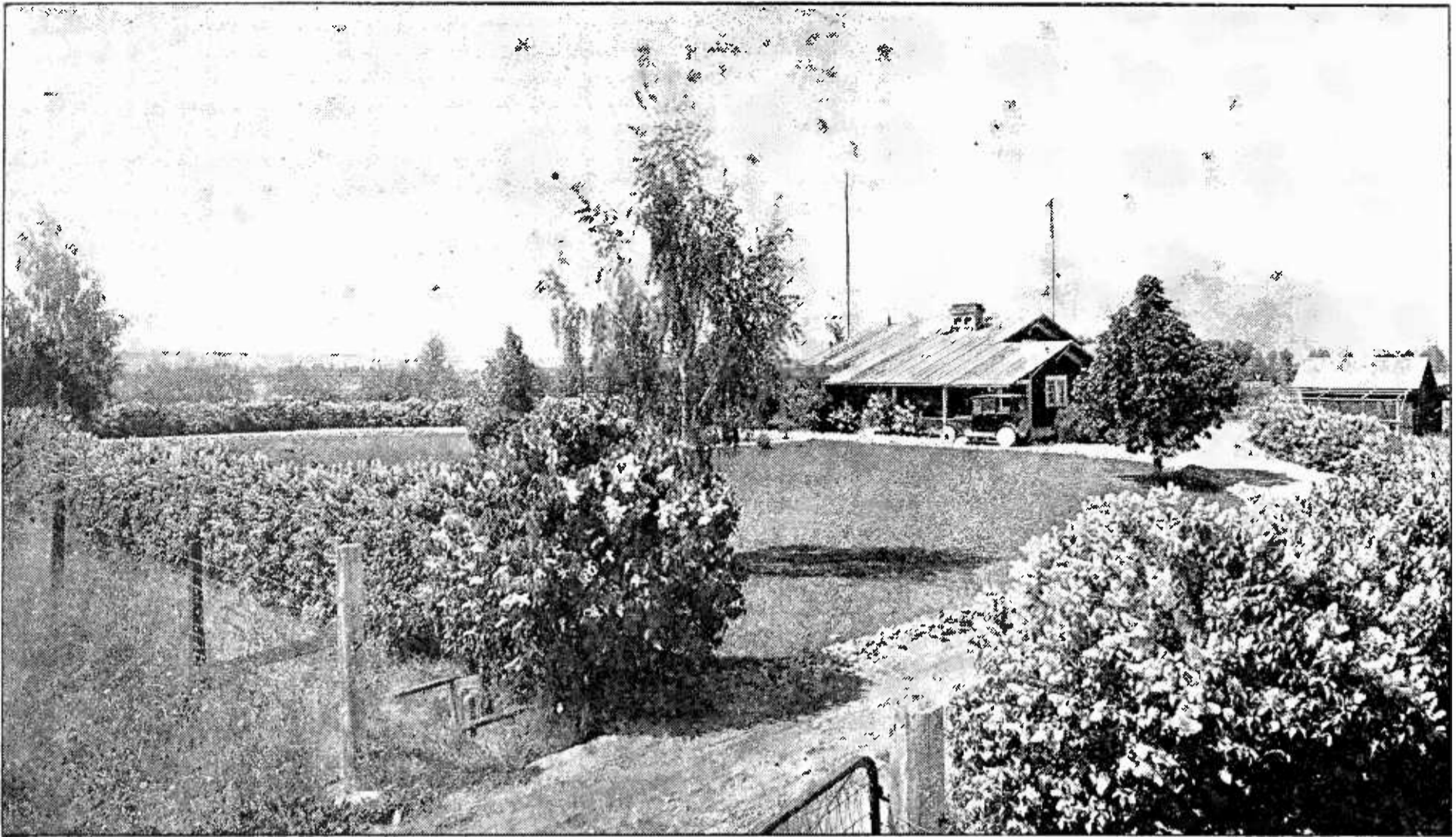

“THE FLOWERS THAT BLOOM IN MONTAN’, TRA LA . . .”

And what we could get was of the most discouraging kind. “Bring radio waves over 10,000-foot mountains and down to the floor of the valley? Impossible.” The antenna (that wire we had heard about) would have to be a couple of hundred feet high, and even then we would probably find we were in a “radio shadow,” and the trouble and expense would be for nothing. Hope was blasted, and for a time we gave up the idea.

While in Missoula one day in June we happened to get into conversation with a music dealer friend. He had a picture of a radio receiver which he contemplated taking the agency for. But he, too, had heard adverse reports about what we could expect, and was hesitant about taking up the matter.

A few days after our conversation with this gentleman, we departed for California on a vacation trip. Radio was still a topic of interest, and we intended to find out just what we could learn about its wonders while in San Francisco. There were radio stores and department stores handling radio receivers and supplies. We made life miserable for many a good-natured clerk asking this and that. We saw for the first time some of the mysterious boxes, and learned that the “lamps” were called tubes, and were not the garden variety of tungsten light. We were told by ambitious

salesmen that we could expect to get something every once in a while, even in the mountains, if we would buy this or that particular set. The advice was taken and appreciated, but having in mind the picture of the set we had seen in Missoula, no purchase was made.

In July, after our return, the music dealer and the writer determined to take a wild chance, and order a radio set each. The local Forest Ranger was hunted up and asked permission to get a couple of poles out of the forest preserve. Several pages might be filled with the story of how we got these poles down from the mountain side and set up in the ranch yard. Antenna wire was bought in Butte, and finally everything was ready to hook on the little box.

It was evident that the radio set we had decided upon enjoyed a measure of popularity, as the factory could not fill our order for over two months. But all things have an end, and in September our box of tricks came. It was carried thirty miles from the city to the ranch and set up as per directions that afternoon. Evening, only a few hours off, seemed days in coming. Fear and anticipation alternated, and we had but little hope that our gamble against nature, with a man-made machine, would be other than a total loss.

“This is KDN, located on the Fairmont Hotel. Our next selection will be ‘Three

O'Clock in the Morning.'” KDN! Fairmont Hotel! Why, KDN and the Fairmont were in San Francisco, eight hundred miles away. The Fairmont was where we had stopped just a few weeks before. And wonder of wonders, the son in the family had visited the studio of KDN, had talked with the announcer, and his was the first voice of the air to be heard on our new set, easily recognized as the same voice heard in person a short while before. Open before us was a vista of the winter to come. Gone was the fear of winter and its snow. KDN had voiced the promise of delights to follow!

KDN is gone, and the mighty KPO has taken its place. Now the thunder of Hale Brothers' organ, received, amplified, and released through a loud speaker, all located in a little back room called our “den,” fills not only the living room, but the entire house with its melody. WJAZ of Chicago, KHJ of Los Angeles, WGM and WSB of Atlanta, WWJ of Detroit, and now and then KDYX of Honolulu, as well as a host of others, have all contributed their share to the long winter evenings' entertainment. But never will anything sound as sweet to us as did that particular “Three O'Clock in the Morning,” from old KDN.

The writer would wish to stop here, as anything to follow seems to him an anti-climax. However, a tabloid sketch of radio progress

on this ranch might be of interest. In September, 1922, we lighted our first tube. To-day the son is a licensed commercial radio operator, and the writer holds an amateur's license. Each has his own transmitting set with which communication is had every night with other amateurs in the western half of the United States. Stations 7IT and 7ACP are known from Los Angeles to Minnesota. And to-night, September 23rd, we open our own broadcasting station, Radio KFJR, at 8 P. M. This station, designed by Mr. Abner R. Willson, radio engineer of Butte, Mont., is entirely home-made, the work being done by the writer and his son.

The same antenna we use for receiving serves for the amateur transmitters as well as KFJR. The poles are not a couple of hundred feet high, but only fifty. And every now and then, for a radio stunt, the antenna is disconnected, and music or speech picked up with a bell cord tacked to the picture rail in the den, from stations as far away as WJAZ, in Chicago, loud enough to be heard through the loud speaker a hundred feet from the house.

Winter is now a season of anticipation and joy. Summer—the poetic Western summer of gentle breezes and sunshine—is tolerated as a necessary evil, preceding the season of snow and blizzard, made perfect by the “voices of the air.”

“The Choice of a Receiving Tube,” by B. S. Havens, omitted from this issue, will appear next month

The Transatlantic Broadcasting Tests and What They Prove

(Continued from page 191)

interference now experienced on the broadcasting wavelengths. Those now used by ship and shore stations have been adopted by international convention and it will be impossible to change them before the next international conference. However, an effort is being made to reduce this interference to an absolute minimum by regulations of the companies in charge of ship and shore stations.

Receiving sets which in themselves act as

transmitters when improperly operated, must be abandoned. Scattered owners of receivers have appreciated this fact for some time, but these tests have brought it home to many more listeners-in. They found it almost impossible to evade the disturbance these sets created.

Our own conception of the great influence that the international exchange of ideas through radio broadcasting will have, is nowhere better expressed than in these words from



Mr. Young's speech from WGY: "Men who talk with each other daily, with the object of better understanding, do not fight. Let these international conversations go on. Let the work of the engineers go on." Or, as Neal O'Hara wrote of these tests in the *New York Evening World*: "It looks like radio is doing its best to cloud up the next war."

MISS CATHERINE MOORE
The first girl radio fan to report picking up the now famous "Hello America" in RADIO BROADCAST'S transatlantic tests

ADDRESS BY MAJOR-GENERAL HARBORD TO LISTENERS-IN OF GREAT BRITAIN
FROM STATION WGY, NOVEMBER, 28TH, 1923

The privilege I now enjoy of addressing people of the old and the new world without having even to raise my voice above conversational tone, is so unique, so impressive, that I am awe-struck at its potentialities. This is indeed an age of miracles. It is only three years ago that experiments in radio broadcasting commanded the awakening interest of our entire country. People marveled at the wonderful agency which made it possible for them to capture from the very atmosphere about them the voice and personality of some artist or speaker perhaps a hundred miles away.

Since then we have passed through a period of development, so rapid and vast as to place it beyond ordinary powers of description. To-day, it can truthfully be said that there is not a community in the United States to which one or more stations of our comprehensive broadcasting systems do not carry their messages of utility and varying entertainment. Leaders of political thought, culture, science and the arts are enabled to address millions of their countrymen in all walks of life, in city and in country with an ease rivalling the intimacy of the telephone.

From those across the sea, our kinsmen by blood and tongue, have come your own statesmen in recent months, and served by this same genie, radio, their voices have reached millions of our people.

And now, scarcely before we have been able to grasp and assimilate the tremendous import of it all, we are invited to speak to our British cousins across the weary stretches of three thousand miles of the intervening Atlantic.

It is a matter of tremendous pride to you and to us that this new accomplishment is the logical outcome of the intensive research and development that has been untiringly carried on by scientists in both our countries since the inception of radio broadcasting.

As my voice reaches the people of England to-night, my memory pictures the great service and unfailing hospitality that our American soldiers received at your hands, while on their way to France. Your splendid cooperation in those trying months will never be forgotten. Nor can we forget how considerate and tender was your care for our wounded, and how our men were welcomed to your homes at a time when perhaps anything more than the barest frugality could be ill-afforded by your generous people in the throes of a great war.

Our nations are closely cemented by unity of democratic purpose, by the same high ideals, and by a common language. Let us hope that this first exchange of thought by voice across the broad Atlantic will serve to strengthen our existing friendship in permanent bonds of understanding.

The program of this National Radio Week have constituted the first attempt to reach you through organized broadcasting, and to receive your acknowledgment from your own broadcasting stations. Surely radio is the harbinger of a closer tie, more thorough understanding, among the nations of the earth.

I shall be very glad to hear from those of you in Great Britain who may have heard my voice this evening. This is the President of the Radio Corporation of America, speaking from station WGY on the occasion of the first organized broadcasting tests between America and Great Britain—tests instituted by one of our publications known as RADIO BROADCAST and staged during our National Radio Week. Thank you. Good-night!



THE WRITER, THE SCEPTICAL GUIDE, AND W. A. MIVELEZ

Listening-in in Mammoth Cave

An Account of the First Radio Tests Conducted
in Kentucky's "Eighth Wonder of the World"

By FRED G. HARLOW

GIVEN: One Cave, Mammoth, located in Kentucky, 102 miles from Louisville; one broadcasting station, WHAS, in Louisville; one four-tube non-regenerative loop receiver; one assistant, W. A. Mivelez; one Negro cave-guide, tolerant though sceptical.

To FIND: Radio waves, deep down in aforementioned cave.

PROCEDURE: As Junior Operator of WHAS, I had arranged with J. Emmett Graft, Senior Operator at the *Courier-Journal* and *Louisville Times* station, to have signals transmitted at stated times, and my companion and I betook ourselves to Mammoth Cave. While sitting in our hotel room 360 feet above the Rotunda in the cave, where we expected to make our first underground test the next day, we tuned-in

WHAS and heard the concert with great distinctness, thus assuring ourselves that our instruments were in good working order. If we did not catch our station down in the mysterious caverns we could be reasonably sure that some agency in the earth was acting as a screen or counter-attraction for the radio waves.

The next morning, with the Negro guide whom the cave authorities had very kindly put at our disposal, we left the hotel for our great adventure, feeling no little excitement in the knowledge that we were to be the first persons to make radio tests down in what is frequently called the Eighth Wonder of the World.

Following a wooded path along a steep declivity for a quarter of a mile we came at last to the great entrance, a huge mouth of black-



THE ENTRANCE TO THE CAVE

ness from which issued a continuous breath of cool fresh air. The Cave is said to "breathe" but twice a year, taking a long inhalation during the winter months when the outside air is cooler than 54 degrees, and an equally long exhalation when the outside air is warmer. It apparently holds its breath during the periods when the outer and inner temperatures are balanced.

At the brink of this great hole in the earth my companion and I stopped and looked at each other. Would we catch the Louisville station? Well, . . .

Descending the long stairway we proceeded into the cave, deeper and deeper. The winds were blowing stronger, but we soon found that when the entrance had been well passed these currents ceased, or at least, were not perceptible to our faces.

The guide had lighted lanterns, and as we moved forward along a narrowing passageway, not a little awed by the strangeness of the place, I said in half a whisper to my companion:

"Hope we'll get WHAS through all this."

With characteristic cheerfulness, he answered in the words of Dante:

"All hope abandon, ye who enter here."

About six hundred feet from the entrance, we emerged into the sublime Rotunda, with its arched ceiling sixty feet above the floor, unsupported by columns although its widest span is about two hundred and seventy-five feet across. We were standing now 360 feet directly below the hotel in which we had slept

the night before. Near by were the remains of wooden vats where in 1811 and 1812 lime nitrate was made in solution and syphoned through a crude log pipeline to the entrance there to be made into saltpeter, and thence "waggoned" across the mountains to Philadelphia for the manufacture of gunpowder.

Our watches told us that in three minutes WHAS would be on the air. We searched hastily for soil free enough from rock to drive down our iron ground-spike, and it is no wonder if our fingers trembled a little as we adjusted the instruments

and made ready to tune-in.

The guide watched us with large eyes. He did not understand these "goings-on." Although we had told him our mission—that we were there to see if we could hear music being played by a band in Louisville—he refrained from comment.

For ten minutes we listened intently, tuning this way and that. But not even a suspicion of a band in Louisville, or anywhere else, was noticeable. There was no static. There was no anything. Our earphones were as silent as the blackness around us. We had failed.

This being undeniable, we then looked for the cause of our failure. The instruments were in perfect adjustment. The aerial was the same that we had used with success the night before on top of the earth. Either the ground connection was faulty or radio waves would not penetrate Mammoth Cave. This conclusion led to a minute inspection of the soil.

Here, indeed, could readily have been the trouble, because the iron spike had penetrated a substance as dry as powder. Holding our flickering torches lower we could find no symptom of moisture anywhere; all was finely pulverized limestone dust, so light that it could be crushed in the hand and blown as easily as flour. Surely we might as well have had no ground connection as this.

We turned to the guide then, explaining the trouble and suggesting that we go on to a place where we could find moisture. We threw in a few technical terms to impress him, but

he was not at all impressed. He picked up his lantern in a leisurely way, adding now to his former polite tolerance a frankly amused smile. But, after all, who could blame him? He had guided in that cave for twenty-five years. He knew as much of it as any living man, and in all that time he had never heard any music down there, unless somebody sang or whistled. Appreciating his point of view, it is really a wonder that he did not shove us into the Bottomless Pit for a pair of escaped lunatics. At any rate, if it was moisture we wanted he intended to see that we were plentifully supplied. He said as much, and we moved forward into one of the passages leading from the Rotunda.

A quarter of a mile farther found us squirming our way like rats through the Corkscrew that eventually leads to a level eighty feet below. Another quarter of a mile brought us to the Great Relief, a spot well named in the opinion of one who carried parts of a delicate receiving set through such a tortuous climb as the Corkscrew.

Here we would gladly have made another test, as it lacked but ten minutes of the hour for transmitting, but there was no adequate place for driving our spike. And the Dead Sea, farther on, lay fifty feet below the ledge on which we were traveling. In another hundred yards, however, a good place appeared—but, alas, our watches told us that WHAS had signed off a minute before. There would be an hour to wait.

The guide did not seem to be at all affected by our disappointment. He merely suggested in his tolerant sceptical way that we should go on to Echo River and “listen to the echoes of the Louisville band there.”

So we proceeded along the Great Walk. For nearly a mile we slipped and staggered over loose stones, fearful of an accident to the vacuum tubes. The time for the next concert was approaching, yet there was no place discernible for driving our rod. The way became more hazardous, because the floor now sloped sharply off to one side, and once I not only fell but

slid toward a hole that seemed to be blacker and deeper than any abysmal pit in the entire cave. My companion made a frantic grab and checked me just as I was slipping over the brink. Only the guide remained imperturbable, and soon assured us that what we had thought was a yawning chasm was only a ledge about six or eight feet deep.

“Granting all that,” I replied, as gently as I could, “a headlong plunge of six or eight feet on rocks even as soft as limestone might have shaken up our instruments. And even a radio operator isn’t tough enough to stand that sort of thing.”

He may not have believed this, but he laughed pleasantly and said that “maybe the hole warn’t more’n four or five feet, anyway.” So I let it go at that. But we had lost another opportunity of catching our home station.

Soon we passed through the section of the cave called Purgatory—a name too mild, by far—and then came to the famous Echo River, with its eyeless fish and white crayfish. Tied to a slippery landing was a flat-bottomed skiff into which we deposited our instruments and pushed off.

It would be nearly half an hour before the next WHAS concert, so we left ourselves to the guide’s slow paddling over the hushed water. The arched ceiling, varying in height from five to thirty feet, was a mass of sparkling drops, apparently ready to fall, gorgeously re-



“BOOTH’S AMPHITHEATRE”
With some of the old saltpeter vats at the right

flecting the flames of our lamps. Outside, Green River was low, and therefore Echo River was low. It was remarkably transparent, too, giving one the feeling that the clumsy boat was, by some magic, being floated upon air.

The time was approaching for another radio concert, and we began to prepare for it. Here, with the very best of ground connections—by letting down our iron bar to the bed of the river—we felt sure of success.

Both pairs of phones were on our heads when the hour came. We listened. We tuned. We listened again, and again we tuned. The disappointment on our faces was reflected in the sceptical smile of our guide. But the test was not all failure this time, because we caught the clear, sharp whistle of the WHAS carrier wave. That was all, however; and when the time was up this abruptly ceased.

Once more we began diligently to investigate the cause of this partial failure. We had achieved something by catching the carrier wave. But, if the carrier wave, why not the voice and music? We finally hit upon a reason—certainly plausible, and one that after events strengthened. In our position on Echo River, with roof and sides simply dripping moisture, we were as a matter of fact sealed within a

thoroughly wet apartment—as though in a diving bell on the ocean bed—and the electromagnetic waves were sponged out by this condition. Our receiving set and aerial were being insulated from the WHAS wave as effectually as if they were in an iron box with all parts grounded, for everything about us—top, sides, bottom—was grounded by the saturated condition of the rocks and soil.

It required courage to tell the guide that our failure this time was due to *too much* moisture!

We had left the hotel about ten o'clock in the morning and it was now after three. The regular afternoon concert would begin from WHAS at four, and if we did not catch anything then we would have to wait until half past seven, as nothing had been arranged between this and the night concert hour. So we chained the boat to its landing, took up our packs and started in search of another promising spot.

It seemed that we had walked nearly a mile when, immediately at our feet, the flickering lamps showed a moist spot in the soil. This looked hopeful because the ceiling and walls were dry, and with good cheer we drove down the iron spike as far as it would go. The loop aerial, too, was set, our compass giving us the direction of Louisville.

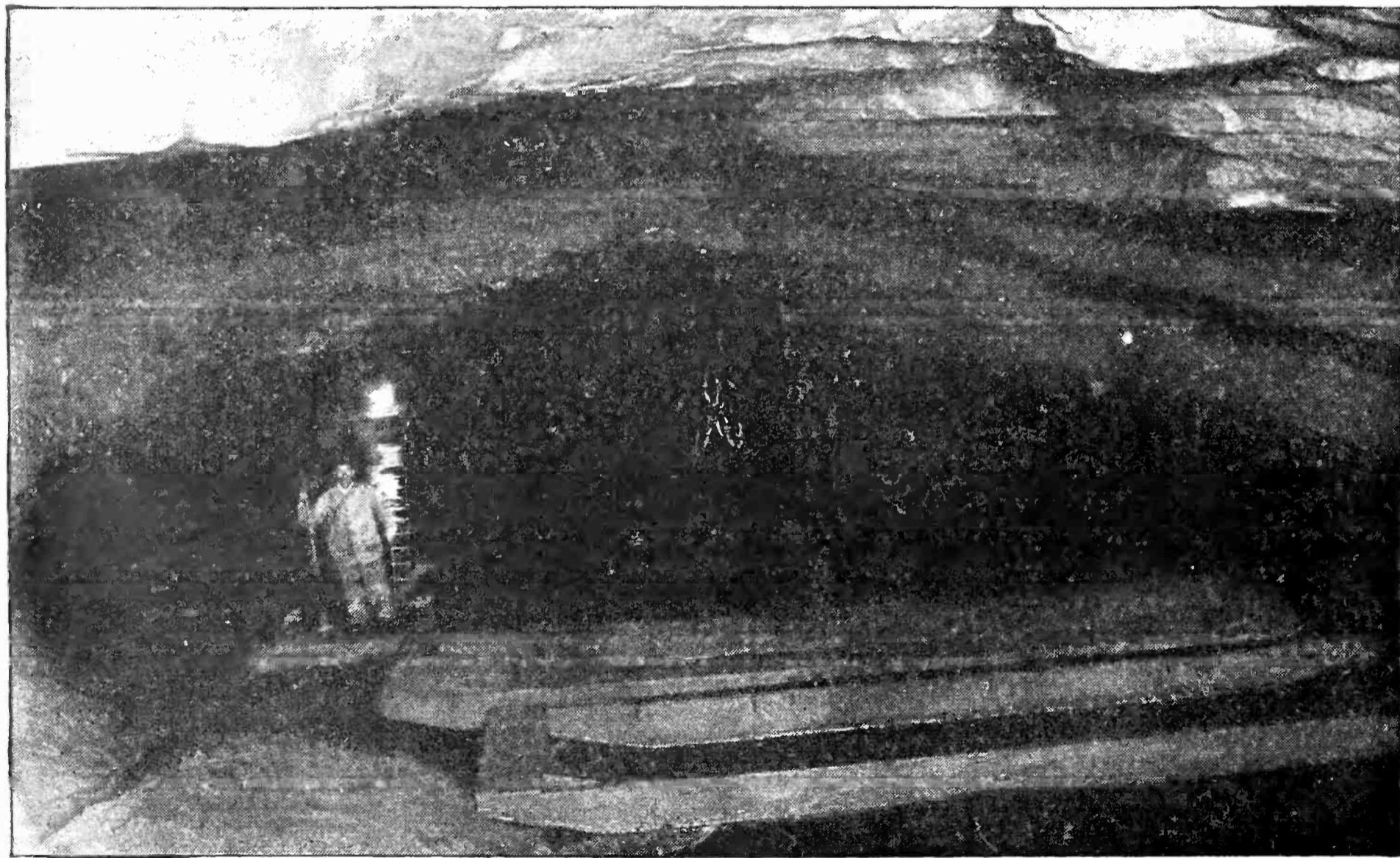

ECHO RIVER, FAR DOWN IN MAMMOTH CAVE
Where the author's second attempt to receive signals from Louisville was made

Four o'clock came, and with earphones in place we tuned. Without a moment of hesitation, a strong, clear voice came to us, saying:

"This is WHAS, the radiophone broadcasting station of the *Courier-Journal* and *Louisville Times*, at Louisville, Kentucky. WHAS, at Louisville, Kentucky, is sending out its usual afternoon concert."

The first number was announced, and then came the music as vigorously as though we had been in Louisville. I leaned quickly over and slipped the phones on our guide's head. With a cry he sprang back, making a gesture as if to slap them off. But we steadied him, and thenceforth he was both an amazed and a

happy man. Although we could hear the music quite six feet away from the phones, we let him keep that pair to his ears. For the entire hour he listened in rapt attention.

CONCLUSION: This spot was, according to our guide, about a mile from the entrance, and 370 feet below the surface. We had successfully carried out the first radio test ever made in Mammoth Cave. Moreover, to WHAS goes the distinction of being the first broadcasting station ever received within the Cave. It may continue to be so for a long time, as a matter of fact, because after it had signed off we tried diligently to get other stations which we knew were on the air, but could not bring in even their whistles.

What You Should Know About Antennas and Grounds

By R. H. G. MATHEWS

Chief Engineer, Chicago Radio Laboratory

THE purpose of a receiving antenna is perhaps more often misstated than that of any other device used in connection with radio. To understand just what a receiving antenna does, let us consider for a moment the form in which radio energy is transmitted. In the first place a radio telephone or telegraph transmitter simply radiates energy in an all-pervading medium called the ether. Electrical energy, as such, is *not* radiated by a radio antenna.

One of the most popular analogies to a radio transmitter is the old but serviceable example of a stone dropped into a pool of water. A chip floating in the pool is agitated by the ripples or waves set up by the dropping of the stone. No part of the stone is transmitted from the point at which it is dropped to the chip. The energy, however, acquired by the stone in dropping is transformed into wave motion in the water, a portion of which in turn is communicated to the chip, causing it to move. In a radio transmitter, the energy generated in the station produces a series of disturbances in the ether, which travel out in expanding hemispherical shape *in all directions*.

You who studied, or even merely took physics, remember that the principles of opera-

tion of an ordinary direct-current generator are summarized in a rule which runs like this: "When moving conductors cut lines of force, electrical energy is produced."

In a radio receiving antenna we have a somewhat similar condition. We have, in place of rotating conductors, an antenna of one or more wires, and we have, "cutting" this antenna, the incoming radio waves, which correspond to the magnetic field or lines of force mentioned in our generator rule. Here we have a fixed conductor with a moving field, which gives us nearly the same effect as in our generator, and accordingly we have in our receiving antenna the vibration energy of the ether wave transformed into electrical energy again.

OVERCOMING ANTENNA LOSSES BY PROPER INSULATION

THE novice, in installing a set, considers that almost anything in the way of a wire stuck up on his roof in the most convenient manner is a satisfactory antenna. As a matter of fact, the antenna is one of the most important features of the receiving installation. If the infinitely small amount of energy collected on the antenna is subjected to all kinds of losses before it ever reaches the receiving set, how can



A GOOD ANTENNA IS EASY TO ERECT

Make it 75 to 150 feet long including the lead-in; insulate it at both ends

the average receiving set compensate for these losses? We would do far better, in many cases, if we would preserve more carefully the energy collected by our antennas. Then we might achieve the same result with less amplification, and hence with less possibility of distortion.

ANTENNA INSULATION

THE greatest source of loss in the average antenna is in its insulation. An antenna of any kind may be regarded as a condenser. Any condenser consists of two conductors having between them an insulating material known as a dielectric. In the case of an antenna, the air acts as a dielectric between the antenna and the ground. The fact that a composition of some kind is a good insulator does *not* mean that it is a good dielectric material. Receiving antennas handle very low voltages, and consequently we do not have to worry about our insulators from the standpoint of voltage break-down, but, unfortunately, manufacturers of antenna insulators usually consider only what is necessary to avoid a voltage break-down when they design their insulators.

Porcelain and glass are comparatively good insulators, whereas moulded compositions are relatively poor. Pursuing our idea of the aerial

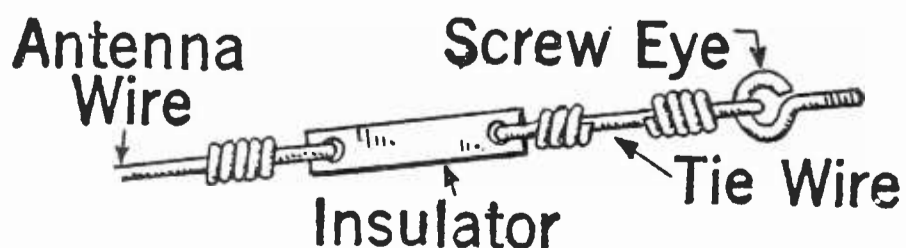

HOW TO ATTACH THE FAR END OF THE ANTENNA

as a condenser a little further, we would hardly build any condenser with a heap of miscellaneous junk under one end, a coal shed under the other end, a few trees somewhere in the middle, and various other structures along the line. The ideal antenna should have as few obstructions as possible between it and the ground. Trees, buildings, and other obstructions are sure to cause losses in antenna efficiency.

It is frequently impossible for us to find a clear space to put up an antenna. If this is the case, we must then raise our antenna wire as high as possible over obstructions that we cannot eliminate. For this reason, an antenna on an apartment building should be as high above the roof as possible, and it will be found that an increase in height even at a sacrifice of length will secure better results.

ANTENNA LENGTH

THE influence of the length of a receiving antenna on reception is frequently exaggerated. Many users of receiving apparatus believe that to increase the signal strength, one has only to lengthen his antenna. This is not necessarily true. An antenna of a given length has a certain natural wavelength of its own, and with the average receiving set the wavelength of the aerial should be somewhat below that of the wavelengths of the various stations which are to be received. There is a point at which extension of the antenna adds so much to its capacity and inductance that its inherent wavelength becomes greater than that of the stations from which reception is desired. Our receiving set, therefore, will not function properly on such an antenna without a condenser in series with the antenna to cut down the wavelength of the aerial to a point where reception can be accomplished satisfactorily. It has been found that with the average radio-phone receiving set now on the market, an antenna about 125 feet long is to be recommended. The length of the lead-in is included in the length of the antenna proper. No allowance has to be made because of the fact that the lead-in is generally made of insulated wire.

A single-wire antenna is generally as good with the average receiving set as a multi-wire one, and it is generally found that a single-wire antenna will give somewhat sharper tuning

and consequently greater selectivity and elimination of interference than an antenna of more than one wire.

It has been found by the writer that in many

the wavelength to which the antenna is tuned, which counteracts a certain amount of the resistance or loss in the antenna. This theory is only applicable to the regenerative or oscillating

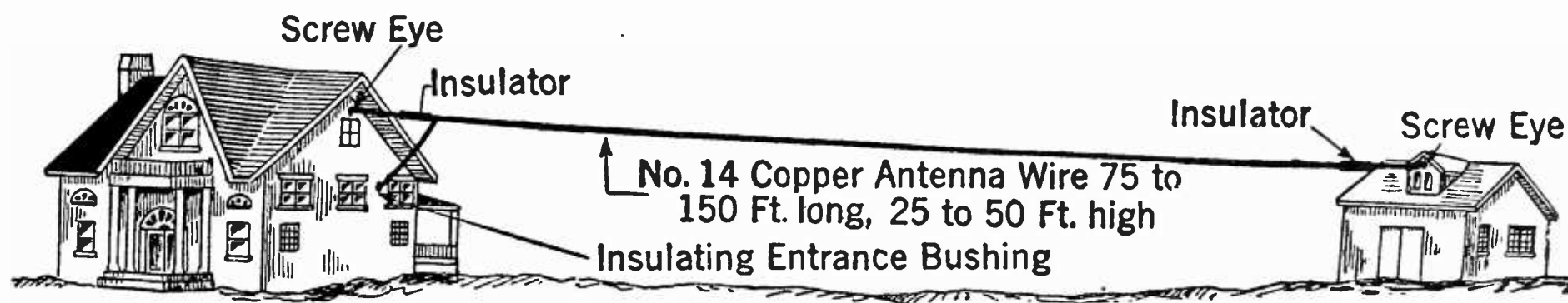

THIS ANTENNA INSTALLATION WOULD STRAIN NEITHER ARM NOR POCKETBOOK

The lead-in may be soldered to the antenna, but it should not merely be wrapped around it. .
The best way is to have the lead-in actually a continuation of the antenna wire itself

cases where interference from amateurs and ships is complained of bitterly, the trouble is due primarily to the use of too long and too complicated an antenna system, which absolutely prevents selective tuning of the receiving set. When the complicated antenna is eliminated and a short single wire substituted, the interference usually disappears entirely.

THE USE OF REGENERATIVE RECEIVERS

IT IS claimed by many radio engineers that the losses outlined in the preceding paragraphs are to a large extent neutralized when a regenerative receiver is used. That is to say, a regenerative receiver will function better on a poor antenna than will any other type of receiver, the argument in favor of this belief being that in a regenerative receiver, when the set is in proper operation, the tube is feebly oscillating; that is, when the set is brought up to the point of maximum signal intensity, just before the point of full oscillation—the antenna is absorbing a certain small amount of energy from the tube through the receiving set. This can easily be proved in the case of a regenerative receiver having an aperiodic or non-resonant primary circuit, by the fact that if our regenerative receiver is adjusted to the point of maximum sensitivity, and the antenna then is disconnected, the set will break into full oscillation, demonstrating that the antenna, when connected, is absorbing sufficient energy to keep the tube from oscillating freely. This energy is naturally being absorbed by the antenna at the wavelength of the incoming signal, since that is the wave to which the receiver is tuned. Since this is the case, we are creating in the antenna circuit negative resistance. That is, we are feeding in a certain amount of energy on

type of receiver. There are good grounds for believing the theory to be a true one.

NON-RESONANT ANTENNA CIRCUITS

WHILE it is necessary in nearly all receivers to adjust or tune the antenna circuit (which is the inductance and capacity in the antenna circuit of the set) to the wavelength of the incoming signal, there are on the market several sets which require no antenna tuning. In these sets the antenna circuit simply collects the received energy which is then transferred to the secondary coil of the receiving set at whatever wavelength the secondary may happen to be tuned.

CONCERNING GROUNDS

ALONG with the study of antennas we cannot neglect that of grounds. A great many receiving troubles blamed on the radio receiving set are actually due to a poor ground. The mere connection of a wire to a pipe which leads eventually into the ground, does not make that connection a good radio receiving ground. Our ground lead is subject to the same losses in somewhat lesser degree as our antenna and lead-in. It is generally desirable, especially where a long ground lead is used, to insulate the ground lead with porcelain or glass insulators just as we did our antennas. A water pipe in the average apartment is generally a fair receiving ground, as it goes more or less directly to the basement, and then into the ground. The connections in water pipes are generally tight. Steam pipes are usually poor grounds, as they go in a very indirect way to the ground proper. The ground connection here is usually made through the steam radiator pipes to the boiler, and through the boiler to the water pipe which

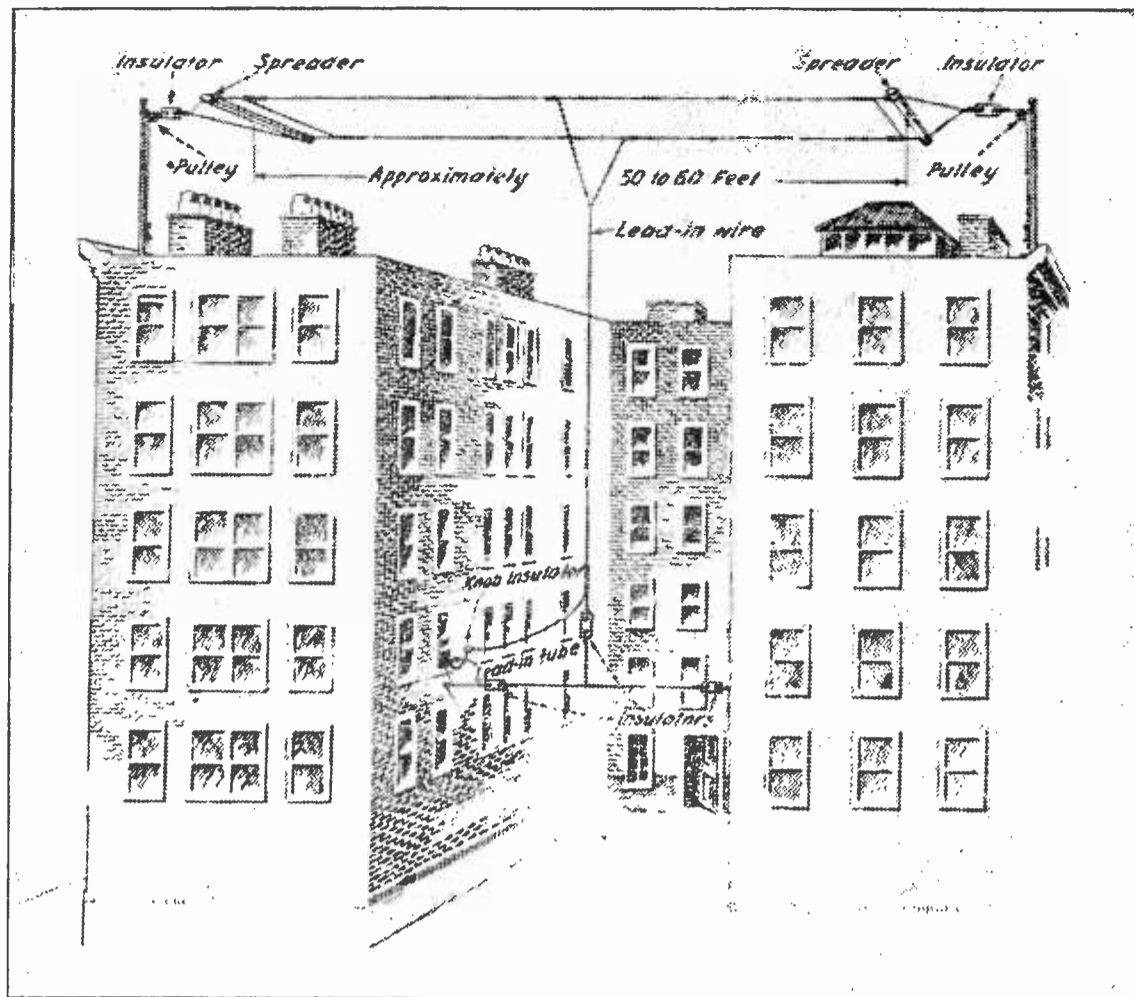

AN APARTMENT-HOUSE ANTENNA INSTALLATION

This shows a good way to bring the lead-in through the rear court. The farther from the building the lead-in is kept, the better

supplies the water from which the steam is made. Frequently steam or hot water pipes have non-metallic joints to allow for the expansion and contraction of the pipes under various conditions of temperature. Such pipes should never be used as ground connections. Gas pipes are similarly poor, because the gas meter usually is equipped with an insulating joint, which effectually insulates the house pipes from the incoming pipe which is the true ground.

Above all these is to be preferred the outside ground. However, by this is not meant a $\frac{1}{4}$ " galvanized iron rod driven two feet in the ground. By an outside ground is meant a sufficient metallic surface buried in the ground, deep enough in damp soil to insure a low resistance ground connection. A copper plate 4 feet square is an excellent contact ground if buried sufficiently deep. Driven rods are generally not desirable because of the small amount of surface in actual contact with the earth. The amount of surface in direct con-

tact with moist earth is of the utmost importance.

Another type of ground which is very desirable may consist of several wires, each 25 or 30 feet in length buried radially or in fan shape out from the ground lead. These wires should be buried no less than two feet deep and preferably in damp soil. As many of them should be used as is possible.

The ground lead itself may be of insulated or bare wire, and to conform with the requirements of the Fire Underwriters, should be of copper and of no less size than No. 14, B and S gauge. The ground wire should be as short and run in as direct a line from the receiving apparatus to the ground as possible. The shorter the ground lead, the longer the antenna and lead-in can be without giving the aerial and ground system excessive wavelength. Naturally, the longer

our antenna and lead-in are, still keeping below the wavelengths on which reception is desired, the better our reception will be.

The directional effect of an antenna system is a thing that generally worries the beginner in radio. As a matter of fact, the directional effect of the average receiving aerial is almost too small to be measured, and it is therefore something over which we should not have the slightest concern. If we stretch our antenna over as clear a space as possible, running the wire in a straight line, supporting it on porcelain or glass insulators and bring our lead-in down from it in a direct and short line, supporting it also in the same way with the same type of insulators, and if we keep the length of our aerial within the limit outlined in the foregoing and if we get it as high as we possibly can, and then make a good ground connection, we should have an efficient installation. When we introduce complicated antenna systems, we also increase the possibility of loss.

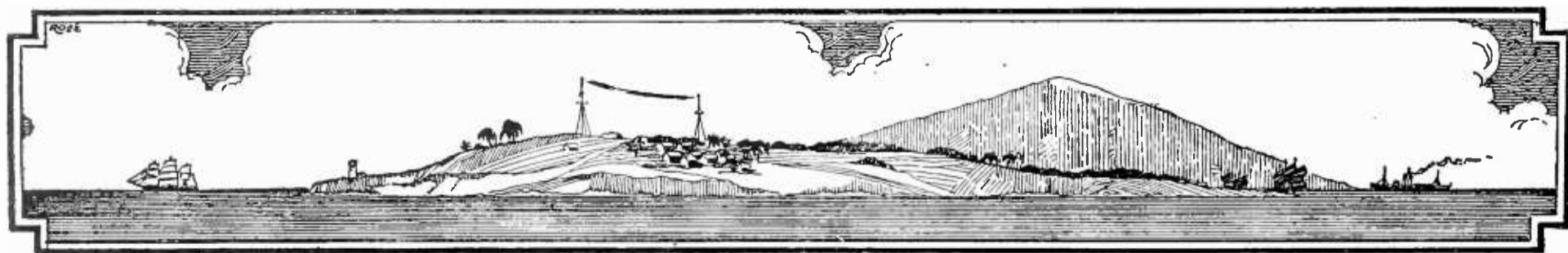

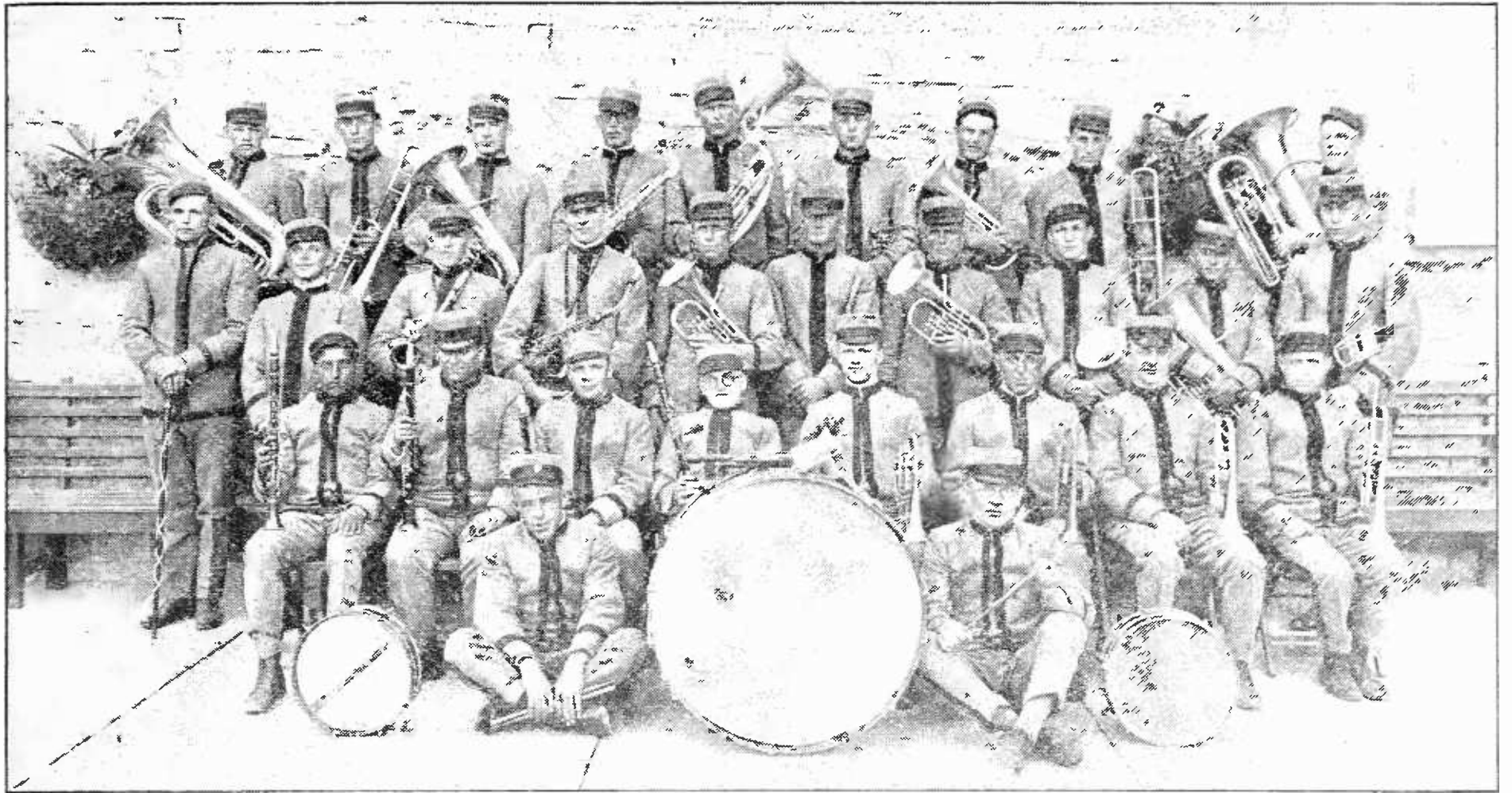

THE MISSOURI STATE PRISON CONCERT BAND

When the Prison Band Goes on at WOS

How the Missouri State Prison Musicians Captivate Their Radio Audiences to the Extent of 2000 Letters a Concert, not to Mention Sympathy, Cigars, and Cigarettes

By J. M. WITTEN

Announcer, Station WOS

IF IT has been your good fortune to tune-in one of the delightful concerts of the aggregation known as the Missouri State Prison Band I know that you have been well repaid; and that you still had your head-set on, or the loud speaker going, when the blowing of Taps—the last feature on an M. S. P. B. program—was rendered.

This band broadcasts every other Monday night at nine o'clock (C.S.T.), from WOS, Missouri State Marketing Bureau, Jefferson City, Missouri. The broadcasting equipment at WOS is a 500-watt Western Electric installation in the dome of the State Capitol. It is a Class B station, transmitting on 441 meters or 680 kilocycles. The concerts by the band have been distinctly heard and greatly enjoyed, according to reports, in Honolulu, Hawaii, Alaska, Cuba, Santo Domingo, Porto Rico, Newfoundland, British Columbia, every province in Canada, several states of Mexico, every state

in the Union and ships in the Atlantic, Pacific and Arctic Oceans and the Caribbean Sea.

This organization has very probably received more radio mail in appreciation of its efforts than any band or similar organizations in the country, as the mail following each concert had averaged two thousand cards and letters. Eighty telegrams and forty-five long-distance calls have been received during a single concert.

In addition to the cards and letters of appreciation on the entertainments, the "boys" of the band are the recipients of hundreds of "tailor-made" cigarettes and cigars which they would otherwise be unable to procure.

Many of the letters and cards offer help and consolation to the boys. Letters from welfare workers are not uncommon and are generally offers of assistance. A certain member of the band, by his beautiful rendition of a solo part, aroused the interest and sympathy of a welfare

worker. She addressed her letter to the announcer and wanted to know what crime he was confined for, about his appearance, age, family, and did the announcer think he would make good when discharged. I promptly replied to her letter answering all the questions possible, and I know from talking to this prisoner that she is making necessary arrangements to assist him in making a fresh start in life upon his discharge.

Another member has secured a position in a community band in western Kansas, because he favorably impressed the band-master, over the radio, with his ability.

Many telegrams read like this: "Take the band out of jail—they ought to be in heaven"; "If I were governor of the state I would open the gates of the prison to them tonight after their wonderful concert"; or "Buy the boys a box of cigars and send me the bill." And then there is the millionaire banker's daughter somewhere in Arkansas, who, according to one of the cornetists, sends him cigarettes, candy, etc.

During a concert, the "boys" have a spirit that goes far toward putting a program over in fine shape, and a willingness and obedience that are hard to find elsewhere.

The "boys" of the Missouri State Prison Band have been convicted of about all kinds of crime from embezzlement and burglary to

murder, and the sentences imposed on them are from two years to life.

They were recently given a complete receiving set with loud speaker by a large Chicago radio jobber, and they have derived much pleasure from listening-in to the outside world. Ninety per cent. of the members of the band had never heard a radio concert themselves until the set was received by them but had played and furnished entertainment for many thousand radio fans.

Because of the small size of our studio—fourteen by seventeen feet—the band that regularly furnishes the concerts from WOS is cut down to nineteen members and a band-master. The man who has made the prison band concerts possible is the warden of the Missouri State Prison, Judge Sam Hill, who takes a very warm interest in the welfare of all the boys, especially the prison band, and his first words when he meets the station staff are: "How many did we get on the last one?" referring to the number of letters and cards received on the last radio concert by the band.

The station force at WOS is probably the smallest station staff in the United States operating a Class "B" station. It is composed of Arthur T. Nelson, Commissioner; R. J. Engler, Chief Engineer; and J. M. Witten, Announcer and Program Director.

THE OPERATING ROOM AT WOS, JEFFERSON CITY, MO.

At the desk is J. M. Witten, Announcer and Program Director. Behind him is R. J. Engler, Chief Engineer of the station

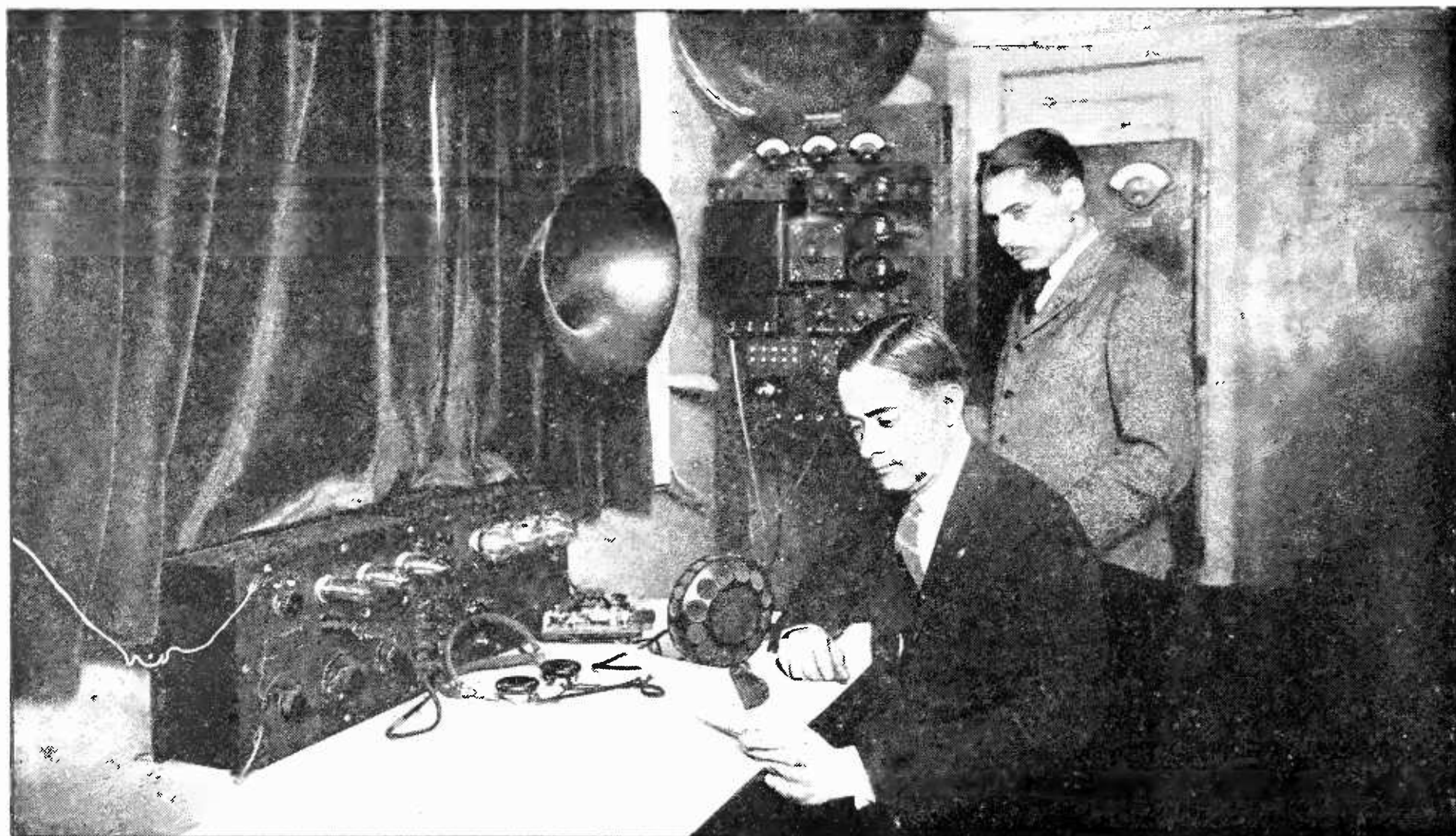



RADIO ON WHEELS

Here is a six-tube Murad radio-frequency receiver, with the loop inside the door under the handle. The loud-speaker operates behind the cane front. When a station has been tuned-in, the leaves can be folded and all apparatus concealed

The Aristocracy of Radio Receivers

WHILE there are still in use plenty of unprepossessing and shy crystal receivers and many "ham sets" composed of little more than the conventional rubber boot and tin can, an aristocracy of receiving sets is emerging from the common horde of inductances and capacities, tubes and jacks, and what-not.

The most casual and disinterested observer at the recent New York radio show was struck by the many fine examples of receiver design and resplendent cabinet work. Many an enthralled amateur stopped before these beautiful sets, lost in the last stages of what the newspaper reporters love to call "open-mouthed wonder."

The radio manufacturers have found that there is a market for self-contained sets, well

built and finished with all the care of a sonorous piano. The perfection of the loop antenna and the wide use of amplification—radio and audio—have made self-contained sets possible.

So, with the aid of the cabinet manufacturer, certain types of radio receivers have come to be designed more as pieces of fine furniture—to decorate fine rooms—than as rough and not too-efficient pieces of experimental apparatus, curiosities which had their proper place in some inconspicuous corner where a mess of wires, tools and parts was not objectionable.

Many of the receivers made for "discriminating purchasers" require an outside antenna and ground, but generally have their operating batteries and tubes installed in the cabinet itself. Several sets have been built which operate from loop antennas attached to or within the cabinet.

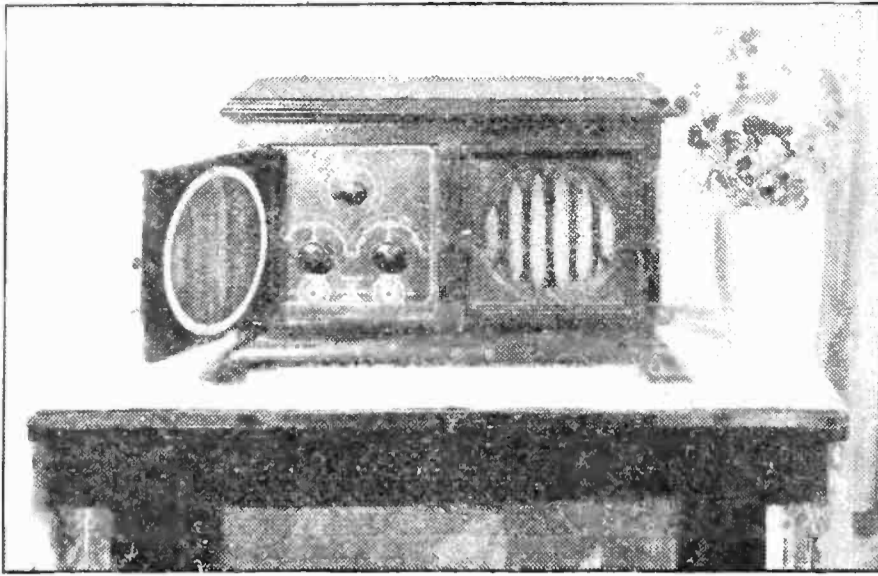

OPEN FOR BUSINESS

Here is the compact and well-built Radiola IV. This is a three-tube set. And it adds to, instead of detracts from, the appearance of any room

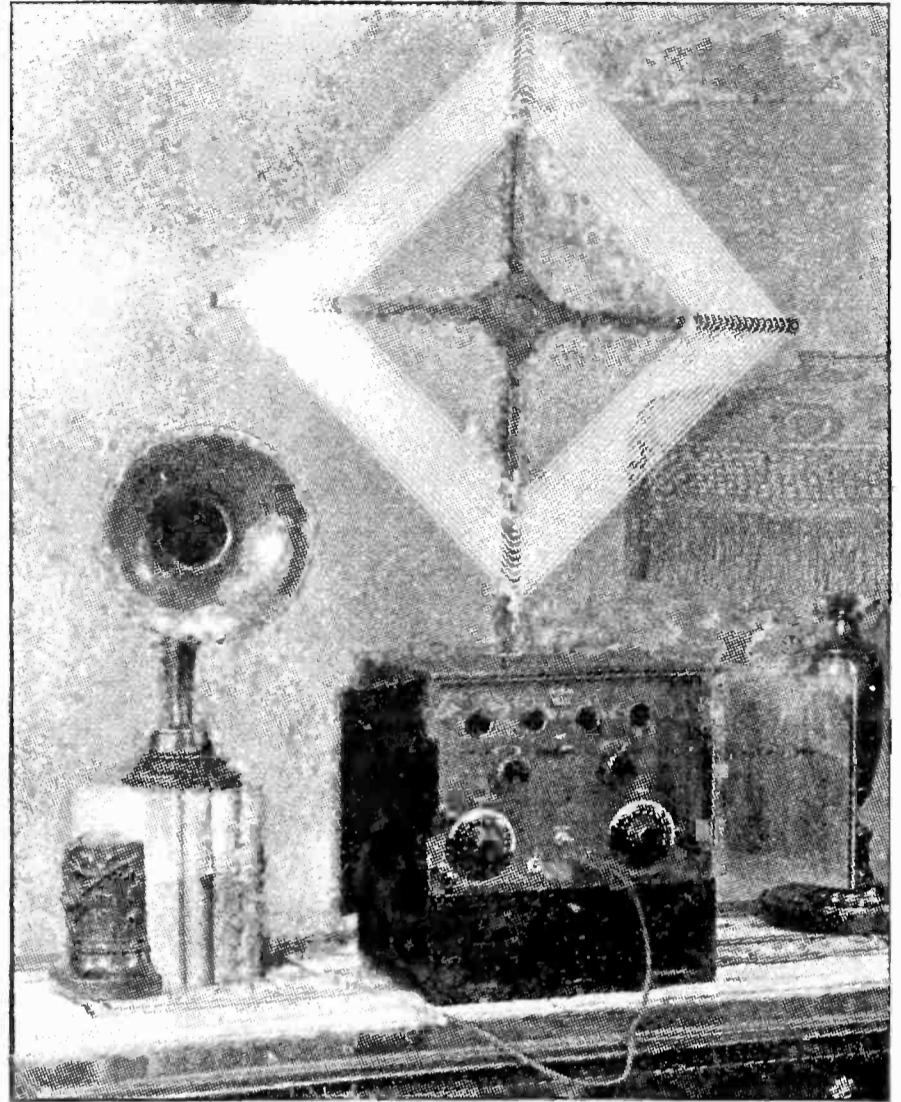

THIS FITS ON ANY LIBRARY TABLE

Or on the crude boards of a camper's lean-to. It is a De Forest D-10 four-tube reflex set, using dry-cell tubes

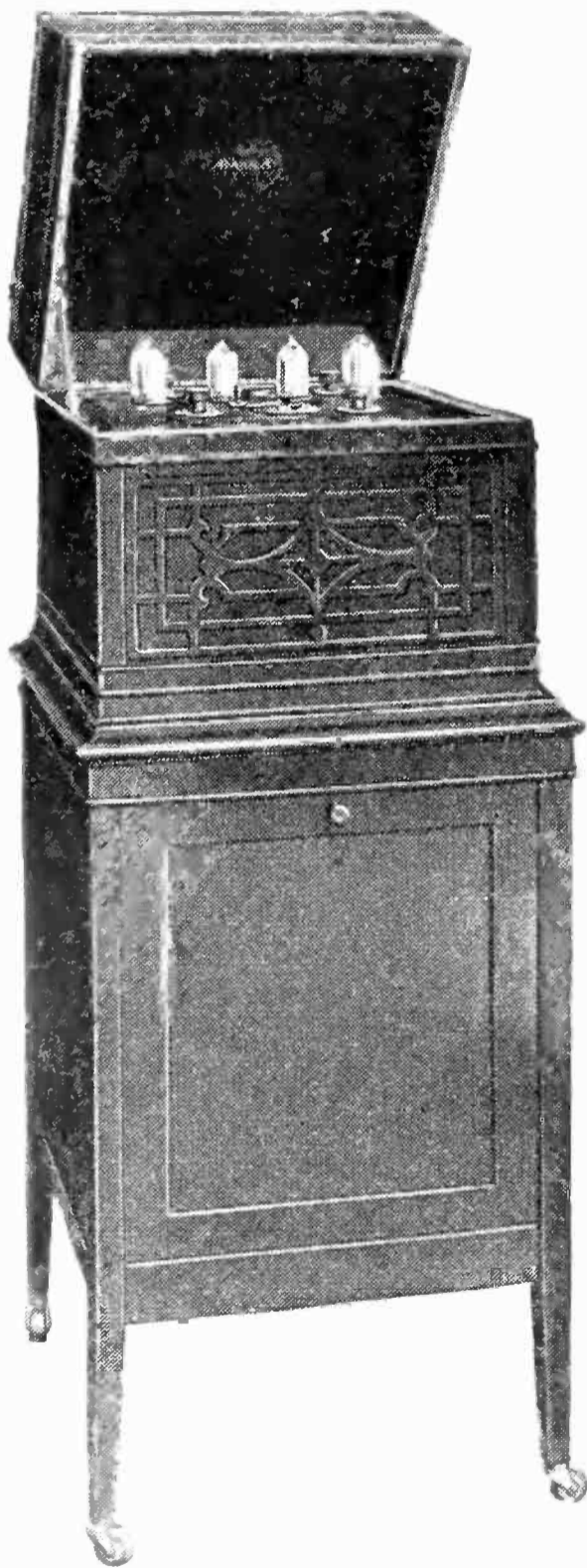

"HIS MASTER'S VICE"

Here is an upright type of receiver, looking suspiciously like a phonograph. It uses an outdoor, or "open," antenna



A RECEIVER FIT FOR A KING

A Zenith-Brunswick model which would grace any regal tiring-room (you know, the place where the king could put his feet on the table). All trace of radio apparatus has been cleverly concealed

There are *de luxe* receivers large and small. One may purchase small cabinets which will blend perfectly with library furniture or "go" nicely on a table. There is one receiver built in a standard unit of a sectional book-case, another which looks precisely like a tea-wagon and can be used as one. Perhaps the most popular type of expensive and decorative receiver is built in cabinets very much like those used for phonographs. These types range from the rather modest small size shown in an accompanying illustration to the large console type with rich and elaborate cabinet work.

Many of these receiver cabinets are useful as well as ornamental. The most unusual and striking example is the tea-wagon type, but sets are being built into fine tables, which have obvious uses.

Fine hardware is being used on these *de luxe* sets—one receiver has heavily nickled piano hinges along the full length of its cover. The advantage of this refinement will be appreciated by those who have labored long and impatiently to replace screws which have worked loose on small cheap cover hinges.

De luxe receivers have a sound appeal to any

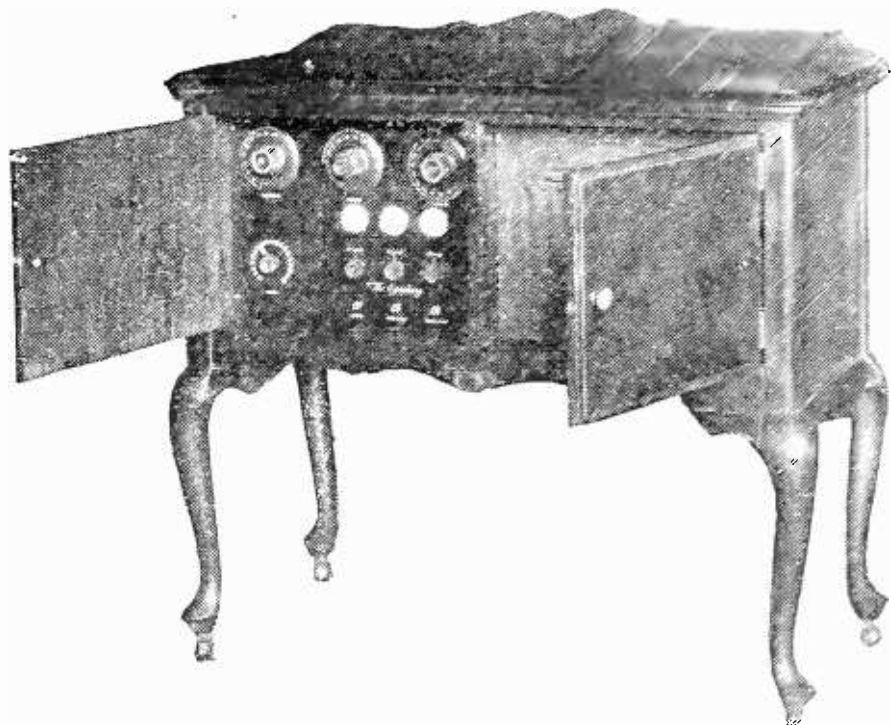

"AND WHEN THE DOORS WERE OPENED. . . .
"The birds began to sing." Any tired broadcaster should perk up at the thought of being received by such a set

"radio prospect" who does not want to experiment with radio, but who wishes a receiver, attractive in appearance and efficient and dependable in operation. As Christmas presents many of these receivers would make rich and unusual gifts.



A GOOD BOOK ON RADIO

FALL has passed and winter has arrived, yet apparently we are not to be deluged with such a flood of "popular" books as inundated the country a year ago. Many of the books which the fond parents of them christened "popular" didn't become nearly so popular with the public. As a matter of fact, there was a great deal of trash dumped on the market, stuff written by people who know neither radio nor writing; the familiar sentence to the effect that a certain book "had been used in training radio officers for the war" made us wonder just how much these poor officers really knew about radio after graduating from their courses.

Having in mind this type of radio "literature," it is a relief to see the appearance of a simple book on radio, written in an interesting style, by an engineer who knows radio well, both theoretically and practically. The *Outline of Radio*, by John V. L. Hogan, a radio engineer who has been one of our contributors in the past, and from whom we hope to have more articles in the future, is a well-written book, giving the story of radio as it should be presented for the layman. Those who are beginning the study of radio will do well to start with Mr. Hogan's book.

-THE EDITOR.

A Simplified Super-Heterodyne

By A. J. HAYNES

Vice-President, Haynes-Griffin Radio Service

Mr. Haynes has distilled the results of twenty experimentally built super-heterodyne sets into this one article. He gives complete information regarding parts and prices and directions for assembling the set. The first night this set was tried out in the RADIO BROADCAST laboratory, WHAS, in Louisville, Ky., and the three Chicago stations came pounding in, too loud on one stage of audio for comfort. WHB, in Kansas City, came in loud enough to be heard a block away. The antenna system was a two-foot loop which cost one dollar. Experimenters who are capable of building a receiver such as Mr. Haynes describes, will, we are sure, be more than satisfied with the results. It certainly does "deliver."—THE EDITOR.

THE super-heterodyne system of radio reception has received so much publicity, praise, and explanation since its development by Major Armstrong during the World War that it hardly seems necessary to discuss further its merits and theory of operation. It is without question the closest approach to the ideal receiver that we have to-day. The operation of this circuit is simplicity itself, provided of course, that the electrical design and mechanical construction are correct. When tuning in distant stations it is even easier to operate than the single-circuit regenerative receiver! This sounds like a broad statement to the radio fan

who has never operated such a set, but as a matter of fact, a properly designed super-heterodyne may be built with but two tuning controls, neither of which is critical.

Right here it might be well to point out the distinction between *critical* tuning and *sharp* tuning. Critical tuning is not desirable whereas sharp tuning is a most decided asset to any receiver. A critical control is one which goes in or out of adjustment with a hair-breadth movement of the tuning dial. A good example of this is the ordinary regenerative receiver when used with maximum regeneration or, as we say, on "zero beat" adjustment. Such a circuit has very critical control on long-range reception

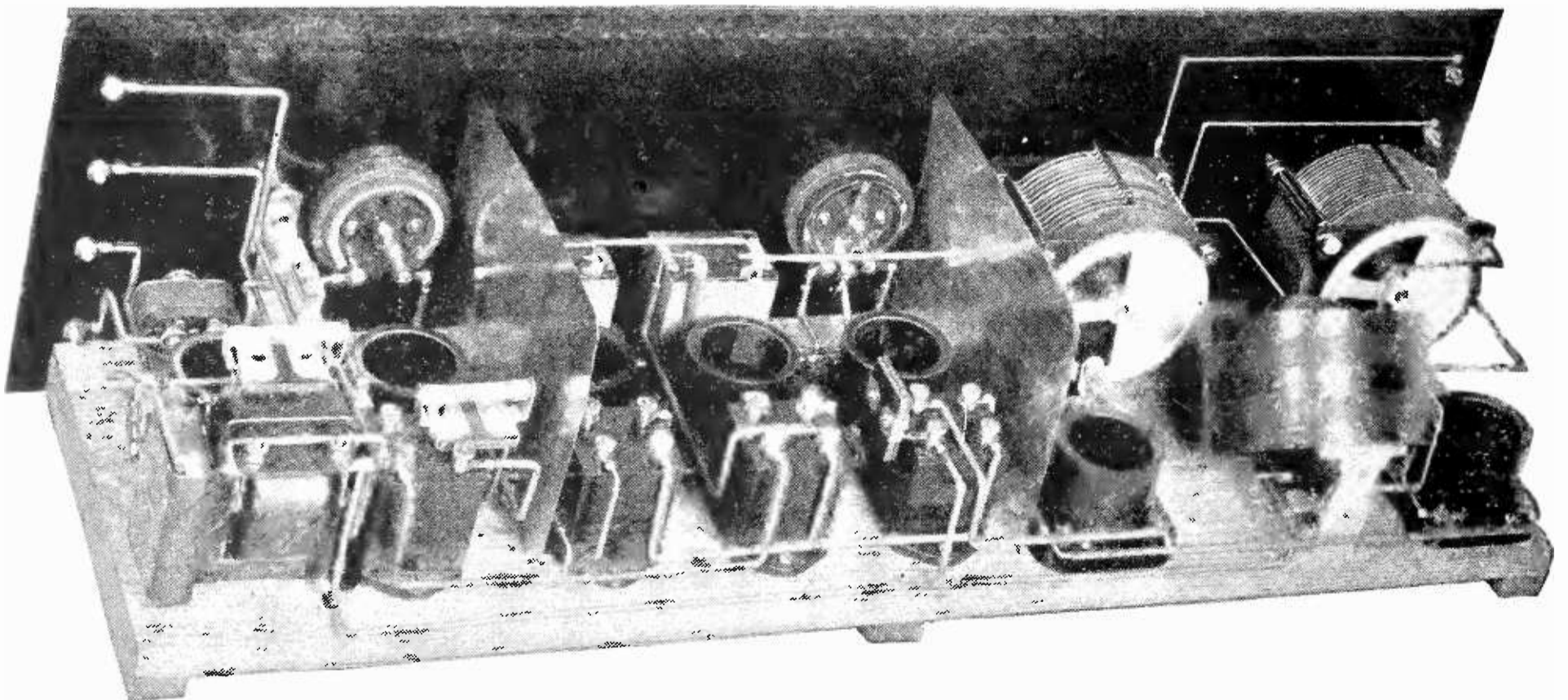

FIG. 1

This set was found to be the best after twenty had been built. Two straight shields for the radio-frequency are used. With a two-foot loop this set will bring in stations 1000 miles away with great volume. The front of this panel is shown in Fig. 9

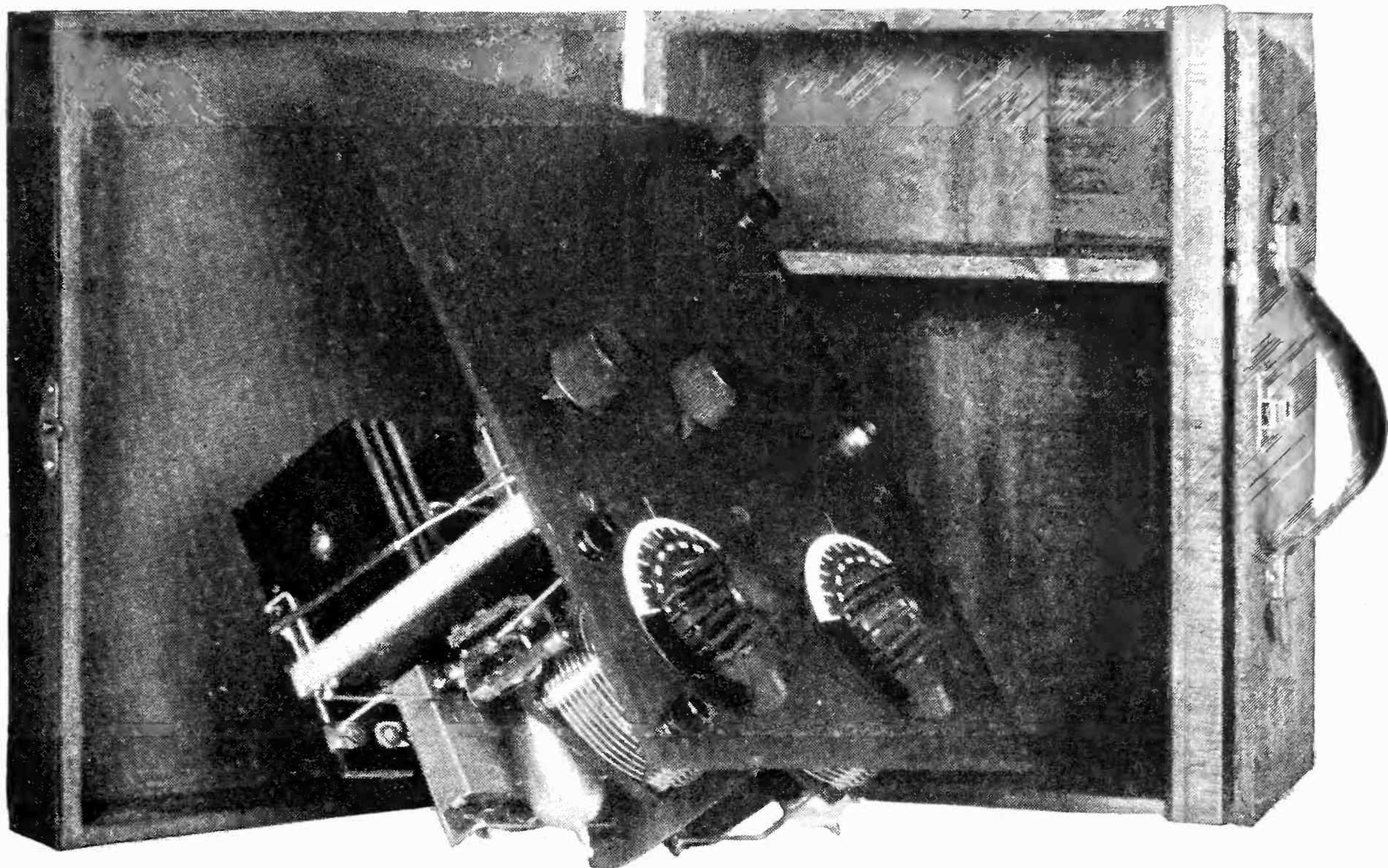

FIG. 2

A small portable super-heterodyne set with one stage of audio amplification. Its compactness is remarkable. Note the foot rule at the right of the case, near the handle

and yet may be so broad in its tuning that it is impossible to eliminate the local stations.

The super-heterodyne possesses the very desirable characteristic of being extremely sharp in tuning, and not at all critical. As the two dials—tuning and oscillator control—are moved up or down the scale in unison, the various stations, both local and long distance, come in and go out, one after another, distinct and separate from each other. Moreover, *the settings on the oscillator dial do not vary, regardless of the type of antenna or loop with which the set is used.* Thus a chart may be kept of the oscillator dial settings of all stations heard so that they may be tuned in immediately at any time. These settings vary a little, however, with different tubes and a new set of calibrations is necessary with each new tube used in the oscillator.

DESIGN AND CONSTRUCTION

WHILE a good super-heterodyne is a very simple set to operate, the layout of the apparatus and mechanical difficulties encountered in its construction—particularly when it is assembled as a single unit—make it a rather difficult receiver for the average layman to con-

struct, unless he has some mechanical skill and is familiar with radio wiring practice.

Therefore, I am writing this article, not to give A.B.C. instructions to the layman for building a super-heterodyne, but to assist the radio experimenter who is capable of doing design work for himself and is at least able to comprehend a schematic diagram and distinguish between the various circuits.

To this end, I am including a number of cuts showing various super-heterodyne receivers, each varying somewhat in design. These were picked from a rather large number which have been built and disassembled in an effort to arrive at a most satisfactory design.

A REAL PORTABLE SET

I WISH to give credit to my assistant, Mr. McMurdo Silver, for a very large part of the work done on these sets, particularly on the small portable set shown in Fig. 2. This is a six-tube super-heterodyne incorporating one stage of audio amplification. It uses UV-199 tubes and is contained complete, including the A and B battery compartment, in a cabinet measuring $5 \times 8 \frac{3}{4} \times 11 \frac{1}{2}$." Mr. Silver built this portable set in six hours time from

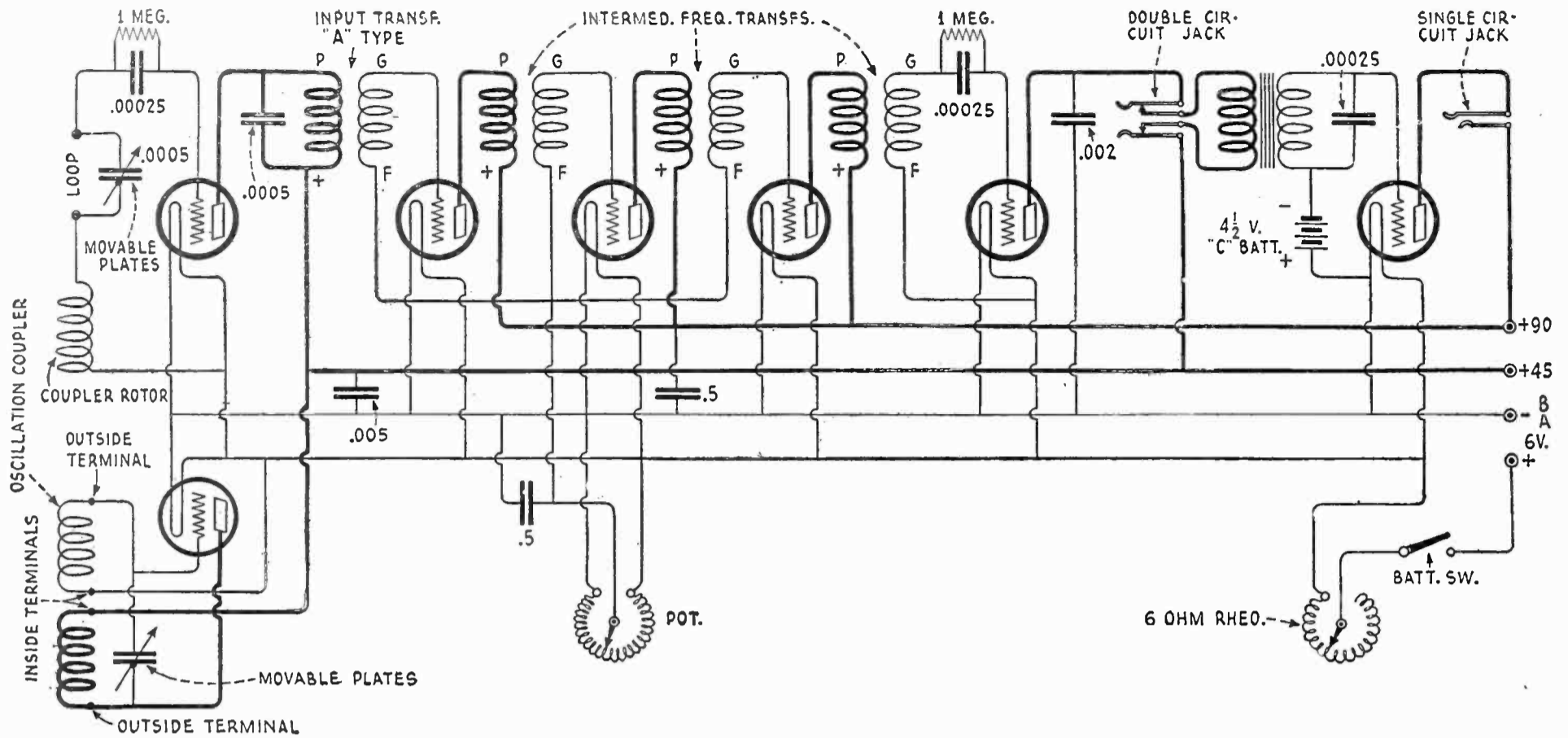

FIG. 3

Circuit diagram of super-heterodyne shown in Fig. 1 and Fig. 9

beginning to end, starting work on it late one afternoon and finishing it the same evening. It operates beautifully, and I consider it the finest portable set I have ever seen.

While it is not recommended that such a small receiver be attempted, still it serves as a good illustration of what can be accomplished by careful design and skillful mechanical work.

In arriving at what I consider to be the most practical design for this circuit, upward of twenty different sets have been built and disassembled, each being slightly different in details of design and shielding. The object of

this work was to arrive at a design which would incorporate the following points to the greatest possible degree.

1. Amplification
2. Smoothness and ease of control
3. Sharpness of tuning (without sacrificing quality)
4. Accessibility and simplicity of wiring
5. Simplicity of mechanical construction
6. Minimum of shielding.

Fig. 4 shows a set incorporating a maximum of shielding (top and rear shields have

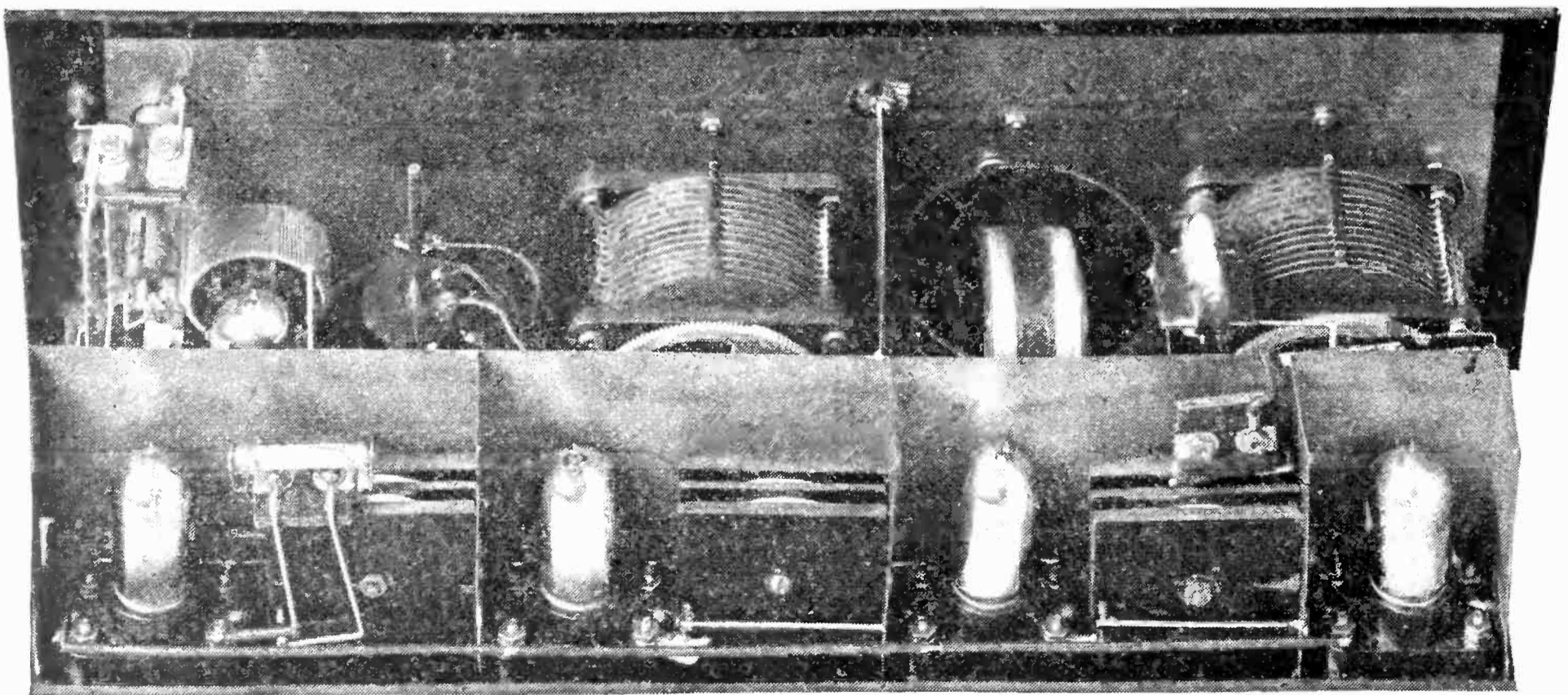

FIG. 4

This receiver is designed with complete shielding. The result is great selectivity, with somewhat less volume than the unshielded model

been removed for photograph), while Fig. 5 shows an extreme in the other direction where shielding is absolutely eliminated. A comparison of the operation characteristics of these two sets is interesting. The receiver shown in Fig. 4 gave extremely sharp tuning with very good stability and operated with the radio frequency grid return directly on the negative side of the A battery (no potentiometer was used). On the other hand, it did not give as great a degree of radio-frequency amplification as the set shown in Fig. 5. This latter set, however, would not tune as sharply as the former and required a potentiometer to stabilize the radio-frequency amplifier, although even in this case the grids of the radio-frequency tubes were operating with a sufficient negative potential.

The fact that the radio-frequency transformers appear to be different in each set may

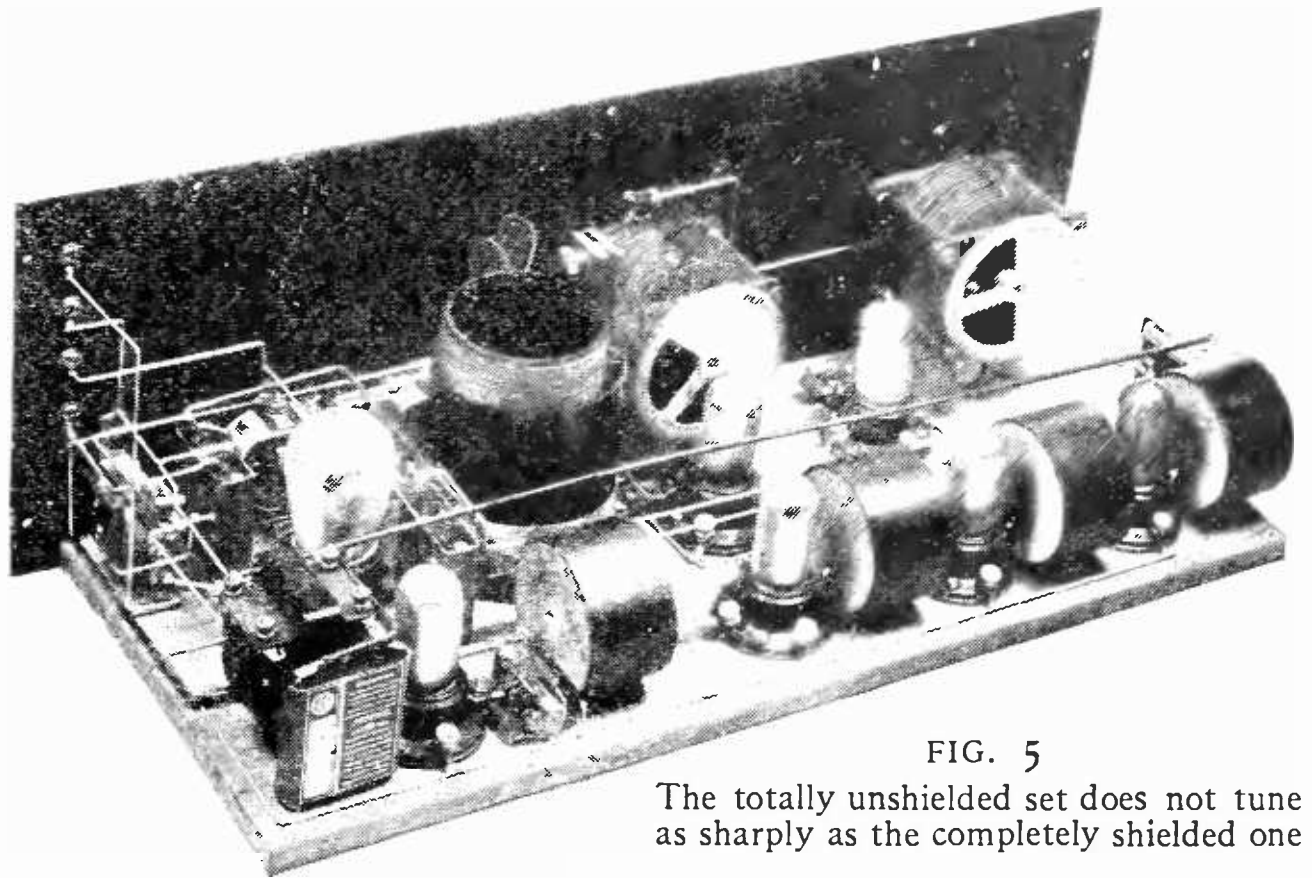

FIG. 5
The totally unshielded set does not tune as sharply as the completely shielded one

be criticized. This is not however the case, as their electrical characteristics, spacing of windings, etc., are identical.

THE MOST PRACTICAL DESIGN

THE design which was finally found to be the most satisfactory from every standpoint is shown in Figs. 1 and 9. Two straight

MATERIAL USED FOR THE SUPER-HETERODYNE

| | APPROXIMATE PRICE | |
|--|-------------------|----------------|
| | EACH | TOTAL |
| 1 7 x 24 x $\frac{3}{16}$ -inch hard rubber panel, drilled | | 3.00 |
| 1 Sub-base (seasoned wood) 7 x 23 x $\frac{1}{2}$ inch | | 1.00 |
| 2 Metal shields, 5 x 6 inch (optional) | .15 | .30 |
| 2 .0005 mfd. vernier condensers (among those recommended are General Radio, Lombardi, Felt & Kimmel, or Cardwell—with mechanical dial vernier) | 6.00 | 12.00 |
| 1 Potentiometer | | 1.50 |
| 1 $4\frac{1}{2}$ -volt C battery | .45 | .45 |
| 1 6-ohm rheostat | | .75 |
| 7 Bakelite sockets (square type) | .75 | 5.25 |
| 1 Haynes-Griffin "Input Transformer" | 4.25 | 4.25 |
| 3 Haynes-Griffin "Intermediate-Frequency Amplifying Transformers" | 4.25 | 12.75 |
| 2 .00025 mfd. Micadon with grid leak clips | .45 | .90 |
| 1 Audio-frequency amplifying transformer | 5.00 to 7.00 | 5.00 |
| 2 1 megohm grid leaks | .50 | 1.00 |
| 1 .00025 mfd. Micadon (for audio transformer) | | .45 |
| 2 .5 mfd. condensers (or larger may be used) | .90 | 1.80 |
| 1 .0005 mfd. Micadon | | .35 |
| 1 .002 mfd. Micadon | | .45 |
| 1 .005 mfd. Micadon | | .60 |
| 1 Haynes-Griffin oscillation coupler | | 3.50 |
| 1 Double-circuit jack | | 1.00 |
| 1 Single-circuit jack | | .75 |
| 1 Battery switch | | .60 |
| 6 Binding posts | .06 to .12 | .60 |
| 1 Cabinet for 7 x 24 panel with 8-inch depth | | 6.00 |
| Brass wire, spaghetti, soldering lugs, etc. | | 3.00 |
| | | <u>\$67.25</u> |

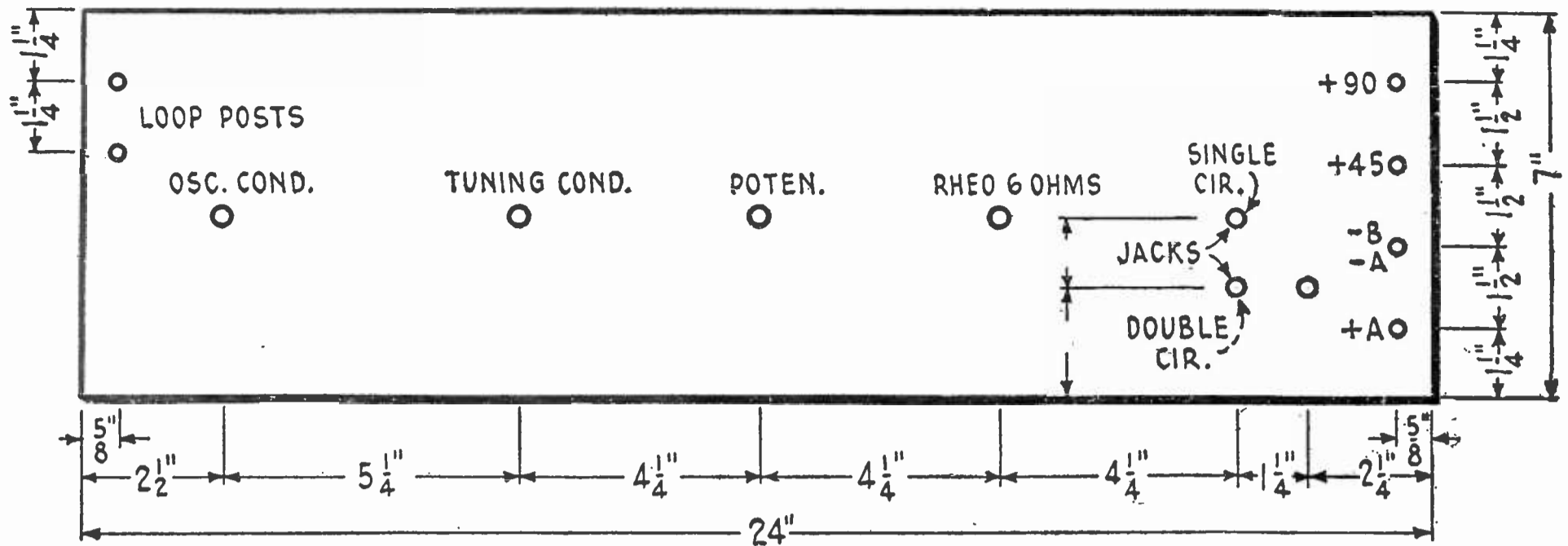

FIG. 6

The layout for the front of the panel

shields are used to isolate the radio-frequency amplifier, without decreasing its efficiency, and this has also helped in reducing the mechanical construction difficulties to a minimum. In fact, even these two shields may be omitted with very slight difference in the operating characteristics being noted.

Fig. 7 shows the sub-base assembly and wiring which should be done before the panel is attached. By assembling, and, as far as possible, wiring both the sub-base and panel layouts before the two are mounted together, the mechanical wiring difficulties are greatly reduced. It should be noted in Fig. 7 that the sub-base wiring is kept as low as possible, thus permitting the shields to be slipped into place by merely notching their edges where they cross the wires.

Fig. 1 is a rear view of the completed set, showing the wiring finished and shields in place. These shields are cut from sheet tin or brass with two narrow tabs on their lower edge.

These tabs are bent at right angles to the shield and slipped under adjacent sockets and transformers to hold the shields in place.

The oscillation coupler is shown behind the two variable condensers. After it is once adjusted it needs no further attention. The filament adjustment of this set with either UV-199 or UV-201-A tubes is not critical, and for that reason, only one rheostat is provided for all tubes. This arrangement does not provide for turning off the audio amplifier tube when it is not used, but on the other hand, it allows one to tune in a station using the head-phones and detector tube only and then plug in on the amplifier with the loud speaker, *without making any other adjustments in the set.* This would not be true if the filament of the last tube were not kept lit.

The only point to be stressed in the selection of these parts is that they should be of good quality. Beyond this requirement, the exact make of rheostats, jacks, etc., which are used

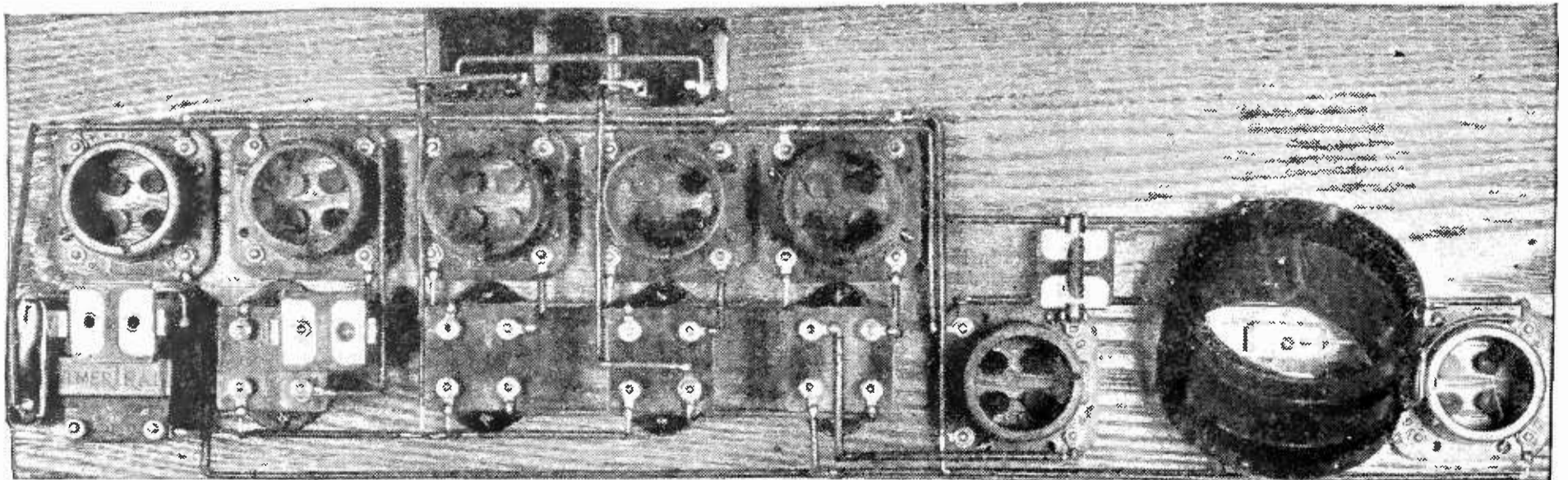

FIG. 7

Layout of the base of the super-heterodyne. The wiring is kept close to the base and it should be completed before the panel is attached

is of little consequence. This, of course, does not apply to the special radio-frequency amplifying transformers or the oscillation coupler. These instruments were designed particularly for this circuit and are responsible in no small measure for its success.

LAYOUT

IN THE panel layout in Fig. 6 only the center or shaft holes of the various instruments are indicated, as the holes for the mounting screws will vary with different makes of apparatus.

The general layout of the instruments on the sub-base can be seen quite clearly in Fig. 7.

I would suggest that the panel assembly should first be completed and the panel screwed to the sub-base temporarily before any wiring is done. The sockets, transformers, etc., can then be arranged on the sub-base and screwed in place. The panel should then be removed and the wiring started.

WIRING

HALF-HARD No. 14 tinned copper wire is recommended for hooking up the set. Spaghetti may be used where necessary. If it is desired to "bunch" the filament and B battery leads and use ordinary No. 18 annunciator wire, this may be done, and is good electrical practice, although it detracts somewhat from the appearance of the wiring job.

The grid leads from the radio-frequency transformers should be kept as short as possible.

The shields should be connected to the negative A battery lead.

It will be noted that the transformers and

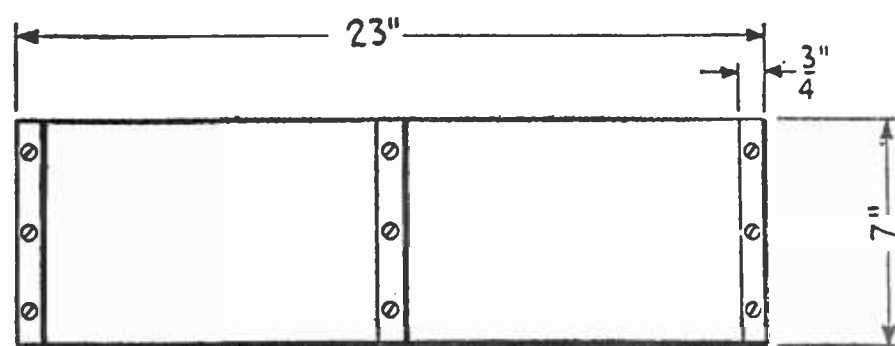

CLEATS ON BOTTOM $7 \times \frac{1}{2} \times \frac{3}{4}$ "

FIG. 8

Diagrammatic plan of the base layout

sockets are so placed that a shield may be placed between each radio-frequency stage, if it is so desired, and this should be done if it is not possible to run the potentiometer more than half way toward the negative side. If the wiring is carefully done, however, this shielding will not be necessary.

OPERATION

IT DOES not seem necessary to go into the details of operating the super-heterodyne. This has already been done in this and other radio publications.

It is recommended that UV-201-A tubes be used throughout, although very good results may be had with UV-199's (use 4-volt A battery with latter). The tubes should be shifted around until the best combination is obtained. When they are properly balanced, the amplifier should slide gradually into oscillation with a slight hiss as the potentiometer is brought over to the negative side.

When the filament rheostat and potentiometer have been once adjusted, they may be

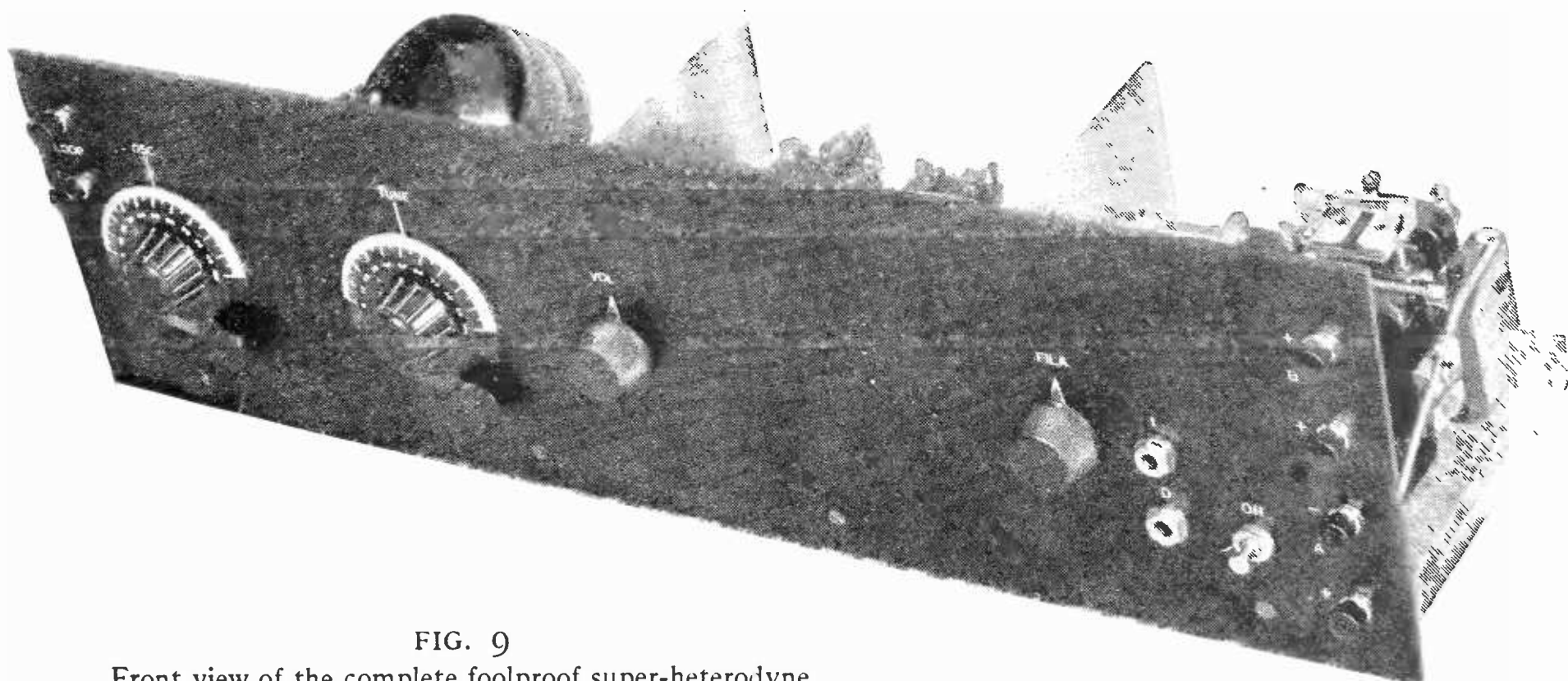

FIG. 9

Front view of the complete foolproof super-heterodyne

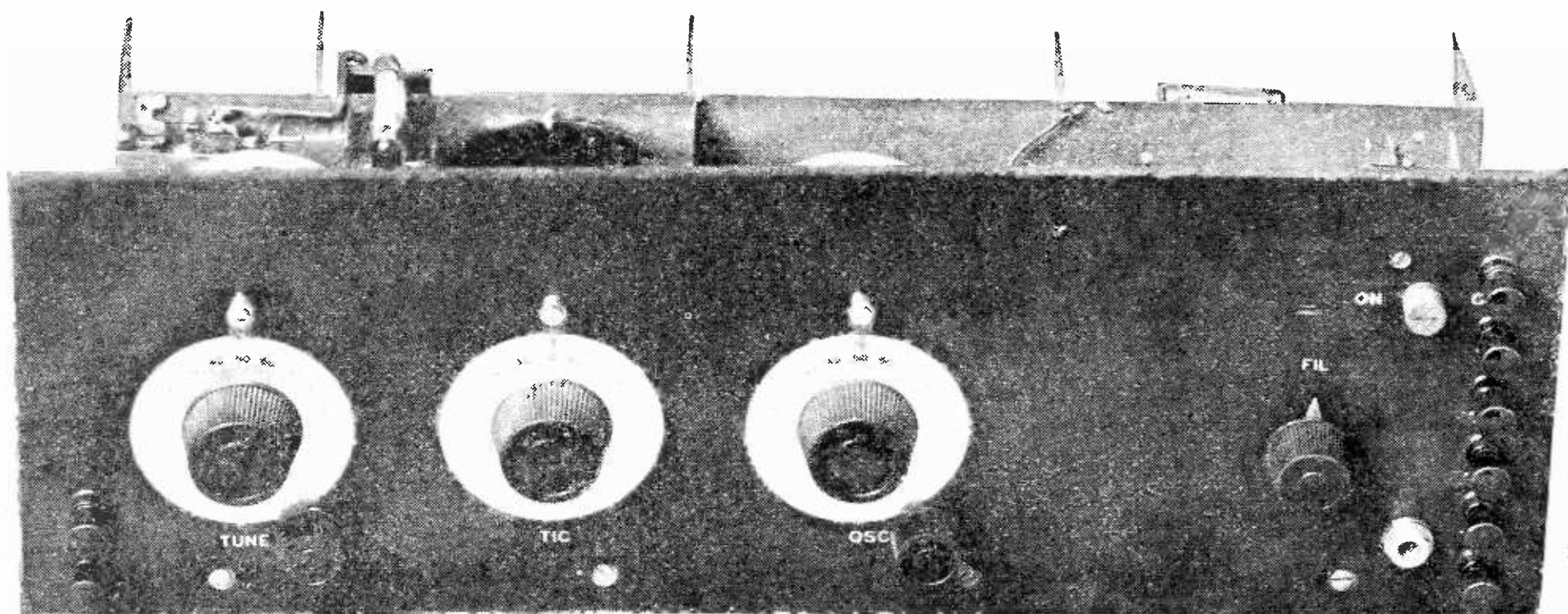

FIG. 10

Front view of one of the completely shielded sets

left alone and all tuning is done with the two condensers. After a station is tuned in, the potentiometer may be used as a volume control.

As there is no manufactured superheterodyne on the market to-day, it can be seen that this circuit is still in a comparatively experimental stage, and even though a receiver as described above is far ahead of any standard set now on the market, still the vast possibilities of this circuit have not by any means been fully realized. It is this fact that should make

this circuit have a very strong appeal to the serious radio experimenter.

There are a vast number of variations possible, such as using crystal detectors, reflexing, etc. It is also possible to do away with the separate oscillator tube and use the first detector as an autodyne with very good results.

However, as a word to the wise, I would suggest that the ambitious experimenter build such a set as is here described first, and use it as a standard of comparison if he intends to carry his experiments further.



“WITHOUT
BENEFIT
OF
CLERGY”

Various Circuits and What They Mean

PART II

What Inductance Is and How It's Used

By ZEH BOUCK

INDUCTANCE" is a thing encountered invariably in radio circuits, and so often referred to, that a genuine comprehension of circuits is impossible with no idea of what inductance is.

To define it clearly we must go back to our high-school physics, or even to those first electrical books we read in the days when our electrical research was concerned mainly with an electric doorbell, a wet cell, and a horse-shoe magnet. Those books told of a mysterious something called "induction," concerning which the only thing most of us were able to grasp was the fact that if one circuit or wire was near another circuit or wire, and the current was turned on or off in the first circuit, a current would be "induced," i.e., created, and made to flow in the second circuit. And that is pretty nearly all we need to know concerning induction in order to comprehend inductance.

Here are several things about inductance, however, which young fellows, digging into school text-books, are likely to be unable to assimilate: Whenever a current flows through a conductor (most often a wire), a "magnetic field"—the same sort of thing that attracts nails to a horse-shoe magnet—springs up about it. When the current is turned off, the field drops. If the current becomes weaker, or stronger, the field does likewise. So we may say that with any change of current, the magnetic field caused by this current, "moves."

Now if a circuit is crossed by a *moving* magnetic field, a current is induced in the circuit. This sort of induction is very pronounced in the case of alternating currents, because, as such currents are always changing, the magnetic field is doing likewise—and *this induced, or secondary, alternating current is always flowing in a direction opposite (at the instant of induction) to the direction of the primary current which induces it.* Just why these things are so, we have left to the world's great scientists to find out.

At any rate, this evidence of induction is exactly what inductance is, namely, *the ability of*

*a circuit to induce a current by electromagnetic induction when the original supplied current varies.*¹

For the simplicity of the illustration, we have spoken of *two* circuits, one close to the other, the original or primary current flowing in one wire, and the secondary or induced current flowing (always in the opposite direction) in the adjacent conductor. But supposing we make a coil of the original conductor (a piece of copper wire, let us say). Then the magnetic field about one turn will cut the adjacent turns, and we will have an induced current in the *same* circuit. It is apparent that the number of turns in the coil, their closeness together, etc., will directly determine the inductance of the coil.

Thus the inductance with which we have mostly to deal may be defined as the ability of a circuit, in which is generally included a coil of wire (which furnishes almost all of the inductance) to generate a secondary current (in itself or in a near by circuit) when the original current varies. So much for "inductance."

WHAT IS AN INDUCTANCE?

AN INDUCTANCE is something possessing the quality of inductance. The name is most commonly applied to a coil of wire, because a coil is predominantly characterized by inductance. It is like a cigarette, which is so closely associated with smoke, that a cigarette is often referred to as "a smoke"—or a passenger, generally paying a fare in a public conveyance, who is often simply designated as "a fare."

Hence any coil of wire may correctly be called an inductance.

FAMILIAR FORMS OF INDUCTANCES

THE circuit in Fig. 1 is the diagram of what is becoming an exceedingly popular receiver, the one-tube reflex. The photograph in Fig. 2

¹Inductance can be measured, and its unit is the "henry," named after Joseph Henry, one of America's pioneers in the field of electromagnetism. A circuit has an inductance of one henry when a current changing at the rate of one ampere a second induces an E. M. F. (electromotive force) of one volt.

shows the instruments indicated on the diagram. These will illustrate three forms of inductance most commonly encountered in radio experiments.

T_1 is a coupler, and in this case, the primary is wound over the secondary. If either the primary or the secondary were movable in respect to the other winding, the instrument would be what is known as a variocoupler. The primary and secondary are the inductances which make up this piece of apparatus. A coupler is generally wound with No. 20 to No.

nothing more than a coupler) the primary and secondary are the inductances.

T_3 is an audio-frequency amplifying transformer, consisting of some thousands of turns of very fine wire on the primary, and about four times as many turns on the secondary. These windings are made on an iron core which concentrates the magnetic field and greatly increases the inductance. The necessity for the iron core will be explained in discussing the uses of inductance. Again the primary and the secondary are the inductances.

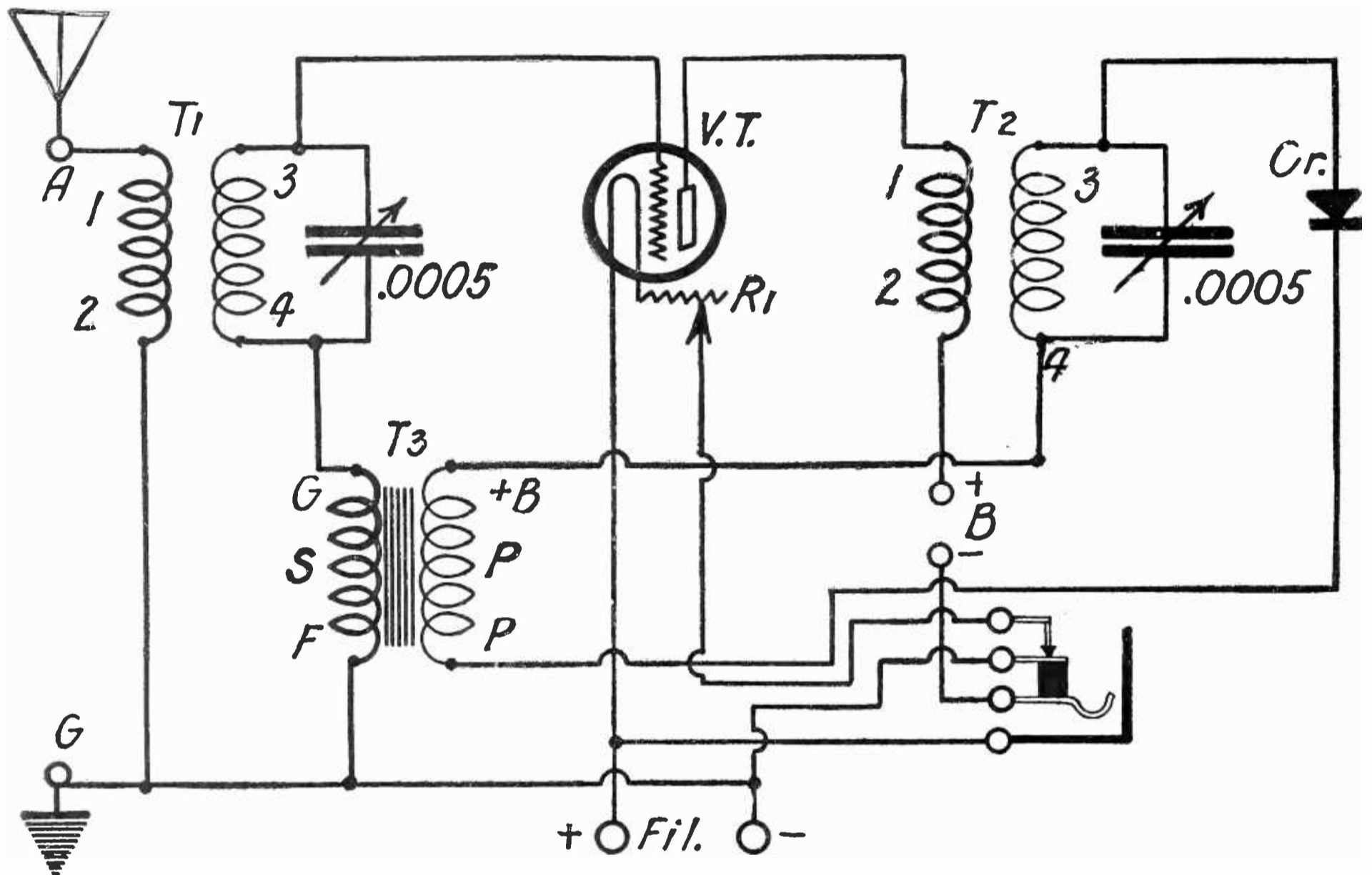

FIG. 1

A circuit showing three familiar forms of inductances (T_1 , T_2 , and T_3). This is the wiring diagram of the "knock-out" one-tube reflex receiver described in RADIO BROADCAST for November, 1923

24 wire. The primary, if fixed, has about 16 turns of wire, and about 50 turns if variable by taps. The secondary is wound with about sixty turns. A tube about $3\frac{1}{2}$ inches in diameter is generally used for the primary winding form, with the secondary wound either alongside or on a tube or ball rotating within the primary form. Such a coupler will work nicely where no special data for a specific set are given.

T_2 is a radio-frequency amplifying transformer, which it is usually more satisfactory to buy than to build. As in the case of the coupler (in fact the radio-frequency transformer is

As will be shown later, T_2 and T_3 are called transformers because they transform energy from the primary to the secondary circuit. But T_1 also does this, so the unit is sometimes, and quite correctly, termed a receiving transformer.

Fig. 3 is the diagram of a two-slide tuning coil, common to all single-circuit sets. The two-slide tuning coil is, of course, another type of inductance. In effect it is a two-winding coupler, for the turns between X and Z act as primary, and those between Y and Z as the secondary. Because of the self-contained double action, such windings are often referred to

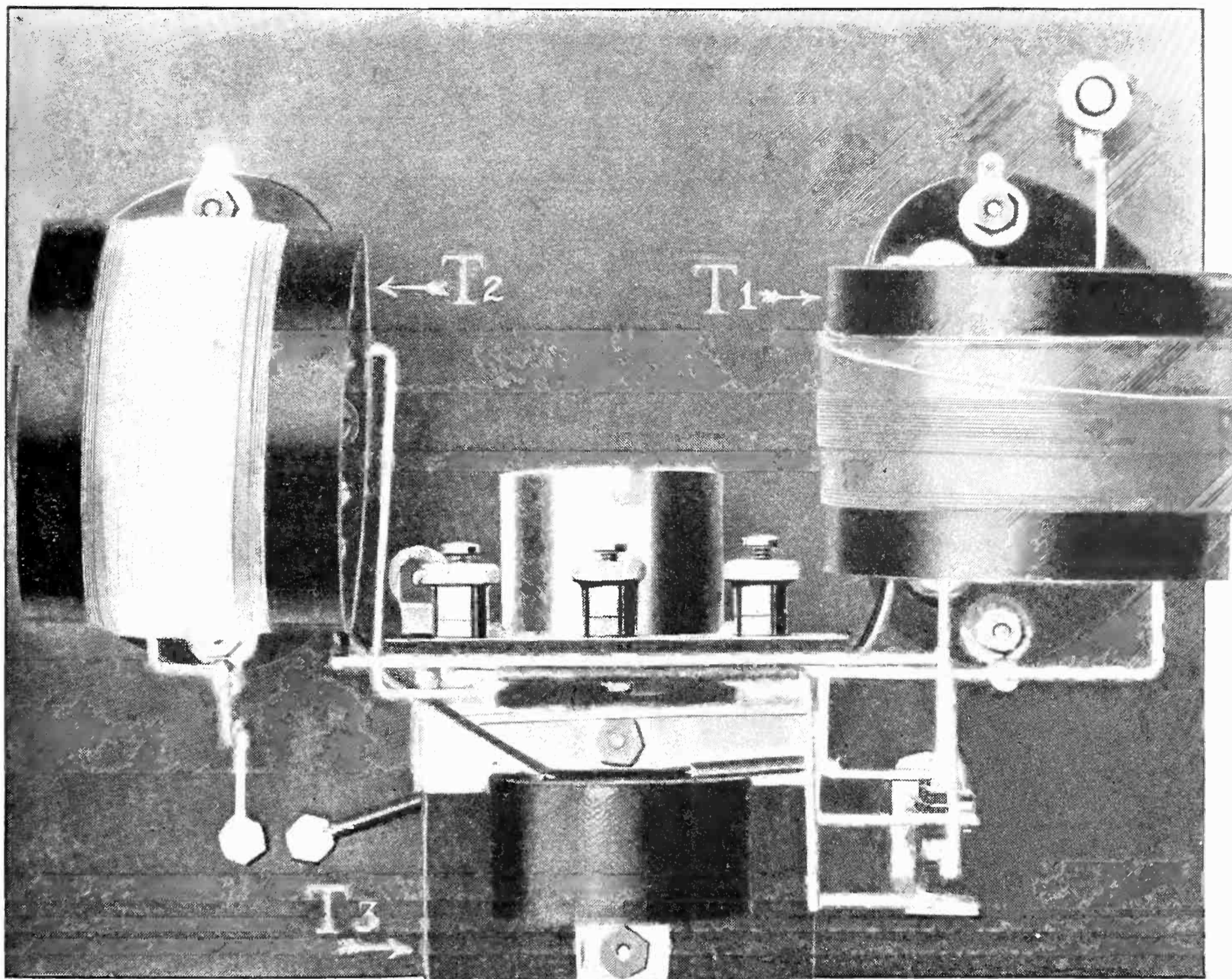

FIG. 2

The inductances shown diagrammatically in Fig. 1

as auto-transformers. About 80 to 100 turns of wire on a 3-inch winding-form are about right for such a tuner.

The variometer, which is a continuously variable inductance, as well as all other forms of coils—chokes, honeycombs (which are often used as primaries, secondaries, and plate or “tickler” coils) are inductances.

HOW INDUCTANCES ARE USED

THE most common use of radio inductances is to transfer the energy from one circuit to another. This transfer is made from the antenna and its circuit which “picks up” the signals, to the detector (variocoupler or tuning coil) or, inductances transfer energy from the output circuit of one tube to the input circuit of another tube. This is done by a combination of inductances called an amplifying transformer. This energy transfer is accomplished

—chiefly by induction—the phenomenon which we outlined in our opening paragraphs. It need only be remembered that the reason an inductance is an inductance is because of its ability to induce a current in a near by circuit (or in itself).

Now the action of radio-frequency transformers and couplers does not occur so much by the phenomenon of induction, in a narrow sense of the word, as it does by re-radiation. Whenever a radio-frequency circuit is tuned to a radio impulse, it re-transmits part of the energy it picks up. Guy wires and metal fences, etc., in the neighborhood of a powerful transmitter, are often affected by the radiation from the antenna and send out additional waves. So the primary in a radio-frequency circuit is really a small transmitting antenna which transmits its mite of energy across the intervening inch or so to the secondary. How-

ever, as radio reception is fundamentally a species of induction, the action of a vario-coupler, or a radio-frequency amplifying transformer is often explained simply occurring by "induction."

In radio-frequency circuits, the magnetic field, through this process of radiation, spreads out from the conductors, apparently moving at so high a frequency that its inertia (tendency to keep on going) is so great that it cannot reverse and return to the wire. It "disconnects" itself and shoots off into space. In audio-

frequency circuits, this phenomenon does not occur. The audio-frequency waves, which act somewhat like rubber bands, merely stretch a little (the frequency or the up-and-down motion is comparatively slow) and come back to the wire again. The "rubber band" never "breaks" and flies away. Hence, to effect any transfer of audio-frequency energy across even the slight distance between primary and secondary windings, the magnetic field must be concentrated by the use of a core.

It has been mentioned that the current induced in a coil by its own primary current is always in the opposite direction to the current that induced it, so it follows that this opposition of current will have a certain undesirable effect on the inducing or primary current, or, say, the incoming radio signals. It has also been shown that this induced current varies directly with the rapidity of change of the primary current. Then this undesired effect of opposition by the secondary current on the inducing current will vary directly with the frequency, kilocycles or wavelength (the rapidity of change) of the incoming signals. This partly explains the necessity for tuning, that is, changing the values of inductance in the circuit. In radio-frequency circuits, the inductance must be kept comparatively low, and this is one of the reasons why iron cores are eliminated from such circuits. Where high inductances are a part of a radio-frequency circuit, such as telephone receivers and the windings of audio frequency amplifying transformers, these inductances are shunted by fixed condensers which "by-pass" the high-frequency impulses. These capacities are in particular evidence in the Grimes and other reflex circuits.

FIG. 3

The tuning coil which forms the inductance in most single-circuit sets. As explained in the text, this is a type of "auto-transformer"

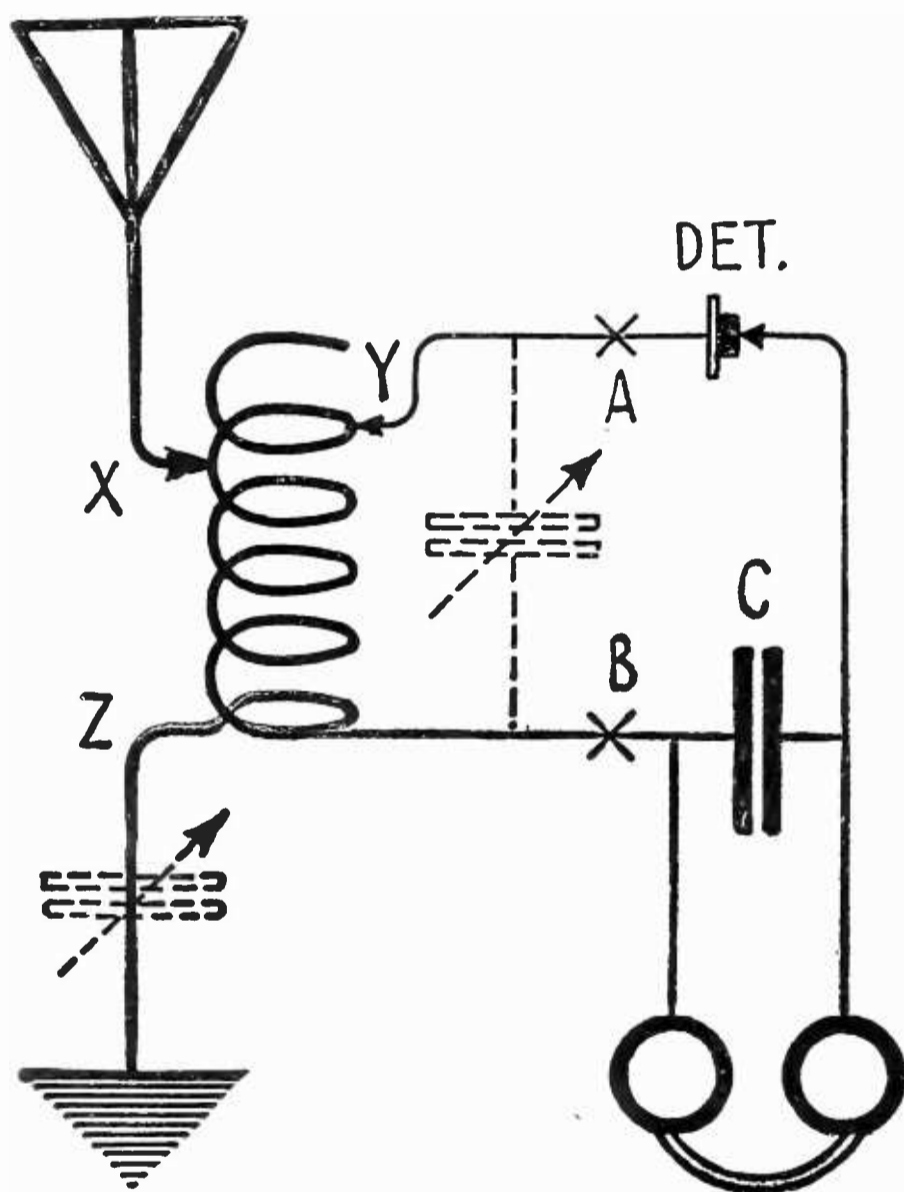

Mr. Bouck's third article in this series will appear next month.

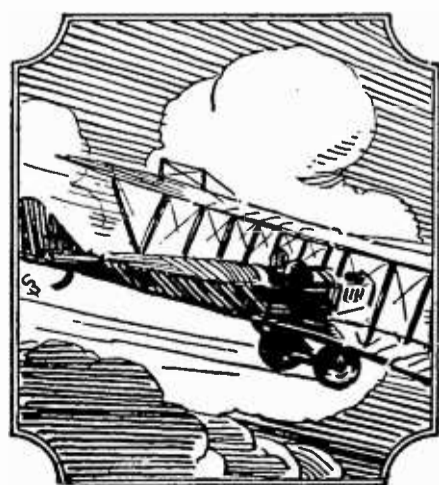
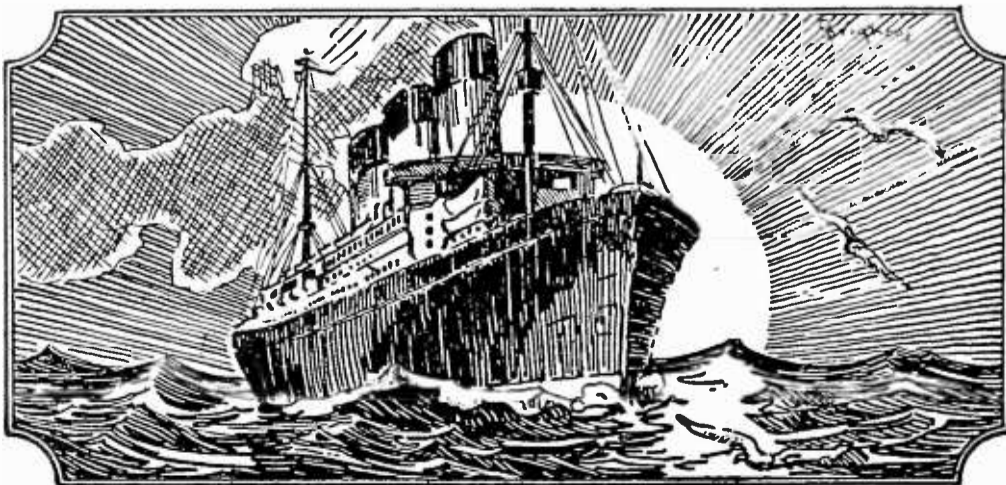

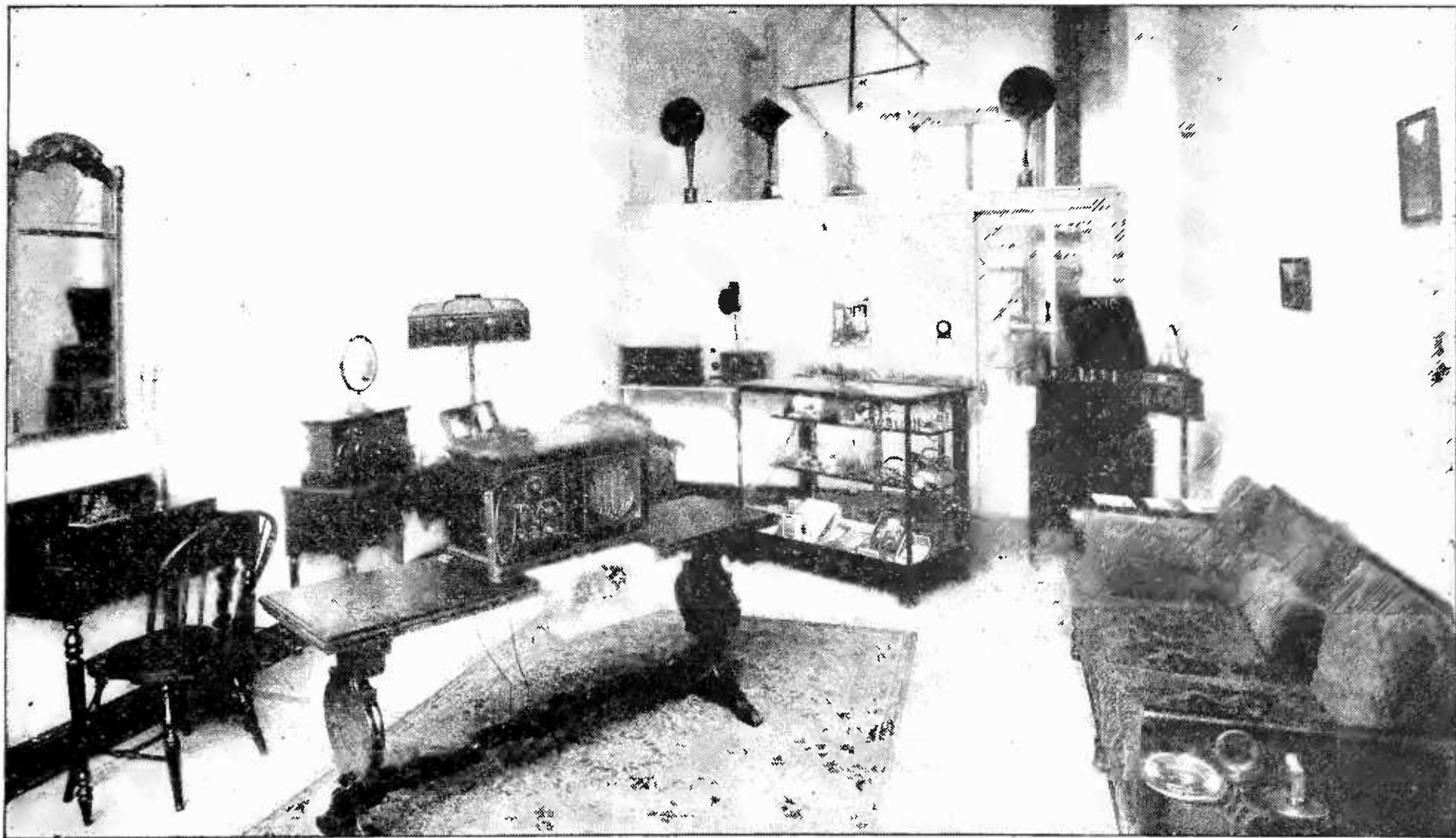

MR. STEVENS' SHOP IN WASHINGTON, D. C.

Where the simplicity, neatness, and attractive appearance of modern receiving sets are made evident to the uninitiated

Making Radio Attractive to Women

A Sales Plan Adopted by a Dealer in Washington, D. C., and the Reasons for Its Success

By LEWIS WOOD

IF YOU saw a receiving set installed in the living room of your own home in such a way that it harmonized with the furnishings of the room—seemed to “go well” there, as we say—would you be any more inclined to want it than if you saw it against the background of a lot of shelves packed with electrical equipment?

Donald G. Stevens, of a radio sales company in Washington, believes you would, and therefore he has adopted a plan which has been very little developed in the field of radio merchandising. It took some courage to start such a venture as the outlay necessary was considerable, but he was convinced that the ability to realize just how radio “fits” and looks in the home would, in time, prove a great inducement to purchasers.

Accordingly, he furnished his place of business, not like a store at all; he got away from

shelves and counters, replacing these with furniture in the fashion of a parlor or a drawing room. He put a big, comfortable davenport against one wall, and along the other side of the room a desk and a table. In the middle he placed one of the long tables that are so often seen in modern homes. He did not crowd his quarters but selected his furniture with taste and discretion. As will be seen from the photograph above there are enough chairs, tables, and desks in the room, and enough pictures on the walls to secure the desired effect. Besides, three or four different types of furniture are provided in order that each prospective purchaser may pick out pieces resembling his own as much as possible.

“I have tried to make it so that the prospective customers who come in here, especially the women, do not have to draw entirely upon their imaginations,” said Mr. Stevens.

“My idea is to have enough variety to suggest the corner or center of almost any living room to-day.”

Justification for this novel plan of merchandising seems to be ample, for the sales of the establishment during the second month of its existence were one fourth larger than those of the first, while sales during the third month nearly tripled those of the second!

“It’s a satisfaction to me that we have been able to prove to the public that the radio business can stand alone,” remarked Mr. Stevens. “We sell radio and nothing else, and I suppose it’s because of that very thing that the public will come here when it won’t go to some other places. Customers must realize that since we deal in nothing but

radio, we know this work as no one who manages it as one of many side-lines can ever do. If more and more dealers would go into the strictly radio business instead of making it a side-line, public confidence would grow steadier all the time.

“Radio has a special demand of its own,” he continued, “just as the talking machine or the moving picture has. Some people think the talking machine will disappear with the increase of radio’s popularity, but that’s a mistaken theory. The phonograph will continue in its own sphere, and it’s my idea that it will become a sort of vocal library, preserving voices just as the printed words are preserved in a book, while radio will be a sort of talking daily newspaper.”



MOST
PEOPLE
STOP,
AND
MANY
GO
INSIDE

How to Neutralize the Neutrodyne

The Second of a Series of Three Articles on Building, Neutralizing, and Operating a Five-Tube Hazeltine Circuit Receiver

By KIMBALL HOUTON STARK

Chief Engineer, F. A. D. Andrea, Inc.

MANY people who have constructed neutrodyne receivers have possibly found the adjusting or "balancing out" of the set before it is ready for use, a difficult task. In most cases, it has been difficult, not because the process itself is complicated but because of a misunderstanding of the results to be obtained and the methods of obtaining them.

It may be well at this time to consider the function of the neutrodyne circuit in order to understand just what is accomplished when we balance out or adjust it for capacity neutralization.

Professor Hazeltine devised a method of neutralizing both the stray circuit capacities and the inherent capacity of the vacuum tube, i.e., the capacity existing between the filament or cathode and plate or anode of the tube. It is the presence of these coupling capacities in an ordinary tuned radio-frequency amplifier circuit that causes the circuit to regenerate and oscillate when the tuned amplifier circuits are in resonance, unless some means is provided for controlling the grid potential of the tubes, which usually results in a loss of efficiency.

Such parasitic oscillations make it impossible to secure pure radio-frequency amplification and in addition cause very decided signal and

speech distortion. Every listener-in knows the disadvantages of tuning-in to a local concert and hearing all sorts of "birdies."

In Professor Hazeltine's arrangement, however, coupling capacities are made to counteract each other and each individual tube circuit is balanced against another tube circuit so as to reach a condition where no signals can be heard in the phones because of passing through coupling capacities existing in the circuit.

In the neutrodyne circuit, the electromagnetic coupling between the neutroformers is approximately zero. The effect of this is to make one portion of the circuit capacity balance against another practically equal portion of circuit and tube capacity, so as to eliminate or neutralize the effect of the parasitic feed-back capacities of the entire circuit.

HOW TO NEUTRALIZE THE CIRCUIT

IN PRACTICE, the balancing-out process consists of exciting the coupled receiver circuits with a comparatively strong signal and then adjusting the special neutralizing capacities or Neutrodons, as they are called, to a point where that signal becomes inaudible. The fact that this adjustment of the neutralizing capacities is made toward a minimum or inaudible signal and can accordingly be made very exact, gives us proof that the method of neutralization is a true process of actual circuit

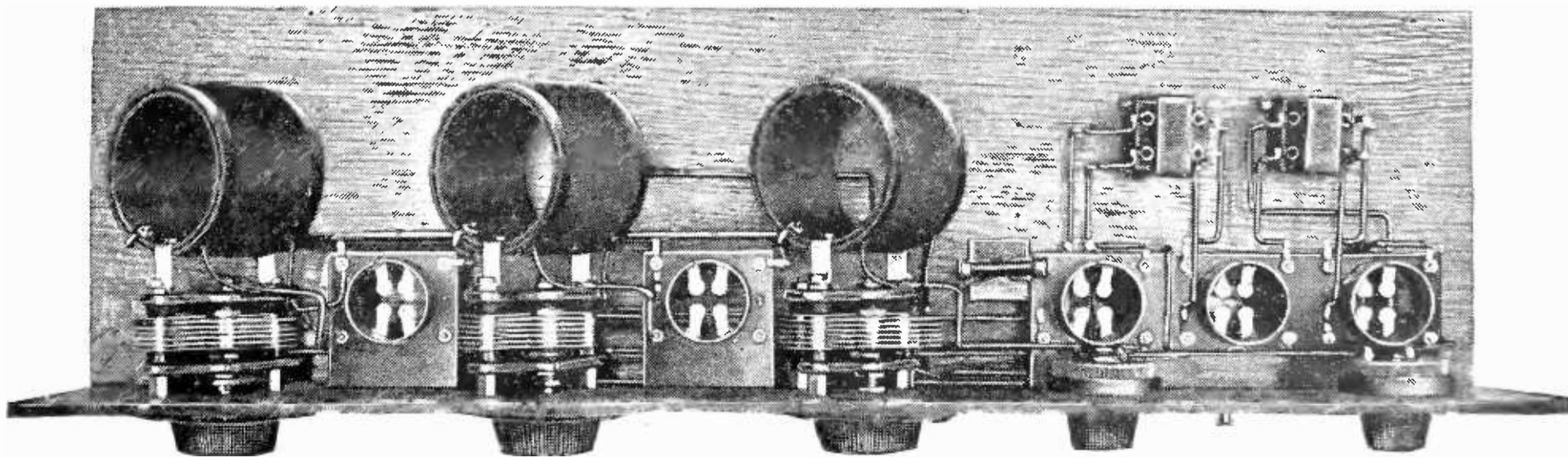

FIG. 1

Top view of the five-tube neutrodyne receiver. This is the set described in the December, 1923, RADIO BROADCAST

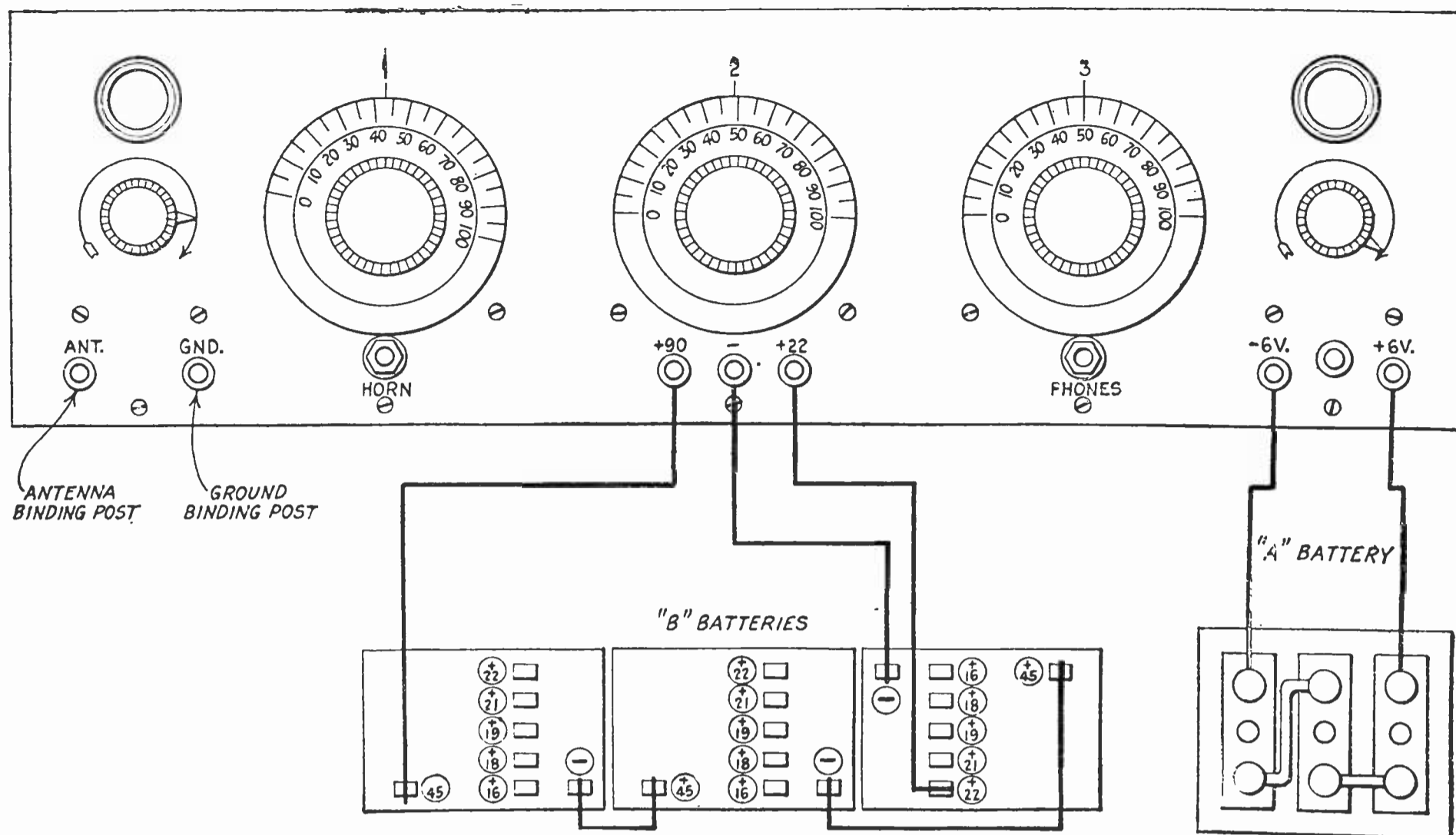

FIG. 2

The method of connecting the A and B batteries. This cut shows the four-tube receiver, but the binding posts and markings of the five-tube set are precisely the same

capacity neutralization and not a method of preventing or reducing regeneration. This is even more forcibly brought out when it is realized that the adjustment is made *without lighting the filament of the tube you are adjusting*.

The five-tube receiver, after you have completed the assembly and wiring, will appear as shown by the photograph on page 126 of RADIO BROADCAST for December and by the top view of the receiver pictured in Fig. 1 of this article. Fig. 2 shows how to connect the A and B batteries.

In addition to the battery connections, a special balancing-out circuit must be hooked up. The balancing-out circuit consists of an inductance and a variable condenser excited by a buzzer and coupled to the input or antenna terminal of the completed receiver. It is usually desirable to place this adjusting circuit 10 or 15 feet away from the actual receiver and lead a single wire over to the antenna binding post. To complete the balancing-out circuit arrangement, a wire is connected from the main terminal of the receiver to the ground such as a water pipe, etc. The wiring and circuit constants of such a circuit are shown in Fig. 3.

With the adjusting or balancing-out circuit connected as above and with the A and B

batteries connected as shown in Fig. 2, we are ready to start balancing out our receiver. The method is as follows:

1. Turn the knobs of both detector and amplifier rheostats as far to the left as possible.
2. Insert two UV-201-A or C-301-A vacuum tubes in the radio-frequency amplifier tube sockets (the two single-tube sockets at the left end of the receiver looking from the panel front). In the detector-tube socket (the one directly above the phones jack), insert a UV-200 or C-300 detector tube.
3. Pull out the filament switch between the phones and horn jack, thus closing the filament circuit, and turn the amplifier rheostat (the one at the extreme left of the panel) so that the pointer points directly at the number three Neutroformer dial. This is about the correct position of the rheostat for the Uv-201-A tubes. Turning this rheostat to this position will light the filament of the first two left-hand tubes. Now turn the knob of the detector rheostat about three quarters of the way around or approximately with the pointer at the right and pointing toward the pointer of the amplifier rheostat. It is best to adjust the detector rheostat slightly so that when the phones are plugged into the phone jack, the detector rheostat will be adjusted just below a

point where a decided sizzling and frying sound is heard in the phones.

4. With the buzzer of the balancing-out circuit running, rotate all three Neutroformer dials from the front of the panel, about in step with each other, and pick up the buzzer signals with the variable condenser of the adjusting circuit set at approximately 15 or 20 degrees (an approximate wavelength of 225 meters). The buzzer signals should be picked up at about the same settings, near 15 or 20 degrees on all three of the dials. When buzzer signals are picked up, all three Neutroformer dials should be adjusted very slowly until buzzer signals come in at their maximum. At this point the dials should have approximately the same settings.

5. Remove the tube from the left-hand tube socket.

6. Readjust the three Neutroformer dials again for maximum signals.

7. Take the UV-201-A tube removed from the left-hand socket and place a small piece of paper over either one of its filament contact pins so that the paper will remain in position when the tube is again inserted in its socket.

8. Place the tube with the insulated contact pin back in its socket. This allows the connection of the plate and grid of this tube to the receiver circuit, but as one of the filament contacts is insulated, the filament of the tube will

point is the one where signals are very weak or disappear entirely and no sound is heard in the phones. To prove the minimum signal point, the tube can be lifted out of the socket and immediately signals can come in at their maximum as they did at the end of the adjustment 6 above. Replacing the tube in its socket (with the paper still in place) will cause the signals to disappear or be heard at the minimum signal intensity. The ideal condition for the Neutrodon adjustment is for the signal to disappear entirely when the tube is in its socket (with the paper in place) and at this point the Neutrodon clamp should be tightened down securely. For a more permanent adjustment of the Neutrodon, the clamp after being tightened down can be directly soldered to the sliding brass adjustment tube.

9. This covers the neutralizing adjustment for the first radio-frequency amplifying tube (the one on the extreme left.) The same procedure is followed with the second radio-frequency amplifying tube (the second tube from the left looking from the panel front). In this case the first left-hand tube and the detector tube are kept in their sockets and lit, and the second left-hand tube removed and its filament terminals insulated, after which the neutralization adjustment covered in paragraphs 7 and 9 should be followed out in detail, adjusting the second Neutrodon from

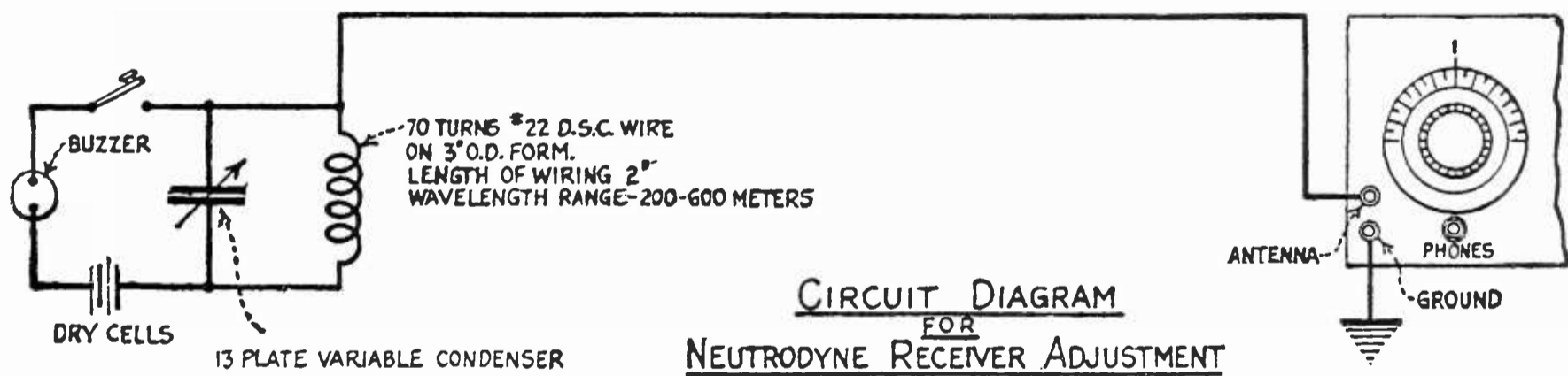

FIG. 3

An arrangement for use when it is impossible to adjust the set by taking advantage of loud broadcast signals

not light. With the tube in its socket and the filament unlit, signals will still undoubtedly be heard, but with considerably less volume than before. It will be found that by adjusting the brass tube of the first or left-hand Neutrodon lengthwise over the glass insulating tubing, the strength of signals heard with the tube in its socket with the filament circuit inoperative can be varied from loud to a minimum or inaudible signal. The desired adjustment

the left end of the baseboard and securing the adjustment at the given inaudible signal point.

The most important point to follow in this balancing-out process is to adjust all three Neutroformer dials for a maximum signal when either the first or second tube is taken out of its socket and before the neutralization and adjustments are made with the insulated filament contact pin of either the first or second tube in its respective socket.

A further test, to determine that the circuit is properly balanced out, is made with the A batteries still connected and with the antenna and ground connected to their respective binding posts, all tubes being in the receiver without any of the terminals insulated. One can try to receive broadcast signals by adjusting the receiver dials, etc., similar to method of tuning for balancing out signals described above.

By tuning the receiver one should be able to receive broadcasted signals without hearing beat notes, whistling, etc., which are the usual indications of regeneration or oscillation. If,

under any circumstances, such whistles are encountered, the entire receiver should be carefully gone over and possibly re-wired and readjusted, as will be described in detail in the third article of this series. If beat notes, etc., are heard, it is proof that the circuit is not functioning according to the neutrodyne principle and most satisfactory results cannot be obtained. The experimenter is cautioned to make sure that his receiver is adjusted properly and that no parasitic disturbances are caused by the improper capacity neutralization in the circuit, otherwise the value of the neutrodyne circuit will not be realized.

Music Dealers: Logical Salesmen of Radio Sets

By T. M. PLETCHER

President, Q. R. S. Music Roll Co.

THE articles of Mr. George J. Eltz, Jr. and Mr. W. L. Eckhardt on the question, "Is the phonograph dealer or the electrical dealer going to prove best qualified to provide sales and service for broadcast listeners?"* have interested me. Both are good articles. Both men display knowledge of their subject. Mr. Eckhardt has the music man's point of view, with which I am heartily in sympathy. I should be inclined to cast my vote with him. As a member of the music trade, and because I have strong convictions on the subject of radio due to more or less intimate contact with its development, I should like to take a hand in the discussion to try to throw some additional light on it. I do business with most of the music merchants of the country, and, enjoying a large personal acquaintanceship among them, am rather intimately familiar with their status and their problems. I should like to be permitted, therefore, to increase the scope of the question by substituting "Music Dealer" for "Phonograph Dealer." Many piano dealers do not handle phonographs but can sell radio. "Music Dealer" will embrace both the phonograph and piano merchant.

I cannot improve on Mr. Eckhardt's treatment of the matter in hand except perhaps to submit several considerations in addition to his.

My observation will take the form of answering Mr. Eltz in the sequence of his remarks, touching

*These articles appear in the November, 1923, issue of Radio Broadcast.

upon those only that in my judgment raise an issue.

His classification of radio business into two divisions, one having to do with the sale of complete sets and the other with the sale of radio parts, leaves nothing to be desired. It is an interesting item of information that previous to radio broadcasting there were approximately 150,000 amateurs in the United States intensely interested in radio and that practically every one of these amateurs had at one time or another manufactured a receiver. My view of the amateur set is that it has served as the greatest incentive to business in the complete radio set. The home-made creation is responsible for the wave of popularity beginning to sweep the country for the factory-made complete set. It did more than anything else to introduce radio to the public. There are many amateurs, however, who are not satisfied with their own efforts. They realize their handicap for want of machinery and laboratory facilities, and have begun to buy professionally made radio. The parents of many an amateur are growing tired of the difficulties which beset the home-made product, and want to satisfy their desire for a set which will reach out to every part of the country, which is comparatively free from trouble, and which at the same time represents the latest advance of the science. I have talked to some about radio parts business and understand that the tendency is towards a tapering down. Whether this is true generally, I do not know, but it would be the natural result of the changing conditions.

Here is the common-sense aspect of the case: the dealer in radio will of course follow the lines of least resistance. Complete radio sets offer more profit, less trouble, less stock investment than radio parts. The reasonable tendency will be towards the complete sets. Add to this the fact that so many boys have had their fling at "rolling their own" and are willing to acknowledge that without factory facilities they are at a disadvantage, it would seem entirely probable that the parts business has seen its best days and that it is now on the downward swing. I am basing my hypothesis on purely psychological grounds.

PLENTY OF TECHNICAL MEN AVAILABLE TO THE MUSIC DEALER

THE distinctions which the writer makes between the phonograph and radio are theoretical rather than practical. I agree that the radio set is more complex, that it presents greater mechanical difficulties and more or less of a problem in both the installation and operation. All this, however, is not in a degree to require a man of any more training than is needed to install or repair a talking machine or tune a piano. A talking-machine department cannot be without a practical man. A piano department cannot be without a practical man. The radio department can as little as these afford to be without someone capable of taking care of the difficulties arising on the mechanical side. The radio man does not require four years of college, a post-graduate course and a long apprenticeship any more than the music-merchant's repair man or the piano tuner. As a matter of fact, the degree of expertness of the radio man is not nearly as high as that of the tuner, and what is more, a radio man is easier to get. In "Why the Electrical Dealer is the Proper Outlet for Radio" the statement is made that even before broadcasting there were 150,000 amateurs in the country. There are not anything like 15,000 piano tuners nor 15,000 talking-machine repair men. The ratio is 10 to 1 in favor of the radio man.

The author of the article in question makes extended consideration of the question. Which class of merchant serving the public at the present time is best fitted to carry on the sale of radio? He mentions five classes of channels through which radio purchases can be made: the hardware dealer, department store, phonograph dealer, electrical dealer, and special radio store.

His first objection to the music dealer successfully handling radio is: "The personnel employed by phonograph dealers is not trained in the particular way necessary for the sale of radio equipment." He is right in saying that the personnel is not yet trained in radio, but my contention is that some of the successes made by music stores handling radio show that the music men learn very quickly and that competent radio help is easy to get.

He mentions, "The average phonograph dealer or phonograph salesman is in every sense of the word a salesman." There he hit the bull's-eye. That is one of the biggest arguments in favor of the music man handling radio. He will succeed with radio because he is a salesman. Development of the business depends more on selling than technical ability. Arrange the business so that each man can function at his best. Here is the plan:

A radio department, whether it is part of an electrical business or part of a music business, should be complete in itself irrespective of the size of the general business. The music dealer in the small town should have a radio department just as clearly defined as his piano and talking-machine departments. Whenever you find a store with different commodities jumbled together without distinct departments, you will see an unprogressive establishment. Pianos need at least one salesman and a practical man. Which is true also of talking machines. No reason why the radio department

should not be equally well manned. How many successful automobile men are there who happen to be combination salesmen and practical men? Let the salesman sell radio, and let someone else do the installing and the repair work.

ADDITIONAL EXPENSES OF A RADIO DEPARTMENT JUSTIFIED

MR. ELTZ contends that the establishment of a radio department "is an additional expense which will naturally reflect itself either in an increased price of material to customers, or in decreased profit." But can you imagine how much business a man would do in complete sets by simply stocking them and having someone with a thousand-and-one duties incident to the electrical business, merely attempt to sell radio as a side-line to his regular activities? Selling cost in such case would be little, of course, but there would be little or no business. On the other hand, a man devoting all of his time to radio, and being paid for what he accomplished in radio, would have to sell a certain quantity of sets each week to earn a living, and correspondingly more to earn an attractive income. There can be no question of outlay when there is enough business to justify the expense. And certainly the most economical way, no matter who handles radio, is to have a separate and distinct department with competent help—at least one salesman and a handy man.

The author talks about the needless "additional expense of establishing a radio department", yet he also recommends that the radio dealer "install a special department in which the more profitable lines of electrical merchandise, other than radio, are sold." Because of his unfamiliarity with the music business, he evidently does not see the analogy

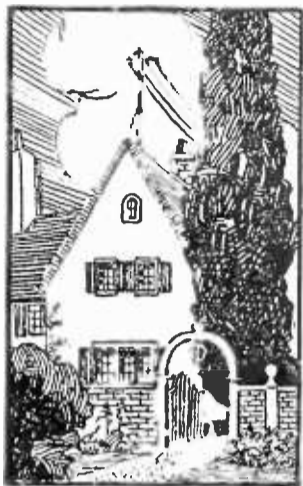

between one and the other activity, and how in each case the various commodities should be handled in distinct departments.

Mr. Eltz dwells on the qualifications of the electrical dealer permitting him to sell radio equipment readily, and mentions his training to think along electrical lines, and to explain the operation of electrical devices, and to maintain and install apparatus. In the piano business, the man who knows much about construction and about tone, is usually getting a mechanic's wage, or very little more. The average salesman earns at least three times as much and generally is burdened with no more knowledge about construction than to answer the usual question of the layman. It is natural for one to talk about that with which he is most familiar. The radio expert talks glibly in the radio vernacular about things which are mysterious to the average man, who on hearing the highly technical explanation becomes more befogged than ever. The salesman's gift is to understand the importance of selling the results rather than the means, the pleasure of radio and the instruction it affords, rather than the intricate mechanical make-up. He knows how to speak in the language of his listener. He knows how to reach into his listener's experience, and he also realizes the importance of keeping technical and mechanical questions in the background. I should rather have the sales staff of my radio department, were I to introduce one, comprise good salesmen, who learned a little something about radio, than expert radio men who had learned a little something about selling.

Of course, all this discussion has to do primarily with the selling of complete radio sets. It stands to reason that the electrical dealer is best fitted to sell radio parts, because they can be handled just like many other similar articles with which the electrical store is filled.

To quote: "The greatest argument in favor of the electrical dealer handling radio equipment is that outside of the investment required for a stock of radio equipment, the electrical dealer is required to go to almost no additional expense." Another discussion is entered into about the increase of operating expense by having a separate department and how that expense will reflect in the profits of the dealer, and have a tendency to increase the price to the consumer, and at the same time decrease volume business. I have yet to find a merchandising proposition with promise, with any one or more elements lacking. A business cannot be run without stock, without salesmen, and without a certain expense. This is fundamental.

Who can conceive of a flourishing radio business when the interest in it is no more than casual? In a busy electrical store, who will take enough interest in radio to advertise it as it should be advertised,

demonstrate it as it should be demonstrated, spend his evenings calling on prospective buyers, outside of him who is devoting all of his wakeful hours to radio and gets his income from that end of the business? If in the personnel of an electrical store there is a man capable of selling \$100, \$200, \$500 radio sets, he should not be spending his time selling supplies. He is in the wrong pew. He might happen to be busy selling someone a binding post when a \$250 radio prospect walked in the door.

That kind of prospect needs a different brand of attention from what the ordinary electrical clerk can give.

A GOOD SALESMAN CAN QUICKLY LEARN ENOUGH ABOUT SETS TO SELL THEM INTELLIGENTLY



IF I turned over a live and intelligent young salesman to the sales manager of a large concern dealing in radio equipment, how long would it take the sales manager to tutor him in all that he needed to know to make a satisfactory demonstration of your most complicated radio set in the store and to answer the average run of questions from the layman? Am I correct in stating two weeks at the outside? Now, if that young man is put to work and he sells from three to five radio sets a week on a commission basis of 10 per cent. or 15 per cent., would the concern make any money? Supposing, then, I found another such fellow, and then a third! Of course, the sales manager would be increasing his personnel, but would he mind? Couldn't he, in addition to these three men, add a professional repair man and installer?

Let me put the matter in still another way. A music merchant in a town of 10,000 establishes a radio department and puts one of his phonograph men to sell radio and hires an amateur for installations and the possible tinkering. The phonograph salesman gets the necessary fundamentals in radio from the amateur and starts out to tell the people whom he has sold talking machines about the wonders of radio. Helped by his imagination and a ready tongue, he induces one after another individual to accept a demonstration at home. The amateur puts up the set and demonstrates it, and the salesman supplies the adjectives and the enthusiasm. Won't that pair, whose income will depend on volume of business, be a better means of developing trade than having the clerk back of the counter in the electrical store pause in his grind to show an inquirer a radio set?

Thus far I have touched on specific points raised in Mr. Eltz's article. I stated at the outset that my views about the music dealer handling radio coincided with those of Mr. W. L. Eckhardt. There is abundant proof that the music dealer can handle radio. I don't hesitate to say that as a general proposition the music dealer is better

fitted to sell complete radio sets than the electrical dealer.

EXISTING ELEMENTS WHICH FIT THE MUSIC DEALER FOR HANDLING RADIO

THE music dealer has learned how to departmentize his business. He gives due importance to the selling and due importance to the mechanical needs. He is used to hiring salesmen, tuners, repair men. He is usually a good business man, made so perhaps by virtue of his contact with the banking fraternity. The up-to-date merchant is one who knows how to borrow money at the bank. But the banker won't loan money to one on installment paper unless he knows quite well that the borrower is running his business in a business-like way. Otherwise, the paper is apt to be of no value. Perhaps the biggest source of instruction to the music merchant is his banker. Then again, the environment of the music store is often best adapted for the sale of a commodity such as the complete radio set. It is equipped with booths for demonstration, and generally has elaborate appointments, more inviting to the public than the crowded, frequently noisy and distracting electrical shop. Being used to sell a high-priced article he knows how to "talk" a quality product. Then, and this to my mind is extremely important, he is a chronic and keen advertiser, something that cannot be said of the average electrical dealer. Look through the Chicago papers, or the New York, Philadelphia, Pittsburgh, Kansas City, San Francisco papers, count the lines of musical-instrument advertising, as against those

of electrical-instrument advertising, and you will have your eyes opened to a very vital difference between the two dealers. The public will know much more about radio through the music merchant than through the electrical dealer, because he advertises his wares extensively. The music dealer is a public benefactor in the sense that, missionary like, he preaches in print the more or less unknown want of music or of anything that he sells.

True, there are some electrical stores with equipment equal to that of the finest music stores, and the advertising is equally extensive and potent, but they are exceptions.

There is nothing about this radio merchandising that cannot be learned in a short time, but there is a lot about a well regulated business institution such as the modern music store, that is the result of long experience and training—the art of selling, the art of advertising, the art of effective stock display, the art of financing, the art of successfully selling on the installment plan, the art of giving service—all of which, turned into any channel, whether radio, motor cars, pianos or talking machines, can have but one result—large and satisfactory distribution. These elements in the same degree are lacking, to my mind, in the average electrical shop, and they are the ones upon which I should rely for the development of business in the complete radio set. They are all at the disposal of the radio manufacturer, and they are readily accessible if he will but go to the music dealer, who represents these elements in the highest degree.

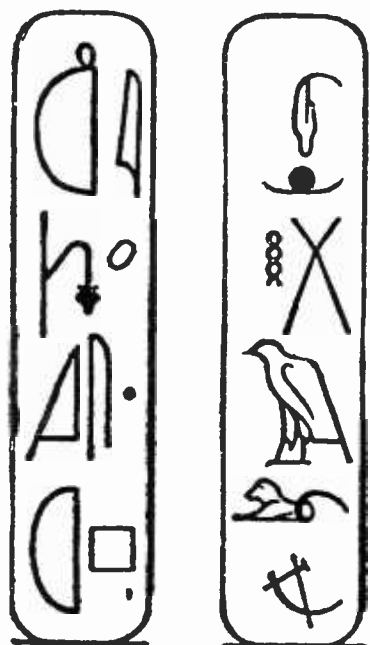

NOT A NEW CIRCUIT

Nor a recently discovered Egyptian coat-of-arms. By folding one set of hieroglyphics inward against the other, then folding back the right-hand symbols along the middle, you will achieve a result to make certain Canadian broadcasters smile

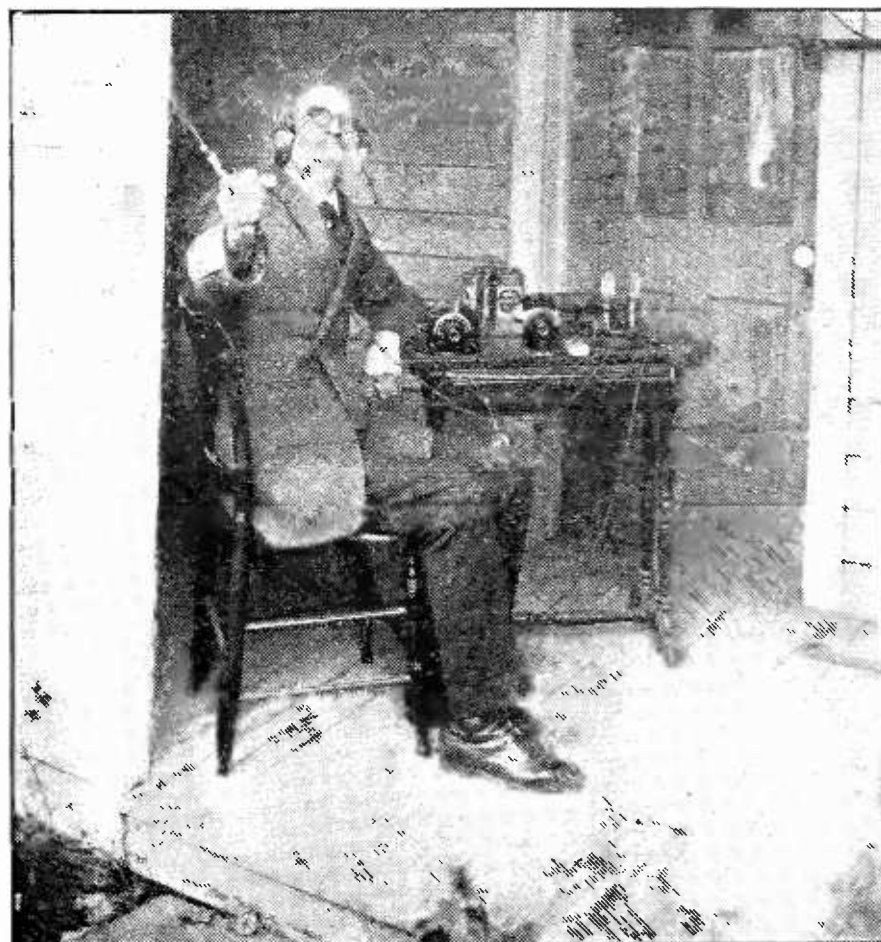

RADIO AND THE VILLAGE BELL

C. J. Waldron is receiving the noon-time signals from station WGY and tolling the village bell which broadcasts the correct time to farmers in Medusa, Albany County, N.-Y.



What Our Readers Write Us



A Spare-Parts One-Tube Reflex

THIS LETTER—one of a great number inspired by the article on the one-tube reflex receiver in our November number—is of particular interest because it shows how wide are the bounds within which one can build a given set successfully, provided the circuit is correct.

This does not mean that hit-or-miss work will result in satisfaction. If one is to make substitutions, he must know what to substitute. A knowledge of the fundamentals makes the going much easier than trying to follow a circuit and description without a single deviation. If you know what the circuit should be like, it ought to be easy to use some of the material you have on hand, as Mr. Fern has done.

Editor, RADIO BROADCAST
Doubleday, Page & Co.,
Garden City, L. I.

DEAR SIR:

This letter is written as an expression of the appreciation felt as a result of the remarkable performance of the "Reflex Knock-out" described in the November issue of your magazine. I have already succeeded in getting stations on either coast, and most of the intermediate broadcasting stations. These results are all the more remarkable in that I made use of odds and ends about the laboratory. For example: pasteboard forms No. 27 S. C. C. wire and celluloid for a dielectric (from a Ford side-curtain) were used in the coils, and vernier condensers and a Bradleystat were used in place of the equipment specified.

Please accept my thanks for making public this circuit, *which is the first in my experience to do more than is claimed for it.*

Very truly yours,
J. G. FERN
Hammond, Ind.

A Duplicate of the Prize-Winning Tube Set

THE letter printed below is from the winner of the RADIO BROADCAST prize contest held to "determine who has done the best work with any kind of receiver and any number of tubes."

The results were printed in our August, 1923, number. The prize was a De Forest D-10 Reflex set. It is interesting to know that the writer has tested another edition of his set with so much success. Mr. Bartholomew has furnished us with complete verification of the program from KHJ he heard on the night of October 23rd.

Editor, RADIO BROADCAST
Doubleday, Page & Co.,
Garden City, L. I.

DEAR SIR:

First let me thank you for the D-10 set and say that it is some machine. My wife has laid claim to it and taken it to Connecticut with her.

I also thought that you might be interested in the fact that I am now making, or rather have made, a machine trying as far as possible to duplicate mine. This machine is for Dr. W. C. Wolverton of Linton, N. D. My purpose is to see if it is the machine that is good, or the location, and I want it tried out well in the States.

Now I know it is possible to duplicate the machine and have it work about the same, for last night I made my first real test with the following results: WLW, WGY, WDAF, KSD, KDKA, WHB, WSB, WBAP, WJAX, WEA, WIP, and WMC and KHJ in Los Angeles.

KHJ, I picked up at 11:55 our time, and held until I stopped working at 12:30. I will enclose a summary of what I heard from them in case you want to check them. I am doing this because I received a few rather questioning letters from the article in the October issue of RADIO BROADCAST and want you at least to feel that I was not stretching it a point.

Sincerely,
R. Bartholomew
Garrochales, P. R.

When Will Sets Be Sold Really "Complete?"

PLENTY of letters have come in to our office complaining that radio dealers do not quote complete prices to prospective buyers. The set will be "complete," but strangely lacking in tubes, or batteries, or something. There are probably many prospective purchasers, knowing very little of radio, who want a

complete set, and do not want to be bothered with details of tubes, batteries, loops, antennas and whatnot. Dealers who are striving to improve their service can perhaps get an insight into conditions in some localities from the accompanying letter:

Editor, RADIO BROADCAST
Doubleday, Page & Co.,
Garden City, L. I.

DEAR SIR:

Intending to buy a radio receiving set for the past several weeks, I have written to several of your advertisers. A few have replied, quoting "list" prices and requesting me to write another firm, their dealer in the district, etc. Those that have quoted real prices seem to quote only on the receiver without the tubes, batteries, etc.

Finally, I went to see a man in an electrical retail store (and I paid him for the time taken by the interview). He said a good plan would be to buy the parts and have a man he knew assemble them. He wrote down a list of articles and said the cost would be about \$50.

I told him that I would see the man he recommended to assemble the set but he refused to tell me where I could reach him, saying that after I bought the articles, he would tell me who he was. As I was leaving, he mentioned that the list of parts he made did *not* include a cabinet.

Now I have gone into some detail in this matter and for a good reason. You can see how much trouble I have had in trying to buy a radio receiver.

Respectfully yours,
N. A. Brown
Williamsport, Pa.

The Position of the Loop Antenna

Editor, RADIO BROADCAST,
Doubleday, Page & Co.,
Garden City, L. I.

DEAR SIR:

For the past year I have been a silent partner in regard to my husband's radio experiments. I have even been supposedly disinterested, but little by little I have absorbed enough knowledge to know an antenna from a ground, a variometer from a variocoupler, and an A battery from a B battery (for we've bought batteries galore).

I know a tube from an electric light bulb, mostly because of the difference in price. I know the difference between just a horn and a loud speaker for the same reason. Audio-frequency and radio-frequency don't phase me any more and as for hook-ups and diagrams I know there are many more to come.

The other night my husband hooked up his favorite five-tube set using a directional loop antenna on

the dining table. He set the loop in the generally accepted fashion as in Fig. 1.

The talk came in clearly but not with any amount of energy. I was rather sleepy but suggested that he turn his loop around 90° as in Fig. 2. At once a most astounding change took place. The voice came in much louder, and as clear as before. We then changed the position of the loop from Fig. 1 to Fig. 2 repeatedly, and always Fig. 2 brought in the better results.

We have now incorporated the square position

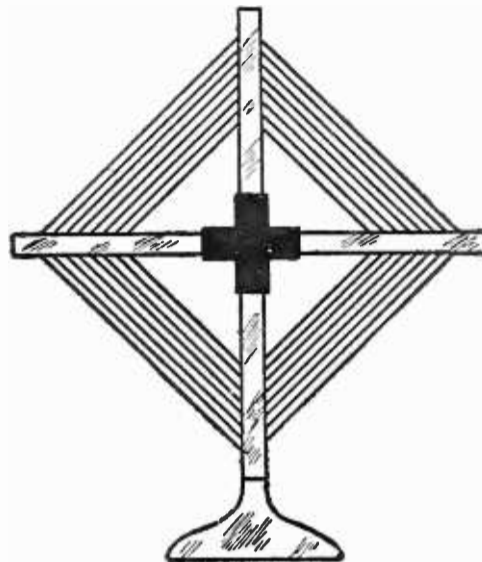

FIG. 1

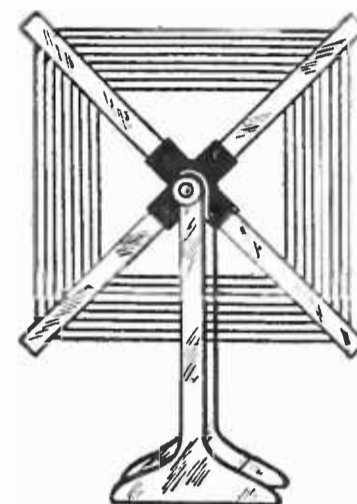

FIG. 2

Which way does your loop work best? Mrs. McArdeLL prefers the position shown in Fig. 2

idea in a gate-loop on the wall. It swings through an arc of 180 degrees, thus giving every direction needful in a directional loop.

However, it is often desirable to have a portable loop. This could be so mounted that it would be not only directional but would pivot in any position in a vertical plane either as Fig. 1 or Fig. 2 or any degree between the two positions.

Very truly yours,
ALICE R. McARDELL,
Brooklyn, N. Y.

Attention Announcers!

THE accompanying letter is one of a great many of similar nature. An effort to correct the annoying omission of call letters by station announcers would undoubtedly be widely appreciated.

Editor, RADIO BROADCAST
Doubleday, Page & Co.,
Garden City, L. I.

DEAR SIR:

I am making an appeal for many of my B.C.L. friends who like to "fish" for distant stations. We are greatly disappointed in the stations which fail to announce their call signal after each part of the program. It is most annoying to wait through several long pieces, and then hear—"The next

selection will be—.” WHY *can't* and WHY *don't* ALL stations give their call signal, and also their location, after every item? So many times, for one reason or another, we cannot decipher it, and we vainly wait through another piece until, in disgust, we try something else.

Combinations including B, C, D, E, G, P, Z, etc., are confusing, but we almost always can understand the name of the city and state.

We'd all appreciate it so much, if through the columns of RADIO BROADCAST, which is invaluable to us, you might make this criticism of some of the stations.

E. H.
Winchester, Mass.

For Those Who Are Generally Considered Deaf

IF THE mechanism of a person's ear is completely destroyed, it is of course impossible to produce any sound in a way that is audible to him; but it is safe to say that all the so-called deaf people who can hear with the aid of "acousticons" can also hear radio signals with an ordinary receiver and headset. The handicaps and the loneliness of living in a silent world are something which probably no one with normal hearing can fully appreciate. It should be the duty of all of us, then, to acquaint any deaf people we know with the possibilities for enjoyment which radio may offer them.

Editor, RADIO BROADCAST
Doubleday, Page & Co.
Garden City, L. I.

DEAR SIR:

It is quite generally known that deaf persons are often able to carry on a telephone conversation with little, if any, difficulty. Even though the deafness is so acute that they can hear only when spoken to in a loud tone, a telephone conversation, particularly with one whose voice is familiar, can be heard readily. It apparently has not yet become common knowledge even among radio "fans" that a person who is so deaf as to be unable to hear even a brass band can hear the sound of the voice and music from broadcasting stations.

Experiments were first made on a standard regenerative set, variocoupler and two variometers, with two stages of amplification using UV-200 and UV-201 tubes. The set was tuned to a point where the signals roared and could be heard all over the house. The location was about thirty miles from station WEAJ and a few miles more from WJZ (at that time at Newark, N. J.) Several makes of phones

were tried with apparently a slight difference in favor of a pair which had a tone which was decidedly "tinny." Good results were obtained with other phones, but those having a soft tone were not successful. At first, the only signals recognized, by a person ordinarily considered deaf, were the names of the stations, but as the voices of the announcers became familiar the announcements and weather reports were readily understood. The best reception of musical numbers appeared to be a single voice with piano accompaniment, a tenor voice being a little clearer than a soprano.

Another set comprising three stages of radio, detector, and two stages of audio was built, using D-X radio transformers, Acme audio transformers with UV-200 for detector and UV-201 for both radio and first stage of audio with a 216-A in second stage. This combination gave considerably more volume and a much clearer tone. On this set, the numbers heard included grand opera, church services, speeches, concerts, and orchestras.

A great variation was observed in the reception of voice. No speaker was heard so clearly and distinctly as the announcers. In general, it seems that a man's voice is more readily understandable than a woman's. A speaker who clips his words short and whose voice rises and falls is recognized only as a man talking but is not understood. Reading from a book or other copy is not as clear as a speech, probably because the reader looks at his copy instead of at the transmitter. Familiar music or singing is better understood than something the listener does not know, and the simpler the better. No one who is actually "deaf as a post" should expect to start on music by Debussy, for instance, and be able to hear and understand it. For those whose nearest and most powerful broadcasting station happens to be one that gives the weather reports, there is probably nothing better on which to make a beginning.

These experiments were made with a person so deaf as to be unable to hear the shouting at a ball game, a military band, or any other known sound. *Absolutely no results were obtained with loud speakers.* As nothing is heard until the set is tuned to nearly its greatest volume, it is necessary at first to have someone who can hear tune it, but after becoming familiar with the operation of the set and noting the position of the dials, the deaf person can tune the set without assistance. The volume of sound is such that no one with normal hearing can wear a headset and the only way those who are not deaf can listen comfortably at the same time is to leave another pair of phones on the table at a distance of several feet.

Yours very truly,
BEECHER OGDEN.
Pleasantville, N. Y.

How Germans Use Radio at Auto Races

THE throng of bankers, betters, beggars, and others who line the Grünwald automobile race-course near Berlin are able to follow the progress of their favorite dare-devils at all points in the long course.

The racers are clocked as they pass the umpires' stand and their time is transmitted, by means of a 30-watt tube set, to a number of other timers' booths at scattered points along the track. An attendant at each one of these outposts chalks up the time on a bulletin-board for the edification of the onlookers, who otherwise would not know what was going on over the considerable part of the course not within their range of vision. The timers at the booths also advise the umpires by radio telephone of the readings on the drivers which pass their stations. The wavelength band used in this communication system is 200 to 1,000 meters.

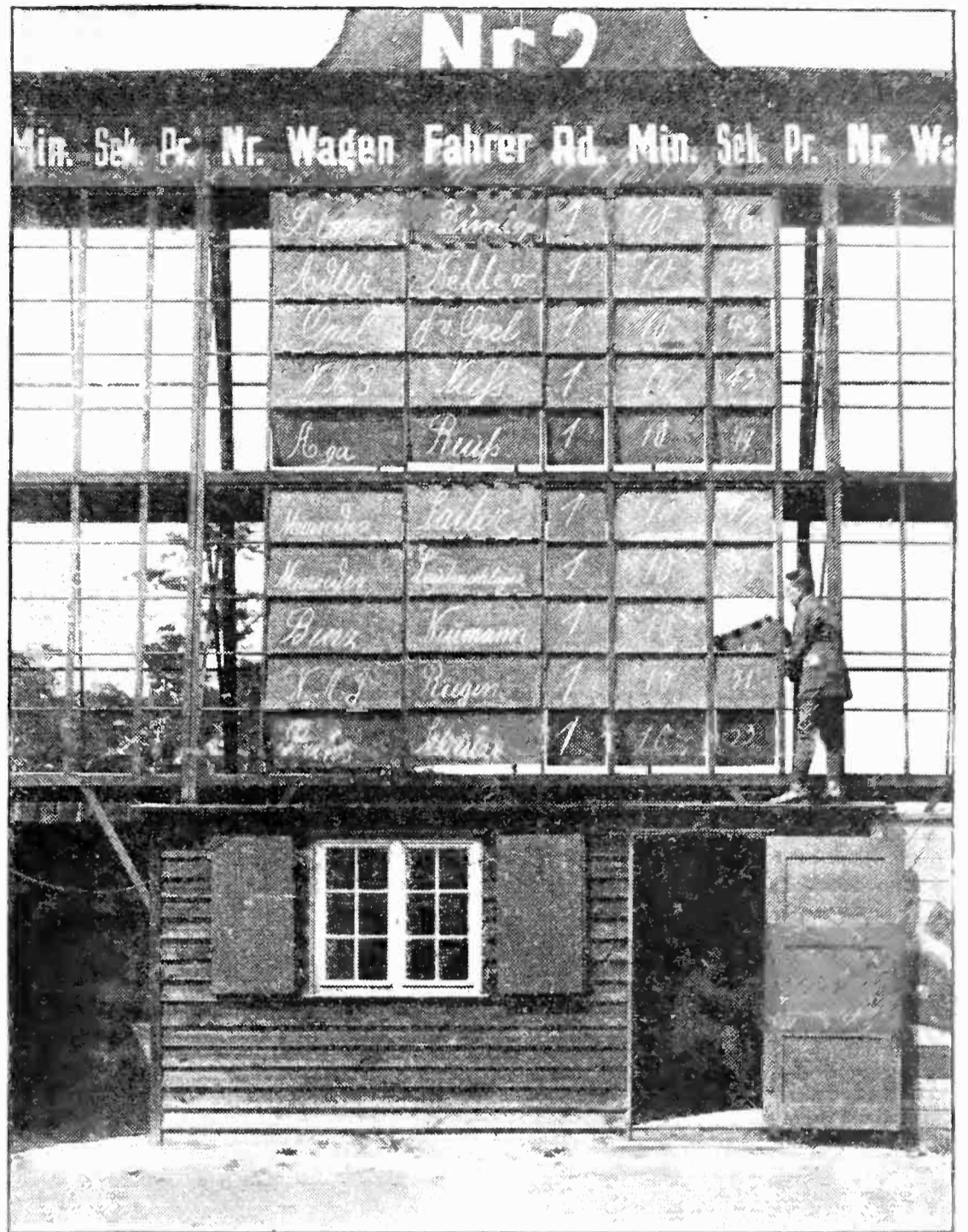

HERE THE RACERS ARE TIMED AND SCORED
The operator can be seen just inside the door

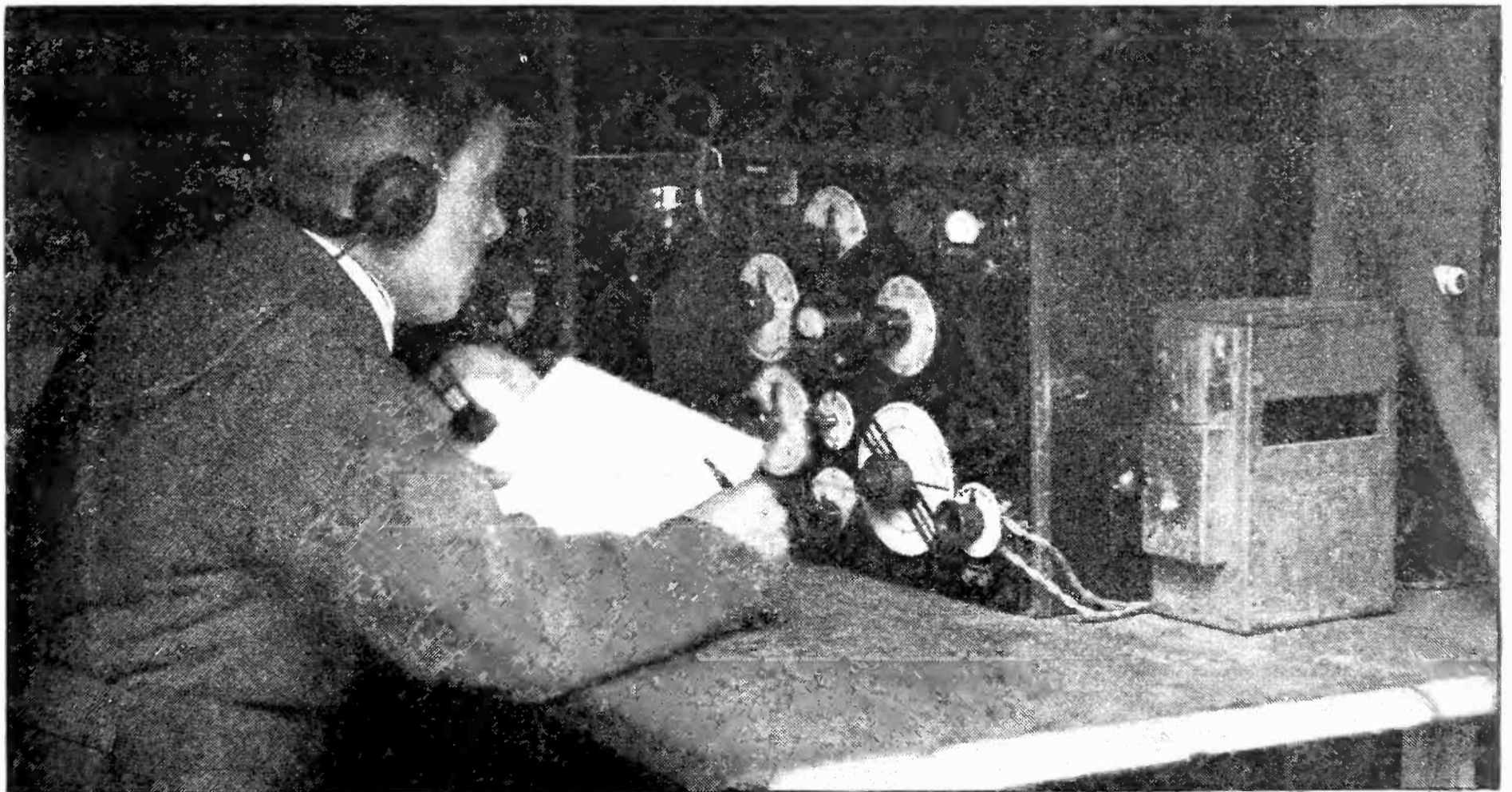

THE GERMAN RACE-COURSE OPERATOR AT HIS SET
A thirty-watt tube set is used for communication with the judge's stand

What Radio Means to Me

By W. FRANCIS GOODREAU

And the night shall be filled with music,
And the cares that infest the day,
Shall fold their tents like the Arabs,
And as silently steal away.

Longfellow.

SOMEHOW, whenever I think of radio I also think of these lines by Longfellow; they express so well something of what radio means to me. After having spent almost three years in a hospital, I know what a boon radio has proved to me and others in hospitals.

I entered the hospital in November, 1920. At that time radio was very little used for entertainment purposes. To take up my time and pass the weary hours away, I tried many things such as basket-making and reading, but nothing seemed to satisfy me for any length of time. Something else was needed to make my stay in the hospital more pleasant, something that would grow more interesting day by day.

I was wondering what to do next, when I was told that we were to have a radio concert. As I had never heard music by radio, I was naturally impatient for the concert to start. It was given through the kindness of Troop 5, Providence Boy Scouts. They used a set with a two-stage audio amplifier and loud speaker. The concert was given in a large ward, but the music could be heard plainly in every corner. The concert lasted only about one hour, but I received more enjoyment in this one hour than I had ever had in any one hour in the hospital.

Thus I received my introduction to radio. From that day I have been, and always will be, a radio "bug." I decided I would have a radio set, but was a little puzzled how to get one. I had almost decided to purchase an outfit when I was told by a friend that it was easy to make a simple crystal receiver. That suggestion appealed to me, for I could while away much of my time in making it. By making my own I would be sure to get a better idea of radio and would perhaps enjoy a simple receiver that I had built myself more than one I might purchase. I secured several books on radio, from which I got at least a faint idea of radio sets and

how to build them. I decided that a two-slide tuner was what I wanted. I secured the material and built one. Strange to say, it worked, and I must confess that my first radio set gave me more pleasure than all the radio sets I have had since.

I used this set for some time and then decided that I had outgrown it. I had heard that a two-circuit tuner would give better results, so I built one. It worked splendidly, so I commenced to study radio in earnest; I studied radio books on an average of five hours a day. At last I had found what I had been seeking, that something which should pass time away and give greater pleasure the longer I worked with it.

In the daytime I studied my books and worked on my radio set; at night I listened to music until I became tired and went to sleep. I had been using this radio set (the two-circuit one) for about two months, when I thought I could undertake a tube set. I purchased several new parts and built a three-circuit regenerative set using a WD-11 tube given me by a friend. I was somewhat disappointed with this set because, like many other beginners with a tube set, I expected too much of it at first. I expected to hear stations a thousand miles away the first night, but I didn't. In fact, for the first week I heard nothing that I could not hear on my crystal set. However, as time went on, I became more expert. Soon I found no trouble in reaching every evening those stations that I had long wanted to hear.

To share my pleasure with the others in the hospital, I found I would need a two-stage amplifier and some kind of a loud-speaker. Well, the two stage was soon secured and a friend kindly loaned his loud-speaker. Permission was obtained for us to give a concert one Sunday evening in a ward. As there was a good program scheduled, we made our initial bow under favorable conditions. This

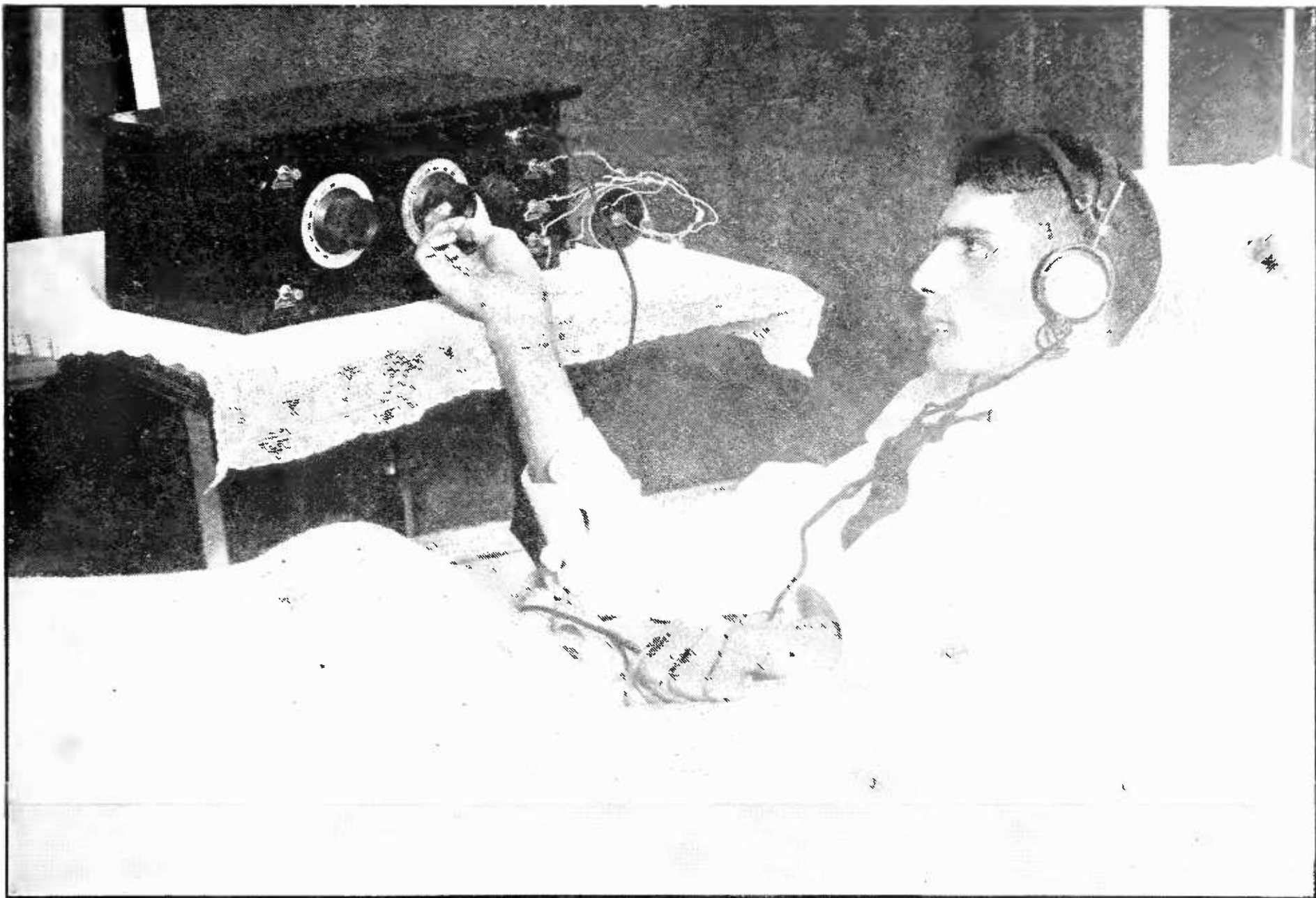

THE WIDE WORLD BUT TWO FEET AWAY

concert consisted of selections by one hundred harps, vocal selections, etc. The patients told me that they enjoyed it a lot. Some of them decided that they would like to have radio sets and asked me if I would help them make them. I did, and soon there were twelve sets in our ward. No one but those who have had the experience can ever know how much enjoyment radio is giving to those who are shut in.

To the person shut in, radio means more than just a new means of hearing music. Although the music we hear is excellent, the greatest benefit we derive from radio is *the feeling of intimate touch with the world*. We cannot go to the theatre nor the ball game, but

thanks to radio they can and do come to us. A turn of the wrist and we have our choice of entertainment for the evening.

Truly radio means much to me. Those in charge of our hospitals are coming to realize how much radio can help them in their great work, and as fast as they can, they are installing radio for the benefit of those in their care. Unfortunately, many hospitals have not the funds to install radio. However, I am sure when it is realized just how much radio means and how much good it can do, the funds will be found somehow. Radio began to interest me eighteen months ago and to-day I realize it has filled a place in my life that nothing else could ever do.

What Would You Like to Have in RADIO BROADCAST?

The editors would be pleased to hear from readers of the magazine on the following (or other) topics:

1. *The kind of article, or diagram, or explanation, or improvement you would like to see in RADIO BROADCAST.*

2. *What has interested you most, and what least, in the numbers you have read so far.*

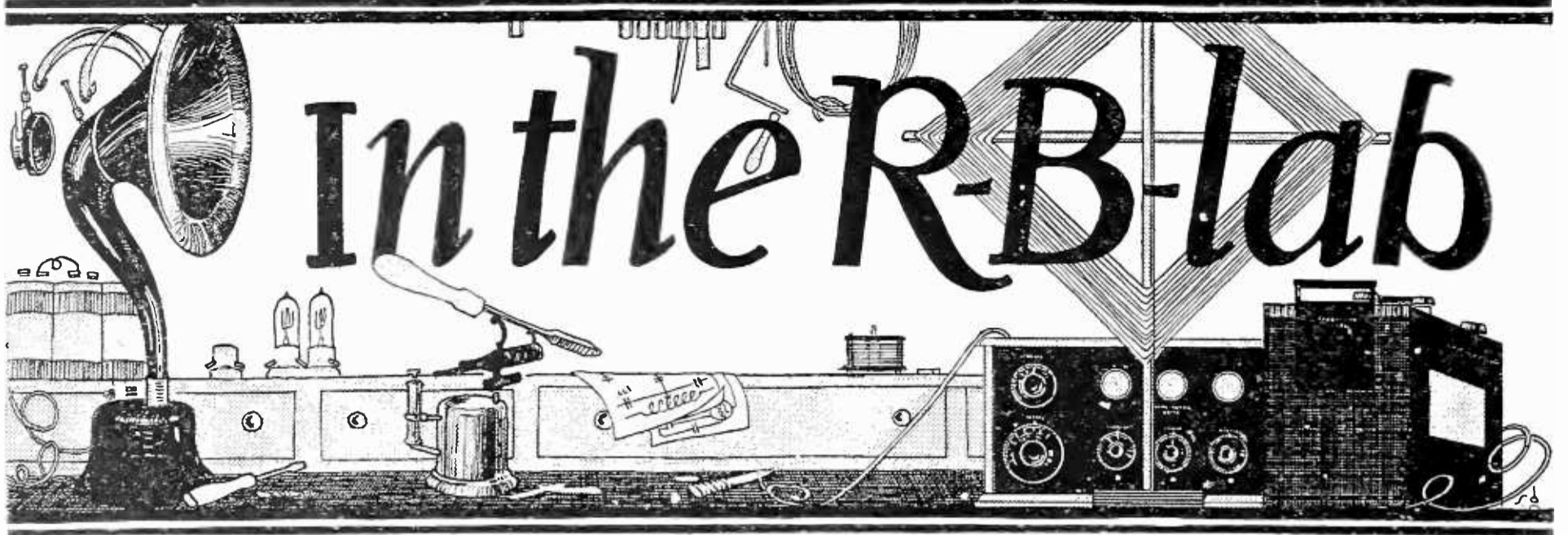

So much corking good Lab material is piling up that we are forced to devote more space to it this month than we originally intended it to occupy. Our successful experiments with the apparatus described, and the many letters of inquiry, appreciation, and suggestions that have come to our office since the R. B. Lab was started, in October, persuade us that we could not employ these pages to better advantage.

Upon observing the one-tube reflex circuit in operation and seeing a sample of a Ballantine Variotransformer sent us for test, Mr. Zeh Bouck, Editor of the R. B. Lab. suggested the unique arrangement he describes below. We then asked the manufacturers of the transformer to build up a circuit in the manner described. A comprehensive report from that company indicates that the results obtained check with our own, and that the Variotransformer works about as well in the circuit as the radio-frequency transformer and variable condenser combination described in R. B. for November and used by Mr. Bouck.

RADIO BROADCAST will be pleased to buy from its readers, at prices from three to five dollars, commensurate with the value of the data, kinks, devices, original ideas, etc., with photographs if possible, which the editor may consider eligible for this department.—THE EDITOR

IMPROVING THE ONE-TUBE REFLEX SET

THE article by Mr. Kenneth Harkness, in the November RADIO BROADCAST, on the best one-tube reflex set that has ever been brought to the attention of this magazine, furnished the Lab with material for additional experiments. The object of the tests was the elimination of the predominant and admitted defect of such sets, namely the tendency toward self-oscillation. This fault was overcome to a considerable extent in Mr. Harkness' set, and though remarkably stable for apparatus of this type, the set will nevertheless oscillate at certain adjustments on the radio-frequency transformer (T₂, page 14, RADIO BROADCAST for November). These adjustments are: (1) when the single tuning condenser across the secondary of the transformer does not effect sufficient resonance between the primary and secondary (when they are not tuned sufficiently near to the same wave), and (2) when a high-resistance contact is made by the cat-whisker on the crystal detector, an adjustment, incidentally, which is often the most sensitive one.

The reason for oscillations at such adjustments is this: If a circuit has a tendency to oscillate, such as is a characteristic of the plate circuit of the bulb in the one-tube reflex, and another resonant circuit is coupled to it, so much energy will be absorbed by this second circuit that not enough will remain to sustain oscillations. But of course the moment that this second circuit is detuned (or imperfect resonance is established, as often happens with the single tuning condenser), or the circuit is opened (as is virtually the case when the resistance of the crystal detector contact, which is in series with this additional circuit, is raised very high), oscillations will start.

However, these difficulties would be obviated if the transformer unit could be so arranged that there would always be so perfect a resonance between the primary and secondary windings, that even with a high-resistance crystal contact, sufficient energy would be absorbed to smother oscillations. The development of the Ballantine Variotransformer, which is a tunable radio-frequency amplifying trans-

former having a range from 200 to 600 meters, suggested this instrument as the solution to the problem. This transformer has both primary and secondary continuously variable by turning a single knob, and both windings are always tuned to the same wavelength, i. e., in resonance with each other!

Fig. 1 shows the set as made up under the supervision of the R. B. Lab and in which our theory was maintained beautifully in practice. The circuit is identical with that shown on page 14 of the November RADIO BROADCAST, except that the Ballantine Variotransformer is substituted for T₂, and, of course, the variable condenser across the secondary of T₂ is not used.

WHAT THIS SET WILL DO

ON THE single tube shown in the photograph and on the diagram, it will bring in signals more loudly and clearly than a one-tube, single-circuit regenerative set. Reception is generally superior to that achieved with the set described by Mr. Harkness in the November RADIO BROADCAST.

With one exterior stage of audio amplification, it will bring in local broadcasts so as to fill a large room (the single tube itself will actuate a *good* loud-speaker) giving a volume exceeding that of the average regenerative set with two stages of audio amplification.

It gives signals of remarkable clarity, with freedom from crackling sounds (excepting static, of course) and other extraneous sounds.

It will tune sharply with a minimum of effort, and with greater ease than any single-circuit regenerator.

WHAT THIS SET HAS DONE

(The following four paragraphs, by the Editor of this magazine, indicate what he, personally, has done with the receiver under discussion.)

WE HAVE tried this one-tube reflex with all kinds of tubes in all kinds of places. In every case it has proven to be a "knock-out." On Long Island, 23 miles from New York, we have heard two stations in Chicago on a loud-speaker, using a 60-foot antenna and a single UV-199 tube with about 80 volts on the plate. The music was not loud enough to dance to or keep the neighbors awake, but it could be heard in a room of moderate size. Speech was perfectly understandable, and several of our friends who witnessed the performance were as amazed as

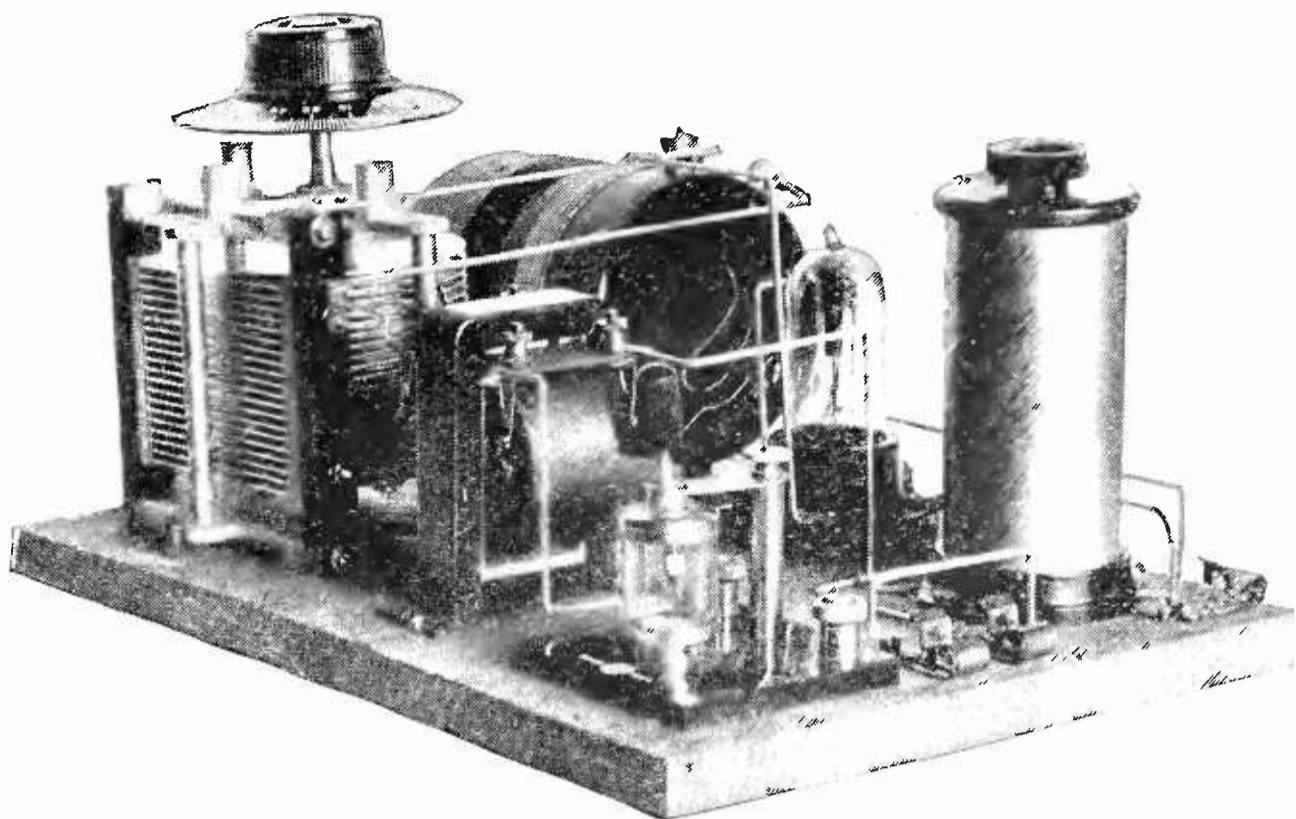

FIG. 1

Showing the one-tube reflex circuit made up by the R. B. Lab. The Ballantine Variotransformer is used. We reprint the original circuit diagram on page 218

we were. Truly, we did not expect such results. To date, we have heard (from Garden City, L. I.) KDKA, WGY, WJAZ, and WDAP on a loud-speaker, with the equipment described above, which is not too bad. The local stations can be heard on a loud-speaker either night or day and many other long-distance stations have been heard on the phones.

During the radio show in New York, some of our out-of-town friends were anything but polite in letting us know that our enthusiastic statements regarding this one-tube reflex were taken with a grain of salt. One went so far as to say, "Radio and golf will surely make liars of us all." That was the last straw. We took a train for Long Island, grabbed our little set from the living room table, amid shouts of objection from an erstwhile happy family, and returned to New York. We made directly for the room of our friend, our pockets jammed with dry cells, B batteries, a pair of phones, and a coil of annunciator wire. Under one arm we carried the receiver; under the other a loud speaker.

In a few minutes all the connections were made. A cuspidor-weighted wire swung from a window on the twenty-first floor of an exclusive New York hotel. We were less than two blocks (or squares) from the powerful broadcasting station of the Radio Corporation at Aeolian Hall. We had no trouble in tuning out that station and bringing in other New York stations on the loud speaker—which does not speak badly for the selectivity of the receiver!

WHAT THIS SET WILL NOT DO

THE set will not oscillate, or "spill over," to your own annoyance and that of your neighboring enthusiasts (except as described above).

It is apparently immune to body capacity effects, shielding being quite unnecessary.

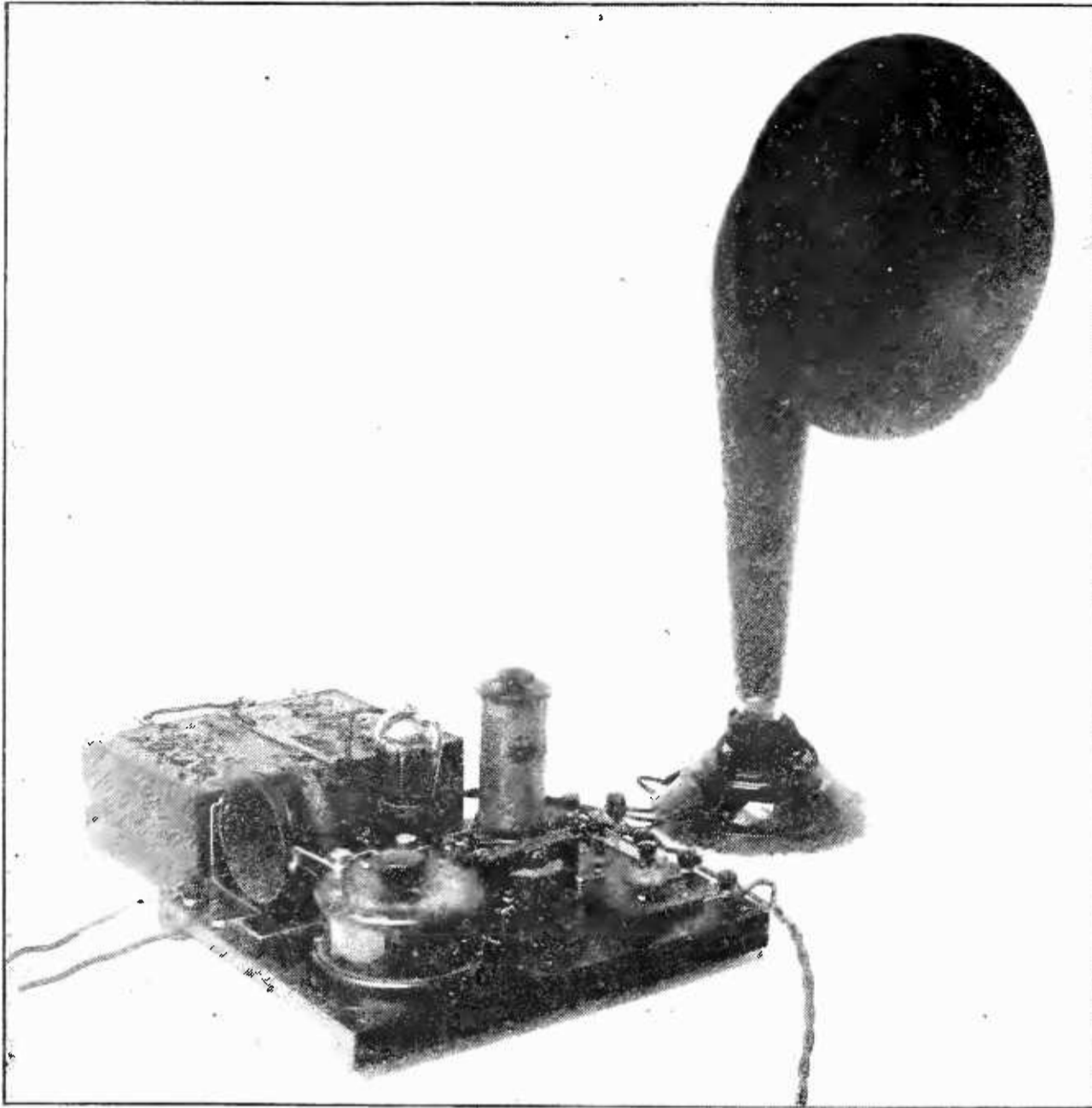

FIG. 2

The one-tube reflex described below. It will operate a loud speaker on local stations

For a description of the parts, other than the Variotransformer, and for constructional data, the reader is referred to the November issue of RADIO BROADCAST. This set can be mounted on a panel, the Variotransformer being made in panel-mounting style.

THE ONE-TUBE REFLEX WITH A BALLANTINE VARIOTRANSFORMER

(Report by Dr. L. M. HULL of experiments conducted by him at Radio Frequency Laboratories, Inc., Boonton, N. J.)

THE circuit described in the article "A Single-Tube Reflex Receiver" has been assembled and tested, using as the radio-frequency transformer, T_2 , a Ballantine Variotransformer, Model 5. Transformer T (refer to Fig. 1 in the above designated article) was constructed for our test circuit according to the specifications supplied by the writer. The transformer, T_3 , was a General Radio "Amplifying Transformer" having a turn ratio of approximately 4:1. A type UV-201-A tube was used, with approximately 80 volts on the plate.

As a crystal detector we used alternatively an iron point on iron pyrites or a combination of pyrite and ferro-silicon which we have found to possess particularly fine rectifying qualities.

Assuming that the main point of interest is the performance of the circuit containing a Variotransformer relative to its performance with the transformer specified in the article, a second tuned transformer was constructed according to the specifications supplied for T_2 , and for purposes of comparison this transformer (which will hereafter be designated the " T_2 coupler") was substituted for the Ballantine Variotransformer at given adjustments of the crystal detector. For the reception of signals an antenna and counterpoise were connected between terminals A and G* hav-

ing in combination an effective capacity of 700-500 micro-microfarads between 300 and 600 meters and an effective resistance varying from 13 to 16 ohms in this wavelength range.

When this circuit was excited by a locally generated modulated radio-frequency E.M.F., the Ballantine Variotransformer produced an appreciably greater amplification than the T_2 coupler at wavelengths between 300 and 400 meters, indicated by a louder signal in a head set connected between the jack terminals (see Fig. 1, page 218) as well as by the production of an audible sound with the Variotransformer from a signal so weak as to be inaudible with the T_2 coupler: there was no appreciable difference in selectivity in this range. Between 400 and 500 meters the signal intensity appeared to be very closely the same with either radio-frequency transformer. It was possible, by selecting a high-resistance contact on the crystal to force regeneration to the point of strong sustained oscillation with the T_2 coupler, thereby increasing the sharpness of tuning above that obtainable with the Variotransformer. The circuit containing the Variotransformer was by far the more stable of the two, since it was found to be impossible to throw the circuit into oscillation with any adjustment of the crystal and

*Shown in diagram on page 218.

any tuning combination. At wavelengths above 500 meters there was no apparent difference between the behavior of the two circuits, although in subsequent tests signals from spark transmitters on 600 meters were received with appreciably greater intensity when using the Variotransformer.

In comparative reception tests, telephone signals were received from the New York stations (distances from 30 to 35 miles), from Chicago, Schenectady, and Buffalo. At the lower wavelengths, transmitted by WHN and WGY, signals were received with slightly greater intensity when using the Variotransformer.

At wavelengths above 400 meters there appeared to be little choice between the two transformers, as regards intensity and quality of the sounds produced.

One difference between the behavior of the two circuits was noticed, however, in that the tendency of the circuit toward self-oscillation when using the T_2 coupler depended largely upon the nature and location of the detector contact, whereas no oscillations whatever were produced when using the Variotransformer. Thus with the Variotransformer

the tuning adjustment was entirely independent of the adjustment of the detector for sensitivity, and this stability and relative ease of operation were not offset by any appreciable decrease in the relative signal strength.

No quantitative measurements were made of the signal intensity obtained with the Variotransformer in this circuit. The programs broadcast by stations WEA and WJZ on the night of October 12th were received on this circuit and reproduced with good intensity in a high-impedance loud speaker.

THE DANIELL CELL AS AN "A" BATTERY

By DR. E. BADE

THE dry cell is not an ideal source of power for any closed-circuit work (i.e., where current is being consumed steadily) such as is encountered in the lighting of low-amperage filaments. The production of electric current in a battery, wet or dry, is accompanied by a chemical action within the cells, one of the elements being gradually destroyed as the current is generated. The best type of cell is that which permits an almost total destruction of the at-

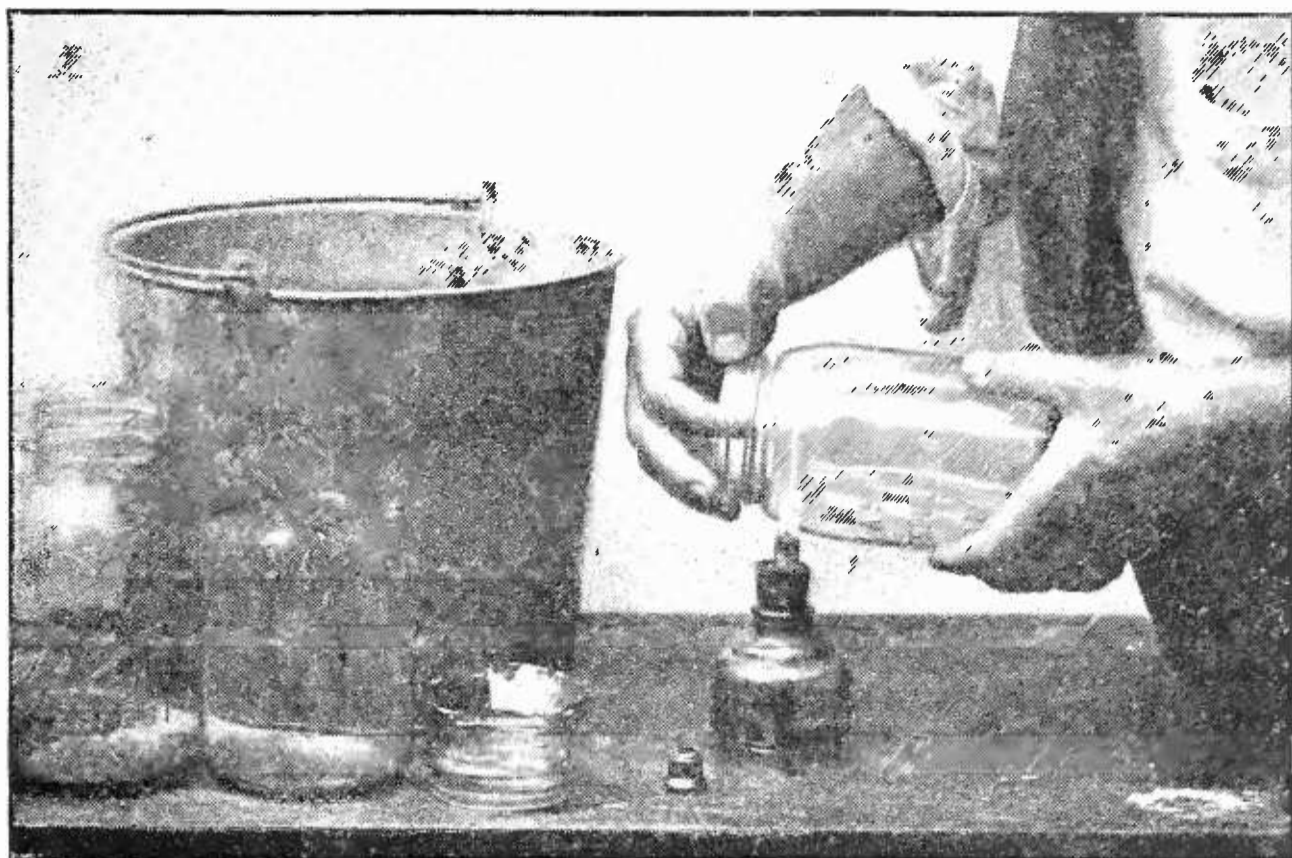

FIG. 4

Removing the top from the preserve jar at the shoulder

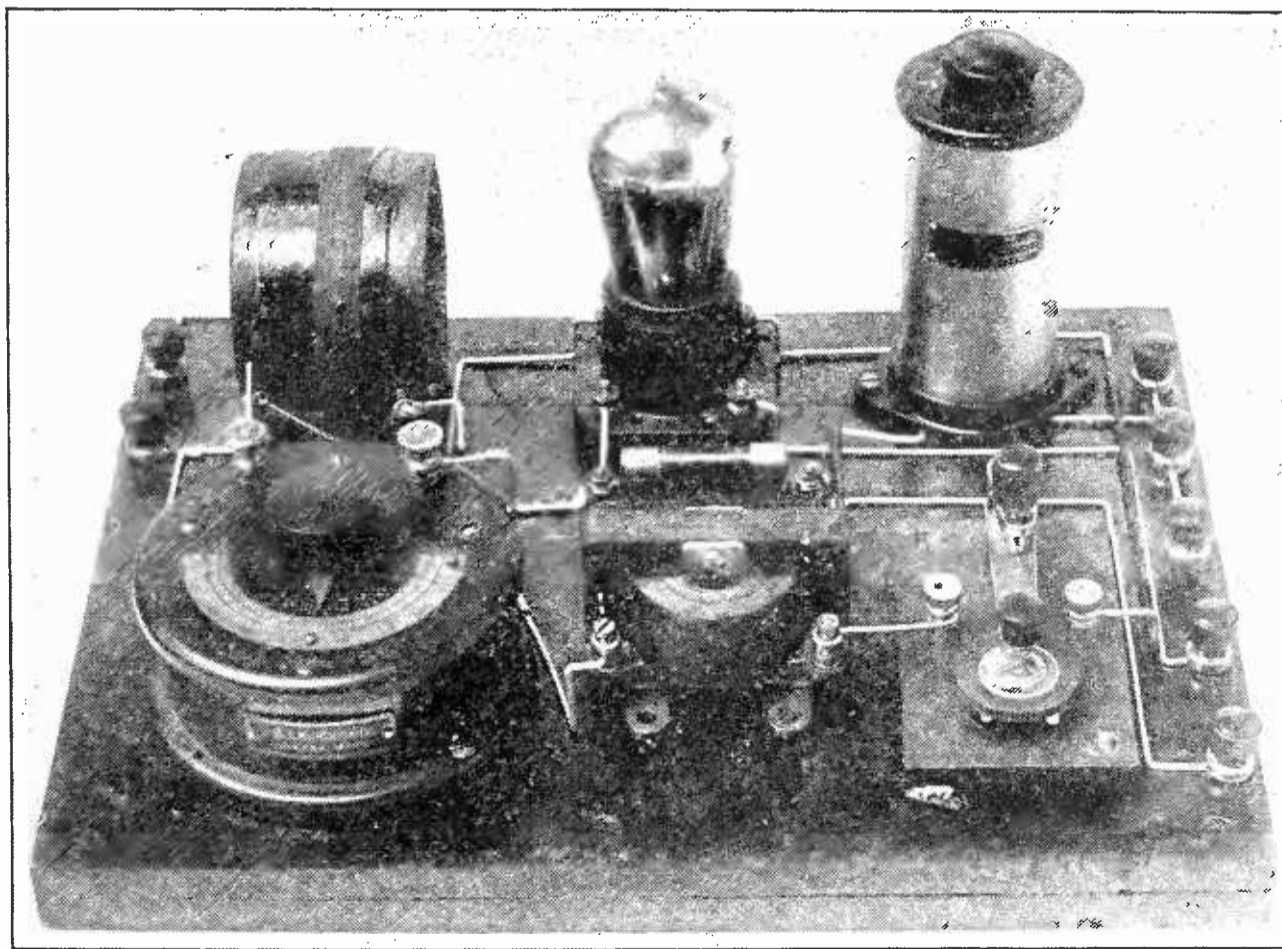

FIG. 3

The set made up by Radio Frequency Laboratories, Inc., showing the primary of the antenna coupling (See Fig. 1, page 218) wound over the secondary. In the R. B. Lab's model (p. 237) the two windings are laid on side by side

tacked element before its efficiency, or current generating ability, is seriously impaired. In the dry cell, the outer zinc case (the element which decomposes) is only slightly eaten away before the cell is rendered useless by either polarization or the drying up of the salt filling compound. If such a cell could be used until the zinc were totally destroyed, its life as a radio A battery would be prolonged many months.

The making of a cell which will give a strong electric current until the zinc is considerably decomposed is neither difficult nor expensive. A set of six such cells, each giving about 1.1 volts, can be made at home for approximately the cost of four dry cells. The dry cells will give the same total voltage but have a much shorter life. Such a cell is that of which the Daniell battery is composed (a "battery" is merely two or more cells) and is easily made according to the following directions:

THE MATERIALS

Six neckless quart jars
 Three ounces of mercury
 Four pounds of plaster of Paris
 Six sheets of zinc $7\frac{1}{2}$ " by 8"
 " " " copper 3" by 6"
 Two pounds of copper sulphate
 Eight ounces of sulphuric acid

The jars may be easily made by removing the necks from Mason or quart preserve jars. A line is scratched with a glass cutter around the shoulder of the jar. The scratch is then moderately heated over an alcohol or bunsen flame (Fig. 4) and the top of the jar immediately dipped into a pail of cold water. The shoulder of the jar should crack at the scratch and fall into the water, leaving a very satisfactory battery jar, such as is shown alongside the pail in Fig. 3.

The porous cup of plaster of Paris is next made. A heavy paper cylinder with a bottom

is formed for the outside of the mold. This, for the quart size jar, should be about 7" high and $2\frac{1}{2}$ " in diameter. A smaller tube, $1\frac{1}{2}$ " in diameter, is also made. The plaster of Paris is mixed in a convenient bowl (mix, at a time, only as much as is immediately needed) to a paste-like consistency. This is poured into the large paper cylinder until the bottom is covered to a depth of one-half inch; the smaller tube is now placed in the middle of the larger one, and the plaster of Paris poured in between

the walls until a complete cup is formed (Fig. 5), when it is permitted to harden.

The zinc electrode (negative pole) is now prepared. The sheet is first thoroughly cleaned by wiping with a dilute solution of sulphuric acid. A drop of mercury (quicksilver) is then placed on the zinc and "rubbed in" with a piece of cotton

moistened with the dilute acid. Both sides of the zinc are similarly treated, the coating of quicksilver forming an amalgamation with the zinc. The amalgamated zinc is rolled into a cylinder that will fit over the plaster of Paris cup, and a wire either soldered or bolted to one corner. The joint between the wire and the zinc should be coated with beeswax or vaseline.

The positive pole or copper electrode is also a cylinder (or it may be merely a strip), but should be made smaller, so as to fit loosely within the porous cup.

One quart of a saturated solution of copper sulphate should be made up. This is most easily accomplished by heating the water to just below the boiling point and dissolving in it, by vigorous stirring, all the copper sulphate crystals it will take up. Some of the blue crystals will be precipitated upon cooling, showing that the solution contains all that can be dissolved.

The battery may now be assembled. The jar is half filled with water to which are added a few drops of sulphuric acid. Fig. 6 shows the



FIG. 5
Molding the porous cup

cell being put together, the zinc element standing alongside the jar with the dilute acid solution, and the porous cup in the act of being placed in the center of the glass container. Several completed cells are shown in the photograph. When the plaster cup is placed, the zinc sheet is fitted about it, and the copper electrode placed inside of it. The sulphate solution is poured about the copper element, and a few extra sulphate crystals thrown in, which are replenished from time to time. The cell is now ready for use as soon as the few minutes elapse necessary for the plaster of paris to absorb the required amount of the solutions. It is a good idea to short-circuit this cell for several hours immediately after assembling.

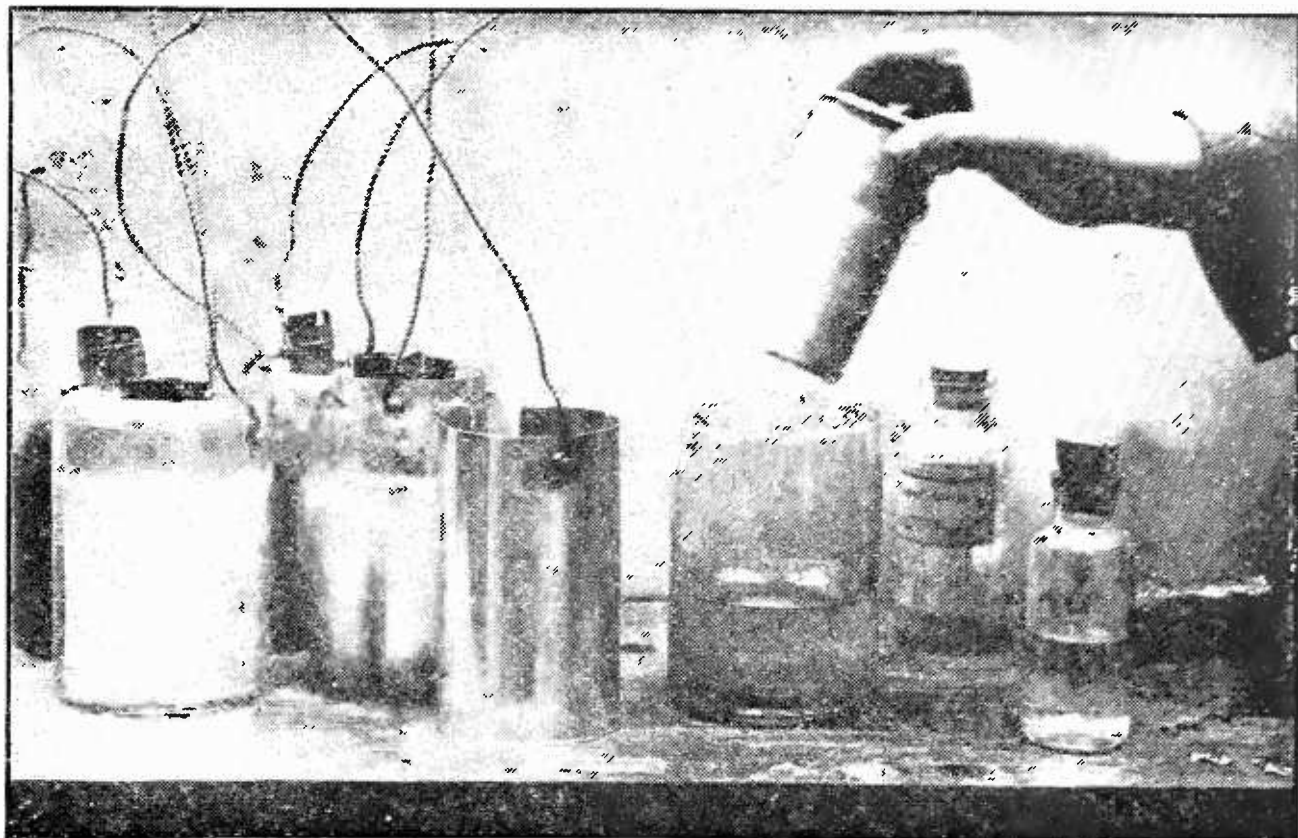

FIG. 6
Assembling the cell

The Daniell cell is a closed-circuit cell, and will give its best service when used almost constantly, day after day, four and five hours each evening. Three cells make an excellent battery for the UV-199, while a single cell, without rheostat, may be used on the WD-11 and WD-12.

When the zinc is practically eaten away, the internal resistance of the battery becomes very high, and it is, at last, necessary to renew the elements of the cell. New solutions and zinc should be added, at a cost of a few cents, and

the cell is again ready for long and steady service.

A "SUPER" WAVE-CHANGER FROM A THREE-CIRCUIT REGENERATIVE RECEIVER

Recently, we've had a few hunches on the building of super-heterodyne receivers from parts such as those that the average experimenter already owns. (We refer you also to the timely and well-executed articles in the November and December, 1923, numbers by George J. Eltz, Jr.) And below we present the results of some work of our own on a home-made "super." Some of the illustrations have appeared in RADIO BROADCAST be-

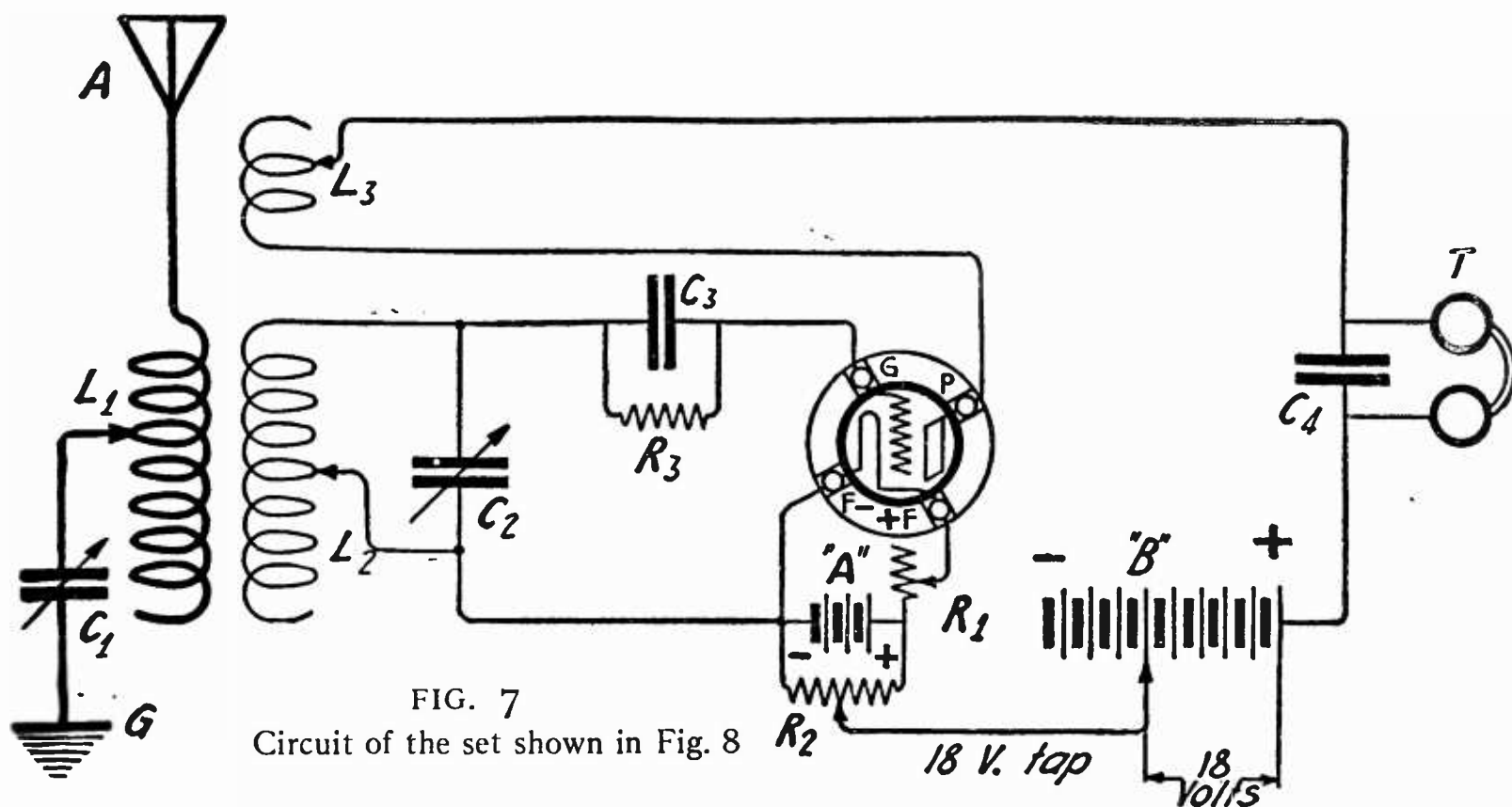

FIG. 7
Circuit of the set shown in Fig. 8

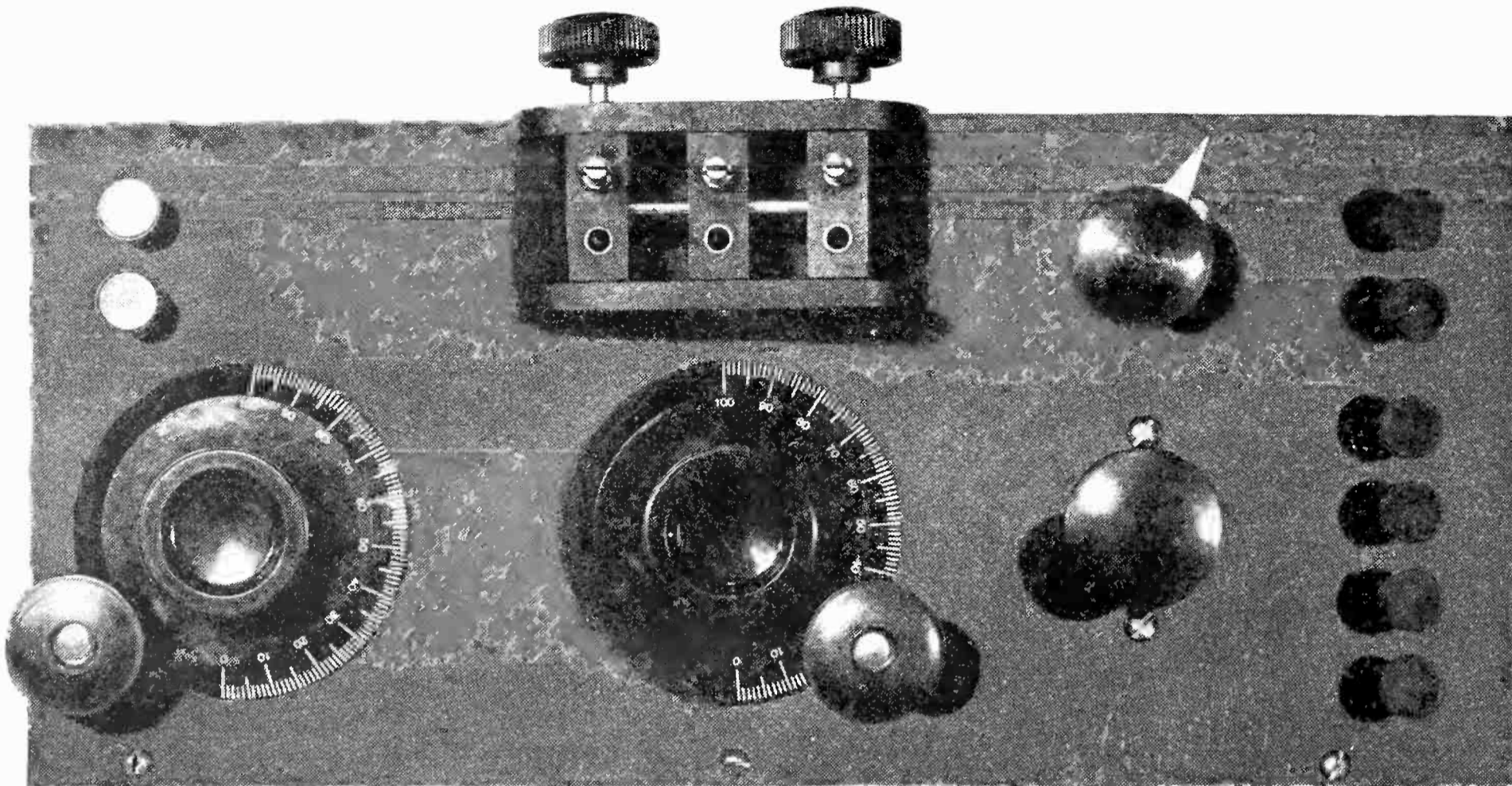

FIG. 8

The three-circuit receiver before being converted (see Figs. 9, 10, and 11. This receiver was described on page 136, RADIO BROADCAST for December, 1922). The upper left hand posts are for antenna and ground, and are replaced by a jack (upper right in Fig. 12) into which the loop aerial is plugged

fore; in fact they were used to illustrate A. Henry's article, "Paris and Honolulu Are Calling You," in our December, 1922, number. We have converted Mr. Henry's three-circuit regenerative outfit (Fig. 8) into a wave-changer simply by the addition of a tube socket, a two-coil mounting, and two large coils to couple the output of the wave changer to the intermediate-frequency amplifier. By combining this wave-

changer with such a circuit as illustrated in Fig. 1 of Mr. Eltz's article (p. 145, Dec., 1923), we have a complete super-heterodyne.

Fig. 10 shows the panel with coils mounted. The two upper left-hand posts connect to a loop. The diagram (Fig. 11) shows the connections. The layout has been altered very little. The diagram shows clearly the values of duo-lateral coils employed. A new

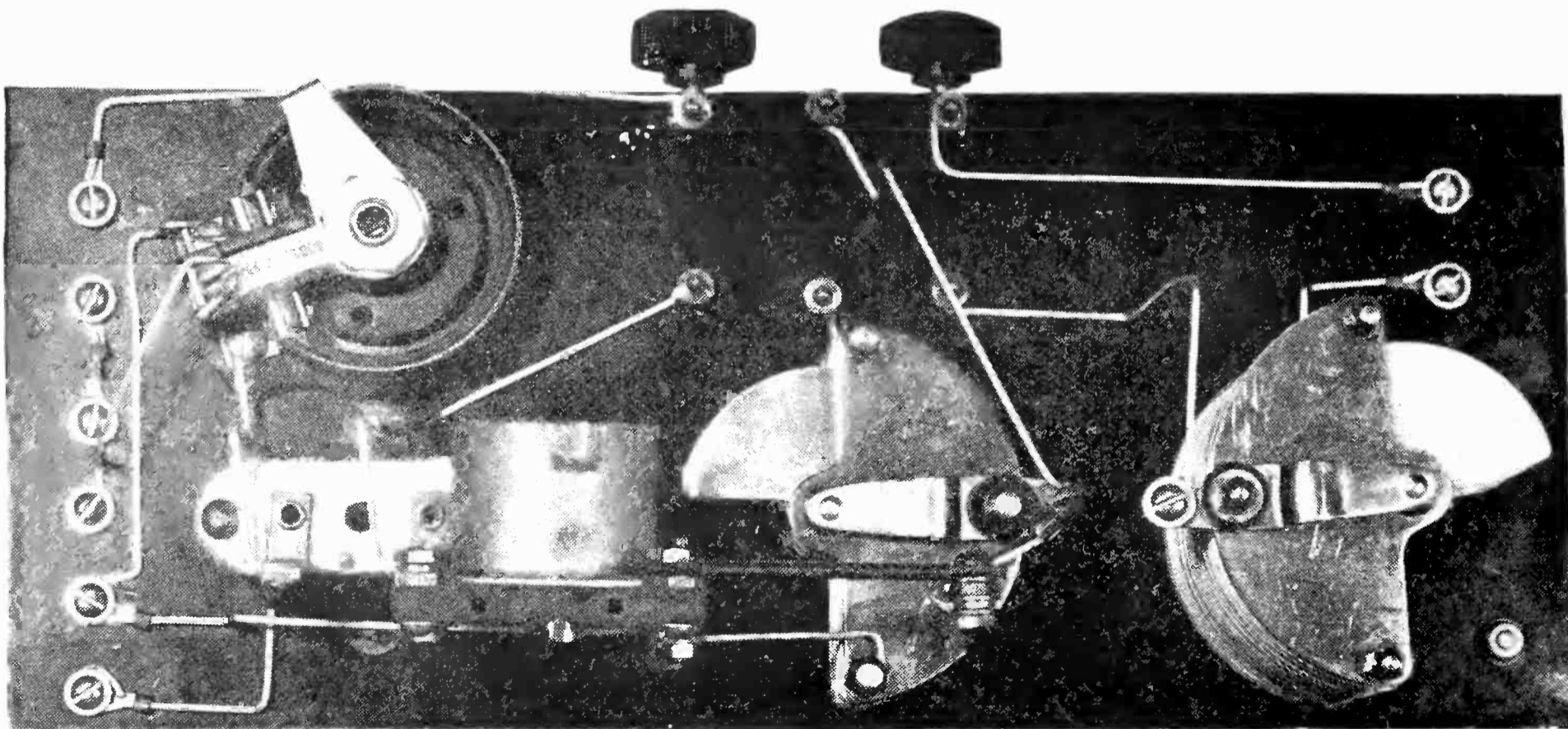
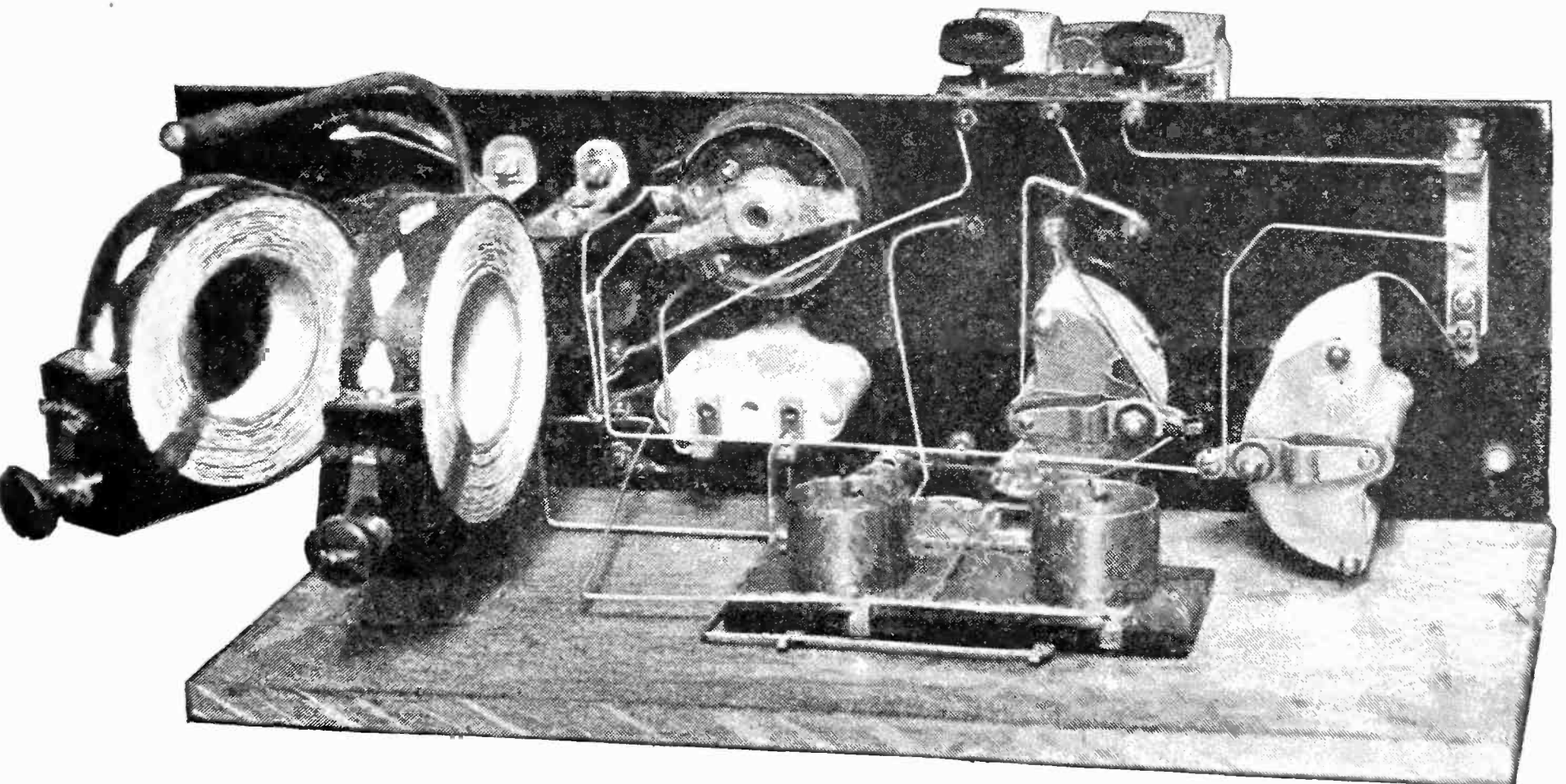
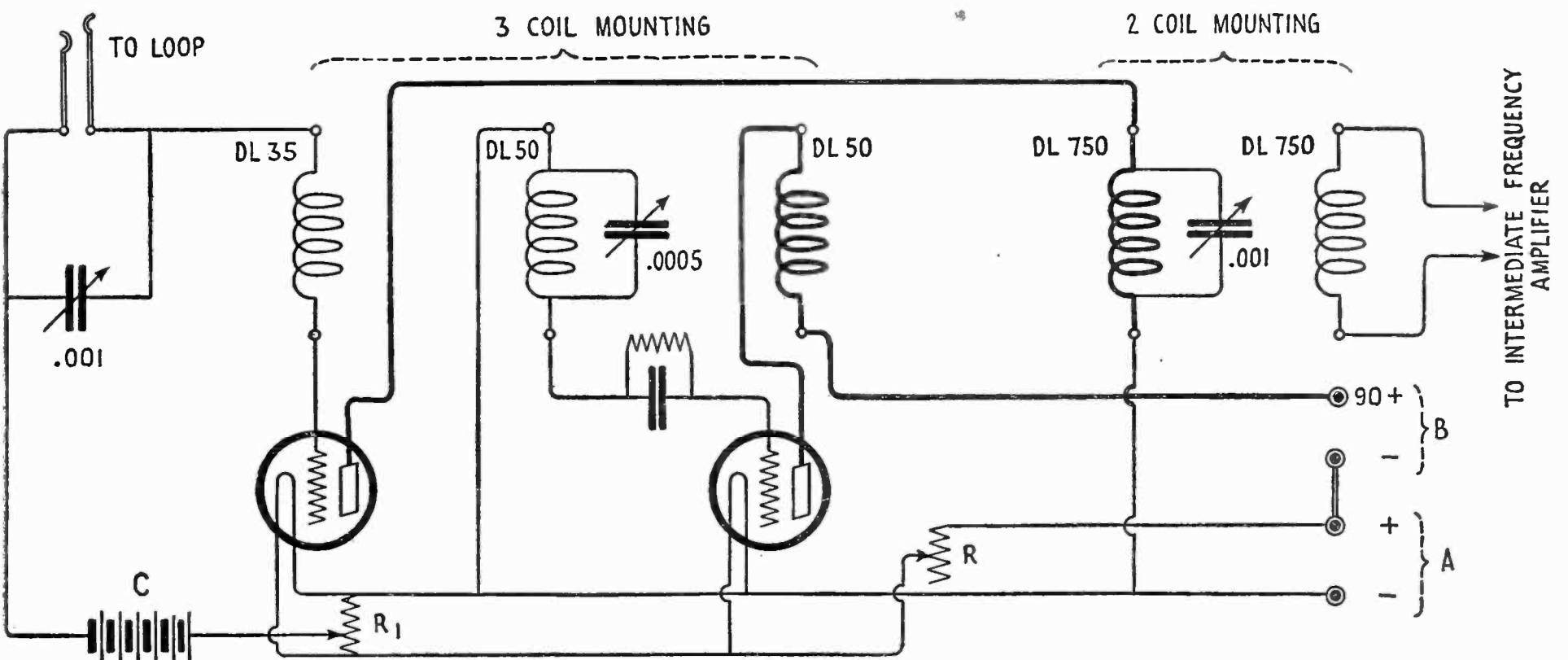
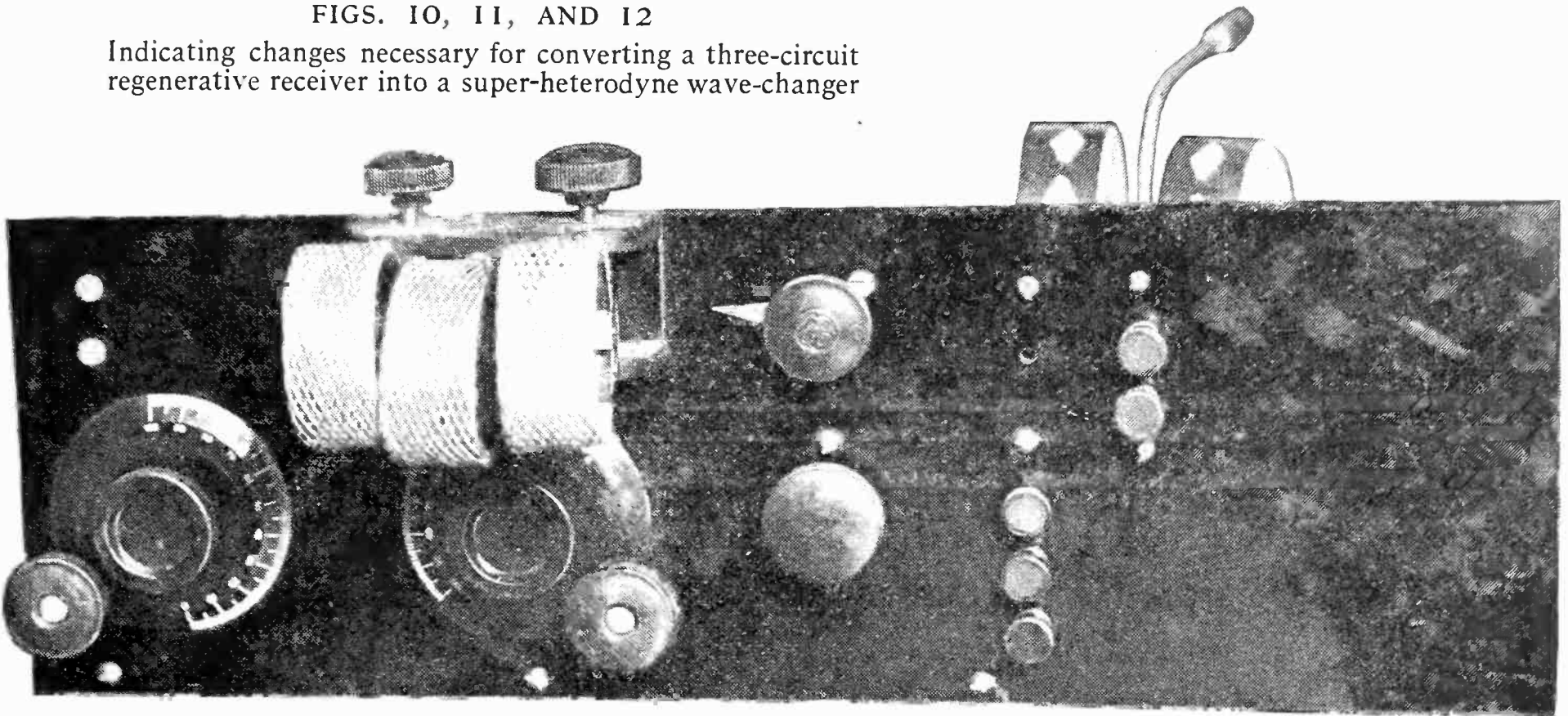

FIG. 9

Rear view of the set shown in Fig. 8

FIGS. 10, 11, AND 12

Indicating changes necessary for converting a three-circuit regenerative receiver into a super-heterodyne wave-changer



tube socket has been added and the new two-coil mounting is indicated on the diagram (Fig. 11) and at the extreme left in Fig. 12.

Fig. 11 has been drawn with the apparatus shown in the exact position from left to right that it occupies on the panel. In Fig. 12, note the jack installed at the right in which a loop may be plugged. The coils in Fig. 11 (DL-750) are both shown in the photo (Fig. 12) as variable, but DL-750 has been found to be the proper size.

The installation of the two-coil mounting allows the output to be fed to an intermediate-frequency amplifier.

LEAVES FROM AN OLD TIMER'S NOTEBOOK

Amplifier Squeal In The Last Stage: This annoyance is often encountered in using a third stage of audio amplification, and, occasionally,

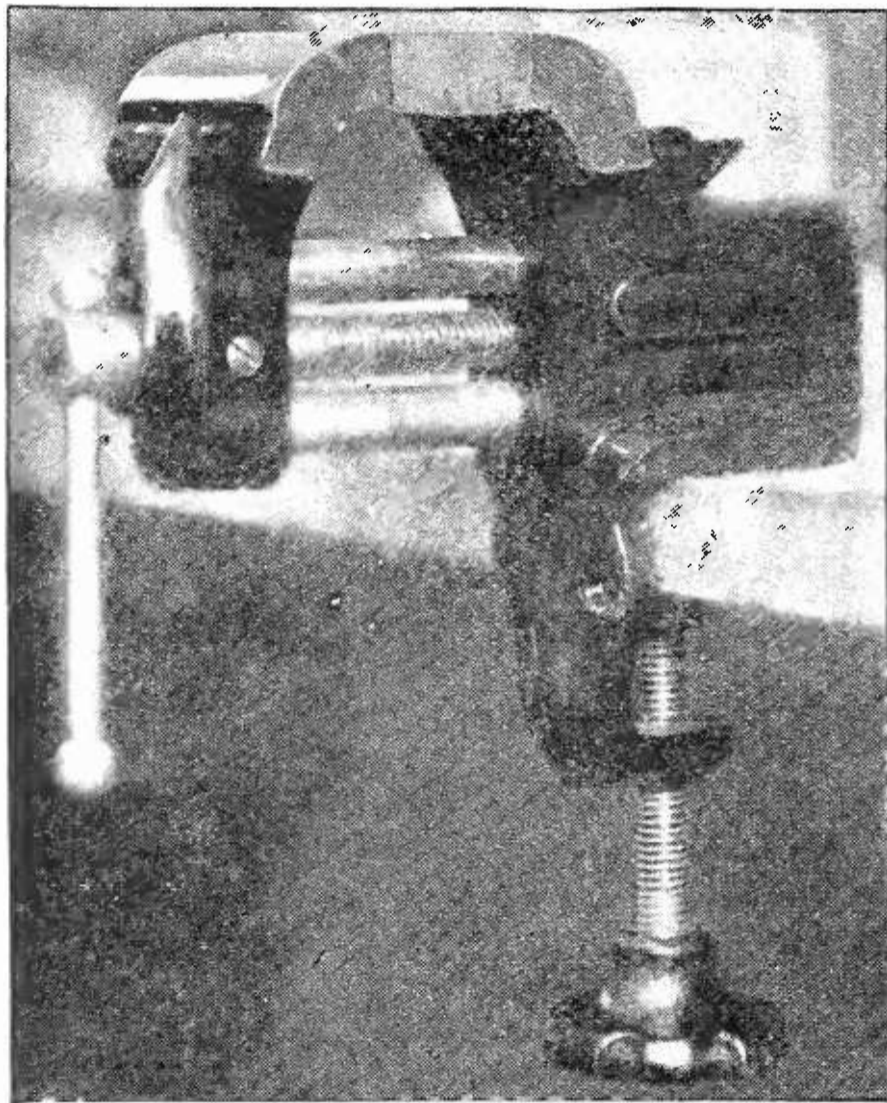

FIG. 13

A fine vise of the approved type. Note the massive construction, and the two guide bars

on the second stage. *Every metallic object in the immediate vicinity of the set, but not electrically connected to it, should be grounded.* The high voltage wires (those running from the B

battery) should be run in grounded lead covering.

Specific instance: Third stage of amplifier possessed a very high (in the upper limits of audibility) squeal, a persistent peanut whistle which was more nerve-racking than if it had broken up the signals. All wiring was run in lead-covered duplex which was grounded. Instruments were perfectly spaced, shielded in places, and of the best electrical design. Special telephone cam switches were used for cutting out amplification stages. As a last resort, the metal frames of the switches were connected together and grounded. The squeal stopped!

BUILDING YOUR OWN LAB

RADIO BROADCAST'S suggestion for this month's addition to the budding laboratory is a vise—*but not of the five and ten cent store variety.* The experimenter should pay about two dollars for the vise. It should be of a reliable, well-known make. It should have steel jaws with at least a two-inch separation. A vise of the recommended type is shown in Fig. 13.

The vise is one of the most useful tools in the workshop, but one that is often the last thought of by the average amateur, and it is generally not added to his equipment for many months, or even years, after he has accumulated less useful tools. The uses of this "third hand" are so many that there is scarcely a bit of radio construction in which it will not save time and extra labor, as well as lending accuracy and finish to the completed work. It will hold panels for drilling after one or two instruments are already mounted: It will hold rods and tubing for threading; bakelite, rubber or wood for working and sawing; metal strips, etc., for bending and filing, and many other materials for many similar tasks where a slip means minutes or even hours of additional labor.

When used for holding wood, or panel material, for drilling, planing, etc., small blocks of wood should be placed between the jaws and the material, in order to prevent marring under the tight grip of the steel jaws.

The vise lends itself to perfect coöperation with the drill, taps and dies which we have recently suggested as additions to the laboratory.

RADIO BROADCAST will be pleased to buy from its readers, at prices from three to five dollars, any kinks, devices, original ideas, etc., with photographs if possible, which the Editor may consider eligible for this department. Address all communications to the R. B. Lab Editor.

Alone Before Thousands



AGNES LEONARD

With her ukelele and her charming voice, she sings the youngsters to sleep on Friday evenings from WJZ, New York



DOROTHY GISH

Bidding farewell to movie fans who are also radio fans, just before leaving for Italy to start work on a new picture



PARIS HORRORS LOSE NOTHING THROUGH THE MICROPHONE

The Grand Guignol Players, on their tour of this continent, stopped off at Station CKAC, Montreal, and gave one of their most blood-curdling offerings, "Une Nuit au Bouge" ("A Night in a Den")

If You Like Them, Let Them Know It

By MYRA MAY

WHAT is it like to play to an unseen audience? How do famous artists, used to applause and adulation, feel when they perform before a

“tin can” as their sole spectator?

Charles B. Popenoe, director of WJZ, has watched hundreds of seasoned stage stars make their radio debut. He says nearly all of them get radio fright.

“Practically everyone is self-conscious before

the microphone,” he explained. “Professionals during their first concert by radio are always as nervous as amateurs on their first appearance. The only exception I ever saw was the Hasty Pudding Club, of Harvard. These boys, dressed in feminine attire, came up to the studio prepared for a good time. Nothing in the world could phase them. Even the ‘little tin can’, as the microphone is disrespectfully called, failed to dampen their enthusiasm.

“They cracked their jokes and sang their



E. H. SOTHERN AND JULIA MARLOWE

Who are almost as well known to radio audiences as they are to inveterate Shakespeare play-goers

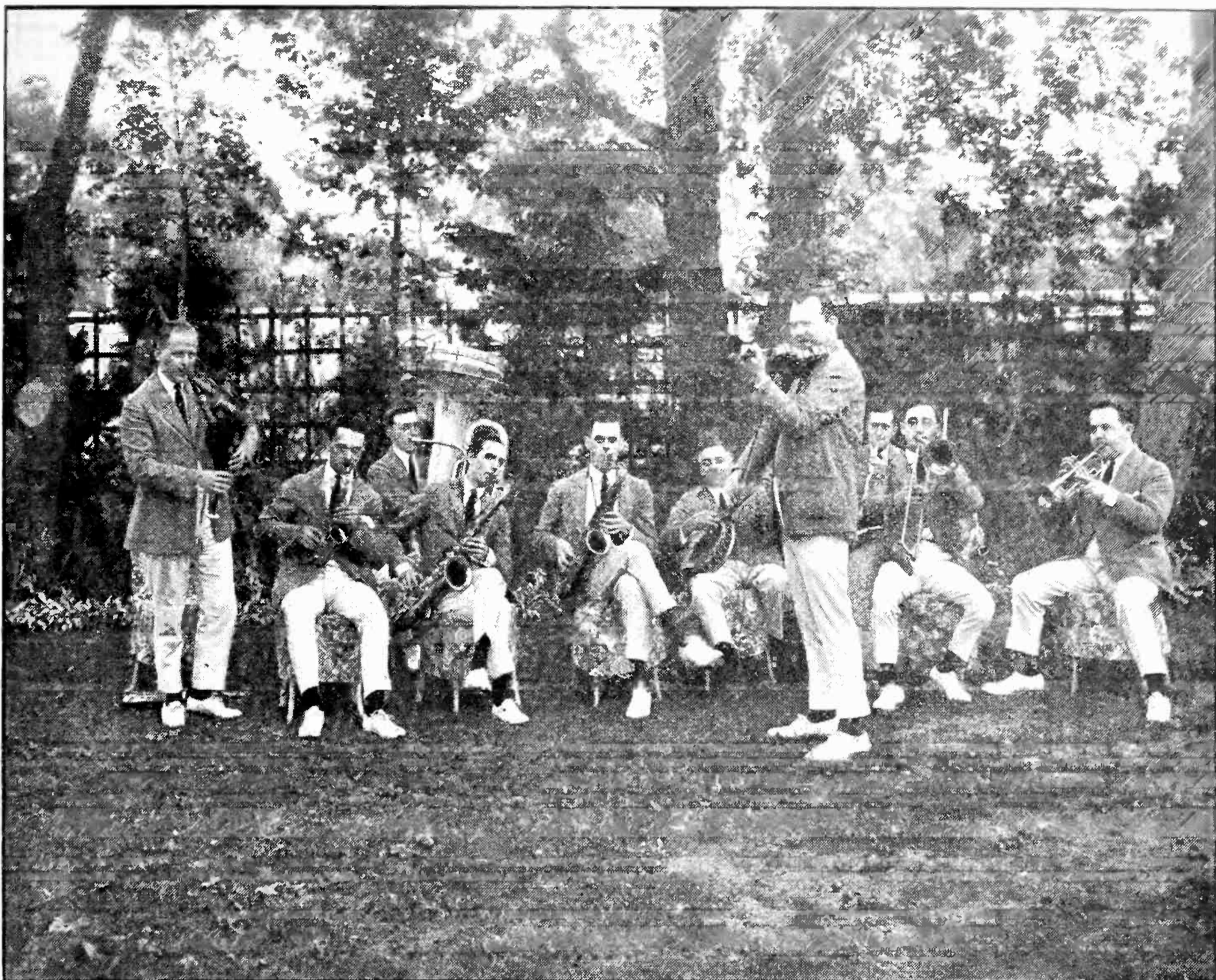

PAUL WHITEMAN AND HIS DANCE ORCHESTRA

Frequent performers before the microphone. Paul Whiteman's song, "Wonderful One," was written for a radio birthday party which he gave, in New York, for his mother in far-away Denver

songs. It didn't make any difference to them that the audience was scattered in all parts of the world, that in hundreds of homes, families had hooked up the old set and were listening-in. The boys were honestly enjoying what they were doing so that the inevitable reaction was that the audience enjoyed it too.

"The average professional is nervous for the first two minutes. He thinks of the vast audience—many thousands of people—hearing him. His reputation is at stake, for never has there been so large a crowd at entertainments as the radio has made possible. Then he thinks of one person out in this vast audience to whom he wishes to perform. Automatically he forgets the multitude who are listening-in, and works for that person alone. Frequently he does the best work of his career, for his thoughts are on the person far away to whom he is pouring out his soul."

The first show ever broadcasted was "The Perfect Fool" with Ed Wynn. Now, Ed Wynn, as everybody knows, is one of our funniest comedians. When he is on the stage, the audience keeps up a steady roar of laughter. It never occurred to him how close is the relation between an actor and his audience until "The Perfect Fool" company went to a studio to give the play by radio.

Ed Wynn approached the microphone gingerly. He looked at it suspiciously. The time came for him to perform. As with all professionals, he was a trifle nervous. The nervousness, however, wore off, but Wynn was appalled by the silence. He had told some of his best stories and had not even heard a snicker.

Wet with perspiration, he turned to the announcer. "I can't do anything," he said.

The announcer quickly assembled all the

people from around the studio. Electricians in shirt sleeves, scrubwomen with their skirts tucked up, telephone operators, and artists who were billed later on the program, were invited to come into the studio-theatre and enjoy the show. It was a strange audience but their approbation turned the trick. With their giggles, guffaws, and shouts of merriment to encourage him, Wynn proceeded with the entertainment. He needed only the responsive sight of his hearers doubled over with laughter. Had he been a more frequent radio performer, he would have been able to imagine the fans in their homes, tuned-in to his program and convulsed with mirth.

An audience, although silent, is not necessarily unappreciative, according to Paul Whiteman, the well-known jazz orchestra leader. His first experience with the radio audience was rather terrifying. Now that he is used to it, he says he enjoys imagining all his various hearers—some in homes dancing, some in remote localities with a radio set as their only home tie. And sometimes, he likes to visualize the crew of Captain Mac-Millan's *Bowdoin* up near the North Pole, perhaps giving the Eskimos the benefit of a jazz band concert, while he plays on. Whiteman is quite a radio fan, himself. That is one reason why so many radio fans went to a party he gave a few months ago.

He had always gone home for his mother's birthday. Last October, when the birthday came around, he was in New York unable to go to Denver to be with his mother. About a week before the birthday, as he sat before his professional looking set, a sudden inspiration came to him. It was such a wonderful idea that it didn't seem possible, but Whiteman said nothing to any one and went to work.

A few days later, a sweet faced little lady

in Denver heard from her son that because he couldn't come home for the birthday, he was going to give her a party that day. Three million persons had been invited; the party would be held on the evening of the birthday. Part of the schedule when the son was at home, was his playing on his violin, his mother's favorite songs. It was this custom which Whiteman was to incorporate in his birthday party. Only instead of playing to his mother

alone, he arranged to bring his ten-piece orchestra with him to Newark and broadcast the entire program. Many of you fans probably attended the party. The guest of honor, Mrs. Whiteman, calls it her happiest day. Instead of a birthday cake, the party had a birthday song, "Wonderful One," which Paul Whiteman himself wrote especially for the occasion.

"At first," Whiteman relates, "I felt ill at ease. My orchestra and I had never played before such a silent assembly. We were used to a crowd which encored the numbers they liked and which inspired us to better playing. This quiet studio was an entirely new thing for us; we felt alien. Then I realized that this was my mother's birthday, that way out in Denver she and my father were listening to me. A new spirit was infused in us; we felt that although the audience was silent, they were not necessarily unappreciative. Responses would come later, we believed. They did. Hundreds of birthday congratulations came to my mother, hundreds of letters of thanks came to the orchestra, from our birthday guests. It takes longer to get the applause from a radio audience than it does from an audience there in person, but the people who listen-in are no less enthusiastic and grateful."

Cecil Arden, Metropolitan Opera singer, is



CECIL ARDEN

"I don't mind singing to an unseen audience. To me, the only drawback in radio is the inability to gauge how your audience likes you"

one of the most popular artists on radio programs. When her vibrant personality goes over the air, the radio audience falls under the spell of it, as surely as do the crowds at the Metropolitan Opera House.

"Singing by radio is a spooky experience," Miss Arden confides. "There is something so vast, so indefinite about singing into a microphone. I always have the feeling that I don't know where my voice is carrying, who is hearing me, how my singing is being reproduced. On one occasion I sang in Kansas City and my program was broadcasted. Some friends of mine unknown to me, were in Dallas enjoying a receiving set. Suddenly tuning-in to the Kansas City station, they heard me singing and recognized my voice. Immediately they sent me a telegram and within nine minutes after they had heard me, I received the telegram. To me, that was a revelation of the power of radio."

Miss Arden is a radio "veteran." She made her debut almost two years ago as the first opera singer to give a concert broadcasted.

"My first impression was one of wonder. I thought of the message—'What hath God wrought'—that Morse sent after he had invented and perfected the telegraph," Miss Arden explained. "No, I was not nervous the first time I sang. I was too struck with the wonder of it all. Later on, when I began to realize the size of my audience, I got scared. But by that time I had received letters of thanks and I felt reassured.

"I don't mind singing to an unseen audience. To me, the only drawback in radio is the inability to gauge how your audience likes you. On the stage you immediately know whether the people out front are gay or sad, whether

they want rollicking tunes or a classic program. A radio entertainer never knows exactly how his number gets across. He is at the mercy of a diverse number of people, weather conditions, and freaky sound waves which are apt to distort the most perfect rendition.

"When I am singing a program that is being broadcasted, I like to think of the shut-ins and the people in the hospitals, to whom I am trying to bring a little pleasure. I like to reach the audience who has little communication with the outside world, that audience which by the invention of radio has been given something for which to live."

In speaking with artists whose programs are frequently broadcasted, you are struck with their interest in the moods of their audiences. Most of the entertainers feel that the disadvantage of playing to an unseen audience is the inability to tell how the selection is being received. If we knew how our hearers liked us, we wouldn't mind performing to a microphone, we wouldn't even mind the stony silence, the radio artists say. It is the dreadful uncertainty of knowing how the public likes their work that worries the entertainers.

So, radio fans, there is just one thing for you to do. When you like a number, write and tell the artist that you enjoyed his selection. Not only will the artist feel repaid for his work but he will appreciate the courtesy of the letter. Audiences in a concert-hall sometimes have to pay several dollars for the pleasure of hearing a certain player or singer; radio audiences often have the music of the same artists brought to them free. A letter of thanks is small payment. Radio fans, it is up to you to show your applause in writing.



A Two-Stage Amplifier for Your Receiver

By CARL GOUDY

Assistant Instructor of Mechanical Engineering, Pratt Institute

A home-made two-stage amplifier of sound electrical design and strong mechanical construction, which may be hooked up with any tube or crystal set, is well worth looking into. It helps those who have been receiving principally local stations, sufficiently loud really to enjoy them, bring in the distant ones louder; it enables them to use a loud speaker on signals that would operate only the phones without it; so that a roomful of people, can enjoy the programs. We put our enthusiastic "OK" on the amplifier described below. We have been trying one of these amplifiers made in exact accordance with these instructions. It has plenty of "kick" both with dry-cell and storage-battery tubes, and brings in signals unusually clear.

Mr. Goudy has followed out our suggestions in designing and describing this apparatus in a manner that should make the building of it a comparatively simple matter. It is designed for use with any type of amplifying tube, and room enough has been allowed for the use of any transformer or combination of transformers and other parts now on the market.—THE EDITOR

IN OFFERING this amplifier to the radio amateur and broadcast listeners, the writer has endeavored to design an instrument of marked simplicity in detail, and one that may readily be constructed with a minimum number of tools. This amplifier has the following outstanding features:

1. Dead jacks when not in use. In most amplifiers using jacks for the different stages of amplification, the nipples extending through the panel are alive whether the set is in operation or not. An inspection of the accompanying wiring diagrams will show that the frames of the first and second jacks are entirely out of the circuit, this being accomplished by the selection of the correct jack for the particular part of the circuit. If a high B battery voltage is carried by the usual jack, the radio fan using live jacks is exposed to a severe jolt when inserting the phone plug.

2. The entire frame and transformer cores are at ground potential, with transformers well spaced, reducing the chance of howling to a minimum.

3. Grid leads are extremely short and well separated from the plate circuit.

4. Transformer leads are mechanically secured by means of the binding post provided, but also soldered direct to the coil terminal, thus assuring absolute contact.

5. A variable C battery is used to provide a suitable grid bias for the plate voltage used and is incorporated within the set and placed so that advantage may be taken of the differ-

ent steps of voltage. When using high B battery voltages, say above 60, a C battery is necessary. It will be found to improve the quality of amplification quite naturally.

6. Input and output jacks and binding posts are used, making a truly universal amplifier that may be quickly connected or "plugged" to most any type of receiver. This is important, since the receivers change but the amplifier still remains the same.

GOOD PARTS ARE ESSENTIAL

TO HAVE a well-designed receiver or amplifier function properly after building it from a set of construction drawings, the instruction and drawings should be followed closely, good material and dependable equipment should be employed, and each item of apparatus should be tested before it is placed in the set and hooked up.

It is very much like assembling an automobile engine or a watch—I have drawn a wide comparison, but fundamentally the idea is the same. Take in the first case: if the carburetor is carefully looked into, you are sure that the gas passage is clear and that it is ready to function as a unit; the magneto is given the same inspection, timing is checked—and, in so many words, every detail is examined. The result is that the motor will run; of course, it will have to be tuned or adjusted, but you have variables in the radio set that may be adjusted as well. You may try a leak here and a condenser there and find that it is worth while.

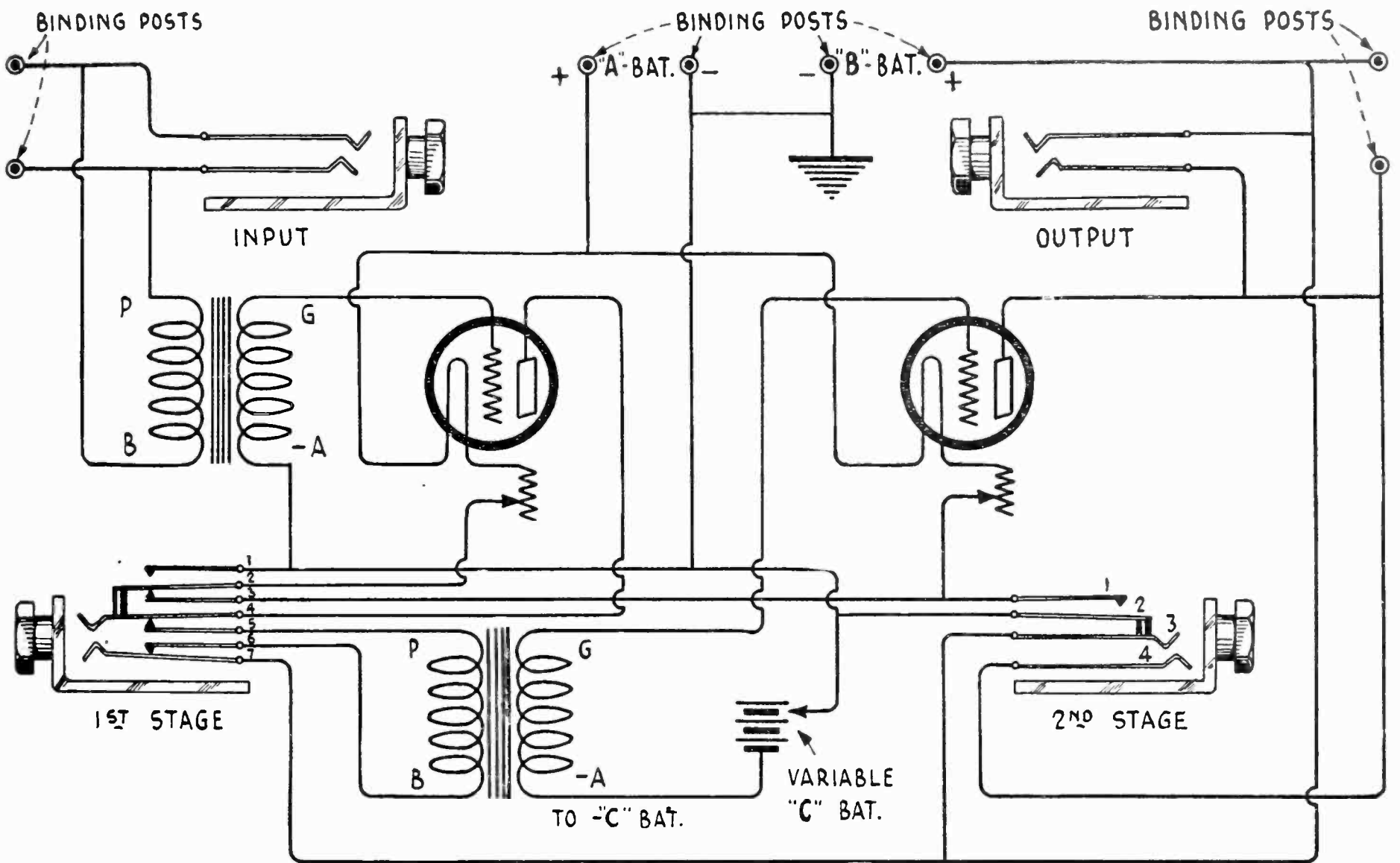

THE ENTIRE CIRCUIT

Have you ever watched a jeweler assemble a watch? Notice how carefully he inspects every part before putting it in place. It's the same in radio work. If you check every part carefully and hook it up correctly, it has got to work.

The time to "shoot" our trouble is before the set is assembled, and I propose that

you "shoot" it dead now. This fiddling around, trying to make it operate after it is all intact, is very unsatisfactory and certainly will make a carefully assembled job look as though someone had pulled a rake through it.

The writer was called in to render first aid to a set a short while ago. The detector functioned perfectly, but nothing was to be had from the

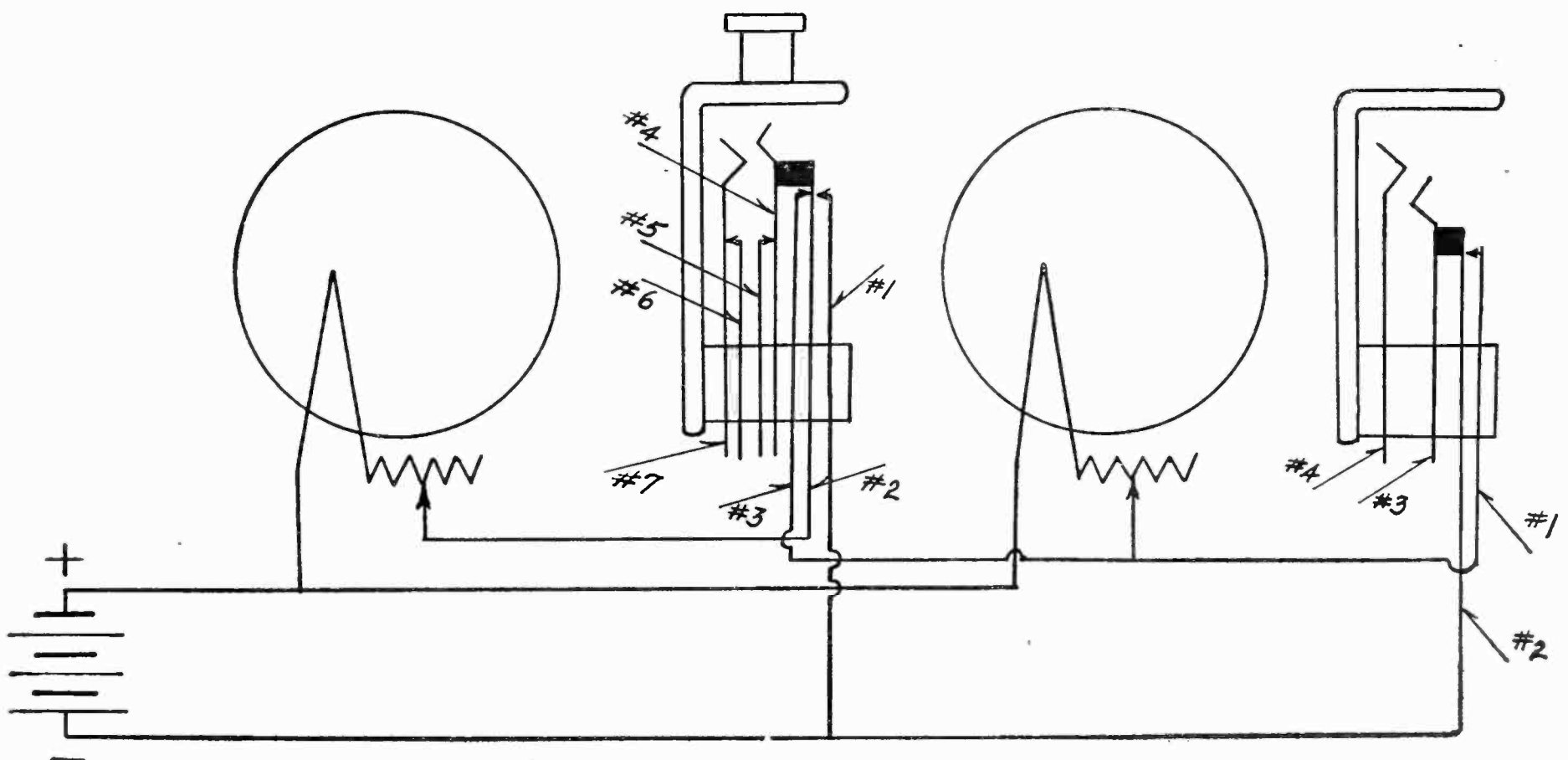

HOW TO WIRE THE FILAMENT CIRCUIT

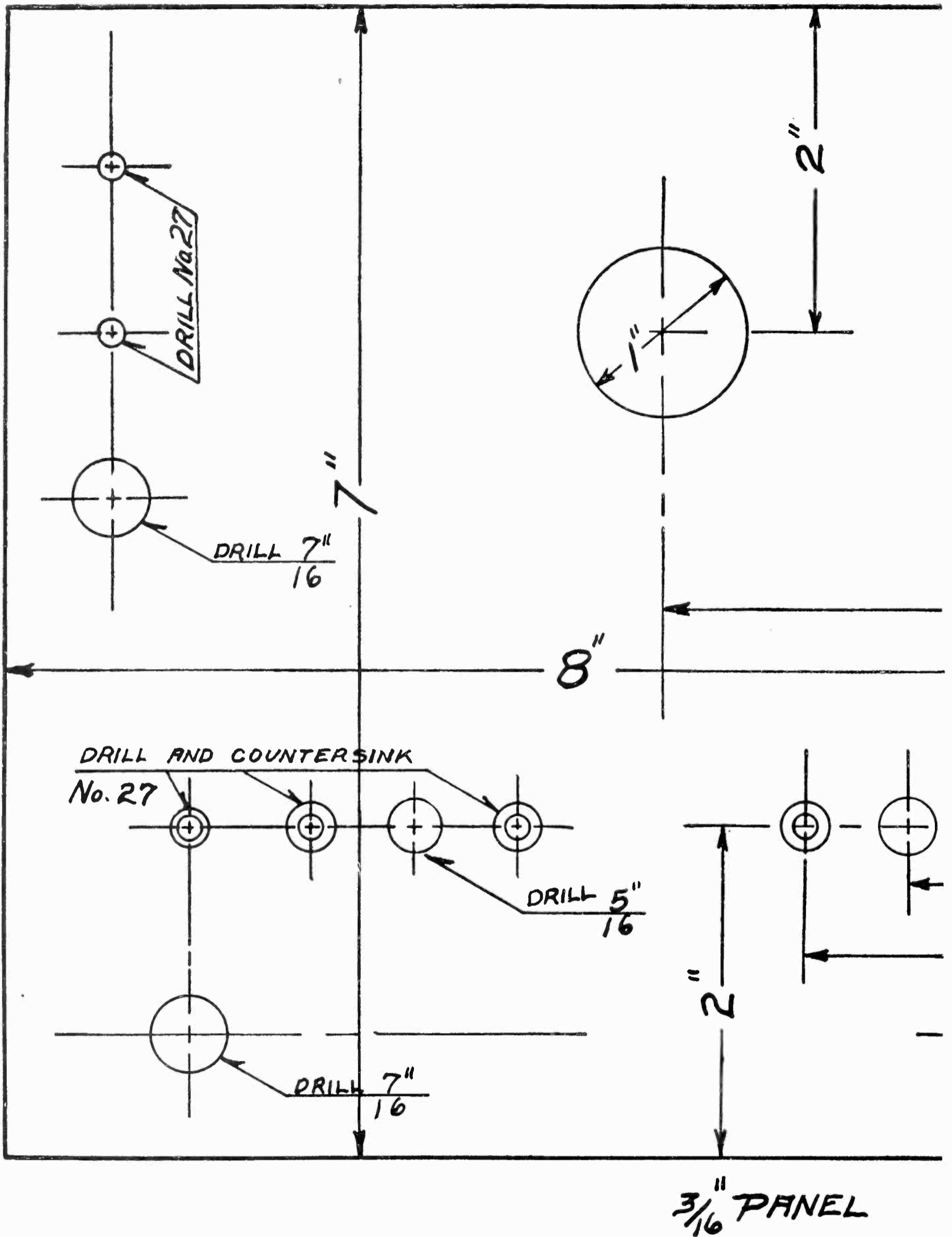

ACTUAL SIZE FOR—
 Cut out the two parts of the pattern, on this page and the opposite page, and join—
 template" is fixed to the panel with light paste, it will be easy to locate the center of—
 center punch, and will save a great deal of measuring—

amplifier end. The trouble was in the jacks. The jack springs were not of spring stock and failed to return to position. The result was a failure to make contact, thus leaving the circuit for the amplifier open. The jack was removed and the springs bent to make proper contact, but this measure could only be temporary. There is no more troublesome part to replace in a radio set than a jack, or a piece more vital in its proper functioning.

HOW TO CHOOSE THE PROPER RHEOSTAT

THE law connecting volts, amperes, and ohms (known as Ohm's law) is expressed as follows:

$$\text{ohms} = \frac{\text{volts}}{\text{amperes}}$$

This law applies to the whole circuit or to any part of it.

The table below shows that a UV-199 tube requires 3.0 volts 0.06 ampere. We can compute its resistance by Ohm's law. It is

$$\frac{\text{volts}}{\text{amperes}} = \text{ohms} \quad \text{or} \quad \frac{3.0}{.06} = 50 \text{ ohms}$$

If this tube is to be operated from a 4.5-volt battery (three dry cells in series) the extra 1.5 volts (4.5-3.0) must be taken by the rheostat. Since the tube and the rheostat are in series, the current in the rheostat should also be 0.06 amperes when the correct voltage is obtained. We can then compute the resistance required in the rheostat by Ohm's law. It is

$$\frac{\text{volts}}{\text{amperes}} = \text{ohms} \quad \text{or} \quad \frac{1.5}{.06} = 25 \text{ ohms}$$

The rule for determining the resistance required in a rheostat is therefore as follows:

Subtract the volts required by the tube from the volts at the battery.

Divide the remainder by the tube amperes.

It is best to select a rheostat with a resistance somewhat greater than that computed and adjust it down to the required value.

Approximate D. C. characteristics of popular tubes:

| TYPE | E (VOLTS) | I (AMP) | R (OHMS) |
|-------|-----------|---------|----------|
| 200 | 6 | 1 | 6 |
| 201 | 6 | 1 | 6 |
| 201-A | 6 | .25 | 24 |
| 199 | 3 | .06 | 50 |
| 215-A | 1.5 | .25 | 6 |
| WD-11 | 1.5 | .25 | 6 |
| WD-12 | 1.5 | .25 | 6 |

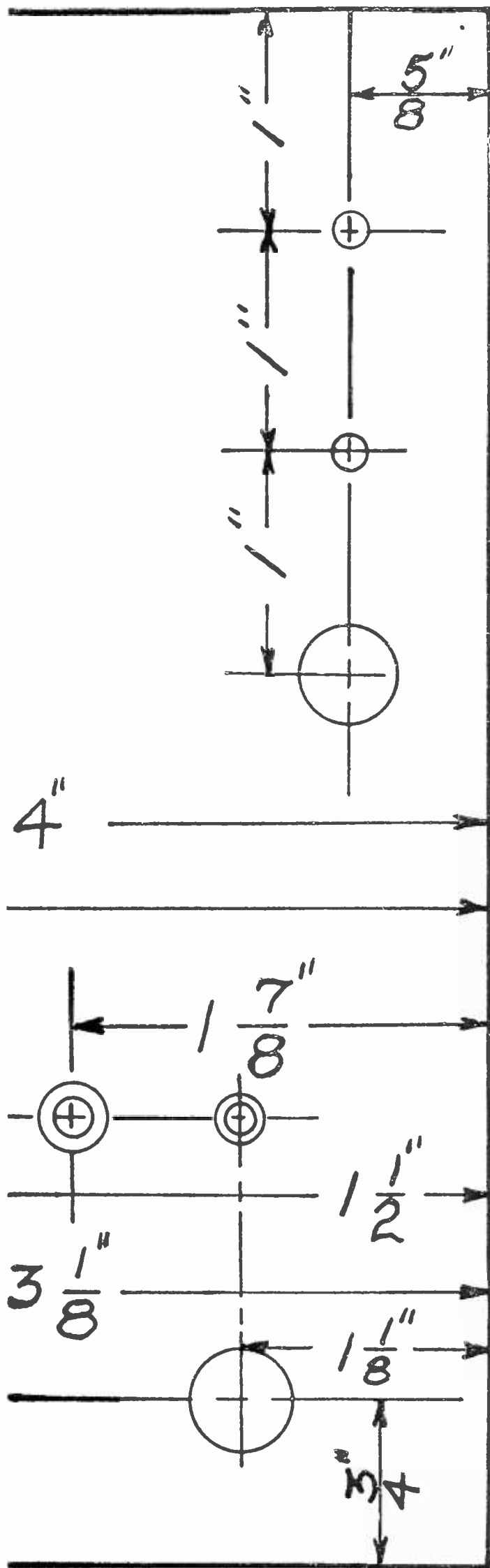

—MAIN PANEL

—them together. If this "pattern, or the drill holes with the aid of a and marking.

tubes such as the 201-A, and WD-12, while adaptors may be employed to make use of other tubes such as the WD-11 and the UV-199.

The transformers may be readily tested by connecting a battery to the primary post and touching the other primary post, thus completing the circuit. If a wire is brought from one secondary post to the other but not quite touching it, leaving a slight air gap, a spark may be seen to jump across to the second secondary post, giving assurance that the primary and secondary windings are all right.

THE TOOLS YOU NEED

ONLY a small number of tools are necessary to complete the job. They are:

- A small hand drill
- 1 No. 27 drill for all screw holes and binding posts
- 1 5/16 drill for rheostat shafts
- 1 7/16 drill for jacks (unless jacks of another size are used)
- 1 flat file, center punch, square, dividers, hammer.
- 1 countersink, hack saw or fine-tooth back saw, screw driver, pliers, soldering iron, and soldering material

Even this list can be cut down to some extent, the countersink may be replaced by regrinding the 7/16 drill to an angle of 60 degrees; in fact, it will do better work in drilling the thin panel if used in this manner. The 5/16 drill may be replaced by first drilling the hole for the rheostat shaft with the No. 27 drill, and then using the countersink from both sides until it will accommodate the rheostat shaft, but this practise is not recommended. The No. 27 drill is necessary for a good job, and you will find it is slightly larger than a 1/8-inch drill.

LIST OF MATERIAL

- 1 Panel, 3/16 x 7x12 inches
- 2 Sockets
- 2 Rheostats
- 2 Transformers
- 8 Binding Posts
- 1 seven-spring automatic jack
- 1 four-spring automatic triple-circuit jack
- 28 inches of 1/16 x 1/2-inch brass
- 24 8/32 x 3/4-inch round-head brass machine screws
- 2 8/32 x 5/8-inch flat head brass machine screws
- 5 lengths tinned bus wire
- 2 Heavy-duty jacks
- Markers for jacks, INPUT, OUTPUT, 1st STAGE, 2nd STAGE
- Markers for battery binding posts

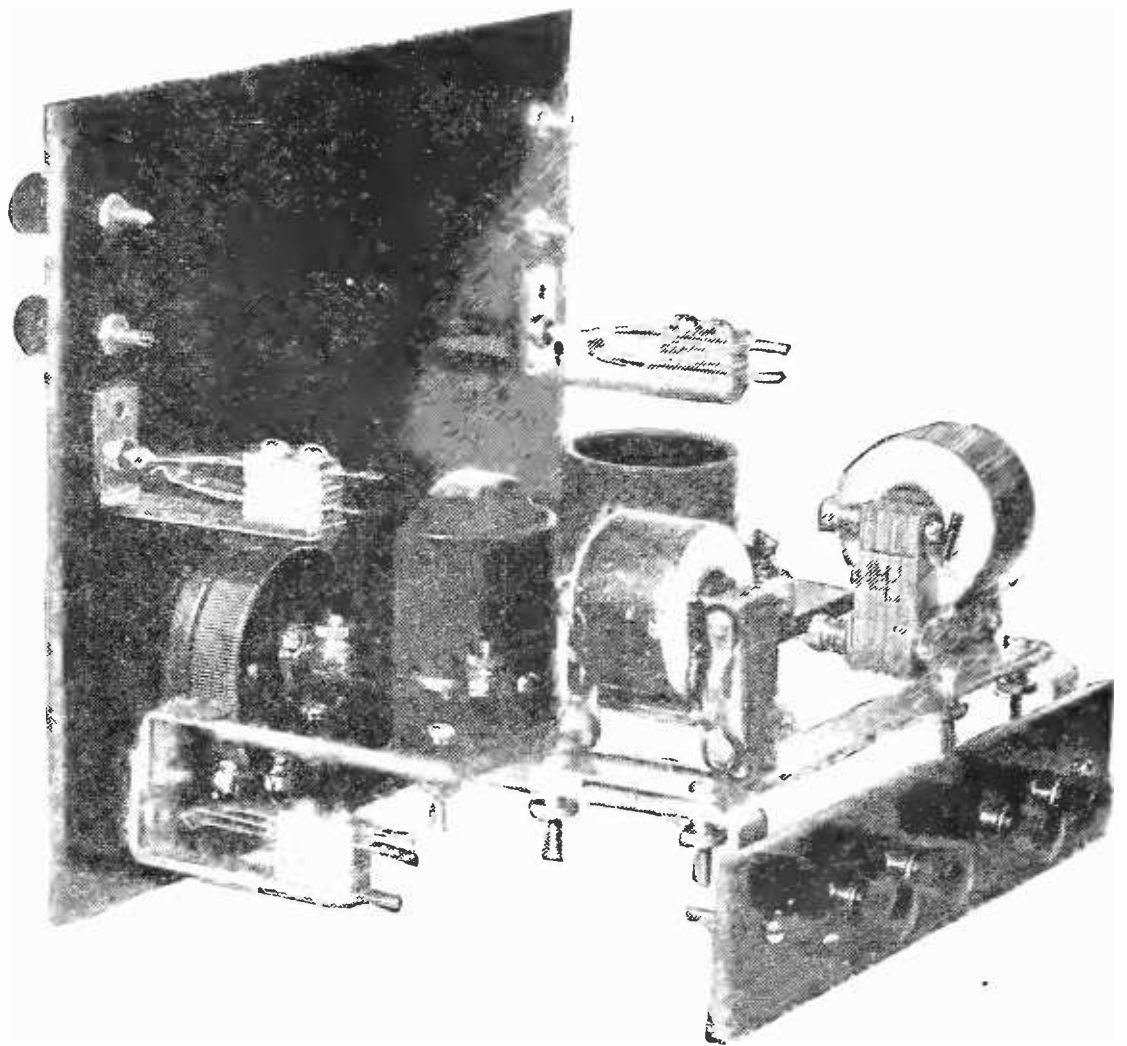

REAR VIEW

With main panel, rheostats and input and output jacks and binding posts

WORKING THE PANELS

IN PURCHASING the panel it is well to procure one of standard make because the sides are more likely to line up square. Now we are ready to prepare the panel. Look it over carefully and select the best side. See

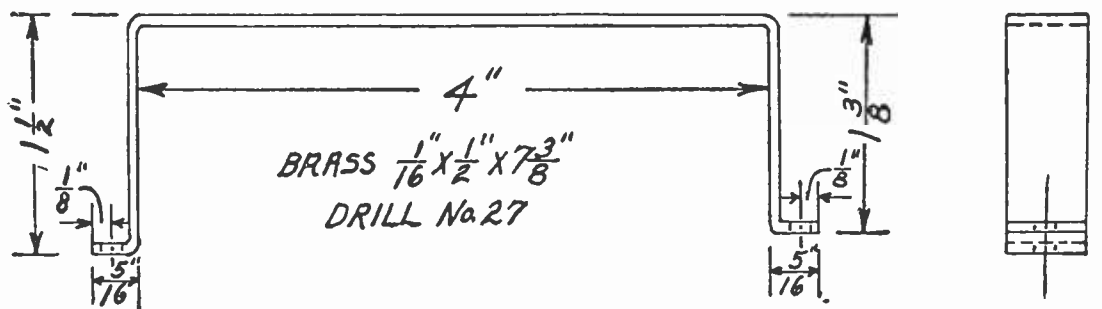

CLIP FOR C BATTERY

The clip shown is correct for Burgess type 2370 battery or the Eveready No. 771. If other batteries are used, the clip will have to be changed to fit

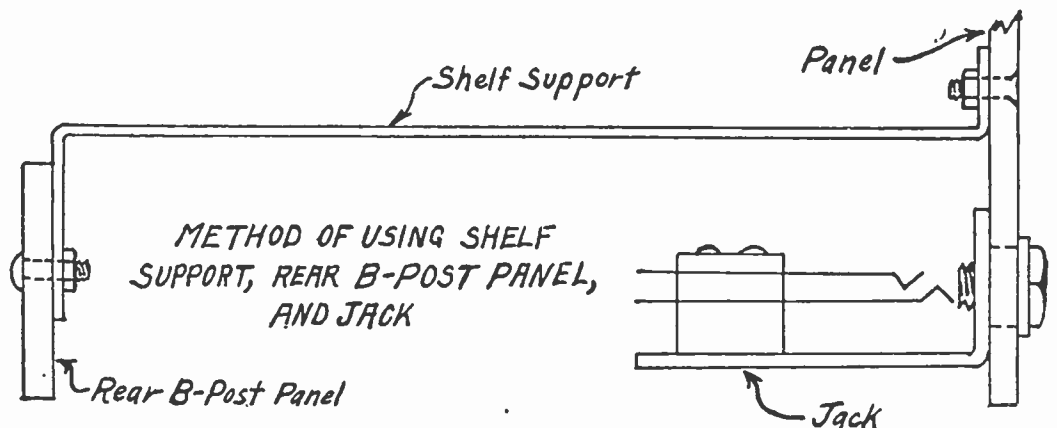

SHOWING METHOD OF MOUNTING Supporting shelves and jacks to main and rear panels

that the trade-mark, if one is stamped in it, is located so that it will cut out of the panel proper. Lay off $2\frac{1}{2}$ -inches from one of the short ends, so you may cut a piece 7 inches long or the height of the panel. Then lay off 8" from the other end as shown in the drawing.

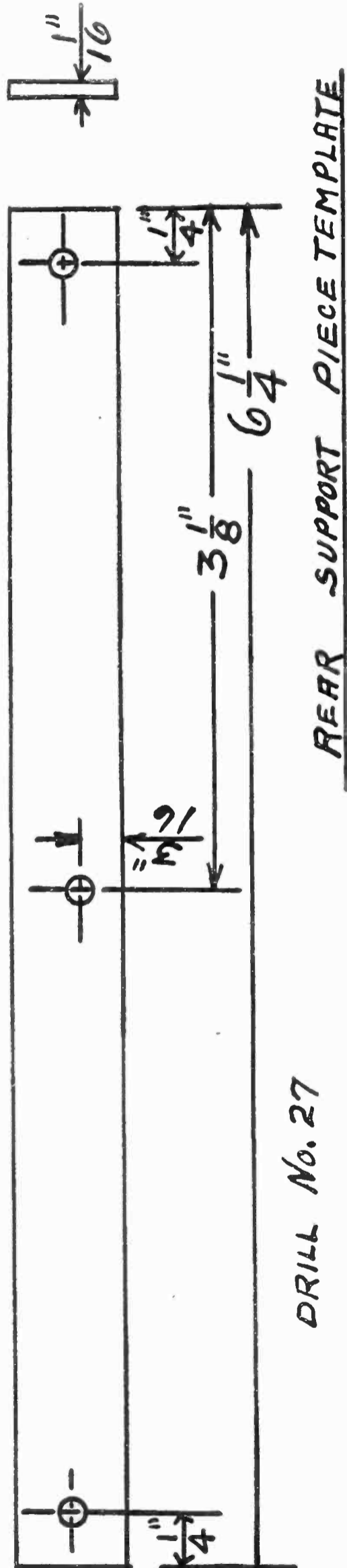

Square carefully and mark with a sharp pointed tool, and then saw with a hack saw or a fine-tooth saw. Allow the saw to have a good slant, as this will prevent the panel from chipping from the under side. A hacksaw will take care of this point, because the frame will prevent a vertical cut. By cutting the small pieces first, namely, the socket shelf and the rear binding

post panel, you will enjoy some practice for the final cutting of the main panel. It is well to square the large piece by filing with a flat file. Then the large panel may be laid out and cut. It is well to check your measurements and refer back to the drawing and be doubly sure you are right. Break all the sharp edges with a file.

Now lay out the holes to be drilled as per the drawing and mark lightly. Check this layout from all sides as an added precaution. You will find it a good point to set your dividers to the radius of the drill to be used and scribe every hole according to the drawing. It may save you running the $\frac{5}{16}$ drill through where the No. 27 should be. What it will certainly do, however, is to insure the hole being drilled where you intended, and after a few turns of the drill you can inspect it and see that the drill is located directly in the center of the circle, and if not, you may easily correct it by drifting the drill in the proper direction. The window was cut with a fly cutter and, of course, is optional and may be replaced with the conventional six small holes design. In reality, it is unnecessary as far as ventilation goes when using the tubes of small current capacity. It does add somewhat to the appearance of the panel.

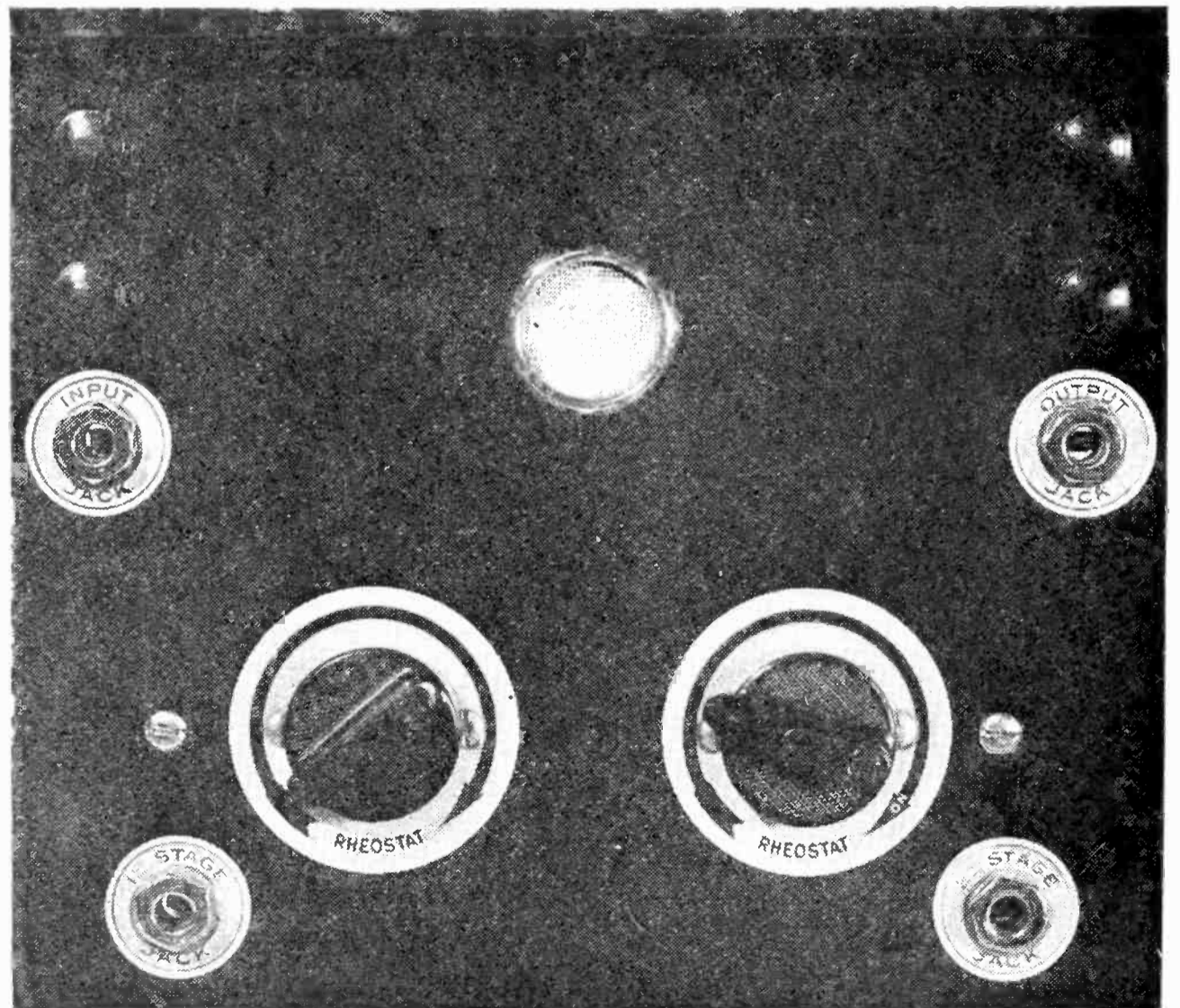

FRONT VIEW

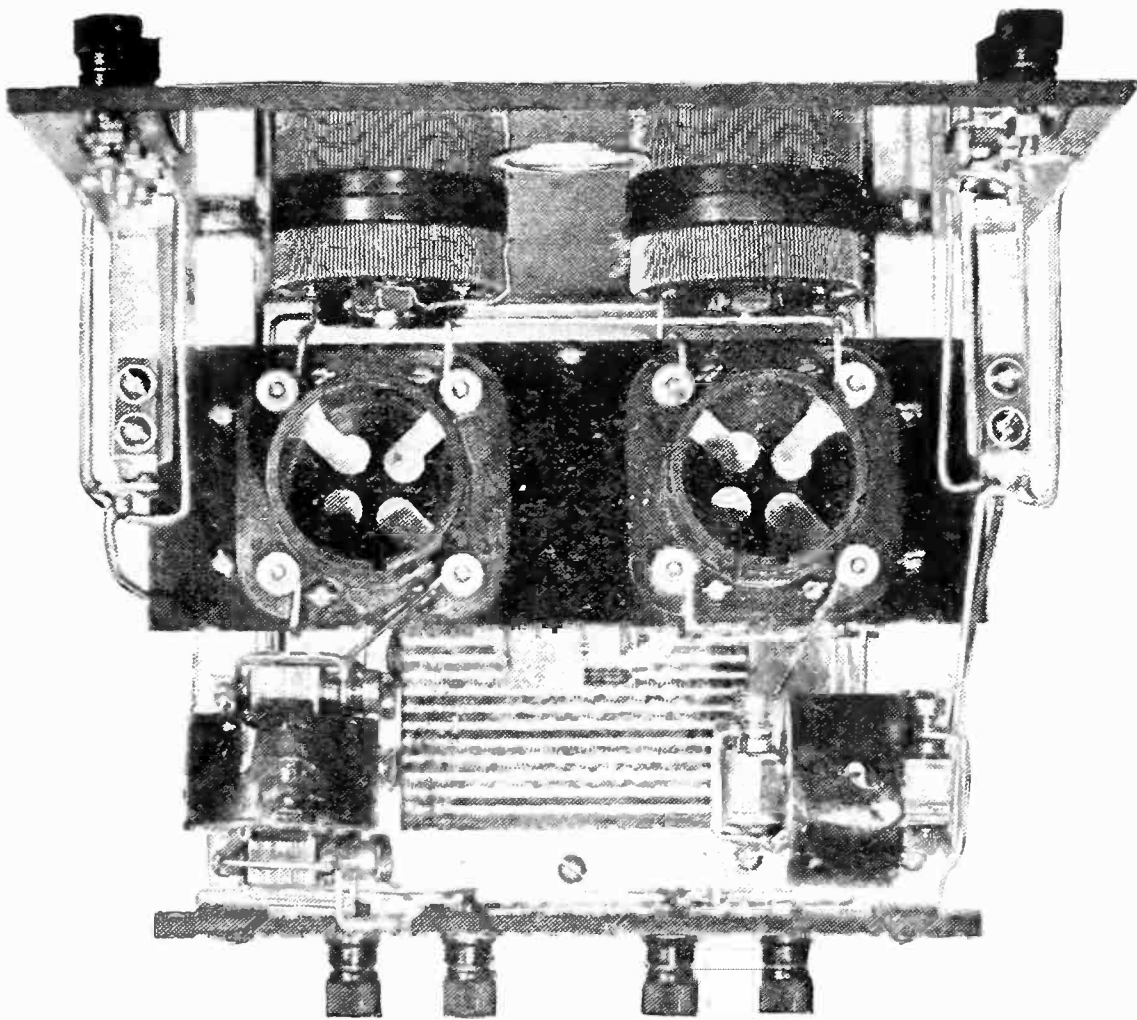

THE COMPLETED UNIT
Looking from above

In laying off the socket shelf you will find it easier if only two of the four holes for securing the socket are drilled. The remaining two holes may be drilled after the sockets are in place. The same may hold true when the extreme end holes on the shelf are drilled. The slightest error will cause these holes not to line up properly.

MAKING THE BRASS FRAMEWORK

THE three brass frame members may now be laid out, drilled and bent as shown in the drawing. Do not try to make too sharp a bend. Bite or grip both strips in the same manner. This may be done by placing them side by side in a vise. If this is done, you will find that the two pieces will be shaped up to match. Now drill all the holes. If the countersink is used, in order to break the sharpness of the holes, the assembly will be easier.

ABOUT THE ASSEMBLY

NOW is the time to pick up the tools and clean up the table. You cannot do a careful job if the table is cluttered with tools, brass filings, and chips. If you are going to keep the original polish on the panel, take care in removing all the brass chips from the table, for they will invariably mar the panel. Now mount the rheostats, binding posts, and jacks

on the panel. The sockets may be screwed to the shelf and the balance of the holes drilled. The rear binding post panel piece is ready for the binding posts, and with the brass shelf support secured to the panel the amplifier has suddenly grown up and the next thought is the wiring.

THEN THE WIRING

THE soldering iron, soldering material, bus wire, and pliers are all that are

needed now to complete the job. Study the diagram and instead of making a maze of it, try to see how each instrument is hooked into the circuit. To make it easier, the filament circuit has been drawn separately from

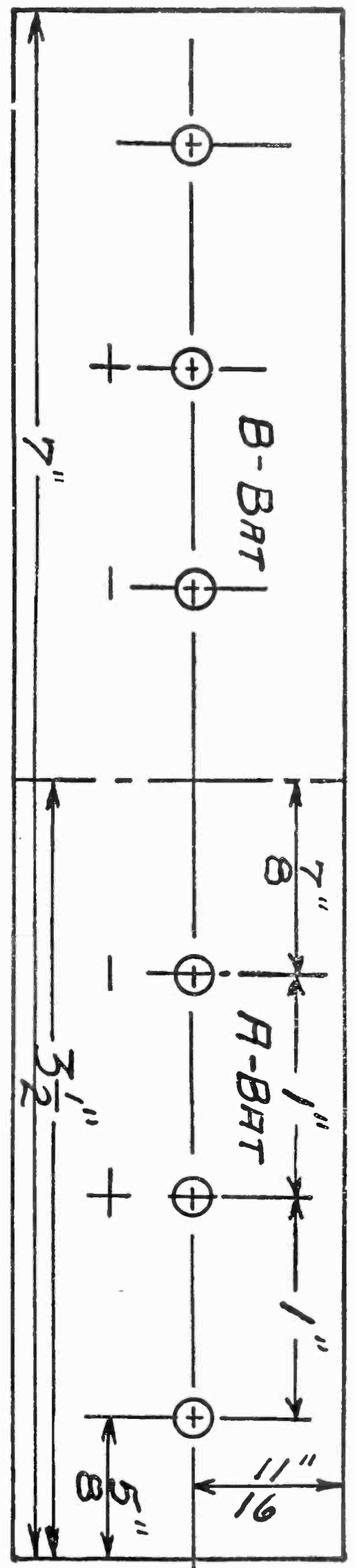

PATTERN OF REAR
Binding post panel

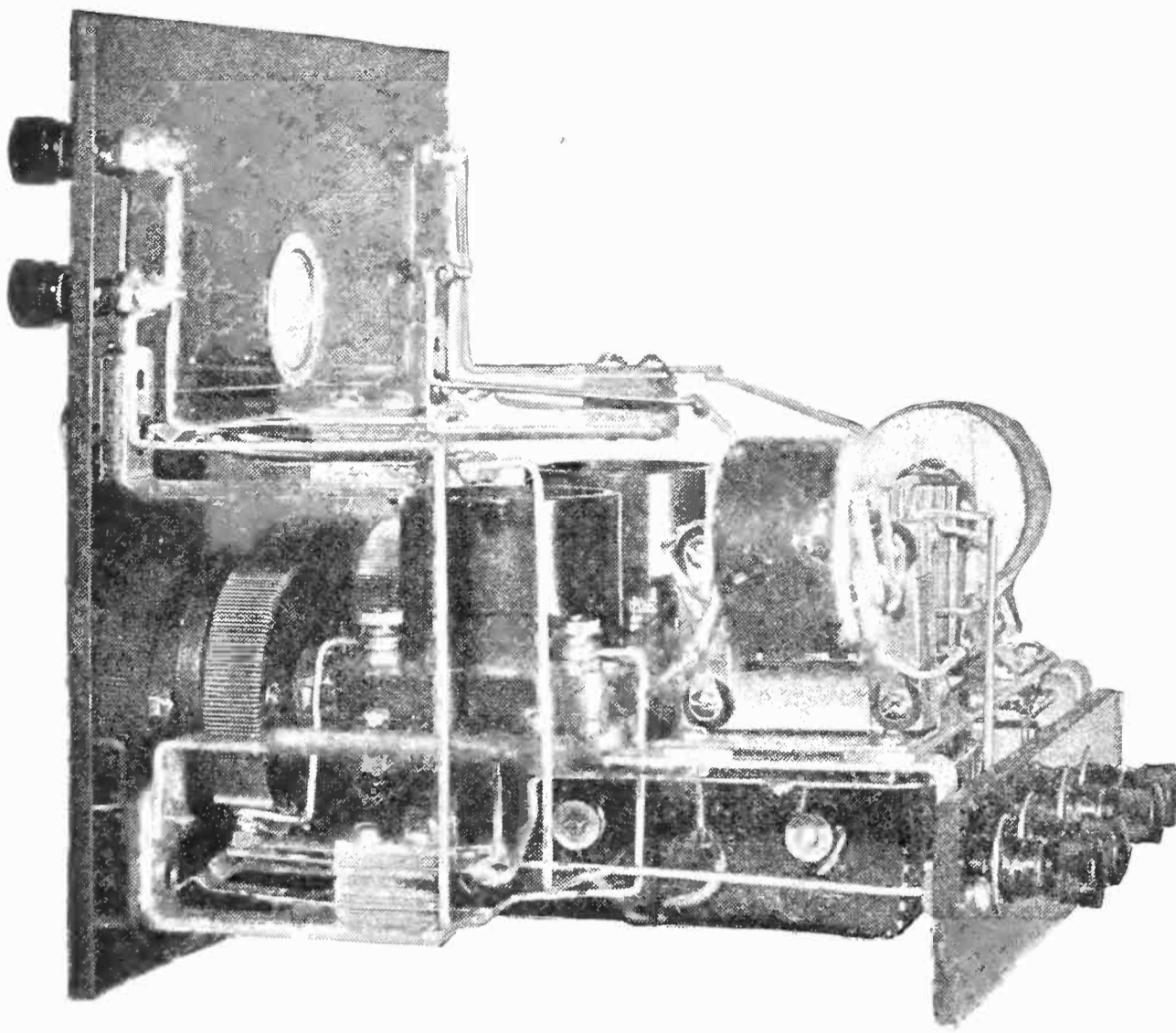

FROM THE LEFT REAR
Showing the arrangement of the parts and wiring

the entire hookup, in an accompanying drawing. This is the circuit to tackle first, and with it off your hands the rest is easy sailing. With the filament circuit completed, try it out and see that the jacks operate correctly before you go any farther. Take the B battery and plate circuit next, after which the grid circuit should be completed.

HOW TO SOLDER

IN NEARLY every instance of soldering, the instrument end has been taken care of by first having been tinned. If you will do the same to the bus wire after it has been bent to the desired shape, you will find upon applying the iron to the parts to be joined that they will knit neatly without the usual dropping of solder into the set.

The point to bear in mind when soldering is this: both members to be soldered must come up to the same heat, and this is not attained by briskly rubbing the soldering iron over the parts to be soldered, but is obtained, instead, by first having a hot, clean iron, which is simply held against the parts to be joined. Both members to be soldered must first be tinned. In connecting the transformers, carry the bus wire to the binding post and then around—keeping clear of the frame of the transformer—to the clip, where the wire emerging from the coil is attached. This method gives you a true soldered connection. If you must use the paste soldering compound, try benzine instead of alcohol for removing the paste after the joint is made.

See that the C battery is connected correctly

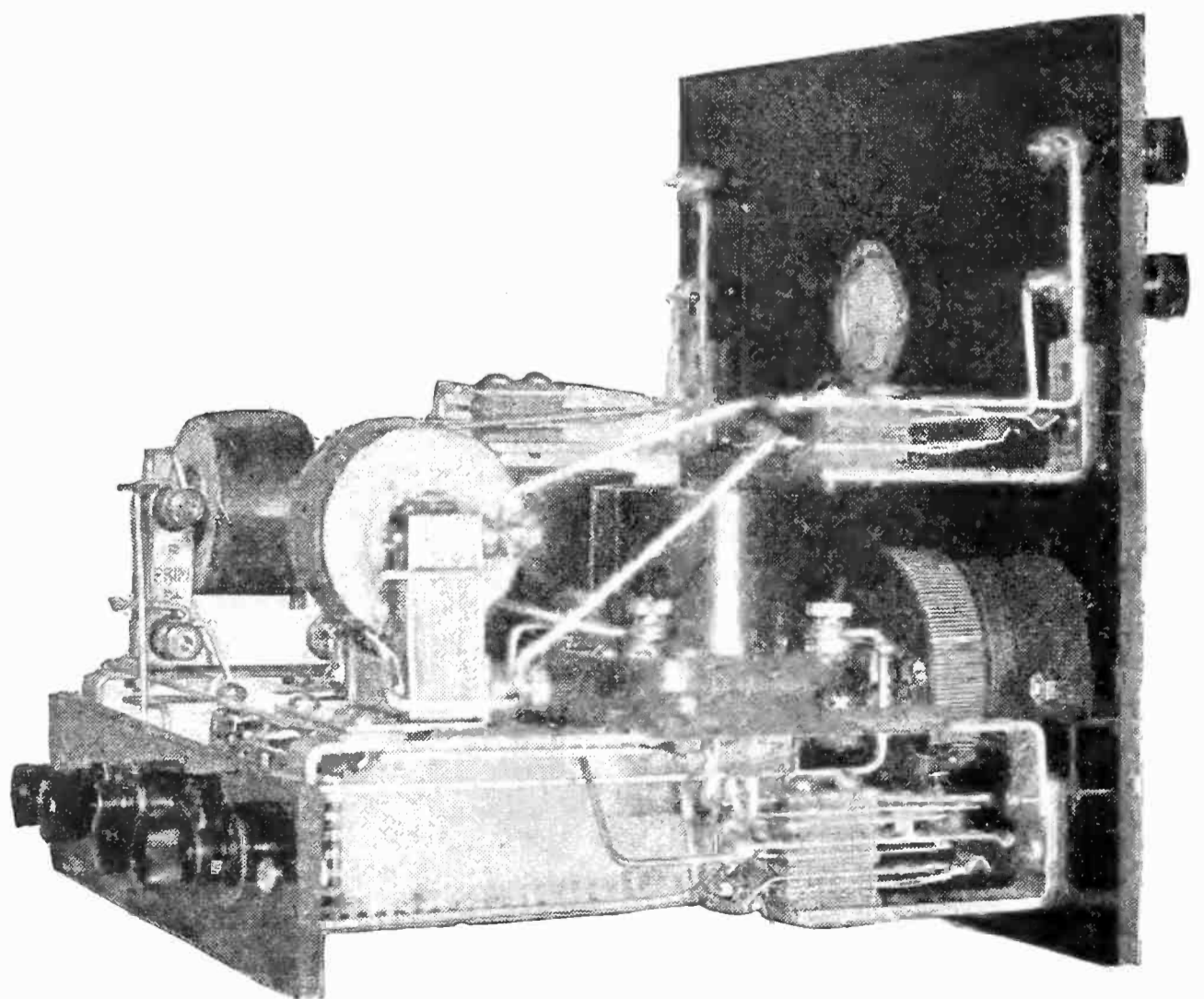

FROM THE RIGHT REAR

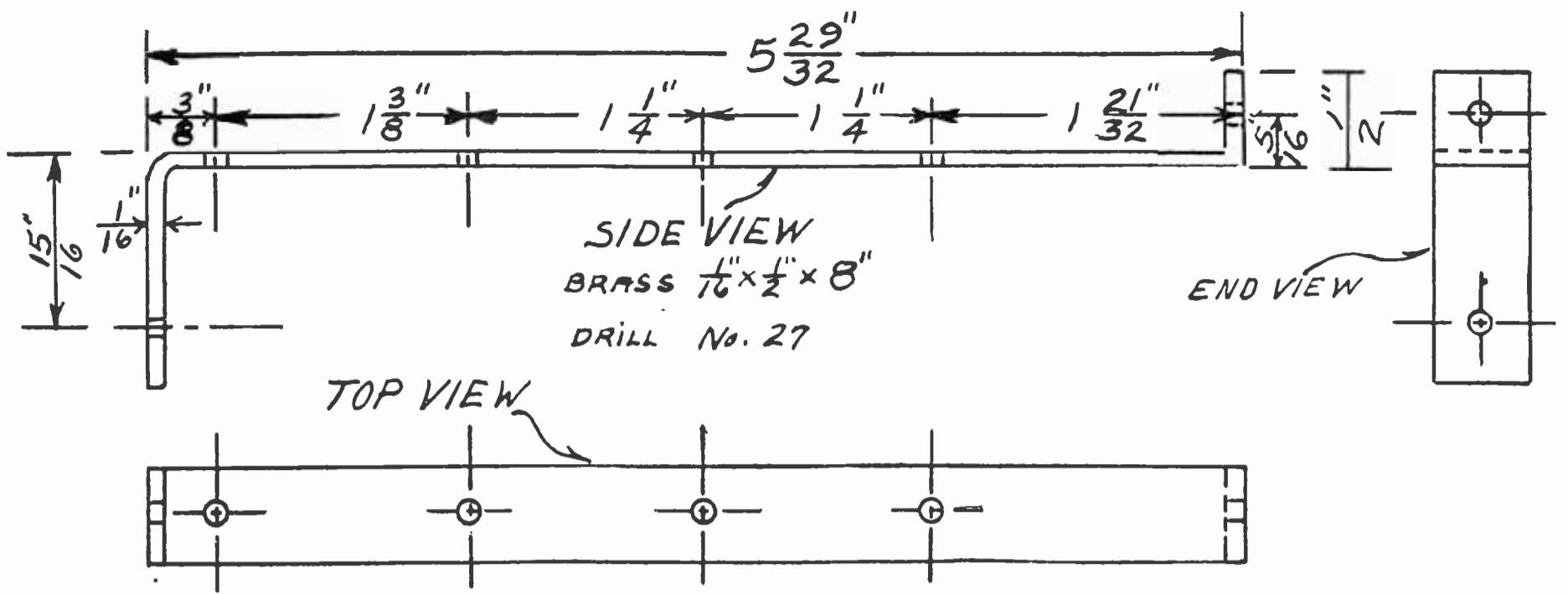

DETAILS OF SHELF SUPPORT

with the positive side to the minus side of the A and B batteries. They in turn are grounded to the frame, thus bringing the transformer cores to ground potential.

To check the B battery circuit it is well to connect the A battery to the B battery binding post and see if by chance the tubes light, showing that you have made a mistake. This may save the life of a tube which might otherwise be burned out.

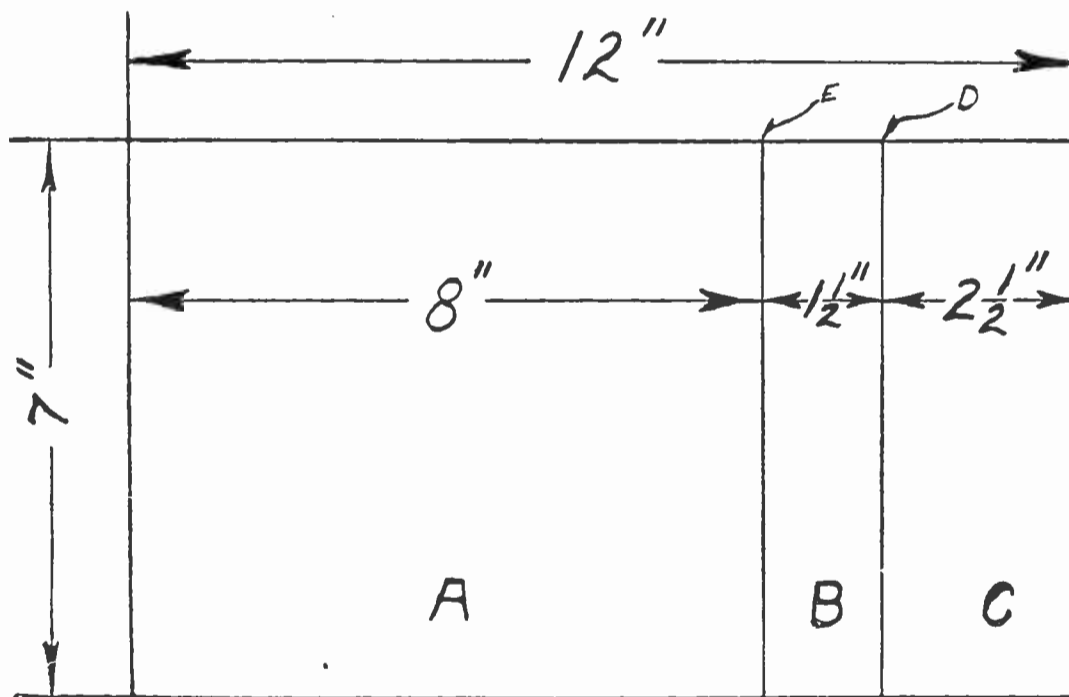

PANEL LAYOUT

Laying off 8" from the left and $2 \frac{1}{2}$ " from the right leaves a piece about $1 \frac{1}{2}$ " in between. Saw line D first. In sawing line E keep the saw well to the right of the line and thus allow some leaway for squaring up the edge of the front panel with a file. It will be found that the pieces B and C will not actually measure $1 \frac{1}{2}$ " and $2 \frac{1}{2}$ " respectively due to the loss of material caused by the sawing



The Grid

QUESTIONS AND ANSWERS

The Grid is a Question and Answer Department maintained especially for the radio amateurs. Full answers will be given wherever possible. In answering questions, those of a like nature will be grouped together and answered by one article. Every effort will be made to keep the answers simple and direct, yet fully self-explanatory. Questions should be addressed to Editor, "The Grid," RADIO BROADCAST, Garden City, N. Y.

ADDING AUDIO AMPLIFICATION TO THE R. B. ONE-TUBE REFLEX

I have built the one-tube reflex set described in the November RADIO BROADCAST, and I must say it is a wonderful little set. I should like to add one stage of additional audio amplification to it, and should appreciate your showing me just how it is done. I should like to use filament control jacks, as one of this type is already in the single tube set.

R. O. O., New York City.

THE accompanying diagram Fig. 1 shows the connections for adding one stage of exterior, or straight audio-frequency amplification to the single-tube reflex set. Filament control jacks, of the most easily obtainable type, have been indicated, but readers not possessing jacks of this design may use any other type that will accomplish the same thing. The reader having any doubt concerning

the connections for the particular type of jack which he finds it necessary to employ, is advised to read the article on "Jacks and How to Use Them" appearing in the April RADIO BROADCAST. Of course, straight double-circuit non-filament-control jacks may be used if desired, the filaments being turned off by a switch, if a balance resistance such as the "Amperite" is used, or by a rheostat, which acts as a switch when in the "off" position.

Observant readers may notice that the positions of the telephone receivers and the "B" battery have been reversed. The reason for this is explained in the amplification article in the July RADIO BROADCAST, which readers desiring to add amplification to any set, will find it worth while reading. The diagram is otherwise quite self-explanatory. Any well known and reliable amplifying transformer can be used. This one additional stage will probably be all that will ever be desired on this remarkable little set.

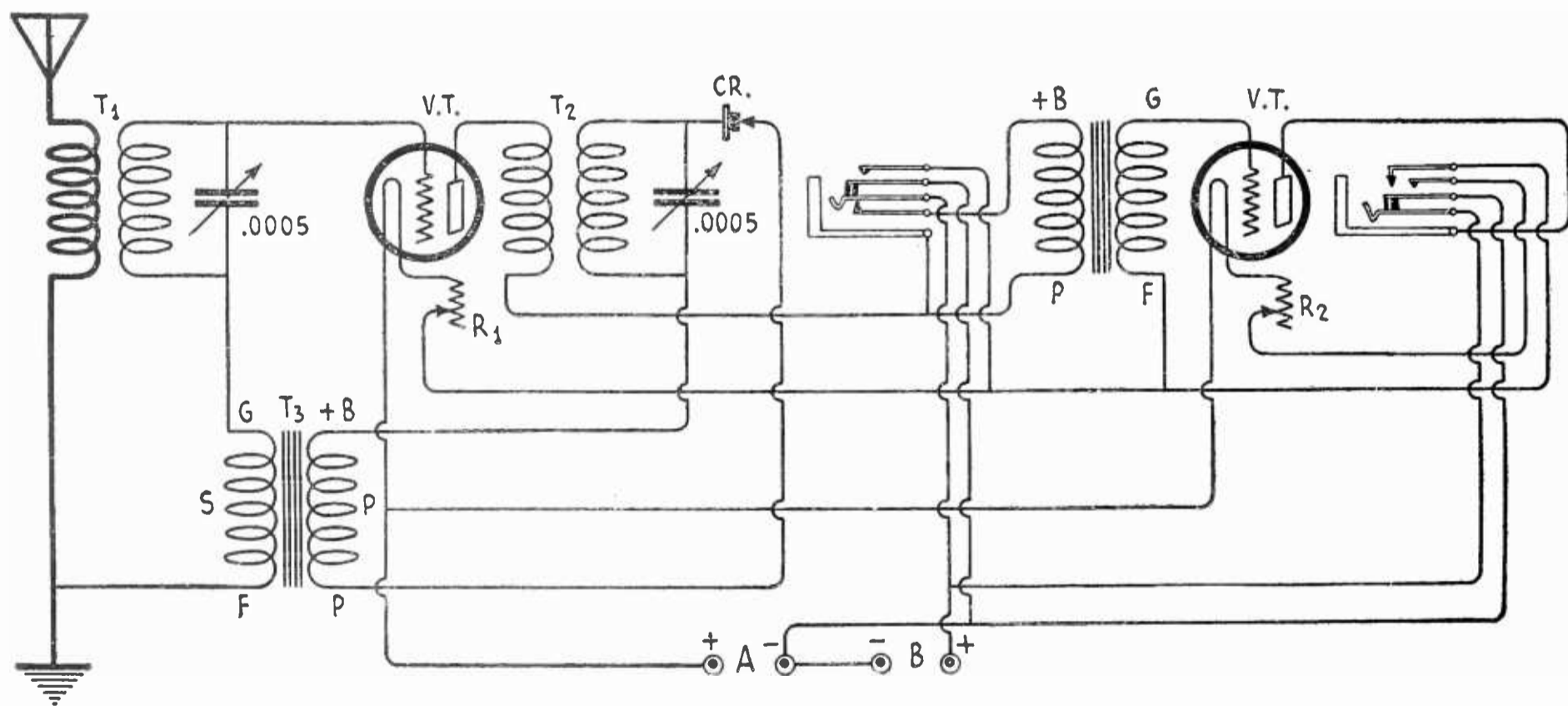
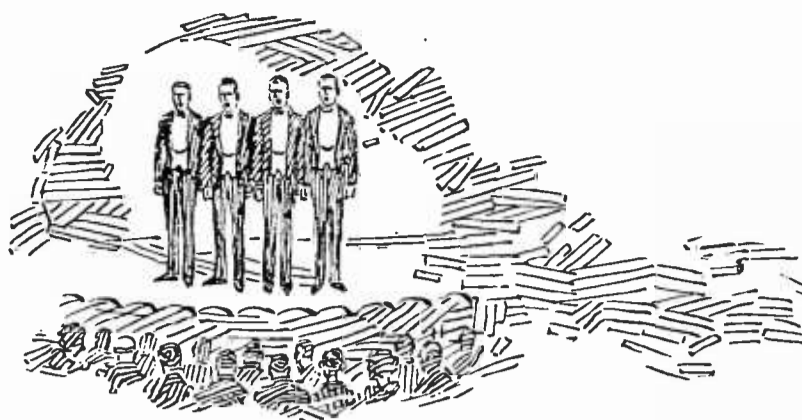
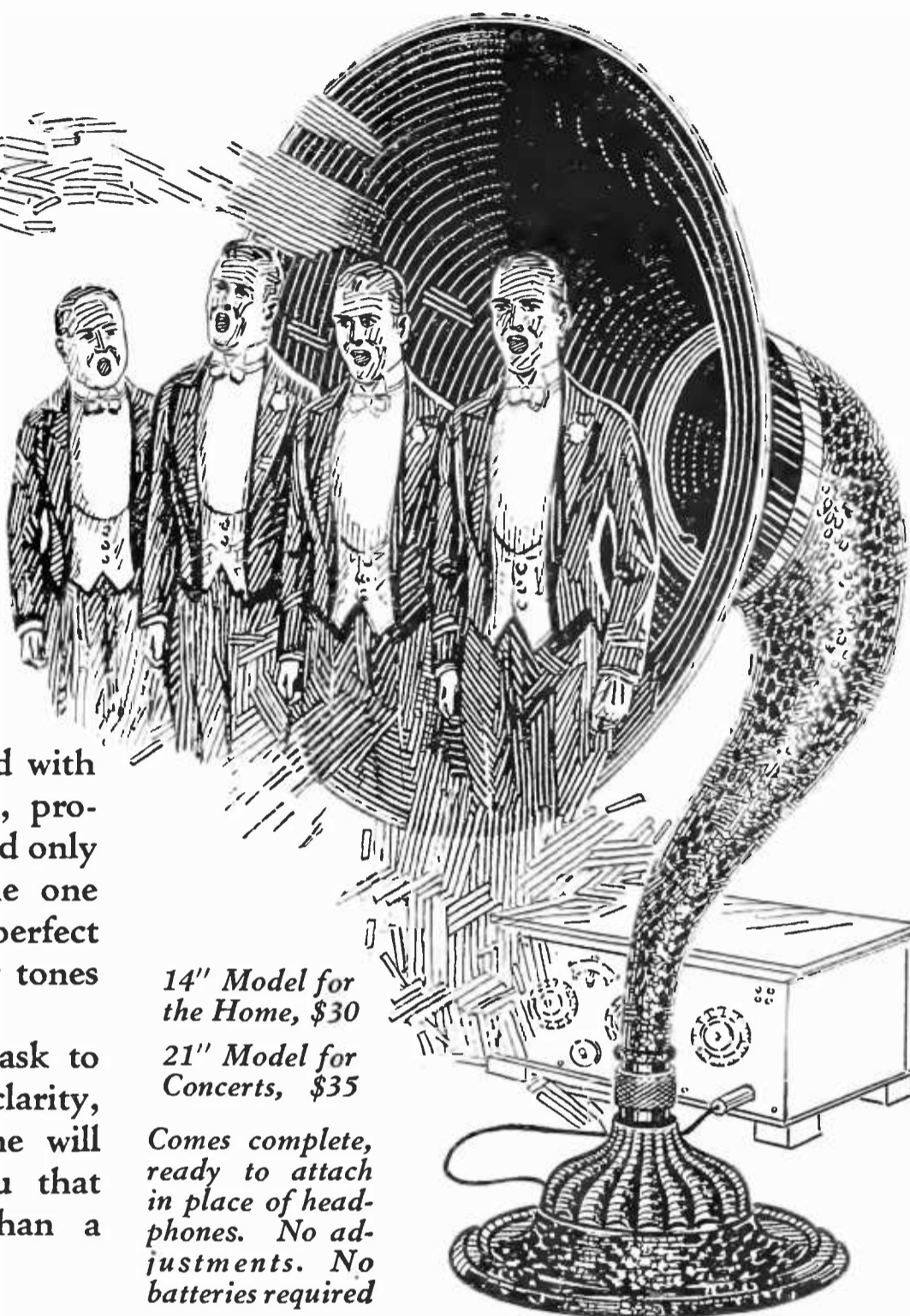

FIG. 1

One stage of audio added to the one-tube reflex set. Note the position of telephones and "B" batteries



WOOD'S The Thing!!



MUSIC MASTER is equipped with a *wood* amplifying bell. Wood, properly shaped as a horn,—furnished only with MUSIC MASTER,—is the one material that makes possible perfect reproduction of the actual, living tones themselves.

Go to your radio dealer and ask to hear MUSIC MASTER. Its clarity, brilliance and naturalness of tone will delight you—and prove to you that MUSIC MASTER is more than a name.

DEALERS EVERYWHERE

14" Model for the Home, \$30

21" Model for Concerts, \$35

Comes complete, ready to attach in place of headphones. No adjustments. No batteries required

MUSIC MASTER CORPORATION

(Formerly General Radio Corporation)

Makers and Distributors of High-Grade Radio Apparatus

CHICAGO

S.W. Cor. 10th and Cherry Sts., PHILADELPHIA PITTSBURGH

Music Master

RADIO REPRODUCER



★ Tested and approved by RADIO BROADCAST ★

Among Our Authors



W. W. ROGERS

services and other radio topics.

E F. McDONALD, JR., who has something interesting to say this month on "What We Think the Public Wants," is President of the National Association of Broadcasters and head of the Zenith Radio Corporation. He confessed to us from Chicago the other day that he was born in Syracuse, N. Y., and positively does not play golf, but likes yachting and hunting. He accompanied Mac Millan on the *Bowdoin* as far as Labrador last summer.



E. F. McDONALD, JR.

L A. HAZELTINE is the inventor of the neutrodyne circuit. He is head of the Department of Electrical Engineering at Stevens Institute of Technology at Hoboken. He is also manager of the Institute of Radio Engineers and served as a member of Secretary Hoover's Radio Conference Board.



R. H. AND W. B. MARRIOTT

W W. RODGERS, who contributes "Broadcasting Complete American Programs to All England" in this issue, lives in the industrial smoke of Pittsburgh. He has contributed to our pages before on broadcasting church

graduated from Ohio State. Mr. Marriott sends this photograph of himself and his son on their way to make a "Siwash" camp in Alaska. "On this occasion," Mr. Marriott writes, "the boy got a trout sixteen inches long. We caught a deer, as well."

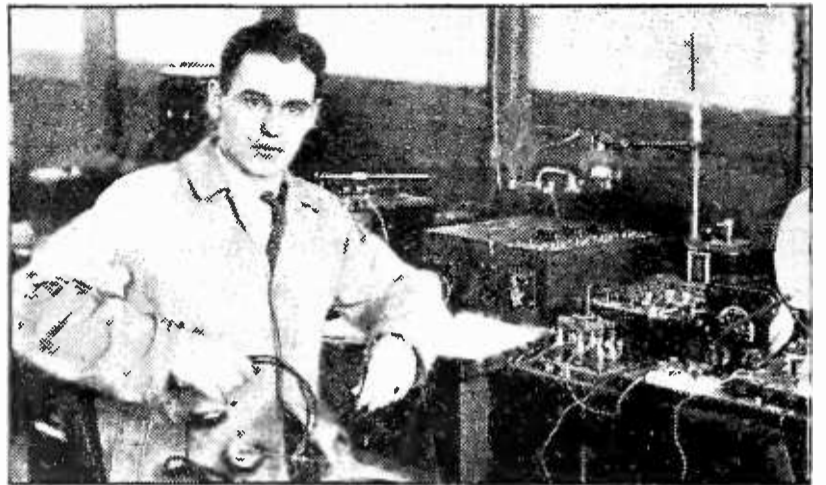

LEWIS M. HULL

I FIRST BECAME interested in radio when an undergraduate at the University of Kansas in the days when carborundum and Gen. Dunwoody were equally famous, and the rotary spark gap was an innovation," says Lewis M. Hull of the Radio Frequency Laboratories at Boonton, N. J. He adds, speaking of his research at Cruft Radio Laboratory at Harvard and at the Bureau of Standards in Washington: "and I've since been making futile but persistent efforts to see things invisible and hear things inaudible." Doctor Hull admits a fondness for historical novels and counterpoint.

C ARL DREHER sends us the second article of his interesting series on the receiver and the received this month. He is a radio engineer who is as much at home in the unrelated fields of philosophy, sociology, and literature as among the big quiet tubes of a broadcasting station. He is a quiet sort, but mention of the movies is apt to cause trouble. He is in charge of WJZ and WJY.

W ALTER VAN B. ROBERTS is doing research work in physics at Princeton. In the intervals he plays golf and writes radio articles.



W. VAN B. ROBERTS

R OBERT H. MARRIOTT writes this second article in his series from Bremerton, Washington, where he is a radio engineer at the Puget Sound Navy Yard. He first became interested in radio in 1901 after he



THE SIEGE

OF TROY

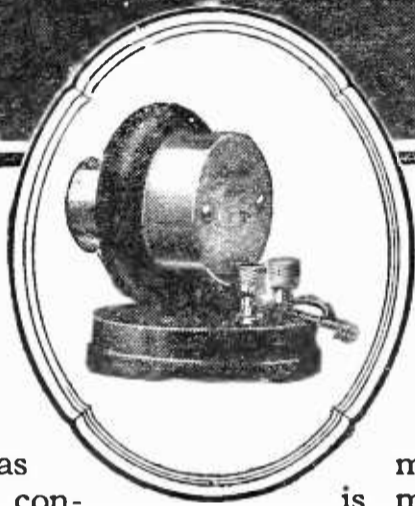

AT the dawn of civilization the signal fire was the principal means of conveying information over distances.

During the ten-year siege of ancient Troy, the Greeks under Agamemnon by this means maintained constant communication throughout their encircling camps.

To-day there has been developed a series of instruments that enable us to communicate and even project our actual personalities over vast distances.

Of all the instruments that make Radio possible none is more important than the Headphones or Loud Speakers. These transform into sound the delicate electric currents produced in your receiving set. If they are imperfect, the results are unsatisfactory.

HOLTZER-CABOT Headphones and Loud Speakers embody the latest developments in the art and will greatly increase your enjoyment of Radio.

| | |
|--|----------------|
| Holtzer-Cabot Loud Speaker, | \$25.00 |
| Loud Speaker Phonograph Attachment, | 10.00 |
| No. 2 Universal Headphones, | 9.50 |
| No. 4 National Headphones, | 6.00 |

Write for booklets explaining how the exclusive features of these instruments enable you to enjoy the wonders of Radio

THE HOLTZER-CABOT ELECTRIC CO.
 125 Amory Street, **Boston, Mass.**
 6161-65 South State Street, **Chicago, Ill.**
 Dept. A

Holtzer-Cabot
 BUSINESS ESTABLISHED 1875

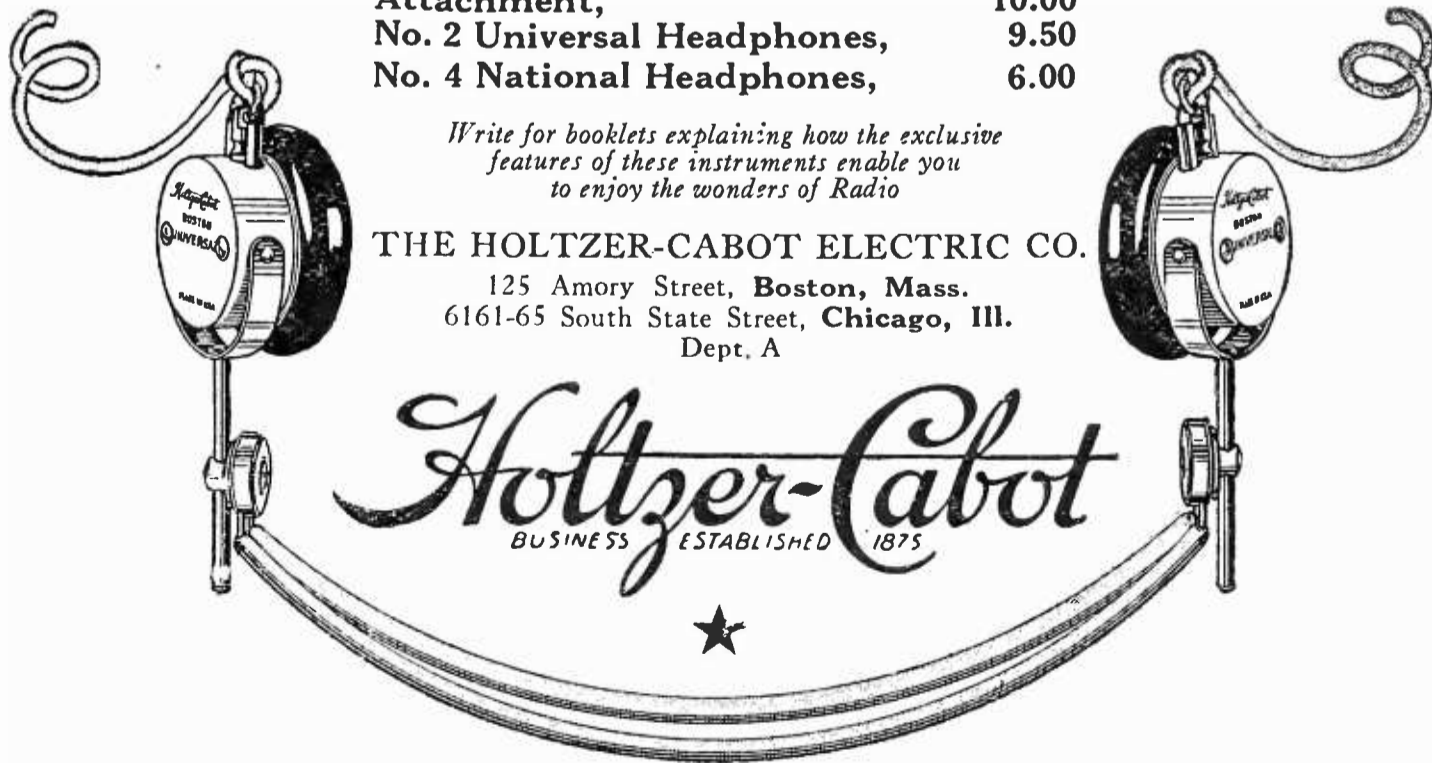

★ Tested and approved by RADIO BROADCAST ★

More About the Super-Heterodyne

ARTICLES have appeared in this magazine on the super-heterodyne receiver in the February, August, November, December, 1923, issues, as well as in January and March, 1924. There will be another important article in our April number.

Since all of these articles, except that of Mr. Paul Godley in February, 1923, and that of Mr. Walter van B. Roberts in August, 1923, specify intermediate frequency transformers—type UV-1716—which have become difficult to purchase, many eager experimenters have not been able to build one of these sets. Transformers are now appearing on the market for this purpose. In our April issue, we will publish the details of transformers which may easily be built, which will effectively replace the UV-1716 and others necessary for the super-heterodynes we have described.

On page 347 of our August, 1923, issue, Walter Roberts describes the windings and characteristics of a suitable intermediate frequency amplifier which will work quite satisfactorily.

Mr. Godley's article in February, 1923, was introductory, showed fundamental circuits of an excellent receiver he built. In August, 1923, Mr. Roberts described a six-tube outfit with UV-199 tubes, of which he writes: "this receiver has all the advantages of the super-heterodyne control, the neutrodyne type amplifier, and the "reflex" system rolled into one."

In Mr. George Eltz's two articles, he describes in December, how to make a "super" out of extras around the laboratory. In his November, 1923, contribution, he describes a seven-tube outfit which has been very neatly installed and arranged.

Mr. Haynes in January, 1924, and in this present issue, has described his seven-tube super, avoiding the use of the unobtainable UV-1716 transformer. In our Lab section for the April, 1924, issue, we will have an article describing how to make a satisfactory intermediate frequency transformer, which may be used in the Haynes super-heterodyne circuit, as well as information on the super-heterodyne for 100 meter reception.

How Spark Interference Was Reduced

By JACK BINNS

Radio Editor, *New York Tribune*

MUCH of the interference encountered by broadcast listeners comes from commercial spark stations which use the wavelength of 450 meters. The recent conference at New York, presided over by Arthur Batcheller, Supervisor of Radio, Second District, which abolished this wavelength, was called as a result of the interest of the Radio Club of America and its President, George Burghard.

The agreement by which the 450-meter wave was abandoned and most ship to shore communication moved up above 600 meters came as a direct result of the personal interest which President Coolidge has taken in the entire radio art. This interest commenced when his address to Congress was broadcast. Shortly after that a committee headed by George E. Burghard, president of the Radio Club of America, called upon the President to bring to his attention the serious interference caused by ship to shore communication on the 450-meter wave. The committee pointed out to the President that the 450-meter wave was only used by the United States and was not authorized under the International Radio Convention.

This agreement, however, is entirely voluntary and has no binding force. The radio inspector cannot legally enforce it, so that at any time, any of the operating companies may violate, it should occasion arise.

In view of the tremendous improvement which

has been effected as a direct result of the agreement, steps should be taken immediately to see that it is embodied in an act of Congress that will give the full force of the law behind it. In this connection, every radio fan should write to his particular representative, urging the enactment of such a rule.

Since the new order went into effect, officers of the Radio Club of America have been carrying on a very careful study of the resulting situation, particularly to determine just how much interference has been cut down. The survey included constant listening-in to distant as well as local programs with highly sensitive receivers such as the super-heterodyne. This work has been carried on by the officers of the club, including Major E. H. Armstrong.

IMMEDIATE IMPROVEMENT

IN OUTLINING results, George E. Burghard, president of the club, said: "The effect of the agreement became apparent immediately, especially on the higher wavelengths used by the broadcasting stations in different parts of the country. For instance, in the City of New York, with a super-heterodyne receiver, we have been able to reproduce, with a great deal of regularity, the programs from station KSD, in St. Louis, which operates on the wavelength of 546 meters. This reception has been done with practically absolute freedom from spark interference.