

"Roxie's" Own Story

# RADIO BROADCAST

Four Complete "How To Make It" Articles

A Broadcasting Service

From Your Lamp Socket

With MacMillan in the Arctic

Choosing the Proper Rheostats

for the  
Tubes  
You Use

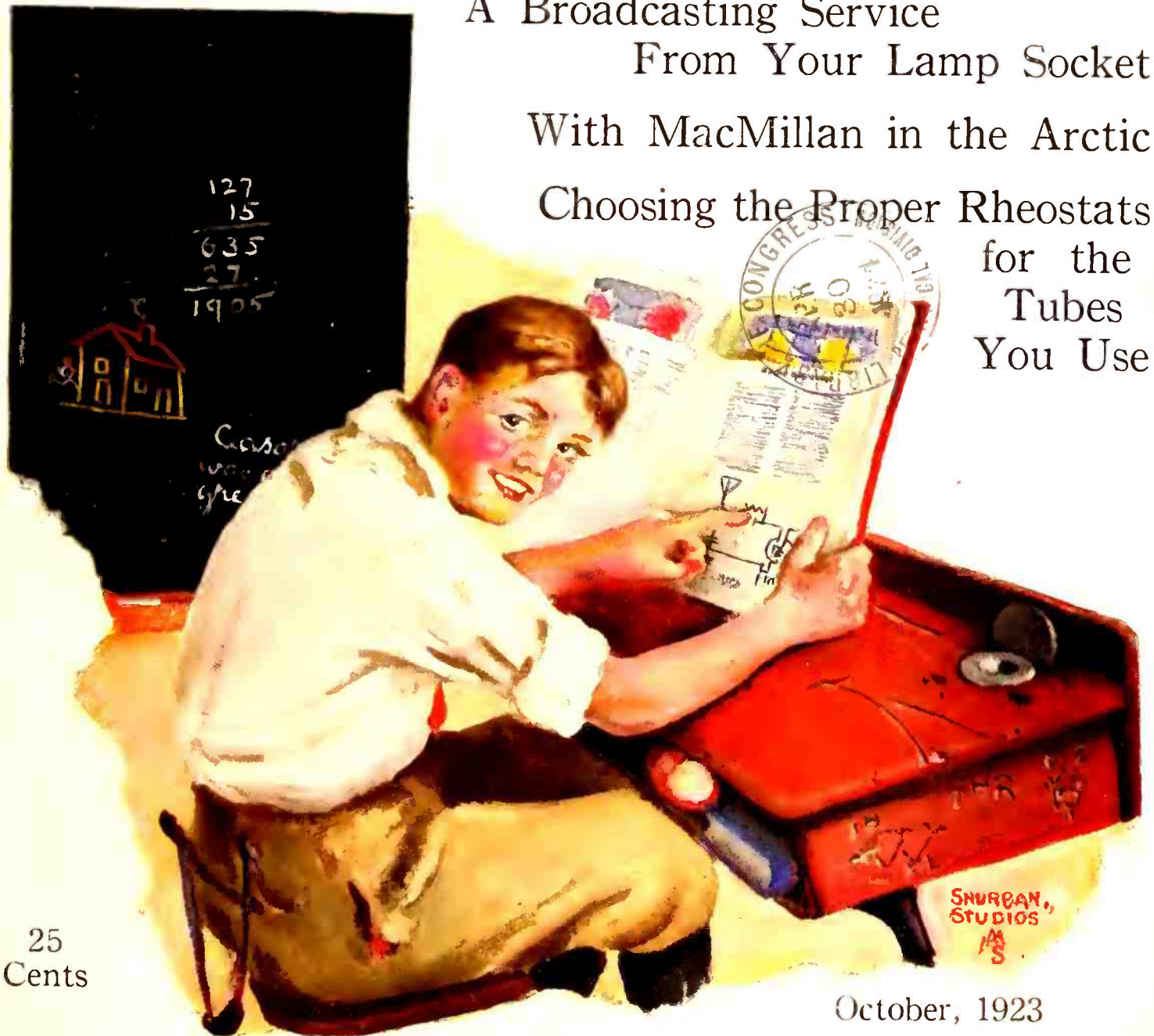

25  
Cents

October, 1923

Published by

DOUBLEDAY, PAGE & CO.

Garden City, N. Y.

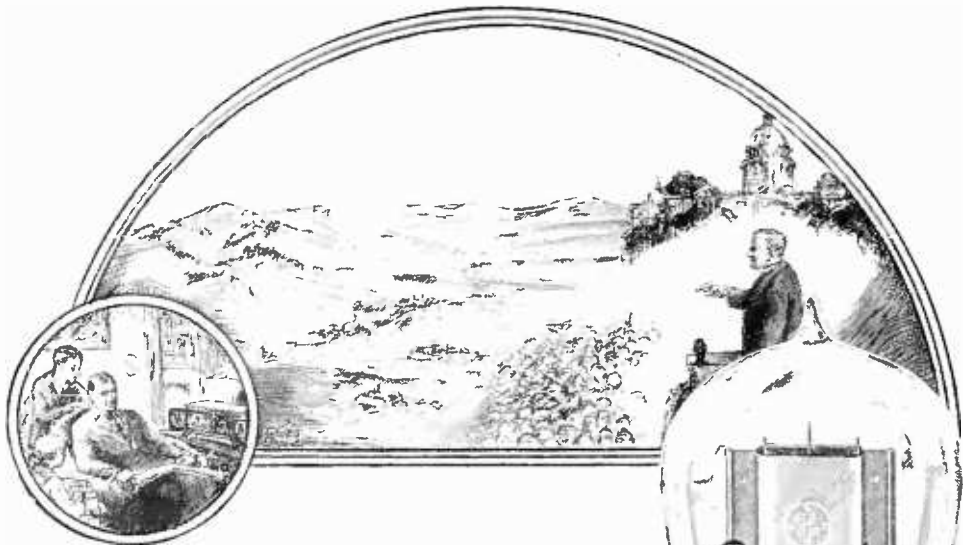

## Carries Great Messages Around the World

**T**HAT statement adequately expresses what is perhaps the greatest influence of radio in developing and bettering human fraternal interest—not only between people of one community, of one country, of one state, or even a single nation, but between all nations and all peoples of the world.

Be these messages from government leaders—from the heads of the world's greatest educational institutions or from those who stand foremost in the arts of the world—they will serve to bring the human race into closer contact.

In the past ages great orators and writers, famous poets and musicians have swayed the destinies of nations, and have been instrumental in the rise and downfall of mighty empires.

In the future these same influences of similar great minds will, through radio, create a better understanding and a greater fraternal spirit between the people of the nations.

It is the vacuum tube that has made possible this broad and far reaching application of radio telephony, and that plays the most important part in the operation of your receiving set.

Cunningham Vacuum Tubes, standard for all makes of receiving sets—built by one of the world's largest manufacturers with unlimited resources—are the product of years of manufacturing experience and the creative genius of the engineers of that great scientific organization, the Research Laboratory of the General Electric Company.

### Cunningham Radio Tubes

C-301A—6 Volts ¼ amp. Amplifier . . . . .	\$6.50
C-299—3 Volts .06 amp. Dry Battery Det. & Amp . . . . .	6.50
C-300—6 Volts Gas Con- tent Detector . . . . .	5.00
C-11—1.1 Volts .25 amp. Dry Battery Det. and Amp. Special Base . . . . .	6.50
C-12—Similar to C-11 with standard base . . . . .	6.50

### Patent Notice:

*Cunningham tubes are covered by patents dated 11-7-05, 1-15-07, 2-18-08, and others issued and pending. Licensed for amateur, experimental, and entertainment use in radio communications. Any other use will be an infringement.*



## CUNNINGHAM National Tube Week

September 24 to  
October 1, 1923

*\$5000 in Cash Prizes  
to Radio Dealers*

*A. J. Cunningham Inc.*

**Home Office:**  
248 First Street  
San Francisco, Calif.

154 West Lake Street  
Chicago, Illinois

30 Church Street  
New York City, N. Y.

★ Tested and approved by RADIO BROADCAST ★

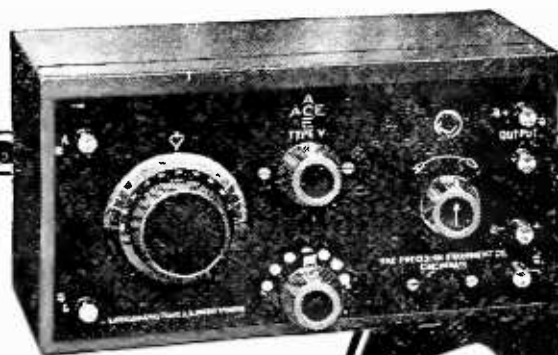

Licensed under  
Armstrong U. S. Patent  
No. 1,113,149



## A Highly Efficient Set at a Moderate Price

Here is an inexpensive set that receives signals clear and distinct. It is a long range regenerative, radio receiver and under ordinary conditions stations from coast to coast are heard. We have many letters from owners praising the efficiency of the Ace Type V.

The low cost of this set in addition to its remarkable simplicity of operation increases its popularity among radio fans day by day.

A loud speaker can be operated in connection with the Ace Type V by adding an Ace Type 2 B, a new two-stage Audio Frequency Amplifier, which sells for \$20.00. With this addition, music or voice can be heard distinctly all over the room or house.

The modest price of this set makes it possible for everyone to enjoy radio. Don't be without radio entertainment any longer—get an Ace Type V and listen to the world's best musical concerts.

### The Precision Equipment Company

Powel Crosley Jr., PRES.

1020 Vandalia Avenue, Cincinnati, Ohio

*Armstrong  
Regenerative  
Receiver*



If your dealer cannot supply you, order direct, mentioning his name. Ask for "Simplicity of Radio." Your copy is *Free*.

DEALERS: Write on your letterhead for attractive sales proposition.

★ Tested and approved by RADIO BROADCAST ★

# Radio Broadcast

ARTHUR H. LYNCH, EDITOR



## CONTENTS FOR OCTOBER, 1923

<i>Major-General George O. Squier</i> - - - - -	<i>Frontispiece</i>
THE MARCH OF RADIO - - - - -	J. H. M. 447
A BIT ABOUT MYSELF - - - - -	("Roxie") S. L. ROTHAFEL 458
GIVING THE PUBLIC A LIGHT-SOCKET BROADCASTING SERVICE	
	WILLIAM HARRIS, JR. 465
WHEN THE BUG BIT IN SAMOA - - - - -	QUINCY F. ROBERTS 471
IN THE WAKE OF THE CONTEST WINNERS - - - - -	477
A Better Broadcast Receiver - - - - -	(Honorable Mention) ARTHUR L. MUNZIG 477
A Set You'll Like To Make - - - - -	(Honorable Mention) FRANK NELEM 480
A Set With a Tuned R. F. Amplifier - - - - -	(Honorable Mention) J. W. DENNING 484
A Home-Made Three-Tube Outfit - - - - -	(Honorable Mention) L. REITH 486
Summary of Receiving Contest Entries - - - - -	489
A NEW STATION AT WASHINGTON, D. C. - - - - -	PIERRE BOUCHERON 494
RHEOSTATS FOR THE TUBES YOU USE - - - - -	ZEH BOUCK 496
WITH MacMILLAN AND RADIO, NORTH OF CIVILIZATION	
	E. F. McDONALD, JR. 500
WHAT BALLOON RACERS DID WITH RECEIVING SETS - - - - -	507
WHAT YOU SHOULD KNOW ABOUT CONDENSERS, II	ALLEN D. CARDWELL 510
TRUE PIANO MUSIC FROM A NEW MICROPHONE - - - - -	516
WHAT OUR READERS WRITE US - - - - -	517
IN THE R. B. LAB. - - - - -	520
ADDITIONAL BROADCASTING STATIONS IN THE UNITED STATES - - -	523
NEW EQUIPMENT - - - - -	524
THE GRID—Questions and Answers - - - - -	526
AMONG OUR AUTHORS - - - - -	534

Copyright, 1923, by Doubleday, Page & Co. All rights reserved  
TERMS: \$3.00 a year; single copies 25 cents

F. N. DOUBLEDAY, Pres.	ARTHUR W. PAGE, Vice-Pres.	NELSON DOUBLEDAY, Vice-Pres.
RUSSELL DOUBLEDAY, Sec'y.	S. A. EVERITT, Treas.	JOHN J. HESSIAN, Asst. Treas.

## DOUBLEDAY, PAGE & CO.

THE WORLD'S WORK	COUNTRY LIFE	THE GARDEN MAGAZINE	SHORT STORIES	EDUCATIONAL REVIEW
CHICAGO: People's Gas Bldg.	GARDEN CITY, N. Y.		NEW YORK: 120 W. 32nd Street	
BOSTON: Tremont Bldg.	LOS ANGELES: Van Nuys Bldg.			



**FORMICA**



is used in the new  
**FREED-EISEMANN**  
*N R Neutrodyne\* Receiver*

**T**HE panels of the new Freed-Eisemann Neutrodyne Receiver are Formica. This is natural because Freed-Eisemann have long been consistent users of Formica in all their past radio products.

It is the endorsement of leading radio concerns of this caliber from one end of the country to the other that makes Formica so staple and desirable a product for the radio dealer to handle. Amateurs know and want it.

Formica panels may be had promptly in *any desired size*. It isn't necessary to take a size that some one else wants to sell.

THE FORMICA INSULATION COMPANY  
 4628 Spring Grove Avenue Cincinnati, Ohio

*Sales Offices*

50 Church St.	New York, N. Y.	1210 Arch St.	Philadelphia, Pa.	414 Finance Bldg.,	Cleveland, Ohio
422 First Ave.	Pittsburgh, Pa.	1819 Lyndale Ave.,	S. Minneapolis, Minn.	9 S. Clinton St.	Chicago, Ill.
1042 Granite Bldg.,	Rochester, N. Y.	Sheldon Bldg.	San Francisco, California	313 Title Bldg.	Baltimore, Md.
415 Ohio Bldg.	Toledo, Ohio	Whitney Central Bldg.	New Orleans	47 King St.	Toronto, Ontario

Reg. U. S. Pat. Off.

**FORMICA**  
 Made from Anhydrous Redmanol Resins  
**SHEETS TUBES RODS**

★ Tested and approved by RADIO BROADCAST ★



**MAJOR-GENERAL GEORGE OWEN SQUIER**

Chief Signal Officer of the U. S. Army, whose experiments in "wired wireless" have made possible a practicable, paying service which will furnish "subscribers" with news, entertainment, and educational matter. Such a service is already being successfully operated on Staten Island, N. Y. (See page 465)

# RADIO BROADCAST

Vol. 3 No. 6



October, 1923

## The March of Radio OCEAN TO OCEAN BROADCASTING

**A**LTHOUGH it is not to be expected that developments in radio will rush to greet us every month (for it is bound to happen, now and then, that radio, like any other development, marks time), nevertheless several of the events which came to our attention during the past month do indicate the orderly progress of the art. Especially is this the case with the plans made for the rôle which radio was to play on the night when our late President was scheduled to address, personally, an audience in the Civic Auditorium in San Francisco, and, by land lines and radio, another audience "measured in the millions." We get so used nowadays to hearing of radio audiences measured in millions, that such an announcement scarcely arouses interest; but in this case it should, because this prospective audience undoubtedly was of this size. It is so easy to say that at least one person out of a hundred in our country *must* be listening in on a radio set, and that, inasmuch as there are a hundred million people in the land, the audience must be a million!

It is extremely doubtful if an audience of a million persons had ever been possible before this demonstration was arranged. The audience which would have listened to the President, had not his fatal illness prevented it, was not to have been the clientèle of one station—there were to have been *six* broadcasting stations, from Coast to Coast, actuated simultaneously by the President's voice. To think of a low, well-modulated voice being thrown out into the air

at such strategic points that it is heard at the same instant over the whole land—one man quietly addressing, intelligibly, a million of his fellows! In the olden days it required no such feat as that to be classed as a miracle.

If this plan had gone through, a peculiar effect might have been observed by an experimenter located somewhere about the middle of our country. The transcontinental telephone line, over which the voice currents were to travel to actuate the stations on the Eastern Coast, is partly of the "loaded type." To keep the voice currents from being wasted to an excessive degree as they take their long journey it is necessary to put iron-cored coils in series with the wires at regular intervals—every few miles for overhead lines and every mile for cables. The electric current travels over such a loaded line less rapidly than it does over a pair of ordinary overhead wires. For two copper wires, supported on poles by good insulators, the speed of the signal is practically the same as that of light—186,000 miles a second. In the loaded line, however, the coils slow down the current to the extent that it takes about one-fifteenth of a second for the signal to travel from San Francisco to New York. If, then, a listener with a good set, located about half way between these two points, should be able to tune in on a West Coast station at the same time as he did on an East Coast station, that voice from the East would arrive in his ears one fifteenth of a second later than that from the West: the voice

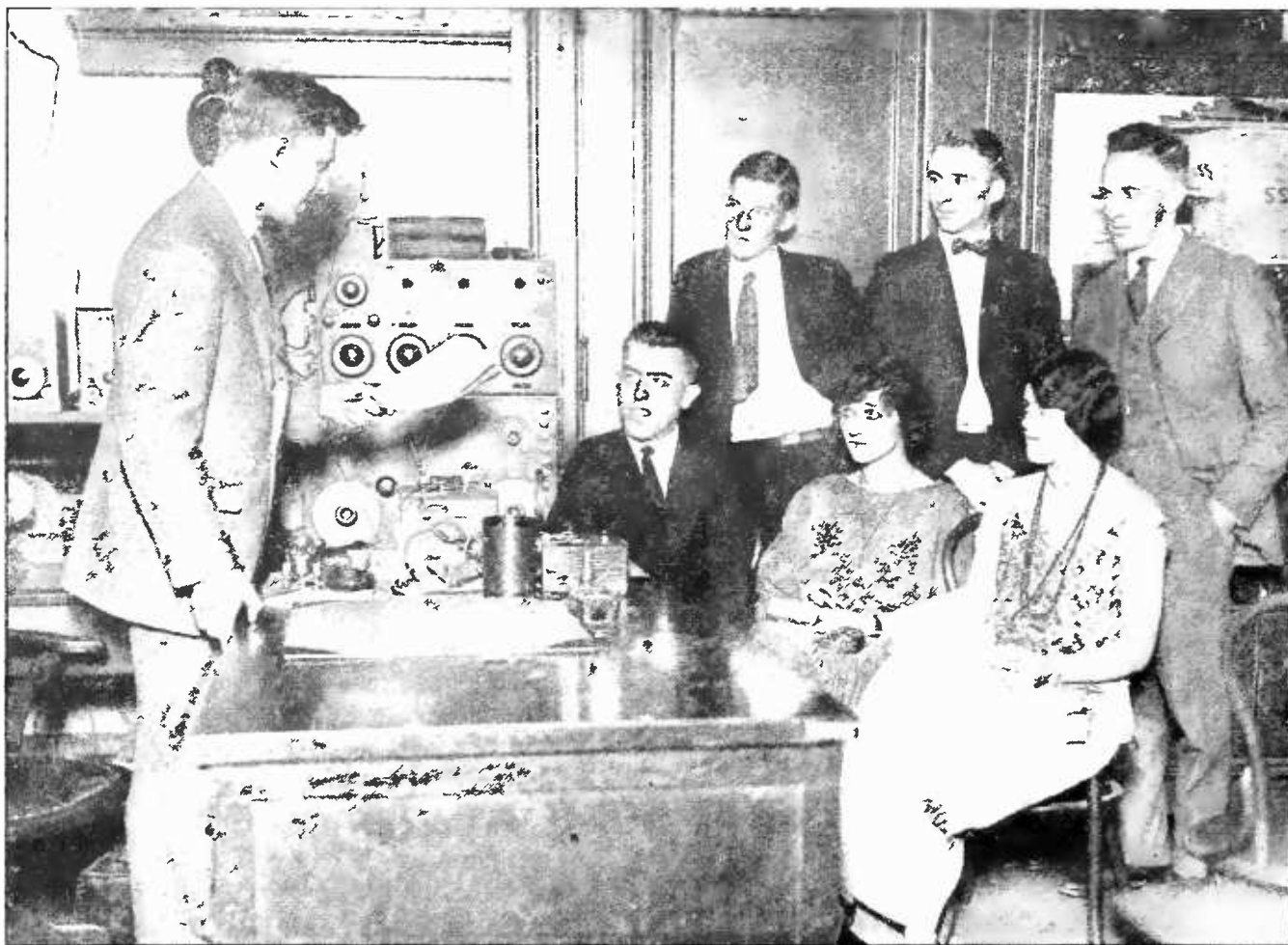

#### LAYING DOWN THE LAW TO PROSPECTIVE AMATEUR OPERATORS

When the successful applicant in New York passes his test for an operator's license, he is given a talk by J. W. Swanson, Radio Inspector, who is seen at the left. The incipient ham is asked not to transmit during broadcasting hours, be on the alert for SOS signals, and generally maintain the best traditions of the amateur

from the New York station would sound like an echo from the San Francisco station. Since the test was not carried out, however, no one had the opportunity of hearing such a phenomenon.

#### The Telephone Company's Part in This Work

IT IS interesting to us that our guess as to the reasonable and probable development in radio broadcasting is so quickly being vindicated. That the development and execution of this new form of communication would undoubtedly be carried out by the great research and engineering staffs of our nation-wide communication organization—The American Telephone and Telegraph Company—seemed to us the only logical possibility. This company has spent a tremendous amount of money in training its research staff and in accumulating information essential in the field of speech transmission. Any other organization would

necessarily have to incur similar expense to be on an equal footing in the game, and even if this uneconomical step should be decided upon it would still be a long way behind the Telephone Company in the race for new and better accomplishment.

It seems assured that radio broadcasting must necessarily be completely interlinked with the wire network covering our country; we cannot conceive of it growing independently here and there over the land, in isolated spots. This is not the way it will really develop into a country-wide service. No matter how good the isolated stations may be they must still play a minor rôle in the tremendous field which radio is destined to fill.

It is a very good thing for the art that there are so many excellent stations operating independently of the Telephone Company; competition makes for greater progress and stimulates the engineers and managers to produce better and better programs, all of which ben-



efits the listening public. These independent stations cannot perform the same service, however, as a network of stations, scattered all over the country and interconnected for operation by the same voice. It is this possibility that gives to radio broadcasting its great potential value and importance; the Chief Executive addressing the country is no longer a dream, it can be accomplished to-day.

By using part of their transcontinental, high-quality, telephone line, the telephone engineers were ready to deliver, the President's voice all the way across the country with imperceptible distortion. At San Francisco, Omaha, Chicago, New York, and Round Hill, the modulators of the radio stations were regulated to function as well as though the speaker were personally in the studio. Three thousand five hundred miles of telephone line were to be tied up in the demonstration, a fact which shows at once how it is that radio broadcasting must become an integral part of the rest of the country's communication scheme.

### Simplified Receiving Sets

**D**URING the past year, nearly every issue of a radio journal or newspaper has brought glad tidings of a new and more efficient receiving circuit. We long ago stopped trying to keep a record of these supposedly novel ways of using a vacuum-tube detector, because it seems that in the end, after all the required refinements are made, they amount to about the same thing. Experts tell us that it makes but little difference what circuit is used—that if sufficient skill and intelligence are displayed in properly proportioning the various parts, practically the same results can be obtained with any of the recommended circuits. This seems a logical conclusion to one understanding the principle of the vacuum tube, yet many times the enthusiast solemnly declares one circuit is incomparably better than the one he has been using (and which he recommended to us only a few days before) and which we haven't yet had time properly to try out. We have one ac-

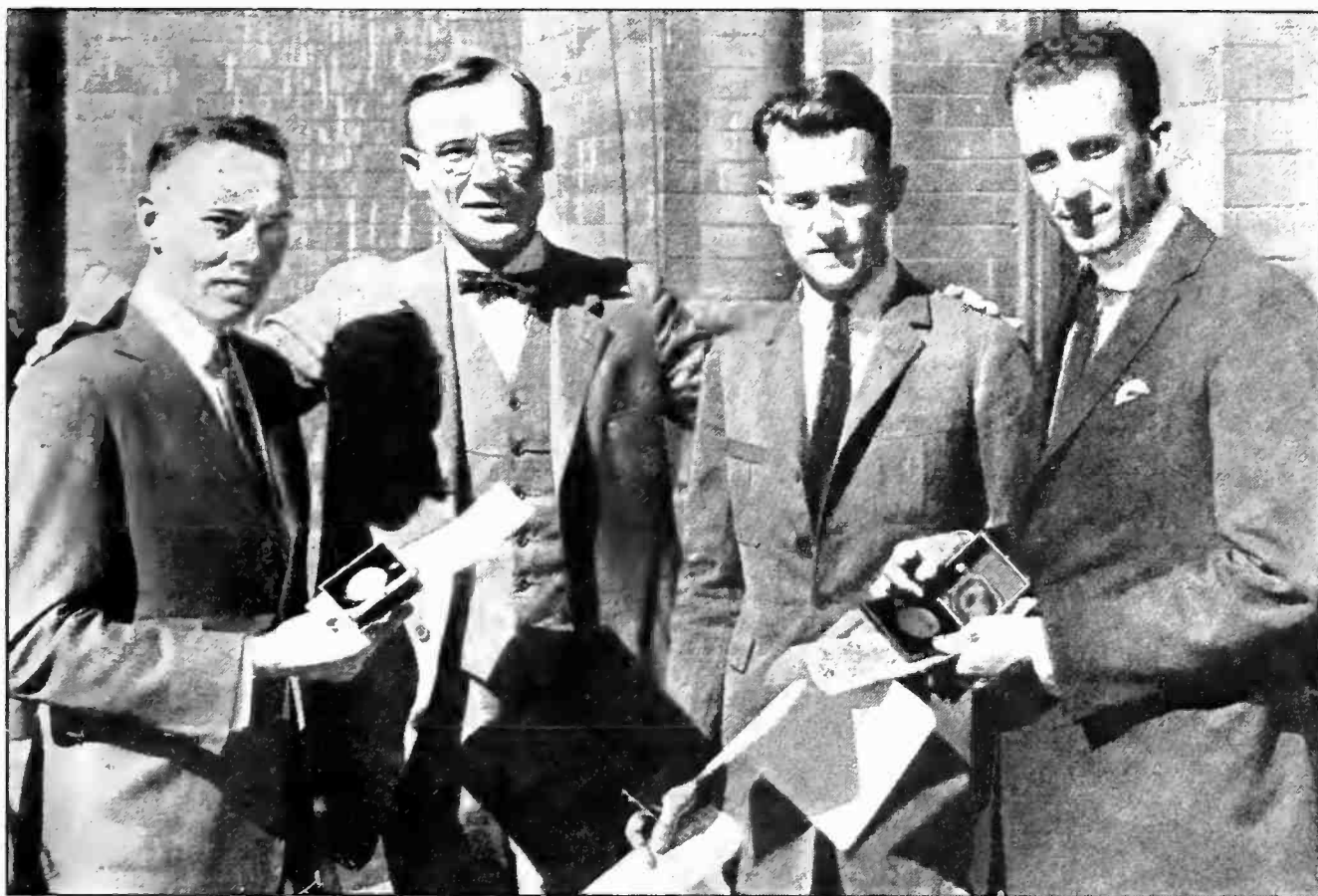

THE FIRST THREE HEROES TO RECEIVE THE RADIO MEDAL

The award of this medal is restricted to wireless operators, and the first three were presented to the three operators of the *City of Honolulu* which burned and sank in the Pacific last spring. Mayor Cryer of Los Angeles made the presentation for the Radio Corporation of America. Left to right: N. C. Kumler, Mayor Cryer, Walter P. Bell (Chief Operator), and H. D. Hancock

quaintance whom we have dubbed the "circuit shark." He can draw out at any time practically any circuit which has been shown to him; it seems as though his brain must be filled with short circuits with all those connection schemes loaded one on top of the other. His last circuit is always the best. Probably all of you number someone like him among your acquaintances.

However much various circuits of the same general kind measure up to one another as regards their sensitiveness, it is a fact that one particular circuit may be much superior to another in the ease with which the requisite adjustments can be carried out. In this we see a great chance for improvement in the future receiver; surely the one-dial receiver is bound to come. The average non-technical man cannot be expected to acquire the skill demanded by the very sensitive sets, requiring the simultaneous adjustment of perhaps four dials, condensers, coils, filament current, coupling, regeneration, and what not. Many people don't care for the tinkering part of the job; they want the sets for

the programs they bring in. For such listeners, the manipulation of the set should be the simplest possible. The popular Westinghouse RC receiver was a good attempt to simplify the adjustments required with a regenerative set but this still leaves much to be desired. It requires considerable skill to get the best results, and furthermore has the bad feature of re-radiation from the antenna.

As we look at the various good sets available to-day it seems that the difficulty of proper adjustment is a necessary result of trying to get the very best results out of each tube in the set—naturally a very desirable condition. But, if much can be gained in simplicity by sacrificing some of the sensitiveness of the tubes, it should be worth while. As the present tubes use so little power for the filament and plate, the increase in upkeep of a set having, say, two more tubes than the present sets, would not be great. It seems to us that a set having radio- and audio-frequency amplification, without regeneration, must be possible in such a design that the only

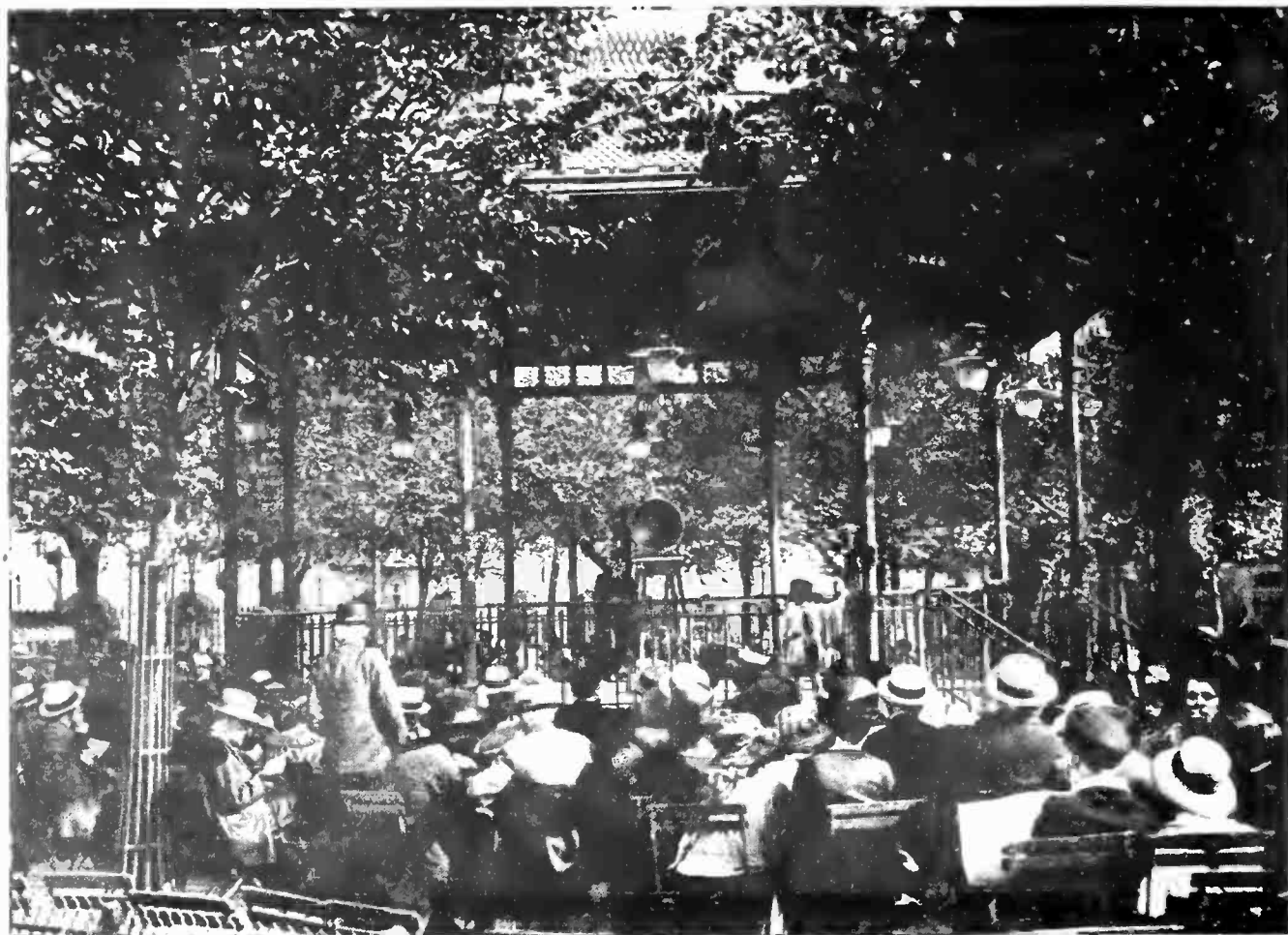

#### RADIO CONCERTS IN PLACE OF PUBLIC BANDS IN PARIS

Here is a crowd gathered about one of the old band stands on the Champs Élysées, listening to music from the Eiffel Tower station just across the river

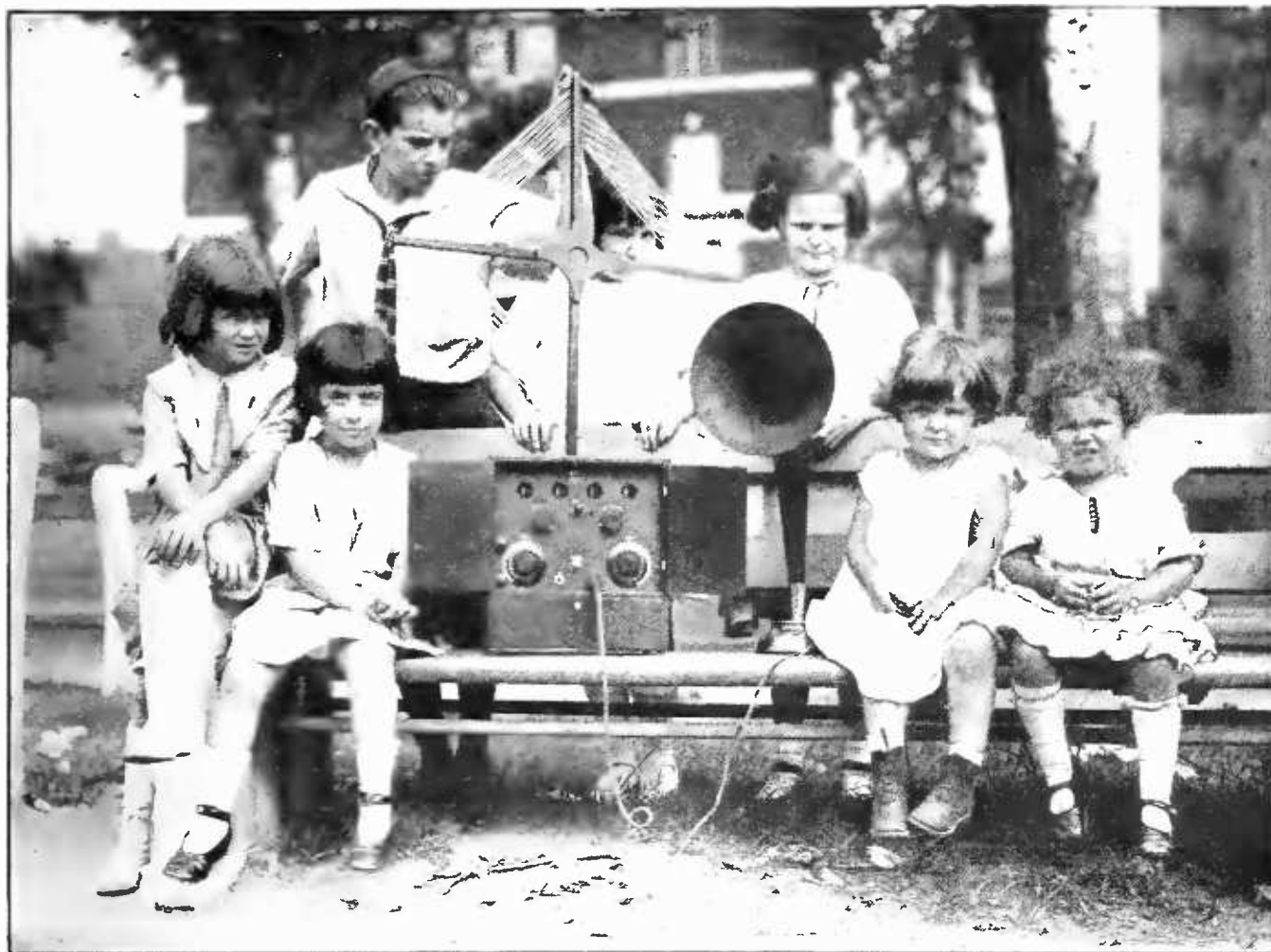

THE PROGRAM DOESN'T SEEM TO AGREE WITH CURLY HAIR  
All the other "members of the radio audience," however, seem gravely attentive to the output of the receiver with which they are being entertained in Central Park, New York

adjustment required is the one dial tuning the antenna circuit—the antenna being a loop. A good loop antenna is sufficiently selective, both because of low resistance and directive qualities, to tune out ordinary interference, and such an antenna with three steps of untuned radio-frequency amplification with two steps of audio-frequency amplification should be sufficiently sensitive to bring in any station within reasonable distance.

If such a set is not practicable, then a superheterodyne outfit should be possible which with about seven tubes would give all the volume and all the selectivity desired. Such a set is feasible with only one adjusting dial, and although the first investment for tubes would be high, it seems that it would be worth while for the average radio customer to-day. To do away with the tinkering—simply to turn one handle to a definite, marked point and get the station wanted, if it is transmitting—that is the kind of a set which will probably find a good deal of favor in the future.

### The Size of Radio Audiences

**I**N TWO circulars emanating from the news bureau of the General Electric Company, there is given some interesting information which illustrates the optimism of the broadcasting station manager—information which enables us to picture quite well the distribution of the radio audience of such a powerful station as WGY, Schenectady, N. Y.

In the first circular we learn that WGY has received in all 65,000 letters from its enthusiastic listeners, since the inauguration of broadcasting activities sixteen months ago. These letters come from points as widely separated as Hawaii and England and as Vancouver and Valparaiso. With such landmarks to delineate his nightly audience, it is no wonder the manager counts his listeners by the million.

We learn that "there are at least 2,000,000 radio sets in the country and of that number 1,500,000 are almost nightly within range of

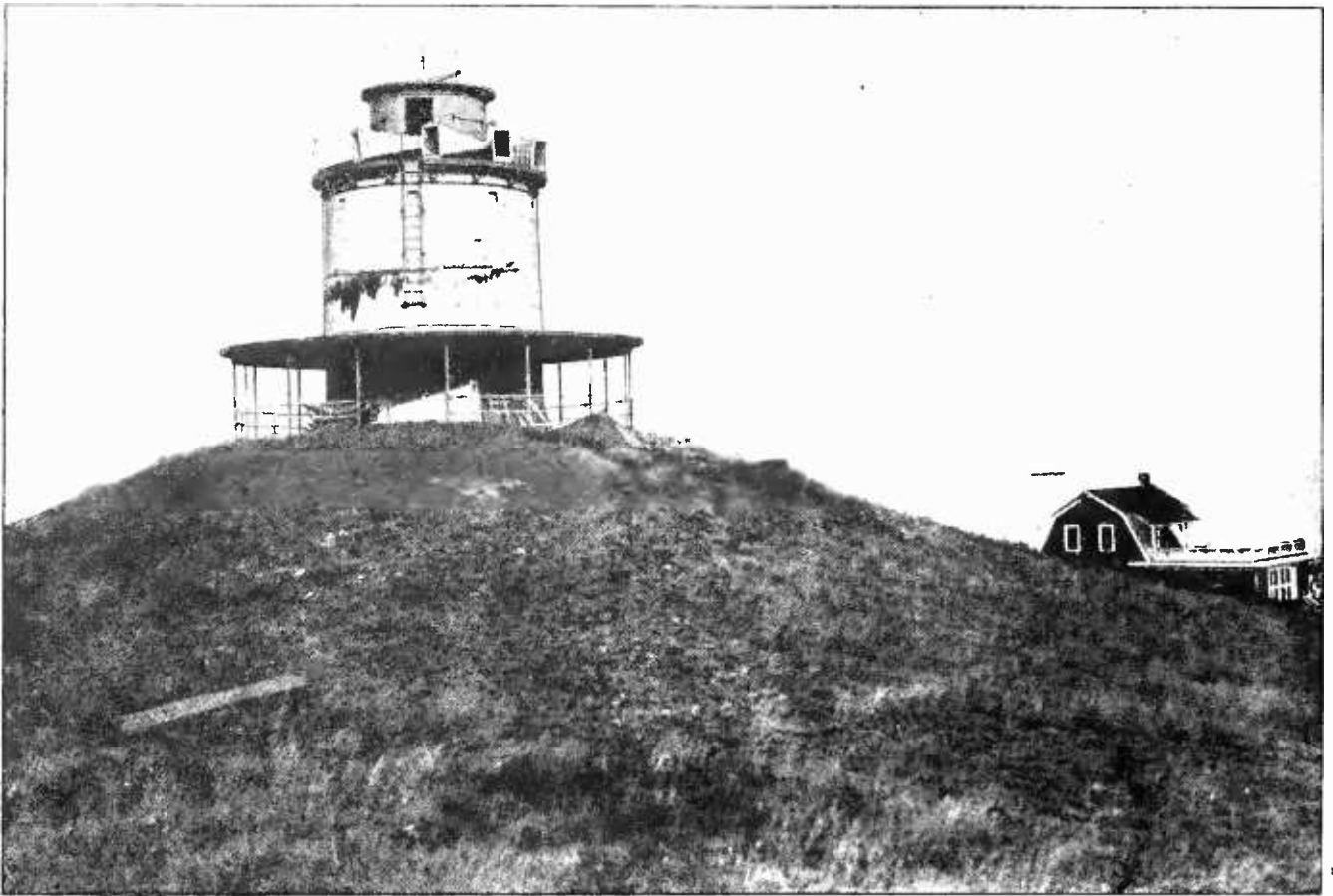

PEOPLE SIX MILES AWAY OBJECTED TO THIS LOUD SPEAKER

Programs were sent out on sound waves from this tower over the whole countryside by Colonel Edward H. R. Green, son of the late Hetty Green, of South Dartmouth, Mass. Residents over in Nonquitt were not so keen as was the Colonel, however, for this unusual volume of sound, and accordingly the concerts were discontinued

WGY." Even with no further data to establish a judgment, one would be entitled to the conclusion that in Schenectady some optimism-giving fluid must still be obtainable; and in the other circular a very interesting bit of information is contained in these words: "After a recent minstrel show broadcast by WGY, 1400 letters were received by the station within 24 hours. Over 2000 letters were received within a week, referring to this particular entertainment." Now these two sentences furnish us with apparently reliable data as to the distribution of WGY's audience, and incidentally that of any similar station.

As no mail collections are made late in the evening (after the radio concert) all of these 1400 letters must have started on their way to WGY's manager the next morning,—and they all reached him that same day, *after a necessarily short journey!* It would appear that they could not have travelled more than perhaps 200 miles if they were to be delivered in Schenectady the same day, so it seems reasonable to believe that 70 per cent. of the audience of WGY, one

of our most powerful stations, is not more than about 100 miles away from the station. In view of the first statement quoted, this would lead one to believe that of the "2,000,000 sets in the country," 1,500,000 of them are in the vicinity of Schenectady. We are willing to admit the attractiveness of certain parts of this country town, but surely the radio station's manager is over-enthusiastic about it when he puts about half the country's radio listeners within a short day's journey of his city. Well—such optimism is what makes the news look attractive.

De Forest Company Beaten by the  
Westinghouse Company

**A** BOUT ten years ago, Armstrong was granted the patent on vacuum-tube operation which was destined to play an important part in the commercial development of radio in the coming decade. Many of us didn't then appreciate the commercial possibility of the patent—in fact it would have taken a man with a super-imagination to pic-

ture, then, the radio development which was to take place during that span of years. From five thousand sets to five million—that simple comparison gives very nearly the relative numbers of radio listeners, and of course also indicates the increase in the value of such a patent as Armstrong was granted. Roughly speaking, this fundamental patent, which has been interpreted by the Courts to cover any scheme which makes possible the transfer of the B battery energy back into the grid circuit, has thus increased in value a thousand fold during the less than ten years of its life.

In the early days of the patent, of course, broadcasting was unknown as we have it today, and practically the whole value of the patent lay in the possibility of selling regenerative sets to the radio amateur; but the radio amateur, it developed, isn't a very good customer for complete sets, because, after he knows how, he generally prefers to build his own. Because of this situation Armstrong was not then able to realize much on his idea. Seventeen companies did agree to make regenerative sets under a license granted them by Armstrong for a nominal fee, his returns to be had from royalties on the sales of the manufacturing companies.

These licenses were rather restricted in that they limited the activities of the manufacturing

companies to making and selling sets for amateurs, experimenters, and scientific schools—moreover the licenses were not transferable. In those days, De Forest probably did not appreciate the value and uniqueness of Armstrong's patent. Apparently he thought he could do as well himself in the patent office, so he did not consider it worth while to take out a license. His attitude is perfectly easy to understand—a pioneer of his standing, having undoubted right to the audion patents, applying to a young student for permission to use his own device in a circuit very similar to that he had always used, and to pay money to the young student, who had frequently publicly challenged De Forest's understanding of the action of the audion, for permission to put an extra coil or condenser in his circuits—this must have seemed out of the question to the inventor of the audion, and he didn't do it.

As a result, a few years later he found his company rather embarrassed in the competition for the radio-receiver market. People wanted a regenerative set because the technical press told them this was the only reasonable set to purchase. As the patent had in the meantime been acquired by the Westinghouse Company for a goodly sum, he found that the valuation placed on a license had gone up by leaps and bounds so that it seemed now not a question of pride, but



THE RADIO CORPORATION'S NEW MESSAGE CENTRE AT 64 BROAD STREET, NEW YORK

In this room, messages are exchanged at high speed between America and France, Norway, Germany, and Great Britain via the great transmitting station at Rocky Point, L. I. and the receiving station at Riverhead, L. I. The wavelengths used are from 10,000 to 20,000 meters



ANOTHER RECORD FOR THE "LEVIATHAN"

Chief Radio Officer Pickerill and his assistant, A. C. Tamburino, are holding some of the 4000 messages sent and received during the vessel's first trip to Europe and back since her reconditioning

## The *Leviathan* Breaks Some Records

ACCORDING to an announcement of the Western Electric Company, the radio apparatus installed on our largest liner has set a new mark for merchant-marine radio. The ship not only broke all previous communication records by transmitting 15,000 words a day, to and from shore, but managed to keep in constant touch with land radio stations from one thousand to thirteen hundred miles away. By means of new apparatus specially designed for it, the *Leviathan* operated simultaneously, for long periods of time, two different sending and receiving sets. The steamship carries four antennas,

two for sending and two for receiving.

### A Radio Blind Spot

rather of finances, in acquiring a license. Again he didn't do it. A possible loophole was, however, still left to him—to absorb one of the small concerns which had obtained a patent license and thus market his wares through a properly licensed company. This was apparently done, and various other methods of making the best of a rather disadvantageous situation were subsequently attempted.

Under a decree recently issued, the U. S. District Court of New Jersey decided the case against the De Forest Company and the Radio Craft, Incorporated (the small company which, although retaining its name, had been essentially absorbed by the De Forest Company). The verdict of the Court was in favor of the owner of the patent, the Westinghouse Electric and Manufacturing Co.

The Court's decision also contained a warning for those unlicensed companies which have been putting out non-regenerative receivers so built that they might readily be changed into the regenerative type by the addition of a simple connection, or by a similar subterfuge. This perfectly just and proper decision of the Court emphasizes the advantage which the Westinghouse Company acquired in purchasing patent No. 1,113,149.

FROM far-away Oregon comes an interesting letter telling of experiments being carried out in the mountainous region of that state to find out definitely some of radio's reputed aversion for certain locations. Station KFAY is located in Medford, among the mountains of southwest Oregon. Its signals are heard as far away as Montana, to reach which they must travel right across the state. Directly in their path is the town of Prospect, only forty miles away from Medford—and yet the station is never heard in Prospect. The waves apparently jump right over Prospect in their haste to reach Montana! Tests at points around the "dead spot" seem to show it to be very definitely limited. At a point twelve miles past the dead zone the signals come in strong and clear. The question of bad grounds at one point and good grounds at others, has been taken up in the experiments.

We are gradually learning that such things really do exist, and many of our readers have probably experienced much difficulty in getting certain stations while other stations,

not so powerful, or more distant, come in with plenty of volume. It is worth while, therefore, to record such a phenomenon, when it is vouched for by the careful experimenters of KFAY, who sent us the account of the tests.

We mentioned quite some time ago that very careful measurements by radio engineers showed that the radiation from WEAJ was only one twentieth as strong in a certain direction as it was in others; that there was a kind of radio hole, actually mapped and measured quantitatively, for which the probable cause seemed to be the absorption of the signal by the steel structures of Manhattan. Of course, no such cause as this can be ascribed to the Medford station, as the skyscrapers haven't yet arrived in that city. It may be that there is a very large ore body around Medford playing pranks with the waves.

A knowledge of radio "blind spots" is well worth gaining; if the region is sufficiently important (as it is in the case of WEAJ) a small station could be located near the dead region and operated from the main station by land wires, thus giving local radiation to "fill up the hole."

Incidentally, the map of the country surrounding the station at Medford (sent to show the kind of country in which the effect occurred) is incorporated in a circular setting forth the attractions of southeast Oregon. Looking the circular over made us quite forget the trouble with radio waves, and regret that our vacation trip was already over. If these words happen to come to the attention of the Chamber of Commerce of Medford, they may feel assured of having procured at least one visitor in the near future, because, if they really have such fishing as the circular boasts, we shall probably bring our camping outfit along and stay in that exceedingly attractive region for quite some time.



CORNELIUS COLE, 101, AND RICHARD HEADRICK, 6, AT KHJ

### A Man Who Knew Lincoln

PRECEDING the hordes of strong men who swept across the western plains in the gold rush of '49 came Cornelius Cole. He found something more precious than gold in California—the joy of service to this country and to humanity.

The aged statesman and centenarian—he celebrates his 101st birthday in September—was a United States senator and a confrère of Abraham Lincoln in the dismal days of the Civil War. He was born on September 17, 1822, during the administration of President Monroe.

On July 3rd last, he sat in the studio of the Los Angeles *Times*' radio station, with little Richard Headrick, film actor and violin prodigy, 6 years of age, on his knee, and gave a graphic recital of his personal recollections of Lincoln. His words from a Los Angeles radio station, personally commemorative of President Lincoln, and his description of the law abolishing slavery, in which he took an active part,



© Underwood &amp; Underwood

## IN THE CRYSTAL STUDIO AT WJAZ

Guests at the Edgewater Beach Hotel, Chicago, can see the performers in the broadcasting studio through plate glass windows which are three-ply and hence absolutely sound-proof. The microphone is concealed under the lamp at the left of the picture

were a privilege which probably will never again be had. July 3rd was an anniversary of the Battle of Gettysburg and Mr. Cole told the radio listeners of his feelings as he sat on the platform a few feet from the Great Emancipator while the latter was sounding the phrases of his immortal Gettysburg address.

The sight of the venerable pioneer with the youthful "star" on his knee was something never to be forgotten by the guests in the studio.

## New Super-Cable

SOME time ago we quoted one of the telegraph executives as prophesying that the ocean cable was soon to have certain improvements which would discount the rapid strides transoceanic radio has been making. Although minor improvements are continually

being made in the receiving apparatus used with the ocean cable, little real progress has been made since radio started on its phenomenal advance. Contrary to what many people think, electric currents do not always travel with the speed of light; especially is this true, with the currents passing over the ocean's bottom through the gutta-percha-covered cables guiding them across. An appreciable fraction of a second elapses after the switch is closed in Europe, before the sensitive receiving galvanometer records the arrival of any current in America. Owing to the absorption of the electric charge by the rubber insulation, and a lack of an appreciable magnetic field around the cable, the maximum available speed of transmission is a comparatively few words a minute. The rubber insulation used has much to do with this slowness of travel, but this rubber is required to maintain the high insulation, otherwise the comparatively weak currents would all leak out into the

ocean before going far in the cable. If a stronger magnetic field could be set up around the cable, when it is carrying its signaling current, the speed of signaling might be considerably increased.

According to an announcement of Mr. Carlton, of the Western Union Telegraph Company, such a scheme is now available and is being installed by his company, in a cable which is to reach from the United States to Italy. The engineers of the Western Electric Company's research laboratories have discovered a new alloy which has such magnetic properties that a thin layer of it wound over the rubber insulation will increase the magnetic field around the cable many times, and thus make possible quicker signal transmission. Such a cable was suggested many years ago by a Danish engineer, Krarup, but the proper kind of iron was not then



available to make his idea feasible. The speed of signaling with this new cable will, according to Mr. Carlton, be several times as great as with the older type of cable.

### Is Wired Wireless the Future of Broadcasting?

**W**E HEAR from time to time about the experiments being carried on to show the feasibility of using high-frequency currents, sent over wires, to displace the present broadcasting scheme, in which radiated, as contrasted with guided, high-frequency power is used. This idea is generally credited to Major-General Squier, Chief Signal Officer of the U. S. Army, who carried on extensive experiments with "wired wireless" in Washington, D. C.

The attractive feature about this method of furnishing service is the ease with which revenue could be equitably collected for financing the scheme. The subscriber could pay for the evening's entertainment just as he now pays for the ordinary telephone service. Furthermore, there should be less interference with such a scheme than there is with the present broadcasting scheme. Certainly, such channels of communication as do require radio (ship-to-ship and ship-to-shore traffic), would have available more frequencies than they now have.

It is true that there is a tremendous plant in the form of telephone installations which work but a very small part of the time, so that any other service which can be furnished over the present wire system would be economically desirable—provided of course that it did not interfere with the present necessary service.

Granted however that carrier-current installation does offer possibilities for a new service over the wires—and the account, in this issue of RADIO BROADCAST, of the wired Radio Service Company's successful experiments on Staten

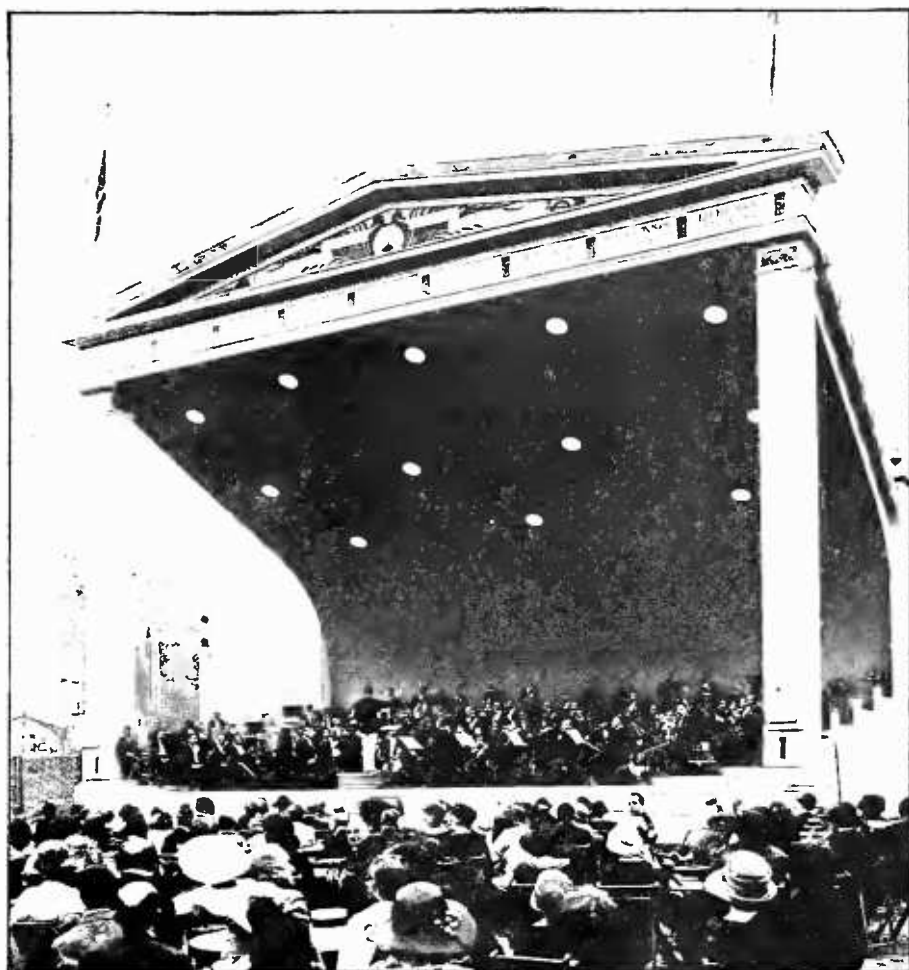

THE NEW STAND BUILT FOR THE N. Y. PHILHARMONIC ORCHESTRA  
Willem Von Hoogstratem is shown conducting his orchestra of 106 men, at one of the Stadium concerts in New York. The stand, erected by the General Electric Company, is portable and adapted especially for the broadcasting of the orchestra's programs. The two black dots, one above the other, to the right of the left-hand pillar, are the microphones

Island seems to support this premise—it will be an addition to radio broadcasting, instead of a substitute for it. We have the strongest kind of conviction that radio has become a permanent part of our day's activities and that in the future it will be even more necessary to us than at present. Radio broadcasting reaches many places where there are no wires and probably always will do so. The real service that broadcasting can furnish is a demonstrated fact, and the other service still needs to be proved. For many of us, "tuning-in" on various stations has a fascination which "wired wireless" would lack entirely. It seems probable that in the larger cities, where the telephone system may be suitably adapted to give carrier-current entertainment without unreasonable expense, it will be done, so that subscribers may either tap the wires or tap the ether for their evening's entertainment. J. H. M.



"ROXIE"

S. L. Rothafel, whose informal and witty announcements during the concerts broadcasted by his Capital Theatre Orchestra and "Gang" have made him very popular among the radio audience. He tells of his past history—from \$2-a-week days and failure in book-agenting to struggles with a country moving-picture theatre and final success in New York



THE "GANG" AND "ROXIE"

Top Row: Left to Right: William Axt ("Dr. Billy"), Carl Scheutze, Helena Marsh, Yascha Bunchuk, Frederick Jagel  
 Middle Row: Eugen Ormandy ("The Blue Blond"), Melanie Dowd, Louise Scheerer, Mme. Elsa Stralia, Editha Fleischer, Bruce Benjamin

Lower Row: Edna Baldwick, Nadia Reisenberg, S. L. Rothafel ("Roxie"), "Betsy" Ayres, Evelyn Herbert

## A Bit About Myself

The Story of the Early Struggles, Varied Experiences, and Final Success of a Man Who is Well Known to Thousands Who Listen to the Capitol Theatre Concerts Broadcasted Through W E A F, W C A P and W M A F

By "ROXIE" (S. L. ROTHAFEL)

Presentation Director, Capitol Theatre, New York

**I**N THIS helter-skelter life in which we find ourselves, our minds are likely to focus almost exclusively on the situation of the moment; we are wont to forget, in following the pace of the present and preparing for the immediate future, the varied joys of yesterday. As a rule, the bygone years, in retrospect, are shaded to a great degree by the incomparable brush of Father Time in a manner that blends sadness and happiness into a picture of subdued color and great beauty. The business of to-day renders the thoughts of yesterday a pleasure that most of us can—or at least, do—find little time for, despite the many blessings which a bountiful passing of years has showered upon us.

My friends—and I feel justified in believing that most of you who read these few words

are my friends—the preparation of this sketch makes it possible for me to look over the departed years as they pass in review and are recorded here at my pen-point. This form of indoor sport is rarely my lot, and before I began it struck me as just another obstacle to overcome; but as the words form beneath my hand the pleasure of the writing increases. I trust that you, too, will find it increasingly interesting.

It is quite unlikely that any day in my life was or will be as important as July 9, 1882—that was my birthday and necessarily marks the beginning of my career (18 years to 1900, plus 23—total 41. Right!). Whether I was a good baby or not is a subject for discussion, for I have heard varying reports and must admit that my memory is not keen enough for



WILLIAM AXT

Known to those who have heard "Roxie" introduce him, as "Dr. Billy"

me to vouch for the authenticity of any of them. My birthplace was Stillwater, Minnesota, a hamlet made famous in song and story by some sage who attributed to it the quality of running deep.

As a youngster, I was like most others of the day and of the environs of Stillwater—given to a certain amount of mischief. An occasional broken window as the result of an improperly aimed bit of snowball or the report of a bit of sharp-pointed hardware having been placed upon someone's chair was always sure to bring down the paternal ire upon my head.

After spending thirteen years in Stillwater, my family moved to New York. We were folks of less than moderate means, and the cost of our journey, coupled with my being rather well set up for my years and having a healthy desire to put my energies to work, culminated in my looking for a job. After quite a search I was able to persuade John B. Collins, who was

then in business on 14th Street, that I would be a valuable asset to his business as a cash boy. Perhaps he was impressed by my earnestness, for he agreed to hire me at the grand and glorious salary of \$2 a week. After the first week, however, he showed signs of impatience. The end of the second week found me with my second \$2 but without a job.

## DREAMING AND SELLING BOOKS

**D**URING the next year or so I landed, and lost, one job after another. I cannot blame those good but gossiping persons who came to regard me as the family black sheep and ne'er-do-well. Yes, I was shiftless and a dreamer,



EDNA BALDWIN

This young pianist is a popular member of the popular "Gang"

THREE CAPITOL—  
AND THREE—

They have contributed—  
evening concerts given—  
transmitted, through—  
enthusiastic and in—



ERNESTO LECUONA

He is a Cuban pianist, and has been playing some of his own compositions at the recent Sunday night concerts

but in all my shiftlessness I was building up, entirely unknown to myself, a symposium of impressions which has followed me though the years and left with me a keener, deeper and more appreciative picture of human frailties and kindnesses. I have been in intimate contact with some pretty rough characters, but have yet to find the one in whose soul there is no flame of decency or humanity or even a hidden love, despite an exterior that would indicate none of these attributes. There is, I believe, a way to the heart of every one of us—and when the way is found, true friendship follows.

But that is somewhat aside from my past, though it may serve to reveal a part of the



© Underwood & Underwood  
MME. ELSA STRALIA

From the Royal Opera, Covent Garden, London. She possesses a dramatic soprano voice and has had great success in opera and concert abroad for a number of years. She is a native of Australia, and came to America in 1922

—PIANISTS

—CAPITOL VOICES

- greatly to the Sunday
- at the theatre and
- Station WEAF, to an
- creasing radio audience



WILLIAM ROBYN

Alias "Billy." His lyric tenor voice is heard from time to time at the Capitol. He has also made Victor records and now has a long-term contract with the Cameo Phonograph Company



LOUISE SCHEERER

This contralto has long been a member of the "Gang," and sings in the Capitol quartet

mental processes, born years ago, which remained unshaken as the days rolled by.

When I was still in my teens, I became a book-agent and made myself a most unwelcome visitor at many homes. I believed in the books I was offering for sale, felt sure they would bring pleasure and profit to those who would read them; but the reception extended me, as soon as the object of my mission was made known, was a most frosty negation. This kind of thing discouraged me greatly. I found it difficult to reconcile my ideas of what life should be, with life as I found it.

Like many another discouraged youth who finds it hard to make an honest living and has



(LEFT) THE "BLUE  
BLOND"

Otherwise known as Dr. Eugen Ormandy, concert master and soloist at the Capitol Theatre



(RIGHT) ERNO RAPEE

Whose dynamic baton has conducted the various programs at the Capitol. Born in Budapest, he enjoys the reputation of being a brilliant pianist and a composer of no small talent. He has conducted symphonic concerts and opera throughout the principal cities of Central Europe

no particular trade or talent to fall back on, I joined the Marines. The years of my enlistment were among the best years of my life. I met other young men from every walk of life and profited by my contact with them. My duties took me to all parts of the world and my vision was broadened as only travel can broaden one. The discipline, exercise and training were entirely different from anything I had previously experienced. It quickened my actions, sharpened my wits, and provided me with a feeling of independence and self-confidence I had not known before.

Fortified by this training, I undertook again what I had found to be my hardest job: I became a comparatively successful book-agent. My book peddling carried me into the coal fields of Pennsylvania, and it was in Pennsylvania that I met my wife-to-be. We soon found that the old saying that two could live as cheaply as one was never set to music by a married person. Our entrance into matrimony cut a rather large slice in the family fortune and we held a council of war on the two subjects of Finance and Future.

The findings of the council were that we should go into the motion-picture business immediately. So we did. That was about fifteen years ago. In a small town in Pennsylvania we were able to locate room enough to accommodate a fair-sized audience, behind a bar-room. The hall, as it was called, was used for meeting purposes and it was supplied with camp chairs by the local undertaker. Inasmuch as the same chairs were used for meetings, funerals and our movie enterprise, our per-

formances were more or less movable feasts, sandwiched in between the other uses for the camp chairs.

This family "theatre" of ours called for a great deal of work and though my wife had all the duties of our small home to bother her, she still found time to assist and encourage me when the burden at the show-house was particularly heavy. I did the janitor work, painted the signs, secured the meagre publicity available, and attended to the thousand and one details of the small-town theatre.

After the evening performance, when the audience had left and the house had again been put in order, I used to experiment with the projector in an effort to improve the quality of our pictures. Then, too, there was the presentation to be worked out, for, even in those days, I realized that the form of presentation was to play a great rôle in the success or failure of the silent drama. In order to save enough to pay the musicians and others it was necessary for me to run my own machine. But the return for all this effort was not great, and showed me that the field was not large enough.

I went to Philadelphia after a job and was taken up by the Keiths. During my stay there, I originated and developed what has come to be called twilight projection, which is a system of subdued lighting making it possible to do away with the dark theatre.

#### A MEETING WITH SARAH BERNHARDT

LATER, when I was working in Milwaukee, it was my good fortune to meet Sarah Bernhardt whose screen version of "Queen Eliza-

both" we were showing. She encouraged me greatly by commenting favorably upon the presentation of her picture and predicting a great future for me. This marked the turning point in my career, for this picture and its presentation secured national recognition for me.

Then I came to New York and opened at the Regent Theatre where I employed my own type of presentation which proved to be a sensation. Then I opened the Strand on Broadway and later built the Rialto and the Rivoli. At present I am finding the business of arranging the productions at the world's largest theatre the most difficult and absorbingly interesting job I have yet experienced.

As many of you know, last fall the American Telephone and Telegraph Company conducted a series of experiments at the Capitol Theatre which resulted in the broadcasting on a particular Sunday evening of our musical program. Reports from radio listeners-in came from Chicago, Canada, Cuba, Georgia, Kentucky and vessels at sea. All the reports contained enthusiastic approval and the experiment was repeated with such tremendous success that weekly concerts from the Capitol Theatre have now become a regular feature of the programs from WEAf.



"ROXIE" OFF DUTY

He is an enthusiastic handball player. Recently he won the Handball Tournament at Rolley's Gymnasium, New York, where this picture was taken

The idea occurred to me as these broadcasts went on, that here was an ideal medium for us to use in making friends for the Capitol by sending the most beautiful of songs and music into the homes of the unseen audience. We were inspired by the thought that we could make life more livable and bright for those shut-ins who for one reason or another could not leave their homes, who, in a word, are deprived of those pleasures which we so freely enjoy and frequently fail to appreciate.

BROADCASTING WITH THE "GANG"

THE result was that we had a special studio arranged and each Sunday evening my "Gang"—composed of the artists who entertain in the theatre—and I have an hour before the microphone, poking fun at each other and at you, and sending upon the waves of ether the world's best music. It is one hour of the week to which we all look forward with pleasure, for during this hour we meet many friends who write us, approving our efforts and thanking us for the entertainment we give them.

We have been fortunate in being able to get personality into the microphone, and I believe that our departure from the regular method of

佳音  
羅君之  
你乃甚寬仁  
每禮拜晚以  
音樂悅眾  
財有友吾無  
望天公保  
為此善作  
並候安

The above means..  
Dear Mr. Reichert:-  
you are indeed generous and  
unselfish in giving so much pleasure to  
the public thro the Radio on Sunday evening.  
Undoubtedly you have plenty of the  
world's goods and friends. There is  
nothing else that I can wish for you  
than, May the River of All Good Things  
keep you and your associates in good  
health so that you all can continue  
the good work.  
With grateful heart & esteem.  
Respectfully,  
J. J. Jones.

AN INTERESTING LETTER SENT TO "ROXIE"

This is one of the many thousands that have poured into his office since the Capitol first went on the air



ON AN EVENING WHEN THEY PLAYED "OVER THE RADIO"

Left to right: Eugen Ormandy ("The Blue Blonde"), Yascha Bunchuk (a Russian, "Sheik of the Capitol"), Bruce Benjamin (tenor), William Axt ("Dr. Billy"—pianist), Louize Scheerer (contralto), Evelyn Herbert (soprano), Dorma Lee (in rear—contralto), "Roxie" himself, Edna Baldwin (pianist), and "Betsy" Ayres (soprano)

broadcasting has made listening-in more pleasant. Indeed, I have received some very complimentary letters, which indicate quite clearly that we of the Capitol have been responsible for the installation of receiving sets in many homes where they had not been considered previously. And I must say that my many years

of showmanship have only made me keener to produce entertainment of a nature that makes the audience feel thankful that they are alive and in a world where, despite the cynics, there is plenty of happiness for those who will make even a slight effort to brighten the lives of their fellows.





# Giving the Public a Light-Socket Broadcasting Service

How "Wired Radio," Invented by General Squier, is Being Employed to Supply News, Entertainment, and Instruction to Staten Island Subscribers at So-Much-a-Month. Economy and Reliability are the Chief Assets of the System Which may be in Use Everywhere Soon

By WILLIAM HARRIS, Jr.

**S**UPPOSE you had a compact little single-control receiving instrument which you plugged into any one of your electric light sockets and received, at specified times, the latest world and local news, music of all kinds, play-by-play (or blow-by-blow) reports of the big sporting events, extension courses in whatever might interest you, information regarding where to shop for everything from footwear to furniture, authoritative talks on the theatre, books, health, cooking, etiquette, and what-not—all with a minimum of interference, three hundred and sixty-five days in the year.

And suppose you could get all this at about half the cost and none of the bother or uncertainty of the common broadcast receiver.

You *can*—if you happen to live on Staten Island!

But if you don't, never mind; because the first commercially practicable "wired radio" broadcasting service, which has just been put into operation by the Wired Radio Service Company, gives promise of such universal popularity that similar services will no doubt spring up throughout the land almost before you have time to read up about it.

Of course the old-fashioned kind of broadcasting (about two years old now, isn't it?) will not immediately curl up its aerials and die, leaving a vast and sentimental radio audience weeping over the expensive carcass. No, the two services will continue side by side. You can probably think of various reasons why this will be so. Here are a few:

1. Fans will always want to tune-in "distance," both because it's distance and because arriving at success as a result of their own skill will never fail to give a very real pleasure.

2. The appeal of wired wireless is not primarily to the amateurs and fans—it is to that far greater part of the population which either does not own receiving sets or is temperamentally disinclined to fuss with them.

3. "Space" broadcasting will always be the more economical system in sparsely settled regions. The wired wireless service is essentially for towns and cities, where the expense per subscriber is low.

In brief, this is the way the Staten Island service came into being: The North American

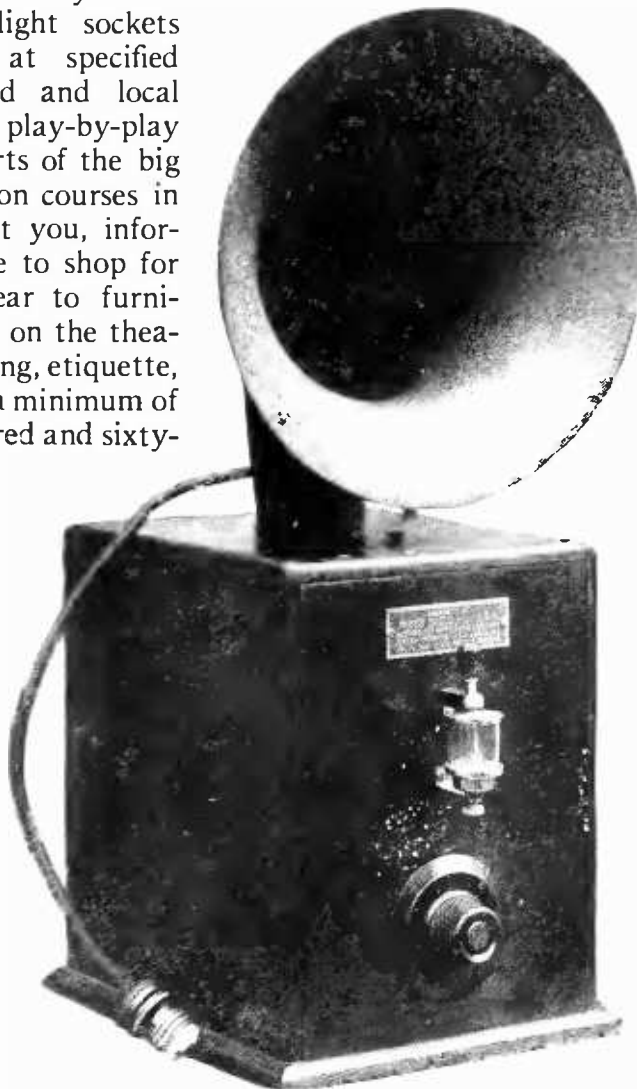

THE SET USED MOST FOR WIRED RADIO RECEPTION

The single tuning control is the outstanding feature of this two-tube receiver. A semi-permanent crystal may be clipped in place instead of the one shown. No A batteries are required as the lighting circuit supplies the filament current. To put the set in operation, the light switch is turned on; when the subscriber is through with the set, he simply turns off the light switch

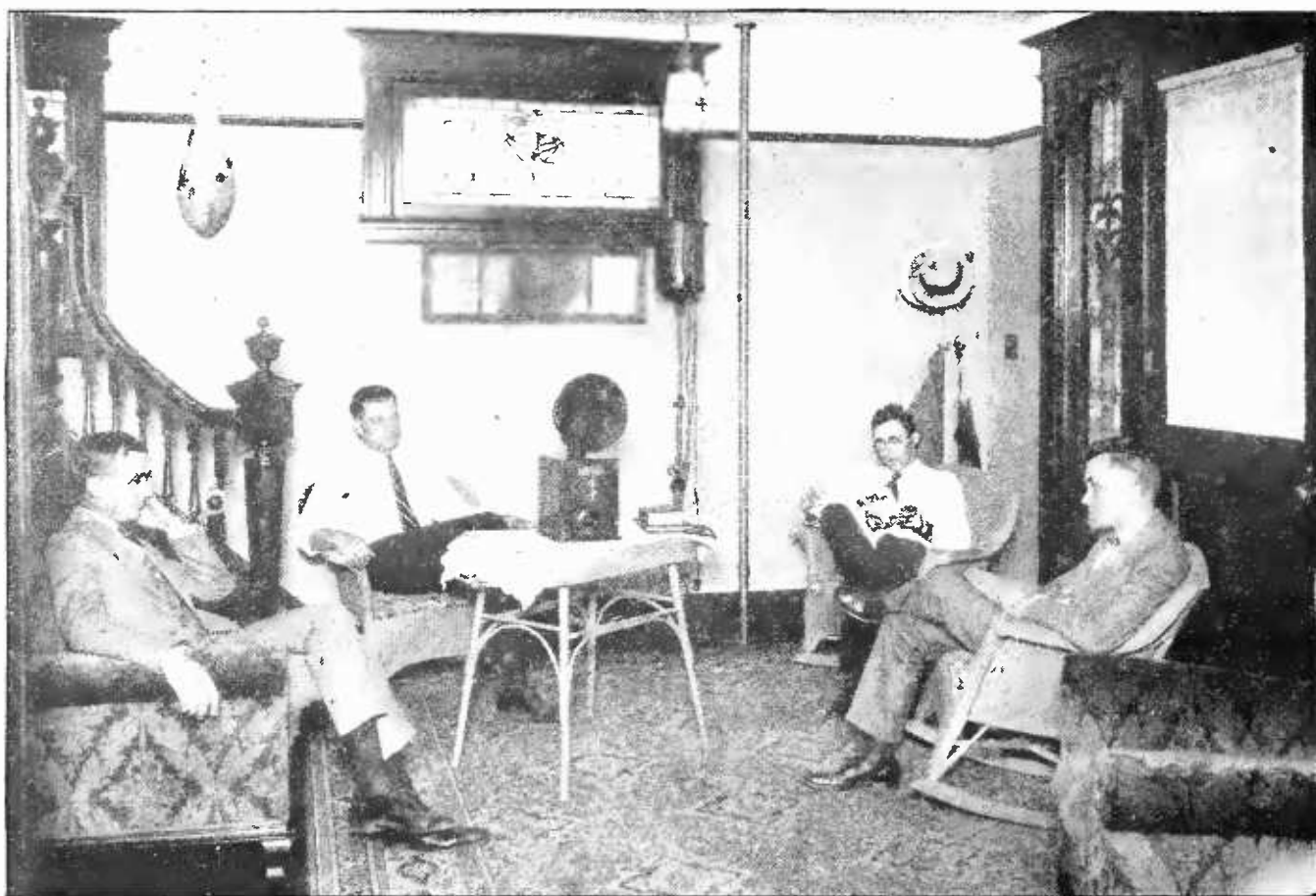

TRYING THE LOUD-SPEAKER SET IN THE ROOM ADJOINING THE STUDIO

From left to right: J. Arch Mears, President of the Wired Radio Service Company; E. W. Danals, who has aided in the development of the one- and two-tube wired radio sets; Samuel Isler; and R. D. Duncan, Jr., Chief Radio Engineer of The North American Company who formerly worked with General Squier at Washington and has been in charge, during the past year, of the experimental work of the Wired Radio Service Company

Company, a public utility holding company operating electric lighting and power companies in Cleveland, St. Louis, and many other places, obtained a sixty-day option from General Squier on a license to use his invention commercially. Experiments in Cleveland during this sixty-day period gave the officials of the company confidence in the tremendous possibilities of wired wireless if properly applied for public service. The license was obtained forthwith, and further experiments over the circuits of the Potomac Electric Company in Washington were eminently successful.

The rehearsals having been given, so to speak, the show was presented to the public—on Staten Island. Mr. C. W. Hough, President of Wired Radio, Incorporated, which is controlled by the North American Company, is in general charge of all this wired radio work; and the Wired Radio Service Company, mentioned above, is a subsidiary of Wired Radio, Inc., formed to carry on operations throughout New Jersey and in parts of New

York and Connecticut. It is this latter organization which has just started supplying a daily broadcasting service to Staten Island homes over the ordinary, unchanged house lighting wires.

Mr. J. Arch Mears, President of the Wired Radio Service Company, says:

There are about 25,000 potential subscribers to the service which we have established on Staten Island; but they are only a fraction of the number which our company expects to be supplying before long. When you consider that there are in the country 12,000,000 houses wired for electrical power, of which the organizations associated with the North American Company supply approximately 1,500,000 with electric service, you can see that if even a comparatively low percentage of these subscribed to the broadcasting service, the revenue from the tremendous business that would result would be sufficient to enable us to procure the very best talent, the most important and interesting programs. There are between 3,000,000 and 4,000,000 potential subscribers (families or organizations) within 200 miles of New York City, the greatest

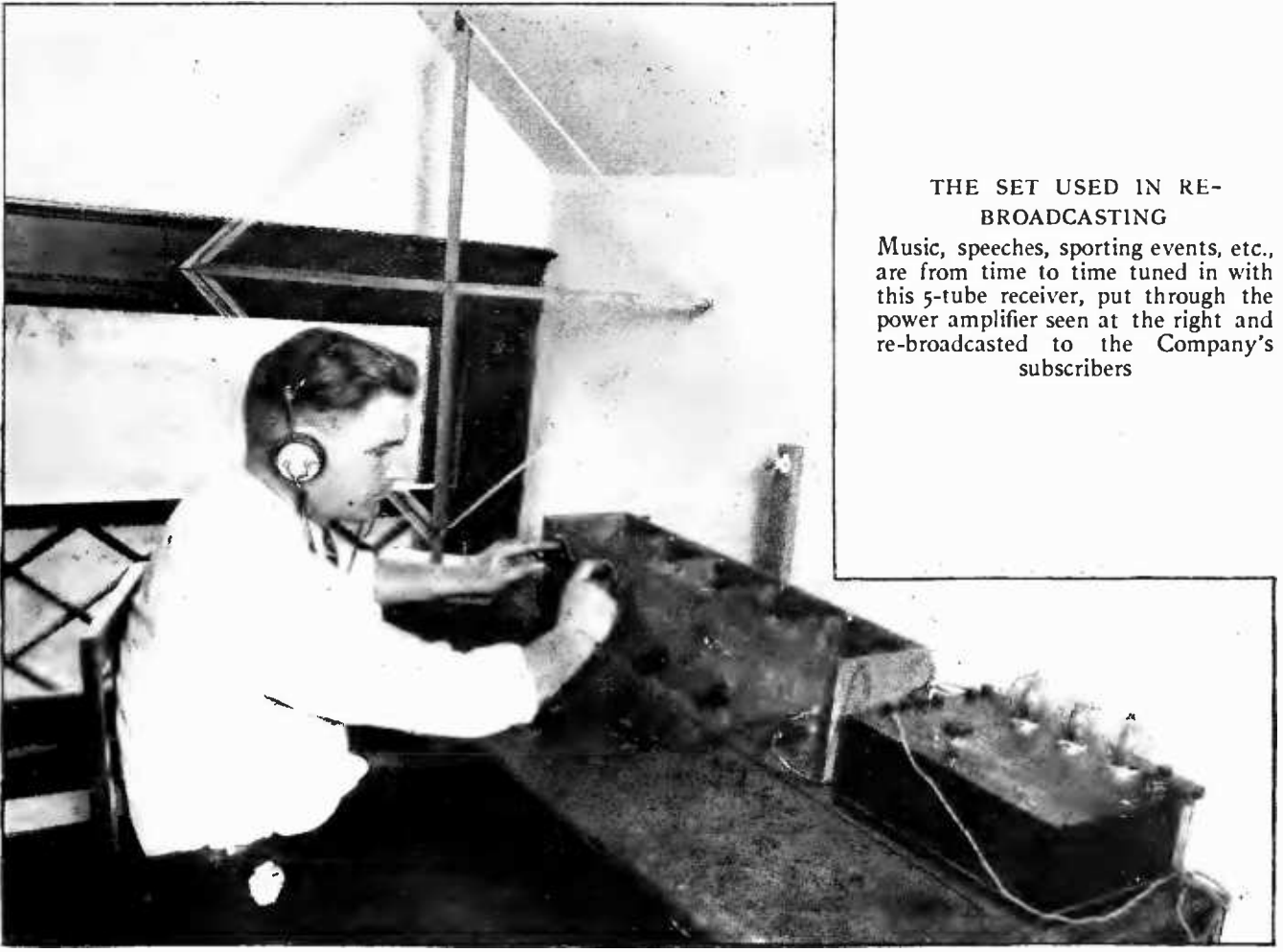

THE SET USED IN RE-  
BROADCASTING

Music, speeches, sporting events, etc., are from time to time tuned in with this 5-tube receiver, put through the power amplifier seen at the right and re-broadcasted to the Company's subscribers

program source in the world. The probable—in fact, the inevitable—growth of wired radio which we are going to see within a few years fairly staggers the imagination.

WHAT IS HAPPENING OVER ON STATEN ISLAND

**B**UT let us cross over to the broadcasting plant on Staten Island and see what is going on there. It is a half-hour ferry trip from the Battery to St. George, then a couple of miles' train ride to West Brighton, where the studio is located. The broadcasting is done from a three-story stucco house leased by the company. On the first floor are the reception room and studio, the latter, like the ordinary radio studio, being hung with heavy monk's cloth to absorb all sounds except those entering the microphone.

On the second floor is the transmitter room, containing the apparatus which delivers the radio-frequency impulses directly to the 2,300-volt power lines. There are two transmitters: the small one shown at the left in the photo on page 470 is a spare set for use in case the large set should be out of commission. The oil switch

for the 2,300-volt lines is seen mounted above the control panel in the centre.

THE WIRED RADIO NEWSPAPER

**I**N AN adjoining room is the automatic apparatus which receives news directly from the United Press Association's offices in the World Building, New York City; for not the least important part of the wired radio service is the news summaries delivered to the subscribers' loud speakers or phones at the same time that they are sent to some seven hundred newspapers all over the country. Mr. James T. Kolbert, of the United Press Association, is Editor of this newly established wired radio newspaper.

This phase of the service is not provided as a substitute, as one might at first imagine, for the ordinary daily paper of wood pulp and printer's ink. It is true that it supplies news of local and world-wide importance, but it is rather as an arouser of interest that its sponsors expect it to prove of greatest value. What is important or interesting for people to read about is told briefly.

Before long an advertising wavelength will be operated, at some morning hour suited to the convenience of the women, who are the chief buyers. They will be told, by women, just where and when to shop for their special requirements. It will be readily seen that the printed newspaper will always have the advantage that, although it may arrive several hours later than the radio bulletins, it can be picked up at the reader's pleasure, read as leisurely and as often as may be desired and contains much more completely the facts and discussions that are broadcasted over the lighting wires. It is expected, however, that the radio newspaper service will broaden people's interests in a way that a daily paper alone cannot do. Those whose interests have revolved chiefly about their own local worlds will find themselves following, from day to day, in the press and in the conversations of their associates, what the world at large is doing and thinking. This, if brought about on a large scale by intelligent and discriminating wired broadcasting, will be a tremendous thing. The instrument is a powerful one, and the responsibility that goes with the privilege of using it, is great.

#### DISTANCE MADE POSSIBLE ON A CRYSTAL SET

**U**P ON the third floor of the broadcasting house is a five-tube loop receiver, whose output may be switched directly on to the electric lighting lines and received by the subscriber. It need scarcely be pointed out that the chief significance of this phase of the Wired Radio Service Company's activities is that it makes distant programs available for crystal receivers.

Thus, we find three distinct sources of broadcasts—performers in the studio, news from the United Press Association, and space radio re-broadcasted—all sent over the same lines and audible to every subscriber whose apparatus—built by

and rented from the company—is plugged into one of his light sockets.

#### THE RECEIVING SETS SUPPLIED TO SUBSCRIBERS

**V**ARIOUS types of sets have been designed and provided by Wired Radio, Inc. which are leased to subscribers at prices ranging approximately from two to five dollars a month. (This charge, by the way, is tacked on the subscriber's lighting bill.) All the sets have crystal detectors. The simplest one has a semi-permanent crystal and a single tuning control. The crystal is of a type which is less sensitive to weak signals than the ordinary mineral, but equally good on strong signals; and since all signals received over the lighting lines are as strong as necessary, this type of crystal is just the thing! The beauty of it is that after you have adjusted it by turning a thumb-screw slightly, it stays set for an indefinite period, in spite of jarring the table, moving the set from place to place, and other actions fatal to the adjustment of the ordinary crystal. These sets are designed for use with headphones.

#### JAMES T. KOLBERT IN THE NEWS ROOM

This room, on the second floor of the house, from which the wired broadcasting is done, is connected directly with the United Press Association's offices in the World Building in New York. Mr. Kolbert, a representative of the United Press Association, is acting in the capacity of Editor of the Wired Radio News Service

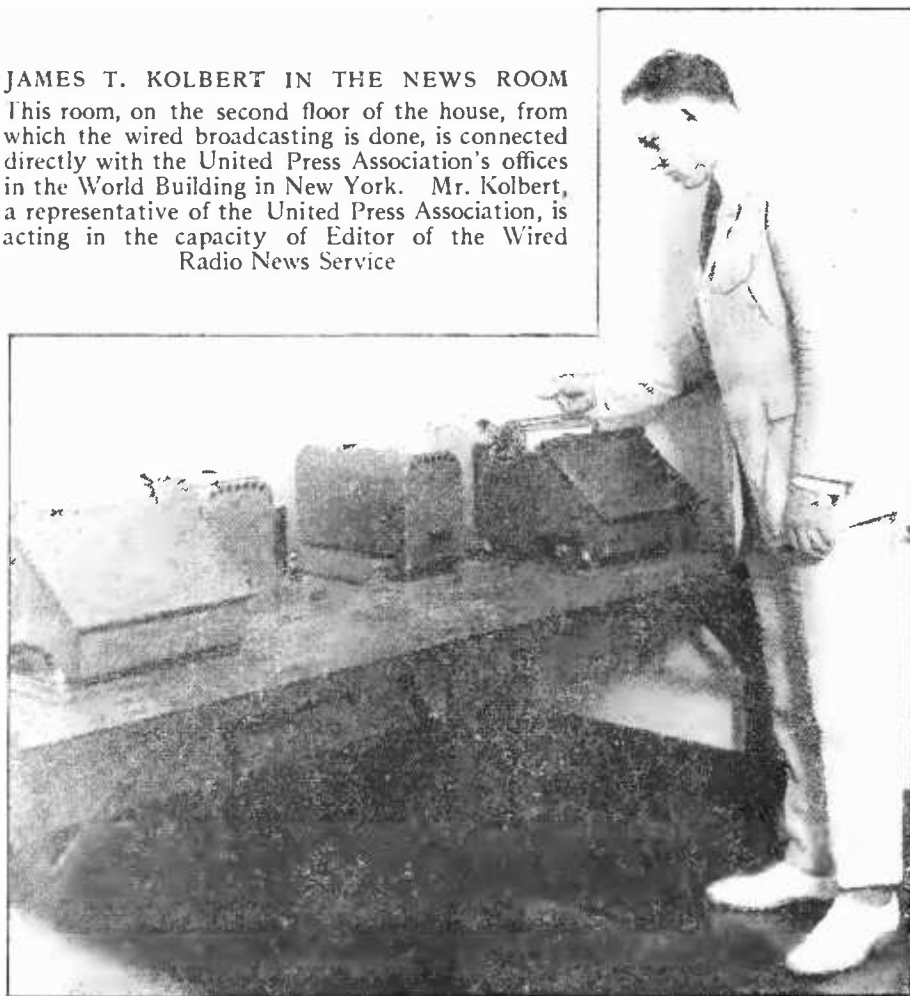

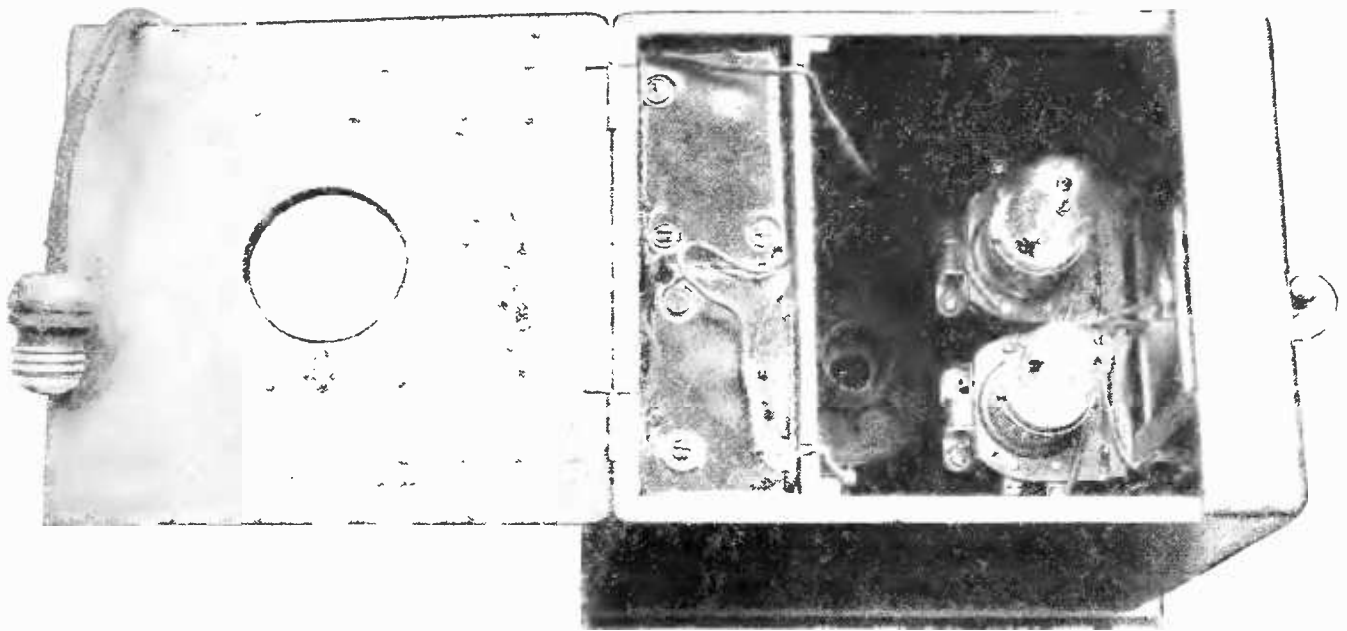

THE INSIDE OF THE SET SHOWN ON PAGE 465

On the left are the small B batteries; at the bottom is seen the loud speaker unit in which the base of the fibre horn is fitted; the two WD-12 tubes and the crystal (seen at the extreme right, outside the cabinet) give one R. F. stage, detector, and two A. F. stages, as one of the tubes is reflexed

Most people prefer to listen to their radio entertainment from a loud speaker instead of having to wear headphones, which are often heavy, and, in summer especially, decidedly hot. For such subscribers, a compact little outfit has been developed which reproduces signals received over the lighting lines with volume sufficient to fill the ordinary-size living-room. It contains only two tubes—WD-12's—but one of them is reflexed, so that the effect is obtained of one radio-frequency stage, detector (crystal), and two audio-frequency stages. This set is shown below and on page 465.

Still another receiving set, which has not yet been put in service, has been designed for use in stores, theatres, and other places where a particularly loud signal is needed. As in the case of the other models, the filament current will be supplied from the lighting wires, and the tuning will be simple enough for any one to master without much practice or instruction. Radio is thus handed to the non-technical, non-experimenting "general public" on a silver platter. There is not much to go wrong, and if anything does, a man from the company will come around and remedy the trouble, like the telephone service man. In other words, when a subscriber pays so-much-a-month for a receiving set, he is paying at the same time for whatever service may be necessary to keep it in good order.

There is no reason why one house should not

operate several sets at the same time if desired. No interference or diminution of signal results. And there is no reason why a triple socket, for instance, should not have plugged into it a toaster, a flat-iron, and a receiving set. As in the case of any other electrical appliance, the radio set, when once connected to the socket, is put in use simply by turning on the electric light switch.

At present, all programs are transmitted on the same wavelength—about 8,000 meters—but the company expects soon to operate a dance wavelength, an advertising wavelength, and an educational wavelength simultaneously. Practically anything the subscribers indicate that they want in the way of programs can be supplied. If enough of them, for example, want a half-hour talk on books and literature each evening, they will be given it on a special wavelength. They will also be able to turn their single tuning control to dance music, which will be on tap practically every evening, or to opera, or lectures. This, it will be seen, approaches rather closely the "fantastic" imaginings of writers and artists a few years ago who pictured a small box from which all sorts of entertainments could be drawn at will, like things to eat at the Automat.

How quickly and how widely the public is going to take up wired radio cannot yet be foretold with accuracy. Nor can it be said how cheaply an A1 service can be offered to

large communities. The cheapness and the quality, of course, depend principally upon the number of subscribers obtained in any given district. In New York and the vicinity, for instance, the best conditions may well be expected.

Programs originating in a wired radio broadcasting studio in New York could be sent as far as Chicago if it were necessary to do so. But the difference in time in Chicago (which would make bedtime stories from the Metropolitan area, for example, an hour too early for the Windy City's younger generation), as well as the fact that people will generally prefer programs of more local interest, make it unlikely that wired radio will ever be used over distances of many hundreds of miles. Space broadcasting will take care of the long-distance work sufficiently well.

Wired radio, then, is not going to "revolutionize" broadcasting, since it differs greatly

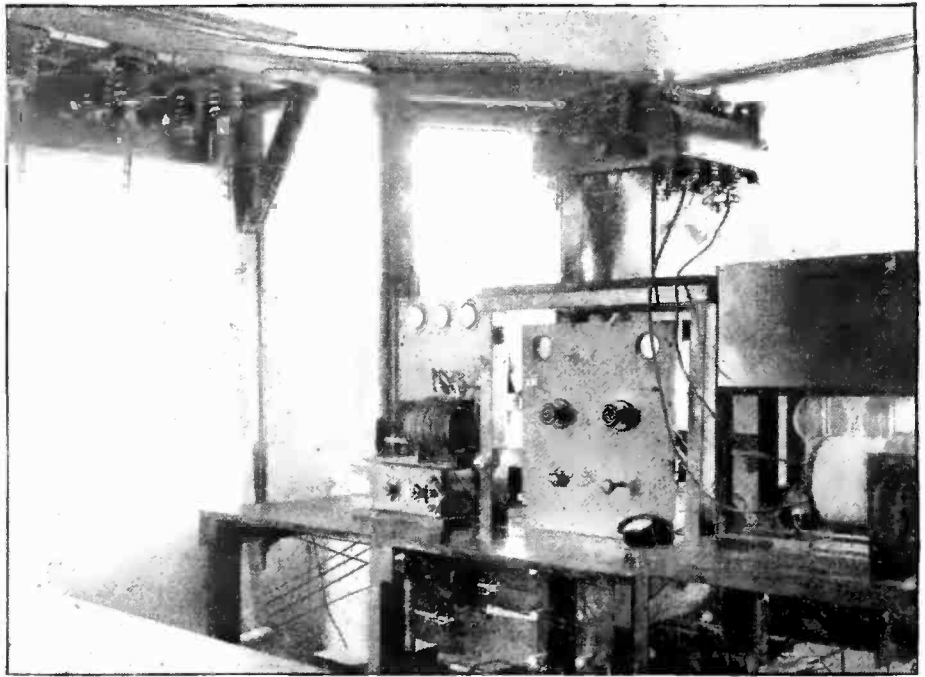

THE TRANSMITTING SETS AND THE LIGHTING LINES

The small set at the left is for use principally in emergencies. The larger set, at the right, is used regularly in broadcasting over the lighting lines. Above the control panel in the centre is the oil switch for the 2300-volt lines

from "space" radio as regards the people it appeals to and the service it offers. If it revolutionizes anything, it will be the point of view of thousands of people whose interest will be stimulated in things worth while, through a service within the reach of practically everyone.



BETWEEN THE ACTS WITH CYRIL MAUDE

The well-known English actor, who has been playing in "Aren't We All?" at the Gaiety Theatre, New York, tried out a receiving set in his dressing room. He failed to hear 2LO, near his home in London, but was apparently entertained by some local advice to housewives on preparing spinach

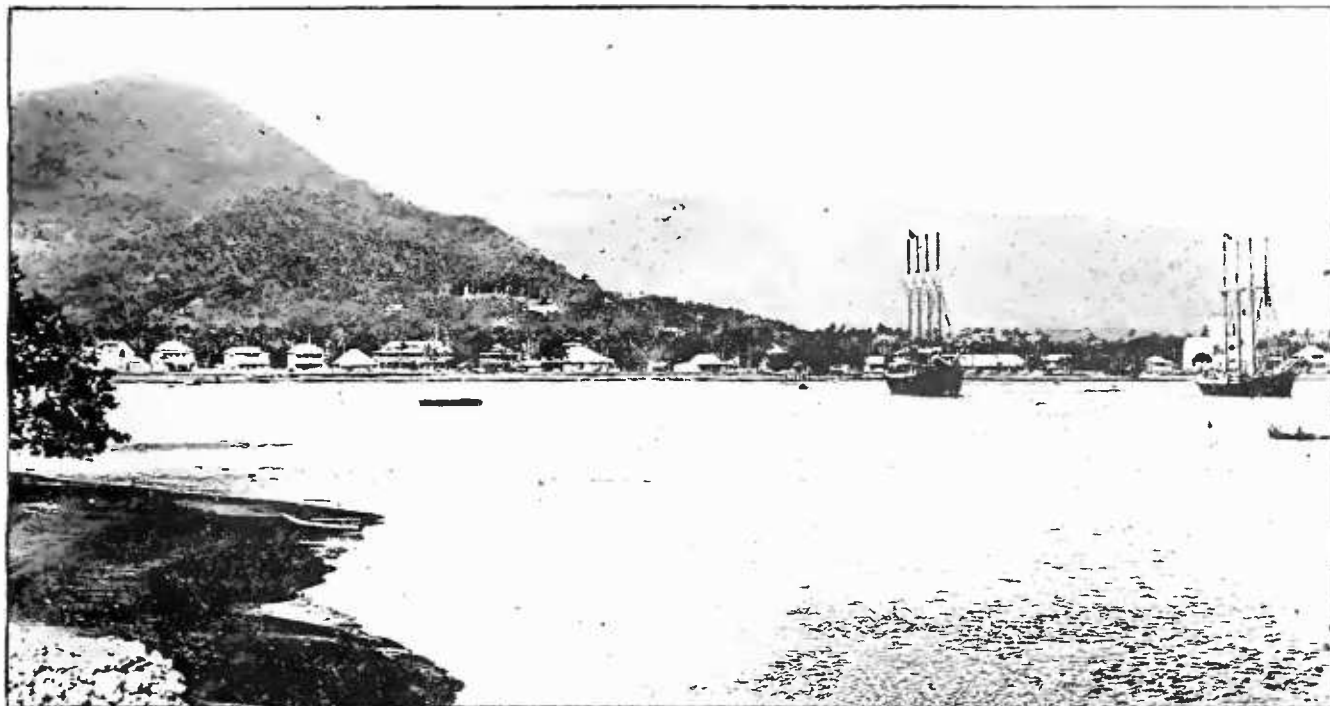

APIA, SAMOA—5000 MILES FROM 'FRISCO AND 2,500 FROM HAWAII

A small group of enthusiastic set-owners at this remote settlement are now hearing concerts from California regularly

## When the Bug Bit in Samoa

The Difficulties of Obtaining Apparatus on a South Sea Island, Experiences With Local Red Tape, and Final Success in Accomplishing 5,000-Mile Reception

By QUINCY F. ROBERTS

American Vice-Consul, Apia, Samoa

SAMOA is approximately five thousand miles from San Francisco and two thousand five hundred miles from Honolulu. Mails arrive twice every nine weeks. At the time of writing, March 25, 1923, I am reading in my latest New York paper a program transmitted by WJZ, forty-seven days ago. The January issue of RADIO BROADCAST has not yet arrived. My latest radio magazine is dated February 10, 1923, and I must await the arrival of the mail steamer sixteen days away before finishing a continued article on super-regeneration.

Interesting scenes, places, and peoples surround me. In the distance, part way up the ridge, I see the smoke of Vailima, Robert Louis Stevenson's old home. To the right is the wooded hill chosen by the beloved author for his tomb. Back of the Consulate I hear the beat of the hollow log, calling my brown-skinned neighbors to church. Tofaeone,

the Village Chief, barefooted, bareheaded, in spotless white coat and lava lava, glancing aloft to see if yesterday's storm has brought down my aerial, leads his subjects to service.

In the office are records dating back to 1857. The volumes of manuscripts contain the history of turbulent Samoa—a story of clashes between the Consuls, bitter commercial strife, bloody native wars, and the deeds of bold, desperate men cut off from the outer world without swift means of communication. Around the point on the reef and the beach lie the dismal wrecks of the U. S. S. *Vandalia* and the German warship *Alder*, monuments to the struggle between Germany, Great Britain, and the United States for control of the Pearl of the Pacific, Samoa.

Radio in the stormy past would have prevented bloodshed and saved the lives of our sailors. Wireless would have created new island empires in the South Seas. Its use, in

fact, would have changed Pacific history, for the naval and consular authorities of the interested powers were without instructions when they were sorely needed. Immediate action was imperative; decisions were reached without the guidance of the home governments. Radio, annihilating distance, would have settled the questions between the nations and more than fifty years of political struggles and warfare in Samoa would not have been written.

To-day, Apia is linked with the rest of the world by a high-powered radio station. Its four-hundred-foot umbrella antenna and its two sparksets of eight and sixty kilowatts keep open the lines of communication with New Zealand, Fiji, Tonga, Tahiti, Australia, American Samoa, Hawaii, and California. VMG, as Apia is known in the wireless world, is the link between Paris and the French colonial empire of the South Seas. How differently situated were my predecessors in the South Pacific before the age of radio, when telegrams were dispatched by mail to Auckland, New Zealand, to be transmitted by cable to Washington.

Each day the Minister of External Affairs in Wellington, New Zealand, condenses the world's news into a hundred-word radiogram for Samoa. At odd moments between commercial messages the operators at VMG listen in for the press news from Hawaii to the Far East. Apia with its small weekly newspaper cannot support a press service, so that the stray bits of news collected by VMG and the Minister's telegram make up the press news. You with your tremendous news-gathering agencies serving up the last-minute news by radio, telegraph, cable, telephone, steamship, railroad, and aeroplane, can little imagine how eagerly the short news bulletin is assimilated by the starved whites of Samoa. People cluster about the board, chewing over and over the slender morsels, seeking the interpretation of an obscure phrase or a missing word dropped by an operators' carelessness or a crash of static.

The radio bug, migrating south and west from the United States, has reached this peaceful

island and a severe outbreak of radio amateurs is expected by the Radio Officer of Samoa. Eighty-four regulations, numerous forms, and various licenses are ready to cope with the impending infection.

Some time ago the Editor of RADIO BROADCAST requested me to write an article on radio and its uses in the South Seas. He told me that interesting stories of radio in places remote from Manhattan are appreciated by readers of the magazine. Eight months ago, when his letter arrived, I knew little about radio. Of course, I knew that Apia Radio handled my telegrams efficiently and supplied me with American election returns. The operators occasionally called me up to read messages out of hours. Now and then I had noticed short news items in the New York papers about the opening of broadcasting stations. I had seen the radio programs sent out by the high-powered stations in the United States, but the great developments in radio since my departure from the United States had escaped me.

My wife was reading a letter from home when I happened upon the Editor's letter.

Looking up, I casually remarked, "The radio craze must be sweeping the United States. Here is a letter from Doubleday, Page and Company about a magazine called RADIO BROADCAST written for radio fans. Let's get a radio outfit."

"That's strange," she replied, "I was going to say the same thing. My sister writes me about the concerts she receives on her new radio receiver."

Blissful in our ignorance, we discussed the wonders to be brought about by the new instrument. The World's news would be ours. In Samoa we would listen to London, Paris, Berlin, Rome, and Washington. Speeches, music, and operas from the United States would break the monotony of our island life. Thus did the Editor's radio bug mark two more victims, and the ranks of the radio amateurs in Samoa increased three-fold.

Then my hectic life as a radio amateur began. Perhaps you prefer the term novice, but continue with me—I am certain that you will ac-



QUINCY F. ROBERTS

Who relates the experiences of a broadcast fan miles from "civilization"



cord me the distinction of being called an amateur.

First, I needed information. The radio operator of the mail steamer reluctantly left the cool shadows of the village swimming hole to have luncheon with me. Carefully we went over the ground. He said that I needed a good text book on radio, a radio magazine, a receiver ranging from 200 meters to 24,000 meters, a two-step amplifier, tubes, batteries, and telephones. He produced a worn copy of an American amateur radio magazine published in 1920, and we made out the order amounting to \$120.00 for my San Francisco agents to purchase and ship to me.

The U. S. Naval Radio Station at Pago Pago, American Samoa, supplied me with Bucher's "Practical Wireless Telegraphy" and I plunged into study of radio theory while waiting for the arrival of my equipment two months hence. I floundered through magnetism, induction, electrical measurements, and intricate circuits. I pored over diagrams and pictures, trying to visualize curious instruments and apparatus strange to the South Seas.

I learned that a buzzer for code practice could be made from an electric bell, so the beach was combed for the bell. Only one could be found in all Samoa, and as this was used in the local garage to test ignition circuits the

engineer would not part with it. At last I landed at the Public Works Department and made known my want.

Next the key and dry cells. The strip of brass along the edge of the office rule and the handle of the library paste brush were commandeered for the key. The Apia merchants were without a single cell. Their shipments had missed: none would be available until the arrival of the next mail. Following a very slight clew, I discovered six dry cells on board one of the copra boats. Considerable argument induced the owner to lend me the cells until the arrival of fresh supplies. Code practice began.

Weeks passed and the steamer which was to bring my radio set arrived. No wireless material was on the manifest and there was not a line in the mail to tell me why the shipment was not on the steamer. Three weeks later a letter arrived from Fiji from the representatives of my San Francisco agents saying it was not understood why the enclosure was sent to Fiji. I looked at the enclosure. It was a letter from San Francisco. The radio set would cost \$475.00, consequently new instructions were desired. A two-page folder described the outfit. There were no catalogues, no magazines, and no books. I found the lot of a radio enthusiast in Samoa very hard. Four months

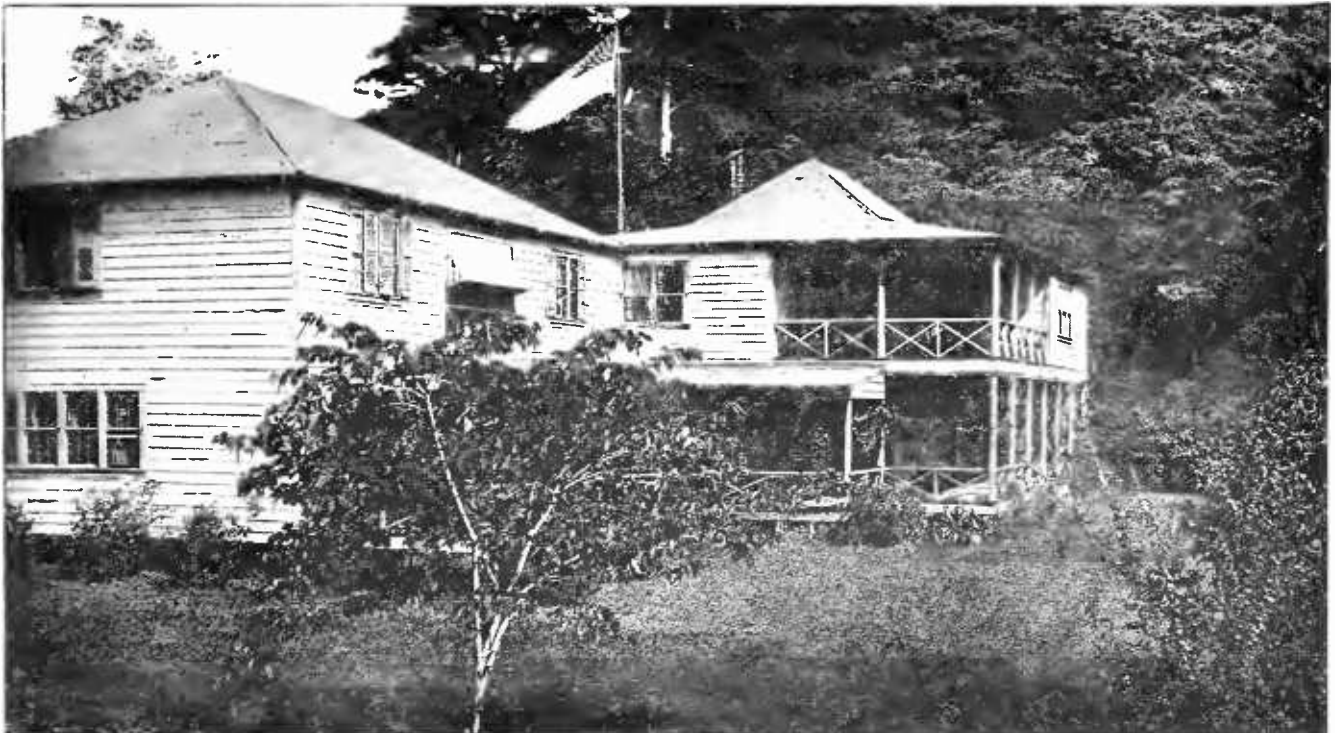

ROBERT LOUIS STEVENSON'S HOME IN SAMOA

It was here that Stevenson spent the last four years of his life—1890-1894



RADIO AMATEURS OF WESTERN SAMOA  
Mr. and Mrs. (Doctor Regina Keyes) Roberts  
in their garden at the American Consulate

must elapse before the arrival of my radio equipment, two for the catalogues and two for the order to arrive.

By this time my radio education had shown considerable progress. Why wait for a tube set? A crystal set could be made in my work shop and the experience would be useful to me. After two days' search I found 300 feet of cotton-covered No. 18 bell wire, the only small wire in Western Samoa. No one knew why it had been imported. Three dozen  $\frac{3}{16}$  inch brass machine screws, the entire stocks of the garages and hardware stores in Samoa, were purchased for the multiple point switch. Part of the strip of brass from the office rule and the handle of a passport visa stamp completed the switch assembly. Three drug containers placed end to end and wrapped in oil paper served as a tube for winding the single coil I planned. A piece of galena crystal was given me by the radio operator on an American yacht

which was in port. The spare telephones on board could not be purchased, but I borrowed them until the arrival of my head set. A coil of No. 14 bronze wire quietly taken from the telephone scrap pile was used for the aerial. My eighty-foot flag pole and a near by coconut tree served to support the antenna. Father Dumas, a Catholic missionary and my lone brother amateur in Samoa, came in to inspect my work. At his station, forty miles from Apia by boat, he had been experimenting with radio for more than six months. He was the proud possessor of a loose-coupler, Baldwin telephones, one variable condenser, and three pieces of crystal. He overhauled my aerial. Critically he examined my coil.

"A single-wire aerial is no good," he said. You will not get results. The wire on your coil is too large. The connections on the switch must be soldered."

Mr. Dunwoodie, Radio Officer of Samoa, met me and said he heard that I contemplated installing a receiving set.

"Better put in an application," he advised and handed me a long form.

It called for my full name, nationality, the nationality of my antecedents for three generations, my knowledge and experience with radio, and the circuits to be used. At the bottom was a space for my signature to the oath of secrecy which bound me never to divulge public messages and never to permit any unauthorized person to use my equipment. Three weeks after handing in my application I called to learn my fate. The Colonial Secretary pushed a large mass of papers toward me. It was my application with sheet after sheet of endorsements and comments attached to it.

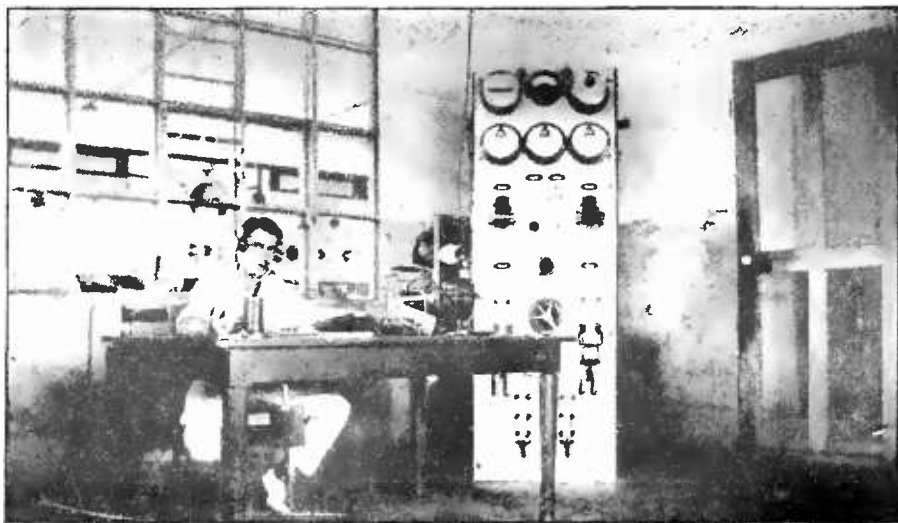

THE RECEIVING ROOM AT STATION VMG

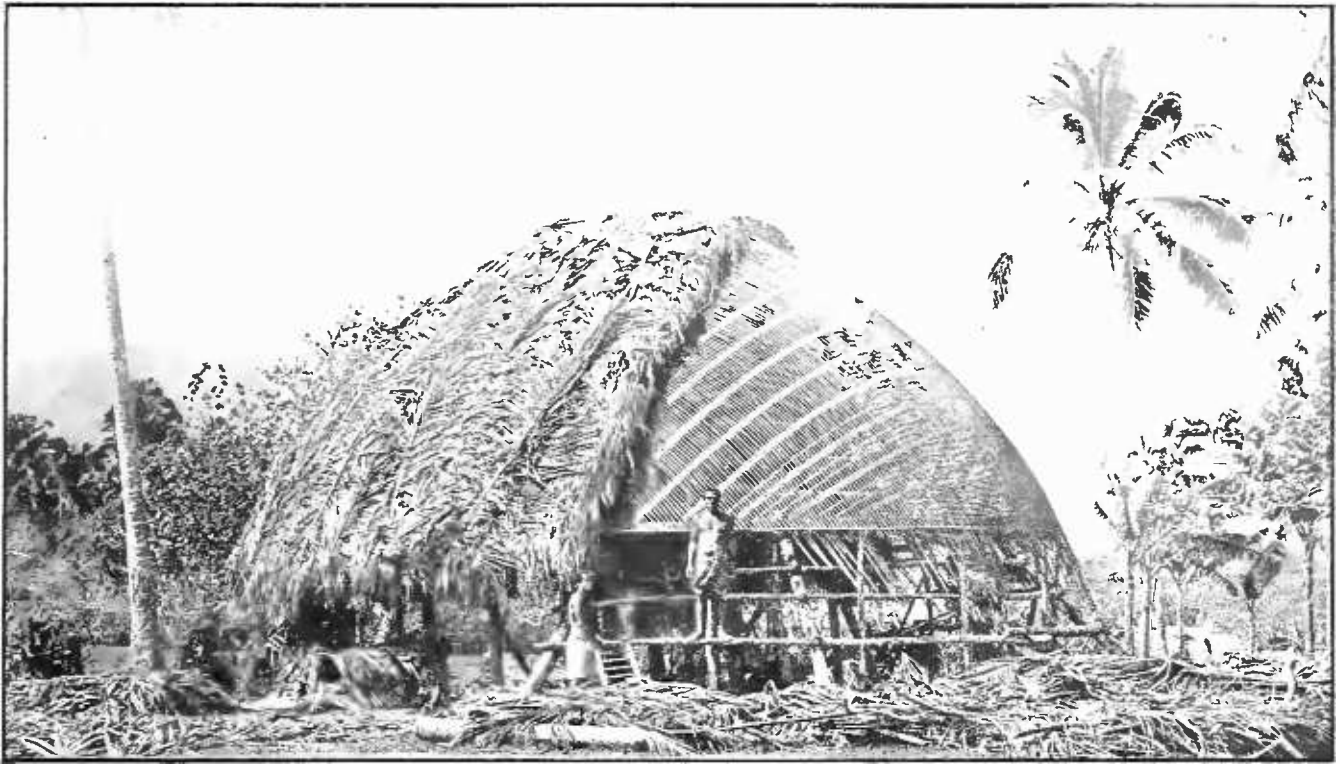

NATIVE SAMOANS PUTTING THE ROOF ON THEIR HOUSE

First, it had been referred to the Commissioner of Police and the Superintendent of Mental Hospitals in Samoa. He recommended that it be referred to the Radio Officer of Samoa. The Police Department, after carefully considering the application, had found that it was without regulations. The Radio Officer was without instructions from New Zealand as to the policy to be followed in granting amateur licenses. He suggested that the question be referred to the New Zealand Cabinet. As to the particular case before him he saw no objection to granting a temporary permit for a crystal set. The opinion of the Crown Law Officer followed. Acts of Parliament, Orders in Council, decrees, ordinances, and laws were marshalled in bewildering array. To my befuddled brain the decision was: "New Zealand regulations may or may not apply to Western Samoa." I was permitted to install the crystal set pending a final decision from New Zealand.

We were impatient to begin. The Samoan village had not missed a move. Village lads jumped to stretch the aerial and make it fast to the top of the coconut tree. Tofaeono called for his Sunday suit and his Chief's badge to come to the trial. The last connections were made and I searched the crystal for a good point. VMG came in clear as a bell. The telephones passed from head to head. The air had

been conquered and it was yielding up its secrets in dots and dashes. Tofaeono was elated. The white man's magic was in his village. His fame would spread throughout Samoa. His orators could boast of the only wireless station outside the commercial station. We could not read the signals, but they came in strong. My home-made outfit was a success. I did not learn until long afterward that any coil and an ordinary land telephone receiver would bring in VMG's signals.

The Radio Officer and I were now very good friends. He respected my enthusiasm if not my knowledge of radio. He agreed to help me in my difficulties. Three new radio receivers had arrived for experimental work at the radio station. Concerts were being tuned in nearly every night on the new receivers. The operators were enjoying music from Honolulu broadcasting stations. One of the new receivers would go to Father Dumas and the other spare one could be sold to me. Dunwoodie installed the receiver. Under his expert hand, Tahiti, Tutuila, and Nukualofa came in.

"Here is the concert from Honolulu," he said, "But you will not recognize it as a concert."

I listened. Yes, music was surging through the whistle. Now and then I thought I heard a word. It was a great day in Samoa.

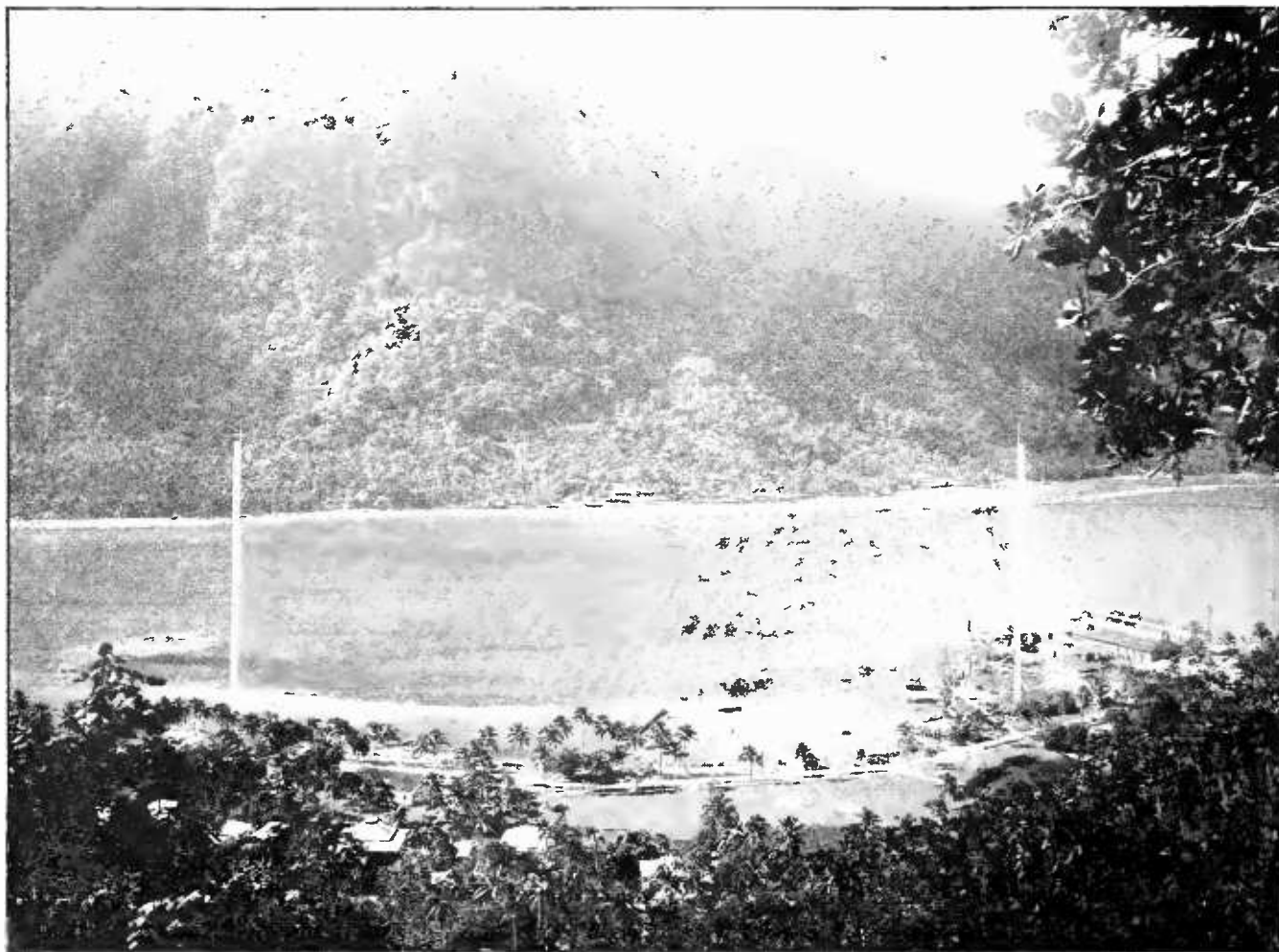

© Underwood &amp; Underwood

ONE OF OUR RADIO OUTPOSTS IN A PICTURESQUE SETTING

A view of the harbor and steep hillsides of Pago Pago, island of Tutuila, Samoa, showing the towers of the U. S. Government station

Since that time KHJ, KFI, and KPO, all California stations and 5,000 miles away, have been heard many times. My single-tube regenerative set has grown too small. I am now waiting for materials and supplies for super-regeneration and radio-frequency amplification. The radio fever is in my veins. More magazines, more books, and more equipment are the only palliatives that bring relief.

My wife and Father Dumas and I are proud of the amateur work in Samoa. We have no Radio Relay League, we do no DX work in the small hours, we have no transmitters. They are to come. Our little radio club of three has blazed the trail for those who follow in our footsteps. Regulations governing the use of radio for experimental, broadcasting, or amateur use are now in force in Western Samoa. A telephone transmitter is in Apia for installing on the Island of Savaii; another should arrive next week for the other side of Upolu. The Governor saw our work and became convinced

that radio telephony is feasible for inter-island communication. Three applications for receiving permits are now pending. Other people are interested. The local theater is planning to install radio receivers for the public. A broadcasting station in Samoa is being discussed. All this has been brought about by our little radio club.

Running true to form I can not refrain from boasting of my own achievements. On my single-tube regenerative set, eliminating all spark stations and C. W. telegraphy, I have logged 450,000 miles in 90 days (counting each station every day it comes in). My letters to KHJ reporting the reception of their programs at my station have been broadcasted by Uncle John. Fellow radio fans in the United States have flooded me with requests for postage stamps, seeds, and diagrams of my circuits. They say that one third of my results would satisfy them. Am I awarded the title of amateur?

# In the Wake of the Contest Winners

Four Complete "How-to-Make-it" Articles by Runners-Up in the Receiving Contest Who Merit Honorable Mention. A Summary of the Contest Results

In the August number, we published the article by Mr. Richard Bartholomew, of Porto Rico, which won the contest held "to determine who has done the best work with any kind of receiver and any number of tubes." Last month appeared the second, third, and fourth prize articles, submitted by Mr. Eric G. Shalkhauser of Peoria, Illinois, Miss Abbye M. White, of Hanover, Pa., and Mr. Harry Blumenfeld, of Cleveland, Ohio, respectively. These four winners did excellent work, and we heartily congratulate them. They had some pretty close competitors, too—broadcast enthusiasts who not only deserve some recognition of their efforts, but whose articles on construction and operation, and whose photos and diagrams are much too good and too useful for those of you who "build your own," to keep out of the pages of RADIO BROADCAST. So here they are. We shall always be glad to hear from readers who experiment with sets described in these—or any other—articles.—THE EDITOR.



## AT THE RIGHT YOU SEE THE MAN WHO WON FIRST PRIZE

When Mr. Bartholomew, who captured first place and the DeForest four-tube reflex loop set, sent us his photo, at our request, he said, "I'd be glad to hear from any one using this circuit of mine (or better, any one copying my set), whether they have success or not"

## A Better Broadcast Receiver

Mr. Munzig Has Pulled in 87,870 Miles Worth of Stations With the Outfit Here Described, 13 Stations Being More Than 2000 Miles from His Home in Redlands, California

BY ARTHUR L. MUNZIG

(HONORABLE MENTION)

**N**EARLY every old-timer in this fascinating radio game has some certain method of radio reception or transmission that he specializes on. The writer, having used an arrangement a little out of the ordinary, wishes to present to the readers of RADIO BROADCAST a design he uses that results in a *better* regenerative receiver. This receiver has the advantages of both tickler- and tuned-plate methods, oscillating and regenerating over a broader waveband. Moreover, the arrangement gives *increased signal strength* over all other methods tried. The writer frankly believes this regenerative design to be the most efficient and sensitive regenerative method now available.

The one little instrument in this receiver that is responsible for this super-sensitiveness con-

sists of a variometer with an inductance coupled on to the left side of it. To embrace the broadcasting, amateur and commercial wavelengths, 65 turns of No. 24 D.C.C. copper wire are wound on a tube  $3\frac{1}{2}$  inches in diameter and 4 inches long. Taps are taken at the 25th turn and at the end of the wire by inserting small binding posts. A flexible lead is then used to change the amount of inductance desired by inserting it in the first binding post for 200-360-meter broadcasting and in the last post for commercial telegraph stations or any reception up to 800 meters. From the photo, Fig. 1, the reader can get an idea of how all this is done. The tube used to wind the wire on was a salt box. It would be better to use a fiber or bakelite tube because of its superior insulating qualities. If the salt box is used, however, take care to coat the box with shellac to ex-

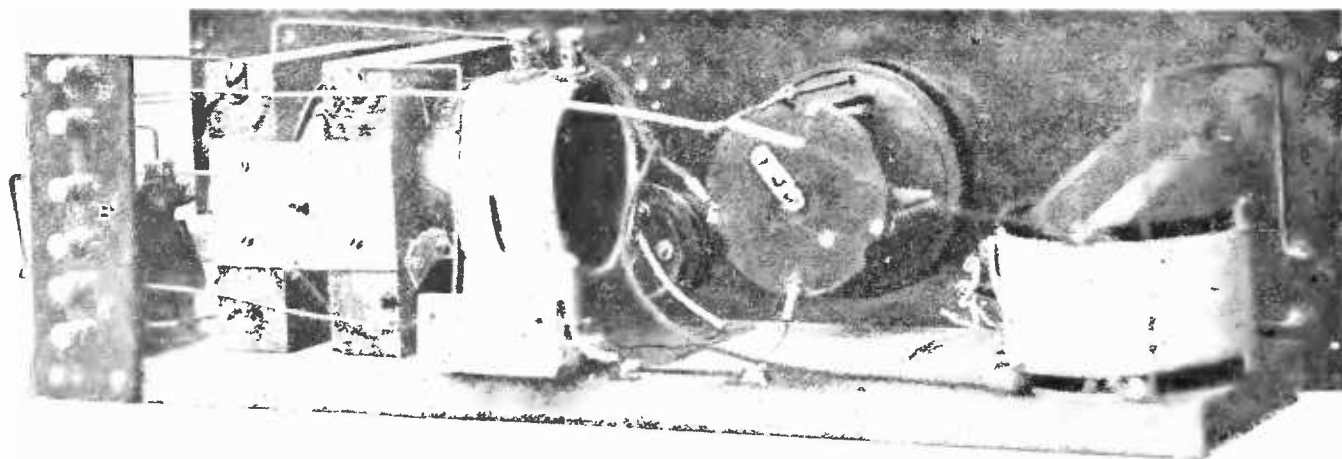

FIG. 1

Showing how the inductance is placed with relation to the variometer

clude moisture. Using two small brass angles, the inductance is fastened to the variometer, as seen in Fig. 1.

If the reader wants to include longer wavelengths than those covered by this receiver, all that is necessary to do is to wind a larger number of turns on the salt-box inductance. Bring out a tap about every 15 or 20 turns and fasten them to contact points and a switch on the panel. If wavelengths up to and including 6000 meters are desired, make the inductance bank-wound<sup>1</sup>. If this is done, don't forget that it is also necessary to load the antenna circuit.

This regenerative receiver was originally designed for 200-meter reception, in which capacity it functioned very efficiently—but, with the advent of broadcasting, a secondary load was needed to tune properly to these comparatively longer wavelengths; so an inductance was added in the grid circuit. Desiring to get the most out of the set that could be had, this load coil was placed in inductive relation to the plate circuit, to take advantage of the radio-frequency present. You can imagine the writer's delight when this resulted in a *decided increase* in signals!

In Fig. 2 is given the circuit used. Circuit students will recognize this as the Paragon circuit—but with a few modifications. A variometer is used to tune the plate circuit, while a variable condenser and a secondary load tune the grid circuit. Regeneration and oscillations are obtained by tuning the plate with the variometer and by having the grid and plate circuits in close proximity.

<sup>1</sup>Such inductances can, of course, be bought. Instructions for bank-winding will be given in detail in an article by Jesse Marston in next month's RADIO BROADCAST.—  
THE EDITOR.

One stage of amplification was all that was desired by the writer, the assumption being that if signals are audible on one stage of amplification, two stages increase only the volume of sound. It also magnifies the noises of the tubes as well as atmospheric disturbances. If the ear is subject to loud signals continuously, it becomes less and less responsive and eventually its susceptibility to weak signals may be deadened. So you can see the advisability of no audio amplification (when using phones), or if any, just one step.

Below is given a list of materials necessary for the construction of this receiver:

- 1 Bakelite panel 6" x 21" x  $\frac{3}{16}$ "
- 1 White pine base 7" x 20" x  $\frac{3}{4}$ "
- 1 Large knob and pointer
- 1 Switch and contact arm
- 8 Contact points
- 2 Stops
- 2 3" knobs and dials
- 2 Rheostats (one with vernier)
- 10 Nickered binding posts
- 1 1" x 6" terminal panel
- 1 Set of parts for a Crosley variometer
- 1 Set of parts for a Crosley variocoupler
- 1 43-plate variable condenser
- 2 Porcelain tube sockets
- 1 Grid condenser
- 1 Federal amplifying transformer
- 2 Phone condensers (.001 mfd.)
- Enough No. 24 D.C.C. copper wire to wind secondary load
- Enough No. 14 hard-drawn bare copper wire to connect the respective parts

Using the insulated copper wire furnished with the variocoupler, 80 turns are wound on the stator tube, a tap being brought out at every 10th turn. This makes a total of 8 taps, which are soldered to the 8 contact points and switch, as shown in the circuit diagram in Fig. 2.

Not much difficulty should be experienced in assembling the variometer. Care should be

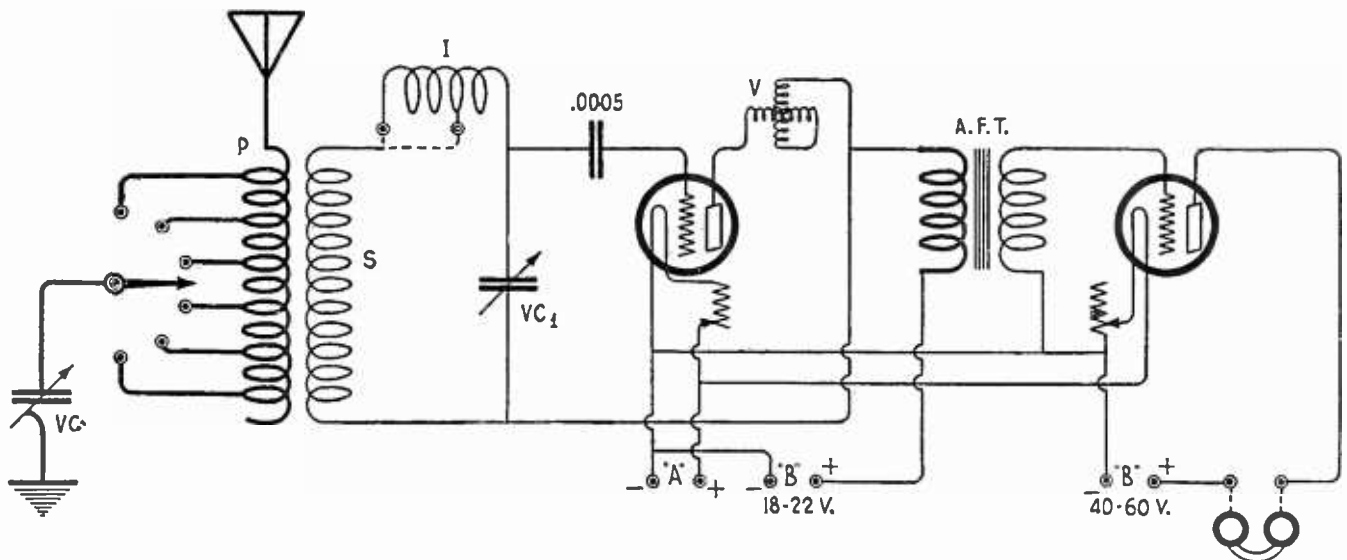

FIG. 2

Mr. Munzig's hook-up, a modified "Paragon" circuit; VC may be omitted

exercised in getting the rotor and stator windings wound in the same direction. Otherwise their mutual inductance will not change and the variometer will not function properly. The bearings for the rotor shafts were not strong enough and so were substituted with larger ones cut from heavy sheet brass. This added a rigidity that the bearings furnished could not give.

Fig. 3 shows the front view of the receiver. An idea of the panel layout can be had from this. The controls from left to right are: coupling control of the variometer, primary inductance switch, variable condenser control, detector rheostat control, plate variometer control, amplifier tube rheostat control, and the output binding posts. The binding posts at the extreme left are: the upper one for the antenna and the lower one for the ground. A variable condenser has been used in the ground

for close adjustments—however, it can be left out.

An idea can be had from the photo, Fig. 1, of how the respective parts are arranged and how connections are made. No. 14 bare copper wire was used for connections between parts.

The variable condenser seen in Fig. 1 is an old Murdock instrument that was pressed into service. The shaft was lengthened by soldering a small piece of the same size shafting on, covering them both with a small brass sleeving. So far it has given no trouble.

The "engraving" on the panel was done by scratching the highly polished panel with a sharp tool, using a steel rule as a guide. This left a fairly deep impression into which white crayon was rubbed. The circular arrows were made the same way, but with a steel compass. It's easy—try it!

FIG. 3

The dials and knobs, from left to right, control: the secondary of the variocoupler (S in Fig. 2), the taps on the primary (P), the variable condenser (VC1), the detector tube filament, the variometer (V), and the amplifier tube filament



# A Set You'll Like to Make

A Michigan Fan's Complete Data for Building a Simple Regenerative Outfit. Can You Do as Neat a Job as His?

By FRANK NELEM  
(HONORABLE MENTION)

FOR those who desire a receiving set which is inexpensive, quite simple in operation, and which will give excellent results, especially on distant stations, I am giving a list of materials and detailed instructions for building and operating a short-wave receiver of the single-circuit feed-back type. One or two stages of audio frequency amplification can very easily be added to it if desired.

The following is a list of materials needed:

- 1 Panel 6" x 21" x  $\frac{1}{8}$ "
- 1 Variable condenser (vernier adjustment if possible)
- 4 Oz. No. 23 single silk covered magnet wire

- 2 Inductance switches
- 16 Switch points and 4 switch stops
- 6 Binding posts
- 1 Combined grid leak and condenser (grid leak, 1 megohm; condenser, .0005 mfd.)
- 1 Porcelain tube socket
- 1 Vernier rheostat
- 1 UV-200 Radiotron detector tube
- 1 .001 Fixed phone condenser

This list of materials amounts to about \$15.00 without batteries or phones. Of course the WD-11 or dry-cell tube may be used instead of the 6-volt tube with fair results, but personally I prefer the 6-volt tube, especially for use with a stage of amplification.

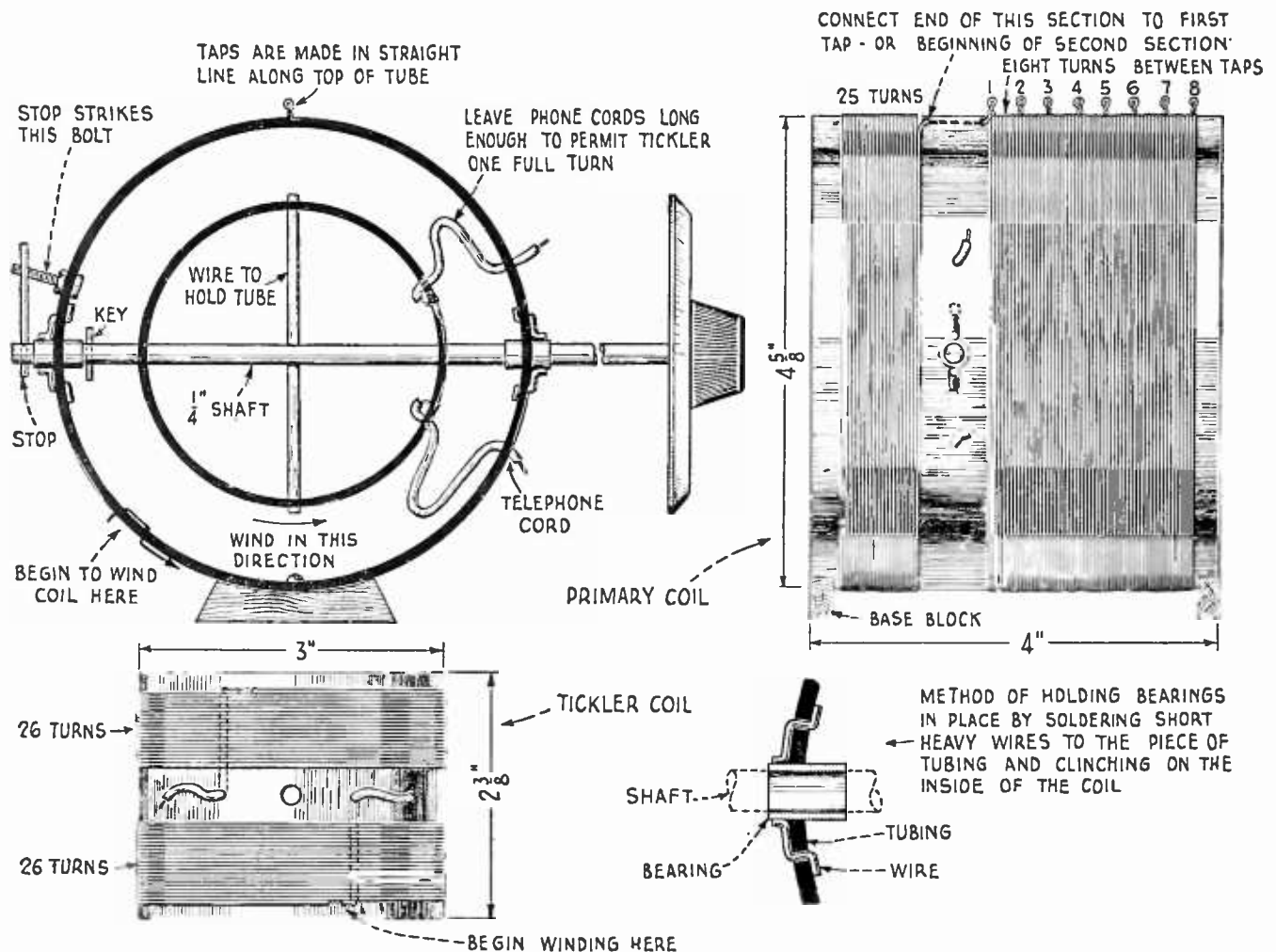

FIG. 1

Details of construction of the primary coil and the tickler



In regard to the construction of this set, you will be well repaid if you do the work in a neat manner, soldering connections throughout. Make connections as short as possible, especially to the grid and the parts which carry high-frequency current, such as the variocoupler.

#### MAKING THE VARIOCOUPLER PRIMARY

**WE WILL** begin with the construction of the variocoupler: Obtain a cardboard tube  $4\frac{5}{8}$ " in diameter and 4" long. Soak the tube in melted paraffin or apply shellac to prevent shrinking. Next punch or bore a hole in the tube  $1\frac{1}{2}$ " from the end. This hole should be the proper size to take a piece of brass or copper tubing  $\frac{3}{4}$ " long in which the shaft can be inserted. The method of inserting these bearings will be easily understood from the drawings. Half way around the tube and  $1\frac{1}{2}$ " from the end punch or bore another hole to take the other bearing.

Begin winding the coil with No. 23 single silk covered wire, as indicated on the drawings, about  $\frac{3}{8}$ " from the end of the tube. Run the end of the wire in and out of two pin holes to hold it and wind in the directions of the arrows. Wind on a section of 25 turns without a tap. Then run the wire along the tube  $\frac{3}{4}$ " to the beginning of the second section. A tap is then made (No. 1 in the drawing, Fig. 1). To make a tap twist the wire into a simple loop and continue winding. Wind the second section with eight complete turns. Then make a tap. Wind eight turns more and make a tap. Continue with the winding, making eight turns and then a tap until seven eight-turn sections have been made. The end of the last section acts as a final tap. Secure this end by running it through pin holes in the tube.

#### WINDING THE TICKLER COIL

**WIND** the tickler coil on the 3" tube, using the same size wire as on the primary coil (No. 23 S.S.C.) Run the end of the wire through two pin holes  $\frac{1}{4}$ " from the end of the tube, leaving about 2" for connection. Now

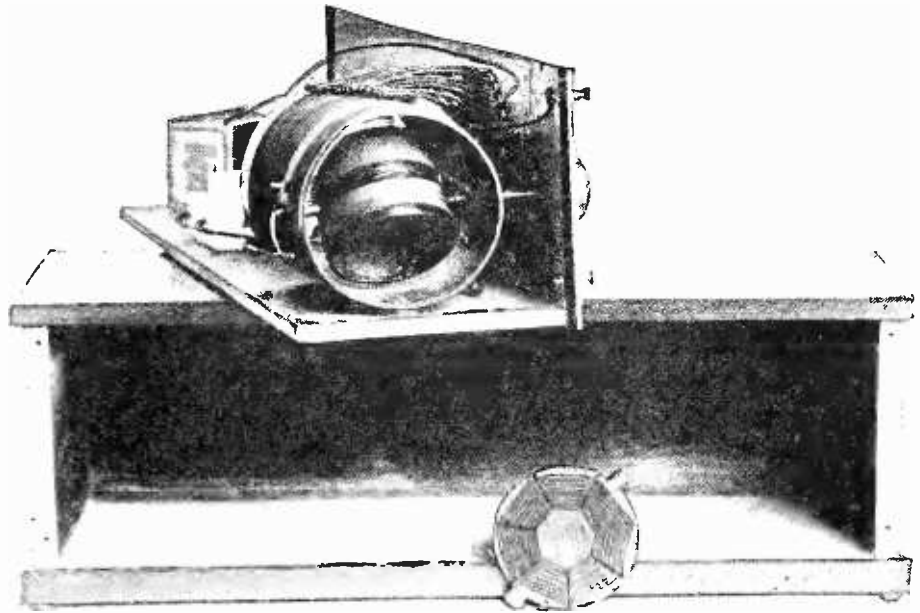

FIG. 2

The set and its cabinet. The spider-web coil shown in front of the cabinet may be used inside the primary coil instead of the cylindrical tickler

start winding in the direction of the arrow shown on the drawings. Wind on 26 turns. This forms the first section. Without cutting the wire, keep on winding diagonally across the space between the sections on the back of the tube. (This is shown by the dotted line in the drawing of the tickler coil.) Keep this wire well away from the holes for the shaft. The wire may be held in place by a drop or two of sealing wax. Then begin winding the second section, being careful to start this section the same distance from the centre of the tube as the last turn of the first section. Wind 26 turns and pass the end through two pin holes made in the tube. Leave about 2" for connecting. About 1" above the  $\frac{1}{4}$ " hole that the shaft passes through, bore a hole and insert a 4" piece of telephone cord or other wire that is quite flexible. This cord or other wire should be soldered to the 2" of wire (inside the tube) at the beginning of the winding. The telephone cord may be held by a drop of sealing wax where it passes through the tube. Bore a hole below the hole for the shaft and insert another piece of telephone cord. Solder this to the end of the second section.

#### THE SPIDER-WEB TICKLER

**THERE** is another tickler coil which is equally satisfactory, if properly constructed. That is the spider-web. If you want to use it, instead of the tickler coil just described, cut out a disc from cardboard which just clears the inside of the primary nicely. By cutting off the

shaft and slotting the ends with a hacksaw the coil may be held in place so as to rotate inside the primary. Cut any *odd* number of slots in the disc (I used 7—see Fig. 2), and wind the wire in and out through the slots until all the wire possible is wound on (about 40 turns). Connect the two ends to pieces of telephone cord. It will be found that this tickler will give more selective tuning on account of preventing

screws against the sides of the cabinet. This feature makes it very easy to remove the set from its cabinet. The panel is screwed to the edge of the base.

Place the variocoupler in position as close to the end of the base as possible so the tickler coil will clear the side of the cabinet when turned. Now slip the base blocks under the ends of the variocoupler and locate on the panel the hole for

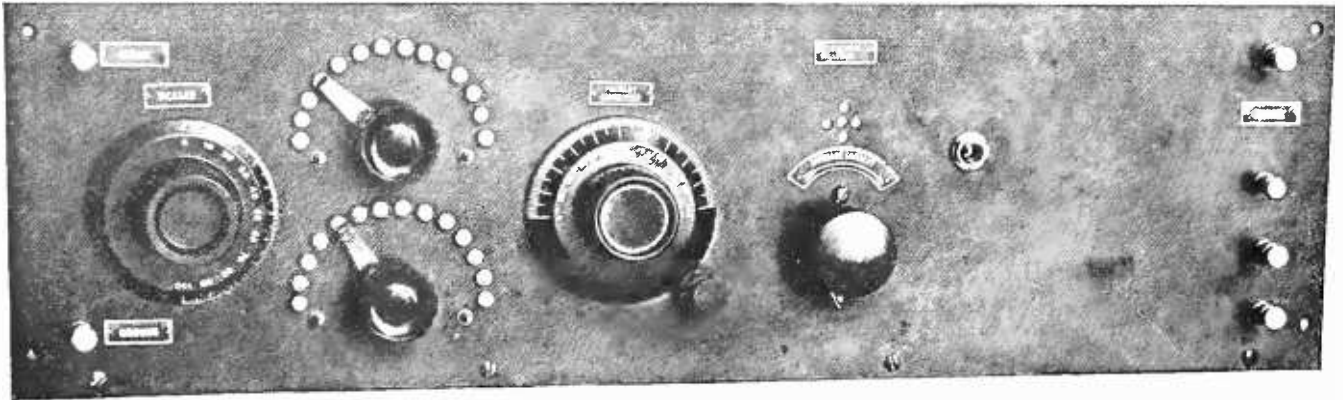

FIG. 3

A neat, attractive panel, with room at the right for the additional peep-holes, phone-jack and rheostat needed if a step of amplification is added

electrostatic coupling and increasing the electro-magnetic coupling.

#### ASSEMBLING THE VARIOCOUPLER

THE shaft, which is about 7" long, has two small holes bored near the back end. The stop wire runs through one hole and strikes against a small bolt or switch point. A small key is inserted on the inside of the bearing to prevent the shaft from slipping endways. The tickler coil is secured by a small wire running through the shaft, the ends just passing through the tube.

First run the telephone cords attached to the tickler coil through two holes in the primary tube. One of these holes is above and the other below the bearing, or if preferred the cords may be held with a small bolt inserted in the holes. Next slip the shaft through the bearings and the tickler coil. Fasten the stop and pin in the holes at the end of the shaft, and secure the tickler coil by a small wire running through the tube and shaft. The variocoupler rests upon two small base blocks of wood or fiber.

#### ASSEMBLING THE SET

OBTAIN a board for the base about 8" wide and  $\frac{3}{8}$ " thick. Cut to a length that will just nicely slide into the cabinet. This board is somewhat shorter than the panel, as the panel

the shaft turning the tickler. The hole for the shaft of the variable condenser should be on a line with that of the tickler and the two shafts about 6" apart. The dials are about 3" in diameter. Unscrew the panel from the base. Bore the holes for tickler and condenser shafts. Centre the two inductance switches and bore the holes. Bore eight holes for each row of switch points so that the heads of the switch points will not be too far from each other for the switch lever to pass smoothly over them. Bore also the holes for the switch stops. The small knob at the lower right of the condenser dial in the photograph (Fig. 3) is a homemade friction vernier attachment made from a binding post cap and a short piece of threaded shaft. A rubber disc rubs on the edge of the dial. This is almost a necessity unless one has a vernier condenser, as very sharp tuning is required. Bore the holes for the rheostat next, placing it as near to the condenser as possible without interference. The phone jack is optional but is necessary for a stage of amplification. Bore the holes for the six binding posts: aerial, ground, phones and A battery. The phone condenser is of the paper and tinfoil type. Mica and copper are considered a better combination but this type has worked satisfactorily for me.

Glue tinfoil on the back of the panel to act as a shield for body capacity. This runs just as

far as the rheostat. Cut the tinfoil away from all metal shafts and rows of switch points by a margin of at least  $\frac{1}{8}$ ". Also cut it from around the aerial binding post, but do not cut it away from the ground binding post as it must make contact with the ground. Shielding must be done carefully, for if the tinfoil touches a shaft or screw the set may fail to operate.

After this is done, screw the switch points in and put in the inductance switches. Run a wire from the ground binding post to the upper inductance switch and solder it. Bare wire covered with rubber tubing or spaghetti may be used throughout. The wire used in this set is No. 18 covered with black cotton. Cut eight pieces of wire about eight inches long. Take one of these and solder one end to the first switch point in the lower row. Run this wire up to the first switch point in the upper row. Leave about five inches for connection to the first tap on the variocoupler. Connect up the two rows of switch points in this manner. The second switch point in the upper row connects to the second in the lower row. Solder one end of a wire to the lower inductance switch and leave the wire long enough to reach the lower binding post at the right of the panel.

The panel may now be mounted on the base board. Place the variocoupler on the base board with the shaft through the hole in the panel and with the dial attached move the variocoupler until it rests level and square with the panel. Fasten it to the base with wood screws running through the base blocks. Solder the wires from the upper row of switch points to the taps in the coil, the first switch point to the first tap, etc.

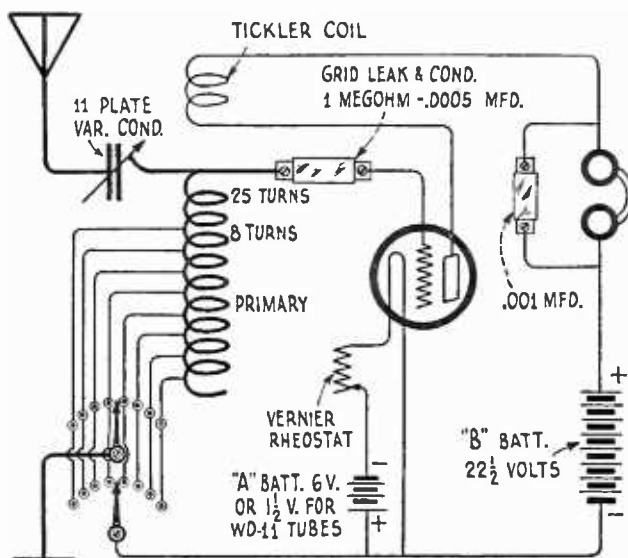

FIG. 4

This single-circuit regenerative hook-up is about the simplest tube hook-up there is. It is *not* recommended in thickly-populated districts, because it causes interference by re-radiation; but it is very efficient and just the thing for the person who lives in the country and hasn't much to spend on a set

Connect the aerial binding post to the rotary plates of the variable condenser. Run a wire from the stationary plates of the variable condenser to the beginning of the primary winding. Connect the plate terminal of the vacuum tube socket to the lower terminal of the tickler coil. Run a wire from the upper binding post and phone condenser over to the upper terminal of the tickler coil. Connect the wire soldered to the lower inductance switch to the lower right hand binding post which will be a positive A battery terminal. Connect the positive ("plus") terminal of the socket to this wire. Run a wire from the negative side of the socket

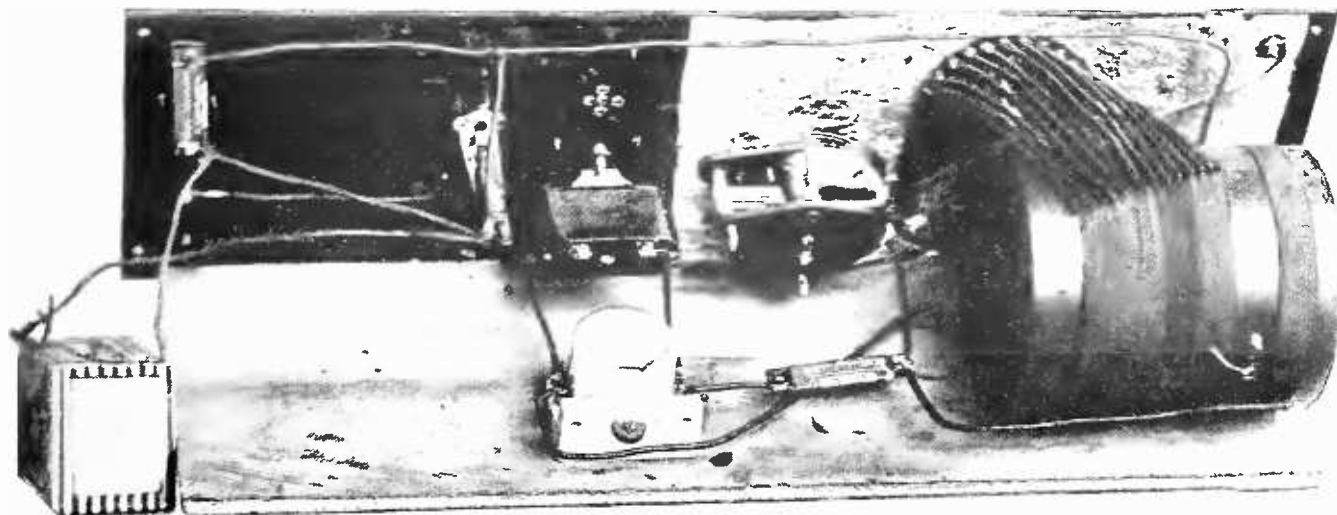

FIG. 5

Mr. Nelem purposely made his panel 21 inches long, so that he could add a step of audio-frequency amplification when he wanted to

to the rheostat and one from the rheostat to the negative A battery binding post, which is second from the bottom. The negative pole of the B battery connects on the positive A or bottom post. The positive B goes to the phone condenser. The grid leak and condenser connect to the beginning of the primary winding. Constant reference to the three photographs and the diagrams should enable any one who follows these instructions carefully to build a set like mine without difficulty.

#### OPERATION OF THE SET

WHEN tuning in a broadcasting station set the inductance switches on about the fourth points (with a hundred-foot aerial). Turn on the rheostat until the bulb starts to hiss. Then, with the tickler coil lying horizontally, turn the variable condenser around slowly being careful not to pass over the signals. If this does not bring in signals, turn the tickler coil half way over and try again. It will be found that the condenser will be used most in tuning. When the condenser is at zero capacity a very loud howl will be heard in the phones. The use of the vernier rheostat must not be slighted, however, as this will give clearness of tone and help to prevent howling. Do not

turn the rheostat on too far. If the grid leak is of the right resistance, a sharp click will be noticed when turning on the rheostat. Keep the filament current just below this click to get the strongest and clearest signal.

I have used the electric light wiring in the house for an aerial and find that it is almost as good as my outside aerial which is about 100 feet long and 30 feet high. With one stage of audio-frequency amplification I have heard stations in Los Angeles (from my home in East Tawas, Michigan) using the light wires as an aerial and the bed springs as a counterpoise. Using the light wires as an aerial, I have connected one wire to either the centre or side contact in the electric-light socket and run this wire to the set, turning on the switch in the lamp socket. The variable condenser stops any current from passing into the set. By connecting the ground to the aerial binding post I have heard stations 500 miles distant.\*

One stage of amplification can very easily be added at the right of the detector tube. It was with the idea of this addition that the panel was made 21 inches long.

\*Mr. Nelem's total mileage is 61,100—92 stations over 150 miles distant, of which four were 2000 miles or over.

## A Set With a Tuned R. F. Amplifier

A Non-Regenerative Outfit Designed Primarily for Quality, Not Quantity

By J. W. DENNING

(HONORABLE MENTION)

WHEN a radio fan's craving for distance and innumerable new stations is satisfied—as it always is sooner or later—he begins to

study methods of improving the quality of what he receives and the stability of his set. The single-tube set which he usually starts with does not satisfy him, and he begins to tuck on more tubes and try all sorts of hook-ups. Certain stations become old friends to him—he tunes in on them regularly and often listens to them until they sign off. The advantages of a set

giving good quality of reproduction, plenty of volume, and which does not require continual manipulation to keep it in tune, soon become apparent to him.

The writer some time ago found himself converted to this attitude, and the receiver herein described is a result of considerable study on the matter. It was early recognized that regeneration, while able to cover great distances and with proper amplification giving good volume, at its best was unstable and tended to distort. R. F. amplification seemed to offer a way out of these difficulties.

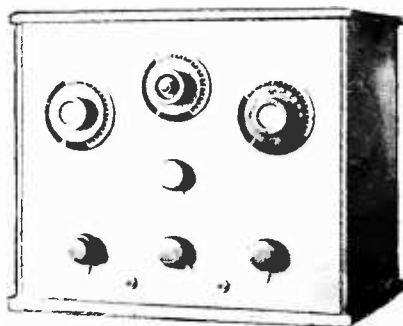

THE "QUALITY FIRST" BOX  
It has 4 tubes, no regeneration

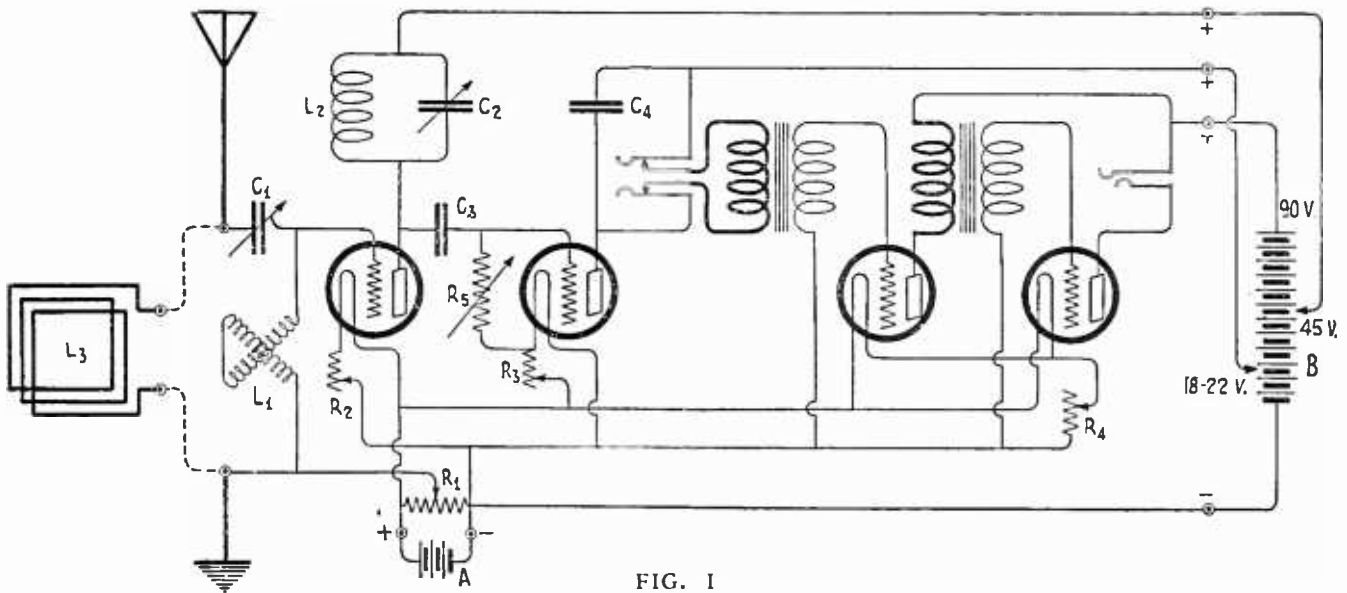

FIG. 1

The grounded side of condenser  $C_1$  is the rotar. A plug and jack arrangement, or a double-pole double-throw switch, may be used to advantage for quickly changing from antenna and ground to the loop,  $L_3$

All the available commercial R. F. sets were carefully studied and various R. F. transformers experimented with as they came on the market. It was found that, while several untuned types of transformers worked very satisfactorily they required a highly selective tuner with rather loose coupling. Since loose coupling meant a reduction of transferred energy, a method of obtaining selective tuning with a single-circuit aerial tuner was sought, and found in the tuned transformer and tuned impedance methods of radio-frequency amplification. The latter method was adopted as being simpler than the tuned transformer and equally efficient. An added feature was its adaptability to any type of tube, which was not the case with transformers, making it possible to use dry-cell tubes when so desired. The set illustrated is one of a number constructed on this principle, all of which have given entire satisfaction.

Referring to the circuit diagram, the principal constants are as follows:

$L_1$ —A well built variometer with a fairly large range of inductance to cover a wide band of wavelengths.

$L_2$ —A honeycomb coil of 35, 50, or 75 turns, set so that it will not be too closely coupled inductively to  $L_1$ .

$L_3$ —Loop aerial for "static nights", 10 to 12 turns, flat wound, two feet on a side. It may be used with the outside aerial as indicated.

$C_1$ —11-plate variable condenser, giving fine tuning in aerial circuit. Note: a series-parallel switch will increase the wavelength range of this set very much when used with this condenser and  $L_1$ .

$C_2$ —23-plate variable condenser, preferably with vernier, used to tune  $L_2$  to resonance with the grid circuit.

$C_3$ —Fixed grid condenser of from .00025 mfd. to .0005 mfd. It should be a good mica condenser.

$C_4$ —Fixed phone by-pass condenser, capacity .001 mfd.

$R_1$ —200- to 400-ohm potentiometer, used to control regenerative tendency of amplifier tube and prevent oscillations.

$R_2, R_4$ —6- to 25-ohm rheostats, depending on tubes used.

$R_3$ —6-ohm rheostat for detector filament. Vernier helps if detector is soft.

$R_5$ — $\frac{1}{2}$  to 5 megohms. This is the grid leak for the detector tube and is preferably a good variable leak.

The tubes recommended for best results are as follows:

Detector: soft tube such as UV-200.

A. F. Amplifiers: Hard tubes such as UV-201 or 201-A, or De Forest.

R. F. Amplifier: Hard tube such as UV-201 or 201-A. The 201 seems to work as well as, if not better than the 201-A.

WD-11, WD-12, or UV-199 tubes may be used if desired, although they are not as good amplifiers as the above mentioned tubes.

It will be noted that a separate plate lead is brought out for the radio-frequency tube. It

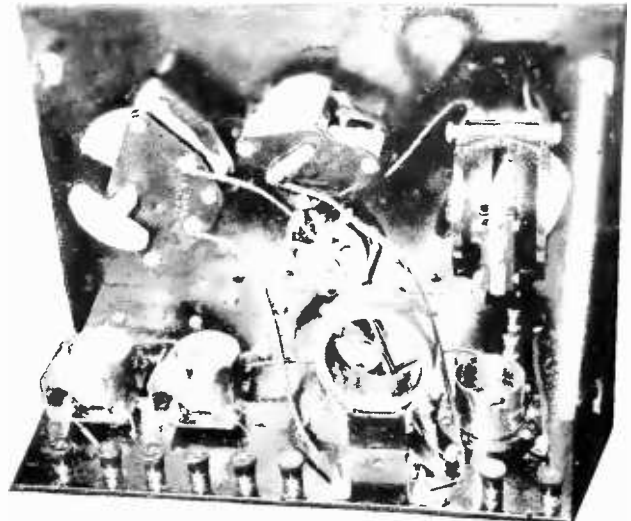

FIG. 2

Showing relative positions of the various units

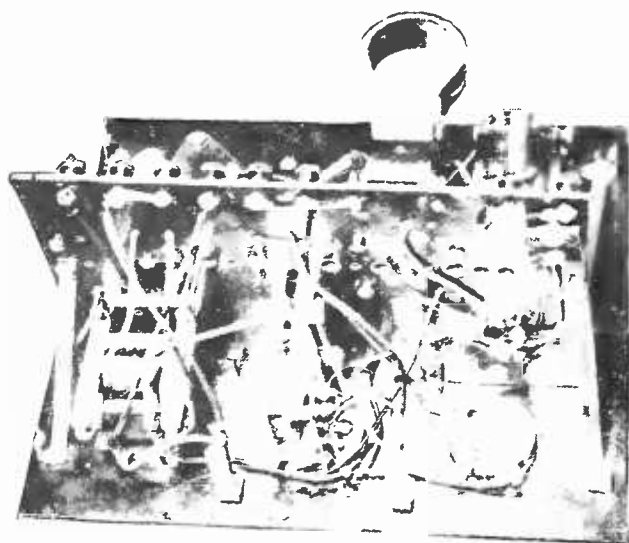

FIG. 3

The set of Fig. 2 has been tipped back, to show the transformers, mounted under the shelf which is fastened in back of the panel

will be found that this tube will operate best at a lower voltage than the A. F. tubes. A. F. transformer filament leads should be connected to the negative of the A battery with the rheostat in the negative lead to the sockets. The grid leak should run to the positive terminal on the detector socket.

#### TUNING

THE principle involved is this: when the grid circuit and plate circuit are both in tune with the incoming signal only the signal

tuned to will be amplified, all others "falling by the wayside." It is important that the distributed capacity in  $L_1$  and  $L_2$  be low, thus giving the sharpness of tuning which is so much desired. By setting the potentiometer as near the negative as possible without starting oscillations and moving  $L_1$  and  $C_2$  simultaneously, the corresponding resonance positions will soon be found and stations easily tuned in. Fine tuning is done with  $C_1$  and the vernier on  $C_2$ . This set will usually operate best with low values of  $C_1$ , on the outside aerial, and medium values when used with the loop. (This can be accomplished by careful adjustment of the variometer.) Careful setting of  $R_1$  makes for maximum amplification. It should be turned as far to the negative side as possible without producing oscillations. Oscillations are manifested by the set suddenly "going dead," an effect which can be easily identified. When oscillating, it makes a very good receiver of undamped waves. Since phone signals cannot be received when the set is oscillating, there is no inclination to use it in the oscillating condition on broadcast reception, hence it does not cause interference as regenerative sets often do.

Although the writer isn't much of a "radio golfer," some of his friends have made very creditable records in an evening with the set just described. The total mileage is 71,125, with 89 stations logged, the farthest (from Boulder, Colorado) being PWX in Havana.

## A Home-Made Three-Tube Outfit

It is Easy to Build and Easy to Operate. It Has Brought in 100 Stations, Two of Them Being 2000 Miles from the Writer's Home in Marion, Indiana

BY L. REITH

(HONORABLE MENTION)

THIS set is made up of three parts—tuner, detector, and two stage amplifier. It is very efficient and selective, easy to tune and works equally well on all wavelengths from 150 to 700. It works better than several other sets I have made, running from single circuits to the variometer and variocoupler hook-up, and has given excellent results from the very first minute it was tested out.

The tuner circuit is composed of a stationary primary coil, movable secondary coil in

inductive relation to the primary, a stationary secondary loading coil in series with the secondary, a movable tickler coil in the secondary loading coil, and a 23-plate variable condenser.

For the primary coil, wind 65 turns on a tube  $3\frac{1}{2}$ " in diameter and  $2\frac{1}{4}$ " long, tapping at turns 15, 18, 21, 24, 27, 30, 35, 40, 45, 50, 55, 60 and 65, making 13 taps.

The secondary loading coil is wound with 38 turns on a tube  $3\frac{1}{2}$ " in diameter and  $1\frac{3}{4}$ " long, tapping the tenth and the last turns.

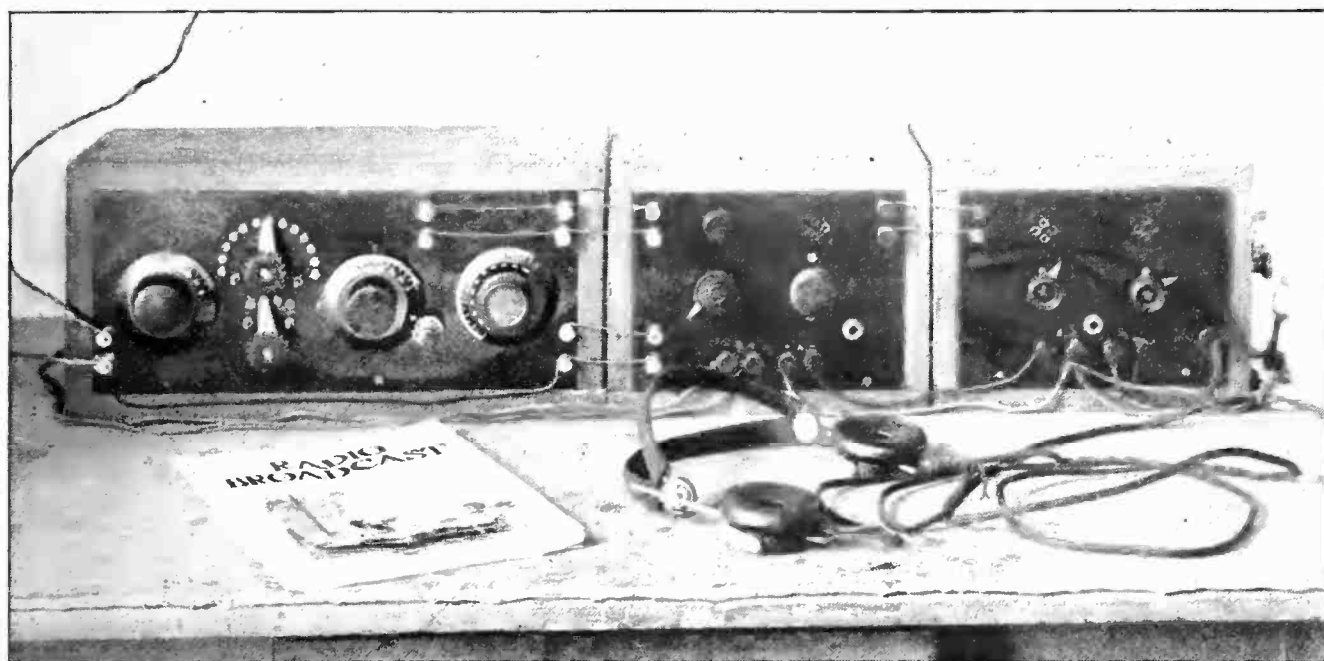

THE OUTFIT COMPLETE, AND READY TO FURNISH AN EVENING'S ENTERTAINMENT

In the left-hand cabinet are the tuning units only, in the middle one is the detector, and in the right-hand cabinet are the two steps of A. F. amplification

These two coils are mounted on the panel at right angles as shown in one of the photos, with small brass angles or pillars so as to set them back  $\frac{1}{4}$ " from the panel.

The secondary and tickler coils are exactly alike, being 3" in diameter and  $1\frac{1}{4}$ " long, wound in two sections, each  $\frac{3}{8}$ " long, with a space of  $\frac{3}{8}$ " between to allow for the shaft. The shafts are made of  $\frac{3}{16}$ " brass rod 5" long, threaded on one end for about one inch, and from the other end up to the thickness of the panel from the first threads. This small place left is for

the bearing on the panel. If this bearing is carefully made, no rear support for the shaft will be needed. It is a good plan to use a panel bushing such as those on switches, but if these are not at hand, screw on the short threaded end of the shaft a nut as tight as it will go, put the shaft through the hole in the panel (be sure that it is not a bit larger than necessary for the rod to slip through) and put two nuts on the other side of the panel, using the last one as a lock-nut. Get them close enough to the panel to make a good bearing for the shaft. It is well

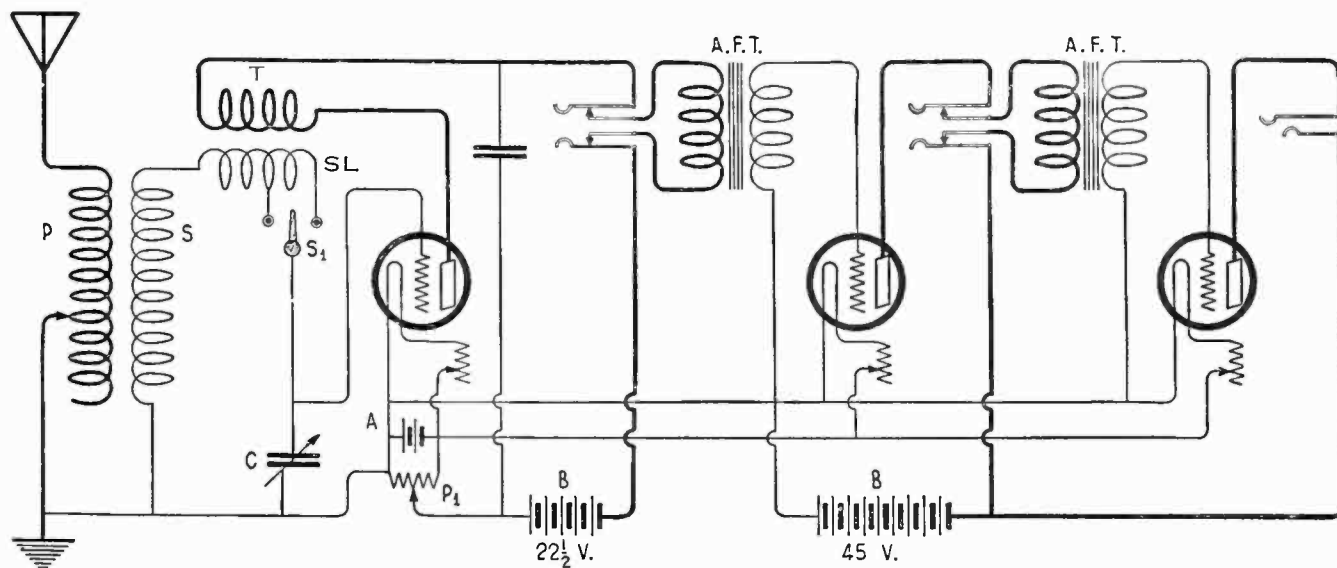

FIG. 1

P-primary coil, S-secondary coil, SL-secondary loading coil, T-tickler, S<sub>1</sub>-switch for cutting in inductance, C-23-plate condenser with rotor grounded, P<sub>1</sub>-potentiometer

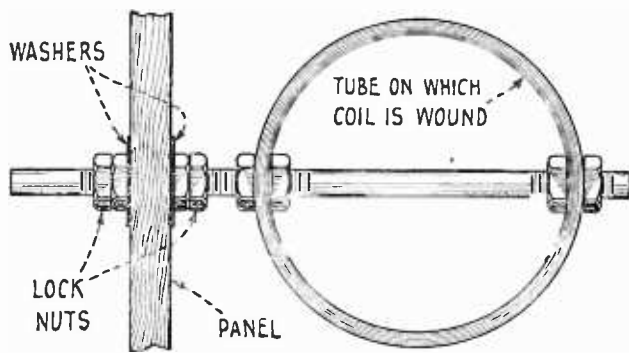

FIG. 2  
Showing bearing for movable coils

to include washers next to the panel on both sides. Then put on the coil, using a nut on each side of the tube at both places where it goes over the shaft to hold it in place. These should be placed to hold the coil in the right position for turning without touching the larger coils. Run leads from the coils to their proper connecting places. All winding was done with 20-strand No. 38 Litzendraht.

The detector and amplifier are of standard construction and hook-up. The list of materials needed for this set is as follows:

- 1 tube,  $3\frac{1}{2}$ " dia. and  $2\frac{1}{4}$ " long
- 1 "  $3\frac{1}{2}$ " "  $1\frac{1}{4}$ " "
- 2 "  $3$ " "  $1\frac{1}{4}$ " "
- 2 brass rods,  $\frac{3}{16}$ " x  $5\frac{1}{8}$ "
- 2 switch levers
- 1 23-plate variable condenser
- 3 3" dials
- 1 potentiometer
- 1 Bradleystat
- 2 rheostats
- 3 sockets
- 2 two-circuit jacks
- 1 one-circuit "
- 2 amplifying transformers
- 1 .001 mfd. fixed condenser
- 1 grid leak and condenser
- 200 ft. 20 No. 38 Litzendraht

Connecting wire  
Switch points  
Binding posts  
Panels  
Miscellaneous bolts and nuts

#### INSTRUCTIONS FOR OPERATING

USING dials with a 90-degree scale, 0-50, set so that they are at 0 with both coils in a vertical position. Then proceed as follows:

Set the secondary dial at about 40 and the tickler dial at about the same. These will be approximately the best positions for these dials on all wavelengths. Then set the switches on taps best for the particular wave wanted; for example, for 360 or 400 meters, put the primary on tap 7 and the secondary on tap 2. The best positions for these will be easily found after a little experimenting. Turn the rheostats up until oscillation just begins, and move the condenser dial until you get a carrier-wave squeal. Tune as well as possible with this and finish tuning with the secondary dial, as this acts as a vernier on the condenser and will give very fine tuning. Adjust the tickler so that the signals are loudest without distortion. Waves up to 300 meters come in best in my case with the secondary switch on tap 1; over 300, on tap 2.

On the end of the amplifier box are a switch and binding posts for connection to a loud-speaker if wanted, so that either it or the phones or both, may be used.

A good loud speaker can be made by getting an old-style phonograph horn and soldering on it a bracket and a plate or can lid large enough to take a receiver and with a hole just the size of the neck on the horn. Put a piece of felt on this and clamp the receiver on with rubber bands or any kind of clamping device.

#### THE OUTFIT OPEN FOR INSPECTION





# Summary of Receiving Contest Entries Arranged in Order of Mileages

*The following report includes the work of all contestants having a total mileage of 40,000 or over, but does not include the Prize Winners or Honorable Mentions:*

JOHN C. Peters, Casper, Wyoming. 305,420 miles. His receiver employs the principle of "resistance neutralization" developed by his brother, Leo J. Peters, Radio Research Engineer for the University of Wisconsin. For information regarding this principle, Mr. Peters refers us to the Journal of the A.I.E.E., Vol. 41, March, 1922.

Otho Currie, 3305 Avenue H, Fort Worth, Texas. 283,330 miles. One-tube single-circuit regenerator. He has heard every state in the U. S., 10 stations in Canada, 1 in Porto Rico, 2 in Hawaii, 1 in Alaska, and 1 in Cuba.

Milton S. Johnson, 938 So. 4th St., Atchison, Kansas. 199,988 miles. 3-circuit set using one step of radio, detector, and one audio. He comments on the "great feeling, to be able, any ordinary evening, to slip your phones on your ears and listen to any one of the better class broadcasting stations in the United States." However, he remarks: "I have made one discovery and that is that the real fun in radio is to have a C.W. and 'fone' transmitter, belong to the A.R.R.L., and talk back and forth to China and London." Yes, we have no objections.

Leland K. Hill, Wellsville, Utah. 179,588 miles. Single-circuit regenerative set with a two-stage home-made amplifier. During the cold weather nights he has stayed up into the small hours and heard a number of 2000-mile stations, the farthest being Halifax, Nova Scotia, 2,490 miles from Wellsville.

Captain J. H. Halsey, skipper of the S. S. *El Cid*, which runs between New York and Galveston, Texas, made his own 3-tube outfit in conjunction with a friend. 172,960 miles. "We average eighteen nights a month at sea," he writes, "where we have a very clear atmosphere. The antenna runs from masthead to masthead, above the ship's antenna, and direct to my cabin. The set is surely good company."

Fergus Sunshine McKeever (age 12), University Heights, Lawrence, Kansas. 170,000 miles. Grebe CR-9 (three-tube regenerative set), with Baldwin phones and a W.E. loud speaker. This youthful contestant has "listened as late as three o'clock getting 65 stations in one evening." He claims to have heard a station in Portugal, one fine winter's night.

Arthur Chapelle, Woodburn, Ore. 168,690 miles. Three-circuit, tickler regenerative set, two tubes. Mr. Chapelle sent us one of the excellent spider-web coils which he makes himself, and to which he ascribes much of his success in pulling in far-away stations.

E. Woody Kulman, 1046 36th St., Des Moines, Iowa. 148,255 miles. His home-made receiver, of the standard single-circuit type, cost him \$37.40. He observes that Des Moines has a conveniently central location for reception from all points of the compass.

J. B. Slaughter, Jr., U Lazy S Ranch, Post, Texas. 147,680 miles. He has heard 203 different stations, all on a 3-tube set with a Magnavox R loud speaker. "Radio on the ranch," says Mr. Slaughter, "is the greatest invention yet, for ranchers, as a rule, are a great distance from any entertainment or late news of any sort; with the coming of radio we are right alongside the large cities. We get the baseball results, for instance, even before they do, unless they have radio sets installed. The broadcasting of cattle and crop quotations is very valuable on ranches, as we can tell better when to ship our cattle and grain. Any one ever in this part of the country is extended a cordial invitation to visit the ranch and see my set."

T. W. Sharpe, Jr., (age 15), 1816 North Colorado St., San Antonio, Texas. 147,325 miles. Detector and two of audio again, with an improvised loud speaker to which the headphones are attached.

W. E. Davison, 538 Charlotte St., Sydney, Nova Scotia. He has tried many circuits but finally settled on the common or garden variety of single-circuit regenerative hook-up, which, it is to be hoped, causes less interference in Nova Scotia than it does in other places we might mention.

Robert Allen, Mendota, Ill. Amateur 9CTF. 133,011 miles. A Grebe CR-8 receiver with a three-stage audio amplifier. Mr. Allen says: "This set with one tube, no R.F., has picked up KF1 on a three-foot loop, and I believe that this is something worth while trying to duplicate. I base the success of my outfit on the aerial that I have, which is 305 feet long suspended between two trees. The ground consists of three 6-ft. pipes driven in moist earth."

A. T. Hull, Jr., 318 Armistead Avenue, Hampton, Va. 123,470 miles. "Down by the sea in Hampton, Va., radio has full swing. Coming home this evening I counted four aeriels within 100 yards of my house." Single-circuit outfit, with two stages of audio.

Theodore Nelson, 1451 Thomas St., St. Paul, Minn. 122,320 miles. Three-circuit, single-tube, with plate variometer.

Alvin J. Meyers, 69 New St., Blue Island, Ill. 119,223 miles. Home-made three-tube outfit.

W. Hall Moss, Dayton, Tenn. 115,155 miles. Three-circuit set, home-made.

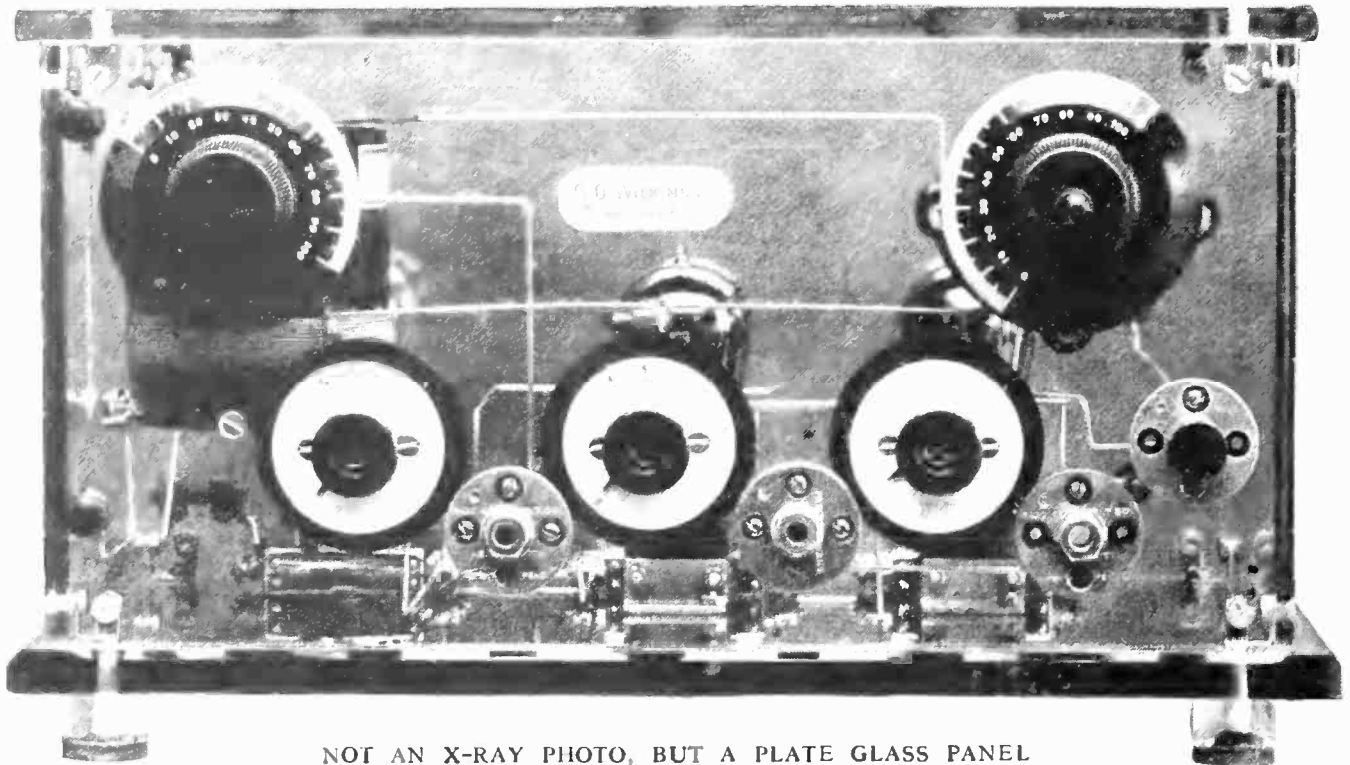

NOT AN X-RAY PHOTO, BUT A PLATE GLASS PANEL

The set is the work of G. O. Wilkinson of Philadelphia, Pa. The "Home-Built" Coil, which he manufactures, is an important part of this set. One of them is seen behind the upper left-hand dial

## Various Sorts and Sizes, All Home-Made

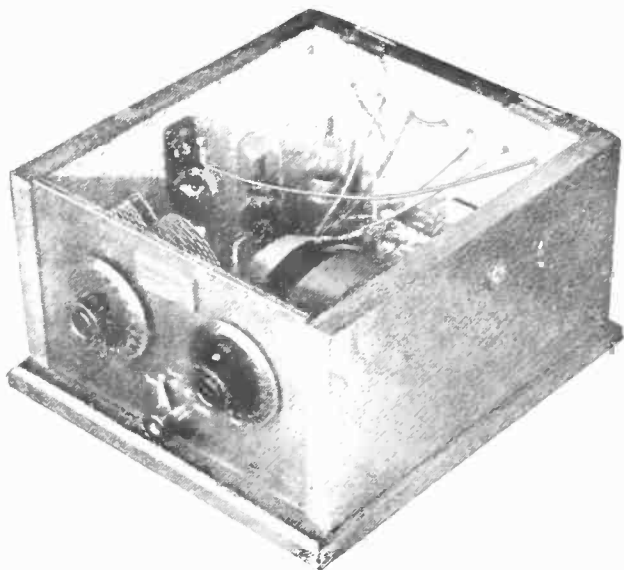

A 3-TUBE SET IN A SMALL SPACE

It was built by William J. MacChesney of Summit, N. J. The switch between the two dials turns on and off the filaments, at the same time changing the number of turns of the primary coil



GEORGE WOODRUFF, OF WINCHESTER, VA.  
With the single-circuit outfit he made

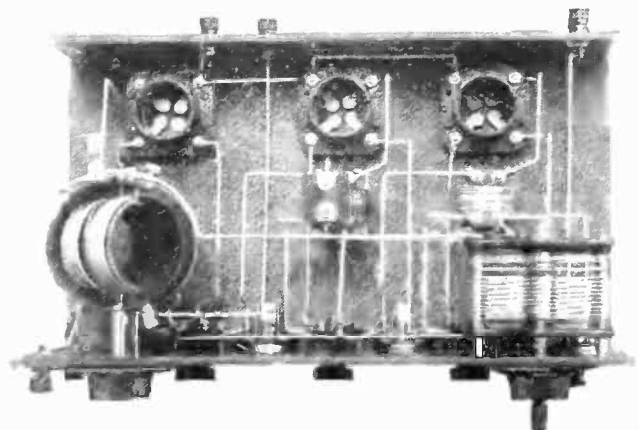

A NEAT JOB, DON'T YOU THINK?  
Another view of Mr. Wilkinson's receiver

J. H. Taylor (age 13), 1434 Meridian Pl. N.W., Washington, D. C. 110,021 miles. Home-made single-circuit regenerator, plus two stages of audio. Three-wire antenna 55 feet long and 50 feet high.

H. S. Fredrickson, 406 Howard St., Charles City, Iowa. 109,500 miles. 170 different stations, of which 121 were heard on one tube (single-circuit).

Lester Witherby, in care of W. B. McClure, 263 E. 43rd St., Seattle, Wash. 108,122 miles. See July, 1923, RADIO BROADCAST, page 236.

Edward A. Block, 1805 Peabody Ave., Dallas, Texas. 104,605 miles. Reinartz circuit.

Albert Hiller, Jr., 701 N. 39th St., Philadelphia, Pa. 104,230 miles. Two radio, detector, and two audio, home-made.

George Kingston, 722 First St., Fort Meyers, Fla. 103,180 miles. A De Forest D-7 reflex loop receiver, used with a three-foot loop *and* outdoor antenna *and* ground. During parts of February and March, Mr. Kingston heard Los Angeles almost every night. One night he pulled in four stations on the West Coast.

Cecil Newton, Webster, N. Y. 101,665 miles. Home-made single-tube set. Says Mr. Newton: "I think, of all the evenings of enjoyment I ever had the first evening with my set was the best. 'Ain't it a grand and glorious feeling when you have accomplished something that works."

Thomas Mahoney, 1900 Crockett St., Dallas, Texas. 100,600 miles. Reinartz tuner, home-made with two stages of audio.

Edward M. Starkey, Le Sueur, Minn. 99,675 miles.

Fred R. Nicholls, Cle Elum, Wash. 107 stations on his home-made Reinartz and two audio equipment.

L. W. Carlisle, Lisbon, N. D. 96,673 miles. Aeriola Sr. with one stage of home-made audio-frequency amplification. He got WJZ (1300 miles from Lisbon) on May 5th, after trying all winter.

Elmer Gruneske, 1282 W. 106th St., Cleveland, Ohio. 95,485 miles. Westinghouse RC and two steps.

Joseph Gretter, Grandin, N. D. 94,387 miles. One-tube, single-circuit home-made.

Roscoe Robinson (age 14), Ponca City, Okla. 93,475 miles. See page 237, RADIO BROADCAST for July, 1923.

George W. Miller, Box 293, Manitou, Colorado. 91,420 miles. Three-circuit regenerator with two stages of audio. Mr. Miller has received voice from coast to coast and from the Gulf to the north of Canada. He mentions that from his home in Colorado he has also brought in code from distant points at sea and from Germany.

Harold D. Smith, Box 131, Ducor, Calif. 90,055 miles.

Daniel Lamb, 220 West 1st St., Mesa, Ariz. 88,795 miles. See page 238 in July issue.

Edgar I. Eisenstadt, Highland Park, Ill. 87,840 miles.

W. S. Neely, Chester, S. C. 85,509 miles.

Alvin Rasmussen, Box 503, Chinook, Montana. 85,185 miles.

A. J. Master, Highgate, Ontario, Canada. 84,965 miles.

Wm. J. MacChesney, 34 Hawthorne Place, Summit, N. J. 84,100 miles.

Henry Duderstadt, 6041 Main St., Kansas City, Mo. 81,040 miles. See page 238 in July issue.

G. O. Wilkinson, 417 Walnut St., Philadelphia, Pa. 79,985 miles. Photos of his set are published in this issue, page 490. He sent us a sample of the well-made "Home-Built" tuning coil which he manufactures.

W. E. Dougherty, Box 44, Ault, Colo. 78,405 miles.

L. J. Love, Warrensburgh, N. Y. 78,015 miles.

Wesley Thomas, Little Falls, N. J. 77,550 miles.

Lloyd Saxon, Box 214, Clovis, Calif. 77,324 miles.

Robert R. Taylor, Prospect Ave., Willow Grove, Pa. 74,505 miles. He has logged Los Angeles 13 times, San Francisco once, Calgary once, and Denver 3 times. Grebe CR-5 and Sleeper two-stage amplifier.

Dwight V. Johnson, Box 242, Ludington, Mich. 71,965 miles all on loud speaker. Three-circuit, single-tube twin-variometer set. In tests aboard a steamer on Lake Michigan, Mr. Johnson brought in KFI and KHJ on two successive nights, so loud that their programs could be heard all over the ship's cabin.

Curtis Herbert, 185 Montrose Ave., Rutherford, N. J. 69,501 miles. See page 238, July RADIO BROADCAST.

Bruce MacDonald, 1817 E. 3rd St., Duluth, Minn. 69,175 miles.

Stephen Carleton Rogers, 21 Red Rock St., Lynn, Mass. 68,755 miles.

Jack Ryder, 1100 Westwood Ave., Columbus, Ohio. 67,920 miles.

Howard H. Weston, Palisade, Colo. 65,850 miles.

George O. St. Charles, 408 Lincoln Avenue, Wayne, Mich. 65,188 miles.

W. F. Delp, Rural Retreat, Va. 63,939 miles.

Edwin M. Nisson, Radio 9EAM, 2544 Washington St., Denver, Colo. 63,780 miles. See page 238 July RADIO BROADCAST.

Ted Lehman, 520 W. Greenup Ave., Ashland, Ky. 62,915 miles.

Q. Scott, Aurora, Nebr. 60,903 miles

R. P. Mc Elhiney, Madison, Me. 59,840 miles. See page 238, July RADIO BROADCAST.

Leo M. Dilley, Sunfield, Mich. 59,391 miles.

Arthur Weld, Radio 9DHH, Cleveland, N. D. 58,795 miles.

Jonathan Eldridge, Jr. (age 14), Chatham, Mass. 58,585 miles.

Sten Anderson, 3247 Q St., Lincoln, Nebr. 58,480 miles.

Rolland R. La Pelle, Takoma Park, Washington,

D. C. 56,905 miles. See page 238, July RADIO BROADCAST.

Wilbur S. Nay, 415 16th St., Manhattan, Kansas. 55,931 miles.

Gerard Curtiss, Wauwatosa, Wis. 54,765 miles.

Robert Selby, 1014 Bacon St., Pekin, Ill. 52,651 miles.

J. H. L. Fincke, 511 Elliott St., Evansville, Ind. 52,040 miles. See photo, page 418.

E. D. Harrington, 2331 Blake St., Berkeley, Calif. 51,974 miles. See page 234, July RADIO BROADCAST.

M. A. Jaeger, Englewood, Colo. 51,525 miles.

Sam Terranella, 1101 Preston St., Dallas, Texas. 51,370 miles.

Harry B. Davenport, 1631 N. 61st St., West Philadelphia, Pa. 50,758 miles.

H. Wilbur Polson, Geneseo, Ill. 50,600 miles.

Louis I. Roland, U. S. Navy Radio Station (NPL), Point Loma, Calif. 47,800 miles.

Fred and Albert Yohn, Norwalk, Conn. 47,748 miles.

William S. Best, in care of Washburn, Crosby Co., Minneapolis, Minn. 47,046 miles.

A. W. Bothwell, 2921 P St., Lincoln, Nebr. 44,400 miles.

James W. Brennan, 36 Front St., Beverly, Mass. 44,220 miles.

Don Ross, 123 Hibbert St., Ironwood, Mich. 44,040 miles. See photo, page 238, July RADIO BROADCAST.

Arthur H. Phillips, 207 Victor St., Winnipeg, Manitoba. 43,825 miles.

John D. Wylie, Lancaster, S. C. 43,517 miles. Mr. Wylie says: "I am sure that mine is no record, but when one considers that I am too deaf to hear a loud speaker, a conversation, a sermon, the tick of a clock (except at PWX in Havana, Cuba), or a telephone ring, I think it is truly wonderful that I have been able, alone, to tune in so many stations, hear the call letters and announcements clearly, and then the programs, with a pair of ear phones, using an RC set consisting of a detector and two stages of amplification. The radio is a joy to the deaf. I did not realize before I bought my radio that music sounded so sweet."

W. R. Bradford, *The North American*, Philadelphia, Pa. 43,320 miles. One of the drawings that Cartoonist Bradford sent in with his entry is reproduced on page 493.

Franklin S. Bradfield, Lawrence, Mich. 43,160 miles.

John H. Dixon, Plant Engineer at Station VMG, Apia, Samoa. 41,225 miles. This is interesting—Mr. Dixon lists only 9 stations, but none of them is under 4290 miles from his receiving set! Seven of them are California stations, and the other two are in Kansas City, 5460, and Davenport, Iowa, 5735! His letter left Samoa on April 10th, before he knew of this receiving contest. Explanation follows:

Radio Station  
Apia, Samoa.

April 10th, 1923.

THE EDITOR,  
RADIO BROADCAST,  
DEAR SIR,

Now that your "How Far Have You Heard on One Tube?" Contest is finished, perhaps you will be having another for two tubes. To start it, if so, I send the following, all well over 4200 miles from Apia. To eliminate any stray references to "fish yarns" I include proofs of reception in every case. In regard to the reception from KFI, the speech comes in so well that if the announcer was to speak slow enough to enable me to write his remarks down, I could do so without error at least four nights a week all the year round. I'd do it oftener, but Old Man Static lives here.

All these stations are received on an amateur aerial swung between two California pine trees. The trees have been imported and are about the only ones of their kind in Samoa. Perhaps they like music from home.

The circuit I am using is an adaptation of the super-regenerative using two valves. I can get the same results with a five-valve receiver using three stages of radio-frequency amplification (tuned transformer). Both sets are home-made.

#### COMMENTS ON THE CONTEST

IT IS a pleasure to be able to say, that although no discrimination was made against the single circuit in judging the Receiving Contest, three-circuit sets, or other than single-circuit types, won the contest "hands down." Although the single-circuit hook-up is satisfactory for isolated districts, we are, of course, opposed to its use in communities where the re-radiation is likely to disturb listeners-in. Of the four Prize Winners and four "Honorable Mentions," only two described a single-circuit outfit.

What conclusions are we to draw from the fact that comparatively few people with ready-made sets entered the Contest? It may be that many of them thought the Contest was open only to those with home-made apparatus, in spite of our announcement, "any kind of a receiver . . . any number of tubes." Another explanation, and one that seems logical, is that the purchaser of a ready-made set is generally interested primarily in the entertainment rather than the experimental phase of broadcasting; while the builder of a set is often "out after distance," and learns more about fine tuning than the owner of a bought set.

Be all this as it may, the "turn-out" in the contest was mighty good. We congratulate those contestants whose articles have been printed in these pages, and to all the others who sent in articles, photos, and hook-ups we wish to express our admiration of the fine work which they have done and our thanks for the reports which they submitted.



THIS AMATEUR HEARS LONDON REGULARLY

But this is scarcely strange because—he lives there. Frederic L. Hogg, Radio 2SH, of Highgate, London, numbers the following stations among his American acquaintances: WJZ, WGI, WGY, WOO, WOR, WEA, and WDAF (Kansas City)! About 60 amateurs in the United States have also been heard, including 5ZA in New Mexico. Mr. Hogg says that his 10-Watt transmitter has been heard all over Europe

## Some Pictures the Contest Brought In

These Were Picked from Among Several Hundred, to Illustrate Various Phases of the Broadcasting Game. Home-Made Equipment Predominated

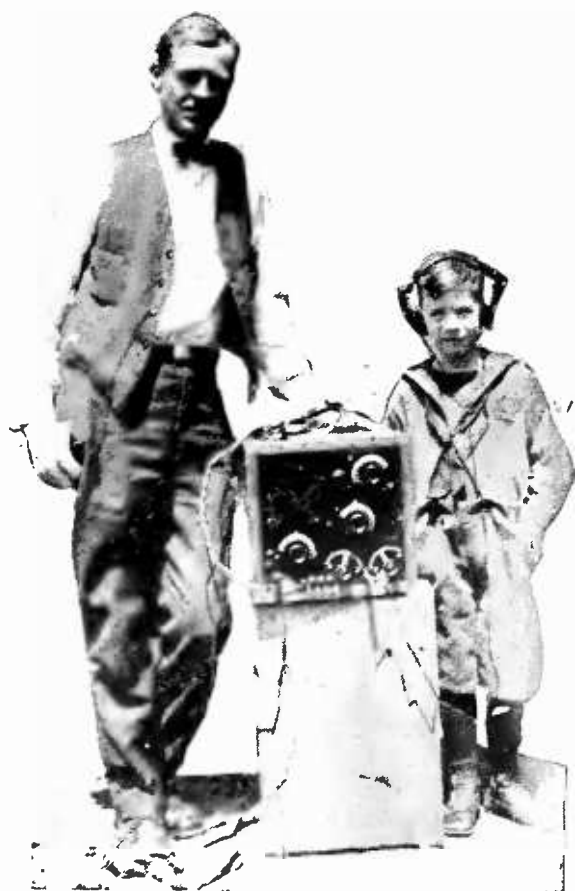

MR. J. H. L. FINKE AND SON BOB Of Evansville, Indiana. With this one-tube of theirs, they have heard Los Angeles in a pouring rain



CARTOONIST BRADFORD SENT US THIS

When not drawing for the Philadelphia *North American*, he experiments with receiving sets which he builds himself



THE BETTER THE GROUND, THE BETTER THE SOUND

Bruce MacDonald, of Duluth, Minn., shows how heavy wire, a standard ground clamp, and a well-scraped pipe are "all there is to it"



THE CAPITAL CITY VIEWED FROM ONE OF THE CROSS-ARMS AT WRC

# A New Station at Washington, D. C.

A Description of WRC and its Meaning to the Capital

By PIERRE BOUCHERON

**O**N AUGUST 1st there was dedicated to the American public at Washington, D. C. another link of the great chain of broadcasting stations of the Radio Corporation of America. WRC has fittingly enough been named by its sponsors "The Voice of the Capital." To every corner of the United States, this powerful station may carry the words of great men in political and diplomatic life, the progress of world events as they transpire, and the music of our nation as well as of other nations rendered by visiting musicians. This station provides an instantaneous link between the country's political centre and the American home. A better understanding of government, of the issues involved in political campaigns, and of the questions which arise in our relations with foreign countries, cannot fail to result from its operation.

There is a wealth of material available in Washington from which to make the programs of WRC most enjoyable and educational. At once it is possible that the ceremonies accompanying the dedication of memorials to great Americans, the features of the many conventions held in this city, and the spiritual counsel of the clergy may be carried to the transmitter and sent forth so that the whole country may hear and appreciate them.

Momentous events, of interest to the nation, do not, of course, occur every day. The greater part of this station's operating hours will be devoted to the broadcasting of the musical and dramatic talent of Washington and other events of special interest to residents of this city. Washington is rich in both professional and amateur talent and every effort will be made by those in charge to arrange programs so that these local interpreters of music and

drama may be heard from time to time.

#### LOCATION IDEAL FOR RADIO

**T**HE Riggs National Bank Building, in which both studio and equipment are accommodated, is one of the highest points in the city, with no tall steel structures near by to absorb and influence the waves radiated from the station. The office, studio, and equipment are all on the second floor of the building. Within the studio, which is one of the largest used in America for broadcasting work, all is harmonious, dignified, and restful. The panelled walls are done in old ivory and brown while the windows are draped with heavy hangings of maroon. A feature of the walls, which is not apparent while looking at them, is discovered when one touches the panels. The lightest pressure of the finger will bend them outward. These walls play an important rôle in broadcast transmission. They are made of wax-treated muslin laid over felt and absorb all sound waves not entering the microphone. This acoustically correct construction prevents even the minutest echo which might otherwise blur the clearness necessary to enjoyable entertainment.

#### "SEEING" THE BROADCASTED VOICE

**A**LL THE experience and recent improvements which are part of the Broadcast Central, the Radio Corporation's duplex station in New York, are embodied in Station WRC.

An important feature of this station, and one which further assures perfect transmission of programs, is the device known as the oscillograph, by which the operators have before them "a working picture of the voice." This delicate instrument may be switched into any one of the many circuits, and shows, by means of an undulating, ever-varying beam of

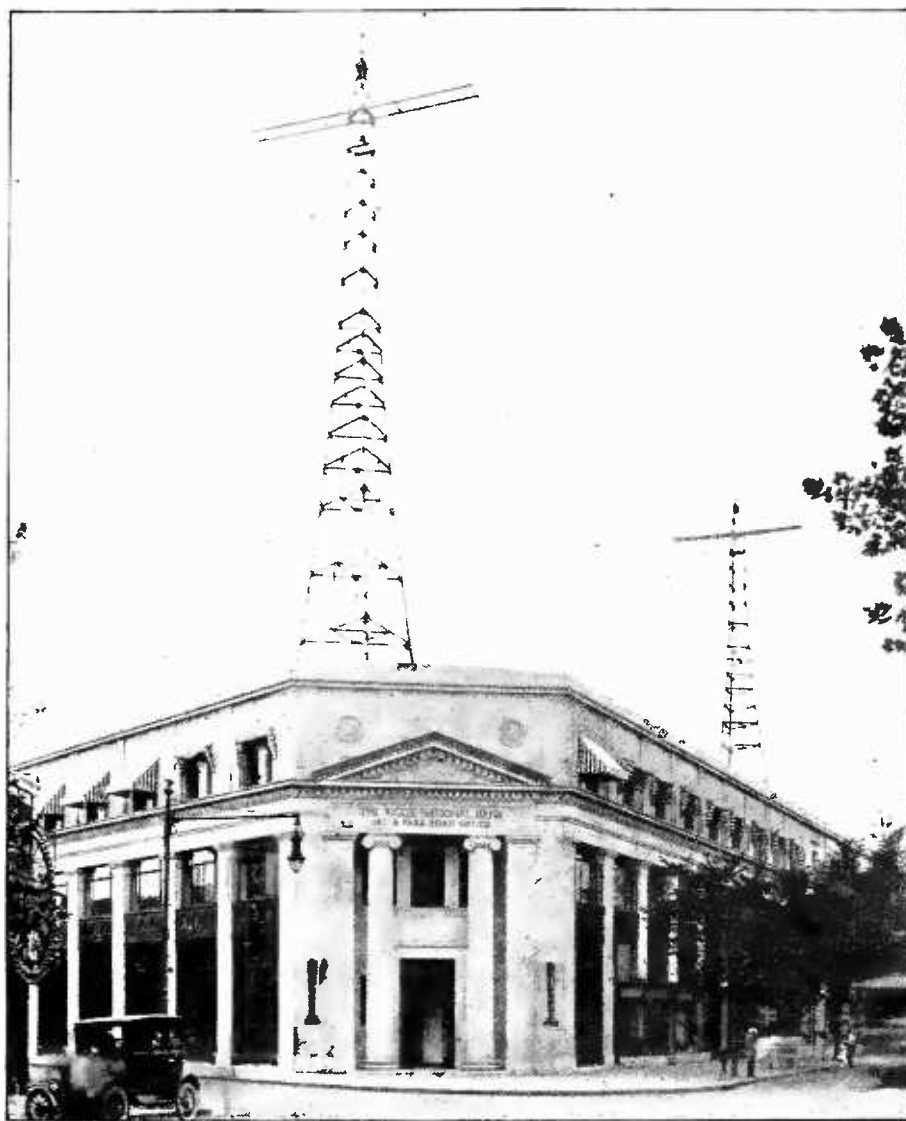

THE AERIAL WIRES ARE 150 FEET ABOVE THE STREET LEVEL

And there is nothing in the vicinity of the Riggs Bank Building which can obstruct the radiation of waves from this station

light, exactly how the artist's voice or music is affecting the radio current. By watching this little tell-tale beam, as reflected from revolving mirrors, one knows instantly whether the sound waves are too weak, too great in volume, or blurred.

Broadcasting is a living, vibrant force that has as its chief aim the improvement, both spiritual and intellectual, of mankind. When conducted on such a high plane as this, WRC cannot but thrill the distant listener with a constantly varying entertainment that falls little short of magic. It is the hope of those who conceived and built this great broadcasting plant that "The Voice of the Capital" will always entertain and instruct only with what is for the good and the advancement of the thousands who will nightly tune-in its message.

# Rheostats for the Tubes You Use

How to Select the Proper Rheostat. Operating Different Kinds of Tubes From the Same Battery. Using Tubes in Series and in Parallel.

By ZEH BOUCK

THE advent of the dry-cell tube, while making radio a more simple and economical proposition, has by chance complicated matters when enthusiasts have attempted to operate such tubes from voltages other than those for which they have been designed—a possibility that is often made desirable by the possession of a six-volt storage battery. Similar difficulties are encountered when it is endeavored to light different makes of dry-cell tubes, with their individual filament requirements, from the same battery, and haphazard experiments by many fans have resulted in blown tubes. Such disasters, however, would have been obviated by an understanding of perhaps the most fundamental of electrical axioms, Ohm's law, and its application in solving the problems of the proper battery and rheostats.

Ohm's law is a statement of the three predominant characteristics of an electrical circuit, the voltage, current, and resistance, and the limitations imposed by any two of these qualities upon the remaining one, i. e., their inter-relation.

In the pioneer days of electricity, helped along by the fluid theory of electric currents that then prevailed, physicists were led by observations to the correct conclusion that electrical phenomena possessed two characteristics, voltage and current, the former being the pressure that sent the current through the wire, and the current itself being the density or heaviness of the electrical stream. It was found that this last quality, current, depended on two things, first upon the voltage or pressure and secondly, upon the resistance of the conductor or wire. As the pressure increased, it was quite natural that the current would become heavier; as would a lazy stream of water in a pipe when the force applied to the reservoir end was multiplied. It also followed, that as the resistance of the conductor was made greater, for instance by using a smaller wire, the current was decreased, as would be the flow of

water in the aforementioned pipe were a plumber to substitute a smaller diameter pipe or place some obstruction (*resistance*) within it. This law of electric currents is expressed in the equation,

$$I = \frac{E}{R}$$

I, E, and R mean, respectively, current in amperes, potential or pressure in volts, and resistance in ohms. Hence we might substitute for the abbreviations or symbols, and state the equation,

$$\text{current} = \frac{\text{potential}}{\text{resistance}}$$

or, still another way,

$$\text{amperes} = \frac{\text{volts}}{\text{ohms}}$$

By obvious algebraic transpositions, the two following equations are simply derived from the original statement:

$$R = \frac{E}{I} \text{ for finding resistance}$$

and

$E = I \times R$  for finding voltage or "voltage drop."

These equations are of inestimable value in all electrical work, and are particularly applicable, as will be shown, to the calculation of filament resistances and voltages.

## WHAT SIZE RHEOSTAT SHALL I USE?

THE accompanying chart, Fig. 1, shows the three laws, and indicates the various computations in which they are commonly involved. The equation most readily applicable to the operation of the dry-cell tube is the second, and which declares that the resistance is equal to the voltage divided by the current.

We shall presume that the reader is interested in the construction of a portable set with detector and one step, using the UV-199 tubes. Referring to Fig. 2 (or to the circular accompanying the UV-199 when it is bought), it will



be found that this tube consumes .06 ampere at its normal filament potential of three volts. Three volts are the equivalent of two dry cells, but as the voltage of such a battery drops quickly, three cells should be used, in which case the deterioration can be compensated for by lowering the rheostat. We now encounter the problem, "Using these three dry cells, what size rheostat shall I get? Will not the six- or ten-ohm size be too low?" Or, more technically, it is desired to determine what resistance is required to drop the potential of the battery to three volts, or in terms of the second formula, what total resistance in series with the  $4\frac{1}{2}$  volt battery (three dry cells) will permit but .06 ampere to traverse the circuit.

To find this out, it is merely necessary to substitute the known quantities, volts ( $4\frac{1}{2}$ ) and amperes (.06) for the corresponding letters in the second equation, i.e.,  $R = \frac{E}{I}$  thus  $R = \frac{4.5}{.06}$ , or seventy-five ohms must be the resistance of the entire circuit. But, again referring to Fig. 2, it will be found that the resistance of the UV-199 filament is fifty ohms, which is necessarily included in the circuit, and forms the greater part of the seventy-five ohms resistance. Hence the extra resistance, or rheostat, need be only 25 ohms. (This is the *extra* resistance necessary to drop the  $4\frac{1}{2}$  volts to 3 volts, the working potential of the tube. That this is so will be proved by substituting in equation three:  $E = 25 \times .06 = 1.5$ —i.e., the voltage drop is 1.5, which subtracted from  $4\frac{1}{2}$  volts gives the required 3 volts!)

To find the resistance for any rheostat, substitute, in equation number two, the voltage of the battery and the current of the tube. From this answer, which is the total resistance of the circuit, subtract the resistance of the filament. (It is always desirable to add a few ohms to the result of this calculation in order to take full advantage of low filament consumption. Thus a 30-ohm rather than a 25-ohm rheostat is suggested for the UV-199.)

If the filament resistance is neither known

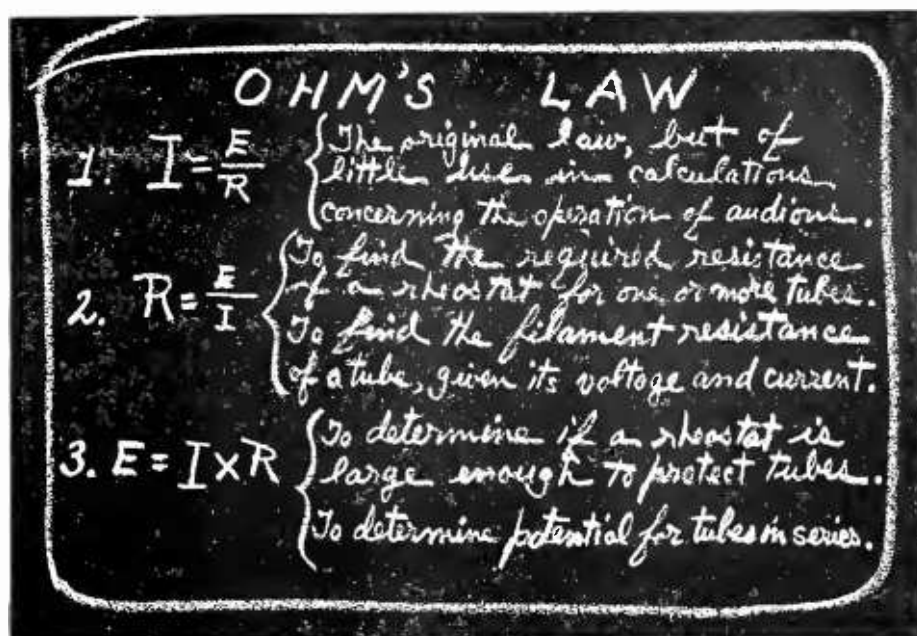

FIG. 1

Three ways of expressing the inter-relation of voltage, current, and resistance. They help you select the proper rheostats for your tubes

nor covered in the RADIO BROADCAST chart, it is easily calculated from the voltage and amperage furnished by the manufacturer of the tube, by means of this same equation two. Substituting these values in the case of the UV-199 just discussed, our equation is  $R = \frac{4.5}{.06} = 75$  ohms.

#### DIFFERENT TUBES WITH THE SAME BATTERY

IT IS quite possible that the owner of the portable set mentioned above will desire to substitute a WD-11 or WD-12 ( $1\frac{1}{2}$  volts,  $\frac{1}{4}$  ampere) for the UV-199 as detector. If the A battery is made up of three standard dry cells, a single one of these may be used to light the detector filament, obviating the necessity for any calculations. However, if a three-cell flashlight battery is employed, as is the probability, it will be easier to resort to resistance than to break through the insulating compound and tap the battery. Due to the different direct-current characteristics of this tube, it is quite obvious that its rheostat requirements will differ from those of the UV-199. (However, as the WD-11 does not require so high a resistance, as will be shown, it would not be positively necessary to change the rheostat.) The value of this rheostat is obtained by again substituting in the second formula, viz.,  $R = \frac{1.5}{.25} = 6$  ohms. Subtracting from this the resistance of the WD-11 filament, and adding a few ohms for safety and adjustment, the

desirable rheostat will have a resistance of 15 ohms.

#### IS MY RHEOSTAT LARGE ENOUGH?

ANOTHER problem which quite frequently confronts the experimenter running the eternal gamut of circuits and tubes, is the question as to whether a rheostat which adequately controlled a previous tube, possesses a resistance sufficiently high to safeguard the audion in his new experiment. This can, of course, be solved in a round-about fashion by the  $R = \frac{E}{I}$  formula, but by the third equation,  $E = I \times R$ , it admits of an easier solution, and it is only necessary to know the current consumption of the tube and the resistance of the rheostat.

We shall assume that the experimenter has been using in his amplifier Western Electric VT-2's, the 5-watt transmitting tubes. He has lighted these from an 8-volt storage battery through 6-ohm rheostats. Without changing his battery or other equipment, he now desires to substitute for these uneconomical bulbs the 201-A, a 6-volt,  $\frac{1}{4}$ -ampere tube. Will the 6-ohm rheostats be sufficient? . . . will they give a 2-volt drop (8 to 6)?

$$E = I \times R$$

$$E = .25 \times 6$$

$$E = 1.5 \text{ (the voltage drop)}$$

No! A larger rheostat will be necessary.

*To determine if a certain rheostat is sufficient to drop a high voltage to a required lower potential, substitute for I and R in formula three. The answer will be the voltage drop.*

#### TUBES IN PARALLEL

MANY enthusiasts have endeavored to operate dry-cell tubes and others in parallel from a single rheostat, the voltage dropping function of which was augmented by the increase in current passing through it. It will be observed from study of the last formula, that E, or the voltage drop, depends directly upon the amperage. If the current through a rheostat is raised, the voltage drop will be increased in proportion. For instance, if the experimenter is desirous of working a two-bulb set using UV-199's, from a 6-volt storage battery through individual rheostats, he will find by calculations in formula two, which we have described, that he will require rheostats of 50-ohms resistance each. However, if he connects the filaments of the two tubes in parallel,

lighting them through a single rheostat, only a 25-ohm rheostat will be required. (This fact will also be furnished by formula two, if it is remembered that the current is now doubled.) In terms of the third formula, this condition is as follows:

$E = 25 \text{ (R in ohms)} \times .12 \text{ (current of two .06 ampere tubes)}$ . Carrying it out,  $E = 3$ .

Hence the voltage drop is three, which subtracted from six leaves 3, the correct voltage for the UV-199.

A single rheostat of 25 ohms is much easier to obtain than two 50-ohm instruments. However, the writer does not approve of nor recommend this *apparent* economy. On the contrary he advises strongly against it for the very reasons (Ohm's law number three) outlined above and which, at first sight, appear to favor this system. A little thought

will indicate the disaster which would, in such a circuit, accompany the failure of one of the tubes to light, either from socket or connection trouble, or burning out. Such a failure would lessen the current through the single rheostat and correspondingly curtail the voltage drop, and a disastrously high potential would be applied to the remaining tube.

To demonstrate mathematically (the reader cannot become over familiar with the algebra of Ohm's law): It was found that on two bulbs a 25-ohm rheostat was sufficient to drop the six volts to the required three volts. However, supposing that one tube ceases to function due to filament trouble, we shall find that the voltage drop,  $E = I \times R = .06 \times 25 = 1\frac{1}{2}$  volts. This would leave  $4\frac{1}{2}$  volts on the tube, sufficient to burn it out in a few seconds.

#### TUBES IN SERIES

THE alternative for using one rheostat with a plurality of tubes is connecting them in series, but this practice, while free from the hazards of the parallel system, multiplies the voltage, practically by the number of tubes. However, this system has been successfully used and is quite justified with amplifying tubes which number in radio-frequency circuits three and more (including audio), and where the higher voltage has been at hand or easily built up. The required battery for such a connection is simply determined by formula three. (It should be borne in mind that the answer given in this equation is the voltage drop in passing through the *mentioned* resistance. If



all the resistance in the circuit is substituted for  $R$ , the voltage drop will be the total applied potential, or *the required voltage for the operation of the circuit under the stated conditions of amperage and resistance*. Thus, in the case of the 199, where the filament has a resistance of 50 ohms, and for normal operation consumes a current of .06 ampere, the voltage will equal  $E = I \times R = .06 \times 50 = 3$  volts).

If it is desired to use four UV-199's (to continue with this popular bulb) in series and with a single 10-ohm rheostat, the following calculation is carried out:

First,  $R$  must equal the total resistance of the circuit, i.e., the resistance of all the filaments plus the resistance of the rheostat. (The resistance of the battery and wiring is negligible and merely adds a factor of safety.)

Second,  $I$  is the current of *one* tube, for the same current flows through all tubes and is not divided or split as is the case when passing through filaments in multiple.

Then  $R$  will be:  $10 + 50 + 50 + 50 + 50 = 210$ , and  $I$  will be: .06, and the equation.

$E = .06 \times 210 = 12.6$  or roughly eight dry cells (12 volts).

To find the required resistance for the operation of a series of tubes with a given rheostat, substitute the total resistance of the circuit and the amperage of one tube in formula three. If a fraction results, use the first whole number below it—the rheostat can always be turned up.

When the occasion arises for a calculation involving a single resistance controlling more than one tube, remember that filaments in

series multiply the filament resistance of one tube by the number of bulbs, and filaments in parallel divide it by the number of bulbs.

#### CONCLUSION

THE first Ohm's law or equation finds but little application to the subject discussed. The correct value for  $I$  is almost always known; it is determined by the designer of the tube, not by the chance values of  $E$  and  $R$ , and the two derived equations will solve in a more satisfactory way whatever filament questions the reader may refer to Ohm's law.

It will be observed that the writer, in discussing dry-cell tubes, has not confined himself to their operation from such a battery, but has even suggested their use from the storage type. The low-amperage tube has not merely made possible the elimination of the storage battery in certain justifiable cases, but has also added greatly to the utility of that battery. The storage battery possesses cer-

tain desirable qualities which are missing in dry cells, and in view of the slow discharge when used with dry-cell tubes, they deserve serious consideration as the filament source in all but portable sets.

In conclusion, the writer desires to emphasize that Ohm's law is not confined in its audion applications to any particular class of tubes, or voltages. It may be used in filament calculations involving 32-volt farm lighting plants, 110-volt D. C. system, and with any tubes whatever.

TYPE	E	I	R
200	6	1	6
201	6	1	6
201-A	6	.25	24
199	3	.06	50
215-A	1.5	.25	6
WD-11	1.5	.25	6
WD-12	1.5	.25	6

FIG. 2

If you know any two of the three predominant tube characteristics—voltage ( $E$ ), amperage ( $I$ ), and resistance in ohms ( $R$ )—you can find the third by the formulas given in Fig. 1



THE CREW OF THE "BOWDOIN," ROUNDED UP TO LOOK PLEASANT

Left to right: Donald H. Mix (radio operator), Tom McCue (mate), Richard Goddard (from the Carnegie Institute in Washington), Captain MacMillan, Jaynes (engineer), and Ralph Robinson (ship's doctor and official photographer)

## With MacMillan and Radio, North of Civilization

Adventures on the First Part of the Arctic Expedition, as Related by Mr. McDonald, Who Went with the *Bowdoin* as Far as Battle Harbor, Labrador. How the People in the North React to Radio, and What the Crew and Captain MacMillan Think of it

By E. F. McDONALD, JR.

**J**OHN Bunyan was a pious man and had lots to say about Sloughs of Despond and Giants Despair, but what a pity his well-known Pilgrim—ever on the watch for stepping-stones to progress—should have overlooked the rocks of Labrador and the well-trapped shores of Greenland. For *there* are regions for you with their very names all made to order for an allegory!

Think, for example, of the adventures that valiant fighter might have had while skirting "Anxiety Point" and "Escape Reef" and "Cape Hold with Hope," while dodging through "Frozen Strait" and "Cut-Throat Tickle,"

while sailing up "False River" and back, while circling "Ragged Island" or "Deadman's Cove" or "Devil's Bay"; and how great his triumph might have been when he finally sighted the "Isle of God and Mercy" and brought his errant craft around "Cape Comfort" through "Hopewell Narrows" and into "Refuge Cove!"

On such a voyage, on the twenty-third of June, sailed forth the staunch ship *Bowdoin*, captained by Donald B. MacMillan, the noted Arctic explorer, and carrying in its forecabin a radio transmitting and receiving set—the first of these sets to venture into the land of per-

petual ice and snow. Captain MacMillan was accompanied by a cook (a tremendously necessary person), several scientists, his friend, Sheldon Fairbanks, and myself. I left the party at Battle Harbor, Labrador.

#### THE DEPARTURE FROM WISCASSET, MAINE

IT WAS a brilliant scene at Wiscasset, Maine, when the *Bowdoin*—decks piled high with supplies and provisions, and masts strung with flags of the international code—set sail for the Arctic. All the people of the countryside turned out to bid the crew Godspeed. Whistles blew and cannon boomed

On board the ship for the first short stage of the journey (to Boothbay) were General A. W. Greely, oldest living Arctic explorer, and Langdon Gibson, who accompanied Commander Peary on his earlier Arctic expeditions. On shore, and in communication with the ship by radio, were Hiram Percy Maxim, the distinguished inventor, and Messrs. K. B. Warner and Fred Schnell, associated with Mr. Maxim in the American Radio Relay League, of which he is President. These last-named gentlemen had temporarily set up on the dock a Zenith receiving set, and for the first five miles or more they used it to receive and *transmit* messages. To accomplish this latter purpose, they set the secondary tuning on the wavelength that the *Bowdoin* was operating on, threw the tickler into the extreme oscillating position, and by touching the primary circuit with a moistened finger sent back their replies in international Morse code.

Donald H. Mix, radio operator aboard the *Bowdoin*, was furnished to the expedition by The American Radio Relay League, at the League's expense. He was chosen from among a great number of applicants for the coveted position. Long coded news stories are being received from the *Bowdoin* (station WNP) every week by various member-stations of the A. R. R. L., which expect to keep in communi-

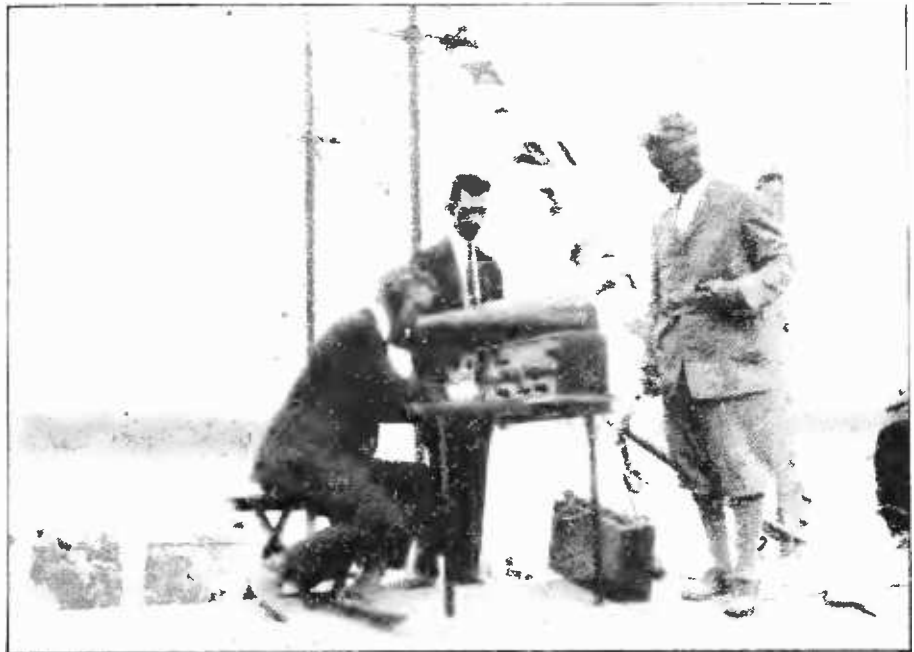

OFFICIALS OF THE A. R. R. L. AT WISCASSET, MAINE

On the right is Hiram Percy Maxim, President of the American Radio Relay League, the organization which is sending operator Mix with the MacMillan expedition; at the left is F. H. Schnell, Traffic Manager of the A. R. R. L.; and behind the receiving set is K. B. Warner, Secretary of the League and Editor of *Q S T*. The picture was taken at Wiscasset harbor, just before the *Bowdoin* sailed, and the set was used in testing with WNP during the first few miles of her long journey

cation throughout the winter, when the expedition will be at its farthest north, some 600 miles from the Pole.

From Monhegan Island we put to sea in earnest, and within the very first hour ran into an enormous school of blackfish. These are a species of whale, and some of them ranged a full forty feet in length. They were sunning themselves on the surface of the water, and so complacently did they regard us that we were able to approach within close hailing distance—so close, in fact, that Tom McCue got a rise out of one of them by heaving a can of pemmican against his tough black hide.

Clouds of fog enveloped us practically all the way from Monhegan to Sydney, Nova Scotia. Notwithstanding the impenetrable mist, however, we crossed the Bay of Fundy and rounded Cape Sable without mishap, and except for the glimpse of a mysterious ship during one of the night watches—which on our approach extinguished all her lights—we made our port without adventure. Not knowing whether the ship in question was a rum runner or a rum-runner *chaser*, we made no attempt to overhaul her.

From the moment the last visitor stepped off the gang plank at Boothbay, strict discipline was in force on board the *Bowdoin*. The day



THE CAPTAIN IN HIS QUARTERS

Behind him on the wall, may be seen several of the guns which he will use in the Far North

was divided into four watches: six hours on and six hours off, with one man at the wheel and two on lookout. We had breakfast at six, dinner at noon, supper at six, and a "mug-up" at midnight.

#### THE "BOWDOIN" AND WHAT'S ABOARD HER

"THERE is not much room to spare on the *Bowdoin*—as you can imagine when I tell you all that she carries. Not only is every available inch of space below decks used, but the main deck is crowded with barrels of fuel and lubricating oil, and miscellaneous provisions of an imperishable nature. The *Bowdoin* is only eighty-nine feet over all—the smallest ship that ever ventured an Arctic expedition—yet into her hold, amidships, have been packed not only provisions and supplies sufficient to sustain the party for several years, but also quantities of dolls, clothing, knickknacks, and phonographs, these latter to be presented to the Eskimos of the most northerly tribes. It was with difficulty that the hatch was battened down!

Back of the hold is the engine room, a solid

mass of machinery. Its four walls are enormous fuel tanks of kerosene, which give this ship the greatest cruising range of any small ship in the world. This enormous fuel supply is needed when one considers that for many days, with the engine running full speed, the ship, which normally makes nine knots an hour, makes less than nine knots a day against the heavy ice jams of the Arctic. In the forward end of the engine room are two  $\frac{3}{4}$  KW Delco generators and two complete sets of 32-volt storage batteries. At present, one generator and set of batteries are being used to light the ship. The other generator and batteries are for the radio, which consumes a great deal of power in hurling its wireless messages back to civilization.

Back of the engine room, in the after end of the ship, are the Captain's quarters, very small and compact. One of the two berths shown in the picture is Captain MacMillan's.. the other that of the ship's doctor, official photographer and general handy-man, Ralph Robinson. In the middle of the cabin stands the Captain's chart table with its chart rack

and navigating instruments. Lining the upper wall is a very complete library of scientific books. The forward wall presents the scene of an arsenal, with at least twenty rifles, ranging in calibre from the small .22 equipped with Maxim silencer, to the large .401-calibre bear and walrus rifles.

Small side-arms have no place on this expedition. As a matter of fact, there is only one revolver on the ship, and that is owned by Richard Goddard, representative of the Carnegie Institute of Washington. He explained to me that he carries it only for protection while away from the ship making observations in terrestrial magnetism. On the back wall of the Captain's quarters are fastened two delicate chronometers, which are being checked by the radio time signals from Arlington each day. For this purpose an extension wire has been run from the Zenith receiving set in the forward part of the ship to a position directly alongside the chronometers, which position is

incidentally directly alongside the head of the Captain's berth. While the extension was primarily for setting the chronometers, the Captain sometimes lies in his berth with the headphones over his ears and listens to the concerts that are being broadcast from the stations along the Atlantic Coast and from WJAZ, Chicago, and WOC, Davenport, Iowa.

#### UP FORWARD, WHERE THE RADIO SHACK IS

THE forward end of the ship is taken up with the fore-castle, comprising the radio room, living and sleeping quarters of the crew, and the galley. The radio room is in the peak of the fore-castle, berths for six men are along the sides, the mess table is in the centre, and the galley in the after end of the fore-castle.

"I tell you, things were lively in the fore-castle when the radio started! In such close quarters, it made as much noise as a steam locomotive tearing up and down the passageway! The first night it was in operation the



THE DECK, FROM THE CROW'S NEST

The *Bowdoin* is driving north under sail and motor-power, heavily loaded with drums of fuel and oil, and supplies and provisions enough to last several years



E. F. McDONALD, JR., WHO TELLS OF EXPERIENCES ABOARD THE "BOWDOIN"

He returned from Labrador recently, having left the expedition there after accompanying it from Wiscasset, Maine. Mr. McDonald is connected with station WJAZ, in Chicago, which is keeping in constant communication with the *Bowdoin* and is sending out special programs for those on board

cook arose in great consternation, believing bedlam had broken loose. He rubbed his eyes furiously, finally discovered the source of the disturbance, and exclaimed: 'I have been shipmates with a lot of powerful snorers, but never with such a noisy beast as that there animal.' Strangely enough, however, a few nights' companionship with the set made its noise as undisturbing as the town-clock to a good New Englander, and every man of us was able to sleep as soundly as a village constable.

#### THE EXPEDITION'S RECEPTION IN NOVA SCOTIA

SYDNEY, Nova Scotia, was our first important stopping place. Anchor was dropped at North Sydney the first night because of the intense fog. Next day found the *Bowdoin* gracefully gliding into Sydney Harbor amid the roar of salutes from the French gunboat, *Regulus*, anchored in the harbor. At first the cannonading worried us, because we had heard the night before of a strike waging in the coal mines and steel mills, of Canadian troops moving in, and of threatening trouble. But our doubts soon gave way to delight over the warm

reception and extreme courtesy of which the cannonading was the first evidence. The guns were not turned toward us. This was July first. I shall never forget what a thrill it gave to see the American, Canadian and French flags flying from the Royal Sydney Yacht Club. and from public buildings and private residences. Such was the interest shown in the MacMillan exploration trip on the national holiday of the Canadians.

Sydney is the outpost of civilization—the last place on the trip showing signs of modern-day progress. Here Captain MacMillan had his last ice cream. Considering the climate of the Polar regions, he will probably be able to bear the separation from ice cream fairly well.

Leaving Sydney we headed northeast through a dense fog and caught only a glimpse of Newfoundland as we passed by. This was Port-aux-Basques. Fog whistles blew at other points along the Newfoundland shore, but only at the one point did the fog lift its veil long enough to permit a view. Likewise most of the coast of Labrador remained a mystery to us. Often we thought land directly ahead, but



as we approached the dim outline of the supposed land there was gradually revealed the form of an iceberg. So many icebergs strewed the way that traveling was exceedingly dangerous.

#### PUFFINS AND ICEBERGS

OUR first stop in Labrador was in back of Greeneley Island, at night and under cover of fog. Next day when the sun rose, about 3:00 A. M., we found ourselves within 100 yards of shore. Had it not been for the wonderful navigating of Captain MacMillan, we should many times have been piled on the rocks along that formidable Labrador shore. Captain MacMillan made this stop to visit and examine Parquet Island, which is a rookery of the puffin. These puffins are known as the "Parrots of the Arctic," are wonderfully colored, have the characteristic parrot bill, but feed on fish. Millions of them swarm the island which is scarcely a mile square.

To bring the puffins out of their hiding places, it was only necessary for us to lie on the ground for about five minutes. Then the heads began to bob up all around. We took some specimens of these birds and also some of the eggs. These are as large as hens' eggs and are one source of food to the natives.

While the Captain, Fairbanks and I were on this island, three of the crew decided to visit their first iceberg. Directly after they left it, the iceberg decided to turn over. It was interesting to hear the Captain tell these men, upon their return, of the lurking dangers of the iceberg. Parquet Island is located in the Canadian Labrador Section. On the mainland, half a mile away, a tent was pitched in open view. This, we were later informed, belonged to the Government Game Warden, but the Canadian Government, although equipping him most excellently in every other way, failed to furnish him with a boat!

#### FOG, AND A FORBIDDING COAST

AS WE passed north along the coast of Labrador, it was seldom that the fog

permitted us to see land. The curtain very accommodatingly rose as we passed Point Amour, where we were given an opportunity to take pictures of the wreck of the battleship *Raleigh*, once the pride of the British Navy, but now piled high and dry on the rocks. Even her guns are still mounted. While we were passing through some of the thickest of the thick fog, with the rocky shore of Labrador only a short distance from us on our port side but completely shut off from view, the cook, who was on his first trip to the Arctic, came on deck; and the Captain, pointing towards where he knew the land was, said: "Well, Cooky, how do you like your view of Labrador?" The cook gazed intently and seeing nothing but fog, asked: "Is it always like this?" "No, not always," replied the Captain; but at that point Robinson confided the surprising information that only once in his fifteen years of Arctic exploration, had the Captain seen the whole coast of Labrador without fog. The coast, when visible, is an enormous pile of unfriendly rocks.

In Captain Cartwright's "Journal of Labrador," written 143 years ago, he says: "In sailing along this coast, the astonished mariner is insensibly drawn into a conclusion that this country was the last which God made and that he had no other view than to throw together there the refuse of his materials of no use to mankind. Yet the mariner no sooner pene-

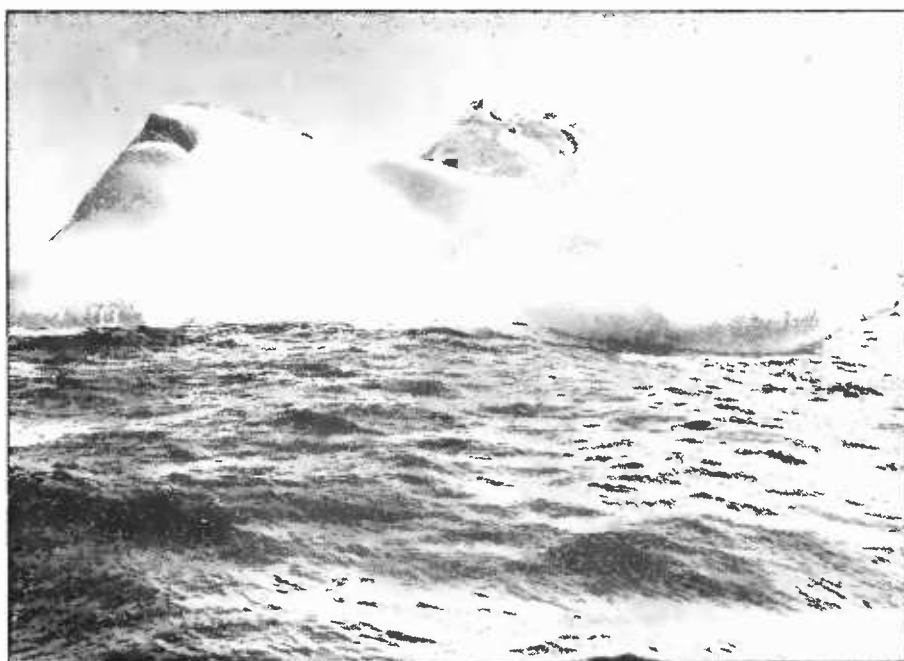

ONE OF THE BIG ONES PASSED BY THE "BOWDOIN"  
Only about one-tenth of it shows above the water

trates a few miles into a bay than the great change, both of the climate and prospects, alters his opinion. The air then becomes soft and warm; bare rocks no longer appear; the land is thickly clothed with timber, which reaches down almost to high-water mark, and is generally edged with grass. Few stout trees are to be met with, until you have advanced a considerable distance and have shut the sea out." Perhaps; but we found this country dismally cold, barren, rocky, and uninviting.

The natives of the villages who make their living by fishing for cod and salmon have in their backyards piles of wood, sometimes 15 to 20 feet high, the largest piece not exceeding two inches in diameter. It is all of scrub growth. The missionaries told us that in the winter the poor inhabitants must travel miles and miles with their dog sleds, quite content to find even this scrub growth. It is true that the air becomes warmer as you travel inland, but it is also true that the moment it does become warmer you see flies as you have never seen them before. The air is literally thick with them.

There is snow everywhere on the mountain tops and enormous balls of ice on the shore. At one point 89 icebergs were visible from our crow's nest. One of these icebergs was in the form of an arch, so high that had we been sure the water was clear below we could have sailed our ship through. The very names of the bays, capes, and islands indicate the hardship that has been experienced in this God-forsaken country. Some have already been named. Here are others strongly descriptive:

Mistaken Cove	Cold Foot River
Lower Savage Islands	Battle Harbor
God Haven	Windy Tickle
Misery Bay	Fly Away Cape
Cape Farewell	Punch Bowl
Death River	Lost Hope
	Dead Man Lake

#### WHEN THE NATIVES LISTENED-IN

AS WE entered each of these Labrador ports a group of small dories would invariably put out from the shore, and a race would start among the fishermen to see which could reach us first. After the usual preliminaries of getting acquainted they would ask: "Is there a doctor on board?" Next, they asked for clothing of any description. We found many

of the hardy fishermen, bronzed, weather-worn, and thin, clothed in a pair of old cast-off-looking oilskin trousers, a threadbare sweater, a battered pair of boots, and nothing more. The fishing has been bad for the past two years. There is an abundance of fish this year, but the inhabitants are faring poorly because of the enormous quantities of ice which tears their nets to pieces and often carries them away completely. These people are mostly of French, Irish and Scotch descent. In one port a native offered us lobsters for sale. He had a dozen and apologetically explained that the price of lobster was very high this year. Having left the States but recently the argument of short supply and over-demand was not new to us, and we were quite prepared for a South Water Street price. So he asked the exorbitant figure of ten cents apiece for the lobsters.

Wherever we went, people were all agog with excitement over the radio carried on board. They were glad of visitors, glad of the chance to exchange courtesies, but glad especially to view the equipment of the *Bowdoin*. Their wonderment struck its height when they listened to voices and music from far-away places in the United States, the land which they know but little, and none had seen. It was gratifying to notice their frank and open reaction, so childlike, so sincere. Electric lights, telephones, and such developments which have long been "necessities" with us, are of course only names to these people.

On July 4th, with the icebergs completely surrounding us, we received the returns of the Dempsey fight. The pool which we started on board for the man who guessed the number of rounds that the fight would last was temporarily won by Jaynes, the engineer, and paid to him when the fight had gone to twelve rounds, that being the number he selected. But the money was promptly taken away from him when the fight went on to fifteen rounds.

In Battle Harbor, Labrador, where I left the expedition, we were met at the dock by the doctors and nurses of one of those wonderful institutions, the Grenfell Mission, where self-sacrificing men and women give their time and energy without remuneration, caring for the sick and injured that are brought to them from miles around. Contact with them was especially delightful. They made an indelible impression for their devotion to a noble cause,



their unselfishness, their genuineness and ease of manner, and their lively interest in us as visitors. They visibly enjoyed everything quite as heartily as the natives, but had the added advantage of education and refinement. They too were absorbed with the Zenith radio outfit and not only enjoyed listening to the concerts but took every opportunity to dance to the strains from far-away stations, even the Edgewater Beach Hotel station in Chicago.

What I enjoyed as much as, if not more than anything on the whole trip was the opportunity to get to know that wonderful optimist, Captain Donald B. MacMillan. To me, his optimism is unparalleled. If it rains, it rains. If it is cold, it is cold. If there is a mishap of any kind, it is accepted by Captain MacMillan in contented spirit, and in full confidence that no matter what occurs, it is for the best. He never looks backward, always forward. He sees a bright side to every situation, every occurrence.

Captain MacMillan and his crew were well and happy when I took my leave. One comforting thought over the separation was in realizing that communication with them would not be cut off as it had been until their return to civilization on previous trips, but would be main-



MACMILLAN—SKIPPER OF THE "BOWDOIN"

tained by means of the first radio outfit to be introduced to the land of the Eskimo.

Every Thursday at midnight, WJAZ, the Zenith Edgewater Beach Hotel station broadcasts a summary of the week's news to these men in the frozen North, together with messages from their relatives and friends. Hundreds of miles from civilization, utterly surrounded by ice, they will yet have the news of the world as quickly as we at home, and may relax from their strenuous vigils to listen to the identical strains, perchance, to which their friends in the States may at that very moment be dancing on the polished hotel floors!

## What Balloon Racers Did With Receiving Sets

How Contestants in the National Event Held on July 4th Obtained Storm Warnings and Entertainment. Their Recommendations for Future Races

**L**IEUTENANT R. S. OLMSTEAD, winner of the National Balloon Race which started from Indianapolis on July 4th, attributes his success in a large measure to radio. Lieutenant Olmstead said that during the early part of the flight the air was remarkably free from static,

but that on July 5th, when west of Buffalo and at an altitude of 8,000 feet, he experienced considerable interference during a period when an electrical storm was brewing. His balloon was equipped with a standard airplane antenna—that is, about 300 feet of copper wire. For a ground, he used 25 feet of three-foot

copper screening, such as is used for fly screens. His official report, in part, follows:

"1—In compliance with request, there follows a brief account of our experience with the radio set 'Radiola 11' carried on the U. S. Army Balloon S-6 and furnished by the General Electric Company.

"2—The radio installation complete with antenna and counterpoise weighed about 30 pounds. In weight, therefore, it represented roughly one bag of sand ballast. Both Lieut. Shoptaw, my aide, and myself agreed many times, upon receiving a particularly enlightening bit of information, that it was worth several times its weight in sand.

"3—Immediately upon taking off, we dropped our antenna, connected our ground, and made plans to receive. The results were uniformly good from the start. One musical program after another came in with great clearness, and incidentally the returns on the Dempsey-Gibbons fight, round by round. There seemed to be music in the air at all times and to any one who has experienced the monotony, when everything is going well, of the hours of darkness in a balloon-race flight, the value of such restful relief therefrom is very evident. It materially added to our efficiency through assuring rested nerves. At times, the

audibility of the set was sufficient to allow us to leave the headset hanging to the side of the basket.

"Now for the more primely important features of having such an instrument along. From Detroit, Chicago and Schenectady, particularly Schenectady, we received quite definitely the weather reports consisting of general flying conditions, wind directions and velocities, cloud conditions, and—of great importance—the pressures recorded at various important cities. This information was quite conclusive in influencing our tactics to obtain a suitable direction of flight in order to obtain maximum endurance and distance.

"A feature which should be added to the radio set, if possible—one which we keenly felt the need of while out of sight of any landmarks or other means of locating our position or rate and direction of progress over Lake Erie—is a direction-finding apparatus.

"A point of vital importance in a race, and one which had considerable bearing on our decision to land at the time we did, was the advice received by radio of the location of our various competitors from time to time. At the time of landing, we knew that all but three of our competitors had been accounted for, and we were quite certain through deductions



LIEUTENANT OLMSTEAD JUST BEFORE THE START

He is shown with the two-tube dry-cell outfit which helped him win the race. Radio rendered material assistance to the balloonists through the weather reports sent out from five broadcasting stations

from information previously received of the progress of others that we were at least in one of the three winning positions and eligible for the team to go to Belgium for the International race. Had we not had this information, we might have tried to cross Lake Ontario without sufficient ballast, failure in which would have disqualified us.

"4—My recommendations are that most emphatically a radio set should be installed in every racing balloon; that directional apparatus should be added, and that two head-sets should always be provided."

#### CAPT. MILLER PRAISES RADIO

BESIDES Olmstead's balloon, the three other army balloons which entered in this race were equipped with receiving apparatus. Captain Lester T. Miller wrote the General Electric Company as follows:

"Lieut. Brown and myself during our flight found your set worked very satisfactorily in every way. As you know, the counterpoise we used was a seven-strand copper wire, woven fifteen times about our basket. For our aerial, we used 300 feet of the same kind of wire. During the night of July 4 and on July 5, we flew at an altitude of about 4,000 feet. All our weather reports were received very clearly; in fact, the clearness of tones surprised both of us, as they were clearer than our regular station sets on the ground.

"On July 5, after 8:30 A.M., we flew at a higher altitude, and at heights of 5,000 feet and above we found the static was so bad that we were not able to receive satisfactory signals."

Ralph Upson, another of the contestants in the race, also equipped by the General Electric Company with the same kind of a receiving outfit, says there was a total absence of static at 3,000 feet. For six weeks preceding the race, Upson had used the set in his home and had become thoroughly familiar with its operation under various conditions. One of the uses he planned for his radio outfit in the race was to detect thunder-storms before the lightning was visible, so he took pains to learn how the static came in under various weather conditions.

Five of the principal broadcasting stations had arranged to send out special weather reports regarding the upper air currents during the first night of the race and the following morning. In regard to this, Upson says:

"Andrus, my aide, acted as chief radio oper-



A SAIL THROUGH THE SILVER LINING

This photo was taken by Mr. Ralph Upson from his own balloon, during the national race which started at Indianapolis on July 4th

ator. He began listening-in at 8:30 o'clock the night of the race. At first he could hear nothing but code signals, concerts from various stations, and a radio drama that was being sent out from a Chicago station. For an hour, this was about all we could hear. Then at 9:45 o'clock, Central time, Andrus picked up the latter part of the weather report being broadcasted from WGY in Schenectady. We heard just enough of it to make us wish we had heard the entire report. However, our disappointment was short, for a few moments later the whole report was repeated, every word being received clearly and distinctly. It was *just* the news we wanted.

"As a result of the information, we decided to go a little higher but not to try any high altitudes unless forced to it by thunder-storms. The report gave us full confidence of reaching New York State, and possibly New England. Everything seemed so favorable that I turned in to sleep."

# What You Should Know About Condensers

Condenser Losses. Variable Air Condenser for Radio Use. Disadvantage of the Conventional Form of Condensers. What Materials Are Best for Condensers

By ALLEN D. CARDWELL

## PART II

Last month Mr. Cardwell explained the theory underlying the construction of condensers and their function in electrical circuits. In this second and last part of his article, various practical considerations are taken up, with the purpose of showing the radio enthusiast how to select the best apparatus. As stated last month, "If receiving set owners would buy their variable condensers after a survey of the mechanical and electrical characteristics of the types on sale, rather than from a comparison merely of general appearance, hearsay, and price, there would be less trouble with thousands of receiving sets and less apparatus of inferior quality on the market . . . . A familiarity with good and bad condenser construction is worth any enthusiast's while to obtain."—THE EDITOR.

**L**OSSES in the dielectric used in a condenser are one source of signal "damping" as pointed out at the conclusion of the last article. These losses are high in solid dielectrics and low with air dielectrics.

The first thing we observe when a condenser is used in a high-frequency circuit is that the current may be dissipated in the dielectric. Thus, if we force 1 ampere of current into a condenser and when it discharges we only get back .9 amperes, there has been a dielectric loss of .1 ampere due to the creepage across the space between the plates. Some of the current must have "leaked" through the dielectric or have been absorbed in the dielectric itself.

These losses are normally too small to measure when the dielectric is only dry air, but under certain conditions the leakage can increase to an appreciable extent. In a solid dielectric, this loss is always appreciable and accounts in one way for the preference of radio engineers in using air as a dielectric wherever possible.

The next effect we observe is that some of the current may be dissipated in the conducting plates. If the different plates are so assembled that there are uneven pressures at supporting points or along the frame, we have loss from "contact resistance" aggregating a fairly high value.

Again we have condensive effects set up in any insulation used to support the condenser

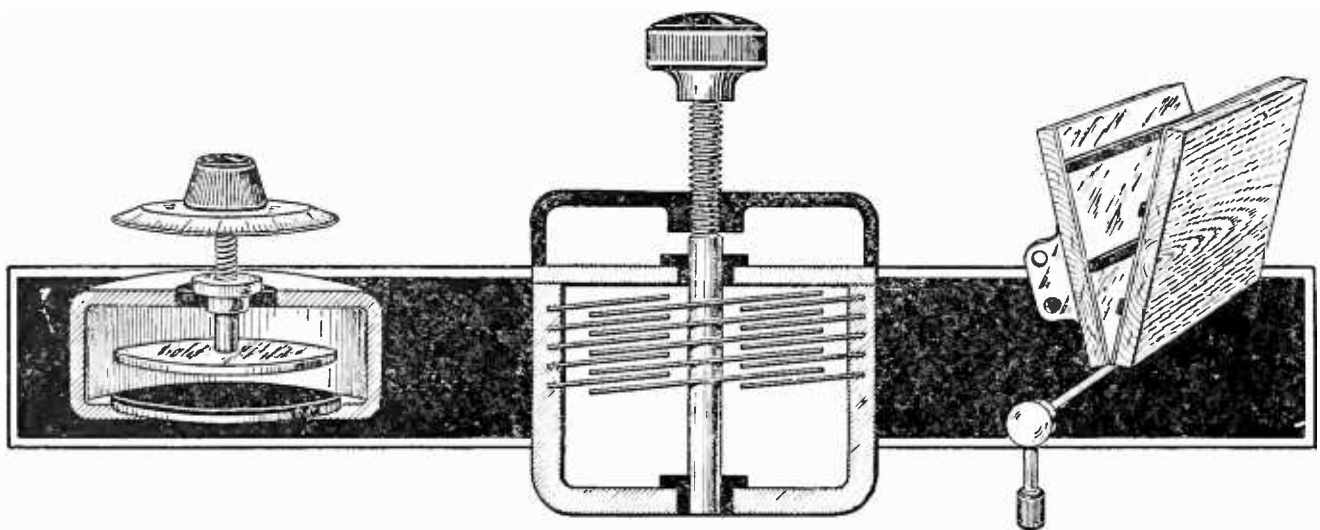

THREE TYPES OF VARIABLE AIR CONDENSERS  
"Up and Down" Motion—"Cork-Screw" Type—Book Leaf Type

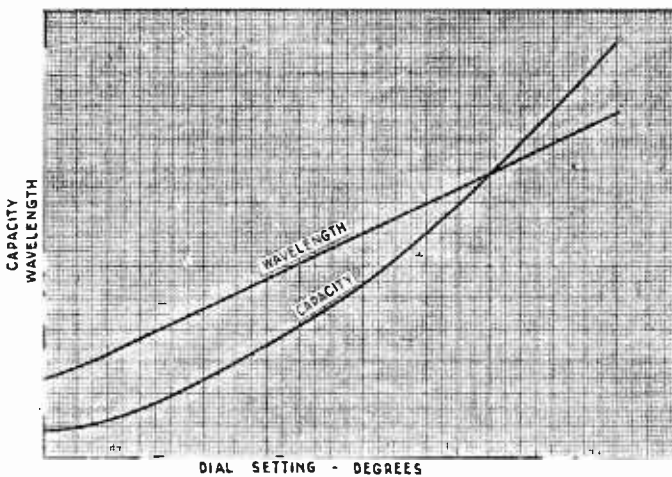
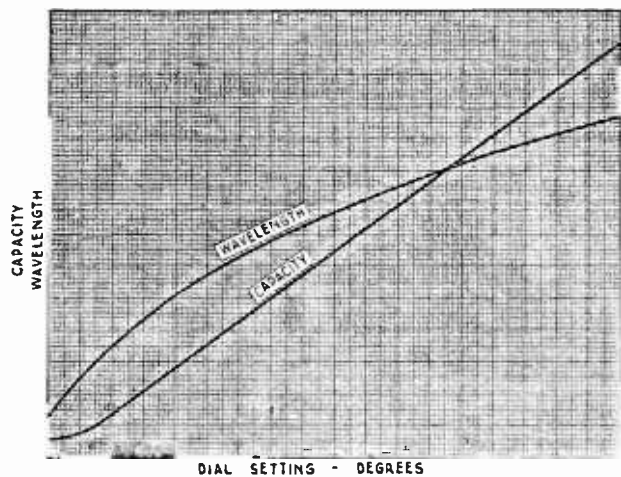

CURVES FOR "STRAIGHT LINE" AND "DECREMETER" CAPACITY RANGES

The curve at the left shows how a condenser having a constant capacity increase varies for wavelength when used with a given coil. The curve at the right shows how an eccentric-shaped plate will correct this and give a constant increase in wavelength when used with the proper inductance

walls. Although these insulation pieces may not be intended as part of the dielectric, they are sometimes so placed as to be in the electrostatic field and some of the current works into this supporting insulation and causes losses from leakage, and from a source we call "dielectric hysteresis." Hysteresis losses are the result of impurities or cellular structure, as in wood, where the arteries of the grain may have innumerable moist passages to shunt the current from point to point. Thus the insulation may pass minute currents in and out internally and may refuse to yield up the current with a uniform speed—in any event less quickly than the dielectric proper and thus cause resistance effects merely by failing to discharge synchronously with the main dielectric. This reveals the important factor of time or rate of discharge in dielectrics. We can charge a dielectric material such as paper to a given potential and upon short circuiting get back most of the charged current, but if we short circuit it a second time (after a minute has elapsed) we may get back additional current which we did not think was still in the dielectric or paper.

An ideal dielectric is perfectly elastic electrically. It springs back to its normal condition of equalized potential of zero grade the instant it is short circuited.

Another consideration is the possibility of losing a certain amount of current by "stray field" or parasitic effects. If a body of metal is in or near the dielectric field, it will act as a supplementary condenser in interaction with one or the other sides of the condenser alter-

nately. Thus, with many receiving sets, the panel is shielded. This means that the shield acts as part of the condenser and in doing so, a secondary condenser exists and losses may be caused since the shield may have conduction resistances as well as insulation hysteresis effects.

The losses in a condenser may thus be summarized as follows:

- 1 Dielectric leakage
- 2 Dielectric hysteresis
- 3 Insulation leakage
- 4 Direct-current resistance in plates
- 5 Stray field capacity
- 6 Insulation hysteresis

*These losses can be reduced to such a point that the most sensitive instruments devised to measure resistances cannot accurately indicate or check any losses whatever.* This is not an exaggeration. It does not mean, however, that there are no losses, but that the losses are so small that it is impossible, with unusually delicate equipment, to determine them.

Let us therefore consider various designs of variable air condensers (with which we are primarily concerned). Where do the various types of such condensers excel and where do they fail to secure proper efficiency?

A variable air condenser as generally designed consists of a series of fixed plates of semi-circular shape, so spaced that a second set of similar plates can intermesh between the fixed plates. The fixed plates are called the stator plates and the movable plates are called the rotor plates.

We can vary the capacity by the amount of

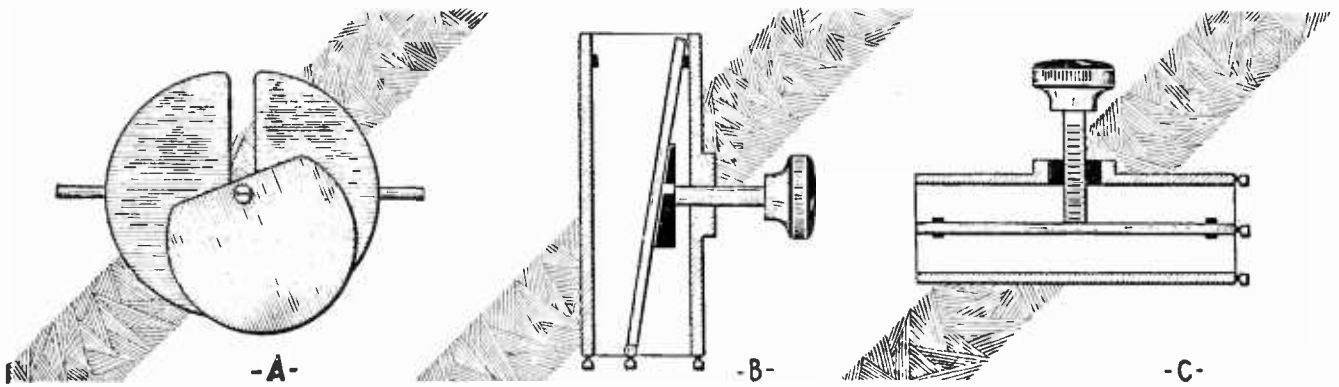

Three new types of coupling condensers: A—the Jones condenser used in neutralizing circuits; B—an old French design, revived recently by Allen D. Cardwell for use with the capacity-coupled, double-circuit tuner; C—a navy type coupling condenser

intermeshing of the rotor and stator plates. The variation of the intermeshing can be made to cause an equal increase of capacity for each degree of rotation. This may be an advantage in that it makes the controlling dial cause capacity changes directly proportional to the number of degrees through which the condenser dial is turned, but it does not increase wavelength uniformly. To do this, an eccentric shape is made for the rotor plates, and when used with a given coil the condenser changes cause a straight-line wavelength variation. In this case it is called "linear" because its wavelength variation, shown in a graph, would be a straight line. At the same time the advantages of the "straight line" or linear shape are relatively small for ordinary tuning, compared with the added cost of manufacture and the disadvantages of the extra cubic volume required for given capacity.

A variable condenser can also be constructed so that the plates (generally limited to two in

practice) are moved closer or farther apart in a direction at right angles to the planes of their surfaces. Owing to the necessity of using a thin sheet of insulation between the plates to prevent short-circuiting, this type of condenser will not vary proportionately with the mechanical control variation. As the space or dielectric thickness decreases, the capacity increases more rapidly than the turns on the threads or knob-mechanism, because the amount of solid dielectric has become greater in proportion to the amount of air dielectric and most solid dielectrics have greater specific inductive capacity.

A third system for a variable condenser is to hinge two plates and vary the spacing by closing or opening the free ends, as a book cover is opened or

closed. In this type of condenser the capacity also increases rapidly as the distance between plates is reduced beyond a certain point and, as in the reciprocating system, a good capacity rating is secured only by closing up the dielectric gap so closely that short circuiting would occur if solid insulation of some type is not placed in the electrostatic field. This means an air and solid dielectric are used so that what convenience is gained in higher capacity of the

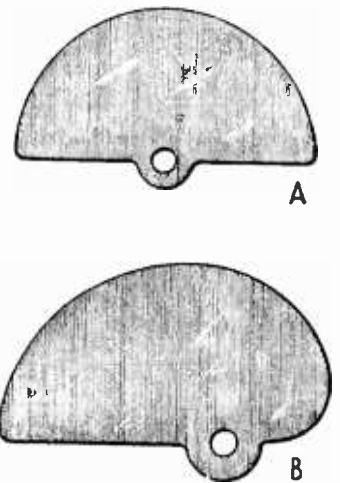

ROTOR PLATE SHAPES

A is the normal or standard shape, giving a "straight line" capacity increase

B is an eccentric shape to give a constant wavelength increase when used with the proper coil

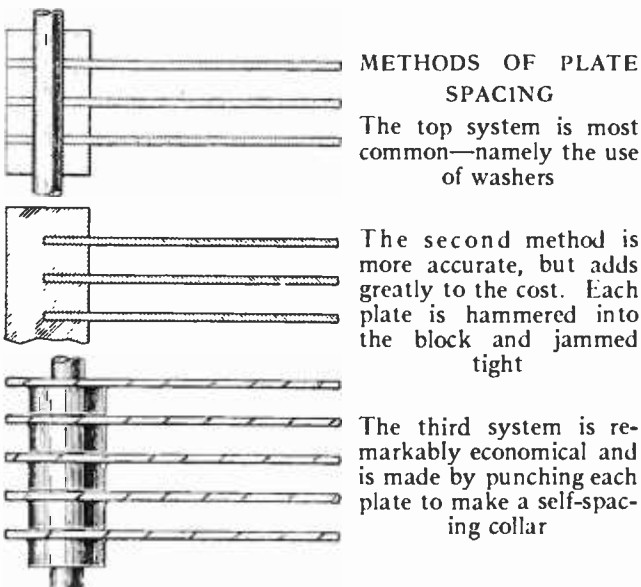

METHODS OF PLATE SPACING

The top system is most common—namely the use of washers

The second method is more accurate, but adds greatly to the cost. Each plate is hammered into the block and jammed tight

The third system is remarkably economical and is made by punching each plate to make a self-spacing collar



plates when close together is thus lost by the resistance of the solid dielectric.

A fourth style of condenser has occasionally been proposed—namely, a “screw type” in which the rotor plates are cast as a continuous “cork screw.” Being a complete circle, the plates can double the capacity per plate area and increase the capacity at a very slow, constant rate.

Other rudimentary methods of varying capacity have been used—for example, a set of moving plates sliding along grooves into the fixed plates, or some with one tube telescoping over another. These designs have in general one or another of the following defects:

- 1 The increase in capacity is not linear
- 2 The cost of production is too high
- 3 The maximum capacity is either small or secured by high dielectric losses
- 4 The mechanical construction is not strong or is clumsy or bulky
- 5 Variable settings for given capacity

For tuning receiving circuits, a condenser should occupy small space, increase wavelength evenly with all changes of the dial, and have a large range of capacity from minimum to maximum.

The intermeshing-rotor design has become the standard in radio practice.

In the design of the standard variable air condenser a number of mechanical methods

are followed. In spacing the plates of either rotor or stator, washers are often used. These are placed on supporting rods so that on assembly a plate is held in position by the flat faces of the alternating spacers.

This system has disadvantages. In the first place the spacers require tedious hand assembly. In a 43-plate condenser, for example, there would be three spacers per plate, or in all 129 spacers to be set as well as 22 plates of the stator and 21 plates of the rotor. Where the spacers are also used on the rotor, it would entail more than 256 distinct hand motions aside from locking the end plates and tightening all adjustments.

In itself, the labor is not as serious as the electrical inefficiency. A certain amount of oil, moisture, or surface unevenness is cumulative where each spacer touches a plate. The resistance is thus multiplied by the 256 or so contacts and aside from any other losses, the resistance may be considerable. Even soldering the joints does not satisfactorily overcome the mechanical weakness of the design. Fusing the metal would be the only way of assuring permanent low contact resistance.

A better method of design is to cut a solid die by which the plates are cast as a solid part of the frame support—usually a flat semi-circular wall, thus supporting the plates by half of their circumference and having minimum resistance in the support. This type of condenser with

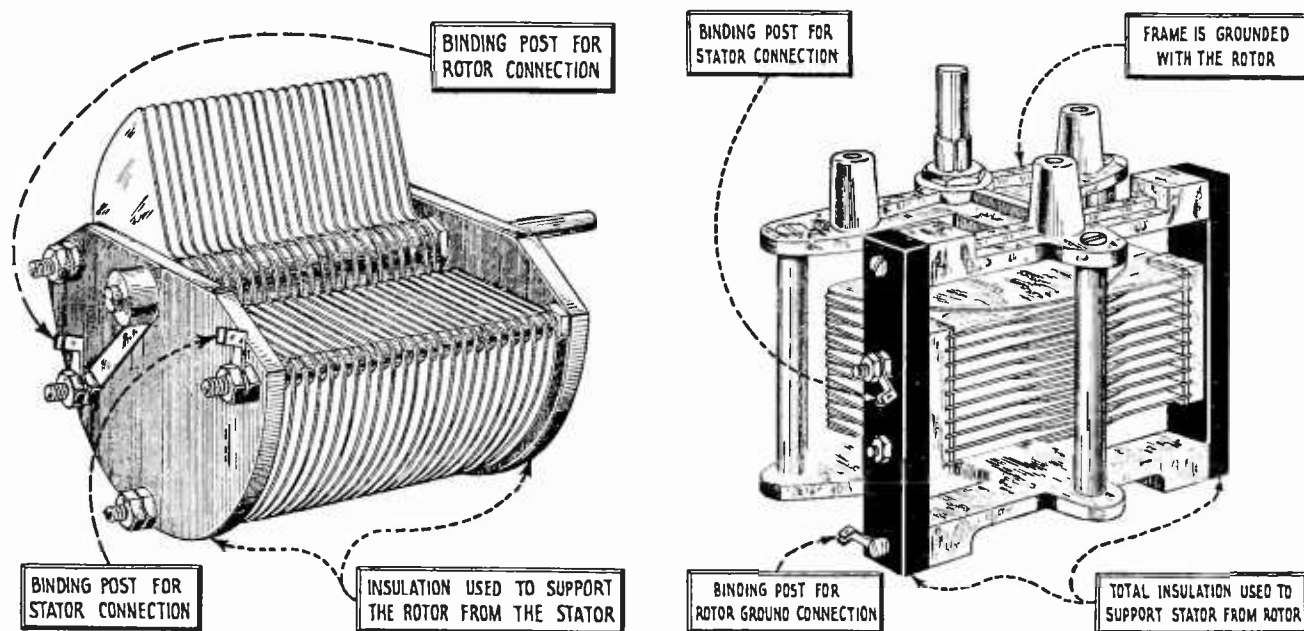

TWO WAYS OF INSULATING THE STATOR FROM THE ROTOR

At the left, the rotor is supported by end plates of insulation. Either rotor or stator can be grounded. The condenser on the right shows a design in which the rotor is part of the frame connection, permitting the use of less insulation. Only the rotor can be grounded

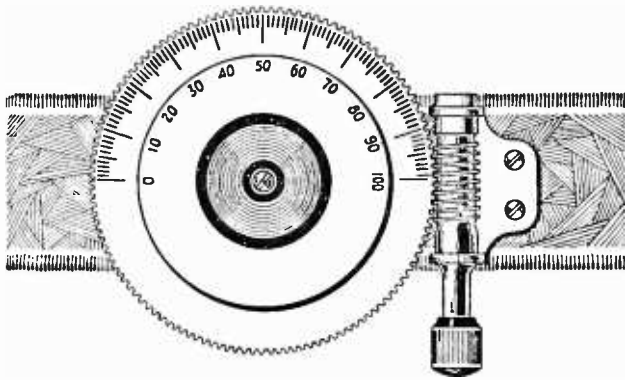

MECHANICAL VERNIER

This type gives a ratio of 256 to 1 which is truly a micrometer control

good bearings can be very closely spaced, that is, the dielectric thickness or clearance between stator and rotor can be extremely small. The cost however is high, due to the shape and accuracy required.

The surfaces of the plates cannot be smoothed down and are difficult to keep free from dust which will quickly cause minute short circuiting paths. Even when invisible to the eye, this dust will vary the capacity as it accumulates.

Again, the cast condenser requires a high degree of shielding, and its eddy current losses, due to so much metal serving only as support and not as true plate surface, add to the losses.

A third type of spacing can be used by cutting grooves into spacing pillars, or posts, into which the plates can be set with remarkably accurate spacing and with proper mechanical strength. This system is superior in its economy and efficiency *if the plates are properly fixed in the grooves.*

The proper design depends upon the method of fixing the contacts so positively that surface contact resistance is avoided.

For the rotor element, either die casting or washer spacing can be used. A few are made in which the rotor plates are set in position and the hot metal poured into a mould to form the center shaft.

In general, we may say that the conduction current losses due to washer spacing for either stator or rotor will be small, but the accuracy of the spacing will be difficult if washers are used for the stator. Every rotor shaft or bearing will eventually wear or have some parallel plate error, and an ordinary allowance can be made for this occurring on the rotor if the stator plates do not vary also. In short, by keeping the accuracy of spacing in the rotor, we could reduce the spacing to half of that required for

washer spacing in both rotor and stator and hence secure high capacity for the amount of plate surface used.

The real difficulty in condenser design is in arranging the support of the rotor and stator and in insulating them from each other. This involves the utmost mechanical strength and is most commonly attained by making the frame a part of the stator system and insulating the rotor by means of a metal bushing set in an end plate of insulation.

Three standard ways of doing this are used, and in each case there are decided electrical disadvantages. In the first case, where the end plates are large insulating masses, the dielectric hysteresis losses are generally considerable. When the surface of the insulator is large, the possibility of conduction across the surface is greatly increased. In the second case, the bearings are supported in such a way that the bushing becomes part of the dielectric and suffers also by having a large metal-to-insulation contact surface, thus increasing the dielectric losses. In type three, the insulation design is good, but the mechanical ruggedness is low. But in all these types the capacity of the operator's hand is carried to the dial by the rotor shaft and is bound to cause some body capacity effects in tuning regardless of shielding.

It is therefore desirable to reverse the usual procedure and instead of "grounding" the stator, to ground the rotor. This means that the stator is insulated from the frame. The frame can then be attached to the panel and by grounding will not be influenced by any "body capacity" brought near the panel. This is a highly important feature in tuning long dis-

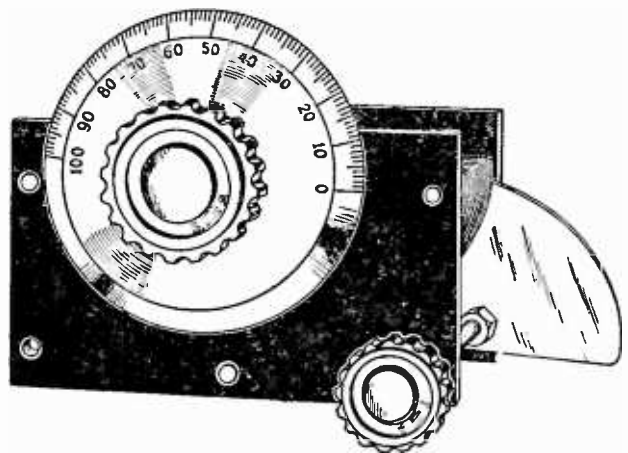

PLATE VERNIER

This design illustrates a simple method of getting a vernier effect by the use of a single plate on a second shaft

tance stations where the signal current is so weak that any variation of wavelength in the secondary or primary due to stray capacity fields will cause the desired station to fade out when the adjustment is fixed and the hand removed from the dial. To hold the station when the wavelength setting has been made it is therefore necessary to ground every part which may directly or indirectly be affected by body capacity. This can only be done by grounding the stator. Shielding does not entirely accomplish the desired end if the stator and frame are grounded, since the shaft of a rotor is part of the high potential side and passes through the shield and panel.

Another feature of design which is serious in the grounded stator type is the method of making contact with the moving rotor. If contact is made by friction, the amount of bearing surface is so small that a film of oil or dust or other foreign matter creeping into the bearing causes a high resistance. To avoid this unusually wide bearings must be used or a lead of flexible wire soldered to the rotor and carried to some connecting point.

This point brings up the subject of counter balancing. A condenser bearing gradually loosens with wear and can eventually become so loose that the rotor will slip around due to its own weight when the semi-circular plates are not at perfect balance.

Thus, great difficulty is caused in using a loosened condenser mounted with the shaft

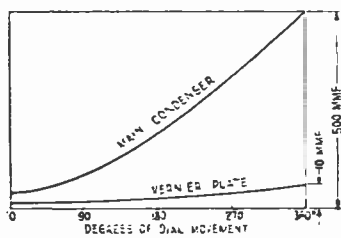

Note that although the ratio of the separate vernier plate to the main condenser is about 50 to 1 at maximum it is less than 4 to 1 at minimum settings, due to the high minimum capacity of this condenser design

horizontal on the panel as is generally the case. To overcome this objection some manufacturers place a counter-weight of moulded lead on the rotor so that even if the bearings loosen, the adjustments will not be altered by gravity. Other manufacturers resort to "two-side" construction, dividing half the rotor and half the stator plates symmetrically in opposite sides of the rotor shaft. Thus the same objective is attained. Both methods, however, add to the cost of the condenser, and its bulk, and make its minimum capacity high. Instead of three stator support rods as many as five or six

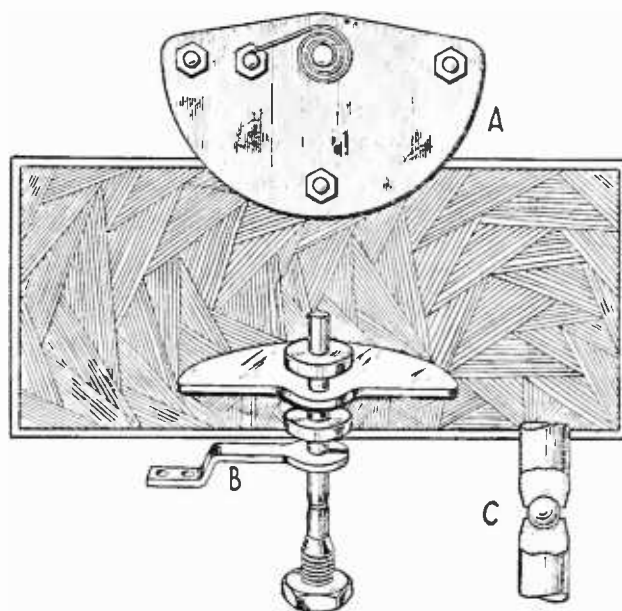

THREE TYPES OF ROTOR CONNECTIONS

- A—Pig-tail connection used for many rotor contacts
- B—A friction "pig-tail" spring which has a very good surface contact. The parts are moved open to show the relative positions
- C—A ball bearing which can be used on rotor-grounded condensers. This affords a perfectly centered bearing not subject to end play

posts are required with the "two-side" construction, multiplying the spacing problem proportionately. The weight of the stator, when counter balanced, is nearly doubled. All this can be avoided by placing a friction sleeve on the rotor shaft. By using a slotted sleeve, practically even and permanent pressure is secured which avoids any possible slippage from gravity.

A debatable issue is involved when the question of verniers is brought up. An efficient condenser which has a firm, even bearing requires no vernier when used by an experienced operator. Because some types of receivers, such as regenerators, require very critical tuning, vernier devices are often used. The vernier may take the form of a second condenser of one or two rotor plates built on the frame with the main condenser. It may also take the form of a gear system attached between the rotor control and the rotor shaft.

With the separate condenser vernier there is introduced a double electrostatic field—such that when the main condenser is set the small condenser may do more than vernier—it may increase or decrease the first capacity far out of proportion. What is more serious is the necessity for a more complicated shielding and insulating system. The cost is considerably increased and the design mechanically less

rugged in all cases, since one shaft must be contained inside the other shaft and must be fairly loose to operate at all. Possibility of wear or disalignment of plates can easily occur.

A mechanical vernier is preferable. By suitable gearing, a real vernier ratio is secured. A true micrometer effect is determined only by the gear ratio. With the separate condenser vernier, the ratio of increase is too low. Thus if the maximum capacity of the large condenser is 500 mmf. (micro-microfarads) and the maximum capacity of the vernier is 10 mmf., the ratio is 50 to 1, which is good. Usually, however, the interacting capacity of the vernier often runs up to 50 mmf. while in many condensers of this type the larger units hardly reach 400 mmf. Thus, in practice, the ratio becomes 400 to 50 or 8:1 which is not sufficiently large. By a mechanical vernier, such as a rubber roller on the edge of a 3-inch dial, the ratio is about 6:1 which is also too low. The best solution is by using a gear in which a single main condenser is varied by a ratio of turn of 50 to 1 or higher. This, however, is not altogether desirable for quick tuning and, in general, most experienced radio operators do not like verniers preferring to use a circuit in which a vernier is not required. This is worth careful study. Specially designed vernier dials are on the market which afford an 80:1 ratio, and, when mechanically rugged, they offer an ideal solution of vernier controls.

#### WHAT MATERIALS ARE BEST FOR CONDENSERS?

WE MAY now discuss the various types of materials used in the manufacture of the condenser. As the condenser should be light, some metal such as aluminum is almost universally used. The resistance of aluminum is almost as low as that of copper. Plates of aluminum, if more than .0025 inches thick, are reasonably strong and will not be easily bent. They are also springy enough to stay in shape even if accidentally pressed or hit, if made from hard stock. Aluminum also makes a good cast frame. Sheet aluminum is almost universally used for the plate material. It can be polished, and if made in constant thickness and of high purity it is satisfactory in all respects. Plates of brass and some other metals may be nicked but this is not necessary if the spacing is greater than .05 inches as the possibility of dust short circuiting the plates is very small. Aluminum is not easily corroded under ordinary conditions, and the surface resistance is not

an important factor. For the rotor shaft, a good grade of case-hardened steel is desirable. The end bearings should be of dissimilar metal from the shaft and preferably bronze or brass. Spacers should be about  $\frac{3}{4}$  of an inch in diameter for the rotor. On the three-post types, used for stator spacing, washers of at least  $\frac{3}{8}$ -inch diameter are desirable. The bearings must always be made of the best steel and brass and where pressure is exerted, be so assembled that the wear is properly taken up by adjusting screws so that after long use the tension or position of the plates can be restored.

"Pig tail" connections for the moving element contact are generally made of braided copper wire of about twelve or more strands. If ribbon wire is used, it must be very flexible and not subject to twists when coiling or uncoiling; or a flat connector like a watch-spring may be used.

It is difficult to specify the best kinds of insulation without treading on trade names of different manufacturers. Phenol compositions have good insulation characteristics if not in the electrostatic field, but any solid material is bound to cause resistance in this respect. Fibrous materials rank somewhat below the phenolic compounds. Hard rubber of pure composition is particularly good for supports and insulation. A good design calls for the smallest possible contact with any solid insulation. On the other hand a fixed condenser uses a good deal of insulation, as the dielectric and the resistance characteristics then play an important part. Porcelain is electrically good but mechanically poor owing to its brittleness.

Back of all these factors in design, workmanship and materials is the basic efficiency of the condenser—resistance. No beauty of assembly, no perfection of material or convenience of design can offset resistance effects. Furthermore, if the condenser has only a low range of capacity variation it is inefficient and if it has proper maximum range but excessive bulk it is also undesirable.

The measurements of the resistance of a condenser are extremely difficult. The best way is by a comparison test, using as the standard a special condenser with plates suspended by silk threads and all stray field effects carefully isolated. Such a measurement involves very delicate and accurate devices and considerable engineering skill. The rating given must be based upon the reputation of a recognized authority.



# What Our Readers Write Us



## *A Bouquet for the Broadcasters*

Editor, "RADIO BROADCAST"

DEAR SIR: I am deeply impressed by the requests which come so often over the radio for listeners-in to write to the artists, lecturers, singers, and others who entertain the unseen audience.

It seems a small matter to write such letters, and I have written a great many; but I think most radio fans realize that it is impossible to write as many as the people who entertain would hope to get, and I should like, through your magazine, to express my appreciation of the enormous trouble and work undertaken by these stations, which give us such a vast variety of good material suited to every taste. As I cannot listen to the radio and write letters all the time, I ask that you may find room for this letter of general appreciation in your magazine.

I have just returned from a trip to London, where broadcasting is paid for through a license which every person who owns a receiver must possess, and the entertainment provided, both in variety and quality, as well as in amount, is insignificant compared with the service given in this country without pay. I am sure that the letters which the stations receive do not adequately represent the gratitude of people who own radio receiving machines.

Very truly yours,  
F. N. DOUBLEDAY.

## *A Report on the Grimes "Inverse Duplex"*

A MAGAZINE for and about radio is in somewhat different relation to its "Dear Readers" than most other periodicals, in that there is more correspondence with the editor. There is quite a bit of familiarity and good fellowship. There are many bouquets received and some brick-bats—which we are happy to say are much in the minority. We do try to make our magazine helpful as well as entertaining, and we like to know that our efforts meet with your approval. For this reason we are always glad to receive letters such as this one, from those who have successfully followed the instructions in our "How to Make It" articles.

GENTLEMEN:

I wish to extend my thanks for your article in the April number of RADIO BROADCAST. "1,300 Miles With a One Foot Loop," and especially for the

wiring diagram of the Grimes Inverse Duplex receiver. Shortly after reading the article I set about building an Inverse Duplex. I have had several types of receivers, including crystal detector, ultra-audion, plain VT detectors, and three-circuit regenerators, including variometer and variocoupler tuners and triple spider-web tuners and this set (Inverse Duplex) sure has them all beat. Although on the loop it is not quite so loud as some of the other sets with a two-stage A. F. amplifier, the ease of tuning, freedom from interference and other noises more than make up for the slight decrease in the volume. Several of my friends have heard it and say it is better than any they have ever heard.

In the four weeks I have been using this outfit there has been only one night when I could not hear anything. One night when static was quite bad on outdoor aerial outfits, I could cut through to WGY 1,000 miles with very little annoyance from static, on the loop.

Thanking you again for the article, and for all the other interesting articles in your magazine I am

Sincerely yours,  
ARTHUR E. TABRAHAM  
Bloomington, Ill.

## *Selling Records by Radio*

AS SOON as someone suggests selling by radio, most thumbs go down. However, it is being done, and, to a great extent, being so well done that we are all learning to like it. Good publicists have been able to "sell" religion by making it entertaining; plays and operas have been "sold" to the public and lately we find that the large movie houses can sell their entire program by letting the radio audience hear a part of the good music that drowns the click of the projector as the silent drama is screened. In the accompanying letter our correspondent outlines a very practical plan, which, it would seem, could be brought into action with satisfactory results.

DEAR SIR:

I wish to make a suggestion of a plan whereby radio and the phonograph might be made to cooperate with each other instead of conflicting and competing as they do now. The history of the telephone and the telegraph shows us that one can never entirely eliminate the use of the other, but that the development of the entire field of use for both

together has made the share of business of each invention much greater than if one interest had entirely eliminated the other.

At present the phonograph people have the best talent in the country under contract and are able to pay large sums for good entertainment. The broadcasting stations are still furnishing high class entertainment, but when performing before the microphone has lost some of its novelty the problem of paying the artists and collecting from the radio public will have to be solved.

My plan is this: Use radio broadcasting to advertise phonograph records. I don't mean to broadcast phonograph music by any means, for everyone knows how little satisfaction there is in tuning a radio set just to get a poor reproduction of phonograph music that you can listen to first hand with no trouble at all. But why cannot the microphone of some good broadcasting station be installed in the studio where records are being made by famous artists and give the radio public a free sample of what the next issue of records is going to be like so that they will want to go down and buy the record.

The movies are running short parts of films to advertise coming attractions, new foods are often advertised by free samples, the circus gives a free show or parade to advertise the main attraction, the music stores all have concert rooms to play the new records for prospective customers, so why shouldn't the record manufacturers avail themselves of the absolutely free means of handing out a sample of part or all of a few of their coming issues of records to many thousands at a time of a class of people that are all interested in good music and a large share of whom are owners of phonographs?

Very truly yours,

FRED W. TEMPLE  
Lenwood Hospital  
Augusta, Georgia.

### *Playing the Game*

IT IS doubtful that the devotees of any pastime are more sportsmanlike than radio enthusiasts. It is true that, for a time, there was, and in some few places there still is, a squabble between the folks interested in broadcast reception only, and those out and out brass-pounders who are now known as "hams." Wherever any ill-feeling is found, it is more than likely to result from a mutual misunderstanding and it may be smoothed over by a chat. Such chats usually require more than average goodwill and gumption on the part of one of the people concerned and there are not enough of such people. The suggestions made by our correspondent, who signs himself, "A Ham," may make such chats unnecessary and life more livable for all of us.

DEAR SIR:

Within the past few months we have seen a great many receiving circuits exploited in radio magazines and radio sections of the newspapers. Some of these circuits are nothing more than modifications or complications of circuits that have been known for some time. In many instances their chief advantage consisted in giving the magazine or paper something to describe and radio dealers something to sell. When the time came for performance, many of these outfits produced nothing but disappointment. Many novices attempted to construct these circuits and after they have invested their good money for the purchase of parts to build up these so-called phenomenal receivers, found that it was not difficult to eliminate one half or more of the parts and secure about the same results, and by so doing, getting back to the original circuit of which the new circuit was a complication.

It happens that a great many of these receivers are of the radiating type, that is, they are made in exactly the same fashion as radio telephone transmitters except that they are made to operate on considerably less power. The fact that they do transmit cannot be questioned.

The efficiency of these receivers is obtained in a manner that in the long run can do nothing but harm the radio business. This is particularly noticeable in the case of the Reinartz and the Flewelling circuits. The case of the single-circuit regenerative receiver has received so much attention that it is unnecessary to discuss it further here, but in comparison to these other receivers it is actually a *mild* transmitter.

If radiating receivers are used close to each other, we find that a great deal of whistling results. Take for instance an apartment house with five or six antennas all leading to regenerative receivers that are in almost an oscillating condition. Suppose two or three of them are tuned in on the same distant broadcasting station and for some reason or other the signals from this station become weak. The operators of the three receivers begin very delicate adjustments to build up this signal strength and in doing so one of them may reduce his wavelength; another may go up on his; and the third may satisfy himself with increasing his regeneration to the point of oscillation. Nothing more than a din is the result. Sooner or later this type of receiver will be a thing of the past, for there are indications, even now, that other types of receivers may be made which will perform equally as well without causing this interference. In the meantime *the sportsmanlike thing to do is to manipulate your receiver in such a manner as to permit your neighbors to secure the benefits from theirs that you would like to receive from yours.* This may be done if the receiver is kept well below the oscillating condition.

One serious cause of disturbance is utilizing what is called "zero beat" reception. Zero beat reception

is brought into play by getting the regenerative or plate circuit in exact resonance or tune with the incoming signals and is a very difficult method to employ satisfactorily. You can recognize the fact that you are employing zero beat reception when tuned to a given station, you find that by moving your wavelength dial a hair's breadth to the left or right, you are greeted by a whistle. That whistle means that you are going slightly above or slightly below the wave of the transmitting station and the wave of your regenerative receiver combines with the incoming wave from the transmitter and produces what is called a beat note. This beat note is picked up by other receivers in your neighborhood and if these receivers are connected to amplifiers and loud speakers, the result is a pronounced shriek which is doing more to injure radio than any other agency.

Have you ever invited a number of friends in to listen to a concert in which you thought they would be particularly interested? For a while the magic music may be delightful and at about the time that everyone concludes that radio is a very wonderful

thing, one of the shrieks to which we are referring comes out of the loud speaker. Those who are unfamiliar with radio are astounded. Their eyes widen and it is not unlikely that someone will exclaim: "What is that horrible noise? If this is radio I'll take the phonograph."

There are two methods for eliminating this interference. The first is by operating your receiver below the oscillating point; the second is by adding a single stage of radio-frequency amplification before the detector. It is well, in determining upon the receiver you ought to build, to find out whether or not the circuit you contemplate employing will radiate. It is better to employ some circuit that will permit long distance reception without interfering with your neighbors, who in turn have the privilege of employing a similar arrangement to interfere with you and continued back-biting of this sort is as disagreeable to the innocent bystander as to the quarrelers themselves. *Will you do your share to make radio better for everybody?*

A "HAM"  
Chicago, Ill.



"IS IT PITTSBURGH, MR. GALLAGHER?" "NO, CHICAGO, MR. SHEAN"

Gallagher and Shean, the not unknown comedians, are here shown behind the scenes waiting for their act to go on, listening in to some station, the exact location of which was not learned, owing to the fact that when the photographer left, they were still arguing as to whether it was Chicago or Pittsburgh

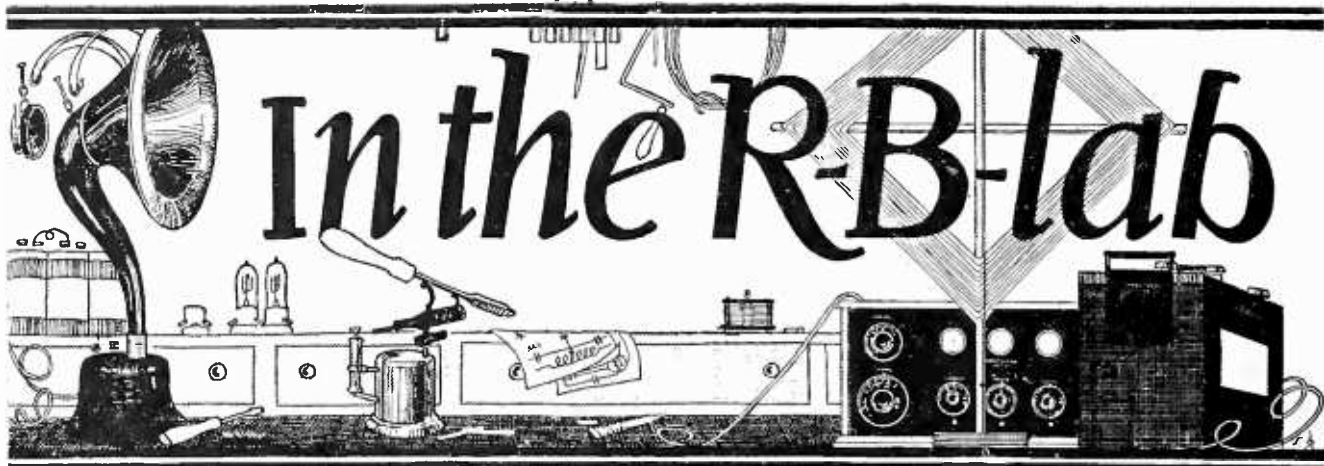

The "Lab" department has been inaugurated by RADIO BROADCAST in order that its readers may benefit from the many experiments which are necessarily carried on by the makers of this magazine in their endeavors to publish only "fact articles" backed by their personal observations.

Under this heading will also be published practical pointers, brief write-ups of interesting experiments, additions to and improvements on previously published circuits—in short, anything of genuine value and interest to the reader, which, due to the brevity with which it can be covered, does not justify a special article.

RADIO BROADCAST will be pleased to buy from its readers, at prices from three to five dollars, commensurate with the value of the data, kinks, devices, original ideas, etc., with photographs if possible, which the editor may consider eligible for this department.

Address all communications to the R. B. Lab EDITOR.

## PLAYING WITH THE GRIMES CIRCUIT

**T**HE Grimes Inverse Duplex receiver, which has been described in several past issues\* of RADIO BROADCAST, has proven on merit the most popular of the many reflex circuits. However, there is little doubt that the original circuit admits of considerable improvement, and the attention of not only the inventor but of individual experimenters has been devoted to this effort. Experiments by this department have resulted in data which will be of interest to the reader engrossed in the complications of this ingenious circuit.

The RADIO BROADCAST experiments were roughly divided into two parts: ascertaining the possibilities of different kinds of tubes in detecting and amplifying combinations, and investigating the possibility of increased signal strength through regeneration.

In all cases it was found that reception was much improved by the inclusion of a grid condenser and leak in the detecting circuit, rather than the direct metallic connection indicated in many diagrams.

The following combinations were attempted,

\*For circuits and further constructional data, see the April, July, August, and September issues of RADIO BROADCAST.

reception being effected on the small two-foot loop shown in the photograph (Fig. 1), all comparative tests being made on Station WOR, fifteen miles away:

1. Using three UV-201's for both amplifiers and detector: The result was a very stable set, and reception was little affected by adjustment of the limiting potentiometer. Signal strength was fair in the headphones, but weaker than in any of the succeeding experiments.

2. Using 201's in the amplifier and a UV-200 in the detector: Signal strength was considerably improved, but the set became more critical, and howled unmercifully on certain adjustments. This might have been obviated, however, by biasing the amplifier tubes.

3. Using UV-199's throughout: Signal strength was equal to test number two, but best results were not secured until the tubes were varied from detector to amplifier sockets and the most efficient combination determined.

However, distortion was particularly noticeable with these tubes when an amplifying plate voltage over forty was employed, and sixty to eighty volts was required for the highest intensification. Biasing the grids of both amplifying tubes with three volts negative, improved matters, reconciling quality to amplification.



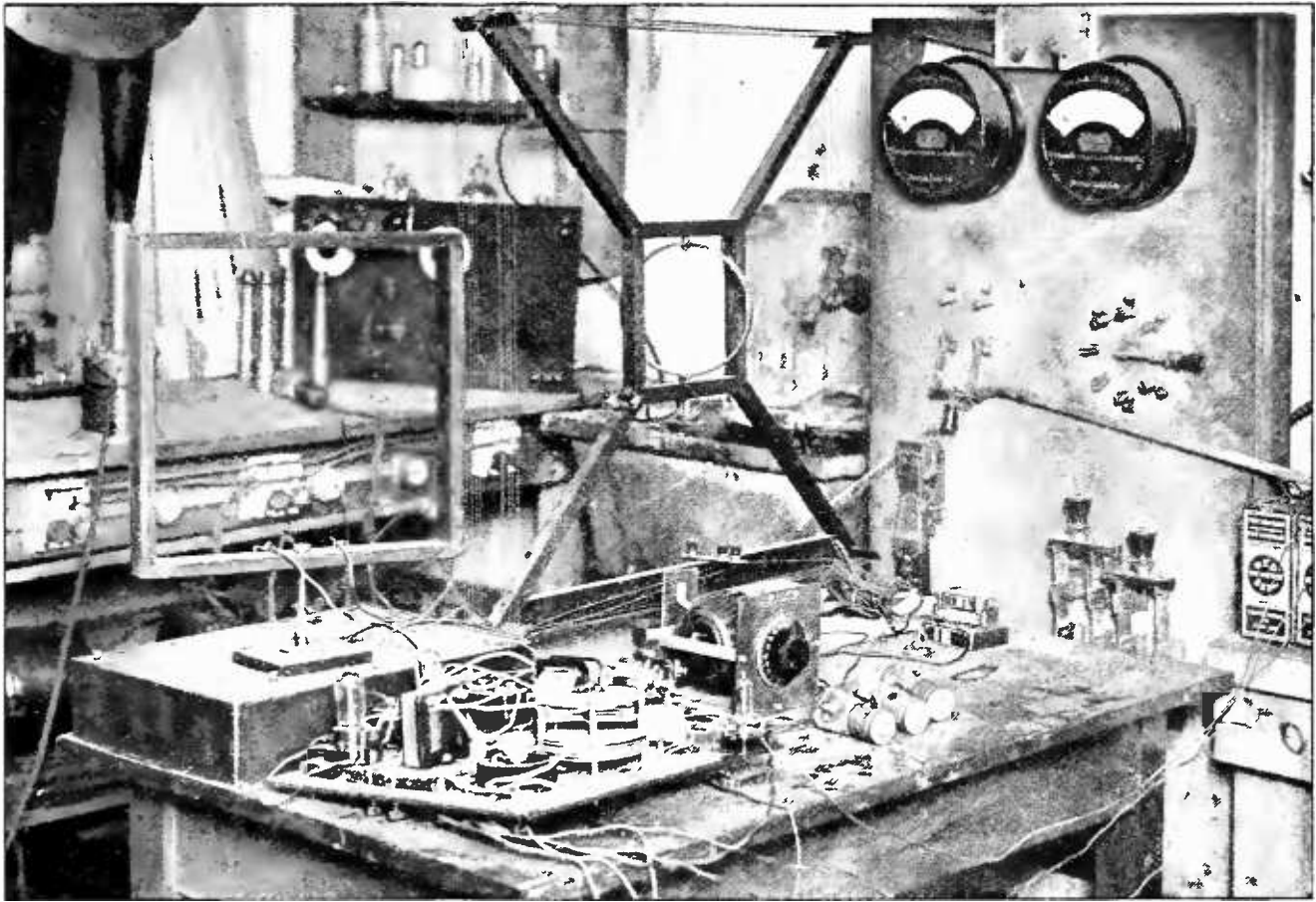

FIG. 1

Trying a plate variometer in the detector circuit of the Grimes receiver. UV-199's are in the amplifying sockets and a W. E. 215-A in the detector socket

The limiting potentiometer was here found quite necessary.

4. Using UV-199's for amplifiers and a 215-A—(W. E. peanut tube) for the detector: It was first discovered that these last tubes are not altogether uniform. One of three, however, proved an excellent detector, and this combination gave results superior to any of the preceding experiments. Signals were sufficiently loud to operate a small loud-speaker, though on more distant stations we should advise an additional stage of separate A. F. amplification.

On each of the foregoing combinations, regeneration was attempted by both the tickler feed-back and variometer methods. The former system was found unstable when it had any effect whatever, and results did not justify the expense and clumsiness of the extra winding on the loop.

However, using a standard variometer in the plate circuit of the detector, in experiment three, had a marked effect of regeneration, and signal strength was considerably improved. In tests one and two, it proved critical and un-

stable, while in the last it produced little or no effect.

From the foregoing experiments, the following conclusions may be arrived at:

1. A grid condenser and leak are desirable to the efficient operation of the Grimes circuit.
2. Howling and general instability of the circuit can be reduced and reception improved by biasing the grids of the amplifying tubes. (See page 123, June 1923 RADIO BROADCAST.)
3. Certain qualities in some detector tubes antagonistic to the best reception can be remedied by the use of a plate variometer.
4. The plate variometer is especially valuable with the UV-199 tube.
5. On the whole, an extra regenerative system in combination with the Duplex is neither desirable nor practicable.

#### MAKING YOUR GRID-LEAKS

(Photograph and data contributed by Carter Fiske)

**G**RID-LEAKS of different values are essential to the most efficient operation of radio receiving circuits, and poor results with many homemade regenerative sets have been

traced to an improper grid adjustment. The enthusiast who is becoming an experimenter should be equipped with the means of varying the grid-leak on the various tubes and sets with which he is experimenting. A variable leak is of course one solution, but many of these are unsatisfactory, and as there are often several sets in the shop, the most economical plan is to supply one's self with a dozen or so homemade fixed resistances.

A very efficient leak can be made by coating a small piece of card or bristol board with Higgins' Waterproof 'White Label' India ink. Different resistances are obtained by repeated coatings of ink.

The bristol board is cut into small strips an inch and a half long by a quarter of an inch wide. They are coated on one side to within an eighth inch of each end by applying the undiluted ink with the quill furnished on the stopper (Fig. 2). The resistance of three quarters of one inch of single coating is approximately 5 megohms (5,000,000 ohms); of two coatings,  $2\frac{1}{2}$  megohms; five coatings, 1 megohm, and so on. The experimenter is advised to make up a collection of resistances from 5 megohms to one half megohm.

The exact resistances of the leaks can be determined if the enthusiast possesses a microammeter or a galvanometer calibrated in fractions of an ampere. It will merely be necessary to connect the leak in series with a high-voltage battery (from one hundred to



FIG. 2

Making the grid leak. The India ink is applied to the surface of the bristol board, the number of applications determining the resistance

one hundred and fifty volts) and the meter, read the current indication, and apply Ohm's law (see article beginning on page 496, this issue) which states that the resistance is equal to the voltage divided by the current.

In a large laboratory, the resistance of the grid-leak would be measured directly by a very interesting instrument, an English invention, known as the Megger. This instrument is fundamentally nothing more than a D. C. meter reading in ohms directly, rather than volts or amperes. The Megger supplies its own potential by means of a small hand-driven, 250-volt generator. The ingenious part of the instrument exists in the differential winding of the meter which automatically compensates

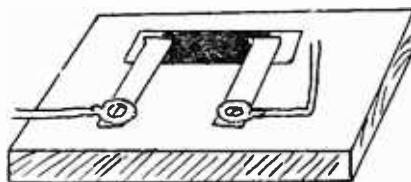

FIG. 3  
A simple mounting  
for the grid leak

for any variation in the voltage caused by the inconstant speed of the generator. If a grid-leak is connected to a Megger of the proper range, and the handle turned, the needle will indicate on the scale the exact resistance of the exterior circuit.

The ingenuity of the experimenter will devise numerous ways of mounting the India ink resistance. A convenient method of mounting is suggested in Fig. 3, where the resistance element is slipped under two brass or copper strips screwed to a small block, base, or panel.

#### BUILDING YOUR OWN LABORATORY

A WELL equipped radio laboratory is the ambition and dream of the true fan. A laboratory, however, unlike Aladdin's palace, is not to be built overnight. Rather the various tools and equipment are slowly accumulated with experience and as the pocket-book allows. But the building of a laboratory can be greatly facilitated if its acquisitions and purchases are effected with the advice and under the supervision of those who have paved the way.

RADIO BROADCAST plans to devote a section of this department to the interest of those readers who are slowly adding to their equipment, laying the foundation of a genuine radio lab. Every month, if space permits, one or two instruments or tools well within the financial resources of the average reader will be

suggested as additional equipment, and their functioning or use carefully explained.

Fig. 4 shows two pieces of laboratory equipment, a small hand-drill and a wet cell, the first being indispensable for rapid and accurate construction, and the latter most useful as an *always ready* auxiliary or spare battery. The hand-drill will cost from two to three dollars, and should be purchased along with an 18 and a 27 drill. These sizes will pass respectively, an 8 and a 6 screw, the two sizes most commonly encountered in radio work. The hand-drill may be used on wood, bakelite, hard rubber, etc., and on metal. It is equally useful in drilling cabinets, panels, or brass and steel supporting brackets. It is many times more rapid than the cumbersome brace and bit.

The wet cell equals in voltage the dry cell, and in emergencies it may be temporarily substituted for the latter. However, it is not recommended for continual service due to rapid polarization, an effect that renders the battery inoperative.

The wet cell costs about seventy-five cents, and renewals (zinc and sal-ammoniac) perhaps fifteen cents. When it is desired to use the



FIG. 4

Two useful additions to the amateur laboratory

battery, six ounces of sal-ammoniac are dissolved in the jar two-thirds filled with water. It is suggested that when the cell has done its duty—perhaps rescued a concert which a failing dry cell would no longer bring in well—that the solution be bottled and the carbon cylinder and zinc rod dried. The battery is now ready for the next emergency, and with such care renewals will not be necessary for several years.

### Supplemental List of Broadcasting Stations in the United States

LICENSED FROM JULY 14 TO AUGUST 7 INCLUSIVE

CALL SIGNAL	STATION	FREQUENCY (Kilocycles)	WAVE-LENGTH	POWER WATTS
KFBC	Nielson Radio Supply Co., Phoenix, Ariz.	1260	238	10
KFIY	Brott Laboratories, Seattle, Wash.	1270	236	15
KFIZ	Daily Commonwealth, Fond du Lac, Wis.	1100	273	100
KFJC	Post Intelligencer, Seattle, Wash.	1290	233	100
KFJF	National Radio Mfg. Co., Oklahoma City, Okla.	1190	252	20
KFJH	The Sugar Bowl, Selma, Calif.	1100	252	10
KFJI	Liberty Theatre, Astoria, Ore.	1190	252	10
KFJK	Delano Radio & Elect. Co., Bristow, Oklahoma.	1290	233	100
KFJL	Hardsoog Mfg. Co., Ottumwa, Iowa.	1240	242	10
WSAU	Camp Marienfield, Chesham, N. H.	1310	229	10
WSAW	Curtice & McElwee, Canandaigua, N. Y.	1090	275	100
WTAF	Gallo, Louis J., New Orleans, La.	1240	242	20

#### DELETIONS FROM JULY 1 TO JULY 31

KFAT	Eugene, Ore.	WMAD	Rockport, Mo.
KDFD	Casper, Wyo.	WMAW	Wahpeton, N. D.
KFIC	Denver, Colorado	WNAB	Bowling Green, Ky.
KFJB	Marshalltown, Iowa.	WNO	Jersey City, N. J.
WAAQ	Greenwich, Conn.	WPAS	Amsterdam, N. Y.
WABA	Lake Forest, Ill.	WPI	Clearfield, Pa.
WCAZ	Carthage, Ill.	WQAJ	Ann Arbor, Mich.
WFAQ	Waterford, N. Y.	WQAK	Dubuque, Iowa.
WGAX	Washington C. H., Ohio.	WQAT	Richmond, Va.
WIAV	Binghamton, N. Y.	WRAN	Waterloo, Iowa.
WIAW	Saginaw, Mich.	WSAA	Marietta, Ohio
WIZ	Cincinnati, Ohio.	WTP	Bay City, Mich.
WJAJ	Dayton, Ohio.		

# New Equipment



## A VERNIER VARIOMETER

Made by the National Chelsea Radio Corporation. It has a wide inductance range, is ruggedly built, and is intended for either panel or table mounting. Price, \$8.00

## EVEREADY "THREE" RADIO BATTERY

This battery merits every radio set user's attention. It may be used as an A battery for receivers employing UV-199's, as a B-battery booster for any tube set, and as a C battery for any amplifier. Size 4" x 3" x 1 3/8", 14 oz., 3 to 4 1/2 volts. The booklet describing the uses of this little battery may be had from the National Carbon Company, Inc., Long Island City, N. Y. Price, 70 cents

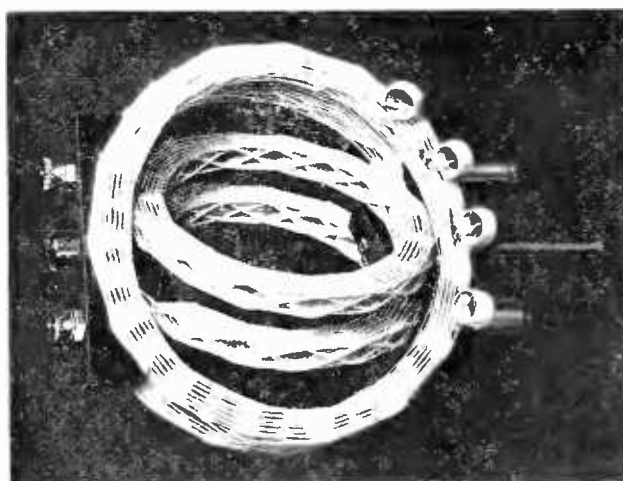

## A TUNED R. F. TRANSFORMER

Designed for use in neutrodyne circuits, but suitable for any arrangement employing tuned radio frequency. Information regarding its use in various circuits may be had from the

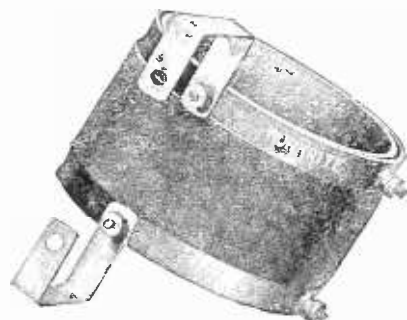

manufacturers. Workrite Manufacturing Company, Cleveland, Ohio. Price, \$2.00

## THE R. M. C. VARIOCOUPLER

This is one of a number of tuning instruments made by the Radio Manufacturing Company, of Springfield, Massachusetts. With a pair of variometers of similar construction, this variocoupler may be used to advantage in the construction of a good three-circuit receiver

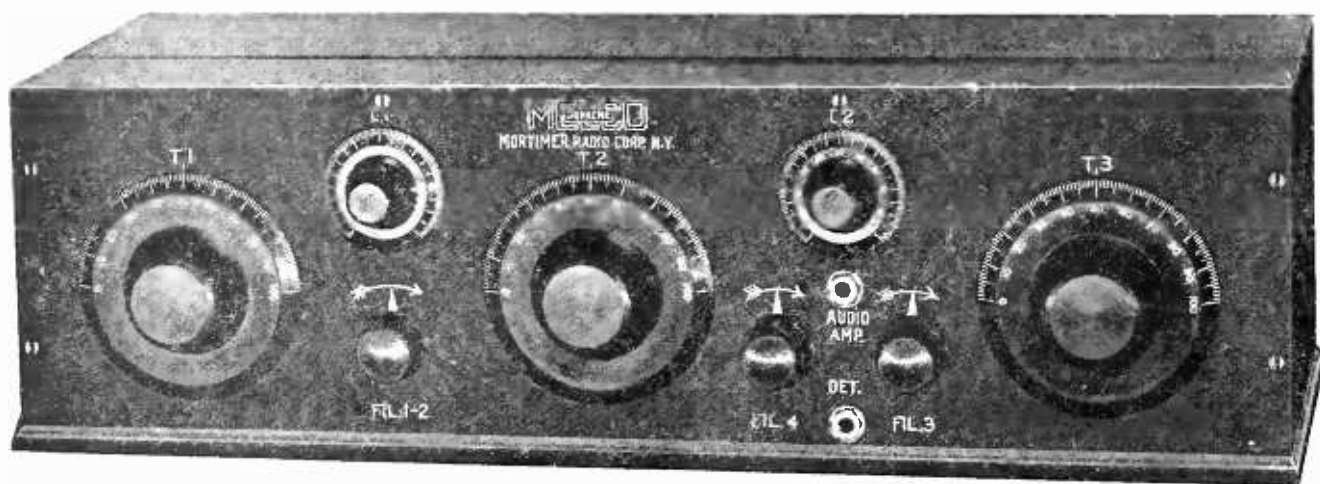

## A BROADCAST RECEIVER EMPLOYING THE NEUTRODYNE PRINCIPLE

Two steps of radio-frequency amplification, detector, and one step of audio gives enough volume to operate a loud speaker. The tuning is accomplished by special Telos variometers. Dials C<sup>1</sup> and C<sup>2</sup> control the neutrodyne condenser, in order that the various values of capacity in the tubes employed may be compensated for



## “What panel shall I use?”

ONE of the first questions you probably will ask yourself when you get ready to build your radio set will be about the choice of a good panel. Your answer will determine, to a large extent, the efficiency of your set.

Of course you want a panel that has superior insulating properties. Celoron Radio Panels are used by fans who appreciate the value of a good radio panel. They have high dielectric strength and great volume and surface resistivity. Celoron panels are uniform in quality, and do not warp or crack.

You will find Celoron panels easy to saw, drill, and tap. They engrave evenly without feathering, and enable you to build a set that is neat and attractive as well as efficient.

### Approved by Uncle Sam

Celoron Radio Panels are approved by the U. S. Navy Department Bureau of Engineering and the U. S. Signal Corps. Many of the leading manufacturers of radio equipment use Celoron in their standard parts.

Each panel is wrapped separately in glassine paper and carries complete instructions for working and finishing. Ask your dealer for one of the following sizes:

1—6 x 7 x $\frac{1}{8}$	5—7 x 18 x $\frac{3}{16}$
2—7 x 9 x $\frac{1}{8}$	6—7 x 21 x $\frac{3}{16}$
3—7 x 12 x $\frac{1}{8}$	7—7 x 24 x $\frac{3}{16}$
4—7 x 14 x $\frac{3}{16}$	8—12 x 18 x $\frac{3}{16}$

We also furnish Celoron in full-sized sheets and can cut special sizes if desired. If your dealer has not yet stocked Celoron panels, ask him to order for you, or write direct to us. Indicate by number the size you want.

### Send for free booklet

Our booklet, “Tuning in on a New World,” contains a list of the leading broadcasting stations in the United States and Canada, several efficient radio hook-ups, and an explanation of the symbols used in radio diagrams. Write at once and be sure of getting yours before the supply is exhausted.

*To radio dealers: Send for special dealer price list showing standard assortments*

## Diamond State Fibre Company

BRIDGEPORT

(near Philadelphia)

PENNSYLVANIA

BRANCH FACTORIES AND WAREHOUSES  
BOSTON CHICAGO SAN FRANCISCO

Offices in Principal Cities

In Canada: Diamond State Fibre Company of Canada, Limited, 245 Carlaw Ave., Toronto



CONDENSITE  
**CELORON**  
STANDARD RADIO PANEL

## New Equipment--Continued



**FILAMENT LIGHTING FROM A LAMP SOCKET**  
Is now possible where alternating current of 110 or 220 volts is available. This little machine will furnish enough current for the lighting of more than a dozen 6 volt tubes. It is being included by several manufacturers of complete receivers as standard equipment and is the first machine to be marketed as a substitute for the storage battery. Simplex Electrical Laboratories, Inc. 144 Livingston St. Brooklyn, N. Y.

## The Grid

## QUESTIONS AND ANSWERS

The Grid is a Question and Answer Department maintained especially for the radio amateurs. Full answers will be given wherever possible. In answering questions, those of a like nature will be grouped together and answered by one article. Every effort will be made to keep the answers simple and direct, yet fully self-explanatory. Questions should be addressed to Editor, "The Grid," RADIO BROADCAST, Garden City, N. Y.

## A TUNED PLATE CIRCUIT

*Will you please publish a book-up containing the following equipment, and explain the functioning of each piece of apparatus:*

*One variometer*

*One 43-plate condenser*

*One stage tuned radio-frequency amplification*

*One stage audio-frequency amplification*

*About how far should such a set receive?*

C. P., Norristown, Pa.

**W**E APPEND the diagram which our correspondent desires, in Figure 1. It is suggested that the instruments be mounted in the left to right order indicated in the diagram, and on a panel not shorter than twelve inches.

$C_1$  is the 43-plate condenser which tunes the wavelength to which the loop responds. This last is simply constructed and the reader is referred to this department for May, in which clear directions are given for building it.

Potentiometer  $R_3$  varies the charge on the grid of the first tube, according to the position of the slider or knob, which may be varied between the positive and negative terminals of the A battery. This variation is called biasing and permits the radio-frequency tube to be operated at its most efficient grid potential, and results in maximum amplification with a minimum of distortion.

Variometer  $V$  comprises the tuned plate circuit in which the radio-frequency amplification is effected in a manner not easy to explain to readers unfamiliar with radio theory. Its functioning is, perhaps, most easily disposed of by stating that it offers infinite impedance to the currents of the

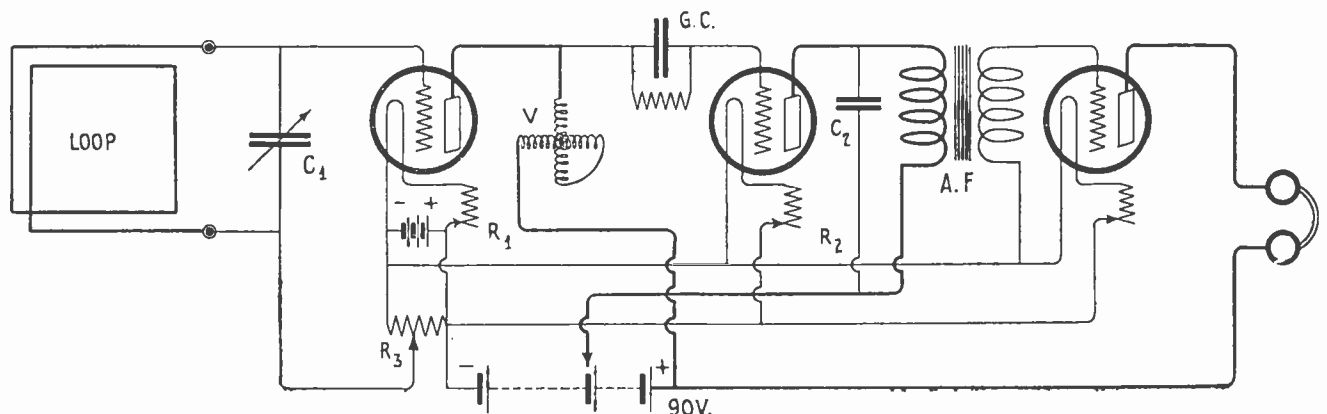

FIG. 1

# Magnavox Radio

## Reproducers and Amplifiers

IT has been the dream of every Radio user to own in one unit a Power Amplifier and electro-dynamic Reproducer, thus insuring perfect radio reproduction. The new instruments of the unit type here illustrated in one and two stages of amplification may be had through dealers everywhere.



*New Magnavox Combination Set A1-R*

There is now a Magnavox for every receiving set. The full line embraces:

### *Magnavox Reproducers*

R2 with 18-inch curvex horn . . .	\$60.00
R3 with 14-inch curvex horn . . .	35.00
M1 with 14-inch curvex horn. Requires no battery for the field . . .	35.00

### *Magnavox Combination Sets*

A1-R consisting of electro-dynamic Reproducer with 14-inch curvex horn and 1 stage Amplifier . . .	59.00
A2-R consisting of electro-dynamic Reproducer with 14-inch curvex horn and 2 stage Amplifier . . .	85.00

### *Magnavox Power Amplifiers*

A1—new 1-stage Power Amplifier . . .	27.50
AC-2-C—2-stage Power Amplifier . . .	55.00
AC-3-C—3-stage Power Amplifier . . .	75.00

The new Magnavox semi-dynamic Reproducer M-1, designed for dry battery receiving sets, is also of great interest to radio users. Write for complete catalog.

**THE MAGNAVOX CO., Oakland, Cal.**



New York Office: 370 Seventh Avenue

PERKINS ELECTRIC CO., LTD., MONTREAL, CANADIAN DISTRIBUTORS

★ Tested and approved by RADIO BROADCAST ★

wavelength to which it is tuned, with the result that the oscillations which would ordinarily return through the variometer are forced upon the grid circuit of the succeeding tube.

The grid condenser and leak (GC) function for the detector tube much after the manner of the potentiometer in the R. F. amplifier, and maintain the electrical condition of the detecting grid in the state most conducive to detection.

C<sub>2</sub> is a telephone bypass or shunt condenser of the usual type, generally .002 mfd. capacity, and may be purchased for thirty-five or fifty cents. It passes radio-frequency currents in the detector tube which otherwise would be impeded by the high reactance of the primary of the audio amplifying transformer. This passage of the R. F. current has a slight effect of regeneration, and while not altogether necessary on this type receiver, it often improves operation.

The audio transformer merely relays the output of the detector on to the amplifying tube, where it is intensified, and finally sent through the phones or loud-speaker.

The receiving possibilities of such a set rest largely upon the experience of the operator, and in the winter season reception distances may range anywhere from one hundred to a thousand or more miles.

WINDING SPIDER-WEB COILS

In the May, 1923, issue of RADIO BROADCAST appeared an article by Walter Van B. Roberts describing "A Single-Tube Loop Set in a Brief-Case." The article mentions that the grid and tickler coils are wound, spider-web fashion, "over three and under three." I should appreciate it if you would illustrate in a drawing just how these directions are to be carried out.

M. S., CONELY ISLAND, N. Y.

THE "over three and under three" method of winding can be used to advantage for any receiving set provided that the number of turns and diameter of the coils are suited to the wavelengths on which it is desired to receive. The accompanying illustration (Fig. 2) shows how the inductance is to be wound. Starting at the inside end of any one of the "spokes", the wire passes over three "spokes" (looking edgewise at the wheel or winding form) and then under three, round and round until the wire has packed up the required distance from the inside (1 3/4" in the case of the coil described by Mr. Roberts). Nineteen spokes should be used, but if a form having greater or less than nineteen is more convenient, almost any reasonable number may be employed. Care should be taken, however, that the number of "spokes" is always divisible by three, plus one, i. e., ten "spokes" (nine plus one), thirteen "spokes", twenty-two, etc.

The winding form is generally made in one of two ways: it may be built up of wooden spokes (such as toothpicks) stuck into the edge of a small wooden or heavy cardboard disk; or, perhaps the more simple method, by cutting out the complete form from fibre or heavy cardboard, as Mr.



FIG. 2

Roberts did (see tickler coil in photo on page 18, May issue.)

Any one who contemplates winding his own spider-webs will do well to read the clear and detailed instructions on pages 428 and 429 of RADIO BROADCAST for March, 1923. In that case, 45 toothpicks were used, the wire being wound over two and under two.

A THREE-CIRCUIT LAYOUT WITH AMPLIFIER

Since becoming a reader of your excellent publication, I am contemplating the construction of a regenerative receiver built in such a manner that two stages of amplification can be conveniently added to the same at a later date. Will you kindly furnish a diagram of the wiring, as well as a drawing showing the approximate size of the panel and the placing of the various tuning instruments? I intend to use a variocoupler and two variometers. How many taps should there be on the variocoupler?

H. A. K., Fergus Falls, Minn.

IT IS suggested that H. A. K., and readers interested in similar apparatus, build the tuner and detector in a single cabinet, and later, if desired, the two steps on a separate panel and according to the instructions detailed in the article on amplifiers appearing in the July issue of RADIO BROADCAST. The circuit diagram, and the preferred order in which the instruments may be mounted, are shown in the Fig. 3 and Fig. 4, which also suggests the desirable dimensions for the panels.

The number of taps on the variocoupler will vary with the make, averaging, perhaps, ten. The better instruments are tapped in both units and groups of turns, necessitating two rows of taps and two switch levers, but eliminating the series antenna condenser.

This receiver is the renowned amateur standby and in the opinion of many operators, it is without peer for distance, loudness, and selectivity. It was a set of this type that won RADIO BROADCAST's "How Far" contest.

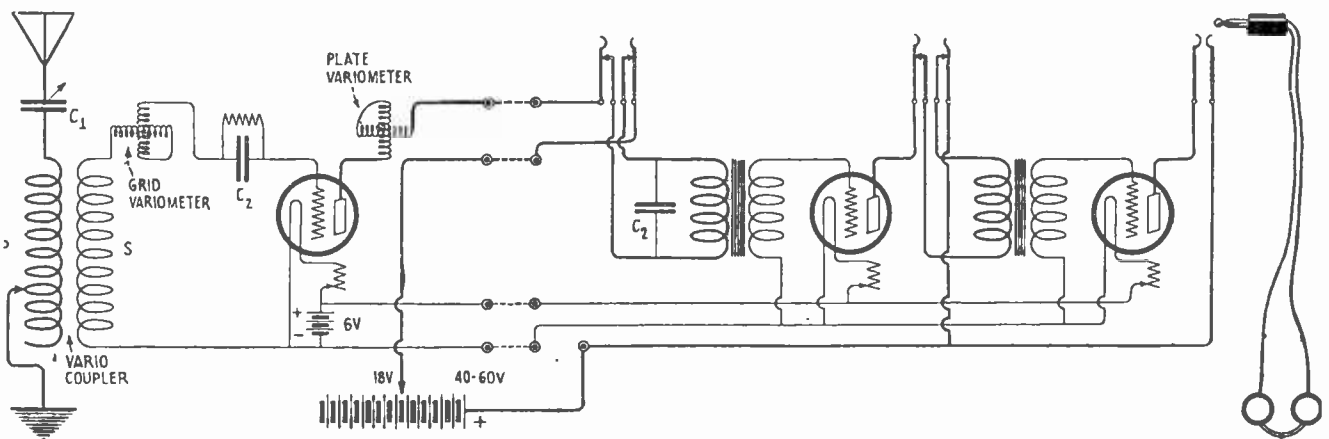

FIG. 3





## Midgets in size—but giants in power

**I**MAGINE a radio storage battery so light you can lift it on the palm of your hand, but powerful enough to supply all the current you need for long-distance receiving—and then some!

The new two- and four-volt Exide A Batteries for low-voltage tubes weigh only five and six pounds each. And they are wizards of efficiency—right in step with the latest developments in radio receiving.

These sturdy little batteries are neat and compact. They were specially designed for WD-11 and UV-199 vacuum tubes, but can be used with any low-voltage tube. The two-volt Exide A Battery consists of a single cell. It will heat the filament of a quarter-ampere tube for approximately 96 hours. The four-volt A Battery, having two cells, will light the filament of a 60-milliamper tube for 200 hours.



### For six-volt tubes

Like all Exide Storage Batteries, the Exide A Battery for six-volt tubes is dependable and long-lasting. It is made in four sizes, of 25, 50, 100 and 150 ampere hour capacities.

noiseless current. It permits the niceties of adjustment that make radio receiving an unalloyed

pleasure. The Exide A Battery for six-volt tubes has extra-heavy plates, assuring constant potential and uniform current over a long period of discharge. Like all Exide Batteries, it embodies the finest materials available.

### In marine and commercial wireless

On sea and on land the Exide plays an important role in the industrial life of the nation. In marine wireless, Exide Batteries provide an indispensable store of emergency current. A majority of all government and commercial wireless plants are equipped with Exides.

Exide Radio Batteries are sold by radio dealers and Exide Service Stations everywhere. Ask your dealer for booklets describing in detail the complete line of Exide Radio Batteries. Or write direct to us.



### Exide B Batteries

give noiseless, full-powered service over a long period of discharge. Designed throughout to prevent electrical leakage. Capacity, 3 ampere hours.

# Exide

## RADIO BATTERIES

THE ELECTRIC STORAGE BATTERY COMPANY, PHILADELPHIA

*Oldest and largest manufacturers in the world of storage batteries for every purpose*

Service Stations Everywhere

Branches in Seventeen Cities

★ Tested and approved by RADIO BROADCAST ★

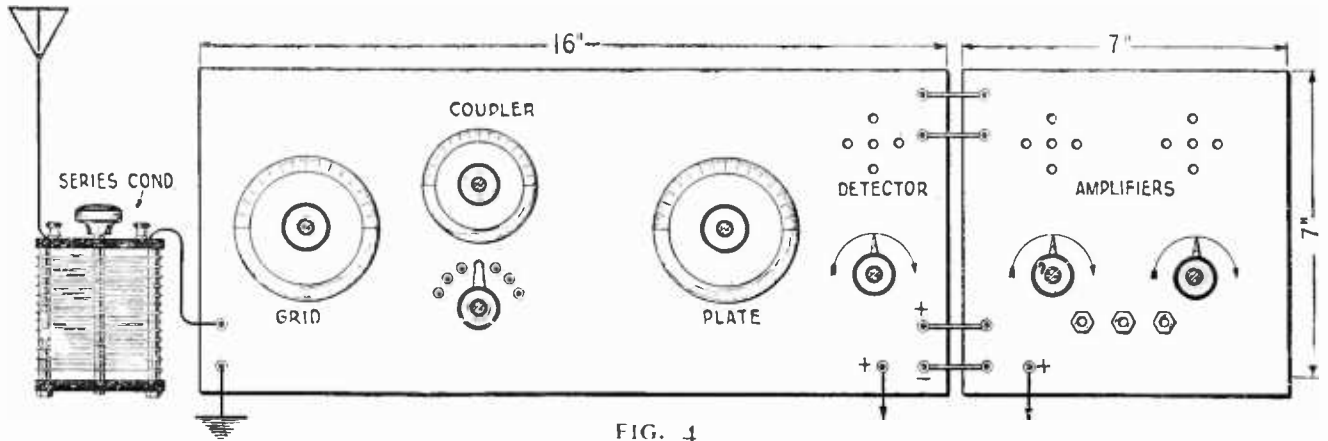

FIG. 4

## TROUBLE WITH A FOUR-STEP AUDIO AMPLIFIER

I have a four-stage audio-frequency amplifier, the results from which have not come up to my expectations. While amplification on the second and third stages is quite satisfactory, volume being consistent with the number of tubes, and the signals clear, there is apparently no further amplification on the last step, and the set howls unmercifully. Can you suggest any way in which this can be remedied?

L. B. L., TIGNAL, GA.

THE writer of the above encloses a diagram of his apparatus, showing a conventional receiver, the output of the detector being impressed on a straight four-stage amplifier. L. B. L. uses common A and B batteries, as well as what is, perhaps, too many C batteries.

The ordinary three-step amplifier is a precarious proposition, to say nothing of another additional stage. When such an amplifier is built in a single cabinet, there is almost certain to be a fatal amount of feed-back, due to the proximity of the transformers, wiring, etc., and the comparatively dense magnetic fields to which the strong plate currents in the higher steps give rise. In order to prevent howling, it is often necessary to add an unusually high C battery (the voltage applied under certain conditions to the grid) which generally causes the tube to be operated on an inefficient portion of its characteristic curve. This will tend to increase distortion, rather than reduce it, although it is for the purpose of reducing distortion that the C battery is used.

Our correspondent, and other readers contemplating similar amplifying apparatus, are strongly advised to break up the amplifier into two sections, in individual cabinets, the first containing two steps of amplification with ordinary amplifying tubes to which are applied plate voltages under one hundred volts. A C battery should be used in the second stage only when it is justified by an improved output. The second division should comprise the "power amplifier," consisting of special transformers (if the experimenter is able to secure them), power tubes (five-watt bulbs) and a separate B battery up to 350 volts. With such plate voltages, C batteries will be necessary, the voltage of which, varying with different tubes and plate potentials, must be determined by experiment. (The GRID does not advise the use of voltages in excess of 150 volts on other than special power-amplifying transformers.)

A four-step amplifier built in accordance with the foregoing general instructions should give as satisfactory results as may be expected from such a degree of intensification. However, The GRID does not consider the fourth stage of amplification justified either by results or ninety-nine

per cent. of volume requirements. An ordinary two-step amplifier will give more than sufficient volume for home entertainment, while a third stage of "power" amplification (a very efficient ready-made unit has been placed on the market) will further intensify the signals for re-broadcasting on sound waves from an open window or veranda.

Audio amplification is limited, particularly when the apparatus is constructed and operated by the average broadcast enthusiast, by distortion, and by the extraneous sounds which are often amplified more efficiently than the music, and which are generated in each additional stage.

## POLARITY

What is meant by the positive and negative poles of a battery?

E. J. L., LIBERTY HILLS, VA.

PLUS and minus, or positive and negative, are merely signs arbitrarily applied to the poles of a battery in order to name a difference that *does exist*. In the pioneer days of electricity, when man's insight into the science was limited to the observance that when a piece of flint glass and a bit of cat's fur were rubbed together they tended to attract one another, it was discovered that the electrical world was divided into two dissimilar charges. For instance, though fur and glass adhered to each other after a brisk rubbing, it was found that a second piece of glass, similarly electrified, repelled the first piece of glass! Further experiments added to the puzzle by demonstrating that while two pieces of glass, electrified by friction with fur, repelled each other, the fragment of glass thus charged was attracted to a piece of glass electrified with cotton! In other words, it became apparent that there existed two kinds of electricity, which, for want of better words, were called positive and negative. For no particular reason, the piece of glass electrified by fur was held to have a negative charge, while that electrified by cotton a positive charge. A great number of experiments substantiated the theory of the like charges (plus and plus, minus and minus) repelling each other, and unlike charges (minus and plus which is the same as saying negative and positive) being mutually attractive.

The significance became more apparent that followed Franklin and Faraday. The two wires coming from a cell were found to be characterized by these same different charges, and a battery would build up an accumulative potential only when the individual cells were connected positive to negative. Dynamos were found to possess similarly different poles, and a relation was established between

**Radiotron  
WD-12**  
The standard  
base dry cell tube  
\$6.50

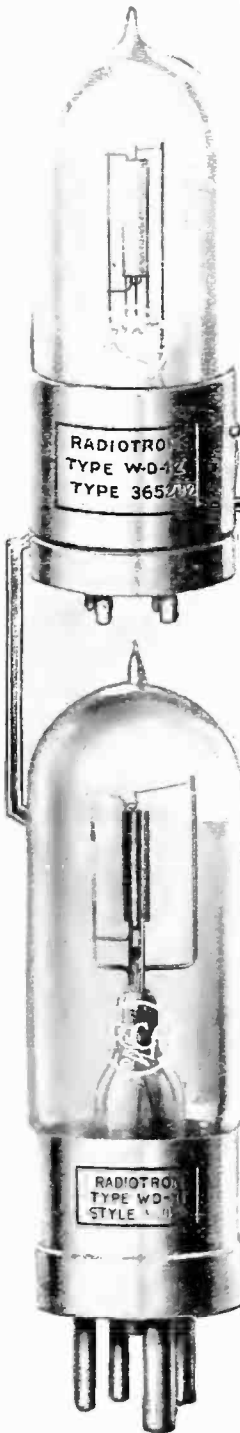

**Radiotron  
WD-11**  
The ideal  
dry battery  
detector \$6.50



**Radiotron  
UV-201-A**  
The super-  
amplifier  
tube \$6.50



**Radiotron  
UV-199**  
The little tube of  
big performance  
\$6.50



**Radiotron  
UV-200**  
The long  
distance  
detector  
\$5.00

# 3,600,000 Radiotrons/ already made and sold!

This one fact reveals at a glance the growth of radio! 3,600,000 RADIOTRONS already sold! It was the perfection of the RADIOTRON that made popularization of radio possible—and every vacuum tube set needs RADIOTRONS for clear reception and amplification—for sensitivity—and long distance reception.

RADIOTRONS were developed in the world's largest radio laboratories, where hundreds of modern radio achievements had their beginnings. There, they have been steadily perfected to give ever greater service. And now RADIOTRONS have been developed to meet new needs of both transmission and reception. When you ask for a RADIOTRON, take a good look to be sure the name is on it—and the trade mark!

This symbol  
of quality  
is your pro-  
tection



**Radio Corporation of America**

Sales Dept., Suite 2066: 233 Broadway, New York  
District Sales Offices:

10 South LaSalle Street, Chicago, Ill.

433 California Street, San Francisco, Cal.

# Radiotrons

REG. U. S. PAT. OFF.

★ Tested and approved by RADIO BROADCAST ★

magnets and the polarity of wire carrying electric currents. Finally, with the advent of the electron theory of matter, the difference between positive and negative electricity assumed a new significance, and science to-day declares the universe to be built up of these unlike charges, which, arranged in different formations, are manifest as everything—gases, liquids, and solids!

In a less general field, it is believed that a current of electricity is nothing more than a flow of small negative charges, electrons, from negative to positive (away from the repelling charge to that which attracts), an action that is demonstrated conclusively in the vacuum tube; for, unless the pole called positive on the B battery is connected to the plate of the audion, no current will flow through the tube, and the set will be inoperative.

We only know that there are two kinds of electricity. We note the characteristics of each in their relation to each other and to neutral charges, and call them positive and negative.

#### AMPLIFYING PHONOGRAPH MUSIC

*Will you kindly publish a diagram showing how a two-stage amplifier and a loud-speaker may be connected to a phonograph? The idea is to amplify the phonograph music considerably, for lawn dances, etc.*

*Will any other apparatus other than radio be required?*

W. H. J., HILO, HAWAII.

THE most simple way to achieve what our correspondent desires is to purchase reproducing and amplifying apparatus designed especially for this purpose. It is manufactured by two of the largest makers of loud-speakers, and has been in the market for several years. The

manufactured equipment consists of an especially designed microphone built into a phonograph tone-arm, and two steps of power amplification, the first transformer of which is wound to take the low-voltage input from the microphone.

However, a system almost equal to the manufactured article can be made up by the radio fan almost entirely of radio equipment. The necessary parts are as follows:

One 6- or 12-volt microphone with a battery of the corresponding voltage. The transmitter may be of the standard type, salvaged from a discarded telephone.

One telephone induction coil. This may be purchased new for thirty-five or fifty cents, or, like the microphone, it may be removed from a defunct Bell instrument.

Two sockets, rheostats, and amplifying tubes.

One amplifying transformer for the second step.

Sixty to ninety volts of B battery.

Loud-speaker.

One A battery, which may also be used to supply the microphone current.

The circuit is shown in Fig. 3, and it will be observed that, excepting that the telephone induction coil substitutes for the usual first-step amplifying transformer, the bulb system is the standard amplifying arrangement.

The microphone should be placed where it will pick up the sounds emanating from the phonograph, and it is most conveniently fitted far back in the throat of the horn. A more ingenious and satisfactory method, which was used by The GRID for the radio transmission of phonograph music, is to build up an auxiliary tone arm with the microphone at the far end. The opening should so duplicate the standard tone arm that the reproducer may be fitted over it when it is desired to amplify the records.

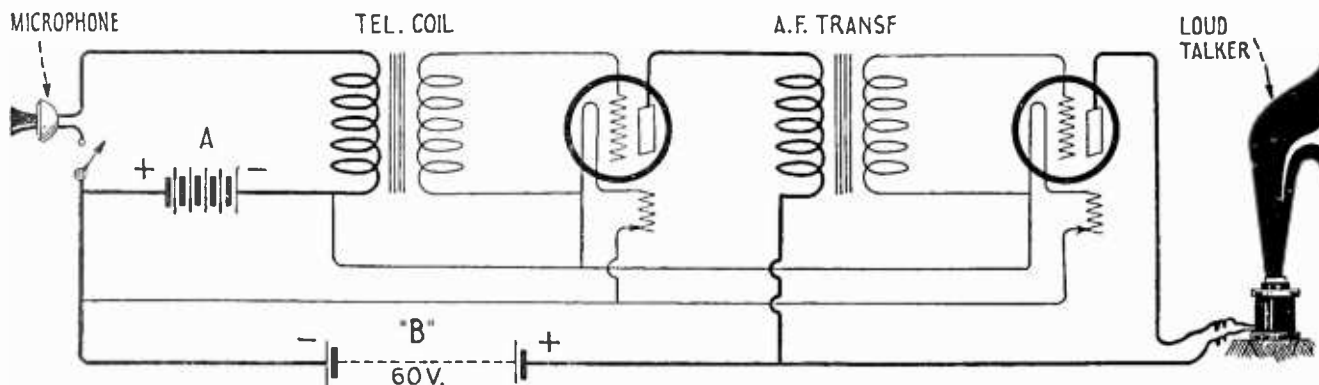

FIG. 5

#### NEXT MONTH

*For months we have been looking for the ideal single tube receiver. In a single evening IN AUGUST, using a WD-12, we heard two stations in Chicago, one in Pittsburg, one in Boston, and many nearer our testing station on Long Island. Photographs, diagrams, and complete instructions next month.*

### What Would You Like to Have in Radio Broadcast?

*The editors would be pleased to hear from readers of the magazine on the following (or other) topics:*

1. *The kind of article, or diagram, or explanation, or improvement you would like to see in RADIO BROADCAST.*
2. *What has interested you most, and what least, in the numbers you have read so far.*

# The Receiver of Tomorrow



## The Symphony ★

Tomorrow in Radio means a wider and more useful as well as more entertaining broadcasting. Therefore, to the purchasers of receiving sets, the design, the material, the workmanship, the circuit and the assembly, all play an important part in the quality of reception, and distance heard.

The placing of a Symphony in your home is a permanent investment that will win your instant approval, and occupy a prominent place among your most cherished possessions.

The clear reception and unusual volume are the results of the high grade units, the fine workmanship, the most

efficient circuit, and the correct assembly. The improved circuit used in the Symphony combined with the accuracy of its construction, has increased the selectivity to a marked degree.

The range of the Symphony Receiver is unlimited. Recently, in Chicago, Havana, Cuba, was tuned in not only on a head set but heard plainly on a loud speaker.

The Symphony Receivers are made in two types—Three and Two stages of audio frequency amplification.

If your dealer cannot furnish information on the Symphony, write for illustrated catalog, giving us his name.

### JONES RADIO COMPANY

Lytton Building, Chicago

The Symphony is manufactured under the U. S. Patent No. 1113149, Armstrong Regenerative Circuit

*All parts used in the Symphony are built and guaranteed by the Kellogg Switchboard & Supply Company for twenty-five years manufacturers of complete telephone equipment*

★ Tested and approved by RADIO BROADCAST ★



## The Loud-Speaker With the Natural Tone

The Bristol "Audiophone" will bring into your presence the actual "tonal personality" of the speaker, the singer or the player. You will hear them as they are—not disguised by mechanical distortion. The "Audiophone" is a true sound reproducer, retaining all the fine gradations of tone quality, volume and feeling which distinguish the original performance of the artist. You forget the instrument, in your enjoyment of the entertainment it brings to all your household and the guests who may join you.

BRISTOL ★  
TRADE MARK

# AUDIOPHONE

PATENTS PENDING, DESIGN PATENTS PENDING

## LOUD-SPEAKER

Years of research in sound reproduction, in the laboratories of an established engineering concern, have made the "Audiophone" what it is—have given it its round, full tone, its ample carrying power, its distinctive freedom from blurring and distortion. It needs no separate storage battery for magnetizing current, and can be used with any two or three stage power amplifiers.

"AUDIOPHONE SR." Complete, 15-inch bell \$32.50  
"AUDIOPHONE JR." Complete, 13-inch bell \$22.50

A new Bristol single stage power amplifier for use with the usual two stage amplifier can be furnished, which will greatly increase the range of the Audiophone where desirable. Price \$25.00

*Ask your dealer to demonstrate the "Audiophone". If he hasn't it, write us—we will see that you are supplied.*



**THE BRISTOL COMPANY**  
WATERBURY, CONNECTICUT

★ Tested and approved by RADIO BROADCAST ★

RADIO BROADCAST. May, 1923. Published monthly. Vol. III, No. 1. Published at Garden City, N. Y. Subscription price \$3.00 a year. Entered at the Post Office at Garden City, N. Y., as second class mail matter. Doubleday, Page & Company, Garden City, N. Y.

# Burgess, the *Radio Battery*

*Specified by radio engineers — designed and built by wireless specialists—and recommended by leading manufacturers of radio equipment.*

Burgess Radio Batteries, the result of years of careful experiments are built under exacting manufacturing standards which must meet the requirements of strict laboratory formulae and tests — a supervision that insures their perfect operation.

For professional or amateur radio use, where noiselessness, long life, high capacity and uninterrupted, dependable service are essential, Burgess has no superior.

Burgess Batteries are built for both "A" and "B" circuits. The Burgess No. 6 is used and found most satisfactory on the "A" or filament circuits equipped with the new type one and one-half volt vacuum tubes. The Burgess "B" Battery is everywhere recognized as the Standard of Quality in the wireless field.

**BURGESS BATTERY COMPANY**  
**Engineers — Dry Batteries — Manufacturers**  
**FLASHLIGHT — RADIO — IGNITION — TELEPHONE**

General Sales Office: Harris Trust Bldg., Chicago  
Laboratories and Works: Madison, Wisconsin

*Branches:*

New York Boston Washington St. Paul Kansas City New Orleans

In Canada: BURGESS BATTERIES, Ltd.  
Winnipeg, Toronto, Montreal



# BURGESS RADIO BATTERIES

"ASK ANY RADIO ENGINEER"



★ Tested and approved by RADIO BROADCAST ★

# Dependable Radio Sets *and* Service

Can always be had from local dealers  
who have been honored with the

## M. R. C. FRANCHISE

For Three Reasons:

1. Franchise is granted only to merchants of standing and financial responsibility, with sufficient technical experience to render intelligent service.
2. "Michigan" Radio Sets are the finest examples of correct Regenerative radio engineering, expressed in superlatively good workmanship.
3. The Michigan Guarantee is as valid as a Bond. For back of it stands the strongest independent Radio manufacturing concern in the United States.

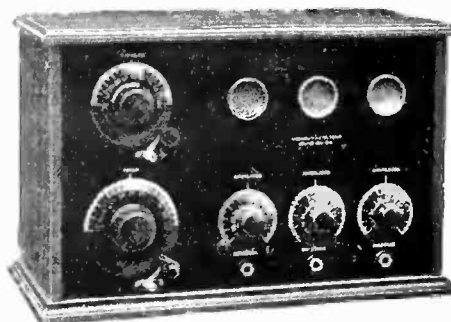

"SENIOR" SET

## M. R. C. Regenerative Receiving Sets ★

are built under Armstrong License (U. S. Pat. 1,113,149 and letters patent No. 607,388). This means that they embody the latest development in Regeneration—the soul of radio.

### Long Distance Wonder Workers



"JUNIOR" SET

The "Senior Set" includes both detector and amplification, and can be used with either headphones or loud speakers or both.

The "Junior Set", a detector unit only, is limited to headphone reception. It can however, be hooked up with the Michigan Amplifier unit for loudspeaker reception.

Send for the M. R. C. Circular, giving full information on both sets and parts, and telling of some of the long-distance triumphs of M. R. C. set owners.

## MICHIGAN RADIO CORPORATION

GRAND RAPIDS, MICHIGAN

★ Tested and approved by RADIO BROADCAST ★



**General Radio Type 300 Amplifier Unit—**

Works equally well with crystal or tube detectors. Is a compact unit, wired ready for external connections. Two or more units may be used together to obtain multi-stage amplification.

**Prices**

Type 300-A Amplifier Unit for WD-11 Tubes, complete except for tube and batteries, \$7.50

Type 300-B Amplifier Unit, for standard 6 Volt Tubes, \$8.00

**Type 231-A Transformer**—Gives the maximum amplification possible without distortion. Like all Amplifying Transformers manufactured by The General Radio Company, the Type 231-A is guaranteed.

Price \$5.00

**General Radio Type 214 Rheostat—**

A convenient, practical instrument, equally well adapted for experimental service or permanent installations. You'll never cause unpleasant noises in the phones when you rotate the contact arm of a Type 214 Rheostat.

**Price**

For the new UV201-A Tubes, 20 Ohms.  
For the newer UV199 Tubes, 50 Ohms.  
For the Standard Tube, 7 Ohms. \$2.25

**Type 214 Potentiometer—**

To get your gas detector on that sensitive kink by fine adjustment of the plate potential, use this General Radio 400 Ohm Potentiometer. It will control regeneration in your radio frequency amplifier by a positive grid bias.

Price \$3.00

**Amateurs—**

Bring your problems to us. Our Engineering Staff is always at your disposal.



For more than eight years, among men who know and use Radio Apparatus of the better sort, the name—General Radio Company—has been accepted as a guarantee of all that goes to make up satisfaction and as synonymous with the advances in theory and practice which accompany all true Radio progress.

As an example—for the amateur who wants real Radio efficiency—there is no single piece of apparatus which more completely fills its niche than the General Radio Type 300-A Amplifying Unit—the Amplifying Unit which requires no storage battery.

If you are interested in Radio Apparatus in which price is subordinated to satisfaction, send for Bulletin 914B. It is an educational pamphlet for the amateur who wants better equipment.



**GENERAL RADIO CO.**

Manufacturers of  
Radio and Electrical Laboratory Apparatus  
11 Windsor Street Cambridge, Mass.

5160

★ Tested and approved by RADIO BROADCAST ★



**A high quality 1000-meter tuning coil for \$3.00**

**H**ERE'S as fine a tuning coil as you ever saw at a price that insures tremendous value. Made in such large quantities that price is no index of its quality. Mahogany-finished hardwood ends, nickel-plated metal parts, silk-covered wire on seamless tube. Double slides insure clear, sharp tuning. Order one from your dealer.

**FROST-RADIO**

The complete Frost Radio line of Frost Fones, Plugs, Jacks, Jac-Box, Microphones, Tuning Coils, Receiving Transformers, Extension Cords, offers

radio users the highest quality apparatus at quantity-production prices. Another example of Frost Radio value is the No. 400 Receiving Transformer shown here. Mahogany-finished hardwood base and ends; polished nickel-plated metal parts. 200 to 4000 meter range. Silk-covered wire wound. See it at your dealer's. Retail price: \$8.50.

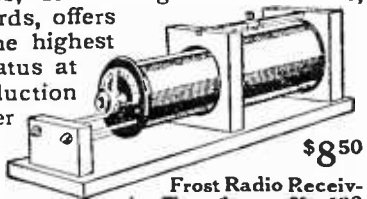

Frost Radio Receiving Transformer No. 400

The dealer who sells Frost Radio is a good man to know. He guarantees Frost merchandise because he knows it is right. See him today.



The same fine quality which has made Frost Fones the world's fastest-selling headset is back of every Frost piece of Radio apparatus.

"Like Postage-Stamps"

Used Everywhere"

**HERBERT H. FROST, Inc.**  
154 WEST LAKE STREET, CHICAGO, ILLINOIS.



**Recharge Your Battery at Home**

Charges Both A and B Radio Batteries

Don't be without the use of your Radio Receiving Set while your battery is being charged. Get a Valley Charger and charge your battery right at home. Attach the Charger to your home lamp socket—attach the clips to the battery terminals and you will get a quick, tapering charge which just exactly charges your battery, but cannot overcharge or harm it in any way. Will charge the A 6 volt battery at a 5 ampere rate, and the B 22½ volt battery at the required ½ ampere rate. 46 volt B batteries may be connected in parallel so that they can also be charged. **SATISFACTION GUARANTEED** If your local distributor cannot supply you, write direct to

VALLEY ELECTRIC COMPANY, ST. LOUIS, MO.

Department G

**\$18.00**

F. O. B. St. Louis

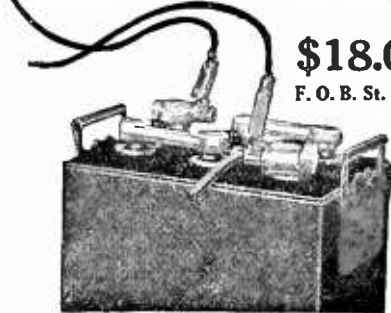

**FREE Radio Catalog**



Our big stock of standard makes of radio sets, parts and supplies, fully illustrated. Play safe—buy standard equipment from a reliable house. We ship from stock. Send \$5.00 for Murdock Loud Speaker, including fibre horn, stand and adjustable phone unit. Requires no battery.

**Julius Andrae & Sons Co.**

In Business Since 1860

112 Michigan St.

Milwaukee, Wis.

**Weston Filament Voltmeter**

Makes it possible to prevent premature tube burn-outs—facilitates exact tuning—duplicates results instantly.

Write for Circular J

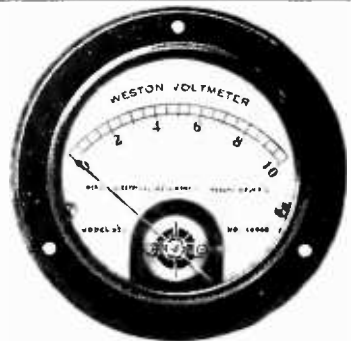

**Weston Electric Instrument Co.**

179 Weston Avenue

NEWARK, N. J.

# Try the Bradleystat on Your Radio Set, to-night

## *A New Thrill Awaits You!*

*Pull in those distant stations that you lose with Wire Rheostats*

Does your receiving range enable you to pick up concerts over great distances? If not, try the Bradleystat.

Read this interesting letter from Chas. H. M. White of Massachusetts Institute of Technology at Cambridge, Massachusetts:

*"I have tried the Bradleystat on my radio set. The improvement is really remarkable and beyond all my expectations. Previously I only picked up local stations and WJZ, but on my first trial with the Bradleystat I heard KYW (Chicago), WOC (Davenport) and many other stations."*

Get the Bradleystat, today, from your nearest radio dealer and get more enjoyment from your radio set. Insist on the genuine Bradleystat.

**Allen-Bradley Co.**  
Electric Controlling Apparatus

278 Greenfield Avenue • Milwaukee, Wisconsin  
Member of the National Radio Chamber of Commerce



Retail Price

**\$1.85**

P.P. 10c extra



### *Other Radio Products*

The Bradleyometer, a perfect potentiometer and the Bradley-adaptor for the WD-11 tubes are two new radio products equal in quality to the Bradleystat.

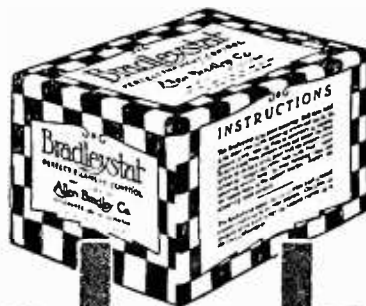

# Bradleystat

REGISTERED U. S. PAT. OFF.

## PERFECT FILAMENT CONTROL

★ Tested and approved by RADIO BROADCAST ★



## Steady, Full-powered Batteries

EVERY radio set has its own peculiarities—little niceties of adjustment at which best results are obtained. Battery voltage and amperage must be just so. And once adjusted, current must have sustained evenness and steadiness.

Get good batteries. They're the most satisfactory and economical in the end. Westinghouse Radio Storage Batteries will settle the problem practically for good. They last indefinitely and are easily and repeatedly rechargeable. Built by Westinghouse—you know they're *RIGHT*.



At radio dealers and Westinghouse Battery Service Stations everywhere. Write for illustrated folder, "Westinghouse Radio Storage Batteries."

WESTINGHOUSE UNION BATTERY CO.  
Swissvale, Pa.

# WESTINGHOUSE

**RADIO**  
"A" "B" and "C"  
**BATTERIES**

Westinghouse "A" Batteries are carefully constructed, full-capacity, slow-discharge, long-life batteries. Made in 4, 6, and 8-volt sizes with 5, 9, and 13 plates per cell, to meet the various filament-battery requirements.

Westinghouse "B" Batteries. The Westinghouse 22-M G-2 (22 volts) is a marvel for steady, noiseless, full-powered service. Glass case; visible interior; sealed-in tops. Larger types, too; also 2-volt single cells for "C" batteries.

**NOVO** ★

**"B" BATTERIES**

NOISELESS      DEPENDABLE

NOTE THE INSULATED BINDING POSTS AND 7/16" WIRE CONNECTOR

**NOVO MFG CO.**  
424 W. 33<sup>rd</sup> ST.      531 SO. DEARBORN ST.  
NEW YORK      CHICAGO

**Super-Sensitiveness!**

THE crystal is the "bull's-eye" of your crystal receiving set. Unless it is super-sensitive you are wasting time and entertainment and cannot "hit" the combination for best results. Insist upon the genuine original Arlington Tested NAA Detector Minerals. They are carefully selected from bulk stock, individually tested and guaranteed super-sensitive.

Galena, Silicon or Goldite price per crystal, 25c. Same mounted in brass cup, 40c. Obtainable at your dealer's or sent direct (post-paid) on receipt of price.

*The Newman-Stern Co.*

Newman-Stern Building      Cleveland

**RADIO "A" & "B" STORAGE Batteries CHARGED at Home For a Few Cents Overnight with "The PATENTED FULL WAVE" 100-130 Volts 60 Cycle A. C. Magnetic Taper Charge Design**

All Types But "B"  
Charge  
AUTO  
Batteries  
Overnight  
Right in  
Your CAR

**\$ 15**

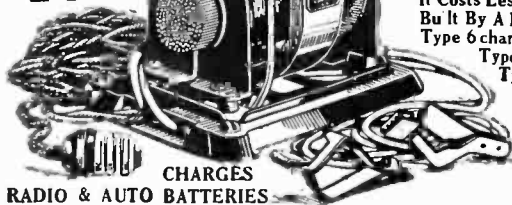

CHARGES  
RADIO & AUTO BATTERIES

## F-F RADIO RECTIFIER

Eventually You Will Buy An F-F RECTIFIER. Why Not Now? The Sooner You Buy It; The More You Save. A-B Charges 6 Volt "A" & Auto: & up to 120 Volts Of "B" & Loud Speaker Storage Batteries In Series Inductively At Home Overnight; Disconnecting & Multiple Connections Unnecessary. Charging Circuits Separate. No Chance For Grounds Or Short Circuits. Nothing To Stop Over, Be Filled, Burn Out. Need Attention Or Cause Trouble. Infusible Rectifying Brushes Maintain Constant Efficiency Uninterruptedly. Complete Portable Automatic. No Skill Required. AMMETER Eliminates Guess Work. Nothing Like It Made. Lasts Lifetime. Screw Plug In Lamp Socket; Snap CLIPSON Battery Terminals; Turn Switch & Battery Is Charged In Morning. Charged Batteries Mean Fewer Expensive Replacements. It Costs Less To Buy An F-F RECTIFIER than To Be Without One. INSIST on The F-F RECTIFIER Bu It By A Master Of The Art in 7 TYPES. Thousands Sold Make Possible These POPULAR PRICES.

Type 6 charges "A" 6 Volt Battery At 6 amperes \$15    Type 12 charges 12 Volt Battery At 5 amperes \$15  
Type B charges Radio "B" Batteries Up to 120 Volts \$15    Type A-B is Combination Of Types 6 & B \$20  
Type 166 charges 6 Volt Battery At 12 amps \$20    Type 1612 charges 12 Volt Battery At 7 amps \$20  
Type 1626 is a Combination of Types 166 & 1612 and Charges Both 6 & 12 Volt Batteries \$28  
The 3 Lower Types are recommended for heavy Batteries, or where time is limited.

SHIPPING WEIGHTS Complete with AMMETER & BATTERY CLIPS 11 to 15 lbs.  
Purchase from DEALER, or Mail Check for Prompt Shipment. Include Postage and Insurance Charges for P. P. Shipment, or Write us to Ship Type desired C. O. D.  
Order Now, or WRITE Immediately for FREE Descriptive BOOSTER Bulletins 41 & 41A.  
**FRANCE MFG. CO., CLEVELAND, OHIO, U. S. A.**

★ Tested and approved by RADIO BROADCAST ★

# CROSLEY Model X

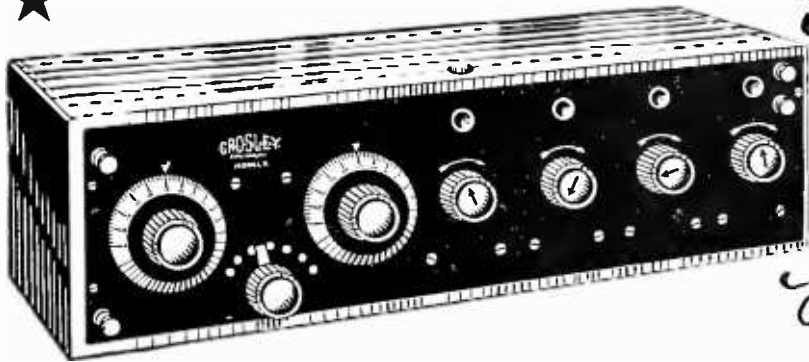

# \$55

*A 4 tube  
Radio*

THE HIT OF THE RADIO WORLD

For Sale by Good Dealers Everywhere

*Free Catalogue on request to Dealer or Consumer*

*Frequency Set*

## CROSLEY MANUFACTURING COMPANY

520 ALFRED ST.

CINCINNATI, OHIO

# CROSLEY Model Vc

# \$20

*Regenerative Receiver Set*

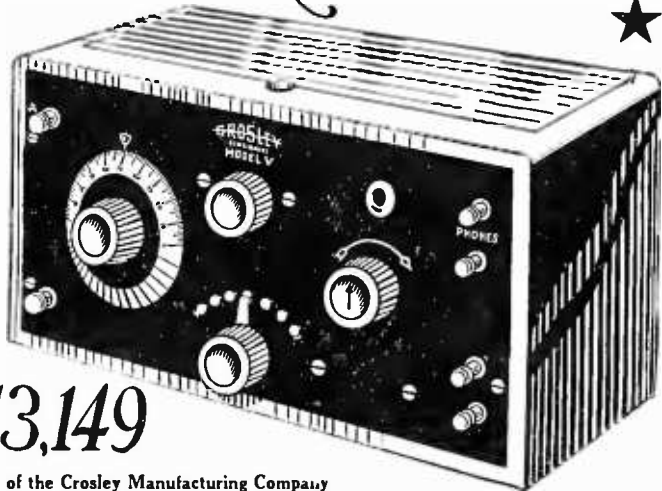

*Licensed  
under Armstrong  
U.S. Patent No. 1,113,149*

The trade name "Crosley" is used by permission of the Crosley Manufacturing Company

*Write for Free Catalogue*

## THE PRECISION EQUIPMENT CO.

*Powel Crosley Jr. President*

520 GILBERT AVE.

CINCINNATI, OHIO

★ Tested and approved by RADIO BROADCAST ★

★

## Holtzer-Cabot No. 2 Universal

**The Latest Achievement in Radio  
Head Sets**

After exhaustive experiments and actual manufacturing experiences we have produced a receiver which, for tone quality, has no equal.

It is tested, not by "listening-in," but by a specially designed scientific instrument which gives its true tone quality by actual sound measurement.

Our new head bands are covered with flexible rubber, making them comfortable and sanitary.

Weight, only twelve ounces  
Price \$12.00.

*The Holtzer-Cabot Electric Co.*  
Boston and Chicago



# C H E L S E A



**PRICE \$40.00**

**REGENERATIVE RECEIVER** ★  
A REAL BROADCAST RECEIVER

Licensed Under Armstrong U. S. Patent No. 1113149.  
For amateur use only.

Write for Catalogue No. 7 of New Chelsea Radio  
Equipment.

**CHELSEA RADIO CO.**  
152 5th St., Chelsea, Mass.

*Determines*  
**RANGE  
OF  
YOUR SET**

**\$1**  
Complete



*Determines*  
**DISTANCE OF  
CALLS  
RECEIVED**

**\$1**  
Complete

## The McNeary Radio Scalometer

*and Official Radio Map*

After you recover from the thrill you get every time you tune in on an out-of-town station, the first thing you want to know is HOW FAR was that?

With the Scalometer mounted on the official map you read the distance directly on the tape—instantly and correctly.

<p><b>SCALOMETER</b> An instrument of precision in a beautifully finished aluminum case.</p>	<p><b>RADIO MAP</b> Authoritative, up-to-the-minute, showing broadcasting stations, time zones, radio districts, cities and towns of the United States and Canada.</p>	<p><b>BROADCAST DIRECTORY</b> In handy booklet form with all broadcasting stations alphabetically arranged by call letters.</p>
--	--	---

*If your dealer cannot supply you, send one dollar to*  
**EMBLEM MANUFACTURING CORPORATION**  
253 Middle City Bldg., Philadelphia, Pa.

★ Tested and approved by RADIO BROADCAST ★



# Federal Is A Large User Of Formica

THE Federal Telephone and Telegraph Company of Buffalo is a large factor in the radio industry and has an excellent reputation for the quality of its product.

It is a very extensive user of Formica insulation not only in the complete sets which it produces but in the radio parts, variometers, variocouplers, head sets of which it is a large manufacturer.

A list of the users of Formica reads like a directory of the leading independent radio manufacturers. So many of the best informed radio men in America cannot be mistaken in their opinion that Formica is most uniform, the best looking, and the most efficient radio insulation.

*Dealers and amateurs can safely follow these great concerns in selling or using Formica.*

## THE FORMICA INSULATION COMPANY

4628 Spring Grove Avenue  
Cincinnati, O.

### SALES OFFICES

50 Church St., New York, N. Y.  
422 First Ave., Pittsburg, Pa.  
1042 Granite Bldg., Rochester, N. Y.  
415 Ohio Bldg., Toledo, Ohio

1210 Arch St., Philadelphia, Pa.  
1819 Lyndale Ave., S. Minneapolis, Minn.  
Sheldon Bldg., San Francisco, Calif.  
Whitney Central Bldg., New Orleans

414 Finance Bldg., Cleveland, Ohio  
9 S. Clinton St., Chicago, Ill.  
313 Title Bldg., Baltimore, Md.  
47 King St., Toronto, Ontario

# FORMICA

Made from Anhydrous Redmanol Resins  
SHEETS TUBES RODS

★ Tested and approved by RADIO BROADCAST ★



THE SYMBOL OF SERVICE

# CONTINENTAL

*"New York's Leading Radio House"*

## TRANSFORMERS

**Model UV-712 and Model UV-1714**  
*"Audio Frequency" "Radio Frequency"*

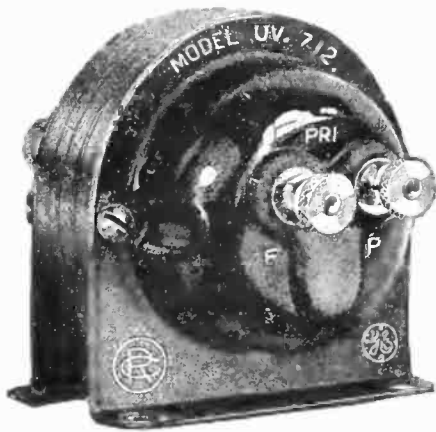

Model UV-712 and UV-1714 two transformers designed especially by the Radio Corporation for their detector tubes UV-200 and UV-201.

Important features—Ranges may be doubled or tripled.  
 Distortion greatly reduced.  
 Selectivity greatly increased.  
 Vacuum tube noises practically eliminated.  
 Further information on request.

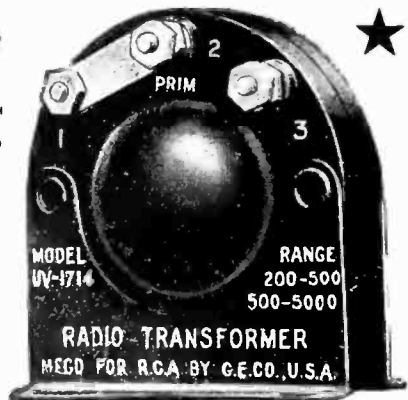

*"Modern Radio"*—a two hundred and eight page catalogue of our Radio supplies, equipment and apparatus sent for twenty-five cents.

2031-Q

**CONTINENTAL RADIO AND ELECTRIC CORPN.**

6 AND 15 WARREN ST. - - - - - NEW YORK, U. S. A.

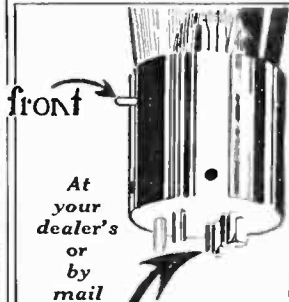

### Spilled Milk

and burned out bulbs are much alike. The time to attend to them is before they happen. Care is the best safeguard for the milk; and the

### RADECO SAFETY FUSE

(Patent Pending)

is the only absolute and positive means of protecting the tube.

The RADECO Safety Fuse fits directly on the filament terminals where no excess current, even an accidental short from faulty wiring can possibly get by. It fits any standard tube used in any standard socket and does not affect the efficiency of your set.

4 in standard package \$1.00

For WD11, 50 cents For WD12, 50 cents

For 201A, 50 cents

For other tubes, 4 for \$1.00

Different tubes require different capacity fuses. State what tube fuses are for.

### Radio Equipment Co.

630 Washington St. Boston, Mass.

*New England's Oldest Exclusive Radio House*

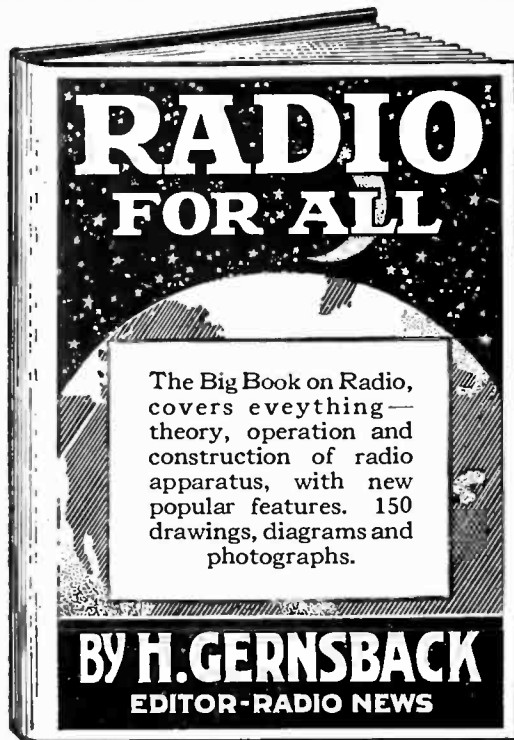

The Big Book on Radio, covers everything— theory, operation and construction of radio apparatus, with new popular features. 150 drawings, diagrams and photographs.

**BY H. GERNSBACK**  
 EDITOR-RADIO NEWS

At all Bookstores, \$2.00

or postpaid for \$2.10. Write for circular B.

J. B. LIPPINCOTT CO.

226 S. Sixth Street

Philadelphia, Pa.

★ Tested and approved by RADIO BROADCAST ★



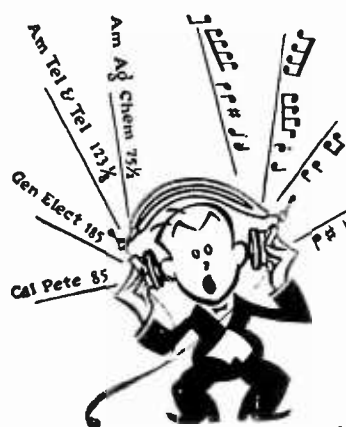

# Soprano Solos by The Stock Exchange

When you try to tune in with a single circuit receiver, it is not surprising that songs should suddenly turn into market quotations and bedtime stories into weather reports.

For with several hundred powerful broadcasting stations all operating on one narrow wave band, it takes real selectivity and sensitivity to get a satisfactory radio programme.

Get a Paragon three-circuit receiver. Then you will have the pleasure and satisfaction of obtaining the station you want when you want it. Clear, complete programmes without interruption or disturbance.

Ask some experienced amateur what he knows about

# PARAGON

Reg. U. S. Pat. Off.

## RADIO PRODUCTS ★

The amateur will tell you that the Paragon three-circuit receiver, because of its great superior selectivity and sensitivity, can pick and choose between broadcasting stations of about the same signal strength with less than one per cent differential.

This means that with a Paragon receiver you get what you want when you want it—complete messages and clear music from the station you tune in on, without interruption and jamming. Until you have listened in with a Paragon three-circuit receiver, you cannot guess the real pleasure and fascination of radio.

Long before broadcasting popularized radio with the general public, Paragon equipment was the choice of the experienced amateur. He will tell you today that if you want quality and satisfaction, Paragon Radio Products are the best and safest buy on the market.

*An illustrated Catalog of Paragon Radio Products Is Yours For the Asking*  
DEALERS—The Adams-Morgan Company has an interesting proposition to make to reputable radio dealers who believe in quality merchandise. Details on request.

ADAMS-MORGAN COMPANY  
10 Alvin Ave., Upper Montclair, N. J.

Also Manufacturers of PARAGON  
Radio Telephone Amplifier  
Transmitters Transformers  
V. T. Control Units Control Dials  
Rheostats Amplifiers  
Potentiometers Receivers  
V. T. Sockets Switches  
Detectors Variometers

Type RD-5 Regenerative Receiver and Detector—\$75.00  
Type A-2 Two-Stage Amplifier—\$50.00  
(Licensed under Armstrong Patents.)



★ Tested and approved by RADIO BROADCAST ★



## ★ Thrills!!!

Thrills never end when you have a Tuska Popular—the regenerative receiving set that experts recommend. Signals clear and sharp come in night after night from far-away stations. And for nearby programs, plenty of volume without distortion. Every part Tuska-made; known for 12 years as fine radio instruments.

**The C. D. TUSKA Co.**  
Hartford, Conn.

### Tuska Popular No. 225

Regenerative Receiving Set, Tuska receiver, detector and 2-stage amplifier, licensed under Armstrong U. S. Patent No. 1,113,149. Catalogue No. 13-A, showing Popular and other sets, on request.



# TUSKA RADIO



And Feel the Difference, Too!

**Y**OUR RADIO fan wears his head set several hours at a time. He probably bought it because the dealer let him "listen to the difference," and he very quickly learned the character of the true musical tone CIC gave him, because of its non-metallic diaphragm. He learned something more, however, after several hours' use. The big, comfortable caps covering the entire ear—the broad, well fitting aluminum band—they soon showed him that CIC not only means beauty of tone. It means also "Solid Comfort." Point this out to your trade, too!

**CONNECTICUT INSTRUMENT CO.**  
Stamford Connecticut

## FREE HAND BOOK OF RADIO HOOKUPS

We will send you free a useful Hand book containing 25 easily understood diagrams of tested radio hookups. Just enclose 2c. stamp for postage.

We will appreciate it as a favor if you will mention the name and address of the radio dealer with whom you prefer to trade, and whether he now carries All-American Audio- and Radio Amplifying Transformers.



**RAULAND MFG. CO.**  
200 No. Jefferson St. Chicago, Ill.



## LEARN RADIO

Here's your opportunity. Radio needs you. Win success in this fascinating field. Trained men in demand at highest salaries. Learn at home, in your spare time.

### Be a Radio Expert

I will train you, quickly and easily, to design, construct, install operate, repair, maintain and sell all forms of Radio apparatus. My new methods are the most successful in existence. Learn to earn.

**\$1,800 to \$10,000 a Year**

**FREE** Wonderful home-construction, tube receiving set, of latest design. Write for "Radio Facts" free. Engineer Mohaupt.

American Electrical Association  
Dept. B5 4513 Ravenswood Ave., Chicago

★ Tested and approved by RADIO BROADCAST ★

# MURDOCK

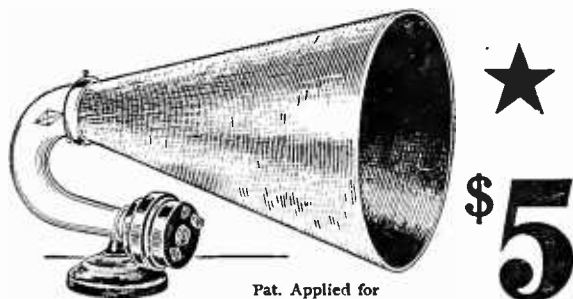

*for the new*  
**MURDOCK  
LOUDSPEAKER**

Never before have you been able to get so good a Loudspeaker for such a low price.

Complete with our new Loudspeaker phone unit, fibre horn, aluminum tone chamber and molded base.

You do not need extra batteries to use the Murdock Loudspeaker. It works splendidly with amplification. Do not use on a crystal set.

For 18 years Murdock Headphones have been leaders in their field. Huge production has made it possible to sell this quality product at a low price—2000 ohms \$5.00; 3000 ohms \$5.50.

Now the new Murdock Loudspeaker is becoming a real sensation in the Radio field—another quality product at an unheard of price.

Get one of these new Loudspeakers from your dealer. Be sure it's a Murdock.

If your dealer cannot supply you with either Murdock Headphones or a Murdock Loudspeaker, send your order and dealer's name direct to us.

## WM. J. MURDOCK COMPANY

*General Offices and Factory*

341 Washington Avenue, Chelsea, Mass.

*(Sales offices)*

New York   San Francisco   Chicago  
Los Angeles   Seattle

# RADIO

STANDARD APPARATUS SINCE 1904

★ Tested and approved by RADIO BROADCAST ★

# MIRACO GETS 'EM 1500 MILES AWAY

Users of the MIRACO Radio Frequency Broadcast Receiver report wonderful results. St. Louis hears Schenectady—Dayton hears Newark—Cincinnati hears San Francisco.

Reception is clear and distinct, tuning is very sharp, and there's practically no interference.

MIRACO sets may be used with either WD 11 tubes and 1½ volt dry cell or 6 volt tubes and 6 volt storage battery.

Order *your* MIRACO set TO-DAY and be sure to specify tubes to be used.



Retail Price \$54.50

### DEALERS

When you get our proposition in detail—you'll **WANT TO PUSH THE MIRACO LINE.**

### AGENTS

Wanted Everywhere.

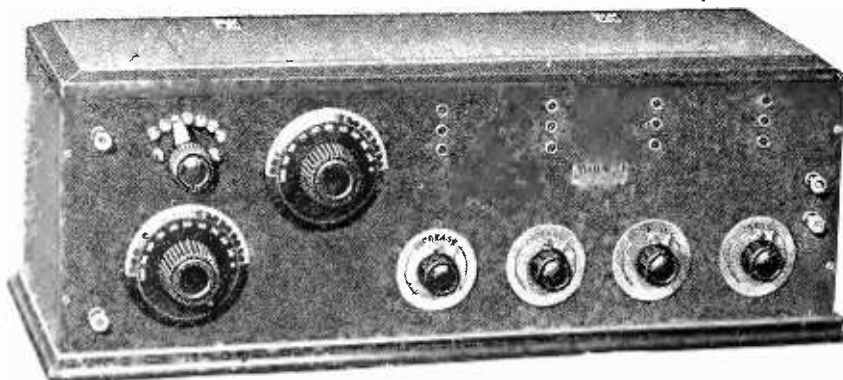

THE MIDWEST RADIO COMPANY

806 Main Street, Cincinnati, Ohio

# BRACH VACUUM RADIO PROTECTOR

ASK YOUR  
★ INSURANCE AGENT

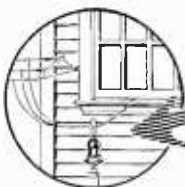

Approved by  
National Board  
Fire Underwriters



*The Choice of the Foremost  
Engineers for over 17 Years* \$3

# SOLDERALL

The Only Convenient Metal Solder  
Every Electrical Connection  
Needs SOLDERALL  
For Perfect Reception



AT JOBBERS  
AND DEALERS OR BY MAIL  
25¢ A TUBE  
L. S. BRACH MFG. CO.  
NEWARK, N. J.

**"BUILD YOUR OWN"**  
With "RASCO" Parts!  
If you need small radio parts in a rush, "RASCO" will supply them cheaper, better and quicker than any one. Be sure to get our great 68-page catalog. Over 500 different parts, 300 illustrations. This catalog contains 75 Vacuum Tube Hook-Ups, all values being shown. Due to great cost, catalog sent only upon receipt of 15c, stamps or coin.  
Radio Specialty Co., Inc.  
102 Park Place, New York

*Rasco*

# The FRENCH BINDERS

*Good books with artistic binding*

COUNTRY LIFE PRESS GARDEN CITY, N. Y.

**FREE** to Car Owners, Garagemen, Mechanics. Send TO-DAY for FREE COPY of the American Automobile Digest. Contains helpful, instructive information on overhauling, ignition, carburetors, storage batteries, wiring adjusting, repairing, etc. Profusely illustrated.

American Automobile Digest, 669 Butler Bldg., Cincinnati, O.

★ Tested and approved by RADIO BROADCAST ★

# CONNECTICUT RADIO

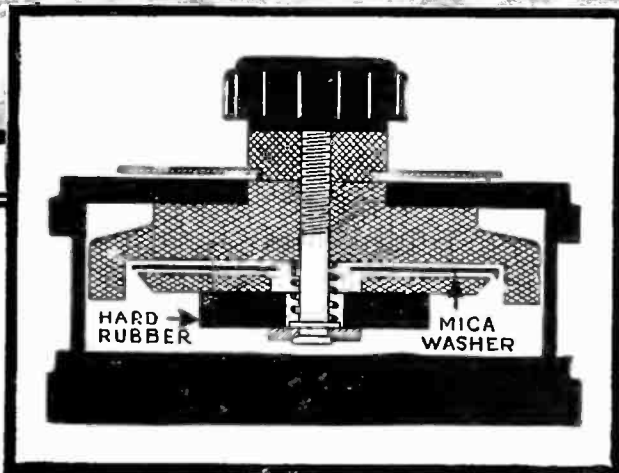

*Finer  
Adjustments  
Better  
Selectivity  
Greater Signal  
Strength*

*Simple as the  
Symbol that  
Stands for it*

## *The Secret of Its Efficiency*

It is a well-known fact that losses in radio condensers take place in the solid insulating material used in their construction.

And it is equally true that a condenser increases in efficiency of signal reproduction as its losses decrease.

The CONNECTICUT Variable Condenser not only employs the two best insulating materials known—mica and hard rubber—but the smallest possible amount of each. This, then, is the reason for its extremely low resistance—0.2 ohm—as well also the secret of its high efficiency at short wave lengths.

*Descriptive bulletin 100-E upon request*

Panel type, J-108, \$5.00

Portable type, J-107, \$6.00



**CONNECTICUT**  
MERIDEN

**TELEPHONE  
& ELECTRIC**  
RADIO DIVISION

**COMPANY**  
CONNECTICUT





"These phones sure have a mellow tone"

## You Can Get BASCO Phones Despite Demand

**N**O NEED for accepting substitutes. Every possible measure is being taken by the manufacturers of BASCO Phones to keep up to the demand—and it's being done without slighting mechanical exactness. Close inspection guards BASCO Phone quality irrespective of demand. BASCO quality—keen sensitiveness—deep, natural-voice pitch—lightweight—head comfort—these features should direct your choice in selecting BASCO Phones for allround satisfaction.

See BASCO Phones and other units of the complete BASCO Radio Line. If your dealer can't supply you, write us direct.

**\$6.00** 2000 Ohms      3000 Ohms **\$7.50**

Jobbers and Dealers!

Write for attractive selling proposition and name of our nearest local factory representative.



**BASCO** **Briggs & Stratton Co.**  
"PRODUCT" Milwaukee, Wisconsin

Showing One Phone

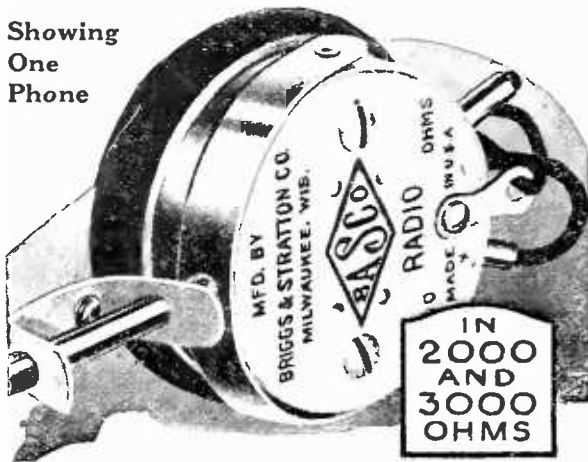

IN 2000 AND 3000 OHMS

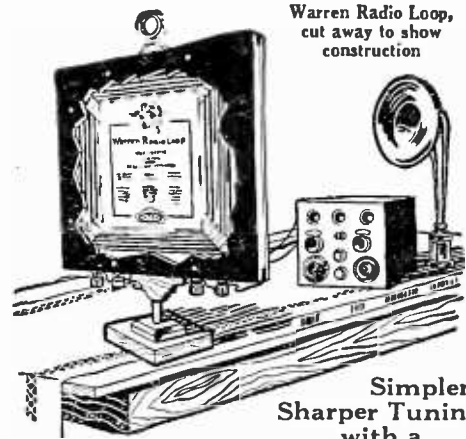

Warren Radio Loop, cut away to show construction

Simpler, Sharper Tuning with a

## Warren Radio Loop

**A**ERIAL and tuning device all in one. Tunes not only to wave length but to wave direction. An aid to selection. Eliminates atmospheric. All enclosed,—damp and dust proof, fool-proof and surprisingly compact, neat and durable. Write to-day for Bulletin X-102 containing hookups.

A Type for Every set At the Best Dealers

- Type-A-737 (300-700 meters) 6 inches square—non-directional.....\$10.
- Type-A-7236 (175-1000 meters) 6 inches square—non-directional.....\$12.
- Type-B-2537 (300-700 meters) 18 inches square—directional.....\$20.
- Type-BL-2520 (200-18,000 meters) with honeycomb coil. 18 inches square—directional.....\$25.

V-DE-CO RADIO MFG. CO.  
Dept. B      Asbury Park, N. J.

## 6 Volt 120 A.H. RADIO BATTERY IN LEAK \$25.00 PROOF RUBBER CASE

The Radio Battery You Have Been Waiting For

A high grade, long-life, 11 plate radio battery in absolutely leakproof rubber composition case with victrola style cover. Protects your rugs and floors from destructive acid. Makes your "A" battery as handsome as your receiving set.

Positive 18 Months Guarantee Guaranteed for full 18 months of service. Non-warping cedar separators, highest quality plates of generous thickness. 6 Volt—120 Ampere hour type. Sealed terminals save electrolyte and protect connections. Positively will not short circuit. Fitted with convenient handle and anti-drip tray. Price, complete, fully charged, \$25.00. Neat switch in cover supplied for \$1.50 extra.



"As good as its name"

NOTE THESE LOW "A" BATTERY PRICES

Noble Radio "A" Batteries in Everlasto Rubber Cases		Noble "A" Batteries in Maple Cases, Black or Mahog. Finish	
Type	Rating Plates Price	Type	Rating Plates Price
Junior ...	80 Amp. 7 \$14.80	Junior ...	80 Amp. 7 \$12.75
Senior ...	100 Amp. 9 17.90	Senior ...	100 Amp. 9 15.90
Standard	120 Amp. 11 19.70	Standard	120 Amp. 11 17.75
Superior ..	140 Amp. 13 21.70	Superior ..	140 Amp. 13 19.45

Covers for above batt. \$1 extra. You may be able to buy batteries as good as ours, but none that are better.



Address Dept. B

Order today, sending check or P. O. money order, or we ship express C. O. D. same day order is received.

**NOBLE BATTERIES**  
1454 MONADNOCK BLOCK - CHICAGO

## THE RADIO SET OF THE FUTURE

IT cannot be foretold what combination of units will be used, or the circuits that may be employed in the Receiver of tomorrow. It is obvious, however, that today's conventional set will soon be considered crude and antiquated.

Little prescience is required to realize that the panel of insulating material, with its shielded background, is doomed to obsolescence. The use of a great mass of expensive insulating material to provide for "live shafts" was merely a temporary expedient. Progressive practice has eliminated the electrical difficulties connected with live shafts and also obviated the necessity for massive insulation.

Carrying primary leads to the panel, and the drilling of numerous holes for a switch, will cease because of the waste such labor entails. To make the tap-switch an integral part of the instrument is the expedient thing to do.

Knobs add nothing to the appearance of a panel, and will in time become a relic of bygone days. The concave dial and bar control, giving ease of adjustment without cramping the hand, is far more sensible and attractive.

### EISEMANN PARTS AND PANELS

Permit changing circuits and re-location of parts on panel—all units being interchangeable.

Make unnecessary the use of shielding—the metal panel itself accomplishing this purpose.

Eliminate mounting of tap-switches and soldering of primary leads.

Give the many advantages of concave dials—a natural position of the hand in tuning, added attractiveness in appearance and ease in packing for transportation.

*Write for descriptive literature.*

### EISEMANN MAGNETO CORPORATION

William N. Shaw, President

BROOKLYN, N. Y.

DETROIT

CHICAGO



EISEMANN

# AUDIOLA CHICAGO

GET acquainted with Radio by buying an Audiola Crystal Receiving Set.

The 23-plate variable condenser insures sharp and accurate tuning. It is a complete unit, in a rich mahogany finished case, with nickel plated fittings.

Needs no batteries, no tubes, no fussing. Just connect it with aerial, ground and head phones, and "listen in."

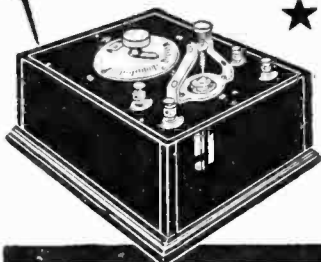

★ Price \$10

Complete  
(without headphones)  
At your dealer or write direct  
for illustrated booklet.

Audiola Radio Co.  
430 S. Green St., Chicago

We can use a few high-class  
representatives for ex-  
clusive territory.

## 1200 MILES With a Crystal Set Using



★ THE WORLD'S GREATEST  
RADIO CRYSTAL

A Needles, California, radio fan writes:  
"Using M. P. M. Crystal, I picked up Los Angeles, San Francisco, Salt Lake, Denver and St. Louis. It is far superior to any crystal I have ever used."

Before Discarding Your Crystal Set for an Expensive Tube Outfit, Give M. P. M. Crystal a Trial

⚠ Beware of Imitations. The genuine Million Point Mineral is sold only in separate crystals packed by our company in boxes bearing the trade-mark "M. P. M."

Send 25c and name of your Radio Dealer for a sample M. P. M. Crystal—concert-tested and guaranteed.  
35c for mounted Crystal.

M. P. M. SALES CO.

Dept. B

247 So. Central Ave. Los Angeles, Cal.

# Wave Trap

TRADE MARK  
PATENT APPLIED FOR

The Missing  
Link  
in RADIO



## Stops Interference!

The "WAVE TRAP" will eliminate interfering broadcasting stations and enable you to listen to your favorite station.

It will work on any set, greatly increase its selectivity and clearness, and eliminate code and spark stations.

It is mounted on a Formica panel in a handsome mahogany finished cabinet 6x5x6: It is a high grade instrument throughout and a valuable addition to the operation and appearance of any set. It comes to you complete and there are no extras to buy. It is installed in a minute by changing only one outside connection.

Use the "WAVE TRAP" for real results.



Perbend Electric Co.  
19 E. SOUTH WATER ST.  
CHICAGO

☞ Circular on Request

## Waiting in the Wilderness

by ENOS A. MILLS

Adventures close to nature in the Rocky Mountains, with pleasant by-paths into the realms of animal lore. A book no one could help enjoying. Illustrated from 16 beautiful photographs. Net, \$2.50.

DOUBLEDAY, PAGE & CO. GARDEN CITY, N. Y.

# MARKO



The Mark o Quality for RADIO  
ALWAYS DEPENDABLE

MARKO STORAGE BATTERY CO.

1408 Atlantic Ave.

Brooklyn, N. Y. ★



The New  
**Pathé**

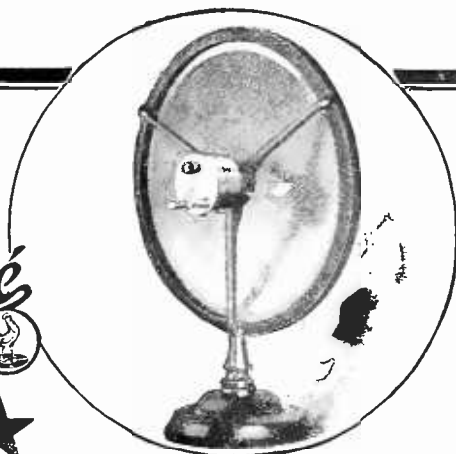

# Reproducing Revolutionized

Based on our experience of over a quarter of a century, as manufacturers of musical instruments—and as highly specialized accoustical engineers, we have produced the **PATHE LOUD SPEAKER** which will mark a new era in loud speakers.

It is something decidedly different. It utilizes an entirely *new* principle. And as a result it converts tone with an exactness never before accomplished by a "loud speaker."

No horn of any type is used. No small metallic diaphragm is hidden away at the end of a horn or in the depths of a cabinet. What you suppose on first inspection to be a stubby sort of a horn, is a parchment diaphragm of abnormal size.

**WITHOUT DISTORTION** the sounds are given directly from this diaphragm, propagating the waves in free air rather than by reflection from a horn.

The Pathé Loud Speaker possesses an unrivaled combination of distinct advantages. Briefly:—

It distributes the sound in all directions—and *does not* confine or "shoot" it toward one point as a horn does.

It does not require an extra battery. Simply attach it in place of the ear phones.

On the home sets of two steps of amplification it will flood the room with clear tone. On larger sets, it will produce any volume of sound required—**WITHOUT DISTORTION**.

It is compact, size 14½" high x 7" wide, and it will grace any living room.

The cost is much lower than you expect—

**\$24. for nickel finish**

**\$22. for Japan Green finish**

If your dealer has not received his Pathé Loud Speakers, we will make you shipment direct from the factory. Simply enclose money order or check and say, send me The Pathé Loud Speaker.

**Pathé Phonograph & Radio Corporation**  
Dept. 4345      20 Grand Ave.      Brooklyn, N. Y.

## Send the Coupon

**Pathé Phonograph & Radio Corp.,**  
Dept. 4345, 20 Grand Ave., Brooklyn, N. Y.

Please send me the Pathé Loud Speaker.

I am enclosing \$\_\_\_\_\_ It is distinctly understood that I may return the Loud Speaker if it is not entirely satisfactory—and my money will be cheerfully refunded.

Name \_\_\_\_\_

Address \_\_\_\_\_

Town \_\_\_\_\_

*Pathé the World Over*

★ Tested and approved by RADIO BROADCAST ★



## The Meaning of the Star

**T**HE chief danger in the development of radio is the prevalence of inferior and unsatisfactory apparatus. The demand for radio equipment that, for a time, could not be fully met by the manufacturers of standard goods, naturally flooded the market with radio sets and parts of poor design and slipshod workmanship. Many new enthusiasts turned away with disgust because of failure resulting from this so-called "bootleg" apparatus. Much of it is still offered for sale with ridiculous claims at cut prices.

To Safeguard Its Readers, RADIO BROADCAST will permit manufactures to include a black star in the advertisements of sets, materials, parts, and accessories that have been tested by its experts and found to be worthy of indorsement. This approval will cover both design and workmanship.

The absence of the RADIO BROADCAST star will mean that the article advertised has not been offered for test and that this magazine's experts have not personally used it. The acceptance of an advertisement in itself indicates a belief in the integrity of the manufacturer. But, the appearance of the star means, in addition:

**Tested and Approved by RADIO BROADCAST**

# Read this again!!

## Filkostat Proven Best Filament Control

Comparison of Fine Adjustment Control Range of Filkostat With Rheostats and Other Filament Controls Clearly Indicates Filkostat Superiority, as it Permits Perfect and Gradual Current Increase With Infinite Adjustments.

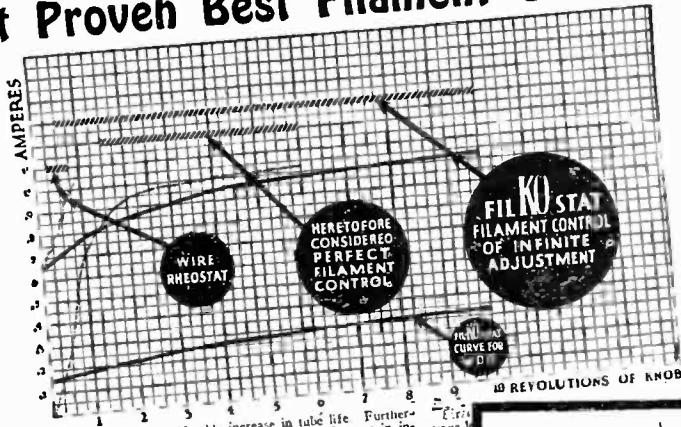

**I**n the Filkostat, a new filament control just perfected by S. R. Hipple, well known as an inventor of apparatus for the control of electric currents, there is at last presented an instrument which is distinctly designed to utilize the great tuning possibilities of the vacuum tube itself. Radio set builders, amateurs and manufacturers have been looking forward to the advent of just such a device. They have realized that all rheostats and other so-called filament regulators, are merely adaptations of pre-radio day devices, not capable of adjusting the infinitesimal gradations of filament HEAT which adjustments are essential to perfect tuning.

### PERFECT TUBE CONTROL

The Filkostat permits perfect regulation of filament heat. Since the heat emitted varies as the square of the current, fine current regulation becomes extremely necessary to accomplish. This governs the flow of electrons. Proper control of the electronic flow in the tube permits the very finest tuning conceivable. The fine adjustment of the Filkostat starts slightly before the tube begins to function. With other filament controls, what minute adjustment there is, starts when the filament is almost at maximum heat. Between 1800 degrees—

considerable increase in tube life. Furthermore the extreme degree of fineness in increase and decrease of electronic flow by infinitesimal variations, makes the Filkostat control ideal.

The perfection of design including ample internal contact is the cause of this new instrument being non-microphonic, absolutely silent, and free from all noises.

### IDEAL FOR WWII'S AND DX WORK

The lower curve on the graph above is the testimony as to the Filkostat's adaptability to any dry cell tube. These tubes using only a fraction of an ampere demand an instrument that is so finely adjusted that this fractional current can be perfectly regulated. This the Filkostat accomplishes.

### OTHER FILKOSTAT FEATURES

The Filkostat has a definite off. It is so designed that the filament extinguishes abruptly indicating that the A battery supply is completely disconnected.

At Full On the Filkostat resistance is practically zero.

The Filkostat consists of a hollow cylinder containing the special resistance material placed between two large adjustable contacts controlled by turning the knob.

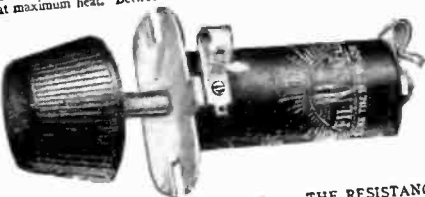

The Filkostat is to all purposes "fool proof". It is compact in form, takes very little space on the panel and so mountable that it can replace any other control without re-drilling.

drill red glow—and 2050 degrees—white heat—the Filkostat control is so fine that increases of temperature of fractions of a degree, with corresponding variations of electronic flow from the filament to the plate, are obtainable.

### LONGER TUBE LIFE; NO NOISES

The initial inrush of current prevents the crystallization of the filament which so many experts claim occurs when the current is fed too slowly at first as is done in other forms of filament controls. This means

THE RESISTANCE ELEMENT is so finely divided that no further division is possible. There are no disks to break or chip.

THE RESISTANCE remains CONSTANT at any position eliminating current variations once set. Such variations are not apparent to the person tuning excepting in "fading out" of stations and noises. But in the laboratory, where such a test as that shown on the above graph can be made by anyone, this feature and all the other points of superiority of the Filkostat are immediately apparent.

**FIL-KO-STAT**  
CURRENT INCREASE PERFECT AND GRADUAL  
**LIKE THE RISING SUN**

**\$200**

**—and here's why you need it!!**

- Designed For Vacuum Tube adjustment and not just an old method adapted to it.
- NOT a Rheostat**  
—but a REAL Filament Control.
- Infinitesimal Control—of filament heat**  
and therefore of electronic flow.
- Very Finest Tuning for DX**  
is realized with Fil-Ko-Stat.
- Controls Fractional Currents**  
—making it ideal for use with any dry cell tube.
- Fine Adjustment Starts**  
—where tube commences to function increasing the AREA OF FINE ADJUSTMENT CONTROL.
- Definite Off—**  
an important feature indicating complete 'A' Battery disconnection.
- Resistance Practically Zero**  
at "full on" there is practically no resistance in circuit.
- No Disks To Break or Chip**  
Resistance Element is so finely divided further division impossible.
- Absolutely Silent**  
The Fil-Ko-Stat is non-microphonic and operates free of all noises.
- Fahnestock Clips**  
and solder contacts on connection posts.
- Adjustable Mounting**  
—no re-drilling of panel necessary.

**GUARANTEED**

The FIL-KO-STAT is to all purposes "fool proof". Each instrument is packed with the maker's guarantee that it will be replaced if broken within one year.

Replace Old Style Current Controls with the **NEW FIL-KO-STAT** a real Filament Control ON SALE AT RADIO DEALERS EVERYWHERE.

Manufactured By



If your dealer has none in stock yet send \$2.00 and his name direct to

SOLE INTERNATIONAL DISTRIBUTORS  
**RADIO STORES CORPORATION**  
Dept. R. B. 218-222 West 34th Street, New York

# The Autostat

A Super Radio Rheostat

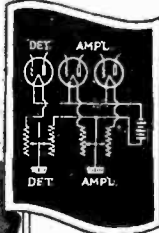
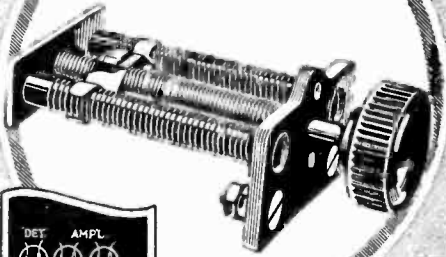

Can be used with 6-volt or WD 11 detector tubes, two amplifying bulbs or one 5-Watt power tube.

The difference between a jumbled mass of signals coming from everywhere and the "sharply-tuned" concerts received clearly and distinctly from far-away stations depends largely upon the careful adjustment of your detector filament current.

Heretofore, sharp tuning has only been partially obtained thru skillful "hair-breadth" manipulations of the filament rheostat. But with

# The Autostat

A Super Radio Rheostat

these much-sought-for results can be secured by anyone. Just "twirl the knob"—a full turn produces a finer adjustment than a "hair's-breadth" turn on any other.

Economical—neat—small—compact. No carbon to break or change resistance. Unqualifiedly guaranteed. Popularly priced—\$1.35.

*If the Best is none too good for the set you are building or have bought, see the Autostat at any good radio or electrical dealer Today. Or write direct for Free Bulletin which shows why the Autostat is radio's Best rheostat.*

**DEALERS — JOBBERS**  
Write or wire for Radio's most attractive merchandising proposition.

THE AUTOMATIC  
ELECTRICAL DEVICES CO.  
128 WEST THIRD ST.  
CINCINNATI, OHIO

Builders of Precision  
Rheostats since 1914

## Convert Your Crystal Set Into Tube Set at Small Cost

You can now enjoy wider range, greater volume of sound and purer tone and do away with feeling around for a sensitive spot, if you make a Tube Set out of your Crystal Set by adding the Peanut Tube W. T. 501 and a few other inexpensive accessories. Full directions packed with every W. T. 501.

### Welsh PEANUT Detector Tube W. T. 501

can be used on three dry cells or one regular 6-V "A" battery. Consumes less than half as much current as ordinary tubes, consequently does not use up batteries as fast.

Nickel-plated socket, moulded base, double-spring contacts, 40c extra. Adaptor for standard V. T. Socket, 75c extra.

If not at your dealer's, send us his name and address with money order and we'll see that you are supplied. Include 10c extra for registration.

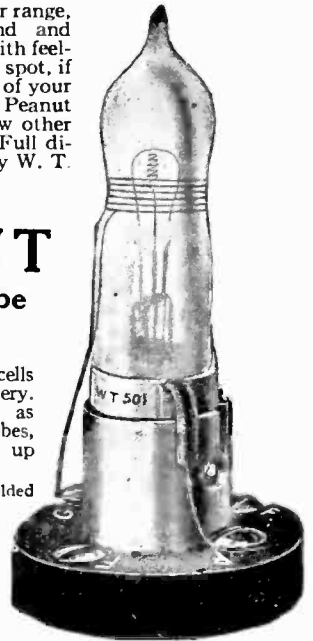

Radio Research Guild **\$2.00**  
40 Clinton St. Newark, N. J. Immediate Delivery

## HOW ABOUT— Your Summer Radio Reading Plans ???

Here's a chance to order RADIO BROADCAST for 5 months at reduced price. Just sign and send in coupon below

### Read these articles in RADIO BROADCAST for June—

The New Westinghouse System of Broadcasting  
Blind, but He Built His Own Radio Set  
All About Our Boy Scouts Prize Contest  
How to Build a Single Tube Loud Speaker  
Operating a Radio on a Yacht in Mexican Waters

**FIVE BIG ISSUES FOR ONE DOLLAR!**

Doubleday, Page & Company **MAIL NOW**  
Dept. 523-R, Garden City, N. Y.

Enclosed please find \$1.00 for which special price kindly send me the next 5 issues of RADIO BROADCAST, commencing with June.

Name.....

Address.....

City..... State.....

# Gust Out

4<sup>th</sup>  
Edition  
\$1.00

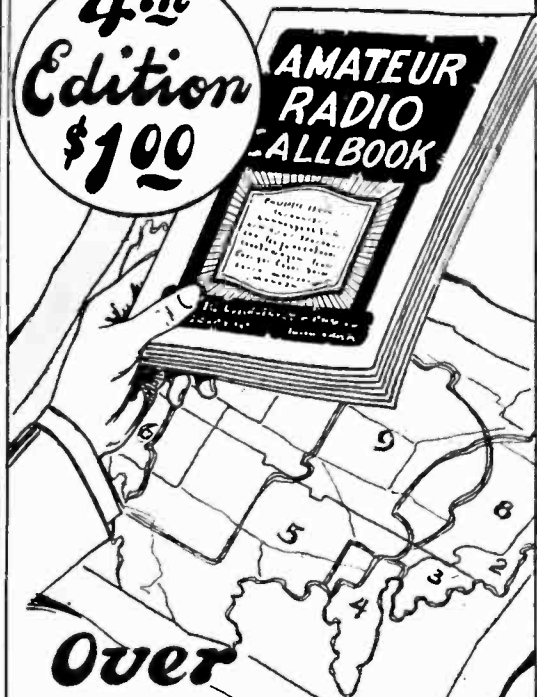

Over  
**20,000 Call Letters**  
and Map-size 2x3ft

**I**NDISPENSABLE to every radio owner. Contains up-to-date list of over 20,000 Amateur, Commercial, Army, Navy, Transoceanic High Powered, and Broadcasting Stations in the United States and Canada; International Morse Code and Convention Signals; the construction and operation of the Reinartz Tuner, Detector, and one-stage Amplifier; also an abundance of other useful information.

Included with the book is a splendid two-color map of the United States and Canada, 2 x 3 ft., showing radio district boundaries, standard time lines, geographical location of broadcasting stations, etc.

*Buy the book with the blue cover.*

Greatest dollar value on the radio market. At your dealers or direct by mail. Use check or money order. Do not send stamps.

*Dealers: Write for proposition*

**RADIO DIRECTORY AND PUBLISHING CO.**  
45-W Vesey Street New York City

## CHARGE YOUR RADIO BATTERY at HOME for a NICKEL

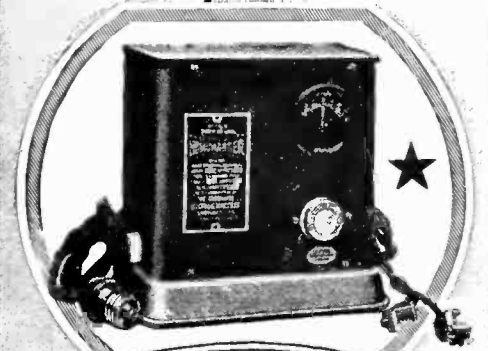

**PATENTED ARMATURE**  
The HOMCHARGER'S only moving and wearing part, replaceable after thousands of hours' use for \$1.00. Tungsten contacts now used exclusively. Will not stick, corrode or wear excessively.

Enjoyable concerts and maximum receiving range are obtained only when your battery is fully charged.

### THE HOMCHARGER

charges your "A" or "B" battery **OVER NIGHT** for a nickel without removing it from your living room. Operates silently—charging rate governed automatically. No muss—no trouble—no dirt—requires no watching.

The HOMCHARGER is the **ONLY** battery charger combining all of these necessary features. **SELF-POLARIZING**—FIVE to EIGHT-AMPERE charging rate—**UNDERWRITERS' APPROVAL**—beautifully finished in mahogany and old gold—**UNQUALIFIEDLY GUARANTEED**. Over 100,000 now in use.

*The minute you buy a radio set you need a Homcharger—get it then. All good radio and electrical dealers sell it complete with ammeter, etc., for \$18.50. \$25.00 in Canada.*

Write for **FREE** circular showing why the HOMCHARGER is the **BEST** battery charger at any price.

**MOTORISTS** — THE HOMCHARGER will also charge your **AUTO** Battery.

**THE AUTOMATIC  
ELECTRICAL DEVICES CO.**  
128 WEST THIRD ST.  
CINCINNATI, OHIO

Largest Manufacturers of  
Vibrating Rectifiers in the World

★ Tested and approved by RADIO BROADCAST ★



**HERE'S WHAT YOU GET FOR \$10**

1. "The How and Why of Radio Broadcasting"—the book and working charts that tell you just what you need to know about radio, free with each order until further notice.
  2. Parts for the receiver cabinet.
  3. Specially finished front panel.
  4. All the parts, including stators, rotors, axles, friction washers, rotor balls, and wire for two variometers.
  5. All the parts for one vario-coupler.
  6. Metal indicators.
  7. Control knobs for tuning devices.
  8. Vacuum tube socket.
  9. Rheostat.
  10. Wire for winding vario-coupler and variometers.
  11. Grid leak and condenser unit.
  12. Inductance switches for vario-coupler.
  13. Contact points for vario-coupler.
  14. Spring connectors for making an easy job of the wiring.
  15. Eight binding posts.
  16. Hard drawn copper wire for making substantial, bus type connections.
  17. Metal foil for making the shield which cuts out "howling," due to "body capacity," effect.
  18. Complete soldering outfit, including soldering iron, solder, resin and scraper—just the thing for radio work.
- Everything is here to enable you to build a receiver, without any special tools, without requiring any knowledge of radio, without any complicated parts—but with all the advantages of an expensive receiver at about one-sixth its usual cost. And you have all the fun of making it.



**1300 Miles and More On a KD-10 Receiver**

Using a 2 wire antenna less than 40 feet above the ground and a receiver he built for \$10, Theodore Bedell, Jr., of Freeport, L. I., hears Havana, Cuba; Davenport, Iowa; Atlanta, Ga., and many other distant broadcasting stations.

**Just the Outfit for that Boy!**

Send money order to-day for a KD-10—the biggest \$10 worth you ever bought. Add postage for points outside the U. S. A.

We can also supply standard radio equipment of all makes at list prices.

**KAY DEE RADIO SUPPLY CO.**  
487 Fulton Street, Brooklyn, N. Y.

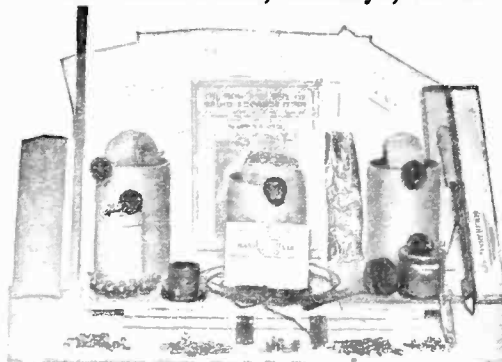

**ALL THESE PARTS FOR \$10**

**BROOKS VARIABLE CONDENSER**

Two Ribbons furnished (Max. .0005 Min. .00001)  
Easily interchangeable (Max. .001 Min. .00001)

Adaptable to all receiving circuits.

Shortening of plates eliminated.

Nicety of adjustment.

Straight line capacity curve.

Low internal resistance.

Loud Signals

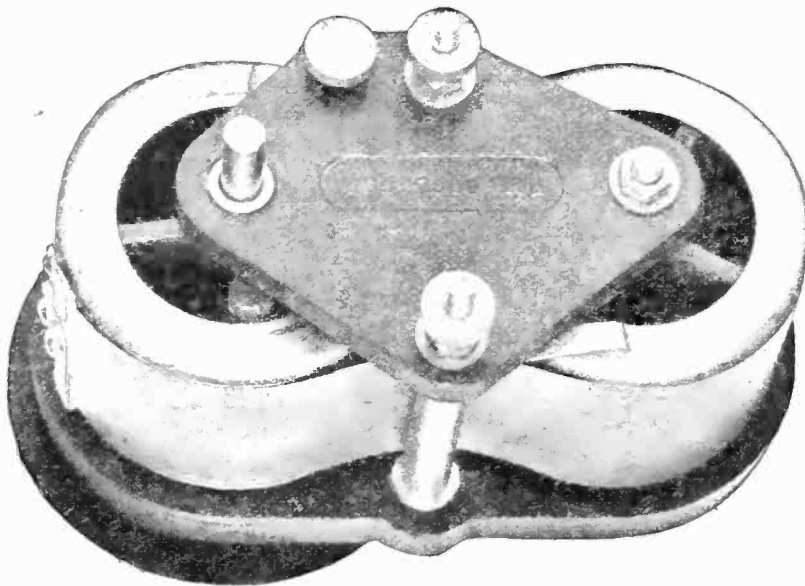

Jobbers Wanted

Write for prices and discounts

Retail price \$4.75 each, complete with dial.

Manufactured by  
**METRIC METAL WORKS**  
of  
**AMERICAN METER COMPANY, INC.**  
ERIE, PA.

★ Tested and approved by RADIO BROADCAST ★



# HAVANA!

Theodore Bedell, Jr.,  
operating the set he made.

## AT LAST!

You Can Now *Make*  
*Your Own Receiver* at a  
**TOTAL COST of ONLY \$10.00**

**T**HE HOW AND WHY OF RADIO BROADCASTING, by Arthur H. Lynch, is the book radio amateurs all over the country have been looking for. It is complete in every detail and makes it possible for you to build a modern set, capable of receiving over great distances, without interference.

To buy a similar receiver would cost you at least five times as much.

Four working patterns accompany each book and they are used for making the panel, cabinet and electrical units.

One of the receivers built by the author is in use in the office of "Radio Broadcast" and is giving entire satisfaction.

The set is designed for use with a single vacuum tube, but amplifiers may be used if desired.

The stations mentioned in this letter include two in Newark, N. J., two in New York; one each in Schenectady, Pittsburgh, Philadelphia and Atlanta, Ga., one in Havana, Cuba, ranging from 30 to 1350 miles. Still greater distances are possible.

39 Bedell Street, Freeport, N. Y.  
September 9, 1922.  
Doubleday, Page & Co.,  
Garden City, N. Y.  
Gentlemen:  
It may interest you to know the results I am getting from the vacuum tube receiver I made from the plans which came with your pamphlet "The How and Why of Radio Broadcasting," by Arthur H. Lynch.  
The stations of WJZ, WOR, WEAJ and WBAY come in regularly and very clearly. Also, I receive from WGY, KDKA and WOO and have no trouble to tune them in over the above named stations.  
**We hear Havana, Cuba, very well.**  
Being an amateur and with no radio experience whatsoever two months ago, I attribute the results I am getting to your publication, which is certainly complete and easy for anyone to understand.  
In connection with the receiver, I use an aerial 100 feet long, 2 wires—2 feet apart, 40 feet high—and a 35-foot lead in. Also a single vacuum tube, a six volt storage battery and a 22½ volt "B" battery.  
I also wish to state that the tone of reception is excellent, and in comparison with outfits owned by friends, costing five or six times as much as mine, my results compare favorably and in many instances surpass.  
Yours very truly,  
**THEODORE BEDELL, JR.**

**This book tells you all you have to know:**

How to put up your antenna in accordance with the new regulations of the National Board of Fire Underwriters—

How to wind coils, drill the panel, make the cabinet, solder connections—shield your receiver—

How to operate your set intelligently—

How to overcome interference and other troubles—

How to prolong the life of your vacuum tube—

How to use "vernier" adjustments—

In short—everything you want to know about in radio language you can understand.

There are more than two dozen photos and diagrams in addition to the four working patterns.

**DOUBLEDAY, PAGE & COMPANY**  
Dept. RB-2, Garden City, New York

Gentlemen: Enclosed please find one dollar for THE HOW AND WHY OF RADIO BROADCASTING by Arthur H. Lynch. If not satisfied I can return this book within 3 days and have my deposit refunded.

Name.....

Address.....

# RADIO

— *“they last longer”*

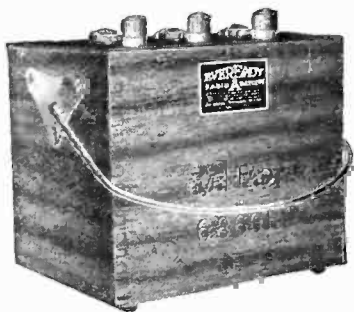

For Storage Battery  
Tubes use EVEREADY  
Storage “A” Bat-  
teries



For Dry Cell Tubes  
use EVEREADY  
Dry Cell Radio  
“A” Batteries



For All Vacuum  
Tubes use EVEREADY  
“B” Batteries

NATIONAL CARBON COMPANY, Inc.  
Long Island City, N. Y.

Atlanta Chicago Cleveland Kansas City San Francisco

*Insist on Eveready—  
Accept no Substitute*



**EVEREADY**  
**Radio Batteries**  
*—they last longer*

★ Tested and approved by RADIO BROADCAST ★



# MU-RAD RECEIVERS SUPREME



LIKE THE POWERFUL TELESCOPE that makes us neighbors to the stars, MU-RAD Receivers annihilate distance with delightful ease. Honolulu is as near to St. Louis by MU-RAD reception as New York.

So marvelously sensitive that it requires only a 2-foot loop aerial. Distinct reproduction with hair breadth selectivity, and yet easy for even a novice to operate. Conservatively guaranteed for 1000 miles.

*Write for literature*

*The New  
Star in  
the Radio  
World*



## MU-RAD LABORATORIES, INC.

★ 803 FIFTH AVE. ASBURY PARK, NEW JERSEY

★ Tested and approved by RADIO BROADCAST ★

# Long distance

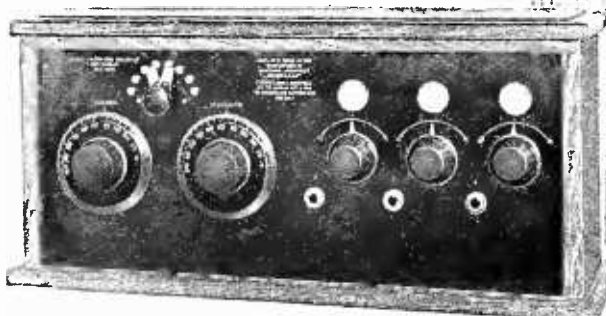

Licensed under Armstrong U. S. Patent No. 1,113,149, manufactured by Oard Radio Laboratories, Stockton, California, Atlantic-Pacific Radio Supplies Co., Sole Agents.

You are losing a vast amount of radio enjoyment every day you are without *Type AR-10 Long-distance Regenerative Receiver and Two-stage Amplifier*. It brings in distant programs, too. The reception of music and speech a *thousand miles* and beyond is considered not at all extraordinary by owners of this marvelous set.

It is simple, beautiful, sturdy, and efficient—a complete set of the most practical type with the latest accepted improvements.

And so compact—with WD 11 (“Peanut”) tubes there is room for both A and B batteries inside the cabinet, and only two external outlets are required, one for ground, and one for antenna. (Standard tubes can be used if preferred.)

The low price only possible because of quantity production and organized facilities of manufacturer, who is one of the oldest in radio.

Don't delay. For several months the demand for AR-10s will probably exceed the number that can be produced. Mail the coupon *NOW!*



## ATLANTIC-PACIFIC RADIO SUPPLIES CO.

650 Mission St., San Francisco, California

### MANUFACTURERS' REPRESENTATIVES

- Cutler-Hammer Mfg. Co. .... Rheostats and Potentiometers
- Alden-Napier Co. .... Sockets and Dials
- Carter Radio Co. .... Telephone Plugs and Jacks
- Dayton Fan & Motor Co. .... Variometers and Variocouplers
- A-P Quality Line .... Transformers, Condensers, etc.
- Oard Radio Laboratories. .... Oard Phantom Receptor

**JOBBERS and DEALERS invited to stock these lines**

*regenerative receiver with two-stage amplifier-*

for

**\$75**

**Construction and Performance FULLY GUARANTEED**

### MAIL THIS COUPON

Atlantic-Pacific Radio Supplies Co.  
650 Mission St., San Francisco, Cal.

Gentlemen:—Without cost or obligation, please mail me folder giving full information on your Type AR-10 Regenerative Receiver and two-stage Amplifier.

NAME \_\_\_\_\_

ADDRESS \_\_\_\_\_

CITY \_\_\_\_\_ STATE \_\_\_\_\_

*My favorite radio dealer is—*

NAME \_\_\_\_\_

ADDRESS \_\_\_\_\_

CITY \_\_\_\_\_ STATE \_\_\_\_\_

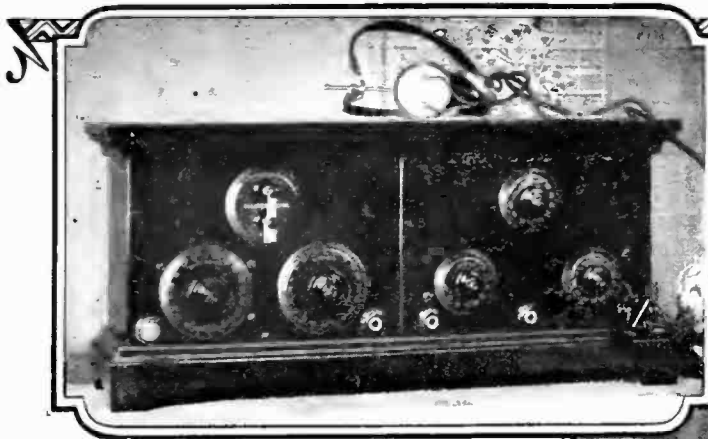

**Radiola V**

*Mohogany finished case, of rugged build. A three tube Radiola—detector and two steps of amplification.*

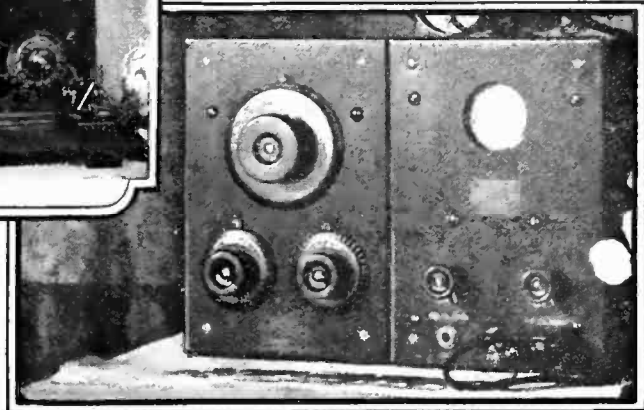

**Radiola RC**

*Three tube set—detector and two step amplifier. Solid mahogany, attractively finished.*

# A New Improvement Lowers the Cost!

Dry cells replace storage batteries. A new vacuum tube has made it possible. Radiola V and Radiola RC have been topping them all in popularity for dependability and long range—receiving over thrilling distances—up to 1,500 miles and more. Now both are converted to dry battery operation. This means greatly lowered cost—does away with bulky storage batteries—gives the far-away farmer the same good service it gives the city man.

No more need for expensive storage battery and charger. A big saving! And a saving made greater by the new offer—a combination offer of receiver and accessories—complete at a price remarkably low.

★ *“There’s a RADIOLA for every purse”*  
at the nearest Radio or Electrical Store

# Radiola

REG. U.S. PAT. OFF.

**Radio Corporation of America**

*Sales Department*

233 Broadway  
New York

*District Sales Offices*

10 So. LaSalle St.  
Chicago, Ill.

433 California St.  
San Francisco, Cal.

*This symbol of  
quality is your  
protection*



**Radiolala V or  
Radiola RC**  
Complete \$142.50

*The New Way:* Complete for dry battery operation, including three WD-12 Radiotron vacuum tubes; head telephones; “A” battery consisting of three dry cells; “B” battery consisting of three 22½ volt units. \$142.50.

*The Old Way:* The price of Radiola V or Radiola RC when equipped for storage battery operation, formerly came to \$207.50.

*Send for this Free Booklet*  
There are Radiolas from \$25 to \$350. Send for the booklet that describes them all.

**RADIO CORP. OF AMERICA**  
Dept. 2066, 233 Broadway, New York  
Please send me your free Radio Booklet.

Name \_\_\_\_\_  
Street Address \_\_\_\_\_  
City \_\_\_\_\_ R. F. D. \_\_\_\_\_  
State \_\_\_\_\_

★ Tested and approved by RADIO BROADCAST ★

# New Equipment



**A SOCKET FOR THE WD-11**

This socket, made by the Alden Mfg. Co. of 52 Wil-  
low St., Springfield, Mass., is provided with a sub-  
base that makes the socket very substantial, and the  
spring contactors are arranged to make a wiping con-  
nection with the tube terminals. The price is 75  
cents



**THE MUSIC MASTER**

Is a loud speaker of exceptional quality.  
For use with two stages of A. F. amplifica-  
tion, it is hard to beat. Its tone is mel-  
low, and the price is fair. The home  
model has a 14-inch horn and sells for  
\$30. General Radio Corporation, 624  
Market St., Philadelphia, Pa.



**THE SONOCHORDE**

Is the first loud speaker to appear with a horn of  
gutta-percha. It is designed for use without any  
field-exciting current. It is indeed a quality in-  
strument, made by The Boudette Mfg. Co., 79  
Beach St., Revere, Mass.



**THE PACENT RHEOSTAT**

Is mechanically and electrically good and its  
appearance is in keeping with that of the high-  
quality receiving equipment for which it has  
been made. Pacent Electric Co., 22 Park Pl.,  
New York City



*The famous FADA "ONE SIXTY" with the NEUTRODYNE circuit—*

## Neutrodyne



is the name given to a marvelous new radio receiver circuit invented by Professor L. A. Hazeltine of Stevens Institute of Technology, Hoboken, N. J. and used in the FADA "ONE SIXTY" receiver.

Only four vacuum tubes are used. The selectivity is remarkable and yet the dials can be adjusted to receive distant stations with great ease.

The FADA "ONE SIXTY" will receive broadcasted concerts from the Atlantic to the Pacific and with loud speaker intensity.

Denver, Colo., San Antonio, Tex., Havana, Cuba and Los Angeles, Calif. are some of the far distant stations listened to from New York City.

The FADA "ONE SIXTY" is the ideal receiver—the cost \$120.00.

F. A. D. ANDREA 1581-B Jerome Ave. New York City

*The* **FADA "ONE SIXTY"**  
**- WITH THE NEUTRODYNE CIRCUIT -**

★ Tested and approved by RADIO BROADCAST ★

# Cotogrip ★

"Built First to Last"

This little beauty was approved by our engineers only when convinced that they had produced the one socket that combines all the essential features of a good socket.

1. Positive Cotogrip Contacts.
2. Hard Rubber Insulation.
3. Rugged Construction.
4. Compact Design.
5. Concealed Mounting.

It is impossible to show the unique mechanical action of Cotogrip contacts in a photograph. It is different from any other socket you have ever seen. This socket will interest you in every way.

You ought to have one.  
Ask Your Dealer



## COTO-COIL CO. PROVIDENCE

Pacific Coast Branch, 329 Union League Bldg., Los Angeles, Cal.

### WHY METRO HEADPHONES ARE SUPERIOR

#### ACTUATING COIL CORES

METRO HEADPHONES faithfully reproduce every sound variation so that reception is always clear and natural. The magnetic current which operates the diaphragm is transmitted by the actuating coils through the soft Arnono Iron Cores, which allow a ready change of magnetic strength.

It is this remarkable ability of the actuating coil cores to react faithfully to every magnet impulse that helps to produce Metro sensitivity. A small detail, but perfection is made up of such details. Insist upon Metro Headphones because you can be sure that every detail is as it should be.

\$6.00

**Little Giant Receiving Set**  
A surprisingly compact set. Simplest tuning device. Complete with Metro Headphones. . . . . \$14.00

**Metro Wave Selector**  
Makes any set highly selective. Completely separates 380 from 400 meters. . . . . \$7.50

**METRO ELECTRICAL CO., Inc.**  
Manufacturers of Metropolitan Radio Products  
67 Goble Street Newark, N. J.

★ Tested and approved by RADIO BROADCAST ★



## *A Real Musical Instrument*

**ACTUAL** re-PRODUCTION, of the artist's music as broadcasted, is at last attained in the Atlas Amplitone Loud Speaker, without blast or distortion. The artist's personality breathes again in the full, natural, vibrant tones of the Amplitone Re-PRODUCTION. Musical critics and radio fans, who have heard the Amplitone, agree that, at last, the musical superiority of even the finest phonographs has been surpassed.

Embodies exclusive acoustic principles including the marvelous double diaphragm.

# *Atlas* **AMPLITONE** LOUD SPEAKER



The Atlas Amplitone Unit, (without base or horn), with Grafonola Attachment, for use with your own horn or base, or to convert any phonograph (except the Brunswick) into a loud speaker.

**\$13.50**

Write for illustrated booklet and the name of your nearest *Amplitone* dealer. No other loud speaker can take the place of the *Amplitone*.

**NO** loud speaker is perfect, unless it can be adjusted to your own individual set. The Atlas Amplitone is adjustable to any set. Complete with connecting cord

**\$25.00**

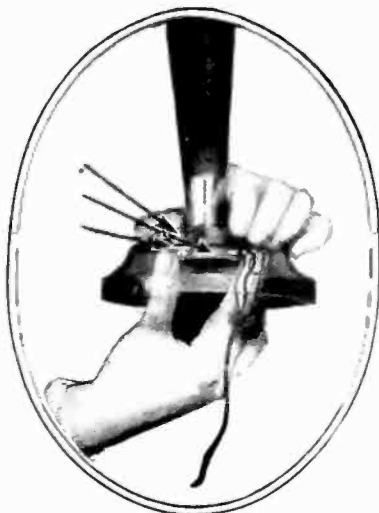

**Multiple Electric Products Company**  
5 Orange Street Newark, N. J.

# New "UNITED" Vernier

A Miracle-Worker In Fine, Selective Tuning. Operates on a New Principle.

Will bring in the elusive stations that have thus far defied you, by giving at least *twice* as fine a tuning as has ever been possible



with the best condensers thus far developed.

Can be attached to any plate condenser, by drilling one hole in top plate. Price, each Postpaid \$2.50.

"UNITED" VARIABLE CONDENSERS WITH NEW VERNIER

43-plate—each \$6.50    23-plate—each \$6.00  
11-plate—each \$5.50

## "UNITED" TRANSFORMER

Audio Frequency. Amplifies detected signals so they come in clear and strong, for either headphone or loudspeaker reception. Each \$4.50.

Send for catalogue of United Products

## UNITED MFG. & DISTRIBUTING CO.

536 Lake Shore Drive  
New York Office  
50 Church St., New York, N. Y.

CHICAGO, ILL.  
San Francisco Office  
709 Mission St., San Francisco, Cal.

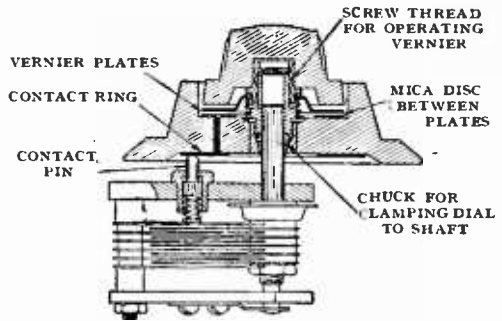

## CHARGE YOUR BATTERY WHILE YOU SLEEP

Hook the Leich NON TUNE Rectifier to your battery after the evening's entertainment and let it charge all night—no danger—you needn't watch it.



Its 2 ampere charging rate is sufficient for home use when three or four 5-watt tubes are operated.

With the increased use of quarter ampere tubes the NON TUNE Rectifier will soon be in a class by itself; because of its high efficiency it uses less than 40 watts of current at full load.

NON TUNE FEATURE gives this charger flexibility in its operation, allowing for considerable voltage and frequency variation of the power circuit.

A PATENTED RELAY LOCK keeps the battery circuit open when the power current fails.

LEADING RAILROAD COMPANIES have used NON TUNE Rectifiers for years.

Try a NON TUNE. Ask your dealer or write for Bulletin 100-A.

**LEICH ELECTRIC CO., Mfrs., Genoa, Ill.**  
Non Tune Rectifiers—Leich comfortable headphones

## DANIEL BOONE

*Wilderness Scout*

by Stewart Edward White

An out-of-doors story for fathers and sons

At bookstores, \$1.75

Doubleday, Page & Co.

## Tune In To

### WDAP

—the powerful broadcasting station at

# The DRAKE

Lake Shore Drive and Upper Michigan Avenue  
CHICAGO

From Porto Rico to lonely ranches in Alberta and Saskatchewan, from sunny San Diego to Quebec, and even a thousand miles out in the Atlantic and Pacific oceans, programs from THE DRAKE are picked up. You'll be particularly well repaid by tuning in Tuesday, Thursday, Saturday, and Sunday evenings—concerts include selections by THE DRAKE Ensemble Orchestra.

WDAP Station is but a single interesting feature of THE DRAKE, Chicago's finest hotel. When in Chicago be sure to stop at THE DRAKE. See how concerts are broadcasted, and enjoy the world famous service and surroundings of this wonderful hotel. Information on request.

Under The Blackstone Management, the world's standard in hotel service.

★ Tested and approved by RADIO BROADCAST ★



# “Having time of my life getting most splendid results from the ‘Socostat’” says one radio fan

(Socket and Rheostat)

THE “Socostat” is a combination of socket and rheostat that eliminates the wiring of two separate parts. Saves time, material and money.



Single-unit socket and Rheostat for Table or Panel Mounting

No exposed wires. The internal rheostat permits very sensitive filament adjustment. Tube noises reduced to a minimum. Bakelite base and cover. Nickel plated receptacle takes any standard detector and amplifier tube. Rings and screws all nickel plated. The “Socostat” simplifies your construction and improves the appearance and operation of your set. Guarantees a smooth and positive contact.

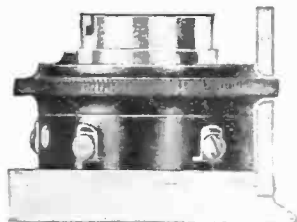

View showing panel mounting of “Socostat”

We guarantee that you will be satisfied.

Price \$2.50 at your dealer or write.

Another radio expert writes: “The ‘Socostat’ practically eliminates the usual tube noises and gives better results than the socket and rheostat in every way. Have shown it to several of the boys and all agree that it is O. K. It should go big with the Radio Bugs.”



View showing cover and ring removed.

**FEDDERS MANUFACTURING CO., INC.**

59 Tonawanda Street

Buffalo, N. Y.

# RADIO ADVANCES and LUDWIG HOMMEL & CO. DEALERS WITH IT

**DISTRIBUTORS FOR  
Radio Corporation of America**

  
 Westinghouse General Electric  
 Acme Atwater Kent Baldwin  
 Brach Brandes Burgess  
 Chelsea Clapp-Eastham  
 Cunningham Cutler-Hammer  
 Dubilier Fada Fahnestock  
 Formica Frost General Radio  
 Hipco Homecharger Hopewell  
 Kellogg Kennedy Klosner  
 Murdock Omnigraph Pacent  
 Radio Service Radiall (Amperite)  
 Remler Rhamstine Tuska  
 Western Electric  
 and other Leading Manufacturers



Established radio dealers will recall the hectic days of last spring when any radio material could be sold and standard makes were at a premium. Radio has become more stabilized, and crude material has given way to perfected apparatus. Your trade will want the newest and best in Radio. Can you satisfy the demand for:

- Vernier Condensers
- Vernier Rheostats
- Vernier Adjusters for Variometers
- WD-11 Socket Adapters
- Coupled Circuit Tuners
- Radio Frequency Sets
- Console Type Dry Cell Tube Sets
- Power Amplifier Loud Speakers

Ludwig Hommel & Co. dealers have these items illustrated in Hommel's Encyclopedia of Radio Apparatus and are kept in touch with all developments in the art.

It pays to tie up with a jobber who wholesales exclusively and gives his dealers 100% service.

Send your next order to Hommel's and ask for our new Illustrated Encyclopedia 225 B. It's free to dealers.

## LUDWIG HOMMEL & CO

530-534 FERNANDO ST.  PITTSBURGH, PENNA



Na-ald Special Socket No. 499

### It's the contact that counts

The Na-ald Special Socket No. 499 is a sturdy little socket for the G. E. No. 199 dry cell tube. It has special slot construction, is moulded from genuine Bakelite, and because of thorough cure and high dielectric properties it keeps plate to grid losses at a minimum (of particular importance in Flewelling Circuit, or in Radio Frequency).



The Na-ald De Luxe V. T. Socket is of highest quality throughout. Its laminated phosphor bronze strips press firmly with a side wipe action on the contact pins, keeping surface clean and insuring perfect contact.

Send stamp for dial, small-space socket, condenser and R.F. transformer circulars

These sockets retail at 75c. each

ALDEN MANUFACTURING CO.  
formerly Alden-Napier Co.  
 Dept. B, 52 Willow St., Springfield, Mass.



Na-ald De Luxe, No. 400



Booklet with wiring design instructions for Hazeltine's Neutrodyne and the Flewelling Super-regenerative Circuits, and a number of standard circuits, packed with each socket.

### "Circuits of Victory"

By A. Lincoln Lavine

\$3.00 at your bookstore

Doubleday, Page & Co., Garden City, N. Y.

## FREE CATALOGUE

Make D X Records  
 With D X Supplies

This Catalogue should be called "Recipes for Long Distance." It was written to help amateurs pull in the most distant stations.

To Get Your Copy  
 Write Department 1471

D-X Radio Company

123 Liberty St.

New York City

★ Tested and approved by RADIO BROADCAST ★



**MUSIC  
MASTER**  
Radio  
**AMPLIFIER**



## Rich Resonance that Only WOOD Can Give

14-inch Amplifier  
complete, \$30  
21-inch Amplifier  
complete, \$35

### JOBBERS — DEALERS —

A MUSIC MASTER will be sent to you with full privilege of return. Write for full description of the GERACO line, and prices.

THEY call MUSIC MASTER the "Stradivarius Among Amplifiers." For its horn is WOOD, with that pure, mellow-sweet tonal quality of the human voice that wood alone can simulate. (Phonograph experts proved the principle before radio.)

A powerful amplifying unit in the art-metal base of MUSIC MASTER sends sounds up through a cast-aluminum "gooseneck"—cast-aluminum, so it won't vibrate. This conveys true tones to the wooden horn, where they are beautifully enriched, humanized and given to the audience as they are actually sung, played or spoken.

There is only one MUSIC MASTER: Get it and you won't regret it! Hundreds of orders are pouring in daily. Demand actually exceeds supply, so get your order in NOW! Comes complete, ready to attach in place of head 'phones. No extras to buy. Hear MUSIC MASTER at your dealer's to-day. COMPARE it with any other amplifier, regardless of price! Literature on request.

Ask about the GERACO Phonograph attachment which makes an efficient radio loud-speaker of your Victrola or Columbia. Only \$10.

## GENERAL RADIO CORPORATION

Makers and Distributors of High-Grade Radio Apparatus

Walter L. Eckhardt, President

CHICAGO

624-628 Market St., PHILADELPHIA

PITTSBURGH



**GERACO**  
PROVEN RADIO PRODUCTS

★ Tested and approved by RADIO BROADCAST ★

# ECHOPHONE

## Regenerative Radio Equipment

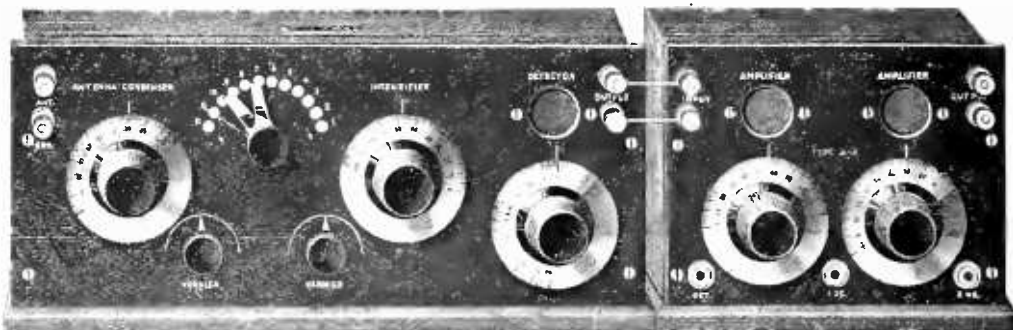

Licensed under Armstrong Patent No. 1,113,149

The Lowest Priced GOOD Radio Set on the Market

THE latest word in radio development. Made in various types. It has proved results in *long-distance reception*. Has unusual ease of operation for the beginner. Can be used with headphones or loud-speaker. Made by the Radio Shop of St. Louis, Mo., and Sunnyvale, Cal., having 10 years' experience in making dependable radio sets on sound engineering principles.

Prices Range from  
\$70 to \$160

**ECHOPHONE CORPORATION**  
1922-28 Chestnut St. St. Louis, Mo.

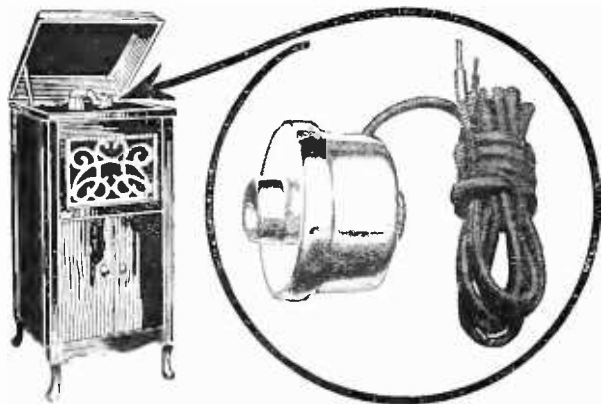

### RADIO LOUD SPEAKER for Phonographs

The MORRISON Loud Speaking Unit, for use on phonographs, takes the place of awkward headsets. Possesses a tone value 100% true—an achievement never before attained in a loud speaker.

#### Attaches in Place of Reproducer

Slips on tone-arm of phonograph in place of reproducer, or can be used with horn. Adapted to any huls set with one or more stages of amplification. Adjustable from soft to loud tone. Cannot possibly rattle or loosen through excessive amplification. A popular-priced Loud Speaker that compares with most expensive instruments on the market. Thousands in use giving perfect satisfaction. Handsomely nickel plated, complete with 5 ft. cord, \$10—at your dealer's or direct. Sent C. O. D., if desired. Fully guaranteed. Money back if not satisfied. (When ordering, specify make of phonograph).

**MORRISON LABORATORIES, Inc.**  
Dept. 10, 536 Griswold St. Detroit, Michigan

### Increase the Efficiency of Your Set With a ★ PROUDFOOT VERNIER CONDENSER

#### Special Features

Plates Cannot Short Fool Proof  
No Adjustments to Get Out of Order  
Two Dials But Only One Knob—one dial to indicate position of group plates and one to show relationship of vernier to group plates.

Higher Efficiency—the vernier plate being one of the group plates, allows the vernier adjustment without the additional electrical losses due to the usual construction of the vernier being separated from the main plates.



STYLE	M. F. CAP	PRICE
11 plate	.00025	\$5.00
21 "	.00055	6.00
43 "	.0011	7.00

CRUVER MFG. COMPANY  
2456 W. Jackson Blvd. Chicago, Ill.

The most satisfactory book for beginners that has yet appeared.—Public Ledger.



### RADIO SIMPLIFIED

By KENDALL & KOEHLER  
Radio Instructors

#### WHAT TO BUY HOW TO BUILD HOW TO OPERATE

A clear explanation of Radio in simple language with complete directions for assembling and installing home radio equipment. Will aid you in getting the best results from your set.

96 Illustrations including picture diagrams showing hook-ups, etc. Cloth, 250 pages, \$1.00.  
On sale at Booksellers or mailed on receipt of price  
THE JOHN C. WINSTON CO., 34 Winston Bldg., Philadelphia, Pa.



CATALOGUE NO. 85

## An Improved RHEOSTAT ★ another PACENT development

SIMPLE—STURDY—FINELY ADJUSTABLE—EASY TO MOUNT

You'll welcome the many advantages in the new PACENT RHEOSTAT. It is beautifully constructed, flawless in performance, the simplest to assemble or take apart when mounting. The turn of one screw separates the two units (as illustrated). Unit 1 consists of the pointer, knob and shaft moulded in one piece. Unit 2 remains intact when rheostat is separated, permitting the careful contact adjustment made at factory to remain undisturbed. Changing from panel to table mount-

ing is simply a matter of a few seconds. The wire element will safely carry  $1\frac{1}{2}$  Amp. continuously. The base of the rheostat is heat-resisting and will not crack or warp. The rheostat turns with the smooth "velvety" feel of precision instruments, making perfect control easy. Another instance of PACENT quality at reasonable cost.

The PACENT Potentiometer (same size and incorporating all of the advantages of the PACENT rheostat) Catalogue No. 88, \$1.25.

*Write for Descriptive Bulletin B-5*

**"DON'T IMPROVISE—PACENTIZE"**  
**PACENT ELECTRIC COMPANY**

INCORPORATED

Executive Offices: 22 Park Place, New York, N. Y.

**SALES OFFICES**

Chicago  
Philadelphia  
San Francisco

Washington, D. C.  
Minneapolis  
St. Louis



Canadian and British Licensees:  
Colonial Radio, Ltd., Hamilton, Can.  
Members, Radio Section, Associated  
Mfrs. of Electrical Supplies

★ Tested and approved by RADIO BROADCAST ★

12487 125

**XX Grade  
is right  
for  
Radio**

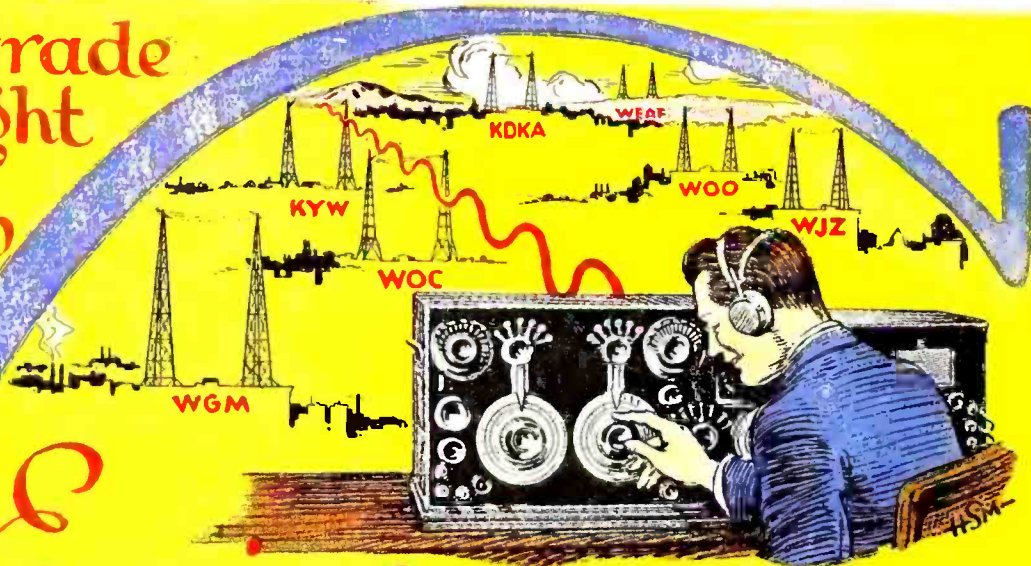

**Easier to Pick 'em  
with Proper Panels!**

Program-choosing demands delicate tuning and your radio panel must be right if you want to get and *keep* a station without variations and interferences. For panels, bases and partitions, no other material is more satisfactory than tough, unchanging, handsome Bakelite-Dilecto, XX grade



**bakelite-dilecto!!**

**[A Laminated Phenolic Condensation Product]**

Where protection of lives, homes, ships, cities and national safety depend on Radio, Bakelite-Dilecto panels are found in use.

Bakelite-Dilecto resists heat, water, steam, oils, solvents and the milder acids. Cannot warp or swell. Made in sheets, rods, tubes and special shapes in black and brown for all insulation requirements.

Accepting the next best thing to Bakelite-Dilecto will not do if you seek highest radio results. Any electrical dealer can get it cut and drilled to size for you. Write us direct for complete story of wonderful Bakelite-Dilecto.

**The Continental Fibre Company**

Factory: Newark, Delaware

Service From:

New York, 233 Broadway  
Chicago, 332 S. Michigan Avenue  
Pittsburgh, 301 Fifth Avenue  
San Francisco, 75 Fremont Street  
Seattle, 95 Connecticut Street  
Los Angeles, 411 S. Main Street

★ Tested and approved by RADIO BROADCAST ★

THE COUNTRY LIFE PRESS, GARDEN CITY, NEW YORK