

1300 Miles on a One-Foot Loop

# RADIO BROADCAST

V. 2 #6

LIBRARY OF  
MAR  
28  
1923



There Are No Noisy B Batteries

What Good is a Patent?

Coöperative Competition in Radio?

Jacks and How  
to Use Them



APRIL, 1923  
25 Cents



Filament potential	5 volts
Filament current	.25 amp.
Plate potential	20 to 100 volts
Plate impedance	16,000 ohms
Amplification constant	6.5

**Immediate Demand for  
New**

**Cunningham  
Amplifier  
Tube** ★

Type C-301-A

List Price \$9.00

The most efficient vacuum tube ever placed on the market for amateur and experimental use. The engineers of the General Electric research laboratories have at last succeeded in perfecting a tube that every owner of a radio set has been waiting for.

**Greater  
Power Amplification  
Only 1/4 Amp. Filament Current**

**T**HIS new and improved Cunningham C-301-A Amplifier is a high vacuum tube designed for use as an amplifier and detector, containing a new Tungsten Filament, the characteristics of which are long life, low power consumption, low operating temperature and greater power amplification than any previous amplifier tube. The tube has a standard four prong base, and the glass bulb has the same dimensions as the C-300 and the C-301.

The greatly reduced filament current permits the use of four of these tubes without exhausting the A battery any faster than when using one of the previous type of amplifier tubes.

Complete instructions for the care and efficient operation of this new Amplifier Tube are packed with every tube.

Insert a C-301-A in your amplifier set to-day. Note the improved quality and increased audibility.

*The Cunningham Technical Bureau is at your service. Address your problems to Dept. B*

*E. J. Cunningham*

248 First Street, San Francisco, California

154 W. Lake Street, Chicago, Illinois

★ Tested and approved by RADIO BROADCAST ★

# KENNEDY USES

KENNEDY  
EQUIPMENT



KENNEDY  
EQUIPMENT

## Formica Panels and Insulation ★

**T**HE COLIN B. KENNEDY COMPANY uses Formica exclusively for its panels, tubes and other insulating parts in its entire line of Receiving Sets.

The handsome appearance of Formica, its high dielectric strength and wonderful uniformity meet the exacting Kennedy standards and have contributed to the creation of the splendid Kennedy reputation.

A list of the companies who use Formica Insulation reads almost like a directory of the leading independent radio manufacturers.

This patronage of men who know radio insulation establishes Formica's claim to leadership in its line.

**DEALERS:** Formica advertising and sales support is the most aggressive and effective in the industry. The Formica Insulation Company treats you right.

### THE FORMICA INSULATION COMPANY

4628 Spring Grove Ave. Cincinnati, O.

#### SALES OFFICES

50 Church St., New York, N. Y.  
422 First Ave., Pittsburg, Pa.  
1042 Granite Bldg., Rochester, N. Y.  
415 Ohio Bldg., Toledo, Ohio

1210 Arch St., Philadelphia Pa.  
1819 Lyndale Ave., S. Minneapolis, Minn.  
Sheldon Bldg., San Francisco, Calif.  
Whitney Central Bldg., New Orleans

414 Finance Bldg., Cleveland, Ohio  
9 S. Clinton St., Chicago, Ill.  
313 Title Bldg., Baltimore, Md.  
47 King St., Toronto, Ontario

---

# FORMICA

Made from Anhydrous Redmanol Resins  
**SHEETS TUBES RODS**

---

★ Tested and approved by RADIO BROADCAST ★

# Radio Broadcast

ARTHUR H. LYNCH, EDITOR



## CONTENTS FOR APRIL, 1923

<i>Aeolian Hall, New York</i> - - - - -	<i>Frontispiece</i>
THE MARCH OF RADIO - - - - -	443
THERE ARE NO NOISY B BATTERIES - - - - -	E. E. HORINE 454
WHAT GOOD IS A PATENT? - - - - -	ROGER SHERMAN HOAR 458
Decorations by Ralph Milne Farley	
KEEPING YOUR STORAGE BATTERY WORKING AT ITS BEST	W. S. STANDIFORD 462
WHAT GOES ON AT A TRANSATLANTIC STATION - - - - -	CARL DREHER 464
Drawings by Tom Monroe	
1300 MILES ON A ONE-FOOT LOOP - - - - -	CHARLES H. DURKEE 472
MY FIRST VOYAGE AS A SEA-GOIN' TELEGRAPHER - - - - -	A. HENRY 477
JACKS AND HOW TO USE THEM - - - - -	G. Y. ALLEN 485
ONE OF THE FINEST AMATEUR STATIONS ALIVE - - - - -	ZEH BOUCK 494
STATIONS THAT ENTERTAIN YOU - - - - -	498
RADIO-FREQUENCY AMPLIFICATION FROM THE GROUND UP	*ARTHUR H. LYNCH 499
HOW FAR HAVE YOU HEARD ON ONE TUBE? - - - - -	504
An Evening's Trip Around the Whole United States - - - - - MILO SHUTT	
The Automatic Regenerative Circuit - - - - - H. L. PETERSON	
Cheap at Twice the Price - - - - - FRANK J. MYERS	
Summary of Results of the One-Tube Contest	
ANOTHER RECEIVING CONTEST! - - - - -	514
UP BEFORE THE MICROPHONE - - - - -	515
"COÖPERATIVE COMPETITION" - - - - -	JOHN K. BARNES 516
WHO WILL ULTIMATELY DO THE BROADCASTING? - - - - -	522
THE GRID—QUESTIONS AND ANSWERS - - - - -	526
ADDITIONAL BROADCASTING STATIONS IN THE UNITED STATES - - -	528

Copyright, 1923, by Doubleday, Page & Co. All rights reserved  
TERMS: \$3.00 a year; single copies 25 cents

F. N. DOUBLEDAY, Pres.

RUSSELL DOUBLEDAY, Sec'y.

ARTHUR W. PAGE, Vice-Pres.

S. A. EVERITT, Treas.

NELSON DOUBLEDAY, Vice-Pres.

JOHN J. HESSIAN, Asst. Treas.

### DOUBLEDAY, PAGE & CO.

THE WORLD'S WORK

COUNTRY LIFE

THE GARDEN MAGAZINE

SHORT STORIES

EDUCATIONAL REVIEW

HEALTH BUILDER

CHICAGO: People's Gas Bldg.

GARDEN CITY, N. Y.

NEW YORK: 120 W. 32nd Street

BOSTON: Tremont Bldg.

LOS ANGELES: Van Nuys Bldg.



A. F. GREBE & CO., Inc.  
 Richmond Hill, N. Y.  
 Western Branch  
 451 East 3rd St., Los Angeles, Cal.



Write for  
 "Musings of  
 Dr. Mu."

“What is whispered — in  
 the ear is heard miles away.”  
 said Mencius.  
 The wise radioist hears voices  
 a thousand miles  
 away with a **Grebe Receiver.**

*Doctor Mu.*

Licensed under Armstrong  
 U. S. Pat. No. 1113149

★ Tested and approved by RADIO BROADCAST ★



AEOLIAN HALL, NEW YORK

Where many of the world's greatest singers and instrumentalists appear. It is likely to become the music centre of America, for the music of the masters may be enjoyed by a greatly enlarged audience

# RADIO BROADCAST

Vol. 2 No. 6



April, 1923

## The March of Radio

### A START ON STANDARDIZATION

**W**E HAVE heard much recently regarding the standardization of radio apparatus—not so much about what has been standardized as about what ought to be. It would seem that the movement for standardization probably originates with the dealers rather than with those responsible for the design and building of apparatus. The Army and Navy officials want standardization, for one reason, so that in case of another war it would be easier to assemble sets from apparatus already existing (this having been standardized) than to design and make completely new sets.

We can well imagine that the buyer of apparatus for a large department store would appreciate standardization of the most thorough kind—he would undoubtedly like to purchase sets on the basis of, say \$25 per hundred miles of guaranteed reception. If then the purchaser couldn't hear distinctly a station one thousand miles away with a set which he had purchased for \$250, woe betide the manufacturer of the set! But let it be said once for all—such standardization as this in the radio game is impossible. The degree of skill of the operator and the atmospheric conditions count so much that guarantees of distance are practically meaningless. For example, with certain apparatus Espenschied in 1915 picked up a telephone conversation from Arlington 5,000

miles away. If the same apparatus had been in the hands of some one having the same ability as the average purchaser of radio equipment to-day, it probably would not have proved successful for 1,000 mile reception, much less 5,000 miles. The variability in behaviour of a set, of course, increases generally with the number of tubes and adjustments used so that it would be inadvisable for a manufacturer to guarantee any but possibly crystal sets, or tube sets having no regeneration, on a mileage basis. Such receiving apparatus may be standardized for distance within reasonable limits. A regenerative set, on the other hand, or one having radio frequency amplification of the ordinary variety, requires a certain amount of skill and knowledge of the functioning of the different parts of the circuit to get the best results, and the difference in reception distance may easily be five to one for the same apparatus, used on different antennas by different operators.

There are certain features of the radio game, however, that can well be put on a more reliable basis than they are to-day. We refer to the actual electrical characteristics of the parts of a set. Coils, condensers, resistances, telephone receivers and tubes—that's about all there is of importance in a radio receiving set. Can these be standardized with benefit to the radio public? The answer is certainly Yes, if we mean by standardization the certification of the

electrical constants of the apparatus. As regards the mechanical features of the device—ruggedness, accessibility, durability, etc.—the purchaser can use his own judgment, as he does when he buys a lawn mower or dish-washing machine, but the electrical constants of a coil or condenser cannot be estimated even by an expert, so they should be certified just as they are in any other branch of the electrical industry. If we want an incandescent lamp to use 50 watts on a 110-volt circuit, we can buy a lamp which will have these characteristics within several per cent. If we want a one-half horse-power motor to run 1,800 revolutions a minute on a 220-volt line, we can buy just such a motor, guaranteed by the manufacturer to perform as we specify.

Can we buy radio apparatus which has its electrical constants thus guaranteed? In most instances, most assuredly not. Could it be done, to a reasonable degree of accuracy, without increasing the selling price appreciably? It could. Hence here is a field where standardization and guarantees may reasonably be expected and they should be called for by any body that takes upon itself the task of starting standardization in the radio field.

The most flagrant case of non-standardization to-day is in the matter of condensers. A condenser is supposed to have a certain electrical capacity, just as a gallon jar is supposed to hold a certain amount of liquid. A condenser should be sold with a guaranteed capacity, yet it is generally sold to-day by the number of plates—a 23-plate condenser or a 43-plate condenser. A more absurd specification was never heard of. It makes us think of a certain radio editor who, in his descriptions, continually gives the number of turns in a coil to be used in a radio set and never mentions the diameter of the turns! He evidently doesn't know that the diameter of a coil makes a difference in its electrical behavior. Two novices, building radio sets from the same description, use, we will say, 23-plate condensers, as the specification calls for. One uses A's 23-plate condenser and the other uses B's 23-plate condenser and their sets may differ in wavelength range by one hundred meters, because of the difference in the two condensers. One buys the .0008-mfd. kind and the other buys the .001-mfd. kind, and they are both 23-plate condensers. *Condensers must be sold with a guaranteed capacity—that's the first step any standardizing body should take.*

A coil used in a radio set enables the tuning of certain stations because it has a certain amount of inductance, yet coils are practically never sold with a guaranteed inductance. One variometer on the market may have an inductance of 800 micro-henries and another 1,500 micro-henries, yet both are sold by the clerk, and bought by the customer, as being electrically equivalent. Coils should be sold with a guaranteed inductance, and this should be marked on the device, just as the capacity should be marked.

The excellence of either coil or condenser, in so far as its electrical behavior is concerned, depends upon how low the electrical losses are, when used for receiving a signal; the lower these losses the sharper is the tuning and the louder is the signal. The electrical expert knows that a device should have a low effective resistance if it is to function well, and the easiest way of covering this point in specifications is to call for the power factor of the device. This should be as low as possible. The guarantee of power factor, at various wavelengths, will require a higher grade of technical skill than is generally available in the small companies but it should be called for nevertheless. Practically no electrical company to-day is selling motors, transformers, and other devices without guaranteeing their efficiency, and the power factor of a coil or condenser is a measure of its efficiency as a component part of a radio set.

At a meeting of the representatives of nearly all branches of the radio art held recently, it was voted to have the Institute of Radio Engineers and the American Institute of Electrical Engineers act as sponsors for getting together a committee on standardization, and its decisions will undoubtedly clear up some of the points mentioned above. As the decisions of such a committee must have great weight in guiding future radio development, it is well that the scheme for organizing the committee was so propitiously chosen and that the functioning of the committee has been so specified that its actions will be thoroughly reviewed and passed upon by the sponsor societies before being accepted as recommendations for practice. The technically trained members of these two engineering societies well know the deterrent effects of too much standardization in an art growing as rapidly as is radio and will see to it that only conservative, well conceived, steps along the line of standardization are taken.



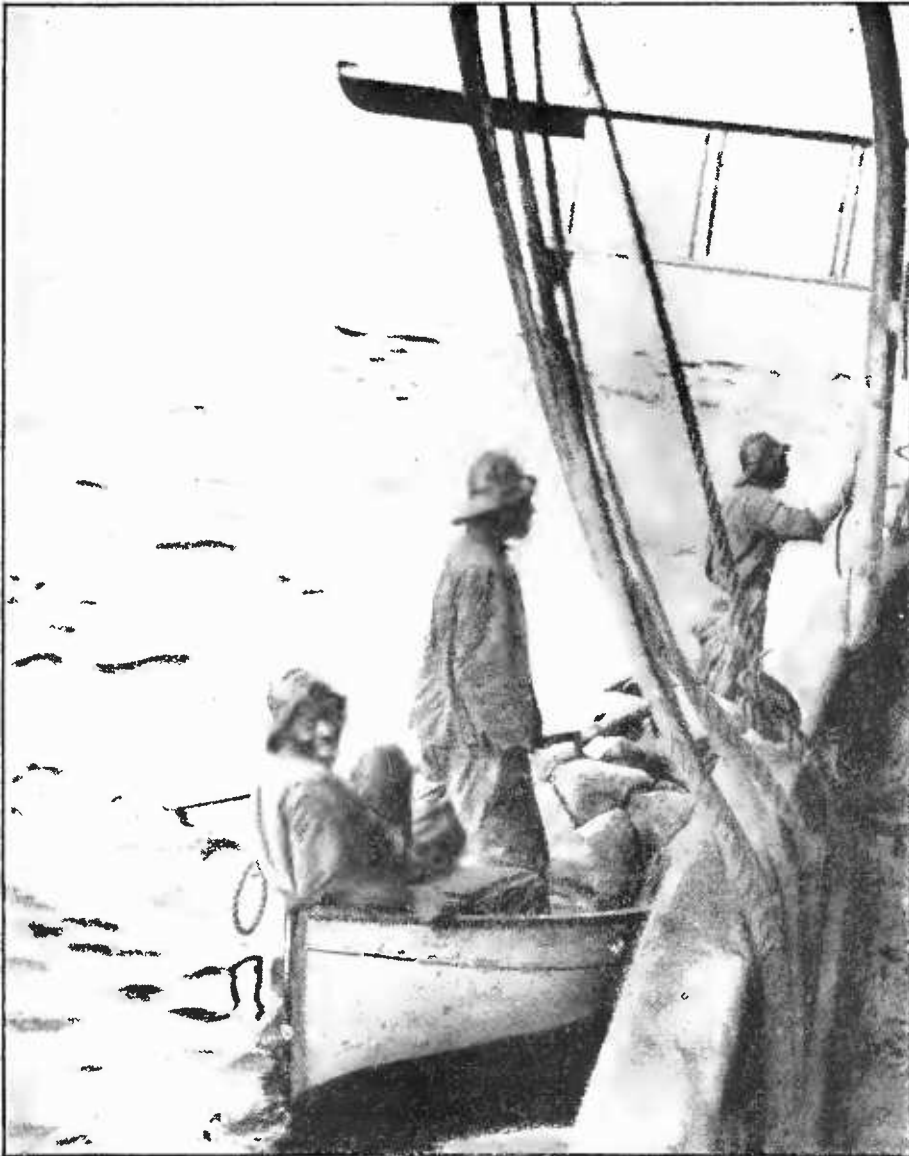

© Pacific and Atlantic Photos

#### QUENCHING THE GREAT AMERICAN THIRST

Liquor is smuggled from the Bahamas to our own shores via schooner, dory, and airplane, and radio is used to arrange meetings between the ships and those whose task it is to get the contraband ashore. This picture was taken just outside the three-mile limit off the Long Island coast by one of the men who has adopted bootlegging as a "calling." The seaplane, which has its berth in one of the inlets along the coast, flies out, takes on its cargo and returns under cover of darkness. The dory here shown, laden to capacity with bottles of high alcoholic content, and handled by Bahaman natives, is about to leave the side of the rum-runner for the seaplane, the wings of which can be seen in the background

#### The Necessity for Accurate Wavelength Standards

ON SEVERAL occasions recently, the public, or at least the radio portion of it, has been severely scored by the trained radio engineers because of the complaints regarding interference between broadcasting stations—interference which might be avoided if the public knew more about radio technique. There are two methods by which

information on, and skill in, the adjustment of apparatus can be acquired by the public. Elementary books on radio, and the radio articles in the daily press should keep the listener sufficiently well informed so that he may know theoretically how to avoid interference when it is possible to do so; and the actual manipulation of his set, intelligently carried out, should soon show him when the theoretical results can be attained, and when they cannot. Now, before delivering reprimands to the public, the radio engineer would do well to consider the reliability of these two sources of knowledge.

We recently heard one of the newspaper radio editors deliver a broadcast talk in which he made the statement that a vacuum tube had been constructed which could deliver one million kilowatts of energy. What he really meant was power, not energy, and in his enthusiasm for making striking statements he forgot the difference between a watt and a kilowatt—if he ever knew it. In one of his recent articles on new circuits, a diagram was given of a circuit highly recommended to his readers, in which the only way the electrons could get from the

plate back to the filament was by jumping across a condenser. As long as such material as this is served up for the education of the public it cannot be expected that an understanding of interference will be soon reached.

Another matter which is the cause of much confusion to those whose knowledge of radio is not sufficient to permit an intelligent discrimination in what they accept and reject, is the subject of wavelengths of the various broadcasting stations. These are given in govern-

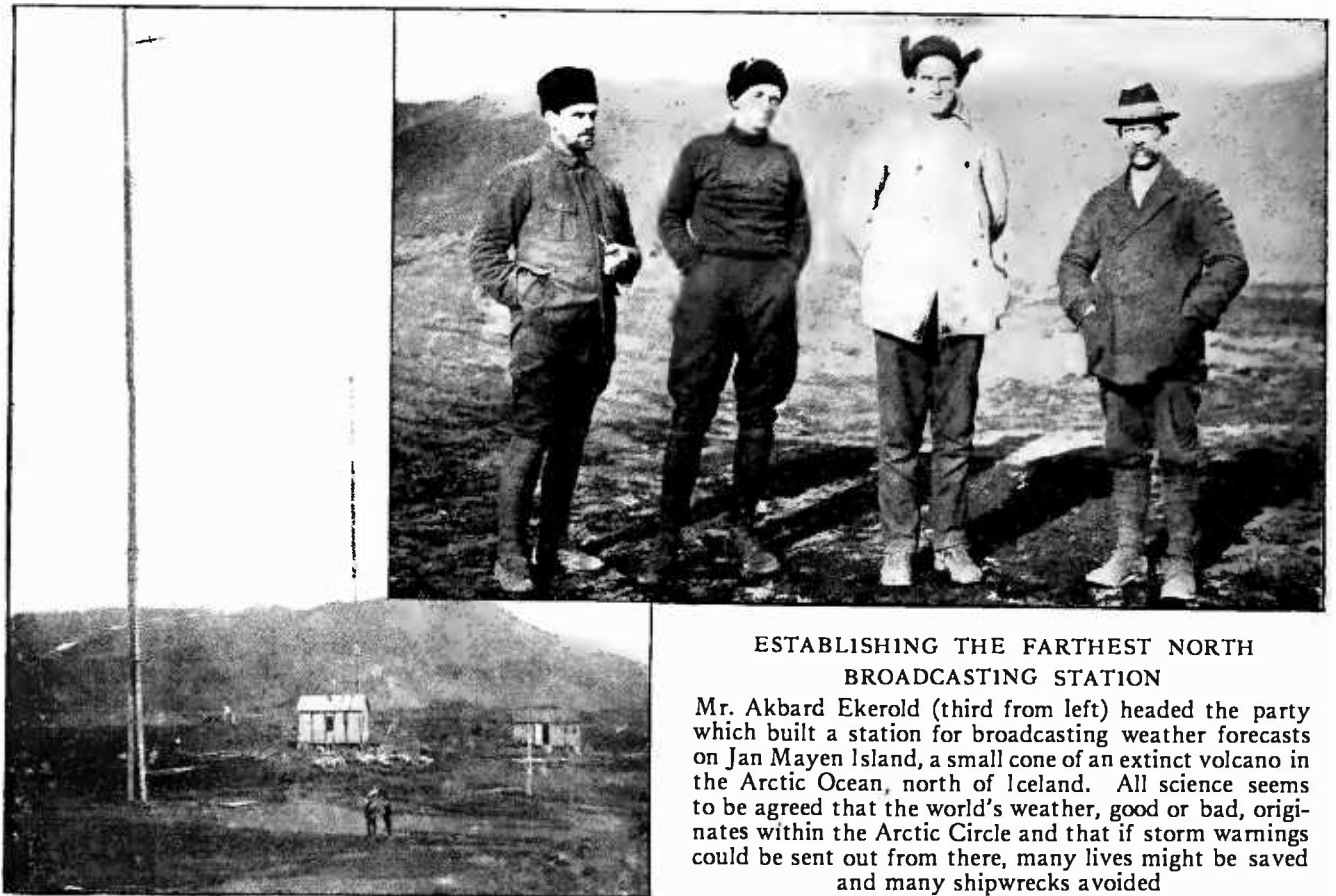

#### ESTABLISHING THE FARTHEST NORTH BROADCASTING STATION

Mr. Akbard Ekerold (third from left) headed the party which built a station for broadcasting weather forecasts on Jan Mayen Island, a small cone of an extinct volcano in the Arctic Ocean, north of Iceland. All science seems to be agreed that the world's weather, good or bad, originates within the Arctic Circle and that if storm warnings could be sent out from there, many lives might be saved and many shipwrecks avoided.

The picture at the left shows the station which has been established in the desolate Arctic territory. Mr. Ekerold now proposes to put up three other stations in the far North, with which he believes the weather forecasting of the world can be broadcasted daily.

ment bulletins as either 360 or 400 meters; in the press an occasional station is advertised as 370 meters, or 403 meters, etc. The fact is that very few of these stations actually transmit on their advertised wavelength—if they did it would be impossible to hear both of them at once as we actually can do to-day. Of two well-known stations, A is advertised as being on 400 meters and B on 403 meters yet B tunes in with less capacity in the receiving circuit than is required for A! How can it be expected that the layman will gain a knowledge of radio by study of the action of his set when such anomalies exist.

It is time wavelengths were somewhat more significant than they are to-day. The question is a simple technical one and could easily be remedied. The standardization of wavelengths throughout the country should be attacked at once by some such representative and capable organization as the Bureau of Standards; it is realized that the Bureau has but a small staff and they are overloaded with work, but it seems that this question is of enough importance to warrant putting aside other work if necessary. If the broadcasting stations actually transmitted on their specified wavelengths, receivers could easily be calibrated for

wavelength when they are installed. Such calibration is generally impossible until the set is in place and connected to its antenna. Let us hope that it will soon be impossible for a listener to tune a 403-meter station with less capacity than he uses for a 400-meter station. Then the public may have a fair chance to learn the elements of radio by observing the action of their sets.

This standardization of wavelengths is a familiar idea to those who worked with the Signal Corps in France. The military service was so crowded with signals that it was necessary to use channels separated by only ten meters. With the present accuracy of our broadcasting stations this would be impossible—a station would not only be out of its own proper channel but in that of some other station. During the war, standard signals were sent out from Eiffel Tower periodically, on specified wavelengths and the various radio experts of the army used these signals for calibrating their wave-meters. By this scheme they were able to maintain their communica-

tion system with a minimum of interference in spite of the very narrow band of waves allowed for each channel.

### England Tells About Hearing WJZ

THE following letter and a newspaper clipping, describing an American broadcasting programme heard in England, and throwing some interesting sidelights on the English reaction to our after-dinner speakers, have been received by the Editor. The programme mentioned has been verified as that of the Radio Corporation—Westinghouse station at Newark, N. J., on January 19th.

Derby Wireless Club, Eng.,  
22nd January, 1923.

DEAR SIR:

I gather that you welcome communications from wireless amateurs, so I think you may be amused at enclosed cutting from the Derby *Daily Express* of 20th January.

Possibly the station may have been WJZ and not WJD, as I think you pronounce Z as "zee" and not as "zed" as we do over here.

Anyway if you could identify the station we should be pleased to know which it was, and we should much like a list of call signs of your broadcasting stations so that we could endeavor to track them down.

The banquet referred to in the article was probably in a marble hall devoid of carpets and curtains—judging by the resonant quality of the voices—and we noted an entire absence of the popping of corks!

I am,

Yours truly,  
S. GRIMWOOD TAYLOR.

Here is the clipping, in full:

#### LISTENING-IN TO AMERICA

Some interesting experiments were carried out locally last evening, or rather during the early hours of this morning, using different types of circuits. An American broadcasting station was soon picked up, calling itself WJD (or possibly WJP or WJB), sending out Tannhauser on the organ, followed by selections from Mendelssohn, with some preliminary explanation by the wireless director. After half an hour of this—and it must be allowed the organ was magnificent—a gentleman who had just returned from the Ruhr, a Mr. Abbott, proceeded to tell America all about it. He referred specially to the withdrawal of the American troops and dwelt volubly on the moral superiority of the American nation, and said what good Samaritans they were. He spoke for about half an hour, and was most useful for testing purposes, and then we were switched on

to after-dinner speeches at a banquet of leading educational authorities. The principal of the University of Iowa appeared to be presiding, and reference was made to the head of Michigan University, who received some applause.\* The first speaker had obviously the gift of fluency, and indulged himself in some rather florid oratory. The next was a more typical American after-dinner style of speech. The speaker laughed at his own jokes, and everybody laughed with him, until he unexpectedly dropped into a serious vein and declared that money isn't everything. A dismal silence followed on a ridiculous sentiment of this kind. Perhaps they were all thinking of Mr. Baldwin, or else their darling dollars.

By this time, it was 2.30 A. M., and the experiments were discontinued. It is, however, a novel experience, listening-in to after-dinner speeches in New York.

The aerial used was a single wire one, running north and south—about as unsuitable as possible for the test. The circuits comprised the well-known local capacity-resistance 3-valve amplifier, a tuned-anode high frequency two-valve set, a high frequency transformer, and a double note magnifier, with arrangements for switching in whichever circuit was desired. One of the orators was loud enough to be faintly heard on a "loud speaker." He wound up with a beautiful peroration exhorting his hearers to carry their responsibilities in all sobermindedness, and to do their utmost to re-establish a unified American ideal. The applause following this was quite as loud as what Mme. Melba received at Covent Garden the other night.

### Locating Mineral Deposits and Communicating Through Earth

THE technical press has frequently mentioned the possibility of locating ore by radio waves, either by sending radio waves through the ore body and measuring the absorption, or by reflection from the ore body. Some capable and enthusiastic experimenters are putting all their efforts into the investigation of the feasibility of this scheme and it seems likely that radio will soon be performing valuable service for the mining geologist.

The Bureau of Mines is interested in another phase of underground radio, as an adjunct to their other schemes for life saving, when accidents occur which shut the miners off from ordinary outside communication. In connection

\*The announcement of this programme was published in New York papers on January 19th as follows:

7:30 P. M.—Estey organ recital from the Estey Auditorium, New York. 8:30 P. M.—Literary programme. 9:00 P. M.—After-dinner speeches at the Western College Conference, Hotel Astor.

with some of the engineers of the Westinghouse Electric and Manufacturing Company, experts of the Bureau of Mines have found that the radio waves do penetrate through perhaps one hundred feet of cover and it is quite possible that they will find it feasible to communicate through several times this distance when the best wavelength has been found and suitable receiving amplifiers are used. We know that signals penetrate sea water about one hundred feet before being attenuated beyond recovery and it seems that penetration in ordinary earth should be greater than in sea water which is a fairly good conductor. Because of the comparative absence of atmospheric disturbances it should be possible to use greater amplification than is advisable with the ordinary antenna reception.

### Eliminating the Carrier Wave

**I**N THE ordinary radio telephone transmission, the antenna is excited by a wave of a certain frequency, e. g., 1,000,000 cycles a second for a 300-meter wave. When the microphone is idle, this frequency is radiated from the antenna with no variation of amplitude. This is the frequency which gives the whistling note when received by an oscillating tube detector.

When the microphone is actuated by the sound waves of the voice the amplitude of this 1,000,000-cycle wave is varied in accordance with the voice wave and this variation of amplitude occurs periodically, say 500 times a second for an upper C note. This variation of amplitude of the 1,000,000-cycle current is equivalent to sending out from the antenna a 1,000,000 radiation plus two other frequencies, 1,000,500 and 999,500 cycles. If the musical note varies in pitch, these two latter frequencies spread out into a band, e. g., the upper might be from 1,001,000 to 1,000,100 and the lower from 999,900 to 999,000 cycles per second. These are called the side-band frequencies and the 1,000,000-cycle wave is called the carrier. Ordinary radio telephone transmission sends out all three, the two side bands and the carrier, and these recombine in the detector circuit to give the original musical note.

In the recent tests by the American Telegraph and Telephone Company in which speech was successfully carried across the Atlantic, not as a stunt but as a commercially justifiable proposition, the casual listener-in received nothing but a jumble of sounds. A set, built

to receive the usual broadcasts perfectly, would yield nothing intelligible in these tests. The engineers responsible for the development had decided to transmit only one side band, suppressing altogether the other one and the carrier. Now, one side band by itself is unintelligible. It is not necessary to have both side bands for successful speech, it is only necessary to have the carrier in addition to one side band, in order to get sounds which can be understood. The trick in this transmission is to put the carrier frequency back into the signal at the receiving station so that although it has not come the two thousand or more miles traversed by the signal, in so far as the detector tube is concerned, its action is just the same as though it had. This scheme of not sending the carrier wave along with the signal saves about 50 per cent. in the capacity of the transmitting tubes required.

In listening to this one side band radio transmission it is therefore necessary to have at the receiving station besides the ordinary tube receiving set, a small oscillating tube set; this oscillating set is made to generate a frequency just equal to that of the carrier frequency at the transmitting station and to feed into the receiving antenna just sufficient of this carrier frequency so that the signal which gets to the detector is just the same as though the carrier frequency had been sent across the ocean with the side band. Nothing if not ingenious!

### A Suggestion for Announcers

**M**ANY of our correspondents join in a suggestion which we think well worth bringing to the attention of station managers; it has to do with the announcing of the call letters of the station just before and after broadcasting. One correspondent mentions the fact that many, if not most, radio enthusiasts are more interested in picking up a distant station, even if faint, than in listening to even a good programme from a near-by station. Although some believe this phase of radio will gradually be subordinated to reliable entertainment from the nearest high-grade station, while there are so many listeners straining their ears to catch the station 2,000 miles away their interests must be cared for. Our correspondent writes:

We have all had the experience of listening patiently through some long-winded speech or unin-

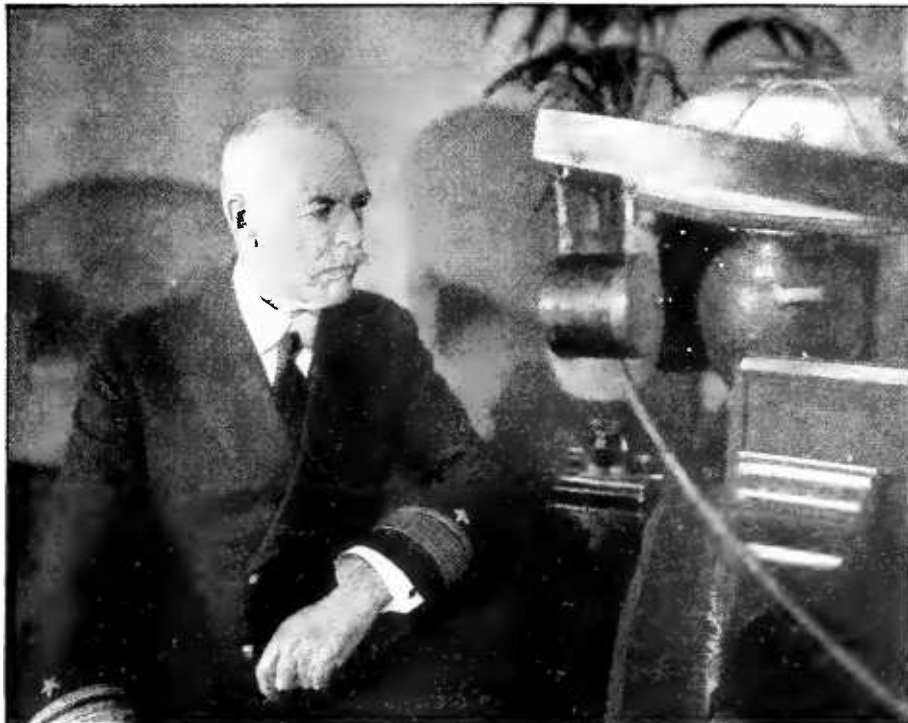

REAR ADMIRAL C. P. PLUNKETT, U. S. N.

Through whose courtesy a series of monthly concerts is being broadcasted from station NAH at the Brooklyn Navy Yard. The station operates on a wavelength of 507 meters. Admiral Plunkett is here shown at WJZ, Newark, N. J.

teresting musical number, waiting for the announcement of the station call which we hope will be forthcoming, but we are often disappointed in this respect and find that before the announcement is made the station has faded or local interference has arisen. It would help very much if all stations would give their call letters and location immediately after each selection, as some stations do now.

We think the idea a good one and hope the managers will pay heed to it.

### Directional Effects

**B**Y COMPARING notes, radio enthusiasts find that, contrary to what ordinary theory teaches, the waves do not travel outward in all directions from a transmitting station with equal intensity. Until many observations, by different experimenters, had been obtained, it seemed possible that the skill of the various operators might account for apparent discrepancies in the distance a given station could reach. Thus station ABC might be heard consistently by a listener 1,000 miles west of a certain position and practically never by a listener 200 miles east or south. Such an effect was at first attributed to the greater skill of the first listener, or superior apparatus, but by comparing many observations, by many

observers, we now know that stations do not penetrate equally well in all directions and an apparently simple explanation is at hand.

It has been known for some time that a mountain range of conducting material, such as iron ore, acts as a rather effective screen for radio waves, and, of course, theory would predict just such an occurrence. Thus it is often impossible for two ships on opposite sides of a mountainous island to communicate with each other when both are close to the island, but if they each steam away in opposite directions, say 100 miles, communication becomes easy. The mountain range casts a radio shadow, the conducting ore

bodies of the mountain range absorbing the radiation which tries to penetrate them. In a similar manner any ordinary body casts a light shadow, either because it absorbs the light which tries to penetrate it, or reflects it.

It seems also that in a city of tall iron-frame buildings such as New York, a large part of the power radiated from the antenna of a station is absorbed within a few miles of the station. The conducting framework of the buildings have currents set up in them by the traveling waves and these currents represent just so much energy abstracted from the radio waves. The effect is much like that which would occur in trying to set up waves in water filled with floating sea weed; the ripples are able to advance only a short distance through the weed-filled water before their energy is completely used up and they disappear, whereas if set up in clear water with no floating obstructions they might travel several hundred feet.

A modern steel-building city seems to act toward the radio waves just as a patch of seaweed does to the water waves. Because of this effect, it may well be that a station located, let us say, in the western part of such a city, is heard at points a thousand miles west and only a hundred miles or so in the easterly direction. The eastward traveling waves have to travel

over the city and have much of their energy abstracted before they have gone very far. We have heard of a geologist being consulted as to the best place to sink a well for oil; he looks the ground over thoroughly, makes borings, etc., and then gives an intelligent guess as to where the best chances lie. In locating a broadcasting station in or near a large city (as all good stations must be located for accessibility to the performers), it seems that similar expert advice will be required in order to place the station so that minimum absorption will occur in the important directions.

### How the British Do It

**I**N VIEW of the remarkable activities of our amateurs during the last ten or fifteen years and of the country-wide interest and participation in the recent broadcasting developments, it would be natural for us to jump to the conclusion that the other countries can offer us no suggestions in this field which merit our attention. But such is not the case.

It seems to us that the wholesale licensing of broadcasting stations, only a few of which will be able to send out programmes of reasonable technical and artistic quality, is storing up trouble for us in the near future, when it is attempted to get rid of the mess of interference which exists to-day. Our British cousins are apparently cognizant of such a possible trouble and are therefore going to license but few broadcasting stations, each of which will be carefully regulated as to wavelength. But in the matter of receiving stations they have taken a step which, while putting a few difficulties in the way of the manufacturer, will eliminate the source of much of our present trouble—receiving sets which generate oscillations in the antenna.

All receiving sets put on the market in Great Britain must be approved by the Post Office authorities, and before their approval is bestowed, certain regulations must be complied with. The sets must be able to receive any wavelength in the broadcast band, 350 to 425 meters, with an antenna of any length between thirty and one hundred feet; sets must also be so built that it is difficult to change the connections without unsoldering joints (that wouldn't stop the average American boy very long!) and some other similar requirements. But most important among the requirements are those having to do with sets having regenerative

features. No set will have the approval of the Post Office if it can be made to set up oscillations in the antenna; it will be tested under all reasonable conditions with extra plate voltage, extra filament current, etc.—and if oscillations are set up in the antenna, the apparatus is to be condemned.

Shouldn't we have erected, or at least tried to erect, this barrier against the interference of oscillating receivers? It might mean more expense for the enthusiast who wants to receive continuous-wave telegraph signals, but the slight inconvenience to a few would be more than offset by the resulting freedom from interference of this kind. This restriction does not mean that the remarkable improvement in reception which regeneration makes possible could not be utilized in our receiving sets, but the regenerative feature would have to be applied in a circuit not directly coupled to the antenna.

### High Tension Wires Transmit the Voice

**T**HE idea of sending the voice over wires by using modulated high-frequency currents is apparently to be the subject of legal action between General Squier and the Western Electric Company, but even though the priority of the idea is in question its application keeps right on growing. The method is actually used by the telephone company in some of its trunk lines, where it goes by the name of "carrier telephony." General Squier calls it "wired wireless."

Within the last few years electric power companies have been attempting to use wired wireless as an extra link in the communication system connecting their various stations and substations. Especially in case of storms is it necessary that the various parts of the power system be closely coordinated and on just such an occasion is it likely that the overhead telephone wires may be down. So, partly to reduce telephone expense, but principally with the idea of assuring the continuity of communication, the effort has been made to send the weak high-frequency carrier currents over the same wires as those carrying the powerful high-voltage currents for operating railways and lighting systems.

Reasonable success has attended the experiments. Recently the General Electric Company announced the satisfactory operation of such an installation through forty miles of

70,000-volt transmission line. The modulated high-frequency current, generated by a 50-watt triode transmitter is supplied to a wire about a thousand feet long which is strung underneath the transmission line wires, at a safe distance. Sufficient power is thus sent into the high-voltage wires, by induction, to send the current along the wires, and a similar arrangement—a “pick-up” wire—at the receiving station enables the operator to receive the signal without danger of shock from the high-voltage lines. No trouble from fading or atmospheric disturbances is encountered and no government rules restrict the application of this idea. Thus the scheme seems likely to win an important place in the field of communication. The only feature which had to be worked out for this application of carrier telephony was the connection of the transmitting and receiving apparatus to the power wires of very high voltage without danger of shock to the operators.

### Radio in South American Politics

OUR politicians would do well to turn their eyes southward when laying plans for their next campaign. Of course there must be uppermost in their minds the question as to how radio may best serve their candidate. During the last elections a start was made in the use of radio for campaigning, and we were able to sit comfortably at home and listen to the various candidates extol their own virtues. But the managers who sent their candidates to the broadcasting stations for a few evenings, and were content with that, should read of the exploit of the Colorado party of Uruguay.

A broadcasting station of considerable power has been installed at Montevideo, we learn through a communication from our consul there. This station was rented by the management of the Colorado party—rented for the whole period up to election day. It naturally follows that their opponents didn't profit much by the

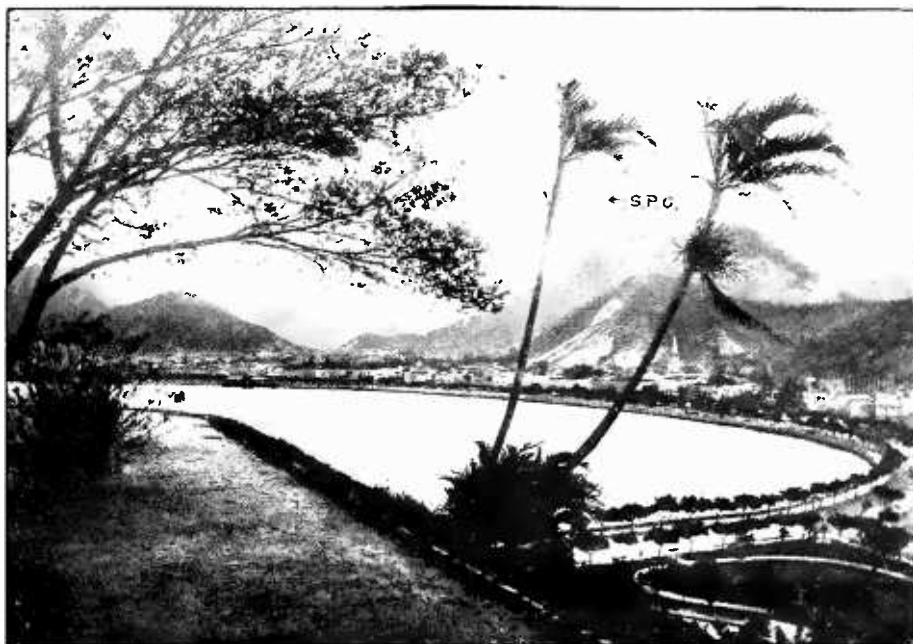

### BROADCASTING IN A DRAMATIC SETTING

On top of the peak which rises precipitously above the city of Rio de Janeiro is station SPC, erected by the Westinghouse Company and used for broadcasting the Rio operas and other entertainment during the exposition

messages which were sent out and as this is the only radio station in Uruguay it seems that there the ether played a rather more biased rôle than we have ordinarily assigned to it. It would be interesting to know how much of a part radio plays in our elections, but we shall never find out unless each of the parties will voluntarily desist from using radio propaganda every other election, for instance. If each party could have the sole control of the broadcasting on alternate elections we might be able to evaluate radio as a political asset—but the politicians probably will not agree to try the experiment.

### Receiving with Horizontal Loops

ONE of the anomalies encountered by the student who tries to bring into agreement the theory and practice of radio transmission occurs in connection with the loop antenna; according to the generally accepted views of radio waves a loop must be placed vertically if it is to pick the energy out of the advancing waves. Yet dwellers in apartment houses who have recourse to loops (to avoid a conflict with the landlord which is likely to occur when the subject of antennas on the roof is mentioned) find that a horizontal loop receives about as well as does a vertical one.

The reason is undoubtedly to be found in the action of the steel framework of the building; this itself acts as a receiving antenna, picking up appreciable energy from the signal waves as suggested above in discussing the directional effects of stations. These currents in the steel framework flow in haphazard directions and are as likely to affect a horizontal loop as a vertical one.

That such effects do occur in steel frame buildings is seen when the attempt is made to get directional data on stations by using a loop in a steel building. The direction of a station is seldom obtained correctly, and often no directional effect at all can be found. In no position will the coil yield zero signal and there is no appreciable maximum, regardless of the direction in which the coil is turned.

### What Broadcasting Regulation is in Store for Us

UPON the passing of the White Bill we are likely to find a marked tendency toward suggestions for altering the scheme of broadcasting wavelengths and schedules. Many of these suggestions will come from those who make and sell some particular kind of receiver or who have some other axe to grind.

Properly arranged, we feel that the wave bands suggested by Secretary Hoover's committee would work out satisfactorily if good receivers are used. Reviewing the recommendations of this committee, we find broadcasting wavelengths treated in the following manner:

Government and public broadcasting . . .	1050-1500 meters
Government and public broadcasting, 700 miles inland . . .	700-750 meters
Private and toll broadcasting . . .	310-435 meters
City and State public safety broadcasting .	275-285 meters

Further along, we find the terms described in this manner:

"Broadcasting" signifies transmission to an unlimited number of receiving stations without charge at the receiving end. It includes:

1. *Government Broadcasting*, signifying broadcasting by departments of the Federal Government;

2. *Public Broadcasting*, signifying broadcasting from public institutions, including state governments, political subdivisions thereof, and universities and such others as may be licensed for the purpose of disseminating informational and educational service;

3. *Private Broadcasting* signifying broadcasting by the owner of a station, as a communication company, a store, a newspaper, or such other private or public organization or person as may be licensed for the purpose of disseminating news, entertainment and other service, and

4. *Toll Broadcasting* signifying broadcasting by a public service radio telephone company as a paid service.

Some few months ago the National Radio Chamber of Commerce sent out a questionnaire to representative radio people throughout the country. The recipients were asked for their views on radio legislation and were told that a symposium would be arranged from their replies.

The Chamber reports a very hearty and wholesome response to the questionnaire and is working upon a report to be submitted to its members and forwarded to those who regulate such matters at our National Capital, as the Chamber's view of how the wavelength and similar matters should be handled. The findings in brief, are these:

The following requirements are urgently needed:

1. Reduction of interference between broadcasting stations.

2. A method for permitting three stations in a given district to operate simultaneously.

3. Broadcasting stations to arrange their schedules to include:

A. Technical or advanced music

B. Popular music

C. Educational features

Each of these classes to be on an individual wavelength in a given district.

4. Establishment of a silent period to permit long-distance reception.

By dividing the country up into districts, the size of the district depending upon the population; dividing the operating hours between the three stations in a district; arranging wavelengths, time periods, power and classes of broadcasting, it is thought that great relief from existing conditions may be brought about soon. Rotating of the time periods allotted each district should result in a fair division of time for the broadcasters and much more satisfaction for the listener-in.





“OUT-OF-THE-STUDIO” BROADCASTING IN THE JAPANESE CAPITAL  
The Viscount Shibusawa addressing a vast crowd in Hibiya Park, Tokio

The report points out that sharp tuning in a radio set is possible, but that a vast majority of the receiving equipment available now would not function satisfactorily, especially in the hands of an unskilled operator, unless the wavelengths of various stations were fairly well separated.

The amateur has not been disregarded in the matter of wavelengths, and it is quite likely that the immediate future will find him better off than he is at present.

If the proposed arrangements of the Chamber were followed, the value of the average receiving set would be increased some 300 per cent., while an even greater increase in value is promised for the set of more than average sensitivity.

From a study of both these plans, made by the Department of Commerce Conference on Radio Telephony and the National Radio Chamber of Commerce, it would seem as though the interference problem is anything but

an insurmountable one and relief from the present chaos should soon be at hand.

### Radio Again Serves in Its Most Important Rôle

FIRST and last the rôle for which radio is preëminently fitted is that of saving life at sea. The freighter *Montello* met with such terrific storms on her trip out from Philadelphia on her way to Marseilles that in mid-ocean it became necessary to abandon her. An SOS call, giving the location of the sinking vessel was picked up by the Italian liner *Guiseppe Verdi* and in half a day she had located the sinking ship and started the rescue work. Ultimately, she was able to save the entire crew. The life boats of the *Montello* had been smashed by the mountainous seas and it seems certain that all on board would have been lost, had it not been for radio.

J. H. M.

# There Are No Noisy B Batteries

By E. E. HORINE

National Carbon Company

THE appearance of the usual block type B battery is more suggestive of a paving brick than a fine musical instrument, yet in radio-telephony the B battery becomes one of the most versatile musical instruments known. On occasion, it reproduces perfectly the music of a violin, a French horn, or an entire symphony orchestra, for everything heard from a radio set, whether it be speech, or music, or code signals, proceeds directly from the B battery to the ear of the listener.

True, the immediate source of sound is the telephone receiver, or loud speaker. But these devices do not generate the sound; they merely serve to transform electrical energy into sound, much as the electric lamp transforms electrical energy into light. In the case of the lamp, the real source of light is the generator in the power station; with the telephone receiver, the actual source of sound is the B battery, for it supplies the current which operates the receiver.

The work done by the B battery in reproducing sound is rather complicated, and to get some idea of its nature, it will be necessary to touch lightly upon the subject of sound.

Sound is a wave motion, consisting of alternate layers of compressed and rarified air. Sound waves may be generated by any vibrating body. In radio receiving sets, they proceed from the vibrating diaphragm of the telephone receiver.

Each sound in nature has a wave-form which differs in shape from the wave-form of every other sound. These wave-forms are usually quite complex, and the difference between them is sometimes minute, but it is the tiny variations in the shape of the waves which enable the ear to distinguish between musical instruments, or to identify individuals by the sound of their voice.

When a sound wave strikes a diaphragm, the compressed layer of air pushes it in one direction, and the rarified layer pulls it back in the opposite direction. If the diaphragm is properly constructed, and is sensitive enough, its motions will follow accurately the wave-form of the sound.

The illustrations (Figs. 1 to 5) were made by recording the motions of such a diaphragm. The motion of the diaphragm is transferred by suitable mechanical devices to a small mirror, on which is concentrated a beam of light. As the mirror swings back and forth due to the motions of the diaphragm, the spot of light reflected from the tiny mirror also swings back and forth on a sensitive photographic film, which moves past the mirror at a uniform speed. The moving spot of light is thus made to trace on the film a permanent record of the sound wave. These records were made by Professor Dayton C. Miller in his laboratory at Case School of Applied Science, and will serve to illustrate the manner in which sound waves from various sources differ from each other.

Fig. 1 is a reproduction of the sound wave produced by a tuning fork vibrating 256 times a second (Middle C). This is an example of a pure tone, consisting as it does of the fundamental only. It is a pure sine curve, and is, perhaps, the simplest sound wave in nature.

The curve in Fig. 2 is somewhat similar to that of Fig. 1, but it will be observed that there is a series of overtones superimposed on the fundamental, appearing as minor ripples on the main curve. It is the number, amplitude and position of these overtones that give "quality" to the sound, and enable the ear to identify the instrument producing it. This particular record was made by a violin.

Fig. 3, was produced by a French horn. Here the overtones almost overshadow the fundamental, which accounts for the peculiar booming quality of the sound produced by this instrument.

Figs. 4 and 5 are records of the human voice. Both were made by the same individual, Fig. 4 being produced by the sound "ōō", and Fig. 5 by pronouncing the vowel "ēē".

These curves are comparatively simple, representing as they do a single sound proceeding from only one instrument or voice. The complexity of the curve which results from blending the individual wave-forms of seventy or more instruments all playing at once is simply beyond comprehension! And yet, if a

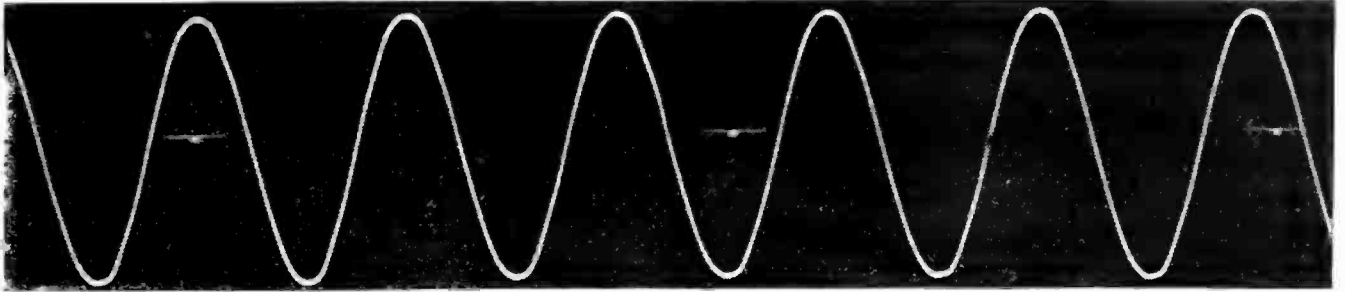

Fig. 1—Tuning fork

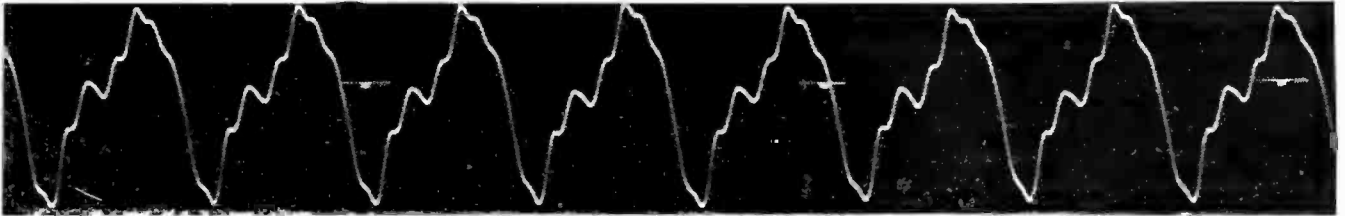

Fig. 2—Violin

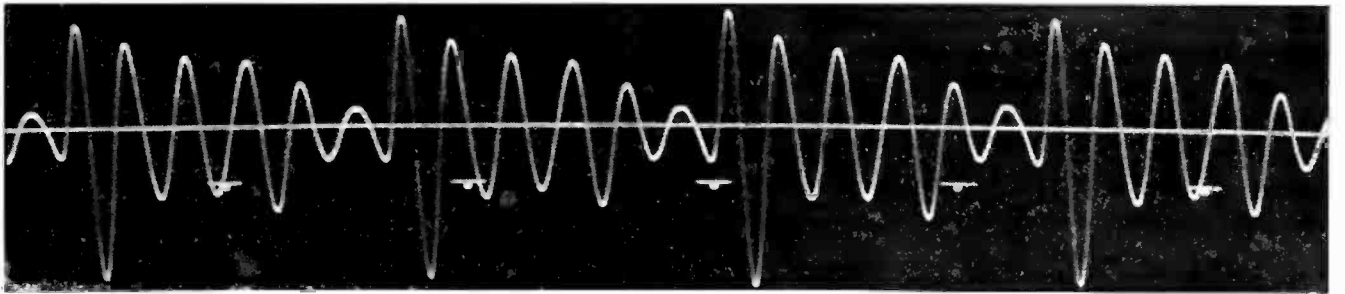

Fig. 3—French horn

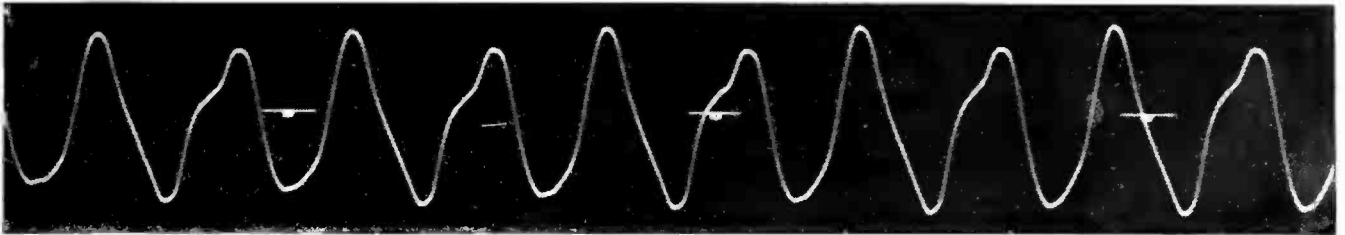

Fig. 4—Human voice, sound "oo"

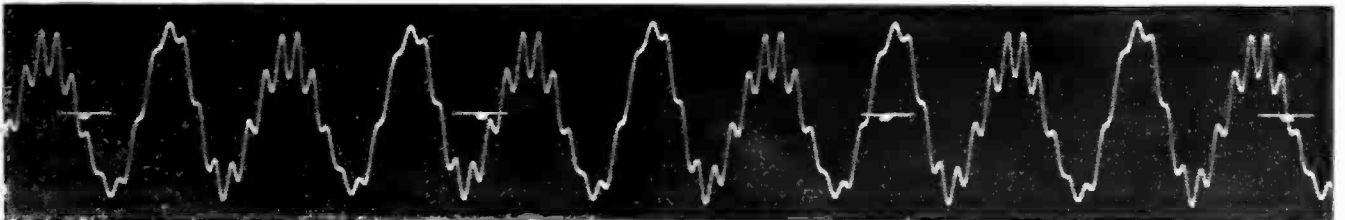

Fig. 5—Human voice, sound "ee"

## PHOTOGRAPHIC RECORDS OF SOUND WAVES

telephone receiver is to reproduce a symphony orchestra, its diaphragm must vibrate strictly in accordance with that unbelievably complex curve. It seems impossible that any man-made thing could do this, but the telephone receiver undoubtedly does, for the air is full of orchestra music every night, and any one possessed of a radio set can hear it.

To make a receiver diaphragm vibrate, it is necessary to furnish it a current which fluctu-

ates accurately in accordance with the waveform of the sound to be reproduced. While the curves shown in Fig. 1 to 5 are really photographs of sound waves, they might as well have been labeled "B Battery Current," for the two are identical.

It is characteristic of batteries in general that the current delivered by them is steady and free from all traces of fluctuations. There is no property in a battery itself which enables it to

establish fluctuations in its own current, hence some external device must be employed to change the steady battery current into a fluctuating one.

Fig. 6 illustrates an elementary method of accomplishing this result. As long as the handle of the rheostat is stationary, the current flowing in the circuit will be steady, and the receiver remains silent. By moving the handle back and forth from A to B the current is caused to vary in strength. When the current is strongest, the pull of the permanent magnet is increased, and the diaphragm is deflected to position b; when it is weakest, the attractive force of the magnet is diminished, and the diaphragm recedes to a. As the controller handle is moved back and forth, the diaphragm also moves back and forth, keeping step with the motions of the handle. If the motions are sufficiently rapid, the receiver will emit a note. It is conceivable that some one endowed with an extra amount of agility might be able to manipulate the handle in such a manner as to cause the current flowing in the circuit to assume the form shown in Fig. 2, in which case the sound emitted by the receiver would be a perfect reproduction of a violin. The act of setting up desired fluctuations in an otherwise steady current is called "modulation."

It is, of course, beyond the bounds of human ability to modulate the B battery current manually, as just outlined. In radio receiving sets, this function is performed by the vacuum tube.

Fig. 7 is exactly like Fig. 6, except that the

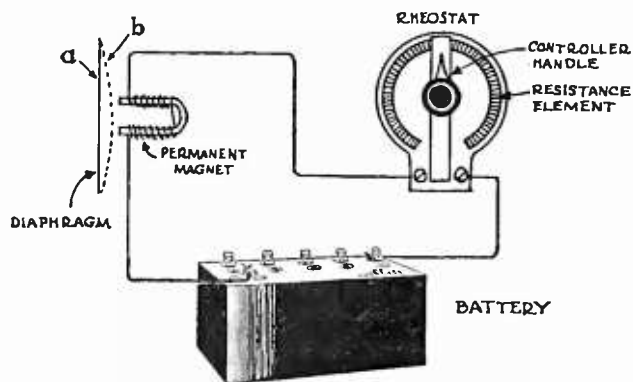

FIG. 6

Illustrating how the B battery causes the receiving diaphragm to vibrate and thus produce sound

rheostat is replaced by a vacuum tube. The space in the tube between the plate and the filament corresponds to the resistance element of the rheostat, and the grid becomes the controller handle. Under the action of the radio waves, the grid causes the resistance of

the tube to fluctuate, which results in corresponding fluctuations in the current drawn from the B battery, and since this same current also flows in the coils of the telephone receiver, the diaphragm is thrown into vibration, and thus the B battery energy is transformed into sound.

The ultimate purpose of the vacuum tube is to set up these desired fluctuations in B battery current. Unfortunately, however, there are occasionally other agencies at work which set up undesired fluctuations, and when this happens, the result is noise.

Noise in radio receiving sets is always the result of irregular, non-periodic fluctuations in B battery current, just as speech or music is the result of regular, accurately-controlled fluctuations. Noise is simply current fluctuations out of control, and anything which acts to introduce these outlaw fluctuations in the B battery current becomes a source of noise. *And just as it is necessary to resort to some device external to the battery to produce the desired fluctuations, it is also necessary to look for something outside the battery when seeking the cause of undesired fluctuations, or noise.*

A great deal has been said and written from time to time about noisy B batteries, and the impression is rather general that certain noises occasionally heard in radio sets are "battery noises." The arguments presented by the proponents of the noisy B battery, sound logical and convincing, especially to those possessing rudimentary knowledge of the chemistry of the battery; but to one who has thoroughly studied the subject, they are ridiculous.

The truth of the matter is, batteries are never noisy. It does not matter whether it is a dry B battery or a storage B battery (unless the storage battery is "gassing"); there is nothing in either type which could possibly make it noisy. Of course, if there is a loose or faulty connection anywhere in the battery, the connection may cause noise. A poor contact will do that anywhere in a radio set. But in a well designed, carefully constructed B battery the chances of poor connections are extremely remote.

It is probable that loose connections in the radio set account for most of the so-called battery noises. To produce noise in a radio set a contact does not have to be very poor; a joint which would be called perfect on a lighting circuit might easily be unfit in a radio set. It does not follow that because a joint

is soldered it is a good joint; it not only must be soldered, it must be well soldered. Some mysterious noises have been traced to the use of dissimilar metals in different parts of the radio circuit. Whether the noise was due to galvanic action between the metals, or to thermo-electric effects, cannot be said. But it was due to one of these causes.

Under certain circumstances the grid leak

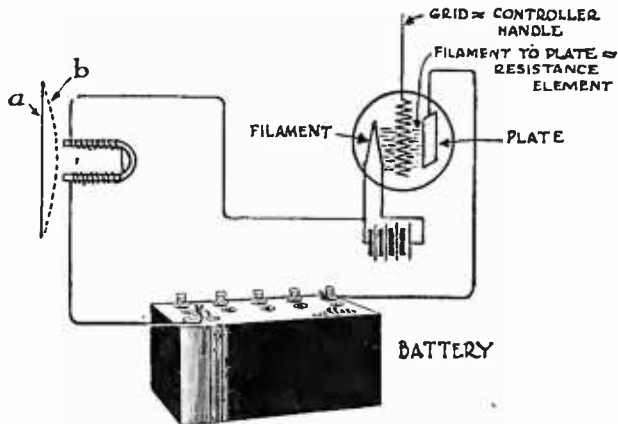

FIG. 7

Here the rheostat of Fig. 6 is replaced by a vacuum tube. When the resistance of the tube is made to fluctuate by incoming radio waves, the B battery current fluctuates correspondingly, producing sounds in the telephone receiver similar to those producing the incoming waves

may become a source of noise. Most leaks are constructed by drawing a line between terminals with India ink. Under the microscope, such a line reveals itself as myriads of tiny particles of carbon, loosely touching each other. Here are literally millions of loose contacts, and the worst part of it is, they are in the grid circuit, where even the tiniest fluctuation results in greatly magnified variations in B battery current.

Accumulations of dust on the plates of variable condensers can produce noise. There are four possible loose contacts in the average tube socket. Many a case of alleged B battery noise has been cured by pushing a tube down more firmly in its socket. The usual wire-wound filament rheostat presents another chance for loose connections. Varico-couplers and the variometers with brush connections to the moving element may become noise producers. The list is almost endless.

These things are listed as possible noise producers. It is not claimed that they invariably cause noise. If well designed and carefully made, they give satisfactory service. But the average radio enthusiast seems to think it possible to buy a thirty-cent article and get

two-dollar performance from it. And when he doesn't, nine times out of ten he blames the poor results on his B battery!

In addition to noises which can be traced directly to a loose contact in some form or other, there are at times other noises which are not so easily accounted for. The causes of these mysterious noises are not definitely known, but it has been observed that the tendency to produce noise is increased by sub-normal B battery voltages. This is why B batteries are believed to become noisy when nearly exhausted. Substituting a new battery for the old one will stop the noise, not because the old battery was noisy, but because this procedure restores the voltage to normal.

At present, it appears that certain of the so-called battery noises are due to some unknown peculiarity of receiving sets. The exact reason for these noises will probably be discovered in the course of future radio developments which may upset many of our present ideas. However, one thing is sure: future developments may revolutionize certain parts used in radio sets, but in doing so, they will surely bear out the statement, "There is no such thing as a noisy B battery".

The same thing was true of the telephone. In the early days when this remarkable instrument was first coming into general use, a great deal of trouble was encountered with what was then believed to be noisy batteries. Those old noises were exactly like the present-day "battery noises" encountered in radio sets, and everything pointed to the battery as the offender. Yet, as the telephone underwent its natural process of development and refinement, the battery noises ceased. And to-day, a noisy telephone battery is unheard of, although there are millions of dry cells in telephone service. To be sure, the telephone dry battery underwent a similar process of refinement, so that, to-day it possesses greatly increased capacity, and gives much more dependable service over longer periods, but nevertheless, chemically, it is the same dry battery of thirty years ago.

No one would have the temerity to say that present-day receiving sets are the final product. It is impossible to say what the ultimate set will be. But it is safe to predict that radio receiving apparatus will undergo the same process of development and refinement as did the telephone; and it is also safe to say that the result will be the same: it will eliminate the belief that the battery is a noise producer.

# What Good is a Patent?

What a Patent is, and is Not. How to Play the Game According to Hoyle

By ROGER SHERMAN HOAR, A. B., M. A., L. L. B.

Former Assistant Attorney General of Massachusetts

Decorations by RALPH MILNE FARLEY

**I**N ORDER that there may be no misunderstanding, let me state at the outset that it is not the object of this article to attempt to explain the present patent situation with respect to radio. That situation is pretty nearly in a hopeless chaos, a veritable de Forest of technicalities. The radio inventors are the boys who put the TNT in patent; so the best advice which I can give in this connection is never to blow down the muzzle of a radio patent, unless you are sure it isn't loaded.

But, seriously speaking, this situation is bound to rectify. In the meantime, the amateur experimenter ought to know just what his rights and duties are under the general patent law, and just what steps he should take for the future protection of any bright ideas which he may originate in the course of his experiments.

To what extent may an experimenter legally duplicate a patented device? Is it lawful to repair a patented machine oneself? What steps should an inventor take to protect an idea, so that he can eventually patent it, or at least so that some later inventor may not exclude him from the use of his own invention? How should one go about getting a patent, what will it cost, and how much good will it be when issued? These are but samples of the many legal questions which undoubtedly occur daily to many radio fans.

Do you remember how, when you first took up radio, you were mystified by the glib way

in which full-fledged fans juggled the following words: audion, audio frequency and radio frequency, capacity, counterpoise, dielectric, electron, filter, impedance, modulation, microfarad, potentiometer, super-regeneration, variocoupler, etc? Yet how simple they seem to you now! You are now equally mystified when a patent attorney learnedly mentions the terms: prior art, constructive reduction to

practice, and interference — which to you vaguely suggest painting, architecture, and radio, respectively, but otherwise mean absolutely nothing in your young life.

Yet patent law is A B C compared with radio. The object of the series of four articles of which this is the first is to explain the general principles and technical terms of this law, so that they can be digested by any intelligent person at one reading.

The great trouble with most inventors, engineers, and scientific experimenters—

the present reader, of course, excepted—is not that they fail to realize the need of some smattering of knowledge on this subject, but rather that they have absorbed much of the heterogeneous mass of popular superstition and misinformation which passes current for patent law.

As Josh Billings used to say: "What we don't know don't hurt us as much as knowing a lot of stuff that ain't so."

The most firmly entrenched erroneous idea concerns the very nature of patents themselves. Therefore it will be my first task to lay the

The author, a well-known writer on law and mechanics, is at present Head of the Patent Department of the Bucyrus Company, Milwaukee, Wisconsin. This article is the first of a series of four by Mr. Hoar, in which various angles of patent law will be simply explained.

In experimenting with radio you are likely to stumble on some peculiar and new arrangement of great value. By protecting your discovery properly, it may mean a great deal to you. Lacking this protection, a fortune may slip through your fingers.

Most experimenters know little of patent law, sometimes because they hesitate to plow through a mass of dull technicalities. But this series of articles, lightened by the author's humor, will make interesting reading for anyone.

Next month, Mr. Hoar will answer the question, "What Can Be Patented?"—THE EDITOR.

foundation for the rest of the series by explaining just what a patent is.

The Constitution of the United States empowers the Congress to "promote the Progress of Science and useful Arts, by securing for limited Times to Authors and Inventors the exclusive Right to their respective Writings and Discoveries." Pursuant to this power, the Congress on April 10, 1790 enacted our first patent statute, the terms of which have remained practically unchanged since 1870.

Under this law the Commissioner of Patents, after an investigation has satisfied him that the applicant is the original and first inventor of some new and useful improvement, will grant to the applicant a "patent," which will be good for seventeen years from the date of issuance.

The most important thing to realize about patents in general is that a patent is *not* a license to manufacture; in fact, most owners of patents cannot manufacture their own patented device without thereby infringing someone else's earlier patent.

To make this point more clear I shall employ a fictitious illustration, to which I shall often revert during succeeding articles of this series. Let us suppose that a Mr. Adam conceives of, and makes, the first desk ever known, and secures a patent on his broad basic idea. A few years later, along comes John Smith, with the bright conception of a desk with a round hole in the middle, and applies for a patent on *his* invention. If he can show that the hole serves some useful purpose, he has clearly made an improvement on the first invention; and, if his claims all mention the hole, his patent will issue without the examiner ever once mentioning the Adam device.

Let us now suppose that Smith, with his patent, goes to a furniture manufacturer to induce him to make such desks on a royalty basis.

"Are you sure that we are safe in going ahead?" asks the manufacturer.

"Here is my patent, guaranteeing us the right," replies Smith, "My case was so clear that the Patent Office did not cite a single patent against me."

So the royalty agreement is drawn up and executed, and the desks-with-the-hole are put on the market. But one day, to the surprise of the manufacturer, along comes Adam's lawyer, armed with an injunction prohibiting the making of any more desks.

"But, look here!" exclaims the manufac-



"I'LL INVENT SOMETHING YET! THE FIRST HUNDRED YEARS ARE THE HARDEST"

turer, "I own Smith's patent, which states in so many words that it grants him the exclusive right to make, use, and vend his invention throughout the United States."

"Ah!" replies the lawyer, "but Adam's patent grants *him* this same right with respect to *his* invention; and, as Adam's grant is earlier than Smith's, and broader than Smith's, Smith's patent is subject to Adam's prior rights."

There you have it in a nutshell, just why a patent does not guarantee to the owner the right to use his own invention, but merely guarantees to him the right to prevent others from using it. Adam, who invented the first desk, can keep any one else from making desks of any sort. Smith, who invented the desk-with-the-hole, can keep any one else from making *that sort* of a desk. He can keep even Adam from making desks-with-holes; but that fact does not entitle Smith himself to make them. Smith's only hope would be to offer to license Adam to make the improved desk, in return for a cross-license, entitling Smith to make his own invention himself!

Oh, how many heartbreaks would be spared, if the Patent Office would kindly add to the grant-words of a patent, the phrase "Subject however to any prior rights of others," for that

is the real intent and effect of every valid patent.

Please note that we have assumed that Smith's patent was valid. If so, its *validity* was in no way affected by the production of Adam's patent, though its value was greatly reduced. The grounds on which a duly issued patent may later be declared to be *invalid*, will be treated elsewhere in this series.

Having now seen what a patent is, namely merely a license to prevent others from using your invention, let us now consider just what



"YOU CAN'T MAKE DESKS WITH HOLES"

constitutes the infringement of a patent. There is a deal of misinformation current on this subject as well.

Infringement consists in the unauthorized making, using, or selling of the invention of another, during the life of his patent. And yet almost any one will give you the gratuitous misinformation that it is perfectly all right

for you to manufacture, and even to use a patented invention, provided that you don't sell it or otherwise make any money out of it. That this is incorrect is seen by reverting to the wording which occurs on the face of every patent stating that the government grants to the patentee "the exclusive right to make, use and vend the said invention throughout the United States and the Territories thereof."

But these words are not to be taken too literally, for the making of the patented invention for amusement or for scientific investigation, although technically an infringement, nevertheless cannot be prevented or made the basis of a suit. The reason for permitting scientific experimenting with an invention is that the object of the whole patent system is, as we have seen, "to promote the progress of science and useful arts." The reason for permitting a man to amuse himself with another's invention is probably based upon the legal maxim that "Courts refuse to bother about trifles."

There is, however, an exception to this right to make and use the device of another for pur-

poses of amusement: namely, that you cannot so use a patented game, toy, radio outfit, etc., for otherwise the whole object of patenting such an invention would be destroyed.

At all events, manufacture or use, for any other purpose than experiment or play, can be stopped by injunction, or made the basis of a suit for damages, or both. Making money out of the device, of course, takes the use effectively out of the experiment-or-play class, and *sale for any purpose* is an infringement.

Infringement is not avoided by the substitution of an equivalent for one of the elements of the invention. In determining the question of infringement, each claim of the patent is treated as though it were a separate patent; thus one claim may be held to be valid and infringed, another claim may be held invalid, and another claim may be held valid but not infringed, all in the same patent. To sell an element, knowing that it is to be used in assembling an infringement, is in itself a contributory infringement. So also is the selling of a machine, useful only in the production of infringements.

Right here comes in a very important point, which is generally overlooked, namely that the innocent purchaser of an infringing article can be enjoined from its use and can be sued for damages by the patentee. In fact, this is the means usually employed by manufacturers of patented articles in order to bring suit in a convenient jurisdiction against an infringing competitor. Furthermore, it is much more annoying to such a competitor to have its customers jumped on one by one, than it would be to have a single suit brought against itself.

So it would pay the radio fan to be very careful lest he get himself into trouble by buying some infringing piece of apparatus from some outlaw concern. And yet this question of infringement by an innocent purchaser is more of a practical, than a legal, one. In the first place, it is extremely unlikely that the owner of a patent is going to bother himself about such small-fry as individual users. In the second place, it would be bad business for the owner of a patent to antagonize a lot of potential customers. And in the third place, the infringing manufacturer, if he is at all reputable, is going to back up those to whom he has sold.

The following rather technical question sometimes arises, which can best be illustrated by reverting to the desk-with-the-hole. Suppose that either Adam (holding the basic desk pa-



tent) or Smith (holding the desk-with-the-hole patent) should sell you a desk-with-a-hole, and then should acquire the other patent. He could not, under the second patent, prevent you from using the desk which he had sold you under the first. A great many similar applications can be made of this principle of fairness, which applies equally well to licenses under one or more of a group of several patents.

And now suppose that you own a patented machine, legally bought by you from the patentee. To what extent can you repair it yourself without infringing the patent? Obviously you have the right to use it until worn out, and therefore you can repair it and substitute new parts for old, so long as you do not destroy the identity of the machine. You cannot legally, however, reconstruct or rebuild a worn-out patented machine. No general rule can be laid down by which to determine the exact line of demarkation between legitimate repairs which the purchaser of a patented machine can rightfully make, and a reconstruction or reproduction which will constitute infringement. Each case must be decided on its own facts, taking into consideration the scope of the invention and the actual intentions of the purchaser. Also it should be noted that, if the repairs consist in replacing some part, which is itself specifically patented or which constitutes the patented feature of the whole machine, then this would amount to the *making*, rather than the *repairing*, of a patented article, and hence would not be permissible.

There can be no infringement of a patent before it is issued, which fact is often important in determining whether or not to rush proceedings in the patent office. But note that, although a machine can be legally made and legally sold without the permission of the owner of a *pending* patent; yet, as soon as the patent issues, the patentee can stop the purchaser from *thereafter* using the machine. The fear of this is what makes even a merely pending patent of some value.

The inventor's remedy for infringement consists in an injunction, damages, and an accounting for profits, all obtainable by suit in the Federal Court of the District in which the infringer lives, or in which the infringement takes place. The plaintiff has the burden of proving both the validity of his patent and the fact of infringement by the defendant.

A preliminary injunction (i.e., an injunction issued before the final termination of the suit) will not be granted except when irreparable injury to the plaintiff is clearly imminent. It will usually not be granted if the defendant is financially responsible. If the defendant is *not* financially responsible, he will usually merely be required to give bond to pay whatever damages may be awarded. If the validity of the patent is disputed and has never been previously established by a court decision or been generally acquiesced in by the public, then an injunction will be refused.

But an injunction can always be obtained at the end of a successful suit.

Damages are to be measured by the actual loss to the plaintiff, and will be confined to the particular part of the machine covered by the patent, although the entire damage will be assessed if the entire value of the machine is due to the patented feature. License fees charged to others are a good guide. The judge, in his discretion, can allow double or treble the amount of the damages.

No damages can be collected unless the infringer actually knew of the patent, or at least had "constructive notice" because of the proper marking (i.e., "patented" and the date) on all machines lawfully made under the patent. And in no event can damages be collected further back than six years prior to the commencement of the suit.

Where there is no other means of estimating the damages, the profits made by the infringer may be considered; but the real test is what the plaintiff lost, rather than what the defendant gained.

However, the plaintiff can collect, in addition to damages, an amount representing the gains and profits of the defendant. These consist in the saving or advantage in the use of the patented improvement, as compared with former substitutes. When an infringer profits on some sales and loses on others, he is liable for the profits without deduction for the losses.

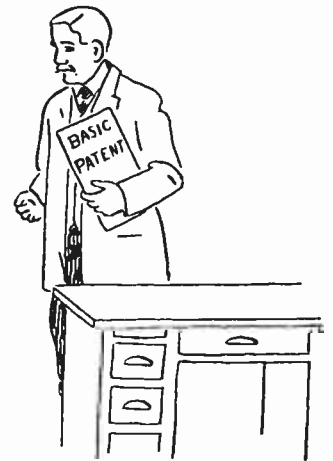

"YOU CAN'T MAKE  
ANY KIND OF DESK"

To emphasize some of the foregoing points, let us revert again to Smith and his desk-with-a-hole. When Adam, as owner of a more basic patent, stops him from manufacturing, he goes to a patent attorney to see if there isn't some other way to make a living out of his patent. Smith lives in Boston. The Golden Gate Co. of San Francisco is making desks-with-holes.

"Sue them," suggests the attorney.

But the expense of a suit in California frightens Smith. However, it appears that the Golden Gate Co. has sold quite a lot of its desks right in Massachusetts. Smith gets a list of these customers and goes over it with his attorney.

Customer 1 is using his desk as a bean-bag game to amuse his children, and so can't be touched.

"Too bad we didn't mention that use in our specifications; then we could get him," laments the attorney.

Customer 2 is a furniture maker. He has taken his desk to pieces to see how it works and is trying to improve on it. He can't be touched, either.

But five or six other customers are employing the desk as a desk, or for some other useful purpose. Smith has nothing to lose by their antagonism, for Adam has forced him out of business, so he sues them all in the District Court of Eastern Massachusetts, collects damages enough to pay for his trouble, and compels the Golden Gate Co. to make a royalty agreement with him.

Then, on the side, he sues two of his own customers for repairing the desks which he had sold them. He wins against one who has put a new top on his desk, but loses against the other who has merely put on a new leg.

We have seen that the value of a patent lies chiefly in the protection which it gives the inventor in manufacturing his own device (subject, of course, to prior more basic patents), and in the power which it gives him to enjoin competition and to collect royalties, damages, and profits.

In conclusion, let me point out that even an *invalid* patent may be valuable. I know of one actual case where a patent, very vital to an entire industry is held by the A Company. All of its competitors, except the B Company, pay a royalty of \$50.00 for this device on every machine that they build, these royalties aggregating some \$100,000.00 per year. The reason that B Company pays no tribute, is that it has found and bought a machine, embodying the patented feature, and made more than two years before the filing of the patent application. A exacts no royalty from B, and in return B keeps the existence of this machine a secret, for its production in any Court would at once result in A's patent being declared absolutely void.

But note that A's patent is *not* void—yet! And until it is declared void by some Court of competent jurisdiction, there is nothing illegal, or even immoral, in A continuing to collect royalties.

## Keeping Your Storage Battery Working at Its Best

By W. S. STANDIFORD

**T**HE storage battery is one of the most important pieces of apparatus used in receiving sets. If it is not functioning well, your set will give you poor entertainment, or none at all.

But since many newcomers are joining the ranks of radio enthusiasts, and since it is easy to keep a battery working efficiently, some practical information on this most abused and least understood appliance may be of interest.

There are two types of storage batteries on

the market, the first consisting of specially prepared lead plates standing in a sulphuric acid solution. The other is known as the Edison battery; its plates are made of nickel steel, containing nickel peroxide and spongy iron immersed in a solution of caustic potash. Both kinds have their advantages and disadvantages, there being no perfect storage cells made. Storage battery capacities are rated by their manufacturers in ampere-hours. Thus theoretically, a 60-ampere-hour cell will supply

6 amperes of current for about 10 hours; 3 amperes for about 20 hours and 1 ampere for about 60 hours. In practice, however, as the discharge rate is increased the capacity of a single charge is reduced, and a 60-ampere-hour battery would deliver 10 amperes for five hours instead of six. It would ruin such a battery to take 60 amperes out of it in one hour's time, however; the plates would buckle under such a rapid discharge. From this it will readily be seen that holding a thick wire across the terminals to see it get red-hot, is an expensive experiment. Batteries in radio service as contrasted with those used for automobile lighting and starting, operate at extremely low discharge rates, one, two or three amperes being about an average current, although it depends upon the number of tubes used. In purchasing and using storage batteries, the radio enthusiast should realize that while a 40-ampere-hour battery costs less than one of 120-ampere-hours, capacity the former will become exhausted sooner than the larger one, thus making it necessary to bother with frequent recharging, which costs money and takes time.

For the benefit of those who have a charging outfit and are unable to tell when a storage cell is fully charged, the following pointers will be of help. The completion of charging is told by several signs. The density of the acid is brought back to its highest value, 1,300. The pressure is more than 2 volts per cell and in some cases may be 2.5 at the end of recharging. Copious streams of gas bubbles are given off from both plates—oxygen at one and hydrogen at the other. These bubbles appear at first in small quantities, but increase as the plates become more completely charged. The acid and water mixture at this stage looks quite milky. When nearing completion of the charge, a fine spray is given off from the surface of the electrolyte. This is hydrogen and as it is very inflammable the battery ought to be kept away from all flames.

This spray is also corrosive and it should be kept away from carpets, clothes, etc. The most used device for determining whether a storage battery is fully charged is called a "hydrometer" and can be bought at any automobile or electrical supply store. The explanation of the working of this instrument is simple. Sulphuric acid used in battery solutions and known as "electrolyte" is heavier than pure water. The hydrometer merely indicates the relative weight of the solution as compared

with that of pure water. As a charged storage battery discharges, the sulphuric acid leaves the water and goes into the plates, forming lead sulphate. When a battery is discharged, a large amount of the fluid has combined with the lead compounds in the plates. Naturally, as the solution is weak in acid, it is lighter, and the indicator in the hydrometer tube sinks deep. But when a battery is fully charged and the acid is in the mixture, the mixture has become heavier thus forcing the hydrometer indicator to ride high.

At this stage a fully charged battery should read 1,300. A specific gravity of 1,260 indicates a quarter discharged battery, 1,225 shows that it has been one half discharged, 1,185 three fourths discharged, and 1,150 entirely discharged. Under no circumstances is it advisable to let your battery get more than three-quarters discharged, because the formation of an insoluble lead sulphate on the plates increases so rapidly that it is difficult to dissolve it by charging. Another important point to remember is that a fully charged battery, even if it is not used, will gradually discharge itself through electrical leakage, in from 90 to 110 days. Ordinary water from faucets ought not to be used to make electrolyte on account of the iron and other impurities in it. Use nothing but distilled water and also chemically pure sulphuric acid. They can be obtained at any garage.

Always keep a close watch on the water in the battery, adding enough to come  $\frac{1}{2}$  of an inch above the tops of the plates, twice a month. The acid does not evaporate and needs replacing only if it has been spilled, or due to accumulated plate impurities. In making up acid electrolyte, always *pour the acid slowly into the water*, stirring slowly with a glass rod; do not pour water into acid or it will fly up into your face. In fact the best way is to add no acid—let a battery expert do it if it becomes necessary.

Winter weather is hard on storage batteries. They should not be kept in any place where they will freeze, because, once thoroughly frozen, a storage battery is totally ruined.

To sum up, then, keep your battery well charged, keep plenty of distilled water in it, and don't let it stay in a freezing temperature if you can help it. If these points are observed, you should be able to hook in your filament battery and forget about it. Otherwise, it may remind you of its presence at a time when you least expect or want it.

# What Goes On at a Transatlantic Station

By CARL DREHER

Drawings by TOM MONROE

THE popular idea of commercial high-power radio is highly romantic. People imagine a transatlantic station somewhat as follows: A lonely shack on the beach at 2 A. M. The operator sits with the telephones pressed to his ears and a strained expression on his features. Suddenly his face lights up. "Ha! A call!" The operator scribbles feverishly. After a few minutes he relaxes, and proudly contemplates his copy. A message from Europe! In some way, after that, the radiogram proceeds from the beach shack to its destination, inland, while the operator waits patiently to "catch" another communication on its westward flight. By a reversed but equally simple process, messages jump off from the States to Europe. Thus we have high-power radio.

This picture is in no wise exaggerated. In fact, far more fantastic notions are prevalent. Under ordinary conditions, all the west-bound commercial radio traffic over the Atlantic between Europe and the United States passes through the Radio Corporation's station at Riverhead, Long Island, and thence by wire to the Broad Street central telegraph office in New York City. Non-technical visitors to the station, being told this, almost always imagine that the Riverhead staff of four or five engineers, of whom usually only one is on duty actually copies at Riverhead the thousands of daily messages from England, France, Germany, and Norway, and relays them over the wires. In reality, of course, the traffic flows automatically through Riverhead, as through a telephone repeating station, and all the copying and recording takes place in New York. And some visitors have felt much injured when the man on watch was unable to let them hear music. They came to the station expecting to hear radio concerts, and were disappointed at being offered nothing except indecipherable buzzing noises, somewhat like those emitted by a water faucet when it needs a new washer.

When one considers the situation for a moment, it is obvious that trans-ocean radio communication must be systematized like any other business—like cable communication, for example—and that a highly specialized organization is necessary to perform its functions. But radio's long association with romance—rescues at sea, the exploits of war, and so on—has made it hard to realize that it is based, like any other engineering enterprise, on more or less humdrum machinery and a trained designing and operating personnel.

The equipment and upkeep of a trans-ocean radio circuit are so expensive that it cannot be maintained except on a basis of practically continuous service. If it were to be used only as often as the average ship station, for example, its owners could never hope for a return on their investment. The 2 A. M. beach shack of popular fancy might serve as a fair representation of shore-to-ship radio fifteen years ago. At that time messages were few, and if the operator heard nothing for an hour it may have been due to his silicon crystal jarring out of adjustment, but, just as likely, there were simply no ships within range. But a modern trans-ocean station is a different matter. The operating personnel consists, not of three recluses on a sand bar, but of a community approaching the size of an incorporated village, with its hotel, cottages, water supply, and heating system, perhaps a few hundred acres of land, and means of transportation to and from the near-by towns and railroad stations.

The plant itself, if it is a transmitting station, reminds one of nothing so much as one of the sub-stations of the electric light company in a large city, and its upkeep is commensurate with that of a good-sized electric power plant. The entire radio system consists of perhaps a dozen such stations, all of necessity connected by wire lines leased or owned outright, and in either case highly expensive in upkeep and initial outlay. Then there are urban telegraph offices for collection and distribution

of messages; the central offices of the concern with executive officers, accountants, and the usual business organization; and an associated manufacturing body. All this is very far removed from the free-lance-tour-the-world notion of the radio art.

The writer has no intention of discussing here, however, all these parts and ramifications of an international communication system. The object of this article is to give non-technical readers an idea of how messages are sent and received over long distances, how the stations—particularly the receiving stations—are operated, and to enable broadcast listeners to form some conception of what the life of an engineer or operator in high-power radio is like.

In a modern long-range system the functions of transmitting and receiving are entirely separated. In a ship station the transmitter and receiver are of necessity in the same cabin. But, as the two are entirely different in their functions and nature, it is expedient, when the thing is done on a grand scale, to separate them. The transmitter is a power apparatus, like the motor of an electric train. Its object is to generate power and to dissipate it in a certain way—specifically, in the case of radio, to make a noise at a distance. The receiver is a detection apparatus, somewhat on the order of a seismograph for detecting earthquakes, and its characteristic is sensitivity. When the transmitter and receiver are close together the operator cannot send and receive at the same time. But this factor of simultaneous transmission and reception, or duplex working, as it is termed, is essential in the high-power field, and so in general we find the receiving station located from twenty to several hundred miles from the transmitting station. The seismograph, that is, is not mounted in the same building with a rock-crusher.

Transmitting stations are characterized by their high aerials. To transmit effectively, no substitute has been found for a high,

large antenna structure. Hence transmitting stations have towers from 400 to 800 feet high, built, usually, by contractors specializing in structural steel erection. Up to a few years ago radio engineers thought it necessary to use high antennas also for receiving; the plans for the 1913 Marconi receiving stations, for ex-

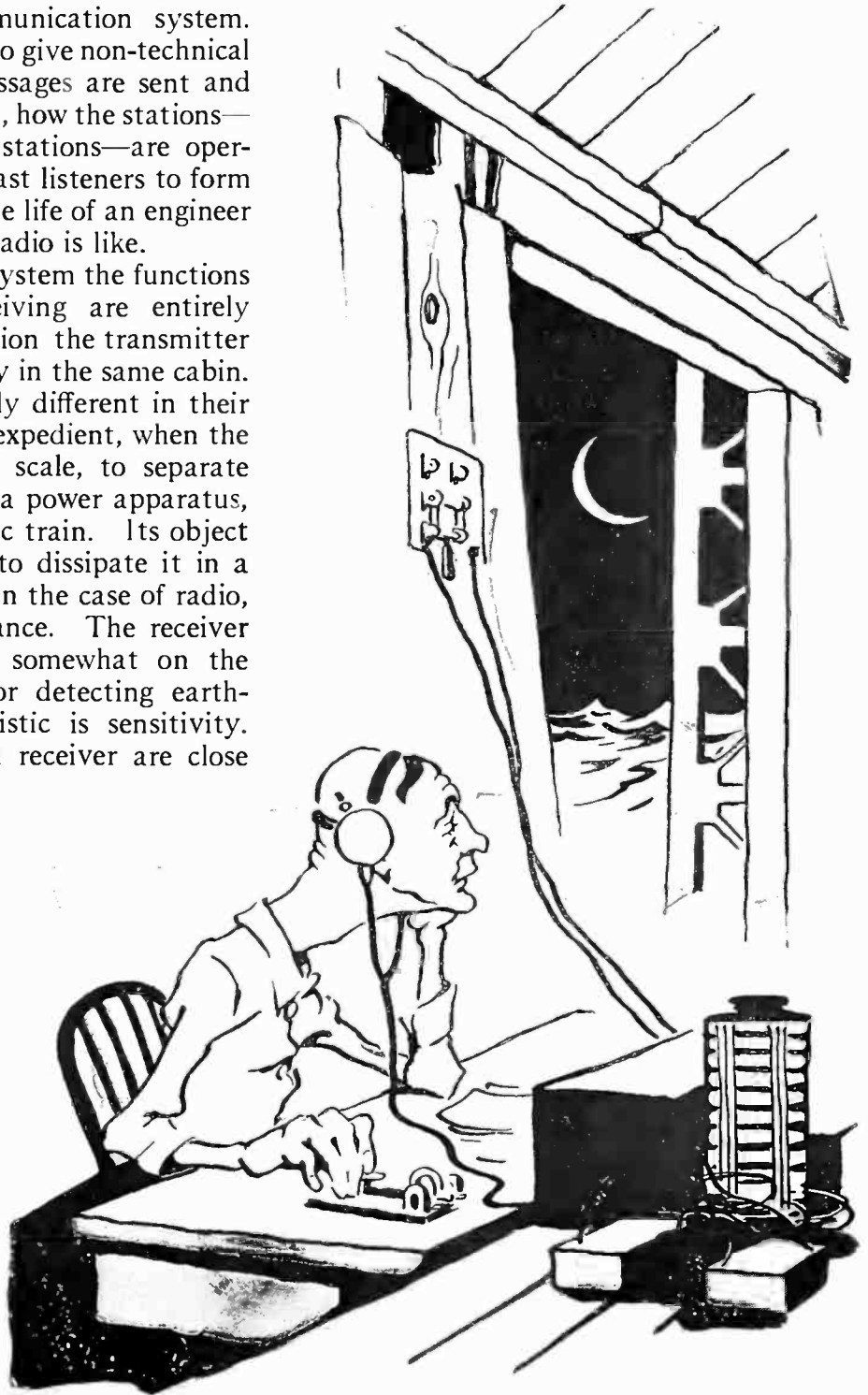

#### A MESSAGE FROM EUROPE!

Scene: a lonely shack on the beach at 2 a. m. The operator (according to the romantic popular idea) sits with the telephones pressed to his ears and a strained expression on his features. When a call comes, he scribbles feverishly

ample, included a line of 400 foot towers. But with the development of sensitive vacuum-tube receivers the costly high receiving antenna could be discarded. It was discovered, furthermore, that small or low antennas offered possibilities in the way of reducing static interference. Thus the French have used small frames, some four feet on a side, for receiving American signals; and in the United States the "wave antenna," developed for high-power reception, is run on ordinary telephone poles only thirty feet high. In either case the appearance of the receiving station is totally different from that of the sending station; and at the present time high towers may be safely taken as the index of a transmitting station.

Taking up the operation of a receiving station, we may describe an actual large American station as it was only a year or two ago. The Belmar, N. J. plant of the Radio Corporation of America will serve as an example. The system has changed considerably since that time, and these alterations will be discussed later. The description as given will hold approximately, however, for a number of European stations in their present form.

Unlike the ship station, in which one operator both tunes the receiver and copies the message, in the high-power station the apparatus is adjusted by a receiving engineer, and the

operator has nothing to do with the handling of the equipment. At Belmar the tuners and

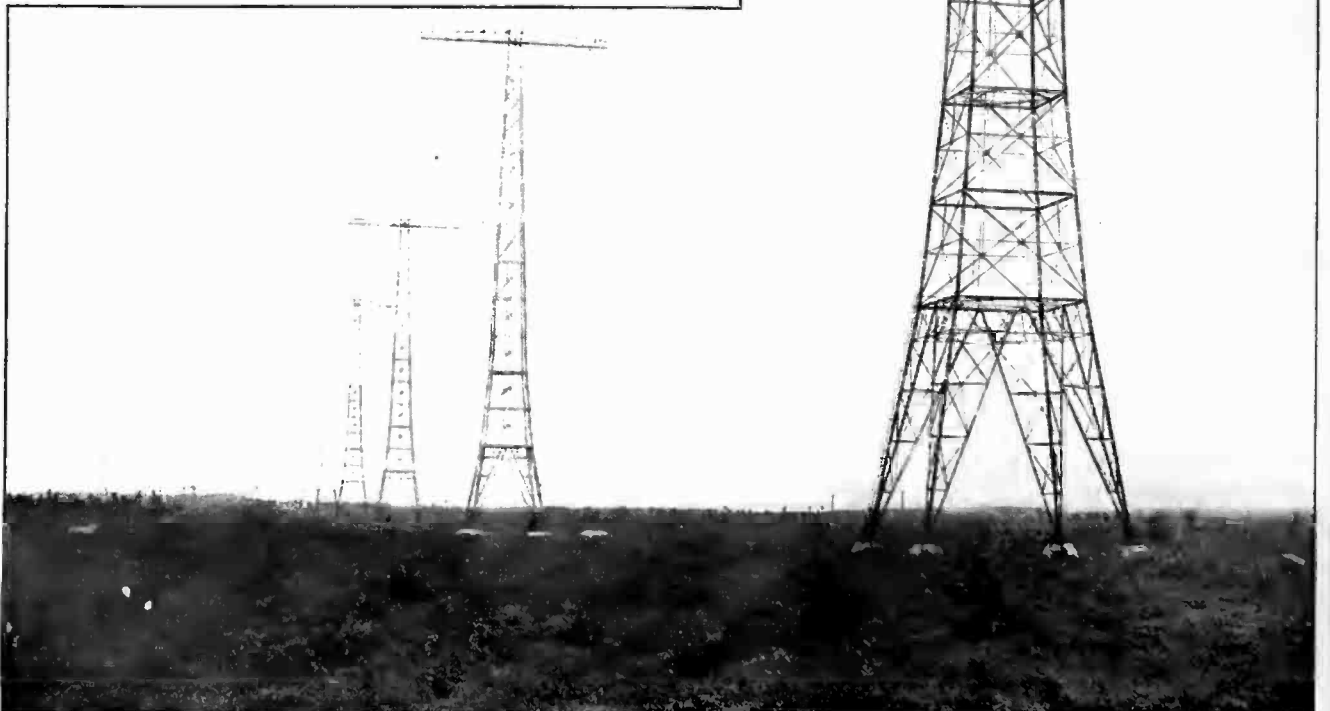
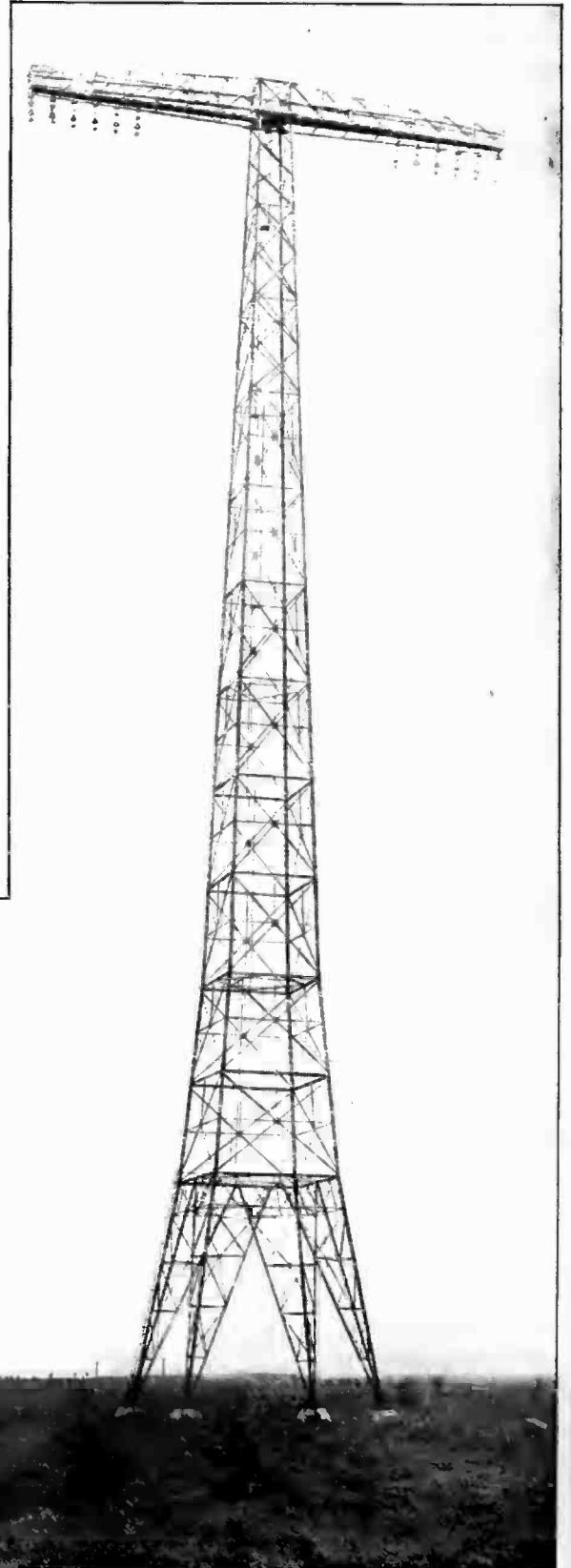

THE TWELVE TOWERS AT ROCKY POINT, LONG ISLAND

These towers carry the antennas used in transmitting to European stations. The power which radiates from the antennas is controlled by delicate mechanism in New York City, 55 miles away

amplifiers, in fact, were in a separate room. The engineer had his own pair of telephones plugged in on the signal and thereby he could tell when anything went wrong in the set, adjust the static balance for optimum reception, and generally supervise the working of the circuit.

In the telegraph room messages were copied on the typewriter, one operator being assigned to each overseas circuit. Belmar, for example, at one time handled the circuits from Carnarvon, Wales; and Lyons, France. Accordingly there was an MUU (Carnarvon) operator, and a YN (Lyons) operator. Each man would copy as fast as conditions permitted, usually below thirty words a minute at that time, and throw the message blanks into a wire basket. At intervals a check clerk would come, count the number of words in each message, compare it with the check given in the preamble of the radiogram, and enter the figure in an abstract. If there was no discrepancy, the message was taken across to the wire operator, who sent it on an ordinary telegraph line, using a sounder with its click signal as distinguished from the buzzing or whistling signal of the radio circuit, to New York City. At the central telegraph office in New York the message was copied and re-dispatched via wire to the point of destination. The radio station, therefore, was in effect the junction of the radio circuit with the radio company's wire circuit, and the central telegraph office was the junction between the radio company's wire circuit and the land telegraph company's wires, and two receptions and two transmissions, with the attendant possible errors and certain delays, were necessary on this side of the water alone.

In the event that an error was discovered in the check of the message, or when the radio operator missed a certain word or was not sure of its correctness, an "RQ", or message of inquiry, was sent to the transmitting station. The answer to the "RQ" was termed a "BQ". These designations are still used and continue to puzzle a great many amateurs who listen in on the long-wave circuits and wonder what it is all about. Two operators, termed the RQ clerk and the BQ clerk, respectively, took care of the numbering, sending, and tabulating of these verification messages.

The transmitting station, which in the case of Belmar was located at New Brunswick, N. J., fifty miles away, was controlled from Belmar by means of a wire line. The Belmar operator,

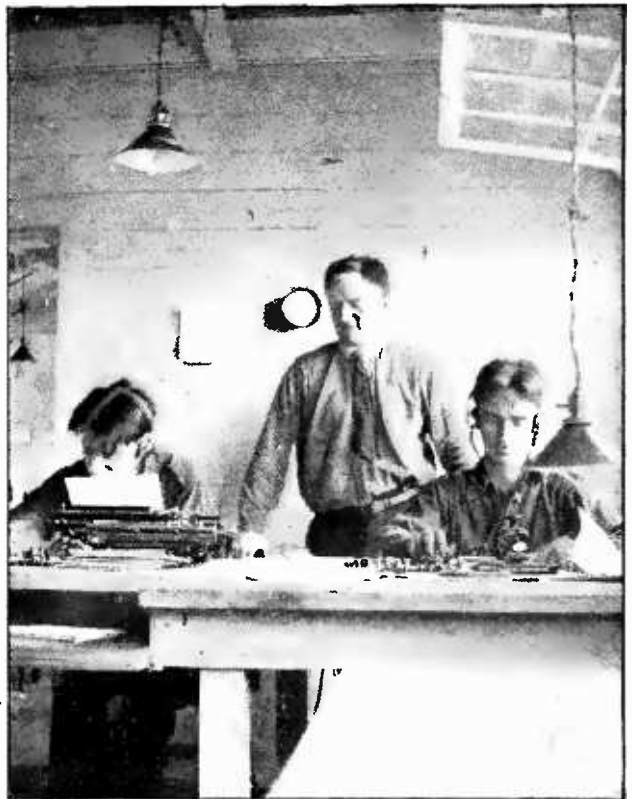

TRANSATLANTIC WORK AT LAKEWOOD, N. J.

This picture was taken three years ago, before all the Radio Corporation's messages to and from Europe were handled at one central station in New York. In this picture, the man at the left is copying a message from Carnarvon, Wales, on the typewriter. The operator on the other side of the supervisor is sending to England on a key which controls the New Brunswick, N. J. transmitter

that is, controlled the dots and dashes sent into the air from New Brunswick directly with his key. Messages came by wire line to Belmar and were thence dispatched to Europe. Belmar could also "break" the European sending operator, when a word was missed in reception on this side, by making the symbol "BK", whereupon the distant operator would re-send the last word correctly received and proceed. At an early date, direct control of the transmitters from New York was instituted, but the outlying receiving stations continued to possess an auxiliary control for "breaks" only. "Breaks" save RQ's, which take longer and are more costly to the service. A "break" is like saying, "I beg your pardon," to a man with whom one is talking; an RQ is like writing him a letter afterward to verify what he said.

In charge of the operators was a supervisor, who saw to it that all the circuits were worked to capacity, that no disputes occurred on the wires—nothing is easier than to fight with a man at the other end of a cable if one does not fancy his style of sending—and that the busi-



ONE OF THE "LONELY SHACKS"

Which used to house the long-distance receiving apparatus, but which now exist only in the popular imagination, at least as far as transatlantic work is concerned

ness of the station was transacted efficiently during his tour of duty. Under the supervisor there were as many as twenty operators during busy stretches.

There were three daily watches: Midnight to 8 A. M., 8 A. M. to 4 P. M., and 4 P. M. to midnight. Each watch had its staff of operators and supervisor, and the watches were changed every week, so that a man did not have to stand the graveyard watch, as it is called in steel mills, more than seven days in succession. This placated the operators' wives by widowing them not over a week at a stretch.

The station was in charge of a superintendent, who in turn reported to the New York office, discharging the usual functions and assuming the ordinary responsibilities of an official in charge of an outlying factory or branch office of a corporation. As there might be as many as fifty skilled operators at a receiving station, with power house and radio engineers, linemen, cooks, servants, gardeners, and other help, this was quite a sizeable job.

The unmarried men lived at a large brick hotel maintained by the company on its property. There were cottages in which the superintendent and other officers lived. The social life of the place was much livelier than that of the average small community, for inasmuch as almost all professional radio men have served an apprenticeship on shipboard, the men at the stations were generally well-traveled and often highly interesting in conversation. There was always a fair percentage of Britishers, as is usual in any communication enterprise, for England has a far-flung empire, whose natives learn communication as a matter

of course, and go wherever cables are laid or wires are strung. The atmosphere of the recreation rooms was highly cosmopolitan. At one of the stations, for example, there was a supervisor who had sailed with William McFee, and had heard Titta Ruffo sing "Hamlet" at the Milan opera, which is more than many literary and operatic critics can boast of. All this is a far cry from the lonely beach shack. And as for isolation, it was nothing for the staff to have twenty girls, vigilantly chaperoned and matroned, down from New York for a week-end party, and not a few of them were quite at home in the smart supper clubs of the town to which all the wires run and where all good circuits, line and radio, find their end.

But efficiency required that the signals be received in New York City directly, and to-day Belmar is only an experimental station. All the operators are now at the Broad Street Central Telegraph Office. At the same time it would not be expedient to pick up the signals in New York, for an urban receiving location is generally inferior to a rural one, and the present system of static elimination requires a large amount of space—specifically an eight-mile line on poles, which of course could not be readily obtained in the city. The problem was solved by the development of line-transfer apparatus. That is, the signals as they come out of the audio-frequency amplifiers at the receiving stations, are put through repeating coils on to metallic wire circuits, and at Broad Street re-amplified and given to the operators. In short, there is a system of audio-frequency tones sent along wires, following the radio-frequency oscillations sent through space. Under normal conditions the operator in New York hears exactly the same signal that the engineer in Riverhead, say, listens to. This system, of course, is subject to the usual troubles of a wire telegraph under bad weather conditions, but by the use of good lines, spare pairs, and other standard expedients, serious delays are obviated, and the advantages of a single central telegraph office and an outlying receiving station effectively combined.

The Radio Corporation's main receiving station is at Riverhead, L. I., at the head of Peconic Bay, about eighty miles east of New York City. The antenna runs southwest to Eastport, a distance of about nine miles. This collecting system, the invention and development of Mr. H. H. Beverage of the Radio Corporation and Messrs. Chester Rice and



E. W. Kellogg of the General Electric Company, has been described at considerable length in non-technical publications, and a technical account has appeared in the A. I. E. E. Proceedings, so that only a brief description is warranted here. The salient feature of the wave antenna, as it is known, is that it will pick up signals from the northeast, say, if properly oriented, and be sensibly "deaf" to the southwest. By suitable adjustments, therefore, in the United States, it may be made receptive for the European stations to the northeast, while blocking out station interference and static from the southwest. In this way the wave antenna makes the radio circuits proof against practically all forms of disturbance except local lightning, which is seldom of serious duration. At the same time, by virtue of its length, the antenna collects a great amount of signal energy, and as it is not in itself tuned to any wavelength, any number

of tuned receiving sets, within reason, may be connected to it. It is thus possible to terminate six or a dozen radio circuits in one small building and to transfer the signals to wire lines at this point.

The visitor to Riverhead sees, in a room twenty-five feet square, three long open cabinets slightly higher than a man, each holding three shelves. A receiving set is placed on each tier. The component parts of these sets—tuning apparatus and amplifiers—were built by the General Electric Company. They are designed for hard, continuous service in a fixed installation. The various units are enclosed in large iron cases, and the appearance is that of power apparatus rather than the usual laboratory impression given by radio instruments.

By means of plug and jack boards, somewhat like those in a telephone exchange, any signal may be put on any pair of wires to New York, a

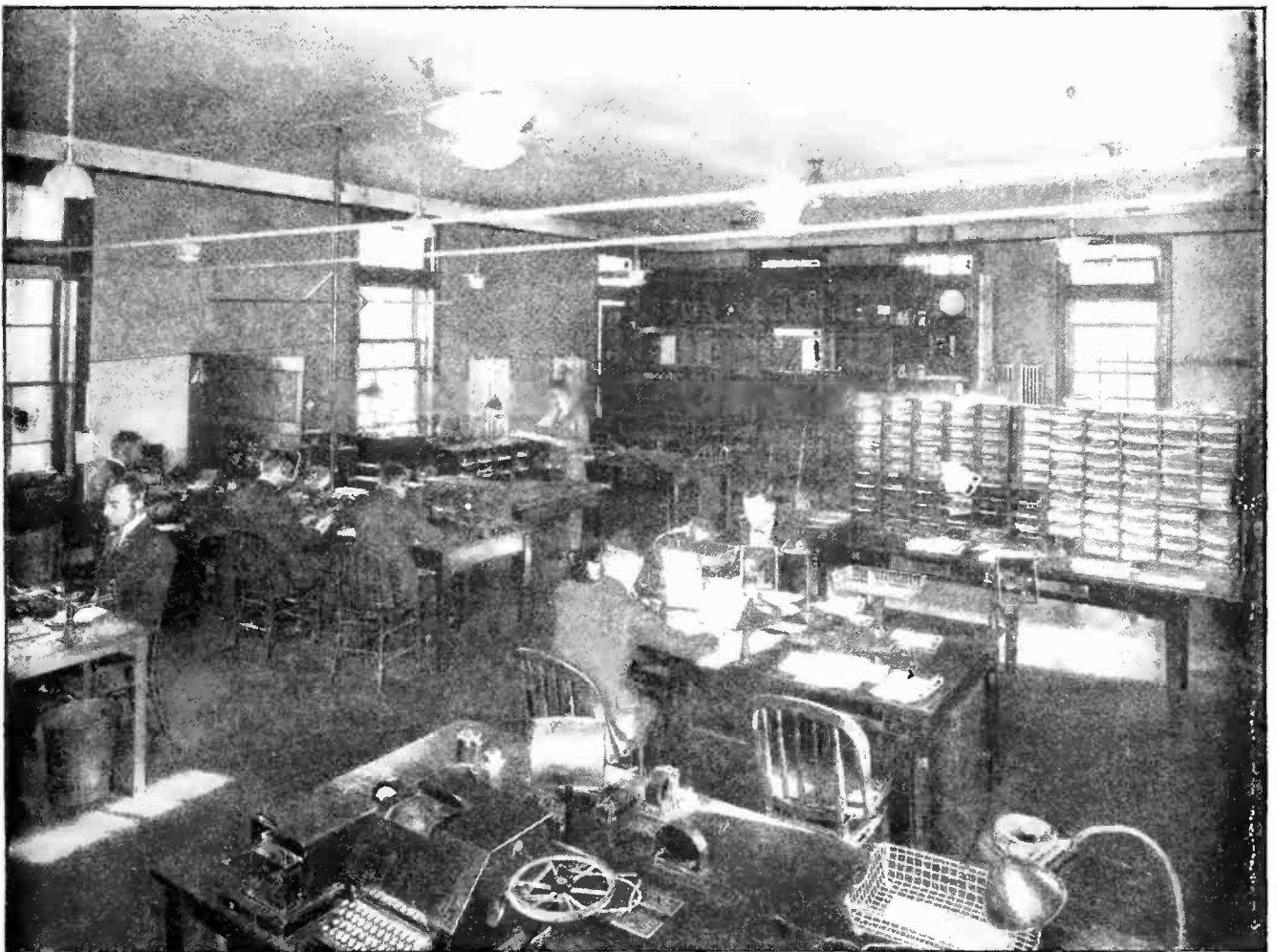

A VIEW OF THE CONTROL STATION AT BROAD STREET, NEW YORK CITY

In the foreground is a modified typewriter keyboard used in conjunction with a perforating machine which punches out dots and dashes on the tape. The tape is later fed into an automatic transmitter which controls the key circuit of the transatlantic transmitter according to the dots and dashes on the tape

signal may be duplicated on two or more tone channels, wires may be tested, sets changed, and all the other possibilities of a highly flexible arrangement realized.

The stations at present handled via Riverhead are MUU, Carnarvon, Wales; LCM, Stavanger, Norway; OUI, Hanover, Germany; POZ, Nauen, Germany; and UFT, Saint Assize, France. Thus five receiving sets are continuously in service, with a sufficient number of spares in case of breakdown. When, occasionally, the European station has no traffic—is “running idle” or is “out”—the set is left on until the station resumes traffic. The tubes are not turned off and a set may be in use continuously for months.

These stations all operate on long wavelengths—between 12,000 and 15,000 meters. People often inquire whether the multitude of local broadcasting stations do not interfere with transatlantic reception. Inasmuch as the broadcasters do not go above 400 meters, it is obvious that they are not likely to “jam” stations whose waves are thirty or forty times as long.

Power is supplied to the station from a 2200-volt transmission line. The filament and plate supply to the tubes is from storage batteries “floating” on A. C.-to-D. C. motor generators. When the A. C. power is interrupted, the amplifiers will run on the storage battery reserve for a period of about a day, which is sufficient to tide the station over any conceivable breakdown in the power supply.

Communication between the engineers at Riverhead and the traffic personnel at Broad Street is maintained over a wire telegraph line. The engineer at Riverhead must therefore also be a competent wire operator, so that instructions and information may be rapidly sent over the line and good contact maintained between the two parties. The Broad Street end of the wire is manned by the Office Electrician on watch. Personal calls are used in order to secure the maximum degree of coöperation between the two departments. The system has proved very effective and is practically equivalent to the antedating arrangement wherein the engineer and sets were in the next room.

A corrupted form of Phillips's Code is used in conversation on the Riverhead-Broad Street wire. Phillips' Code is the system of symbols and abbreviated spelling used on commercial press wires and fast bonus circuits. Of course when one has to spell out every word, as one does in telegraphing, one is apt to be in favor of highly simplified spelling. “That” becomes “tt”, “ing” is cut to “g”, “what” is “wt” and so on. The Phillips' on the Riverhead wire, however, is somewhat unique and may be compared to Ward Line Spanish, familiar to every good radio man. Also, while most of the communication is of necessity terse, during light periods, flashes of fancy have been known to slip through, as the following at four o'clock one morning:

“Hey, brush off the Swede,” which, translated, means, “Clear up the LCM (Norway) signal.”

Over the water, most of the service messages and traffic directions are in English, but occasionally the English is a little unsteady, and may be abandoned altogether, as once when the French operator delivered himself of the following:

“Pse Mr OM we have much msgs o h can you take a grande vitesse?” which means, “Please Mister Old Man we have much messages on hand—can you take high speed?”

Many such gems could be picked up by anyone listening for them, but in the press of traffic they go unnoticed and are lost.

Curious incidents sometimes occur to break up the routine of operation. Wire trouble, for example, sometimes originates in unusual ways. In one case three tone channels were thrown out of service for twenty hours by a piece of haywire slung over the line by some boys at an isolated spot. On another occasion an ice-house some five stories high, and large in proportion, caught fire and fell over upon the main telephone trunk line in the middle of Long Island, carrying the Radio Corporation's wires down with the rest. All circuits went out with an unprecedented bang. One or two telephone pairs were left intact, and soon Broad Street and Riverhead were in communication by telephone. But not for



A PRESS BROADCAST FROM POZ, NAUEN, GERMANY

This strip is part of a message received at the Riverhead, L. I. station on an ink recorder. The letters have been written in above the lines representing dots and dashes of the Continental telegraph code



"DIT DIT DAH DAH DIT DIT"

It is related that when the Broad Street official began to warble and chant into the telephone, the office broke into a commotion and he narrowly escaped being rushed to a psychopathic ward

long. The surviving pairs began to be affected by the heat, terrific crackling noises and roars broke up the conversation, and, while voices could still be heard, the speech was unintelligible. The single engineer left at Riverhead—the rest of the staff having rushed to the scene of the fire in cars—then conceived the idea of howling code mouth signals into the telephone transmitter, thus:

"Dah dah dit dah—dit dah dit—dah dah—dit dit dah dah dit dit" (QRM—Interference—Repeat, repeat).

The Broad Street Office Electrician replied in kind, and communication was maintained through the wire noises until the regular wires were patched temporarily with twisted pair lying on the ground. The Riverhead man, being by himself, had nothing to lose, but it is related that when the Broad Street official began to warble and chant into the telephone, the office broke into a commotion and he narrowly escaped being rushed to the psychopathic ward. So a man may be misunderstood when he is behaving most rationally.

The receiving engineers' time is normally taken up keeping the sets accurately in tune (a transmitting station's frequency may shift

slightly, necessitating compensating changes at the receiving end); balancing static; keeping a log of observations on the conditions of the circuits and the rate at which traffic is moving, and taking care of contingencies which arise, such as trouble on the tone lines, or interference between transmitters whose wavelengths are not far separated. In this respect a radio man's business differs greatly from selling shoes or running a movie house, occupations subject only to local disturbances, for when one is receiving from Europe some arc transmitter in Hawaii or the Philippines may, under certain conditions, cause one as much trouble as a fire next door. Again, while many other occupations are subject to only minor variations from day to day, in a radio station one may have little to do one minute, and the next instant trouble may start, and one is listening to Europe with one phone on and the other ear turned to the sounder, twirling knobs with both hands, and trying to open a switch with one's feet. But the man whose temperament is not adjusted to rapid changes belongs in some other business than radio. . . . No doubt a few specialists in the broadcasting end of the industry can be found to second this.

# 1300 Miles On a One-Foot Loop

Three Tubes are used in a Clever Arrangement to Give R. F. and A. F. Amplification in the New Grimes Circuit

By CHARLES H. DURKEE

**U**NTIL very recently, in this country, radio-frequency amplification was a closed book to all but a select few. This is rather hard to explain in view of the fact that the European radio enthusiasts have long been using practically nothing else. From time to time information has arrived from across the ocean both in the form of patents and articles, but still little resulted. Even the war, which brought hundreds of our radio men in direct touch with radio-frequency did not seem to stir up a great deal of enthusiasm for its use in the United States.

It may surprise many to know that radio-frequency amplification was introduced in this country at about the same time as the now famous Armstrong circuit. So, speaking in relative terms, instead of being a recent development, it is really rather old.

There are several decided advantages in radio-frequency amplification, but there have been also several serious drawbacks, as seen when it is compared with the regenerative arrangements. It has been the drawbacks which have outweighed the advantages in the past as far as this country was concerned. When radio frequency is operated properly there results a purity of tone in broadcast entertainments which is hard to equal with the regenerative set even though extreme care is taken in adjustment (although the latter is more selective). This difference in quality becomes more and more noticeable as high enough amplification is obtained for loud speaker use, unless great precautions to eliminate it are employed.

Another advantage in using radio frequency is that the reception of distant stations even on a loop becomes a simple matter, both with respect to volume and to ease of operation, as compared to the regenerative circuit in the hands of the uninitiated.

And last, but not least, is the overwhelming advantage of radio frequency in that it does not regenerate back into the air—an action which sometimes causes annoyance to everyone

possessing any kind of radio receiver within several hundred feet. These disturbances are the familiar and ever increasing number of rising and falling whistles which are heard when you have comfortably adjusted your set for an evening's entertainment.

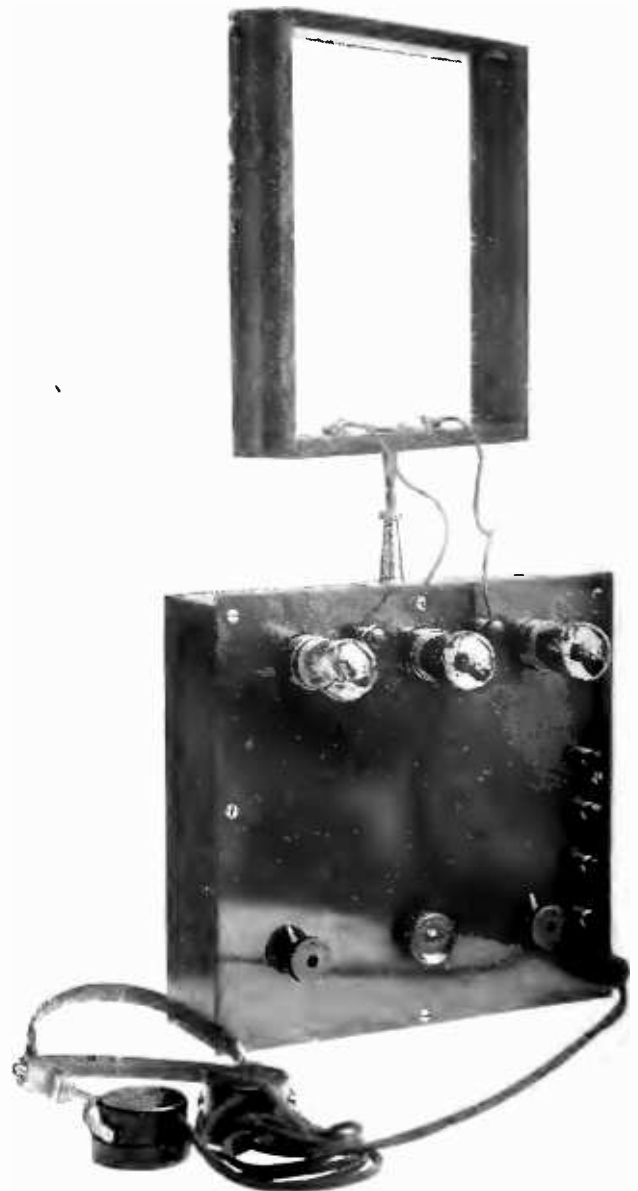

THE COMPLETE "INVERSE DUPLEX" RECEIVER  
One of these sets has been tried out by the Editor of RADIO BROADCAST. The first night, he heard, from his home on Long Island, PWX (Havana, 1300 miles) and WDAF (Kansas City, 1080 miles)

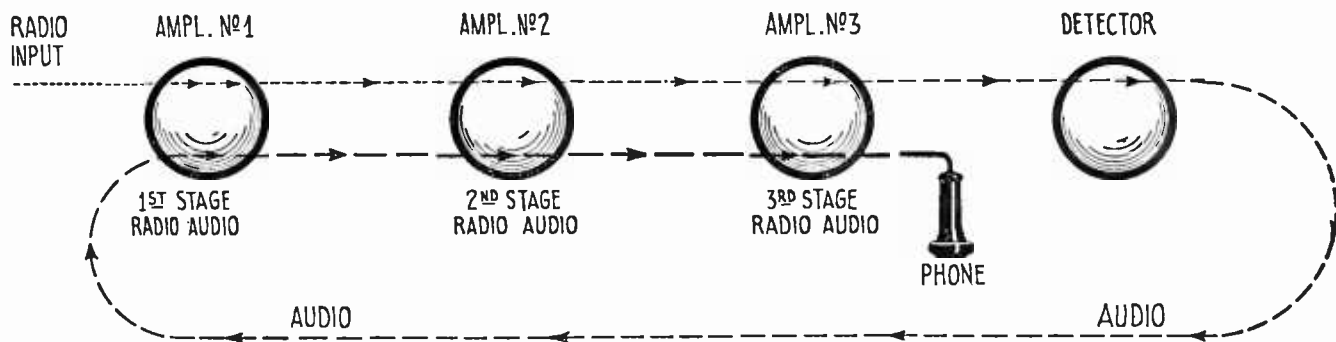

FIG. 1

Schematic diagram of French circuit employing 3 steps of radio, detector, and 3 steps of audio-frequency amplification

The disadvantages of radio-frequency amplification have been, mainly, that it has required several more vacuum tubes than other types of receivers—an expense in more ways than one when power and depreciation are considered—and that it has not been satisfactory for local reception, the radio-frequency tubes being practically useless on near-by high-power stations.

Naturally, in Europe, where the circuit has been most popular, several more or less successful attempts have been made to overcome these drawbacks. One noteworthy and commendable attempt has been called the La Tour circuit—a French development. This circuit has recently appeared on the American market in commercial form. Only one of these American types, however, shows a radical departure from the French principle.

The French principle consists in employing some of the amplifying tubes in a dual capacity to amplify both the radio and audio currents. It was hoped by this arrangement to reduce the number of tubes and thus compete with the regenerative circuit from the standpoint of expense, thereby overcoming the main objection to radio-frequency amplification. Difficulties and objections arose, however, in actual practice, and it is the various solutions of these difficulties which form the basis of the commercial sets made in this country.

It is the object of this article to disclose the details of a circuit developed by Mr. David Grimes of Grasmere, Staten Island, New York. His circuit offers the logical solution to the difficulties outlined and he alone has radically departed from the general scheme of performing the dual process of amplification employed in all other sets of this type.

Mr. Grimes is a graduate of the Electrical Engineering College at the University of Minnesota. He studied radio while at college and

during the war, and although he enlisted as a private, he was soon placed in full charge of radio instruction at Kelly Field, Texas, one of the largest flying fields in America. He was later ordered overseas to carry on investigating work in connection with radio navigation of bombing planes. It was while engaged in this work that he ran many tests which led up to the present circuit. For some time after the war he was employed in the Development and Research Department of the American Telephone and Telegraph Co. and it was here that he gained experience in judging voice qualities, and, realizing this weakness with respect to quality that existed in most commercial sets, he resigned to devote all of his time to this work.

Mr. Grimes calls his circuit the Inverse Duplex—the name being derived from the unique way in which the audio energy is amplified through the tubes with respect to the radio. The sketch shown in Fig. 1 is a schematic form of the La Tour circuit using four tubes. The radio enters amplifier tube No. 1, and passes on through amplifier tubes No. 2 and No. 3 to the detector. Here it is changed to an audio-frequency current and is then led back through the first three tubes in the same manner and sequence as the radio. This arrangement has several inherent disadvantages.

In the first place it is readily seen that amplifier tube No. 3 is greatly overloaded by trying to carry both strong radio energy and strong audio energy. The whole system is thus limited to the carrying capacity of the third tube. This prohibits its use generally for local reception. Another serious difficulty with this arrangement (Fig. 1), is that if any leakage currents of radio frequency pass from the output of the detector tube through the audio circuit to the input of the first audio tube, it will there be amplified as radio three times

again before reaching the input of the detector. This causes radio-frequency oscillation and renders the circuit almost inoperative. Obviously this arrangement is very unstable. A third and very important trouble encountered in suburban homes with the circuit shown in Fig. 1 is that the least 60-cycle and harmonic energy picked up from the electric light wires by the loop is amplified at audio frequencies through three stages before reaching the phones, and three stages of audio-frequency amplification can usually make a very loud noise from one that is almost inaudible originally. The humming noise is extremely annoying, often completely predominating over the radio signals of a distant station.

An improvement is shown in the schematic sketch Fig. 2. Here the audio-frequency current is brought back through but two of the three amplifying tubes although still in the same sequence as the radio amplification. The overloading of tube No. 3 is somewhat relieved by the dropping of one stage of audio amplification. It is still noticeable, however, especially on local reception. The stability is partially improved by the fact that only two steps of radio-frequency amplification now exist between the output and input of the detector circuits. Even two stages of radio, however, cause no end of exasperating oscillations. Of course the trouble from 60-cycle interference is overcome here in separating the loop from the audio amplifying circuits by one stage of pure radio amplification which passes no audio energy.

Fig. 3 shows an adaptation of the above where the detector tube is replaced by a crystal. This crystal, inasmuch as it merely rectifies whereas the tube both rectifies and amplifies, so reduces the energy passing through the circuit that no appreciable overloading of amplifier No. 3 occurs. For the same reason the

radio leakage currents in the audio output circuit of the crystal are practically nil; so that the two successive stages of radio between the input and output of the crystal are of no consequence so far as disturbance from inherent oscillation is concerned. This circuit is also free from the 60-cycle noise picked up by the loop for the reason mentioned in connection with Fig. 2.

Fig. 4 is a schematic diagram of the Grimes Inverse Duplex Circuit using four tubes, and Fig. 5 gives the details of a three-tube arrangement which is thought to be sufficient for most purposes. Considering Fig. 4, the radio passes through amplifiers No. 1, No. 2, and No. 3 into the detector in the same manner as before. The audio currents from the output of the detector tube are then led back through amplifier tube No. 3 as the first stage of audio. From here they pass around through amplifier tube No. 2 for the second stage of audio and then through amplifier No. 1 for the third and last stage of audio.

In this manner the first tube carries weak radio and strong audio currents. The second tube carries medium energies of both and the third amplifier tube passes strong radio and weak audio currents. The load on the tubes is thus equalized and greater volume of signals results. All these amplifying tubes are used to their maximum capacity, instead of being limited by the overloading of the third tube, while the other tubes are delivering less than their full capacity as in the standard La Tour circuits. This enables the circuit to be used for loud-speaker operation on near-by stations, overcoming one of the difficulties of radio-frequency amplification.

Another decided advantage of this design is that no matter how many tubes are added to the set, there never exists more than one stage of radio amplification between the output and

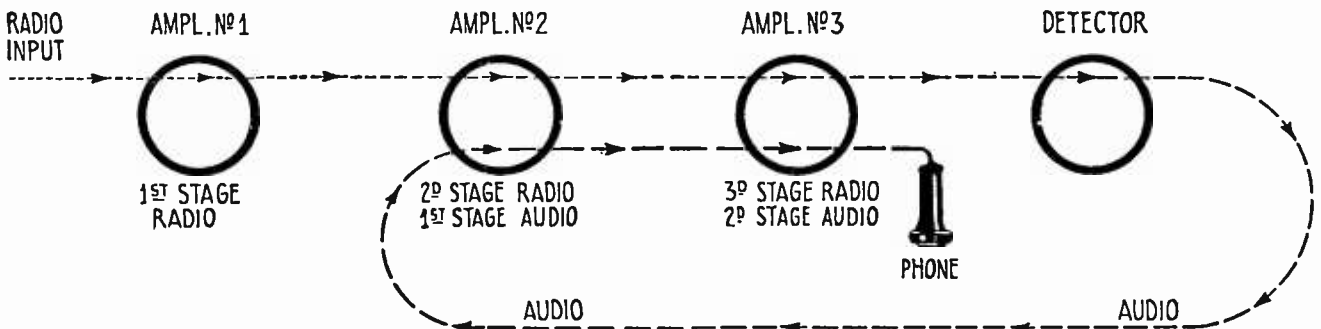

FIG. 2

Here 3 stages of R. F., a tube detector, and 2 of A. F. amplification are used

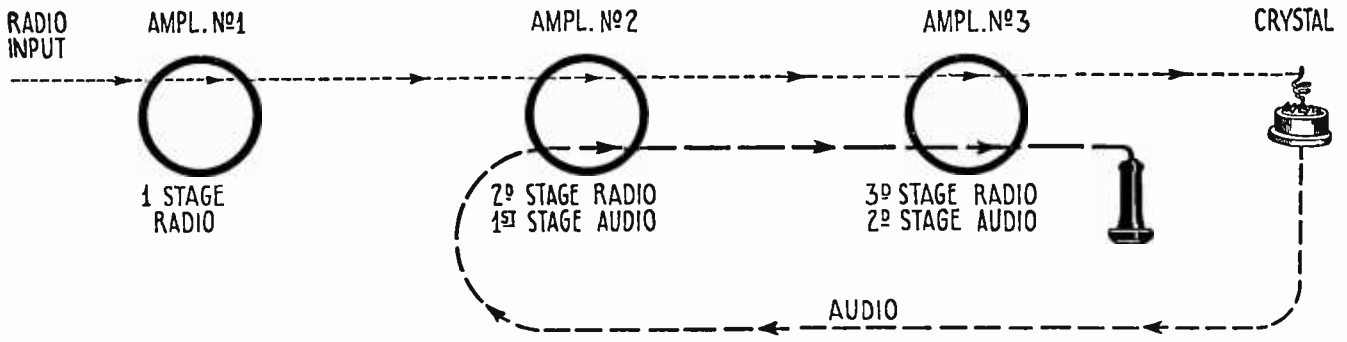

FIG. 3

This shows the French circuit employing a crystal detector and having 3 steps of R. F. and 2 of A. F. amplification

input circuits of the detector. Any radio leakage currents passing out of the detector through the audio path are given the benefit of only one stage of amplification and inasmuch as these leakage currents are very small one stage is not sufficient to cause howling. With the ordinary connections two or more stages of consecutive radio-frequency amplification cause this leakage current to become appreciable and howling results.

The third important advantage of this circuit is seen in always placing the phones in the plate circuit of the first amplifying tube. No matter how many tubes are used, the phones should be in this position. In this way the audio induction current picked up by the loop from such a source as a 60-cycle power line is never amplified by more than one stage before going through the phones. As a rule this one stage of amplification is not sufficient to make the induction audible.

Stability, uniform loading, and freedom from induction noise are the salient points in this circuit, and this means ease of operation, volume with quality, and long distance without an outdoor antenna, but economically. Other minor improvements in the circuit are found in the radio-frequency paths. Here the radio energy is led back to the tube directly after passing through the radio transformers.

It is not by-passed around the audio transformers and through the B battery, as the resistance here is very liable to cause "cross-fire" between the radio currents of the several tubes, resulting in a tendency toward oscillation, which is recognized by the novice as "howling."

Another improvement is the tuning and radio control circuit. Many radio-frequency circuits to-day are very broadly tuned and therefore susceptible to interference. This is because an attempt is made to control the quantity of radio energy passing through the tubes by placing a slightly positive biasing potential on the grid of the first tube. This reduces the radio amplification, but it also makes the grid-filament circuit a resistance path instead of acting as a small condenser, as is the case when the grid is negative. This resistance path is directly across the tuning circuit and causes an appreciable loss in that circuit. Any loss in a tuning circuit immediately broadens the tuning. In the Grimes circuit the grids of the tubes are all connected to the negative ends of the filaments and the radio input to the first tube is regulated by means of a variable 400-ohm resistance rheostat. This rheostat is so placed that it is in series with the small capacity of the tube and in view of the fact that the impedance of this shunt path is already high,

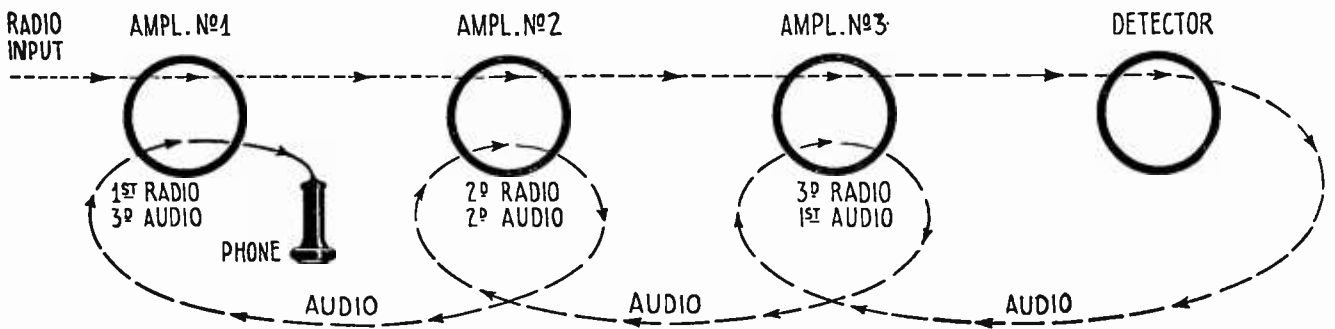

FIG. 4

Schematic diagram of the Inverse Duplex circuit

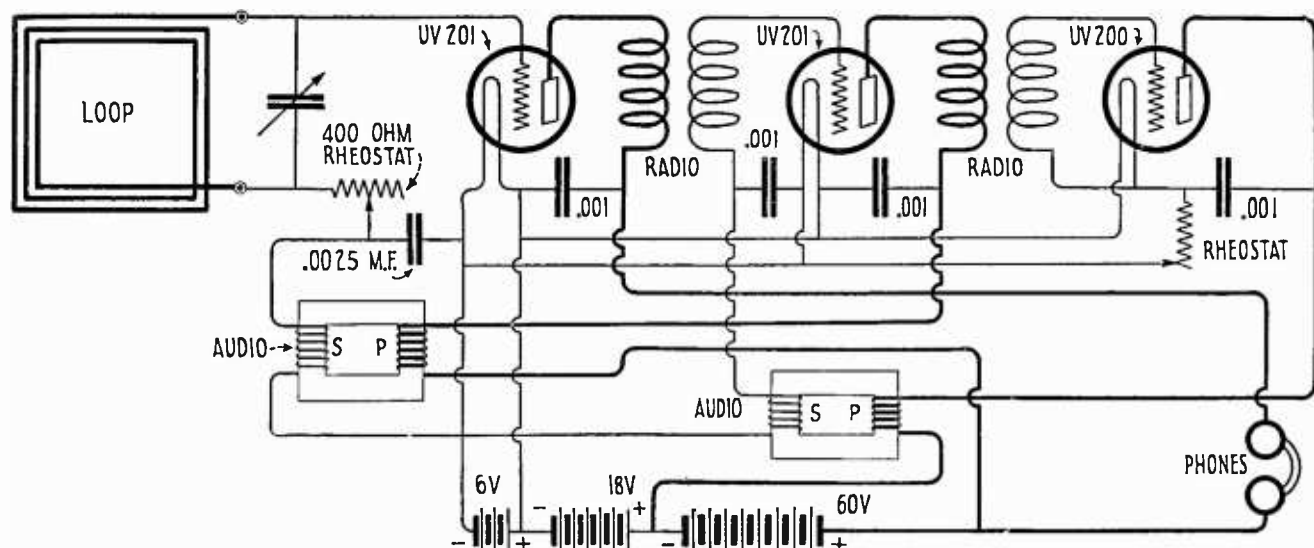

FIG. 5

The Grimes Inverse Duplex circuit as used in the set shown on page 472

the addition of this comparatively low resistance has practically no effect in broadening the tuning, as it causes little or no loss in the tuning circuit. It is this feature combined with the loop that enables the operator of this circuit to pick up distant stations even while the local stations are broadcasting.

In closing, a word or two may be in order about the results and suggestions as to methods of operating this circuit. Under ordinary conditions with the set shown in Fig. 5, Chicago, Davenport, Atlanta, Havana, and other distant stations have been brought in quite easily and consistently with a one-foot loop on Staten Island, New York City. Pittsburgh, and Schenectady are brought in regularly with all of the local New York and Newark stations broadcasting and with no interference.

It has probably been noticed by the reader that only three controls are necessary to obtain these results. A tuning condenser, preferably arranged for vernier control—a rheostat for adjusting the detector tube—and a rheostat for regulating the quantity of radio-frequency energy. It is this latter control which is new and therefore perhaps the least understood. On near-by stations, radio-frequency amplification has not been very effective simply because the detector tube refuses to rectify more than a certain maximum quantity of radio. It overloads, and the additional radio amplification is wasted. It is this fact which has reacted against radio-frequency, because the person desiring distance was compelled to add additional tubes which were almost useless for local reception. In the Inverse Duplex ar-

angement the radio may be cut down by the 400-ohm resistance to a point where the detector is not overloaded, permitting full audio amplification, as the grids are always on the negative side of the filament. It operates, then, just as effectively on near-by stations as on distant ones and in each case every tube is being fully utilized.

For best results it is wise to run the set with as little radio-frequency energy as is necessary to operate the detector. Obviously, if the tubes are overcrowded with radio energy which is wasted by the detector, there is little room left for satisfactory audio amplification. The first thing that happens upon boosting the radio too high for a given station is poor quality, generally known as distortion. If boosting of the radio amplification is still continued, the excessively strong radio currents will set up powerful magnetic fields about the radio-frequency transformers. These fields when strong enough react upon each other, causing howling. Howling is a sure sign of too much radio amplification, and poor quality means that the limit of the tubes is being approached. The remedy in either case is adjusting the 400-ohm rheostat. On distant reception, this resistance will be nearly if not all out. On local stations it will be practically all employed.

The mica condensers used for by-passing the radio are so connected in the circuit that the plate voltage is constantly across them. If these happen to be slightly leaky a crackling sound is continuously produced. These condensers are mentioned because this is a special problem that arises in duplex circuits.



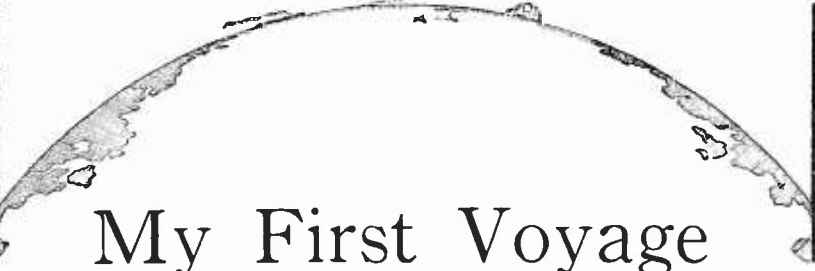

# My First Voyage As a Sea-goin' Telegrapher

Sea-sickness, Home-sickness, Practical Jokes, Bed-bugs and Shipwreck,  
If Taken in a Single Dose, are Likely to Make One Sick of the Sea

By A. HENRY

**G**OOD MORNING, Sparks!" bel-  
lowed the Captain as he grabbed  
a fried egg in each hand from a  
platter in the centre of the table  
and flopped them one on top of

the other on his plate. "What kind of a night  
did you have and how  
do you feel?"—this  
last with a twinkle in  
his eye—"Here's your  
seat, right beside me,  
so's I can see that you  
behave yourself."

"Good-morning,  
sir," was my reply, "I  
never felt better in my  
life and it is a pleasure  
and honor to occupy  
the seat next to the  
Captain."

Whatever possessed  
me to add the touch  
of blarney I have no  
idea, but it must have  
been a master stroke,  
for it struck the old  
fellow just right. Any-  
one, even as inexperienced as I, could have  
seen that the Captain was pleased, for his chest  
went out and he sat straight up on his stool and  
made room for me to pass behind him.

Possibly you dislike descriptive narrative as  
much as I do, but in order to let you appreciate  
the utter ridiculousness of my position, it is  
necessary for me to ask your indulgence.

Shortly after my father had seen me safely  
aboard the Standard Oil tug *Astral* (for I had

never before been away from home alone), he  
departed and left me to my own devices.  
After unpacking my bags and tinkering with  
the radio equipment for awhile I fell gladly  
into my bunk and into the arms of Morpheus.  
Meanwhile, our tug pulled out from the coal

dock, picked up the  
barge we were to tow,  
at dawn, off Staten  
Island, and made for  
the open sea and ports  
to the south. So, by  
the time the mess  
boy poked his hand  
through my door, ring-  
ing a huge bell and  
bawling "Breakfast,  
*Breakfast!*" we were  
well beyond Ambrose  
Channel Lightship and  
down the Jersey Coast.

I had jumped up,  
dressed in a hurry and  
made every effort to  
look as presentable as  
possible, putting on a  
good suit, a collar and

tie and shining shoes which were hardly in need  
of the attention. The Captain's remarks, as I  
entered the mess-room, were at once discon-  
certing and reassuring, for I had expected to  
find the Captain more sedate—the fact that  
good nature beamed from every wrinkle of his  
weather-beaten countenance and that he  
seemed anything but unapproachable smashed  
some of the theories about captains that one  
learns in a radio school.

## Have You Taken Your First Ship to Sea?

In this article, the author, who has spent  
many years in radio as an amateur, a sea-going  
operator, an investigator of long-wave phenom-  
ena at high-powered trans-ocean stations,  
and an instructor in radio at an army officers'  
training school in the A. E. F., tells of his  
first trip to sea. There is much about it that  
one would not relish—but it is life in the rough.  
One article of this series by A. Henry appeared  
in RADIO BROADCAST for March under the  
title, "What About Operating as a Career?"  
In a third article of this series of true stories  
about radio as a career, Mr. Henry will tell,  
next month, of his first passenger assignment.

—THE EDITOR.

The mess room (that word "mess" always grated upon my nerves and I could never bring myself to think of "food" and "mess" being at all synonymous and it was very difficult to refrain from calling the room in which the process of eating was accomplished, the "dining-room") was an institution of an entirely new character to me and is, no doubt, to many of the young fellows who leave good homes for a life on the ocean wave. The room itself was located in the forward part of the main deck housing just beneath the pilot house. There were several port holes in the forward bulkhead and two on either side. Entrance could be made through doors from the deck on either side, or through the companionway from the galley—which in everyday language means kitchen. This last was used only in heavy weather. A huge table filled most of the room and chairs were out of the question; we sat on stools. If the sea was the least bit frolicsome, the stools might be found individually or collectively cavorting about beneath the table. After reclaiming one, the reminder that there were others by a crack on the shins invariably resulted in a volume of anything but edifying ejaculations—and a laugh all around. In seas of this sort, racks were put on the table and the cloth put over the racks. The racks occasionally prevented one's plate of soup from unceremoniously becoming tired of being respectable and racing across the table into someone else's lap.

Upon recovering from the temporary embarrassment brought about by the unceremon-

ious reception of the Captain, and seated solidly upon my stool, I was introduced in a general sort of a way to the others at the table.

"Sparks," said the Captain, his fork poised deftly in his left hand and his knife pointing in the direction of a begrimed gentleman whose sole preparation for breakfast could only have been a wash of the "lick-and-a-promise" variety, "that old-looking duffer over there is the Chief Engineer. Engineers ain't good fer nothin' but makin' trouble and this particular one is worse'n most. You'll find out, when you need juice for that wireless business o' yours. If it wasn't for his assistant who's on watch now and that oiler over there—pointing to another gentleman whose upturned coat collar was intended to disguise the fact that he was at the table in his undershirt—this old tub wouldn't ever leave the dock. It's always boiler tubes or spark plugs or somethin' goin' wrong and he don't know what it's all about. Look out for him, boy, he's a bad actor." And with these remarks, stuffing a jellied pancake in his mouth, using his hand for a pusher, he made his departure before the Chief Engineer had time to reply.

Then the Mate came in and occupied the Captain's chair, smiling in my direction and wishing me good-morning. He was entirely different from the other men and reminded me of ads I had seen for young men's clothes. If Douglas Fairbanks had been romping on the screen in those days, no doubt he would have reminded me of him. A young, powerful giant and possibly the only American among

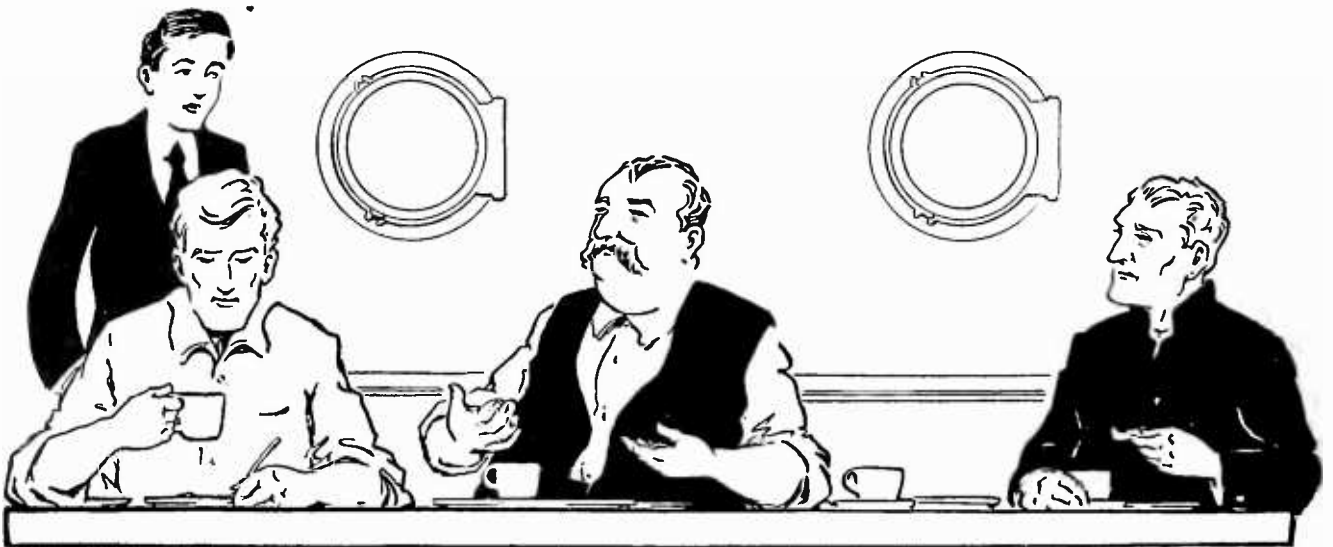

"GOOD MORNING, SPARKS!" BELLOWED THE CAPTAIN

As he grabbed a fried egg in each hand from a platter in the centre of the table and flopped them, one on top of the other, on his plate

the Norwegians and Danes and Englishmen and Skyhoovians who made up our crew. And his speech was as perfect as one would wish. In others words a gentleman. Here, thought I, was one who could teach me much of the world and in language I could fathom. Here was a young man, second in command, who held the respect of his subordinates, some of them twice his age, because he knew his job and even the old salts could not bluff him.

Everything seemed to be going along very nicely. My new acquaintances were surely rough diamonds—but diamonds, none the less.

I went back to my room and listened-in for awhile, finally starting my transmitter and calling the barge we had in tow, which was also equipped with radio. The operator happened to be on and we agreed upon a regular schedule for communicating with each other. Following this we “chewed the rag” a little and signed off.

Most of my morning was spent in roaming about the vessel, “getting the lay of the land” and becoming acquainted with those men who had been on watch at breakfast time. About eleven o'clock, however, I decided to polish some of the bright work on the radio outfit and write a letter or two. On entering my room I found one of the mess boys lying in my bunk, his hands clasped over his stomach and a look of anguish on his pale face.

“Don't put me out, Sparks,” he begged, “I'm nearly dead. When do we get to Wilmington?” Then in a terrible fright he pleaded, “Quick! Quick! Air, Sparks, I'm dying.”

I dragged him out of the bunk, pushed him toward the door, grabbed him by the shoulders while I straddled his back and braced my feet against the top of the rail to prevent him from falling overboard.

“Gosh!” he sputtered, when it was over; “never so sick in my life. Better now—thanks --guess I'll drift in and get the table ready for lunch.” And he walked up the deck after the fashion of one who has lain long in bed. His knees were very wobbly.

I noticed that we were rolling around a little but felt anything but sick. I had a ravenous

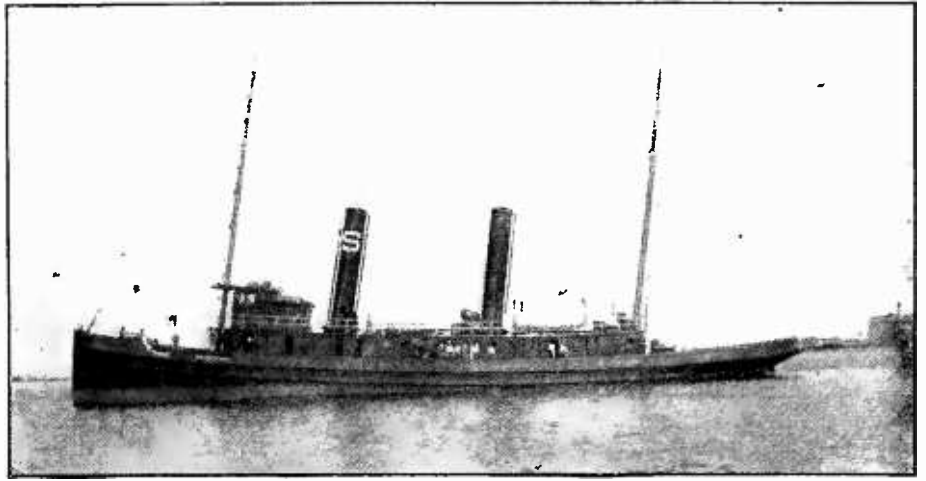

EVEN A TUG MAY BE A HAPPY ENOUGH HOME

If a fellow does not mind rearranging his digestion to function with the new variety of food he gets. This picture shows the S. G. T. (sea-going tug) *Astral*

appetite and waited with some impatience for the dinner bell to sound.

During the course of the morning stroll, I had picked up quite a little sea-going lingo and etiquette. For instance, one of the oilers said that it was customary to wait for the “Old Man” before taking one's place at the table, so under the guise of examining one of the lifeboats, I watched for him to leave his room for the mess room and then followed immediately.

We had soup. Mine was about half finished when I felt a sort of “all gone” feeling in the pit of my stomach. Cold perspiration began to appear on my brow and cold shivers raced up and down my spine. My appetite disappeared like a flash and I could feel the blood leaving my face. A weak feeling came into my knees and I gripped the under side of the table and didn't move. For a moment I felt better and then a thousand per cent. worse. I knew what was coming and excused myself, leaving the table amid a burst of uproarious laughter and mock sympathy, and a hundred suggestions for obtaining relief. I shall draw a veil over the events of the next two minutes. But afterwards, I felt much relieved, and returned to finish my lunch.

They were rather surprised and a little taken aback at my reappearance, but presently suggested many and contradictory remedies to ward off a recurrence of my malady.

“Stuff yourself, Sparks,” volunteered the Captain, and the Chief Engineer said, “Don't pay any attention to that old fool, Sparks, he can't even steer a straight course, much less practice medicine. You eat light and an hour after you're through, get a rope and tie it to a

bucket. Then drop the bucket over the side and get some sea water and drink two glasses every hour. That's a real cure."

Many other suggestions were made, but for the most part the men in the deck department agreed with the Captain, and the Chief Engineer's men agreed with him. As for me, I paid little attention to any of them and ate according to the dictates of my appetite, which might be characterized as indifferent.

Just before the after-lunch pow-wow was about to break up, the cook, who was a good-natured looking old devil, came in and said, "There's no use in ever gettin' sick again, Sparks, come on out on deck and I'll show you what to do."

Everyone left his seat and made for the deck as though it were a foregone conclusion that I was going to submit to the cook's treatment. The First Assistant Engineer confided, in a whisper, as we passed through the door together, something to the effect that the cook was the best doctor he had ever seen.

So they gathered around in a semi-circle having its opening in the direction of the rail, and the cook took his place beside me, saying, "Here y'are, just swallow this and you'll be all hunky-dory." He offered me a cube of salt-pork almost an inch on a side and to my objection that there was a string tied to it, he said that was to prevent choking if it stuck in my throat. After two unsuccessful trials I got it down and the cook then assumed the attitude

of a dentist about to pull a tooth. Holding on to the string he gradually retrieved the piece of pork. . . .

Some one cried, "He's sick, get a bucket." So they got a bucket, dropped it over the side, and a fellow with his arm around my neck offered me a glass brimful of salt water. I drank it, but it, also, stayed on my stomach but a few seconds. If you've ever been sea-sick, you know how I felt, but the treatment, severe as it was, must have been effective, for the wildest of seas never nauseated me again and that evening I enjoyed a good supper.

My radio duties were very light, so I retired early and was soon lulled to sleep by the drone of the engine and unsteady but now pleasant rolling motion. I had seen no sign of a bath tub and because I was too sleepy to have used it any way, inquiry concerning it was, for the time being, postponed.

During the night my sleep was made restless by an itchy feeling on my legs and neck. For a time I scratched myself in my sleep but a severe irritation on the back of my neck woke me and my return to consciousness was accompanied by a peculiar bewilderment and I was rolled around like a weighted toy clown as I sat in my bunk and switched on the light. When I woke, the itchiness disappeared so I sat in my chair and listened-in for awhile, gradually becoming sleepy and returning to bed. Before sleep overtook me, the itchy feeling returned and I sat up for another little while. This sort

of hide and seek went on for some time until, in scratching one particularly itchy spot, I felt something under my nail. I switched on the light and found that I was holding some sort of a red insect. Quick as a flash I tore the clothes from the bed and there they were—possibly a dozen of them—racing to get away from the light. I became acquainted with some uninvited guests of a species previously unknown to me. They were bed bugs! This part of my experience may best be told by merely stating that the bed was given over to the exclusive use of the nocturnal callers, while



#### LIFE ON A TUG IS HARDLY LIVELY

And a fellow welcomes an opportunity to paint the deck or shine brass or do any of the things the union might object to

the bed clothes, after a thorough shaking, served very comfortably when spread on the floor. (They call the "floor" the "deck" at sea, but it is just as comfortable for sleeping purposes, under either name.)

The next day I inquired for the bath tub and was led to a remote corner of the engine room, where a round wooden wash tub, of the variety used in old-fashioned country places, graced a stick which protruded from one of the steel ribs that held the ship's sides in place. Near by there was a steam pipe which could be swung in any direction. By inserting this pipe in a pail of water and turning on a valve, cold water could be transformed into hot at a moment's notice. It was necessary to carry the water to this "bathroom" from the deck above and the engine room grating and iron stair and lower deck was very slippery. To lose one's balance could result in a too intimate relation with the crank shaft and other heavy parts of the engine. I felt that the degree of privacy was about the same as one would expect in the bleachers at a world's series base-ball game. One soon learns to worry little about such delicacies, on a tug, however, and becomes quite adept at bathing beneath a noisy crank shaft or in a boiler room, emerging equally dirty in either case.

Nothing much happened for the next few days and I began to feel more of a sailor than ever. Plenty of food—of a strange sort to which I was becoming acquainted, for it was of an entirely new variety to me—plenty of sleep, and I was feeling a growing affection for the scribbler who penned the tale of "Life On the Ocean Wave."

At lunch there was some talk about approaching Diamond Shoals Lightship, which is located off Cape Hatteras, reputed among those who know nothing about it as the roughest point on the Atlantic Coast.

"Sparks," said the Chief Engineer, "how would you like to go up in a bos'n's chair and watch for the lightship from the mast-



#### ON A LINER, HOWEVER

There is so much "going on" socially that it is difficult to know which functions to pass up in order to get enough sleep to be able to stand the hours of watch!

head? The skipper will let you, won't you Cap'n?

To which there was an affirmative grunt and a few minutes later I was strapped in the chair and being hoisted up the mainmast by two husky deck hands. The masts on our tug were nearly ninety feet high and the expanse of water with not another vessel in view was a sight to fill one with awe. They permitted me to enjoy the scenery for a while and then began lowering me. The wind was in my direction and heavy black smoke from the stacks blew right at me. When I got to the midst of it they stopped the lowering process and let me enjoy the smoke. No black-faced comedian was ever as black as I, when they eventually did lower me to the deck. Of course they weren't looking for the lightship at all and the Captain and Chief Engineer had framed the joke up before lunch and the firemen produced all the smoke they could.

By the time we did approach Diamond Shoals Light, the head wind had changed to a gale and it took us two days to go four miles. Diamond Shoals remained off our starboard beam for two days and nights. On the third day, the wind abated and once again we were on our merry way, with the storm nothing but a memory. Of course I copied the press from the N. Y. Herald Station at night and HA (Cape Hatteras) in the morning. This, along with a daily



**THERE IS LITTLE NEED FOR A UNIFORM**

On a ship where the Captain calls the fireman "Joe" and the fireman calls the Captain "Bill"

message to the Standard Oil Co., the owners of the tug, completed my duties and there was plenty of time for sleep.

Awaking one sunny morning, I found that we were at dock in Wilmington, North Carolina, and there were several letters at my place at the table when I appeared for breakfast. They were all read and re-read before the meal was touched and the next thing to do was to make a combined sight-seeing and shopping tour of the city.

By the time the shopping, which included the purchase of lythia tablets and Peterman's Discovery to purify the ship's water and fight off my nocturnal visitors, it was lunch time and I enjoyed the customary mariner's choice of food after a voyage, namely, ham and eggs. A strange sort of feeling came over me as I sat alone, many miles from home—an experience I had never had before—and it was not wholly unpleasant.

After lunch, a trolley ride, and then back to the ship for supper to find someone to go to the movies with me. Several of us went and there was one of those "home and mother" thrillers being shown to the tune of an automatic orchestra that seemed to delight in playing ragtime regardless of the scene depicted on the screen. Then I became homesick. Just what the sickness is I can't tell you but it is worse than any other malady I've become acquainted with and I've had the "flu" and the malaria fever in Mexico where you get it correctly,

and the usual run of unpleasant though popular forms of sickness. I felt like crying and my head felt as though it would split. None of the others seemed to be in any such plight and you may be sure I was glad to get back aboard and asleep.

None of the sailors or firemen had gone ashore because the Captain would give them no money. He did give them some the next day, however, despite the fact that we were to sail for Baton Rouge at noon.

My morning was spent writing letters and post cards and taking a few pictures.

One by one, the men began returning in various stages of insobriety. This all occurred some time prior to the passage of the Volstead Act. During lunch, the firemen's and sailors' mess waxed quite noisy but there was no real excitement until the firemen told the mess boy to tell the cook the potatoes were not cooked and they wanted cooked ones. In no uncertain language the cook told the mess boy to give the firemen his compliments and tell them to go to the devil. He, too, had imbibed a bit too freely of the flowing bowl. The mess boy did as he was bidden and a delegation of firemen immediately made their way to the galley to talk it over with the cook. That gentleman lost little time talking and by way of demonstrating his feelings in the matter punctured one fireman's chest with the point of a carving knife. The injured one gave an unearthly yell and several of us ran into the galley in time to see the firemen in the act of setting the cook on top of his stove. Before the Captain could bring order about, the air had become well permeated with the odor of burning flesh.

Here indeed was adventure of the most blood-curdling variety. I was less than two weeks on my trip to experience, and here, before my very eyes, was a man saved from being roasted alive while another had just been stabbed but a few feet from where I was enjoying a mid-day repast. Verily this was Diamond Dick and Nick Carter and Jesse James stuff all rolled into one. It was better than the movies because it was real.

Due to the performance in the galley, our departure was somewhat delayed, but night found us once again in the open sea and bound south.

During the beautiful days that followed I tore down the four bunks in my room and applied so much Peterman's Discovery that I'm afraid he will have to discover a substitute, but all to little avail. One of the sailors sold me a hammock which he told me was made at Sailor's Snug Harbor. That was one of the best investments I ever made, and the only trouble was that the Captain frequently woke me in the morning by upsetting it and dumping me on the floor which he thought a huge joke.

And thus the days rolled by until we approached the coast of Florida when I was made the butt of many a joke, such as bottling water from the Gulf Stream and sealing the bottle. This water was supposed to turn to Florida Water in a month and to have a delightful odor. There was some truth in its being Florida water, I suppose, and after a month it surely had an odor.

In sailing south it is quite customary to pass between the Gulf Stream and the Florida Coast and it is not an uncommon thing for

vessels to travel near enough to the shore for those on board to see the famous winter resorts at Palm Beach and Miami as well as people in the surf. We looked forward to this sight and I retired to my hammock somewhat earlier than usual so as to be on hand when the beauty spots were to be seen in the morning.

A rather rough hand began swinging my hammock in an uncomfortable up and down motion. I woke and remember saying, "Cut it out! Cut it out!" without so much as opening my eyes.

In a moment or two my hammock was again shaking violently and when I awoke one of the Norwegian sailors with whom I had become quite chummy was tugging at it and calling to me in broken English.

"Spark! Spark!" he shouted, "get up, hurry up, *Astral* run on beach, Captain come in. minute wireless for help."

At first I thought it was another hoax but his face surely wore a troubled expression and I was brought to realize the seriousness of the situation by an occasional thud which meant that we were aground and getting a bumping. Grabbing a bath-robe I rushed for the deck where I could hear the roar of the surf breaking on the beach and it seemed but a stone's throw

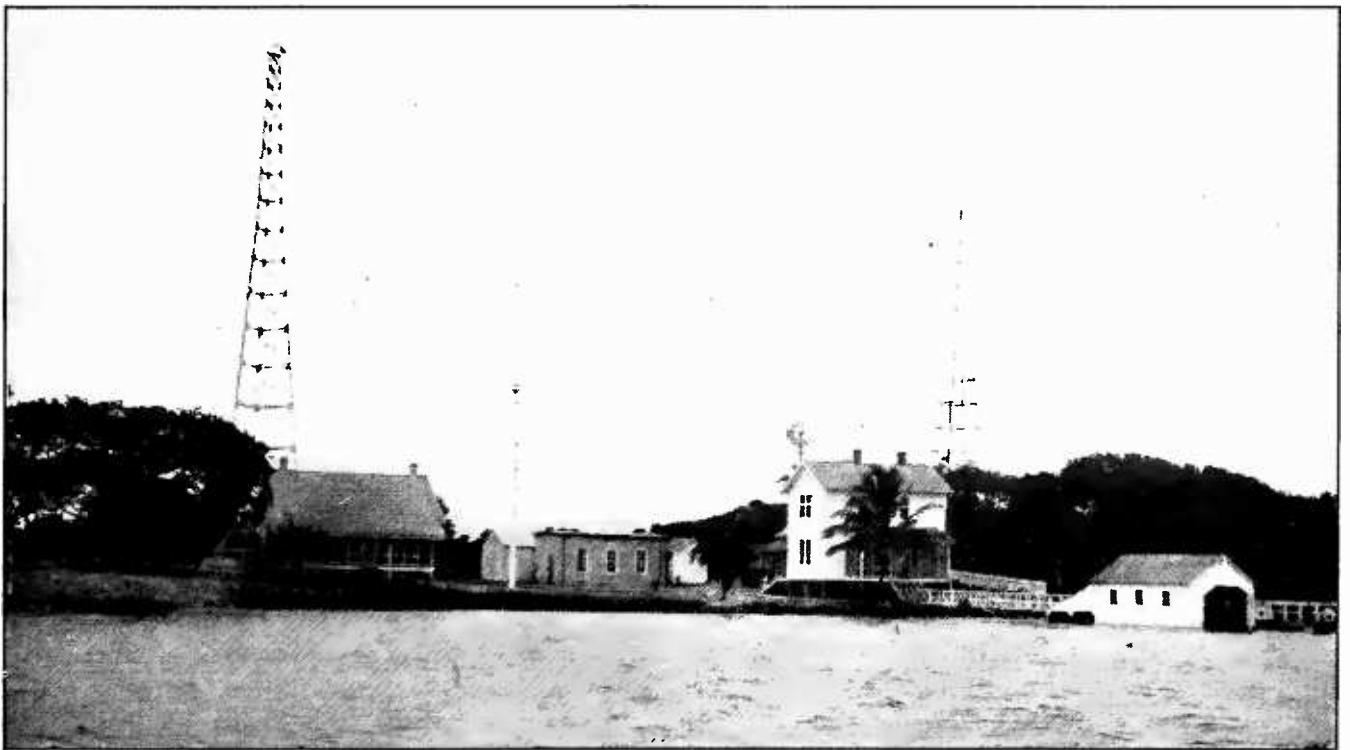

THE U. S. NAVAL RADIO STATION AT JUPITER INLET, FLORIDA  
This was but a few short miles from the point where the *Astral* struck the beach, yet the SOS rent the ether for four hours before an answer was received

from our vessel to where there was a lighthouse. Men rushed up and down the deck while the mate bawled orders on the after deck and the Captain bawled his from the pilot-house window. The barge we had been towing was closing in on us and looked for a time as though she would ram us, but we saw her, too, pile up on the beach.

Men on the after deck were grappling with hawsers and chains and slice bars in an effort to get the rudder, which had broken, under control, but they were making little headway and every swell drove us against the bottom with a sickening thud. I went back to my room and called the barge by radio but could get no answer. The captain sent a message to me by a sailor and wanted it sent to the barge. There was only one way of getting it across and knowing that it was received and that was by sending the code symbols with a light. All the hand flashlights were engaged so there was nothing to do but connect a switch in the line to the main mast light. By standing on the engine room settee with my head poked through a port hole and manipulating the switch, the message was sent and a flashlight on the barge signalled back the answer. A second message from the barge told me that the operator could receive by wireless and would answer by flashlight. That helped a lot and we shot messages from one captain to the other with little loss of time. We were within plain view of the Jupiter Inlet Lighthouse and I made an effort to raise the Jupiter Inlet Naval Radio Station but to no avail.

The Captain came fuming into my room and wanted to send a message to the Naval Station and went into a tantrum when I told him it couldn't be done. Eventually he reappeared and told me to call for help.

I threw on all the power there was and boomed out SOS several times, followed by a message the Captain gave me, telling our position and condition. Then I listened but heard nothing. After repeating this discourag-

ing performance four or five times it occurred to me that my receiving set might possibly be inoperative, though an occasional burst of static did get through. So I called the barge and asked the operator to reply by the flashlight method if he heard me and if he had heard any response to my distress call. The flashlight told me that our signals were very strong but that no replies had been heard. We could not understand the silence of the Navy radio station and my SOS kept droning a periodic tattoo upon the ether for nearly four hours. Then the operator at the Jupiter Inlet Radio Station informed me that they had heard our first call and had followed our operation ever since. They could not reply because of trouble with the gasoline engine that drove their generator.

In the meantime, however, they had been able to get another station by land wire and through it had reached a revenue cutter, which was speeding to our relief and had been for nearly three hours.

This news delighted the Captain, who had begun to call radio all sorts of names, not the worst of which was "a useless damn nuisance."

The night was a strenuous one for all hands and it was a great relief to get in communication with the Revenue Cutter *Yamacraw* and later have the beam of her powerful searchlight thrown upon us. Little could be accomplished in the darkness, however, and no great harm could result from waiting until morning.

The cutter had little difficulty in towing the *Astral* and the barge off the beach and then towing both to Jacksonville, Florida, where we spent a few days in the dry dock. They found our tug in worse shape than we expected and, to make a long story short, I was sent back to New York. The only regret I had at my homecoming was that I was out of a job, but that was fairly well repaid by the reception accorded me by my family, to say nothing of the local press which capitalized on a lot of bunk hero business.





# Jacks and How to Use Them

By G. Y. ALLEN

Westinghouse Electric and Manufacturing Company

THE use of plugs and jacks for quickly making and breaking electrical connections dates back to the early days of the telegraph. When the wire telegraphic art had developed to the point where more than one line came into an office, it was found desirable to provide for connecting quickly any line to any instrument, and for this purpose it became the practice to have each line end in two brass blocks with tapered holes, and to provide the ends of the wires leading to the instruments with tapered brass plugs, as shown in Fig. 1. With this

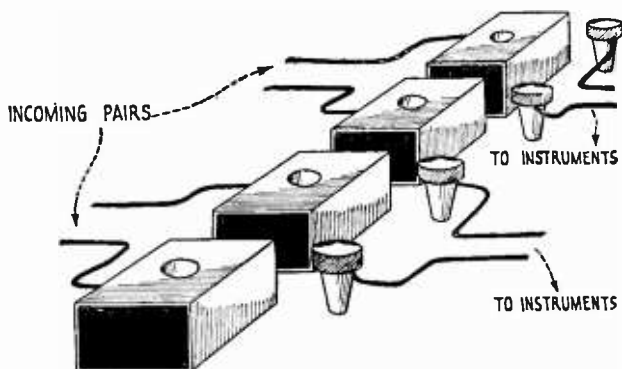

FIG. 1

How connections were made in the early days of the telegraph

system, any instrument could be connected to any incoming line.

Flexible leads were found to be troublesome, and so the practice of connecting the plugs to the line was somewhat later superseded by connecting the incoming lines to vertical brass strips such as are shown at A, Fig. 2, and to connect the instruments to brass blocks arranged in a horizontal line, as shown at B. By inserting tapered plugs in the holes, which are drilled half in the vertical blocks and half in the horizontal blocks, any instrument could be connected to any line.

Another early telegraph jack is shown in Fig. 3, and was known as the spring jack. It differed from the earlier types in that the pressure was supplied by a heavy spring and thus was more constant and reliable than the tapered pin type. When the plug was inserted, the contact surfaces were automatically cleaned

of any dust that might have accumulated, and thus one fundamental feature of good plug and jack design was discovered and incorporated in one of the earliest of the jacks developed.

It will be noted that the two types of jacks mentioned are single-circuit jacks. That is, two operations were necessary to change the two wires of a circuit. This is unquestionably the most flexible arrangement, but at the same time is the most cumbersome where the most frequent operation involves a change of two wires. It is a simple transition from the simple circuit jacks above mentioned to the type shown in Fig. 4. Here the two plugs are merely mechanically attached together by means of a piece of insulating material. Such a device, while being simple to make, has disadvantages, among which is the comparatively large amount of space that it occupies and furthermore the difficulty involved in getting the prongs of the plug and the holes in the jack in perfect alignment.

The development of the telephone art is responsible for the remarkably compact and efficient plugs and jacks that we have to-day. The big problem in the telephone practice is, of course, to provide for making connections between any two of the myriads of lines quickly and perfectly. For the sake of economy in operators, and to reduce the time required to complete connections to the minimum, compactness in the design of jacks and plugs is essential and very early in the telephone de-

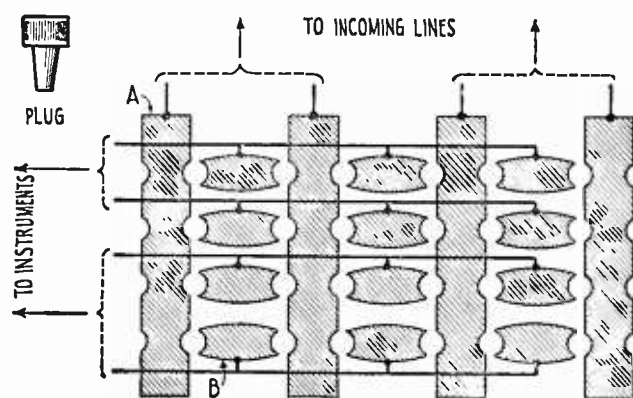

FIG. 2

Flexible leads were avoided with this system

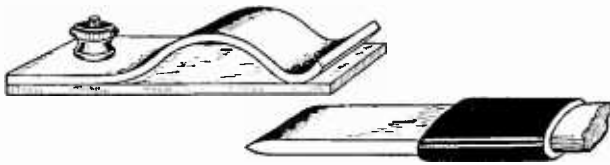

FIG. 3

The spring jack. One plug made one contact

velopment the cylindrical type of plug, comprising two and three circuits, was evolved.

The two-circuit plug consists of a metal shell called the "sleeve" carrying within itself and insulated from it, a metal pin mechanically and electrically connected to a ball-shaped piece called the "tip." The flexible cord is connected with one terminal to the pin and one to the sleeve.

When inserted into the jack, a flat spring is arranged to make contact with the tip and one with the sleeve. In some of the designs, the part of the jack through which the plug passes is made of metal and serves the dual purpose of guiding the plug and making electrical contact.

Very early in the history of the telephone, it was found necessary to develop a signaling system so that the act of inserting a plug into a jack would not only make the desired electrical connections between lines, but would also indicate, either through a mechanical or electrical indicator, that the plug had been inserted. In some systems, it was found necessary to complete additional electrical circuits on inserting the plug. These requirements soon were met by many ingenious attachments to the jack and plug, some of which operated mechanical signals right at the switchboard and some of which operated additional electrical circuits.

The mechanical devices, some of which are in use to-day, were generally actuated by the spread of the springs when the plug was inserted. The electrical circuits were controlled either by making or breaking contact through

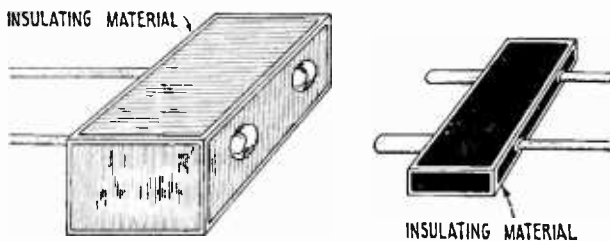

FIG. 4

This improvement was also cumbersome, and the prongs did not always fit. Later, each block, had one hole and one plug, to prevent the reversal of polarity

the spread of the springs on inserting the plug, or by means of relays which were controlled by local circuits operated as above. One development that is only of passing interest to the radio user was the three-circuit plug and jack which is in use in all of the large telephone exchanges to-day. The plug was provided with three contact making portions known as the "sleeve," the "ring," and the "tip." The ring and the tip comprised the talking circuit and the sleeve in conjunction with one of the other parts completed the control circuit. This plug is not generally used in radio, as other types seem to do the work more satisfactorily.

When radio communication was in its infancy, the telephone art was a full grown child.

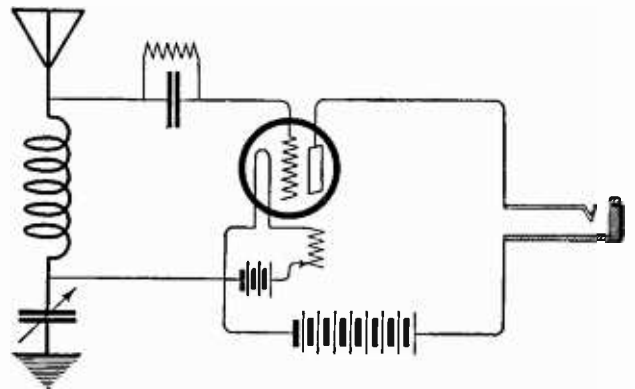

FIG. 5

The simplest method of using a jack in a circuit. This is an open-circuit jack, and it merely connects the telephones

It was but natural, therefore, for the younger art to absorb from its predecessor those developments which applied. Practically no change in the fundamental design was necessary, as the audio-frequency currents in a radio receiving circuit are of telephone magnitude and frequency.

The widest use of the plug and jack has been in the head telephone circuit. Since the advent of the vacuum tube and its use in amplifiers, it has been found very desirable to be able to change the head set quickly from the plate circuit of the detector tube to the plate circuits of any of the amplifying tubes. To accomplish this conveniently, the practice has become common to provide radio sets with as many jacks as there are tubes and to provide telephone head sets with plugs. A standard size plug has become common, this plug being one of the standard sizes adopted in telephone practice.

The first plugs employed were identical with those used in the telephone field. The diameter

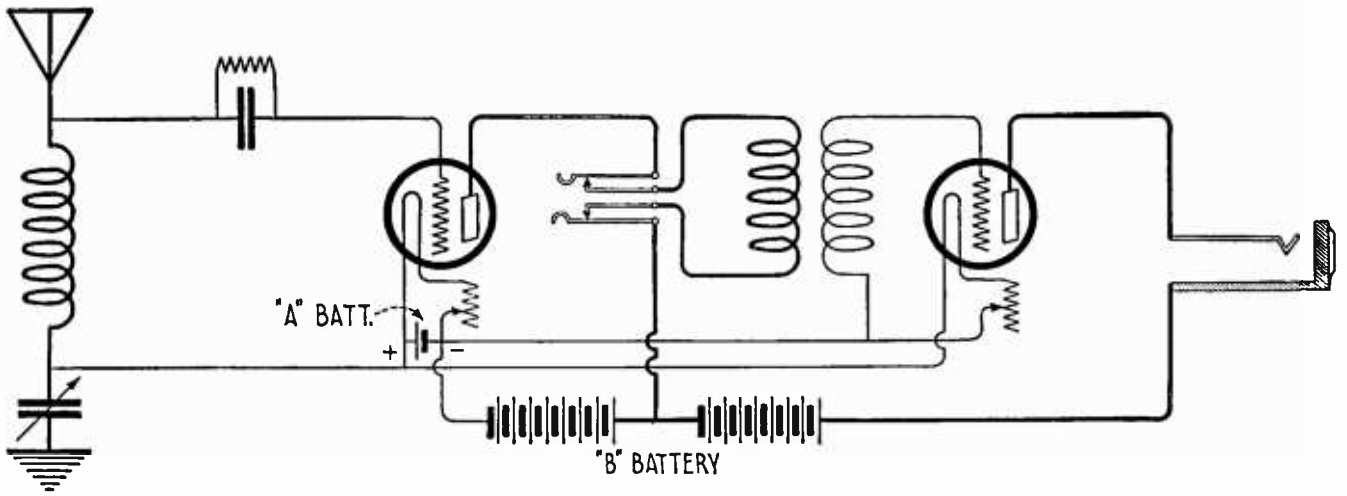

FIG. 6

When the plug is placed in the first jack, the A. F. transformer is cut out. When the plug is withdrawn, the transformer is connected, and the telephones are then placed in the second jack

of the handle was very small, which was a desirable feature in telephone practice on account of the necessity of having to place jacks as closely together as possible. The available space for making connections to the flexible cord, however, were very meagre and required a special type of cord terminals.

Now, in the radio field, the requirements are somewhat different. In the first place, the space requirements are not so rigid and furthermore there had grown up a practice among the manufacturers of head telephone receivers of attaching pin terminals to their cords. The conventional telephone plug would not take these terminals, of course, and the temporary result was that special cords were required whenever it was desired to use a plug.

This condition soon stimulated manufacturers to design a special plug for radio purposes that provided means for attaching the plug to the standard pin terminal cord. In fact, some of

the plugs on the market to-day will take practically any kind of cord tip, either pin, spade, or plain wire.

CIRCUITS EMPLOYING PLUGS AND JACKS

THE simplest circuit in which a plug and jack may be used is one involving the connection of a head set to a simple crystal or vacuum detector set with no amplification. The elements of this circuit are shown in Fig. 5. The only reason for using a plug and jack here would be in the event that it was desired to use the same head set on other sets or that it was desired to remove the head set frequently for some other purpose.

The simple jack may also be used for connecting the head set to any of the stages of a multi-stage amplifier, but with an efficiency below that which may be obtained using a pair of auxiliary springs.

The simple jack may also be used in any of

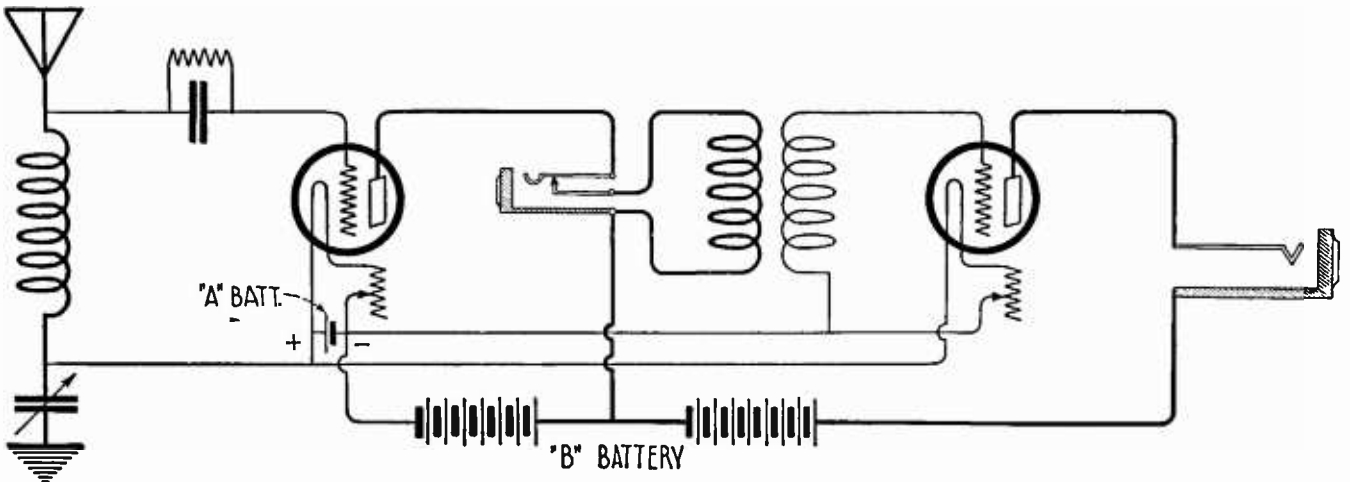

FIG. 7

This arrangement is similar to that of Fig. 6, except for the difference in the type of jack used

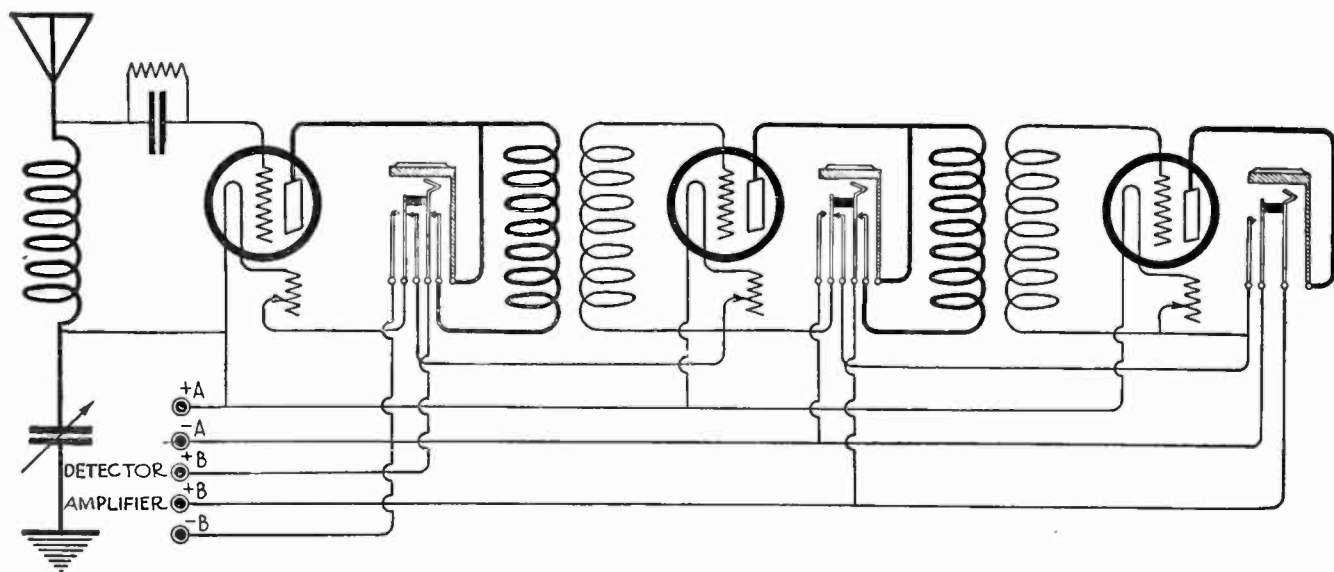

FIG. 8

An automatic filament control is provided by the multi-contact jacks shown here

numerous other places where circuits are to be disconnected rapidly. For instance, the antenna wire and ground wire also, may be provided with plugs which may be plugged into jacks mounted in the set. In non-regenerative sets, it is not advisable to use the same plug or jack for both antenna and ground, although there would be the requisite number of circuits. The reason for this is that the insulation in both the plug and jack operates to raise the effective resistance of the antenna circuit which will reduce the strength of the received signal. In regenerative sets, the increase in antenna resistance caused by the insulation of the plug and jack can be compensated for to a certain extent by the regenerative feature. The effect of the capacity in both plug and jack,

however, which will increase the effective antenna capacity and thus reduce the amount of inductance with corresponding reduction in signal strength and selectivity, cannot be compensated for, and in general it is best to use two separate plugs and two separate jacks for antenna and ground.

A very convenient method of mounting a small loop antenna consists in providing the end of the mounting stick with a plug and arranging a jack in a vertical position to receive the plug. The ends of the loop are connected to the plug and the circuit completed through the jack. The loop may be instantly removed if desired, and may also be turned in any direction.

Undoubtedly the most popular use of jacks

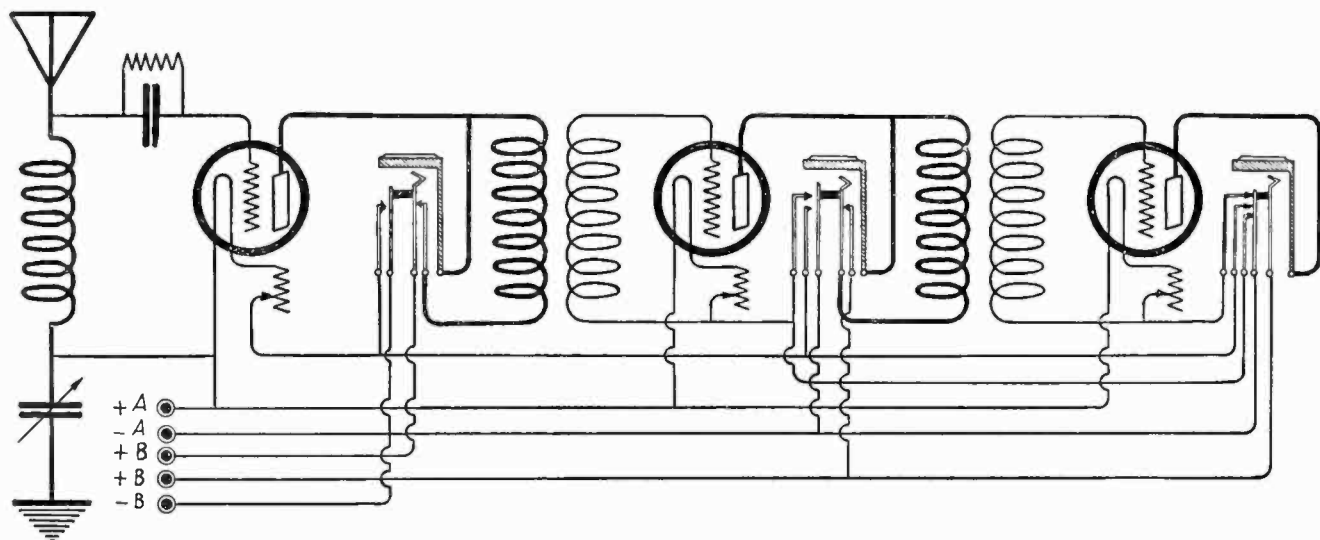

FIG. 9

Three types of jacks are used in this arrangement, the chief difference being in the number of filaments controlled by each jack: the first controls one, the second two, and the third all three filaments

in radio sets to-day is to change the head set or loud speaker from one stage of amplification to another. To accomplish this efficiently, one or two additional springs are needed on the jack. Figs. 6 and 7 illustrate the schematic connections.

An improvement on the more simple arrangement shown herewith is a connection in which all filaments are extinguished except those that are in actual use. That is, when it is desired to use less than the entire number of stages of amplification only the filaments of the tubes used are connected to the circuit, thus saving both tubes and batteries. To do this complicates the wiring somewhat, especially when there are more than two stages of amplification, but if less than the maximum number of stages are used frequently, the extra complication is well worth while on account of the economy involved. Furthermore, with the more uniform tubes that are now being produced, the tendency is toward the use of fewer filament rheostats, and as the filament rheostat on most sets is the only means of control, the filament control jack is becoming more and more desirable from the standpoint of economy.

Two methods of automatically controlling the filaments are shown in Figs. 8 and 9. By following these two circuits out it will be seen that only the filaments of the tubes in use are operated. The circuit shown in Fig. 8 requires jacks with three extra springs for the detector

and for all stages except the last, where two additional springs are needed. The circuit shown in Fig. 9 requires a different type of jack for each position.

At times, it is desired to use the amplifying part of a complete two-stage amplifier, detector, and tuning set with another set in which no amplifier is provided. This is particularly true in the case of very complete amateur stations where a number of different sets are used to get different wavelength ranges. It is desirable in such cases to provide the amplifying set with means to facilitate these connections.

A suitable wiring diagram that provides for great flexibility in this direction is shown in Fig. 10. The terminals marked "External A battery" are for connecting to the A battery terminals of the detector tube set. It is intended that the terminals of the non-amplifying set that are normally connected to the telephone headset shall be connected to a plug and that the plug shall be inserted into the jack marked "External Detector." With the connections shown, the filament control feature is retained and only the tubes in actual use will have their filaments connected to the battery.

It may be well here to say a word to the uninitiated on the use of sets using filament control jacks. The filament of a vacuum tube draws an appreciable amount of current and therefore the voltage drop in all of the filament

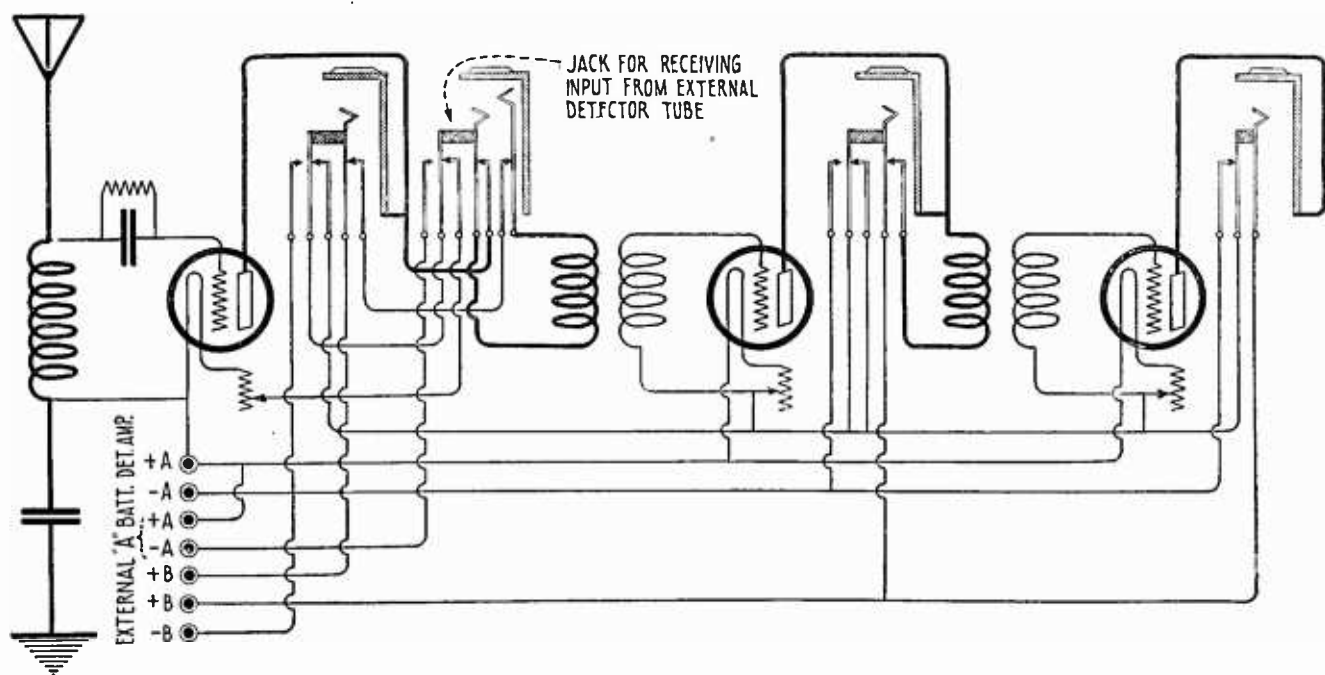

FIG. 10

By this arrangement, the signals from any receiver may be amplified by using the amplifying part of this complete receiver. In this case, the tuning elements are automatically cut out and those in the external set are used

wiring is an appreciable percentage of the voltage drop across the filament. Now, assume that the telephone plug is inserted in the detector jack and all adjustments have been carefully made. On attempting to use the amplifier, by shifting the plug to the amplifier jacks, it may be found that the added voltage drop due to automatically cutting in the additional amplifier tubes may be sufficient to decrease the detector tube filament current below its most sensitive spot. It is well, therefore, to readjust all filament rheostats after changing the number of stages of amplification used in any filament control jack set.

Various other uses of jacks will suggest themselves. In small tube transmitters, the favorite key or telephone microphone may be plugged into any one of more sets by suitable jack connections. Experimental sets can well afford to use jacks and plugs to facilitate the trial of any connections that may be desired. Two-circuit jacks should seldom be used in radio-frequency circuits on account of the losses in the insulation at these high frequencies and also on account of the capacity added. When it is desired to use jacks in high-frequency circuits, a separate jack should be used for each wire.

#### TYPES OF PLUGS AND JACKS

ALTHOUGH both plugs and jacks are comparatively simple devices, yet there are several points in their design that very largely determine their efficiency. One of the

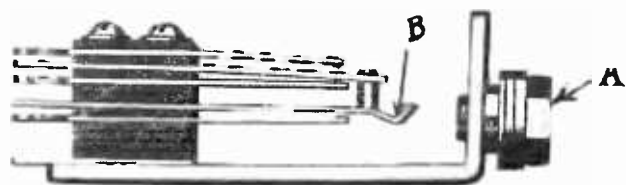

FIG. 11

prime requisites of any electrical connection, of course, is that it shall give good electrical conductivity at all times. This requirement is particularly important in circuits employing telephone receivers because the slightest variation in contact resistance, even though the average conductivity of the circuit may be good, can be heard. And with vacuum-tube amplifiers, any slight variations in circuit resistance in the detector or first stages of amplification are heard in the head set as loud responses. It is thus important that the design of jacks for

radio work be such as to remove the slightest possibility of poor contact.

The points constituting good design of both plugs and jacks can perhaps be best illustrated by showing photographs of actual apparatus.

Fig. 11 illustrates a jack of a type commonly

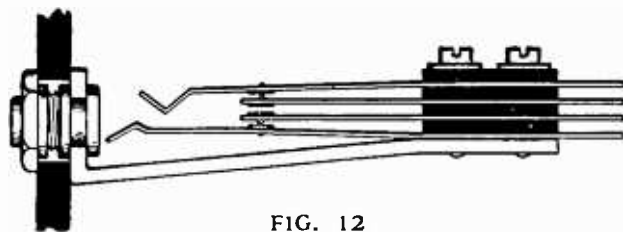

FIG. 12

used. The frame is made of sufficiently heavy metal to give rigidity and to permit the engagement of enough threads of the screws to prevent stripping of the threads. Micarta, bakelite, and hard rubber are satisfactory for insulation between springs. Fibre should never be used, as it absorbs moisture, which reduces the insulating qualities and furthermore its physical dimensions change with variations in atmospheric conditions, which may either strip the threads or lessen the springs. Springs should be either of German silver or of phosphor bronze, and should be heavy enough to exert from one to two pounds pressure against the plug. The springs should in all cases be long enough so that when the plug is inserted they will not be bent in any one position sufficiently to exceed the elastic limit of the material from which they are made. Otherwise, the spring pressure will gradually diminish.

All auxiliary contacts should be designed so that in addition to moving in a direction perpendicular to their surfaces, they will have a wiping effect. This is necessary to keep the surfaces clean of dust and to insure good contact at all times.

As all plugs are standard and as the dimensions of the tip must be small, the tolerances in

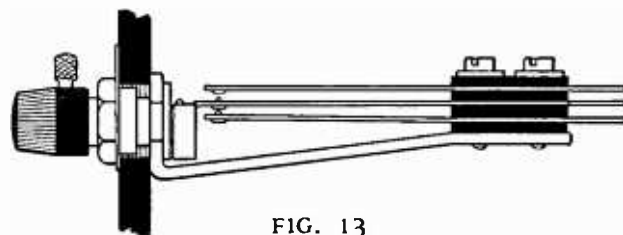

FIG. 13

the distance from the surface A to the centre of the tip spring B in Fig. 11 must be small. In this particular design, washers are provided

to maintain this distance constant when the jack is used on panels of different thickness.

A jack of somewhat different construction is shown in Fig. 12. It will be noted that the frame of this jack is so bent that the large pile-up of insulating material is avoided. Also, the part of the jack that guides the plug is rigidly attached to the frame, thus maintaining a constant distance between surface A and the middle of the tip spring without the use of washers for different

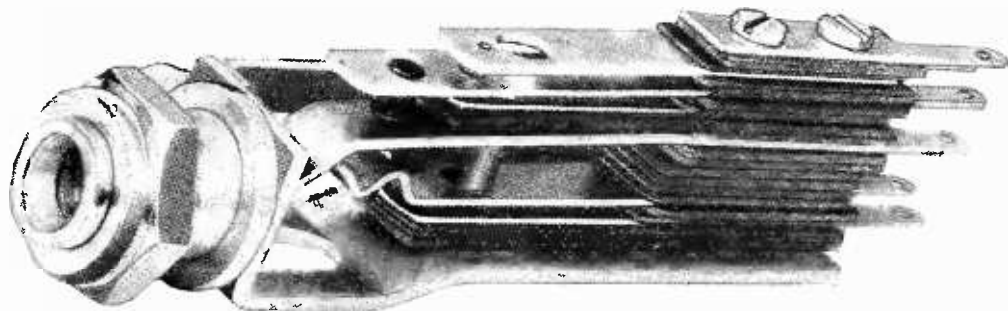

FIG. 14

This heavily built jack has two spring contacts and does not rely on the sleeve for connection to the plug jacket



Left: This jack extends but an inch in back of the panel. Soldered contacts are unnecessary



Right: Same as above, but of the double-circuit type

FIG. 15

thicknesses of panel. A good appearance on panels of all thicknesses within the limits of application is preserved through an ingenious design of hexagon nut.

On this particular jack, auxiliary contacts of pure silver are used. This metal seems to give excellent results when very small currents are to be broken.

An interesting and useful adaptation of this type of this jack is shown in Fig. 13. A cam has been inserted in the guide sleeve, and by turning the knurled head, many types of circuits can be controlled.

Fig. 14 illustrates a radically different construc-

tion. In this type, the frame is of the angle type which makes for extreme rigidity. The contact between the sleeve of the plug and the guide surface of the jack is not relied on for electrical contact, but a spring is used for the sleeve as well as for the tip. It might be stated here, that a point of good jack design requires that all jacks relying on the plug guide for contact should always have all springs pressing on one side of the plug only. If springs are applied to both sides of such a jack, there is a possibility of the spring pressures on the opposite sides of the plug just balancing, which may cause the plug sleeve to make poor contact with the plug guide.

A jack differing somewhat in its basic design from those already described is shown in Fig. 15. As will be seen, all springs are mounted on a circular piece of insulating material which in turn is attached to the back of the panel. This type of jack is much shorter than the conventional type and, where it is not necessary to mount them closely together, it gives excellent results. One convenient feature of this type is that screw connections make it unnecessary to solder the connections.

The jack shown in Fig. 16 is designed for a totally different field than those heretofore described. It is intended for mounting wholly

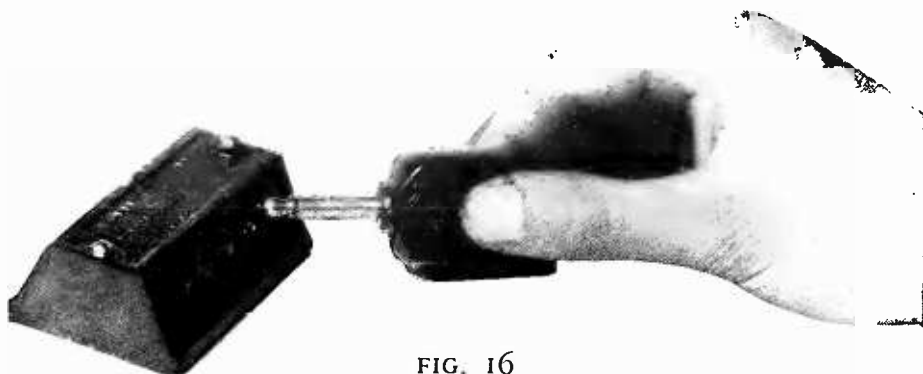

FIG. 16

One, two, or three pairs of telephones may be plugged into this jack at the same time



FIG. 17

This plug will take two sets of telephones

outside the set and is more adapted to completed sets that do not have jacks as a part of their regular equipment. It is made in the one type only, and has provision for taking three plugs. The springs are so arranged that all plugs are connected in series with the circuit and on withdrawing a plug, the springs of that particular jack are short circuited so that, regardless of the number of plugs used, the circuit is continuous. The instrument is made from moulded composition and presents a neat appearance.

As stated at the beginning of this article, the modern plug designed for radio can be used with cords with pin terminals. Various methods have been devised for securely holding the cord terminals, and much thought has been applied to reduce to a minimum the number of tools required to make connections. Many of the plugs on the market can be attached to the cord with no tools at all while others require but the assistance of a small screw driver or thin coin.

A cylindrical type of plug that requires but a thin coin for making connections is shown in Fig. 17. One of the advantages of this design is that two head sets may be connected to the same plug if desired. The holding screws are arranged to take any type of terminal. The composition cylindrical cap may be unscrewed from the plug without tools.

A plug with a split moulded handle is illustrated in Fig. 18. A screw driver is needed in this case to make the connections.

The plug illustrated in Fig. 19 is also of the moulded split type, but has the outstanding feature that no tools whatsoever are necessary



FIG. 18

You need a screw driver to fasten the telephone terminals in this plug

for making connections to the cord tips. Thin steel springs tightly grip the tips, making very good connection. This type of plug, however, is not adapted to taking spare terminals.

For the sake of those not fully acquainted with the uses of jacks in various circuits different types are given in Fig. 20.

In conclusion, let it be said that with the numerous well designed plugs and jacks on the market to-day, there is no excuse for the radio manufacturer, be he professional or novice, for incorporating poor jacks into his radio set. Although comparatively small in size, they

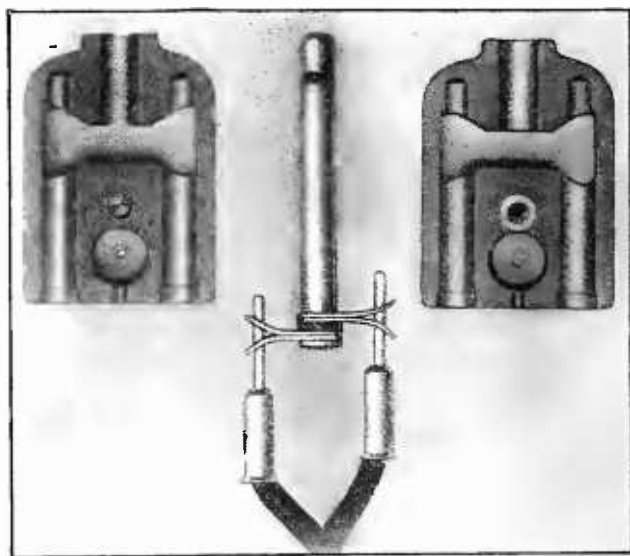

FIG. 19

Spring clips hold the telephone tips in this case. No tools are necessary

are largely instrumental in determining the over-all efficiency of the set. Only the best designs should be tolerated. Many of the manufacturers of plugs and jacks for the radio trade have had years of experience in the telephone field, and they are able now to place this experience at the disposal of the radio manufacturer. If the points governing good jack and plug design are kept in mind when purchases are made, serviceable plugs and jacks will be assured and by following the diagrams given herewith, the efficiency of the entire radio set will be greatly augmented.



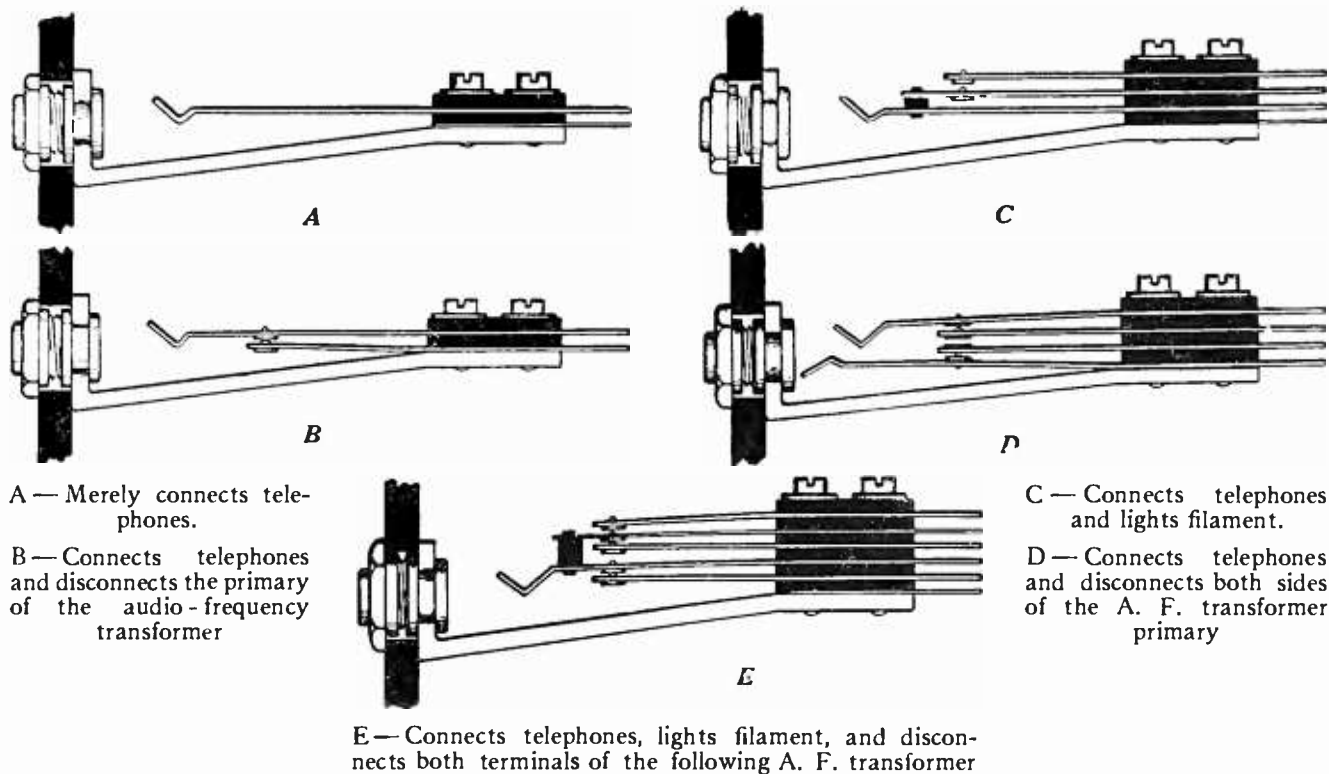

FIG. 20

## If You are Thinking

*Of submitting an article to RADIO BROADCAST, you may save yourself and the editors time and trouble by considering the following notes as to what we want and what we cannot use:*

### WE WANT:

*True accounts of the uses of radio in remote regions.*

*Short, true stories of adventures in which radio played an important part: unusual and interesting occurrences to you or your acquaintances.*

*Clear explanations of new or especially effective circuits or uses for apparatus.*

*Concise and logical discussion of some important problem or phase of radio, whether in the field of broadcasting, constructing, operating, buying or selling; or of reading or writing that has to do with radio.*

*True accounts, of some particular interest, relating "What Radio Has Done For Me."*

*Humor, when the object is not merely to appear funny, but to present some phase of radio in an attractive, amusing way. The same applies to drawings.*

*Clear, unusual photographs are always in order, as are good circuit diagrams.*

*A liberal rate is paid for material used.*

### WE CANNOT USE:

*Fiction, unless it deals in a striking way with some subject of interest to those interested in radio. Articles or illustrations to which RADIO BROADCAST would not have the exclusive rights.*

*The best way to do is to read through several numbers of the magazine to get an idea of the various kinds of articles we publish.*

# One of the Finest Amateur Stations Alive

2 FZ is Very Much Alive, and It is the "Bee's Knees" in Amateur Stations, as They Say in Our Language

By ZEH BOUCK

**T**HE term "amateur" has long since freed itself from the restrictions of Webster, who defined it merely as differentiating between one who follows a field as a means of livelihood, and one who devotes himself to it purely from motives of non-professional interest. The connotation of inferiority, as in the expression "a rank amateur," exists only in the minds of those who have forgotten or have never known of the

ability of our leading football and collegiate baseball players, some of our most artistic and able photographers, and the many possessors of private but none the less exquisite art collections. There is no illusion more false than the prevalent picture of the amateur radio operator as a malignant youngster in short trousers, horns and a forked tail!

Many amateur stations are far superior to the average run of commercial installations,



2FZ, ONE OF THE MOST ELABORATE AMATEUR STATIONS IN EXISTENCE

The entire station, with its myriad switches, motor-generators, dynamotors, tubes, and batteries, is at the finger tips of the operator, who may effect a hundred and one different combinations of apparatus without rising from his chair



THE MAP WHICH FLASHES THE POSITION OF VARIOUS STATIONS

The illuminated map of the United States is, to the layman, perhaps the most interesting feature of station 2FZ. With a flip of a telephone switch on the control box, the coast lines become dotted with dark green lights indicating the ship-shore commercial stations. Another switch is thrown, and red lights flash the position of the naval stations, and the constellation is completed by a sparkle of white dots—the broadcasting stations

which exceed them only in power, the general amateur being restricted to a single kilowatt input on a wavelength of two hundred meters.

Such a station is 2FZ of the Bronx, New York, owned by Mr. Frank Frimmerman, and operated by a corps of experienced men. This station, though merely typical of amateur installations in its efficiency and embodiment of progress, is of especial interest because of the elaborate equipment, combined with simplicity of operation due to an ingenious development of remote control. The entire station, with its myriad switches, motor-generators, dynamos, tubes and batteries, is at the finger tips of the operator, who may effect a hundred and one different combinations of apparatus without rising from his chair. What may be described as "the central nervous system" of the station, is located in the small control box in the centre of the operating table (shown in picture on page 494) and the flip of a telephone switch, or the plugging into a jack, commands the miracles of Aladdin! The thousand-volt generator slips into its gentle whine; the trans-

mitting tubes light simultaneously with the whir of the cooling fan before them; indicators jump on the switch-boards; and tiny red and green pilot lamps flash above the controls, indicating the functioning of every circuit!

To the left in the first illustration (also to the right in the one just above), is shown the transmitting equipment, exclusive of the power supply. The tubes and auxiliary apparatus are mounted in an open board arrangement, permitting adequate cooling and instant inspection for trouble. The meters at the top of the mounting panel indicate the values of the various voltages and currents supplied to the bulbs, as well as the antenna output, which, on a single tube, is three amperes at two hundred meters. The input meters register the plate and filament voltages and the space current. The inductance, of edgewise wound copper strip, is mounted to the right of the meters. The transmitting bulbs are 50-watt Radiotrons, three being used individually for radio telephony as oscillator, modulator, and speech amplifier. In low-power sets, this last

tube may be dispensed with, but with higher outputs, the unaided voice is not sufficiently strong to control, or modulate, the radiated output. The speech amplifier strengthens the comparatively weak voice impulses, and applies them as powerful electrical vibrations to the grid of the second or modulating tube. Instant change from voice to buzzer modulation (telegraph) is effected at the control box by plugging in buzzer and key. Switches are provided for throwing the transmitting tubes in parallel for continuous-wave transmission, which, if it is desired, may be broken into I. C. W. (interrupted continuous wave) by the motor-driven chopper in the foreground.

Between the control box and the receiving equipment, is a land-line telegraph instrument, at present not in operation.

The receiving apparatus is in perfect keeping with the elaborateness of the transmitter. A Reinhartz tuner is used for amateur reception, particularly of continuous waves; while broadcast and the higher wavelengths are brought in on the honeycomb set. Change of tuners is effected by a single-pole double-throw antenna change-over switch. Separate bulbs are used in each receiver, a detector and one step of audio-frequency amplification with the Reinhartz, and detector and two stages on the honeycombs, thereby avoiding a multiplicity of switches or plugs where capacitative and inductive effects are especially undesirable. The output of either receiver may be plugged into a single-stage power amplifier with loud-speaker, operative from B batteries or dynamotor.

The first picture also shows the main switchboard containing power and storage battery controls. The Tungar rectifying tube at the top of the board charges the six- and twelve-volt batteries through the horizontally mounted double-pole double-throw switches. The batteries are shelved beneath the board, and consist of twelve- and six-volt units, respectively, lighting the receiving filaments and providing current for the indicating lights, relays, etc.

The condition of the fuse bank below the rectifying tube is flashed by the omnipresent red and green lights—green being the normal operating color, and red indicating a blown fuse.

The meters indicate the conditions of the two batteries in respect to charge, and individual discharge and voltage. The lower half of

the panel contains the power switches and two relays which are part of the remote control system.

To the rear of the station (see photo, page 497) are located the connection rack, the receiving high-potential control panel and the motor-generators.

The connection rack (A) is unique, and is found in few stations. Its main advantage lies in the facility with which it permits the tracing of circuits and shooting trouble, for, with few exceptions, all power and control leads pass through this framework en route to the various pieces of apparatus. The rack also makes possible the bridging of one circuit upon another, with an almost infinite variety of connections for experimental purposes.

The comparatively diminutive switchboard in the background regulates the receiving high-voltage supply, both directly and by means of controlling the dynamotors suspended beneath the panel and the smaller of the motor-generators. The B batteries, mounted on the lower shelf, generally suffice for receiving with ordinary amplification, while the dynamotors supply the high plate potential for power amplification, individual machines feeding the two-step amplifier and power bulbs. The dynamotors run from the fifty-five-volt motor-generator previously mentioned, and their output is regulated from one to three hundred and fifty volts, by varying their speed with series rheostats, the control wheels of which project from the front of the switchboard. The four meters above the controls indicate both the current consumption of the receiving set in milli-amperes and the voltage at which it is supplied.

The motor-generator in the rear is a thousand-volt, quarter-kilowatt machine, generating the transmitting potential, and is under relay control from the operating table. Both machines are mounted on massive concrete blocks, eliminating vibration and assuring silence.

The photo on page 495 shows the opposite side of the operating room, and the transmitting apparatus already described. The illuminated map of the United States is, to the layman, perhaps the most interesting feature of station 2FZ; and even an operator, were the air dead, might while away an evening playing with its lights. The map is divided by the heavy lines into the nine radio districts of the United States, each section being indicated by a num-

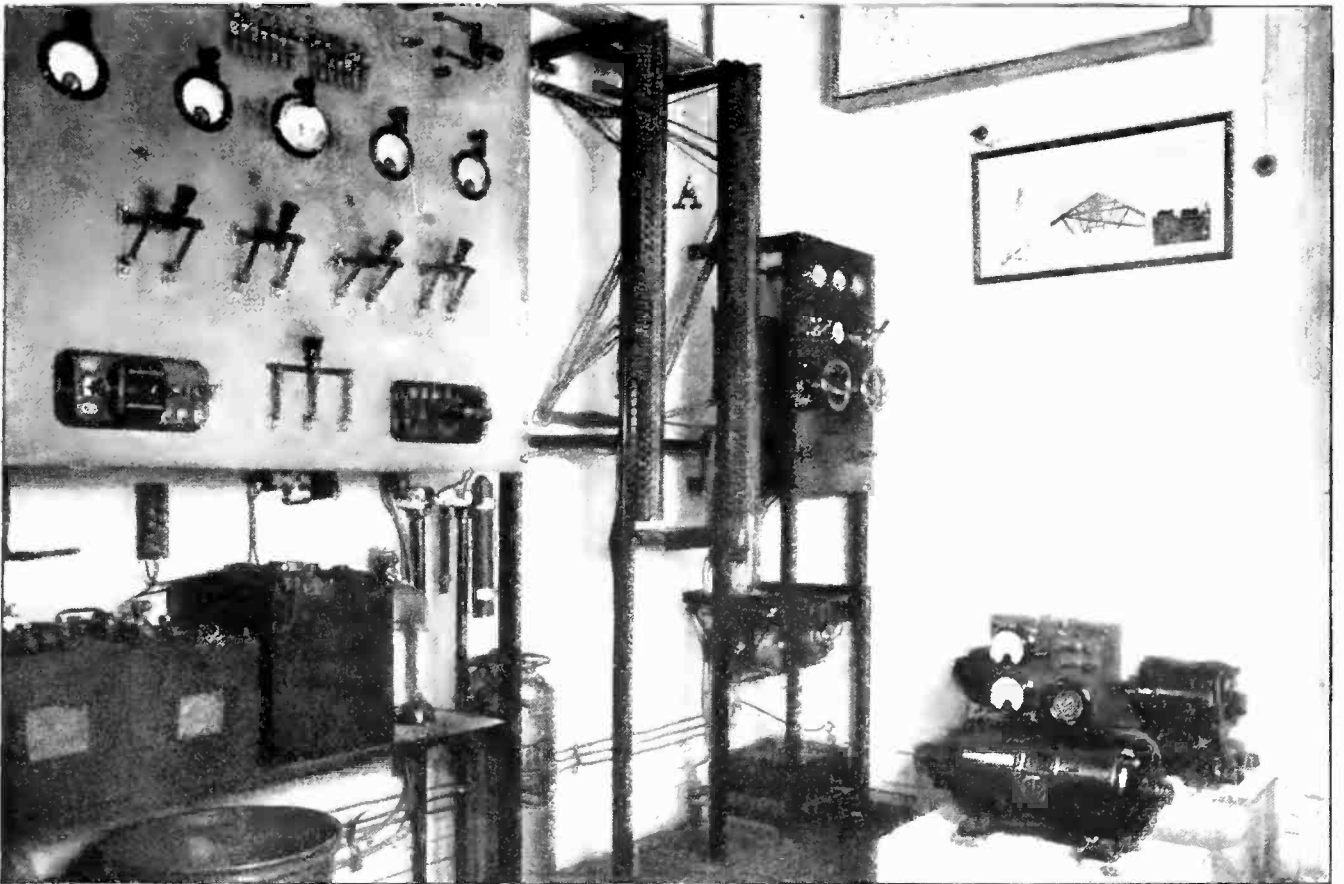

A VIEW OF THE SWITCHBOARDS, MOTOR-GENERATORS AND CONNECTION RACK

The connection rack (A) is unique, and is found in few stations. Its main advantage lies in the facility with which it permits the tracing of circuits and shooting trouble, for, with few exceptions, all power and control leads pass through this framework en route to the various units of apparatus

bered electric light. With the flip of a telephone switch on the control box, the coast lines become dotted with numbers of dark green lights indicating the ship-shore commercial stations. Another switch is thrown, and red lights flash the position of the naval stations. A moment later the Atlantic coast is dappled with light green flares, marking the locations of the long-wave, trans-ocean stations; and the constellation is completed by a sparkle of white dots—the broadcasting stations.

The map is also speckled with tiny pins locating the distant stations that have heard and worked 2FZ; and they dot the map from west of the Mississippi to the frame out in the Atlantic ocean! Until recently, the map of the United States sufficed, but with the verified report of the reception of 2FZ's signals in England and Honolulu, the old map has been supplemented by that of The World! Pins are ready, and this new mural addition is now being wired for similar electrification—and the rainbow searched for new combinations!

The antenna system of 2FZ is consistent with the operating department. The transmitting aerial is a three-and-a-half-foot cage, seventy-five feet long, "T" type, with a cage lead-in, and seventy-five feet above ground. The receiving antenna is a single wire, six hundred feet long, and swung at right angles to the transmitting aerial to minimize the absorption of energy. It is permanently connected to the receiver, obviating the necessity of a change-over switch, and permitting the station with which communication is being carried on to "break in" for correction when 2FZ is transmitting.

Station 2FZ, in recognition of its place in the DX (distance) field, is the office of the Bronx City Manager of the American Radio Relay League. Communication with both western and New England stations is consistent, and traffic to the extent of hundreds of messages a month, routed via New York City, is relayed through it to points perhaps a thousand miles nearer its destination.

# Stations That Entertain You



WGI, THE AMERICAN RADIO & RESEARCH CORPORATION'S STATION AT MEDFORD HILLSIDE, MASS.  
The 100-watt transmitter, shown at the right, has been heard in Kansas, Texas, and Cuba

THE STUDIO AT KDZE, RHODES DEPARTMENT STORE, SEATTLE, WASHINGTON

A wall of plate glass allows shoppers to see the broadcasting in progress



# Radio-Frequency Amplification From the Ground Up

Applying Radio-Frequency to Single-Circuit, Three-Circuit, Super-Heterodyne and Reflex Methods of Reception and Some Suggestions for Combining the Last Two Methods

By ARTHUR H. LYNCH

PROVIDED with a circuit of the type shown in Fig. 1, it is possible for us to obtain many interesting and satisfactory results from almost any of the more common forms of receivers. Last month the application of a circuit of this variety to three-circuit tuners and loop antennas was explained, and now some comment upon applying radio-frequency to a single-circuit receiver may be of interest.

To begin with, the single-circuit receiver used in conjunction with Fig. 1, may be regenerative or non-regenerative, depending upon what is used to connect  $X^4$  and  $X^5$ . For simplicity of operation, the non-regenerative method may be used, but where long distance and greater selectivity are sought, regeneration is helpful. If a short piece of wire connects  $X^4$  and  $X^5$ , the regenerative action of the detector tube is not brought into play, but a variometer or the tickler coil of the common single-circuit regenerator inserted between these two points will, on the other hand, take advantage of re-

generation, which may be controlled in the usual manner.

The character of the antenna circuit of the single-circuit outfit makes but little difference. It may be a variable condenser and tapped coil between the antenna and ground; a fixed condenser and a variometer in a similar position, or merely a variometer. Connection to the points  $X^2$  and  $X^3$  are made to the upper and lower ends of the *active* turns of the inductance. Condensers, either fixed or variable may best be placed between  $X^2$  and the antenna. By *active* turns, in speaking of inductance, is meant those turns actually in use. For instance, one common form of single-circuit regenerator employs a variable condenser and a vario-coupler as its turning units. The primary of the latter is tapped. The upper end of the primary winding is connected to  $X^2$  while the various taps are connected to switch contacts and the switch lever is connected to  $X^3$ . This arrangement is shown in Fig. 2.

Audio-frequency amplification may be added

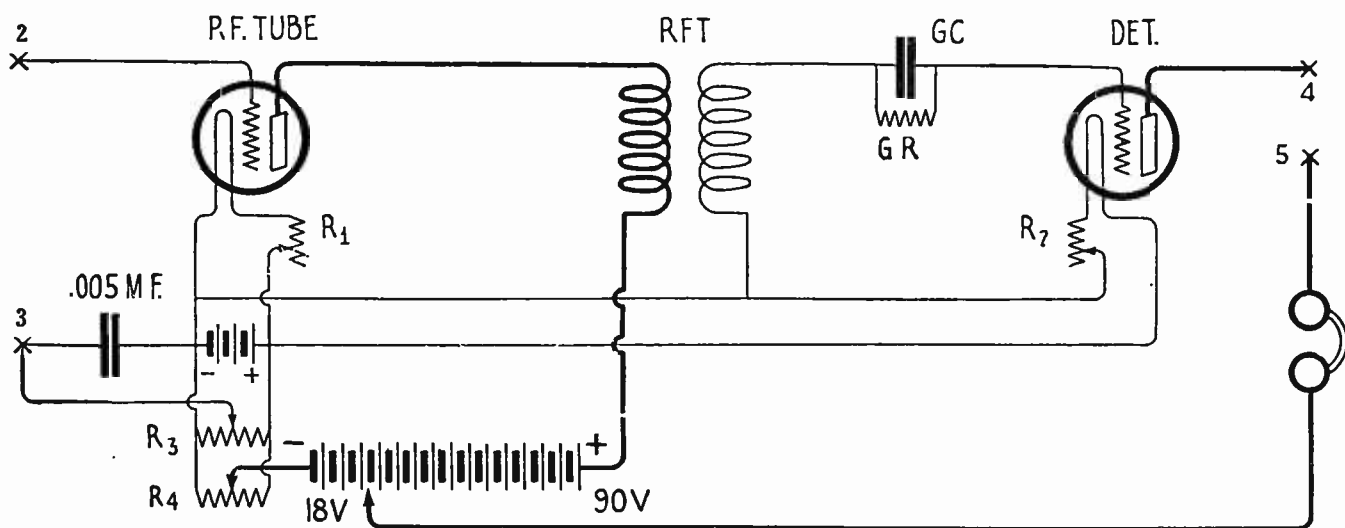

FIG. 1

A single-stage, transformer-coupled, radio-frequency amplifier and vacuum-tube detector applied to a standard coil mounting. Various adaptations of this arrangement are possible

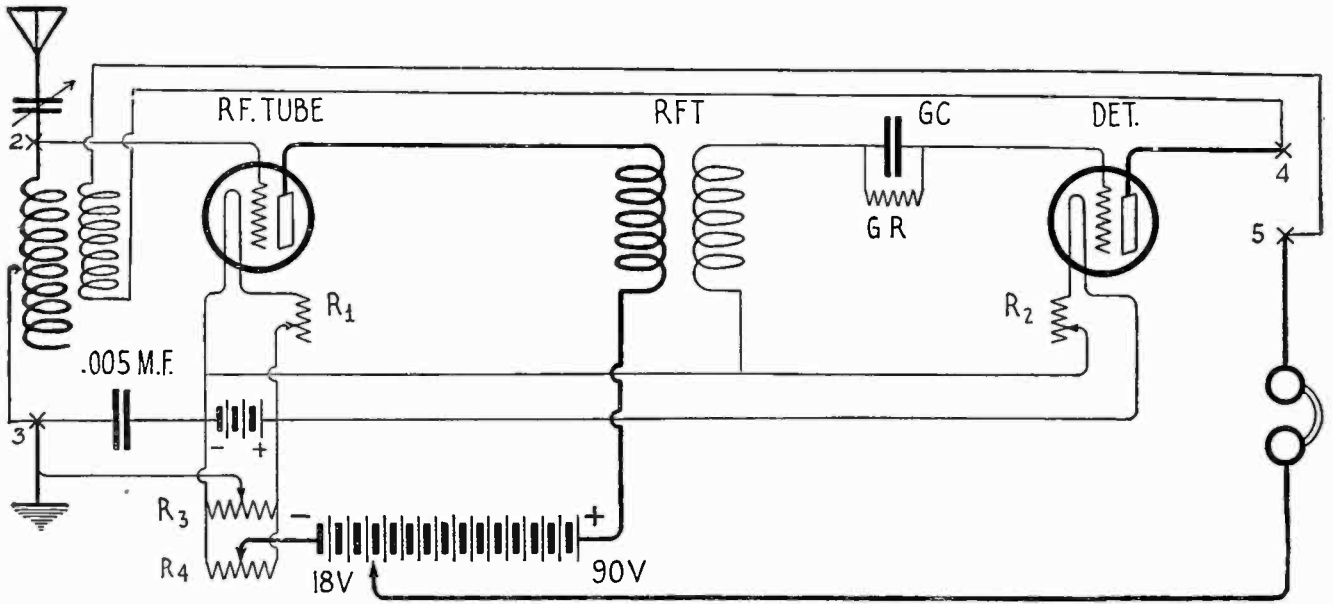

FIG. 2

By making the connections indicated here, the range of a single-circuit regenerative receiver may be greatly increased. If regeneration is not desired, a direct connection between X<sub>4</sub> and X<sub>5</sub>, and the elimination of the tickler coil, are the only changes necessary

to a circuit of this variety in the usual manner, though it is not necessary unless a loud speaker is to be used. For this purpose a single stage will usually suffice for local stations and two stages for the more remote stations.

REGENERATIVE R. F. AMPLIFICATION

FOR those who use the vario-coupler and twin variometer circuit, the addition of a single stage of radio-frequency is a comparatively simple matter. It is but necessary to take the grid condenser and leak out of the circuit in which they are usually found and make

a direct connection to the grid in their place. If you wish to leave the wiring as it is, the grid condenser and leak may be short-circuited by a small piece of wire. An amplifier tube is then put in the socket which formerly held the detector and the plate voltage is raised from the customary  $16\frac{1}{2}$ - $22\frac{1}{2}$  to 45-90. It is then but necessary to couple the output of the regenerative amplifier tube to the input of a detector tube circuit. This arrangement is shown to the right of the plate variometer in Fig. 3.

The units required for this circuit arrange-

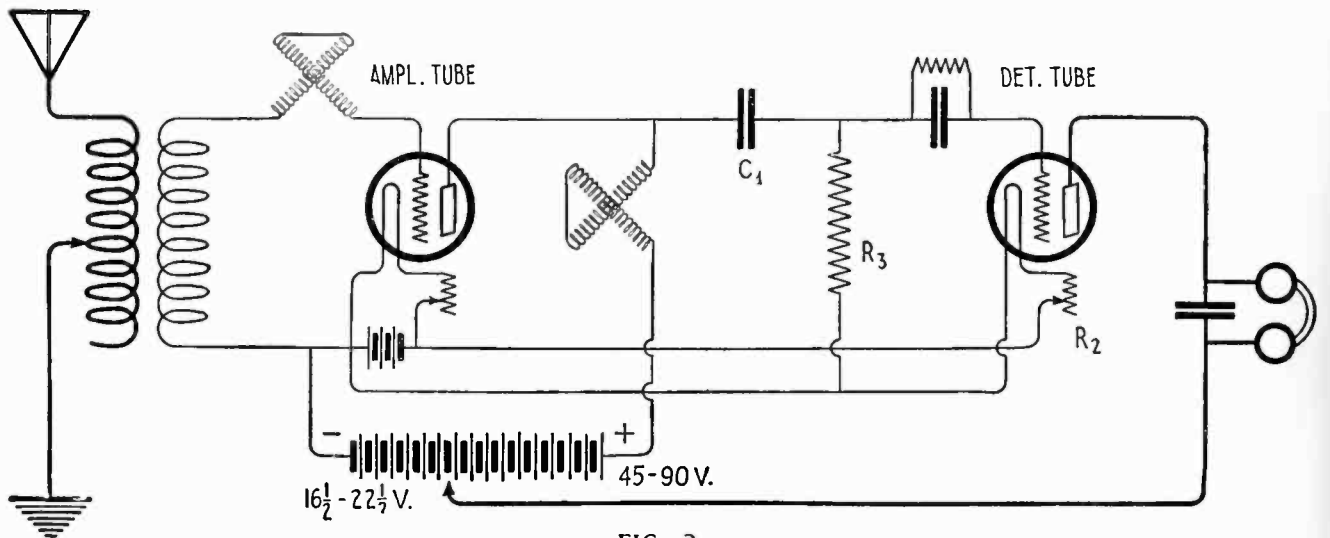

FIG. 3

A standard vario-coupler and twin-variometer regenerative receiver will have a stage of tuned radio frequency added to it if the arrangement shown here is followed



ment, in addition to those in use with the regenerative receiver, include:

R<sup>2</sup> Filament rheostat (with vernier or compression type preferred)

C<sup>1</sup> Fixed Condenser, .001 M. F.

R<sup>3</sup> Resistance may be a grid leak resistance, its resistance is not a critical factor.

A vacuum-tube socket, an amplifier tube and from one to three additional B batteries complete the list.

The necessary elements for this circuit may be included in the receiver cabinet, or an additional cabinet for the coupling elements and detector control may be added. In fact there is plenty of room in most of the detector control units now on the market to mount the condenser and resistance in them. Such units, however, are not frequently provided with rheostats capable of very delicate filament control and this is very desirable where a "gassy" detector is used.

#### REFLEX AMPLIFICATION

ONE of the most economical methods of long-range radio reception is found in the system of employing vacuum tubes to serve the dual purpose of radio- and audio-frequency amplification. Some of the history of this arrangement, which is not new, was told by Frank M. Squire, Chief Engineer of the De Forest Radio Telegraph & Telephone Company, in RADIO BROADCAST for February. Another article, describing the Grimes method of reflexing, by Charles Durkee, appears on page 472 of this issue.

Since the introduction of the WD-11 dry-cell tubes and the new coated-filament tubes, designed for storage-battery operation, much of the objection to the use of several tubes has been removed, and we can now operate three of the new 5-volt tubes with less drain on the storage battery than a single tube of the old type required.

The cost of tubes has ever been a factor among those of us who build our own sets, but the cost of several tubes has been more or less overshadowed by the cost and inconvenience of keeping a storage battery well charged. Now, however, these difficulties have been greatly reduced, and it is not surprising to find a rapidly increasing interest in circuits which because of first cost and upkeep, found little favor in the past. With the reduction of operating cost and an economical method of making tubes do double duty, there is a growing tendency toward receivers which are easy to install and easy to operate. Loop antennas, which usually require at least two additional tubes and their accessories to produce a signal equal in strength to that picked up by an average outdoor antenna may be used at comparatively small additional expense.

Of all the receivers the radio art has developed, it is doubtful that any has more possibilities and has received less attention than Armstrong's super-heterodyne. This is especially true in view of the great improvement made in the art since this receiver was developed. The one striking disadvantage of this form of receiver has been found in the great number of tubes required: eight to ten or more, in most of the receivers that really performed well.

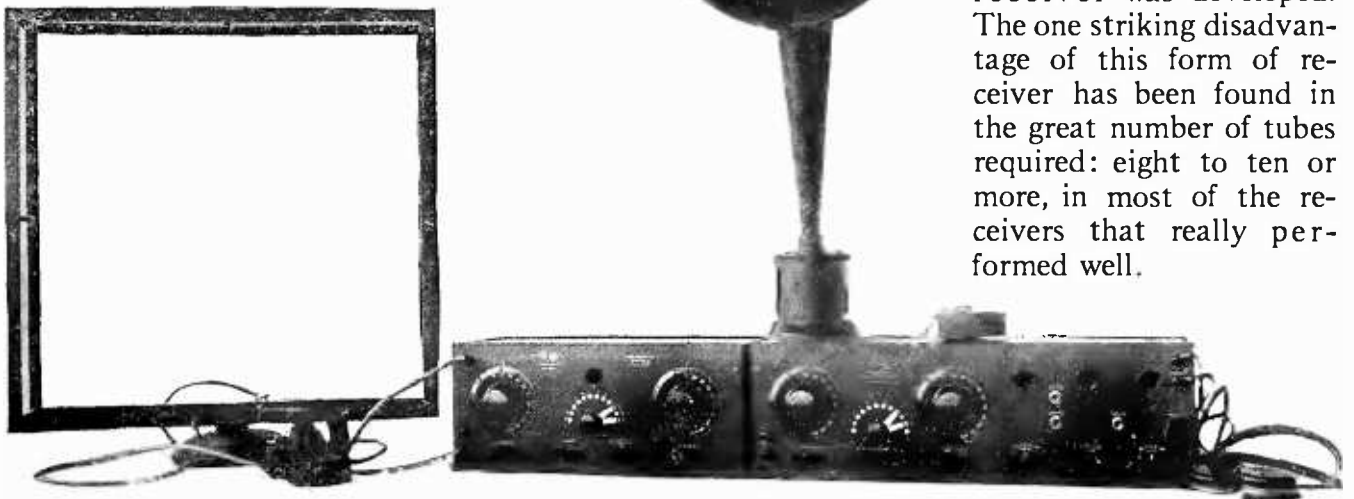

WITH THIS OUTFIT, A LISTENER IN CHICAGO HEARD STATIONS ON THE EAST AND WEST COASTS. It consists of a two-foot loop, a Grebe tuned R. F. amplifier, tuner with detector and two-stage A. F. amplifier, and Western Electric loud speaker. The R. F. amplifier may be used with any receiver and has a wavelength range of from 150 to 3,000 meters

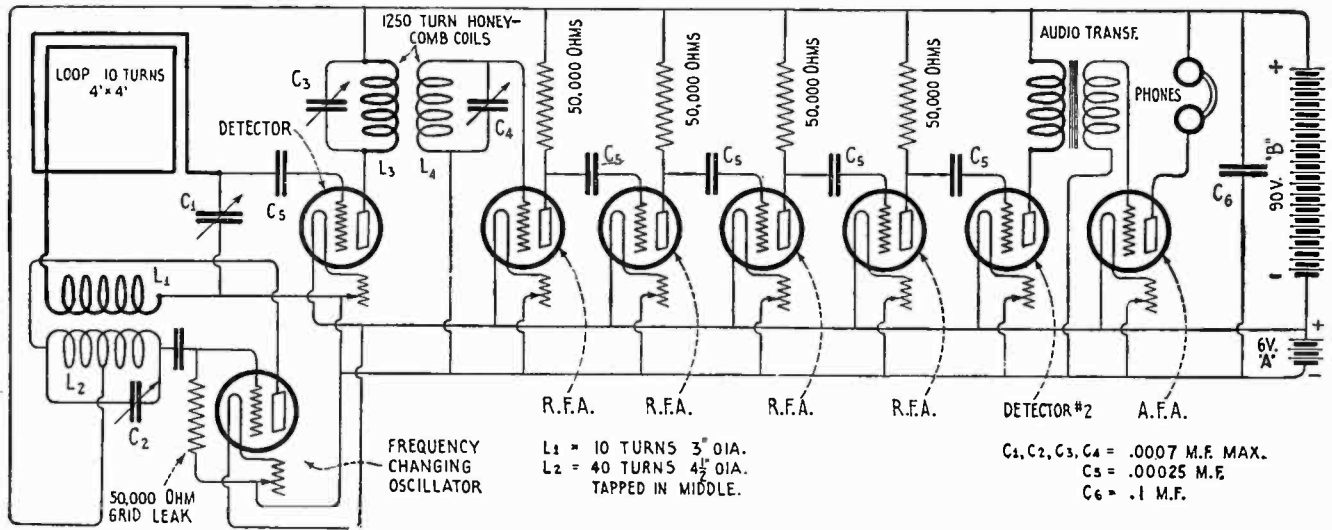

FIG. 4

R. F. amplification of the resistance-coupled variety is employed in this super-heterodyne circuit. (Described by Paul Godley in RADIO BROADCAST for February, 1923)

Paul F. Godley was one of the first to bring the value of this receiver to the attention of the amateur world by using it to receive American amateur signals across the Atlantic. His experience with the super-heterodyne covers a long period, and an article by him describing its construction and operation appeared in RADIO BROADCAST for February. One of the simplest forms of the super-heterodyne is shown in Fig. 4.

In describing this invention before a meeting of the Institute of Radio Engineers, Mr. Armstrong said that two stages of resistance-coupled radio-frequency amplification were necessary to bring the signal up to its original intensity after it passed through the first detector tube. Additional stages were then necessary, if any

increase over the original value was desired. That meant the use of a great many tubes.

In a recent lecture before the Radio Club of America, Mr. George Eltz, Jr. told of some very important improvements in the super-heterodyne method and demonstrated an outfit in which but seven WD-11 tubes were used in conjunction with a three-foot, nine-turn, loop antenna and a loud speaker.

His circuit arrangement is shown in Fig. 5. It will be noted that iron-core radio-frequency transformers are employed, and Mr. Eltz explained that they are well warranted because they improve the amplification, per stage, some five to six hundred per cent. over the resistance-coupled variety, thus reducing the number of tubes necessary. The transformers in his cir-

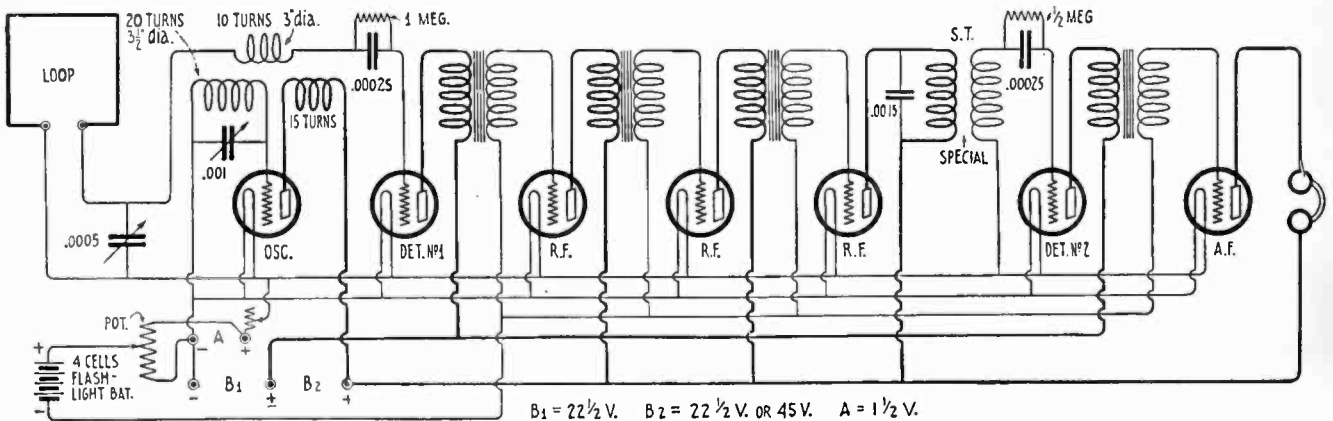

FIG. 5

This super-heterodyne arrangement was described and demonstrated by George Eltz, Jr., before the Radio Club of America. Seven WD-11 dry-cell tubes are employed and the Radio Corporation UV-1716 R. F. transformers are used in the radio-frequency amplifying circuits

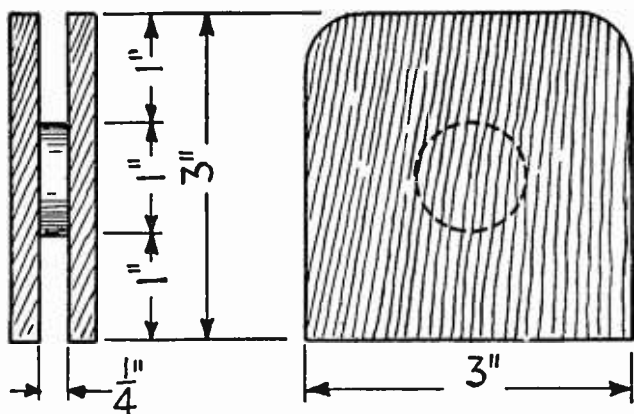

FIG. 6

This special transformer is used to couple the last R. F. tube to Detector Tube No. 2 in Fig. 5, and provides a sharp resonant point for the radio-frequency circuit. The walls of this transformer may be made of bakelite or hard rubber. The primary is wound with 200 turns of No. 29 D. S. C. and is separated from the secondary, which has 1500 turns of No. 36 D. S. C., by several layers of empire cloth

circuit are the Radio Corporation's type UV-1716, (Fig. 7) which may be used to cover a very broad band of frequencies. Each stage of R. F. is shielded by rather heavy metal shielding.

Another advantage of the arrangement shown in Fig. 5, lies in the fact that the tuned R. F. coupling transformer (S. T.) which determines the frequency at which the intermediate frequency circuit must function is placed directly before the second detector tube rather than directly following the first detector tube, is as the case in Fig. 4. The construction of this transformer is indicated in Fig. 6. Its advantage lies in the fact that whatever losses are brought about in this circuit may be sacrificed with less ultimate loss after the amplification has taken place.

#### A SUGGESTION

FOR those who would use the super-heterodyne and would care to cut down the expense of its operation, we would suggest a method for reducing still further the number of tubes required. We have not had time to give this method the trial which usually precedes the publication of information in RADIO BROADCAST and therefore refrain from publishing the circuit we have in mind, but there is no apparent reason for any difficulty being experienced with it.

Where such high amplification is used, there seems to be no reason for overlooking a good crystal detector to follow the R. F. amplifiers. That would eliminate one tube.

There seems to be much logic in the Grimes method of reflexing and if Armstrong's contention is true, the current flowing in the first two R. F. tubes is very small indeed. Why not go back to them, then, for the audio-frequency, thus doing away with two more tubes without a great loss in over all performance.

In suggesting this arrangement, we have not lost sight of the fact that a tube used in a reflex arrangement may not be serving at its best as a radio or audio-frequency amplifier, but this loss does not seem to be a very serious matter. For the experimenter who is anxious to produce great volume, the use of three stages of audio-frequency is to be considered. In this last arrangement, however, a great variety of difficulties are likely to arise.

The production of uniform tubes for use in amplifying circuits operating on very low filament consumption and amplifying transformers that will cover a great band of frequencies make it possible for us to look for some very marked improvements in reception. To the best of our knowledge these suggestions have not been made before, and RADIO BROADCAST would like to hear from those who attempt to put them into practice.



FIG. 7

The UV-1716 R. F. transformer has a wavelength range of from 5,000 to 25,000 meters. It may be used at the frequencies found in the intermediate frequency circuit of the super-heterodyne and produces a much greater amplification, per stage, than is possible with the resistance-coupling

# How Far Have You Heard on One Tube?

Results of the First Contest. Three Final Articles on One-tube Reception: "An Evening's Trip Around the Whole United States," "The Automatic Regenerative Circuit," and "Cheap at Twice the Price." Some Further Points on Constructing and Tuning. Summary

The contest which closed February first, and of which the final reports are printed in this issue, has brought to light a wealth of interesting and useful information about hook-ups, constructing, tuning, and in general getting the best out of one-tube sets. Some painstaking and excellent work has been done by experimenters in gathering complete details regarding their receivers and working them up, with the help of photos and diagrams, into clear descriptions from which any one can profit.

Now that the net has been hauled in and the deep-sea catch examined, what do we find in it that seems to be of particular significance?

## Three Facts Stand Out Strikingly

1. The great distance that is possible with a single tube. *A score of contestants have heard stations more than 1,500 miles away*, while 1,000-mile reception is common. A dozen or so report an aggregate mileage of more than 50,000 (the record is 111,240 miles, made by Russell Sheehy. His circuit is given in Fig. 1), and many have identified more than sixty different broadcasting stations!

2. The excellent showing that single-circuit regenerative sets and variometer regenerative sets have made in reaching out after the distant stations. A glance at the summary of results on page 436, last month, and page 513, this month, will show this clearly.

3. The remarkable work done by those operating homemade, makeshift (this does not mean carelessly made!) apparatus. What accounts for it? Is it because the man who "winds his own" learns more about the fine points of operation through being thoroughly familiar with every unit that goes into his finished receiver? Or is it because this type of experimenter is just naturally forever changing the elements in his circuits, experimenting, improvising, and improving until everything is adjusted for maximum efficiency *under his particular conditions*? In any case, those who have done the splendid work described in this and previous issues have well earned their success, and we congratulate them.

## Two Prizes Awarded

Contestants whose reports we have published have been sent checks for their articles. Two of these articles have been considered by RADIO BROADCAST so interesting and instructive with regard to text, so well illustrated with photos and diagrams, and so exceptional in the number and distance of stations heard, that they have been unanimously awarded First Place and Second Place in the contest, and two prizes, voted by the Editors, have been sent them.

We announce, then, as winner of the "How Far Have You Heard on One Tube?" Contest, MR. RUSSELL SHEEHY, whose article, "Feeling the Nation's Pulse" appeared in the February issue. He will receive a Grebe CR-8 Regenerative Receiver and Two-Stage Amplifier.

And as second in the contest, we announce MR. E. V. SEAGER, author of "A Practical, Long-Range, Single-Tube Receiver" (See page 428, RADIO BROADCAST for March.) He will receive a Paragon Two-Stage Audio-Frequency Amplifier.

It will be noticed that the manuscripts chosen for publication in this contest—appearing in the December, January, February, March, and April numbers—have not necessarily been those with the highest mileage reports. As previously announced, a high aggregate mileage was considered one of the principal factors in judging contributions, but the interest, clearness, and general worth of the articles also carried great weight.

We hope that the hundreds of contestants who sent in their contributions to this contest will read the announcement of the *new contest* on page 514, and will send us some interesting material on what they have done with *any number of tubes*.

The three articles which follow wind up the one-tube contest with a variety of material which will be of wide interest to all long-distance broadcasting experimenters and in which everyone should find some hook-up, receiving wrinkle, or bit of information to suit his own particular demands.—THE EDITOR.

# AN EVENING'S TRIP AROUND THE WHOLE UNITED STATES

By MILO SHUTT

**I** HAVE read the articles on "How Far Have you Heard?" with great interest and am sure the records which I have made will be of interest to the readers of RADIO BROADCAST.

My set has been in operation for about three months and I have not tried particularly to break any long distance records, but have tried to tune in, from my home in Alliance, Ohio, the different stations in consecutive order, beginning at either Schenectady or Boston and going down the Atlantic coast and the Gulf and following the stations westward until I stop at the Pacific Coast, which also includes the Canadian stations.

My idea has been to take a trip to the Pacific Coast, which requires me to stay at it until 1:30 or 2:30 A.M.

I like to listen-in on the proceedings of the "Put a Tack" Club of Dallas and the "Radio Bug" and "Night Hawk" clubs of Kansas City.

My outfit consists of a modified three-circuit

regenerative set using spider-web coils, which may be seen in the accompanying photographs. The price of the outfit by parts is as follows:

1 set Goodman coils and mountings . . . . .	\$6.50
1 43-plate vernier condenser . . . . .	3.80
1 23-plate vernier condenser . . . . .	2.90
1 tube socket . . . . .	.60
1 ammeter . . . . .	3.00
1 Bradleystat . . . . .	1.85
1 series-parallel switch . . . . .	.85
1 Dubilier grid leak and condenser . . . . .	1.50
1 7 x 18 x 3-16 inch Radion panel . . . . .	1.60
Total cost of parts, less tube and phones	\$22.60

The tuner consists of a Goodman spider-web mounting which I have arranged with a device for tuning from the front of the panel and is capable of vernier adjustment, thus allowing very fine tuning.

I find that the vernier condensers are a great help, especially in preventing interference from several stations broadcasting at the same time. I can set my outfit for WEA, New York, and rotate the vernier on the 23-plate condenser  $\frac{1}{4}$  of a turn to bring in WOC, Davenport, Iowa. I have had very little interference from spark stations.

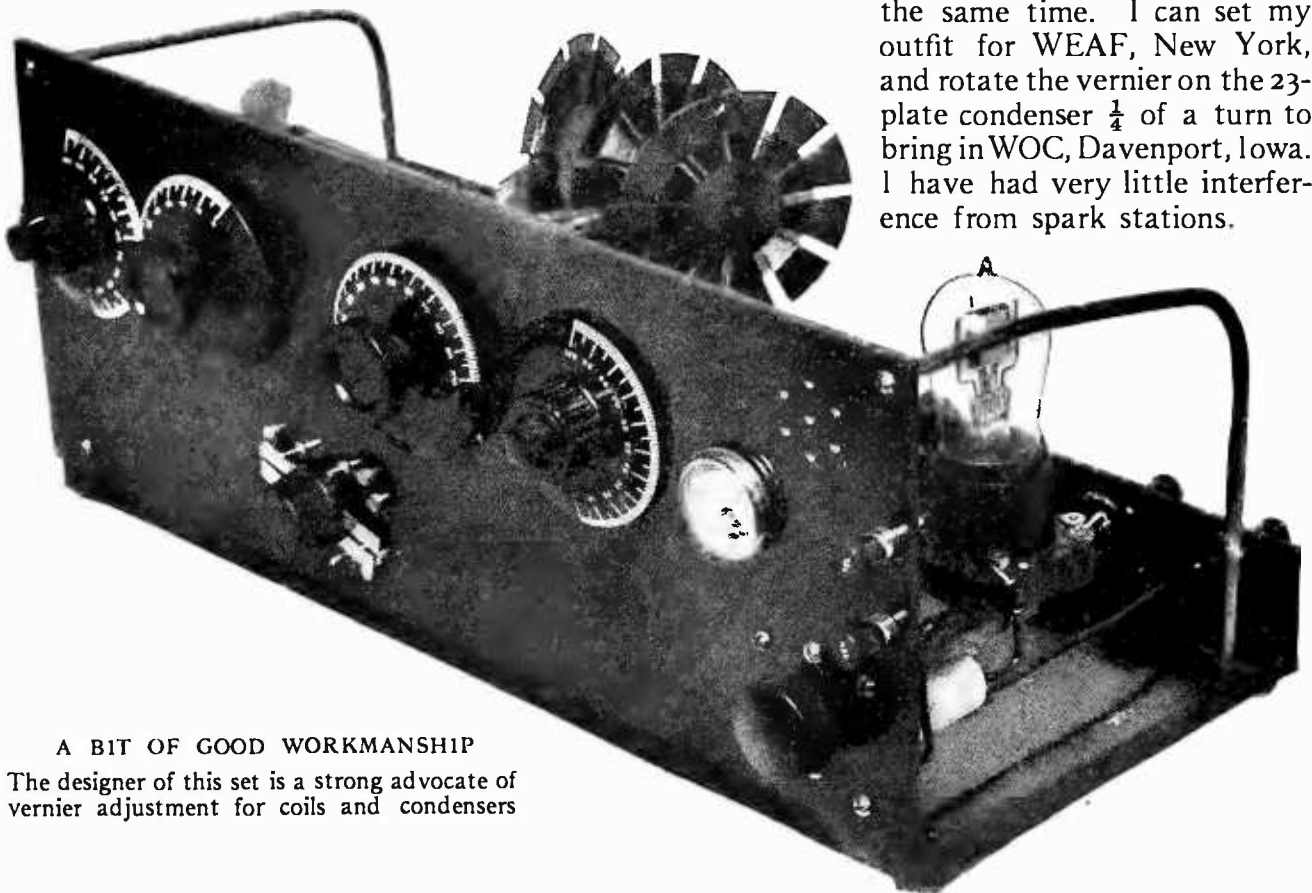

A BIT OF GOOD WORKMANSHIP

The designer of this set is a strong advocate of vernier adjustment for coils and condensers

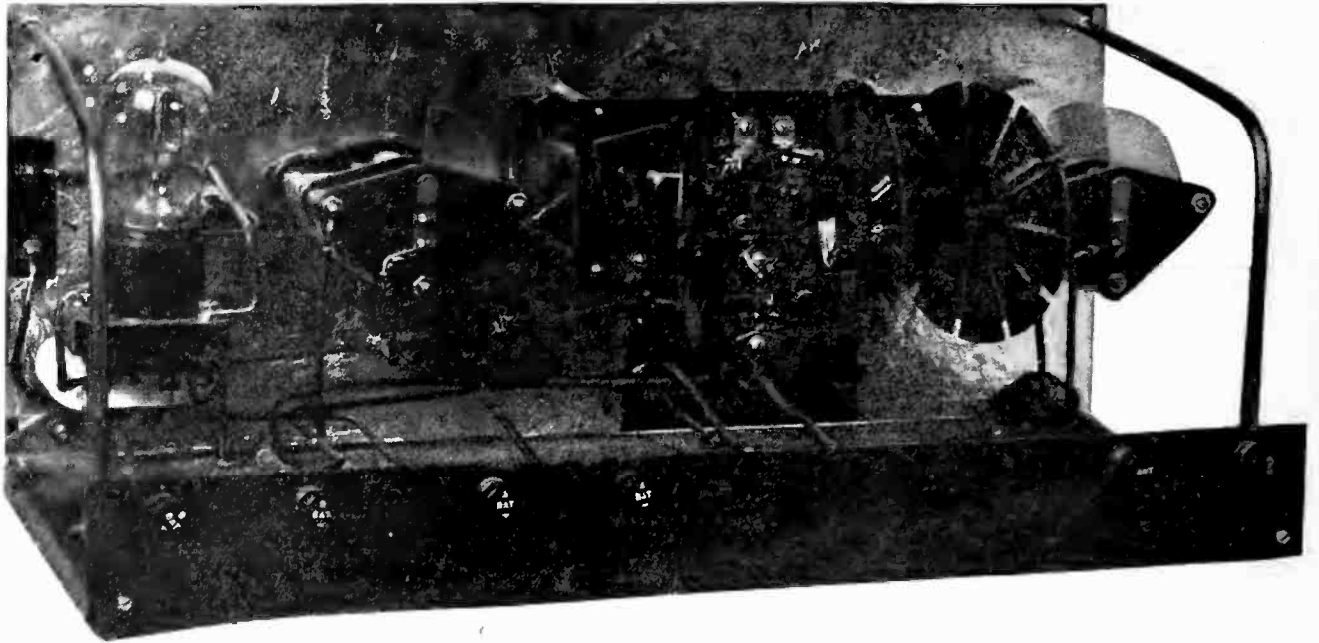

SHOWING THE NEAT ARRANGEMENT OF THE UNITS, AND THE CAREFUL SHIELDING

My aerial is a single wire about 110 feet long and averages 25 feet in height. It is not in an ideal location as there are several small trees under the wire. However, I have it stretched as taut as a fiddle string which I find brings in the signals better. I can get any of the large



ALLIANCE, OHIO, IS THE STARTING POINT FOR MANY A TRIP  
 In a single evening, Mr. Shutt can jump from Spokane to "San Antone," from the Ca'linas to California, and from Cuba to Calgary

stations in the United States or Canada. All of the stations which I have heard were received not only once but have been verified by other listeners. I can get all the big Midwestern stations any night they are broadcasting except under very unusual conditions.

The following is a list of a few of the stations which I have heard, 14 of them totaling a distance of 20,997 miles:

Los Angeles	KHJ	2171
San Francisco	KUO	2286
Spokane	KOE	1941
Calgary	CHCO	1797
Winnipeg	CJCG	1050
Denver	KDZU	1308
Las Cruces	KOB	1581

San Antonio	WGAR	1308
Ft. Worth	WBAY	1093
Dallas	WFAA	1064
Miami	WFAW	1078
Palm Beach	WKAH	1020
Ensenada, P. R.	WGAD	1950
Havana	PWX	1350

Total distance of 14 stations 20,997

The photograph of the map shows the location of all the stations heard which were more than 1,000 miles away and no stations are listed which were less than 100 miles distant.

I think I am safe in saying that with a good aerial I can get any high-powered station in North America.

## THE AUTOMATIC REGENERATIVE CIRCUIT

A Simple but Very Efficient Single-tube Hook-up

By H. L. PETERSON

**I** LIVE out in the "Garden Spot of the World"—in the state "where the tall corn grows"—good old Iowa. I am a little more than a thousand miles from the Atlantic seaboard, from the Gulf of Mexico and from the Rocky Mountains. Within that circle of 1,000 miles I believe I have heard all the important broadcasting stations, and the only reason I have not heard any farther away is because there are no more, except in the West where the mountains seem to interfere.

Almost any night, I listen in on such stations as WGY, WFAF, WJZ, WOR, WSB, WGM, WAAC, WEAY, WOAI, and KFAF—all of them in good volume. In fact I hear them as loudly on this single-tube set as some other people get them on "tailor-made" sets using one and sometimes two stages of amplification.

Since the first of July, I have heard more than seventy different stations. Fourteen of these are a thousand miles or more distant. Leaving out of reckoning the stations that we consider "local," that is less than 300 miles away, I have a list of fifty stations heard, whose aggregate mileage is over 39,000, or an average of nearly 780 miles per station, and that you may not think that I am counting in a lot of "freak" records I will say that I have often tuned in more than twenty stations in a single evening with an average mileage, counting local and distant stations, of more than 500 miles per station.

A word about the set: you will at once be struck with the extreme simplicity of the circuit. It contains, I believe, the fewest wires and the fewest connections of any known single-tube hook-up. It is regenerative, automatically so, and affords really surprising results, sometimes bordering on super-regeneration. Owing to the few parts and the simplicity of the wiring, the set can easily be mounted in a box 8" square and leave room for the B battery inside the box. I use an aerial 100 feet long and 50 feet high.

The efficiency of the circuit depends largely upon its simplicity, although the happy placement of the variable condenser, and the feedback from the plate, play an important part. There is in reality but one control, viz.: the 23-plate variable condenser. The inductance switch need never be moved after the correct tap has been determined. At any rate, I have never found any occasion to move mine. Stations are tuned in or out by merely turning the dial a few degrees. Frequently a movement of a single point will tune out one station and bring in another loud and clear.

While the tuning is so exceedingly simple, the set is capable of very close selection. I have read with a great deal of surprise the complaints of "fans" who were not able to tune apart stations on 360 and 400 meters. My difficulty has been in trying to separate stations on the same wavelength so that when you get

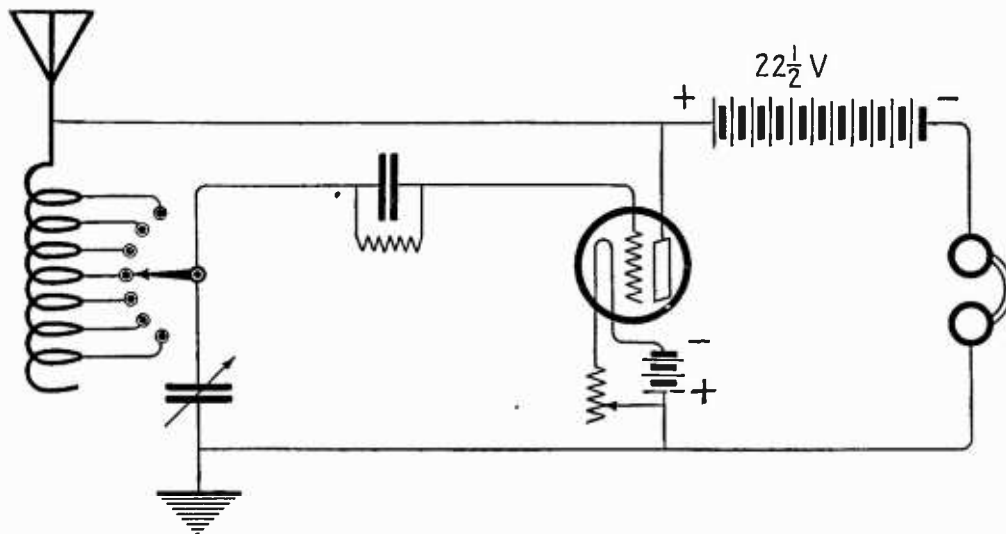

IT WORKS IN  
 "GOOD OLD IOWA"  
 This is the circuit Mr. Peterson uses. When the inductance switch and rheostat are once adjusted, all tuning is done with the 23-plate condenser

thirty sets in town patterned after mine, and they are getting as good results as I am, or better.

List of 50 sta-

one you do not get the other equally clear. There appears to be sufficient margin now between the various stations so that interference here is infrequent. At least, 360- and 400-meter stations never conflict with each other, and I am able to get stations that others, with more elaborate outfits—two- and three-circuit affairs—seem to be unable to tune in.

In constructing the set, it is advisable, though not necessary, to use vernier controls on both the condenser and rheostat. The parts necessary are as follows:

100 feet aerial wire and insulators . . . . .	\$ 1.00
1 23-plate condenser . . . . .	2.50
100 feet No. 22 D. C. C. wire for inductance, etc.	.30
1 inductance switch complete . . . . .	.75
1 grid leak and grid condenser . . . . .	.35
1 vernier rheostat . . . . .	1.50
1 vacuum tube socket . . . . .	.40
1 vacuum tube, Radiotron or Cunningham . . . . .	.50
1 2000-ohm head set . . . . .	5.00
8 binding posts . . . . .	.40
1 B battery . . . . .	1.00
1 A battery . . . . .	12.50
	<hr/>
	\$30.70

You will notice that the set will cost but \$6.20 if you leave out of reckoning the things that are classed as "extras" when you come to buy the "ready made" article.

I have made no mention in the above list of panel or base. I have seen many successful sets using a wooden panel. While it is true that Bakelite or Formica or some such material makes the best mounting for radio instruments, good results have been secured on wooden panels thoroughly dry and well shel-lacked, if the sets are not kept where they are likely to absorb moisture.

In closing, lest I may be accused of undue enthusiasm concerning the "Automatic Re-generative," I will say that there are about

tions heard, 300 miles or more away:

CFCA	Toronto, Canada . . . . .	725 miles
DN4	Denver, Colo. . . . .	700 "
KDKA	Pittsburgh, Pa. . . . .	700 "
KDYS	Great Falls, Mont. . . . .	1,000 "
KFAF	Denver, Colo. . . . .	700 "
KLZ	Denver, Colo. . . . .	700 "
KSD	St. Louis, Mo. . . . .	350 "
KYW	Chicago, Ill. . . . .	300 "
WAAC	New Orleans, La. . . . .	975 "
WBAP	Fort Worth, Texas . . . . .	800 "
WBL	Anthony, Kan. . . . .	500 "
WCX	Detroit, Mich. . . . .	500 "
WDAF	Kansas City, Mo. . . . .	300 "
WJZ	Newark, N. J. . . . .	1,000 "
WEAF	New York, N. Y. . . . .	1,000 "
WJAD	Waco, Texas . . . . .	950 "
WLK	Indianapolis, Ind. . . . .	450 "
WLW	Cincinnati, O. . . . .	550 "
WMAB	Oklahoma City, Okla. . . . .	600 "
WMAK	Lockport, N. Y. . . . .	750 "
WNAD	Normal, Okla. . . . .	600 "
WOH	Indianapolis, Ind. . . . .	450 "
WPA	Fort Worth, Texas . . . . .	800 "
WSB	Atlanta, Ga. . . . .	825 "
WW1	Ft. Dearborn, Mich. . . . .	500 "
WWJ	Detroit, Mich. . . . .	500 "
WDY	Roselle Park, N. Y. . . . .	1,000 "
WEAY	Houston, Texas . . . . .	1,000 "
WFAA	Dallas, Texas . . . . .	800 "
WGAQ	Shreveport, La. . . . .	750 "
WGM	Atlanta, Ga. . . . .	825 "
WGY	Schenectady, N. Y. . . . .	1,000 "
WHAS	Louisville, Ky. . . . .	550 "
WHB	Kansas City, Mo. . . . .	300 "
WJX	New York, N. Y. . . . .	1,000 "
WKN	Memphis, Tenn. . . . .	600 "
WLAJ	Waco, Texas . . . . .	900 "
WOAI	San Antonio, Texas . . . . .	1,100 "
WOK	Pine Bluff, Ark. . . . .	600 "
WDA.A	Nashville, Tenn. . . . .	600 "
WOO	Philadelphia, Pa. . . . .	975 "
WNAV	Knoxville, Tenn. . . . .	700 "
WOR	Newark, N. J. . . . .	1,000 "
DD5	Denver, Colo. . . . .	700 "
WDAJ	College Park, Ga. . . . .	825 "
NOF	Anacostia, D. C. . . . .	1,000 "
KHJ	Los Angeles, Cal. . . . .	1,500 "
WCK	St. Louis, Mo. . . . .	350 "
PWX	Havana, Cuba . . . . .	1,500 "
WOS	Jefferson City, Mo. . . . .	300 "

39,350 miles



# CHEAP AT TWICE THE PRICE

By FRANK J. MYERS

EDITORIAL NOTE:

Any rags, any bones, any bottles to-day?  
 If you have any junk, don't throw it away—  
 Mr. Meyers will put it inside of a box,  
 And hear all the programmes, from wos's to woc's!

**H**ERE is a photo of a receiving set which I put together recently. It employs a single-circuit regenerative circuit, with 50 turns on a 3½ inch tube for the primary and 15 turns on a 3-inch tube for the secondary. The first evening that I tried it out, I tuned in seventeen broadcasting stations with little or no interference. They came in loud and clear and the results were very gratifying, as this set compared favorably with my standard receiver which sells for \$130.00. The net cost of this receiver was \$1.98, which included one socket, one rheostat, one condenser and grid-leak unit, wire, and binding posts. I already had a 43-plate variable condenser that is panel mounted, and counting that, the set would come to not more than four dollars. I made the dial out of heavy paste-board. The panel and entire cabinet are of odd pieces of boards. I used a piece of number eight fence wire for the shaft and an electric light switch knob on the dial; and I wound number twenty-two cotton covered wire on two pieces of paste-board boxes that I picked up in my studio. The time consumed in making the cabinet and assembling the entire outfit was eight hours. The loudness and clearness of both music and voice are almost unbelievable until you have tried this circuit out; even PWX, Havana, Cuba, WOAI, San Antonio, Texas, and Denver, Colorado come in loud enough to be heard while holding the phones away from your ears several inches. I might also add that I can hear Ft. Worth and Dallas, Texas, every night they are on, and they are nine hundred and thirty-five miles from my home in Kendallville, Indiana. As stated above, I heard programmes from seventeen stations the first night I tried it out, and then on the following night I heard eighteen new stations with it and since then I have been getting one or two new stations each evening.

The following list of forty-one stations, ranging from 150 miles to 1300 miles from Kendallville, Indiana, was heard in three evenings.

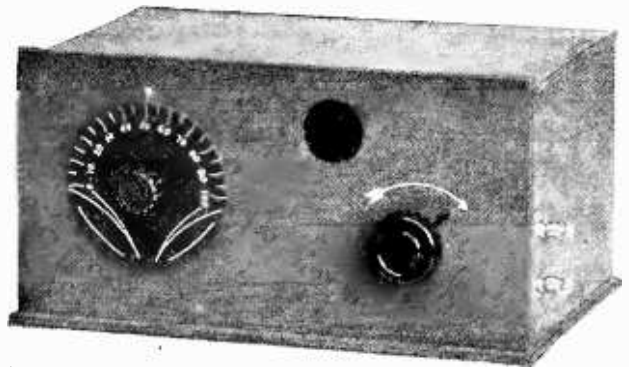

THIS BROUGHT IN 17 STATIONS THE FIRST EVENING

It cost the owner \$1.98, plus an old 43-plate condenser, plus 8 hours' work

	MILES
PWX	Havana, Cuba . . . . . 1300
WPA	Ft. Worth, Texas . . . . . 935
WLAJ	Waco, Texas . . . . . 980
WBAP	Ft. Worth, Texas . . . . . 935
KFAF	Denver, Colo. . . . . 1100
WLW	Cincinnati, O. . . . . 175
WDAF	Kansas City, Mo. . . . . 525
WHAZ	Troy, N. Y. . . . . 625
WOAI	San Antonio, Texas . . . . . 1165
WIAO	Milwaukee, Wis. . . . . 270
WDAP	Chicago, Ill. . . . . 150
KSD	St. Louis, Mo. . . . . 340
WBAJ	College Park, Ga. . . . . 585
WFAA	Dallas, Texas . . . . . 925
WMAQ	Chicago, Ill. . . . . 150
WMAT	Duluth, Minn. . . . . 535
WSB	Atlanta, Ga. . . . . 575
WHB	Kansas City, Mo. . . . . 525
WEAF	New York City . . . . . 600
WGM	Atlanta Ga. . . . . 575
WGY	Schenectady, N. Y. . . . . 625
KYW	Chicago, Ill. . . . . 150
KDKA	Pittsburgh, Pa. . . . . 300
WSY	Birmingham, Ala. . . . . 575
WHAM	Rochester, N. Y. . . . . 400
WOS	Jefferson City, Mo. . . . . 440
WBT	Charlotte, N. C. . . . . 510
WNAD	Norman, Okla. . . . . 815
WLAG	Minneapolis, Minn. . . . . 490
WAAP	Wichita, Kansas . . . . . 700
WJAS	Pittsburgh, Pa. . . . . 300
WJAX	Cleveland, O. . . . . 185
WHAS	Louisville, Ky. . . . . 265
WBZ	Springfield, Mass. . . . . 675
WJZ	Newark, N. J. . . . . 515
WOC	Davenport, Iowa. . . . . 275
WAAQ	Greenwich, Conn. . . . . 625

TOTAL . . . . . 20,815

## SOME POINTS ON CONSTRUCTING AND TUNING FROM SEVERAL NIGHT-OWLS

## THE HOOK-UP THAT WON THE CONTEST

THE circuit diagram used by Russell Sheehy, winner of the one-tube contest, is here reprinted from the February issue, together with some information which he has supplied on the construction and operation of his set.

"My entire outfit is home-made," he says, "including the vario-coupler, which is wound with 35 turns on the stator and 35 on the rotor. No switch points or taps are used. The only trouble I had with this circuit was in the paper condensers, and I strongly advise the use of mica condensers and tubular leaks in the grid circuit. The .001 mfd. variable condenser across the phones and batteries may be substituted by a .002 mfd. fixed condenser or sometimes on near-by stations by a .005 mfd. fixed condenser. In the last instance, the signal strength is very materially increased. The entire circuit is quite simple of operation and most of the tuning is done with the condenser in the aerial circuit and the tickler control. . . . I operate my filament on 4.4 volts and very rarely have to change it. With most of the detector tubes I have tried, the best B battery voltage is 18. . . . I have

found that two potentiometers are quite an asset when long-distance signals are desired. . . . The potentiometer with the slider grounded at the correct position of the tickler may cause the tube to oscillate, by moving it toward the negative side, and it is just before this point of oscillation that signals are clearest and loudest. The set is operating at its best when you find that moving the condenser either way produces no oscillation, but there is a sort of "purr" on each side of your signal. . . . Don't turn your filament right off. Turn it off a little at a time. . . . Keep your aerial *well* insulated at both ends. . . . Don't run No. 24 wire to your A battery; use No. 14 at least."

Mr. Sheehy's complete description of his set, and his aerial and ground system, is found in RADIO BROADCAST for February (pp. 336 and 337). A statement including a complete list of stations heard up to January 31st, was sworn to before a notary public and forwarded to RADIO BROADCAST. The total mileage for the 159 stations is 111,240, the most distant station being KHJ, Los Angeles—2,610 miles from Mr. Sheehy's New Hampshire home.

J. Kelly Johnson of Oskaloosa, Iowa who has piled up an aggregate of 81,145 miles, is a strong advocate of soldered connections throughout his set. Those who have been bothered with crackling noises in the phones which they have reason to believe is not static, or who have had to stop and readjust a poor contact in the middle of an effort to bring in some long-distance station, will do well to take Mr. Johnson's advice to heart. He says: "The current supplied to a radio set from an antenna is extremely minute. A very slight resistance in the circuit very materially decreases the amount of current. So the first consideration is electrically perfect joints. The most satisfactory method of securing these is by means of soldering. All connections in the efficient radio sets are soldered. Granted that some sets are successful when no solder has been used, how long will their efficiency last? For a short time only. Such joints oxidize or pull apart and are bound to weaken signal strength, cause disturbing noises, and make increasing annoyance." Here is some further sound advice about making home-made coils: "If you make your own coils, here is another important consideration. Take care that the

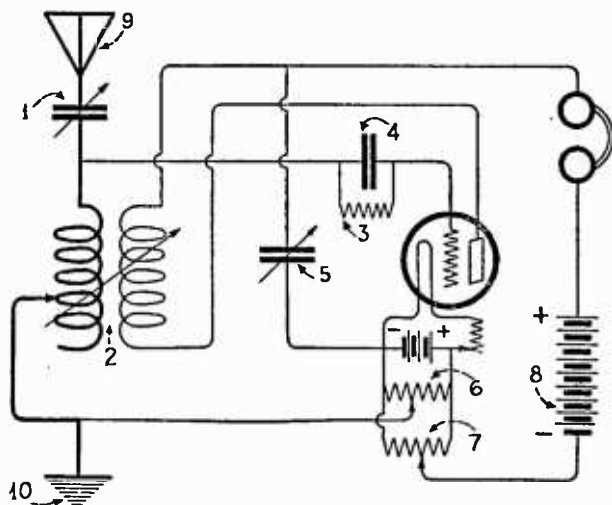

MR. SHEEHY'S EFFICIENT HOOK-UP

- 1 Variable condenser of .001 mfd. capacity.
- 2 Any variocoupler of standard make, range 150 to 600 meters.
- 3 1-megohm grid leak.
- 4 Grid condenser of .0005 mfd. capacity.
- 5 Variable condenser of .001 mfd. capacity.
- 6 200-ohm potentiometer.
- 7 200-ohm potentiometer.
- 8 B battery, 16½ to 22 volts for UV200 tube.
- 9 Antenna 125 feet long, 40 feet high, 7/22 stranded.
- 10 Counterpoise ground. Single wire 125 feet long, buried one foot deep, under the antenna.

windings are tight and will stay so. Paste-board tubes should be treated with parafine, shellac, or other such substance in order to exclude moisture, so that they will retain their original shape and size. Bakelite or formica tubes are much to be preferred as coil forms. Loose windings experience sudden erratic changes in capacity and inductance, are liable to spring off their forms, cause mechanical annoyances, and are generally inefficient."

Another contestant, Carol Nason, of Livermore, California, echoes the "solder everything" advice of Mr. Johnson and cites an interesting example.

"Before wiring with copper strip and soldering every joint," he says, "number 18 bell wire was used. This worked fine for two or three days, but after that the set began to hiss. All the connections were shined up—and the hissing stopped! Another thing that is apt to produce undesirable noises is poor A battery connections, both at the battery and on the rheostat. Keep your eye on them all the time. In conclusion, I might say that it takes some patience to get distant broadcasts, but you feel repaid and then some when you hear an announcement 2000 miles or so away. There is no trick in it. It requires a good set and a decent aerial and a little close tuning.



THE HOLMSES, OF PRESTON, ONTARIO, WITH THEIR HOLM-MADE SET

One other thing: When you use a detector alone you get to know your set much better than if you use two steps to start with. Then, when you do put in one or two steps you have a real set." Mr. Nason's aggregate mileage is 56,477, made with a standard regenerator.

One of the highest mileage reports received is that of Milton L. Johnson, who seems to be bringing in about everything worth hearing from his conveniently central home in Atchison, Kansas. He has heard 175 stations in all and has piled up an aggregate of 110,755 miles. His set is a standard 3-circuit regenerator.

Several reports were received in which the stations heard on a single night were recorded.

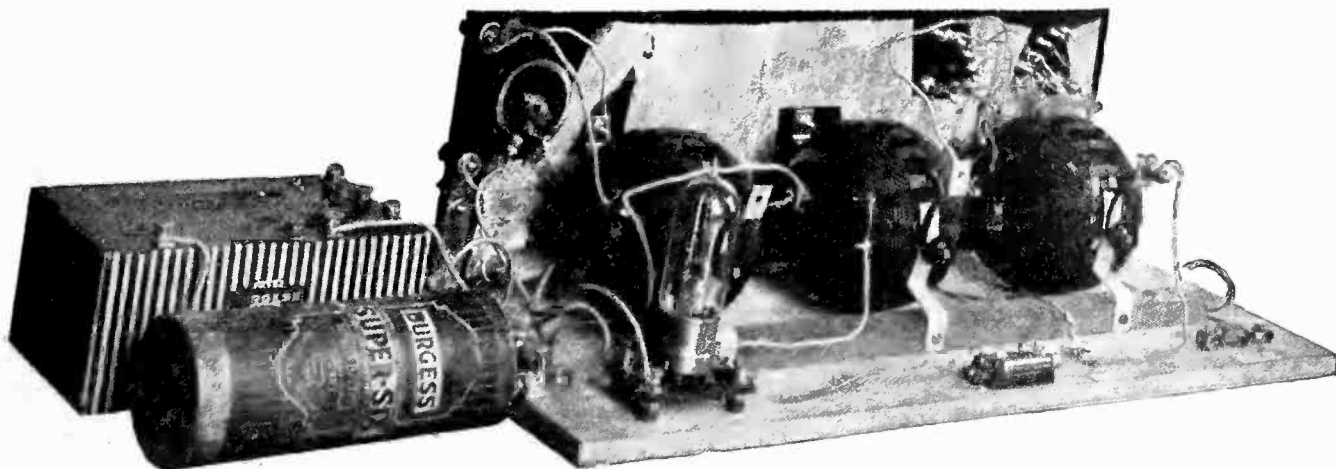

RALPH S. RAMSAY, IN MADISON, WISCONSIN, HEARS LOS ANGELES WITH THIS  
It employs the twin-variometer, variocoupler arrangement, and the tube is a WD-11.

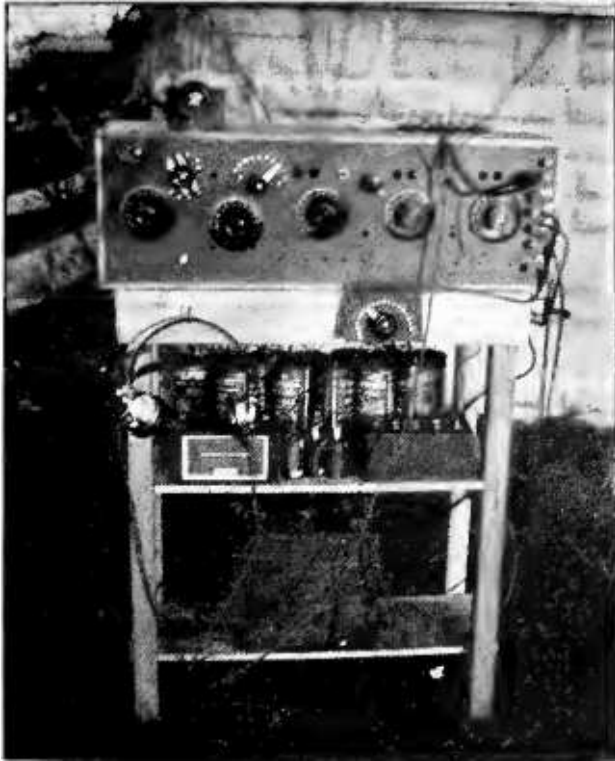

#### A PRODUCT OF THE BUCKEYE STATE

Willis Danback, of Tiffin, Ohio, is the designer of this receiver. It has 2 stages of A. F. amplification, but he has done some good work with one tube

Vernon Trigger, of Carsonville, Michigan, relates making a score of 25,500 miles in six and a half hours. "This little long-distance hop," he tells us, "was accomplished with the aid of a home-constructed standard regenerative receiver. By the way, it appears that the old 'stand-by' seems to be losing out to the new and numerous single-circuit outfits. The trouble with three circuits, using two variometers and a vario-coupler, is the difficulty of tuning them. Hauling in 2000-mile stations with another about 150 miles away ripping along with a beautiful carrier-wave is the result of a fifty-fifty mixture of perseverance and perspiration."

J. E. Bradley, of Justin, Texas, reports practically the same mileage, 25,010, in one evening. That particular evening, he and Mrs. Bradley started listening-in at 5:45 p. m. and finally called it a day, or rather a night at 3:18 A. M. Has a sort of familiar sound, hasn't it? We wonder if there is one among our readers who hasn't sat down at his set with a firm resolve to spend fifteen or twenty minutes at it, and then put off the quitting time again and again until the bell in the clock-tower from somewhere outside boomed in the news that it was 1 G. M.!

Charles H. Hewitt, of Southern Pines, North Carolina relates hearing stations all over the country on a single-circuit regenerator, to the tune of 109,025 miles. Much of his DX results he obtained after 2 A. M. He uses a vernier condenser in parallel with the usual variable in the ground circuit. This is a good point, and ought to improve the tuning of any set.

Ralph S. Ramsay, of 625 North Frances St., Madison, Wisconsin, has been using a dry-cell tube with a home-made set, and gets Los Angeles (1500 miles), Calgary (1200 miles), and San Antonio (1000 miles) consistently. He lists only 21 of the stations he has heard. These aggregate 15,975 miles.

D. C. McCoy, of Charleston, West Virginia, who has been a radio bug for some thirteen years says that he recalls with a smile the old days when he "used to sit up half the night to get a few signals from some station 50 to 100 miles away." He made his present set out of various improvised, bought, and salvaged parts, making all connections as short as possible between the various units and soldering everything—even the connections on the prongs of the tube, instead of using a tube socket. The set is of the single-circuit regenerative variety. Mr. McCoy's longest jump is 2150 miles, and his aggregate is 28,205.

The final summary of results follows:

#### SUMMARY OF RESULTS OBTAINED BY OTHER ENTRANTS WHOSE COMPLETE RECORDS HAVE NOT BEEN PUBLISHED PREVIOUSLY

SINGLE-CIRCUIT REGENERATORS					Name and Address				
Name and Address	No. of Stations	Nearest Station	Farthest Station	Aggregate Mileage	No. of Stations	Nearest Station	Farthest Station	Aggregate Mileage	
F. W. Cray, Carsonville, Mich.	116	150	2175	85,100	Maury Simmons, 2700 Darian St., Shreveport, La.	91	175	2020	72,820
Leland Whitelock, 408-9th St., Petersburg, Ind.	153	160	1775	81,081	Perkins Benneyan, 637 Poplar Ave., Fresno, Calif.	79	160	2500	69,690
Harrie R. Eachus, Sutter, Calif.	80	150	2540	74,765	J. W. Bowser, 206 Greenwood Ave., Punxsutawney, Pa.	82	150	2375	60,725

Name and Address	No. of Stations	Nearest Station	Farthest Station	Aggregate Mileage	Name and Address	No. of Stations	Nearest Station	Farthest Station	Aggregate Mileage
C. D. Mason, Kirby Bldg., Cleveland, O.	102	150	2100	59,050	Leo A. Mondt, Pont. College Josephinum, Columbus, O.	29	500	1460	22,515
Roy R. Hess, Jr., Edna, Texas	60	150	2040	46,190	Albert J. Bezek, Ely, Minn.	32	220	1720	22,350
James S. Norton & Frank D. Baker 902 N. Mariposa Ave., Los Angeles, Calif.	46	210	2250	43,450	S. A. Robinson, Lucketts, Va.	43	150	1175	22,335
Ray Dannenbaum, 313 Georgia St., Vallejo, Calif.	38	350	2504	43,168	Eric Burrell, Nova Scotia Sanatorium, Kentville, N. S.	26	375	2000	20,675
Wendell Thomas, Trenton, Mo.	68	150	2000	41,800	E. H. Swift, Rossville, Ill.	36	150	1875	19,615
W. K. Kreuits, Clifton Forge, Va.	76	175	1065	38,035	Edward F. Armstrong, White Plains, N. Y.	24	190	1500	18,090
Laurance Angel, Jr., Huntington, N. Y.	54	150	1475	36,401	STANDARD REGENERATORS				
George Jesse Schottler, Dexter, Minn.	50	150	1650	35,164	Joe McCormack, 1018 Peachtree St., Gadsden, Alabama	103	160	2800	85,560
Norman Olding, New Glasgow, N. S.	43	475	3025	33,576	C. W. Cooper, 810 N. Jackson St., Waukegan, Ill.	96	185	1750	53,770
C. T. Nelson, 2824 Clermont Ave., Pittsburgh, Pa.	68	175	2125	33,570	Alfred Magnuson, Lincoln, Ill.	59	150	1700	30,900
A. J. Muldowney, Highland, Wis.	55	150	1700	33,295	Caesar Cone, Greensboro, N. C.	54	260	1025	27,780
Jose Hernandez Banza, Calle 27, No. 307, Vedado, Cuba.	26	700	2350	31,800	Horace W. Wardle, Qu'Appelle, Sask.	25	300	2325	24,240
Ray L. Atkinson, Lakeworth, Fla.	34	185	1860	31,730	VARIOMETER REGENERATORS				
Paul Glaister, Napanoch, N. Y.	52	150	1950	31,130	Robert Shafer, Croton, O.	107	150	2000	58,835
Gilbert Edwards, 428 Marsh Ave., Reno, Nevada.	46	150	1950	30,000	Edwin E. Pike, Fairgrove, Mich.	83	165	1400	46,520
Vine Stoddard, Aurora, Iowa	47	175	1550	27,350	A. C. Van der Bent, 3436 Walnut St., Philadelphia, Pa.	37	150	1700	32,520
Arthur Hulteen, 636 White Bear Rd., St. Paul, Minn.	39	150	2023	26,955	Theodore Bedell, Jr., 39 Bedell St., Freeport, N. Y.	57	150	1500	32,185
Richard Haynes, Northeast Harbor, Me.	38	200	1840	26,505	9756 Prospect Ave., Chicago, Ill.	46	175	1800	23,630
Werner R. Nygren, 174 Whaley St., Freeport, N. Y.	42	150	1500	25,095	A. C. Callen, West Virginia University, Morgantown, W. Va.	49	160	1225	21,680
H. A. Sanders, Jr., Greenville, Me.	33	350	2200	24,600	Earl Hassler, 425 S. Lahoma St., Norman, Okla.	26	175	1350	20,010
R. H. Shell, Gregory, Texas	29	150	1775	24,280					
Charles Salter, 1516-8th Ave., Lewiston, Idaho.	26	175	2200	23,250					

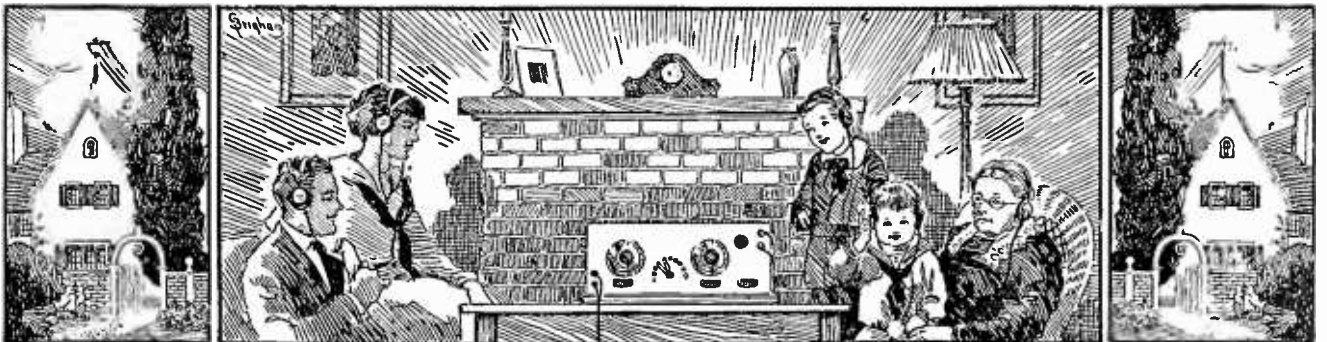

# Another Receiving Contest!

## Any Number of Tubes—Any Kind of Receiver

The "How Far Have You Heard On One Tube?" Contest, which closed February 1st, has been a great success. The hundreds of reports, diagrams, questions, and suggestions which we have received indicate the keenest interest in long-distance receiving throughout the country. The final reports of this contest appear in RADIO BROADCAST this month.

AND—we take pleasure in announcing, owing to the enthusiastic response to this contest, A SECOND LONG-DISTANCE RECEIVING CONTEST, to determine who has done the best with ANY NUMBER OF TUBES AND ANY TYPE OF RECEIVER.

## The Four Prizes

### First Prize: DE FOREST D-7 REFLEX LOOP RECEIVER

This receiver, described in RADIO BROADCAST for February (page 297), is the latest product of the De Forest Company: it makes three amplifying tubes and a crystal detector do the work of six tubes. The loop antenna aids in selectivity because of its directional properties. An ordinary antenna and ground may be used, however, if desired. Recently, a man in Brooklyn, N. Y. heard a broadcasting station in Seattle, Wash., with one of the sets.

### Second Prize: GREBE TUNED RADIO-FREQUENCY AMPLIFIER, TYPE "RORN"

Illustrated on page 352, RADIO BROADCAST for February. This amplifier, which has a wavelength range of from 150 to 3000 meters, may be used with any form of home-made or bought receiver. It is the most recent development of a company widely known for the excellence in design and workmanship of its products.

### Third Prize: Choice of

THREE OF THE NEW RADIOTRON UV-201-A AMPLIFIER TUBES (6 volts,  $\frac{1}{4}$  of an ampere). or

THREE AERIOTRON WD-11 DRY CELL TUBES ( $1\frac{1}{2}$  volts,  $\frac{1}{4}$  of an ampere).

### Fourth Prize: TIMMONS LOUD-SPEAKER UNIT

This unit, which may be connected directly to the output of your amplifier, has a diaphragm adjustable for sounds of different intensities, and when used with two stages of amplification reproduces broadcasted programmes about as loud as the music from the average phonograph.

## Rules of the Contest

1. You should list all broadcasting stations 150 or more miles away from the receiving point, which you have heard distinctly (announcement of location as well as of call letters.)
2. Measure distances accurately, and give aggregate mileage. (This is the sum of all the distances, each station counted once, but two or more stations in the same city being counted separately.) An aggregate mileage of less than 15,000 miles will not be considered.
3. Manuscripts should include the following: description of set, directions or advice for constructing and operating it; any "wrinkles" or makeshifts which you have used to advantage; photograph of your apparatus; circuit diagram; in general, anything you have to tell that will make your story more interesting and helpful. Manuscripts should not be longer than 2000 words. Typewritten reports preferred.
4. Data should be arranged in three columns, under the headings: call letters, location, distance.
5. For material used, a liberal rate will be paid.
6. In judging contributions, the quality and interest of photographs, text, and drawings, and the originality and general effectiveness of the apparatus described, will have greater weight than the list of stations heard, although a long list of distant stations will distinctly help.
7. The Contest begins now and closes May 31st, 1923.
8. Address: Receiving Contest, RADIO BROADCAST, Doubleday, Page & Co., Garden City, N. Y.

# Up Before the Microphone



MISS HARRIET WILLIAMS AT PWX

When she was playing, recently, from the Havana station, her mother, listening in at Toledo, Ohio, heard the programme clearly. And more remarkable still, when Miss Williams also sang, at PWX, the same evening, she was heard in Douglas, Alaska, 3,500 miles away



THE "WAVE FROM LAKE ERIE"

He rolls in from WJAX, the Union Trust Company's station in Cleveland. In private life, the "wave" is E. G. Johnson. He has a deep bass voice which, it is reported, knocks 'em dead all the way from the Atlantic Coast to the Mississippi and from Nova Scotia to Cuba



STATION PERSONNEL AT WJZ, NEWARK, N. J.

Standing, left to right: J. L. Watt ("AWN announcing"), G. E. Oliver (OON), P. W. Harrison (OWN), and M. J. Cross (AJN). Seated, left to right: H. E. Hiller (OHN), G. E. Bliziotis (OBN, Chief Operator), and R. F. Guy (OGN)

# “Coöperative Competition”\*

The Agreement of Automobile Manufacturers of Vision to Exchange Patents, and the Resulting Growth to the Industry. Cannot a Similar Agreement Well Form the Basis for the Settlement of Present and Future Radio Disputes?

By JOHN K. BARNES

Financial Editor of *The World's Work*

**A**FTER the automobile had passed the “horseless carriage” age of the late nineties, and the pleasure of skimming over the roads without a slow-going horse ahead of one overcame the public ridicule that greeted the first cars, it became evident that this infant industry had been born with a silver, if not a gold, spoon in its mouth. The making and selling of four thousand curved-dash Oldsmobiles in 1903 showed many people the possibilities in the business. The early dreams of Charles E. Duryea, Elwood Haynes, R. E. Olds, and other pioneers were coming true. Then began the great growth of the industry. The bicycle manufacturers followed Alexander Winton and E. R. Thomas into this new field. The wagon makers, led by the Studebakers and Mitchell, became interested. The Cadillac Company and the Ford Motor Company sprang up and became successful. Henry B. Joy, Buick, Marmon, and others, in addition to those who had been trained at the Olds Motor Works in Detroit, started with companies of their own. In the next few years many others entered the industry. And there was enough business for all, for the public demand for automobiles grew beyond all expectations. Companies which had good management, sufficient capital, and produced cars that the public liked made large profits.

But the industry was not without its failures—many of them. Young men of mechanical bent but little manufacturing ability got into it. Some were financed by rich fathers and then that backing was withdrawn before they had established a place for their cars. In fact one of the great drawbacks in the whole industry was the lack of capital. Bankers were almost unanimous in the belief that the “craze” for automobiles would die out. Then later they complained that there were already too many companies in the field; they would

not risk their money in new ventures. If the industry had not been established on a cash basis at the start, and if the parts-makers had not extended liberal credit to the companies, this timidity of capital might have proven fatal to the young industry. It certainly would have retarded its marvelous growth. Fortunately there were a few rich men who had the vision of the future of the automobile and were willing to risk their money in it. But when the 1907 money panic came a good many automobile companies went under. And in 1910 the death rate was as high as one a week.

Among the men with money who became interested in the business was Henry B. Joy, of Detroit, known by his friends as Harry Joy. He not only invested his money, but went into the industry himself and became an important element in its successful development. He had tried to buy one of Henry Ford's early experimental cars, but Mr. Ford had told him to wait for the next one, that it would be a better car. Meanwhile Mr. Joy heard of the phaeton Col. J. W. Packard was making in Warren, Ohio, and he went down there and got one. At that time, Mr. Joy and Mr. Emory W. Clark, now president of the First and Old Detroit National Bank, were making plans to start in the banking business. After Joy got his Packard phaeton, however, Clark saw little of him for a month or more. Joy was out on the roads around Detroit at all hours, in and under his new car, testing it and tinkering with it. His enthusiasm for the automobile grew rapidly and it was contagious enough to influence other Detroit men of means to put money into the building of a large factory in Detroit for the manufacture of the Packard car in quantities. Col. Packard was to come on from Warren to run it. At the last minute, however, he could not come, and it devolved upon Joy to take charge of this four hundred thousand dollar plant. The first year the company lost two hundred thousand dollars. The factory became known around Detroit

\* From an article in *THE WORLD'S WORK*, May, 1921.



as the “millionaires’ folly.” But Joy increased the production schedule for the next year, and by his own untiring efforts, together with the financial backing of his directors, made the Packard Company a success.

MR. SELDEN AND HIS  
PATENT

FOR several years the Selden patent was a dominating influence in the industry. Mr. George B. Selden, a patent lawyer of Rochester, N. Y., with inclinations toward mechanics, invented the gasolene automobile in 1879. He immediately made application for a patent, but there followed repeated delays—apparently encouraged by Selden himself, who was trying to interest capital in his new invention—and it was not until 1895 that the patent was issued. Mr. Selden did not manufacture under it and in 1899 sold control of his patent to the Columbia & Electric Vehicle Company which soon afterward became the Electric Vehicle Company. Eastern capitalists were interested in this company. They began a campaign of vigorous enforcement of the patent the next year. Suit was brought against the Winton Motor Carriage Company for infringement. This suit ran along until 1903 when the Association of Licensed Automobile Manufacturers was formed and ten companies signed an agreement recognizing the validity of the Selden patent and agreed to pay a royalty of  $\frac{1}{4}$  per cent. of the retail price of all cars sold by them. The Electric Vehicle Company had an arrangement with Mr. Selden as to

amount of the royalty he was to get. Mr. James Rood Doolittle, who wrote “The Romance of the Automobile Industry,” estimates that Mr. Selden realized about two hundred thousand dollars from his invention.

As the industry grew, this  $\frac{1}{4}$  per cent. royalty soon began to run into large sums and the payments became burdensome on the industry. It was then that Henry B. Joy, president of the Packard Company, led a vigorous fight within the ranks of the Association of Licensed Automobile Manufacturers to have the royalty reduced, and was successful in first having it cut to 1 per cent. and then to  $\frac{1}{8}$  of 1 per cent.

It was in the fall of 1903 that the famous test suit against the Ford Motor Company was instituted by the Electric Vehicle Company at the request of the Association of Licensed Automobile Manufacturers. This case was in the courts eight years and the testimony taken fills thirty-six large volumes. In 1909, Judge Hough, in the United States District Court, rendered an opinion sustaining the Selden

Why Not “Coöperative Competition” in Radio?

Last month, in our editorial, “Monopolizing Production of Apparatus,” attention was called to the possible harmful results of the patent litigation of the Radio Corporation, involving various smaller manufacturers of radio apparatus. It seems to us that there is a marked similarity between the patent situation in the radio business and that which existed in the automobile industry until an agreement resulting in “coöperative competition” was reached. This agreement is described in the accompanying article.

There is one essential point of difference between the radio and the automobile patent situations: The Radio Corporation, with its associated companies, in all likelihood holds patents of greater value than those of all the other companies together, and the working out of an equitable arrangement may be an even more difficult problem than that which the automobile industry had to face. It does seem, however, that a study of the agreements made by the automobile companies might result in a working plan that will save millions of dollars, not only for those now vitally interested—the manufacturers—but also for those who ultimately pay the piper—the users of radio apparatus.

Many people view with alarm what seems to be an attempt by the Radio Corporation to form a monopoly in the production of radio apparatus. Perhaps the litigation is designed merely to test the validity of certain basic patents and thereby to determine their commercial worth. If this is the case, should not the public be informed by the Corporation how it expects to use the power acquired if the courts decide in its favor?—THE EDITOR.

patent in every particular and granting an injunction and an accounting. Ford appealed the case to the United States Circuit Court of Appeals and gave bond to cover damages to the complainants while the case was pending. The other so-called “independents,” who were interested with Ford in the fight, but were not as strong financially as the Ford Company, decided, after Judge Hough’s sweeping decision, that they could no longer afford

to run the risk of heavy penalties, and practically all of them went into the Association of Licensed Manufacturers. Ford continued the fight alone. In January, 1911, Judge Noyes delivered the opinion of the Circuit Court of Appeals that the patent was valid, but that Ford did not infringe it because Selden described an engine of the Brayton type while the defendants and almost all modern automobile makers used the Otto type. Mr. Ford said that the advertising his company got from this case was worth more than all it cost.

It was in this Association of Licensed Automobile Manufacturers; in the American Motor Car Manufacturers Association, formed to combat it, and in the National Association of Automobile Manufacturers, organized in 1900—before the other two—including both “licensed” and “independent” companies, that the leading figures in the automobile industry learned many lessons in coöperation. They also learned something regarding the costs of patent suits and the uncertain value of patents. But the full fruits of this knowledge would probably never have been realized if there had not been drawn into the industry at an early date a man who had seen at first hand the disastrous results of patent litigation in another field, and who had the perseverance to follow an ideal for many years, until he finally got practically all the automobile manufacturers of the country to accept it.

This man is Mr. Charles C. Hanch, who started in the automobile business with the Nordyke & Marmon Company of Indianapolis. That company was, and still is, a large manufacturer of flour milling machinery.

When the Nordyke & Marmon Company entered the automobile field, Mr. Hanch saw that there was likely to be the same rapid development as in the flour milling machinery business, and he foresaw that unless something was done to prevent it there would be even a worse tangle of patent litigation. He went to see Mr. Chester Bradford, of Indianapolis, who had been an attorney in much of the flour milling machinery litigation. Mr. Bradford suggested that a Maine corporation be formed to take over the patents of the various automobile companies, to issue stock to the different companies in proportion to the value of their patents, and to fix reasonable royalties to be charged for the use of the patents. Mr.

Hanch talked to some of the automobile manufacturers about this. They all said, “Go to Detroit and see Harry Joy. If you can get him interested in the scheme, there is a chance of getting it adopted by the industry.” So Hanch went to Detroit, but Mr. Joy could see no possibility of getting the automobile manufacturers to agree to such a plan. Mr. Hanch’s hopes were checked, but he did not abandon his idea.

That was in 1909. In 1915, practically all the companies in the National Automobile Chamber of Commerce, the successor of all the earlier organizations of manufacturers, which includes all the leading automobile producers except the Ford Motor Company, agreed to a plan of cross-licensing their patents which permits of their use by every other member *free of charge*. It is not surprising to find that C. C. Hanch was chairman of the



patents committee that put this plan through. The chief credit belongs to Hanch. In the six years between the birth of the idea in his mind and 1915 he had not been idle. Upon every suitable occasion he had advocated a scheme that would eliminate patent litigation. He had the background of experience in the flour milling machinery industry to draw upon for horrible examples. But even he never dreamed at first that a plan could be effected that would permit of the free interchange of patents. It was when the committee started work on a definite plan and the difficulties of appraising the value of patents and fixing royalties for their use became apparent that it was suggested that no charge at all be made. As no manufacturer had patents worth as much as the aggregate value of the patents of all the others, there was a sound basis of fairness in this proposal. It was this argument that finally convinced the automobile manufacturers in the N. A. C. C. and induced them to adopt the plan. Each one had much more to gain from it than he was asked to contribute.

#### THE EXCHANGE OF PATENTS

THIS cross-licensing agreement does not cover radical patents, for it was felt that any company making inventions of a striking character, involving a radical departure from what is known, should be entitled to special compensation if such inventions proved valuable. At present there are no patents owned

by the members of the National Automobile Chamber of Commerce that have been determined to be of this class. Nor are design patents which apply to the outward appearance of a car—its shape and lines—included in this agreement. But all other patents, such as improvements on the engine or on other parts of the car, come under the cross-licensing agreement and can be used by all the parties of this agreement free of charge. There are about eight hundred such patents owned by the members of the N. A. C. C.

The practicability of this agreement is clearly evident when one stops to realize that a patent of this kind does not give the holder the right to manufacture a car. If it is an improvement on an engine, for instance, the holder of the patent must get licenses from the holders of all other patents on that engine before he can manufacture it. And none of these holders of other patents could make use of his improvement, which might be highly valuable, until they had gotten the right to do so from him. It is obvious that the development of an industry can be seriously retarded by patent conflict and litigation.

The nearest thing to this cross-licensing agreement that had existed up to that time was an agreement between the General Electric and the Westinghouse Electric companies covering an interchange of certain of their patents. But there a compensation was paid. The scheme has since been adopted by the aircraft industry, but never before had it been contemplated for an entire industry.

WHAT “COÖPERATIVE COMPETITION” IS

THUS did the automobile makers solve in a new and sensible way one of the most difficult problems that faces young manufacturing industries. There has never been keener competition than in the automobile field, and yet there is wholesome coöperation. A phrase has been coined to describe this situation: “coöperative competition.” By eliminating the rock on which manufacturers in other industries had been wrecked, or had been forced to combine for their own salvation, the automobile makers reaped some of the advantages of combination without losing any of the benefits of competition. The life of this agreement was fixed for its trial at ten years, but it has operated so successfully that there is

little doubt that when it expires in 1925 it will be extended.

The National Automobile Chamber of Commerce performs other valuable service for its members in connection with patents. It maintains a patent department under the management of Mr. Robert A. Brannigan, which studies every patent that relates to the automobile industry. As one of every four patents issued by the Patent Office in Washington does relate to the automobile, this keeps several men busy. When any patent is brought to the attention of a member of this Chamber, it is referred to this patents department. If it seems to be a valid patent and the invention is one that has merit, the patents department then undertakes the negotiation of a uniform license for the benefit of the members of the Automobile Chamber of Commerce and the industry as a whole.



An example shows how this works. A man named Wright invented a hinge for the engine hood that was protected from the rain by a fold in the upper part of the hood. He licensed one company to use his patent at twenty-five cents a car; then he licensed another at fifteen cents, and another at ten. This got him into trouble with the companies that were paying the higher royalties. When he died, leaving his patent to his wife, she was realizing practically nothing from it. Other companies had seen the hinge and started using it. Several members of the National Automobile Chamber were charged with infringement of the patent. Mr. Hanch, as chairman of the patents committee, saw Mrs. Wright. He explained to her that a small uniform royalty would not only be fairer to the industry, but also more profitable to her. Mrs. Wright fixed a five cent royalty. To-day she is receiving a handsome income from her husband's invention as it is being used on about eight hundred thousand cars a year.

A case of the opposite character, where it seems clear that the inventor is not getting anywhere near what he might, because he asked too much, is that of the Knight sliding sleeve valve motor. Mr. C. Y. Knight invented this type of engine in 1904 and patented it in 1910. At that time the poppet valve motor in general use was not entirely satisfactory. The Knight motor was apparently an improvement over it. But Ameri-

can manufacturers would not consider using the new invention at the high royalty Mr. Knight asked for it. He went to Europe and was successful in getting some foreign makers of high-priced cars to adopt it. They agreed to a royalty based on horse-power that averaged about sixty dollars a car. They stipulated that if manufacturers in any other country were licensed at a lower rate, they were to get the benefit of the lower rate. Then Mr. Knight came back to this country and found American manufacturers more interested in his motor. But when he told them his rate of royalty again they said it was too much. And to-day only four companies in this country use the Knight motor, and under an agreement which, without changing the rate of royalty, limits the amount of payment each year to a fixed maximum. This, in effect, greatly reduces the royalty per car for a large producing company. (If the foreign companies' production ever brings their royalties up to this maximum they will enjoy the same limit.) It is believed that if Mr. Knight had not demanded a royalty that was regarded as prohibitive, the automobile industry would have adopted the Knight motor and abandoned the other. Instead of that it went ahead in its efforts to improve the poppet valve motor and the result has been that now the poppet valve motor compares favorably with the Knight motor.

The National Automobile Chamber of Commerce defends its individual members against patent suits when it is considered in the interest of all the members to do so. This protects the industry from patent hold-ups which might gain headway by starting with small companies that could not afford to defend suits. Through its legislative department its members are heard as a unit in regard to legislative matters. There are also good roads, commercial vehicle, foreign trade, and service departments, through which coöperative work is carried on in those various fields.

In the constitution of the National Automobile Chamber of Commerce is this clause: "Each manufacturing member shall render

to the corporation [the N. A. C. C.] within the first fifteen days of January, April, July, and October of each year, written reports under oath setting forth the number and kinds of self-propelled vehicles made and sold, or otherwise disposed of, by such member, during the preceding three calendar months, and the aggregate net amount charged therefor. . . ."

This clause is an inheritance from the old Licensed Association, as is much of the coöperative spirit in the industry. This information was necessary then in figuring the royalties under the Selden patent. To-day it is used as a basis for collection of dues in the Automobile Chamber of Commerce, but it is of much more value than that. These reports go out to each member. Each one, therefore, knows just what his competitors are producing. That places them all in much better position to make plans for the future. The cards in the automobile industry are on the table; the game is a friendly one.

Differences and misunderstandings arise among the members of the N. A. C. C. just as they do in every other industry, but four times a year representatives of the member companies are brought together in a general meeting—the Chamber pays the traveling and hotel expenses of these men—and their differences are brought out into the light of day and subjected to the views of all the members. The inevitable result is the correction of misunderstandings and usually the composition of differences. Friendly coöperation is thus maintained. Back of this is another man—Mr. Charles Clifton, chairman of the board of directors of the Pierce-Arrow Motor Car Company, who has been president of the National Automobile Chamber of Commerce since its organization. His great vision in regard to the industry, his remarkable personal charm and firm hold on the affections of its leaders, have been largely responsible for the safe course that has been steered past the rocks of discord and dissension which have upset other industries.

Much could be learned by the radio industry from the "coöperative competition" in the automobile field.

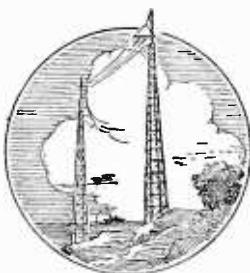



## When every hour counts

**B**ILL wanted to make his radio set as quickly as possible. But at the very beginning there was a delay in getting his panels. It wasn't a long delay, but he was impatient and wanted to make every hour count.

You, Bill, and every radio set-builder can avoid such a delay by getting Celoron Standard Radio Panels. You don't have to wait for your panel to be cut. There's no extra expense for cutting to your order. You go to your dealer and give him the size. He has a Celoron panel which you can carry home with you at once.

Each panel comes trimmed and

wrapped separately in glassine paper to protect the surface. On each one are full instructions for working and finishing.

Celoron makes an ideal panel. It is easily worked, machine drilled and tapped, and will engrave evenly without feathering. It has high surface and volume resistivity, high dielectric strength, and low dielectric losses.

Select from these sizes the one you need:

- |                             |                               |
|-----------------------------|-------------------------------|
| 1. — 6 x 7 x $\frac{1}{8}$  | 4. — 7 x 18 x $\frac{3}{16}$  |
| 2. — 7 x 9 x $\frac{1}{8}$  | 5. — 9 x 14 x $\frac{3}{16}$  |
| 3. — 7 x 12 x $\frac{1}{8}$ | 6. — 7 x 21 x $\frac{3}{16}$  |
|                             | 7. — 12 x 14 x $\frac{3}{16}$ |

*Make every hour count in making your radio set. If your radio dealer has not yet stocked these panels, ask him to order for you. Or write direct to us. Be sure to designate by number the size you want.*

## Diamond State Fibre Company

BRIDGEPORT (near Philadelphia) PENNSYLVANIA

BRANCH FACTORIES AND WAREHOUSES  
 BOSTON CHICAGO SAN FRANCISCO  
 Offices in Principal Cities

In Canada: Diamond State Fibre Company of Canada, Limited, 245 Carlaw Avenue, Toronto

★ CONDENSITE  
**CELORON**  
 STANDARD RADIO PANEL

# Who Will Ultimately Do the Broadcasting?

There Were 570 Active and 67 Discontinued Broadcasting Stations in the United States as of December 1, 1922. Radio and Electrical Manufacturers and Dealers, and Educational Institutions, Seem to Be the Most Permanent in the Broadcasting Field. Statistics\* by Months and by Businesses

**T**ABLE No. 1 shows the monthly growth in the number of broadcasting stations during the past year for the entire United States, including Alaska, Hawaii, and Porto Rico. The deletions were deducted each month so that the figures given represent the total active stations at the beginning of the month.

It seems that the point of saturation in broadcasting stations as determined by present conditions has about been reached. As of December 1st, there were 570 active and 67

cause for discontinuance of stations is the fact that large stations of superior quality have now been installed in many territories, these making unnecessary and inadvisable the continuance of small, poorly equipped stations—unnecessary from the standpoint of stimulating receiving set sales and inadvisable from the standpoint of relations between the owner and the radio public.

Table No. 1 shows also the number of stations that were deleted in this country, beginning April 1, 1922, before which time there

TABLE NO. 1  
REPORT ON RADIO BROADCASTING STATIONS FOR YEAR 1922

	TOTAL NUMBER OF STATIONS AS OF											
	Jan. 1st	Feb. 1st	Mar. 1st	Apr. 1st	May 1st	Jun. 1st	July 1st	Aug. 1st	Sept. 1st	Oct. 1st	Nov. 1st	Dec. 1st
ACTIVE STATIONS . . . . .	28	36	65	133	217	314	378	441	496	539	554	570
DELETED STATIONS . . . . .				4	4	8	12	14	16	22	44	67

discontinued stations, *but during the month of December alone, 20 stations were deleted.* The last four months of 1922 show a distinct decline in the net monthly gain in stations as follows:

	Oct. 1st	Nov. 1st	Dec. 1st.	Jan. 1st.
New Stations	48	38	38	33
Discontinued	6	22	23	20
	42	16	15	13

Many broadcasting stations were continued in operation up to September 1st, last year, with the expectation of another "boom" similar to that of the previous year. When the sale of receiving sets was seen to follow a more healthy and less spectacular growth, these stations began to drop out of the broadcasting field in increasing numbers. Another

were no deletions. It will be seen that 570 stations were still active as of December 1, 1922, a total of 67 stations having been discontinued up to that date.

Table No. 2 is particularly interesting and significant. It shows the businesses engaged in by the various broadcasters in each state, with the totals for states and businesses. Those broadcasters classed as unknown include individuals and companies whose businesses were not evident from their names or from other available sources. The radio and electric manufacturers and dealers make up 40% of the owners of stations, with publications and educational institutions coming second and third, although with totals far below that of the manufacturers and dealers.

In Table No. 3 is indicated the stability of various lines of business doing broadcasting, with the percentage of the total in a given

\*From statistics compiled from Government Bulletins by the American Telephone and Telegraph Company.



## Do you lug your battery to have it charged?

Do you put off lugging it until it fails to give good results?

How many concerts do you miss or only half hear?

With Tungar—the go-between—from the house lighting circuit to storage battery—you are prepared for best results always.

Just turn it on and leave it. It charges your battery while you sleep. Its cost of operation is low. It makes convenient the necessary charging that prolongs battery life.

Tungar has no moving parts to cause trouble. It is *certain, clean, quiet.*

Good for the auto battery too—the same Tungar.

See it at any good electrical shop, or write for literature. Address Section RB-4.

Merchandise Department  
General Electric Company  
Bridgeport, Connecticut

*Tungar Battery Charger operates on Alternating Current.*

*2 ampere outfit—\$18.00.*

*5 ampere outfit—\$28.00*

*(east of the Rockies)*

*Special attachment for charging 12 or 24 cell*

*"B" Storage Battery—\$3.00*

*—fits either size Tungar.*



*Charge 'em at Home, with*

# Tungar

**BATTERY CHARGER**

A GENERAL ELECTRIC PRODUCT

★ Tested and approved by RADIO BROADCAST ★

TABLE NO. 2  
BUSINESSES ENGAGED IN BY OWNERS OF BROADCASTING STATIONS

	Radio and Electric Manufacturers and Dealers	Newspapers and Publications	Educational Institutions	Department Stores	Auto and Battery Cos. and Cycle Dealers	Music and Musical Inst. and Jewelry	Churches and Y.M.C.A.'s	Hardware Stores	Police, Fire and City	Banks and Brokers	Stock Yards, Poultry Farms and Grain Dealers	Clubs and Societies	Mine Supplies, Marble, Oil Cos.	Railroads and Power Companies	Tel. & Tel. Cos.	Parks and Amusements	State Bureaus	Theatres	Laundries	Unknown	TOTAL
Alabama . . . . .	2		1																		4
Arizona . . . . .	2	1		1																1	5
Arkansas . . . . .	1	1				1														2	5
California . . . . .	28	9	2	4	1	1	2		2	2	1					1		1	1	12	68
Colorado . . . . .	6	1	1				1													1	11
Connecticut . . . . .	2	1			1								1							1	5
Delaware . . . . .	1																				1
D. of Columbia . . . . .	4			2	1		1														8
Florida . . . . .	4	3																		2	9
Georgia . . . . .	3	2	2											1							8
Idaho . . . . .	3		1		1		1														6
Illinois . . . . .	6	5	2	1	1	1			1							1		1		2	21
Indiana . . . . .	7	5	1																	1	14
Iowa . . . . .	10	2	3		1	1				2										4	23
Kansas . . . . .	10	1	1		2								1							1	16
Kentucky . . . . .		2						1												3	6
Louisiana . . . . .	4	2	2																	1	9
Maine . . . . .	3							1													4
Maryland . . . . .	2	1				1															4
Massachusetts . . . . .	4		2	1				2													9
Michigan . . . . .	3	3	2		1				1											3	13
Minnesota . . . . .	7	1	3																	2	13
Mississippi . . . . .																					0
Missouri . . . . .	3	4	3	2	1	2	1										1			7	24
Montana . . . . .	1	2	1																	1	5
Nebraska . . . . .	8	4	3														1			4	23
Nevada . . . . .	1				1																2
New Hampshire . . . . .	1																				1
New Jersey . . . . .	6		1	1	1			1	1			1								1	13
New Mexico . . . . .			1											1							2
New York . . . . .	12	2	5	1					1						3					4	28
North Carolina . . . . .	2		1																		3
North Dakota . . . . .	3																				3
Ohio . . . . .	19	2	7	1		1	1			1	1									2	35
Oklahoma . . . . .	6	2											1							1	10
Oregon . . . . .	6	2	1			2		1			1									2	15
Pennsylvania . . . . .	12		4	10	1	1											1			4	33
Rhode Island . . . . .	1			2	1											1					5
South Carolina . . . . .	4																				4
South Dakota . . . . .	1	1	3																		5
Tennessee . . . . .						1									1					2	4
Texas . . . . .	13	5	4	2					1				1							8	34
Utah . . . . .	1	2																		1	4
Vermont . . . . .			1																	1	2
Virginia . . . . .	3		1																	1	5
Washington . . . . .	9	2	2	1	1		2													7	24
West Virginia . . . . .	1		1					2													4
Wisconsin . . . . .	3	1	2	1	1							1								2	11
Wyoming . . . . .	1					1	1														3
Alaska . . . . .																				1	1
Hawaii . . . . .	1	1																		1	3
Porto Rico . . . . .	1		1																		2
TOTAL . . . . .	231	70	65	30	17	12	10	8	7	5	4	4	4	4	4	3	3	2	1	86	570

line of business who have discontinued the use of their station. From this table, it will be seen that radio and electrical manufacturers and

dealers, and educational institutions are apparently the most permanent in the field of broadcasting.



# 3 Letters! and they will be interesting to every — radio user.

5701760  
130

**HUDSON MOTOR CAR COMPANY OF N.Y.**

**HUDSON AND ESSEX MOTOR CARS**  
1422 BEDFORD AVE.  
BROOKLYN

November 23rd, 1922

Acme Apparatus Company  
Cambridge, Mass.

Gentlemen:—

It will possibly be of interest to you to know that with the aid of your radio Frequency Transformers R2, R3 and R4, I have built an ideal set. This set brings in PWX, Havana, as clear as a bell any time that I care to hear him. I have also reached other stations that I never knew existed. Last night I hooked up 3 Transformers in place of yours, and with the stations that I received there was enough howls and yells to make one think that all Hell was let loose at once, so put the old Acme's back and the loud speaker started to give out some real music. This set has given such satisfaction that I simply couldn't refrain from writing you to let you know that you have satisfied at least one Radio Bug. However, I might add that I am using a loop antenna and my tuner consists of only 2 Variable condensers, one 43 plate and one 3 plate hooked right across the loop outlet.

Please do not think that this is the first set I have ever seen and that my enthusiasm is running away with me. I have owned a . . . . a step and a . . . . and have also built numerous other sets, but this Acme Radio Frequency Transformer sure has the world licked.

Very truly yours,

Hudson Motor Car Company of N. Y., Inc.



Service Manager

YOU can purchase all Acme Transformers at radio stores. If your dealer does not carry them, we will see that you are taken care of. Leaflets describing hook-ups for various Acme Transformers will be sent on request.

**THE ACME APPARATUS COMPANY**

*(Pioneer transformer and radio engineers and manufacturers.)*

CAMBRIDGE, MASS., U. S. A.

New York  
Chicago

1270 Broadway  
184 W. Washington Street

**ACME APPARATUS COMPANY**

TRANSFORMER & RADIO ENGINEERS & MANUFACTURERS

186 MASSACHUSETTS AVENUE  
CAMBRIDGE 38, MASS., U.S.A.

December 7th, 1922

Mr. John M. Craig  
510 St. Marks Avenue  
Brooklyn, N. Y.

Dear Sir:—

We wish to thank you for your letter of November 23rd and would like to know if you would be willing to allow us to use this as a testimonial either with or without your name.

We worked for practically nine months before putting a radio frequency amplifying transformer on the market and it is exceedingly gratifying to receive such letters as yours as a reward for this endeavor.

Yours very truly,

ACME APPARATUS COMPANY



Per Chief Engineer

**HUDSON MOTOR CAR COMPANY OF N.Y.**

**HUDSON AND ESSEX MOTOR CARS**

1402 BEDFORD AVE.  
BROOKLYN

December 8th, 1922

Mr. G. E. M. Bertram  
186 Massachusetts Ave.,  
Cambridge, Mass.

Dear Sir:—

Your letter of the 7th instant came to hand this morning, and in reply would say that you are at liberty to use my letter of November 23rd, in any way you desire, with or without my name. I might add that I know of four sets copied from mine that are giving results equal to mine.

On Wednesday evening I had a transmission engineer from the New York Telephone Company out to my home and believe me he was the most surprised man I have seen in some time. Without having ever seen my set, in twenty minutes he tuned in PWX, WOC, WBAP, WSB and several near stations. What pleased him especially was that he could tune in the 200 meter stations as well as the 400 meter boys.

Very truly yours,

Hudson Motor Car Company of N. Y., Inc.



Service Manager

JMC:N  
510 St. Marks Avenue  
Brooklyn, N. Y.

# ACME for amplification

★ Tested and approved by RADIO BROADCAST ★

TABLE NO. 3  
STABILITY OF VARIOUS LINES OF BUSINESS IN BROADCASTING FIELD

Business	Active Stations	Deleted	Total	Per Cent Deleted
Educational Inst. . . . .	65	5	70	7.1
Churches and Y. M. C. A.'s . . . . .	10	1	11	9.1
Radio and Elec. Mfg. and Dealers . . . . .	231	26	257	10.1
Plumbing and Hardware . . . . .	8	1	9	11.1
Newspapers and Publications . . . . .	70	12	82	14.6
Unknown . . . . .	86	17	103	16.5
Clubs and Societies . . . . .	4	1	5	20.0
Parks and Amusements . . . . .	3	1	4	25.0
Railroads and Power Companies . . . . .	4	3	7	43.0

# The Grid

## QUESTIONS AND ANSWERS

The Grid is a Question and Answer Department maintained especially for the radio amateurs. Full answers will be given wherever possible. In answering questions, those of a like nature will be grouped together and answered by one article. Every effort will be made to keep the answers simple and direct, yet fully self-explanatory. Questions should be addressed to Editor, "The Grid," Radio Broadcast, Garden City, N. Y. The letter containing the questions should have the full name and address of the writer and also his station call letter, if he has one. Names, however, will not be published.

### MOTOR-GENERATORS FOR RECEIVING PLATE VOLTAGE

*Can a motor-generator be used to furnish 110 volts for the operation of a W. E. loud-speaker and amplifier set?*

*How should one test an Edison nickel-iron storage battery?*

*What are the operating characteristics of the old-style Audiotron tube, such as its A and B batteries? How do they compare in sensitivity with the bulbs now on the market?*

E. H. B., HARRISBURG, PA.

**S**UPPLYING the plates of a power amplifier from the average motor-generator is not practicable due to the impossibility of eliminating the hum caused by commutation.

However, generators and dynamotors have been developed especially for this purpose which quite adequately replace the B battery. Such a generator is preferably a high-speed machine, running over 3000 revolutions per minute, and should have no less than 36 commutator segments. The resulting 900- or 1000-cycle ripple is more easily smoothed out than a lower frequency.

The filter for the elimination of generator hum consists of choke-coils and condensers, the later aggregating no less than 10 mfd. The reactances or chokes may be wound on any convenient soft iron core with two and a half pounds of double-cotton covered wire. Two such chokes should be constructed, and the filter wired according to the diagram in Figure 3. The commutator must be kept scrupulously clean by an occasional light scouring with the finest grade of sand-paper. (Emery cloth must not be used.)

Generators and dynamotors designed for this purpose,

generally supply up to 350 volts, and many of the latter machines are operative from a six-volt source.

As the specific gravity of the Edison Cell is constant regardless of its state of charge or discharge, it is impossible to determine the condition of the battery with a hydrometer. In large banks of nickle-iron batteries, an ampere-hour-meter is used for this purpose. An ampere-hour-meter is an instrument which registers the amount of current drawn from or fed to the battery.

Voltmeter readings, however, are fairly sure indications as to the condition of the battery. When fully charged, the Edison cell should read 1.9 volts on open circuit. This drops rapidly at first, and then gradually falls to .7 at which voltage it should be placed on charge. The Edison battery may be completely discharged and severely overcharged without damaging the plates. For further details concerning battery charging, the reader is referred to the January GRID.

The old style tubular Audiotron operates from a six-volt battery in series with the standard rheostat. The tubes were seldom uniform, and the plate voltage varied from eighteen to forty.

There is little electrical difference between the Audiotron and the modern soft bulbs, except that the latter are more consistently good.

### A VARIOMETER TICKLER CIRCUIT

*I enclose a circuit which I stumbled on while experimenting with my honeycomb set. It is giving me remarkable results with an unusual wave range on a single set of coils. Is there anything new about the circuit?*

T. O. B., NEW YORK CITY.



# Radiotrons



*This symbol of quality  
is your protection*



- Radiotron UV-200**  
*The long distance detector . . \$5.00*
- Radiotron WD-11**  
*The ideal dry battery detector 6.50*
- Radiotron UV-201**  
*The amplifier tube . . . . . 6.50*
- Radiotron UV-201A**  
*The super-amplifier tube . . . 9.00*

*At the Nearest  
RCA Dealer*

Radio in a million homes already—and the vast majority of vacuum tube receivers choose Radiotrons for reception and amplification!

It was perfection of the Radiotron that made the swift success of broadcasting possible—and the Radiotron still stands alone, as it did from the first.

The only name by which anyone demands a vacuum tube is *Radiotron*—the key to clear, true reception of speech and music, with the simplest set or the most imposing.



*Sales Dept., Suite 2066*

*District Sales Offices*

*233 Broadway  
New York, N. Y.*

*10 South LaSalle Street, Chicago, Ill.  
433 California Street, San Francisco, Cal.*

★ Tested and approved by RADIO BROADCAST ★

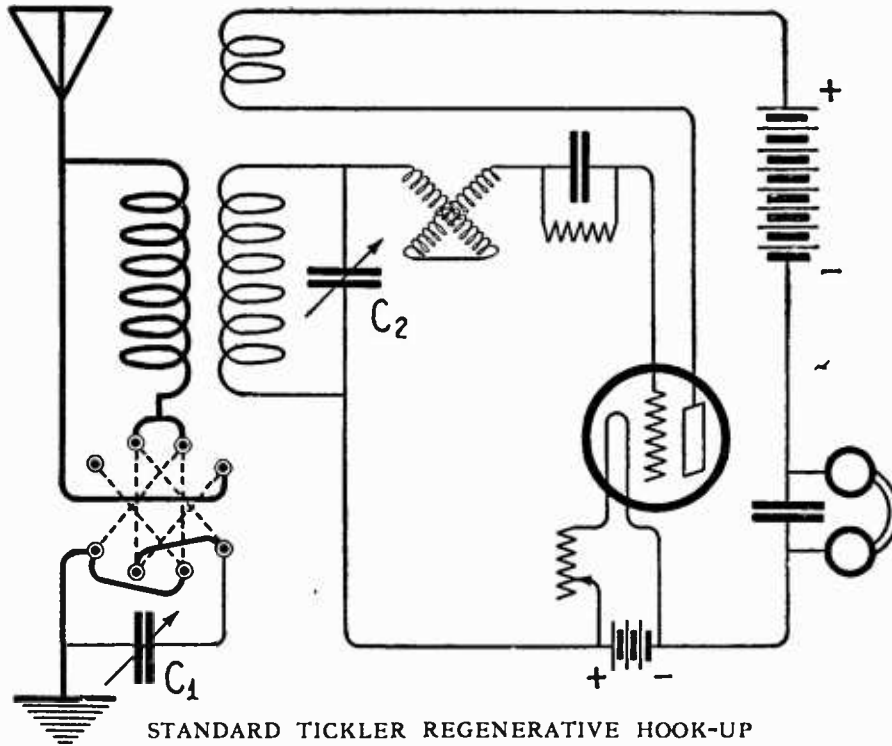

STANDARD TICKLER REGENERATIVE HOOK-UP  
With a grid variometer which aids in selective tuning

THE circuit (shown at left) is not new, and it differs from the usual three-coil, tickler regenerative hook-up only by the inclusion of the grid variometer. The variometer doubtless adds to selectivity by its assistance in tuning, and in conjunction with the primary condenser, switched to shunt, permits the set to tune higher waves than is ordinarily possible without changing coils.

It would be well to make the variometer according to the directions given in the December GRID, as the majority of purchased instruments are rather large for this circuit. For still higher waves, providing they do not exceed the limit of the primary, a single-pole double-throw switch may be included for throwing the condenser C2 across both variometer and secondary.

With some tubes it might be possible to improve the circuit further by shunting the tickler coil with a .0005 mfd. (23-plate) condenser.

SUPPLEMENTAL LIST OF BROADCASTING STATIONS IN THE UNITED STATES FROM JANUARY 14 TO FEBRUARY 9 INCLUSIVE

CALL SIGNAL	OWNER OF STATION	LOCATION
KFCP	Flygare, Ralph W.	Ogden, Utah
KFCV	Mahaffey, Jr., Fred.	Houston, Texas.
KACY	Western Union College	Le Mars, Iowa.
KFDR	Bullock's Hardware & Sporting Goods	York, Nebraska.
KFGB	Loewenthal Bros.	Pueblo, Colo.
KFGF	Buchanan Stevens & Co.	Mt. Vernon, Wash.
KFI	Anthony, Earle C., Inc.	Los Angeles, Calif.
KPO	Hale Bros., Inc.	San Francisco, Calif.
WCAZ	Compton, Robert	Carthage, Ill.
WEAJ	University of South Dakota	Vermillion, S. D.
WMC	Commercial Publishing Co.	Memphis, Tenn.
WPAY	Bangor Radio Laboratory	Bangor, Maine
WPAZ	Koch, Dr. John R.	Charleston, W. Va.
WQAD	Whitall Elect. Co.	Waterbury, Conn.
WQAH	Brock-Anderson Elect. Eng. Co	Lexington, Ky.
WQAJ	Ann Arbor Times News	Ann Arbor, Mich.
WQAM	Electrical Equipment Co.	Miami, Fla.
WQAO	Calvary Baptist Church	New York, N. Y.
WQAR	Press Publishing Co.	Muncie, Indiana.
WQAS	Prince-Walter Co.	Lowell, Mass.
WRAC	State Normal School	Mayville, N. D.
WRAD	Taylor Radio Shop	Marion, Kansas.
WRAJ	Pickering Co., M. H.	Pittsburgh, Pa.
WRAM	Lombard College	Galesburg, Ill.
WRAV	Antioch College	Yellow Spring, Ohio.
WSAA	Sprague, B. S. Elect. Co.	Marietta, Ohio
WSAB	Southeast Missouri State Teachers' College	Cape Girardeau, Mo.
WSAH	Leonard, A. G., Jr.	Chicago, Ill.
WSAL	Franklin Elect. Co.	Brookville, Ind.

# Burgess, the *Radio Battery*

*Specified by radio engineers — designed and built by wireless specialists—and recommended by leading manufacturers of radio equipment.*

Burgess Radio Batteries, the result of years of careful experiments are built under exacting manufacturing standards which must meet the requirements of strict laboratory formulae and tests — a supervision that insures their perfect operation.

For professional or amateur radio use, where noiselessness, long life, high capacity and uninterrupted, dependable service are essential, Burgess has no superior.

Burgess Batteries are built for both "A" and "B" circuits. The Burgess No. 6 is used and found most satisfactory on the "A" or filament circuits equipped with the new type one and one-half volt vacuum tubes. The Burgess "B" Battery is everywhere recognized as the Standard of Quality in the wireless field.

**BURGESS BATTERY COMPANY**  
Engineers — **Dry Batteries** — Manufacturers  
FLASHLIGHT — RADIO — IGNITION — TELEPHONE

General Sales Office: Harris Trust Bldg., Chicago  
Laboratories and Works: Madison, Wisconsin

*Branches:*

New York Boston Washington St. Paul Kansas City New Orleans

In Canada: BURGESS BATTERIES, Ltd.  
Winnipeg, Toronto, Montreal

## BURGESS RADIO BATTERIES

"ASK ANY RADIO ENGINEER"



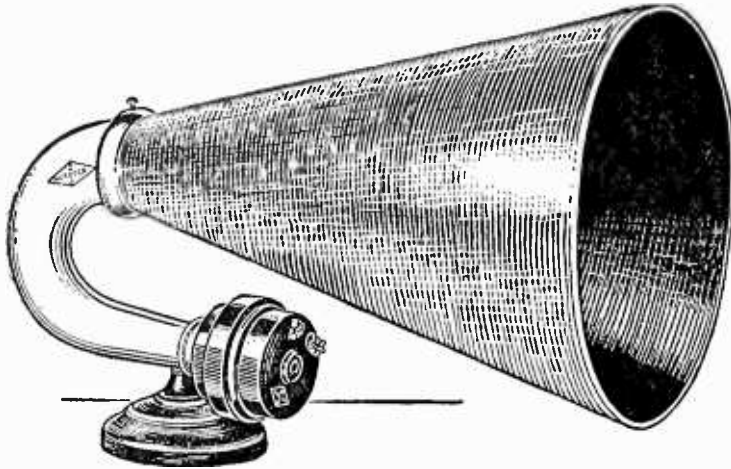

**\$5**  
**for the new**  
**MURDOCK**  
**LOUDSPEAKER**

*Complete with new  
loudspeaker phone unit.  
The sensation of radio  
at an unheard of price.  
Backed by the oldest  
manufacturer of Radio  
head phones. Get one today  
from your dealer.*

**WM. J. MURDOCK COMPANY**  
341 Washington Ave., Chelsea (Boston), Mass.

**SALES OFFICES:**

Wilson Bldg.....New York  
509 Mission St.....San Francisco  
524 Marquette Bldg.....Chicago

**F**OR over 18 years Murdock Head-  
phones have been used by Radio  
experts all over the world—they have  
given universal satisfaction because  
they are scientifically correct for the  
best reproduction of sound.

Insist on Murdock phones when pur-  
chasing.

If your dealer cannot supply you with  
Murdock Apparatus send remittance  
direct and your order will be filled.

**DEALERS**

Write us for full information about  
the new Murdock Loudspeaker. Get  
on our list.

**MURDOCK HEADPHONES**

No. 56—2,000 Ohms

**\$5.00**

No. 56—3,000 Ohms, \$5.50

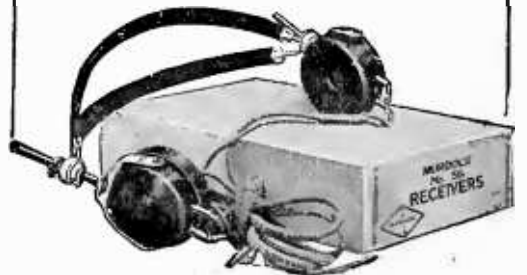

**MURDOCK RADIO**

*STANDARD APPARATUS SINCE 1904*

# IMPORTANCE OF AMPLIFICATION

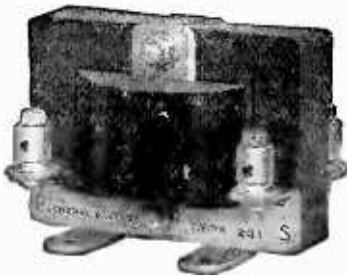

**TYPE 231-A  
AMPLIFYING TRANSFORMER**

The simplicity of audio frequency amplification still makes it the most practical and popular type. It is adapted to all types of receiving sets and is free from tuning adjustments. With the proper choice of amplifying instruments, audio frequency amplification is accomplished with a minimum of distortion.

The amplifying transformer is the most important of these instruments. The General Radio Co. was the first company to have available a closed core audio frequency amplifying transformer. This was before the United

States entered the war. Many of these transformers were supplied to the army and navy during the war, and with the return of amateur radio after the war, thousands have been supplied for use in this country and abroad.

Our latest type is the 231-A. This transformer is designed to give the maximum of amplification possible without distortion. It is the result of careful engineering design. It is particularly adapted to the WD-11 and UV-201 tubes. The electrical constants of the windings are as follows:

	Primary	Secondary
Direct Current resistance, ohms . . . . .	1,100	5,500
A. C. Resistance at 1000 cycles, ohms . . . . .	11,000	130,000
Reactance at 1000 cycles, ohms . . . . .	66,000	700,000

**PRICE, COMPLETELY MOUNTED, \$5.00**

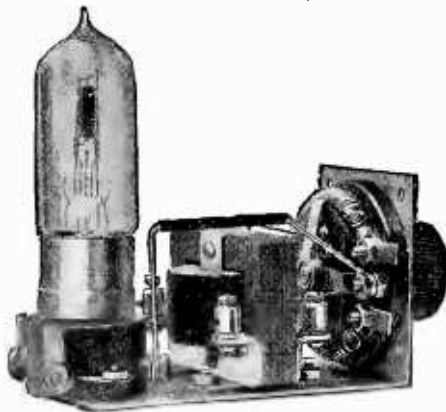

**TYPE 300-A AMPLIFIER UNIT, PRICE \$7.50**

For those who desire a compact amplifier unit, we recommend the Type 300. This unit consisting of our Type 231-A Amplifying Transformer, Type 255 Filament Rheostat, and Type 282 Tube Socket mounted on a nickel finished brass plate, is all ready for the external connections. It may be used as a table unit or mounted behind a panel, in which case only the rheostat knob projects. Connections are properly made so as to keep the unit from howling.

For those who desire to use the UV-201 tubes, this unit may be supplied with a standard base socket—our type 156.

**TYPE 300-B AMPLIFIER UNIT, PRICE \$8.00**

Send for NEW FREE RADIO BULLETIN 913-B and learn about these instruments.

## GENERAL RADIO COMPANY

MASSACHUSETTS AVENUE AND WINDSOR STREET

CAMBRIDGE 39

MASSACHUSETTS

Do not confuse the products of the GENERAL RADIO CO. with those of other concerns using the words "General Radio." The General Radio Co. has been manufacturing radio and scientific instruments for many years. It has no affiliation with any other company.

*Standardize on General Radio Equipment Throughout*



Price \$29.50

One of the outstanding features of the various types of MIRACO sets is that they may be used with either *WD-II* tubes and a 1½ volt dry cell to light all tubes or Radiotron Tubes and a 6 volt storage battery. In ordering be sure to specify which tubes are to be used. Bulletin on Request.

A Money-Making Proposition for Dealers. Agents Wanted Everywhere.

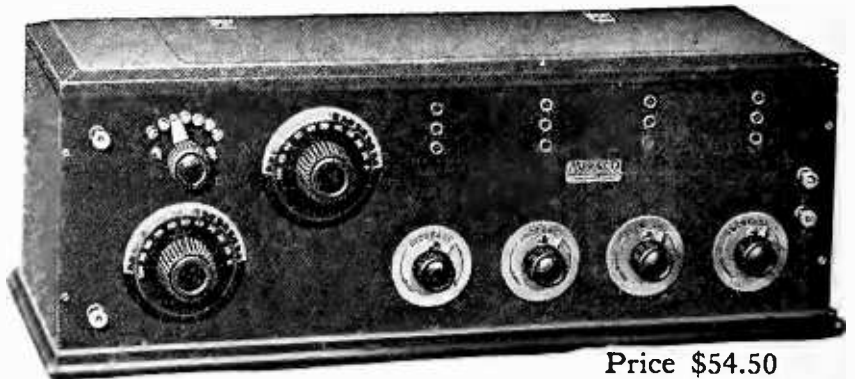

Price \$54.50

THE MIDWEST RADIO COMPANY, 806 Main Street, Cincinnati, Ohio

*Listen to the Difference!*



© CONN. INST. CO.

If you want to get true musical sound over your radio use the head set with non-metallic diaphragm

CONNECTICUT INSTRUMENT CO.  
STAMFORD, CONN.

Don't Be Careless—Protect Your Radio Set With the Dependable

# BRACH VACUUM RADIO PROTECTOR

IT LASTS FOR YEARS

Acknowledged by the most experienced engineers to be the best of all instruments for reducing static interference. Positively protects apparatus against lightning. In use for over 17 years.

Approved by the National Board of Underwriters.

Mend Your Wires and Joints With

## SOLDERALL

A Metal in Paste Form



At all Dealers or by Mail at 25c a Tube.

Insures perfect reception. All you need is a tube of this paste solder and a match to heat it. Results guaranteed equal to bar or wire solder.



L. S. BRACH MFG. CO.  
Newark, N. J.

Coast Representatives:  
Pacific States Electric Co., San Francisco. Los Angeles.  
Oakland, Seattle, Portland, Spokane.



# Bradleystat Superiority Confirmed by Oscillograph Tests

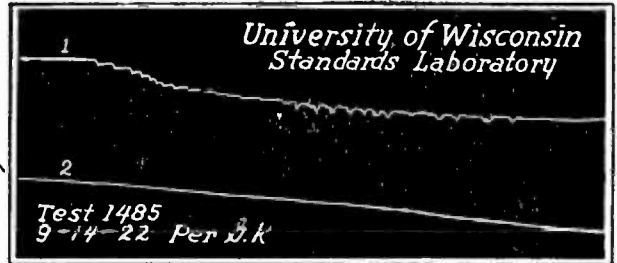
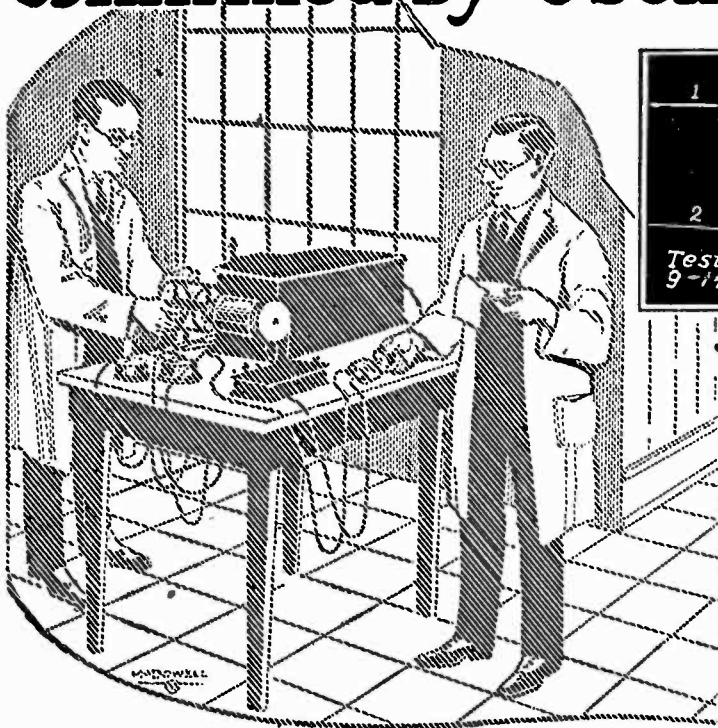

### An Important Test

The Oscillograph is a delicate instrument which records on a moving photographic film any fluctuations in electric current flowing through a rheostat connected to the oscillograph.

Test No. 1—See the violent fluctuations, the jerky, noisy control of a regular wire rheostat. Imagine the hissing and whistling such rheostats create in your detector tube.

Test No. 2—Now look at the smooth, stepless control of the Bradleystat. No hissing, no frying nor loss of exact control. Such noiseless, gradual control extends your range immensely.

Fully  
Guaranteed

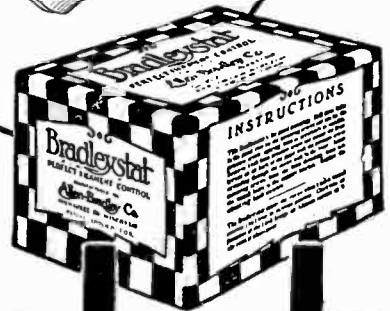
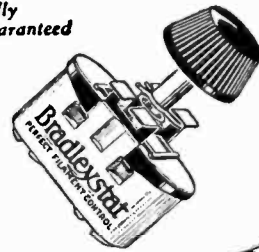

### Replace your Rheostats with Bradleystats

Just compare the oscillograph curves above, made in the Standards Laboratory of the University of Wisconsin. The superiority of the Bradleystat is strikingly evident. Thousands are now installing Bradleystats in place of their wire rheostats, and get quicker tuning, greater range and louder detection. Try one, tonight, and note the amazing improvement.

A new Allen-Bradley product is the Bradleyometer, the Perfect Potentiometer. If you use a potentiometer in your set, send for a Bradleyometer bulletin.

**Allen-Bradley Co.**  
Electric Controlling Apparatus

278 Greenfield Ave. Milwaukee, Wis.  
Member of the National Radio Chamber of Commerce

Retail Price  
**\$1.85**  
P.P. 10c extra

# Bradleystat

REGISTERED

U. S. PAT. OFF.

## PERFECT FILAMENT CONTROL

# HOMCHARGE



*Your*  
**RADIO  
BATTERY**  
*for*  
**A NICKEL**

Enjoyable concerts and maximum receiving range are obtained only when your battery is fully charged.

## THE HOMCHARGER

charges your "A" or "B" battery over night for a nickel without removing it from your living room. No muss—no trouble—no dirt—requires no watching.

After the concert connect to any lamp socket, snap the clips on your battery and "turn in." While you sleep the HOMCHARGER is silently charging your battery, the charging rate being governed automatically. In the morning it is fully charged. No OTHER battery charger can boast of such *quick* and *economical* performance.

The HOMCHARGER is the only battery charger combining all of these NECESSARY HOMCHARGING features—SELF-POLARIZING—FIVE to EIGHT AMPERE charging rate—UNDERWRITERS' APPROVAL—beautifully finished in mahogany and old gold—UNQUALIFIEDLY GUARANTEED. OVER 60,000 NOW IN USE.

Sold complete with ammeter, etc. by all good radio and electrical dealers for \$18.50. (\$25.00 in Canada.)

See the RADIO HOMCHARGER DE LUXE at your dealer or write direct for our FREE circular showing why the HOMCHARGER is the BEST battery charger at any price.

### MOTORISTS

The HOMCHARGER will also charge your AUTO battery.

## The Automatic Electrical Devices Co.

128 West Front Street, Cincinnati, Ohio  
*Largest Manufacturers of Vibrating Rectifiers in the World*



## Recharge Your Battery at Home

Charges Both A and B Radio Batteries

Don't be without the use of your Radio Receiving Set while your battery is being charged. Get a Valley Charger and charge your battery right at home.

Attach the Charger to your home lamp socket—attach the clips to the battery terminals and you will get a quick, tapering charge which just exactly charges your battery, but cannot overcharge or harm it in any way.

Will charge the A 6 volt battery at a 5 ampere rate, and the B 22½ volt battery at the required ½ ampere rate. 46 volt B batteries may be connected in parallel so that they can also be charged.

**SATISFACTION GUARANTEED.** If your local distributor cannot supply you, write direct to

**VALLEY ELECTRIC COMPANY,**

Department G

ST. LOUIS, MO.

**\$18.00**

F. O. B. St. Louis

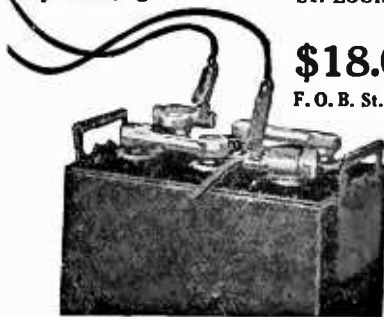

## "CIRCUITS OF VICTORY"

By A. LINCOLN LAVINE

\$3.00 at your Bookstore

Doubleday, Page & Co.

# MARKO



*The Mark of Quality* for **RADIO**  
**ALWAYS DEPENDABLE**

MARKO STORAGE BATTERY CO.

1408 Atlantic Ave.

Brooklyn, N. Y.



—And they're all talking at once these nights! If you want what you want when you want it, you might as well stop struggling with single-circuit receivers.

Under present conditions, with several hundred powerful broadcasting stations all operating on one narrow wave band, the single-circuit receiver is utterly inadequate to give you satisfactory results.

The Paragon three-circuit receiver gives you the station you want when you want it—and *no other*. You can tune in accurately on any station and get a clear, complete program without interruption or disturbance.

Ask some experienced amateur what he knows about

# PARAGON

Reg. U. S. Pat. Off.

## RADIO PRODUCTS

The amateur will tell you that the Paragon three-circuit receiver, because of its great superior selectivity and sensitivity, can pick and choose between broadcasting stations of about the same signal strength with less than one per cent differential.

This means that with a Paragon receiver you get what you want when you want it—complete messages and clear music from the station you tune in on, without interruption and jamming. Until you have listened in with a Paragon three-circuit receiver, you cannot guess the real pleasure and fascination of radio.

Long before broadcasting popularized radio with the general public, Paragon equipment was the choice of the experienced amateur. He will tell you today that if you want quality and satisfaction, Paragon Radio Products are the best and safest buy on the market.

*An illustrated Catalog of Paragon Radio Products Is Yours For the Asking*

**DEALERS**—The Adams-Morgan Company has an interesting proposition to make to reputable radio dealers who believe in quality merchandise. Details on request.

**ADAMS-MORGAN COMPANY**  
10 Alvin Ave., Upper Montclair, N. J.

<b>Also Manufacturers of PARAGON</b>	
Radio Telephone	Amplifier
Transmitters	Transformers
V. T. Control Units	Control Dials
Rheostats	Amplifiers
Potentiometers	Receivers
V. T. Sockets	Switches
Detectors	Variometers

Type RD-5 Regenerative Receiver and Detector—\$75.00  
Type A-2 Two-Stage Amplifier—\$50.00  
(Licensed under Armstrong Patents.)





THE SYMBOL OF SERVICE

# CONTINENTAL

"New York's Leading Radio House"

for 25c!

Get it  
To-day

## 208 PAGE "MODERN RADIO"

Sent postage paid if you write for it now. Ten pages of circuit diagrams—fifteen pages on operating—nine pages of popular hook-ups—tables, data, symbols, codes, wire sizes, list of radio books—information and pictures of standard equipment, parts, supplies—all the "dope" you ought to have. Use the handy coupon below—and why not use it now!



CONTINENTAL RADIO and ELECTRIC CORP'N.  
SIX AND FIFTEEN WARREN STREET, NEW YORK

CONTINENTAL: Enclosed is 25c—Send MODERN RADIO

To .....

Street .....

City and State .....

2028-Q

### Weston Filament Voltmeter

Makes it possible to prevent premature tube burn-outs—facilitates exact tuning—duplicates results instantly.

Write for Circular J

Weston Electric Instrument Co.

179 Weston Avenue

NEWARK, N. J.



### "B" Storage Battery Plates

Lead type, size,  $\frac{5}{8}$  x 2- $\frac{1}{2}$  inches. For high voltage "test-tube" or "bottle" batteries.

Write for descriptive matter

J. A. RITTER

Lansdowne, Pa.

Patents Procured and Trade-Marks Registered

Advice and terms upon request

ROBB, ROBB & HILL

1415 Hanna Bldg.,  
Cleveland, Ohio

954 McLachlen Bldg.,  
Washington, D. C.

RADIO "A" & "B" STORAGE BATTERIES CHARGED at Home For a Few Cents Overnight with "The PATENTED FULL WAVE" 100-130 Volts 60 Cycle A. C. Magnetic Taper Charge Design

They Also Charge AUTO Batteries Overnight Right In Your CAR

\$20

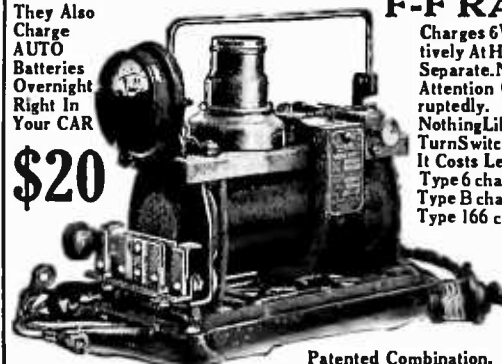

Patented Combination.

### F-F RADIO RECTIFIER

Eventually You Will Buy One. Why Not Now? The Sooner You Buy It; The More You Save. It Charges 6 Volt "A" & Auto; & up to 120 Volts Of "B" & Loud Speaker Storage Batteries In Series Inductively At Home Overnight. Disconnecting & Multiple Connections Unnecessary. Charging Circuits Separate. No Chance For Grounds Or Short Circuits. Nothing To Stop Over, Be Filled, Burn Out, Need Attention Or Cause Trouble. Infusible Rectifying Brushes Maintain Constant Efficiency Uninterruptedly. Complete Portable Automatic. No Skill Required. AMMETER eliminates Guess Work. Nothing Likelt Made. Lasts Lifetime. Screw Plug In Lamp Socket; Snap CLIPS on Battery Terminals; Turn Switch & Batterys Charged In Morning. Charged Batteries Mean Fewer Expensive Replacements. It Costs Less To Buy An F-F RECTIFIER than To Be Without ONE. 7 Types. POPULAR PRICES Type 6 charges "A" 6 Volt Battery At 6ampercs \$15 Type 12 charges 12 Volt Battery At 5 ampercs \$15 Type B charges Radio "B" Batteries Up to 120 Volts \$15 Type A-B is Combination of Types 6 & B \$20 Type 166 charges 6 Volt Battery At 12 ampercs \$20 Type 1612 charges 12 Volt Battery At 7 ampercs \$20 Type 1626 is a Combination of Types 166 & 1612 and Charges Both 6 & 12 Volt Batteries \$28 The 3 Lower Types are recommended for heavy Batteries, or where time is limited. Shipping Weights Complete with AMMETER & BATTERY CLIPS 11 to 15 lbs. Purchase from Dealer, or Mail Check for Prompt Shipment. Include Postage & Insurance Charges for P. P. Shipment, or Write us to Ship Type desired C. O. D. Write For 12 Battery GROUP CHARGING Automatic F-F ROTARY Bulletin 41A. ORDER Now, or WRITE Immediately for FREE Descriptive BOOSTER Bulletin 41

CHARGES "A & B" RADIO & AUTO BATTERIES.

THE FRANCE MFG. CO.,

CLEVELAND, OHIO, U. S. A.

Canadian Distributor: The Jack V. Elliot Company, Hamilton, Ontario, Canada.

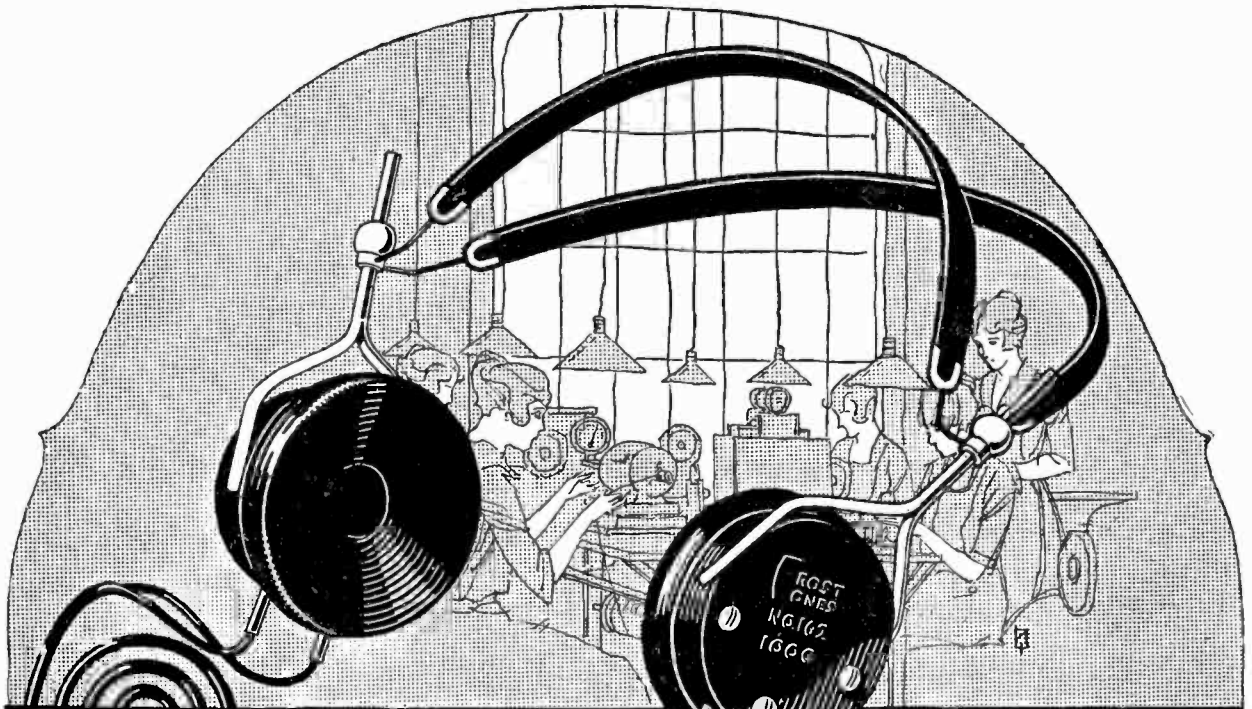

# Super-Inspected Quality

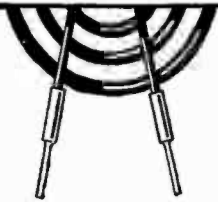

No. 162

2000 Ohm Set

**\$5.00**

No. 163

3000 Ohm Set

**\$6.00**

*Your dealer sells  
Frost Fones. See  
him to-day*

**F**ROST Fones always have been true to an engineering ideal. Built for precision and sensitivity, they quickly won national repute.

Today Frost Fones are the largest selling head fones in the world. Frost ideals of quality — of precision in manufacture — of rigid inspection during every stage of the making of these famous fones — insure permanent satisfaction to every one who buys a pair.

Each item in the Frost Radio line is made up to highest standards of radio engineering. You can order Frost Fones, Plugs, Jacks, and other apparatus from your dealer with the certain assurance that your money buys the best that can be made, at prices which only quantity production makes possible.



**HERBERT H. FROST, Inc.**  
154 WEST LAKE STREET, CHICAGO, ILLINOIS.



## ENJOY RADIO at its *best*

Dependable, even-powered batteries mean quicker and sharper tuning—more complete and constant mastery of your radio set. Westinghouse Batteries are right in step with the latest advancements in radio receiving. Can be easily and repeatedly recharged. No discouraging results from run-down batteries!

**Westinghouse "A" Batteries** are carefully constructed, full-capacity, slow-discharge, long-life batteries. Made in 4-, 6- and 8-volt sizes with 3, 5, 9 and 13 plates per cell, to meet all filament-battery requirements.

**Westinghouse "B" Batteries.** The Westinghouse 22-MG-2 (22 volts) is a marvel for steady, noiseless, full-powered service. Glass case; visible interior; sealed-in tops. Larger types, too; also 2-volt single cells for "C" batteries.

*Write for illustrated folder,  
"Westinghouse Radio Storage Batteries"*  
WESTINGHOUSE UNION BATTERY CO.  
Swissvale, Pa.

# WESTINGHOUSE

RADIO "A," "B" and "C"

## BATTERIES

Warren Radio Loop,  
cut away to show  
construction

What  
You Can Do  
With the—

### WARREN RADIO LOOP

**S**ELECT your stations, just by turning the loop in the direction of the station desired.

**M**AKE any set portable.

**T**UNE on range up to 1,000 meters, using a honey-comb coil.

**M**ANY other advantages described in Bulletin X, 102.

If your dealer is out of Warren Radio Loops, send us your order, with his name

*Sold by dealers who sell the best*

V-DE-CO RADIO MFG. CO.  
Dept. B Asbury Park, N. J.

## PRICES SMASHED

Each sale has created new friends and customers, with the result that we now announce drastic reductions in our quality lines. All goods prepaid. Send card for complete list. You'll be surprised. You'll tell your friends. A sample saving follows—

**Complete Regenerative Vacuum Tube Set—Range 1000 miles**

	Our price	Others
Panel 7" x 12"—Bakelite—drilled.....	\$1.75	\$2.65
Cabinet of 3 ply wood to fit above panel.....	1.50	2.50
Two 3" dials @ 35c each.....	.70	1.40
16 switch points with nut @ 1c each.....	.16	.48
4 switch stops with nut @ 1c each.....	.04	.12
8 nickel plated binding posts @ 3c each.....	.24	.48
2 switch levers @ 25c each.....	.50	.90
1 filament rheostat. Highest grade.....	.65	1.10
1 vario-coupler with 7 multiple, 7 single taps.....	2.25	4.00
1 23 plate variable condenser. Built right.....	1.95	3.50
1 tube socket.....	.45	.85
1 grid condenser and leak.....	.15	.25
1 phone condenser.....	.20	.25
1 support for tube socket.....	.15	.25
12 feet of spaghetti tubing @ 4c per foot.....	.48	.84
15 feet copper connecting wire.....	.15	.30
Blueprints giving details to assemble outfit.....	.10	.25
	<b>\$11.42</b>	<b>\$20.12</b>

**Other articles taken at random from our list are:**

Detector tubes—Cunningham—New. Not rebuilt	\$4.25	\$5.00
Transformer—Audio frequency.....	2.95	4.50
Variometer—Stators 4 1/2" square. Assembled	2.45	4.00
Frost Fone.....	3.95	5.00
Kelloggs.....	2,400 ohms.....	8.75
Western Electric.....	2,200 ohms.....	9.25
Two Stage amplifier—Knocked down. Cabinet and drilled panel.....	12.95	23.50
Blueprints giving detail of two stage amplifier.....	.10	.25
Two step amplifier assembled. Wired. Cabinet.....	18.95	35.00

Send for full list to-day or order from above. Goods sold subject to return for rebate or exchange. YOU SIMPLY MUST BE PLEASED.

**RADIO PARTS MANUFACTURING CO.**  
Dept. "B"—2150 Montclair Detroit, Mich.



## The Loud-Speaker With the Natural Tone

The Bristol "Audiophone" will bring into your presence the actual "tonal personality" of the speaker, the singer or the player. You will hear them as they are—not disguised by mechanical distortion. The "Audiophone" is a true sound reproducer, retaining all the fine gradations of tone quality, volume and feeling which distinguish the original performance of the artist. You forget the instrument, in your enjoyment of the entertainment it brings to all your household and the guests who may join you.

**BRISTOL**  
TRADE MARK

# AUDIOPHONE

PATENTS PENDING, DESIGN PATENTS PENDING

## LOUD-SPEAKER

Years of research in sound reproduction, in the laboratories of an established engineering concern, have made the "Audiophone" what it is—have given it its round, full tone, its ample carrying power, its distinctive freedom from blurring and distortion. It needs no separate storage battery for magnetizing current, and can be used with any two or three stage power amplifiers.

"AUDIOPHONE SR." Complete, 15-inch bell \$40.00  
"AUDIOPHONE JR." Complete, 13-inch bell \$22.50

A new Bristol single stage power amplifier for use with the usual two stage amplifier can be furnished, which will greatly increase the range of the Audiophone where desirable. Price \$25.00

*Ask your dealer to demonstrate the "Audiophone". If he hasn't it, write us—we will see that you are supplied.*



**THE BRISTOL COMPANY**  
WATERBURY, CONNECTICUT

## A Set is Only as Good as Its Parts!

Most of these sets which are the proudest possession of their builders are made up of the famous De Forest Parts.



Perhaps it's a tube socket whose strength and correct construction are giving fine service; perhaps a reversible filament rheostat, with its smooth running phosphor bronze finger, making possible the most critical of adjustments.



Then there are such new developments as the beautifully built Vernier Variable Condenser, preferred by advanced amateurs and engineers for the most critical of circuits. In a word, if it's marked De Forest it's marked by satisfaction and service.

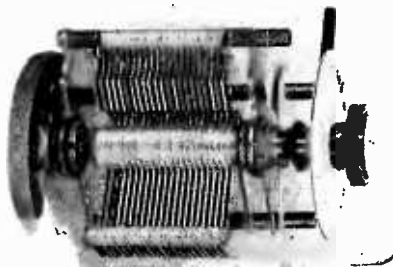

De Forest Radio Tel. & Tel. Co.  
Jersey City, N. J.



## For Clear-Tone, Long-Distance Radio Reception, Use Only "UNITED" Condensers and Transformers

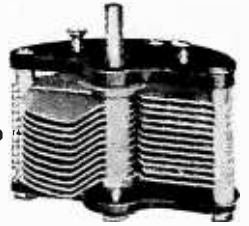

Products of an \$800,000.00 plant, equipped with the highest type of precision machinery, manned by expert mechanics, and backed by a seasoned staff of radio engineers. The guarantee of this old established Electrical House stands back of our products.

### "UNITED" Variable Condensers

Cannot short-circuit, because hard aluminum plates are held mechanically in true and permanent alignment. Ends are Bakelite; trimmings brass, nickel plated.

Prices, without dial or knob			
43 plate	• • \$4.50	5 plate	• • \$2.75
23 plate	• • 4.00	3 plate	• • 2.25
11 plate	• • 3.50		Postpaid

### "UNITED" Audio-Frequency Amplifying Transformers



A fine example of precision-workmanship; completely shielded, in shell of original design. Amplifies detected signals, bringing them to phone or loudspeaker, clear, strong, pure-toned.

Price postpaid. \$4.50

Try your dealer first, before ordering by mail. Send name and address of dealer with order. Circular free.

UNITED MANUFACTURING & DISTRIBUTING CO.  
536 Lake Shore Drive, Chicago, Ill.

# C H E L S E A



PRICE \$40.00

## REGENERATIVE RECEIVER A REAL BROADCAST RECEIVER

Licensed Under Armstrong U. S. Patent No. 1113149.  
For amateur use only.

Write for Catalogue No. 7 of New Chelsea Radio  
Equipment.

CHELSEA RADIO CO.  
152 5th St., Chelsea, Mass.



# Paul F. Godley's Amazing Experience With

## ★ **BURGESS** RADIO BATTERIES

PARAGON RADIO PRODUCTS  
GENERAL OFFICES & FACTORY  
UPPER MONTCLAIR, N.J.  
November 29, 1922

Mr. Duncan Keith, Vice-President,  
Burgess Battery Company,  
Chicago, Illinois.

Dear Mr. Keith:

In reply to yours of the 21st of November,  
I am always pleased to recommend a first-class article.

A year ago this month I received a shipment  
of Burgess Batteries for use in conjunction with my re-  
ception of American amateur signals in Scotland. These  
batteries were taken to Scotland, used for ten days while  
actually sitting in the mud underneath a rough table upon  
which the apparatus. They gave entire satisfaction dur-  
ing all this time. Some of them were brought back to the  
United States and purposely left outside my home all dur-  
ing the summer in sun and rain. Last night I connected  
them into circuit connection with the regenerative receiver  
and two-stage amplifier. They functioned perfectly. I  
am sending one of these batteries to you by parcel post  
and should be glad to have you take it and place it in  
your "museum".

Knowing "B" batteries as I do, I consider this  
as a very remarkable one.

I am,

Yours very truly,

*Paul F. Godley*  
Paul F. Godley

PEG: 15

**T**WICE across the stormy At-  
lantic, engulfed in oozing  
mud, and exposed for months  
to the destructive action of the ele-  
ments, Paul Godley's set of BUR-  
GESS Radio Batteries, wind-  
swept, rain-drenched and sun-  
scorched though they were, re-  
sponded instantly and powerfully,  
with the vital energy necessary to  
the perfect operation of his deli-  
cate receiving set.

While it is seldom that a radio bat-  
tery is required to function under  
the stress of conditions a fraction  
as difficult as these, Paul Godley's  
experience stands out as a remark-  
able and heretofore unheard-of ex-  
ample of the long life, high capacity,  
tenacity of power and indestructible  
construction of Burgess Batteries—*en-  
during qualities that are built in.*

### BURGESS BATTERY COMPANY

Engineers—DRY BATTERIES—Manufacturers  
FLASHLIGHT — RADIO — IGNITION — TELEPHONE

General Sales Office: Harris Trust Bldg., Chicago  
Laboratories and Works: Madison, Wisconsin

#### BRANCHES:

NEW YORK BOSTON WASHINGTON  
KANSAS CITY ST. PAUL NEW ORLEANS

In Canada: BURGESS BATTERIES, Ltd.  
Winnipeg Toronto Montreal

**"ASK ANY RADIO ENGINEER"**

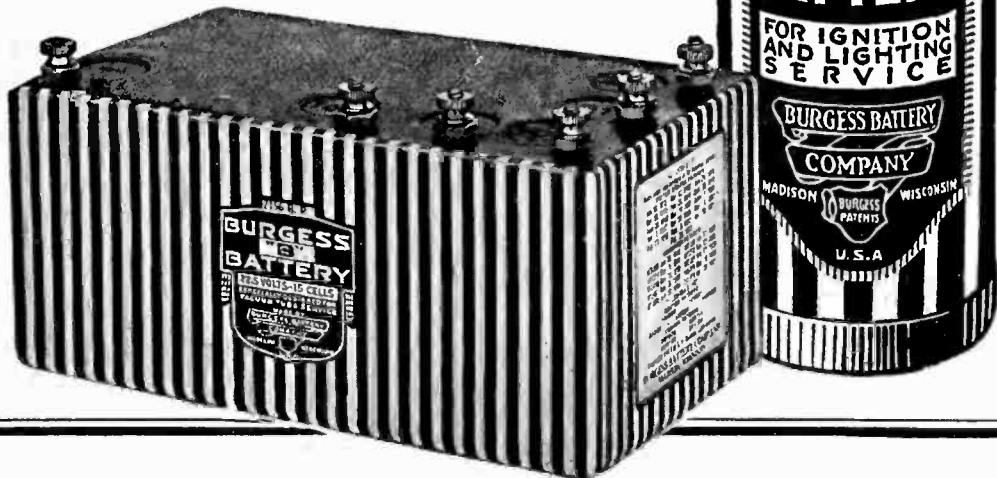

★ Tested and approved by RADIO BROADCAST ★

# RADIO in Strong Hands

NOW, at last Radio sets and parts are offered by an independent corporation possessing large capital, a modern plant—a staff of seasoned radio engineers and experts—a House that is in business to *stay* whose *guarantee* offers complete and permanent protection



SENIOR SET

**Long Distance Wonder Workers**

Sweep the country from coast to coast, giving their owners their pick of the daily and nightly programs broadcasted by the 500 stations in the United States and Canada.

THE "SENIOR SET" embodies both detection and amplification, and can be used with either headphones or loudspeakers, or both. THE "JUNIOR SET" a detector unit only. is limited to headphone reception. It can however, be hooked up with the Michigan Amplifier unit, for loudspeaker reception.

## M. R. C. Regenerative Radio Receiving Sets

are built under Armstrong License (U.S. Pat. 1,113,149 and pending letters patent No. 807,388). This means that they embody the latest development in *Regeneration*—the soul of radio.



JUNIOR SET

MICHIGAN ACCESSORIES includes variometers, grid variocouplers, variable condensers, all-wave couplers, vernier rheostats, plain rheostats, etc.

Send for full information on both sets and parts.



**MICHIGAN RADIO CORPORATION**

GRAND RAPIDS, MICHIGAN

★ Tested and approved by RADIO BROADCAST ★

# IMPORTANCE OF AMPLIFICATION

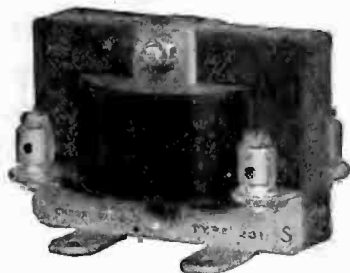

**TYPE 231-A  
AMPLIFYING TRANSFORMER**

The simplicity of audio frequency amplification still makes it the most practical and popular type. It is adapted to all types of receiving sets and is free from tuning adjustments. With the proper choice of amplifying instruments, audio frequency amplification is accomplished with a minimum of distortion.

The amplifying transformer is the most important of these instruments. The General Radio Co. was the first company to have available a closed core audio frequency amplifying transformer. This was before the United

States entered the war. Many of these transformers were supplied to the army and navy during the war, and with the return of amateur radio after the war, thousands have been supplied for use in this country and abroad.

Our latest type is the 231-A. This transformer is designed to give the maximum of amplification possible without distortion. It is the result of careful engineering design. It is particularly adapted to the WD-11 and UV-201 tubes. The electrical constants of the windings are as follows:

	Primary	Secondary
Direct Current resistance, ohms . . . . .	1,100	5,500
A. C. Resistance at 1000 cycles, ohms . . . . .	11,000	130,000
Reactance at 1000 cycles, ohms . . . . .	66,000	700,000

**PRICE, COMPLETELY MOUNTED, \$5.00**

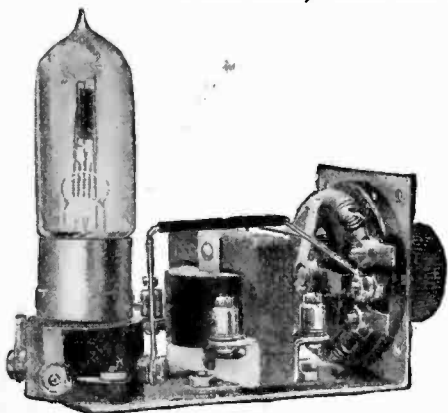

**TYPE 300-A AMPLIFIER UNIT, PRICE \$7.50**

For those who desire a compact amplifier unit, we recommend the Type 300. This unit consisting of our Type 231-A Amplifying Transformer, Type 255 Filament Rheostat, and Type 282 Tube Socket mounted on a nickel finished brass plate, is all ready for the external connections. It may be used as a table unit or mounted behind a panel, in which case only the rheostat knob projects. Connections are properly made so as to keep the unit from howling.

For those who desire to use the UV-201 tubes, this unit may be supplied with a standard base socket—our type 156.

**TYPE 300-B AMPLIFIER UNIT, PRICE \$8.00**

Send for NEW FREE RADIO BULLETIN 913-B and learn about these instruments.

**★ GENERAL RADIO COMPANY**  
 MASSACHUSETTS AVENUE AND WINDSOR STREET  
 CAMBRIDGE 39 MASSACHUSETTS

Do not confuse the products of the GENERAL RADIO CO. with those of other concerns using the words "General Radio." The General Radio Co. has been manufacturing radio and scientific instruments for many years. It has no affiliation with any other company.

*Standardize on General Radio Equipment Throughout*

MU-RAD  RECEIVERS  
SUPREME



*EVERYDAY RECEPTION* over distances that far outstrip the commonly accepted records — this (not baseless claims) is the evidence of Mu-Rad superiority. The only set that can achieve such astonishing sensitivity, using a small loop aerial. Delightfully fine selectivity. With all this efficiency and completeness, utterly simple to operate. Each set guaranteed for 1000 miles reception.

*The New  
Star in  
the Radio  
World*

**4300 MILES'**

*on an indoor loop aerial*

Four thousand, two hundred and seventy-eight miles away in Honolulu, the Royal Hawaiian Orchestra plays for delighted listeners in St. Louis, U. S. A., through their Mu-Rad Receiving Set. An example of MU-RAD supremacy.

*Write For Literature.*



**MU-RAD LABORATORIES, INC.**

★ 803 FIFTH AVE. ASBURY PARK, NEW JERSEY

★ Tested and approved by RADIO BROADCAST ★

# Audiola adopts the Bradleystat

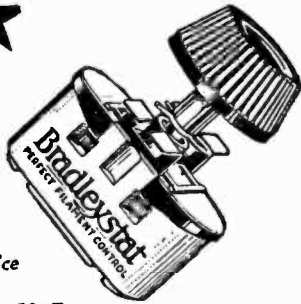

Retail Price  
**\$1.85**  
Parcel Post 10c Extra

*Another Radio Manufacturer  
discards the wire rheostat!  
Why? Read this letter—*

January 2, 1923.

Allen-Bradley Co., Milwaukee, Wis.  
Gentlemen:

Regarding the Bradleystat in the Audiola Receiving Set, we wish to advise that while your rheostat is more expensive than the wire-wound type, we would not go back to the wire rheostat and have standardized on the Bradleystat.

The Bradleystat is noiseless, permits more accurate tuning and increases the loudness of signals and the range of our set. Since incorporating the Bradleystat, we have received many letters from dealers and users stating that they are receiving stations 700 to 1,100 miles distant with our single tube detector set.

Yours very truly,  
AUDIOLA RADIO COMPANY.



For bulletins, write to  
**Allen-Bradley Co.**  
Electric Controlling Apparatus  
278 Greenfield Avenue  
Milwaukee, Wis.

*A. E. Anderson*  
Sales Manager.



# Bradleystat

REGISTERED U. S. PAT. OFF.  
**PERFECT FILAMENT CONTROL**

★ Tested and approved by RADIO BROADCAST ★

★ **FOR RADIO FREQUENCY SETS**  
*Constantly Making New Distance Records*  
**Here's a Complete Assortment**



**CROSLEY MODEL VI**

This set consists of one stage of Tuned Radio Frequency Amplification and Audion Detector. It is normally for use with head phones but is especially recommended to be used with any type of loud speaker. Additional amplification is unnecessary if head phones, and horn are used in receiving local stations. With the Crosley Receiver Model VI distant broadcasting stations are brought in loud and clear. It also eliminates static to a large extent.

Mounted on formica panel, Adam brown mahogany finished cabinet without tubes, batteries or phones. Price . . . . . \$30

**CROSLEY MODEL VIII**

A new set offering exceptional value. Contains one stage of tuned radio frequency amplification, detector and one stage of audio frequency amplification. Also offered as a portable instrument, using 1½-volt tube. Price, without batteries, tubes and phones, Regular Model VIII, \$48.00, Model VIII, Portable, \$60.00.



**CROSLEY MODEL X**

The most complete receiving set on the market. A 4-tube set consisting of one detector, one stage of tuned radio frequency and two stages of audio frequency amplification. In placing this receiver on the market, we are offering you a unit whose range, volume and selectivity is remarkable. Nothing can compare with it at twice the price. Developed in the CROSLEY laboratories, this unit is absolutely the last word in long range Radio Receiving Apparatus. Used with head phones and loud speaker, it will bring in distant stations all over the house. Price without phones, batteries or tubes, \$55.00



**CROSLEY RECEIVERS**

From our smallest complete receiving outfit at \$25, including other sets incorporating Crosley radio frequency tuned amplification at \$28, \$48, \$55, and upto our beautiful Console Model XXV, price \$150, Crosley instruments offer the highest efficiency at the lowest cost.

**CROSLEY**

*Better—Costs Less*

**RADIO RECEIVERS**

**CROSLEY PARTS**

We also manufacture a complete line of parts for those who wish to make their own outfit. Among these are Variable Condensers, Knobs and Dials, V-T Sockets, Variometers, Vario-Couplers, Rheostats and the well-known Crosley Radio Frequency Amplifying Tuner.

**CROSLEY MANUFACTURING COMPANY**

420 ALFRED ST.

CINCINNATI, OHIO

★ Tested and approved by RADIO BROADCAST ★

**Crosley  
ACE** Regenerative Receiver . \$ **20<sup>00</sup>** and up ★  
**ANNOUNCEMENT**

Powel Crosley, Jr., President of the Crosley Manufacturing Company, has acquired controlling interest of the capital stock of The Precision Equipment company, of Cincinnati, licensed to manufacture regenerative apparatus under Armstrong Patents. Crosley management, production and sales methods already have enabled us to offer even better apparatus at lower prices.



**ACE TRU**  
**Regenerative Radio Receiver**

No powerful station in the United States is so far away to be copied by owners of the Tru radio receiver. The cabinet of the Tru is beautifully finished, the panel is of genuine formica and all the parts are the most efficient obtainable. Without amplification, the Tru will bring in distant stations loud and distinct. In comparison with any of the highest quality instruments available, the Tru receptor will equal, if not surpass, the performance of any of them. If the owner desires to operate a loud speaker, an amplifier must be added, and we recommend the AV-2, illustrated below. Price of the Tru Receptor (formerly \$65) now.....\$35.00.

**CROSLY MODEL V Regenerative Receiver**

Remarkable records are being achieved by owners of the Crosley Model V regenerative radio receiver, which is the greatest result-producing one-tube set being manufactured to-day. With a range of from 150 to 600 meters, this little wonder brings in amateur, broadcasting and commercial stations. Concerts broadcast more than 1,000 miles away are heard by those who own the model V. The cabinets are arranged to permit use of the one and one-half volt tubes, with which they operate very efficiently. Use of these tubes eliminates necessity of buying more expensive "A" batteries. The name "Crosley" is used by permission of the Crosley Manufacturing Company. Made in two models. Both have Adam brown mahogany finished cabinets and beautifully engraved panels. The Crosley two-step amplifier matches this unit perfectly.

Model V-C.....\$20.00. Model V-D.....\$19.00.  
Model V-D has overhanging lid, otherwise it is the same as Model V-C.

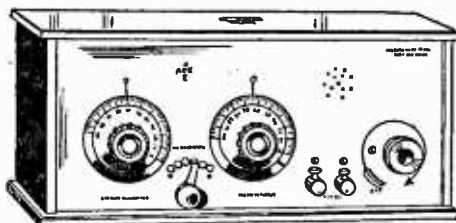

**ACE AV-2 Two-Step Amplifier**

The AV-2 Two-Step Amplifier designed to be added to the Tru radio receiver, with which it matches perfectly, may be used in conjunction with any audion receiver. Ace type transformers and sockets are used in the AV-2. The cabinet is beautifully finished. The panel is of genuine formica. There is a switch permitting use either of one or two stages of amplification, and also special binding posts for the use of head phones in conjunction with a loud speaker. Experiments have shown that the amplification constant is approximately twenty times that of the incoming signal on the first stage and 400 times on the second. Price of the AV-2 (formerly \$65) now.....\$35.00.

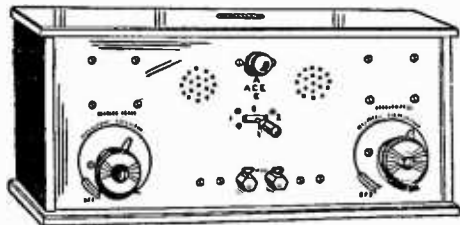

**ACE Transformer**

Enormous amplification has been attained and foreign noises have been eliminated through use of the Ace transformer. A generous core of high-grade transformer iron supports rugged primary and secondary windings. The core, in turn, is supported by two nickelplated cones, which permit of base or panel mounting. Plainly marked terminals through insulation bushings in the shell provide convenient connections in the circuit. Price.....\$5.00

**ACE Condenser**

Capacity .0005 Mfd.

Exclusive features of this condenser are too numerous to dwell upon. These, however, include balanced non-warping plates, carefully adjusted, and a fine positive gear vernier, with a five to one ratio. Price with Vernier.....\$7.50  
Without Vernier.....5.00

**ACE Tube Socket**

A real good socket, built to stand long and hard service. There is no moulded base to melt when the soldering iron is applied. Instead this is of real sheet formica, one quarter inch thick. Substantial metal die casting—pure phosphor bronze springs. This socket has been designed to prevent short-circuiting and burning out of the expensive vacuum tubes. Prong contacts are carefully adjusted. One and one-half volt tubes may be used in these after adapters are inserted. We recommend the adapters made by the Crosley Manufacturing Company. Price.....\$1.00

Licensed under Armstrong U. S. Patent No. 1,113,149 October 6, 1914. For use by radio amateurs in radio amateur stations, to radio experimenters and scientific schools and universities, for use in experimental and scientific schools or university radio stations. The Crosley Manufacturing Company has discontinued the sale of regenerative radio receivers, but Crosley dealers will be able to supply you with those made by the Precision Equipment Company.

**WRITE FOR CATALOGUE OF COMPLETE SETS**

**THE PRECISION EQUIPMENT COMPANY**

POWEL CROSLY, JR., PRESIDENT

420 GILBERT AVE.

CINCINNATI, OHIO



# Double As Good

The scientifically correct design of the Fada Variocoupler enables a very gradual variation of coupling over 180 degrees.

Ordinary couplers give only a 90 degree variation, and hence the Fada 180 degree type has double the efficiency.

Its simplicity and high efficiency in signal selection by vernier control of coupling has given the Fada 180 degree coupler universal demand.

## VERNIER RHEOSTATS

The nationally famous Fada Rheostat with a new vernier attachment.

No. 150-A Fada Vernier Rheostat...\$1.25

## POTENTIOMETERS

Mechanically perfect spacing and winding of the resistance wire resulting in smoother adjustment.

No. 152-A Potentiometer (200 ohm).....\$1.00

No. 154-A Potentiometer (400 ohm).....\$1.00

Fada ingenuity—manufacturing economy—value—guarantee—and low prices are responsible for the popularity of Fada radio parts.

## F. A. D. ANDREA

1581-B JEROME AVE. NEW YORK CITY



*The FADA HANDBOOK gives facts about the use of each radio part, and will be of aid to you in your radio construction work. Send 10c for your copy.*



*Listen to the Difference!*



© CONN. INST. CO.

## HEADSET (with Non-Metallic Diaphragm)

Here is the head set made especially for radio work—it's non-metallic diaphragm transmitting the true musical sound as no metallic diaphragm can do. You can prove this to yourself by plugging a CIC Head Set in on a multiple jack on your receiver with any other head set—and "listen to the difference." If your dealer cannot supply you, write us direct. Price \$8.00 complete with super-comfort light weight aluminum head band. The greatest radio engineers will use no other head set but CIC.

CONNECTICUT INSTRUMENT CO.  
STAMFORD, CONN.

★ **Westwyre Variable Condensers**  
WESTWYRE RADIO CO.  
Westfield, Mass.

Patents Procured and Trade-Marks Registered  
*Advice and terms upon request*  
**ROBB, ROBB & HILL**  
1415 Hanna Bldg., 954 McLachlen Bldg.,  
Cleveland, Ohio Washington, D. C.

*The most satisfactory book for beginners that has yet appeared.—Public Ledger.*



## RADIO SIMPLIFIED

By KENDALL & KOEHLER  
Radio Instructors

### WHAT TO BUY HOW TO BUILD HOW TO OPERATE

A clear explanation of Radio in simple language with complete directions for assembling and installing home radio equipment. Will aid you in getting the best results from your set. 96 Illustrations including picture diagrams showing hook-ups, etc. Cloth, 250 pages, \$1.00. On sale at Booksellers or mailed on receipt of price THE JOHN C. WINSTON CO., 34 Winston Bldg., Philadelphia, Pa.





## Elegance and Scientific Precision Combined!

YOU will welcome a Kennedy Receiving Set in your home. Its distinguished appearance lends itself to the most refined surroundings and outwardly reflects the accuracy and precision exercised in its manufacture.

In a cabinet of beautifully finished hardwood and mounted behind a richly polished panel you will find a series of precision instruments—each correctly designed in itself and each exactly co-ordinated with the balance of the set.

Ease of control, long distance reception, elimination of interference and the utmost pleasure and satisfaction in its use are assured with a Kennedy receiver.

*Arrange with your Kennedy Dealer for a demonstration. Or write us direct for further information.*

THE COLIN B. KENNEDY COMPANY  
SAN FRANCISCO                      SAINT-LOUIS



*The Kennedy Variometer*  
This, as well as all other parts, is scientifically constructed by Kennedy artisans. The minute clearance between rotor and stator, the firm windings and positive contact eliminate dielectric losses and increase sharpness of tuning.

# KENNEDY

*The Royalty*  *of Radio*

★ Tested and approved by RADIO BROADCAST ★



**The Superlative Inductance**

Four years of careful attention to the details of manufacture of this type of inductance unit has yielded a product of unquestioned superiority. And with increased efficiency in manufacturing methods, moderate prices prevail for all sizes

Ask Your Dealer

**Cotoco** ★

"Built First to Last"

**COTO-COIL CO. PROVIDENCE**

**LEARN RADIO**

Here's your opportunity. Radio needs you. Win success in this fascinating field. Trained men in demand at highest salaries. Learn at home, in your spare time.

**Be a Radio Expert**

I will train you, quickly and easily, to design, construct, install, operate, repair, maintain, and sell all forms of Radio apparatus. My new methods are the most successful in existence. Learn to earn

**\$1,800 to \$10,000 a Year**

**FREE** Wonderful, home-construction, tube receiving set, of latest design. Write for "Radio Facts" free. Engineer Mohaupt.

**American Electrical Association**  
Dept. E-4 4513 Ravenswood Ave., Chicago



**Super-Sensitiveness!**

THE crystal is the "bull's-eye" of your crystal receiving set. Unless it is super-sensitive you are wasting time and entertainment and cannot "hit" the combination for best results. Insist upon the genuine original Arlington Tested NAA Detector Minerals. They are carefully selected from bulk stock, individually tested and guaranteed super-sensitive.

Galena, Silicon or Goldite price per crystal, 25c. Same mounted in brass cup, 40c. Obtainable at your dealer's or sent direct (post-paid) on receipt of price.

*The Newman-Stern Co.*

Newman-Stern Building Cleveland

**RADIO "A" & "B" STORAGE Batteries CHARGED at Home For a Few Cents Overnight with "The PATENTED FULL WAVE" 100-130 Volts 60 Cycle A. C. Magnetic Taper Charge Design**

They Also Charge AUTO Batteries Overnight Right In Your CAR

**\$20**



Patented Combination. CHARGES "A" & "B" RADIO & AUTO BATTERIES.

**F-F RADIO RECTIFIER**

Eventually You Will Buy An F-F RECTIFIER. Why Not Now? The Sooner You Buy It; The More You Save. It Charges 6 Volt "A" & Auto; & up to 120 Volts Of "B" & Loud Speaker Storage Batteries In Series Inductively At Home Overnight; Disconnecting & Multiple Connections Unnecessary. Charging Circuits Separate. No Chance For Grounds Or Short Circuits. Nothing To Stop Over, Be Filled, Burn Out, Need Attention Or Cause Trouble. Infusible Rectifying Brushes Maintain Constant Efficiency Uninterruptedly. Complete Portable Automatic. No Skill Required. AMMETER eliminates Guess Work. Nothing Like It Made. Lasts Lifetime. Screw Plug In Lamp Socket; Snap CLIPS on Battery Terminals; Turn Switch & Battery Is Charged In Morning. Charged Batteries Mean Fewer Expensive Replacements. It Costs Less To Buy An F-F RECTIFIER than To Be Without ONE. 7 Types. POPULAR PRICES. Type 6 charges "A" 6 Volt Battery At 6 amperes \$15 Type 12 charges 12 Volt Battery At 5 amperes \$15 Type B charges Radio "B" Batteries Up to 120 Volts \$15 Type A-B is Combination Of Types 6 & B \$20 Type 166 charges 6 Volt Battery At 12 amperes \$20 Type 1612 charges 12 Volt Battery At 7 amperes \$20 Type 1626 is a Combination of Types 166 & 1612 and Charges Both 6 & 12 Volt Batteries \$28

The 3 Lower Types are recommended for heavy Batteries, or where time is limited. SHIPPING WEIGHTS Complete with AMMETER & BATTERY CLIPS 11 to 15 lbs. Purchase from DEALER, or Mail Check for Prompt Shipment. Include Postage and Insurance Charges for P. P. Shipment, or Write us to Ship Type desired C. O. D. Order Now, or WRITE Immediately for FREE Descriptive BOOSTER Bulletins 41 & 41A. **THE FRANCE MFG. CO., CLEVELAND, OHIO, U. S. A.**

Canadian Distributor: The JACK V. ELLIOT COMPANY, Hamilton, Ontario, Canada.

★ Tested and approved by RADIO BROADCAST ★



# Riding in the Day Coach is Cheaper

But the greater comfort and convenience of a Pullman chair are certainly worth the difference in price that is asked. In most things—including radio equipment—you *get what you pay for*.

You can buy a single-circuit receiving set for considerably less than you will pay for a Paragon three-circuit receiver. Of course, with a single-circuit receiver you must expect mixed messages, continuous jamming between different stations and generally unsatisfactory results.

With a Paragon three-circuit receiver, you can tune in accurately on the station you wish to hear, on any night that it happens to be broadcasting, and get a complete programme, clearly rendered.

Ask some experienced amateur what he knows about

# PARAGON

Reg. U. S. Pat. Off.

## RADIO PRODUCTS ★

The amateur will tell you that the Paragon three-circuit receiver, because of its great superior selectivity and sensitivity, can pick and choose between broadcasting stations of about the same signal strength with less than one per cent differential.

This means that with a Paragon receiver you get what you want when you want it—complete messages and clear music from the station you tune in on, without interruption and jamming. Until you have listened in with a Paragon three-circuit receiver, you cannot guess the real pleasure and fascination of radio.

Long before broadcasting popularized radio with the general public, Paragon equipment was the choice of the experienced amateur. He will tell you today that if you want quality and satisfaction, Paragon Radio Products are the best and safest buy on the market.

*An illustrated Catalog of Paragon Radio Products is Yours For the Asking*

DEALERS—The Adams-Morgan Company has an interesting proposition to make to reputable radio dealers who believe in quality merchandise. Details on request.

ADAMS-MORGAN COMPANY  
10 Alvin Ave., Upper Montclair, N. J.

Type RD-5 Regenerative Receiver and Detector—\$75.00  
Type A-2 Two-Stage Amplifier—\$50.00  
(Licensed under Armstrong Patents.)

Also Manufacturers of PARAGON	
Radio Telephone	Amplifier
Transmitters	Transformers
V. T. Control Units	Control Dials
Rheostats	Amplifiers
Potentiometers	Receivers
V. T. Sockets	Switches
Detectors	Variometers

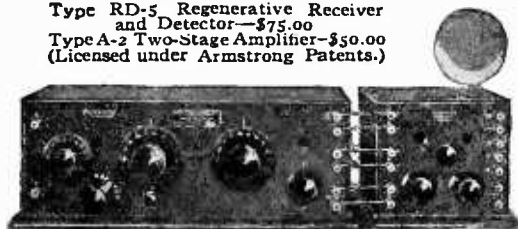

★ Tested and approved by RADIO BROADCAST ★

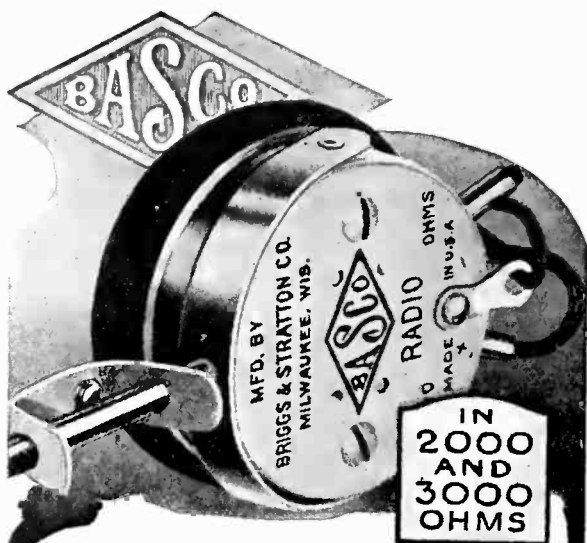

## Designed! Not just "made"

THE market is over-run with head phones. Some are "made to sell"—others "designed" to perform a service—a service measured in terms of sensitiveness, tone quality, clarity—phone efficiency.

Such is the BASCO Radio Head Phone—built first for service. Designed—not just "made". One year on the market—and a phenomenal sales success. Why? Examine one.

They are tuned to a deep, natural-voiced pitch—and keenly sensitive. Perfectly balanced—clear, scratchless reproduction. Coils encased in aluminum shell—light weight easy on the head. Employ solid horseshoe magnet—no laminations. Compare this construction with the highest priced phones on the market. The diaphragm is extra light—set to thousands-

**\$6.00**  
2000 Ohms  
**\$7.50**  
3000 Ohms

of-an-inch accuracy from magnet poles. Basco Head Phones are clean-cut—ruggedly designed throughout. See them before you buy.



Jobbers and Dealers! Write for our exceptional discount proposition on our complete line of parts and name of our nearest representative.

**Briggs & Stratton Co.**  
MILWAUKEE, WISCONSIN  
PRODUCT

## NON TUNE RADIO RECTIFIER

Reliable "A" Battery charger for home use.

### CHARGING RATE

The Non Tune Radio Rectifier charges at a uniform rate which will maintain a Radio Battery, yet will not damage the battery plates if neglected for a time greater than regular charging period.

Takes less than a forty watt lamp to operate.

### RELAY LOCK

A most important feature of the Non Tune type of rectifier is the relay lock which will prevent a discharge of any current whatsoever from the storage battery back into rectifier if power current fails.

### RELIABILITY

Thousands of Non-Tune Rectifiers are now being operated continuously 24 hours daily in connection with Railway signal batteries where reliability is absolutely essential. In this service, contacts of Non Tune Rectifiers operate years without requiring renewals.

Ask your dealer or write giving your dealer's name

Request Radio Bulletin No. 101 A

**LEICH ELECTRIC CO., Mfrs., Genoa, Ill.**

Non Tune Rectifiers—Leich comfortable headphones

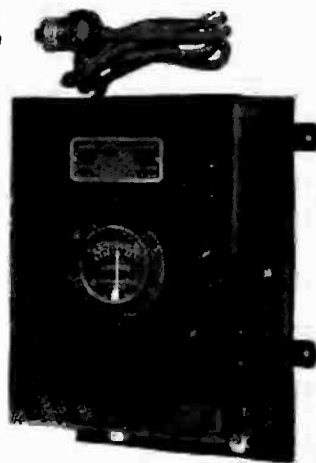

## Increase the Efficiency of Your Set With a ★ PROUD FOOTVERNIER CONDENSER

### Special Features

PLATES CANNOT SHORT FOOL PROOF  
NO ADJUSTMENTS TO GET OUT OF ORDER

TWO DIALS BUT ONLY ONE KNOB—one dial to indicate position of group plates and one to show relationship of vernier to group plates.

HIGHER EFFICIENCY—the vernier plate being one of the group plates, allows the vernier adjustment without the additional electrical losses due to the usual construction of the vernier being separated from the main plates.



STYLE	M. F. CAP	PRICE
11 plate	.00025	\$6.00
21 "	.00055	6.50
43 "	.0011	7.00

**CRUVER MFG. COMPANY**  
2456 W. Jackson Blvd. Chicago, Ill.

## "ALL AMERICAN" ★

### Transformers

(Audio and Radio Frequency)

Amplify, strengthen and clarify broadcasted signals

R-10 Radio Frequency (150-550 meters)  
R-12 Audio Frequency (Ratio 5 to 1)  
R-13 Audio Frequency (Ratio 10 to 1)  
R-21 Audio Frequency (Ratio 5 to 1)

FREE—BOOK OF RADIO HOOK-UPS  
CONTAINING DIAGRAMS OF OVER  
25 CIRCUITS

Send 2c stamp to cover postage

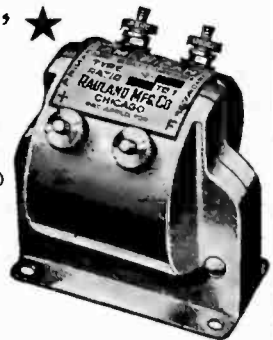

**RAULAND MFG. CO.**  
35 So. Dearborn St. Chicago, Ill.



★ Tested and approved by RADIO BROADCAST ★

## PROGRESS

**N**ATURALLY, at this early stage, the Art of Radio Communication is not standing still. It is undergoing a normal evolution.

The low-hung, straight line automobile of today is unlike its cart-like predecessor of twenty years ago, although the principle of locomotion remains the same.

So, too, the design of Radio apparatus advances. Insulated panels and live shafts are supplanted by metal panels and completely insulated instruments—the obvious thing to do, making unnecessary the use of a shield. Un-sightly, protruding knobs are replaced by recessed dials and straight tuning bars, permitting fine adjusting without cramping the hand. The tap switch is removed entirely from the panel and becomes an integral part of the variocoupler, being placed *inside* the rotor, thus eliminating all soldering of primary leads.

It is significant that all these improvements have been developed in the Eisemann laboratories.

*Descriptive literature will  
be sent upon request*

EISEMANN MAGNETO CORPORATION

WILLIAM N. SHAW, *President*

DETROIT

BROOKLYN

CHICAGO



# HOMCHARGE

*Your*  
**RADIO  
BATTERY**  
*for*  
**A NICKEL**



Enjoyable concerts and maximum receiving range are obtained only when your battery is fully charged.

## ★ THE HOMCHARGER

charges your "A" or "B" Battery over night for a nickel without removing it from your living room. No muss—no trouble—no dirt—requires no watching.

After the concert connect to any lamp socket, snap the elips on your battery and "turn in." While you sleep the HOMCHARGER is silently charging your battery, the charging rate being governed automatically. In the morning it is fully charged. No OTHER battery charger can boast of such quick and economical performance.

The HOMCHARGER is the only battery charger combining all of these NECESSARY HOMCHARGING features—SELF-POLARIZING—FIVE to EIGHT AMPERE charging rate—UNDER WRITERS APPROVAL—beautifully finished in mahogany and old gold—UNQUALIFIEDLY GUARANTEED. OVER 90,000 NOW IN USE.

Sold complete with ammeter, etc., by all good radio and electrical dealers for \$18.50. (\$25.00 IN CANADA.)

See the RADIO HOMCHARGER DE LUXE at your dealer's or write direct for our FREE circular showing why the HOMCHARGER is the BEST battery charger at any price.

### MOTORISTS

*The HOMCHARGER will also charge your AUTO Battery.*

The Automatic Electrical Devices Co.  
128 West Third St. CINCINNATI, OHIO

*Largest Manufacturers of Vibrating Rectifiers in the World*



Warren Radio Loop, cut away to show construction

What You Can Do With the—

### WARREN RADIO LOOP

**S**ELLECT your stations, just by turning the loop in the direction of the station desired.

**M**AKE any set portable.

**T**UNE on ranges from 175 to 18,000 meters, according to type of loop.

**M**ANY other advantages described in Bulletin X, 102.

If your dealer is out of Warren Radio Loops, send us your order, with his name

*Sold by dealers who sell the best*

V-DE-CO RADIO MFG. CO.  
Dept. B Asbury Park, N. J.

## Wave Trap

TRADE MARK

PATENT APPLIED FOR

The Missing Link in RADIO



### Stops Interference!

Get rid of the interference that is spoiling your evening concert. By using the "Wave Trap" you eliminate it.

It is installed in a minute by changing only one connection and is indispensable on any receiving set, with any type of antenna. It is mounted on a Formica panel in a handsome mahogany finished cabinet 6x5x6, and is a high-grade instrument throughout.

**850** Ferber Electric Co.  
19 E. SOUTH WATER ST.  
**CHICAGO**  
Circular on Request

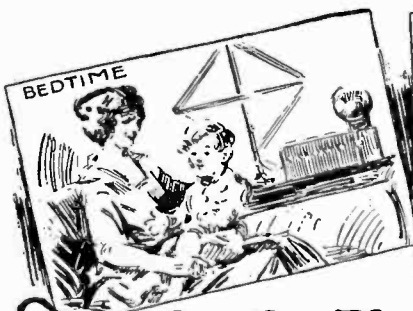

# The Family Pleasure Box

If it's a Radio Ranger Model J. R. H. Receiving Set, it's the Family Pleasure Box. The little "tots," big brother, and sister—yes even Dad and Mother thoroughly enjoy the evening entertainment. No outside aerial, but only an indoor loop as pictured with the set. Concerts from all over the U. S. and they'll be as "clear as a bell," too.

Would you like our folder entitled "A front orchestra seat in your home?" Drop us a line.

Thursday, December 28, 1922

Time	Station	City
5:00	KDKA	Pittsburgh
6:30	WIAO	Milwaukee, Wis.
6:40	KOP	Detroit, Mich.
6:45	WGY	Schenectady, N. Y.
6:52	WOC	Davenport, Iowa
6:58	2XB	New York City
7:00	WOR	Newark
7:10	WHAM	Rochester
7:20	WBAP	Ft. Worth
7:27	WWJ	Detroit
7:35	WBZ	Springfield, Mass.
7:45	WEAF	New York
8:00	WLAG	Minneapolis
8:05	WHB	Kansas City
8:30	WMAK	Lockport
9:00	KYW	Chicago
9:05	WHAS	Louisville
9:15	CFCA	Toronto
9:20	WCAE	Pittsburgh
9:25	WCX	Detroit Free Press
9:30	WOO	Philadelphia
10:05	KSD	St. Louis
10:15	WJAX	Cleveland
10:30	WGM	Atlanta Constitution
10:45	WGI	Med. Hillside
11:00	WMAC	Cazenovia, N. Y.
11:12	WLW	Cincinnati
11:20	WMAF	So. Dartmouth
11:30	WDAJ	College Park, Ga.
11:45	WSB	Atlanta Journal
12:25	KSD	St. Louis
12:50	WDAF	Kansas City

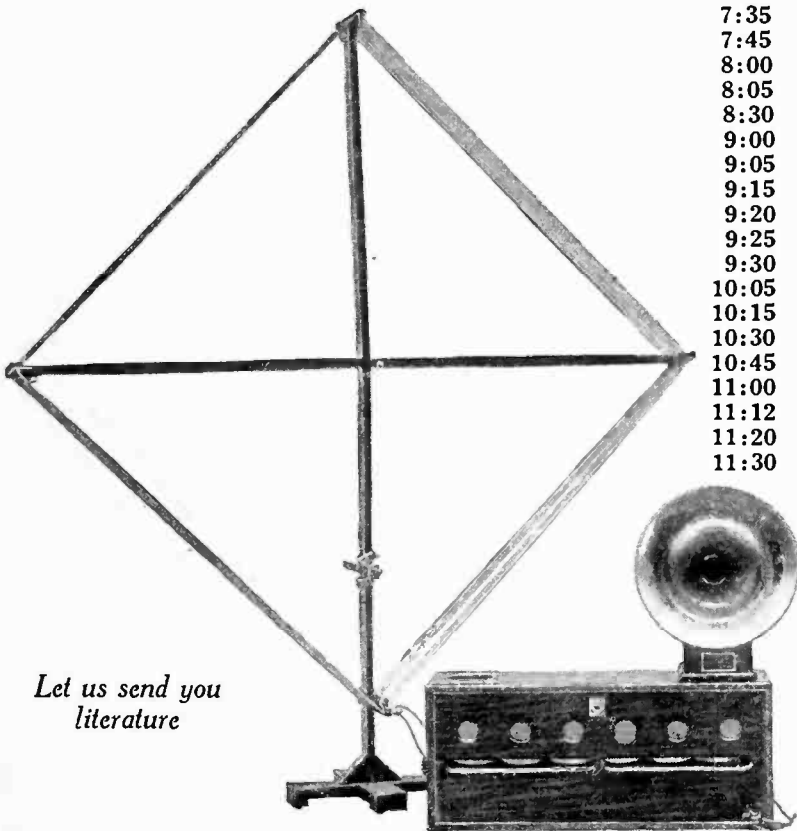

Let us send you literature

Besides the above list, stations from these cities are frequently heard from Buffalo with this set.

- Los Angeles
- Vancouver, B. C.
- Portland, Ore. Oregonian
- Denver
- Winnipeg, Manitoba, Canada
- Havana, Cuba
- Dallas, Texas
- Salt Lake City

FEDDERS MANUFACTURING CO., Inc., 59 Tonawanda Street, Buffalo, N. Y.

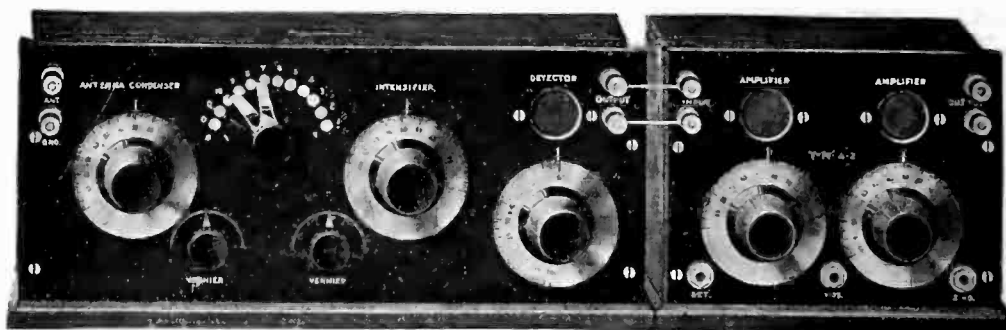

# ECHOPHONE

## Regenerative Radio Equipment

Licensed under Armstrong Patent No. 1,113,149  
and U. S. Application No. 807,388.

*The Lowest Priced GOOD Radio Set  
on the Market.*

THE very latest word in radio development, with proven results in long distance reception. **Results** are what count in radio. ECHOPHONE radio equipment is made by The Radio Shop of Sunnyvale, Cal., and St. Louis, Mo., a pioneer company of 10 years' experience in manufacturing dependable radio sets on sound engineering principles.

## ECHOPHONE CORPORATION

St. Louis, Mo.

International Life Bldg., St. Louis, Mo.

Sunnyvale, Cal.

Dealers Recommend the

# BRACH

## VACUUM RADIO PROTECTOR

*Because They Know It's Best*

The very fact that it has been the leader in its field of electrical defense for over 17 years is sufficient proof of the superiority and stability of the Brach Arrester.

Baffles Lightning      Prevents Interference  
Approved by the National Board of Underwriters.



Mend Radio Wires and Joints With

# SOLDERALL

—The Metal In Paste Form



At all Dealers or by Mail  
at 25c a Tube.

Insures perfect reception.  
A tube of this paste solder and a match to heat it are all you need to connect wires. Results guaranteed equal to bar or wire solder.

★ **L. S. BRACH MFG. CO.**  
NEWARK, N. J.

Coast Representatives:  
Pacific States Electric Co., San Francisco, Los Angeles,  
Oakland, Seattle, Portland, Spokane

# 1000 MILES With A Crystal Set by using



★ **THE WORLD'S GREATEST  
RADIO CRYSTAL**

A Needles, California, radio fan writes:

*"Using M. P. M. Crystal, I picked up Los Angeles, San Francisco, Salt Lake, Denver and St. Louis. It is far superior to any crystal I have ever used."*

The discovery of M. P. M. has revolutionized the possibilities of ordinary crystal sets.

Send 25c and name of your Radio Dealer for a sample M. P. M. crystal—concert tested and guaranteed.

**M. P. M. SALES COMPANY**  
DEPT. B  
247 S. Central Ave.      Los Angeles, Calif.

★ Tested and approved by RADIO BROADCAST ★





# Radio

## Catalogue

# FREE

One copy of this complete Catalogue of Radio Outfits, parts, Dictionary of Radio Terms, Instruction Book, and Guide to Successful Radio Work—one copy is yours Free.

Simply write us a post card and we will mail the complete book to you Free, by return mail.

It quotes the lowest prices, amazingly low prices on everything for the expert and the amateur. Every improved part, the most up-to-date outfits, everything that is needed of the most modern type—at the lowest possible prices.

It gives a list of broadcasting stations, and gives much information about radio construction and operation. Every one interested in Radio needs this complete catalogue and book of instruction.

### Why Pay Higher Prices?

Montgomery Ward & Co. has for fifty years dealt on a Money-Back basis, absolutely guaranteeing everything they sell. With quality absolutely assured, why pay higher prices elsewhere? Write today for this Free Radio Book and see for yourself the Saving it will bring you.

One copy is yours Free. You need only write us a post card.

Write to the house nearest you, Address Department 27R

Chicago Kansas City St. Paul  
Fort Worth Portland, Ore.

# Montgomery Ward & Co.

≡ The Oldest Mail Order House is Today the Most Progressive ≡

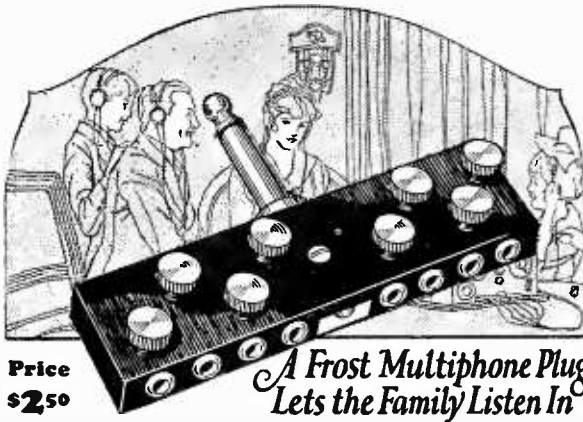

Price  
\$2.50

*A Frost Multiphone Plug  
Lets the Family Listen In*

## FROST-RADIO

**NOW** the family can listen in, thanks to the Frost Multi-Phone Plug. Each member of the family may have his or her own Frost-Fones, enjoying the broadcasting program with no loss of clearness or efficiency in reception.

Made with engineering precision, like all Frost Radio Products. May be used with any number of Frost-Fones up to and including four. This superior plug connects the Fones in series. Our tests have shown this to provide best results.

Go to your dealer today. Ask him for a Frost Multi-Phone Plug. The price is low for a product of such high quality. At the same time secure a set of Frost-Fones for every member of your family. You then will have obtained radio enjoyment for all, at a surprisingly small outlay.

## FROST-FONES



Frost-Fones — "like postage stamps, used everywhere" — are today the world's fastest-selling head-fones. Their high quality, clear, sweet tone, and low price have made them so. Order several sets for use with Frost Multi-Phone Plug.

No. 162  
2000 Ohm Set  
**\$5.00**

No. 163  
3000 Ohm Set  
**\$6.00**



**HERBERT H. FROST, Inc.**  
154 WEST LAKE STREET, CHICAGO, ILLINOIS.



## Recharge Your Battery at Home

Charges Both A and B Radio Batteries

Don't be without the use of your Radio Receiving Set while your battery is being charged. Get a Valley Charger and charge your battery right at home.

Attach the Charger to your home lamp socket — attach the clips to the battery terminals and you will get a quick, tapering charge which just exactly charges your battery, but cannot overcharge or harm it in any way.

Will charge the A 6 volt battery at a 5 ampere rate, and the B 22½ volt battery at the required ½ ampere rate. 45 volt B batteries may be connected in parallel so that they can also be charged.

**SATISFACTION GUARANTEED.** If your local distributor cannot supply you, write direct to

**VALLEY ELECTRIC COMPANY,**  
Department G ST. LOUIS, MO.



**\$18.00**

F. O. B. St. Louis

## THE FRENCH BINDERS

*French binding—in America*

Country Life Press Garden City, N. Y.

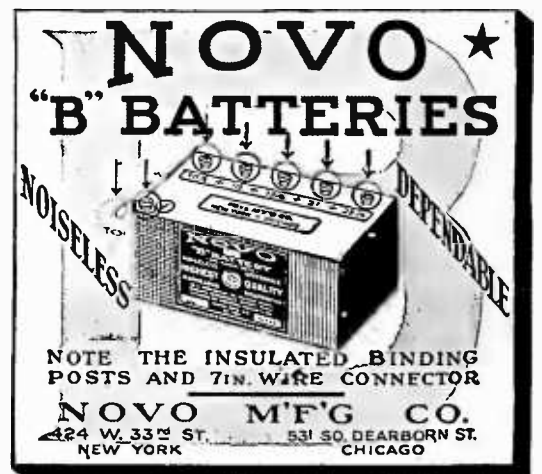

NOTE THE INSULATED BINDING POSTS AND 7 IN. WIRE CONNECTOR

**NOVO M'FG CO.**  
424 W. 33<sup>RD</sup> ST. NEW YORK 531 SO. DEARBORN ST. CHICAGO

★ Tested and approved by RADIO BROADCAST ★

# DOUBLE GUARANTEE OR RISK Ludwig Hommel & Co. or Others

**DISTRIBUTORS FOR**  
Radio Corporation of America



Westinghouse General Electric  
Acme Atwater Kent Baldwin  
Brach Brandes Burgess  
Chelsea Clapp-Eastham  
Cunningham Cutler-Hammer  
Dubilier Fada Fahnestock  
Formica Frost General Radio  
Hipco Homecharger Hopewell  
Kellogg Kennedy Klossner  
Murdock Omnigraph Pacent  
Radio Service Radiall (Amperite)  
Remler Rhamstine Tuska  
Western Electric  
and other Leading Manufacturers



Material purchased from a reliable manufacturer can be relied upon.

Defective material will be replaced, for that manufacturer has an honorable name to uphold.

Buying from a jobber who wholesales to dealers only insures you satisfaction, for that jobber must please his dealers. They take 100% of his products.

Your double guarantee is in Ludwig Hommel & Co., and the apparatus they distribute.

You can fill all your requirements from their manufacturers. Their well advertised apparatus makes your sale easy. When you sell their apparatus you profit by their advertising—

when you sell nameless products you have to overcome their advertising.

Sell reputable material and order your requirements from the jobber who wholesales exclusively and does not compete with you.

## RELIABLE HOMMEL APPARATUS

Hommel Antenna Package Complete.....	\$ 4.00	List
Hommel Phone Condensers, .002 Unmtd.....	.25	"
Hommel Phone Condensers, .002 Mtd.....	.60	"
Hommel Galena Crystals, Unmtd.....	.25	"
Hommel Silicon Crystals, Unmtd.....	.25	"
Hommel Grid Condensers, .0005 or .00025 Unmtd.....	.20	"
Hommel Grid Condensers, Mtd.....	.60	"
Hommel 3" Dial.....	.35	"
Hommel Phonograph Attachment with Baldwin Phone, cord and Plug. Specify make of machine.....	10.00	"

## DISTINCTIVE HOMMEL POLICY

- Liberal Discounts
- Wholesale Exclusively
- Large Stock and Prompt Shipment
- Dealers' Service Department
- Refer Users' Inquiries to Dealers

*Hommel's Illustrated Encyclopedia No. 225-B is free to dealers*

WE SELL TO NO OTHERS

**LUDWIG HOMMEL & CO**  
530-534 FERNANDO ST.  PITTSBURGH, PENNA

# AUDIOLA

CHICAGO

GET acquainted with Radio by buying an Audiola Crystal Receiving Set.

The 23-plate variable condenser insures sharp and accurate tuning. It is a complete unit, in a rich mahogany finished case, with nickel plated fittings.

Needs no batteries, no tubes, no fussing. Just connect it with aerial, ground and head phones, and "listen in."



★ **Price \$10**  
Complete  
(without headphones)  
At your dealer or write direct for illustrated booklet.

**Audiola Radio Co.**  
430 S. Green St., Chicago

*We can use a few high-class representatives for exclusive territory.*

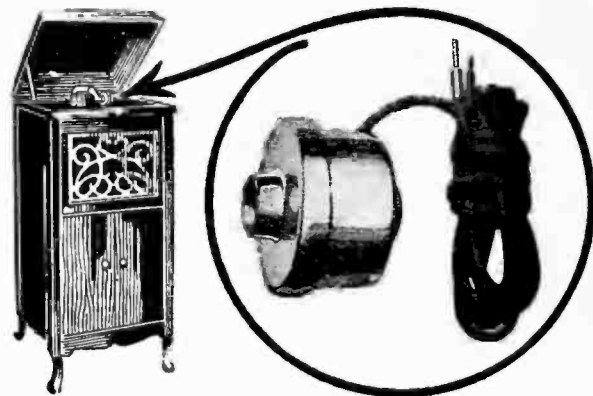

## RADIO LOUD SPEAKER for Phonographs

The MORRISON Loud Speaking Unit, for use on phonographs, takes the place of awkward headsets. Possesses a tone value 100% true—an achievement never before attained in a loud speaker.

### Attaches in Place of Reproducer

Slips on tone-arm of phonograph in place of reproducer, or can be used with horn. Adapted to any bulb set with one or more stages of amplification. Adjustable from soft to loud tone. Cannot possibly rattle or loosen through excessive amplification. A popular-priced Loud Speaker that compares with most expensive instruments on the market. Thousands in use giving perfect satisfaction. Handsomely nickel plated, complete with 5 ft. cord, \$10—at your dealer's or direct. Sent C. O. D., if desired. Fully guaranteed. Money back if not satisfied. (When ordering, specify make of phonograph).

**MORRISON RADIO LABORATORIES**  
Dept. 10, Lewis Block Detroit, Michigan



**\$6.50 Gone!**

—not a joke at all, but something actually likely to happen any second to a vacuum tube operated without the

## RADECO

### SAFETY FUSE

(Patent pending)

the only fuse made that affords *absolute* protection against "blowing out" the filament. Fits directly on filament terminals where no excess current can possibly get by. Fits any standard tube used in any standard socket. In standard packages of

**4 for \$1.** at your dealer's or by mail

*Different tubes require different capacity fuses. When ordering state exactly what tube fuses are for*

**Radio Equipment Co.**  
630 Washington St. Boston, Mass.  
*Boston's Oldest Exclusive Radio House*

## FREE Radio Catalog



Our big stock of standard makes of radio sets, parts and supplies, fully illustrated. Play safe—buy standard equipment from a reliable house. We ship from stock. Send \$6.50 for genuine Westinghouse WD-11 "peanut" tube—no storage battery needed. 60 cents extra for signal socket. \$1.00 for Bradley Adapter. Wonderful results.

**Julius Andrae & Sons Co.**  
*In Business Since 1860*  
112 Michigan St. Milwaukee, Wis.

# MARKO



The Marko Quality **for RADIO**  
**ALWAYS DEPENDABLE**

**MARKO STORAGE BATTERY CO.**  
1408 Atlantic Ave. Brooklyn, N. Y. ★

★ Tested and approved by RADIO BROADCAST ★

# BRISTOL

ONE STAGE

# POWER AMPLIFIER

Patent Pending

## Needs No "C" Battery

This latest Bristol radio product marks another big forward step in the refinement of radio entertainment by the elimination of mechanical effects that impair tone quality and clearness.

It is constructed on a new principle which uses a circuit in which no "C" battery is needed to maintain the grid negative. This circuit permits the use of a highly efficient transformer of special design; and the voltage that can be used is limited only by the tube.

The Bristol Power Amplifier has been carefully worked out to avoid the distortion of speech and music which are apt to mark the performance of other amplifiers with improper grid control and transformers of inferior design. When used with loud speakers of the better class, and particularly with the Bristol **Audiophone**, music and speech are reproduced without any distortion that the ear can detect.

The Bristol Power Amplifier can be used with the detector and one or two stage amplifiers now on the market. Any desired amplification can be had by connecting several Bristol One Stage Amplifiers together. Price.. **\$25.00**

### The Bristol Audiophone

With this perfected loud-speaker, radio has reached a new plane of high-class performance. It is a true sound reproducer, free from blurring, mechanical distortion and metallic effects. It brings to the home or the public hall the distinctive qualities of the original performance.

Write for the circulars on Bristol Radio Products. If your dealer cannot supply you, write us and we will see that you are accommodated.

**THE BRISTOL COMPANY**  
WATERBURY                      CONN.



★ Tested and approved by RADIO BROADCAST ★



**HERE'S WHAT YOU GET FOR \$10**

1. "The How and Why of Radio Broadcasting"—the book and working charts that tell you just what you need to know about radio, free with each order until further notice.
  2. Parts for the receiver cabinet.
  3. Specially finished front panel.
  4. All the parts, including stators, rotors, axles, friction washers, rotor balls, and wire for two variometers.
  5. All the parts for one vario-coupler.
  6. Metal indicators.
  7. Control knobs for tuning devices.
  8. Vacuum tube socket.
  9. Rheostat.
  10. Wire for winding vario-coupler and variometers.
  11. Grid leak and condenser unit.
  12. Inductance switches for vario-coupler.
  13. Contact points for vario-coupler.
  14. Spring connectors for making an easy job of the wiring.
  15. Eight binding posts.
  16. Hard drawn copper wire for making substantial, bus-type connections.
  17. Metal foil for making the shield which cuts out "howling," due to "body capacity," effect.
  18. Complete soldering outfit, including soldering iron, solder, resin and scraper—just the thing for radio work.
- Everything is here to enable you to build a receiver, without any special tools, without requiring any knowledge of radio, without any complicated parts—but with all the advantages of an expensive receiver at about one-sixth its usual cost. And you have all the fun of making it.



**1300 Miles and More On a KD-10 Receiver**

Using a 2 wire antenna less than 40 feet above the ground and a receiver he built for \$10, Theodore Bedell, Jr., of Freeport, L. I., hears Havana, Cuba; Davenport, Iowa; Atlanta, Ga., and many other distant broadcasting stations.

**Just the Outfit for that Boy!**

Send money order to-day for a KD-10—the biggest \$10 worth you ever bought. Add postage for points outside the U. S. A.

We can also supply standard radio equipment of all makes at list prices.

**KAY DEE RADIO SUPPLY CO.**  
487 Fulton Street, Brooklyn, N. Y.

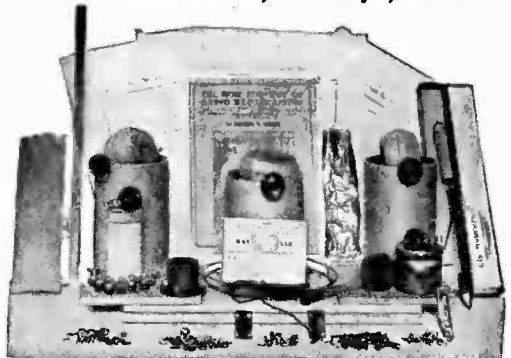

**ALL THESE PARTS FOR \$10**

**BROOKS VARIABLE CONDENSER**

Two Ribbons furnished (Max. .0005 Min. .00001)  
Easily interchangeable (Max. .001 Min. .00001)

Adaptable to all receiving circuits.

Shortening of plates eliminated.

Nicety of adjustment.

Straight line capacity curve.

Low internal resistance.

Loud Signals.

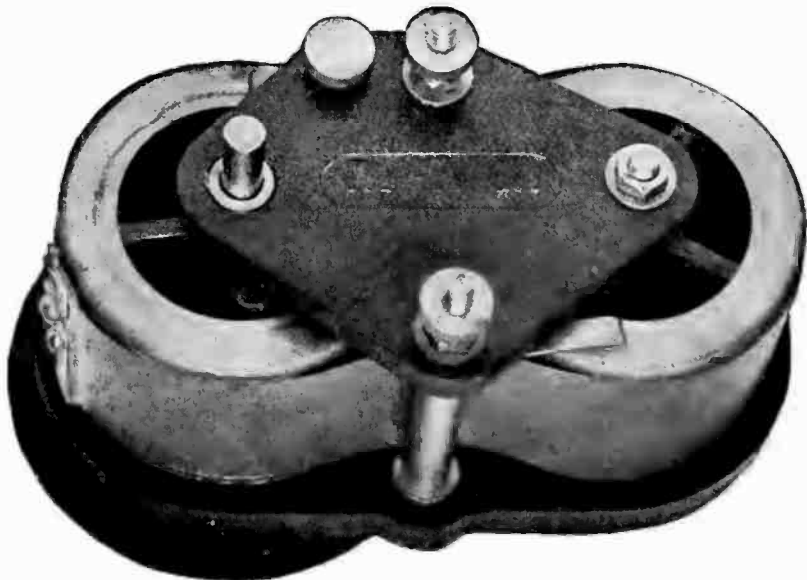

Jobbers Wanted

Write for prices and discounts

Retail price \$4.75 each, complete with dial.

Manufactured by

**METRIC METAL WORKS**

of

**AMERICAN METER COMPANY, INC.**

ERIE, PA.

★ Tested and approved by RADIO BROADCAST ★

# HAVANA!



Theodore Bedell, Jr.,  
operating the set he made.

## AT LAST!

You Can Now *Make*  
*Your Own Receiver* at a  
**TOTAL COST of ONLY \$10.00**

**T**HE HOW AND WHY OF RADIO BROADCASTING, by Arthur H. Lynch, is the book radio amateurs all over the country have been looking for. It is complete in every detail and makes it possible for you to build a modern set, capable of receiving over great distances, without interference.

To buy a similar receiver would cost you at least five times as much.

Four working patterns accompany each book and they are used for making the panel, cabinet and electrical units.

One of the receivers built by the author is in use in the office of "Radio Broadcast" and is giving entire satisfaction.

The set is designed for use with a single vacuum tube, but amplifiers may be used if desired.

The stations mentioned in this letter include two in Newark, N. J., two in New York; one each in Schenectady, Pittsburgh, Philadelphia and Atlanta, Ga., one in Havana, Cuba, ranging from 30 to 1350 miles. Still greater distances are possible.

39 Bedell Street, Freeport, N. Y.  
September 9, 1922.  
Doubleday, Page & Co.,  
Garden City, N. Y.

Gentlemen:

It may interest you to know the results I am getting from the vacuum tube receiver I made from the plans which came with your pamphlet "The How and Why of Radio Broadcasting," by Arthur H. Lynch.

The stations of WJZ, WOR, WEAJ and WBAY come in regularly and very clearly. Also, I receive from WGY, KDKA and WOO and have no trouble to tune them in over the above named stations.

**We hear Havana, Cuba, very well.** Being an amateur and with no radio experience whatsoever two months ago, I attribute the results I am getting to your publication, which is certainly complete and easy for anyone to understand.

In connection with the receiver, I use an aerial 100 feet long, 2 wires—2 feet apart, 40 feet high—and a 35-foot lead in. Also a single vacuum tube, a six volt storage battery and a 22½ volt "B" battery.

I also wish to state that the tone of reception is excellent, and in comparison with outfits owned by friends, costing five or six times as much as mine, my results compare favorably and in many instances surpass.

Yours very truly,  
THEODORE BEDELL, JR.

**This book tells you all you have to know:**

How to put up your antenna in accordance with the new regulations of the National Board of Fire Underwriters—

How to wind coils, drill the panel, make the cabinet, solder connections—shield your receiver—

How to operate your set intelligently—

How to overcome interference and other troubles—

How to prolong the life of your vacuum tube—

How to use "vernier" adjustments—

In short—everything you want to know about in radio language you can understand.

There are more than two dozen photos and diagrams in addition to the four working patterns.

**DOUBLEDAY, PAGE & COMPANY**  
Dept. RB-2, Garden City, New York

Gentlemen: Enclosed please find one dollar for THE HOW AND WHY OF RADIO BROADCASTING by Arthur H. Lynch. If not satisfied I can return this book within 3 days and have my deposit refunded.

Name.....

Address.....

WHY METRO HEADPHONES ARE SUPERIOR

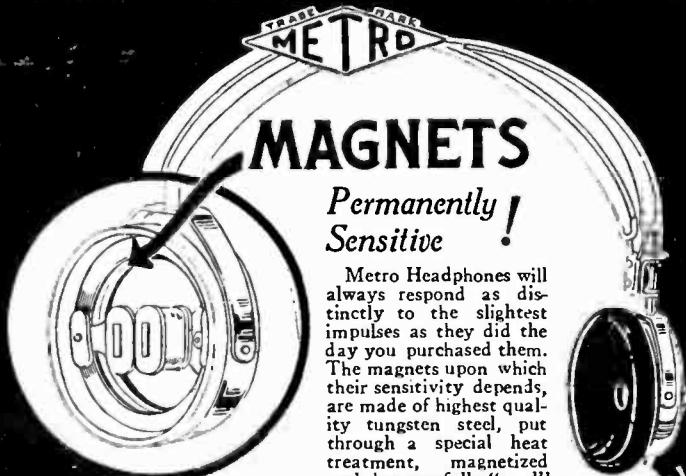

**MAGNETS**

*Permanently!  
Sensitive!*

Metro Headphones will always respond as distinctly to the slightest impulses as they did the day you purchased them. The magnets upon which their sensitivity depends, are made of highest quality tungsten steel, put through a special heat treatment, magnetized and then carefully "aged"

to a uniform magnetic strength. These magnets will not weaken or lose their magnetism. If you want lasting sensitivity, you should insist on *Metro Headphones*. Price **\$6.00**

**Little Giant Receiving Set**

A surprisingly compact set. Cabinet, highly polished American Walnut finish. Simplest, easiest tuning device. Complete with Metro Headphones **\$14.00**

**Metro Wave Selector**

Makes any set highly selective. Completely separates 300 from 400 meters. Adds only one control without changing set. Cabinet, highly polished American Walnut finish. **\$7.50**

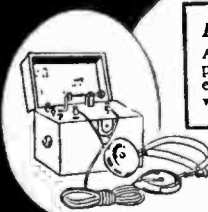

**METRO ELECTRICAL CO., Inc.**

Manufacturers of Metropolitan Radio Products

67 Goble Street

Newark, N. J.

**Sidbenel**

**"B" BATTERY**

LASTS **5** YEARS



Exceptionally powerful. Makes weak signals strong. A single charge will last six months, recharged (for less than 1/2c) from any lamp socket or farm lighting generator. Patented high ampere plates charged and formed before leaving the factory.

Positively eliminates battery noises often blamed on static. Container will not leak and is made of genuine hard rubber. Size 2 1/2" x 3" x 4 1/2".

You assemble the battery easily and pleasurably in less than ten minutes. Complete illustrated directions with each battery.

Large illustrated circular on request.

One Single unit, 23 volts, variable from 2 volts up.....	\$ 4.25	Four Single units .....	\$15.25
Two Single units .....	8.10	Five " " .....	18.50
Three " " .....	11.75	Six " " .....	22.25
		Seven Single units .....	\$25.75

Assembled per unit..... \$4.65

Rectifier for A. C. current 35c. D. C. current requires none.

**Sidbenel Radio Equipment Mfg. Co., Inc.**

1663 Jerome Avenue

New York City



**KEEP A DAY AHEAD**

of the headlines of tomorrow's newspapers!

Don't be satisfied with the regular broadcasted programs! Get the most nut of radiol! Hundreds of radiol enthusiasts are doing it!

Equip your vacuum tube set with a

**FINCH RADIO RELAY ★**

and you will automatically receive and at the same time have a permanent record of all the important and interesting news events of the world, whether or not you know the code.

Send To-day for Booklet B2

**FINCH RADIO MFG. CO.**  
303 FIFTH AVE. N.Y. CITY.

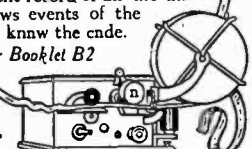

**"Circuits of Victory"**

By A. Lincoln Lavine

\$3.00 at your bookstore

Doubleday, Page & Co., Garden City, N. Y.



# Proof!

Graphic proof of FIL-KO-STAT superiority as shown here can be had in any laboratory equipped with Bureau of Standards instruments.

Practical proof of FIL-KO-STAT superiority is evident the moment you put FIL-KO-STATS in place of the devices you now use to regulate filament action.

Here's the Comparison of Fine Adjustment Control Range of FIL-KO-STAT With Rheostats and Other Filament Controls Clearly Indicating How FIL-KO-STAT Excels, and Showing Wherein it Permits Perfect and Gradual Current Increase With Infinite Adjustments.

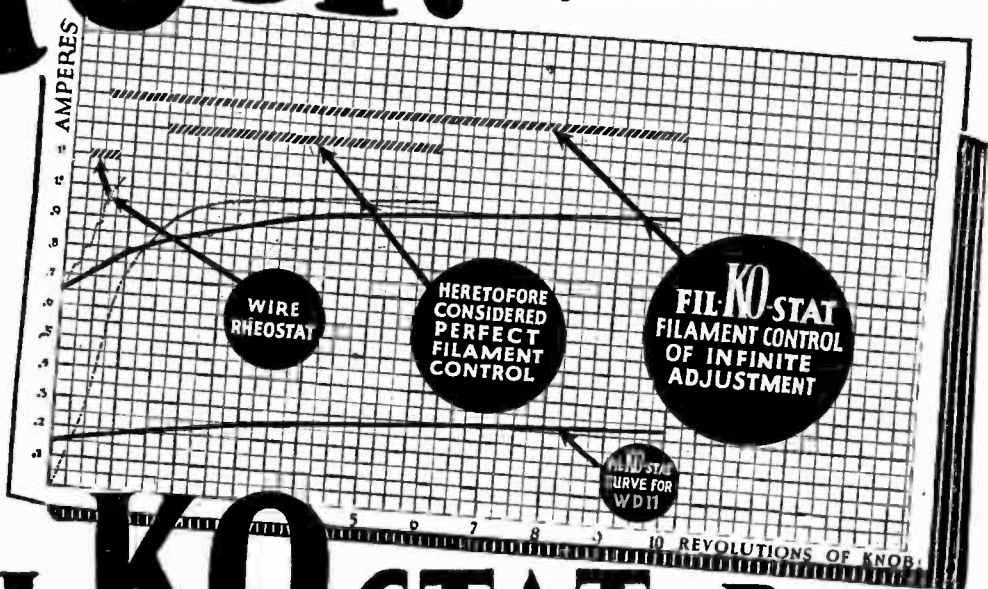

# FIL-KO-STAT Best Filament Control



- Infinitesimal Control**  
Of Electronic Flow.
- Definite Off**  
Indicating complete "A" Battery disconnection.
- Fine Adjustment**  
Starts where tube begins to function.
- At Full On**  
Resistance practically zero.
- Absolutely Silent**  
Non-microphonic free of all noises.
- No Current Variations**  
Resistance constant at any setting.
- No Discs to Break or Chip**  
Resistance element so finely divided further division impossible.

**GUARANTEED!**  
*The FIL-KO-STAT is to all purposes "fool proof." Each instrument is packed with the maker's guarantee that it will be replaced if broken within one year.*

Manufactured by



—a step forward in Radio. Not an adaptation of some old method of current control. Not a rheostat. A **FILAMENT CONTROL**, distinctly designed to utilize the great tuning possibilities of the vacuum tube itself. FIL-KO-STAT regulates FILAMENT HEAT. Gives absolute control of ELECTRONIC FLOW, consequently permits **FINEST TUNING POSSIBLE**. Perfect, gradual increase of filament heat assures longer life to tubes. Fine adjustment of fractional currents makes it ideal for Dry Cell tubes. Infinitesimal control of electronic flow gives a corresponding fine adjustment so very essential in DX tuning.

Say "FIL-KO-STAT" to your dealer today. If he has none in stock send his name and your remittance direct to

PRICE  
**\$2.00**

SOLE INTERNATIONAL DISTRIBUTORS  
**RADIO STORES CORPORATION**

Dept. R. B. 218-222 W. 34th St. New York

WIRE ORDERS FILLED TO JOBBERS AND DEALERS

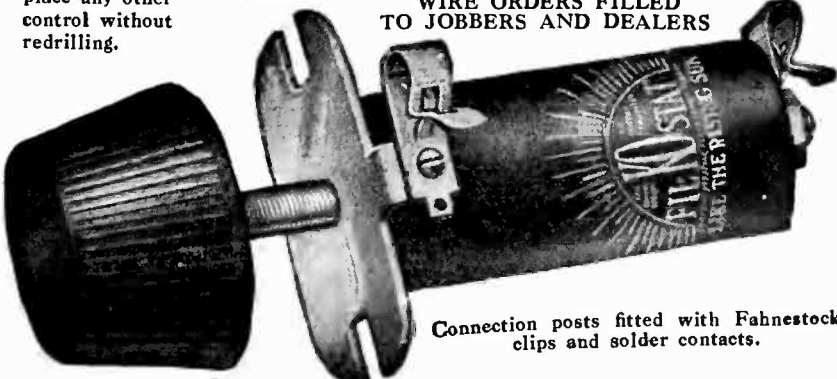

Pat. Applied For.

Connection posts fitted with Fahnestock clips and solder contacts.



## The Meaning of the Star

THE chief danger in the development of radio is the prevalence of inferior and unsatisfactory apparatus. The demand for radio equipment that, for a time, could not be fully met by the manufacturers of standard goods, naturally flooded the market with radio sets and parts of poor design and slipshod workmanship. Many new enthusiasts turned away with disgust because of failure resulting from this so-called "bootleg" apparatus. Much of it is still offered for sale with ridiculous claims at cut prices.

To Safeguard Its Readers, RADIO BROADCAST will permit manufacturers to include a black star in the advertisements of sets, materials, parts and accessories that have been tested by its experts and found to be worthy of endorsement. This approval will cover both design and workmanship.

The absence of the RADIO BROADCAST star will mean that the article advertised has not been offered for test and that this magazine's experts have not personally used it. The acceptance of an advertisement in itself indicates a belief in the integrity of the manufacturer. But, the appearance of the star means, in addition:

**Tested and Approved by RADIO BROADCAST**

# CONNECTICUT RADIO

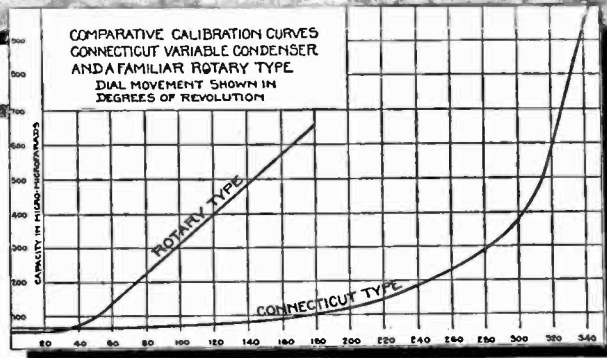

## *This Tells the Tale*

### *Which Variable Condenser is Best for Your Set*

Up to 400 micro-microfarads—the extreme capacity ordinarily employed in designing circuits for short wave lengths—the CONNECTICUT Variable Condenser has over 300 degrees of dial movement.

This gives a working range two and one-half times greater than that of the plate type instrument. Dial movement makes such slight capacity change that most accurate settings are possible.

These features together

with the neatness of its design, the compactness of its construction, the lengths of its scale (350° against 180°), the low waste of signal energy, the impossibility of short circuiting, and the way in which it is shielded from outside fields, all combine to give the CONNECTICUT Variable Con-

denser an immense advantage over the ordinary plate type of instrument, and make it the most practical improvement you could adopt for your set.

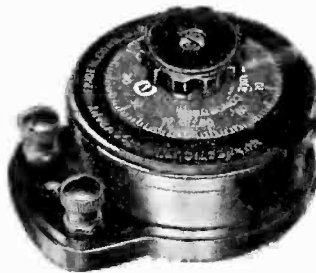

*Panel Type, J-108*  
\$5.50

*Portable Type, J-107*  
\$6.50

*Booklet 100-E describing CONNECTICUT Variable Condensers  
in detail will be sent upon request*

RADIO DIVISION



**CONNECTICUT**  
MERIDEN

**TELEPHONE  
& ELECTRIC**

**COMPANY**  
CONNECTICUT



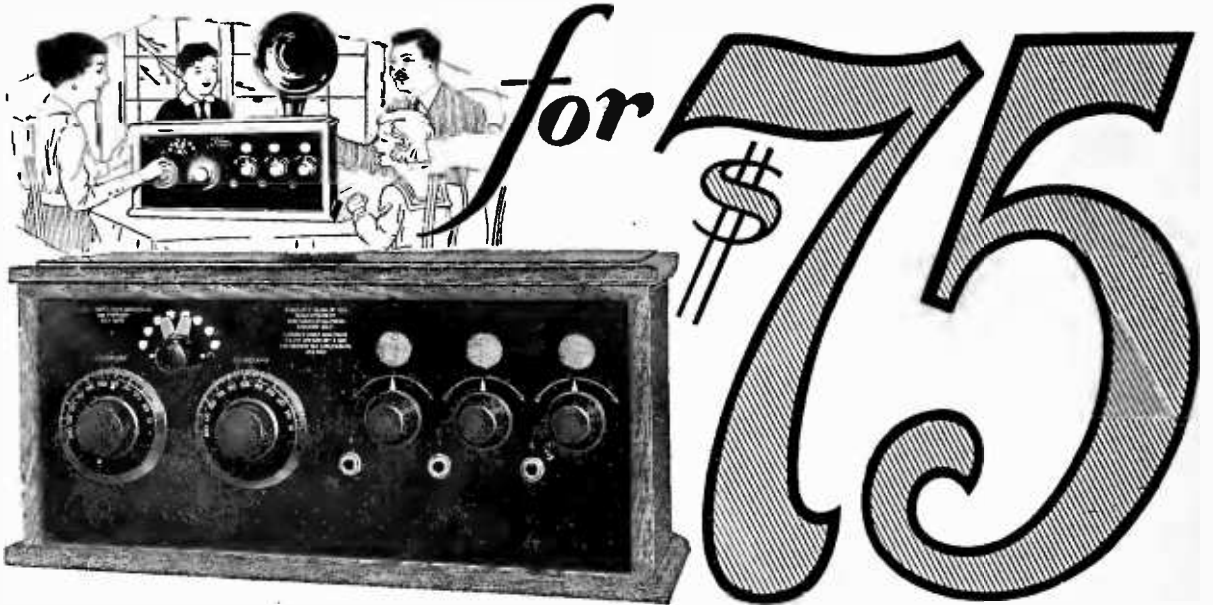

Licensed under Armstrong U. S. Patent No. 1,113,149, October 6, 1914, for amateur and experimental use only. Oard Radio Laboratories, Stockton, Cal., Mfrs.

# Type AR-10 Long-distance Regenerative Receiver, Detector and 2 Stage Amplifier.

Listen! hear that music—those rich, full tones, the AR-10 is bringing that concert to you over a thousand miles. Where are the batteries? "Peanut" tubes are being used, and both the A and B batteries are inside the cabinet. A splendid idea isn't it? Saves scattering the apparatus about.

Don't see any wires either do you; just the lustrous Bakelite panel in front, mounted in a sturdy quarter sawed oak cabinet, with a beautiful French grey finish. For, when "Peanut" (WD 11) tubes are used, the AR-10 requires only two external outlets, one for the ground, one for the antenna, both in the rear. No mass of wires to detract from the compact, handsome, artistic appearance. Quality, the highest quality, in every line and feature. Absolutely nothing omitted that would increase either efficiency or attractiveness. A supreme product of a pioneer radio manufacturer.

Mail the coupon below for folder, and in the margin write the name and address of your favorite radio dealer so that we may make arrangements for you to witness a demonstration of this marvelous set. Don't delay. It is probable that for several months the demand will far exceed the AR-10s that can be produced. Mail the coupon NOW.



—brings in broadcasted programs a thousand miles or more.

—saves cost of 2 stage amplifier, this included in set.

—saves room, both A and B batteries can be placed inside the cabinet, with "Peanut" tubes.

—appearance, quality, workmanship, and performance FULLY GUARANTEED.

## Atlantic-Pacific Radio Supplies Co.

Manufacturers' Agents—648 Mission St., San Francisco, California

Also included in the A-P quality line distributed by this company are the following:-

- Cutler-Hammer.....Rheostats
- Cutler-Hammer.....Potentiometers
- Carler Radio Co.....Plugs & Jacks
- Dayton Fan & Motor Co.....Variometers
- Dayton Fan & Motor Co.....Variocouplers

A-P RADIO PARTS—Transformers, Condensers, etc.

OARD PHANTOM RECEPTOR—the no-ground, "na aerial" set.

**MAIL THIS COUPON**

Atlantic-Pacific Radio Supplies Co., 648 Mission St., San Francisco, California

**GENTLEMEN:—**  
Without cost or obligation, please send me folder describing your Type AR-10 Long-distance Regenerative Receiver, Detector and 2 Stage Amplifier.

NAME \_\_\_\_\_

ADDRESS \_\_\_\_\_

CITY \_\_\_\_\_ STATE \_\_\_\_\_

*Write name and address of your favorite Radio Dealer in the margin*

It's Here!



50¢



## A Quality Plug at A Popular Price

*This plug will do everything that can be expected of any plug at any price.*

PACENT  
—of course

*Don't improvise  
"PACENTIZE"*

The PACENT aim, for over fifteen years, has been to facilitate radio work with plug and jack devices. The PACENT New Universal Plug No. 40 removes the barrier heretofore existing between the user's desire for a quality plug and cost. As with its senior, No. 50 PACENT Universal Plug, this new plug insures a permanent biting contact by its patented method of connection with cord tips. Its remarkably low price enables you to enjoy the convenience of plug connections on every piece of radio equipment—and to keep extra plugs always on hand for emergency use.

*Write for Descriptive Bulletins RN4*

## PACENT ELECTRIC COMPANY INCORPORATED

Executive Offices: 22 Park Place, New York, N. Y.

### BRANCH OFFICES

Philadelphia  
Chicago  
St. Louis

Washington, D. C.  
San Francisco  
Minneapolis



Canadian and British Licensees:  
Colonial Radio, Ltd., Hamilton, Can.  
Members, Radio Section. Associated  
M'frs. of Electrical Supplies

★ Tested and approved by RADIO BROADCAST ★

# REMLER

*Cumingham*

APPARATUS THAT RADIATES QUALITY

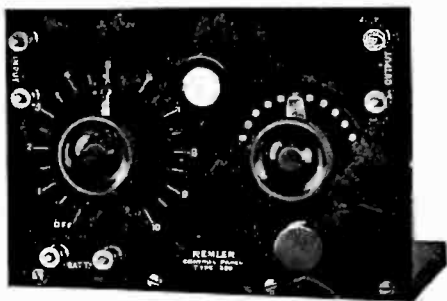

Remler Type 330 Detector Panel. Price \$8.50

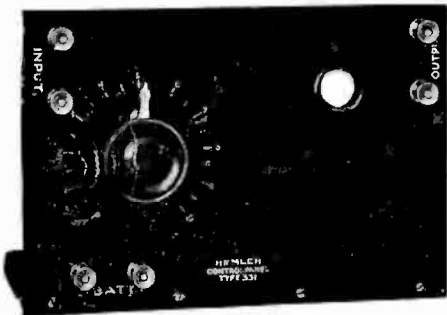

Remler Type 331 Amplifier Panel less transformer Price \$6.00

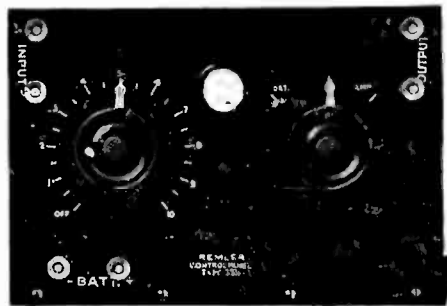

Remler Type 333 Amplifier Panel less transformer Price \$9.00

## THE MOST POPULAR Panels ★ ON THE MARKET

**I**N designing these Remler Control Panels, Remler Engineers combined every point necessary for efficient detector and amplifier tube control with special features of construction for the convenience of the user. No process of manufacture that would make these panels efficient in operation and beautiful in appearance has been neglected.

Each panel is a complete unit, mounted on a hardwood base for table use, but so designed that it may be easily mounted in a cabinet. The input and output binding posts are located on opposite sides of the panel at a standard height to facilitate the neat and easy connection of other Remler units.

The 330 Detector Panel contains the Remler Grid Condenser and Variable Grid Leak unit. Also the patented Remler "A" Battery Potentiometer for plate voltage control—an item very necessary for obtaining maximum efficiency from the sensitive gas filled detector tubes.

The 333 Amplifier Panel contains the Remler Rotary Cam Switch which does the work of two jacks and plug in cutting in or out steps of amplification.

All panels are of highly polished black Bakelite and only Remler standard Quality parts are used in the assembling of the unit. All lettering is recessed and filled with a special white enamel that will not discolor or chip out.

### NEW REMLER CATALOGUE

Send 10c for new 40 page Remler catalogue just off the press containing circuit diagrams for Remler Apparatus and other useful information, including a table of inductance, capacity, and wave length

# REMLER RADIO MFG. CO.

FACTORY AND HOME OFFICE  
248 FIRST ST. SAN FRANCISCO, CAL.

EASTERN REPRESENTATIVE  
154 W. LAKE ST. CHICAGO, ILL.

★ Tested and approved by RADIO BROADCAST ★

THE COUNTRY LIFE PRESS, GARDEN CITY, NEW YORK