

RADIO BROADCAST

RADIO FOR EVERY PLACE AND PURPOSE



Making Life Safe
at Sea



Radio Has
Gripped Chicago



King Electron
Tells About
Detection



Choosing a
Radio School



One Vessel Radio
Might Have Saved

Super-Sales and Service

Super-sales are to the radio industry what super-regeneration is to the radio experimenter. During the broadcasting year just closing, the 20th Century Radio Corporation sold more Westinghouse equipment than any other radio distributor in the United States.

Super-Service made these super-sales, and to-day the 20th Century Radio Corporation supplies more successful dealers with radio equipment than any other distributor, because skilled organization and strategic location of distributing depots make for super-service.

In accordance with the policy of this corporation to handle the output of only reliable and responsible manufacturers whose products are of unquestioned quality and merit, we announce that we have accepted distributorship for the complete line of Paragon Products manufactured by the Adams-Morgan Company. America and England know these products for their unparalleled performance on both distance and selectivity.

Complete literature and prices on the Paragon line together with delivery schedule has been included in our extensive list which is now available to dealers.

20th Century Radio Corporation

6548 Murray Hill

565 Fifth Avenue

New York, N. Y.

BRANCHES

Detroit, Mich.
2311 Woodward Ave
Main 7809

Norwalk, Conn.
17 High St.
Norwalk 675 Ring 4

Newark, N. J.
587 Broad St.
Market 3265

Brooklyn, N. Y.
102 Flatbush Ave.
Sterling 6349

White Plains, N. Y.
2-4 Mamaroneck Ave.
White Plains 1030

Radio Broadcast

ARTHUR H. LYNCH, EDITOR



CONTENTS FOR OCTOBER, 1922

Paul F. Godley - - - - - *Frontispiece*

THE MARCH OF RADIO - - - - - 455

MAKING LIFE SAFE AT SEA - - - - - ARTHUR H. LYNCH 465

THE SELECTIVE DOUBLE-CIRCUIT RECEIVER - - - JOHN V. L. HOGAN 480

DEVELOPMENTS IN HIGH-POWER RADIO, PART II
 COMMANDER STANFORD C. HOOPER, U.S.N. 484

ONE VESSEL THAT RADIO MIGHT HAVE SAVED - - ORTHERUS GORDON 489

CHOOSING A RADIO SCHOOL - - - - - HOWARD S. PYLE 493

KING ELECTRON TELLS ABOUT DETECTION - - - - - R. H. RANGER 497

RADIO HAS GRIPPED CHICAGO - - - - - GEORGE P. STONE 503

"WITH THE NIGHT MAIL" - - - - - DONALD WILHELM 512

SHIELDED RECEIVERS - - - - - THOMAS C. TIBBEY 517

RADIO PERSONALITIES - - - - - 520
 Commander Stanford C. Hooper, U.S.N. - - - - - DONALD WILHELM

RADIO IN REMOTE REGIONS - - - - - 524
 A Sign in the Wilderness - - - - - SUE M. HARRISON
 Radio on Robinson Crusoe's Isle - - - - - W. H. C., JR.

BROADCASTING NEARLY TO THE ARCTIC CIRCLE - - FRASER M. GERRIE 527

PROGRESS OF RADIO IN FOREIGN LANDS - - - - - 529

THE GRID—QUESTIONS AND ANSWERS - - - - - 532

JOHN BULL'S WORLD-WIDE RADIO - - - - - J. CONRAD FLEMMING 536

ADDITIONAL BROADCASTING STATIONS IN THE UNITED STATES - - - 538

Copyright, 1922, by Doubleday, Page & Co. All rights reserved
TERMS: \$3.00 a year; single copies 25 cents

F. N. DOUBLEDAY, Pres. ARTHUR W. PAGE, Vice-Pres. NELSON DOUBLEDAY, Vice-Pres.
 RUSSELL DOUBLEDAY, Sec'y. S. A. EVERITT, Treas. JOHN J. HESSIAN, Asst. Treas.

DOUBLEDAY, PAGE & CO.

THE WORLD'S WORK COUNTRY LIFE THE GARDEN MAGAZINE SHORT STORIES EDUCATIONAL REVIEW
CHICAGO: People's Gas Bldg. GARDEN CITY, N. Y. NEW YORK: 120 W. 32nd Street
 BOSTON: Tremont Bldg. LOS ANGELES: Van Nuys Bldg.



PAUL F. GODLEY
One of America's foremost radio experimenters

RADIO BROADCAST

Vol. 1 No. 6



October, 1922

The March of Radio

THE DANGERS IN UNRELIABLE BROADCAST LECTURES

TO SPEAK of censorship to a "free" people is generally like waving a red flag at a bull. The mere fact that some one is going to censor something before letting it be publicly disseminated arouses at once a violent antagonism to the movement. But if the censorship be a wise one, evidently administered for the public good, we should support and welcome it. We are constantly subject to such censorship in the United States mail service, for example, and only those who would make themselves rich at the expense of the gullible part of the public by floating some fake stock scheme, or dispensing obscene literature, really object to it.

Recently, a lecture was delivered from WJZ by a Mrs. Hale on the subject of cancer treatment. This lecture should never have been permitted. As the lecturer proceeded, it was evident that instead of benefiting the public, here was a case where the broadcasting service was being used—no doubt unintentionally—with positively harmful effects.

With increased power must always come increased responsibility. Thus a broadcast lecture, with its possibly hundred thousand listeners, must be examined for false statement and dangerous advice much more thoroughly than when the lecture is delivered in a hall to a few dozen people. This examination is still more necessary in the case of the radio lecture because the use of the station

itself vests the lecturer with a certain authority and furthermore the audience does not have the face-to-face contact with the speaker by which can be judged, to some extent at least, the reliability of the statements made.

The message this particular lecturer had to offer was contained in the advice to treat cancer by a dietary régime. From the manner in which the speaker proceeded it might be concluded that the medical profession had recently adduced proof from experimentation to the effect that cancer was a blood disease and could be controlled or eliminated by certain dietary precautions. If such were the case no greater benefit could be conferred on the human race than the rapid dissemination of such information, but any one with common sense knows that this would not have been left for a lecturer who was evidently not even familiar with the well-known sources of information on cancer treatment, and whose knowledge of the subject has been recently gleaned from a superficial reading course not properly absorbed because of lack of scientific training and ability.

As counter-evidence to the so-called authorities which the lecturer quoted, we learn by interview with Dr. Francis C. Wood, one of the acknowledged eminent specialists on cancer and its treatment, that "we can safely say that 90,000 physicians in the United States do not believe what this woman says."

For the information of those who may have been influenced by this talk on cancer, we note in passing that the diet treatment for cancer was advocated and practised by the old Roman and Arabian physicians and that the records show that one of the Roman Emperors died from cancer after having been subjected to a strictly controlled diet; that some of the sources quoted gave out over fifty years ago the ideas presented by the lecturer; that one of the better known physicians quoted has because of his unbalanced views, been publicly repudiated by the hospital on the staff of which he formerly served; that the dog experiments referred to as proving that cancer was a blood disease involved the treatment of a growth the nature of which was not even identified with that of cancer; and that since 1875 active work has been carried on by well trained, disinterested observers to find any relation between diet and cancer growth *and none has been found!*



A fact often cited by diet enthusiasts to support their theories is the comparative absence of cancer among prisoners, due presumably to the simple diet of prison life. The real reason for this is found to have nothing whatever to do with the diet. Statistics give the average age of the inhabitants of our prisons as about twenty-four and statistics further show that the average age at which cancer shows itself is forty-five!

In addition, we were offered the advice of some physician advocating a theory of "electronic vibration rates." Now it so happens that we are well enough schooled in the activities of electrons to know that this combination of words is a camouflage for a woeful "electronic" ignorance, calculated to impress a susceptible clientèle. We have been able to find no evidence connecting electrons with cancer and believe the whole idea nothing but pure "bunk."

If any one hearing this lecture was influenced by it in such a way as to put off immediate consultation with a reputable physician in a suspected case of cancer, then instead of having dispensed a truth which "may reach and help save some life," the lecturer has jeopardized some life which by prompt measures might have been saved. The next time a broadcast lecture on health topics is to be given let us hope those in charge of the station will get the best information they can as to the harm or

good likely to result, before permitting its presentation.

INTER-DEPARTMENTAL ADVISORY COMMITTEE TO HELP REGULATE ALL GOVERNMENT RADIO

A FEW years ago government officials cared but little which of them assumed authority over the growth and application of radio communication. With the recent tremendous growth, however, it was inevitable that some dispute should arise between different departments as to whose traffic was the more important and so should have "the right of way." It is evident that there must be much difference of opinion in such matters and that some super-departmental control is necessary to harmonize the various requirements.

The supervision of radio has long belonged to the Department of Commerce, it having been primarily a ship service. The Navy is of course vitally interested, as radio communication probably trebles the fighting efficiency of the fleet. The Signal Corps must be continually developing radio as it will often be the most valuable means of communication available on a battle front. We understand that even in peace times the Signal Corps operates 58 traffic stations and that somewhat over 200 official messages are transmitted from Washington daily by Army radio. The Post Office, with its airplane service now well under way, is naturally much interested in radio regulations because of the relation they bear to air navigation. The Department of Agriculture is awaking to the fact that radio service for the farmers is an important field for its activity.

Because of these varied interests and their conflicts, there has been recently organized an inter-departmental committee, the business of which is to advise Secretary Hoover regarding priority of material and schedules for stations disseminating government information. The activity of the committee will be advisory only; its first recommendation will undoubtedly be to have the different departments cease using radio channels for traffic which can just as well be carried over land wires. There are at present eight primary government broadcasting stations sending out news and information. This number will undoubtedly increase so that the advice of the committee will soon be needed by Secretary Hoover in allotting channels, time schedules and material.

The personnel of the committee, headed by Dr. S. W. Stratton, includes representatives from the departments of Agriculture, Interior, Justice, Labor, Navy, Army, Post Office, State,

at Newark, has been using the 360-meter ether channel, during what seems to certain other stations a disproportionately large share of the time, and has refused to agree with these

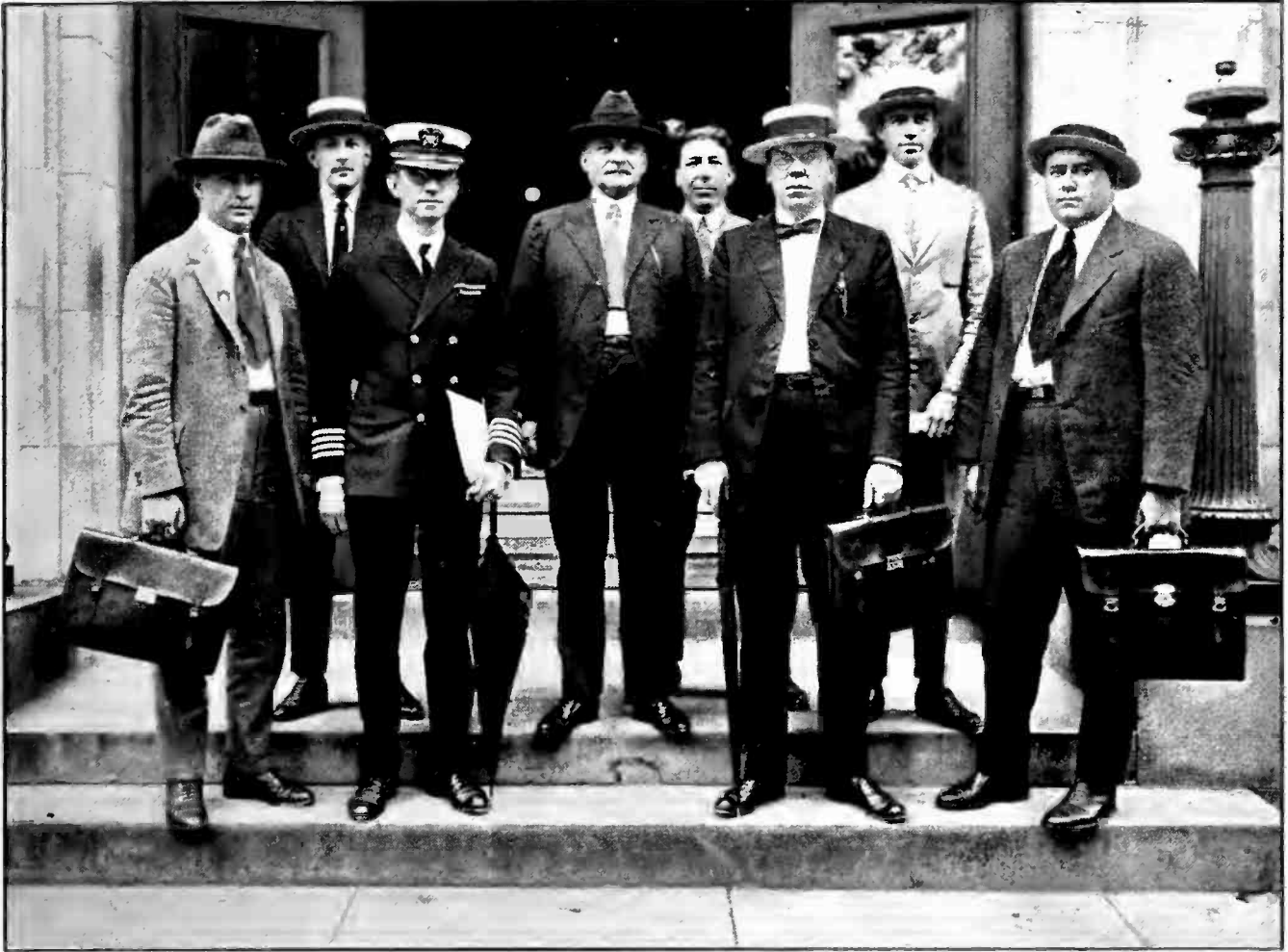

© Harris & Ewing

THE INTERDEPARTMENTAL ADVISORY COMMITTEE ON GOVERNMENT BROADCASTING

From left to right: James C. Edgerton, Post Office Department; F. P. Guthrie, Shipping Board; Capt. H. P. Perrill, Chief Coördinator's Office; Dr. S. W. Stratton, Bureau of Standards; J. C. Gilbert and W. A. Wheeler, Department of Agriculture; A. E. Cook, Department of Labor and L. J. Heath of the Treasury Department. Dr. Stratton has been made chairman of the board

Treasury, Budget, Shipping Board, and the Bureau of Standards.

WAR BETWEEN BROADCASTING STATIONS

IT WAS a foreordained fact that there would eventually be conflicts between various broadcasting stations, especially in the neighborhood of New York, where a large number of them have been installed. This has recently come to pass. We have had the experience of listening to a jumble of signals of just the kind anticipated—dance music competing with a lecturer for the ear of the radio audience.

From the press notices it seems that WJZ, the Radio Corporation—Westinghouse station

other stations on what they think a reasonable division of hours. It is probably because of this attitude on the part of the Radio Corporation station that the Radio Broadcasting Society has been organized recently, banding together broadcasting stations for the purpose of allotting them hours in what they regard a reasonable division, with the idea of averting the kind of interference to which we have recently been treated. It seems that WJZ felt itself above such a conference—that its right to the ether should be unchallenged by later comers and it was not until the counsel for the Broadcasting Society had started action to have the license of WJZ revoked by the federal

authorities, that a temporary peace and agreement were made possible.

It seems to us that here a most critical situation has been reached. We believe that the activities of such a society as the one projecting itself into this situation may result in very serious harm to radio. It is natural that the policy of such a body should demand what they regard as a legitimate division of the time to be determined largely by the society's members. With the interests of no particular station at heart, but with the primary idea of furthering the progress of radio, we should regret exceedingly and condemn vehemently any allocation of hours based upon the investment and advertizing desires of the various companies operating these stations. This is settling the question in the interest of the companies rather than in the interest of the radio public.

It is of no concern to us how much money has been invested by any company in their station, nor how much the company expects to increase their sales from the advertising value of their programmes. Broadcasting from the station *should not be allowed unless the station is operated in the most excellent manner possible.* By the best manner possible we mean that not only should the technical action of the station be as good as the present state of the art will permit, but also that the character of the programme sent out shall be the equal of that offered by other stations. It would be sheer nonsense to stop the operation of WJZ for one minute, so that some dry goods store might send out a scratchy fox-trot phonograph record which is mixed up with a loud commutator hum and "blocking" or over-modulation of tubes. The time has gone by when the public should have to listen to such stuff, because there are stations which have been properly designed and to which it is a pleasure to listen.

We think that just as the Department of Commerce refuses to license a ship or shore station operating with spark telegraphy, unless the technical characteristics of the apparatus pass certain requirements, so broadcasting licenses should be refused unless the radio inspector is convinced that the messages will be transmitted with the best possible articulation and constancy of frequency. As soon as the quality of transmission deteriorates to such an extent that people say of radio "it isn't as

good as a phonograph"—which could have been truthfully said on several recent occasions—the license to operate should be revoked.

In the meantime we wish to asseverate, as strongly as possible, that the proper allocation of broadcasting hours must be settled entirely in the interest of the listening public; the selfish interests of grocery and department stores should not count one iota. If, in the interests of the listeners, it is advisable to let WJZ operate all the time, to the complete exclusion of all others, then let it be settled that way. The only criterion which must serve to guide in the allocation of hours is excellence of programme excellently produced.



REGENERATIVE RECEIVERS MUST BE CONTROLLED

AS ONE listens nowadays for the evening concert he is continually bothered by whistling noises coming from his receiver, generally, it seems, at a critical point in the programme. Just as the singer endeavors to show the radio audience how well her voice can execute a pianissimo passage, a series of peeps (of which fortunately, she is not aware), spoils the whole effect.

These whistling interruptions are due to some regenerative receiving circuit in the neighborhood of the listener, radiating from its antenna continuous-wave power which, combined with the power sent out from the broadcast station, produces a disagreeable beat note in other receiving sets in the vicinity. When a regenerative set is made to oscillate it really becomes a miniature continuous-wave transmitting station, sending out perhaps one hundredth of a watt of power. It might seem that such a small amount of power could do no harm but it is to be remembered that the amount of power picked up by an antenna from the distant broadcasting station is only a very small fraction of this. In fact, if the oscillating receiving set is within a mile or so of the listening station being disturbed, the amount of power received from the broadcasting station may be only a small fraction of the amount received from the interfering oscillating receiver.

As more receiving sets are installed, the nuisance from this source continually increases at a much faster rate than does the number of receiving stations. This trouble must be controlled and stopped in some way, either by the good sense of the operators or by requiring that

receiving sets shall not be allowed which are capable of oscillating at the frequencies used for broadcasting. If Armstrong's super-regenerative idea is used by an appreciable

showed it to be an attempt of the "independent" radio manufacturers to gain strength by combination; it evidently did not anticipate including the Radio Corporation of America.

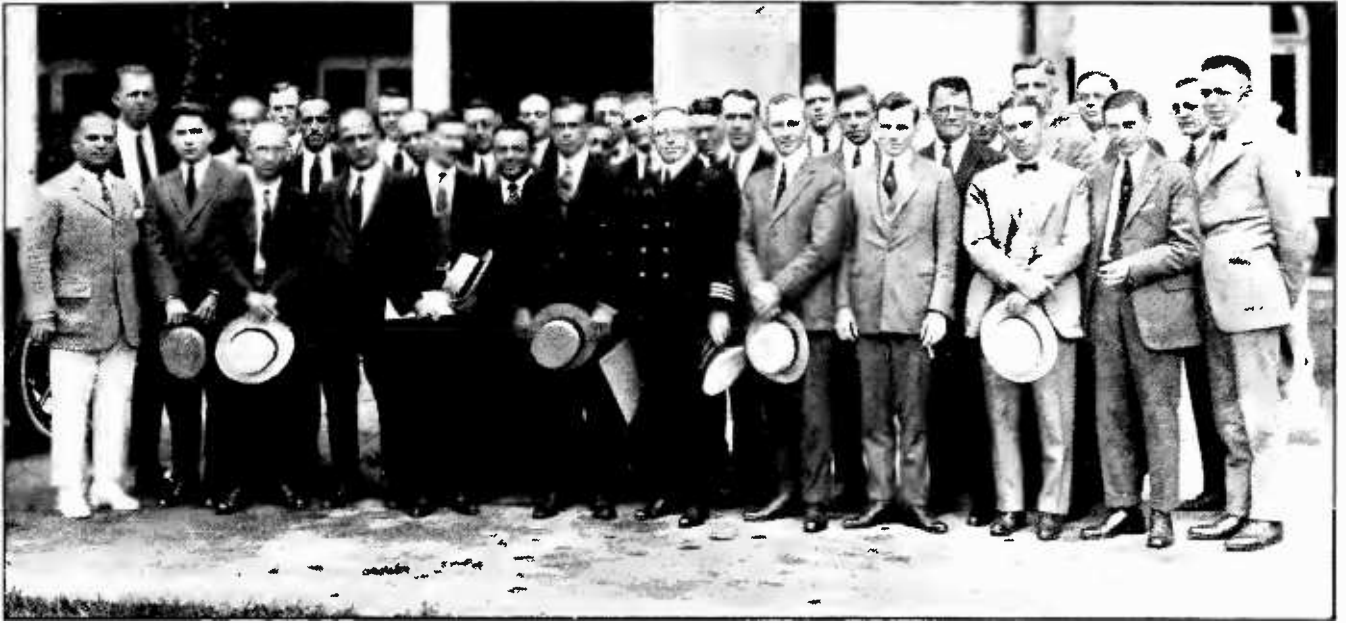

FORMING THE NATIONAL RADIO CHAMBER OF COMMERCE

Among those who attended the convention, were; Maj. L. B. Bender, S. C., U.S.A., Harry L. Bradley and F. F. Looch, Allen-Bradley Co.; S. F. Briggs, Briggs & Stratton; Dr. L. Clement; C. B. Cooper, Ship Owners' Radio Service, Inc.; Powell Crosley, Jr., Crosley Mfg. Co.; W. L. Y. Davis, Eastern Radio Corp.; Dr. J. H. Dellinger and R. S. Ould, Bureau of Standards; A. A. Danda, Fahnestock Elect. Co.; Wm. Dubulier and W. A. Eaton, Dubilier Condenser and Radio Corp.; Alex Eisemann and J. D. R. Freed, Freed-Eisemann Radio Corp.; M. Glacier, Editor, *Masonic Review*; F. P. Guthrie, U. S. Shipping Board; W. F. Hurlburt, Wireless Improvement Co.; H. Hyams, Radio Service & Mfg. Co.; A. M. Joralemon, National Carbon Co., Inc.; Abraham Kutner; Arthur H. Lynch, Editor, *Radio Broadcast*; Byron L. Moore, Federal Tel. & Tel. Co.; Wm. B. Nevin, Radio Distributing Co.; F. W. Magin, Industrial Controller Co.; H. J. Power, American Radio & Research Corp.; G. C. Sleeper, Sleeper Radio Corp.; I. P. Rodman, Gardner-Rodman Corp.; W. C. Russ; Charles E. Stahl, Conn. Tel. & Elec. Co.; E. Steinberger, Electrose Mfg. Co.; P. G. Weiller, Gregg & Co.; C. T. Maloney, Cutler-Hammer Co.; Wm. C. Hill, Formica Insulation Co.; and C. D. Lefevre, Westinghouse Union Battery Co.

number of receivers, on elevated antennas, the trouble will be immeasurably worse and some regulation should be at once put into effect to prohibit the use of these sets except on loop aerials, which radiate comparatively little power. A regenerative, oscillating set may be used without causing this trouble if it is preceded in the receiving circuit by a radio-frequency, non-oscillating amplifier, a scheme not yet used to any great extent.

REGULATION AND STANDARDIZATION BY THE NATIONAL RADIO CHAMBER OF COMMERCE

THERE has recently been organized an association of manufacturers of radio apparatus, "banded together for the purpose of creating a favorable public opinion towards the radio industry by maintaining a high standard of quality and dependability in the manufacture of radio apparatus." The original outline of activity of the association

The anticipated activities of the association are classified as manufacturing, marketing, technical, government, patents, educational, and employment. Information on materials entering into the manufacture of radio sets; standardization of nomenclature, marking, etc.; factory costs, methods of packing and marketing apparatus, and similar items are to come under the supervision of the association, according to the prospectus. Although price fixing will not be directly attempted, we learn from the same outline that agents will make studies of prices "with the view towards regulation of overcharging for apparatus of inferior quality." It seems, then, that we should be happy to have the amount of overcharge for inferior goods "regulated," but should not a society with such an imposing name prevent overcharging altogether instead of merely regulating it? In fact, why should such an association, with the avowed

intention of getting the good will of the public, countenance the marketing of inferior apparatus at any price?

A laboratory for testing radio apparatus and material is planned; a member firm may submit any of its technical problems to the laboratory staff for solution. It will be remembered that last month we mentioned the fact that the National Retail Dry Goods Association had requested the Bureau of Standards to formulate tests of radio receivers, which tests were to be carried out by the Electrical Testing Laboratories, so it seems that very soon the public should be getting receiving sets that are tested and guaranteed.

A reorganization of the society was effected in Washington on July 26 resulting in a change of officers. The first president, Mr. Alexander Eisemann, a well known radio manufacturer, was replaced by Mr. W. H. Davis, of Pennie, Davis, Marvin and Edmonds, probably the most capable attorney engaged in radio litigation. The other new officers include Harold Powers, of the American Radio and Research Corporation, Cloyd Marshall of the Dubilier Condenser Company, and George Lewis of New York. It is to be hoped that with the change of officers there will be formulated a policy promising more to the radio public than did that contained in the original prospectus.

At the meeting when the reorganization took place, army representatives urged upon the members the advisability of standardizing the smaller parts of radio equipment so that, in case of necessity, the tremendous amount of apparatus scattered throughout the country could at once be applied to outfitting the Army and Navy.

We believe that the Chamber will do well to proceed cautiously on this standardization programme. In such a rapidly growing art, little standardization of parts can be effected without seriously hampering further development. Tubes, for example, have already been standardized too much; the present type of tube with its four terminals coming through close together and having the four-terminal base is acknowledged to be of poor design. Its electrical characteristics could be greatly improved by a different arrangement, but a change of construction now would result in the scrapping of much of the apparatus in

use to-day. If an independent company were free to manufacture tubes to-day, they would by no means follow the present standardized form; a different construction, with different base, would greatly improve the action of the tube at high frequencies, so much so that the present standardized type would probably soon be discarded.

As we see it, there is no likelihood of the military branches of the Government requiring our receiving sets during the next few years. The possibility is so remote that the development of radio equipment should be controlled by this consideration only in such matters as screw sizes and like details, and the sizes of units might be standardized without altering their electrical characteristics. Sets are changing so rapidly that before the next war our present equipment will be completely antiquated. Standardization should be applied only to those details in which nothing is to be gained by change.

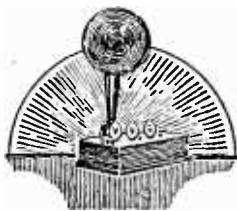

DID PETER COOPER HEWITT DISCOVER THE GRID?

IN A recent annual report of Cooper Union there appeared a tribute to the late Peter Cooper Hewitt from his friend and fellow scientist, Professor M. I. Pupin. It is evident that Pupin thought very highly of the inventive and scientific ability of Hewitt, almost as much as he did of the more human traits of his character.

A visit to the Hewitt laboratory, which was dismantled shortly after the inventor's death, showed that he had been intensely interested in radio development; much of the apparatus installed in the laboratory had evidently been used in high-frequency experiments, especially in the phenomena occurring in vacuum tubes of various kinds. A pair of huge Tesla coils, which he had used at the two ends of his laboratory, as transmitter and receiver, showed that Hewitt had been interested in radiation phenomena since the early days of its demonstration by Hertz; recent vacuum tube appliances showed that his interest in this line of work had been carried into the most recent developments.

An extremely interesting note in Pupin's eulogy of the inventor of the mercury vapor lamp is that in which he states that Hewitt was the real discoverer of the grid and its functioning in a three-electrode tube. Pupin evidently had personal knowledge of this dis-

covery of Hewitt's as he makes this statement unequivocally. Evidently Hewitt did not appreciate the importance of his discovery or he would have covered his priority with letters patent, as he did so many other ideas arising from his experimental work.

On this basis, then, it appears that De Forest gets credit for an idea really first discovered by Hewitt and it seems strange that, in a similar way, Armstrong gets credit for discovering that an audion would oscillate, as it undoubtedly had done for De Forest many times, without his realization of the importance of the action.

We remember some early experiments of De Forest's in which he was trying to show the applicability of his audion as a telephone repeater, and some of the audions *squealed* when connected to the repeating circuits. Undoubtedly the squealing tubes, which were classed at the time as defective, were oscillating. The inventor of the audion had brought about the proper conditions for setting the tube into oscillation and had produced the oscillations, but without realizing it. So as Hewitt approached the discovery of the three-electrode tube, and as De Forest approached the discovery of the oscillating tube, so many times may we be close to an important discovery, yet fate lets us pass it by and we go on to oblivion instead of fame.

THE LIGHTING WIRE AS AN ANTENNA

MUCH has been said lately about the bother of the outdoor antenna, and many owners of radio receivers, especially those in apartment

houses where landlords' rules are obstacles to be overcome, have been only too ready to grasp at a more easily installed substitute. The coil aerial is a *bona fide* substitute but of course it

requires several stages of amplification before it becomes electrically the equal of the ordinary elevated antenna. When the idea of using the ordinary lighting wires as an antenna was suggested, many were ready to give this new antenna a trial—and a number of these have been sadly disappointed. In many cases not only is the lighting system not so good as an outdoor antenna but it refuses to work at all.

The reason is more or less evident to any one

who has an elementary knowledge of radio transmission and when it is noted how lighting wires are installed in a house. In practically no apartment house can the lighting wires be a very efficient antenna, because throughout their whole length, from the lighting company's sub-station to the lamp socket, they are either actually underground or else installed in a grounded iron pipe or metallic casing. Such a wiring system can take comparatively little energy from the advancing radio wave and so can give but little signal. On the other hand dwellers in the suburbs, where the electric wires are installed overhead on poles, may possibly get very strong signals from their lighting system, depending somewhat upon the style of wiring used in the house. If the house wiring is carried in iron pipes or conduits grounded to the water pipes, poor results will generally be obtained. If armored wire is used, such as BX cable, somewhat better signals may be



THE LATE PETER COOPER HEWITT

expected, and probably the best results are obtained when the old-fashioned "tube-and-knob" wiring has been installed.

One side of the house wiring system is generally grounded to the water pipe where the wires come into the house; evidently using such a wire for an antenna will prove rather futile. The ungrounded side of the wiring system is the one which should be used to pick up the radio signal, but this wire must not be connected directly to the receiving set as a short circuit is almost sure to result, burning out house fuses and quite likely damaging the radio set. The special plugs sold for the purpose of using the lighting wires for antennas are fitted with condensers which will let through whatever radio currents there may be on the wires and still prevent the lighting current from leaking to ground and damaging the apparatus. The plugs sometimes used for this purpose have cheap paper condensers in them, which may or may not give sufficient protection from the lighting current; only those plugs which have been subjected to a high voltage test should be used.

In tests recently conducted in New York City, where the wiring was all underground, the signal received was poor, and much disturbing noise, evidently originating in the motors used in neighboring factories, was encountered. But the same power system gave fairly good results, fair signal and but little disturbing noises, in the outlying parts of the system, where the wiring was overhead and there was no machinery operating in the vicinity. When a signal is received from an underground system the effect is due to the fact that radio waves do penetrate a conducting medium to a certain extent; this penetration of the waves into the earth is not mysterious but might be calculated if the local conditions were exactly known. It is this earth penetration which accounts for the success of the Rogers underground antennas as described in our August number.

ELIMINATING "A" AND "B" BATTERIES BY GETTING POWER FROM THE LAMP SOCKET

SOME months ago there appeared a notice that the physicists of the Bureau of Standards were ready to hand over to the radio public a wonderful boon in the shape of a triode amplifier which required no batteries of

any kind for its operation. To many of us whose enjoyment of a concert has been spoiled by the sudden giving out of the filament storage battery, or who have been bothered by noisy, loose connections or bad cells in the plate battery, this announcement was indeed welcome. The interest of the public in the new device was so great that the Bureau had to get out a form reply to the numerous inquiries as to how soon the description of this battery-less amplifier would be ready.

In the July number of the Journal of the A.I.E.E. there is an interesting description of this amplifier by Physicist Lowell, of the

Bureau, who has done the major part of the development work in the perfection of the new apparatus. The article shows the growth of the idea from a simple three-tube arrangement to the final product, which has the Bureau's seal of approval, an amplifier and rectifier outfit using altogether seven tubes and a crystal rectifier. Three tubes are used to make a radio-

frequency amplifier feeding into a crystal detector circuit, which changes the modulated high-frequency current into an audio frequency current; from this crystal circuit the current passes through two stages of low-frequency amplification into a loud speaker.

The filaments of all tubes are supplied with power from the secondary of a specially wound transformer, the primary of which draws its power from the ordinary sixty-cycle alternating current supply available in the average home. One rectifier tube, in combination with choke coils and condensers suitably connected supplies plate current for all the tubes and the other rectifier tube supplies the current used to excite the magnetic field of the loud speaker used. The latter tube is of the gas-filled variety, the Tungar tube used in small storage battery charging outfits. This type of tube, by the way, is a direct outgrowth of the Hewitt mercury arc rectifier, the source of electrons being a hot filament instead of the hot spot in the pool of mercury as used in Hewitt's rectifier.

The transformer and rectifier tubes are conveniently mounted in one box and the five-tube amplifier unit is compactly arranged in another; in order to make the amplifier operate it is necessary only to connect the flexible cord in the ordinary lamp socket. The amount of power drawn from the house circuit is about



the same that is used by an ordinary fifty-watt lamp.

It seems incongruous to incorporate a crystal rectifier in a modern receiving set; we have

factorer will probably see their sales fall away to some extent, but the radio public—at least that part of the public which can afford to maintain a seven-tube receiving

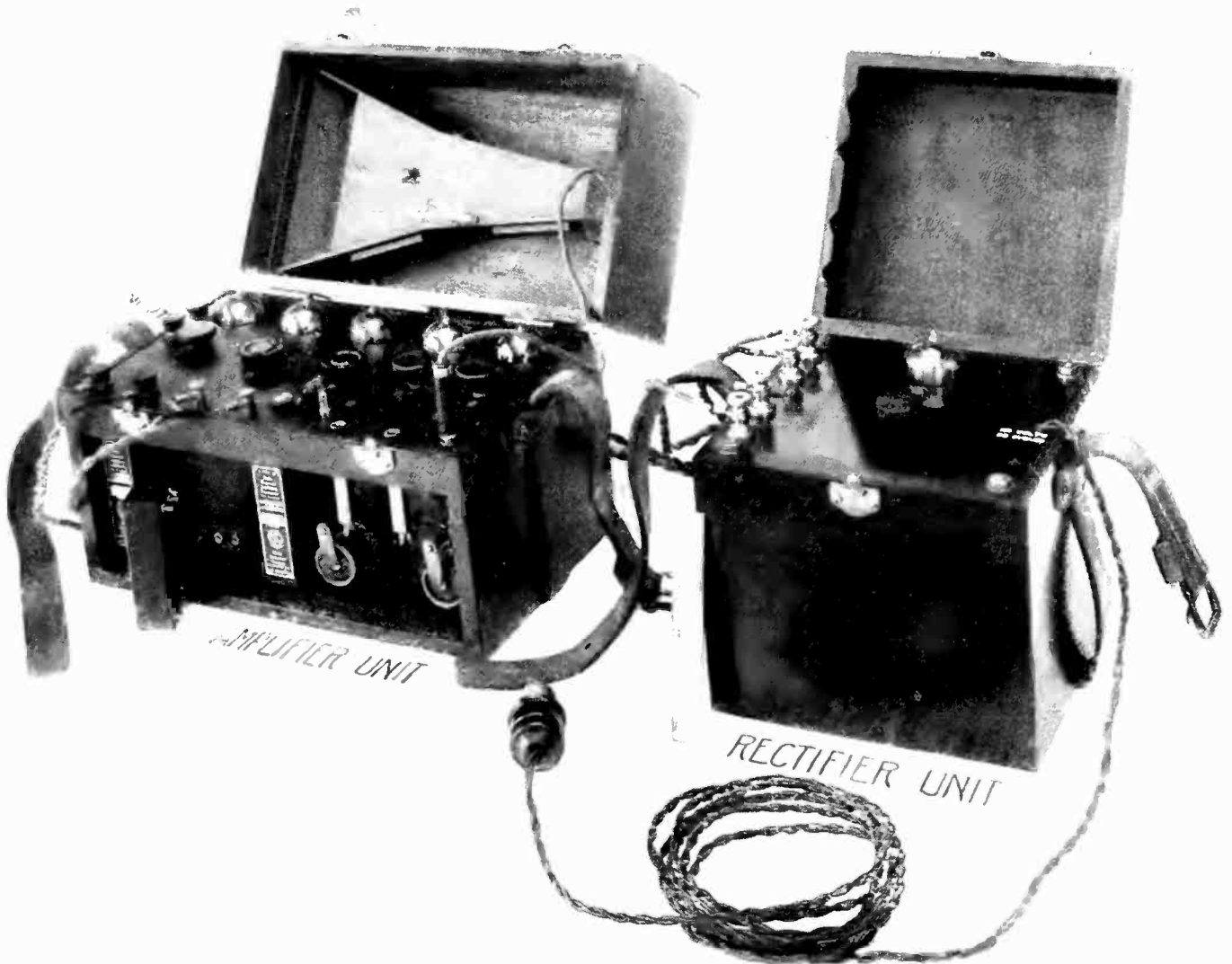

Courtesy A. I. E. E. Journal

REPLACING "A" AND "B" BATTERIES

This equipment, developed by the Bureau of Standards, does away with batteries for reception. Six tubes are employed in addition to a crystal detector. The Bureau is working on a device which will make use of a vacuum tube in place of the crystal

thought that crystals were due to go into the discard, but this apparatus apparently gives them a new lease on life. Developments are being carried out in the tube laboratories, however, which will soon give us a tube of peculiar construction such that it may fill the place occupied by the crystal in this latest amplifier circuit.

With this new tube available, the bureau will undoubtedly substitute it for the crystal rectifier and this amplifier of Lowell's will then be the most convenient outfit we have seen. The dry cell and storage battery manu-

set—will be greatly benefited by this new apparatus.

ARBITRATION SOCIETY OF AMERICA MAY END RADIO DISPUTES

ALTHOUGH the founding of this society has nothing directly to do with the present progress of radio, it is not at all impossible that some of the wrangles, necessarily occurring in an art going forward at such a rapid rate as is radio, may find their way into the court of the Arbitration Society and thus be settled much more expeditiously and fairly than is the

case with most of the radio patent suits; the action may also be settled at much less cost to the litigants.

It appears that there exists, in New York State, an Arbitration Law, amended in 1920, which makes possible and advisable such an association as this newly formed Arbitration Society. The law is probably known to-day to only a few outside the legal profession but if the Society functions as we anticipate and hope, in a few years more cases will be settled under this law than in the ordinary courts of justice. In brief, this law provides that two parties involved in an actionable difference may have this difference settled, legally, by arbitration. If both parties have agreed, in writing, to have the action settled in this manner, the award of the arbitrator is binding and irrevocable. The authority of the arbitrator is the same as that of a judge of a court, in fact his award will be confirmed by the court, if necessary, and it is as final as though the case had been settled by regular trial procedure.

The cost of carrying a case through the Arbitration Court will be negligible; there will be no red tape or peculiar legal technicalities to observe as in present trials; each party may tell his side of the story completely without being subjected to a bull-doing cross examination by a legally trained ignoramus as is frequently the case in present methods. No expensive expert witnesses will be required by either side. Practically the whole cost will be that entailed for the rent of the rooms used and a nominal fee for the arbitrator, who is selected by the disputants themselves.

The movement owes its origin to the vision of a prominent New York lawyer and former judge, Moses H. Grossman: on the present Board of Governors are deans of law schools bankers, business and professional men. Its start has been most propitious and augurs well for a career of increasing usefulness to the American public. It has received unanimous commendation from the legal fraternity and the press throughout the country, largely because it provides relief from the long and expensive process by which difficulties are at present legally settled, a process which, as the Society's outline announces, constitutes in

many cases a denial of justice rather than an administration of it.

There is practically no limit to the scope of its services, any action other than criminal or divorce cases being within its jurisdiction. It is not impossible that in a short time the record of the Society will be such that its services will be at once invoked for the settlement of those complicated trade questions which are at present fomenting so much trouble and loss in our industrial life.

In a typical case already settled by this method the taking of evidence for both sides lasted an hour and fifteen minutes and on the following day the arbitrator's award was made; it was evidently fairly satisfactory to both parties. The movement surely has our best wishes and its founders our respect and congratulations for a service so highly conceived, so intelligently planned, and so propitiously started.

SHIPS AND AIRPLANES SHOULD CARRY EMERGENCY ANTENNAS

WE HAVE passed legal enactment which requires that all vessels, falling within a certain classification as regards passenger traffic, shall have in addition to the regular radio equipment a complete emergency outfit, so that in case of need, with the regular apparatus out of commission, the emergency outfit can be used for sending out a call for help.

Now, it seems not at all impossible that an accident bringing disaster to a vessel may also carry away her antenna, without which the emergency equipment is of little avail. It seems that in such cases a kite-supported antenna might prove of the utmost importance; there is nearly always sufficient wind at sea to support a kite and it seems as though in the provision for emergency equipment we might well require that proper apparatus for sending up one of these emergency antennas be included. Such a kite-flown antenna, or possibly a small balloon-supported antenna might also be a very valuable adjunct to the radio equipment of an airplane. In case of a forced landing in some remote spot, it might well make the difference between death and rescue.

Making Life Safe at Sea

A Discussion of Some of the Scientific Aids to Navigation Which Will Go a Long Way Toward Promoting Our Ocean Commerce and Reducing the Hazard of Sea Travel

By ARTHUR H. LYNCH

NOT many of us do a great deal of sea traveling, and those of us who do frequently board our marine carrier with perfect confidence in the line, the captain, the "wireless" and good luck. Little, if any thought is given to the danger—and there is danger every time we go up the gang-plank, whether it be for a trip of a hundred or many thousand miles.

Radio telegraphy has undeniably reduced the danger factor of yesteryear, but even that great instrument for safety has its limitations. Systems are available, however, which can make navigation practically safe from a standpoint of collision or running aground in an effort to pick up a lighthouse or vessel in thick weather.

Unfortunately, these scientific achievements are not in general use. There seems to be a cycle of time necessary before any new marine aid is applied. To those who have followed the trend of progress, it must be apparent that instances are few in number of a new scientific achievement being put to practical use soon after its discovery. In the words of a man who has ardently devoted himself to the safety of life at sea, "Only a terrible disaster wakes the people to a realization of the possibilities of sea safety devices. Prompted, perhaps, by the immensity of the loss of life and property, and its attendant publicity, the layman asks, 'Couldn't something have been done to prevent it?' After every great marine disaster investigations take place and the public seeks to avoid a similar catastrophe."

Does it not seem strange that the makers of our marine laws, in whose trust is left the safety of life and property on the high seas, do not concern themselves more quickly and more intelligently with man-made devices which can accomplish this result? Is it because they are hampered by insufficient funds to carry on their work? If so, let us all do what we can to see that the necessary appropriations are

made. If it is simply the fact that they need a little pushing, let us all push together.

In bringing this matter to general consideration, and in pointing out a most valuable marine safety system, it is, perhaps, advisable to consider the details of some marine tragedies which in all likelihood could have been avoided. It is remotely possible that such consideration may lead, directly or indirectly, to safer sea travel.

CONCERNING THE "REPUBLIC" AND "TITANIC"

THE much-heralded story of the saving of the steamer *Republic* by radio, and the averting of a disaster which would doubtless have taken place without it, greatly stimulated the framing of laws requiring vessels, which carry a certain number of people, and travel a certain distance, to be provided with radio equipment.

Regarding this particular collision, which occurred on January 23rd, 1909, it is significant that even with her radio the lives on this vessel might not have been saved had it not been for a certain device we are to consider further along which is not in universal use to-day, and for which there is no compulsory legislation.

The value of radio to the safety of life at sea found little support or interest among maritime legislators until after the sinking of the *Titanic*, on April 15th, 1912. Radio saved more than seven hundred lives in this most terrible of marine tragedies, but the loss was so great that it set the world to thinking—for a little while.

Marconi had proven in 1899 that radio was a valuable aid to safe navigation, after having brought his equipment to a point of practicability. However, little consideration was given to his conclusive evidence until 1910, and it was not until 1913 that radio even began to receive the attention it deserved! Since that time, it has gone through a series of rapid changes, and improved equipment is continually finding its way from the factories.

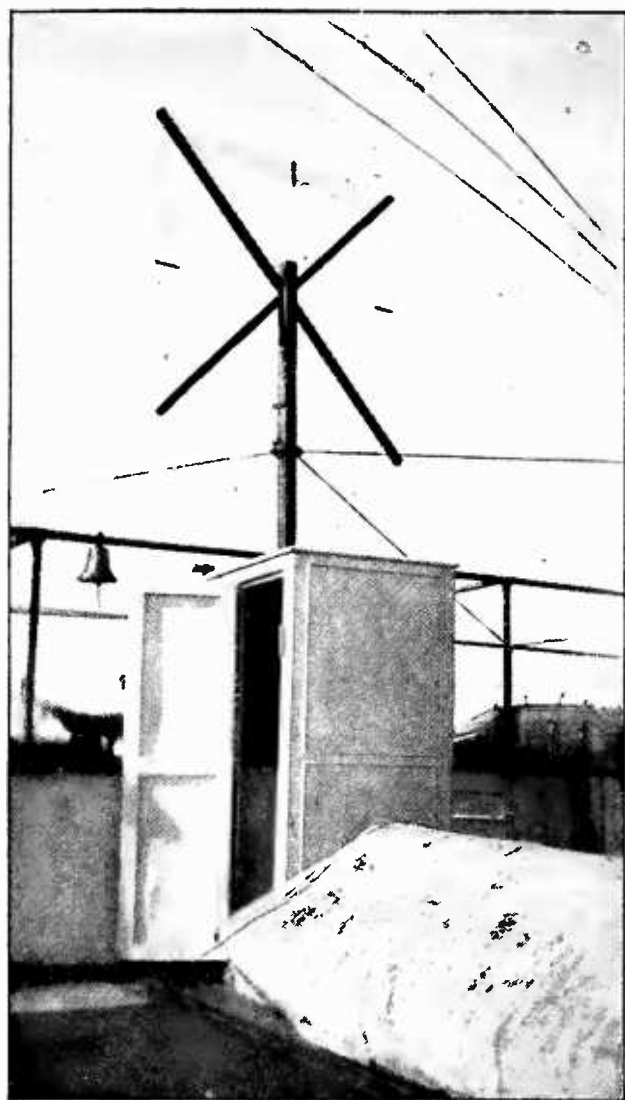

CAPTAIN MAXSON'S LOOP

Before the use of the radio compass became general, Capt. Maxson of the S. S. *Momus* built his own radio compass with which he made many interesting observations

Although the radio direction finder was given some scientific consideration before the war and did manage to find itself on one or two vessels, it was thought to be a refinement more costly than valuable. Little attention was paid to it in other than government shipping circles and the only improvements made were of a scientific rather than a practical nature. When the war god drew his sabre and the brains of the world concentrated upon the means to win back peace, it was natural that scientific devices which could be used would be immediately developed. Radio engineers, here and abroad, strove to perfect the radio compass, because it assisted them in locating enemy troops by determining the direction of signals coming from the latter's radio stations. Many other applications of the compass were

evolved and put into practice, especially in connection with the guiding of bombing airplanes on night errands.

The radio compass was also used on some of our transports and other fighting craft for locating hostile submarines, as well as for general navigation.

It was developed to a point of comparative practicability before the end of the war, and since that time it has been the direct means of averting many marine disasters. Much of the work done in perfecting the radio compass could not have been successful without the development of the vacuum tube, which it made possible more accurate observation over greatly increased distances, than was possible with the older types of equipment.

RADIO COMPASSES AND BEACONS

THERE are two distinct methods for the application of the radio compass idea, for guiding vessels in foggy weather or for any of the other maritime uses to which it may be put. Our Navy Department and our Bureau of Lighthouses have contributed much to the perfecting of a system for guiding ships when all other forms of navigation would be valueless.

The radio compass, in the form most common in this country, consists of several turns of wire wound on some sort of a frame which may be orientated by a handle or other device, coupled to the proper tuning apparatus. As the coil is rotated, the operator can notice a marked increase in the signal strength from a given station, at a given point on the scale mounted below the handle of an indicating device. Where a magnetic compass is used in conjunction with this device it is possible to determine with only a slight error the direction from which the signals emanate. By employing this system, vessels at sea can determine their bearing or direction from some receiving station on the coast whose latitude and longitude is known. It is not necessary for the ship itself to be equipped with a radio compass for the direction is determined at the shore station, where a compass coil is in operation, and the result is then sent by radio to the vessel. It is possible for a vessel to secure a very definite idea of its position, as well as its bearing from a given point. In this case, however, it is necessary to receive bearings from two shore stations located at different points. The point at which the bearings cross indicates the position of the vessel. Stations of this char-

acter are called radio compass stations and are located along our coast line and at the entrance to many of our larger harbors. Within the past few years they have rendered a remarkable service.¹

Professor J. H. Morecroft of Columbia University in an editorial in the August RADIO BROADCAST, has made the very practical suggestion that radio compasses operating on short wavelengths could be manned by any member of a ship's crew with very little instruction. By a

signals and report them to the navigating officer.

An arrangement of this character would in no wise interfere with existing services. It could be made a very simply operated device, and infinitely more worth while than the present practice of employing a bow watchman even though the latter is supplied with a powerful glass.

There is another type of station used for marine work, based on the same principle but



DIAMOND SHOALS LIGHTSHIP

This modern light vessel is located off Cape Hatteras and is equipped with submarine signaling equipment radio beacon, and other modern appliances for the guidance of navigators

timing arrangement, it would be possible to have signals automatically transmitted by a special, low-power, short-wave outfit, and during the periods of silence a receiving compass coil, tuned to the wavelength employed could be automatically rotated. The observer would merely have to note the direction of incoming

¹Much valuable work in this application of radio may justly be credited to Frederick A. Kolster, formerly Physicist of the Bureau of Standards and now with the Federal Telegraph Company, as well as to Francis W. Dunmore, Associate Physicist of the Bureau of Standards. "The Direction Finder and its Application to Navigation" which was prepared jointly by these two men, is a comprehensive booklet thoroughly describing and illustrating the principles involved. It is listed under "Scientific Papers of the Bureau of Standards" as No. 428.

using a method which is exactly the reverse of the one we have just considered. This type is known as the radio beacon. In the same manner as a lighthouse employing a flashing light may be distinguished by the length of the flash or the number of flashes, the radio beacon may be recognized by the signals it is made to transmit. In heavy weather these stations send signals at regular intervals, in all directions, which may be picked up by any ship within their range.

In this instance it is necessary for the ship desiring to know her direction from a beacon station to be equipped with a radio compass of the type we have just considered for shore

observation. The ship then makes an observation of the direction of the signals coming from the beacon station, and, if there are two beacon stations, can determine her position.

LIMITATIONS OF THE RADIO COMPASS

Granting that the error of the average ship radio compass does not exceed two degrees of arc, which is a very generous concession, it is readily appreciated that it is subject to some rather serious drawbacks from this consideration, as well as from some others which are even more important, especially in the open sea. Principal among these limitations, is the fact that it offers no method whereby distances may be measured, unless it is possible to make simultaneous observations from two beacon stations or secure reports from two shore compass stations.

The measuring of sea distances in foggy weather is very important, for upon it depends the safety of many lives. An experienced radio compass operator can estimate fairly accurately the distance between his compass and the station he is receiving from, if he is familiar with the power employed at the transmitting station, but his estimate at best is only a guess, and guesswork in navigation is to be avoided.

THE NEED FOR ACCURATE SEA MEASUREMENT

It would seem as though the determining of the distance a vessel would have to run in a certain direction, in order to pick up a lightvessel or lighthouse in foggy weather, would be of value in entering a harbor. As two vessels approach each other, their distance apart taken at intervals would indicate the time at which they would pass and enable their

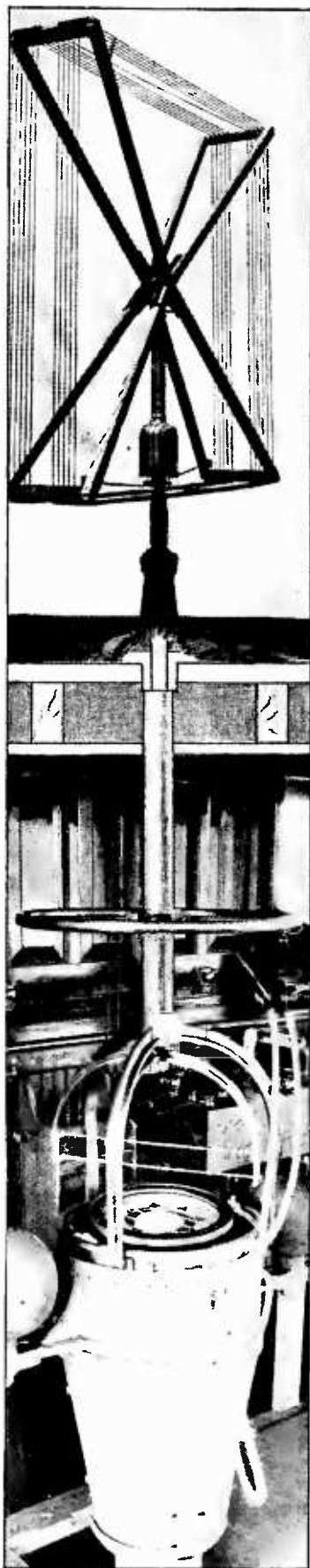

A MODERN SHIP'S COMPASS

Combining the magnetic needle and the loop antenna

navigators to avoid each other with greater certainty and less anxiety than is possible to-day.

Unfortunately, the value of modern marine appliances has not been thoroughly appreciated in shipping circles; there is a tendency to oppose any expenditure, regardless of its value to ships and shipping. Perhaps a reason for this is that shipowners are charged a rate of insurance for their vessels, dependent to a great extent upon the record of their line and the record of casualties, on the route in which the steamer is engaged, rather than upon the efforts of the owners to make the individual vessel safe. The law of averages seems to remain, regardless of the efforts made in individual cases. There is no such thing as a reduction in the insurance premium for the installing of safety devices, such as is the case in automobile insurance or in insuring buildings. There are many fire-detecting and extinguishing devices made for marine use, but their adoption does not alter the premium rate one iota, directly. If a steamship line happens to run all its vessels safely for a number of years, and keeps them on routes where marine disasters have never, or infrequently, occurred, a slightly better premium rate may be obtained. An officer in one of our largest companies once remarked before a meeting at which this subject was brought up, "If, by the grace of God and a fair wind a line manages to fight shy of accidents, it is quite likely to be able to secure a comparatively low rate or premium."

There is all manner of loose talk about a merchant marine and a subsidy—or some other form of government backing for steamship lines which is a subsidy when the war paint is removed—but there is very little common-sense legislation dealing with the protection of property at sea and.

making it attractive for owners to provide ships with safety devices which are practical.

FOG—THE GREATEST MENACE

WE HAVE made great progress in marine engineering, and storms no longer hold the danger they formerly did. Derelicts are systematically sought and removed. Icebergs are located and their positions broadcasted to mariners by radio. Careful charting of the Seven Seas, accomplished at great cost by the various countries, and the establishment of lights on dangerous shoals and promontories have stripped the sea of much of its former risk, but one great hazard remains—the one mariners fear most—fog!

Millions have been spent for fog-horns and other sound-producing devices but they are all subject to error, due to variations in atmospheric density which prevent the sound waves from traveling in a given direction. Sound waves may be refracted from side to side or up and down, resulting in certain areas where the sound is not heard at all.

VESSELS LED TO DISASTER BY REFLECTED SIGNALS

IN a paper presented at the 29th Annual Convention of the American Institute of Electrical Engineers in Boston, June 27, 1912, Mr. H. J. W. Fay pointed out that from 1893 to 1902 between 900 and 1000 vessels were wrecked by aberrations of sound or by being drawn on a false course by echo. The approximate loss in property amounted to \$57,500,000 and no less than 530 human beings were sacrificed.

These statistics became an appeal for the mariner, and encouraged inventors to renewed efforts which were at last realized in a successful system of submarine signaling.

SUBMARINE SIGNALING: ITS ORIGIN

THE system which has been perfected for sea warnings is based upon the fact that sound travels through water without the distortion, reflection and refraction which obtains where air is the carrying medium. Sound under water has another advantage: it travels faster than in air.

It is impossible to determine with accuracy the originator of this form of communication, and, were the truth known, it is quite likely that primitive man made use of some form of under water signaling, however crude his instruments

may have been. It is said that the natives of Ceylon used this knowledge many years ago to signal each other when at sea in their fishing boats. They used an earthen "chatty" which was submerged and struck with some hard object. A sharp percussive clink was thus produced which could be heard by placing the ear against the bottom of a boat many miles distant.

In 1826 we find that two scientists, Messrs. Colladon and Sturm, sought to measure the velocity of sound in water. They struck a submerged bell with a hammer and listened for the sound by submerging one end of a common ear trumpet and holding the other end to the ear. It is quite likely that they were aware of the experiments made in 1767 by a Scotch scientist who managed to hear a large hand bell at a distance of 1200 feet by the simple expedient of submerging his head.



It would seem, therefore, that there is nothing very new about submarine signaling—at least in theory. It was known long before anyone thought of securing patents on it or putting it to any practical use.

EARLY DEVELOPMENT OF UNDERSEA SIGNALING

THE first published record of any attempt to apply the principles of under-water signaling to some useful purpose is found in an English patent issued in 1878 to Henry Edmunds. This patent describes a system for ringing a submarine bell by electricity: for attaching a bell to a buoy and taking advantage of the wave motion to supply power for operating the bell, as well as the suggestion that sounds could be created under water by submerging and energizing an ordinary telephone receiver.

The underlying principles of this patent are quite like those in use to-day, though they have been greatly refined.

For a receiver, Mr. Edmunds suggested the use of an oar with its blade under water and

the handle end pressed against the ear. He also suggested the use of an ordinary telephone microphone which could be submerged to pick up the sound, but he gave no details of its construction.

In 1887, W. G. Spiegel obtained a U. S. patent for a submarine sending and receiving system which was found to be of little practical value.

The next year, 1888, Neale and Smallpage, in England, applied for a patent pertaining to microphonic and acoustic receiving devices, but they seem never to have passed the patent stage.

In 1889, Professor Lucien I. Blake was granted a patent for a receiving device of similar design to that described by Neal and Smallpage. Professor Blake also proposed the use of the under-water siren, which has since been developed practicably.

Apparently the invention of the telephone in 1876 urged a number of inventors to re-attack the subject of submarine signaling, for between 1876 and 1891 we find independent effort bent in this direction in many quarters of the globe. Among these are A. Benari of France; Mario Russo d' Assar of Italy; Thomas A. Edison, William G. Spiegel, John M. Batchelder, Lucien I. Blake, E. Huber, and F. J. Kneuper of the United States; Henry Edmunds, F. N. Boyer, N. T. Neale, J. H. Smallpage, Walter Walker, and others in England.

Following the exhaustion of the ingenuity or the resources of these inventors, very little was accomplished and nothing of a commercially practical nature was produced until May, 1898, when Arthur J. Mundy of Boston took up the task and succeeded in developing a practical

system of undersea sound propagation and reception.

Professor Elisha Gray joined Mr. Mundy in the experimental work, and before his death in 1901, the project had reached a stage where a submerged bell could be heard a considerable distance by means of a microphonic receiver, also submerged.

DETERMINING THE DIRECTION OF SOUND

THERE was one great drawback to this system: the receiving microphones would function satisfactorily at sea only when they were cast overboard from a vessel in a calm sea with the vessel motionless and noiseless. This meant tedious work and many mariners would not bother with it, regardless of fog or other hazard.

Then, too, it was impossible to determine the direction from which the sound arrived, although it was early realized that a device which would accomplish this would help shipping tremendously. Ships approaching each other in fog could avoid collision if they knew the direction they bore from one another. It rested with Mr. Mundy to solve this problem. He did it in the manner shown in an accompanying sketch.

A microphone is suspended in a water-filled tank on each side of the vessel, below the waterline and far enough from the bow to be free from the noise caused by the cutting of the water as the ship is under way. In present-day systems, two microphones are placed in each tank to make certain that the signaling system is not entirely crippled if one of them fails to function.

In this diagram three methods of operating submarine bells are indicated. The bell at the left is operated entirely by the motion of the waves, and it is interesting to note that one such bell during eleven months' service struck over four million times without any indication of wear on the moving parts. The centre bell is controlled by an electric cable operated from the lighthouse. The bell at the right is operated by a pneumatic pump on board the light vessel.



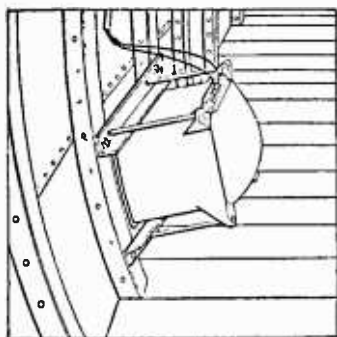

RECEIVING TANK

This is a receiving tank, two of which are employed for submarine signal receiving; one on either side of the forward part of the vessel. The receiving microphones are suspended in water in this tank

This method of receiving obviated the necessity for "heaving to" to make observations, as well as eliminating the disturbing noises caused by machinery aboard the vessel.

By a system patented by Mundy and Millet in August, 1894, it was possible to determine the direction sound was coming from, applying the method shown in an accompanying diagram.

THE SENDING APPARATUS

THE first sound producers were 120-pound bells of the ordinary locomotive type with a rate of 320 vibrations per second. 300-pound bells with a rate of about 400 were also tried. Some were made of bell metal and others of steel, and some were excited electromagnetically by alternating current.

The final choice was a 220-pound bell having a vibration rate of 1215 per second—the type now in general use.

FIRST MARINE INSTALLATIONS

THE first vessel on which submarine signal-receiving apparatus was installed was the U. S. Revenue Cutter *Seminole*. Tests carried on in Boston Harbor resulted in hearing an 800-pound church bell with rate of 450 vibrations a distance of about half a mile.

The next boat so equipped was

a steel passenger vessel plying between Boston and Gloucester, Mass. This, by the way, was the first vessel on which tests were made while under way. Running at half speed the ship heard signals from a bell at Egg Rock at a distance of three-quarters of a mile. Then came the *Chippeta*, a wooden ship, used for experimenting.

All manner of receiving schemes were tried, including the use of a microphone diaphragm as part of the ship's skin, below the water line. Microphones were attached directly to the ship's skin, but this location proved undesirable because noises were produced in the receivers by the ship's machinery and by the impact of rushing water when the vessel was under way.

Then wooden tanks were constructed in the fore-peak of the *James S. Whitney* using the outer skin of the vessel for one side of the tank. They were filled with 64 cubic feet of water and it was found that by their use, signals could be heard from ten to fifteen miles while steaming at fifteen miles an hour.

Followed much experimental work resulting in the development of a cast iron tank 16 inches square and 18 inches deep with a rubber gasket to make it watertight, while also serving as a sound insulator, preventing noises on the vessel from reaching the microphone.

The *Metropolitan* fleet was then equipped, and the Allan Liner *Tunisian* was the first

transatlantic vessel to be fitted with this apparatus.

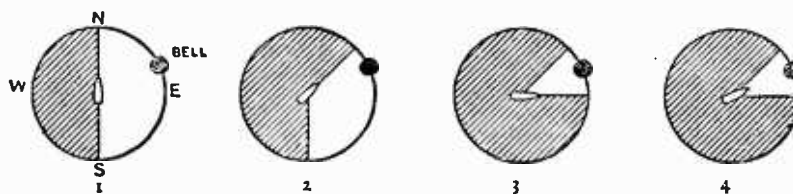

SUBMARINE SIGNAL DIRECTION FINDING

By the Mundy and Millet method

- These diagrams show how the direction of the bell or oscillator may be determined on board ship by using the submarine signal receiving apparatus. Starting with ship heading north, with bell E. N. E.
1. Shows the ship headed north when the first observation is made. With the semaphore switch set to starboard the bell sound is heard, but with the semaphore switch set to port no bell sound is heard, showing that the bell is located in the unshaded portion of the circle. (At distances less than one mile the sound may be heard faintly on the opposite side of the ship from the bell.)
 2. Shows the ship swung to starboard four points, heading northeast, and the louder bell sound still being heard on the starboard side; the shading is extended, leaving only the small, unshaded portion of the arc to be explored. A faint sound may now be heard on the port side.
 3. Shows the ship swung to starboard four points more, heading east, but in this position the louder bell sound is heard on the port side and the weaker bell sound on the starboard side, and the shading is again extended, showing that the ship has been swung past the bell, which now bears on the port bow.
 4. Shows the ship swung two points to port, heading on the bell, in which position the volume, quality and tone of the bell will be equal on both port and starboard sides, showing that the bell is located dead ahead.

IS THE GAME WORTH THE CANDLE?

IT WOULD seem logical from an economic standpoint that, unless any system of safety devices resulted in a saving greater than the cost of its installation, operation and maintenance, we might well do without it. But when we think of marine

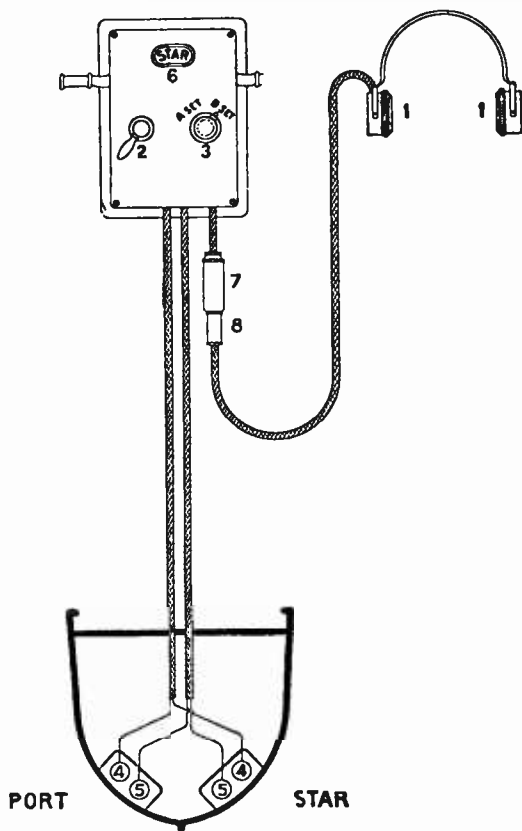

1. EAR PIECES
2. HANDLE
3. KNOB
4. A MICROPHONES
5. B MICROPHONES
6. SEMAPHORE
7. SOCKET
8. PLUG

THE ULTIMATE
RESULT OF
MUNDY'S WORK

This diagram illustrates the standard type of submarine signal equipment. By manipulating the switch on the receiving box, the operator is able to tell whether signals are coming from his port or starboard side. Each receiving tank is fitted with two microphones so that the possibility of the apparatus becoming inoperative is quite remote.

safety devices, we must forget dollars and cents and consider the value of human life.

Who knows but there may have been a man on the French submarine *Pluaise*, which was sunk with all hands, who would have perfected some devices for the betterment of mankind? The *Pluaise* met the uncommon fate of rising to the surface and striking the cross-Channel boat *Pas de Calais*. Had the *Pluaise* been equipped with submarine signal-receiving gear she could have heard the noise made by the approaching steamer and avoided the collision.

THE REPUBLIC DISASTER

THE sinking of the American S. S. *Republic* on January 23, 1909 is the first marine disaster in which radio played a significant part. Coupled with the sinking of the *Titanic*, this

tragedy stirred up enough interest and action to have radio equipment made compulsory on certain classes of vessels.

Had it not been for the timely application of submarine signaling and the resourcefulness of an officer of the S. S. *Baltic*, the historic rescue of the *Republic's* passengers and crew might not have been effected. Little has been said about this in the stories told of this great radio achievement.

The *Republic* was reported in distress, by radio, but was located by submarine signals. When Jack Binns sent out his history-making CQD (now SOS). It was received by Jack Irwin who was on duty at the Marconi station at Siasconsett. Irwin eventually got in touch with the *Baltic* and made known the condition and position of the *Republic* and the *Florida* which had collided. The accompanying sketch was made by an officer of the *Baltic* and indicates the method employed.

The *Baltic*, bound from Europe had picked up the submarine bell of the Nantucket Shoals light vessel and had laid her course for New York. She had proceeded eighty miles when Irwin informed her that the *Republic* was in distress.

Captain Sealby of the *Republic* informed the *Baltic* that he was in range of the Nantucket Shoals bell and gave his bearing as determined by the Mundy & Millet method. In seeking the *Republic*, the *Baltic's* first move was to get back in range of the Nantucket bell.

By learning the bearing of the distressed vessel from the lightship it was possible to seek her intelligently, but much time was lost, even when this method was employed. Had the *Republic* been equipped with a submarine bell or some other form of sound producer, she could have been located much more rapidly.

After taking the passengers of the *Florida* and the *Republic* aboard, the *Baltic* proceeded to New York in a dense fog, making Fire Island and Ambrose Channel lights by the submarine signal method.

THE FESSENDEN OSCILLATOR

A GREAT advance in submarine signaling is credited to Reginald A. Fessenden* a noted American inventor. A device called an oscillator, shown in an accompanying illustration has been perfected by him. A section of the ship's skin is cut away below the water line, and the surface of the oscillator takes its

*See RADIO BROADCAST for July, page 227.

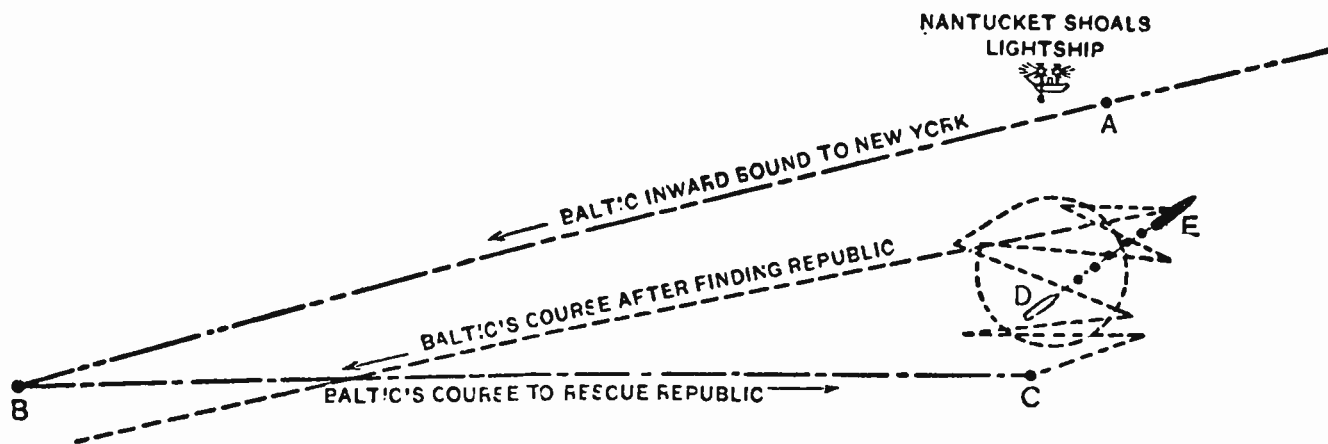

CHART MADE BY AN OFFICER ON THE S. S. "BALTIC"

Shows how the disabled *Republic* was finally located by means of submarine signals and illustrates how much more rapidly the rescue could have been effected had she been equipped with some sort of sub-sea signaling device

place. An alternating current, vibrating at about one thousand cycles causes the steel diaphragm to vibrate, thus producing a shrill note, somewhat similar to the note produced in a radio receiver by a spark transmitter fed by a 1000-cycle generator.

Although the diaphragm of the oscillator is of steel about three-quarters of an inch thick, it was found that, used as a receiver, sounds could be received many miles when it was connected with vacuum tube amplifiers. In an

address delivered August 30, 1920, Mr. Hammond V. Hayes, Chief Engineer of the Submarine Signal Company, said of this phase of the business, "Not only were such sounds audible in telephones, but phonograph records were made of them and, possibly even more remarkable, photographs of the sounds produced by invisible ships were taken."

These under-water sounds are produced by the movements of propeller blades in the water and by ships' auxiliary machinery. Most ships, it was found, had their own distinguishing noises, and it became possible later for men expert in listening, not only to report the type of



FESSENDEN OSCILLATOR

Used for producing and receiving submarine signals. The note produced by this oscillator is quite similar to the 500-cycle quenched spark radio transmitter

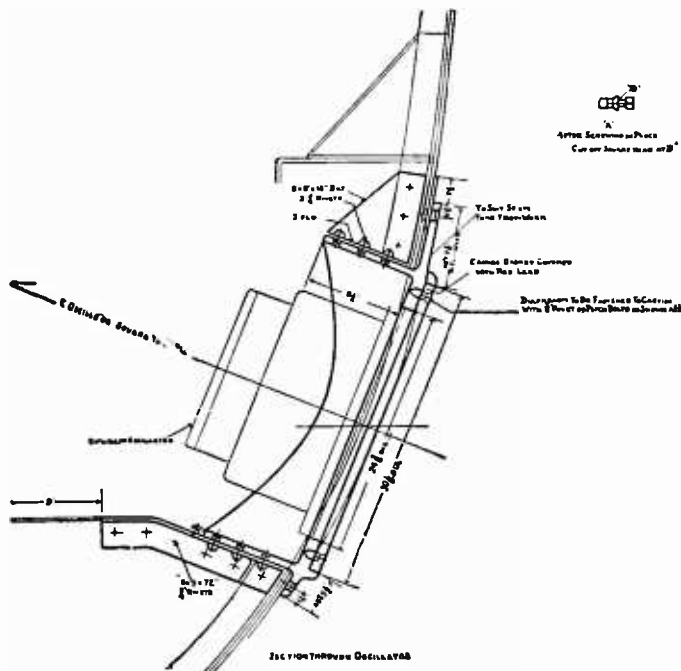

METHOD OF INSTALLING

The Fessenden oscillator on shipboard. Part of the vessel's skin is cut away and the hole is filled up by the front surface of the oscillator

ship, but the individual ship, by recognizing some characteristic of the sounds heard. Moreover, it was found that even a submarine, lying at the bottom of the ocean, gave sufficient noises to indicate its presence, unless extraordinary precautions were taken on board it



THE SUBMARINE DETECTOR

Used extensively during the war to locate enemy submarines. Men in the U. S. Navy became so skillful in the operation of this device that they could recognize vessels by certain characteristic sounds made by their main or auxiliary engine. The device at the lower right is an acoustic compensator—a mechanical substitute for the human “binaural sense of direction”

against the movement of men and machinery. The detection of submarines, as developed during the war, was confined almost entirely to undersea sound receiving.

OUR BINAURAL SENSE

MR. RICHARD FAY has developed a receiving device which takes advantage of the principle by which the human ear distinguishes the direction of the source of any sound. If, for instance a cannon is fired at a distance to our left, we know more or less accurately its direction. Although few of us know what makes this possible, the reason is a simple one—the sound from the cannon reaches our left before it does our right ear and the difference in time is unconsciously converted into direction. When the cannon is directly in front of

us the sound reaches both ears simultaneously, and we can then determine its direction without seeing it.

By a scientific application of this principle, employing microphones under water for electric ears and an acoustic balance or compensator, it is possible to determine quite accurately the source of under-water sounds.

MEASURING SEA DISTANCES BY SYNCHRONOUS SIGNALING.

WE HAVE seen that vessels can not only communicate with one another and learn of each other's existence by submarine signaling and by radio, but that they can determine to a nicety the direction they bear from one another. We have seen, also, that vessels approaching a port or a light may do so with some certainty, regardless of weather conditions. But there still remains a problem of the greatest importance: how to determine with precision the distance from the source of sound to the point where it is received. This problem has been solved by an ingenious system of synchronous signaling.

Briefly, radio and submarine signals are sent out simultaneously; when the difference in time between the arrival of the radio and the submarine signals—due to the difference in speed of propagation of radio and sound waves—is determined, and

given the speed at which the waves travel, it is a simple matter to compute the distance between the transmitter and receiver.

The computations are made as follows: We know that the signals from a radio transmitter travel with the speed of light—186,000 miles in a single second. And we know that the signal from a submarine-signaling device travels approximately 4,800 feet per second, depending upon the water. Observations of the latter have resulted in the following table:

TEMPERATURE	DISTANCE PER SECOND	
	FRESH WATER	*SALT WATER
50 degrees F.	4,719	4,836
59 "	4,783	4,901
68 "	4,849	4,970

*3% salinity This table does not apply in measuring depth.

For all practical purposes, therefore, it is possible to consider the radio signal as instantaneous and the speed of the submarine signal as 4800 feet per second. By arranging a synchronous transmission system and employing a stop watch at the receiving station, the elapsed time between the arrival of the two signals may be measured in seconds. Multiplying the number of seconds by the 4,800 feet for each second, we have the distance of the receiving station from the source of the signals.

THE RESULTS OF TWO TRIALS

AS FAR back as 1911, the U. S. Government made tests to determine the value of synchronous signaling. The chart on page 476 shows graphically the results obtained. It should be borne in mind that at the time this test was made, vacuum tubes were not in use, nor were radio compasses. It is quite likely that these would greatly increase the accuracy, and extend the range over which signals could be heard.

The morning of September 10, 1911, during which the experiments were made, was very hazy, but the Nantucket Shoals Lightship could be seen from a distance of about 5 miles. There were light airs from the west-northwestward. The barometer stood at 30.11 inches of mercury. The sea was calm.

Starting near the lightship, a course was steered to the westward for a distance of 8 miles, and then, turning to the southward and proceeding east-southeastwardly, the lightship was passed on the port beam at a distance of 3,450 yards. Standing on for 8 miles more and then turning to the northward, a northwesterly course was pursued, passing the lightship on the port beam at a distance of 4,600 yards, and thence turning to the southward and approaching and passing near the lightship on a southwesterly course at the close of the observations.

The track of the *Washington* in relation to the lightship is shown on the accompanying chart in a continuous black line, which was determined by range-finder readings, compass bearings, and distances run, after making careful allowance for the tidal currents that were found setting generally to the northward during the course of the experiments.

The preconcerted signals from the lightship consisted of simultaneous signals from the wireless-telegraph apparatus and the submarine-bell at the instants when the steam fog-whistle gave a blast.

The sound blast from the fog-whistle was blown at intervals of one minute—the maximum interval at which the timing device attached to the whistle permitted it to act. At the instant the whistle blew, the wireless-telegraph operator gave a tick of two or three seconds in duration and the valve of the striking mechanism of the submarine-bell was tripped and gave a stroke of the bell. This was accomplished accurately, as could be tested by the coincidence of all three signals when the observers were close to the lightship.

The results of the experiments, are best shown graphically,

two loci have been laid down on the chart of the track pursued during the experiments representing in red and black, respectively, the locus of the distance of the observing vessel from the lightship, as determined by the distance traveled by sound in water, between the time of arrival of the Hertzian waves and the signals from the submarine signal-bell and the locus of the distance of the observing vessel from the lightship, as determined by the distance traveled by sound in air, between the time of arrival of the Hertzian waves and the signals from the steam fog whistle.

A remarkable feature, which will be noticed on the chart, is that the sounds from the steam fog-whistle were lost after steaming half a mile to the westward of the lightship at the beginning of the experiments, whereas, in proceeding to the eastward, they were carried throughout the run. The times of losing the bell and the whistle are marked along the charted track of the *Washington*. The wireless-telegraphic signals were of course carried all the way through.

The times of arrival of the wireless-telegraphic signals and the fog-whistle signals were noted by means of a Hack chronometer, and the times of arrival of those from the submarine bell by a stop watch. The same observer noted both the wireless tick and the submarine-bell signal.

The following temperatures of the air and the water were recorded in the course of the experiments:

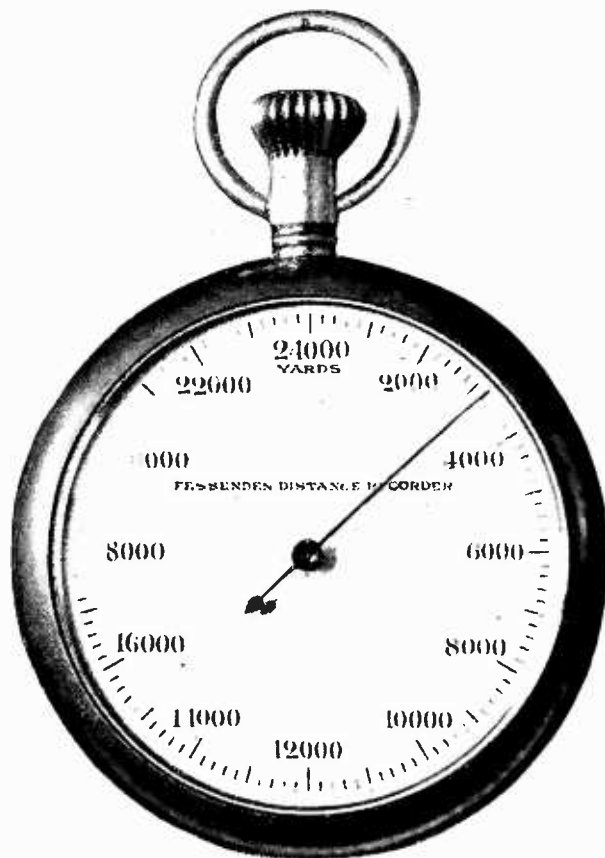

FESSENDEN DISTANCE RECORDER

As the radio signal is heard, the watch stem is depressed which sets the indicator in motion. When the submarine signal is heard, the stem is depressed a second time, stopping the movement of the indicator. The distance from the source of the submarine signal may then be read from the dial in yards. More elaborate indicators are available and are generally mounted on the wall and controlled by an electric switch

TIME	ON BOARD THE WASHINGTON		TIME	ON BOARD THE LIGHTSHIP	
	Temperature—air Fabr.	Temperature—water Fabr.		Temperature—air Fabr.	Temperature—water Fabr.
7 a. m. .	67°	66°	7 a. m. .	67°	59°
8 a. m. .	67	67			
9 a. m. .	67	67			
10 a. m. .	69	65			
11 a. m. .	69	65	1 p. m..	71	59

For the purpose of computing, from the observed intervals of time, the distances which are recorded in the table and graphically shown in the loci on the chart, the velocity of sound in air at a temperature of 68½° Fahrenheit was deduced as 1,132 feet per second, and Dorsing's determination of the velocity of sound in water as 4,794 feet per second at 19° centigrade or 66° Fahrenheit was adopted, both values being derived from the fifth revised edition of the Smithsonian Physical Tables.*

miles with good results. On the day of the official trials, all observations were made with the *Patricia* (engines stopped) close to the *Shipwash* Lightvessel, a distance of about 11 miles.

"The actual distance determined by sights was found to be 23,000 yards, assuming that the charted position of the *Sunk* and *Shipwash* lightvessels are correct.

"Thirty synchronous signaling observations were made, the maximum and minimum figures being 23,600 and 22,500 yards respectively and the mean 22,900 yards. The mean error, 100 yards, is negligible, and is doubtless partly due to errors in the positions of the two lightvessels concerned, whilst the errors in the individual observations are so small as to be of practically no importance.

"As was to be expected, it was found that the

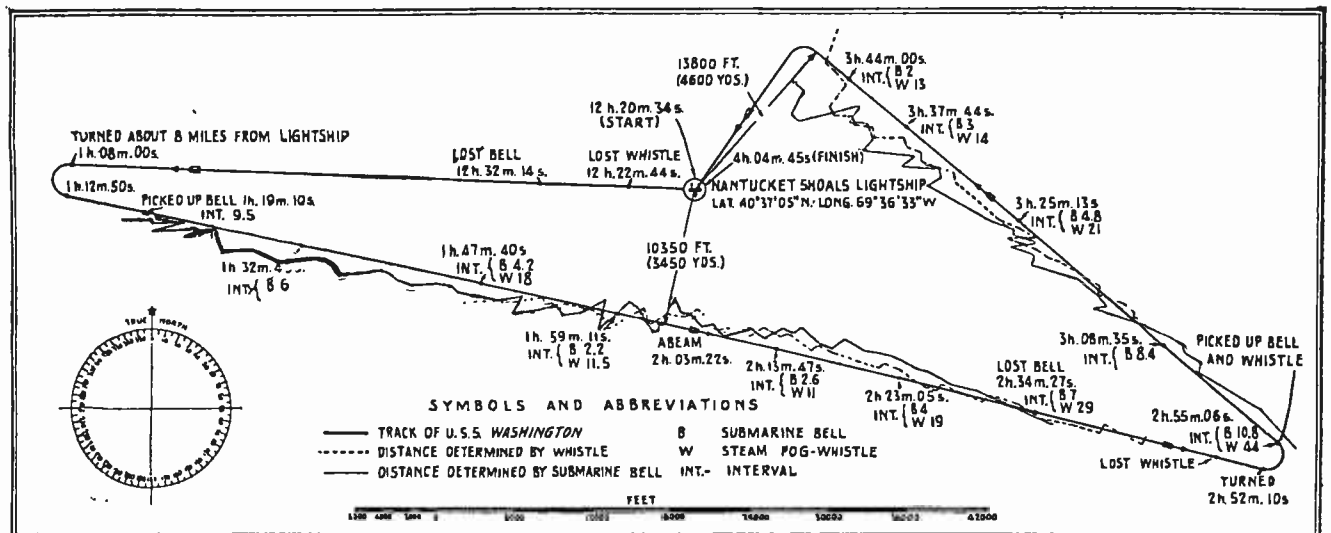

BLACK TRACK OF U.S.S. WASHINGTON BLACK DISTANCE DETERMINED BY WHISTLE RED DISTANCE DETERMINED BY SUBMARINE BELL

SYNCHRONOUS SIGNALING

As carried on between *Scotland Lightship* and the U. S. S. *Washington* produced the results shown on this chart. Radio, a submarine bell and a steam whistle were employed

On a test carried on between the Steam Yacht *Patricia* and *Sunk* Lightvessel by the London office of the submarine Signal Company on August 26, 1921, witnessed by a committee of Elder Brethren of Trinity House, both the oscillator and the submarine bell being used for submarine sound transmitting, the following report was made:

"Preliminary observations were made with bell and oscillator at distances up to about 17

*From the Hydrographic Office, Washington. Supplement to the Pilot Chart of the North Atlantic Ocean, 1911.

bell and oscillator gave equally accurate results although the latter gave louder signals."

Unfortunately this system, invaluable as it will unquestionably prove to be during the next few years, is not yet in general use. To be sure, it is scarcely out of the experimental stage; but when manufacturers and ship-owners do take it up, it should be easily developed or adapted from existing equipment; for many ships are now supplied with both radio and sound-wave reception apparatus. No changes would be required, except that the in-

stallations would have to be arranged so that one observer could employ both. The observer would wear a head-set of the type employed at present, but one receiver would be connected to the submarine signal receiver and the other to the radio receiver.

THE COLLISION PREDICTOR

DESCRIBING the application of synchronous signaling to navigation, Mr. J. Joly, Professor of Mineralogy in the University of Dublin and a Commissioner of Irish Lights,

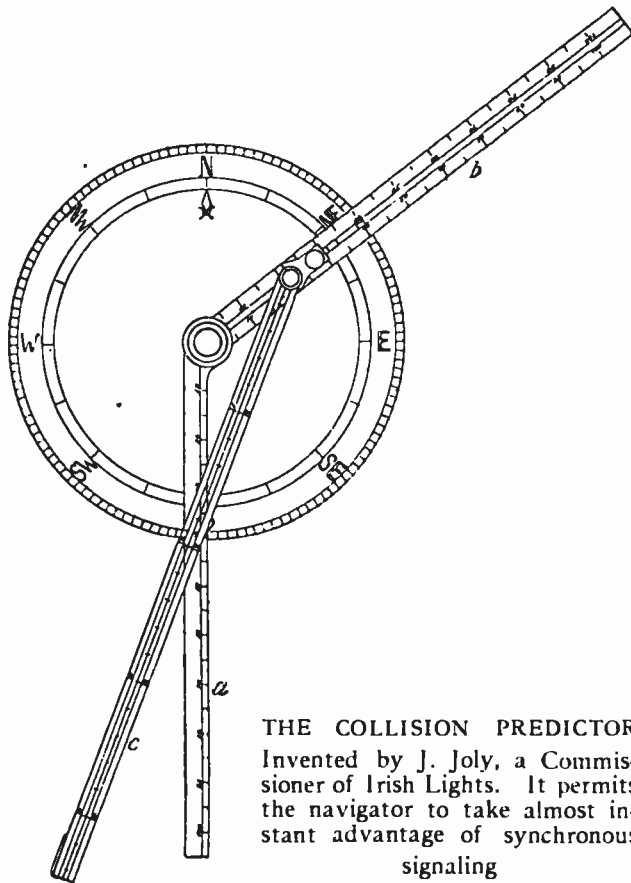

THE COLLISION PREDICTOR
Invented by J. Joly, a Commissioner of Irish Lights. It permits the navigator to take almost instant advantage of synchronous signaling

tells of an invention he has named the "Collision Predictor." This, a comparatively simple device, enables the navigating officer to take advantage of synchronous signaling in a rapid, reliable manner. The device itself and the theory on which it is based are shown in accompanying illustrations.

"The theory of the Collision Predictor is simple enough," writes Professor Joly. "In the diagram we suppose A., sailing due south, has started at the point O and will reach the positions 1,2,3, etc., in successive intervals of two minutes. B is at the distance d_0 when A is at O. If a circle is drawn with O as centre and d_0 as radius, B must be on this circle. B is moving in a NE $\frac{3}{4}$ E direction. We lay off the

course of B from O accordingly, and along the line O-B we lay out points corresponding to the travel of B in successive intervals of two minutes (the interval of time between each group of synchronous signals). This gives the points 1',2',3', etc.

"Now, if keeping the distance d_0 as radius we strike circles from the points 1', 2', 3', etc., the ship B must be transferred from one of these circles to the next every two minutes. In the figure only portions of the circles are shown, marked I, II, III, etc.,

"When the second signal arrives at A, A is at I and B somewhere on the circle I. The distance is now d_1 . With I as centre we describe a circle to this radius. B must be on this circle, and as we know that she is also on circle I she can only be at one or the other of the points of

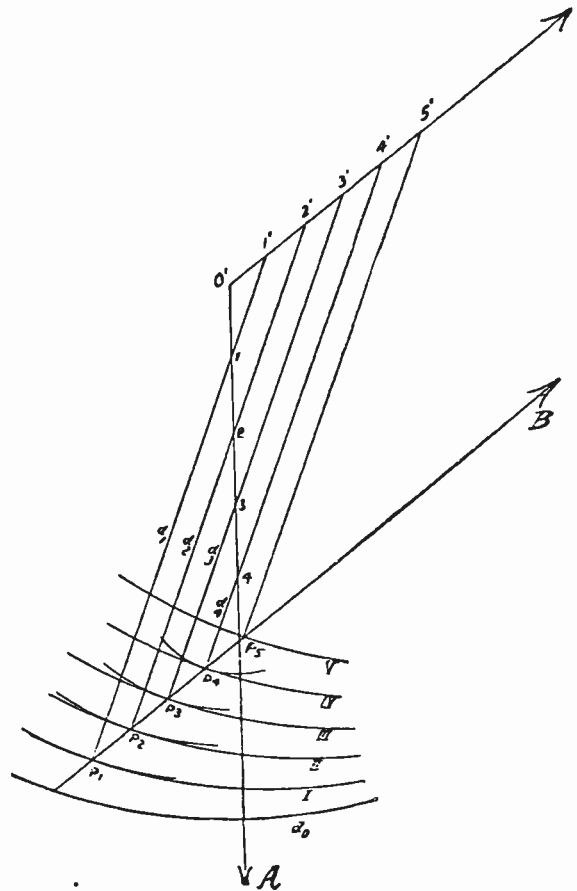

THE THEORY OF THE COLLISION PREDICTOR
Is graphically illustrated in this diagram. The method of calculation is explained in the text

intersection of these circles. Or, if the circles do not intersect but touch on a point of tangency, she must be at that point. We can at this stage predict risk of collision or safety. If the circles intersect, there is safety. If they merely touch, there is going to be a collision.

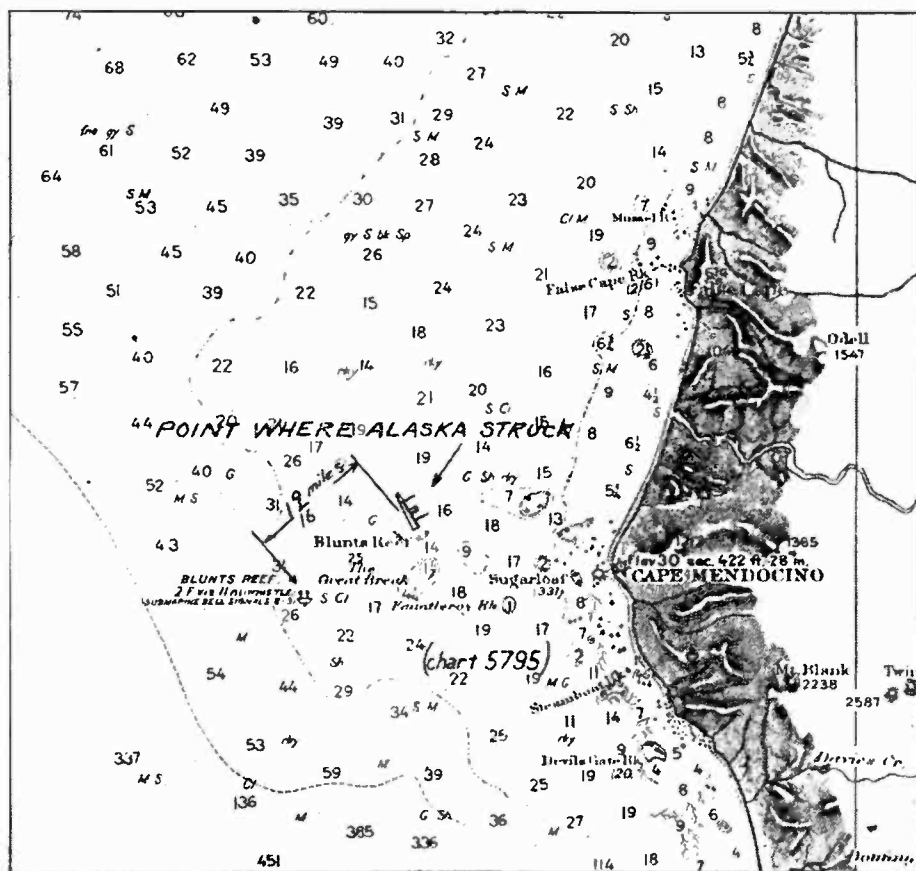

WHERE THE S. S. "ALASKA" SANK

Is shown on this map. Thirty-nine lives were lost. A submarine bell was operating 11 1/2 miles away and this disaster might have been avoided had the vessel been equipped with submarine signal receiving equipment

Before proceeding we can see in a general way the truth of this deduction. For if B may be either of two points and all the conditions of course and speed be satisfied, there cannot be collision. Obviously, there cannot be two possible lines leading to collision; it can only occur if both vessels are making for a common point, and, as two parallel lines cannot pass through the same point the two possible N.E. $\frac{3}{4}$ E. lines cannot conform to the conditions of collision.*"

FINDING THE OCEAN'S DEPTH

UNTIL recently there have been sections of the ocean which were never "sounded," but it is now possible not only to ascertain depth, but also to make topographical maps of the ocean bed—thanks to another application of submarine signaling.

The U. S. S. *Stewart* has recently completed a series of tests, employing the submarine oscillator and microphone receivers to determine depth. The oscillator is mounted near

*"Synchronous Signaling in Navigation," page 41, by J. Joly, T. Fisher Unwin, Ltd., London, 1916.

the stern of the vessel with its diaphragm pointing downward. A key closes a circuit which sets the diaphragm in vibration and thus causes sound to be sent out under water. The sound waves travel to the bottom and are reflected back, in echo fashion, and the time period is measured in seconds. Dividing the time period by two (for the sound travels both ways before it is received) and multiplying this result by the distance sound travels in water per second, indicates the depth. The speed of sound in this instance varies with the depth and tables are being prepared by the U. S. Navy to show this speed.

A system of this nature is liable to some error where the surface of the bottom is particularly irregular, due to refraction and reflection, but it is

infinitely more reliable than the time-honored practice of heaving a lead sinker having a hole in its bottom filled with soap to which some of the ocean bed clings. It is quite unlikely that the latter system is of much use except to the men who have sounded the bottom enough in the same place to know its appearance.

This new sounding system should prove valuable to cable companies because it enables them to determine with accuracy the location of the valleys in the ocean bed which may be followed with a great saving of cable.

By this system it is also possible to locate icebergs, derelicts, or other hazards in the path of a vessel.

LESSONS FROM THE "EGYPT" AND THE "ALASKA"

IT DOES not take long for the terror of a marine accident to pass away, and the outcome of investigation can never replace a single life lost at sea. For instance, no effort made now can avail any of those 102 lost when the British steamer *Egypt* collided with the French steamer

Seine and was sunk 15 miles off Armen Light, Island of Ushant, on May 27th.

Nor can the coroner's jury or others do more than fix the blame for the sinking of the American steamer *Alaska*, which ran ashore off Cape Mendocino, 11⁹/₁₆ miles from Blunt's Reef Lightship. This occurred during a heavy fog on August 6th, last year. Thirty-nine lives were lost.

The coroner's jury, after several weeks of testimony taking, recommended that more general use be made of radio compass bearings furnished by the U. S. Radio Service, and that owners of passenger vessels be required to equip their vessels with a listening device for the detection of submarine signals, and commented upon the fact that the bell on the Blunt's Reef Lightship was ringing when the *Alaska* sunk less than two miles away.

The Neptune Association, which is composed of Merchant Marine Officers, wrote the Board of Supervising Inspectors at Washington, following the sinking of the *Alaska*, and expressed the belief that, had the *Alaska* been equipped with apparatus for receiving submarine signals, the wreck would probably have been avoided. In addition to wishing to make navigation safer, the Neptune Association stated that they desired that masters be exempt

from responsibility of loss when all necessary equipment had not been provided for the proper operation of vessels.

BUT LIFE CAN BE SAFE AT SEA

REGARDLESS of the catastrophes which have occurred in the past, it is possible to reduce them greatly in the future, by employing the electrical aids to navigation now available.

For direction finding, and for navigation at long distances from shore, the radio compass is sufficiently accurate to guide us to a point in range of a submarine signal station.

Then, reaching the lightship by submarine signaling makes it possible to pick up a submarine cable and follow it, even in the thickest fog, directly into port.

Distances may be accurately determined by synchronous signaling, depth need no longer be a matter of guess-work, and the berg of the frozen seas can now be detected and avoided by application of the same device which tells the depth.

With these scientific advantages at our disposal, are we going to continue to have *Republics* and *Titanics* and *Egyptis*, pointing with scorn at our civilization?

SUBMARINE BELL INSTALLATION ON OUR COASTLINES

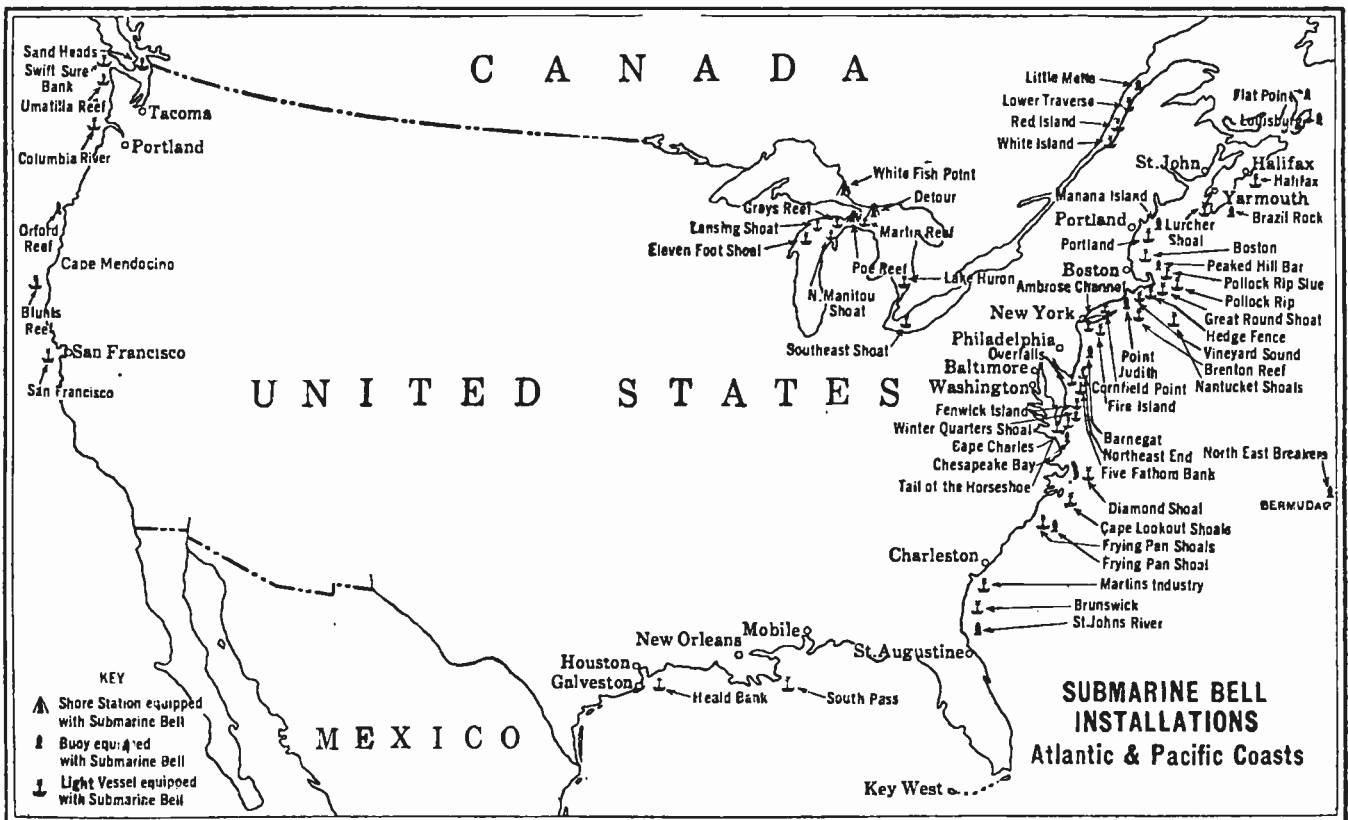

The Selective Double-Circuit Receiver

BY JOHN V. L. HOGAN

Consulting Engineer, New York; Fellow and Past President, Institute of Radio Engineers;
Member, American Institute of Electrical Engineers

WHEN we use a receiver embodying a type of detector such as that including the crystal variety, which is capable of absorbing a relatively large amount of electrical energy, it is necessary to arrange some way of controlling and restricting the voltage applied to the detector system if sharp tuning is to be secured.* As the proportion of voltage applied to the detector (in comparison with the total voltage developed in the tuning system) is reduced, less energy is drawn from the persistently oscillating circuits and the anti-resonating resistance effect of the detector assembly is made smaller. To secure maximum selectivity by radio-frequency tuning, we must provide condenser and coil circuits which can oscillate freely and in which resistance is minimized.

The receiving circuits illustrated in the earlier articles of this series contained only a single tuned or resonating circuit, i. e., that which included the aerial itself. By coupling the detector system somewhat loosely to this tuned antenna circuit it is possible to sharpen its resonant selection considerably, as has been explained. But the aerial and ground resistances, as well as the re-radiation resistance effect, remain in the circuit and put a limit to the improvement in tuning sharpness which can be secured by reducing the detector voltage; even under the best conditions of adjustment this single circuit tuner is hardly selective enough for working through severe interference.

It is entirely feasible to add to the receiver a second tuned circuit in which resistance or damping effects are further reduced, and which consequently adds materially to the sharpness of tuning in the system. Fig. 1 shows the simplest way in which this tuned secondary circuit may be arranged with a crystal detector. The usual antenna circuit

contains the primary tuning condenser and the primary coil; inductively coupled to this latter is the secondary tuning coil, and across its terminals is directly connected the new element, a secondary tuning condenser. Suitable choice of the sizes of secondary coil and secondary condenser (which should be variable) produces a closed resonating circuit in which the antenna and ground resistances appear only to the small degree reflected through the inductive transformer. Thus the sharpness of tuning in this secondary circuit, and its resonant selectivity, will be very high. The only serious limitation to the selection power of the simple two-circuit receiver of Fig. 1 is the effect of detector resistance; as may easily be seen, the entire secondary voltage is applied to the crystal branch and hence damping due to the detector will be a maximum. However, if the by-pass or telephone-shunting condenser is made of moderately small capacitance (say 0.005 microfarad) fairly sharp tuning will be had.

The selectivity of the double-circuit tuner may be greatly increased by reducing the proportion of the secondary voltage applied to the detector. A simple way to do this is

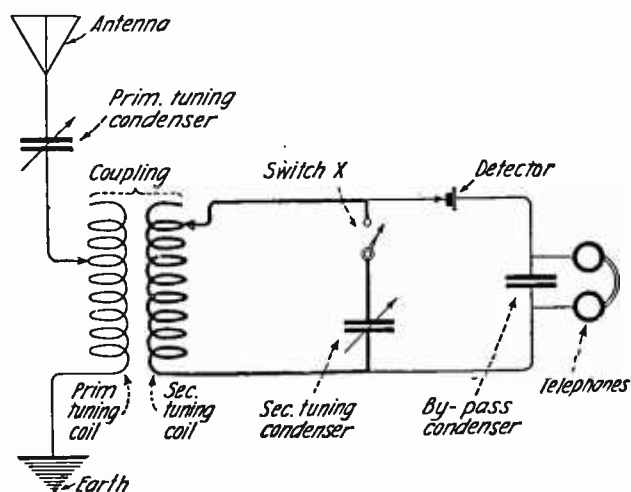

FIG. 1

The Double-circuit Tuner with Crystal Detector: the tuned secondary is shown in heavy lines

*See "Sharpness of Tuning in a Radio Receiver," by John V. L. Hogan, RADIO BROADCAST for August, 1922, pp. 348.

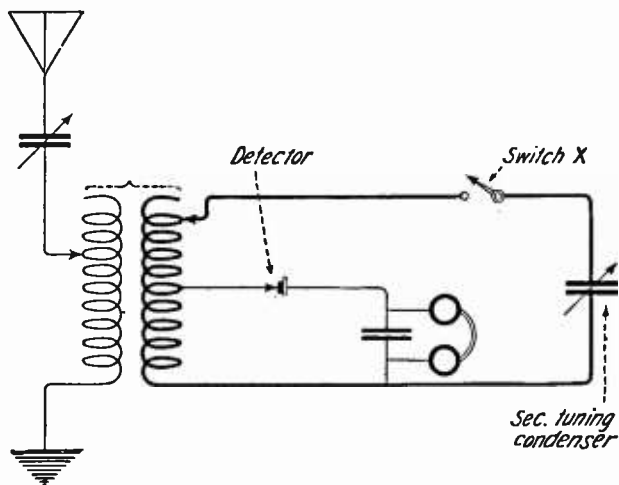

FIG. 2

In this form of double-circuit tuner the damping produced by the detector is reduced

shown in Fig. 2, which differs from Fig. 1 only in the connection of the detector and telephone circuit across a part (instead of the whole) of the secondary tuning coil. In this manner the effect of detector resistance upon the secondary tuning may be cut down substantially, with a corresponding gain in resonant discrimination between arriving waves of slightly different frequencies. Another method, which has the additional advantage of providing easy variation in the detector coupling, is to use a second oscillation transformer as shown in Fig. 3. The less the inductive coupling between the coils of this second transformer, the smaller will be the damping introduced into the tuned secondary circuit on account of detector resistance. In both these circuits (Figs. 2 and 3) the telephone shunting condenser may well be of rather large capacitance; instead of the value 0.005 microfarad suggested for Fig. 1, a condenser of 0.02 microfarad may be used with some improvement in signal strength.

The operation of any one of these three circuits, but perhaps particularly of that shown in Fig. 2, will be a pleasant surprise to anyone who has come to believe that receivers using crystal detectors are necessarily poor in tuning or selective qualities. For best results it is of course necessary to adjust carefully, and the apparatus itself must be well made in order that losses of received energy in conductor resistance, condenser leakage, poor connections, etc., will not overshadow the gains to be secured through the secondary tuned circuit with reduced detector coupling. A properly built crystal receiver of this type,

accurately adjusted, will give signals as loud as or louder than those from ordinary single-circuit crystal sets and, in addition, a degree of selectivity which can be surpassed only by the best vacuum tube outfits. Moreover, the absence of batteries and the freedom from tone distortion which are characteristic of crystal receivers may be taken together with the selectivity obtainable in the manner just described to recommend such arrangements for most reception over short or medium distances (up to about 25 or 30 miles from broadcasting stations or 100 miles from radiotelegraph plants) where good receiving aerials may be erected and when ordinary head-telephone listening is satisfactory.

When it is desired to receive over longer distances, one should take advantage of the greater sensitiveness inherent in the three-electrode vacuum-tube detector. As has been pointed out, this instrument draws very little power from the tuned receiving circuit to which it is connected, and, consequently, modern audion receivers are generally more highly selective than those using crystal detectors. The vacuum tube of course requires a battery for lighting its filament and for supplying telephone-circuit current; on the other hand it is at least several times as sensitive as the crystal (a critically adjusted "gassy" or soft detector tube may give responses some fifteen times as loud as would a crystal, to the same weak signal) and so may be used with smaller receiving aerials or for working over longer distances.

The vacuum tube detector will give fairly good resonant selection in a single circuit re-

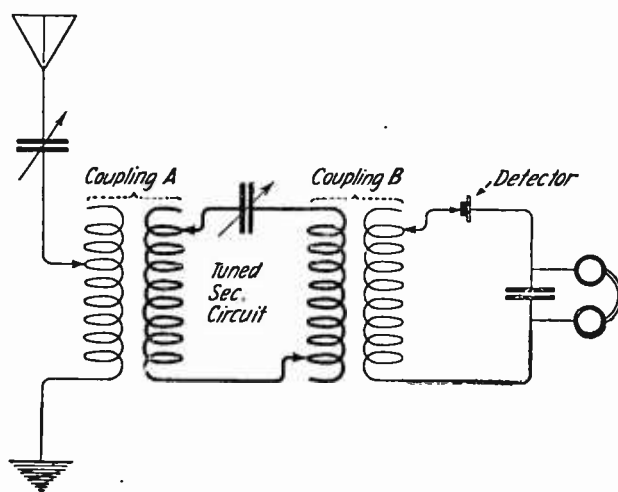

FIG. 3

The detector may be placed in a third circuit inductively coupled to the tuned secondary

ceiver even when coupled quite closely to the antenna, or, in other words, when the detector voltage is a large proportion of the total. A great improvement may be made, however, by using a double-circuit tuner similar to that of Fig. 1. Such an arrangement, adapted to the most sensitive detector tubes of the soft variety, is drawn in Fig. 4; here the full secondary potential is applied to the grid circuit of the detector, but since so little power is drawn by the audion not much selectivity is lost because of this connection. Where the secondary circuit is of unusually low resistance it is possible to gain something in sharpness of tuning by using the tapped coil plan of Fig. 2 with the tube detector, but this is not ordinarily of much value in short-wave reception.

The great gains in freedom from interference which may be secured through the use of the double-circuit tuner, as compared to the simple resonant aerial circuit type, must be paid for by increased care in adjustment. To tune an ordinary double-circuit receiver properly is an operation which may require several minutes, since (starting from a condition of complete de-tuning) the following steps are necessary for most satisfactory adjustment of the arrangements of Figs. 1, 2, and 4:

A: Be certain that the detector is in sensitive condition. When using a crystal this should be determined by means of a test buzzer; a "gassy" tube detector is adjusted by noting the beginning of the soft hissing in the telephones when filament current or plate potential is increased.

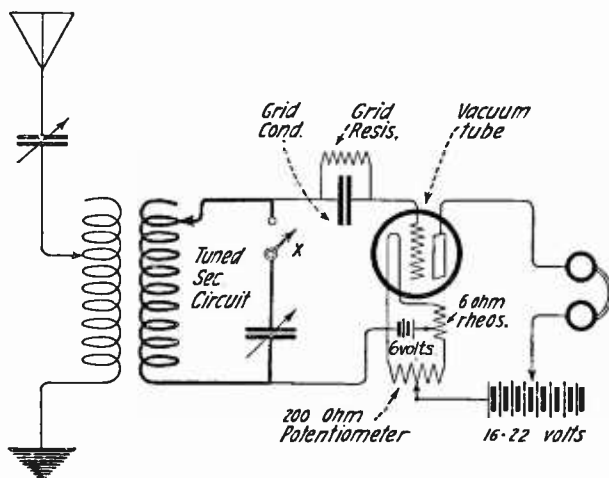

FIG. 4

The double-circuit tuner with accessories for using a "soft" vacuum tube detector.

B: Disconnect the secondary condenser (by opening switch X) and move the primary and secondary coils near together or to practically maximum coupling.

C: Adjust the primary tuning condenser and, if necessary, the primary tuning coil until the loudest signals are heard from the desired station.

D: Weaken the primary-secondary coupling somewhat, close switch X and adjust the secondary tuning condenser until the desired signals are again heard at a maximum strength.

E: Move the primary condenser setting slightly to increase signal intensity still further.

F: Having secured approximate adjustment as above, find by experiment the best coupling value for the signal-intensity and interference-freedom desired, remembering that for every change in coupling it may be necessary to retune slightly on both primary and secondary condensers in order to retain the greatest signal strength.

After once having learned the rough settings for any given wavelength, the tuning operation may of course be limited to the final step given above. It will be found that careful tuning will give results well worth the effort.

Since the tuned condition of either primary or secondary circuit represents agreement between the frequency of the arriving waves and the natural or free oscillation frequency of the circuit, longer wavelengths will always be received with greater values of tuning inductance and capacitance than will shorter waves. Nevertheless, the same wavelength will produce resonant maxima of response at many values of inductance, the corresponding condenser being reset to compensate for the change. Thus, when a desired signal has been picked up, it is a good plan to try reducing the inductance of the primary tuning coil, of course increasing the primary condenser by a corresponding amount each time. Some particular ratio of primary inductance to capacitance will ordinarily be found to give the strongest signals; the coupling and the secondary condenser should be slightly readjusted as each change is made in order to maintain complete resonance. In the same way, for a given wavelength it is desirable to try various ratios of secondary capacitance to secondary in-

ductance; with the vacuum tube detector, best results will ordinarily be had with relatively small condenser values in the secondary.

When a vacuum tube detector is used, it is feasible to utilize its radio-frequency amplifying power so as to neutralize a substantial portion of the receiving antenna resistance. This resistance-reducing property is one of the most valuable features of vacuum tube operation, and is obtained by means of the feed-back or regenerative action discovered by Armstrong. To use the tube detector for this purpose it is not necessary to rely upon the double tuned circuit receiver; regeneration applied directly to the aerial-to-ground circuit will give excellent results in selecting sharply between signals from moderately distant stations on slightly different wavelengths.

The feed-back circuit is based upon the discovery that the audion detector repeats into its plate circuit, in amplified form, the radio-frequency currents applied to its grid. In other words, the tube not only converts the arriving signal energy into an audible current form suitable for operation of the telephones, but at the same time transfers to the telephone circuit an enlarged copy of the radio signal impulses. If we place a condenser of moderate size across the telephone terminals so as to shunt these repeated radio-frequency currents across its winding (without disturbing the lower-frequency currents which are to act on the diaphragm), the amplified oscillations will pass freely through the entire plate circuit. By inserting a radio-frequency coil in this circuit, next to the plate connection, where the potential variations are greatest, we may set up a strong high-frequency magnetic field produced by the amplified oscillations. If, as indicated in Fig. 5, this coil is placed near to the antenna tuning coil it will act inductively upon the aerial circuit; by selecting the direction of current flow correctly, part of the plate-circuit oscillations may be caused to add their effects

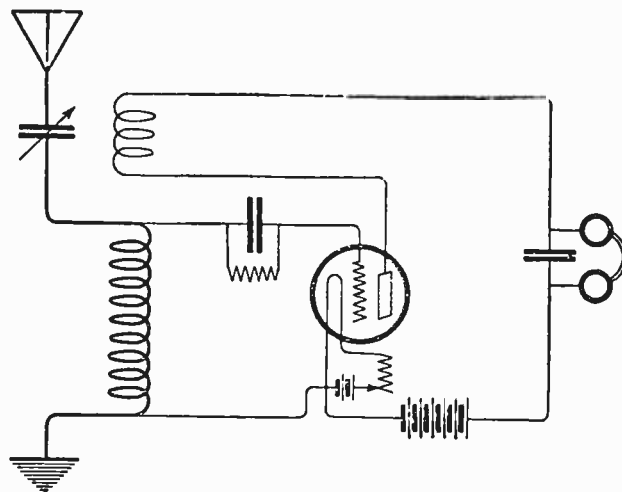
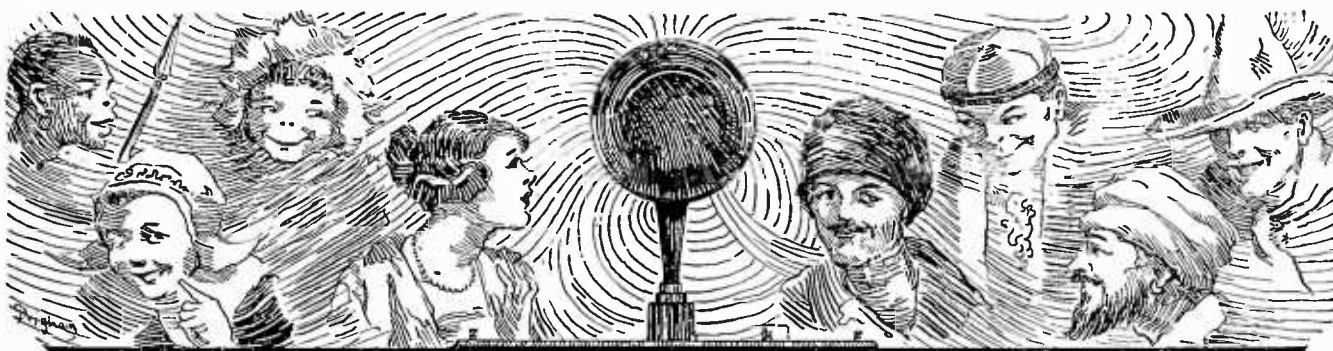

FIG. 5

A so-called single circuit receiver employing a tickler or feed-back coil for regeneration

to those of the oscillations already flowing in the antenna, so as to produce a great increase in the total current strength. This is equivalent to reducing the antenna resistance, in its final effect, for, with no increase in the voltage which the arriving electromagnetic waves impress upon the aerial, there is produced a much greater flow of current of radio frequency.

Perhaps the most interesting feature of this regenerative effect is that it amplifies to a maximum only the signals to whose frequency the circuit is tuned: thus the behavior of the system is as though the aerial-to-ground resistance were greatly reduced for a single comparatively narrow band of wave frequencies. Sharpness of selection is therefore a prominent characteristic of the properly adjusted feed-back receiver, just as of any other low-resistance resonant circuit. The arrangement of Fig. 5, however, is subject to some disturbance from powerful near-by transmitters operating at wavelengths sometimes widely different from that being received. The cure for these transient interference effects is to use a combination of Figs. 4 and 5.



Developments in High-Power Radio

And Its Practical Application in the Services of the United States Navy

By COMMANDER STANFORD C. HOOPER, U. S. N.

Head of the Radio Division in the Bureau of Engineering, Navy Department

PART II

THE passage by Congress of the Naval Appropriation Act of August 22, 1912, contributed greatly to the advancement of the radio art as regards the development of high-power radio, not only in the United States but throughout the world. It gave to the Naval radio service a great opportunity, but it also placed a heavy responsibility on those entrusted with the direction and administration of the service.

This Act appropriated \$1,500,000 for the establishment of six of the Navy's projected high-power stations, those to be located in the Isthmian Canal Zone, on the California Coast, in the Hawaiian Islands, in American Samoa, at Guam and in the Philippines. This constituted a programme of great magnitude in high-power radio construction and one which obviously was difficult of accomplishment at that period. The trail had not yet been blazed in this direction and little information of a practical nature was available. The Arlington station was under construction but had not yet been finished; so that definite information was not available as to what could be expected from a station of this type.

The plans for the six new stations therefore must necessarily be held in abeyance pending the completion and testing of the pioneer high-power Arlington station. Being a pioneer in substantial high-power radio construction, this station must be regarded in the light of an experiment. Because of insufficient scientific knowledge at that time, mistakes were made in the establishment of the Arlington station, principal among which were locating the station on high ground and placing the steel towers too close together, but nevertheless this station has rendered most valuable service to the Government ever since it was placed in commission, and moreover it served as a guide by which similar mistakes on a larger scale were avoided. It also made

available a high-power station for testing different types and makes of apparatus in actual service, thereby enabling the selection of the most efficient type of equipment available for service at that time. It was, in short, the agency by which delay was avoided in establishing the extensive radio system required to meet the needs of our Atlantic, Pacific, and Asiatic Fleets and other government agencies.

The Arlington station may justly be regarded as the pioneer development in high-power radio in the world, as well as the fountain head of the Navy's existing radio service, a service of which the stations on shore extend more than one quarter the distance around the world and whose signals are constantly encompassing the globe. The true significance of the Arlington station will not be fully appreciated until the history of radio is finally written.

THE POULSEN ARC TRANSMITTER

UNDOUBTEDLY the second feature of importance in connection with the development of radio in the United States, especially as regards high power, is the Poulsen-Federal arc converter. This type of transmitter, successfully developed by the ingenuity of American radio engineers from powers of 30 KW to 1,000 KW within a brief interval of ten years, and manufactured in the United States, is the outstanding unit of apparatus in the Naval radio service. Arc transmitters have given satisfaction in the services where they have been employed for powers from 2 KW to 1,000 KW. The Navy has used this type of apparatus in its high-power stations continuously since the first 30-KW arc transmitter was tested out in the Arlington station ten years ago. Arc transmitters produce harmonics as do other types of transmitters. They also produce a form of interference called "mush," the cause of which is not yet thoroughly understood. Two waves were also radiated, instead of one, in the system of signaling

originally employed. All three undesirable features are gradually being eliminated, however, and it is expected that the arc will then radiate as pure a wave as any of the other existing transmitters.

By originally adopting the arc transmitter for its high-power stations, the Navy has obtained satisfactory service from the beginning and it has not yet become necessary to replace the original installation in order to keep abreast of the progress in radio. It

thereby avoided the expense which the Marconi Wireless Telegraph Company of America (now the Radio Corporation of America) found it necessary to assume when that company was obliged to scrap practically new spark transmitters and install alternators in all its high-power stations in order to carry on transoceanic traffic satisfactorily. It also avoided long delay in establishing its transcontinental, transpacific chain of high-power stations such as has been experienced by the British in establish-

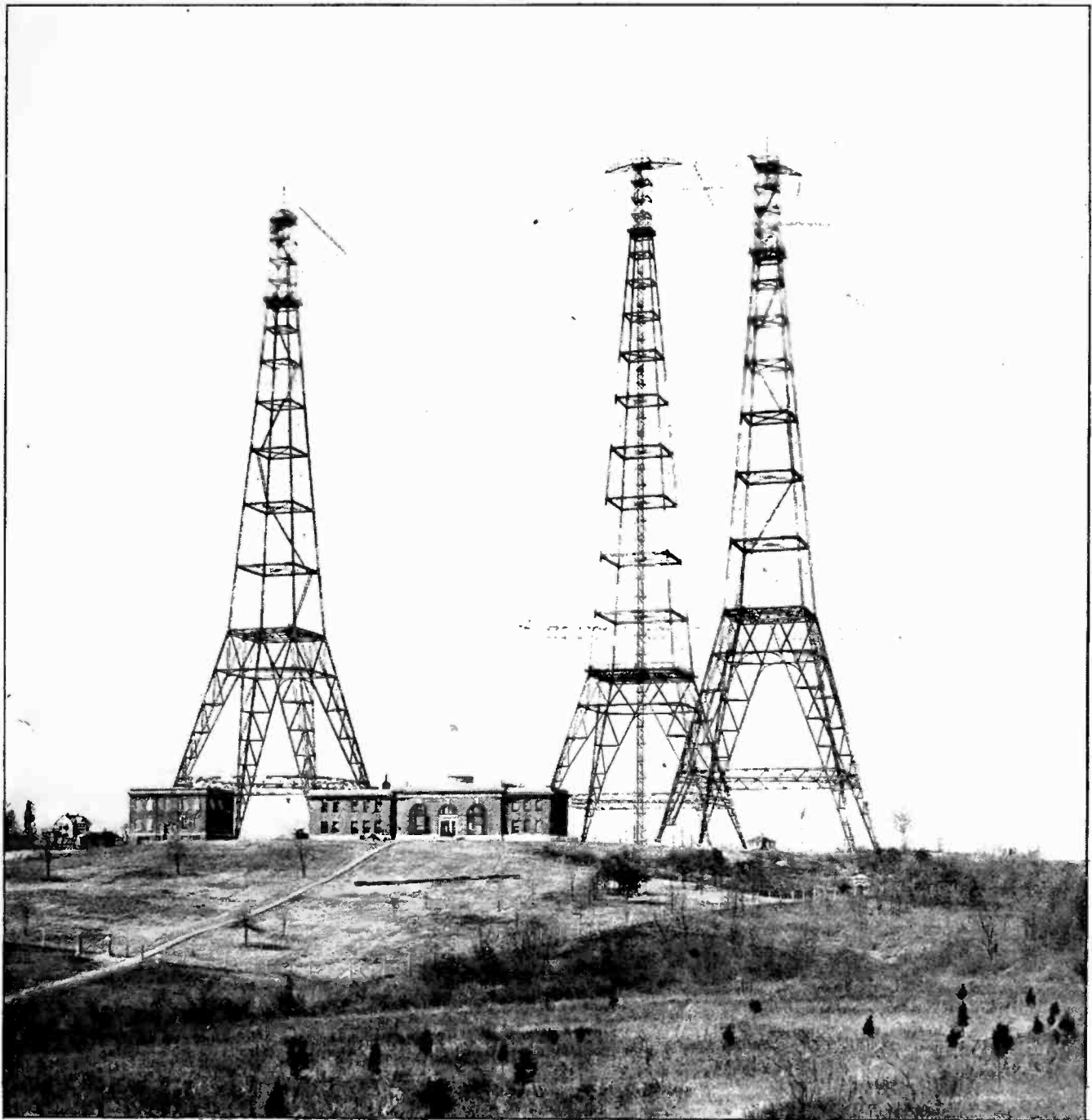

ARLINGTON

Probably the best known radio station in the world. All manner of new developments are tried out by the Navy at this station. Mariners listen for its time signals and weather reports the world over

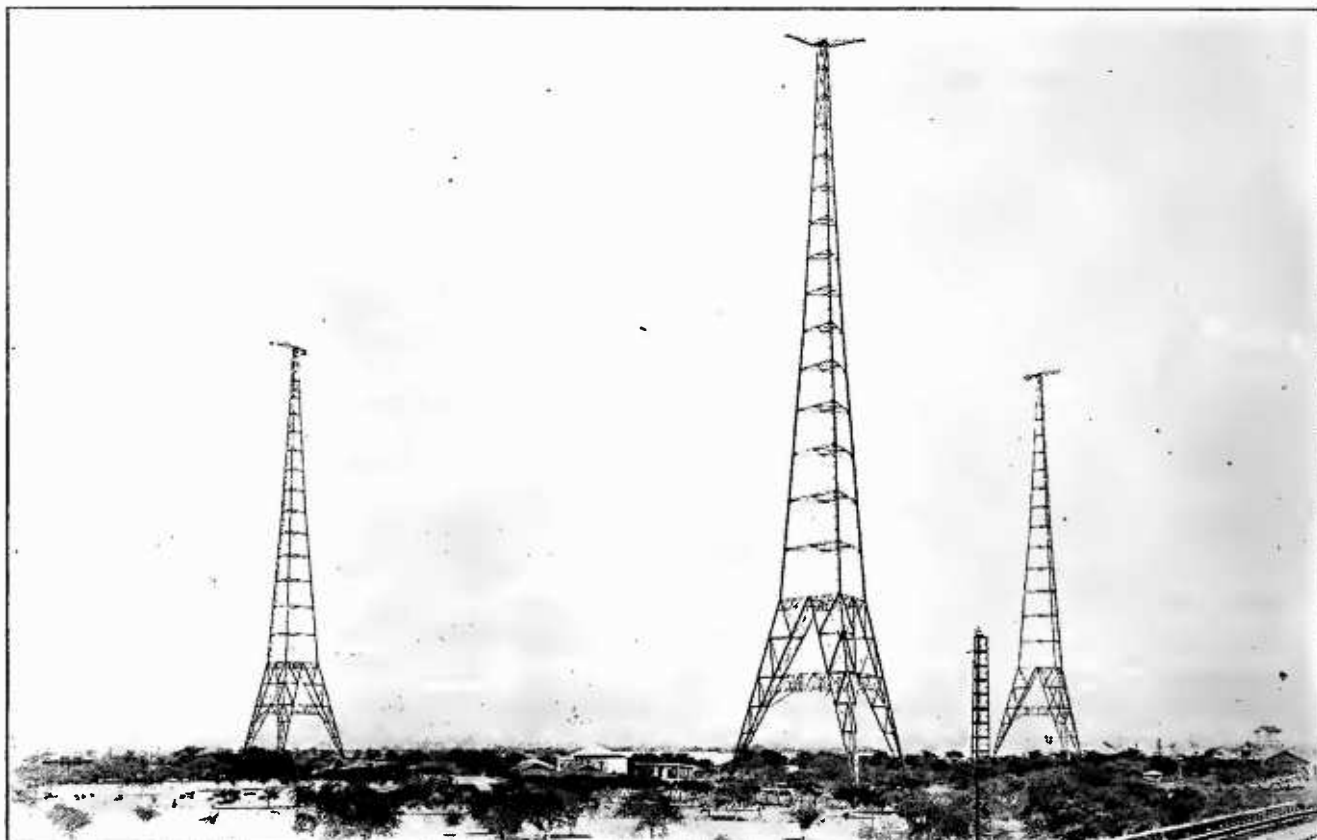

PEARL HARBOR, HAWAII

The U. S. Navy high-power station in mid-Pacific. It is not uncommon for experienced amateurs as far away as our eastern seaboard to copy messages from this giant

ing the Imperial Wireless Chain, this delay being reflected by the fact that one of the first of this chain of outlying stations, that at Cairo, Egypt, has only recently been completed, although the Navy's stations have all been in daily operation for several years. The Navy's stations were ready and rendered most important services after our entrance into the war.

It is worthy of note, in this connection, that a commission appointed by the British Government made a study of the arc type of transmitter with a view to its possible adoption for use in the stations of the Imperial Wireless Chain, about the same time the Navy was investigating it for use in its high-power stations. The British Commission's report, which was promulgated after the Navy had definitely decided to adopt the arc, was to the effect that this type of apparatus was unsatisfactory for the purpose intended and it was therefore not recommended for use. Notwithstanding this fact, the arc transmitter is now being installed in stations in the Imperial Wireless Chain.

Vested with the authority granted by Congress in 1912 and being satisfied with the

performance of the arc type of transmitter as a result of the Arlington tests and further extensive tests carried on subsequently with the 100-KW arc converter installed in the new Canal Zone station at Darien, the Navy, in 1914-15 went ahead with the project of establishing the five additional high-power stations. Sites for these stations were selected about five miles from San Diego, California, within the Naval Station at Pearl Harbor in the Hawaiian Islands, within the Naval Station at Tutuila, American Samoa, at a point about five miles from Agana on the Island of Guam, and within the Naval station at Cavite about twelve miles from Manila.

Three-legged, self-supporting steel towers, similar to those designed for the Arlington station, were erected at all of the stations with the exception of Tutuila where 300-foot wood, guyed, lattice masts were used, owing to insufficient funds for steel ones. Three 600-foot towers were erected at the San Diego, Pearl Harbor, and Cavite stations. Two 450-foot towers were erected at Guam. Two 300-foot wood masts were erected at Tutuila.

A 200-KW arc converter was installed at Challas Heights, 350-KW at Pearl Harbor, 500-KW at Cavite and 30-KW at Tutuila and Guam.

All five stations were completed and in commission within two years thereby linking our most distant possessions, the Philippines and other islands in the Pacific with Washington by radio. As a result of the establishment of this chain of high-power stations and with the stations at Cordova, Alaska and Cayey, Porto Rico, subsequently established, and the replacement of the Arlington station by the more powerful Annapolis plant, the Navy Department is enabled to keep in constant touch with our three fleets, with their auxiliaries and with their bases. The Government now has a system of communication radiating from Washington and covering our entire coasts and our outlying possessions, a system entirely independent of the land lines and the meagre cable facilities in the Pacific.

The Naval radio service is used by all the government departments and agencies. It serves the Army for communicating with its forces in the Philippines and our other possessions in the Pacific, with the Canal Zone and the West Indies. It serves the Weather Bureau, the Bureau of Lighthouses, the Bureau of

Fisheries, the Coast Guard and similar government agencies. It provides channels of communication with our outlying possessions which make them entirely free of foreign-owned or controlled cables and therefore it is a potential asset for the development and fostering of our trade.

The Naval radio service normally handles approximately 20,000 words per day across the Pacific, this volume of traffic being greatly increased during cable breaks. About 5,000 words are normally handled between Puget Sound, Washington, and Cordova, Alaska, and when breaks occur in the Army's cable between Seattle, Washington, and Valdez, Alaska, the number of words averages between 30,000 and 35,000 per day. About 8,000 words are exchanged daily through the Darien station in the Canal Zone and about 5,000 words through the Cayey station in the West Indies.

Messages are constantly passing between the various coastal stations on shore and naval and merchant vessels at sea. Government messages are sent daily from the Annapolis high-power station to corresponding stations in Europe and are received at the special receiving station at Bar Harbor, Maine, and relayed over leased land wires to Washington.

All of the Navy's high-power stations are

CAYEY, PORTO RICO

The Insular outpost of the Navy's high-power system

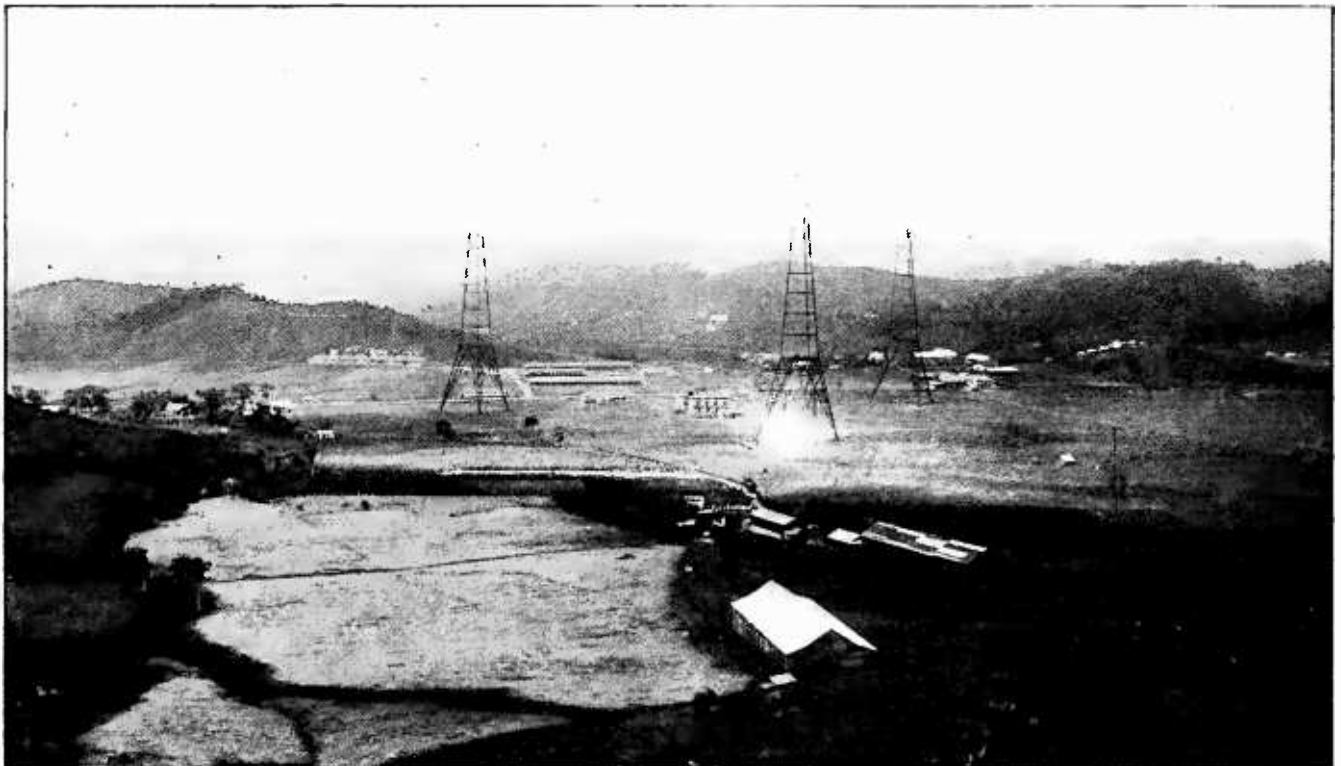

operated duplex to enable messages to be received at the same time other messages are being sent from the same station or unit. This is accomplished by establishing a control and receiving station at a distance of about ten or twelve miles from the transmitting stations and connecting the two stations by land wire telegraph. Radio men are posted at the transmitting stations to start and stop the machinery and to regulate the apparatus, the functioning of which for transmitting messages, however, is controlled by the operator at the central and receiving station. In practically all the Navy's high-power stations there are installed a medium-power and a low-power transmitter in addition to the high-power set. Operators at the central and receiving station may be sending out messages with the three transmitters simultaneously and other operators may receive from distant stations at the same time.

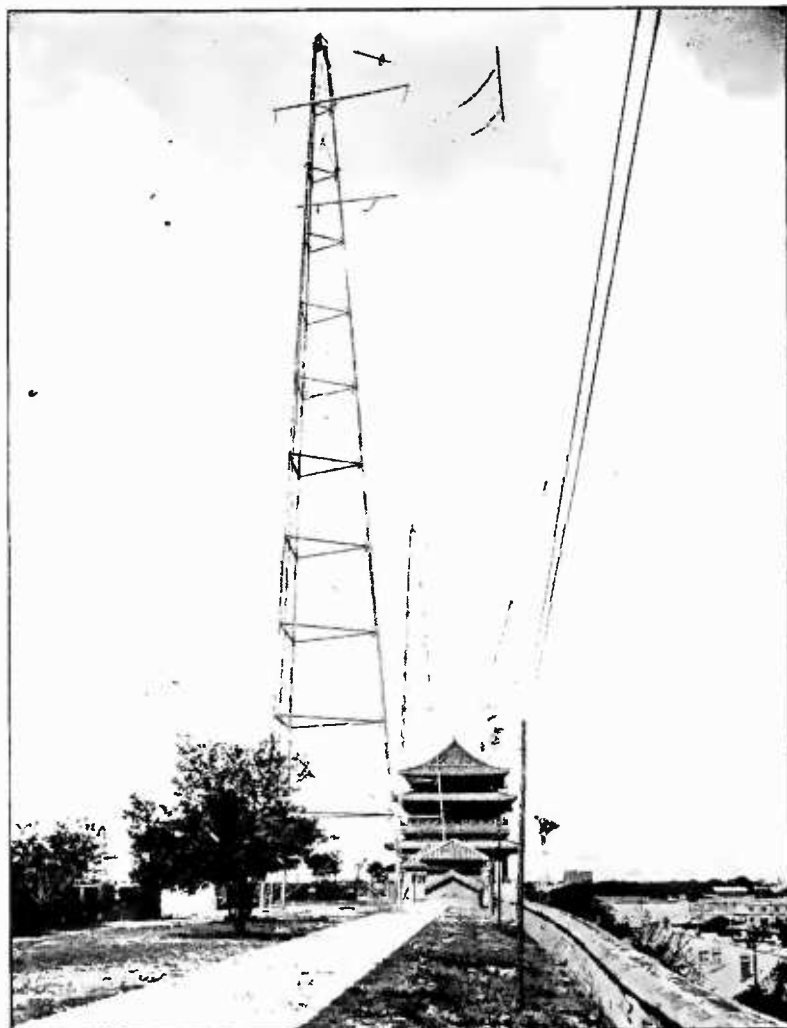

THE U. S. NAVY STATION AT PEKING, CHINA

Operated by the U. S. Marines located at the American Legation Compound which is within the famous 40-foot Tartar Wall. Two of the towers are atop the wall

The naval stations in the Pacific and in Alaska would be almost completely isolated from the United States were it not for the Army's cable and the Navy's radio service. The Army's cable has deteriorated considerably with age and consequently is frequently broken. At such times the radio service takes over all cable traffic in addition to its normal traffic and passes it on to stations situated along our Pacific Coast. In the Pacific, reliance is also placed on a single cable and when this fails, the only remaining medium of communication is radio. There is no connection with American Samoa except by radio but entirely satisfactory service is maintained between Tutuila and Pearl Harbor over the Navy's radio circuit, about 2,000 words being exchanged daily.

The Navy's transpacific high-power radio circuit may be said to extend into China and temporarily at least, into Siberia. A station of 30-KW power has been established within the Peking Legation Compound, surrounded by the 40-foot-high Tartar Wall, which encloses the American Legation, to prevent the American Minister from becoming isolated from the outside world when internal disorders are in progress in China. The ordinary communication facilities in China are unreliable under normal conditions and the service is frequently interrupted altogether when disorders are in progress. The Navy's radio station at Peking has afforded the only medium of communication on more than one occasion, not only for the American Minister, but also for the other foreign diplomats in Peking. The Peking station is operated by members of the Marine detachment guarding the American Legation. This station exchanges communications with the high-power station at Cavite, with the flagship of the Asiatic Fleet, with vessels of the Yang Tse Patrol and with the station at Vladivostok.

The Navy took over from the Russian Government the then incomplete radio station at Vladivostok as a result of the dispatch of American troops to Siberia during the war. This station has since been

operated by Naval radio operators under the direction of the Commander-in-Chief of the Asiatic Fleet, and communicates with Cavite, Peking, and Naval and merchant vessels in Asiatic waters. The existing naval radio circuit extends eastward from Vladivostok and Peking through the Philippines, Guam, the Hawaiian Islands, American Samoa, to San Francisco, thence northward along the Pacific Coast to Puget Sound, Washington, and to Alaska; from San Francisco, southward to the Isthmian Canal Zone; from San Francisco through San Diego and across the continent to Washington; from Washington along the Atlantic Coast, the Gulf of Mexico and along the Great Lakes; from Washington southward to the Isthmian Canal Zone and the West Indies; and again from Washington across the Atlantic where contact is made with stations in European countries

including the 1,000-KW station established by the Navy at Croix d' Hens, near Bordeaux, France to insure contact with our Expeditionary Forces in the event of the cutting of the transatlantic cables by submarines during the war.

The fact that the aggregate cost of the six successful naval high-power stations was within \$1,500,000 is worthy of considerable reflection on the part of commercial companies engaged in building radio stations during the period 1914 to 1917.

The development of the Navy's high-power radio system cannot fairly be reviewed without paying tribute to Rear-Admiral R. S. Griffin, U. S. Navy, now retired, who, as engineer-in-chief of the Navy, was responsible for the building up of the naval radio service during his term as chief of the Bureau of Engineering from 1913 to 1921.

One Vessel that Radio Might Have Saved

By ORTHERUS GORDON

HOW long will it be before small ship owners will realize that a wireless outfit placed on their sloops and schooners may pay for itself hundreds of times over, on the first voyage? Day after day they are confronted with evidence that ought to convince them of its value, yet they continue to send their barges, their tugs, and their sailing craft down coast without proper means of calling for help should they suddenly need it.

A striking example of what radio might have done toward the saving of property for at least one merchant came to my attention with the sinking of the three-masted schooner *Tarok*, a year and a half ago. At that time, I was on board a large oil tanker going south in ballast. We had experienced rough weather from Cape Hatteras down and learned from passing ships that conditions farther south had been rough and unsettled for some days. The second morning below Hatteras we sighted a small black object one point off the port bow and

soon made it out to be a small boat. As we approached it, we saw that there were five people aboard, and that one of them was waving a red tablecloth from the end of a spar. Coming alongside, we hauled them aboard—they were too weak to climb—hoisted their boat clear of the water, and made it fast alongside our port lifeboat. Then, while we continued our journey, we heard the story of the *Tarok*.

Her captain was as bitter as he was weary. He had recommended a thorough overhauling and a spell in dry-dock for his vessel. He had also wanted radio, if nothing more than a small spark transmitter to be run from a storage battery; and a crystal receiving set with which to set his chronometers occasionally, from the Arlington or Key West time signals. He had tried for these, but without success. The owners said the ship didn't need the first thing, and that he didn't need the second. They had told him it was absurd to equip with wireless a vessel that didn't go more than one hundred

miles outside of land and that didn't leave a beaten steamship track for more than twelve hours. The captain answered that there were days and days, even in the most crowded waters, in which he hadn't seen a ship of any kind, yet he knew there were scores of them within radio call—just beyond the horizon. Wouldn't it be wise to be able to summon help if help was needed? They laughed at the captain. He was getting old, they said, and was losing his skill.

The truth of the matter was that he had only wished to reinforce his skill; and that very trip was to show the owners how easily a vessel might fill with water and sink, within the very sight of land, for all that the "skill" of an old seaman could do to prevent it.

The *Tarok* with her crew of captain, mate, steward, and two sailors, left Atlanta, Georgia, on February twenty-sixth, 1921, and turned her nose toward Porto Rico. She had as a cargo, fifty-two thousand feet of finished lumber—all ready to transform into native houses upon arrival at its island destination. Her holds were full and her deck was full—for her owners were the kind that under-manned and under-supplied their vessels, but overloaded them—and she struggled along under full canvas with as little life as if she were towing lead.

Six hours out and barely in the Gulf Stream, when they were descended upon by a furious storm. They bared their masts and pounded into it, each hour carrying them farther from their course and bringing them north with the sweep of the Stream. All night they were in the thick of it, and next morning discovered that they had sprung a leak. It was not a fast leak, but a slow, insistent one somewhere in the depths of the lumber-piled hold. They could not locate it, try as they would, and the water was steadily rising in the bilges. Inch by inch, it crept up the side of the hold, and inch by inch, the *Tarok* settled down. She labored heavily now and wouldn't answer her helm. As much canvas as possible was carried, but to no avail; the good old ship was caught and would have to stay that way until someone came along and rescued her.

Think of it! In this day and age, a vessel with a ten thousand dollar cargo forced to depend on chance for the saving of her cargo and the lives of her crew!

When the crew were flooded out of their quarters forward, and the captain and mate out of their quarters aft, the entire outfit gathered on the roof of the after deck-house to talk the situation over. As long as the weather

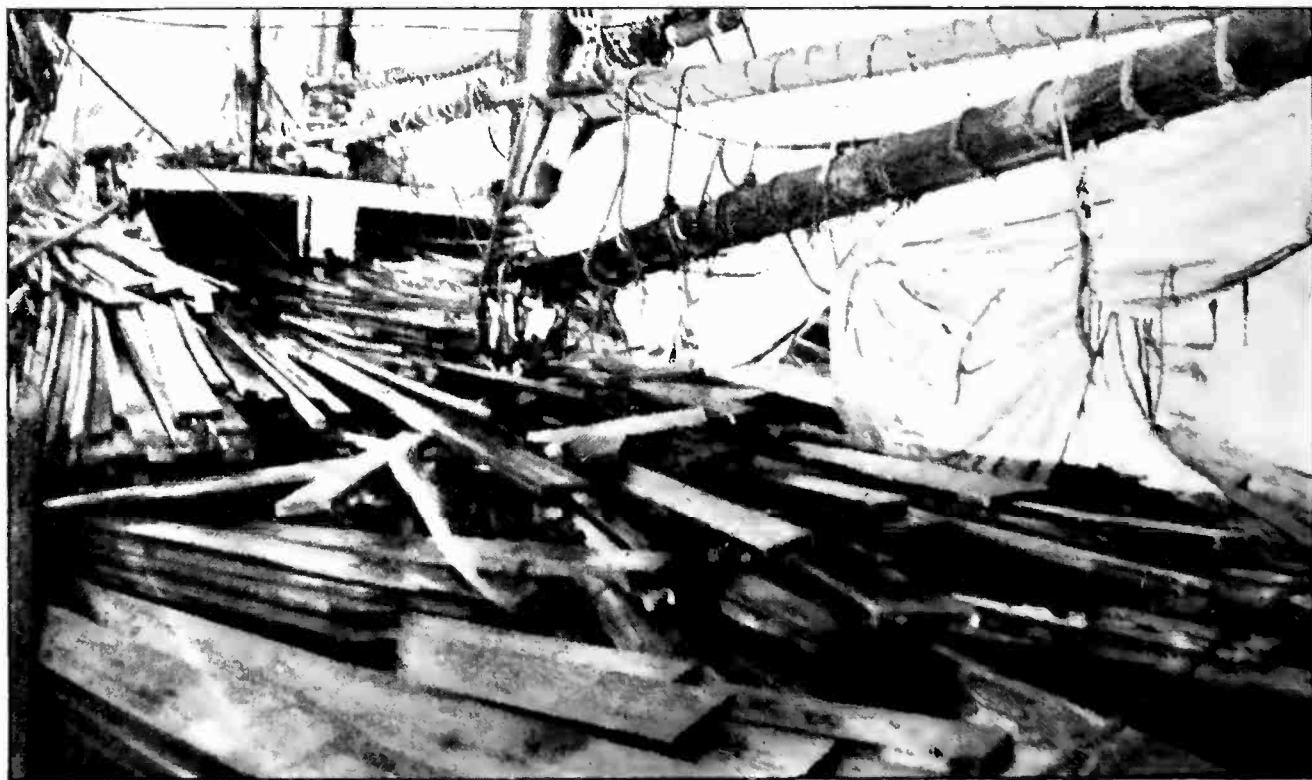

HER HOLDS WERE FULL AND HER DECK WAS FULL

For her owners were the kind that undermanned and undersupplied their vessels but overloaded them

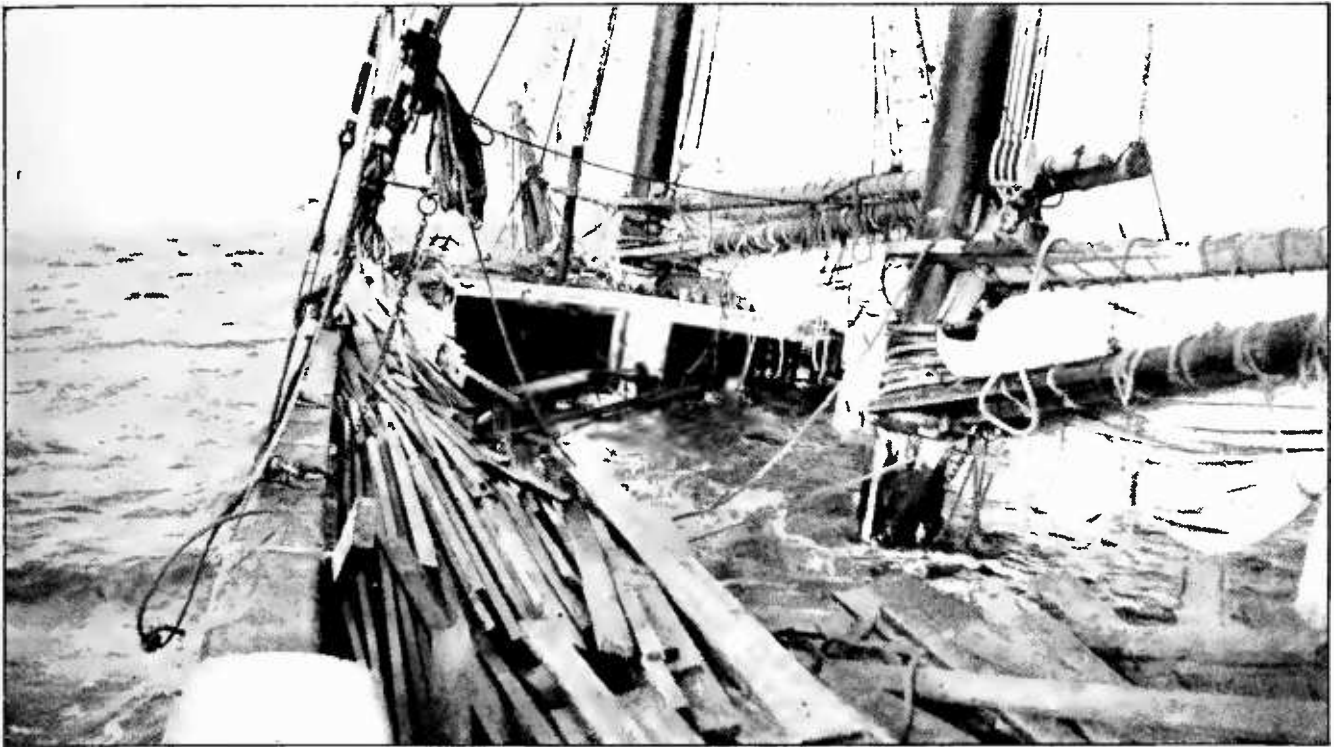

IT WAS NOT A FAST LEAK
But a slow, insistent one, somewhere in the depths of the lumber-piled hold

held, they were all right. But the least blow, and over she'd flop, and that would be the last of her. Before that happened, perhaps help would come—some passing ship, some north-bound tanker or freighter. But the *Tarok* was in the Gulf Stream being carried rapidly away from any ship that might be behind her, yet without sufficient speed to catch up with any ship that might be ahead. So for twenty-four hours they watched—and saw nothing. They were low, and the visibility was poor; their horizon could not have been more than four miles away. Now, on the chart of the Atlantic Ocean, a circle eight miles in diameter is no larger than a pin prick, and the chances of a vessel entering the area in which the *Tarok* was sinking were few indeed.

Here is where radio would have brought them vital help. If they had a set that could send only ten miles, it might reach out beyond the horizon and bring some ship with a tow-line and a lift into the nearest port. But the captain didn't even have that—so he did what he could, and then sat disconsolately on the roof of the deck-house with the remainder of his crew.

On the morning of the twenty-ninth, the situation hadn't improved a bit—they were still scanning the horizon for a ship. At ten

o'clock they saw one—a tramp freighter, crossing the Stream and heading in for a coast port. She was about four miles away, and the men on the raft that had once been a ship could see her plainly. But would she see them? They did what shipwrecked sailors always do. They shouted, they waved things, they danced. The mate climbed the rigging with a white cloth. All to no avail. The ship went unseeing on its way, and hope left the hearts of the captain of the *Tarok* and his crew.

That night, there was a recurrent storm—and the *Tarok* turned turtle. The men managed to pile into the lifeboat and cast loose in time to avoid going over with it; but in the lifeboat their condition was none too enviable. The seas rose to tremendous heights; it rained, and the wind blew harder.

How they lived through the night, and until we found them two hundred and ten miles away from the spot where the *Tarok* had first run into the storm, is a mystery to them all.

The *Tarok*, of course, was a total loss. She was reported as a derelict by our ship and in the course of events was probably located by one of the Coast Guard cutters and blown to bits by powerful charges of well-placed dynamite.



THINK OF IT!

In this day and age, a vessel with a ten thousand dollar cargo forced to depend on chance for the saving of her cargo and the lives of her crew

“Here ends the first scripture lesson.” I know I am not alone in hoping that it will prove to be a lesson and that it will lead to a radical

change in the attitude of small-ship owners who still belong, serene in their antiquity, back in the Middle Ages.



THAT NIGHT SHE TURNED TURTLE

And it was only by good luck and good seamanship that the men managed to pile into the lifeboat and cast loose in time to avoid going over with her

Choosing a Radio School

By HOWARD S. PYLE

YESTERDAY, imaginative and adventuresome young people were known to run away to sea, eager to try the sailor's rough and varied life in all corners of the globe.

Times may have changed, but human nature hasn't: to-day also, there are those who long to sail the seven seas; hundreds of would-be sailors, likewise imaginative, likewise adventuresome. But how different, in many cases, is their picture of sea life from that which fired the enthusiasm of their predecessors! The job of cabin-boy gives way to the position of radio operator; the work is concerned less with coils of tarred rope than with coils of fine wire; less with activity in which physical strength is demanded, than in which technical knowledge is of supreme importance.

Particularly among young men of high school and college age will be found the desire to try this modern game, to taste the life of the searover, even if only for a trip or two, or long enough to see some of the far places of the world, before passing up the carefree life of marine operator for a more prosaic application of the scientific side of radio in some factory or laboratory.

And in radio, as in all worth while fields of endeavor, we may learn much from others. For this reason we have schools, colleges, trade schools, and the modern correspondence methods of supplying information. Electricity, chemistry, medicine, all the most important sciences have been brought within the understanding of the American public through institutions of learning, which have provided the keys with which to open the doors of the minds best informed in these classes of learning. The result has been scientific specialists of world renown. Should we not then expect as great things from our radio schools, teaching exclusively, as they do, this new science?

THE FIRST WARNING

BUT—there seems to be a certain amount of bad in all good things. As soon as the question of money is involved, we find persons who live by preying on those who are too easily

persuaded. Hence we have numerous small schools of the fly-by-night variety, who advertise "in a loud voice" for a short while, take our money, promise much—and give precious little in return. This, unfortunately, hurts our many conscientious and excellently conducted schools of good standing.

Now, radio, as applied commercially, is a very new art, and like all infant enterprises, is sometimes beset with unscrupulous methods. In choosing a radio school, therefore, we must be on our guard. Let us consider, to begin with, the matter of advertising. It is the attractive presentation of the opportunities in radio that first catches the eye of the layman, through the advertisements in popular trade magazines.

Let us suppose that you are one of those who have a keen desire for knowledge of radio, but know nothing more about it than what you may have gleaned from the daily paper. Or perhaps you have been interested enough occasionally to purchase a copy of a radio periodical. You glance through its pages, and while much of the matter therein is in terms unintelligible to you, merely to read some of the less technical items, describing the marvels accomplished by radio, fills you with a desire to know more clearly and more thoroughly how all these things are brought about. More particularly, if you are a student, or perhaps a dissatisfied office worker, and of a mechanical turn of mind, it will not be long before your fingers will itch to grasp the subject and have a hand in the molding of its future applications. At about this time, you turn a page and come face to face with a large ad, fairly radiating opportunity (and consequent life of ease and plenty to be yours in a few short months), if you will only "sign and mail the coupon to-day". Please note that such advertising is seldom found at the front of the magazine, but generally toward the end, where the reader will find it after being warmed to his subject by a perusal of the text. This is good business. I do not disparage the advertising efforts; advertising is the real foundation of any business. What I want to drive forcibly into your mind is a caution not to allow the glamor of the ad-

vertising, with its carefully cloaked phrases, to cause you to make too hasty a decision as to choosing a school. How then to proceed?

READ THE ADVERTISEMENTS CAREFULLY

LET us first read carefully all the statements contained in the advertisements of the various radio schools. Consider them particularly with regard to what reference they make to wage scales for radio operators. The writer has taken note of the fact that at the present time, while the salaries paid marine operators have taken a drop, some schools still advertise—"a position which pays you \$125 monthly and expenses, to start." Beware of this. The condition does not now exist. \$125 and expenses was the wage scale until recently, for *chief operators*. \$110 was paid to juniors. Seldom does a radio school graduate receive, as his first assignment, the berth of chief operator. Even so, it would pay, at this writing, only \$90 or \$105 at most, depending upon the class of ship. This is but one point which you must watch for yourself. The trade journals do not knowingly accept misleading ads. containing false statements, but sometimes they do slip through.

THE TRUE EMPLOYMENT SITUATION

NOW let us consider another point brought out prominently in radio school ads.—that of employment. Practically all radio schools conduct an employment service, and the majority do conscientiously endeavor to place you after you have completed their course. The radio game, however, as far as the operating field is concerned, depends greatly upon shipping, which is dependent upon foreign commerce. Consequently, shipping is more or less spasmodic, based on the law of production and demand. It naturally follows that if shipping is irregular, the demand for radio operators is, also. This is not mere in-

ference, it is fact. At this moment, the writer is 500 miles south of New York, northbound from Haiti, on a sugar-laden vessel. Three weeks ago, at the time of signing on for this voyage, operators were scarce around Norfolk, from which port we sailed. One month ago, in Seattle, there were three operators for every vacancy on west coast vessels. A few years ago, from the same Puget Sound port, an operator could pick his vessel; he was almost

begged to take a trip. Supply and demand again, you see, with the unsettled condition of shipping naturally occurring.

Another point to be considered while on the employment subject: There are, at present, a large number of the "old timers" in the game who are idle; men who have thousands

of miles and many ships to their credit. The radio operating companies are making every effort to place these men—giving them preference, naturally, over newcomers. Then where will the green school-graduate stand? Let me tell you what each of six different employers of marine operators recently told me. I questioned them as to the prospect of employment for graduates of radio schools. The replies were alike, in effect: "we accept their applications, smile at the proudly displayed diploma done in gold and seals, and give the jobs to the old-timers. If we need a man in a hurry, or for an unimportant job, these lists of school graduates prove useful at times." There you are.

NOW, in talking to some who have aspired to be radio operators, I have been told, "But I do not intend to go to sea, I expect to go to work in a shore station." But a shore station wireless telegrapher must of necessity be an *operator*, and a radio school graduate is *not* an operator—*yet*. True, he has a Department of Commerce license, but radio operating in a shore station, or on the high seas, is a far cry from your theory classes or code work. Take



A BEAUTIFUL HOTEL FOR RADIO MEN

Turning a page you meet an "ad" fairly radiating opportunity and consequent life of ease and plenty for you if you will but "sign and mail the coupon to-day"

the man who wants the shore job. Can he sit down before a tuner and vacuum tube detector with multi-stage amplifier, skillfully eliminate all interference, pick out a particular spark note or style of sending through bad interference, and put the signals down in good readable copy on a typewriter as they come in? I've never yet seen the green man do it! Or, take a high-power circuit ashore; can he sit down to a typewriter, listen to a perfect, clear-cut "bug" sending at 30 or 35 words a minute, translate the characters into combinations of the Philips code, further translating them into readable English, and turning out perfect, deliverable copy from his typewriter, without a falter? So much for your shore positions.

There is one other phase of the game, other than operating. A radio school course, and a first class license will probably enable you to secure a position as clerk in a radio store, or radio department, or to become associated with a radio manufacturing company in a small position. All of this will give you valuable experience, but a position as manager of a radio store, or radio inspector, specialist or other high sounding title, will distinctly *not* follow immediately upon the heels of your graduation. There is always a place for you, as is true in any line, *after* you have proved your worth—but in no line will you be led into a general manager's office and given the chair of authority with no more than a school diploma for experience. You must earn your job. So much for the employment question.

Let us suppose you have given the foregoing careful thought, and are still determined to enter the radio field and blaze your own trail. In that case, take a course in a good radio school by all means. It can be either a resident or correspondence school—more on this later—but be sure it is good. And don't stop there;

study, study, study, and subscribe to the leading radio periodicals, make apparatus for yourself, put yourself into it heart and soul!

YOUR SCHOOL MUST GIVE PRACTICAL TRAINING

I WARN you to pick a *good* radio school. You say, "how shall I know it is good?" Here's how: no subject can be taught well from books alone. It must be supported and clarified with actual practice. For instance,

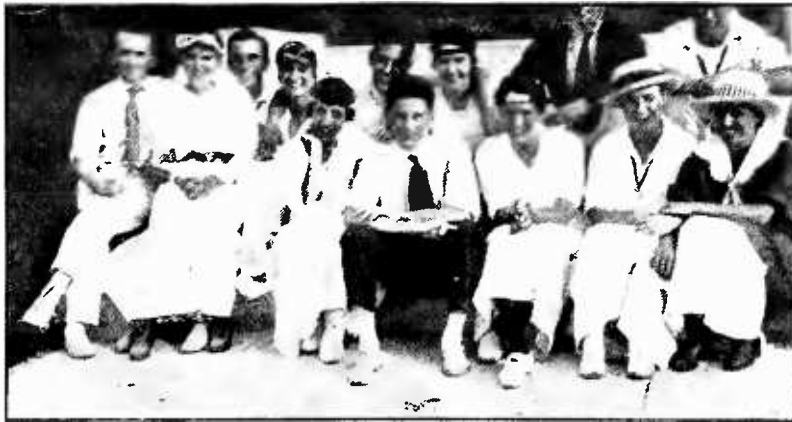

LIFE AT SOME OF THE HIGH-POWER STATIONS TRULY HAS ITS SOCIAL ADVANTAGES

And sight of them is never lost by the advertising men of the radio correspondence schools. Mention is not generally made of the fact that a job at such a station means copying trans-ocean signals at high speed on a typewriter eight hours a day, seven days a week

take languages. The writer has been in many foreign ports, and has been much amused at the conversational efforts of some of the members of ship's crews. Men who were excellent, At Spanish students in college had a terrible time in Chile, a Spanish-speaking country! They knew Spanish, pure Spanish, but not the ver-

sion that the Chileans use. The same applies to radio. You may have a perfect theoretical understanding of the "hows and whys," but would be in an awkward position were you confronted with the necessity of repairing a burned out generator at sea.

The value of experience shows itself particularly in cases where the apparatus breaks down in an emergency. The operator who can send out messages in the face of apparently insurmountable difficulties is worth his weight in gold. The following incident is taken from an operator's log:

"I was sent home on another vessel, signing on as a wiper. The vessel ran out of fuel. No response being received to our S O S, I was called up from the engine room to see if I could assist the operator in establishing communication.

Investigation showed that all units of the transmitting condensers were broken down. This was overcome by using in their place the series condensers in the short-wave circuit. An improvised radiation ammeter had to be

constructed, and the antenna circuit direct coupled and retuned. Communication was then established with a vessel which relayed our message to Havana, but soon the motor generator burned out beyond repair.

To rig a transmitter again we had to change the power transformer from closed-core to open-core type, and to construct an electrolytic interrupter. Having no gasoline for a blow-torch, we had great difficulty in shaping in the galley fire, heavy gauge glasses for the interrupter, while the ship was rolling heavily, but we managed to get it working well enough to reestablish communication.

Before assistance reached us we were out of glass tubes for the interrupter and had to close down until we rigged up one of the ship's large alarm buzzers for a transmitter. This worked well up to a distance of seventeen miles, daylight, and communication was handled by relay.

Two days later we were picked up and towed into port."

Choose a school that is fully equipped with modern apparatus covering all that you are likely to encounter at sea. This should comprise a complete arc transmitter, quenched spark panel transmitter, tube transmitter, storage batteries, generators, and a goodly number of receiving sets, both of the crystal and vacuum tube varieties. Above all, the school should offer unlimited opportunity to the student to dig down into the heart of the apparatus and see what makes it work and why. A complete station should be in constant operation, with advanced students as operators.

CORRESPONDENCE COURSES

NO CORRESPONDENCE course in radio is of the highest practical value *in itself*. You can learn theory from it, but if, after completing the course in a way satisfactory to

the school, you were to be confronted with various parts of a standard installation, it is doubtful if you could distinguish between them. If, however, you have access to a radio factory, or can visit a radio station ashore or aboard ship frequently, enlisting the services of the operator to explain the apparatus to you, in connection with your correspondence course, you should gain a good foundation upon which to build a practical radio education.

I do not wish to discourage aspirants to the radio operating field, but merely wish to point out that all is not music that makes a loud noise. We don't want to see the radio field filled up in a year or so with a group of disillusioned young people, who blithesomely followed their courses, with fond hopes of taking the radio world by storm, only to find that there were many others ahead of them.

The writer has recently completed a three months' investigation of radio oppor-

tunities, and knows that they exist for the trained man. He has also visited many radio schools, taught in a number, and been closely allied with such institutions for some years past. Therefore, he knows whereof he speaks. The facts are here.

If you have the determination and the stuff in you to follow it up, the radio field will welcome you. If you are fired with the idea of being a radio operator in four months, traveling the world over at \$125 a month and expenses, to start with, sheer off. It's a man's game, and as such takes a solid foundation. Don't be fooled by glaring promises of high-salaried, big-titled jobs at the end of a few months' training. In radio, as in any line, you *must* earn your place. There is just as big a position for you in the radio field as anywhere—perhaps bigger—if you'll work for it and earn it.

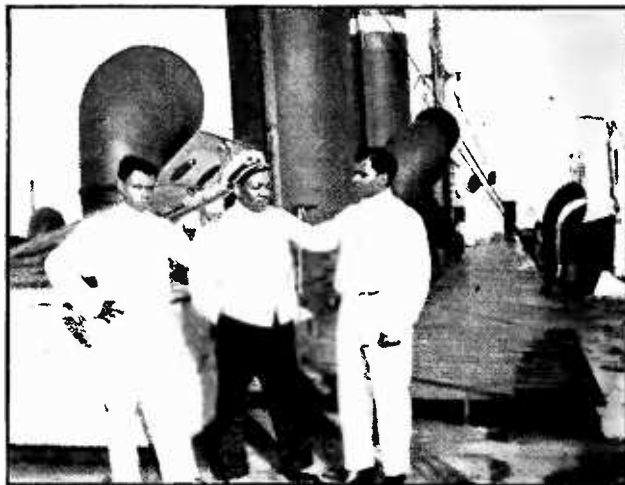

ON THE LARGER LINERS BELL BOYS DELIVER THE MESSAGES

For the radio man, and a steward caters to his every need—on some freight ships the radio man delivers the messages himself and has to scrap with the oilers for a place at the mess table where he receives cold "slum gullion" and other similar delicacies of the sea-going variety



KING ELECTRON

Tells About Detection

By R. H. RANGER

Engineer, Radio Corporation of America.

Author of "The Radio Pathfinder."

Trade Mark "King Electron" for illustrations registration pending, R. H. Ranger.

Illustrated by TOM MONROE

WILL it ever be possible to hear radio signals directly without the need of receiving sets?"

Maybe, — provided broadcasting keeps up for the several thousand years sufficient to develop in successive generations of radio enthusiasts an ear attuned to the new waves in space. But let us hope not, as one of the chief advantages of radio broadcasting is that the receiving set may be shut off when not desired.

The ears we have are attuned to air waves. The air waves in which we are interested are those caused by the vibrations of our vocal organs or musical instruments. Unfortunately, many other happenings in every day life always give rise to sound waves which we usually characterize as noise.

The piano scale affords a fair idea of the useful range of sound vibration. The lowest note vibrates back and forth at a frequency of some twenty-seven times a second; the highest note at some 4,200 vibrations a second. To produce sounds by the ordinary telephone, electric cur-

rents vibrate back and forth in the telephone wires at the same frequency or time of vibration as the corresponding sound. But it has not proved practical to send out radio waves in space at these low rates of vibration. Vibrations of the order of a million per second are necessary in order to broadcast in an economical manner from the transmitting station to many receivers, and this is much too fast for the ear to hear. So for the next few thousand years it would seem to be necessary to have radio-receiver ears.

These radio ears consist of receiving apparatus which will translate the radio vibrations of about a million cycles a second in ether into sound waves in air. This explains the need of a "detector", to detect the changes in these radio waves which correspond to the sound frequencies.

King Electron and his band of many million runners are at the service of the radio man. At each receiving station they stand ready to rush around in the approved manner to produce music out of the fast-vibrating radio waves coming through the ether.

An aerial wire connected to a receiving set constitutes an electric path of definite length for these electrons to move back and forth upon. It takes them a certain time to rush from one end of this path to the other and back again. If the surges are coming through the ether from the transmitting station at just the proper frequency to push these electrons on their happy way back and forth on the rises and falls of the radio waves, the maximum commotion will be produced in the receiving set. The process of tuning adjusts the length of this path to make the time of travel just right for the particular radio waves desired. So, when the tuning is correct, the electrons will rush back and forth with the incoming waves.

PRODUCING SOUND BY ELECTRICITY

AT THE sending station, sounds in the air are controlling the output of the radio transmitter. A mouthpiece is arranged to pick up the sound waves. These waves are much slower in their number of vibrations per second than radio-frequency waves which are being sent out into space. But the mouthpiece is connected to the radio transmitter in such a manner that the air pressures of the sound waves striking the mouthpiece will con-

trol the intensity of the radio waves transmitted. As a result the million or so radio waves per second will leave the transmitting station, but their intensity or power will vary up and down in step with the sound waves which strike the mouthpiece.

In consequence, the electrons in each of the receiving stations will move back and forth most rapidly in step with the incoming radio waves, but the intensity or force of their motion will vary depending upon the variable intensity of the incoming radio waves. As a result of this, the intensity of their motion will correspond to the sound vibrations at the transmitting station. To discover these changes in intensity and translate them into sound is the function of the receiving set.

HOW THE TELEPHONE RECEIVER WORKS

THE most practical device so far developed for changing electric effects into sound is the telephone receiver invented by the late Alexander Graham Bell. In this, electric currents of the same frequency as the desired sound, vibrate in the electric coils and in so doing pull the thin iron diaphragm of the receiver back and forth, pushing and pulling the air around the receiver to correspond, and in consequence

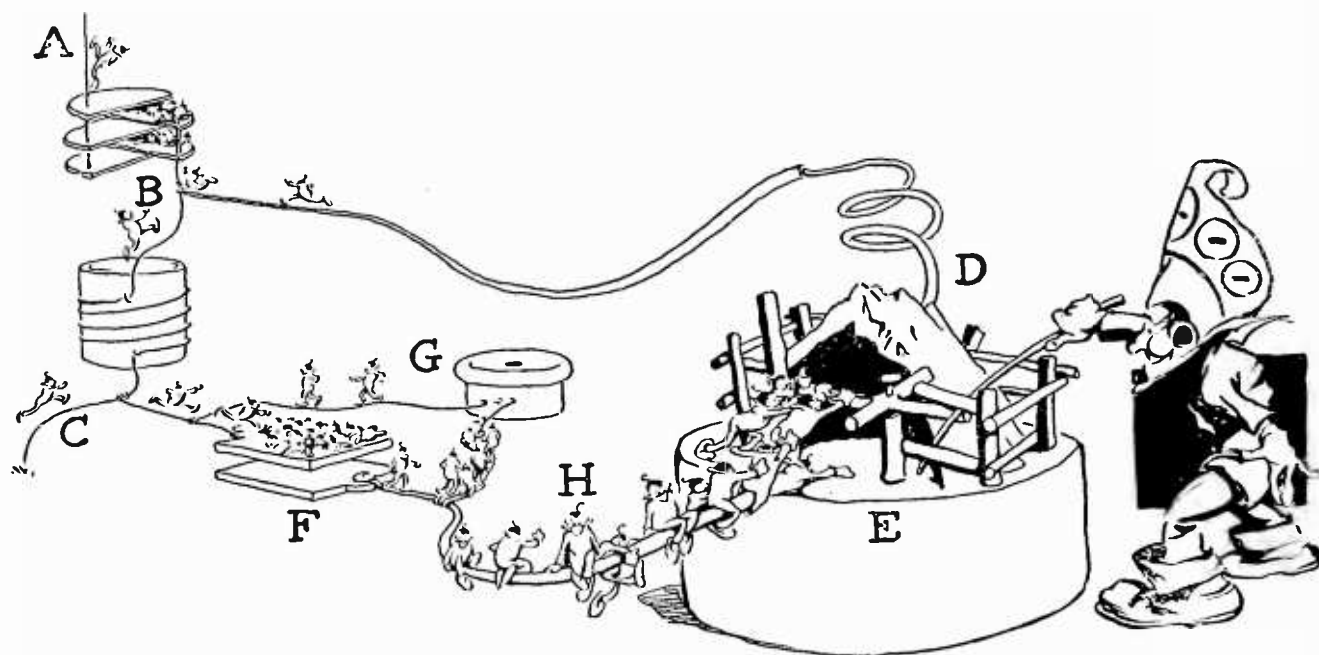

KING ELECTRON HOLDS THE TURNSTILE

On the dip in the radio-wave, the accommodating electrons rush back from the ground at C, through the tuner coil to B, to the tuning condenser and out to the antenna at A. This change of affairs makes those in the alternate crystal-detector route around through F, H, E, and D to B want to return; but the turnstile action of the crystal detector prevents them, and the trapped electrons at H have nothing left to do but continue around through the telephone receiver and out through G. The result is that the activity of the electrons urged on by the radio waves shows itself by a continued action in *one direction* through the telephone receiver, moving the receiver diaphragm and making sound.

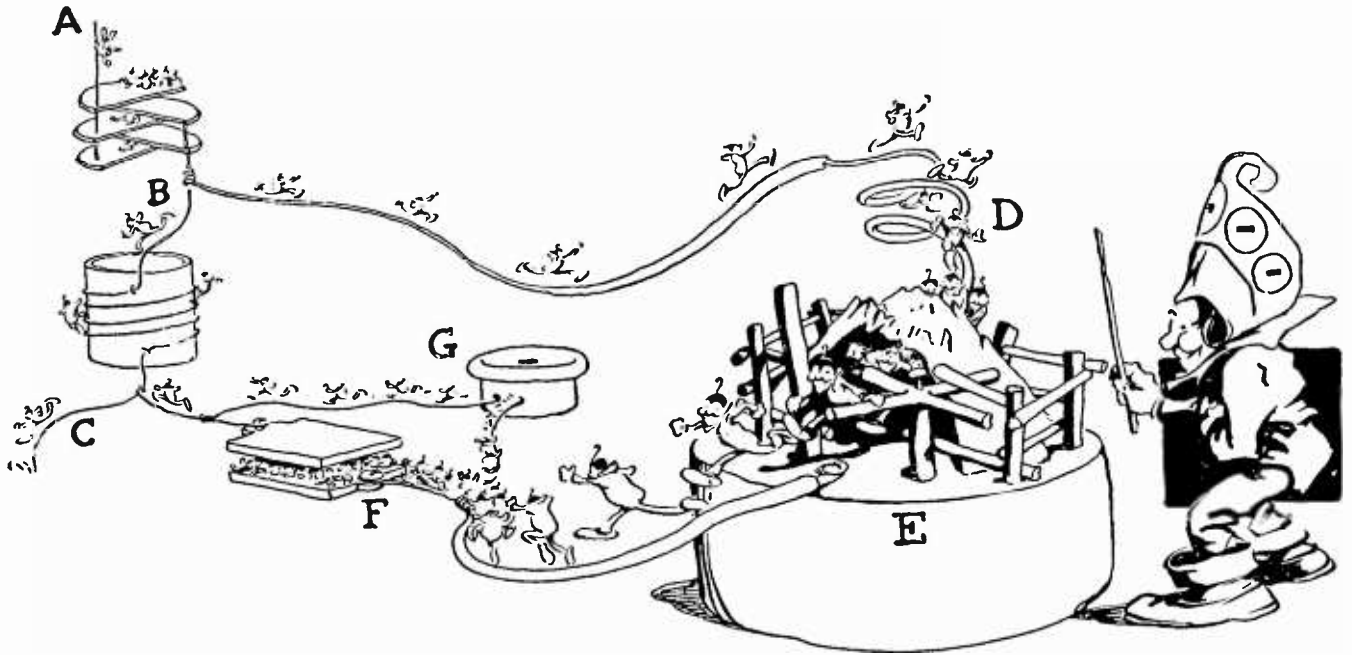

KING ELECTRON TELLS HIS BOYS TO WATCH THEIR STEP

Down from the antenna they come, urged on by a radio wave coming through space. At A they come to the variable condenser where they crowd on one side. Off their mates rush from the other side of the condenser. At B these divide, some rushing down through the tuning coil to the ground at C; the others take the right-hand path to the steel wire "cat whisker" at D. These continue on through the one-way crystal detector at E which acting as a turnstile, will let them through. On they go to F where they pile up on the by-pass condenser. They begin to go through the slower acting telephone receiver at G and around to the ground at C.

producing sound waves. Where the telephone receiver is used for radio the detector comes between it and the fast-moving electrons in the tuned aerial circuit.

If a one-way turnstile could be set up so that electrons could pass only in one direction through it, the perfect detector would be found. Such a turnstile would be placed in a wire leading from one side of the tuning coil in the receiving set. From this turnstile a wire path would lead on to the telephone receiver, and from there to ground. Whenever there was a rush of electrons down from the aerial, some would take this path through the turnstile and rush down through the telephone receiver. With the return swing of the electrons, back into the aerial, none of them could get back through the telephone receiver because the turnstile would be set against them. With the million vibrations per second, there would be a million rushes of the electrons in one direction through the turnstile and through the telephone receiver. If the ether waves were steady in value, this would mean that all of the little impulses through the telephone receiver would have the same value. The telephone receiver iron diaphragm is too slow moving to respond to each of the million impulses, but it will take

up an average position pulled by the impulses in one direction in the coils.

As long as the waves keep up their steady vibration, the telephone diaphragm will hold this position, but if the radio waves change in strength, the strength of the little impulses rushing in one direction through the receiver will change also, and the receiver diaphragm will move to correspond. As the changes in the intensity of the radio waves are caused at the transmitting station by sound vibrations, the changes will be passed along into the receiver diaphragm and corresponding sound will be given out by the telephone receiver, and the complete process of broadcasting will be realized.

THE USE OF A CRYSTAL DETECTOR

NO PERFECT turnstile for electrons has been invented yet, but there are many partial solutions. The Crystal Detector is the simplest. This consists of two dissimilar substances which have different electric characteristics at their surfaces. When they are placed in contact with each other this difference makes it easier for electrons to go through the combination in one direction than it is for them to go through in the other direction.

One of the most common forms of crystal detector is a piece of galena and a steel point just touching it. The steel point is adjusted until signals are heard best in the receivers. When this is done, the perfect turnstile is more nearly realized. How near this is will be understood when tests have shown that none of the known detectors has an efficiency over 15 per cent. (This is eliminating any amplification or regenerative effects accomplished with vacuum tubes.)

Just how the turnstile effect is produced in a crystal detector has never been clearly shown. If it were, it might be possible to raise this percentage for detectors. The fact that many investigators have spent years of study on the problem, and the fact that many thousands of conceivable combinations have been tried would seem to indicate that new investigators would have a rather difficult job improving on the work that has already been done. Late experiments indicate that the crystal detector action is caused by the thin film of moisture present on the crystal surface which makes a small battery cell out of the combination of the two dissimilar substances. This small cell has, of course, very small capacity, and the electron current in one direction will aid this cell action, and in the other direction the electrons will practically stop the cell action. As a result, they work on together in one direction and they practically stop in the other.

Other investigators consider the effect to be one of heat. The rushing electrons heat the small contact which gives rise to "thermal electricity." Thermal electricity is caused by heating the contact of two dissimilar substances. This thermal current is in one direction only so that the rapid variations across the contact will heat it; and this heat will develop the thermal current which going in one direction will work around through the telephone receiver and give a reproduction of the changes in intensity.

CARE OF CRYSTAL DETECTORS

SOME practical points may be mentioned in the care of crystal detectors. The first and most important is that the crystal be kept clean. Fingers are the worst offenders. Do not touch the crystal surface. A crystal may be washed with alcohol, or even soap and water. The soap should be thoroughly washed off.

The steel point or "cat whisker" should always be clean and fairly sharp. It must not

be too sharp, however, as this will cause it to "burn" off too quickly.

THE "BY-PASS" CONDENSER

MUCH unnecessary mystery surrounds the use of the by-pass condenser used to improve the efficiency of detectors, connected around the telephone receiver.

A condenser consists of two conducting metal plates pressed close together with an insulating substance between them. The metal plates will allow electrons to gather on them, but the insulation will keep the electrons from crossing from one plate to the other.

There are electrons everywhere. Therefore, in what might be called the state of rest, or "zero" electric pressure, there are still a large number of electrons present on everything, including the two sides of a condenser. Electrons are quite human in not liking to be crowded too much. If more electrons are then forced upon one side, the density of the electrons will, of course, be increased on that side, which means more electric pressure, and there will be a rush of the electrons off the other metal side. For very rapid movements back and forth of electrons, the condenser will therefore act exactly like a straight wire connection, as there will be a motion of electrons into it on one side and out of it on the other. So such a condenser will let such electron vibrations pass through it easily. A good value for a by-pass condenser is one or two one-thousandths of a microfarad. This condenser is connected across the telephone receiver, making it possible for the rapid electron impulses to pass through the turnstile detector quickly and on through the by-pass condenser to ground. They would have much more difficulty in getting through the telephone receiver at this rapid rate, due to the many turns of fine wire of which it is made.

"But doesn't this lose all the benefit of the electron action as fall as the telephone receiver is concerned?"

No, because although the effect is such as to have a quick motion of electrons along this path through the by-pass condenser, there is no actual motion of electrons from one side of the condenser to the other across the insulation put there to keep them from crossing. So they will pile up on one side. When the impulse has reversed, the trapped electrons cannot return through the turnstile set against them. So, this extra number of electrons has but one

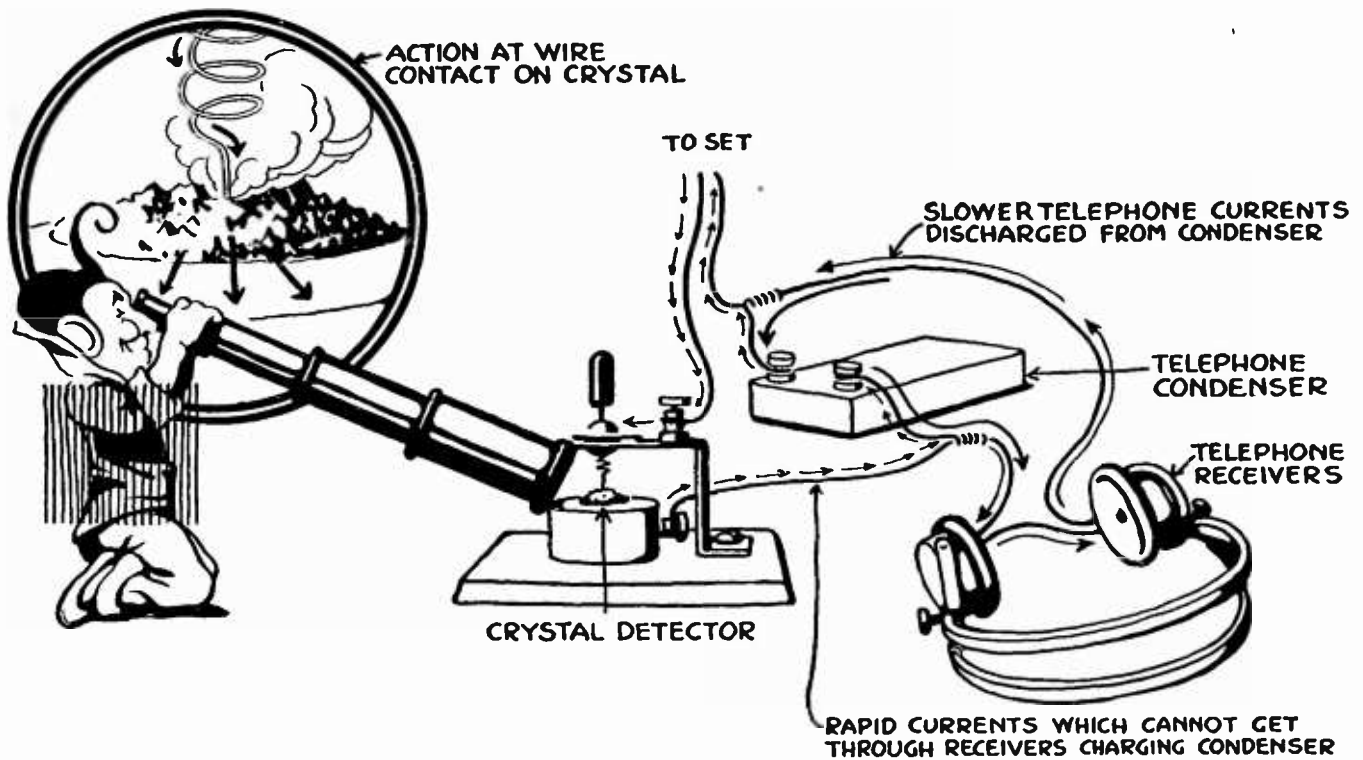

KING ELECTRON STUDIES THE CRYSTAL ACTION

This may be a "heat" effect, where the small contact between the "cat-whisker" steel and the crystal is heated by the rapid rush of electrons. This heat means high vibration of the particles of the wire and crystal at the point of contact. The result of this rapid vibration is to make the electrons move in one direction only across the point of contact. This motion of electrons is called "thermal electric current." As it is in one direction, it will work through the telephone receiver and produce a motion of the receiver diaphragm, causing sound.

choice, and that is to go through the telephone receivers. What it means is that the electrons on these rapid pulses will pile up on one side of the by-pass condenser, and then they will slowly work their way around to the other side of the condenser to ground by passing through the telephone receiver. When the word "slowly" is used, it is meant slowly with respect to the million frequency of radio waves, because the action through the telephone receiver will still be quite fast enough to correspond to the sound vibrations of the order of some one thousand vibrations a second. Thus the action of a by-pass condenser is to improve the efficiency of the detector-telephone receiver combination first, by giving the radio electrons a quick path to move along; and second, by acting as a storage tank to take these electrons and then allow them to pass off through the telephone receiver.

As a matter of fact, any two metal surfaces separated by an insulator act as a condenser. Two such metal surfaces are the two wires leading to the telephone receivers in the telephone cord. So the cord acts as a by-pass condenser itself. This makes it necessary only

to add a rather small capacity to give the best efficiency for the detector action.

THE BUZZER TEST

NOWADAYS, as there are so many signals in the ether all the time, there is less need of a testing outfit for the crystal detector adjustment. Still, for receivers at a distance from the transmitting stations, such a device may be a great help.

In its simplest form it consists of an ordinary electric buzzer, which as it buzzes constitutes a small radio transmitter, and will therefore act on a receiving set which is properly adjusted. It is necessary only to connect a buzzer with a dry battery and a push button in series. Every time the button is pushed the buzzer will send out the small radio signals on the sparking at the contact. These will be sufficient to work the receiving set. If the buzzer is not quite strong enough, the effect may be increased by adding one extra insulated wire attached to one of the buzzer binding posts. The insulation of the extra wire is taken off only at the buzzer end. The other end of the wire is wrapped around one of the crystal detector

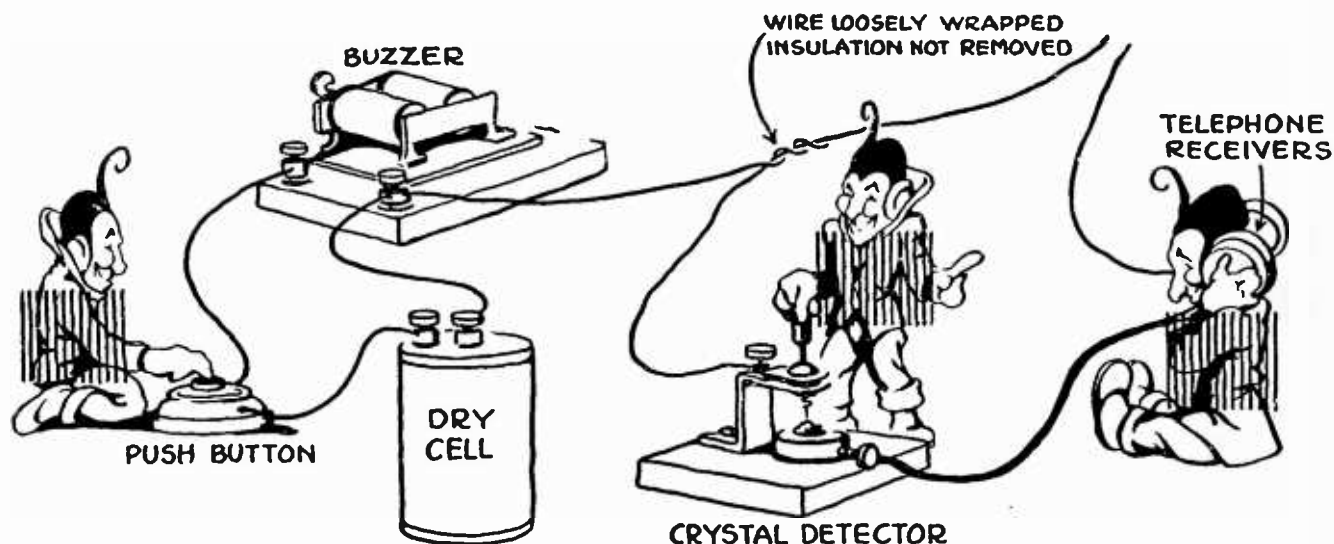

TESTING OUT THE CRYSTAL DETECTOR

An ordinary buzzer is requisitioned by King Electron. This acts as a small radio transmitting set. Its transmitting antenna is a short length of wire attached to one binding post of the buzzer and brought near the receiving set. A dry battery and a push button in series with the buzzer complete this test transmitter. As it buzzes, the cat-whisker is adjusted until the signals are heard nicely, when the tester is shut off and the tuner is adjusted for distant radio waves.

wires loosely, or it may be wrapped around the aerial wire. Usually it is sufficient just to bring the wire near the aerial or antenna.

With the buzzer working, the crystal detector is adjusted until the signals are heard best. It does not pay to find the ultra-sensitive point, as it will be found that such a point will only last for a little while until a crash of static "burns" it up.

When the detector has been adjusted for good average results with the buzzer, the buzzer is shut off, and any signals that are passing through the ether should be heard nicely.

In all work with radio, it is a very good plan to start with something known, and then work for the more difficult and more sensitive results. The buzzer tester falls into the first class, as

by its use the receiving set detector may be well adjusted, which indicates that the detector and the telephone receiver with the by-pass condenser are all working well. With continued practice, it may be possible to remove the buzzer to quite a distance from the receiving set and still get the test. Under these conditions it is certain that the receiving set is in the most sensitive condition.

The action of the crystal detector is fundamental, as the action of the other detectors is better understood from this viewpoint. So next month the much greater activity of King Electron in the Grid Leak-Detector connection with the vacuum tube will be taken up, together with the action of the Heterodyne.



Radio Has Gripped Chicago

The Ears of the Entire Middle West Were in the Auditorium Opera House Last Winter, and Boys are Building Thousands of Sets

By GEORGE P. STONE

FEW landscapes in all the world are more depressing than the barrens of Chicago's great west side. The scene consists of a seemingly endless succession of mean streets, across which dispirited tenements and glum "workmen's cottages" glare grumpily one at another. Soot is on everything—the buildings, the sky, the infrequent and listless trees, and the swarms of children. It is a desert scene, more disheartening than the Sahara because it is wrapped perpetually in gloom and crowded with thwarted human lives.

But since winter, a queer blooming has occurred in the desert. The elevated railways' intrusions upon the backyard life of the region reveal a strange vegetation on the housetops. The vegetation is not heavy, it casts no shade, it does not even comfort the casual eye; but to the imaginative beholder it is tremendous with promise. Ugly as it is in outward form, the vegetation lets down beauty and pleasure and a new interest in life into hundreds and hundreds of gloomy tenements.

Each of the numerous shoots of wire intimately connects some desert dweller and his family with such luxury as used to belong only to the wealthy few. Grand opera, news expensively and quickly gathered, the words of political and religious leaders, instrumental music by great artists—all these are carried by the house-top antennas down into dingy rooms for the comfort of persons for whom such things simply did not exist a year ago.

The alacrity with which antennas have appeared on the skyline of the west side is the most dramatic and most hopeful phase of the development of radio broadcasting in Chicago. Crude homemade aerials are on one roof in ten along all the miles of bleak streets in the city's industrial zones. For thousands of families, life has acquired new savor through radio.

It is hard to imagine the splendor of the vistas which radio must have opened to many of these people. Picture, if you can, John Taplowski, foundry helper, listening to Mary

Garden and Lucien Muratore in "The Love of Three Kings" over little John's school-made radio set! Then reckon on several thousand John Taplowskis in the grim back streets along the muddy Chicago River and the wastes of frame shacks out "back o' the yards," feasting on an inexhaustible variety of radio entertainment! Staggering, isn't it? And it indicates the folly of saying that "the public will soon tire of this fad."

For some the radio is indeed only a new toy, soon to be dropped, but for the owners of the clumsy antennas on the tenement roofs of the west side, wireless telephony is a miracle which cannot stale. It is making life over.

Chicago has another radio audience for whom the daily broadcasts are more than a temporary palliative of boredom. On the prairies of all the Middle West, from the Alleghanies to the Rockies and the northern border to the Gulf, the broadcasters have a farmer clientele which gets not only excellent entertainment but also vastly helpful news of prices and weather and current events from the air.

These—the humbler folk of the city and the farmers with few other social contacts—are more than "fans." Their interest in radio is genuine. It will last. It is the dependable factor on which plans for the future are being based.

Chicago caught the radio fever in earnest last fall, when the Westinghouse Company established Station KYW on the roof of a downtown skyscraper. Its KDKA station, in East Pittsburgh, had then been broadcasting for nearly a year, and stations had been created or were being built at Newark, N. J., and Springfield, Mass. The Chicago staff of the company wanted to get abreast of the others. The approaching season of the Chicago Opera Company seemed an opportunity.

Now the Westinghouse people do not pretend to be philanthropists. Their broadcasting service is business, and they admit it. They manufacture radio sets. They want a market for those radio sets. To create a market they

must make the sets valuable to purchasers. Hence the broadcasting. Hence, too, the excellence of the broadcasted programmes, for the better the entertainment the larger the audience.

In arranging for the opening of their Chicago station the Westinghouse radio men found a willing ally in Miss Mary Garden, then director general of the Chicago Opera Company. Efforts were being made to enlist the public generally in support of opera. Wealthy guarantors were wearying of paying the bills. Miss Garden and her associates in the management of the company were appealing to all Chicago to back the enterprise out of civic pride.

The suggestion that opera be broadcasted by radio was welcomed. Grand opera is an exotic dish. Taste for it is not instinctive, but acquired. Miss Garden saw in the broadcasting plan a chance to instill a liking for good music in thousands of minds outside the range of any other appeal, and so the plan was adopted.

The story of the amazing manner in which the Chicago Opera Company obtained a nightly audience hundreds of times greater than the capacity of any theater in the world has been told so often that to repeat it here would be useless. It is enough to say that every opera given by the company in the winter season was broadcasted by Station KYW so that the ears, at least, of all the Middle West were in the Auditorium Opera House six nights a week.

The consequences were amazing. In Chicago at the opening of the opera season were approximately 1,300 radio sets. Announcement of the fact that opera was to be broadcasted started a clamor for equipment. As the season advanced and professional critics added their praises of radio transmission to the ecstatic comments of radio enthusiasts the clamor in-

creased. To "listen in" on the opera became the most fashionable and popular of winter sports. Home, it seemed, couldn't be home without a radio set.

But no radio sets were on the market!

Manufacturers and dealers had not foreseen such a demand. Who could have foreseen it? Until the fall of 1920, radio sets were not very saleable. Only industrial users and a compar-

atively few "experimenters" wanted them. As well have tried putting turbine engines in the household furnishing field. After the first rush nothing was left for the hundreds of frantic radio customers save "bootleg stuff"—sets rebuilt or manufactured in defiance of patent restrictions. And all the while the finest opera in America literally was wasting its fragrance on the desert air.

Came then the small boy to the rescue. He is the hero of Chicago's radio drama, the small boy is. Frank Conrad, who began the broad-

casting, and H. P. Davis, who established the "granddaddy station" at East Pittsburgh, and Miss Mary Garden, who made broadcasting of opera possible, have their places in the cast, but the fellow in the spotlight is the American boy.

The normal Yankee youngster's insatiable desire to "see what makes it go" always has been a stimulant to mechanical progress. Every American invention from the cotton gin to the airplane has felt the boy's influence. Tinkering in their impromptu backyard workshops, young Whitneys and Edisons and Wrights have done important things in mechanics, simply out of boyish curiosity about what's inside the darn thing.

Just as their grandfathers fiddled with bicycles and their fathers with automobiles, the young Chicagoans of 1921 began fiddling with the radiophone. And presently the number of radio sets in KYW's field had tripled, although the dealers in electrical supplies had only one



A FAMILY PARTY

Some boys get the radio fever when very young

answer for customers: "We haven't a thing; perhaps next month. . . ."

Families were compelled sometimes to sacrifice physical comfort for the sake of having a radio set in the house. One young genius appeared in his high school physics class with a home-made set neatly housed in a mahogany silver chest, for which his mother doubtless was searching at that very moment. Another lad dared the parental thunderbolts by snatching springs off his father's bed. Whole platoons of zealots discovered simultaneously the peculiar fitness of rolled oat containers and appropriated them as material for "tuning coils" sometimes without regard for the breakfasts stored away inside.

In one way or another radio sets were contrived out of the amazing collections of junk always to be found in the woodsheds and cellars of families with boys. And they worked! And the opera got new hearers.

The tremendous enthusiasm of the youngsters threw an embarrassing burden on the public schools. Boys who had been yawning through their physics and manual training classes came suddenly to life as the enthusiasm for radio spread. They demanded that their teachers

unfold without delay the secrets of wireless telephony. They wanted an explanation of the phenomenon and instruction in radiophone construction. And with a few exceptions the teachers were caught off base.

For six months a breathless teaching staff was hard put to keep the necessary one jump ahead of its hungry charges. Instructors found themselves compelled to outstrip their classes in study. To their credit be it said that they stood to their guns. As soon as it became apparent that radio broadcasting was to be an institution, special classes in radio were organized, materials for set construction were put at the disposal of manual training groups, and students were encouraged to build and practise with radiophones of their own.

At the close of the opera season the number of sets in use in the city of Chicago had increased from 1,300 to something like 20,000. And you have the word of experts for it that boys of high school age were responsible for at least 75 per cent. of the increase. Grown-ups occasionally took flyers in the new game, but those who made the home sets work, who contrived makeshifts to take the place of unavailable gear, were mechanics in short trousers.



© Underwood & Underwood

GEORGE FROST

The 18-year old president of the Lane Technical Club with a cup which he recently won at an exhibition

The departure of the opera company left the Westinghouse company in a quandary. By broadcasting the music of Miss Garden's organization, KYW had established a radio audience of thousands. That audience wasn't going to wait ten months for another opera season; it wanted entertainment without delay. Undeniably it was KYW's move.

A musical director and a staff of performers were engaged. The newspapers, by now awake to the fact that radio was claiming as much public interest as baseball and divorce, offered coöperation. And when the curtain fell on the last operatic performance of the winter, KYW was ready with an all-day broadcasting programme. Twelve-hour service has been given daily ever since, and will be maintained.

The beginning is at 9:25 A.M., Chicago daylight saving time, when the opening market quotations of the Chicago Board of Trade are broadcasted by means of a straight connection between a phone booth in the pit and the KYW set. At half-hour intervals thereafter the fluctu-

ations of the market are reported to radio users until, at 1:20 P.M., the closing report is available.

This grain market service has proved itself of the greatest value to farmers throughout the Middle West. It has done much to bring the grower and the dealer into harmony. Thanks to his radiophone, the wheat grower in the remotest prairie is on an equal footing with the speculator in Chicago. He would be in no better position were he at La Salle street and Jackson Boulevard, watching the bidding and selling in the world's greatest grain market. He is enabled by radio to sell at the most opportune moment, and his suspicion of grain dealers is abating as his confidence grows.

Livestock quotations are broadcasted, too, through an arrangement with the stockyards. Stockmen all through the West get news of receipts and sales and prospects immediately.

The first general news report of the day goes out at 2:15 P.M., with the livestock market reports. Important happenings the world over



TRANSMITTING MARKET QUOTATIONS

From the Chicago Board of Trade through a microphone to Westinghouse station KYW, operating the latter automatically

The image shows a large blackboard in a trading room, covered in handwritten market quotations. The board is organized into columns for different commodities and their respective months. The commodities listed include Oats, Corn, Wheat, Rye, Pork, Lard, and Short Ribs. Each commodity has a set of columns for different months (e.g., APR, MAY, JULY, SEPT). The prices are written in numbers, often with a letter 'B' or 'F' indicating a specific type of contract or quality. The handwriting is dense and fills most of the board's surface.

TICKER QUOTATIONS OF THE CHICAGO BOARD OF TRADE

Posted here, and the radio operator is in a position to note every price change promptly

are bulletined, often before they are in print. Forty-five minutes later the lineups for every American and National league baseball game are sent into the air, to be followed at intervals of thirty minutes by bulletins of the progress of each game. If Babe Ruth or Ken Williams slams out a home run in New York or St. Louis, the radio bleachers get the word in less than half an hour. And the wallop which gave Georges Carpentier his recent victory over Kid Lewis in London was reported in Chicago homes and on Oklahoma farms almost before the cheering had stopped around the ring.

At 4:15 KYW's huge audience gets another batch of news about happenings generally, the grain and livestock markets, and the stock quotations. This report is followed at 6:30 by financial and baseball finals, and the radiophones can knock off for chow.

The children come in for their share of the programme at 7:15, when a bedtime story is sent out. Just as soon as the story has been told and the children have been tucked into bed, father and the boys are given a concise summary of the sports news of the day, with particular emphasis on baseball.

Then the real entertainment begins. KYW has tried to keep its evening musical programmes up to the standard set by the opera company

in the first months of Chicago broadcasting. To do so is good business. Audiences can't be held with second-rate stuff. Not all of the entertainment is on the artistic level of the opera of course. The radio audience is heterogeneous. To send out nothing but highbrow music would be to discourage many listeners. But nothing amateurish is permitted. Jazz is mixed with the classic, but it must be accomplished jazz, and there must not be too much of it.

A programme chosen at random from the summer schedule of KYW will indicate the sort of entertainment given to the station's clientèle.

This is what radio fans in the Chicago broadcast zone heard on August 15th:

8:00 P. M.—Musical by Ethel S. Wilson, soprano; Herman Salzman, baritone; Rosalyn Salzman, accompanist; Bernard W. Wienbroer, cellist; Isadore Witte, pianist. "Pale Moon," Logan, and "Rose in Bud," Forster; "Berceuse," from "Jocelyn," Godard, and "Romance," Kronold; "Toreador Song" from "Carmen," Bizet, and "The Little Irish Girl," Lohr; "Sonata Pathetique," Beethoven, and "Prelude in B Minor," Chopin; "Sunrise and You," Penn, and "One Fine Day," from "Madama Butterfly," Puccini; "Traumerei," Schumann,



DURING TERM TIME

Such groups as this are not uncommon in the high schools of Chicago

and "Ave Maria," Schubert; "On the Road to Mandalay," Speaks, and "Rose of My Heart," Moret; "Polonaise Militaire," Chopin, and "Moths," by Phillip, "Prelude in A Major," Chopin.

Every Sunday afternoon chapel services are held by radio, with some distinguished Chicago preacher speaking at the KYW studio. And on Mondays, Wednesday and Fridays KYW gives an hour in the afternoon and an hour in the evening to WBU, the Chicago city hall station, which offers special features.

No one has been brash enough to attempt a reckoning of KYW's daily audience, but it is tremendous. New towers just installed, 495 feet above the street, give the station a normal range of 2,000 miles and an occasional range of 3,500 miles. Letters of praise or censure have come to the musicians of the station from auditors as far away as Catalina Island, Cal., Medbury, Mass., and San Francisco. Indeed, Miss Evelyn Goshnell, who came to Chicago early in the spring with a play, brought commendation for a KYW concert she heard in mid-Atlantic.

The letters which come daily to the station reflect the genuine interest of the farflung radio audience. A Nebraska farmer asks for "less of that highbrow piano playing." A critic in Montana notes that "Miss So-and-so's songs were just fine, but don't ever let that Mr.

Whosis play again." The applause and the booing are as frank and emphatic as the demonstrations of a gallery crowd in a theater. They keep the performers on their toes.

Naturally the pleased interest of all these radio users has been contagious. In spite of the shortage of supplies, the number of sets in operation has increased steadily from month to month. No searching census has been made, but the broadcasters know of 30,000 radio sets in the metropolitan district to-day.

The summer has brought a lull in the radio demand. Talk of "summer static" has spread as talk of German spies and enemy airplanes spread during the war, so that the hundreds of shops which flaunt hastily painted "Radio Supplies" signs over their doors are less busy than they were four months ago. Prospective radio fans are awaiting the coming of more favorable weather. The midsummer apathy distresses no one, except perhaps the apathetic themselves. Manufacturers are from three to four months behind their orders now, and the dealers simply can't see daylight. An idle summer will restore something like a balance between supply and demand, and all signs point toward a vigorous revival of radio interest in the fall.

In the middle of June the public schools turned loose several thousand young manufacturers of radio sets. These boys (and girls,

too) have spent much of their vacation time in practising the radio craft they learned in school last winter and spring. Those who are watching the radio field closely expect Chicago to have 75,000 sets in use by fall.

That the youngsters learned the craft and learned it well is to their own and the city schools' credit. They furnished the impetus, and the schools supplied the instruction. Chicago's public school system always has been wide awake in technical matters. The four great technical high schools—Crane, Lane, Harrison, and Washburn—are admittedly without superiors in the country, and the vocational training departments of the grade schools and general high schools have served as models for other communities. This flair for technical training was directed radio-ward as soon as it became evident that broadcasting was going to make wireless telephony interesting.

A. G. Bauersfeld, supervisor of technical work in all the Chicago schools, had been

encouraging interest in radio before the present era began. Lane Tech had a radio club as early as 1904, and instruction in wireless transmission is not a new thing in that or other city high schools. When interest began to widen, Mr. Bauersfeld prodded his instructional corps into action. Teachers were urged to encourage students who seemed interested and to study the subject themselves.

Every school in the city soon began to feel the effects of the radio fever. Classes in electrical theory doubled and redoubled. Shop classes came suddenly to life as boys who had refused to become interested in the manufacture of furniture awoke to realization of the fact that by becoming proficient in furniture-making they would learn to make good radio cabinets.

The students' interest in radio was helpful generally. Boys aren't content with knowing that by turning a dial this way or that they can evoke sounds from a radiophone. They



© Underwood & Underwood

RADIO SETS MADE IN MANUAL TRAINING CLASSES

Radio fans from twenty-four Chicago high school clubs met early in June in the office of Albert C. Bauersfeld, supervisor of technical education in the public schools, to listen to talks by prominent electricians and display some of their handiwork. In the picture, from left to right, are William Helm, Clarence De Butts, Milo E. Westbrooke, W. J. Bogan, Sup't. Peter A. Morterson, and Corwin Eckel

must know the why and wherefore. So they didn't rest with instruction in the building of sets, but quit their afternoon ball games to study theory.

Boys began besieging the KYW station, the *Chicago Tribune's* wireless plant, and WBU. They were at the doors early and late.

"And of all the visitors we have," a KYW guide said, in talking of the younger generation's passion for radio, "we get the most fun out of the boys. Grown men simply 'Ah!' and 'Oh!' or ask silly questions. The boys get right down to brass tacks. I've seen kids in short pants stagger our radio men with questions that went straight to the heart of things."

School teachers had similar experiences. "For a while I was almost ashamed to go to school in the morning," one high school instructor confessed, "because the boys were shooting over my head. I had to do the hardest sort of grinding before I could face them. They took to the business like ducks, and were speaking the lingo with the fluency of experts before the radio fever was a month old."

Radio clubs in the schools are supplementing the work in the classroom. Lane Tech's pioneer club served as a model and has, in fact, been instrumental in organizing the radio interest of other schools. George Frost, the 18-year-old president of the Lane club, has been indefatigable. Unaided he produced the first radio-equipped automobile in Chicago and he serves at schools as a sort of unofficial instructor.

Through the efforts of young Frost and others of the Lane club, radio clubs have been formed in most of the schools, until now the organizations include thousands of young wireless experimenters. The growth of Marshall High School's club illustrates the speed with which these organizations develop interest in their hobby. This club was formed in May, with a membership of 100. By June 1 the secretary had 400 names on his book. A set is now being built at the school. When it has been finished the club will have 750 members, the officers say. And before a year is out most of the 750 will have put radio sets into their own homes. Thus the wireless audience grows.

The Chicago Association of Commerce has contributed fuel to the boys' enthusiasm. For several years the association has fostered civic-industrial clubs in the high schools. The

clubs devote their energies to neighborhood work in Americanization, study of social and political problems and first-hand observation of Chicago industry, business, and government. Because the backers of these clubs foresee that the interested boys of to-day will be the informed men of to-morrow they are encouraging the radio hobby. The Association of Commerce wants to make Chicago the radio centre of America. To that end it is helping the high school enthusiasts by opening for them the doors to great electrical plants and laboratories.

The boys' clubs are not the only ones. Although the popular excitement over radio is less than a year old in Chicago, a Chicago Radio Club already has been organized. It has a clubhouse near the lake shore and is bringing together men interested in wireless, not for technical purposes only, but for social ends as well. It uses radio just as the large athletic clubs use sports, that is, as a binder.

But the sandlots have turned out more big leaguers than all the athletic clubs combined, and the radio experts of to-morrow are more likely to come from the high school groups than from the elaborate clubhouse on the lake front.

Chicago's two great universities—Northwestern and Chicago—have been pretty well immune from the radio fever, probably because neither is a technical school and the students' ambitions and interests already were fixed in other directions. Armour Institute, Lewis Institute and the many lesser technical institutions in Chicago have noticed some increase in the demand for instruction in wireless, but there, as in the cultural universities, previous fixation of undergraduates' interest has had a restraining influence. The real fever will not reach the colleges until the high school enthusiasts begin graduating.

None of the colleges has availed itself of the opportunity to broadcast helpful lectures. WBU, the city hall station, is the only broadcasting agency which has attempted education in anything except music, and WBU's efforts have had a political tinge. City officials lecture by radiophone six times a week on matters of importance to Chicagoans as citizens, explaining the work of the police department, the manner in which the streets are kept clean, ways of avoiding disease and accident, and so forth.



The city has in mind a far more important radio experiment. George E. Carlson, commissioner of gas and electricity, and Chief of Police Fitzmorris are seeking from the city council an appropriation of \$68,000 for radio-equipped automobiles. In its fight to prevent crime the police department sends out daily fleets of automobile patrols, each assigned to a definite area, so that the pursuit of robbers may be delayed as little as possible. Commissioner Carlson and Chief Fitzmorris want to equip these patrols with radiophones, in order that they may be kept constantly in touch with headquarters.

Experiments with a model patrol have been successful, but as yet the council has withheld the money needed for equipment of a fleet.

If the radio patrols live up to expectations, an effort will be made to equip every roundsman with a radiophone. Next fall may find the city hall radio operator in touch at all times with every policeman in the city, so that cordons can be thrown about the scene of a crime

before the criminals have had time to get away.

City officials, newspapers, manufacturers, dealers and schools are accepting the general interest in radio at its face value. They are convinced that every American home will some day be radio-equipped; that in the near future the wireless telephone will be considered as necessary as the commercial telephone is considered now.

Most of our social troubles, it is pretty generally agreed, grow out of misunderstanding. We base our hopes and prejudices and faiths on widely different sets of facts, variously interpreted. Democracy, they say, whose business it is to spread intelligence, cannot flourish until knowledge of events reaches the masses quickly, clearly, and wholly.

If that be true, what present-day phenomenon is more encouraging than the new look of the dingy skyline of Chicago's hinterlands, fringed with radio antennas thrust up for long-denied draughts of sweetness and light.

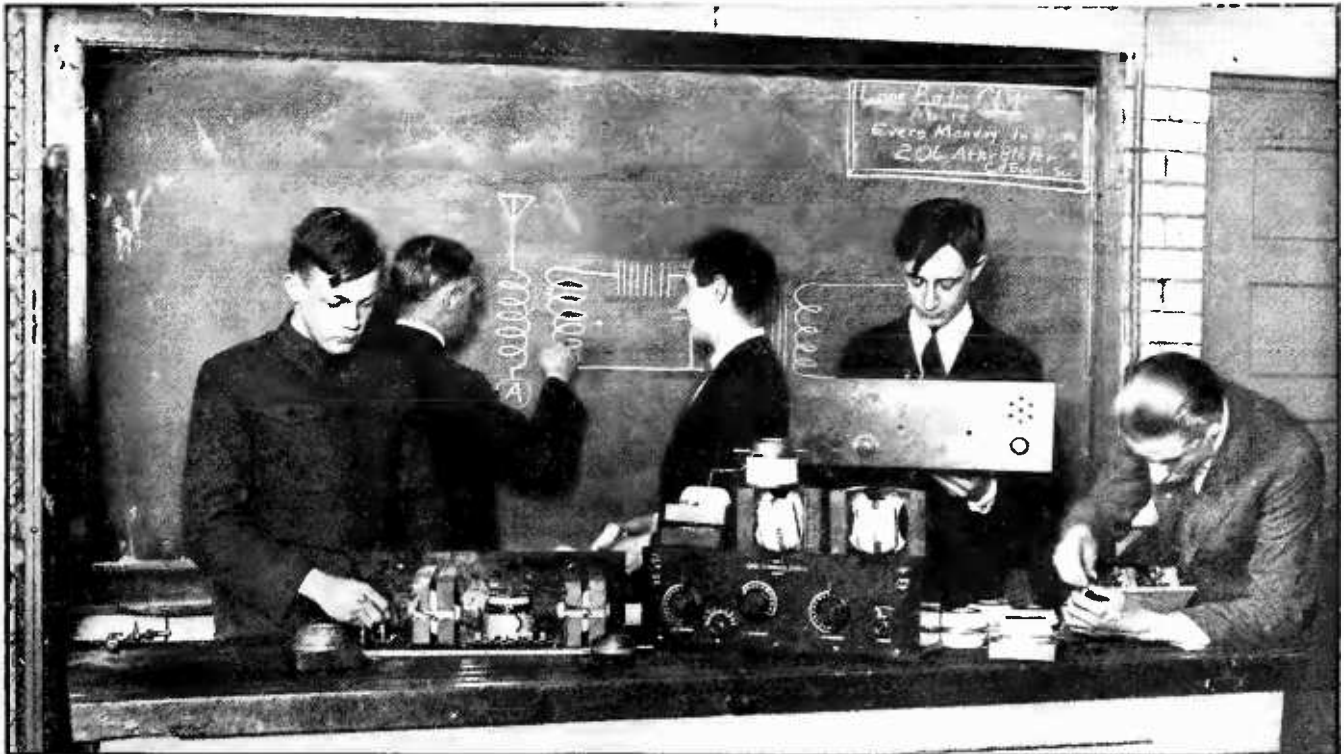

© Underwood & Underwood

A CLASS AT LANE TECHNICAL HIGH SCHOOL STUDYING RADIO

This school not only teaches radio, but instructs pupils in how to manufacture their own instruments, and boasts the pioneer boys' radio club

“With the Night Mail”

By DONALD WILHELM

BECAUSE of its great distances, favorable topography, willingness to try out new devices, and characteristic appetite for speed in travel and communication, America is the natural habitat of both radio man and flyer. The plane and the electromagnetic wave—these two annihilators of time and space—came into being almost simultaneously. Their secrets Man discovered and applied within the span of one generation. Now the Twin Sciences, both coming of age, must grow together, for even if radio can do without the plane, the plane cannot do without radio. Soon, too, federal regulation of commercial aeronautics, which is quite as necessary to the development of aviation in America as was federal regulation of radio, is to be lodged under Secretary Hoover—either cop extraordinary—in the Department of Commerce.

Order in the air, settlement of questions of liability in case of accident, practicable insurance rates and extremely large capital for investment in commercial aviation await this event. Pending it, moreover, and all propaganda to the contrary notwithstanding, in aviation as in radio, America is leading the way. Thus—for one thing—our Air Mail Service is without question the largest and most successful achievement in regular, commercial flying in the world to-day.

During the next six months or so, the Air Mail will attempt something extremely significant in the history of the Twin Sciences. It will attempt regular night flying, by using radio direction finders, radio field localizers and the radiophone to guide the mail pilots all the way

from hop-off to landing. With these aids, it expects to be able to fly mail across the continent daily, both ways, in somewhere around twenty-four hours.

THE TEST TRANSCONTINENTAL FLIGHT

ONLY once has mail been carried from Coast to Coast so fast—about 125 times as fast as the Forty-niners crept across the endless plains, and five times as fast as the fastest express train. On February 22, 1921, on a test transcontinental flight without the aid of radio, and at the cost of one pilot's life, the mail plane covered the long trip of 2,650 air miles (you add a third usually in calculating railway distance), in twenty-five hours. Then Pilot Nutter hopped from the San Francisco field before dawn and, mostly in the dark, and partly at a height of 18,000 feet, crossed the Sierras and ran

on to Reno, 187 miles, in two hours. Pilot Eaton ran the mail on to Elko, Nevada, and thence to Salt Lake City, 437 miles. Murray reached Cheyenne, 381 miles, and there Yager carried the mail on into the night, reaching North Platte at 7:48, Middle Time, 110 miles. Then it was Jack Knight who flew the 248 miles to Omaha, and, because no other plane or pilot was available, in the middle of the night, with nothing to guide him except the instincts of a homing pigeon and a few farmers' bonfires at long intervals, he continued till dawn and landed safely on Checkerboard Field, near Chicago, 424 miles away. From there, other pilots flashed in relay on to New York.

These distances and details are important; for, until planes fly at twice their present speed,

Some years ago, Rudyard Kipling wrote a fanciful story called "With the Night Mail," describing an imaginary air mail service in the year 2000 A. D. between London and Quebec. We still have seventy-eight years in which to realize his prophecies, but can we doubt, when we consider the advances made in only eighteen years, that in *less* than that time there actually will be an airplane mail service from Europe to America? Not equipped with the huge and clumsy dirigibles of Kipling's fertile imagination, perhaps, but with trim, swift planes of an improved type, as to which, even in 1922, we can only make guesses.

Meantime, our own Government is perfecting an airplane night mail service between the Atlantic and Pacific seaboard. Its beginnings, struggles, successes, and hopes for the future are dealt with in this article.—THE EDITORS.

if the mail is to be carried from coast to coast in twenty-four hours, *a gap of a thousand miles or so must be flown at night*, and, the Air Mail insists, such routine night flying is clearly out of the question without radio. But with radio the project is thought to be entirely practicable. It has no terror for most of the postal pilots. There are some who have said to the writer that they would rather fly at night if they have the guidance of radio than in the daytime when, on some of the runs, fog often lies in wait for them and forces them to fly very low, dodging all manner of obstacles. "But," said one, "give me radio direction-finding apparatus that really works and I'd a lot rather fly at night, 'way up, than take a chance in the daytime in thick weather with the best compasses, turn indicators, distance recorders and drift indicators I've ever seen in a plane. Our compasses

spin, and most of these other instruments are as good as a pile of junk when you get twisting around in a tight corner at a hundred miles an hour."

So the Radio Division of the Air Mail, after years of experimentation with radio in coöperation with other Federal agencies, and years of yearning for sufficient funds, is making ready to use radio to guide its pilots, and is having a survey made of the transcontinental route. The man at the head of the Post Office Radio Division is, you may take it, qualified to judge of the difficulties. For long before the war he was an ardent amateur, then a teacher of physics and radio, then a war pilot—one of the few trained at Ellington Field for night flying—and, when the war was over, the first man successfully to fly the mail both ways between New York and Washington, over the initial Air Mail run.

THE AIR MAIL RADIO STATION IN WASHINGTON

© Harris & Ewing

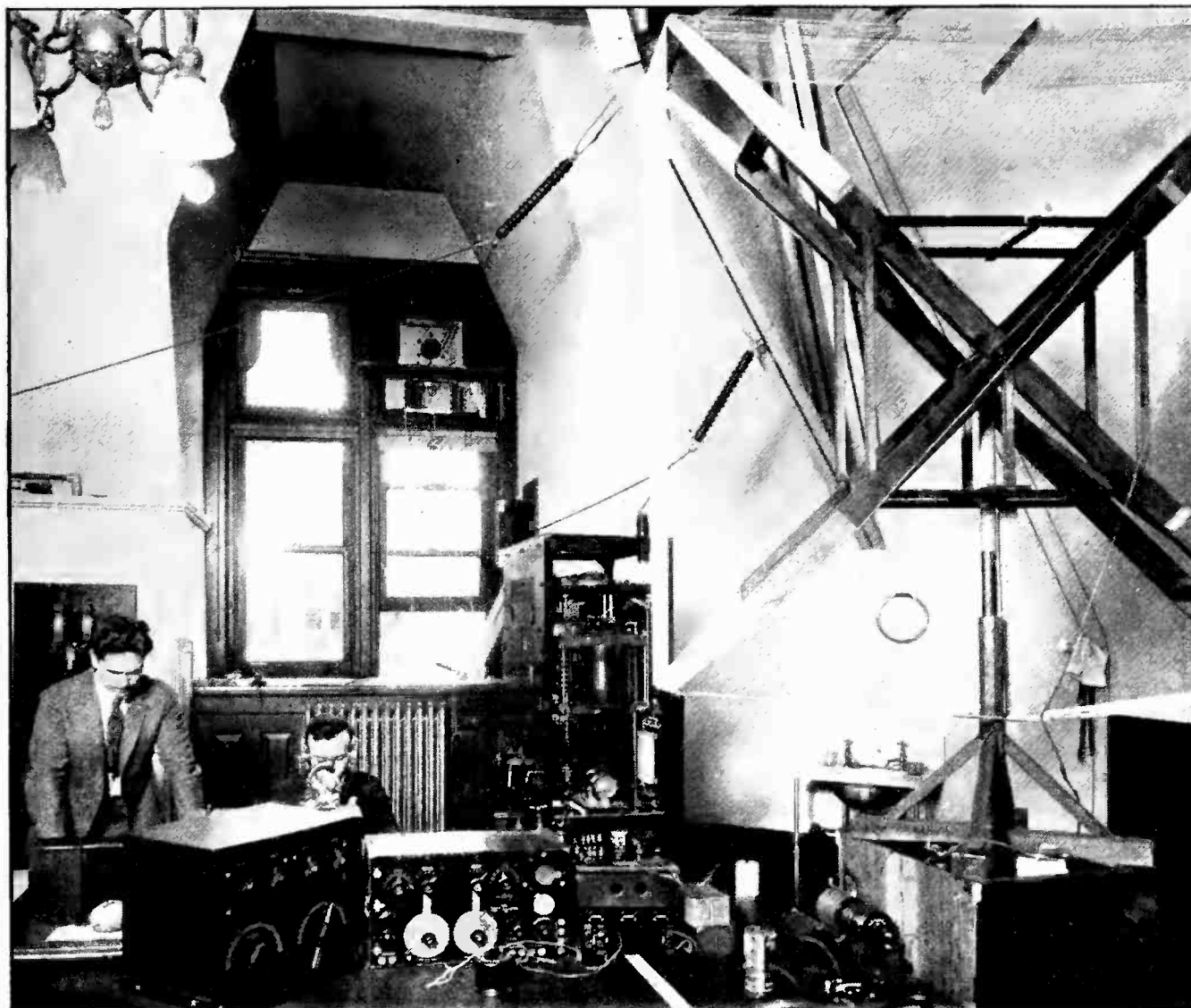

"The problem of night flying and of using radio to assist the Air Mail to cross the Continent in a day," he explained in the authorized interview following, "boils down to three major questions:

(1) Which stages of the long trip shall be flown at night?

(2) What kind of radio equipment shall be used on the planes and on the ground?

(3) What types of field and between-field lighting shall be employed?"

The third question, he says, is already settled: so-called gas accumulating searchlights, which operate automatically for months at a time without attention, have obvious advantages. Pointed skyward, placed conspicuously at the fields and at intervals of fifty miles or so between fields, such lights, both in point of effectiveness and simplicity, are the best answer to the least difficult of the three major problems.

Which gaps between New York and San Francisco shall best be covered at night is a larger problem. It may be, Mr. Edgerton explains, because of the enormous demand—notably by banks—for the swiftest possible service between New York and Chicago, that the entire run of 753 miles between these cities will be covered, eventually, at night. Yet this great distance includes the New York to Bellefonte, Pa., run, the worst run of all heretofore, mainly because of its fogs and mountains. Certainly, he adds, the Reno-San Francisco gap, to cover which a pilot must fly higher than in crossing the Alps, is out of the question both as a matter of safety and of Post Office strategy in expediting the mails across the continent.

But the remaining question, concerning radio equipment, will be to most of us the most interesting aspect of the Air Mail's ambitious plan.

Here the problem is twofold.

One phase of it has to do with supplying means by which the pilot, high up, clipping the welkin in the middle of the night, can keep in continuous touch with ground stations, and possibly with amateurs now and then.

The other phase has to do with providing what Mr. Edgerton calls navigation aids—radio direction finders and radio field localizers.

"These things," Mr. Edgerton believes, "are possible of accomplishment. Ideally, the pilot simply wears a special radio telephone helmet, designed to exclude motor noise. On

his plane a coil of wire is wound—about the struts for instance—and is connected to a receiving set on board. Then, as when a direction finder is mounted on a ship, and is oriented, the signals from a given transmitting station, or radio beacon, are loudest when the coil is pointed directly at the station. Moreover, if such a coil is mounted rigidly on a plane so that it points in the same direction as the plane, it can readily be seen that if the pilot pivots the plane so as to keep a maximum signal in his ears, he is bound to fly, as on an imaginary line, straight toward the beacon. Then, flying high, he can evade or fly through fog, his worst enemy, instead of having to fly low where he must dodge physical obstacles. But if the beacon is at the point of destination, the pilot will still be unable to locate the field exactly in thick weather because there is apparently a blind spot around each regular transmitting station, or beacon, which increases in size with the length of waves used. On a clear night, if he is careful not to level out to land too soon, and if the field is properly lighted, he can usually land all right. But if the night is not clear he will lose his direction, experiments show, just when he needs it most.

"It was to help him land that the radio field localizer was developed in 1918 and 1919 with the assistance of the Bureau of Standards radio section and the Navy. Various designs were tried out. One consisted of an insulated wire laid on the ground round the edges of the field, charged with low-frequency current and intended to operate like an audio cable such as the Ambrose Light cable, perfected by the Navy. But the device that we expect to use—experiments to develop which were begun at the Bureau of Standards in August, 1918, and then carried on at our former field at College Park, Maryland—is a peculiar kind of radio transmission aerial which transmits vertically in the form of a cone that gains diameter with increased altitude. At a height of about 3,000 feet above the field such a cone can, we believe, be made to have a diameter of nearly a mile. Distinguishing between the direction finding and landing signals, and spiraling down inside this theoretical cone, the pilot can, as he approaches the field, approximate its centre and his own altitude and effect a landing."

Experiments to apply the principles of radio direction finding to postal airplanes were begun, in coöperation with the Navy, in February, 1919. At that time a direction finder was

installed on a Curtiss R4L mail plane powered with a Liberty motor; so that the findings made (which had to be extensively altered to be satisfactorily applied to twin-engine planes), are applicable to the present postal planes which are practically all DH4B's, having single Liberty motors. This type was adapted first by the Post Office itself from the well-known DH4's—"coffin-boxes," they were called, because the gasoline tank was lodged between the seats. The principles of the "Robinson method," explained below, were utilized in the Post-Office-Navy experiments. Two definite problems were found: one, eliminating ignition disturbances of a severe nature, the other, providing a circuit reliable and simple enough to be used by a pilot unskilled in radio.

The ignition disturbances were caused by the low- and high-tension sides of the ignition circuit, which causes produced two separate and characteristic sounds. At first an attempt was made to shield the entire ignition circuit by means of metallic sheathing, but difficulty was experienced in securing adequate and frequent grounds. Next, an attempt was made to get results by sheathing only the direction-finding circuit, but here again, when the apparatus and batteries were sheathed with metal, although not of course the loops themselves, the weight was excessive and there was little improvement in the diminution of the disturbances. Finally a successful attempt was made by placing the direction-finding loops at the most distant point from the motor that the plane afforded. The Robinson method called for fixed "A" and "B" coils wound at right angles to each other, with the planes vertical. Both coils were constructed with rubber-covered aircraft wire and, at variance with accepted policy, were bunched together, since this materially aided in shortening the installation time and increased the wavelength of a given number of turns. The "A" plane of the coil, parallel to the longitudinal axis, was wound between the extreme entering and trailing edge struts. All loops were wound on a form placed on the side of a building, taped, then transferred to their permanent positions where they were again taped into place on the struts and wing surfaces with airplane linen, which was then "doped." The two leads from each coil were carried in a taping on the trailing edge of each lower wing to the fuselage. The "B" coil, at right angles to the "A" coil, was wound between the second and third rear struts



THE AIR MAIL MAN

Carries emergency rations in tin cans and bottles

away from the fuselage and on the opposite side from the "A" coil.

The second plane problem, that of providing a circuit reliable and simple enough for a pilot untrained in radio, was solved by mounting the instruments, including "B" batteries, six-stage amplifier, variable condenser and one double-pole double-throw switch, in one unit, on detachable brackets carrying elastic cord supports. These brackets were located beneath the pilot's seat along with the filament storage battery, which was also mounted on a bracket.

With the plane equipment, including an improved helmet with close-fitting receivers, rubber ear cushions and an outer hood over all working satisfactorily, the problem of developing field localizers was than continued, with the coöperation of the radio section of the Bureau of Standards. The Army and Navy were much interested in all this, for they had used radio direction finders for planes during the war, but neither had developed satisfactory radio field localizers. Since a plane approaching a field while receiving direction-finding signals from a station on the field can come safely within half a mile, the problem was to obtain a means of supplying a localized signal, intelli-

gible to the pilot and strong in the immediate vicinity of the field, but decreasing very rapidly with distance from the field. The experiments extended from various applications of alternating current with relatively low frequency to the use of radio transmitting and relatively high frequencies. This latter method made it possible for the pilot to use the same helmet. Moreover, when a very quiet engine was used, and using 20 amperes of 1,000-cycle current in the transmitting circuit, signals were heard when the plane was at a height of 6,000 feet, and there were indications of faulty tuning in the receiving circuit, at that.

The proposed set-up of radio beacons and localizers offers some practical difficulties, especially while Congress holds the Post Office Radio Division down to \$87,000 a year, as at present. The present Post Office radio chain used for administering the Air Mail consists of only twelve stations (Washington, Hazelhurst, L. I.; Bellefonte, Pa; Cleveland and Bryan, O; Chicago, Iowa City, Omaha, Cheyenne, Wyo.; Salt Lake City, Utah; Reno, Nev.; and San Francisco). Three of these are Navy stations (Cleveland, Chicago and San Francisco). Since radio beacons and localizers, to be adequate, must be actually on the postal fields, and these three are not on the postal fields, new ones must be provided. Again, some of the postal stations are too far apart, as indicated above, to keep a plane in communication with one station or another. And, once more, since the power of receiving beacon signals is limited, and since a plane steers toward

them, not away from them, provision must be made accordingly. However, if field stations are provided at Chicago and Cleveland, the distances between Chicago and New York are not large: from Chicago to Bryan by air is 178 miles, from Bryan to Cleveland 152 miles, from Cleveland to Bellefonte 206 miles and from Bellefonte to Hazelhurst 217 miles.

The transcontinental chain of stations of the Air Mail used for administrative purposes, incidentally, are not identical with the postal stations used for broadcasting agricultural information. There are eight now broadcasting: Washington (the only one using the radiophone); Bellefonte, Omaha; North Platte, Neb.; Rock Springs, Salt Lake City, Elko, and Reno.¹

It is to be noted that in no instance is the broadcasting equipment identical with that required for serving planes en route. So the problems confronting the Radio Division of the Air Mail must comprehend broadcasting administration, communication with planes, interpoint communication and radio beacon and field localization, along with radio equipment of the planes themselves.

Clearly, if the Air Mail, solving these problems, can develop and perfect night flying, it will have done much to advance the cause of aviation in America. And, further than this, it will have contributed a great deal toward demonstrating radio as the super-messenger that neither under the sea, upon the land, nor in the clouds, knows any limitation.

¹The Air Mail expects, by the way, to use the wavebands 1050-1500 for broadcasting, 950-1050 for its beacons and localizers, and 850-950 and 500-525 for its aircraft.

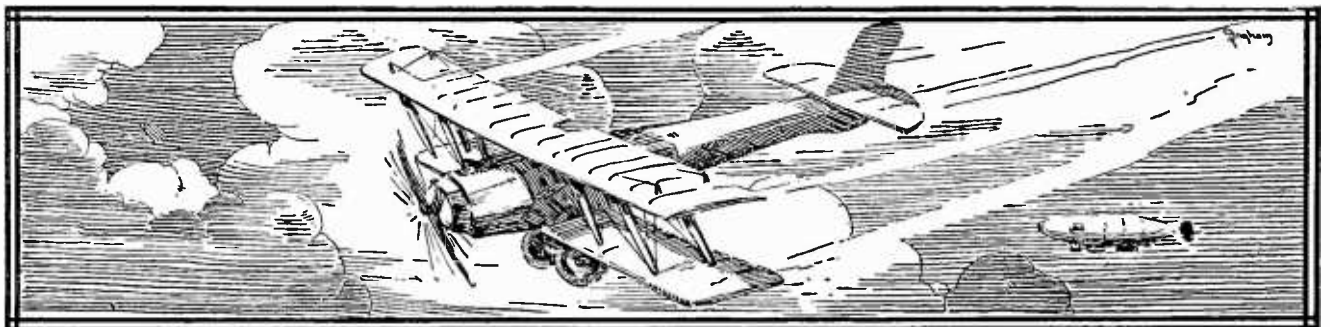

Shielded Receivers

By THOMAS C. TIBBEY

UNTIL the advent of the modern regenerative receiver, the term "shielding," as applied to radio apparatus, was quite unknown. The regenerative receiver, however, being super-sensitive to all electrical influences, has been found to require protection against external electrical disturbances. Shielding accomplishes this. It is the process of surrounding the entire receiver, and sometimes even the individual circuits therein, by a metallic surface. This usually takes the form of a copper lining in the receiver cabinet and on the rear of the panel itself. This shielding absorbs any electrical influence which would normally find its way to the windings of the receiver, and induce in them an electric current, in the same manner that radio waves induce electric currents in a receiving antenna. In this instance the windings of the receiver virtually act as an antenna, absorbing energy from the ether. This energy may be radio telegraph or radio telephone signals, "induction" from electric light or power lines, or the summer pest of Radio—Static.

SHIELDING IN RADIO COMPASS WORK

THE Radio Compass, or as it is sometimes called, the Direction Finder, has been rendered accurate only by effective shielding of the apparatus.

The heart of the Radio Compass is the "Compass Loop" which is a square coil of wire about two feet on a side and wound with six to twelve turns of insulated wire. These turns are spaced about one inch apart and held in this position by means of notched bakelite strips on the edges of the square frame of the coil. This coil is usually mounted above the operating room and arranged so as to be revolved by a shaft which passes through the roof into the room to be operated by means of a hand wheel. Wires leading from the terminals of the coil are likewise brought into the room and connected to the tuning apparatus.

When the coil is revolved so that its edge is pointing toward a transmitting station, the signals are received with maximum intensity, decreasing as the coil is revolved, until the point

is reached where the coil is broadside to the station. At this point no energy is induced in the coil, and no signals are heard.

It follows, therefore, that when using the compass coil or "loop antenna"—a name probably more familiar to most of us—only those stations are heard which lie along the line in which the coil points. Under ordinary conditions this is not absolutely true, and here is where shielding plays an important rôle.

As we have seen, the leads from the coil extend to the apparatus. These leads, together with the windings in the receiver and the wiring of the entire set, comprise an antenna, of no mean proportions. It may be readily understood, that when the coil is pointing so that no signals are being received from a certain station on the Compass Loop, they are being received on the wiring of the set. This wiring, acting as an antenna, has no directional properties and therefore seriously interferes with accurate determination of direction, or elimination of unwanted signals.

The entire apparatus and leads, are therefore enclosed in a copper shield. This usually takes the form of a very fine mesh copper screen which surrounds the room, covering all windows and doors. This shielding effectually prevents the effect we have spoken of, and renders the Radio Compass an accurate and valuable agent for the guidance of ships at sea.

AN IMPORTANT ADJUNCT IN BROADCAST RECEPTION

FIGURE 1 illustrates what is probably the most highly developed receiver available to-day. This receiver is entirely shielded. The receiver cabinet is lined with copper, as well as the rear of the panel. Openings are provided in the panel shielding, in order that no part of the receiver wiring come in contact with the shield. A further refinement is effected by separating the primary, or antenna circuit, from the secondary, or detector circuit, except through such coupling as is controlled by a coupling coil. This type of shielding is valuable for preventing undesired reactions between the circuits of the receiver. A schematic wiring diagram of this receiver is shown in Figure 3.

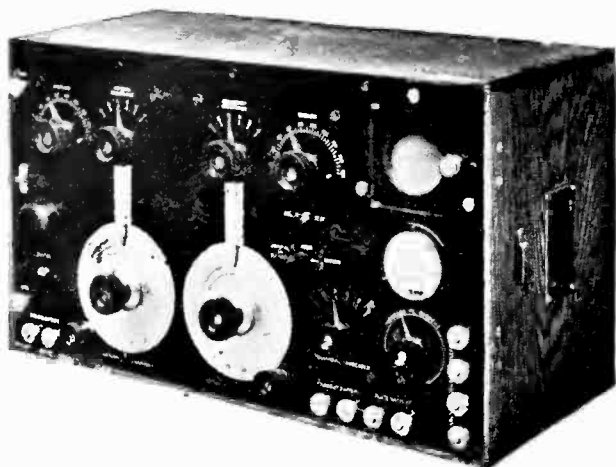
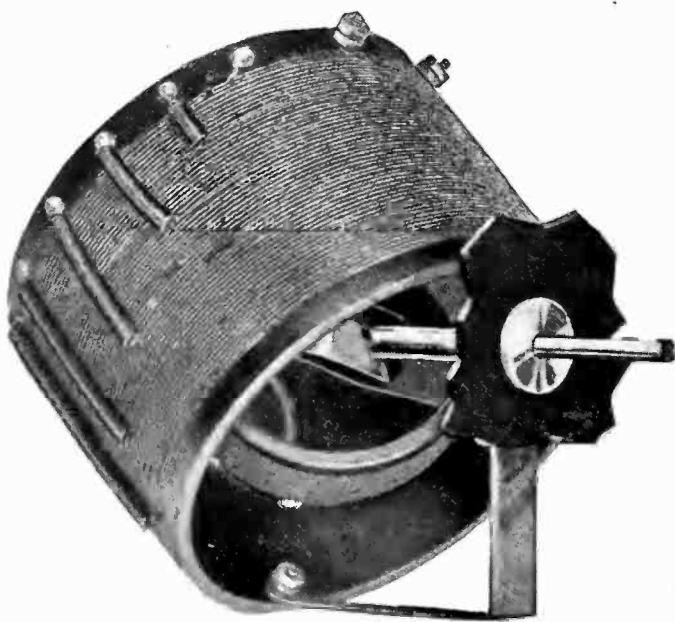

FIG. 1
A highly developed shielded receiver

It has recently been brought to the writer's attention that there is now available for amateur use a novel coupler employing a separate secondary load coil, which may be applied to this circuit. If the circuit is employed and the apparatus shielded, an extremely sensitive and selective receiver is available for long distance Radiophone reception, which should enable us to enjoy broadcasting without undue interference from nearby radio telegraph stations.

With the apparatus generally in use, a great many of us are bothered by interference from nearby commercial and amateur stations while receiving Radiophone broadcasts. In cases where the interfering stations are located close to the receiving station the antenna effect of



THE "ULTIMATE" COUPLER

the receiver wiring is very marked. Upon first thought one would think this phenomenon helpful, whereas in truth it is really detrimental.

Let us consider the case of the receiving set acting as an antenna. Unless the receiver, especially one having a large wavelength range, is equipped with "dead-ending" devices on the windings, the adjustment of the inductances, more particularly the primary, will have very little effect upon the intensity of the incoming signals.

Assuming the normal intensity of a near-by spark station when tuned in to have a value of 100, if we disconnect our antenna, it will be found that we can receive the station over a comparatively wide range of adjustments with

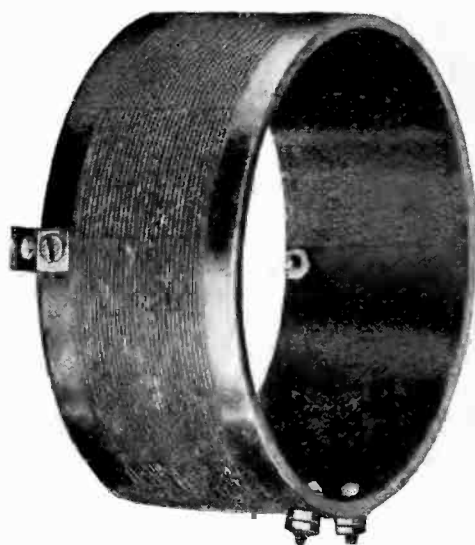

THE SEPARATE SECONDARY LOAD COIL

an intensity of perhaps 10. This would be sufficient to interfere seriously with broadcast reception. In the case of the usual commercial spark station at a distance of 5 miles, and on a wavelength of 600 meters, and a broadcasting station at a distance of 10 or 15 miles on 360 meters, the above example is a fair estimate of the relative intensities.

Thus we see that the least intensity with which we can normally receive the commercial station even without the antenna, is 10 when we are tuned to the broadcasting station on 360 meters. It follows that we shall be unable to tune the spark station out entirely no matter how selective the receiver.

Now, if we can prevent the receiver itself from "picking up" any signals, we shall at once greatly reduce the intensity of the interference and the selectivity will depend entirely upon the inherent characteristics of the antenna

and receiver. This may be accomplished by "shielding" the receiver.

SHIELDING THE RECEIVER

IN SETTING about to shield the apparatus, the entire interior of the receiver cabinet should be covered with copper foil which must be connected to the ground post of the receiver, great care being taken to have all pieces in perfect electrical contact. This can only be done by lapping and soldering the joints. Before the foil is put in place, the interior surfaces of the cabinet should be given a coat of shellac or varnish, allowing it to become very "tacky." This will render it easy to smooth out the foil and hold it so. As each side is laid in, the foil should be further secured by $\frac{1}{4}$ inch brass brads driven through the foil into the wood. The nailing should be done through the lapped seams near the edges, after a row of brads has been placed lengthwise along the centre line of the sides.

Cutting the foil in such shape that the entire box may be lined with a single piece of metal will remove the necessity of soldering any joints. The shape of the metal is shown in Figure 2. Copper foil, however, is not readily obtainable in widths greater than 8 inches, and in case it cannot be obtained sheet copper known as "twelve pound" should be employed.

The shielding of the cabinet should project sufficiently to enable connection to be made with the shielded rear surface of the panel. If the panel is set in a rabbet, the foil should project over the face of the rabbet and be secured by brass brads which should be sunken flush

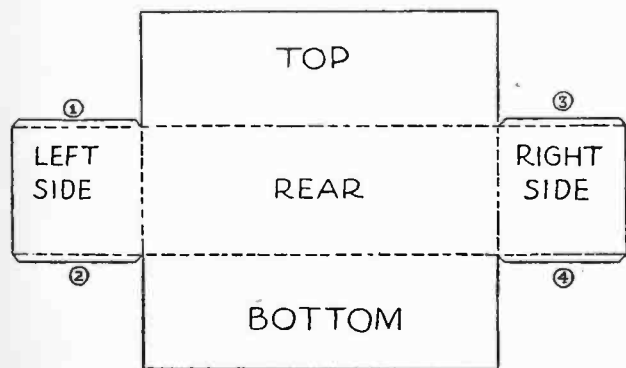

FIG. 2

with the surface by means of a nail set, so that the shielding of the panel will make good contact with it when the panel occupies its position in the box.

It is most important that the panel be shielded, as this serves the dual purpose of preventing the effect explained above, and also preventing "detuning" due to the presence of the hand or body near the receiver. No doubt all who use unshielded regenerative receivers have had this annoying experience.

The shield for the rear of the panel should

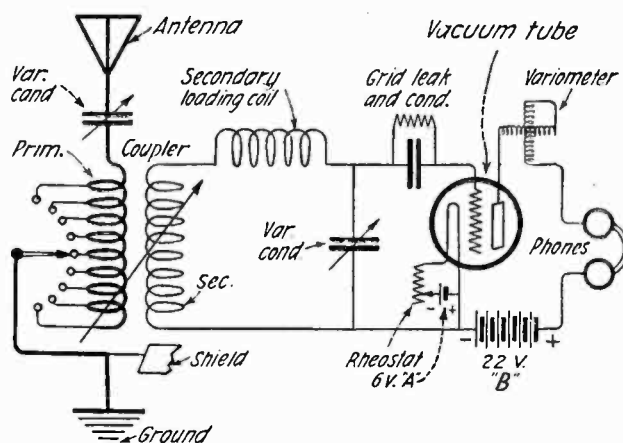

FIG. 3

be cut to size, and openings provided with $\frac{3}{8}$ inch clearance around all projecting switch points and terminals, with the exception of the "ground" binding post, to which it should be soldered.

After cutting the required openings in the foil, the rear of the panel should be coated with shellac or varnish and allowed to become very tacky. The copper foil is then warmed, laid in position on the rear of the panel, rubbed smooth, and dried under a slight pressure such as may be provided by placing a perfectly flat piece of wood—previously oiled to prevent its sticking—on the shielded side of the panel, and resting a weight upon it. Unless great temperature changes are experienced, the foil applied in this manner will retain its close contact with the panel. However, to make certain, thin strips or discs of bakelite may be placed under any nuts on the rear of the panel, projecting over the cut out space on to the foil, thus securing it. With panels of $\frac{1}{16}$ inch in thickness or more, "blind" holes may be drilled in the panel from the rear to within not less than $\frac{1}{8}$ inch from the face of the panel. These holes should be tapped for a suitable thread with a bottoming tap, or an ordinary tap with the point ground off, to accommodate round head machine screws, the heads of which will secure the shield. This is an operation which requires considerable skill in order not to have the panel bulge where the drill almost

penetrates, and is only recommended on the heavier panels.

The shielded receiver as it now stands, will prevent any undesired effects due to the coils picking up energy but we may still further utilize shielding to prevent undesired coupling between circuits, which often causes erratic performance of the receiver.

To shield a receiver internally it is necessary to cut a piece of wood to form a partition, and covering one side and the rear edge with copper foil in the manner described. This should be placed in the proper position and secured to the rear and sides with flat head wood screws countersunk flush with the surface. This shield should then be soldered to the shielding in the rear of the cabinet.

The internal shield should be so placed as to separate the coupler from the plate variometer,

and should be equidistant from both if possible. The front edge of the internal shield should extend not quite to the front of the box, a space of approximately one inch from the rear of the panel being allowed for the necessary wiring to connect the apparatus in the two sections. All wiring should be covered with varnished tubing and kept as far away from the shielding as possible.

It will of course be necessary to modify the above directions somewhat to suit conditions, especially if the shielding is going to be applied to a receiver which is already constructed, but if the general scheme is followed out, the operator will have a receiver which tunes sharply, which is unaffected by induction noises of any kind, other than those picked up by the antenna, and which performs in a consistent and efficient manner.

Radio Personalities

V

COMMANDER STANFORD C. HOOPER, U. S. N.

By DONALD WILHELM

Commenting on Commander Stanford C. Hooper's article "Keeping the Stars and Stripes in the Ether," which appeared in the June number of RADIO BROADCAST, Mr. Owen D. Young, Chairman of the Board of Directors of the General Electric Company, said: "Commander Hooper did not do himself justice, as, indeed, it would be impossible for any modest man to do himself justice under similar circumstances. The facts are that the initiative which brought into being our American radio policy and resulted in preventing us from being outdistanced by other nations started with Hooper. It was he who spurred on Admiral Bullard in his negotiations with the General Electric Company, and he was always ready to help overcome every kind of difficulty. I don't want to detract in any way from the able work of Admiral Bullard. Commander Hooper could not have accomplished what he did without the Admiral's assistance. But the original thought, the initiative and the persistent pushing were Hooper's, and he should have full credit for them." We are therefore publishing the following personality sketch of the naval officer whom Mr. Young esteems so highly, and who has been a valued contributor to this magazine.—THE EDITORS.

COMMANDER Stanford C. Hooper cannot remember the time when communication by means of electricity did not hold a fascination for him. When he was only eight years old, he knew the Morse code. When he was ten he was nosing out more of the secrets of signal strength and dots and dashes. When he was twelve he was an office messenger with an eye and an ear cocked at his main chance at a telegraph key. When he was fourteen he had qualified himself as a telegrapher. Then, with such an education as he had pieced out in San

Bernardino while spending his summers working independently for the Southern Pacific, substituting for professional telegraphers during their vacations, he made plans to enter the Naval Academy, at Annapolis.

Young Mr. Hooper, aged seventeen, with the unusual distinction of having been a telegraph messenger and operator, entered the Naval Academy on September 6, 1901, three years after the Signal Corps successfully demonstrated wireless phenomena for the first time in the United States, and two years after Marconi provided facilities, at the expense of



© Harris & Ewing

COMMANDER STANFORD C. HOOPER
Head of the Radio Division in the Bureau of Engineering, Navy Department

the New York *Herald*, for reporting the international yacht race between the *Shamrock* and *Columbia*. With such a background of practical experience as the young midshipman had, it is no wonder that some of his classmates have said that he was even then a "bug" on wireless. Actually, it may be imagined, he had some clear ideas on the future of radio before the Navy saw anything in it. It may even be that he had dreamed that it would sometime bind the remote places of the world together and reach clear across from Wrangel to Casablanca, from Colombo to Penang, from Zanzibar to Togoland and Heart's Content. At any rate, after being graduated on January 31, 1905, serving as midshipman on the *Chicago*, the destroyer *Perry*, the monitor *Wyoming*, and later on various ships as an ensign—still tinkering with radio apparatus at every opportunity—1910 found him, a lieutenant-commander, back at the Academy as an instructor of electrical engineering, physics and chemistry, there to preach his favorite doctrine that there should be a navy man assigned as a radio officer with the Atlantic Fleet. So the Navy came right back at him and made him the first fleet radio officer, which work brought him down, not only through the incidental business of being present at the capture of Vera Cruz, but to the brewing and spilling of war in Europe.

At this point, it is worth remembering that Naval officers are not usually what any one would call effusive in publicly describing one another. So it behooves one to read what Lieutenant-Commander C. N. Ingraham solemnly recorded in the Annals of nothing less than the proceedings of the United States Naval Institute:

"The first fleet radio officer under whom I served, then Lieutenant-Commander S. C. Hooper, could operate faster and with a greater degree of accuracy than any man under him. He was the fleet radio officer in the days when, if ship operators were kept out of port unexpectedly, they might ask one of the shore operators, 'Say, old man, how is it to call Gertrude and say I can't get in to-day'; when Morse and Continental were mixed according to the desire of the sender, and when no regard was given to any form. By continual practice he learned to tell each vessel in the fleet by her spark, almost unerringly, and to distinguish, by certain peculiarities, the sending of each man under him. He was not the only competent officer in the fleet, but in being one, and

realizing its importance, he was able to take the necessary steps to see that all radio officers be detailed for radio duty alone, and that they give to their work a certain number of hours each day including one watch. Though all of these did not take advantage of the opportunity to become proficient operators, a certain percentage took enough interest in the work to master operating. I know that some of those who made good disliked the assignment at first as much as, or more than, those who did not make good, but later became interested through the determination to do their best in any position assigned. For it is interesting after the long and tedious practice necessary to acquire proficiency is finished. It is as much a real game as auction bridge, and requires infinitely more finesse.



"When this officer left the fleet, he had brought it to the highest state of efficiency possible at that time with the apparatus provided. Every operator in the fleet wanted, above all else, to 'burn up' the fleet radio officer, and at the same time send 'good stuff.' They could not do this, but they kept trying. Each

operator hated to be obliged to ask for a repetition of any part of a message because the fleet radio officer never did. Mr. Hooper would tell them he had transmitted so many miles, or had received such and such a distance with a stated apparatus, and they would endeavor to beat that record. At one time, in Vera Cruz, at a conference, he said he had copied a message from Nauen, Germany, where a new spark station had just been installed. One operator, I know, sat up all night the following night with a radio room completely shut up—not even a fan going, for fear of induction—and copied a complete message from the same station, on a crystal detector where the fleet radio officer had used an audion. You may say that such things as this officer was able to do are not possible with the fleet at its present proportions. No, not as a whole, but distinctly YES, if all forces, squadrons, and divisions, had officers well versed in operating and in procedure."

Next, the Navy sent Commander Hooper abroad as an observer, with "a receiving set in his pocket," to listen in on radio abroad and learn whether the European countries were using new and better methods than those used by the Navy. Thus he listened in and heard the Germans entering Brussels, at the very outset of the war.

After that duty, the Commander reported back to the Department in Washington to take part in the first thorough reorganization of the Navy's radio. After this, from 1915 to 1917, he served as the head of the Radio Division in the

Bureau of Engineering, which has charge of the Navy's radio research, construction, and material (whereas the Naval Communications Service, whose radio section was formerly under Engineering, handles the radio and other communication traffic). Except for one short interval, through the eventful years when it may be said Navy radio and all radio with it was coming of age, he has held this office. That interval, in the year of 1917 to 1918, saw him do what any Commander yearns to do in an emergency—it saw him bolt for the bridge of the destroyer *Fairfax*, doing convoy duty across the Atlantic. But the Navy called him ashore again: it may be presumed that he was needed.

He has the insignia of the French Legion of Honor, and more such, home in his trunk. He served on the Advisory Committee of the Arms Conference, had a consulting part in the recent Radio Conference, and has had other incidental honors and functions.

But the thing that the Navy will remember him for will be his skill as an executive, and his technical skill. As the Navy puts it, "He is a practical radio man." And that, in the Navy, means a lot. In this instance at least it means that Commander Hooper started very young, stuck at it, and has been able to put to good ends the understanding of men and the skill he began to pile up when a boy messenger and telegrapher in San Bernardino, California.

As a result of his practical, direct, alert, and canny make-up, it is understandable that he was the initiating force in seeking the Conference between himself and Admiral Bullard on the one hand, and the officers and directors of the General Electric Company on the other hand. This latter conference was described in detail in the June issue of RADIO BROADCAST—that conference, on April 7, 1920, which was the birthplace of the Radio Corporation of America and of America's world-wide radio chain.

For the sake of finding out who really made the first recommendations for this all-important conference, I have turned to the authorities—to various Naval officials then high in office, to letters from officials of the General Electric Company, and in direct touch with the subject. I have had letters and verdicts by officers in interviews that establish the fact that it was Commander Hooper who saw the drift of the American chain into the hands of the Marconi Companies, saw the opportunity for the General Electric to refrain from giving over their patents or patent rights to anyone other than Americans, and accordingly, in the nick of time, took the initiative. One of the officers with whom I conferred and with whom I correspond is Commander George C. Sweet, now a consulting radio engineer in New York City, who was present at the meeting at which Commander Hooper put the situation up to his ranking officer in Naval

Communications, Admiral Bullard, has stated that "Hooper was responsible for the scheme to confer with the General Electric Company."

We now know the important results that have come from his initiative. One can trace, too, his effective work as an executive in dozens of spots in the history of radio development in the Navy, all of which would constitute too long a tale here. For there is hardly a phase of development of radio in which the Navy has not had a part, and the records show that many of the Navy's supreme achievements in radio came while Hooper was head of the Radio Division, and are still coming.

To many of us, after all, the most interesting fact is that he started as a boy-of-all-work in a telegraph office of the Southern Pacific, tried out the Postal Company as well, then, after having started out, as we have seen, from San Bernardino, California, progressed successfully all the way to the post he now occupies.

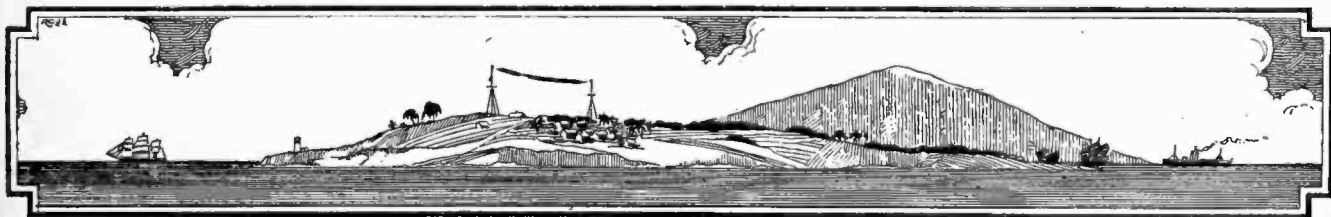
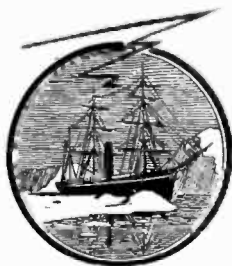

Radio in Remote Regions

This department is devoted to stories of the use and benefits of radio communication in regions devoid of telephone and telegraph wires, and which are not reached by cable. Radio is proving a great boon, not only to explorers in the Arctic, the Tropics, and other distant places of the earth, but to mariners and lighthouse tenders on solitary islands, to distant army and trading posts, to hunters in the woods and ships at sea, to station agents at lonely junctions, and even to farmers dwelling in the midst of our country but separated by many days or hours from news of the rest of mankind. RADIO BROADCAST will welcome incidents and photographs which illustrate the value of radio in remote regions, and will pay for those accepted at its regular rates.—THE EDITORS.

A Sign in the Wilderness

By SUE M. HARRISON

The story of an extraordinary sign and an extraordinary sort of wilderness. The author writes: "This narrative, while not dealing with far-off countries, does deal with the most remote region, right in our midst, that one could find in the United States. Where but in these Carolina mountains can you find seventy-five American men and women who have never used a telephone?"—THE EDITORS.

I HAD been visiting in Ashville, North Carolina for about a week, when my hostess suggested a trip through the mountains for the coming Sunday. About four o'clock in the afternoon we passed a little school house, deserted as far as school teaching was concerned, but far from deserted as we saw it. About sixty mountaineers were studying this sign on the front of the building:

"Preaching Here Tonite By Radiophone
Mountaineers All Welcome Free"

Radiophone—the latest and most wonderful product of science—here in a desolate place where there had been no school for years, where even the telephone was a mysterious thing—often unknown.

We found our way down a narrow path and came to a little spot of green, a cosy tent, and—the Moores. Mr. and Mrs. Moore are two young people of Chicago, Illinois, who are making an extensive tour of the United States. And on their way they are shedding joy and making hosts of friends, from the Atlantic to the Pacific, because they are sharing with everyone they can find, at every stop, a certain little black box. For the magic thing is equally wonderful on prairie or mountain top. The little black box is the specially-designed container for the latest addition to their complete camp outfit—the Radiophone. It is a remarkably sensitive set: they are able to hear concerts

over a thousand miles, and the telegraph reaches them from twice that distance.

Such a set is unheard of in many places, and in many others it is an impossible luxury. So the Moores are trying to shed a little of the unmatched pleasure that radio can bring. The mountains particularly appeal to them, for there they find a lack of other amusements, and of other means for education and information that makes the radiophone a greater blessing. Toward evening they inquire for a deserted school—the more secluded the better—and they are easily found, for there are many deserted schools in these mountains.

A short time after their camp is up, there are generally half a dozen mountain men about the school. And of course they see the sign "Preaching Tonite—." When they find that the strangers are glad to have them at the camp, one or two will slip away and return in a short time with several others. The mountains, apparently so desolate, are in reality alive with human beings, all trying to live and learn under conditions that are most pitiful. Many get to town only once a year; many of the women never leave the mountains from the day they enter them as brides to the day they are "toted" out to be laid to rest. Imagine what the little sign on the side of the deserted school house means to such as these!

Men who live within themselves, drawn by a curiosity they cannot resist, talk as they talk

few times in their lives. For these men know life from living; they know nature from contact; and religion from faith. And so they talk, not as scholars, but as men who sense the deep truths of life and who strive to express the feeling, with a simplicity that is stunning.

Women whose children can scarcely read or write, who know neither history nor promise of the future, women who have been deep within the mountain for years, come out with eyes as timid as a wild deer, with hands as calloused as a boy's bare feet.

What does the little sign mean to them?

To answer this question, our little party decided to wait until seven-thirty, when the service would begin. Early that evening the mountain folk began to gather about the camp. I was most surprised to note the number of women. It must have been an effort for them to come out to meet utter strangers. But their men had told them of a strange, wonderful thing, a thing that would bring them "preachin'" from the great churches in the city, that would bring them music from a massive organ such as none of them had ever seen—music with swells and tremolo as perfect as the sigh of the wind in the high pine-tops. So whatever timidity they felt, they conquered, for they were there, all that could come.

Mr. Moore tuned in KDKA (Westinghouse Electric Co. of East Pittsburgh). The service was coming to their broadcasting rooms from one of the churches in Pittsburgh. After the regular service they broadcasted a twenty-minute musical programme. The sweet strains of a violin came over the mountain tops, down the slopes, over the hundred feet of antenna, through the mysteries of the little black box to our eager ears. One lad listened with a tragic expression on his face. The music ceased. His expression did not change. Awe, wonder, joy, and fear struggled for control. Then the announcement—and music. He leaned forward and closed his eyes. It was the music he dreamed of, it was the reality of those sobbing symphonies he heard in the moaning pines of his own mountains. It was expression, that vital thing that few mountaineers know.

More than seventy-five men and women listened to the evening service and to the music. Only three had ever used the ordinary telephone. Many, indeed the majority, could not write, and could read but very little. Yet these men and women are close to us, they are our own blood, they are in our own country, they are in



the heart of the most famous range of mountains in Eastern America. And the sad part is, that these people do not realize what to do with the help often kindly offered them: they are so ignorant of civilization, yet possess the inert refinement and deep-rooted pride of their forefathers—America's founders and defenders.

To these, the Moores are bringing the greatest wonder of the modern age, they are showing the boys how to make or obtain a thing that will mean more to them than anything else they could possibly have. For the Radiophone brings them religion, education, music, and news of events, from all over the world.

What greater thing can the Radiophone do than this? I doubt if radio ever brought a church service to a more intense audience than that grouped about the Moore camp. I know that radio never brought a message more gratefully received and more *thoroughly appreciated* than that sermon from hundreds of miles away. I know that radio never made a sign—in the wilderness of any country—a sign of progress and of hope—that could kindle interest in life and in the world more than the sign that will live in the memory of every one of those sturdy mountaineers.

Radio on Robinson Crusoe's Isle

IF ROBINSON CRUSOE, upon his first reconnoitering party after landing on the island, had been greeted with the menacing, whining, snapping voice of a $1\frac{1}{2}$ -KW spark transmitter, he would undoubtedly have run back to the beach and swum out to sea again. He would never have found "the print of a man's naked foot . . . which was very plain to be seen in the sand." In due time he would have succumbed to the undertow, and later on, poor Friday would have been served up as fricassee by his cannibal captors. In short, we would have been done out of one of the finest adventure stories ever written. Fortunately, however, this did not occur and could not have occurred until some two hundred years after the events of which Daniel Defoe wrote.

What put the whole idea into Defoe's head,

CUMBERLAND BAY, JUAN FERNANDEZ



Courtesy of Houghton, Mifflin & Co.

THE FOOTPRINT IN THE SAND

you will remember, was the account of the exile of Alexander Selkirk on the island of Juan Fernandez. For four years and four months (1704-1709), Selkirk had lived there in solitude. The island where this took place, and which became in Defoe's story Robinson Crusoe's isle, lies about 360 miles out in the sea, west of Valparaiso. It is at present owned by the Chilean Government, which maintains a radio station there, of sufficient power to communicate with Valparaiso.

Between Selkirk's time and the present, the island of Juan Fernandez has been the scene of many strange doings. In the eighteenth century,

it was a favorite rendezvous of pirates and of the French and British sea rovers. More recently—in 1915—the hunted German commerce raider *Dresden* was sunk by British warships there, in Cumberland Bay. The ac-

companying photograph, taken from the rugged mountains that surround this bay, shows the small fishing village of San Juan Bautista.

The radio station is situated on one of the high points some 1000 feet above the sea. It is operated by the Chilean Navy, which expects soon to replace the $1\frac{1}{2}$ -KW "chispa" (spark) transmitter with more modern and more powerful apparatus.

What Would You Like to Have in Radio Broadcast?

The editors would be pleased to hear from readers of the magazine on the following (or other) topics:

1. *The kind of article, or diagram, or explanation, or improvement you would like to see in RADIO BROADCAST.*
2. *What has interested you most, and what least, in the numbers you have read so far?*

Broadcasting Nearly to the Arctic Circle

The Edmonton Journal Has Established a Station in Alberta, Canada, and Prophecies that the Hudson's Bay Company Will Do Likewise

By FRASER M. GERRIE

EDMONTON, Alberta, boasts the world's farthest north radio broadcasting station.

Hunt up the family atlas, O ye blasé New Yorkers who nightly tune up your instruments and "listen in" on whatever may be winging its way through the ether in your immediate vicinity, and who imagine perhaps that this modern miracle has not extended to the uttermost parts of this terrestrial sphere. Not that Edmonton can exactly be classed in the "uttermost parts," but just thumb over the pages of your atlas and appreciate how the great world-wide radio audience is extending in an ever-widening circle. That this radio circle has already extended fully a thousand miles north of Edmonton, and not such a great leap from the arctic circle, is already a matter of common knowledge. "Carpentier knocked out in the fourth round" was the message flashed through thousands of miles of air from Jersey City July 2, 1921, and almost ere the fatal word "ten" had died away the news that Jack Dempsey had retained his fistic crown was known at Fort Norman, a thousand miles and more north of Edmonton.

But it is only within the last four months that radio broadcasting on a commercial scale has been started in Alberta. The "farthest north" broadcasting station is located in the office of *The Edmonton Journal*, and every afternoon and evening since May 1st, residents of Alberta within a radius of five hundred miles of the city have been delighted with these nightly entertainments. The pioneer Marconi set installed last

May has given splendid satisfaction, and the entertainments have been heard as far away as Victoria, B. C., and in practically every part of the province.

Lest a wrong impression be gathered, it should be stated that radio in the far North, a thousand and more miles from Edmonton, is far from being at the stage where lonely trappers; and prospectors gather in some

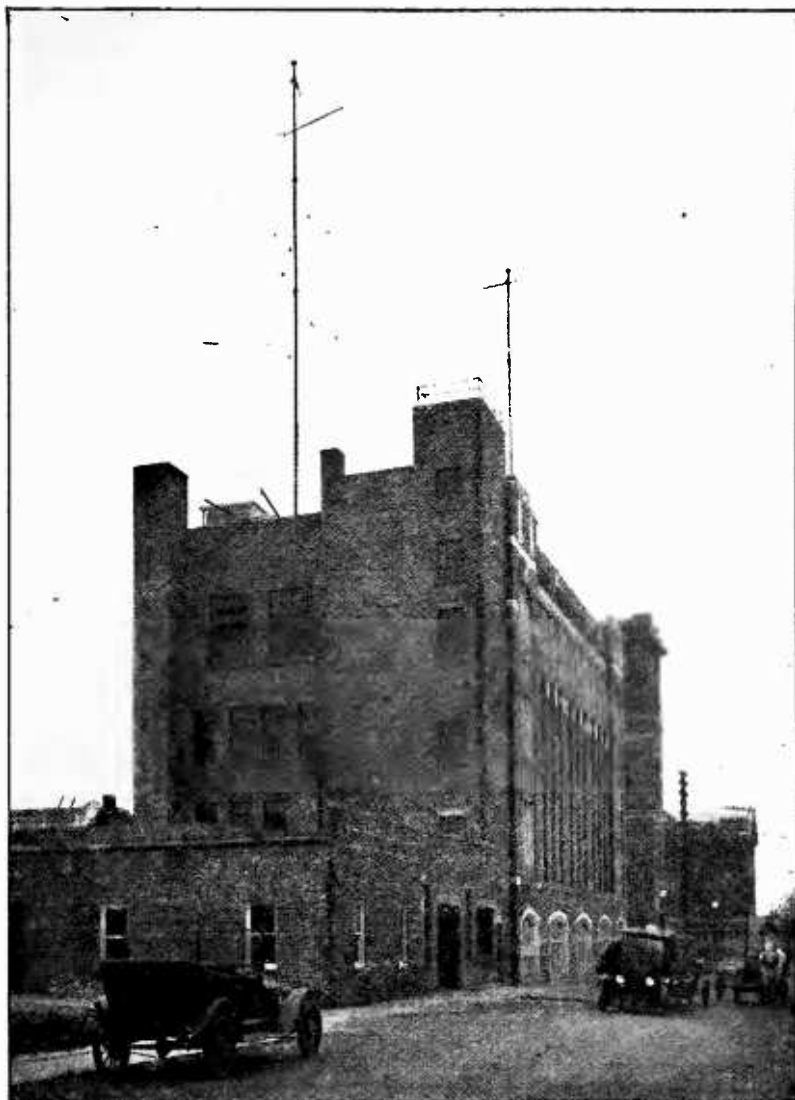

THE ANTENNA ABOVE THE EDMONTON JOURNAL BUILDING
IN EDMONTON, ALBERTA, CANADA

frontier dwelling and "listen in" on messages and concerts from a long distance. The Jersey City message already referred to was received over a high-power Dominion Government receiving set taken in by a survey party. J. B. Henderson, the Ottawa expert in charge of this set, arrived in Edmonton one day this spring on his way north for the summer. Before leaving he set up his apparatus, connected it with the largest aerial in the city, and picked up time signals from the Lyons, France, the Annapolis, and the Darien, Panama stations.

The possibilities of radio in the far North country, which stretches all the way to the Arctic circle, are tremendous. That radio stations will soon be scattered all over that

territory at outposts and forts on the fringe of civilization seems to be a certainty. *The Journal* has received applications and requests for information from points as far north as Fort Chipewyan and Finley Forks at the junction of the Peace River and Athabasca.

That the big northern trading and transportation companies, such as the Hudson's Bay Company, will soon be availing themselves of the wonderful possibilities, is a foregone conclusion. Officials of the Imperial Oil company are considering radio, and have cited the trip of Ronald McKinnon where two months were required to bring word of the far north wells, whereas by radio this information would have been available in a few seconds.

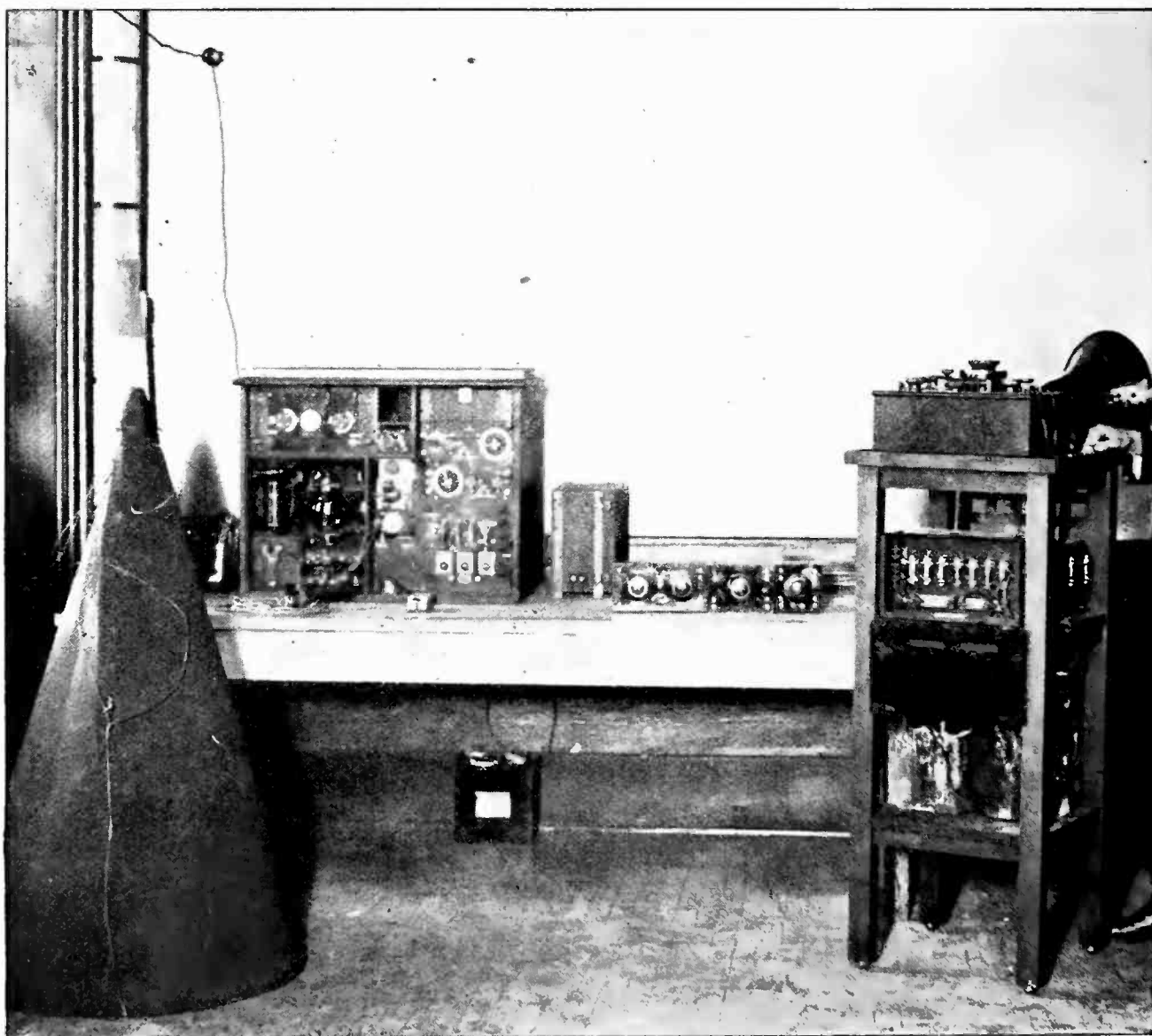

THE INTERIOR OF THE EDMONTON JOURNAL'S BROADCASTING STATION

Most of the transmitting and receiving equipment is of English manufacture. The receiving tubes, located on the panel at the right are quite different in form from the American tubes, and the receiving set above them is also quite different from those we use

Progress of Radio in Foreign Lands

REVENUE FOR THE BROADCASTING ORGANIZATIONS

FOR the time being, at least, we are fortunate as regards our radiophone programmes. The broadcasting stations maintain a high standard and their services are free. Furthermore, there is nothing to prevent anyone from listening in, and small but adequate receivers can be made without great difficulty or expense. In Great Britain, however, no one is willing to do the broadcasting unless assured of some definite return. Consequently it is not surprising to learn that the British radio organizations which are to do the broadcasting have asked the Postmaster-General not to license a receiving set unless made by a member of one of the broadcasting organizations. In this way, the profits derived from the sale of radio receiving equipment would go to those who maintain the broadcasting services. Still another plan is to have the Postmaster-General exact a modest fee for each receiving license, and then turn over a part of the receipts to the broadcasting organization. Already the British radio enthusiasts have been asked for voluntary contributions toward the maintenance of the station in Holland which is providing entertainment for so many of them.

POWERFUL FRENCH STATION EXCELLENT IN TESTS WITH NEW YORK

ACCORDING to a Reuter news dispatch, the radio station of Sainte Assise in France, which has been under construction for the past two years, has unofficially opened communication with New York. The American technicians in communication with the French station, which is the most powerful so far constructed, state that they consider it gives the clearest signals they have ever received from France. The new station will be placed at the disposal of the general public as soon as the authorization of the French Government has been given.

BELGIAN AMATEURS SERIOUSLY RESTRICTED

RADIO TELEPHONY, which is now becoming popular in England and France, evokes comparatively little interest in Belgium. The reason seems to lie in the rigid restric-

tions placed on radio stations by the decree of August 7, 1920, which prohibits radio broadcasting and limits receiving stations to time signals and meteorological messages. Detailed regulations prohibit the use of vacuum tubes unless specially authorized, require secrecy in regard to all messages which are not public property, forbid receiving stations to accept any remuneration in connection with their work, and provide for cancellation of the license and other penalties in case of violation of the regulations.

VIENNA WILL HAVE MARCONI COMPANY RADIO CENTRAL

THE Austrian Government has granted a charter to Marconi's Wireless Telegraph Company for the establishment of a central radio station in Vienna, in coöperation with an Austrian company. It is stated that the Austrian Government will participate to the extent of 30 per cent. of the capital, and a group of Austrian banks will assist the Marconi Company in founding the Austrian Company. This concession is said to have been obtained in spite of strong competition on the part of the Telefunken interests of Berlin.

GREAT PROGRESS IN RADIO IN ITALY SINCE THE WAR

THE war was the cause of a very rapid development in radio telegraphy in Italy. Figures before and after the war show that the number of ship stations has increased from 54 to over 400, that the number of words per year between ships and coast stations has increased from 80,000 to about 1,000,000, and that traffic between Italy and her colonies has risen from 150,000 to 900,000 words per annum. From *Elettrotecnica*, we learn that international traffic is carried on by two sending stations, San Paolo and Centocelle, and three receiving stations, Monterotondo, Taranto, and Covitavecchia, all controlled by the Rome telegraphic central. The operating is duplex. Arcs, alternators, and musical sparks are employed for transmission, vertical and loop antennas, amplifiers, and Wheatstone apparatus for reception. The Coltano station

is being altered to render it capable of working with North America. The San Paolo station is capable of sending 30 words per minute, but with a transmitter which is now being built, it will be able to send 50 words per minute.

BRITISH ARMY OPINIONS ON RADIO IN THE NEXT WAR

ADDRESSING the cadets of the Royal Military Academy, Woolwich, at the semi-annual inspection recently, the Earl of Cavan, who did such remarkable work during the war, particularly in Italy, and who is now Chief of the Imperial General Staff, said that he had learned with regret that for financial reasons instruction in radio at the Academy had been dropped. He hoped that the courses might soon be restored. During the war he was horrified at the number of casualties among men engaged in burying telephone wires, and with the advance of radio the question arose, "Why not abolish telephone wires?" In this connection, the Army Council had decided that from division headquarters to the front line there would be no telephone wires in the future. Therefore the Earl of Cavan looked to all young officers to obtain a practical knowledge of radio.



IMPROVING THE SOUTH AFRICAN RADIO SERVICE BEATING THE STATIC AT PORT ELIZABETH

THE British Imperial Government plans to connect Great Britain with South Africa via Cairo and Nairobi, by a series of short-range stations. The South African station of this chain is to have a range of from 2,000 to 2,500 miles. The present radio equipment in South Africa, operated by the Post Office Department, consists of three stations—one at Slangkop on the Atlantic coast, near Cape Town, one at Durban, and one at Port Elizabeth, opened about a year ago. This latter station is of $1\frac{1}{2}$ -kilowatt power and is designed to cover the coastal area between Cape Hermes and Cape Agulhas, hitherto screened from or out of range of the Slangkop and Durban radio stations for vessels sailing close to the coast. The new station is fitted with a spark transmitter having a musical note and provides satisfactory communication for the whole of this area, even under the worst daytime conditions. In addition, this station is of considerable value to

the commercial community of Port Elizabeth, affording it a ready means of communicating with vessels approaching Algoa Bay.

RESEARCH CONDUCTED BY THE INTERNATIONAL UNION OF SCIENTIFIC RADIO TELEGRAPHY

THE International Union of Scientific Radio Telegraphy was organized two years ago for the purpose of furthering the study of fundamental problems of radio communication. Separate branches have been formed in a number of different countries, and the work of the American section has been in progress for over a year. Recently, according to *Radio Service Bulletin*, measurements have been made at stations in the United States of the intensity of signals received from various French stations, and by a continuance of these measurements it is expected that more comprehensive knowledge will be obtained of the phenomena attending transatlantic transmission. At a recent meeting of the American section, various committees reported on their study of wave intensity, atmospheric disturbances, variations of wave direction, measurements of radiations which cause interference, and electron tubes. Particularly in the case of measurements of the intensity of radio waves, is it important that international cooperation be promoted, since it is only by frequent simultaneous measurements made by widely separated sending and receiving stations, that accurate and valuable data may be obtained.

INTERESTING NEW EQUIPMENT FROM ENGLAND— A DIRECTION-FINDER OF GREAT ACCURACY

THE Annual Inspection of the National Physical Laboratory, which recently took place in England, disclosed a number of interesting radio devices. Among the exhibits in the wireless hut were inductance coils suitable for use on a 2,000-volt circuit. All live parts are carefully protected, and where it is necessary to see the interior of the instrument, windows are used made of non-inflammable transparent material. *The Electrician* states that the self-capacity, in inductances of this kind, must be very small. Consequently, copper strip spirals are used for inductances up to 300 microhenries, and multi-stranded wire, wound in basket form, for capacities from 0.3 up to 3 millihenries. In the latter case

the conductors are made of 80 strands of No. 40 wire, all separately insulated. A modified frame or loop antenna was shown for obtaining bearings by radio. For this purpose a single loop is commonly used; but in this instance a smaller loop has been fixed at right angles to the first and on the same axis with it. The object of this is to avoid complete silence in the direction of the signals, as the bearings are thus more easily obtained. A commutator is also fitted, so that the winding of the main loop can be reversed at any moment; the reversal shows at once whether any local c. m. f. is affecting the signals. It is said that bearings can be taken to an accuracy of one degree or less.

COLLECTIVE EUROPEAN WEATHER REPORT FROM THE EIFFEL TOWER

AMERICAN data is now added to the collective European radio report which is transmitted daily at 11:30 A. M. (Greenwich Mean Time) from the Eiffel Tower in Paris. The observations broadcast consist of the barometer reading and the direction and force of the wind at 1 A. M. (G. M. T.) on the day of issue, at about 30 places scattered over the Continent, now including Bermuda, Chicago, Cleveland, Denver, Cape Hatteras, Salt Lake City, San Francisco, Washington, and Winnipeg. Approximate positions of the centres of cyclones and anti-cyclones are also indicated.

RADIOPHONE RECEPTION AS A SIDE SHOW

THE public radio station which has been established at Southport, England, is claimed to be the largest of its kind in the world. It is built like a small entertainment hall. On the "platform" a large receiving set has been installed, from which 60 distributing wires radiate. These are suspended, at well-spaced intervals, from the ceiling, and to the end of each is attached a hand phone, suspended within easy reach of the seated patron. Arrangements are made with certain broadcasting stations to send out music between specified hours.

BETTER EQUIPMENT FOR SHIP STATIONS

IT IS a well-known fact that aside from the real greyhounds of the ocean, most ships are provided with a rather poor and antiquated

lot of radio instruments. In fact, the average radio amateur has a far better receiving set than the average ship station; yet it is surprising what the skilled ship operators accomplish with crystal detectors and old spark transmitters. Nevertheless, F. J. Chambers, writing in a recent issue of *The Electrician*, of London, points out the necessity of employing better instruments on shipboard. He pleads for the installation of better detectors and for amplifiers, as well as for continuous-wave vacuum-tube transmitters, as a relief from confusion and interference in the ether, as well as for greater range. Already we learn that the Marconi Company has installed 3-kilowatt vacuum-tube transmitters on board the principal liners. Heretofore, range has been obtained by the simple but inefficient expedient of piling on power. Now the tide has set in the opposite direction. Simple but inefficient spark transmitters of $1\frac{1}{2}$ -



kilowatt rating are being replaced with quenched spark transmitters of $\frac{1}{2}$ -kilowatt rating on board small ships. Ultimately, it is safe to presume that vacuum-tube continuous-wave transmitters will be employed.

In the same article the author makes a plea for the ending of the monopoly which has been legitimately built up as the result of radio development and radio patents, and for the introduction of competition so that ship installations may be made up of the best equipment available.

RADIO AND AVIATION

A RECENT issue of *Radioélectricité* contains an interesting historic account by P. Brenot, describing the gradual development of radio telegraphy and telephony aboard aircraft from the beginning of this phase of the art, in 1910, to the present day. It seems that the builders of aircraft and the manufacturers of radio equipment have not collaborated any too well. As a result, extensive alterations costing a great deal and resulting in serious time losses have to be made in aircraft in order to accommodate radio installations. The author makes a plea for closer coöperation between aeronautical constructor and radio engineer, with a view to securing the best results with a minimum of alteration.

The Grid

QUESTIONS AND ANSWERS

The Grid is a Question and Answer Department maintained especially for the radio amateurs. Full answers will be given wherever possible. In answering questions, those of a like nature will be grouped together and answered by one article. Every effort will be made to keep the answers simple and direct, yet fully self-explanatory. Questions should be addressed to Editor, "The Grid," Radio Broadcast, Garden City, N. Y. The letter containing the questions should have the full name and address of the writer and also his station call letter, if he has one. Names, however, will not be published.

Some receiving sets are provided with dials, marked from 0 to 100 and others are marked from 0 to 180. How is it possible to determine the wavelength for a given setting of the dials?

B. T. H. Los Angeles, Cal.

THE marking on most receiving sets can not be used as a direct method of determining the wavelength of received signals and is provided so as you may have some definite idea of where to look for certain stations, *after you have once been able to tune them in.* After a station has been heard, you may make a record of the position of the dial or dials and it is quite likely that the same station may again be heard by making the same adjustment. There are some sets, which are used extensively, such as the Westinghouse and the Grebe, which are provided with dials which do not indicate wavelengths directly, but we have become accustomed to using them and know about where to find stations operating on given wavelengths. Provided the antenna is of the dimensions recommended, it is found that most broadcasting stations may be picked up by the Westinghouse "RC" receiver with the dial indicating approximately 30. The Grebe receivers of the variocoupler and twin variometer type are provided with a wavelength chart which indicates the wavelength for dial settings in the secondary circuit. By this method, stations of known wavelength may be picked up by setting the proper dial and then adjusting the others. The wavelength of any station within range of the set may be measured by first properly tuning the receiver and then reading the wavelength from the chart for the particular setting of the secondary tuning dial. In instances of this sort the wavelengths are not very accurate but serve quite well for all practical purposes, and where accurate measurements are required a wavemeter should be employed.

What is the best crystal for a receiving set and how far should it be possible to receive from a broadcasting station with a well-designed crystal set?

A. B. K. Galveston, Tex.

FOR all around reception, it is doubtful that any crystal will give better results than may be had from galena. Merely procuring a piece of galena and putting it in your set, however, will not do. It is necessary to procure a large-sized piece and break it up into smaller pieces, testing each piece. It may be necessary for you to try a great many pieces before you find one which is truly sensitive, but the task is entirely worth while.

A very good method of testing crystals is to have a double detector stand or two detectors which may be thrown into the same receiving circuit at will; one is used with any crystal and the other is used as the test stand by placing var-

ious crystals in it. As soon as one crystal is found which gives satisfactory results it may be used as the standard and others may be compared to it. In making the comparison, some single transmitting station should be picked out and the strength of its signals used as the determining factor.

The crystal is the heart of the crystal receiving set and some of the sets which have been thrown back on the hands of their manufacturers by dissatisfied purchasers would have given satisfaction if a little more care had been exercised in selecting the crystals with which they were equipped.

It comes more or less as a shock to most new radio enthusiasts to learn that the commercial operators on ship-board have received signals with crystal sets, without any amplification whatever, over distances in excess of eight thousand miles. One operator, in making a trip from New York to San Francisco by way of the Straits of Magellan, received press dispatches from the old Telefunken Station, located at Sayville, Long Island, nearly every night of his voyage. Another operator, on a trip from an East Coast port, through the Panama Canal, to Corral, Chile, which is some two hundred miles south of Valparaiso, received press, weather reports, and time signals from the U.S. Naval Station at Arlington over his entire trip with the exception of four days, and these four days were spent in the Torrid Zone where the static was extremely severe. No amplifiers were used and the results obtained are not at all uncommon.

No such results as these may be expected from a broadcasting receiver, but you may be sure that the range over which your set will operate depends to a very great degree upon the sensitivity of the crystal you employ and the skill with which you are able to locate its most sensitive points, and this skill comes with continued use.

How is the regeneration accomplished with the standard variocoupler and two-variometer hook-up, when there is no inductive relationship between the placement of these three units?

L. P. New York City

YOUR question is quite like many others we have received, and the following explanation may be helpful, though it is truly a repetition of material already published in articles appearing in Radio Broadcast.

To begin with, you are not quite correct in the assumption that there is no inductive relation between the elements for the primary and secondary of the variocoupler are in inductive relation to each other. The grid variometer is usually connected in series with the secondary of the variocoupler and thus becomes a part of the same circuit and, though it is not in direct inductive relation to the pri-

When Marconi heard the AERIOLA GRAND



© UNDERWOOD & UNDERWOOD



Look for this trademark
at your dealer's.

“IT comes closest to the dream I had when I first caught the vision of radio’s vast possibilities. It brings the world of music, news and education into the home, fresh from the human voice. It solves the problem of loneliness and isolation.

“The Aeriola Grand is at present the supreme achievement in designing and constructing receiving sets for the home—a product of the research systematically conducted by scientists in the laboratories that constitute part of the R C A organization.”

G. Marconi

The Importance of the Symbol R C A

Crude Radio apparatus of a kind can be made even by embryonic organizations. But the vitally important inventions that have made radio the possession of every man, woman and child are those protected by patents owned by the Radio Corporation of America and developed as the result of costly research conducted in the engineering laboratories of the Radio Corporation of America.

The name-plate of a Radio Set is all-important in the purchase of radio apparatus. If it bears the letters “R C A” the public and the dealer are assured that at the time of its introduction it is the highest expression of the advancing art of radio.

In tone quality, in simplicity of manipulation the Aeriola Grand is unrivalled. A child can snap the switch and move the single lever that tunes the Aeriola Grand and floods a room with song and speech from the broadcasting station.

Any R C A dealer will be pleased to show you the Aeriola Grand and to let you judge its wonderful tone quality for yourself.

There is an R C A set for every purse—Prices range from \$18 to \$350.

Aeriola Grand
with stand
\$350



Radio Corporation
of America

Sales Dept., Suite 2066
133 Broadway
New York City

District Office
10 South La Salle St.
Chicago, Ill.



What Radio Is Doing For Me

LaFayette, Ind.
April 26th, 1922.

EDITOR,
Radio Broadcast,
New York City.

DEAR SIR:

I am enclosing a photo of myself using a radio receiving set.

By way of introduction wish to say that I am a bed fast shut-in whose life has been greatly brightened by the wireless. From the leading stations I am able to bring to my bedside the best of talent.

My outfit consists of a three-tube set and a loud speaker. Chicago, Detroit, Indianapolis, Pittsburg, Newark, Schenectady, and many other places I hear regularly. Often the sounds are so loud as to flood the room with music and voice.

I have purchased my radio with my own earnings. In 1918 I opened a magazine subscription business in this city. In four years I have built a good business. Last December I handled twelve thousand letters.

I declare that my radio is an investment! As a means of creating a wide circle of friends it is invaluable. My room is the most popular place in the community. I have used it as an excuse to invite in folks with whom I have long wanted to get better acquainted. The new friends I have enlisted by use of my radio mean more business for me.

In a very short time I honestly believe that a wireless telephone will be as common in the home, and especially in any room where there is sickness, as the electric fan and other conveniences.

Hospitals are installing radio to facilitate recovery among the sick. Having listened in to daily entertainments, I declare myself less susceptible to fatigue, more alive to everything, and a more contented person. Radio has done for me what medical science failed to do.

Very Sincerely,

A. J. DELONG.

A. J. DELONG,
LaFayette, Indiana.

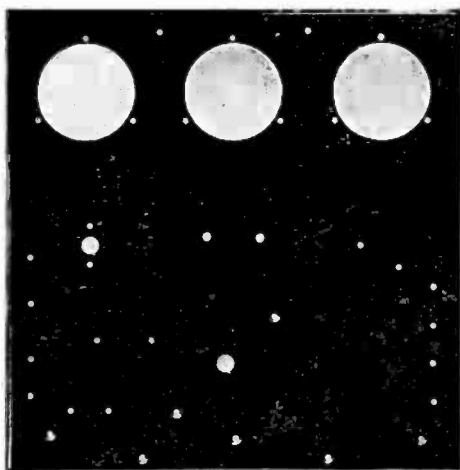

CONDENSITE CELORON

Sets a New Standard in Radio Panels and Parts

This strong, handsome, jet black, insulating material gives you a surface and volume resistivity greater than you will ever need and a beauty that will make your set the envy of your friends. It is the ideal material for making radio panels because it machines readily—engraves with clean cut characters and can be finished with a high natural polish or a rich dull mat surface.

If you want the highest type panel you can obtain—a panel made from a material approved by the Navy Department Bureau of Engineering—a panel that will give you continued satisfactory service—insist upon a Condensite Celoron Panel.

Make Your Next Panel of Condensite Celoron

If your local radio dealer cannot supply you with a genuine Condensite Celoron Panel get in touch with us direct. We'll see that you are supplied.

An Opportunity for Radio Dealers

Condensite Celoron Radio Panels offer a sales opportunity unequalled to the live wire dealer who is keen on building business on a quality basis. Write us to-day for our special Dealer's Proposition and let us give you all of the facts.

Diamond State Fibre Company

**Bridgeport (near Philadelphia), Pa.
Branch Factory and Warehouse, Chicago.**

Offices in principal cities

In Canada: Diamond State Fibre Co. of Canada, Ltd., Toronto.

mary, changes in the variometer cause changes in the wavelength of the entire grid circuit of which the secondary of the variocoupler forms a part and the inductive relation between the primary and secondary is therefore altered.

The major adjustment of the "coupling," as it is called, is generally accomplished by changing the position of the secondary with relation to the primary. - This may be done by rotating the secondary, which changes the plane of its winding with relation to that of the primary, or by moving the secondary away from the primary, which has the same effect, that is, reducing the coupling or the influence of one winding on the other.

When the secondary winding lies in the same plane as the primary winding, the transfer of energy from one to the other is most pronounced and the coupling is "tight," and the same holds true when the secondary is brought close to the primary, provided the planes of the two windings coincide.

The relation of the primary to secondary—in this case, the grid circuit—changes with the number of active turns in each, as well as with the placement of their windings with relation to each other. Most circuits of the character you refer to are provided with variocouplers having a secondary winding which is "fixed," that is, the number of turns can not be changed, and the wavelength of the grid circuit is regulated by adjusting the variometer. However, the primary of the vario-coupler is generally provided with taps to permit the use of any number of turns, and the turns actually in use are termed the "active turns." Although the relation of the two windings may not be altered, there is a change in coupling with every change in the number of active turns in the primary winding.

Having disposed of this relationship, we come to the explanation of the regeneration or feed-back, as it is commonly called here, or reaction, as it is termed in England. Here the relationship between the circuits is of a different nature and one is affected by the other through the vacuum tube and there is no direct inductive relationship between the variometer in the plate circuit and the elements which comprise the grid or secondary circuit. The term, reaction, used by the English, by the way, is much less a misnomer than either of our names and smacks less of mystery.

It has been found—and there are many, many claimants to the finding—that a receiver employing a vacuum-tube detector will produce a greatly augmented signal when the electrical period of the wiring in the plate circuit is identical to that in the grid circuit, and a correct voltage is supplied the plate.

The variometer in the plate circuit is merely a simple means for altering the electrical length of the circuit at will, to compensate for wavelength adjustments in the primary and secondary, for all three must be identical if the maximum signal is to be had.

When the current passing through the turns of the rotary element of the variometer opposes the current in the stationary winding, the wavelength of this unit is shortest, but when the current in each half of the unit is flowing in the same directions, the wavelength is longest. The range of a given variometer depends upon the number of turns in the elements as well as the distance between the rotary and stationary elements and the distance between the turns in the windings of each, as well as the particular kind of wire employed and the insulating material or varnish used.

Some forms of regenerative circuits are made with a fixed inductance—the number of turns can not be altered—mounted so that its position with relation to the secondary circuit may be altered. In this instance the coil takes the place of the variometer and the reaction effect is obtained by altering the position of the feed-back or "tickler" coil, as it is commonly called. In this case there is, of course, and inductive relation between the secondary and plate circuits, whereas in the variometer-tuned arrangement this indicative relation does not exist and the reaction occurs directly through the vacuum tube when the current in the plate and grid circuits is in phase, that is, when it is passing through the same electrical length in each circuit and when the rising and falling of current in each circuit occurs simultaneously.

Perhaps the case may be better understood from consideration of the action of the vacuum tube functions for this particular purpose. We know that the greatest energy transfer, from the antenna to ground circuit, which includes the primary of the variocoupler, occurs when the secondary or grid circuit is of the same wavelength and the coupling between the two circuits is properly adjusted. We also know, from a study of what happens when the vacuum tube is used as a detector, that the current imposed on the grid controls the current flowing in the plate circuit, but the current in the latter is greatly increased because it is drawn from a local reservoir, the "B" battery. By adjusting the wavelength of the plate circuit, it is possible to have the current flowing in the grid circuit and that in the plate circuit in step with each other. By doing this, we find that a greater current finds its way to the grid, and as the current in the plate circuit depends upon the variations in the grid current, a greatly augmented signal results.

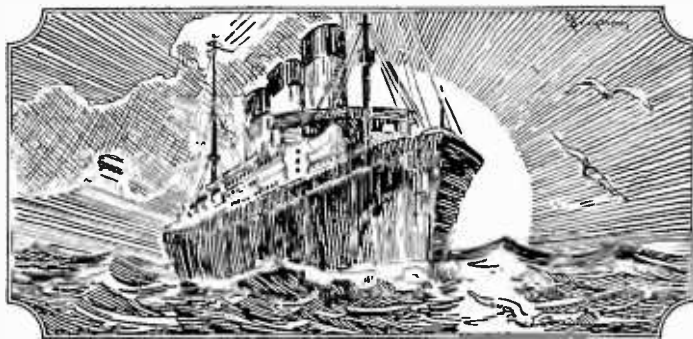
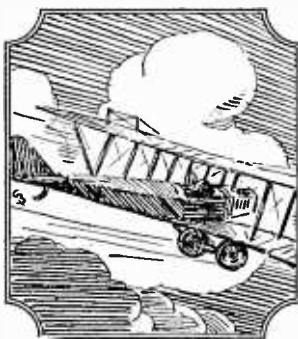



Unlimited resources of entertainment with the Magnavox Radio

IT is the Magnavox Radio which is invariably selected for demonstrations of technical or public interest. The two sizes of Magnavox Radio meet every requirement of volume and range—from the home gathering to the largest public audience.

R 2 Magnavox Radio with 18-inch horn . . .	\$85.00	Model C Magnavox Power Amplifier 2 Stage—AC-2-C . . .	\$ 80.00
R-3 Magnavox Radio with 14-inch horn . . .	45.00	3 “ —AC-3-C . . .	110.00

*The Magnavox products may be had of good dealers everywhere.
Our interesting new booklet (illustrated in 3 colors) sent on request.*

THE MAGNAVOX COMPANY, Oakland, California; N.Y. Office, 370 Seventh Ave.

MAGNAVOX RADIO

The Reproducer Supreme

John Bull's World-Wide Radio

Interesting Facts from the Technical Report of
the Imperial Wireless Telegraphy Commission

By J. CONRAD FLEMMING

IF JOHN BULL did not have a world-wide radio scheme on his mind, he would not rank among the leading nations of the world. Uncle Sam has his own extensive radio system pretty well under way, with the partial completion of the Radio Central at Rocky Point, Long Island, while France is rushing the work on the huge Sainte Assise station, which will be the largest in existence. Germany has, or rather had, an ambitious world-wide radio system, with the powerful Nauen and Eilvese stations as the starting point.

But we are primarily interested in John Bull's world-wide radio scheme in this case, because of a report of the Wireless Telegraphy Commission which, in accordance with the suggestion of the Imperial Wireless Telegraphy Committee, was appointed in 1920 to make recommendations regarding the sites and apparatus for the stations of the Imperial Wireless Chain. The Commission comprises such eminent men as Lord Milner, Dr. W. H. Eccles, the well-known authority on radio communication, L. B. Turner, E. H. Shaughnessy, and Lt. Col. C. G. Crawley. So the report, as might well be expected, is replete with interesting facts concerning long-distance radio communication, incorporating, as it does, the best existing practice as well as the revelations of the radio laboratory.

The report starts out by pointing to the fact that the Imperial Wireless Telegraphy Committee recommended that the vacuum tube transmitters should be capable of delivering at least 120 kilowatts to the aerial and that double this power may be within the range of possibility in the near future. Mention is made of the excellent results obtained with large silica vacuum tubes. To-day, four or five $2\frac{1}{2}$ -kilowatt vacuum tubes of the silica type are being produced every week for the British Admiralty. It is estimated that twenty-four large tubes would be required to deliver 120 kilowatts to the aerial. If a vacuum tube transmitter were operated 24 hours per day,

without rest, it would require between 36 and 108 tubes per year for renewals. If glass tubes were employed instead of silica, then about four times as many would be required for equipment and for renewals. So for the present the problem is to key up the vacuum tube industry in order to turn out the requisite number of tubes.

The Report goes into a discussion of costs for vacuum tubes and replacements. It is claimed that the filaments of burnt-out tubes can be renewed, thus reducing replacement costs materially. It is hoped to realize a filament life of 2,000 to even 6,000 hours, eventually.

That vacuum tubes are not altogether an experiment in long-distance communication is evident from the report's mention of the Marconi Company's experiments with this type of transmitter. Commercial traffic has been established across the Atlantic by means of vacuum tubes, so we are told, using less than 30-kilowatt input at Clifden, Ireland. The German Telefunken Company has also had good results with vacuum tubes. The Commission visited the Carnavon station and witnessed the trials with the largest vacuum tube set yet constructed. Forty-eight glass vacuum tubes were assembled, with an input of about 100 kilowatts. By overloading the tubes it was possible to employ an input of 150 kilowatts. The signals were intercepted in India and Australia.

The matter of wavelengths is an important one. Extensive experiments have been conducted by the Wireless Telegraphy Commission between the Admiralty station at Horsea and Egypt. The conclusion is that the best signals are those obtained at night by the use of relatively short waves, while the best day signals are those using long waves.

Then there is the question of transmitting aerials and masts and towers. In connection with vacuum tube transmitters, it is held that the high aerial with relatively small area is preferable to the low aerial with a large area.



“Why the menagerie?”

YOU wouldn't stand for a young menagerie howling around the house. Why permit your radio set to act that way? It's unnecessary. For just five dollars you can add an Acme *Audio* Frequency Transformer to your set. This ends the howling and distortion so prevalent in the ordinary detector unit and at the same time it greatly increases the volume of incoming sound. Music and the human voice assume their natural tones. No more thin, squeaky voices and tiny elfin wails.

You will also want the Acme *Radio* Frequency Amplifying Transformer. You can use it with either a vacuum tube or a crystal detector set. It greatly increases the distance over which you can receive broadcasting programs. Just the same price as the Acme *Audio* Frequency

Transformer. Two stages of Acme *Audio* Frequency Amplification with two stages of Acme *Radio* Frequency Amplification will give you maximum range, volume and certainty of natural tone. Your set is incomplete without them.

The Acme Apparatus Company (pioneer transformer and radio engineers and manufacturers) also make detector units, detector and two stage amplifying units, the Acme Clear Speaker, the Acme phone, also C. W. and spark transmitting apparatus. Acme Apparatus is for sale at radio, electrical and department stores. If one is not close at hand, send money direct. Ask also for interesting and instructive book on Transformers. The Acme Apparatus Company, Cambridge, Mass., U. S. A. New York Sales Office, 1270 Broadway.



Type A-2 Acme Amplifying Transformer
Price \$5 (East of Rocky Mts.)

ACME

for amplification

When it comes to the supports for the aerial, the ideal mast is one made of insulating material. Wooden structures are an approximation of the ideal, although they are unsatisfactory for use in the tropics. Steel structures, on the other hand, are parasitic—they take away from the useful radiation of the station, although much of the parasitic loss can be overcome by insulating various portions of the mast and placing the mast on an insulating base.

The conditions for receiving have also received considerable study, and experiments have been conducted with a view to developing suitable directive systems which would reduce interference to a minimum. It is suggested that each station should have as many receiving units as the number of stations with which it is to communicate. The receiving units should be grouped together at a distance of 20 to 40 miles from the transmitting station.

Static—that bugbear of long-distance radio communication—comes in for its share of attention. Experience recently gained in England and Egypt is reported to indicate that atmospheric interference may be appreciably reduced by each of three distinct methods as follows: (1) Atmospheric balancing, in which an ingenious system of tuning causes the more or less complete cancellation of the undesired static. (2) Limiting the strength of the received signals, and therefore the strength of the atmospheric disturbances at the same time, since increasing the sensitiveness of the detector and the degree of amplification generally increases the static noises to such a degree that even the amplified signals are not clearly heard. It is better to receive weaker signals through very slight static. (3) Barraging, which is an elaborate tuning system for reducing static.

All of which gives John Bull's radio men plenty to do, for the present.

SUPPLEMENTAL LIST OF BROADCASTING STATIONS IN THE UNITED STATES FROM JUNE 16 TO AUGUST 10 INCLUSIVE

CALL SIGNAL	OWNER OF STATION	LOCATION OF STATION	WAVE LENGTH
AGI	Signal Corps School	San Francisco, Calif.	360
KDPM	Westinghouse Elect. & Mfg. Co.	Cleveland, Ohio.	360
KDZT	Seattle Radio Assn.	Seattle, Wash.	360
KFAC	Glendale <i>Daily Press</i>	Glendale, Calif.	360
KFAD	McArthur Bros. Mercantile Co.	Phoenix, Ariz.	360
KFAE	State College of Washington	Pullman, Washington	360
KFAJ	University of Colorado	Boulder, Colorado	360
KFAN	Electric Shop.	Moscow, Idaho	360
KFAP	Standard Publishing Co.	Butte, Montana.	360
KFAQ	City of San Jose	San Jose, Calif.	360
KFAR	Olesen, O. K.	Hollywood, Calif.	360
KFAS	Reno Motor Supply Co.	Reno, Nevada	360
KFAT	Donohue, Dr. S. T.	Eugene, Oregon.	360
KFAU	Independent School District of Boise City	Boise, Idaho.	360
KFAV	Cooke & Chapman	Venice, Calif.	360
KFAW	Radio Den, The	Santa Ana, Calif.	360
KFBA	Ramey & Bryant Radio Co.	Lewiston, Idaho	360
KFBB	Buttrey & Co., F. A.	Havre, Mont.	360
KFBC	Azbill, W. K.	San Diego, Calif.	360
KFBD	Welsh, Clarence V.	Hanford, Calif.	360
KFBE	Horn, Reuben H.	San Luis Obispo, Calif.	360
KFBF	Smith, F. H.	Butte, Mont.	360
KFBG	First Presbyterian Church	Tacoma, Wash.	360
WAAB	Jensen, Valdemar	New Orleans, La.	360
WFAU	Lewis, Edwin C. Inc.	Boston, Mass.	360
WFAV	University of Nebraska	Lincoln, Nebr.	360.485
WFAW	Miami <i>Daily Metropolis</i>	Miami, Fla.	360
WFAZ	Kent, Arthur L.	Binghamton, N. Y.	360
WFAZ	Daniels Radio Supply Co.	Independence, Kansas	360
WFAZ	South Carolina Radio Shop.	Charleston, S. C.	360
WGAC	Orpheum Radio Stores Co.	Brooklyn, N. Y.	360
WGAD	Spanish American School of Radio Telegraphy	Ensenada, Porto Rico	360
WGAF	Goller Radio Service.	Tulsa, Okla.	360
WGAH	New Haven Elect. Co.	New Haven, Conn.	360
WGAJ	Gass, W. H.	Shenandoah, Iowa	360
WGAJ	Lancaster Electric Supply & Const. Co.	Lancaster, Pa.	360
WGAM	Orangeburg Radio Equipment Co.	Orangeburg, S. C.	360
WGAN	Lloyd, Cecil E.	Pensacola, Fla.	360

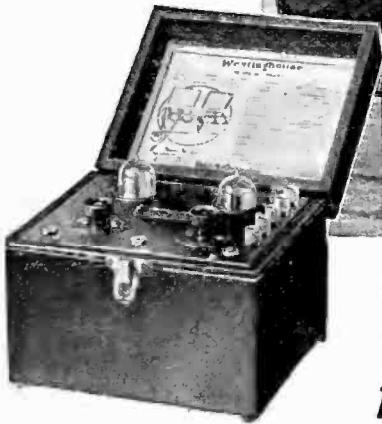
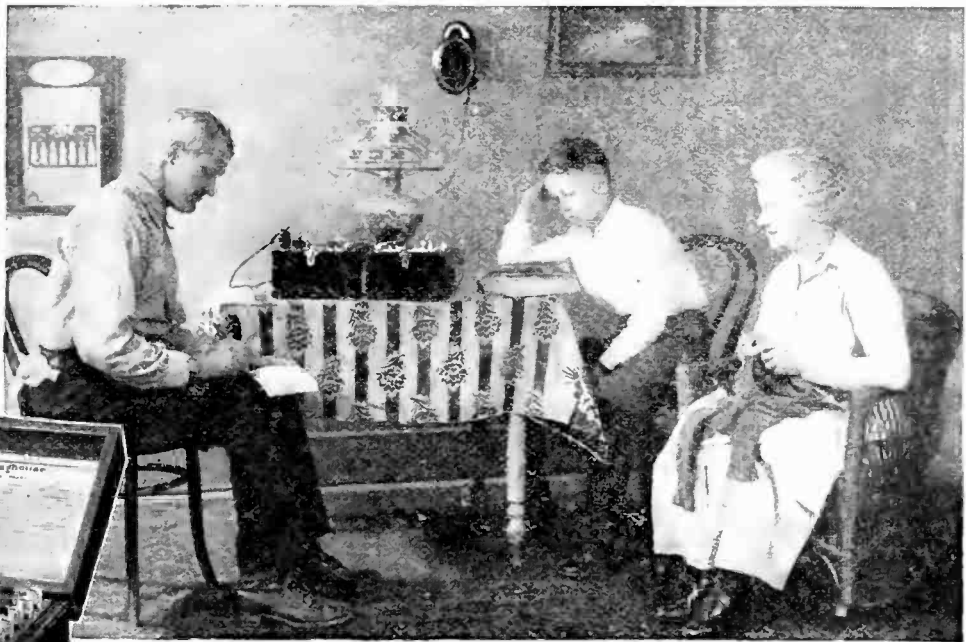

The AC AMPLIFIER for the AERIOLA SR.

AERIOLA AMPLIFIER
Model A C
Complete with two WD II-A
dry battery tubes
without batteries - \$68.00

Vacarola Loud-speaker
Model L V - - - - \$30.00

THE Aeriola Sr., simplest and most efficient of all single-tube receiving sets, becomes still more efficient with the new model A C amplifier.

No storage battery is required. With only two dry cells, two tubes, and a 45-volt plate battery the model A C amplifier greatly increases the Aeriola Sr.'s range of reception. Used with the Vocarola loud-speaker, the amplifier connected with an Aeriola Sr. fills a whole room with concerts received over distances of ten to thirty miles.



*This symbol of quality is
your protection*

Anybody can make the simple connections required, including mother and the girls.

Before buying radio apparatus, always consult the book "Radio Enters the Home." Price 35 cents by mail.

Because there are no storage batteries to charge, because both the Aeriola Sr. and this new model A C amplifier are so light and handy, the combination is ideal for the broadcasting enthusiast who has no storage battery charging facilities. Ready at your Dealer's October 1st.



Sales Dept., Suite 2066, 233 Broadway, New York City
District Office, 10 South La Salle Street, Chicago, Ill.

WGAQ	Patterson, W. G..	Shreveport, La.	360
WGAR	Southern American	Fort Smith, Ark.	360
WGAS	Ray—Di—Co. Organization	Chicago, Illinois	360
WGAT	American Legion, Dept. of Nebraska	Lincoln, Nebraska	360
WGAU	Limb, Marcus G..	Wooster, Ohio	360
WGAV	B. H. Radio Co.	Savannah, Ga.	360
WGAW	Albright, Ernest C.	Philadelphia, Pa.	360
WGAY	North Western Radio Co. Inc.	Madison, Wisconsin	360
WGAZ	South Bend <i>Tribune</i>	South Bend, Ind.	360
WHAA	State University of Iowa	Iowa City, Iowa	360
WHAB	Thompson, Clark W.	Galveston, Texas	360
WHAC	Cole Bros. Electric Co.	Waterloo, Iowa	360
WHAD	Marquette University	Milwaukee, Wisconsin	360
WHAE	Automotive Electric Serv. Co.	Sioux City, Iowa	360
WHAF	Radio Electric Co.	Pittsburgh, Pa.	360
WHAG	University of Cincinnati	Cincinnati, Ohio	360
WHAH	Griffin, John T.	Joplin, Mo.	360
WHAJ	Radio Equipment & Mfg. Co.	Davenport, Iowa	360
WHAK	Bluefield <i>Daily Telegraph</i>	Bluefield, W. Va.	360
WHAL	Roberts Hardware Co.	Clarksburg, W. Va.	360
WHAM	Phillips Jeffery & Derby	Lansing, Michigan	360
WHAN	University of Rochester	Rochester, N. Y.	360
WHAO	Southwestern Radio Co.	Wichita, Kansas	360
WHAP	Hill, F. A.	Savannah, Ga.	360
WHAQ	Otta, Dewey L.	Decatur, Ill.	360
WHAR	Semmes Motor Co.	Washington, D. C.	360
WHAS	Paramount Radio & Electric Co.	Atlantic City, N. J.	360
WHAT	<i>Courier Journal & Louisville Times</i>	Louisville, Ky.	360,485
WHAU	Yale <i>Democrat</i> & Yale Telephone Co.	Yale, Okla.	360
WHAV	Corinth Radio Supply Co.	Corinth, Mississippi	360
WHAW	Wilmington Electrical Specialty Co.	Wilmington, Del.	360
WHAX	Pierce Elect. Co.	Tampa, Florida	360
WHAY	Holyoke Street Ry. Co.	Holyoke, Mass.	360
WHAZ	Huntington <i>Press</i>	Huntington, Indiana	360
WIAA	Rensselaer Polytechnic Institute	Troy, N. Y.	360
WIAB	Waupaca Civic & Commerce Assn.	Waupaca, Wisconsin	360
WIAC	Joslyn Automobile Co.	Rockford, Illinois	360
WIAD	Galveston <i>Tribune</i>	Galveston, Texas	360
WIAE	Ocean City Yacht Club	Ocean City, N. J.	360
WIAF	Zimmerman, Mrs. Robert E.	Venton, Iowa	360
WIAG	De Cortin, Gustav A.	New Orleans, La.	360
WIAH	Matthews Elect. Supply Co.	Birmingham, Ala.	360
WIAI	Continental Radio Mfg. Co.	Newton, Iowa	360
WIAJ	Heers Stores Co.	Springfield, Mo.	360
WIAK	Fox River Valley Radio Supply Co.	Neenah, Wisconsin	360
WIAL	<i>Journal Stockman</i> , The	Omaha, Nebraska	360,485
WIAN	Standard Radio Service Co.	Norwood, Ohio	360
WIAO	<i>Chronicle & News</i> Pub. Co.	Allentown, Pa.	360
WIAP	School of Engineering of <i>Milwaukee & Wisconsin News</i>	Milwaukee, Wisconsin	360
WIAR	Radio Development Corp.	Springfield, Mass.	360
WIAS	<i>Chronicle</i> Publishing Co.	Marion, Indiana	360
WIAT	Rudy & Sons, J. A.	Paducah, Ky.	360
WIAU	Burlington <i>Hawk Eye</i> —Home Electric Co.	Burlington, Iowa	360
WIAV	Noel, Leon T.	Tarkio, Mo.	360
WIAW	American Trust & Savings Bank	Le Mars, Iowa	360
WIAX	New York Radio Laboratories	Binghamton, N. Y.	360
WIAY	Saginaw Radio & Elect. Co.	Saginaw, Michigan	360
WIAB	Capital Radio Co.	Lincoln, Nebr.	360
WJAC	Woodward & Lothrop	Washington, D. C.	360
WJAD	Electric Supply Sales Co.	Miami, Fla.	360
WJAE	American Radio Co.	Lincoln, Nebraska	360
WJAF	Redell Co., The	Joplin, Mo.	360
WJAG	Jackson's Radio Eng. Lab.	Waco, Texas	360
WJAJ	Texas Radio Syndicate	San Antonio, Texas	360
WJAK	Huse Publishing Co.	Norfolk, Nebraska	360
WJAL	Y. M. C. A.	Dayton, Ohio	360
WJAN	White Radio Laboratory	Stockdale, Ohio	360
WJAR	Victor Radio Corp.	Portland, Me.	360
WKAA	Peoria <i>Star</i> & Peoria Radio Sales Co.	Peoria, Ill.	360
WKAC	Kelly Duluth Co.	Duluth, Minn.	360
WKAD	Outlet Co., The	Providence, R. I.	360
WKAE	Paar, H. F. & <i>Republican Times</i>	Cedar Rapids, Iowa	360
WKAF	<i>Star</i> Publishing Co.	Lincoln, Nebr.	360
	Looff, Charles	East Providence, R. I.	360
	W. S. Radio Supply Co.	Wichita Falls, Texas	360

For this Broadcasting Receiver thousands have been waiting

EVER since broadcasting became the vogue, there has been a demand for a receiver which would fill a whole room with music of perfect tone quality but which would be so simple that anyone could tune in by moving a single lever.

This ideal has at last been realized in the Aeriola Grand—the supreme achievement of present-day radio.

When you hear the voice and the music that comes from the Aeriola Grand it is as if the lecturer or singer at the broadcasting station were in your presence. The whole family listens and marvels.

The Aeriola Grand stands unrivaled not only as a radio receiver but as a piece of cabinet work.

PRICES

- Complete with mahogany stand, storage battery, battery charger, antenna equipment and all accessories.....\$409.50
- Without stand, storage battery, charger and receiving antenna equipment.....\$325.00
- With stand, but without storage battery, charger and antenna.....\$350.00
- Mahogany stand only.....\$35.00

See the Aeriola Grand at your nearest dealer
 Before you buy any receiver, secure a copy of the book "Radio Enters the Home." It tells the real story of radio and will help you to get the most out of this new art. 128 pages—over 200 illustrations—35c. a copy. At your dealer or write direct to



What the Guests Heard at the Jacksons' Aeriola Grand Party

- Baseball Scores
- Dance Music
- Songs by a great ballad singer
- Lecture on the "Wedding Ring, Past and Present"
- A story by a famous author
- Chamber music by a noted string quartet
- The whole opera "Cavalleria Rusticana" with explanations.
- News of the day
- Weather forecast for the following day

Radio Corporation of America
 WORLD WIDE WIRELESS

Sales Dept., Suite 2066
 233 Broadway New York, N. Y.
 District Office
 10 So. La Salle St. Chicago, Ill.

New Equipment



The latest type receiving set is here illustrated, and were the doors closed it might well be taken for a phonograph. All the necessary equipment, including the tuning elements, the storage battery, and plate batteries, is within the cabinet. The reproducing element is directly connected to the horn in the same manner as in phonographs. The receiver is of the vacuum tube regenerator type employing detector and three stages of audio frequency amplification and has a wave length range of 150-3000 meters. This elaborate machine is known as "Radiotone" and is manufactured by A. H. Grebe & Company.

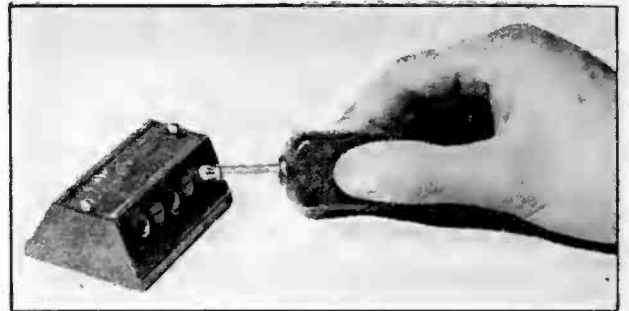

By means of the clever arrangement shown above, one, two, or three telephone plugs may be connected in the circuit without making any change in the wiring. This device is made by Pacent Electric Co.



A double telephone plug has been devised by the Pacent Electric Co., permitting the use of two pairs of telephone receivers connected in circuit as illustrated above

Use Kennedy Receivers for Effective Reception

You can't go wrong—Quality always counts

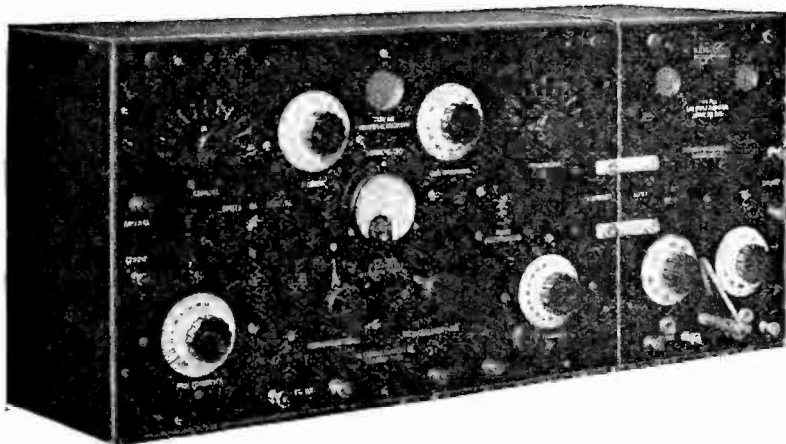

KENNEDY Look for the
EQUIPMENT Trade Mark

TYPE 110 UNIVERSAL REGENERATIVE RECEIVER, WITH TYPE 525 TWO STAGE AMPLIFIER. WRITE FOR BULLETINS.

All Kennedy Regenerative Receivers are licensed under Armstrong U. S. Patent No. 1,113,149.

A UNIVERSAL RADIO RECEIVER, in fact, as well as in name, the Kennedy Receiver Type 110 can be made to detect, regenerate or oscillate at will, over its entire range of 175 to 25,000 meters. Cabinet is of solid walnut, hand rubbed finish—Kennedy Quality and Workmanship evident throughout.

Like the Universal Receiver, Type 525, two-stage amplifier is built for dependable service. It matches the receiver in height, depth and general finish.

THE COLIN B. KENNEDY COMPANY
INCORPORATED

RIALTO BUILDING

SAN FRANCISCO

HOME-O-FONE

Radio Telephone Receiving Set

LISTEN IN with a sturdy, practical radio set that you can be proud of—not a toy or a makeshift. You will not know what a crystal set can do unless you get a Home-O-Fone, the quality package outfit. You are sure of satisfying results with a HOME-O-FONE because it is scientifically correct. But in addition, this De Luxe Package set is constructed of only the highest grade materials and designed to retain its handsome finish as well as its efficiency. An addition to the appearance of any room. Tuned with one simple adjustment—no extra parts required. Guaranteed to hear* the broadcasts in your own or nearby city.

Complete Outfit Includes:—

HOME-O-FONE No. 2 RECEIVER with prevision tune adjustment, in handsome cabinet-finish case with cover and compartment for headset, etc.—**DOUBLE HEADSET**, with two special "RR" concert 'phones, 2200 ohms, headband and long telephone cord—**ANTENNA WIRE**—150 feet.—**GROUND CLAMP**.—**HIGH INSULATION RADIO RECEIVER CABLE** for room connection—25 feet. **SPECIAL PORCELAIN INSULATOR** for antenna—4.—**"ANCHOR" AUTOMATIC RADIO LIGHTNING PROTECTOR** as required by National Underwriters' Rules.—**INSTRUCTION FOLDER**.

IMMEDIATE DELIVERIES

Send for folder containing Antenna drawing. A few select territories still open for live dealers.

RADIO RECEPTOR COMPANY, INC.
No. 1 Madison Avenue New York, N.Y.

\$24
COMPLETE
including Antenna, etc.
No batteries or tubes needed
Every Set **GUARANTEED**

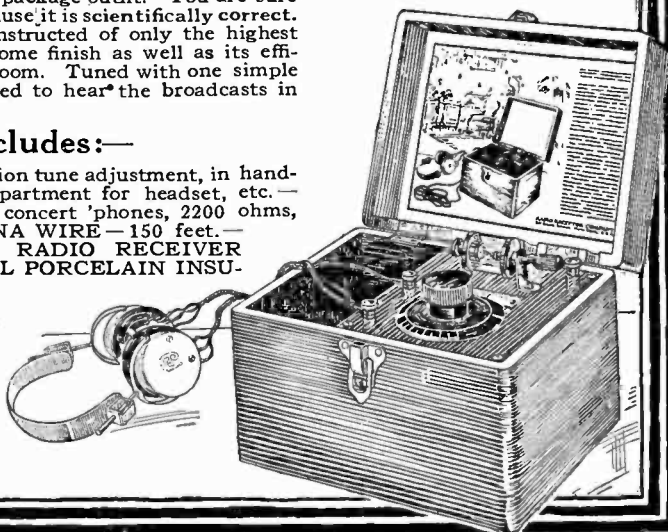

What to Call Them

THE recommendations of the Committee on Nomenclature of the Radio Telephone Conference called by Secretary Hoover of the Department of Commerce in Washington were as follows:

1. In place of the word "Wireless" and names derived from it, use the prefix "Radio"; Radio Telegraphy, Radio Telephony.

2. Instead of "Statics" or "X's," use "Atmospheric Disturbances" or "Atmospherics."

3. Disturbances produced by other stations to be designated as "Interference."

4. For the title of a triode employed in one of its regular modes, use "Rectifier triode," "Amplifier triode," "Generator triode."

5. In describing coupling of high frequency circuits, use "Resistance Coupling," "Inductive Coupling" (by self-inductance or mutual inductance), "Capacity Coupling."

6. For the generic title for a system of conductors for radiating or absorbing radio waves, use "Aerial."

For an open circuit aerial use "Antenna."

For a closed circuit aerial use "Coil."

7. For a receiving arrangement in which beats are produced by a separate local oscillator, use "Heterodyne."

For a receiving arrangement in which the same electron tube is used for generating oscillations and detecting, use "Self-heterodyne."

8. Classification of waves emitted by radio transmitters.

Type A—Continuous Waves.

Waves that in the permanent state are periodic and such that their successive amplitudes of oscillations are identical.

Type A₁—Manipulated Continuous Waves.

Continuous waves of which the amplitude or frequency vary under the action of hand telegraphic manipulation.

Type A₂—Continuous Waves with audible frequency modulation.

Continuous waves of which the amplitude or the frequency vary according to a periodic law of audible frequency. This is commonly referred to as ICW method of transmission.

Type A₃—Continuous waves with speech modulation.

Continuous waves of which the amplitude or the frequency vary in accordance with speech vibrations (radio telephony.)

Type B—Damped Waves:

Waves composed of successive trains in which the amplitude of the oscillations after having reached a maximum decreases gradually. This refers to waves from spark transmitters or other types of transmitters having a characteristic decrement similar to spark transmitters.

NOTE 1. If in continuous wave transmitters the rectified plate voltage is not substantially constant direct voltage, the station should be classed under Type A₂.

NOTE 2. In ICW transmitting stations if the variation in the wave length or frequency of the transmitted wave is effected in a gradual way (sinusoidally) the station should be classed under Type A₂. If the variation in frequency or amplitude is abrupt (chopper method) it should be classed in Type B.

In order to differentiate between the amateur and the experimenter, the following definitions are suggested for consideration:

The amateur is one who operates a radio station transmitting, receiving, or both, in a non-professional way, merely for personal interest or in connection with an organization of like interest.

An experimenter is one who operates a transmitting or receiving station, or both, for exclusively technical or scientific investigations.

NOTE. Further recommendations or nomenclature to be added later.



This is station K.S.&S.Co.

ANNOUNCING Better Radio Equipment Kellogg Built Throughout



No. 69A Head Set



No. 2. Tube Socket



Iron Core Choke Coil



Air Choke Coil



No. 501. Plug



No. 501. Jack



No. 502. Grid Condenser
on Single Mounting



No. 503. Grid Leak and Con-
denser on Double Mounting



No. 21. Microphone



Strain Insulator



No. 501 Dial



No. 501. Variometer

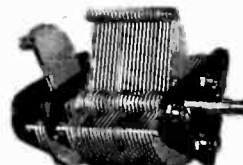

No. 505. Variable
Condenser

KELLOGG STANDARD RADIO APPARATUS

is made in standard resistances and ratings. Only the highest grade material is used, and first-class workmanship assures a product that guarantees high efficiency and durability.

Send for our latest radio Bulletin

Kellogg Switchboard & Supply Co., Chicago

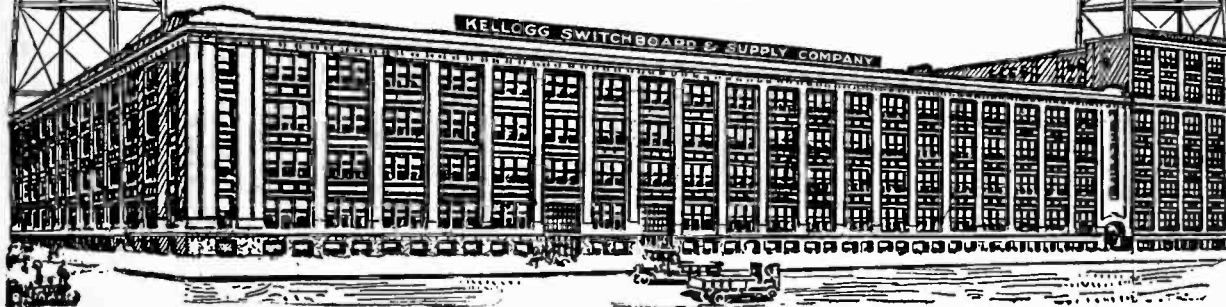

HOMMEL

Order NOW for Fall

WHEN vacation time is over and the days get shorter, Radio is going to take its place again in filling up the long chilly evenings both in the city and on the farm. There will be big demand for both parts and complete sets. Will your stocks be up to date and able to take care of all this trade?

DISTRIBUTORS FOR
 Radio Corp. of Amer.
 Westinghouse
 General Electric

Frost	Kellogg
Remler	Acme
Fada	Brach
Murdock	Homcharger
General Radio	Signal
Brandes	Pacent
Baldwin	Rhamstine
Burgess	Connecticut
Hipco	Arkay
Chelsea	Radio Service
Holtzer-Cabot	Tuska

Clapp-Eastham
 and other leading
 manufacturers



Now is the time to put your stock in order for Fall, not at the last moment, when we are rushed with orders and deliveries may not be so prompt.

Order Now. To-day. Our new, illustrated catalog No. 200 B will help you.

Send for it.

WHOLESALE ONLY

LUDWIG HOMMEL & CO

530-534 FERNANDO ST.

PITTSBURGH, PENN'A

Burgess, the *Radio* Battery — construction fully patented

When you buy a Burgess "B" Battery you get more than long life, noiselessness, high capacity, and moderate price. You get also Burgess special radio construction, perfected by wireless specialists and fully patented! This exclusive *radio* construction is found in no other battery on the market today.

What does this mean to users of radio batteries? It means clear receiving. It means lowest cost per hour of service. It means long shelf life and highest current capacity. It means that Burgess "B" Batteries are the best *radio* batteries it is possible to produce. Don't take our word for it—ask any radio engineer.

Leading manufacturers of radio equipment specify "Burgess." Burgess "B" Batteries are handled by all progressive jobbers and dealers. "Look for the Black and White Stripes." If your dealer doesn't handle Burgess "B," just address:

BURGESS BATTERY COMPANY Engineers — Dry Batteries — Manufacturers

Offices and Warehouses at:

CHICAGO, ILL., 111 W. Monroe St. NEW YORK, N. Y., 50 Church St. BOSTON, MASS., 136 Federal St.
ST. PAUL, MINN., 2362 University Ave. KANSAS CITY, MO., 2109 Grand Ave. MADISON, WIS., Main & Brearly Sts.

In Canada: BURGESS BATTERIES, Ltd.
Winnipeg, Toronto, Montreal

BURGESS "B" BATTERIES

"ASK ANY RADIO ENGINEER"

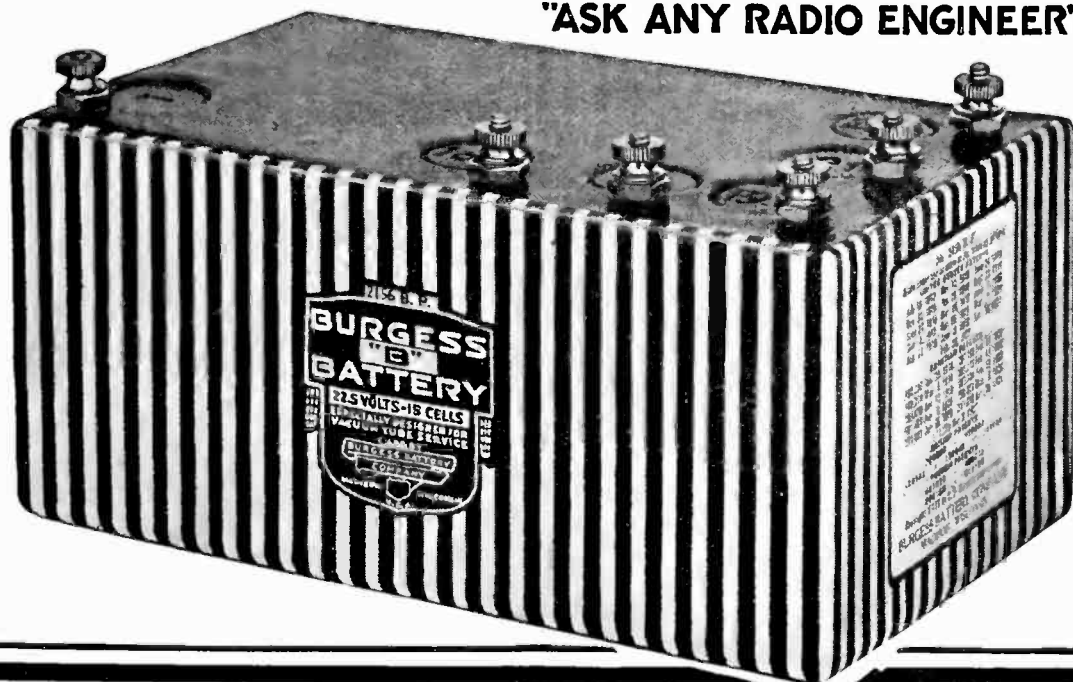



Cunningham tubes

*The Heart of
Your Home Receiving Set*

**AMPLIFIES AS
IT DETECTS**



**TYPE C-300
GAS CONTENT
DETECTOR
\$5.00**

**TYPE C-301
HIGH VACUUM
AMPLIFIER
\$6.50**

PATENT NOTICE
Cunningham tubes are covered by patents dated 11-7-05, 1-15-07, 2-18-08 and others issued and pending. Licensed only for amateur or experimental uses in radio communication. Any other use will be an infringement.

*—enjoy clear reception by
using Cunningham Tubes*

Cunningham Detector Tube known as type C-300 insures clearest reception for all radio messages, concerts, press and weather reports.

The rigid specifications to which these tubes are built in the General Electric Laboratories determine their uniform operation and perfect clearness.

Cunningham Amplifying Tube known as type C-301 is conceded to be the most efficient amplifier ever produced. For complex and multi-stage circuits, freedom from distortion and absence of all tube noises as well as for the operation of loud speaking telephones and devices requiring considerable power, this tube has no equal.

If your dealer cannot supply you write us direct for the name of a Radio Dealer who can.

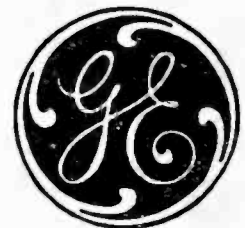

Trading as
AUDIOTRON MFG. COMPANY

248 First Street, San Francisco, California
154 West Lake Street, Chicago, Illinois

The trade mark GE is the guarantee of these quality tubes. Each tube is built to most rigid specifications.

REMLER

Cunningham

Giblin-Remler COILS INDUCTANCE

**APPARATUS
- THAT -
RADIATES
QUALITY**

Type and Number of Turns, Mounted	Price, Mounted	Type and Number of Turns, Unmounted	Price, Unmounted	Inductance in Milli-henrys at 1000 cycles Accuracy $\frac{1}{2}\%$	Natural Wave Length in Meters, Accuracy $\frac{1}{2}\%$	Distributed Capacity in micro-micro-farads, Accuracy 1%	Wave Length Range in Meters using Condenser of .001 max. and .0004 mfd. min.		High Frequency Resistance in Ohms at Wave Length Show				
							Min.	Max.	200	500	1000	2000	
RG 20M	1.50	RG 20U	.70	.030	39	14.3	63	334	...	1.1
RG 25M	1.50	RG 25U	.70	.041	47	15.2	75	389	...	1.5
RG 35M	1.50	RG 35U	.70	.083	87	25.4	128	550	...	3.5
RG 50M	1.60	RG 50U	.80	.169	114	21.6	185	785	...	8.8	4.4
RG 75M	1.65	RG 75U	.85	.377	163	19.8	266	1170	...	28.3	12.1	6.2	...
RG 109M	1.70	RG 100U	.90	.666	217	19.9	358	1550	...	80.3	26.8	12.6	...
RG 150M	1.75	RG 150U	.95	1.503	281	14.8	512	2320	1000	2000	5000	10000	...
RG 200M	1.80	RG 200U	1.00	2.68	374	14.7	690	3110	69.8	23.8	7.1
RG 250M	1.90	RG 250U	1.10	4.20	424	12.1	860	3880	...	50.6	12.5
RG 300M	2.00	RG 300U	1.20	6.11	494	11.2	1030	4680	...	87.5	19.9
RG 400M	2.10	RG 400U	1.30	11.04	618	9.7	1380	6360	...	141	29.3	13.8	...
RG 500M	2.30	RG 500U	1.50	17.50	747	9.0	1730	7900	54.6	22.3	...
RG 600M	2.40	RG 600U	1.60	29.2	1024	10.1	2260	10250	93.1	34.9	...
RG 750M	2.65	RG 750U	1.85	39.0	1249	11.3	2660	11850	2000	5000	10000	20000	...
RG 1000M	3.40	RG 1000U	2.50	71.6	1620	10.3	3570	16000	...	111	43.8
RG 1250M	3.80	RG 1250U	2.90	108.0	1930	9.7	4380	19700	64
RG 1500M	4.40	RG 1500U	3.50	159.8	2390	9.3	5300	23800	123

This table compiled by Robert F. Field of Cruft High Tension Electrical Laboratory, Harvard University, Cambridge, Mass.

The Ideal Loading Coil

These new inductance coils will increase the wavelength range of your short wave receiving set.

There is nothing more fascinating than the reception of radio messages from high-power stations located thou-

sands of miles away. These stations use wavelengths between 1000 and 25,000 meters. This is far above the receiving range of the average receiver designed for amateur broadcast reception.

Inserting Giblin-Remler Coils of the proper values (determined from the table shown on this page) and shunted by a variable condenser, in series with the antenna circuit and the secondary circuit of your receiver, will increase its wavelength range any desired amount.

The Giblin-Remler Coil makes possible the reception of high-power, long wave foreign stations, as well as time signals, press and weather reports from various naval stations throughout the United States.



Maximum Inductance and Minimum Distributed Capacity

Remler Radio Mfg. Co.

E. T. CUNNINGHAM, General Manager
248 First Street, San Francisco, Calif.
154 W. Lake Street, Chicago, Ill.



Just Off the Press

The Radio Experimenter's Handbook

By M. B. SLEEPER

Gives wiring diagrams and hookups, explains the theory and operation of damped and undamped transmitting sets, and receiving equipment. The book is profusely illustrated. Tells you the things you want to know about wireless in simple, untechnical language. In this respect, it differs from most radio books in that it tells you what you want to know, and not what the author thinks you ought to know. 16 chapters. Fully illustrated. Price \$1.00.

Other Popular Radio Books

Radio Hook-Ups, by M. B. Sleeper . . \$.75
Indispensable to the radio amateur who designs or builds his own receiving apparatus.

Radio Design Data, by M. B. Sleeper . . .75
Gives tables and data for designing, receiving and transmitting apparatus.

Construction of New Types Trans-Atlantic Receiving Set, by M. B. Sleeper75
Tells how to listen to the high-power telegraph stations of foreign countries.

Construction of Radiophone and telegraph Receivers for Beginners, by M. B. Sleeper75
Tells in detail the building of radio apparatus.

How to Make Commercial Type Radio Apparatus, by M. B. Sleeper .75
Describes in detail many commercial types of transmitting spark and vacuum tube sets, both telephore and telegraph and receiving equipment of all kinds.

A B C of Vacuum Tubes Used in Radio Reception, by E. H. Lewis . . 1.00
A book explaining in detail all about vacuum tubes.

Experimental Wireless Stations, by P. E. Edelman 3.00
A book describing all modern improvements.

Wireless Telegraphy and Telephony Simply Explained, by A. P. Morgan 1.50
A book the radio experimenter cannot afford to be without.

FREE! Catalogue of Wireless, Automobile and Other Books Sent Free on Request.

SUPPLY DEALERS. Write for special terms.

The Norman W. Henley Publishing Co.
2 West 45th Street, New York

"East and West, the Globe is Best"

GLOBE RADIO HEAD PHONES



Highly sensitive
Matched receivers
Natural in tone
Each receiver tested by radio
Light weight (11 oz.)
Comfortable to wear
Will not distort signals, when amplified
Articulation perfect

2200 ohms List price only \$9.00

There are many types of head sets on the market but not too many good ones. The GLOBE RADIO HEAD SET incorporates a knowledge of acoustics based on nearly fifteen years of experience in making high grade sound producing and receiving instruments. It embodies correct design with the best of materials. The Globe Phones are for those who discriminate.

Ask about the Globe Antenna Attachment Plug for connecting your radio set to your electric light circuit. Buy from your local dealer, or write us direct.

GLOBE PHONE MFG. COMPANY
READING, MASSACHUSETTS, U. S. A.

"United" Radio Products

"United" Audio Frequency Transformers



Two finishes: Black Enamel or Buffed Nickel Plated, \$4.50

The beauty of the outside of this transformer is but a reflection of the superb workmanship under the shell—no hewling—no distortion—clear amplification for one or more stages.

United Mfg. & Distributing Co.

536 Lake Shore Drive
Chicago Illinois

"United" Variable Condensers

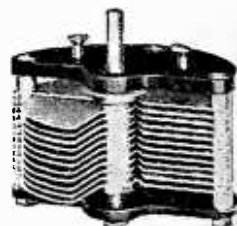

Prices

43 plate, \$4.50; 23 plate, \$1.00; 11 plate, \$3.50; 5 plate, \$2.75; 3 plate, \$2.25, without dial or knob.

That "United" Condensers have become the standard with manufacturers of radio sets, by which all others are judged, is, in itself, the strongest endorsement of their superior construction and effectiveness.

Ask your dealer to show you this condenser. Then, you, too, will appreciate why it has been accepted as the standard.

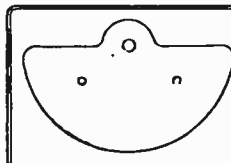

Mounting made easy by our template for locating panel holes, packed free with each condenser.

NOTE: Any advertised claim of having an arrangement with us to sell our products at special prices, is fraudulent.

Finest Filament Control We Have Ever Used, *Says Radio Guild, Inc.*

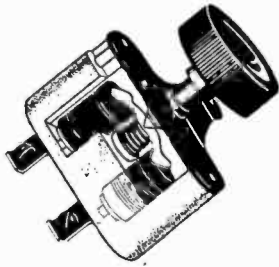

How It Works!

Graphite discs (not loose carbon grains) provide the delicate control for vacuum tubes. A single knob, without vernier, gradually applies or removes pressure from the discs, thereby changing the filament current more smoothly and noiselessly than any vernier rheostat.

Louder reproduction, quicker tuning, and a greater receiving range follow the installation of Bradleystats in your radio set. Twenty years of experience in precision control, and a one-year guarantee protect you.



Allen-Bradley Co.
Electric Controlling Apparatus
278 Grandfield Ave. Milwaukee, Wis.



RETAIL PRICE
\$1.85 P.P. 10¢
Extra

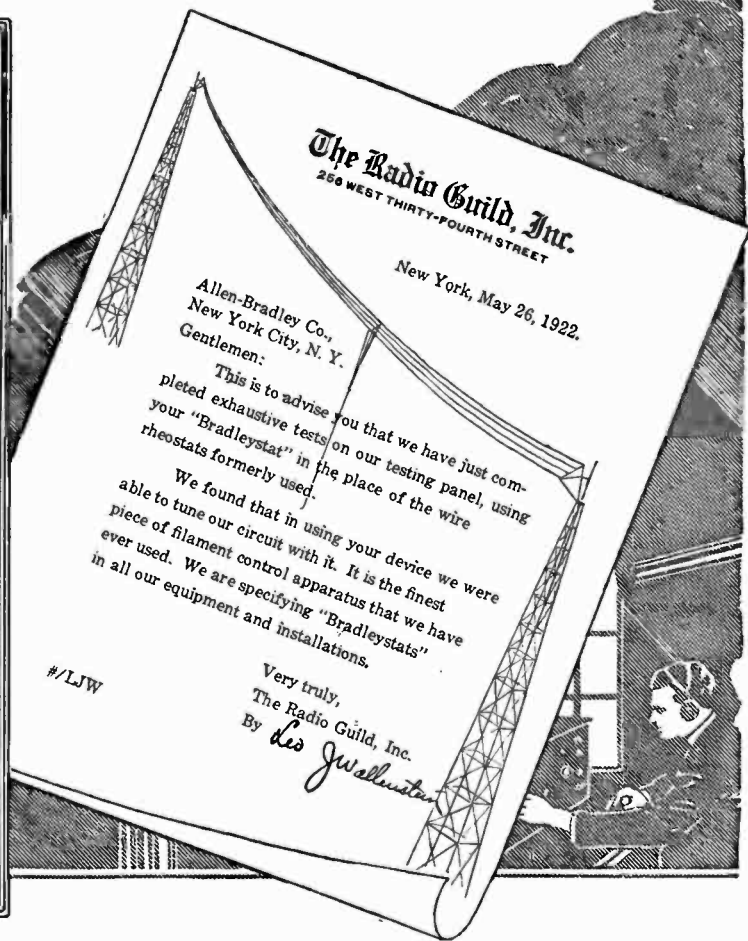

Bradleystat

REGISTERED U.S. PAT. OFF.

PERFECT FILAMENT CONTROL

RADIO HEADQUARTERS QUALITY --- PRICE PROMPT SERVICE

We list below a few popular items from our large stock of standard Radio Supplies. Play Safe—buy standard equipment. Order from this list.

Westinghouse RC Receiver.....	\$132.50	Murdock No. 3660 43-plate Var. Condenser, no case.....	4.00	Baldwin Type F Phones.....	\$ 16.00
Westinghouse RA Tuner.....	68.00	Murdock No. 3680 23-plate Var. Condenser, no case.....	3.25	Baldwin Type G Phones.....	16.00
Westinghouse DA 2-Stage Amplifier	70.00	ABC No. 650-11 11-plate Var. Condenser.....	4.00	Western Electric Phones.....	15.00
Clapp-Eastham HZ Rcvr-Amplifier	100.00	ABC No. 650-3 3-plate Var. Con.	2.25	Westinghouse Vocacola.....	30.00
Clapp-Eastham HR Regenerative Receiver.....	40.00	Radion 3-inch Dial.....	1.00	Magnavox R-3, 14 inch Horn.....	45.00
Clapp-Eastham HZ 2-Stage Amplifier.....	40.00	Radion 4-inch Dial.....	1.00	Acme A-2 Amplifying Trans-former, mounted.....	7.00
Grebe CR-9 Receiver-Amplifier.....	130.00	Moulded Bakelite 3-inch Dial... Cunningham C-301, Radiotron	.75	Acme A-2 Amplifying Trans-former, semi-mounted.....	5.00
Grebe CR-5 Receiver.....	80.00	UV201 Amplif. Tube.....	6.50	Jefferson No. 41 Amplifying Transformer.....	4.25
Grebe RORK 2-Stage Amplifier.....	55.00	Cunningham C-302, Radiotron	8.00	Jefferson No. 45 Amplifying Transformer.....	7.00
Remler No. 330 Detector Panel.....	8.50	VV202 Power Tube.....	1.00	R. C. UV-712 Amplifying Trans-former.....	7.00
Remler No. 331 Amplifier Panel.....	6.00	Jefferson No. 48 Tube Socket... R.C. UT-541 Porcelain Tube Socket	1.00	Murdock No. 358 .0007 Mfd. Fixed Cond.....	1.70
Remler No. 333 Same with Cam Switch.....	9.00	Signal R-75 Tube Socket.....	2.50	Federal No. 15 Universal Plug..	1.75
Remler No. 505 Panel-mounted Variocoupler.....	12.00	Clapp-Eastham HT Bakelite Panel Socket.....	1.40	Frost No. 132 Plug.....	1.00
Remler No. 502 Panel-mounted Variometer.....	9.75	Remler No. 810 Jr. Filament Rheostat.....	1.00	Frost No. 137 Plug.....	1.25
Remler No. 500 Moulded Variometer	6.50	Remler 1 1/2-Amp. Panel Rheostat No. 811.....	1.00	Frost No. 131 Jack.....	.90
Remler No. 501 Same with No. 100 Knob and Dial.....	7.50	Remler 3-Amp Panel Rheostat No. 813.....	1.75	Frost No. 133 Jack.....	.65
Remler No. 503 Variocoupler.....	5.40	Paragon No. 1023 Panel Rheostat	1.75	Frost No. 134 Jack.....	.75
Remler No. 504 Same with No. 100 Knob and Dial.....	6.40	Bradleystat Filament Controller..	1.85	Frost No. 135 Jack.....	1.00
Clapp-Eastham F-735 43-plate Var. Condenser.....	4.75	R. C. PR-535 Rheostat.....	3.00	Frost No. 136 Jack.....	1.25
Clapp-Eastham F-774 17-plate Var. Condenser.....	4.25	Cutler-Hammer H-1 Vernier Rheostat.....	1.50	Rotary Lever Switches... See our catalogue	1.50
Chelsea No. 1 43-plate Var. Condenser, mounted.....	5.00	Cutler-Hammer H-2 Plain Rheostat	1.00	Remler Standardized Switch Parts Cabinets and Panels... See our catalogue	3.00
Chelsea No. 2 23-plate Var. Condenser, mounted.....	4.50	R. C. PR-536 "A" Battery Potentialmeter.....	2.00	Brach No. 223 Outdoor Vacuum Gap Protector.....	3.00
Chelsea No. 3 43-plate Var. Condenser, with Dial.....	4.75	Batteries..... See our catalogue	5.00	Brach No. 200 Indoor Vacuum Gap Protector.....	2.50
Chelsea No. 4 23-plate Var. Condenser, with Dial.....	4.25	Frost Pones No. 162, 2000 ohms	6.00	Keystone Radio Lightning Arrester	2.00
Murdock No. 367 43-plate Var. Condenser, in case.....	4.50	Frost Pones No. 163, 3000 ohms	6.00	Antenna Insulators, Magnet Wire, Cardboard Tubing, Bakelite Tubing, Fiber Tubing, Spaghetii, Radio Books, Crystal Detector Supplies, Battery Chargers, Loading Coils, etc. See our catalogue	
Murdock No. 368 23-plate Var. Condenser, in case.....	4.00	Murdock No. 56 Phones, 2000 ohms	5.00		
		Murdock No. 56 Phones 3000 ohms	6.00		
		Baldwin Type C Phones.....	16.00		
		Baldwin Type E Phones.....	16.00		

Free Catalogue illustrated, sent on request

In business since 1860

Julius Andrae & Sons Co.

354 Broadway, Milwaukee, Wis.

Dealers—Buy reliable equipment from a house of established reputation. Send for catalogue of tested and approved apparatus and our discount sheet.

THE Supercouple "A" BATTERY

FOR RADIO

NEEDS WATER ONLY ONCE A YEAR

Entirely different from the modified vehicle batteries sold for this purpose. No leakage or seepage of battery acid, no fumes or spray, no corrosion of connecting wires, no separators. Write for illustrations. 80 AMPERE HOURS \$18.00.

J. A. RITTER

LANSDOWNE, PA.

BUILD YOUR OWN



Special offer, complete 50c text book for only 20c postpaid. Wonderful information makes you understand radio. Tells how radio messages are received. Tells how to make eight different classes of crystal and vacuum tube receiving sets with range of 25 to 2000 miles. Detail drawings and complete bills of material given for each set. We enclose our price list of parts. Buy direct from factory and save many dollars. Nothing else like this book on the market. Money back if not satisfied. Desk 22, RADIO PARTS MANUFACTURING CO., PARK PLACE, DETROIT, MICHIGAN

20c

PATENTS

PROTECT YOUR INVENTION TO-DAY

Write for 1922 Illustrated Book, Free

Radio-Electrical, chemical, and mechanical experts; over 20 years experience.

A. M. WILSON, Inc. (Radio 3 ARH)

311-19 Victor Building

Washington, D. C.

(Successors to business established 1891 by A. M. Wilson.)

WESTINGHOUSE AND OTHER STANDARD RADIO SETS AND PARTS

Liberal commissions paid for interesting others which enables you easily to

EARN YOUR SET AND MAKE MONEY

Write for Price List and Proposition

WHEELER-THOMAS RADIO CO., Dept. 27, Holland, N. Y.



MARSHALL VARIABLE CONDENSERS

Precision Instruments, which are built from outfits of finest quality parts, to the exact capacity of the experimenter's own set. 3, 5, 9, 17, 23, 35, 43, and 67 plate sizes. For further information write

NEW HAVEN RADIO COMPANY

61 Hamilton Street,

New Haven, Conn.

Pacific Coast Representative:

H. SALMON, Berkeley Inn, Berkeley, Cal.

Here's the Fada Receiver!



and There's the Facts about it.

An Ideal Home Entertainer

THE Fada receiver, a result of the same perfection in design and construction that distinguishes all Fada products, is gaining popularity as an ideal home entertainer.

When it's radio time in your home you can sit back in your favorite chair among the family circle, and command at your fingers touch such noted artists as May Petreson, Percy Grainger, Mme. Margaret Namara, Lydia Lipkowska—the Russian Coloratura soprano of the Imperial Opera of Petrograd.

You marvel that their voices come into your home with such depth of emotion and true personality. Such music is an inspiration to everyone, it goes to the very soul of things and brings joy to all.

With a Fada receiver this is all possible in your own home.

The new Fada handbook will be sent you upon receipt of 5c to cover postage. It's a How-To-Do-It book and you should have it.

THE FADA HANDBOOK
of
FADA-FACTS

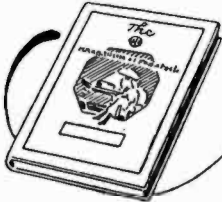

FRANK A. D. ANDREA

1581-B Jerome Ave.

New York City

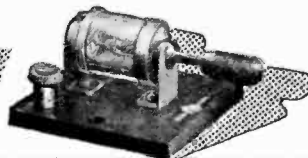
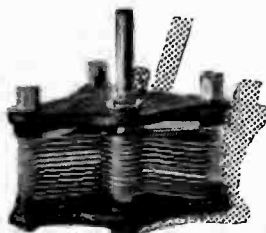

Cleveland Dulce-Tone Junior.

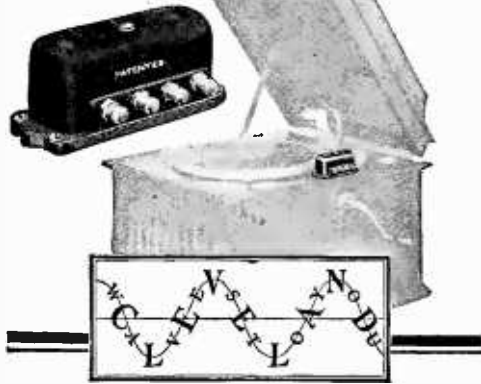

Radio Music Perfectly Reproduced Through Your Phonograph

The Dulce-Tone Junior converts your phonograph into the finest of loud talkers without detracting in the least from its power to play phonograph records.

The radio music comes to you with cello-like sweetness, even more clearly than that reproduced from your records.

The Dulce-Tone Junior is adaptable to any phonographic instrument. When you consider that you are using the wonderful sound-box, tone-arm and even the needle which has been perfected only after years of experimenting, you can realize the **QUALITY** and **SWEETNESS** of the tone, which is so faithfully reproduced through the Dulce-Tone Junior.

Any one can attach the Dulce-Tone Junior in a few minutes. To operate, simply swing the tone arm allowing the needle to rest on the small center element of the Dulce-Tone Junior. This ingenious instrument eliminates the necessity of numerous expensive headphones when entertaining a room full of people—is a true economy.

The Dulce-Tone Junior is the instrument of the century—an instrument that will improve any radio set. Put one on your phonograph to-day and realize the possibilities of radio music for quality of tone.

Retail Price.....Only \$15.00
(\$17.50 West of the Rockies)

If your dealer does not handle the Dulce-Tone Junior fill out the coupon below, mail it with one dollar and we will forward this wonder instrument to you C. O. D. at \$14.00.

THE CLEVELAND RADIO MFG. CO.
238 St. Claire Ave., N. E., Cleveland, Ohio
Sole Licensees under KAEHNI Circuit Inventions and Patent Applications.

THE CLEVELAND RADIO MFG. CO.
238 St. Claire Ave., N. E., Cleveland, Ohio

Enclosed find one dollar for which send me a Dulce-Tone Junior (\$14.00, balance due C. O. D.).
Send me your folder entitled "Waves to You Through Your Phonograph."

Name

Address

Town & State.....

NOVO
"B"
BATTERIES FOR RADIO

22½-45 & 105 VOLTS

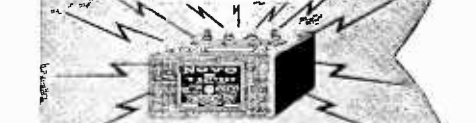

NOISELESS
DEPENDABLE
GUARANTEED

ASK YOUR DEALER

NOVO MANUFACTURING CO.

424-438 W. 33rd ST.
NEW YORK

531 SO. DEARBORN ST., CHICAGO.

Vacuum Tube Detector, \$5.50

Including complete cabinet with all instruments wired ready for use.

Detector and Two Stage Amplifier, \$22.50



With transformers and all other instruments in cabinet, ready for operation. This equipment is of high quality, and distances of as high as 3000 miles have been obtained with ease.

BATTERIES AND TUBES EXTRA

"Superior" Receiving Set, \$4.75



In Cabinet, complete, as shown

Guaranteed to bring concerts louder than any other crystal set made regardless of price. We will prove this to your satisfaction or refund your money.

Parts for "SUPERIOR" set ready for assembling, \$3.25. Variometers, \$4.25
2000 Ohm Head Phones, \$5.00

SOUTH HILLS WIRELESS SHOP
411 Charles St., Knoxville, Pittsburgh, Pa.

Which Will You
Judge By—
Results or
Unproved Claims?

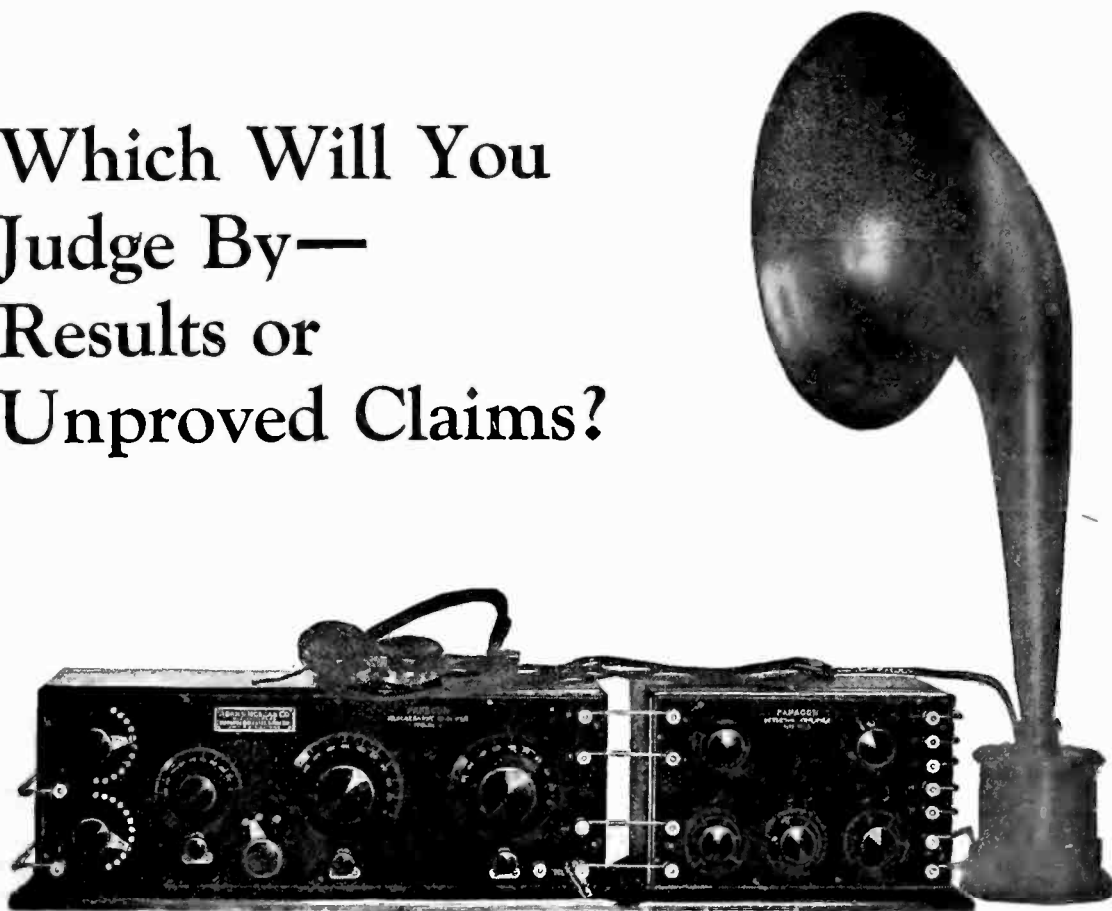

Type R-A-10 Receiver

Licensed Under Armstrong Patents

D-A-2 Detector-Amplifier

Also Manufacturers
of
PARAGON
Radio Telephone
Transmitters
V. T. Control Units
Rheostats
Potentiometers
V. T. Sockets
Amplifier
Transformers
Detectors
Control Dials
Amplifiers
Receivers
Switches
Variometers

Paragon Stands on its Record

In 1915 Paragon was the *first* regenerative receiver manufactured.

In 1916 Paragon effected the *first* transcontinental reception (not prearranged) from New York to California.

In 1917-18 Paragon receivers, due to better sensitivity and selectivity, proved superior to all others in interception of enemy signals by the U. S. Army and Navy.

In 1921 Paragon effected the *first* transatlantic amateur reception, registering American amateur signals at Ardrosan, Scotland, a distance of 3500 miles.

In 1922 Paragon Products are a safe investment in a market in which it is difficult to judge values.

Paragon needs no extravagant claims; but we guarantee our customers this:—that Paragon Products are reasonable in price, sound in design and thorough in workmanship.

If your dealer does not sell Paragon Products, send for catalogue (free) and we will supply you promptly.

ADAMS-MORGAN CO., 10 Alvin Ave., Upper Montclair, N. J.

PARAGON

Reg. U. S. Pat. Off.

RADIO PRODUCTS



PATENT APPLIED FOR

Pickles and Warts SOUND FUNNY

But did you ever stop to think that you always find them together? Wherever you find a "live" radio dealer, there you will find

THE ALAMO SOCKET

Specifications:

Insulated Feet; Nickel Plated Barrel; Barrel Reamed to size insuring no vibration of vacuum tube; Large Phosphor Bronze Springs; Base Polished Finished Formica Properly Labeled.

LIST PRICE \$1.00

—BRACKETS—

Nickel Plated for Single Panel Mounting 16c
Double Mounting 40c, Triple Mounting 50c

**UNUSUALLY ATTRACTIVE DISCOUNTS
WRITE OR WIRE FOR PROPOSITION**

THE ALAMO SALES CORP.

National Distributors

812 Peoples Bank Bldg., Indianapolis, Indiana
PACIFIC COAST REPRESENTATIVES:

TILTZ ENGINEERING AND EQUIPMENT CO.
LOS ANGELES SAN FRANCISCO
WRIGHT-COLLENDER BLDG. MONADNOCK BLDG.



Radio Telephone Headsets

DON'T let them substitute any other make of Headset for your Radio Outfit. The tonal quality of what you hear is vitally important. Holtzer-Cabot Headsets are the result of many years' experience and skill in making Telephone Headsets.

Insist Upon

Holtzer-Cabot

Telephone Headsets

Sold by all responsible dealers

THE HOLTZER-CABOT ELECTRIC CO.

Boston, Mass.

Chicago
Philadelphia

New York
Cleveland

Baltimore
San Francisco

States Radio Receiving Equipment



Its outward beauty puts the States Receiving Set in a class by itself; and on top of this, its mechanical perfection is as "beautiful" to the radio engineer as its fine appearance to the layman.

The receiver section contains one Radio Frequency—one detector—one audio frequency amplifying tube. The amplifier unit has two stages of audio amplification. Both cabinets are solid mahogany with a piano finish. The panel has a highly polished, lustrous black finish with silver plated letters and dials.

Simple to operate—it is offered to you only after exhaustive tests have satisfied this company that this receiving set will give you the best results it is possible to obtain with any equipment.

Write for illustrated folder

STATES RADIO CORPORATION

501 South Jefferson Street

Chicago

Illinois

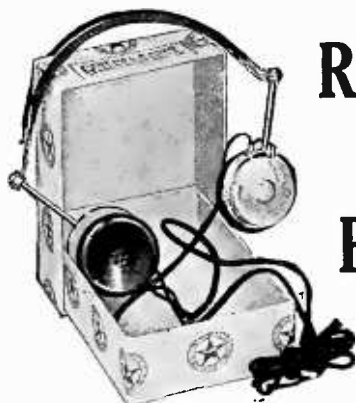

Red Star Head Phones

Why take a chance with your receiving set by using poor head phones, for after all your radio receiver set is no better than your head phones.

Red Star head phones speak up sharp and clear. Light in weight, they fit the head

comfortably and do not tire, they are easily adjusted over the ears.

Protect your receiving set, by buying good head phones—ask your dealer to show you Red Star phones. You will be surprised at the results you will attain.

Monocoil 2000 ohms—\$5.00
Long-distance 3200 ohms—\$6.00
Including head band and 6ft. cord

GENERAL RADIO EQUIPMENT CO.
1139 Diversey Pkway. Chicago

TUSKA

Market Reports



RADIO



Tuska Variometer Type 200

The Tuska Variometer was the first moulded Variometer on the market; not only first to arrive, but first in quality.

All TUSKA RADIO follows this example. The name Tuska is a standard. Insist on Tuska Sets and Tuska Parts.

Send 5c for Tuska Catalog No. 3

The C. D. Tuska Company

Bartholomew Ave., Hartford, Conn.

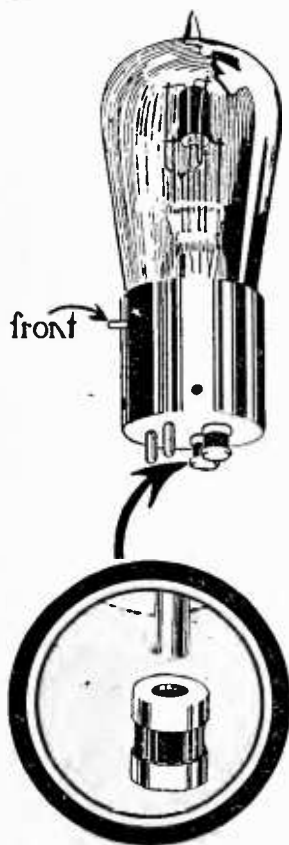

Saves Tubes--

Attached right where all "juice" going into the filament must pass, the

RADECO Safety Fuse

makes it impossible for you to "burn out" a bulb-filament from any excessive amperage whatever, even an accidental short. Good on any standard tube used in any standard socket.

4 for \$1

Buy from your dealer or direct by mail.

When ordering, specify exactly what make and number tube fuses are wanted for.

RADIO EQUIPMENT CO.
630 Washington St.
Boston, Mass.



Every
Radio "Bug" needs
a **HANDY ANDY**
SOLDERING SET

INCLUDES two specially designed, high grade, copper irons, large coil of resin-centered solder and liberal quantity of Sal Ammoniac. The small iron for all intricate work, the large one for outside work. Handy Andy is ideal for radio amateurs and manufacturers, plumbers, garage men, and radiator shops, tin shops and battery service stations. Sent postpaid on receipt of

ONLY \$1.00



With
HESLARADIO
The World is Your Neighbor

Heslar Equa-Tone Phones	\$10.00
Heslar improved sockets	\$ 1.25
Heslar Var. Condensers	
23 Plate	\$ 3.60
43 Plate	\$ 4.50

HESLAR
RADIO CORPORATION
INDIANAPOLIS-USA

Dealers! Write today for attractive dealer offer on Heslar Radio Parts and Complete Sets

BELL V. T. SOCKET

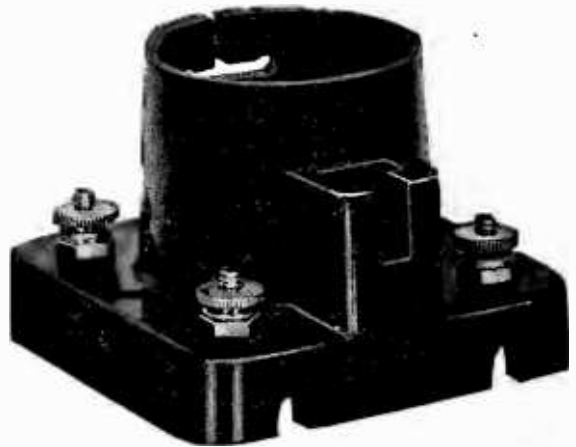

Price \$1.25

Genuine Bakelite. Heavily nickelled phosphor bronze springs, making double electrical contact. Adapted for panel or base mounting.

Reinforced T slot, allowing use of both sending and receiving tubes without adjustments.

Manufacturers of moulded insulation since 1911

BELL MANUFACTURING CO.
13 Elkins Street Boston, Mass.

This Is How
RADIO BROADCAST

Supplements the Easy Course in Home Radio this month

"A Guide for Listeners In" is supplemented this month by "The March of Radio" by Professor J. H. Morecroft.

"Radio Simply Explained" finds its continuance in "King Electron Tells About Detection"—the second of R. H. Ranger's uniquely illustrated articles.

"Tuning and What it Means" is carried on by our article titled "The Selective Double Circuit Receiver" by John V. L. Hogan.

"Installing the Home Set" is dealt with in a very comprehensive article on "Shielded Receivers," by Thomas C. Tibbey.

And the "Additional List of of Broadcasting Stations" makes "Bringing Music to the Ear" a simpler undertaking.

If you do not own the Easy Course in Home Radio, you will find it advertised in this issue. The regular price for the course is \$3.00. The regular price of Radio Broadcast is \$3.00. Our price for both \$5.00. Send your order direct to us.

RADIO BROADCAST
GARDEN CITY, NEW YORK

For Charging Radiophone and Automobile Batteries at Home, use



The Sterling

Portable Rectifier

It is not necessary to lug your battery to a service station. Rectifier charges your battery without its being disconnected from radio outfit.

Mechanism simple, effective and durable.

One thumbscrew does all adjusting. Either clip can be attached to positive terminal. No danger of injuring battery.

Price complete, \$16.00. (West of the Rocky Mts.) \$17.00

Initial charging rate 6 volt battery either 5 or 10 amps.

We also manufacture: Radio Frequency Transformers, \$6.00; Audio Frequency Transformers, \$4.00; Filament Rheostats, \$1.25; Filament D. C. Ammeters and Voltmeters, \$4.00.

Sterling Pocket Voltmeters for testing Type "B" Batteries: \$4.00 (0-30 volts) \$2.25; \$4.00 (0-50 volts) \$2.75.

Write for Booklet giving full information



THE STERLING MFG. CO.
2833 Prospect Ave., Cleveland, Ohio

Over two and one-half million Sterling Electrical Devices in use to-day



MURDOCK RADIO

WHEN men everywhere *insist* on Murdock apparatus, we realize that *quality* manufacture has imposed on us a *quantity* obligation, sometimes hard to meet.

Examine Murdock apparatus at your dealers.

There are no other phones so good at so low a price. *After you have bought*, a 14 day trial privilege assures satisfaction with your purchase.

WM. J. MURDOCK COMPANY

Washington Avenue Chelsea, Mass.
1270 Broadway, New York City
509 Mission Street San Francisco, Cal.

No. 56—2000 Ohm—\$5.00

No. 56—3000 Ohm—\$6.00

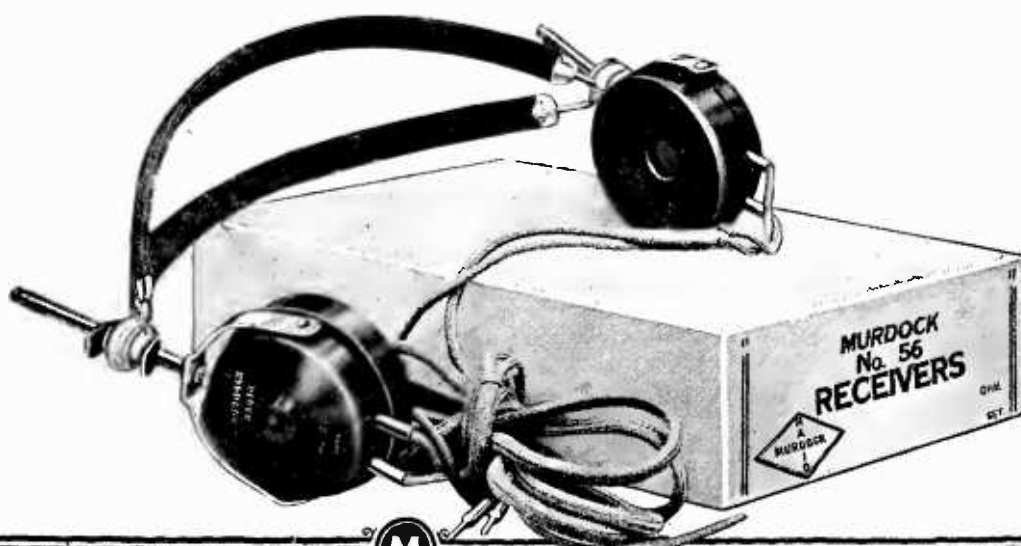



'True Gold,'
said Confucius,
'does not fear the fire'
— and
"Grebe Radio
survives the most
exacting tests."

Doctor Wu.

MAKE your radio con-
certs a source of never-
ending entertainment and
delight for yourself and friends.
Tiresome experiments and ad-
justments—unpleasant interrup-
tions and noises are eliminated
in the famous Grebe CR-5.

Correctly designed for thoroughly
satisfactory service on all radio
telephone work. Its range em-
braces all wave lengths from the
amateur to the Arlington time
signal.

A complete regenerative receiver
in which but two simple tuning
adjustments are used.

ASK your dealer to
demonstrate—If he
is unable to do so, send
us his name for inter-
esting circular.

A. H. GREBE & CO., Inc.
Richmond Hill, N. Y.

Grebe Radio Apparatus
is
Licensed under
Armstrong U. S. Patent
No. 1,113,149





The Recognized Symbol of Superior Performance



Amrad Radio Frequency Broadcast Receiver

RADIO FOR THE HOME

OWNERS of Amrad Short Wave Sets are bringing in broadcasting programs from even greater distances by adding the new Amrad 2-Stage Radio Frequency Amplifier to their equipment.

This new Amrad development may be added to any short wave or regenerative receiver. It makes audible many distant stations ordinarily never heard. It does not amplify static or local stations as much as audio-frequency amplification. Connections are easily and quickly made.

If you have an Amrad or other standard short wave set send for Bulletin R describing this 2-Stage Radio Frequency Amplifier. If you have no Set send for Bulletins R and L describing the combination illustrated above.

Complete Amrad Catalogue 10c stamps

AMERICAN RADIO AND RESEARCH CORPORATION

Sales Division

Department 20

MEDFORD HILLSIDE, MASS.

(4 miles north of Boston)

NEW YORK

CHICAGO

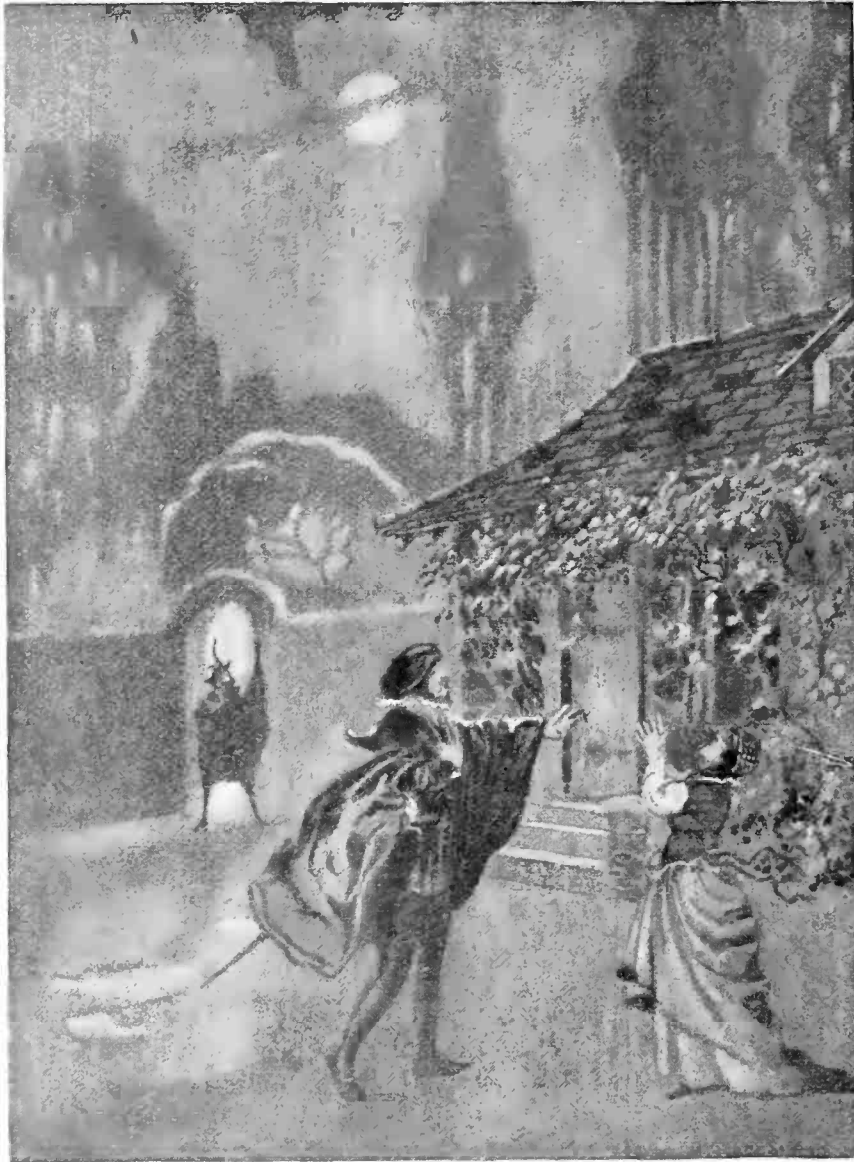

Scene from the Opera "Faust"



The New
Star in
the Radio
World

MOMENTOUS events in the arts and sciences are the result of rising above out-worn principles, independent of the tools of mediocrity. Beginning where others have been content to finish, a forward-looking group of radio engineers, comprising the Mu-Rad Laboratories, have designed and successfully constructed radio apparatus which is as advanced as the twenty-one-jewel watch is over the key-winder. Prices of this apparatus insure that great numbers will benefit from their achievements. Descriptive literature upon request.



MU-RAD
LABORATORIES
INCORPORATED
ASBURY PARK
NEW JERSEY

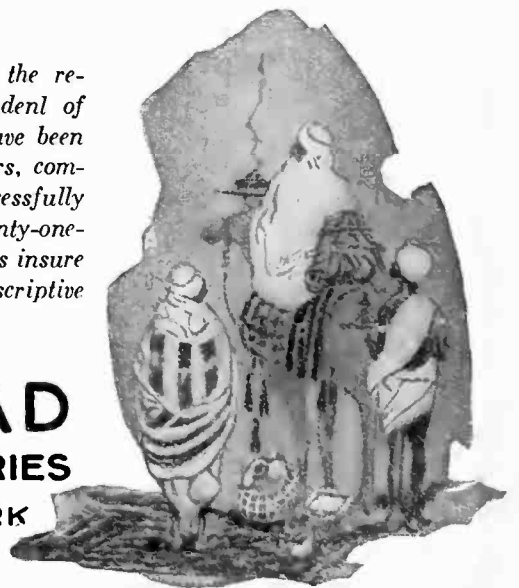

“What’s new in Radio, Mr. Jones?”

Everything’s new in radio, of course, but the newest, most-complete-in-itself device to-day is the



“SOCOSTAT”

(Socket-rheostat)

How Would a “Socostat” Improve My Radio Set?

The “Socostat” saves money, time and material, eliminates the wiring of two separate parts and has no exposed parts. It’s simple to install adds to the appearance of your set to say nothing about the extra efficiency of your receiving apparatus.

You have heard propaganda about the static conditions of the atmosphere during the warm months. With up-to-date radio equipment good results can be obtained under any weather conditions. Try a “Socostat” and you will be convinced of this fact. The static and tube noises will be reduced to a minimum.

I’ll certainly give it a fair trial. If it does all you say I know it will be worth a great many times the initial cost to me. And I am taking no chances as the “Socostat” is guaranteed.

The “Socostat” has a bakelite base and cover. The nickel plated receptacle takes any standard detector and amplifier tube. Rings and screws all nickel plated. The internal rheostat permits

very sensitive filament adjustment by turning the knurled cover. If your dealer can’t supply you, write direct to us. \$2.50 post-paid. Descriptive literature upon request.

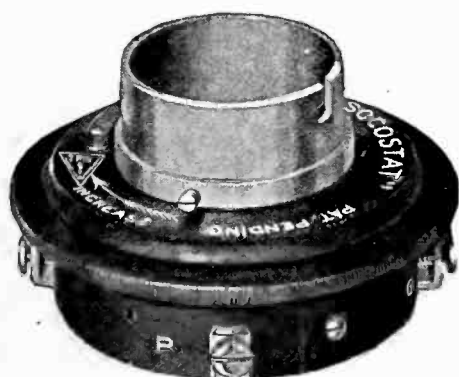

Single-Unit Socket and Rheostat for Table or Panel Mounting

Jobbers and dealers write
Automotive Electric Service Corp.
206 Amsterdam Ave., New York City

Manufactured by

FEDDERS MFG. CO., Inc.

57 Tonawanda St. Buffalo, N. Y.

Radio



The Greatest Radio Offer of the Year—Absolutely Complete, \$49.50

This special receiving outfit will give as good results as any outfit of this improved type on the market. It is absolutely complete, there is nothing extra to buy. We include everything—you simply put up the aerial, connect the instruments, which is easy to do, and in less than half an hour you can be receiving signals, radio music, lectures, stock reports, market reports, or any other radio program sent out.

In making tests with this set in Chicago we regularly heard Detroit, Pittsburgh and other stations were often tuned in. Of course, atmospheric conditions affect the range of this or any other receiving set made.

Highest Development in Radio Receiving

This outfit will equal in results any outfit of this type regardless of price. It is especially made for us and has behind it the fifty year old guarantee of Montgomery Ward & Co.: "Satisfaction guaranteed or your money back." You take no risk whatever in ordering this set.

Long Distance Vacuum Tube Receiving Set

The complete outfit includes our special Combined Tuner and Detector; Special 2000 ohm Double Head Set; Radio Storage Battery; one Detector Tube, one "B" Battery; and complete antenna and connecting equipment including 150 feet bare copper wire and 25 feet insulated wire, porcelain tube; double throw switch; 2 antenna insulators; lightning protector; ground clamp, 2 screw eyes and 25 feet of wire for instrument connections.

Order this set at our risk. It will be packed carefully and shipped immediately from our nearest house. Shipping weight 40 pounds. 563Z599—Complete Outfit..... **\$49.50**

Order this outfit today and start at once enjoying in your home the most marvelous invention of the age.

Price of receiving Set without batteries, head piece, switch and aerial, shipping weight 8 pounds: 563Z598 — \$27.50. Send money order or check to the one of our five houses that is nearest to you.

MONTGOMERY WARD & CO., Dept. 27-R
Chicago Kansas City Saint Paul Fort Worth Portland, Ore.



RADIO CATALOG FREE

This FREE catalog tells you the kind of Wireless Equipment to own, so that you receive in your own home all the latest news, music, Church services, lectures, —everything that is broadcasted.

Every home should have a wireless telephone outfit. We now offer complete outfits from \$12.95 up.

Everyone interested in radio should see our low prices on parts and accessories. Write for this book. Learn about the miracle invention of the age. Easy to install, simple to operate.

One copy of this booklet is yours FREE. Write for your copy.

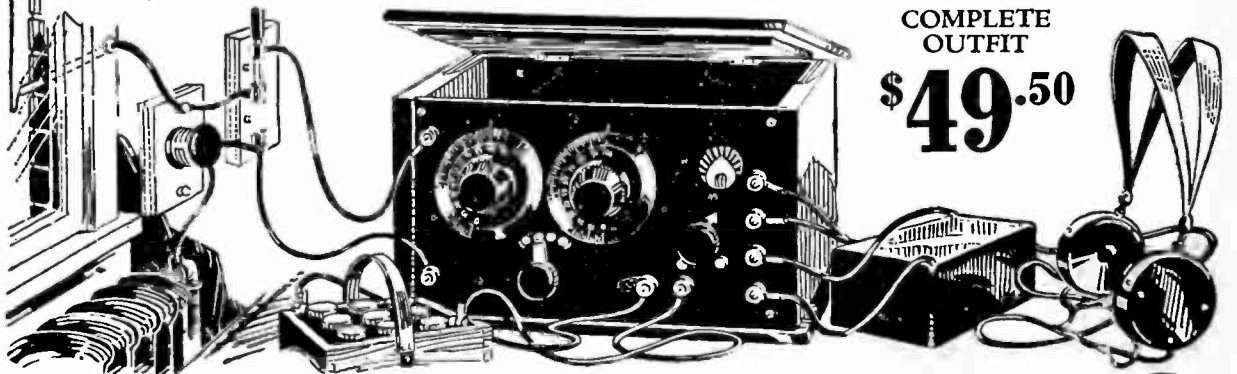

COMPLETE
OUTFIT
\$49.50

Montgomery Ward & Co.

≡ The Oldest Mail Order House is Today the Most Progressive ≡

CROSLEY

Better—Costs Less

Two Outfits That Are Taking the Country by Storm

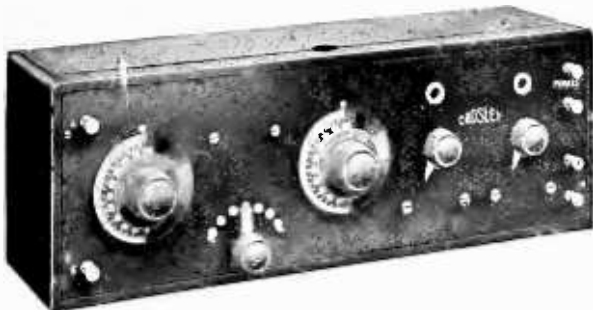

CROSLEY RECEIVER MODEL VI. This set consists of one stage of Tuned Radio Frequency Amplification and Audion Detector. It is normally for use with head phones, but is especially recommended to be used with any type of loud speaker. Additional amplification is unnecessary if head phones and horn are used in receiving local stations. Price without phones, batteries or tubes.....\$30.00

A REVELATION to those who have had the opportunity to try them out, the Tuned Radio Frequency Amplification feature of the CROSLEY MODEL VI and MODEL X and other larger models have met with universal success.

BY PLACING one stage of Tuned Radio Frequency Amplification before the detector tube we not only amplify the signals before they reach the detector, enabling it to work more efficiently, but also make sharper tuning possible and eliminate interference and static to a wonderful degree. These sets are especially designed for broadcast reception, covering a range of from 200 to 600 meters and we believe they cannot be equaled at any price.

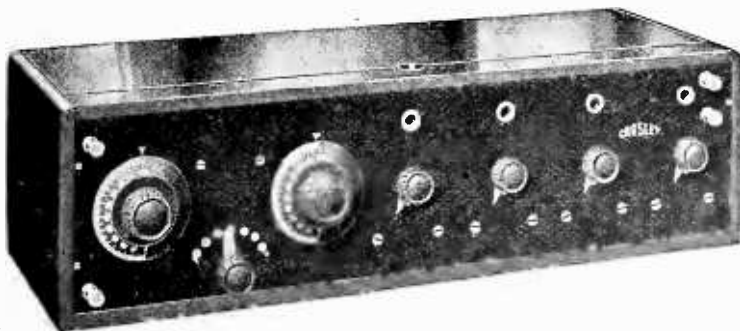

CROSLEY RECEIVER MODEL X. Is the same as MODEL VI with two stages of Audio Frequency Amplification added. In placing this receiver on the market we are offering you a unit whose range, volume and selectivity is remarkable. Nothing can compare with it at twice the price. Developed in the CROSLEY laboratories, this unit is absolutely the last word in long range Radio Receiving Apparatus. Used with head phones and loud speaker it will bring in distant stations all over the house. Price without phones, batteries or tubes. \$55.00

WE HAVE not only incorporated every refinement of detail in the mechanical features of our sets, but are offering you a beautiful piece of furniture with highly polished cabinet and neatly engraved formica panels as well. The knobs and dials are of solid moulded composition and of excellent design, making an outfit that will compare with anything on the market.

We also manufacture Receivers for from \$25. up and all kinds of Radio parts.

Write for our new illustrated and descriptive catalogue.

Sold through dealers and jobbers everywhere. If your dealer does not handle CROSLEY instruments write us direct.

CROSLEY MANUFACTURING COMPANY
DEPT. RB 10 CINCINNATI, OHIO



A Word About Price!

*Something that everyone interested
in Radio should know*

THE Automatic Electric Head Set has been developed and completed to give a maximum loudness and clearness under all conditions.

Some of the outstanding features have been discussed in these pages. Price has been quoted at \$10.00, with plug attached \$11.50. This is a fair price. It covers development and manufacturing costs plus a reasonable profit.

On account of the widespread demand for Radio equipment, it is difficult to judge real values by the various prices you see quoted. High price may not necessarily mean commensurate quality. That is why it is safer to buy a product whose origin you know.

Automatic Electric Company has been making high class telephone apparatus for over thirty years. This perfected Radio Head Set is the result of years of experience and technical knowledge, backed by the reputation of this house. And it is our aim to give you the best Head Set ever produced, to fit all requirements.

Some of the Important Points of Superiority of the Automatic Electric Head Sets are:

Single pole construction — (a single powerful electro-magnet which takes effect at the exact center of the diaphragm).

The soft iron magnetic path assures minimum loss of strength and character to the diaphragm vibrations.

The coil design — a single coil wound on a cylindrical core. No sharp corners. The core of the coil is very small and the electric resistance per average turn is correspondingly low.

High resistance, as you know, sounds impressive but means practically nothing. The thing that counts most is PROPER effective impedance. This is governed chiefly by the number of turns of wire, amount of iron in the magnetic circuit, and its construction.

If your dealer sells high class Radio apparatus, he can tell you all about Automatic Electric Head Sets. Ask him. If he cannot supply you, order from us direct. Price is \$10.00, postpaid — with plug attached \$11.50.



Automatic Electric Company

ENGINEERS, DESIGNERS & MANUFACTURERS OF THE AUTOMATIC TELEPHONE IN USE THE WORLD OVER
HOME OFFICE AND FACTORY: CHICAGO, U. S. A.

This is the high grade plug that comes attached, when desired, to Automatic Electric Head Sets. It will take care of any kind of cord terminals, will fit any kind of jack and will accommodate two head sets. With this plug attached to our head set you can be sure the head set is properly "poled."



Ask Uncle Sam He knows!

BY FAR THE BEST FOR RADIO PANELS

Uncle Sam has used Bakelite-Dilecto X. X. on electrical and wireless equipment in the Navy and Signal Corps for over *eight years*.

That's proof this unique material outdoes hard rubber, wood or marble. Uncle Sam does not adopt anything until he has tested everything!

Bakelite-dilecto!!

Amazingly adaptable for RADIO panelling and insulation. Gives positive and permanent insulation and utterly eliminates vibration. Imparts a professional finish to any home-made set.

Tests highest in every particular. Unheard-of dielectric strength (proved constant 5.2). Resists water, heat and milder acids. Cannot warp or swell. Finished a sleek, everlasting black. Tough and hard; yet *easily machined*.

Tell us who your electrical supply man is and we will write you where to get Bakelite-Dilecto X. X. cut to your exact requirements.

THE CONTINENTAL FIBRE COMPANY
Factory, Newark, Delaware

Dealer service from

NEW YORK	233 Broadway
ROCHESTER	85 Plymouth Av., S.
CHICAGO	332 S. Michigan Av.
PITTSBURGH	301 Fifth Av.
SAN FRANCISCO	75 Fremont St.
LOS ANGELES	411 S. Main St.
SEATTLE	1927 First Av., S.

bakelite dilecto

GRADE XX

Broadcasting a Message of Radio Reliability

Cotoco

TRADE MARK REG. U. S. PAT. OFF.

Buy by this Name and You Buy Right

COTO-COIL CO. is not a mushroom growth in the Radio Field. We were winding electrical coils long before the radio boom. We are here to stay. Our products are right to hold their own in any comparison for quality. Electrically correct and mechanically accurate. Even the Cotoco Dial is a better product—practically unbreakable, with metal insert to assure smooth action.

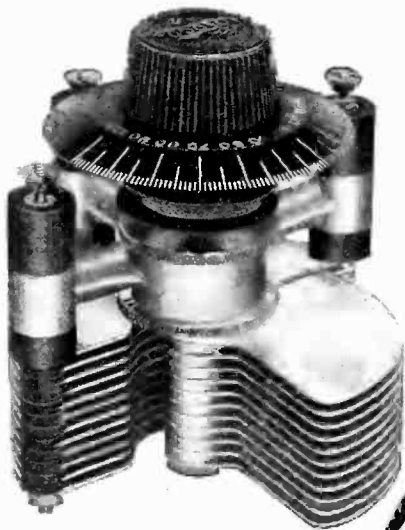

COTOCO VARIABLE AIR CONDENSER

Scientifically correct for minimum of electrical losses. A fine machine product that is as superior as it looks.

The perfected protection against distortion in headphones or loud speaker. Stable audibility over a wide range of frequencies.

COTOCO AMPLIFYING TRANSFORMER FOR AUDIO FREQUENCY

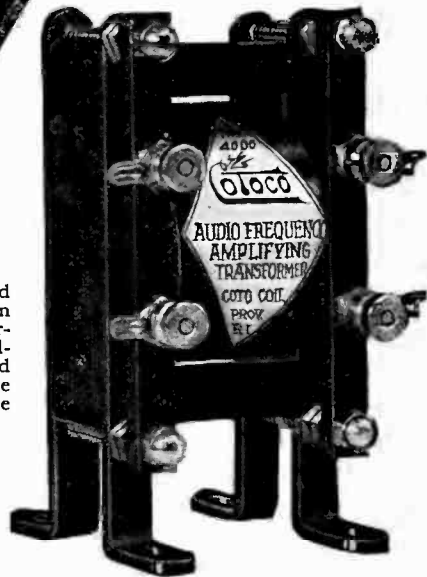

COTOCO HONEYCOMB INDUCTANCE COIL

Yet to find its equal as a compact, neat and remarkably efficient inductance unit. The original. Still the best.

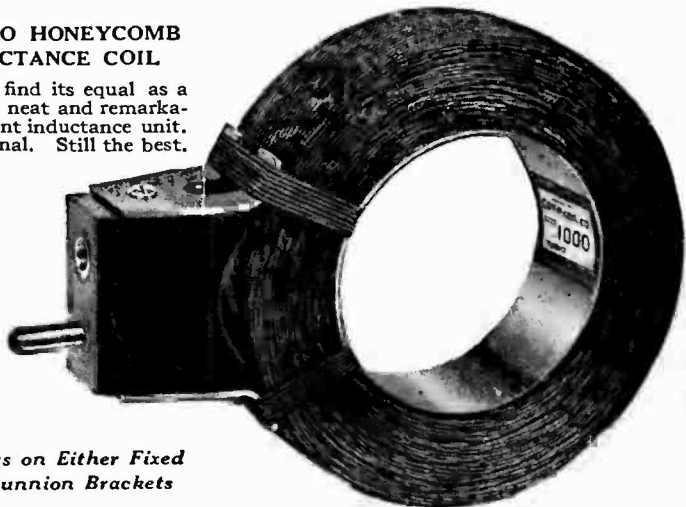

Mounts on Either Fixed or Trunnion Brackets

Send Us Your Dealer's Name

if he does not carry Cotoco Products. We will mail you **FREE** Connection Diagrams for Loop Aerial set and see that he can supply you.

**COTO-COIL CO.
87 Willard Ave.
Providence, R. I.**

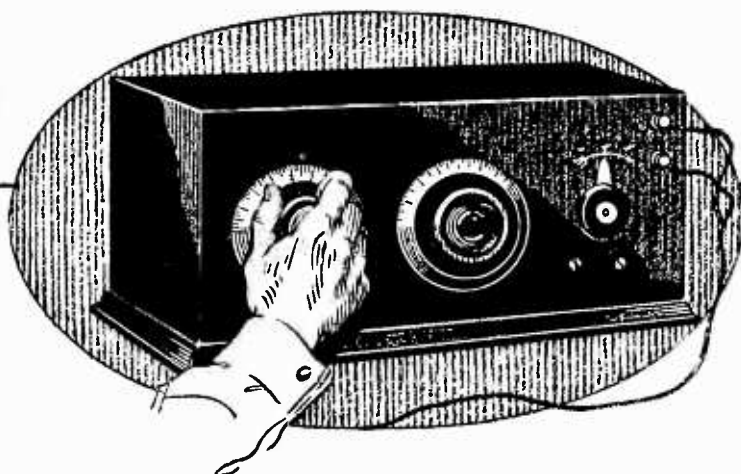

You Can get the best insulation *now!*

ANY dealer can get Formica quickly now so there is no longer any need to use an insulation in which you have less confidence.

Our large capacity makes it possible for us to keep fully abreast of the large radio demand—and to serve all of our customers promptly.

When you insist on Formica you get an insulation that is approved by the navy and signal corps—and one that is known by the makers of the finest radio apparatus as being leak-proof, warp-proof, and remarkably uniform in insulating quality.

Formica works well with ordinary tools. You can produce a perfect panel, and all you need is a drill. It has a wonderfully attractive finish and holds it during a long life. Dampness, fumes, chemicals, do not injure Formica. It is almost immune to conditions.

That is why it is the most popular of all radio insulating materials.

DEALERS: We have many valuable dealer helps. Store cards, folders, plates for advertising. Call on us for coöperation.

THE FORMICA INSULATION COMPANY

4628 Spring Grove Ave.
Cincinnati, Ohio

SALES OFFICES

50 Church Street...New York, N. Y. 414 Finance Bldg....Cleveland, Ohio 422 First Avenue.....Pittsburg, Pa.
9 South Clinton Street...Chicago, Ill. 1042 Granite Bldg...Rochester, N. Y. 1210 Arch Street...Philadelphia, Pa.
415 Ohio Building.....Toledo, Ohio 313 Title Building....Baltimore, Md. Sheldon Building San Francisco, Cal.

FORMICA

A Laminated Phenolic Condensation Product
SHEETS TUBES RODS

BRACH vacuum LIGHTNING ARRESTER

The Highest Development in Radio Protection

Ordinary common sense will lead the average radio user not only to comply with the rules of municipal authorities to insure the safety of his radio equipment, but he will do it to make possible clear signals and enjoyable entertainment.

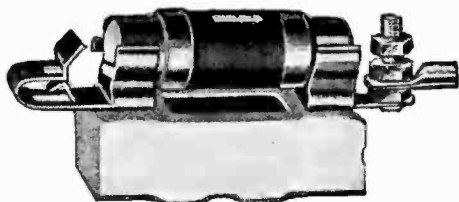

Indoor Type, \$2.50

Listed by the Underwriters' Laboratories.

L. S. BRACH MFG. CO. Newark, N. J.

16 Years' Specialists in Lightning Protective Apparatus
Makers of Solderall—Mends Metals; Connects Wires

Coast Representatives—Pacific States Electric Co.
San Francisco, Los Angeles, Oakland, Seattle, Portland, Spokane

Unless static interference is nullified there is bound to be disappointment no matter how well planned the concerts and lectures at the broadcasting stations.

The Brach Vacuum Lightning Arrester has demonstrated its superiority through over 16 years of service to the big railroad and telegraph companies, large fire alarm systems and the U. S. Army. It is built up to a standard; not down to a price.

Sold by Leading Radio and Electrical Dealers



Outdoor Type, \$3.00

BUS-BAR JACKS

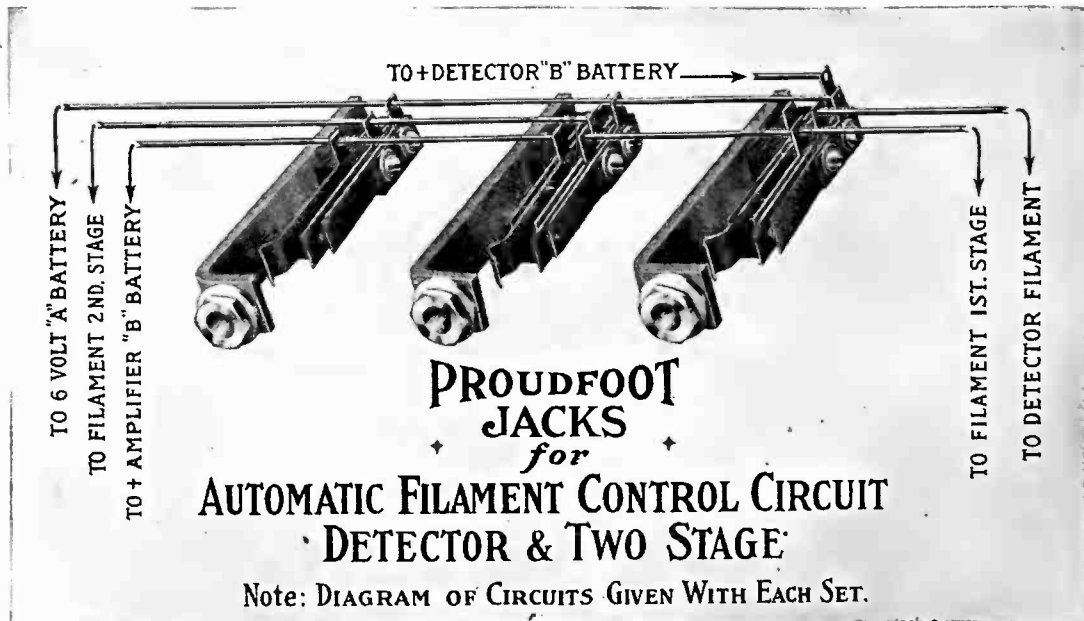

Price Per Set \$3.00

CRUVER MFG. CO., 2456 W. Jackson Blvd., Chicago, Ill.



HOMCHARGE your Radio Battery for a nickel!

Enjoyable Radio Concerts and maximum receiving range are obtained only when your battery is fully charged. Don't be bothered with the inconvenience and expense of taking your battery to a service station every few days for recharging.

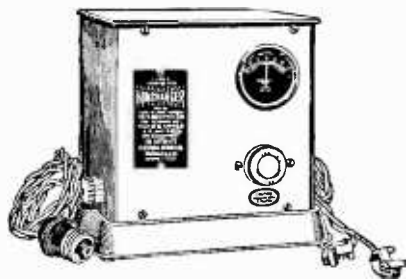

Type "R" (Portable)
Radio Homcharger De Luxe

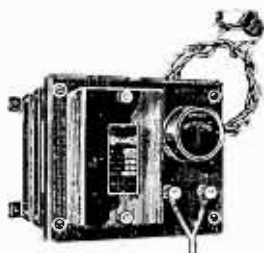

Type "W" Homcharger for
Wall Mounting
Over 50,000 in Use

RADIO HOMCHARGER DE LUXE

has been designed especially for this purpose. It charges your "A" or "B" battery over night without removing it from your living room. The Homcharger is silent and clean in operation—no muss—no trouble—no dirt—requires no watching.

Simplicity itself. Attach to any lamp socket and connect to battery. Fully automatic in operation—cannot overcharge or injure the battery. Constructed of the best materials—moulded Bakelite Base—Jewell Ammeter—Oversize Silicon Steel Transformer. No castings to break—only the finest stampings used thruout.

SAFE—all parts entirely enclosed—no danger from fire—approved by Fire Insurance Underwriters everywhere. Unconditionally guaranteed—lasts a lifetime.

An Ornament For Your Living Room

Beauty has been combined with utility in the NEW RADIO HOMCHARGER DE LUXE. The body is beautifully finished in rich Antique Mahogany—the base and fittings in a handsome dull gold. Equipped with rubber feet, it cannot mar polished surfaces. It harmonizes with the finest living room.

Over 50,000 HOMCHARGERS IN USE

50,000 users have heartily endorsed the HOMCHARGER. Beware of imitations when buying as there is only one HOMCHARGER. Insist on the genuine which bears our registered trade name, HOMCHARGER.

Furnished complete with attachment cord and plug, charging cable and battery clips. No extras to buy. Price at all good radio, accessory and electrical dealers, \$18.50, or shipped prepaid upon receipt of purchase price, if your dealer does not carry it.

Booklet illustrating the NEW RADIO HOMCHARGER DE LUXE in actual colors is FREE for the asking. Send for your copy today.

The Automatic Electrical Devices Co.
128 West Third Street Cincinnati, Ohio

Largest Manufacturers of Vibrating Rectifiers in the World

*BRANCH OFFICES: New York - Chicago - Pittsburgh - Detroit - Dallas - Philadelphia
Los Angeles - Baltimore - Minneapolis - Kansas City - St. Louis - Atlanta.*

KENNEDY EQUIPMENT

*The Standard by which
to judge Radio Equipment*

SO careful has been the manufacture of Kennedy Equipment since its inception that radio enthusiasts everywhere proclaim it the standard by which to measure all radio receiving apparatus.



Kennedy Regenerative Receivers are licensed under Armstrong U. S. Pat. No. 1,113,149, and are sold by good dealers everywhere.

KENNEDY *Short-Wave Regenerative Receiver Type 281*

is a sturdy example of the quality which has made the name Kennedy synonymous with good radio equipment everywhere. Type 281 possesses selectivity and efficiency to a high degree, these features being insured by the correct use of inductively coupled circuits.

WRITE FOR LATEST BULLETIN C-3
Address our nearest office

The COLIN B.

KENNEDY
C O M P A N Y
INCORPORATED

SAN FRANCISCO U. S. A. SAINT LOUIS

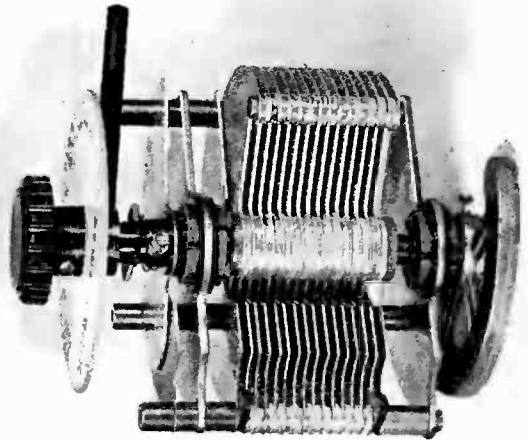

Thanks For Your Patience!

THE radio public was very patient when we were unable to supply De Forest Vernier Condensers, because they knew that all we could make were going into the famous De Forest MR-6 Receiving Sets.

Now, however, you can have the satisfaction of putting genuine De Forest Condensers on that special set you are building. The CV-1003 and CV-1503 Vernier Condensers are now again available. Production has been increased as fast as was possible—always remembering the maintenance of De Forest quality.

It is only necessary to remind you of some of the reasons why these Condensers have been declared perfection by radio experts. The movable plates are heavier than those in any other. The separately controlled Vernier plate gets you "in on the peak" and gives you 20 per cent. louder signals. The securely fastened counterweight acts as a balance and permits smooth, accurate operation in any position. Each Condenser is individually tested at 500 volts. The whole construction is a fine example of scientific precision laboratory equipment.

Used with De Forest Honeycomb Duo-Lateral Coils these Condensers provide tuning equipment unsurpassed for selectivity, sharpness, and all-round efficiency.

De Forest Radio Tel. & Tel. Co.
Jersey City, N. J.

De Forest



Exide

BATTERIES



How will you choose your battery?

If you are technically inclined, you will be much interested in the construction of the Exide Battery designed especially for radio. From plates to connector terminals, each detail is the result of experience gained in every field by the oldest and largest manufacturers of storage batteries in the world.

If you buy a battery on reputation, consider these facts: Exide was the pioneer battery not only in the automobile but long before the days of automobiles. Great industries of all kinds rely on the Exide's ungrudging power. Every time you use the Bell telephone an Exide Battery sends your voice over the wire. Most of the government and commercial wireless plants are Exide-equipped.

The Exide Radio Battery gives uniform filament current for all types of vacuum tubes. It is rugged and long-lasting.

You can get an Exide Radio Battery at every place where radio equipment is sold and at all Exide Service Stations.



THE ELECTRIC STORAGE BATTERY CO.
Philadelphia

*Oldest and largest manufacturers in the world of
storage batteries for every purpose*

You Get Better Results With Erla Radio Frequency



Voice and music a thousand miles distant are heard perfectly through a loud speaker, using only one stage of ERLA radio frequency amplification. And this result is accomplished with complete absence of tube noises and distortion. Furthermore, tuning is extremely simple and non-critical, so that even the most inexperienced amateur has no difficulty in getting perfect results. Write for free diagrams of hook-ups. Address Dept. B

Electrical Research Laboratories, Chicago

On sale by first class dealers.
Or send us your order direct,
with your dealer's name.
Special proposition to jobbers.

Price: Types AB1, AB2, AB3,
\$6.00 each

Write for literature and prices
on bezels, phone plugs, tube
sockets, grid leaks, grid con-
densers, and other standard
ERLA products.

ERLA

TRADE MARK REGISTERED



"Corn is up a cent"

Lic. Under Armstrong U.S. Pat. 1113149



TRESCO RADIO

J. Matheson Bell, Sales Mgr.

Davenport, Iowa, U.S.A.





“How to make your radio set work best”

IN ORDER to make your radio set work, let's briefly consider the requisites necessary and then apply a definite method to achieve this end.

To receive signals of maximum intensity, the open and closed circuits of the receiver *must be accurately tuned to each other and to the frequency of the incoming wave.* Tuning in the circuits of a radio receiver is accomplished by means of the variable elements of inductance and capacity.

The best results in tuning to a wave length are obtainable by means of a variable condenser, always providing that this instrument has been constructed with *micrometer exactness* as is the Westwyre Variable Condenser.

Not only does this instru-

ment enable you to more readily *select the station you desire* where two or more are broadcasting at approximately the same wave length, but *it tends to increase the strength of incoming signals* and *eliminate interferences* from near-by stations which ordinarily drown out those farther off.

In a weighing operation, weights of several pounds are first placed on the scales, while the delicate balancing is accomplished by a sliding beam-weight. So in a radio set the inductance may be varied in rather large steps while the finishing off is left to one or more Westwyre Variable Condensers which are capable of exceedingly fine wave length adjustment.



43 plate, .001 mfd with dial - - - \$5.00
23 plate, .0005 mfd with dial - - - 4.00

11 plate, .00025 mfd with dial - - - 3.50
3 plate, vernier with dial - - - 3.00

Westwyre Variable Condensers



THE WESTWYRE RADIO CO., Westfield, Mass., U. S. A.

I am attaching money order check forPlate, Westwyre Condenser, shipped by parcel post.

Please send radio catalogue.

Name

Street.....

City.....



"As good as Brandes"

ONLY if a headset bears the name Brandes can it be "as good as Brandes." And genuine Brandes *Matched Tone* headsets cost no more than less sensitive and less rugged imitations.

Send ten cents in stamps for the "Beginner's Book of Radio," which explains radio in terms that anyone can understand.

Distributors and District Offices:

Munsey Bldg., Washington, D. C. 76 Pearl St., Boston, Mass. 33 S. Clinton St., Chicago, Ill. 709 Mission Street, San Francisco, Cal. International Electric Company, Wellington, N. Z.

C. Brandes, INC.
"Matched Tone" Headsets
 237 Lafayette St., New York

Made in Canada by Canadian Brandes, Ltd., Toronto
 Distributed by Perkins Electric, Ltd., Montreal

Result of 14 Years' Experience

Making the Most of Radio with DUBILIER Products



No antenna, no loop — just the Ducon in a lamp socket.

SCREW the Dubilier Ducon into any lamp-socket. No antenna or loop is required.

The Dubilier Ducon is a perfect safety device. It prevents the lighting current from reaching the set and permits only the feeble radio oscillations to pass.

Price, at your dealer, \$1.50.

Dubilier Micadons Reduce Tube Noises

Tubes howl partly because condensers fluctuate in capacity. Dubilier Micadons are mica condensers *permanent in capacity*. Hence they reduce tube noises and greatly improve the reception of broadcasted concerts and lectures.

Dubilier Micadons, made in several types, meet every radio need. The price varies from 35 cents to \$1.00 each, depending on type and capacity.



Micadon type 600. Molded case. With and without grid-leak mounting. Price 75c to \$1.00 each, depending on capacity.



Micadon type 60x. Made with eyelet terminals. Price 35c to 40c each, depending on capacity.

BRANCH OFFICES:

San Francisco, Cal. 709 Mission Street, Suite 701-704
 St. Louis, Mo. Syndicate Trust Building, Suite 1409
 Washington, D. C. Munsey Building
 Chicago, Ill. 15 E. Monroe Street

DUBILIER
 Condenser & Radio Corp.
 48-50 West 4th St. N.Y.

Jobber and Dealer orders now being filled

Canadian Distributors: Canadian General Electric Co., Toronto, Canada

AMPLIFICATION

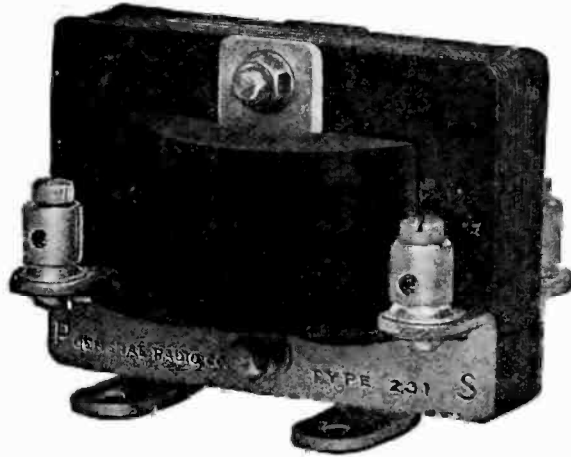

Amplification was first made practicable by the use of the three electrode tube. To take full advantage of the amplifying feature of the vacuum tube, the impedance of the grid circuit of the amplifier tube must be adapted to the impedance of the plate circuit of the detector, or preceding amplifier tube. This correct arrangement of impedance values can best be accomplished by a transformer. The primary and secondary windings, as well as the magnetic circuit can then be designed so as to give the maximum change of potential on the grid of the amplifier tube.

Amplification in this manner is only about a decade old. One of the first companies to design amplifying transformers was the General Radio Company. This Company has, furthermore, the distinction of being the first in this country to supply the experimenter with a closed core amplifying transformer.

Since the introduction of the first transformer, the subject of amplification has received much attention in our research laboratory and new improvements have been developed from time to time. Our Type 231-A amplifying transformer represents a six-year study of the problems of amplification. It embodies the best features in amplifier design.

There are several transformers on the market to-day having as high an amplification factor as the Type 231-A transformer. At certain resonant points, some are even higher. Extraordinary amplification at a single frequency is seldom to be desired. High amplification over a wide band of frequencies is the true measure of a satisfactory amplifying transformer. With the increase in radio telephony, this feature is not only to be desired but is essential. It is in this feature that the Type 231-A amplifying transformer excels. It is designed to give the maximum amplification possible without distortion when used with a Radiotron UV-201 vacuum tube.

The core construction is such that there is little tendency for the setting up of external fields with the resultant howling in the audio frequency circuit. The distributed capacity of the secondary is low so that the maximum potential is obtained on the grid of the tube.

The constants of the transformers are as follows:

	Primary	Secondary
Direct current resistance.....	1,100 ohms	5,500 ohms
A. C. resistance @ 1,000 cycles.....	11,000 ohms	130,000 ohms
Reactance @ 1,000 cycles.....	66,000 ohms	700,000 ohms

PRICE, COMPLETELY MOUNTED, \$5.00

Send for Free Radio Bulletin 911-B

GENERAL RADIO COMPANY

Massachusetts Avenue and Windsor Street

CAMBRIDGE, 39

MASSACHUSETTS

Standardize on General Radio Equipment Throughout

Federal RADIO APPARATUS

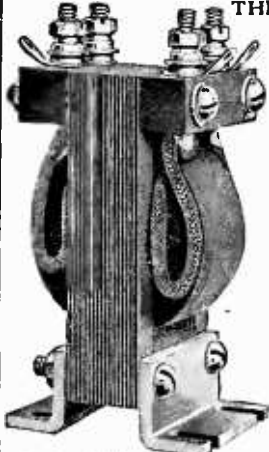

No. 226-W Voice Frequency Amplifying Transformer

THE RECOGNIZED STANDARD

YOU WILL BE REPAID IN SATISFACTORY RESULTS if you equip your set with

Federal PARTS

We illustrate here two articles that were in general use throughout the WORLD WAR in Army and Navy equipment and have met with the hearty endorsement of the Radio Fan ever since. They represent the highest degree of perfection yet attained in Radio Apparatus and are typical of the complete line we manufacture.

FOR SATISFACTORY RESULTS
INSIST THAT YOUR DEALER SUPPLY GENUINE FEDERAL EQUIPMENT

Federal Telephone and Telegraph Company BUFFALO, N. Y.

CHELSEA Variable Condensers (Die-Cast Type)



No. 1. Price \$5.00

Amplifying Transformer No. 50

The Chelsea Amplifying Transformer gives the highest amplification possible and at the same time will not squeal, howl, or in any way cause noisy circuits. It is beautiful in design and embodies electrical characteristics unequalled by any. Guaranteed for all circuits up to 500 volts with a high safety factor. It will not fail in service.

- No. 1—,0011 m.f. mounted \$5.00
- No. 2—,0006 m.f. mounted 4.50
- No. 3—,0011 m.f. unmounted 4.75
- No. 3—,0011 m.f. unmounted, without dial 4.35
- No. 4—,0006 m.f. unmounted 4.25
- No. 4—,0006 m.f. unmounted, without dial 3.85

Top, bottom and knob are genuine bakelite, shaft of steel running in bronze bearings, adjustable tension on moveable plates, large bakelite dial reading in hundredths, high capacity, amply separated and accurately spaced plates.

Unmounted types will fit any panel and are equipped with counterweight. Guaranteed for circuits up to 1,000 volts.



Price \$1 00

Bakelite Socket No. 60

This socket includes a bakelite base supporting four external readily accessible binding posts. The tube receptacle is highly polished nickel and will take any standard detector or amplifying tube as well as the smaller size power tubes. Although primarily intended for receiving circuits it will operate satisfactorily on any circuit up to 1,000 volts. It may be mounted either on table or panel. Positive contact springs.

An added beauty to any radio station.



Price \$4.50

Purchase Chelsea Radio Equipment from your dealer. If he does not carry it send to us. Write for our new No. 6 catalogue.

CHELSEA RADIO CO., 150 Fifth Street, Chelsea, Mass.
Manufacturers of Radio Apparatus and Moulders of Bakelite and Condensite.



"Comin' In Great!"

At Last! —

High Efficiency Receivers at a Down-to-Earth Price

ELEVEN years in the manufacture of delicate electrical units and apparatus—eleven years concentrated in the production of one line of equipment—all electrical, *means* something in accumulated experience and facilities.

That's the answer to how we have been able to place on the market this super-sensitive radio head set for \$6.00.



All the high-priced qualities. Sensitiveness—balance—natural voice pitch—no scratching. Light weight, aluminum case—solid horse shoe magnet—no laminations—bus-bar connections, no loose wires.

Light diaphragm, set to thousandths-of-an-inch accuracy from magnet poles. Clean cut, rugged design throughout. Comfortable on the head—good to look at. Compare them with other makes irrespective of price and you'll be convinced they're quick sellers.

Write for exceptional dealer proposition and name of our local factory representative nearest you.

Briggs & Stratton Co.
 Milwaukee — PRODUCT — Wisconsin



Put up in attractive orange-colored cartons

2000 Ohm.....\$6.00
 3000 Ohm.....\$7.50



Tune 20 times faster

The "Amplitrol" controls the amplifier tube circuit without the use of jacks, plugs or any additional switches. No necessity of plugging in from one stage to the next—simply attach phones or loud speaker to binding posts and turn on any stage at will.

The "Amplitrol" not only adjusts the filament to its maximum efficiency, but it automatically controls the plate circuit at the same time, thus eliminating an extra operation. Unlike an automatic filament control, the "Amplitrol" does not put a sudden strain on the filament. A real necessity for amplifier tubes. Price \$4.00.

The Amplitrol
PAT. PEND.

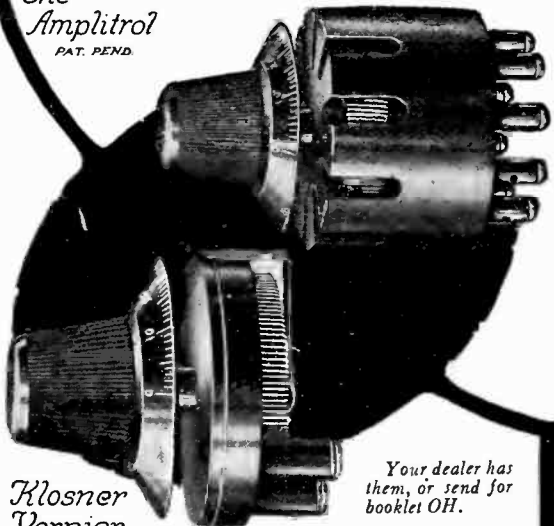

Klosner Vernier Rheostat Model 200
PAT. PEND.

Your dealer has them, or send for booklet OH.

What the "Amplitrol" is to the amplifying tube, so the Klosner Rheostat is to the detector tube. The new improved Rheostat Model 200 embodies some vast changes and improvements.

These are too numerous to list, but your inspection will immediately win your approval. Price \$1.80.

The "Amplitrol" and the Klosner Rheostat are the ideal combination for vacuum tube control. They do not employ the graphite-disc principle, but that of wire wound. This feature insures perfect contact at all times, making tuning 20 times quicker and louder and giving greater range.

Klosner Improved Apparatus Company
2024 Boston Road ~ ~ New York



for **SATISFACTION**
demand these high quality radio parts

Bethlehem Variable Condensers
Capacities .001, .0005, .00025 M.F. and Vernier. \$2.50 to \$4.00

Bethlehem Radio Plugs
Type AX1, standard; and AX2, universal. \$1 each.

Bethlehem Radio Jacks
Type BX1, open circuit, 60c. BX2 closed circuit, 75c. BX3, double circuit, 90c. BX4, single filament control, \$1.10 each.

Bethlehem Radio Tool
Invaluable for many assembly operations. 75c. each.

Bethlehem Radio Dials
70c. each.

Every BETHLEHEM product is GUARANTEED to be exactly as described and free from all defects in materials and workmanship

Write for full descriptions. Ask for dealers' names.

Bethlehem Spark Plug Company, Inc.
Bethlehem, Pennsylvania

Bethlehem

1898---1923---25 Years Experience in Head Phone Equipment Your Guarantee

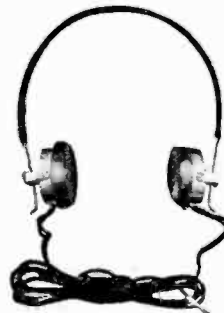

YOU will be surprised at the clear, distinct ring of the message received over the Leich Radio head phones. This company began making head sets in 1898—thus the refinements and improvements of years of actual service tests are incorporated into the Leich head phones.

The head band is light—both ear phones fit evenly and firmly, and can be worn for hours without discomfort—the band can be adjusted by the thumb nut, and remains fixed—no readjustment is necessary.

- No. 1-D. 1500 ohms - - - \$ 7.00
- No. 1-B. 2000 ohms - - - 7.50
- No. 1-C. 3000 ohms - - - 10.00

Equipped complete with head band and 6 ft. cord
Ask your dealer—if he cannot supply write us

Leich Electric Company
Genoa, Ill.

no ground aerial

The A-P Special Receiving Set

One of the most important, most revolutionary developments since the discovery of radio. The receiving set thousands have been waiting for. A set that requires no ground, no aerial. For general use a single wire not exceeding 15 feet in length, concealed in the picture moulding, laid on the floor, or, if out-of-doors, placed on the ground, is all that is necessary. Stations 400 miles distant have been heard under these conditions. For distant service a wire not over 50 feet long will produce better results than can be obtained with the elaborate 150 to 200 feet aerial and ground, or loop system required by other types of receivers.

The A-P Special has the apparent advantages of radio frequency amplification without its delicate and complicated adjustments. It is remarkable for its simplicity of control and marked selectivity, and ideal both as a home set and for use as a portable in camping or outing.

Bulletin B contains complete information on this wonderful set. Write for it and name of our nearest dealer. We are now in position to make prompt shipments.

The Oard PHANTOM no ground circuit

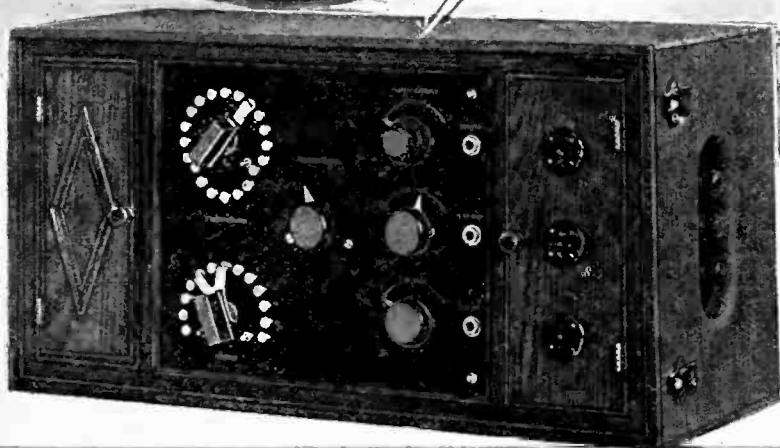

Set closed with cover
for use as portable

**U.S. AND FOREIGN
PATENTS PENDING**

Atlantic-Pacific Radio Supplies Co.
Operating K.Z.Y. 646-650 Mission St. Radio
Broadcasting Station San Francisco, Cal. Supplies

ELIMINATE OUTSIDE AERIAL USE LIGHT CIRCUIT

No longer is it necessary to contend with the dangers incident to stringing antenna wires. You can now listen to the world by just inserting "Super-Antenna" plug in any electric light socket. This unit has been designed by one of the country's foremost Radio Engineers. *Gives perfect results—Saves expense.* Operates on any electrical circuit D. C. or A. C. with switch "ON" or "OFF."



MAKES YOUR RADIO SET PORTABLE

By using the "SUPER-ANTENNA" unit you can move your set from room to room, or house to house. *Entertain your friends anywhere.* This wonderful unit safeguards your set. Eliminates A. C. hum—is shockproof—will not blow fuses and reduces static effect. Has 8 different hook-ups that give good results on any circuit. **ORDER TO-DAY. Price \$2.80** If your dealer cannot supply you send us his name enclosing check or money order. West of Rockies \$3.00. Canada \$3.70.

F.R.L. Super-Receiver—Radio Frequency

This set is months ahead of any other unit offered the Radio Public. Made of best materials obtainable—tested by skilled engineers and gives perfect modulation of music, speech, and signals without distortion.

30 Mile Range without Antenna or Ground

This unit has 1,000 mile receiving radius and a range of 150 to 600 meters. Has no equal for sensitiveness and efficiency. Price including tubes \$240.00.



DEALERS and JOBBERS—Wire or Write for Discounts and Special Territory.

SUPER-ANTENNA COMPANY

Dept. 910

Quincy, Ill.



FROST-RADIO PROTECTOR

Listed by Underwriters' Laboratories under April, 1922, regulations. No interference with clear Radio receiving.

Never Grounds Mounts Indoors

Price \$1.50

Good deliveries on this approved device.



FROST-RADIO

Extension Cord and Plug
Comes in lengths from 10 to 100 ft. Loud speaker can be placed anywhere and connected with Radio set with FROST-RADIO Extension Cord.

OTHER FROST-RADIO LEADERS

Frost-Fones Frost-Radio Improved Plugs and Jacks
Frost-Radio Receiving Transformers Cunningham Vacuum Tubes
Remler Radio Apparatus

Inquire of your Local Dealer.



HERBERT H. FROST
NATIONAL FACTORY DISTRIBUTORS
TO THE ELECTRICAL-RADIO JOBBER
154 W. LAKE ST. CHICAGO, ILL.

The Mark of the Quality Radio Store—



WHEN you see this sign on the clean plate-glass window of a radio shop you may enter—assured that the apparatus and prices are right; the stock complete; a competent radio expert in charge;—and the Golden Rule in force.

"It pays to buy at the Sorsinc Store"

Mr. Dealer:—If you are a progressive merchant, you may display the Sorsinc sign. Let us tell you how.

Ship Owners Radio Service, Inc., 80 Washington Street, New York
Wholesale Distributors

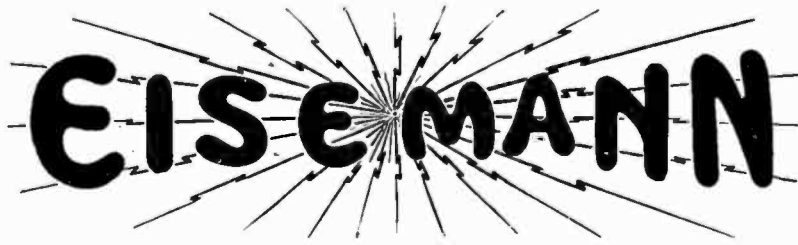

WITHIN the last few months many concerns have engaged in the manufacture of radio parts, and the market has become flooded with apparatus of varied design and wide price range.

Obviously, greater discrimination must be practised by the buyer of radio materials.

Is not the guarantee of a responsible Corporation a factor to be considered? For twelve years the Eisemann trademark has been recognized in the automotive industry, as an assurance of quality and dependability. The same high standards are maintained in the manufacture of radio parts.



Audio Frequency Amplifying Transformer

This part used as an intervalve unit in a cascade amplifying outfit, utilizes to the highest degree amplifying properties of all makes of vacuum tubes. Maximum amplification within the tube limits is made possible and distortion of the signal is eliminated. The ratio is nine to one.

Highest degree of insulation of the primary and secondary windings is assured by the vacuum impregnating process in manufacture.

Price each \$6.00



Head Set

The Eisemann Head Phone will faithfully reproduce all broadcasted musical and spoken sounds. It is of simple design, yet rugged and sturdy of construction. The set is unequalled for quality of tone and balance of the receivers.

Specifications:

- Receiver case—aluminum.
- Coils—wound with highest grade enamelled insulated copper wire.
- Resistance—2,200 Ohms.
- Magnets—High percentage tungsten steel—permanent.
- Diaphragm—Rust-proof.
- Cord—Six foot.
- Head Band—Approved spring wire—self-adjusting sliding rod type.

Price complete—\$8.00

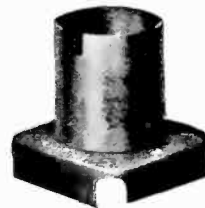

Vacuum Tube Socket

The contact points or fingers are supported by a single piece, tempered steel spring of proper tension. The four terminals are insulated from this spring by Bakelite insulation.

The socket is an all-metal, non-breakable type with provisions for table or panel mountings.

Price each 50c

Send for Folders describing Eisemann Radio Equipment.

**RADIO DIVISION
EISEMANN MAGNETO CORPORATION**

William N. Shaw, *President*

32 - 33rd Street, Brooklyn, N. Y.

DETROIT

CHICAGO

The radio industry is still young. The manufacturers who are looking to the future are building for permanence. That is why we put every ounce of our ability into the making of

UNION RADIO Apparatus and Accessories

That we are justified in this endeavor is attested to by the popularity Union Radio equipment has attained in the eyes of radio fans who are demanding quality and "best result" performance.

Our expert engineers are constantly at work on new improvements. Pictured below is the new (patent applied for) Union Radio Filament Rheostat.

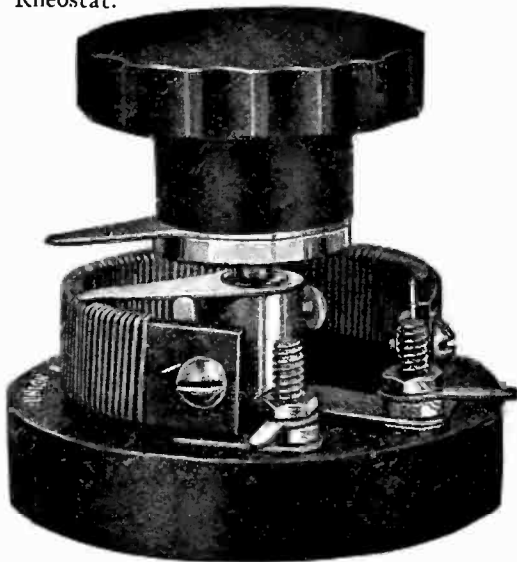

Price with Knob (as shown above) \$1.20
Price with 2 1/2 in. Condensite Dial \$1.50

Base Knob and Dial Genuine Moulded Condensite

This Rheostat, our Vacuum Tube Receptacle and our Phone Tip Jacks (all patents applied for) are only three of the new developments that are making Union Radio apparatus and accessories such favorites.

We guarantee without reservation all Union Radio apparatus and accessories as to workmanship and materials.

Union Radio products include complete receiving sets, 2 step amplifiers, variable condensers, condensite dials, filament rheostats, receiving vacuum tube receptacles and telephone Tip Jacks.

Write now for your copy of our catalogue, "Radio Apparatus B."

Retailers and Wholesalers

Samples of our guaranteed, reasonably priced "Quality Products," sent on request. Our terms and trade discounts are liberal. Write for our proposition.

UNION RADIO CORPORATION
200-MT PLEASANT AVENUE, NEWARK, N.J.
NEW YORK OFFICE 116 WEST 32nd STREET.



GET acquainted with Radio by buying an Audiola Crystal Receiving Set.

The 23-plate variable condenser insures sharp and accurate tuning. It is a complete unit, in a rich mahogany finished case, with nickel plated fittings.

Needs no batteries, no tubes, no fussing. Just connect it with aerial, ground and head phones, and "listen in."

Price \$10

Complete
(without headphones)
At your dealer or write direct for illustrated booklet.

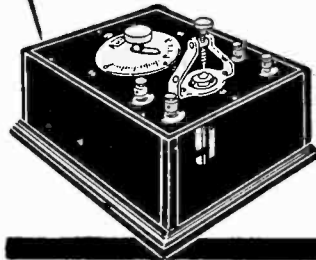

Audiola Radio Co.
430 S. Green St., Chicago

We can use a few high-class representatives for exclusive territory.



Our Radio Department is conducted by electrical engineers, which assures you dependable and highly efficient Radio equipment, either in complete sets or separate units, such as Head Receivers, Variocouplers, Variometers, Cabinets, Detectors,

Antennas, Rotary Spark Gaps, Sliders, Panels, Dials, Knobs, Condensers, Grid Leaks, Contacts, Galena Crystals, etc.

We especially recommend our popular Receiving Set, RESODON, which is one of the most desirable outfits for the home, club, etc. This set comes in a beautiful mahogany finished cabinet. Write for literature.

PAUL G. NIEHOFF & CO., Inc.

Electrical Laboratories and Manufacturers

240 E. Ohio Street

Chicago, Illinois



Na-ald
Small-Space
V. T. Socket

35c Each; 3 for \$1.00

Moulded genuine Condensite. Requires but small space for mounting. Readily accessible binding posts. No excess metal to interfere with efficiency. Unaffected by heat of bulbs or soldering iron. Phosphor bronze contacts; nickel plated brass binding screws. Slash-cut slot.

Prices possible only because of enormous production.

Special proposition for dealers and jobbers

Alden-Napier Co.

52 Willow St., Dept. B.

Springfield, Mass.

Gilbert Radio Apparatus



No. 4084
Variometer

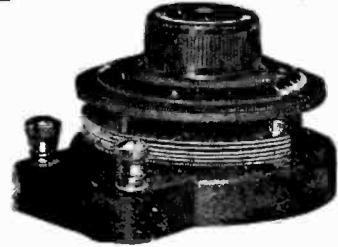

No. 4082. Variable Condenser

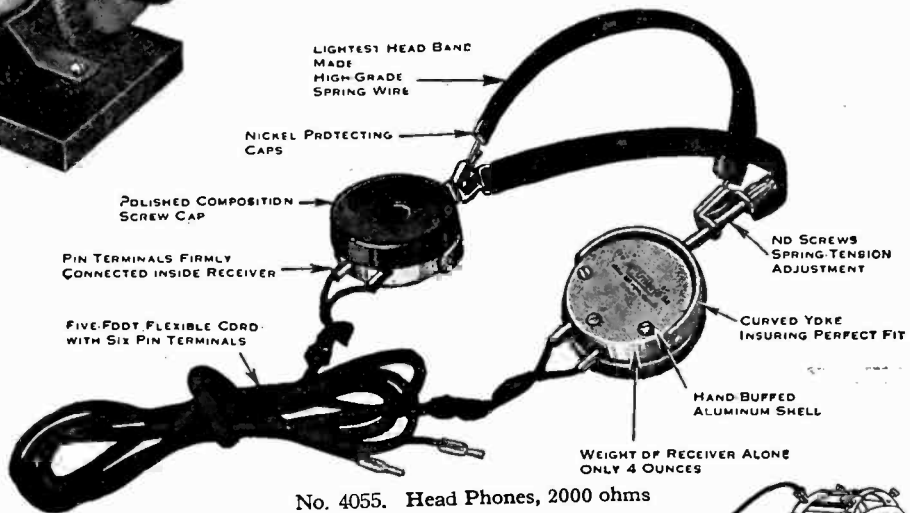

No. 4055. Head Phones, 2000 ohms

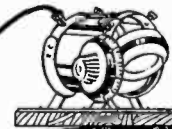

Quality Radio Parts at Popular Prices

From the very beginning of Radio, Gilbert Radio Apparatus has kept pace with the times. As new developments were found to have merit, we were among the first to put them on the market.

Our engineering department is constantly in touch with Radio improvements; therefore when you buy Gilbert Radio Apparatus you can be sure it is not only the best but the latest in its field.

Gilbert Radio Parts are scientifically constructed instruments, carefully and sturdily built, and so designed that anyone can build a Radio Receiver second to none. All of the most necessary and advanced parts are included in the Gilbert Line, some of which are illustrated above.

Write for Catalogue No. 55, just off the press

THE A. C. GILBERT COMPANY

Dept. H, New Haven, Conn.

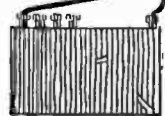
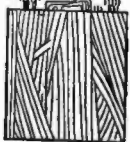



3000 OHMS

List Price
\$8.00



RADIO HEAD PHONES "MELLOTON"

Are highly sensitive and will register weakest messages, and faithfully reproduce speech and true tone of music.

Twenty-eight years' experience in phone manufacture insures perfect design, best materials and workmanship.

Have matched receivers, carefully tested, weighs only 11 ounces, is very comfortable and may be adjusted without removing. Moderate price.

Attractive Offer to Dealers

S. H. **Couch** Co., Inc.
TELEPHONES
TRADE MARK

Norfolk Downs, Massachusetts

BE A RADIO WIZARD

Get the best results from your set by knowing radio. Know the answers to radio questions. Substitute knowledge for guess work by reading the Standard Radio Encyclopedia—a practical guide to radio by A. Howland Wood, formerly an Instructor and Radio Engineer in the U. S. Navy. From this book you can get new knowledge of just how and why radio works.

EASY ORDER BLANK

PERRY & ELLIOTT CO.,
146c Summer St., Boston, Mass.

Enclosed is \$2.00 for which send me the Standard Radio Encyclopedia with the understanding my money will be returned if the book is not satisfactory.

Name

Address

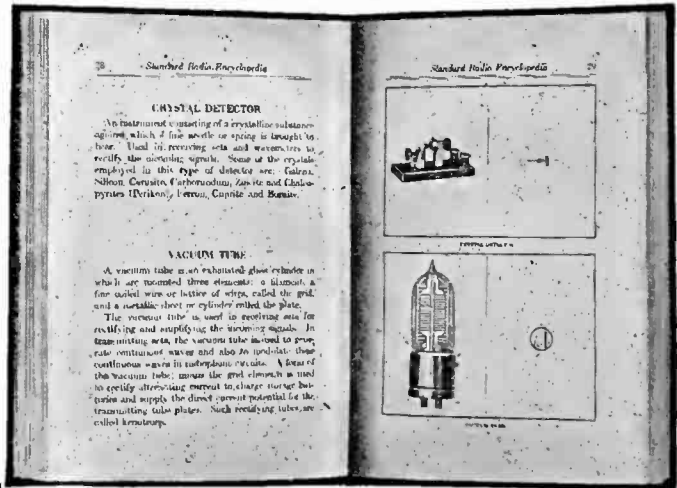

Helps Expert or Beginner

Easy to read and easy to understand. Every instrument and part clearly explained. Makes technical books simple. Over 100 attractive illustrations and wiring diagrams. You will enjoy your set more when you have the clear understanding of radio which you will get from this complete guide book. The price is only \$2.00 and will be gladly refunded if you are not entirely satisfied. Just pin the bills to the order blank and mail to

PERRY & ELLIOTT COMPANY
146c Summer Street BOSTON, MASS.

Let Your Apparatus Speak for Itself

AMERICAN RADIO EXPOSITION

A national exposition for radio manufacturers, dealers, inventors, and amateurs, covering the entire field of radio.

A complete exhibition of apparatus, accessories, and materials.

Daily demonstrations, broadcasting, lectures, orchestral concerts, Grand Opera artists in person—motion pictures illustrating practical uses of radio and the principles of its operation.

TO BE HELD AT

GRAND CENTRAL PALACE

46th St. to 47th St. and Lexington Avenue

The heart of the great terminal zone, close to the busiest shopping districts,

NEW YORK CITY

December 21st to 31st, 1922

Schools and colleges will be closed, making it convenient for young folks to attend. To these young people the magic of radio makes a specially strong appeal.

Manufacturers and Dealers should contract for space now

Address inquiries as to rates, etc., to

AMERICAN RADIO EXPOSITION COMPANY

Telephone: John 0009

120 Broadway, New York

EDUCATIONAL AND INTERESTING

THIS IS A "REGAL" YEAR

Five Big Reasons for the Enormous Sale of "Regal" Receiver and "Regal" Amplifier

1. Designed by our own radio engineers and a scientific precision instrument, simple and easy to operate.
2. Has wave-length range from 150 to 1800 meters—guaranteed.
3. Built entirely in our own factory with all "REGAL" parts.
4. Backed by our thirty years experience of precision manufacturing.
5. Priced at \$40.00 instead of \$100.00. Reason—we build it ourselves.

"REGAL" VACUUM TUBE RECEIVER

"REGAL" TWO STAGE AMPLIFIER



Price \$40.00

To triple range and increase audibility Price \$35.00

Some Excellent Features of the "Regal"

Minimum number of controls, all clearly marked, with taper knobs and etched silver dials. Unique "REGAL" Telephone Connector, permitting use of three pair of head phones (doing away with all jacks and plugs). Fine potentiometer plate control—so necessary to efficient tuning of modern vacuum tube detector. New "REGAL" Rheostat (6 ohms—2.2 amperes). New "REGAL" Inductance Switch, doing away with all unsightly switch points and insuring fine electrical connections. "REGAL" 23-Plate Condenser. "REGAL" TUBE SOCKET. Mahogany piano finished cabinet. Rear Panel Connector for all wires—no wires in front of cabinet.

"REGAL" INDUCTANCE SWITCH..	\$2.50	"REGAL" TELEPHONE CONNECTOR...	\$1.50
"REGAL" RHEOSTAT.....	1.25	"REGAL" CONDENSERS, 43-Plate.....	4.50
"REGAL" VARIO-COUPLER.....	5.00	23-Plate.....	3.50
"REGAL" TUBE SOCKET.....	.75	11-Plate.....	3.00

Dealers and Jobbers—Send for our handsome new catalogue No. 10.

THE AMERICAN SPECIALTY MFG. COMPANY

BRIDGEPORT, CONN.

COILS



These are needed for the

Armstrong Super- Regenerative Circuit

5-Millihenrie Choke Coils	\$2.50
100-Millihenrie Choke Coils	3.00
12000-Ohm Non-inductive Resistances - - - - -	3.00
1250-Turn Honeycomb Coils	2.00
1500-Turn Honeycomb Coils	2.50
.005 Micon fixed Cond. - - -	.75
.0025 " " " " "	.50

Attractive discounts to dealers and jobbers and immediate shipments.

These coils are guaranteed correct to within 2% and may be returned within six days if found unsatisfactory.

DURHAM & COMPANY

Radio Engineers

1936 Market St. Philadelphia, Pa.



LIST
\$8.50

EVERETT DOUBLE RADIO PHONES

*"Not the loudest but
the clearest"*

Light in weight, withstand
amplification without dis-
tortion.

AT ALL DEALERS

Everett Electric Corp.

320 Broadway New York



35c Each; 3 for \$1.00

Na-ald

Genuine Condensite Dial

The dial that runs true

Numerals engraved on bevel and knob so shaped that fingers do not hide them. Thin edge with clear graduation to make reading easy. Concealed set screw in metal insert. Will not warp or chip. Finish and enamel permanent.
Low price with this quality possible only through automatic production methods.

Special dealer and jobber proposition—on opportunity!

Alden-Napier Co.

52 Willow St., Dept B.

Springfield, Mass.



"All-American" Audio Frequency Amplifying Transformers

Two Types—Ratio 10 to 1.
(Type R3) Designed for 1st.
stage. Ratio 3 to 1 (Type
R2) for 2nd and 3rd stages.

Type R2—\$4.25
Type R3—\$4.50

Send for Bulletin des-
cribing Radio and Audio
Frequency Transformers.

RAULAND MFG. CO.
35 So. Dearborn St., Chicago Ill.

MIRACO Radio Frequency Broadcast Receiver

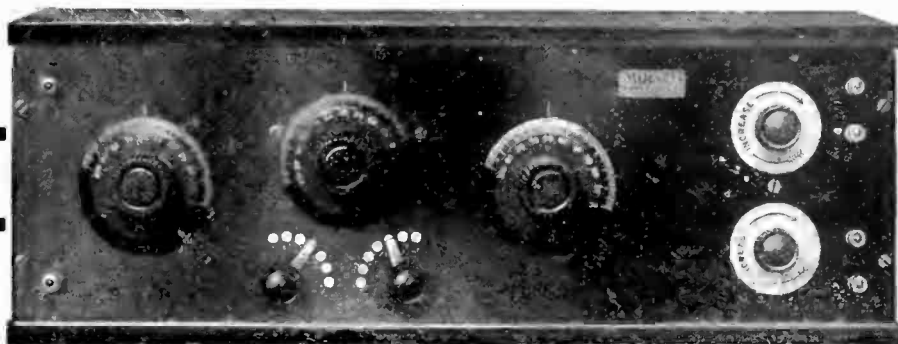

REPRESENTING THE LATEST DEVELOPMENT IN LONG DISTANCE RADIO RECEIVING SETS

Provides sharper tuning, with less controls, eliminates interference and reduces static to a minimum.

AMPLIFIES BEFORE IT DETECTS which makes it capable of bringing in concerts and signals from extremely long distances.

Dealers write now. Send for literature descriptive of this and other "MIRACO" Products.

\$45.00 Prepaid: less tubes, phones, and batteries

MIDWEST RADIO COMPANY

806 MAIN STREET
CINCINNATI, OHIO

Transcontinental Reception

By using three stages of DX RADIO FREQUENCY TRANSFORMERS, one radio amateur listens to Hawaii, California, Colorado, Texas, Georgia, Massachusetts and New York broadcasting stations.

Manufacturers are standardizing their sets using DX TRANSFORMERS.

Use the Best

Immediate delivery in quantity



Patents Pending

**RADIO
INSTRUMENT COMPANY, INC.
WASHINGTON, D. C.**

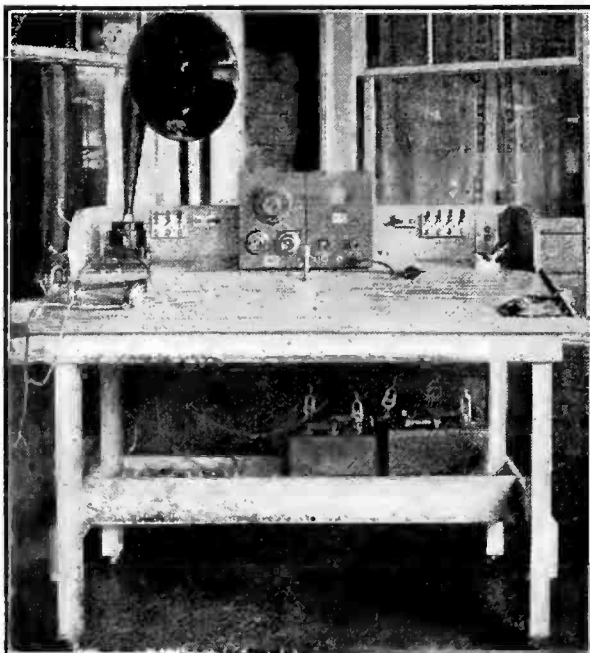

This Table Makes Your Radio Convenient

PRICE In Knock-down Form, Complete with Screws and Casters **\$12.00**

An experienced wireless operator designed the IDEAL RADIO TABLE. Mount all your instruments on it, batteries, charging outfit, loud-speaker. Have everything neat, compact, accessible, with the switches and controls at your hand. Take it anywhere on easy-rolling casters.

The IDEAL RADIO TABLE is furnished only in knock-down form; easily assembled from diagram. Accurately and neatly made of white pine and packed in a box. Shipping weight about 45 lbs. Size of table 24" wide x 36" long by 32" high. Shipped immediately on receipt of price, \$12, f.o.b Milford, N. H. Specify choice of stain, Mission Brown, Mahogany, or in natural wood; also freight or express.

SPRING LUMBER CO.
MILFORD NEW HAMPSHIRE



High Efficiency Head Sets

ARMY AND NAVY TYPE:

2500 Ohm, per pair \$10.00
3200 Ohm, per pair 12.00

SWEDISH-AMERICAN TYPE:

2200 Ohm, per pair \$ 8.00

Ask For Prices On Our Radio Parts

American Electric

COMPANY

6450 STATE STREET CHICAGO, U. S. A.

KNOTT Microdenser

(Trade Mark Registered)

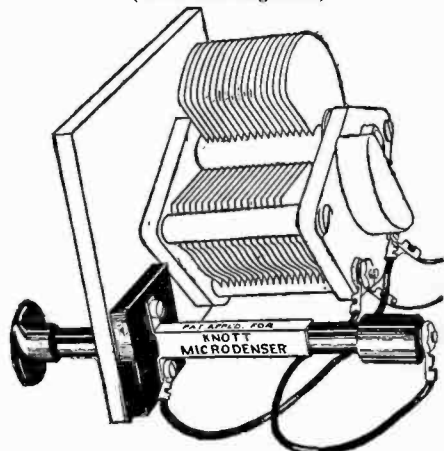

Showing how you connect to your condenser.

It Takes the Nervousness Out of Tuning

Tune your condenser to the whistle and bring in the message with this Micro.

It will stretch the critical adjustment on your condenser to two inches of adjustment.

Buy it of your dealer or send us \$3.00 for one by return mail postage paid complete with connecting wires and wrench-screwdriver.

Ask about Knott Sure Ground, Knott Radio Name Plates, Patent Dial, Rheostat, Quodcoil, Cinqcoil, Microstat.

Jobbers write for our proposition, it will interest you.

E. R. Knott Machine Company, 1 Ellery Street, Boston 27, Mass.



WESTINGHOUSE RADIO BATTERIES

Eliminate all Battery Troubles from Radio Sets

The Westinghouse "A" Battery is a full capacity, low voltage, slow discharge, long-life storage battery built exclusively for radio work.

For "B" battery requirements Westinghouse has perfected a baby storage battery. No more throwing away exhausted cells. No more continuous "B" battery expense.

The Westinghouse "B" is a permanent battery. It never has to be replaced. It will discharge its load with constant, steady voltage. Then it can easily be recharged. It gives continuous service to the point of exhaustion without growing "scratchy." If your vacuum tube is inclined to be noisy you can adjust the contact on the Westinghouse "B" to take off the exact voltage the V. T. requires.



Get a Westinghouse "A" and "B" from your dealer or the nearest Westinghouse Battery Service Station and eliminate all your radio battery troubles.

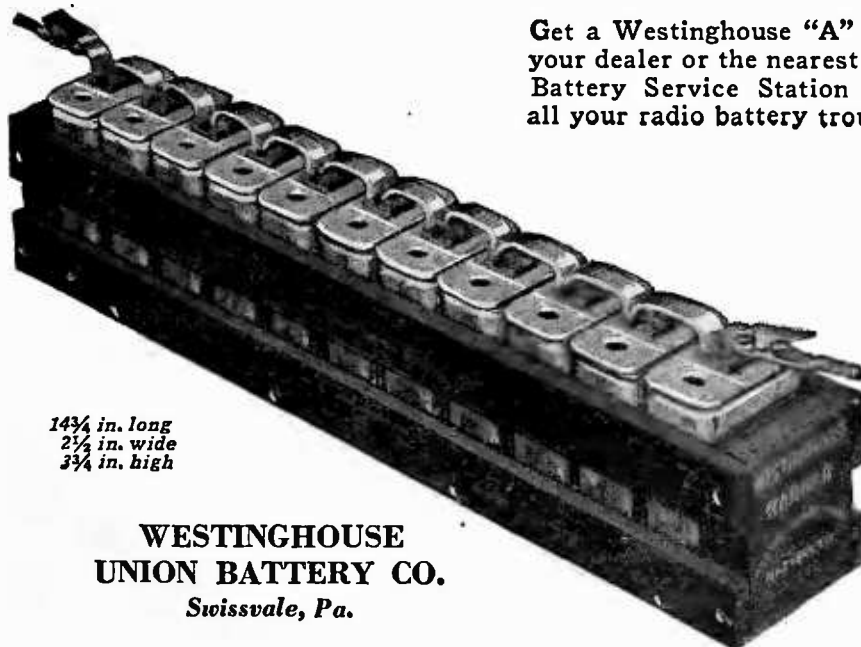

14 $\frac{3}{4}$ in. long
2 $\frac{1}{2}$ in. wide
3 $\frac{3}{4}$ in. high

WESTINGHOUSE
UNION BATTERY CO.
Swissvale, Pa.

*"The best
Westinghouse
can build."*

A New Member of the Plug and Jack Family



THE PACENT DUO JACK

This new Pacent Radio Essential, like all previous members of the Pacent Plug and Jack Combination, fills a definite existing Radio need.

The Duo Jack enables you to instantly convert an ordinary set equipped only with binding posts to a plug and jack set. It also facilitates connecting two pairs of phones or a loud speaker and a headset to your receiver.

The illustrations will suggest many applications for this very ingenious device.



Cat. No. 53 - - \$1.50

The Pacent Duo Jack will be in production by October 1 but dealers and jobbers are advised to place advance orders at the earliest possible date. Outline of Pacent Sales plan sent upon request.

DON'T IMPROVISE—PACENTIZE

Pacent Radio Essentials increase the pleasure of operating your equipment.

**Pacent Universal Plugs
Pacent Radio Jacks
Pacent Multijack**

**Pacent Twin Adapter
Pacent Audioformer
Pacent Duo-lateral Coils**

Pacent Universal Detector Stand

SEND FOR DESCRIPTIVE BULLETINS

PACENT ELECTRIC COMPANY

INCORPORATED

Manufacturers and Distributors of Radio and Electrical Essentials

Executive Offices:

**22 PARK PLACE
NEW YORK, N. Y.**



Branch Offices:

PHILADELPHIA, PA. Bourse Bldg.
CHICAGO, ILL. 33 So. Clinton St.
WASHINGTON, D. C. Munsey Bldg.

Member Radio Section, Associated Manufacturers of Electrical Supplies

REMLER

Cunningham

APPARATUS THAT RADIATES QUALITY

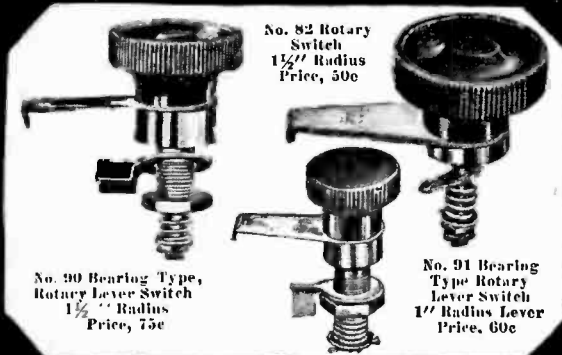

No. 90 Bearing Type, Rotary Lever Switch
1 1/2" Radius
Price, 75c

No. 82 Rotary Switch
1 1/2" Radius
Price, 50c

No. 91 Bearing Type Rotary Lever Switch
1 1/2" Radius Lever
Price, 60c

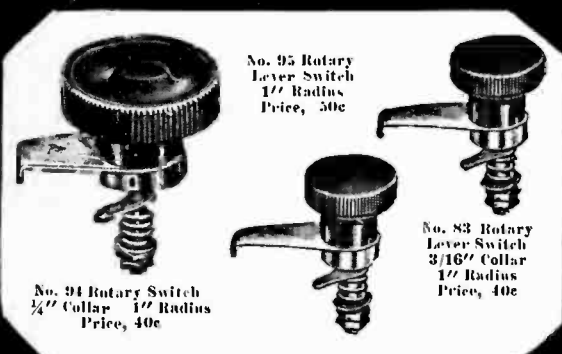

No. 94 Rotary Switch
3/4" Collar 1 1/2" Radius
Price, 40c

No. 95 Rotary Lever Switch
1 1/2" Radius
Price, 50c

No. 83 Rotary Lever Switch
3/16" Collar
1 1/2" Radius
Price, 40c

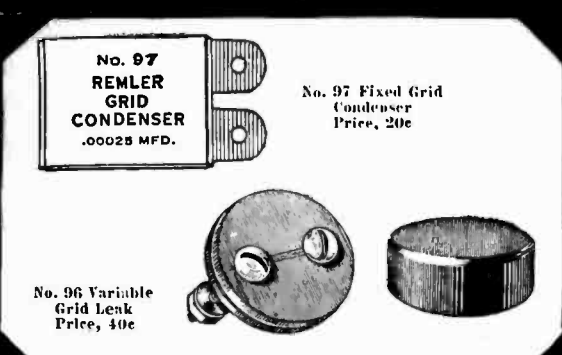

No. 97
REMLER
GRID
CONDENSER
.00025 MFD.

No. 97 Fixed Grid Condenser
Price, 20c

No. 96 Variable Grid Leak
Price, 40c



Type No. 100
3-inch Bakelite Dial with Knob and Bushing 75c

Remler Parts For Your Set

On this page are shown the popular line of Remler switches, the Remler Fixed Grid Condenser, the Remler Variable Grid Leak and the famous Remler Dial.

This represents but a small fraction of the Quality Radio Apparatus that has put Remler in the leading position it holds to-day. This small fraction, however, is built with the same care, accuracy and precision that has made the entire Remler line universally known as Quality Radio Apparatus.

It is becoming more and more apparent that Remler Apparatus is preferred in the building of sets because of its uniformity of construction—the well balanced proportion of each item giving an accurate and a pleasing appearance to the finished set.

Insist on Remler parts. If your dealer cannot supply you, write us direct for the name of a Radio dealer who can.

REMLER RADIO MFG. CO.

E.T. CUNNINGHAM GENERAL MGR.

248 FIRST ST. SAN FRANCISCO, CAL.

154 W. LAKE ST. CHICAGO, ILL.

BRISTOL
LOUD SPEAKER

TRADE MARK

AUDIOPHONE

PATENTS PENDING DESIGN PATENTS PENDING

Multiplies the Pleasure
of Radio

It will make your radio outfit a source of entertainment for the entire household—for all your family and for the friends who join you. Its rich, full tones carry from room to room—clearly audible and with no blurring of sound. The "Audiophone" is complete in itself—needs no separate storage battery for magnetising current—and can be used with all types of two or three stage power amplifiers. Its graceful lines and dull bronze finish adapt it for even the finest interiors.



Distinguished By Its NATURAL Tone
And Perfect Articulation

The "Audiophone" reproduces either voice or instrument with fidelity and with a remarkable freedom from all mechanical distortion. It has a Natural tone—clear and strong and round, with ample carrying power. It is the outgrowth of years of development in sound reproduction, by an established engineering firm. It is for those who must have the best.

A new single stage power amplifier for use with the usual two stage amplifier can now be furnished, which will greatly increase the range of the "Audiophone" where desirable. List price \$25.00—write for the circular.

"AUDIOPHONE" Complete, 15-inch bell, List Price \$40.00

Ask your dealer for a demonstration. If he hasn't the "Audiophone" in stock, write us. We will see you are supplied.

THE BRISTOL COMPANY
WATERBURY, CONN.

