

# RADIO BROADCAST

RADIO FOR EVERY PLACE AND PURPOSE



The United Fruit Company's Radio System

Developments in High Power Radio

Shall We Have Music or Noise?

Armstrong's Super-Regenerative Circuit



## **“All the World and His Wife”—**



to say nothing of the children—are enthralled by the magic spell of Radio. And as Radio takes its place among the essential conveniences and accepted methods of entertainment of modern life, the demand for apparatus of high efficiency and dependability increases. This demand is most satisfactorily met by the



## **Westinghouse Type RC Receiver**



As national distributors of the products of leading manufacturers of radio equipment, we are at all times in position to make immediate quantity deliveries on this superior and popular instrument, as well as



**Westinghouse Aeriola Grand  
Westinghouse Aeriola Sr.  
Westinghouse Aeriola Jr.**



*An American sugar planter in Tuiniqua, Cuba, gets perfect reception on Westinghouse RC from Newark, Pittsburg, and Chicago, 1400 miles away*

*Write us to-day for descriptive pamphlets and full information concerning radio equipment of every kind.*



## **20th CENTURY RADIO CORPORATION**



*National Distributors*

**Executive Offices, 565 Fifth Avenue, New York, N. Y.**

**Straus Building, Suite 710**

**Telephone Murray Hill 6548**







EDWIN H. ARMSTRONG  
Inventor of the regenerative and super-regenerative circuits

# RADIO BROADCAST

Vol. 1 No. 5



September, 1922

## The March of Radio

### MARCONI'S VISIT

ON MANY other occasions we have unmistakably shown our appreciation of the inventor of radio, but never before have he and his work been of such widespread interest. Technical societies have, in the past, showered upon him tokens of their appreciation, universities have bestowed honorary degrees upon him in acknowledgement of his scientific achievements, but on this occasion a million radio enthusiasts from all over the country were directly interested in his comings and goings.

The outcome of his pioneer wireless work was of everyday interest to them. Tuning—static—wavelength—interference—words which on Marconi's previous visits had been meaningless terms to all but a few of the technical men, are terms which we use as glibly as we do spark plug and carbureter.

Probably no other inventor has seen the results of his early endeavors so rapidly become a part of the life of the people, or has seen himself so suddenly become a public figure. Of course a Babe Ruth can climb to popularity with even greater speed than has Marconi, but the reason for the popularity is hardly on the same plane with that which accounts for the reception Marconi has just received. The education which comes from seeing the ball fly out of bounds into the bleachers and that which one acquires in investigating and studying the action of a radio receiving set, are

hardly to be compared. Marconi's contribution to our lives is of lasting and growing importance; his work has probably stimulated popular interest in science more than the efforts of a hundred teachers of Physics and Electricity.

If we inquire as to just what specific contribution to the radio art of to-day is responsible for the bestowal of the much-coveted medals of the Institute of Radio Engineers and the American Institute of Electrical Engineers, which Marconi has just received, the answer is not apparent. His improved coherer and magnetic detector have long been relegated to the museum, and his spark transmitting sets will soon rapidly disappear. It seems, after reading over his early experiments and efforts, that the most important of his contributions, which still dominates the radio art, is the grounded, vertical antenna.

Hertz, of course, had not found it necessary to ground either his transmitting sets or his receiving loops for getting his wireless signals; because of the short distance between his receiving and transmitting apparatus, the scheme worked perfectly well with ungrounded apparatus. Marconi, however, soon found out that to communicate over greater distances, a high vertical antenna was all important, and that, further, its transmitting and receiving action were both much improved if the antenna was suitably connected to moist earth at its lower end. This grounding of the antenna

seems to be the one important contribution which still persists. It was not many years ago, at a meeting of the A.I.E.E. that Professor Pupin, in reviewing the work of Marconi, said that the line of demarcation between the work of Hertz and that of Marconi was that fixed by the grounding of the antenna—that Hertz's electric waves were free to spread out in space untrammelled by connection to the earth, whereas Marconi waves had their "feet" fastened to the earth. This fastening of the feet of the waves to the earth's surface was what resulted from the grounding of the antenna.

So it seems that the grounded antenna may be regarded as Marconi's principal contribution to the art as we know it to-day. How long the grounding of the antenna will be regarded as important is problematical—many of the best stations, when using short waves, do not ground their antennas at all. Instead of connecting the antenna to a water pipe, or to iron stakes driven into moist earth, as is the custom, the "ground" wire of the set is connected to a network of wires suspended several feet above the earth, and carefully insulated therefrom. In many cases it is found that the use of this network, or counterpoise, as it is called, makes the antenna much more effective than if it were actually grounded. The large station at Sayville, which, during the early part of the war, was the principal connecting link between Germany and America, does not ground its antenna, but uses such a counterpoise, the network of wires being many acres in extent. For receiving antennas we are inclining more and more to the coil aerial; practically the same thing as used by Hertz.

In the experiments which Marconi showed to his audience on one occasion he used a simple Hertzian oscillator for a transmitter and a similar device for a receiving antenna. To be sure, they were excited by waves generated in a modern vacuum tube instead of by the sparks of Hertz, but in so far as the structure of the sending and receiving aeriels was concerned they were Hertzian rather than Marconian. For this backsliding from grounded Marconi waves to the ungrounded waves of Hertz Professor Pupin facetiously chided Marconi; he (Pupin) had previously shown that Marconi had made tremendous progress over the work of Hertz by using the grounded antenna, and now Marconi had deserted his child, the grounded antenna, and gone to tread in the footsteps of Hertz.

But even though all of Marconi's specific contributions to radio are supplanted by something better (which must necessarily soon be the case with such a rapidly advancing art) Marconi will still be the creator of radio; its apparatus may be much changed in appearance and action from that which he first used to span the Atlantic—others may have appeared in the radio field who understand the action of modern apparatus better than does Marconi—apparatus and methods may be worked out which are millions of times as sensitive as anything Marconi was able to devise—in spite of all this Marconi is the one to whom all credit is due for the present status of Radio. He it was who conceived the idea of radio communication—he it was whose judgment and perseverance accounted for the initial successes which made the future of radio so promising and certain, and it is for these qualities and accomplishments that we now do him honor, giving him our medals and crowding his meeting places to overflowing.

#### REFLECTION AND ABSORPTION OF RADIO WAVES

**A**LTHOUGH the fact may have been stated many times, it is apparently rather difficult for one to comprehend that radio waves and light waves are essentially the same in that they are governed by exactly the same laws. On the occasion of his talk before the Institute of Radio Engineers, Marconi showed an experiment on the reflection of waves and, from the admiration and applause which the success of the demonstration elicited, it was evident that even this audience, largely composed of technically trained men, had not yet really accepted as true the fact stated above, that light waves and radio waves act alike.

In the demonstration there was used as a transmitting antenna a simple vertical copper rod about 18 inches long, excited by a vacuum tube at the proper frequency so that radio waves about one meter long were sent off; possibly one watt of power was radiated. Suspended from a wooden framework built about the transmitting antenna, were other copper rods, hung vertically, of exactly the same length as the first, these other rods being completely insulated from everything. These additional rods were arranged about the antenna in the form of a parabola; a view of these additional rods from straight above would have shown them arranged in a curved line of the same form as the cross-section of an

AN IMPORTANT ADVANCE  
IN RADIO TRANSMISSION

Drs. W. R. Whitney and Irving Langmuir showing Mr. Marconi their new vacuum tube which it is thought will revolutionize long distance radio communication, eventually supplanting the high frequency alternators

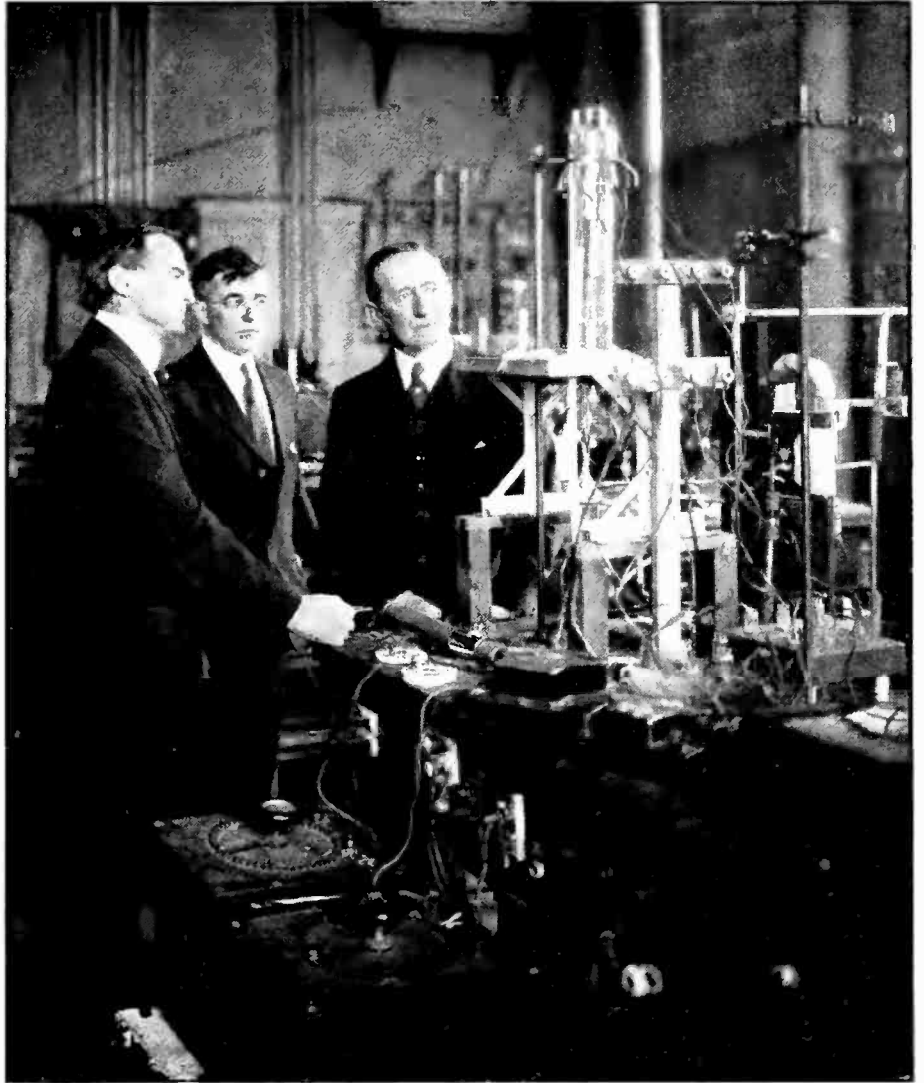

automobile headlight mirror, the transmitting antenna having the same position with respect to the curved line of the others as the filament of the headlight has to the curve of the headlight mirror. The transmitting antenna was at the focus of the parabolic curve formed by the other rods.

The action of the parabolic headlight mirror is to send all the electromagnetic light rays, coming from the filament, straight forward, in an approximately parallel beam. In Marconi's experiment the electromagnetic radio waves, coming from the antenna, were similarly reflected and sent forward from the mirror-like arrangement in a nearly parallel beam, and, by rotating the mirror about its axis, the beam could be sent in any direction desired. That the beam of radio waves was thus rotated was readily shown by having a stationary receiving antenna (another copper rod of the same length as the others) suitably connected to an amplifier and loud speaking horn. As

the transmitting mirror was rotated, the beam of radio waves could be made to impinge or not on the receiving antenna, as evidenced by the loud speaker.

It undoubtedly occurred to many of the observers that this scheme should be used in ordinary radio communication, but it is to be remembered that a mirror, to be effective in reflecting light, must have dimensions several wavelengths long. To get good reflection of light for example, the mirror must be not less than about one-hundredth of an inch square. The same considerations hold for the reflection of radio waves; the mirror must be commensurate in size with the wave length used. Marconi's mirror to reflect waves a meter long, was about a meter on a side and of course gave very poor reflection compared to the straight line reflection of light given by the ordinary mirror because it was so small compared to the radio wavelength. Evidently to construct a mirror to reflect an ordinary

360-meter wave would be prohibitively difficult.

The shielding effect of a single wire, of the same length as the transmitting and receiving antennas (so as to be in tune with them), was shown remarkably well by interposing such a wire between the transmitter and receiver, rather close to the receiver. This extra antenna, tuned to the oncoming waves, is set into electrical vibration, and will itself radiate so that in the neighborhood of the extra antenna the actual radiation will be the summation effect of the original waves and those sent out by the extra antenna.

An accurate analysis shows that there will result in the space between the extra antenna and the original transmitter more radiated energy than would exist if the extra antenna were not there; the extra energy we say is due to the reflected energy from the extra antenna. Behind this antenna, however, that is, in the space between the extra antenna and the receiver, the summation of radiated energy is less than if the extra antenna had not been put there, in fact close to the extra antenna the radiation is nearly zero; we say there is a radio shadow in this region. The intensity of this radio shadow, *i. e.* how nearly the actual radiation is reduced to zero, decreases at greater distances, just the same as the shadow thrown by a tree trunk becomes less and less definite with increasing distance from the tree.

The intensity of the radio shadow also depends upon how well the extra antenna is tuned to the oncoming waves and how low its resistance is; Marconi showed, in his experiments, that if the extra antenna was 16 inches long instead of 18 inches, it threw scarcely any shadow at all. It is to be noticed that a low-resistance, tuned antenna throws a definite shadow, because it reflects the oncoming wave, and the lower the resistance and better the tuning, the better the reflection. If a high resistance antenna is interposed between a transmitter and receiver, the shadow would be noticed, as before. However there would be but little reflected energy; the extra antenna absorbs the oncoming radio wave, thus producing the shadow, but instead of reflecting the original beam, it uses it up in producing heat. This absorption effect is the one noticed by dwellers in steel structure buildings who try to receive radio signals from a broadcast station with steel buildings intervening. A vertical antenna run up the side of a steel frame

building will give fair reception if not placed too close to the building and if it is on that side of the building facing in the direction from which the signals are coming. If the antenna is located on the opposite side of the building almost nothing will be received; in this case the receiving antenna is in the radio shadow of the building. Although the steel frame of the building is not tuned to the signal wave, it has a sufficiently high resistance to absorb nearly completely the energy of the signal wave.

These ideas of reflection and absorption deserve the attention of every one interested in radio; they frequently account for the exceptionally good reception obtained in one locality and exceptionally poor reception at another.

It is not necessary to have metallic conductors to bring about reflection and absorption; any partially conducting medium will accomplish the same thing to an extent depending upon how good a conductor the medium is. The rarified air and partially conducting clouds in the upper regions of our atmosphere are just such conducting bodies, and they bring about reflection and bending of the radio waves to a remarkable degree. Just as the peculiar formation of reflecting surfaces in "whispering galleries" permit a whispered sound to be heard at a point hundreds of feet distant, so the reflection of radio waves from clouds, etc. occasionally permit the normally infinitesimal power from a distant low-powered transmitting station to focus and concentrate at some points of the earth's surface and so permit the exceptionally long distance records for communication to be established. These effects, it must be remembered, are generally rare in their occurrence; it seems however, from reliable data, that in certain localities this concentrating effect occurs more or less consistently. It seems likely that the structure of the earth's crust may very likely bring about bending and focusing of radio waves; certain stations consistently report satisfactory communication with a distant station while others, much closer, are able to communicate only occasionally and this in spite of the fact that the receiving apparatus is equally good at all these receiving stations.

It is to be noted that these ideas of reflection and absorption shown by Marconi are by no means original with him; the wonderfully keen mind of the real pioneer, Hertz, saw all these phenomena with remarkable clarity. In his book, "Electric Waves," prin-





#### THE INTEREST IN RADIO

May be judged by this photograph, taken after a meeting of The Radio Club of America, at which E. H. Armstrong revealed the secrets of his super-regenerative circuit

cially a compilation of the results of his experiments, there appears a paper entitled "On Electric Radiation." This paper was published in 1888 and in it are given all the effects shown by Marconi and others. For example, besides the reflection effects with mirrors, it is shown how a large prism of pitch enabled Hertz to actually bend his narrow beam of radio waves, just as a glass prism bends light waves. Those whose interest in radio has carried them past the "turn the knob and listen" stage will find Hertz's reports of his experiments interesting and entertaining reading.

#### ARMSTRONG'S SUPER-REGENERATION

**A**FTER waiting eagerly for some months for the disclosure of the much heralded discovery of Armstrong by which he made two tubes do the work ordinarily accomplished by eight or ten, the radio public in the neighborhood of New York had two opportunities recently of hearing the circuits explained and demonstrated by the inventor himself. He first presented this new scheme before the Institute of Radio Engineers; in the proceedings of that body the first reliable, printed analysis of the scheme will soon appear. The auditorium was filled to overflowing at this session, but the jam at the meeting of the Radio Club of

America, at which he spoke shortly after, was much worse. Although held in one of the largest assembly rooms of Columbia University, there were hundreds who could not fight their way to within hearing distance of the speaker. The enthusiasm displayed at these meetings shows that the public interest in radio has by no means begun to wane, as some jobbers in radio supplies seem to think.

From the experimental demonstrations, it is evident that the amplification of signals is surely as much as the inventor claims for it; the results were simply astounding to those who have done much work with triodes, and so are fairly familiar with their ordinary possibilities. In both cases the demonstration was given in rooms inside buildings with heavy steel frames and covered with grounded copper roofs. One could almost call such places Faraday cages—electric "holes" where radio waves do not penetrate. In both cases Armstrong was able, with two tubes (of considerably more power than the ordinary tube, however) to receive signals from a broadcast station, about fifteen miles distant, on a two-foot loop, and to receive them sufficiently loud to be heard throughout the auditorium. Such amplification almost passes one's comprehension.

On neither occasion was the quality of re-

ceived speech as good as we get by the more prosaic schemes of amplification; this, however, may have nothing to do with the operation of the circuits themselves, but may have been due to the action of the loud speaking horn used. Judgment as to quality of received speech (by which any scheme of amplification must stand or fall) must be reserved until more people have tried it out with various types of loud speakers. The inventor himself says the quality is as good as can be obtained by any other scheme of amplification.

By the time this is in print there will probably be many of these super-regenerative sets in use and we shall know whether the scheme is as good as it looks—whether it is a scheme the average skilled amateur can successfully manipulate. Of course on this point we recollect that many said the ordinary regenerative scheme was too ticklish a circuit for the average amateur to handle, but development seems to have shown otherwise. Undoubtedly, this new circuit of Armstrong's requires more manipulative skill, to get much out of it, than does the ordinary regenerative circuit, but perhaps it will not be beyond our ability.

The inventor estimates that his new scheme gives amplification thousands of times as great as his ordinary regenerative connection; as an instance of what it may be expected to do, he states that at his home, a three-tube combination arranged for the super-regenerative action, working into a loud speaking horn, gave a signal on a three-foot loop loud enough to be heard 1,000 feet away, the signal coming from a 500-watt broadcast station 25 miles away.

The action of the new arrangement can be understood only by one familiar with the ordinary regenerative circuit. The simplest form of the regenerative circuit uses a tickler coil in the plate circuit, which is coupled to the grid circuit. As the tickler coupling is increased, the grid and antenna circuits being continually kept tuned, the signal strength increases gradually at first and then very rapidly. Just as it seems as though the amplification is going to be extremely large the tube starts to oscillate and the expected increase in signal is never reached.

Evidently (at least, evidently to one familiar with the action of the circuit) if the tickler coupling could be increased past the critical value at which oscillations start, and still oscillations be prevented, the anticipated amplification might be obtained. This, Armstrong

himself had frequently said was quite impossible, but then he found out he was mistaken. It was possible, and he found out how to do it in a most ingenious way.

It takes time for a tube to set itself into the oscillating state, an appreciable fraction of a second. If the tickler coil coupling is suddenly increased, very large amplification can be obtained while the tube is getting itself into the oscillatory state, but the duration of this condition is extremely short, perhaps one ten-thousandth of a second; this time depends upon the relative values of inductance and capacity used in tuning the circuit. What Armstrong's new idea amounts to is this—by excessive tickler coupling he makes the tube give excessive amplification as it is getting itself into the oscillating state, and then, before the tube actually reaches its steady oscillating state he has a second circuit act on the tube to stop completely the oscillations which have started. In a brief fraction of a second this second circuit stops its action and the first tube again gives excessive amplification as it again endeavors to get itself into the oscillating state.

If these periods of excessive amplification follow one another with great rapidity, the signal is given excessive amplification in pulses, with the same rapidity; if the frequency of these pulses of excessive signal is above audible range, the ear interprets the received signal as a continuous one. The ingenuity of the scheme is now apparent; let the tube amplify while it is in a changing state, in which super-amplification can be obtained, and then bring it back again and make it start over again to go through this critical condition repeatedly. And make it go through this critical condition with sufficiently high frequency so that the ear interprets the signal as a continuous one, it actually being a series of pulses. The scheme involves ear deception in the same way that the moving-picture, by changing with sufficient rapidity, makes the eye perceive a continuous impression.

Although by a very delicate arrangement of doubly tuned circuits it is possible to carry out the scheme with only one tube, the scheme generally requires two tubes, and the inventor recommends the use of three tubes by those attempting to use the idea. The three-tube arrangement is better than the two in that it is possible to make the various required adjustments independent of one another.

A 200 K.W. HIGH-FREQUENCY ALTERNATOR

Of the type used for transoceanic communication. Recent developments indicate that these huge machines may be supplanted by vacuum tubes

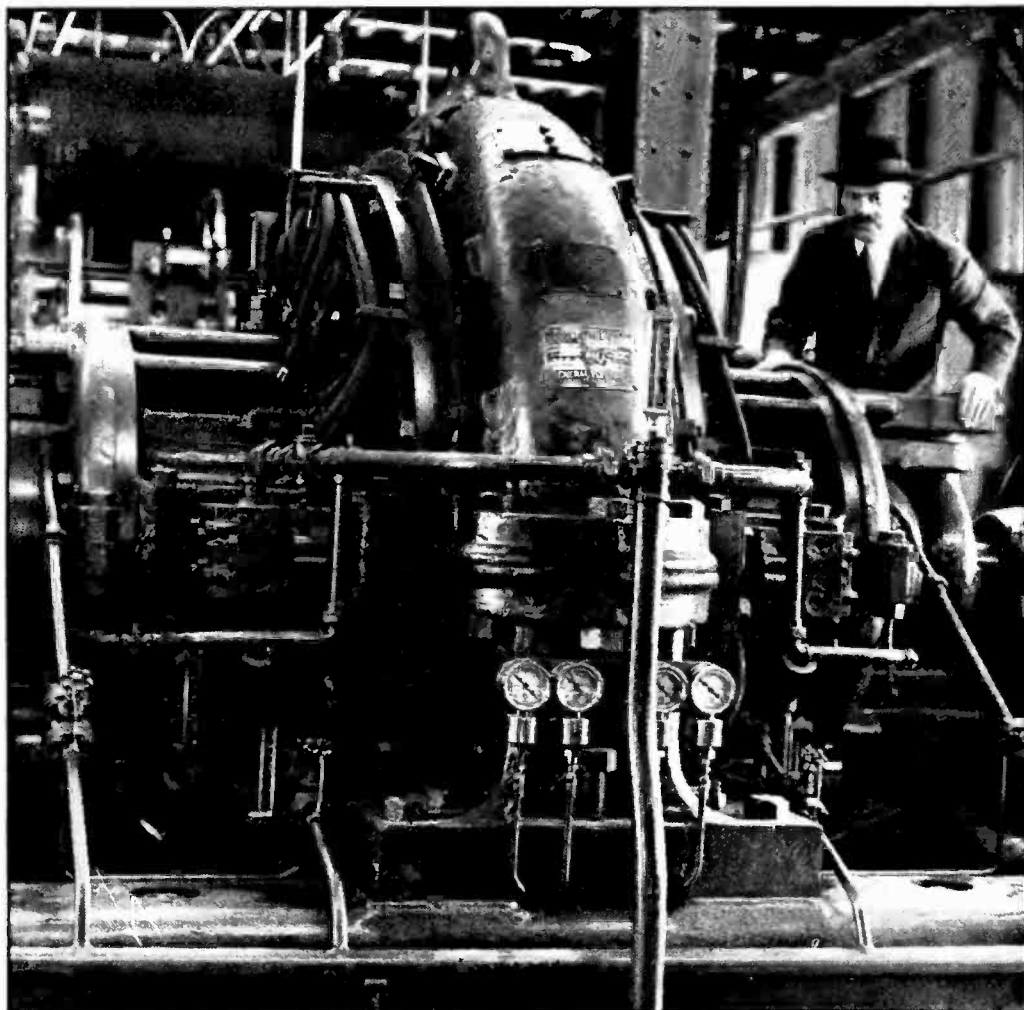

As it is essentially an improvement on his older scheme, the new idea is commercially useful only to those who control his earlier patent; of course this phase of the subject doesn't interest the real amateur as he "builds his own" anyway and so is not bothered by patents. For the benefit of these enthusiasts Armstrong, in his last talk, gave the complete circuit arrangement for his new scheme, giving the proper values of coils, condensers, resistances, etc. which he regards as most suitable for getting the best results.

One of our contemporaries recently gave out the statement that the use of coil aerials "virtually eliminates static." If this were so (which it isn't) Armstrong's super-regenerator brings static back again; although he used coil aerials in his demonstrations, the static disturbance was frequently much stronger than the voice, making it unintelligible part of the time. The coil aerial by no means eliminates static; it should normally increase the ratio of signal strength to static over that obtained with the ordinary antenna, but it is not im-

possible that some of the sets using excessive amplification offset this advantage by amplifying static more than they do the signal.

#### RADIO CURRENT GENERATORS

**I**N A radio transmitting set the electrons in the conductors must be made to oscillate back and forth with inconceivable rapidity from 20,000 times per second to several million, depending upon the wavelength it is desired to radiate.

In the early days of wireless, the only feasible scheme for bringing this about was to charge a condenser to a high voltage and let it discharge through a spark gap and inductance; under such conditions the discharge is oscillatory. Such high-frequency currents rapidly die away, as the original energy of the condenser is used up in the form of heat and radiation.

It was early realized that if the high-frequency currents could be maintained of constant amplitude as long as the sending key was held down, the power radiated from a given antenna could be greatly increased and the

receiving apparatus could be made much more sensitive and more free from interference. So we have the development of Dudell's singing arc. This was improved sufficiently by Poulsen and Pederson so that it was for a time the best type of high-frequency generator for large transmitting stations—in fact it is a question even to-day as to whether or not it isn't the best generator for the largest stations. Our large naval stations, and the large station in France which our engineers constructed during the war, use Poulsen arc generators.

Naturally an engineer wants to use a rotating machine for a generator, rather than such a device as an arc, so we have to-day the wonderfully designed, and wonderfully built machines which are the outcome of the work of Fessenden, Alexanderson, Goldschmidt, and Latour. In these revolving generators, electrical and mechanical design have been carried to the limit. Iron of the best electrical and magnetic properties, in sheets about one-thousandth of an inch thick, finely stranded wires for the conductors, best dielectrics for insulation to keep losses low, air gaps between stationary and revolving parts dangerously small, speeds on the edge of the rotating members which approach the speed of a cannon ball—these are a few of the special features involved in the construction of a high frequency alternator.

In one case, due to the expansion of the parts of the machine as it warmed up in operation, the air gap, which was very small to begin with, disappeared altogether and the stationary and moving parts came together, resulting in the complete wreckage of the machine! On the other hand, some of these high-frequency alternators have given satisfactory service for years, apparently requiring but little more attention than the normal generator for low frequency currents.

All of these high-frequency generators have rather low efficiency; the Poulsen arc delivers to the antenna, as high frequency power, less than one half of the power supplied to it by the continuous current machine from which it draws its energy; the rotating machines are better than this, but even they have excessive losses, except at the very lowest radio frequencies.

To take advantage of one of the most important features of continuous-wave radio it is essential that the frequency of current supplied to the antenna must be exceptionally constant; this means that the speed of the

rotating machines must be held constant to a degree undreamt of in ordinary engineering work. The speed must not vary more than about one hundredth of one per cent. even when full load is suddenly applied or taken off. Most ingenious and intricate schemes have been devised which do hold the speed constant to this degree.

During the last ten years the size of the electron tube, or triode, designed for the generation of high-frequency power has been gradually increased until to-day it seems to be steadily advancing into the field at present held by the Poulsen arc and the high-frequency alternators. In a broadcast lecture on the triode, a few months ago, it was predicted that before the last Alexanderson alternator was installed in the great Radio Central building on Long Island, the triode would have advanced to such a stage that it would be advisable to take out the generators and put in tubes in their place.

We remember that only four years ago Alexanderson, the designer of the 200-KW machines used in this station, conceded that for one KW of high frequency power, the tube was a potential competitor of the alternator; to-day his company presents Marconi with 20-KW tubes and we have reliable reports that 100-KW tubes are well along the stages of development and that much greater ones are being planned.

Of course, in comparing the size and cost of the triode and the Alexanderson alternator, it must be remembered that a high-voltage, continuous-current machine is required to furnish power to the tube and that the present cost of upkeep on tubes is rather high. The filaments of triodes burn out after a life very short compared to the life of an alternator, and the present cost of replacement is high. However there is no reason why the tubes should not last much longer than they now do. The high electron current should be emitted from a heavy tungsten target instead of from the thin filament, which by its evaporation, causes the tube to fail. The heavy target, heated by electron bombardment from a comparatively cool filament, would last years without appreciably evaporating. With this, and with the water cooling which is required in the larger tubes, and better knowledge regarding the making of air-tight joints between metals and such insulators as silica or glass, the possible size of triodes seems to be unlimited.

With high voltage supplied to the plate cir-

cuit, the tube may have an efficiency well over 90 per cent. and as the high-voltage generator may have an equal efficiency, the triode may deliver to the antenna over 80 per cent. of the energy supplied to the set.

The one feature of the triode oscillator which makes it so much superior to a machine is the constancy of the frequency it may be made to generate, and the consequent very fine adjustment it is possible to carry out at the receiving station amplifiers. After a triode has been operating some time, so that its parts have reached a fairly constant temperature, the frequency may remain, for long periods of time, constant to within one-thousandth of one per cent. Besides this constancy of frequency to recommend it, another feature which makes it so flexible compared to the generators is the ease with which its frequency may be changed if desired, and also the ease with which its output can be controlled, by means of the grid potential.

#### CHURCH SERVICE BY RADIO

WE HAD outlined in our last number a typical radio installation in a Southern church, and it was evident from the story that the broadcasting of church services might well be one of the legitimate fields in which radio may be expected to expand. Now we have a report from Atlanta, Ga. that there has been launched by the Wesley Memorial Church a campaign to devote \$1,000,000 of the Methodist Church's educational fund for the establishment of radio receiving sets in the several thousand small churches in the South where services are held only when the itinerant pastor finds time to pay a visit.

In these small churches, where a regular pastor could not be supported, it seems as though the radio service from the metropolitan church with its inspiring music, the like of which is never available to the country church congregations, will serve well as an adjunct to the itinerant preacher. It will never displace him—because religion is essentially personal. It would be difficult for us to conceive of our early religious impressions having come from a Magnavox, or a Western Electric horn, wouldn't it? But then, times change.

#### RADIO AT THE POLE

THE day has gone when explorers set out on a voyage of discovery and were lost to civilization until their return, or perhaps forever, or when, on their return, they had to

rely on speech and notes to describe their adventures. Amundsen, starting on a North Polar expedition which he anticipates will take four years to carry out, expects to be in constant communication with the world he has left behind. He will have with him moving-picture machines, aeroplanes, and radio apparatus for both transmitting and receiving. What data is available on the transmission of radio waves over frozen wastes indicates that there is a very much greater absorption there than exists in the temperate zones. That radio can however travel through the polar regions is evidenced by the recent announcements of Marconi that many times radio signals have been observed at the antipodes after having travelled completely over one polar region or the other. Amundsen's wireless reception in the frozen north will add to our knowledge of transmission, besides being of immediate importance to him in keeping touch with his base.

#### RADIO VS CABLES

WHEN the wireless telegraph was first shown practicable it was frequently stated that the wire telegraph was doomed—that it could not possibly compete commercially with a system which did not need to carry the overhead charges necessitated by the expensive wire system and right of way. Evidently radio has not encroached upon the territory of the ordinary telegraph at all, but, on the contrary, has brought it additional business.

The competition between land wires and radio really never could be regarded as serious by one understanding the possibilities of the two methods. But in the field of trans-oceanic communication it might well be argued that radio would hurt the other schemes of communication, namely, the cables. Cabling is slow compared to the possible speed of radio transmission, and cannot be speeded up with our present equipment, as the cable itself carries the electric signalling current rather slowly compared to the 186,000 miles per second of radio.

But evidently, even in this field, radio is to prove an adjunct, rather than a competitor. In a recent interview President Carlton, of the Western Union Telegraph Co., stated that the Radio Corporation was carrying only twelve to fourteen per cent. of the trans-oceanic business, in spite of the fact that the radio rates are appreciably lower than the cable rates. He feels

that whatever growth there comes to the radio traffic will come from part of the new business created—that cables will always carry the larger part, and will not suffer from the competition.

It seems strange that the cable companies should be worried so little by radio competition; to be sure they have the element of secrecy which radio lacks, but the speed of signalling by radio is increasing so rapidly that it seems as though their rates could soon be lowered to such an extent that the cable rates, which probably cannot be materially reduced, will be prohibitively high. Mr. Carlton speaks however of a new type of cable being developed which will increase the speed of cabling perhaps ten times. Should this prove to be a fact, the cables would probably be able to carry on traffic at a greater speed even than radio. We have often heard boasts as to how fast traffic can be carried on by radio, but every amateur knows that the present average rate of radio transmission across the ocean is probably not more than ten words a minute, when the number of "repeats" required is taken into account.

Static disturbances, which so seriously limit the speed of radio transmission have but little effect on the cables; they do have their sources of trouble, principally in the earth currents, but they are not as bad as the trouble caused to radio by static. In ending his interview, Mr. Carlton said: "It (radio) is not yet an equal rival of the cables and probably never will be. It is, and probably will continue to be, a valuable adjunct to the cables."

#### STANDARD TESTS FOR RADIO RECEIVERS

THE members of the National Retail Dry Goods Association are evidently worried over the quality of the radio outfits they have been selling. Apparently at their request, the

Bureau of Standards, in coöperation with the Electrical Testing Laboratories of New York, has arranged a tentative schedule of inspection and performance that completed sets are to be subjected to before the dry goods dealers will handle them. The bulletin of the Association, from which we have our information, announces that it is hoped the scheme will be in operation in time to supply the fall trade with "certified" sets.

The schedule of tests and inspection to be carried out seems rather extensive and much more elaborate than the situation demands. Such elaborate data is obtained on no other goods sold by the retailers, we surmise. Among other things which the dry goods people will learn as a result of the tests are whether or not washers are used, size of wire used for connections, the size of the cabinet, type, size, and construction of binding posts, finish of the edge of the panel, and many similar important features! It is stated that the schedule will be expanded as occasion requires.

Radio sets will eventually be sold the same as practically any other commodity, on the reputation of the manufacturer. For a short time the retail dry goods dealers may need the information which these elaborate tests will give them; when their managers and clerks know a little more about this type of goods, the tests will not be required to the same extent. In one way the tests may be of much value to the radio public: they may prevent some of the dealers making such exorbitant claims for their apparatus as they did last spring; we recall distinctly one advertisement in which it was claimed that apparatus which could be purchased for \$35 was good for reception from any station within 500 miles! Reliable tests will prevent such unreasonable claims and thereby the public will be benefited.

J. H. M.

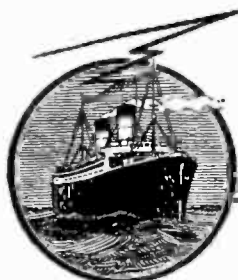



SWAN ISLAND IN THE CARIBBEAN SEA

# The History of the Development of the United Fruit Company's Radio Telegraph System

By ROY MASON

The story of how the United Fruit Company built up its big radio telegraph system has never before been told. Through the courtesy of the Company's officials, RADIO BROADCAST is enabled to give it to the public for the first time.—THE EDITORS.

THE story of what the United Fruit Company has accomplished in developing its system of radio communication, the installation of which was begun in 1904, is the history of the development of the radio art in the United States since that date. This American company, which is the greatest agricultural, as well as one of the largest steamship enterprises in the world, has shown an initiative and progressiveness in developing this system which is unparalleled in the commercial radio art.

Its steamships, comprising the "Great White Fleet," are built especially for service in tropical waters, and furnish regular passenger, mail, and freight service between the Atlantic and Gulf ports of the United States and Cuba, Jamaica and the Atlantic ports of Central America and Colombia, and, through the connecting lines at the Panama Canal, with the west coast ports of Central and South America.

In 1904, the entire eastern coast of Central America and the northern coast of Colombia, South America, were without any direct means of communication with the United

States, with the single exception of a cable station at Colon, Panama. The route which messages from the United States for Central America had to follow up to that time, was by cable through Galveston, Texas, across Mexico and down the west coast of Central America to San Juan del Sur, Nicaragua, and thence via government owned and operated land wires to points of destination. These land lines—traversing as they did swamps and jungles, and being subject to the usual adverse conditions encountered in certain parts of this tropical section, with its torrential downpours and consequent washouts and floods,—made it extremely difficult, and in a great many cases impossible, to maintain a constant and thoroughly reliable telegraphic service. As a consequence, messages to some parts of this territory were subject to delays of hours and often days.

Dealing as it does in such a perishable product as the banana, and directing the movement of a large number of steamships at tropical ports, the United Fruit Company has always been dependent upon quick, reliable telegraphic

and telephonic communication, not only between its offices in the United States and Central America, but between its various banana plantations and division headquarters in the tropics. Therefore, delays to its messages, or inability to send them at all, were of most serious consequence.

In 1904 the Company had already established its own telegraph and telephone lines between its banana plantations and division headquarters in the individual countries of Central America, and was expanding this system to connect the division headquarters of each country.

That year the late Mr. Mack Musgrave, who was in charge of the Company's telegraph and telephone service in Costa Rica, was instructed to make a trip overland between Port Limon and Bocas del Toro, to report on the practicability of constructing a telegraph and telephone line between the headquarters of its Costa Rica Division at Port Limon and the headquarters of its Panama Division at Bocas del Toro, a distance overland of about 150 miles and by sea of about 75 miles. At this time the only means of "quick" (?) communication with Bocas del Toro was by means of canoe from Port Limon. Messages from the Company's offices in the United States for Bocas del Toro were telegraphed to Galveston, Texas, and then cabled to San Juan del Sur, Nicaragua, where they were given to the Nicaraguan Government land lines, which in turn transferred them at the border to the Costa Rican Government land lines for transmission to the Company's office at Port Limon. These messages were then entrusted to natives, who would make the trip in a canoe on the open sea between Port Limon and Bocas del Toro in from 30 to 60 hours, depending upon weather conditions. This canoe service, although it served a purpose, was not only expensive (\$25.00 gold for the trip) but was unsatisfactory, as in many instances messages sent to advise the manager at Bocas del Toro of the expected time of arrival of a steamship, or of delays to steamships en route to that port, would not be received until after the bananas had been cut, and in many cases not until after the arrival of the steamship to which the message referred. As a result, whole trainloads of bananas, cut and transported to the seaboard on the assumption that a steamship would arrive at least within twelve hours of scheduled time, would necessarily be left

on sidings or in the freight yards, where they would soon spoil.

Or again, a steamship would arrive without the Company's manager having received the message apprising him of her expected arrival, and it would then be necessary to hold her in port until the bananas could be cut and transported to seaboard. These same conditions were true to a greater or less extent at other of the Company's tropical division points.

The establishment of a means of quick communication with the Company's tropical divisions, and particularly with the rapidly growing Panama division, was, therefore, of paramount importance, and the Company was prepared to go to almost any expense to insure against undue delays to its messages, which so seriously affected its principal business of growing and transporting bananas to the United States and Europe.

After making the overland trip from Port Limon to Bocas del Toro, Mr. Musgrave reported that, on account of the numerous rivers and swamps to be crossed and the character of the country in general, it was his judgment that wire telegraph or telephone lines could be constructed only with great difficulty and that on account of floods and washouts, the service which could be maintained over such a line, were it established, would be subject to frequent interruption. He therefore suggested the establishment of radio stations at Port Limon and Bocas del Toro, which recommendation was adopted, and he was instructed to proceed to the United States and purchase the necessary equipment.

This was shortly after the International Yacht Races off Sandy Hook between the *Reliance* and the *Shamrock III* had been successfully reported by radio by the original American De Forest Wireless Company, later known as the United Wireless Telegraph Company. Mr. Musgrave purchased from the former company the transmitting and receiving sets for the stations at Port Limon and Bocas del Toro. The apparatus purchased for the latter station was the selfsame set used in reporting the International Yacht Races. It was installed at Bocas del Toro in 1904, and the transmitter continued in operation as a "standby" until 1921, the engine and generator of this set being still in service at Almirante, Panama, as auxiliaries to other power equipment.

The radio service between Port Limon and





RADIO STATION AT PORT LIMON  
Headquarters of the United Fruit Company's Costa Rican Division

Bocas del Toro was inaugurated early in 1905, and was the first to be established in Central or South America. There being no other means of telegraphic communication with Bocas del Toro, that station handled not only all telegraphic business of the United Fruit Company, but that of the general public as well, until 1921, when the station was moved to Almirante, Panama, a few miles away, where the Company had established its new divisional headquarters. Messages for the general public at Bocas del Toro are now handled via Almirante, and thence by telephone.

The original Bocas del Toro station consisted of one 200-foot self-supporting steel tower and umbrella antenna, and a combined dwelling and operating house, all situated on a hill overlooking Almirante Bay.

The Port Limon station comprised two 200-foot self-supporting steel towers having a span of 200 feet, an inverted L antenna, a power house and an operating house, all erected on the seaboard. The towers and engines are still in use, but in 1912 the original transmitting apparatus was replaced by a Fessenden 5 K. W. 500 cycle rotary synchronous spark transmitter. Steel towers 200 feet in height were a distinct departure from the wooden masts of from 125 feet to 185 feet in height, which carried the antenna at the majority of coast stations in those days.

The receiving apparatus at both stations has been changed from time to time as the radio art advanced. The original receivers were of the De Forest two and three slide tuner types, having as detectors the old "goo" responder, and later the electrolytic of both the Fessenden and Shoemaker types, which were subsequently replaced by the Pickard crystal detectors.

These first radio stations of the United Fruit Company were installed under the direct supervision of Mr. Henry O. Easton, who will be remembered by the pioneers in radio as one of the first installers and operators employed by the old American De Forest Wireless Company. Mr. Easton is still with the Company as Superintendent of its tropical stations, and is also Division Superintendent at New Orleans of the Tropical Radio Telegraph Company.

The operation of these two stations convinced the Directors of the United Fruit Company that, regardless of

the many imperfections in radio apparatus, and notwithstanding the static and other conditions, which made the operation of radio stations in the tropics in those days extremely difficult, radio communication would be practicable and would ultimately prove extremely valuable in the handling of such a highly perishable product as the banana.

#### BOCAS DEL TORO, PANAMA

Where the United Fruit Company established the first radio station in Central America. Until 1904 all messages for this point had to be carried by canoe on the open sea from Port Limon. The trip took from 30 to 60 hours

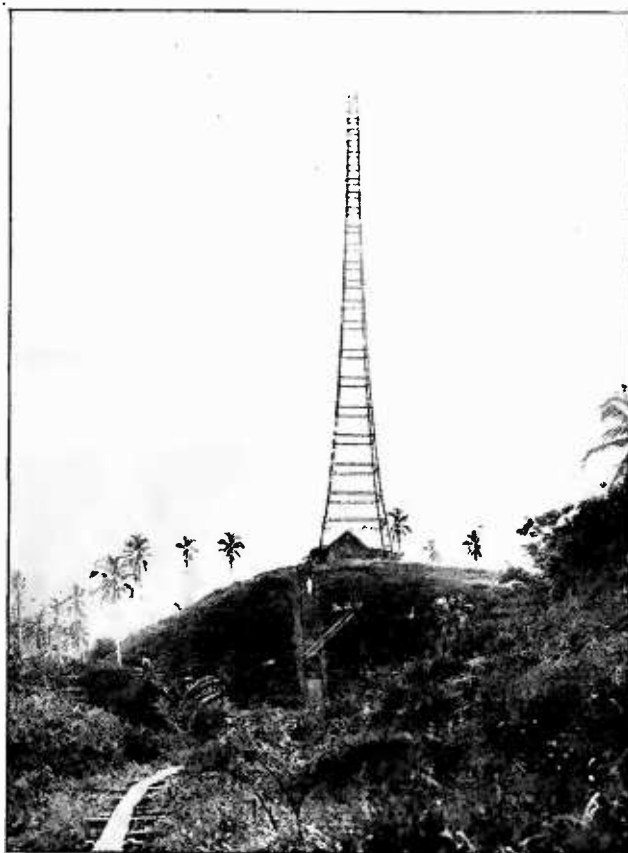

These two stations, while representing the best in radio equipment at that time, were far from perfect. Static, always much more severe in the tropics than elsewhere in the world, caused untold annoyance and often heart-breaking delays. However, the directors of the United Fruit Company did not lose their confidence in the commercial application of this new science, and, a year later, in 1906, authorized the construction of radio stations at Bluefields and Rama, Nicaragua, neither of which had telegraphic service sufficiently reliable to serve the purpose of the Company. These stations were erected and placed in operation that year, and handled not only all of the Company's telegraphic business but also approximately 90% of that of the

#### THE RADIO STATION AT BLUEFIELDS, NICARAGUA

Erected in 1906, and still handling the bulk of the telegraphic business of the general public between that point and the United States and Europe



general public between those places and the United States and Europe.

The Bluefields station is still in operation, and is handling the bulk of the telegraphic business of the general public between Bluefields, the United States and Europe. Bluefields is also now connected by government operated land wires with Managua, the capital of Nicaragua, which gives it a cable outlet to the outside world. The Rama station, situated on the Escondido River, about forty miles above Bluefields, was abandoned when the Company discontinued its banana producing and exporting activities in Nicaragua.

Up to 1907 all of the United Fruit Company's radio communication had been confined to these four original stations at Port Limon, Bocas del Toro, Bluefields and Rama. However, as a result of the experience with these stations and the need for quicker and better communication facilities between the United States and the east coast of Central America, Mr. Andrew W. Preston, President and Mr. Minor C. Keith, Vice President of the Company, decided that not only the interests of the Company but those of the United States demanded that improved communication facilities be established, and that radio should be the means. Their ambition, voiced at that time and now all but accomplished, was to connect all the republics of Central America and Colombia, South America, by radio communication with the United States, either direct or by relay, so as to give hourly communication. The Company had demonstrated that radio communication was not only a useful adjunct to its tropical divisions, but to its steamship service as well. The Board of Directors accordingly authorized the equipment of the Company's steamships with radio apparatus of the very latest type.

It was planned that the United States terminal of this radio system should be at New Orleans and that a relay station be established on Swan Island. Accordingly, in 1907, the Company purchased from the United Wireless Telegraph Company their station at New Orleans, which was to be enlarged, and also their station at Burrwood, La., at the mouth (southwest pass) of the Mississippi River, about ninety miles south of New Orleans. This latter station was to be used principally for communicating with ships at sea, leaving the New Orleans station free for long distance work.

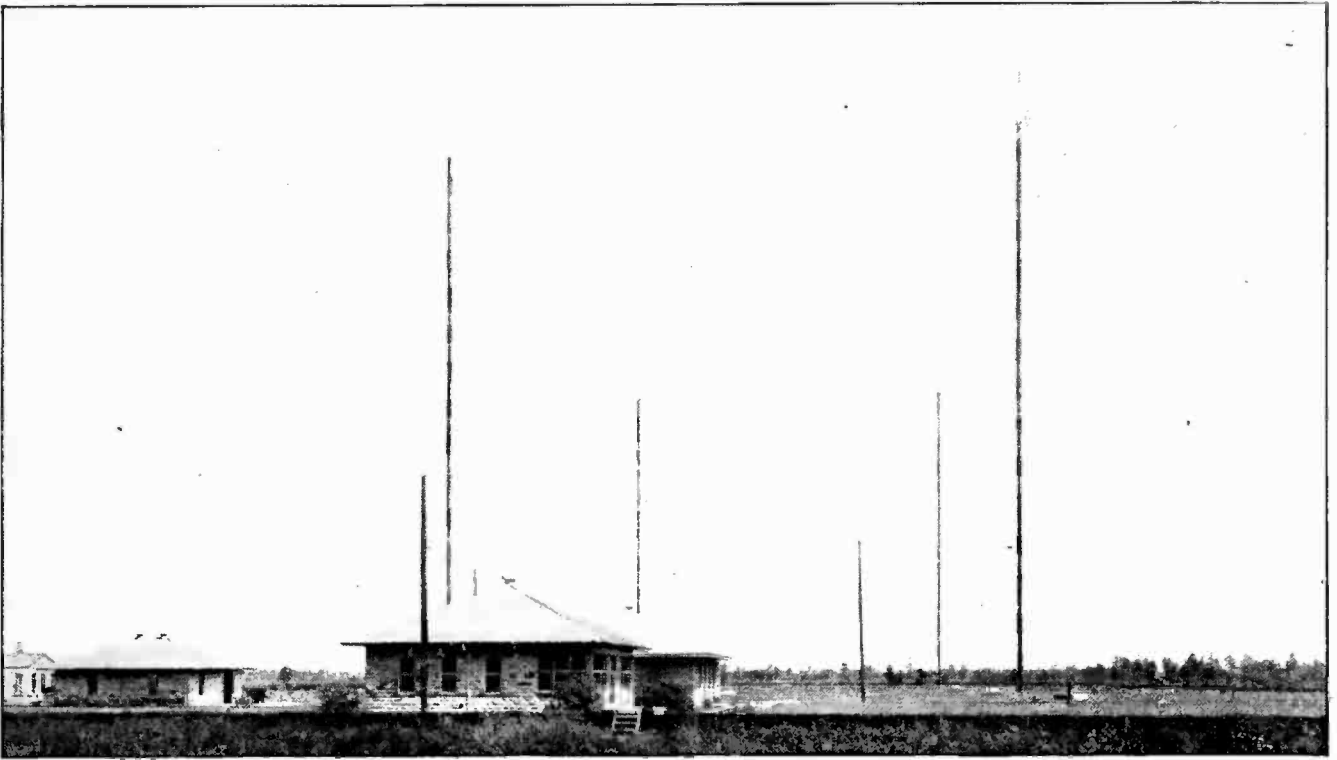

#### THE NEW ORLEANS RADIO STATION

Showing its store house, operating house, generator house, and four 320-foot tubular steel masts

In 1907 Mr. Musgrave again came to New York, and got in touch with Mr. Harry Shoemaker, then Chief Engineer of the International Telegraph Construction Company, and purchased from him a 10 K. W., 60-cycle

spark apparatus for installation at Swan Island. Only a few stations were equipped at that time with transmitting apparatus of more than 5 K. W. power, and the design and manufacture of a 10 K. W. set was therefore a special

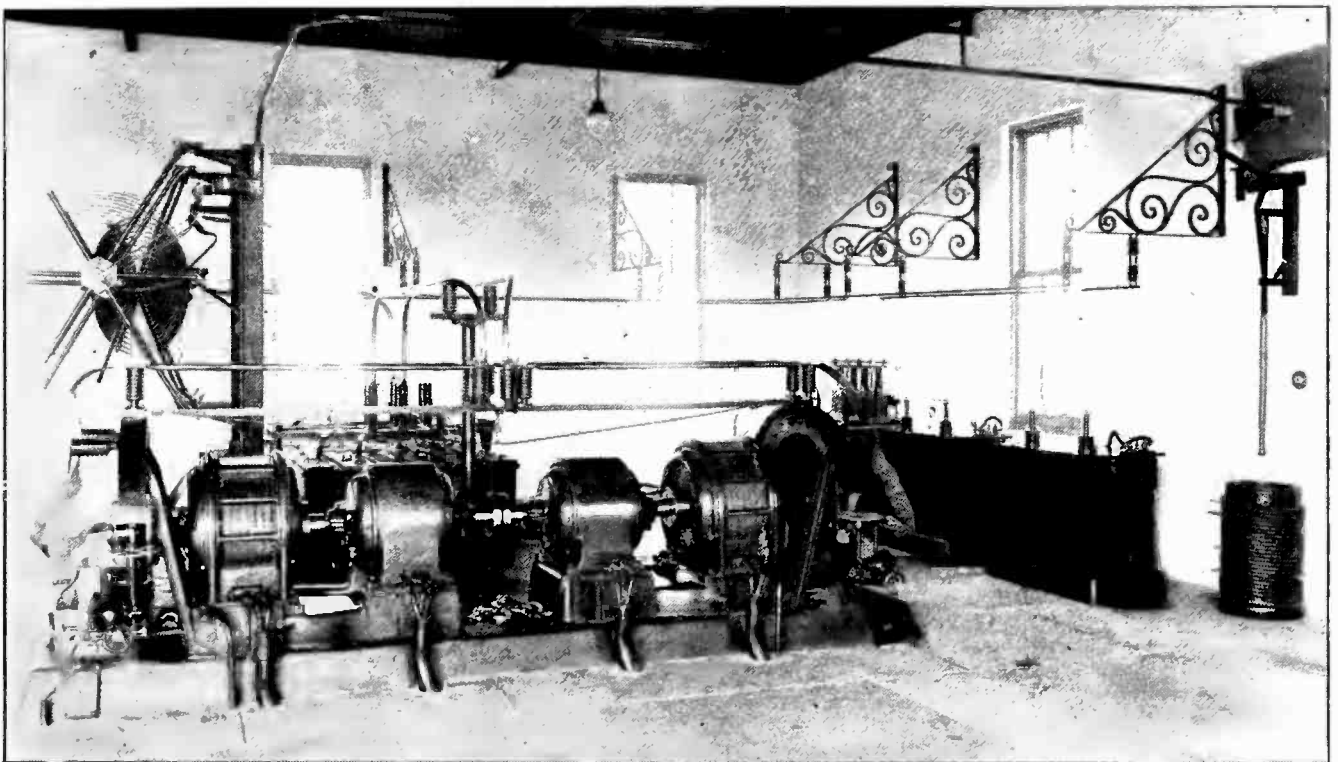

The generator room of the New Orleans Radio Station, showing two 40 K. W. units

undertaking. Mr. Musgrave also purchased additional equipment for the Port Limon station to increase its power. Two 200-foot self-supporting steel towers were also purchased for Swan Island and likewise for New Orleans.

Swan Island, which had been selected as the relay point, is an island about one mile wide and two miles long in the Caribbean Sea about nine hundred miles south of New Orleans and ninety miles northwest of Honduras. It has no harbor, and the average ship cannot come closer than within one-half mile of the beach, while the larger ships must lay off nearly a mile. In the days of the Spanish Main, it was the headquarters of a group of buccaneers who ravaged the Central American coast, and there are yet evidences of their occupation of the island. At the time of the establishment of the Company's radio station there, its only inhabitants were a Captain Adams and a few Grand Cayman laborers, who were shipping phosphate and growing coconuts for the Swan Island Commercial Company, an American company which owned the island. It is one of the most beautiful little spots in the Caribbean Sea, enjoying an even temperature the year round.

As ships stopped at Swan Island only at irregular intervals, several months apart, and as everything had to be transported in row-boats on the open sea between the ship and the beach, the construction of the radio station presented many difficulties, particularly in the handling of the tower steel, oil storage tanks and the heavy engines and generators. It was therefore impracticable to ship materials piecemeal. A ship was accordingly chartered and everything necessary for the construction of the station was loaded and shipped at one time, accompanied by a construction gang. The erection of the plant required about eight months and it was placed in operation during the latter part of 1907. Only one man was stationed there at this time.

In those days radio communication was largely a matter of cut and try. Radio engineers and scientists, of whom there were then only a very few, had not yet acquired the experience nor worked out the formulæ under which modern radio stations are constructed. They knew something of static, but had only a more or less vague idea of its tremendous volume and long duration in the tropics.

It was found that, while under favorable atmospheric conditions, the Swan Island sta-

tion could communicate with both New Orleans and Port Limon, at certain seasons of the year, during the period of static (which prevails nine months out of the year and which is particularly strong on the longer wave lengths in the tropics) spark apparatus of the only type then available of 10 K. W. power was insufficient to maintain communication with New Orleans. The Swan Island station, however, was worth the effort and proved its value on many occasions.

Radical improvements came almost overnight in those days, and it was realized that the spark apparatus of the type so recently installed at both Swan Island and New Orleans would soon be obsolete. While the Company's ambition for uninterrupted and reliable communication between the United States and Central America had not yet been realized, the tests then being conducted by Professor Reginald A. Fessenden between Brant Rock, Massachusetts, and Machrihanish, Scotland, with his 500-cycle rotary synchronous spark sets, lent every encouragement. The 500-cycle note of the Fessenden transmitters came through the static much more readily than the 60-cycle note of the apparatus then installed at the Company's stations. Signals received at Swan Island and Port Limon from Brant Rock were of such a fine tonal quality and were so strong that it was apparent to the Company that a decided improvement could be made in their radio service by installing similar apparatus.

Accordingly, Mr. Musgrave in the latter part of 1907 again visited the United States and got in touch with Col. John Firth, who was at that time the selling agent for the newly invented crystal detectors of Professor Greenleaf W. Pickard, and for other radio specialties. Through Col. Firth Mr. Musgrave met Mr. George Schley Davis, who was then in charge of the United States Naval Radio station at the Brooklyn Navy Yard. Mr. Davis, both in his capacity as instructor in the Naval Radio School and as manager of the Navy Yard Radio Station, had been testing and reporting on all the various types of radio apparatus submitted to the Navy Department for test. Mr. Musgrave explained to him the communication problems of the United Fruit Company and requested his advice. The successful tests between the Fessenden stations at Brant Rock, Massachusetts, and Machrihanish, Scotland, and of other Fessenden apparatus coming

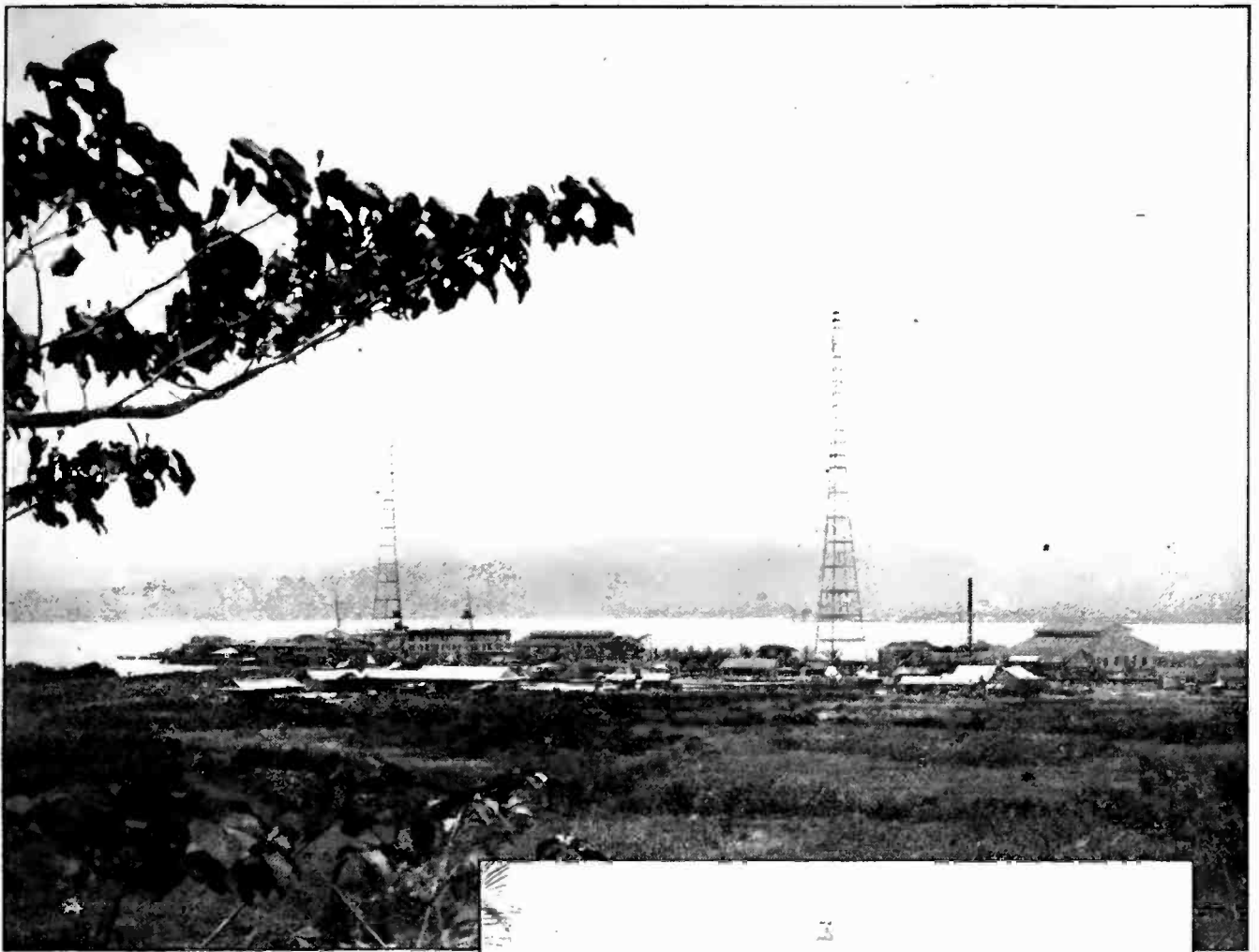

Above. The Radio Station at Almirante, Panama, as it looked on April 1st of this year



To the right. A tower of the Almirante Radio Station seen through tropical foliage

under Mr. Davis's observation, led him to recommend that system.

As a result, Mr. Musgrave promptly communicated with Professor Fessenden, and, in conjunction with him, mapped out a comprehensive plan for installing his latest inventions in the United Fruit Company's stations. It was also determined to erect a second relaying station at Cape San Antonio, Cuba. Accordingly the Company ordered from Professor Fessenden's company two 25 K. W. 500 cycle rotary synchronous spark transmitters, one to be installed at New Orleans and the other at Cape San Antonio, Cuba, which would give the Company a relay connection between New Orleans and Swan Island. If these two sets proved successful, similar sets were to be installed at Port Limon, Costa Rica, Santa Marta, Colombia, and Colon, Panama.

The Company at this time also ordered for each of its ships the Fessenden 2 K. W. 500-cycle rotary synchronous spark transmitters, which were the last word in radio transmitters. The Company was the first to put them into commercial operation on shipboard and they soon became known the world over, not only for the high-pitched tone of their sparks, but for the distances at which they were heard. Signals from the Company ships, while in the Caribbean Sea, were heard both in Port Said, Egypt, and by ships in the vicinity of Honolulu—a remarkable achievement in those days. The performance of these ship sets had a marked influence on ship installations in general, and other companies were soon installing ship sets having similar characteristics.

It is worthy of note and an index of the progress of the radio art that the Company paid from \$6,000 to \$8,000 each for these ship transmitting sets now costing \$4,000, and \$50 each for crystal detectors, selling to-day for \$2.50. The crystal detector receiving sets for which the Company paid \$500. each sell to-day for \$100.

The tube, as a detector and amplifier, had not yet come into use, and Dr. Lee De Forest was still experimenting at his New York laboratories in Park Avenue, with the "third element" of the present-day tube. At about this time also, Dr. De Forest was working in cooperation with Professor Thaddeus Cahill, who had established "Telharmonium Hall" at Thirty-second Street and Broadway, New York City, from which they were broadcasting music generated by Professor Cahill's tel-

harmonium machine. This was probably the first time in history that music was broadcasted by radio for entertainment purposes, and it naturally attracted a great deal of attention. According to Mr. Davis, this music was successfully transmitted by radio from "Telharmonium Hall" to the New York Navy Yard Radio Station, and there transferred to the wire telephone and thus distributed to the various offices of the Navy Yard.

While the construction of a radio station in such an isolated place as Swan Island was very difficult, it was infinitely more so at Cape San Antonio, located at the extreme western end of Cuba. The only site available for the radio station was fifteen miles from the nearest native habitation and fifty miles from the nearest railroad. The Cape was infested with mosquitoes, sand flies, chiggers and almost all other known pests, and construction facilities were wholly lacking. Even the rock for concrete had to be hauled and then broken by hand, and sea sand had to be dug from the beach and the salt washed out of it before it could be used.

The Cape San Antonio station was planned for only one tower 250 feet high with an umbrella type antenna, an operating house and residence and a power and store house. All of the radio apparatus, tower steel, kerosene oil engines and building materials (except sand and rock) were loaded on a steamship at Baltimore and shipped to Havana, where they were transferred to a chartered schooner and transported to their destination. Cape San Antonio resembles Swan Island in only one respect, *i. e.*, it has no harbor or wharf facilities and everything must be unloaded on the beach from rowboats and small lighters in the open sea. The apparatus and materials were shipped the latter part of 1908 and the station erected during the summer of 1909. The new Fessenden apparatus had in the meantime been installed at New Orleans, and communication between Cape San Antonio and New Orleans was established during this same summer.

Even with a 25 K. W. 500-cycle spark set, communication between New Orleans and Cape San Antonio, a distance of only 600 miles, suffered at times from delays due to the severe static, although, during perhaps six months of the year, good service could be maintained at night or in the early morning hours.

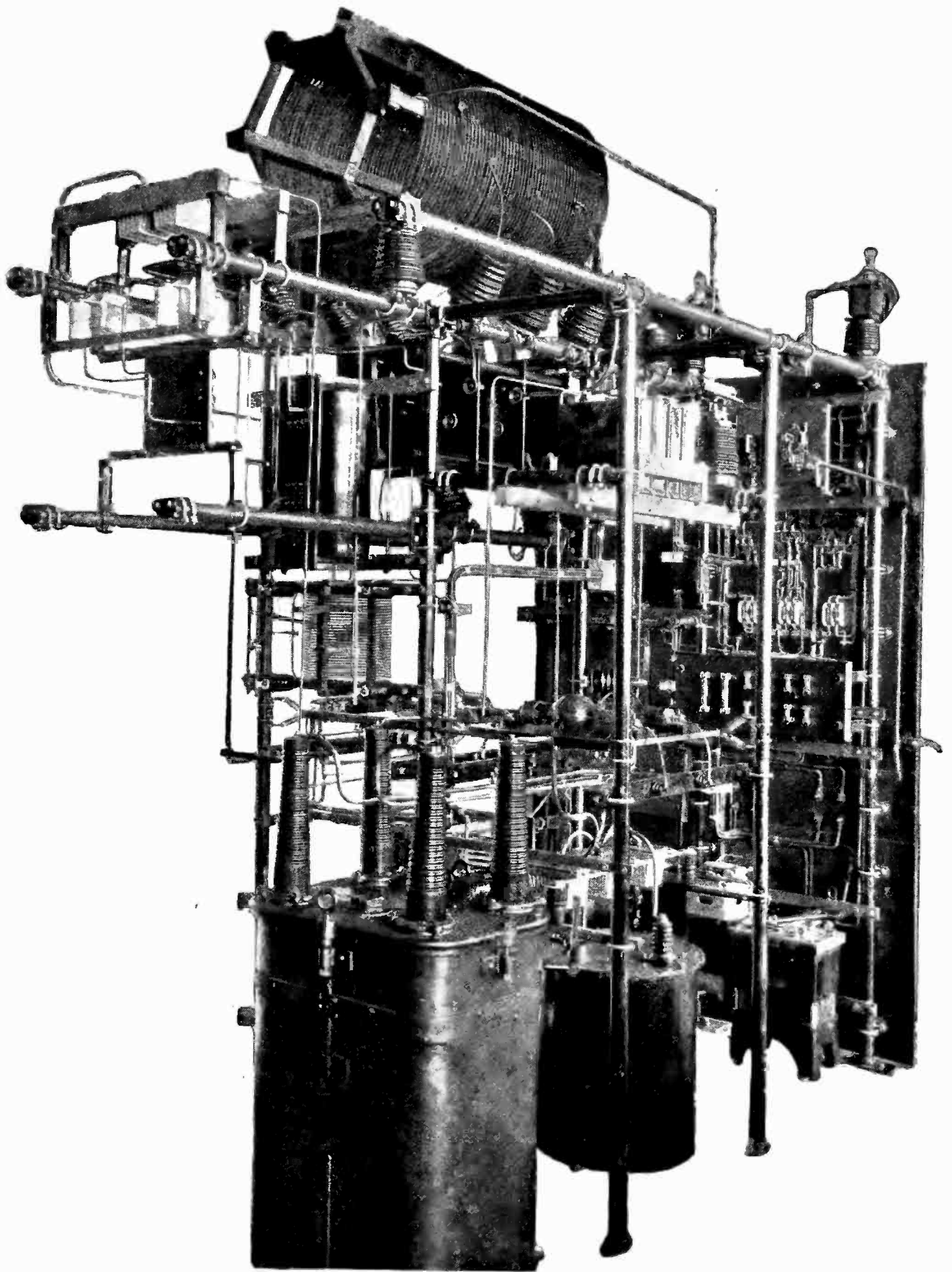

THE ALMIRANTE TRANSMITTER

The Company had not yet, even with the new Cape San Antonio and New Orleans stations in operation, attained uninterrupted hourly communication between the United States and Central America. It was during this period that the Company conceived the idea of a part cable and part radio connection between the United States and Central America to tide over the time until new and better radio apparatus could be developed and installed at its stations. The schedules of their steamships, equipped with 2 K. W. Fessenden radio sets, were so arranged that one of these vessels was in Colon harbor six days out of each week. These ships, while lying at the dock in Colon, could communicate with Port Limon and thus came into being the telegraphic route to Central America known as "Via Colon Radio." Messages over this route were sent by direct cable from New York to Colon, where they were delivered to the United Fruit Company offices and then to their ships in port for transmission to points in Costa Rica, Nicaragua and to Bocas del Toro via Port Limon radio. Service over this route was first established in 1909, and it materially decreased the time required for telegraph service between the United States and Costa Rica and Nicaragua, as well as materially increasing the efficiency of telegraph communication between these coun-

tries. This Colon radio service via United Fruit Company ships continued without interruption until the passage of the law prohibiting the use of radio transmitters on ships in Colon harbor. Since that time messages over this route have been handled through the United States Government Radio Station at Cristobal and thence via Port Limon.

It is interesting to note in connection with the "Via Colon Radio" route that during the Nicaraguan revolution against President Zelaya in 1909, when cable communication between the United States and Europe with Nicaragua and Costa Rica was interrupted at San Juan del Sur, Nicaragua, it was only by means of the Company's radio service, through its ships at Colon, that telegraphic communication was possible with those countries. This service, during the Nicaraguan revolution, was so important both to the Government and to the commercial interests of the United States that the Company exerted every effort to keep it going and secured for its ships the best land wire and cable operators in New York. This was prior to the passage of the law prohibiting the use of the American Morse code and requiring operators to be licensed, so that it was possible in those days to procure operators from a wire or cable office and place them on board ship, without previous radio training. Operating, while at the dock in

Below. View of the Radio Station at Swan Island, once the haunt of buccaneers in the days of the Spanish Main



Above. In spite of its loneliness and perils, the Swan Island radio men are not always depressed





GEORGE SCHLEY DAVIS

In charge of the United Fruit Company's Radio Activities. Mr. Davis is General Manager of the Radio Telegraph Department, General Manager of the Tropical Radio Telegraph Company, and President of the Wireless Specialty Apparatus Company, and is a Director of the Radio Corporation of America and of the Wireless Specialty Apparatus Company

Colon, was no sinecure; the noise from deck winches and the static made the work of these operators exceedingly difficult. However, during the period of the Nicaraguan revolution and for a considerable time thereafter, the Colon-Port Limon radio route was one of the fastest and most accurate telegraphic routes in the world.

It was during this period that the Company made it a standard requirement of its service for all receiving operators to transcribe radio messages directly on the typewriter. Although used in wire telegraph offices for a long time previous, typewriters had not up to this time been considered essential as a time-saving factor in the receipt and delivery of radio messages. So far as is known, this is the earliest adoption of typewriters as standard equipment for a ship or shore radio station, and the United Fruit Company was the first to make compulsory the use of the typewriter by radio operators.

During the hurricane season of 1909, the Cape San Antonio station was partially blown away. It was rebuilt but again seriously damaged by a hurricane the following year. It was again rebuilt, but in August, 1915, an unusually severe hurricane swept the western end of Cuba, completely demolishing the station. It was not again restored because of the refusal of the Cuban Government to permit the Company to move the station about fifty miles inland, out of the centre of the hurricane zone.

Early in 1909, it had become obvious to the Company officials that radio communication was of such permanent importance and their radio-construction programme had assumed such proportions that it required additional trained radio personnel. Mr. Musgrave therefore invited Mr. George S. Davis to join the Company's organization as his assistant. Mr. Davis secured his release from the Navy Department, and joined the Company in Sep-

CAPE SAN ANTONIO, CUBA

The Radio Station, photographed after a hurricane in 1915

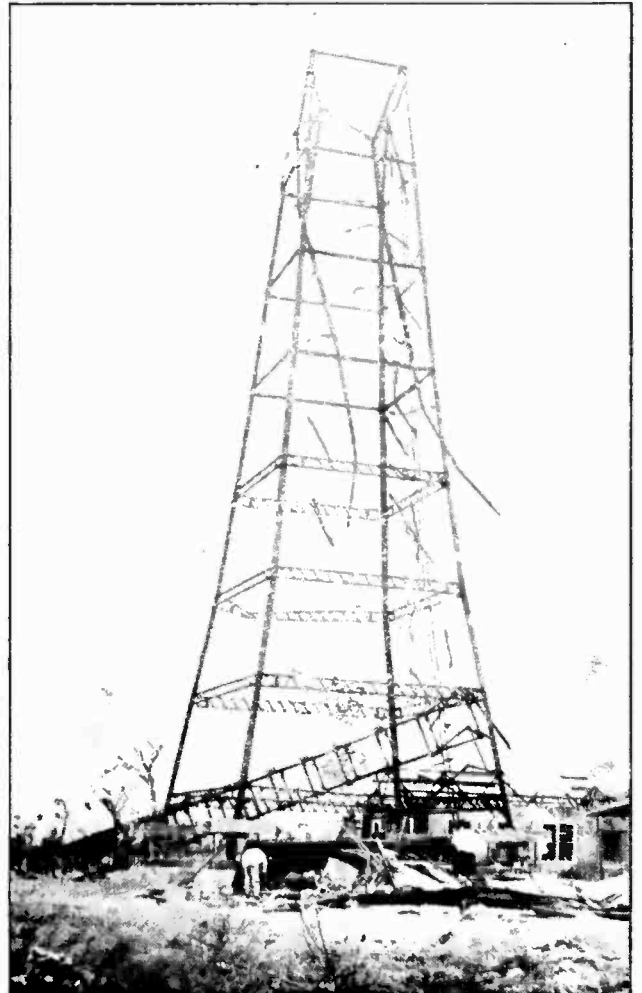

tember, 1909. His first work was to organize the radio department as distinct and separate from the electrical department, and to rebuild the Cape San Antonio station, to complete the installation of the Fessenden radio sets on all of the Company ships and to supervise the experimental work and tests being conducted at the New Orleans station. What is believed to be the first commercial use of the famous Fessenden heterodyne invention was between Cape San Antonio and New Orleans during 1910 and 1911. New and improved receiving apparatus was installed at all stations at about this period, and additional transmitting apparatus installed at both Port Limon and Bocas del Toro.

In the latter part of 1911, Mr. Musgrave resigned from the Company and went to Alaska, returning about two years later to Seattle, where he died. To his persistence, in the face of discouragements and construction difficulties always encountered by the pioneer, is largely due what is to-day a very important link in commercial communication facilities between the United States and Central America. Upon the resignation of Mr. Musgrave, Mr. Davis was appointed General Superintendent of the Radio Department, the headquarters of which were moved from New Orleans to New York.

Also in this year the United Fruit Company acquired an interest in the Wireless Specialty Apparatus Company, established in 1907 for the purpose of exploiting the radio inventions of Professor Pickard. The Company had been paying high prices for its radio equipment, and its activities had grown to a point where radio laboratory facilities became essential for developing the ideas of its own personnel and

particularly so that it could, in a measure, control the design of radio apparatus particularly fitted to withstand tropical conditions. Since 1911 the Wireless Specialty Apparatus Company has supplied all of the United Fruit Company's transmitting apparatus up to 5 K. W. power and all of its receiving equipment. The United Fruit Company is now purchasing its high powered transmitting apparatus from the Radio Corporation of America. The General Electric Company later became associated with it in the Wireless Specialty Apparatus Company.

By 1911 certain parts of the New Orleans and Cape San Antonio stations had become more or less obsolete, and, as they did not fulfil all of the exacting requirements of the Company, it was decided to select a new and permanent station site at New Orleans where a more modern and powerful station could be erected, to rebuild and re-equip Swan Island in its entirety, and to establish a new high-powered station at Santa Marta, Colombia. Accordingly, a contract was made with the Marconi Wireless Company of America to furnish for each of these stations 50 K. W. 500-cycle rotary synchronous spark transmitting apparatus.

At New Orleans the site selected occupies twenty acres of ground upon which were erected four steel masts of the guyed Marconi type, 320 feet in height which permitted of the erection of a directional antenna measuring 300 feet by 600 feet, with an effective height of approximately 275 feet. The station buildings were of concrete and consisted of operating house, power house and machine shop.

At Swan Island the original site was en-

THE RADIO STATION AT SANTA MARTA, COLOMBIA  
Showing the power house, operating house, and residence for employees



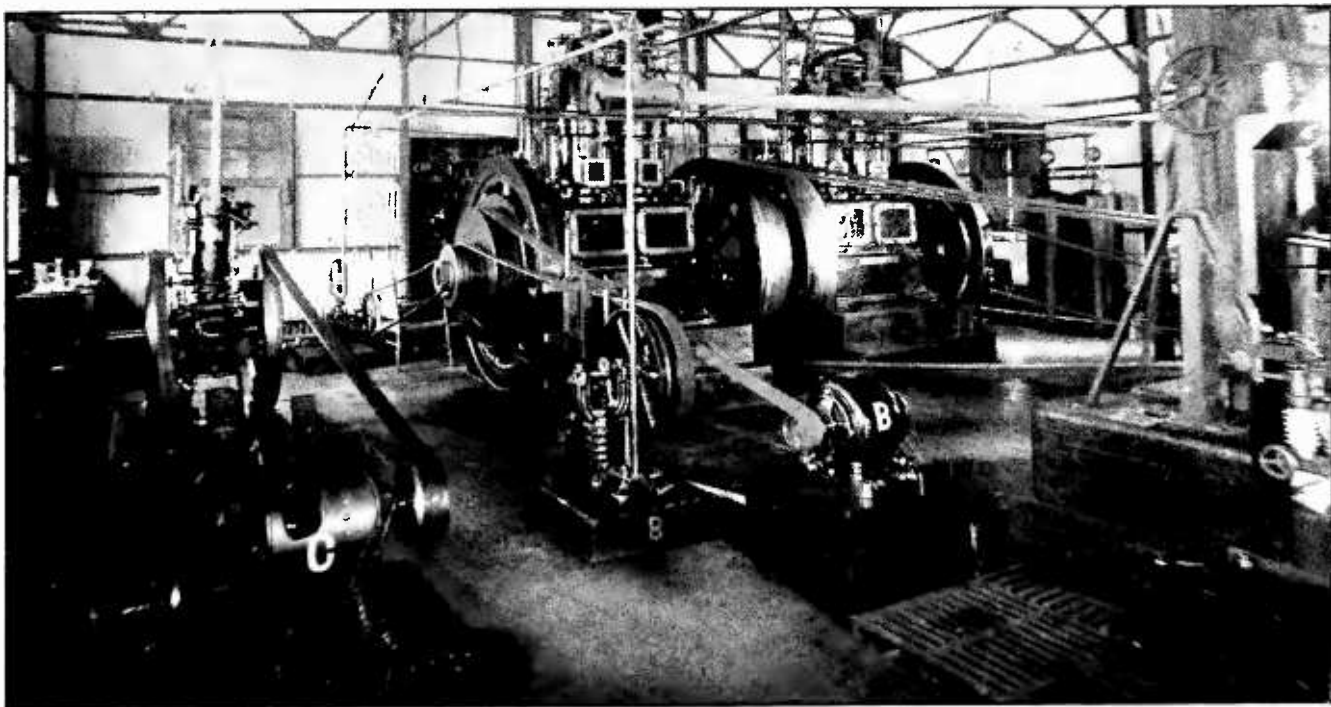

THE 100 H. P. RADIO STATION AT SANTA MARTA, COLOMBIA

This view of the power house shows two 50-H. P. kerosene oil engines, air compressor, exciter, a small radio set for ship work, and other machinery

larged to permit the erection of two additional 250-foot towers and an antenna similar to that at New Orleans. The height of the two original towers was increased to 250 feet. The construction of the new Swan Island station, on account of its location and lack of facilities, was no small undertaking. It was necessary to provide two 75 H. P. kerosene oil engines, and also auxiliary engines and generators for operating the small power radio set, as well as to provide electric current for the refrigerating plant, machine shop and also the beacon light which the Company maintains for shipping. It required approximately two years to complete the new station.

The Santa Marta station was identical in every respect to that of New Orleans, but here the construction difficulties were no greater than are usually encountered in tropical countries.

The three new stations—New Orleans, Swan Island and Santa Marta—were placed in commission during 1912 and 1913 and are still in operation. Direct communication is maintained between New Orleans and Swan Island, the latter station acting as a relay point for stations in Colombia, Costa Rica and Honduras, as well as a relay point between Jamaica, Cuba and Central America.

In 1914 the transmitting apparatus of the New Orleans station and the interior of the

power house were damaged by fire. No time was lost by the Company in restoring this station and putting it on the most modern basis possible, which included the installation of 60 K. V. A. 500-cycle rotary synchronous spark transmitters.

It was during this same year that a hurricane swept over Swan Island and blew down one of the towers, which was immediately rebuilt. In the following year a hurricane, which reached a velocity estimated at 130 miles per hour, blew down three of the Swan Island towers. Although the buildings, due to their steel, concrete and asbestos construction, were not seriously damaged, it was several days before the apparatus could be placed in commission and work resumed, using an antenna strung from the stubs of the towers. An idea of the unusual force of this hurricane may be gained from the fact that it blew down practically all of the coconut trees on the island, some of which had withstood the hurricanes and high winds of twenty years or more.

As a result of experience, it is the Company's idea that its radio stations should be so constructed that they will function at all times regardless of hurricanes, floods and earthquakes and can be relied upon when all other means of communication fail. Although the towers

and buildings at both Cape San Antonio and Swan Island, as well as New Orleans, were designed to withstand the average hurricane, the experience with hurricanes at those places indicated that a much heavier construction and a different design should be used. They therefore called in Mr. A. W. Buel, consulting engineer, of New York, who had been associated with the design and construction of the Company's railway bridges in Central America. In coöperation with Mr. Davis, he has designed and the Company is now erecting, towers which will withstand wind forces up to 140 miles per hour. These latest towers, which the Company has adopted as standard, are 420 feet in height, are self supporting and triangular in shape, and have at the top a bridge arm 150 feet across. The towers are designed to be installed with a span of 1,100 feet and to carry an antenna of 20 wires, each 1,000 feet long.

It is hardly surprising to find that all steamships of the "Great White Fleet," in addition to providing for the special comfort of passengers, have been equipped with the most modern safety devices and are prepared to meet almost any emergency. One of the precautions thus taken was to install on each steamship storage batteries as an emergency power source for operating the radio transmitter, and for an emergency lighting system to be used in case of failure of the main dynamos. With characteristic thoroughness, Mr. Davis selected this equipment by a process of elimination, the main considerations of which were reliability of operation under adverse conditions, and the fact that emergency power should be such as would enable the radio operator to obtain it instantaneously for the radio equip-

ment as well as for the emergency lighting system.

Mr. Davis states that storage batteries seemed to come nearer these requirements (for auxiliary power purposes) than either steam or internal combustion engines, in that they could be brought into use by merely throwing a switch on a switch-board.

The installation of such an elaborate equipment is not compulsory but was made possible by the broad policy of the Company to leave nothing undone, regardless of the expense involved, for the safety and convenience of its passengers and crews. It was the first company to recognize the value of complete storage battery equipment in connection with the operation of the main radio apparatus on board ship, and to install on its ships a complete emergency lighting system operated from storage batteries. All of its steamships will finally be equipped with the Pickard radio Pelorus, which will enable the captains to determine their bearings from the radio beacon stations now being established by the U. S. Department of Commerce.

In 1914, the Company abandoned the old Burrwood, La., station and erected a new plant at a point nearer the mouth of the Mississippi River. The Burrwood station was originally intended for marine work, but, on account of its ideal location—from a radio receiving standpoint—in the marshes bordering on the Gulf Coast, the Company contemplates making it its principal radio receiving terminus in the

United States, and from here remotely controlling the high-powered transmitter in New Orleans.

At the present Burrwood station there are two 250-foot towers set on a span of 650 feet,

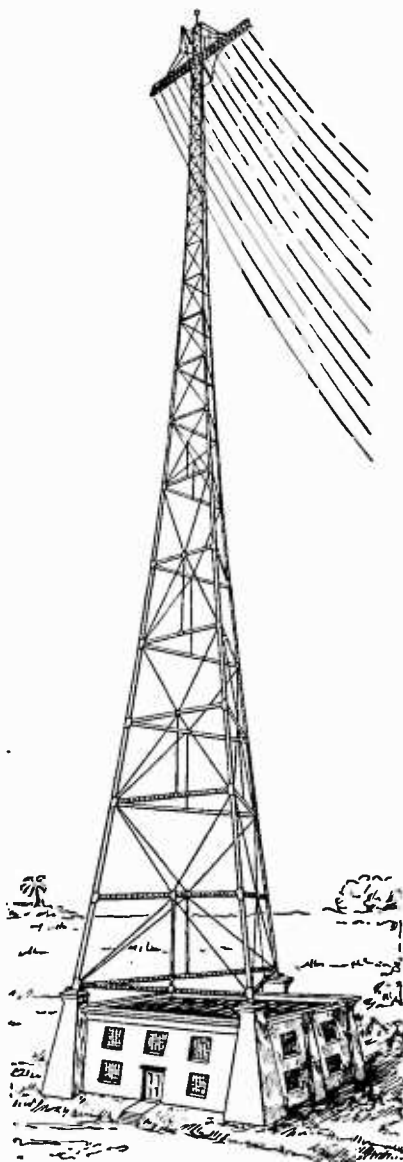

THE "EGYPTIAN MONOLITH"  
TYPE OF TOWER

Especially designed for the United Fruit Company to withstand wind forces up to 140 miles an hour, and now adopted as standard. These triangular towers, 420 feet in height, are self-supporting and have a bridge arm 150 feet across. They are designed to be installed with a span of 1,100 feet and to carry an antenna of 20 wires, each 1000 feet long

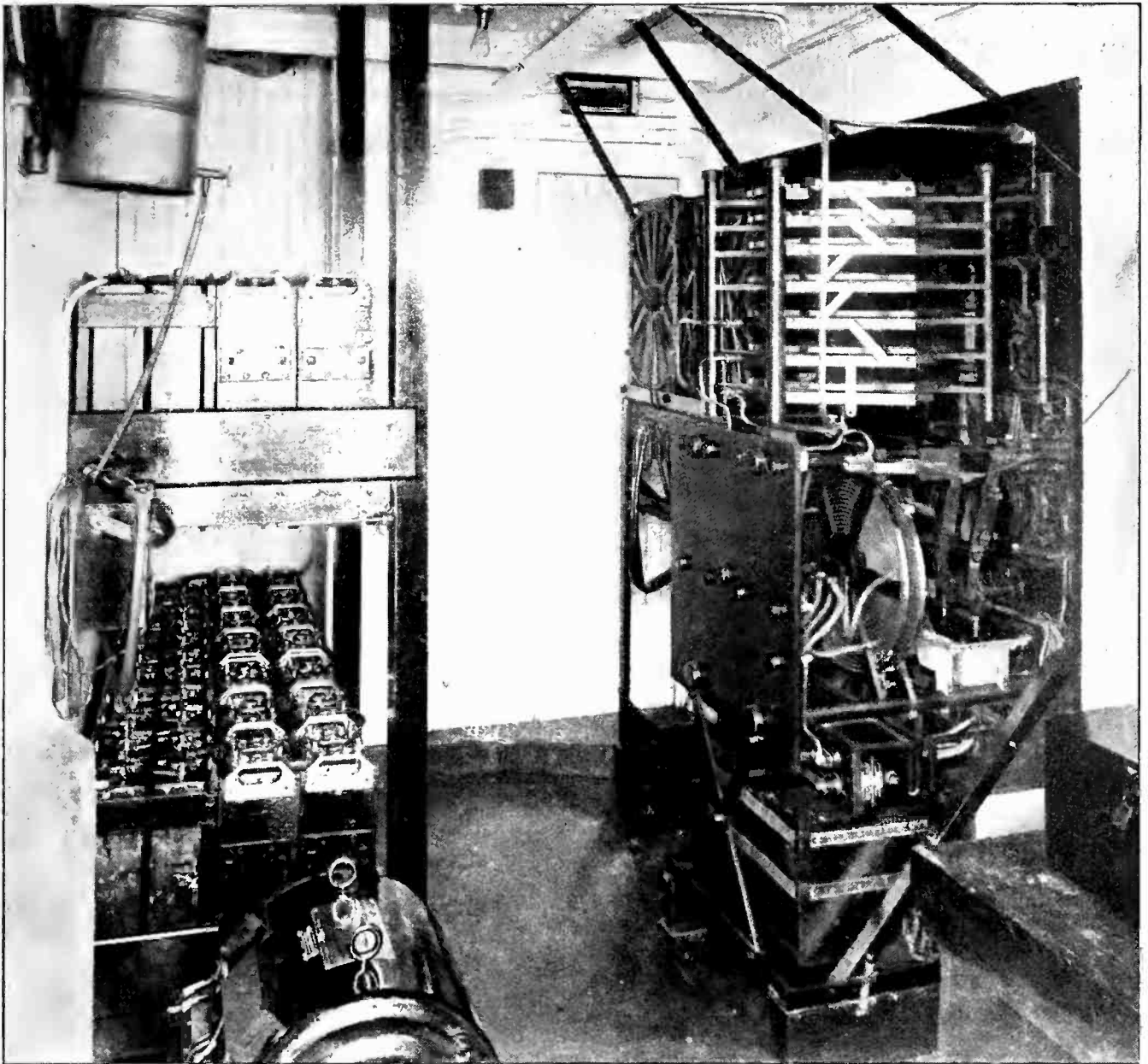

GENERATOR ROOM ON THE S. S. "ULUA"

The motor-generator may be seen in the foreground to the left. Directly behind it are the two banks of Edison storage batteries used for radio as well as lighting in emergency. To the right is the 2 K.W. transmitting outfit which is automatically controlled by switches located in the operating room

a combined operating house and residence, and a power house. The only site available for this station, or in fact for any station near the mouth of the Mississippi River, is in the swamps extending for miles back. The towers rest on piles, as do the buildings and sidewalks. This station has thus far withstood the high winds encountered during the hurricane season in the Gulf. It offers the most direct means of communication between the Southwest Pass of the Mississippi River and New Orleans.

In 1913 the Tropical Radio Telegraph Company was organized as a subsidiary of the United Fruit Company to handle the radio

business of its steamships and of its stations in the United States. The activities of this subsidiary company have since been extended to cover Honduras and Nicaragua.

In 1914 the Tela Railroad Company (a subsidiary of the United Fruit Company) opened up the banana district around Tela, Honduras, and a radio station for communication with Swan Island was constructed for that company. A year or two later a similar station was built for the Truxillo Railroad Company (also a subsidiary of the United Fruit Company) at Puerto Castella, Honduras. Both of these stations, communicating as they do exclusively with



THE RADIO STATION AT TELA, HONDURAS

United Fruit Company stations, are part of this company's radio system.

The partial destruction by hurricanes of the Swan Island station and the total destruction of the Cape San Antonio station was enough to discourage the average company from attempting to build against them, but these difficulties were finally overcome and the Company now has stations which it believes are hurricane proof in every sense of the word.

The report of the final destruction of the Cape San Antonio station by the 1915 hurricane is illustrative of the type of men employed by the United Fruit Company at its stations, and of the force of these storms. The following are extracts from the report made by John A. (Jack) Cole, one of the old-time radio operators who was at that time in charge of the Cape San Antonio station.

About 3:00 P. M. on September 13th, I took a barometer reading and noted that it was unusually low, about 29.60. At 4:00 P. M. I was in communication with Swan Island and ascertained that his barometer was also low, and suggested to him that we get special weather observations off to the Weather Bureau at once. I immediately sent these messages to the Weather Bureau via New Orleans, repeating them again on the night schedule. Everything was made in readiness to withstand a storm and I also made up monthly reports together with the Weather Bureau report in order to have them ready if anything happened. These were fortunately saved and were later forwarded from Havana.

On the morning of the 14th the barometer was still dropping and I got in touch with the ships who gave me their reports and observer messages. The barometer was falling and the wind increasing and a few minutes after communicating with Swan Island, the wind increased in velocity and blew down a portion of the aerial. In the meantime, repairs having been made, storm warnings had been sent to all ships and were being repeated at intervals. About 9:00 A. M. the entire aerial was blown away

and from that time on the wind blew stronger and stronger and about 11:00 A. M. was blowing with hurricane force. The Cuban Government wind gauge had by this time been blown away, but I judged the velocity of the wind was not less than 100 miles an hour and the barometer still falling.

Our kitchen was the first to go, then the gas plant, warehouse and roof of water storage plant were blown down, and some of the iron roofing carried for miles into the woods.

Next the tower, which had been guyed with four 1" steel cables, broke in two about half way up, breaking the guys which blew straight out with the force of the wind.

The roof of the operating house was next blown off and the windows and doors blown in. Myself, the cook and engineer were inside at the time and we then took shelter in the engine house. The operating house, although of steel construction on concrete foundation, was moved about 8 feet off of its foundation. The roof and floor of the veranda were wrenched from the house, but the house itself stood, although badly damaged.

The engine house, where we went for shelter, stood only about twenty minutes after we got there. This being the last house, we started for the woods.

The radio log entry of Mr. Cole at this juncture tells perhaps more vividly than anything else could what happened.

"Part of antenna blown away," reads one entry; "made repairs". A little later another entry reads: "Antenna gone." "Storehouse gone." "Operating house gone." Then a fourth entry records a similar catastrophe to the engine house.

The final climactic summary reads:

"Everything gone, we are going to the woods."

Then he buried the station records and the radio log, and, with R. C. Attaway, the engineer, started for the woods about 400 yards distant. Continuing, Mr. Cole says:

We got a little protection behind some large

stumps. After being there for about an hour, there was a lull. The wind subsided and we returned to the station. We found that the Cuban Government barometer (the United States Government barometer was destroyed early in the storm) which has a scale graduated to read from 27.5 to 32.00, was down to the lowest mark; in fact, the indicator was against the pin at 27.6. I do not know how much farther it would have gone if the pin had not been there.

When I found that the barometer was as low as it would go, and the wind again increasing, we decided to go to the lighthouse, three miles away. This is a stone structure and we thought it would stand. In the meantime the wind had gotten stronger than ever. It took us about four hours to reach the lighthouse, which we did at 7:00 P. M., having had to crawl most of the way amidst flying sand, timbers, falling trees, etc. On our arrival at the lighthouse we found that the prisms had been blown in, putting the light out of commission. We found there the wreck of a Honduranian schooner. The captain had come in as close as he could get, but before he could get a boat out, the anchor chain parted and the vessel started out to sea. All hands jumped overboard and somehow got ashore.

The vessel was blown to sea and disappeared in less than 30 minutes.

We spent the night at the lighthouse and returned to the station on the 15th, finding that all provisions, furniture and kitchen utensils had been destroyed or buried under the sand. About 10:00 A.M. a native family, carrying five dead bodies, arrived at the station on their way to the lighthouse. This family, named Soto, who had lived in this locality for three generations, lost five of their number during this storm.

We endeavored to clean up a bit and get a place to sleep, but the mosquitoes, gnats and crabs which invaded the house, would not permit.

On the 18th I hired a small sailboat and started for Arroyos, 50 miles distant, but a few miles out sighted a Cuban revenue cutter, which took me on board and landed me at La Fe at night, from which place I proceeded to Havana.

Until some ten years ago, the United States Weather Bureau had been without adequate weather reports from the Gulf of Mexico and the Caribbean Sea, and, during the hurricane season, August 15th to September 15th particularly, the lack of such facilities was a



RADIO OPERATOR'S ROOM  
On the "Great White Fleet" *S. S. Toloa*

THE S. S. "ULUA"  
Of the "Great White Fleet." The radio equipment on this vessel duplicates that on the *Toloa*

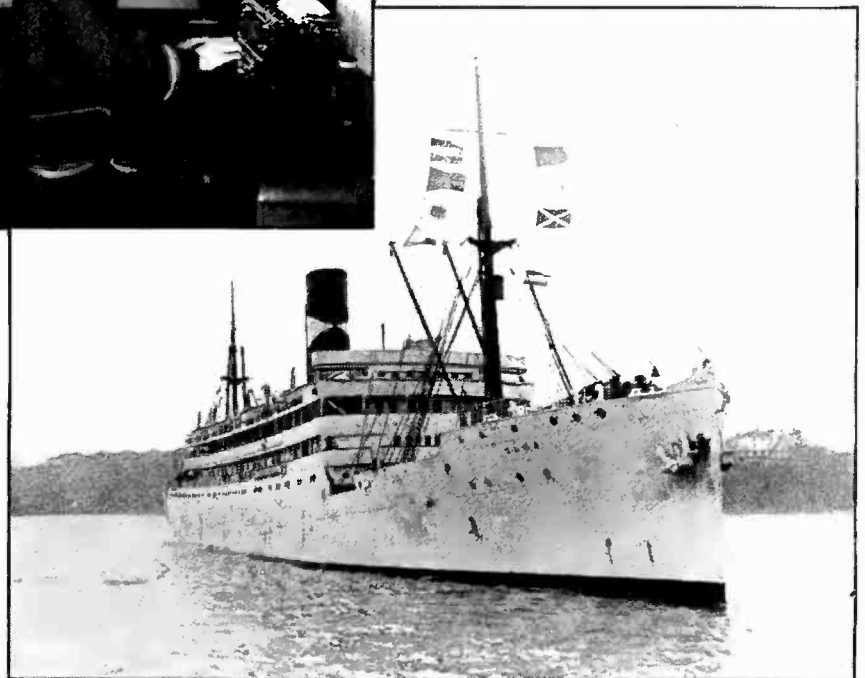

great handicap to merchant shipping in those waters. The United Fruit Company had inaugurated, as a part of its own radio service, a system whereby its ship captains kept each other advised as to weather conditions encountered. With the coöperation of the United Fruit Company, the U. S. Government was enabled to extend its Weather Bureau Observation Service to all the Company ships and shore radio stations. All the ship captains of the "Great White Fleet" were appointed special deputy weather observers, as were the chief radio operators at Burrwood, La., Cape San Antonio, Cuba, Swan Island, and Bluefields, Nicaragua. Weather observations from the Company ships and from these shore stations are made twice daily, and relayed through Swan Island and New Orleans and thence by wire to the Weather Bureau in Washington. These weather observations, in addition to those received by cable from the Windward and Leeward Islands by the Weather Bureau at Washington, enable it to report accurately the occurrence of hurricanes, plot their tracks and determine their force, and thus to issue reliable storm warnings for the information of all shipping and for the Gulf Coast of the United States and for Cuba, which has resulted in the saving of millions of dollars in property and of many lives. These storm warnings are broadcasted in the Gulf and the Carribean Sea by the United Fruit Company radio stations for the benefit of all shipping, and it not infrequently occurs that, through information thus disseminated, ships are enabled to steer clear of hurricanes or can be held in port until the storm has passed.

While the Company's project for direct radio communication with Central America has been attained, owing to the recent marked improvements in radio apparatus it now plans further to improve its service by completely rehabilitating all of its ship and shore radio stations, with the end in view of ultimately establishing radiotelephonic communication with Central America. All of its Central American stations will be open to the public as soon as the necessary permits are granted by the respective governments.

Its radio building programme contemplates the installation of tube transmitters for both radiotelegraphic and radiotelephonic purposes on its ships, enabling passengers to talk with the shore from their staterooms at any time during the voyage.

The Tropical Radio Telegraph Company is now erecting in Tegucigalpa, the capital of Honduras, one of the most powerful tube transmitting stations on this continent, which it is expected will be in operation by December of this year. It is interesting to note in connection with this station that the 420-foot steel towers, radio apparatus, oil engines and building materials must be shipped to Amapala, Honduras, on the Pacific coast, where they are lightered ashore and then hauled over an 80-mile mountain trail to Tegucigalpa. Steel gangs and installing engineers have been sent from the United States.

Powerful tube transmitting apparatus will also be installed at New Orleans and at a new station which the Tropical Radio Telegraph Company proposes to erect in the vicinity of Miami, Florida.

The Tropical Radio Telegraph Company plans to have in operation in 1924 a tube transmitting station at Managua, the capital of Nicaragua, which will give direct communication with the United States through Miami and New Orleans.

Later, similar equipment will be installed in Colombia, Costa Rica, and Swan Island, and possible in Cuba, so that probably by 1925 this great radio system will have been completed and the plan of the United Fruit Company to provide the general public as well as itself with a fast, reliable and instantaneous means of communication between the United States and Central America and Colombia will be complete. Further, what is perhaps of more importance to those countries, it will bring together out-of-the-way places and thus pave the way for closer commercial and political relations between the Americas.

The United Fruit Company has spent more than \$3,000,000 in the development of its radio system, and upon the completion of its projected radio building programme its investment in radio will probably exceed \$4,000,000.

Radio operators in the service of the Fruit Company are all carefully selected men trained to meet its special requirements and to uphold the high standards of the Company. On its ships the radio operators rank with the pursers and have excellent cabin accommodations. The salaries paid to ship operators are based both on their ability and on length of service with the Company; chief operators receive from \$105 to \$140 per month and second operators from \$85 to \$105 per month, and found.



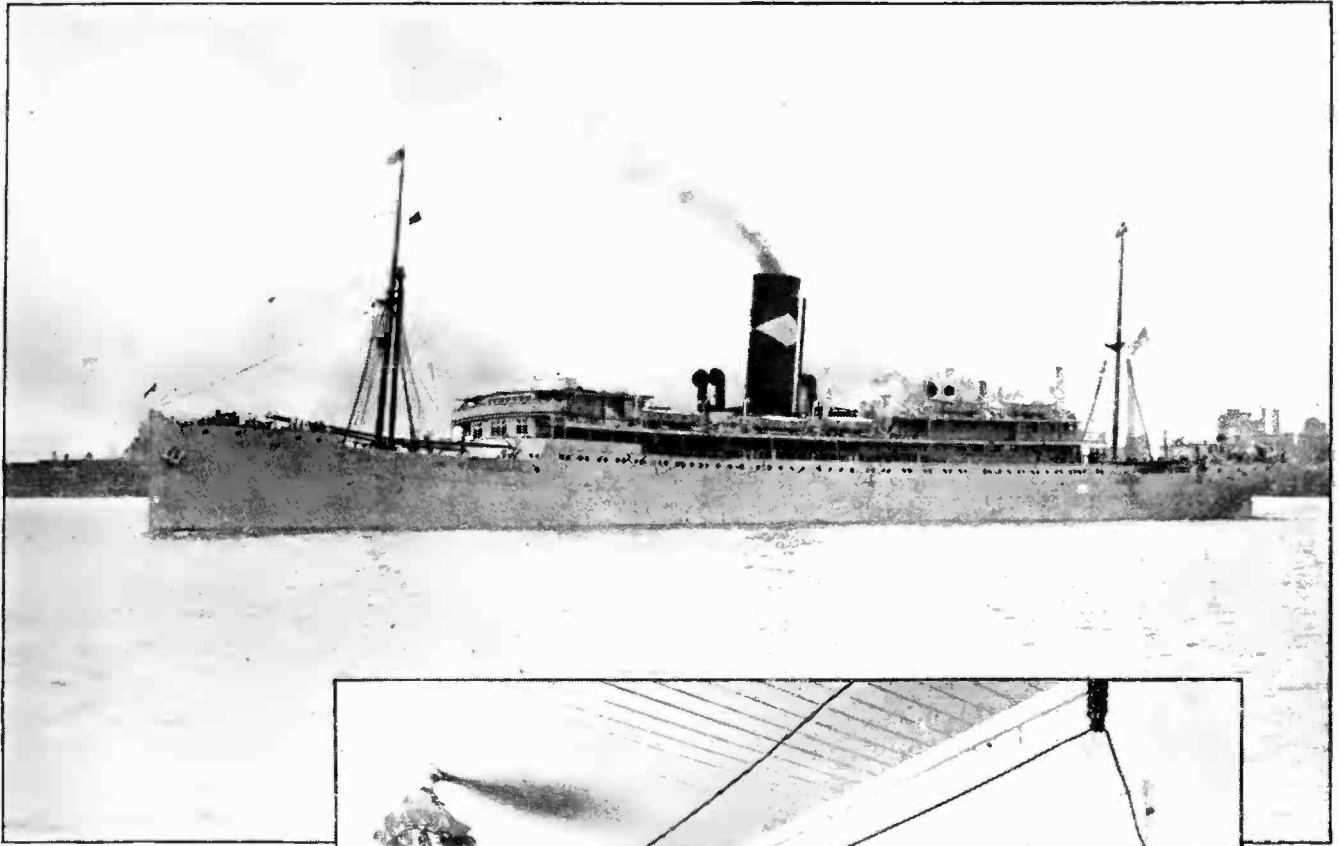

THE "S. S. PASTORES"  
OF THE "GREAT WHITE  
FLEET"

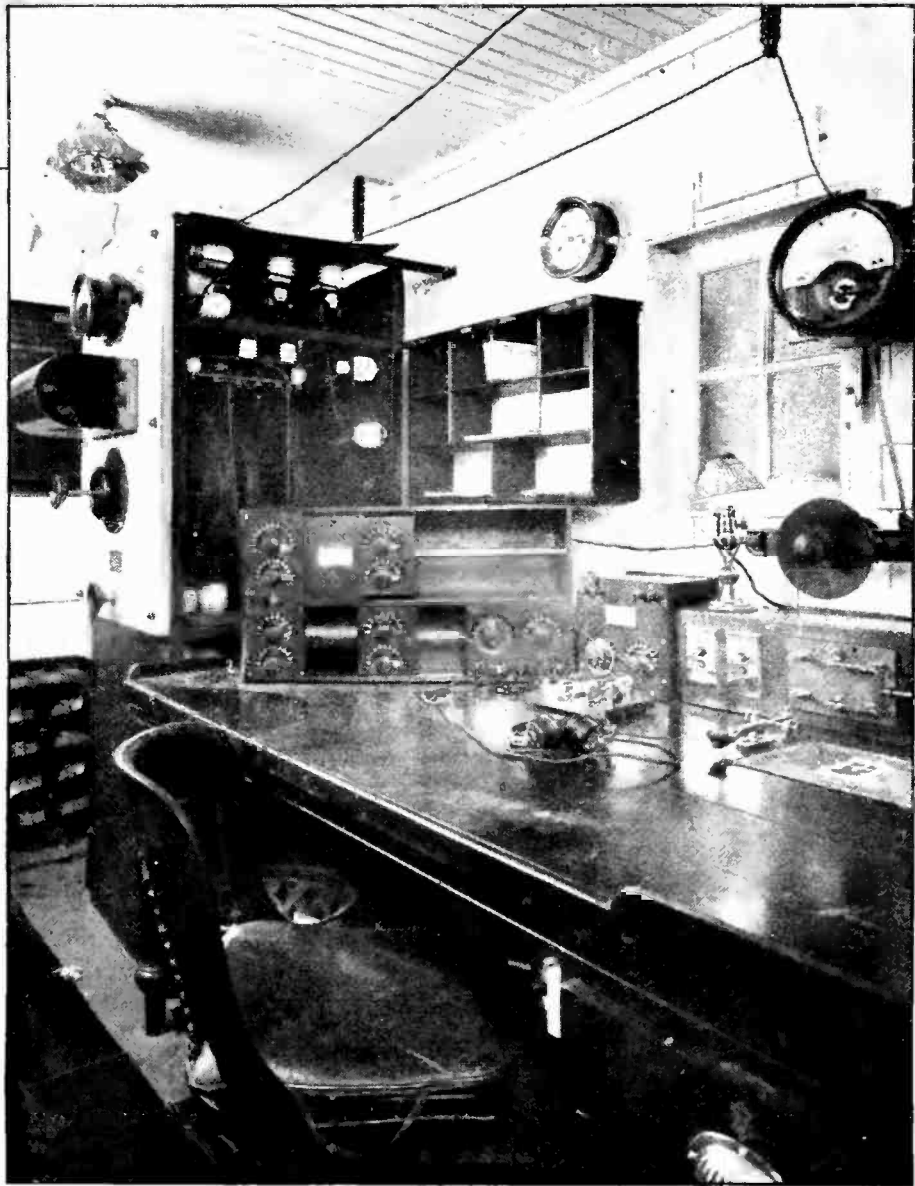

RADIO OPERATOR'S  
ROOM ON THE "S. S.  
PASTORES"

In the tropics the company provides living quarters for the operators, and for their families in localities where it is possible for an operator to have his family. The salaries paid to chief operators in the tropics range from \$150 to \$250 per month, depending upon the length of service and assignment. At Swan Island the company also maintains the mess and furnishes a cook and mess attendant.

Operators in the tropics are given an opportunity to learn the banana business from the ground up. One of the Company's former operators is now a banana farm superintendent in Honduras; one is the president of a well known radio manufacturing company; another is secretary of a steamship company and others have been promoted to other responsible positions on shore and to pursers and engineers on shipboard.

It is no exaggeration to say that today the United Fruit Company is organized around its ability to communicate quickly by means of its own communication system, without which the conduct of its shipping, but more especially the banana business, would be seriously interfered with, since it enables the management to keep in close touch with its outlying divisions and thus to advise them instantly on the conditioning, cutting and shipping of bananas. Through the use of radio the cutting and moving of bananas to seaboard in the tropics can be timed to coincide with the arrival of steamships at the loading ports, and thus the losses which would result from cutting this perishable fruit too soon are reduced to a negligible sum.

The conception and carrying out of its radio policy was a big thing not only for the United Fruit Company but for the commercial interests of both the United States and Central America, and great credit is due Mr. Preston, Mr. Keith and the Board of Directors for their foresight and courage which enabled the Company to complete, in the face of tremendous discouragements and adversity, a construction and operating programme of such far-reaching importance. It is characteristic of the true American spirit of initiative, and indicates what can be accomplished by American enterprise abroad. It also demonstrates the mutually beneficial results which can be secured through the development of a great public utility by private initiative under wise government regulation rather than under government ownership and operation.

Since 1911 the radio activities of the United Fruit Company in all its branches have been under the immediate direction of Mr. George S. Davis, who is General Manager of their Radio Telegraph Department. He is also President of the Wireless Specialty Apparatus Company, General Manager of the Tropical Radio Telegraph Company and a Director of the Radio Corporation of America. He is a Fellow of the Institute of Radio Engineers and a member of various other scientific organizations.

While in the United States Navy, Mr. Davis became interested in electric propulsion for steamships, and, largely as a result of his initiative, the United Fruit Company decided to give electric ship propulsion a trial. Their newest steamship, the *San Benito*, was accordingly equipped with electric drive by the General Electric Company, and has proven so satisfactory that additional ship tonnage when built will probably be propelled by electric machinery.

Assisting Mr. Davis in the Company's radio engineering and construction work is Mr. William E. Beakes, Chief Engineer of the Radio Telegraph Department and of the Tropical Radio Telegraph Company. Mr. Beakes was with Professor Fessenden's company from 1904 until 1912 and participated in the early work at both the Brant Rock, Massachusetts, and Machrihanish, Scotland, stations. He represented the Fessenden Company in the installation of the United Fruit Company stations at Cape San Antonio, Cuba, and New Orleans, entering the service of that company in 1912.

Colonel W. P. Rothrock, formerly Chief Designing Engineer of the Fort Pitt Bridge Works and well known among structural steel builders as having supervised the third tracking of a large section of the New York Elevated system, and the construction of some of the largest war material plants, is superintendent of tower and building construction for the Radio Department of the Fruit Company. He erected the new 350-foot towers at Almirante, and is now in Honduras, erecting the 420-foot towers at Tegucigalpa.

This article would hardly be complete without a few words concerning the United Fruit Company's activities—what it is and does. It was incorporated on May 30, 1899, and is engaged primarily in the production and transportation of tropical products, principally

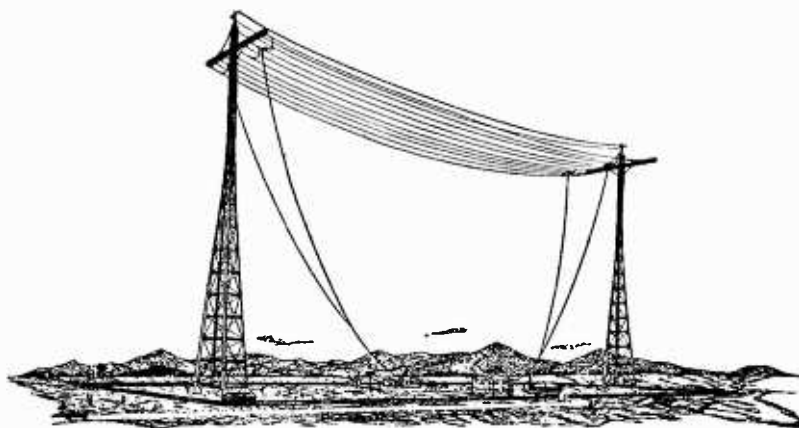

NEW STATION AT TEGUCIGALPA, HONDURAS  
Now being built by the Tropical Radio Telegraph Company

bananas, sugar, cacao and coconuts. It also conducts an extensive freight and passenger business.

Its tropical divisions are located in Colombia, Costa Rica, Cuba, Guatemala, Honduras, Jamaica, Panama and the Canary Islands. During the past ten years it has shipped from the tropics 284,000,000 bunches of bananas.

It has on its payrolls, including those of its subsidiaries, approximately 67,000 employees. It owns 1,536,000 acres of land of which more than 365,000 are cultivated. In addition it leases 125,000 acres of land of which 30,000 are cultivated.

It operates more than 1,300 miles of railways, 500 miles of tramways and over 3,500 miles of telephone and telegraph lines, in addition to its radio system.

In Latin America it does a mercantile business amounting to more than \$10,000,000 a year.

The United Fruit Company is one of the most complete and best equipped organizations devoted to the production of sugar. This fact is not generally known by the public, which regards it solely as a banana and steamship enterprise. It has in Cuba 87,000 acres of cane and two large sugar mills located at the seaboard, and owns the Revere Sugar Refinery at Boston, which is one of the most modern plants of its kind in the world.

Before closing the story of this remarkable company and its achievements, mention should be made of its medical service in the tropics. Probably few realize the magnitude of this service including, as it does, not only

the care of the sick, but preventive medicine and supervision of sanitation. Yet on the preservation of health and improved conditions which make living in the tropics safe and enjoyable has depended in a large measure the success of all that the United Fruit Company has attempted and achieved.

An annual medical service, which is expressed in six figures, commands attention. During 1921 the number of patients cared for in the tropics by the Company's medical department was 208,000, of whom 33,000 were non-employees.

A large personnel of experienced executives, doctors and nurses, recruited from all over the world, is carrying on the work of this department of the United Fruit Company's activities.

The cost last year of operating hospitals and dispensaries was \$240,000 in excess of receipts. Through other departments directly associated with but not included in its medical service, the company spends annually in sanitation \$275,000; for parks and street cleaning \$200,000; and \$300,000 in excess of receipts for electric light plants and waterworks.

The Company has expended more than \$200,000,000 toward the development of the Latin American countries where it does business and is the most potent factor in the extensive commercial relations of the United States with these countries.

These few salient facts concerning the United Fruit Company and its operations clearly indicate the varied interests served by its ex-

#### OPERATING HOUSE UNDER CONSTRUCTION

At the new Tegucigalpa station of the Tropical Radio Telegraph Company. All the buildings at this station will be made of stone



tensive and rapidly growing radio system. Radio—a dream of the scientists two decades ago—has firmly established its place in the commercial and political life of the world. Too much credit cannot be given the inventors and pioneers for their courage and perseverance in accomplishing this result.

The United Fruit Company has just announced the inauguration of a free medical radio service from its hospitals in the various countries of Central America and from its passenger steamships to all ships at sea. This service is available without charge so far as the United Fruit Company and subsidiary companies are concerned to ships of all nationalities through the following radio stations operated by the United Fruit Company or the Tropical Radio Telegraph Company:

<i>Radio Stations</i>	<i>Radio Call Letters</i>
New Orleans, Louisiana	WNU
Burrwood, Louisiana	WBW
Fort Morgan, Alabama	WIO
Swan Island, Caribbean Sea	US
Tela, Honduras	UC
Puerto Castilla, Honduras	UA
Tegucigalpa, Honduras (Open Nov. 1922)	UG
Port Limon, Costa Rica	UX
Almirante, Panama	UB
Santa Marta, Colombia	UJ
All passenger steamships of the United Fruit Company	For ships' call letters see International Radio Call Letter List

Radiograms requesting medical advice should be signed by the captain of the ship and should state briefly, but clearly, the symptoms of the person afflicted. Such radiograms should be addressed "UNIFRUITCO" (name of place) and may be sent to any of the United Fruit Company's hospitals listed below:

- Santa Marta, Colombia
- Port Limon, Costa Rica
- Almirante, Panama
- Tela, Honduras
- Puerto Castilla, Honduras
- Puerto Barrios, Guatemala

All United Fruit Company passenger ships carry doctors, and free medical service may be secured by radio from any of them by a radiogram addressed "Ship's Doctor" followed by the name of the steamship.

This free medical service is established primarily for the benefit of ships not carrying doctors; however, should occasion require, ships' doctors may hold consultation by radio with the United Fruit Company ships' doctors and hospital staffs.

It is requested that when sending medical advice radiograms, radio operators check them "(number of words) DH Medico."

"DH Medico" radiograms will be given preference over all other radiograms, excepting SOS calls, throughout the radio service of the United Fruit Company and subsidiary companies.

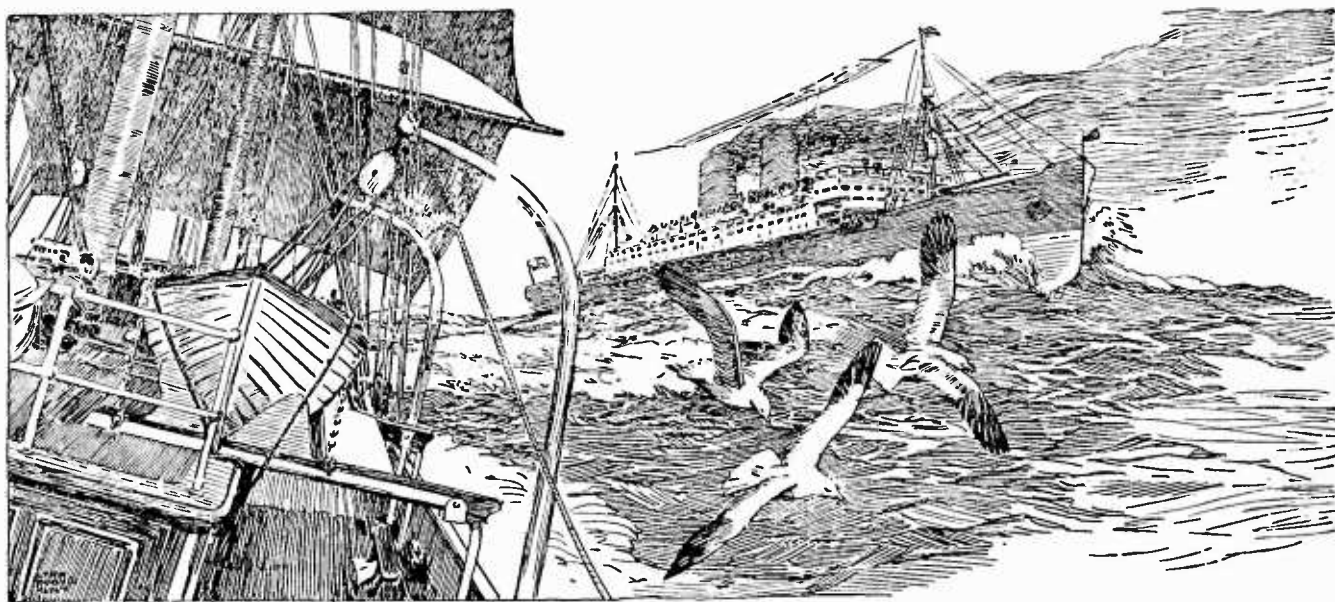

# Developments in High-Power Radio

And Its Practical Application in the Services of the United States Navy

By COMMANDER STANFORD C. HOOPER, U. S. N.

Head of the Radio Division in the Bureau of Engineering, Navy Department

**A**PPROXIMATELY twenty-five years ago, or to be exact, in February of the year 1896, a young scientist of Italian and Irish parentage journeyed from Italy to England in the hope of interesting the British Government in an invention by the use of which the claim was made that communications could be exchanged between distant points without utilizing the ordinary connecting wires or other visible connecting medium.

Doubtless he experienced some difficulty in getting in touch with the government officials in London, and, presumably, when he did, his claims were listened to with a degree of skepticism comparable to that which would probably now confront a man who suddenly claimed to have exchanged communications with inhabitants on the Moon. It would be only natural that such an attitude would prevail because the only method then known for exchanging rapid communications between points separated by distances considerably beyond the range of visibility was to utilize the land line wire telegraph, telephone, or ocean cable systems, and it was generally believed to be impossible to exchange rapid communications over great distances without utilizing connecting wires.

However, the expression "wireless telegraphy" or communications without wires, naturally envisaged communications with ships at sea and between ships separated by great distances at sea, and doubtless the authorities of the leading maritime power of the world would not let pass any proposition, however fantastic, that might possibly bring this about.

Needless to say, the young inventor to whom reference has been made was Marconi.

We learn that six months after Marconi arrived in England he conducted a series of trials before the British Post Office officials and navy and military officers on Salisbury Plain, and succeeded in establishing communication over a distance of one and three quarter miles. About one year later Marconi increased this

distance to four miles, and a few months later he increased the distance to eight miles.

Thereupon news of the performances of the young inventor began traversing the ocean cable systems of the world radiating from London (the cable systems themselves having been in successful operation only about twenty-five years) and a skeptical world was apprised of the remarkable new invention of "wireless telegraphy."

Thus we see introduced into the world within a generation two remarkable inventions enabling the exchange of rapid communications over long distances, namely, the ocean cable and wireless, or radio telegraphy.

Now, after these systems have been developed and largely perfected, we find ourselves on the threshold of another remarkable development in connection with the exchange of rapid communications over long distances, namely, wireless telephony or the radiophone, about the future possibilities of which it is difficult to hazard even a conservative prediction.

Obviously the world is advancing rapidly and with great strides in the development and inauguration of new means for exchanging rapid communications over long distances, thereby linking the remote regions of the world together with the less remote regions, bringing the more backward peoples into close contact with the less backward; in fact, gradually consolidating all the peoples of the world into one great human family by providing channels for readily exchanging rapid communications.

As a matter of fact, the shortening, in effect, of the vast intervening distances separating the different principal parts of the world, and the opening up of regions hitherto regarded as more or less inaccessible, as a result of the inauguration of the new methods of exchanging rapid communications, has already come to be regarded as so commonplace as not to excite unusual interest or comment.

During the interval of time from the year 1897 to 1912, developments took place in wireless or radio telegraphy so rapidly that the



Riggers replacing a defective insulator in the Navy's Pearl Harbor high power radio station antenna

range of communication increased from eight miles to as much as three thousand miles under the most favorable conditions, and the application of this method of communication to practical uses, particularly in connection with sea-going ships, especially as regards the preservation of life at sea had been amply demonstrated by the rescue of the passengers and crew of the ill-fated American passenger steamship *Republic* on January 23, 1909, before that vessel went down, assistance having been summoned by the stricken vessel by wireless.

About three years later, or on April 15, 1912, the lamentable *Titanic* disaster occurred. It will be recalled that the one radio operator carried by the steamship *Carpathia*, while he was preparing to retire for the night, but while still wearing his radio headphones, almost accidentally overheard the radio distress calls, or S. O. S. signals, of the *Titanic*, and as a result, the *Carpathia*, after steaming at full speed throughout the night, arrived in the early morning hours at the position previously given by the *Titanic* and rescued the occupants of the *Titanic's* boats after the great vessel had gone down in mid-Atlantic carrying with her a large number of her passengers and crew. The *Titanic* disaster convinced the world of the

inestimable value of radio as an agency to safeguard life and property at sea, and it resulted in much beneficial legislation being enacted by the various governments of the world, especially as regards the equipping of sea-going passenger-carrying vessels with reliable radio outfits and also the carrying of more than one radio operator. The very great value of radio in naval and military tactics and as an agency to influence world trade was also coming to be generally recognized, and plans began to be formulated by the various leading powers of the world, notably by Great Britain, Germany, and the United States, with a view to establishing chains of high-power radio stations on shore to meet the national and trade requirements.

Germany undertook the establishment of a high-power station in the United States to work with a similar station near Berlin. Great Britain contemplated an "Imperial Wireless Chain" designed to connect all of her outlying possessions with England by radio.

The United States Navy established its first high-power station at Arlington just outside of Washington as the terminus of a projected trans-Continental trans-Pacific High Power Circuit to connect the Navy Depart-

ment by radio with our Atlantic, Pacific, and Asiatic Fleets and to afford our government a means of communicating with our outlying possessions in the West Indies, the Panama Canal Zone, Alaska, the Hawaiian Islands, Samoa, Guam, and the Philippines, either directly or through intermediate radio relay stations, and entirely independent of cable facilities.

The Navy's main high-power circuit was to comprise, in addition to the Arlington station, primary high-power stations at points on the California coast, in the Hawaiian Islands, and in the Philippines. It was hoped that reliable trans-Continental service could be maintained between the Arlington station and a primary station on the California coast, thence with Hawaii and thence with the Philippines.

Secondary high-power stations in the primary chain were planned, one for the Canal Zone, one for the West Indies, one for Alaska, one for Samoa, and one for Guam, to work with Arlington direct or through one or more of the primary stations. Other stations of medium power were planned, but these nine stations were to be the principal reliances or key stations for exchanging communication with our three Fleets and with our outlying possessions.

Work was gotten under way without delay, and within five years all of the eight remaining stations were completed and placed in operation as were also several less important stations.

These nine key stations are located at Arlington in Virginia, Darien in the Panama Canal Zone, El Cayey in Porto Rico, San Diego in California, Pearl Harbor in the Hawaiian Islands, Cordova in Alaska, Tutuila in American Samoa, Guam in the Mariana Islands, and Cavite in the Philippine Islands.

These stations, extending nearly halfway around the world, have been maintained in daily operation since their establishment and they have rendered the service originally expected and required of them, with the exception of the Arlington station, this station having been supplanted as the terminus of the high-power circuit by the more powerful station subsequently established at Annapolis, Maryland.

Thus it will be seen that within an interval of about twenty-five years after Marconi's epoch-making demonstrations when he signalled, without utilizing connecting wires, over distances of from one to eight miles, the United States Navy had in daily operation in the

services of its Fleets and the Government in general, a chain of radio stations whose signals constantly were encompassing the globe, this chain of stations being the most widely extended, most effective and reliable, and comprising the greatest number of high-power radio stations of any country in the world.

The effective working ranges of these stations throughout all periods of the day and night and all seasons of the year is from 2,000 miles for the less powerful stations to 6,000 miles for the most powerful stations, such as the Cavite station in the Philippines; and these effective ranges, together with the widely separated locations of the stations and the fact that they are operated practically continuously, results in electrical impulses corresponding to the "dots" and "dashes" of the radio code com-

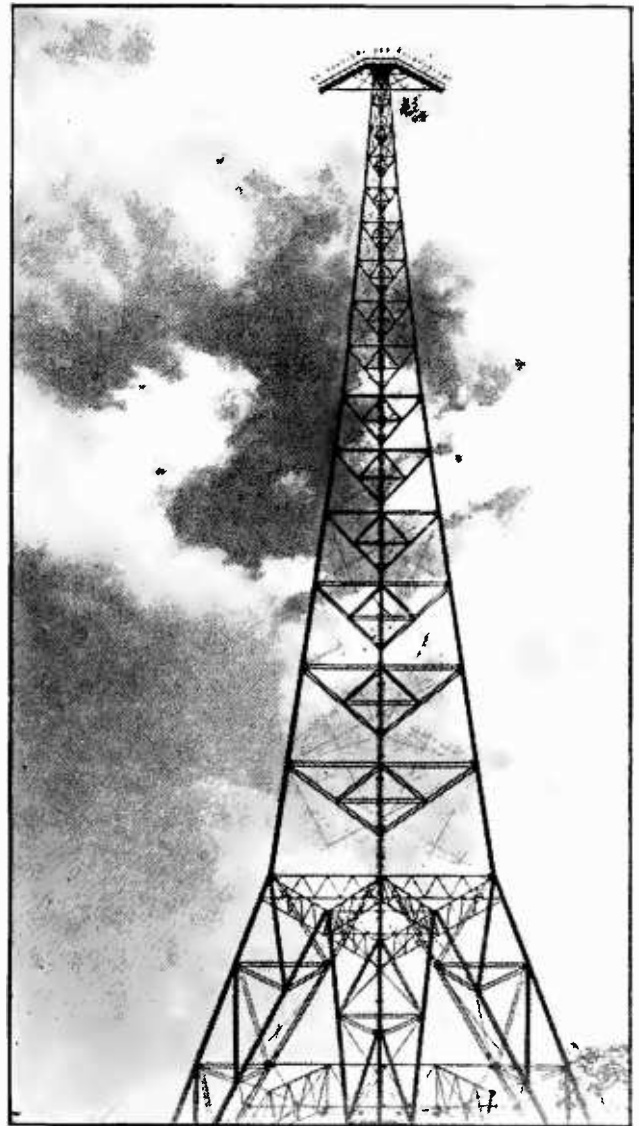

Upper section of one of the Navy's standard 600-foot self-supporting towers extending high up into the clouds. Note that the large antenna insulators are barely visible

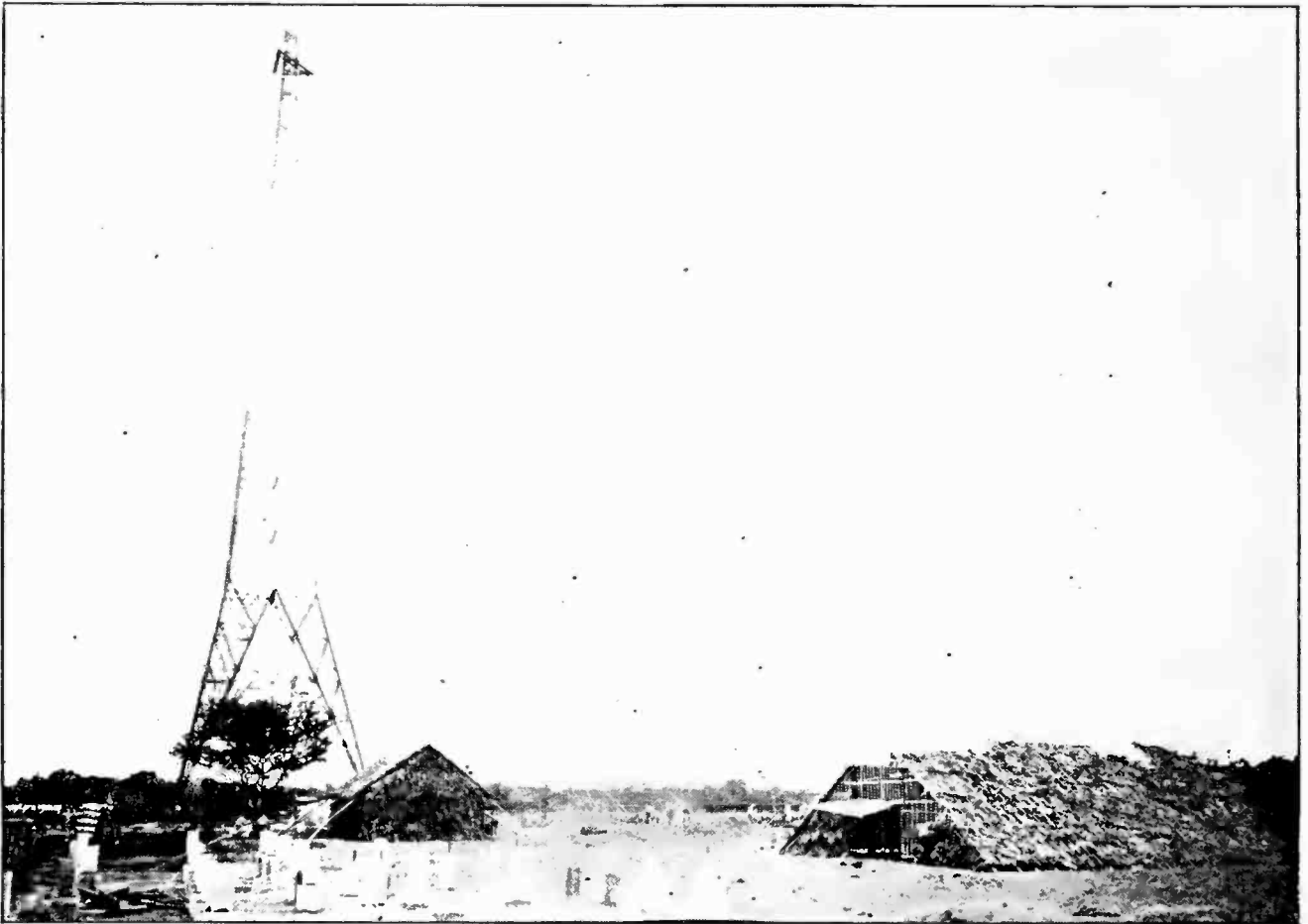

The application of science in the forward march of civilization. View of 600-foot self-supporting steel tower being erected among the native huts at Cavite, Philippine Islands

prising messages in the English language constantly spreading over the entire Earth.

Obviously the establishment and successful operation of this widely extended chain of high-power radio stations involved very great difficulties, not only from the constructional point of view but also the technical aspects of the situation.

In a pioneer undertaking of this kind when dealing with a new art whose development was then and is now rightly regarded as being only in its infancy, especially as regards the use of high power, very little authentic information was available as a guide as to what results could actually be expected in service, and the question of the most suitable type of antenna supports, antenna and ground systems, antenna insulators, types of transmitter, power supply, etc., were matters of theoretical contention based largely on personal opinions.

Time has proven that experience, and successful experience alone, is the only true guide in designing a radio system. This experience was not then available to the Navy. Nothing

is easier than to take a map, mark out radio station sites, connect them by straight lines and call the arrangement a radio system; but nothing is more fallacious in radio. The type of transmitter to be adopted was, of course, of very great importance, as was also the type, height, and location of antenna supports. Other important features could be modified, if required, after the stations were placed in service without involving excessive interruption to service; but it would be an extremely difficult and costly matter to replace transmitters or to rearrange the antenna supports.

One of the fundamentals in radio technique is that the strength of signals at a distant receiving station is dependent upon the effective height at which the overhead wires of the antenna system are suspended above the earth, and the value of the current delivered to the antenna without causing brushing or corona formation at the transmitting station.

Obviously, therefore, regardless of all other considerations, it is always desirable to suspend the transmitting antenna the greatest distance



that is possible above the earth, to insulate effectively the antenna from its supports, and to deliver the greatest possible current value from the transmitter into the antenna for communicating over long distances such as distances of 2,000 to 6,000 miles.

Three types of antenna supports were available from which a selection could be made, namely guyed wooden lattice masts, guyed steel pipe or steel lattice masts, and self-supporting steel towers.

A variety of factors must be considered in the selection of the type of antenna supports to be used, particularly at high-power stations, where the initial cost and subsequent upkeep must be given careful consideration, such as the area of the ground available for the station site and the cost required to purchase, if not already available, the availability, locally or otherwise, of suitable timber, in the case of wood masts, transportation facilities and labor costs, intensity of prevailing winds, nature of soil in connection with foundations, etc.

The Navy decided on self-supporting steel towers as antenna supports in preference to steel or guyed wood lattice masts in the interests of permanency, dependability, and comparative low cost of upkeep, notwithstanding the fact that the effective antenna height would be reduced thereby in the order of 15 per cent. as compared with guyed wood masts.

The tower height was fixed at 600 feet and to be of sufficient strength to withstand a hori-

zontal antenna pull at the top of 20,000 pounds. Three towers were decided upon for each station, the towers to be erected at the apices of a triangle 1,000 feet on a side.

Broadly speaking, there were only two classes of radio transmitters available for selection, one the damped wave system, and the other, the undamped or continuous wave system. The first question to be decided was which of the two systems should be adopted, whether the system of damped waves, or the system of undamped or continuous wave transmission, and the second question was the selection of a type of transmitter of the system decided upon.

The damped wave system as originally used by Marconi, based on the earlier experiments of Hertz, had been in general use in the radio services of Great Britain, the British Marconi Company and its various affiliated companies, including the Marconi Wireless Telegraph Company of America, for low power and medium power stations but it had not been successfully demonstrated for use in high power stations to work reliably over long distances.

In the damped or spark system of radio telegraphy the antenna is given a series of electrical impulses of considerable intensity but of very short duration at comparatively infrequent intervals, and the average power is thus a very small fraction of the maximum. If communications are to be exchanged over extremely long distances, the energy to be handled during one of these impulses becomes

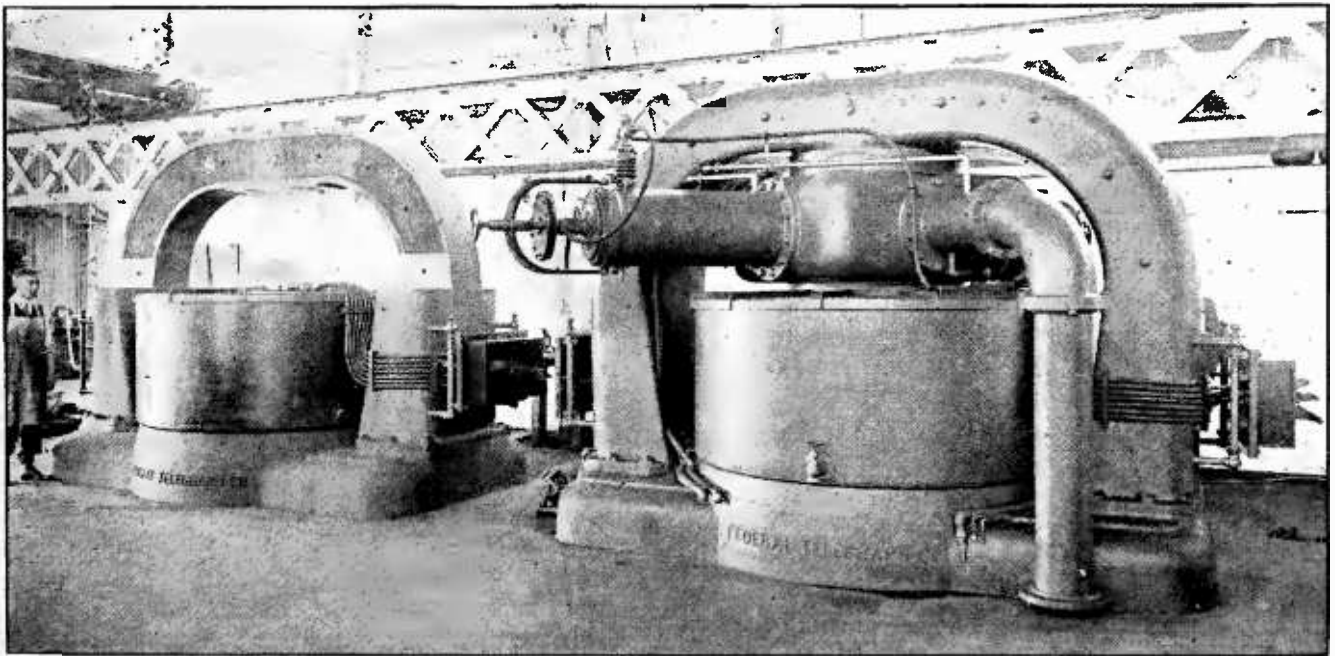

View of the Cavite and Pearl Harbor arc converters under manufacture and assembly at the Federal Telegraph Company's factory at Palo Alto, California

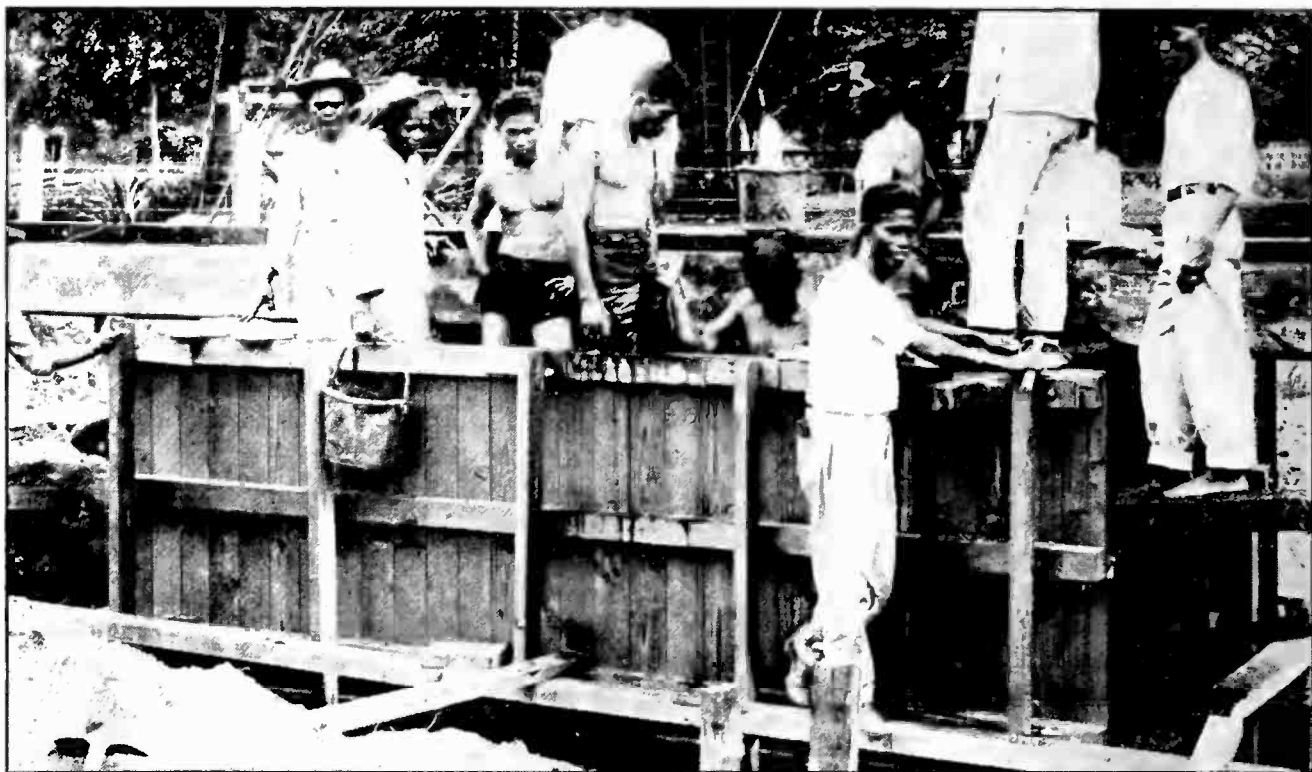

Native Filipinos working on the construction of the Navy's high power radio station at Cavite, Philippine Islands

so large as to be impracticable. Moreover, as a result of the increment and decrement of the oscillations, the effect of the method is to produce the simultaneous radiation of a wide range of wavelengths, or very "broad" waves, which seriously interfere with receiving stations which may be attempting to copy the signals of other stations. These facts were not generally recognized as early as the year 1912, but they are undisputed at this time.

About this time the Navy found itself in a most fortunate position, principally as a result of the early start it had obtained in the establishment of the high-power 100-kilowatt station at Arlington, and also two medium 25-kilowatt stations, one at Key West, Florida, and one at Colon in the Canal Zone. These stations, together with various other receiving stations, provided facilities by the use of which the relative efficiencies of transmitters of the damped and undamped systems could be tested under actual service conditions, and the results of these tests, when undertaken, proved conclusively that the undamped wave system was far superior for long-distance work.

Spark or damped wave transmitters had been installed in the Arlington, Key West, and Colon stations, a Fessenden synchronous spark set at Arlington, and similar, but smaller sets, at Key West and Colon. The various stations

were operated daily in service and the reliability and quality of the service under regular operating conditions and varying atmospheric and seasonal conditions had been determined.

Spark sets of from one half to five kilowatts power had also been installed in many other stations ashore and on shipboard, but these three stations represented what were then considered to be high-power stations.

#### THE ARC SYSTEM

**I**N ADDITION to the damped, or spark system, there became available, about this time, the undamped arc system as invented by Dr. Valdemar Poulsen and Prof. P. O. Pedersen of Copenhagen, Denmark, in 1902. This type of transmitter was just emerging from the elementary stages, and had not yet been developed for powers greater than thirty kilowatts.

An American radio company, the Federal Telegraph Company which had recently been formed, had purchased the exclusive rights in the Poulsen arc system for the United States and had also purchased two arc sets from the Danish Company, one set rated at five kilowatts and one at twelve kilowatts. The Federal Telegraph Company established a laboratory and factory at Palo Alto, California, for the purpose of developing and manufacturing arc radio transmitters, and undertook the establishment

of a few low-power stations along the Pacific Coast of the United States.

The Federal Company also established a 30-kilowatt station at San Francisco and a similar station at Heliia in the Hawaiian Islands, for trans-Pacific service. Fairly reliable service was established between the United States and Hawaii through these stations, the distance being approximately 2,500 miles.

The Navy's station at Arlington constituted at this time the most pretentious high-power radio station in the world, and while its signals could be heard over distances of 5,000 miles under the most favorable conditions, that is, at night during the winter months, the service was far from satisfactory during all periods of the day and night, and during all seasons of the year for distances of 2,000 miles.

The Arlington station, in which a 100-kilowatt damped wave set was in operation, and whose antenna was supported by one 600-foot and two 450-foot towers, made available most excellent facilities for a test of the spark or damped wave system of radio telegraphy as compared to the arc or undamped wave system.

#### COMPARISON OF SPARK AND C. W. TELEGRAPHY

**A**RRANGEMENTS were therefore made with the Federal Telegraph Company for the installation of one of their most powerful

transmitters, a 30-kilowatt set, in the Arlington station for comparative tests. In addition to the comparative audibility of the signals from the 100-kilowatt spark and 30-kilowatt arc Arlington installations at Key West and Colon and various other distant receiving stations, comparisons could also be had of the 25-kilowatt spark signals from Key West and Colon at the Arlington station.

Upon completion of the arc installation at Arlington, an antenna current of slightly more than 50 amperes was obtained, as compared to slightly more than 100 amperes obtained with the spark set. Notwithstanding this difference in antenna current in favor of the spark set, the average received signal strength of the arc set at Key West, Colon, and other distant stations exceeded that of the 100-kilowatt spark set under the varying conditions imposed during the observations.

The signals of the arc were audible at San Francisco and even at Pearl Harbor under most favorable conditions, the distance between Arlington and Pearl Harbor being approximately 5,000 miles. This demonstration clearly indicated the superiority of the undamped wave system of radio telegraphy over the damped wave system, particularly for use over long distances, and it proved to be the determining factor which influenced the Navy

Naval radio operators on duty in the receiving "hut" of the Navy's trans-Pacific high power station at Cavite, Philippine Islands

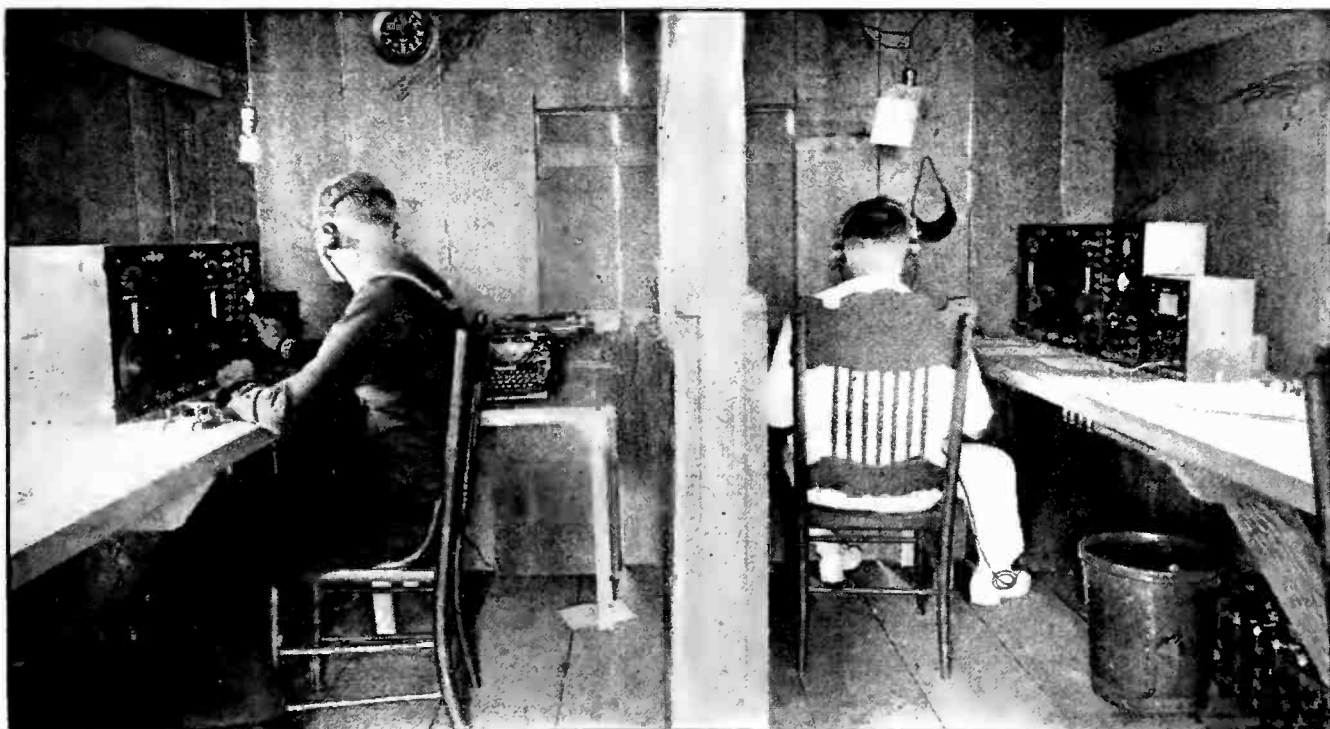

in the selection of the type of equipment to be employed in its high-power stations. As a further check and assurance as to the superiority of the arc, the cruiser *Salem* was dispatched on duty in the Atlantic Ocean, and exhaustive receiving tests were made on this vessel comparing the signal strength and quality of the Arlington spark and arc installations. The results of these receiving tests at sea confirmed, without the shadow of a doubt, the results of the previous tests made by distant stations on land. During the cruise of the *Salem*, the signals from the Arlington arc set were of readable audibility all the way to Gibraltar, whereas the signals emitted by the spark set were not at all times readable and at times were so extremely weak as to be scarcely audible, although the spark set employed more than three times the energy of the arc set.

The arc set was purchased from the Federal Telegraph Company and allowed to remain in the Arlington station. Shortly afterward a contract was awarded to that company for a 100-kilowatt arc transmitter, for installation

in the projected high-power station for the Canal Zone to be established at Darien midway between Colon and Panama City, this action being taken in spite of powerful opposition by commercial radio interests which were interested in the manufacture of the damped wave or spark transmitting equipment. The Darien set was the result of developments carried on in the United States in connection with the production of arc radio transmitters for high power, and further developments were undertaken resulting in the gradual production of 200 kilowatt sets for the San Diego station, 350 kilowatts for the Pearl Harbor station, 500 kilowatts for the Cavite station and the Annapolis station, and finally 1,000 kilowatt sets for the Lafayette station, the establishment of which the Navy undertook at Croix d' Hens near Bordeaux, France, during the war, as a precaution to insure the maintenance of uninterrupted communications with our Expeditionary Forces in the event of the cutting of the transatlantic cables by submarines.

*(To be Continued)*

1000-Kilowatt super high-power radio transmitting station erected by the U. S. Navy at Croix d'Hens, near Bordeaux, France, during the war to insure facilities for rapid communication between the U. S. Government and our Expeditionary Forces in France in the event of the expected cutting of the transatlantic cables by submarines. Eight 820-foot self-supporting steel towers as radio antenna supports, each tower weighing 550 tons or a total of 4,400 tons of fabricator steel support aloft an antenna weighing  $3\frac{1}{2}$  tons. Will this station eventually be developed into a world wide radio telephone station?

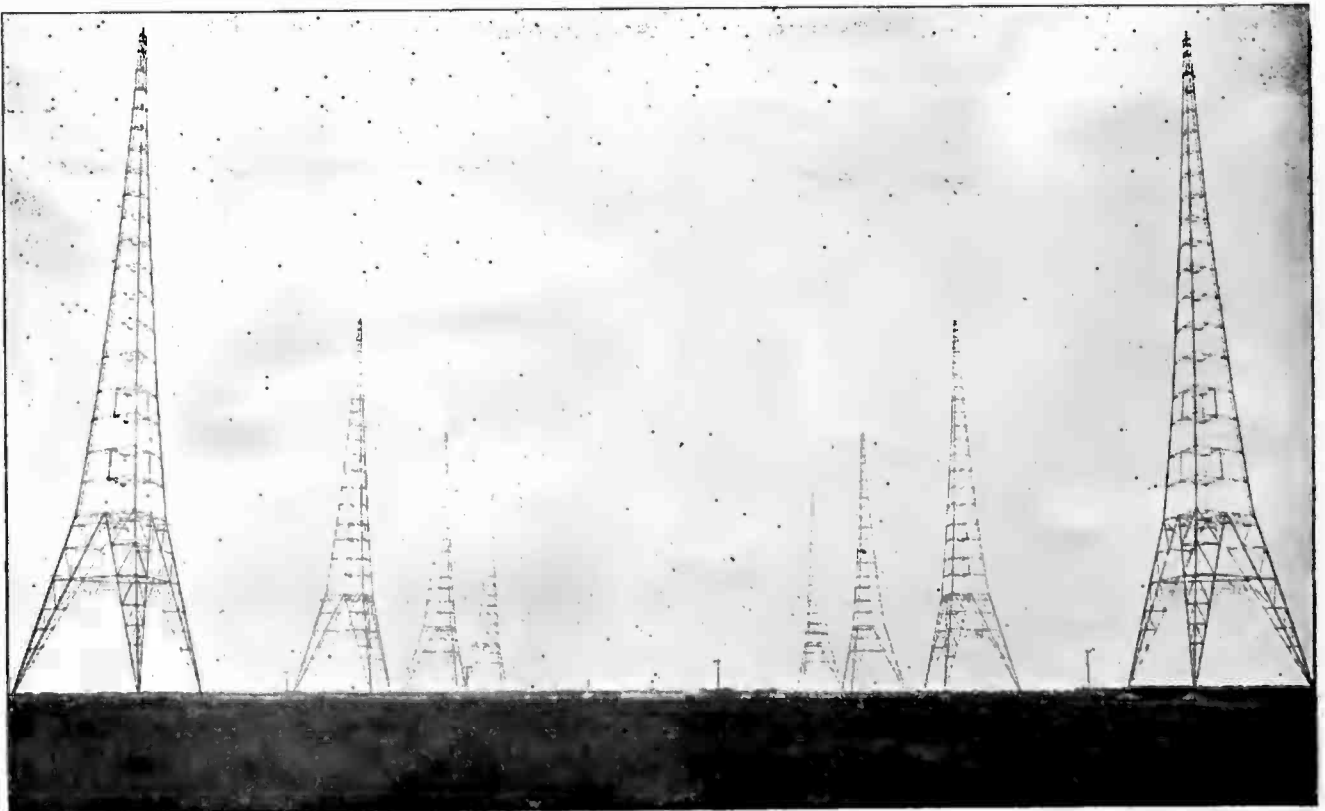

# Radio in the Forest Service

How Electric Waves are Used to Fight the Timber-Devouring Fire God

By DONALD WILHELM

**T**HE worst blow-down in the history of the Forest Service occurred on the Olympic Peninsula in Washington in the winter of 1920-21. There, in an impenetrable tangle of fallen trees, lay a huge potential pyre covering a thousand square miles, a nature-built bonfire ready for a match. Near the heart of that jungle, one day, appeared a settler with the match. Up above droned an Air Service airplane. Its observer, an "air ranger" assigned by the Forest Service, saw the settler apply the match and start to burn brush. He wirelessed down. A forest ranger five miles away got the message, relayed to him by land phone, and pounced on the settler in less than half an hour. That's one way in which radio has become useful to the Forest Service.

Without question, forest fires afford a distinctive opportunity as well as a unique problem to radio. What holocausts are to large cities; what mine disasters, summoning whole countrysides to mine entries where the instinct of every man is to rescue, are to mining communities; what war is, in fact, to whole nations, that, conflagrations are to great forests. They duplicate all the fires of war. They defy distance, once they get under way, and travel with terrific speed, roaring like the thunder of a thousand approaching guns. They strike terror to all the creatures of the forest: birds, snakes, animals, large and small, even insects, flee pell mell, before them. They seem to rise on their toes and topple forward to grab whole mountainsides and gorge themselves with huge mouthfuls of our remaining timber.

To stop such fires before they get under way—that is the only hope of the Forest Service. "To catch them quickly and catch them small," Chief Forester William B. Greeley told me, "that is the problem. The passage of time—the shortest possible lapse of time between the detection of a forest fire and reaching it—that is what tells the tale. Ordinarily the lapsed time is less than three or four hours, and then it is generally possible to get the situation under control. But it is often next to impossible to

reach the fire after it has been observed. When roads or trails have to be made, as in Idaho in 1920, for instance, when fires started one hundred miles from a railroad, you are apt to find an uncontrollable conflagration—frequently several in different spots."

## HOW FAST FOREST FIRES TRAVEL

**D**URING dry seasons fire alarms are sometimes reported in a given area every few minutes, and the speed of the fire's spread is amazing. In one instance a fire galloped up a slope eight hundred feet high and more than a mile long in twenty minutes. In one of the forests in Idaho a fire traveled twenty miles in the course of a single afternoon. Another fire, near Missoula, Montana, devoured 24,000 acres of timberland in a day, racing over a distance of fifteen miles in five hours. In a National forest in California, the Klamath, a series of lightning storms started forty-eight fires in six days, while in the Trinity Forest a single disturbance in one day started seventy fires, also causing a number of others in neighboring areas.

And when the forest fire-fighting crews reach the scene of a fire, they find none of the facilities afforded by a city fire department. There are no high pressure mains, no fire-boats, no hose, no handy assistance in the shape of second, third, and fourth alarms bringing fresh men and equipment; there is generally no water. There is smoke. There is danger. There are frequently no roads or trails, and usually no fire-fighting apparatus except shovels and saws, picks and axes, dynamite, and the human ingenuity of volunteers in fighting fire with fire—that is, by means of backfires.

This is obviously a situation where your means of communication tell the tale. Without adequate means of communication, i. e. without hope of prompt assistance, an individual confronting a great forest fire covering whole square miles could expect to do nothing except join the creatures of its animal world and flee. But, with adequate means of communication, an individual has a chance of



#### THE FOREST PATROLMAN

Often finds himself above snow-capped peaks or rugged valleys, trusting in his machine. A forced landing here would mean disaster . .

holding his ground and staying the flames by rallying everyone available to his assistance.

#### OUR STAGGERING FOREST FIRE LOSSES

THESE are, in the 156,000,000 acres of our National Forests alone, approximately 6000 fires each season; there will probably be even more in the present season because the number of man-made fires increases steadily with the number of visitors using the National Forests. In 1921, the Chief Forester says, there were, in the National Forests alone, 3,000 man-made fires—fewer than usual because of favorable climatic conditions. From 1914 to 1917 there were from 4,300 to 5,600 each year. In the last 11 years there have been 42,000. "If, now," Colonel Greeley insists, "the number of man-made fires increases hand in hand with the increasing number of campers and hunters using the National Forests, the problem of fire control is wellnigh hopeless." The stake at issue, moreover, is not only material wealth, but human lives. The populace of Oregon, for instance, is in nearly all ways dependent upon forest fire control. The lumber industry is our second largest industry. It's annual production varies from \$35,000,000 to \$40,000,000 a year, and dependent upon the industry as a whole, the head of the Lumber Division of the Department of Commerce estimates, are about 700,000 Amer-

icans. And this industry looks to our National Forests as its last reserve!

These additional facts should also be kept in mind: in a few more decades, Colonel Greeley points out, if we continue our present rate of timber and lumber consumption, we shall reach the beginning of the predictable end of our lumber supply, which, even now, must be transported enormous distances at high freight rates, over single-track railways for the most part, when needed in most sections of the United States. Forest fires are thus more than sheer waste; they constitute a huge menace to our existing stands of virgin timber, to the young growth beneath it, to watersheds feeding some of our most prolific valleys, to one of our major "key" industries, to products that are used in virtually every unit, large and small, from the chair in which we sit to the home in which we live, of building and manufacture.

Now, in grappling with the fire god in those five states—Idaho, Washington, Montana, Oregon, and California—which hold eighty per cent. of our government timber, the forest fire departments include, in a volunteer sense, every man jack for miles around. The regular fire fighters, previous to 1919, consisted principally of lookouts on peaks or plateaus, and rangers on horse, on foot, or in automobiles where roads were practicable.

In 1909 a new factor came into play—the airplane, the lookout above the mountain. This new factor caught the popular fancy. In the two years following its advent the people of Washington and Oregon alone subscribed \$75,000 of their own funds, and in many cases much of their own volunteer labor, to provide adequate flying fields. Cities, counties, states, the Forest Service, and the U. S. Army Service did the rest. The Air Service established airplane routes over thousands of miles of mountains and valleys which the Forest Service observers could now read for signs of fire as one reads an open book.

In 1919, and in 1920 too, the airplanes did really wonderful work, not only in establishing a highly creditable record in reporting fires, for the most part without the use of radio, but also in reconnaissance and other work such as the incident related at the outset of this article.

#### AND NOW THE RADIO NET

**T**HE tremendous value of the airplane not only in mapping areas like that of the great blow-down on the Olympic Peninsula, but also in directing the attack against widespread and treacherous fires, emphasized the value to the

Forest Service of aircraft, and, by the same token, the value of radio in order to make their observations almost instantaneously available. So in the season of 1921 an unprecedented use of radio as regular airplane equipment was expected.

It is not in point here to detail the disappointments that came with interruptions to the air patrols on account of the decrease in the size of the Army and the shortage in its supply of oil and gasoline—a shortage that public and private contributions, along with an unexpected expenditure by the Forest Service of \$7,500, rather tardily but for the most part remedied. The point is that, during that year, radio was for the first time used in a large way to supplement the system of land wires developed by the Forest Service.

Recognizing the fact that radio communication is the most important factor in the success of airplane Forest Patrol, the Radio Department of the Air Service interviewed the Forest Service relative to the employment of qualified licensed amateur radio operators to be stationed at the latter's headquarters in each National Forest. This plan provided for continuous contact with the airplanes, and also for



A FOREST FIRE

Filmed from the air by the Oregon Patrol

communication by radio between headquarters to supplement the land lines—one-party lines, in most cases, which often took from two to three hours to get a message through to the forester interested.

Then, preparatory to making this plan most effective, the Air Service established at Mather Field in California a radio school for sixty men, along with a liaison officers' school to

but the range obtained on the forest patrols in 1921 averaged one hundred miles, and in several instances two hundred miles. This is remarkable, and is due principally to the location of the receiving antenna, receiving apparatus, ability of the operators, and the altitude at which the patrol was flying."

This type of sending apparatus made it possible for the ground stations to keep in

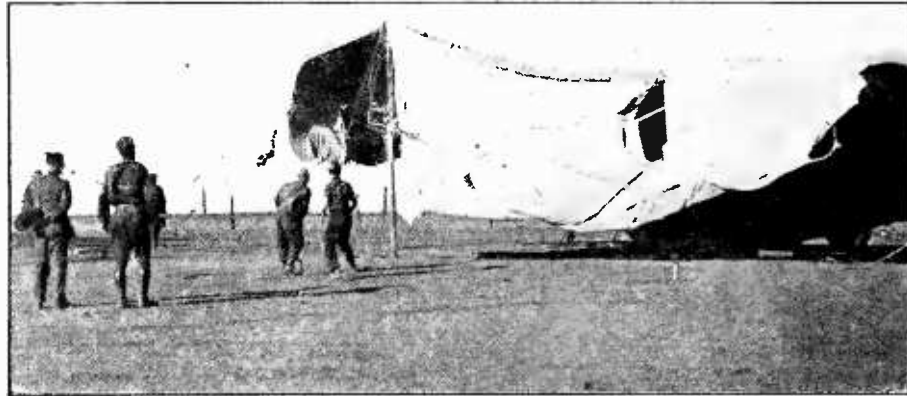

A TENT HANGAR IN A WIND STORM .  
Which causes a temporary activity rivalled only by fire

quality officers to use the radiophone and telegraph from airplanes in directing fire fighting on the ground. Next, ample supplies were requisitioned and tested. Then the radio net, including the four airplane bases and fifteen other stations, was set up. Finally, in the opinion of both the Air Service and the Forest Service, it worked!

#### TYPE OF EQUIPMENT USED

THE regular Signal Corps set, type S C R-73, was used exclusively for radio telegraph transmission from the airplanes of both the Ninth and Ninety-first squadrons, employed in this work. The Ninety-first Squadron, patrolling the Oregon and Washington forests, equipped its airplanes with two complete sets and two antennas, one to be held in reserve. The Ninth Squadron, on the other hand, equipped its airplanes with only one antenna but two keys, one in each cockpit, so that either the pilot or observer could telegraph.

The Air Service officer in charge reported about this set that, "if properly installed and taken care of, this equipment is an efficient and reliable airplane damped-wave transmitter. The S C R-73 set was originally intended to have a range of approximately forty miles,

touch with the airplanes and even to maintain a considerable "overlap" while the planes were in transit between main station and sub-bases. The period allotted each observer to transmit his messages was so arranged that no two airplanes within the same range of reception of either radio station transmitted at the same time. As a result of this arrangement both stations could copy the airplane's messages. Each main and sub-base operates on a different wave length.

#### AIRPLANE SETS CAN TRANSMIT FROM GROUND

ANOTHER interesting fact about this transmitting set is that the patrol airplanes are equipped with the F-5 fairleads of the Air Service Radio Department, which are the insulating tubes passing through the fuselage of the airplanes for the antennas to be passed through, and they could transmit, when on the ground, by using the high-power tap of the set, signals that were audible at their home stations. This ability to transmit while on the ground was particularly useful when these airplanes were required to fly long patrols, or landed at outlying gas supply stations, none of which were equipped with transmitting sets.





THE FIELD AT COLLEGE PARK, WASHINGTON

## THE RADIO TELEPHONE TRIED ALOFT

THE S C R-68 and-68A airplane telephone transmitting sets were installed on two airplanes at each of the main and sub-bases to be used for direct communication from the airplane to the ground and vice versa in combatting large fires. The plan was to have the airplane fly directly over the fire areas carrying a Forestry Liaison Officer to direct the fire fighters. However, the loud speaker used with the receiving set on the ground for this purpose during large fires proved of no value in some instances because the noise of falling timber, wind, etc., drowned it out, although communication by this means from the airplanes to the lookouts proved fairly successful. Accordingly,

the Air Service Radio Department immediately started experimenting at Crissey Field, San Francisco, with the power amplifier to adapt that instrument successfully to all emergency use.

The receiving sets used were also of standard Signal Corps design, with crystal detector sets as part of the equipment of all the amateur radio stations for use in the reception of signals from airplanes on patrol over immediate areas, and as a practical measure, since almost all of the amateur stations were a long way from the battery charging stations. Amplifiers formed part of all the main, sub-base and amateur stations, and battery charging apparatus was installed at all the main and sub-base stations for keeping airplane, radio and automobile batteries in good condition.



TAKING IT EASY AT BEAR MOUNTAIN CAMP

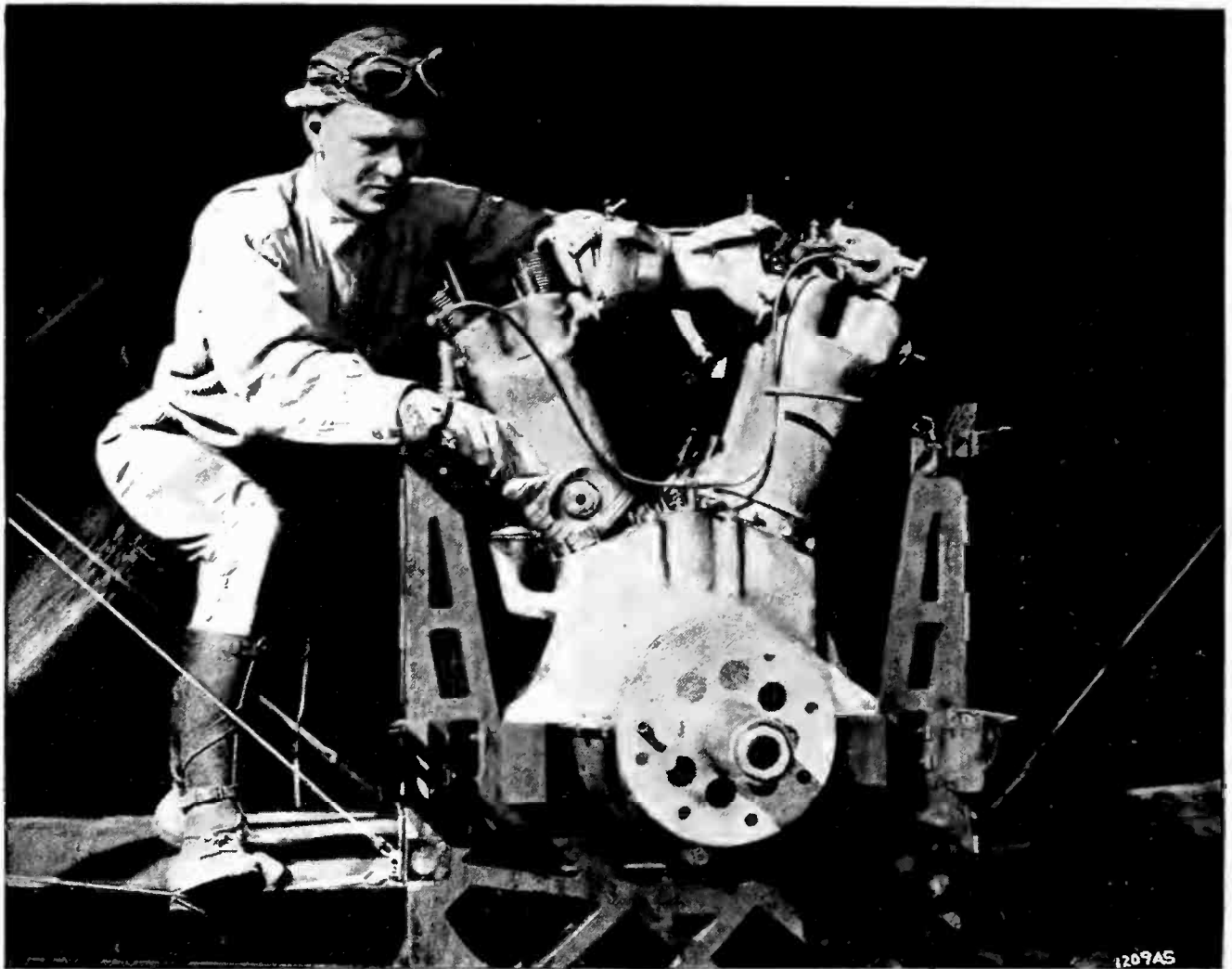

#### THIS FOREST PATROLMAN'S PISTON GAVE WAY

While in the air near Eugene. Broken crank shafts or other mechanical ills necessitating a forced landing on the side of a rocky mountain are part of the airman's daily life

The antenna installed at the main and sub-bases that were equipped with two-way (ground) radio communication consisted of the "T-type," the directional effect being used to favor the routes of the airplane patrol. The masts used were eighty-foot trees, felled, hewed, and transported from the forests by the Air Service personnel. The umbrella type of antenna was used at the sub-bases that had no transmitting sets, with the legs of the umbrella spaced so as to provide the directional effect desired on the patrol routes.

#### MODERN APPARATUS

FOR inter-field work the patrol net was equipped with three 1-kilowatt De Forest transmitting sets located at Mather Field and Corning, in California, and Eugene, Oregon,

as well as with two radio tractors, at Camp Lewis and March Field, in California; and an S C R-67A set improvised to use continuous wave telegraphy on occasions when it was not possible, because of interference, to use the voice, at Crissey Field, San Francisco. In addition, the two-control, free net system was used from Eugene, Oregon, and Mather Field—the control stations for Washington and Oregon on the one hand and for California on the other. The two-control stations had three closed periods each day to conduct their administrative business and transmit reports, weather news, etc. These periods were from 7 to 8 A. M., from 12 noon to 1 P. M., and from 6 to 8 P. M. At other times than these the net was free for each control station to use as its operator desired.

The Air Service officers in charge also pointed out in their recommendations the advantage of equipping all airplanes with continuous wave transmitting sets, and recommended the use of three powerful S C R-108 sets, the use of two 80-foot steel towers, and, besides these the employment of radio direction finding apparatus. "This system," their recommendations pointed out, "would greatly increase efficiency in locating fires, enabling the airplane to send the fire signal when directly over the fire, and the ground station or receiving station to determine the exact location of the conflagration, thus doing away with the necessity for an observer on forest patrol."

With such recommendations as these carried out, and with the steady increase in amateur stations, radio, one can readily see, has a promise—when Congress shall have forgotten its present passion for saving pennies while throwing caution, in some directions, to the winds—of serving, as no other means of communication can, in battling conclusively with the fire menace. The Forest Patrol net has proved its worth. The Forest Service has it down in black and white that, "radio was tried out last year on an extensive scale, and was a decided success."

There remains now only to point out that, thanks in part, of course, to the careful

personal selection of amateur operators by the Air Service Radio Officer who made the recommendations to the Forest Service, the radio amateur phase of the project was a success. Indeed, at the close of the 1921 season, no thought of giving up amateur service was even entertained.

Not much more needs to be added to the Forest Patrol radio net. It is pointed out that, in general, it can be used or readily developed to supplement the existing wire facilities and to consolidate the entire area of the National Forests in a communication scheme that will link together every lookout on the mountain and every airplane above the mountain with the main bases and sub-bases whence the rangers go forth on foot, on horseback, or in automobiles.

Yet, at the time this is written (late in June), this opportunity, this challenge to the fire god, seems destined for the present to go by default, unless you and I and all the rest of us who help to make up public opinion raise our voices in remonstrance, because the Forest Service cannot carry on the Air Patrol and hasn't radio equipment; because the War Department argues that it cannot afford the enterprise this year; because Congress told the War Department, "We're saving money this session."

## Charging the "B" Storage Battery

By G. Y. ALLEN

In this article the author has covered in a most comprehensive manner various types of storage "B" batteries and methods for charging them from both alternating and direct current sources. Although this article deals primarily with "B" batteries, the principles involved are identical with those where the "A" battery is cared for with the exception that lower voltages are dealt with in the latter instance. A thorough study of this article should enable our readers to secure better results from their receiving apparatus.—THE EDITORS.

**C**OINCIDENT with the advent of the vacuum tube there appeared the necessity of a source of high voltage direct current to supply the plate circuit of the tube. Before the days of high amplification, small flash-light dry cells connected in series in sufficient number to give the proper voltages were used

with success. With the coming of high amplification, however, and particularly with the invention of the regenerative circuit, the old type of dry cell was found to create considerable noise. Dry Battery Companies have improved their product, but there seems to be an inherent variation in voltage in any dry cell, due to the internal chemical action that has defied the

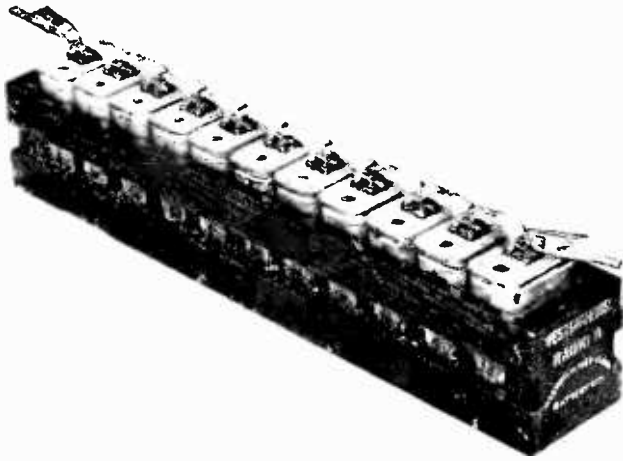

FIG. 1  
A storage "B" battery of 11 cells

attempts of inventors to remove, and even the best dry batteries are guilty of producing many of the frying noises that are heard in most amplifying radio sets.

When radio traffic was limited to telegraph signals, no great objections were raised by the operating personnel to these battery noises. In fact they were considered a good omen as they indicated that the receiver was "alive." The telegraph signals could easily be read through the "hissing" sound and manufacturers concentrated in improving the quality of their batteries. It is true that during the war substitutes were sought for the plate dry battery or "B" battery as it is commonly known, but this was not done as a remedy for the noise created by the battery but due to the perishable factor in any dry battery and to the consequent difficulty of shipping batteries from this country and having them arrive in France in a usable condition.

Among other things, radio broadcasting has brought with it a demand for quality of reception. Music that may be perfectly pleasing to the experimenting amateur may be extremely irritating to the ear of the trained musician. The people who are now interested in radio are demanding perfect undistorted music from their radio receivers. It is with the thought of eliminating the inherent noise of dry batteries that storage battery manufacturers have developed a storage battery of size and capacity suitable for supplying the high voltage direct current needed by all vacuum tubes now on the market.

The action of the storage battery gives a very uniform discharge and it is practically free from any noise-creating action. Until

recently the design of a storage battery in small units has been impracticable. Within recent months, however, several reputable battery manufacturers have placed on the market batteries ideally designed for any radio receiver.

As the current consumed by the plate of the average radio receiving tube is but a few thousandths of an ampere, and as the plate area of a storage battery is proportional to the current it must supply, the plate area of a battery needed for the plate supply of vacuum tubes is very small. The height and width of the batteries now on the market varies from two to six inches.

Regardless of the size, each storage cell furnishes about two volts. The average vacuum tube is designed to employ from 20 to 100 volts in the plate circuit. Batteries are therefore made up in most cases of 11 or 12 cells arranged in some form of tray and delivering an average of about 20 to 25 volts. By connecting batteries in series, any voltage may be obtained.

Typical storage batteries are shown in Figs. 1, 2, 3 and 4. Figs. 1 and 2 show batteries of conventional design using heavy glass jars, lead plates, and dilute sulphuric acid electrolyte. Fig. 3 shows a somewhat radical departure from usual design in that there are in reality no jars for containing the acid, but it is held within moulded material pressed into intimate contact with lead discs which also hold the active elements of the battery.

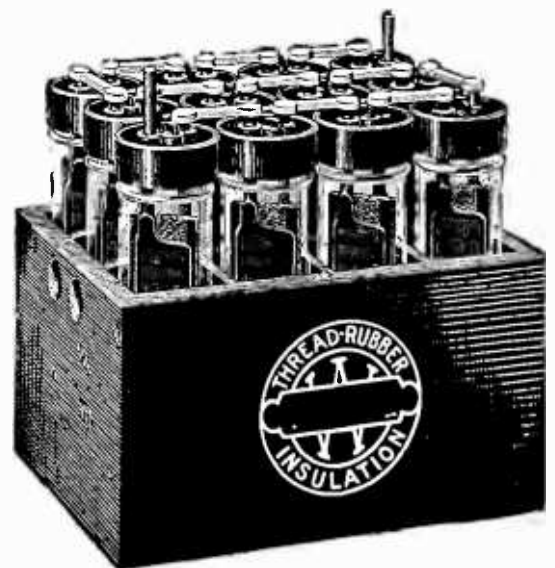

FIG. 2  
A lead type storage "B" battery

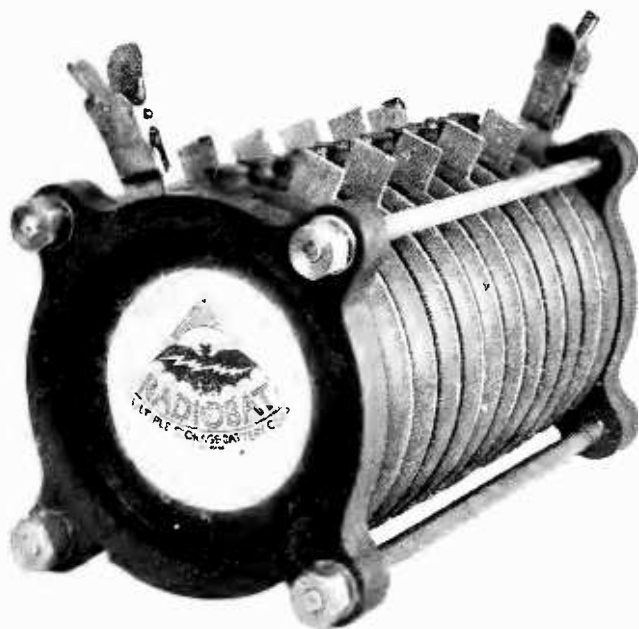

FIG. 3  
A Storage "B" Battery of 11  
cells utilizing gelatinous electrolyte

The one objection to any storage battery is that it must be kept charged. This means it must be connected to a source of direct current every two to four weeks and the energy consumed by the radio set must be replenished. Furthermore, even if the radio set has been idle for a considerable period, the battery must still receive its periodic charge to keep it in proper condition.

#### CHARGING FROM DIRECT CURRENT SOURCE

FOR those fortunate enough to live where they are supplied with direct lighting current, the matter of charging is extremely simple. It resolves itself into merely connecting the battery to the lighting system. Care should be used to see that the positive side of the electric power line is connected to the positive side of the battery or the battery will be further discharged and ruined instead of receiving a replenishing charge.

As the average direct current lighting current is 120 or 230 volts, and as the voltage of the plate batteries that the average radio set requires will total around 45 to 60 volts, the battery should not be connected directly to the line, but a voltage-reducing resistance should be interposed. This may consist of a 25- to 40- watt lamp of the voltage rating used for lighting, or a charging resistance may be used such as is shown in Fig. 5. If the electric bulb is used, the proper polarity may be

ascertained by noting the brilliance with which the lamp burns. The circuit should be connected momentarily first in one direction and then in the other. *It should be left in the direction which produces the dimmer light condition.*

When using the charging resistance shown in Fig. 5, the proper direction of the current may be noted by watching a milliammeter connected in the circuit. The ammeter is also helpful in showing how rapidly the battery is charging. The manufacturer always specifies the most desirable rate at which to charge the battery. Higher rates are detrimental and lower rates take more time than necessary.

Figs. 6 and 7 illustrate the proper connections for charging the plate battery from a direct current supply.

#### CHARGING FROM ALTERNATING CURRENT SOURCE

THE homes of the majority of buyers of radio receivers are supplied with alternating electric lighting current. The reason for this is that alternating current can most economically be sent over great distances and it is just as good for lighting as is direct current. It is, however, totally unsuited for charging storage batteries.

A better understanding of why this is will be gained from Fig. 8. The curve conventionally illustrates an alternating current. The horizontal line indicates equal time units and the vertical line indicates the instantaneous voltage. When the curve is above the horizontal line, the current is assumed to be going in what we will call the positive direction, and when it is below the line the current will flow in the opposite or negative direction. It will



FIG. 4  
A 20-volt, 3-ampere-hour storage battery of the unspillable type. Each cell is made up in a transparent compartment

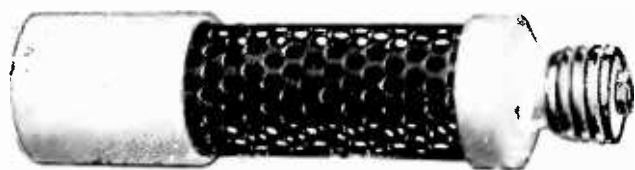

FIG. 5  
Charging Resistance

be seen from this curve that one half of the time the alternating current flows in one direction therefore, and during the other half of the time it flows in the reverse direction. Furthermore, these reversals of flow occur at the rate of from 50 to 120 per second.

Now a storage battery must receive a current in one direction only if it is to be recharged. If a storage battery should be connected to an alternating current line directly, it would perhaps receive a slight charge during, we will say, the positive half of the current, but it would receive an equal discharge during the reversal of the current. The result would be that the battery would probably slowly discharge instead of charge.

To charge a storage battery successfully from an alternating current line, therefore, something must be interposed between the line and the

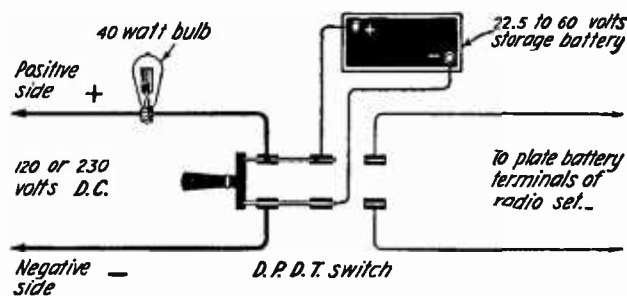

FIG. 6  
Charging from a direct current supply

battery to insure the battery receiving current in one direction only.

This device may take the form of a kind of check valve that permits current to flow in one direction only or it may take the form of a motor generator, the motor being suitable for operation from the alternating current supply and the generator delivering a current suitable for charging the battery. In general, the former method is to be preferred as the apparatus costs less and is usually somewhat more efficient.

There are three standard principles on which these valves or rectifiers, as they are generally

called, are built. These are known as the chemical rectifier, the gas rectifier, and the mechanical vibrating rectifier.

#### CHEMICAL RECTIFIERS

THE chemical rectifier depends for its action on the fact that a current will flow in one direction only between a piece of metallic aluminum and certain kinds of electrolyte in which it may be immersed. If an aluminum rod is therefore immersed in a solution of ammonium phosphate, and if another electrode of some metal such as lead is also immersed in the solution, current will flow from the lead to

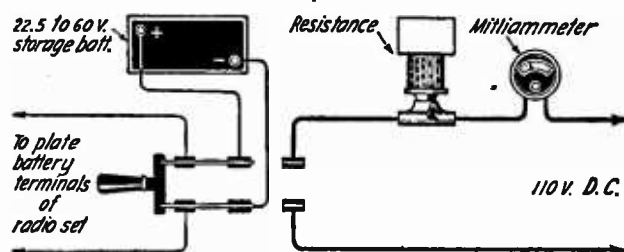

FIG. 7

The voltage varies with the time as shown here

the aluminum rod, but will be prevented from passing in the opposite direction. The reason for this is that on attempting to pass current from the aluminum rod to the lead, a large number of minute bubbles of gas are immediately generated around the aluminum, effectively insulating it from the solution and thus preventing current flow. In this analysis, the current is assumed to flow from the positive side of a battery toward the negative side. Most recent scientific investigations indicate that the current actually "flows" in the opposite direction, but the actual direction of current flow is unimportant as long as it is remembered that the chemical rectifier allows current to pass through in one direction only.

Fig. 9 shows a chemical rectifier now on the market, and Fig. 10 shows the most simple method of connecting it so that it will charge a "B" battery.

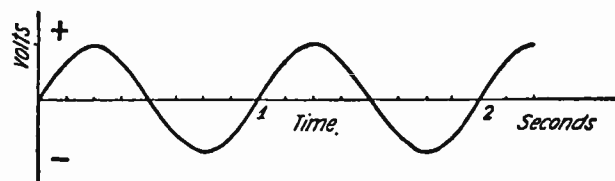

FIG. 8



FIG. 9

Electrolytic rectifier suitable for charging 20 to 60 volt B battery from alternating current

Fig. 11 shows the kind of current the battery receives. It will be noted that this current takes the form of a series of periodic impulses, all of which, however, are in the same direction. The battery is being charged but half of the time it is connected to the line, but this does not indicate necessarily a low efficiency as there is no current flowing during the other half of the time and so no power is consumed.

If it is desired to charge the battery in a shorter time without damage, four rectifiers may be used as shown in Fig. 12. The battery will now receive a charge continuously.

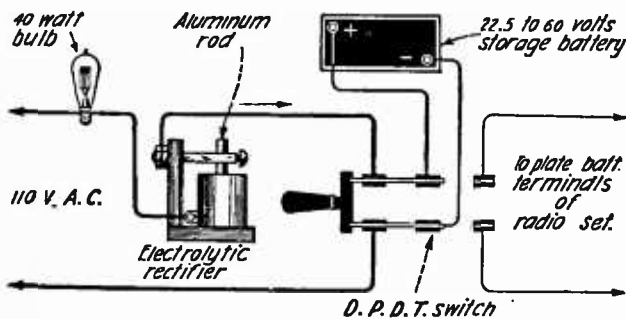

FIG. 10

An electrolytic rectifier and ordinary lamp in series combined with a D.P.D.T. switch is a good arrangement

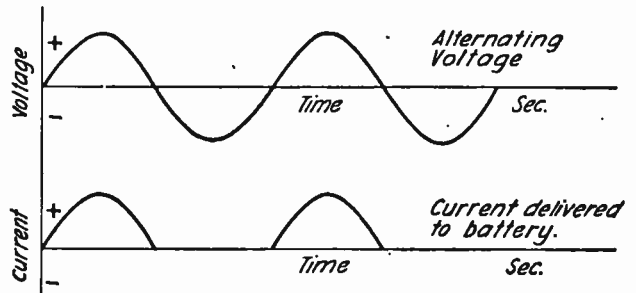

FIG. 11

Where a single rectifier is used the resultant current flows into the battery in the manner depicted in the lower graph

THE GAS-TYPE RECTIFIER

THE second type of rectifier, namely, the gas type, depends for its action upon the phenomenon of current passing in one way only through a tube filled with an inert gas when one of the terminals is comparatively cold and the other is composed of proper material and is heated.

A cross section of such a tube is shown in Fig.

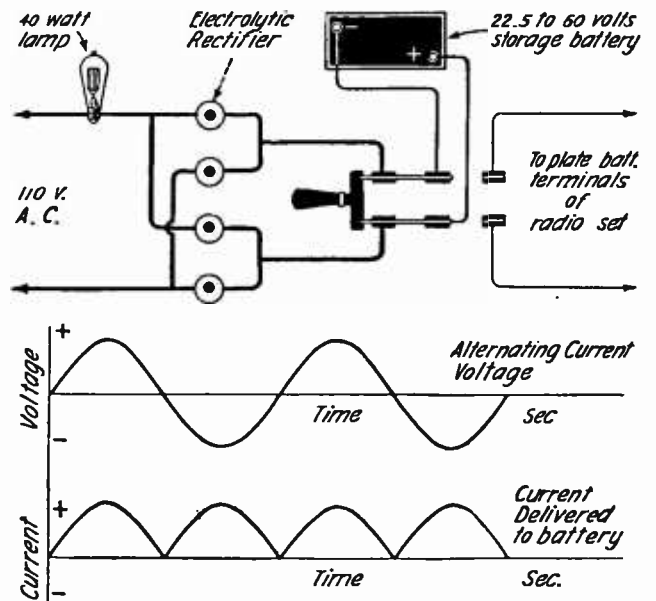

FIG. 12

The method of connecting electrolytic rectifiers and a lamp in circuit. The curves illustrate the resultant currents. The switching arrangement makes it easy to throw the batteries either "on charge," or into operation

13, and its action, briefly stated, is as follows:

The filament is heated to incandescence by some independent source of current. The filament, being of tungsten, gives off little particles known as electrons. These electrons are really negative charges of electricity, and if a positive charge is placed on the anode, they

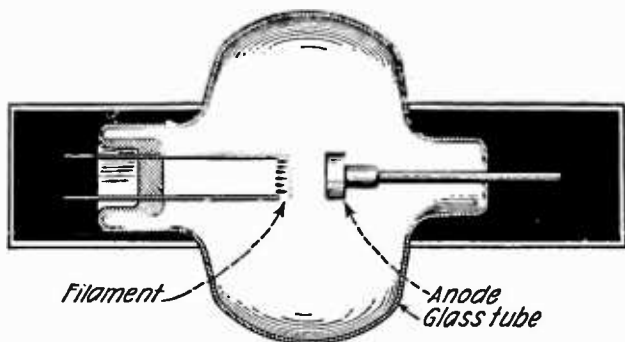

FIG. 13  
Gas tube rectifier

are attracted in this direction. They attain such a speed that, in passing through the gas with which the tube is filled, they collide with its molecules, actually breaking them apart and setting free additional electrons. The final result is the existence of a large number of electrons, all of which will be attracted to the anode of the tube. Now these electrons really are electricity in motion and they thus serve to carry current across the space in the tube. As the conventional way of assuming the current flow is from the positive to the negative side of a battery, and as these electrons travel

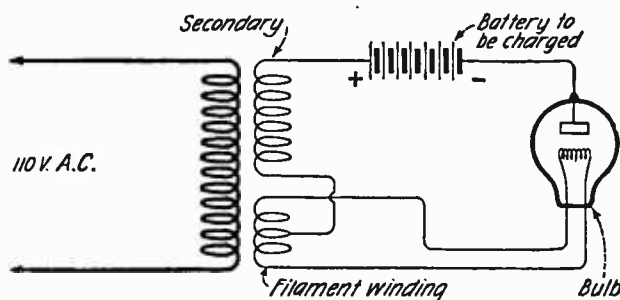

FIG. 14  
A schematic diagram of a gas-filled charger

from the negative to the positive electrode of the tube, it is customary to say that the current flows in opposite direction to that of the electron flow.

If an attempt should be made to reverse the current flow by making the cold electrode negative and the filament positive, none of the negative electrons can leave the filament because they are highly attracted to the filament by virtue of the positive charge and are furthermore repelled by the cold electrode on account of its negative charge.

It at once becomes apparent, therefore, that current will pass in one direction only through a tube of this form, and it becomes worthy of

consideration in charging a storage battery from alternating current.

The schematic connections of a rectifier using a gas tube is shown in Fig. 14. As the voltage of the supply is generally considerably above even the voltage of the plate battery, a transformer is used to reduce the voltage economically. Two secondary windings are placed on the transformer, one carrying the actual battery charging current, and one simply for heating the filament.

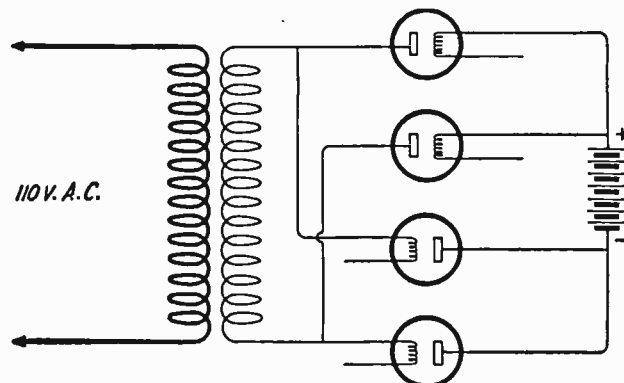

FIG. 15  
Using both sides of the A.C. is made possible with this arrangement

With the connections shown, the filament will burn to incandescence as soon as the current is turned on. Now, if the battery to be charged is connected as shown, it will receive a pulsating charge every time the secondary alternating current is in a direction in which the tube will allow it to pass. On the reversal, the tube will not allow passage of current. The graph of the charging current will be practically identical with that shown in Fig. 11.

Rectifier tubes can also be arranged for charging from both halves of the cycle as shown in Fig. 15. The filament heating connections

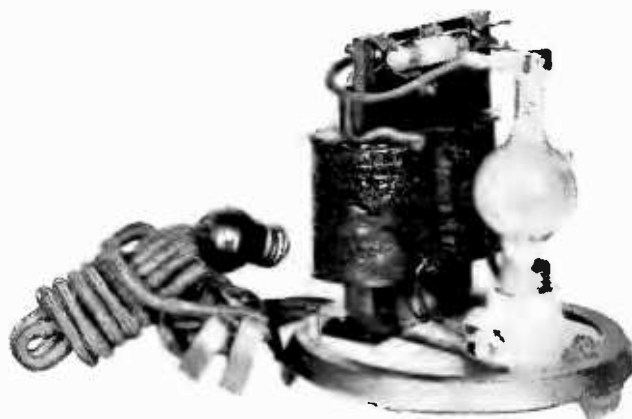

FIG. 16  
Gas tube rectifier with cover removed



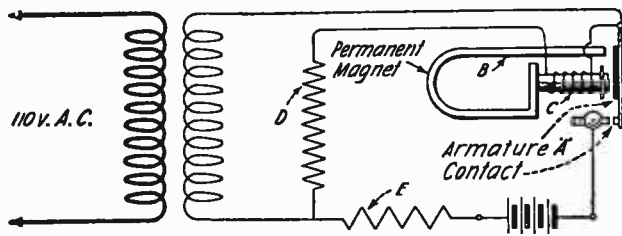

FIG. 17  
Another form of vibrating charger

are not here shown, but they would be similar to Fig. 14.

One form of gas rectifier on the market is shown in Fig. 16. On examining the illustration carefully, it will be noted that there are two possible positions for the fuse. By placing it in one set of clips, the voltage is suitable for charging 6-volt filament battery, whereas the alternate position supplies a voltage suitable for the "B" battery.

MECHANICAL RECTIFIERS

THE vibrating rectifier differs from the above two types by depending on mechanical means for its action. It is simply an automatic scheme for mechanically connecting the battery to the line at each cycle when the current is flowing in the proper direction and disconnecting it when the current reverses.

A typical rectifier of this type is diagrammatically shown in Fig. 17.

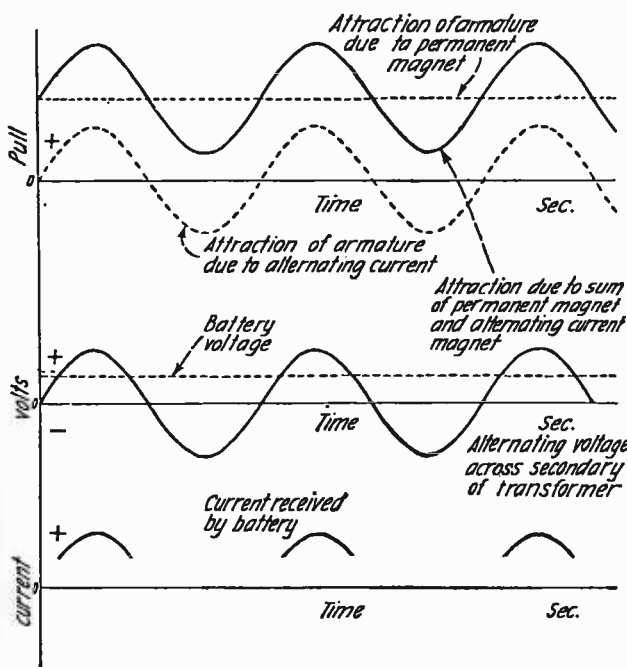

FIG. 18  
This is what happens when the charger shown in Fig. 17 is in action

As in the case of the gas rectifier, it is customary to step the alternating current voltage down to a value suitable for the battery by use of a transformer.

In the diagram, "A" is an armature supported at one end and free to vibrate. Its mechanical natural period is adjusted to that of the alternating current on which the rectifier is to be used. "B" is a permanent magnet with one pole placed near to the vibrator. The other pole is in the form of a spool on which is wound a coil. Contacts are mounted on the vibrator which make contact with the stationary part as the vibrator operates. "D" and "E" are resistances to limit the flow of current.

As the vibrating magnet is wound on the

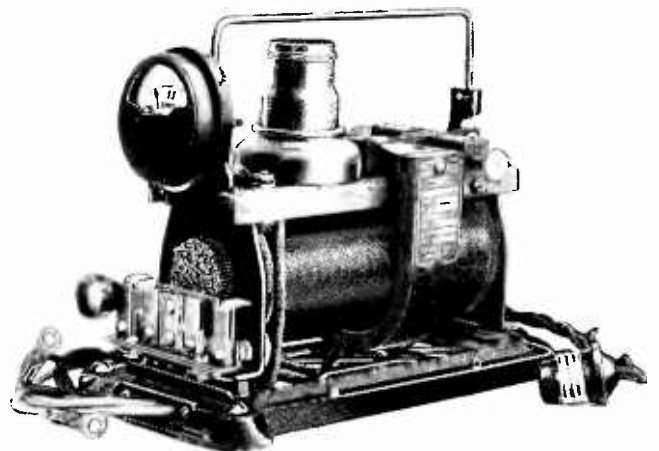

FIG. 19  
A vibrating rectifier with switch for charging at different rates

pole of a permanent magnet, the attraction for the armature will decrease when current through the coil is in one direction and will increase when it is in the other. If the armature is mechanically tuned to the frequency of the current, and if it is provided with proper resisting springs, it will vibrate in synchronism with the alternating current.

If contacts are placed as shown, they will close when the current is in one direction and open when the current reverses. If the battery is placed in the circuit as shown, the vibrator may be adjusted to give the battery a charge in one direction only.

A better understanding of just what occurs can be gained by referring to Fig. 18. The first graph shows two curves, one indicating the constant attraction of the permanent magnet and one showing the variable attraction due to the alternating current. These attractions



FIG. 20  
Another charger made on the vibrating principle

add to each other, giving the effect shown by the heavy line. It will be seen that the attraction for the armature increases and decreases once during each cycle. This will tend to make the armature vibrate back and forth once per cycle, which will close the contacts at the same rate. Using proper polarities, therefore, the battery will be connected to the secondary of the transformer every time the current flows in the proper direction.

There is one point of difference between this form of rectifier and the electrolytic and gas types. These two types inherently prevent the possibility of current flowing in the wrong direction and so discharging the battery. In the vibrating form of rectifier, on the other hand, this feature must be obtained by proper adjustment. This will be understood by reference to the second curve in Fig. 18. The dotted line represents the battery voltage, and the solid curve indicates the alternating voltage. If the contacts should be allowed to remain closed until the alternating voltage is less than the battery voltage, the battery would discharge, and the time of charging would be greatly increased. The third curve in Fig. 18 shows the battery charging current with proper adjustment. In this ideal case, the vibrator is assumed to make contact at the instant that the alternating voltage equals the battery

voltage and to break contact when they are again equal.

Figs. 19 and 20 illustrate typical types of vibrating rectifiers. These are both provided with ammeters so as to show the proper direction of the current.

There is one type of rectifier on the market that automatically takes care of the proper polarity and thus prevents improperly connecting the battery to the line. A schematic diagram of this charge, is shown in Fig. 21. It will be seen that there are two coils used, one being connected directly across the battery to be charged. This coil is used instead of the permanent magnet and its polarity, of course, depends upon which way the battery terminals are connected to the charger terminals. As the armature of the vibrator always closes the circuit between the line and the battery when the sum of the attractions due to the constant pull (in this case caused by the coil connected to the battery) and the alternating pull is greatest, the battery will always be charged regardless of which terminals of the charger it is connected to. With this type of rectifier, therefore, it is impossible to connect the battery improperly.

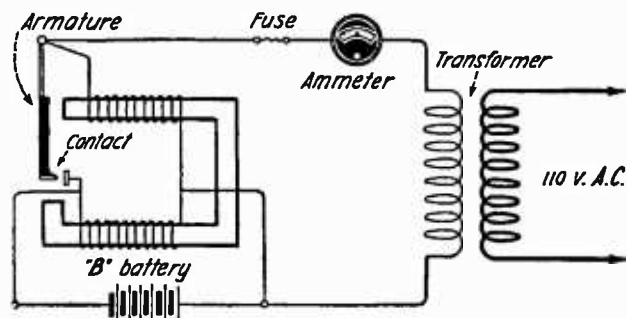

FIG. 21  
A typical circuit arrangement of the vibrating type of battery charger

The only disadvantage of this type of charger is that low battery voltages will evidently cause a small amount of attraction due to the battery magnet, and if the battery is very badly discharged, it is possible that the rectifier will not function. If the battery is kept charged, however, this trouble should not occur.

From the above, it will be readily appreciated that the advantages of a "B" storage battery can be enjoyed by all, even those located in districts served with alternating current.



# KING ELECTRON

## Tells About Radio Regeneration

By R. H. RANGER

Engineer, Radio Corporation of America.

Trade Mark "King Electron" for illustrations registration pending. R. H. Ranger

**T**HERE is a squeaking and squawking in the radio receiver. The expressive word "birdies" has been used to describe them. But it is certain that everyone has noted them, particularly one who has a tube set. They are caused by false oscillations either in the home set or in a neighbor's set. A better understanding of the actions involved may reduce this nuisance.

Regeneration does not mean getting something for nothing; it does mean making the most use out of the incoming signal to release the power of the batteries in the receiving set to give out sound. With the vacuum tubes as detectors or amplifiers, the receiving set may be considered as a trap ready to be sprung by the received signals.

*Electrons.* The little particles of negative electricity called electrons are everywhere as well as in the vacuum tubes. They are running around in any receiving set trying their best to follow the adjustments of the radio fan. In wires their paths are rather confined, but in the vacuum tubes they have considerable freedom, and as a result they can produce five or more times as much effect in a vacuum tube as they can in other ways.

*When a Radio Wave Arrives.* For this par-

ticular consideration, suppose a radio receiving aerial is set up connected through the condenser and coil of a tuning set to ground. On the reception of a radio signal, little electrons are sent scurrying down the aerial and the connected tuner to ground.

Of course, there may be many millions of these electrons concerned in any particular episode of radio action. But it may be just as well to represent the relative motions by only a few. In the drawings, consider that each electron represents a million million or so.

*In the Tuner.* Now the purpose of the tuner is to make a low resistance path for the travel of these electrons, such that with the continued waves coming from the transmitting station, they will develop quite a swinging motion, the sum total effect of which will be imposed upon the detector and telephone receivers.

If, due to the wave action, the electrons have rushed away from the top of the coil in the tuner, down toward the ground, the electrons from the vacuum tube will try to make up for the deficiency by going to the left from the grid of the vacuum tube through the grid-leak condenser to the top of the coil.

*Grid Action.* Now, one electron removed

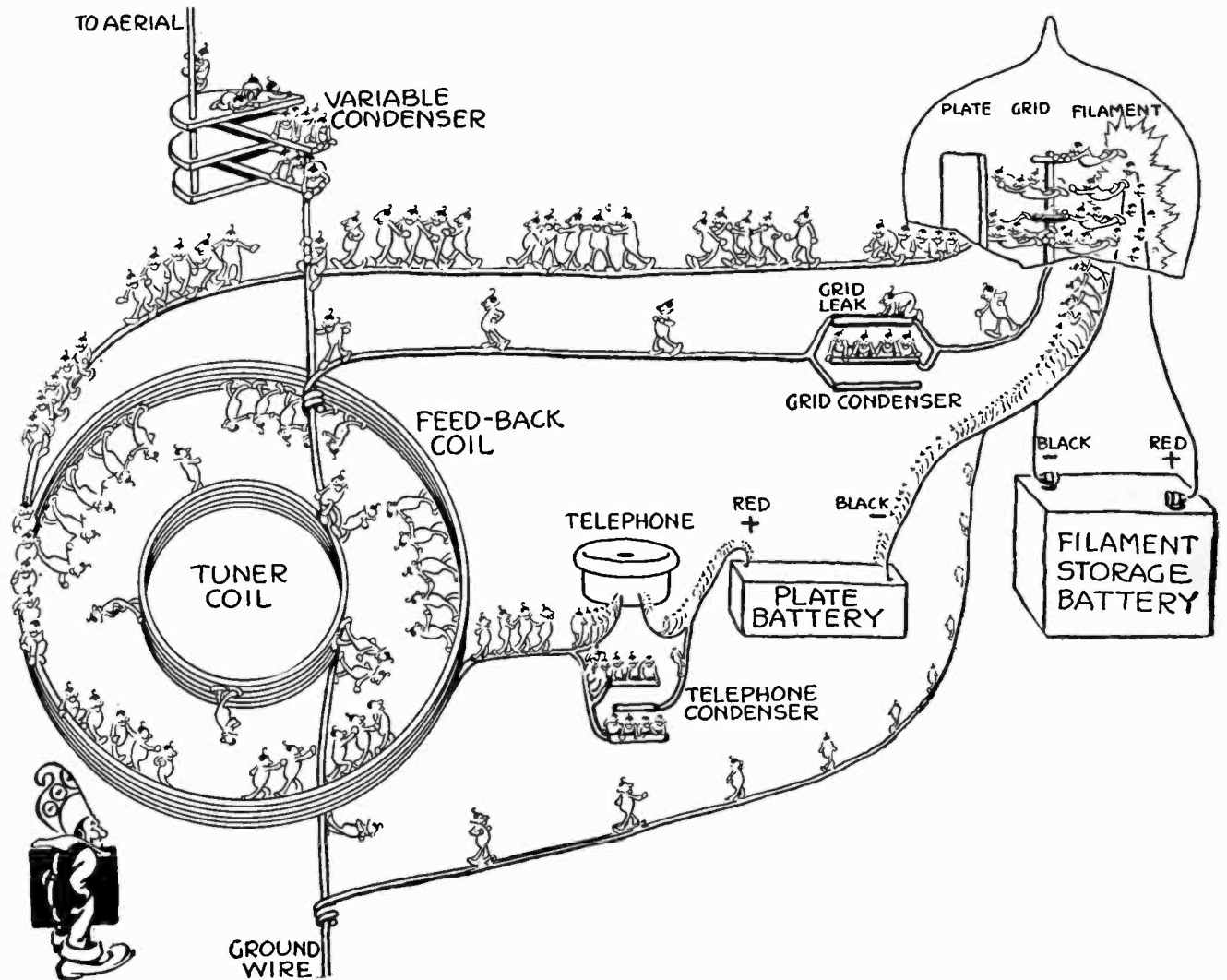

KING ELECTRON'S PICTURE OF THE RADIO RECEIVER AT REST

That is, before the radio signal puts in its appearance. The electrons in the antenna circuit, which comprises the antenna, variable condenser, tuner coil and ground are just waiting for something to happen. Because the storage battery is heating the filament of the vacuum tube, at the right, the electrons are leaving for the grid. In their flight they are attracted by the positive charge on the plate where they end their trip through space—although only about one of every six actually does land on the grid. The electrons which land on the plate continue their voyage by wire, moving through the feed-back coil and the telephone with its by-pass condenser, to the plate battery which supplies the driving force, eventually returning to the filament. The electrons which landed on the grid pass over the grid leak and its by-pass condenser to the tuner coil, through the ground lead, and back to the filament. "There are, then," says the King, "two circuits in action, waiting for their comrade, the antenna circuit, to join in the frolic"

from the grid may mean that six more will try to make up the deficiency in the tube and rush from the filament toward the grid. But only one will hit the grid and the rest will speed to the plate. This means that the plate current of the vacuum tube may be increased five times as much as the original current which caused the effect.

On the next swing of the ether wave coming from the transmitting station, the electrons will surge up in the aerial. These will become concentrated on the bottom plate of the tuning condenser. As this is directly connected to the grid of the tube, the grid will also have more than the usual number of electrons on it. This

will cut off the flow of the electrons through the vacuum tube. As before, the effect will be much greater in the plate circuit of the tube than the original current. So each swing of the grid will cause a much greater swing of the plate current. This is called amplification. As it is occurring in this case as fast as the radiowaves come through space, it is called radio frequency amplification. Although, with the regenerative connection, the vacuum tube is normally connected as a detector, to the extent just described, it is also a radio frequency amplifier.

*Feed-Back Coil.* To take advantage of this amplification, it is necessary to feed-back the amplified plate current into the grid of the

tube. This is done with the feed-back coil. The feed-back coil is connected directly in the plate circuit of the tube and is brought close to the aerial tuning coil. If a direct connection was taken from the plate circuit of the vacuum tube back to the grid circuit, the battery forces used to work the tube would get all mixed up. That is why this device of using a separate coil is used.

*Transformer Action.* Now, if the current in the feed-back changes, a new situation develops. Whenever electrons speed up or slow down, they react back on any other electrons that happen to be around. In other words, if for some reason electrons decide to rush

along a wire, the electrons in a separate wire near them will try to make up for this activity by running in just the opposite direction. They are just like a lot of people that always want to force themselves against any change, forward as well as backward. This is just the situation between the tuner coil electrons and the feed-back coil electrons. But the feed-back electrons have the best of it as there are more of them, and they have a greater driving force behind them. So when they start to rush around the feed-back coil, the electrons in the tuner coil rush the other way. This is the basis of the "transformer" action used in all electrical work.

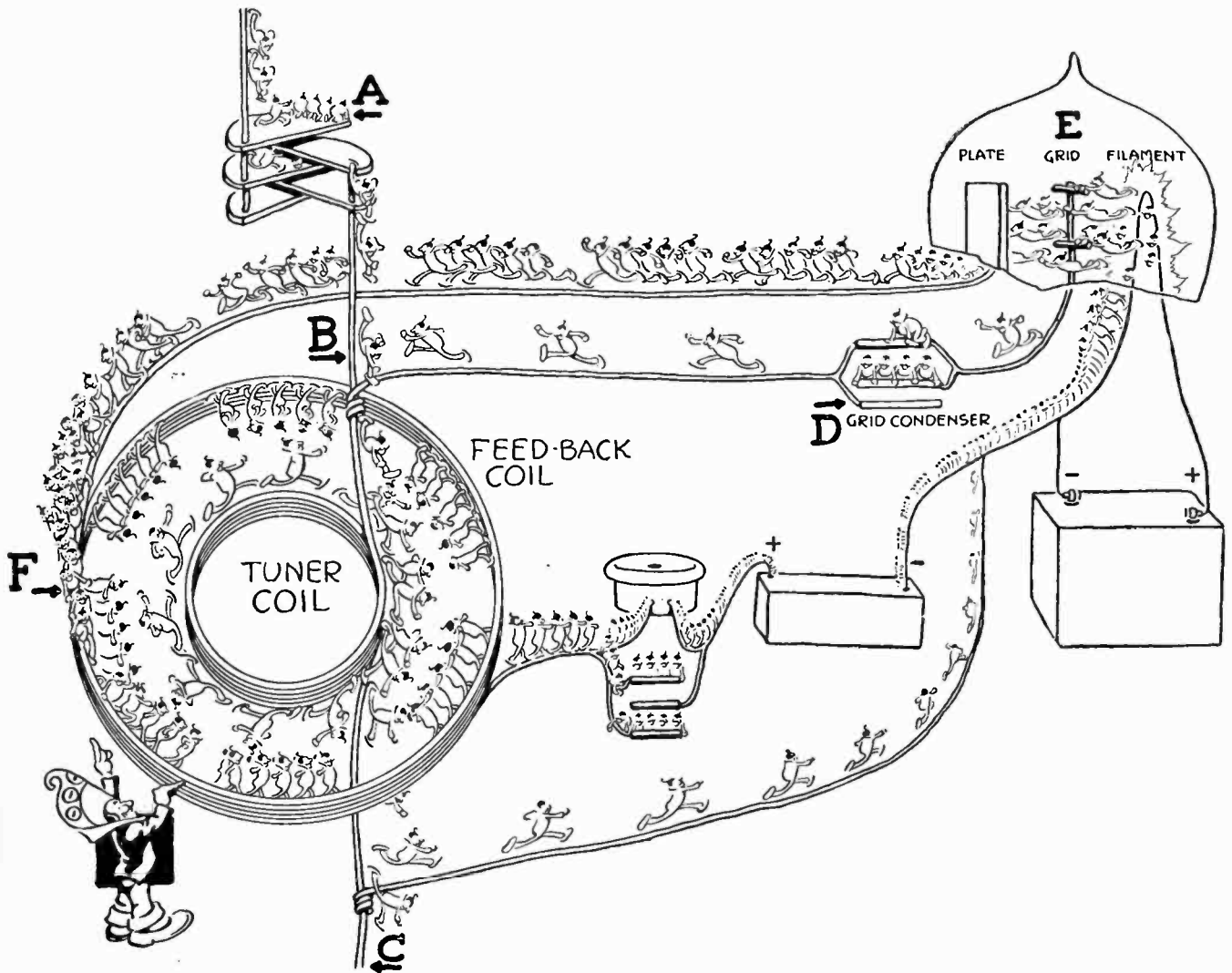

"BEHOLD!" SAYS KING ELECTRON, "A RADIO WAVE HAS ARRIVED ON THE ANTENNA

And has put new life into my lazy boys."

The wave forces the electrons down the antenna lead-in wire to the variable condenser, A. The electrons which were on the lower plates rush down through the tuner coil to the ground. While they hasten away they are joined by the grid circuit electrons, racing from the grid. This group only joins the fun while passing through the coil, for their home is in the filament and they return by branching off at C. Their departure from D, meanwhile, causes more to run down from E. So many come that they pile up and force their way across the grid-leak resistance. As the electrons leave the grid, E, their place is immediately taken by others, from the filament. Most of those leaving for the grid are attracted by the plate and finding that they can not return, race through the feed-back coil at F. The electrons have not noticed all that is happening and King Electron warns them

*Feed-Back Connection.* Now, the progressive radio-fan takes full advantage of this reactionary movement. The feed-back coil is so placed with respect to the tuner coil that the kick-back produced in the tuner coil by the feed-back or "tickler" electrons will force even more electrons to run down the tuning coil. This in turn takes more electrons away from the grid as before. At the grid, this speeds up the plate electrons again and the feed-back principle is carried as far as wise. From this it would seem as though the electrons were lifting themselves by their boot straps in this quickly rising process, and, with the batteries supplying the necessary power, that is exactly the case. The electrons are merely the agents and the radio-fan is the director.

Naturally this process must not be carried too far. If it were, the reaction would carry the rise to the limits of the number of electrons given off by the filament in the vacuum tube, irrespective of the strength of the received signals. It is absolutely essential that the output of the vacuum tube should be proportional to the strength of the incoming signals, in order that they may represent the variations which constitute speech and music at the transmitter. So the feed-back must only be carried to a point just below the complete swing.

*Continuous Oscillations.* When this critical position is reached, the electrons will act as though they were swinging to the limits of the pendulum-like action. When the limit is reached, the pendulum begins its return and makes a vigorous swing in the reverse direction, aided again by the feed-back principle which forces a swing started in the downward direction just as well as it forces one upward. As a result, the receiver will continue to oscillate electrically, even though no signals may be coming in.

As the set is connected to an aerial, these oscillations will be sent out exactly as radio transmission. They will cause interference on all the receivers in the neighborhood that are trying to receive signals near the same frequency as the oscillations. The result is the familiar squeak. For his own sake as well as his neighbor's, the radio fan will do well to promote "courtesy of the-ether" by keeping his set from reaching this oscillating stage which may be recognized by the mushy noise in the telephone receivers when oscillating occurs.

*Feed-Back Design.* As a matter of design, the radio fan will have two ways of controlling

the amount of feed-back. One consists in having a fixed number of turns in the feed-back coil (their number depending upon the wavelength to be received), and in adjusting its position with respect to the tuning coil. If the feed-back coil is directly inside or next to the tuner coil with the turns in the same direction in both coils, the effect will be at a maximum. If the feed-back coil is moved away from the tuner coil or turned with respect to it, the effect will be decreased accordingly.

Another way is to have the feed-back coil sectionalized with taps so that more or less turns may be used. With more turns, the feed-back will naturally be greater. It is also to be observed that more "tickler" action, as this feeding back is frequently called, is necessary for the longer wavelengths than for the shorter. The feed-back may also be accomplished by a condenser connection from the plate, back to the grid. Still another way is to allow the condenser action of the plate of this tube to react back on the grid inside the tube. In the latter case, it is necessary to put a tuning coil called a "variometer" in the plate circuit of the tube, so that it will tune this circuit of the tube to the frequency of the desired signals. These methods of course require more adjustment.

*Operation.* The radio fan should tune his set and adjust the feed-back or "tickler" at the same time. When the desired signals are heard, the tuner should be carefully adjusted for maximum signal strength and then the "tickler" should be carefully brought up to the point just below which "howling" occurs. If the howling starts, the "tickler" should be reduced rapidly and then brought up to a position just below the critical point.

*Distant Signals.* It is possible to find distant weak signals by using a little more "tickler" than usual. This will produce a singing note when the set is nearly tuned to the desired signal. By careful tuning, this note will be made to decrease in pitch to a vanishing point or "zero beat" position as it is called. The "tickler" action should then be reduced until articulate speech is heard. It must be remembered, however, that all the stations in the vicinity will receive the benefit of this experiment in the form of the squealing above referred to, so it should not be done when they may be listening to broadcasting on nearly the same wavelength.

*Major Armstrong.* Two little points of his-

tory are interesting in Major Armstrong's first work with regeneration.

While he was making his first tests, he said to one of his friends, "I have got something but I haven't quite figured it all out." That he did have something has certainly been amply sustained by science and the law.

At about that time tests were being made at Belmar, N. J., at the new receiving station of the Marconi Wireless Telegraph Company of America on the reception of signals from England. A series of 400-foot high towers extended for more than a mile from the receiving station. Engineers had been working for a considerable period trying to get worth while signals when

Mr. E. H. Armstrong came down from New York with a black box carefully painted to conceal its contents. With this device, readable signals were received from England by Mr. David Sarnoff, now General Manager of the Radio Corporation. A modest consideration would have obtained the full rights to the regenerative receiver inside the box, but the engineers stated that it was the mile of towers that did the trick. As a result, Major Armstrong had a long tussle ahead in getting the merited recognition for regeneration which proved such a valuable adjunct to radio reception during the World War, and which has now come to mean so much in broadcast reception.

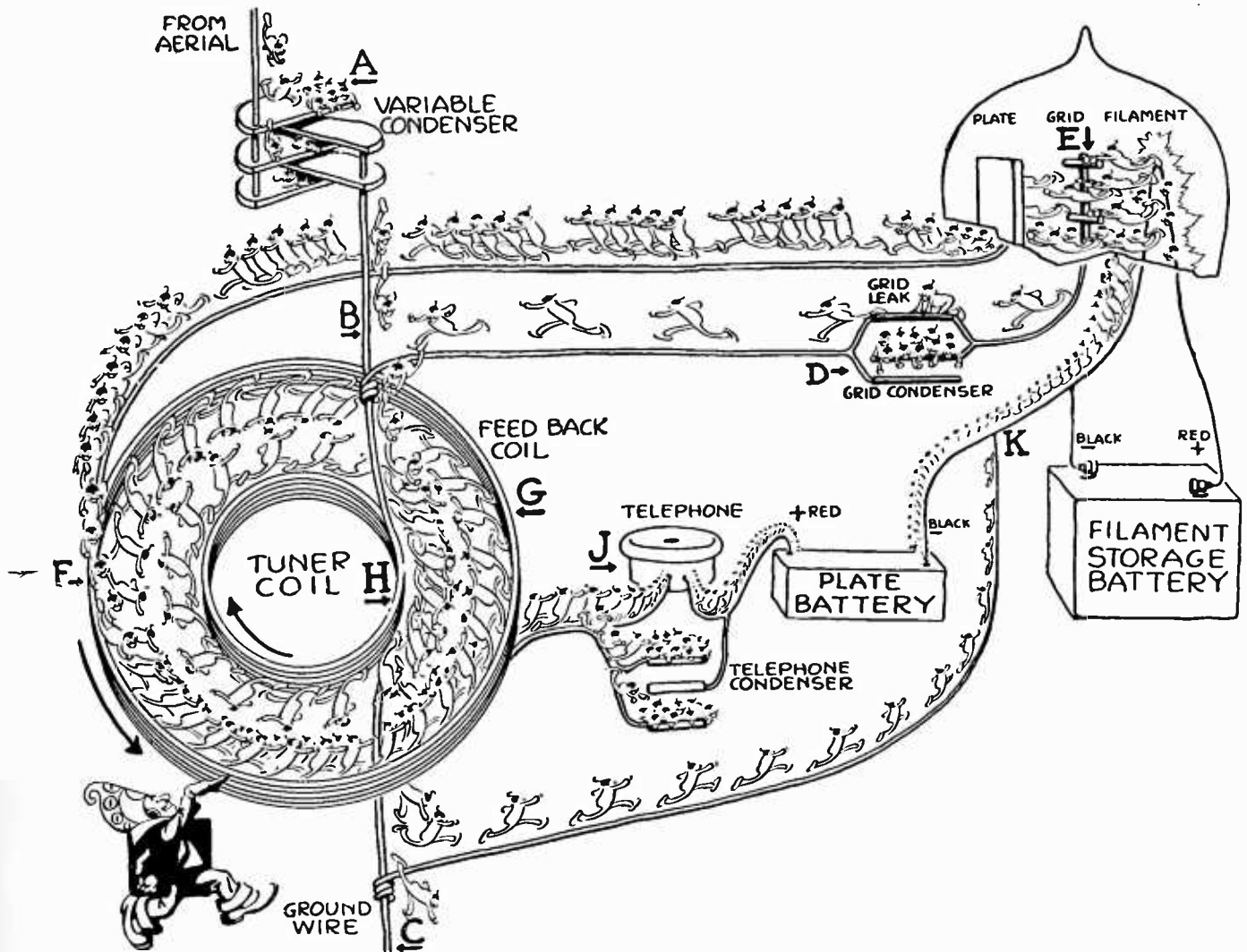

"KEEP THE POT A-BOILING," SAYS KING ELECTRON

As all the little electrons are on the go, around the feed-back coil and up to the telephone receiver at J. Here is a "house of too much trouble:" some of the electrons become disgusted, and pile up on the by-pass condenser to wait their turn to enter. From the receiver and condenser they rush on through the plate battery and back to the filament, K. The electrons in the feed-back coil have so much fun that those in the tuner coil become jealous and rush even faster in the opposite direction in an attempt to bring the average motion back to zero. They have been travelling in the opposite direction, but now there is actually a stampede. This action causes excitement among the electrons on the grid. The movement of the plate electrons is then at its height. With the repeated arrival of radio waves, the grid condenser, at D, tends to keep the grid negative, resulting in an increased average passage of electrons through the telephone receiver, making its diaphragm move back and forth in synchronism with the changes of the broadcasting transmitter

# Armstrong's Super-Regenerative Circuit

A Discussion of its Advantages, Limitations and Some of its Variations, from the Standpoint of Assembly and Operation

By PAUL F. GODLEY

The author of this comprehensive article tells in a very concise way just what he has learned of the new circuit which, after it has been somewhat refined, is likely to revolutionize our system of reception. Mr. Godley has employed various forms of this circuit for several months and his observations should greatly assist experimenters in finding the right road.—THE EDITOR.

**W**HAT is super-regeneration? It is a remarkably clever combination of electrical phenomena which will relentlessly grip the thoughts and imaginations of radio folks everywhere. There is no doubt about that. At the time this is written but a few days have elapsed since Armstrong's disclosure of the new method of radio reception yet literally tens of thousands of folks are wrestling with the super-regenerative circuit in an effort to master it and learn its limitations. Oh yes—it has limitations. But what great steps forward do not have?

To the city dweller—the man who finds himself hedged in on every side by steel and stone, or to the man who is harassed by someone who is lightning-shy, super-regeneration will prove a boon. To the radio fan with experimental leanings it will come as a heaven-sent gift, for the combinations of the circuits it is possible to employ are extremely numerous, and in them lies endless fascination. But there seems to be some doubt whether the circuit is of great advantage to those who are able to erect an antenna, or to those who find themselves upwards of 75 miles from a broadcasting station. Commercial application alone can fully show its usefulness.

## THE ACTION IS COMPLEX

**T**HE actions within a super-regenerative circuit are manifold, and, given the equipment ready for operation, the large percentage of those who will attempt its use in experimental form are quite sure to experience difficulty in getting the circuit into proper operation, and many will find themselves completely discouraged by mysterious whist-

lings and hissings and squawkings. But, the objectionable sounds have each a meaning, and a very interesting one. Knowing something of their language, they serve well as a guide to successful operation.

The super-regenerative receiver is based upon the regenerative receiver shown in Figure 1, while both depend for their operation upon that property of the audion—the three-element vacuum tube—which enables it to reproduce very faithfully in greatly amplified form any feeble pulse of electrical energy which is fed into it. Thus, if an electrical pulse be induced in the grid circuit (see Fig. 1) it will appear in greatly magnified form in the plate circuit. The oscillatory pulse in the grid circuit will die very shortly in its effort to overcome the resistance of the grid circuit. Likewise that magnified oscillatory pulse in the plate circuit for the same reasons.

## AMPLIFICATION LIMITED ONLY BY TUBE AND BATTERY CAPACITIES

**B**UT, if the plate circuit be “coupled” to the grid circuit in such way that its magnified energy reinforces the decaying pulse of the grid circuit, the effects of the resistance of the circuits upon the pulse may be either partially or wholly offset. That is, the initial pulse may be propagated for a short time or over an infinite period. The batteries supply the energy necessary for this action. If the regenerative action of the plate circuit upon the grid circuit is less than sufficient to offset inroads which circuit resistance makes upon it, the death of the energy pulse is but postponed. If the regenerative action of the plate circuit upon the grid is more than enough to offset resistance loss, the pulse grows rapidly



larger and larger due to the magnifying characteristics of the vacuum tube. This amplifying action is limited only by the carrying capacity of the tube and the ability of the batteries to supply energy. When the capacity of either one or the other is reached the growth of the pulse stops, but it continues its unceasing oscillatory movement through the circuits.

Suppose then, that our circuit is so adjusted as to make an energy pulse grow as it passes through the tube recurrently. A pulse acts upon the tube, increasing very rapidly in size until it taxes the full capacity of the tube, *and continues thus indefinitely leaving no opportunity for subsequent incoming pulses of energy to affect the action of the circuits in any way.* In this condition the circuits are of no value for reception. They must act on each of a long chain of pulses in exactly the same manner to be of service.

#### THE "CONSERVATIVE" RECEIVER

**W**HAT we have previously used and termed a regenerative receiver is not, strictly speaking, regenerative in its action. It is but conservative, and might now better be termed "the conservative receiver," for, to be of value the simple regenerative action may be carried only to that point where the energy fed back into the grid circuit by the plate circuit is somewhat less than that lost through toll taken by the circuit resistance. It is necessary that the first pulse be allowed to die out in order that the track may be cleared for its successor, and so on, and on. No true regeneration there; only conservation—though the energy conserved is quite large indeed and results in signals 100 to 200 times greater than had been previously possible.

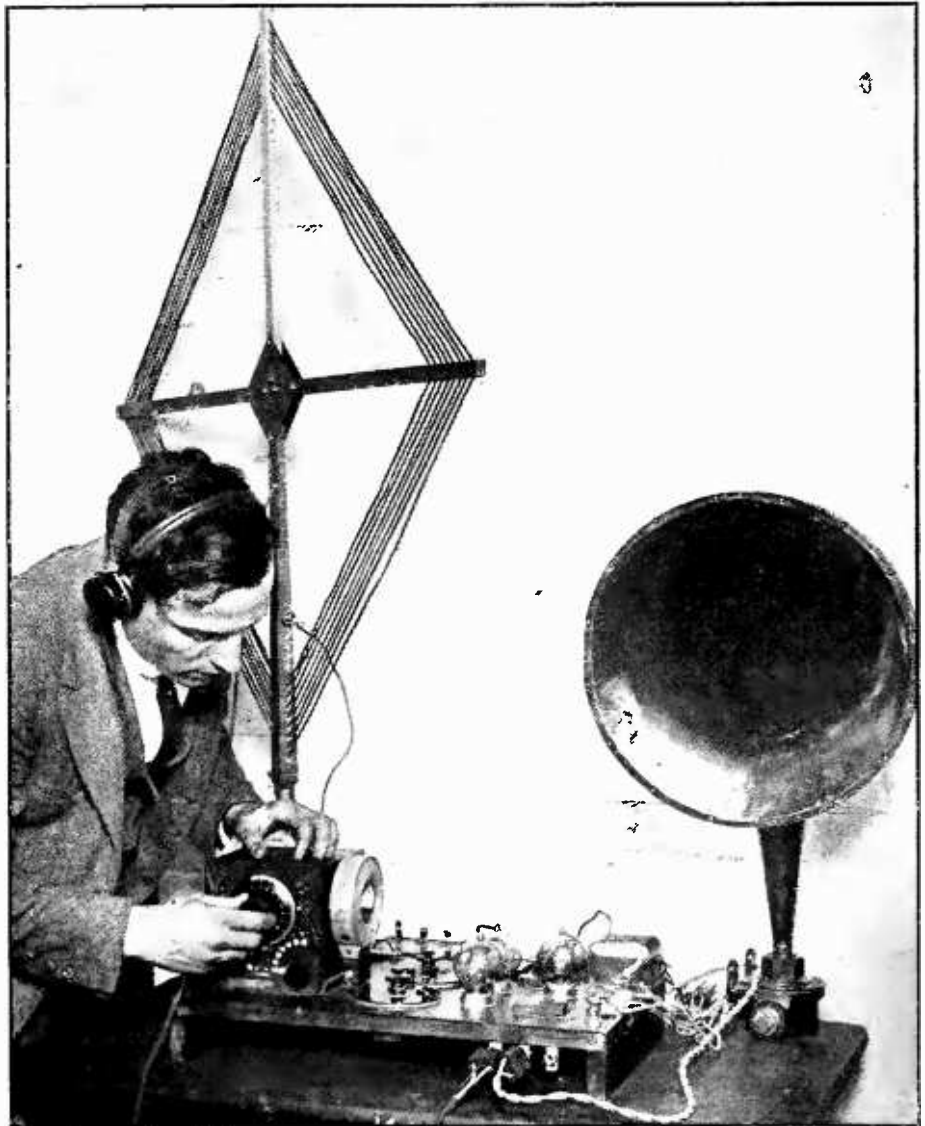

©Kadel & Herbert

#### A THREE-TUBE SUPER-REGENERATIVE RECEIVING OUTFIT

Used by E. H. Armstrong at the Radio Club of America's meeting held in Columbia University. Signals from a loud speaker were clearly heard over the entire auditorium

To reach the capacity of the tube and supply battery, the average feeble signal energies must complete the circuit through the tube perhaps fifty times. If at the end of that time it were possible to kill the oscillation, amplification would have been accomplished and the path would be clear for subsequent pulses. On broadcasting waves (400 meters) fifty oscillations occur in approximately one sixteen-thousandth part of a second. It would then be necessary to stop the amplifying action sixteen thousand times per second approximately. The action may be stopped by throwing a high resistance into the circuit.

Armstrong does this in effect by throwing positive charges upon the grid of the tube—one every sixteen-thousandth of a

second, approximately. The instrument for accomplishing this remarkable feat comprises a second regenerative vacuum-tube circuit which perpetually oscillates at a frequency of say, 16,000 cycles (equivalent to a wavelength of approximately 20,000 meters), and which is

cation is enormous, being equal to the twenty fifth power of 2. During the positive half of the oscillator cycle, the grid of the oscillator tube is positively charged. This being true currents will flow by conduction from the filament of the oscillator tube to the grid,

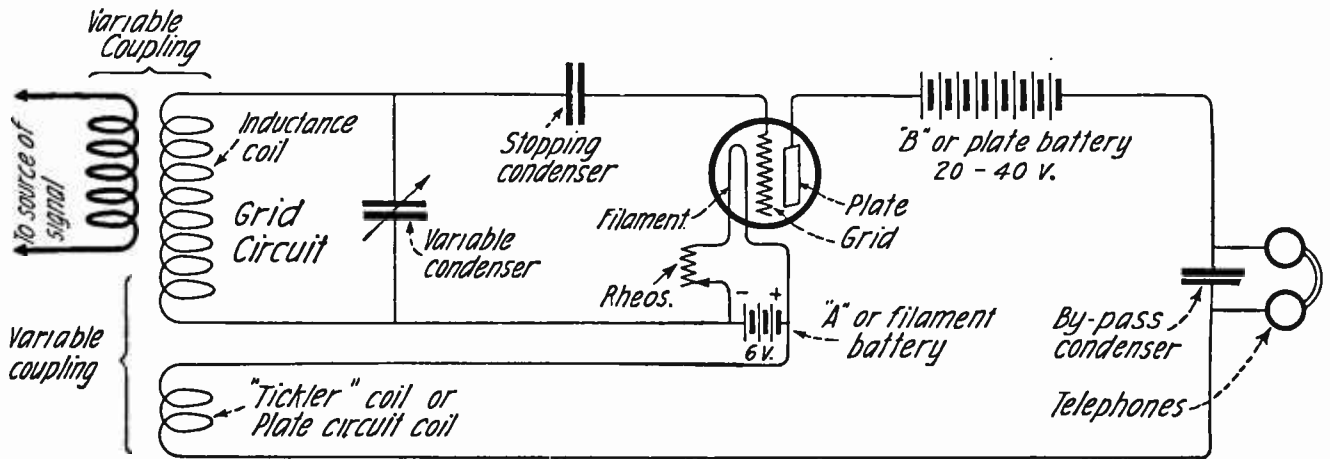

FIG. 1

properly associated with or coupled to the grid of the receiver tube, which thus receives, alternately, 16,000 each of positive and negative charges per second (Fig. 2). While the negative charge is upon the grid of the receiver tube it will function. While the positive charge exists it cannot function. While the oscillator tube is in the negative half of its cycle, the receiver (regenerative) tube is amplifying. While the oscillator tube is in the positive half of its cycle the regenerative tube is, for all practical purposes, doing nothing.

Thus energy is actually withdrawn from across the terminals of the regenerator inductance  $L_1$  by the tube  $O$ , the path of this conduction current being from  $L_1$  to filament, to grid, through  $C_3$  and back to  $L_1$ . The effect of this action is the same as though a considerable resistance had been placed in the regenerator circuits, sufficient energy being dissipated to stop the action of the regenerator. Thus the arrangement is highly effective.

That which will be of interest to most is an analysis of and details concerning the most likely of the several methods which Armstrong has devised for accomplishing super-regeneration.

Figure 4 shows the arrangement of the circuit of Figure 3 in such way as to call for but one set of batteries. By rearrangement of the oscillator circuit and the addition of an air core choke to confine properly the regenerated signal currents, preparation is made for further

THE MOST SUITABLE CIRCUIT

FIGURE 3 shows the schematic arrangement of the two tubes. The action in this circuit is as follows: assume the oscillator tube to be undergoing the negative half of its cycle (duration approximately one thirty-thousandth part of a second.) During this period the regenerative circuits are amplifying the signal pulse received by it from the antenna, and at a wavelength of approximately 400 meters the signal pulse would have made approximately 25 round trips through the regenerator tube. Assuming that each passage through the tube resulted in a magnification of 2 times, it is apparent that the total amplifi-

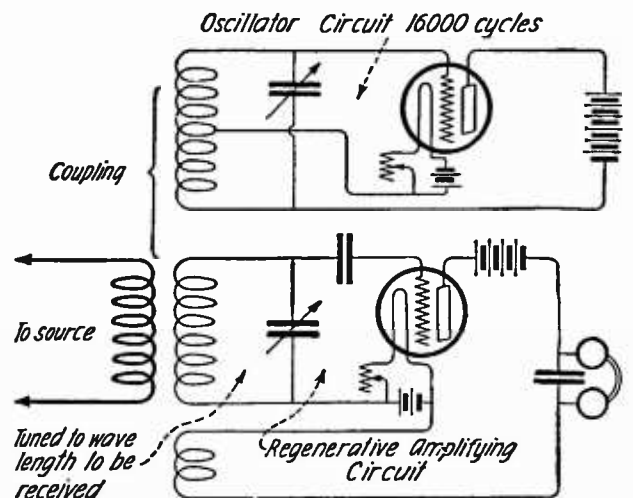

FIG. 2

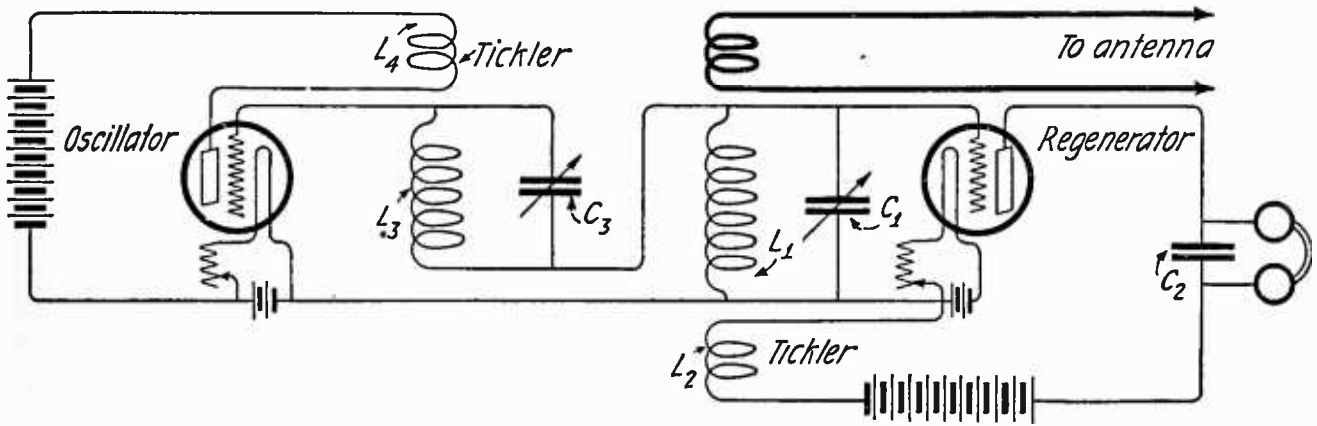

FIG. 3

improvement. The same method for controlling the action of the regenerator is still used however.

A list of materials necessary to put this circuit into operation is as follows:

- 1 Vario-coupler of special design (see Fig. 5 and text.) This coupler comprises  $L_1$  and  $L_2$ .
- 1 Loop antenna having 12 turns each  $3\frac{1}{2}$  feet on a side.
- 1 6-volt storage battery.
- 4 to 6  $22\frac{1}{2}$ -volt blocks of "B" battery.
- 2 1500 turn honeycomb coils: ( $L_3$  and  $L_4$ ).
- 1 air core choke ( $L_5$ ). May be made by winding 300 turns of #28 insulated magnet wire on a form 4 inches in diameter.
- 3 Variable air condensers having a maximum capacity not less than .001 MF. ( $C_1$ ,  $C_3$ , and  $C_4$ .)
- 1 Fixed condenser, capacity .005 MF ( $C_2$ ).
- 2 Filament current rheostats.
- 2 Vacuum tube sockets.
- 1 Pair phones.
- 2 Amplifier vacuum tubes. These tubes must be of the hard variety. Soft, or gassy tubes will not function satisfactorily. The regenerator

tube may be a Moorehead, Radiotron UV-202 or any one of the Western Electric tubes such as Types E, J, V, or L. The oscillator tube should preferably be one of the latter, though either Radiotron UV-202 or UV-203 may be used, preference being given the latter.

The inductive coupler shown in Figure 5 may be made according to that sketch. Care should be taken to see that the windings of the "regenerator inductance coil" run in the same direction as those of the stationary coil of the tickler if the device is to be connected into the circuit as indicated in the sketch. In case this is not done, the terminals of the tickler may be reversed.

With reference to Fig. 4, it will be seen that the condenser  $C_4$  is connected through the inductance  $L_5$  to the grid of the regenerator tube on the one side, and through the "B" battery to the filament circuit of this same tube on the other. The inductance  $L_5$  is interposed in this circuit to choke back the high-frequency currents of the regenerative circuit. Without this, these currents would pass through the

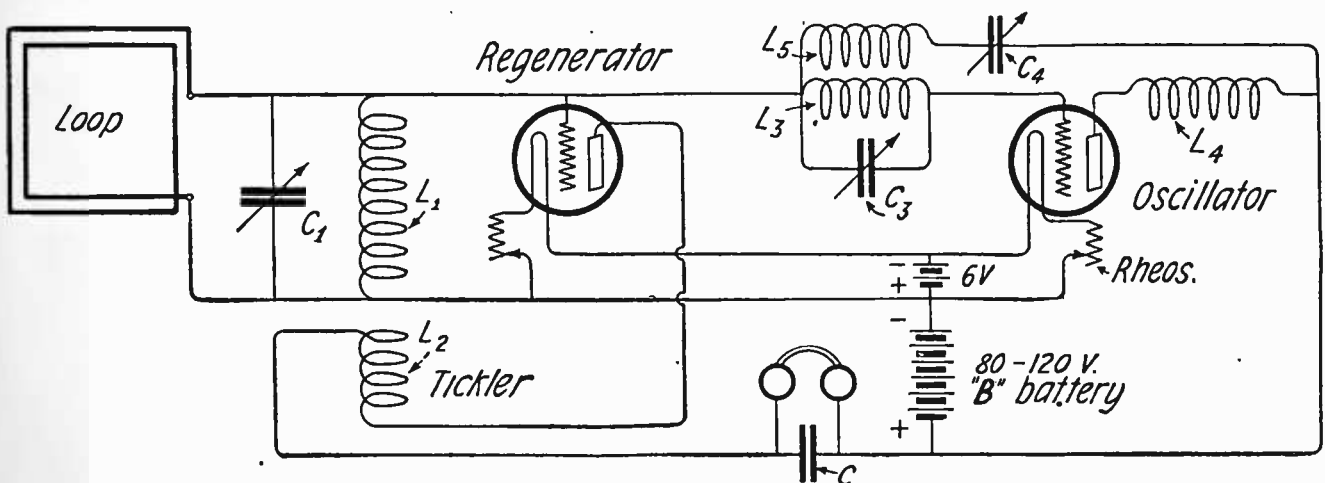

FIG. 4

condenser C<sub>4</sub> and very effectually prevent operation.

The action which takes place in this circuit has already been explained. However, it would appear from operation of the circuit as shown in Fig. 4 that in addition to acting as oscillator the second tube is also effecting some amplification, and this is quite possible. Full advantage of this possibility is to be taken in a later circuit.

HOW TO OPERATE THIS CIRCUIT

**T**O PLACE this circuit in operation, insert a pair of telephone receivers between the "B" battery and the inductance L<sub>4</sub>. After lighting the oscillator tube, set the condenser C<sub>3</sub> at a point near its full value. Follow this by adjustment of the filament current, plate battery, and condenser C<sub>4</sub> until a high pitched audible note is heard in the telephones. If this is not forthcoming, look over connections. If it is forthcoming, the tube is oscillating at an audible frequency. This is as it should be.

Remove the telephones from the plate circuit of the oscillator tube and close the circuit. Oscillations will continue. An easy way of doing this is by employing a telephone jack and plug, which will make a complete circuit even when the plug is withdrawn.

To get final adjustments it will now be necessary to light the regenerator tube. The filament current and plate battery of this tube are also adjusted so that by advancing the tickler from a minimum toward a maximum value oscillations may be started. The presence of oscillations may be determined by placing the finger upon the grid terminal of the regenerator tube. If a decidedly pronounced click is heard, both when the finger touches

and leaves the grid terminal, oscillations are in process.

If a wavemeter is available it will come in handy at this time to those who are strangers to the circuit. Set it at the wavelength at which reception is to be effected and start the buzzer. Condenser C<sub>1</sub> may then be adjusted for the approximate proper value, and the tickler brought into play for the amplification. If no wavemeter is available a given station may not be picked up so readily. Suffice it to say that when the condenser is set at about half its value, the circuits will be tuned to approximately 350 meters, providing directions

as to construction have been followed. Attention is called to the fact that for regenerative action of the proper sort with this circuit much closer coupling between the plate and grid circuits of the tube is required than when the simple regenerative circuit is employed.

In advancing the tickler from minimum toward maximum a point will be reached where a

great hissing is heard in the telephones. Regenerative action is setting in at that point. Continue the advance of the tickler. The hissing noises will cease, or nearly cease, and it is at this time that the tickler coupling is adjusted to approximately the correct value. If this is borne in mind, the loop circuit may be varied over fairly wide limits in wavelength and the circuits at the same time kept in a fairly sensitive condition

WHEN THE SIGNAL ARRIVES

**W**HEN a signal is heard the best obtainable settings for strength should be made at C<sub>1</sub> and with the tickler. All adjustments should then be gone over. Vary the filament brilliancy of the two tubes for maxi-

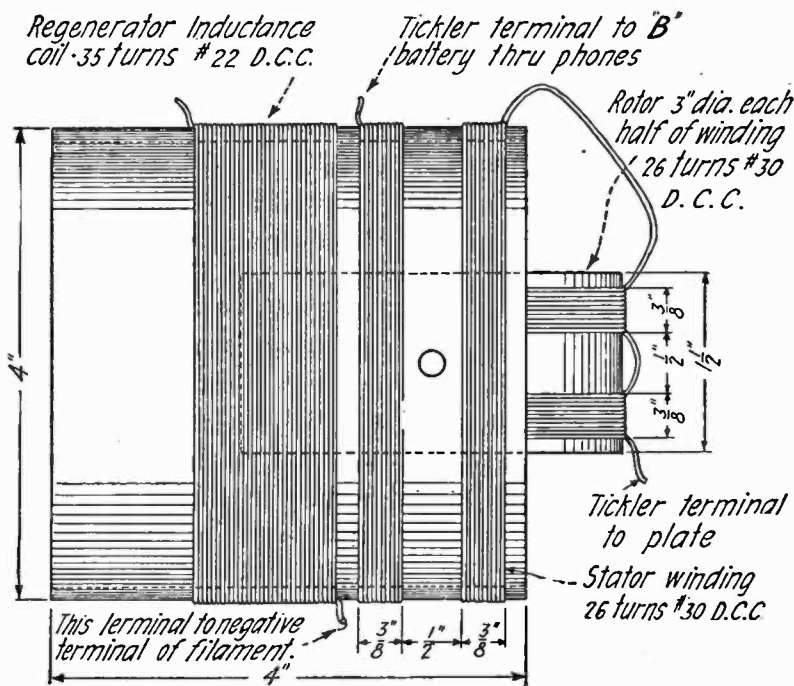

FIG. 5

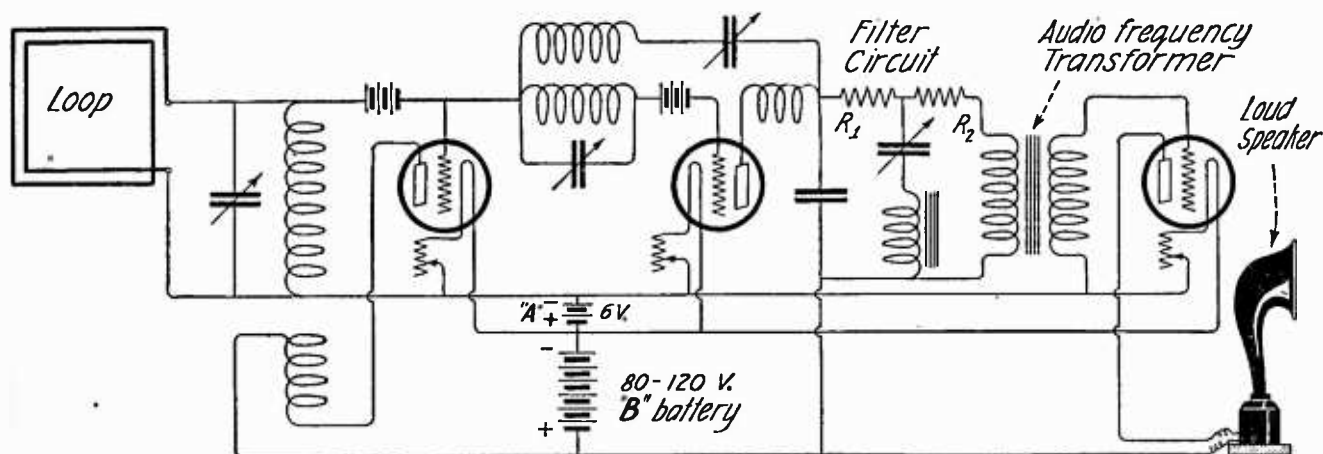

FIG. 6

mum signal strength. Likewise, search for the best value of plate battery for each tube, and swing the loop into that position where signal is loudest. For, it must be remembered a loop receives best only those signals which advance in a direction parallel to its plane. Do not, however, expect too great directionality from the loop. The wires and coils in the circuits themselves, as set up on the table will pick up some energy. The energy picked up by the circuits on the table will not usually add to those picked up in the loop. Use of the circuit will soon indicate this fact. When this is taken into consideration, the loop may always be swung through an arc of 180 degrees to ascertain in which position greatest signal is to be had.

With further reference to Figure 4, this variocoupler may be assembled by setting a variometer of standard construction alongside and quite close to a coil similar to the regenerator inductance coil of the figure. For the standard variometer it will probably be necessary to use a 5-inch tube. In this case about twenty-eight turns of wire will suffice.

#### A MORE COMPLICATED CIRCUIT

FIGURE 6 shows a further step toward increasing the effectiveness of the circuit. It consists in taking the signal out of the oscillator circuit instead of the regenerative circuit. In addition to its previous functions, the oscillator tube now acts as rectifier and amplifier. The potentials generated across the terminals of the inductance  $L_1$  modulate a resultant of the oscillations of the oscillator tube. This is rectified, amplified regeneratively by the oscillator tube circuits, and again rectified with a considerable additional amplification as the result.

The difficulties with this circuit are somewhat greater, the principal one being that, unless careful adjustment is made, beats occur between harmonics of the oscillator circuits and those energies which exist in the regenerative circuits. Also, since the telephones are in the oscillator circuit, the audible tone of the oscillator is heard at all times. The first is perhaps the most objectionable of the two from the experimenter's standpoint, for, if the pitch of the oscillator frequency is sufficiently high the ear will soon become deadened to it. But, from the standpoint of good quality of tone where voice or music is to be received, the latter is by far more objectionable, particularly where the third tube is added for the addition of a loud-speaking telephone.

If an inaudible frequency is used in the oscillator circuit, amplification will be less, for the lower the frequency of this oscillation, the greater the amplification. A compromise must therefore be made between amplification and quality where it is desired to receive broadcast programmes. This compromise is somewhat mitigated by the use of a filter system which is interposed between the oscillator circuit and the telephones or amplifying tube, and so constructed and adjusted as to bar all tones above 3,000 cycles which is the upper limit of tone frequencies of the voice and of musical instruments.

The construction of such a filter is not easy for the average experimenter, although the parts which it calls for may be purchased with little difficulty. The resistances  $R_1$  and  $R_2$  should be non-inductive and have a value of between 10,000 and 15,000 ohms. The inductance is made with an iron core and has a value of approximately 1 henry. The variable condenser has a maximum value of .005 MF.

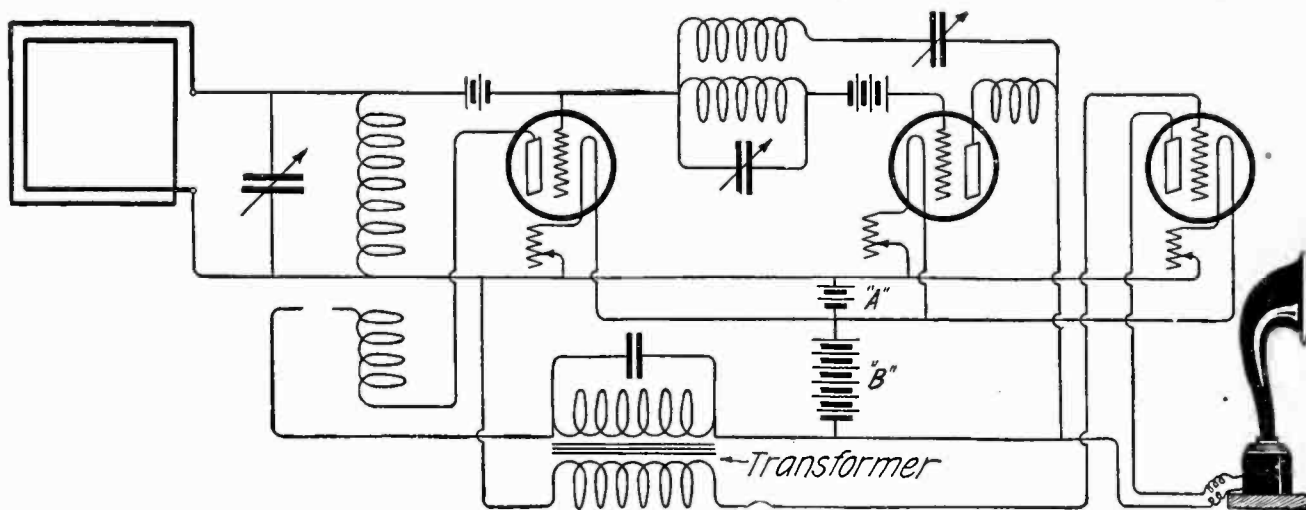

FIG. 7

The circuit comprised by the variable condenser and inductance of the filter is adjusted for minimum oscillator tone in the telephones or loud-speaker.

A COMPROMISE FOR BETTER TONE QUALITY

FIGURE 7 shows an arrangement for three tubes which is a compromise, the audio frequency amplifier tube being coupled into the regenerative circuit. This circuit will prove easier of operation, and, without the greater difficulties encountered in the circuit of Fig. 6, give good volume and quality.

FOUR FUNCTIONS WITH A SINGLE TUBE

ATTENTION is called to the biasing batteries in the grid circuits of the tubes in the last mentioned figures. This battery needs to be variable in  $1\frac{1}{2}$  volt steps and to have a range up to about 6 volts. The use of these batteries gives considerable additional stability

to the circuits and thus enables greater amplification.

Figure 8 shows an extremely interesting application of the circuit. Here, one tube performs all functions,—regeneration, amplification, oscillation, rectification. Here one tube is used with very great effectiveness. The circuits are not particularly easy of adjustment but are recommended for trial to those who have found it possible to master the previous circuits.

A careful study of the actions which take place in the super-regenerative circuit and a little patience will be rewarded. The combinations of the circuit which will be suggested to those who do understand the principles of action are unlimited. Only a few have been pointed out here, and it is to be expected that for months to come a great deal will be heard as to what has been done by countless amateurs with this new method.

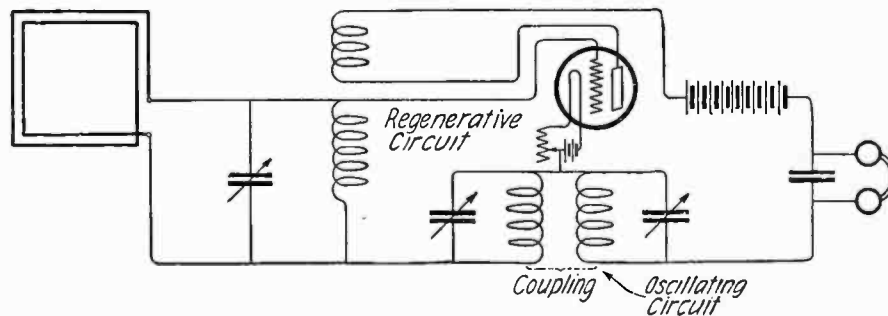

FIG. 8

# Radio's Great Future

By Herbert C. Hoover

Secretary of Commerce

**R**ADIO implies the extension and betterment of means of communication everywhere. It is incredible that the new science will, therefore, prove to be a fad of merely passing importance. For, clearly, from the very beginnings of recorded history, man has struggled against the barriers of distance in his effort to impart and to receive information, to discover and to afford diversion, to develop transportation and trade.

Before the advent of the wireless, although we had the telephone and telegraph for inter-point communication on land and via sea cable, there was no way by which we could communicate with moving bodies either on land, in the air, on or under the surface of the sea. Now radio serves such carriers. Again, before the advent of the radio telephone, there was no instantaneous means of communication for use in broadcasting information and entertainment to tens of thousands of listeners simultaneously.

Now, because radio bridges these and similar gaps, the ideal of universal communication, which has long aimed to inter-relate everyone possessing the necessary equipment anywhere on this earth, is in its realization predictable and must be accepted as an augury of better understanding and of swifter means of accomplishment throughout the world.

Fortunately, too, as a result of the Radio Conference called by this Department early in the present year, bills are now before Congress which promise to provide order instead of anarchy in the ether. The new radio industry is unique in that everyone is unanimous in the common desire for legislation and regulation that will make the new science of the greatest possible good to the greatest possible number of Americans.

The accomplishment of this legislation may, accordingly, be considered as the next important step in the progress of radio and in the extension of its use throughout the United States.

© Underwood & Underwood



# Shall We Have Music or Noise?

PERCE B. COLLISON

THE facts brought out in this article will interest the three groups most interested in radio-telephone broadcasting. First, the broadcaster, then the merchant who is entering upon an entirely new field, that of demonstrating and selling radio apparatus, and last but not at all the least, the general public—the consumer.

Radio-telephone broadcasting is epochal and is here to stay, but we must concede that much must be done to bring it to a point where it will approach perfection.

Our congratulations and thanks to “KDKA”, “WJZ” and those other splendid pioneers, but unfortunately there are many individuals operating inefficient and poorly designed equipment, more or less conglomerate collections of miscellaneous parts assembled by persons with a rudimentary knowledge of radio-telephony.

For example,—the writer has been listening to a certain broadcasting station for a couple of months and was thoroughly disgusted with the quality of their signals and their programmes. The operators of this station frequently ask for comments on their signals and usually at the close of their evening programme acknowledge with thanks the many “complimentary” letters and telephone communications they have received. But their efforts do not deserve such praise and it is suspected that they receive no such compliments, or that if they do, they come from poor judges.

On a certain evening a piano selection was being “rended” in a wretched style and I was goaded into calling these people by telephone and protesting. A young man answered the phone and in response to my unwelcome criticism he stated that he was surprised to learn that their signals were poor and asked for suggestions. I explained what I thought was wrong and to demonstrate what I meant I placed the transmitter of the telephone a few feet from my “loud speaker” and let him drink his own poison. He was inclined to believe that my receiver was at fault so I picked up another better station and let him listen to

some good signals. This finally convinced him that his station was greatly at fault and he promised to do better. But did he? He did not. Night after night they continue to flood the ether with squawkings that bring unpleasant remembrances of the old tin-horned gramophones. This stuff, for that is all the title it merits, will discourage thousands of prospective purchasers of radio-telephone receiving apparatus and should be ruled out of the ether.

These and other malefactors, even though they may be operating with the best of intentions, are arousing a storm of protest and harsh criticism that will react against every broadcasting station in the country unless something is done to improve their programmes. Their main fault lies in imperfect modulation and wrong methods of recording. As a general rule a single voice singing gives much better results than a chorus. Likewise a few stringed instruments sound better than an entire symphony orchestra. Jazz bands are an abomination and should be absolutely eliminated, not because the public does not like jazz but because the scrambled mess of disjointed harmony that is jazz just cannot crowd into a telephone transmitter, with the result that all the public hears is a babel that bears no resemblance to music. What the public wants is music, not excitement!

Piano music, if used at all, should be carefully chosen and then played by an artist. Canned music is not wanted, that of phonographs or any other instrument. We all have our share of good phonographs and player-pianos and they give us much better music than has ever been broadcasted by radio-telephone. The writer has listened to a score of piano concerts and has noticed one particular fault. In many compositions certain softly played portions are hardly audible and then when the artist crashes into a grand finale the telephone diaphragms go crazy. Something should be done to keep the volume more even, if necessary instruct the recording artists not to play either too softly or too loudly. Impress upon them that there are certain limitations to a radio-telephone transmitter and let them keep within



those limits. Artists when making phonograph records must observe certain rules, and radio-telephone broadcasting should be governed by similar rules.

Speeches! Unless the speaker has a message to deliver that is of great importance or of assured public interest he or she should neither be asked nor permitted to bore several hundred thousand people with some lengthy discourse on abstract subjects. Propagandists, politicians blowing their own horns, well meaning but terribly uninteresting welfare workers, rabid attacks on city or state governments,—these and others of the same type,—please stop them. Give us authentic briefs of the day's news, crop reports, information regarding the science of agriculture, fashion and house-keeping hints for the women-folks, sporting news for the young folks, perhaps a bed-time story for the children once in a while, and then only in fifteen-minute doses. Every programme, every day, should be planned to be of some interest to every member of the family, else interest will lag. The present rush to buy radio-telephone apparatus is the result of clever press agent work and its decided novelty. If this interest becomes dulled because of uninteresting broadcasted programmes the industry will suffer throughout.

The general public has purchased receiving apparatus to be amused and interested, and if the broadcasting stations do not maintain a

high standard they will defeat their own purposes.

So much for the broadcaster.

Now I am going after the merchant.

Just recently the writer was walking along a busy street and observing a crowd in front of a building a few blocks away, and, being possessed of the usual amount of metropolitan inquisitiveness, he decided to investigate. Upon approaching the crowd he was greeted with a babel of noise that sounded like the wild whoops that are showered upon Babe Ruth when he swats another ball into "the great beyond." The cause of all this commotion was a "loud speaker" connected to a radio-telephone receiver. The assemblage was not at all impressed with this free "concert", but, on the contrary, there were many murmurings and quite a few loud spoken comments to the effect that "If that's this here radio that the papers are talking about I don't want none of it."

And right at this minute there are hundreds of such unconvincing demonstrations of radio-telephone broadcasting being perpetrated upon the suffering public, and I say it's a doggone shame. Not one person in that large crowd would offer anything but a cold response to any attempt to sell them a radio-telephone receiver; indeed, any such attempt would have met with instant ridicule.

Being an enthusiastic radio bug and having several friends in the business of manufacturing



and marketing radio-telephone apparatus, the writer decided to remedy this deplorable condition and to do so at once. Elbowing his way through the crowd he bravely walked into the store and politely asked for the proprietor. A precocious youngster in his late 'teens said that the "boss" was out, and volunteered the information that he did not want to buy anything as business was rotten. It sure was. He was then asked if the "concert" which he was thrusting upon a wholly disgusted but unmistakably curious crowd was bringing in any results. To this he replied in perfect metropolitan slang, "Naw, those eggs are just stickin' around for the base-ball scores and as soon as I cut this stuff they will all beat it." It was a wonder to me that those "eggs" would stick around at all. But it was a true demonstration that the public *is* interested in radio, and it will take a whole lot of abuse to drive them away from it. Surely we do not intend to make any great effort to drive them away, do we?

Standing upon the counter was a radio-telephone receiver, of honest parentage, connected to a well known "loud speaker". The writer knew that these two units could give considerably better results and thereupon decided that, come what may, he was going to adjust that receiver so that it would no longer defame the good name of its creator. While the youngster stared and protested, the proper adjustments were made, and, as if by magic, the blare disappeared and in its stead there came from the horn of the "loud speaker" a decidedly good reproduction of violin music played by an artist of no mean ability. The signals were coming from one of the best broadcasting stations in the country, and, with a little finer adjustment, the music cleared into an almost perfect reproduction. The crowd was visibly impressed and crushed closer to the store in order that they might not miss any of this musical treat. Three or four serious-minded individuals separated from the crowd and came into the store in order that they might get even closer to the instrument, and they were just bubbling over with enthusiasm and questions,—and more kept coming. But alas, the clerk was no nimble wit, and failed to grasp a golden opportunity. He was more frightened than anything else. And his "boss" was probably wandering around trying to sell out the business and cussing at himself for having ever entered the radio game. Having no further

interest, I sneaked out, leaving the store and its prospects to fate.

When will the newcomers into radio merchandising realize that the selling of radio-telephone apparatus requires at least as much knowledge of the business as that usually at the command of a live-wire automobile salesman? Or are they relying upon the present "craze" to offset their shortcomings? And coupled with this rudimentary technical knowledge should be a real ability to "tune" in stations and thereby give a creditable demonstration. I have had several of these merchants try to sell me apparatus, and they all go through the same performance. After making a few introductory remarks intended to impress upon the prospective purchaser that the particular piece of apparatus they are selling is so superior to anything else on the market that they are inclined to pity their competitors, they point out a few of the "points of superiority." These usually are unimportant details such as the design of an adjustment handle, the finish of the panel, but never do they go into the technical design of the instrument. Why? Because they don't know anything about it, or if they should happen really to understand something about the goods they offer they do not know how to explain these things. With the proper use of analogies I can explain the operation of a radio-telephone receiver to an intelligent boy twelve years old. If he does not understand me, I stop trying to sell him anything because he is going to be a perpetual source of annoyance to me after he buys. Then comes the "demonstration," the execution and torture, I should say. These people seem to think that the public wants quantity and not quality even in music,—they are all wrong. We have been well educated to good music by our phonographs and the excellent symphony orchestras at the leading motion-picture houses, and are not going to be impressed with anything less satisfying. They sizzle the filaments of vacuum tubes, jam in the tickler coupling until the telephones howl with rage and then beam upon you, expecting to see you become joyfully enthusiastic and buy the whole store. Do you do it? Well, hardly.

A well known radio engineer recently remarked that by careful compilation of the reports he had received he had concluded that there were eleven radio engineers in this country and no less than 350,000 "radio experts." I say to you, beware the "radio experts."

Whence came they? Are they the aftermath of those hurriedly and half trained radio operators that were pressed into emergency service during the late war? Every store selling radio supplies now has its "radio expert." The newcomers into radio merchandising are too quickly falling prey to these "experts." Perhaps, if radio apparatus were not being offered for sale by haberdashers, stationers, drug stores, etc., these "experts" would not find so many soft berths where they can prey upon a credulous and mystified public. If manufacturers were not so anxious to flood the country with apparatus and make a quick profit (and perhaps an equally quick getaway), and restricted their agencies to electrical dealers, *bona fide* radio supply houses, and other agencies equipped by training and personnel to distribute technical apparatus, this evil would be automatically corrected.

Automobile manufacturers demand that their distributors maintain a "service and repair station." The general public has a great deal to learn about radio apparatus, and, unless helped along by intelligent "service", there will be a reaction more violent than the original "boom."

Now for our friends, the general public, without whose support and good will we cannot maintain anything. I suggest that you purchase only that apparatus that is "trade-marked" by reliable and well known manufacturers. Avoid the "unknown" outfits. Perhaps they may appear to be cheaper at first, but the usual thing is that the purchaser is either disgusted with the results or decides to replace them with proper equipment. In any case the original purchases represent financial loss. Having acquired a standardized well-engineered piece of apparatus, follow the installation instructions and operating suggestions usually given by the manufacturer. Take no advice from any other person unless you have learned by previous experience to respect his judgment. The manufacturers will gladly answer questions, and it naturally follows that they are the best source of information for their own products.

Regarding "accessories." Do not purchase any additional equipment that may be suggested by a zealous salesman until you are sure that you understand its proper application and that you really need it. Many a well

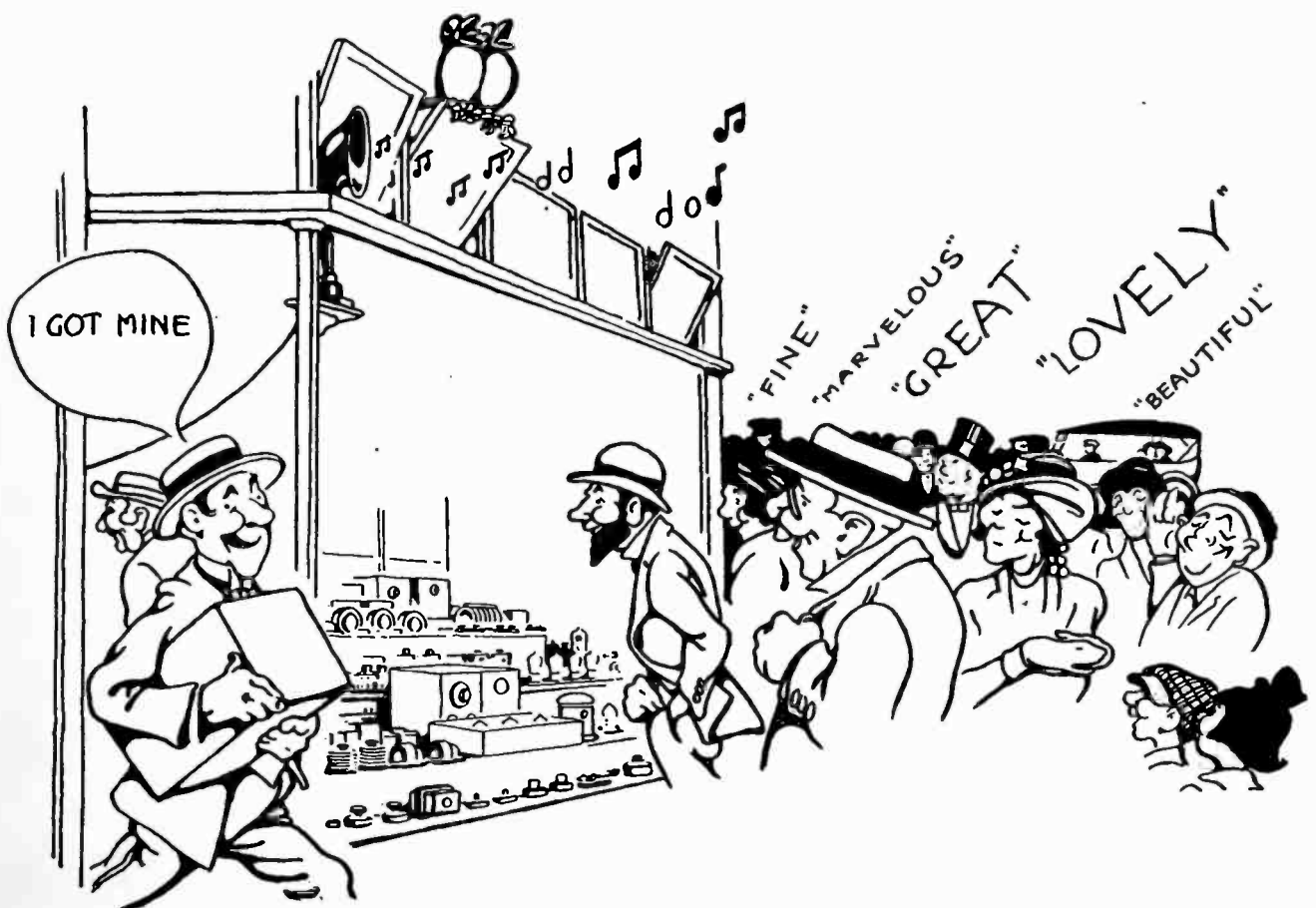

conceived piece of apparatus has been either ruined or rendered ineffectual by an attempt to "improve" it. The manufacturing engineers usually design each and every element for a particular purpose and to work best only in conjunction with certain other elements. Substitution for any of these parts usually results in a loss of efficiency. Wait until you are thoroughly familiar with the apparatus you have and are certain that it is not operating to best advantage before you begin to tear it apart. There are many really excellent pieces of standardized apparatus now on the market, and it is always safe and sure to buy equipment

identified by the trademark of a well known manufacturer.

In conclusion let me assure you that I have not intended to appear pessimistic or unreasonably critical but just brave enough to state frankly what hundreds of us are murmuring to ourselves and to our immediate friends.

This radio-broadcast proposition requires the closest kind of helpful and friendly coöperation during this trying period of its development, and, if we all honestly endeavor to do our share it will be quickly brought to a high degree of perfection, and then, surely, we shall have Music and not Noise.

SUPPLEMENTAL LIST OF BROADCASTING STATIONS IN THE UNITED STATES FROM JUNE 1 TO JUNE 15 INCLUSIVE

CALL SIGNAL	OWNER OF STATION	LOCATION OF STATION	WAVE LENGTH
KDZU	Western Radio Corporation	Denver, Colo.	360
KDZW	Claude W. Gerdes	San Francisco, Calif.	360
KDZX	Glad Tidings Tabernacle	San Francisco, Calif.	360
KDZZ	Kinney Bros. & Sipprell	Everett, Wash.	360
KFAB	Pacific Radiofone Co.	Portland, Oreg.	360
WEAN	Shepard Co.	Providence, R. I.	360
WEAO	Ohio State University	Columbus, Ohio	360,485
WEAP	Mobile Radio Co.	Mobile, Ala.	360
WEAQ	Young Men's Christian Association	Berlin, N. H.	360
WEAR	Baltimore American & News Publishing Co.	Baltimore, Md.	360
WEAS	Hecht Co.	Washington, D. C.	360
WEAT	John J. Fogarty	Tampa, Fla.	360
WEAU	Davidson Bros. Co.	Sioux City, Iowa	360
WEAV	Sheridan Electric Service Co.	Rushville, Nebr.	360
WEAX	T. J. M. Daly	Little Rock, Ark.	360,485
WEAY	Will Horwitz, Jr.	Houston, Tex.	360
WEAZ	Donald Redmond	Waterloo, Iowa	360
WFAA	A. H. Belo & Co.	Dallas, Tex.	360,485
WFAB	Carl F. Woese	Syracuse, N.Y.	360
WFAC	Superior Radio Co.	Superior, Wis.	360
WFAD	Watson Weldon Motor Supply Co.	Salina, Kan.	360
WFAF	H. C. Spratley Co.	Poughkeepsie, N. Y.	360
WFAG	Radio Engineering Laboratory	Waterford, N. Y.	360
WFAH	Electric Supply Co.	Port Arthur, Tex.	360
WFAJ	Hi-Grade Wireless Instrument Co.	Asheville, N. C.	360
WFAK	Domestic Electric Co.	Brentwood, Mo.	360
WFAL	Houston Chronical Publishing Co.	Houston, Tex.	360,485
WFAM	Times Publishing Co.	St. Cloud, Minn.	360
WFAN	Hutchinson Electric Service Co.	Hutchinson, Minn.	360,485
WFAP	Brown's Business College	Peoria, Ill.	360
WFAQ	Missouri Wesleyan College & Cameron Radio Co.	Cameron, Mo.	360
WFAR	Hall & Stubbs	Stanford, Me.	360
WFAS	United Radio Corporation	Fort Wayne, Ind.	360
WFAT	Daily Argus Leader	Sioux Falls, S. Dak.	360
WGAB	QRV Radio Co.	Houston, Tex.	360

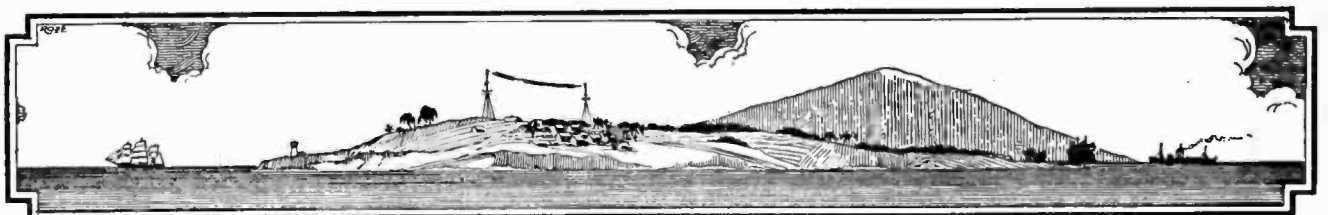

# Books About Radio

By John V. L. Hogan

Consulting Engineer, New York; Past President, Institute of Radio Engineers

ONE of the constantly recurring and seldom answered questions of the day is "What is a good book on radio?" There are several reasons why it is not easy to reply to this query; chief among them is that radio signaling is already so huge a topic that no one book can cover it accurately and completely. Again, the written treatment which one person requires will be utterly unsuited to the needs of other readers; there must be provided both the detailed technical descriptions of single branches of the art to suit the demands of engineer-students, and the simplified (sometimes obviously sugar-coated) expositions intended for beginners. Between these extremes one finds a host of radio publications, some good and many unutterably bad, each attempting to cater to some group of persons interested in radio either as an art, a science, a service, or an amusement.

There lie before me as I write (to quote Captain Fitzurse) more than eighty books on radio. Some of these are old standbys; some are worthy newcomers into the field of radio literature; and some are apparently written solely because their authors or their publishers thought that there was a good market for any book with "radio" or "wireless" in its title. It will not be possible for me to review all of these in the space of this article, nor even to describe all the good ones. However, I can perhaps select a number which can be depended upon in the main and which will appeal to each of the groups which wants to read about radio.

Let us take up first those intended for the beginner, who has possibly been attracted by the broadcast services and who desires to learn something about radio in general. Readable and clear presentations of radio principles and their earlier applications will be found in Professor Kennelly's "Wireless Telegraphy and Telephony"<sup>1</sup> and Professor Fleming's "The Wonders of Wireless Telegraphy"<sup>2</sup>; although both were printed a decade ago, their interest and accuracy make them valuable to-

day. Another well prepared book of the same period is "Wireless Telegraphy"<sup>3</sup> by Professor C. L. Fortescue. A more recently revised book is "Wireless Telegraphy and Telephony"<sup>4</sup> by Alfred P. Morgan; this volume is neither so closely confined to radio principles nor so exhaustive in its explanations of them as those above mentioned, and it takes space to describe many obsolete instruments, but it aids in giving a newcomer something of a general view of the radio field. Recent books which treat the uses of radio in a broad way, outlining for the reader a picture of the applications beyond radiophone broadcasting, are "Radio for Everybody"<sup>5</sup> by A. C. Lescarbours and "The Complete Radio Book"<sup>6</sup> by R. F. Yates and L. G. Pacent.

For readers who desire to learn about the transmission of speech and music by wireless, several books can be recommended. An interesting historical treatment of the earlier years is given in "Wireless Telephony"<sup>7</sup> by Ernst Ruhmer. This is brought down to 1918 in a volume which is more logically arranged and in which the author discusses the mode of operation of many types of apparatus, "Radio Telephony"<sup>8</sup> by Dr. A. N. Goldsmith. A simplified discussion of the present-day radiophone, with emphasis on the vacuum tube but little historical matter, is contained in "Elements of Radio Telephony"<sup>9</sup>, by W. C. Ballard, Jr. One of the newest books, which gives an exceedingly clear presentation of radiotelephonic principles and authoritative descriptions of the operation of modern sending and receiving apparatus, is "Radio Phone Receiving,"<sup>10</sup> edited by Dr. Erich Hausmann and written jointly by a number of well-known radio engineers.

Another extensive group of radio readers includes those who want information on how to make their own instruments. There have been many articles, pamphlets, and books printed for amateur apparatus builders, but it is a sad fact that the great majority of the designs presented are either impractical or inefficient, if not both. Many radio writers

have given explicit directions for constructing transmitters and receivers which (so far as one can judge from the almost obvious faults in the suggested instruments) they have probably never tried to build and certainly never succeeded in working. In contrast to this sort of thing are two helpful books by M. B. Sleeper, entitled "Construction of Radio Phone and Telegraph Receivers for Beginners"<sup>11</sup>, and "Design Data for Radio Transmitters and Receivers"<sup>12</sup>; full working details for building a modern variometer type receiver (together with some interesting comments on radio telephony) will be found in "The How and Why of Radio Broadcasting"<sup>13</sup> by Arthur H. Lynch; and much information of utility is given by E. E. Bucher in "The Wireless Experimenter's Manual"<sup>14</sup>.

A number of special subjects in the application of radio have been treated individually. "Radiodynamics"<sup>15</sup> by B. F. Miessner tells an interesting story of the control of distant mechanisms by means of wireless waves; "Wireless Transmission of Photographs"<sup>16</sup> by M. J. Martin describes many unusual experiments along the line which the title indicates; and "The Alexanderson System for Radio Telegraph and Radio Telephone Transmission"<sup>17</sup> by E. E. Bucher will interest any one who would enjoy exploring a modern high-powered trans-oceanic wireless station. Another special subject, which on account of its importance has received much attention by authors, is the vacuum tube now in such wide use. Elementary books describing its action as detector, amplifier, and oscillator are "The Oscillation Valve"<sup>18</sup> by R. D. Bangay, and "The ABC of Vacuum Tubes in Radio Reception"<sup>19</sup> by E. H. Lewis, both of which are clear and generally accurate. A somewhat less recent book on the same subject, which, however, gives an easily understood graphical description of the working of the device, is Bucher's "Vacuum Tubes in Wireless Communication".<sup>20</sup> For the advanced or scientifically trained student "The Thermionic Vacuum Tube and its Applications"<sup>21</sup> by H. J. Van der Bijl will be found a splendid treatise. Two other highly technical books on tubes are "The Thermionic Valve and its Developments in Radio Telegraphy and Telephony"<sup>22</sup> by J. A. Fleming, and "Thermionic Tubes in Radio Telegraphy and Telephony"<sup>23</sup> by John Scott-Taggart. The former gives much historical matter of interest and value, as well as Professor Fleming's mathematical analyses of

tube action; the latter is a very recent publication which describes present day British practice in the design and construction of valve outfits.

Two other rather specialized books which will be of greatest use only to the technical student are "Telephony without Wires"<sup>24</sup> by P. R. Coursey and "Continuous Wave Wireless Telegraphy"<sup>25</sup> by W. H. Eccles. The first of these is quite different from the purely popular accounts of wireless telephony; it treats the radiotelephone technically as a division of radio signaling and assumes that the reader is fairly well familiar with wireless telegraphy. The second book is a full engineering development of the electrical theory of continuous-wave circuits and instruments, including vacuum tubes.

Having passed to the technical publications in radio, we must now consider those which go into the subject in a general but somewhat advanced way. The non-technical reader will have difficulty in getting very much from most of these books, but any one with even a small mechanical or electrical aptitude or education will be able to dig out a good deal of immense value. F. K. Vreeland's book called "Maxwell's Theory and Wireless Telegraphy"<sup>26</sup>, containing a translation of the famous paper by Poincaré, is not abstruse; the presentation of the principles underlying modern radio is vivid and easily read, so that the book, though nearly twenty years old, is interesting to-day. Another of the older books which still is attractive is the "Principles of Wireless Telegraphy"<sup>27</sup> by Dr. G. W. Pierce; here the emphasis is placed upon the action of resonant circuits and receiving instruments. A somewhat later publication is Zenneck's "Wireless Telegraphy,"<sup>28</sup> translated by A. E. Seelig, which is a classical work on the fundamentals of radio design and practice. Another radio classic is Professor J. A. Fleming's "Principles of Electric Wave Telegraphy and Telephony"<sup>29</sup>, which first appeared in 1906 but which has been brought up to 1919 in a revised fourth edition; this volume is an exhaustive historical, theoretical and descriptive treatment of the development of radio signaling.

In the past year or two there have appeared three other general radio books, each of which is noteworthy in its particular classification. "Electric Oscillations and Electric Waves"<sup>30</sup> by Professor G. W. Pierce is a highly technical discussion of the theories and operations under-

lying the whole science of radio; here engineering students well accustomed to handling the tool of mathematics will find much to clarify and reduce to quantitative relations the ideas which are generally considered only qualitatively. The second book, "Principles of Radio Communication"<sup>31</sup> by Professor J. H. Morecroft, is much more understandable to the average technical man, for although mathematical analyses and developments are not slighted they are supplemented with abundant graphical illustrative data. Moreover, this volume does not stop with abstract considerations, but goes into the basic detail of modern radio instruments. It is valuable both as a course of study and as a reference book. The third of this recent group is the U. S. Army Radio Pamphlet (something of a misnomer) No. 40, named "The Principles Underlying Radio Communication" (Second Edition)<sup>32</sup> which is intended for students with comparatively little mathematical training but who desire a quite comprehensive presentation of electromagnetism and its applications in radio.

Although a good many of the books mentioned above contain material the most important use of which is for reference, there are certain others whose greatest value appears when one has before him some particular problem for the solution of which certain quantitative data are required. Among these are "Wireless Telegraphy and Telephony; a Handbook of Formulae, Data and Information"<sup>33</sup> by W. H. Eccles, "Standard Tables and Equations in Radio Telegraphy"<sup>34</sup> by Bertram Hoyle, and "The Wireless Telegraphist's Pocket Book of Notes, Formulae and Calculations"<sup>35</sup> by J. A. Fleming. The U. S. Bureau of Standards has issued as its Circular No. 74, under the title "Radio Instruments and Measurements"<sup>36</sup> a valuable collection of radio data. In this connection, special mention must be made of Ralph Batcher's "Prepared Radio Measurements"<sup>37</sup> which contains some sixty self-computing or alignment charts designed to obviate much numerical work in simple radio computations.

Another useful reference work is the "Yearbook of Wireless Telegraphy"<sup>38</sup>, which comes out annually and contains the radio laws of various countries, a five-language radio glossary, a list of the land stations throughout the world, and much other information. Finally, every radio station should have the U.S. Department of Commerce radio pamphlets

"Radio Communication Laws of the U. S."<sup>39</sup>, "Amateur Radio Stations of the U. S."<sup>40</sup> and "Commercial and Government Radio Stations of the U.S."<sup>41</sup> which contain essential data as to license requirements, the call letters and locations of important radio stations, etc.

So brief a description as I have given of each book will hardly suffice to bring out its real value to the reader. Nevertheless, by arranging the volumes in a rough classification and by mentioning only a few of the leading books in each class, I trust that I have succeeded in indicating which (of the many publications now available) are most likely to fill certain needs in a reasonably satisfactory way.

\* \* \*

Books noted in the above article, in the order of reference to them:

- 1: "Wireless Telegraphy and Telephony"; A. E. Kennelly; Moffat, Yard & Co., New York, 1910; 279 pages; (out of print).
- 2: "The Wonders of Wireless Telegraphy"; J. A. Fleming; Society for Promoting Christian Knowledge, London, 1913; 279 pages; price \$1.40.
- 3: "Wireless Telegraphy"; C. L. Fortescue; G. P. Putnam's Sons, New York, 1913; 143 pages.
- 4: "Wireless Telegraphy and Telephony"; Alfred P. Morgan; Norman W. Henley Pub. Co., New York, 1922; 154 pages; price \$1.50.
- 5: "Radio for Everybody"; A. C. Lescarbours; Scientific American Pub. Co., New York, 1922; 334 pages; price \$1.50.
- 6: "The Complete Radio Book"; R. F. Yates and L. G. Pacent; The Century Co., New York, 1922; 330 pages; price \$2.00.
- 7: "Wireless Telegraphy"; Ernst Ruhmer; Crosby Lockwood & Son, London, 1908; 224 pages; price .
- 8: "Radio Telephony"; A. N. Goldsmith; The Wireless Press, New York, 1918; 247 pages; price \$2.50.
- 9: "Elements of Radio Telephony"; W. C. Ballard, Jr.; McGraw-Hill Book Co., New York, 1922; 132 pages; price \$1.50.
- 10: "Radio Phone Receiving"; E. Hausmann, A. N. Goldsmith, L. A. Hazeltine, J. V. L. Hogan, J. H. Morecroft, F. E. Carnavaciol, R. D. Gibson, and P. C. Hoernel; D. Van Nostrand Co., New York, 1922; 183 pages; price \$1.50.
- 11: "Construction of Radio Phone and Telegraph Receivers for Beginners"; M. B. Sleeper; Norman W. Henley Pub. Co., New York, 1922; 142 pages; price 75 cents.
- 12: "Design Data for Radio Transmitters and Receivers"; M. B. Sleeper; Norman W. Henley Pub. Co., New York, 1922; 85 pages; price 75 cents.
- 13: "The How and Why of Radio Broadcasting"; Arthur H. Lynch; Doubleday Page & Co.,

- New York, 1922; 32 pages and 4 charts; price 50 cents.
- 14: "The Wireless Experimenter's Manual"; E. E. Bucher; The Wireless Press, New York, 1920; 340 pages; price \$2.25.
- 15: "Radiodynamics"; B. F. Miessner; D. Van Nostrand Co., New York, 1916; 206 pages; price \$2.00.
- 16: "Wireless Transmission of Photographs"; M. J. Martin; The Wireless Press, Ltd., London, 1916; 114 pages; price \$2.00.
- 17: "The Alexanderson System"; E. E. Bucher; The Wireless Press, New York 1920; 55 pages; price \$1.25.
- 18: "The Oscillation Valve"; R. D. Bangay; The Wireless Press. Ltd., London, 1920; 215 pages; price \$2.75.
- 19: "The ABC of Vacuum Tubes"; E. H. Lewis; Norman W. Henley Pub. Co., New York, 1922; 132 pages; price \$1.00.
- 20: "Vacuum Tubes in Wireless Communication"; E. E. Bucher; The Wireless Press, New York, 1918; 174 pages; price \$2.25.
- 21: "The Thermionic Vacuum Tube"; H. J. Van der Bijl; McGraw-Hill Book Co., New York, 1920; 391 pages; price \$5.00.
- 22: "The Thermionic Valve and its Developments in Radio Telegraphy and Telephony"; J. A. Fleming; The Wireless Press, Ltd., London, 1919; 279 pages; price \$5.00.
- 23: "Thermionic Tubes in Radio Telegraphy and Telephony"; John Scott-Taggart; The Wireless Press, Ltd., London, 1921; 424 pages; price \$8.00.
- 24: "Telephony without Wires"; P. R. Coursey; The Wireless Press, Ltd., London, 1919; 414 pages; price \$5.00.
- 25: "Continuous Wave Wireless Telegraphy"; W. H. Eccles; The Wireless Press, Ltd., London, 1921; 407 pages; price \$8.00.
- 26: "Maxwell's Theory and Wireless Telegraphy"; H. Poincaré and F. K. Vreeland; McGraw Pub. Co., New York, 1904; 255 pages; (out of print).
- 27: "Principles of Wireless Telegraphy"; G. W. Pierce; McGraw-Hill Book Co., New York, 1910; 350 pages; price \$3.00.
- 28: "Wireless Telegraphy"; J. Zenneck, translated by A. E. Seelig; McGraw-Hill Book Co., New York, 1915; 442 pages; price \$5.00.
- 29: "The Principles of Electric Wave Telegraphy and Telephony"; J. A. Fleming; Longmans, Green & Co., London, 1919; 707 pages; price \$14.00.
- 30: "Electric Oscillations and Electric Waves"; G. W. Pierce; McGraw-Hill Book Co., New York, 1920; 517 pages; price \$5.00.
- 31: "Principles of Radio Communication"; J. H. Morecroft; John Wiley & Sons, New York, 1921; 935 pages; price \$7.50.
- 32: "The Principles Underlying Radio Communication"; Signal Corps, U. S. Army; Government Printing Office, Washington, 1922; 619 pages; price \$1.00.
- 33: "Wireless Telegraphy and Telephony"; W. H. Eccles; D. Van Nostrand Co., New York, 1918; 514 pages; (temporarily out of print).
- 34: "Standard Tables and Equations in Radio Telegraphy"; Bertram Hoyle; The Wireless Press, Ltd., London, 1919; 159 pages; price \$3.25.
- 35: "The Wireless Telegraphist's Pocket Book of Notes, Formulae and Calculations"; J. A. Fleming; The Wireless Press, Ltd., London, 1915; 347 pages; price \$3.50.
- 36: "Radio Instruments and Measurements"; Bureau of Standards; Government Printing Office, Washington, 1918; 329 pages; price 60 cents. Reprinted by The Wireless Press, New York, and bound in cloth; Price \$1.75.
- 37: "Prepared Radio Measurements"; Ralph Batchner; The Wireless Press, New York, 1921; 132 pages; price \$2.00.
- 38: "The Yearbook of Wireless Telegraphy and Telephony"; The Wireless Press, Ltd., London; issued annually; about 1200 pages; price \$6.00.
- 39: "Radio Communication Laws of the U. S."; Department of Commerce; Government Printing Office, Washington; price 15 cents.
- 40: "Amateur Radio Stations of the U. S."; Department of Commerce; Government Printing Office, Washington; price 15 cents.
- 41: "Commercial and Government Radio Stations of the U. S."; Department of Commerce; Government Printing Office, Washington; price 15 cents.

Note: The books published by The Wireless Press, Ltd., London, may be obtained from The Wireless Press, New York, at the prices given.

## Progress of Radio in Foreign Lands

### ENGLAND'S BROADCASTING PROBLEM

ENGLAND is still discussing radiophone broadcasting, while numerous English radio amateurs storm and fume as they read our American radio periodicals. Now we learn that Postmaster General Kelleway of Great Britain, in a recent speech, announced the com-

pletion of plans for radiophone broadcasting by the General Post Office at a nominal sum to patrons for a permit, which will be the only expense involved. The normal hours for broadcasting will be from 5 P.M. to 11 P.M. except on Sundays, when there will be no limit. Certain regulations are to be issued later with



regard to the character and class of news which the authorized agencies will be allowed to transmit. Until last September the manufacture, sale, or possession of radio apparatus was greatly restricted by the General Post Office, under the provisions of the Defense of the Realm Act (regulation No. 22). With the lapse of that war-time regulation, the authority of the Post Office is limited to that conferred by the Wireless Telegraphy Act of 1904, which requires the possession of a license before any radio apparatus can be installed or worked. For these reasons, radio telephone broadcasting in Great Britain has heretofore been limited to occasional demonstrations by the General Post Office and Marconi's Wireless Telegraph Company; as late as last October, the *Wireless World*, of London, was receiving subscriptions from radio amateurs in England to insure the continuance of the radio concerts conducted by the Nederlandsche Radio Industrie at The Hague, in Holland. The Marconi Company has recently announced its intention to broadcast radio telephone news and concerts. The general development of the field by the Post Office will be far reaching

in its effects in establishing a new industry that will give employment to large numbers of people, as it has done here.

#### BRITISH VALVES AND OUR VACUUM TUBES

FOR a long while back our British friends have been using "valves," as they call vacuum tubes, for their high-power radio telegraphic communication. For this purpose the British Admiralty has developed a special type of glass with a high silica content, which stands considerably more heat than ordinary glass. The silica valves, as the tubes employing the special silica walls are called, are covered by the Admiralty Patents and the sole licensees and manufacturers are the Mullard Radio Valve Company. At present, the Mullard organization makes a Mullard audio-frequency tube with a continuous anode consumption of 15 milliwatts and a filament consumption of 150 milliwatts—a "dry cell" proposition, at the lower end of the scale, and a high-power silica valve with a continuous anode consumption of 2.5 kilowatts and a filament of 0.25 kilowatts at the upper end of the scale. The power tubes are mounted in neat cartridge-like

#### A SCOUT TROOP IN AN ENGLISH SCHOOL

Being taught the construction and use of the radiophone. There are very few scout troops in America as well supplied with radio equipment as these boys are



holders which may be handled with a minimum danger of breakage.

#### INCREASING THE RANGE OF NAUEN

THAT famous long-distance radio station, Nauen, in Germany, is to be altered so as to increase its range and to meet the increasing traffic in the United States and Argentine Republic. Twenty-five million marks additional capital is being raised by the Trans-Radio Company, and a beginning has already been made with the constructive work. The plans include the erection of seven new masts, each 689 feet high, and the dismantling of four of the existing masts. Until now the Nauen signals have been picked up in the United States by amateurs possessing tuners of extreme wave length range, as well as vacuum tube detectors and two-stage audio-frequency amplifiers. With the increased power of Nauen after the alterations, the signals should be picked up even more readily.

#### LONG-DISTANCE BROADCASTING OF NEWS

THE Central Telegraph Office of England is now carrying on wireless services to Berlin, Cologne, Posen, Rome, and Egypt. News handed in at that office is broadcasted from the Post Office radio station at Leafield, near Oxford, and is picked up in India and

#### RADIO BROADCASTING IS FINDING ITS WAY INTO INDIA

Where, it is thought, the new science will materially reduce the tendency toward revolt



Australia, except when atmospheric conditions are unfavorable, while a regular radio news service is carried on with Halifax in Nova Scotia.

#### THE FRENCH MILITARY CHAIN AND OTHERS

THE French Military Chain, is now nearly completed, much of it having been planned since the Armistice. Paris is, or shortly will be, linked by first-class stations with the Soudan, the Congo, Antananarivo, Pondicherry and Cochin China. All these steps are of the 2,000-mile order or less, except that from Antananarivo to Pondicherry, which is 3,100 miles. Besides the Military Chain, France possesses a first-class Naval station at Nantes, and two magnificent stations at Bordeaux and Lyons. The Italian state-owned scheme, on the other hand, embraces two modern stations in Italy, and two spark stations in North East Africa. The Rome station was built by the British radio engineer, Mr. Elweel, during the war, and the Coltano station is being equipped by the Marconi Company. The longest distance between the Italian stations is about 2,500 miles. Still another scheme was the German Chain, which contemplated three stations in Africa, one in the Java Seas, and one in Yap. Those which were erected were lost during the war. The distance from the Nauen station to the

Kamina station is 3,400 miles, and proved too great for real work. Windhuk is nearly 2,000 miles south of Kamina, and is believed to have exchanged scarcely any signals successfully during its short active life.

#### BELGIUM'S EXPANDED RADIO SERVICE

THE Belgian merchant service, which before the war included ten radio units, now possesses more than 120, which are controlled by the Administration des Télégraphes. Belgium is building a high-power radio station which will insure communication with her colonies and with distant countries, and make her independent of the cables, if need be.

# Radio panels and Radio Parts

**S**TART right. The panel is the very foundation of your set. High volume and surface resistance are essential factors. Make sure that you get them in both the panels and parts that you purchase. To make doubly certain look for the dealer displaying this sign

CONDENSITE  
**CELORON**

## Radio Panel Service

Condensite Celoron Grade 10—approved by the Navy Department, Bureau of Engineering—is a strong, handsome, waterproof material, high in resistivity and dielectric strength. It machines easily, engraves without “feathering”, and is particularly desirable for panels. It is also widely used for making many other important radio parts such as tube bases, platform mountings, variable condenser ends, tubes for coil winding, bases, dials, knobs, bushings, etc. We are prepared to make these various parts to your own specifications.

Where economy is a factor we can supply panels of Vulcanized Fibre Veneer made of hard grey fibre veneered, both sides, with a waterproof, phenolic condensation product. This material has a hard, smooth, jet-black surface, machines and engraves readily and will give excellent service where very high voltages at radio frequencies are not involved.

Shielded plates (patent applied for) are made with a concealed wire shield. This shield, when properly grounded, effectively neutralizes all howl and detuning effects caused by body capacities.

### Send to-day for our Radio Panel Guide

Are you an enthusiast? This Guide describes our panels in detail—gives tests—and tells just how much the panel you want will cost.

Are you a Radio Dealer? Let us tell you how easily and profitably Celoron Radio Panel Service enables you to supply your customers with panels machined and engraved to their specifications. Write to-day for our Dealer's Proposition covering panels, dials, knobs and tubes.



## Diamond State Fibre Company

Bridgeport (near Philadelphia) Pa.

BRANCH FACTORY AND WAREHOUSE, CHICAGO

Offices in principal cities

In Canada: Diamond State Fibre Co. of Canada, Ltd., Toronto.

# U. S. Weather Reports for Ships Without Radio

By S. R. WINTERS

**O**RDERS have been promulgated and recently issued to managing agents and masters of the vessels of the United States Shipping Board to signal by international code or other methods storm warnings picked up by radio to ships devoid of wireless facilities. Described as a courtesy of the seas, this departure in the constantly expanding uses of radio communication is made possible by arrangements with about twenty high-powered stations of the world to broadcast storm warnings on schedules furnished wireless operators on board government-operated ships.

The safeguarding of life and property is the objective of the government instructions, which are mindful of all vessels not equipped with radio, irrespective of the nationality of the ship. The innovation recognizes the fact that many vessels are cruising along the coast without these facilities. Whenever any such ship is met on the high seas by a vessel of Uncle Sam, storm warnings picked up during the preceding twelve hours will be made available to it. This friendly service includes weather reports intercepted through foreign as well as domestic radio stations.

Stations cooperating in the world-wide service which brings weather forecasts to vessels on the high seas with quite the effect and frequency that the approach of storms is foretold to farmer and city dweller on land include: Poldhu, 2,700 meters; Malta, 2,700 meters; Eiffel Tower, 2,500 meters—stations located in Europe; Melbourne, 600 meters, and Sidney, 600 meters, in Australia; Shanghai Zi Sapawei; Papeete and Ile Tahite, 600 meters, in French Oceania; Pearl Harbor, 600 meters, Calcutta, 200 meters, in India; in Hawaiian Islands; Choshi, 600 meters, in Japan; Campeche, 600 meters, in Mexico; Capetown and Durban, 600 meters, in South Africa; and the

following stations in the United States—Arlington, 2,500 meters; Annapolis, 1,700 meters; Key West, 1,500 meters; Santiago, 600 and 950 meters; San Francisco, 600 and 950 meters.

The vessels of the United States Shipping Board, are equipped with radio apparatus of the latest type. Transmitters, receivers, and auxiliary storage batteries for emergencies are included in the outfits. Recently Uncle Sam adopted the policy of providing all new ships with continuous-wave transmitting sets of the Poulsen 2-kilowatt type. Likewise vacuum tube detectors are in service. By the method of relaying used between Shipping Board vessels messages filed on ships plying on usual passenger routes can be transmitted to any point in the universe. Special effort is being made by the Shipping Board to develop its communication system in conjunction with that of the United States Navy Department and high-powered commercial stations located in this country that its vessels will be within receiving distance of one of these stations regardless of their location on the high seas.

Creditable records in radio communication have been established recently by cargo-and-passenger-carrying agencies of the Shipping Board. The *S. S. Aeolus* on an errand from New York City to South America communicated with *S. S. Venezuela* near the Hawaiian Islands. On passenger vessels plying between New York and Montevideo, in South America, passengers were supplied current news and reports from stock markets at home daily throughout the trip, unless severe static conditions in southern waters interfered.

The broadcasting of storm warnings, it would seem is a courtesy of the seas that will not only render a practical service but stimulate friendly relations between passengers on vessels of all nationalities.



*"Listening in"  
with the Magnavox  
Radio, the repro-  
ducer supreme—*



## Essential to the full enjoyment of your wireless receiving set is the MAGNAVOX RADIO

A FEW months ago the Magnavox Radio occupied a relatively unimportant position in the list of Magnavox products—today even our greatly increased production facilities are taxed to supply the demand for Magnavox Radio, the reproducer supreme.

It is the Magnavox Radio which gives every receiving set its greatest enjoyment and use—doing away with the restrictions

and limitations of the *individual headset*. The receiving set only *brings* the message, while Magnavox Radio *tells* it clearly and in full volume to all within reach of its voice.

The Magnavox Radio operates with any good type of receiving apparatus, and was not designed for any one particular make. Without the Magnavox Radio no receiving set is complete.

*Any radio dealer will demonstrate; or write us  
for descriptive booklet and name of nearest dealer.*

**THE MAGNAVOX CO.** Home Office and Factory:  
OAKLAND • CALIFORNIA

New York Office: 370 Seventh Avenue

# The Grid

## QUESTIONS AND ANSWERS

The Grid is a Question and Answer Department maintained especially for the radio amateur. Full answers will be given wherever possible. In answering questions, those of a like nature will be grouped together and answered by one article. Every effort will be made to keep the answers simple and direct, yet fully self-explanatory. Questions should be addressed to Editor, "The Grid," Radio Broadcast, Garden City, N. Y. The letter containing the questions should have the full name and address of the writer and also his station call letter, if he has one. Names, however, will not be published.

*Will a loop aerial work as well, or nearly as well, as a single wire antenna 100 feet long?*

D. C.

Gloucester, Mass.

IF THE single wire is outside and isolated from surrounding objects and is 25 feet or more above the ground, it is doubtful that any loop will function as well, unless the deficiency in signal strength obtained is compensated for by the use of radio frequency amplification. Armstrong's latest circuits work very satisfactorily with a loop but they are very critical in their operation. In any event the energy picked up by an outside wire is generally greater than that picked up by a loop.

*I am enclosing a photograph of a receiving set published in Radio Broadcast. Will you kindly send me the general requirements for this set and how to construct it?*

E. H. C.

Brooklyn, N. Y.

YOUR letter is typical of a great number requesting detailed information on equipment illustrated in RADIO BROADCAST. It is impossible to comply with such requests for the reason that the photographs in many instances are supplied by manufacturers and it would be unfair to them for the details which they have spent considerable time and money in perfecting to be made general information. However, from time to time, the details for the construction of equipment designed by individuals appear in the text of the magazine.

*Can you tell me where I can find diagrams of radio hook-ups by Armstrong?*

LIBRARIAN

Bridgehampton, N. Y.

MANY of the fundamental circuits for the Armstrong regenerative system are included in the copy of Patent No. 1,113,149 which may be had upon application to the Patent Office, for five cents. This patent contains some very useful information. Among other things, various circuit arrangements are shown in which the wavelength is regulated by varying the inductance, capacity, or both. As the wave length of any circuit depends upon the aggregate values of inductance and capacity it contains, variation of either, or both results in a change of wavelength. In order to accomplish various results, it is advisable to make the changes in various ways. For instance a tickler or regenerative coil provided with a slider for regulating the number of turns in the coil may well be substituted by a variometer. The design and action of Armstrong's latest invention, the super-regenerative circuit, is rather completely covered in an article by Mr. Paul Godley appearing in this issue. Circuit diagrams and the values of the various elements necessary for their arrangement are given.

*Is it possible to establish a broadcasting station which would give satisfactory results in an outdoor delivery, especially where there are many trees, etc? What does a broadcasting station consist of and approximately what would such a station cost to install?*

H. H. S.

Miami, Florida

THERE would be very little difficulty in broadcasting from out-of-doors. The microphone into which the artist or lecturer speaks at most broadcasting stations is located some distance from the transmitting apparatus itself. For outdoor delivery, the microphone might well be placed on the speaker's platform beside the customary pitcher of water.

A broadcasting station comprises a group of vacuum tubes along with the necessary generators for supplying the comparatively high voltage used in connection with the tube plates. In some broadcasting stations alternating current from an ordinary 60-cycle supply line is stepped up by transformers and then passed through rectifiers which convert it into direct current, following which it is smoothed out by a combination of condensers and choke coils. In this instance the high voltage generators are not necessary.

The price of a good broadcasting station suitable for transmitting over distances in excess of one hundred miles is several thousand dollars. Further information regarding stations of this character may be had by addressing the American Telephone & Telegraph Company, New York City or the Western Electric Company, New York City.

In contemplating a broadcasting station you should be certain that its operation is not going to render you liable to damage suit for patent infringement. As broadcasting is considered in the sense of commercial radio, the operation of a station for broadcasting is placed in the commercial category and equipment sold for amateur or experimental use only, when used in a broadcasting station makes the owner of that station liable to suit.

*Can a person equip a truck and travel from city to city giving radio concerts? What would such a station cost including the license?*

W. H. S.

Cleveland, O.

UNDOUBTEDLY a good radio receiving set could be installed on a truck and used as you suggest provided the distance from the broadcasting stations did not become too great. It is doubtful that an antenna permanently attached to a motor truck would be large enough to receive from more than forty or fifty miles with intensity enough to be heard by an audience of any size.

An outfit of this character would cost at least \$500. If you contemplate this project as a commercial enterprise, the receiving equipment will cost a great deal more because



## Putting the "howler" to sleep

**T**HERE'S more than one "howler" to put to sleep these days. Your radio set can put on the greatest squalling and howling demonstration you ever dreamed of. The surest way to stop this howling and keep it peaceful is to add an Acme *Audio* Frequency Amplifying Transformer.

Most any amplifying transformer can magnify the incoming sounds but it also amplifies the howling and distortion of stray fields in the circuit. Acme Transformers with their specially constructed iron cores and coils eliminate this disagreeable feature—and it only takes five dollars to buy one.

Acme assures your receiving a large volume of sound that possesses the

natural tones so lacking in the ordinary receiving set. Then, too, you will want the Acme *Radio* Frequency Transformer which costs the same as the Acme *Audio* Frequency Transformer. It can be used on both crystal detector and vacuum tube sets. It greatly increases the range of either.

You can buy either transformer at your nearest radio store or write the Acme Apparatus Company (pioneer transformer and radio engineers and manufacturers), Cambridge, Massachusetts, U. S. A. (New York Sales Office, 1270 Broadway.) Ask also for interesting and instructive booklet on the use and operation of amplifying transformers.



Type A-2 Acme Amplifying Transformer  
Price \$5 (East of Rocky Mts.)

# ACME

*for amplification*

it will have to be licensed for commercial use. Otherwise you are likely to infringe on patents. A better arrangement might be to install a complete station on the truck but make arrangements in the towns visited for the erection of a temporary outdoor antenna.

*Will you please publish a wiring diagram of the Armstrong super-regenerative circuit indicating the values of the various elements?*

N. M.

New York City.

**Y**OU will find the answer to this question very completely covered in Mr. Godley's article, "The Armstrong Super-regenerative Circuit", appearing in this number.

*We have a large factory which, we believe, could be turned over to the manufacture of receiving sets. Of course, we cannot manufacture Armstrong regenerative sets but contemplate an inexpensive crystal receiver which, we understand, infringes no patents. Are there any objections to this procedure?*

J. D.

Brookfield, Mass.

**T**HE manufacture of crystal receiving outfits has been indulged in quite generally for the reason that manufacturers considered that there were no restrictions on such devices. However, The Wireless Specialty Apparatus Company' which is associated with the General Electric Company and the Radio Corporation of America, controls the Pickard patents on crystal detectors and receiving

circuits employing crystals. They have advertised the fact that crystal receiving outfits infringe these patents in an open letter to the public and trade.

The Freed-Eisemann Radio Corporation has entered suit against The Wireless Specialty Apparatus Company alleging that the latter's advertising has seriously damaged the former's business and that the crystal receiving sets manufactured by the Freed-Eisemann Corporation do not infringe the patents referred to. The Freed-Eisemann Corporation is a member of The Independent Radio Manufacturers, Inc. and the association is to defray the cost for the suit which the company is pressing. The outcome of this and other suits dealing with crystal receivers, which are to receive court attention shortly, will probably clear up one of the most serious situations in radio. Further information regarding this situation may be had from The Independent Radio Manufacturers Association, Inc., 165 Broadway, New York City.

Many companies have been able to manufacture and sell units which infringed patents which they honestly did not know existed. This condition has been the result of the unprecedented demand for radio equipment and the effort being made by large manufacturers who held the patents to supply the demand. Due to the temporary let-up in radio during July and August these patent holders have been able to devote their attention to this part of their business and it is advisable for any company contemplating the manufacture of any type of radio equipment to have as its first requisite a thorough assurance that the devices they are to make are not patent infringing.

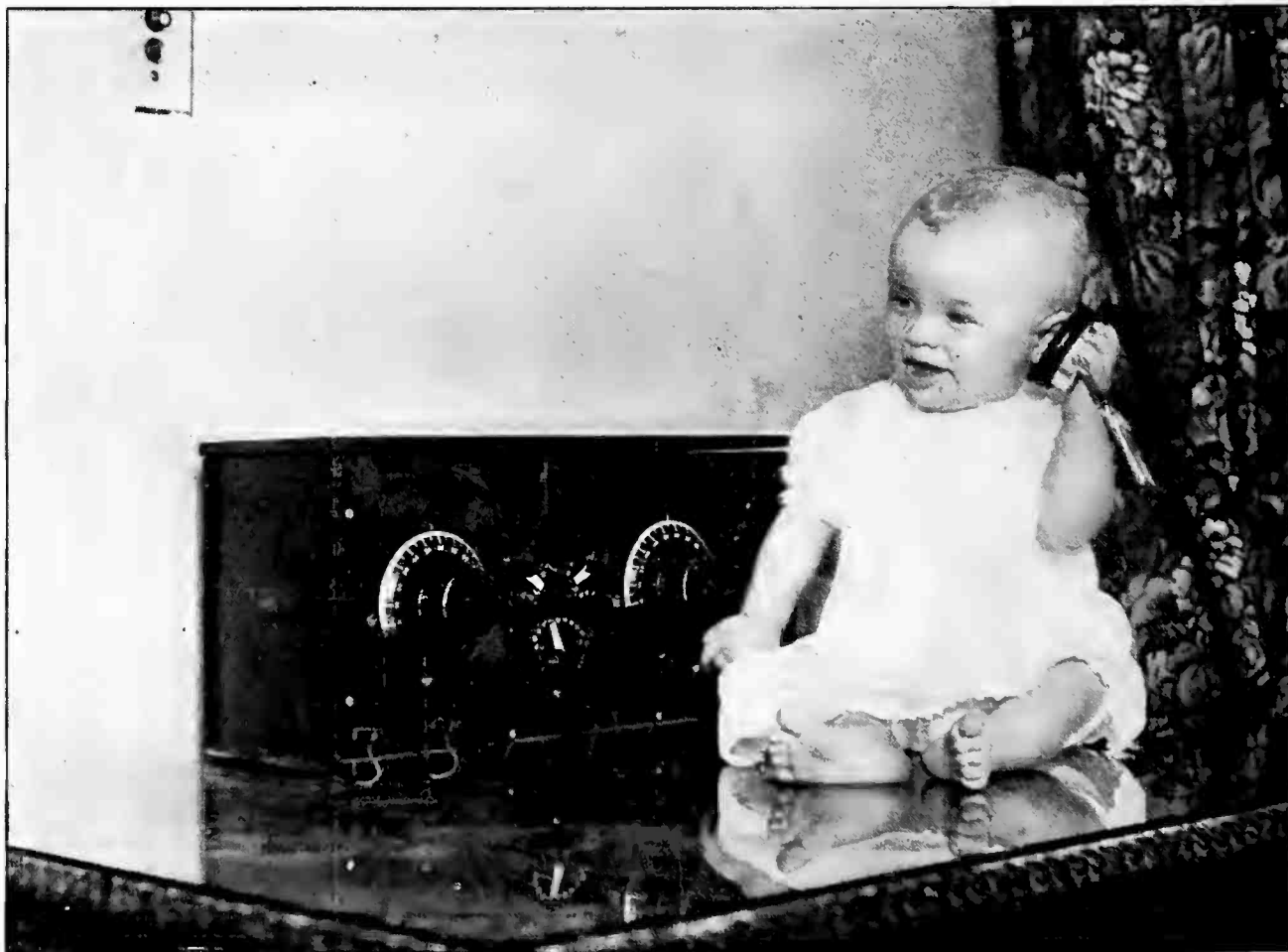

ROY YATES SANDERS, JR.  
A Radio-mite listening to the birdie