

RADIO
ANNUAL
TELEVISION
YEAR BOOK

ZIV'S "HOUR OF STARS"



MUSIC!



**TONY
MARTIN**

**GINGER
ROGERS**

UP TO 75 SPOTS PER WEEK SOLD IN "HOUR OF STARS"

**LOOK
AT THESE
STATION
SELL-OUTS!**

WSAI CINCINNATI, OHIO
"HOUR OF STARS" . . .
SOLD OUT!
75 SPOTS WEEKLY ON FIRST AUDITIONS
TO THESE ALERT ADVERTISERS . . .

- ALBERS SUPER MARKET
- JUMBO PEANUT BUTTER
- PEPSI-COLA
- HOTPOINT APPLIANCES (dealer)
- BAVARIAN BREWING CO.
- MR. MUSTARD
- WORTHMORE SOUP
- DORSEL'S FLOUR

All 8 Sponsors New to WSAI

KLMR LAMAR, COLORADO
"HOUR OF STARS" . . .
SOLD OUT!
75 SPOTS WEEKLY TO THIS
GREAT GROUP OF SPONSORS . . .

- FLORA REXALL STORE
- MILNE INSURANCE CO.
- LAMAR LIGHT & POWER CO.
- PEERY ELECTRIC
- POWER'S FIRESTONE STORE
- CUT RATE GROCERY & MARKET
- DON WESTFALL CREDIT BUREAU
- MAIN CAFE
- MORANS HARDWARE STORE

Hour of Stars Creates New Business!

WDOY
"HOUR OF STARS"
SOLD OUT!
75 SPOTS WEEKLY TO THIS
GREAT GROUP OF SPONSORS . . .

- EMANUEL'S
- DOVER HADY
- PHILCO DEALER
- VOGUE SHIRT S
- DANNEMANS
- NAP & SPINCE
- SANDERS JEW
- WESTERN ELECT
- GENERAL ELECT
- HUBER BREAD

Hour of Stars

the BIGGEST show...The LOWEST price...in History



**DICK
WELL**

**PEGGY
LEE**



EXCITEMENT!

FUN!



**AWARE
IT!**

- KRESGE 5 & 10
- GENERAL MILLS FLOUR
- COLGATES VEL
- MAXWELL HOUSE COFFEE
- PERTUSSIN
- FLETCHER'S CASTORIA
- ZENITH TV
- 7-UP BOTTLING CO.
- FORD DEALER
- PONTIAC DEALER
- DODGE DEALER
- B-C HEADACHE POWDER
- HOOVER APPLIANCE DISTRIBUTORS
- BABBITT CLEANER
- NATIONAL PREMIUM BEER
- GENERAL ELECTRIC DEALERS

**NATIONAL
ADVERTISERS
LIKE THESE:**

**ARE BUYING
PARTICIPATION
IN "THE HOUR
OF STARS" ON
FINE STATIONS
LIKE THESE:**

- WING, Dayton, Ohio
- WSAZ, Huntington, W. Va
- KSO, St. Louis, Mo
- WFAA, Dallas-Ft. Worth
- WKOY, Bluefield, W. Va
- WSPD, Toledo, Ohio
- WHOO, Orlando, Fla
- WMC, Memphis, Tenn
- WSDC, Marine City, Mich.
- KXYZ, Houston, Texas

**PULLING SPONSORS AND
PROFITS FOR STATIONS
IN OVER 300 MARKETS!**

*BE SURE YOUR MARKET, YOUR STATION IS
IN THE MONEY WRITE, WIRE OR PHONE*





"CHANCE OF A LIFETIME"

DENNIS JAMES

Personal Management

AARON B. STEINER

RADIO DAILY
TELEVISION DAILY

01
\$800

Presents

1954 RADIO ANNUAL

SEVENTEENTH ANNUAL EDITION

JACK ALICOATE
Editor-in-Chief

Copyright 1954 by RADIO DAILY CORP., 1501 B'way, New York 36, N. Y.

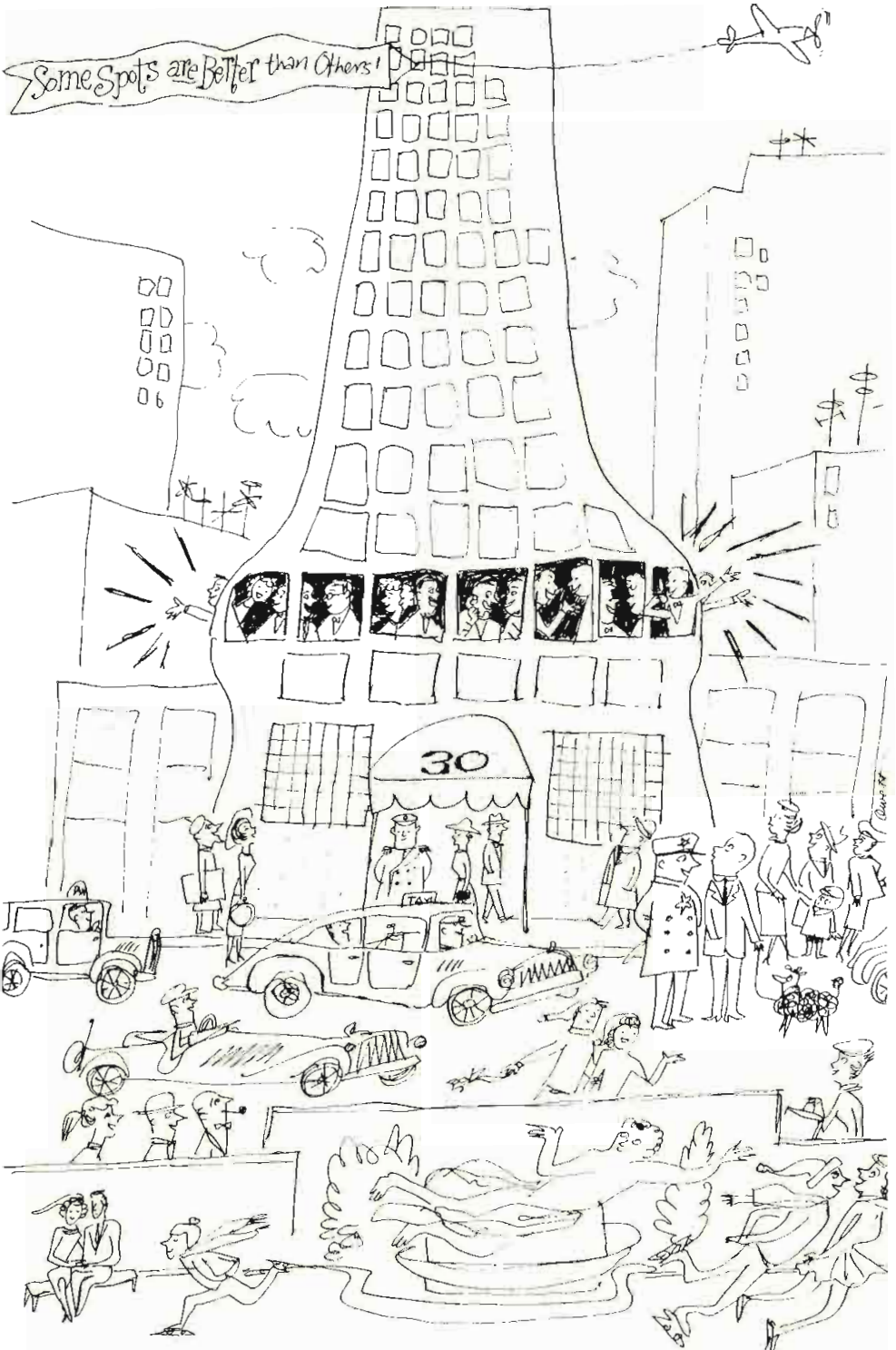

Nothing unusual, things are always poppin' at NBC SPOT SALES!

Foreword

THIS year's edition of Radio Annual is a progress report on radio broadcasting. Page after page tells the moving story of radio's continued gains despite the growth of television. The wealth of information about networks, stations, programming agencies and allied services is proof positive that radio as a commercial communications service is vital and continues to prosper.



THE enthusiastic support received from the radio broadcasting industry in compiling this seventeenth annual edition bespeaks their sustained interest in the volume and their confidence in the future of radio. It is documentation of the untiring creative efforts of all who have contributed so much to the success of this indispensable medium.



A GAIN we are grateful to all who have contributed to the success of this volume. Without their contributions the dramatic story of a growing service could never have been so completely told.

JACK ALICOATE
Editor-in-Chief

FOR WORLD-WIDE NEWS . . .

FOR CLEAR, COMPREHENSIVE

COVERAGE . . .

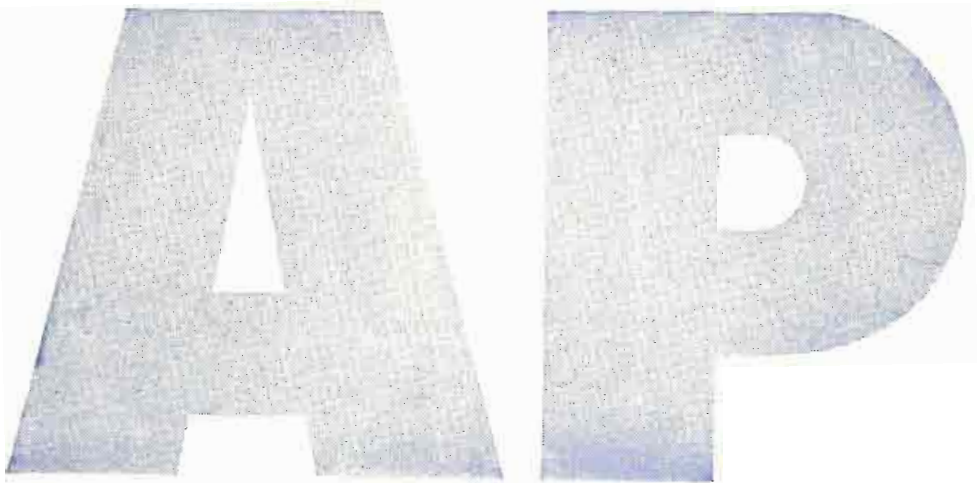
The image shows two large, stylized letters, 'A' and 'P', side-by-side. They have a textured, woven appearance, similar to fabric or a coarse mesh. The 'A' is on the left and the 'P' is on the right. The letters are filled with a light blue and white pattern, giving them a three-dimensional, tactile quality.

FOR:

AM-FM-TELEVISION

50 ROCKEFELLER PLAZA, NEW YORK 20, N. Y.

EDITORIAL

1954

INDEX

1954

A

Academy of Television Arts & Sciences..	757
Actors	1049
Actor's Equity Association.....	757
Actresses	1049
Adams, Stanley..... Article.....	1195
Advertising Index	25
Advertising Agencies	133
Advertising Council, The.....	757
Advertising Federation of America.....	757
Advertising Research Foundation.....	757
Agencies, Adv., Personnel, Accounts....	133
Agency & Sponsor Network Billings....	125
Agents & Managers, Talent.....	252
Alabama: AM Stations.....	316
Families (total in state).....	316
FM Stations	1210
Population	316
Radio Homes (total).....	316
TV Stations	847
Alaska: AM Stations.....	655
TV Stations	926
Alaska Broadcasting System.....	289
Alberta: AM Stations.....	675
Alicoate, Jack..... Introductions.....	3, 769
Allard, T. J..... Article.....	53
Almanac of Holidays & Special Events..	1284
Aloha Network	289
American Assn. of Advtg. Agencies....	757
AMERICAN BROADCASTING CO.:	
Commercial Programs-AM	1240
Commercial Programs-TV	1258
Executives & Personnel, Radio..	262
Executives & Personnel,	
Television	800
Kintner, Robert E..... Article	259
Network Billings	125
Network Map-AM	260-1
Network Map-TV	798-9
Stronach, Alexander, Jr. Article..	796
TV Executives Biographies.....	797
American Communications Assn.....	757
American Federation of Musicians.....	758
American Federation of TV & Radio	
Artists (AFTRA)	758
American Guild of Musical Artists, Inc..	758

American Marketing Association.....	758
American Newspaper Publishers Assn...	758
American Women in Radio-Television	
Inc.	758

ARTICLES: RADIO

Allard, T. J.....	53
Arnold, Murray	111
Azcarraga, Emilio	79
Baker, Dr. W. R. G.....	81
Burke, Frank	35
Byron, James A.....	87
Dodge, Fred N.....	77
Dunton, Davidson	95
Fellows, Harold E.....	65
Folsom, Frank M.....	55
Fouce, Frank	709
Frank, Milo O., Jr.....	85
Gallagher, Robert R.....	119
Grillo, Basil F.....	83
Hyde, Rosel H.....	33
Kellogg, Ted	115
Kintner, Robert E.....	259
Lewis, Dorothy	89
Murphy, Adrian	265
O'Neil, Thomas F.....	271
Ross, Betty	756
Sarnoff, Brig. Gen. David	47
Secrest, James D.....	61
Seiler, James W.....	59
Streibert, Theodore C.....	63
Weaver, Sylvester L., Jr.....	277
Weil, Ralph N.....	91
Weis, Pierre	93
Wolf, Sidney J.....	283
Ziv, Frederic W.....	75

ASCAP:

Stanley Adams... Article	1195
Personnel, Functions	1195
Publisher Members	1196
Amplitude Modulation (AM) Stations in	
U. S.	297
Announcers-MC's	1145
Arizona: AM Stations	326
Families (total in state).....	326
FM Stations	1210
Population	326

MARTIN BLOCK



AND HIS

MAKE BELIEVE BALLROOM

STARTING ITS

20th

YEAR

NOW ON

WABC — N. Y.

AND ABC RADIO NETWORK

SELLING BLUE CHIP ADVERTISERS TO AMERICA

715 FIFTH AVENUE · NEW YORK CITY · PLAZA 9-6154

EDITORIAL INDEX

Radio Homes (total).....	326
TV Stations	847
Arizona Broadcasting System.....	289
Arizona Network	289
Arkansas: AM Stations	330
Families (total in state).....	330
FM Stations	1210
Population	330
Radio Homes (total).....	326
TV Stations	848
Arnold, Murray....Article.....	111
Arrowhead Network	289
Artists, Radio-TV	1049
Artists' Representatives Assn., Inc.....	759

AMP:	
Personnel	759
Publisher Members	1199
Wall, Charles A.... Article.....	1199
Associated Press	117
Associations (Organizations)	757
Assn. of Canadian Advertisers, Inc.....	759
Assn. of National Advertisers, Inc.....	759
Assn. of Radio News Analysts.....	759
Associations, State Broadcaster.....	663
Authors Guild of the Authors League of America, Inc., The	759
Authors League of America, Inc., The..	759
Awards—Editors Poll	39
Azcarraga, Emiño.... Article	79

B

Bahamas-AM Stations	705
Baker, Dr. W. R. G.... Article.....	81
Behind The Mike, Before The Camera, (Radio-TV Artists)	1047
Bergmann, Ted.... Article	812
Bibliography, TV Reference Books.....	1292
Billings, Network, Agency & Sponsor....	125
Billings, Network, Estimated.....	37
Biographical Sketches:	
ABC TV Executives	797
CBS TV Executives.....	805
Du Mont Executives.....	813
NBC TV Executives.....	821
TV Personalities	999
Brand Names Foundation, Inc.....	760
British Broadcasting Corporation, The...	760
British Columbia: AM Stations	676
Broadcast Advertising Bureau, Inc.....	760
Broadcast Music, Inc.:	
Haverlin, Carl.... Article.....	1200
Personnel, Functions	760
Publisher Members	1201
Broadcasting and Film Commission,	
National Council of Churches.....	760
Broadcasting Corp. of America Network.	289
Brokers, Play and Story	1283
Brown, Charles B.... Article.....	1035
Paul Bunyon Network.....	289

Bureau of Broadcast Measurement, The..	761
Burke, Frank.... Article.....	35
Business Section	123
Byron, James A.... Article.....	87

C

California: AM Stations	337
Families (total in state).....	337
FM Stations	1210
Population	337
Radio Homes (total).....	337
TV Stations	849
California Northern Group.....	290

CANADA:

Allard, T. J.... Article.....	53
Canadian Assn. of Radio- Television Broadcasters	671
Canadian B'casting Corp.....	672
Dunton, Davidson.... Article.....	95
Station Representative	227
Stations-AM	675
Station Index	673
Stations-TV	927
Canadian Assn. of Radio-TV Bcstrs.....	761
Cartoon Producers	1042
(Also See Television Film Producers)	
Catholic Actors Guild of America, Inc...	761
Catholic Writers Guild of America, Inc...	761
CDC Tri-State Network.....	290
Chicago Telephone Numbers.....	102
Chronology of Color.....	41
Colorado: AM Stations	359
Families (total in state).....	359
FM Stations	1210
Population	359
Radio Homes (total).....	359
TV Stations	855

COLUMBIA BROADCASTING SYSTEM:

Commercial Programs-AM.....	1240
Commercial Programs-TV.....	1258
Executives & Personnel, Radio..	268
Executive & Personnel, Television	808
Murphy, Adrian.... Article.....	265
Network Map-AM.....	266-7
Network Map-TV.....	806-7
Van Volkenburg, J. L.... Article.....	804
TV Executives Biographies.....	805
Columbia Pacific Network.....	290
Columbia Television Pacific Network....	290
Columbine Network	290
Commentators: News	1105
Sports	1089
Women	1181
Commercial AM Programs.....	1240
Commercial AM-TV Programs 1953.....	1239
Commercial TV Programs.....	1258



"THE
PERRY COMO
SHOW"



♦ ♦ ♦ EDITORIAL INDEX ♦ ♦ ♦

Composers, Authors and Publishers	
Assn. of Canada, Ltd.....	761
Conductors, Musical, Radio-TV.....	1135
Connecticut: AM Stations.....	365
Families (total in state).....	365
FM Stations.....	1210
Population.....	365
Radio Homes (total).....	365
TV Stations.....	857
Connecticut State Network, Inc.....	290
Consulting Engineers.....	1236
Critics Awards for 1953.....	39
Cuba: AM Stations.....	702
TV Stations.....	927

D

Dairyland Network.....	290
Davis, Phil.... Article.....	1187
Delaware: AM Stations.....	368
Families (total in state).....	368
FM Stations.....	1210
Population.....	368
Radio Homes (total).....	368
TV Stations.....	858
Denmark: TV Stations.....	928
Directors, Radio-TV.....	1173
Disc Jockeys.....	1117
Distributors and Producers, TV Film.....	935
District of Columbia: AM Stations.....	370
Families.....	370
FM Stations.....	1210
Population.....	370
Radio Homes (total).....	370
TV Stations.....	858
District of Columbia Telephone Numbers.....	103
Dodge, Fred N.... Article.....	77
Dominican Republic: AM Stations.....	705
TV Stations.....	928
Don Lee Broadcasting.....	291
Dramatists Guild of the Authors League of America, Inc., The.....	761
DU MONT TELEVISION NETWORK:	
Commercial Programs.....	1258
Executives, Biographies.....	813
Network Map.....	814-5
Personnel.....	816
Dunton, Davidson.... Article.....	95

E

Editorial Index.....	5
Editors, Radio-TV.....	1272
Engineers, Consulting.....	1236
Episcopal Actors Guild of America, Inc.....	761
Equipment Section.....	1217
Equipment Manufacturers.....	1218
Estimated Families for 1954.....	296
Estimated Billings, Network.....	37

F

Favorites of 1953.....	39
Federal Communications Bar Assn.....	761
FEDERAL COMMUNICATIONS COMMISSION:	
Hyde, Rosel H.... Article.....	33
Licenses, How to Obtain.....	244
Members of Commission, Staff.....	240
TV Allocations.....	829
Federal Trade Commission.....	762
Fellows, Harold E.... Article.....	65
Film Producers and Distributors, TV.....	935
Florida: AM Stations.....	372
Families (total in state).....	372
FM Stations.....	1211
Radio Homes (total).....	372
TV Stations.....	859
Folsom, Frank M.... Article.....	55
Foreign Language Quality Network.....	291
Fouce, Frank.... Article.....	709
Frank, Milo O., Jr.... Article.....	85
French Broadcasting System (Radiodiffusion Francaise) in North America, The.....	762
Frequency Modulation (FM) Stations.....	1209
Frey, George.... Article.....	820

G

Gallagher, Robert R.... Article.....	119
Georgia: AM Stations.....	381
Families (total in state).....	381
FM Stations.....	1211
Population.....	381
Radio Homes (total).....	381
TV Stations.....	860
Georgia Associations of Local Stations.....	291
Germany, East-TV Stations.....	928
Germany, West-TV Stations.....	928
Granite State Network.....	291
Grass Roots Network.....	291
Great Britain, TV Stations.....	928
Great Northern B'casting System.....	291
Grillo, Basil F.... Article.....	83
Growth of Broadcasting.....	45
Guam AM Station.....	656
Guilds (Organizations).....	757
Guy Gannett B'casting System.....	292

H

Haiti: AM Stations.....	705
Haverlin, Carl.... Article.....	1200
Hawaii: AM Stations.....	656
FM Stations.....	1211
TV Stations.....	926
Heinecke, Paul.... Article.....	1205
Holiday & Special Events, Radio-Television Daily's Almanac, The.....	1284
Home Economists.....	1181
Hyde, Rosel H.... Article.....	33



HARRY WISMER

Broadcasting and Telecasting

TOP SPORTING EVENTS

ACROSS THE NATION

EDITORIAL INDEX

I

Idaho:	AM Stations	394
	Families (total in state).....	394
	FM Stations	1211
	Population	394
	Radio Homes (total).....	394
	TV Stations	863
Illinois:	AM Stations	397
	Families (total in state).....	397
	FM Stations	1211
	Population	397
	Radio Homes (total).....	397
	TV Stations	863

Indexes:

Advertising		25
Canada AM Stations		673
Editorial		5
TV Personalities		1000
U.S. AM Stations		299
U.S. FM Stations		1209
U.S. TV Stations		843
Indiana: AM Stations		408
	Families (total in state).....	408
	FM Stations	1211
	Population	408
	Radio Homes (total).....	408
	TV Stations	865
Institute for Education by Radio-TV		762
Institute of Radio Engineers, Inc.		762
Intercollegiate Broadcasting System		762
Intermountain Network		292
International		695
International News Service		117
International Stations of the U.S.		708
International Stations of Canada		708
Iowa: AM Stations		414
	Families (total in state).....	414
	FM Stations	1211
	Population	414
	Radio Homes (total).....	414
	TV Stations	867

J

Jamaica: AM Stations		705
Jewish Theatrical Guild		762
Joint Committee on Education Television		763
Jingle Writers		1191

K

Kansas: AM Stations		421
	Families (total in state).....	421
	FM Stations	1212
	Population	421
	Radio Homes (total).....	421
	TV Stations	868
Kellogg, Ted. Article		115
Kentucky: AM Stations		426

Families (total in state).....	426
FM Stations	1212
Housing Units	426
Population	426
Radio Homes (total).....	426
TV Stations	869

KEYSTONE BROADCASTING SYSTEM:

Affiliates	284-5
Executives & Personnel.....	288
Wolf, Sidney J. Article	283
Kintner, Robert E. Article	259

L

Lamb, Edward. Article	1208	
Lambs, The	763	
Latin American TV Stations.....	927	
Lewis, Dorothy. Article	89	
Lone Star Chain, Inc.	292	
Los Angeles Telephone Numbers	104	
Louisiana: AM Stations	432	
	Families (total in state).....	432
	FM Stations	1212
	Population	432
	Radio Homes (total).....	432
	TV Stations	869
Lowell Institute Cooperative Broadcasting & Station WGBH.....	763	

M

Madden, Edward D. Article	1133	
Magazines, Trade, Fan, Tech., General	1277	
Maine: AM Stations	437	
	Families (total in state).....	437
	FM Stations	1212
	Population	437
	Radio Homes (total).....	437
	TV Stations	871
Maine Broadcasting System	292	
Managers & Agents, Talent.....	252	
Manitoba: AM Stations	678	
Manufactured Since 1946, Total TV Sets	828	
Manufacturers of Equipment (Radio-TV)	1218	

MAPS—RADIO, TV:

ABC—Radio Net	260-1	
ABC—Television Net	798-9	
CBS—Radio Net	266-7	
CBS—Television Net	806-7	
Du Mont Television Net.....	814-5	
MBS—Radio Net	272-3	
NBC—Radio Net	278-9	
NBC—Television Net	822-3	
Maryland: AM Stations	441	
	Families (total in state).....	441
	FM Stations	1212
	Population	441
	Radio Homes (total).....	441
	TV Stations	873

UP

1400 radio stations from coast to coast receive from United Press an average of more than 40 news programs and news features every day—in addition to scores of extra shows of seasonal and special topical interest throughout the year. And some 200 kinds of sponsors buy them. The U.P. bureau nearest you is ready to present further information promptly.

United Press news programs for radio

United Press news programs for radio

TYPE	TITLE	MINUTES	DAYS
BASIC NEWS	World News Roundup	15	Weekdays, 7 times; Sun., 6 times
	The World in Brief	5	Weekdays, 14 times; Sun., 11 times
	The World in a Nutshell	1	Weekdays, 7 times; Sun., 6 times
SPORTS	Speaking of Sports	5	Monday through Saturday
	The Sports Lineup	5	Every Day
	The Sports Roundup	5	Twice Daily
	Great Moments in Sports	5	Monday through Saturday
	Sizing Up Sports	15	Sunday
FOR WOMEN	In the Woman's World	5	Monday through Friday
	Mainly for Women	5	Monday through Friday
	Women in the News	5	Monday through Friday
	Your Home	5	Saturday
HUMAN INTEREST	Names in the News	5	Monday through Friday
	Time Out	5	Monday through Friday
	In Your Neighborhood	5	Monday through Saturday
	In Movieland	5	Saturday
	Flashback	1	Monday through Friday
	United Press Almanac	1	Every Day
	Do Tell	5	Sunday
	In Their Own Words	5	Sunday
FARMING	Let's Take a Trip	5	Saturday
	On the Farm Front	5	Monday through Saturday
	Daily Farm Market Survey	5	Monday through Saturday
	Rural Roundup	5	Tuesday through Saturday
	R-F-D Review	5	Sunday
COMMENTARY & REVIEW	Today's United Press Commentary	5	Every Day
	Under the Capital Dome	5	Monday through Saturday
	United Press News Analysis	5	Monday through Friday
	Highlights of the Week's News	15	Sunday
	This is Washington	15	Sunday
BUSINESS & SCIENCE	United Press Reporting	15	Sunday
	Weekly Business Review	5	Sunday
	Tomorrow's Business	5	Saturday
	Today in Science	5	Monday through Friday
	Calling All Drivers	5	Sunday

EDITORIAL INDEX

Massachusetts: AM Stations	444
Families (total in state)	444
FM Stations	1212
Population	444
Radio Homes (total).....	444
TV Stations	874
Mayers, Arche....Article	998
MC's-Announcers	1145
McClatchy-Beeline	292
Metropolitan Network	292
Mexico: AM Stations	697
TV Stations	927
Michigan: AM Stations	451
Families (total in state).....	451
FM Stations	1212
Population	451
Radio Homes (total).....	451
TV Stations	875
Michigan Radio Network.....	292
Mid-South Network	292
Minnesota: AM Stations	462
Families (total in state).....	462
FM Stations	1212
Population	462
Radio Homes (total).....	462
TV Stations	878
Mississippi: AM Stations	467
Families (total in state).....	467
FM Stations	1212
Population	467
Radio Homes (total).....	462
TV Stations	879
Mississippi B'casting Co.....	293
Missouri: AM Stations	473
Families (total in state).....	473
FM Stations	1212
Population	473
Radio Homes (total).....	473
TV Stations	879
Montana: AM Stations	480
Families (total in state).....	480
Population	480
Radio Homes (total).....	480
TV Stations	883
Murphy, Adrian....Article	265
MUSIC:	
ASCAP	1195
AMP	1199
BMI	1200
SESAC	1205
Song Hits of 1953.....	48
Music Publishers' Contact Employees (A. F. of L.).....	763
Music Publishers' Protective Assn., Inc.....	763
Musical Commercial Producers.....	1191
Musical Conductors, Radio-TV.....	1135
MUTUAL BROADCASTING SYSTEM:	
Commercial Programs-Radio	1240
Executives & Personnel.....	274
Network Billings	129
Network Map	272-3
O'Neil, Thomas F....Article.....	271

N

National Assn. for Better Radio and TV.....	763
National Assn. of Broadcast Unions and Guilds	763
National Assn. of Educational B'casters.....	763
Officers	248
Membership List	249
National Assn. of Performing Artists.....	764
National Association TV and Radio Farm Directors	764
NATIONAL ASSOCIATION OF RADIO- TELEVISION BROADCASTERS:	
Fellows, Harold E....Article..	65
Personnel, Committees	246
Television Code	771
National Better Business Bureau, Inc....	764
NATIONAL BROADCASTING CO.:	
Commercial Programs-AM	1240
Commercial Programs-TV	1258
Executives & Personnel-AM.....	280
Executive TV Biographies.....	821
Executives & Personnel-TV.....	824
Network Map-AM	278-9
Network Map-TV	822-3
Weaver, Sylvester L....Article	277
Frey, George....Article	820
National Soc. of Television Producers, Inc.	764
National Television Film Council.....	764
National Variety Artists, Inc.....	764
Nebraska: AM Stations	483
Families (total in state).....	483
Population	483
Radio Homes (total).....	483
TV Stations	885
Negro Actors Guild of America, Inc.....	764
Network Billings	125
Network News Selections of '53.....	57
Network Section	257
NETWORKS:	
ABC Executives & Personnel.....	262
ABC Executives & Personnel (TV Net)	800
ABC Network Map-AM.....	260-1
ABC Network Map-TV	798-9
ABC-TV Exec. Biographies.....	797
Bergmann, Ted....Article	812
CBS Executives & Personnel.....	268
CBS Executives & Personnel (TV Net)	808
CBS Network Map-AM.....	266-7
CBS Network Map-TV.....	806-7
CBS-TV Exec. Biographies.....	805
Du Mont Exec. & Personnel.....	816
Du Mont Exec. Biographies.....	813
Du Mont Network Map.....	814-5
Frey, George....Article	820
KBS Affiliated Stations.....	284-5
KBS Executives & Personnel.....	288



ATTENTION!

**ALL TELEVISION and
RADIO STATIONS . . .**

**A PLUS SERVICE FOR YOUR
SPONSORED PROGRAMS . . .**

WRITE-WIRE-TELEPHONE

CENTURY NEWS PHOTO SERVICE

MYRON FIRKSER

Executive Offices:
2525 Broadway
New York 25, N. Y.

BARRY FIRKSER

Telephone:
ACademy 2-1750

- **NEW ACCOUNTS**
- **ADDED INCOME**
- **PUBLICITY**

A Distinctive News Photo Service

EDITORIAL INDEX

Kintner, Robert E.... Article	259
Murphy, Adrian.... Article	265
MBS Executives & Personnel	274
MBS Network Map-AM	272-3
NBC Executives & Personnel (TV Net)	824
NBC-TV Exec. Biographies	371
NBC Network Map-AM	278-9
NBC Network Map-TV	822-3
O'Neil, Thomas F.... Article	271
Regional Networks	299
Stronach, Alexander.... Article	793
Van Volkenburg, J. L.... Article	871
Weaver, Sylvester L.... Article	277
Wolf, Sidney.... Article	783
Networks, Regional	299
Nevada: AM Stations	486
Families (total in state)	486
FM Stations	1213
Population	486
Radio Homes (total)	486
TV Stations	887
New Brunswick: AM Stations	679
New England Regional Network	293
New Hampshire: AM Stations	488
Families (total in state)	483
FM Stations	1213
Population	483
Radio Homes (total)	488
TV Stations	887
New Jersey: AM Stations	489
Families (total in state)	483
FM Stations	1213
Population	489
Radio Homes (total)	483
TV Stations	887
New Mexico: AM Stations	492
Families (total in state)	492
Population	492
Radio Homes (total)	492
TV Stations	888
New TV Stations Scheduled for '54	333
New York: AM Stations	495
Families (total in state)	495
FM Stations	1213
Population	495
Radio Homes (total)	495
TV Stations	338
New York City Telephone Numbers	100
Newfoundland: AM Stations	693
News Commentators	1105
News Events of 1953, Top Ten, Editors Poll	43
News Selections, Network, 1953	57
News Services	117
North Carolina: AM Stations	520
Families (total in state)	520
FM Stations	1213
Population	520
Radio Homes (total)	520
TV Stations	893

North Dakota: AM Stations	532
Families (total in state)	532
Population	532
Radio Homes (total)	532
TV Stations	896
Northwest Network	293
Nova Scotia: AM Stations	681

O

Ohio: AM Stations	533
Families (total in state)	533
FM Stations	1214
Population	533
Radio Homes (total)	533
TV Stations	897
Oklahoma: AM Stations	547
Families (total in state)	547
FM Stations	1214
Population	547
Radio Homes (total)	547
TV Stations	902
Oklahoma Network	293
O'Neil, Thomas F.... Article	271
Ontario: AM Stations	682
Orchestra Leaders, Radio-TV	1135
Oregon: AM Stations	553
Families (total in state)	553
FM Stations	1214
Population	553
Radio Homes (total)	553
TV Stations	903
Oregon Trail Network	293
Organists, Radio-TV	1135
Organizations (Radio-TV Groups, Unions, Assn.)	757
Organizations, Research	109

P

Paul Bunyan Network	289
Palmetto Broadcasting System	293
Pennsylvania: AM Stations	560
Families (total in state)	560
FM Stations	1214
Population	560
Radio Homes (total)	560
TV Stations	905
Personalities, TV	999
Philadelphia Radio and Television Broadcasters Assn.	765
Play and Story Brokers	1283
Press Association, Inc.	117
Prince Edward Island: AM Stations	688
Producers and Distributors, TV Film	935
Producers, Network & Independent	1173
Producers, Radio-TV Programs	713
Professional Music Men, Inc.	765
Programs, Commercial AM	1240
Programs, Commercial AM-TV, 1953	1239
Programs, Commercial TV	1258



We demand the best
for you . . . our facilities
are the most complete,
most modern . . . our staff
is highly skilled in every
phase of recording . . .
an unbeatable combination
designed to achieve
the ultimate in sound
reproduction to meet your
every requirement.



OUR
BUSINESS

IS

SOUND

. . . and sound
reproduction
of the finest
quality
is our credo



AUDIO-VIDEO



recording company, inc.

PLaza 7-3091

730 fifth avenue, new york 19

◆ ◆ ◆ EDITORIAL INDEX ◆ ◆ ◆

Publications, Trade, Fan, Tech.....	1277
Puerto Rico: AM Stations.....	659
TV Stations.....	926

Q

Quaker Network.....	293
Quebec: AM Stations.....	688

R

RADIO ANNUAL, TELEVISION YEAR-BOOK, Offices, Personnel.....	1281
Radio Cadena Nacional, S. A.....	706
AM Member Stations.....	707
Radio-Electronics-TV Mfrs. Assn. (RETMA)	1233
Radio Free Europe.....	765
Radio-Newsreel-Television Working Press Assn. of N. Y., Inc.....	765
Radio Pioneers Club, The.....	765
Radio Programs de Mexico, S. A.....	706
Radio-TV Artists.....	1049
Radio-TV Directors.....	1173
Radio and TV Directors Guild (A. F. of L.)	765
Radio and Television Executives Society, Inc.....	766
RADIO-TELEVISION DAILY, Offices, Personnel.....	24, 1281
Radio-TV Mfrs. Assn. of Canada.....	766
Radio-Television News Directors Assn., The.....	766
Radio-TV News Events of 1953, Ten Top (Editors Poll).....	43
Radio-TV Program Materials.....	766
Radio-TV Program Producers.....	713
Radio-TV Station Brokers.....	1044
Radio Writers' Guild of the Authors' League of America, Inc., The.....	766
Receiver Production in '53, Radio-TV.....	933
Recording Companies.....	737
Regional Networks.....	289
Repplier, T. S.... Article.....	1103
Representatives, Radio-TV Station.....	227
Representatives, Talent.....	252
Research Organizations.....	109
Reuters.....	117
Rhode Island: AM Stations.....	581
Families (total in State).....	581
FM Stations.....	1214
Population.....	581
Radio Homes (total).....	581
TV Stations.....	911
Rocky Mountain Broadcasting System...	293
Ross, Betty.... Article.....	756
Rural Radio Network.....	294

S

Sambrook, A. B.... Article.....	1116
Sarnoff, Brig. Gen. David.... Article.....	47
Saskatchewan: AM Stations.....	692

Screen Actors Guild, Inc.....	766
Secrest, James D.... Article.....	61
Seiler, James W.... Article.....	59
Services to TV Producers.....	1037

SESAC:	
Heinecke, Paul.... Article.....	1205
Personnel, Functions.....	766
Publisher Members.....	1206
Silleman, Michael.... Article.....	1045
Singers (Vocal Artists).....	1081
Sinn, John L.... Article.....	794
State, Sam.... Article.....	1079
Society of Motion Picture and TV Engineers.....	766
Song Hits of 1953.....	48
Song Writers' Protective Assn. (SPA)....	767
South Carolina: AM Stations.....	583
Families (Total in State).....	583
FM Stations.....	1214
Population.....	583
Radio Homes (total)....	583
TV Stations.....	912
South Dakota: AM Stations.....	588
Families (Total in State).....	588
FM Stations.....	1215
Population.....	588
Radio Homes (total)....	588
TV Stations.....	913
Southern California Broadcasters' Assn.	767
Sports Broadcasters Assn.....	767
Sports Commentators.....	1089
State Broadcaster Associations.....	663
Station Representatives Assn., Inc.....	767
Station Representatives, Radio-TV.....	227

STATIONS:

Alaska-AM.....	655
Alaska-TV.....	926
Bahamas.....	705
Canada-AM.....	675
Cuba-AM.....	702
Cuba-TV.....	907
Dominican Republic-AM.....	705
Dominican Republic-TV.....	928
Guam-AM.....	656
Haiti-AM.....	705
Hawaii-AM.....	656
Hawaii-TV.....	926
Jamaica.....	705
Mexico-AM.....	697
Mexico-TV.....	927
Puerto Rico-AM.....	659
Puerto Rico-TV.....	926
United States-AM.....	297
United States-FM.....	1209
United States-Int'l.....	708
United States-TV.....	841
Steinman Stations.....	294
Streibert, Theodore C.... Article.....	63
Story and Play Brokers.....	1283
Stronach, Alexander, Jr.... Article.....	796

Our Fifth Year on CBS-TV
for
GENERAL ELECTRIC

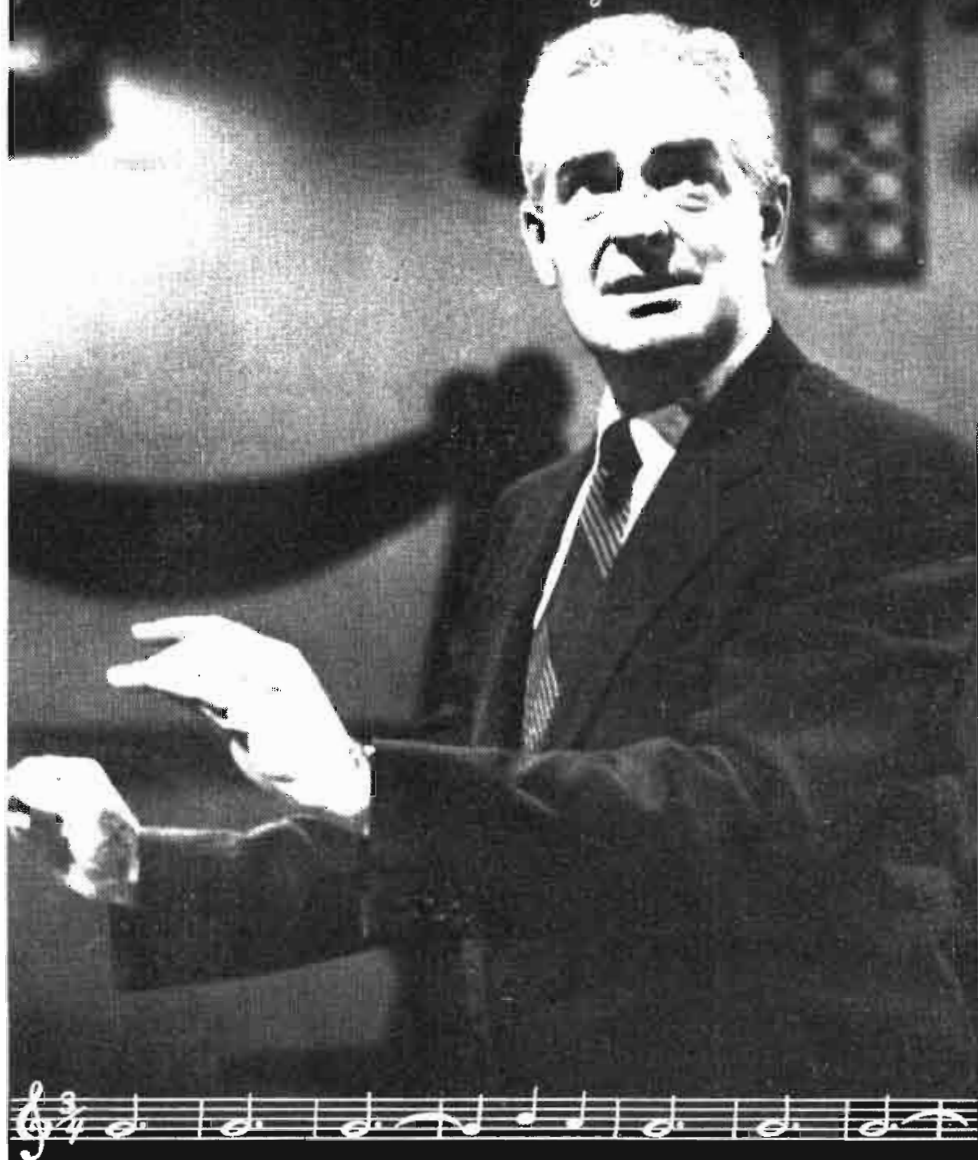

FRED WARING AND HIS PENNSYLVANIANS

TELEVISION YEAR BOOK

♦ ♦ ♦ EDITORIAL INDEX ♦ ♦ ♦

Academy of Television Arts and Sciences	757	Commercial AM-TV Programs (1953)....	1239
Actors	1049	Commercial TV Programs (1953).....	1258
Actresses	1049	Consulting Engineers	1236
Alaska, TV Stations	926	Costumes	1044
Alicote, Jack—Introduction	769	Cuba, TV Stations in	927
Allocations (FCC)	829	Denmark TV Stations	928
AMERICAN BROADCASTING CO.:		Directors, Radio-TV	1173
Commercial TV Programs	1258	Disc Jockeys	1117
Executives, TV—Biographies	797	Distributors and Producers, TV Film	935
Map, TV Network	798-9	Dominican Republic, TV Stations in	928
Network Billings	125	DU MONT TELEVISION NETWORK:	
Television Personnel	800	Commercial TV Programs	1258
Announcers, MC's	1145	Executives, TV—Biographies	813
Argentina, TV Stations in	928	Map, TV Network	814-5
ARTICLES, TELEVISION:		Personnel	816
Adams, Stanley	1195	Editors, Radio-TV	1272
Bergmann, Ted	812	Engineers, Consulting	1236
Brown, Charles	1035	Equipment Firms	1218
Davis, Phil	1187	Equipment Section	1217
Frey, George	820	Estimated Families for 1953	296
Haverlin, Carl	1200	FCC Allocations	829
Heinecke, Paul	1205	Film Producers, Distributors—TV	935
Lamb, Edward	1208	Hawaii, TV Stations in	926
Madden, Edward D.	1133	INDEXES:	
Mayers, Arche	998	Advertisers	25
Repplier, T. S.	1103	Editorial	5
Sambrook, A. B.	1116	TV Personalities	1000
Sillerman, Michael	1045	TV Stations	843
Sinn, John L.	794	Jingle Writers	1191
Slate, Sam	1079	Laboratories	1039
Stronach, Alexander, Jr.	796	Latin American TV Stations	927
Taylor, Herbert E., Jr.	842	Large Screen	1038
Van Volkenburg, J. L.	804	Lenses	1038
Wall, Charles A.	1199	Magazines—Trade, Fan, Tech., Gen.	1277
Artists, Radio-TV	1049	Manufactured Since '46, Total TV Sets	828
Artists, Vocal	1081	MAPS:	
Background Processes	1038	ABC TV Network	798-9
Before the Camera	1047	CBS TV Network	806-7
Behind the Mike	1047	Du Mont TV Network	814-5
BIOGRAPHICAL SKETCHES:		NBC TV Network	822-3
ABC TV Executives	797	MC's—Announcers	1145
CBS TV Executives	805	Mexico, TV Stations in	927
Du Mont TV Executives	813	Musical Commercial Producers	1191
NBC TV Executives	821	Musical Conductors... Radio TV	1135
TV Personalities	999	NARTB Television Code	771
Brazil, TV Stations in	928	National Association of Radio and Tele- vision Broadcasters	246
Brokers, Radio-TV Station	1044	NATIONAL BROADCASTING CO.:	
Canada, TV Stations	927	Commercial TV Programs	1258
Carpets	1038	Executives, TV—Biographies	821
Cartoon Producers	1042	Map, TV Network	822-3
Code, Television—NARTB	771	Personnel, TV	824
Color Processes	1042	National Society of Television Producers, Inc.	764
COLUMBIA BROADCASTING SYSTEM:		National Television Film Council	764
Commercial TV Programs	1258	NETWORK EXECUTIVES, TV:	
Executives, TV, Biographies	805	(Biographical Sketches)	
Map, TV Network	806-7	ABC	797
Personnel	808	CBS	805
COMMENTATORS:		Du Mont	813
News	1105	NBC	821
Sports	1089		
Women	1181		



"Craftsmanship in Recording"

- Complete Engineering Facilities
Studios • Disc • Tape • Film
Mobile equipment.

Western Electric Film Recorders
Ampex and Fairchild Tape Machines
Fairchild and Scully Lathes
35 and 16 mm facilities.

711 FIFTH AVE. • NEW YORK 22, N. Y. • PLaza 3-5400

♦ ♦ ♦ EDITORIAL INDEX ♦ ♦ ♦

Network News Selections of 1953.....	57
News Commentators, Radio-TV.....	1105
News Events in 1953, Top 10 (Editors' Poll).....	43
Orchestra Leaders, Radio-TV.....	1135
Organists, Radio-TV.....	1135
Organizations.....	757
Personalities, TV.....	999
Personalities, TV—Index.....	1000
Prizes, Premiums.....	1042
Producers and Distributors, TV Film.....	935
Producers, Network and Independent.....	1161
Producers, Radio-TV Program Package.....	713
Programs, Commercial AM-TV (1953).....	1239
Programs, Commercial TV.....	1258
Programs, Producers, Radio-TV.....	713
Projectors (TV).....	1038
Publications, Trade, Fan, Tech., Gen.....	1277
Puerto Rico, TV Stations in.....	926
Puppet Makers.....	1044
Radio and TV Directors Guild.....	765
Radio and TV Executives Society.....	766
Radio-TV Artists.....	1049
Radio-TV Stations Brokers.....	1044
Radio-TV Station Representatives.....	227
Radio-TV Vocal Artists.....	1081
Raw Stock.....	1041
Receiver Production in '53—Radio-TV.....	933
Representatives, Talent (Managers and Agents).....	252
Research Organizations.....	109
Screening Rooms.....	1043
Services to TV Producers.....	1037
Singers (Vocal Artists).....	1081
Sports Commentators, Radio-TV.....	1089
Spot and Flood Lamps.....	1038
Station Representatives—Radio-TV.....	227
Stations, TV, to Open in '54.....	930
Stations, U. S., TV in operation.....	841
Stock Shot Libraries.....	1042
Storage Vaults.....	1042
Television Film Producers-Distributors.....	935
Television Personalities.....	999
Television Programs, Commercial.....	1258
Television Stations Outside U. S.....	927
TELEVISION STATIONS, U. S.:	
Alabama.....	847
Arizona.....	847
Arkansas.....	848
California.....	849
Colorado.....	855
Connecticut.....	857
Delaware.....	858
District of Columbia.....	858
Florida.....	859
Georgia.....	860
Idaho.....	863
Illinois.....	863
Indiana.....	865
Iowa.....	867
Kansas.....	868
Kentucky.....	869
Louisiana.....	869

Maine.....	871
Maryland.....	873
Massachusetts.....	874
Michigan.....	875
Minnesota.....	878
Mississippi.....	879
Missouri.....	879
Montana.....	883
Nebraska.....	885
Nevada.....	887
New Hampshire.....	887
New Jersey.....	887
New Mexico.....	888
New York.....	888
North Carolina.....	893
North Dakota.....	896
Ohio.....	897
Oklahoma.....	902
Oregon.....	903
Pennsylvania.....	905
Rhode Island.....	911
South Carolina.....	912
South Dakota.....	913
Tennessee.....	913
Texas.....	915
Utah.....	920
Virginia.....	920
Washington.....	922
West Virginia.....	923
Wisconsin.....	924
Wyoming.....	925
TELEVISION YEARBOOK	
(Facing Page 768)	
Top Ten News Events of '53.....	43
TV Code, NARTB.....	771
TV Film Producers and Distributors.....	935
TV Service Firms.....	1037
Background Processes.....	1033
Carpets.....	1038
Cartoon Producers.....	1042
Color Processes.....	1042
Costumes.....	1044
Laboratories.....	1039
Large Screen.....	1038
Lenses.....	1038
Prizes, Premiums.....	1042
Projectors.....	1038
Puppet Makers.....	1044
Radio-TV Station Brokers.....	1044
Raw Stock.....	1041
Screening Rooms.....	1043
Spot and Flood Lamps.....	1038
Stock Shot Libraries.....	1042
Storage Vaults.....	1042
Ventilation Equipment.....	1042
TV Stations to Open in '54.....	930
TV Stations Outside U. S.....	927
TV Stations, U. S. Index by Call Letters.....	843
TV Stations, U. S. Personnel.....	841
Ventilation Equipment.....	1042
Vocal Artists, Radio-TV.....	1081
Women Commentators.....	1181
Writers, Radio-TV.....	1178



THE NATIONAL DAILY NEWSPAPER OF COMMERCIAL RADIO AND TELEVISION

1501 BROADWAY
NEW YORK 36, N. Y.

Telephone
Wisconsin 7-6336

John W. Alicoate

PUBLISHER

Marvin Kirsch

ASSOCIATE PUBLISHER

Frank Burke

Editor

WILLIAM NOBLE

Managing Editor

MARTIN ZUZULO

Night Make-up Editor

RUTH ABELMAN

Editorial Staff

TED GREEN

Columnist

HAL PERSONS

Music Columnist

GILBERT FUTTERMAN

Statistician

Charles A. Alicoate

Executive Vice-President

MARY McDONNELL

Staff Writer

ROBERT GALLAGHER

*Associate Editor
Radio Annual—TV Year Book*

ARTHUR SIMON

Special Representative

EVELYN ROBINSON

Advertising Staff

ELIZABETH RAE McKEAN

Advertising Dept.

EUGENE MORRISON

Assistant Circulation Mgr.

MORRIS ALTSCHULER

Circulation and Production Mgr.

Publishers of
RADIO-TELEVISION DAILY
RADIO ANNUAL-TELEVISION YEAR BOOK

WEST COAST OFFICES

Paul K. Devoe, Western Division Manager

Jerry Tidwell

6425 Hollywood Blvd.

Ethel Rosen

Phone: Hollywood 5-8436

WASHINGTON BUREAU

Ted Kellogg

Office: 983 National Press Building

Telephone: NATIONAL 8-9152

Home Phone: JEFFerson 2-5957

CHICAGO BUREAU

Herb Kraus

Suite 505

140 No. Dearborn St.

Phone: RANDolph 6-3088

HOME OFFICE: John Perdicari, Ludovisi 16. PUERTO RICAN BUREAU: Antonio Alfonso, Edificio Ochoa, San Juan, P. R.; P. O. Box 3485; Telephone: 3-2750. FAR EAST BUREAU: Glenn F. Irelan, Box 13, Setagaya Post Office, Tokyo, Japan.

ADVERTISING

1954

INDEX

1954

— A —

ABC Film Syndication... 940
 ABC Radio Network... 98-99
 ABC Television
 Network 802-803
 Acme Film Laboratories. 978
 Advertiser Magazine,
 The 1278
 Affiliated Artists 732
 Alda, Robert 90
 Allen, Mel 62
 Allen, Steve 1072
 Allied Record Mfg. Co. 742
 All-Canada Radio
 Facilities Ltd. 674
 American National
 Studios, Inc. 969
 Ampex Corporation 264
 Amsterdam, Morey 1070
 Anderson, Eddie 1068
 Anderson, Leonard 982
 Animated Prod. Inc. 759
 Annis & Thomas Prods.
 Inc. 1064
 Applewhite, Charlie 154
 Arden, Eve 1076
 Argyle Television Films,
 Inc. 964
 Armbruster, Robert 1141
 Arnell, Peter 160
 Arnold, Edward 1070
 ASCAP 1194
 Asher, William 1172
 Associated Press
 4 and Run of Book
 Service 748
 Audio-Video Recording
 Co., Inc. 16
 Audivox Records 751

— B —

B.B.D. & O., Inc. 132
 Baker, Art 1153

Bandy Productions 974
 Banghart, Kenneth 1109
 Baragrey, John 156
 Barnes Printing Co., Inc.,
 The 1177-1186
 Barnett Intern'l Forward-
 ers, Inc. 981
 Barnum, Pete 1163
 Barry, Enright & Friendly,
 Inc. 722
 Barton, Eileen 155
 Barty, Billy 1074
 Beck, Jackson 1052
 Bell, Dorese 1051
 Benny, Jack 36
 Benson, Red 1149
 Berg, Gertrude 1056
 Berle, Milton 38
 Bixby, Carl 1179
 Bleyer, Archie 1134
 Blinkey Prod., Inc. 981
 Block, Martin 6
 Bolam, Guy 230
 Bonded Film Storage Co.,
 Inc. Facing Page 1296
 British Information
 Services 953
 Britt, Jim 1095
 Broadcast Music, Inc. 778-779
 Broidy, Wm. F.,
 Productions 728
 Brooks Costume Co. 1043
 Bulova Watch Co., Inc. 126
 Bunce, Alan 1063
 Burke, Caroline 1166
 Burns, George and
 Allen, Gracie 1053
 Buttons, Red 46

— C —

CKLW 452
 CBS Radio Network. 112-113
 CBS Television 810-811
 CBS Television Film Sales 840
 Caesar, Sid 68
 Camargo, Ralph 1075

Canadian Association of
 Radio and Television
 Broadcasters 670
 Capitol Records 116
 Caribbean Networks, Inc. 660
 Carney, Art 1054
 Carson, Jack 1066
 Case, Nelson 1153
 Cassidy, Dale 164
 Century News Photo
 Service 14
 CFRB 668
 Charter Oak 982
 Chasman, Pola 1119
 Christ-Koplan Production. 1078
 Cineffects, Inc. 949
 Cinema Research 963
 Circle Film Laboratories. 1041
 Coastal Record Co., Inc. 752
 Coca, Imogene 69
 Cohan, Arnold, Corp., The 140
 Collins Radio Co. 276
 Collyer, Bud 1148
 Color Service Co., Inc. 955
 Columbia Transcriptions. 736
 Commonwealth Film and
 Television, Inc. 962
 Como, Perry 8
 Consolidated Film
 Industries 780
 Cowan, Louis G., Inc. 124
 Crest Television
 Productions 975
 Criar, Robert G. 1166
 Crosby, Bing, Enterprises,
 Inc. 782
 Crosby, Bob 1058
 Culhane, Shamus,
 Productions 961
 Cullen, Bill 1144

— D —

Daniels, Marc 1176
 Davis, Joan 1056
 Davis, Phil, Musical
 Enterprises, Inc. 1190

BRadshaw 2-2244

PLaza 8-1492

SAWYER-WIRTH ASSOCIATES, INC.

 *Television Programming*

430 NORTH RODEO DRIVE
BEVERLY HILLS, CALIFORNIA

745 FIFTH AVENUE
NEW YORK 22, N. Y.

** Producers of 2000 hours of National Television*

◆ ◆ ◆ ADVERTISING INDEX ◆ ◆ ◆

Day, Gordon, M.
Productions 1191

Del Valle, Jaime 1164

Demby Productions, Inc. 732

Desilu Productions, Inc. 88

DeVol, Frank 1136

Dixon, Bob 166

Doherty, Clifford, Steers &
Shenfield, Inc. 140

Don Lee Broadcasting
System 336

Dragnet 721

DuMont, Allen B., Labora-
tories, Inc. 768

DuMont Television
Network 818-819

Durante, Jimmy 44

— E —

Eastman Kodak Co. 784

Edwards, Douglas 1109

Edwards, Ralph 84

Empire Broadcasting
Corp. 746

Endorsements, Inc. 733

Erickson, Corydon 1072

Erickson, Helene W. 1083

Erwin, Wasey & Co., Ltd. 138

"Ethel and Albert" 1063

— F —

Fedderson, Don, Prods. ... 974

Ferraday, Lisa 168

Ferrin, Frank 1164

FilmCraft Productions ... 968

Film Daily 1280

Fine Sound, Inc. 22

Finley, Larry 1119

Fisher, Eddie 76

Fitzmaurice, Michael ... 1068

Foley, George F., Inc. ... 712

Ford, Art 1121

Ford, Mary 152

Foster, Preston 158

Framer, Walt,
Productions 731

Frandsen, Tom 1077

Franklin, Joe 1123

French Broadcasting
System, The 120

Fromkess, Leon 985

Fuller, Sam 1169

Fulton Recording Co. 751

— G —

Gart, John 146

General Film Laboratories
Corp. 965

German, W. J., Inc.
Facing Page 769

Gerry Gross-Norman Baer
Productions 710

Gillo Publications 1193

Gleason, Jackie 50

Godfrey, Arthur 130

Goldswan Productions ... 1192

Goodman, Al 1134

Goodman, Harry S. 943

Goodson-Todman
Productions 716

Graham, Joe 1174

Graham, Lee 170

Graham, Virginia 162

Grauer, Ben 1111

Gregson, Jack 1152

Gruenberg, Axel 1162

Guild Films Co., Inc. 952

— H —

Hall, Helen 96

Hamilton, Gene 1073

Hammond, Earl 1074

Harmon, Larry 1075

Harrice, Cy 1151

Harriscope, Inc. 731

Headley-Reed Co. 228

Heatherton, Ray 1069

Henley, Arthur,
Productions 720

Herlihy, Ed. 1046

Herlihy, Walter 1150

Hermann, Cleve 1097

Hope, Bob 40

Howard, Mary,
Recordings 754

Hughes, Gordon T. 1170

Hurdle, Jack 1166

— I —

Inter-Continental
Television Films 985

Irving, Charles 1055

Irving, Hollis 1055

Irving, Richard 1174

— J —

Jackson, Jay 1151

James, Dennis .. Facing Page 1

Janis, Hal 67

— K —

KBIF 338

KBIG 338

KCOP 850

KEYT 854

KFMB 350

KFMB-TV 853

KFVD 343

KFYR-TV 897

KGO—KGO-TV 353

KGW 556

KNBC 354

KNBH 846

KNX 344

KOWL 345

KRLD-TV 916

KROD-TV 917

KSD-TV 880

KSL 823

KSTM-TV 882

KTLA 852

KUAM 657

KYJC 557

Kagram Corporation 723

Kander, Allen 1043

Kaufman, Murray 1067

Kaye, Gerald O. and
Associates Corp. 1168

Kaye, Sammy 86

Keene, William 1061

Kennedy, Kevin 1147

Keystone Broadcasting
System, Inc. 286-287

King, Carl 1076

Kudner Agency, Inc. 134

— L —

Lally and Love, Inc. 967

Landers, Lew 1175

Lawrence, Jerry 1074

Lawrence, Mort 1150

Lazar, Bill 1146

Lear, Les, Productions ... 727

Le Bow, Guy 1092

Lee, Bert 1097

Lee, Peggy 1080

Lescoulie, Jack 51

Levenson, Sam 60

Levine, Henry 1139

Levy, Ralph 1167

R*



* Take MODERN for T.V. Film Traffic Problems

Modern fills the gap between production and telecast projection to supply agencies, syndicators, and producers with a reliable custom tailored service for the traffic of television films.

Clients being served by Modern can be assured that their film program with its proper commercial content will be at the right TV station on the right date, at the right hour for advance scheduled telecast.

for further information

**MODERN
TALKING
PICTURE
SERVICE**

48 West 48th St., NEW YORK, N. Y.

140 East Ontario St., CHICAGO, ILL.

3450 Wilshire Blvd., LOS ANGELES, CALIF.

◆ ◆ ◆ ADVERTISING INDEX ◆ ◆ ◆

Lewis, Al 1172
 Lewis, Jerry 52
 Lewis, Robert Q. 54
 Liberace 118
 Liebman, Max 74
 Lombardo, Guy 34
 Lusk, Freeman 726
 Lynch, Peg 1063

— M —

MCA-TV, Ltd. 948
 MGM Records 753
 MKM Motion Pictures, Inc. 30
 MacGregor, C. P. 750
 "Mama" 1064
 Mansfield, Irving 1160
 Mark VII, Ltd. 721
 Marshall-Hester
 Productions, Inc. 730
 Martin, Charles 148
 Martin, Dean 52
 Martin, Don, School. 1072
 Martin, Jean 1083
 Martinson, Leslie H. 1176
 Maurer, J. A., Inc. 936
 Maxwell, Robert, &
 Associates 976
 McBride, Mary Margaret. 1054
 McCann-Erickson, Inc. 136-137
 McCleeny, Albert 1165
 McCune, Hank 1062
 McGee, Fibber and
 Molly 1049
 McLeod, Victor 1167
 McNeill, Don 64
 McNellis, Maggi 1068
 McVey, Pat 1072
 Mercer, Johnny 1058
 Merrill, Robert 1085
 "Mike and Buff" 1057
 Miller, Sidney 1078
 Milverne Productions,
 Inc. 734
 Miner, Jan 1071
 Modern Talking Picture
 Service 28
 Montgomery, Robert 82
 Morris, Howard 72
 Morris, William, Agency,
 Inc. 128
 Morse, Carlton E. 1179
 Motion Pictures for Tele-
 vision, Inc. 942
 Movielab Film Labora-
 tories, Inc. 1040
 Murphy, Bob 1070
 Murray, Jan 150
 Music Service, Inc. 1191
 Mutual Broadcasting
 System, The 110

— N —

NBC Radio Network 114
 NBC Spot Sales 2
 NBC Television 826-827
 National Comics Publica-
 tion, Inc. 20
 National Jewelers Co. 142
 National Screen Service. 958
 National Telefilm Associ-
 ates, Inc. 960
 Nelson, Jimmy 58
 Neuman, Alan 1172
 Nimmo, Bill 49
 Nola Studios, Inc. 749
 Norwood Studios 983
 Nusbaum, Mort 1121

— O —

O'Connor, Bill 1123
 O'Connor, Donald 1048
 Official Films, Inc. 954
 Olsen, Johnny 1070
 Owens, Jack 1060

— P —

Paddock, Douglas Sterling 730
 Palmer, Bud 1090
 Parsonnet TV Film
 Studios Inc. 946
 Paul, Charles 1141
 Paul, Les 152
 Paul, Ralph 94
 Peerless Film Processing
 Corp. 1036
 Philco Television
 Playhouse 770
 Pickens, Jane 1084
 Polacheck, Charles 1166
 Precision Film Labora-
 tories, Inc. 934
 Presto Recording Corp. 1216
 Product Services, Inc. 145
 Pulse, Inc. 108
 Putnam, George 1106

— R —

RCA Back Cover
 RCA Custom Record
 Sales 738
 RCA Recorded Program
 Services 744-745
 Radio Cadena
 Nacional 694-696

Raeburn, Bryna 1059
 Raye, Martha 80
 Reed, Carol 1052
 Reeves Sound Studios,
 Inc. 947
 Reiner, Carl 71
 Ringling Bros. & BMB. 32
 Rio, Rosa 1136
 Ritz Brothers, The. 1071
 Rockhill Productions, Inc. 714
 Rogers, Roy 92
 Rose, David 1137
 Ross, Murray 1138
 Rounsaville Chain, The. . 384
 Rountree-Presbrey, Inc. . 725
 Roy, Michael 1076
 Russell, Bob 1069
 Russell, Jack 70
 Russell, Todd 1148

— S —

Sanford, Charles 73
 Satenstein, Frank 1174
 Savage, John 1152
 Sawyer, Stan 1066
 Sawyer-Wirth Associates,
 Inc. 28
 Scharf, Walter 1140
 Schneider, Dick 1176
 Schwab, Larry 1175
 Scott, Mark 1099
 Screen Gems, Inc.-TV. 956-957
 Sesac, Inc. 1188
 Sharbutt, Del 1154
 Shear, Barry 1172
 Sheldon, Earl 1138
 Sherman & Marquette. . 138
 Sherwin, Wally 1077
 Silbert, Bill 1125
 Silver, Joe 1068
 Skelton, Red 42
 Skinner, The Charles E.,
 Prods. 724
 Smith, Kate 56
 Smith, Sid 1176
 Smith, Sidney 1169
 Smith, Sydney 1076
 Snader Productions, Inc. . 966
 Sponsor 1276
 Stahl, Al. Animated
 Prods., Inc. 959
 Stark, Wilbur-Layton,
 Jerry, Inc. 718
 Steen, Cort 1174
 Sterling, Jack 1062
 Sterling Television Co.,
 Inc. 941
 Stern, Bill 1088
 Stewart, Cecil,
 Productions 172

MKM MOTION PICTURES, Inc.

Laveen, Arizona

In Preparation on New Television Series

"PETER ANGEL"

The Gripping Adventures of a Wandering Man of God and his dog

Direction, Story and Screen Play

by

LEA KNOX MARLOW

Produced by

DON KEITH

Starring

JOHN BROMFIELD

and

Chinook

(Academy Award Winner Wonder Dog)

All Television Supervision by

CARL HUGHES CONS

All rights and privileges of use of title and story "Peter Angel"

Exclusive property of

MKM MOTION PICTURES, Inc.

Address all communications to:

L. K. MARLOW

Hollywood Representative

8556 Hillside Ave., Hollywood, Calif.

Phone: HOLLYWOOD 9-5110

◆ ◆ ◆ ADVERTISING INDEX ◆ ◆ ◆

Stewart, Jay1073
 Stone, Cliffie1050
 Storer Broadcasting
 Co.254-255
 Streech, Wilbur,
 Productions 983
 Streng, Walter1168
 Studio Films, Inc. 944
 Studio TV Productions,
 Inc. 970
 Sussan, Herbert1173
 Susann, Jacqueline1074
 Swayze, John Cameron...1104
 Sylvern, Hank1137

— T —

Teevee Co., The 734
 Telecast Films, Inc. 971
 Television Programs of
 America938-939
 Tel Ra Productions 984
 Tennessee Ernie1050
 Thayer, Guy V., Jr.1162
 Thomas, Danny 78
 Thomas, Shirley1064
 Thorgeresen, Ed 977
 Times Square Produc-
 tions, Inc. 984
 Tonken, Phil1149
 Tower Productions 729
 Trendle-Campbell-Meuer,
 Inc. 258
 TV Movie Club Inc. 979
 TV Workshop, The 973

— U —

Ullman, Furth1170
 Unique Turntable and
 Display Co. 980
 United Press 12
 United Recording Labs. . 754
 United States Steel Hour,
 The 144
 United Television
 Programs 950
 United World Films, Inc. . 972
 Unity Television Corp.
 Inside Back Covers

— V —

Valentino, Thomas J., Inc. 747
 Van Praag Productions.. 951
 Video Pictures, Inc. 945

— W —

WAAM 870
 WAPA 660
 WATV 886
 WAZL 567
 WBAL 44C
 WBAP-TV-FM 606
 WCCC 365
 WCIN-TV 384
 WCMB-TV 565
 WCTC 491
 WCYB 626
 WDTV 908
 WEAV 514
 WELL 453
 WENT 514
 WERC 564
 WEVD 505
 WFAS 519
 WFIL 570
 WFMJ-TV 900
 WGLV 904
 WGN 398
 WGN-TV 862
 WHBF 407
 WHEN 894
 WHLI 500-511
 WHLM 561
 WHOL 560
 WHOM 504
 WHP-TV 566
 WHUM-TV 910
 WHWL 577
 WIAC 658
 WIBG 573
 WICC-TV 856
 WIDE 438
 WIP 572
 WISL 577
 WJAC-TV 906
 WJBK-TV 876
 WJNO 380
 WKBW 498
 WKLO-TV 868
 WKRC-TV 536
 WLEE 630
 WLIB 508
 WLOU-TV 384
 WLS 400
 WMAR-TV 872
 WNET 912
 WNEW 506
 WOAI 617
 WOND 491
 WOR 298
 WORA 658
 WOV 510
 WPIX 890
 WPOR 439
 WPRO 580
 WPRP 658

WPTR 496
 WQXI-TV 384
 WQXR 512
 WRAK 579
 WRBL 386
 WRC 370
 WRGB 892
 WRNL 631
 WRNY 515
 WSAI 538
 WSAZ-TV 923
 WSB 382
 WSIX-TV 914
 WSJS 896
 WSRS 541
 WSYR 516
 WTAM 540
 WTIC 364
 WTRY 518
 WTVI 884
 WVDA 445
 WVKO 542
 WWDG 371
 WWI-TV-FM 450
 WWRL 519
 WXEL 898
 WXYZ-TV 454
 Wakely, Jimmy1082
 Walker, Joan 72
 Waring, Fred 18
 Waye, Wendy1086
 Welk, Lawrence1065
 Welles, Barbara 96
 Westfall, Kay1070
 Williams, Billy, Quartette 71
 Willis, Richard1060
 Wisbar, Frank1160
 Wismer, Harry 10
 Wolf Productions 717
 Workshop TV Distrib., Inc. 973
 WORLD Broadcasting
 System, Inc.740-741
 Writers of Your Show of
 Shows 72

— Y —

Yankee Network, The... 256
 Young & Rubicam, Inc. . 122
 Young, Victor1139

— Z —

Zenith Radio Corp. 772
 Ziv, Frederic W., Co.
 Inside Front Covers
 Ziv Television Programs,
 Inc.774-775

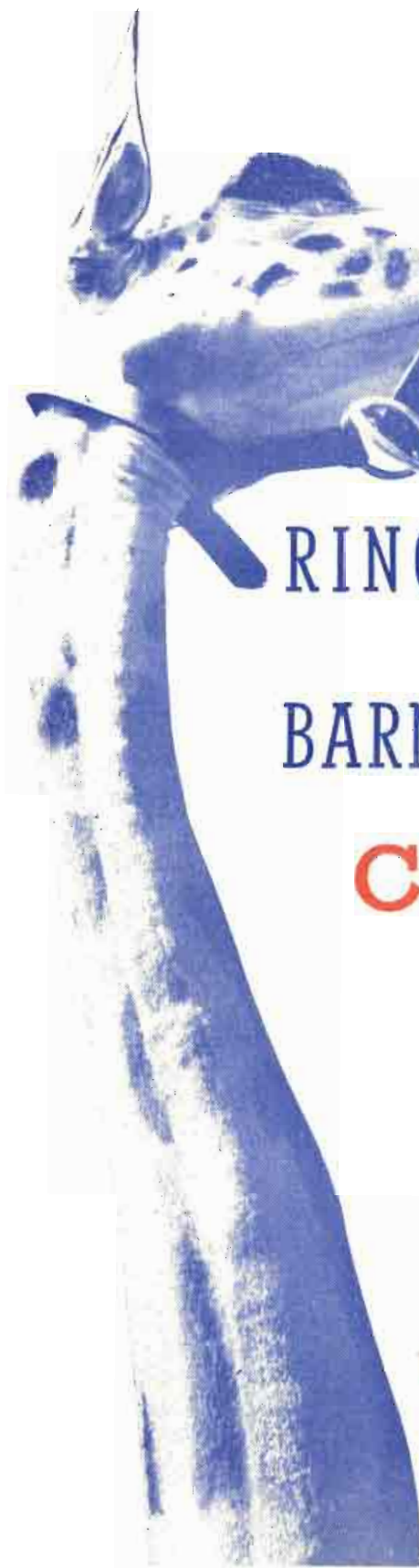

Greetings from

RINGLING BROS.

and

BARNUM & BAILEY

CIRCUS

BEVERLY KELLEY
DIRECTOR of RADIO and
TELEVISION PUBLICITY

THE GREATEST SHOW ON EARTH



Rosel H. Hyde
Chairman

Expansion of Communications Highlights FCC Annual Report

For Fiscal Year Ended June 30, 1953

HISTORICALLY, the fiscal year 1953 marked the 25th anniversary of early television experiments, pioneer transoceanic radiophoto transmission, inauguration of the first police municipal radio system, and the initial functioning of the Federal Radio Commission which preceded the Federal Communications Commission.

Currently, the 19th year of the Federal Communications Commission closed with nearly 1,100,000 radio authorizations on its books. Over 235,000 of these were for safety and communication purposes on land, sea, and air, almost 5,500 others were broadcast, and the remainder consisted of various types of radio operator authorizations. The radio station authorizations cover the use of about 600,000 transmitters, of which number more than 430,000 are mobile.

Television—In the first 12 months of processing applications for new TV stations following the lifting of the freeze, 398 new TV stations were authorized and about 600 applications (mostly competitive) were pending. Eighty-nine of the new grantees received authority to go on the air with interim equipment, to augment the 108 pre-freeze operating stations. Of the post-freeze TV grants, 256 were for operation in the new UHF (Ultra High Frequency) bands, and 142 were for VHF (Very High Frequency) operation.

Seventeen grants were made to non-commercial educational TV stations, one of which started operating. Municipalities in which channels have been reserved for noncommercial educational use were increased to 245.

TV stations have been authorized in all states except Vermont (where the only two applicants were in competition), and grants have been made in Hawaii and Puerto Rico. TV authorizations at the year end totaled 500.

In mid-1953 the Commission received various petitions to adopt the National Television System Committee (NTSC) "compatible" color TV specifications to replace the present "noncompatible" standards.

AM.—The older commercial AM (amplitude modulation) broadcast service continued to expand. The 2,584 authorized stations at the close of the year was an increase of 164 over 1952. Most of the newcomers were low-power daytime stations.

FM.—The number of authorized and operating FM (frequency modulation) stations continued to decrease — to 601 and 551 respectively — which was a loss of 47 construction permits and 31 licenses during the year. However, noncommercial educational FM gained 12 stations.

Miscellaneous. — In addition to the broadcast services mentioned previously, there were 259 auxiliary TV stations (an increase of 38); 1,305 remote pickup stations (a gain of 130); 47 studio-transmitter links, 1 developmental station, and a fluctuating number of international broadcast stations.

Safety of life and property at sea, in the air and on the land is aided by many of these services. There are nearly 40,400 stations in the marine services, more than 39,000 in the aeronautical services, and over 13,600 land public safety stations such as police, fire, forestry-conservation, highway maintenance and special emergency. The marine services use nearly 39,000 transmitters; the aeronautical services, over 44,000, and the public safety services, nearly 142,000. Of the latter number, more than 97,000 are employed for police communication.

The land transportation services embrace nearly 10,000 stations and 116,000 transmitters. They are utilized by railroads, city transit systems, intercity buses, taxicabs, highway trucks, and automobile emergency services.



GUY LOMBARDO

and his

Royal Canadians

AMERICA'S NUMBER ONE BAND

PRODUCER
1954-1955
"ARABIAN NIGHTS"
SPECTACLE
JONES BEACH, NEW YORK

HOTEL ROOSEVELT GRILL, NEW YORK
ON TELEVISION FOR LINCOLN-MERCURY
F. W. ZIV CO. TRANSCRIPTIONS
DECCA RECORDS
CONCERTS

NUMBER ONE WITH FANS AND EDITORS

Publicity: DAVID O. ALBER ASSOC.. Gene Shefrin



Broadcasting Industry Nears Billion Dollar Mark

By FRANK BURKE
Editor
Radio-Television Daily

WHEN Hal Fellows, President of NARTB, recently made the prediction that the broadcasting industry would have its first billion dollar year in 1954 he was not amiss, for indications are that both radio and television will enjoy their greatest year of revenue in the months ahead.

The NARTB president thinks that television will gross over \$500 million during the 1954 business year and that radio will come close to matching that figure. This forecast holds prospect of coming true and leaders of both the radio and television industry share his enthusiasm.

With about 2½ radios for every American home and upwards of 2,500 radio stations now on the air the coverage and commercial impact of radio has reached an all-time high. Over 13,000,000 radio sets were manufactured in 1953.

The television story is even more impressive. Upwards of 27,000,000 receivers are now in American homes and the prospects are that the total will be well past the 30,000,000 mark before year's end. During the past year approximately 7,250,000 TV sets were produced by RETMA manufacturers and production for this year should be comparable, if not higher than in 1953.

Match the production and distribution of TV receivers with the rapid expansion of TV stations in key center cities and secondary areas of the United States and you obtain a greater appreciation of phenomenal growth of the sight and sound medium. On January 1st there were 343 VHF and UHF stations in operation and about 25 others testing to go on the air. By next January the total number of TV stations in operation should come close to reaching the 500 mark with virtually all the nation's population within range of a TV transmitter.

Television's expansion was given added impetus last December when the Federal Communications Commission approved National Television System Committee's

standards for compatible, electronic color television and allowed the commercial networks to proceed with color programming. The subsequent developments have been significant. NBC and CBS have begun experimental commercial colorcasting and major manufacturers have been tooling up for production of color receivers using the new tri-color tube. Already some sets have been produced and before year's end about 100,000 color receivers are expected to be on the market.

The outlook for color expansion is not the only aspect of the progress of television. Recently RCA at their Princeton Laboratories gave a dramatic demonstration of use of tape recording both in color and black and white and stressed the economic savings that would follow when the system is released for commercial use. On the west coast Bing Crosby Enterprises have also perfected a system of tape recording which they forecast will be ready for commercial use this year.

While television has pretty much held the spotlight during the past year Broadcast Advertising Bureau has been hard at work driving home the potency of commercial radio. Their campaigns have been productive of good and many new clients have been attracted to radio especially on the level of local stations. NARTB, like BAB, criticized by some of its membership for having devoted too much time to television at the expense of radio, took steps at the recent board meeting to establish an office of vice-president in charge of radio to further the industry organization's crusading for the medium.

The year 1953 was a good year for the broadcasting industry and the year 1954 promises to be better. This outlook, without question, dispels some of the pessimistic prophecies that we are in for a business recession.

JACK BENNY

Chronology of Color Development from 1941 to 1953

- 1941:** FCC allocates spectrum space for black and white television.
- 1945:** FCC expands frequency bands for black and white television; reserves ultra high frequency bands for future expansion of black and white and color TV.
- 1946-47:** CBS petitions for commercialization of color TV. After lengthy hearing, FCC denies request.
- Sept. 26, 1949:** First phase of TV hearing, dealing with color, gets under way.
- Nov. 22, 1949:** Color sessions recess; field-test notice issued by commission.
- Feb. 23, 1950:** Comparative color demonstrations held by FCC; systems shown by CBS, RCA and Color Television Inc.
- July 11, 1950:** FCC begins deliberations on color TV. Participants submit final summations July 10.
- Sept. 1, 1950:** FCC issues its "First Report" on color TV favoring CBS system but advancing plan for manufacture of TV receivers with "bracket standards" as means of delaying final decision to permit further studies.
- Oct. 11, 1950:** FCC issues "Second Report" on color, adopting CBS standards effective Nov. 20, 1950.
- Oct. 17, 1950:** RCA and two subsidiaries, NBC and RCA Victor Distributing Corp., file suit against FCC on color decision in U. S. District Court in Chicago.
- Nov. 16, 1950:** Chicago court, after two days of hearings in which seven manufacturers, servicemen and others took RCA's side, grants temporary restraining order.
- Nov. 20, 1950:** National Television System Committee, all-industry group of engineers and technicians, appoints committee to study the possibility of developing color TV standards.
- Dec. 22, 1950:** Chicago District Court, in a 2-1 decision, upholds FCC's approval of CBS color system, but prohibits start of commercial operations pending a ruling by the Supreme Court.
- Jan. 26, 1951:** RCA initiates appeal to U. S. Supreme Court for itself and two subsidiaries.
- March 26-27, 1951:** Supreme Court hears oral argument on color TV case.
- May 28, 1951:** Supreme Court, by 8-0 vote, affirms lower court ruling in favor of CBS color.
- June 25, 1951:** First commercial color telecast by CBS.
- Oct. 19, 1951:** At request of Defense Mobilizer Wilson, manufacturers agree to cease color equipment production for duration of Korean War.
- March 6, 1953:** Sen. Edwin C. Johnson (D-Colo.) charges "powerful interests" are seeking to delay introduction of color TV.
- March 13, 1953:** Rep. Charles A. Wolverton (R-N.J.), chairman of House Interstate and Foreign Commerce Committee, announces color TV inquiry.
- March 24-27, 1953:** House Commerce Committee holds inquiry into status of color TV.
- March 26, 1953:** National Production Authority revokes ban on manufacture of color TV equipment.
- April 14-15, 1953:** House Commerce Committee views compatible color TV in Princeton, N. J., and New York City, demonstrated by RCA, CBS and Chromatic Television Labs Inc.
- June 25, 1953:** Petition to authorize NTSC compatible color TV standards filed with FCC by RCA and NBC.
- July 21, 1953:** NTSC approves final specifications for compatible color TV signal.
- July 22, 1953:** NTSC files petition with FCC asking authorization of its compatible color TV signal specifications.
- Aug. 7, 1953:** FCC issues notice of proposed rule-making relative to authorizing NTSC specifications for color TV.
- Sept. 8, 1953:** Comments on FCC's proposal filed by NTSC, Westinghouse Radio Stations Inc., Admiral, Hazeltine, CBS, American Television Inc., Paramount Television Productions, Chromatic Television Labs., and two radio engineers, Soghoian and Cooke, of Richmond, Va.
- Oct. 15, 1953:** Comparative color TV demonstration held in New York for FCC by NTSC and industry members.
- Dec. 17, 1953:** FCC approves NTSC compatible color TV signal specifications, effective 30 days after publication in the *Federal Register*.

Red Skelton

GROWTH OF BROADCASTING REVEALED IN FCC TABLES

Editor's note: At the close of each fiscal year the Federal Communications Commission issues a comprehensive report on the year's activity in the field of broadcasting. Statistical information, presented on this page, is taken from the 19th Annual FCC Report for the fiscal year ended June 30, 1953.

The number of authorized and licensed commercial AM, FM, and TV broadcast stations at the close of each fiscal year for the past 11 years is shown in the following table:

	AM		FM		TV		Total	
	Author-ized	Licensed	Author-ized	Licensed	Author-ized	Licensed	Author-ized	Licensed
1943	912	911	48	37	6	6	966	954
1944	924	912	52	45	9	6	985	963
1945	955	931	53	46	25	6	1,033	983
1946	1,215	961	456	48	30	6	1,701	1,015
1947	1,795	1,298	918	48	66	6	2,779	1,352
1948	2,031	1,693	1,020	142	109	7	3,163	1,842
1949	2,179	1,963	865	377	117	13	3,161	2,353
1950	2,303	2,118	732	493	109	47	3,144	2,658
1951	2,385	2,248	659	531	109	81	3,153	2,833
1952	2,420	2,333	648	582	108	96	3,176	3,011
1953	2,581	2,439	601	551	483	101	3,668	3,091

Broadcast Authorization Deletions

Commercial broadcast station deletions in fiscal 1953 numbered 108 as compared with 72 in 1952 and 161 in 1951. FM deletions rose from 36 in 1952 to 79 in 1953. The 23 AM deletions in 1953 were 2 less than the year previous. There were 6 TV deletions in the past year; 1 in 1952. Monthly figures for 1953 were:

Month	AM	FM	TV	Monthly total
1952				
July	1	4	0	5
August	1	5	0	6
September	1	4	0	5
October	4	5	0	9
November	3	3	0	6
December	2	12	0	14
1953				
January	2	5	0	7
February	0	1	0	1
March	3	5	0	8
April	2	12	1	15
May	2	11	1	14
June	2	12	4	18
Year's total	23	79	6	108



RED BUTTONS



Impact of Compatible Color Will Highlight New Year

By BRIG. GENERAL DAVID SARNOFF

*Chairman of the Board
Radio Corporation of America*

THE date December 17, 1953, on which the Federal Communications Commission approved standards for the commercial broadcasting of compatible color television, will be remembered in the annals of communications along with the historic date of April 30, 1939, when RCA-NBC introduced all-electronic black-and-white television as a new broadcast service to the public at the opening of the World's Fair in New York.

RCA is proud of the leadership its scientists and engineers achieved in developing the all-electronic compatible color television system and the RCA tri-color tube.

Fortunately, the color television system developed by RCA is compatible. This means that existing television sets can receive color programs in black-and-white without any changes or additional devices. For this principle and feature of compatibility in television, RCA fought hard and long, not only to achieve it scientifically, but to advance such a system as the only logical and practical service in the interest of the public and the television industry.

Because of compatibility, no one need hesitate to buy a black-and-white television set. It will not be obsolete because of color, and it will perform many years of service. Color television sets at the outset will cost from \$800 to \$1,000, and production will be in relatively small quantities until the industry is geared for mass production.

The National Broadcasting Company has completed program plans for color television's introductory year that call for each of NBC's regular productions to be broadcast in color at least once during the year—at the average rate of two programs a week.

Intensive color production activities are under way at NBC's Colonial Theatre, world's first fully equipped studio for compatible color. At the Colonial, NBC's color corps has pioneered in techniques of lighting, staging and make-up. NBC also has in operation another color

studio in Radio City, and plans have been laid for conversion to color of studio facilities in Brooklyn and in Burbank, California.

Television stations throughout the country are alert to the tremendous possibilities of color television and by slight modifications in their transmitting equipment they are enabled to pick up from the network and broadcast color shows. Five NBC-owned stations and 65 NBC affiliated stations have announced their intentions of doing so and more will follow in 1954.

Orders have been accepted by RCA Victor from one or more stations in 57 cities for color broadcast equipment. Throughout December, color equipment was air expressed as rapidly as completed and tested while crews of the RCA Service Company rushed the installations. As a result, 30 stations were equipped for colorcasts by December 31.

Color television presents a myriad of opportunities for broadening the services of electronic communications. Color adds a new dimension to the entertainment arts. It gives a new power to advertising and greatly increases merchandising opportunities through the use of television. A new realism is added to journalism. Television as a social and educational force is greatly intensified by color, thereby opening the way for significant advances in broadcasting.

During the past year television service was expanded and improved. Today, there are more than 27,000,000 receiving sets, or almost 60 per cent of American homes are television equipped.

Progress continues in television programming, as both the art and science of this great new medium advance hand in hand.

Progress in the use of UHF (ultra high frequencies) in television broadcasting during 1953 is convincing evidence that expansion of television in this direction will continue during 1954. Already

(Continued on Page 97)

SONG HITS OF 1953

January 1, 1953 to January 1, 1954

The 35 song hits with the largest radio and television audiences listed below in order of the total ACI points received in the ACI surveys during 1953. (Songs in stage or film productions are indicated. Songs currently active are marked with an asterisk. Songs whose activity began on the ACI surveys during the fall of 1952 are noted by the 1952 date.)

SONG TITLE AND PUBLISHER	TOTAL ACI POINTS	NUMBER OF WEEKS ON ACI SURVEY
I Believe (Cromwell).....	34,339	36
Song From Moulin Rouge (Broadcast).....	33,272	37
April in Portugal (1952) (Chappell).....	29,310	43
*No Other Love (Williamson).....	29,007	31
Side By Side (Shapiro-Bernstein).....	28,983	38
Don't Let the Stars Get in Your Eyes (Four-Star).....	25,769	24
Till I Waltz Again With You (Village).....	25,271	26
Pretend (Brandon).....	24,458	31
*Vaya Con Dios (Ardmore).....	24,121	28
Your Cheatin' Heart (Acuff-Rose).....	21,870	31
*You You You (Mellin).....	21,138	27
*Ebb Tide (Robbins).....	20,754	22
Ruby (Miller).....	19,013	27
I'm Walking Behind You (Leeds).....	18,651	29
*Oh (Feist).....	17,731	24
Doggie in the Window (Santly-Joy).....	17,392	26
Keep It a Secret (1952) (Shapiro-Bernstein).....	17,059	17
Why Don't You Believe Me (1952) (Brandon).....	16,868	18
*Many Times (Broadcast).....	15,084	17
How Do You Speak to An Angel (Chappell).....	14,447	20
*I Love Paris (Chappell).....	13,024	21
I'm Sittin' on Top of the World (Feist).....	12,683	20
Because You're Mine (1952) (Feist).....	12,091	12
*Ricochet (Sheldon).....	12,029	17
*Rags to Riches (Saunders).....	11,764	17
Just Another Polka (Frank).....	11,493	21
P. S. I Love You (La Salle).....	11,422	20
Wild Horses (Simon).....	11,391	20
Lady of Spain (1952) (Sam Fox).....	10,611	25
*Stranger in Paradise (Frank).....	10,163	9
Nearness of You (Famous).....	9,920	25
Hush-A-Bye (Remick).....	9,442	19
Crying in the Chapel (Valley).....	9,231	17
*That's Amore (Paramount).....	9,215	13
*Granada (Peer).....	9,039	27

(Copyright, 1954. Office of Research, Inc.)



JACK LESCOULIE

announcer for

JACKIE GLEASON

DAVE GARROWAY

BUICK

Best Wishes

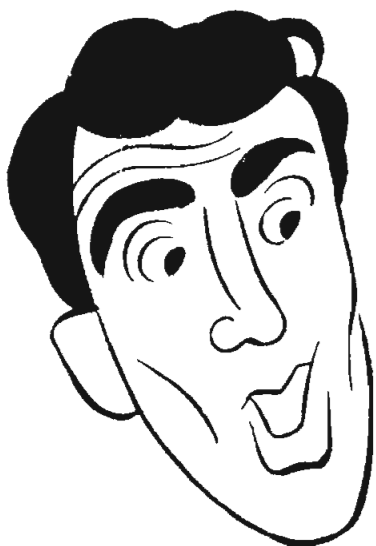

DEAN & JERRY



CARTB Enters New Year With Strong Membership

by T. J. ALLARD
General Manager

Canadian Association of Radio and Television Broadcasters

THE Canadian Association of Radio and Television Broadcasters starts 1954 with its membership at the highest level in its history—120 member stations out of a potential of the 140 non-government stations located in Canada.

Formerly known as the Canadian Association of Broadcasters, a change in name was effected during 1953 because of the Association's activities bearing fruit in one most important direction. There are now four television stations operating in Canada, apart from government TV stations, due to the CARTB's attempts to secure non-government TV licensing. Hence application was made to the proper authorities to have the name officially changed to "The Canadian Association of Radio and Television Broadcasters."

Although government policy now permits licensing of non-government TV stations in some areas, the CBC still maintains its own television monopoly in the six major cities of Canada. During 1954, a large part of CARTB's efforts will be designed to rectify this unfortunate situation.

Another forward step marked the past year in the semi-political field. Following the customary CARTB presentation to the now annual Parliamentary Radio Committee, that body recommended that the CARTB's case for a "separate regulatory body" merited further study. Previous pleas of CARTB for such a non-competitive regulating body have been dismissed. There now seems hope that the government of Canada is studying with greater care and sympathy the CARTB's often reiterated request for a "separate regulatory body," similar to the FCC, which would hold regulatory authority of proper degree and extent over both CBC and the non-government stations, in place of the present situation wherein CBC holds the regulatory authority, a monopoly on all networks and network arrangements, and competes

with the non-government stations at the same time for both audience and business.

While not agreeing with the CARTB case concerning a separate regulatory authority, the CBC itself seems to be showing signs of desiring greater cooperation with the non-government stations on operating problems and policies. The new CBC regulations are an improvement on the old, and an even greater improvement upon the new proposals originally published.

In the year just past, the CARTB undertook an extensive and ambitious job-analysis and cost accounting survey of broadcasting stations in Canada. The survey set up job specifications, gave average ranges, and undertook detailed analysis, by types of business, of station sales, costs and like statistical material.

The Sales office of the Association widened its presentations to agencies and advertisers outlining the benefits of broadcast advertising. An accurate listing was prepared which gives, for the first time in Canada, a detailed accounting of what accounts and types of accounts do and do not purchase broadcast advertising, and the extent to which all accounts invest in any type of advertising.

Arising from action taken at an Annual Meeting of CARTB, plans are being explored in Canada to set up an impartial research directorate to outline standards for program popularity polls, to validate this and other types of research, to set up a sort of "good housekeeping" seal of approval for research companies which meet these standards, and to provide information to agencies and advertisers on the use of researchers figures. This research directorate, it is planned, will function under the general direction of the Bureau of Broadcast Measurement, jointly supported and financed by broadcasters, agencies, and advertisers.



Regards from Robert Q. Lewis

Exclusive Representative:
TED ASHLEY ASSOCIATES

Press Relations:
SOLTERS-O'ROURKE ASSOCIATES



Sales Outlook Good in Radio-TV Industry

By FRANK M. FOLSOM

*President
Radio Corporation of America*

THE growing importance of the radio-television industry in the progress of America was demonstrated convincingly in 1953. New dimensions of television and sound, in particular, and the continuing electronic requirements of government and military services, provided major areas of development and production. The industry reached an annual going rate estimated at nearly \$8 billion.

It proved an excellent year for the Radio Corporation of America, with sales of products and services attaining an all-time high volume, well over the \$800 million mark.

RCA's dollar backlog of government orders at year-end was the largest in the company's history, exceeding by a considerable margin that of the World War II period.

Abundant sales opportunities are ahead in such fields as black-and-white television, compatible color television, industrial TV, transistors, high fidelity phonograph instruments and records, office and home communication systems, radio sets, and electronic equipment for industry and military uses, as well as the older lines of communication apparatus.

RCA recognizes that American merchandising reached a significant turning point in 1953, presenting new challenges and opportunities for the coming year—a year that can be good for business.

The new trend in merchandising represents a closer approach to normal business operations. The 14-year old sellers' market is gone. Many industries are now adjusting their operations to meet the demands of a buyers' market. Careful planning and hard work are needed to maintain the sales volume developed during the years that business enjoyed a sellers' market.

The changed market condition requires evaluation by business leaders, not only along economic lines, but in overall strategy of operations.

RCA is charting a positive course of action to maintain relatively high vol-

umes in production and sales during 1954. Among major steps being taken to achieve this aim are:

1. Reshaping of productive capacity to meeting changed merchandising trends and to increase efficiency so that values of products may be enhanced for the consumer.
2. Streamlining of operations and selling organizations.
3. Establishment of closer teamwork between retailers, wholesalers and manufacturers.
4. Strengthening of distribution system so that consumer demands in certain areas can be more readily met by wholesale outlets nearer to dealers.
5. More assistance to dealers.

Television continued to expand and improve its service to the American public during 1953, with more than 27 million black-and-white receivers in use by year-end. This represented an increase of approximately six million over the previous year.

Two significant trends were reflected in consumer television buying patterns—one was the increasing popularity of larger screen sets, such as the 21-inch RCA Victor models, and the other was the impact of UHF (ultra high frequency) television stations as added programming outlets. Many of the sets sold were equipped to receive both VHF (very high frequency) and UHF transmissions.

RCA expects sales of black-and-white television sets to continue in the millions, during the orderly introduction of compatible color television in 1954, and plans to accelerate promotional activities to achieve this. The importance to the public of compatibility in television cannot be over-emphasized. It means that color programs can be received in black-and-white on all existing sets, at no additional cost to set owners, and without added devices. Color sets can also receive black-and-white programs in black-and-white.

(Continued on Page 121)

Kate Smith

1953 NETWORK NEWS SELECTIONS

The network's evaluation of the top ten news stories follows:

— ABC RADIO —

- 1—The signing of the Korean truce.
- 2—The death of Premier Stalin.
- 3—Execution of the Rosenbergs.
- 4—The Harry Dexter White case.
- 5—Russia's hydrogen bomb.
- 6—The Greenlease kidnap-murder.
- 7—Inauguration of Eisenhower.
- 8—Coronation of Queen Elizabeth.
- 9—Death of Senator Taft.
- 10—Yankees win fifth Series.

— ABC-TV —

- 1—Korean Truce.
- 2—Eisenhower takes over.
- 3—Stalin's death and Red unrest.
- 4—McCarthy vs. Eisenhower.
- 5—Taxes.
- 6—Atomic crisis.
- 7—White case.
- 8—Rosenbergs' execution.
- 9—Queen's coronation.
- 10—Taft dies.

— CBS RADIO —

- 1—Inauguration of Eisenhower.
- 2—Death of Stalin and rise of Malenkov.
- 3—Armistice and Prisoner Exchange in Korea.
- 4—Coronation of Queen Elizabeth.
- 5—The Rosenberg Case.
- 6—Death of Senator Taft.
- 7—Harry Dexter White Case.
- 8—Big Three Conference.
- 9—Eisenhower world atomic stockpile plan.
- 10—Battle for European Defense Community.

— CBS-TV —

- 1—Power shift in Russia—death of Stalin, Malenkov's accession, ouster of Beria.
- 2—Signing of Korean Armistice, and subsequent negotiations, prisoner return, prisoner explanations.
- 3—Eisenhower speech to UN on atomic controls.
- 4—Berlin riots.
- 5—Coronation of Queen Elizabeth.
- 6—Harry Dexter White case.
- 7—Inauguration of Eisenhower.
- 8—Execution of the Rosenbergs.

- 9—Death of Senator Taft.
- 10—Greenlease kidnapping.

— DU MONT-TV —

- 1—Korean Truce.
- 2—Death of Stalin.
- 3—Soviet Hydrogen Bomb.
- 4—Eisenhower Address to U.N.
- 5—Inauguration of Eisenhower.
- 6—Greenlease Case.
- 7—Rosenbergs' Execution.
- 8—Dutch Floods.
- 9—Death of Senator Taft.
- 10—Coronation.

— MUTUAL-RADIO —

- 1—Armistice ends fighting in Korea.
- 2—The death of Stalin.
- 3—Coronation of Queen Elizabeth.
- 4—The Harry Dexter White case.
- 5—East German Riots.
- 6—Execution of the Rosenbergs.
- 7—The death of Sen. Taft.
- 8—The Greenlease kidnapping.
- 9—The Eisenhower Atomic Plan.
- 10—Changes in the United States Supreme Court.

— NBC RADIO —

- 1—The Inauguration.
- 2—The Coronation.
- 3—The Berlin riots.
- 4—The Greenlease kidnapping.
- 5—The McCarthy-Dulles Conflict.
- 6—Korean coverage: atrocities, POW's: Mrs. Howe and her son; reluctant GI's, and the POW exchange.
- 7—Death of Stalin.
- 8—Brownell-Truman.
- 9—Death of Senator Taft.
- 10—Farmers' fight on Benson.

— NBC-TV —

- 1—Inauguration of Eisenhower.
- 2—Coronation of Queen Elizabeth.
- 3—The Greenlease kidnapping.
- 4—Death of Stalin.
- 5—Berlin riots.
- 6—Korean truce and POW exchange.
- 7—The Harry Dexter White case.
- 8—The tornadoes.
- 9—The Trieste problem.
- 10—The McManus case.



JIMMY NELSON
DANNY O'DAY
"THE MAHOGANY KID"
and
HUMPHREY HIGSBY

EXCLUSIVE BOOKINGS



PERSONAL MANAGEMENT

LOUIS W. COHAN

1776 BROADWAY
203 N. WABASH AVE.

NEW YORK, N. Y.
CHICAGO, ILL.



FARFEL



Surveys Uphold Constancy of Television Audiences

By JAMES W. SEILER

Director

American Research Bureau

WITH the television industry well out of its swaddling clothes and now passing into a rapidly achieved adult state, the myriad questions which could not be answered during the youngster's uncertain infancy are receiving increased attention.

American Research Bureau, Inc., in the course of its individual market and nation-wide audience surveys for the last four and a half years, has been coming up with many of the answers.

Certainly one of the long-standing \$64 questions has involved the constancy of television audiences. Would they love the medium in December as they did in May?

In the late 1940's, it took something less than a gross of slide rules or a mechanical brain to determine that the family's first television set was likely to be in almost constant use. Practically all program fare was received enthusiastically. Dire predictions that prolonged small-screen viewing could lead to myopia or spots (20-second) before the eyes, failed to curb an audience prepared to take all that the tube could bear.

Such immediate response, however, could not quiet an ever-present fear in the industry that the first flush of enthusiasm would subside. The peak of viewing time among owners of new sets, many felt, would inevitably be followed by a substantial drop to a much lower plateau of hours spent watching TV once the novelty had worn off.

ARB studies now indicate these fears were unfounded.

Since 1949, ARB has been conducting diary surveys of television viewing and publishing reports which have gained acceptance among those who must have reliable and statistically accurate figures. During these sampling operations, respondents have been asked to supply the purchase date of their sets. By now, ARB has on file thousands of week-long viewing records of families of all categories in terms of length of set ownership.

ARB reports from a group of representative markets where television pro-

gramming has been in effect for a few years quickly lay to rest the fear that enthusiasm for the medium is short-lived. The accompanying chart shows today's average viewing hours per family in these areas, broken down by date of set purchase, both for the Monday through Friday daytime hours and for the evening hours of the entire week.

FAMILY VIEWING HABITS	
DAYTIME	
Set purchased	hrs. M-F
1949 or earlier	8.2
1950	7.8
1951	7.8
1952	8.1
1953	9.7
EVENING	
Set purchased	hrs. per wk.
1949 or earlier	21.7
1950	20.0
1951	18.9
1952	19.0
1953	21.0

These figures amply demonstrate that there is not too wide a variance in time devoted to viewing among families who bought their sets in recent years. True, the weekday viewing in homes where the set was purchased in 1953 exceeds that of the family who acquired a set in 1950 by over 20 per cent. It is to be expected, however, that the impetus of new set ownership must reveal itself to some extent. Yet the same comparison with 1949 purchasers of sets shows only 18 per cent more viewing during the daytime period by those who became set owners in 1953. And the 1949 purchasers are now watching television 0.7 more hours per week during the evening than the johnny-come-latelies whose purchase of a set was made last year.

The figures put the viewing picture into focus.

The complete picture is a cheerful one for the industry, cancelling out the stereotype of the jaded set owner increasingly turning away from television once the first rapture of enthusiasm has passed.



SAM LEVENSON

"THIS IS SHOW BUSINESS"

CBS-TV

"TOAST OF THE TOWN"



New Production Records Set by Manufacturers

By JAMES D. SECREST
Executive Vice President

Radio-Electronics-Television Manufacturers Association

THE radio-TV and electronics industry broke all production records in 1953 by turning out sets, electronic equipment, transmitters, and tubes and parts with a combined factory value of more than \$5 billion. This was \$1 billion more than the industry's output in 1952.

About one million more television receivers and above two million more radios were manufactured in 1953 than during the preceding year. While neither production was an all-time high, their combined value was exceeded only by that of 1950 when the outbreak of the Korean War started a buyers' panic due to fear of wartime shortages.

Preliminary tabulations show that about 7,250,000 television receivers and 13,500,000 radios, including auto sets, were produced in 1953. Their total factory sales value was more than \$1.5 billion.

The broadcast equipment segment of the industry experienced a boom as the Federal Communications Commission surprised everyone by the rapidity with which it issued TV construction permits.

Sales of replacement parts through jobbers and service shops continued to rise as TV set ownership throughout the United States passed 27 million.

An upsurge in public demand for good music in the home brought high fidelity equipment from the custom shops to the mass ready-made market. Even the radio-less phonograph—with high fidelity accessories—returned to the high price shelf.

The most significant long-range development in 1953, however, was in the engineering research field. The National Television System Committee, which was formed by the Radio-Electronics-Television Manufacturers Association three years before, did what many thought impossible in 1950 and recommended to the FCC tested standards for transmission of a compatible color television signal. The Commission, which had previously approved non-compatible standards pro-

posed by the Columbia Broadcasting System promptly adopted the new specifications.

Indicative of the expanding character of the industry, the manufacturers' trade association added the word "electronics" to its title only three years after it incorporated "television." Thus the radio industry which existed before World War II and which did an annual business of \$250 million (factory sales) became the radio-electronics-television industry with a yearly output valued at more than \$5 billion.

The essentiality of electronic equipment in modern warfare and defense was responsible for the greatest part of the expansion of plants and facilities since 1950. Much of this type of manufacturing is expected to turn to new industrial and commercial electronic equipment once military procurement declines. However, there appears little prospect that this decline will occur in 1954 or for several years to come.

The outlook for 1954 TV set production is not as clear as heretofore due to the uncertainty of the effect of color television on black and white receiver sales.

Many manufacturers believe that the display of a few "sample" color sets at from \$700 to \$1,000 in 1954 actually will stimulate the buying of black and white sets. They believe the comparison of prices and values of black and white against color sets, together with the limited number of color programs, will win over many persons who have been waiting for color in the mistaken belief that it would be as cheap and have as large screens as black and white.

Set and parts manufacturers in an informal poll following a RETMA meeting estimated that about 5,000,000 black and white sets and under 200,000 color receivers will be manufactured in 1954.

Radio receiver production, which has maintained a remarkably high level in spite of television, is expected to continue at twice the rate of the TV set output.



MEL ALLEN



Progress On The Overseas Information Front

By THEODORE C. STREIBERT

Director

U. S. Information Service

ON August 1, last, the President formed the U. S. Information Agency to carry on the overseas information program of the United States. The new Agency has responsibility for programs formerly conducted by the Department of State and the Mutual Security Agency. The Director of the new Agency is responsible to the President through the National Security Council.

In a public announcement on October 22, the President gave the new Agency its mission. This was the first time in history that any government had ever announced to the people of the world what it was trying to accomplish through its overseas information program.

The President has given the new Agency the job of presenting factual evidence to the other peoples of the world that the U. S. shares with them the same aspirations they have for freedom, peace, and progress. Further, the Agency has the job of trying to persuade these people that they can best achieve their legitimate aspirations in cooperation with the U. S.

In doing its job, the U. S. information Agency is directed to concentrate on objective, factual news reporting and appropriate news commentaries.

Distortions or misrepresentations of fact are not permitted. Use of a strident, antagonistic tone must be avoided.

This does not mean that the U. S. Information Agency is going to be "soft" about communism. Quite the contrary. The Agency will continue to hit hard at Soviet lies about the United States.

But by sticking to the facts, not haranguing, we should be able to do a better job. For if we are to succeed, our message must be credible if it is to be convincing. Facts and comments associated with facts are, of course, far more compelling than accusations or mere assertions.

Our radio broadcasts to Russia and the satellites provide a good example of the new policy in action. Important distor-

tions are being made in the contents of our broadcasts to these areas.

In our broadcasts to Russia, the attempt will be made to gain a reputation for credibility and factual news reporting, instead of being only anti-Soviet.

In the satellite countries, the situation is somewhat different. Here there are captive peoples who have known a better system than communism. The U. S. Information Agency will give them straight news too. But it will also hit hard at Soviet imperialism and try to keep alive their hopes that someday they will again be free.

The radio operations are one example. Less reliance than before is being placed on long range, short-wave broadcasts from the U. S. Instead, more emphasis is being placed on relaying short wave broadcasts on the standard band from points closer to our listening audiences.

The broadcasting service of the U. S. Information Agency is also providing our overseas missions with prepared programs on tapes and recordings. These are being placed on local stations abroad.

In addition to these radio activities, the broadcasting service is also supplying TV material regularly to 15 countries.

The revised program of the new U. S. Information Agency also gives much greater emphasis to the importance of the cooperation of business and civic groups. To date, over 750 private organizations have participated in projects of value to our overseas information effort. Their cooperation has saved American tax-payers several million dollars. More important, they have accomplished things which the Government would not have done.

Active participation is needed by more civic groups and industrial organizations. Non-government resources must be utilized to a far greater extent to help in the big job there is to do.

The U. S. Information Agency is striving in every way possible to stimulate and assist this private participation.

**DON McNEILL'S
BREAKFAST CLUB
Now on
ABC Television
and ABC Radio**



*From the
Terrace Casino
Room of the
Morrison Hotel
Chicago
8 to 9 a.m.*



Neither Boom Nor Gloom in Broadcasting's Destiny

By HAROLD E. FELLOWS

President
NARTB

TO me, the current hue and cry concerning this nation's economic outlook is reminiscent of the period six scant years ago when prophets of doom were chanting that radio was a "dead duck."

Perhaps this is an inevitable result of long-standing American custom of her heralding in each new year with backward analyses and forward prophecies. So-called experts are called upon to bespeak themselves with authority and all at once 'til they have to shout over the crowd to gain audience.

"Downward curve," "levelling-off," "recession" whatever the pessimistic definition, may, as I have indicated, be likened to the year of 1948 when television suddenly swept into popular acceptance and radio was labeled a "dead duck." History has since written that radio was not destined to be so labeled—any more than newspapers were destined to lock their doors when radio appeared.

Such shouting from the roof-tops about recession is a clarion call to arms—it heralds clashes, controversies, sometimes temporary bitterness, but the final, end product is readjustment—then the renewed march forward.

Personally, I am not convinced by the gayer economists that business will soar to new heights in 1954, nor am I persuaded by the sadder among this gentry that we shall descend into the slough of depression. But some place between those two extremes, it would appear, lies our destiny in the field of business activity for 1954.

In too many of our approaches to the daily problem of living, we are frenetically trying to run forward while looking backward. Forward lies the challenge—forward where one can see even more prosperous living for all of our people; expanding markets; new developments in transportation, in housing, in communications. Forward lies the challenge to men who are so dissatisfied with this day that they would make tomorrow better.

And therein lies the forward challenge of media—all media, newspapers, magazines, outdoor, direct mail, radio and television. Perhaps media muscles got a little flabby during the immediate post war years when we were in a sellers' market. Now in 1954, the pendulum has swung to a buyers' market and it is up to media to move the goods.

Indisputably, this nation has the finest advertising talent in the world. Moreover, this nation is blessed with the kind of leadership in its industries which does not falter in the face of adversity.

The goal before all media is consumption. Since people are the ultimate consumers, it bodes well that the field of research has at long last come into its own. It is through research that we can study the consumer and his motives for buying.

The markets of America will be served even more widely by the great communications media of radio and television in 1954. As this is written, FCC statistics show that at the conclusion of 1952 there were on the air 2399 AM stations, 672 FM stations and 137 TV stations. At the end of 1953, the FCC reported on the air 2521 AM stations (an increase of 122); 560 FM stations (a decrease of 52); 356 TV stations (an increase of 219).

As for the NARTB, we're 1116 strong in AM against 1024 at the end of 1952. In FM, we've dropped from 365 to 340—nearly holding our own despite the fact that many FM stations went off the air. In TV, we've gone up from 102 to 229.

The figures will be even greater next year this time. The broadcasting industry has never stood still. It never will. We're moving ahead. There will be color tubes and vest-pocket radios, new horizons in broadcast education and service to the public. There will also be new and continuing problems. If we stick together and work together as an industry, we'll handle them all. That's a challenge and a promise.

YOUR
SHOW
OF
SHOWS



**YOUR SHOW
OF SHOWS**



HAL JANIS

YOUR SHOW OF SHOWS

**YOUR SHOW
OF SHOWS**



SID CAESAR

"O Boy O Boy"

**YOUR SHOW
OF SHOWS**



IMOGENE COCA

"What a Beautiful Gesture"

**YOUR SHOW
OF SHOWS**



JACK RUSSELL

**YOUR SHOW
OF SHOWS**



CARL REINER



**BILLY
WILLIAMS
QUARTETTE**

**YOUR SHOW
OF SHOWS**



HOWARD MORRIS



JOAN WALKER

MELL TOLKIN — LUCILLE KALLEN — MEL BROOKS
TONY WEBSTER — JOE STEIN — DANNY AND DOC SIMON

WRITERS

OF

"YOUR SHOW OF SHOWS"

**YOUR SHOW
OF SHOWS**



CHARLES SANFORD

MUSICAL DIRECTOR

OF

MAX LIEBMAN'S "YOUR SHOW OF SHOWS"

NBC-TV

YOUR SHOW
OF SHOWS



Max Liebman

Producer-Director

"Your Show Of Shows" — WNBT



The Radio Revolution; Analysis of Programming

By **FREDERIC W. ZIV**

President

Frederic W. Ziv Company

THE revolution in radio has been taking place for several years now. It is a peaceful revolution, although a far reaching one. And it has been going on long enough now so that certain patterns have emerged and taken shape.

It is increasingly evident to all, even the most pessimistic, that the radio industry will not only survive the television revolution, but that it will emerge as an infinitely more stable and perhaps, even stronger entertainment and advertising medium.

It is at the local and regional level that radio is vitally alive. It is here that radio is setting new records and giving ample promise of new goals yet to be reached. And we of the Ziv Company are keenly aware that it is our function to supply, at the local and regional levels, the new, modern programming techniques that radio demands.

Our "Hour Of Stars" series is an outstanding example of the success which awaits those who program in the new way for today's radio. At this moment the "Hour Of Stars," is being broadcast by 527 radio stations in the United States. But more important, never before in our history, have we received so many glowing and enthusiastic reports from the stations, telling us of their success in securing local, regional and national spot advertisers. The decision to program an hour long segment of time, every week-day — to program it imaginatively and with showmanship, has certainly paid off for our stations. It was our belief that a show with four of America's greatest stars — Tony Martin, Ginger Rogers, Dick Powell and Peggy Lee — presenting the kind of entertainment America loves best, just couldn't fail. It didn't.

Encouraged by the success of the "Hour Of Stars," we determined to take an even bigger step. What we wanted was one of the top three radio stars of all time. We wanted in short, a comedian who had sky-rocketed to success in radio. We were convinced that one of

radio's top comedians, a man who had always been able to command a tremendous listening audience, could, if programmed in the new and modern technique, rise to even greater heights.

We have been fortunate to secure the services of Red Skelton. Red is indeed, one of the three all time comedy greats of radio. And we have been able to make Red Skelton available in a half-hour show to stations, agencies and sponsors on a five time a week basis. I think you will agree that the impact of the "Red Skelton Show," programmed five times a week across the board, is exciting to contemplate. And because of the vitality and growth of local and regional radio, we can look forward to extending this program into more markets than we have ever reached before and thereby offer it to each station or sponsor at prices that are among the lowest in our history.

As this piece is written, we have been offering the "Red Skelton Show" for just two weeks. It has been the biggest two weeks that our company has ever enjoyed from a sales standpoint.

This is the new radio. This is radio's dynamic answer to the demand of its audiences and advertisers for a new approach — a top comedy star in five half-hour programs every week — a form of programming not contemplated in the 1940s, never before available to the stations and sponsors on a local and regional basis. The immediate, enthusiastic response to this new plan for radio programming and selling today is a real tribute to the growing vitality of this medium.

These successes are not *ours*. They are industry successes. They stand, I believe, as testimony to the strength and power of radio, to its ever increasing appeal as an advertising medium. They stand too, as evidence that radio still offers a challenge to the showman and to the salesman. And further, that new successes and new achievements await those who successfully meet the challenge.

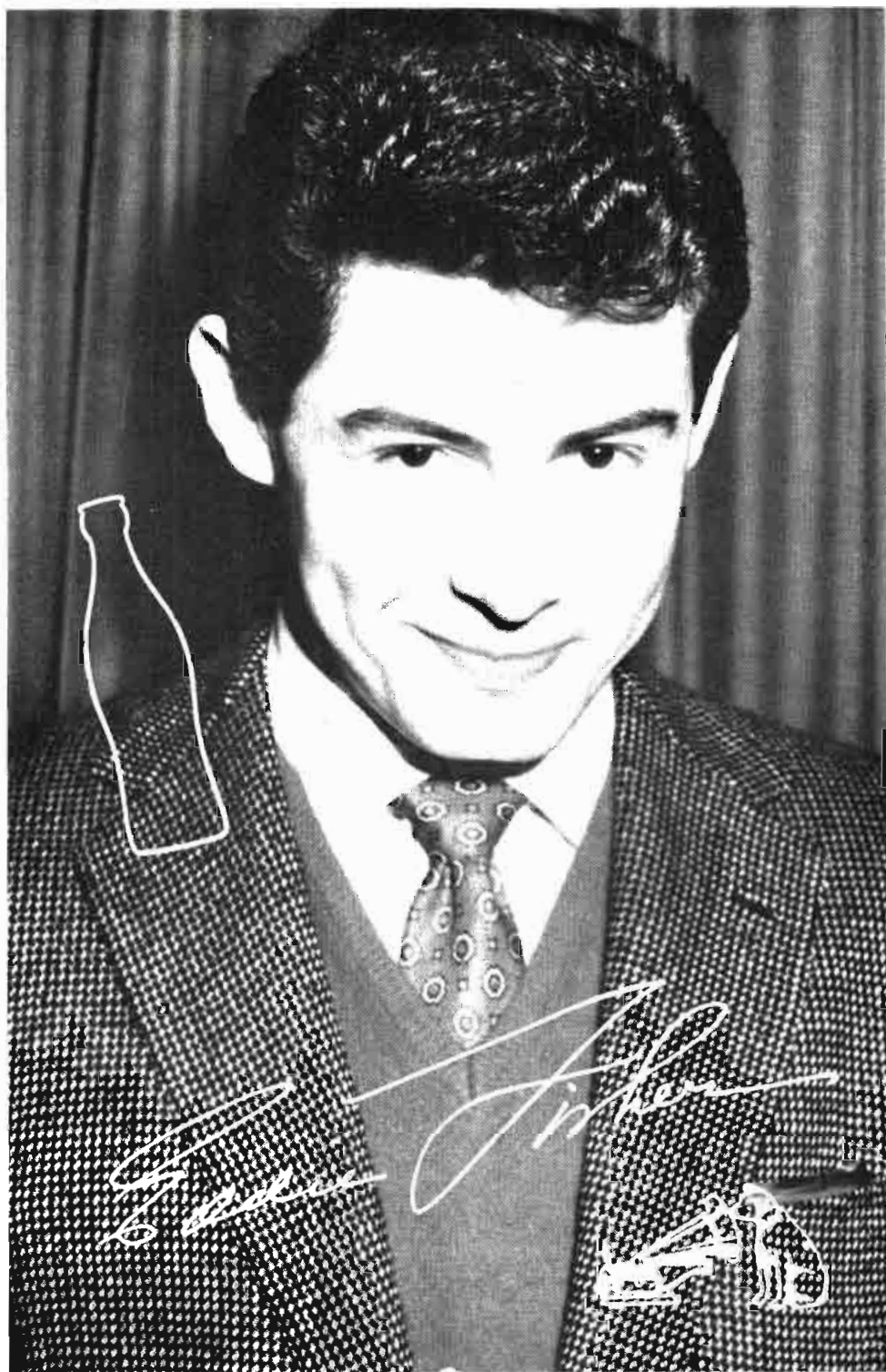



Merchandising Methods As Practiced by Network

By FRED N. DODGE

NBC Merchandising Director

FIRST, let us remember always, that advertising is bought, whether it is in a newspaper, magazine, billboard, radio or television, for just one reason; that is to help an advertiser sell his services or product. For years advertising media of all kinds have created and presented glowing presentations of the selling effectiveness of their medium. However, in most cases when the order was booked they considered their responsibility discharged and when any advertiser asked for help in merchandising his advertising at the point of sale and moving his product, the howls were long and loud. This was particularly true in radio and television. However, during the past two and one half years the picture in this field has changed.

When NBC launched its Merchandising Department on January 1, 1952 no other network offered a complete merchandising service and few stations had embraced merchandising, despite the pioneering of the granddaddy of them all, WLW in Cincinnati, for over 17 years. Being a subject that was new to most broadcasters, merchandising erupted in the industry during the past two years in many and sundry forms and concepts. Unfortunately, in many cases, much of this so-called merchandising is designed to impress the advertiser, with nothing concrete being done about the real target, SALES. Further, in many cases, these merchandising plans have constituted a form of rate cutting. However, gradually the sounder merchandising techniques are prevailing and merchandising, a subject to which scant heed had been paid in the past, is becoming firmly established.

Although we are concerned with network merchandising, emphasis here is being placed on the growth of merchandising among stations because a network's affiliated stations make a most important contribution to network merchandising. This is for the simple reason

that all merchandising is local and no advertising medium could afford to foot the bills accruing to the establishment of local merchandising operations in all of the key markets. However, a network, and only a network, can present a well rounded and sound media merchandising service to national advertisers because it is represented in these markets by its affiliated stations. When a sound cooperative program between a network and its affiliates is established in the interests of network sponsors then, and only then, is true network merchandising effectiveness achieved.

Obviously, an understanding of the advertiser's problems, his sales goals and his methods of distribution are essential to the cutting of a merchandising pattern suitable to his individual needs. This requires experience and the "know-how" of professional merchandising men. Accordingly, the NBC merchandising field force is made up of men who average better than twenty years of advertising, sales, marketing and merchandising experience and are fully qualified as sales and merchandising, consultants. Further, any merchandising plan in which the promise is not performed is bound to lead to distrust and, to say the least, loss of interest on the part of sponsors. Therefore, one of the most important functions of the NBC Merchandising District Supervisors is the policing of the cooperative agreements with retail factors which they have obtained in the interest of our advertisers.

The importance of merchandising is fast being recognized by both advertisers and agencies and the demand upon media growing. Daily the case histories are piling up as indisputable evidence of sound merchandising's value and place in today's sales battle. In brief, the day has passed when advertising media can consider their obligation to the advertiser fulfilled when they have made the sale of time or space.

DANNY THOMAS

"MAKE ROOM FOR DADDY"

ABC-TV

for

LUCKY STRIKE CIGARETTES

and

DOODGE PLYMOUTH DEALERS



IAAB Activities Expand In Latin America

By EMILIO AZCARRAGA

President

International Association of Broadcasters

ON October 4th of this year, the Inter-American Association of Broadcasters was eight years old. This date has been christened in this Hemisphere as "Broadcasting Day" and it marks, shall we say, the reaching of age of this wonderful medium of diffusion.

In fact, the great progress and maturity reached by radio in the different countries of America had not had, prior to that time, an organized entity for the purpose of determining and summarizing the duties of the broadcasters toward the people whom they serve and to point out the moral responsibilities inherent in the privilege of addressing them and to accept as one of those duties, undoubtedly the most sacred one, the defense of the ideals of liberty, democracy and respect of human dignity, as the most secure path to permanent peace and tranquility.

The IAAB also promoted liberty of expression and made a reality of it through practice, which in its double aspect of free communication of ideas and the rights of the people to free access to all events and opinions, without obstacle or deviation, should be considered as the most efficient guaranty and safeguard of the rest of the essential rights of man.

The IAAB proclaims that there are no theoretical liberties. Each individual is entitled to practice and enjoy all of them and it is liberty of expression which in great measure contributes to strengthen in men the consciousness of their rights, enable them to repudiate lies and deceit and save them from becoming new victims of ideologies that poison the spirit and spread destruction.

Notwithstanding all the formulae of protocol which, it is assumed, are international obligations, the IAAB, as well as its twin sister, the Interamerican Press Association, has a very difficult task to perform, because day by day liberty of expression is a victim of violations and abuses in one place or another,

and has become in some countries a permanent victim of a dictatorial will built upon a sole and supreme law.

In all its activities the IAAB proclaims and supports the principles of living together, solidarity and cooperation, which serve as a basis for the United Nations Organization and the Organization of American States. In summation, all of its work is but the application and defense of the purposes and goals of such organizations. Thus the IAAB has been recognized and has been given the category of a non-governmental cooperative medium, by virtue of which it maintains a permanent contact with them.

During the coming year of 1954, intensive work awaits all Directors of the IAAB. Furthermore, we are creating special commissions with representatives of all regions of the Continent who, together with the Committees of the Interamerican Press Association, will keep vigil over liberty of expression and the application of the "Panama Doctrine." These Committees will be permanent and it is expected that their performance will contribute, in a very effective way, to the aims of the Press Association and our Association.

We also have before us the task of persuading the Organization of American States to call a conference to unify, in broadcasting matters, the legislation of the countries of this Hemisphere, not in its technical aspects which have been the subject of several world, continental and regional treaties now in existence, but as to the contents of the transmissions themselves, in order that the domestic legislation of each country confirm and guarantee the liberty of expression.

The IAAB is filled with great faith and an indefatigable persistence. It places both at the service of liberty, within the formulae which the people of our countries have chosen as the best to reach their fulfillment.

Best Wishes



Martha



NTSC and Color Television

A Review of Developments

By DR. W. R. G. BAKER

*General Electric Vice President and Chairman
National Television System Committee*

COLOR television, long-awaited and much discussed, today is a living, growing monument to more than 200 top electronics scientists and engineers from several score television and broadcast companies and laboratories.

In what must be an unparalleled example of industry cooperation, more than one million man-hours and an estimated \$10,000,000 was expended in the development and the testing of the technical signal specifications for color television proposed by the National Television System Committee. No one company, nor any single individual can claim the credit for the development of the FCC approved color television standards. It must be shared by all.

Certainly Chairman Charles A. Wollerton of the House Committee on Interstate and Foreign Commerce expressed it well when he said that the words of former Chairman Fly of the FCC concerning the work of the first NTSC on monochrome television "are as appropriate today as they were when he uttered them." Chairman Fly said, "This is another example of the best that is in our democratic system, with the best in the industry turning to on a long and difficult job in an effort to help the government bodies in the discharge of their functions so that a result may be achieved for the common good of all."

The National Television System Committee concerned itself solely with a significant and highly challenging technical problem; how best to achieve the optimum in terms of a color television system. Those persons on the Committee and associated with its work were scientists and engineers of special technical qualifications, or others with a deep interest in the progress of color television. The Committee did not concern itself with any phase of production equipment, nor with considerations involving the proprietary interests of members or companies in the industry.

Taking two fixed points; (1) the 6-megacycle band width established by the FCC for this service, and (2) the physiological and psychological characteristics of the human eye—the NTSC attempted to evolve the finest conceivable system, one not only practical for the immediate public interests to be served, but one which also contains the necessary growth potential for the long-range public interests.

In the development of the standards for a compatible color system, the NTSC had the full and complete cooperation of the companies comprising the industry. The source of an idea was disregarded completely. The only questions were: Is this the best idea? Is this the best way to do the job? During its two and a half years of active work the NTSC produced a number of significant contributions, not only on a system basis, but also in details. The standards evolved by the NTSC provide first, the transmission of excellent pictures in full color to color receivers. The detail is practically equal to that of monochrome telecasts. In chromatic quality—that is, fidelity of color reproduction—the color television images match or excel color movies.

Secondly, the NTSC system fulfills the compatibility requirements. It produces the program on monochrome receivers, producing images in black and white which are better than those provided by standard monochrome broadcasts. The investment of the public in 25 million monochrome receivers is fully protected. No modification of these receivers is required, in fact, no adjustments whatever are needed except the normal operation of the front panel controls used in monochrome reception.

This is the successful result of the work of the NTSC and of the engineers and the scientists of the television industry.

ROBERT MONTGOMERY

Presents

YOUR LUCKY STRIKE THEATRE

and

THE JOHNSON'S WAX PROGRAM

NBC - TELEVISION

MONDAYS 9:30 - 10:30 PM EST



Future of Tape Recording in Television

By **BASIL F. GRILLO**
Executive Vice President
Bing Crosby Enterprises, Inc.

THIS year — 1954 — looks like the year for introduction of television recording on tape. And we mean not just another “demonstration” of technique but a practical, commercial device such as our VTR (Video Tape Recorder), that will accomplish the promises we made and revealed physically more than a year ago.

In July of this year, we illustrated near perfection of our black and white picture. It was a picture that any technician working in this newest field of electronics would be proud to achieve in such a comparatively short period of experimentation as we have experienced.

Readers of the Yearbook may ask: “What’s this fellow talking about black and white tape recording when everybody else is working on color?”

The best answer to that is, “First things first.” Let it hastily be added that we are taking second place to none in the development of color TV tape recording.

The most important thing about the perfection of black and white tape recorders is the extent to which they will advance color television programming. We believe that our VTR will so revolutionize the TV industry and its present system of black and white broadcasting, that by virtue alone of the tremendous savings it will enjoy through simplification of techniques, resources now employed in present methods may be put to use in developing color programs.

The ability of the television industry to achieve a great transformation from black and white to color TV has been questioned, in view of the motion picture industry’s inability to accomplish a general switch to color after more than 20 years of trying. We feel the impracticability of such a transformation is just as real to TV as long as expensive color film must be employed. But, with the introduction of color tape and its comparative minor cost, this change may be expected with little effort.

What are Bing Crosby Enterprises doing about color tape?

It might better be asked: What are manufacturers doing about color receivers?

For, until suitable receivers are obtained for color broadcasts at costs that are within reach of a majority of viewers, color tape is virtually a surplus commodity.

That doesn’t mean that we are sitting idly by waiting the day of general color TV broadcasting nor until everybody in America has a color receiver. Our engineers have virtually perfected tape recording of black and white television signals. To include color is a matter of a few refinements that already are known and being perfected. It is a matter of present minor concern because we know we have answered this need and will supply it when the industry is ready to adopt it.

One other new factor worth consideration in the rapidly changing picture of TV broadcasting is the possible general advent of subscription type receiving, now undergoing trial in various communities of the nation. Unquestionably, the American public is usually a discriminating audience on most occasions. It has not proven particularly so with respect to television, perhaps because it still is quite a novelty in many areas. TV on tape may prove extremely helpful in the promotion of subscription viewing however, and the profitable conduct of this type of operation.

Tape recording will also eliminate expensive filming processes and provide numerous and timely duplicate pictures for many widespread areas.

After all, viewers can look at only one show at a time. So what happens when two or more first rate productions are in direct competition. Some advertiser must be a loser. But, if he can salvage his production on tape, he can salvage audiences by showing it again at another time or another place, and, with tape he achieves the highest quality duplicate at extremely low cost. That’s the real beauty of this coming process—tape recorded TV.

**R
A
L
P
H

E
D
W
A
R
D
S**



THIS IS YOUR LIFE

for

Hazel Bishop — NBC TV

TRUTH OR CONSEQUENCES

for

Pet Milk — NBC Radio

TARGET PRODUCTIONS

GEMINI PRODUCTIONS



Casting for Television As Viewed by Expert



By MILO O. FRANK, Jr.

CBS-TV Talent and Casting Director

CASTING for Television involves public relations on an international scale. Let us start out by saying that the Casting Director is generally not the most popular man in the world. It is true that at certain times with certain people he is very popular, but this is liable to change as quickly as one is able to say "no." No matter what nationality the actor may be, "no," seems to be understood in any language. Unfortunately, part of a Casting Director's job is to say, no. The above is on the negative side and actually there are many wonderful and exciting things in casting for television.

Obviously we deal in actors; however, many strange and varied performers come our way. Among these, one of the most notable was a horse which waited patiently outside the building. We do not have many horse parts, so there was not much we could do.

Seriously though, the actual method of casting is to the best of our ability a fast and accurate process. A script is broken down, a budget is applied to the breakdown, a casting meeting is held with the producer and the director of the show, the choices of actors are made, the availabilities ascertained, the offer made to the agent, the deal is set, the contracts are drawn, and we are ready for the next show. Probably one of the most interesting phases of casting is the ever increasing search for new talent. In my opinion, Mr. Hubbell Robinson deserves a great deal of credit for his planned thinking in this respect. Being Vice-President in charge of the CBS-TV Program Department, he is a pretty busy gentleman, but nevertheless he always finds time to discuss and think about new talent. CBS approaches this problem in three ways:

1. Auditions
2. Artist's Representatives
3. Field trips

We hold auditions twice a week; on Tuesday—Variety auditions, and on Thursday—Dramatic auditions. These are open to any and all artists who wish to

appear on CBS Television. The appointments are secured by interview, letter, or phone. Appointments are given for specific times and we generally are booked some time in advance. For the dramatic audition an individual must furnish his own material. This is necessary because we want the performer to do whatever he likes and feels he is best in. It would be impossible for us to have on hand sufficient material to cover this wide range. We are always glad to suggest material if a performer is doubtful about what to do. The actor prepares his own scene, memorizing the lines, and presents it at the appointed time. The audition board consists of two or more Casting Directors who are qualified to determine the value of a performer. A written report is made and the actor is notified whether or not he has passed the audition.

The Variety audition is run in a similar manner, with the one exception that we furnish a piano and accompanist if the artist desires.

All of the members of the Casting Department attend as many of the forms of entertainment as frequently as they can. Field trips are made and every possible avenue of new talent is looked into. These field trips are not limited to the state of New York, but extend as far as necessary.

It is interesting to note that the CBS Casting Department goes beyond the call of duty in that we suggest performers for night clubs, legitimate stage, and other allied media. For this the network gets no monetary gain; however, we gain in another direction. We have the good will of the actor and we enable the actor to gain more experience and become more proficient in his chosen field.

Contrary to many opinions, Casting Departments are anxious and ready to help actors. They do not wish to cut an actor's salary, nor do they wish to cut his billing. They only wish to get the best possible show on the air within the limitations imposed upon them by the nature and budget of the show.



SAMMY KAYE

RADIO: Cameo Serenade Room — ABC
Sunday Serenade — MBS

TELEVISION: So You Want To Lead A Band!

COLUMBIA RECORDS

RCA THESAURUS

MANAGEMENT: David Krengel

607 Fifth Avenue

New York City

PLaza 3-2636



RTNDA Gains Stature As Radio-TV Organization

By JAMES A. BYRON

President

Radio-Television News Directors Association

IT no longer is news to the broadcasting industry that news has become firmly established as a primary rather than supplementary factor in station programming. Polls of the past year have rather clearly indicated that radio stations with good news programming were the first to emerge from those television-inspired doldrums that settled over some areas. And television stations are beginning to learn that there is no more readily marketable commodity than intelligently presented news programs handled by competent newsmen.

The Radio-Television News Directors Association is not inclined to take undue credit for this most satisfactory turn of events. Its officers and members know full well that there still remains room for considerable improvement. But RTNDA does feel its aims now have become the industry's goal to a remarkable degree, and that the association's opportunity for service both to news departments and station management never was greater.

During 1953 RTNDA sponsored jointly with the Medill School of Journalism, Northwestern University, Evanston, Illinois, a television news seminar whose praises still are being sung by those who attended. Faculty members were drawn from the top bracket of television newsmen who provided a wealth of visual and oral material on "how to do it." A great part of the seminar's value lay in the fact that the problems of the "beginners" were placed foremost, and that the entire program was arranged in full awareness of the fact that there are more small- and medium-size stations than large ones.

The jointly-sponsored seminars are to be continued annually under the direction of Prof. Baskett Mosse of Medill.

Other services to newsmen and management in the broadcasting field are being expanded as RTNDA itself expands. Five regional vice-presidents provide "field" representation for the organization and they, together with RTNDA's

other officers and board members, frequently are called on for talks to journalism students, regional and state radio and television news organizations and civic bodies.

The continuing work of RTNDA's Freedom of Information Committee has received recognition not only within the industry itself but within similar committees set up by other news media as well. The right of the radio and television newsman to carry the tools of his trade into many places is still being resisted by some. But the determination of the organization to see to it that radio and television news people receive equal access to the news now has been fully established and more bans are lifted every year. These benefits accrue to all radio and television newsmen and women whether members of RTNDA or not.

Membership in RTNDA provides radio and television news directors with correspondents and reporters all over the country. The association has stressed since its beginning the value of inter-station cooperation in news.

The 1954 convention of the association will be held at Chicago in line with RTNDA's ever-present desire to meet in the city most readily accessible to most members. Under a recommendation adopted by the 1953 convention the association's annual meetings henceforth will be held at Chicago in alternate years.

Since its organization in October of 1946, RTNDA has had as its first objective the establishing of all possible methods of help to its members and their stations in presenting radio and television news accurately, fully and interestingly. This and other objectives of the association have the endorsement and full support of many of the leading managers and owners of radio and television stations, and of other organizations which concern themselves with the progress and general well-being of the broadcasting industry as a whole.

AWARDS ???

I LOVE LUCY

MAKE ROOM FOR DADDY

EVE ARDEN

VIVIAN VANCE

(Academy of Television Arts & Sciences — 1953)

The same superior quality and excellence of production that helped to earn these awards are now available for the filming of commercial subjects.

Desilu Productions, Inc.

846 No. Cahuenga Blvd.
Hollywood 38, California



U. N. Radio Does World-Wide Job of Serving Listeners

By DOROTHY LEWIS

Coordinator

U. S. Relations, United Nations Radio

PERHAPS the most important factor in diplomacy is that mass public opinion is a living force in international affairs. News reaches us from all corners of the globe almost as quickly as if we had been eye-witnesses. We are parties to an action practically at the very moment it is undertaken. It is the expression of a democratic mass civilization that is still in its infancy, giving to the man in the street and to group reactions a new significance in foreign policy."

These comments made by United Nations' new Secretary General, Mr. Dag Hammarskjold, during his address before the Foreign Policy Association on October 21, 1953, indicate his awareness of media's role and particularly that of radio and television as instantaneous means of intelligence transmission. This new factor of public opinion and government action inspires increasing responsibility on the international staff of the United Nations. Moreover, each year that horizons of the United Nations and its specialized agencies are extended, thus requiring greater skills in accurate interpretation. The year 1953 saw the cessation of hostilities in Korea. United Nations Radio watched and reported on this day-to-day drama with circuits from Korea, from Paris and many U. N. Information Centers around the world. These furnished the daily recorded news interviews and proceedings for inclusion in all daily U. N. Radio broadcasts in 25 languages, to member states.

Of special note were two documentary programs aired over ABC entitled "The Korea Story." Narrated by Dick Powell and Helen Hayes, these broadcasts gave the political history, as well as an account of Korean Reconstruction. During the summer, U. N. Radio produced another series of six documentaries called "We Saw Tomorrow," aired over NBC, based on recordings made in eight Latin American countries on a 25,000 mile tour by a U. N. information team.

In cooperation with NARTB and the

U. S. Committee, U. N. Day, October 24, was celebrated with special radio and television programs. Of particular note was a transcribed documentary "The Grand Alliance," narrated by Joseph Cotten, which was released to 2,800 U. S. stations, and a spectacular television tour of United Nations Headquarters entitled "U. N. Open House," produced by CBS jointly with the U. N. Department of Public Information, carried coast to coast, giving to millions a glimpse of the setting for the sixty government operation.

Human Rights Day, December 10, was highlighted by a documentary program entitled "Letter from Father," narrated by Sir Laurence Olivier, produced by U. N. Radio and UNESCO in cooperation with the American Broadcasting Company and heard during the week over 600 independent stations.

A survey of 2,300 U. S. stations yielded a 29 per cent return from 48 states and Alaska and Hawaii. An average of 1,000 U. S. stations carried the regular prize-winning network programs: MBS—"U. N. Today"; CBS—"U. N. On The Record" and transcribed series "U. N. Story." As a result of the survey, 100 more subscribing stations were added. In addition, 330 more stations requested the "Weekly News Summary" for their news directors and 283 women broadcasters' names were added to the 3,500 subscribers for the monthly "U. N. News for Women Broadcasters." U. N. Radio will add another service in 1954 in the form of regular news releases to radio editors of local newspapers coast to coast.

U. N. television coverage reached an all time high during the special session of the Seventh General Assembly. CBS carried a daily half hour coverage of the entire Eighth General Assembly sessions. Climaxing this operation was the full TV and AM network coverage of President Eisenhower's address on December 8, kines and circuits of which were sent around the world.



ROBERT ALDA

STARRING

IN

"SECRET FILE U. S. A."

FOR TV

90



Local Radio Reported "Healthier Than Ever"

By **PIERRE WEIS**
General Manager

World Broadcasting System, Inc.

MORE than 1,000 Radio Stations now subscribe to World." This announcement was made by the World Broadcasting System at the end of 1953. Radio's health and radio's success are reflected in this new record, as well as in a tremendous increase in local sales reported by World affiliate stations during the past year.

In spite of the competition of television, radio has continued to grow and it is estimated that the total radio revenue for 1953 will have reached a new high and be in the neighborhood of 490 million dollars. When analyzing these figures, it is most interesting to note that the greatest increase was made by the local radio stations in their billings to local and regional advertisers. Ingenuity in programming and aggressive sales efforts at the local level not only offset the reduction in so-called national business but also enabled the stations to show a substantial increase in their billings, in scores of cases to new record highs.

Gone are the days, however, when radio station salesmen were merely selling time. To be successful today, a salesman must be equipped with ideas, have the proper tools to enable him to attract a local sponsor; he must have a definite plan which has been tested and at the same time be able to back the on-the-air campaign with the proper merchandising and promotion which will insure its success. With this in mind, in 1953 World furnished its affiliate stations with a great number of diversified new features, and station managers continuously report that with the help of our sales features their business is steadily increasing and they have been able to secure a host of new sponsors who, up to this time, had not been using radio.

The function of a transcription service has completely changed in the past few years. No longer does it supply only new music accompanied by script shows. A successful transcription service today must be a constant well of new ideas de-

signed to help the sales department as well as the program department—to open up wide new areas of business from new advertisers and expanded schedules from veteran radio users.

A typical example — World's new telephone quiz show, "YOU WIN!" was released in mid-year, and by the end of the summer over 3 million dollars in local business was reported by World affiliate stations selling this show. Stations reported selling the program to individual sponsors, but in many instances they expanded the earnings potential by offering it on a participating basis either 30 minutes or one hour a day on a 52 week schedule. "YOU WIN!" brought as many as 30 participating advertisers to many World stations, which reported a waiting list of dozens more anxious to get on this show's return through sales to spot advertisers at premium rates ranging upwards of 25 per cent above the station's one-time spot announcement rate, and the net figures reported ranged from \$3,000 to more than \$10,000 in a 52-week period.

The need for aggressive selling on the part of radio stations in 1954 will be greater than ever. World affiliates will be ready to meet this challenge. We have allocated the largest budget in the history of our Company for the release of new features of unusual appeal and entertainment and selling value designed to produce sales returns far surpassing anything that has ever been attempted before.

The business is there — it is up to us to build sales tools to help the local radio station get it.

World's next premiere feature, soon to be announced, will be another step forward and will top by far anything that has ever been done in the transcription field. The magnitude of this new project is definite proof of the confidence that this Company has in the future of local radio.

Yes! Local Radio Is Healthier Than Ever.



RALPH PAUL

"STRIKE IT RICH"

CBS-TV

"SOUND STAGE"

NBC-TV



Canadian Broadcasting Corp.

Activities in 1953

By DAVIDSON DUNTON

Chairman, Board of Governors

Canadian Broadcasting Corporation

THE tempo of the past year's broadcasting activities has produced considerable advances in both Canadian sound broadcasting and the development of television. Naturally, the greater impetus was evident in the latter field, but this did not detract from improvements in Canadian radio. During 1953 several new repeater stations were added to CBC radio networks in the continuing effort to complete radio coverage in all remote parts of Canada. These repeater stations now number thirty-five. More independent private stations joined CBC networks during the year as well, bringing to 94 the total of private stations now receiving CBC network program service.

CBC radio schedules in 1953 continued to offer the same quantity and variety of program fare as in the past. Among the special program highlights was CBC participation in radio coverage of the Coronation in June. The interest of sponsors in Canadian radio programs saw very little change, despite the advent of TV.

In the International Service, the CBC's shortwave service, expansion continued with the addition of two more language transmissions—Ukrainian and Polish—bringing to 16 the number of different languages in which I. S. presently transmits. The International Service is now reaching 30 countries around the globe.

While Canada's domestic and shortwave facilities continued to grow steadily throughout the past year, the most dramatic expansion was recognized in Canadian television. By January, 1953, four months after the CBC's first Canadian television stations opened in Toronto and Montreal, the program schedule had grown from 18 to 30 hours a week. In January also live shows from American networks joined the Canadian schedule for the first time with the completion of the microwave relay link between Buffalo and Toronto. By the end of May the microwave facilities between Toronto, Ottawa and Montreal were ready for service and in June the first

Canadian TV network connecting these points became a reality. This brought a new CBC station, CBOT in Ottawa, into operation on Coronation Day. Thus, in less than a year, Canadians had built three television stations (two of them major production centres) to carry Canadian TV to one-third of Canada's population.

This year has also seen the commencement of work on CBC stations in Vancouver, Winnipeg and Halifax, and a second transmitter (for telecasts in English) in Montreal. The Vancouver station, CBUT, is expected on the air by the middle of December. Fourteen privately-owned stations have also been authorized in the past twelve months, in Sydney, N. S., St. John, N. B., Rimouski and Quebec City, P. Q., Kingston, Hamilton, London, Kitchener, Windsor and Sudbury in Ontario, Regina and Saskatoon, Sask., and Calgary and Edmonton in Alberta. Two of these, CKSO-TV, Sudbury and CFPL-TV, London have commenced operations within the past two months.

The seven CBC and fourteen privately-owned television stations now authorized will, upon completion of construction, bring Canadian television within range of 75 per cent of Canada's population within the next two years. Until the microwave relay reaches from coast to coast in Canada—it is expected to reach Windsor, Ontario on the west and Quebec City on the east sometime in 1956—all Canadian television stations beyond the present network will receive about 10½ hours of kinescoped CBC programs each week. All Canadian TV stations are required to serve as outlets of the national television service in addition to producing their own programs.

It is reasonably safe to assume that the pace established in television in the past year will continue to be more than matched by public interest in the medium in the year ahead. In fact, we look to a decided increase in the tempo of CBC sound and television activities for some time to come.



HELEN (*Barbara Welles*) HALL

Impact of Compatible Color

By BRIG. GENERAL DAVID SARNOFF

(Continued from Page 47)

there are 120 UHF stations in operation, included in the total of more than 350 TV stations now on the air.

Radio broadcasting in 1954 moves into its 34th year and during that period has become intimately integrated with American life. Naturally, over such a long period, any service undergoes fundamental changes to keep pace with the times, and in the case of radio it has confronted television as a new competitive service.

Nevertheless, radio has continuing economic opportunities for it performs where television and other media of communication and information do not reach. Today there are more than 45 million radio families in the United States. There are 26 million automobile radios, and many millions of portable sets. In 1953 alone, 13 million radio sets, including nearly 5 million auto radios, were produced.

Since the end of World War II, great advances have been made in the military application of communications, radar, missile control, airborne television and many other phases of electronics which fit into the modern ramparts of our Nation's security. Our objective is not only to produce electronic weapons and instruments, but through research and engineering to keep the United States at the forefront of science in its relationship to military electronics.

A new era of "Electronic Photography" was ushered in during 1953 when on December 1, RCA demonstrated magnetic tape recordings of both black-and-white and color television. This is a development of great significance to the motion picture world as well as television.

Eventually magnetic tape recording of video signals should make it possible for television set owners to make their own recordings of television pictures in the home. Then they can be "performed" over and over through the television receiver just as a phonograph record is played at will. Many more new uses will undoubtedly be developed as means are found for the packaging of magnetic tape in low cost cartridges.

Transistors, introduced only 5 years ago, already have proved their worth in many varied applications. Because of their small size and low current demands

they will make possible smaller electronic computers as well as more compact radio and television receivers. The transistor is finding increased use in equipment for the Armed Forces especially where size, weight and battery consumption are vital factors.

Electronics, the advent of which began with discovery of the electron in 1897, has progressively expanded into four great fields—(1) Communications; (2) Radio Broadcasting; (3) Radar and other military applications; (4) Television. Each of these has signified new and expanded services for some segment of our national life, and from each have stemmed discoveries and inventions which have motivated each succeeding era.

The year 1953 brought into focus the electronic developments which augur expansion into a new or fifth great area—electronization of industry. Electronics, by performing tasks that relieve human drudgery and make the most efficient use of man's productive efforts, promises to make manufacturing plants far more automatic than ever before.

Major developments such as rapid freezing have provided food of improved quality at lower year-round cost. Now the technique of sterilization of these foods with high-voltage electrons offers the possibility of increasing benefits such as reduction of waste through spoilage and less expensive packaging. Tests reveal that this influence of electronic sterilization may first be felt in the preservation of grain. Annually throughout the world a substantial percentage of the grain harvested is lost through the ravages of insects, bacteria and other organisms. Electronic sterilization, therefore, is expected to reduce such infestation.

RCA now enters its 35th year dedicated, as in the beginning, to pioneering and steadfast in purpose to give America preeminence in communications. Pioneering, vision and scientific research are vital factors in long-range planning. The opportunities ahead for business and industry, for employment, for new and useful services to the public are truly great. We will continue our efforts to do our part to advance and to merit the faith and confidence the American people have in "RCA" as an emblem of quality, dependability and progress.



Frankly, we don't know, but it takes a great many. And a great many of anything – whether they be hairs or homes – are valuable. That is why an advertising franchise on ABC Radio is growing increasingly valuable. Today, ABC's morning schedule delivers more homes than a year ago . . . more than two years ago . . . and no other network can make that statement. *(Nielsen)*

Not only are more homes listening to ABC's morning programs,

Barber, barber, shave a pig

how many hairs

will make a wig?

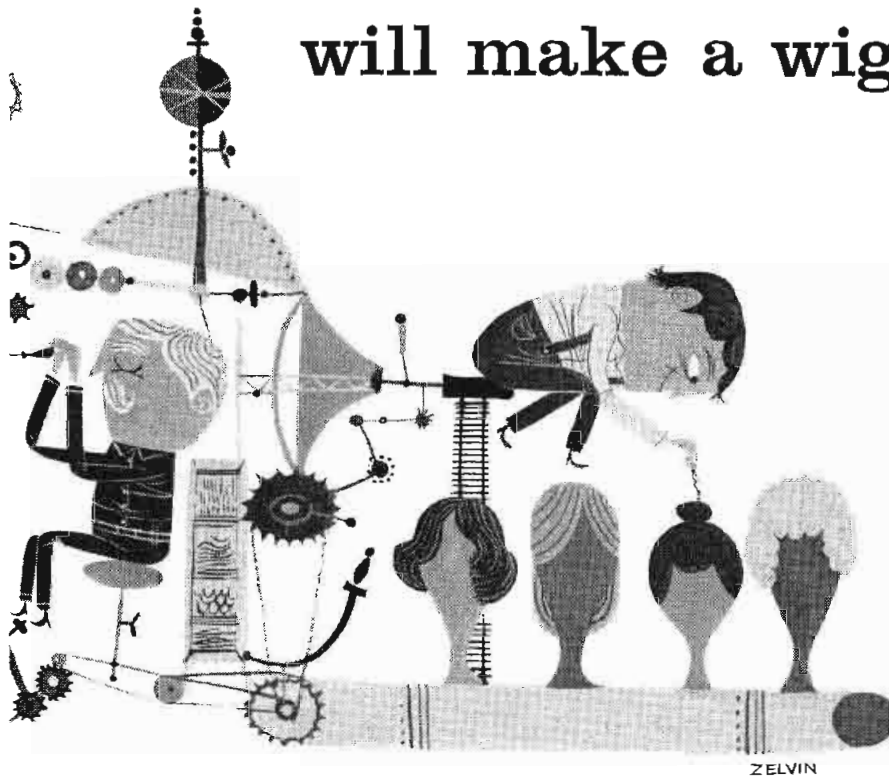

but they are *better* homes. Better for the advertiser because there is a larger proportion of young-housewife homes, and of large-family homes in the ABC audience than that of any other network. (*Nielsen*) These homes use bigger market baskets.

If you want to fill *your* basket with audience bacon...if you want to shave costs-per-thousand instead of pigs...ABC Radio is *your* advertising razor.*

ABC Radio Network

**and you can invest the savings (if you wish) in the prettiest peruke this side of Poetello.*

Radio and Television

TELEPHONE NUMBERS

in NEW YORK

AM Radio Stations

WABC	SUSquehanna	7-5000
WBNX	MElrose	5-0333
WCBS	PLaza	1-2345
WEVD	PLaza	7-0880
WFAS	WHite Plains	9-6400
WGBB	FReport	9-1400
WHLI	OLympia	8-1100
WHOM	CRicle	6-3900
WINS	BRyant	9-6000
WKBS	OYster Bay	6-2500
WLIB	ORegon	9-2720
WMCA	CRicle	6-2200
WMGM	MURray Hill	8-1000
WNBC	CRicle	7-8300
WNEW	PLaza	3-3300
WNYC	WHitehall	3-3600
WOR	LONgacre	4-8000
WOV	CRicle	5-7979
WQXR	LAKowanna	4-1100
WWRL	NEwton	9-3300

FM Radio Stations

WABC-FM	SUSquehanna	7-5000
WABF-FM	TEmpelton	8-5400
WCBS-FM	PLaza	1-2345
WFAS-FM	WHite Plains	9-6400
WGHF	LExington	2-4927
WGNR	NEw Rochelle	6-1460
WHLI-FM	OLympia	8-1100
WMGM-FM	MURray Hill	8-1000
WNBC-FM	CRicle	7-8300
WNYC-FM	WHitehall	3-3600
WOR-FM	LONgacre	4-8000
WQXR-FM	LACKawanna	4-1100

TV Stations

V/ABC-TV	SUSquehanna	7-5000
WARD	MURray Hill	8-2600
WATV	BARclay	7-3260
WCBS-TV	PLaza	1-2345
WNBT	CRicle	7-8300
WOR-TV	LONgacre	4-8000
WPXI	MURray Hill	2-6500

National Networks

American Broadcasting Co.	SUSquehanna	7-5000
Columbia Broadcasting System	PLaza	1-2345
Keystone Broadcasting System	PLaza	7-1460
Mutual Broadcasting System	PENnsylvania	6-9600
National Broadcasting Co.	CRicle	7-8300

Station Representatives

ABC Spot Sales	SUSquehanna	7-5000
Avery-Knodel, Inc.	JUDsan	6-5536
Hil F. Best	LExington	2-3783
John Blair & Co.	MURray Hill	2-6900
Blair-TV, Inc.	MURray Hill	2-6644
Guy Bolam	MURray Hill	2-0810
The Bolling Co., Inc.	PLaza	7-8150
The Branham Co.	MURray Hill	4-1860
Burn-Smith Co., Inc.	MURray Hill	2-3124
CBS Radio Spot Sales	PLaza	5-2000

CBS TV Spot Sales	PLaza	5-2000
Henry I. Christal	MURray Hill	8-4474
Thomas F. Clark Co., Inc.	MURray Hill	3-4266
Clark-Wandless-Mann, Inc.	MURray Hill	4-1910
Continental Radio Sales	LExington	2-2450
Donald Cooke, Inc.	MURray Hill	2-7270
Devney & Co.	MURray Hill	7-5365
Everett-McKinney, Inc.	PLaza	9-3747
Forje & Co., Inc.	PLaza	5-8501
Free & Peters, Inc.	PLaza	1-2700
Mechor Guzman Co., Inc.	CRicle	7-0624
H-R Representatives, Inc.	MURray Hill	9-2606
Hoadley-Reed Co.	MURray Hill	5-8701
George P. Hallingbery Co.	BRyant	9-3960
The Katz Agency, Inc.	PLaza	9-4460
Joseph Hershey McGillvra, Inc.	MURray Hill	2-8755
Robert Meeker Associates, Inc.	MURray Hill	2-2170
National Bstg. Co. (Spot-Local Sales)	CRicle	7-8300
Pan American Bstg. Co.	MURray Hill	2-0810
John E. Pearson Co.	PLaza	1-3366
John H. Perry Associates	ELdorado	5-3197
Edward Petry & Co., Inc.	MURray Hill	8-0200
Radio Representatives	MURray Hill	8-4340
William G. Rambeau Co.	MURray Hill	6-5940
Paul H. Raymer Co., Inc.	PLaza	9-5570
The O. L. Taylor Co.	MURray Hill	8-1088
The Walker Representation Co., Inc.	MURray Hill	3-5830
Weed & Co.	MURray Hill	7-7772
Adam J. Young, Jr., Inc.	MURray Hill	9-0006

Advertising Agencies

Anderson & Cairns, Inc.	MURray Hill	8-5800
N. W. Ayr & Son, Inc.	CRicle	6-0200
Badger & Browning & Hersey, Inc.	CRicle	7-3719
Ted Bates & Co.	JUDsan	6-0600
Barton, Barton, Durstine & Osborn	ELdorado	5-5800
Benton & Bowles, Inc.	MURray Hill	8-1100
The Biow Co., Inc.	PLaza	9-1717
Franklin Bruck Advertising Corp.	CRicle	7-7660
Calkins & Holden	PLaza	5-6900
Campbell-Ewald Co., Inc.	MURray Hill	8-3190
Cecil & Presbrey, Inc.	MURray Hill	8-1234
Compton Advertising, Inc.	CRicle	6-2800
Cunningham & Walsh, Inc.	MURray Hill	3-4900
Dancer-Fitzgerald & Sample, Inc.	ORegon	9-0600
D'Arcy Advertising Co.	PLaza	8-2600
Doherty, Clifford & Shenfield, Inc.	BRyant	9-0445
Donahue & Coe, Inc.	COLUMbus	5-2772
Doremus & Co.	WORth	4-0700
Dowd, Redfield & Johnstone	MURray Hill	8-1275
Roy S. Durstine, Inc.	CRicle	6-1400
Erwin, Wasey & Co., Inc.	LExington	2-8700
William Esty & Co.	OXford	7-1600
Federal Advertising Agency, Inc.	MURray Hill	8-4200
Foote, Cone & Belding	MURray Hill	8-5000
Albert Frank-Guenther Low	CORlondt	7-5060
Fuller & Smith & Ross, Inc.	MURray Hill	6-5600
Gardner Advertising Co.	COLUMbus	5-2000
Geyer Advertising, Inc.	PLaza	1-3300
Grey Adv. Agency, Inc.	OXford	5-2000
Hirshan-Garfinkel, Inc.	MURray Hill	8-8900
Charles W. Hoyt Co., Inc.	MURray Hill	2-2000
Duane Jones Co., Inc.	PLaza	3-4848
Kastor, Farrell, Chesley & Clifford, Inc.	PLaza	1-1400
The Joseph Katz Co.	MURray Hill	8-1223
Kenyon & Eckhardt, Inc.	MURray Hill	8-5700
Abbott Kimball Co., Inc.	PLaza	3-9600
Kudner Agency, Inc.	MURray Hill	8-6700
Al Paul Lefton Co., Inc.	VANDerbilt	6-4340
Lennen & Newell, Inc.	MURray Hill	2-5400
Marfree Adv. Corp.	LONgacre	4-7190

RADIO-TV TELEPHONE NUMBERS IN NEW YORK

Marschalk & Pratt Co.	Y	Anderbilt	6-2022
J. M. Mathes, Inc.	LE	Lexington	2-7450
McCann-Erickson, Inc.	JU	Judson	6-3400
Emil Mogul Co., Inc.	JU	Judson	2-5200
Morey, Humm & Johnstone, Inc.	LO	Longacre	4-2240
Morse International, Inc.	OX	Oxford	7-2100
George R. Nelson	CI	Circle	5-5430
Peck Adv. Agency, Inc.	PL	Plaza	3-0900
Pedlar & Ryan, Inc.	PL	Plaza	5-1500
Fletcher D. Richards, Inc.	JU	Judson	6-5400
Ruthrauff & Ryan, Inc.	MU	Murray Hill	6-6400
Sherman & Marquette, Inc.	PL	Plaza	7-6400
Street & Finney, Inc.	WA	Watkins	4-8510
Sullivan, Stauffer, Colwell & Bayles	OR	Oregon	9-2500
J. D. Tarcher & Co., Inc.	CI	Circle	6-2626
J. Walter Thompson Co.	MU	Murray Hill	3-2000
J. Franklyn Viola	CH	Chickering	4-3254
Warwick & Legler, Inc.	MU	Murray Hill	4-5800
William H. Weintraub & Co., Inc.	PL	Plaza	1-0900
Weiss & Geller, Inc.	PL	Plaza	3-4070
Ward Wheelock Co.	PL	Plaza	3-7120
Young & Rubicam, Inc.	MU	Murray Hill	9-5000

Federal Communications Comm.	WA	Watkins	4-1000
Federal Trade Commission	WH	Whitehall	3-8000
Institute of Radio Engineers	RE	Regent	7-9600
Music Publishers' Protective Association	CI	Circle	6-3084
NAPA	CI	Circle	7-8194
Professional Music Men, Inc.	CO	Columbus	5-7362
Radio Writers' Guild	GR	Gramercy	7-9190
SESAC, Inc.	MU	Murray Hill	5-5365
Song Writers' Protective Assn.	CI	Circle	6-2536
Station Representatives Assn.	MU	Murray Hill	5-4141

Radio-TV Program and Transcription Cos.

Publications

Advertising Age	MU	Murray Hill	6-8180
Advertising & Selling	LO	Longacre	5-3320
Billboard, The	PL	Plaza	7-2800
Broadcasting	PL	Plaza	5-8354
Editor & Publisher	BR	Brant	9-3052
Film Daily	BR	Brant	9-7117
Printers' Ink	MU	Murray Hill	3-6500

RADIO-TV DAILY Wisconsin 7-6336

Radio & Television Weekly	WA	Walker	5-2576
Sales Management	LE	Lexington	2-1760
Sponsor	MU	Murray Hill	8-2772
Standard Rate & Data Service	MU	Murray Hill	9-6620
Television Magazine	PL	Plaza	3-3671
Tide	MU	Murray Hill	3-7700
Variety	JU	Judson	2-2700

News Associations

Associated Press	PL	Plaza	7-1111
International News Service	MU	Murray Hill	7-8800
Press Association, Inc.	PL	Plaza	7-1111
Reuters	BR	Brant	9-8558
United Press Associations	MU	Murray Hill	2-0400

Talent Agencies

Affiliated Artists	PL	Plaza	3-1862
Columbia Artists Management, Inc.	CI	Circle	7-6900
Consolidated Radio Artists, Inc.	CO	Columbus	5-3580
Frank Cooper Associates	VA	Vanderbilt	6-5661
Fanchon & Marco, Inc.	CH	Chickering	4-3956
Gale, Inc.	PL	Plaza	7-7100
William McCaffrey Agency	EL	El Dorado	5-1076
Management Corp. of America	PL	Plaza	9-7500
Music Corp. of America	PL	Plaza	9-7500
Marjorie Morrow	CH	Chickering	4-0644
William Morris Agency, Inc.	JU	Judson	6-5100
National Concert & Artists Corp.	PL	Plaza	9-6000
Robbins Bros.	MU	Murray Hill	7-2033
Show Artists Corp.	MU	Murray Hill	8-2230

Organizations, Unions and Government Agencies

Actors' Equity	PL	Plaza	7-7660
Advertising Federation of America	BR	Brant	9-0430
AAAA	LE	Lexington	2-7980
American Communications Assn.	CO	Corlond	7-1374
American Federation of Musicians	PL	Plaza	8-0600
AFRA	VA	Vanderbilt	6-1810
ASCAP	MU	Murray Hill	8-8800
AMPA	JU	Judson	2-1790
Broadcast Music, Inc.	PL	Plaza	7-1800

Advance Television Pictures Service	CI	Circle	5-6873
Affiliated Program Service, Inc.	MU	Murray Hill	7-1881
Air Features	MU	Murray Hill	9-5900
Altan Alexander Productions	LO	Lorraine	8-3100
American Institute Food Products	JU	Judson	6-7600
Apex Recording Studios, Inc.	PL	Plaza	7-7067
Associated Program Service	PL	Plaza	7-7710
Audio-Video Recording Co.	PL	Plaza	7-3091
Barry & Enright Productions, Inc.	TE	Templeton	2-8600
Basch Radio & TV Productions	MU	Murray Hill	2-8877
V. S. Becker Advtg. Service	JU	Judson	2-1040
Ford Bond Radio Productions, Inc.	CI	Circle	7-2236
The Bruce Chapman Co.	WI	Wisconsin	7-9244
Cineffects, Inc.	CI	Circle	6-0951
Coastal Recording Co.	CI	Circle	6-3900
Columbia Transcriptions	TE	Templeton	8-2082
Louis G. Cowan, Inc.	PL	Plaza	9-3700
Frederic Damrau, M.D.	PL	Plaza	5-3638
Gordon M. Day Productions	OR	Oregon	9-3595
Decca Records, Inc.	CO	Columbus	5-2300
Roy DeGroot, Consultants, Inc.	MU	Murray Hill	7-6865
Empire Broadcasting Corp.	PL	Plaza	9-4500
Allen A. Funt Radio Productions	JU	Judson	6-5227
Gale, Inc.	PL	Plaza	7-7100
General Artists Corp.	CI	Circle	7-7543
John E. Gibbs & Co.	PL	Plaza	7-5959
Horry S. Goodman Radio Productions	PL	Plaza	5-6131
Laurence Hammond Productions, Inc.	PL	Plaza	9-2210
Arthur Henley Productions	IL	Illinois	9-6729
Hummert Radio Features	MU	Murray Hill	9-5900
International 16mm Corp.	PL	Plaza	7-2265
Roger Kay Enterprises	PL	Plaza	3-0549
Keystone Broadcasting System, Inc.	PL	Plaza	7-1460
Lang-Worth Feature Programs, Inc.	JU	Judson	6-5700
Bob Loewi Productions, Inc.	PL	Plaza	5-0958
Phillips H. Lord, Inc.	PL	Plaza	5-2211
Charles Michelson, Inc.	PL	Plaza	7-0695
William Morris Agency, Inc.	JU	Judson	6-5100
Motion Picture Stages, Inc.	PL	Plaza	3-4840
Music Corp. of America	PL	Plaza	9-7500
Muzak Corp.	PL	Plaza	7-7700
NBC Radio Recording Div.	CI	Circle	7-8300
National Concert & Artists Corp.	PL	Plaza	9-6000
Nelson Productions, Inc.	MU	Murray Hill	6-5862
Press Association, Inc.	PL	Plaza	7-1111
Procter Productions, Inc.	JU	Judson	6-4830
Radio Artists Corp.	MU	Murray Hill	8-0940
Radio Features of America	JU	Judson	2-5130
Reemack Enterprises, Inc.	MU	Murray Hill	7-7979
Reeves Sound Studios, Inc.	OR	Oregon	9-3550
Rockhill Radio	PL	Plaza	9-7979
Bernard L. Schubert, Inc.	MU	Murray Hill	8-0940
SESAC, Inc.	MU	Murray Hill	5-5365
K. R. Smith	JU	Judson	2-3791
Henry Souvaine, Inc.	CI	Circle	7-5666
Richard Stark & Co.	CI	Circle	6-7337
Television Screen Productions, Inc.	PL	Plaza	5-0808
Transcribed-Radio Shows	JU	Judson	2-3530
Transfilm, Inc.	JU	Judson	2-1400
United Press Associations	MU	Murray Hill	2-0400
Thomas J. Valentino, Inc.	CI	Circle	6-4675
Chick Vincent Co.	EL	El Dorado	5-0734
Von Baumann Studio	RH	Rhineland	4-5508
Roger White Productions	PL	Plaza	5-3560
Wolf Associates, Inc.	PL	Plaza	5-7620
World Broadcasting System, Inc.	MU	Murray Hill	8-4700
Wright, Wynn Associates	PL	Plaza	3-4417
Frederick W. Ziv Co., Inc.	MU	Murray Hill	8-4700

Radio and Television

TELEPHONE NUMBERS

in CHICAGO

AM Radio Stations

WAAF	RAndolph	6-1932
WAIT	FRanklin	2-0660
WBBM	WHitehall	4-6000
WBEZ	DEarborn	2-7801
WCFL	MOhawk	4-2400
WCRW	EAStgate	7-6860
WEAW	AMBassador	2-1128
WEDC	ROckwell	2-9461
WENR	ANdover	3-0800
WGES	SAcramento	2-1700
WGN	SUperior	7-0100
WHFC	CLiffside	4-7411
WIND	WHitehall	4-2170
WJJD	STate	2-5466
WLS	MONroe	6-9700
WMAQ	SUperior	7-8300
WMBI	Mlchigan	2-1570
WNMP	SHeldroke	3-1590
WSBC	MONroe	6-9060

FM Radio Stations

WEAW	AMBassador	2-1128
WEFM	STate	2-1357
WFMT	NEvada	2-2240
WXRT	MONroe	6-9060

Television Stations

WBBM-TV	WHitehall	4-6000
WBKB	RAndolph	6-8210
WENR-TV	ANdover	3-0800
WGN-TV	SUperior	7-0100
WNBQ	SUperior	7-8300

National Networks

American Broadcasting Co.	ANdover	3-0800
Columbia Broadcasting System	WHitehall	4-6000
Keystone Broadcasting System	STate	2-6303
Mutual Broadcasting System	WHitehall	4-5060
National Broadcasting Co.	SUperior	7-8300

Station Representatives

Avery-Knodel, Inc.	ANdover	3-4710
John Blair & Co.	SUperior	7-8659
The Bolling Co.	DEarborn	2-5277
The Branham Co.	Central	6-5726
Burn-Smith Co.	Central	6-4437
Copper Publications	Central	6-5977
CBS Radio Sales	WHitehall	4-6000
Thomas F. Clark Co.	STate	2-1663
Crosley Broadcasting Corp.	STate	2-6693
Everett-McKinney, Inc.	RAndolph	7-9052
Forjoe & Co.	DElaware	7-1874
Free & Peters, Inc.	FRanklin	2-6373
Headley-Reed Co.	FRanklin	2-4686
George P. Hollingbery	ANdover	3-2636
H-R Representatives	RAndolph	6-6431
The Katz Agency	Central	6-7343
Joseph Hershey McGillvra, Inc.	STate	2-5282
J. P. McKinney & Son	SUperior	7-9866
Robert Meeker Associates, Inc.	Central	6-1742
National Broadcasting Co.	SUperior	7-8300
John E. Pearson Co.	STate	2-7494

John H. Perry Associates	HArrison	7-8085
Edward Petry & Co., Inc.	WHitehall	4-0011
William G. Rambeau Co.	ANdover	3-5566
Paul H. Raymer Co.	SUperior	7-4473
The Taylor Co.	STate	2-5260
Sears & Ayer, Inc.	SUperior	7-8177
Walker Co.	ANdover	3-5771
Weed & Co.	RAndolph	6-7730
Adam Young, Jr., Inc.	ANdover	3-5448

Advertising Agencies

Aubrey, Finlay, Marley & Hodgson, Inc.	Financial	6-1600
N. W. Ayer & Son, Inc.	RAndolph	6-3456
A. N. Baker Adv. Agency, Inc.	FRanklin	2-8895
BBDO	SUperior	7-9200
Beaumont & Hohman	Central	6-4230
Blackett Hill	SUperior	7-6500
Bozell & Jacobs, Inc.	Central	6-0870
Buchanan & Co., Inc.	ANdover	3-6611
Leo Burnett Co., Inc.	Central	6-5959
Campbell-Ewald Co.	Central	6-1946
Campbell-Mithun Inc.	DElaware	7-7553
Dancer-Fitzgerald-Sample	Financial	6-4700
W. B. Doner & Co.	DEarborn	2-4674
Doremus & Co.	Central	6-9132
Erwin Wasey & Co.	RAndolph	6-4952
Foote, Cone & Belding	SUperior	7-4800
Albert Frank-Guenther Law, Inc.	DEarborn	2-6424
Goodkind, Joice & Morgan, Inc.	SUperior	7-6746
Graon, Best, Co., Inc.	STate	2-5060
Grant Advertising, Inc.	SUperior	7-6500
Henri, Hurst & McDonald, Inc.	FRanklin	2-9180
Robert Kahn & Assoc. Inc.	DElaware	7-5480
H. W. Kastor & Sons Advertising Co.	Central	6-5331
MacFarland, Aveyard & Co.	RAndolph	6-9360
Malcolm-Howard	ANdover	3-0022
Maxon, Inc.	WHitehall	4-1676
McCann-Erickson	WEBster	9-3701
Arthur Meyerhoff & Co.	DElaware	7-7860
C. L. Miller Co.	Central	6-1640
Needham, Louis Brorby, Inc.	STate	2-5151
Olian Advertising Co.	STate	2-3381
O'Neil, Larson & McMahon	ANdover	3-4470
Presba, Fellers & Presba, Inc.	Central	6-7683
L. W. Ramsey Co.	FRanklin	2-8155
Rache, Williams & Cleary	RAndolph	6-9760
Ruthrauff & Ryan, Inc.	Financial	6-1833
Schwimmer & Scott	DEarborn	2-1815
Russel M. Seeds Co.	DElaware	7-1045
Sherman & Marquette, Inc.	DElaware	7-8006
Tatham-Laird, Inc.	HArrison	7-3700
J. Walter Thompson Co.	SUperior	7-0303
Wade Advertising Agency	STate	2-7369
Weiss and Geller	WHitehall	3-2100
Young & Rubicam	Financial	6-0750

Radio-TV Program and Transcription Cos.

Air Shows, Inc.	SUperior	7-0506
Louis G. Cowan & Co.	RAndolph	6-2022
Columbia Records Corp.	WHitehall	4-6000
Decca Records, Inc.	MOhawk	4-4800
Feature Productions	Michigan	2-6015
Green Associates	WHitehall	4-0818
L. S. Toogood Recording Co.	Central	6-5275
William Morris Agency	WHitehall	3-1744
Jewell Radio Productions	Financial	6-4474
Herbert S. Laufman	WHitehall	4-2370

Radio and Television

TELEPHONE NUMBERS

in CHICAGO

Les Leer Productions Corp. FRanklin 2-7840
 Monogram — Chicago ANdover 8-7169
 Morton Radio Productions, Inc. CEntral 6-4144
 Music Corp. of America DElaware 7-1100
 NBC Radio Recording Division SUperior 7-8300
 RCA Manufacturing Co. WHitehall 4-4600
 Standard Radio Trans. Service, Inc. CEntral 6-0041
 Hal Tate Radio Productions FInancial 6-5450
 Frederic W. Ziv Co. RANdolph 6-9318

News Agencies and Ass'ns.

Associated Press SState 2-7700
 International News Service ANdover 3-1234
 Press Associates, Inc. SUperior 7-0907
RADIO-TV DAILY FRanklin 2-8961
 United Press RANdolph 6-4172

Radio, Television and Government

TELEPHONE NUMBERS

in WASHINGTON

Federal Departments and Agencies

American National Red Cross REpUBLIC 7-8300
 Archives, National REpUBLIC 7-7500
 Capitol, U. S. (Senate, House of
 Reprs.) NAtional 8-3120
 Census, Bureau of The LUdlow 4-3000
 Commerce, Department of STerling 3-9200
 Copyright Office, Library of Congress STerling 3-0400
 Court of Customs and Patent Appeals NAtional 8-4696
 Defense Mobilization, Office of EXecutive 3-3300
 Executive Mansion (White House) NAtional 8-1414
 Federal Communications Commission EXecutive 3-3620
 Federal Trade Commission EXecutive 3-6800
 Government Printing Office STerling 3-6840
 Interior, Department of The REpUBLIC 7-1820
 Justice, Department of REpUBLIC 7-8200
 Labor, Department of EXecutive 3-2420
 National Labor Relations Board STerling 3-7373
 National Military Establishment:
 Air Force, Department of The LIBerty 5-6700
 Army, Department of The LIBerty 5-6700
 Navy, Department of The LIBerty 5-6700
 National Production Authority STerling 3-5200
 National Research Council EXecutive 3-8100
 Patent Office STerling 3-9200
 Post Office Department STerling 3-3100
 Radio Correspondents Galleries (Senate and
 House of Representatives) NAtional 8-3120
 State, Department of REpUBLIC 7-5600
 Supreme Court of the United States EXecutive 3-1640
 White House NAtional 8-1414

Non-Governmental

Clear Channel Broadcasting Service EXecutive 3-0255
 National Association of Radio and TV
 Broadcasters DEatur 2-9300
 National Press Club REpUBLIC 7-2500

RADIO-TV DAILY NAtional 8-9152

Radio, Electronics-Television Manufacturers
 Association NAtional 8-3902
 Radio Corporation of America (Frequency
 Bureau and RCA Victor Div.) DIstrict 7-1260
 Westinghouse Radio Stations STerling 3-0903

AM Radio Stations

WARL JAcKson 7-7800
 WEAM JAcKson 7-7100
 WFAX JEFFerson 2-0900
 WGAY JUiper 9-1050
 WGMS EXecutive 3-8676
 WINX POplar 2-4357
 WMAL KELLogg 7-1100
 WOL MEtropolitan 8-0010
 WOOK REpUBLIC 7-8000
 WPIK OVerlook 3-3000
 WRC ADams 4-5400
 WTOP EMerson 2-9300
 WWDC STerling 3-3800

FM Radio Stations

WASH-FM DIstrict 7-1356
 WBUS JORDan 8-1300
 WCFM REpUBLIC 7-8688
 WGAY-FM JUiper 9-1050
 WGMS-FM EXecutive 3-8676
 WMAL-FM KELLogg 7-1100
 WOOK-FM STerling 3-7625
 WRC-FM ADams 4-5400
 WTOP-FM EMerson 2-9300

Television Stations

WMAL-TV KELLogg 7-1100
 WNBW ADams 4-5400
 WTOP-TV EMerson 2-9300
 WTTG STerling 3-5300

News Services

Associated Press DIstrict 7-1500
 International News Service NAtional 8-1733
 United Press EXecutive 3-3430

Networks

ABC REpUBLIC 7-6013
 CBS EMerson 2-9300
 MBS MEtropolitan 8-1551
 NBC ADams 4-5400

Radio and Television TELEPHONE NUMBERS in LOS ANGELES

AM Radio Stations

KALI (Pasadena)	RYan	1-7148
KBIG	HOLlywood	3-3205
KECA	HOLlywood	2-3141
KFAC	WEbster	0-161
KFI	DUnkirk	2-2121
KFOX	MADison	2-247
KFVD	DUnkirk	8-2345
KFWB	HOLlywood	3-5151
KGER	MADison	2-551
KGFJ	PRospect	9-629
KGIL (Sherman Oaks)	STAnley	7-3467
KHJ	HOLlywood	2-2133
KIEV (Glendale)	CHApman	5-2388
KLAC	HOLlywood	2-7311
KMPC	HOLlywood	9-5341
KNX	HOLlywood	9-1212
KOWL (Santa Monica)	EXhrook	4-6761
KRKO	MADison	2-121
KUSC	RIchmond	6-362
KWKW (Pasadena)	RYan	1-6744
KXLA (Pasadena)	RYan	1-6991

FM Radio Stations

KUTE (Glendale)	CItrus	4-1414
KFWB-FM	HOLlywood	3-5151
KHJ-FM	HOLlywood	2-2133
KNX-FM	HOLlywood	9-1212
KFDX (Long Beach)	MADison	2-247
KNOB (Long Beach)	Long Beach	8-5519
KECA	HOLlywood	2-3141
KFAC-FM	WEbster	0-161
KNX-FM	HOLlywood	9-1212
KRXD-FM	MADison	2-121
KUSC	RIchmond	6-362
KWKW-FM (Pasadena)	RYan	1-6744
KCBH	CRestview	1-8124

Television Stations

KECA-TV	NOrmandy	3-3311
KHJ-TV	HOLlywood	2-2133
KLAC-TV	HOLlywood	2-7311
KNBH	HOLlywood	9-6161
KNXT	HOLlywood	9-1212
KPIK-TV	HOLlywood	3-3205
KTLA	HOLlywood	9-3181
KTTV	HOLlywood	2-7111

Networks

American Broadcasting System (Television Center)	NOrmandy	3-3311
American Broadcasting System (Radio Center)	HUdson	2-3141
Columbia Broadcasting System	HOLlywood	9-1212
CBS-Radio	HOLlywood	9-1212

CBS Television—Television City	WEbster	8-3014
Multon-Don Lee Broadcasting System	HUdson	2-2133
National Broadcasting System	HOLlywood	9-6161

Station Representatives

American Jewish Broadcasting	HOLlywood	2-2748
Atkinson Co.	DUnkirk	8-8158
Avery-Knoddell, Inc.	WEbster	3-9583
Waller Biddick Co.	RIchmond	6-184
John Blair & Co.	HOLlywood	7-6103
Blair TV, Inc.	HOLlywood	7-6103
The Branham Co.	WEbster	1-1551
Howard C. Brown Co.	HOLlywood	2-3223
Burn-Smith Co., Inc.	DUnkirk	2-3200
CBS-Radio Spot Sales	HOLlywood	9-1212
FM Reprs., Inc.	HOLlywood	4-2450
Forjoe & Co.	MADison	6-8329
Free & Peters	HOLlywood	9-2151
Gene Grant & Co.	YORk	8812
W. S. Grant Co.	MADison	9-2653
Irene Griffith Co.	HOLlywood	4-3912
Harrington, Righter & Parsons, Inc.	WYoming	5151
Headley-Reed Co.	HOLlywood	4-7738
H-R Representatives, Inc.	HOLlywood	7-1480
George P. Hollinberry	MADison	6-3633
The Katz Agency	TUcker	3219
Keenan, Hunter & Dietrich	DUnkirk	2-8458
Joseph Hershey McGilvra, Inc.	CRestview	5-2022
Tracy Moore	HOLlywood	9-5408
NBC-KNBH Spot Sales	HOLlywood	9-6161
Oakes, Harlan G., Associates	DUnkirk	2-3200
Lee F. O'Connell Co.	CRestview	5-2022
John Pearson Co.	DUnkirk	7-4388
Edward Petry Co.	MIchigan	8729
Radio Sales	HOLlywood	9-1212
Wm. G. Rambeau Co.	HOLlywood	4-0388
Paul H. Raymer	HOLlywood	2-2376
Walker Co.	DUnkirk	2-3200
Weed & Company	HOLlywood	4-8611
Young, Adam J., Jr.	HOLlywood	9-0965

Advertising Agencies

Abbott Kimball Co. of Calif.	DUnkirk	7-7305
Ad Associates	WEbster	3-7507
Advertisers Production Agency	PRospect	7761
Alber, R. H., Co.	HOLlywood	9-8273
Allied Advertising Agency	DUnkirk	7-7331
Altman, Bruce, Adv. Agency	BRodshaw	2-5446
Anderson-McConnell Adv. Agency	WEbster	1-1761
Arnold, Ruoff, Adv. Agency	DUnkirk	2-0805
Associated Advertising Agency	CRestview	1-7227
Atchison, R. B., Adv. Agency	PRospect	1913
Atherton Advertising Agency	WEbster	3-8488
Ayer, N. W., & Son, Inc.	HOLlywood	3-4871
Baldwin, Ben, Adv. Agency	BRodshaw	2-7126
Ball, Ted H., & Co.	HOLlywood	9-7127
Benning Co.	DUnkirk	8-3456
Barnes Chase Co.	DUnkirk	4-1193
Barnes, John, & Assot	HOLlywood	3-0327
Bates, Ted., & Co.	HOLlywood	9-2161
Botton, Barton, Durstine & Osborn (Hollywood)	HOLlywood	9-7337
(Los Angeles)	WEbster	1-1234
Bcaumont & Hohman, Inc.	MADison	9-2676
Bennett, Harry, Adv. Agency	TRinity	2391
Benton & Bowles, Inc.	HOLlywood	4-9151

RADIO-TV TELEPHONE NUMBERS IN LOS ANGELES

Berghoff Associates, Inc.	CRestview	5-6151	Kaufmann, Hans E., & Co.	HOLLYWOOD	3-3800
Biow Co., Inc.	HOLLYWOOD	3-2377	Kellaga, Edward S., Co.	DUNKIRK	7-5213
Bishop & Assoc. Inc.	NORMANDY	2-1158	Kelso, M. H., & Co.	DUNKIRK	2-2072
Black, Robt. J. Adv.	BRADSHAW	2-4072	Kenyan & Eckhardt, Inc.	HOLLYWOOD	3-2101
Block Advertising Agency	HOLLYWOOD	2-5668	Kimball, Abbott, Co. of Calif.	DUNKIRK	7-7305
Bogarts, The	HOLLYWOOD	3-6871	Klitten, Martin R., Co., Inc.	DUNKIRK	7-8396
Bocker-Cooper, Inc.	AXMINSTER	6656	Knight Advertising	WEBSTER	1-8123
Bothwell, W. Earl, Inc.	HOLLYWOOD	7-6114	Lannen & Sanders, Inc.	MUTUAL	8060
Boyd, John R., Co.	LOGAN	1644	Lawrence Co., The	BRADSHAW	2-5820
Bozzall & Jacobs, Inc.	HOLLYWOOD	5-3083	Lennen & Newell, Inc.	CRESTVIEW	1-7221
Brand, Michael, Assoc.	CRESTVIEW	6-2991	Lenz, J. M., Advertising	HOLLYWOOD	4-6411
Broadcasting Advertising	BRADSHAW	2-4840	Logan, Dudley L., Adv.	DUNKIRK	2-8471
Brooks Advertising Agency	TRINITY	0558	Mack-Wharton, Advertising	RICHMOND	7-5477
Brown, Byron H., & Assoc.	DUNKIRK	7-1226	MacManus, John & Adams, Inc.	WEBSTER	3-9569
Buchanan & Co., Inc.	CRESTVIEW	5-5231	Mann Advertising Co., Inc.	DUNKIRK	2-1179
Burnett, Leo, Co., Inc.	HOLLYWOOD	4-7347	Martha's Adv. Service	MADISON	6-4897
Calkins, Holden, Carlock, McClinton & Smith, Inc.	YORK	5145	Marto, Walter, Adv. Agcy.	SYCAMORE	6-2239
Campbell-Ewald Co.	RICHMOND	6204	Matthews, Anne D., Adv. Agency	SYCAMORE	2-3816
Caples Co., The	DUNKIRK	7-4255	Mayers Co., Inc., The	DUNKIRK	8-2111
Carson-Roberts Inc.	BRADSHAW	2-2719	Mayne, Charles H., Co.	WEBSTER	3-8261
Case, Jack, Adv. Counselor	NORMANDY	1-1820	Mays & Co., Advertising	TRINITY	8534
Case, Roger T., Assoc.	LONG BEACH	7-4474	McCann-Erickson, Inc. (Los Angeles)	MUTUAL	1181
Castor & Assoc.	CRESTVIEW	5-2292	McCreery, Walter, The	BRADSHAW	2-2168
Cecil & Presbry, Inc.	CRESTVIEW	2-2324	McElroy Advertising Agency	PROSPECT	2047
Clark, Darwin H., Co.	MADISON	9-1661	McKee, Burns Advertising	DUNKIRK	7-8377
Coleman-Packard Adv.	OLYMPIA	1104	McNeill & McCleery	HOLLYWOOD	2-2337
Coliara, Clark, Adv. Agency	DUNKIRK	3-4688	Mercury Adv. Agency, Inc.	BRADSHAW	2-2287
Columbian Advertising Agency	HOLLYWOOD	9-7187	Miner, Dan B., Co.	DUNKIRK	8-3301
Compton Advertising, Inc.	HOLLYWOOD	9-8107	Morgan, Raymond R., Co.	HOLLYWOOD	3-4194
Consolidated Adv. Directors	CRESTVIEW	6-4012	Nathan, Edw. N., Adv. Agency	PROSPECT	1767
Crank Chet, Co.	HOLLYWOOD	3-5128	Needham, Louis & Brarby, Inc.	HOLLYWOOD	2-2391
Crossley & Jeffries, Inc.	CLEVELAND	7-8271	Nelson Advertising Service	DUNKIRK	7-8368
Culp Earl R., Co.	DUNKIRK	2-8406	Newman, Mike, & Assoc.	REPUBLIC	2-6211
Cunningham & Walsh, Inc.	HOLLYWOOD	7-6131	Newman, N. J., Adv. Agency	TRINITY	7664
Dancer-Fitzgerald-Sample, Inc.	HUDSON	2-3256	O'Connell, Robert, Adv. Agency	STATE	7-2535
D'Arcy Adv. Co.	DUNKIRK	8-3462	Pacific Advertising Service	PROSPECT	5803
Davis, Charlie, Advertising	AXMINSTER	3-5598	Parton-Lowell, Inc.	BRADSHAW	2-1749
Davis, John G., Adv.	TRINITY	0354	Pardee Co., The	HOLLYWOOD	2-7306
Davis-Harrison-Simmons, Inc.	HOLLYWOOD	3-7101	Perrett Co., The	MUTUAL	2388
Degner & Assoc.	DUNKIRK	7-2273	Peters, Lyman, Inc.	CHARLESTON	5-3619
Donoid, Dick, Adv.	DUNKIRK	8-2371	Porter, Wesley H., Adv.	AXMINSTER	3-0400
Dozier & Eastman Adv.	PROSPECT	7091	Ringer, Lee, Advertising	DUNKIRK	7-8131
Dunkle, W. Donald, & Assoc.	HOLLYWOOD	2-6414	Riordan, John H., Co.	DUNKIRK	4-2125
Durstine, Roy S., Inc.	DUNKIRK	8-3411	Roberts, Jack, & Associates, Inc.	TEXAS	0-2842
Ebberts, Dan, Adv. Serv.	LOGAN	4242	Robinson, Elwood J., Adv.	MUTUAL	6293
Edwards, Adv. Agency, The	BRADSHAW	2-5616	Ross, Charles, Adv. Agency	HOLLYWOOD	2-1184
Edwards, John I., & Assoc.	HUDSON	2-3377	Ross, Ellsworth, Inc.	DUNKIRK	8-3608
Eisenberg, Ralph, Advertising	YANDIKE	0439	Ross Gardner, & White Advertising	WEBSTER	3-7131
Erwin, Wasey, & Co., Ltd.	WEBSTER	1-1211	Ross, Roy, Inc.	HOLLYWOOD	9-6263
Ewell & Thurber Assoc.	HOLLYWOOD	9-4994	Ross, W. B., Assoc., Adv.	DUNKIRK	8-1107
Factor, Brayer, Inc., Agency	DUNKIRK	8-8131	Ruthrauff & Ryan, Inc.	DUNKIRK	8-0571
Fennell Adv. Agcy.	HOLLYWOOD	9-8351	Scholtz Advertising Service	MICHIGAN	2396
Fishell, Dick & Assoc.	CRESTVIEW	5-4557	Seeds, Russell M., Co., Inc.	HOLLYWOOD	9-1103
Foote, Cone & Belding (Hollywood)	HOLLYWOOD	9-6265	Seidel Advertising Agency	HOLLYWOOD	4-0255
Foote, Cone & Belding (Los Angeles)	MADISON	9-3611	Shane, Leonard, Agency, The	DUNKIRK	8-3215
Forester, Gene, & Assoc.	SUNSET	2-7228	Sheldon, Lisle Adv.	HOLLYWOOD	3-2366
Free, Newton A., Co., The	MUTUAL	2161	Shore Assacs.	HOLLYWOOD	4-8201
Freiburg, John, & Co.	NORMANDY	3-2111	Simmons, Dean	WEBSTER	1-1311
Gardner, H. M., & Assoc.	DUNKIRK	5-1474	Simmons Co.	WALNUT	2753
Geissinger, W. B., & Co.	WEBSTER	3-7178	Smalley, Levitt & Smith	MUTUAL	5336
General Advertising Agcy., Inc.	HOLLYWOOD	3-5128	Smith, T. Tyler, Adv. Agcy.	HOLLYWOOD	3-9239
Gill Clifford Agency	CRESTVIEW	6-1606	Stebbins, Barton A., Adv.	TRINITY	8821
Glasser-Gailey, Inc.	DUNKIRK	4-2141	Stebbins, Hal, Inc.	PROSPECT	5317
Glenn Advertising, Inc.	WEBSTER	3-9369	Stevens, Stuart	STANLEY	7-1554
Gonda, Francis D., Adv. Agency	DUNKIRK	7-6126	Stadel Adv.	HOLLYWOOD	9-7163
Goodman, Kent	HOLLYWOOD	5-7168	Sullivan Stauffer Colwell & Bayles, Inc.	HOLLYWOOD	4-2119
Grant Advertising, Inc.	HOLLYWOOD	9-5371	Swafford & Co.	BRADSHAW	2-2784
Grant, Will, Adv. Agcy.	DUNKIRK	7-3361	Taggart & Young	WEBSTER	3-8108
Greenhal, Monrow, Co., Inc.	STANLEY	7-5953	Thompson, J. Walter, Co.	HOLLYWOOD	3-7201
Gregory, Willard G., & Co.	TRINITY	0531	Tullis Co., Inc., The	HOLLYWOOD	3-6831
Harrington-Richards	WEBSTER	3-5577	Universal Advertising Agency, Inc.	HOLLYWOOD	4-8218
Harvey, William W., Inc.	DUNKIRK	2-1393	Vaughn, Jack Adv. Agcy.	ROCHESTER	9-2535
Heintz & Co., Inc.	MICHIGAN	6061	Wade, Geoffrey Adv. Agency	HOLLYWOOD	4-7457
Hilman, David S., Inc.	BRADSHAW	2-6586	Ward Wheelock Co.	HOLLYWOOD	4-9221
Hixson & Jorgensen, Inc.	DUNKIRK	8-3121	Warwick & Legler, Inc.	DUNKIRK	3-1141
Hael, John D., Adv. Agcy.	RYAN	1-7131	Webster, R. W., Adv.	MADISON	9-2283
Houston Adv. Services Co.	DUNKIRK	9-4171	Weinberg, Milton, Adv. Co.	DUNKIRK	3-4134
Huber-Whiteman, Advertising	PROSPECT	8131	Wessells, George M., Company	YORK	7668
Hubley Adv. Agency	MADISON	6-0555	West-Maruqis Inc.	MADISON	9-2214
Hunter Advertising Agcy.	HOLLYWOOD	4-4191	Wheelock, Ward, Co.	HOLLYWOOD	4-9221
Industrial Adv. Assoc.	BRADSHAW	2-6708	Willis, Harry G., & Assoc.	CHAPMAN	5-3325
Irwin Co., Inc.	BRADSHAW	2-5455	Yambert, Prochnow, McHugh & Macaulay	BRADSHAW	2-5418
Jaffee & Jaffee Adv. Agcy.	CRESTVIEW	1-6211	Young, M. M., Adv.	DUNKIRK	7-3265
Johnson, J. Howard	MICHIGAN	8464	Young & Rubicam, Inc.	HOLLYWOOD	9-2731
Jordan Co., The	DUNKIRK	2-2248			
Juneau, C. B., Inc.	WEBSTER	3-7131			

Radio-TV Program and Transcription Cos.

Alexander Film Co. HOLLYWOOD 9-7396
 American Broadcasting Co. HOLLYWOOD 2-3141
 Bates, Bill HOLLYWOOD 3-6436
 B & B Recording Studios PLeasant 8-1397
 Berman-Swartz Productions HOLLYWOOD 9-5981
 Bob White Productions WALnut 5398
 Brocken Productions, Inc ARIZona 9-3645
 Coston Productions CRestview 5-0113
 Cheshire & Associates HOLLYWOOD 9-4580
 Columbia Records, Inc BRAdshaw 2-5411
 Commodore Productions CRestview 4-2023
 CMooley, Spade Enterprises BRodshow 2-4493
 Crosby, Bing, Enterprises BRAdshow 2-2771
 Custom Recorders HOLLYWOOD 5-5168
 Dudley, Television Corp. CRestview 1-7258
 Eccles Recordings, Inc. HOLLYWOOD 4-8351
 Electro-Vox Recording Studios HOLLYWOOD 5-2189
 Fairbanks, Jerry, Inc. HUDson 2-1101
 Five-Star Productions HEMsted 4807
 General Artists Corp. CRestview 1-8101
 General Television Enterprises Inc. HOLLYWOOD 5-4146
 Gibson, Groce, Radio Prods. HOLLYWOOD 7-5543
 Gray, Jeanne, TV & Radio Prods. CRestview 4-5720
 Guedel, John, Radio Productions YORk 6291
 Hayes-Keith Productions HOLLYWOOD 9-4584
 Hickox, Andres G., Prods. HOLLYWOOD 9-2281
 Hollywood Central Recording Studios Inc. HOLLYWOOD 3-2131
 Lawrence & Lee Productions HOLLYWOOD 4-0101
 MacGregor, C. P., Sound Studios DUnkirk 4-4191
 Morquis, Arnold, Productions, Inc. CRestview 6-8796
 M-G-M Radio Attractions TEXas 0-3311
 Music City HOLLYWOOD 9-8211
 National Film Attractions, Inc. HOLLYWOOD 5-4750
 Oxarart & Ste3,ner, Inc. HOLLYWOOD 9-1171
 Patrn, Ray, Productions HOLLYWOOD 2-1147
 RCA, Victor Division HOLLYWOOD 4-5171
 Radio Recorders, Inc. HOLLYWOOD 3-3282
 Raison, Dorothy N. HOLLYWOOD 4-0426
 Proscenium Productions, Inc WEBster 1-1147
 Reynolds, Stu, Prod. CRestview 1-6155
 Rockett, Frederick K., Co. HOLLYWOOD 4-3183
 Rocket Pictures, Inc. HOLLYWOOD 7-7131
 Ross, Jack HOLLYWOOD 9-0419
 Rourke, Jack, Productions HOLLYWOOD 3-7178
 Rubens Productions HOLLYWOOD 7-6930
 Sode, Robert HOLLYWOOD 5-6181
 Screen Gems, Inc. HOLLYWOOD 2-3111
 Snader Telescriptions Corp. CRestview 5-4451
 Song Ads HOLLYWOOD 5-6181
 Standard Radio Transcription Service Inc. HOLLYWOOD 5-2195
 Stokey, Mike, Productions HOLLYWOOD 2-1241
 Studio & Artists Recorders HOLLYWOOD 4-8241
 Sutherland, John, Prods., Inc DUnkirk 8-5121
 Telefilm, Inc HOLLYWOOD 9-7205
 Telepix Corp. HOLLYWOOD 4-7391
 TV Ads, Inc DUnkirk 8-1323
 TV Spots HOLLYWOOD 5-5171
 TeeVee Co., The CRestview 5-1076
 Telemount Pictures Inc. HOLLYWOOD 9-8321
 Television Guild Productions HOLLYWOOD 9-2895
 Thomas Co., The HOLLYWOOD 4-6564
 Universal Recorders HOLLYWOOD 9-8282
 Von Ronkel Productions, Inc DUnkirk 7-8184
 WRS Recording Lab. HOLLYWOOD 5-1454
 Western Recorders HOLLYWOOD 3-6811
 Wilding Picture Prods. of California WEBster 0183
 Wiley, Fletcher, Prods. HOLLYWOOD 9-1212
 Williams-Nickolas Animated Productions HOLLYWOOD 9-8948
 Wixson, Herbert SUNset 2-3580
 World Broadcasting System HOLLYWOOD 3-5121
 Wright, Carter, Enterprises, Inc. HOLLYWOOD 9-0944
 Ziv, Frederic W. HOLLYWOOD 3-5121

Radio and TV Artists Agencies

Ainsworth, Helen CRestview 62062
 Allen, Larry HOLLYWOOD 3-0421
 Allied Casting HOLLYWOOD 3-7124
 Alvarado, Carlos . CRestview 57203
 American Copyright CRestview 60369
 American Federation of Radio Artists HOLLYWOOD 4-5125
 Artists, Ltd. CRestview 67015
 Auer, Miles CRestview 17141
 Borne, William, Agency ARIZona 9-6647
 Bender-Ward CRestview 17241
 Bergerman, Stanley, & Co. CRestview 6-4124
 Bernie, Herman . CRestview 50117
 Bloom, Phil, Agency CRestview 6-1339
 Bonafides, Bob, Agency HOLLYWOOD 5-6978
 Business Administration Co. CRestview 67071
 Columbia Artists Management MADison 62327
 Cooper, Ray CRestview 69769
 Cukar-Lipton CRestview 6-8989
 Dorrow, Agency ARIZona 30951
 Donaldson, Jack CRestview 4-6291
 Demling, Gus CRestview 12161
 Deuser, Lewis J. CRestview 19134
 Dilson, Clyde CRestview 61825
 Doaks, Virginia CRestview 54177
 Edington-Cloutman Agency CRestview 4-5141
 Famous Artists CRestview 15222
 Federal Telefilm, Inc. HOLLYWOOD 7-5111
 Feil, Murray, Artists' Manager CRestview 5-5569
 Feins, Bernard CRestview 51155
 Frings, Jurt CRestview 16115
 Fralick, Freddie CRestview 1-2142
 Fry, Clinton L. HOLLYWOOD 9-4567
 Gabriel, Milton, Agency CRestview 5-5074
 General Artists BRAdshaw 2-4259
 Gertz, Mitchell CRestview 45491
 Gold, Sid CRestview 17149
 Goldstone, Jules CRestview 51191
 Goldstone, Nat CRestview 61071
 Gollob, Harry, Agency HOLLYWOOD 4-0277
 Grashin, Mourri CRestview 16449
 Gregory Ass'ts. BRAdshaw 25084
 George Greif & Assoc. GRAnite 7197
 Greshler, Abner CRestview 45339
 Grossman, Milton M., Agency CRestview 6-6163
 Gwynn, Charles E. CRestview 5-4179
 Halliburton, Jeanne CRestview 5-5575
 Halliburton-Weintraub CRestview 11137
 Hamilburg, Mitchell CRestview 54171
 Heasley, Jack CRestview 4-5273
 Hecht, Harold CRestview 15246
 Henry, Edd CRestview 50186
 Herdon-Sherrell CRestview 15236
 Herzbrun, Walt CRestview 64157
 Irwin, Lou CRestview 17131
 Jackson, Edith GRAnite 0155
 Jacobson, Vernon CRestview 52545
 Jaffe Agency CRestview 66121
 Katz, Fred, Agency CRestview 6-3189
 Kingston, Al, Agency CRestview 5-4505
 Kohner, Paul CRestview 15165
 Kramer, Earl CRestview 62338
 Lonca, Leon CRestview 66014
 Loney, George CRestview 15246
 Lazar, Irving CRestview 56153
 Leonard, Fred HOLLYWOOD 4-7546
 Lesser, Ted BRAdshaw 23655
 Levca, M. C. CRestview 6-6285
 Lewis, Henry CRestview 55129
 Lewis-Molson CRestview 16111
 Linsk, Lester CRestview 54396
 Longenecker, Robt. CRestview 6-1093
 McConkey Artist, Corp. HOLLYWOOD 3-7141
 Mack, Roy P. Lyone Lou, Agency CRestview 1-2141
 McMillan, Hazel, Agency CRestview 1-7781
 MacQuarrie Agency CRestview 67162
 MCA Artists CRestview 62001
 Manuel-Baird CRestview 45288
 Martyn, Morty CRestview 58607
 Marx, Burt CRestview 17171
 Medford, Ben CRestview 17021
 Messinger, Lili CRestview 67015

◆ ◆ ◆ RADIO-TV TELEPHONE NUMBERS IN LOS ANGELES ◆ ◆ ◆

Meyer, Art	CRestview	57865
Meyers, Walter	CRestview	18161
Minter, Ethel	CRestview	1-6161
Mishkin Agency	CRestview	45416
Monter-Gray-Armstrong	CRestview	11191
Moore, Lola	CRestview	65401
Morris, William	CRestview	16161
Nunes, A. R., Agency	HOLLYWOOD	2-4448
Ochs, Al	HOLLYWOOD	96470
Ohman, Ernie	CRestview	61071
Oliver, Maurine	HOLLYWOOD	4-0257
Orsatti & Co.	CRestview	66241
Personalities, Inc.	CRestview	15147
Pomeroy, Jack	CRestview	45148
Powers, Richard	CRestview	19134
Preminger, Ingo, Agency	CRestview	6-1023
Rocamora, Wynn	CRestview	45431
Rollo, Joe, Agency	CRestview	5-5244
Rosenberg, Geo.	CRestview	18121
Radio Artists Corp	CRestview	17111
Rubens & Associates	HOLLYWOOD	7-6903
Rush, Art	HOLLYWOOD	4-5161
Ryan, Frank	CRestview	14627
Salkow, Lester	CRestview	54505
Saphier, James	CRestview	17231
Sargent, Jan	HOLLYWOOD	3-9716
Silber-Arthur, Agency	HOLLYWOOD	4-9105
Sharpe, Don	CRestview	62044
Shauer, M. A.	CRestview	11103
Show-Ingersoll	HOLLYWOOD	7-0862
Sherman, Edward	CRestview	50186
Shiffrin, William	CRestview	17261
Short, Antrim	CRestview	54137
Shurr, Louis	CRestview	11116
Small, Paul	CRestview	15246
Schnitzer-Fritschi	HOLLYWOOD	9-6271
Somlyno, E. T.	CRestview	62041
Stempel-Olenick	CRestview	1-7141
Stewart, Rosalie	CRestview	46123
Swanson, H. N.	CRestview	15115

Swaverland, Harold	HOLLYWOOD	4-7265
Thompson, D. H.	CRestview	12188
Ullman, George	CRestview	45238
Vitt, Angie	CRestview	64484
Wadsworth, J. B.	CRestview	60698
Weiner, Jack	CRestview	67081
Weintraub, Murry	CRestview	1-1137
Welch, Suey, Agency	MADISON	6-3938
Wendling, Chas	CRestview	62348
White, Wm. B.	CRestview	46301
Wiley, Richard	CRestview	54170
Wilkins, Paul	CRestview	16188
Winkler, Daniel M.	CRestview	17244

Publications

Billboard Publishing Co.	HOLLYWOOD	9-5831
Broadcasting-Telecasting	HOLLYWOOD	3-8181
Hollywood Reporter	HOLLYWOOD	4-7411
Radio Artists Directory	HOLLYWOOD	4-0101
RADIO-TV DAILY	HOLLYWOOD	5-8436
Radio-Television Mirror	CRestview	6-6293
TV Guide Publication	NORMONDY	2-3101
TV-Radio Life	HOLLYWOOD	4-9275
TV Time Magazine, Inc.	HOLLYWOOD	5-2194
Televiws Magazine	BRADSHAW	2-5816
Variety	HOLLYWOOD	9-1141

Radio-TV Audience Surveys

Coffin, Cooper & Clay, Inc.	CUMBERLIN	3-3149
Facts Consolidated	WYOMING	3181
Moffett Research Co.	HOLLYWOOD	3-S653

Estimated Radio-TV Network Billings.....See Page 37

Favorite Stars of 1953.....See Page 39

Chronology of Color.....See Page 41

Ten Top Radio-TV News Events.....See Page 43

Song Hit of 1953.....See Page 48

In the Nation's Television & Radio Markets

Albany
 Albany
 Albuquerque
 Allentown
 Atlanta
 Augusta
 Bakersfield
 Baltimore
 Bangor
 Battle Creek
 Beaumont Ft. Worth
 Billings
 Birmingham
 Boston
 Brunswick, Ga.
 Buffalo
 Canton
 Charlotte
 Chattanooga
 Chicago
 Cincinnati
 Cleveland
 Columbia
 Columbus, Ga.
 Columbus, Ohio
 Concord
 Dallas
 Dayton
 Denver
 Detroit
 Erie
 Flint
 Fort Worth
 Fresno
 Grand Rapids
 Greenville
 Hartford
 Houston
 Indianapolis
 Jackson, Miss.
 Jacksonville
 Kansas
 Kansas City
 Lancaster
 Lansing
 Lawrence, Mass.
 Los Angeles
 Louisville
 Memphis
 Miami
 Milwaukee
 Minneapolis-St. Paul
 Mobile
 Monterey
 Nashville
 New Haven
 New Jersey
 New London
 New Orleans
 New York
 Norfolk
 Omaha
 Orlando
 Philadelphia
 Phoenix
 Pittsburgh
 Port Huron
 Portland, Ore.
 Providence
 Quad Cities
 Reading
 Richmond
 Roanoke
 Rochester
 Salt Lake City
 San Antonio
 San Bernardino
 San Diego
 San Francisco-Oakland
 Savannah
 Scranton
 Seattle
 Sioux Falls
 Spokane
 Springfield, Mass.
 St. Louis
 Syracuse
 Tucson
 Toledo
 Trenton
 Tulsa
 Unco-Bone
 Valdosta
 Washington, D. C.
 Waterbury
 Wilkes-Barre
 Wilmington
 Winona-Salem
 Worcester
 York



PULSE PULSES ARE IMPORTANT

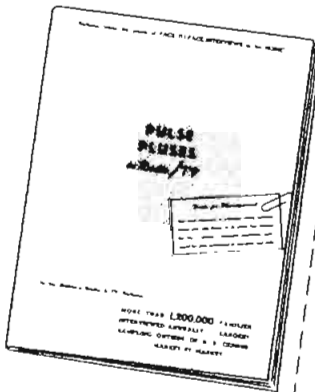

THIS NEW STUDY describes the complete Pulse service. Copies now being distributed. If you have not yet received yours, write.

The Service with the most subscribers



PULSE, Inc., 15 W. 46th St., New York 36

RESEARCH ORGANIZATIONS

ADVERTEST RESEARCH

90 Bayard St., New Brunswick, N. J.
Phone: CHarter 7-1564

AMERICAN RESEARCH BUREAU, INC.

National Press Bldg., Washington, D. C.
Phone: National 8-0822
516 5th Ave., New York City
Phone: MUrray Hill 7-3787
234 S. Garfield, Los Angeles, Calif.
Phone: CUMberland 3-3149

AUDIENCE RESEARCH, INC.

110 E. 42nd St., New York 17, N. Y.
Phone: LEXington 2-2368
Princeton, N. J.
Phone: PRinceton 335
6305 Yucca St., Hollywood, Calif.
Phone: HILLSide 8103

A. S. BENNETT—CY CHAIKIN, INC.

333 Madison Ave., New York, N. Y.
Phone: MUrray Hill 9-0734

CROSSLEY, INC.

330 W. 42nd St., New York 18, N. Y.
Phone: BRyant 9-5462
And
Mercer St., Princeton, N. J.

ELLIOTT-HAYNES LTD.

(Radio Research Division)

515 Broadview Ave., Toronto 6, Ont., Canada
Phone: GERRard 1144

C. E. HOOPER, INC.

(Executive Office)

10 East 40th St., New York 16, N. Y.
Phone: LEXington 2-3000
Dry Hill, Norwalk, Conn.
Phone: VICTor 7-2461

RICHARD MANVILLE RESEARCH

230 Park Ave., New York 17, N. Y.
Phone: OREGon 9-2435

MARKET RESEARCH CORP. OF AMERICA

122 East 42nd St., New York 17, N. Y.
Phone: OXFord 7-3540
425 N. Michigan Ave., Chicago 11, Ill.
Phone: MOhawk 4-4600

A. C. NIELSEN COMPANY

2101 Howard Street, Chicago 45, Ill.
Phone: HOLlycourt 5-4400
500 Fifth Ave., New York 18, N. Y.
Phone: PENnsylvania 6-2850

OFFICE OF RESEARCH, INC.

3470 Broadway, New York 31, N. Y.
Phone: AUDubon 6-7455

ALFRED POLITZ RESEARCH, INC.

270 Park Ave., New York 17, N. Y.
Phone: PLaza 9-5200

THE PULSE, INC.

15 W. 46th St., New York 7, N. Y.
Phone: JUDson 6-3316

RADIO COPY

43-18 163rd Street, Flushing, N. Y.
Phone: FLushing 8-2600

RADIO REPORTS, INC.

220 East 42nd Street, New York 17, N. Y.
Phone: MUrray Hill 7-6658

RESEARCH SERVICES, INC.

1441 Welton St., Denver 2, Col.
Phone: CH 2742

ELMO ROPER

30 Rockefeller Plaza, New York 20, N. Y.
Phone: PLaza 7-4900

N. C. RORABAUGH CO.

347 Madison Ave., New York 17, N. Y.
Phone: MUrray Hill 6-2193-4

ROSS FEDERAL RESEARCH CORP.

2 W. 45th St., New York 36, N. Y.
Phone: VANDerbilt 6-0600

DANIEL STARCH AND STAFF

Boston Post Rd. & Beach Ave.
Mamaroneck, N. Y.
Phone: MAMaroneck 9-5400
101 E. Ontario St., Chicago, Ill.
Phone: DELaware 7-2888

TRENDEX, INC.

347 Madison Avenue, New York 17, N. Y.
Phone: MU 4-4328-9

VIDEODEX, INC.

342 Madison Ave., New York, N. Y.
Phone: MUrray Hill 7-8837

TO OPEN NEW DOORS

in all the 48 states for profitable selling throughout '54

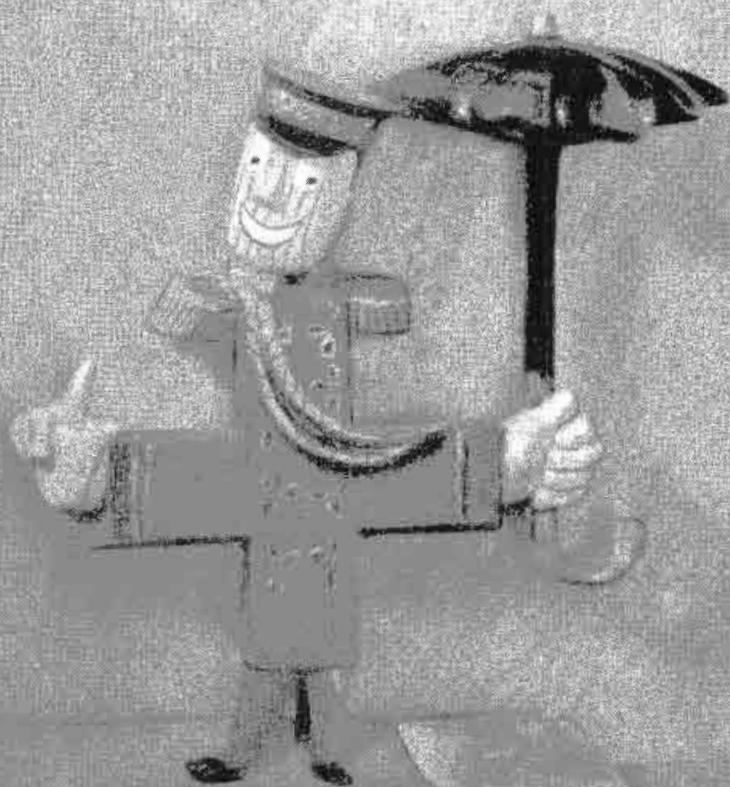

the 560 stations of **MUTUAL**

the network for radio... PLUS!



Radio Girds for Action As TV Invades Parlor

By MURRAY ARNOLD
WPEN, Philadelphia, Pa.

LET'S kick off the New Year and this minor radio epic by underscoring a very basic fact—television is calling the shots!

TV's pushed us out of the comfy, all-inclusive living room, and swept us into the exclusive bedroom, bathroom, kitchen, den, and garage. With that fact, we must live, like it or not, forever and a day.

And along with a change of location, TV has radically shifted the frontiers of time-listening, causing an advertising revolution which is just now beginning to come to fruition. I believe that certain very definite patterns have already emerged from this welter of crises, and it is with these changing tides that I wish to confine myself in this paper.

However, before exploring these new facets of broadcasting, and programming for broadcasting, I must get this point through to you. I believe it is extremely imperative that we in radio divorce ourselves from a great chunk of the past. Sales executives from the networks and from many individual stations have spawned many new and intriguing ideas in the commercial field. But the field of exploration has hardly been scratched.

From my own vantage point, it appears that the ideal approach to our problem in broadcasting is to begin clean and spanking new. Suppose we start with the following assumption.

There is no radio. Every home in our area has a TV set. We have been granted an AM license by the FCC, and after the usual tribulations and trials, we bring forth a radio station. Now, Brother Broadcasters, how do we program same? Perforce, our credo must be "as much audience as we can get most of the time."

Do we follow the patterns of radio programming circa 1940, when TV was just a gleam in General Sarnoff's eye? Every station operator in the country will rise with vehemence and shout a resounding "NO"!

Yet, what do we find in radio in this year of 1954?

1940 programming!

And we in radio broadcasting sit back and smugly say to ourselves, "That TV competition is sure brutal"!

But sooner or later, we must swing with the times. And before it is too late, shouldn't we now ask ourselves. . . .

What does the TV audience want for radio fare when it tunes out TV at night?

Are there enough youngsters listening from 5 to 6 to warrant kid shows?

Since TV viewing is comparatively low on Sunday mornings, am I driving radio audiences away with religion instead of Dave Rose or Ralph Flannagan?

Can we step up our value to our listeners by sprinkling in more news headline station breaks? Weather Reports? Traffic Bulletins? The questions are endless; the answers as wide and broad as our own imaginations.

But as sure as you hold "Radio Daily Annual" in your hands right now, those questions will have to be asked; answers will have to be formulated.

If your area has already been smitten by the optical marijuana of video, you know this to be true. If it hasn't, your day is coming, sooner than you think. And even those who already have felt the big blow of the TV hurricane, remember the successive shock waves are still to come . . . when color TV smashes through; when subscription TV hits the videolanes; when three-D TV color becomes a reality, when heaven alone knows what else follows these fabulous innovations.

It seems clear that the time has come to take stock of the situation. To review right now the over-all picture, to decide which track we intend to travel on. If we flounder with indecision, we may wake up some morning and find our audience captured by our competition, and we wind up with the buggy whip manufacturers, full of glorious memories and no business.



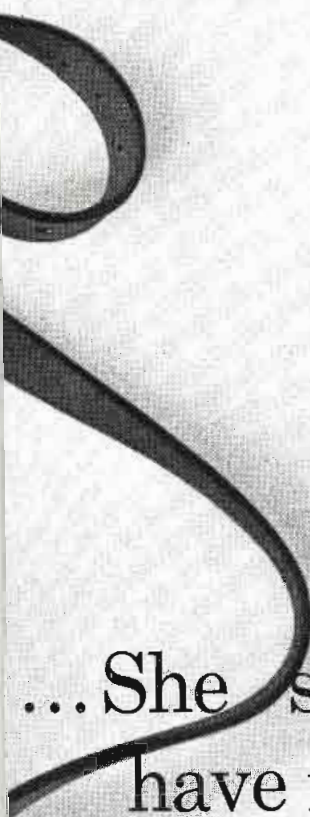

... She shall
have radio
wherever
she goes

Funny about radio: the lighter it gets, the more weight it carries.

For no other advertising medium turns up in so many different shapes and sizes, to reach out to so many different customers. And no other's on such intimate terms that it goes wherever the customer goes — from home to car to pocketbook, *right up to the point of sale.*

All because of one thing: wherever they go, whatever they're doing, Americans like to listen to radio.

Today — by adding a new outlet every 3 seconds — radio is growing faster than any other advertising medium.

Radios now fit any pocket...
Radio always has.

CBS RADIO NETWORK

... where America listens most

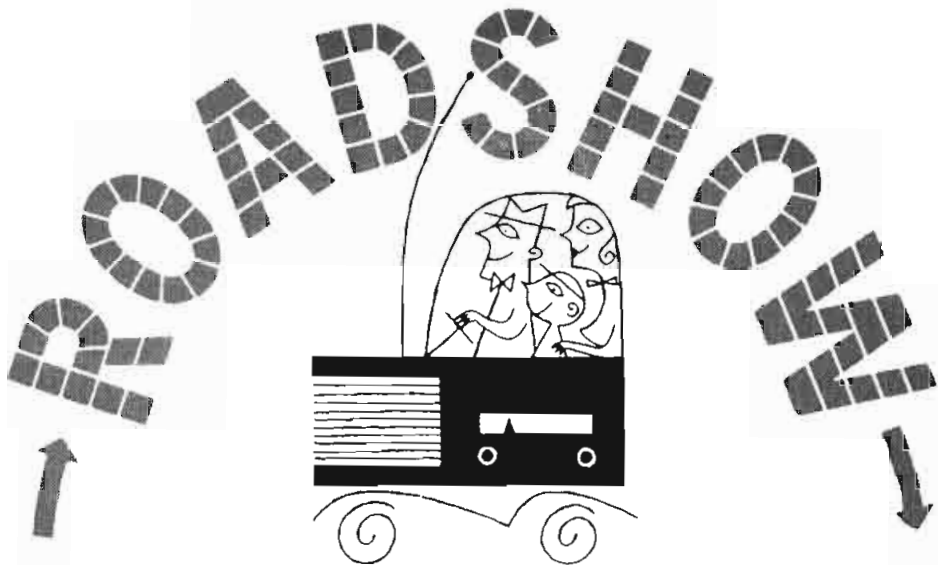

CALLING 26 MILLION CAR RADIOS!

"ROADSHOW" is here, the first national program in radio history beamed directly at Saturday's motoring millions! Popular Bill Cullen emcees contests... cash awards... songs and stars... news... traffic tips... safety limericks, a whole afternoon of *service* and special entertainment for drivers!

CALLING ALL ADVERTISERS!

Hit the road and hit the jackpot with "Roadshow." Sell *cars* and *car-insurance* to car-minded millions, *gas* while they're checking the gas-gauge, *tires* while they're worrying about blow-outs, *anti-freeze* while they're freezing, *cigarettes* while they're reaching for a smoke. Ride in the front seat when your prospects are in the very mood to buy. The most economical, most productive one-minute participations you can find!

Call your NBC Sales representative.

NBC RADIO





"Never A Dull Moment" Describes D.C. Developments

By TED KELLOGG

Washington Bureau, Radio and Television Daily

NEVER a dull moment" can be applied no more appropriately than to Washington developments affecting radio and TV during 1953, and as 1954 gets underway the quip appears unlikely to lose any of its succinct verity — in fact, the odds are that this year's developments will be as important to the industry, as well as to its X-million audience, as any since the human voice began traveling the air waves via electronic gadgets built by man.

In the past year we have seen such major "news breaks" as FCC's adoption of the new compatible color standards, following hundreds of thousands of man-hours of industry research and labor; we have seen the commission dig into the pile of applications for new television stations and bring the number of authorized stations from approximately 300 at the beginning of the year to more than 550 at its end; we have seen the industry "investigated" and given a clean bill of health, and we have seen a new President in the White House who recognizes the value of radio and television reporting.

At the other end of Pennsylvania Ave., radio and television reporting of the activities of Congress and Congressional Committees has been given a wider field of operation, constituting evidence of the recognition by Congress as well as the executive of the increasing importance of radio and television in reporting to the people the story of their government.

These, of course, have been highlights. Between the highlights have come numerous lesser peaks rising above a high plateau of day-to-day activity. Some of these peaks may be ticked off as:

The outstanding coverage given the Inaugural parade and other activities in connection with the swearing in of President Eisenhower. It was one of the biggest events in the industry's history.

Approval by FCC of the merger of ABC-UPT.

Decision of the Commission that theater applicants for transmission of programs by common carrier TV channels would receive consideration on an indi-

vidual basis, but that specific channels would not be set up for theater-TV.

Departure of Paul A. Walker as chairman of the commission, of which he had been a member for 19 years, and appointment of Rosel Hyde, a veteran of 7 years as a member of the commission and an employee for the FCC and its predecessor FRC since 1928, to the chairmanship.

The marked upswing in activity looking toward establishment and operation of non-commercial educational TV stations, and the first national conference in Washington on educational TV.

One of the few soft spots in the otherwise healthy progress of the industry in 1953, as measurable and possibly correctable from the Capital, has been the plight of the FM's, and, to a degree, of the UHF TV stations.

Already, just before 1953 expired, the commission has taken at least one step to help the FM stations (which decreased in number by more than two score during the past year) to improve their financial status and at the same time make further use of the FM broadcast band. The step, which became effective early this year, permits the FM broadcasters to engage in certain non-broadcast utilizations of the band. More help may be expected to be forthcoming during the year.

The plight of UHF licensees and permittees, as considered by the commission, is less serious in degree perhaps only because the number of stations is not so great nor so widespread. Both are suffering from the fact that they are Johnnies-come-lately, after AM on the one hand, and VHF on the other, had been established, stations were operating, receiver manufacture was on a production basis and the newcomers have had an uphill battle.

It has been recommended from several sources, some of them within the commission itself, that sweeping investigations be held of both the suffering media to see if regulatory steps may be taken to correct their ills — these may be among the 1954 highlights.

Capitol
Custom
Recording
and Pressing

Studios in Hollywood and New York
 Processing and Pressing Plants in
 Scranton, Pa., and Los Angeles, Calif.

Let us show you how many hours
 and dollars (*and headaches!*)
 you can save by using

**CAPITOL RECORDS STUDIO
 & RECORDING SERVICES
 AND PRESSING FACILITIES**

Large and small studios — audience
 accommodations — most modern, specially
 designed equipment — finest mastering,
 processing and pressing — live and
 off-the-line recording —
 skilled and careful tape editors —
 fastest — most dependable service

**get the very best — get
 Capitol's high fidelity sound!**



STUDIO & RECORDING SERVICES SALES DIVISION

CAPITOL RECORDS DISTRIBUTING CORP.

151 West 46th Street
 New York 36, New York
 Columbus 5-4758

HERB SACHS
 Eastern Sales Manager

5515 Melrose Avenue
 Hollywood 38, California
 Hollywood 3-7114

WALT HEEBNER
 General Manager

NEWS SERVICES

Associated Press

New York—50 Rockefeller Plaza.....PLaza 7-1111

Executives

Executive Director.....Kent Cooper
General Manager.....Frank J. Starzel
Asst. General Manager for Radio.....Oliver Gramling
Secretary.....Charles Honce
Radio News Editor.....John A. Aspinwall

International News Service

New York—235 East 45th Street.....MUrray Hill 7-8800

Executives

General Manager.....Seymour Berkson
Editor-In-Chief.....Barry Paris
King Features Sales.....Frank J. Nicht
Business Manager.....Robert W. Brown
Managing Editor.....Philip G. Reed

Press Association, Inc. (Associated Press)

New York—50 Rockefeller Plaza.....PLaza 7-1111

Executives

President.....Frank J. Starzel
V.P.....Oliver Gramling
Radio News Editor.....John A. Aspinwall

Reuters

New York—Times Bldg., 229 West 43rd Street.....BRyant 9-8558

Executives

Manager.....D. Kimpton Rogers
News Editor.....A. W. V. King
Accountant.....M. Hathaway
Chief Washington Correspondent.....Paul Scott Rankine
North American Service Editor.....Charles B. Lynch

Telenews Productions, Inc.

New York—630 Ninth Ave.....JUdson 6-2450

President.....Herbert Schefftel
Exec. Vice-President.....Alfred G. Burger
General Manager.....Charles N. Burris
Comptroller.....A. Douglas Comeaux

United Press Associations

New York—220 East 42nd Street.....MUrray Hill 2-0400

Executives

President.....Hugh Baillie
Vice-President & General Business Manager.....Jack Bisco
V.P. and General News Manager.....Earl J. Johnson
Radio News Manager.....John J. Madigan
V.P., Mgr. Movietonews.....William C. Payette
V.P. & General Sales Manager.....Leroy Keller



Liberace



George Liberace
Musical Director



Radio-TV Manufacturing Turns in Peak Performance

By ROBERT R. GALLAGHER

Associate Editor

Radio Annual & Television Year Book

PREDICTING business trends can be a risky business, but those staunch citizens who heralded 1953 as a peak year in radio and television manufacturing certainly knew what they were prognosticating about. New television markets, record radio set demands, and hectic requests for television studio and transmitting equipment joined forces to send dollar volume of business soaring well beyond the \$2 billion mark.

Manufacturers, hustling to keep pace with their industry, turned out 7,250,000 television receivers, 1,000,000 units above the 1952 total, and more than 13,000,000 radios, a 2,000,000-unit increase. A record harvest of TV set sales was reaped during the year as the FCC introduced more and more new markets to the medium. Radio receiver sales were similarly hyped by vast technical improvements and the now universal realization that "sound-alone" is still a welcome companion in the home.

Transmitter manufacturers, on the other hand, spent 1953 facing up to the herculean task of supplying needed equipment to the many new post-freeze television stations. This industry facet experienced the most productive year in its history, with the major portion of its work still to be done.

An unusual element amidst all the feverish activity during 1953 was the trend taken by a major portion of the industry stocks on the New York Stock Exchange. With the exception of a few of the more diversified manufacturers, such as General Electric and Westinghouse, a general downhill pitch was felt in stock prices. The trend, however, becomes less significant, when one considers that the stock market, as a whole, spent the most part of the year below sea level.

CBS A and B stock turned in the best performance, A going from 39 to 48½, and B from 39½ to 48. American Broadcasting-Paramount Theater prices showed a slight increase for the last three quarters, running from 14¾ to 14%. Admiral stock was down 30½ to 19¼, as were

the others: Philco, from 35¼ to 28½; RCA Common, 28¾ to 23¾; Avco, 7¾ to 4¾; Stewart-Warner, 22½ to 20¼, and Zenith Radio, 81 to 63¼.

Bleak as the 1953 stock prices may seem, don't be misled. There is a brighter and more realistic approach in analyzing the year's business return. Let's take a look at a few year-end statements. RCA, for example, reported the largest volume of business in its 34-year history with an \$830 million return on its products and services. Seventy per cent of this total was attributed to manufacturing.

Similarly, Emerson Radio and Phonograph Corporation, for the fiscal year, ended October 31, 1953, reported an all-time record volume for the company, amounting to \$75,926,546. Magnavox Company, for the last six months of 1953, registered a 37 per cent business increase with sales in excess of \$35,500,000. Looking at 1953 from a profit and loss angle there were few, if any, who suffered.

Apart from business volume, the greatest single achievement of the manufacturing industry during the past year was the development of compatible color television standards. December 17, 1953, the day on which the FCC voted its approval of the NTSC-proposed standards, will be looked upon, always, as a red-letter day in the history of television. The effects which the proximity of color-TV will have on the traffic of black-and-white sets, during the coming year, are dubious. Consensus of opinion holds that the new medium will not be ready for mass-consumption, either from an economical or practical standpoint, until, at least, 1956.

Meanwhile, manufacturers are concerning themselves with what the public appears to want "now." Production schedules for 1954 are optimistically aimed at higher levels than were achieved during 1953. All of the elements which favored the industry throughout the past year, at present, show promise of multiplying rather than diminishing. Will '54 top '53? Let's wait and see.

"Direct From Paris"

RDF

**THE FRENCH BROADCASTING SYSTEM (RDF)
OFFERS YOU FREE OF CHARGE A REGULAR
TRANSCRIBED SERVICE**

MUSICAL PROGRAMS

Symphonic
Folklore
Popular



ENTERTAINMENT

Theatre
Arts
Books

WOMEN'S PROGRAMS

Fashion
Cuisine
Home Life



**AND BY SPECIAL SHORTWAVE FEED
ON-THE-SPOT NEWS • INTERVIEWS • REPORTS**

These broadcasts are distributed to American stations as part of a goodwill program to promote better understanding between the peoples of France and the U. S.

THE FRENCH BROADCASTING SYSTEM

PIERRE CRENESSE — *Director in North America*

972 Fifth Avenue • New York 21, N. Y. • REgent 4-150!

Sales Outlook Good in Radio-TV

By FRANK M. FOLSOM

From Page 55

Only because of this compatibility, designed and engineered into color television by RCA, can color and black-and-white television extend their magic harmoniously, without the slightest disruption of service, or inconvenience either to the owners of black-and-white or color TV receivers.

RCA commercial planning for color TV made substantial progress in 1953. Production schedules were mapped to provide more than 30 stations with necessary equipment to broadcast network-originated color programs in key cities by the end of 1953. Pilot production of color components—including the RCA tricolor tube—was underway. Pilot production of RCA Victor compatible color receivers was begun. During the fall of 1953, RCA followed the same policy in preparing for the introduction of color as it did for black-and-white television, making its developments and technical know-how available to the industry by means of clinics and seminars held for broadcasters as well as competing manufacturers.

Sales of radio sets—the “hardy perennial” of home entertainment—continued good in 1953. The industry manufactured nearly 13 million new radio receivers, and the number of sets in use established an all-time high of 115 million. Technical improvements and attractively styled cabinet designs pointed the way toward increased public acceptance.

Particularly in demand were battery-powered portables in lightweight plastic cases available in many colors; clock radios which can function as alarms; and improved table models which found expanding acceptance in almost every room of the home.

During 1954, radio will play a major role as a communication and entertainment service to the public, and sales of receivers can be expected to continue in substantial volume.

A new potentially important market for industrial television was opened by RCA in 1953, with the introduction of the “TV Eye” closed-circuit or “private-line” camera system. With a price of under \$1,000 the “TV Eye” is finding widespread acceptance in schools, stores, hotels, prisons, hospitals, small factories and even homes.

A new magnetic sound tape recorder, developed by RCA for non-professional

use, was introduced in 1953, and found wide acceptance in homes, schools, and businesses. It incorporates advances that are proving attractive to customers. These include automatic push-button operation; light-weight portability; easy tape-threading; smart luggage-type case; and dual-speed operation for maximum recording time. Also available is a complete line of RCA tape recorder accessories.

The phonograph and record industry is expected to continue its impressive growth in 1954, with a 10 per cent rise in record sales—on top of a 12 per cent increase in 1953—expected to push industry volume past the \$250,000,000 mark.

Chief factors in the increase in record sales have been notable improvements in both the making of records and in their presentation to the public.

Records produced today, thanks to recent advances in the art and science of recording and reproduction, mean better sound for music buyers. Introduction of high fidelity instruments and records provided the trade with powerful, new selling ammunition and the public with added musical enjoyment.

One of the most sweeping advances in home entertainment came in the field of high fidelity sound recordings and reproduction. Until 1953, high fidelity—more commonly known as “Hi-Fi”—was the special interest of relatively small groups of music lovers, electronic technicians and hobbyists who made an expensive pastime of seeking perfection in recorded sound by assembling component parts into a super-quality music reproduction system.

During the fall of 1953, RCA introduced to the public high fidelity “Victrola” phonographs, designed to provide the average family with a new concept of life-like realism and quality in recorded music, at relatively low cost.

Now being mass produced by RCA Victor, these instruments give promise of providing millions of Americans with a whole new world of musical enjoyment. In addition to the complete “Victrola” phonographs, the company also is marketing a full line of intermatched highest quality components for persons desiring to assemble their own high fidelity systems.

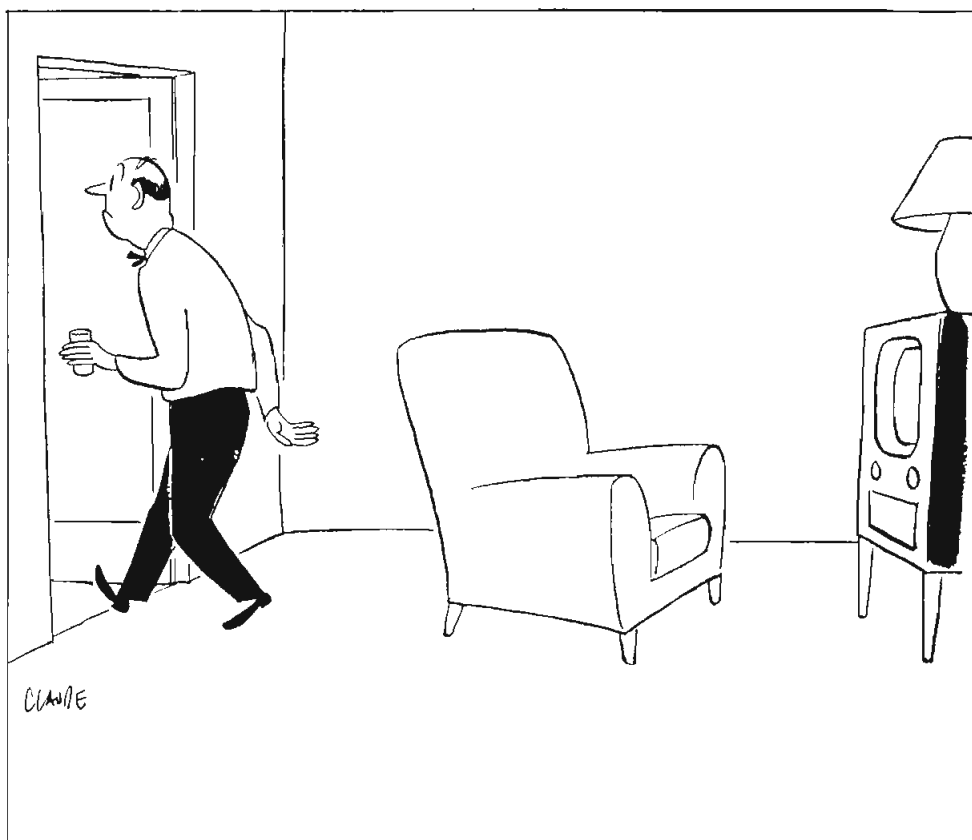

Vanishing American

There's only one thing that can keep this new breed of vanishing Americans from vanishing when *your* commercials come on . . . creative ingenuity.

YOUNG & RUBICAM, INC.

ADVERTISING

New York Chicago Detroit San Francisco Los Angeles Hollywood
Montreal Toronto Mexico City London

Business

•
**AGENCY and SPONSOR
NETWORK BILLINGS**

•
NEWS SERVICES

•
ADVERTISING AGENCIES

•
STATION REPRESENTATIVES

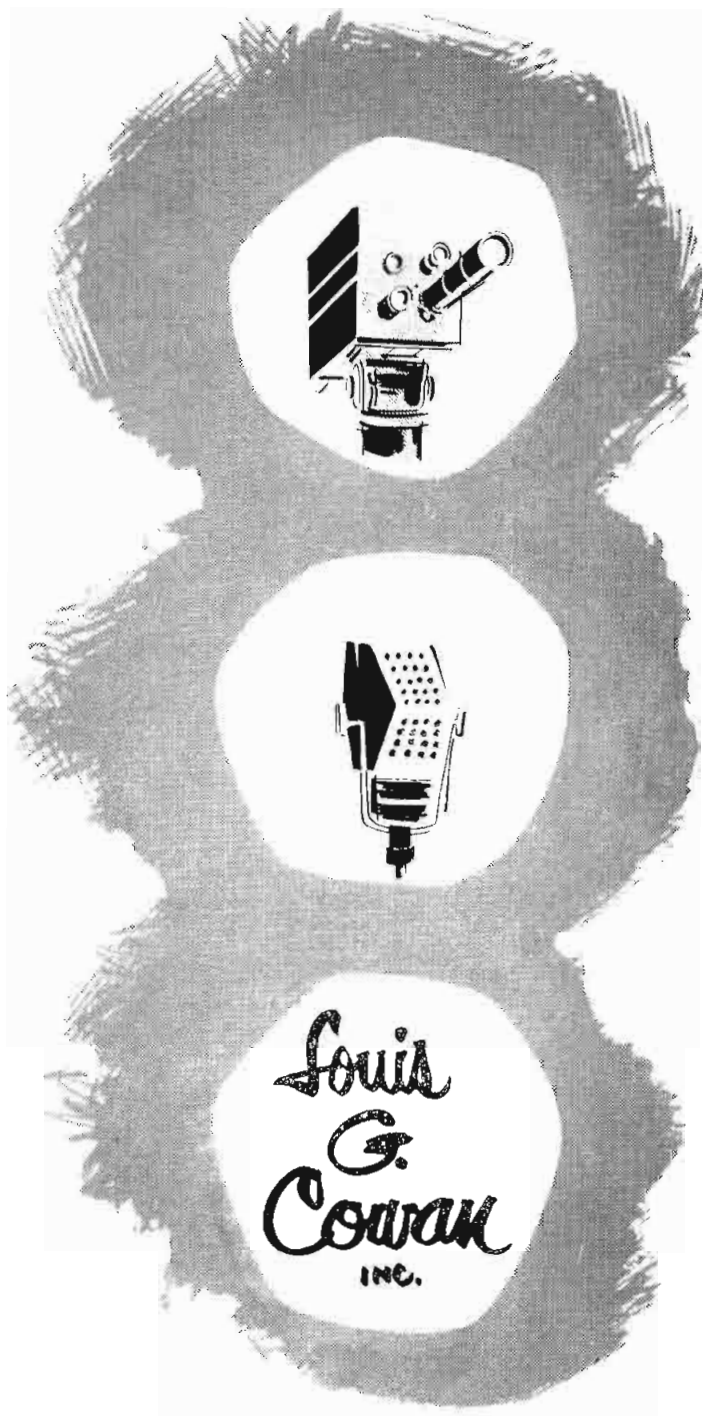

NEW YORK 575 Madison Avenue, New York 22, N. Y. PLaza 9-3700
CHICAGO 8 S. Michigan Avenue, Chicago 3, Ill. RANDolph 6-2022

NETWORK BILLINGS

AGENCY AND SPONSORS

1953

American Broadcasting Co. 1953 Sponsor Expenditures (AM Radio)

General Mills, Inc.	\$4,342,065
Swift & Company	2,533,065
Sterling Drug, Inc.	2,420,377
Philco Corporation	2,062,298
Toni Co.	1,702,220
Liggett & Myers Tobacco Co.	1,228,529
Campbell Soup Co.	1,143,535
Prudential Life Assurance Co. of America	843,928
P. Lorillard Co.	786,346
Gillette Safety Razor Co.	766,908
Gospel Broadcasting Association	699,679
O' Cedar Co.	634,251
General Motors Corp.	629,012
Electric Companies Advertising Program	555,262
Anheuser-Busch, Inc.	519,010
Ralston Purina Co.	508,439
Billy Graham Evangelistic Ass'n, Inc.	469,515
Gruen Co.	454,915
Chevrolet—Division of General Motors	426,651
Packard Motors Co.	420,860
Congress of Industrial Organi- zation	409,852
Hot Point Co.—Division of Gen- eral Electric Co.	378,564
Highland Churches of Christ	356,871
Goodyear Tire & Rubber Co.	333,508
Lambert Co.	322,282
Bristol Myers Co.	311,810
Durkee Famous Foods—Divi- sion of the Glidden Co.	310,244
Texas Company	283,896
Wine Corporation of America	279,006
Voice of Prophecy, Inc.	256,515
Dr. Thomas Wyatt	256,018
Ex-Lax, Inc.	239,400
Burlington Mills Corp.	219,359
Christian Science Publishing Society	192,560
Carter Products, Inc.	178,994
Belltone Hearing Aid Co.	177,819
Quaker Oats Co.	161,200
Pharmaco, Inc.	151,783
Free Methodist Church of North America	135,465
Burton Dixie Corp.	122,499
General Products	114,819
American Bakeries Co.	113,107
M. J. B. Co.	109,390
Seeman Bros., Inc.	109,020
Radio Bible Class	108,424
Western Union	72,598
Healing Waters, Inc.	55,198
Brown Shoe Co.	48,804
Fred Jordan Church in the Home	46,809
Club Aluminum Products Co.	46,719
Pacific Mercury Radio Co.	46,298
Church of God	32,378
Willys Overland Motors	31,972

Pepperell Mfg Co.	28,471
Thomas Nelson & Sons	25,000
Tide Water Oil	21,340
Jackson Perkins Flower Divi- sion	20,971
Charles Antell, Inc.	20,190
Dr. Hiss Shoe Stores	19,369
Ameriann Medical Association	17,569
SSS Division Wilco Co.	14,155
Skinner Mfg. Co.	12,347
White House Co.	10,244
Shipstad Johnson, Inc.	8,936
Stanley Home Products, Co.	8,459
McCall Frontenac, Inc.	3,263
Arden Farms	1,590
Sunnydale Packing Co.	1,455
Music Masters	1,000
Doubleday	758
San Francisco United Palsy	543
Parfums, International	496
National Bus Property Ex- change	490
Chemicals, Inc.	106
	<hr/>
	\$29,376,709

American Broadcasting Co. 1953 Agency Gross Billings (AM Radio)

Dancer Fitzgerald Sample, Inc.	\$6,071,634
J. Walter Thompson Co.	2,713,834
Hutchins Advertising Co., Inc.	2,064,298
Maxon, Inc.	1,566,332
Kudner Agency, Inc.	1,246,352
Cunningham & Walsh, Inc.	1,230,528
Leo Burnett Co., Inc.	1,156,313
Ward Whellock Co.	1,143,857
Calkins, Holden, Carlock, Me- Clinton & Smith, Inc.	841,050
Turner Advertising Agency	756,749
R. H. Alber Co.	699,679
Knox Reeves Advertising, Inc.	694,360
Lennen & Newell, Inc.	652,716
Walter F. Bennett Co., Inc.	604,979
Weiss & Geller, Inc.	599,155
N. W. Ayer & Son, Inc.	555,262
D'Arcy Advertising Co.	519,009
Gardner Advertising Co.	508,439
Tatham, Laird, Inc.	484,806
Doherty, Clifford & Shenfield & Steers, Inc.	463,592
McCann, Erickson, Inc.	454,914
Campbell-Ewald Co., Inc.	426,651
Henry J. Kaufman & Associates	409,852
Lambert & Feasley, Inc.	322,281
Western Advertising Agency,	256,515
Century Advertising Agency	256,017
Warwick & Legler, Inc.	239,196
Donahue & Coe, Inc.	219,359
Ross Roy, Inc.	208,174
Walton Butterfield Adv.	192,560
O'Lian & Bronner, Inc.	177,819
Martin Co.	148,696



More Americans saw
BULOVA ON TV
than any other product

**Thanks to America's Largest Spot Campaign
and Your Fine Cooperation**

● Again in 1953, as in years past—more Americans chose BULOVA than any other fine watch in the world. Again, we at BULOVA continued to depend upon spot television and spot radio as our principal advertising media. In fact, more than 200 TV stations carried BULOVA messages in 1953! And, we know that the success

of these campaigns was due, to a large extent, to the magnificent cooperation of the radio and television stations and their representatives throughout the country.

So, once again, to all of you—our sincere appreciation. We look forward to many more years of pleasant and profitable association.

AGENCY—NETWORK—SPONSOR BILLINGS

Batten, Barton, Durstine & Osborn, Inc.	131,334
Young & Rubicam, Inc.	127,060
Dean Simmons	114,819
Tucker Wayne & Co.	113,648
Wm. H. Weintraub & Co., Inc.	109,019
J. M. Camp Co.	108,423
Ted Bates & Co.	107,774
Footo, Cone & Belding	99,888
Albert Frank-Guenther Law, Inc.	72,598
Sullivan, Stauffer, Colwell & Bayles, Inc.	71,220
White Advertising	55,198
Southgate Advertising Agency	46,808
The Buchen Co.	46,719
Edwards Agency	46,298
Huntington Parmelle Advertising	32,410
Ewell & Thurber Associates	31,972
Benton & Bowles, Inc.	28,471
Buchanan & Co., Inc.	21,339
Maxwell Sackheim Co., Inc.	20,971
Television Advertising Assoc.	20,679
Hal Stebbins, Inc.	19,368
Kent Goodman	14,151
Bozell & Jacobs, Inc.	12,347
National Mail Order Network	10,241
Walter McCreey, Inc.	8,936
Charles W. Hoyt Co., Inc.	8,459
Erwin Wasey Co. of Canada, Ltd.	3,262
Productive Advertising Agency	1,590
Russell Harris Wood	1,455
Frank Gold	1,000
Thwing & Altman, Inc.	758
Joseph Perillo Agency	495
Sidney Garfield Association	105
<hr/>	
	\$29,376,799

**American Broadcasting Co.
AM Industrial Classifications**

Food and Food Products	\$9,138,241
Drugs & Toilet Goods	6,116,556
Radios, Ref., & Electrical Appliances	2,666,911
Religion	2,634,463
Cigars & Cigarettes & Tobacco	2,016,874
Automobiles, Trucks & Accessories	1,841,970
Household Furnishing & Accessories	1,064,237
Institutional	965,114
Beverages	907,414
Insurance & Personal Loans	843,724
Jewelry & Accessories	454,914
Lubricants, Petroleum Products & Fuel	315,516
Clothing & Dry Goods	287,532
Miscellaneous	122,602
Publications	758
<hr/>	
	\$29,376,799

**American Broadcasting Co.
1953 TV Gross Network
Sales
Sponsors**

General Mills, Inc.	\$2,727,087
American Chicle Co.	1,130,228
Kellogg Co.	1,018,676
Sweets Co. of America, Inc.	988,827
Rosefield Packing Co.	950,576

Mars, Inc.	800,553
P. Lorillard Co.	768,907
Procter & Gamble Co.	749,977
S. C. Johnson & Son, Inc.	654,961
C. A. Swanson & Sons	606,917
Ralston Purina Co.	605,262
Sterling Drug, Inc.	526,882
Lambert Co.	461,583
Bayuk Cigars, Inc.	453,814
Derby Foods, Inc.	429,408
Gruen Watch Co.	407,659
Hotpoint Co.	361,609
Ekco Products Co.	358,410
Kraft Foods Co.	348,000
Billy Graham Evangelistic Assn., Inc.	325,255
Hazel Bishop, Inc.	305,500
Thor Corp.	297,265
Sunkist Growers, Inc.	282,336
Brown & Williamson Tobacco Corp.	277,566
Faith For Today, Inc.	265,900
Charles Antell, Inc.	251,171
Walter H. Johnson Candy Co.	241,645
Ironrite, Inc.	229,790
U. S. Steel Corp.	225,000
E. I. Du Pont De Nemours, Inc.	218,880
Speidel Corp.	204,886
American Cigarette & Cigar Co.	202,995
American Tobacco Co.	196,838
Brown Shoe Co.	190,682
Pepsi-Cola Co.	187,920
Jacques Kreisher Mfg. Co.	169,224
Plymouth Motor Corp.	166,752
Ex-Lux, Inc.	151,920
Motorola, Inc.	135,000
B. B. Pen Co.	129,855
Sherwin-Williams Co.	126,720
American Home Products Corp.	125,375
Political	116,670
Duffy-Mott Co., Inc.	99,435
Armour & Co.	97,500
Bristol-Myers Co.	97,500
Sealy, Inc.	96,175
Burton-Dixie Corp.	94,119
Standard Oil Company of Indiana	90,756
F. W. Amend Co.	85,434
Gemex Co.	85,045
Carter Products, Inc.	68,940
Falstaff Brewing Corp.	31,870
Willys Overland Motors, Inc.	27,272
Reymer & Bros., Inc.	23,692
Philco Corp.	15,203
Handmacher Vogel, Co.	10,773
A. C. Weber & Co.	10,380
Touj Co.	7,002
Gordon Baking Co.	5,920
Garden Research, Lab.	4,303
Voice of Prophecy, Inc.	4,153
<hr/>	
	\$20,329,953

**American Broadcasting Co.
1953 TV Gross Network
Sales
Agencies**

Dancer Fitzgerald-Sample, Inc.	\$4,810,651
Leo Burnett Co., Inc.	2,011,223
Needham, Louis & Brorby, Inc.	1,082,789
Moselle & Eisen	991,045
Guild, Bascom & Bonfigli, Inc.	950,764
Lennen & Newell, Inc.	768,458
Batten, Barton, Durstine & Osborn, Inc.	725,763
Knox Reeves Advertising, Inc.	716,833
Tatham, Laird, Inc.	613,919
Gardner Advertising, Co.	605,262
McCann-Erickson, Inc.	198,414

*Since
1898
The
Agency
Of
The
Show
World*



WILLIAM MORRIS AGENCY, INC.
NEW YORK · CHICAGO · BEVERLY HILLS · LONDON · PARIS

Sullivan, Stauffer, Caldwell & Bayles, Inc.	476,821
Lambert & Feasley, Inc.	461,583
Ellington & Co., Inc.	453,814
Henri, Hurst & McDonald, Inc.	382,700
Foote, Cone & Belding	375,119
Maxon, Inc.	361,609
J. Walter Thompson Co.	348,000
Walter F. Bennett & Co.	325,255
The Biow Co.	313,295
Raymond Spector Co., Inc.	305,500
Ted Bates & Co.	277,566
Rockhill Co.	265,899
Television Advertising Assn.	251,170
Franklin Bruck Adv.	241,644
Brooke-Smith, French & Dorance, Inc.	229,789
Young & Rubicam, Inc.	196,935
N. W. Ayer & Son, Inc.	172,672
Hershon-Garfield, Inc.	169,224
Warwick & Legler, Inc.	151,920
Ruthrauff & Ryan, Inc.	135,000
Hiltner & Riggio, Inc.	129,855
Fuller & Smith & Ross, Inc.	126,750
Furman, Feiner & Co.	116,669
Weiss & Geller, Inc.	96,175
Robert Wesley Associates	94,119
Ewell & Thurber, Inc.	27,272
Ketchum, MacLeod & Grove, Inc.	23,692
Hutchins Advertising Co., Inc.	15,203
Carl Reimer Co., Inc.	10,773
Bozell & Jacobs, Inc.	10,380
Huber, Hoge & Sons, Inc.	4,303
Laughlin, Wilson, Baxter & Persons, Inc.	4,153

\$20,329,953

**American Broadcasting Co.
TV Industrial Classifications**

Food & Food Products	\$7,073,908
Confections	3,251,108
Cigars, Cigarettes & Tobacco	1,909,120
Drugs & Toilet Goods	1,867,524
Laundry Soaps & Cleaners	1,404,937
Radio, Ref., Electrical Appliances	1,016,026
Jewelry & Accessories	866,814
Religion	595,308
Household Furnishings & Accessories	453,162
Hardware	358,410
Beverages	342,917
Lubricants, Petroleum Products & Fuel	309,636
Steel	225,000
Automobiles, Trucks and Accessories	194,021
Clothing & Dry Goods	190,682
Miscellaneous	133,708
Politicals	116,669

\$20,329,953

**American Broadcasting Co.
Gross TV Time Sales—
1953 By Months**

MONTH	1953	1952
January	\$1,572,872	\$1,977,981
February	1,461,747	2,081,014
March	1,710,283	2,046,739
April	1,610,000	1,666,215
May	1,762,593	1,503,742
June	1,477,727	1,152,525
July	1,254,174	1,004,779
August	1,161,561	980,507

September	1,230,616	1,150,274
October	2,226,631	1,150,405
*November	2,371,393	1,402,474
*December	2,460,356	1,281,455
	\$20,329,953	\$17,697,140

* November and December Billings Estimated.

**American Broadcasting Co.
Gross AM Time Sales—
1953 By Months**

MONTH	1953	1952
January	\$2,651,059	\$3,232,255
February	2,511,883	3,122,688
March	2,753,115	3,324,072
April	2,616,174	3,198,206
May	2,547,616	3,272,751
June	2,083,829	2,960,261
July	1,996,578	2,289,833
August	1,916,753	2,222,150
September	2,102,015	2,485,641
October	2,630,522	2,905,188
*November	2,724,699	2,571,339
*December	2,842,496	2,806,932
	\$29,376,799	\$34,301,316

* November and December Billings Estimated.

**Mutual Broadcasting System
1953 Gross Network Sales
Advertisers***

S. C. Johnson & Son, Inc.	\$2,113,165
Sterling Drug, Inc.	1,371,502
P. Lorillard Co.	1,352,277
Miles Laboratories, Inc.	1,259,496
American Federation of Labor	1,189,125
Quaker Oats Co.	1,114,349
Johns-Manville Corp.	830,065
American Home Products	773,348
Falstaff Brewing Corp.	756,270
Willroot Company, Inc.	740,321
Kellogg Co.	675,794
Liggett & Myers Tobacco Co.	596,038
Motor Products Corp.-Deep-freeze Appliance Division	591,479
Derby Foods, Inc.	552,415
VCA Laboratories	524,439
Credit Union National Ass'n.	519,166
Philip Morris Co. Ltd., Inc.	194,645
R. J. Reynolds Tobacco Co.	414,000
Holland Furnace Co.	397,012
Lutheran Laymen's League	389,931
Radio Bible Class	363,190
State Farm Mutual Auto Insurance Co.	317,727
Naumkeag Steam Cotton Co.	325,274
Christian Reformed Church	315,844
Union Pharmaceutical Company, Inc.	315,084
Lever Bros.	303,000
Voice of Prophecy, Inc.	290,123
Reatemon-Puritan Co.	277,629
Consolidated Cosmetics	245,334
Murine Co.	228,176
National Homes Corp.	226,198
Gillette Safety Razor Co.	210,501
Dawn Bible Students Ass'n.	185,766
General Mills, Inc.	182,100
Block Drug Co.	179,821
Wings of Healing	167,261
Admiral Corp.	162,686
Swift & Co.	146,273
Kraft Foods Co.	111,729

Arthur Godfrey

AGENCY—NETWORK—SPONSOR BILLINGS

The Coca-Cola Co.	131,584
J. R. Wood & Sons, Inc.	130,693
White House Co.	129,247
Motorola, Inc.	119,103
S.O.S. Co.	118,500
North American Van Lines, Inc.	109,937
Emerson Drug Co.	108,000
Libby, McNeill & Libby	107,652
Bristol-Myers Co.	100,000
Sylvania Electric Products, Inc.	82,718
Procter & Gamble Co.	76,500
Mennen Co.	62,109
Jacques Kreisler Mfg. Corp.	61,500
Sterling Drug Mfg., Ltd.	59,574
Burlington Mills Corp.	56,765
A. C. Weber & Co.	55,251
Walking Doll Co.	52,229
Cartor Products	52,200
Miller Brewing Co.	39,538
The Scholl Mfg. Co., Inc.	35,514
Williamson Candy Co.	32,577
Fillex Co.	26,632
Pacific Mills	23,688
Vick Chemical Co.	16,826
General Motors Corp.—Buick Motor Divn.	16,317
General Tire & Rubber Co.	16,000
Mutual Benefit Health & Acci- dent Ass'n.	14,715
Crowell-Collier Publishing Co.	7,500
Olsen Rug Co.	6,891
Grand Duchess Steaks	6,685
Lnok Magazine	6,000
Jackson & Perkins, Inc.	5,214
Poundex Products	4,635
Colonial Studios, Inc.	3,854
Curtis Circulation Co.	3,500
Avco Mfg. Corp.—Crosley Elec- tronics Divn.	3,045
Cowles Magazines, Inc.	3,000
Crosley White Goods Divn.— Avco Mfg. Corp.	2,975
Ulster County Citizens Commit- tee	779

*December Billings Estimated

Mutual Broadcasting System
1953 Agency Gross Billings*

Needham, Louis & Brorby, Inc.	\$3,013,307
Dancer-Fitzgerald-Sample, Inc.	2,187,316
J. Walter Thompson Co.	1,768,573
Batten, Barton, Durstine & Osborn, Inc.	1,500,951
Lennen & Newell, Inc.	1,460,277
Geoffrey Wade Advertising	1,259,196
Furman, Feiner & Company, Inc.	1,189,125
Sherman & Marquette, Inc.	1,114,349
Sullivan, Stauffer, Colwell & Bayles, Inc.	773,348
Leo Burnett Co.	675,794
Cunningham & Walsh, Inc.	596,038
Roche, Williams & Cleary, Inc.	591,479
The Biow Co.	494,615
William Esty Co.	414,000
Lindeman Advertising Agency	397,012
Gotham Advertising Co.	389,931
Grey Advertising Agency, Inc.	377,193
Kastor, Farrell, Chesley & Clifford, Inc.	374,554
Applegate Advertising Agency	336,135
Direct	325,779
Jackson & Co.	325,274
Glenn-Jordan-Stoetzel, Inc.	315,814
Western Advertising, Inc.	290,123
Schwimmer & Scott, Inc.	277,629
Stanley G. Boynton	273,491
Maxon, Inc.	210,501
Wm. Gleason & Co.	185,766

Cecil & Presbrey, Inc.	179,821
Tatham-Laird, Inc.	167,800
Century Advertising	167,261
Erwin Wasey & Co.	162,686
Ansbery, Finlay, Marley & Hodgson	151,680
D'Arcy Advertising Company	131,584
McCann-Erickson, Inc.	129,000
Doberty, Clifford, Steers & Shenfield, Inc.	100,000
Donahue & Coe, Inc.	92,279
J. M. Camp & Co.	89,699
Victor & Richards, Inc.	88,554
Roy S. Durstine, Inc.	82,718
Benton & Bowles, Inc.	79,475
Bozell & Jacobs, Inc.	69,966
Foote, Cone & Belding	61,500
Duane Jones Company, Inc.	60,253
Ted Bates & Co.	52,200
National Mail Order Network	40,693
Mathisson & Associates, Inc.	39,538
Harry B. Cohen Advertising Co.	18,608
Morse International, Inc.	16,826
Kudner Agency, Inc.	16,317
Knox-Keeves Advertising	14,300
Presba, Fellers & Presba, Inc.	6,891
Phil DiNoscio Advertising	6,685
Maxwell Sackheim & Company, Inc.	5,214
Ruthrauff & Ryan, Inc.	4,635
Radio Advertising of America Co.	3,854

Mutual Broadcasting System
1953 Industrial Classifications

Drugs and Toilet Goods	\$6,616,512
Cigars, Cigarettes & Tobacco	2,856,960
Food & Food Products	2,823,529
Soaps, Cleansers & Polishes	2,308,165
Religious	1,712,115
Building Materials, Equipment & Fixtures	1,453,275
Labor and Politics	1,189,904
Beer	795,808
Major Appliances	649,705
Institutional	535,166
Household Furnishings & Services	465,790
Radios, TV Sets & Phonographs	367,552
Insurance	362,442
Confectionery & Soft Drinks	305,890
Dairy, Poultry & Livestock Feed	239,377
Jewelry	192,193
Miscellaneous	190,544
Wearing Apparel	56,765
Publications	20,000
Automotive	16,317

\$23,158,000

* December Billings Estimated

Mutual Broadcasting System
Gross Time Sales—1953

	Monthly	Cumulative
January	\$1,786,134	\$1,786,134
February	1,638,075	3,424,209
March	1,995,478	5,419,687
April	2,008,990	7,428,677
May	2,038,210	9,466,887
June	1,926,865	11,393,752
July	1,830,167	13,224,219
August	1,738,248	14,962,467
September	1,792,736	16,755,203
October	2,185,598	18,940,801
November	2,090,007	21,030,808
December	2,127,192	23,158,000

* December Billings Estimated.

To the people who
help us spread
the word

It takes as many as 38 people to put
together a 20-second chainbreak.

And thousands can be involved
in the broadcasting of
a network show.

To all you announcers, performers
and technicians who help us
sell our clients' wares
on radio and TV, BBDO sends
appreciative greetings.

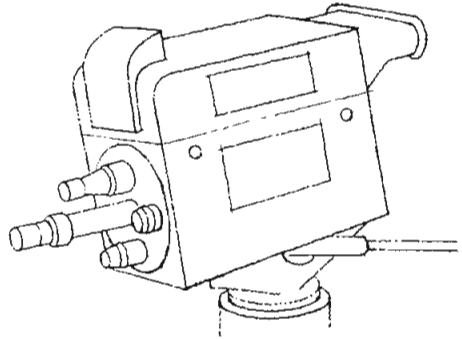
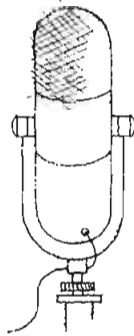
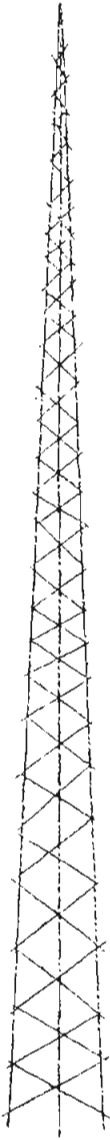

BBDO

Batten, Barton, Durstine & Osborn, Inc.

Advertising

NEW YORK • BOSTON • BUFFALO • CHICAGO • CLEVELAND • PITTSBURGH
MINNEAPOLIS • SAN FRANCISCO • HOLLYWOOD • LOS ANGELES • DETROIT

ADVERTISING AGENCIES



— AGENCY RECOGNITION SYMBOLS —

- AAAA—AMERICAN ASSOCIATION OF ADVERTISING AGENCIES
- ABC—AUDIT BUREAU OF CIRCULATION
- ABP—ASSOCIATED BUSINESS PAPERS
- ABA—ADVERTISING FEDERATION OF AMERICA
- ANPA—AMERICAN NEWSPAPER PUBLISHERS' ASSOCIATION
- APA—AGRICULTURAL PUBLISHERS ASSOCIATION
- NOAB—NATIONAL OUTDOOR ADVERTISING BUREAU
- PPA—PERIODICAL PUBLISHERS' ASSOCIATION
- SNPA—SOUTHERN NEWSPAPER PUBLISHERS' ASSOCIATION

A. D. ADAMS ADVERTISING

277 Broadway, New York 7, N. Y.
Phone: REctor 2-6980
ABP

Owner.....A. D. Adams
Radio Accounts: Spirling Products Co. (indoor TV antenna), New York; Dynavox Corp. (phonographs), Long Island City, N. Y.
TV Accounts: Dynavox Corp. (phonographs), Long Island City, N. Y.; Spirling Products (indoor TV antenna), New York.

A. W. ADV., INC.

6 E. 39 St., New York 16, N. Y.
Phone: MU 4-3320
ANPA—APA

PresidentBliss Woodward

AD FRIED ADVERTISING AGENCY

318 15th St., Oakland 12, Calif.
Phone: HIgate 4-6580

Owner, Radio & TV Director.....Ad Fried
Radio, TV Time Buyer.....Phyllis Rose
Music Director, Librarian.....Elaine Fried
TV Art, Production Dir....Gerhard Jacobi
Radio Accounts: American Upholstering Co. (Furniture Mfr.), Oakland; Bower-Smith Co. (Marine Switches), Oakland; Cochran & Celli Chevrolet Dealers (Chevrolet), Oakland; Commercial Sales Co. (Trucks), San Leandro; Davi Miracle Foam (Rug Cleaners), Oakland; Betty Elizabeth Shampoo (Shampoos), Oakland; Duplex Dean Plans (Real Estate), Danville; Elemis Supreme Formula (Vitamins), Berkeley; Fidelity Roof Co. (Siding, Roofing, etc.), Berkeley; Rhodes & Jamieson, Ltd. (Ready-Mix-Concrete), Oakland; Buy Rite Truck & Equipment Co. (Surplus Equipment), Port of Oakland; Dick's Home Furnishers (Home Furnishings), Oakland; Smith Bros. (MAC Compounds), Walnut Creek; Oakland Police & Firemen (Campaigns), Oakland; Oakland Light Opera Assn. (Musicals), Oakland;

Lo Fare Cab Co. (Taxi Service), Oakland; Grimshaw Nurseries (Plants, etc.), Hayward; Agalite Bronson Co. (Glass Shower Doors), Oakland; Mica-Seal Mfg. Co. (Paint), Berkeley; The Quiet Hour (Religious), Oakland; Lou Winston Co. (Surplus), Oakland; Western Gem Co. (Rutile Gems), Hayward; Lake Merritt Hotel (Dancing), Oakland; Roto-Rooter of Bay Area, Oakland; Span-A-Form (Bldg. Forms), Oakland.

TV Accounts: Bell Smoked Fish Co. (Tarabell Brands), San Francisco; Betty Elizabeth Shampoo (Shampoos), Oakland; Davi Miracle Foam (Rug & Upholstery Cleaners), Oakland; Roto-Rooter of Bay Area (Sewage Service), Oakland-Richmond; The Quiet Hour (Religious), Oakland; Lo Fare Cab (Taxi Service), Oakland; G & W Refrigeration Co. (Ice Machines), Oakland; Lake Merritt Hotel (Night Club), Oakland; Oakland Police & Fireman (Campaigns), Oakland; Cochran & Celli (Calif. Oldest Chevrolet Dealer), Oakland; Oakland Light Opera Assoc. (Musicals), Oakland.

WILLIAM HART ADLER, INC.

919 N. Michigan Ave., Chicago 11, Ill.
Phone: WHitehall 4-5210
AAAA—ABP

Pres.-Treas.....William Hart Adler
Exec. Vice-President.....Kenneth C. Ring
SecretaryBettilon Sickinger
Prod. Manager.....John Petrie
Art Director.....Leslie Meyers
Acct. Executives.....W. H. Adler,
K. C. Ring, A. B. Stone, Thorpe Wright
Radio Accounts: A. J. Canfield Co. (Beverages), Chicago; Reo Motors (Trucks, etc.), Lansing, Mich.; Aladdin Industries, Inc. (Lamps, etc.), Nashville, Tenn.

ADMASTERS ADVERTISING, INC.

15th and New York Ave., Washington 5, D. C.
Phone: District 7-0551
PPA

President.....John E. Waterfield

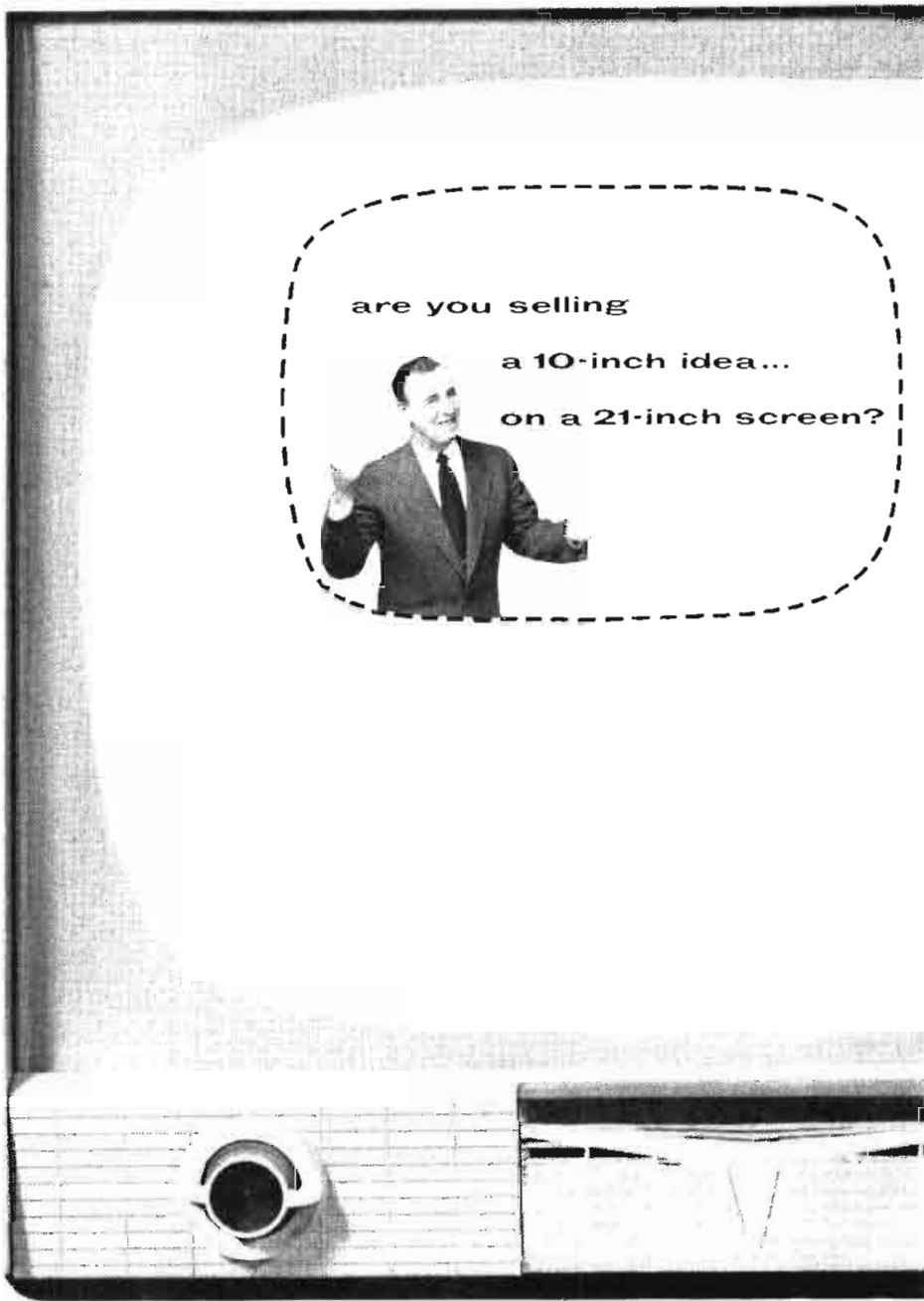

are you selling

a 10-inch idea...

on a 21-inch screen?



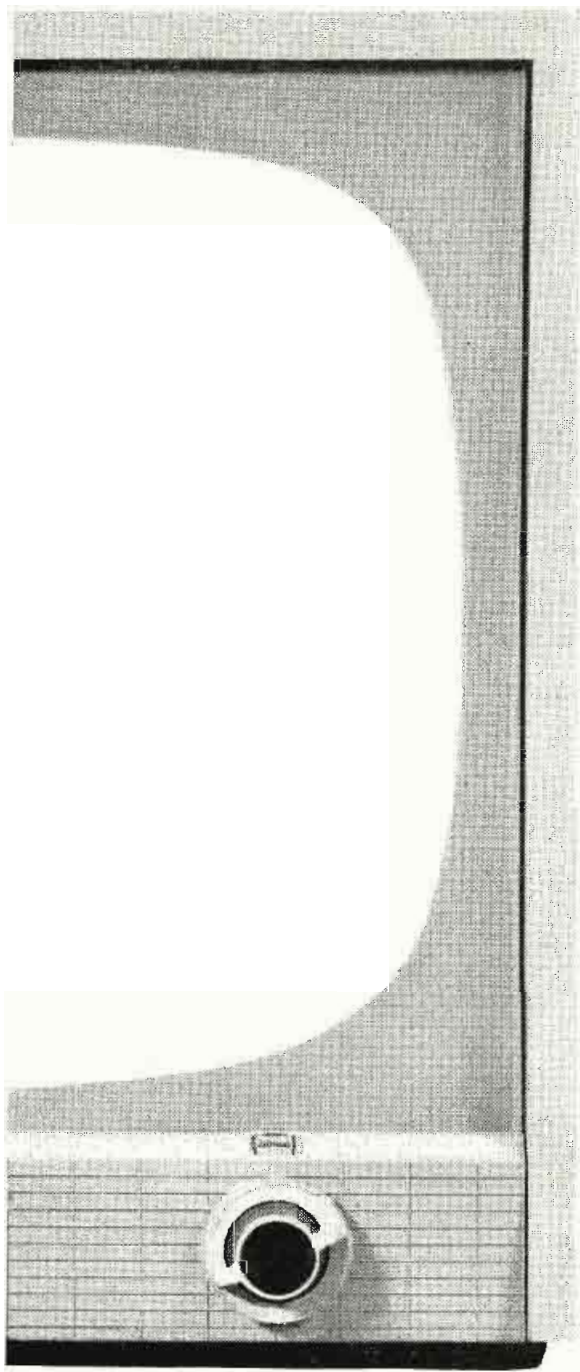

TV moves fast.

Are your commercials giving you the jump on competition—or are they lagging a couple of years behind? Think it over. Could be your sales curve is caught in a creative backwater.

McCANN-ERICKSON, Inc.
Advertising

New York • Boston • Cleveland • Detroit
Chicago • Cincinnati • San Francisco
Los Angeles • Hollywood • Portland and
offices throughout the world

ERWIN, WASEY &
COMPANY, LTD.



Advertising

5045 Wilshire Boulevard, Los Angeles 36, California

Telephone WEbster 1-1211

NEW YORK · CHICAGO · MINNEAPOLIS · LOS ANGELES · OKLAHOMA CITY
TORONTO · RIO DE JANEIRO · LONDON · PARIS · STOCKHOLM

SHERMAN & MARQUETTE

ADVERTISING



CHICAGO

NEW YORK

HOLLYWOOD

Secretary.....E. H. Bell
Copy ChiefJ. DuVall

ADVERTISERS' B'CASTING CO.

117 West 46th St., New York 36, N. Y.
Phone: PLaza 7-3650

Radio Director.....Sholom Rubinstein
ProducerBernard Rubinstein
Program Planning.....David M. Hausdorff

Radio Accounts: Foreign Language Programs: General Food Corp. (Maxwell House Coffee, Instant Maxwell House Coffee, Diamond Crystal Salt, Jell-O Puddings); R. B. Davis Co. (Davis Baking Powder, Coconut); Colgate-Palmolive-Peet Co. (Colgate Dental Cream, Colgate Cchlorophyll Toothpaste, Halo, Ajax, Vel, Fab); Whitehall Pharmaceutical Co. (Anacin); Kraft Foods, Inc. (Philadelphia Brand Cream Cheese, Kraft Oil, Parkay Margarine); The Best Foods, Inc. (H-O Cream Farina, H-O Oats, Hellman's Real Mayonnaise, Nucoa Margarine); Duffy-Mott Co. (Sunsweet Prune Juice, Mott's Apple Juice); Penick & Ford, Ltd., Inc. (My-T-Fine Desserts); The Borden Company (Borden's Cream Cheese); Dugan Bros. (Dugan's Breads and Cakes); Florida Citrus Exchange (Florigold Orange & Grapefruit); Cream of Wheat Co. (Cream of Wheat); The Nestle Co. (Nescafe, Nestea); Seeck & Kade, Inc. (Pertussin); Lever Bros. Co. (Spry); The Procter & Gamble Co. (Crisco, Tide, Joy); Hoffman Beverage Co. (Hoffman Beverages); Standard Brands, Inc. (Instant Chase & Sanborn Coffee); American Home Foods, Inc. (Chef Boy-Ar-Dee Products, etc.); Sunshine Biscuits, Inc. (Sunshine Crackers); Wesson Oil & Snowdrift Sales Co. (Wesson Oil); Secuman Brothers, Inc. (White Rose Tea); Detergents, Inc. ("All"); International Salt Co. (Red Cross Salt); The Musterole Co. (Musterole); Pharmaco Co. (Feen-a-mint).

TV Accounts: Republican State Committee; General Foods Corp. (Instant Maxwell House Coffee).

ADVERTISING, INC.

1523-31 Central National Bank Bldg.
Richmond 19, Va.
Phones: 3-2809
ANPA—APA

President.....J. Lynn Miller
Vice-President.....M. T. Miller
Secretary, Radio Dir.....A. G. Timewell
Production Manager.....F. T. Cook
Radio-TV Dept.

TV Director.....Aubrey F. Watson
Production Manager.....F. T. Cooke

Branch Office
416 E. Main St., Richmond 19, Va.
Phone: 3-5667

Manager.....A. F. Watson
Radio-TV Accounts: Virginia Electric & Power Co. (Public Utility), Richmond; Virginia Hospital Service Assn. (Blue Cross); Lawyers Title Inc. Corp.; Greentree's (Retail Clothing); Henry R. Hasse (Furs); Mosmiller (Florist); R. F. & P. Railroad Co.;

Radio Station WRVA, Richmond, Va.; Virginia Dairy Co.

AGENCY SERVICE CORP.

66 E. S. Water, Chicago 1, Ill.
Phone: CEntral 6-5255

ABP—ANPA—APA—NOAB

President, Treasurer.....James Langer
Vice-Pres., Time-Talent Buyer.....G. P. Hixon
SecretaryM. Cecl

Radio-TV Accounts: North American Acceptance Corp. (Finance); Chicago Motor Club Travel Bureau (Travel information & reservations); Inter-Insurance Exchange of Chicago Motor Club (Auto Insurance); Chicago Motor Club (Club Memberships), Chicago 1, Ill.; Car Service Inc. (Car Maintenance); Motor News (Publication); North Central Finance Corp. (Loans).

THE AITKIN-KYNETT CO.

1400 South Penn Square,
Philadelphia 2, Pa.

Phone: RIttenhouse 6-7810

AAAA—APA—NOAB—ABP—ANPA
PPA—ABC—BMB

Senior Partner.....H. H. Kynett
Partners.....M. E. Goldman,
H. A. Medholdt, George B. Barnard

Art Director.....F. Wade Lane
Production Manager.....W. B. Turner
Media Rate Dept.....E. M. Gretz

Acct. Executives....Harold B. Montgomery,
Allen C. Smith, C. W. Eigenbrot, W. J.
Culbertson, Bernard Toll, David Strousse

Radio-TV Accounts: Bachman Bakeries, Inc. (Pretzels), Reading; Wm. Montgomery Co. (Coffee), Philadelphia; Mrs. Paul's Kitchens (Frozen Seafood), Philadelphia; Pennsylvania Refining Co. (Carhuretor Cleaner), Cleveland; Van Wagenen & Schick-lause Co. (Div. of Swift & Co.) (Meats), Newark and Jersey City; Lummis & Company (Peanut Products), Philadelphia; Stephano Brothers (Tobacco Products), Philadelphia. Corkran, Hill & Co., Inc. (Div. of Swift & Co.) (Meats), Baltimore; Girard Trust Corn Exchange Bank (Banking), Philadelphia; Aero Service Corp.; Atlas Powder Co.; Bearings Company of America; Bonney Forge & Tool Works; Campbell Chain Co.; Chilton Co.; Collier's Magazine; Crescent Company; Daly Inc.; H. C. Derby Co.; Drew & Co., Inc.; Einco Cement Easterbrook Pen Co.; First Camden National Bank & Trust Co.; General Coal Co.; Globe Hoist Co.; Linear Inc.; P. R. Mallory & Co. Inc.; Minneapolis-Honeywell Regulator Co.; Penn Mutual Life Insurance Co.; Permacel Tape Corp.; Philadelphia Badge Co.; Signal-Stat Corp.; Speakman Co.; Taylor Fibre Co.; Thermoid Co.; Walker Mfg. Co.; Wico Electric Co.; Wilson Refrigeration, Inc.; Wolf's Head Oil Refining Co.; Wrigley Co.

R. H. ALBER CO.

439 N. Larchmont Blvd., Los Angeles 4, Calif.
Phone: HOLlywood 9-8273

ANPA



The **ARNOLD COHAN** Corporation

Advertising
Television
Radio

460 WEST 34TH STREET • NEW YORK 1, NEW YORK • WISCONSIN 7-4700



**Where millions
turn for
entertainment**

FOR BRISTOL-MYERS CO.

"Man Behind The Badge" - CBS-TV

"This Is Nora Drake" - CBS-Radio

"Arthur Godfrey Digest" - CBS-Radio

"Garry Moore Show" - CBS-TV

"Harry Babbitt" - CBS-Radio (Coast)

FOR THE BORDEN COMPANY

"Kate Smith Hour" - NBC-TV

FOR PHARMACO, Inc.

"Front Page Farrell" - NBC-Radio

"Dr. Paul" - NBC-Radio (Coast)

**DOHERTY,
CLIFFORD, STEERS &
SHENFIELD, INC.**

ADVERTISING

350 FIFTH AVE., NEW YORK 1, N. Y.

Exec. Vice-Pres.,
 Director Radio, TV.....Pauline Hagen
 Secretary.....Evelyn R. Jones
 Dir. of Radio & TV.....Pauline Hagen
Radio Accounts: Gospel Broadcasting Assn., Los Angeles, Calif.; Unity School of Christianity, Kansas City, Mo.

**DON ALLEN & ASSOCIATES,
 ADVERTISING**

409 S.W. 13th, Portland 5, Oregon
 Phone: Capitol 9445
 ANPA—APA—PPA

PresidentDon Allen
 Vice President.....Irvin H. Walsh
 Sec.-Treas.....Everett A. Mitchell
 Production Manager....Robert McCullough
Radio-TV Accounts: Benj. Franklin Fed'l Savings & Loan Assn.; Windolph Pontiac Co., Pontiac dealer, Portland, Ore.; Zell Bros., Jewelers, Portland, Ore.; A-J Aircraft Co.; Douwill Co.; Freightliner Corp.; Ketell Corp.; Mobilift Corp.; Mont Blanc Co.; Skyway Luggage Co.; Tradewinds Inc.; White Motor Co.; Windolph Tractor Co.; Wolf Radio & Supply Co.

ALLEN & REYNOLDS

1300 Woodmen of the World Bldg.,
 Omaha 2, Neb.
 Phone: Atlantic 4445
 AAAA—ABP—ANPA—APA
 ABC—NOAB—PPA

Partners.....Milton H. Reynolds,
 R. H. Reynolds, Q. H. Moore, Helen C. Moeller, Milton J. Stephan, Kermit Hansen, W. J. Newens
Radio Accounts: Omaha Public Power District (Public Utility); P. F. Petersen Baking Co. (Bakery Products); Byron Reed Company (Real Estate, Farm Management); Merchants Biscuit Company (Bakery Products); T. H. Maenner Company (Real Estate); United States National Bank; Fairmont Foods Co. (Poultry and Livestock Feed), Tekseed Hybrid Co. (Hybrid Corn), Carpenter Oil Co. (Gas, Oil and other Automotive Products), Northrup-Jones (Cafeteria, Bakery); Walnut Grove Products, Inc. (Livestock Feeds); Evans Laundry.
TV Accounts: Omaha Public Power District (Public Utility); Merchants Biscuit Co. (Bakery Products); P. F. Petersen Baking Co. (Bakery Products); Fairmont Foods Co.; United States Nat'l Bank.

ALLIED ADVERTISING AGENCIES

167 So. Vermont Ave., Los Angeles 4, Calif.
 Phone: DUnkirk 7-7331

President.....W. Fehr Gardner
 General Manager.....Stuart Heinemann
 Space Buyer.....Maxine Blankenship
 Art Director.....Jack Robbins
 Production Manager....Stuart Heinemann
 Account Execs.....Dick Gardner,
 Milton Hoffman.
Radio Accounts: Arden Farms (Dairy Products); Gold Furniture Co. (Furniture

& Appliances); Pavode Grande (Turkeys); Pridom Davis (Optometrist); Stylart Card Co. (Greeting Cards); Fisher's Compression Seal (Automatic Compression Seal); Dr. F. E. Campbell (Dental Services); United Radio & Appliance (Sporting Goods & Appliances); West Pico Furniture Co. (Furniture).

TV Accounts: Gold Furniture Co. (Furniture & Appliances); Dr. Pridham Davis (Optometrist); United Sporting Goods (Sporting Goods); Arden Farms (Dairy Products); Pavo de Grande (Turkeys).

ANDERSON & CAIRNS, INC.

488 Madison Avenue, New York 22, N. Y.
 Phone: MU 8-5800
 AAAA—ABP—ANPA—APA

Chairman of the Bd...T. Hart Anderson, Jr.
 President.....John A. Cairns
 Executive Vice-Pres.....Joseph H. Smith
 TreasurerAbraham Fisher
 Director of Radio and

TelevisionVictor Seydel
Branch Offices

Anderson, Smith & Cairns, Ltd.
 1510 Drummond St., Montreal 25, Canada
 Phone: Plateau 4448

Vice-Pres. & Manager...A. Collin Rayment
 Anderson, Smith & Cairns, Ltd.
 50 King Street West, Toronto, Canada
 Phone: Empire 3-5341

Manager.....Vernon R. Birtwistle
Radio Accounts: Rootes Motors, Inc. (Hillman Minx Automobiles); National Home-furnishings Show (Exposition), New York, N. Y.; C. H. Masland and Sons (Rugs and Carpets), Carlisle, Pa.; Baldwin Pianos (Pianos), New York, N. Y.; Brooklyn Paint and Varnish (Paint), Brooklyn, N. Y.; Assoc. Bulb Growers of Holland (Bulbs), New York, N. Y.; Thom McAn (Shoes), New York, N. Y.; J. Martinson & Sons (Coffee), New York, N. Y.

TV Accounts: C. H. Masland and Sons (Rugs and Carpets), Carlisle, Pa.; Rootes Motors, Inc. (Hillman Minx Automobiles), New York, N. Y.; National Home-furnishings Show (Exposition), New York, N. Y.; Thom McAn (Shoes), New York, N. Y.; Brooklyn Paint & Varnish (Paint), Brooklyn, N. Y.; J. Martinson & Son (Coffee), New York, N. Y.

CLAUDE ANIOL & ASSOCIATES

2700 Transit Tower, San Antonio, Tex.
 Phone: Fannin 9148
 SNPA—PPA

President.....Claude B. Aniol

ARNOLD & CO., INC.

262 Washington St., Boston 3, Mass.
 Phone: Richmond 2-1220
 ABP—ANPA—PPA—APA—NOAB

President, Treasurer.....Arnold Z. Rosoff
 Secretary.....Evelyn F. Korbly
 Vice-Pres.....Harold Glickman
Radio Accounts: Home Owners Federal

The Industry's Jeweler



CM110



CD262



P760



CD335



C7832

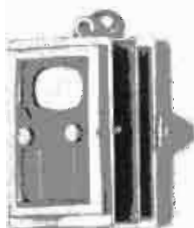

CD243



CD351



CD218

AMERICAN GUILD OF JEWELRY ARTISTS

BRANCH OF THE ASSOCIATION OF PROFESSIONAL JEWELERS
 APPROVED WITH THE AMERICAN FEDERATION OF LABOR
 NATIONAL LABOR COUNCIL

David D. Eisenhower

Rudolph *Cook*

A G V A LIFE MEMBERSHIP CARD EXECUTED IN 14K GOLD

This is but a small selection of the many fine 14K GOLD presentation items we carry. Write for our wholesale catalog of the Nation's finest line of DIAMONDS WATCHES JEWELRY

National Jewelers Co.

Manufacturers-Importers-Wholesalers
 DIAMONDS · WATCHES · JEWELRY

630 FIFTH AVENUE, ROCKEFELLER CENTER, NEW YORK 20, N. Y.
 SUITE 842

Savings Bank (Bank), Boston; Old Monastery Wine Co. (Wines), New Haven; International Harvester (Refrigeration), New England; Mass. Motors (Autos), Boston.

TV Accounts: Old Monastery Wine Co. (Wines), New Haven, Conn.; Jenny Mfg. Co. (Gasoline), Chestnut Hill, Mass.

FREDERICK ASHER, INC.

20 N. Wacker Dr., Chicago 6, Ill.

Phone: 2-4410

ABP—ANPA

President Frederick Asher
 Vice-President Charles Compton
 Secretary-Treasurer Roberta Miller

TV-Radio Accounts: Silver Skillet Brands, Inc. (Canned Meat), Skokie, Ill.; Consolidated Book Publishers (Books), Chicago, Ill.

ASSOCIATED ADVERTISING AGENCY, INC.

First National Bank Bldg., Cincinnati 2, Ohio

Phone: Main 2811

ABP—ANPA

Chairman Bruce W. Brown
 President Sam Malcolm Levy
 Exec. V.-P. Templeton Briggs
 Director Radio-TV W. Wilson Lang

ATHERTON ADVERTISING AGENCY

8455 Melrose Pl., Los Angeles 46, Calif.

Phone: WEBster 3-8488

AAAA—ABP—ANPA

Owner & Acct. Exec. Alfred A. Atherton
 Radio & TV Dir. Herbert H. Wixson

Radio Accounts: Pacific Citrus Products Co. (Hawaiian Punch), Fullerton, Calif.; Acousticon Int'l (Hearing Aids), Los Angeles, Calif.

TV Accounts: Pacific Citrus Products Co. (Hawaiian Punch), Fullerton, Calif.; Anchor Motors (Used Cars), Wilmington, Calif.

ATHERTON & CURRIER, INC.

420 Lexington Ave., New York 17, N. Y.

Phone: LEXington 2-8795

ANPA—PPA—APA

President J. W. Atherton
 Exec. Vice-President Lester Stone
 Vice-Pres., Secretary W. T. Tieman
 Treasurer Z. A. Torok
 Vice-Pres., Dir. Copy & Plans J. D. Molnor
 Vice-Pres., Radio Dir. & Talent
 Buyer J. P. A. Atherton

Branch Office

Coneourse Bldg., Toronto, Ont., Canada

Vice-President William McDonald

AUBREY, FINLAY, MARLEY & HODGSON, INC.

230 N. Michigan Ave., Chicago 1, Ill.

Phone: FInancial 6-1600

ANPA—ABP—PPA—APA—NOAB—ABC

Chairman of Board James T. Aubrey
 President John J. Finlay

Space & Radio Time Buyer &

TV Director Gene Fromherz

Radio Accounts: International Harvester Co., Williamson Candy Co. (Oh Henry), McKenzie Panecake Flour, Dubuque Packing Co., Double-Cola.

N. W. AYER & SON, INC.

West Washington Square, Philadelphia 6, Pa.

Phone: LOMBard 3-0100

ANPA—ABP—ABC

Chairman of Board H. A. Batten
 President Warner S. Shelly

Radio-TV Department

30 Rockefeller Plaza, New York 20, N. Y.

Phone: CIRCLE 6-0200

Vice Pres. & Dir. of

Radio-TV James E. Hanna

Radio-TV Plans T. J. McDermott

Programming &

Production T. H. Calhoun

Copy Chief John M. Caldwell

Publicity Dorothy Doran Lewis

Sports Broadcasting R. A. Mortensen

Dir. Radio Research H. L. Smith, Jr.

Film Production G. D. Gudebrod

Time Buyers Charles M. Wilds,

Paul F. Kitzenberger, Richard S. Bunbury,

Joan Rutman, Helen Hartwig, Elaine Sloat

Branch Offices

30 Rockefeller Plaza, New York 20, N. Y.

Phone: CIRCLE 6-0200

Vice-President John D. Upton

Statler Office Bldg., Boston 16, Mass.

Phone: HUBbard 2-4970

Vice-President E. Craig Greiner

135 S. LaSalle St., Chicago 3, Ill.

Phone: RAndolph 6-3456

Vice-President Sterling E. Peacock

4170 Penobscot Bldg., Detroit 26, Mich.

Phone: WOODward 5-3322

Vice-President J. Widman Berth

714 Taft Bldg., Hollywood 28, Calif.

Phone: HOLLYwood 3-4871

Manager Glenhall Taylor

235 Montgomery St., San Francisco 4, Calif.

Phone: SUTter 1-2534

Vice-President Carl Zachrisson

231 Dillingham Bldg.,

Honolulu 16, Hawaii

Phone: HONOLulu 6193

Manager James Smith

Radio Accounts: The Atlantic Refining Company, B. C. Remedy Company, Bell Telephone System, Chesapeake & Potomac Telephone Company, Chrysler Corporation—Plymouth Division, Reuben H. Donnelley Corporation, Electric Companies Advertising Program, Gordon Baking Company, Hawaiian Pineapple Company, Hills Bros. Coffee, Inc., Howard D. Johnson & Company, Illinois Bell Telephone Company, Michigan Bell Telephone Company, Sheffield Farms Milk Company, Jones Milk Co., United Air Lines, Chestnut Farms, Kiwi Polish Company, Regal Shoe Co., Seabrook Farms.



TV'S GREAT NEW SHOW!

the
**UNITED STATES
STEEL HOUR**

The full-hour show that's already won a top place with the critics and the nation's TV audience. It brings both the familiar and the rising young stars of stage and screen into the home—in new plays and adaptations of famous novels. Produced by The Theatre Guild.

Alternating weeks
over the
ABC network and
TV stations
throughout the country

TV Accounts: The Atlantic Refining Company, B. C. Remedy Company, Chesapeake & Potomac Telephone Company, Chrysler Corporation—Plymouth Division, Reuben H. Donnelley Corporation, Gordon Baking Company, Hill's Bros. Coffee, Inc., Charles E. Hires Company, Illinois Bell Telephone Company, Michigan Bell Telephone Company, John Morrell & Co., National Dairy Products Company, United Air Lines, Electric Companies Advertising Program, Hawaiian Pineapple Co., Penn Fruit Co., Seabrook Farms, Zippo Manufacturing Co.

AYLIN ADVERTISING AGENCY

904 Lovett Blvd., Houston, Texas

Phone: Lynchburg 3766

AAAA—ABP—APA—SNPA

President.....Robert N. Aylin
 Vice-President.....Mrs. Betty W. Aylin
 Secretary.....Julitta Straus
 Account Executive.....Robert N. Aylin
 Account Executive.....Alston P. Cameron
 Account Executive.....Charles H. Lewis
 Radio & TV Dir.....Luana K. Lewis
 Research Director.....Carol Baldwin
 Art Director.....Roger I. Helm
 Production Mgr.....Jerrold E. Pierce

Radio Accounts: Black-Brollier, Inc. (Concrete Building Materials), Houston, Texas; Henke & Pillot, Inc. (Chain Supermarkets), Houston, Texas; Jackson Motors, Ltd. (New & Used Cars), Houston, Texas; Johnston Motor Company (New & Used Cars), Houston, Texas; Taylor Lumber Company (Retail Lumber & Building Materials), Houston, Texas; Weldon Cafeteria (Cafeteria), Houston, Texas; William Cameron & Co. (Millwork), Waco; Rheem Mfg. Co. (Heaters), Houston; Armstrong Lumber Co., San Angelo; Golf Salt Co., Houston; Clark & Courts (office supplies), Houston, Texas.

TV Accounts: James Bute Company (Paint and Wallpaper), Houston, Texas; Henke & Pillot, Inc. (Chain Supermarkets), Houston, Texas; Johnston Motor Company (New & Used Cars), Houston, Texas; Weldon Cafeteria (Cafeteria), Houston, Texas; Moncrief-Lenoir Mfg. Co. (Steel Products), Houston; Libbey, Owens, Ford Glass Co. (Corulux Div.), Houston, Texas.

**BACHRODT, NEWELL,
 O'KANE & GANO**

75 E. Wacker Dr., Chicago 1, Ill.

Phone: FRanklin 2-4883

APA—NOAB—ABP—PPA—ANPA

President.....J. C. Bachrodt
 Vice-President.....R. C. Gano
 Secretary.....Katherine Jansen
 Treasurer.....R. B. Newell
 Account Executives.....J. C. Bachrodt,
 R. B. Newell, Ashley Kennedy

Radio Accounts: Win. Frank Co.; Globe Oil & Refining Co., Chicago; Kano Laboratories, Chicago; Lumenite Electronic Co., Chicago; Marks Shoe Co., Chicago.

**BADGER & BROWNING &
 HERSEY, INC.**

630 Fifth Ave., New York 20, N. Y.

Phone: Circle 7-3720

ABP—ANPA—PPA

Chairman of Board.....J. L. Badger
 President.....R. W. Hersey
 Treasurer.....F. S. Browning
 Radio-TV Director.....Jack Wilcher

**THE BAKER ADVERTISING AGENCY,
 LTD.**

1315 Yonge St., Toronto, Ont., Canada

Phone: Princess 2101

ABC—ANPA—CARTB

President.....W. R. Baker
 Vice-President.....H. F. Baker
 Personnel.....R. C. Baker
 Copy Chief.....W. E. Trimble
 Secretary-Treasurer.....A. N. Nisbet
 Account Executives.....H. S. Baxter,
 K. W. Jones, C. S. Wallace, R. D. Albertini,
 J. E. McEachern, G. H. Sloan, D. E. Smith, Carl Brown

Space Buyer.....S. Cook
 Radio Director.....Jack F. Horler
 Asst. Radio Dir.....W. (Doc) Lindsey
 Production.....Arnold Acton
 Radio & Time Buyer.....Lenore Dighton
 1557 MacKay St., Montreal, Que.

Phone: Harbour 9247

Manager.....Gabriel Langlais

**PRODUCT
 SERVICES inc.**

Advertising—

★ TELEVISION

★ RADIO

17 East 45th St., New York City 17
 MUrray Hill 7-0204

JOHN GART

Conductor-Composer

THE PAUL WINCHELL SHOW — WNBT

DENNIS JAMES

CHANCE OF A LIFE TIME

Radio Accounts: General Foods, Ltd.; Canada Packers, Ltd. (Soap Division); Adams Brands Sales, Ltd.; Frigidaire Products of Canada, Ltd.; The Carnation Co., Ltd.; White Laboratories, Inc. (Feenamint); Supreme Drug, Ltd. (Ammi-dent and Polident); Manufacturers Life Ins. Co.; Canadian Cannery Ltd.; Gordon Mackay & Co. Ltd..

TV Accounts: Frigidaire (Products) of Canada, Ltd.; Adams Brands Sales Ltd.; General Foods, Ltd.

BALDWIN, BOWERS & STRACHAN, INC.

374 Delaware Ave., Buffalo 2, N. Y.
Phone: Madison 6020

AAAA-ABP-ANPA-AFA-NOAB-PPA
President.....William M. Baldwin
Vice-President.....Everett L. Bowers
Treasurer.....Kenneth Strachan
Radio-TV Director...Everett L. Thompson
Copywriters & Producers..Joseph H. Radder,
Catharine D. Walsh, Malcolm L. Barney,
Leon A. McNamara

Traffic....Helen L. Goodwin, Nora L. Cuff
Radio and TV Accounts: Buffalo Industrial Bank, Buffalo; Crystal Beach Transit Co., Buffalo; Erie County Savings Bank, Buffalo; Kelly Bros. Nurseries, Inc., Dansville; Milk Dealers & Producers, Buffalo; Niagara Frontier Transit System, Buffalo; Old Dutch Foods Inc., Blasdell; Pratt & Lambert, Buffalo; Sears Roebuck & Co., Buffalo; William Simon Brewery, Inc., Buffalo; Joseph Strauss Co., Inc., Buffalo; Trico Products Corp., Buffalo.

BARLOW ADV. AGENCY, INC.

742 James St., Syracuse, N. Y.
Phone: SYracuse 9-6644

AAAA-ABP-ANPA-AFA
President.....H. H. Goodhart
Vice-Pres. & Acct. Exec.....E. S. Crawford
Vice-Pres. & Copy Chief.....J. J. Hines
Media Director.....F. B. Tompkins
Art Director.....H. C. Millard
Prod. Mgr.....Mark Hughes
TV-Radio Director.....Bud Stapleton

Radio Accounts: Dairyman's League Co-op (Milk, Cheese, Ice Cream), New York, N. Y.; Lincoln Bank (Commercial Bank), Syracuse, N. Y.; Procino-Rossi (Macaroni Products), Auburn, N. Y.; C. A. Durr Packing Co. (Meat), Utica, N. Y.; General Electric (Community Relations), Syracuse, N. Y.; Will & Baumer Candle Co. (Candles), Syracuse, N. Y.; Hosid Products (Glamur Upholstery Cleaner), Syracuse, N. Y.

TV Accounts: Dairyman's League Co-op (Milk, Cheese, Ice Cream), New York City; Will & Baumer Candle Co. (Candles), Syracuse, N. Y.; C. A. Durr Packing Co. (Meat), Utica, N. Y.; General Electric (Community Relations), Syracuse, N. Y.; Hosid Products (Glamur Upholstery Cleaner), Syracuse, N. Y.; Lincoln Bank (Commercial Bank), Syracuse, N. Y.; Procino-Rossi.

BARNES CHASE COMPANY

530 Broadway, San Diego 1, Calif.
Phone: Belmont 3-7771

AAAA-ABC-ANPA-APA-NOAB

President.....N. R. Barnes
Vice-Pres., Acct. Exec....George L. Hawkins
Vice-Pres., Acct. Exec.....Norman Foster
3450 Wilshire Blvd., Los Angeles 17, Calif.
Phone: DU 4-1193

Manager.....Charles V. Davis

Radio-TV Accounts: Qualitee Dairy Products (Dairy Products), Security Bank (Banking), Sunset Oil Company (Golden Eagle Gasoline), Rohr Aircraft Corporation (Aircraft Parts), San Diego Gas & Electric Co. (Public Utility), J. Jessop and Sons (Jeweler).

TED BATES & CO.

630 Fifth Ave., New York 20, N. Y.
Phone: JUDson 6-0600

AAA-ANPA-PPA-NAOB-ABC-FAAG
Partners.....Theodore L. Bates,
Joseph R. Busk, Thomas J. Carnese,
Walker G. Everett, Clinton S. Ferris, Thos.
F. Harrington, Edward F. Hudson, Wil-
liam H. Kearns, John M. Lyden, D. Robert
Parman, Clifford N. Parsells, H. Austin
Peterson, T. Rosser Reeves, Edward P.
Small, Frank Kimball, Rudolph Monteglas,
Alman Taranton

Chg. Radio-TV.....James C. Douglas
Business Manager.....John Doherty
New Prog. Dev.....Vincent Rowe
Film Production.....Thomas McAndrews,
Thomas Hanlon

TV Commercials.....Herb Gunter
Mgr. Time Buying Dept.....Ned Midgeley
Time Buyers.....MacDonald Dunbar,
Bill Kennedy, Chris Lynch, Al Petcavage.
Radio & TV Producers.....Jay Clark,
Allan Dingwall, Jr., John Thompson, Grant
Tyler, Ed Brown
Director Press Dept.....Benson Inge

Branch Office

Room 1014, Taft Bldg.,
1630 North Vine St., Hollywood 28, Calif.
Phone: HOLlywood 9-2161

Partner in Charge of
Radio & TV.....Austin Peterson
Producers.....Harry Saz, Frank O'Connor,
Phil Krim.

Office Mgr.....Mae Collins
Radio Accounts: Colgate-Palmolive-Peet Co. (Colgate Dental Cream, Palmolive Shave Creams, Palmolive Soap, Octagon Products), Continental Baking Co. (Wonder Bread, Hostess Cup Cakes), Grocery Store Products (Kitchen Bouquets), Carter Products, Inc. (Carter's Little Liver Pills), Standard Brands, Inc. (Blue Bonnet, Royal Puddings), Brown & Williamson (Kool, Viceroy Cigarettes, Life Cigarettes), American Sugar Refining Co. (Domino Sugar), Minute Maid Corp. (Minute Maid Frozen Orange Juice, Minit Maid Lemonade Mix), Anahist Company, Inc. (Super Anahist), Cantrell-Coch-

CHARLES MARTIN

Producer – Director – Writer

PHILIP MORRIS PLAYHOUSE

CBS-TV

rane Corporation (Super Soft Drinks), CBS-Columbia, Inc. (CBS-Columbia TV Receivers), Morton Packing Company (Morton Frozen Meat Pies), Pillsbury Mills, Inc. (Duff's Mixes).

TV Accounts: Colgate-Palmolive-Peet Co. (Colgate Dental Cream, Palmolive Shave Cream, Palmolive After Shave, Palmolive Soap), Continental Baking Company (Wonder Bread), Brown & Williamson (Kool, Viceroy Cigarettes), Minute Maid Corp. (Minute Maid Frozen Orange Juice, Minit Maid Lemonade Mix), Standard Brands, Inc. (Blue Bonnet Margarine, Royal Puddings), Carter Products (Carter's Little Liver Pills, Nair), Anahist Company, Inc. (Super Anahist), Cantrell-Cochrane Corp. (Super Soft Drinks), Pillsbury Mills, Inc. (Duff's Mixes).

BATTEN, BARTON, DURSTINE & OSBORN, INC.

383 Madison Ave., New York 17, N. Y.
Phone: ELdorado 5-5800

AAAA-ABC-ABP-ANPA-APA-NOAB
PPA-SNPA

Chairman of Board.....Bruce Barton
Vice-Chmn. of Board.....Alex F. Osborn
Pres. & Chair. of Exec. Com.....B. C. Duffy
Exec. V.P. in Chg. Western Offices

John C. Cornelius
Exec. V.P. in Chg. Creative Services
Charles H. Brower

Exec. V.P. in Chg. Client
Relations.....J. D. Danforth
Exec. V.P. in Chg. Oper.,

Treasurer.....F. B. Manhee
Secretary.....Eugene T. McQuade
V.P. in Chg. Radio, TV...Arthur Pryor, Jr.
V.P. in Chg. of New Program
Development.....James Bealle

Chairman Radio-TV Plans Bd.
Carroll P. Newton

V.P. in Chg. of TV.....Robert L. Foreman
Talent Contracts.....Katherine V. Winn
V.P. in Chg. of Media.....Fred Barrett
Dir. of Prod. in Chg. of all TV

Producers and Directors.....Hugh Rogers
Super. Com'l. Copy.....Arthur Bellaire
Radio-TV Network

Supervision Frank Silvernail, Tucker Scott
Director of Public Relations and

Publicity Dept.....W. Barry McCarthy
Group Head Time Buyers..Elenore Scanlan,
Fred Stoutland, Robert Tatum, George Polk

Time Buyers.....Mary Ellis,
Hope Martinez, Richard McKeever, Ted Wallower

Mgr. of Radio Prom. and
Merchandising.....R. C. Brown

Branch Offices

1220 Statler Office Bldg., Boston 16, Mass.
Phone: HHubbard 2-0430

Vice-President.....Francis W. Hatch
Rand Building, Buffalo 3, N. Y.

Phone: CLeveland 7915

Vice-President.....Alan M. Ward

919 N. Michigan Ave., Chicago 11, Ill.

Phone: SUPERior 7-9200

Vice-President.....H. H. Haupt
1050 Terminal Tower, Cleveland 13, O.

Phone: TOWers 1-7270

Vice-President.....E. E. Haring
1856 Penobscot Bldg., Detroit 26, Mich.

Phone: WOODward 5-0620

Vice-President.....Robert E. Anderson
1680 N. Vine St., Hollywood 28, Calif.

Phone: HOLLYwood 9-7337

Vice-President.....Wayne Tiss
6363 Wilshire Blvd., Los Angeles 36, Calif.

Phone: WEBster 1-1234

Vice-President.....A. W. Neally
N. W. Band Bldg., Minneapolis 2, Minn.

Phone: LINcoln 8401

Vice-President.....E. A. Cashin
V.P. in Chg. Western Offices

J. C. Cornelius

Grant Bldg., Pittsburgh 19, Pa.

Phone: GRant 1-9900

Vice-President.....Leon D. Hansen
2200 Russ Bldg., San Francisco 4, Calif.

Phone: SUTter 1-2232

Vice-President.....J. G. Motheral

Radio and TV Accounts: Peter Hand Brewery Co., M. J. B. Co., Tea Garden Products Co., Penick & Ford, Inc., Nehi Corp., Wynn Oil Co., Minneapolis Brewing Co., F. & M. Schaefer Brewing Co., Consolidated Edison Co., Polaroid Corp., Carr-Consolidated Biscuit Co., Vick Chemical Co., Foley Mfg. Co., Easy Washing Machine Corp., Northrup King Co., George A. Hornel Co., Rexall Drug Co., Barcalo Mfg. Co., Curtis Circulation Co. (N. Y.), Blum's Candies, DeSoto Division (Chrysler Corp.), B. F. Goodrich Co., Wildroot Co., Inc., Murine Co., Inc., Westlox (div. of General Time Corp.), Gallo Winery, E. & J., Pacific Telephone & Telegraph Co., Minnesota Mining & Mfg. Co., American Tobacco Co., D. L. Clark, Marine Midland Trust Co., Ethyl Corp., General Baking Co., E. I. duPont de Nemours & Co., Hamilton Watch Co., United Fruit Co., Fort Pitt Brewing Co., Cream of Wheat Corp., Farmers & Mechanics Savings Bank (Minn.), Minneapolis Brewing Co., Scott-Atwater Mfg. Co., Inc., Northwestern Bell Telephone Co., Bausch & Lomb Optical Co., Tennessee Coal, Iron & RR Co., Armstrong Cork Co., General Electric Co., United States Steel Corp., Crosley Division Avco Corp., Electrolux Corp., Personal Products (Jonny Mop), Libby McNeil & Libby (Frozen Foods), National Cranberry Assoc., Genex Watch Bands, Lever Bros. (Breeze & Swan), Zenith Radio Corp. (Hearing Aid), J. R. Wood & Sons.

ADRIAN BAUER ADVERTISING AGENCY, INC.

1528 Walnut St., Philadelphia 2, Pa.

Phone: KINGSley 5-7870

ANPA

Chairman.....Adrian Bauer

President.....Alan R. Tripp



JAN MURRAY

"DOLLAR A SECOND" — DUMONT NETWORK (117 Stations)
SUNDAY — 10-10:30 P.M. E.S.T.

Management:
WILLIAM MORRIS AGENCY

Vice-President Harold Finestone
 Vice-President.....W. Laurence LePage
 Vice-President.....David X. Miller
 Vice-President Frederick Goldman
 Copy Chief.....Frederick Goldman
 Radio & TV Director.....David Kaigler

Radio Accounts: J. Frank & Sons (Carbonated Beverages); C. F. Simonin's Sons, Inc. (Popcorn Oil seasoning), Philadelphia, Pa.; Woodlawn Farm Dairy Co., Scranton, Wilkes-Barre, Pa.; General Electric (Electric Blankets), Philadelphia, Pa.; Philadelphia Dairy Products Co., Inc.; John Bartram Hotel, Philadelphia, Pa.; Allied Florists of Greater Philadelphia, Inc.; Shore Bros., Inc. (Automobiles), Philadelphia, Pa.; Lehigh Foundries, Inc., Easton, Pa.

TV Accounts: Quaker City Chocolate & Confectionery Co., Inc. ("Good and Plenty" Candy), Phila., Pa.; Phila. Dairy Products Co., Inc.; General Electric (TV, Elec. Blankets, etc.), Philadelphia, Pa.; J. Frank & Sons (Ice Cream), Philadelphia, Pa.; D. G. Yuengling & Son, Inc. (Beer), Philadelphia, Pa.; C. F. Simonin's Sons, Inc. (Seazo Oil), Philadelphia, Pa.; Sansou Hosiery Mills, Inc. (Magic Stitch Stockings), New York, N. Y.

BEAN ADV. AGENCY

136 N. Delaware St., Indianapolis 4, Ind.
 Phone: FRanklin 4248

OwnerHarold Bean
Radio-TV Accounts: L. S. Ayres & Co., Wayside Floral Gardens; Central Supply Co., Indianapolis Custom Auto Show.

BEAUMONT, HELLER & SPERLING, INC.

6th & Walnut Sts., Reading, Pa.
 Phone: 5-4311
 ABP-ANPA

President.....Donald T. Beaumont
 Vice-Pres. & Sec.....L. J. Sperling
 Vice-Pres. & Treas.....R. F. Heller
 Art Director.....R. R. Glassmire
 Gen. Production Mgr.....H. Fetterhoff
 Publicity Director.....Marion W. Nagle
 Media & Research Dir.....K. W. Erdman
 Radio & TV.....Doratheia Hassler

Radio Accounts: Bowers Battery (Batteries & Spark Plugs), Reading; Maier's Bakery, Reading; St. Lawrence Dairy Co., Reading, Pa.; Consumers Gas Co.; Eastern Gas Assn.; Ontelaunce Orchards.

TV Accounts: Crystal Rock Bottling Co. (7-Up), Reading, Pa.; Lancaster County Gas Co. (Public Utility); The Lebanon Valley Gas Co. (Public Utility); The Harrisburg Gas Co. (Public Utility); York County Gas Co. (Public Utility).

HERBERT S. BENJAMIN ASSOCIATES, INC.

234 Main, Baton Rouge 1, La.
 Phone: 3-2847
 AFA

President.....Herbert S. Benjamin

Vice-PresidentLee Herzberg, Jr.
 Vice-President.....Allan R. Brent
 Secretary.....R. K. Goldberger
 TreasurerDorothy Dennis

Radio Accounts: Capital Building & Loan Association (Loans), Baton Rouge, La.; Fidelity National Bank (Banking), Baton Rouge, La.; Kornmeyer Furniture Company (Furniture), Baton Rouge, La.; E. J. Gonzales Finance Co. (Loans), Baton Rouge, La.; Community Coffee Co., Baton Rouge, La.

TV Accounts: The Fidelity National Bank, Baton Rouge, La.; E. J. Gonzales Finance Co. (Loans), Baton Rouge, La.; The Capital Building & Loan Assn., Baton Rouge, La.; Community Coffee Co., Baton Rouge, La.; Kornmeyer Furniture Co., Baton Rouge, La.; United Credit Co. (Loans), Baton Rouge, La.

VICTOR A. BENNETT CO., INC.

511 Fifth Ave., New York 17, N. Y.
 Phone: MURray Hill 7-2186
 ABP-ANPA-PPA

President.....Victor A. Bennett
 General Manager.....Edward D. Kahn
 Art Director.....Lazslo Razel

Radio Accounts: Longines-Wittnauer Watch Co., Inc. (Longines-Wittnauer Watches).

Radio-TV Accounts: Longines-Wittnauer Watch Co., Inc. (Longines-Wittnauer Watches), Your Lucky Star Lobster (Foods), New York, N. Y.

BENNETT, WALTHER & MENADIER, INC.

69 Newbury St., Boston 16, Mass.
 Phone: Kenmore 6-3820
 ANPA

PresidentNelson Bennett
 Exec. V.P.....Edwin C. Whittemore
 Vice. Pres.....Henry E. MacDaniel

BENTON & BOWLES, INC.

444 Madison Ave., New York 22, N. Y.
 Phone: MURray Hill 8-1100
 ANPA-AAAA-APA-NOAB
 ABP-PPA

Chair. of Exec. Com.....Atherton W. Hobler
 Chair. of the Board...William R. Baker, Jr.
 President.....Robert E. Lusk
 Vice-President & Secy.....Edward R. Beach
 V.P. in Chg. Radio-TV.....L. T. Steele
 Bus. Mgr. Radio-TV...William E. Schneider
 V.P. in Chg. TV-RA Prg...Tom McDermott
 Dir. Radio Production.....Paul Roberts
 Dir. Film Production.....Herb Leder
 TV Production Dir.....William Vallee
 Casting Director.....Ann Howard
 Directors.....Wilfred S. Roberts,
 Oliver Barhour, Charles Fisher, Carl Eastman, Don Wallace, Ralph Starr Butler, Jr., Arthur Richards, Lawrence White, Maximilian Bryer, Douglas Burch, Elizabeth Shay, Irwin Segelstein
 V.P. Dir. Bcst. Planning.....Dan Potter

LES PAUL

and

MARY FORD



GAC

Gibson Guitars

Personal Mgt.

Gray Gordon — Mel Shauer

667 Madison Ave.
New York 21, N. Y.
TEmpleton 8-2746

9120 Sunset Blvd.
Hollywood, Calif.
CRestview 1-1103

Capitol
RECORDS

Radio & TV Time Buying

SupervisorsPaul Benson
 Mary McKenna, Tom Carson
 Time Buyers.....Frank Garvel,
 Marion Jones, Ann Janowicz, Leroy Cur-
 rin, Raymond Healy, Helen Kowalsky,
 William Murphy, Grace Porterfield, John
 J. Sinnott, Jr., Richard Atwood Trea,
 Samuel Vitt
 V.-P. & Dir. Pub. Rel.....Holcombe Parkes
 Director Publicity.....Richard K. Bellamy

Branch Offices

6253 Hollywood Blvd., Hollywood 28, Calif.
 V.-P. in Chg. of

West Coast Operations.....Al Kaye
 Radio Program Prod.....Murray Bolen
 TV Program Prod.....Murray Bolen
 Hollywood Office Mgr.....Mary Edith Stahl
 West Coast Pub. Mgr.....Jean Meredith
 91 Yonge Street, Toronto, Canada

William H. Fleischman

Radio Accounts: Association of American
 Railroads; General Foods Corp. (Post's 40%
 Bran Flakes, Post's Sugar Crisp, Post's
 Raisin Bran, Post's Puffed Products, Dia-
 mond Crystal Salt, Maxwell House Coffee,
 Instant Maxwell House Coffee, Ridgways
 Tea, Yuban Coffee, Bliss Coffee, Gaines Dog
 Food, Log Cabin Syrup, Snider Condiments,
 Baker's Chocolate, Certo, Sure-Jell); The
 Procter & Gamble Company (Tide, Camay,
 Ivory Snow, Prell, The White Naptha); The
 Best Foods Company (Hellman's Mayon-
 naise, Best Foods Mayonnaise, Nucoa, H-O
 Oats, Presto, Farina, Old Homestead French
 Dressing); The AVCO Manufacturing Corp.—
 Crosley Division (Crosley Electric Ranges,
 Freezers, Dishwashers, Air Conditioners,
 Complete Kitchens, Shelvador Refrigerator-
 ers); The Pepperell Manufacturing Co.;
 American Express (Travelers Cheques);
 Norwich Pharmacal Co. (Pepto-Bismol, Un-
 guentine, Zemaol, Norwich Aspirin);
 Brewing Corp. of America (Carling's Red
 Cap Ale); Benson & Hedges (Parliament
 Cigarettes, Virginia Rounds Cigarettes);
 French Government Tourist Office; American
 Express Company (Travelers Cheques,
 Money Orders); Brewing Corp. of America
 (Carling's Red Cap Ale); Diamond Crystal
 Salt Company; Diamond Match Company
 (Toilet Tissue, Waxed Paper, Matches);
 M & R Dietetic Laboratories, Inc., Food
 Products Division; Mutual Life Insurance
 Company of New York.

TV Accounts: General Foods Corp. (Max-
 well House Coffee, Post's Cereals, Ridgways
 Tea, Diamond Crystal Salt, Instant Maxwell
 House Coffee, Bliss Coffee, Baker's Choco-
 late, 4-in-1 Cocoa Mix, Certo, Yuban Coffee,
 Gaines Dog Food); Procter & Gamble Com-
 pany (Tide, Camay, Prell, Ivory Snow);
 The AVCO Manufacturing Corp.—Crosley
 Division (Crosley Electric Ranges, Shelva-
 dor Refrigerators, Freezers, Complete Kitch-
 ens, Dishwashers, Air Conditioners); The
 Best Foods, Inc. (Nucoa, Hellmann's Mayon-
 naise, Presto, H-O Oats, Farina, Sandwich

Spread, Horseradish, Mustard, Fannings
 Bread and Butter Pickles, Old Homestead
 French Dressing); Norwich Pharmacal Com-
 pany (Pepto-Bismol, Norwich Aspirin);
 Brewing Corp. of America (Carling's Red
 Cap Ale); Benson & Hedges (Parliament
 Cigarettes); American Express Company
 (Travelers Cheques, Money Orders); Con-
 tinental Oil Company (Conoco Petroleum
 Products) Diamond Crystal Salt Company;
 Diamond Match Company (Waxed Paper);
 General Electric Company, Chemical Dept.
 (Plastics & Chemicals); M & R Dietetic La-
 boratories, Inc., Food Products Division;
 Pepperell Manufacturing Company (Sheets,
 Blankets).

**ALFRED PAUL BERGER COMPANY,
 INC.**

9 East 48th St., New York 17, N. Y.

Phone: PLaza 9-4703

ABP—PPA—PANY

Pres. & Treas.....Alfred Paul Berger
 SecretaryFlorence Berger
 Space Buyer.....Jane Ellenbogen
 Account Executive.....Sidney Rosendorf
 Production Manager.....Gilbert Tockerman
Radio-TV Accounts: Pilot Radio Corp.,
 Long Island City, N. Y.; Toffenetti Restau-
 rant, N. Y. C.; Orpheum Shops, N. Y. C.

BERGHOFF ASSOCIATES, INC.

511 No. La Cienega Blvd., Los Angeles 48,
 Calif.

Phone: CR 56151, BR 2-2625

PresidentJoseph Berghoff
 Vice-President.....Jerry Berghoff
 Secretary.....Frances H. Berghoff
 Art Director.....Daniel Miller
 Research Dept.....Marilyn Livermore
Radio Accounts: Baby Line Furniture Co.,
 Southwest Steel Rolling Mills, Pride Pro-
 ducts Company, Art Metal Appliance Co.,
 Scy-Co Products, Van-Rex Gourmet Foods,
 Phillip E. Green Company, Alladin Plastics.
TV Accounts: Baby Line Furniture Co.,
 Southwest Steel Rolling Mills, The Teevee
 Company, Art Metal Appliance Co., Phillip
 E. Green Co., Rose Enterprises, Van-Rex
 Gourmet Foods, Anthony Distributors.

**BERMINGHAM, CASTLEMAN &
 PIERCE**

136 East 38th St., New York 16, N. Y.

Phone: LExington 2-7550

AAAA—ABP—APA—NOAB

PresidentArch Bermingham
 DirectorsHerbert Lorentzen,
 James Walker, Porter F. Leach
 Radio, TV Director.....John H. McNeil
 Production Manager....Robert E. Rosegren
Radio Accounts: Griffin Mfg. Co., Inc.
 (Shoe Polish); Pilgrim (Laundry Service);
 Whitbread & Co., Ltd. (Imported Ale &
 Stout), London, England; Aerolineas Agen-
 tinas (Airlines).
TV Accounts: Griffin Mfg. Co. (Shoe
 Polish), Brooklyn, N. Y.



CHARLIE APPLEWHITE

TV'S NEW SINGING STAR

RECORDINGS:

DECCA

Personal Management: WYNN LASSNER
1619 Broadway
PL 7-0876-7



EILEEN BARTON

RECORDINGS:

CORAL

Personal Management: WYNN LASSNER
1619 Broadway
PL 7-0876-7



JOHN BARAGREY

Studio One
Philco-TV Playhouse
Kraft Theatre

U. S. Steel Hour
Suspense
Danger

You Are There

SU 7-5400

Empire Sate Bldg., New York 1, N. Y.
 Phone: BRyant 9-4845
 Vice-PresidentElizabeth Eyerly
Radio Accounts: Columbia River Packers Assn. (Tuna—Bumble Bee Brand, Astoria, Ore.; Olympia Brewing Co. (Olympia Beer), Olympia, Wash.; Lucky Stores, Inc. (Super Markets), San Leandro, Calif.; Sego Milk Products (Sego Evaporated Milk), San Francisco, Calif.; Mayfair Hotel (Hotel), Los Angeles, Calif.; Crispie Potato Chip Co. (Potato Chips & French Fries), Stockton, Calif.; First Federal Savings & Loan Association of Portland, Portland, Ore.; Perfect-Fit Mfg. Co. (Perfect-Fit Auto Seat Covers), Portland, Ore.; Washington State Ferries (Ferry Service), Seattle, Wash.; New Washington Hotel (Hotel), Seattle, Wash.; Cascadian Hotel (Hotel), Wenatchee, Wash.; California Prunes Advisory Board (California Prunes), San Francisco, Calif.; Scott Co. (Plumbing Heating Contractors), San Francisco, Calif.

TV Accounts: Olympia Brewing Co. (Olympia Beer), Olympia, Wash.; Sego Milk Products (Sego Evaporated Milk), San Francisco, Calif.; Poultry Producers of Central Calif. (Nulaid Eggs), San Francisco, Calif.; Crispie Potato Chip Co. (Crispie Potato Chips & "Small Fry" French Fries), Stockton, Calif.; Columbia River Packers Assoc., Inc. (Bumble Bee Sea Foods), Astoria, Ore.; Bank of California, Seattle, Wash.; Washington State Ferries (Ferry Service), Seattle, Wash.; Western Hotels, Inc. (Hotels), Seattle, Wash.; California Prunes Advisory Board (California Prunes), San Francisco, Calif.; The Emporium (Department Store), San Francisco, Calif.; Old English Co. (Dog Food), San Jose, Calif.; Lucky Stores (Super Markets), Oakland, Calif.

STANLEY G. BOYNTON & SON

159 Pierce St., Birmingham, Mich.
 Phone: Jordan 4-5888
 President.....Stanley G. Boynton
 Secretary.....Amelia E. Silvestri
 Radio Time Buyer.....Ruth A. Spelman
Radio Accounts: Radio Bible Class, Wesley Radio League, Calvary Hour.

BOZELL & JACOBS, INC.

510 Electric Bldg., Omaha 2, Nebraska
 Phone: Jackson 8030
 President.....Morris E. Jacobs
 Exec. V.-P.....F. C. Miller
 Copy Chief.....Henrietta Kieser
Branch Offices
 205 N. LaSalle St., Chicago 6, Ill.
 Phone: Central 6-0870
 President.....Nathan E. Jacobs
 V.-P., Dir. Radio-TV.....Philip Rouda
 1812 N. Meridian St., Indianapolis 2, Ind.
 Phone: Wabash 4524
 V.-P. & Manager.....Chas. A. Gallup
 2123 Smith Tower, Seattle 4, Wash.
 Phone: Main 0145
 V.-P. & Manager.....R. H. Wensberg

2 W. 45th St., New York 36, N. Y.
 Phone: MUrray Hill 7-6210
 Chairman of Bd.....Morris E. Jacobs
 President.....Donald D. Hoover
 625 Second Ave., Minneapolis 2, Minn.
 Phone: Main 4527
 V.-P. & Manager.....Sam Kaufman
 Vice-PresidentLloyd Borg
 Fairfield Bldg., Shreveport, La.
 Phone: 3-6124
 V.P., Manager.....Walter T. Pfeiffer
 703 United Gas Bldg., Houston 2, Texas
 Phone: Fairfax 4106
 V.-P. & Manager.....Carlton Storey
 813 Thomas Bldg., Dallas 1, Texas
 Phone: Randolph 5428
 V.-P. & Manager.....M. O. Rike, Jr.
 702 Sheraton Bldg., Washington, D. C.
 Phone: Sterling 2406
 ManagerDon Underwood

Radio Accounts: Mutual of Omaha (Insurance), Omaha; Staley Milling Co. (Animal & Poultry Feeds), Kansas City, Mo.; Storz Brewing Co. (Beer), Omaha; Nebraska Clothing Co., Omaha; Metropolitan Utilities District, Omaha; Gland-O-Lac (Poultry Medicine), Omaha; Skinner Mfg. Co. (Macaroni Prods., Cereals), Omaha; J. L. Brandeis & Sons (Dept. Store), Omaha; Iowa Master Breeders, Inc. (Hatchery), Onawa, Ia.; Ak-Sar-Ben (Horse-, Livestock Shows, Rodeos, etc.), Omaha; Stock Yards Natl. Bank, Omaha; Higgins Cleaners, Omaha; Eaton Metal Prods. Co. (Storage Tanks, etc.), Omaha; Yager Seed & Nursery Co. (Hybrid Seed, Corn, etc.), Fremont, Nebr.; General Appliance Co., Omaha; Livestock Nat'l Bank, Omaha; Major Appliance, Omaha; Omaha & Co. Bluffs Street Railway, Omaha; Occidental Bldg. & Loan Co., Omaha; Milder Oil Co., Omaha; Phoenix Table Mat Co. (Stove Mats), Chicago, Ill.; Leaf Brands (Gunn, Candy), Chicago; Northwestern Tel. Co., Freeport, Ill.; Pfaff Sewing Machine Corp., Chicago, Ill.; Central Natl. Bank, Chicago; Earl Hayes Chevrolet Co., Dallas; Finney Bakery, McKinney, Tex.; Radio City Distributing Co. (Appliances), Dallas; Dallas Zone Chevrolet Dealers, Dallas.

TV Accounts: Mutual of Omaha (Insurance), Omaha; Staley Milling Co., K. C., Mo.; Storz Brewing Co., Omaha; Nebraska Clothing Co., Omaha; Metro. Util. Dist., Omaha; Skinner Mfg. Co., Omaha; J. L. Brandeis & Sons, Omaha; Milder Oil Co., Omaha; Stock Yards Natl. Bank, Omaha; General Appliance Co., Omaha; Livestock Natl. Bank, Omaha; Northern Natural Gas Co., Omaha; Omaha & Council Bluffs Street Railway Phoenix Table Mat Co., Chicago, Ill.; Wholesale Plant Growers Assn., Chicago; Pfaff Sewing Machine Co., Chicago; Earl Hayes Chevrolet Co., Dallas, Tex.; Dallas Zone Chevrolet Dealers, Dallas; Radio City Dist. Co., Dallas.

PETER ARNELL

CBS-TV

Exclusive Management
TED ASHLEY ASSOCIATES

Press Representative
SOLTERS-O'ROURKE ASSOCIATES

ARTHUR BRAITSCH ADV.

15 Westminster St., Providence 3, R. I.
 Phone: DExter 1-5313, 1-4115
 ABP—APA—ANPA

Radio Director.....Arthur Braitsch
 Secretary.....Frances N. Goodwin
 Time Buyer.....John A. Lorimer

Radio Accounts: Baird-North, Inc., Oliver Johnson Co., Inc., Mule Battery Mfg. Co., Rocky Point Park, Inc., Roger Williams Savings Fund & Loan Assoc., Sally's Fur Studio, Strand Theater, G. H. Walker & Co., Weybosset Markets.

MICHAEL BRAND ASSOCIATES

8820 Sunset Blvd., Hollywood 46, Calif.
 Phone: CRestview 6-2991

ABP

PresidentMichael Brand

THE J. CARSON BRANTLEY ADV. AGENCY

Owen Bldg., Salisbury, N. C.
 Phone: 900

Pres.-Radio Dir.....J. Carson Brantley
 Sec.-Treas.....A. R. Monroe
 ProductionJune Brantley
 Art Director.....Gladys Dudley

Radio Accounts: Carolina Beverage Corp. (Cheerwine, Caravan), Isenhour Brick & Tile Co., Salisbury; Duke Power Co., Charlotte; Owen Drug Co. (O-N for Colds), Salisbury, N. C., L. B. Coulter Co. Cosmetics, Free Enterprise Train.

TV Accounts: Caroline Beverage Corp. (Wine).

R. C. BRETH, INC.

310 Pine St., P. O. Box 128, Green Bay, Wisc.
 Phone: HHoward 134
 ABP—ANPA—APA

President.....R. C. Breth
 Vice-PresidentVictor G. Geisel
 Vice-PresidentBlaine Williams

Radio Accounts: Woodlot Seed Co., Norway, Mich.; Fairmon Foods, Green Bay, Wisconsin; WBAY and WBAY-TV, Green Bay, Wisconsin; D. J. Murray Mfg. Co., Wausau, Wisconsin; Miller Electric Mfg. Co., Appleton, Wisconsin.

TV Accounts: Fairmont Foods, Green Bay, Wisconsin.

J. F. BRINLEY ADVERTISING AGENCY SERVICES

4602 Cedar Street, Bellaire 1, Texas
 Phones: MAdison 8686 & MOhawk 4400
 ABP—SNPA—APA—NBP

Gen. Mgr., Dir. of Copy, Sales Prom., & Mkt. Tsch.....J. F. Brinley
 Sec., Treas.....V. H. Brinley
 Assoc. Radio Dir.....R. G. Dunn
 Associate TV Dir.....T. E. Light
 Assoc. Art Dir.....D. Ackley

BRISACHER, WHEELER & STAFF

1660 Bush Street, San Francisco 9, C.Hf.
 Phone: PProspect 6-2600
 AAAA—ABC—ABF—ANPA

President.....Franklin C. Wheeler
 Exec. Vice-President.....Walter Purdon
 Vice-PresidentRobert Brisacher
 Vice-Pres. & Art Dir.....Ettore Firenze
 Secy.-Treasurer.....Mrs. Emil Brisacher
 Copy Chief.....Lester Friedman
 Space Buyer.....Gladys King
 Media Director.....Richard Clark
 Radio & TV Time Buyer...Mary Liz Loeber
 Prod.-Traffic Mgr.....Jules P. Daniel
 Radio & TV Producer....Humphrey Ireland
 Dir. Research.....Charles Roach
 Public Relations Dir.....Robert Hoffman
 ControllerBryant Miley

Branch Offices

350 Fifth Ave., New York 1, N. Y.
 Phone: BRyant 9-5600

V.P. & Mgr.....Richard Ide
Radio Accounts: Van Camp Sea Food Co. (Chicken of the Sea & White Star Tuna), Terminal Island, Calif.; Hershel California Fruit Products (Contadina Tomato Paste), San Jose, Calif.; Richmond Chase Co. (Hearts Delight Nectars), San Jose, Calif.; Pictsweet Foods, Inc. (Frozen Foods & Juices, Canned Corn, Peas and Beans), Mt. Vernon, Wash.; Wheatena Corp. (Wheatena Cereal), Rahway, N. J.; Parsons Ammouia, New York; San Francisco Milk Industry; California Dairy Industry Advisory Board, Sacramento; East Bay Producers Council (Milk), Oakland, Calif.; Langendorf United Bakeries (Butter-Nut Bread), San Francisco, Calif.; Sacramento Milk Council; Bay View Federal Savings and Loan Association, San Francisco, Calif.; Pacific Intermountain Express, Oakland, Calif.; San Francisco, Examiner.

TV Accounts: Van Camp Sea Food Company, Inc. (Chicken of the Sea & White Star Tuna), Terminal Island, Calif.; Pict-Sweet Foods, Inc., Mount Vernon, Wash.; California Dairy Industry Advisory Board; San Francisco Milk Industry; East Bay Producers' Milk Council, Oakland, Calif.; Langendorf United Bakeries (Butter-Nut Bread), San Francisco, Calif.

BROADCAST ADVERTISING

170 S. Beverly Dr., Beverly Hills, Calif.
 Phone: Bradshaw 2-4840

President.....Van C. Newkirk
 Production Manager.....John G. Fryer
 Office Manager.....Betty Lester

Radio Accounts: Bible Institute of Los Angeles, Los Angeles; Church of the Open Door, Los Angeles; Morning Chapel Hour, Los Angeles, Calif.; Haven of Rest; World Vision, Inc., Los Angeles, Calif.; King's Ambassador, Los Angeles, Calif.; Radio Missionary Movement, Inc., Los Angeles, Calif.; Dr. William W. Orr, Altadena, Calif.

TV Accounts: Bible Institute of Los Angeles.



VIRGINIA GRAHAM

"BOHACK'S FOOD FOR THOUGHT"
DUMONT 12 NOON DAILY

— Radio and Television Fashion and Beauty Moderator —
Wishes You All a Wonderful Year.

BROOKE, SMITH, FRENCH & DORRANCE, INC.

East Jefferson at Burns, Detroit 14, Mich.
Phone: Valley 2-9700

AAAA-ABP-NOAB-ANPA-APA-PPA

Chairman of Board.....Sturges Dorrance
President.....Willard S. French
Secretary-Treasurer.....Guy C. Smith
Exec. Vice-President.....Walter C. Ayers
Vice-Presidents.....Wm. F. Austin, Jr.,
L. C. Barlow, H. R. Bayle, L. Grant Hamilton,
George Johnston, H. Kenneth Jones,
C. Allison Monroe, Richard Reins, Blount
Slade, J. G. Williams, Clarke C. Wilmot
Director of Radio-TV.....Hugh Hole
New York Division

52 Vanderbilt Ave., New York 17, N. Y.
Phone: MUrray Hill 6-1800

Chairman of Board.....Sturges Dorrance
Exec. Vice-President.....Thayer Ridgway
Vice-President.....H. E. Pengel
149 California St., San Francisco 11, Calif.
Phone: YUkon 6-6836

PresidentRoyce Russell
TreasurerKing Harris
SecretaryParker Wood
Radio Accounts: Goebel Brewing Co.,
Hudson Motor Car Co., Mullins Mfg. Corp.
(Youngstown Kitchens).
TV Accounts: Mullins Mfg. Corp., The
Ironite Ironer Co., Hudson Motor Car Co.,
Goebel Brewing Co.

BROOKS ADVERTISING AGENCY

416 W. 8th St., Los Angeles 14, Calif.
Phone: TRinity 0558
ANPA-APA-ABP-PPA

RadioMary McCauley
Time Buyer.....A. R. Brooks
SecretaryBarbara Vosburgh
Radio-TV Accounts: Bekins Van and Storage
Company, Western Stove Company.

D. P. BROTHER & CO., INC.

General Motors Bldg., Detroit 2, Mich.
Phone: TRinity 2-8250
APA-AAAA-ANPA-ABP
NOAB-PPA-ABC-AFA

President.....D. P. Brother
Executive Vice President.Clarance Hatch, Jr.
Vice Presidents.....Joseph S. Howell,
Carl Georgi, Jr., Guy S. Warren, Jr.
Media Director.....Carl Georgi, Jr.
Dir. of Marketing....Vincent H. Bergmann
Art Directors.....L. R. Mange, E. J. BOWENS
Publicity Director.....T. H. Moriarty
Radio & TV Director...Kenneth G. Manuel
Radio-TV Accounts: Oldsmobile Division,
General Motors Corporation (Automobiles);
AC Spark Plug Division, General Motors
Corporation (Accessories).

FRANKLIN BRUCK ADVERTISING CORP.

RKO Bldg., Rockefeller Center,
New York 20, N. Y.
Phone: Circle 7-7660

PresidentFranklin Bruck
Secretary.....M. J. Kleinfeld
TreasurerMort Heineman
Radio Time Buyer.....Joseph Gavin
TV Director.....David Davidow
Mdse. Director.....Herbert Gold

Branch Office

532 N. Cherokee Ave., Los Angeles, Calif.
Phone: HOLlywood 3-1153

ManagerHoward Blake
Radio Accounts: North American Accident
Insurance Co., Fashion Frocks, SitRoux Tis-
sues.

TV Accounts: Walter H. Johnson Candy
Co., Chicago; Fashion Frocks, Inc., Cincin-
nati; Bishop & Co., Los Angeles; Rexor
Corp., New York; Hi-V Corp., Newark;
Sitroux, Inc., New York.

CHARLES BRUNELLE ADV. AGENCY

15 Lewis St., Hartford 3, Conn.
Phone: 7-0726
ABP-PPA-APA

President & Treasurer....Charles Brunelle
Vice-PresidentRobinson Smith

BUCHANAN & CO.

1501 Broadway, New York, N. Y.
Phone: BRyant 9-7900
APB-ANPA-APA-PPA-AAAA
ABC-NOAB

Exec. Vice President.....William Dasheff
Account Executives.....George Richardson,
John McEvoy, W. Boley, A. Van Brunt
Vice President.....Paul Gaynor
Radio-TV Dir.....Nat Strom

Branch Offices

451 N. La Cienega Blvd., Hollywood, Cal.
Phone: CRestview 5-5231
155 Montgomery Street, San Francisco
Phone: YUkon 6-2927

Radio Accounts: Reynolds Metals Co.,
Eskimo Pie Corp., Acousticon, Air France,
New York Paramount Theatre, Western Air-
lines Inc., Wilbur Clark's Desert Inn, Para-
mount Pictures Corp., Tidewater Associated
Oil Co., Newport Soap Co.

TV Accounts: Lionel Corp., Eskimo Pie
Corp., New York; Paramount Theatre, Para-
mount Pictures, Western Airlines Inc., Wil-
bur Clark's Desert Inn, Tidewater Associ-
ated Oil Co., Regent Canned Food, Newport
Soap Co.

BUCHANAN-THOMAS ADV. CO.

410-412 S. 19th St., Omaha 2, Nebr.
Phone: ATLantic 2125
ABP-ANPA-APA-NOAB-PPA

PartnersR. Savage,
R. Foster, C. Harding, R. Dundis
Ptnr., Dir. Radio-TV....Adam Reinemund

BURLINGAME-GROSSMAN ADV.

207 So. Wabash Ave., Chicago 4, Ill.
Phone: WABash 2-3383
AAAA-ABP-ANPA

Owner.....S. W. Grossman
General Manager.....S. S. Kain



DALE CASSIDY

Art Director.....Al Jacobs
 Production Manager.....Don Rubin
 Media Manager.....Fred Walder
 Acct. Executives.....S. Grossman,
 M. Harvis, S. Brichta

Radio Accounts: Arvey Corp. (R. V. Lite Window Material), Blue Crown Spark Plug Co. (Spark Plugs), Chicago, Ill.; Bulk Petroleum Co., Chicago, Ill.

TV Account: Blue Crown Spark Plug Co., Chicago, Ill.; Bulk Petroleum Co., Chicago, Ill.

BURNET-KUHN ADV. CO.

520 N. Michigan Ave., Chicago 11, Ill.
 Phone: SUperior 7-3800
 ANPA—APA—PPA

President.....Francis J. Woods
 Vice-President.....Phillip D. Simons
 Account Executive.....Ellis T. Gash
 Secy.-Treas.....James H. Kristof
 Radio Director.....William Coop

LEO BURNETT COMPANY, INC.

360 N. Michigan Ave., Chicago 1, Ill.
 Phone: CENtral 6-5959
 AAAAA

President.....Leo Burnett
 Exec. Vice-Pres.....Richard N. Heath
 Treasurer.....E. Ross Gamble
 Vice-Pres. in cbg. Radio.....W. L. Weddell

Branch Offices

677 Fifth Ave., New York 22, N. Y.
 Phone: MURray Hill 8-9480

Manager.....Stanford Meigs
 1680 N. Vine St., Hollywood 28, Calif.
 Phone: HOLLywood 4-7374

Manager.....William Coons
Radio Accounts: Bauer & Black (Curity Products), Chicago, Ill.; Brown Shoe Company (Buster Brown Shoes), St. Louis, Mo.; Kellogg Company (Rice Krispies, Corn Soya, Corn Pops), Battle Creek, Mich.; Mars, Inc. (Milky Way, Three Musketeers, Coconut Bar, Snickers), Chicago, Ill.; Pillsbury Mills, Inc. (All Products), Minneapolis, Minn.; The Pure Oil Company (Petroleum Products, Bedtime Horlicks), Chicago, Ill.; Converted Rice (Uncle Ben's Rice), Houston, Texas.

TV Accounts: Brown Shoe Company (Buster Brown, Roblee, Air Step, Naturalizer, Life Stride & Westport Shoes), St. Louis, Mo.; Converted Rice (Uncle Ben's Rice), Houston, Texas; Dean Milk Company (Dairy Products), Chicago, Ill.; Globe Mills (Globe A-1 Flour, Globe Biscuit Mix), Los Angeles, Calif.; Green Giant Co. (Green Giant Brand Peas, Niblets Brand Corn, Mexicorn, Niblets), LeSueur, Minn.; Kellogg Company (Brand Cream Style Corn, Rice Krispies, Corn Soya, Corn Pops), Battle Creek, Mich.; Mars, Inc. (Forever Yours, Snickers, Three Musketeers, Mars Bar), Chicago, Ill.; Pillsbury Mills, Inc. (All Products), Minneapolis, Minn.; The Pure Oil Company (Petroleum Products), Chicago, Ill.

WALTON BUTTERFIELD ADV.

33 West 42nd St., New York 36, N. Y.
 Phone: WISconsin 7-7341

Owner, Manager.....Walter Butterfield
Radio Accounts: The Christian Science Monitor (Newspaper), Boston, Mass.; Maggyanne, Inc. (Wearing Apparel), Los Angeles, Calif.; Pulaski Monuments Co. (Monuments), New York, N. Y.

BYER & BOWMAN ADVERTISING AGENCY

66 So. 6th St., Columbus 15, O.
 Phone: MAIn 3276
 ABC—ABP—ANPA—AFA

Partners.....Herbert Byer,
 Gus K. Bowman, Joel Burghalter
 Radio Director.....John D. Metzger
 Account Executives.....Reg Testement,
 Herbert Wise, W. P. Brown, F. W. Munro,
 Jr.; Nicholas Popa, Gene Hameroff

Radio Accounts: Ashland Oil & Refining Co. (oil & gasoline), Ashland, Ky.; August Wagner Breweries (Gambrinus beer and Augustiner beer), Columbus, O.; Dollar Federal Savings & Loan (bank), Columbus; City National Bank (bank), Columbus; Buckeye Foods (potato chips), Columbus; Universal Concrete Pipe Co. (concrete products), Columbus; The Styron-Beggs Co. (food products), Newark.

TV Accounts: The Ohio Fuel Gas Co. (public utility), Columbus; Ashland Oil & Refining Co. (oil & gasoline), Ashland, Ky.; Dollar Federal Savings & Loan (bank), Columbus; August Wagner Breweries (Gambrinus beer), Columbus; T. Marzetti Co., (salad dressings), Columbus; Buckeye Foods, Inc. (potato chips), Columbus; Clean Products (wallpaper cleaner), Columbus.

HAROLD CABOT & CO., INC.

136 Federal St., Boston 10, Mass.
 Phone: HANcock 6-7600
 AAAAA—ABP—ANPA—ABC—AFA

President.....Harold Cabot
 Vice-Presidents.....Edward F. Chase,
 Russell Hunt, James I. Summers, William H. Ganick, John Spellman, George R. Griffin, Joseph Wallace, Courtney Crandall
 Exec. V.P. & Treasurer.....Richard P. Holland
 Secretary.....Edward Glacy
 Production Manager.....Robert Griffin
 Editorial Chief.....H. W. Patterson
 Copy Chief.....Courtney Crandall
 Art Director.....Yale Rachlin
 Media Director.....Kay Chille

Radio Accounts: Boston Consolidated Gas Co. (Public Utility), Boston; Boston and Maine Railroad (Public Utility), Boston; Boston and Maine Transportation Co. (Public Utility), Boston; H. P. Hood & Sons (Dairy Products), Charlestown; New England Electric System (Public Utility), Boston; New England Electric System (Gas Div.) (Public Utility), Boston; New England Telephone & Telegraph Co. (Public



BOB DIXON

THANKS TO:

**AMERICAN OIL CO.
PROCTER & GAMBLE
BEST FOODS, INC.
R. J. REYNOLDS CO.
FALSTAFF BREWING, INC.
GENERAL FOODS, INC.**

Utility), Boston; S. S. Pierce Company (Importers and Grocers), Boston; Red Coach Grills (Restaurant Chain), Boston; Rock of Ages Corporation (Monuments), Barre, Vt.

TV Accounts: Boston Consolidated Gas Company (Public Utility), Boston; Boston and Maine Railroad (Public Utility), Boston; H. P. Hood and Sons (Dairy Products), Charlestown; New England Electric System (Gas Division (Public Utility), Boston; New England Telephone and Telegraph Company (Public Utility), Boston.

CAHN-MILLER, INC.

510 St. Paul Place, Baltimore 2, Md.
Phone: SARatoga 7-4466
PPA

President.....Louis F. Cahn
Vice-Pres. & Treas.....C. LeRoy Miller
Radio & TV Dir.....Louis C. Pedlar, Jr.
Radio Accounts: Eutaw Savings Bank, Baltimore; Fidelity Trust Company, Baltimore; Jarman Motors, Inc. (Auto Sales & Service), Baltimore; Popular Club Beverage Co., Styleplus Clothes.

TV Accounts: Eutaw Savings Bank, Baltimore; Hanliue Bros. (paints), Baltimore; Jarman Motors, Inc. (Auto Sales & Service), Baltimore; Fidelity Trust Co., Hirschberg Paint Co., Popular Club Beverage Co., Modern House, Styleplus Clothes.

CALKINS & HOLDEN, CARLOCK, McCLINTON & SMITH, INC.

247 Park Ave., New York 17, N. Y.
Phone: PLaza 5-6900
AAAA-ABP-ANPA

Chairman of Board....J. Sherwood Smith
Vice-Chairman of Bd.....Rene Clark
President.....Harold L. McClintock
Secy.-Treas.James Jeffrey
Chairman of Exec. Comm.....Z. C. Barnes
Vice-Presidents.....M. E. Carlock,
Paul Smith

Art Director.....Wilfred L. Chausse
Copy Director.....George S. Thomson
Production Manager.....Fred Oughton
Manager Outdoor Dept ... F. J. Fitzgerald
Media Director.....Thomas H. Young
Dir. Pub. Relns. & Pub....Robert W. Robb
Research Director.....Thomas P. Crollius
Merchandising Dir.....J. H. Apeler
Director of Radio-TV.....Henry F. Hull
Copy Chief.....Phil Young

Branch Offices

333 No. Michigan Ave., Chicago, Ill.
Phone: Randolph 6-3831

ManagerPhilip M. White
Citizens Wilshire Bank,
Los Angeles, Calif.
Phone: York 5145

Manager.....Harry W. Witt
Radio Accounts: Crane & Company (stationery), Dalton, Mass.; A. S. Harrison Company (floor waxes), South Norwalk, Conn.; Marcalus Mfg. Co., Inc. (household papers), East Paterson, N. J.; Marshall Field & Co.,

Chicago, Ill.; Oakite Products, Inc. (cleaning compound), New York City; Pacific Wines, Los Angeles, Calif.; Prudential Insurance Company of America, Newark, N. J.; Stokely-Van Camp, Inc. (canned foods), Indianapolis, Ind.; Newcomb Audio Products (Hi-Fi), Hollywood; Eppen S. Smith Company (Coffee & Tea), Long Island City, N. Y.; Parade Publications, Inc., New York City, N. Y.

TV Accounts: A. S. Harrison Company (floor waxes), South Norwalk, Conn.; Marcalus Mfg. Co., Inc. (household papers), East Paterson, N. J.; Marshall Field & Co., Chicago, Ill.; Oakite Products, Inc. (cleaning compound), New York City; Prudential Insurance Company of America, Newark, N. J.; Stokely-Van Camp, Inc. (canned foods), Indianapolis, Ind.; Crane & Company (stationery), Dalton, Mass.; Newcomb Audio Products, Inc. (Hi-Fi), Hollywood, Calif.; Eppens-Smith Company (coffee & tea), Long Island City, N. Y.

CAMPBELL-EWALD CO.

General Motors Bldg., Detroit 2, Mich.
Phone: TRinity 2-6200
AAAA-ANPA-NOAB-PPA
ABC-ABP

President.....Henry G. Little
Sr. V.-P., Gen. Mgr.....E. E. Rothman
Sr. V.-P., Secy.-Treas.....L. R. Nelson
Sr. V.-P., Media Dir.....J. J. Hartigan
Comptroller.....H. P. Cook
V.-P., Copy Chief.....L. T. Robinson
Vice Presidents.....Colin Campbell,
Halsey Davidson, W. P. Stewart, John Terns, W. A. Moffet, W. H. Gage, Jr., M. P. Coyle, L. T. Robinson, W. A. Chalmers
Sr. V.P. Radio & TV.....Winslow H. Case

Branch Offices

1 E. 57th St., New York 22, N. Y.
Phone: MURray Hill 8-3190

Vice-Pres. & Mgr.....Frank W. Townsend
Vice-President.....J. H. Neebe
230 N. Michigan Ave., Chicago 1, Ill.
Phone: CEntral 6-1946

V.P. & Manager.....Earl W. Clements
714 W. Olympic Blvd., Los Angeles 15,
Calif.
Phone: Richmond 6204

Vice-Pres. & Manager.....R. C. Francis
235 Montgomery St., San Francisco 4, Calif.
Sutter 1-8736

Vice-Pres. & Manager...T. Milburn Johnston
45 Edgewood Ave., Atlanta 3, Ga.
Phone: Lamar 3858

Manager.....C. G. Thom
1737 "H" St., Washington 6, D. C.
Phone: REpublic 7-7400

Manager.....Wm. F. Armstrong, Jr.
Bryan & Bullington Sts., Dallas 1, Texas
Phone: RAndolph 2094

Manager.....George A. Back
4010 Washington Ave., Kansas City 11, Mo.
Phone: Jefferson 5601

Manager.....R. W. Beehtel



LISA FERRADAY

RADIO

TELEVISION

MOTION PICTURES

PL. 9-2428

1680 No. Vine St., Hollywood 28, Calif.
 Phone: Hollywood 5-4136
 Vice-President & Mgr. . . . Richard C. Francis
Radio Accounts: Chevrolet Motor Division, General Motors Corporation, The Detroit Edison Company, Local Metropolitan Chevrolet Dealer Groups, General Motors Acceptance Corp.

TV Accounts: Chevrolet Motor Division, General Motors Corporation, The Detroit Edison Company, Local Chevrolet Dealers Association, Inc. (New York), Allen B. Du Mont Laboratories, Inc., Local Metropolitan Chevrolet Dealer Groups.

CAMPBELL-MITHUN, INC.

1370 Northwestern Bank Bldg.,
 Minneapolis 2, Minn.
 Phone: LIncoln 8824

ABC—ABP—ANPA—APA—NOAB—PPA
 President. Ray O. Mithun
 Exec. Vice-Pres. Albert R. Whitman
 Vice-Presidents. John W. Forney,
 B. E. Howard, R. L. Forrest, Lee A. Terrill, M. Oakley Birdwell
 Vice-Pres. & Asst. to Pres. . . . Ralph Zenthen
 Treasurer. Beatrice N. Sandquist
 Secretary Evelyn Brugette
 V.P., Radio-TV Dir. Arthur H. Lund
 V.P., Art Dir. E. W. Turner
 V.P., Copy Dir. Joe E. Ratner
 Copy Chiefs. Mort Henderson,
 Arnold Aslakson, Leo Kennedy

Acct. Execs.: Blake Cox, Lawrence Dunham, R. L. Forrest, Walter Geckler, B. E. Howard, Edward Boyce, Robert Blegen, Kenneth Ruble, Lee A. Terrill, William Wheeler, Ralph Wittgraf, Ralph Zenthen, Peter Edmonds, Dan Hulbert

Branch Office

1024 Palmolive Bldg., Chicago 11, Ill.
 Phone: DElaware 7-7553

V.P. & Gen. Mgr. Don S. Manchester
 Vice-President Phelps Johnston
 Acct. Execs.: C. E. Hentrich, Pete Kreer, Robert Noel, Chas. A. Mittelstadt, Robert Nevin

Radio Accounts: Gold Seal Company (Wax Products & "Snowy"), Bismarck, N. D.; Great Northern Railway Co. (Railroad), Griggs, Cooper & Co. (Food Manufacturers), Theo. Hamm Brewing Co. (Hamm's Preferred Stock Beer), Land O'Lakes Creameries, Inc. (Dairy Products), Northern States Power Co. (Electric Power), Our Own Hardware Co. (Wholesale Hdwe. & Paint), F. H. Peavey & Co. (Feeds), Minneapolis, Minn.; Quality Chekd Ice Cream Asso. (Industry Advertising & Merchandising), Chicago, Ill.; Zinsmaster Baking Co. (Bakery Goods), Minneapolis, Minn.; American Dairy Association (Product Advertising & Merchandising), Chicago, Ill.; Charmin Paper Mills (Paper Towels, etc.), Green Bay, Wis.; Griggs, Cooper & Co. (Food Manufacturers), Minneapolis, Minn.; R. M. Hollingshead Corp. (Automotive Products), Camden, N. J.; Malt-O-Meal Co. (Wheat

Cereal), Minneapolis, Minn.; Pillsbury Mills, Inc. (Biscuits, Flour & Mixes), Minneapolis, Minn.

TV Accounts: American Dairy Assoc. (Product Advertising & Merchandising), Chicago, Ill.; Campbell Cereal Co. (Malt-O-Meal), Minneapolis, Minn.; Gold Seal Company (Wax Prod. & "Snowy"), Bismarck, N. D.; Griggs, Cooper & Co. (Food Manufacturers), Theo. Hamm Brewing Co. (Hamm's Preferred Stock Beefs), St. Paul, Minn.; Larsen Co. (Canned Foods), Green Bay, Wis.; Minnesota Consolidated Canneries, Inc. (Butter Kernel Prod.), Minneapolis, Minn.; Zinsmaster Baking Co. (Bakery Goods), Minneapolis, Minn.; Northwestern Nat'l Bank, Minneapolis, Minn.; Charmin Paper Mills (Paper Towels, etc.), Green Bay, Wis.; R. M. Hollingshead Corp. (Automotive Products), Camden, N. J.; Land O'Lakes Creameries, Inc. (Dairy Products), Minneapolis, Minn.; Pillsbury Mills, Inc. (Oven-Ready Biscuits), Minneapolis, Minn.

SOLIS S. CANTOR ADV. AGENCY

1711 Walnut St., Philadelphia 3, Pa.
 Phone: LO 7-8141

PPA—ABC—ABP—ANPA

Pres. & Acct. Exec. Solis S. Cantor
 Vice-President Kathryn Cantor
 Secretary Corrine Kolb
 Art Director. Robert Herseb
 Account Executive. Bernard Binnick

CARTER ADV. AGENCY

912 Baltimore, Kansas City 5, Mo.
 Phone: HA 1356

ABP—ANPA—APA—NAAN—NOAB
 PPA

President. Charles W. Carter
 Exec. Vice-President. . . . William G. Rowe
 Vice-President. Fred Klemp, Jr.
 Sec't., Treas. Josephine Dahlin
Radio-TV Accounts: Edward Aaron Corp. (Poultry), K. C.; May Potato Chip Co., K. C.; Seid Litz Paint & Varnish Co., K. C.

CASMI R ADVERTISING CO., INC.

551 Fifth Ave., New York 17, N. Y.
 Phone: MURray Hill 2-2014

ABP—ANPA

Pres. & Treas. David C. Casmir
 Vice-Pres. Marvin Casmir
 Copy Chief. Harriet Carter
 Art Directors. William E. Burgess,
 Owen Scott

TV Accounts: D'amico Fifth Avenue (Beauty Consultant), Artists' GUILD of America (Talent School).

CAYTON, INC.

9 East 40th St., New York 16, N. Y.
 Phone: LEXington 2-1711

ABP—ANPA—ABC

President. William D'Arcy Cayton
 Secretary. D. R. Roberts
 Art Director. Bob Lee
 Production Manager. C. F. Lucchese
 Radio-TV Director. Allen Black



LEE GRAHAM

STAR OF

"LETTER TO LEE GRAHAM"

WABD

170

TR 3-7300

Asst. Radio-TV Dir.....Janc Nickum
 Donna Quigley
 Copy Chief.....Fred Laderman
Radio Accounts: The Wall-Tex Co. (Wall Covering), N. Y. C.; Miracle Adhesives Corp. (Adhesive Products), N. Y. C.; Segal Safety Razor Corp. (Safety Razors & Blades), N. Y. C.; Pulpaper Co. (Plastic Wall Coverings), N. Y. C.
TV Accounts: Chesebrough Mfg. Co., The Wall-Tex Co., Miracle Adhesive Corp.

CECIL & PRESBREY, INC.

247 Park Ave., New York 17, N. Y.
 Phone: MURray Hill 8-1234

AAAA—ANPA—APA—NOAB—PPA—ABC
 Chairman.....James M. Cecil
 President.....T. J. Maloney
 Exec. Vice-Pres.....S. Dalsimer
 Secretary.....J. D. Tarcher
 Treasurer.....David C. Thomas
 Vice-Presidents.....Edward B. Noakes,
 Guild Copeland, Harvey L. Kneeland,
 David G. Lyon, T. F. MacGrath, John Legler,
 Archibald M. Foster, J. Frank Gilday
 Media Director.....Harry Parnas
 Radio-TV Dir.....J. Frank Gilday
 Exec. Prod. Dir.....W. C. Patterson
 Time Buyer.....Herbert Gruber

Branch Office

Union Central Bldg., Cincinnati, O.
 Manager.....R. L. Lowander
Radio Accounts: The Block Drug Co., Inc. (Am-i-dent, Polident, Poligrip, Py-Co-Pay, Green Mint Mouth Wash), Jersey City, N. J.; The Electric Auto-Lite Co. (Spark Plugs, Batteries and parts), Toledo, Ohio; McCormick & Co. (Tea, Spices, Extracts, Hy-Gro, B-Brand Insecticide), Baltimore, Md.; The Nestle Company, Inc. (Cookie-Mix, Ever-Ready Cocoa, Bars, Quick, Semi-Sweet), White Plains, N. Y.; Redtop Brewing Company (Redtop Beer & Ale, 20 Grand Ale), Cincinnati, Ohio; Topps Chewing Gum (Chewing Gum and Candy), Brooklyn, N. Y.; Union Dime Savings Bank, N. Y. C.; Whitehall Pharmaceutical Co.; Edna Wallace Hopper, N. Y. C.

TV Accounts: Block Drug Company, Inc. (Am-i-dent, Polident, Poligrip, Py-Co-Pay, Green Mint Mouth Wash), Jersey City, N. J.; The Electric Auto-Lite Co. (Spark Plugs, Batteries and parts), Toledo, Ohio; McCormick & Co. (Tea, Spices, Extracts), Baltimore, Md.; The Nestle Company, Inc. (Cookie-Mix, EverReady Cocoa, Bars, Quick, Semi-Sweet), White Plains, N. Y.; Philip Morris & Co., Ltd. (Marlboro, Philip Morris), N. Y. C.; Redtop Brewing Company (Redtop Beer & Ale, 20 Grand Ale), Cincinnati, Ohio; Sylvania Electric Prod., Inc. (TV Sets, Fluorescent Lighting Fixtures, Photo Lamps, parts), N. Y. C.; Whitehall Pharmaceutical Co., Edna Wallace Hopper, N.Y.C.

NELSON CHESMAN COMPANY

240 East 11th Street, Chattanooga 1, Tenn.
 Phone: 6-4942

ABP—APA—SNPA

President.....Harry A. Lundborg
 Secy.-Treas.....Richard H. Leiper
 Space & Time Buyer.....Sara Kelly
 Art., Prod. Mgr., Copy Chief, Radio-TV
 Talent Buyer.....Richard H. Leiper
Radio Accounts: Fleetwood Coffee Co., Chattanooga, Tenn.
TV Accounts: Fleetwood Coffee Co., Chattanooga, Tenn.

CHICAGO ADV. AGENCY

20 W. Jackson Blvd., Chicago 4, Ill.
 Phone: WAbash 2-5732
 ANPA—PPA—APA—ABC

Pres. & Space Buyer.....J. L. Wade
 Radio Director.....Simon Levin
Radio & TV Accounts: Advance Spectacle Co., American Products Corp., Art Publishing Co., D-Frost-O-Matic Corp., Diamond Motto Co., Empire Merchandise Corp., Lee Novelty Co., Simons Shoes, Winkler & Co., Owen Wood.

JAMES THOMAS CHIRURG CO.

414 Park Square Bldg., Boston 16, Mass.
 Phone: HANcock 6-7310

AAAA—ABC—ABP—ANPA—APA
 NOAB—PPA—SNPA

President.....James Thomas Chirurg
 Asst. to Pres.....Gerald Higgins
 Treasurer.....Leo J. Hardiman
 V.P. in Chg. of Mdsq...J. Norman McKenzie
 Media Director.....Edward B. Pope

Branch Office

122 E. 42nd St., New York, N. Y.
 Phone: MURray Hill 7-5040

Vice-President.....George A. Frye
Radio-TV Accounts: W. L. M. Bendsorp Co. (Cocoa), Boston; H. C. Baxter & Bro. (Canned White Potatoes), Brunswick, Me.; Borden Company (Chemical Dept.), N. Y. C.; Thayer Company, Gardner, Mass.; Huron Milling Co., Mich.

C. P. CLARK, INC.

James Robertson Hotel, Nashville 3, Tenn.
 Phone: 6-4179

Pres. & Treas.....D. G. Goodwin
 Copy Chief & Secy.....Sara Nolan
Radio-TV Accounts: First American National Bank (Institutional), Nashville Coal.

ROBT. E. CLARKE & ASSOC., INC.

1614 Du Pont Bldg., Miami 32, Fla.
 Phone: 3-5486
 ANPA—SNPA—NOAB

Pres. & Space Buyer.....Robt. E. Clarke
 V.P., Secy. & Treas.....C. B. Clark
 Art Dir. & Prod. Mgr.....J. H. Freeman
 Radio & Puh. Dir.....E. S. Hamburger
 Media Dir. & Radio Time Buyer..C. Bonnell

CLEMENTS COMPANY, INC.

Horn Bldg., Philadelphia 3, Pa.
 Phone: RIttenhouse 6-0236
 ANPA



Cecil Stewart's Royal Rogues
AMERICA'S GREATEST SINGING GROUP

CHICAGO SUN-TIMES Cecil Stewart's Royal Rogues, a singing quintet, each of whom also has featured solo parts. Blend their magnificent voices in a medley of stirring songs. They bring the show's first stanza to a sock climax

LOS ANGELES EXAMINER "Truly one of the greatest singing organizations to come out of the West Coast in many a year"

MILTON BERLE "This is the greatest group I have ever had the privilege of working with"

Now Playing the Current Nite Spots on the West Coast



Cecil Stewart's Roguettes

TV's Five Sweethearts of Song

For past 3 years the singing stars of Ina Ray Hutton's all-Girl TV Show

With half million TV Fans this sensational group is a "natural" for your program.

These two acts can be combined with sensational effects, using special choral arrangements of favorite show tunes.



Cecil Stewart

A WORD ABOUT THE PRODUCER

Cecil Stewart, originator and director of "The Roguettes", "The Royal Rogues", "The Royal Revellers" and "The Vigilantes", is also well known in Southern California musical circles. Director of highly successful musical comedies and light operas, he has been associated with many outstanding musical stars, as well as with the late Sid Grauman in the production of his fabulous productions. A composer of note, Mr. Stewart has recently completed the score of a new Musical slated for production soon. Stewart, as well as being director of his various groups, also makes all their vocal and orchestral arrangements.

IF YOUR AGENT CANNOT OBTAIN THEM FOR YOU

Phone or Write

Cecil Stewart Productions

344 SOUTH ALVARADO STREET LOS ANGELES 57, CALIFORNIA

Phone: OU 4-6820

President.....Alice V. Clements
 V.P. & Copy Chief.....Elizabeth M. Zindel
 V.P. & Direc. of Radio TV..Robert H. Smith
Radio Accounts: Network: Hudson Coal Co., Horn & Hardart.

HARRY B. COHEN ADV. CO., INC.
 1 E. 57th St., New York 22, N. Y.
 Phone: MUrray Hill 8-3030

President.....Harry B. Cohen
 Vice-Pres.-Treas.....Edith S. Cohen
 Exec. Vice-Pres.....Edward Aleshire
 Vice-President.....Edward Rosewald
 Vice-Pres. & Copy Chief.....Thomas Greer
 Radio-TV Director.....Mary Dunlavey
Radio Accounts: The Grove Laboratories (Grove's Chill Tonic, Pfunder's Tablets, Dr. Porter's Antiseptic Oil) St. Louis, Mo.; Pearson Pharmacal Co. (Dew Deodorant, "Ennds" Chlorophyll Deodorant Tablets), New York, N. Y.; The Chattanooga Medicine Co. (Syrup of Block Draught), Chattanooga, Tenn.; The Beaumont Co. (4-Way Cold Tablets), St. Louis, Mo.; Lydia E. Pinkham Medicine Co., Lynn, Mass.; West End Brewing Co. (Utica Club Beer & Ale), Utica, N. Y.

TV Accounts: The Grove Laboratories, Inc., The Beaumont Co., New York, N. Y.; Pearson Pharmacal Co.

THE ARNOLD COHAN CORP.

460 W. 34th St., New York, N. Y.
 Phone: WISconsin 7-4700

Pres., Treas.....Arnold Cohan
 Secretary.....Edna Fleischman
Radio Accounts: Bruno-New York, Inc. (TV-Radio Appliances); The New York Times, N. Y. County Democratic Committee, John Wanamaker (TV-Appliances).

TV Accounts: Bruno-New York, Inc. (Appliances); Star Time; Rootie Kazootie; N. Y. County Democratic Committee.

COMER & REAMS, INC.

15 West 10th, Kansas City 5, Mo.
 Phone: HARRison 3964
 APA—ANPA—PPA—ABP

President.....Ruth E. Comer
 Exec. Vice-Pres.....Gardner Reams
 Secy. & Publicity Dir.....C. Alec Pollard
 Treasurer.....Mrs. E. W. Gollither

COMPTON ADVERTISING, INC.

630 Fifth Ave., New York 20, N. Y.
 Phone: CIRCle 6-2800
 ANPA—PPA—NOAB—ABC—APA
 ABP—AAAA

President.....Robert D. Holbrook
 Vice-Presidents.....Barton Cummings, Allen Flouton, Willard J. Heggen, Alfred J. Seaman, Jr., Loren B. Stone, Seaward M. Woodward, Edward Battey, Merrell E. Boyce, Chester Dudley, C. James Fleming, Jr., John A. Hise, Jr., L. O. Holmberg, Jack Rees

V.P. & Dir. of Radio & TV Prod.L. H. Titterton

V.P. & Dir. of Radio & TV Copy.....Alfred Seaman
 Dir. of Publicity.....Joseph Field
 V.P. & Dir. of Media.....Guy Richards
 Asst. Media Dir.....Frank B. Kemp
 Head Time Buyer.....Henry Clochessy
 Time Buyers.....Martin Hansen, Alfred Ritter, Genevieve Schubert, Donald Carret, Jeanne Bahr, John Neale

Branch Offices

Bd. of Trd. Bldg., 141 W. Jackson Blvd., Chicago 4, Ill.
 Manager.....L. O. Holmberg
 Keith Bldg., Cincinnati, O.
 Manager.....Robert P. Marsh
 744 N. 4th St., Milwaukee, Wis.
 Manager.....Richard Davis
 Equitable Bldg., Hollywood 28, Cal.
 Phone: HOLlywood 9-8107

V.P. & Mgr.....James Seaborne
Radio and TV Accounts: The Allis Chalmers Manufacturing Company; Campbell Soup Company (Campbell's Tomato Juice & Campbell's Pork & Beans); The Cochran Foil Company (Aluminum Foil); M. K. Goetz Brewing Company (Country Club Beer); The Goodyear Tire & Rubber Company, Inc. (Shoe Products); The Hubinger Company (Quick Elastic Starch); Kelly Springfield Tire Company; New York Life Insurance Company; The Personal Products Corporation (Yes Tissues); The Procter & Gamble Company (Ivory Soap, Ivory Flakes, Crisco, Duz and Drene); The Socony-Vacuum Oil Company; Standard Brands, Inc. (Chase & Sanborn Coffee, Instant Chase & Sanborn Coffee, Tender Leaf Tea, Instant Tender Leaf Tea).

COMSTOCK & COMPANY

344 Delaware Avenue, Buffalo 2, N. Y.
 Phone: MOhawk 2252
 ABP—ANPA—AFA—ABC

Partner.....Henry W. Comstock
 Partner.....H. Earl Close
 Partner.....Frank J. Hess
 Dir. of Marketing &

Research.....T. Sloane Palmer
 Director of Media.....Robert Williams
 Account Executives.....L. W. Simonds, John B. Morton, Sterling J. Hiles, William J. Daley, Jr., Grant F. Hess, George B. Conner, J. Roderick Greig, William L. Couner, Jr., Robert H. Hedger

Radio-TV Director.....Duane J. Miller
Radio Accounts: Manufacturers and Traders Trust Company (Banking Services), Buffalo, N. Y.; O-Cel-O, Inc. (Cellulose Sponges), Buffalo, N. Y.; Bell Aircraft Corp. (Aircraft), Niagara Falls, N. Y.; Frontier Oil Refining Corporation (Gasoline & Oil), Buffalo, N. Y.; Hospital Service Corp. of Western N. Y. (Blue Cross & Blue Shield), Coca-Cola Bottling Co. of West N. Y.

TV Accounts: Manufacturers and Traders Trust Company (Banking Services), Buffalo, N. Y.; Frontier Oil Refining Corporation (Gasoline & Oil), Buffalo, N. Y.; O-Cel-O,

Inc. (Cellulose Sponges), Buffalo, N. Y.; Bell Aircraft Corp. (Aircraft), Niagara Falls, N. Y.; Coca-Cola Bottling Company of Western, N. Y., Inc. (Coca-Cola), Buffalo, N. Y.; Hospital Service Corp. of Western N. Y. (Blue Cross & Blue Shield), Buffalo, N. Y.

CONNER, JACKSON, WALKER, McCLURE

461 Market St., San Francisco 5, Calif.
Phone: YUkon 6-0196
ABP—ANPA—APA—PPA

President.....E. W. Conner
Exec. Vice-President.....Shirley Walker
Vice-President.....J. H. Jackson
Treasurer.....B. H. McClure
Copy Chief.....Audrey Janisen
Art Director.....Fernando Penalosa
Production Manager.....Marie Scholtz
Media Buyer.....Billie Grove
Radio Accounts: Golden Nugget Sweets, Ltd. (Big Hunk Candy Bar), San Francisco, Calif.; The Fox Shoppe (Restaurant, Redwood City, Calif.; Douglas Shaw Candies (Confections), San Francisco, Calif.; Western Dairy Prod.; California Turkey Federation.
TV Accounts: Western Dairy Products; California Turkey Federation.

THOMAS F. CONROY, INC.

1101 Majestic Bldg., San Antonio, Texas
Phone: Garfield 3456
AAAA—ABP—ANPA

Pres.....Thomas F. Conroy
General Manager.....D. Guthridge
Creative Director.....C. B. Foll
Personnel Dir.....F. E. Weinhold
Media Dir.....Robert W. Richards
Art Director.....E. E. Ogilvie
Radio Accounts: Anderson, Paul, Co. (Stationers), San Antonio, Texas; Conal Cottons (Manufacturing), New Braunfels; Fomby's (Men's Clothing), San Antonio, Texas; Hoffman & Hayman Coffee Co. (Coffee), San Antonio, Texas; Lone Star Brewing Co. (Beer), San Antonio, Texas; Mission Provision (Meat Packers), San Antonio, Texas; Perry Shankle Co. (Wholesale Distr.), San Antonio, Texas; Pioneer Flour Mills (Millers' Flour), San Antonio, Texas; Security Finance (Loans), San Antonio, Texas; Sommers Drug Stores (Chain Drug Stores), San Antonio, Texas; Studers, Inc. (Photo Finishers), San Antonio, Texas; Mode-O-Day (Ladies Ready-to-Wear), San Antonio, Texas; Ormsby Chevrolet Co. (Automobiles), San Antonio, Texas; Texas Central Airlines (Airline), San Antonio, Texas; H. E. Butt Food Stores (Food Stores Chain), San Antonio, Texas.

TV Accounts: Hoffman & Hayman Coffee Co. (Coffee), San Antonio, Texas; Lone Star Brewing Co. (Beer), San Antonio, Texas; Sommers Drug Stores Co. (Chain Drug Stores), San Antonio, Texas; Studers, Inc. (Photo Finishers), San Antonio, Texas; Arthur Murray (Dancing School), San An-

tonio, Texas; Randall-Christal Co. (Food Brokers), San Antonio, Texas.

CO-ORDINATED ADVERTISING CORP.

9 E. 38th St., New York 16, N. Y.
Phone: MUrray Hill 9-1440

President.....Lester "L" Wolf
Treasurer.....Irving Herz
Vice-President.....Matty Miller
Dir. TV & Radio.....Charlotte Armstrong

COX & TANZ ADVERTISING

950 Drexel Bldg., Philadelphia 6, Pa.
Phone: Lombard 3-1720

President.....Eugene R. Tanz
Office Manager.....R. Di Carlo
Copy Chief.....J. Kirkconnell
Art Director.....R. Rivers
Time Buyer.....R. Di Carlo
Research Director.....L. Louzon
Radio Accounts: Badder and Snoko (Jerman Shoes); Colonial Floor Covering; ABC Chick Hatchery (Baby Chicks); Brooklawn Garden Mart (Flowers); Jim Brady (Shoes); Crowl Chemical Co. (Cough Remedy); Crescent Nut & Chocolate Co.; Van Sciver Furniture Co.; Excel Products Co. (Aluminum Products); Republic Fuel & Burner Co.; Export-Import Clothing Co.; Miller North Broad Storage Company.
TV Accounts: Badder & Snoko (Shoes); Crescent Nut & Chocolate Co.; Excel Products Co. (Aluminum Products); Republic Fuel & Burner Co.

COWAN & DENGLER, INC.

527 Fifth Ave., New York 17, N. Y.
Phone: MUrray Hill 2-0940
ANPA—PPA—NOAB—APA

President.....Stuart D. Cowan
Vice-Pres. & Treas.....H. W. Dengler
Vice-Presidents.....James F. Kelly,
J. Clement Boyd, Stuart D. Cowan, Jr.,
Wm. A. Boeger, Jr.
Media Director.....A. Marie Maus
Radio-TV Director.....T. H. Moore, Jr.
Radio Accounts: Frank G. Shattuck Co. (Schrafts Stores & Restaurants), New York; Bankers Trust Co., Lone Star Cement Co., Seamless Rubber Co., Raytheon Mfg. Co. (R-TV Div.).
TV Accounts: Raytheon Mfg. Co. (R-TV Div.).

JOHN GILBERT CRAIG ADV., INC.

913 Washington St., Wilmington, Del.
Phone: 5-6185
ABP—ANPA—AAAA—AFA

President.....J. Gorman Walsh
Sec.-Treas.....Kathleen A. Walsh
Account Executives.....Donald B. Madden,
William H. Gordy
Radio Accounts: Joseph Bancroft & Sons Co. (Textile Finishing), Brosins & Smedley (Lumber-Millwork-Coal), Wilmington, Del.; Delaware Coach Co., Delaware Power & Light Co., Wilmington, Del.; Diamond Ice

& Coal Co. (Fuels, Home Products), Equitable Trust Co., Greenhill Dairies, Inc., Wilmington, Del.; Group Hospital Services, Inc.; Home Sales, Inc. (Housing), Newark, Del.
TV Accounts: Equitable Trnst Co., Wilmington, Del.; Delaware Power & Light Co. (Gas & Electric Service), Wilmington, Del.; Group Hospital Services, Inc.; Home Sales, Inc. (Housing), Newark, Del.

THE CRAMER-KRASSETT CO.

733 North Van Buren St., Milwaukee 1, Wis.
 Phone: DALY 8-3500

AAAA-ABC-ABP-ANPA-AFA

President.....A. W. Seiler
 Exec. Vice-President.....H. N. Pasteur
 Vice-Pres.-Treas.....C. W. Faude
 Secretary.....F. Annueller
 Vice-Pres. in Chg. Media.....L. H. Ness
 Vice-Presidents.....H. Dyson, C. H. Brehm,
 R. F. Timm, N. L. Telander
 Radio-TV Director.....Roger W. LeGrand
 Radio-TV Time Buyer.....Loretta Mahar
 Radio-TV Acct. Supers.....R. LeGrand,
 K. Hegard, J. Pritchard

Radio Accounts: Plankinton Packing Co. (Meat Products), Ed. Schuster & Co., Inc. (Department Store), First Federal Savings & Loan Association of Wisconsin (Savings & Loan Assoc.), Milwaukee, Wis.; The Milwaukee Co. (Investments), Milwaukee; Blue Cross (Hospital Plan); Humphrey Chevrolet; Schroeder Hotel; Wisconsin Telephone Co.; W. B. Place Co. (Deerhide Products).

TV Accounts: Plankinton Packing Co. (Meat Products), Milwaukee Gas Light Company (Gas Utility), Milwaukee, Wis.; Wisconsin Telephone Co., Milwaukee; Altorfer Bros. Co. (ABC-O-Matic Washer), Peoria, Ill.; Aluminum Goods Mfg. Co. (Cooking Utensils), Manitowoc, Wis.; Blue Cross; Evinrude Motors (Outboard Motors); Heil Co. (Heating Equipment); Humphrey Chevrolet; Wisconsin Plumbing & Heating Co.

CREAMER & COMPANY

6777 Hollywood Blvd., Hollywood 28, Calif.
 Phone: GRanite 4137

ANPA

Media Buyer.....Edward Loveton
 Production Chief.....J. J. Franz, Jr.
 TV Director.....Chas. Hutchings

CRITCHFIELD & COMPANY, INC.

720 North Michigan Ave., Chicago 11, Ill.
 Phone: Superior 7-3061

ANPA-APA-PPA-NOAB-ABP

President.....E. P. Nesbitt
 V.P., Radio-TV.....R. D. Cunningham
 Vice-President.....P. J. Johnson
 Secretary.....C. J. Nesbitt
 Media Director.....E. Groenboom

CRUTTENDEN & EGER

201 No. Wells St., Chicago 3, Ill.
 Phone: FInancial 6-3630

ABP

Partners....Leon H. Lewis, George M. Stern

Radio Accounts: Midwest Dairy Products Corp., Chicago, Ill.; Hudson-Ross (Retail Appliances), Chicago, Ill.

TV Accounts: Midwest Dairy Products Corp., Chicago, Ill.

CUNNINGHAM & WALSH, INC.

260 Madison Ave., New York 16, N. Y.
 Phone: MURray Hill 3-4900

AAAA-ANPA-PPA-ABP-NOAB
 ABC-APA

Pres., Treas.....F. H. Walsh
 Exec. Vice-President.....J. P. Cunningham
 Secretary.....R. L. Strobridge

Branch Office

8420 Sunset Blvd., Hollywood 46, Calif.
 Phone: GR 6131

Radio Accounts: Northwest Orient Airlines, E. R. Squibb & Son.

TV Accounts: Sunshine Biscuits; Permutit (Water Softener, Northwest Orient Airlines, Walter Kidde & Co. (Fire Extinguishers), E. R. Squibb & Son (Pharmaceuticals).

CURTIS ADVERTISING COMPANY

270 Park Ave., New York, N. Y.
 Phone: PLaza 5-6333

ABP-APA

President.....Lawrence R. Curtis
 Vice-President.....S. R. Combs
 Secy.-Treas.....Rose Berg
 Art Director.....J. Curtin
 Prod. Mgr., Space Buyer.....M. Lerman
 Publicity Director.....I. Nichols
 Radio-TV Dir.....E. R. Shapiro
 Research Dir.....R. Blumenthal

Radio-TV Accounts: American Sponge & Chamois Co.; Apex Dir Cutting Corp.; Bar Mart, Inc.; Brett, Wyckoff, Potter, Hamilton; Carolina Shirt Lining Corp.; Cineque Laboratories Colorfilm; Circle In The Square; Cloud Coach Airlines, Inc.; Eastern Tea Corp.; Federated Purchaser, Inc.; Flora Mir Candy; Fotoshops, Inc.; Gentry Magazine; Gotham Instrument & Machinery Co., Inc.; MacFadden Foundation; National Pix Slide Co.; O'Connell Hat Corp.; Rands Food Chain; Regent Shirt Co., Inc.; Scoffee; Silver Lining, Inc.; Stern, Bill Sports Shirts; Super-Cel Cellulose Sponges; Three Star Appliances; Webb & Knapp, Inc.

DANCER-FITZGERALD-SAMPLE, INC.

347 Madison Ave., New York 17, N. Y.
 Phone: ORegon 9-0600

AAAA-ANPA-APA-PPA

Chm. of Bd.....C. L. Fitzgerald
 President.....H. M. Dancer
 Vice-Pres.-Secy.....F. T. Leighty
 Compt. & Asst. Treas.....Wm. Maughan
 V.P. Radio-TV Dir.....Alvin Kabaker
 V.P.s & Acct. Execs.....C. T. Birch,
 Lyndon O. Brown, Ramon J. Cabrera, R. R. Etienne, Charles C. Fitzmorris, Jr., Joseph H. Holmes, Jr., W. A. Irwin, Gordon Johnson, David Loomis, H. A. Mat-

toon, Donald Manchester, J. James Neale, Victor Piotrowski, Richard A. Porter, Frank N. Riggio, A. W. Spence, Jr., George G. Tormey, Clifford Wolfe, S. J. Hamilton, Stuart Upson

Branch Offices

221 N. La Salle Street, Chicago 1, Ill.
Phone: FI 6-4700

Exec. Vice-Pres.....F. Sewall Gardner
V.P. & Acct. Exec.....E. R. Detchon
1680 N. Vine St., Hollywood 28, Cal.
Phone: Hudson 2-3256

V.P.-Mgr.Al Kabaker
Dancer-Fitzgerald-McDougall, Inc.
114 Sansome St., San Francisco 4, Cal.
Phone: DO 2-5107

Vice-President.....W. B. Dugan
6 King Street East, Toronto 1, Ontario
Phone: EMpire 3-2851

ManagerGilbert Nunns
Radio-TV Accounts: American Chicle Company, B. T. Babbitt, Campbell Soup Co., Falstaff Brewing Corp., General Mills, Inc., Lewis-Howe Co., Procter & Gamble Co., Sterling Drug, Inc., U. S. Army, U. S. Air Force and Organized Reserve Corps Recruiting Service, Consolidated Royal Chemical Co., Ekco Products Co., Nestle Co., Inc.

D'ARCY ADVERTISING CO.

Missouri Pacific Bldg., St. Louis 3, Mo.
Phone: CEntral 6700

AAAA-ABP-ANPA-NOAB-PPA
Chairman of the Board.....P. J. Orthwein
President.....J. F. Oberwinder
Vice-Pres.-Treasurer.....E. D. Cronk

Branch Offices

515 Madison Ave., New York 22, N. Y.
Phone: PLaza 8-2600

Vice-President.....J. Y. Brown, Jr.
V.P., Radio-TV Director.....Paul Louis
Terminal Tower Bldg., Cleveland 13, O.
Phone: TOWN 1-3911

Vice-President.....Stanley P. Seward
57 Bloor St. W., Toronto, Ontario, Can.
Phone: Princess 3991

Vice-President.....G. P. Altenbernd
75 Eighth St. N.E., Atlanta 5, Ga.
Phone: VE 8815

Vice-President.....J. Hixon Kinsella
Radio Accounts: The Coca-Cola Co., Atlanta, Ga.; Anheuser-Busch, Inc., Leaded Gas Light Co., St. Louis, Mo.; General Tire & Rubber Co., Akron; Cleveland Electric Illuminating Co., Cleveland, O.

TV Accounts: Anheuser-Busch, Inc., St. Louis, Mo.; Coca-Cola Co., Atlanta, Ga.

JIMM DAUGHERTY, INC.

706 Chestnut St., St. Louis 1, Mo.
Phone: MAIn 0790-1

PPA-NOAB-APA

Pres., Space Buyer.....James M. Daugherty
Secretary-Treasurer.....Pauline Otto Daugherty
Radio Accounts: St. Louis Dairy Co.; Vi-Jon Laboratories, Inc.; Pepsi-Cola Bottlers of St. Louis, Inc.

TV Accounts: General Electric Supply

Corp.; St. Louis Dairy Co.; Pepsi-Cola Bottlers of St. Louis, Inc.; Armour and Co.

BEN DEAN ADVERTISING AGENCY

207 Houseman Bldg., Grand Rapids 2, Mich.
Phone: 8-0666
APA-ABP

OwnerBen Dean
Production Manager.....Mildred Juneau
Account Executive.....Ben Dean, Jr.

HERSCHEL Z. DEUTSCH & CO., INC.

575 Madison Ave., New York 25, N. Y.
Phone: PLaza 3-1788
ABP

PresidentHerschel Z. Deutsch
Secty.....M. A. Deutsch
Treas.Robert Stone
Research Dir.....Shirley Walode
Media Director.....Madeleine Allison
Radio Accounts: E. T. Browne Drug Co. (Palmer's "Skin-Success"), New York; M. J. Breitenbach Co. (Pepto-Mangan), New York; Lander Co. (Dixie Peach), New York; Household Products, Inc. (Sulfur-8), Stamford, Conn.

DEUTSCH & SHEA, INC.

230 West 41st St., New York 36, N. Y.
Phone: LOngacre 4-5900
ABP-APA-AAAA-ANPA

President.....Arnold R. Deutsch
Vice-President.....Van M. Evans
SecretaryHenry Geissenheimer
Production Mgr.....Richard Gazley
Space Buyer.....Erwin Lowen

DICKLOW ADV. AGENCY

1324 National City Bldg., Dallas 1, Tex.
Phone: RAndolph 8293
APA-SNPA

Owner-Radio Buyer...Irene Scott Dicklow

DOE-ANDERSON ADV. AGENCY

Martin Brown Bldg., Louisville 2, Ky.
Phone: WAbash 3193
ANPA-APA-PPA-SNPA

Partners..Elmer H. Doe, Warwick Anderson
Acct. Execs.....Elmer H. Doe,
Warwick Anderson, George W. Emerson,
Richard W. Smith
Media Buyer.....Miss G. P. Wagner
Production Manager.....J. B. Peterkin

DOHERTY, CLIFFORD, STEERS & SHENFIELD, INC.

350 Fifth Ave., New York 1, N. Y.
Phone: BRyant 9-0445

AAAA-ABC-ABP-ANPA-APA
NOAB-PPA-AFA

President.....Donald K. Clifford
Exec. V.P., Secy.....William E. Steers
Vice-President.....Francis J. Doherty
Treasurer.....Nelson O. Argueso
Asst. Secy.....Marie L. Brennan
Vice-Presidents.....William E. Holden,
Chester MacCracken, James F. Egan, Harry

M. Ireland, Dr. Philip Reichert, Robert Hayes, Robert E. Shaw, R. C. Bradley, Frank Dennis, R. Fehr, N. W. Glenn, A. M. Menadier

Dir. of Radio & TV.....Chester MacCracken
Radio Accounts: Bristol-Myers Company (Trushay, Sal Hepatica, Ipana, Bufferin and Resistab, Anmen Vitalis, Mum, Vitalis Hair Cream, Benex), New York, N. Y.; The Borden Co. (Borden's Instant Coffee), New York; Pharmaco, Inc. (Feen-A-Mint), Kenilworth, N. J.

TV Accounts: Bristol-Myers Company (Ipana, Vitalis, Resistab, Sal Hepatica, Trushay, Bufferin, Mum), Welch Grape Juice (Grape Juice, Preserves), New York, N. Y.; Borden Co. (Borden's Inst. Coffee); Pharmaco, Inc. (Medigum), Kenilworth, N. J.; Pioneer Ice Cream—Div. the Borden Co., N. Y. C.

THE RALPH L. DOMBROWER CO., INC.

11 E. Franklin St., Richmond 19, Va.
 Phone: Richmond 3-1113

ABP—APA—SNPA

Pres.-Treas. Space Buyer (News)
 Ralph L. Dombrower, Sr.
 Vice-Pres.....Ralph L. Dombrower, Jr.
 V.P., Sec. & Radio Time Buyer
 Malcolm B. Dombrower

Art Director.....Hobart Britton
 Radio Dir.....T. Michaux Moody
 Media & Space Buyer (Mag.)..Phyllis King

Branch Office

Woodward Bldg., Washington, D. C.
 Phone: REpublic 7-1420

ManagerPhilip Rosenfeld
Radio Accounts: Etchison Hat Co., Inc., Chesterfield Hat Corp., Richmond, Va.; East Coast Freight Lines, Richmond, Va.; Home Brewing Co., Richmond; Planters Fertilizer Co., Charleston, S. C.

DONAHUE & COE, INC.

1270 Ave. of Amer., New York 20, N. Y.
 Phone: COlumbus 5-2772

President.....E. J. Churchill
 Dir. Motion Picture, Radio
 & TV Div.....A. Carl Rigrod
 Time Buyer.....Clifford Botway

Branch Office

411 Hurt Bldg., Atlanta 3, Ga.
 Phone: MAin 5662

Vice-President.....H. L. Morrill
Radio Accounts: Burlington Mills, Inc. (Bur-Mil Cameo Hosiery), New York, N. Y.; Loew's Inc. (Motion Pictures, Loew's Theatres), New York, N. Y.; Metro-Goldwyn-Mayer, Inc. (M-G-M Pictures), New York, N. Y.; Monarch Wine Co. (Manischewitz Wine), New York, N. Y.; New York World-Telegram & Sun (Newspaper), New York, N. Y.; River Brand Rice Mills, Inc. (Carolina & River Brand Rice), New York, N. Y.; Rockefeller Center, Inc. (Radio City Music Hall), New York, N. Y.; State of Israel Bonds; Miles Shoes.

TV Accounts: Burlington Mills, Inc. (Bur-Mil Cameo Hosiery), New York, N. Y.; General Cigar Company (Robt. Burns Cigar), New York, N. Y.; Loew's, Inc. (Loew's Theatres), New York, N. Y.; Metro-Goldwyn-Mayer (Motion Pictures), New York, N. Y.; Monarch Wine Co. (Manischewitz Wine), New York, N. Y.; New York Herald-Tribune (Newspaper), New York, N. Y.; New York World-Telegram & Sun (Newspaper), New York, N. Y.; Miles Shoes; River Brand Rice Mills, Inc.

W. B. DONER & COMPANY

505 Washington Blvd. Bldg., Detroit 26, Mich.
 Phone: WOODward 5-7400
 ABP—ANPA—PPA

President.....W. B. Doner
 Exec. Vice-Pres.....Charles F. Rosen
 Treasurer.....Julian A. Grace
 Vice-PresidentFelix Hower
 Secretary & Art Dir.....Ben Goldstein

Branch Office

201 N. Wabash Ave., Chicago 1, Ill.
 Phone: DEa 2-4676

Exec. Vice-Pres.....Marvin H. Frank

Branch Office

2051 W. Wisconsin, Milwaukee 3, Wis.
 Phone: WEst 3-9315

Gen. Mgr., V.P.....Marvin H. Frank
Radio Accounts: Altes Brewing Company (Beer), Detroit, Mich.; Speedway Petroleum Corp. (Gasoline), Detroit, Mich.; Feigenson Bros. Co. (Faygo Beverage) (Soft drinks & mixes), Detroit, Mich.; Hub Appliance Stores (Appliances), Detroit, Mich.; Rose Jewelry Co. (Jewelry), Detroit, Mich.; Big Bear Markets (radio & TV) (Super Markets), Detroit, Mich.; Federal Department Stores (radio & TV), Detroit, Mich.; Michigan Wineries (radio & TV) (Wines), Paw Paw, Mich.; D. W. C. Cigar Corp. (El Verso Cigars), Detroit, Mich.; Michigan Bank (Banking), Detroit, Mich.; Detroit Chevrolet Dealers Assoc. (New & Used Cars), Detroit, Mich.

TV Accounts: Altes Brewing Company (Beer), Detroit, Mich.; Speedway Petroleum Corp. (Gas & Oil), Detroit, Mich.; Feigenson Bros. Co. (Soft drinks & mixers), Detroit, Mich.; Rose Jewelry Co. (Jewelry), Detroit, Mich.; Hub Appliance Stores (Appliances), Detroit, Mich.; Famous Furniture Co. (Furniture & Upholstering), Detroit, Mich.; Delsoy Distributors (Delsoy Topping), Dearborn, Mich.; Hygrade Food Products Corp. (Honey brand Ham), Detroit, Mich.; Cherrin Bros. Co. (Party Sweet Candies), Detroit, Mich.; D. W. Cigar Corp. (Elverso Cigars), Detroit, Mich.; Michigan Bank (Banking), Detroit, Mich.; Detroit Chevrolet Dealers Assoc. (New & Used Cars), Detroit, Mich.

DOREMUS & COMPANY

120 Broadway, New York 5, N. Y.
 Phone: WOrth 4-0700

Chairman of Board.....Wm. H. Long, Jr.

Vice-Board Chairman... Walter H. Burnham
Radio & TV Dir. Edwin R. Rooney, Jr.

Branch Offices
208 LaSalle St., Chicago 4, Ill.
Phone: CEntrol 6-9132

V.P. & Mgr. Chas. C. Greene
53 State St., Boston 9, Mass.
Phone: LAfayette 3-0770

Senior Vice-Pres. W. J. Sheehan
425 Bush St., San Francisco 8, Cal.
Phone: Yukon 2-4080

V.P. Ronald Brindley
Radio Accounts: Chemical Bank & Trust Company (Bank), New York City; Kidder, Peabody & Co. (Brokerage), New York, Boston & Chicago; Union Trust Co. (Bank), Washington, D. C.; Calvin Bullock (Brokerage), New York City; Boston Federal Savings & Loan Association (Bank), Boston; Boston Five Cents Savings Bank (Bank), Boston; R. L. Day & Co. (Brokerage), Boston; Estabrook & Co. (Brokerage), Boston; Vance, Sanders & Co. (Brokerage), Boston; Waltham Fed. Savings & Loan Association (Bank), Boston; Automatic Heating Corp., Boston; Pastene Wine & Spirits, Boston; Seiler's, Inc. (Frozen Foods), Boston; Methodist Radio Society of Philadelphia, Philadelphia; Pennington, Colket & Co. (Brokerage), Philadelphia; Provident Trust Co. of Philadelphia (Bank), Philadelphia; St. Paul Federal Savings & Loan Assor. (Bank), Chicago; Crocker First National Bank (Bank), San Francisco.

TV Accounts: Kidder, Peabody & Co. (Brokerage), New York, Boston, Chicago; Union Trust Co. (Bank), Washington, D. C.; Calvin Bullock (Brokerage), New York; Cities Service Oil Co. (Dealers), Boston; The Wellington Co. (Brokerage), Philadelphia; Smith, Kline & French (Pharmaceuticals), Philadelphia; Standard Coil, Chicago.

DOREMUS-ESHLEMAN COMPANY

1522 Locust St., Philadelphia 2, Pa.

Phone: Kingsley 5-2590

ABP—ANPA—PPA—APA—NOAB

V.P. Benjamin Eshleman
Vice-Pres. & Mgr. E. Howard York, III
V.P. B. Franklin Eshleman, II
V.P. L. H. Greenhouse
V.P. J. J. D. Spillan
Dir. of Media. Jos. R. Rollins, Jr.

Radio Accounts: Sears Roebuck & Co. (mail order), Philadelphia, Pa.; Sun Shipbuilding Co. (shipbuilding), Chester, Pa.; Provident Trust Co. (bank), Philadelphia, Pa.; Wellington Fund (mutual investment), Philadelphia, Pa.; Allan Wood Co. (steel fabricator), Conshohocken, Pa.

TV Accounts: Sun Shipbuilding Co. (shipbuilding), Chester, Pa.; Smith Kline & French (pharmaceutical), Philadelphia, Pa.; Wellington Fund (mutual investments), Philadelphia, Pa.

JOHN C. DOWD, INC.

212 Park Square Bldg., Boston 16, Mass.

Phone: Hubbard 2-6050
ANPA NOAB-PPA

Radio & TV Dir. Joseph L. Tully
Space & Radio Time Buyer. Charles Bucklin

Branch Office

*Dowd, Redfield & Johnstone, Inc.
501 Madison Ave., New York 22, N. Y.
Phone: MU 8-1275

President. John C. Dowd

* Affiliated office.

Radio Accounts: Albany Carpet Cleaning Co. (Rugs & Carpets), Allston, Mass.; Boston Edison Co. (Electricity), Boston Mass.; Cott Beverage Corp. (Soft Drinks), New Haven, Conn.; First National Stores (Food), Somerville, Mass.; Martin L. Hall Co. (Coffee & Tea), South Boston, Mass.; Harvard Brewing Co. (Ale & Beer), Lowell, Mass.; National Company (Radio Receivers & TV Sets), Malden, Mass.; Boston Globe (Newspaper), Boston, Mass.; Cott Bottling Company (Soft Drinks), Manchester, N. H.; Megowen-Educator Food Company (Crackers & Biscuits), Lowell, Mass.; House of Old Molineaux (Wines), Boston, Mass.; Northeast Airlines, Inc. (Airlines), East Boston, Mass.; Paine Furniture Co. (Furniture), Boston, Mass.; Pepsi-ine Schizer, Inc. (Drugs), Jamaica Plain, Mass.; Workingmen's Co-operative Bank (Banking), Boston, Mass.

TV Accounts: Albany Carpet Cleaning Co. (Rugs & Carpets), Allston, Mass.; Carpenter-Morton Co. (Paints), Everett, Mass.; Cott Beverage Corp. (Soft Drinks), New Haven, Conn.; First National Stores (Food), Somerville, Mass.; Martin L. Hall Co. (Coffee & Tea), South Boston, Mass.; Eugene Rothmund, Inc. (Sausages & Frankfurters), Somerville, Mass.; Boston Edison Company (Electricity), Boston, Mass.; Boston Globe (Newspaper), Boston, Mass.; Cott Bottling Co. (Soft Drinks), Manchester, N. H.; R. G. Sullivan, Inc. (Cigars), Manchester, N. H.

DOWD, REDFIELD & JOHNSTONE, INC.

501 Madison Ave., New York 22, N. Y.

Phone: Murray Hill 8-1275

APA-PPA-ABP-ANPA

President. John C. Dowd
Exec. Vice-Pres. Edmund F. Johnstone
Treasurer. Edward D. Parent
V.P., Gen. Mgr. Michael A. Raymond
Radio-TV Director. Wallace Langton

Radio Accounts: Block Drug Company (various drug products), Jersey City; Stahl-Meyer, Inc. (canned meats), Bonoil Packing Co. (olive oil products), Albert Ehlers, Inc. (coffee), Cott Beverage Co. (soft drinks), New Haven; Bristol Myers Co. (Mum deodorant), New York; Rapi-dol Distributing Corp. (Blensol), New York; Continental Glass Heat Co. (heating panels), Dornin, Inc. (sleep capsules), New York.

TV Accounts: Rapi-dol Distributing Corp. (Blensol), New York; Stahl-Meyer, Inc.

(meat products), New York; Block Drug Co. (Omega Oil, Poslam), Jersey City; Albert Ehlers, Inc. (coffee), New York; Cott Beverage Corp. (soft drinks), New Haven; Bristol Myers Co. (Mum deodorant), New York; Dormin, Inc. (sleeping capsules), New York.

L. J. DuMAHAUT ADV. AGENCY

Book Tower, Detroit 26, Mich.
Phone: WO 2-8246

Owner.....L. Jerome DuMahaut
Pers. Dir.-Off. Mgr.....Hazel R. Belman
Copy Chief.....G. B. Deery

DUNDES & FRANK, INC.

64 West 48th Street, New York 19, N. Y.
Phone: PLaza 7-0750

President.....Ben Frank
Treas. & Sec.....Harold Dundes
Space Buyer.....Daisy Grosswirth

ROY S. DURSTINE, INC.

730 Fifth Ave., New York 19, N. Y.
Phone: CIRcle 6-1400

NOAB—PPA—APA—ABC
President.....Roy S. Durstine
Vice-Presidents.....Wm. E. Dempster,
John Malone, Jr., Ralph D. Allum, J. R.
Gilman
Treasurer.....T. Arnold Rau
Head Art Dir.....Harvey A. Spooner
Art Director.....J. Burton Stevens
Radio-TV Time Buyer.....Maria Carayas
Radio Prod.....Hubert Wilkie

Branch Offices

3440 Wilshire Blvd., Los Angeles, Calif.
Phone: DUNkirk 8-3411

Exec-in-Charge.....William D. Sloan
156 Montgomery St., San Francisco, Calif.
Phone: YUkon 6-6917

Exec-in-Charge.....Robert B. England
Radio Accounts: Sylvania Electric Products, Inc. (Radio & Television Division) (television sets, radios, radio clocks), Buffalo, N. Y.; Van Houten & Zoon, Inc. (cocoa), New York, N. Y.; Clarke-Cleveland, Inc. (Thyoquent), Binghamton, N. Y.

TV Accounts: Macmillan Petroleum Corporation (motor oil), Los Angeles, Calif.; Clark-Cleveland, Inc. (Thyoquent), Binghamton, N. Y.; Modglin Company, Los Angeles, Calif.; Pacific Can Company, San Francisco, Calif.; Podesta Baldocchi (flowers, gifts), San Francisco, Calif.; American Cyanamid Company (Snperset), New York, N. Y.

ADAM F. EBY & ASSOC.

336 Andrews Bldg., Buffalo 2, N. Y.
Phone: MADison 2921

Owner.....Adam F. Eby
Treasurer.....Virginia Eby
Radio Accounts: Sports Show (Show), Buffalo, N. Y.; S. R. Gerber Sausage Co. (Wieners and Sausage), Buffalo, N. Y.; Chip Steak Co. (Chip Steaks), Buffalo, N. Y.; Culligan Soft Water (Water Softening Ser-

vice), Buffalo, N. Y.; J. C. Crosby (Lincoln-Mercury), Buffalo, N. Y.; Murray's Potato Chips, Ft. Erie, Ont.; Lang's Creamery, Buffalo, N. Y.; Loretto Foods, Olean, N. Y.

TV Accounts: S. R. Gerber Sausage (Wieners & Sausage), Buffalo, N. Y.; Culligan Soft Water (Water Softening), Buffalo, N. Y.; Chip Steak Co. (Chip Steaks), Buffalo, N. Y.; J. C. Crosby (Lincoln-Mercury), Buffalo, N. Y.; Lang's Creamery, Buffalo, N. Y.; Loretto Foods, Olean, N. Y.

EDELSTEIN-NELSON ADV. AGENCY, INC.

203 North Wabash St., Chicago 1, Ill.
Phone: ANdover 3-3867

ABP
President.....Edward Edelstein
Vice-President.....Irving Karlin

ELLINGTON & CO., INC., ADV.

535 Fifth Ave., New York 17, N. Y.
Phone: MURray Hill 7-4300

ANPA—APA—NOAB—PPA—ABC
President.....Jesse T. Ellington
Vice-Presidents.....Theodore S. Strong,
Hyland L. Hodgson, Charles W. Marshall,
Chauncey L. Landon, Van Davis, William
A. Bartel

Treasurer.....Gordon M. Kingman
Exec. Dir. Radio & TV.....Hal James
Exec. Producer.....A. Burke Crotty
Radio & TV Time Buyer.....Dan Kane
Radio Accounts: Celanese Corporation of America (Yarns, Fabrics, Plastics), New York, N. Y.; Harriet Hubbard Ayer (Cosmetics); McKesson & Robbins (Drugs).

TV Accounts: Cadbury-Fry America, Inc. (Candy), Celanese Corporation of America (Yarns, Fabrics, Plastics), New York, N. Y.; McKesson & Robbins; Bayuk Cigars, Inc.; J. Wiss & Sons (Scissors & Shears).

ELLIS ADVERTISING CO.

Erlanger Theatre Bldg., Buffalo 1, N. Y.
Phone: Cl. 6780

ABP—ANPA—APA—NOAB—PPA
Partners.....Michael F. Ellis,
Jerome R. Ellis
Radio Director.....Joanne Taylor
TV Director.....Marcia Daggett

Branch Offices

77 York St. W., Toronto, Ont.
Phone: Wa 9902

Manager.....Al May
Ford Bldg., Vancouver, B. C.
Phone: Ma 2631
Manager.....W. Val Warren

ROBERT J. ENDERS ADVERTISING, INC.

1001 Connecticut Ave., N.W., Washington 6, D. C.

Phone: Sterling 3-2222
President.....Robert J. Enders
Exec. Vice-President.....Howard A. Enders
Vice-President.....Rudy Vallee

Secretary-Treasurer.....Melvin Alan Bank
 Radio-TV Director.....Margot Phillips
 TV Film Director.....Robert L. Friend

Branch Offices

270 Park Ave., New York, N. Y.
 Phone: PLaza 5-4952

Vice-Pres.Howard Enders
 6611 Santa Monica Blvd., Hollywood, Calif.
 Phone: HIllside 6118

ManagerJohn Swallow

Radio Accounts: Amvets (American Veterans of World War Two), Georges Radio & Television Co., Government Services, Inc., Washington, D. C.; Travel Inc., Washington, D. C.; McCoy's (Radio, Television & Appliances), Washington, D. C.; Goodwill Industries of America, Inc.; Aircoach Transport Assoc., Phillips, National Safe Drivers Association, Randolph D. Rouse Enterprises, Modern Vacuum, Buchanan Hearing Aids, Standard Gas Appliances, Public Service Contractor, William Boubrest Distributors.

TV Accounts: George's Radio & Television Co., Goodwill Industries of America, Inc.; National Paint, Varnish & Lacquer Assoc.; Aircoach Transport Association, National Safe Drivers Association, Randolph D. Rouse Enterprises, Modern Vacuum, Buchanan Hearing Aid Company.

ENGEL ADVERTISING, INC.

185 N. Wabash Ave., Chicago 1, Ill.

Phone: RAndolph 6-7220

ANPA-PPA-APA-NOAB

President & Treasurer.....Frank L. Engel
 Vice-Pres. & Sec.....M. L. Engel
 Art Dir. & Copy Dir.....A. L. Rumry
Radio Accounts: Superior Match Pants Co.

ENNIS-ANDERSON ADV. AGENCY

218 Anglo Bank Bldg., Fresno, Calif.

Phone: Ph. 3-2613

President.....E. E. Anderson
 Vice-President.....Frank Ennis
 Art Director.....Milton M. Young
 Radio Director.....Lon McAdams

Radio Accounts: National Dollar Stores, Fresno Macaroni Co., Perfection Macaroni Sauce.

ERWIN, WASEY & CO., INC.

420 Lexington Ave., New York 17, N. Y.

Phone: LEXington 2-8700

AAAA-ANPA-APA-NOAB-PPA

APB ABC

Chairman of the Board.....Louis R. Wasey
 President.....Howard D. Williams
 Exec. V.P. & Secy.....George E. Wasey
 Asst. to Pres.....David B. Williams
 Treasurer.....James F. O'Connor
 Business Mgr. Media.....Keith B. Shaffer
 Dir. Radio-TV Creative Prod.....Michael Levin
 Radio Dir. (L. A.).....Robert L. Redd
 Time Buyer (L. A.).....Glen Bohannon
 Media Dir. (Chicago).....John Gwynn

Branch Offices

230 N. Michigan Ave., Chicago 1, Ill.

Manager.....L. R. Northrup
 5045 Wilshire Blvd., Los Angeles 36, Calif.

Exec. Vice-Pres.....Emmett C. McGaughey

523 Marquette Bldg., Minneapolis 2, Minn.

President.....Mac Martin

1st National Bank Bldg., Oklahoma City, Ok.

President.....Howard D. Williams

1170 Bay St., Toronto, Ont., Can.

Manager.....Ralph L. Lawson

1121 St. Catherine St. W., Montreal, Que.,

Canada

Manager.....Ralph L. Lawson

Radio Accounts: Barbasol Co. (Barbasol),

Indianapolis, Ind.; Musterole Co. (Musterole),

Cleveland, O.; Carnation Co. (Evaporated

Milk, Ice Cream, Malted Milk), Los

Angeles, Calif.; Albers Milling Co. (Cereals,

Flapjack Mix, Friskies Dog Food), Seattle,

Wash.; Consolidated Cigar Corp. (Harvester

Cigars, Dutch Masters Cigars), Zonite Pro-

ducts Corp. (Larvex), New York, N. Y.;

Nash Coffee Co. (Coffee), Minneapolis,

Minn.; S. C. Johnson & Sons, Inc. (Wax

Products), Racine, Wis.; KRO Company

(Rodenticides), Springfield, O.; Jacob Ries

Bottling Works (Soft Drinks), Minneapolis,

Minn.; E. F. Hutton and Co. (Securities),

Los Angeles, Calif.; McCoy Products (Vita-

mins), New York, N. Y.; Olive Tablet Co.

(Laxative), Columbus, O.; Springs Cotton

Mills Co. (Spring Maid Sheets), Lancaster,

S. C.

TV Accounts: Carnation Co. (Evaporated

Milk), Los Angeles, Calif.; Albers Milling

Co. (Friskies Dog Food), Seattle, Wash.;

Consolidated Cigar Corp. (Harvester

Cigars), New York, N. Y.; Springs Cotton

Mills (Spring Maid Sheets), Lancaster, S. C.;

Musterole Co. (Musterole), Cleveland, O.;

North American Philips Co. (Norelco Duo-

Vue), New York, N. Y.; Admiral Corp.

(Refrigerators, TV and Radio Receivers),

Chicago, Ill.

WILLIAM ESTY COMPANY, INC.

100 E. 42nd St., New York, N. Y.

Phone: OXFord 7-1600

AAAA-ABC-ABP-ANPA-AFA

President.....James J. Houlahan

Exec. V.P.....G. I. Chatfield

Vice President.....Dr. Wallace H. Wulfeck

Secretary-Treasurer.....E. H. Cummings

V.P. Chg. TV Prog.....Samuel Northcross

Radio Director.....Wendell Adams

V.P. Chg. TV Commercial.....Stanley A. Lomas

Branch Office

6331 Hollywood Blvd., Hollywood 28, Cal.

Exec. Prod. Dir.....Arnold J. Wester

Radio Accounts: Colgate (Rapid-Shave,

Fab, Vel), Jersey City; National Carbon Co.

("Eveready" Batteries, "Prestone" anti-

freeze), New York; R. J. Reynolds Tob. Co.

(Camel Cigarettes, Cavalier Cigarettes,

Prince Albert Smoking Tobacco), Winston-

Salem; Coca Cola Bottling Co., New York;

General Mills; Paquin, Inc.

TV Accounts: Colgate (Fab, Rapid Shave,

Vel), Jersey City; National Carbon Co.

("Eveready" Batteries, "Prestone" anti-freeze), New York; R. J. Reynolds Tob. Co. (Camel Cigarettes, Cavalier Cigarettes), Winston-Salem, N. C.; Coca-Cola Bottling Co., New York; General Mills.

EVANS & ASSOCIATES

Dan Waggoner Bldg., Fort Worth, Tex.

Phone: EDison 9521

ABC—PPA—ABP—ANPA—APA
NAAN—NOAB

Partners.....Albert Evans, Jr., Stanley Schlenther

Radio Accounts: Williamson Dickie Mfg. Co. (Men's Work Clothes); Foremost Dairies (Southwest Div.).

TV Accounts: Williamson Dickie Mfg. Co.; Foremost Dairies.

EVANS-WORK ADV. AGENCY

624 East Capitol Ave., Springfield, Ill.

Phone: 23868

President.....Clarence R. Evans
Art Director.....John Robert Work
Continuity Director.....Imogene Kundig

Radio Accounts: Arch Wilson, Inc., B & F Toggery, Bootery, Bridge Jewelry Co., Camera Shop, Capital Wood Works, Community Bakery, Constantino Packing Co., Ray's Brand Products, Dellert's Paints, Faultless Milling Company, Fink's Cleaners, Graham's, Jack Harman, Kennedy's Laundry & Dry Cleaners, Lincoln Trail Turkey Farm, Henry Nelch & Son, Public Super Market, Punzak Air Conditioning & Heating Co., Quality Dairy, Rolands, Royal Crown Bottling Co., Security Federal Savings & Loan, Senate Theatre, Springfield Motors, Swanson's Camera Shop, Woodward & McCullough Jewelers, Abraham Liucolin Hotel, LaBonte's Luggage Shop, Schlitt Hardware, Vredenbnrgh Lumber Co., Jonny's Rexall Drug Store.

TV Accounts: First National Bank, Barker-Lubin Company.

EWELL & THURBER ASSOCIATES

23 East Jackson Blvd., Chicago 4, Ill.

Phone: WEbster 9-0911

President.....James Cady Ewell
Vice-President.....C. E. Rickerd
Copy Director.....St. Clair Carver
Production Manager.....Bruce Guest
Radio Director.....A. J. Engelhardt

Branch Offices

520 Madison Ave., Toledo 4, Ohio

Phone: Main 8205

Exec. Vice-Pres.....Hal H. Thurber
270 Park Ave., New York 17, N. Y.

Phone: PLaza 1-2770

Vice-President.....Steve Mudge
6671 Sunset Blvd., Hollywood 28, Calif.

Phone: HOLlywood 9-4994

Manager.....Ernest Belt
Radio & TV Accounts: Chicago, Indianapolis & Louisville Railway Co.; Great China Food Products Co.; Ideal Dog Food; Juergens & Anderson Co.; Nicolay-Dancey, Inc.; Ostermoor & Co., Inc.; Pullman Couch Co.;

Rap-in-Wax Paper Co.; Sanford Ink Co.; Straub, W. F., & Co.; Super Foods Merchandising; Willys-Overland Export Co.; Willys Motors, Inc.; Wilson & Company; Wilson Sporting Goods Co.

FARQUHAR AND COMPANY, INC.

First National Bank Building, Utica 2, N. Y.

Phone: 2-6109

President.....John T. Farquhar
Vice-President.....Ted R. Darvoe
Secretary.....Roger H. Williams
Treasurer.....Jay C. Anderson
Radio-Television.....John T. Farquhar
Media Buyer.....Eleanor Crimmins

Radio Accounts: Utica Brewing Company (Fort Schuyler Beer & Ale), Utica, N. Y.; Dawes and Judkins Inc. (Floor Covering Dealer and Distributor), Utica, N. Y.; F. J. Baker & Sons (Wholesale, Retail Florists), Utica, N. Y.; Wm. Parry & Sons Inc. (Dairy Products), Utica, N. Y.; Jean's Foods of Utica Inc. (Food Products), Utica, N. Y.; Harry Heiman Inc. (Chrysler-Plymouth Distributor), Utica, N. Y.; Bonide Chemical Co. (Insecticides, Fungicides), Utica; Rome Savings Bank, Rome; Ribyat's Furniture, Utica.

TV Accounts: Utica Brewing Company (Fort Schuyler Beer and Ale), Utica, N. Y.; Dawes and Judkins Inc. (Floor Covering Dealer and Distributor), Utica, N. Y.; Bonide Chemical Co., Utica; Harry Heiman Inc. (Chrysler-Plymouth Dist.), Utica; Ribyat's Furniture, Utica.

**FEIGENBAUM & WERMEN
ADVERTISING AGENCY**

1922 Spruce St., Philadelphia 3, Pa.

Phone: LO 4-1536

ABP—ANPA—NOAP

Partner.....Harry Feigenbaum
Partner.....David Wermen
Radio-TV Director.....Stanley Goldstein

Radio Accounts: Grabosky Bros. (Royalist, Amerada cigars), Philadelphia; Federal Savings & Loan Assns. (savings and loan), Philadelphia; Hardwick & Magee Furniture (rugs & furniture), Philadelphia; Cumberland Brewing Co. (Old Export Beer), Cumberland, Md.; The Arrow Store (men's furnishings), Philadelphia; Laundry Board of Trade (Philadelphia laundries), Philadelphia; Fox Weis (furriers), Philadelphia; Garden State Motors (automobiles & motors), Camden, N. J.; Bandler's (furniture), Philadelphia; Reliable Pontiac (automobiles), Philadelphia.

TV Accounts: Kasser Distillers (wine), Philadelphia; B. S. Pincus & Co. (meat products), Philadelphia; Booth's Bottling Co. (carbonated beverages), Philadelphia; The Arrow Store (men's apparel), Philadelphia.

FELLOWS ADVERTISING AGENCY

410 Larned Bldg., Syracuse, N. Y.

Phone: 2-4175

ABP—APA

Pres., Space & Radio
 Time Buyer.....Byron F. Fellows, Jr.
 Secretary-Treasurer.....Marjorie Hughes
Radio Accounts: Cortland Baking Company (Cobakeo Bread), Cortland, N. Y.; Norwich Knitting Company (Character Sweatshirts), Norwich, N. Y.
TV Accounts: Cortland Baking Co. (Cobakeo Bread), Cortland, N. Y.; Norwich Knitting Co. (Character Sweatshirts), Norwich, N. Y.

COURTLAND D. FERGUSON, INC.

Rm. 315, National Press Bldg.,
 Washington, D. C.
 Phone: NAtional 8-7713
 APA—PPA

President.....Courtland D. Ferguson
 Secty.-Treas.....Lucille Pierce Ferguson
 Radio Copy Dir.....George Ely
 Executive Asst.....Walter J. Kerwin
 Art Director.....Gilbert Meckins
 Production Manager.....William Cooper
 Time Buyer.....Nan Hannum

Branch Offices

45 Rockefeller Plaza, New York, N. Y.
 Manager.....Phillip N. Jackson
 Southern State Bldg., Richmond, Va.
 Manager.....Richard Nall
Radio Accounts: L. S. Briggs, Inc. (Meat Products), Washington, D. C.; Schindler Peanut Products (Peanut Butter & Peanuts), Wash. & Balt.; Mann's Potato Chips, Wash. & Richmond; Smith's Storage Co., Washington; Lincoln Warehouse Corp., New York; Little Tavern Shops (Restaurants), Washington & Baltimore.
TV Accounts: Briggs (Meat Products), Smith's Storage Co., Washington, D. C.; P. D. Gwaltney Co., Smithfield, Va.

LAWRENCE FERTIG & CO., INC.

149 Madison Ave., New York 16, N. Y.
 Phone: MUrray Hill 9-7100
 ABP—ANPA—APA—PPA

President-Treasurer.....Lawrence Fertig
 Vice-President.....Philip Lukin
 Media Director.....Miss Selma Grosswirth
 Art Director.....Stanley Dusek
 Production Manager.....Ken Miller
 Radio-TV Time Buyer, Dir.....Jos. H. Mintzer

ROBERT G. FIELDS & CO.

Sudekum Bldg., Nashville 3, Tenn.
 Phone: 6-1977
 ABP—PPA—SNPA—APA

President.....Robert G. Fields
 Account Executive.....W. R. Culbertson
 Secretary.....A. Ferguson
Radio Accounts: Robt. Orr & Co. (Coffee), St. Bernard Coal Co. (Coal), Coal Heating Service (Coal).
TV Accounts: Red Acc Petroleum Co. (Coal & Oil); Hester Battery Co., Nashville.

FIRESTONE-GOODMAN ADV. AGENCY, INC.

541 Syndicate Bldg., Minneapolis 2, Minn.
 Phone: Main 4393

Pres., Radio Dir. &
 Copy Chief.....Allan L. Firestone
 Treas. & Art Director.....Archie Goodman
 Secretary.....R. S. Firestone
 Space Buyer.....L. Koehller
Radio, TV Accounts: Fisher Nut & Chocolate Co. (Nut Confections); American Television & Radio Co.; Goodman's Jewelers; Great Minneapolis Surplus Store.
Radio Account: Minneapolis & St. Paul House Furnishing Cos.

M. M. FISHER ASSOCIATES

134 N. LaSalle St., Chicago 2, Ill.
 Phone: CEntral 6-1610-1611

Owner.....Jack L. Fisher
 Radio & TV Dir.....Jack L. (Bud) Fisher, Jr.
Radio Accounts: Bell Savings & Loan Assn. (Local Radio), Cook Co. Central Democratic Committee—Political (Radio-selected Localities), National Foundation for Infantile Paralysis (Midwest Rep.), New York & Chicago; Tam O'Shanter Country Club (Golf Tournaments Only), Chicago; United Artists Corp. (Motion Picture), Chicago (Radio Selected Localities); Universal-International Pictures (Motion Pictures), Chicago (Radio Selected Localities); Clark Theater (Movie Theater), Chicago; House of Carter (Furniture), Chicago; Goodman Furniture Co. (Furniture), Chicago; Monroe Theater (Movie Theater), Chicago; TV Time Foods (TV Time Popcorn), Chicago; 20th Century Fox Film Corp. (Motion Pictures), Chicago.
TV Accounts: Cook Co. Central Democratic Committee (Political), Chicago (Selected Localities); Tam O'Shanter Country Club (Golf Tournaments), Chicago; Nat'l Foundation for Infantile Paralysis, Chicago & N. Y.; United Artists Corp.; Universal-International Pictures Corp.; Bell Savings & Loan Assn. (Bank), Chicago; Monroe Theater (Movie Theater), Chicago; TV Time Foods (TV Time Popcorn), Chicago; 20th Century-Fox Film Corp. (Motion Pictures), Chicago.

FITZGERALD ADVERTISING AGENCY

Lee Circle Building, New Orleans, La.
 Phone: TUlane 3131
 Partners....Joe L. Killeen, Jos. H. Epstein.
 Roy M. Schwarz, Leonard Gessner, E. W. Rector Wooten, Warren G. Posey
 Media Dir.....Harley B. Howcott
 Radio Director.....Aubrey Williams
 Radio Time Buyer.....Mrs. Marie O'Meara
 TV Director.....Tom Newman
Radio Accounts: Alabama-Georgia Syrup Company (Alaga Syrup), Montgomery, Ala.; Blue Plate Foods, Inc. (Mayonnaise-Peanut Butter-Preserves & Jellies, CDM Coffee), New Orleans, La.; H. G. Hills Stores (Chain

Grocery Stores), New Orleans, La.; Jackson Brewing Company (Jax Beer), New Orleans, La.; Pan-Am Southern Corporation (Motor Oil & Gasoline), New Orleans, La.; Wesson Oil & Snowdrift Sales Co. (Wesson Oil, Snowdrift, Scoco and Crustene Shortening), New Orleans, La.

TV Accounts: Blue Plate Foods, Inc. (Mayonnaise-Peanut Butter-Preserves & Jellies), New Orleans, La.; Godchaux Sugars, Inc. (Sugar), New Orleans, La.; Higgins, Inc. (Flooring & Misc. Products), New Orleans, La.; H. G. Hill Stores (Chain Grocery Stores), New Orleans, La.; Jackson Brewing Company (Jax Beer), New Orleans, La.; La. State Rice Milling Co. (Ricc), Abbeville, La.; Wesson Oil & Snowdrift Sales Co. (Wesson Oil & Snowdrift & Crustene), New Orleans, La.; Pan-Am Southern Corporation (Motor Oil & Gasoline), New Orleans, La.; Southern Shell Fish Co. (Canned & Frozen Seafoods), Harvey, La.

FLACK ADV. AGENCY, INC.

1110 Hills Bldg., Syracuse 2, N. Y.

Phone: 2-3129

AAAA—ABP—ANPA—APA—PPA

President William Conklin
 Vice-President Grover Hubbell
 Secretary Henry Fraser
 Treasurer J. K. Bowman
 Account Executives William P. Conklin,
 Grover H. Hubbell, Alfred Bollinger

FOLEY ADVERTISING AGENCY

N. B. C. Bldg., Cleveland 14, O.

Phone: CHerry 1-1490

President Robert B. Foley
 Sec.-Treas. Helen M. Little
 Director Robert B. Foley
Radio and TV Accounts: I. J. Fox, Inc. (Retail Furrier), Nokes-Findley Wallpaper & Paint Co., Cleveland.

THE RICHARD A. FOLEY ADV. AGENCY, INC.

1528 Walnut St., Philadelphia 2, Pa.

Phone: KINGSley 5-1560

AAAA—ABC

President Charles H. Eyles
 V.P.-Treas. Lee E. Hood
 V.P.-Gen. Mgr. A. Edward Morgan
 V.P.-Media Director Wesley Winnig
 Copy Director Raymond Barr
 Radio-TV Director Frank M. Knight, Jr.
 Time Buyer Alice Mooney
Radio Accounts: Abbotts Dairies, Inc. (Milk, Cheese & Ice Cream), Beneficial Saving Fund (Banking), Delaware Steeplechase & Race Assn. (Horse Racing), Wilmington, Del.; Louis Burk Co. (pork products), Phila; B & O Railroad (Transportation), Baltimore; Glix Dog Candy, Rochester, N. Y.; Silva Silver Polish, Rochester, N. Y.
TV Accounts: Abbotts Dairies (ice cream, milk), Philadelphia; Baltimore & Ohio Railroad (passenger travel), Baltimore;

Louis Burk Company (pork products), Philadelphia; R. T. French Company (bird seed), Rochester; Atlantis Sales Company (Klix Dog Candy and Silvo Silver Polish), Rochester; Delaware Steeplechase & Race Assn. (Horse Racing), Wilmington, Del.; Mrs. Smith's Pies (Pies), Philadelphia.

FOOTE, CONE & BELDING

247 Park Ave., New York 17, N. Y.

Phone: MURray Hill 8-5000

ANPA—AAAA—PPA—APA—ABP—NOAB—ABC

Chairman of the Bd. Robert F. Carney
 V.P. & Director Frank E. Delano
 V.P. Chg. Finance, Secretary & Director A. E. Rood
 V.P. & Director Elwood Whitney
 V.P. Chg. International Division M. P. Franceschi
 V.P.-Radio & Telev. Edmund L. Cashman
 V.P. Chg. Media Harold H. Dobberteen
 V.P. Chg. Research Paul E. J. Gerhold
 V.P. & Mgr. Eastern Mot. Pic. Div. Harold Holt
 V.P.-Radio & Television Roger Pryor
 Asst. Treas. & Asst. Sec. Charles H. Newbrand

Dir. of Merchandising Everett F. Braden
 Dir. of Prog. Devel. Thomas McDonnell
 Dir. Media Joseph S. Spiegel
 Mgr. Production Dept. J. A. Koebler
 Office Manager Tyrell G. Rogers

Branches Offices

155 E. Superior St., Chicago 11, Ill.

Phone: SUPERior 7-4800

President Fairfax M. Cone
 V.P. & Director Robert J. Koretz
 V.P. & Director John F. Hunt
 Treas. & Asst. Sec. Jos. W. King
 V.P. & Prod. Dir. George Heiland
 V.P. Carl C. Hertzberg
 V.P. & Gen. Mgr. Harold H. Webber
 Educational Dir. Leah Anderson
 V.P. & Media Dir. Robert Hussey
 V.P. Chg. Res. Richard Tully
 Radio & Telev. Bus. Mgr. Harry Dieter
 Radio & Telev. Time Buyer Genevieve Lochrer

Office Mgr. M. R. Loehrke
 Statler Center, 900 Wilshire Blvd., Los Angeles 17, Cal.

Phone: MADison 9-3611

Chairman Exec. Comm. Don Belding
 Vice-Pres. & Mgr. William J. Pringle
 V.P. & Art Dir. Robert Freeman
 Dir. of Media George Weaver
 Dir. of Research Paul Henley
 Mgr. Prod. Dept. Brougham J. Morris
 Radio Time Buyer Lydia R. Hutton
 235 Montgomery St., San Francisco 4, Calif.
 Phone: SUTter 1-2355

Vice-Pres. & Mgr. Ford Sibley
 Media Director Llew A. Jones
 6233 Hollywood Blvd., Hollywood 28, Calif.
 Phone: HOLlywood 9-6265

Vice-Presidents C. Bert Oliver,
 Elliston Vinson

Box 4223, Houston 14, Texas
Phone: Justin 5461

Manager.....Stephen R. Wilhelm
Pacific Bldg., Portland 4, Oregon
Phone: BRoadway 3732
Leith F. Abbott

Radio Accounts: General Foods, Liebmann Breweries, Inc., New York Central, Lever Bros. American Bakers Assn., Armour & Co., Frigidaire Division General Motors, Hall Brothers, Inc., International Cellucotton Products Co., Acme Brewing, Bullock's, Hoffman Radio, Hughes Aircraft, Lockheed, Porex Corp. Ltd., Security-First National Bank, Sunkist Growers.

TV Accounts: General Foods, Liebmann Breweries, Inc., Intern'l Latex, Lever Brothers, Armour & Co., Frigidaire Division General Motors Corp., Hall Brothers, Inc., International Cellucotton Products Co., Beatrice Foods Company, Security-First National Bank, Acme Brewing, Bullock's, Hoffman Radio, Hughes Aircraft, Porex Corp. Ltd., Sunkist Growers.

MARSHALL FORD ADV. AGENCY

918 11th St., Sacramento 14, Calif.
Phone: Gilbert 2-3645
APA

President.....M. J. Ford
Secretary-Treasurer.....Marshall J. Ford
Art Director.....Thomas Fong
Media Buyer.....Hal Kranig

Radio Accounts: Pureta Sausage Co. (Sausage Products); Broili-Parks Co. (Zenith Radios), Sacramento, Calif.; Dalton Motors, Inc. (DeSoto-Plymouth Distributor), Home Milk & Ice Cream Co. (Dairy Products), General Beverages Western (Donald Duck Soft Drinks), Monterey; F. Pirrone & Sons, Inc. (Wines), Salida; Seven Up Bottling Co. (Sacramento & Stockton).

TV Accounts: Pureta Sausage Co.; General Beverages Western (Donald Duck Soft Drinks), Monterey; Broili Parks Co. (Zenith Radio-TV Dist.), Sacramento.

ALBERT FRANK-GUENTHER LAW INC.

131 Cedar St., New York 6, N. Y.
Phone: COrtlandt 7-5060

ABP-ANPA-APA-NOAB-PPA-ABC

Chairman of the Bd.....Howard W. Calkins
President.....Frank J. Reynolds
Sr. Vice-Pres.....Victor J. Cevasco
Exec. Vice-Pres.....Richard A. Cullinan
Vice-Pres. & Treas.....S. A. Speake
Vice-Pres. & Sec.....E. G. McAdie
Vice-Presidents.....Frank D. Cruikshank,
Howard C. Allen
Dir. of Radio & TV.....Robert W. Day

Branch Offices

One La Salle St., Chicago 2, Ill.
Phone: DEarborn 2-6424

Vice-President.....R. W. Dawson

10 Post Office Square, Boston 9, Mass.
Phone: HANcock 6-5900

Vice-President.....Joseph R. Hamlen
Packard Bldg., Philadelphia 2, Pa.
Phone: RIttenhouse 6-3915
Vice-President.....Milton T. Kyle
125 Bush St., San Francisco, Calif.
Phone: YUkon 6-4641
Manager.....Lucrezia H. Kemper

FRANKEL, JONES, CO.

130 N. Wabash Ave., Chicago 1, Ill.
Phone: DEarborn 2-5745
NOAB-ABP-ANPA-APA-PPA

President.....Jones B. Frankel
Account Executives.....Jones B. Frankel,
A. G. Gaines, Lew Sanders
Space Buyer.....Helen Eich
Radio-TV Director.....Lew Sanders
Radio Accounts: Lion Chemical Co., Rolin Sales, Valmor Prod.
TV Account: Rosin-Starr.

FRANKLIN & GLADNEY, INC.

10 East 49th St., New York 17, N. Y.
Phone: PLaza 9-7950
ABP

President.....Dolph Franklin
Media Dir.....Edith Schless
Radio-TV Time Buyer.....Lucille Master
TV Accounts: Stern Department Stores; Mawson De Many (Furrier), Philadelphia, Pa.; L. Fish Stores (Furniture), Chicago, Ill.; Hecht's Department Stores (Department Stores).

THE FREDERICK-CLINTON CO., INC.

545 Fifth Ave., New York 17, N. Y.
Phone: MUrray Hill 2-7433
ABP-ANPA

President.....F. C. Burger
V.P., Treas.....H. S. Rieff
V.P., Secretary.....R. S. Buckbinder
V.P., Art Director.....E. Gambale
Radio Accounts: Adler Shoes, New York; Modene Paint Co. (paint products), Chelsea, Mass.; Vim Electric Co. (RCA, Thor, Hallcrafters), New York; Chock Full O'Nuts (Coffee), N. Y. C.; Modene Paint Co., Chelsea, Mass.

TV Accounts: Adler Shoes for Men, N. Y. C.; Chock Full O'Nuts (Coffee), N. Y. C.; Vim Radio & Television (Appliances), N. Y. C.

CURT FREIBERGER & CO.

1439 Court Place, Denver 2, Colo.
Phone: ALPine 2048
AAAA-ANPA-ABP

President.....C. J. Freiburger
Secretary.....Charles A. Haskell
Treasurer.....Doris Fleischer
TV Director.....Bob Swysgood
Radio Accounts: American Beauty Macaroni Co. (macaroni products), Denver; Central Bank & Trust Co. (banking), Denver; Associated Grocers of Colo. (groceries), Denver; Colorado Potato Flake Co. (potato

chips), Denver; Guardian Savings & Loan Ass'n. (savings & loan), Denver; Sears Roebuck & Co. (dept. store), Denver; Toner's, Inc. (peanut butter), Denver; Vincent Syrup Co. (syrups) Denver; Central Bank & Trust Co. (banking), Denver; Continental Tours & Travel Service (travel service), Denver; Gus' Butter Maid Bake Shop (bakery goods), Denver.

TV Accounts: Beatrice Foods (dairy products), Denver; Central Bank & Trust Co. (banking), Denver; Zefer Products (salad dressings), Denver; American Beauty Macaroni Co. (macaroni products), Denver; Denver Conv. & Visitors Bureau (travel), Denver; AlSCO of Colorado (storm windows), Denver; Dottie's Quickie Cookies (Frozen Cookies), Denver; Grandview Builders (builders), Denver; Gus' Butter Maid Bake Shop (bakery goods), Denver; Nebraska Packing Co. (meat processor—dog food), North Platte, Nebraska; B. K. Sweeney Mfg. Co. (Distributors), Denver.

FREITAG ADV. AGENCY

988 Spring St., N.W., Atlanta 5, Ga.

Phone: Elgin 1056

ANPA—NOAB—PPA—AAAN—SNPA

Owner.....J. V. Freitag
Account Executive.....M. K. McGowan
Sec.-Treas.....R. W. Wallace

Radio Accounts: Columbia Baking Co.

OAKLEIGH R. FRENCH & ASSOCIATES

4235 Lindell Blvd., St. Louis 8, Mo.

Phone: NEwstead 0037

AAAA—APP—NOAB—ANPA—PPA

Partners.....Oakleigh R. French,
Mazie G. French

Art Director.....Matthew Falk
Dir. Client Service.....Richard C. Lynch
Media Director.....C. Sewell Pangman

Radio Accounts: H P Coffee Company,
St. Louis.

AD FRIED ADVERTISING AGENCY

(See Complete Listing Under "A")

FRIEND REISS McGLONE

221 W. 57 St., New York, N. Y.

Phone: PLaza 7-8030

ABP—ANPA—PPA—APA

Partner & Gen. Mgr.....B. M. Reiss
PartnerLee Friend
Partner.....James W. McGlone
Res. & Mkt. Dir.....Henry Brenner
Production Manager.....Julius Brown
Radio-TV Director.....Edward Ratner

Radio Accounts: Moly Motor Products (Liqui-Moly), N. Y. C.; Merkin Paint Co., N. Y. C.; Sweet Orr (Workclothes), N. Y. C.; Lafayette Radio, N. Y. C.

TV Accounts: Merkin Paint Co., N. Y. C.; Levolor Lorentzen (Venetian Blinds), N. Y. C.; Aptitude Shoe Co., N. Y. C.

HARRY M. FROST CO., INC.

260 Tremont St., Boston 16, Mass.

Phone: Liberty 2-0183

ANPA—APA—PPA

President.....Karl M. Frost
Vice-President.....Harold E. Bessom
Treasurer.....Harry M. Frost
Asst. Treasurer.....Florence A. Dondero
Sec'y., Radio Dir.....Harvey P. Newcomb
Newspaper Space Buyer...Anna V. Turner
Magazine Space Buyer & Prod. Mgr.

Harold E. Bessom

Radio Accounts: Durkee-Mower, Inc. (Marshmallow Fluff), Lynn, Mass.; Winslow Chip Company (Potato Chips, Products), Marblehead, Mass.; LcPage's Inc. (Glue Products), Gloucester, Mass.; General Electric Supply Corp. (Electrical Products), Boston, Mass.; Gentles Baking Co. (Gentles Bread), Mattapan, Mass.; Campbell-Fairbanks, Inc. (Sportsmen's Shows), Boston, Mass.; Jasper Wyman & Sons Co. (Wyman's Blueberries), Millbridge, Me.; Natl. Cranberry Assoc. (Ocean Spray Products), Hanson, Mass.; Eastern Raving Assoc. (Suffolk Downs), East Boston, Mass.; Boston Nash Co. (Automobile Service), Boston, Mass.

TV Accounts: Durkee-Mower, Inc. (Marshmallow Fluff), Lynn, Mass.; Gentles Baking Company (Gentles Bread), Mattapan, Mass.; General Electric Supply Corp. (Electrical Appliances), American Crabmeat Co. (3 Little Kittens Cat Food), Met. Boston Nash Dealers (Automobile Service), Boston Mass.; Winslow Chip Co. (Potato Chips, Products), Marblehead, Mass.; LePages, Inc. (Glue Products), Gloucester, Mass.

FULLER & SMITH & ROSS, INC.

1501 Euclid Ave., Cleveland 15, O.

Phone: CHerry 1-6700

AAAA—ABP—ANPA—APA—NOAB—PPA
President.....Allen L. Billingsley
Exec. Vice-Pres.....E. L. Andrew
V.P. & Mgr. (Cleveland Office) W. A. Wright
Secretary-Treasurer.....C. C. Reidenbaugh
Asst. to Pres. (Cleveland)....J. C. Maddox
Media Dept. Mgr. (Clvld.)..W. G. Chalkley
Media Dept. Mgr.

(Chicago).....C. W. Billingsley
Radio, Film, TV Dept. Mgr.

(Cleveland Office).....David Adam

Branch Offices

71 Vanderbilt Ave., New York 17, N. Y.

Phone: MURray Hill 6-5600

Vice-Pres. & MgrR. E. Allen
105 W. Adams St., Chicago 3, Ill.

Phone: ANdover 3-5041

Vice-Pres. & Mgr.....E. J. Lanesen
Radio Accounts: Westinghouse Elec. Corp.

(Various), Plymouth Cordage Co. (Rope), Hercules Powder Co. (Toxaphene), Aluminm Cooking Utensil Co. (Wear-Ever), Bryant Heater Corp. (Gas Heaters), Penzoil Gasoline & Oil), Keystone Steel & Wire Co. (Fencing), Linen Thread Co., Mellon National Bank & Trust Co., Nickel Plate Road (Railroad), Oldsmobile Dealers, Sherwin-



Williams Co. (Paint), A. E. Stoley Mfg. Co. (Feed), Sterling-Lindner-Davis Co. (Dept. Store), Webster-Chicago Corp. (Phonographs), American Greetings Corp. (Publishers), American Society of Metals, Central National Bank, Chicago & Eastern R. R., Harry Ferguson, Inc. (Farm Equipment), Jack & Heintz (Precision Equipment).

TV Accounts: Central Nat'l Bank of Cleveland, American Greeting Card Publishers, Westinghouse Elec. Corp., Pennzoil Company, Sherwin-Williams Co., Sterling-Lindner-Davis Co., White Sewing Machine Corp., Commercial Solvents, Ferro Corporation, Inter Chemical Corp., International Silver Co., Mellon National Bank & Trust Co., Oldsmobile Dealers.

FURMAN, FEINER & CO., INC.

117 W. 46th St., New York 19, N. Y. Phone: PLaza 7-7393 ABP

Pres., Radio Time Buyer...Norman Furman Vice-President...Irving J. Gottlieb Secretary...Nathan Rothenberg Art Director...Edwin R. Swaback Acct. Execs...Helen Grobin, Lon Shaw Space Buyer...Laura Lustig

Radio Accounts: American Federation of Labor, Washington, D. C.; International Ladies Gar. Workers Union, Liberal Party, Colomby Watch (Jewelry), New York, N. Y.; Ganeles-Lenger Wine Corp., New York; National Health Aids, Inc., New York.

GARDNER ADVERTISING CO.

915 Olive St., St. Louis 1, Mo. Phone: Central 3200 AAAA-ABC-ABP-ANPA-APA NOAB-PPA

President...E. G. Marshutz Sec. & Treas...H. S. Gardner, Jr. Vice-President...Beatrice Adams V.P. Chg. Radio-TV...William Fisher

Branch Office

9 Rockefeller Plaza, New York 20, N. Y. Phone: COLUMbus 5-2000

Chairman of Board...H. S. Gardner Vice-President...Roland Martini Radio Accounts: Grove Laboratories, Inc. (Bromo-Quinine, Fitch Shampoo, 4-Way Cold Tablets), St. Louis; Lion Oil Company, Eldorado, Ark.; Nebraska Consolidated Mills Company, Omaha, Neb.; Pet Milk Co., Purina Mills, Ralston Purina Company, St. Louis; Southwestern Bell Telephone Co., St. Louis; Union Electric Company of Missouri, St. Louis; First National Bank, St. Louis; St. Louis Independent Packing Co.

TV Accounts: Grove Laboratories, Inc., Pet Milk Co., Ralston Purina Co., Monsanto Chemical Co., St. Louis; First National Bank, St. Louis; Nebraska Consolidated Mills, Omaha, Neb.

W. W. GARRISON & COMPANY

400 N. Michigan Ave., Chicago 11, Ill. Phone: SUperior 7-8388

NOAB

Sec., Space & Radio Time Buyer...G. P. Schill V.P. & Acct. Excc...Earl Lines Art Director...O'Cal Hanson Radio Accounts: Tanglefoot Co., Grand Rapids, Mich.; Gibson Refrigerator Co.

GAYNOR & COMPANY, INC.

10 East 49th St., New York 17, N. Y. Phone: PLaza 5-5751

President...Paul Gaynor Copy Chief...Guy Ganty, Jr. Publicity Director...Will Barbeau Traffic-Prod. Mgr...George Cisneras Treasurer...Ed Marra Radio & TV Accounts: Fairchild Engine & Airplane Corp.; All-American Engineering; Link Aviation, Inc.; J. A. Maurer, Inc.; Precision Film Laboratories, Inc.; McGraw-Hill Publishing Co.; B. G. Corporation; Fairchild Recording Equipment Corp.; G. M. Giannini & Co., Inc.; American Moninger Greenhouse Co.

GEARE-MARSTON, INC.

22nd & Locust St., Philadelphia 3, Pa. Phone: LOcust 4-0530

AAAA-ABC-ABP-ANPA-APA NOAB-PPA

President...Norman W. Geare V.P.-Media Director...Frank C. Murphy Secretary...William C. Huckel Treasurer...Elizabeth A. Heath Dir. of Service...Bates Compton Public Relations Director...Wm. C. Faust Radio-TV Dir...Frank C. Murphy

Branch Office

420 Lexington Ave., New York 17, N. Y. Phone: LEXington 2-0880

Vice-President...Charles S. O'Donnell Radio Accounts: Strawbridge & Clothier (Dept. Store), Western Saving Fund Society, Philadelphia, Pa.; Skinner & Eddy (Icy Point Salmon), Seattle, Wash.; Henry Diston & Son (Chain Saws), Pennsylvania Salt Mfg. Co. (Chemicals), Philadelphia, Pa.

TV Accounts: Western Saving Fund) Society (Savings Bank), Strawbridge & Clothier (Dept. Store).

GERTH-PACIFIC ADV. AGENCY

604 Mission St., San Francisco 5, Calif. Phone: GARfield 1-1081

AAAA-APA-ABP-ANPA-NOAB

President...E. P. Gerth Vice-President...J. W. Clark Media Director...Donna Thompson Radio Accounts: David D. Bohannon Orgn., Stringer Driver Moving & Storage Co.

THE GETSCHAL CO., INC.

49 E. 51st St., New York 22, N. Y. Phone: PLaza 9-1332 ABP-ANPA

President...Budd Getschal Vice-President...Len Stein Radio-TV Accounts: Sealy Mattress Co. (mattresses), N. Y. C.; Lerner Co. (furniture), N. Y. C.; Ludwig Baumann & Spear's

(furnishings), N. Y. C.; Rotiss-O-Mat Corporation (rotisseries), N. Y. C.

GEYER ADVERTISING AGENCY, INC.

745 Fifth Ave., New York 22, N. Y.
Phone: PLaza 1-3300

AAAA-ABC-ABP-ANPA-AFA

President.....B. B. Geyer
Exec. V.P. & Gen. Mgr.....Harold Jaeger
Treasurer.....John R. Kunz
V.P. & Copy Director.....Amedee J. Cole
V.P., Mktg. Dir.....R. C. Robertson
Vice Pres.....Frank Kearney
Vice Pres.....Donald Gill
Vice-Presidents.....A. LaSala,
Sam M. Ballard, C. Dubois
V.P. & Art Director.....W. J. Loveman
V.P. & Art Director.....A. A. Surin
V.P. & Dir. Public Rel.....E. F. Thomas
Director of Radio-TV.....George Wolf
Time Buyers.....Elizabeth Powell,
Carol Sleeper
Radio-TV, Comm. Dir.....William Lewis
TV Film Supervisor.....James Manilla
TV Art Director.....Paul Martin
Radio-TV Bus. &
Traffic Super.....Don McGuinn

Branch Offices

14250 Plymouth Rd., Detroit 32, Mich.
Phone: Webster 3-5520

V.P., Mgr.....Ralph Wolfe
931 Third National Bldg., Dayton 2, Ohio
Phone: Fulton 4-145

Vice President & Mgr.....E. G. Frost
1680 North Vine St., Hollywood 28, Calif.
Phone: Granite 7-6114

Vice President.....Wright Nodine
Radio Accounts: Nash-Kelvinator Corp. (Nash Cars, Kelvinator Household Appliances), Detroit, Mich.; U. S. Industrial Chemical Co., U.S.I. (Super-Pyro Anti-Freeze); American Home Products (Household products), N. Y. C.; American Home Foods (Burnett's Instant Puddings), N. Y. C.; Tetley Tea Co., Inc. (Tea), N. Y. C.; The Wolcott Co. (Easy-Off oven cleaner), Hartford, Conn.; Weston Biscuit Co. (Cookies), Passaic, N. J.; Flotill Products, Inc. (Tasti-Diet); National Paper Co. (Tissues), N.Y.C.

TV Accounts: Nash-Kelvinator Corp. (Nash Cars, Kelvinator Household Appliances), Detroit, Mich.; American Home Products (Household Products), N. Y. C.; American Home Foods, Inc. (Burnett's Instant Puddings), N. Y. C.; Tetley Tea Co., Inc. (Tea), N. Y. C.; The Wolcott Co. (Easy-Off Oven Cleaner), Hartford, Conn.; Kenwill Corp. (Magi Koter Paint Roller), Painesville, O.; Weston Biscuit (Cookies), Passaic, N. J.; Flotill Products, Inc. (Tasti-Diet); National Paper Co. (Tissues), N. Y. C.; U. S. Industrial Chemical Corp. (Anti-Freeze), N. Y. C.

GIBBONS ADVERTISING AGENCY, INC.

802 Daniel Bldg., Tulsa 3, Okla.

Phone: 4-2444

ABC-ABP-ANPA-AFA-SNPA-APA

Pres. & Treas.....J. Burr Gibbons
Vice President.....John B. Gibbons
Secretary.....Viola Neese
Radio-TV Dir.....Mercedes (Dee) Freiday

Radio Accounts: National Bank of Tulsa (banking and trust services), Tulsa; Stanley's Funeral Service (funeral service), Tulsa; State Federal Savings & Loan Association (savings, loans and investments), Tulsa; Wortz Biscuit Co. (crackers and cookies), Fort Smith, Ark.; Tom P. McDermott, Inc. (tire sales, service & recapping, home appliances, anti-freeze & motor oil & batteries), Tulsa, Oklahoma City, Amarillo; Sand Springs Farms (turkeys and eggs), Sand Springs, Okla.; John Brown University (schools and camps); Liberty Glass Co. (milk and beverage bottles), Sapulpa, Okla.; Pedrick Laboratories, Inc. (Vigo Dog Food), Sand Springs, Okla.; Southwest Steel Co. (ornamental iron), Sand Springs, Okla.; Prayson Candies Co. (candy), Tulsa; Comet Moving & Storage Co. (moving and storage), Tulsa; Community Loan & Investment Co. (loans), Ardmore; Prayson Candies Co. (candy), Tulsa; Tulsa Cabinet Shop (wooden furniture), Tulsa.

TV Accounts: National Bank of Tulsa (banking and trust services), Tulsa; Tom P. McDermott, Inc. (tires & appliances, anti free, motor oil), Tulsa; State Federal Savings & Loan Assn. (savings, loans, investments), Tulsa; Wortz Biscuit Co. (crackers and cookies), Fort Smith, Ark.; Comet Moving & Storage Co. (moving), Tulsa; Tulsa Cabinet Shop (wooden furniture), Tulsa; Pedrick Laboratories, Inc. (Dog Food), Sand Springs; Southwest Steel Co. (ornamental iron), Sand Springs.

J. J. GIBBONS LIMITED

200 Bay St., Toronto, Ont., Canada
Phone: Empire 4-2111
ABC-CDNA-CWNA-CNN & PA
CAAA-APA

Chairman of Board.....R. A. Stapells
President.....Mrs. J. J. Gibbons
Vice-President.....H. M. Tedman
Vice-Pres. & Gen. Mgr.....R. B. Pattinson
V.P. & Secy.-Treas.....E. T. Saunders
Production Mgr.....J. A. Walsh

Branch Offices

924 Dominion Square Bldg., Montreal, Que.
Manager.....R. L. Burdick
272 Scott Block, Winnipeg, Manitoba
V.P. & Manager.....A. B. Johnston

GIBRALTAR ADV. AGENCY, INC.

17 E. 45th St., New York 17, N. Y.
Phone: MUrray Hill 7-7896

President.....Charles J. Basch, III
Vice-President.....Leo Berman
Treasurer.....Clarence Schmidt
Secretary, Radio & TV Dir.....Frances Scott
Radio & TV Time Buyer.....Gloria Lubin

Rad. TV Accounts: Bonafide Mills, (Bonny Maid Linoleums, Tilemasters, & Versa Tile), New York, N. Y.; Davis Handkerchief Corp.; Parke-Edwards, Ltd.

Other Accounts: Kurt A. Baer, Inc. (Mfrs. Representatives of non-ferrous metals); Alpha Products Co. (Distributors of Automotive equipment oil and chemicals); Diamant Marine Corp. (Distributors of boating supplies); Safety Zipper Corp. (Safety Zippers & Sliders), 350 Fifth Avenue, N. Y. C.; Bonafide Mills, Inc. (Bonny Maid Linoleum), N. Y. C.; Leonard Salon; Dean Parker, Inc.

GILLHAM ADVERTISING AGENCY

500 Continental Bank Bldg., Salt Lake City
J, Utah

Phone: 4-5516

ABP-ANPA-APA-PPA

President-Treasurer.....M. C. Nelson
Exec. Vice-President.....Lon Richardson
Vice-President.....Robert F. Rohlfing
Vice-President.....Wendell J. Ashton
Secretary.....Marjorie Farrell
Space Buyer.....Esther Gook

Radio Accounts: Cloverleaf Dairy (Milk, Cream, Milk Products), Salt Lake City, Utah; Colville Ice Cream Co. (Ice Cream, Bars, etc.), Salt Lake City, Utah; First Federal Savings, Salt Lake City, Utah; Fisher Brewing Company (Beer), Salt Lake City, Utah; Freed Motor Company (DeSoto-Plymouth Cars), Salt Lake City, Utah; General Electric Supply Corp. (Appliances, etc.), Intermountain Area; Mountain Fuel Supply Co., Salt Lake City; Ogden First Federal Savings, Ogden, Utah; Petty Motor (Ford Dealer), Salt Lake City, Utah; Porter-Scarpelli Macaroni Co. (Frit-lets, Spaghetti, etc.), Portland, Ore.; Purity Biscuit Company (Town House Crackers, Cookies, Saltine Crackers, etc.), Salt Lake City, Phoenix, Butte; Royal Baking Company (Table Queen Bread, Other Bread Products), Salt Lake City; Sego Milk Products Co. (Sego Evaporated Milk), Salt Lake City; Streater Chevrolet Co., Salt Lake City; Sweet Candy Company (Renown Chocolates, Other Candies), Salt Lake City; Union Pacific Railroad, Salt Lake City; Utah Oil Refining Co. (Gasoline, Oil, Atlas Products), Salt Lake City; Utah Power & Light Co. (Electric Service), Intermountain Area; Walker Bank & Trust Co., Salt Lake City.

TV Accounts: Cloverleaf Dairy (Milk, Cream, Milk Products), Salt Lake City, Utah; Colville Ice Cream Co. (Ice Cream, Bars, etc.), Salt Lake City, Utah; First Federal Savings, Salt Lake City, Utah; Fisher Brewing Company (Beer), Salt Lake City, Utah; Freed Motor Company (DeSoto-Plymouth Cars), Salt Lake City, Utah; General Electric Supply Corp. (Appliances, etc.), Salt Lake City, Utah; Mountain Fuel Supply Co., Salt Lake City, Utah; Petty Motor (Ford Dealer), Salt Lake City, Utah; Purity Biscuit Company (Town House Cookies, Crackers), Salt Lake City, Phoenix; Royal Baking Company

(Table Queen Bread, Other Bakery Products), Salt Lake City; Sego Milk Products Co. (Sego Evaporated Milk), Salt Lake City; Sweet Candy Company (Renown Chocolates, etc.), Salt Lake City; Union Pacific Railroad, Salt Lake City; Utah Power & Light Co. (Electric Service), Salt Lake City.

BERT S. GITTINS ADVERTISING

739 N. Broadway, Milwaukee 2, Wis.

Phone: BR 6-5948

AAAA-ABC-ABP-ANPA-AFA

Owner.....Bert S. Gittins
Agriculture Director.....Carlton Stoddard
Industrial Director.....James Costello
Prod. Dir.....Stewart Carlson
Media Dir.....Esther Block
Copy Dir.....Harold Nelson
Ind. Copy Dir.....Franklin J. Beezley
Office Mgr.....Erwin R. Holtz
Radio & TV Dir.....Gerald L. Sraman

Radio Accounts: Allis-Chalmers Mfg. Co. (Farm Tractors & Equipment), Milwaukee, Wis.; Group 8-Wisconsin Bankers' Assn. (Banking Service), Milwaukee, Wis.; The Page Milk Company (Evaporated Milk), Merrill, Wis.; Wm. F. Renk & Sons (Hybrid Corn), Sun Prairie, Wis.; Manitowac Equip. Co. (Food Freezer), Manitowac, Wis.

TV Accounts: Allis-Chalmers Mfg. Co. (Farm Tractors & Equipment), Milwaukee, Wis.; Group 8-Wisconsin Bankers' Assn. (Banking Service), Milwaukee, Wis.; Manitowac Equip. Co. (Food Freezer), Manitowac, Wis.

GLASSER-GAILEY, INC.

301 S. Harvard Blvd., Los Angeles 5, Calif.

Phone: DUNKirk 4-2141

AAAA-ANPA-PPA

President.....G. F. Glasser
Secretary-Treasurer.....Howard W. Cambrill
Art Director.....J. Gelehel Seaker

Radio Accounts: Ralph Grocery Co., Tropical Preserving Co., L. B. Laboratories, Inc. (Hair Preparations), Los Angeles.

GLEW ADVERTISING AGENCY

211 N. Lafayette Ave., Grand Rapids, Mich.

Phone: 9-4052

GOLDEN ADVERTISING AGENCY

44 Court Street, Brooklyn 2, N. Y.

Phone: MAIN 4-1375

ABP-ANPA-AFA

President.....Ben Golden
Account Executive.....William Goldstein

Radio Accounts: EDCO Electric Co. (Sylvania & Thor Washers), New York; Nosstrand Radio Co. (TV Receivers), Brooklyn.

GOODKIND, JOICE & MORGAN, INC.

919 North Michigan Ave., Chicago 11, Ill.

Phone: SUPERior 7-6746

AAAA-ANPA-ABP

President.....Clyde M. Joice
Treas. & Copy Chief.....Garrick M. Taylor

Secy. & Media Dir... Florence A. Neighbors
 Asst. Med. Dir., Prod. Mgr.... J. Alden Joice
 Vice President..... Henry Nathan
 Vice President..... Joseph J. Klein

Radio Accounts: Planters Nut & Chocolate Co., Goldenrod Ice Cream Co., Planters Edible Oil Co., Jewel Tea Co., Inc., The Illinois Canning Co., C. H. Runciman Co., Lowell, Mich.; Huniston-Keeling & Co., Radex Corporation, Nutrition Research Laboratories.

TV Accounts: Goldenrod Ice Cream Co. (Ice Cream), Chicago, Ill.; The Illinois Canning Co.; C. H. Runciman Co., Lowell, Mich.; Planters Edible Oil Co., Wilkes-Barre, Pa.; Humiston-Keeling & Co.

GOTHAM ADVERTISING CO.

2 W. 46th St., New York 36, N. Y.

Phone: LUXemburg 2-2880

ABP—ANPA—ABC

Chairman of Bd..... G. Ellsworth Harris
 President..... Duncan D. Sutphen, Jr.
 Exec. V.P. & Treas..... Arthur A. Kron
 Vice Pres..... Robert F. Kendall
 Vice Pres..... Arthur F. Connolly
 Secretary..... Chester A. Priest
 Dir. Radio & Television... Arthur A. Kron
 Dir. Pub. Relations..... C. W. Alexander

Branch Offices

Gotham de Mexico, S. A.
 Bolivar 8, Despacho 607, Mexico D.F., Mexico
 Director..... Edwin J. Ryan
 Coudrey-Gotham Prop. Ltd.
 5-7 Barrack St., Sydney, Australia

Director..... C. J. Coudrey
Radio Accounts: Lutheran Laymen's League (Lutheran Church-Missouri Synod), St. Louis, Mo.; L. A. V. (Venezuelan Airlines), New York, N. Y.

TV Accounts: Lutheran Laymen's League (Lutheran Church-Missouri Synod), St. Louis, Mo.

GRAY & ROGERS

12 South 12th St., Philadelphia 7, Pa.

Phone: WALnut 2-40808

ABC—ANPA

Partner..... Jerome B. Gray
 Partner..... Edmund H. Rogers
 Partner..... Robert W. Graham
 Partners..... Sherman G. Landers,
 Russell K. Carter, William B. Edwards,
 William S. Harvey, Edmond G. Thomas,
 Atherton Seeley, David B. Arnold, Thelma Beresin.

Radio-TV Dept. Head... Walter M. Erickson
Radio Accounts: The M. A. Hanna Company (Coal), Philadelphia, Pa.; Philadelphia Saving Fund Society (Banking Services), Philadelphia, Pa.; American Chemical Paint Co. (Plant Foods), Ambler, Pa.; Associated Hospital Service of Philadelphia (Blue Cross-Blue Shield), Philadelphia; Bell Telephone Co. of Pa. (Services), Philadelphia; Chevrolet Dealers Assn. of Philadelphia, Philadelphia; Diamond State Telephone Company (Services); Delaware; Fritz & La Rue (Carpets), Philadelphia; Lee Tire

& Rubber Co. (Tires), Conshohocken; Philadelphia Zone Planning Assn. (Chevrolet Dealers), Philadelphia; Wilen Brothers, Inc. (Wines), Philadelphia.

TV Accounts: Fidelity-Philadelphia Trust Co. (Banking Services), Philadelphia, Pa.; Keystone Automobile Club (Services), Philadelphia, Pa.; Philadelphia Saving Fund Society (Banking Services), Philadelphia, Pa.; American Chemical Paint Co. (Plant Foods), Ambler, Pa.; Associated Hospital Service of Philadelphia (Blue Cross-Blue Shield), Philadelphia; The Bell Telephone Co. of Penna. (Services), Philadelphia; Chevrolet Dealers Assn. of Philadelphia; Diamond State Telephone Co. (Services), Delaware; Charles Marchand Company (Hair Rinses), N. Y. C.; Philadelphia; Zone Planning Assn. (Chevrolet Dealers), Philadelphia; Pyrene Manufacturing Company (Fire Extinguishers), Newark; Wilen Brothers, Inc. (Wines), Philadelphia.

GREEN-BRODIE

420 Madison Ave., New York 17, N. Y.

Phone: PLaza 9-3330

ANPA—ABP

Partners..... Julian P. Brodie, Alan Green
 Space & Time Buyer..... Betty Gershon
 Art Director..... Cecil Baumgarten
 Production Mgr..... James West
Radio Accounts: Pieter de Wilt, Inc., The Viking Press, Krasdale Foods, Inc. (Canned Foods), New York, N. Y.

TV Accounts: Krasdale Foods, Inc. (Canned Foods), New York, N. Y.

MONROE GREENTHAL CO., INC.

445 Park Avenue, New York 22, N. Y.

Phone: PLaza 9-3640

ANPA—APA—PPA

Pres., Treas..... Monroe W. Greenthal
 Vice-President..... Albert L. Reinitz
 Production Mgr..... Gene Cofsky
 Radio & TV Dir..... Samuel G. Gallu
 Media Dir., Space Buyer..... Heth Hauser

GREY ADVERTISING AGENCY, INC.

166 W. 32nd St., New York 1, N. Y.

Phone: OXford 5-2000

AAAA—ABP—ANPA—APA—NOAB—PPA
 President..... Lawrence Valenstein
 Asst. to Pres..... Norman J. J. Berger
 Executive Vice-Pres..... Arthur C. Fatt
 Media & Research Dir.... Herbert A. Vitriol
 V.P. & Radio-TV Dir... Alfred L. Hollender
 Media Director..... Richard Bean

Radio Accounts: Ronson Art Metal Works, Inc. (Lighters & Accessories), Newark, N. J.; Kirsch Beverages, Inc. (Soft Drinks), Brooklyn, N. Y.; Phillips-Jones, Inc. (Van Heusen Shirts & Men's Wear), New York, N. Y.; American Safety Razor Corp. (Gem Razors & Blades); Doughnut Corp. of America (Howdy Doody Ice Cream); Esquire, Inc. (Coronet Magazine); Krueger Brewing Company (Quisana Foot Powder & Mennen Baby Products); Union Pharmaceutical Corp. (Inhiston & Saraka).

TV Accounts: Ronson Art Metal Works, Inc. (Lighters), Newark, N. J.; American Safety Razor Corp. (Gem Razors & Blades); Anson, Inc. (Jewelry); Artra Cosmetics (Imra); Associated Products, Inc. (Deodorant Pads & Pipes); Doeskin Products, Inc. (Tissues & Napkins); Doughnut Corp. of America (Howdy Doodly Ice Cream); Esquire, Inc. (Coronet Magazine); Girard Perregaux (Watches); Kirsch Beverages, Inc. (No-Cal Soft Drinks); Krueger Brewing Company, Inc. (Beer & Ale); The Mennen Company (Quinsana Foot Powder & Mennen Baby Products); Prince Gardner (Wallets); Shwayder Bros., Inc. (Samsonite Luggage & Furniture); The Ullman Company (Princess Plastics); Union Pharmaceutical (Inhi-ton).

THE GRISWOLD-ESHELMAN CO.

1400 Terminal Tower, Cleveland 13, O.
Phone: Tower 1-3232

AAAA—ANPA—PPA—APA—ABP
NOAB—ABC—SNPA

President.....Kenneth W. Akers
Vice President.....Charles Farran
Vice President.....S. A. Lewis
Vice President.....E. R. Preble
Secretary-Treas.....John F. Davis
Media Dir.....William A. Weaver
Dir. of Radio & TV.....Richard Woodruff

Radio Accounts: Fisher Bros. Co. (Retail Food Chain), Cleveland, O.; Thompson Products Co. (Tapco Div., Automotive & Aviation Parts), Cleveland, O.; The Warner & Swasey Co. (Machine Tools), Cleveland, O.; Lincoln Electric Co. (Electric Arc Welding Equipment), Cleveland, O.; The Wellman Engineering Co. (Material Handling Equipment), Cleveland, O.; The Eric Railroad Co. (Passenger Service), Cleveland, O.; Brush Development Co. (Piezoelectric Mat's for Recording, Reproducing and Measuring), Cleveland, O.; Fleet-Wing Corp. (Gasoline & Oil), Cleveland, O.; Youngstown Sheet & Tube (Steel), Youngstown, O.; Jenney Mfg. Co. (Gasoline & Oil), Boston, Mass.; Society for Savings (Banking Service), Cleveland, O.; Tennessee Products & Chemical Corp. (Chemicals), Nashville, Tenn.; The Halle Bros. Co. (Retail Stores), Cleveland, O.; Motorists Mutual Insurance Co., Columbus, O.; B. F. Goodrich Co. (Tire Division), Akron, O.; Cockshutt Farm Equipment Co., Bellevue, O.; Milk Producers Federation of Cleveland; First National Bank, Louisville, Ky.

TV Accounts: Fisher Bros. Co. (Retail Food Chain), Cleveland, O.; Thompson Products Co. (Tapco Div., Automotive & Aviation Parts), Cleveland, O.; Society for Savings (Banking Service), Cleveland, O.; Jenney Mfg. Co. (Gasoline & Oil), Boston, Mass.; Tappan Stove Co. (Ranges), Mansfield, O.; The B. F. Goodrich Co. (Tires, Drugs, Etc.), Akron, O.; Milk Producers Federation of Cleveland; The Halle Bros.

Co. (Retail Stores), Cleveland, O.; Warner & Swasey Co. (Turret Lathes), Cleveland, O.

JULIAN GROSS ADV. AGENCY

11 Asylum St., Hartford 3, Conn.
Phone: 7-7179
ABP—NAAN

Pres., Treas., Pub. Dir.....Julian Gross
Vice-President.....Beulah Gross
Art Director.....Declan Powers
Sec., Media Dir., Radio Time
Buyer.....Libby Dunn

**ART GRUBER ASSOCIATES,
ADVERTISING**

5316 S. Girard Ave., Minneapolis 19, Minn.
Phone: REgent 1307; 0373

APA

Pres., Treas.....Arthur R. Gruber
Secretary.....E. M. Gruber
Art Director.....Donald Layman
Radio Accounts: Midwest Wine Company (Temple Wine), St. Paul, Minn.; Plymouth Dealers' Ass'n (Plymouth Automobiles), Minneapolis-St. Paul, Minn.; Slawik Motors, Inc. (DeSoto Plymouth), Willard's Terrace Cafe (Restaurant-Catering), Minneapolis, Minn.

TV Accounts: Kline Oldsmobile, Inc. (Automobiles), St. Paul, Minn.; Midwest Wine Co. (Temple Wine), St. Paul, Minn.; Newmans (Women's Apparel), St. Paul, Minn.; Plymouth Dealers' Ass'n (Plymouth Automobiles), Minneapolis-St. Paul, Minn.; Rusco Window Company (Self-Storing Windows), Minneapolis-St. Paul, Minn.; Slawik Motors, Inc. (DeSoto-Plymouth), Minneapolis-St. Paul, Minn.

GUILFORD ADVERTISING AGENCY

350 Fifth Ave., New York 1, N. Y.
Phone: PENnsylvania 6-8518

ANPA

Account Executive.....Frances C. Guilford

JOHN L. HALPIN ADVERTISING

207 State St., Schenectady 5, N. Y.
Phone: Schenectady 2-0492

Partners..John L. Halpin, Marion G. Halpin
Copy Chief.....S. P. Levine

Radio Accounts: Mohawk National Bank, Schenectady, N. Y.; Cobleskill Agricultural Society, Cobleskill, N. Y.

TV Accounts: Cobleskill Agricultural Soc., Cobleskill, N. Y.

**HANLY, HICKS & MONTGOMERY,
INC.**

500 Fifth Ave., New York 18, N. Y.
Phone: LOngacre 5-5671

AAAA—ABP—ANPA—PPA—APA
NOAB—ABC

Chairman of Board.....C. P. Hanly
President.....H. M. Montgomery
Sec.-Treas. & Media Dir.....H. E. Lehman

HART-CONWAY CO., INC.

Genesee Val. Tr. Bldg., Rochester 14, N. Y.
Phone: LOcust 3520

ANPA—APA—PPA—ABP

President & Treasurer.....H. Lyman Hart
 Exec. Vice-President....Harold E. Kennedy
 Vice-President.....Joseph Brown
 Secretary.....John P. Street
 Account Executives.....E. Ward Phillips,
 John M. Nixon

Radio Accounts: Blue Boy Dairy (Dairy Products), Rochester, N. Y.; Blue Bus Lines (Intercity Bus Lines), Batavia, N. Y.; Columbia Bkg. Svc. & Loan (Savings Bank), Rochester, N. Y.; Crescent-Puritan Laundry, Rochester, N. Y.; Genesee Valley Trust Co. (Bank), Rochester, N. Y.; Genesee-Monroe Racing Assoc. (Harness Racing Track), Batavia, N. Y.; Haxton Foods, Inc. (Blue Boy Canned Foods), Oakfield, N. Y.; Levis Music Stores, Rochester, N. Y.; Qualtop Beverage Co., Inc. (Makers of Soft Drinks), Rochester, N. Y.; Security Trust Co. (Bank), Rochester, N. Y.; Standard Brewing Co. (Brewery), Rochester, N. Y.; Sheraton Hotel, Rochester, N. Y.; Whiting-Buick, Inc. (Buick Distributor), Rochester, N. Y.

TV Accounts: Blue Boy Dairy (Dairy Products), Rochester, N. Y.; F. Cappellino & Sons, Rochester, N. Y.; Crescent-Puritan Laundry, Rochester, N. Y.; Genesee Valley Trust Co. (Bank), Rochester, N. Y.; Genesee-Monroe Racing Assoc. (Harness Racing Track), Batavia, N. Y.; Haxton Foods, Inc. (Blue Boy Canned Foods), Oakfield, N. Y.; Levis Music Stores, Rochester, N. Y.; Qualtop Beverage Co., Inc. (Makers of Soft Drinks), Rochester, N. Y.; Rochester Gas & Elec. Corp., Rochester, N. Y.; Security Trust Co. (Bank), Rochester, N. Y.; Standard Brewing Co. (Brewery), Rochester, N. Y.

GEORGE H. HARTMAN CO.

307 N. Michigan Ave., Chicago 1, Ill.

Phone: STate 2-0055

ABP—ANPA—APA—NOAB—PPA

President.....George H. Hartman
 Vice-President.....Rowland Laughlin
 Vice-Presidents.....Alfred Festen,
 John T. Holloway

Secretary-Treasurer.....Frank R. Hartman
 V.P., Radio-TV Dir.....Thomas Kivlan

Radio-TV Accounts: P. A. Starck Piano Co. (Pianos), M. J. Lanahan Co. (Automobiles), Chicago Tribune (Newspaper), Hartz Mountain Products (Bird Food), New York, N. Y.; Neumode Hosiery Co. (Hosiery), Sawyer Biscuit Co. (Crackers & Cookies), Chicago; Manchester Biscuit Co. (Crackers & Cookies), Fargo, No. Dak.; Omaha, Neb.; Sioux Falls, So. Dak.; Hekman Biscuit Co. (Crackers & Cookies), Grand Rapids, Mich.

THE F. H. HAYHURST COMPANY LIMITED

7 King St. W., Toronto, Ontario, Canada

Phone: EMpire 6-0731

President.....W. P. Hayhurst
 Vice-President.....Geo. F. Hayhurst
 V.P.....H. W. E. Pepler
 V.P.....N. L. Drynan

Director.....D. J. Leonard
 Radio-TV Director.....R. D. Amos

Branch Office

1405 Peel St., Montreal, Que.

Phone: HARbour 0131

Manager.....B. J. Leopold

Radio Accounts: Bromo-Seltzer Ltd. (Bromo-Seltzer), Toronto, Ont.; Purity Flour Mills Ltd. (Purity Flour, Purity Oats & Cake Mix), Toronto, Ont.; Templeton's Limited (Raz-Mah & T-R-C's), Toronto, Ont.; Brading Breweries Ltd. (Beer & Ale), Ottawa, Ont.; Canadian Cannery Limited (Soups, Baby Food), Hamilton, Ont.; Mecano Limited (Toys), Toronto, Ont.; Procter & Gamble (Camay Soap), Toronto; Acousticon (Hearing Aids), Toronto; Minibrix (Rubber Toys), Oshawa.

TV Accounts: Minibrix (Rubber Toys), Oshawa; Aconsticon (Hearing Aids), Toronto.

HENRI, HURST & McDONALD, INC.

121 W. Wacker Drive, Chicago 1, Ill.

Phone: FRanklin 2-9180

AAAA—ABP—ANPA—APA—ABC

Chairman of Bd. of Dir.....W. D. McDonald
 President.....W. B. Henri
 Exec. Vice Pres.....E. F. Hascall
 Sec.-Treas.....R. H. Eaton
 Media Director.....Charles Pumpian
 Radio-TV Director.....John Scott Keck
 Radio-TV Time Buyer.....L. R. Hall
 General Manager.....E. F. Hascall, Jr.

Radio Accounts: Fred W. Amend Co. ("Chuckles" and Chuckles Spice Drops), Chicago, Ill.; International Shoe Co. (Peters Branch; Roberts, Johnson & Rand; Vitality Shoe Co.), St. Louis, Mo.; Lennox Furnace Co. (Warm Air Heating Systems), Marshalltown, Iowa; Milnot Company (Milnot), Litchfield, Ill.; Perma Starch, Inc. (Perma Starch), Illiopolis, Ill.; Skelgas Division of Skelly Oil Co. (Skelgas Bottled Gas), Kansas City, Mo.; Skelly Oil Co. (Motor Oils, Skellysolve, etc., Petroleum Products, Gasoline), Kansas City, Mo.; A. O. Smith Corporation (Line Pipe & Casing, Pressure Vessels, Glass-Lined Tanks, Welding Electrodes and Machines, Smithway Automatic Water Heaters, Pumps, Smithway Volume Flow Water Heaters and Heating Equipment, LPG Systems Electric Motors, International Division), Milwaukee, Wis.; Ready-to-Bake-Foods, Los Angeles, Calif.

TV Accounts: Fred W. Amend Co. ("Chuckles" and Chuckles Spice Drops), Chicago, Ill.; International Shoe Co. (Peters Branch; Roberts, Johnson & Branch, Vitality Shoe Co.), St. Louis, Mo.; Lennox Furnace Co. (Warm Air Heating Systems), Marshalltown, Iowa; Milnot Company (Milnot), Litchfield, Ill.; Perma Starch, Inc. (Perma Starch), Illiopolis, Ill.; Field Entpr., Chicago, Ill.; Kitchen Arts Foods, Chicago, Ill.; Ready-to-Bake Foods, Los Angeles, Calif.; Skelly Oil Co.; A. O. Smith Corp., Thor Corp.



AL HERR ADVERTISING AGENCY

225 E. Michigan St., Milwaukee 2, Wis.
Phone: Broadway 2-8040
AAAA-ABP-ANPA

Pres., Acct. Exec. Al Herr
Vice-President John Rock
Radio and TV Dir. Pat Kocian
Radio Accounts: Pate Oil Company (Gasoline, Lubricants, etc.), Milwaukee, Wis.; John Graf Company (Soft Drinks), Milwaukee, Wis.; Kellers, Inc. (Beverage Distributor), Milwaukee, Wis.; Milwaukee Florists Assn. (Flowers), Milwaukee, Wis.; Luick Dairy Company (Dairy Products), Milwaukee, Wis.; Luick Ice Cream Company (Ice Cream), Milwaukee, Wis.

TV Accounts: Pate Oil Company (Gasoline, Lubricants, etc.), Milwaukee, Wis.; John Graf Company (Soft Drinks), Milwaukee, Wis.; Milwaukee Florists Assn. (Flowers), Milwaukee, Wis.; Luick Dairy Company (Dairy Products), Milwaukee, Wis.; Luick Ice Cream Company (Ice Cream), Milwaukee, Wis.

HEWITT, OGILVY, BENSON & MATHER, INC.

575 Madison Ave., New York, N. Y.
Phone: MURray Hill 8-6100
ANPA -APA -IPA -NOAB -ABC

President David Ogilvy
Vice-Presidents Rollin C. Smith, David Margaretten
Treasurer Shelby H. Page
Dir. of Radio-TV Howard Connell
Radio-TV Time Buyers Walter J. Bove, Martin Kane
Art Director Vincent DiGiacomo
Radio & TV Accounts: Appleby & Co., Augustein & Co., Austin Motor Co., Blouse-maker, Inc., British Industries Fair, British Travel & Holidays Association, Conmar Products Corp.; Gonrielli Inc., Hathaway Co., William Hollins & Co., Inc., Lever Bros. Co., Reed & Barton, Rubinstein Cosmetics, Schweppes Ltd., Josiah Wedgwood.

HICKS & GREIST, INC.

420 Lexington Ave., New York 17, N. Y.
Phone: MURray Hill 3-9135
ABP-ANPA-APA-PPA-NOAB

President & Secretary H. L. Hicks
V.P. & Treasurer E. H. Greist
V.P. J. A. Drake
Media Director Mrs. E. M. Sheldon
Radio & TV Director Peter A. Krug

Branch Offices

3450 Wilshire Blvd., Los Angeles, Calif.
Phone: AR 3-2731

Executive Peyton Carroll
Radio Accounts: Blackstone Corp.; Dixie Paper Cup Co.; Eberhard Faber Pencil Co.; General Floorcraft, Inc.; Glamorene; Louis L. Libby Food Products; Serval, Inc.; Wolcott Company.

TV Accounts: Lewyt Corp., Brooklyn; Dixie Cup Co., Easton, Pa.; Blackstone

Corp.; Eberhard Faber Pencil Co.; General Floorcraft, Inc.; Glamorene; Louis L. Libby Food Products; Wolcott Company; Serval, Inc.; Waring Products.

HIRSHON-GARFIELD, INC.

745 Fifth Ave., New York 22, N. Y.
Phone: MU 8-8900
NOAB-ANPA-APA-PPA

President Sidney Garfield
Exec. Vice-Pres. Lewis Nemerson
Vice-President Judah Katz
Gen. Mgr. Julian Braun
Radio & TV Director Robert F. Lewine
Radio & TV Mgr. William Sheppard
Production Supervisor Eli Gutterman

Branch Offices

Park Square Bldg., Boston, Mass.
Phone: LIBerty 2-0485

Executive-in-Charge Gabriel Stern
Radio Accounts: Adam Hat Stores (Men's Hats & Furnishings), New York, N. Y.; Prentis Clothes (Men's & Boys' Clothing), New York, N. Y.

TV Accounts: Adam Hat Stores (Men's Hats & Furnishings), New York, N. Y.; Jacques Kreisler Mfg. Corp. (Watchbands), North Bergen, N. J.; Prentis Clothes (Men's & Boys' Clothes), New York, N. Y.; U. S. Time Corp. (Watches), Bridgeport, Conn.

HOAG & PROVANDIE, INC.

136 Federal St., Boston 10, Mass.
Phone: HANcock 6-8580
ABP-ANPA-APA-PPA-AAAA

President J. Paul Hoag
Vice-President Paul H. Provandie
Vice-President Langley C. Keyes
Production Mgr. Bertha L. Aldrich

W. F. HOLLAND

2530 Auburn Ave., Cincinnati 19, Ohio
Phone: CApital 1252-3-4
Owner William F. Holland
Radio-TV Director Earl Holland

HONIG-COOPER COMPANY

333 Montgomery, San Francisco 4, Calif.
Phone: EXbrook 2-7004
AAAA-ABC-ABP-ANPA-APA-PPA-NOAB

President & Treasurer S. R. Hutton
Exec. Vice President Louis Honig
Secretary Fred Glauser
Media Director John W. Davis
Production Manager Thomas H. Nason

Branch Office

455 Skinner Bldg., Seattle 1, Wash.
Phone: MAin 6435

Vice President Warren E. Kraft
Radio Accounts: Italian Swiss Colony (Wine), San Francisco, Calif.; Marlo Packing Corp. (Canned Meats), San Francisco, Calif.; Calso Water Co. (Calso Water), San Francisco, Calif.; Colgate-Palmolive-Pect Co. (Pect's Soap), Berkeley, Calif.; Duart Manufacturing Co., Ltd. (Kolor-treet Shampoo), San Francisco, Calif.; National Lead Co.

(Dutch Boy Paints), San Francisco, Calif.
TV Accounts: Italian Swiss Colony (Wine), San Francisco, Calif.; Calso Water Co. (Calso Water), San Francisco, Calif.; Marlo Packing Corp. (Canned Meats), San Francisco, Calif.; Colgate-Palmolive-Peet Co. (Pee't's Soap), Berkeley, Calif.; National Lead Company (Dutch Boy Paints), San Francisco, Calif.; Haas Bros. (Trupak Foods), San Francisco, Calif.; A. Giurlani & Bro. (Star Olive Oil), San Francisco, Calif.

**HOUCK & COMPANY, INC.—
 ADVERTISING**

625 First St., S.W., Roanoke 16, Va.
 Phone: 2-3411

ABP—ANPA—APA—PPA—SNPA

President.....C. B. Houck
 V.P., Radio-TV Dir.....William B. Houck
 Secretary.....Kathryn H. Ferguson
 Art Director.....Edwin R. Deady
 Copy Chief.....Otto Whittaker, Jr.
 Production Manager.....Paul H. Long
 Asst. Production Mgr.....W. Leon Mitchell

Branch Office

Houck & Co. of Florida, Inc.
 (Separate Corporation)

Alfred I. duPont Bldg., Miami, Fla.
 Phone: 82-1475

President.....Karl Bishopric
 Time Buyer.....Marguerite Brown
 V.P., Radio-TV.....Robert Venn
 Production Manager.....Richard V. Sutton

Radio Accounts: Crowley Sausage Company (Meat Products), Kellysville, W. Va.; Chase Federal Savings & Loan (Financial Institution), Miami Beach, Fla.; State-Planters Bank & Trust Co. (Financial Institution), Richmond, Va.; Florida National Bank (Financial Services), Miami, Fla.; Miami Battle Creek (Sanitorium), Miami Springs, Fla.; Valleydale-Packers, Inc. (Meat Products), Salem, Va.

TV Accounts: Chase Federal Savings & Loan (Financial Institute), Miami Beach, Fla..

HORTON-NOYES COMPANY

1800 Industrial Trust Bldg.,
 Providence 3, R. I.
 Phone: Dexter 1-3316

AAAA—ABC—ABP—ANPA

Partner.....Frederick C. Noyes
 Partner.....C. Darrell Prutzman
 Partner.....Carroll H. Rickard
 Media Buyer.....Eben S. Church
 Time Buyer.....Florence S. McCarroll

Radio Accounts: Industrial Trust Company (Banking), Providence, R. I.; The Narragansett Electric Co. (Electrical Equipment), Providence, R. I.; Peoples Savings Bank (Savings), Providence, R. I.; The Collins Co. (Axes, Machetes, & other edge tools), Col-linsville, Conn.

TV Accounts: General Ice Cream Corp. (R. I.) (Ice Cream), Providence, R. I.; Industrial Trust Company (Banking), Providence, R. I.; Westfield Mfg. Co. (Bicycles),

Westfield, Mass.; Narragansett Electric Co. (Public Utility), Providence, R. I.; Peoples Savings Bank (Financial), Providence, R. I.

CHARLES W. HOYT CO., INC.

380 Madison Ave., New York 17, N. Y.

Phone: MURray Hill 2-2000

Radio-TV Director.....Wm. Philip Smith
Branch Office

15 Lewis St., Hartford 3, Conn.

Vice-Pres. & Mgr., Hartford Office

Frank A. Whipple

Radio Accounts: Blueberry Cooperative Assn. (Tru-Blu-Berries), New Lisbon, N. J.; Charles Gulden, Inc. (Gulden's Mustard), New York, N. Y.; Mail Pouch Tobacco Co. (Kentucky Club Tobacco), Wheeling, W. Va.; Monticello Drug Co. (666 Cold Tablets), Jacksonville, Fla.; Stanley Home Products (Household Products), Westfield, Mass.; Knox Gelatine; Rutland Fire Clay Co.; South African Rock Lobster Assn.; Switzerland Cheese Assn.; The Taylor-Reed Corp.

TV Accounts: Mail Pouch Tobacco Co. (Kentucky Club Pipe Tobacco), Wheeling; Chas. B. Knox Gelatine Co. (Knox Gelatine), Johnstown, N. Y.; Monticello Drug Co. (666 Cold Preparations), Jacksonville, Fla.; American Molasses Co.; Arnold Bakers Inc.; Blueberry Cooperative Assn.; Milton-Bradley Co.; Brazil Nut Advertising Fund; Brock-Hall Dairy Co.; Frank E. Campbell Funeral Church; Flako Products Corp.; Lebn & Fink Products Corp.; Michigan Blueberry Growers Assn.; N. Y. & New England Apple Institute.

**H. B. HUMPHREY, ALLEY &
 RICHARDS**

1235 Statler Bldg., Boston 16, Mass.

Phone: LIBerty 6100

370 Lexington Ave., New York, N. Y.

Phone: LEXington 2-3020

Ch. of Board.....H. L. Wittemore
 Vice-Pres. & Secy.....H. M. Billerbeck

HUTCHINS ADVERTISING CO., INC.

42 East Ave., Rochester 4, N. Y.

Phone: HAMilton 1160

APA—ANPA—PPA—ABP—NOAB

Director.....Frank A. Hutchins
 Director.....F. Irving Hutchins
 President.....Frank M. Hutchins
 Vice-Presidents.....John P. McCarthy,
 William F. Lacey, Homer C. Scheck,
 Charles S. Wilkinson

Branch Offices

3701 N. Broad St., Philadelphia 40, Pa.

Vice-Presidents.....John R. Maxwell,
 W. H. Maxwell

16-18 W. 46th St., New York, N. Y.

Vice-Presidents.....H. Pierson Mapes,
 James Burton

1244 Dufferin, St. Toronto Ont., Canada

Manager.....William Bounsall
Radio Accounts: Philco Corp., Schulers
 Potato Chip Co., Lincoln Rochester Trust
 Co., McCurdy & Co., Scrantom's; Beaucaire,

Inc., F. E. Bausch & Son Co., Hub Oil Co., Projansky, Inc.
TV Accounts: Phileo Corp., Schulers Potato Chip Co., Beaucaire, Inc., Lincoln Rochester Trust Co.

JACKSON & COMPANY

62 Worth St., New York 13, N. Y.
 Phone: WOrth 4-7005
 ABC-ABP-ANPA

Managing Partner.....Paul E. Jackson
 General Manager.....John Yeargain
Radio Accounts: Pequot Mills (Sheets & Pillowcases), Salem, Mass.; Heyward Hosiery, N. Y. C.

JESSOP ADVERTISING CO., INC.

1st National Tower Bldg., Akron 8, Ohio
 Phone: FRanklin 6-2169

President & Treas.....M. K. Jessop
 Vice-President.....Charles A. Jessop
 Radio & TV Director.....R. Gilbert
 Secretary.....R. D. Moss
 Radio Time Buyer.....R. J. Cobak

DUANE JONES COMPANY, INC.

570 Lexington Ave., New York 22, N. Y.
 Phone: PLaza 3-4848
 ABC-ABP-ANPA-AFA

Chairman of Bd. & Pres.....Duane Jones
 Exec. Asst. to Pres.....E. M. Bresett
 Treasurer.....Raymond Coyle
 Secretary.....Vera Whelpley
 Space Buyer.....Frances Kyle
 Time Buyer.....Betty Nasse
 Public Relations.....Mark Larkin
Radio & TV Accounts: John Andre Products, New York; Walking Doll Company, Inc.; Save-By-Mail, Inc.; Today's Hit Record Company; Mil-Hi Laboratories; Package Products Company; National Selected Products, Inc. (7-Minit Pie Crust, Lemon Pie, Coconut Pie, Chocolate Pie, Pumpkin Pie, etc., 6-O'Clock Vanilla Cream Pudding, Chocolate Tapioca Pudding), New York.

THE RALPH H. JONES COMPANY

3100 Carew Tower, Cincinnati 2, O.
 Phone: GARfield 2300

AAAA-ABC-ABP-ANPA-AFA

Pres. & Treas.....C. M. Robertson, Jr.
 V.P. & Gen. Mgr.....Stanley A. Willer
 Vice-President.....James M. Nelson
 Secretary.....Elmer A. Vehr
 Space Buyer.....Maurice Oshry
 Radio-TV Director.....Kathryn M. Hardig
 Radio & TV Time Buyer.....Rita Kennedy

Branch Office

580 Fifth Ave., New York 36, N. Y.
 Phone: PLaza 7-4600

Manager.....W. A. Powers
 Vice-President.....Theodore Fremd
Radio Accounts: The Kroger Company, Miami Margarine Company, Martin Rosenberger Wallpaper Co., Cincinnati, O.; Heckin Incorporated, The Drackett Company (Charge Division), Cincinnati, O.

TV Accounts: The Kroger Company, Miami Margarine Company, Martin Rosenberger

Wallpaper Co., Cincinnati, O.; The Drackett Company (Charge Division), Cincinnati, O.

KAL, EHRLICH & MERRICK, INC.

314 Evening Star Bldg., Washington 4, D. C.
 Phone: EXecutive 3-3700
 ANPA

President.....Norman C. Kal
 Exec. Vice-Pres.....Harry L. Merrick
 Secretary.....Bernard R. Linkins
 V.P. in Chge. of Radio-TV...Alvin Q. Ehrlich
 Copy Chief.....David P. Thomas
 Time Buyer.....Nella Manes
 Account Executives.....Joseph Weinstein, Alexander Charles, Wm. B. Mullett, Forest Entwisle, Philip Berne, Wm. Roberts.

H. W. KASTOR & SONS ADV. CO.

75 E. Wacker Dr., Chicago 1, Ill.
 Phone: CENTral 6-5331

ABC-NOAB-ANPA-PPA-APA

President.....A. G. Kastor
 V.P. & Gen. Mgr.....Marvin Harms
 Vice-President.....Herman Kastor
 V.P. & Copy Chief.....Ashley Belbin
 Radio-TV Director.....James H. West
Radio Accounts: Procter & Gamble Co. (American Family Flakes), International Milling Co. (Robin Hood Flour), Union Starch & Refining Co. (Pennant Syrup).

KASTOR, FARRELL, CHESLEY & CLIFFORD, INC.

400 Madison Ave., New York 16, N. Y.
 Phone: PLaza J-1400

ABP-ANPA-APA-NOAB-PPA

President.....H. Kastor Kahn
 Exec. Vice-Pres.....W. S. Chesley, Jr.
 V.P. & Copy Director.....C. E. J. Clifford
 V.P. & Media Director.....J. B. Peters
 Radio & TV Dir.....Harry Walsh
Radio Accounts: Hickok Mfg. Co., Rochester, N. Y.; Schnefel Bros., Newark, N. J.; Pierre's Proprietaries, New York.
TV Account: Hickok Mfg. Co., Rochester, N. Y.

THE JOSEPH KATZ COMPANY

10 W. Chase St., Baltimore 1, Md.
 Phone: Lexington 1500

President.....Joseph Katz
 Vice Pres.....J. T. McHugh

Branch Offices

488 Madison Ave., New York 22, N. Y.
 Phone: MURray Hill 8-1223

V.P. & Gen. Mgr.....Perry Schofield
 Radio-TV Dir.....Richard Katz
Radio Accounts: American Oil Co., Madera Bonded Wine & Liquor Co., Maryland Pharmaceutical Co., Gunther Brewing Co., Inc., Baltimore Contractors, Inc., Motor Sales Co., S. & N. Katz, Inc.

TV Accounts: American Oil Co., Maryland Pharmaceutical Co., Baltimore Contractors, Inc., Baltimore, Md.; Madera Bonded Wine & Liquor Co., Baltimore, Md.; Gunther Brewing Co., Inc., Motor Sales Co., S. & N. Katz, Inc.

HENRY J. KAUFMAN & ASSOCIATES

1419 H St., N.W., Washington 5, D. C.
Phone: District 7-7400
ABP—ANPA—ABC

General Manager.....Henry J. Kaufman
Creative Director.....Wm. F. Sigmund
Radio Director.....Jeffrey A. Abel
TV Director.....Robert S. Mauer
Service Dir. & Asst.

Gen. Mgr.....Alfred H. Edelson
Art Director.....Eugene T. Hoover
Copy Chief.....Theodore D. Mandelstam

Radio Accounts: Capital Garage (Chrysler-Plymouth dealer); Group Health Association (medical & hospital plan); S. Kann Sons Company (department store); King's Credit Dept. Store (department store); Lacy's, Inc. (radio-TV & electric appliances); Liberal Credit Clothing Co., Inc.; Manhattan Auto & Radio Co. (retail auto accessories); Md. & Va. Milk Producers Ass'n.; Northeast Motor Company (Ford sales & service); Old Dominion Bank; Peake Motor Company (DeSoto-Plymouth dealer); Pepsi-Cola Bottling Co. of Wash.; Potomac Electric Power Co.; Saks (furs); Simon Distributing Corp. (elec. appliances); State Loan & Finance Corp.; Tom's Auto Service, Inc. (Chrysler-Plymouth dealer); Trew Motor Company (Dodge-Plymouth dealer); Willys Overland Distributors.

TV Accounts: C.I.O.; First Federal Savings & Loan Assn.; Fort Lincoln Cemetery; Lacy's, Inc.; Pepsi-Cola Bottling Co. of Wash.; Simon Distributing Corporation; Trew Motor Company.

KEELING & CO., INC.

1028 Chamber of Commerce Bldg.,
Indianapolis 4, Ind.
Phone: PL 1476

AAAA—ABP—ANPA—ABC

Pres. & Treas.....Hal R. Keeling
Exec. V.P. & Secy.....Wm. M. Hutchison
Vice-Presidents.....Ralph B. Roberts,
Lowell H. Stormont, Victor G. Varmo

Radio-TV Dept.

Time Buyer.....M. C. Dill

Radio Accounts: Casite Corporation (Casite), Hastings, Mich.; Wilson Milk Co. (Evaporated Milk), Union Federal Sav. & Loan Co., Indianapolis, Ind.; Marion County Milk Assn.

TV Accounts: Casite Corporation (Casite), Hastings, Mich.; Wilson Milk Co. (Evaporated Milk), Union Federal Sav. & Loan Assn., Indianapolis, Ind.

KEELOR & STITES CO.

3001 Carew Tower, Cincinnati 2, Ohio
Phone: Parkway 1310

President.....P. R. Hume
Exec. V.P.—Treas.....J. T. Nolan, Jr.
Secretary.....H. J. Darby
Radio-TV Director... ..A. A. Radkey

THE KEILSON CO.

117 W. 46th St., New York 19, N. Y.
Phone: Judson 2-1797

Partners...M. Keilson, J. Keilson, I. Keilson
Scripts & Commercials.....Janet Sternberg
Program Director.....Phyllis Pion

KELLY, ZAHRNDT & KELLY, INC.

2343 Hampton Ave., St. Louis 10, Mo.
Phone: HI 2684

PPA—APA—SNPA—ANPA

President.....Virgil A. Kelly
Vice-Pres. & Space Buyer...W. W. Zahrndt
Secretary.....E. M. Kelly
Acct. Execs....Robert Kelly, Herb Knopp,
Wm. Thomson

Radio Accounts: Visit St. Louis Committee, St. Louis; Joseph A. Mrazek Moving & Storage, St. Louis; Newberry Radio Company, St. Louis; Sterling Pen Co.

TV Accounts: Sterling Pen Co., St. Louis, Mo.; Mrazek Moving & Storage, St. Louis, Mo.

HELEN A. KENNEDY ADVERTISING

360 - 17th St., Oakland 12, Calif.
Phone: TEmplebar 6-2582

Owner.....Helen A. Kennedy
Office Exec.....Peter Hannaford

Radio Accounts: First Savings & Loan Association; Prudential Realty & Finance Co.; K/R Orinda Realtors.

KENYON & ECKHARDT, INC.

247 Park Ave., New York 17, N. Y.
Phone: MU 8-5700

AAAA—ABP—ANPA—PPA—ABC
NOAB—APA

Chairman of the Bd. Thomas D'Arcy Brophy
Chmn. Exec. Comm.....Dwight Mills

President.....William B. Lewis
Sr. Vice-President.....Edwin Cox

Sect.—Treas. & Gen. Mgr....David C. Stewart
Vice Presidents.....George N. Beecher,

G. T. C. Fry, William Green, Grayson F. Lathrop, George MacGregor, Donald J. Maggini, E. W. Newson, John H. Owen, Malcolm F. Smith, T. K. Carpenter, Glen Wiggins, Garth Montgomery, Leslie Munro, Howard M. Wilson

Art Director.....Gerald Link
V.P., Media Dir.....Joseph P. Braun

V.P., Prom. Dir.....Hal Davis
V.P., Dir. of Radio-TV..Wickliffe W. Crider

V.P., Dir. of Research.....G. Maxwell Ule
Talent Buyer.....Sylvan Taplinger

Publicity Director.....Herb Landon
Time Buyer Director.....Philip C. Kenney

Time Buyers...Mary Dwyer, Lucy Kerwin,
Thomas Viscardi

Branch Offices

345 Griswold St., Detroit

Vice Pres.....Don C. Miller
Equitable Bldg., Hollywood, Cal.

Vice Pres.....Robert D. Wolfe
620 Market St., San Francisco

Vice Pres.....Sydney G. Walton

304 Bay St., Toronto, Ont.
 Vice Pres. William J. Frost
Radio Accounts: American Maize-Products Company (Prepared Desserts, Starches, Syrups), New York; Beech-Nut Packing Co. (Chewing Gum, Coffee, Baby Foods), Canajoharie, N. Y.; Ford Motor Co. (Institutional), Dearborn, Mich.; General Electric Co. (Air Conditioning), Bloomfield, N. J.; Hudnut Sales Co., Inc. (Beauty Preparations), New York; Lincoln-Mercury Division of Ford Motor Co. (Lincoln & Mercury Cars), Detroit, Mich.; Lincoln-Mercury Dealer Associations; National Brewing Co. (National Premium & National Bohemian Beers), Baltimore, Md.; The Mennen Co. (Men's Toiletries), Newark, N. J.; Pepperidge Farm, Inc. (Bakery Products), Norwalk, Conn.; Wesson Oil & Snowdrift Sales Co., New Orleans, La.

TV Accounts: Same as above with the exception of Beech-Nut (no television).

KETCHUM, MacLEOD & GROVE, INC.

111 Seventh Ave., Pittsburgh 19, Pa.
 Phone: COurt 1-5100
 AAAA-ABP-ANPA

President George Ketchum
 Exec. V.P. Robert E. Grove
 Radio & TV Dir. Lansing B. Lindquist
 Asst. Radio & TV Dir. Edgar J. Donaldson
 Asst. Radio & TV Dir. John D. Held
 Radio & TV Timebuyer. William B. Krocke

Branch Offices

Rm. 309, Brisbane Bldg., Buffalo 3, N. Y.
 Field Rep. David Fernow
 State Street Bldg., Harrisburg, Pa.
 Field Rep. George K. Keet
 Room 609 Mercantile Trust Bldg.,
 Baltimore, Md.
 Field Representative. W. R. Millford
 1801 Central Nat'l Bank Bldg.,
 Richmond 19, Va.

Field Rep. C. W. Crowder
Radio Accounts: Braum Baking Company; Chevrolet Zone Dealers; Colonial Trust Co., Pittsburgh; Dairymen's Cooperative Sales Association, Pittsburgh; Hospital Service Association, Pittsburgh; Jones & Laughlin Steel Corp.; Peoples First National Bank, Pittsburgh; Peoples Natural Gas Co., Pittsburgh; Rieck Dairy Co.; Thorofare Markets, Inc., Pittsburgh; Westinghouse Electric Corp.; Calgon; The Natural Gas Companies, Pittsburgh; Manufacturers Light and Heat Company, Pittsburgh; Allegheny Airlines, Washington, D. C.; The East Ohio Gas Company, Cleveland; Reymer and Brothers, Inc., Pittsburgh.

TV Accounts: Braum Baking Company, Pittsburgh; Calgon; Chevrolet Zone Dealers; Colonial Trust Co., Pittsburgh; East Ohio Gas Co., Cleveland, Ohio; Natural Gas Companies, Pittsburgh; Peoples Natural Gas Co., Pittsburgh; Reymer & Brothers Inc., Pittsburgh; Rieck Dairy Co., Pittsburgh; Thorofare Markets, Inc., Pittsburgh;

Westinghouse Electric Corp.; Tappan Stove Company; Allegheny Airlines, Washington, D. C.; Dairymen's Cooperative Sales Association; Colonial Trust Company, Pittsburgh; Peoples First National Bank & Trust Company, Pittsburgh; Manufacturers Light and Heat Company, Pittsburgh.

KIESEWETTER ASSOCIATES, INC.

9 E. 40th St., New York 16, N. Y.
 Phone: LExington 2-0023
 AFA-ABP-ANPA-APA-PPA

President. H. M. Kiewewetter
 Radio-TV Exec. Horace Hagedorn
 Radio-TV Exec. Samm S. Baker
 Radio-TV Time Buyer. E. Thompson
 Radio-TV Copy. Ben G. Allen
 Pub. Relations. Edward Chase
 Radio-TV Art Dir. Frederick Russell
Radio Accounts: Bathasweet Corp. (Bathasweet Bath Products), Standard Laboratories (Sloan's Lintiment and Balni), V. La Rosa & Sons, Inc. (La Rosa Macaroni Products); Stern's Nurseries (Nursery Products), Geneva, N. Y.; Courtley, Ltd. (Courtley Men's Products); Sterns Garden Products, Inc.

TV Accounts: Abraham & Straus (Dept. Store); V. La Rosa & Sons, Inc. (La Rosa Macaroni Products); D. P. Harris Co. (Rollfast Bicycles); Stern's Garden Products, Inc., Geneva, N. Y.; Courtley, Ltd. (Courtley Men's Toiletries); S. A. Schonbrunn, Inc. (Medaglia d'Oro Coffee), N. Y. C.; Turner Hall Corp. (Men's Toiletries), N. Y. C.

ABBOTT KIMBALL CO., INC.

250 Park Ave., New York 17, N. Y.
 Phone: PLaza 3-9600
 AAAA-ABC-ABP-APA-ANPA
 NOAB-PPA-AFA

Chairman Abbott Kimball
 President. W. C. Matthews
 Comptroller Monica Riley
 Dir. Radio-TV,

Time Buyer. Miriam Traeger

Branch Offices

520 N. Michigan Ave., Chicago 11, Ill.
 Phone: MIchigan 2-0300
 Manager George Enzinger
 638 So. Van Ness Ave., Los Angeles, Calif.
 Phone: DRexel 7305

Chairman Hugo Scheibner
 105 Montgomery St., San Francisco, Calif.
 Phone: EXbrook 5188

President Alfred Ducato
Radio Accounts: Drake America Corp., Brondow, Inc., Norcross, Inc.

TV Accounts: Drake America Corp., Firth Carpet Company, Trifari, Krussman & Fishel, Inc., Norcross, Inc.

LEW KING ADVERTISING

149 W. McDowell, Phoenix, Arizona
 Phone: 4-5548
 FAAG

Owner Lew King
 Sec. Treas. Elinore Klein
 Radio & TV Dir. Jack Beveridge

Radio-TV Accounts: Arical Co., Arizona Floor Covering, Best Cleaners, Dcer-O Paints & Chemicals, Ltd., Farm Fresh Markets, The Flame Restaurant, Funk Jewelry, Garbage Service Co., Gil-Barts Dept. Store, Hepler's Combat Service Stations, Klein Motor Sales, Mor-Powr Battery Company, Photographic Supply Co., Paradise On Wheels, Virgil Vance Automotives, Weatherford Hotel, Western Village Motel.

KIRCHER, HELTON & COLLETT, INC.

19th Floor, Hulman Bldg., Dayton 2, O.
 Phone: FULton 5161
 AAAA-ABP-APA-PPA-NOAB

President.....Ralf C. Kircher
 Vice-Presidents.....James M. Hadley,
 R. M. Collett, Watson B. Metcalfe
 Treas. & Dir. Prod.....Carter B. Helton
 Art Director.....L. E. Brinkman
 Production Manager.....Hap Moon
 Secretary.....R. L. Mills
 Account Executives.....Ralf Kircher,
 James M. Hadley, R. M. Collett, Watson B.
 Metcalfe, Norman Van Zant, C. B. Helton
 Radio & TV Dir.....Ralph Kaufman
Radio Accounts: Gem City Bldg. & Loan
 Assoc. (Home Loans), Dayton, O.; Liberal
 Market (Food Chain Store), Dayton, O.;
 Zephyr Ventilated Awning Co. (Awnings),
 Dayton, O.; Dayton Pump & Mfg. Co. (Water
 Systems), Dayton, O.; Soft Water Indus-
 tries (Institutional-Soft Water), Dayton, O.
TV Accounts: Stuart Fox Company (Food
 Brokers), Dayton, O.; Gem City Build-
 ing & Loan Assoc. (Home Loans), Day-
 ton, O.; Liberal Market (Food Stores), Day-
 ton, O.; Dayton Pump & Mfg. Co. (Water
 Systems), Dayton, O.

KIRKLAND-WHITE & SCHELL

101 Marietta St., Atlanta 3, Ga.
 Phone: LAmAR 3682
 APA-SNPA-ANPA

Partners.....J. A. Kirkland,
 Frank W. White, James B. Schell
 Account Executive.....Arch Ragan

KNOLLIN ADV. AGENCY

391 Sutter St., San Francisco 8, Calif.
 Phone: SUtter 1-6110
 AAAA-APA-ABP-ANPA-NOAB

President.....James C. Knollin
 Asst. Gen. Mgr.....Robert H. Knollin
 Art Director.....Sigurd Mortenson
 Space Buyer.....Bernice Rosenthal
 Acct. Executive.....Richard L. Tevis
Radio Accounts: Mannings, Inc.; San Fran-
 cisco Federal Savings & Loan Assoc.; Cali-
 fornia Savings & Loan Assoc.; Mark Morris
 Tire Co.
TV Accounts: California Savings & Loan
 Company; Arthur C. Maryon Co.

KOEHL, LANDIS & LANDAN, INC.

588 5th Ave., New York 36, N. Y.
 Phone: JUDson 2-1370

ABP-ANPA-APA-NOAB-PPA
 Pres. & Treas.....Albert E. Koehl
 Vice-Pres. & Sec.....A. A. Landis
 Space Buyer.....A. Lasity
Branch Office
 National City Bank Bld., Cleveland 14, O.
 Vice-Pres.-in-ChgRussell Rowan

KRUPNICK & ASSOCIATES, INC.

520 North Grand Blvd., St. Louis 3, Mo.
 Phone: JEFFerson 1723
 ABP-ANPA-APA-PPA

PresidentSam Krupnick
 Excc. V.P.....Tom Connelly
 Vice-PresidentsRay Armbruster,
 A. Harvey Brown
 Secretary-TreasurerEdgar Kluge
 Media Director.....Harry Sager
 Radio-TV Buyer.....Ray Schoenfeld
Radio, TV Accounts: Griesedieck Bros.
 Brewery Co.; Magic Chef, Inc.; Mercantile
 Trust Co.; The Reardon Company.

KUDNER AGENCY, INC.

575 Madison Ave., New York, N. Y.
 Phone: MU 8-6700

President.....J. H. S. Ellis
 Vice-Presidents.....Sam D. Fuson,
 Myron P. Kirk, Schuyler Kudner, E. J.
 Owens, Norman Nash, Shafto Dene, C. M.
 Rohrabough, J. J. Cochran
 Excc. Dir. TV & Radio.....Myron P. Kirk
 Gen. Mgr., Radio-TV.....Al Reibling
 Time Buyer.....John Marsich
Branch Offices
 New Center Bldg., Detroit, Mich.

Phone: TRinity 5-5315

Executive in Charge.....Martin Rice
 681 Market St., San Francisco 5, Calif.
 Phone: GARfield 1-5433

Executive in Charge.....J. H. Hornell
Radio Accounts: General Motors Corp.,
 Detroit, Mich.; Sonotone Corp., N. Y. C.;
 The Goodyear Tire & Rubber Co., Inc.,
 Akron, Ohio; United States Tobacco Co.,
 N. Y. C.; The Texas Co., N. Y. C.
TV Accounts: The Texas Co.; United
 States Tobacco Co.; General Motors Corp.;
 Buick, Flint, Mich.; Schick, Inc., Stamford,
 Conn.; The Goodyear Tire & Rubber Co.,
 Inc.

KUFF & FELDSTEIN

233 E. 25th St., Baltimore 1, Md.
 Phone: TUXedo 9-1485

President.....I. Harold Kuff
 Vice-President.....Harry Feldstein
 Art Director.....Stan Mossman
 Media Director.....Dorothy Schwarz

KUTTNER & KUTTNER, INC.

646 N. Michigan Ave., Chicago 11, Ill.
 Phone: SUPerior 7-7940
 AAAA-ANPA

TV Director.....S. S. Korshak
 TV Time Buyer.....Stanley C. Kuttner
 Acct. Execs.....Harold E. Kuttner,
 Chester D. Kuttner, Milton J. Klee

Branch Office

New York, N. Y.
130 W. 57th St., New York, N. Y.
Phone: JUdson 6-2358

Radio Accounts: Douglas Lumber Co., Chicago; Sampson Company (Major appliances), Chicago; Holleb & Company (wholesale groceries), Chicago; Capitol Dairy, Chicago; Franks Dept. Store, Chicago; Shainberg Dept. Store, Memphis, Tenn.

TV Accounts: Community Theater (home builders), Chicago.

LAKE-SPIRO-SHURMAN, INC.

Radio Center Bldg., Memphis 3, Tenn.
Phone: 5-1571

ABP—ANPA—APA—PPA—SNPA

President.....Avron Spiro
Secy-Treas.....M. M. Shurman
Radio Time Buyer.....Mrs. L. Simmons
Production Manager.....Mrs. M. Ross
Publicity Director.....Al R. Capley
Acct. Executives.....David Davidson,
Mrs. L. Cunningham, Jane Zussman,
Courtney Shurman

Radio Accounts: Plough Sales Corp.; Liberty Petroleum Co., Mt. Vernon, Ill.; Kelley-Clarke Co. (Canned Salmon), Seattle; Union Planters National Bank, Memphis; Pantaze Drug Stores, Memphis.

TV Accounts: Plough Sales Corp., Memphis.

LAMB & KEEN, INC.

1616 Walnut St., Philadelphia, Pa.
ANPA--APA--PPA--NOAB

Pres. & Treas.....James G. Lamb, Sr.
Exec. V.P. & TV Dir...Kennard G. Keen, Jr.
V.P. & Copy Chief...John O. Ellington, Jr.
V.P., Media Director.....Roy T. Lochten
V.P., Production Mgr.....Walter Mazurek
Acct. Executives.....James G. Lamb, Sr.,
K. G. Keen, Jr., John O. Ellington, Jr.,
H. H. DuBois

LAMBERT & FEASLEY, INC.

60 E. 42nd St., New York 17, N. Y.
Phone: MURray Hill 7-8980
ANPA—APA—PPA—NOAB

Executive V.P.....Gordon K. Seagrove
Sr. V.P.....Frank W. Mace
TV-Radio Dir.....John Bates

Radio Accounts: Phillips Petroleum Co. (Gasoline, Motor Oil), Bartlesville, Okla.; DeVilbis Co., Drilling Specialties Co., Harrower Laboratory Inc., Hat Corporation of America, H V Laboratories Inc., Laclede Laboratories, Inc., Lambert Pharmaceutical Co., Phillips Chemical Co., Pro-Phy-Lac-Tic Brush Co., Saturday Evening Post, Schenley Industries, Inc., TelePrompter Corp., J. A. Wright & Co.

LANDSHEFT & BARBER, INC.

2009 Liberty Bank Bldg., Buffalo 2, N. Y.
Phone: MO 9500

ABP—NOAB—APA—PPA—ANPA

President.....Henry L. Barber

Vice President.....E. T. Drullard
Secretary-Treas.....Vera H. Landsheft
Radio Accounts: Kendall Refining Company (Gasoline and Oil), Bradford, Pa.; Liberty Bank of Buffalo (Banking), Buffalo, N. Y.; P. J. Garvey Co. (Storage), Buffalo.

TV Account: Liberty Bank of Buffalo (Banking), Buffalo, N. Y.; Kendall Refining Co. (Gasoline & Oil), Bradford, Pa.; Pearl Polishes, Inc. (Range & Refrigerator Polish), Buffalo.

PHILIP J. LANE ADVERTISING

1 E. 42nd St., New York, N. Y.
Phone: MURray Hill 7-5117

Owner.....Philip J. Lane
Media Director.....B. Freidman
Television Accounts: Diane Beauty Salon, Ansonia DeLuxe Shops Inc. (Retail Shoe Chain).

LANG, FISHER & STASHOWER, INC.

1010 Euclid Ave., Cleveland 15, O.
Phone: MA 1-6579

AAA-ABP—ANPA—APA—NOAB—PPA
President.....H. Jack Lang
V.P.—Treasurer.....Fred P. Stashower
Vice-Pres. & Sec.....Alvin B. Fisher
Radio-TV Mgr.....Robert F. Gibbons
Prod. Mgr. Radio-TV.....John Cremer
Field Service Mgr.....Garry C. McKelvey

Radio Accounts: Brewing Corp. of America (Carling's Black Label Beer), Cleveland; The Burrows Brothers Co., Inc. (office supplies), Cleveland; Cleveland Baseball Co. (Cleve. Indians baseball team), Cleveland; Cleveland Transit System, Cleveland; General Electric Co., Cleveland; Pick-N-Pay Super Markets, Inc. (super markets), Cleveland; World Publishing Co., Cleveland; Yellow Cab Co., Cleveland.

TV Accounts: Brewing Corp. of America (Carling's Black Label Beer), Cleveland; The Kaynee Co. (boys' wear), Cleveland; Pick-N-Pay Super Markets, Inc. (super markets), Cleveland.

LANGHAMMER AND ASSOCIATES

225 Park Ave., Omaha 2, Neb.
Phone: JACKson 6190
ABP—APA—AAAN

President.....Joe H. Langhammer
Radio Accounts: Inland Manufacturing Company (Radiator Repair Equipment), Omaha, Neb.

TV Account: Blue Star Foods, Inc. (canned, frozen chicken), Council Bluffs, Iowa.

LAUESEN & SALOMON

520 No. Michigan Ave., Chicago 11, Ill.
Phone: SUPERior 7-0738
ABP—APA—ANPA—PPA

President.....A. M. Salomon
Account Executives.....Wendell Walker,
M. H. Sellhorn
Production Manager.....D. L. Cuttie

Radio Account: Foley & Co., Imperial Credit Co.

AL PAUL LEFTON CO., INC.

1617 Pennsylvania Blvd., Phila. 3, Pa.
Phone: RIttenhouse 6-1500
ANPA—APA—NOAB—PPA

President.....Al Paul Lefton
Vice-Pres. & Treas.....H. S. Louchheim
Vice-PresidentsP. Brown,
A. Parker, J. Jensen
Space Buyer.....E. V. Righter
TV & Radio Director.....A. R. Griffin

Branch Offices

521 Fifth Ave., New York 17, N. Y.
Phone: VAnDerbilt 6-4340

President.....Al Paul Lefton
Vice-Pres. & Mgr.....R. J. Herts
435 N. Michigan Ave., Chicago, Ill.
Phone: Superior 7-9511

Vice-Pres. & Mgr.....E. G. Foreman, Jr.
Radio Accounts: Phila. Electric Co. (Light & Power), Borden's Ice Cream, Crawford Clothes, Inc., Metropolitan Jockey Club (Jamaica Race Track), Empire Racing Assn. (Racing), A. Goodman & Sons (Goodman's Noodles), Hotel Bar Butter, C. Schmidt & Sons (Beer and Ale).

TV Accounts: Pal Blade Company, Inc. (Razor Blades), New York, N. Y.; Sylvan Seal Milk Co. (Milk), Metropolitan Jockey Club (Jamaica Race Track), A. Goodman & Son (Goodman's Noodles), Hotel Bar Butter, New York, N. Y.; Schmidt's Beer & Ale, Philadelphia, Pa.

LENNEN & NEWELL, INC.

17 E. 45th St., New York 17, N. Y.
Phone: MURray Hill 2-5400
ANPA—APA—PPA—AAAA—NOAB
ABC—ABP

Chairman of the Bd.....Philip W. Lennen
President.....H. W. Newell
Exec. V.P. & Gen. Mgr.....Adolph J. Toigo
Sr. V.P.....Thomas C. Butcher
Sr. V.P.....John Monsarrat
Sr. V.P.....Jackson Taylor
V.P. & Treas.....John D. Spiers
Sr. Vice President....Walter M. Swertfuger
Sr. V.P.....Gordon D. Cates
V.P. & Asst. to Pres.....J. H. Sheldon
V.P.-Exec. Asst.....C. A. Sante
V.P. in Chg. Production..Michael J. Madar
Art Director.....Hans Sauer
V.P. in Chg. of Radio &

Television.....Nicholas E. Keesely
V.P.—Radio & Television
Copy Chief.....Peter V. Keveson
V.P. in Chg. of Merchandising &
Research.....Daniel E. Shea
V.P. in Chg. of Media....Anthony de Pierro
V.P. & Asst. Exee. Creative
Dir.Maitland Jones

Vice Presidents.....Thomas P. Doughton,
Daniel M. Daley, Jr., Jackson Taylor,
Stephen M. Kenyon
Mgr.—Radio-TV Depts.....Frank A. Daniel
Art Dir. TV.....Clark M. Agnew

Producers.....Charles T. Harrell,
George G. Tompkins, Herbert K. Horton
Time Buyer Radio-TV....William D. Smith
Traffic Mgr. Radio-TV.....George E. Caron

Branch Office

308 N. Rodeo Dr., Beverly Hills, Calif.
Phone: Crestview 1-7221

Radio-TV Dir.....Benjamin R. Potts
Radio Accounts: Colgate-Palmolive-Peet Company (Lustre-Creme Products, Shampoo & Hairdressing, Lustre Color Home Hair Coloring), Jersey City, N. J.; Lehn & Fink Products Corporation (Lysol Disinfectant), New York, N. Y.; Lorillard, P., Co., Inc. (Old Gold Cigarettes, Briggs Pipe Mixture, Muriel Cigars), New York, N. Y.; Tide Water Associated Oil Co. (Tydol Gasoline, Veedol Motor Oil), New York, N. Y. & Tulsa, Okla.; Joseph Schlitz Brewing Co.; Emerson Drugs; Dorothy Gray, Ltd.

TV Accounts: Colgate-Palmolive-Peet Company (Lustre-Creme Products—Shampoo & Hairdressing), Jersey City, N. J.; Lehn & Fink Products Corporation (Lysol Disinfectant), New York, N. Y.; Lorillard, P., Co., Inc. (Old Gold Cigarettes, Briggs Pipe Mixture, Muriel Cigars, Headline Cigars,) New York, N. Y.; Tide Water Associated Oil Co. (Tydol Gasoline, Veedol Motor Oil), New York, N. Y. & Tulsa, Okla.; Joseph Schlitz Brewing Co.; Emerson Drug Co.; Dorothy Gray, Ltd.; R. T. French Co.

AUSTIN C. LESCARBOURA & STAFF

The Adshop, Croton-on-Hudson, N. Y.
Phone: CRoton 1-3444

Senior Partner.....Austin C. Lescarboura
Junior Partner.....Stanley A. Lescarboura
ProductionWinifred Phillips
SecretaryMiriam Lescarboura

Radio Accounts: Aerovox Corporation (Capacitors), New Bedford, Mass.; Clarostat Mfg. Co., Inc. (Controls and Resistors), Dover, N. H.; Allen B. Du Mont Labs. (Cathode-ray Tubes), Allen B. Du Mont Labs. (Television Transmitters), Allen B. Du Mont Labs. (Cathode-ray Instruments), Clifton, N. J.; Allen B. Du Mont Labs. (TV components), East Paterson, N. J.; Henry L. Crowley & Co. (Powdered Iron Cores and Steatite Parts), West Orange, N. J.; Industrial Instruments (Electrical Test Instruments), Jersey City, N. J.; Hudson Wire Company (Magnet and Bare Wires), Ossining, N. Y.; Maryland Etching Co. (Instrument Panel) Towson, Md.; Granco Products, Inc. (UHF Converters), Long Island City, N. Y.; Technical Appliance Corp. (TV Antennas), Sherburne, N. Y.

TED LEVY ADVERTISING AGENCY

811 Cooper Bldg., Denver 2, Colo.
Phone: Main 7133
ABP—ANPA—ABC

President, Time Buyer.....Ted Levy
PartnerGertrude Levy
Copy Chief.....Barbara Aiton
Production Mgr.....William Archenhold

**LEWIN, WILLIAMS & SAYLOR
INCORPORATED**

40 East 49th St., New York 17, N. Y.
Phone: Murray Hill 8-6200

President.....A. W. Lewin
Exec. V.-P. Pres.
and Treasurer.....Sidney Matthew Weiss
Vice Pres. & Sec'y.....Max Green
Vice President.....Walter T. Pollock
V.P., Art. Dir.....Donald Waterbury,
Leslie M. Kay
Radio-TV Dir.....William Seth
Branch Office
11 Commerce St., Newark 2, N. J.
Phone: MI 3-3200

Vice-PresidentLeonard Newsteder
Vice-President.....Richard N. Gulick
Radio Accounts: G. N. Coughlan Co., West
Orange, N. J.; Chimney-Sweep Process 33
(soot remover, paint brush cleaner); Costa
Ice Cream Company, Woodbridge, N. J.;
Harris-Upham & Co. (stock brokers), New
York; Spandy (Taylor-Reed Corp.) (detergent-
sanitizer), Glenbrook, Conn.; Dale Dance
Studios, New York, N. Y.; Carl Fischer, Inc.
(Hi Fidelity Radio-Phonographs), New
York, N. Y.; Norman M. Morris Corp.
(Omega Watch), New York, N. Y.; The
Odell Co. (Trol Hair Tonic), Newark, N. J.
TV Accounts: Costa Ice Cream Company,
Woodbridge, N. J.; G. N. Coughlan Co.
(dehumidifier, paint brush cleaner), West
Orange, N. J.; Spandy (Taylor-Reed Corp.),
(detergent-sanitizer), Glenbrook, Conn.;
Jacoby-Bender Watch Band Company, New
York; The Odell Co. (hair dressing), New-
ark, N. J.; Dale Dance Studios, New York,
N. Y.; Magla Products (Ironing Board
Cover), Newark, N. J.; Norman M. Morris
Corp. (Omega Watch), New York, N. Y.

ADDISON LEWIS & ASSOCIATES

2310 Stevens Ave., Minneapolis 4, Minn.
Phone: AT 6235

ABP-ANPA-ABC-APA-PPA-NOAB
PresidentAddison Lewis
Vice Pres.....Erle B. Savage, Jr.
Treasurer.....Harvey R. Kruse
Secretary.....Wm. A. Dobson
Radio and TV Dir.....Carroll E. Crawford
Research and Media Dir...Preston K. Covey
Prod. Manager.....Bruce E. Segerstrom
Copy Director.....Judd L. Meester
Account Execs.....J. A. Quint,
J. H. Cleland, Sherle Lowe

LILLER, NEAL & BATTLE

Walton Bldg., Atlanta 3, Ga.
Phone: Cypress 6521

AAAA-ABC-ANPA-APA-ABP-AFA
Partner.....C. K. Liller
Partner.....William W. Neal
Radio-TV Director.....Sarah Williams
Account Executives.....J. K. Outley, Jr.,
G. L. Watts, H. G. Axelberg
Branch Office
40 E. 51st St., New York 22, N. Y.
Phone: EL 5-3771

Manager.....Robert B. Kane
Radio Accounts: National NuGrape Com-
pany (NuGrape and SunCrest), Atlanta;
Colonial Stores, Inc. (groceries), Atlanta;
Brook Candy Company (candy bars), Chat-
tanooga; Puritan Mills, Inc. (My-T-Pure
flour), Atlanta; H. W. Lay & Co. (potato
chips), Atlanta; Georgia Peanut (Ravo),
Moultrie, Ga.

TV Accounts: H. W. Lay & Company (po-
tato chips), Atlanta; Colonial Stores, Inc.
(groceries), Atlanta; Puritan Mills, Inc.
(My-T-Pure flour), Atlanta; Georgia Peanut
Co. (Ravo), Moultrie, Ga.; Bank of Georgia,
Atlanta; Trust Company of Georgia, Atlanta.

**LLOYD, CHESTER & DILLINGHAM,
INC.**

9 Rockefeller Plaza, New York 20, N. Y.
Phone: Circle 5-8800

ANPA-PPA-NOAB-ABC
President.....Laurence M. Lloyd
Vice-Pres. & Art Dir.....M. H. Kates
Production Manager.....William T. Kaleb

DUDLEY L. LOGAN ADV.

304 S. Broadway, Los Angeles 5, Calif.
Phone: Dunkirk 2-8471

ANPA-AAAA-PPA-APA-ABP
President.....Dudley L. Logan
Art Director.....Rosemary Doermann
Copy Chief, Media Dir. &
Prod. Mgr.....Jack Waterman

THE W. E. LONG CO.

188 Randolph St., Chicago 1, Ill.
Phone: RAndolph 6-4606
ABP-ANPA-NOAB

President.....E. E. Hanson
Vice-Pres. & Advtg. Dir.....Wm. Goodman
Vice-Pres. & Dir. of Sales.....J. A. Smith
Treasurer.....A. T. Downie
Secretary.....H. G. Mergener
Dir. of Radio & TV...Edward C. Fritz, Jr.
Radio Accounts: Aurheim's Bakery, Inc.,
Springfield, Ill.; Atlanta Baking Co., Atlanta,
Ga.; Mrs. Boelme's Bakery, San Angelo,
Tex.; Bowman Baking Co., Albuquerque,
N. M.; Borek & Stevens, Bridgeport, Conn.;
Butter Krust Baking Co., Sunbury, Pa.; Car-
penter Baking Co., Milwaukee, Wis.; Cotton
Bros. Baking Co., Alexandria, La.; Cross
Baking Co., Montpelier, Vt.; Dietzen's Bak-
eries, Anderson, Ind.; Fisher Baking Co.,
Salt Lake City; Fluhrer Bakeries, Inc., Med-
ford, Ore.; Fuchs Baking Co., So. Miami,
Fla.; Gardner Baking Co., Madison, Wis.;
Gase Baking Co., Saginaw, Mich.; Gunzen-
hauser Bakery, Lancaster, Pa.; Haller's Eagle
Bakery, Inc., Altoona, Pa.; Holsum Baking
Co., Roswell, N. M.; Holsum Bakery,
Ft. Wayne, Ind.; Holsum Bakers, Tampa,
Fla.; Holsum Baking Co., Harlingen, Tex.;
Ideal Baking Co., Tyler, Tex.; Jamestown
Baking Co., Jamestown, N. Y.; Lee Baking
Co., Victoria, Tex.; Master Baking Co., Mt.
Vernon, Ill.; McGough Bakeries Corp., Birm-
ingham, Ala.; Nickles Bakery, Navarre, Ohio.

L. E. McGIVENA & CO., INC.

444 Madison Ave., New York 22, N. Y.

Phone: PLaza 3-7422

ANPA—ABP—APA—PPA—ABC—AAAA

President.....L. E. McGivena
 Secretary, Copy Chief....Howard W. Roper
 Art Director.....Samuel Josephs
 Production Manager.....James J. Preston
 Space Buyer.....Mrs. Marguerite Andrews

McKEE & ALBRIGHT, INC.

1809 Walnut St., Philadelphia 3, Pa.

Phone: LOcust 7-4737

ANPA

President.....Roy J. McKee
 Vice-Pres. & Treas.....David R. Albright
 Vice-Pres. Radio-TV....James A. McFadden
 Time Buyer.....Evelyn Walmsley
 Mdse. Dir.....A. P. Livingston
 Secretary.....T. E. Libby
Radio Accounts: Breyer Ice Cream Co., Philadelphia; General Ice Cream Corp. (dairy), Schenectady; Phila. & Reading Coal & Iron Co. (coal), Philadelphia; Western Maryland Dairy Co. (dairy), Baltimore; Keeler-Weyl Baking Co. (biscuits), Phila.
TV Accounts: Breyer Ice Cream Co., Philadelphia; General Ice Cream Corp. (dairy), Schenectady; Keeler-Weyl Baking Co. (biscuits and crackers), Philadelphia; Phila. & Reading Coal & Iron Co. (coal), Phila.

McKIM ADVERTISING LIMITED

1510 Drummond St., Montreal, Que., Can.

Phone: Lancaster 5192

ANPA—ABC—APA—CDNA—CWNA
 CNN—PA

Chairman of Board.....James M. Baxter
 Vice-Pres., Sec.-Treas.....H. R. McDougal
Branch Offices

47 Fraser Ave., Toronto, Ont. Canada
 Vice-President.....H. D. Roach
 Nat. Trust Bldg., Winnipeg, Man., Canada
 Vice Pres.....A. A. Brown
 591 Burrard St., Vancouver, B. C., Canada
 Manager.....R. E. Jefferson

ARTHUR MEYERHOFF & CO.

410 N. Michigan Ave., Chicago 11, Ill.

Phone: DElaware 7-7860

ANPA—PPA—AAAA—NOAB—APA

President.....Arthur E. Meyerhoff
 General Manager.....J. H. Black
 Production Manager.....J. A. Johnson
 Dir. of Radio & TV.....S. L. Novy
 Assoc. Radio & TV Dir.....George Rich III
 Radio Time Buyer.....K. Knight
 Space Buyer.....Mary Hauser
 Copy Chief.....M. E. Cbon

Branch Office

759 N. Milwaukee St., Milwaukee 2, Wis.
 Manager.....George Grabin
Radio Accounts: Chicago National League Ball Club, Illinois Meat Company, Milwaukee Elec. & Transport Co., Wisconsin & Michigan SS Co., Wm. Wrigley Jr. Company, Patricia Stevens Models' Finishing School, Chicago Transit Authority.

C. L. MILLER COMPANY, INC.

521 Fifth Ave., New York 17, N. Y.

Phone: MUrray Hill 2-1010

ABC—ANPA—APA—NOAB—PPA

President.....C. L. Miller
 V.P., Treas.....G. V. Carhart
 Secretary.....P. P. Hoffman
 Space Buyer.....Miss R. Driscoll

Branch Office

333 No. Michigan Ave., Chicago 1, Ill.

Phone: CEntral 6-1640

Manager.....I. M. Tuteur
Radio Accounts: Corn Products Sales Co. (Karo, Mazola, Linit, Niagara Starch), Bachman Choc. Mfg. Co. (Old Sol Bar); Circle Line Sightseeing Yachts, Blue Channel Corp. (Harris American Crabmeat, Harris American Deviled Crabmeat).

DAN B. MINER CO.

304 S. Kingsley Drive, Los Angeles 5, Calif.

Phone: DUUnkirk 8-3301

AAAA

Chairman of the Board.....Dan B. Miner
 President.....J. C. Morse
 Vice-Presidents.....I. M. Greer,
 Hildred Sanders, Richard Glover, Andrew Carpenter

Secretary-Treasurer.....M. R. Sweeney
 V.P. in Chg. Radio & TV....Hildred Sanders
 Asst. Radio & TV Directors.....Garth Hintz,
 Arthur Trask

Time Buyer.....Kay Ostrander

Radio Accounts: Interstate Bakeries Corporation (Weber's Bread), Los Angeles; Bu-Tay Products, Ltd. (Rain Drops), Los Angeles; Kendall Foods, Inc. (dog food), Los Angeles; Thrifty Drug Stores, Los Angeles; Forest Lawn Memorial Park (cemetery & Mortuary), Glendale; Freeman's Certi-Fresh Foods (frozen fish), Los Angeles; Lakewood Park (housing), Los Angeles, Calif.; Kerr Glass Mfg. Corp. (canning jars), Los Angeles, Calif.; Sues, Young & Brown (appliances), Los Angeles, Calif.

TV Accounts: Bu-Tay Products, Ltd. (Rain Drops), Los Angeles; Kendall Foods, Inc. (dog food), Los Angeles; Forest Lawn Memorial Park (cemetery & mortuary), Glendale; Interstate Bakeries Corporation (Log Cabin Bread), Los Angeles; Thrifty Drug Stores, Los Angeles; Luer Packing Company (meats), Los Angeles; Freeman's Certi-Fresh Foods (frozen fish), Los Angeles; Sues, Young & Brown (appliances), Los Angeles, Calif.; Kerr Glass Mfg. Co. (canning jars), Los Angeles, Calif.

EMIL MOGUL CO., INC.

250 W. 57th St., New York 19, N. Y.

Phone: JU 2-5200

ABP—ANPA—PPA

President.....Emil Mogul
 Secretary-Treasurer.....Helene Mogul
 Exec. Vice-Pres.....Charles L. Rothschild
 V.P. & Gen. Mgr.....Nat Wildman
 Vice-Presidents.....Seth D. Tobias,
 Myron A. Mahler, Rino Negri, Milton Guttenplan, Bill Jacoby

Production Manager.....Al Mauro
Media & Research Dir.....Joel Martin
Dir. Marketing & Mdehe.....Jules Lennard
Dir. Radio-TV Dept.....Lewis Wechsler
Dir. TV Prod.....Nat Eisenberg
Radio Accounts: Barney's Clothes (Men's & Boys' Clothing), Beriolo Import Co. (Berio & Francesconi Oil), New York, N. Y.; Gem Oil, Brooklyn, N. Y.; Canadian Fur Corp. (Women's Furs), New York and New Jersey; Ronzoni Macaroni Co., Long Island City, N. Y.; National Shoes (Children's, Women's & Men's Shoes), Somnyl Pharmaceutical Corp. of America (Nu-Pax), New York; Knomark Mfg. Co. (Esquire Boot Polish), Brooklyn, N. Y.; Commercial Nat'l Bank, N. Y. C.; Stone-Tarlow Co., Inc. (Shoes), Brockton, Mass.; Supreme Wines, Inc. (Old Rabbinical Brand Wine), Long Island City, N. Y.; Rayco Mfg. Co. (Auto Seat Covers), Paterson, N. J.; Kobrand Corp. (Imported Wines & Liquors), N. Y.; Laconia Shoe Co., Inc. (Shoes), Laconia, N. H.; I. Smallman & Son (Billfolds), Paterson, N. J.; Speed Products Co., Inc. (Staplers), Long Island City, N. Y.

TV Accounts: Knomark (Esquire Boot Polish), Brooklyn, N. Y.; National Shoes (Children's, Women's & Men's Shoes), New York, N. Y.; Ronzoni Macaroni Co. (Macaroni & Spaghetti), Long Island City, N. Y.; Rayco Mfg. Co. (auto seat covers), Paterson, N. J.; Gold Medal Candy Corp., Brooklyn.

THE CHESTER C. MORELAND CO.

1104 Times-Star Tower, Cincinnati 2, O.
Phone: Parkway 1178
PPA-ABP-ANPA

President.....Chester C. Moreland
Secretary.....Walter H. Strauss
Vice-President.....Carl H. Press
Radio Accounts: Coney Island, Inc., Coca-Cola Bottling Co., Cincinnati Times-Star.
TV Accounts: Coney Island, Inc., Coca-Cola Bottling Co., Cincinnati Times-Star.

MOREY, HUMM & JOHNSTONE, INC.

350 Fifth Ave., New York 1, N. Y.
Phone: LO 4-2240
ABP-ANPA-APA-AAAA-PPA

President.....Sylvester M. Morey
Exec. Vice-Pres.....Llewellyn B. Van Doren
V.P. & Mgr. Utility & Home
Appliance Dept.....Albert W. Humm
V.P., Chmn. Plans Brd.....J. R. Warwick
Vice-President.....Stanley F. Ellsworth
V.P. & Art Dir.....William G. Sutton
Vice-Pres. & Merch. Dir.....Walter J. Andree
V.P. Chg. Fashion.....Muriel Johnstone
V.P.....Janet Chatfield-Taylor
TV Director.....W. L. Wernicke
Radio Time Buyer.....Kathryn Shanahan
V.P. Chg. Midtown Office.....Muriel Johnstone
Vice-President.....Janet Chatfield-Taylor
Mdsc. Counsellor.....Rosamond Gilmarin
Radio Accounts: Sinclair Refining Co., Richfield Oil Corp. of N. Y.
TV Accounts: Sinclair Refining Co., New

York, N. Y.; Richfield Oil Corp., New York, N. Y.

RAYMOND R. MORGAN CO.

6233 Hollywood Blvd., Hollywood 28, Calif.
Phone: HOLLYWOOD 3-4194
ANPA-APA

President.....Raymond R. Morgan
Exec. Vice-Pres.....Robert C. Temple
Vice-Presidents.....Porter F. Anderson,
James C. Morgan, J. Paul McKinney
Radio-TV Dir.....James C. Morgan
Time Buyer.....Terry Brady

Branch Office

260 California St., San Francisco 11, Calif.
Phone: DOUGLAS 2-6073

Manager.....Porter Anderson
Palmolive Bldg., Chicago 11, Ill.
Vice-President.....H. P. Roberts
Radio & TV Accounts: Planters Nut Choc. Co., J. A. Folger & Co., Los Angeles Soap Co., (White King Granulated Soap, Scotch Foam Action Cleanser; Sierra Pine Toilet Soap); Nehi Beverage Co., Victory Packing Co. (Thoro Fed. Kal Kan dog food); Hollywood Stars Baseball Team.

MORSE INTERNATIONAL, INC.

122 E. 42nd St., New York 17, N. Y.
Phone: OREGON 9-4600
APA-PPA-NOAB

Chairman of the Board.....A. T. Preyer
President.....J. Patterson
Exec. Vice-Pres. & Treas.....M. F. House
Space Buyer.....F. Veleber
Mgr. Radio & TV Dept.....C. C. Slaybaugh
Export Media Mgr.....Aurora Blando
Director of Prod.....L. Waddington
Group Prod. Mgrs.....W. W. Williams,
D. R. Quist, D. Wheatley
Sr. Art Director.....E. P. Ellis
Group Art Directors.....P. Zangas,
S. Nagle
Art Studio Mgr.....C. Scimecca
Account Executives.....Constance Boland,
Reg Goghlan, John Olney, E. R. Korfh. F. Peterson
Radio and TV Accounts: Vick Chemical Co. (Vick Products), The Sofskin Co. (Sofskin Hand Cream), Princee Matchabelli, Inc. Alfred D. McKelvy Co. (Scaforth Men's Toiletries).

MOSER & COTINS, INC.

10 Hopper St., Utica 3, N. Y.
Phone: 3-7544

ABP-ANPA-APA-NOAB-PPA-SNPA
Pres. & Treas.....Arthur S. Cotins
Asst. to President.....Robert MacFarland
Vice-Presidents.....James N. Brown,
L. B. Reigler
Secretary.....Mrs. Mildred S. Benson
V.P. & Art Dir.....A. Montgomery Huntington
Sp. Buyer & Research Dir.....Miss L. B. Mang
Asst. Sp. Buyer.....Miss Christine H. Van Dyke
Asst. Research Dir.....Mrs. Pearl A. Curtis
Production Manager.....Fred Michel
Merchandising Director.....R. Del Dunning

Account Executives.....Arthur S. Cotins, James N. Brown, L. B. Reigler, Geo. P. Hodges, Robert F. MacFarland, Harry T. Duffy, Kenneth S. Duffes, Wm. McCarthy
Radio Accounts: Animal Foundation, Inc. (Hunt Club Dog Meal), Sherburne, N. Y.; Empire Crafts Corporation (silverware), Newark, N. Y.; Mohawk Valley Investing Co., Utica, N. Y.; Saratoga Springs Authority (resort & mineral waters), Saratoga Springs, N. Y.; Fitzgerald Bros. Brewing Co. (Beer & Ale), Troy, N. Y.; Rutland Co. Agricultural Society (County Fair), Rutland, Vt.; Unadilla Silo Co. (Silos), Unadilla, N. Y.
TV Accounts: Animal Foundation, Inc. (Hunt Club Dog Meal), Sherburne, N. Y.; General Ice Cream Corporation (Sealtest Ice Cream), Utica, N. Y.; Duofold, Inc. (Underwear), Mohawk, N. Y.; Fitzgerald Bros. Brewing Co. (Beer & Ale), Troy, N. Y.

MOSS ASSOCIATES

415 Lexington Ave., New York 17, N. Y.
 Phone: MUrray Hill 7-7377
 ABC—ABP—ANPA

President.....Joseph H. Moss
 Vice President.....Miles Shefferman
 Production Mgr.....Martin Lebwth
 Copy Chief.....Gerald H. Bruce
 Media Director.....Marian Rand
 Radio & TV Dir.....B. Math

C. WENDEL MUENCH & COMPANY

75 E. Wacker Drive, Chicago 1, Ill.
 Phone: FIancial 6-3481
 ABP—ANPA

President.....C. W. Muench
 General Manager.....W. O. Yocum
 Media Director.....Victor Fabian
 Production Manager.....Wm. G. Fisher
 Copy Chief.....Proctor Fiske
Radio Accounts: Manrer-Neuer Co. (Meat Products), Kansas City, Mo.; L. C. Forman & Sons Co. (Condiments), Pittsford, N. Y.; Fox De Luxe Foods, Inc. (Poultry), Chicago, Ill.; Pavelka Brothers (Meat Products), Cleveland, O.; Bosch Brewing Company (Beer), Houghton, Mich.; G. A. Goodrich Co. (Good-n-Rich Cake Mixes), Chicago, Ill.; Klarer Provision Co. (Meats), Louisville, Ky.; Neuhooff Brothers Packers (Meats), Dallas, Texas; Oshkosh Brewing Co. (Beer), Oshkosh, Wisc.; Standard Pkg. Corp. (Flexible Vacuum Pkg.), New York, N. Y.; Miracloth Sales, The Visking Corp. (Miracloth), Chicago, Ill.

TV Accounts: The Griffith Laboratories, Inc. (Spices); Monarch Brewing Co. (Beer), Chicago, Ill.; Bosch Brewing Company (Beer), Houghton, Mich.; Fannie May Candy Company, Chicago; Fox De Luxe Foods, Inc., Chicago; L. C. Forman & Sons (Pickles & Relishes), Pittsford, N. Y.; Klarer Provision Co. (Meats), Dallas, Texas; Maurer-Neuer Corp. (Meats), Kansas City, Mo.; Neuhooff Brothers (Meats), Dallas, Texas; Pavelka Brothers (Meats), Cleveland; Standard Pkg. Corp. (Flexible Vacuum Pkg.), New York, N. Y.; Oshkosh Brewing

Co. (Beer), Oshkosh, Wisconsin; G. A. Goodrich Co. (Good-n-Rich Cake Mixes), Chicago; Miracloth Sales, The Visking Corp. (Miracloth), Chicago, Ill.

NATIONAL EXPORT ADVERTISING SERVICE, INC.

405 Lexington Ave., New York 17, N. Y.
 Phone: MUrray Hill 9-6835

President.....Paul R. Kruming
 Exec. Vice-Pres.....Thomas W. Hughes
 Vice-President.....Joseph W. Madden
 Copy Chief.....John L. Albright
 Art Director.....J. La Rosa
 Radio & TV Director.....James G. Zea
 Time Buyer.....Jacqueline Ruta
Radio and TV Accounts: American Safety Razor, Borden Co., Electric Auto-Lite, Esterbrook Pen, H. J. Heinz, Lambert Pharmaceutical Co., Lever Brothers (U. S.), Quaker Oats Co., W. R. Warner, R. Hudnut, Westinghouse.

NEEDHAM, LOUIS & BRORBY, INC.

135 S. LaSalle St., Chicago 3, Ill.
 Phone: STate 2-5151

AAA—ANPA—PPA—NOAB—APA
 ABC—ABP—SNPA

President.....Maurice H. Needham
 Vice-Presidents.....John J. Louis, Melvin Brorby, W. Raymond Fowler, Wm. D. Horne, Jr., Wm. P. Bager, Wm. H. Ohle, Wm. R. Kinnaird
 Vice-Pres. & Media Dir...Otto R. Stadelman
 Vice-Pres. & Radio-TV Dir...J. G. Cominos
 Sec.-Treas.....Max D. Anwyl

Branch Office

1680 North Vine St., Hollywood 28, Calif.
 Vice-Pres. & Mgr.....Frank Pittman
 730 Fifth Ave., New York, N. Y.
 V.P. & Mgr.....Richard Eastland
Radio Accounts: Kraft Food Co., S. C. Johnson & Son, Swift & Co., Wieboldt Stores, Inc., Derby Foods, Inc.

RALPH NELMS, INC., ADV.

318 St. Louis St., Springfield 3, Mo.
 Phone: 4-2555
 APA

President.....Ralph A. Nelms
 Secretary.....Annabelle Gray
 Art Director.....J. H. Richards
Radio Accounts: Wilson Bros. Mfg. Co. (Hooked Rug Materials), Springfield; Wilke Laboratories (Poultry & Livestock Remedies), West Plains; Old Nick Seed Co. (Seed Corn & Treatment), St. Joseph; Pioneer Products, Inc. (Cough Medicine), Hoffman-Taff, Inc. (Chemicals), Springfield; Independent Stave Co. (Wood Products), Lebanon; Reynolds Mfg. Co. (Reyco Tandem), Springfield, Mo.

GEORGE R. NELSON, INC.

208 State St., Schenectady 5, N. Y.
 Phone: 4-4135

Pres. & Treas.....George R. Nelson
 Vice-President.....Helen C. Nelson
 Secretary.....Alice Pach

Art Director.....Arnold Hitchins
 Radio, Copy, Pub. Dir.....Robert S. Cragin
 TV Director.....Robert Stone
 Radio Time Buyer.....D. Nicoletti
 TV Time, Space Buyer.....Robert Groff
 Assoc. TV Prod.Jack Landt

Radio Transcription Production Accounts:
 General Electric Company, Electronics Division (G. E. Radios and TV Sets), Syracuse, N. Y.; Saratoga Association (Racing Association), Saratoga & New York, N. Y.; General Electric Company, Appliance Division (Refrigerators, Stoves, etc.), Bridgeport, Conn.; National Dairy Company (Sealtest Dairy Prods.), Benrus Watch Company (Watch Manufacturer), New York, N. Y.; Marcus Breiers' Sons (Sports Clothing), Mohawk Carpet Mills, Inc. (Rug & Carpet Mfrs.), Amsterdam, N. Y.; Stein Clothes, Inc. (Sir Little Garments), Pepsi-Cola Company, Soft Drink Mfrs.), New York, N. Y.; Spaulding Bakeries, Inc. (Spaulding Baked Products), Binghamton, N. Y.; Block Drug Company (Pharmaceutical Products), Jersey City, N. J.; D. L. & W. Coal Co. (Blue Coal), New York; Shell Oil Co., N. Y.; National Pressure Cooker Co. (Presto Prods.) Eau Claire, Wis.; Robert Hall Clothes, N. Y.

Television Film Production Accounts:
 Pepsi-Cola Company (Soft Drink Mfrs.), New York, N. Y.; Saratoga Association (Racing Association), New York & Saratoga, N. Y.; Mohawk Carpet Mills, Amsterdam, N. Y.

Television Accounts (Time): Mohawk Carpet Mills, Inc. (Rug & Carpet Mfrs.), Amsterdam, N. Y.; William W. Lee & Co. (Save-the-Baby), Watervliet, N. Y.; Saratoga Association (Racing Association), Saratoga & New York, N. Y.; National Pressure Cooker Co.

TED NELSON ASSOCIATES

730 Fifth Ave., New York 19, N. Y.
 Phone: Circle 6-8470

OwnerTed Nelson
 Production Dir.....Sol Lipset
 Publicity Dir.....Nat Fields
 Account Exec.....Jack Fields
 TV Directors.....Perry Bruskin
 Charles Durand

Radio Accounts: Edlie Electronics Corp., Saul Birns, New York, N. Y.; Delta Photo Supply Co., Authentic Publications, N. Y.; Geographia Corp. (Publishers), New York; Ideal Film & Supply Co., N. Y.; Orfeo (High-Fi Equip. Mfr.), N. Y.; R. B. Hathaway (Foot Lotion), N. Y.; TV and Radio Products Co., N. Y.; Barbey Distributors (Poole Clock-Defroster), N. Y.

TV Accounts: Authentic Publications, New York; TV and Radio Products Co., N. Y.; Ideal Film & Supply Co.

NEWMAN, LYNDE & ASSOCIATES, INC.

Florida National Bank Bldg., Jacksonville 7, Fla.

Phone: 98-9721

ABP-ANPA-APA-NOAB

Director.....M. T. Newman
 Pres., Radio Dir.....Hunter Lynde
 V.-P.-TV Dir.....David E. Robeson
 Secy. & Pub. Dir.....Ronald G. Sercombe
 Art Director.....Ed Duckett
 Prod. Mgr.....Ned Hubbard

Radio Accounts: Bond-Howell Lumber Co. (Bldg. Supplies); Sarasota Meat Packing, Tampa.

TV Accounts: Sarasota Meat Packing Co., Tampa, Fla.; Bond-Howell Lumber Company (Bldg. Supplies), Jacksonville, Fla.; Blue Cross-Blue Shield of Fla., Jacksonville, Fla.; American Coolair Corp. (Ventilating Equip.), Jacksonville, Fla.

R. T. O'CONNELL COMPANY

420 Madison Ave., New York 17, N. Y.

Phone: PLaza 3-5412

AAA-ABP-PPA-APA

Pres., Radio-TV Dir.R. T. O'Connell
 Exec. Vice Pres.....Ethel Merklen
 Vice President.....George Miller

Radio Accounts: Pomatex Co., Inc. (Brilliantine), New York, N. Y.; Cushman & Denison, New York; Edward Week & Co., Brooklyn, N. Y.

OLIAN ADVERTISING CO.

909 Ambassador Bldg., St. Louis 1, Mo.

Phone: Central 8380

ABP-ANPA-PPA-APA-NOAB

President.....Harold A. Thomas
 Radio-TV Prod.....Peggy Leonhardt
 V.P., Copy Chief.....Jim Spencer
 V.P., Treas.....Irving R. Ohlsen
 Media Dir.....Alice McDonough
 Comptroller.....Florence Treadway

Radio Accounts: Sayman Products Co. (Sayman Soap); John Bardenheier Wine Co.; Dixie Mills Co.; Allen Kirkpatrick & Co. (Frozen Oysters); Meletio Sea Food Co.; Reddi-Wip Co.; Pappy's Products Co. (Pappy's Sassafras Tea); St. Louis Federal Savings & Loan; Weber Implement & Automobile Co.

TV Accounts: Pevely-Dairy Co. (Reddi-Wip), Ritepoint Co., Knapp-Monarch, General Grocer Co. (Topusot Foods, Manhattan Coffee); John Bardenheier Wine Co.; Bluhill Products Co.; General Electric Appliances; General Grocer Co. (Manhattan Coffee); Allen Kirkpatrick Co. (Frozen Oysters); Pappy's Products Co. (Pappy's Sassafras Tea); Weber Implement & Automobile Co.; St. Louis Federal Savings & Loan Assn.; Sayman Products Co. (Sayman Soap & Salve).

OLMSTED & FOLEY

1209 2nd Ave. So., Minneapolis 3, Minn.

Phone: ATLantic 8166

AAA-ABC-ABP-ANPA-AFA

Exec. Partner.....Ward H. Olmsted
 Exec. Partner.....John T. Foley
 Partner.....John K. Mortland
 Partner.....Robert B. File

TV Accounts: McGough Bakeries Corp., Birmingham; Carpenter Baking Co., Milwaukee; Fuchs Baking Co., So. Miami, Fla.; Old Homestead Bread Co., Denver, Colo.; Phoenix Holsum Bakery, Phoenix, Ariz.; Fisher Baking Co., Salt Lake City, Utah; Amrhein's Bakery, Springfield, Ill.; Nickles Bakery, Navarre, Ohio; Haller's Eagle Bakery, Altoona, Pa.; Nissen's Bakery, Portland, Me.; Cotton Bros. Baking Co., Baton Rouge, La.; Holsum Bakers, Tampa, Fla.; Shipley Bakery, Fort Smith, Ark.; Holsum Bakery, Fort Wayne, Ind.; Gunzenhauser Bakery, Lancaster, Pa.; Mrs. Boehme's Bakery, San Angelo, Texas.

EARLE LUDGIN & CO.

121 W. Wacker Drive, Chicago 1, Ill.
AAAA-ABP-ANPA-APA-ABC
NOAB-PPA

President-TreasurerEarle Ludgin
Exec. Vice-Pres.Vincent R. Bliss
Vice-Presidents..Montgomery N. McKinney,
John H. Wilmarth, Edward Chapman
Time Buyer.....Jane Daly
Radio Accounts: Rit Products Corp., The Best Foods, Inc., W. F. McLaughlin & Co., Allen B. Wrisley (Wrisley Soap), Chicago, Ill.

TV Accounts: Jules Montener, Inc., The Best Foods, Inc., W. F. McLaughlin & Co., Rit Products Corp., (All Purposc Rit), New York, N. Y.

LYNN-FIELDHOUSE

15 S. Franklin St., Wilkes-Barre, Pa.
Phone: Valley 2-7182-3

Partners.....S. C. B. Lynn,
L. S. Fieldhousc
Radio-TV & Media Dir.....W. B. Pritchard
Art Director.....C. L. Steyer

Branch Office

51 E. 42nd St., New York 17, N. Y.
Phone: MURray Hill 2-4048

Radio Accounts: Wise Potato Chip Co. (Potato Chips), Berwick; Planters Edible Oil Co. (Peanut Oil); Wilkes-Barre; Planter's Nut & Choc. Co. (Peanut Butter), Wilkes-Barre, Pa.; Quinlan Pretzel Co. (Pretzels), Reading; Purvin Dairy Co. (Milk), Wilkes-Barre, Pa.; Jack's Tasty Snack Corp. (Cheese Twists), Oneida, N. Y.

TV Accounts: Wise Potato Chip Co. (Potato Chips), Berwick; Quinlan Pretzel Co. (Pretzels), Reading, Pa.; Planter's Edible Oil Co. (Peanut Oil), Planter's Nut & Choc. Co. (Peanut Butter), Wilkes-Barre, Pa.; Jack's Tasty Snack Corp. (Cheese Twists), Oneida, N. Y.

W. D. LYON COMPANY

303 Second Ave., Cedar Rapids, Iowa
Phone: 4-2451
AAAA

President.....W. D. Lyon
Vice President.....R. B. Creswell
Radio-TV Director.....R. H. Schubert
TV Film Producer.....J. C. Ware
TV Film Director.....Dave Russell

Branch Office

373 Orpheum Electric Bldg., Sioux City, Ia.
Phone: 5-4428

ManagerDon Carlos
Radio Accounts: Builders Material, Inc., Cedar Rapids; Century Engineering Corp. (heating equipment), Cedar Rapids; Collins Radio Company (commercial radio equip.), Cedar Rapids; Crescent Electric Supply (appliance distributor), Dubuque; Iowa Dairy Industry Comm., Des Moines, Ia.; Tender-sweet Sales Corp. (canned vegetables), Vinton, Ia.; Kent Feeds (livestock & poultry feeds), Muscatine, Ia.; Potosi Brewing Company, Potosi, Wisc.; Slagle Lumber Yard, Sioux City, Ia.

TV Accounts: Johnson Biscuit Co. (Cookies), Sioux City, Ia.; Peterson Furniture Co. (Home Furnishings), Cedar Rapids, Ia.; Killian Co. (Clothing), Cedar Rapids, Ia.; Tolerton-Warfield Co. (Food Line), Sioux City, Ia.; Cownie-Williges (Furs), Sioux City, Ia.; Hometown Dairies (Dairy Products), Iowa City, Ia.

MACE ADVERTISING AGENCY, INC.

408 Fulton St., Peoria 2, Ill.
Phone: 6-0771

ANPA-ABP-APA-PPA-NOAB-NAAN
President & Art Dir.....J. F. Fellay
Vice-President.....R. W. Steele
Treas. & Gen. Mgr.....Jay J. Keith
Copy Dept.....J. R. Shullaw

MacFARLAND, AVEYARD & CO.

333 N. Michigan Ave., Chicago 1, Ill.
Phone: RANDolph 6-9360

ANPA-ABP-ABC

Chairman of Board.....Hays McFarland
President.....A. E. Aveyard
Exec. V.P.....Allen B. Dicus
V.P., Copy Chief.....R. E. Blackburn
Vice Presidents.....John C. Wheatley,
David W. Stotter

Time Buyer.....Willis E. Adams
Research Director.....Robert Allrich
Media Director.....A. S. Trude, Jr.
Radio-TV Dir.....Wm. A. Mowry
Radio Accounts: Hallicrafters Co., Drewrys, Ltd. (Beer & Ale), So. Bend, Ind.; Stewart-Warner Corp., Alemite Division, Chicago, Ill.; Grocery Store Products Co. (Foulds Macaroni & Spaghetti), Libertyville, Ill.

TV Accounts: Drewrys Ltd., U. S. A., Inc. (Beer & Ale), South Bend, Ind.; Stewart-Warner Corp., Alemite Division, Chicago, Ill.; Grocery Store Products Co. (Foulds Macaroni & Spaghetti), Libertyville, Ill.

MacLAREN ADVERTISING CO., LTD.

372 Bay St., Toronto, Ont.
Phone: Empire 4-0321
ABC-ANPA

President.....J. A. MacLaren
Vice-Presidents.....E. V. Rechnitzer,
J. Ferres
ComptrollerW. D. MacMahon
Director.....W. G. Abel

Radio & TV Dir.....H. Horler
Branch Offices
 410 Dominion Square Bldg., Montreal, P. Q.
 Manager.....F. P. Gill
 RadioLaurent Trudel
 911 Electric Rlwy. Chambers, Winnipeg,
 Manitoba

Manager.....E. P. Thomson
 1240 W. Pender St., Vancouver, B. C.
 Manager.....W. D. M. Patterson
Radio-TV Accounts: Imperial Varnish &
 Color Co., Ltd., Imperial Oil Ltd. (Hockey
 and Baseball), O'Cedar Company of Canada,
 Peoples Credit Jewelers, Tuckett Tobacco
 Limited, Henry K. Wampole & Co., Ltd.,
 Canadian General Electric, Christie Brown,
 Ltd. (Food), Standard Brands, Ltd. Lake of
 Woods Milling Co., Stephen's Paints, Home
 Oil Distributors, W. H. Malkin & Co., Ltd.,
 Nalley's Limited, Ainsworth Motors; General
 Motors of Canada; Canadian Shredded
 Wheat Co.; Canada Dry Ltd.; Aluminum
 Goods, Ltd.; Aspro Limited; Bank of Cana-
 da; British & American Motors Canada,
 Ltd.; British Lace Furnishings, Broadhurst
 Lee Co., Ltd.; Bulova Watch Company,
 Canada Paint Co., Ltd.; Canadian Bank of
 Commerce, Canadian Red Cross, Depart-
 ment of National Defence (Air Force, Navy);
 Dominion Tar & Chemical Co., Ltd. (Javex);
 Dolcis (Canada) Ltd.; Dominion Rubber
 Co., Ltd.; Hertz Driv-ur-Self System, Inc.;
 Home Oil Distributors, Lever Brothers Ltd.
 (Breeze); Moirs Chocolates, Ltd.; Sicks'
 Capilano Brewery, Ltd.; Sherwin Williams
 Co. of Canada Ltd.; Palmers' Limited, Zero
 Manufacturing Co., Ltd.

MacMANUS, JOHN & ADAMS

Bloomfield Hills, Mich.
 Phone: Midwest 6-1000

ANPA-AAAA-ABC-NOAB-PPA-APA
 Chairman.....W. A. P. John
 Pres. & Treas.....James R. Adams
 Exec. Vice-Pres.....Harvey G. Luce
 Vice-Pres., Media Dir...Elmer W. Froehlich
 Radio Time Buyer.....C. N. Campbell

Branch Office

444 Madison Ave., New York, N. Y.
 Manager.....R. A. Brewer
Radio Accounts: Pontiac Motor Division,
 Pontiac, Mich.; Cadillac Motor Division,
 Dearborn, Mich.; Ferry-Morse Seed Co., De-
 troit, Mich.; Stegmaier Brewing Co., Wilkes-
 Barre, Pa.; Dow Chemical Co., Midland,
 Mich.
TV Accounts: Pontiac Motor Division,
 Pontiac, Mich.; Stegmaier Brewing Co.,
 Wilkes-Barre, Pa.

MALCOLM-HOWARD

203 N. Wabash, Chicago 1, Ill.
 Phone: Andover 3-0022
 ABP-ANPA-PPA

Owner.....Arthur M. Holland
 Art Director.....Arthur Anderle
 Copy Chief.....William Bent
 Radio-TV Buyer.....Evelyn Burke

Publicity Director.....Jan Marinella
 Radio-TV Dept.....G. Janda, R. Spencer
Radio Accounts: Hollands (jewelry), Chi-
 cago; Roller Derby, N. Y. C.; Fohman
 Motors, Chicago; Joy Candies, Chicago.
TV Accounts: Ambrosia Brewing, Chi-
 cago; Harry Alter Co. (Crosley appl.), Chi-
 cago; Courtesy Motors, Chicago; Hudson
 Dealers Assn. (autos), Chicago; Mages
 Sports Stores, Chicago; Leo Rose Co. (cloth-
 ing), Chicago; Rubin's (apparel), Chicago;
 Holland, Inc. (jewelry), Chicago; Associated
 Hospital Ins. Co., Chicago; Roller Derby,
 Chicago; Sun-Times (newspaper), Chicago;
 Stiffel Lamp Co., Chicago.

DAVID MALKIEL ADV. AGENCY

172 Newbury St., Boston 16, Mass.
 Phone: Copley 7-5980

ABP-ANPA-APA-AAAN

Production Manager.....Julian Malkiel
 SecretaryMartha Brest
Radio Accounts: Ace Vacuum Stores
 (Vacuum Cleaners), Boston, Mass.

**J. GORDON MANCHESTER,
 ADVERTISING, INC.**

1726 Pennsylvania Ave., N.W.,
 Washington, D. C.
 Phone: ME 8-0060

President.....J. G. Manchester
 Vice President.....Richard P. Ebst
 Asst. Vice Pres.....G. D. McGuiness
 Art Director.....Wm. D. Flieschell
 Dir. Radio-TV.....Kathleen Kane
Radio-TV Accounts: Safeway Stores, Inc.,
 Ottenberg's Bakers, Inc., James G. Gill Co.,
 Inc., W. H. Pope and Sons, American Sta-Dri
 Co., Acacia Mutual Life Insurance Company.

MANHATTAN ADVERTISING

225 West 57th St., New York 19, N. Y.
 Phone: PLaza 7-3340
 ABP-APA

Owner.....Eugene L. Friedman
 Art Director.....Norman Graber
 Art Director.....Gene Fogelman
 Account Executive.....R. J. Friedman

MANSON-GOLD-MILLER, INC.

1004 Marquette Ave., Minneapolis 3, Minn.
 Phone: GENEva 9619
 APA-ABP

Pres. & Treas.....Robert P. Miller
 Vice-Pres. & Sec.....Eleanor L. Miller
 Art Director.....Edward Harris
Radio Account: Snyder Drug Stores.

**MARFREE ADVERTISING
 CORPORATION**

105 West 40th St., New York 18, N. Y.
 Phone: LONgaere 4-7190

President.....Harry A. Friedenberg
 SecretaryRobert Tomasello
 V.P., Treas.....Barnett Friedenberg
 Director Radio.....Harry A. Friedenberg
 V.P. in Charge.....Sheppard Chartoe
Radio Accounts: D-Con Company (D-

Con), Chicago, Ill.; Carlson Industries (Drugs), New York; Crest Records (Records), Long Island; Old Masters (Reproductions), New York; Taylor Razors (Dry-Shavers), Newark; Cadillac Imports (Toys), New York.

MARKS-AIKEN COMPANY

33 West 46th St., New York 36, N. Y.
Phone: COLUMBUS 5-4990
ABP-ANPA

PartnerLawrence Marks
PartnerSigmund C. Aiken
Media DirectorFlorence Saperstein
Production Mgr.....Stanley Marx
Art DirectorMarvin Macnow

MARSCHALK & PRATT CO.

535 Fifth Ave., New York 17, N. Y.
Phone: VANDERHILT 6-2022

PresidentH. C. Marschalk
Vice Presidents.....S. H. Giellerup,
S. L. Meulendyke, C. A. Peterson, R. H. Jones
TV-Radio Director.....Curt A. Peterson
Radio Account: Esso Standard Oil Co. (Petroleum), New York, N. Y.; WTL Nickel Co.
TV Account: Esso Standard Oil Co. (Petroleum), New York, N. Y.; Standard Oil Co. (N. J.).

J. M. MATHES, INC.

260 Madison Ave., New York 17, N. Y.
Phone: LEXINGTON 2-7450
ABP-ANPA-APA-PPA-ABC

PresidentJ. M. Mathes
TreasurerA. E. Cox
SecretaryCarle E. Rollins
Vice-Pres. & Dir.....Wilfred S. King,
W. T. Okie, Lester J. Loh
Vice-Presidents.....David C. Gibson,
Dr. O. L. Tinklepaugh, Jan H. Meyer,
A. F. Monroe, Read H. Wight, Douglas R. Hathaway
Director of Radio & TV.....Read H. Wight
Radio Time Buyer.....Edna S. Cathcart
Radio Accounts: Pure Food Co., Inc. (Herb-Ox Boullion Cuhes-Westchester Chicken), Mamaroneck, N. Y.; Canada Dry Ginger Ale, Inc., N. Y. C.; International Telephone & Telegraph Capehart-Farnsworth Corp., N. Y. C.; Judson Dunaway Corp.
TV Accounts: Wagner Baking Corp. (Mrs. Wagner's Pies), Newark, N. J.; Houbigant Sales Corp. (Liquid Skin Sachet, A/S Deodorant), N. Y. C.; Nortbam Warren Corporation (Cutex, Peggy Sage, Odorono), Stamford, N. Y.; Judson Dunaway Corp. (Vanish-Expello), Dover, N. H.; Luden's, Inc. (Fifth Avenue Candy Bar, Cough Drops), Reading, Pa.; Canada Dry Ginger Ale, Inc., N. Y. C.; Imperial Paper & Color Corp., Glens Falls, N. Y.; The Pure Food Co., Mamaroneck, N. Y.

MATHISSON & ASSOCIATES, INC.

411 E. Mason St., Milwaukee 2, Wis.
Phone: DALY 8-4090

ABP-NOAB-PPA-APA-ANPA

Pres., Art. Dir., Space Buyer,
Research Dir.C. A. Mathisson
Vice-Pres. & Treas.....I. M. Hönkel
Copy Chief, Sec., Media Dir.,
Space Buyer.....Edward G. Ball
Radio-TV Dir.,
Time Buyer.....Charles H. Helliwell

JOSEPH MAXFIELD CO.

87 Weybosset St., Providence 3, R. I.
Phone: GASPEE 1-4456
ABP-ANPA

Pres., Space-Radio-TV-Time
Buyer.....Joseph M. Finkle
Vice-Pres.-Treas.....Archie M. Finkle
Radio Director.....Harold Goodstein
Production Mgr.....Dorothy M. Barry

MAXON, INC.

2761 E. Jefferson Ave., Detroit 7, Mich.
Phone: LORAIN 7-5710

ANPA-APA-PPA-ABC-NOAB

President.....Lou R. Maxon
Vice-PresidentSearle Hendee
Treasurer.....W. I. O'Neil
Secretary.....G. Reginald McKiel
Business Mgr.....T. P. Maguire
Radio & TV Director.....S. James Andrews
Asst. Dir. Radio-TV.....John Mosman

Branch Offices

12 E. 53rd St., New York 22, N. Y.
Phone: PLAZA 9-7676

Vice-Pres., Gen. Mgr.....M. F. Mahoney
664 N. Rush, Chicago 11, Ill.
Phone: WHITEHALL 4-1676
Manager.....L. J. Sholty
Radio and TV Accounts: Gillette Safety Razor Co., Boston, Mass.; Snow Crop Marketers (frozen foods), New York; Peter Paul, Inc. (Mounds & Almond Joy candy), Naugatuck, Conn.; Mobawk Carpet Mills, Inc., Amsterdam, N. Y.; H. J. Heinz Company (canned foods), Pittsburgh, Pa.; General Electric Co. (radio & television sets), Syracuse, N. Y.; Packard Motor Car Co., Detroit, Mich.; Hotpoint, Inc. (appliances), Chicago, Ill.; Griesedeck-Western Brewing Co., St. Louis, Mo.; Pfeiffer Brewing Co., Detroit, Mich.

THE MAYERS CO., INC.

2301 W. Third St., Los Angeles 5, Calif.
Phone: DUNKIRK 8-2111
ABP-APA-NOAB-PPA-ANPA

PresidentHenry Mayers
Vice-PresidentForrest Dolan
Secretary.....Sophie Mayers
ProductionEdith Hemphfling
Media Director.....Bob Hoehn
Radio Accounts: Pennzoil Co. (Oil & Lubricants), Sears Roebuck & Co. (Retail Department Store), Los Angeles, Calif.
TV Accounts: Sears Roebuck & Co. (Retail Department Store); Hoffman Candy Co.; Pennzoil Co.

McCANN-ERICKSON, INC.

50 Rockefeller Plaza, New York 20, N. Y.
Phone: JUdson 6-3400

AAAA-ABC-ABP-ANPA-APA
NOAB-PPA-BMB

Chairman of Board.....H. K. McCann
Vice Chm. & Chm. of

Exec. Comm.....Harrison Atwood
President.....Marion Harper, Jr.
Vice Pres. & Treas.....Robert E. Healy
Asst. Treas. & Compt.....Dixon R. Griswold
Secretary.....Kathryn H. Kelly
Vice Presidents (N. Y.).....Frederick Anderson,
Donald M. Armstrong, Jr., James W. Blackburn,
Donald G. Calhoun, W. H. Conine,
Sidney W. Dean, Jr., J. L. Deane, G. B. Dearnley,
Earl C. Donegan, George H. Giese, Alberta Hays,
C. A. Hoppock, Farish A. Jenkins, Daniel W. Keefe,
Arthur J. Kemp, Alton Ketchum, Ralph B. Koser,
Thomas P. Losee, Rudyard C. McKee,
Florence A. Richards, Margot Sherman,
R. F. Thompson, Samuel P. Walker, E. F. Wilson,
Fred M. Zeder, Jr., Wm. Berelthold,
Wm. Breen, Hendrik Booraem, K. Brautigam,
R. Cramer, W. C. Dekker, J. J. Flanagan.

V.P. in Chgo. Radio-TV.....A. J. Scalpone
V.P. Chgo. New Prog.....Hendrik Booraem
V.P., Radio-TV Crea. Dir...Ralph B. Koser
V.P., Exec. Prod.....Dorothy B. McCann
Dir. Radio-TV Prod.....Edward Sutherland
Mgr. Radio-TV Service...Clifford C. Lubkert
Mgr. Radio-TV Time
Buying.....Thaddus S. Kelly
V.P., Mgr. Hollywood
Office.....J. Neil Reagan

Branch Offices

200 Berkeley St., Boston 16, Mass.
Vice Pres.-Mgr.....Watson M. Gordon
629 Euclid Ave., Cleveland 14, O.
Vice Pres.-Mgr.....Robert Dailey
647 Griswold St., Detroit 26, Mich.
Vice Pres.-Mgr.....Paul Holder
707 Terrace Plaza Bldg., Cincinnati 2, O.
Vice-Pres.-Mgr.....R. M. Alderman
318 S. Michigan Ave., Chicago 4, Ill.
Vice Pres.-Mgr.....Sidney A. Wells
Vice Presidents.....Walter C. Krause,
G. Bowman Krcer, A. W. Sherer
6331 Hollywood Blvd., Hollywood 28, Calif.
Mgr.....J. Neil Reagan
612 S. Flower St., Los Angeles 17, Calif.
Vice Pres.-Mgr.....Burt Cochran
114 Sansome St., San Francisco 4, Calif.
Vice Pres.-Mgr.....H. Q. Hawes
Vice Presidents.....Roswell H. Cochran,
Clarence Hestorff, Frederick H. McCrea
310 Public Service Bldg., Portland 4, Ore.
Mgr.....Willard E. Wilson

Radio Accounts: American Trust Company, American Safety Razor Corp., California Packing Corp., California Spray Chemical, California Wine Association, Chesebrough Mfg. Co., Chrysler Sales Division, Chrysler Corporation, Columbia Records, Inc., Gruen Watch Company, W. P. Fuller &

Co., Lucky Lager Brewing Co., Manufacturers Trust Co., National Biscuit Co., Ohio Bell Telephone Co., Pacific Power & Light Co., Pepsodent Division-Lever Bros. Co., Portland Gas & Coke Co., S. O. S. Company, Southern California Gas Co., South Counties Gas Co., Standard Oil Co. (Ind.), Standard Oil Co. (Ohio), Swift & Company, Leisy Brewing Co., Westinghouse Electric Supply Co. of St. Louis, Allied Van Lines, Inc., Harshaw Chemical Company (Laurel Products Division), Gray Drug Stores, Inc., Milk Foundation, Inc., Pharma-Craft Corp., Seck & Kade, Inc., Stegmaier Brewing Company.

TV Accounts: American Trust Co., California Packing Corp., California Wine Association, Chrysler Sales Division, Chrysler Corporation, Gray Drug Stores, Inc., Gruen Watch Company, "Junket" Brand Foods, Pepsodent Division-Lever Bros. Co., Lucky Lager Brewing Co., Milk Foundation, National Biscuit Co., Ohio Bell Telephone Co., Pacific Coast Borax Co., Soil-Off Mfg. Co., S.O.S. Company, Southern Calif. Gas Co., Southern Counties Gas Co., Standard Oil Co. (Indiana), Standard Oil Co. (Ohio), Leisy Brewing Co., National City Bank of Cleveland, Westinghouse Electric Corp., Westinghouse Electric Supply Co. of St. Louis, Allied Van Lines, Inc., American Safety Razor Corp., Bell Brand Foods, Ltd., California Spray Chemical Corp., Chesebrough Mfg. Company, Chrysler New York Region Dealer Group, Congoleum-Nairn, Inc., Harshaw Chemical Co. (Laurel Products Division), Maytag Sales Company, Portland Gas & Coke Company, Seck & Kade, Inc., Stegmaier Brewing Company.

McCORMICK COMPANY

217 E. 7th Ave., Amarillo, Tex.
Phone: 4-5333

NOAB-ANPA-APA-SNPA

Owner-Manager.....James L. McCormick
Art Director.....Stefan Kramer
Radio Accounts: Shamrock Oil & Gas Corp.

WALTER McCREERY, INC.

9344 Wilshire Blvd., Beverly Hills, Calif.

Phone: CRestview 5-5533

AAAA-ANPA-APA-PPA

Chm. Bd. & Pres.....Walter K. McCreery
Acct. Execs.....Walter McCreery,
Richard Berggren, R. H. Svensson, John R. Gillingham
Time Buyer.....Virginia White
Radio-TV Accounts: Harris & Frank (retail clothing), Los Angeles; Holiday On Ice, N. Y. C.; Ice Follies, San Francisco; Knox, Dick, of Calif. (ceramics mfg.), Capistrano Bearist; Murphy Oldsmobile, Los Angeles; Palm Desert Corp. (resort & real estate), Palm Desert; Pan Pacific Aud., Los Angeles; So. Calif. Muffler Co. (exhaust systems), Los Angeles; San Fernando Valley Times, No. Hollywood.

Partners.....G. C. Hellickson,
Ward Ohnstead

Radio Accounts: Marshall-Wells Company (Appliances, Paints, etc.), Duluth, Minn.; Regan Brothers (Holsum Bread), Minneapolis, Minn.; Rochester Dairy (Dairy Products), Rochester, Minn.; Russell-Miller Milling Company (Occident Flour & Mixes, Farm Feeds, American Beauty Flour & Mixes—Dallas, Texas), Minneapolis, Minn.; Clover Leaf Creamery Co. (Dairy Products), Minneapolis, Minn.; Owatonna Canning Co. (Canned Goods), Owatonna, Minn.; Northland Milk & Ice Cream Co. (Dairy Products), Minneapolis, Minn.; Northwest K-F-Willys (Automotive), Minneapolis, Minn.; Page & Hill Homes (Prefabricated Homes), Shakopee, Minn.; Salisbury Co. (Bedding), Minneapolis, Minn.; Hotel Leamington (Hotel), Minneapolis, Minn.; Boutell Bros. (Furniture), Minneapolis, Minn.; Avocem Co. (Clothes Softener), Minneapolis, Minn.

TV Accounts: 1st National Bank, Minneapolis, Minn.; Regan Brothers (Holsum Bread), Minneapolis, Minn.; Russell-Miller Milling Company (Occident Flour & Mixes, Farm Feeds, American Beauty Flour & Mixes—Dallas, Texas), Minneapolis, Minn.; Country Kitchen (Salad Dressings), Minneapolis, Minn.; Northland Milk & Ice Cream Co. (Dairy Products), Minneapolis, Minn.; Nevens Co. (Laundry & Dry Cleaning), Minneapolis, Minn.; Northwest K-F-Willys (Automobiles), Minneapolis, Minn.; Hotel Dyckman (Hotel), Minneapolis, Minn.; Hotel Leamington (Hotel), Minneapolis, Minn.; Boutell Bros. (Furniture), Minneapolis, Minn.

O'NEIL, LARSON, McMAHON

230 N. Michigan, Chicago 1, Ill.

Phone: And. 3-4470

ABC—ABP—ANPA—AFA

Partner.....Nelson J. McMahon
Partner.....Edw. H. Larson
Exec. V.P.....Walter Zivi
Controller.....J. O. Wehb
Sr. Acct. Exec.....W. P. McWilliams
Acct. Execs.....Ray Snasal,
Frank Stein, Peg Robinson, Norman Larson, Joseph F. Littleton
Media Dir. & Radio-TV Buyer... Wm. Cline
AssistantLois Schultz
Prog. Director.....Stan Kaatz

Branch Offices

290 Madison, New York City

Phone: MU 3-8930

ManagerJack Roberts
67 Yonge St., Toronto, Canada

ROBERT W. ORR & ASSOCIATES, INC.

4 W. 58th St., New York 19, N. Y.

Phone: PLaza 9-8050

ANPA—NOAB—PPA

President.....Robert W. Orr
Vice-Pres.....Eldon Sullivan
Vice-PresidentFreemont Knittle

Asst. to Pres.-Treas.....Robert P. Clark
Radio-TV Director.....Lou Ergman

Branch Offices

9130 Sunset Blvd., Los Angeles, Calif.

Radio Accounts: Andrew Jergens Co. (Woodbury & Jergens), Cincinnati, O.

TV Accounts: Andrew Jergens Co.

MERRITT OWENS ADV. AGENCY, INC.

365 New Brotherhood Bldg.,
Kansas City 11, Kans.

Phone: Dr 7250

ABP—ANPA—APA—FAAG

PresidentMerritt Owens
Vice-President.....R. Grant Neds
Production Mgr.....Glenn A. Scott
TV Director.....Earl Allvine
Art Director.....Bernard L. Wardlow
Radio Accounts: Joe M. O'fill Motor Co. (Nash Dealer), Kansas City, Kan.; Kelley-Williams Motor Co. (Ford), Kansas City, Kansas; Chevrolet Dealers Assoc. (Chevrolet), Greater Kansas City; Home Federal Savings & Loan, Kansas City, Mo.

TV Accounts: Davidson Furniture Co. (Furniture), Kansas & Missouri; Chevrolet Dealers Assoc., Greater Kansas City; DeCoursey Creamery Co. (Dairy Products), Kansas City, Kansas; Inter-State Bldg. & Loan, Kansas City, Kan.; Nash Dealers of Greater K. C. (Nash), Greater Kansas City.

PACIFIC NATIONAL ADVERTISING AGENCY

2124 4th Ave., Seattle 1, Wash.

Phone: ELiot 1401

AAAA

President.....W. H. Horsley
Secretary.....H. O. Stone
V.P. & Radio-TV Dir.....Trevor Evans

Branch Offices

715 Cascade Bldg., Portland, Ore.

Phone: Capitol 1021

V.P. & Manager.....Milton Foland
606 Chronicle Bldg., Spokane, Wash.

Phone: MAin 4371

ManagerVernon Cary
Radio Accounts: Fisher Flouring Mills Co. (Pancake Mix, Biskit Mix, Fisher's Blend Flour, Zoom, etc.), Washington Co-Op Farmers Assn.—Lynden Products (Canned & Boned Turkey, Chicken, Chicken & Noodles, etc.), Seattle, Wash.; Ivar's Acres of Clams (Seafood Restaurant), Imperial Candy Co. (Candy), Wm. O. McKay (Ford Cars), Seattle, Wash.; Wash. State Fruit Company (Cherries, Apricots, Peaches, Pears, Prunes), Yakima, Wash.; Federal Old Line Insurance Co. (Insurance); Washington State Apple Commission (Soft Fruits).

TV Accounts: Washington Co-Op Farmers Assn. (Lynden Products), Seattle, Wash.; Fisher Flouring Mills Company; Washington Cooperative Farmers Association; Ivar Haglund—Acres of Clams; Imperial Candy Company; Washington State Apple Commission; Washington State Fruit Commission;

William O. McKay Company, Howe & Company, Potlatch Yards, Carstens Packing Company; Montag, Inc.

PARIS & PEART

370 Lexington Ave., New York 17, N. Y.

Phone: Murray Hill 9-2424

ABP—ANPA—APA—PPA—ABC—NOAB
 Partners.....A. G. Peart, J. A. H. Rehm
 Comptroller.....F. Dubeck
 Media. Research Dir.....H. L. Mooney
 Art Director.....F. Yelinek
 Production Mgr.....R. Largo
 Acct. Execs.....W. F. James, G. M. Cleland,
 S. C. Bernsley, W. Byrne, D. C. Porteous,
 F. N. McInerney, A. Bindrim, G. Kraus, Jr.

PEARSON ADV. AGENCY, INC.

250 Park Ave., New York 17, N. Y.

Phone: Murray Hill 8-3055

PPA

President-Treasurer.....C. H. Pearson
Radio Accounts: Cooper Razor Blade Co. (Razor Blades), Brooklyn; National Home Owners Assoc., New York, N. Y.; Dime Savings Bank, Brooklyn, N. Y.

PECK ADV. AGENCY, INC.

400 Madison Ave., New York 17, N. Y.

Phone: PLaza 3-0900

ABP—ANPA—APA—NOAB—PPA

Chairman of the Board.....Harry Peck
 President.....Harry Krawit
 Vice-Presidents.....Norman Mack,
 Sidney Alexander, John Schuman
 Radio-TV Director.....S. S. Schweitzer
Radio Accounts: Howard Clothes (Men's & Boys' Furnishings), Old Dutch Coffee & Caffe Espresso (Coffee), Charles of the Ritz (Cosmetics), Street & Smith Magazines (Charm, Mademoiselle, Living), Hearst Publications (Cosmopolitan, Good Housekeeping), Excelsior Frozer, Meat Products (Frozen Meat Products).

TV Accounts: Howard Clothes (Men's & Boys' Furnishings), Old Dutch Coffee & Caffe Espresso (Coffee), Charles of the Ritz (Cosmetics).

THE PHILLIPS-RAMSEY CO.

604 First National Bldg., San Diego 1, Calif.

Phone: BELmont 4-5121

Partners.....William L. Phillips,
 Charles C. Ramsey
 Media Director.....Robert L. Phillips
 Radio-TV Prod. Dir.....Orva W. Chuff
Radio Accounts: Arden Farms Co. (Dairy Products), Silver Gate Bldg. & Loan (Savings & Loan Assn.), Dennstedt Electro Mart (Electrical Appliances), First Nat'l Bank, San Diego, Calif.; Walt Tufford De Soto Plymouth (Auto Dealer), San Diego, Calif.; Alsynite Co. of America (Fiber Glass Panels); Community Chest; Mrs. Conkling's Bakery; Food Basket (Super Market Chain); Severin Building Company; Stanley Andrews Sporting Goods; Walker-Scott Corporation (Department Store); San Diego, Calif.

TV Accounts: Arden Farms Co., First Nat'l Bank, San Diego, Calif.; Alsynite Co. of America; Community Chest; First National Trust & Savings Bank; Food Basket; Silver Gate Building & Loan Association; Stanley Andrews Sporting Goods; Walt Tufford; Walker-Scott Corp.

PITLUK ADVERTISING COMPANY

123 Auditorium Circle, San Antonio 5, Texas

Phone: Cathedral 3-6131

APA—PPA—NOAB—SNPA—TAAN

Partner.....Jack N. Pitluk, Sr.
 Partner.....Jack N. Pitluk, Jr.
 Acct. Execs.....Sam Kiklin,
 C. Carolus, G. A. Knapp, Jr., Evans Wyatt
 Public Relations Dir.....Jim Battersby
 Radio Director.....Margaret Morrison
 TV Director.....Dave Hubbard

Radio-TV Accounts: Joske's of Texas (Department Store), San Antonio, Tex.; Handy Andy Community Stores (Chain Grocery Stores), San Antonio, Tex.; Fehr Baking Company, (Fair Maid Bread & Cakes), San Antonio, Tex.; Roegelin Provision Company (Bacon, Sausages), San Antonio, Tex.

PORTER & ASSOCIATES

1001 No. Western Ave., Los Angeles 29, Calif.

Phone: HOLlywood 5-0580

Owner & Sales Mgr.....Irwin T. Porter
 Partner & Time Buyer.....Gertrude Porter
 Account Executive.....Jean Norah
Radio Accounts: Imperial Card Co., Beemak Plastics, Beverly Termite Control Service, Western Art Studios, Acme Hardware & Builders' Supply, Beverly Motors, Carl's Paints, Roy Braemmer Enterprises, Phelps Mfg. Co.

R. J. POTTS—CALKINS & HOLDEN INC.

2233 Grand Ave., Kansas City 8, Mo.

Phone: Gr 5775

ANPA—APA—NOAB—PPA—ABP

President.....R. J. Potts
 Exec. Vice Pres.....J. B. Woodbury
 Vice Presidents...C. C. Tucker, E. A. Warner,
 C. L. Robinson, W. M. Giesecke, Al Coleman
 Radio & TV Director.....William J. Brewer

POTTS-TURNBULL CO., INC.

912 Baltimore Ave., Kansas City 6, Mo.

Phone: Victor 9400

ANPA—APA—PPA—NOAB

President.....W. J. Krebs
 V.P.—Production Mgr.....D. E. Dexter
 Secretary-Treasur.....C. J. Effie
 V.P. & Radio Dir.....N. P. Rowe

PRATER ADVERTISING AGENCY, INC.

705 Chestnut St., St. Louis 1, Mo.

Phone: GARfield 6490

PPA—SNPA—ABP—ANPA—AFA

President.....George L. Prater

Vice-President.....M. T. Prater
 Secretary.....Mary E. Johnson
 Copy Chief.....Barbara Brock
Radio Account: Falls City Brewing Co.,
 Inc. (Falls City Beer), Louisville, Ky.
TV Account: Falls City Brewing Co., Inc.
 (Falls City Beer), Louisville, Ky.

PRODUCT SERVICES, INC.

17 East 45th Street, New York City
 Phone: MURray Hill 7-0204

President.....Les L. Persky
 Vice-President.....Charles K. Hepner
 Promotion Director.....N. R. Lorman
 Time Buyer.....G. Ligornier
TV Accounts: Cameo Curtains Royal Crest
 Sales (Thrifty House); John Irving Shoe
 Company (Mary Jane Shoes).

RADIO ADVERTISING CORP. OF AMERICA

128 Mallory Ave., Jersey City 5, N. J.
 Phone HENDERSON 4-2332

Pres., TV Dir.....Michael A. Fiore
 Vice-President.....Albert A. Fiore
 Secy.-Treas.....B. V. Fiore
 Radio Director.....Paul Apello
 Account Executives...B. Wilman, G. Fiore,
 B. E. Geise, P. Bernhardt, J. Amitrani,
 A. Bryant

Radio Accounts D. Wolff & Co. (Credit
 Clothing), Newark, N. J.; Stage Coach Inn
 (Night Club), S. Hackensack, N. J.; Spe-
 cialty Sales Company (Mail Order Items),
 Lakewood, N. J.; Coast-to-Coast Vendors,
 Inc. (Vending Machines), New York, N. Y.;
 Crescent Construction Corp., North Bergen,
 N. J.; Leslie Toy Co., Brooklyn, N. Y.;
 No-Worry Chemical Co., Newark, N. J.
TV Accounts: Watchung Lake, Inc. (Swim-
 ming Resort), S. Plainfield, N. J.

THE L. W. RAMSEY ADV. AGENCY

230 No. Michigan Ave., Chicago 1, Ill.
 Phone: FRANKlin 2-8155

Pres. & Treas.....E. G. Naeckel
 Vice-President.....L. H. Copeland
 Vice-President.....N. B. Langworthy
 Art Director.....E. J. McCabe
 Media Director.....Dorothy L. Parsons

THE RANDALL COMPANY

75 Pearl St., Hartford 3, Conn.
 Phone: 7-1179

ABC

President.....Wilbur W. Randall
 Art Director.....Robert I. Berger
 Radio & TV Director....Florence F. Grady
Radio Accounts: Crown Petroleum Corp.
 (Petroleum Products), Connecticut & Massa-
 chusetts; Geo. E. Dewey & Co. (Moving
 Storage), General Electric Supply Corp.
 (Television, Radio), Hartford Gas Company
 (Public Utility), New England Laundry
 (Laundry), Savitt Jewelers (Jewelry), Wach-
 tel's (Dept. Store), Hartford, Conn.

TV Accounts: Country Club Soda Co.,
 Inc., Springfield, Mass.; Crown Petroleum

Corp., Conn. & Mass.; Savitt Jewelers, Hart-
 ford, Conn.; State Line Potato Chips.

THE FRED M. RANDALL CO.

Book Tower, Detroit 26, Mich.
 Phone: WOODward 1-4662

ABP-ANPA-APA-PPA-NOAB

President.....H. Ross Mack
 Vice-President.....Hal. G. Trump
 Secy. & Copy Chief.....George B. Dow
 Radio Director.....R. D. Hughes
 Space & Radio Time Buyer

Charles E. Foerster

Production Manager.....George L. Husted
 Account Executives.....H. Ross Mack,
 Hal G. Trump, R. D. Hughes, Charles
 Foerster, Lee E. Crooks

Radio Account: Booth Newspapers.

RAYMOND ADV. AGENCY

32 Green St., Newark 2, N. J.
 Phone: MA 2-6811

ANPA-ABP-APA

Owner.....Milton C. Tauder
 Art Director.....Henry Krupinski
 Production Manager.....Margaret McDade
 Publicity Director.....Rita Levine
 Research Director.....Shirley Trinker

Radio Accounts: K. Kaufman & Co., Inc.,
 Monroe Savings & Loan Assn., Union Na-
 tional Bank.

CHAS. DALLAS REACH CO., INC.

69 Washington St., Newark, N. J.
 Phone: MARKET 3-5100

AAAA-ABP-ANPA-ABC-AFA

Pres. & Treas.....Chas. Dallas Reach
 Exec. V.P., Gen. Mgr.....F. R. Risley
 Vice-Presidents.....Howard Sands,
 H. H. Black

Sec. & Art Dir.....Everett Sahrbeck
 Asst. Sec. & Treas.....Wm. F. Renz

Branch Office

46 W. 55th St., New York 19, N. Y.
 Phone: Circle 5-4176

Radio Accounts: Dngan Brothers (Baked
 Goods), N. J. Bell Telephone, Newark, N.
 J.; Koppers Co. (Coke Fuel); Philadelphia
 Coke Co.

TV Accounts: Koppers Co. (Coke Fuel),
 New York, N. Y.; Philadelphia Coke Co.;
 Dugan Bros. (Baked Goods).

JAMES R. REESE ADVERTISING CO.

15 West 10th St., Kansas City 6, Mo.
 Phone: VICTor 5269

APA-ABP-ANPA

Owner.....James R. Reese

KNOX REEVES ADVERTISING, INC.

600 First Nat'l-Soo Line Bldg.,
 Minneapolis 2, Minn.

Phone: Bridgeport 7701

AAAA-ABC-ABP-ANPA-APA
 NOAB-PPA-NBP

President.....E. E. Sylvestre
 Executive Vice-Pres.....Wayne Hunt
 Vice-Presidents.....J. H. Sarles,



Helen A. Brown, R. W. Stafford, E. K. Pottle, Dr. A. R. Root, Russell E. Neff, R. H. Burbank
 V.P., Radio & TV Dir.....R. E. Neff
 V.P. & Media Director.....Dr. A. R. Root
 Time Buyer.....Coy Bender
Radio Accounts: General Mills, Inc., Pacific Gamble Robinson Co., Midland National Bank, Art Instruction, Inc.
TV Accounts: Art Instruction, Inc., General Mills, Midland National Bank.

REINCKE, MEYER & FINN, INC.

520 N. Michigan Ave., Chicago 11, Ill.
 Phone: WHitchhall 4-7440
 ABP—ANPA—NOAB—ABC—CCA
 PPA—APA—NBP

PresidentWallace Meyer
 Vice-Pres. & Treas.....C. A. Reincke
 Vice-Pres. & Sec.....A. L. Reincke
 Vice-Presidents...Gordon Taylor, J. J. Finn
 Radio-TV Director.....Frank M. Baker
 Media Director.....John Priebe
 Space Buyer.....J. F. Brown
Radio Accounts: Chicago Burlington & Quincy (Railroad travel), Otarian (Hearing Aids), Chicago, Ill.; von Schrader Mfg. Co. (Detergent Rug Cleaner), Racine, Wis.; Cartan Travel Bureau, Inc., Chicago, Ill.
TV Accounts: von Schrader Mfg. Co. (Detergent), Racine, Wis.; Burgess Cellulose Co. (Sponges), Freeport, Ill.; American Chain & Cable Co., Am. Chain Div. (Weed Tire Chains), York, Pa.; Ander-on Company (Anco Wiper Blades & Arms), Gary, Ind.

THE REINGOLD CO., INC.

10 State St., Boston 9, Mass.
 Phone: CApital 7-7611
 ANPA—PPA—ABP—AAAA—APA

President & Treas.....Harry I. Reingold
 Art Director.....George Wilson
 Production Manager.....Ruleffe Barbour
 Copy Chief.....Harry Dodsworth
 Media Dir. & Radio Time Buyer
 Thomas J. Bowen
Radio-TV Accounts: Table Talk Pastry Co., Inc. (Table Talk Pies), Worcester, Mass.

EMIL REINHARDT, ADVERTISING

1736 Franklin St., Oakland 12, Calif.
 Phone: TEmplebar 2-2408
 ABP—ANPA—APA

OwnerEmil Reinhardt
 Account ExecutiveJoseph Connor
 Time-buyer, Radio & TV....James C. Resor
Radio Accounts: Central Bank, Marysville, Calif.; Golden Crust Bakers (Bread), Chico, Calif.; Kilpatrick's Bakery (Bread), San Francisco, Calif.; Old Home Bakers (Bread), Sacramento, Calif.
TV Accounts: Kilpatrick's Bakery (Bread), San Francisco, Calif.; Par-T-Pak Beverage Co. (Soft Drinks), Oakland, Calif.; Tuttle Cheese Company (Cottage Cheese), Oakland, Calif.

JOSEPH REISS ASSOCIATES

101 W. 57th Street, New York, N. Y.
 Phone: CI 6-4260
 ABP—APA—PPA

PresidentJoseph Reiss
 Copy Chief.....Elizabeth Taubin
 Media Director.....Cliff Greene
 Vice-President.....Cecile B. Reiss
Radio Accounts: Aristocrat Leather Products Co. (hillfolds), New York, N. Y.; The Lander Company (Dixie Peach hair pomade), New York, N. Y.; Helen Neushaefer, Inc. (cosmetics), College Point, N. Y.

E. W. REYNOLDS LIMITED

355 King St., West Toronto 1, Ont., Canada
 Phone: Empire 8-6157
 ABC

Chairman of Bd.....Edward W. Reynolds
 Pres., Gen. Mgr.....C. Warren Reynolds
 Vice-President.....J. H. Mitchell
 Sec. & Treas.....Fred Banks
 Production Manager.....M. Landmann
 Copy Chief.....N. Stuart Walton
 Radio Director.....H. E. Karpus
 Media Director.....Helen Anderson
 Account Executives.....H. D. R. Newby,
 H. Shrimpton

Branch Office

985 Sherbrooke St. W., Montreal, Quebec
 Phone: LANcaster 3745

Exec-in-Charge.....H. J. Tingle
Radio Accounts: Mutual Benefit Health & Accident (Insurance), Toronto; Moffats, Ltd. (Ranges & Refrig.), Toronto; R. M. Hollingshead, Ltd. (Motor Additive), Toronto; Hough & Kohler, Ltd. (Harmonicas & Accordions), Toronto; Dale Estate Ltd. (Roses), Brampton, Ont.; Dairy Farmers of Canada (Dairy Products), Toronto; T. Sisman Shoe Co. (Shoes), Aurora, Ont.; T. S. Simms Co. (Brooms & Mops), St. John, N.B.; B & A Motors (Autos), Toronto.
TV Accounts: Moffats, Ltd. (Ranges), Toronto.

RHOADES & DAVIS ADVERTISING

79 Post St., San Francisco, Calif.
 Phone: EXbrook 2-6468
 ABP—ANPA

Partner.....Robert O. Davis
 Art Director.....Alf Custad
 Media Director.....Edith Curtiss
 Media Asst.....Faye Hanger

Branch Office

1201 West 4th St., Los Angeles, Calif.
 Phone: MIchigan 2396

Partner.....Tom D. Scholts
 (Affiliate: Scholts Advtg.)

FLETCHER D. RICHARDS, INC.

10 Rockefeller Plaza, New York 20, N. Y.
 Phone: JU 6-5400
 AAAA—ABP—ANPA—APA
 NOAB—PPA

Chairman & Pres.....Fletcher D. Richards
 Vice-Presidents.....Eugene I. Harrington,
 Bradley A. Walker, M. J. Casey, J. S.

Davidson, Radcliffe Romeyn, E. D. Hill,
K. Young, E. A. Gray, J. E. Shepherd
Sec.-Treas Duane W. Beurmann
Vice-Pres. & Media Dir. E. A. Elliot
Spvrs. Radio-TV Comm. S. J. Frolick
Radio-TV Prod. Chief. . . . Robert S. Colodzin
Copy Chief. William L. Russell
Radio & TV Dir. Edwin S. Reynolds

Branch Offices

221 N. La Salle St., Chicago, Ill.
Manager. Wayne D. Jordan
HARRINGTON & RICHARDS: Division of
F. D. Richards, Inc.

256 Sutter St., San Francisco, Calif.
Exec.-in-Charge Eugene Harrington
5816 Wilshire Blvd., Los Angeles, Calif.

Exec.-in-Charge. Greacen Mitchell
Radio Accounts: American Machine &
Foundry Co. (Roadmaster Bicycles); Avoset
Company; Joseph F. Dixon Crucible Co.
(Ticonderoga Writing Pencils); Durham-
Enders Razor Corp.; Eastern Air Lines;
Peter Fox Brewing Co. (Fox DeLuxe Beer);
National Sugar Refining Co. (Quaker Cane
Sugar); Squirt Beverage Co.; Times-Colum-
bia Distributors, Inc.; United States Rubber
Company—Tire Division, Footwear Division,
Textile Div., Naugatuck Chemical Div., Fisk
Tire Co. Div.

TV Accounts: Avoset Company; Eastern
Air Lines; Peter Fox Brewing Co.; U. S.
Rubber Company—Tire Division, Footwear
Div. (Keds); American Machine & Foundry
Co.; Hathaway Manufacturing Co.

M. EVANS RICHMOND ADV. AGENCY

127 So. 22nd St., Philadelphia 3, Pa.
Phone: LOeust 7-1674-5
Pres. & Radio Time Buyer

M. Evans Richmond
Art Director. D. Bowers
Production Mgr. D. Blaine

Branch Office

230 Boylston St., Boston 16, Mass.
Exec.-in-Charge. Robert S. Richmond
Yucca Vine Bldg., Hollywood, Calif.
Exec.-in-Charge. Morey K. Reiss

R. C. RIEBEL ADV. AGENCY

151 S. 5th St., Louisville 2, Ky.
Phone: WAbash 6039-30

Owner. R. C. Riebel
Radio Accounts: Bank of Louisville, Com-
monwealth Life Insurance Co., Liberty Na-
tional Bank & Trust Co., Hurry-Up-Broadway.

RINGER & ASSOCIATES, INC.

3142 Wilshire Blvd., Los Angeles 5, Calif.
Phone: Dunkirk 7-8137

AAAA—ABP—ANPA—APA—NAAN
President Lee Ringer
Art Director. Russell Furstnow

DAN RIVKIN AGENCY

1418 Walnut St., Philadelphia 2, Pa.
Phone: PE 5-5766

Owner Dan Rivkin

Radio Accounts: John Kohler (Clothing),
Ford Optical Co., Phila.; Spiro's Apparel,
Schulte Optical Co. (Optical), Philadelphia,
Pa.; New York Sample Dress Shop, Phila.,
Pa.; Moskin Clothes.

ELWOOD J. ROBINSON & CO.

1111 Wilshire Blvd., Los Angeles 17, Calif.
Phone: MUtual 6293
ABP—ANPA—AFA

President. Elwood J. Robinson
Vice-President. Melvin A. Jensen
Secretary. Eola E. Cass
TV Director. Talbot Johns
Media Dir. R. C. Neuman

Radio-TV Accounts: Cinch Products, Inc.
(Cake Mixes, Cornbread Mix), Los Angeles,
Calif.; Loma Linda Food Co. (Ruskets,
Gravy Quik), Arlington, Calif.; Packard-
Bell Co. (Radio and Television Receivers),
Los Angeles, Calif.; California Federal Sav-
ings & Loan Assoc., Los Angeles, Calif.;
Pasadena Savings & Loan Assoc.; Western
Federal Savings & Loan Assoc., Los Angeles,
Calif.; Lincoln Savings & Loan Assoc., Los
Angeles, Calif.

TV Accounts: Cinch Products, Inc. (Bak-
ing Mixes), Los Angeles, Calif.; Loma Linda
Food Co. (Food Products), Arlington, Calif.;
California Federal Savings & Loan Assoc.,
Los Angeles, Calif.; Pasadena Savings &
Loan Assoc.; Western Federal Savings &
Loan Assoc., Los Angeles, Calif.

ROCHE, WILLIAMS & CLEARY, INC.

135 S. LaSalle St., Chicago 3, Ill.
Phone: RAndolph 6-9760

ABC—ANPA—APA—NOAB—PPA—ABP
President. J. P. Roche
Treasurer. D. J. Kelly
Vice-Presidents. J. M. Cleary,
S. Weston, Lloyd Maxwell, J. V. Gilmour,
John Hayes Kelly, M. F. Williamson, W. H.
Savin, George Lyman

Radio Director. Phil Stewart
Time Buyer. N. J. Cavanaugh

Radio Accounts: Chicago, Milwaukee, St.
Paul & Pacific R. R. (The Milwaukee Road),
Chicago; Hardware Mutual Casualty Co.,
Stevens Point, Wis.; John Puhl Products
(Fleecy White Bleach), Revere Camera Co.
(Revere Cameras & Projector), Stewart &
Ashby Coffee Co. (Stewart's Coffee), Chi-
cago; The Studebaker Corp., South Bend,
Ind.

TV Accounts: Stewart & Ashby Coffee Co.,
Chicago; The Studebaker Corp., South Bend,
Ind.

ROCK-ALLAN ADV. AGENCY

1165 Broadway, New York 1, N. Y.
Phone: MUrray Hill 9-3850
ABP

Owner-Copy Allan Rock
Art Director. Ken Saco
Space Buyer. Sally Winston
Radio Manager. Irwin Winehouse



ROCKLIN IRVING & ASSOCIATES

32 W. Randolph St., Chicago 1, Ill.
Phone: RAndolph 6-2324

PresidentIrving Rocklin
Continuity Director.....M. Lovinger
Account Executives.....Sidney Bernberg,
Ira Segall, Gerald Addis, Mal Grossman
Radio Director.....Trina Shuchat
TV Director.....Irving Rocklin
ProductionSue Wurtzburg,
Helen Wurtzburg, Barbara Kunin

Radio Accounts: Walton Motors (Chrysler-Plymouth dealer); Union Life Insurance Co. (Insurance); Linoleum City (Floor coverings); Chicago Furniture Mart (Furniture); Bailey's, Inc. (Clothing); Famous Appliances (Appliances); Balaban Floor Covering (Floor coverings).

TV Accounts: Balaban Floor Covering (Floor covering); Walton Motors (Chrysler-Plymouth dealer); Bailey's, Inc. (Clothing); Cole-Finder, Inc. (Mercury dealer); Roxy Rug & Linoleum Co. (Floor coverings); Picturesome Foods (Foods); Studebaker Sales of Chicago; Chrysler-Plymouth on Devon.

ROGERS & SMITH ADV. AGENCY

20 North Wacker Dr., Chicago 6, Ill.
Phone: DEArborn 2-0020

ABP—ANPA—APA—PPA—SNPA—NOAB
SAAA

President.....Walter E. Smith
Exec. Vice-Pres.....Ray H. Reynolds
Asst. Treasurer.....Howard N. Smith
Treasurer.....George C. Huppertz
Secretary.....Olive A. Kinloch
Vice-Pres. & Copy Chief...Robert L. Headen
Radio Director.....Lawrence E. DuPont

Branch Offices

Reserve Loan Life Bldg., Dallas 1, Tex.
Exec. V.P. & Mgr.....R. E. Brooks
1004 Baltimore Ave., Kansas City 6, Mo.
Exec. V.P. & MgrB. G. Wasser
Radio Accounts: Butterfield Canneries (Canned Fruits and Vegetables), Muncie, Ind.; Little Crow Milling Co. (Coco Wheats Cereal), Warsaw, Ind.

TV Accounts: T. W. Burleson & Son (Honey), Waxahachie, Texas; 1st Nat'l Bank in Dallas, Dallas, Texas; Butterfield Canneries (Canned Fruits and Vegetables), Muncie, Ind.; Little Crow Milling Co. (Coco Wheats Cereal), Warsaw, Ind.; S. E. Mighton Co. (Doggie Dinner Dog Food), Bedford, Ohio.

ROIZEN & RICH, INC.

291 Delaware Ave., Buffalo 2, N. Y.
Phone: MAdison 5915
AAAA—ABP—ABC APA

PresidentManus Roizen
Vice-President.....Arthur H. Rich
Radio Accounts: Music House (Radios, Phonographs, TV), Buffalo, N. Y.; Neuman Motors, Inc. (New Car Dealer), Buffalo, N. Y.; Parkside Furniture Co. (Furniture Store), Buffalo, N. Y.; Rich Ice Cream Co.

(Ice Cream Mfr.), Buffalo, N. Y.; Sattler's, Inc. (Department Store), Buffalo, N. Y.; Vigorettes, Inc. (Vitamin Capsule), Buffalo, N. Y.; Reddy Pharmaceutical Co. (Cough Syrup), Buffalo, N. Y.; Rich Products Corp. (Desert Topping Mfr.).

TV Accounts: Rich Ice Cream Co. (Ice Cream Mfr.), Buffalo, N. Y.; Sattler's, Inc. (Department Store), Buffalo, N. Y.; Vigorettes, Inc. (Vitamin Capsule), Buffalo, N. Y.; Reddy Pharmaceutical Co. (Cough Syrup), Buffalo, N. Y.

RONALDS ADV. AGENCY, LTD.

1440 St. Catherine St. W., Montreal, Can.
Phone: University 6-9471
AAAA—ABC—ANPA

President.....Russell C. Ronalds
Vice-President.....F. deB. Walker
Treasurer.....Angus Ahern
Radio Director.....Frank Starr
Asst. to Radio Director.....H. Williamson
108 Peter St., Toronto, Can.

Vice-President.....R. J. Avery
Radio Accounts: Dominion Government (Army, Canada Savings Bonds), Ottawa; Canadian Industries Ltd. (Agricultural Chemicals Div., Paint & Varnish Division), Bovril (Canada) Ltd. (Bovril), Canadian Arena Co., Bristol Myers of Canada, Ltd., Montreal; Rexall Drug Co. Ltd., Niagara Finance Co. Ltd., Trans-Canada Credit Corp., Toronto; McColl-Frontenac Oil Co., Ltd., Boots Pure Drug Company (Canada), Ltd. (Catarth Capsules), Canadian Shaler Company (Kislon Motor Oil), Fueloil & Equipment Co., Ltd. (Finken Oil Burners), Louis K. Liggett Co., Ltd. (Drug Prescriptions), Harco Laboratories, Limited (Rybutol), Wm. R. Warner & Co., Ltd. (Sloan's Liniment).

CHARLES EDSON ROSE CO.

6570 Sheridan Rd., Chicago 26, Ill.
Phone: HOllycourt 5-8000
ANPA—PPA—ABP—AFA

Owner.....Charles E. Rose
Art Director.....Norton Spitzer
Space & Radio Time Buyers, William Perry,
M. B. Cooper
Radio Accounts: Charms & Cain, H. C. Evans & Co., Winkenweder & Ladd, Inc., Ebron Co., Lombardo Wine Co.

WILLIAM GANSON ROSE, INC.

Williamson Bldg., Cleveland 14, O.
Phone: TOWer 1-6171

Pres., Treas., Radio Dir. William Ganson Rose
Vice-Presidents.....Frank Pelton,
L. C. Brown
Production Mgr.....Joan Burke

Branch Office

3719 Reading Rd., Cincinnati 29, O.
Manager.....L. C. Brown
Radio Accounts: Bailey Co., Higbee Co., Mass. Mutual Life Insurance Co., Public Square Relations.

ROSE-MARTIN, INC.

21 West 46th St., New York 36, N. Y.
 Phone: JUDson 2-3550
 ABP—ANPA—APA

President.....Irl W. Rose
 Secretary-Treasurer.....John B. Martin
 Media Director.....G. M. Rundbaken
 Production Manager.....John A. Boulle
 Comptroller & Off. Mgr.....H. J. Carmichael
 Account Executives.....Irl W. Rose 2nd,
 John A. Boulle

Radio Accounts: Public National Bank & Trust Co. of New York.

IRVING ROSEN ADVERTISING

230 Fifth Ave., New York 1, N. Y.
 Phone: Oregon 9-1926

BuyerIrving Rosen
 Production Mgr.....E. Wayne
Radio Accounts: Fur Dressers & Fur Dyers Assn., The Wenley Co., New York, N. Y.; Ask Pharmacal Co., Astoria, L. I., N. Y.

A. JAMES ROUSE CO.

521 N. LaCienega Blvd.,
 Los Angeles 48, Calif.
 Phone: BRadshaw 2-5608
 ABP—APA

Owner—Radio Dir.....A. James Rouse
 Art Director.....John Fish
Radio Accounts: B.F.P. Enterprises (Toys); House of Fabrics (Fabrics), Los Angeles, Cal.

RUDER & FINN, INC.

32 E. 68th St., New York, N. Y.
 Phone: TRafalgar 9-3600

Chairman of Board.....David Finn
 PresidentWm. Ruder
 General Manager.....Hyman Wagner
 Art Director.....Jay Genser
 Copy Chief.....Ted Levine
 Publicity Director.....Paul B. Zucker
 Radio-TV Director.....Rene Schenker

CHARLES L. RUMRILL & CO., INC.

339 East Ave., Rochester 4, N. Y.
 Phone: BAKer 7900
 AAAA—ABP—ANPA—PPA

President.....C. L. Rumrill
 Treas. & V.P.....H. R. Hanson
 Vice Presidents.....N. A. Gallagher,
 G. M. Prince, W. T. Jensen
 Secretary.....G. G. Wallington
 Radio-TV Director.....Alan Brown
Radio Accounts: Brighton Place Dairy, Community Savings Bank, Rochester, N. Y.
TV Accounts: Community Savings Bank, Union Trust Company.

LOWE RUNKLE CO.

1305 Liberty Bank Bldg., Okla. City 2, Okla.
 AAAA—ABP

PresidentLowe Runkle
 Secretary.....Irene Gammel
 Vice-PresidentsRoger Pishny,
 Howard Neumann, Monty Mann.
 Radio-TV Dir.....Maury Ferguson

Radio Accounts: Cain's Coffee Co. (Coffee, Tea, Spices); Local Federal Savings and Loan; Liberty National Bank & Trust Co. (Banking); Arkansas City Flour Mills (Flour), Arkansas City, Kans.; Dulaney's, Inc. (Appliance Distributors); Simpson Auto Co. (Ford Dealer); Liberty National Bank & Trust Co., Okla. City, Okla.; Hirsch-Swan (Air Conditioning), Oklahoma City, Okla.

TV Accounts: Cain's Coffee Co. (Coffee, Tea, Spices); Liberty National Bank & Trust Co. (Banking); Southwestern Bell Telephone (Telephone Service); Ralston Purina Co. (Purina Chows), St. Louis, Mo.; Oklahoma Publishing Co. (Newspapers); Consolidated Gas (Gas Utility), Oklahoma City, Okla.; Central Oklahoma Milk Producers Assn., Oklahoma City, Okla.

RUTHRAUFF & RYAN, INC.

405 Lexington Ave., New York 17, N. Y.
 Phone: MURray Hill 6-6400

AAAA—ABC—ABP—ANPA—APA
 NOAB—PPA

Chairman of the Board...Frederick B. Ryan
 PresidentFrederick B. Ryan, Jr.
 Exec. V.P.....Robert M. Watson
 Vice-Pres. & Treas.....J. B. Bell
 V.P., Dir. of Radio & Tel...Thomas G. Slater
 Network Rel. & Bus. Mgr....Grant Y. Flynn
 Dir. of Canadian Radio &
 TV Publicity.....Louis de Milhau
 Dir. of New Program &

Talent Development.....Henry Frankel
 Asst. Producer.....Roly Howe
 TV Film Supervisor.....Robert Rubin
 Exec. Prod. TV Film Comm....Pud Lane
 TV Asst. Producer.....Gloria Shaffer
 Dir. Radio-TV Continuity...Bernard Lubar

Branch Offices

360 North Michigan Ave., Chicago 1, Ill.
 Phone: FINancial 1833

Western Manager.....Paul E. Watson
 Chicago Manager.....William P. Littell
 Sr. Vice-PresidentP. E. Watson
 Sr. Vice-PresidentW. P. Littell
 Director Radio & TV.....R. W. Metzger
 Vice Pres.....N. E. Heyne
 Producer (TV).....Edward Simmons
 Producer (TV-AM)Frank Blotter
 Producer (TV)James Taylor
 Producer (AM-TV).....Walter Daspitt

Branch Offices

7430 Second Blvd., Detroit 2, Mich.

Vice-PresidentTod Reed
 Carew Tower, Cincinnati 2, Ohio
 Vice-Pres. & Manager.....John L. Magro
 505 N. Ervay St., Dallas, Texas
 2650 University Ave., St. Paul 4, Minn.
 Mgr.....James R. Rahders
 812 Olive Street, St. Louis 1, Mo.
 Senior Vice-Pres.Oscar A. Zahner
 Gulf Oil Bldg., Houston 2, Texas
 Vice-Pres. & Mgr.....T. F. Keady
 N. Life Tower, Seattle 1, Wash.
 V.P. & Manager.....F. G. Mullins
 235 Montgomery St., San Francisco 4, Cal.
 V.P. & Manager.....John L. Harvey

1680 No. Vine St., Hollywood 28, Cal.
 V.P. & Manager.....J. H. Weiser
 2 Toronto St., Toronto, Ontario
 ManagerJohn Brookman
Radio and TV Accounts: Adler Co., Allied Florists of Chicago, American Airlines, American Kitchens, Baldwin Piano Co., Beltone Co., Capitol Fritos Inc., Chasers Inc., Comfort Mfg. Co., Delaware, Dr. Pepper Co., Drug-gists Supply Corp., Electric Auto-Lite Co. of Canada, Emery Industries Inc., Encyclopedia Britannica, Fehr Baking Co., Florence Stove Co., Fritos Inc., General Shoe Co., Goodall Fabrics Inc., Hancock Oil Co., Horlicks Corp., Kentile Inc., Krey Packing Co., Lewis-Howe Co., Thomas J. Lipton, Thomas J. Lipton, Ltd., Macfadden Publications Inc., Markus Campbell Co., Motorola, Inc., Arthur Murray School of Dancing, Nalley's Inc., Norite Co., OshKosh B'Gosh Inc., Pacific Coast Paper Mills, Pacific Finance Corp., Palm Beach Co., Pepsodent Company of Canada, Ltd., Pharma-Craft Co., Reddi-Wip Co., Morris B. Sachs, Safeway Stores, Sperti Biodyne Inc., A. E. Staley Mfg. Co., Toledo Steel Products Co., United Wallpaper Co., Western Reddi-Wip Co., Wolverine Shoe and Tanning Corp., William Wrigley, Jr. Co., Yale & Towne Mfg. Co., Zonolite Co., American Breeders Service, Bavarian Brewing Co., Chocolate Products Co., Helene Curtis Industries, Inc., Albert Dickinson Co., Doyle Packing Co., Thomas Emery & Sons, Inc., Glaser-Grandell Co., A. D. Goodman Bros., Houston Post, Jacob Ries Bottling Co., Janney Semple Hill & Co., Jel Sert Co., Lincro Products Distributing Co., Minnesota Hospital Service Assoc., Minnesota Consolidated Canneries, Inc., Seattle First National Bank, So Good Potato Chip Co., Sugardale Provision Co., Texas Bank & Trust Co., Waxed Paper Institute, Western Gear Works, Rap-In-Wax Paper Co.

LEWIS EDWIN RYAN

726 Jackson Pl., N.W., Washington 6, D. C.
 Phone: Re. 7-7606

AAAA-ABP ANPA-ABC

OwnerLewis Edwin Ryan
 General Manager.....J. F. Hardie
 Comptroller.....Preston B. Coiner
 Radio TV Div.....William J. Green

BEN SACKHEIM, INC.

The Plaza, 2 West 59th St., New York 19, N. Y.

Phone: PLaza 9-5141

ABP-ANPA-APA-NOAB-PPA

PresidentBen Sackheim
 Vice-Pres.....George B. Pampel
 Vice-PresidentTed Gravenson
 TreasurerMurray Miller
 Copy Chief.....Anne Green
 Art Director.....Arthur Singer
 Production Manager.....Bernard Spire
 Fashion Promotion Director..Ruth Hammer
 Media Director.....M. A. Parmenter
 Service Manager.....H. A. Gigante

Radio-TV Dept.

Research Director.....Dr. J. S. Pearlson
 Public Relations.....B. W. Saas
 Radio & TV Time Buyer...Rita O'Sullivan
 Account Executives.....Jerome G. Hahn,
 Ezra Millstein, George B. Pampel, Glenda
 Sullivan, Herbert L. Steiner, Sylvia Sack-
 heim, Ted Breining, Ted Gravenson

Radio Accounts: The Autoyre Company (Kitchen and Bathroom Accessories), Oak-ville, Conn.; Amalgamated Clothing Work-ers of America; Peter Pan Foundations, Inc. ("Merry-Go-Round" Brassieres), Miss Swank, Inc. (Slips and Pajamas), New York, N. Y.; Davega Stores Corp., New York; Flex-Let Corp. (Flex-Let Watch Bands & Beau Brummel Men's Jewelry), E. Providence, R. I.; Waltham Watch Co., Waltham, Mass.

TV Accounts: Davega Stores Corp. (Retail Sporting Goods and Appliance Chain); Flex-Let Corp., E. Providence, R. I.; Peter Pan Foundations, Inc. (Brassieres), New York; Vita Food Products, N. Y.; Vulcain Watch Co., New York.

ST. GEORGES & KEYES, INC.

250 Park Ave., New York 17, N. Y.

Phone: PLaza 5-1180

ABP-ANPA-PPA-ABC

President.....Stanley J. Keyes, Jr.
 Vice-President.....John L. Fitzgerald
 Vice-Pres-Art Director...Alfred A. Anthony
 Vice-Pres-Copy Chief.....Ward Secley
 Production Manager.....William Koreak
 V.P., Media Dir.....James J. Freeman
 Publicity Directors.....S. B. Garretson,
 Torrey Stearns

Branch Offices

1004 No. Charles St., Baltimore 18, Md.

Phone: PLaza 2-0809

Manager.....Arthur Booth

Radio Accounts: Davison Chemical Corp., Baltimore, Md.

TV Accounts: Revere Copper and Brass (Revere Ware); Romanoff Caviar Co. (Beef Tea), N. Y. C.

RICHARD SALINGER, ADV.

99 Chauncey St., Boston 11, Mass.

Phone: LI 2-5332

Pres., Copy Chief, Rep. & Radio
 Time Buyer.....Richard Salinger
 Production Manager.....Thomas Amos

Radio Accounts: Kussell Furs, Lehrburger & Asher (Furs), Touraine Stores (Women's Specialty), Kay Jewelry Co., Boston, Mass.

TV Accounts: Lehrbuger & Asher (Furs), Boston, Mass.

SALOW & ASSOCIATES

30 Howe Ave., Passaic, N. J.

Phone: GRegory 3-1414

ABP

President.....H. Harvey Salow
 Art Director.....Orvel Carlson
 Copy Chief.....William Levison
 Production Dir.....Donald Canter

Media Director.....Josephine Catanzaro
TV Accounts: Tel-O-Tube Corp. (cathode ray tubes), E. Paterson, N. J.; Awnair Corp. of Amer. (metal awnings), Wayne, N. J.

WALKER SAUSSY ADVERTISING

823 Perdido St., New Orleans 12, La.
 Phone: Magnolia 3218
 ABP—ANPA—NOAB

OwnerWalker Saussy
 Account Executives.....Moise Bloch
 Charles Bloom, II, P. J. Stakelum, Jr.,
 J. C. Shields, Jr.

Radio Accounts: American Brewing Co. (Regal Beer), New Orleans, La.; Elmer Candy Co. (Elmer Candies), Holsum Bakeries, Inc. (Holsum Bread), Petrolane Gas Co. (Eutane & Propane Gas), Wm. B. Reily Co., Inc. (Luzianne Coffee & Tea), L. A. Frey & Sons (meat products); Reily & Co., Inc. (Luzianne Coffee & Tea).

TV Accounts: American Brewing Co. (Regal Beer), New Orleans, La.; Elmer Candy (Elmer Candies), Holsum Bakeries, Inc. (Holsum Bread), Wm. B. Reily Co., Inc. (Luzianne Coffee & Tea), Henderson Sugars; Hibernia Homestead (Building Loans).

FRANK B. SAWDON, INC.

270 Park Ave., New York 16, N. Y.
 Phone: PLaza 5-1324

President.....Frank B. Sawdon
 Vice-President.....Jerry Bess
 Secretary.....Victor Sawdon
 Radio-TV Copy.....Yale Schaefer
 Radio-TV Prod.....James Hackett

Branch Office

75 E. Wacker Drive, Chicago, Ill.
 Phone: Dearborn 2-0826

Office Manager.....Tom Mannos
Radio Accounts—Robert Hall Clothes, Inc. (Men's, Women's & Children's Apparel), New York, N. Y.; Abelson's, Inc. (Jewelers), Newark, N. J.; Bond Television Mfrs.

TV Accounts—Robert Hall Clothes, Inc. (Men's, Women's & Children's Apparel), New York, N. Y.; Abelson's, Inc. (Jewelers), Newark, N. J.

SCHECK ADV. AGENCY, INC.

9 Clinton St., Newark 2, N. J.
 Phone: Market 2-0480
 ANPA—APA—PPA

President.....Julius Scheck
 Secy. & Treas.....Morris Scheck
 V. P., Radio-TV Dir.....E. Grant Scheck
 Prod. Mgr., Art Dir.....Henry R. Scheck
 Copy Chief.....E. Bimberg
 Space Buyer.....Frank M. Craumer
 Account Executives....William H. Andrews,
 E. Grant Scheck, Morris Scheck, Julius Scheck.

Radio Accounts: Charms Co. (Charms Candy), Asbury Park, N. J.; Fischer Baking Co. (Baked Goods), Newark, N. J.; Phila. Dairy Products Co. (Ice Cream), Philadelphia, Pa.; Marlon Confectioners Corp.

TV Accounts: Fischer Baking Co. (Baked Goods), Hanovia Chem. & Mfg. Co. (Health Lamps), Newark, N. J.; Charms Candy, Asbury Park, N. J.; American-Limoges (Dinner Ware).

SCHENKER COMPANY

2301 Wabansia Ave., W., Chicago 47, Ill.
 Phone: ARmitage 6-1600

Pres., Media Dir., Space Buyer
 Sydney R. Raike
 Vice-Pres.....J. E. Schenker
 Art Dir.....M. Rickabaugh
 Radio Time Buyer & Prod. Mgr.
 Space BuyerC. D. Domin
 Account ExecutivesS. R. Raike,
 J. E. Schenker, C. D. Domin

SCHOLTS ADVERTISING SERVICE

1201 W. 4th St., Los Angeles 17, Calif.
 Phone: MICHigan 2396
 ABP—ANPA

Owner.....T. D. Scholts
 Radio-TV Dir.....Cory Simmons
 Art Director.....L. G. Myhro

GORDON SCHONFARBER & ASSOCIATES, INC.

58 Weybosset St., Providence 3, R. I.
 Phone: GASpee 1-4813-4-5

ABP—ANPA—APA—NOAB—PPA—ABC
 Vice-President.....Gordon Schonfarber, Jr.
 Vice-President.....Russell C. Edwards
 Vice-President.....John B. Swift
 Secretary.....Amanda C. J. Olsson
 Radio-TV Dir.....R. J. McVicker, Jr.

Radio Accounts: Gladding's, Inc. (Dry Goods), Old Colony Co-operative Bank (Savings & Loan), Providence; Washington Trust Co. (Commercial Bank), Westerly, R. I.; Warwick Club Ginger Ale Co. (Carbonated Beverages), West Warwick, R. I.; Mal's Baby Shoppes (Toys), Providence & Pawtucket; Paris Fabrics, Providence; Boulevard Florists; Providence Retail Trade Board; Henry Levaur (Automobiles), Providence, R. I.

TV Accounts: Old Colony Cooperative Bank; Gladdings, Inc.; Barton's Chrome Center (Retail Appliances), Providence, R. I.; Mal's Baby Shoppes, Pawtucket & Providence; Providence Retail Trade Board, Providence; Warwick Club Ginger Ale Co., West Warwick, R. I.

SCHWIMMER & SCOTT, INC.

75 E. Wacker Drive, Chicago 1, Ill.
 Phone: DEarborn 2-1815
 AAAA—ABP—ANPA—ABC

Pres. & Treas.....R. J. Scott
 Vice-President.....C. L. Liliemfeld
 Copy Chief.....L. Krakover
 Time Buyer.....E. Vanderploeg
 Art Dir.....A. Thaler
 Secretary.....H. Heilig

Radio Accounts: Chicago Stadium, Puritan Co. of America, Salerno-Megowen Biscuit Co. Schutter Candy Co., Walgreen Co., Haw-



thorne-Mellody Farms Dairy, National Tea Co. (Chicago, Ill.; Milwaukee, Wis.; Indianapolis, Ind.; Minneapolis, Minn.); Spiegel's, Inc., Chicago, Ill.; Helzberg's (Jeweler's), Kansas City, Mo.; F. & F. Laboratories (Cough Lozenges), American Frigid Dough Co. (Frozen Foods), Citrus Products Co. (Kist-Bottled Orange Juice), Red Dot Foods, Inc., Madison, Wis.; Boyer International Lab./H. A. Haic Arranger, Chicago; Buddy Boy Popcorn Co., Chicago; Little Dutch Candy Shops, Chicago.

J. B. SEBRELL ADV. AGENCY

300 S. Los Angeles St., Los Angeles 13, Calif.
Phone: Madison 6-9397
ABP—APA

Owner & Director.....J. B. Sebrell
Media.....P. W. Thomas
Account Executives.....Harry Page,
P. W. Thomas, J. B. Sebrell
Radio-TV Accounts: Eject Donut Sales
(Donut Makers), Children's Mart (Toys).

RUSSEL M. SEEDS CO., INC.

919 No. Michigan Ave., Chicago 11, Ill.
Phone: Whitehall 3-2133
ANPA—APA—PPA

President.....Freeman Keyes
Exec. Vice President.....George Bayard
Vice-Presidents.....A. D. Keyes,
Paul Richey, Harry M. Maus, H. B. Goldsmith, Jr., Fred W. Swanson
Sec. Treas.....E. V. Owen
Director of Res.....James Witherell
Art Director.....Jerry Bryant
Time Buyer.....Merle Myers
Space Buyer.....A. H. Bergsten
Radio-TV Director.....R. B. Young

Branch Offices

Lemeke Bldg., Indianapolis 4, Ind.
Phone: Market 1395

V.P. in Chg.....Paul Richey
7324 Santa Monica Blvd., Hollywood 28, Calif.
Phone: HOLlywood 9-1103

Manager.....Lionel C. Place
Radio Accounts: Brown & Williamson Tobacco Corp. (Raleigh Cigarettes, Wings Cigarettes, Tube Rose Snuff, Bugler Tobacco, Avalon Cigarettes), Louisville, Ky.; H. Fendrich Inc. (La Fendrich & Chas. Denby Cigars, Evansville, Ind.; C. H. Wallerich Co. (Chrysler & Plymouth Distributors), Indianapolis, Ind.

ROSCOE W. SEGAR ADV.

2125 N. E. 48th Ave., Portland 13, Ore.
Phone: TRinity 3445
APA

Owner, Mgr.....Dorothy Segar
Sec. Treas., Radio Dir.....D. D. Segar
Art Director.....D. D. Fitchard
Radio Accounts: Geo. B. Wallace Co., (Buick dealers & servire); Niklas & Son (flowers).

FREDERICK SEID ADV.

127 Montgomery St., San Francisco 4, Calif.
Phone: GARfield 1-0360

ABP—ANPA

Owner-Aect. Exec.....Frederick Seid

THE JAMES C. SEIX CO.

315 Madison Ave., New York, N. Y.
Phone: MURray Hill 6-6368

Pres. & Time Buyer.....James C. Seix
Art Director.....Corienne Albazia
Media Director.....Walter B. Gies
Publicity Dir.....Mallory Dorn
Account Executives.....James C. Seix,
Luc H. Witt, P. J. Rosaly, Frank Whalen

SEWELL, THOMPSON & CAIRE

203 Cigali Bldg., New Orleans, La.
Phone: Tu 2251
SNPA—ABP

President.....Granville Sewell
Vice-Presidents.....R. V. Caire,
Kenneth Thompson, A. Radlaver
Production Mgr.....E. Franz

**SHAFFER, BRENNAN, MARGULIS
ADV. CO.**

4 No. Eighth St., St. Louis 1, Mo.
Phone: MAin 2579
ANPA—APA—PPA

Partner-Space Buyer-Radio Dir.
Sam B. Margulis
Partner-Space Buyer.....S. I. Rosenfeld

ED SHAPIRO ADVERTISING

1612 Market St., Philadelphia 2, Pa.
Phone: LO 4-2877
ANPA—ABP—PPA

President.....Edward Shapiro
Vice-Presidents.....H. H. Shapiro,
Leonard Goldsmith, Elinor L. Brown, J. Rensel
Secretary.....Martin Sacks
Media Dir.....R. Goddes

JOHN W. SHAW ADVERTISING, INC.

716 N. Rush St., Chicago 11, Ill.
Phone: MOhawk 4-6323
ANPA—APA—PPA—NOAB

President & Treas.....John W. Shaw
Vice-Presidents.....David E. Guerrant,
P. L. O. Smith
Media Dir.....Ann Shaffer
Radio Accounts: Jacob E. Decker & Sons (Div. of Armour & Co.) (meat), Mason City, Iowa; Drummond Packing Co. (Div. of Armour & Co.) (meat), Eau Claire, Wis.; Armour & Co. (Dial Shampoo), Chicago; The Quaker Oats Company, Chicago, Ill.; American Motorists Insurance Co. (Insurance), Chicago, Ill.; Lumbermen's Mutual Casualty Co., Chicago, Ill.; Dornmeyer Corp. (Electrical Appliances), Chicago, Ill.; Fred Harvey (Hotels & Restaurants), New Mexico.
TV Accounts: Armour & Company (Dial Shampoo), Chicago; The Quaker Oats Company, Minneapolis; American Motorists Insurance Co., Chicago; Dornmeyer Corp., Chicago.

J. WILLIAM SHEETS

2013 Fourth Ave., Seattle 4, Wash.
Phone: Main 2442

ANPA—PPA—APA—NOAB

Owner.....J. Wm. Sheets
Radio Accounts: Skinner & Eddy Corp.

K. E. SHEPARD ADV. AGENCY

75 East Wacker Dr., Chicago 1, Ill.
Phone: ANdover 3-5966

ABP—APA

President.....Kenneth E. Shepard
Vice-President.....B. F. Homan
Prod. Mgr.....B. Shepard
Radio Accounts: Wilson & Co., National Assu. of Homebuilders.

SHERMAN & MARQUETTE, INC.

919 North Michigan Ave., Chicago 11, Ill.
Phone: Delaware 7-8000

AAAA—ANPA—APA
NOAB—PPA—ABP

Chairman & Treas.....Arthur Marquette

SILTON BROTHERS INC.

131 Clarendon St., Boston 16, Mass.
Phone: CO 7-3730

ABP—ANPA—AFA—PPA

President.....Myron L. Silton
Exec. V.P.....Jason N. Silton
Treas.....Ramon N. Silton
V.P. Art.....Andre B. Paquette
Radio Accounts: Craftsman Insurance Co. (A. & H. Insurance), Boston; New England Provision Co. (Meats), Boston, Mass.; Snider Fuel Company (Fuel), Charlestown, Mass.

TV Accounts: Craftsman Insurance Co. (Accident & Health Insurance); New England Provision Co. (Meats); Barcolene Co. (Household Cleaners), Boston, Mass.

SIMON & GWYNN

Commerce Title Bldg., Memphis 3, Tenn.
Phone: 5-2404

SNPA—ANPA—APA—NOAB—ABP
FAAG

Partners.....Milton Simon, H. N. Gwynn
Branch Office
930 Stahlman Bldg., Nashville, Tenn.
Phone: 5-8909

Chief Exec.....G. K. Leckie
Radio-TV Accounts: American Snuff Co., Donald Furniture Co., The Humko Co., Robilio & Cunco (Ronco Foods), American Tea & Coffee Co.

SIMONS-MICHELSON CO.

1126 Lafayette Bldg., Detroit 26, Mich.
Phone: Woodward 3-3000

AAAA—ANPA—APA—PPA—ABP

Partners.....Leonard N. Simons
Lawrence J. M. Michelson
Prod. Mgr.....Arthur H. Copeland
Space Buyer.....C. Allison Belcher
Art Director.....Al Sielaff
Radio Accounts: Cunningham's Drng Stores (Drug, etc.), Keopplinger Bakery

(Baked Goods), Krun-Chee Potato Chips (Potato Chips), (Pretzels), Marshall Drug Company (Drugs), Cleveland, Ohio; Benjamin Rich (Real Estate), Sealy Mattress Co. (Mattresses), Taylor's Inc. (Dodge-Plymouth), Detroit, Mich.; Velvet Peanut Products (Peanut Butter); E & B Brewing Co. (Brew 103, Golden Ale); Gerson's Inc. (Jewelry); People's Outfitting Co. (Dept. Store); Detroit Free Press; Dossins Food Products (Pepsi-Cola); General Electric Supply Co. (Appliances); Guardian Savings & Loan; King Paint Roller Co.; Lasky Furniture; Leo Adler Co. (DeSoto-Plymouth); Mohawk Lumber Co., Detroit, Mich.

TV Accounts: Cunningham's Drug Stores (Drugs, etc.); Dossin's Food Products (Pepsi Cola); Keopplinger Bakery (Baked Goods); Krun-Chee (Potato Chips); People's Outfitting Co. (Dept. Store); Sealy Mattress Co. (Mattress Mfg.); Taylor's Inc. (Automotive); Velvet Peanut Products (Peanut Butter); E & B Brewing Co. (Brew 103, Golden Ale); Detroit Free Press; General Electric Supply Co. (Appliances); Gerson's Jewelers, Inc.; King Paint Roller Co.; Lasky Furniture; Leo Adler Co. (DeSoto-Plymouth); Mohawk Lumber Co.

R. C. SMITH & SON, LTD.

80 King St., W., Toronto, Ont.
Phone: EMpire 4-9396

President.....Adam F. Smith
Secretary.....W. P. Smith
Treasurer.....M. M. Marugg
Space Buyer.....M. E. Lloyd
Managing Director.....G. A. Phare
Account Executive.....R. G. Fitzpatrick

W. J. SMITH CO.

Martin Brown Bldg., Louisville 2, Ky.
Phone: Jackson 2163
APA—SNPA—ANPA

Pres. & Treas.....W. J. Smith
Vice-Pres. & Secy.....G. B. Smith
Media Dir. & Copy Chief.....H. D. Peltier
Radio Dir.....I. M. Diebold
Account Executives.....R. L. Davis, P. M. Shaughnessy, H. D. Peltier, W. J. Smith
Radio Account: Peerless Mfg. Co.

SMITH, TAYLOR & JENKINS, INC.

223 Fourth Ave., Pittsburgh 22, Pa.
Phone: ATlantic 1-9312

ABP—ANPA—APA—PPA—FAAG

President.....Ronald P. Taylor
Chairman of the Board.....Robert M. Jenkins
Television Dir.....Thomas J. MacWilliams
Radio Director.....Les Sterne
Production Assistants.....Tom Cadden, Diek Pearson

SON DE REGGER ADV. AGENCY

1020 Locust St., Des Moines, Ia.
Phone: 3-3185

ANPA—APA—ABP—FAAG

President, Space Buyer, Radio Time & Acct. Exec.....Les Son De Regger

Secretary.....A. H. Son De Regger
 Art Dir.....D. D. Neal
 Prod. Mgr.....Joseph Daniels
Radio Accounts: National Soap & Refining Co., Grocers Wholesale Co.

SORENSEN & CO.

430 No. Michigan Ave., Chicago, Ill.
 Phone: Delaware 7-5030
 ABP—ANPA PPA—NOAB—APA
 President.....Roy A. Sorensen
 Art Dir.....W. D. MacCourt
 Space Buyer.....Dorothy Samer
Radio Accounts: Bowey's, Inc., J. P. Harding Restaurants.

C. JERRY SPAULDING, INC.

201 Commercial St. Worcester 8, Mass.
 Phone: 3-4789
 Pres., Treas. & Radio Time Buyer
 C. Jerry Spaulding
 Secretary.....H. H. Hartwell
 Art Director.....Harvey Ball
 Prod. Mgr.....Charles Rice
 Acct. Execs.....Robert F. Hayward,
 Robert B. Hanna

Radio Accounts: Coronado Hotel, People's Savings Bank, Mechanics Savings Bank, Worcester Brewing, Hadley Oil Service, Worcester, Mass.

RAYMOND SPECTOR COMPANY, INC.

145 Park Ave., New York 22, N. Y.
 Phone: MURray Hill 8-4407
 ABP—ANPA APA—PPA
 President.....Raymond Spector
 Client Service.....Bert Schwartz
 Art Director.....Irving Trabich
 Copy Chief.....Ismael McCullough
 Production Manager.....Richard Scott
 Dir. of Pub. Rel.....Millie T. Trager
 Research Director.....Cal Morris
 Radio-TV Director.....Don Blauhut
Radio-TV Account: Hazel Bishop, Inc. (Lip-stick and Complexion Glow), New York, N. Y.

WILLIAM SPITZ & CO., INC.

114 So. Warren St., Syracuse 2, N. Y.
 Phone: 2-7228
 ABP—ANPA
 Owner, Acct. Exec.....William Spitz
 Art Director.....Wayne J. Lewis
 Copy Chief.....Janet R. Lyman
 Production Mgr.....Peter Williams
 Space & Time Buyer.....Maxine Constable
 Radio-TV Director.....Ed Herr
Radio Accounts: Community Home Improvement Co. (food-freezer plan, roofing, siding), Syracuse; Empire Card Company (greeting cards), Elmira; Fair City Savings & Loan Assn., Syracuse; Grange Silo Co., Inc. (meat products), Syracuse; Mohican Stores, Inc., Syracuse & Auburn; Oswego Soy Products Corp., Oswego; Pilgrim Packing Company (meat products), Syracuse; Syracuse

Card Company (greeting cards), Syracuse; Syracuse Glass Company (store fronts, mirrors), Syracuse; Syracuse Nationals Shows, Inc., Syracuse; Timerson Canning Co., Inc. (Timco dog & cat food), Fair Haven; University College of Syracuse University (Adult Education Division), Syracuse; Virden Company (food brokers); Baldwin-Hall Co., Inc. (Appliances), Syracuse; Henry Frank Leather Co. (Leather Goods), Syracuse.

TV Accounts: Community Home Improvement Co. (food-freezer plan, siding), Syracuse; Onondaga Supply Co., Inc. (appliances), Syracuse; Spector-Genesee Motor Sales, Inc. (Cadillac-Oldsmobile dealer), Syracuse; Syracuse Nationals Shows, Inc., Syracuse; Timerson Canning Co., Inc. (Timco dog & cat food), Fair Haven; Virden Company (food brokers), Syracuse; Outdoor Store (Sporting Goods), Syracuse; University College of Syracuse Univ. (Adult Education), Syracuse; Syracuse Card Co. (Greeting Cards), Syracuse; Wilson's Leading Jewelers (Jewelers), Syracuse; Empire Card Co. (Greeting Cards), Elmira, N. Y.

SPITZER & MILLS LIMITED

50 King Street W., Toronto 1, Can.
 Phone: EMpire 6-2811
 President.....G. F. Mills
 Exec. Vice-Pres.....J. W. Spitzer
 Gen. Mgr. & Sec.-Treas.....W. H. Reid
 TV Director.....T. R. Hart
 Account Executives.....J. R. Charles,
 F. J. Collins, W. G. Wallace, P. R. L. Charles, L. F. McCartney, G. M. MacDonald, R. W. Saunders, G. F. Mills, W. H. Reid, W. F. Nugent

Branch Office

3405 Addington Ave., Montreal, Quebec
 Phone: WA 0344
 Vice-Pres.....V. L. Hanna
 Acct. Exec.....D. McCrimmon
 Radio Director.....P. E. Corbeil

BARTON A. STEBBINS ADVTG.

1250 Wilshire Blvd., Los Angeles 17, Calif.
 Phone: Trinity 8821
 Owner.....Barton A. Stebbins
 Acct. Execs.....A. W. Gudelman, Nat Jeffras
 Time Buyer.....A. W. Gudelman
 Program Director.....E. C. Bloodworth
Radio Accounts: Brewster's Food Supplement, Los Angeles; Certified Grocers of Calif. (Perfect Host & Guest coffees), Los Angeles; Signal Oil Company (gasoline), Los Angeles; Sleep-Eze Co. (Sleep-Eze), Los Angeles; Knox Co. (Mendo & Cystex), Los Angeles.

TV Accounts: Certified Grocers of Calif. (Perfect Host & Guest coffees), Los Angeles; Signal Oil Company (gasoline), Los Angeles.

STERLING ADV. AGENCY, INC.

535 5th Ave., New York 17, N. Y.
 Phone: MURray Hill 7-3400
 ANPA—PPA

Chairman of Board.....S. M. Broun
 President.....Joseph S. Edelman
 Secretary, Space Buyer.....William Forray
 TreasurerHerbert Goldsmith
 General Mgr.....Arthur Booth
 Radio-TV DirectorMyron L. Broun

FRED D. STEVENS CO.
 14 Devereux St., Utica 2, N. Y.
 Phone: 5-0339

Owner.....Fred D. Stevens
Radio Accounts: Wicks & Greenman, Cornhill Bldg. & Loan Assn.

STOCKTON, WEST, BURKHART, INC.

1300 First Natl. Bank Bldg., Cincinnati 2, O.
 Phone: Dunbar 5600, 01, 02, 03
 AAAA—ABC—ABP—ANPA

Pres. & Treas.....William Z. Burkhardt
 VP, Sec. & Copy Chief.....Ranald S. West
 VP & Dir. of Sales.....Joseph D. Nelson, Jr.
 VP & Dir. TV Dept.....G. Thomas Martin
 VP & Dir. TV Media.....Robert A. McDowell
 Dir. TV Production.....Gary Lee
 Asst. Dir. TV Productions.....Dick Sontag
 TV & Radio Time Buyer.....James Gray
Branch Office

501 Madison Ave., New York 22, N. Y.
 Phone: MUrray Hill 8-6077

ManagerFrank Flagg
Radio Accounts: Hudepohl Brewing Co. (Hudepohl Beer & Chevy Ale), Cincinnati, Ohio; Ohio Oil Company (Marathon Cat Gasoline, V.E.P. Motor Oil), Findlay, Ohio; Mosler Safe Company (Mosler Safes & Chests), Hamilton, Ohio; Cincinnati Gas & Electric Co. (Utility), Cincinnati, Ohio; Gibson Wine Co. (Golden Pheasant Wines), Cincinnati, Ohio; Cincinnati & Suburban Bell Tel. Co.; United States Shoe Corp. (Red Cross Shoes & Cobbies), Cincinnati, O.
TV Accounts: United States Shoe Corp. (Red Cross Shoes), Cincinnati, Ohio; Hudepohl Brewing Co. (Hudepohl Beer & Chevy Ale), Cincinnati, Ohio; Cincinnati Gas & Electric Co. (Utilities), Cincinnati, Ohio; Ohio Oil Company (Marathon Cat Gasoline, V.E.P. Motor Oil), Findlay, Ohio; Central Trust Co. (Banking Institution), Cincinnati, Ohio; Mosler Safe Company (Safes & Chests), Hamilton, Ohio; Gihson Wine Company (Golden Pheasant Wines, Champagne), Cincinnati, Ohio; Cincinnati & Suburban Bell Tel. Co.; Fulham Fish Co. (Four Fisherman frozen fish), Boston, Mass.; Chinking Sales Co., Inc. (Chinese Foods), Duluth, Minn.; Northland Foods, Inc. (Wilderness Pie Fillings), Duluth 2, Minn.

STORM ADVERTISING COMPANY
 72 East Ave., Rochester, N. Y.
 Phone: Baker 9140, 9149

Pres., Treas.....Morry Storm
 V.P.—Radio & TV Dir. &
 Acct. Ex.....Jean Schantz
 Prod. Mgr.....Norman Lndlow, Jr.
 Asst. Radio & TV Dir.....Marian Simpsen

Office Mgr.....Thelma Prinzivalli
Radio and TV Accounts: Harry Forman Cl. Company (men's clothing), Rochester; Gioia Macaroni Company (manufacturers of macaroni products), Buffalo; Vaisey-Bristol Shoe Company, Inc. (manufacturer of children's shoes), Rochester; Wolk Brothers (automobiles), Rochester; Westinghouse Electric Supply Co. (appliances), Rochester, Syracuse; Designs Publishing Company, N. Y. C.; Alhart's Electric Company (appliances), Rochester; Cramer Drug Company (drugs), Rochester; People's Outfitting Co. (furniture & appliances), Rochester; Baker's Jumping-Jack Bootery (Shoes), Rochester-Elmira-Geneva, N. Y.; Morey Carr Sporting Goods, Rochester, N. Y.; A. Lustig Inc. (Food Processor), Brockport, N. Y.; Rudolph's Jewelers, Rochester; Seneca Stores (Appliances), Rochester; M. E. Silver Corp. (Motorola Distributor), Rochester; Snyder's Seat Covers, Rochester; Stanley Optical Co., Rochester; Style House (Rugs), Rochester; Croton Watch Co., New York, N. Y.

STORM & KLEIN, INC.

331 Madison Ave., New York 17, N. Y.
 Phone: MUrray Hill 7-4460
 ANPA—PPA

Chairman Exec. Com.....Charles M. Storm
 President, Secretary.....Allston E. Storm
 Executive Vice-Pres., Treas...Edward Klein
 V.-Pres. & Research Dir....Harry Chapperon
 Time Buyer.....Arthur J. Klein
 Art Director.....Frederick Widlicka
Radio Accounts: The Tintex Company, New York City (Tints and Dyes); Park & Tilford, New York City (Perfumes and Cosmetics).

DANIEL F. SULLIVAN CO.

216 Tremont St., Boston 16, Mass.
 Phone: HANcock 6-7644

AAAA—ABP—ANPA—APA—NBP—PPA
 President.....Daniel F. Sullivan
 Sales Dir.....Robert N. Sullivan
 Treas.....William H. Sullivan
Radio Accounts: Revere Racing Assn. (Greyhound Racing), Revere; R. S. Robie, Inc. (U-Dryvit Auto Rental), Cambridge, Mass.; F. H. Snow Canning Co. (Snow's Clam Chowder, Snow's Fish Chowder, Snow's Lobster Newburgh), Pine Point, Me.; Hickox Secretarial School, Boston.

SULLIVAN, STAUFFER, COLWELL & BAYLES, INC.

437 Fifth Ave., New York 16, N. Y.
 Phone: OREGon 9-2500
 ANPA—APA—NOAB—PPA

President.....Raymond F. Sullivan
 Vice-Pres.....Donald D. Stauffer
 Vice-Pres.....Robert T. Colwell
 Vice-Pres.....S. Heagan Bayles
 Vice-Pres., Sect.....John P. Cohane
 Vice-Pres.Ralph Smith
 Vice-Pres. & Treas...T. Newton Weatherby
 Vice-Pres.....Lloyd W. Baillie

V.P. & Copy Chief.....Joseph Leopold
 V.P. & Media Dir.....Francis Minehan
 V.P. & Merch. Dir.....Daniel O'Meara
 Vice-Pres.....A. K. Spencer
 Vice-Pres.....Joseph Hardie
 Vice-Pres.....Maitland Jones
 Vice-Pres.....Samuel Carter III
 Vice-Pres.....Ida S. Raisback
 Vice-Pres.....Barrett Welch
 Vice-Pres.....William M. Spire
 Vice-Pres.....Clemens F. Hathaway
 Vice-Pres.....Joseph Hardie
 V.P. & Research Dir.....Luther H. Wood
 V.P. & Head Art Dir.....Robert West
 Prod. Mgr.....George Andrew
 Controller.....M. Herbert King
 V.P. & Radio-TV Dir.....Philip H. Cohen
 Radio-TV Bus. Mgr.....Frank Reed

Branch Office

6253 Hollywood Blvd., Hollywood 28, Calif.
 Phone: Hillside 2119
 Vice-Pres.....Jack Van Nostrand

J. WALTER THOMPSON CO.

420 Lexington Ave., New York 17, N. Y.
 Phone: MURray Hill 3-2000
 AAAA—ANPA—ABP—NOAB—ABC
 PresidentStanley Resor
 Vice-Pres. in Charge of Radio & TV
 John U. Reber
 Radio-TV Time Buyers.....James O. Luce,
 Anne Wright, Jayne Shannon
 Radio-TV Talent Buyers..Virginia Spragle,
 H. Bart McHugh, Jr.

Branch Offices

6399 Wilshire Blvd., Los Angeles, Calif.
 Phone: WEBster 3-7201
 Vice-PresidentCornwell Jackson
 Vice-Pres.....Tom R. Cooper
 Time Buyer.....Eileen Henriquez
 410 N. Michigan Ave., Chicago 11, Ill.
 Phone: SUPERior 7-0303
 Vice-Pres. & Gen. Mgr.....George C. Reeves
 Radio Director.....Peter Cavallo
 Radio Tele Time Buyer....E. R. Fitzgerald
 320 Calif. St., San Francisco, Calif.
 Phone: GARfield 1-3510
 Sr. V.P. & West. Div. Mgr.....H. T. Stanton
 V.P. & Pacific Coast Mgr.....Fred Fidler
 Radio Time Buyer.....Frances Austin
Radio-TV Accounts: Atlantis Sales Corp.;
 P. Ballantine & Sons; Ford Dealer Advertising
 Groups; Indiana Bell Telephone; Johns-
 Manville Corp.; Kraft Foods Co.; Lever
 Brothers Co.; Libby McNeill & Libby; Pan
 American World Airways; Pan American
 Grace Airways; Pharma-Craft Corp.; Penick
 & Ford Ltd.; RCA Victor Division of RCA;
 Safeway Stores Inc.; Shell Oil Company,
 Inc.; Standard Brands Inc.; Swift & Co.;
 Ward Baking Co.; J. B. Williams Co.; East-
 man-Kodak Company; Meyenberg Milk
 Products Co.; Mentholatum Co.; W. F.
 Young, Inc.; Pacific Mills; Michigan Hospi-
 tal Service (Blue Cross); Champion Spark
 Plug Co.; Borg-Warner Corp. (Norge Divi-
 sion); Brillo Mfg. Co.; Florida Citrus Com-
 mission; Yellow Cab of Los Angeles; Pond's

Extract Company; Bowman Dairy Co.; Asso-
 ciated Hospital Service; Church & Dwight
 Co.; Devoe & Reynolds Co.; Indiana Motor
 Truck Assoc., Inc.; Mentholatum Co.; Mystik
 Adhesive; National Credit Union Assn.;
 Parker Pen Co.; Quaker Oats Co.; Scott
 Paper Co.; Sophie Mac Candy Corp.; Stazc,
 Inc.; Trailer Coach Manufacturers Assn.;
 United Hospital Service.

TRACY, KENT & CO., INC.

515 Madison Ave., New York 22, N. Y.
 Phone: ELdorado 5-4404
 ABP—ANPA—APA—NOAB—PPA—ABC
 Chairman of Board.....Wm. Irwin Tracy
 Pres.....Frank S. Kent
 Vice-Pres. & Art Dir.....Hugh F. Donnell
 Treas. & Sec.....Geo. M. Pease
 Vice-Presidents.....F. Haas, F. NYC
 Production Mgr.....C. R. Holmberg
 Radio & TV Director.....P. A. Baecker
Radio Accounts: H. C. Brill Co., Inc.
 (Spaghetti Sauce, Spanish Rice), J. W.
 Beardsley Sons (Codfish), Newark, N. J.;
 American Pharmaceutical Co., Inc., New
 York, N. Y.; Dellwood Dairy Co., Inc., You-
 kers, N. Y.; Adolph Goldmark & Sons Corp.
 (Chivers Jams, Ros's Lime Juice), New
 York, N. Y.; Gristede Bros., Inc. (Grocer-
 ies), New York, N. Y.; R. P. Hussey Assoc.
 (Fire Extinguishers), New York, N. Y.;
 Packers Tar Soap, Inc., Mystic, Conn.
TV Accounts: H. C. Brill Co., Gristede
 Bros., Inc., New York; John Opitz, Inc.,
 New York, N. Y.

TRACY-LOCKE CO., INC.

2501 Cedar Springs Road, Dallas 1, Texas
 Phone: Sterling 4741
 AAAA—ABC—ABP—ANPA—APA
 NOAB—PPA—AFA—SNPA
 PresidentMorris Hite
 Excc. Vice-Pres....Clay W. Stephenson, Jr.
 Vice-Pres., Secy.-Treas. John H. Wellenkamp
 Director Radio & TV....Philip L. McHugh
Branch Office
 711 Main St., Houston, Texas
 Phone: CH 5467

Vice-President.....Clay W. Stephenson, Jr.
Radio Accounts: Borden Co. (Southern
 District); Comet Rice Mills, Houston; Mrs.
 Baird's Bakeries, Dallas, Ft. Worth; Ire-
 land's Barbecued Beef & Chili, Houston,
 Abilene, Wichita Falls; Duncan Coffee Co.,
 Houston; Imperial Sugar Co., Sugarland;
 Burrus Mills & Elevator Co. (flour), Dallas;
 Adleta Company, Dallas; Ben E. Keith Com-
 pany (Beer), Dallas, Texas; Reserve Life
 Insurance Co., Dallas, Texas.
TV Accounts: Borden Co. (Southern Dis-
 trict); Comet Rice Mills, Houston; Mrs.
 Baird's Bakeries, Dallas, Ft. Worth; Ire-
 land's Barbecued Beef & Chili, Houston,
 Abilene, Wichita Falls; Duncan Coffee Co.,
 Houston; Imperial Sugar Co., Sugarland;
 King Candy Co., Ft. Worth; Skillerns De-
 partmental Drug Stores, Dallas; Haggard Co.
 (men's slacks), Dallas; Adleta Company,

Dallas; Ben E. Keith Company (Beer),
Dallas; Reserve Life Insurance Co., Dallas.

VICTOR VAN DER LINDE CO.

683 Fifth Ave., New York 22, N. Y.
Phone: ELdorado 5-5185

Partners.....Victor van der Linde,
Charlotte Rains

General Manager.....Agnes Kingsley
Copy Chief.....William T. Malone

Radio Accounts: W. K. Buckley, Inc.
(Jack & Jill Cough Syrup), Buffalo, N. Y.;
Dolcin Corporation (Dolcin), New York,
N. Y.; Kedriu Pharmacals, Inc. (Pharma-
ceuticals), New York, N. Y.; C. F. Mattlage
Sales Co. (Foods), New York, N. Y.;
Tasty Toothpaste Corp. (Tasty Tooth-
paste), Mt. Vernon, N. Y.; Whitehall Phar-
macal Co. (Guards Cold Tablets), New York,
N. Y.

TV Accounts: Dolcin Corporation (Dol-
cin), New York, N. Y.; C. F. Mattlage Sales
Co. (Foods), New York, N. Y.; Tasty Tooth-
paste Corp. (Tasty Toothpaste), Mt. Vernon;
W. K. Buckley, Inc. (Jack & Jill Cough
Syrup), Buffalo, N. Y.

WILLIAM VON ZEHLE & CO., INC.

441 Lexington Ave., New York 17, N. Y.
Phone: MU 2-9010

Chairman.....Wm. von Zehle
President.....V. L. Woodward, Jr.
Vice-President.....Lawrence A. Reis
TreasurerKathleen Banks
SecretaryAnthony Sarnataro

GEOFFREY WADE ADVERTISING

20 N. Waeker Drive, Chicago 6, Ill.
Phone: STate 2-7369
ABC—ANPA

Executive Dir.....Albert G. Wade, II
General Manager.....Paul McCluer
Chairman Copy and Planning

Committee.....Lawrence W. Davidson
Copy Chief.....Chas. W. Tennant
Research Director.....Gordon Norberg
Art Director.....J. B. Hoopes
Production Manager.....Edw. A. Beane
Business Manager.....L. J. Francl
Radio Media Director.....Louis J. Nelson
Space-Radio-TV Time

Buyer.....David S. Williams
Director of Radio.....Jack Farnell
Director of Television.....Booth Luck

Branch Office

6381 Hollywood Blvd., Hollywood 28, Calif.
Phone: Hillside 7457

Manager.....Robt. E. Dwyer
Radio-TV Director.....Forrest F. Owen
Media & Research Dir.....Snowden Hunt

Radio Accounts: Miles Laboratories, Inc.
(Alka-Seltzer, One-A-Day (Brand) Vitamins,
Nervine, Tabcin, Bactine), Elkhart, Ind.;
Miles California Co. Los Angeles, Calif.;
Colonial Dames (Cosmetics); Aireloom
Bedding (Mattresses & Springs), Alhambra,
Calif.; Durham Chemical Co., Los Angeles,
Calif.

TV Accounts: Miles Laboratories, Inc.
(Alka-Seltzer, Tabcin, Bactine), Elkhart,
Ind.; Miles California Co., Los Angeles,
Calif.; De Met's Candies, Chicago; Wait-
Cahill Co. (Cough Syrup), Decatur, Ill.

HUGO WAGENSEIL & ASSOCIATES

Talbott Bldg., Dayton 2, Ohio
Phone: HEmlock 5542
AAAA—AFA

PresidentHugo Wagenseil
Secy.-Treas.G. Wagenseil
Consumer Div.....W. L. Guisewite
Acct. Executive.....W. H. Ford
Radio & TV Director.....F. R. Harwood

**WALKER & DOWNING GENERAL
ADVERTISING**

532 Oliver Bldg., Pittsburgh 22, Pa.
Phone: GRant 1-1900
ABP—ANPA

President.....William S. Walker
Vice-Presidents.....C. P. Richardson,
F. L. Newmeyer, Jr., V. I. Maitland
Account Executives.....C. P. Richardson,
F. L. Newmeyer, V. I. Maitland, C. F.
Hoffman, Frank G. Orr, Bert Young
Radio & TV Director.....R. B. Stevens
Asst. Radio-TV Dir.....W. E. Burge

Radio Accounts: Allegheny Ludlum Steel
Corp. (stainless & special alloys, steels),
Pittsburgh; Duquesne Brewing Co. (beer),
Pittsburgh; Colonial Biscuit (crackers),
Pittsburgh; Sterling Oil Div. of Quaker
State Refining Corp., Emlenton; Pittsburgh
Consolidation Coal Co. (solid fuels), Pitts-
burgh; Galen Laboratories, Inc. (medica-
tions), Pittsburgh; Niagara Manufacturing
& Distributing Co. (mechanical massage
pulsator), Adamsville, Pa. & Buffalo, N. Y.

TV Accounts: Allegheny Ludlum Steel
Corp., Duquesne Brewing Co., Colonial Bis-
cuit Co., Sterling Oil Division of Quaker
State Refining Corp., Pittsburgh Consolida-
tion Coal Company, Galen Laboratories, Inc.,
Kaufmann's Department Store, Pittsburgh;
Wm. G. Johnston Company (printers), Pitts-
burgh; Fan Tan Chewing Gum Corp., Pitts-
burgh; Niagara Mfg. & Distributing Com-
pany.

**WILLIAM WARREN, JACKSON &
DELANEY**

45 W. 45th St., New York 36, N. Y.
Phone: JUdson 6-0350
ABP—APA—PANY

Partners.....Harry Solow, Jr.,
William W. Solow, S. P. Jackson
Radio Dir.....Harry Solow, Jr.
TV Director.....S. P. Jackson
Asst. to Director.....William W. Solow
Mgr. TV Commercials...Courad Mikorenda
TV Program Dir.....Edward O'Brien
Copy Chief.....Enid Berger
Account Executives.....William Solow,
S. P. Jackson, Milton Schwartz, J. C. Sil-
verman, Jack Wilson, Paul Kopp, George
Deller, Jack Halloran

Radio Accounts: Sachs Quality Stores (Dept. Store); Flag Pet Food Corp. (Dog & Cat Food); Strauss Stores (Auto Appliances); Herbert's Jewelry (Jewelry); Sofia Bros. (Movers); Pierce School of Radio & TV; Federal Life & Casualty Co. (Insurance); Rikers Restaurants; Roberts Technical & Trade School; Alexander's Dept. Stores; Monarch Buick Co., Inc.; Ritz Thrift Shop; Colony Motors; Book Find Club; Dale Dance Studios; Bonded Motor Mart; Relaxacizor Sales Co.

TV Accounts: Sachs Quality Stores; Vim Stores; Ritz Thrift Shop; Flag Dog Food; Warren Connolly; North American Van Lines; Sofia Brothers Inc.; Relaxacizor; Fruit of the Loom; Colony Motors; Stevens & Thompson Paper Co.; Wing & Fin; Chinchilla Industries, Inc.

WARWICK & LEGLER, INC.

230 Park Ave., New York 17, N. Y.
Phone: MUrray Hill 4-5800
AAAA-ABC-ABP-ANPA-APA
NOAB-PPA

President.....H. Paul Warwick
Vice-Presidents.....Henry Legler,
S. O. Youngheart, Lester M. Malitz, Arthur
Deerson, C. E. Staudinger, Harry A. Berk,
Thomas H. Shanley, Barrett Brady, Tevis
Huhn, Douglas J. Murphey
Radio & TV Director...William P. Warwick
Asst. Radio-TV Dir...Robert Steen, Joe Gratz

Branch Office

2405 W. 8th St., Los Angeles 57, Calif.
Phone: Dunkirk 3-1141

Vice Pres.....C. E. Staudinger
TV & Radio Dir.....Cecil Underwood
Radio Accounts: Hoffman Beverage Co. (Ginger Ale, Club Soda, Assorted Fruit Beverages), Newark, N. J.; Larus & Bro. Co. (Edgeworth Pipe Tobacco, Holiday Pipe Mixture, Edgeworth & Holiday Cigarettes), Richmond, Va.; Los Angeles Brewing Co. (Eastside Beer), Los Angeles, Calif.; Pabst Sales Company (Pabst Blue Ribbon Beer), Chicago, Ill.; Ex-Lax Company (Chocolate Laxative), Brooklyn, N. Y.; Ben Hur Products, Inc. (Ben Hur Coffee, Tea, Spices, Extracts), Los Angeles, Calif.; H. J. Caruso, Inc. (Automobiles), Compton, Calif.

TV Accounts: Hoffman Beverage Co. (Ginger Ale, Club Soda, Assorted Fruit Beverages), Newark, N. J.; Larus & Bro. Co. (Edgeworth Pipe Tobacco, Holiday Pipe Mixture, Edgeworth & Holiday Cigarettes), Richmond, Va.; Los Angeles Brewing Co. (Eastside Beer), Los Angeles, Calif.; Pabst Sales Company (Pabst Blue Ribbon Beer), Chicago, Ill.

WASSER, KAY & PHILLIPS, INC.

Clark Bldg., Pittsburgh 22, Pa.
Phone: Grant 1-5752

President.....G. S. Wasser
Vice-President.....Lewis G. Kay
Secretary.....F. F. Wasser
Media Director.....Harry Anderson

Television Director.....Alvin Roth
Account Executives...G.S. Wasser, L. G. Kay,
Roy Phebus, Zane Knauss

Radio Accounts: Rosenbaum Dept. Store, Pittsburgh, Pa.; Don Allen (Chevrolet), Pittsburgh, Pa.; Coca Cola of Pgh., Pittsburgh, Pa.

TV Accounts: Isaly Dairy Stores, Pittsburgh, Pa.; Morrison & McCluan (Frozen Foods), Pittsburgh; Rosenbaum Dept. Store, Pittsburgh; Equitable Gas Co. (Appliances), Pittsburgh; G. E. Supply Co., Pittsburgh; Coca Cola of Pgh.; J. A. Williams Co. (Appliances), Pittsburgh; Drake Baking Co., Pittsburgh.

WATTS. PAYNE-ADV., INC.

900 S. Main St., Tulsa 3, Okla.
Phone: 3-8108
SNPA-AAAA-AFA

President.....Don Watts
Vice-President.....Leslie S. Hauger
Treasurer.....Oscar E. Payne
Secretary.....Don Mitchell
Vice-President.....Benton Ferguson
Account Executives.....Ril C. Keefe,
Don Dyer
Radio-TV Director.....Don S. Mitchell

Branch Offices

Fidelity Union Life Bldg., 1511 Bryan,
Dallas, Tex.
Phone: Riverside 5201

Manager.....Burke Gilliam

Radio Accounts: Okla. Tire & Supply Co., Tulsa; Mid-West Chevrolet, Tulsa; 1st National Bank, Tulsa; Watt Plumbing, Tulsa; Commercial Nat'l Bank, Muskogee; 7-Up Distributors, Tulsa; El Wino, Distributors, Tulsa; Pepsi Cola Distributors, Tulsa; Chili Bowl Seasoning, Tulsa; Palace Office Supply, Tulsa; Brookside Bank, Tulsa; United Fed. Sav. & Loan, Tulsa; Bell Oil & Gas Co., Tulsa; Ozark Nurseries, Tahlequah, Okla.; Patterson Roses, Dallas, Tex.

TV Accounts: Oklahoma Tire & Supply Co.; Standard Electric Supply Co., Tulsa; 1st National Bank; Chili Bowl Seasoning; Mid-West Chevrolet.

WEAVER-GARDNER, INC.

405 Oppenheim Bldg., Saint Paul 1, Minn.
Phone: GA 4715
AAAA-ABP-APA

Pres., Treas., Radio Dir....Luther Weaver
Account Executives.....Donald Gardner,
Patricia M. Kelly
Secretary.....Blanche G. Anderson
Vice-President.....D. F. Gardner
Auditor.....A. J. Bergevin

Radio Accounts: Fairway Foods, St. Paul; R. H. Keller & Scotties Dist. (Frozen Foods), St. Paul; Myndall Cain, Inc. (Cosmetics), Minneapolis; Stewart Paint Mfg. Co., Minneapolis; Gopher State Oil Co., Minneapolis.
TV Accounts: Fairway Foods, Inc.; R. H. Keller Co. & Scottie's Dist., Gopher State Oil Co., Minneapolis.

WILLIAM H. WEINTRAUB & CO., INC.

488 Madison Ave., New York 22, N. Y.
Phone: PLaza 1-0900

President.....William H. Weintraub
Exec. Vice-Pres.....Elkin Kaufman
V.P., Treas.....John Davenport Scheuer
Vice-Pres., Chg. TV.....Harry Trenner
Business Manager.....Les Blumenthal
Chief Time Buyer.....Joan Stark

Radio Accounts: Kauser-Willys Sales Division of Willys Motors, Inc.; Blatz Brewing Co.

TV Accounts: Seeman Brothers (Air-Wick, Nylast), New York, N. Y.; Blatz Beer, Kaiser-Willys, Revlon Prod. Corp. (cosmetics), New York, N. Y.; G.H.P. Cigar Company.

WEISS & GELLER NEW YORK, INC.

400 Madison Ave., New York 17, N. Y.
Phone: PLaza 3-4070
ANPA—PPA—APA—NOAB

President.....Max A. Geller
Copy Chief.....Harold Wengler
Art Director.....Arthur Gordon
Production Manager.....Sally Green
Media Dir.....Max Tendrich

Radio Accounts: Nedick's Inc. (Stores & Concentrate for Orange Drink), New York, N. Y.; June Dairy Prod. Co., Inc. (Butter, Eggs, Cheese), New York, N. Y.

TV Accounts: Nedick's, Inc. (Concentrate for Orange Drink), New York, N. Y.; Flagstaff Foods (Wholesale Foods), Perth Amboy, N. J.

E. TAYLOR WERTHEIM

299 Madison Avenue, New York 17, N. Y.
Phone: MUrray Hill 2-0653

Owner, Meçza Dir.....E. Taylor Wertheim
Art Director.....Walter Kolligs
Space Buyer.....Carman Sheehy

WESTERN ADVERTISING AGENCY, INC.

4860 Wilshire Blvd., Los Angeles 5, Calif.
Phone: WEBster 1-1588
ABC—ABP—ANPA

President.....Edward E. Keeler
Exec. Vice Pres.....Kenneth J. Slee
Vice-President.....Paul V. Wickman
Chief Timebuyer.....Claire Koren
Radio-TV Dir.....Edmund A. Lytle

Branch Office

1655 Scheffer Ave., St. Paul, Minn.
Executive in Chg.....Harold L. Maddux

Radio Accounts: Librascope, Inc., Ontra Cafeterias, Los Angeles; Voice of Prophecy, Inc., Glendale, Calif.; Alemite Div., Stewart-Warner Corp., Los Angeles, Calif.; Mills Sales Co., Los Angeles, Calif.; Helaine Seager Piuk Ice, Beverly Hills, Calif.

TV Accounts: Fisherman's Wharf of Long

Beach, Long Beach, Calif.; Voice of Prophecy, Inc.; Pink Ice, Inc.; Alemite Div. of the Stewart Warner Corp.

WEXTON COMPANY

1780 Broadway, New York, N. Y.
Phone: PLaza 7-7835

Partners..Larry Schwartz, Howard Wechsler
Art Director.....Arthur Finer
Merchandising Director..Edward Greenberg
Personnel Director.....M. Breitkopf

WARD WHELOCK CO.

Lincoln-Liberty Bldg., Philadelphia 7, Pa.
Phone: RIitenhouse 6-7500
ANPA—PPA—APA—NOAB—ABC—AAAA
Ch. of Bd.....Ward Wheelock
President.....Arthur A. Baily
V.P. & Dir. Radio-TV.....Russ Johnston
1st Vice Pres.....Wm. R. Farrell
Secretary-Treasurer.....William A. Dunn
Mgr. Radio-TV.....Robert C. Alexander

Branch Offices

444 Madison Ave., New York 22, N. Y.
Vice-President.....R. K. Strassman
Calif. Bank Bldg., Hollywood 28, Calif.

Radio Accounts: Campbell Soup Co., Adam Scheidt Brewing Co. (Valley Forge Beer, Rams Head Ale); Bev-Rich Carbonated Drinks.

TV Accounts: Stephen F. Whitman & Son, Inc.; Campbell Soup Co.; Adam Scheidt Brewing Co.

WINIUS-BRANDON COMPANY

1706 Olive St., St. Louis 3, Mo.
Phone: Chestnut 6380
AAAA—ABP—ANPA

President.....Enno D. Winius
Sr. Vice-Pres.....C. A. Brandon
Vice-President.....W. L. Sanborn
V.P., Radio-TV Dir.....V. L. Morelock
Asst. Radio-TV Dir.....Rosalie A. Pietuch

Radio Accounts: Deep Rock Oil Corp., Tulsa, Okla.; Miller Chemical Co., St. Louis, Mo.; Dorothy Perkins (Cosmetics), St. Louis, Mo.; Katy Railroad, St. Louis, Mo.; American Packing Co.; St. Louis; Boatmen's Bank, St. Louis; H. C. Cole Milling Co., Chester, Ill.

TV Account: Deep Rock Oil Company.

FRANK WRIGHT NATIONAL CORP.

995 Market St., San Francisco, Calif.
Phone: DOuglas 2-5470

Manager.....Frank Wright
Treasurer.....Sylvia Wright
Vice-President.....Perry O. Hatlen
Production Director.....Trudy T. Shebs
Account Executive.....Marjorie Moore

Branch Offices

5746 Sunset Blvd., Hollywood 28, Calif.
Phone HO 2-7111

Radio-TV Accounts: Calo Dog Food Co., Inc., Oakland, Calif.

YOUNG & RUBICAM, INC.

285 Madison Ave., New York 17, N. Y.
 Phone: MURray Hill 9-5000
 ANPA—AAAA—ABC—ABP

President..... Sigurd S. Larmon
 Exec. V.P., Co-Chmn. Plans
 Brd..... Louis N. Brockway
 V.P. Chge. Finance..... Jacob H. Geise
 Sect.-Treas..... Harry H. Enders
 Asst. Treas., Spvsr.
 Accounting..... George N. Farrand
 V.P., Art Director..... Frederick S. Sergenian
 V.P., Copy Director..... H. S. Ward
 V.P., Mgr. Copy Dept..... John B. Rosebrook
 V.P., Dir. Int'l. Div..... Lorimer B. Slocum
 V.P., Legal Advisor..... David Miller
 V.P., Co-Chmn. Plans Brd.,
 Media Dir..... A. V. B. Geoghegan
 V.P., Merchandising Dir..... Samuel Cherr
 V.P., Dir. Pub. Rel..... Ken R. Dyke
 V.P., Dir. Research..... Dr. Peter Langhoff
 V.P., Dir. Radio-TV Dept..... Nat Wolff
 Dir. of Operations..... D. Y. Bradshaw
 V.P. Chge. Comm..... George H. Gribbin
 Vice-Presidents..... Milford Baker,
 Edward Barnes, Harry B. Carpenter,
 George B. Dippy, J. Brooks Emory, Jr.,
 Frank Fagan, John E. Grimm, Jr., Harry
 Harding, Frank L. Henderson, William
 Howard, Alexander Kroll, A. Gardiner
 Layng, Robert P. Mountain, Walter K.
 Nield, William L. Shinnick, Albert Tilt,
 Jr., Walter B. C. Washburn, Edward Bond,
 Robert H. Brinkerhoff, Aldis P. Butler,
 Robert Clayton, Wilson H. Kierstead,
 Montagu G. Miller, Bernard Pagenstecher,
 Paul Richardson, Luis P. Weil, J. P.
 Wilkerson

Branch Offices

333 No. Michigan Ave., Chicago 1, Ill.
 V.P. in Charge..... John F. Whedon
 1866 Penobscot Bldg., Detroit 2, Mich.
 Manager..... James W. Johnson
 6253 Hollywood Blvd., Hollywood 28, Calif.
 V.P. Radio-TV..... Walter Bunker
 235 Montgomery St., San Francisco 4, Calif.
 V.P. in Charge..... Edward A. Merrill, Jr.
Radio Accounts: Thomas J. Lipton, Inc.;
 Piel Bros., Inc.; General Foods Corp.; Gen-
 eral Electric Co.; Cannon Mills, Inc.; Gulf
 Oil Corp.; Procter & Gamble Co.; American
 Home Foods, Inc.; Metropolitan Life In-
 surance Co.; Bristol-Myers Co.; Sanforized
 Div. of Cluett, Peabody & Co., Inc.; Borden
 Co.; Drackett Co.; General Cigar Co., Inc.;
 Hunt Foods, Inc.; International Harvester
 Co.; Life Savers Corp.; Mission Bell Winer-
 ies; Singer Sewing Machine Co.; Time, Inc.;
 Zenith Radio Corp.; P. Lorillard Co.;
 Cudahy Packing Co.; American Bakeries
 Co.; Drake Bakeries, Inc.; Johnson & John-
 son; Northern Paper Mills; Personal Prod-
 ucts Corp.; Petri Wine Co.; Simmons Co.
TV Accounts: Thomas J. Lipton, Inc.;
 Piel Bros., Inc.; Duffy-Mott Co., Inc.; Proc-

ter & Gamble Co.; General Electric Co.;
 General Cigar Co., Inc.; Singer Sewing Ma-
 chine Co.; Borden Co.; General Foods
 Corp.; Gulf Oil Corp.; Simmons Co.; John-
 son & Johnson; Goodyear Tire & Rubber
 Co., Inc.; Bristol-Myers Co.; P. Lorillard
 Co.; American Home Foods, Inc.; Internat-
 ional Silver Co.; Sanforized Div. of Cluett,
 Peabody & Co., Inc.; Drackett Co.; Elgin
 National Watch Co.; Hunt Foods, Inc.; Rem-
 ington-Rand, Inc.; American Bakeries;
 Cudahy Packing Co.; Drake Bakeries, Inc.;
 Max Factor & Co.; Time, Inc.; Petri Wine
 Co.; Permacel Tape Corp.; Northern Paper
 Mills; Mission Bell Wineries; International
 Harvester Co.

THE YOUNT COMPANY

12 East 10th Street, Erie, Pa.
 Phone: 2-2816

President & Space Buyer..... M. A. Yount
 Acct. Executive..... M. John Yount
 Production Mgr..... George R. Rinderle
 Secretary..... Luella Drenning
 Art Director..... Russel Adam
Radio-TV Accounts: The Erie Brewing
 Company (Beer), Erie, Pa.; Sterling Milk,
 Inc. (Milk), Erie, Pa.; Lake Shore Nash,
 Inc. (Automobiles), Erie, Pa.

ZANPHIR, PETER, ADVERTISING

512 Fifth Ave., New York 36, N. Y.
 Phone: MURray Hill 7-3369
 ABP

NOW THAT
 YOU CAN
 HAVE THE
 BEST,
 WHY BE
 SATISFIED WITH
 LESS?
 AP

Station Representatives

•

RADIO

•

TELEVISION

•

**FOR RADIO AND TELEVISION
STATIONS REPRESENTED
TURN TO RADIO-TV STATION
LISTINGS**

These Insignia
Mean
TOPS
in
RADIO*
and
TV SALES†

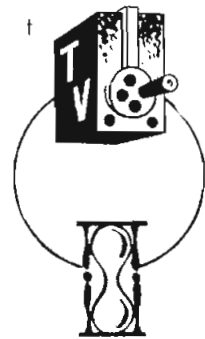
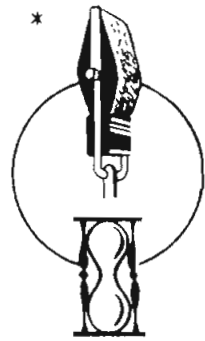

and
AGENCY
RECOGNITION

HEADLEY-REED COMPANY

Radio and Television Station Representatives

NEW YORK • PHILADELPHIA • CHICAGO
ATLANTA • NEW ORLEANS • SAN FRANCISCO • HOLLYWOOD

RADIO-TV STATION REPRESENTATIVES

AIRSPOT SALES

64 East Lake St., Chicago, Ill.
Phone: FRanklin 2-0961

Radio Gen. Mgr.....Joseph Kapps
TV Gen. Mgr.....Capico Kapps

ALASKA RADIO SALES

17 East 42nd St., New York City, N. Y.
Phone: MUrray Hill 2-0813

Network Sales Mgr.....Charles E. Soden
Spot Sales Mgr.....Roy V. Smith

AM RADIO SALES COMPANY

400 North Michigan Ave., Chicago 11, Ill.
Phone: MOhawk 4-6555

Vice-PresidentJohn Carey
ExecutiveJerry Glynn

Branch Offices

1657 Broadway, New York 19, N. Y.
Executiv.....W. H. Losee
5939 Sunset Blvd., Hollywood 28, Calif.

Phone: COlumbus 5-3739

Phone: HOLlywood 5-0695

Executive.....Charles H. Cowling

AVERY-KNODEL INC.

608 Fifth Ave., New York 20, N. Y.
Phone: JUdson 6-5536

President.....Lewis H. Avery
Vice President.....J. W. Knodel
Secretary.....B. P. Timothy
Treasurer.....Arthur H. McCoy
Director.....David H. Sandeberg

Branch Offices

75 East Wacker Dr., Chicago 1, Ill.
Phone: Andover 3-4710

Vice Pres.....J. W. Knodel
235 Montgomery St., San Francisco 4, Calif.
Phone: YUKon 2-3877

Director.....David H. Sandeberg
6399 Wilshire Blvd., Los Angeles 48, Calif.
Phone: WEbster 3-9583

Exec. In Charge.....John R. Markey
41 Marietta St., N.W., Atlanta 3, Ga.
Phone: Cyprss 7545

Executive-in-charge.....Charles C. Coleman
1915 Elm St., Dallas 1, Texas
Phone: STerling 1538

Exec. In Charge.....Clyde B. Melville

BERTHA BANNAN

80 Boylston St., Boston 16, Mass.
Phone: HUbbard 2-4419, 2-4370

OwnerBertha Bannan
Sales Assistant.....William A. Creed, Jr.

HIL F. BEST CO.

Park Ave. Bldg., Detroit 26, Mich.
Phone: WOOdward 2-7298

Gen. Mgr.....Hil F. Best
Sales Mgr.....Michael Best
Sta. Rel.....Wm. Jacobs

Branch Offices

228 N. LaSalle St., Chicago 1, Ill.
Phone: STate 2-5096

101 Park Ave., New York 17, N. Y.
Phone: LEXington 2-3783

5225 Wilshire Blvd., Los Angeles 48, Cal.
15 Harriet St., San Francisco, Calif.
Phone: UNderhill 3-6480

Account Executive.....Larry Hall
Mortgage Guaranty Bldg., Atlanta, Ga.
Phone: ALpine 5084

Account Executive.....Tom Atkinson

WALTER BIDDICK COMPANY

1151 So. Broadway, Los Angeles 15, Calif.
Phone: RICHmond 6184

ManagerGuy Biddick
Asst. Mgr.....Mildred Biddick
Office Mgr.....Josephine Corbet
Traveling Rep.Burt Zoul

JOHN BLAIR & COMPANY

Chrysler Bldg. East, New York, N. Y.
Phone: MUrray Hill 2-6900

Chairman.....John P. Blair
Vice-President.....Robert E. Eastman
Vice-President.....David N. Simmons
Secretary-TreasurerBlake Blair

Branch Offices

520 N. Michigan Ave., Chicago 11, Ill.
Phone: SU 7-8659

Mgr.....Charles F. Dilcher
3010 Russ Bldg., San Francisco 4, Calif.
Phone: DOUglas 2-3188

Mgr.....B. James Richards
6331 Hollywood Blvd., Los Angeles 28, Calif.
Phone: HOLlywood 7-6103

Mgr.....Carleton E. Coveny
1037 Paul Brown Bldg., St. Louis 1, Mo.
Phone: CHEstnut 5688

Mgr.....J. Chris Hetherington
524 Book Bldg., Detroit 26, Mich.
Phone: WOOdward 1-6030

Mgr.....Charles Fritz
Rio Grande Nat'l Bldg., Dallas, Texas
Phone: RIVerside 4228

Mgr.....Clarke R. Brown
20 Providence St., Boston 16, Mass.
Phone: HUbbard 2-3163

Mgr.....Bruce G. Pattyson

◆ ◆ ◆ RADIO-TV STATION REPRESENTATIVES ◆ ◆ ◆

BLAIR-TV, INC.

150 E. 13rd St., New York 17, N. Y.
 Phone: MUrray Hill 2-5644

Chairman.....John P. Blair
 President.....William H. Weldon
 Vice-President.....Lindsey H. Spight
 Secretary-Treasurer.....Blake Blair

Branch Offices

520 N. Michigan Ave., Chicago 11, Ill.
 Phone: SUperior 7-5580

Mgr.....John W. Davis
 3010 Russ Bldg., San Francisco 4, Calif.
 Phone: YUkon 2-7068

V.P.....Lindsey H. Spight
 6331 Hollywood Blvd., Los Angeles 28, Calif.
 Phone: HO 9-1156

Mgr.....Frank Moreland
 1037 Paul Brown Bldg., St. Louis 1, Mo.
 Phone: CHestnut 5688

Mgr.....Richard Quigley
 521 Book Bldg., Detroit 26, Mich.
 Phone: WOODward 1-6030

Mgr.....Charles Fritz
 Rio Grande Nat'l Bldg., Dallas, Texas
 Phone: RIVERSide 4228

1402 Barnett Bank, Jacksonville, Fla.
 Phone: JA 6-5770

Manager.....Harry E. Cummings
 20 Providence St., Boston, Mass.
 Manager.....Bruce Pattysan

Phone: HU 2-3163

Mgr.....Clarke R. Brown

HASKELL BLOOMBERG

39 Kearney Square, Lowell, Mass.
 Phone: LowelL 8751

General Manager.....Haskell Bloomberg

Branch Offices

Cregg Bldg., Lawrence, Mass.
 Phone: 2-2148

Mgr.....Ruth Evans
 28 Carleton St., Cambridge, Mass.
 Phone: Kirkland 7-2355

Mgr.....Mrs. Joseph Bishop

GUY BOLAM

American Sales and Service Agency
 17 East 42nd St., New York 17, N. Y.
 Phone: MUrray Hill 2-0810

Owner.....Guy Bolam

Branch Offices

3 Place de Valois, Paris, France
 President.....Louis Merlin
 38 Hertford St., London W 1, England
 General Manager.....G. Clement Cave

AM & FM Stations Represented—Radio
 Luxembourg "1," "2," "3," & "4," Luxem-
 bourg.

**WANT TO SELL YOUR IDEAS! . . . YOUR PRODUCTS!
 IN EUROPE!**

REACH MORE PEOPLE AT LESS COST THROUGH
 THE WORLD'S TWO MOST POWERFUL COMMERCIAL STATIONS

"RADIO LUXEMBOURG I" 232 k/cs 250,000 watts
 — for all European languages

"RADIO LUXEMBOURG II" 1439 k/cs 250,000 watts
 — for English-language programs

"RADIO LUXEMBOURG III" 50,000 watts short-wave

Exclusive Representative U.S.A.

Guy Bolam, American Sales & Servicing Agency
 17 East 42nd Street
 MUrray Hill 2-0810

THE BOLLING COMPANY, INC.

480 Lexington Ave., New York 17, N. Y.
Phone: PLaza 9-8150

President.....George W. Bolling
Vice-President.....E. Schuyler Ensell
Treasurer.....Robert H. Bolling
Secretary.....E. A. Pancoast, Jr.
Vice-President (TV).....G. Richard Swift

Branch Offices

435 N. Michigan Ave., Chicago 1, Ill.
Phone: WH 3-2040

Executive-in-Charge.....John D. Stebbins
2978 Wilshire Blvd., Los Angeles 5, Calif.
Phone: DU 8-8158

Executive-in-Charge.....George Bolling III
5 Third St., San Francisco, Calif.
Phone: GA 1-6740

Executive-in-Charge.....John T. Coy
80 Boylston St., Boston 16, Mass.
Executive-in-Charge.....Richard Koenig
Phone: HU 2-0346

LOUIS J. BORGATTI, INC.

419 Boylston St., Boston, Mass.
Phone: COMmonwealth 6-0718

Pres.-Treas.....Louis J. Borgatti

THE BRANHAM COMPANY

230 Park Ave., New York 17, N. Y.
Phone: MUrray Hill 6-1860

President.....Engene Corcoran
Vice President.....Joseph F. Timlin

Branch Offices

360 N. Michigan Ave., Chicago 1, Ill.
Phone: Central 6-5726

President.....E. F. Corcoran
Chairman of Board.....John Petrie
V. P.....C. B. Peterson
7236 General Motors Bld., Detroit 2, Mich.
Phone: Trinity 1-0440

Executive-in-Charge.....Ed Charney
1005 Fidelity Union Life Bldg., Dallas 3, Tex.
Phone: Riverside 4884

Executive-in-Charge.....J. S. McCauley
Rhodes Haverty Bldg., Atlanta 3, Ga.
Phone: Walnut 3025

Executive-in-Charge.....H. L. Ralls
Title Guaranty Bldg., St. Louis 1, Mo.
Phone: Chestnut 6192

Executive-in-Charge.....J. E. Nicholson
703 Market St., San Francisco 3, Calif.
Phone: YUKON 2-1582

Executive-in-Charge.....Walter Patzloff
6399 Wilshire Blvd., Los Angeles 48, Calif.
Phone: Webster 1-1551

Executive-in-Charge.....Norman Noyes
2001 Liberty Life Bldg., Charlotte 2, N. C.
Charlotte 2, N. C.
Phone: 2-8839

Executive-in-Charge.....B. C. Finch
1028 Sterick Bldg., Memphis 3, Tenn.
Phone: 8-2344

Executive-in-Charge.....Sidney L. Nichols

BULMER & JOHNSON, INC.

WCCO Bldg., Minneapolis 2, Minn.
Phone: LIncoln 7017

BURN-SMITH CO., INC.

19 W. 44th St., New York 36, N. Y.
Phone: MU 2-3124-5

Vice Pres.-Eastern Mgr.....C. Stanley Bailey

Branch Offices

307 N. Michigan Ave., Chicago 1, Ill.
Phone: Central 6-5936

Pres.-Treasurer.....John A. Toothill
672 S. Lafayette Pk. Pl., Los Angeles, Calif.
Phone: Dunkirk 2-3200

Mgr.Harlan G. Oakes
235 Montgomery St., San Francisco 4, Calif.
Phone: Yukon 6-5819

CAPPER PUBLICATIONS, INC.

1035 Topeka Blvd., Topeka, Kans.
Phone: 3-2377

General Manager.....Ben Ludy

Branch Offices

420 Lexington Ave., New York 17, N. Y.
Phone: LE 2-1250

Executive-in-charge.....William L. McKee.
333 No. Michigan Ave., Chicago 1, Ill.
Phone: CEntral 6-5977

Executive-in-Charge.....Barney Clark
300 Walthower Bldg., Kansas City 6, Mo.
Phone: Victor 3864

Executive-in-charge.....Joseph H. Story, Jr.
609 Union Commerce Bldg., Cleveland, Ohio
Phone: Main 1-6774

Manager.....Andrew M. Gent
1207 Russ Bldg., San Francisco 4, Calif.
Phone: Douglas 2-5220

Executive-in-charge.....Fred Jameson
1151 South Broadway, Los Angeles 15, Calif.
(Walter Biddick Company)

Executive-in-charge.....Guy Biddick

CBS RADIO SPOT SALES

485 Madison Ave., New York 22, N. Y.
Phone: PLaza 1-2345

General Sales Mgr.....Henry R. Flynn
Eastern Sales Mgr.....Milton F. Allison
Mgr. Sales Development.....H. A. Carlborg
Research Mgr.....Richard Hess
Promotion Mgr.....Sherril Taylor

Branch Offices

410 N. Michigan Ave., Chicago 11, Ill.
Phone: Whitehall 4-6000

Western Sales Mgr.....Gordon Hayes
902 Fisher Bldg., Detroit 2, Mich.
Phone: Trinity 2-5500

Manager.....Ralph Patt, Jr.
Palace Hotel, San Francisco 5, Calif.
Phone: Yukon 2-7000

Manager.....Bert West
6121 Sunset Blvd., Los Angeles 28, Calif.
Phone: Hollywood 9-1212

Manager.....Buck Hurs

31 Third St., N.E., Atlanta 5, Ga.
Phone: Elgin 0727

ManagerDavid Kittrell

CBS TELEVISION SPOT SALES

Service of CBS Television

485 Madison Ave., New York 22, N. Y.
Phone: PLaza 1-2345

Vice-Pres. in Charge.....Merle S. Jones
Gen. Sales Mgr.....Sam C. Digges
Business Manager.....Ben Margolis
Research Manager.....Fay Day
Eastern Sales Mgr.....Clark B. George

Branch Offices

410 N. Michigan Ave., Chicago 11, Ill.
Phone: Whitehall 4-6000

Midwestern Sales Mgr.....E. A. Larkin
200 Peachtree St., Atlanta, Ga.
Phone: Elgin 0727

Manager.....H. B. Holtshouser
902 Fisher Bldg., Detroit 2, Mich.
Phone: Trinity 2-5500

Manager.....Warren Abrams
Palace Hotel, San Francisco, Calif.
Phone: YUkon 2-7000

Manager.....Maclean Chandler
1313 N. Vine St., Los Angeles 28, Calif.
Phone: Hollywood 9-1212

Manager.....J. Richardson Loughrin

HENRY I. CHRISTAL CO.

270 Park Ave., New York, N. Y.
Phone: MUrray Hill 8-4414

Manager.....Henry I. Christal

Branch Office

333 N. Michigan Ave., Chicago, Ill.
Phone: CE 6-6357

Manager.....James L. Thompson
Russ Building, San Francisco, Calif.
Phone: YU 2-1204

Manager.....Richard E. Green
2107 Book Building, Detroit 26, Mich.
Phone: WOODward 3-2365

Manager.....Joseph R. Spadea
581 Boylston St., Boston 16, Mass.
Phone: Copley 7-1180

Manager.....Richard Charlton

GEORGE W. CLARK CO.

333 N. Michigan Ave., Chicago, Ill.
Phone: CE 6-2884

Manager.....George W. Clark

Branch Offices

11 W. 42nd St., New York, N. Y.
Phone: Oxford 5-2090

Manager.....David A. Harris
111 No. La Cienega, Beverly Hills, Calif.
Phone: CR 5-2022

Manager.....Lee O'Connell
233 Sansome St., San Francisco, Calif.
Phone: YU 6-2981

Manager.....William A. Ayres

THOMAS F. CLARK COMPANY, INC.

1 East 54th St., New York 22, N. Y.
Phone: ELdorado 5-5666

Pres. & Mgr.....Thomas F. Clark
Asst. Mgr.....Madeline E. Miklos

Branch Office

35 E. Wacker Drive, Chicago, Ill.
Phone: State 2-1663

Manager.....Paul Elsberry
3049 E. Grand Blvd., Detroit, Mich.
Phone: Trinity 1-8981

Manager.....Paul Pequinot
992 William-Oliver Bldg., Atlanta, Ga.
Phone: Lanar 7088

Manager.....Harry Cannon

COLLEGE RADIO CORP.

515 Fifth Avenue, New York 17, N. Y.
Phone: MUrray Hill 7-6865

President.....Edwards R. Hopple
Treasurer.....Robert R. Vance, Jr.
Vice-President.....Charles Mountain
(National representatives for campus radio stations throughout the country.)

CONTINENTAL RADIO SALES

111 S. 5th St., Philadelphia, Pa.
Phone: LOmbard 3-0882

Manager.....R. Butche

Branch Offices

285 Madison Ave., New York 17, N. Y.
Manager.....Stephanie Maytas

228 No. La Salle St., Chicago, Ill.
Manager.....R. Olson

DONALD COOKE INC.

331 Madison Ave., New York 17, N. Y.
Phone: MUrray Hill 2-7270

Pres. & Manager.....Donald Cooke

Branch Offices

1072 Penobscot Bldg., Detroit 26, Mich.
Executive-in-Charge.....Charles J. Sheppard
228 N. La Salle St., Chicago 1, Ill.
Phone: State 2-5096

Executive-in-Charge.....Fred R. Jones
111 N. La Cienega Blvd., Los Angeles 48, Cal.
Phone: Crestview 5-2022

Executive-in-Charge.....Lee F. O'Connell
233 Sansome St., San Francisco 4, Cal.
Phone: YUkon 6-2396

Executive-in-Charge.....William A. Ayres

HARRY E. CUMMINGS

1102 Barnett Bank Bldg.,
Jacksonville 2, Fla.
Phone: 6-5770

Owner.....Harry E. Cummings

DORA-CLAYTON AGENCY, INC.

502 Mortgage Guarantee Bldg., Atlanta 3, Ga.
Phone: Alpine 7841

Operators.....Dora C. Cosse, Clayton J. Cosse

DEVNEY & CO.

535 Fifth Ave., New York 17, N. Y.

Phone: MUrray Hill 7-5365

President.....E. J. Devney

Branch Office

64 East Lake St., Chicago, Ill.

Phone: FR 2-0016

Manager.....Hal Holman

EVERETT-McKINNEY, INC.

40 E. 49 St., New York 17, N. Y.

Phone: PLaza 9-3747

President.....Max M. Everett

Secretary.....M. Jane Callahan

Sales Mgr.....Powell H. Ensign

V.P. & Western Sls. Mgr. Robert Mandeville

Branch Offices

400 N. Michigan Ave., Chicago 11, Ill.

Phone: Superior 7-9052

Executive-in-Charge.....R. Mandeville

111 LaCienega Blvd., Los Angeles 48, Cal.

Phone: Crestview 5-2022

Exec-in-Charge.....Lee F. O'Connell

233 Sansome St., San Francisco 4, Cal.

Phone: Yukon 6-2396

Exec-in-Charge.....William A. Ayres

FORJOE & COMPANY, INC.

29 W. 57th St., New York 19, N. Y.

Phone: PLaza 5-8501

President.....Joseph Bloom

Vice-President.....Zang Golobe

Gen. Mgr.....Joseph Ruggiero

Acct. Executives.....Jim Theiss,

Ed Forrester, Jack Carson, Geo. Tichenor,

Eugene Litt

Research Director.....Billie Judels

Branch Offices

435 N. Michigan Ave., Chicago 11, Ill.

Phone: Delaware 7-1874

Manager.....Tom Sinquina

1127 Wilshire Blvd., Los Angeles, Calif.

Phone: Madison 6-8329

Manager.....Lawrence Krasner

593 Market St., San Francisco 5, Calif.

Phone: Sutter 1-7569

Manager.....Zonabelle Samson

502 Mortgage Guarantee Bldg., Atlanta, Ga.

Phone: Alpine 7844

Co-Manager.....Clayton Cossé

Co-Manager.....Mrs. Dora Cossé

FREE & PETERS, INC.

444 Madison Ave., New York 22, N. Y.

Phone: PLaza 1-2700

President.....H. Preston Peters

Exec. V.P.....Russel Woodward

Vice-Pres-TV.....Lloyd Griffin

Radio Department

V.P., Eastern Sls. Mgr.....Jones Scovern

New Advertisers.....Wm. Morrison

TV Department

Eastern Sales Manager.....John W. Brooke

Promotion Mgr.....Lorin S. Myers

Branch Offices

230 N. Michigan Ave., Chicago 1, Ill.

Phone: Franklin 2-6373

Vice-Pres.....John A. Cory

Radio Department

Midwest Sales Mgr.....Arthur W. Bagge

TV Department

Midwest Sales Mgr.....George F. Stanton

322 Palmer Building, Atlanta 3, Ga.

Phone: Main 5667

Mgr.....James M. Wade

3463 Penobscot Bldg., Detroit 26, Mich.

Phone: Woodward 1-4255

Mgr.....W. W. Bryan

406 W. 7th St., Fort Worth 2, Texas

Phone: Fortune 3349

Mgr.....Dean Milburn

6331 Hollywood Blvd., Hollywood 28, Cal.

Phone: 9-2151

Mgr.....Hal W. Hoag

Russ Bldg., San Francisco, Calif.

Phone: Sutter 1-3798

Radio Manager.....F. Thomas Boise

Television Mgr.....Richard G. Rothlin

GILL-PERNA, INC.

654 Madison Ave., New York 21, N. Y.

Phone: TEmpleton 8-4740

President.....Helen Gill

Exec. Vice-Pres.....John J. Perna, Jr.

Branch Offices

75 E. Wacker Drive, Chicago, Ill.

Phone: CEntral 6-2420

2330 W. 3rd St., Los Angeles, Calif.

Phone: DUnkirk 7-4388

57 Post St., San Francisco, Calif.

Phone: Sutter 1-5568

W. S. GRANT CO., INC.

703 Market St., San Francisco, Calif.

Phone: EXbrook 2-6685

General Manager.....W. S. Grant

Branch Offices

1127 Sunset Blvd., Los Angeles, Calif.

Phone: Madison 9-2653

33 W. 42nd St., New York, N. Y.

Phone: BRyant 9-1374

612 N. Michigan Ave., Chicago, Ill.

Phone: SUperior 7-8177

MELCHOR GUZMAN COMPANY, INC.

45 Rockefeller Plaza, New York 20, N. Y.

Phone: CIrcle 7-0624

President.....Melchor Guzman

Radio Executives.....A. Malecki,

J. Moran, G. Ortiz

*Stations Represented in—*Bolivia, Brazil, Chile, Columbia, El Salvador, Honduras, Mexico, Nicaragua, Peru, Puerto Rico, Uruguay, and Venezuela.

H-R REPRESENTATIVES, INC.

380 Madison Ave., New York 17, N. Y.
Phone: Oxford 7-3120

Pres. & Treas. Frank M. Headley
Exec. Vice-Pres. Dwight S. Reed
Vice-Pres. & Sec. Frank E. Pellegrin
Vice-Pres. Carl S. French
Vice-Pres. Paul R. Weeks
Vice-Pres. Harold Lindley

Branch Offices

35 East Wacker Drive, Chicago 1, Ill.
Phone: Randolph 6-6131

Vice-President Dwight S. Reed
155 Montgomery St., San Francisco, Calif.
Phone: YUkon 2-5701

General Manager James Alspaugh
Equitable Bldg., Hollywood, Calif.

Phone: HOLlywood 7-1180

V.P.-Gen. Mgr. Harold Lindley

HARRINGTON, RIGHTER & PARSONS, INC.

347 Madison Ave., New York 17, N. Y.
Phone: LE 2-1741

TV Department

President John E. Harrington, Jr.
Vice Pres. Volney Righter
Vice Pres. James O. Parsons, Jr.
Asst. Executive John F. Dickinson
Asst. Executive Burton Adams
Asst. Executive Maurice Rasbbaum, Jr.
Account Executive Norman Walt

Branch Office

Tribune Tower, Chicago, Ill.
Phone: Whitehall 4-0074

Executive-in-charge Carroll R. Layman
Russ Bldg., San Francisco, Calif.

Phone: Sutter 4-1125

Executive-in-charge Franklin Dougherty

HEADLEY-REED COMPANY

420 Lexington Ave., New York 17, N. Y.
Phone: MUrray Hill 5-8701

President Frank W. Miller, Sr.
Vice-Pres. Sta. Rel. William B. Faber
Vice-Pres. Gen. Mgr. Sterling Beezon
Vice-President John W. Wrath
Secy.-Treas. Frank W. Miller, Jr.

Branch Offices

230 N. Michigan Ave., Chicago 1, Ill.

Executive-in-charge John W. Wrath
Palmer Bldg., Atlanta 3, Ga.

Executive-in-charge Eli W. Sweatman
300 Montgomery St., San Francisco 4, Cal.

Executive-in-charge Ralph W. Mitchell
Taft Bldg., Hollywood, Cal.

Executive-in-charge Clark N. Barnes
Lincoln-Liberty Bldg., Philadelphia, Pa.

Executive-in-charge Robert S. Dome
Lee Circle Bldg., New Orleans, La.

Executive-in-Charge Milton DeRemna, Jr.

GEORGE P. HOLLINGBERY CO.

307 N. Michigan Ave., Chicago 10, Ill.
Phone: DEarborn 2-6060

President George P. Hollingbery
Branch Offices

500 Fifth Ave., New York 18, N. Y.
Phone: BRyant 9-3960

Executive-in-charge John I. Peterson
411 W. 5th St., Los Angeles 13, Calif.

Phone: MADison 6-1351

Executive-in-charge Harry H. Wise, Jr.
625 Market St., San Francisco 4, Calif.

Phone: DOUglas 2-7192

Executive-in-charge George F. Lindman
233 Peachtree St., Atlanta 3, Ga.

Phone: LAMar 5-710

Executive-in-charge Richard N. Hunter

HAL HOLMAN COMPANY

64 East Lake St., Chicago 1, Ill.
Phone: FRanklin 2-0016

Owner Hal Holman
Branch Offices

535 Fifth Ave., New York 17, N. Y.
Phone: MUrray Hill 7-5365

Executive-in-charge Ed Devney
6381 Hollywood Blvd., Los Angeles 28, Calif.

Phone: Hywd. 9-5408

Manager Tracy Moore
116 New Montgomery St.,
San Francisco 5, Calif.

Phone: EXbrk 2-8033

Manager Tracy Moore

INDIE SALES, INC.

60 East 42nd St., New York 17, N. Y.
Phone: MUrray Hill 2-4813

President Jack Koste
Branch Offices

228 N. LaSalle St., Chicago 1, Ill.
Phone: STate 5096

5225 Wilshire Blvd., Los Angeles 36, Calif.
Phone: YORk 8812

15 Harriet St., San Francisco 3, Calif.
Phone: UNderhill 3-6180

Park Ave. Bldg., Detroit 26, Mich.
Phone: WOODward 2-7298

INTER-AMERICAN PUBLICATIONS, INC.

11 East 42nd St., New York 17, N. Y.
Phone: MUrray Hill 2-0884

President Angel Ramos
Vice-President Jose Oviedo
Secretary Frank Navarro

**INTERSTATE UNITED NEWSPAPERS
—RADIO DIVISION**

545 Fifth Ave., New York, N. Y.
Phone: MUrray Hill 2-5452

Mgr. Radio Div. J. Wootton
Branch Offices

25 East Jackson Blvd., Chicago, Ill.
Phone: WEbster 9-7260

Manager L. J. Pollard

THE KATZ AGENCY, INC.

488 Madison Ave., New York 22, N. Y.
Phone: PLaza 9-4460

President Eugene Katz
V.P., Dir. of Sales Policy... George W. Brett
Treasurer Morris J. Beck
Sales Manager..... Morris S. Kellner
Director of TV..... Edward Codel
Sales Mgr. (TV)..... Scott Donahue

Branch Offices

307 N. Michigan Ave., Chicago 1, Ill.
Phone: Central 6-7343

Vice-President G. H. Guust
Penobscot Bldg., Detroit, Mich.
Phone: Woodward 3-8420

Manager R. Bateman
Bryant Bldg., Kansas City 6, Kans.
Phone: Victor 7095

Manager..... T. J. Flanagan, Jr.
22 Marietta St., Atlanta 3, Ga.
Phone: Alpine 1637

Manager Keith Byerly
2006 Bryan St., Dallas 1, Texas
Phone: RIVERSide 4036

Manager D. Rutledge
Russ Bldg., San Francisco 4, Calif.
Phone: Sutter 1-7434

Manager..... Stanley J. Ruelman
530 W. Sixth St., Los Angeles 14, Calif.
Phone: Tucker 8167

Manager Richard Hashbrook

JOHN KEATING

414 Alderway Bldg., Portland 5, Orc.
Phone: Beacon 4107

Manager..... Don P. Motter
Branch Office

Second and Pine Bldg., Seattle, Wash.
Phone: Elliot 6520

Manager Jack Ellison

THE KENNEDY CO.

1806 Packard Bldg., Philadelphia 2, Pa.
Phone: RITtenhouse 6-8546

Executive Personnel—Malcolm E. Kennedy, Foster G. Bowen, Kathryn B. Peters.

KETTLE-CARTER

200 Berkeley St., Boston 16, Mass.
Phone: Liberty 2-5799

Partner Elmer Kettell
Partner Marjorie Carter

A. LEWIS KING

551 Fifth Ave., New York 17, N. Y.
Phone: MUrray Hill 2-8276

Proprietor..... A. Lewis King

JOSEPH HERSHEY MCGILLVRA, INC.

366 Madison Ave., New York 17, N. Y.
Phone: MUrray Hill 2-8755

President..... Joseph H. McGillvra

Branch Offices

185 N. Wabash Ave., Chicago 1, Ill.
Phone: State 2-5282

V.P. & Manager..... Judd Sparling
111 N. La Cienga Blvd., Beverly Hills, Calif.
Phone: Bradshaw 2-4727

Manager..... Lee F. O'Connell
233 Sansome St., San Francisco 4, Calif.
Phone: YUkon 6-2981

Manager..... William A. Ayres

ROBERT MEEKER ASSOCIATES INC.

521 Fifth Ave., New York 17, N. Y.
Phone: MUrray Hill 2-2170

President..... Robert D. C. Meeker
Eastern Manager..... Louis J. F. Moore
Account Exec..... Edgar B. Filion
Account Exec..... Byron Goodell

Branch Offices

333 N. Michigan Ave., Chicago 1, Ill.
Phone: CE 6-1742

Manager..... Carl F-J Jewett
8 West King St., Lancaster, Pa.
Phone: Lan. 5251

Manager Dick Sheetz
6381 Hollywood Blvd., Los Angeles 28, Calif.
Phone: HO 9-5408

West Coast Manager..... Tracy Moore
339 Russ Building, San Francisco, Calif.
Phone: YUkon 6-4940

Manager Don Pontius

CLYDE MELVILLE CO.

402 Melba Bldg., Dallas, Tex.
Phone: Sterling 1558

Owner Clyde Melville

NATIONAL BROADCAST SALES

222 Simcoe St., Toronto, Ontario
Phone: EMpire 6-3718

General Manager..... R. A. Leslie
Commercial Manager..... W. C. Tierney

Branch Office

1396 St. Catherine St., W., Montreal
Phone: UNiversity 6-1538

Manager..... E. F. Kavanagh

NBC SPOT SALES

30 Rockefeller Plaza, New York 20, N. Y.
Phone: Circle 7-8300

Director..... Thomas B. McFadden
Mgr., New Bus., Prom..... H. W. Shepard
Nat. Manager, TV..... John Reber
Nat. Mgr. (Rad.)..... George Dietrich
Mgr. Represented Stas..... Richard Close
Sales Service Mgr..... Caroline Herbert
Eastern Sales Mgr. (TV)..... Luellen Stearns
East. Sales Mgr. (Rad.)..... Edwin Jameson

Branch Offices

Merchandise Mart, Chicago 54, Ill.
Phone: SUperior 7-8300

Central Radio Sales Mgr.... Robert Flanigan
Central TV Sales Mgr..... John Mulholland

NBC Bldg., Cleveland 4, Ohio
Phone: CHerry 1-0942
 Radio & TV Sales Rep. John G. Treacy
 Sunset & Vine, Hollywood 28, Calif.
Phone: Hollywood 9-6161
 Sales Rep. (Radio) Doty Edouarde
 Sales Rep. (TV) Walter Davison
 NBC Bldg., San Francisco 2, Calif.
Phone: Greystone 4-8700
 Sales Rep. (Radio) Martin Percival
 Sales Rep. (TV) George Fuerst
 Penobscot Bldg., Detroit, Mich.
Phone: WOODward 1-4610
 Radio Sales Rep. Paul Mensing
 TV Sales Representative Allan Kerr

NATIONAL TIME SALES

17 E. 42nd St., New York 17, N. Y.
Phone: MUrray Hill 2-0810
 Sales Manager Arthur Gordon
 A-st. Sales Mgr. Robert J. Kizer
Branch Office
 627 S. Lafayette Park Pl., Los Angeles 5, Cal.
Phone: DU 2-3200
 Manager Harlan G. Oakes
 235 Montgomery St., San Francisco, Calif.
Phone: YUKon 6-5819
 Manager Burt Beggs
 (Following for Station KJWW, San Antonio, Texas only.)
 5225 Wilshire Blvd., Los Angeles 36, Calif.
Phone: YORk 8812
 Manager Gene Grant

HARLAN G. OAKES & ASSOCIATES

235 Montgomery St., San Francisco, Calif.
Phone: YUKon 6-5819
 307 N. Michigan, Chicago, Ill.
Phone: CEntral 6-1437
 672 S. Lafayette Park Pl., Los Angeles, Calif.
Phone: DUNKirk 2-3200
 17 E. 42nd St., New York 17, N. Y.
Phone: MUrray Hill 2-0810

PAN AMERICAN BROADCASTING CO.

17 East 42nd St., New York 17, N. Y.
Phone: MU 2-0810
 Vice-President Eugene Bernald
 Manager Arthur Gordon
 A-st. Mgr. Robt. J. Kizer
Branch Offices
 672 S. Lafayette Pk. Pl., Los Angeles 5, Calif.
Phone: DU 2-3200
 Executive-in-charge Harlan Oakes
 235 Montgomery St., San Francisco, Calif.
Phone: YUKon 6-5819
 Executive-in-charge Burt Beggs

JOHN E. PEARSON CO.

250 Park Ave., New York 17, N. Y.
Phone: PLaza 1-3366
 Owner John E. Pearson

Account Executives Russel Walker.
 William M. Wilson, Ray Henze
John E. Pearson Television, Inc.
 President John E. Pearson
 Vice-President Russel Walker
 Vice-President William M. Wilson
 Vice-President Frank Reed
 Vice-President James Bowden

Branch Offices

333 No. Michigan Ave., Chicago 1, Ill.
Phone: State 2-7494
 Executive-in-charge Frank Reed
 2330 W. 3rd St., Los Angeles 5, Calif.
Phone: DUNKirk 7-4388
 Executive-in-charge R. W. Walker
 57 Post St., San Francisco 1, Calif.
Phone: Sutter 1-5568
 Executive-in-charge Rogers Parratt
 1106 Northwestern Bank Bldg.,
 Minneapolis, Minn.
Phone: Lincoln 5689
 Exec-in-chg. James D. Bowden
 Fidelity Union Bldg., Dallas, Texas
Phone: PRospect 3723
 Executive-in-charge Robert Baird

JOHN H. PERRY ASSOCIATES

128 E. 56th St., New York 22, N. Y.
Phone: ELdorado 5-3197
 General Manager Wm. K. Dorman
Branch Offices
 122 S. Michigan Ave., Chicago 3, Ill.
Phone: HARRison 7-8085
 Executive-in-Charge F. W. Thurnau
 12 S. 12th St., Philadelphia 7, Pa.
Phone: Walnut 2-3555
 Executive-in-Charge Robert Hitchings
 Room 7-268, General Motors Bldg., Detroit 2,
 Mich.
Phone: Trinity 5-1803
 Executive-in-Charge John F. Cole
 1123 Mortgage Guarantee Bldg., Atlanta, Ga.
Phone: ALPine 5081
 Executive-in-charge Thomas H. Atkinson
 2978 Wilshire Blvd., Los Angeles 5, Calif.
Phone: DUNKirk 8-8158
 Executive-in-charge V. E. Atkinson
 5 3d St., San Francisco 3, Calif.
Phone: GARfield 1-6740
 Executive-in-charge George De Close

EDWARD PETRY & CO., INC.

488 Madison Ave., New York 22, N. Y.
Phone: MUrray Hill 8-0200
Radio Department
 President Edward Petry
 Exec. Vice-Pres. Edward E. Voynow
 Vice-Pres-ident H. E. Ringgold
 Eastern Sales Mgr. Lawrence Field
 Sales Prom. Mgr. Wm. H. Steese
 A-st. Sales Prom. Mgr. Wallace Duncan
 Research Manager Geo. Johannessen
TV Department
 V.P., Eastern Sales Mgr. H. E. Ringgold
 Sales Prom. Mgr. Robert L. Hutton, Jr.

Branch Offices

400 N. Michigan Ave., Chicago 11, Ill.
 Phone: Whitehall 4-0011
 Exec. V-P.....Edward E. Voynow
 Sales Mgr. (Radio).....John Ashenbush
 Sales Mgr. (TV).....Louis A. Smith
 Genl. Motors Bldg., Detroit 2, Mich.
 Phone: Trinity 5-1035
 Executives: William Cartwright (AM),
 Franklin M. Walker (TV)
 Russ Bldg., San Francisco 4, Cal.
 Phone: YUKon 2-3631
 Executives.....Earle H. Smith (AM)
 Edward L. Smith (TV)
 523 W. Sixth St., Los Angeles 14, Calif.
 Exec-in-Charge.....Charles G. Matson
 L. D. Larimer (TV)
 Phone: Michigan 9227
 915 Olive St., St. Louis 3, Mo.
 Exec-in-Charge.....George Kercher (AM)
 Richard Hughes (TV)
 Phone: Chestnut 7191
 Life of America Bldg., Wood & Akard Sts.
 Dallas 2, Texas
 Phone: PROspect 3593
 Execs-in-Chg.....Buell Herman (AM)
 Richard E. Drummy, Jr. (TV)

RADIO-TV REPRESENTATIVES, INC.

480 Lexington Ave., New York 17, N. Y.
 Phone: MU 8-4342
 President.....Harry Goodman
 Vice President.....Frank Sawdon
 Vice President.....Peggy Stone

Branch Offices

75 E. Wacker Dr., Chicago 1, Ill.
 Phone: FI 6-0964
 Manager.....Edward Nickey
 111 No. LaCienega Blvd., Beverly Hills, Calif.
 Executive-in-Charge.....Arthur Chipman
 233 Samsome St., San Francisco, Calif.
 Executive-in-Charge.....Wm. Ayres

RADIO REPRESENTATIVES LIMITED

4 Albert St., Toronto 1, Ont., Canada
 Phone: EM 8-6151
 Managing Director.....J. O. Slatter
 Sales Manager.....A. E. Bedard
Branch Offices
 337 Dominion Square Bldg., Montreal, Que.
 Canada
 Phone: UNiversity 6-8058
 Manager.....W. C. Dippie
 Lindsay Bldg., Winnipeg, Manitoba, Canada
 Phone: 9-26374
 Manager.....A. J. Messner
 198 W. Hastings St., Vancouver, B. C., Can.
 Manager.....J. N. Hunt

RADIO TIME SALES (ONTARIO) LTD.

147 University Ave., Toronto, Ontario
 Phone: Empire 6-6680
 General Manager.....N. D. Brown
 Traffic Manager.....Merleen Wilson

WILLIAM G. RAMBEAU CO.

347 Madison Ave., New York 17, N. Y.
 Phone: Murray Hill 6-5940
 President.....William G. Rambeau
 Executive Vice-Pres....James A. Wethington
Branch Offices
 333 N. Michigan Avenue, Chicago 1, Ill.
 Phone: And. 3-5566
 Executive-in-Charge.....Al Brown
 1746 N. Las Palmas Ave., Los Angeles 28,
 Calif.
 Phone: Hillside 0388
 Exec-in-Charge.....Jack Porter
 607 Market St., San Francisco, Calif.
 Phone: GARfield 1-0426
 Executive-in-Charge.....Roy Soderlind
 625 2nd Ave., Minneapolis 2, Minn.
 Phone: Lincoln 7017
 Executive-in-charge.....Vivian Bulmer

PAUL H. RAYMER COMPANY, INC.

444 Madison Ave., New York 22, N. Y.
 Phone: Plaza 9-5570
 President.....Paul H. Raymer
 (Radio Dept.)
 Exec. V.P., Sls. Mgr.....Fred C. Brokaw
 Account Executives.....E. E. Eshelman,
 John S. Hugres, Alfred J. Larsou, Stuart
 Kelly, Lawrence Van Dolen
 (Television Dept.)
 Sales Manager.....Ralph E. McKinnie
 Account Executives.....Edward Daly,
 Geo. Griesbauer, Bates Halsey

Branch Offices

435 N. Michigan Ave., Chicago 11, Ill.
 Phone: Superior 7-4473
 Vice-President.....Garfield C. Packard
 2949 Penobscot Bldg., Detroit 26, Mich.
 Phone: Woodward 3-0764
 Executive-in-Charge.....Robert B. Rains
 1680 Vine St., Hollywood 28, Calif.
 Phone: HOLlywood 2-2376
 Executive-in-Charge.....John D. Gale
 1672 Russ Bldg., San Francisco 4, Calif.
 Phone: Douglas 2-8909
 Exec-in-Charge.....Ray Rhodes
 Glenn Bldg., Atlanta 3, Ga.
 Phone: CYpress 5304
 Executive-in-Charge.....Arch B. Ragan
 1024 Life of America Bldg., Dallas, Texas
 Phone: RIVERSide 5663
 Executive-in-Charge.....Robert E. Stuart

SEARS & AYER, INC.

612 N. Michigan Ave., Chicago, Ill.
 Phone: Superior 7-8177-8
 President.....B. H. Sears
Branch Offices
 295 Madison Ave., New York, N. Y.
 Executive-in-Charge.....P. J. Bogner
 Phone: MUrray Hill 9-2586-87
 5225 Wilshire Blvd., Los Angeles, Calif.
 Executive-in-Charge.....Gene Grant
 Phone: York 8812
 681 Market St., San Francisco, Calif.

Executive-in-Charge.....Gene Grant
Phone: Yukon 6-0621

STORER BROADCASTING CO.

96th St. & W. Bay Harbor Dr.,
 Bay Harbor Island, Miami Beach, Fla.
 President.....George B. Storer
 Exec. Vice-President.....Lee B. Wailes

Branch Offices

118 East 57th St., New York 22, N. Y.
Phone: ELdorado 5-7690

V.P.-Natl. Sales Dir.....Tom Harker
 Sales Prom. & Advt. Mgr.....Art Schofield
 230 N. Michigan Ave., Chicago, Ill.
Phone: FRanklin 2-6498

Manager.....Robert C. Wood
 136 Huron St., Toledo 4, Ohio
 Senior V.P., Treas.....J. Harold Ryan

HORACE N. STOVIN & COMPANY

80 Richmond St. W., Toronto, Ontario
Phone: Empire 3-9184

President.....H. N. Stovin
 Gen. Sale Mgr.....George W. Hellman
 608 Keefer Bldg., Montreal, Quebec
Phone: UNiversity 6-6291

Manager.....T. C. Maguire
 111 Childs Bldg., Winnipeg, Manitoba
Phone: 925-097

Manager.....G. Tudor
 615 Pender St. W., Vancouver, B. C.
Phone: Tatlow 1831

Manager.....J. W. Stovin

TRANSIT RADIO, INC.

1109 Union Trust Bldg., Cincinnati 2, O.
Phone: Dunbar 7775

President.....Richard C. Crisler

VENARD, INC.

141 Madison Ave., New York, N. Y.
Phone: MU 8-1088

Pres.....Lloyd G. Venard
 V.P.....Howard B. Meyers

Branch Offices

35 E. Wacker Dr., Chicago, Ill.
Phone: ST 2560

2978 Wilshire Blvd., Los Angeles, Cal.
Phone: DU 8-4151

Mills Bldg., San Francisco, Cal.
Phone: GARfield 1-7950

119 Boylston, Boston, Mass.
Phone: CO 6-0718

WALKER REPRESENTATION CO., INC.

347 Madison Ave., New York 17, N. Y.
Phone: MURray Hill 3-5830

President.....Wythe Walker
 Vice-President.....C. Otis Rawalt
 Representative.....Howard McFadden

Branch Offices

360 N. Michigan Ave., Chicago 1, Ill.
Phone: AN 3-5771

V.P.....Ralph C. Kelley

1012 Baltimore St., Kansas City, Mo.
Phone: Victor 992

672 S. LaFayette Park Pl., Los Angeles, Calif.
 Exec-in-Charge.....Harlan G. Oakes
Phone: DU 2-3200

1687 N.W., Natl. Bank Bldg., Minneapolis, Minn.

Phone: Geneva 9631

Executive-in-Charge.....Orville Lawson
 Mortgage Guarantee Bldg., Atlanta, Ga.
Phone: Alpine 5084

Executive-in-charge.....Tom Atkinson

WEED AND COMPANY

350 Madison Ave., New York 17, N. Y.
Phone: MU 2-7772

Manager (Radio & TV).....Joseph J. Weed
 Gen. Sales Mgr.....E. J. Fitzsimmons
 East. Sales Mgr.....J. C. Lyons
 Salesmen (Radio).....Sheldon Van Dolen,
 Peter McGurk, Norton Virgien, Bob Muth,
 Paul Frank, A. B. Johnson, Peter A. McGurk

Branch Offices

203 North Wabash Ave., Chicago 1, Ill.
Phone: Randolph 6-7730

Executive-in-Charge.....C. C. Weed
 1707 Book Bldg., Detroit 26, Mich.
Phone: Woodward 1-2685

Executive-in-Charge.....J. J. McEaney
 Glenn Bldg., Atlanta 3, Ga.
Phone: Cypress 4081

Exec-in-Charge.....George Swearingen, Jr.
 5331 Hollywood Blvd., Hollywood 28, Calif.
Phone: HOLlywood 4-8611

Exec-in-Charge.....Lincoln P. Simonds
 625 Market St., San Francisco 5, Calif.
Phone: DOuglas 2-1151

Executive-in-Charge.....Boyd Rippey
 Staller Bldg., Boston 16, Mass.
Phone: Hubbard 2-5677

Executive-in-Charge.....William Walsh

GILBERT A. WELLINGTON

5546 White-Henry-Stuart Bldg., Seattle, Wash.
Phone: Seneca 6682

ADAM J. YOUNG JR.

INCORPORATED

22 East 40th Street, New York 16, N. Y.
Phone: MURray Hill 9-0006

President.....Adam J. Young, Jr.
Branch Offices

55 East Washington, Chicago 2, Ill.
Phone: ANdover 3-5118

Exec-in-Charge.....William J. Reilly
 6331 Hollywood Blvd., Los Angeles 28, Calif.
Phone: HOLlywood 9-0965

Exec-in-Charge.....William L. Wallace
 7 North 7th St., St. Louis, Mo.
Phone: MAine 5020

Exec-in-Chg.....Jack Hetherington

ADAM YOUNG TELEVISION CORP.

Branch Office

Staller Office Bldg., Boston 16, Mass.
Phone: HUbbard 2-6117

Federal Communications Commission

- HOW TO APPLY
FOR FCC LICENSE

- PERSONNEL

National Association of Radio and Television Broadcasters

- PERSONNEL — COMMITTEES

FEDERAL COMMUNICATIONS COMMISSION

HEADQUARTERS: NEW POST OFFICE BUILDING, WASHINGTON 25, D. C.
Phone: EXecutive 3-3620
Personnel as of February 1, 1954

Commissioners

Chairman

ROSEL H. HYDE

(Term Expires June 30, 1959)

Legal Assistant: DEE W. PINCOCK

EDWARD M. WEBSTER

(Term Expires June 30, 1956)

Assistant—RUTH KOPPIALKY

JOHN C. DOERFER

(Term Expires 1954)

Assistant—PATRICIA SIEMIEN

GEORGE E. STERLING

(Term Expires June 30, 1957)

Assistant—NEVA BELL PERRY

FRIEDA B. HENNOCK

(Term Expires June 30, 1955)

Assistant—ARTHUR BLOOSTON

ROBERT T. BARTLEY

(Term Expires June 30, 1958)

Assistant—FARRELL McGONIGAL

ROBERT E. LEE

(Term Expires June 30, 1960)

Assistant—ELIZABETH L. DONNELLY

Office Of The Secretary

Secretary

MARY JANE MORRIS

Assistant Secretary, WILLIAM P. MASSING

Administrative Asst., Laura L. Hollingsworth

INTERNATIONAL TELECOMMUNICATIONS SETTLEMENTS DIVISION

Charlotte S. Smith, *Chief*

MAIL AND FILES DIVISION

Mary E. Sprague, *Chief*

DOCKETS DIVISION

Jessie R. Blaine, *Chief*

TECHNICAL ASSISTANCE DIVISION

Gordon J. Kent, *Chief*

MESENGER DIVISION

John W. Brown, *Chief*

MINUTE BRANCH

Annette Hutterly, *Chief of Branch*

LIBRARY BRANCH

Helen A. Clark, *Chief of Branch*

Office of Hearing Examiners

EXAMINERS

J. D. Bond
William G. Butts
Basil P. Cooper
James D. Cunningham
Thomas H. Donahue
Charles J. Frederick
Millard French
Claire W. Hardy

Isadore A. Honig
Annie N. Hunting
Hugh B. Hutchison
H. Gifford Irton
Fanney N. Litvin
John B. Poindexter
Harold L. Schilz
Herbert Sharfman
Elizabeth C. Smith

Office of Opinions and Review

SOL SCHILDHAUSE, *Acting Chief*
Shirley Puffenberger, *Secretary*

Attorneys

Walter W. Guenther	Donald J. Berkemeyer
Richard M. Hartsock	Paul R. Conway
Edward C. McKenzie	Julian S. Egge
Vernon B. Romney	

Engineers

Horace E. Slone	Hideyuki Noguchi
-----------------	------------------

Accountant

Charles S. Borum

Office of Administration

Executive Officer and Acting Budget Officer

ROBERT W. COX

Richard F. Solan, *Administrative Assistant*

Ozella T. Drake, *Secretary*

ADMINISTRATIVE SERVICES DIVISION

Paul H. Sheehy, *Chief*

BUDGET AND FISCAL DIVISION

James H. Ballard, *Acting Chief*

ORGANIZATION AND METHODS DIVISION

Eric G. Stewart, *Chief*

PERSONNEL DIVISION

Gilbert H. Hatfield, *Personnel Officer*

Office of Reports and Information

GEORGE O. GILLINGHAM, *Chief*

INFORMATION BRANCH

Salina M. Lindo

REPORTS BRANCH

Mary O'Leson
Eva O. Melton

Office of Chief Engineer

EDWARD W. ALLEN, JR., *Chief Engineer*

Virgil R. Simpson, *Assistant Chief Engineer*

John A. Willoughby, *Assistant to the Chief Engineer*

Ruby Floyd, *Administrative Asst.*

FREQUENCY ALLOCATION & TREATY DIVISION

Albert L. McIntosh, *Asst. Chief Engineer*

TECHNICAL RESEARCH DIVISION

William C. Boese, *Chief*

LABORATORY DIVISION

Edward W. Chapin, *Chief Engineer*

Ralph J. Renton, *U. S. Supervisor,*
CONELRAD

CONTROL OF ELECTROMAGNETIC RADIATION GROUP

Ernest D. Thelemann, *Central Zone Supervisor*

Robert D. Linx, *Western Zone Supervisor*

Carl A. Johnson, *Senior Coordinating Engineer*

Broadcast Bureau

CURTIS B. PLUMMER, *Chief*

Joseph M. Kittner, *Assistant Chief*

Lavelle W. Hughes, *Administrative Assistant*

BROADCAST FACILITIES DIVISION

James E. Barr, *Chief*

New & Changed Facilities Branch.

David S. Stevens, *Chief*

Existing Facilities Branch

Wallace E. Johnson, *Chief*

Allocations Branch

Bruce S. Longfellow, *Chief*

TELEVISION FACILITIES DIVISION

Cyril M. Braum, *Chief*

Applications Branch

Joseph N. Nelson, *Chief*

Technical Branch

Hart S. Cowperthwait, *Chief*

HEARING DIVISION

(Vacancy)

Robert J. Rawson, *Asst. Chief*

RULES AND STANDARDS DIVISION

Arthur Scheiner, *Chief*

RENEWAL AND TRANSFER DIVISION

Walter R. Powell, *Chief*

Transfer Branch

Robert H. Ahford, *Chief*

Renewal Branch

(Vacancy)

Compliance Branch

LeRoy Schaaff, *Chief*

LICENSE DIVISION

Clara M. Iehl, *Chief*

Marguerite F. Hubbard, *Asst. Chief*

CONTROL SECTION

Melba Z. Templeman, *Chief*

Office of Chief Accountant

WILLIAM J. NORFLEET, *Chief Accountant*
 Hugo Reyer, *Assistant Chief Accountant*

ACCOUNTING SYSTEMS DIVISION
 John J. Nordberg, *Asst. Chief Accountant*

ECONOMICS DIVISION
 Hyman H. Goldin, *Asst. Chief Accountant*

Regional Managers

CHARLES C. KOLSTER
 North Atlantic Region
 954 Federal Building, 641 Washington Street,
 New York 14, N. Y.

PAUL H. HERNDON, JR.
 South Atlantic Region
 411 Federal Annex, Atlanta 3, Georgia

JOE H. MCKINNEY
 Gulf States Region
 332 U. S. Appraisers Bldg., 7300 Wingate St.
 Houston 11, Texas (P. O. Box 9314)

KENNETH G. CLARK
 South Pacific Region
 323-A Customhouse
 San Francisco 26, Calif.

GEORGE V. WILTSE
 North Pacific Region
 801 Federal Office Bldg., Seattle 4, Washington

WILLIAM J. McDONNEL
 Central States Region
 1300 U. S. Court House, Chicago 4, Illinois

EMERY H. LEE
 Great Lakes Region
 1029 New Federal Bldg., Detroit 26, Michigan

LEE R. DAWSON
 Hawaiian Region
 P. O. Box 1142, Lanikai Oahu T. H.

CHARLES T. MANNING
 Alaskan Region
 Room 52, Federal Bldg.
 Anchorage, Alaska

District Offices and Engineers in Charge

1. NATHAN A. HALLENSTEIN
 1600 Customhouse
 Boston 9, Massachusetts
2. ARTHUR BATCHELIER
 748 Federal Building
 New York 14, New York
3. ROGER A. PHELPS
 1905 U. S. Customhouse
 Philadelphia 6, Pennsylvania
4. HYMAN A. COHEN
 508 Old Town Bank Building
 Baltimore 2, Maryland
5. EDWARD BENNETT
 Room 402, New P. O. Building
 Norfolk 10, Virginia
- Ship Office
 Room 106, U. S. P. O. Building
 Newport News, Virginia
6. W. D. JOHNSON
 411 Federal Annex
 Atlanta 3, Georgia
- Sub-Office
 ANDREW BAHLEY
 214 P. O. Building
 Savannah, Georgia
7. ARTHUR FISH
 312 Federal Building
 Miami 1, Florida
- Sub-Office
 CHALMER H. NEER
 409-410 P. O. Building
 Tampa 2, Florida
8. THEODORE G. DEILER
 400 Audubon Building
 New Orleans 16, Louisiana
- Sub-Office
 GEORGE E. FRANKLIN
 419 U. S. Court House & Customhouse Bldg.
 Mobile 10, Alabama
9. LOUIS L. McCABE
 324 U. S. Appraisers Building
 Houston 11, Texas
- Sub-Office
 ERIC D. COBURN
 329 P. O. Building
 Beaumont, Texas
10. JOHN H. GOMSY
 500 Terminal Annex Building
 Dallas 2, Texas
11. BERNARD H. LINDEN
 539 U. S. P. O. and Court House Building
 Los Angeles 12, California
- Sub-Office
 RAY H. LANDRY
 15-C U. S. Customhouse & Courthouse
 San Diego 1, California
- Ship Office
 J. LEE SMITH
 Room 326, U. S. P. O. and Courthouse Bldg
 San Pedro, California
12. FRANCIS V. SLOAN
 323-A Customhouse
 San Francisco 26, California
13. JOSEPH H. HALLOCK
 307 Fitzpatrick Building
 Portland 5, Oregon
14. HERBERT H. ARLOWE
 801 Federal Office Building
 Seattle 4, Washington
15. WILLIAM E. CLYNE
 521 Customhouse
 Denver 2, Colorado
16. DONALD A. MURRAY
 208 Uptown P. O. and Federal Bldg.
 St. Paul 2, Minnesota
17. HAROLD T. GALLAHER
 3200 Fidelity Building
 Kansas City, Missouri
18. HAROLD D. HAYES
 826 U. S. Court House
 Chicago 4, Illinois
19. EDWIN S. HEISER
 1029 New Federal Building
 Detroit 26, Michigan
20. PAUL A. HOLLOWAY
 328 P. O. Building
 Buffalo 3, New York
21. PAUL R. FENNER
 502 Federal Bldg.
 Honolulu 1, T. H.
22. ARTHUR T. CLINE, JR.
 322-323 Federal Building
 San Juan 13, P. R.
23. HAROLD D. DeVoe
 7-8 Shattuck Building
 Juneau, Alaska
- Sub-Office
 Radio Engineer
 Room 53, U. S. P. O. and Court House
 Anchorage, Alaska

Safety and Special Radio Services Bureau

EDWIN L. WHITE, *Chief*
 Lester W. Spillane, *Assistant Chief*
 Ezra Chambers, *Administrative Assistant*

ENFORCEMENT UNIT

Marshall S. Orr, *Chief*

AVIATION DIVISION

John R. Evans, *Chief*
 Donald Mitchell, *Asst. Chief*

INDUSTRY AND COMMERCE DIVISION

Glen E. Nielsen, *Chief*

MARINE DIVISION

William N. Krebs, *Chief*
 Irving Brownstein, *Asst. Chief*

PUBLIC SAFETY AND AMATEUR DIVISION

George K. Rollins, *Chief*

AUTHORIZATION ANALYSIS DIVISION

Charles R. Weeks, *Chief*
 Robert L. Stark, *Asst. Chief*

Office of General Counsel

WARREN E. BAKER, *General Counsel*

LITIGATION DIVISION

J. Roger Wollenberg, *Chief*

**LEGISLATION, TREATIES AND
 RULES DIVISION**

Richard A. Solomon, *Chief*

Common Carrier Bureau

CURTIS M. BUSHNELL, *Acting Chief*

TELEPHONE DIVISION

Robert E. Stromberg, *Chief*
Services and Facilities Branch
 Edward L. Clinkscales, *Acting Chief*

Domestic Radio Services Branch
 Arthur A. Gladstone, *Chief*
Accounting Compliance Branch
 William M. White, *Acting Chief*

Revenue Requirements Branch
 Bernard Strassburg, *Chief*

Depreciation Rates Branch
 Kosmo J. Affanasiev, *Chief*

Tariffs & Rate Classifications Branch
 John J. Guerard, *Acting Chief*

OFFICE OF FIELD COORDINATOR

Charles R. Makela, *Chief*

TELEGRAPH DIVISION

John R. Lambert, *Chief*
Rates & Revenue Requirements Branch
 Martin R. Haven, *Chief*
Services & Facilities Branch
 Ralph D. Jones, *Chief*

INTERNATIONAL DIVISION

Marion H. Woodward, *Chief*
Rates & Revenue Requirements Branch
 Asher H. Ende, *Chief*
Services & Facilities Branch
 John A. Russ, *Chief*

LICENSE BRANCH

Betty Ferro, *Chief*

STATISTICAL BRANCH

June Anderson, *Acting Chief*

COMMON CARRIER FIELD OFFICES

Atlanta, Ga., 733 Hurt Building—Sydney L. O'Guin, *Chief*
 New York, N. Y., Rm. 604, 90 Church St.—Jack E. Buckley, *Chief*
 St. Louis, Mo., Room 334, 815 Olive St.—H. Pierce Neidermeyer, *Chief*
 San Francisco, Calif., 180 New Montgomery St.—Paul Summerhays, *Chief*

Field Engineering and Monitoring Bureau

GEORGE S. TURNER, *Chief*
 Frank M. Kratokvil, *Assistant Chief*
 John H. McAdister, *Attorney-Advisor*

FIELD OPERATING DIVISION

Frank M. Kratokvil, *Chief*

INSPECTION & EXAMINATION DIVISION

Stacy Norman, *Chief*

ENGINEERING DIVISION

George L. Jenson, *Chief*

MONITORING DIVISION

Irving L. Weston, *Chief*

HOW TO APPLY FOR FCC LICENSE

Official FCC Procedure for AM, FM and TV Licenses

ANY qualified citizen, firm, or group may apply to the Federal Communications Commission for authority to construct a commercial standard (AM), frequency modulation (FM), or television (TV) broadcast station.

Licensing of these facilities is prescribed by the Communications Act of 1934, as amended, which sets up certain basic requirements. In general, applicants must satisfy the Commission that they are legally, technically and financially qualified, and that operation of the proposed station would serve the public convenience, interest or necessity. The Communications Act also recognizes broadcasting as a competitive industry and invests the Commission with the responsibility of allocating facilities so as to provide a fair, efficient, and equitable distribution of radio service.

The licensing procedure is detailed in Part 1 of the Commission's "Rules Relating to Practice and Procedure," while station operation is covered by Part 3, "Rules Governing Radio Broadcast Services," and "Standards of Good Engineering Practice" for AM stations.

Following is a summary of the consecutive steps required in applying for authorization to build and operate a commercial broadcast station.

Selecting a Frequency

Standard (AM) broadcast stations operate on "local," "regional," or "clear" channels. Local stations are of 100 to 250 watts power and serve smaller communities; stations of 500 watts to 5 kilowatts power cover larger centers of population and surrounding areas; stations of 10 to 50 kilowatt maximum power are for large area coverage, particularly at night.

To determine whether an AM frequency is available for assignment in a particular area, it is necessary for the applicant to have a frequency search made by a competent engineer.

An applicant for a commercial FM station must specify a frequency available to the area to be served. The Commission has tentatively allocated geographic blocks of frequencies to accommodate Class A stations (community) and Class B stations (metropolitan, and rural) throughout the United States. The demand for FM sta-

tions has not yet exceeded the supply of available frequencies.

An applicant for a new television station must request a channel assigned in the Table of Assignments to the community involved. However, a channel assigned to any community listed in the table can be requested for operation in any unlisted community within 15 miles of the listed community. Commercial TV stations are authorized for unlimited hours of operation and are of a single class with minimum power determined by the size of the principal city and maximum power dependent on antenna height and allocation zone. Channels are reserved for noncommercial educational TV operation.

Applying for a Construction Permit

Once a prospective licensee has decided upon the type of station he wishes to apply for, the next step is to make application for a construction permit. This application must be in writing on a form supplied by the Commission (Form 301, "Application for Authority to Construct a New Broadcast Station or Make Changes in an Existing Broadcast Station," which covers AM, FM, and TV broadcast). This form requires information about the citizenship and character of the applicant, as well as his financial, technical, and other qualifications to construct and operate a station, plus details about the transmitting apparatus to be used, and the proposed new service. Triplicate copies are required, one of which must be executed under oath or affirmation.

Application Processing

Applications are reviewed in their engineering, legal, and financial aspects by the Broadcast Bureau, which makes recommendations to the Commission.

If, upon examination of an application, the Commission determines that there are no engineering conflicts, that the applicant is qualified, and that all other requirements are met, the application is granted without hearing and a construction permit is issued.

Any grant made by the Commission without a hearing is subject to protest within a period of 30 days, during which the protesting party may request a hear-

ing. Within 15 days thereafter the Commission must determine whether the objection merits a hearing.

The law requires that, in general, final decision on noncontested applications be rendered within three months from the date of the original filing, and within six months from the conclusion of a hearing in those cases which go through a hearing.

Hearings

Where it appears that an application violates provisions of the Commission's rules and regulations; that interference would be caused to another AM or FM broadcast station; or that the minimum separation requirements for TV stations are not met; or if other serious questions of a technical, legal, or financial character are involved, a hearing usually is required before a final decision on the application can be made. Often a hearing is necessary because two or more applicants seek to use the same frequency or immediately adjacent frequencies with such a proximity of stations that excessive interference would result. In such instances, the Commission is compelled by law to accord a hearing to the competing applicants and to make a comparative judgment as to which, if either, should be granted.

If unable to grant an application, the Commission is required to notify the applicant and other known parties of interest as to the reason. The applicant usually is given 30 days in which to reply. After that, if the Commission is still unable to make a grant, a hearing is ordered.

In designating an application for hearing, the Commission gives public notice of the issues for the information of the applicant and other parties who may be concerned. The hearing notice generally allows the applicant a period of 30 days or more in which to prepare. Even after being designated for hearing, an applicant may sometime find it possible to satisfy the issues by amending his application, especially if the apparent deficiencies are of an engineering nature.

All competing applications for the same facility are required to be on file at least 30 days before the start of the scheduled hearing.

Within 20 days after the close of a record by the hearing examiner, each party and the Chief of the Broadcast Bureau of the Commission has the privilege of filing proposed findings of fact and conclusions in support of their contentions. After review of the evidence and statements, the hearing examiner issues an initial decision.

In the event he wishes to contest the initial decision, the applicant or any other interested party has 20 days from the date on which the initial decision was announced to file exceptions and to request oral argument before the Commission. In all cases heard by an examiner, the Commission will hear oral argument on request of either party. After oral argument, the Commission may adopt, modify, or reverse the hearing examiner's initial decision. Within 30 days thereafter, any party involved may petition for rehearing.

If no exceptions are filed, and the Commission does not initiate a review of the hearing examiner's initial decision, the latter becomes effective 40 days after the issuance of the initial decision, unless otherwise ordered by the Commission.

Construction Permit

When and if an application meets statutory and other requirements, it is granted and a construction permit is issued. A maximum of 60 days from date of grant is provided in which construction shall begin, and a maximum of 6 months thereafter as the time for completion (or 8 months in all). Application to modify a broadcast construction authorization, or to make changes in an existing station, or to modify a license, is made on the same form (301) used in seeking initial construction authorization. If the permittee is unable to build his station within the time specified, he can apply for extension of time on Form 701 ("Application for Additional Time to Construct a Radio Station"), giving the reasons. Upon completion of construction the permittee can engage in equipment tests.

License

The final step is to apply for the actual license. All applicants for broadcast license are required to fill out Form 302 ("Application for New Broadcast Station License"). Applicants must show compliance with all terms, conditions, and obligations set forth in the original application and the construction permit. After applying for a license and receiving authority from the Commission, the holder of a construction permit can conduct program tests. A station license is then issued if no new cause or circumstance has come to the attention of the Commission that would make operation of the station contrary to public interest.

AM, FM and TV broadcast stations are licensed for the statutory limit of three years. Applications for renewal of license are made on Form 303.

NATIONAL ASSOCIATION OF RADIO AND TELEVISION BROADCASTERS

Headquarters: 1771 N Street, N.W.,
Washington 6, D. C.
Phone: Decatur 9300

Officers

President—Harold E. Fellows

Justin Miller
Chmn. of the Bd. and Gen. Counsel
C. E. Arney, Jr.
Secretary-Treasurer
Thad H. Brown
V.P., Counsel in Charge of TV Affairs
Richard P. Doherty
V.P., Dir., Employee-Employer Relations
Ralph W. Hardy
V.P., Dir., Government Relations

A. Prose Walker
Manager of Engineering
Robert K. Richards
Administrative Vice Pres.
John H. Smith, Jr.
Manager of Promotion and FM
Vincent Wasilewski
Chief Attorney

DEPARTMENT EXECUTIVES

Louise K. Aldrich, *Librarian*
Richard M. Allerton, *Manager of Research*
Jack L. Barton, *Assistant Manager of State Relations*
Howard H. Bell, *Assistant to the Vice President (Television)*
Edward H. Bronson, *Director of Television Code Affairs*
Abiah A. Church, *Attorney*

Oscar Elder, *Assistant to Vice Pres. (Govt. Relations)*
Fran Riley, *Manager of Information*
John H. Smith, Jr., *Manager of Promotion and FM*
Gregory Reeser, *Field Representative*
Charles H. Tower, *Assistant to the Vice President (EERD)*
William K. Treynor, *Manager of Station Relations*
Vincent T. Wasilewski, *Chief Attorney*

RADIO BOARD OF DIRECTORS 1953-1954

In accordance with Article IV of the By-Laws, the Board of Directors has designated the following composition of each of the 17 NARTB Districts.

Director	District	States Comprising District
Robert L. Krueger.....	1	Connecticut, Maine, Massachusetts, New Hampshire, Rhode Island and Vermont.
E. R. Vadeboncoeur.....	2	New York and New Jersey.
WSYR, Syracuse, N. Y. George H. Clinton.....	3	Delaware, Pennsylvania, West Virginia and Maryland, excluding the counties of Prince Georges and Montgomery.
WPAR, Parkersburg, W. Va. Harold Essex.....	4	District of Columbia, North Carolina, South Carolina, Virginia and Maryland, including the counties of Prince Georges and Montgomery
WGST, Atlanta, Ga. Henry B. Clay.....	5	Alabama, Florida, Georgia, Puerto Rico and Virgin Islands.
KWKH, Shreveport, La.	6	Arkansas, Louisiana, Mississippi and Tennessee

◆ ◆ ◆ NATL. ASSN. OF RADIO-TV BROADCASTERS ◆ ◆ ◆

Director	District	States Comprising District
F. Ernest Lackey.....	7	Kentucky and Ohio.
WHOP, Hopkinsville, Ky.		
Stanley R. Pratt.....	8	Indiana and Michigan.
WSOO, Sault Ste. Marie, Mich.		
Hugh K. Boice, Jr.....	9	Illinois and Wisconsin.
WEMP, Milwaukee, Wis.		
E. K. Hartenbower.....	10	Iowa, Missouri and Nebraska.
KCMO, Kansas City, Mo.		
John F. Meagher.....	11	Minnesota, North Dakota and South Dakota, excluding the counties of Fall River, Shannon, Bennett, Todd, Mellette, Waushabaugh, Washington, Custer, Pennington, Jackson, Jones, Stanley Haakon, Meade, Lawrence, Butte, Harding, Perkins, Ziebach, Armstrong, Dewey and Corson.
KYSM, Mankato, Minn.		
Jack Todd.....	12	Kansas and Oklahoma.
KAKE, Wichita, Kan.		
Kenyon Brown.....	13	Texas.
KWFT, Wichita Falls, Tex.		
William C. Grove.....	14	Colorado, Idaho, Utah, Wyoming, Montana, New Mexico, and South Dakota, including the counties of Fall River, Shannon, Bennett, Todd, Mellette, Waushabaugh, Washington, Custer, Pennington, Jackson, Jones, Stanley, Haakon, Meade, Lawrence, Butte, Harding, Perkins, Ziebach, Armstrong, Dewey and Carson.
KFBC, Cheyenne, Wyo.		
William D. Pabst.....	15	California, excluding the counties of San Luis Obispo, Kern, San Bernardino, Santa Barbara, Ventura, Los Angeles, Orange, Riverside, San Diego and Imperial, Nevada, excluding the counties of Mineral, Esmeralda, Nye, Lincoln and Clark, and Hawaii.
KFRC, San Francisco, Cal.		
Albert D. Johnson.....	16	Arizona, California, including the counties of San Luis Obispo, Kern, San Bernardino, Santa Barbara, Ventura, Los Angeles, Orange, Riverside, San Diego, and Imperial, and Nevada, including the counties of Mineral, Esmeralda, Nye, Lincoln, and Clark.
KOY, Phoenix, Ariz.		
Richard M. Brown.....	17	Alaska, Oregon and Washington.
KPOJ, Portland, Ore.		

DIRECTORS-AT-LARGE

Large Stations

Paul W. Morency
 WTIC, Hartford, Conn.
 John H. DeWitt, Jr.
 WSM, Nashville, Tenn.

Medium Stations

A. D. Willard, Jr.
 WGAC, Augusta, Ga.
 G. Richard Shafto
 WIST, Charlotte, N. C.

Small Stations

Edgar Kobak
 WTWA, Thomson, Ga.

FM Stations

Ben Strouse
 WWDC-FM, Washington, D. C.
 Michael R. Hanna
 WHCU-FM, Ithaca, N. Y.
 Network: Earl M. Johnson
 MBS, New York

TELEVISION BOARD OF DIRECTORS 1953-1954

Robert D. Swezey, Chairman
 WDSU-TV, New Orleans, La.
 Clair R. McCollough, Vice-Chairman
 WGAL-TV, Lancaster, Pa.
 Campbell Arnoux
 WTAR-TV, Norfolk, Va.
 Harold Hough
 WBAP-TV, Fort Worth, Tex.
 Kenneth L. Carter
 WAAM, Baltimore, Md.
 William Fay
 WHAM-TV, Rochester, N. Y.
 Paul Raibourn
 KTLA, Los Angeles, Calif.

Ward L. Quaal
 WLW-TV, Cincinnati, Ohio
 George B. Storer
 Port Industry Co., Toledo, Ohio
 Frank M. Russell
 NBC, Washington, D. C.
 Merle S. Jones
 CBS, New York, N. Y.
 C. J. Witting
 DuMont, New York, N. Y.
 Henry W. Slavick
 WMCT, Memphis, Tenn.
 Alexander Stronach
 ABC-TV, New York

NATIONAL ASSOCIATION OF EDUCATIONAL BROADCASTERS

14 Gregory Hall, Urbana, Illinois
Urbana 7-6611, Ext. 2779 & 3174

OFFICERS FOR 1954 YEAR

President

Graydon Ausmus, Station WUOA, University of Alabama, University, Ala.

Treasurer

Frank E. Schooley, Station WILL, University of Illinois, Urbana, Ill.

Vice-President

John Dunn, Station WNAD, University of Oklahoma, Norman, Okla.

Secretary

Armand Hunter, Station WKAR-TV, Michigan State College, East Lansing, Mich.

DIRECTORS

Region I

James MacAndrew, Station WNYE, 29 Fort Green Place, Brooklyn, N. Y.

Region IV

Richard B. Hull, Director of Radio & TV, Iowa State College, Ames, Iowa.

Region II

Earl Wynn, Station WUNC, University of North Carolina, Chapel Hill, N. C.

Region V

Miss Marguerite Fleming, Station KSLH, 1517 S. Theresa Ave., St. Louis, Mo.

Region III

Paul B. Rickard, Director of Radio & TV, Wayne University, Detroit, Mich.

Region VI

Allen Miller, Station KWSC, State College of Washington, Pullman, Wash.

Past President & Member of the Board

Seymour N. Siegel, Station WNYC, 2500 Municipal Bldg., New York 7, N. Y.

Executive Director

Harry J. Skornia, 14 Gregory Hall, Urbana, Ill.

NAEB MEMBERSHIP LIST

● Active Membership of the National Association of Educational Broadcasters

City	Call Letters	Licensee	Executive
ALABAMA			
University	WUOA (FM)	Univ. of Alabama	Graydon Ausanus, Director Radio-TV
CALIFORNIA			
Berkeley	KPFA (FM)	Pacific Foundation	Richard Moore, Station Director
Los Angeles	KUSC (FM)	Univ. of Southern California	William H. Sener, Hd. Telecommunications Dept.
San Bernardino	KVCR (FM)	San Bernardino Valley College	Dr. John L. Lounsbury, President
San Diego	KSDS (FM)	San Diego City Schools	Edwin G. Barrett, Program Dir.
San Mateo	KCSM (FM)	12th & Russ Streets San Mateo Jr. College	Richard P. Marsh, Prog. Dir.
Stockton	KCVN (FM)	Baldwin Ave. & San Mateo College of the Pacific	John C. Crabbe, Director
COLORADO			
Colo. Springs	KRCC (FM)	Colorado College	Woodson Tyree, Dir. Speech, Drama, Radio
FLORIDA			
Lakeland	WFSI (FM)	Florida Southern College	Ludd M. Spivey, President
Miami	WTHS (FM)	Lindsay Hopkins Vocational Schools	Vernon Bronson, Asst. Dir. Voc. & Admt Ed
Tampa	WTUN (FM)	1410 N.E. Second University of Tampa	Roy A. McGillivray, Director of Radio
Winter Park	WPRK (FM)	Rollins College	Edwin R. Walker, Dean of the College
GEORGIA			
Atlanta	WABE (FM)	Board of Education	Alvin Gaines, Program Director
ILLINOIS			
Chicago	WBEZ (FM)	Board of Education	George Jennings, Director Div. Radio-TV
Elgin	WEPS (FM)	Board of Education	E. C. Waggoner, Dir. Audio-Visual Education
Evanston	WNUR (FM)	Northwestern Univ.	Gene Courtney, Station Manager
Urbana	WILL (AM)	Univ. of Illinois	Frank E. Schooley, Manager
Urbana	WUC (FM)	Univ. of Illinois	Frank E. Schooley, Manager
INDIANA			
Blonmington	WFIU (FM)	Univ. of Indiana	Elmer Sulzer, Dir. Radio & TV Communication
Gary	WGVE (FM)	School City of Gary 524 Garfield St.	Edwin Carmony, Supvr. Audio-Visual Ed.
Greencastle	WGRE (FM)	DePauw University	Harold T. Ross, Manager
Huntington	WVSH (FM)	School City of Huntington	M. McCabe Day, Director Audio-Visual Center
Indianapolis	WAJC (FM)	Btler Univ.	Tom Carnegie
Lafayette	WBAA (AM)	Purdue Univ.	Jim Miles, Dir. of Broadcasting
Minnele	WWHI (FM)	Wilson Jr. H.S.	John V. Maier, Principal
New Albany	WNAS (FM)	New Albany City Schools	Vernon McKown, Director Audio-Visual Instr.
New Castle	WVSN (FM)	New Castle-Henry Twnsp. Schools	Miss J. J. Rucker, Station Mgr.
Wabash	WSKS (FM)	School City of Wabash	James R. Oliver, Dir. Audio-Visual Ed.
IOWA			
Ames	WOI (AM)	Iowa State College	Richard B. Hull, Radio-TV Director
Ames	WOI (FM)	Iowa State College	Richard B. Hull
Decorah	KWLC (AM)	Luther College	Leslie G. Rude, Director of Radio
Des Moines	KDPS (FM)	Des Moines Public Schools 629 Third St.	Clifton F. Schropp, Dir. Audio-Visual
Iowa City	WSUI (AM)	State Univ. of Iowa	Carl H. Menzer, Director
Iowa City	KSCI (FM)	State Univ. of Iowa	Carl H. Menzer
Waverly	KWAR (FM)	Wartburg College	Robert Snyder, Manager

NAEB ACTIVE MEMBERSHIP

City	Call Letters	Licensee	Executive
KANSAS			
Lawrence	KFKU (AM)	Univ. of Kansas	R. Edwin Browne, Director Radio-TV
Lawrence	KANU (FM)	Univ. of Kansas	R. Edwin Browne
Manhattan	KSAC (AM)	Kansas State College	R. Hilgendorf, Radio Manager
Ottawa	KTJO (FM)	Ottawa University	W. D. Bemmels, Dean of the College
Wichita	KMCW (FM)	Univ. of Wichita	G. D. Goodrich, Manager
KENTUCKY			
Lexington	WBKV (FM)	Univ. of Kentucky	Mrs. Camille Holyard, Director of Radio
Louisville	WFPL (FM)	Louisville Free Public Library	H. E. Salley, Head Audio-Visual Dept.
LOUISIANA			
Baton Rouge	WSLU (FM)	Louisiana State University	Miss Lucile Ruby, Acting Director
MARYLAND			
Baltimore	WBJC (FM)	Baltimore Jr. College Alameda & 33rd St.	Clarence T. DeHaven, Manager
MASSACHUSETTS			
Amherst	WMUA (FM)	Univ. of Mass.	Francis V. Donovan, Jr., Manager
Boston	WBUR (FM)	Boston Univ.	Leo Martin, Director Div. Communication Arts
Boston	WGBH (FM)	Lowell Instit. Co-op Broadcasting Council	Parker Wheatley, Manager
Springfield	WEDK (FM)	School Committee of Springfield	William J. Sanders, Supt. of Schools
MICHIGAN			
Ann Arbor	WUOM (FM)	Univ. of Michigan	Waldo Abbot, Director of Broadcasting
Detroit	WDTR (FM)	Board of Education	Kathleen N. Lardie, Supervisor, Radio-Television
Detroit	WDET (FM)	Wayne University	Paul B. Rickard, Director, Radio-Television
East Lansing	WKAR (AM)	Michigan State College	Robert J. Coleman, Dir. of Broadcasting
East Lansing	WKYR (FM)	Michigan State College	Robert J. Coleman
Flint	WFER (AM)	Board of Education	Miss Ola Hiller, Dir. Radio Educ.
Kalamazoo	WMCR (FM)	Western Michigan College of Educ.	Wallace Garneau, Dir. of Broadcasting
MINNESOTA			
Minneapolis	KUOM (AM)	Univ. of Minnesota	Burton Paulu, General Manager
Northfield	WCAL (AM)	St. Olaf College	Milford C. Jensen, General Manager
Northfield	WCAL (FM)	St. Olaf College	Milford C. Jensen
MISSISSIPPI			
Meridian	WMMI (FM)	Municipal Jr. College	James E. Durham, Director
MISSOURI			
St. Louis	KSLH (FM)	Board of Education 517 S. Theresa Ave.	Miss Marguerite Fleming, Director
NEW JERSEY			
Newark	WBGO (FM)	Board of Education 31 Green St.	Marie Scanton, Supervisor Radio-Television
South Orange	WSOU (FM)	Seton Hall College	Lewis E. Arnold, Jr., Program Director
NEW MEXICO			
Albuquerque	KANW (FM)	Board of Education	Mrs. Rose J. Jones, Director
NEW YORK			
Bronx	WTVV (FM)	Fordham Univ.	Edwin J. Turner
Brooklyn	WNVE (FM)	Board of Education 29 Fort Greene Pl.	James F. Maendrew, Dir. of Broadcasting
Floral Park	WSHS (FM)	Sewanhaka H.S.	W. A. Gregory, Director of Radio
Huaca	WITJ (FM)	Huaca College	Fred A. Brewer, Chrm. Dept. of Radio
New York	WNVC (AM)	Municipal Broadcasting System 2560 Municipal Bldg.	Seymour N. Siegel, Director
New York	WNYC (FM)	Municipal Broadcasting System	Seymour N. Siegel
Springville	WSPE (FM)	Griffith Instit. & School 85 Buffalo St.	Paul G. Strassler, Director
Syracuse	WVER (FM)	Syracuse University	Kenneth G. Bartlett, Dir. of Broadcasting
Troy	WHAZ (AM)	Reusscher Polytechnic Institute	Carl J. Kuntz, Chief Engineer

◆ ◆ ◆ NAEB ACTIVE MEMBERSHIP ◆ ◆ ◆

City	Call Letters	Licensee	Executive
NORTH CAROLINA			
Chapel Hill	WUNC (TV)	Consolidated Univ. of North Carolina	Robert Schenkkan, Dir. of TV
Chapel Hill	WUNC (FM)	Univ. of North Carolina	Earl Wynn, Dir. Communications Center
Greensboro	WGPS (FM)	Greensboro Public Schools	Dale F. Keller, Dir. Audio-Visual Educ
High Point	WHPS (FM)	High Point H.S.	D. P. Whitley, Principal
NORTH DAKOTA			
Grand Forks	KFJM (AM)	Univ. of North Dakota	S. Donald Robertson, Director
OHIO			
Athens	WOUI (FM)	Ohio Univ.	J. Daniel Logan, Dir. of Radio
Bowling Green	WBGU (FM)	Bowling Green State Univ.	Sidney Stone, Director
Cleveland	WBOE (FM)	Board of Education	J. J. Stillinger, Director of Radio
Columbus	WOSU (AM)	Ohio State Univ.	Robert C. Higgy, Director
Columbus	WOSU (FM)	Ohio State Univ.	Robert C. Higgy
Delaware	WSLN (FM)	Ohio Wesleyan Univ.	Stuart Postle, Adv. Radio Dept.
Kent	WKSU (FM)	Kent State Univ.	Walton D. Clarke, Dir. of Radio
Oxford	WMUB (FM)	Miami Univ.	Harry Williams, Head Dept. of Speech
Toledo	WTDS (FM)	Toledo Public Schools 1901 Central Ave.	Harry D. Lamb, Dir. Radio-TV
OKLAHOMA			
Norman	WNAD (AM)	Univ. of Oklahoma	John W. Dunn, Director
Norman	WNAD (FM)	Univ. of Oklahoma	John W. Dunn
Oklahoma City	KOKH (FM)	Board of Education	Miss Elaine Tucker, Program Director
Shawnee	KBGC (FM)	Oklahoma Baptist University	Dr. James Ralph Scales, Vice-President
Stillwater	KOAG (AM)	Oklahoma A & M College	John Woodworth
Tulsa	KWGS (FM)	Univ. of Tulsa	Robert A. Wells, Program Director
OREGON			
Corvallis	KOAC (AM)	Oregon State College	James M. Morris, Program Director
Eugene	KWAX (FM)	Univ. of Oregon	D. Glenn Starlin, Director of Radio
Portland	KBPS (AM)	Portland Public Schools	Patricia L. Green, Manager
PENNSYLVANIA			
Grove City	WSAJ (AM)	Grove City College	Dale O. Smock, Chief Engineer
Philadelphia	WPWT (FM)	Philadelphia Wireless Tech. Instit.	William W. Zerling
Philadelphia	WRTI (FM)	Temple Univ.	John B. Roberts
Pittsburgh	WDUQ (FM)	Duquesne Univ.	B. Kendall Crane, Director
Seranton	WUSV (FM)	Univ. of Seranton	Rev. Richard F. Grady, S.J., Director
Pittsburgh	WQED (TV)	Metrop. Pittsburgh Ed'l TV Station	Dorothy Daniel, Asst. to Pres.
SOUTH CAROLINA			
Columbia	WUSC (FM)	Univ. of S. Carolina	Ernest E. Lent, Jr., Director
SOUTH DAKOTA			
Vermillion	KUSD (AM)	Univ. of S. Dakota	Edward J. Slack, Prog. Dir.
TENNESSEE			
Knoxville	WUOT (FM)	Univ. of Tennessee	Jack Westbrook, Acting Director
TEXAS			
Abilene	KACC (FM)	Abilene Christian College	Lowell G. Perry
El Paso	KVOF (FM)	Texas Western College	Virgil C. Hicks, Radio Instructor
Houston	KUHF (FM)	Univ. of Houston	John Schwarzwalder, Station Mgr
WASHINGTON			
Pullman	KWSC (AM)	State College of Washington	Allen Miller, Manager
Seattle	KUOW (FM)	Univ. of Washington	Edwin H. Adams, Head Div. of Radio-Television
Tacoma	KTOY (FM)	Tacoma Public Schools	Merle Kimball
WISCONSIN			
Madison	WHA (AM)	Univ. of Wisconsin	H. B. McCarty, Director
Madison	WHA (FM)	Univ. of Wisconsin	H. B. McCarty
PUERTO RICO			
San Juan	WIPR (AM)	Oficina de Radion-emision Publica	Francisco Arrivi, Acting Director

MANAGERS AND AGENTS

*Address and Telephone Numbers of Talent Representatives
in New York, Los Angeles and Chicago*

NEW YORK

Ablinted Artists Representatives 70 East 53rd St.	PLaza 3-1862
Alexander, Willard, Inc. 30 Rockefeller Plaza	Circle 6-4224
Allen, Buddy, Agency 595 Madison Ave.	ELdorado 5-2230
Appell, James S. 409 Madison Ave.	PLaza 3-7846
Becker, V. S. Advertising Service 502 Fifth Ave.	JUDson 2-1040
Briseno & Goldsmith, Inc. 522 Fifth Ave.	MURray Hill 2-6244
Brooks, Ted 134 East 57th St.	Palza 9-1344
Chase, Cleveland B. Co., Inc. 369 Lexington Ave.	ORegon 9-3691
Collins, Ted 500 Fifth Ave.	CHickering 4-5036
Columbia Artists Management, Inc. 113 West 57th St.	Circle 7-6900
Consolidated Radio Artists, Inc. 30 Rockefeller Plaza	Columbus 5-3580
Cooper, Frank, Associates 521 Fifth Ave.	Vanderbilt 6-5661
DeGroot, Roy, Consultants, Inc. 545 Fifth Ave.	MURray Hill 7-9135
Ediman Associates, Ltd. 1501 Broadway	LAckawanna 4-3514
Famous Artists Corp. of N. Y. 610 Fifth Ave.	Circle 7-6200
Faneon & Marco, Inc. 1501 Broadway	CHickering 4-3956
Herman Fialkoff Agency 1560 Broadway	JUDson 2-4037
Gabbe, Lutz & Heller 1619 Broadway	Circle 5-7998
Gale, Inc. 48 West 48th St.	PLaza 7-7100
General Artists Corp. 1270 Sixth Ave.	Circle 7-7543
Gotts, Clark H., Inc. Gracie Terrace	LEitch 5-4451
Gibbs, John E., & Co. 30 Rockefeller Plaza	PLaza 7-5059
Glaser, Joe, Inc. 745 Fifth Ave.	PLaza 9-1600
Goodman, Martin 65 W. 51th St.	ELdorado 6-1180
Greshler, Abner J. 1270 Sixth Ave.	Circle 7-3057
Grossman, Al 1270 Sixth Ave.	Circle 5-8422
Hallo, Sylvia 113 W. 45th St.	JUDson 6-3733
Hanna, Mark 654 Madison Ave.	TEmpleton 8-8730
Hayward, Lehm, Ltd. 655 Madison Ave.	TEmpleton 8-5100
Hurok Attractions, Inc. 711 Fifth Ave.	PLaza 9-6000
Karn, Estella H. 49 West 45th St.	JUDson 2-2170
Kerr, Bob 65 W. 54th St.	Columbus 5-8051
Leddy, Mark J. 48 West 48th St.	JUDson 6-2760
Leipzig, Syd 1564 Broadway	Circle 6-2367
Lipset, Benjamin B. 1407 Broadway	CHickering 4-2466
Management Corp. of America 598 Madison Ave.	PLaza 9-7500
William McAffrey Agency 501 Madison Ave.	ELdorado 5-1676
Mindling, Louis A. 113 West 57th St.	Circle 5-5370
Morris, William Agency, Inc. 1270 Sixth Ave.	JUDson 6-5100
Morrow, Marjorie 1501 Broadway	CHickering 4-0644
Moses, John H. 739 Fifth Ave.	Circle 6-2677
Music Corp. of America 598 Madison Ave.	PLaza 9-7500
National Concert & Artists Corp. 711 Fifth Ave.	PLaza 9-6000
National Radio & Theatrical Bureau 1650 Broadway	JUDson 6-3550
North, Meyer B. 1561 Broadway	PLaza 7-3445
O'Connor, John 1697 Broadway	Circle 5-4920
Okun, Lillian 6 West 67th St.	TRAdolza 7-8916
Peed, Earl S. 35 West 50th St.	PLaza 7-3726
Pratt, Ben 377 East 50th St.	PLaza 8-0593
Richard, Max 1776 Broadway	PLaza 7-6114
Roberts, Bob Levitt 162 West 50th St.	PLaza 7-4314
Shurr, Louis 1501 Broadway	CHickering 4-8240
Souvaire, Henry, Inc. 30 Rockefeller Plaza	Circle 7-5666
Special Attractions, Inc. 48 West 48th St.	PLaza 7-2280
Stanley, Aileen 1619 Broadway	PLaza 7-6770
Stark, Wilbur 4 West 58th St.	PLaza 3-1742
Storer, Douglas F. 1270 Sixth Ave.	Circle 7-6323
Vallon, Mike 1270 Sixth Ave.	Circle 7-0162
Wolf Associates, Inc. 420 Madison Ave.	PLaza 5-7620
Yost, Ben, Enterprises 1650 Broadway	Circle 6-6542

MANAGERS AND AGENTS

LOS ANGELES

Allen Larry, Inc.
6381 Hollywood Blvd. (28) .Hollywood 3-0421

Ainsworth, Helen, Agency
197 N. Canon Dr. (B. H.) .CRestview 6-2062

Bergerman, Stanley & Co.
141 El Camino (B.H.)CRestview 6-4124

Bernie, Herman
260 S. Beverly Dr. (B.H.)CRestview 5-0117

Bloom, Phil, Agcy.
416 N. Bedford Dr.CRestview 6-1339

Business Administration Co.
360 N. Camden Dr. (B.H.)CRestview 6-7071

Columbia Artists Management, Inc.
427 West 5th St.MAdison 6-2327

Crosby, Everett N., Ltd.
9028 Sunset Blvd. (46)BRadshaw 2-2771

Famous Artists Corp.
9441 Wilshire Blvd. (B.H.)CRestview 1-5222

General Artists Corp.
9028 Sunset Blvd. (46)CRestview 1-8101

Gertz, Mitchell Agcy., Inc.
240-242 S. Beverly Dr. (B.H.)CRestview 4-5401

Nat C. Goldstone Agcy.
9121 Sunset Blvd. (46)CRestview 6-1071

Gregory Associates, Inc.
930 N. La Cienega Blvd.CRestview 5-5943

Hamilburg, Mitchell, Jr.
8776 Sunset Blvd.CRestview 5-4171

Irwin, Lou, Inc.
9165 Sunset Blvd. (46)CRestview 1-7131

Jaffe, Agcy., The
8553 Sunset Blvd. (46)CRestview 6-6121

Kohner, Paul, Inc.
9169 Sunset Blvd. (46)CRestview 1-5166

Kramer, Earl Agcy.
204 S. Beverly Drive (B.H.)CRestview 6-2338

Kurtze, Jack, Agcy.
214 N. Canon Dr. (B.H.)CRestview 4-5403

M. C. Levee
9000 Sunset Blvd.CRestview 6-6285

Linsk, Lester
9606 Santa Monica Blvd. (B.H.)CRestview 5-4396

MCA, Ltd.
9370 Santa Monica Blvd. (B.H.)CRestview 6-2001

McConkey Artists Corp.
7000 Hollywood (28)HEmpstead 7141

Morris, Wm., Agency, Inc.
202 N. Canon Drive (B.H.)CRestview 1-6161

National Concert & Artists Corp.
427 W. 5th St. (13)MAdison 9-1241

Preminger, Inge, Agcy.
204 S. Beverly Dr. (B.H.)CRestview 6-6213

Radio Registry
1519 Cross Rds. of the World. H.Ollywood 3-4811

Rocamora, Wynn
8584 Sunset Blvd. (46)CRestview 4-5431

Rosenberg, George, Agcy., Inc.
211 S. Beverly Dr. (B.H.)CRestview 1-8121

Rush, Art, Inc.
1418 N. Highland Ave. (28) .Hollywood 4-5161

Saphier, James L., Agcy., Inc.
9638 Brighton Way (B.H.)CRestview 1-7231

Schwartz Agcy.
8749 Sunset (46)CRestview 6-7371

Sharpe, Don W.
8511 Sunset Blvd. (46)CRestview 6-2044

Shauer, Melville A., Agcy.
9120 Sunset Blvd. (46)CRestview 6-7975

Sherman, Edward, Agcy.
8580 Sunset Blvd. (46)CRestview 5-0186

Shurr, Lonis Agcy.
327 North Rodeo Dr. (B.H.)CRestview 1-1116

Small, Paul, Artists, Ltd.
448 S. Canon Dr. (B.H.)CRestview 1-5246

Somlyo, E. T.
214 N. Canon Dr. (B.H.)CRestview 6-2041

Stempel-Olenick Agcy.
717 N. La Cienega Blvd. (46)CRestview 1-7141

Wadsworth, J. B.
9172 Sunset Blvd.CRestview 6-0698

Winkler, Daniel M.
9606 Santa Monica Blvd. (B.H.)CRestview 1-7244

CHICAGO

Alexandrov, Norman, Artists' Bureau
410 S. Michigan Ave.WAbash 2-6761

Associated Booking Corp.
203 North Wabash.CEntal 6-9451

Benn Theatrical Agency
64 West Randolph St.DEarborn 2-6850

Consolidated Radio Artists of Ill.
32 W. Randolph St.FRanklin 2-8300

General Artists Corp.
8 S. Michigan.STate 2-6288

Harry Greben Enterprises
535 W. Cornelia.Dlversey 8-4900

Gambiner Management Co.
120 S. LaSalle St.STate 2-0248

Charles E. Hogan
203 North Wabash.CEntal 6-2032

Twet Hogan
203 North Wabash.ANdover 3-6910

Jack & Jill Players Radio Artists Co.
180 E. Delaware St.WWhitehall 4-5100

Lear, Les Productions Corp.
112 W. Randolph.FRanklin 2-7840.
Randolph 6-0905, WAbash 2-1172

Levin, W. Biggie
612 N. Michigan Ave.SUPERior 7-0506

Paul Marr Theatrical Agency
203 North Wabash.DEarborn 2-7416

McConkey Artists Corporation
Congress Hotel.HArrison 7-9660

Morris, William, Agency Inc.
919 N. Michigan.WWhitehall 3-1744

Morse, Sidney P.
203 N. Wabash Ave.RANDolph 6-5495

Mnsic Corporation of America
430 N. Michigan Ave.DELaware 7-1100

Mutual Entertainment Agency, Inc.
203 North Wabash.RANDolph 6-6990

National Concert & Artists Corp.
105 W. Adams St.DEarborn 2-5813

Page, Sidney J.
203 North Wabash.STate 2-7344

Radio Talent, Inc.
35 E. Wacker.FRanklin 2-4351

Schuster, Milton
127 North Dearborn St.DEarborn 2-2580

WLS Artists Bureau
1230 W. Washington Blvd.MOnroe 6-9700

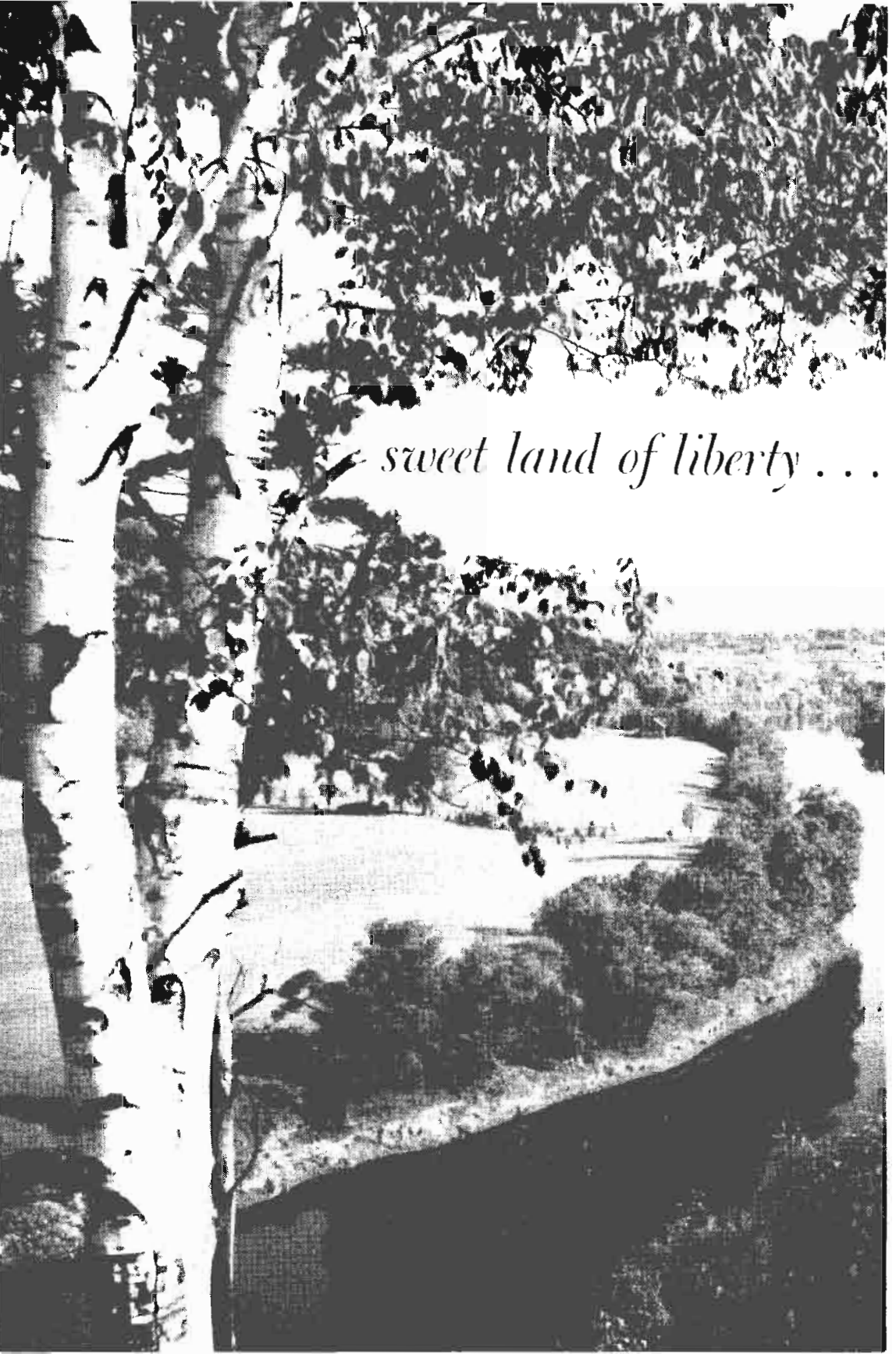
A black and white photograph of a landscape. In the foreground on the left, a tree trunk with peeling bark is visible. The background shows a field with a path or road winding through it, surrounded by trees and bushes. The overall scene is bright and somewhat overexposed.

sweet land of liberty . . .

Just as our mighty land is made up of varying scenes . . . rolling plains, winding rivers, snow-capped mountains . . . so Storer audiences are composed of varying elements . . . differing in income, needs, habits, interests. Storer stations plan their programming with these differences in mind.



STORER BROADCASTING COMPANY

WSPD-TV Toledo, Ohio	WJBK-TV Detroit, Mich.	WAGA-TV Atlanta, Ga.	KGBS-TV San Antonio, Texas	WBRC-TV Birmingham, Ala.		
WSPD Toledo, Ohio	WJBK Detroit, Mich.	WAGA Atlanta, Ga.	KGBS San Antonio, Texas	WBRC Birmingham, Ala.	WWVA Wheeling, W. Va.	WGBS Miami, Fla.

NATIONAL SALES HEADQUARTERS:

TOM HARKER, V. P., National Sales Director

BOB WOOD, Midwest National Sales Mgr.

118 East 57 Street, New York 22, ELdorado 5-7690 • 230 N. Michigan Ave., Chicago 1, FRanklin 2-6498

There's No Problem in New England...

Go Yankee! Go Home Town!

Everything You Need: Complete N.E. Coverage, Greatest Spot Flexibility

★ ★ ★ ★ ★ ★ ★

WNAC-TV

BOSTON : CHANNEL 7

316,000 WATTS

WNAC

BOSTON . LAWRENCE

50,000 WATTS ★ 680 ON THE DIAL

Plus 28

Home Town Radio Stations

OF

THE YANKEE NETWORK

AND THE

MUTUAL BROADCASTING SYSTEM

Plus MANY OUTSTANDING PROGRAMS

INCLUDING

**YANKEE HOME TOWN
FOOD SHOW**

Greater Network Coverage
than any other

New England Food Show

Monday thru Friday 1:15 - 1:45 P.M.

★
★
★
★
★

**YANKEE NETWORK
NEWS SERVICE**

New England's Oldest and Largest
Independent Radio News Service

8 A.M.	9 A.M.	10 A.M.
1 P.M.	6 P.M.	11 P.M.

Plus Promotional and Merchandising Aids

Ask the Man from **H-R** REPRESENTATIVES, INC.

THE YANKEE NETWORK

DIVISION OF GENERAL TELERADIO, INC.

21 BROOKLINE AVENUE, BOSTON 15, MASS.

N*etworks*

- **RADIO**

- **NATIONAL**

- **REGIONAL**



© TLR, INC.

The Producers of

THE LONE RANGER

Radio & Television Programs

on Radio Continuously Since 1933
on Television Since 1949
Sponsored by General Mills (40 States) &
American Bakeries (8 Southeastern States).

Now Have Available

Two Smash Hit Shows with a
Combined Juvenile & Adult Appeal
with Time-Tested Elements of
Merchandising & Promotional Features



© SPOTY, INC.™

SERGEANT PRESTON of the YUKON

AND HIS WONDER DOG **YUKON KING**

For Television Sponsorship

Pilot Film, Black & White or Color,
Available for Screening

Radio Program Broadcast Since 1939
Sponsored by Quaker Oats Co.



© TGH, INC.

THE GREEN HORNET

For Radio & Television Sponsorship

Pilot Film, Black & White or Color,
Available for Screening

Radio Program Broadcast Since 1936

For Complete Details Write — **H. Allen Campbell**

TRENDLE-CAMPBELL-MEURER, INC.

28 W. Adams Ave. — Detroit 26, Michigan — Woodward 2-9184

OR CALL **Frank T. Mincolla** — Asst. to H. Allen Campbell

c/o **Paul H. Raymer, Inc.**, 444 Madison Ave., N. Y. — PLaza 9-5570



Decline in Reign of Ratings Forecast by ABC President

By ROBERT E. KINTNER

*President
American Broadcasting Company*

THE reign of the great king of broadcast advertising—Rating—may be over. He may be dethroned in 1954 by a new monarch of the advertising world who's symbol will be sales—audience cost per thousand.

Those who keep an eye on the nation's economic weather vane predict it could happen in 1954. Here are the economic weather signals already flying: there will be a 10 per cent reduction in personal income taxes in 1954 and, in many cases industrial inventories are at high levels.

Industry looking both at its inventories and at the 10 per cent increase in take-home pay in the hands of the public will be seeking to improve its share of the anticipated increased consumer buying.

This means that advertising will face a severe test in 1954. It can no longer bask in the comfort of spending "tax dollars." Advertising will have to generate peak sales impetus. This will mean that the rating will become second in importance to whether the advertising sells the sponsor's product.

There are many examples of low rated programs paying off for advertisers on a cost per thousand basis coupled with a demonstrated ability to move goods.

I believe that 1954 will bring a widespread search for more of this type programming in radio and television.

In line with this changed emphasis will be a study on the costs of programming to reappraise the advertising values of some of the more costly programs. Where this could lead, of course, is anyone's guess. If advertisers determined they wanted greater exposure for their dollars one avenue would be in more rotating sponsorship of programs. This would be one way in which they could steady their costs and yet spread their dollars and messages to reach a larger audience.

Within our own industry—radio and television broadcasting—I am certain the competition for the audience will be

greater. This I know to be a certainty since my own company, the American Broadcasting Company, has materially strengthened its position both with the audience and the advertiser as a result of our new programming during the final quarter of 1953.

In 1954 we plan to improve our audience position further with more important radio and television programming. In radio, we opened 1954 with the important "Martin Block Show" going out to the afternoon audience over the ABC Radio Network. In February we plan to bring early morning radio's most popular network program, ABC's "Breakfast Club," to the television audience as a simulcast. Beyond this we have further plans for adding to our talent roster with important program and star additions.

Thus, in girding for 1954—a year in which industrial competition will be at its peak, ABC has strengthened its position within the industry in 1953 and has further plans for scaling greater competitive peaks in the year ahead.

Aware of this new era of competition, ABC entered 1954 with completely separate advertising, promotion, sales, programming and research staffs.

This separation within ABC we feel will impart the creative drive and energy so necessary on an individual basis to sell radio and sell television in 1954. From the inventiveness of personnel solely devoted to each medium on a separate basis will come competitive thinking that will meet the tests of what we believe will be newly designed advertising objectives.

In summary, these objectives I feel will tie advertising costs directly to consumer sales during an era of increased consumer income when all industry will be striving to increase, or at least hold, its share of the market.

Viewed in this light, one thing seems certain for radio and television in 1954: sponsors will be more interested in sales than in ratings.

AMERICAN BROADCAST



A M E R I C A N BROADCASTING COMPANY, INC.

(A Division of American Broadcasting-Paramount Theaters, Inc.)

7 West 66th Street, New York 23, N. Y.
(Telephone Number: SUsquebanna 7-5000)

AB-PT Board of Directors

Earl E. Anderson	Robert L. Huffines, Jr.
John Balaban	William T. Kilborn
A. H. Blank	Robert E. Kintner
John A. Coleman	Walter P. Marshall
Charles T. Fisher, Jr.	Edward J. Noble
E. Chester Gersten	Robert H. O'Brien
Leonard H. Goldenson	Herbert Schwartz
Walter W. Gross	R. B. Wilby
Robert H. Hinckley	Owen D. Young

American Broadcasting Company (A Division of AB-PT) Officers

Robert E. Kintner	President
Robert H. O'Brien	Executive Vice-President
Earl E. Anderson	Vice-President
Charles T. Ayres	Vice-President
Slocum Chapin	Vice-President
James H. Connolly	Vice-President
John Daly	Vice-President
Robert H. Hinckley	Vice-President
Earl Hudson	Vice-President
Ernest Lee Jahncke, Jr.	Vice-President
Frank Marx	Vice-President
John Mitchell	Vice-President
Harold L. Morgan, Jr.	Vice-President and Comptroller
Theodore I. Oberfelder	Vice-President
George T. Shupert	Vice-President
Alexander Stronach, Jr.	Vice-President
Charles Underhill	Vice-President
Thomas Velotta	Vice-President
Robert M. Weitman	Vice-President
Paul Whiteman	Vice-President
Geraldine B. Zorbaugh	Secretary
Omar Elder	Ass't Secretary, Ass't Gen. Counsel

New York
30 Rockefeller Plaza
New York 20, New York

Charles T. Ayres... Vice-President in charge of
Radio Network

Engineering & General Services

Frank Marx	Vice-President in Charge
John Bourcier	Operations Supr.
Thomas F. Foy	Purchasing Agent
Richard Hamilton	Supr. of Communications

Clure Owen	Administrative Assistant
John Preston	Director of Engineering Facilities & General Services
Lawrence Ruddell	Recording Director
Joseph J. Spagnola	Office & Studio Services Director
William Trevarthen	Director of Engineering Operations
Reginald Willcocks	Traffic Manager

Finance, Personnel

Walter C. Tepper	Chief Accountant
Jason Rabinowitz	Ass't Comptroller
Marie McWilliams	Director of Personnel

Legal

Geraldine B. Zorbaugh	Secretary & General Attorney
Omar Elder	Ass't Gen. Counsel & Assistant Secretary

Labor Relations

Mortimer Weinbach	Director of Labor Relations
-------------------	-----------------------------

News & Special Events

Thomas Velotta	Vice-President in Charge
Donald Coe	Director of News & Special Events

Program

Robert M. Weitman	Vice-President in Charge of Programming and Talent
Raymond Diaz	National Program Director
Walter A. Gustafson	Supervisor of Sound Effects
William Hamilton	Eastern Program Manager
Helen Hedeman	Supervisor of Casting
Anne Kelly	Announcing Office Manager
J. Ward Mitchell	Manager of Script & Program Promotion
George Sax	Nat'l Dir. of Program Operations
Ruth B. Smith	Spvsr. of Prod. Control Unit
Clayton Shields	Business Manager
Myrtle Tower	WABC Program Director
Frank Vagnoni	Manager of Music Division

Public Relations, Advertising & Promotion, and Continuity Acceptance

John Pacey	Director of Public Relations & Special Features
------------	--

Ruth Crawford Librarian
 Eugene Accas.....Dir. of Net. Sales Promotion
 Ernest E. Stern.....Manager of Publicity
 Ellen Heagerty.....Supervisor of Audience Information
 Dean Shaffner.....Director of Research
 Grace Johnsen.....Director of Continuity Acceptance
 Ruth Trexler.....Executive Producer of Religious and Education Programs

Sales

Norman Cash.....Assistant Sales Manager
 William Fairbanks.....Eastern Sales Manager
 George Huelser.....Sales Service Manager

Station Relations, Operations for Sales & Station Traffic, Research & Sales Development

Ernest Lee Jahncke, Jr....Vice-Pres. & Assistant to the President
 C. Goodwin.....Sta. Rel. Planning
 Frank Atkinson.....Manager of Co-operative Program Sales
 Stewart Barthelme.....Manager of Station Clearance
 Alfred Beckman.....National Director of Station Relations Department
 Donald Buck.....Director of Operations for Sales and Station Traffic
 Alice Stamatis.....Manager of Order Processing
 Oliver Treyz.....Director of the Radio Network
 William A. Wylie.....Manager of Station Relations Department

**Central Division
 20 North Wacker Drive
 Chicago 8, Illinois**

Art Haare.....Manager of WENR
 William P. Kusack.....Dir. of Engineering WBKB-WENR
 Sterling C. Quinlan.....General Manager of WBKB-WENR
 Elliot Henry, Jr.....Dir. of Publicity Promotion
 Matthew Vieracker.....Treasurer
 W. Donald Roberts.....Director of Network for Central Division

**Hollywood
 1539 North Vine Street
 Hollywood 28, California**

Earl Hudson.....Vice-President in Charge of Western Division
 J. Clifford Anderson.....Program Business Mgr.
 Dorothy L. Brown.....Continuity Acceptance Editor, Western Division
 Philip G. Caldwell.....Manager, Engineering & General Services, Western Division
 Francis Conrad.....Director of Radio, Western Div.
 Sam Zelman.....News Editor, Western Division
 Dresser Dahlstead.....Program Manager, Western Division
 Ralph Denechaud.....Engineering Operations Supr.

Florence T. Schiro.....Personnel Director
 John C. Wagner.....Controller, Western Division

**San Francisco
 420 Taylor Street
 San Francisco 2, California**

Andrew E. Akamian.....Merchandising Manager
 James Connolly.....Vice-President in Charge
 A. E. Evans.....Business Manager
 Edith Kirby.....Traffic Manager
 Victor Reed.....Manager of News & Special Events
 William Grandey.....Program Director—Radio
 Henry A. Saroyan.....Auditor
 Harry Jacobs.....Chief Engineer
 Lorraine Duchene.....Continuity Acceptance Editor
 Paul Scheiner.....Manager of KGO
 William E. Williams.....Manager of Publicity, Advertising & Promotion

Owned Radio Stations

Theodore I. Oberfelder.....Vice-President in Charge of Owned Radio Stations
 William Materne.....National Sales Manager, Owned Radio Stations

New York

Theodore I. Oberfelder.....Gen. Manager of WABC
 Michael Renault.....Commercial Manager of WABC

Hollywood

Amos Baron.....Station Manager and National Sales Manager of the Western Division
 Jon Wells Barkhurst.....Director of Radio Promotion-Publicity Department
 Matthew Barr.....Sales Manager of KABC

San Francisco

John Hansen.....Sales Manager of KGO

**Detroit
 (WXYZ, Inc.)**

Harold Christian.....Radio Commercial Manager
 Station Representatives for WABC, KABC & KGO
 Edward Petry & Company
 488 Madison Avenue
 New York 22, N. Y.
 Station Representatives for WENR & WXYZ
 John Blair & Company
 150 East 43rd Street
 New York 17, N. Y.

Radio Stations Advisory Committee

Roger W. Clipp, WFIL, Philadelphia, Pa.
 J. P. Williams, WING, Dayton, Ohio.
 Verl Bratton, WKTY, La Crosse, Wisconsin.
 T. B. Lanford, KRMD, Shreveport, La.
 C. B. Locke, KFDM, Beaumont, Texas
 Frank C. Carman, KUTA, Salt Lake City, Utah.
 J. B. Conley, KEX, Portland, Oregon
 A. D. Willard, WGAC, Augusta, Georgia

For television personnel turn to TELEVISION YEAR BOOK in this volume

From **AMPEX**
the best answers to broadcast recording



YESTERDAY

Transcriptions so "live" they defied detection — this ideal became a reality when Ampex introduced the Model 200. Within months of their introduction, AMPEX Tape Recorders had been installed by a major network throughout its facilities from coast to coast and others were following fast.

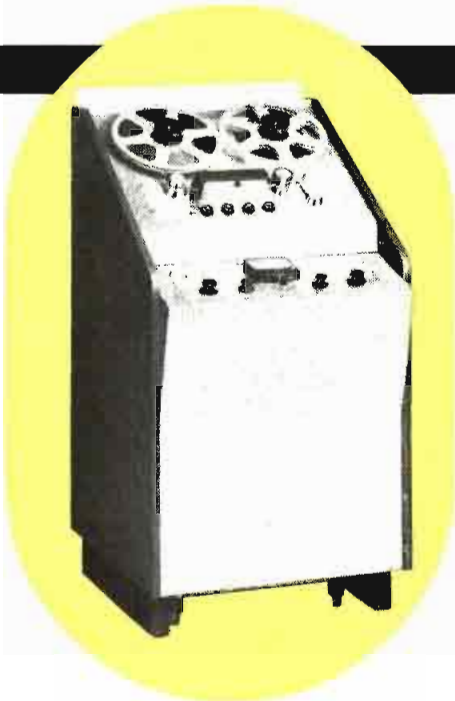

TODAY

Ampex has brought the cost of ultra high fidelity tape recorders down to a quarter of the cost of the original Model 200. The low maintenance cost, durability and fidelity of the AMPEX has made it the established standard of the broadcast industry — yet its superlative performance is within reach of every station from 50,000 watts to 250 watts.

TOMORROW

The AMPEX you buy today will still be giving unsurpassed fidelity and performance, and Ampex will still be setting the pace for the recording industry.

AMPEX

CORPORATION

AMPEX CORPORATION
934 Charter Street • Redwood City, Calif.

For your recording requirements, your best answers today or tomorrow will come from the leader in the tape recording field. If you plan for tomorrow, buy AMPEX today.



Growth of Radio Audience Indicates Medium's Vitality

By ADRIAN MURPHY

President
CBS Radio

DURING 1953 the American public purchased 13 million new radio sets, which not only kept radio out front as the nation's favorite medium, but, in terms of new units added, made it the fastest-growing. Today, U. S. families (over 98 per cent) own an estimated 115 million sets—114 million of them bought new since 1946. Directly supporting this testimony to radio's continuing prosperity and vitality are the 1953 figures for advertising revenue, which overall (network, national spot, and local) exceeded the 1952 total.

More time was sold on the CBS Radio Network in 1953 than during the previous year. The number of clients using the network increased from 90 to 93. As result CBS Radio has the good fortune to enjoy a greater lead in billings than ever before. The reported prosperity across the country of radio stations generally is borne out by the experience of the six radio stations wholly owned by CBS Radio, whose billings too were up over the previous year.

Recently, eleven of the nation's large radio stations joined forces to commission a joint study by Alfred Politz, Inc., in television markets. One of its findings gave a graphic answer to why radio continues to play such a vital role in the nation's life: when asked what they considered the *disadvantages* of radio, 71 per cent of the people interviewed couldn't think of any! As the survey noted, "People actively *like* the medium that is so much their *companion* in fun and information." If people like the companionship radio offers today, they can look forward to even greater companionship tomorrow. 1953 introduced the first truly personal portable radio, a set so small the listener can take it in his pocket wherever he goes.

What gives radio such continuing vitality? One cause is the nature of the medium. It is human and personal: in its simplest form, the voice of one per-

son sharing an experience with, or informing another. And the capacity of the human voice on radio to involve the listener's emotions is powerful. Even so relatively sophisticated a radio fan as Mercedes McCambridge—whose years of experience in serial dramas contributed to her Academy Award for "All the King's Men"—reports that she still finds *listening* to serial drama a compelling emotional experience.

In the past year, radio strengthened its vitality by creative programming efforts. CBS Radio unveiled "Stage Struck," the hour-length program that looks into every corner of the world of the theatre. "21st Precinct," "Crime Classics," "Cathy and Elliott Lewis On-stage," all top-notch dramatic programs. In variety and comedy, "The Johnny Mercer Show," "The Robert Q. Lewis Show," and "That's Rich."

In the field of news and public affairs CBS Radio reported the Coronation, President Eisenhower's Inauguration, the Korean Truce and Prisoner Exchange, and the Bermuda Conference.

In the area of documentary journalism, CBS Radio's Feature Project series presented eight programs which considered social problems as diverse as parole traffic safety, and baseball. And such week-to-week network features as "U.N. on the Record," "Twentieth Century Concert Hall," and the Columbia University Bicentennial series, "Man's Right to Knowledge" brought enlightenment to people everywhere.

1953 saw the record sum of \$170 billion dollars spent by American consumers for the retail goods they want and need to maintain, as somebody said, "their neighbor's standard of living." And by and large, it is advertising which passes along the news of the standards next-door.

Since only advertising can move so many goods to so many people, radio must continue to flourish as the most efficient mass medium.

CBS RADIO

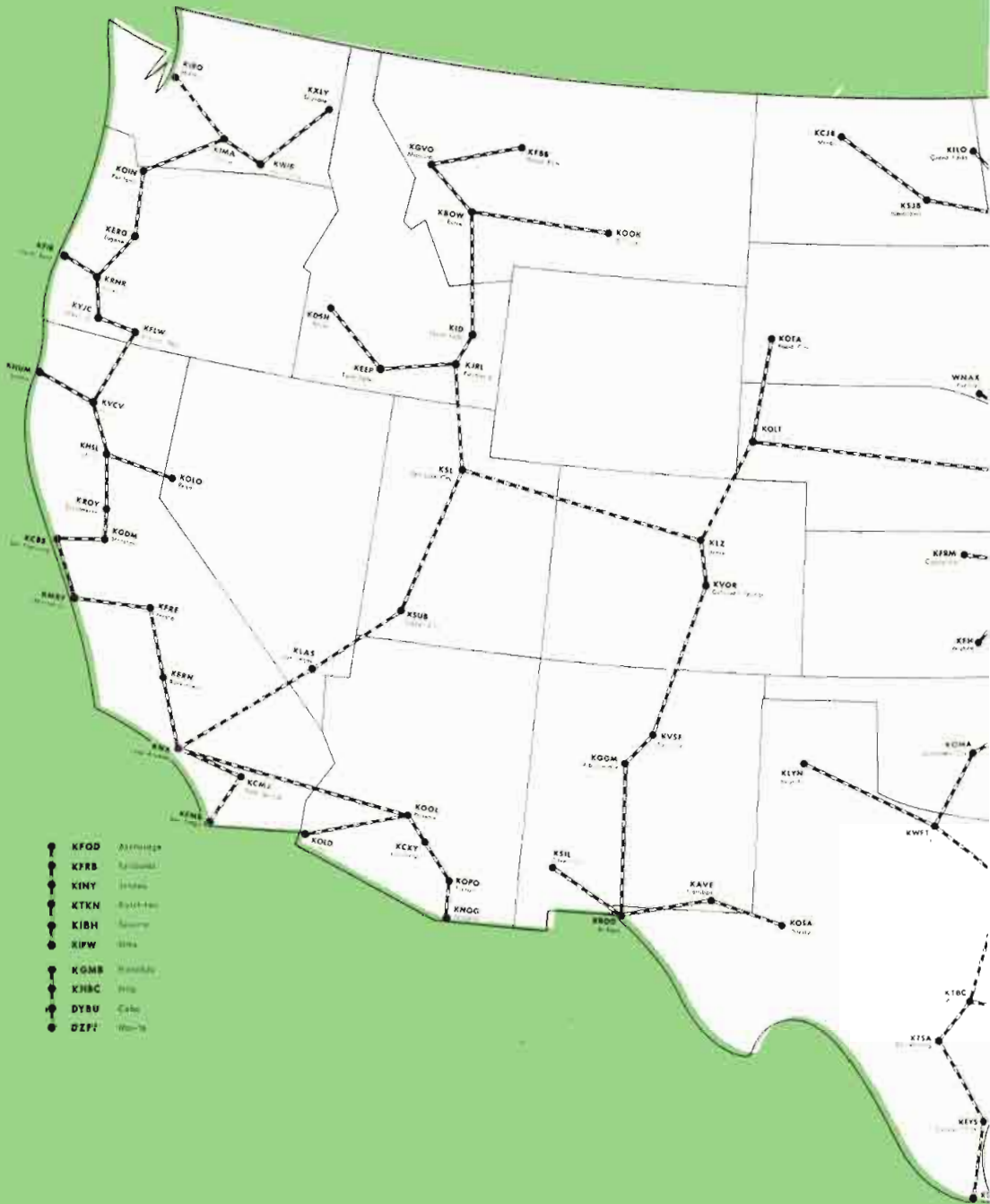

CBS, INC.

CBS RADIO DIVISION

Executives and Staff

485 Madison Avenue, New York 22, N. Y.

Telephone: PLaza 1-2345

Registered Telegraphic Address—COLUMBIA NEW YORK

BOARD OF DIRECTORS CBS, INC.

William S. Paley, Chmn.	James B. Conkling
Leon Levy	Bruce A. Coffin
Samuel Paley	Lloyd H. Coffin
J. A. W. Iglehart	David H. Cogan
Dorsey Richardson	Adrian Murphy
Ralph F. Colin	J. L. Van Volkenburg
Frank Stanton	Robert A. Lovett
Edward R. Murrow	Charles F. Stromeyer

OFFICERS

William S. Paley	Chairman of the Board
Frank Stanton	President
James B. Conkling	Vice President
Earl H. Gammons	Vice President
William C. Gittinger	Vice President
Peter C. Goldmark	Vice President
Lawrence W. Lowman	Vice President
Howard S. Meighan	Vice President
Seymour Mintz	Vice President
Adrian Murphy	Vice President
Daniel T. O'Shea	Vice President
Richard S. Salant	Vice President
Charles F. Stromeyer	Vice President
J. L. Van Volkenburg	Vice President
Julius F. Brauner	Secretary
Samuel R. Dean	Treasurer
Arthur S. Padgett	General Auditor
Herbert C. Hamilton	Assistant Secretary
Milton Neaman	Assistant Secretary
Richard W. Jencks	Assistant Secretary

CBS RADIO DIVISION OFFICERS

Adrian Murphy	President
James M. Seward	Administrative Vice President
J. Kelly Smith	Administrative Vice President

William A. Schudt, Jr.	Vice President in Charge of Station Relations
H. Leslie Aftass	Vice President in Charge of Central Division
Guy della Cioppa	Vice President in Charge of Network Programs, Hollywood
Charles L. Glett	Vice President in Charge of Network Services, Hollywood
Lester Gottlieb	Vice President in Charge of Network Programs
Arthur Hull Hayes	Vice President in Charge of San Francisco Office
John J. Karol	Vice President in Charge of Network Sales

Accounting

Merle S. Wick	Comptroller
Claude Boydston	Director of Accounting

Business Affairs, Network Programs

Henry Howard	Director, Business Affairs
Kenneth Craig	Director, Business Affairs, Hollywood
Anne Nelson	Associate Director, Business Affairs, Hollywood
W. C. Harrington	Manager, Music Copyright Division

Editing

Don Ball	Director
----------	----------

General Engineering Department

A. B. Chamberlain	Chief Engineer
H. A. Chinn	Chief Audio Engineer
J. W. Wright	Chief Radio Engineer

Legal

Robert Dunne.....Senior Attorney

Network Programs

Lester Gottlieb...Vice Pres. Network Programs
Gerald Maulsby...Mgr. of Network Broadcasts
Norman Frank.....Program Supervisor
James Fassett.....Director of Serious Music
Charles S. Monroe...Manager, Program Writing

Network Sales

John Karol.....Vice President in Charge of
Network Sales
Eldon Hazard.....Sales Manager
Dudley Faust.....Eastern Sales Manager
Gilson Gray.....Administrative Manager
E. E. Hall.....Sales Service Manager

Pacific Coast Office

Bob Reitzel.....Sales Manager

Chicago Office, 410 Michigan Avenue

Roger K. Huston.....Manager

Detroit Office, Fisher Bldg.

Ben Lochridge.....Manager

News

Wells Church.....Director of News
Helen J. Sioussat.....Director of Talks
Red Barber.....Counselor on Sports
John Derr.....Director of Sports
George Crothers...Dir. of Religious Broadcasts
Theodore Koop.....Director of News and
Public Affairs, Washington
Robert Skedgell...Director of Special Events
Lewis Shollenberger.....Director of Special
Events, Washington

Public Affairs

Stuart Novins.....Director of Public Affairs

Operations

Horace Guilloite.....Director of Operations
James Siirmons...Manager of Network Operations
Davidson Vorhies...Manager, Technical Operations
and Chief Engineer, WCBS
Hugh Cowham.....Traffic Manager
Julius Mattfeld...Director of Music Library
Lucile Singleton...Manager of Record and
Script Library

Press Information

George Crandall...Dir. of Press Information
Irving Fein.....Director of Public Relations,
Hollywood
Lloyd Brownfield...Director of
Press Information, Hollywood

Sidney Garfield.....Director of Exploitation
Michael Boscia.....Executive Assistant
Edwards Reynolds...Manager, Press Information
Harry J. Feeney.....Assistant to the Director
of Press Information and Trade News Editor
Anne Harding.....Manager, Service Division
Raymond Hughes...Manager, Magazine Division

CBS Radio Spot Sales

Henry Flynn.....General Sales Manager
Milton Allison.....Eastern Sales Manager
George Castleman...Manager, Sales Development
Richard Hess.....Research Manager
Sherrill Taylor.....Promotion Manager

Chicago Office 410 North Michigan Avenue

Gordon F. Hayes.....Western Sales Manager

Memphis Office, 63 S. Main Street

David Kittrell.....Sales Manager

Detroit Office, Fisher Bldg.

Ralph Patt.....Sales Manager

Los Angeles Office, Columbia Square

George E. Hurst.....Sales Manager

San Francisco Office, Palace Hotel

Al Donahue.....Sales Manager

Research

Harper Carraine.....Director of Research
Edward Reeve.....Sales and Promotion
Manager
Howard Miller.....Manager, Coverage and
Marketing Research
Gerhart Wiebe.....Research Psychologist

Sales Promotion and Advertising

George Bristol.....Director
Charles Oppenheim...Administrative Manager
Louis Dorfsman.....Associate Director
Murry Salberg.....Program Promotion Manager
Thomas Means.....Director, Promotion Service,
CBS-Owned Stations
Frank Nesbitt.....Director, Network Sales
Presentations
William Jayme.....Director, Network Copy
Irving Miller.....Director, Art Service, CBS-
Owned Station Promotion
Joseph Tole.....Production Manager
Edward Kaylen.....Sales Analysis and Special
Reports

Station Administration

Wendell R. Campbell...Vice President in Charge

Station Relations

William A. Schudt, Jr. Vice President in Charge of Station Relations
Edward DeGray Director
Ole Morby Western Division Manager, Columbia Square, Los Angeles 28

CBS, Inc., Broadcast Service Departments Building Operations and Ticket Division

James Swenson Manager of Building Operations
Jack Page Asst. Mgr. of Building Operations
Laurette Banks Supervisor of Ticket Division

General Purchasing

John E. Forsander Director of Purchases
Edward Drewes Purchasing Agent

Office Services Department

A. H. Bryant Manager
Maude Stubner Supr. of Program Typing
Emily Schiener Supr. of Program Transcripts

Personnel Relations

Robert Kalaidjian Director
Dr. Jack Nelson Director of Medical Office
Charles Burt Personnel Administrator
John Anderson Personnel and Labor Research Manager
Richard Stanley Employment Manager

Photographic

Walter I. Siegal Manager

Reference

William C. Ackerman Director
May Dowell Manager, General Information Division
Agnes Law Librarian
Esther Dobbins Manager, Program Information Division
Dorothy Boyle Manager, Program Statistics Division

CBS-OWNED STATIONS WCBS and WCBS-FM

485 Madison Avenue, New York 22

Carl Ward General Manager
Henry Untermeyer Sales Manager

Sam Slate Program Manager
Don Foley Promotion Manager
Milton Rich Manager, Press Relations

KCBS and KCBS-FM Palace Hotel, San Francisco 5

Arthur Hull Hayes Vice President in Charge San Francisco Office, General Manager of KCBS and KCBS-FM
Jules Dundes Sales Manager
Pede Worth Program Manager
Evelyn Clark Promotion Manager

KMOX, 401 S. Twelfth Boulevard St. Louis 2

Eugene Wilkey General Manager
Robert Hyland Sales Manager
Mark Russell Program Manager
Foster Brown Promotion Manager

KNX and KNX-FM and Columbia Pacific Network 6121 Sunset Boulevard Los Angeles 28

William Shaw General Manager
Bert West Assistant General Manager and Sales Manager
Robert Sutton Program Manager
James Frost Promotion Manager

WBBM and WBBM-FM 410 N. Michigan Avenue, Chicago 11

H. Leslie Atlass Vice President in Charge of Central Division, General Manager of WBBM
E. H. Shomo Assistant General Manager
William Miller Sales Manager
Thomas A. Bland Program Manager
C. W. Doebler Promotion Manager

WEET and WEET-FM 182 Tremont Street, Boston 12

Harvey Struthers General Manager
Emmett J. Heerdt, Jr. Sales Manager
Eugene King Program Manager
Jack Curry Promotion Manager

HOUSEWIFE'S PROTECTIVE LEAGUE PRODUCTIONS

Edward W. Wood, Jr. General Sales Manager and General Manager, HPL Prog. Services, Inc.

For television personnel turn to TELEVISION YEAR BOOK in this volume



Vitality of Web Radio Ends Obituary Disputes



By THOMAS F. O'NEIL
President
Mutual Broadcasting System

IN any field, the invitation to weigh a new year's outlook against a past year's progress is a dubious honor. In the broadcasting business, this invitation has too often become a summons to membership in the Guild of Clouded Crystal Ball Gazers, a club already overcrowded with prophets of the death of radio. As one who never could detect any signs of rigor mortis in network radio, I am particularly gratified by the great vitality this medium has shown in 1953 — ending (forever, I hope) all need for obituary dispute, and enabling all of us to focus our efforts on the lively future of sound broadcasting.

Even a casual review of the past year reveals several sure symptoms of radio's liveliness. Some of these signs indicate the depth to which radio continues — and increases — to be indispensable to the American people in their round-the-clock living. Other signs make clear the scope to which radio continues — and increases — to serve American industry in its round-the-year selling.

On its bare, over-all dimensions alone, radio set new records in '53. The ownership and maintenance of 110,000,000 receivers by 45,000,000 U. S. families is a landmark in itself. So, too, is the emergence of the medium as an unprecedented *personal* force, through continued uptrends in multiple sets in multiple places-to-listen. And so is the development of America's automobile audience, enormous in mass and mobility, though still inadequately measured.

Radio '54 needs none of these facts of life elaborated in such space as this—but it needs all these facts and more made clear to the leaders of industry, week after week. A shining beacon in this direction was lighted last year by the Politz study of radio in TV areas, with its *qualitative* revelations of listening. In my opinion, this study provides not only an authoritative appraisal of the individuals-in-mass millions whom radio must serve — it also offers a challenging cue

to the sort of market research that will best educate the industrialists whom radio must sell. The "how many" factor of this medium is still an unmatched asset, but the "how" and "why" factors are worthier study subjects today than ever.

Meanwhile, the facts already at hand keep right on affirming the persistent vitality of radio. On one network, anyway, the standard research systems reveal *increased* listening — even at night, and even in time periods when TV has its peak appeal. Over here at Mutual, Sunday afternoon of course continues as a high-level stronghold for radio. But we're also showing listener strength in the evenings, with nearly one-fifth *more* homes tuned in, 8-8:30 p.m., Monday through Friday, than a year ago.

On the record for this one network alone, improved programming, sensibly integrated with the public's entertainment interest, seems to point the way to still more effective broadcasting, day and night. It is this policy which we plan to pursue in the months and years ahead.

As for the fiscal, bodily health of radio at this juncture, the temperature-chart of our own network is better than reassuring. When clients increase their annual investments here by a solid 10 per cent ('53 over '52), when they add to their use of our facilities by an average of 19 per cent more stations per broadcast, and when the over-all result is the second biggest year in our history — then my personal beliefs about network broadcasting seem to be shared by an important panel of judges.

A year ago, on this page, I acknowledged television's contribution to radio in the degree to which advertisers who had never before ventured off the printed page were coming into radio via experiments in TV. During the past 12 months, more new-to-radio advertisers than ever before have discovered — for one reason or another — how well this medium can work for them.

MUTUAL BROADCASTING SYSTEM

Executives and Staff

1440 Broadway, New York 18, N. Y.
Phone, LONgacre 4-8000

Executive Personnel

Board of Directors

Thomas F. O'Neil Chairman
 Elbert M. Antrim WHN, Chicago, Vice-Chmn.
 James E. Wallen MBS, New York, Sec'y-Treas.
 Willet H. Brown Don Lee Network, Hollywood
 H. K. Carpenter WHK, Cleveland
 Gordon Gray General Teleradio, Inc.
 (WOR and WOR-TV Division)
 Benedict Gimbel, Jr. WIP, Philadelphia
 Adolf N. Hult MBS, New York
 Ward D. Ingram Don Lee Network, Hollywood
 Earl M. Johnson MBS, New York
 Robert A. Schmid MBS, New York
 Frank Schreiber WGN, Chicago
 J. Glen Taylor General Teleradio, Inc.
 Linus Travers Yankee Network, Boston

Officers

Thomas F. O'Neil President
 J. Glen Taylor Admin. V.P. in chg. of Policy
 James Wallen Admin. V.P. in chg. of Finance
 E. M. Johnson Admin. V.P. in chg. of Prod.,
 Station Relations & Engineering
 Robert A. Schmid Admin. V.P. in chg. of Sales,
 Advertising & Public Relations
 B. J. Hauser V.P. in chg. of Co-op Programs
 Adolf N. Hult V.P. in chg. of Sales
 Herbert Rice V.P. in chg. of Programs
 Julius F. Seebach V.P. in chg. of Pro. Operations
 George Ruppel Treasurer
 Elisha Goldfarb Assistant Secretary
 Gordon Gray V.P. of General Teleradio, Inc.,
 in chg. of the WOR and WOR-TV Division

Other Personnel

James E. Wallen Secretary & Treasurer
 Elisha Goldfarb Legal Counsel

Beatrice M. Marschner Personnel Director
 Adolph Opfinger Labor Negotiations
 Gaile Dody Supervisor, Central Steno
 Margaret Lanigan Supervisor, File & Reception
 Audrey Zelner Supervisor, Listeners Service
 Ruth Hendler Manager, Mail & Purchasing
 Augusta Hall Telephone Supervisor
 Margaret Riordan Supervisor, Wire
 Communications

Legal Counsel

Keith Masters, Andrew C. Hamilton, Percy H.
 Russel, Jr. of Kirkland, Fleming, Green,
 Martin & Ellis, Washington, D. C. & Chicago
 Emanuel Dannett of McGoldrick, Winn,
 Dannett & Horowitz, N. Y.
 Elisha Goldfarb MBS, New York

Programs

Herbert Rice V.P. in chg. of Programs
 Julius F. Seebach V.P. in chg. of Prog. Operations
 B. J. Hauser V.P. in chg. of Co-op Programs
 Harold Wagner Manager of Program Operations
 Dorothy Kemble Dir. of Radio and TV Clearance
 Emerson Buckley Associate Music Director
 John Boguc Music Librarian
 Nathan Abramson Mgr. of Entertainment Bureau
 Milton Burgh Director of News
 Arthur Feldman Director of Special Events
 Paul Jonas Director of Sports
 George Brown Manager of News Operations

Station Relations and Engineering

Earl M. Johnson V.P. in chg. of Station Relations
 & Engineering
 Robert Carpenter Director of Station Relations
 Robert Kennett Station Contact Representative

Jean Engel.....Supervisor of Station Information
 Roy Danish...Director of Commercial Operations
 Alma Graef.....Manager of Sales Service
 T. E. Danley.....Manager of Sales Traffic
 Sara Joseph.....Supervisor of Contracts
 John Hayes.....Office Manager—Recording
 Chester Cheek.....Sales Manager—Recording
 Leslie Learned.....Chief of Engineering Traffic
 Charles Singer.....Chief Engineer
 Robert O'Connor.....Chief Plans & Allocations
 Engineer

**Advertising Press Information
 and Research**

Robert A. Schmid.....V.P. in chg. of Advertising,
 Public Relations & Research
 James Tyler.....Director of Advertising
 F. Carleton McVarish.....Director of Audience
 Promotion & Merchandising
 Richard Puff...Director of Research & Planning
 Francis X. Zuzulo...Director of Press Information
 Arnold Roston.....Art Director
 Nathan Sakolsky.....Production Manager
 Henry Poster.....Manager of Planning
 Walter Stein.....Manager of Research
 R. Jackson Foster.....Mgr. of Art Presentations

Sales

Adolf N. Hult.....Vice President
 John Overall.....Eastern Sales Manager
 Sidney Allen.....Administrative Manager—
 Network Sales

Washington

Everett Holles.....Dir. of Washington Operations

Chicago

Carroll Marts.....Dir. of Midwest Operations
 Virgil Reiter...Midwest Sales Manager (network)
 Dorothy Reynolds...Midwest Sales Service Manager
 Myrtle Goulet.....Office Mgr. & Prog. Traffic
 George Herro...Promotion and Press Information
 Representative

Hollywood

Rodney Coulson...Press Information Representative

Special Affiliate Advisory Committee

Victor C. Diehm...Chairman, WAZL, Hazelton, Pa.
 Rex Howell.....KFXJ, Grand Junction, Col.,
 Vice Chairman
 Robert McRaney.....WCBI, Columbus, Miss.
 Secretary
 Roy Thompson.....WRTA, Altoona, Pa.
 Carter C. Peterson.....WCCP, Savannah, Ga.
 M. C. Watters.....WCPO, Cincinnati, Ohio
 Don Campbell.....WILD, Birmingham, Ala.
 John M. Walter.....WJPG, Green Bay, Wis.
 Boyd Kelley.....KTRN, Wichita Falls, Texas
 Collin Lowder.....KLO, Ogden, Utah
 Jack Younts.....WEEB, Southern Pines, N. C.
 Hugh Potter.....WOMI, Owensboro, Ky.
 E. J. McKellar.....KVOX, Moorhead, Minn.
 Wendell Mayes.....KBWD, Brownwood, Texas

GENERAL HOLDINGS, INC.

Directors

Willet H. Brown	A. M. Quinn
Edwin F. Chinlund	Robert A. Schmid
Ward D. Ingram	J. F. Seebach, Jr.
Earl M. Johnson	B. W. Smith
Frank W. Knowlton	George W. Steffy
M. O. O'Neil	Jack I. Straus
Thomas F. O'Neil	J. Glen Taylor
W. D. Pabst	H. L. Travers
John B. Poor	James E. Wallen

Officers

Thomas F. O'Neil.....President
 W. D. Ingram.....Vice President
 W. H. Brown.....Vice President
 George W. Steffy.....Vice President
 H. L. Travers.....Vice President
 J. Glen Taylor.....Vice President
 Dwight W. Martin.....Vice President
 Earl M. Johnson.....Vice President
 Robert A. Schmid.....Vice President
 James A. Wallen.....Vice President and
 Treasurer
 Frank W. Knowlton.....Secretary
 John B. Poor.....General Counsel
 Patrick J. Winkler.....General Auditor

Executive Committee

T. F. O'Neil	F. W. Knowlton
J. B. Poor	J. G. Taylor
	M. G. O'Neil

For television personnel look to TELEVISION YEAR BOOK in this volume

COLLINS IS THERE...

WAVU KVSM WROY WIEL WHLB WIRC WLCM WANA WIND WHLN KFMO WHKY KABR W
RFS WSPC WGIL WKIC KWOS WELS KIJV WHMA KSPA WPRC WMBH WFTC KWAT WC
TA WATM KSTN WQUA KRMS WSYD WAPO WJLD KCOK WVLN WINN KSIM WPAQ WOOD
WULA KVEN WHBF WPRT KFEQ WKBC WAGC WWWF KW50 WGBC WIBR KSGM WCEC WIRJ

The call letters of over 700 U.S. broadcast stations reach

WHEP KBOI WBIW KEUN WVMJ WNCA WPLI WFPA KCOL WGBF KVOL WCLD WLPW WK
LF WKIN WJBY WNAB WIKY KAKT WGYM KOVC WNOX WGEA WNHC WWCA KLIC WABG
WADC WIVK WPBB WNLC WBAA KANE WKOZ WCPO WJIM WCOV WATR WBAT WMRY K
TYL WHOC WCOL WSM WNPT WWCO WHOT KRUS KXGN WING WSIX WJHO WGMS WJVA

their listeners through Collins equipment.

KCIJ KGEZ WJER WKDA WAMI WOOK WRSW WHDH KCNI WFIN W5OK WOZK WTAN WT
BC KPIG WBET KMMJ WMOH WDBL WWWR WTTT KCRG WHAI KGFV WMOA KRBC WHBB
WROD KCHA WLYN KELY WPTW KBKI WHTB WJBS WCHE WJDA KENO WWSO KALT W
WWB KCLF WFTL KROS WOCB KRAM KADA KRCT KRUX WARN KSWI WASL WKBR KVSO

Collins engineering and precise manufacturing standards

KEYN KIFN WINZ KSTT WUST WHEB KCRC KTFY KBBA WMBR WOC WCEM WWNH KNOR K
LCN KVAL KELD WLBE KATH WDYK WAAT KOCY KORA KDMS WMMB KLIL W5ID WWBZ
KVLH KDET KFSA WMBM KXIC WKIK KOBE KGFV KSTA KXAR WTMK KRIB WINX KV5F W
FLA KAKC KTAW KWFC WPCF KWPC WGAY WABY KWSH KMCO KCON WWPV KBOE WBBC

give Collins transmitting and speech equipment the extra

WOKO KASH KUNO KENA WTRR KBIZ WDFV WCSS KFJI KRIS KBIS WFOY KFNF WHTC K
BTM WINR KNPT KEYS KAFY WEBK KICD WJMS WGBB KCRO KAND KROP WIRK KWWL
WTCM WGYA WPWA KULP K5JV WGAU KARE KATE WENT WIKK KCLW KXOC WGRA KB
IS KCRB KXRA WHLI LWSH KTXJ KHUM WMOC KXXX KBMW WBUC WPXY KOCA KDAC

measure of reliability so essential to continuous broadcast

WDWD KGNO WKLK WXRA WVPO KSEL KGST WFPW KTSW WEVE WHDL WKOK KRBA WG
MS KBOX WCOH KWBW KGDE WEAV WMBS KMTH KVON WACL KJCK KBZY WYET WHIM
KOSF KROW KEYK KALO WMFG WKAL WWOV KOGT KPPC KPST KSCB KLTF WAGE KFA
C WPAL KFTV KWKW KEEP KLKC WPBC WOLF WCRE KEXX KPRO WOKZ KTOP KOBK WISE

operation. Collins — design leaders in the past, present

WMSC KIWW KGMS WKRO KANS KAAA WCHL WMUJ KITE KGB WCIL WNIR KROC KCR
W WAYS WMRC KCHY KTFS KNAL KTRN KVNU KSVC WCAX WSKI W5YB WWSR WEAM
WDVA WLOW W5AP WPUV WLPW KBKW KWIE KHQ WKOY W6KY WCAW WBLK W5AZ K
FEL WMON WPAR WWYO WBTH WLCX WMNE WMIL WMAW WPDR WIBU WJMC WDSM

and future with the modern concept in AM.

WFHR KOVE KOWB KVR5 KWRL KGOS KWOR WOAY WOSA KIFN WFMO WERH WLON KI
Z WFAH KPHO KXOC KDB KCHR WRRR WPET WJOT WJMW WLMJ WMBR WDBO KRNT
WDAE WGBA WJAT WCNT WEAW KBUR KCRG WEBQ WLBH WMLL WMRI WIMS KVFD W
RSW WOI WSUI KWPC WMCI WSON KRMD WHOP WFMV WPAD WJBO WBZ WHAI KFUD

COLLINS RADIO COMPANY

CEDAR RAPIDS, IOWA

11 W. 42 Street
NEW YORK 36

1930 Hi-Line Drive
DALLAS 2

2700 W. Olive Avenue
BURBANK

Dogwood Road, Fountain City
KNOXVILLE



Advent of Color TV Era Finds Broadcasting Ready

By SYLVESTER L. WEAVER, JR.

President

National Broadcasting Company

THE year of 1954 finds the broadcasting industry in the most exciting and significant era in the history of communications—the era of color television.

Color brings to advertisers their most potent tool. Here is the perfect advertising medium, combining sight, color, sound and movement.

And now color television is a reality. On Dec. 17, 1953, the Federal Communications Commission approved color television signal standards for the industry.

We at NBC have been fortunate because it was our parent company, the Radio Corporation of America, under Brig. Gen. David Sarnoff, which pioneered, the compatible color standards which were endorsed by the whole industry and approved by the FCC. In working with RCA, as its broadcasting service, during years of developmental work, we were able to get off to a head start in the color broadcasting sweepstakes.

This head start was demonstrated most graphically when, in the immediate wake of the FCC decision, NBC broadcast four outstanding commercial programs in color in a period of two weeks. These were: "Amahl and the Night Visitors," the Gian-Carlo Menotti Christmas opera; "Season's Greetings," a one-hour all-star variety show; the Christmas episode of "Dragnet," which marked the first use of color film in commercial colorcasting; and the brilliant Tournament of Roses Parade, which was the first West-to-East transcontinental color transmission.

We at NBC are proud that it is our network which paved the way for commercial color telecasting by developing program techniques that are setting the standards for the entire industry. Even before FCC approval came, these techniques had been demonstrated time and time again during 1953 in experimental colorcasts which drew acclaim in New York, Chicago and Los Angeles.

We have welcomed inquiries from the entire industry on color programming techniques we have developed. Our color

corps specialists have given lectures to technicians and program people representing all the networks. The techniques we have learned are available to all.

Color will give the broadcasting industry an even greater opportunity for service. And a greater responsibility. For, as communications people we are entrusted with the most important instruments since the invention of print.

We have made tremendous strides in color television. But black-and-white television will still be top dog for many years to come. And developments in our black-and-white operation have been considerable. During 1953, we increased the usefulness of television to the advertiser. Through the creation of new programming and sales policies, we made the sales impact of television available to a broader base of advertisers.

In the realm of public service, NBC increased its scope during the past year, with an increase both in quantity and quality of news, information, public discussion and special events.

On the radio side, NBC enters 1954 with a tried and proven medium completely revitalized. The program, sales, advertising and promotion activities of the radio network have been separated from those of television in the interests of strengthening the operation.

On the sales side, new and smaller program packages, making big-time radio available to small-budget advertisers, has placed the best in the audio-only medium within reach of the advertisers who up to now have not been able to afford the best.

The trade press has spoken much in recent months of the "Pat and Bob" team at NBC. Bob Sarnoff, NBC executive vice-president, and myself consider ourselves as a team, and work as a team on program and sales policies. With Bob as team-mate, I am most optimistic about forward strides NBC can make in 1954 in further improving our broadcasting service both as a public service and as a sales medium.

NATIONAL BROAD

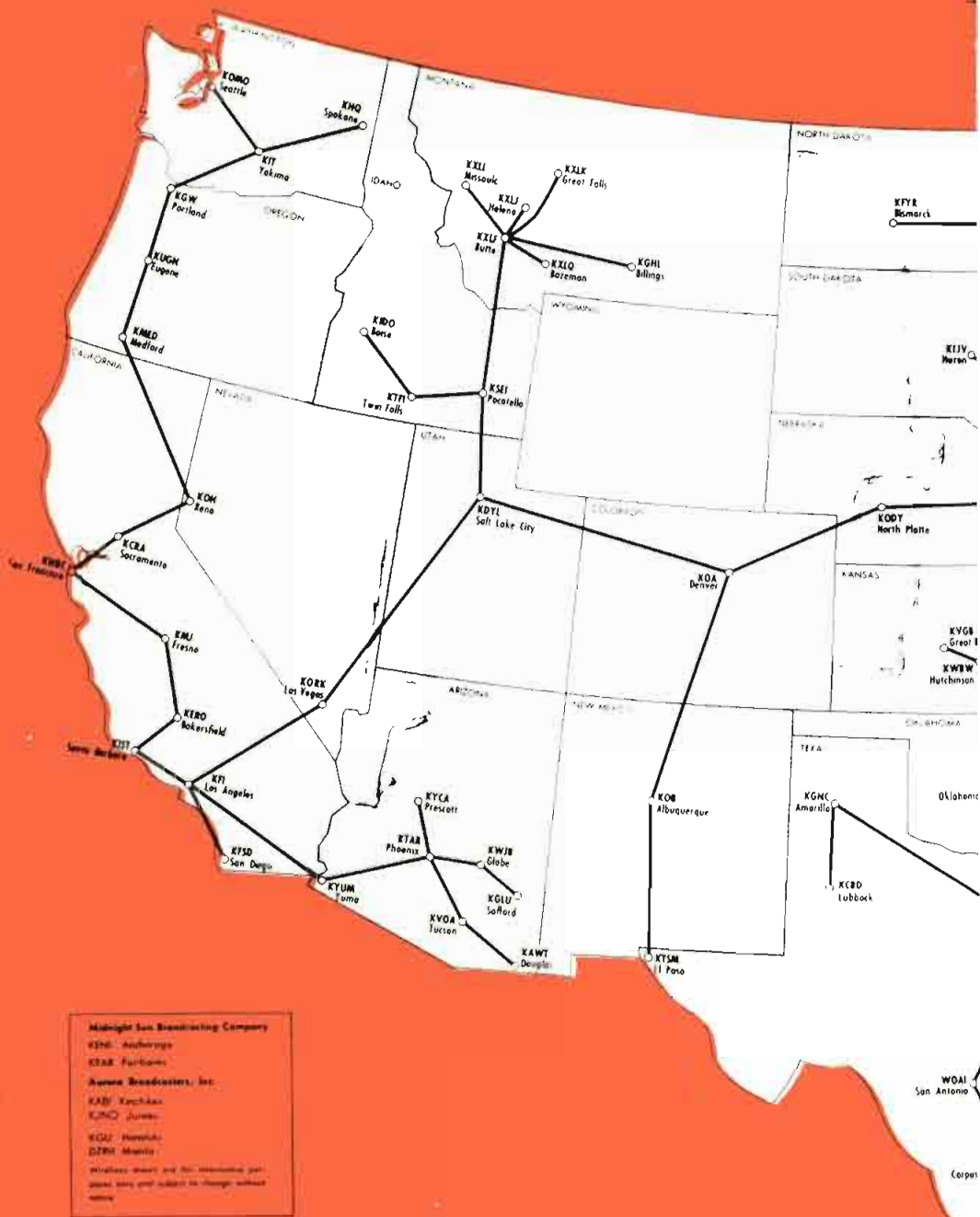

NATIONAL BROADCASTING COMPANY, INC.

30 Rockefeller Plaza, New York 20, N. Y.
Telephone: Circle 7-8300

Registered Telegraphic Address:
NATBROCAST NEW YORK

BOARD OF DIRECTORS

David Sarnoff, Chairman
John T. Cahill Harry C. Ingles
Charles R. Denny Charles B. Jolliffe
Frank Folsom Edward F. McGrady
Harry C. Hagerty William E. Robinson
George L. Harrison Robert W. Sarnoff
Joseph V. Heffernan Sylvester L. Weaver, Jr.
Mrs. Douglas Horton John K. West

OFFICERS

David Sarnoff, Chairman of the Board
Sylvester L. Weaver, Jr. President
Robert W. Sarnoff, Executive Vice President
David C. Adams Vice President
Harry Bannister Vice President
Charles C. Barry Vice President
John M. Clifford Vice President
Ted Cott Vice President
Charles R. Denny Vice President
Sydney H. Eiges Vice President
Thomas E. Ervin Vice President
William H. Fineshriber, Jr. Vice President
George H. Frey Vice President
O. B. Hanson Vice President
William S. Hedges Vice President
Joseph V. Heffernan Vice President
Harry C. Kopf Vice President
Gustav B. Margraf Vice President
Thomas McAvity Vice President
Frank M. Russell Vice President
Emanuel Sacks Vice President
Carleton D. Smith Vice President
Carl M. Stanton Vice President
John K. West Vice President
Frederic W. Wile Vice President
John Q. Cannon Secretary

Paul B. Lynch Assistant Secretary
Joseph A. McDonald Treasurer
George D. Matson Controller
Raymond E. Simonds Assistant Secretary
William A. Williams Assistant Treasurer

ORGANIZATION UNDER THE PRESIDENT AND EXECUTIVE VICE PRESIDENT

Sylvester L. Weaver, Jr. President
Robert W. Sarnoff Executive Vice President

Finance and Services

Joseph V. Heffernan Vice Pres. in chg. of
Finance & Services
David C. Adams Administrative Vice Pres.
Samuel Chotzinoff General Music Director

Engineering

O. B. Hanson Vice Pres. & Chief Engineer
William A. Clark Administrative Assistant
Edward R. Cullen Liaison Engineer
Joseph D'Agostino Liaison Engineer
Raymond F. Guy Manager of Radio &
Allocation Engineering
George M. Nixon Manager of Engineering
Development
Chester A. Rackey Manager of Audio-Video
Engineering
James Wood, Jr. Manager of Technical Services

Station Relations

Harry Bannister Vice Pres. in chg. of Station
Relations
Sheldon B. Hickox Director of Station Relations
Thomas Knode Manager of Station Relations
Harry A. Woodman Manager of Traffic Dept.

Treasurer

Joseph A. McDonald.....Treasurer
William A. Williams.....Assistant Treasurer
Harry F. McKeon.....Director of the Tax Dept.
William D. Bloxham.....Manager of Purchasing

Integrated Services

William S. Hedges...V.P. for Integrated Services
Henry Patrick Hayes...Mgr. Radio Recording Sales
Edward M. Lowell.....Manager Building &
General Services Department
William B. Miller.....Night Executive Officer
Peter M. Tintle.....Manager of Guest Relations
Mildred Joy.....Chief Librarian

Legal

Thomas E. Ervin.....V.P. & General Attorney
John V. Shute.....Assistant General Attorney
James E. Denning.....Senior Attorney
Stockton Helffrich.....Manager of Continuity
Acceptance

Controller

George D. Matson.....Controller
Hamilton Young...Dir. of Auditing and Systems
Francis X. O'Shea.....Chief Accountant
Nicholas Gilles.....Budget Manager

PERSONNEL

John M. Clifford.....V.P. in chg. of Personnel
B. Lowell Jacobsen.....Director of Personnel
Edmund Souhami...Labor Relations Administrator
Lewis R. Tower...Labor Relations Administrator
Ferdinand Wankel...Labor Relations Administrator
Robert Tufts.....Organization Development
Administrator
Donald A. Rutledge...Manager, Training, Policy,
Benefits and Communications
Donald H. Mackenzie...Manager, Employment,
Records and Health
David Broadfoot...Manager, Salary Administration

PRESS AND PUBLICITY

Sydney H. Eiges.....V.P. for Press and Publicity
Richard T. Connelly.....Director of Press Dept.
Don Bishop.....Manager of Program Publicity
Ellis Moore.....Manager of Radio-Television
Business Publicity
John D. McTigue.....Supervisor, Radio Network
Publicity
Kathryn Cole.....Manager of Information
Cornelius Sullivan...Public Relations Representative

ORGANIZATIONS SERVING RADIO NETWORK Research and Planning

Hugh M. Beville.....Dir. of Research & Planning
Dr. Thomas E. Coffin.....Manager of Research
Allen R. Cooper.....Mgr. of Markets & Media
James H. Cornell...Mgr. of Audience Measurement
Barry T. Rumble.....Manager of Plans

Public Affairs

Davidson Taylor.....Director of Public Affairs
William R. McAndrew.....Mgr. of News &
Special Events
Thomas S. Gallery.....Manager of Sports
Edward Stanley...Mgr. of Public Service Programs
Doris Corwith...Supervisor of Religious Broadcasts
— Talks
Joseph O. Meyers.....Chief of the Central News
Desk

Technical Operations

George McElrath...Director of Technical Operations
Paul V. Gallant.....Supervisor of Radio
Broadcasting Operations
Gerald M. Sellar.....Radio Operations
Supervisor
Frederick G. Knoofke...Mgr. of Sound Effects

RADIO NETWORK

William H. Fineshriber, Jr...V.P. in chg. of the
Radio Network
Ted Cott...Operating V.P. of the Radio Network

Programs

John P. Cleary...Nat'l Prog. Dir., Radio Network
Robert L. Wogan.....Supervisor Radio Network
Operations
Merrill Mueller.....Radio News & Features
Executive

Sales

Fred L. Horton.....Dir. of Radio Network Sales
Howard Gardner...Dir. of Radio Network Sales
Development
George W. Diefenderfer...Radio Network Sales
Manager, Central Division
John K. Williams.....Radio Network Sales Mgr.,
Pacific Division
Sackett Miles.....Mgr., Radio Sales Service &
Traffic

Advertising & Promotion

Ridgway Hughes...Dir. of Advertising & Promotion,
Radio Network
James Nelson...Advertising Mgr. Radio Network

Robert Hitchens Sales Promotion Mgr.
Radio Network
Walter Van Bellen . . . Art Director, Radio Network
Frank McMahon Copy Supervisor, Radio Network

Business Manager

Theodore Zaer Business Mgr. Radio Network
Marion Stephenson Division Budget Manager,
Radio Network

Chicago Office — Radio Network Merchandise Mart, Chicago 54, Ill. Tel. SUperior 7-8300

George W. Diefenderfer Radio Network Sales
Manager, Central Division

NBC OWNED STATIONS AND NBC SPOT SALES

Charles R. Denny V.P. in chg. of
NBC Owned Stations and NBC Spot Sales
Henry T. Sjogren Divisional Business Mgr.
Charles H. Colledge Dir. of Technical Operations
Charles C. Bevis, Jr. General Executive
Robert F. Blake Director of Publicity

WNBC, WNBC-FM—New York

Hamilton Shea Gen. Mgr. of WNBC, WNBC-FM
Ernest de la Ossa Station Manager of Stations
WNBC, WNBC-FM
Richard M. Pack Dir. of Programs and
Operations WNBC, WNBC-FM
Peter Affe Mgr. of Operations for
WNBC, WNBC-FM
Max Buck Dir. of Advertising, Sales Promotion
& Merchandising
Robert J. Leder Radio Sales Manager

WMAQ, WMAQ-FM—Chicago

Harry C. Kopf V.P. & Gen. Mgr. of
WMAQ, WMAQ-FM
Jules Herbuveaux Assistant General Manager
Charles Dresser Director of Sales
George Heinemann Director of Programming
John F. Whalley Director of Operations
Howard C. Lutgens Engineer in Charge

WTAM, WTAM-FM—Cleveland

Lloyd E. Yoder General Manager for
WTAM, WTAM-FM
Samuel E. Leonard Engineer in Charge
Brooks Taylor Program Director

KNBC, KNBC-FM—San Francisco

George Greaves General Manager for
KNBC, KNBC-FM
William K. McDaniel Sales Manager

Curtis D. Peck Manager of Radio Technical
Operations & Integrated Services
John Thompson Program Manager

WRC, WRC-FM, Washington

Carleton D. Smith V.P. & Gen. Mgr.
WRC, WRC-FM
Joseph Goodfellow Director of Sales
James Kovach Program Director
Lefferts A. McClelland Director of Operations
John G. Rogers Engineer in Charge

National Spot Sales

Thomas B. McFadden Dir. of Natl. Spot Sales
Richard H. Close Mgr. for Represented Stations
William N. Davidson Natl. Mgr. for Radio
Spot Sales
Harold Shepard Sales Development
Advertising & Promotion Manager
Caroline Herbert Sales Service Manager

WASHINGTON AND PACIFIC DIVISION OFFICES Washington

Frank M. Russell Vice Pres., Washington
George Wheeler Asst. to the Vice Pres.

Pacific Division Sunset Boulevard and Vine Street, Hollywood 28, Calif. Tel. Hollywood 9-6161

John K. West V.P. for the Pacific Division
Thomas C. McCray Dir. of Radio Network
Division, Pacific Division
Lewis S. Frost Director of Public Relations
Frank Dellett Business Mgr., Pacific Div.
Harry Bubeck Radio Network Mgr., Pacific Div.
Richard H. Graham Attorney
Leslie Raddatz Mgr. of Press & Publicity
Alfred Saxton Mgr. of Technical Operations
John K. Williams Network Sales Mgr.,
Pacific Division

Foreign Offices

England: Romney Wheeler, National Broadcasting
Company, Inc., 2 Mansfield Street, London
W1, England.
France: Paul Archinard, William Frye, 52 Avenue
des Champs Elysees, Room 533, Paris 8, France.
Japan-Korea: George Thomas Folster, Wilson Hall,
John Rich, James C. Robinson, Nikkatsu Build-
ing, 1-1 Chome, Yura Kucho Chiyodaku, Tokyo,
Japan.
Germany: Robert McCormick, Press Center
(American), APO 757, c/o PM, New York,
New York.
Italy: Jack Begon, 54 Via Della Mercede, Rome,
Italy.

For television personnel turn to TELEVISION YEAR BOOK in this volume



Local Radio Still Potent Despite Television Gains

By **SIDNEY J. WOLF**

President

Keystone Broadcasting System, Inc.

A GAIN in 1954, the advertiser is confronted with another period of adjustment, created by increased TV coverage—represented by stations presently operating who will expand facilities, and by those that will be in operation by the end of the year. Keystone has, at present, 244 radio stations beyond effective TV coverage area, and as new TV stations are built, there will undoubtedly be many advertisers who will use TV—supplemented with radio, to achieve forceful national radio and TV coverage. Within the past year, many advertisers have effectively supplemented TV operations with Keystone, and as TV markets increase, we believe that the trend to supplement TV schedules with Keystone will be even greater.

Keystone was established to enable advertising agencies to buy a practical “package” of small stations with a single order . . . providing a simplified method for their clients to reach this “plus” audience in the fertile “Home Town and Rural America” market. Entering its fourteenth year of operation, Keystone is proud of having shown a consistent increase in business with each succeeding year. The number of present station affiliates is now in excess of 700, and during 1953, 27 new major advertisers were added, and 79 new affiliates. These figures are evidence of satisfactory performance, and substantiate the advertisers’ faith in Keystone as a medium to increase their sales and profits. And there is every indication that 1954 will be an even better, more profitable year for Keystone, its affiliates and clients.

During 1953, Keystone subscribed to Nielsen Coverage Service for its entire network, enabling us to give advertisers and their agencies the most accurate information regarding market coverage and listenership.

During the past several years, Keystone has strongly emphasized to affiliates the importance of follow-through

merchandising. In 1953 this practice has proved to advertisers using Keystone, that merchandising activities done by our stations as “part of the job,” have effectively increased sales of the many products advertised. Typical merchandising follow-through by Keystone stations includes such activities as personalized local mailings, distribution of displays, messages to merchants encouraging promotional tie-ins, personal calls by the station manager and staff, public demonstrations in keeping with the promotion, etc. We intend to step up even further such merchandising follow-through during the future. No set formula is used for any product; the problems of each advertiser are individually and carefully studied, worked out with the advertiser — who is most familiar with his own sales problems—giving each campaign the best possible advantage in a most practical way.

Keystone merchandising of this type is so effective primarily because the manager and personnel of our type of station is usually *personally* acquainted with all the local business men, and this personalized contact appeal brings about the desired cooperation most easily.

Keystone looks forward to another year of progress . . . helping more advertisers discover and benefit from the richness of America’s “Home Town” stations, whose combination of sales producing ability and merchandising power is the sole factor in the success of the Keystone network.

In 1954, Keystone Broadcasting System — the only national transcription network — will become a medium of even greater importance to the nation’s advertisers who want to reach the world’s most lucrative market. We believe that the coming year will show increased coverage by currently affiliated stations, who improve facilities — and through the addition of stations in new markets not as yet covered by Keystone.

KEYSTONE BROADCAST

ALABAMA

WRFS Alexander City
WCTA* Andalusia
WJLD Birmingham
WFBJ Brewton
WRAG Carrollton
WKLF Clanton
WKUL Cullman
WMSL* Decatur
WXAL Demopolis
W00F* Dhanah
WUFA Eufaula
W0WF Fayette
W0WL* Florence
W0WD Gadsden
W0YV* Greenville
W0SV Guntersville
WBHF* Huntsville
W0BB Jackson
W0WB Jasper
W0MD Mobile
W0MF Monroeville
WJHD Opelika
WELR Phenoxie
W0WR* Russellville
W0BB* Selma
W0FB Sylacauga
W0HT Talladega
W0BF* Troy
W0BC Tuscaloosa
W0TUS Tuskegee

ARIZONA

KCLS Flagstaff
KRIZ Phoenix
KCKY Coolidge

ARKANSAS

KVRC* Arkadelphia
KBTA Batesville
KAMD* Camden
KCON Conway
KAGH Crossett
KDMS El Dorado
KGRH Fayetteville
KXJK Forrest City
KHOZ Harrison
KFFA Hope
KXAR* Hope
KRCH* Hot Springs
KBTM Jonesboro
KVLG Little Rock
KVMA Magnolia
KVSA McGehee
KEMA* Mena
KOSE Osceola
KDRS* Paragould
KOTN Pine Bluff
KPOC* Pechanlas
KX RJ* Russellville
KWCB Searcy
KUDA* Silvan Springs
KBRS Springfield
KWAK Stuttgart

CALIFORNIA

KIBS* Bishop
KBMX Chalinga
KCVR* Lodi
KMBY Monterey
KSF6* Nerdilos
KDAC Ft. Bragg
KPLP Paso Robles
KAFP Petaluma
KBLF Red Bluff
KBLF Sanger
KVCC San Luis Obispo
KMSA Santa Maria
KSPA Santa Paula
KRDG* Sonoma
KTKH Taft
KTUR Tullock
KVVC Ventura

CONNECTICUT

WNLK Norwalk

COLORADO

KGIW* Alamosa
KRLN Canon City

KHAI* Craig
KIUP* Durango
KFTM Fort Morgan
KYDU Greeley
KBNZ La Junta
KLVO* Leadville
KLMO Longmont
KUBC Montrose
K0ZA Pueblo
KVRH* Salida
KCR2* Trinidad

DELAWARE

WJWL Georgetown

FLORIDA

WTRL Bradenton
WTAN Clearwater
WKKO Cocoa
WCNU Crestview
WBRO Fort Lauderdale
WINK Fort Myers
WARN Fort Pierce
W0GG Gainesville
W1VB Jacksonville Beach
WKWF Key West
WIPC Lake Wales
WLBE Leesburg
WNER Live Oak
WYS Marianna
W0WP Miami
W0MC Ocala
W0PF Palatka
W0LP* Panama City
W0PL Plant City
WTRR Sebring
W0KY Sarasota
WJCM Sebring
W0NT Tallahassee
W0BK Tampa
W0SB New Smyrna Beach
W0FY St. Augustine

GEORGIA

WJAZ Albany
W0EC Americus
W0GA Athens
W0UG Augusta
W0GR Bainbridge
W0DG Brunswick
W0RA Cairns
W0BB Carrollton
W0HF Cartersville
W0GA Cedartown
W0JM Cordele
W0LJ Dalton
W0WD Dawson
W0LS Decatur
W0MG Douglas
W0ML Dublin
W0TJ East Point
W0SG Elberton
W0BH Fitzgerald
W0FP Fort Valley
W0FH Hainesville
W0RO Waynesboro
W0FS Cavington
W0GA Gainesville
W0KE Griffin
W0GR* Jessup
W0LAG La Grange
W0DM Marietta
W0VG Milldegeville
W0GA* Moultrie
W0RG Rome
W0NS* Statesboro
W0ST Thomaston
W0WA* Thomson
W0ET* Toccoa
W0VP* Vidalia
W0MO Winder
W0YX* Waycross
W0RL West Point

IDAHO

K0EM Boise
KBIO* Burley
KIFI Idaho Falls
K0PL Moscow
K0WK Pocatello
K0PT Preston

KSPT* Sandpoint
KLIX* Twin Falls

ILLINOIS

W0KZ Alton
W0YS Canton
W0DY Carini
WCNT Centralia
W0CR* Effingham
W0EB* Harrisburg
W0JF Herrin
W0PR Lincoln
W0SM Litchfield
W0MN Elgin
W0KD Urbana
W0KA Macon
W0MD* Metropolis
W0MC Mt. Carmel
W0LN* Diney
W0PR Paris

INDIANA

WCBC Anderson
W0NL Booneville
W0SA Loansport
W0YA Princeton
W0SL Salem
W0CD Seymour
W0VA South Bend
W0TC Tell City
W0KAM Warsaw
W0RX Madison

IOWA

KASI Ames
KJAN Atlantic
KPIG Cedar Rapids
K0DG Centerville
K0HA Charles City
K0SB Creston
K0MA Davenport
K0FD Fairfield
K0IC Iowa City
K0WC Muscatine
K0FJ Webster City
K0E6 Cherokee
K0RB Mason City

KANSAS

K0SK Arkansas City
K0RE Atchison
K0RB Chanute
K0TSW* Emporia
K0UL* Garden City
K0WB Goodland
K0YS* Hays
K0WB Hutchinsen
K0ND Independence
K0LO Leavenworth
K0NE McPherson
K0EK Pittsburg
K0SK Pratt

KENTUCKY

W0LJ Bowling Green
W0CD Campbellsville
W0AIN* Columbia
W0CT* Corbin
W0ZP Covington
W0CPM Cumberland
W0HJ Danville
W0EL Elizabethtown
W0KY Frankfort
W0KA* Glasgow
W0HL Harlan
W0IC Hazard
W0SD Henderson
W0LEX Lexington
W0LN Louisville
W0FM Madisonville
W0FT Maysville
W0MK Middlebrook
W0MI Owensboro
W0KE Pikeville
W0PT Prestonsburg
W0PKY* Princeton

LOUISIANA

KTRY Bastrop
W0KC Bogalusa
K0LA* De Ridder
K0IL Houma
W0HL Hammond
K0LC Monroe
K0CJ* Natchitoches
KANE New Iberia
K0RE* Oakdale
K0LO* Opelousas
K0RS Ruston

MAINE

W0BM* Houlton
W0RM* Rumford

MARYLAND

WNAV Annapolis
WASA Havre de Grace
WPTX Lexington Park

MASSACHUSETTS

WVDM Brookline
W0RE Holyoke

MICHIGAN

W0LM Albion
W0FY Alma
W0TZ Alpena
W0LEW Bad Axe
W0ATT Cadillac
W0ATC Gaylord
W0RT Big Rapids
W0MR Flint
W0HF Houghton
W0KB Iron River
W0JMS Ironwood
W0JD Ishpeming
W0KLA Ludington
W0MT* Manistee
W0DMJ* Marquette
W0CEN Mt. Pleasant
W0MUS Muskegon
W0MBN Petoskey
W0HLS Port Huron
W0SO* Sault Ste. Marie
W0TCM* Traverse City

MINNESOTA

K0SM* Albany
K0BUN* Bemidji
K0BMW Breckenridge
W0LK Cloquet
K0XO Crookston
W0VE Eveleth
K0BZY Grand Rapids
K0KFI International Falls
K0LTF Little Falls
K0NUJ* New Ulm
K0BK Owatonna
W0SHB Stillwater

MISSISSIPPI

W0MPA* Aberdeen
W0GCM Biloxi-Gulfport
W0BIP* Booneville
W0DB Canton
W0LG Centerville
W0LD* Cleveland
W0CJU Columbia
W0CMA* Corinth
W0JPR Greenville
W0GRM Greenwood
W0FDR Hattiesburg
W0MDC Hazlehurst
W0KOZ Kosciusko
W0AML Laurel
W0APF McComb
W0MIS Natchez
W0PMP Passapatan
W0HOC Philadelphia
W0RJW Picayune
W0SSO* Starkville
W0QBC Vicksburg
W0TUP* Tupelo
W0AZF Yazoo City

MISSOURI

K0GMO Cape Girardeau
K0DMO Carthage
K0CRV Caruthersville
K0CHR* Charleston
K0CHI Chillicothe
K0DKO Clinton
K0REI Farmington
K0JCF Festus
K0WOS* Jefferson City
K0IRX Kirksville
K0NIM Maryville
K0NCB Moberly
K0RMO Monett
K0NEM* Nevada
K0WOC* Poplar Bluff
K0TTR* Rolla
K0SGM Ste. Genevieve
K0SMO* Salem
K0DRO Sedalia
K0KCK Springfield
K0DKO Warrensburg
K0WRE* Warrenton
K0WPM* West Plains

MONTANA

KANA Anaconda
K0BMY* Billings
K0JM* Havre
K0CAP Helena
K0XLO* Lewistown

NETWORK FACILITIES AS OF FEBRUARY 1, 1954

* Asterisk following call letters indicates station is outside of current TV coverage.

CASTING SYSTEM

KPRK* Livingston
KRJF* Miles City
KIYI* Shelby
KGCX* Sidney
KLCB Libby

NEBRASKA

KGOV* Alliance
KCNF* Broken Bow
KJSK Columbus
KHAS Hastings
KGFW* Kearney
KLMS Lincoln
KBLL* McCook
KODY* North Platte
KSID* Sidney

NEVADA

KRAM Las Vegas
KATD Reno

NEW HAMPSHIRE

WMOU* Berlin
WLNH* Laconia

NEW JERSEY

WSNJ Bridgeton

NEW MEXICO

KALG* Alamogordo
KABQ Albuquerque
KSPV Artesia
KJAC* Farmington
KGAK* Gallup
KWEW* Hobbs
KENM* Portales
KBIM Roswell
KSIL* Silver City
KCHS* Truth or
Consequences
KTNM* Tucumcari

NEW YORK

WCSS Amsterdam
WBOB Auburn
WOSC Fulton
WLEA Hornell
WHJC Hudson
WJOC Jamestown
WYOS Liberty
WLFH Little Falls
WTCY* Malone
WALL Middletown
WLSB* Ogdensburg
WIRY* Plattsburg
WNBZ* Saranac Lake
WDLA Walton

NORTH CAROLINA

WRCS Ahsokie
WBZ Albemarle
WBBS Burlington
WEGO Concord
WCKB Ounn
WCNC Elizabeth City
WFAY Fayetteville
WBBO Forest City
WVG Fuquay Springs
WIAM Williamston
WOOW New Bern
WLTC Gastonia
WFMC Goldsboro
WHNC Henderson
WHKP Hendersonville
WHPE High Point
WJNC* Jacksonville
WELS* Kinston
WEWO* Laurinburg
WLOE Leaksville
WJRI Lenoir
WBY Lexington
WTSB* Lumberton
WMAF Monroe
WHIP Mooresville
WPAQ Mount Airy
WNNC Newton
WKBG No. Wilkesboro
WRC Reidsville
WCBT* Roanoke Rapids
WCEC* Rocky Mount
WWGP Sanford
WOHS Shelby
WADE Wadesboro
WLSE* Wallace
WHOC Waynesville
WHED Washington

NORTH DAKOTA

KDLR* Devils Lake
KOIX* Dickinson
KNOW* Grand Forks

KGCU Mandan
KQVC Valley City
KWBM* Williston

OHIO

WOHP Bellefontaine
WLEE Canalbridge
WAND Canton
WBEX Chillicothe
WJER Dover
WFOB Fostoria
WJEH Gallipolis
WMOH Hamilton
WIRO Ironton
WWSO Springfield-Urbana
WCHO Washington Court
House
WVST Wooster
WLMT Jackson
WPTW Piqua

OKLAHOMA

KADA Ada
KWHW Altus
KVSU* Ardmore
KWGO Chickasha
KRHD Duncan
KCSO* Durant
KASA* Elk City
KTAT Frederick
KTJS Hobart
KIHU* Hugo
KTMC* McAlester
KGLC Miami
KBIX Muskogee
KNOR Norman
KBYE Oklahoma City
KHBG Okmulgee
KVLH Pauls Valley
KOLS Pryor
KWSH Tri-City
KSIW* Woodward
KALO Poteau
KBWL Blackwell

OREGON

KAST Astoria
KBKR* Baker
KBND* Bend
KASH* Eugene
KLBW* La Grande
KGAL* Lebanon
KMCM McMinnville
KSRV Ontario
KODL The Dalles
KTIL Tillamook
KWRO* Coquille

PENNSYLVANIA

WNGC Barnesboro
WSR Butler
WCDL Carbondale
WHYL Carlisle
WESA Charleroi
WBUX Doylestown
WLEU Erie
WGET Gettysburg
WHUN Huntingdon
WDAD Indiana
WAKU Latrobe
WKRZ Oil City
WPAZ Pottstown
WPAM Pottsville
WKBT St. Marys
WATS Sayre
WYSC Somerset
WMAJ State College
WAYZ Waynesboro
WLYC* Williamsport
WNOW York

RHODE ISLAND

WADK Newport
WPAW Pawtucket
WERI Westerly

SOUTH CAROLINA

WANS Anderson
WACA Camden
WHAN Charleston
WGD Chester
WELP Easley
WOLS* Florence
WFGN Gaffney
WEAB Greer
WHSC* Hartsville
WLBG Laurens
WJAY* Mullins
WBRM* Myrtle Beach
WKDK Newberry
WDX Orangeburg
WRHJ Rock Hill
WSNW Seneca

WFIG Sumter
WBCU Union
WBAW Barnwell

SOUTH DAKOTA

KDSJ Deadwood
KIIV* Huron
KISD Sioux Falls
KWAT* Watertown

TENNESSEE

WLAR Athens
WJZM Clarksville
WKRK Columbia
WHUB* Cookeville
WAW Crossville
WDSG* Dyersburg
WEKR* Fayetteville
WHIN Gallatin
WHBT Harriman
WIRJ* Humboldt
WDXJ Jackson
WKN Kinrossport
WXV Knoxville
WDXE* Lawrenceburg
WCOR Lebanon
WJMJ Lewisburg
WGAP Maryville
WMMT McMinnville
WGNB Murfreesboro
WNAH Nashville
WQKE Oak Ridge
WTPR* Paris
WDBL Springfield
WJIG Tullahoma
WENK* Union City

TEXAS

KVLF Alpine
KBUD Athens
KRUN Ballinger
KIOX Bay City
KRCT Baytown
KTXX* Big Spring
KNEL* Brady
KSTB Breckenridge
KWHI Brenham
KTFY Brownfield
KBOR Brownsville
KBWD Brownwood
KDET* Center
KSTA Coleman
WTAW College Station
KVMC Colorado City
KAND Corsicana
KIVY* Crockett
KXIT* Dalhart
KDLK* Del Rio
KDNT Denton
KURV Edinburg
KELP El Paso
KFLD Floydada
KNAA* Fredericksburg
KGAF Gainesville
KBLP Falfurrias
KLUF Galveston
KCTI Gonzales
KGVJ Greenville
KCLW Hamilton
KXAN Hereford
KHBH Hillsboro
KLSB Houston
KSAM* Huntsville
KEBE Jacksonville
KTXJ* Jasper
KMBL Junction
KQCA Kilgore
KPEI Lamesa
KVDZ* Laredo
KVOW Littlefield
KFRO Longview
KVSP Lubbock
KRBA* Lufkin
KMH* Marshall
KJBC* Midland
KORC Mineral Wells
KVKM* Monahans
KIMP* Mt. Pleasant
KOSF* Nacogdoches
KGNB New Braunfels
KRIG* Odessa
KOGT* Orange
KNET Palestine
KPAT Pampa
KFTV* Paris
KIUN* Peecos
KVOP Plainview
KBOP Pleasanton
KOLJ Quanah
KCLQ San Marcos
KSEY Seymour
KEVA* Shamrock

KTAN Sherman
KDWT Stamford
KSTV Stephenville
KSST Sulphur Springs
KXOX Sweetwater
KTEM Temple
KTFS Texarkana
KTLW Texas City
KTBB Tyler
KVOU* Uvalde
KVCW Vornon
KVIC Victoria

UTAH

KBUH Brigham City
KVVU* Logan
KOPP Ogden
KOAL* Pricer
KEYV Provo
KJAM* Vernal

VERMONT

WIKF* Newport
WSYB* Rutland
WTWN* St. Johnsbury

VIRGINIA

WKLV Blackstone
WINA Charlottesville
WKVE Covington
WCVL Culpeper
WEVA Emporia
WFAX Falls Church
WFVA Fredericksburg
WFRF Front Royal
WBOB Galax
WREL Lexington
WMEV Marion
WMVA Martinsville
WHYU Newport News
WNVA Norton
WSSV* Petersburg
WPUV Pulaski
WRAD Radford
WRIC Richlands
WRIS Roanoke
WHLF South Boston
WLFM Suffolk
WMNT Warsaw
WAYB Waynesboro
WINC Winchester
WYVE Wytheville

WASHINGTON

KXRO* Aberdeen
KPUG Bellingham
KELA Centralia
KCLX Colfax
KFDR* Grand Coulee
KWLK Longview
KSEM* Moses Lake
KGY Olympia
KONP Port Angeles
KPUY Puyallup

WEST VIRGINIA

WHAR* Clarksburg
WDNE* Elkins
WKYR Keyser
WVDW Logan
WEPN Martinsburg
WHJC Matewan
WAJR Morgantown
WMOD Moundsville
WLOH Princeton
WBRW* Welch
WHAW Weston

WISCONSIN

WATW* Ashland
WLDY* Ladysmith
WDLB* Marshfield
WJMN* Medford
WMNE Menomonie
WNAM Neenah
WPPF* Park Falls
WIBU Peynette
WRAC Racine
WGBT Rhineland
WRCD Richland Center
WKLJ* Sparta
WOKW Sturgeon Bay
WTRW Two Rivers
WTTN Watertown
WAUX Waukesha
WOSA* Wausau

WYOMING

KVW* Cheyenne
KLUK* Evanston
KOVE* Lander
KPOW* Powell
KRAL* Rawlins
KVR* Rock Springs
KWYO* Sheridan

KEYSTONE BRC

NO

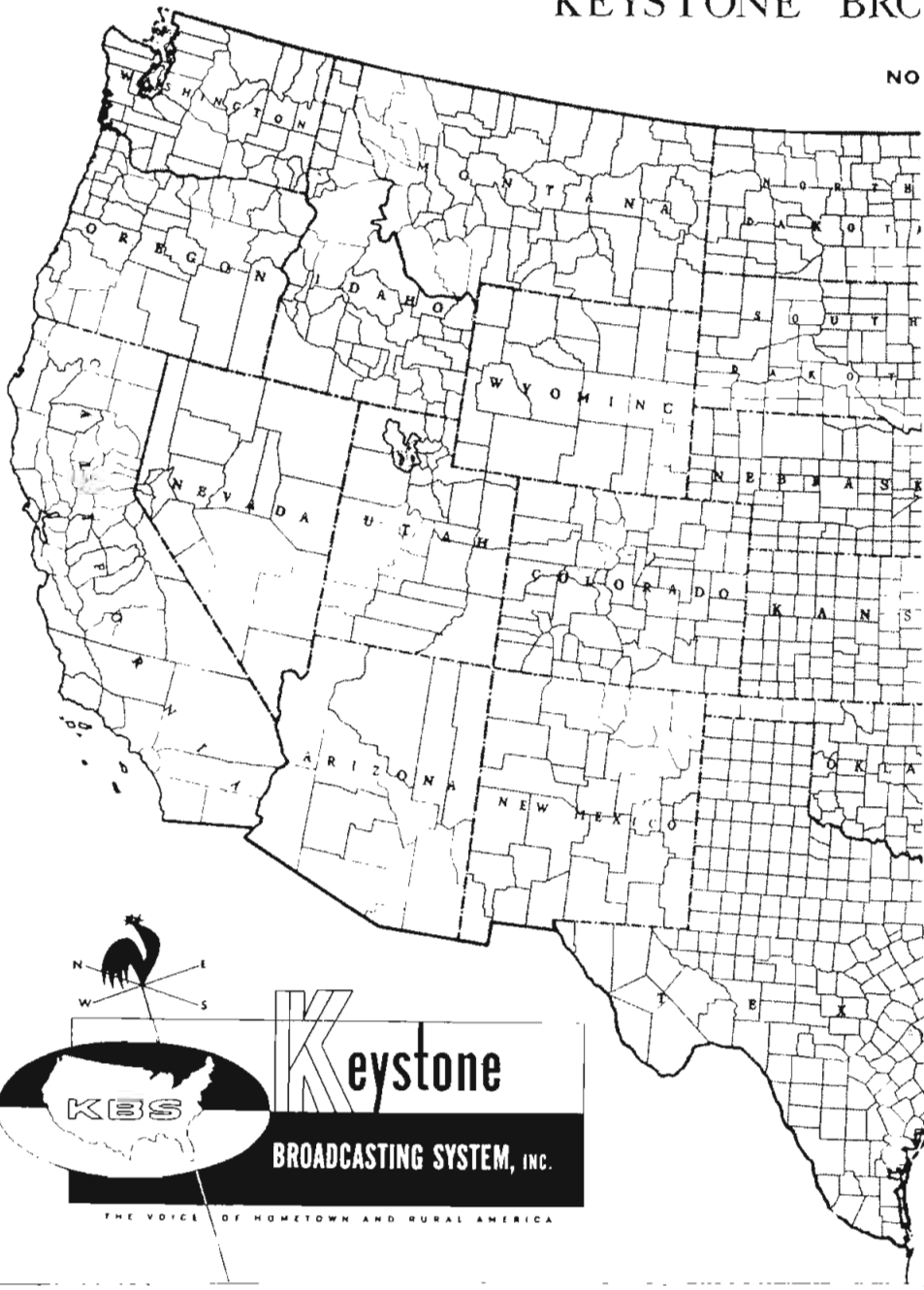

Keystone

BROADCASTING SYSTEM, INC.

THE VOICE OF HOMETOWN AND RURAL AMERICA

CASTING SYSTEM

ER, 1953



SHADED AREAS INDICATE KEYSTONE COVERAGE
BASED ON 1952 NIELSEN COVERAGE SERVICE AREAS

KEYSTONE

BROADCASTING SYSTEM, INC.

111 W. Washington St., Chicago, Ill.

Officers and Directors

Sidney J. Wolf (Director).....	President
Joseph Bayer (Director).....	Vice-President
Noel A. Rhys.....	Vice-President
Edwin R. Peterson.....	Vice-President
William Bayer.....	Vice-President
Arthur Wolf (Director).....	Secretary-Treasurer

New York

580 Fifth Ave., New York 36, N. Y.

Phone: PLaza 7-1460

Noel A. Rhys.....	Vice-President and Eastern Sales Manager
Charles A. Hammarstrom.....	Account Executive
Eve Bannier.....	Office Manager
John Scanlan.....	Research Director

Chicago

111 W. Washington St., Chicago 2, Ill.

Phone: STate 2-6303

Sidney J. Wolf.....	President
Edwin R. Peterson.....	Vice-President
Arthur Wolf.....	Secretary-Treasurer
Paul Kolar.....	Comptroller
Blanche Stein.....	Director of Station Relations
Kay Krause.....	Traffic Manager
Jane McFadgen.....	Program Director

Los Angeles

1330 Wilshire Blvd., Los Angeles 17, Calif.

Phone: DUnkirk 3-2910

William Bayer.....	Vice-President
Henry G. Eschen.....	Account Executive

San Francisco

57 Post Street

Phone: SUTter 1-7440

Don Kerwin.....	Account Executive
-----------------	-------------------

SERVICES OFFERED: The Keystone Broadcasting System is a transcription network which services local radio stations with programming transcriptions, and KBS makes their time available to national advertisers and their agencies at an attractive network package rate.

At present, there are more than 700 Keystone affiliates, located in towns with 10,000 to 100,000 population where they reach both the small town and rural markets. For the most part, these Keystone stations serve those areas which are beyond clear reception areas of the large metropolitan radio stations or other high-power stations. The number of radio homes in these Keystone markets, based on Nielsen Coverage Service areas is 17,181,040. There are an additional 1,382,810 homes in the primary area of 59 KBS stations for which the Nielsen reports were not available, therefore, the total radio homes within the primary area of Keystone represents a total of 18,563,850.

Keystone is a flexible media easily purchased, whole or in part. Entire areas or spot coverage may be selected . . . whichever meets the needs of the advertising program. Regardless of the schedule, Keystone makes its time available at a considerable savings.

In operation, Keystone offers the same advantages as the wired networks. Instead of a large number of individual transactions, KBS reduces your problem to one order, one time clearance, one series of Affidavits of Performance, and one invoice.

Many of the nation's largest advertisers are using the facilities of Keystone. Types of programming vary from 25 word spots to one hour shows.

REGIONAL NETWORKS



Alaska Broadcasting System

(Affiliated with CBS)

830 Securities Building, Seattle 1, Wash.
Phone: SEneca 6333

PERSONNEL

General Manager.....Wm. J. Wagner

BRANCH OFFICES

Station KFQD, Box 1040, Anchorage, Alaska, Chas. Mohler, Station Mgr.; Station KFRB, Box 950, Fairbanks, Alaska, W. R. Nichols, Station Mgr.; Station KINY, Box 1091, Juneau, Alaska, Dick Peter, Station Mgr.; Station KTKN, Box 1308, Ketchikan, Alaska, Dorothy Bussanich, Station Mgr.; Station KIBH, Box 250, Seward, Alaska, Jim Lawson, Station Mgr.; Station KIFW, Box 699, Sitka, Alaska, Wm. Maynard, Station Mgr.; Alaska Radio Sales, 17 East 42nd St., New York 17, N. Y., MURray Hill 2-1811; Duncan A. Scott & Co., Mills Bldg., San Francisco 4, Calif., Garfield 1-7950; Duncan A. Scott & Co., 2978 Wilshire Blvd., Los Angeles 5, Calif.; Willis Harpel, 3256 Barham Blvd., Hollywood 28, Calif.

STATIONS

KFQD, Anchorage, Alaska; KFRB, Fairbanks, Alaska; KINY, Juneau, Alaska; KTKN, Ketchikan, Alaska; KIBH, Seward, Alaska; KIFW, Sitka, Alaska.

The Aloha Network

P. O. Box 1380, Honolulu, T. H.
Phone: 95295

PERSONNEL

General Manager.....R. M. Fitkin
Comm. Manager.....J. D. Allison
Chief Engineer.....Ira G. Mercer

STATIONS

KHON, Honolulu; KIPA, Hilo; KMVI, Wailuku; KTOH, Lihue.

Arizona Broadcasting System

(ABS Network)

1101 No. Central Ave., Phoenix, Ariz.
Phone: Alpine 4-4161

PERSONNEL

General Manager.....Richard O. Lewis
Commercial Manager.....Bill Harvey

STATIONS

KTAR, Phoenix; KVOA, Tucson; KYUM, Yuma; KGLU, Safford; KWJB, Globe-Miami; KYCA, Prescott; KAWT, Douglas-Bisbee.

The Arizona Network

Radio Station KOY

840 N. Central Ave., Phoenix, Ariz.
Phone: Alpine 4-4144

PERSONNEL

Manager.....Albert D. Johnson
Program Director.....John R. Williams
Commercial Manager.....John L. Hogg
KTUC Manager.....Lee Little
KSUN Mgr., owner.....Ario Woolery
KYMA Manager.....William L. Lindsey
KCLS Manager.....Charles J. Saunders

BRANCH OFFICES

Station KTUC, Broadway & Tyndall, Tucson, Ariz.; Phone: 2-3344; Station KSUN, Bisbee, Ariz., Phone 9; Station KYMA, 8th St. and "B" Ave., Yuma; Station KCLS, 110 W. Birch St., Flagstaff.

STATIONS

KOY, Phoenix, KTUC, Tucson; KSUN, Bisbee; KYMA, Yuma; KCLS, Flagstaff.

Arrowhead Network

WEBC Building, Duluth 2, Minn.

Phone: Melrose 2873

PERSONNEL

General Manager.....Walter C. Bridges
Nat'l. Sales Mgr.....Harry Hyett

STATIONS

WEBC, Duluth, Minn.; WMFG, Hibbing, Minn.; WHLB, Virginia, Minn.; WJMC, Rice Lake, Wis.; WEAU Eau Claire, Wis.; WISC, Madison, Wis.

Broadcasting Corp. of America Network

P. O. Box 987, Riverside, Calif.
Phone: Riverside 6290

PERSONNEL

General Manager.....Dick Sampson

STATIONS

KPRO, Riverside; KPOR, San Bernardino; KREO, Indio; KROP, Brawley; KYOR, Blythe.

Paul Bunyon Network

Paul Bunyon Bldg., Traverse City, Mich.
Phone: 2700

PERSONNEL

Pres., Gen. Mgr.Les Biederman

STATIONS

WTCM, Traverse City; WATT, Cadillac; WATZ, Alpena; WMBN, Petoskey; WATC, Gaylord.

California Northern Group

Radio Station KSYC, Yreka, Calif.
Phone: 624
PERSONNEL

Manager Jack A. Mitchell (KSYC)

STATIONS

KBLF, Red Bluff; KSUE, Susanville; KSYC, Yreka.

CDC Tri-State Network

800 Broadway, Cincinnati, Ohio
Phone: GARfield 1331
PERSONNEL

WKRC-TV General Mgr. U. A. Lathan
WHIO-TV General Mgr. Robert Moody
WTVN General Mgr. J. W. McGough
CDC Coordinator Don L. Chapin

STATIONS

WKRC-TV, Cincinnati, Ohio; WHIO-TV, Dayton, Ohio; WTVN, Columbus, Ohio.

Columbia Pacific Network

6121 Sunset Blvd., Los Angeles 28, California
Phone: Hollywood 9-1212
PERSONNEL

Manager William D. Shaw
Gen. Sales Mgr. Bert West
Asst. Sales Manager Thomas Swafford
Sales Promotion Mgr. James W. Frost
Program Director Robert P. Sutton
News Director Jack Beck
Public Affairs Director David Showalter
Chief Engineer Les Bowman

BRANCH OFFICES

Radio Spot Sales, 485 Madison Avenue, New York, N. Y., Phone: PL 1-2345, Henry Flynn, Sales Mgr.; Columbia Pacific Network Sales, Palace Hotel, San Francisco, Calif., YU 2-7000, Jack Donahue, Sales Mgr.; Radio Spot Sales, 902 Fisher Bldg., Detroit, Mich., TR 2-5500, Ralph H. Patt, Jr., Sales Mgr.; Radio Spot Sales, 410 North Michigan Ave., Chicago, Ill., WH 4-6900, Gordon F. Hayes, Sales Mgr.; Radio Spot Sales, 6121 Sunset Blvd., Hollywood, Calif., HO 9-1212, G. E. Hurst, Sales Mgr.; Radio Spot Sales, 800 Peachtree St., Atlanta, Ga., EL 0727, H. W. Majer, Jr., Sales Mgr.

STATIONS

KNX, Los Angeles, Calif.; KCBS, San Francisco, Calif.; KFRE, Fresno, Calif.; KFMB, San Diego, Calif.; KROY, Sacramento, Calif.; KMBY, Monterey, Calif.; KCMJ, Palm Springs, Calif.; KGDM, Stockton, Calif.; KERN, Bakersfield, Calif.; KHUM, Eureka, Calif.; KOIN, Portland, Ore.; KFIR, North Bend, Ore.; KERG, Eugene, Ore.; KFLW, Klamath Falls, Ore.; KYJC, Medford, Ore.; KRNR, Roseburg, Ore.; KIRO, Seattle, Wash.; KXLY, Spokane, Wash.; KWIE, Kenniwick, Wash.; KIMA, Yakima, Wash.; KOLO, Reno, Nev.; KVCV, Redding, Calif.; KHSL, Chico, Calif.

Columbia Television Pacific Network

1313 North Vine St., Hollywood 28, Calif.
Phone: HOLLYwood 9-1212

General Manager J. T. Aubrey, Jr.
Sales Manager Edmund C. Bunker
News Director Frank La Tourette
Business Manager Harry W. Zipper

STATIONS

KPHO-TV, Phoenix, Ariz.; KOPO-TV, Tucson, Ariz.; KHSL-TV, Chico, Calif.; KERO-TV, Bakersfield, Calif.; KIEM-TV, Eureka, Calif.; KMJ-TV, Fresno, Calif.; KNXT, Los Angeles, Calif.; KSBW-TV, Salinas, Calif.; KMBY-TV, Monterey, Calif.; KEYT, Santa Barbara, Calif.; KFMB-TV, San Diego, Calif.; KPIX, San Francisco, Calif.; KKTU, Colorado Springs, Colo.; KLZ-TV, Denver, Colo.; KBOL, Boise, Idaho; KISJ, Pocatello, Idaho; KOOK-TV, Billings, Montana; KOPR-TV, Butte, Montana; KLAS-TV, Las Vegas, Nevada; KZTV, Reno, Nevada; KGGM-TV, Albuquerque, New Mexico; KBES-TV, Medford, Ore.; KOIN-TV, Portland, Ore.; KROD-TV, El Paso, Texas; KSL-TV, Salt Lake City, Utah; KXLY-TV, Spokane, Wash.; KTNT-TV, Tacoma, Wash.; KIMA-TV, Yakima, Wash.; KFBC-TV, Cheyenne, Wyoming; KFIA, Anchorage, Alaska; KFIF, Fairbanks, Alaska; KGMB-TV, Honolulu, Hawaii.

Columbine Network

Security Life Bldg., Denver, Colo.
Phone: Main 4161

PERSONNEL

General Manager Albert G. Meyer
Sales Manager Edwin E. Koepke

STATIONS

KMYR, Denver; KCOL, Fort Collins; KBOL, Boulder; KYOU, Greeley.

The Connecticut State Network, Inc.

555 Asylum St., Hartford 5, Conn.
Phone: 2-0237

PERSONNEL

President Richard K. Blackburn

STATIONS

WNAB, Bridgeport; WNHC, New Haven; WNLC, New London; WSTC, Stamford; WTOR, Torrington; WATR, Waterbury; WTHT, Hartford; WHAY, New Britain.

Dairyland Network

307 W. Sixth St., Willmar, Minn.

STATIONS

KWLM, Willmar; KWNO, Winona; KMHL, Marshall, Minn.; KTOE, Mankato, Minn.; KDMA, Montevideo, Minn.; KAUS, Austin, Minn.; KFAM, St. Cloud, Minn.

Don Lee Broadcasting

1313 North Vine Street, Hollywood 28, Calif.
Phone: HOLLYWOOD 2-2133

PERSONNEL

President Willet H. Brown
Exec. Vice-Pres. Ward D. Ingram
Sec.-Treas. A. M. Quinn
Vice-Pres. in Charge Sales. Norman Boggs
Vice-Pres. Station Relations. Norman Osby
Dir. of Operations. A. J. LaFrano
Nat. Adv. Mgr. Arthur M. Mortensen
KHJ Sales Manager. Terry Mann
Dir. Public Relations. Bud Coulson
Promotion Director. Robert Light
News & Special Events. Les Mawhinney
Chief Engineer Robert Arne

BRANCH OFFICES

1000 Van Ness Avenue, San Francisco, Calif.
Wm. Pabst, Vice-Pres.; 380 Madison Ave.,
New York, N. Y.; James Richards, Eastern
Sales Mgr.; National Reps., H.R. Representatives:
New York, Chicago, San Francisco.
KAFY, Bakersfield, Calif.; KXOC, Chico,
Calif.; KKO, El Centro, Calif.; KIEM, Eureka,
Calif.; KYNO, Fresno, Calif.; KHJ, Los Angeles,
Calif.; KMYC, Marysville, Calif.; KYOS, Merced,
Calif.; KPRL, Paso Robles, Calif.; KVCV,
Redding, Calif.; KXOA, Sacramento, Calif.;
KSBW, Salinas-Monterey, Calif.; KFXM, San
Bernardino, Calif.; KGB, San Diego, Calif.;
KFRC, San Francisco, Calif.; KVEC, San Luis
Obispo, Calif.; KDB, Santa Barbara, Calif.;
KXOB, Stockton, Calif.; KCOK, Tulare-Visalia,
Calif.; KVNI, Coeur D'Alene, Idaho; KRLC,
Lewiston, Idaho; KWAL, Wallace, Calif.;
KATO, Reno, Nevada; KWIL, Albany, Oregon;
KAST, Astoria, Oregon; KBND, Bend, Oregon;
KOOS, Coos Bay, Oregon; KORE, Eugene, Oregon;
KUIN, Grants Pass, Oregon; KFIL, Klamath
Falls, Oregon; KPOJ, Portland, Oregon;
KRXL, Roseburg, Oregon; KSLM, Salem, Oregon;
KXRO, Aberdeen, Wash.; KPUG, Bellingham,
Wash.; KELA, Centralia-Chehalis,
Wash.; KRKO, Everett, Wash.; KWLK, Longview,
Wash.; KGY, Olympic, Wash.; KVL, Seattle-Tacoma,
Wash.; KNEW, Spokane, Wash.; KUJ, Walla Walla,
Wash.; KWNW, Wenatchee, Wash.; KYAK, Yakima,
Wash.; KVEN, Ventura, Calif.; KWIN, Ashland, Ore.

ADDITIONAL GROUPS AVAILABLE: KOY,
Phoenix, Arizona; KTUC, Tucson, Arizona;
KSUN, Bisbee, Arizona; KYMA, Yuma, Arizona;
KCLS, Flagstaff, Arizona; CKWX, Vancouver,
Canada; KFAR, Fairbanks, Alaska;
KENI, Anchorage, Alaska; KJNO, Juneau,
Alaska; KABI, Ketchikan, Alaska; KPOA,
Honolulu, Hawaii; KILA, Hilo, Hawaii.

Foreign Language Quality Network

730 Fifth Avenue, New York 19, N. Y.
Phone: Circle 5-7979

PERSONNEL

Chairman Pat Stanton

President Ralph N. Weil
STATIONS

WNHC, New Haven, Conn.; WTEL, Philadelphia, Pa.; WJMJ, Philadelphia, Pa.; WHOD, Homestead, Pa.; KSAN, San Francisco, Cal.; WSRs, Cleveland, O.; WACE, Springfield, Mass.; WOV, New York City.

Georgia Associations of Local Stations

Box 66, Atlanta, Ga.

PERSONNEL

Sales Director Tom Carr
STATIONS

WDEC, Americus; WGAU, Athens; WATL, Atlanta; WBBQ, Augusta; WGIG, Brunswick; WLBB, Carrollton; WBHF, Cartersville; WGAA, Cedartown; WMJM, Cordele; WMOC, Covington; WBLJ, Dalton; WDWD, Dawson; WMLT, Dublin; WBHB, Fitzgerald; WDUN, Gainesville; WKEU, Griffin; WFOM, Marietta; WMVG, Milledgeville; WMGA, Moultrie; WFRP, Savannah; WWNS, Statesboro; WSET, Thomaston; WWGS, Titon; WLET, Toccoa; WVOP, Vidalia; WAYX, Waycross; WRLD, West Point.

Granite State Network

155 Front St., Manchester, N. H.
Phone: 4-4075

PERSONNEL

President W. J. Barkley
Treasurer William Rust, Jr.
Manager Ralph Gottlieb

STATIONS

WKBR, Manchester; WWNH, Rochester; WTSV, Claremont; WMOU, Berlin, and WTSL, Hanover, all in New Hampshire; W TSA, Brattleboro, Vt.; WGAW, Gardiner, Mass.

Grass Roots Network

412 1/2 Court St., Muskogee, Okla.
Phone: 656

PERSONNEL

President Jimmie Barry
Secy.-Treas. James L. Neal

STATIONS

KOCY, Oklahoma City, Okla.; KAKC, Tulsa, Okla.; KMUS, Muskogee, Okla.; WBBZ, Ponca City, Okla.; KHBG, Okmulgee, Okla.

Great Northern Bestg. System

107 First Ave., N.W., Mandan, North Dakota
Phone: 3584

PERSONNEL

President M. M. Marget
Vice-President John Cooley
Sec.-Treas. M. J. Reichert

STATIONS

KVOX, Moorehead, Minn.; KGDE, Fergus Falls, Minn.; KLPM, Minot, N. D.; KGCU,

Mandan, N. D.; KOVC, Valley City, N. D.;
KDLR, Devils Lake, N. D.; KGCX, Sidney,
Mont.; KNOX, Grand Forks, N. D.

**Guy Gannett B'estug,
System**

390 Congress St., Portland 3, Maine
Phone: 2-7423

PERSONNEL

President.....Guy P. Gannett
Vice-President.....Laurence H. Stubbs
V.-P., Gen. Mgr.....Creighton E. Gatchell
Sales Manager.....Richard E. Bates

STATION

WGAN, Portland.

Intermountain Network

146 S. Main St., Salt Lake City 1, Utah
Phone: 4-3561

PERSONNEL

President.....Lynn L. Meyer
Exec. Vice-Pres.....Jack S. Paige
Eng. Director.....W. D'Orr Cozzens
Chairman of Board.....George C. Hatch

STATIONS

KCSJ, Pueblo, Colo.; KBYM, Billings, Mont.;
KCPR, Butte, Mont.; KCAP, Helena, Mont.;
KOJ, Havre, Mont.; KMON, Great Falls,
Mont.; KXLO, Lewiston, Mont.; KPRK, Living-
ston, Mont.; KRFJ, Miles City, Mont.; KIYL,
Shelby, Mont.; KNEB, Scottsbluff, Neb.; KRAM,
Las Vegas, Nev.; KELK, Elko, Nev.; KFXD,
Nampa, Idaho; KIFL, Idaho Falls, Idaho;
KWIK, Pocatello, Idaho; KLIX, Twin Falls, Ida-
ho; KVNU, Logan, Utah; KLO, Ogden, Utah;
KOAL, Price, Utah; KOVO, Provo, Utah; KSVL,
Richfield, Utah; KALL, Salt Lake City, Utah;
KSPR, Casper, Wyo.; KVVO, Cheyenne, Wyo.;
KOVE, Lander, Wyo.; KPOW, Powell, Wyo.;
KVRS, Rock Springs, Wyo.; KWYO, Sheridan,
Wyo.; KJAM, Vernal, Utah; KGEM, Boise,
Idaho; KLUK, Evanston, Wyo.; KGEZ, Kalispell,
Mont.; KABQ, Albuquerque, N. M.

Lone Star Chain, Inc.

(The O. L. Taylor Co.)

1024 Life of America Bldg., Dallas 1, Tex.
Phone: LAkeside 1041

PERSONNEL

President.....Harold V. Hough
Vice-President.....Fred Nahas
Secretary-Treasurer.....O. L. Ted Taylor
General Manager.....Fred L. Vance

STATIONS

WBAP, Fort Worth; KTBC, Austin; KTSA,
San Antonio; KXYZ, Houston; KROD, El Paso;
KFDM, Beaumont; KRGV, Weslaco; KEYS,
Corpus Christi; KTRE, Lufkin; KTBB, Tyler;
KGNC, Amarillo; KFYO, Lubbock; KFDX,
Wichita Falls.

Maine Broadcasting System

157 High St., Portland 3, Me.
Phone: 2-0181

PERSONNEL

Manager.....William H. Rines
Technical Director.....Daniel H. Smith
News Supervisor.....Philip N. Johnson

BRANCH OFFICES

100 Main St., Bangor, Me., Phone: 2-4656,
Edward E. Guernsey; 175 Water St., Phone:
3-4735, Augusta, Me., Don Powers.

STATIONS

WCSH, Portland; WLBZ, Bangor; WRDO,
Augusta, Me.

McClatchy Beeline

911 Seventh St., Sacramento, Calif.

PERSONNEL

President.....Eleanor McClatchy
Sales Director.....Leo O. Ricketts

STATIONS

(Station Listing not available at press time.)

Metropolitan Network

Munsey Bldg., Washington 4, D. C.
Phone: NATIONAL 8-5308

Natl. Representative.....Richard O'Connell

STATIONS

WPIK, Alexandria; WFAX, Falls Church,
Virginia; WGAY, Silver Spring; WUST, Bethes-
da, Maryland.

Michigan Radio Network

1700 Mutual Bldg., Detroit 26, Mich.
Phone: Woodward 3-8321

PERSONNEL

President.....James G. Biddell
Sales Manager.....H. S. Christian
Dir. Adv. & Sales Prom.....Robert Baldrice

STATIONS

WBCM, Bay City; WTAC, Flint; WJIM, Lans-
ing; WIBM, Jackson; WELL, Battle Creek;
WLAV, Grand Rapids; WGFG, Kalamazoo;
WKBZ, Muskegon; WSOO, Saulte Ste. Marie;
WKLA, Ludington; WHRV, Ann Arbor; WXYZ,
Detroit, Mich.

The Mid-South Network

WCBI, Columbus, Mississippi

PERSONNEL

General Manager.....Bob McRaney

STATIONS

WCBI, Columbus; WELO, Tupelo; WMOX-
Meridian; WROX, Clarksdale; WNAG, Gren-
ada; WROB, West Point.

Mississippi Broadcasting Co.

(Withers Gavin Stations)

PERSONNEL

Pres. & Mgr. Withers Gavin

STATIONS

WCOC, Meridian; WJQS, Jackson; WMBC, Macon; WACH, Columbus, Miss.

New England Regional Network

26 Grove St., Hartford 15, Conn.
Phone: Hartford 5-0801

DIRECTORS

Chairman Paul W. Morency
Directors Joseph E. Baudino,
John J. Boyle, William H. Hines.

STATIONS

WBZ, Boston, Mass.; WCSH, Portland, Me.; WJAR, Providence, R. I.; WLBZ, Bangor, Me.; WTIC, Hartford, Conn.; WRDO, Augusta, Me.

REPRESENTATIVE

Weed & Company

Northwest Network

3415 University Ave., St. Paul W 14, Minn.
Phone: PRIOR 2717

PERSONNEL

General Manager Stauley E. Hubbard
Treasurer Kenneth M. Hance
Nat. Sales Mgr. Karl A. Plain

STATIONS

KSTP, St. Paul-Minneapolis, Minn. (Key station); WEBC, Duluth, Minn.; KYSM, Mankato, Minn.; WMFG, Hibbing, Minn.; WHLB, Virginia, Minn.; KROC, Rochester, Minn.; KFAM, St. Cloud, Minn.; KFYR, Bismarck, N. D.; WDAY, Fargo, N. D.; WEAU, Eau Claire, Wisc.; WJMC, Rice Lake, Wisc.

NATIONAL REPRESENTATIVE

Edward Petry & Co.

Oklahoma Network

Box 642, Ada, Okla.

PERSONNEL

President Bill Hoover (KADA)
Representative O. L. Taylor Co.

STATIONS

KCRC, Enid; KBIX, Muskogee; KADA, Ada; KVSO, Ardmore; KTMC, McAlester; KSWO, Lawton; KWSH, Tri-City.

The Oregon Trail Network

c/o Sta. KBKR, Baker, Oregon

STATIONS

KSRV, Ontario, Ore.; KBKR, Baker, Ore.; KLBK, LaGrande, Ore.

Palmetto Broadcasting System

#1 Martin St., Anderson, S. C.
Phone: 3802

PERSONNEL

President Wilton E. Hall
General Manager Glenn P. Warnock
Production Manager Jimmy Scribner
National Sales Mgr. G. P. Browne
Promotion Director V. Barath
Regional Sales John F. McCallum

BRANCH OFFICES

504 Mortgage Guarantee Bldg., Atlanta, Ga.
Phone: Alpine 7841

Executive C. J. Cosse

STATIONS

WAIM, Anderson, S. C.; WACA, Camden, S. C.; Choice, Charleston, S. C.; WGCD, Chester, S. C.; WCOS, Columbia, S. C.; WDSC, Dillon, S. C.; WJMX, Florence, S. C.; Choice, Greenville, S. C.; WHSC, Hartsville, S. C.; WKDK, Newberry, S. C.; WTND, Orangeburg, S. C.; WTYC, Rock Hill, S. C.; WSNW, Seneca, S. C.; WBCU, Union, S. C.; WALD, Walterboro, S. C.; WRFC, Athens, Ga.; WBGE, Atlanta, Ga.; WGAC, Augusta, Ga.; WGGG, Gainesville, Ga.; WKLY, Hartwell, Ga.

Quaker Network

Headquarters: WFIL, Philadelphia, Pa.

PERSONNEL

Sales Manager Kenneth W. Stowman

STATIONS

WFIL, Philadelphia; WEEU, Reading; WAEB, Allentown; WEST, Easton; WSBA, York; WAZL, Hazleton; WLAN, Lancaster; WGBI, Scranton; WLK, Wilkes-Barre; WHGB, port; WVAM, Altoona; WARD, Johnstown; Castle; WKBZ, Oil City; WBVP, Beaver Falls, Pa.; WCED, DuBois, Pa.; WGET, Gettysburg, Pa.; WDAD, Indiana, Pa.; WMRF, Lewistown, Pa.; WFIL, Philadelphia, Pa.; WPPA, Pottsville, Pa.; WMAJ, State College, Pa.

Rocky Mountain Broadcasting System

179 Television Center, Salt Lake City 1, Utah
Phone: 22-2505

PERSONNEL

President & Gen. Mgr. Frank C. Carman
Vice-Pres. & Sales Mgr. John Schile

STATIONS

KVTV, Salt Lake City, Utah; KOPR-TV, Butte, Mont.; KFBC-TV, Cheyenne, Wyo.; KWIK-TV, Pocatello, Idaho; KLIX-TV, Twin Falls, Idaho; KMON-TV, Great Falls, Mont.; KLAS-TV, Las Vegas, Nev.

Rural Radio Network

306 E. State St., Ithaca, N. Y.
Phone: 4-6357

PERSONNEL

President.....C. L. Dickinson
General Manager.....D. K. deNeuf
Sales Manager.....H. S. Brown
Program Director.....M. N. Knapp
Farm Director.....R. B. Child
Chief Engineer.....T. R. Humphrey
Controller.....G. B. Holland, Jr.

STATIONS

WRRR, Ithaca, N. Y.; WHLD-FM, Niagara Falls; WRRL, Weatherfield; WHDL-FM, Olean; WRRE, Bristol Center; WRRD, De-Ruyster; WRUN-FM, Utica-Rome; WWNY-FM, Watertown; WMSA-FM, Massena; WRRR, Cherry Valley; WFLY, Troy; WEJL, Scranton, Pa.; WRRH, Mt. Beacon, N. Y.; WAGE, Syracuse, N. Y.; WDLA, Walton, N. Y.; WELM, Elmira, N. Y.; WGNV, Newberg, N. Y.; WGY, Schenectady, N. Y.; WHAM, Rochester, N. Y.; WHCU, Ithaca, N. Y.; WHLD, Niagara Falls, N. Y.; WJTN, Jamestown, N. Y.; WKBW, Buffalo, N. Y.; WKIP, Poughkeepsie, N. Y.; WMSA, Massena, N. Y.; WBNF, Binghamton, N. Y.; WRUN, Utica-Rome, N. Y.; WWNY, Watertown, N. Y.; WQAN, Scranton, Pa.

Steinman Stations

8 W. King St., Lancaster, Pa.
Phone: 5251

PERSONNEL

Gen. Mgr.....Clair R. McCollough
Sales Manager.....J. Robert Gulick
Technical Dir.....J. E. Mathiot
Nat'l Representative....Robert Meeker Assoc.

STATIONS

WDEL-AM-FM-TV, Wilmington, Del.; WORK, York, Pa.; WKBO, Harrisburg, Pa.; WGAL-AM-FM-TV, Lancaster, Pa.; WLEY-TV, Bethlehem, Allentown, Easton, Pa.; WEST-AM-FM, Easton, Pa.; WRAW, Reading, Pa.

Tall Corn Network

(Address any Station or John E. Pearson, Reps.)

PERSONNEL

President.....Dietrich Dirks (KCOM)
Vice-President.....Ed Breen (KVFD)
Vice-President.....G. J. Volger (KWPC)
Secretary.....Wm. P. White (KFJB)

STATIONS

KPIG, Cedar Rapids; KROS, Clinton; KSIB, Creston; KFNF, Shenandoah; KDEC, Decorah; KDTH, Dubuque; KVFD, Fort Dodge; KFJB, Marshalltown; KWPC, Muscatine; KWBG, Boone; KICD, Spencer; KRIB, Mason City; KCIM, Carroll; KOEL, Oelwein; KXIC, Iowa City; KBOE, Oskaloosa; KCOM, Sioux City, all in Iowa.

Texas Broadcasting System

Herald Square, Dallas, Tex.
Phone: RA 6811

General Manager.....Clyde W. Rembert

STATIONS

KRLD, Dallas; KABC, San Antonio; KTRH, Houston, Texas.

Texas Plains Stations

KFLD, P. O. Box 955, Floydada, Tex.
Phone: 11

Network Manager.....Ed Holmes

STATIONS

KFLD, Floydada; KPAN, Hereford; KVCM, Colorado City, Texas.

Texas Quality Network

1122 Jackson St. (WFAA), Dallas, Tex.
Phone: Riverside 9631

PERSONNEL

Representative.....Alex Keese (KRIS), P. O. Box 840, Corpus Christi, Tex., Phone: 4-6354, Gen. Mgr. T. Frank Smith; (KPRC), Lamar & Main Sts., Houston, Tex., Phone: Fairfax 7101, Gen. Mgr. Jack Harris; (WOAI), 1031 Navarro St., San Antonio, Tex., Gen. Mgr. Arden X. Pangborn; (WFAA), 1122 Jackson St. (Dal), Dallas-Ft. Worth, Tex., Phone: Riverside 9631, Gen. Mgr. Martin Campbell, WBAP, Ft. Worth, Texas; KGNC, Amarillo, Texas; KRGV, Weslaco, Texas; KCBD, Lubbock, Texas.

Texas State Network, Inc.

1201 W. Lancaster Ave., Fort Worth 1, Tex.
Phone: ED 3473

PERSONNEL

President.....Gene L. Cagle
Vice-President.....Charles B. Jordan
Secretary-Treasurer.....D. C. Hornburg
Sales Manager.....Dale Drake
Traffic Manager.....Forrest W. Clough
Chief Engineer.....James T. Peterson

STATIONS

KFJZ, Fort Worth; KRBC, Abilene; KGKL, San Angelo; KBST, Big Spring; KCRS, Midland; KRRV, Sherman; KPLT, Paris; KABC, San Antonio; WRR, Dallas; KCMC, Texarkana; WACO, Waco; KFRO, Longview; KBWD, Brownwood; KNOW, Austin; KTRH, Houston; KGVJ, Greenville, Texas; KRIO, McAllen; KLYN, Amarillo; KWFT, Wichita Falls, Texas; KTBB, Tyler, Texas.

The Tobacco Network, Inc.

710 Odd Fellows Bldg., Raleigh, N. C.
Raleigh, N. C.

Phone: 8885

PERSONNEL

President.....Lester L. Gould
Vice-President.....Fred Fletcher

Secretary-Treasurer Allen Jones
 General Manager..... Kenneth C. Wilson
 Office Manager Nina J. Livingston

STATIONS

WFNC, Fayetteville; WRAL, Raleigh;
 WGTC, Greenville; WHIT, New Bern; WJNC,
 Jacksonville; WTIK, Durham; WGNI, Wilmington;
 WCEC, Rocky Mount, N. C.; WGBR, Goldsboro,
 N. C.

Union Broadcasting System

PERSONNEL

General Manager.....Jim Healey

STATIONS

WOKO, Albany; WCSS, Amsterdam;
 WWSC, Glens Falls; WHUC, Hudson; WEAV,
 Plattsburg; WBEC, Pittsfield, Mass.; WACE,
 Chicopee; WALE, Fall River; WSYB, Rutland;
 WJOY, Burlington, Vt.; WKNE, Keene, N. H.;
 WGAT, Utica, N. Y.

Upper Midwest Broadcasting System

1687 Northwestern Bank Bldg.,
 Minneapolis, Minn.
 Phone: Geneva 9631

PERSONNEL

PresidentOrville Lawson

STATIONS

KASM, Albany; KXRA, Alexandria; KBUN,
 Benadict; KLIZ, Brainerd; KBMW, Breckenridge;
 Fairbault; KSUM, Fairmont; WEVE, Eveleth;
 KGDE, Fergus Falls; CKFL, International Falls;
 KVOX, Fargo-Moorhead, all in Minnesota; KDLR,
 Devils Lake; KVOX, Fargo-Moorhead; KNOX,
 Grand Forks; KGPU, Bismarck-Mandan; KLPM,
 Minot; KOVC, Valley City; KGCK, Williston-
 Sidney, all in North Dakota; KABC, Aberdeen;
 KIJV, Huron; KORN, Mitchell; KDSJ, Dead-
 wood; KISD, Sioux Falls; KWAT, Watertown;
 and KGFX, Pierre, all in South Dakota; WHDF,
 Houghton; WIKD, Iron River; WJMS, Iron-
 wood; WJPD, Ishpeming; WDBC, Escanaba,
 all in Michigan; WHBY, Appleton; WATW,
 Ashland; WBIZ, Eau Claire; WJPG, Green
 Bay; WLCK, La Crosse; WLDY, Ladysmith;
 WIBU, Madison-Poynette; WLIN, Merrill;
 WOBT, Rhinelander; WTCH, Shawano, and
 WFHR, Wisconsin Rapids, all in Wisconsin;
 KASI, Ames; KCOG, Centerville; KJFJ, Web-
 ster City; KAYL, Storm Lake; KSTT, Davenport;
 KSMN, Mason City; KOXX, Keokuk; KCHA,
 Charles City, all in Iowa; KCNL, Broken Bow;
 WJAG, Norfolk; KFGT, Fremont; KNEB, Scotch-
 bluff, and KJSK, Columbus, all in Nebraska;
 WMRO, Aurora; WCAZ, Carthage, and WLBE,
 De Kalb, all in Illinois; KXGN, Glendive and
 KGCK, Sidney, both in Montana; KBMW,
 Wahpeton-Breckenridge, N. D.; WDLB, Marsh-
 field, Wisc.; WMNE, Menomonie, Wisc.;
 WOSH, Oshkosh, Wisc.; WPDR, Portage,
 Wisc.; WPRE, Prairie Du Chien, Wisc.; WRJN,
 Racine, Wisc.; WRCO, Richland Center, Wisc.;
 WSPT, Stevens Point, Wisc.; WTRW, Two

Rivers, Wisc.; WBKV, West Bend, Wisc.;
 KJAN, Atlantic, Iowa; WKLK, Cloquet, Minn.;
 KBZY, Grand Rapids, Minn.; WSHB, Stillwater,
 Minn.

West Texas Packaged Stations

(Address any Station)

STATIONS

KRBC, Abilene; KBST, Big Spring; KGKL,
 San Angelo; KTRN, Wichita Falls.

Wisconsin Network, Inc.

Nash Block, Wisconsin Rapids, Wis.
 Phone: 723

PERSONNEL

Managing Dir.....George T. Frechette
 President.....John M. Walter
 Vice-PresidentEarl Huth

STATIONS

WRJN, Racine; WCLO, Janesville; WGEZ,
 Beloit; WIBU, Poynette; WHBY, Appleton;
 WHBL, Sheboygan; WJPG, Green Bay; WFHR,
 Wisconsin Rapids; WWCF, Baraboo; WSAU,
 Wausau; WRDB, Reedsburg.

Wyoming Cowboy Network

KFBC, 2923 East Lincolnway, Cheyenne, Wyo.
 Phone: 4-4461

General Manager.....Wm. C. Grove
 Commercial Manager.....C. P. Cahill

STATIONS

KFBC, Cheyenne; KRAL, Rawlins; KWRL,
 Riverton; KWOR, Worland, KOWB, Laramie;
 KVOC, Casper; KODI, Cody; KGOS, Torrington;
 KSID, Sidney; KASL, Newcastle.

The Yankee Network

21 Brookline Ave., Boston 15, Mass.
 Phone: Commonwealth 6-0800

Executive Vice-Pres. & Gen. Mgr.

Linus Travers

Vice-PresidentGeorge Steffy
 Sales, Prom. Manger.....Tom Bateson
 TrafficDick Black
 NewsL. Bickford
 Program Manager.....Jack Maloy

STATIONS

WNAC, Boston, Mass.; WFAU, Augusta,
 Maine; WIDE, Biddeford, Maine; WICC, Bridge-
 port, Conn.; WALE, Fall River, Mass.; WEIM,
 Fitchburg-Leominster, Mass.; WHAI, Green-
 field, Mass.; WONS, Hartford, Conn.; WCOU,
 Lewiston-Auburn, Maine; WLLH, Lowell-
 Lawrence, Mass.; WNBH, New Bedford,
 Mass.; WOCB, Hyannis, Mass.; WNLC, New
 London, Conn.; WBRK, Pittsfield, Mass.; WPOR,
 Portland, Maine; WHEB, Portsmouth-Dover, N.
 H.; WEAN, Providence, R. I.; WWON, Woon-
 socket, R. I.; WSYB, Rutland, Vt.; WWSR,
 St. Albans, Vt.; WWCO, Waterbury, Conn.;
 WDEV, Waterbury, Vt.; WORC, Worcester,
 Mass.; WMAS, Springfield, Mass.

ESTIMATED FAMILIES FOR 1954

STATE	Population Feb. 1, 1954 (Estimated)	Families	Radio Homes	TV Homes	Radio Stations in State
ALABAMA	3,181,000	791,000	655,000	280,500	89
ARIZONA	816,000	296,000	277,000	108,000	29
ARKANSAS	2,000,000	580,000	187,000	102,000	51
CALIFORNIA	12,479,000	4,300,000	4,223,000	2,846,500	145
COLORADO	1,558,000	161,000	146,000	199,500	33
CONNECTICUT	2,097,000	639,000	631,000	485,000	26
DELAWARE	324,000	91,300	87,000	76,000	7
DISTRICT OF COLUMBIA	834,000	271,000	262,000	201,500	7
FLORIDA	3,192,000	1,011,000	905,000	397,500	80
GEORGIA	3,890,000	963,000	802,000	392,500	85
IDAHO	606,000	180,000	176,000	27,500	24
ILLINOIS	9,273,000	2,858,000	2,787,000	1,962,000	81
INDIANA	1,252,000	1,350,000	1,303,000	830,000	18
IOWA	2,647,000	872,000	817,000	422,000	50
KANSAS	1,943,000	583,000	554,000	215,500	40
KENTUCKY	3,004,000	770,000	684,000	359,500	50
LOUISIANA	2,738,000	715,000	602,000	281,500	49
MAINE	922,000	287,000	273,000	69,000	16
MARYLAND	2,366,000	610,000	612,000	691,500	27
MASSACHUSETTS	1,738,000	1,125,000	1,409,000	1,190,500	51
MICHIGAN	6,700,000	1,920,000	1,916,000	1,127,500	70
MINNESOTA	3,127,000	940,000	917,000	439,000	47
MISSISSIPPI	2,200,000	580,000	463,000	120,000	51
MISSOURI	1,031,000	1,215,000	1,146,000	681,500	61
MONTANA	597,000	181,000	176,000	10,500	25
NEBRASKA	1,333,000	126,000	408,000	181,500	25
NEVADA	176,000	66,000	61,000	12,500	10
NEW HAMPSHIRE	551,000	160,000	155,000	86,500	12
NEW JERSEY	5,228,000	1,547,000	1,493,000	1,375,000	20
NEW MEXICO	760,000	195,000	181,000	51,000	29
NEW YORK	15,872,000	4,771,000	4,618,000	3,912,000	99
NORTH CAROLINA	1,221,000	1,130,000	981,000	398,000	107
NORTH DAKOTA	626,000	169,000	164,000	13,500	13
OHIO	8,385,000	2,499,000	2,435,000	2,017,500	78
OKLAHOMA	2,280,000	650,000	582,000	320,000	46
OREGON	1,854,000	620,000	604,000	187,000	47
PENNSYLVANIA	11,223,000	3,145,000	3,001,000	2,375,000	117
RHODE ISLAND	816,000	303,000	299,000	230,000	11
SOUTH CAROLINA	2,181,000	530,000	141,000	195,000	51
SOUTH DAKOTA	666,000	231,000	221,000	18,500	14
TENNESSEE	3,424,000	881,000	768,000	391,000	65
TEXAS	8,986,000	2,793,000	2,463,000	1,129,000	191
UTAH	724,000	217,000	242,000	121,000	18
VERMONT	386,000	110,000	106,000	26,500	11
VIRGINIA	3,452,000	830,000	738,000	512,000	63
WASHINGTON	2,814,000	987,000	965,000	111,500	54
WEST VIRGINIA	2,086,000	502,000	461,000	233,500	41
WISCONSIN	3,607,000	1,063,000	1,037,000	568,500	65
WYOMING	308,000	93,000	90,000	7,500	16
TOTAL	161,500,000	17,900,000	15,159,000	28,500,000	2,144

Amplitude Modulation Stations—AM

•

U. S. STATION INDEX

•

**STATIONS ALPHABETICALLY
LISTED BY STATES — CITIES**

•

KEY PERSONNEL

WOR

Every season... every month... every day,
WOR sells *more* products to *more* people
at *less* cost than any other station
in the United States.

WOR — *New York*

Key station of the Mutual Broadcasting System

Index of Standard Stations of U. S.



CKLW — Detroit-Windsor, Mich.	455	KBMN — Bozeman, Mont.	480
KAAA — Red Wing, Minn.	465	KBMW — Breckenridge, Minn.	462
KABC — Los Angeles, Calif.	342	KBMX — Coalinga, Calif.	340
KABI — Ketchikan, Alaska	656	KBMY — Billings, Mont.	480
KABQ — Albuquerque, N. M.	492	KBND — Bend, Ore.	553
KABR — Aberdeen, S. D.	588	KBNZ — La Junta, Colo.	362
KADA — Ada, Okla.	547	KBOA — Kennett, Mo.	476
KAFP — Petaluma, Calif.	347	KBOE — Oskaloosa, Ia.	419
KAGH — Crossett, Ark.	330	KBOL — Boulder, Colo.	359
KAHU — Waipahu, Hawaii	659	KBON — Omaha, Neb.	485
KAKC — Tulsa, Okla.	552	KBOP — Pleasanton, Tex.	615
KAKE — Wichita, Kan.	425	KBOR — Brownsville, Tex.	601
KALB — Alexandria, La.	432	KBOW — Butte, Mont.	481
KALE — Richland, Wash.	636	KBOX — Modesto, Calif.	345
KALG — Alamogordo, N. M.	492	KBRC — Mount Vernon, Wash.	635
KALI — Pasadena, Calif.	347	KBRL — McCook, Neb.	485
KALL — Salt Lake City, Utah	622	KBRO — Bremerton, Wash.	634
KALM — Thayer, Mo.	479	KBR5 — Springdale, Ark.	334
KALT — Atlanta, Tex.	599	KBRZ — Freeport, Tex.	607
KAMD — Camden, Ark.	330	KBST — Big Springs, Tex.	600
KAMQ — Amarillo, Tex.	598	KBTA — Batesville, Ark.	330
KANA — Anaconda, Mont.	480	KBTM — Jonesboro, Ark.	332
KAND — Corsicana, Tex.	603	KBTO — El Dorado, Kan.	421
KANE — New Iberia, La.	435	KBUC — Corona, Calif.	340
KANI — Kaneohe, Oahu, Hawaii	659	KBUD — Athens, Tex.	599
KANS — Wichita, Kan.	425	KBUH — Brigham City, Utah	621
KAOK — Lake Charles, La.	434	KBUN — Bemiji, Minn.	462
KAPA — Raymond, Wash.	636	KBUR — Burlington, Iowa	414
KAPK — Minden, La.	434	KBWD — Brownwood, Tex.	601
KARE — Atchison-St. Joseph, Kan.	421	KBWL — Blackwell, Okla.	548
KARK — Little Rock, Ark.	332	KBYE — Oklahoma City, Okla.	550
KARM — Fresno, Calif.	340	KBYR — Anchorage, Alaska	655
KASA — Elk City, Okla.	548	KBYZ — Grand Rapids, Minn.	463
KASH — Eugene, Ore.	554	KCAP — Helena, Mont.	481
KASI — Ames, Iowa	414	KCBC — Des Moines, Iowa	416
KASL — Newcastle, Wyo.	654	KCBD — Lubbock, Tex.	611
KASM — Albany, Minn.	462	KCBQ — San Diego, Calif.	349
KAST — Astoria, Ore.	553	KCBS — San Francisco, Calif.	351
KATE — Albert Lea, Minn.	462	KCFH — Cuero, Tex.	603
KATL — Houston, Tex.	609	KCHA — Charles City, Iowa	415
KATO — Reno, Nev.	487	KCHE — Cherokee, Iowa	415
KATY — San Luis Obispo, Calif.	355	KCHI — Chillicothe, Mo.	473
KAUS — Austin, Minn.	462	KCHJ — Delano, Calif.	340
KAVE — Carlsbad, N. M.	493	KCHR — Charleston, Mo.	473
KAVL — Lancaster, Calif.	342	KCHS — Truth or Consequences, N. M.	495
KAWT — Douglas, Ariz.	326	KCID — Caldwell, Idaho	394
KAYL — Storm Lake, Ia.	420	KCIJ — Shreveport, La.	436
KAYO — Seattle, Wash.	636	KCIL — Houma, La.	433
KAYS — Hays, Kan.	422	KCIM — Carroll, Iowa	414
KBAK — Bakersfield, Calif.	337	KCJB — Minot, N. D.	533
KBAR — Burley, Idaho	394	KCKN — Kansas City, Kan.	423
KBBA — Benton, Ark.	330	KCKY — Coolidge, Ariz.	326
KBEL — Idabel, Okla.	549	KCLA — Pine Bluff, Ark.	334
KBHS — Hot Springs, Ark.	332	KCLE — Cleburne, Tex.	602
KBIF — Sanger, Calif.	352	KCLF — Clifton, Ariz.	326
KBIG — Avalon, Calif.	337	KCLO — Leavenworth, Kan.	423
KBIM — Roswell, N. M.	494	KCLS — Flagstaff, Ariz.	327
KBIS — Bakersfield, Calif.	337	KCLV — Clovis, N. M.	493
KBIX — Muskogee, Okla.	550	KCLW — Hamilton, Tex.	608
KBIZ — Ottumwa, Ia.	419	KCLX — Colfax, Wash.	634
KBKI — Alice, Tex.	598	KCMC — Texarkana, Tex.	619
KBKR — Baker, Ore.	553	KCMJ — Palm Springs, Calif.	347
KBKW — Aberdeen, Wash.	633	KCMO — Kansas City, Mo.	475
KBLA — Burbank, Calif.	339	KCNA — Tucson, Ariz.	328
KBLF — Red Bluff, Calif.	348	KCNC — Fort Worth, Tex.	605
KBLI — Blackfoot, Idaho	394	KCNI — Broken Bow, Neb.	483
KBLO — Hot Springs, Ark.	332	KCNO — Alturas, Calif.	337

KCNV -- San Marcos, Tex.	617
KCOG -- Centerville, Iowa	415
KCOH -- Houston, Tex.	609
KCOK -- Tulare, Calif.	358
KCOL -- Ft. Collins, Colo.	361
KCOM -- Sioux City, Ia.	419
KCON -- Conway, Ark.	330
KCOR -- San Antonio, Tex.	615
KCOW -- Alliance, Neb.	483
KCOY -- Santa Maria, Calif.	356
KCRA -- Sacramento, Calif.	348
KCRB -- Chanute, Kan.	421
KCRC -- Enid, Okla.	548
KCRE -- Crescent City, Calif.	340
KCRI -- Cedar Rapids, Iowa	415
KCRV -- Caruthersville, Mo.	473
KCRS -- Midland, Tex.	612
KCRT -- Trinidad, Colo.	363
KCSB -- San Bernardino, Calif.	349
KCSJ -- Pueblo, Colo.	363
KCSU -- Provo, Utah	621
KCTI -- Gonzales, Tex.	608
KCTX -- Childress, Tex.	602
KCUL -- Fort Worth, Tex.	607
KCVR -- Lodi, Calif.	342
KCYL -- Lampasas, Tex.	610
KDAC -- Fort Bragg, Calif.	340
KDAL -- Duluth, Minn.	463
KDAS -- Malvern, Ark.	333
KDAV -- Lubbock, Tex.	611
KDB -- Santa Barbara, Calif.	356
KDDD -- Dumas, Tex.	604
KDEC -- Decorah, Iowa	416
KDEF -- Albuquerque, N. M.	492
KDET -- Center, Tex.	602
KDHL -- Faribault, Minn.	463
KDIA -- Auburn, Calif.	337
KDIX -- Dickinson, N. D.	532
KDKA -- Pittsburgh, Pa.	574
KDKD -- Clinton, Mo.	473
KDLA -- DeRidder, La.	433
KDLK -- Del Rio, Tex.	604
KDLM -- Detroit Lakes, Minn.	463
KDLR -- Devils Lake, N. D.	532
KDMA -- Montevideo, Minn.	465
KDMO -- Carthage, Mo.	473
KDMS -- El Dorado, Ark.	330
KDNT -- Denton, Tex.	604
KDON -- Salinas, Calif.	349
KDRO -- Sedalia, Mo.	479
KDRS -- Paragould, Ark.	334
KDSH -- Boise, Idaho	394
KDSJ -- Deadwood, S. D.	588
KDSX -- Denison, Tex.	604
KDTH -- Dubuque, Ia.	417
KDUZ -- Hutchinson, Minn.	464
KDWT -- Stamford, Tex.	618
KDYL -- Salt Lake City, Utah	622
KDZA -- Pueblo, Colo.	363
KEAN -- Brownwood, Tex.	601
KEAR -- San Mateo, Calif.	355
KEBE -- Jacksonville, Tex.	610
KECC -- Pittsburgh, Calif.	348
KECK -- Odessa, Tex.	613
KEEN -- San Jose, Calif.	355
KEEP -- Twin Falls, Idaho	396
KELA -- Centralia-Chehalis, Wash.	634
KELD -- El Dorado, Ark.	331
KELK -- Elko, Nev.	486
KELO -- Sioux Falls, S. D.	589
KELP -- El Paso, Tex.	605
KELY -- Ely, Nev.	486
KENA -- Mena, Ark.	333
KENI -- Anchorage, Alaska	655

KENM -- Portales, N. M.	494
KENO -- Las Vegas, Nev.	486
KENT -- Shreveport, La.	436
KEPO -- El Paso, Tex.	605
KERB -- Kermit, Tex.	610
KERC -- Eastland, Tex.	604
KERG -- Eugene, Ore.	554
KERN -- Bakersfield, Calif.	337
KERO -- Bakersfield, Calif.	337
KERV -- Kerrville, Tex.	610
KEUN -- Eunice, La.	433
KEVA -- Shamrock, Tex.	617
KEVT -- Tucson, Ariz.	328
KEX -- Portland, Ore.	558
KEXO -- Grand Junction, Colo.	361
KEXX -- San Antonio, Tex.	616
KEYD -- Minneapolis, Minn.	464
KEYE -- Perrytown, Tex.	614
KEYS -- Corpus Christie, Tex.	602
KEYY -- Provo, Utah	622
KFAB -- Omaha, Neb.	485
KFAC -- Los Angeles, Calif.	342
KFAD -- Fairfield, Ia.	417
KFAL -- Fulton, Mo.	474
KFAM -- St. Cloud, Minn.	466
KFAR -- Fairbanks, Alaska	655
KFBB -- Great Falls, Mont.	481
KFBC -- Cheyenne, Wyo.	653
KFBI -- Wichita, Kan.	425
KFBK -- Sacramento, Calif.	348
KFDA -- Amarillo, Tex.	598
KFDM -- Beaumont, Tex.	600
KFDR -- Grand Coulee, Wash.	634
KFDX -- Wichita Falls, Tex.	620
KFEL -- Denver, Colo.	360
KFEQ -- St. Joseph, Mo.	477
KFFA -- Helena, Ark.	331
KFGO -- Fargo, N. D.	532
KFGT -- Fremont, Neb.	483
KFH -- Wichita, Kan.	425
KFI -- Los Angeles, Calif.	342
KFIR -- North Bend, Ore.	557
KFIZ -- Fon du Lac, Wis.	646
KFJB -- Marshalltown, Ia.	418
KFJI -- Klamath Falls, Ore.	555
KFJZ -- Fort Worth, Tex.	607
KFKA -- Greeley, Colo.	361
KFLD -- Floydada, Tex.	605
KFLW -- Klamath Falls, Ore.	555
KFMA -- Davenport, Iowa	416
KFMB -- San Diego, Calif.	350
KFMJ -- Tulsa, Okla.	552
KFMO -- Flat River, Mo.	474
KFNF -- Shenandoah, Ia.	419
KFOR -- Lincoln, Neb.	484
KFOX -- Long Beach, Calif.	342
KFPW -- Fort Smith, Ark.	331
KFQD -- Anchorage, Alaska	655
KFRB -- Fairbanks, Alaska	655
KFRC -- San Francisco, Calif.	352
KFRD -- Rosenberg, Tex.	615
KFRE -- Fresno, Calif.	341
KFRM -- Concordia, Kan.	421
KFRO -- Longview, Tex.	611
KFRU -- Columbia, Mo.	473
KFSA -- Fort Smith, Ark.	331
KFSB -- Joplin, Mo.	475
KFSD -- San Diego, Calif.	350
KFTM -- Fort Morgan, Colo.	361
KFTV -- Paris, Tex.	614
KFUN -- Las Vegas, N. M.	494
KFVD -- Los Angeles, Calif.	343
KFVS -- Cape Girardeau, Mo.	473
KFWB -- Hollywood, Calif.	341

KFXD — Nampa, Idaho	395	KHON — Honolulu, Hawaii	657
KFXJ — Grand Junction, Colo.	361	KHOZ — Harrison, Ark.	331
KFXM — San Bernardino, Calif.	349	KHQ — Spokane, Wash.	637
KFYN — Bonham, Tex.	601	KHSL — Chico, Calif.	339
KFYO — Lubbock, Tex.	611	KHUB — Watsonville, Calif.	359
KFYR — Bismarck, N. D.	532	KHUM — Eureka, Calif.	340
KGA — Spokane, Wash.	637	KHUZ — Borger, Tex.	601
KGAE — Salem, Ore.	559	KIBE — Palo Alto, Calif.	347
KGAF — Gainesville, Tex.	607	KIBH — Seward, Alaska	656
KGAK — Gallup, N. M.	493	KIBL — Beeville, Tex.	600
KGAL — Lebanon, Ore.	555	KIBS — Bishop, Calif.	339
KGAN — Kingman, Ariz.	327	KICA — Clovis, N. M.	493
KGAR — Garden City, Kan.	422	KICD — Spencer, Ia.	419
KGB — San Diego, Calif.	350	KICK — Springfield, Mo.	479
KGBC — Galveston, Tex.	607	KICO — Calexico, Calif.	339
KGBS — San Antonio, Tex.	615	KID — Idaho Falls, Idaho	394
KGBT — Harlingen, Tex.	608	KIDO — Boise, Idaho	394
KGEX — Springfield, Mo.	479	KIEM — Eureka, Calif.	340
KGCU — Mandan, N. D.	533	KIEV — Glendale, Calif.	341
KGCX — Sidney, Mont.	483	KIEW — Sitka, Alaska	656
KGDE — Fergus Falls, Minn.	463	KIFI — Idaho Falls, Idaho	395
KGDM — Stockton, Calif.	357	KIFN — Phoenix, Ariz.	327
KGEK — Sterling, Colo.	363	KIHN — Hugo, Okla.	549
KGEM — Boise, Idaho	394	KIHO — Sioux Falls, S. D.	589
KGER — Long Beach, Calif.	342	KIHR — Hood River, Ore.	555
KGEZ — KallsPELL, Mont.	482	KIJV — Huron, S. D.	589
KGFF — Shawnee, Okla.	551	KIKI — Honolulu, Hawaii	657
KGFJ — Hollywood, Calif.	342	KILA — Hilo, Hawaii	656
KGFL — Roswell, N. M.	494	KILO — Grand Forks, N. D.	532
KGFW — Kearney, Neb.	484	KIMA — Yakima, Wash.	639
KGFX — Pierre, S. D.	589	KIMO — Independence, Mo.	474
KGGF — Coffeyville, Kan.	421	KIMP — Mount Pleasant, Tex.	613
KGGM — Albuquerque, N. M.	492	KIND — Independence, Kan.	423
KGHF — Pueblo, Colo.	363	KINE — Kingsville, Tex.	610
KGHI — Little Rock, Ark.	332	KING — Seattle, Wash.	636
KGHL — Billings, Mont.	480	KINY — Juneau, Alaska	655
KGIB — Bremerton, Wash.	634	KIOA — Des Moines, Iowa	416
KGIL — San Fernando, Calif.	351	KIOX — Bay City, Tex.	599
KGIW — Alamosa, Colo.	359	KIPA — Hilo, Hawaii	657
KGKB — Tyler, Tex.	619	KIRO — Seattle, Wash.	636
KGKL — San Angelo, Tex.	615	KIRX — Kirksville, Mo.	476
KGKO — Dallas, Tex.	603	KISD — Sioux Falls, S. D.	589
KGLC — Miami, Okla.	550	KIST — Santa Barbara, Calif.	356
KGLN — Glenwood Springs, Colo.	361	KIT — Yakima, Wash.	639
KGLO — Mason City, Ia.	418	KITE — San Antonio, Tex.	616
KGLU — Safford, Ariz.	328	KITO — San Bernardino, Calif.	349
KGMB — Honolulu, Hawaii	657	KIUL — Garden City, Kan.	422
KGMC — Englewood, Colo.	361	KIUN — Pecos, Tex.	614
KGMO — Cape Girardeau	473	KIUP — Durango, Colo.	361
KGMS — Sacramento, Calif.	348	KIVY — Crockett, Tex.	603
KGNB — New Braunfels, Tex.	613	KIWW — San Antonio, Tex.	616
KGNC — Amarillo, Tex.	598	KIXL — Dallas, Tex.	603
KGNO — Dodge City, Kan.	421	KIYI — Shelby, Mont.	483
KGO — San Francisco, Calif.	352	KJAM — Vernal, Utah	623
KGON — Oregon City-Portland, Ore.	557	KJAN — Atlantic, Iowa	414
KGOS — Torrington, Wyo.	654	KJAY — Topeka, Kan.	424
KGPH — Flagstaff, Ariz.	327	KJBC — Midland, Tex.	612
KGRR — Fayetteville, Ark.	331	KJBS — San Francisco, Calif.	352
KGRI — Henderson, Tex.	608	KJCF — Festus, Mo.	474
KGST — Fresno, Calif.	341	KJCK — Junction City, Kan.	423
KGU — Honolulu, Hawaii	657	KJEF — Jennings, La.	433
KGVL — Greenville, Tex.	608	KJFJ — Webster City, Ia.	420
KGVO — Missoula, Mont.	482	KJIM — Beaumont, Tex.	600
KGW — Portland, Ore.	557	KJNO — Juneau, Alaska	655
KGWA — Enid, Okla.	549	KJR — Seattle, Wash.	637
KGY — Olympia, Wash.	635	KJRG — Newton, Kan.	423
KGYN — Guymon, Okla.	549	KJRL — Pocatello, Idaho	395
KGYW — Vallejo, Calif.	358	KJSK — Columbus, Neb.	483
KHAS — Hastings, Neb.	484	KJUN — Redmond, Ore.	559
KHBC — Hilo, Hawaii	656	KLAC — Hollywood, Calif.	342
KHBG — Okmulgee, Okla.	551	KLAN — Renton, Wash.	636
KHBR — Hillsboro, Tex.	608	KLAS — Las Vegas, Nev.	486
KHJ — Los Angeles, Calif.	343	KLBM — La Grande, Ore.	555
KHMO — Hannibal, Mo.	474	KLBS — Houston, Tex.	609

KLCB — Libby, Mont.	482	KNEB — Scottsbluff, Neb.	486
KLCN — Blytheville, Ark.	330	KNED — McAlester, Okla.	550
KLEA — Lovington, N. M.	494	KNEL — Brady, Tex.	601
KLER — Lewiston, Idaho	395	KNEM — Nevada, Mo.	477
KLFY — LaFayette, La.	433	KNET — Palestine, Tex.	614
KLIC — Monroe, La.	434	KNEW — Spokane, Wash.	638
KLIF — Dallas, Tex.	603	KNEX — McPherson, Kan.	423
KLJK — Jefferson City, Mo.	475	KNGS — Hanford, Calif.	341
KLIL — Esterville, Ia.	417	KNIM — Maryville, Mo.	476
KLIQ — Portland, Ore.	558	KNOE — Monroe, Lo.	434
KLIR — Denver, Colo.	360	KNOG — Nogales, Ariz.	327
KLIX — Twin Falls, Idaho	396	KNOR — Norman, Okla.	550
KLIZ — Brainerd, Minn.	462	KNOW — Austin, Tex.	599
KLJC — Parsons, Kan.	424	KNOX — Grand Forks, N. D.	532
KLMO — Longmont, Colo.	363	KNPT — Newport, Ore.	557
KLMR — Lamar, Colo.	362	KNUJ — New Ulm, Minn.	465
KLMS — Lincoln, Neb.	484	KNUZ — Houston, Tex.	609
KLMX — Clayton, N. M.	493	KNX — Los Angeles, Calif.	345
KLO — Ogden, Utah	621	KOA — Denver, Colo.	360
KLOG — Kelso, Wash.	634	KOAL — Price, Utah	621
KLOK — San Jose, Calif.	355	KOAM — Pittsburg, Kan.	424
KLOU — Lake Charles, La.	434	KOAT — Albuquerque, N. M.	492
KLPM — Minot, N. D.	533	KOB — Albuquerque, N. M.	493
KLPR — Oklahoma City, Okla.	550	KOBE — Las Cruces, N. M.	494
KLRA — Little Rock, Ark.	332	KOBK — Owatonna, Minn.	465
KLTF — Little Falls, Minn.	464	KOCA — Kilgore, Tex.	610
KLTI — Longview, Tex.	611	KOCO — Salem, Ore.	559
KLUF — Galveston, Tex.	608	KOCS — Ontario, Calif.	347
KLUK — Evanston, Wyo.	653	KOCY — Oklahoma City, Okla.	550
KLVC — Leadville, Colo.	362	KODI — Cody, Wyo.	653
KLVL — Pasadena, Tex.	614	KODL — The Dalles, Ore.	554
KLVT — Levelland, Tex.	611	KODY — North Platte, Neb.	485
KLWN — Lawrence, Kan.	423	KOEL — Oelwein, Ia.	418
KLWT — Lebanon, Mo.	476	KOFE — Pullman, Wash.	636
KLX — Oakland, Calif.	346	KOFO — Ottawa, Kan.	424
KLYN — Amarillo, Tex.	598	KOGT — Orange, Tex.	614
KLZ — Denver, Colo.	360	KOH — Reno, Nev.	487
KMA — Shenandoah, Ia.	419	KOIL — Omaha, Neb.	485
KMAC — San Antonio, Tex.	616	KOIN — Portland, Ore.	558
KMAE — McKinney, Tex.	612	KOJM — Havre, Mont.	481
KMAK — Fresno, Calif.	341	KOKO — Warrensburg, Mo.	479
KMAN — Manhattan, Kan.	423	KOKX — Keokuk, Ia.	418
KMBC — Kansas City, Mo.	475	KOL — Seattle, Wash.	637
KMBL — Junction, Tex.	610	KOLD — Yuma, Ariz.	329
KMBY — Monterey, Calif.	346	KOLE — Port Arthur, Tex.	615
KMCM — McMinnville, Ore.	555	KOLJ — Quanah, Tex.	615
KMCO — Conroe, Texas	602	KOLN — Lincoln, Neb.	484
KMED — Medford, Ore.	555	KOLO — Reno, Nev.	487
KMHL — Marshall, Minn.	464	KOLS — Pryor, Okla.	551
KMHT — Marshall, Tex.	612	KOLT — Scottsbluff, Neb.	486
KMJ — Fresno, Calif.	341	KOMA — Oklahoma City, Okla.	550
KMLB — Monroe, La.	434	KOME — Tulsa, Okla.	552
KMLW — Marlin, Tex.	612	KOMO — Seattle, Wash.	637
KMMJ — Grand Island, Neb.	483	KOMW — Omak, Wash.	635
KMMO — Marshall, Mo.	476	KONG — Visalia, Calif.	358
KMO — Tacoma, Wash.	638	KONO — San Antonio, Tex.	616
KMOD — Modesto, Calif.	346	KONP — Port Angeles, Wash.	636
KMON — Great Falls, Mont.	481	KOOK — Billings, Mont.	480
KMOR — Orville, Calif.	347	KOOL — Phoenix, Ariz.	327
KMOX — St. Louis, Mo.	478	KOOS — Coos Bay, Ore.	553
KMPC — Los Angeles, Calif.	343	KOPO — Tucson, Ariz.	329
KMUR — Murray, Utah	621	KOPP — Ogden, Utah	621
KMUS — Muskogee, Okla.	550	KOPR — Butte, Mont.	481
KMVI — Wailuku-Maui, Hawaii	659	KOPA — Bryan, Tex.	601
KMYC — Marysville, Calif.	345	KORC — Mineral Wells, Tex.	613
KMYR — Denver, Colo.	360	KORF — Eugene, Ore.	554
KNAF — Fredericksburg, Tex.	607	KORK — Las Vegas, Nev.	487
KNAK — Salt Lake City, Utah	622	KORN — Mitchell, S. D.	589
KNAL — Victoria, Tex.	619	KOSA — Odessa, Tex.	613
KNBC — San Francisco, Calif.	352	KOSE — Osceola, Ark.	334
KNBR — North Platte, Neb.	485	KOSF — Nacogdoches, Tex.	613
KNBY — Newport, Ark.	334	KOSY — Texarkana, Ark.	335
KNCM — Moberly, Mo.	477	KOTA — Rapid City, S. D.	589
KNEA — Jonesboro, Ark.	332	KOTN — Pine Bluff, Ark.	334

KOVC — Valley City, N. D.	533	KRMD — Shreveport, La.	437
KOVE — Lander, Wyo.	653	KRMG — Tulsa, Okla.	552
KOVO — Provo, Utah	622	KRMO — Monett, Mo.	477
KOWB — Laramie, Wyo.	654	KRMS — Osage Beach, Mo.	477
KOWH — Omaha, Neb.	485	KRNO — San Bernardino, Calif.	349
KOWL — Santa Monica, Calif.	357	KRNR — Roseburg, Oreg.	559
KOY — Phoenix, Ariz.	327	KRNT — Des Moines, Iowa	416
KPAC — Port Arthur, Tex.	615	KROC — Rochester, Minn.	465
KPAM — Portland, Ore.	558	KROD — El Paso, Tex.	605
KPAN — Hereford, Tex.	608	KROF — Abbeville, La.	432
KPAS — Banning, Calif.	339	KROG — Sonora, Calif.	357
KPAT — Pampa, Tex.	614	KROP — Brawley, Calif.	339
KPBM — Carlsbad, N. M.	493	KROS — Clinton, Iowa	415
KPDN — Pampa, Tex.	614	KROW — Oakland, Calif.	346
KPDQ — Portland, Oreg.	558	KROX — Crokston, Minn.	462
KPET — Lamesa, Tex.	610	KROY — Sacramento, Calif.	349
KPHO — Phoenix, Ariz.	328	KRPL — Moscow, Idaho	395
KPIG — Cedar Rapids, Iowa	415	KRRV — Sherman-Denison, Tex.	618
KPKW — Pasco, Wash.	635	KRSD — Rapid City, S. D.	589
KPLC — Lake Charles, La.	434	KRSN — Los Alamos, N. M.	494
KPLN — Camden, Ark.	330	KRTN — Raton, N. M.	494
KPLT — Paris, Tex.	614	KRUL — Corvallis, Ore.	554
KPMC — Bakersfield, Calif.	337	KRUN — Ballinger, Tex.	599
KPMO — Pomona, Calif.	348	KRUS — Ruston, La.	436
KPOA — Honolulu, Hawaii	657	KRUX — Phoenix, Ariz.	328
KPOC — Pocatontos, Ark.	334	KRVN — Lexington, Neb.	484
KPOJ — Portland, Ore.	558	KRWC — Forest Grove, Oreg.	554
KPOL — Los Angeles, Calif.	343	KRXK — Rexburg, Idaho	396
KPOW — Powell, Wyo.	654	KRXL — Roseburg, Ore.	559
KPQ — Wenatchee, Wash.	639	KSAL — Salina, Kan.	424
KPRC — Houston, Tex.	609	KSAM — Huntsville, Tex.	610
KPRK — Livingston, Mont.	482	KSAN — San Francisco, Cal.	352
KPRL — Paso Robles, Calif.	347	KSBW — Salinas, Cal.	349
KPRO — Riverside, Calif.	348	KSCB — Liberal, Kan.	423
KPRS — Kansas City, Mo.	476	KSCJ — Sioux City, Ia.	419
KPST — Preston, Idaho	395	KSCO — Santa Cruz, Cal.	356
KPUG — Bellingham, Wash.	633	KSD — St. Louis, Mo.	478
KPUY — Puyallup, Wash.	636	KSDN — Aberdeen, S. D.	588
KQV — Pittsburgh, Pa.	574	KSDO — San Diego, Cal.	351
KRAI — Craig, Col.	360	KSEL — Pocatello, Idaho	395
KRAL — Rawlings, Wyo.	654	KSEK — Pittsburg, Kan.	424
KRAM — Las Vegas, Nev.	487	KSEL — Lubbock, Tex.	611
KRBA — Lufkin, Tex.	612	KSEM — Moses Lake, Wash.	635
KRBC — Abilene, Tex.	598	KSEO — Durant, Okla.	548
KRCH — Hot Springs, Ark.	332	KSET — El Paso, Tex.	605
KRCO — Prineville, Ore.	558	KSEY — Seymour, Tex.	617
KRCT — Baytown, Tex.	690	KSFA — Nacodoches, Tex.	613
KRDO — Colorado Springs, Colo.	359	KSFE — Needles, Cal.	346
KRDU — Dinuba, Calif.	340	KSFO — San Francisco, Cal.	352
KRE — Berkeley, Calif.	339	KSGA — Cottage Grove, Ore.	554
KREH — Oakdale, La.	436	KSGM — Ste. Genevieve, Mo.	479
KREI — Farmington, Mo.	473	KSIB — Creston, Iowa	416
KREL — Baytown, Tex.	600	KSID — Sidney, Neb.	486
KREM — Spokane, Wash.	638	KSIG — Crowley, La.	433
KREO — Indio, Calif.	342	KSII — Gladewater, Tex.	608
KRES — St. Joseph, Mo.	477	KSIL — Silver City, N. M.	495
KREW — Sunnyside, Wash.	638	KSIM — Sikeston, Mo.	479
KRGI — Grand Island, Neb.	484	KSIW — Woodward, Okla.	552
KRGV — Westlaco, Tex.	620	KSIX — Corpus Christi, Tex.	603
KRHD — Duncan, Okla.	548	KSJB — Jamestown, N. D.	532
KRIB — Mason City, Ia.	418	KSJO — San Jose, Cal.	355
KRIC — Beaumont, Tex.	600	KSKY — Dallas, Tex.	604
KRIG — Odessa, Tex.	613	KSL — Salt Lake City, Utah	623
KRIO — McAllen, Tex.	612	KSLM — Salem, Ore.	559
KRIS — Corpus Christi, Tex.	602	KSLO — Opelousas, La.	436
KRIZ — Phoenix, Ariz.	328	KSMA — Santa Maria, Cal.	356
KRJF — Miles City, Mont.	482	KSMN — Mason City, Iowa	418
KRKD — Los Angeles, Calif.	343	KSMO — Salem, Mo.	477
KRKL — Kirkland, Wash.	635	KSNY — Snyder, Tex.	618
KRKO — Everett, Wash.	634	KSO — Des Moines, Ia.	417
KRLC — Lewiston, Ga.	395	KSOK — Arkansas City, Kan.	421
KRLD — Dallas, Tex.	604	KSON — San Diego, Cal.	351
KRLN — Canon City, Colo.	359	KSOO — Sioux Falls, S. D.	589
KRLW — Walnut Ridge, Ark.	335	KSPA — Santa Paula, Cal.	357

KSPI — Stillwater, Okla.	552	KTTR — Rolla, Mo.	477
KSPO — Spokane, Wash.	638	KTTT — Springfield, Mo.	479
KSPR — Casper, Wyo.	653	KTUC — Tucson, Ariz.	329
KSPT — Sandpoint, Idaho	396	KTUL — Tulsa, Okla.	552
KSRO — Santa Rosa, Cal.	357	KTUR — Turlock, Cal.	358
KSRV — Ontario, Ore.	557	KTW — Seattle, Wash.	637
KSST — Sulphur Springs, Tex.	618	KTXC — Big Spring, Tex.	600
KSTA — Coleman, Tex.	602	KTXX — Jasper, Tex.	610
KSTB — Breckenridge, Tex.	601	KTXL — San Angelo, Tex.	615
KSTL — St. Louis, Mo.	478	KTXX — Austin, Tex.	599
KSTN — Stockton, Cal.	357	KTYL — Mesa, Ariz.	327
KSTP — St. Paul-Minneapolis, Minn.	466	KUAM — Agana, Guam	656
KSTT — Davenport, Iowa	416	KUBA — Yuba City, Cal.	359
KSTV — Stephenville, Tex.	618	KUBC — Montrose, Colo.	363
KSUB — Cedar City, Utah	621	KUGN — Eugene, Ore.	554
KSUE — Susanville, Cal.	357	KUIN — Grants Pass, Ore.	554
KSUM — Fairmont, Minn.	463	KUJ — Walla Walla, Wash.	639
KSUN — Bisbee, Ariz.	326	KUKI — Ukiah, Cal.	358
KSVL — Richfield, Utah	622	KULA — Honolulu, Hawaii	659
KSVP — Artesia, N. M.	493	KULE — Ephrata, Wash.	634
KSWA — Graham, Tex.	608	KULP — El Campo, Tex.	605
KSWI — Council Bluffs, Iowa	415	KUNO — Corpus Christi, Tex.	603
KSWM — Joplin, Mo.	475	KUOA — Siloam Springs, Ark.	334
KSWO — Lawton, Okla.	549	KURV — Edinburg, Tex.	604
KSWT — Roswell, N. M.	495	KUTA — Salt Lake City, Utah	623
KSYC — Yreka, Cal.	359	KVAN — Vancouver, Wash.	638
KSYL — Alexandria, La.	432	KVAS — Astoria, Ore.	553
KTAC — Tacoma, Wash.	638	KVBC — Farmington, N. M.	493
KTAE — Taylor, Tex.	618	KVCV — Redding, Cal.	348
KTAN — Sherman, Tex.	618	KVEC — San Luis Obispo, Cal.	355
KTAR — Phoenix, Ariz.	328	KVEN — Ventura, Cal.	358
KTAT — Frederick, Okla.	549	KVET — Austin, Tex.	599
KTBB — Tyler, Tex.	619	KVFD — Ft. Dodge, Ia.	417
KTBC — Austin, Tex.	599	KVGB — Great Bend, Kan.	422
KTBS — Shreveport, La.	437	KVI — Seattle, Wash.	637
KTEL — Walla Walla, Wash.	639	KVIC — Victoria, Tex.	619
KTEM — Temple, Tex.	618	KVIM — New Iberia, La.	435
KTER — Terrell, Tex.	618	KVKM — Monahans, Tex.	613
KTFI — Twin Falls, Idaho	396	KVLC — Little Rock, Ark.	333
KTFS — Texarkana, Tex.	619	KVLF — Alpine, Tex.	598
KTFY — Brownfield, Tex.	601	KVLH — Pauls Valley, Okla.	551
KTGS — Little Rock, Ark.	333	KVMA — Magnolia, Ark.	333
KTHT — Houston, Tex.	609	KVMC — Colorado City, Tex.	602
KTIL — Tillamook, Ore.	559	KVNC — Winslow, Ariz.	329
KTIM — San Rafael, Cal.	356	KVNI — Coeur D'Alene, Idaho.	394
KTIP — Porterville, Cal.	348	KVNU — Logan, Utah	621
KTJS — Hobart, Okla.	549	KVOA — Tucson, Ariz.	329
KTKN — Ketchikan, Alaska	656	KVOC — Casper, Wyo.	653
KTKR — Taft, Cal.	358	KVOD — Denver, Colo.	360
KTKT — Tucson, Ariz.	329	KVOE — Santa Ana, Cal.	356
KTLN — Denver, Colo.	360	KVOG — Ogden, Utah	621
KTLO — Mountain Home, Ark.	333	KVOL — Lafayette, La.	434
KTLW — Texas City, Tex.	619	KVOM — Morrilton, Ark.	333
KTMC — McAlester, Okla.	550	KVON — Napa, Cal.	346
KTMS — Santa Barbara, Cal.	356	KVOO — Tulsa, Okla.	552
KTNN — Tucumcari, N. M.	495	KVOP — Plainville, Tex.	615
KTNT — Tacoma, Wash.	638	KVOR — Colorado Springs, Colo.	359
KTOE — Mankato, Minn.	464	KVOS — Bellingham, Wash.	633
KTOH — Lihue, Kauai, Hawaii	659	KVOU — Uvalde, Tex.	619
KTOK — Oklahoma City, Okla.	551	KVOW — Littlefield, Tex.	611
KTOP — Topeka, Kan.	424	KVOX — Moorehead, Minn.	465
KTOW — Oklahoma City, Okla.	551	KVOZ — Laredo, Tex.	610
KTRB — Modesto, Cal.	346	KVPI — Ville Platte, La.	437
KTRC — Santa Fe, N. M.	495	KVRC — Arkadelphia, Ark.	330
KTRE — Lufkin, Tex.	612	KVRH — Salida, Colo.	363
KTRF — Thief River Falls, Minn.	466	KVRS — Rock Springs, Wyo.	654
KTRH — Houston, Tex.	609	KVSA — McGehee, Ark.	333
KTRI — Sioux City, Ia.	419	KVSF — Santa Fe, N. M.	495
KTRM — Beaumont, Tex.	600	KVSM — San Mateo, Cal.	355
KTRN — Wichita Falls, Tex.	620	KVSO — Ardmore, Okla.	547
KTRY — Bastrop, La.	432	KVSP — Lubbock, Tex.	612
KTSA — San Antonio, Tex.	617	KVVC — Ventura, Cal.	358
KTSM — El Paso, Tex.	605	KVWC — Vernon, Tex.	619
KTSW — Emporia, Kan.	422	KVWO — Cheyenne, Wyo.	653

KWAD — Wadena, Minn.	467	KXIT — Dalhart, Tex.	603
KWAK — Stuttgart, Ark.	335	KXJK — Forrest City, Ark.	331
KWAL — Wallace, Idaho	396	KXL — Portland, Ore.	558
KWAT — Watertown, S. D.	590	KXLA — Pasadena, Cal.	347
KWBB — Wichita, Kan.	425	KXLE — Ellensburg, Wash.	634
KWBC — Fort Worth, Tex.	607	KXLF — Butte, Mont.	481
KWBE — Beatrice, Neb.	483	KXLJ — Helena, Mont.	482
KWBG — Boone, Iowa	414	KXLK — Great Falls, Mont.	481
KWBM — Williston, N. D.	533	KXLL — Missoula, Mont.	482
KWBR — Oakland, Cal.	347	KXLO — Lewistown, Mont.	482
KWBU — Corpus Christi, Tex.	603	KXLQ — Bozeman, Mont.	480
KWBW — Hutchinson, Kan.	422	KXLR — Little Rock, Ark.	333
KWCB — Searcy, Ark.	334	KXLW — St. Louis, Mo.	478
KWCJ — Natchitoches, La.	434	KXLY — Spokane, Wash.	638
KWCO — Chickasha, Okla.	548	KXO — El Centro, Cal.	340
KWDL — Kansas City, Mo.	476	KXOA — Sacramento, Cal.	349
KWDM — Des Moines, Ia.	417	KXOB — Stockton, Cal.	357
KWED — Seguin, Tex.	617	KXOC — Chico, Cal.	339
KWEI — Weiser, Idaho	396	KXOK — St. Louis, Mo.	478
KWEM — West Memphis, Ark.	335	KXOL — Fort Worth, Tex.	607
KWEW — Hobbs, N. M.	494	KXOX — Sweetwater, Tex.	618
KWFC — Hot Springs, Ark.	332	KXRA — Alexander, Minn.	462
KWFT — Wichita Falls, Tex.	620	KXRJ — Russellville, Ark.	334
KWG — Stockton, Cal.	357	KXRO — Aberdeen, Wash.	633
KWGB — Goodland, Kan.	422	KRRX — San Jose, Cal.	355
KWHI — Brenham, Tex.	601	KXXL — Monterey, Cal.	346
KWHK — Hutchinson, Kan.	422	KXXX — Colby, Kan.	421
KWHN — Ft. Smith, Ark.	331	KXYZ — Houston, Tex.	609
KWHP — Cushing, Okla.	548	KYA — San Francisco, Cal.	352
KWHW — Altus, Okla.	547	KYAK — Yakima, Wash.	639
KWIE — Kennewick, Wash.	635	KYCA — Prescott, Ariz.	328
KWIK — Pocatello, Idaho	395	KYJC — Medford, Ore.	557
KWIL — Albany, Ore.	553	KYMA — Yuma, Ariz.	329
KWIN — Ashland, Ore.	553	KYNO — Fresno, Cal.	341
KWJB — Globe, Ariz.	327	KYOR — Blythe, Cal.	339
KWJJ — Portland, Ore.	558	KYOS — Merced, Cal.	345
KWK — St. Louis, Mo.	478	KYOU — Greeley, Colo.	362
KWKC — Abilene, Tex.	598	KYSM — Mankato, Minn.	464
KWKH — Shreveport, La.	437	KYUM — Yuma, Ariz.	329
KWKW — Pasadena, Cal.	347	KYW — Philadelphia, Pa.	571
KWLK — Longview, Wash.	635	WAAA — Winston Salem, N. C.	531
KWLM — Willmar, Minn.	467	WAAB — Worcester, Mass.	449
KWNO — Winona, Minn.	467	WAAF — Chicago, Ill.	399
KWNW — Wenatchee, Wash.	639	WAAT — Newark, N. J.	490
KWOA — Worthington, Minn.	467	WABA — Aquadilla, P. R.	659
KWOC — Poplar Bluff, Mo.	447	WABB — Mobile, Ala.	321
KWOE — Clinton, Okla.	548	WABC — New York, N. Y.	503
KWON — Bartlesville, Okla.	548	WABG — Greenwood, Miss.	469
KWOR — Worland, Wyo.	654	WABI — Bangor, Me.	437
KWOS — Jefferson City, Mo.	475	WABJ — Adrian, Mich.	451
KWPC — Muscatine, Ia.	418	WABM — Houlton, Me.	438
KWPM — West Plains, Mo.	480	WABY — Albany, N. Y.	495
KWRC — Pendleton, Ore.	557	WABZ — Albemarle, N. C.	520
KWRE — Warrenton, Mo.	480	WACA — Camden, S. C.	583
KWRF — Warren, Ark.	335	WACB — Kittanning, Pa.	568
KWRL — Riverton, Wyo.	654	WACE — Chitopee-Springfield, Mass.	446
KWRN — Reno, Nev.	487	WACL — Waycross, Ga.	393
KWRO — Coquille, Ore.	553	WACO — Waco, Tex.	620
KWSD — Mt. Shasta, Cal.	346	WACR — Columbus, Miss.	468
KWSH — Wewaka, Okla.	552	WADC — Akron, O.	533
KWSK — Pratt, Kan.	424	WADE — Wadesboro, N. C.	530
KWSO — Wasco, Cal.	358	WADK — Newport, R. I.	581
KWTC — Barstow, Cal.	339	WAEB — Allentown, Pa.	560
KWTO — Springfield, Mo.	479	WAEL — Mayaguez, P. R.	661
KWTX — Waco, Tex.	620	WAEW — Crossville, Tenn.	591
KWWL — Waterloo, Ia.	420	WAFB — Baton Rouge, La.	432
KWYO — Sheridan, Wyo.	654	WAGA — Atlanta, Ga.	383
KXA — Seattle, Wash.	637	WAGC — Chattanooga, Tenn.	590
KXAR — Hope, Ark.	331	WAGE — Syracuse, N. Y.	517
KXEL — Waterloo, Ia.	420	WAGF — Dothan, Ala.	318
KXEO — Mexico, Mo.	477	WAGG — Franklin, Tenn.	592
KXGI — Ft. Madison, Ia.	418	WAGM — Presque Isle, Me.	439
KXGN — Glendive, Mont.	481	WAIM — Anderson, S. C.	583
KXIC — Iowa City, Ia.	418	WAIN — Columbia, Ky.	426

WAIR — Winston-Salem, N. C.	531	WBAP — Fort Worth, Tex.	607
WAIT — Chicago, Ill.	399	WBAR — Bartow, Fla.	372
WAJF — Decatur, Ala.	318	WBAT — Barion, Ind.	412
WAJR — Morgantown, W. Va.	642	WBAW — Barnwell, S. C.	583
WAKE — Greenville, S. C.	585	WBAX — Wilkes-Barre, Pa.	578
WAKN — Aiken, S. C.	583	WBAY — Green Bay, Wis.	646
WAKR — Akron, O.	533	WBBB — Burlington, N. C.	521
WAKU — Latrobe, Pa.	568	WBBC — Flint, Mich.	456
WALA — Mobile, Ala.	321	WBBF — Rochester, N. Y.	515
WALB — Albany, Ga.	381	WBBM — Chicago, Ill.	399
WALD — Walterboro, S. C.	588	WBBO — Forest City, N. C.	523
WALE — Fall River, Mass.	446	WBBQ — Augusta, Ga.	384
WALK — Patchogue, N. Y.	513	WBBW — Youngstown, O.	547
WALL — Middletown, N. Y.	503	WBBZ — Ponca City, Okla.	551
WALM — Albion, Mich.	451	WBCK — Battle Creek, Mich.	453
WALT — Tampa, Fla.	380	WBDM — Bay City, Mich.	453
WAMI — Opp, Ala.	324	WBCO — Bessemer-Birmingham, Ala.	317
WAML — Laurel, Miss.	470	WECU — Union, S. C.	588
WAMS — Wilmington, Del.	369	WEEC — Pittsfield, Mass.	448
WAND — Canton, O.	535	WBEJ — Elizabethton, Tenn.	592
WANE — Ft. Wayne, Ind.	410	WBEL — Beloit, Wis.	645
WANN — Annapolis, Md.	441	WBEN — Buffalo, N. Y.	497
WANS — Anderson, S. C.	583	WBET — Brockton, Mass.	446
WANT — Richmond, Va.	630	WBEV — Beaver Dam, Wis.	645
WAOV — Vincennes, Ind.	414	WBEX — Chillicothe, O.	535
WAPA — San Juan, P. R.	661	WBGE — Atlanta, Ga.	383
WAPP — McComb, Miss.	471	WBGR — Jessup, Ga.	388
WAPI — Birmingham, Ala.	317	WBHB — Fitzgerald, Ga.	388
WAPL — Appleton, Wis.	645	WBHF — Cartersville, Ga.	385
WAPO — Chattanooga, Tenn.	590	WBHP — Huntsville, Ala.	321
WAPX — Montgomery, Ala.	323	WBIG — Greensboro, N. C.	524
WARA — Attleboro, Mass.	444	WBIP — Boonville, Miss.	467
WARB — Covington, La.	433	WBIR — Knoxville, Tenn.	593
WARD — Johnstown, Pa.	568	WRIS — Bristol, Conn.	765
WARE — Ware, Mass.	449	WBIW — Bedford, Ind.	409
WARK — Hagerstown, Md.	443	WBIZ — Eau Claire, Wis.	645
WARL — Arlington, Va.	625	WBKV — West Bend, Wis.	652
WARM — Scranton, Pa.	576	WBLE — Batesville, Miss.	467
WARN — Fort Pierce, Fla.	373	WBLJ — Dalton, Ga.	387
WASA — Havre de Grace, Md.	443	WBLK — Clarksburg, W. Va.	641
WASK — Lafayette, Ind.	411	WBLT — Redford, Va.	625
WASL — Annapolis, Md.	441	WBMD — Baltimore, Md.	441
WATA — Boone, N. C.	520	WBML — Macon, Ga.	389
WATC — Gaylord, Mich.	456	WBMS — Boston, Mass.	444
WATG — Ashland, O.	534	WBNI — Booneville, Ind.	409
WATH — Athens, O.	534	WBNS — Columbus, O.	541
WATK — Antigo, Wis.	645	WBNX — New York, N. Y.	503
WATL — Atlanta, Ga.	383	WBNY — Buffalo, N. Y.	497
WATM — Atmore, Ala.	316	WBOB — Galax, Va.	627
WATN — Watertown, N. Y.	519	WBOC — Salisbury, Md.	443
WATO — Oak Ridge, Tenn.	596	WBOK — New Orleans, La.	435
WATR — Waterbury, Conn.	368	WBOW — Terre Haute, Ind.	413
WATS — Sayre, Pa.	576	WBPD — Lock Haven, Pa.	569
WATT — Cadillac, Mich.	455	WBRC — Birmingham, Ala.	317
WATW — Ashland, Wis.	645	WBRE — Ft. Lauderdale, Fla.	373
WATZ — Alpena, Mich.	451	WBRE — Wilkes-Barre, Pa.	579
WAUD — Auburn, Ala.	316	WBRK — Pittsfield, Mass.	448
WAUG — Augusta, Ga.	384	WBRM — Marion, N. C.	526
WAUX — Waukesha, Wis.	651	WBRN — Big Rapids, Mich.	453
WAVE — Louisville, Ky.	428	WBRO — Waynesboro, Ga.	393
WAVL — Apollo, Pa.	561	WBRW — Welch, W. Va.	643
WAVU — Albertville, Ala.	316	WBRY — Waterbury, Conn.	368
WAVY — Portsmouth, Va.	630	WBSC — Bennettsville, S. C.	583
WAVZ — New Haven, Conn.	366	WESM — New Bedford, Mass.	448
WAYB — Waynesboro, Va.	633	WBSR — Pensacola, Fla.	378
WAYN — Rockingham, N. C.	528	WBT — Charlotte, N. C.	521
WAYS — Charlotte, N. C.	521	WBTA — Batavia, N. Y.	496
WAYX — Waycross, Ga.	393	WBTH — Williamston, W. Va.	644
WAYZ — Waynesboro, Pa.	578	WBTM — Danville, Va.	627
WAZF — Yazoo City, Miss.	472	WBTV — Bennington, Vt.	624
WAZL — Hazleton, Pa.	567	WBTO — Linton, Ind.	412
WBAC — Cleveland, Tenn.	591	WBUD — Trenton, N. J.	491
WBAL — Baltimore, Md.	441	WBUT — Butler, Pa.	562
WBAM — Montgomery, Ala.	323	WBUX — Doylestown, Pa.	563

WBUY — Lexington, N. C.	526	WCOP — Boston, Mass.	444
WBVP — Beaver Falls, Pa.	561	WCOR — Lebanon, Tenn.	594
WBYS — Canton, Ill.	397	WCOS — Columbia, S. C.	584
WBZ-WBZA — Boston-Springfield, Mass.	444	WCOU — Lewiston, Me.	438
WCAE — Pittsburgh, Pa.	574	WCOV — Montgomery, Ala.	323
WCAM — Camden, N. J.	490	WCOW — South St. Paul, Minn.	466
WCAN — Milwaukee, Wis.	648	WCPA — Clearfield, Pa.	563
WCAO — Baltimore, Md.	441	WCPM — Cumberland, Ky.	427
WCAP — Lowell, Mass.	447	WCPO — Cincinnati, O.	535
WCAR — Pontiac, Mich.	460	WCPS — Tarboro, N. C.	530
WCAU — Philadelphia, Pa.	571	WCRA — Effingham, Ill.	402
WCAV — Norfolk, Va.	629	WCRB — Waltham, Mass.	449
WCAW — Charleston, W. Va.	640	WCRE — Cheraw, S. C.	584
WCAX — Burlington, Vt.	624	WCRI — Scottsboro, Ala.	325
WCAZ — Carthage, Ill.	397	WCRK — Morristown, Tenn.	595
WCBA — Corning, N. Y.	499	WCRL — Oneonta, Ala.	324
WCBC — Anderson, Ind.	408	WCRO — Johnstown, Pa.	568
WCBD — Chicago-Zion, Ill.	399	WCRS — Greenwood, S. C.	586
WCBI — Columbus, Miss.	468	WCRT — Birmingham, Ala.	317
WCBM — Baltimore, Md.	442	WCRW — Chicago, Ill.	399
WCBR — Memphis, Tenn.	594	WCSC — Charleston, S. C.	583
WCBS — New York, N. Y.	503	WCSE — Portland, Me.	438
WCBT — Roanoke Rapids, N. C.	528	WCSI — Columbus, Ind.	409
WCCC — Hartford, Conn.	365	WCSS — Amsterdam, N. Y.	496
WCCM — Lawrence, Mass.	447	WCTA — Andalusia, Ala.	316
WCCO — Minneapolis, Minn.	464	WCTC — New Brunswick, N. J.	491
WCCP — Savannah, Ga.	391	WCTT — Corbin, Ky.	426
WCDD — Carbondale, Pa.	562	WCUE — Akron, O.	534
WCDD — Winchester, Tenn.	597	WCUM — Cumberland, Md.	442
WCEC — Rocky Mount, N. C.	528	WCVA — Culpeper, Va.	627
WCED — Dubois, Pa.	563	WCVI — Connellsville, Pa.	563
WCEH — Hawkinsville, Ga.	388	WCVS — Springfield, Ill.	407
WCEM — Cambridge, Md.	442	WCYB — Bristol, Va.	626
WCEN — Mt. Pleasant, Mich.	459	WDAD — Indiana, Pa.	568
WCFL — Chicago, Ill.	399	WDAE — Tampa, Fla.	380
WCFV — Clifton Forge, Va.	626	WDAF — Kansas City, Mo.	476
WCGA — Calhoun, Ga.	385	WDAK — Columbus, Ga.	386
WCHA — Chambersburg, Pa.	562	WDAN — Danville, Ill.	402
WCHL — Chapel Hill, N. C.	521	WDAR — Savannah, Ga.	391
WCHN — Norwich, N. Y.	513	WDAS — Philadelphia, Pa.	571
WCHO — Washington Court House, O.	546	WDAY — Fargo, N. D.	532
WCHS — Charleston, W. Va.	640	WDBC — Escanaba, Mich.	456
WCHV — Charlottesville, Va.	626	WDBJ — Roanoke, Va.	632
WCIL — Carbondale, Ill.	397	WDBL — Springdale, Tenn.	597
WCIN — Cincinnati, O.	535	WDBO — Orlando, Fla.	377
WCJU — Columbia, Miss.	468	WDBQ — Dubuque, Ia.	417
WCKB — Dunn, N. C.	522	WDEC — Americus, Ga.	381
WCKY — Cincinnati, O.	535	WDEF — Chattanooga, Tenn.	590
WCLE — Cleveland, Miss.	468	WDEL — Wilmington, Del.	369
WCLI — Corning, N. Y.	499	WDEV — Waterbury, Vt.	625
WCLO — Jamesville, Wis.	646	WDGY — Minneapolis, Minn.	464
WCLT — Newark, O.	545	WDIA — Memphis, Tenn.	594
WCMA — Corinth, Miss.	468	WDIG — Dothan, Ala.	319
WCMB — Harrisburg, Pa.	565	WDIX — Orangeburg, S. C.	587
WCMC — Wildwood, N. J.	492	WDKD — Kingstree, S. C.	586
WCMI — Ashland, Ky.	426	WDLA — Walton, N. Y.	519
WCMN — Arecibo, P. R.	659	WDLB — Marshfield, Wis.	648
WCMW — Canton, O.	535	WDLG — Port Jervis, N. Y.	514
WCMY — Ottawa, Ill.	405	WDLP — Panama City, Fla.	378
WCNB — Connersville, Ind.	409	WDMG — Douglas, Ga.	387
WCNC — Elizabeth City, N. C.	522	WDMJ — Marquette, Mich.	459
WCNH — Quincy, Fla.	379	WDNC — Durham, N. C.	522
WCNR — Bloomsburg, Pa.	561	WDNE — Elkins, W. Va.	641
WCNT — Centralia, Ill.	399	WDOB — Canton, Miss.	468
WCNU — Crestview, Fla.	372	WDOD — Chattanooga, Tenn.	591
WCNX — Middletown, Conn.	366	WDOG — Marine City, Mich.	459
WCOA — Pensacola, Fla.	378	WDOK — Cleveland, O.	537
WCOB — Meridian, Miss.	471	WDON — Wheaton, Md.	444
WCOG — Greensboro, N. C.	524	WDOR — Sturgeon Bay, Wis.	651
WCOH — Newnan, Ga.	390	WDOS — Oneonta, N. Y.	513
WCOJ — Coatesville, Pa.	563	WDOV — Dover, Del.	368
WCOL — Columbus, O.	541	WDQN — Du Quion, Ill.	402
WCOM — Parkersburg, W. Va.	643	WDRC — Hartford, Conn.	365
WCOR — Cornelius, Ga.	387	WDSC — Dillon, S. C.	585

WDSG — Dyersburg, Tenn.	591	WEVA — Emporia, Va.	627
WDSM — Superior, Wis.	651	WEVD — New York, N. Y.	505
WDSR — Lake City, Fla.	375	WEVE — Eveleth, Minn.	463
WDSU — New Orleans, La.	435	WEW — St. Louis, Mo.	478
WDUN — Gainesville, Ga.	388	WEWO — Laurinburg, N. C.	526
WDUZ — Green Bay, Wis.	646	WEXL — Royal Oak, Mich.	460
WDVA — Danville, Va.	627	WEYE — Sanford, N. C.	529
WDWD — Dawson, Ga.	387	WEZB — Homewood, Ala.	321
WDWS — Champaign, Ill.	399	WFAA — Dallas, Tex.	604
WDXB — Chattanooga, Tenn.	591	WFAH — Alliance, O.	534
WDXE — Lawrenceburg, Tenn.	594	WFAI — Fayetteville, N. C.	523
WDXI — Jackson, Tenn.	592	WFAS — White Plains, N. Y.	519
WDYK — Cumberland, Md.	443	WFAU — Augusta, Me.	437
WDZ — Decatur, Ill.	402	WFAX — Falls Church, Va.	627
WEAB — Greer, S. C.	586	WFBC — Greenville, S. C.	585
WEAM — Arlington, Va.	625	WFBG — Altoona, Pa.	580
WEAN — Providence, R. I.	581	WFBL — Syracuse, N. Y.	517
WEAR — Pensacola, Fla.	378	WFBM — Indianapolis, Ind.	411
WEAS — Decatur, Ga.	387	WFER — Baltimore, Md.	442
WEAT — Lake Worth-W. Palm Beach, Fla.	375	WFCB — Dunkirk, N. Y.	499
WEAU — Eau Claire, Wis.	645	WFDF — Flint, Mich.	456
WEAV — Plattsburg, N. Y.	514	WFEA — Manchester, N. H.	488
WEBC — Duluth, Minn.	463	WFEB — Sylacauga, Ala.	325
WEBJ — Brewton, Ala.	318	WFEC — Miami, Fla.	376
WEBK — Tampa, Fla.	380	WFGM — Fitchburg, Mass.	446
WEBQ — Harrisburg, Ill.	403	WFGN — Gaffney, S. C.	585
WEBR — Buffalo, N. Y.	497	WFHG — Bristol, Va.	626
WEDC — Chicago, Ill.	399	WFHR — Wisconsin Rapids, Wis.	652
WEDO — McKeesport, Pa.	569	WFIG — Sumter, S. C.	588
WEDR — Birmingham, Ala.	317	WFIL — Philadelphia, Pa.	571
WEEB — Southern Pines, N. C.	529	WFIN — Findlay, O.	543
WEED — Rocky Mount, N. C.	528	WFIW — Fairfield, Ill.	403
WEEL — Boston, Mass.	444	WFKY — Frankfort, Ky.	427
WEEK — Peoria, Ill.	405	WFLA — Tampa, Fla.	380
WEEU — Reading, Pa.	576	WFLB — Fayetteville, N. C.	523
WEGO — Concord, N. C.	522	WFLO — Farmville, Va.	627
WEIM — Fitchburg, Mass.	446	WFMC — Goldsboro, N. C.	523
WEIR — Weirton, W. Va.	643	WFMD — Frederick, Md.	443
WEKR — Fayetteville, Tenn.	592	WFMH — Cullman, Ala.	318
WEKY — Richmond, Ky.	431	WFMJ — Youngstown, O.	547
WEKZ — Monroe, Wis.	649	WFMO — Fairmont, N. C.	523
WELC — Welch, W. Va.	644	WFMW — Madisonville, Ky.	429
WELI — New Haven, Conn.	367	WFNC — Fayetteville, N. C.	523
WELL — Battle Creek, Mich.	453	WFNS — Burlington, N. C.	521
WELM — Elmira, N. Y.	499	WFOB — Fostoria, O.	543
WELO — Tupelo, Miss.	472	WFOM — Marietta, Ga.	389
WELP — Easley, S. C.	585	WFOR — Hattiesburg, Miss.	469
WELS — Kinston, N. C.	525	WFOX — Milwaukee, Wis.	648
WELR — Roanoke, Ala.	324	WFOY — St. Augustine, Fla.	379
WEMP — Milwaukee, Wis.	648	WFPA — Ft. Payne, Ala.	319
WENA — Bayamon, P. R.	659	WFPG — Atlantic City, N. J.	489
WENC — Whiteville, N. C.	530	WFPM — Fort Valley, Ga.	388
WENE — Binghamton-Endicott, N. Y.	496	WFRC — Reidsville, N. C.	528
WENK — Union City, Tenn.	597	WFRL — Freeport, Ill.	403
WENT — Gloversville, N. Y.	501	WFRM — Coudersport, Pa.	563
WENY — Elmira, N. Y.	499	WFRO — Fremont, O.	543
WEOA — Evansville, Ind.	409	WFRP — Savannah, Ga.	391
WEOK — Poughkeepsie, N. Y.	514	WFRX — West Frankfort, Ill.	408
WEOL — Elyria, O.	543	WFTC — Kinston, N. C.	525
WEPM — Martinsburg, W. Va.	642	WFTL — Fort Lauderdale, Fla.	373
WERC — Erie, Pa.	564	WFTM — Maysville, Ky.	430
WERD — Atlanta, Ga.	383	WFTR — Front Royal, Va.	627
WERE — Cleveland, O.	537	WFUL — Fulton, Ky.	427
WERH — Hamilton, Ala.	320	WFUN — Huntsville, Ala.	321
WERI — Westerly, R. I.	582	WFUR — Grand Rapids, Mich.	457
WESA — Charleroi, Pa.	562	WFVA — Fredericksburg, Va.	627
WESB — Bradford, Pa.	562	WFGV — Fuquay Springs, N. C.	523
WESC — Greenville, S. C.	585	WFYC — Alma, Mich.	451
WESK — Escanaba, Mich.	456	WGAA — Cedartown, Ga.	385
WEST — Easton, Pa.	563	WGAC — Augusta, Ga.	384
WESX — Salem, Mass.	448	WGAD — Gadsden, Ala.	320
WETB — Johnson City, Tenn.	593	WGAF — Valdosta, Ga.	392
WETO — Gadsden, Ala.	320	WGAI — Elizabeth City, N. C.	522
WETZ — New Martinsville, W. Va.	643	WGAL — Lancaster, Pa.	568

WGAN — Portland, Me.	439
WGAP — Maryville, Tenn.	594
WGAR — Cleveland, O.	537
WGAT — Utica, N. Y.	518
WGAU — Athens, Ga.	383
WGAW — Gardner, Mass.	446
WGAY — Silver Spring, Md.	444
WGBA — Columbus, Ga.	386
WGBB — Freeport, N. Y.	501
WGBF — Evansville, Ind.	409
WGBG — Greensboro, N. C.	524
WGBI — Scranton, Pa.	576
WGBR — Goldsboro, N. C.	524
WGBS — Miami, Fla.	376
WGCB — Red Lion, Pa.	576
WGCD — Chester, S. C.	584
WGCM — Gulfport, Miss.	469
WGEA — Geneva, Ala.	320
WGEM — Quincy, Ill.	406
WGES — Chicago, Ill.	401
WGET — Gettysburg, Pa.	565
WGEZ — Beloit, Wis.	645
WGGA — Gainesville, Ga.	388
WGGG — Gainesville, Fla.	373
WGGH — Marion, Ill.	404
WGH — Newport News, Va.	629
WGIG — Brunswick, Ga.	385
WGIL — Galesburg, Ill.	403
WGIV — Charlotte, N. C.	521
WGKV — Charleston, W. Va.	640
WGL — Ft. Wayne, Ind.	410
WGLC — Centerville, Miss.	468
WGLS — Decatur, Ga.	387
WGMS — Washington, D. C.	370
WGN — Chicago, Ill.	399
WGNC — Gastonia, N. C.	523
WGNI — Wilmington, N. C.	531
WGNS — Murfreesboro, Tenn.	595
WGNV — Newburgh, N. Y.	503
WGOV — Valdosta, Ga.	392
WGPA — Bethlehem, Pa.	561
WGPC — Albany, Ga.	381
WGR — Buffalo, N. Y.	497
WGRA — Cairo, Ga.	385
WGRC — Louisville, Ky.	428
WGRD — Grand Rapids, Mich.	457
WGRM — Greenwood, Miss.	469
WGRV — Greenville, Tenn.	592
WGRY — Gary, Ind.	410
WGSM — Huntington, N. Y.	502
WGST — Atlanta, Ga.	383
WGSV — Guntersville, Ala.	320
WGSW — Greenwood, S. C.	586
WGTA — Summerville, Ga.	391
WGTC — Greenville, N. C.	524
WGTH — Hartford, Conn.	366
WGTL — Kannapolis, N. C.	525
WGTM — Wilson, N. C.	531
WGTN — Georgetown, S. C.	585
WGUY — Bangor, Me.	437
WGVA — Geneva, N. Y.	501
WGVN — Greenville, Miss.	469
WGW — Selma, Ala.	325
WGW — Gadsden, Ala.	320
WGWR — Asheboro, N. C.	520
WGY — Schenectady, N. Y.	517
WGYV — Greenville, Ala.	320
WHAI — Greenfield, Mass.	447
WHAK — Rogers City, Mich.	460
WHAL — Shelbyville, Tenn.	596
WHAM — Rochester, N. Y.	515
WHAN — Charleston, S. C.	583
WHAP — Hopewell, Va.	628
WHAR — Clarksburg, W. Va.	641

WHAS — Louisville, Ky.	429
WHAT — Philadelphia, Pa.	573
WHAV — Haverhill, Mass.	447
WHAW — Weston, W. Va.	644
WHAY — New Britain, Conn.	366
WHB — Kansas City, Mo.	476
WHBB — Selma, Ala.	325
WHBC — Canton, O.	535
WHBF — Rock Island, Ill.	407
WHBI — Newark, N. J.	490
WHBL — Sheboygan, Wis.	650
WHBO — Tampa, Fla.	381
WHBQ — Memphis, Tenn.	594
WHBS — Huntsville, Ala.	321
WHBT — Harriman, Tenn.	592
WHBU — Anderson, Ind.	408
WHBY — Appleton, Wis.	645
WHCC — Waynesville, N. C.	530
WHCU — Ithaca, N. Y.	502
WHDF — Houghton, Mich.	457
WHDH — Boston, Mass.	445
WHDL — Olean, N. Y.	513
WHEB — Portsmouth, N. H.	489
WHEC — Rochester, N. Y.	515
WHED — Washington, N. C.	530
WHEP — Foley, Ala.	319
WHFB — Benton Harbor, Mich.	453
WHFC — Chicago, Ill.	401
WHGB — Harrisburg, Pa.	567
WHHH — Warren, O.	546
WHHM — Memphis, Tenn.	594
WHIL — Medford, Mass.	447
WHIM — Providence, R. I.	581
WHIN — Gallatin, Tenn.	592
WHIO — Dayton, O.	542
WHIP — Mooresville, N. C.	525
WHIR — Danville, Ky.	427
WHIS — Bluefield, W. Va.	640
WHIT — New Bern, N. C.	527
WHIZ — Zanesville, O.	547
WHJB — Greensburg, Pa.	565
WHJC — Matewan, W. Va.	642
WHK — Cleveland, O.	537
WHKC — Columbus, O.	541
WHKK — Akron, O.	534
WHKP — Hendersonville, N. C.	524
WHKY — Hickory, N. C.	524
WHLB — Virginia, Minn.	466
WHLD — Niagara Falls, N. Y.	513
WHLF — South Boston, Va.	632
WHLI — Hempstead, N. Y.	501
WHLL — Wheeling, W. Va.	644
WHLM — Bloomsburg, Pa.	561
WHLN — Harlan, Ky.	427
WHLS — Port Huron, Mich.	460
WHMA — Anniston, Ala.	316
WHMP — Northampton, Mass.	448
WHNC — Henderson, N. C.	524
WHO — Des Moines, Ia.	417
WHOC — Philadelphia, Miss.	471
WHOD — Homestead, Pa.	567
WHOK — Lancaster, O.	544
WHOL — Allentown, Pa.	560
WHOM — New York, N. Y.	505
WHOO — Orlando, Fla.	377
WHOP — Hopkinsville, Ky.	428
WHOS — Decatur, Ala.	318
WHOT — South Bend, Ind.	413
WHOW — Clinton, Ill.	401
WHP — Harrisburg, Pa.	567
WHPE — High Point, N. C.	525
WHRV — Ann Arbor, Mich.	451
WHSC — Hartsville, S. C.	586
WHSY — Hattiesburg, Miss.	469

WHTB — Talladega, Ala.	325	WIRY — Plattsburg, N. Y.	514
WHTC — Holland, Mich.	457	WIS — Columbia, S. C.	584
WHTN — Huntington, W. Va.	641	WISC — Madison, Wis.	647
WHUB — Cookeville, Tenn.	591	WISE — Asheville, N. C.	520
WHUC — Hudson, N. Y.	501	WISH — Indianapolis, Ind.	411
WHUM — Reading, Pa.	576	WISL — Shamokin, Pa.	577
WHUN — Huntingdon, Pa.	567	WISN — Milwaukee, Wis.	649
WHVF — Wausau, Wis.	651	WISO — Ponce, P. R.	661
WHVR — Hanover, Pa.	565	WISP — Kingston, N. C.	526
WHWB — Rutland, Vt.	624	WISR — Butler, Pa.	562
WHWD — Hollywood, Fla.	374	WIST — Charlotte, N. C.	521
WHWL — Nanticoke, Pa.	589	WITA — San Juan, P. R.	662
WHYL — Carlisle, Pa.	562	WITH — Baltimore, Md.	442
WHYN — Holyoke-Springfield, Mass.	447	WITY — Danville, Ill.	402
WHYU — Newport News, Va.	629	WITZ — Jasper, Ind.	411
WIAC — San Juan, P. R.	662	WIVK — Knoxville, Tenn.	593
WIAM — Williamston, N. C.	531	WIVY — Jacksonville, Fla.	374
WIBA — Madison, Wis.	647	WIZE — Springfield, Ohio	545
WIBB — Macon, Ga.	389	WIZZ — Streator, Ill.	408
WIBC — Indianapolis, Ind.	411	WJAC — Johnstown, Pa.	568
WIBG — Philadelphia, Pa.	573	WJAG — Norfolk, Neb.	485
WIBM — Jackson, Mich.	458	WJAM — Marion, Ala.	321
WIBR — Baton Rouge, La.	432	WJAN — Spartanburg, S. C.	587
WIBU — Paynette, Wis.	650	WJAR — Providence, R. I.	582
WIBV — Belleville, Ill.	397	WJAS — Pittsburgh, Pa.	574
WIBW — Topeka, Kan.	424	WJAT — Swainsboro, Ga.	392
WIBX — Utica, N. Y.	518	WJAX — Jacksonville, Fla.	374
WICA — Ashtabula, O.	534	WJAY — Mullins, S. C.	587
WICC — Bridgeport, Conn.	365	WJAZ — Albany, Ga.	381
WICE — Providence, R. I.	582	WJBB — Haleyville, Ala.	320
WICH — Norwich, Conn.	367	WJBC — Bloomington, Ill.	397
WICY — Malone, N. Y.	503	WJBF — Augusta, Ga.	385
WIDE — Biddeford, Me.	438	WJBK — Detroit, Mich.	455
WIEL — Elizabethtown, Ky.	427	WJBO — Baton Rouge, La.	432
WIFM — Elkin, N. C.	522	WJBS — Deland, Fla.	373
WIGM — Medford, Wis.	648	WJBW — New Orleans, La.	435
WIHL — Hammond, La.	433	WJBY — Gadsden, Ala.	320
WIKB — Iron River, Mich.	458	WJCD — Seymour, Ind.	413
WIKC — Bogalusa, La.	433	WJCM — Sebring, Fla.	379
WIKE — Newport, Vt.	624	WJDA — Quincy, Mass.	448
WIKK — Erie, Pa.	563	WJDX — Jackson, Miss.	470
WIKY — Evansville, Ind.	409	WJEF — Grand Rapids, Mich.	457
WIL — St. Louis, Mo.	478	WJEH — Gallipolis, O.	543
WILD — Birmingham, Ala.	317	WJEJ — Hagerstown, Md.	443
WILE — Cambridge, O.	534	WJEL — Springfield, Ohio	545
WILK — Wilkes-Barre, Pa.	579	WJER — Dover, O.	543
WILM — Wilmington, Del.	369	WJET — Erie, Pa.	563
WILS — Lansing, Mich.	459	WJFR — Caguas, P. R.	659
WIMA — Lima, O.	544	WJHL — Johnson City, Tenn.	593
WIMO — Winder, Ga.	393	WJHO — Opelika, Ala.	324
WIMS — Michigan City, Ind.	412	WJHP — Jacksonville, Fla.	374
WINA — Charlottesville, Va.	626	WJIG — Tullahoma, Tenn.	597
WINC — Winchester, Va.	633	WJIM — Lansing, Mich.	459
WIND — Chicago, Ill.	401	WJIV — Savannah, Ga.	391
WING — Dayton, O.	542	WJJD — Chicago, Ill.	401
WINK — Ft. Myers, Fla.	373	WJII — Montgomery, Ala.	323
WINN — Louisville, Ky.	429	WJIL — Niagara Falls, N. Y.	513
WINR — Binghamton, N. Y.	497	WJIM — Lewisburg, Tenn.	594
WINS — New York, N. Y.	505	WJKO — Springfield, Mass.	449
WINX — Rockville, Md.	443	WJLB — Detroit, Mich.	455
WINZ — Miami, Fla.	376	WJLD — Birmingham, Ala.	317
WIOD — Miami, Fla.	376	WJLK — Asbury Park, N. J.	489
WION — Ionia, Mich.	457	WJLS — Beckley, W. Va.	640
WIOU — Kokomo, Ind.	411	WIMA — Orange, Va.	629
WIP — Philadelphia, Pa.	573	WIMB — Brookhaven, Miss.	468
WIPC — Lake Wales, Fla.	375	WIMC — Rice Lake, Wis.	650
WIRA — Fort Pierce, Fla.	373	WIMI — Philadelphia, Pa.	573
WIRB — Enterprise, Ala.	319	WIMO — Cleveland, O.	537
WIRC — Hickory, N. C.	525	WIMR — New Orleans, La.	435
WIRE — Indianapolis, Ind.	411	WIMS — Ironwood, Mich.	458
WIRJ — Humboldt, Tenn.	592	WIMW — Athens, Ala.	316
WIRK — West Palm Beach, Fla.	381	WIMX — Florence, S. C.	585
WIRL — Peoria, Ill.	406	WJNC — Jacksonville, N. C.	525
WIRO — Ironton, O.	544	WJNO — West Palm Beach, Fla.	381

WJOB — Hammond, Ind.	410
WJOC — Jamestown, N. Y.	502
WJOI — Florence, Ala.	319
WJOL — Joliet, Ill.	403
WJON — St. Cloud, Minn.	466
WJOT — Lake City, S. C.	586
WJOY — Burlington, Vt.	624
WJPA — Washington, Pa.	578
WJPD — Ishpeming, Mich.	458
WJPF — Herrin, Ill.	403
WJPG — Green Bay, Wis.	646
WJPR — Greenville, Miss.	469
WJPS — Evansville, Ind.	410
WJQS — Jackson, Miss.	470
WJR — Detroit, Mich.	455
WJRD — Tuscaloosa, Ala.	326
WJRI — Lenoir, N. C.	526
WJTN — Jamestown, N. Y.	502
WJVA — South Bend, Ind.	413
WJVB — Jacksonville Beach, Fla.	375
WJW — Cleveland, O.	541
WJWL — Georgetown, Del.	368
WJWS — South Hill, Va.	632
WJXN — Jackson, Miss.	470
WJZM — Clarksville, Tenn.	591
WKAB — Mobile, Ala.	323
WKAI — Macomb, Ill.	404
WKAL — Rome, N. Y.	517
WKAM — Warsaw, Ind.	414
WKAN — Kankakee, Ill.	403
WKAP — Allentown, Pa.	560
WKAQ — San Juan, P. R.	662
WKAT — Miami Beach, Fla.	377
WKAY — Glasgow, Ky.	427
WKBC — North Wilkesboro, N. C.	527
WKBH — La Crosse, Wis.	647
WKBI — St. Mary's, Pa.	576
WKBN — Youngstown, Ohio	547
WKBO — Harrisburg, Pa.	567
WKBR — Manchester, N. H.	488
WKBS — Oyster Bay, N. Y.	513
WKBV — Richmond, Ind.	412
WKBW — Buffalo, N. Y.	499
WKBZ — Muskegon, Mich.	460
WKCT — Bowling Green, Ky.	426
WKDA — Nashville, Tenn.	595
WKDK — Newberry, S. C.	587
WKDN — Camden, N. J.	490
WKEI — Keweenaw, Ill.	404
WKEU — Griffin, Ga.	388
WKEY — Covington, Va.	626
WKGX — Knoxville, Tenn.	593
WKHM — Jackson, Mich.	458
WKIC — Hazard, Ky.	428
WKID — Urbana, Ill.	408
WKIK — Leonardtown, Md.	443
WKIN — Kingsport, Tenn.	593
WKIP — Poughkeepsie, N. Y.	514
WKJB — Mayaguez, P. R.	661
WKJG — Ft. Wayne, Ind.	410
WKKO — Cocoa, Fla.	372
WKLA — Ludington, Mich.	459
WKLK — Clanton, Ala.	318
WCLI — Sparta, Wis.	651
WCLK — Cloquet, Minn.	462
WKLO — Louisville, Ky.	429
WKLX — Blackstone, Va.	625
WKLY — Hartwell, Ga.	388
WKMF — Flint, Mich.	456
WKMH — Detroit, Mich.	456
WKMI — Kalamazoo, Mich.	458
WKMT — Kings Mountain, N. C.	525
WKNA — Charleston, W. Va.	640

WKNB — New Britain, Conn.	366
WKNE — Keene, N. H.	488
WKNK — Muskegon, Mich.	460
WKNX — Saginaw, Mich.	461
WKNY — Kingston, N. Y.	502
WKOK — Sunbury, Pa.	578
WKOP — Binghamton, N. Y.	497
WKOV — Wellston, Ohio	546
WKOW — Madison, Wis.	647
WKOX — Framingham, Mass.	446
WKOY — Bluetfield, W. Va.	640
WKOZ — Kosciusko, Miss.	470
WKPA — New Kensington, Pa.	571
WKPT — Kingsport, Tenn.	593
WKRC — Cincinnati, O.	537
WKRK — Mobile, Ala.	323
WKRK — Columbia, Tenn.	591
WKRO — Cairo, Ill.	397
WKRS — Waukegan, Ill.	408
WKRT — Cortland, N. Y.	499
WKRZ — Oil City, Pa.	571
WKSJ — Milford, Del.	368
WKSX — Pulaski, Tenn.	596
WKST — New Castle, Pa.	571
WKTG — Thomasville, Ga.	392
WKTM — Mayfield, Ky.	429
WKTY — La Crosse, Wis.	647
WKUL — Cullman, Ala.	318
WKVA — Lewiston, Pa.	569
WKVM — San Juan, P. R.	662
WKWF — Key West, Fla.	375
WKWK — Wheeling, W. Va.	644
WKXL — Concord, N. H.	488
WKXY — Sarasota, Fla.	379
WKY — Oklahoma City, Okla.	551
WKYB — Paducah, Ky.	430
WKYR — Keyser, W. Va.	642
WKYW — Louisville, Ky.	429
WKZO — Kalamazoo, Mich.	458
WLAC — Nashville, Tenn.	595
WLAD — Danbury, Conn.	365
WLAG — La Grange, Ga.	389
WLAK — Lakeland, Fla.	375
WLAM — Lewiston, Me.	438
WLAN — Lancaster, Pa.	568
WLAP — Lexington, Ky.	428
WLAQ — Rome, Ga.	390
WLAR — Athens, Tenn.	590
WLAT — Conway, S. C.	585
WLAU — Laurel, Miss.	470
WLAV — Grand Rapids, Mich.	457
WLAY — Muscle Shoals, Ala.	324
WLBB — Carrollton, Ga.	385
WLBC — Muncie, Ind.	412
WLBE — Leesburg, Fla.	375
WLBG — Laurens, S. C.	587
WLBH — Mattoon, Ill.	404
WLBK — Bowling Green, Ky.	426
WLBK — DeKalb, Ill.	402
WLBK — Lebanon, Ky.	428
WLBK — Lebanon, Pa.	569
WLBK — Birmingham, Ala.	317
WLBZ — Bangor, Me.	438
WLCK — Campbellsville, Ky.	426
WLCC — Lancaster, S. C.	586
WLCS — Torrington, Conn.	367
WLCS — Baton Rouge, La.	432
WLCS — La Crosse, Wis.	647
WLCS — Ladysmith, Wis.	647
WLDS — Jacksonville, Ill.	403
WLEA — Hornell, N. Y.	501
WLEC — Sandusky, Ohio	545
WLEE — Richmond, Va.	630

WLET — Toccoa, Ga.	392	WMFR — High Point, N. C.	525
WLEU — Erie, Pa.	564	wMFS — Chattanooga, Tenn.	591
WLEW — Bad Axe, Mich.	453	WMGA — Moultrie, Ga.	390
WLEX — Lexington, Ky.	428	WMGM — New York, N. Y.	505
WLFH — Little Falls, N. Y.	502	WMGR — Bainbridge, Ga.	385
WLIB — New York, N. Y.	505	WMGW — Meadville, Pa.	569
WLIL — Lenoir City, Tenn.	594	WMGY — Montgomery, Ala.	323
WLIO — East Liverpool, O.	543	WMLD — Atlantic City, N. J.	489
WLIP — Kenosha, Wis.	647	WMIE — Miami, Fla.	376
WLLH — Lowell-Lawrence, Mass.	447	wMIK — Middlesboro, Ky.	430
WLMJ — Jackson, O.	544	WMIL — Milwaukee, Wis.	649
WLNA — Peekskill, N. Y.	514	WMIN — St. Paul, Minn.	466
WLNH — Laconia, N. H.	488	WMIQ — Iron Mountain, Mich.	458
WLOA — Braddock, Pa.	562	WMIS — Natchez, Miss.	471
WLOE — Leaksville, N. C.	526	WMIX — Mt. Vernon, Ill.	405
WLOF — Orlando, Fla.	377	WMJM — Cordele, Ga.	386
WLOG — Logan, W. Va.	642	WMLS — Sylacauga, Ala.	325
WLOH — Princeton, W. Va.	643	WMLT — Dublin, Ga.	387
WLOI — LaPorte, Ind.	412	WMMB — Melbourne, Fla.	376
WLOK — Lima, O.	544	WMMN — Fairmont, W. Va.	641
WLOL — Minneapolis, Minn.	465	WMMT — McMinnville, Tenn.	594
WLON — Lincolnton, N. C.	526	WMMW — Meriden, Conn.	366
WLOS — Asheville, N. C.	520	WMNB — North Adams, Mass.	448
WLOU — Louisville, Ky.	429	WMNC — Morganton, N. C.	527
WLOW — Norfolk, Va.	629	WMNE — Menomonie, Wis.	648
WLOX — Biloxi-Gulfport, Miss.	467	WMOA — Marietta, O.	544
WLPM — Suffolk, Va.	632	WMOC — Covington, Ga.	387
WLPO — LaSalle, Ill.	404	WMOD — Moundsville, W. Va.	642
WLRP — New Albany, Ind.	412	WMOG — Brunswick, Ga.	385
WLS — Chicago, Ill.	401	WMOH — Hamilton, O.	543
WLSD — Big Stone Gap, Va.	625	WMOK — Metropolis, Ill.	405
WLSE — Wallace, N. C.	530	WMON — Montgomery, W. Va.	642
WLSH — Lansford, Pa.	568	WMOU — Berlin, N. H.	488
WLSI — Pikeville, Ky.	431	WMOX — Meridian, Miss.	471
WLSM — Louisville, Miss.	471	WMOZ — Mobile, Ala.	323
WLTC — Gastonia, N. C.	523	WMPA — Aberdeen, Miss.	467
WLVA — Lynchburg, Va.	628	WMPM — Smithfield, N. C.	529
WLW — Cincinnati, O.	537	WMPS — Memphis, Tenn.	595
WLYC — Williamsport, Pa.	579	WMRA — Myrtle Beach, S. C.	587
WLYN — Lynn, Mass.	447	WMRF — Lewistown, Pa.	569
WMAJ — State College, Pa.	578	WMRN — Marion, O.	544
WMAK — Nashville, Tenn.	596	WMRO — Aurora, Ill.	397
WMAL — Washington, D. C.	370	WMRP — Flint, Mich.	456
WMAM — Marinette, Wis.	648	WMRY — New Orleans, La.	435
WMAN — Mansfield, O.	544	WMSA — Massena, N. Y.	503
WMAP — Monroe, N. C.	526	WMSC — Columbia, S. C.	584
WMAQ — Chicago, Ill.	401	WMSL — Decatur, Ala.	318
WMAS — Springfield, Mass.	449	WMT — Cedar Rapids, Iowa	415
WMAW — Menominee, Mich.	459	WMTG — Vanceleve, Ky.	431
WMAY — Springfield, Ill.	407	WMTE — Manistee, Mich.	459
WMAZ — Macon, Ga.	389	WMTR — Morristown, N. J.	490
WMBC — Macon, Miss.	471	WMTS — Murfreesboro, Tenn.	595
WMBD — Peoria, Ill.	406	WMUR — Manchester, N. H.	488
WM ^g — Richmond, Va.	631	WMUS — Muskegon, Mich.	460
WMBH — Joplin, Mo.	475	WMUU — Greenville, S. C.	586
WMBI — Morehead City, N. C.	527	WMVA — Martinsville, Va.	628
WMEM — Miami Beach, Fla.	377	WMVG — Milledgeville, Ga.	389
WMBN — Petoskey, Mich.	460	WMVO — Mt. Vernon, Ohio	545
WMBO — Auburn, N. Y.	495	WMYR — Ft. Myers, Fla.	373
WMBR — Jacksonville, Fla.	374	WMAB — Bridgeport, Conn.	365
WMPS — Uniontown, Pa.	578	WNAC — Boston, Mass.	445
WMC — Memphis, Tenn.	595	WNAE — Warren, Pa.	578
WMCA — New York, N. Y.	505	WNAE — Grenada, Miss.	469
WMCK — McKeesport, Pa.	569	WNAH — Nashville, Tenn.	596
WMDC — Hazlehurst, Miss.	469	WNAM — Neenah-Menasha, Wis.	649
WMDD — Fajardo, P. R.	661	WNAO — Raleigh, N. C.	527
WMDN — Midland, Mich.	459	WNAR — Norristown, Pa.	571
WMEV — Marion, Va.	628	WNAT — Natchez, Miss.	471
WMEX — Boston, Mass.	445	WNAV — Annapolis, Md.	441
WMFC — Monroeville, Ala.	323	WNAW — North Adams, Mass.	448
WMFD — Wilmington, N. C.	531	WNAX — Yankton, S. D.	590
WMFG — Hibbing, Minn.	463	WNBC — New York, N. Y.	505
WMFJ — Daytona Beach, Fla.	372	WNBF — Binghamton, N. Y.	497

WNBH — New Bedford, Mass.	448	WOSH — Oshkosh, Wis.	649
WNBS — Murray, Ky.	430	WOTW — Nashua, N. H.	489
WNEZ — Saranac Lake, N. Y.	517	WOV — New York, N. Y.	511
WNCA — Siler City, N. C.	529	WOW — Omaha, Neb.	486
WNCC — Barnsboro, Pa.	561	WOWL — Florence, Ala.	319
WNDB — Daytona Beach, Fla.	373	WOWO — Ft. Wayne, Ind.	410
WNDR — Syracuse, N. Y.	517	WOXF — Oxford, N. C.	527
WNEB — Worcester, Mass.	451	WOZK — Ozark, Ala.	324
WNEL — San Juan, P. R.	662	WPAB — Ponce, P. R.	661
WNER — Live Oak, Fla.	375	WPAC — Patchogue, N. Y.	514
WNEW — New York, N. Y.	507	WPAD — Paducah, Ky.	430
WNEX — Macon, Ga.	389	WPAG — Ann Arbor, Mich.	453
WNGO — Mayfield, Ky.	429	WPAL — Charleston, S. C.	583
WNHC — New Haven, Conn.	367	WPAM — Pottsville, Pa.	575
WNJR — Newark, N. J.	490	WPAQ — Mt. Airy, N. C.	527
WNLA — Indianola, Miss.	470	WPAR — Parkersburg, W. Va.	643
WNLC — New London, Conn.	367	WPAT — Paterson, N. J.	491
WNLK — Norwalk, Conn.	367	WPAW — Pawtucket, R. I.	581
WNMP — Evanston, Ill.	403	WPAX — Thomasville, Ga.	392
WNNC — Newton, N. C.	527	WPAY — Portsmouth, O.	545
WNNJ — Newton, N. J.	491	WPAZ — Pottstown, Pa.	575
WNNT — Warsaw, Va.	632	WPBB — Jackson, Ala.	321
WNOE — New Orleans, La.	435	WPBC — Minneapolis, Minn.	465
WNOK — Columbia, S. C.	584	WPCF — Panama City, Fla.	378
WNOP — Newport, Ky.	430	WPCT — Putnam, Conn.	367
WNOR — Norfolk, Va.	629	WPDQ — Jacksonville, Fla.	374
WNOS — High Point, N. C.	525	WPDR — Portage, Wis.	649
WNOW — York, Pa.	581	WPDX — Clarksburg, W. Va.	641
WNOX — Knoxville, Tenn.	593	WPEL — Montrose, Pa.	569
WNPT — Tuscaloosa, Ala.	326	WPEN — Philadelphia, Pa.	574
WNRC — New Rochelle, N. Y.	503	WPEO — Peoria, Ill.	406
WNRV — Narrows, Va.	629	WPEP — Taunton, Mass.	449
WNVA — Norton, Va.	629	WPFB — Middletown, O.	544
WNXT — Portsmouth, Ohio.	545	WPFH — Park Falls, Wis.	649
WOAI — San Antonio, Tex.	617	WPGH — Pittsburgh, Pa.	574
WOAP — Owosso, Mich.	460	WPGW — Portland, Ind.	412
WOAY — Oak Hill, W. Va.	643	WPIC — Sharon, Pa.	577
WOBS — Jacksonville, Fla.	374	WPID — Piedmont, Ala.	324
WOBT — Rhinelander, Wis.	650	WPIK — Alexandria, Va.	625
WOC — Davenport, Iowa	416	WPIN — St. Petersburg, Fla.	379
WOCH — West Yarmouth	449	WPIT — Pittsburgh, Pa.	574
WOHI — East Liverpool, O.	543	WPJB — Providence, R. I.	582
WOHP — Bellefontaine, O.	534	WPKE — Pikeville, Ky.	431
WOHS — Shelby, N. C.	529	WPKY — Princeton, Ky.	431
WOKE — Oak Ridge, Tenn.	596	WPLA — Plant City, Fla.	378
WOKO — Albany, N. Y.	495	WPLH — Huntington, W. Va.	641
WOKW — Sturgeon Bay, Wis.	651	WPME — Punxsutawney, Pa.	575
WOKY — Milwaukee, Wis.	649	WPMP — Pascagoula, Miss.	471
WOKZ — Alton, Ill.	397	WPNF — Brevard, N. C.	521
WOL — Washington, D. C.	370	WPNX — Phenix City, Ala.	324
WOLF — Syracuse, N. Y.	517	WPOR — Portland, Me.	439
WOLS — Florence, S. C.	585	WPPA — Pottsville, Pa.	575
WOMI — Owensboro, Ky.	430	WPRA — Mayaguez, P. R.	661
WOMT — Manitowoc, Wis.	648	WPRC — Lincoln, Ill.	404
WOND — Pleasantville, N. J.	491	WPRE — Prairie du Chien, Wis.	650
WONE — Dayton, O.	542	WPRO — Providence, R. I.	582
WONN — Lakeland, Fla.	375	WPRP — Ponce, P. R.	661
WONW — Defiance, O.	542	WPRS — Paris, Ill.	405
WOOD — Grand Rapids, Mich.	457	WPRT — Prestonburg, Ky.	431
WOOF — Dothan, Fla.	319	WPTF — Raleigh, N. C.	528
WOQY — Washington, D. C.	371	WPTR — Albany, N. Y.	496
WOOV — New Bern, N. C.	527	WPTW — Piqua, O.	545
WOPA — Oak Park, Ill.	405	WPTX — Lexington Park, Md.	443
WOPI — Bristol, Tenn.	590	WPUV — Pulaski, Va.	630
WOR — New York, N. Y.	507	WPWA — Chester, Pa.	562
WORA — Mayaguez, P. R.	661	WPXY — Punxsutawney, Pa.	576
WORC — Worcester, Mass.	451	WOAM — Miami, Fla.	376
WORD — Spartanburg, S. C.	587	WQAN — Scranton, Pa.	577
WORK — York Pa.	581	WQBC — Vicksburg, Miss.	472
WORL — Boston, Mass.	445	WQUA — Moline, Ill.	405
WORZ — Orlando, Fla.	378	WQXI — Atlanta, Ga.	384
WOSA — Wausau, Wis.	652	WQXR — New York, N. Y.	513
WOSC — Fulton, N. Y.	501	WRAC — Racine, Wis.	650

WRAD — Radford, Va.	630	WSAZ — Huntington, W. Va.	642
WRAG — Carrollton, Ala.	318	WSB — Atlanta, Ga.	383
WRAK — Williamsport, Pa.	579	WSBA — York, Pa.	581
WRAL — Raleigh, N. C.	528	WSBB — New Smyrna Beach, Fla.	377
WRAP — Norfolk, Va.	629	WSBC — Chicago, Ill.	401
WRBW — Reading, Pa.	576	WSBT — South Bend, Ind.	413
WRAY — Princeton, Ind.	412	WSCR — Scranton, Pa.	577
WRBC — Jackson, Miss.	470	WSDR — Sterling, Ill.	408
WRBL — Columbus, Ga.	386	WSFA — Montgomery, Ala.	324
WRC — Washington, D. C.	371	WSFC — Somerset, Ky.	431
WRCO — Richland Center, Wis.	650	WSFT — Thomaston, Ga.	392
WRCS — Ahoskie, N. C.	520	WSGC — Elberton, Ga.	388
WRDB — Reedsburg, Wis.	650	WSGN — Birmingham, Ala.	317
WRDO — Augusta, Me.	437	WSGW — Saginaw, Mich.	461
WRDW — Augusta, Ga.	385	WSHB — Stillwater, Minn.	466
WREB — Holyoke, Mass.	447	WSIC — Stateville, N. C.	530
WREC — Memphis, Tenn.	595	WSID — Baltimore, Md.	442
WREL — Lexington, Va.	628	WSIP — Paintsville, Ky.	430
WREN — Topeka, Kan.	425	WSIR — Winter Haven, Fla.	381
WREV — Reidsville, N. C.	528	WSIV — Pekin, Ill.	405
WRFC — Athens, Ga.	383	WSIX — Nashville, Tenn.	596
WRFD — Worthington, O.	546	WSJS — Winston-Salem, N. C.	531
WRFS — Alexander City, Ala.	316	WSKB — McComb, Miss.	471
WRFW — Eau Claire, Wis.	646	WSKI — Montpelier-Barre, Vt.	624
WRGA — Rome, Ga.	390	WSKY — Asheville, N. C.	520
WRHC — Jacksonville, Fla.	375	WSLB — Ogdensburg, N. Y.	513
WRHI — Rock Hills, S. C.	587	WSLI — Jackson, Miss.	470
WRHT — Griffin, Ga.	388	WSLM — Salem, Ind.	413
WRIA — Caguas, P. R.	659	WSLS — Roanoke, Va.	632
WRIB — Providence, R. I.	582	WSM — Nashville, Tenn.	596
WRIC — Richlands, Va.	630	WSMB — New Orleans, La.	435
WRIO — Rio Piedras, P. R.	661	WSMI — Litchfield, Ill.	404
WRIS — Roanoke, Va.	632	WSMT — Sparta, Tenn.	597
WRJN — Racine, Wis.	850	WSNJ — Bridgeton, N. J.	489
WRJW — Picayune, Miss.	472	WSNW — Seneca, S. C.	587
WRKD — Rockland, Me.	439	WSNY — Schenectady, N. Y.	517
WRLD — Lanette, Ala.	321	WSOC — Charlotte, N. C.	521
WRMA — Montgomery, Ala.	324	WSOK — Nashville, Tenn.	596
WRMN — Elgin, Ill.	402	WSON — Henderson, Ky.	528
WRNL — Richmond, Va.	631	WSOO — Sault Ste. Marie, Mich.	461
WRNY — Rochester, N. Y.	515	WSOY — Decatur, Ill.	402
WROB — West Point, Miss.	472	WSPA — Spartanburg, S. C.	588
WROD — Daytona Beach, Fla.	373	WSPB — Sarasota, Fla.	379
WROK — Rockford, Ill.	408	WSPC — Anniston, Ala.	316
WROL — Knoxville, Tenn.	593	WSPD — Toledo, O.	546
WROM — Rome, Ga.	390	WSPR — Springfield, Mass.	449
WRON — Roncoverte, W. Va.	643	WSPT — Stevens Point, Wis.	651
WROS — Scottsboro, La.	325	WSRS — Cleveland, O.	541
WROV — Roanoke, Va.	632	WSSB — Durham, N. C.	522
WROW — Albany, N. Y.	496	WSSC — Sumter, S. C.	588
WROX — Clarksdale, Miss.	468	WSSO — Starkville, Miss.	472
WROY — Carmi, Ill.	397	WSSV — Petersburg, Va.	630
WRR — Dallas, Tex.	604	WSTC — Stamford, Conn.	367
WRRF — Washington, N. C.	530	WSTP — Salisbury, N. C.	529
WRRZ — Clinton, N. C.	522	WSTR — Sturgis, Mich.	461
WRSW — Warsaw, Ind.	414	WSTV — Steubenville, O.	546
WRTA — Altoona, Pa.	560	WSUN — St. Petersburg, Fla.	379
WRUF — Gainesville, Fla.	374	WSVA — Harrisonburg, Va.	628
WRUM — Rumford, Me.	441	WSVS — Crewe, Va.	626
WRUN — Utica-Rome, N. Y.	518	WSWN — Belle Glade, Fla.	372
WRVA — Richmond, Va.	631	WSYB — Rutland, Vt.	624
WRWS — Russellville, Ky.	431	WSYD — Mt. Airy, N. C.	527
WRXO — Rexboro, N. C.	529	WSYR — Syracuse, N. Y.	517
WSAI — Cincinnati, O.	537	WTAC — Flint, Mich.	456
WSAL — Logansport, Ind.	412	WTAD — Quincy, Ill.	406
WSAM — Saginaw, Mich.	461	WTAG — Worcester, Mass.	451
WSAN — Allentown, Pa.	560	WTAL — Tallahassee, Fla.	380
WSAR — Fall River, Mass.	446	WTAM — Cleveland, O.	541
WSAT — Salisbury, N. C.	529	WTAN — Clearwater, Fla.	372
WSAU — Wausau, Wis.	652	WTAO — Cambridge, Mass.	446
WSAV — Savannah, Ga.	391	WTAQ — LaGrange, Ill.	404
WSAY — Rochester, N. Y.	515	WTAR — Norfolk, Va.	629
		WTAW — College Station, Tex.	602

WTAX — Springfield, Ill.	407
WTBC — Tuscaloosa, Ala.	326
WTBF — Troy, Ala.	326
WTBO — Cumberland, Md.	443
WTCH — Shawano, Wis.	650
WTCJ — Tell City, Ind.	413
WTCM — Traverse City, Mich.	461
WTGN — Minneapolis-St. Paul, Minn.	465
WTCO — Campbellsville, Ky.	426
WTCW — Whitesburg, Ky.	431
WTEL — Philadelphia, Pa.	574
WTHI — Terre Haute, Ind.	413
WTHE — Hartford, Conn.	366
WTIC — Hartford, Conn.	366
WTIK — Durham, N. C.	522
WTL — Mayaguez, P. R.	661
WTIM — Taylorville, Ill.	408
WTIP — Charleston, W. Va.	641
WTIX — New Orleans, La.	436
WTJH — East Point, Ga.	387
WTJS — Jackson, Tenn.	592
WTKM — Hartford, Wis.	646
WTMA — Charleston, S. C.	584
WTMC — Ocala, Fla.	377
WTMJ — Milwaukee, Wis.	649
WTMV — East St. Louis, Ill.	402
WTNC — Thomasville, N. C.	530
WTND — Orangeburg, S. C.	587
WTNJ — Trenton, N. J.	492
WTNT — Tallahassee, Fla.	380
WTNS — Coshocton, N. C.	542
WTOB — Winston-Salem, N. C.	531
WTOC — Savannah, Ga.	391
WTOD — Toledo, O.	546
WTOK — Meridian, Miss.	471
WTOL — Toledo, O.	546
WTON — Staunton, Va.	632
WTOP — Washington, D. C.	371
WTOR — Torrington, Conn.	368
WTPR — Paris, Tenn.	596
WTPS — New Orleans, La.	436
WTRC — Elkhart, Ind.	409
WTRF — Bellaire, O.	534
WTRL — Bradentown, Fla.	372
WTRP — La Grange, Ga.	389
WTRR — Sanford, Fla.	379
WTRW — Two Rivers, Wis.	651
WTRY — Troy, N. Y.	518
WTSA — Brattleboro, Vt.	624
WTSB — Lumberton, N. C.	526
WTSL — Hanover-Lebanon, N. H.	488
WTSP — St. Petersburg, Fla.	379
WTSV — Claremont, N. H.	488
WTHH — Port Huron, Mich.	460
WTTM — Trenton, N. J.	492
WTTN — Watertown, Wis.	651
WTTR — Westminster, Md.	444
WTTT — Bloomington, Ind.	409
WTUP — Tupelo, Miss.	472
WTUS — Tuskegee, Ala.	326
WTUX — Wilmington, Del.	369
WTVB — Coldwater, Mich.	455
WTVH — Peoria, Ill.	406
WTVL — Waterville, Me.	441
WTWA — Thomson, Ga.	392
WTWN — St. Johnsbury, Vt.	625
WTXL — West Springfield, Mass.	449
WTYC — Rock Hill, S. C.	587
WTYS — Marianna, Fla.	376
WULA — Eufaula, Ala.	319
WUSJ — Lockport, N. Y.	502
WUSN — Charleston, S. C.	584

WUST — Washington, Md.	442
WVAM — Altoona, Pa.	561
WVCG — Coral Gables, Fla.	372
WVCH — Chester, Pa.	562
WVDA — Boston, Mass.	445
WVEC — Hampton, Va.	628
WVET — Rochester, N. Y.	515
WVIM — Vicksburg, Miss.	472
WVJP — Caguas, P. R.	661
WVJS — Owensboro, Ky.	430
WVKO — Columbus, O.	542
WCLK — Lexington, Ky.	428
WVLN — Olney, Ill.	405
WVMC — Mount Carmel, Ill.	405
WVMI — Biloxi, Miss.	467
WVNJ — Newark, N. J.	490
WVOK — Birmingham, Ala.	317
WVOM — Boston-Brookline, Mass.	445
WVOP — Vidalia, Ga.	393
WVOS — Liberty, N. Y.	502
WVOT — Wilson, N. C.	531
WVOW — Logan, W. Va.	642
WVPO — Stroudsburg, Pa.	578
WVSC — Somerset, Pa.	578
WVVW — Fairmont, W. Va.	641
WVWB — Vineland, N. J.	492
WWCA — Gary, Ind.	410
WWCO — Waterbury, Conn.	368
WWDC — Washington, D. C.	371
WWEZ — New Orleans, La.	436
WWGP — Sanford, N. C.	529
WWGS — Tifton, Ga.	392
WWHG — Hornell, N. Y.	501
WWIN — Baltimore, Md.	442
WWJ — Detroit, Mich.	455
WWL — New Orleans, La.	436
WWNC — Asheville, N. C.	520
WWNH — Rochester, N. H.	489
WWNR — Beckley, W. Va.	640
WWNS — Statesboro, Ga.	391
WWNY — Watertown, N. Y.	519
WWOC — Maniwoc, Wis.	648
WWOD — Lynchburg, Va.	628
WWOL — Buffalo, N. Y.	499
WWON — Woonsocket, R. I.	582
WWPA — Williamsport, Pa.	581
WWPB — Miami, Fla.	377
WWPF — Palatka, Fla.	378
WWPG — Palm Beach, Fla.	378
WWRL — Woodside, N. Y.	519
WWSC — Glens Falls, N. Y.	501
WWSO — Springfield, O.	545
WWSR — St. Albans, Vt.	624
WWST — Wooster, O.	546
WWSW — Pittsburgh, Pa.	574
WWVA — Wheeling, W. Va.	644
WWWB — Jasper, Ala.	321
WWWF — Fayette, Ala.	319
WWWR — Russellville, Ala.	324
WWWV — Rio Piedras, P. R.	661
WWYO — Pineville, W. Va.	643
WXAL — Demopolis, Ala.	318
WXGI — Richmond, Va.	631
WXLW — Indianapolis, Ind.	411
WXOK — Baton Rouge, La.	433
WXRA — Buffalo-Kenmore, N. Y.	499
WXRF — Guayama, P. R.	661
WXYZ — Detroit, Mich.	455
WYVE — Wytheville, Va.	633
WZIP — Covington, Ky.	426
WZOB — Ft. Payne, Ala.	320

ALABAMA

Pop. Feb. 1, 1954 (Est.) 3,184,000 — Families 791,000
Radio Homes — 655,000 — TV Homes — 280,500 — Stations in State 89

WAVU

ALBERTVILLE—1948

Frequency: 630 Kc. Power: 500 Watts d.
Owned-Oper. By Sand Mt. Bcstg. Service
Business-Studio Address P. O. Box 250
Phone Number 639
News Service AP
Transcription Service World
Ptnr., Sta. Mgr. Pat M. Courington
Commercial Manager Jim Thompson
Prog. Dir. Mel Evans
Chief Engineer R. W. Hoffman
Publicity Director Jesse Culp

WRFS

ALEXANDER CITY—1947
KEYSTONE

Frequency: 1050 Kc. Power: 1000 Watts
Owned-Operated By Piedmont Service Corp.
Business-Studio Address Main St.
Phone Number Adams 4-2563
News Service UP
Transcription Service World
Representative Sears & Ayer
President James L. Coley
Gen.-Station-Com. Mgr. Jim Whatley
Prog. Dir. Bob McKinnon
Chief Engineer James W. Whatley

WCTA

ANDALUSIA—1946—MBS-KBS

Frequency: 1340 Kc. Power: 250 Watts
Air Time Full Time
Owned-Operated By Andalusia Bcstg. System
Address Sanford Rd.
Phone 1100
News Service AP
Transcription Service World, Thesaurus
Representative Walker-Dora Clayton
Membership NARTB
Exec. V.P., Gen. Mgr. Dige Bishop
Commercial Manager Don Cooke
Program Director Christine Hardage
Publicity Director Don Cooke
Chief Engineer Wes Gardner

WHMA

ANNISTON—1938—ABC

Frequency: 1450 Kc. Power: 250 Watts
Owned-Operated By Anniston Bcstg. Co., Inc.
Business-Studio Address Radio Bldg.
Phone Number 2380
Air Time 5:45 a.m.-11:05 p.m.
Transcription Service Thesaurus
Representative Sears & Ayer
Membership BAB
President Harry M. Ayers
Gen.-Sta. Mgr. Malcolm Street
Commercial Mgr. R. A. Davidson

Program Director Rosamond Ponder
Publicity Director E. Cody Hall
Sales Prom. Mgr. Teena Taylor
Chief Engineer James A. Hudson

WSPC

ANNISTON—1949—MBS

Frequency: 1390 Kc. Power: 5000 Watts d.
1000 Watts n.
Owned-Operated By Model City Bcstg. Co., Inc.
Business Address Jefferson Davis Hotel
Phone 1850-51
Air Time Unlimited
News Service AP
Transcription Service Standard
Representative Walker & Dora-Clayton
Pres., Gen., Sta. Mgr. W. S. Weatherly
Commercial Manager John M. Orrison
Program Director Rosebud Waldrop
Chief Engineer Winfred B. Kennedy

WJMW

ATHENS—1948

Frequency: 730 Kc. Power: 250 Watts d.
Owned-Operated By Athens Bcstg. Co., Inc.
Business-Studio Address Hine St.
Phone Number 565
News Service AP
Pres., Gen., Comm. Mgr. Homer F. Dunnivant
Pgm., Prom., News Dir. Robert V. Dunnivant
Chief Engineer William G. Mitchell

WATM

ATMORE—1949

Frequency: 1580 Kc. Power: 250 Watts d.
Owned-Operated By Southland Bcstg. Co.
Address P. O. Box 59
Phone 50
News Service AP
Transcription Service World
Partner T. C. Miniard
Partner Grady L. Ingram
General Manager T. C. Miniard
Commercial Manager Sam Ford
Program Director Julia Miniard
Chief Engineer T. C. Miniard

WAUD

AUBURN—1947—ABC

Frequency: 1230 Kc. Power: 250 Watts
Owned-Operated By Auburn Bcstg. Co.
Business Address Box 350
Phone Number 1240
Air Time 6 a.m.-Midnight
News Service AP
Transcription Service Associated
Pres., Gen.-Station Mgr. Elmer G. Salter
Sales Prom. Dir. Lowell E. Takles

Chief Engineer.....Lawrence Dobbins
 Publicity Dir.....Elmer G. Salter

WBCO

BESSEMER—BIRMINGHAM—1950

Frequency: 1450 Kc.....Power: 250 Watts
 Owned-Operated By...The Bessemer Bcstg.
 Co., Inc.
 Business Address.....Box 606
 Phone.....Bessemer 5-5241
 Air Time.....6 a.m.-11 p.m.
 Representative.....Natz, Forjoe, etc.
 Pres., Gen. Mgr.....J. E. Lanier
 Program Director.....E. Faush
 Com. Mgr.....Hal Falter
 Chief Engineer.....Jack Warden

WAPI

BIRMINGHAM—1922—CBS

Frequency: 1070 Kc.....Power: 10,000 Watts
 Owned-Oper. By.....Television Corp.
 Address.....P. O. Box 2553
 Phone Number.....4-2466
 News Service.....AP, UP
 Representative.....Radio Sales (CBS)
 Membership.....NARTB, BAB
 Pres., Gen. Mgr.....Henry P. Johnston
 Asst. to Pres.....Ray F. Furr
 Mgr. of Radio Operations.....Herbert Martin
 Publicity Director.....James Chenoweth
 Chief Engineer.....J. V. Sanderson

WBRC

BIRMINGHAM—1925—NBC

Frequency: 960 Kc.....Power: 5000 Watts
 Owned-Oper. By...Birmingham Bcstg. Co., Inc.
 Address.....1727½ 2nd Ave., N.
 Phone Number.....4-4701
 News Service.....INS, AP
 Transcription Service.....Capitol
 Representative.....Paul H. Raymer Co.
 V.P., Gen. Mgr.....J. Robert Kern
 Program Director.....Fox Lightfoot
 Sta. Mgr., Com. Mgr.....James E. Bailey

WCRT

BIRMINGHAM—1953

Frequency: 1260 Kc.....Power: 1000 Watts d.
 Owned-Oper. By.....Chapman Radio-TV Co.
 Business Address.....725 S. 22nd St.
 Phone Number.....7-3019
 Pres., Prog. Dir.....George K. Chapman
 General Manager.....Rudy C. Clark
 Dir. of News.....Ray Shader
 Chief Engineer.....William Chapman

WEDR

BIRMINGHAM—1949

Frequency: 1220 Kc.....Power: 1000 Watts d.
 Owned-Operated By.....Magic City Bcstg. Co.
 Business Address.....1417 Fourth Ave. N.
 Phone Number.....4-0925

Partner.....J. L. Doss
 Gen. Mgr.....John A. Thompson
 Chief Engineer.....John F. Cram

WILD

BIRMINGHAM—1945—MBS

Frequency: 850 Kc.....Power: 10,000 Watts
 Owned-Oper. By.....Pilot Bcstg. Corp.
 Address.....Essex House
 Phone Number.....53-4977
 President.....George A. Mattison, Jr.
 General Manager.....Don D. Campbell
 Commercial Mgr.....J. B. Roberts
 News Service.....UP
 Rep.....H-R Representatives
 Program Director.....Charles White McGehee
 Sales Prom., Pub.....W. E. Mattison
 Chief Engineer.....Ray Lowery

WJLD

BIRMINGHAM—1942

Frequency: 1400 Kc.....Power: 250 Watts
 Owned By.....Johnston Bcstg. Co.
 Business Address.....Box 5767, Birmingham
 Phone No.....54-3466
 News Service.....AP
 Representative.....Interstate
 Pres.-Gen. Mgr.....George Johnston, Jr.
 Station Manager.....James Connolly
 Program Director.....Jane Martindale
 Comm., Sales Manager.....Joe Brewer
 Chief Engineer.....Maurice McKinney

WLBS

BIRMINGHAM—1946

Frequency: 900 Kc.....Power: 1000 Watts d.
 Owned-Operated By.....WLBS, Inc.
 Address.....212 N. 13th St.
 Phone Number.....54-2541
 President.....E. D. Rivers
 General Manager.....Wm. Randall
 Chief Engineer.....Gordon Bishop

W S G N

BIRMINGHAM—1926—ABC

Frequency: 610 Kc...Power: 5000d.; 1000 n.
 Owned-Oper.....Jemison Bcstg. Co., Inc.
 Phone Number.....4-3434
 News Service.....AP
 Transcription Service.....Thesaurus
 Air Time.....Full Time
 Representative.....Avery-Knode
 President.....Bascom Hopson
 Comm. Mgr.....G. O. Privett
 Program Director.....Dave Campbell
 Publicity Director.....Mary Childers
 Chief Engineer.....Jack Shea

WVOK

BIRMINGHAM—1947

Frequency: 690 Kc...Power: 50,000 Watts d.
 Owned-Operated By.....Voice of Dixie Inc.

Business Address..... P. O. Box 2468,
 Phone Number..... 6-2924
 Air Time..... Daytime
 News Service..... UP
 Representative..... Radio Reprs., Inc.
 Membership..... NARTB
 Pres., Gen. Sta. Mgr..... Iralee W. Benns
 Com. Sales Prom. Mgr..... Ira Leslie
 Chief Engineer..... R. G. Blaskow

W E B J

BREWTON—1947—MBS-KBS

Frequency: 1240 Kc..... Power: 250 Watts
 Owned-Operated By..... Brewton Bcstg. Co.
 Business Address..... Box 870
 Phone Number..... 1000
 News Service..... AP
 Transcription Service..... SESAC, Capitol
 Representative..... Dora-Clayton
 Pres., Gen. Mgr..... W. Emmett Brooks
 Program Director..... C. E. Land
 Chief Engineer..... J. A. Sikes

W R A G

CARROLLTON—1951—KBS

Frequency: 590 Kc..... Power: 1000 Watts d.
 Owned-Oper. By..... Pickens County Bcstg. Co.
 Address..... Box 71
 Phone Number..... 2364
 News Service..... UP
 Co-Owners..... Roth E. Hook, W. E. Farrar
 Gen. Mgr..... Douglas Reeh
 Program Director..... Gladys Estis
 Chief Engineer..... Earl Johnson

W K L F

CLANTON—1947—KBS

Frequency: 980 Kc..... Power: 1000 Watts d.
 Owned-Operated By..... Southeastern Bcstg. Co.
 Bus.-Studio Address..... P. O. Box 110
 Phone Number..... 448
 News Service..... AP
 Transcription Service..... World
 President..... Dr. J. Kelley Robinson
 Gen., Sta., Sales Mgr..... Leland L. Hudson
 Pgm., Pub. Dir..... Helen Parrish
 Chief Engineer..... Lester Carter

W F M H

CULLMAN—1950

Frequency: 1300 Kc..... Power: 1000 Watts d.
 Owned-Operated By..... The Voice of Cullman
 Address..... 206 Second Ave. E.
 Phone No..... 910
 News Service..... AP
 Transcription Service..... Associated & Thesaurus
 Pres., Partner, Gen. Mgr..... B. C. Eddins

W K U L

CULLMAN—1946—MBS-KBS

Frequency: 1340 Kc..... Power: 250 Watts
 Owned-Operated By..... Cullman Bcstg. Co.
 Bus., Studio, Trans. Address..... P. O. Box 211

Phone Number..... 863
 News Service..... UP
 Pres., Gen. Mgr..... Hudson C. Millar, Jr.
 Program Director..... Ralph Mann
 Chief Engineer..... Arthur Bachmann

W A J F

DECATUR—1953

Frequency: 1490 Kc..... Power: 250 Watts
 Owned-Oper. By..... J. B. Falt, Jr.
 Business Address..... 112 Grant Street
 Phone Number..... 4016
 Air Time..... Full Time
 News Service..... UP
 Transcription Service..... Langworth
 Station Representative..... Sears & Ayer, Inc.
 President..... J. B. Falt, Jr.
 Station Manager..... Cletus Quick
 Ccmm. Mgr..... Eugene Harwell
 Chief Engineer..... Prince Jones

W H O S

DECATUR—1948

Frequency: 800 Kc..... Power: 1000 Watts d.
 Owned-Operated By..... No. Alabama Bcstg. Co.
 Business-Studio Address..... 212 Jackson St.
 Phone Number..... 991-992
 Air Time..... Sunrise-Sunset
 News Service..... UP, AP
 Partners..... Barrett C. Shelton, John I. Jones
 Gen., Comm. Mgr..... Louis C. Blizzard
 Pgm. Dir..... Jerry Greigs
 Prom. Mgr..... Jim Fouts
 Chife Eng..... G. Upton

W M S L

DECATUR—1953—KBS-MBS

Frequency: 1400 Kc..... Power: 250 Watts
 Owned-Operated By..... Tennessee Valley
 Bcstg. Co.
 Address..... 703 Bank St.
 Phone Number..... 802-803
 News Service..... AP
 Pres., Gen. Mgr..... Frank Whisenant
 Pgm. Dir..... Robert E. Gleason
 Chief Engineer..... Garland Sandlin

W X A L

DEMOPOLIS—1947—MBS-KBS

Frequency: 1400 Kc..... Power: 250 Watts
 Owned-Operated By..... Demopolis Bcstg. Co.
 Phone Number..... 400
 News Service..... AP
 Transcription Service..... World
 Pres., General Manager..... W. M. Jordan
 Commercial Manager..... Henry J. Bley
 Pgm. Dir..... Marsha James
 Chief Engineer..... Barry Collins

W A G F

DOTHAN—1932—NBC

Frequency: 1320 Kc..... Power: 1000 Watts
 Owned-Operated By..... Dothan Bcstg. Co.

Address.....204½ E. Main Street
 Phone Number.....2-9100
 Air Time.....5 a.m.-11 p.m.
 News Service.....AP
 Transcription Service.....World
 Representative.....Joseph Hershey McGillvra
 Membership.....NARTB
 General Manager.....Julian C. Smith
 Sales Prom. Mgr.....Eugene S. McClintic
 Comm. Mgr.....Fred C. Moseley
 Publicity Director.....Pat Elliott
 Program Director.....Lamar Trammell
 Chief Engineer.....Havard T. Kawlinson

W D I G

DOTHAN—1947—ABC

Frequency: 1450 Kc.....Power: 250 Watts
 Owned-Operated By.....Houston Bcstrs.
 Business-Studio Address.....107 E. Adams St.
 Phone Number.....3-4100
 News Service.....UP
 Representative.....Cummings, Reiner
 Pres., Gen. Mgr.....Jess Swicegood
 Prog. Dir.....Earl Hutto
 Chief Engineer.....Charles Lawshe

W O O F

DOTHAN—1948—KBS

Frequency: 560 Kc.....Power: 5000 Watts d.
 Owned-Oper. By.....The WOOF Trust
 Business-Studio Address.....110 So. Foster
 Phone Number.....2-5600
 News Service.....UP
 Transcription Service.....SESAC
 Representative.....Thomas F. Clark
 Membership.....NARTB, BAB
 Station Manager.....R. A. Dowling, Jr.
 General Manager.....Agatha Gay
 Commercial Manager.....Gus Cotter
 Chief Engineer.....Sol Azar

W I R B

ENTERPRISE—1948

Frequency: 1230 Kc.....Power: 250 Watts
 Owned-Operated By.....The Wiregrass Bcstg. Co.
 Phone Number.....30
 News Service.....AP
 Transcription Service.....Langworth
 Gen. Mgr.....R. E. James
 Com. Mgr.....Fred S. Watson
 Prom. Dir.....E. E. Vinson

W U L A

EUFAULA—1948—KBS

Frequency: 1240 Kc.....Power: 250 Watts
 Owned-Oper. By.....Ala.-Ga. Bcstrs., Inc.
 Business-Studio-Trans. Address.....Radio Bldg.
 Phone Number.....745
 Air Time.....6 a.m.-10 p.m.
 News Service.....UP
 Gen. Mgr., Co-Owner.....Edward B. Fussell
 Publicity Director.....Sara Bush
 Chief Engineer.....Hugh G. Chastain

W W W F

FAYETTE—1949—KBS

Frequency: 990 Kc.....Power: 1000 Watts d.
 Owned-Operated By.....Bankhead Bcstg. Co., Inc.
 Address.....Jasper, Ala.
 Phone Number.....23462
 News Service.....UP
 President.....W. W. Bankhead
 General Manager.....James Reese
 Sta., Sales Mgr.....Jack Black
 Chief Engineer.....Hugh Hughes

W J O I

FLORENCE—1946—ABC-ABS

Frequency: 1340 Kc.....Power: 250 Watts
 Owned-Oper. By.....Florence Bcstg. Co., Inc.
 Address.....850 S. Court St.
 Phone Number.....2608
 Pres., Gen.-Sta. Mgr.....Joe T. Van Sandt
 Commercial Manager.....Tom York
 Sales Prom. Mgr.....Virginia Grey
 Pub., Pgm. Dir.....Don E. Spry
 Chief Engineer.....Paul Shannon

W O W L

FLORENCE—1945

Frequency: 1240 Kc.....Power: 250 Watts
 Owned-Oper. By.....Radio Muscle Shoals, Inc.
 Business Address.....800 Cypress Mill Rd.
 Phone Number.....3-800
 News Service.....AP
 Air Time.....Full Time
 Representative.....Rambeau and Dora Clayton
 Membership.....NARTB, BAB
 President, Gen. Mgr.....Richard B. Biddle
 Asst. Gen. Mgr.....James L. Garrett
 Commercial Manager.....Dora M. Biddle
 Sales Prom. Mgr.....Dick Biddle
 Program Director.....Bill Mapes
 Publicity Director.....Dora Biddle
 Chief Engineer.....Lawrence Rohling

W H E P

FOLEY—1953

Frequency: 1310 Kw.....Power: 1000 Watts d.
 Owned-Oper. By.....Alabama Gulf Radio Inc.

W F P A

FT. PAYNE—1950

Frequency: 1400 Kc.....Power: 250 watts
 Owned-Oper. By.....George Gothberg's
 Community Bdcstg. Co.
 Address.....102 So. Gault Ave.
 Phone Number.....1440
 News Service.....AP
 President.....George Gothberg
 Gen. Mgr.....Jerry Carr
 Chief Engineer.....Edward Pierce

WZOB

FT. PAYNE—1950—ABS

Frequency: 1250 Kc. Power: 1000 Watts d.
 Owned-Operated By: Glenn M. Gravitt
 Address: P. O. Box 255
 Phone Number: 1096
 News Service: UP
 Transcription Service: Thesaurus
 Representative: Southern Radio
 General Manager: Glenn M. Gravitt
 Commercial Mgr.: Irvin S. Liber
 Chief Engr.: Jess R. Moore

WETO

GADSDEN—1949—KBS

Frequency: 930 Kc. Power: 1000 Watts d.
 Owned-Operated By: Gadsden Radio Co.
 Address: 722 S. 12th St.
 Phone Number: 69201
 News Service: AP
 Transcription Service: Capitol
 Partner, Gen. Mgr.: Edwin H. Estes
 Partner: Cary L. Graham
 Commercial Manager: Morton Lloyd
 Program Director: Ray Estes
 Chief Engineer: Julius Vessels

WGAD

GADSDEN—1947—ABC

Frequency: 1350 Kc.
 Power: 5000 Watts d., 1000 n.
 Owned-Oper. By: Coosa Bcstg. Co., Inc.
 Air Time: 17½ hrs. daily
 Address: Philipson Bldg.
 Phone Number: 5641, 5642
 News Service: UP
 Membership: NARTB, BAB
 Pres., Gen.-Comm., Sales
 Prom. Mgr.: Curtis DeLamar
 Prog., Pub. Director: June DeLamar
 Chief Engineer: Halley D. Williams

WGWD

GADSDEN—1948

Frequency: 570 Kc. Power: 1000 Watts d.
 Owned-Oper. By: Etowah Bcstrs., Inc.
 Address: 750 Forest Ave.
 Phone Number: 6-6301
 News Service: UP
 President: Oscar P. Covington
 Gen. Mgr.: J. P. Kirby
 Chief Engineer: W. G. Anderson

WJBY

GADSDEN—1927—NBC

Frequency: 1240 Kc. Power: 250 Watts
 Owned-Oper. By: Gadsden Bcstg. Co., Inc.
 Address: 108 Broad Street
 Phone Number: 6-3381
 Representative: Avery-Knodel
 President: Bascom H. Hopson
 Sta. Mgr., Prog. Dir.: Bill Cornelius
 Chief Engineer: D. W. Bearden

WGEA

GENEVA—1953

Frequency: 1150 Kw. Power: 1000 Watts d.
 Owned-Oper. By: Geneva County Reaper
 Business Address: Westville Road
 Phone Number: 456
 Transcription Service: World
 Station Manager: Robert Sidewell
 Program Director: Junior Walker
 Commercial Manager: Gene Free

WGYV

GREENVILLE—1948—ABC-KBS

Frequency: 1400 Kc. Power: 250 Watts
 Owned-Oper. By: Greenville Bcstg. Corp.
 Business Address: P. O. Box 227
 Phone Number: 585
 Air Time: 6 a.m.-10 p.m.
 News Service: AP
 Gen., Sta., Comm. Mgr.: W. H. Miller, Jr.
 Chief Engineer: Jim Bell

WGSV

GUNTERSVILLE—1950—KBS

Frequency: 1270 Kc. Power: 1000 Watts d.
 Owned-Operated By: Gunterville Bcstg. Co.
 Address: P. O. Box 32
 Phone Number: 4131
 News Service: UP
 Transcription Service: Thesaurus
 Membership: NARTB
 President: H. E. Moore
 Gen., Sta., Comm. Mgr.: Edward Z. Correll
 Program Dir., News Dir.: Ray McClendon
 Chief Engineer: Lavelle Jackson

WJBB

HALEYVILLE—1949—MBS

Frequency: 1230 Kc. Power: 250 Watts
 Owned-Operated By: Haleyville Bcstg. Co.
 Address: Haleyville, Ala.
 Phone Number: 389
 Air Time: Full Time
 Membership: NARTB, ABA
 Representative: Indie Sales
 President: W. P. Thielens
 Gen. Mgr.: J. L. Slotton
 Program Director: Jack McNutt
 Chief Engineer: Paul Kelly

WERH

HAMILTON—1950

Frequency: 970 Kc. Power: 5000 Watts d.
 Owned-Oper. By: Marion County Bcstg. Co.
 Address: Box 187
 Phone: 3481
 Air Time: 4 a.m.-Local Sunset
 News Service: UP
 Transcription Service: SESAC
 Representative: Dora-Clayton
 President, Gen. Mgr.: Hugh Fite

Sta., Sales, Prom. Mgr. C. B. Tucker
 Program Director. Johnie Lott
 Publicity Director. Hugh J. Fite
 Chief Engineer. C. B. Tucker

WEZB

HOMWOOD—1953

Frequency: 1320 Kw. Power: 1000 Watts d.
 Owned-Oper. By. Voice of Homewood
 Business Address. Hollywood Country Club
 Phone Number. 2-8211
 President, Gen. Mgr. Gene Newman
 Program Director. Ganus Scarborough
 Promotion Mgr. Johnny Sap
 Chief Engineer. Verl Cisero

WBHP

HUNTSVILLE—1937—MBS-KBS

Frequency: 1230 Kc. Power: 250 Watts
 Owned-Operated By. Wilton H. Pollard
 Bus.-Studio Address. Fifth Ave.
 Phone Number 5000
 Air Time. 6 a.m.-11 p.m.
 News Service. UP
 President, Gen. Mgr. Wilton H. Pollard
 Prog. Dir. Kathryn Moore
 Chief Engineer. James Potter

WFUN

HUNTSVILLE—1946—ABS

Frequency: 1450 Kc. Power: 250 Watts
 Owned-Oper. By. Huntsville Bcstg. Co., Inc.
 Phone Number 2424
 Air Time. 6 a.m.-M.
 News Service UP
 Representative. Sears & Ayers
 General Manager. J. B. Falt, Jr.
 Sta. Mgr., Prog. Dir., Chief Engr., John Garrison

WHBS

HUNTSVILLE—1946—ABC

Frequency: 1550 Kc. Power: 5,000 Watts
 Owned-Oper. By. The Huntsville Times Co.
 Phone Number 2345
 Newspaper Affiliation. Huntsville Times
 News Service. AP
 Representative. Henry E. Cummings,
 Gill-Keefe-Perna
 Membership NARTB
 President. Henry P. Johnston
 General Manager. John F. Neal
 Program Director. Reuben Miller
 Chief Engineer. Victor Bankowski

WPBB

JACKSON—1950—KBS-MBS

Frequency: 1290. Power: 1000 Watts d.
 Owned-Operated By. Jackson Bcstg. Co.
 Pres., Gen. Mgr. T. H. Gaillard, Jr.
 Program Director. Charles Ballas
 Com. Mgr. Guy R. Hester
 Prog. Dir. Charles Ballas

WWWB

JASPER—1946—KBS

Frequency: 1240 Kc. Power: 250 Watts
 Owned-Operated By. Bankhead Bcstg. Co., Inc.
 Business Studio Address. Bankhead-Long
 Building
 Phone Number 23461
 Transcription Service Capitol
 News Service UP
 President. W. W. Bankhead
 Gen. Mgr. James E. Ruse
 Com. Mgr. William C. Edgemon

WRLD

LANETT—1943—ABC-KBS

Frequency: 1490 Kc. Power: 250 Watts
 Owned-Operated By. Valley Bcstg., Inc.
 Address. P. O. Box 312, West Point, Ga.
 Phone Number 2-2771
 News Service AP
 Transcription Service Thesaurus
 Representative McGillvra
 President. J. C. Henderson
 General Manager. C. Jim Murphy
 Program Director. Aileen Love
 Chief Engineer. A. L. Stancel Jr.

WJAM

MARION—1951—ABS

Frequency: 1310 Kc. Power: 1000 Watts d.
 Owned-Operated By. Neely Bcstg. Co.
 Address Bay 221
 Phone Number 7111
 Transcription Service Capitol
 Membership NARTB
 News Service AP
 Representative Southern
 General Manager. L. M. Neely, Jr.
 Station Manager. Erle W. Hanna
 Chief Engineer. Virgil Moore

WABB

MOBILE—1948—ABC-MBS

Frequency: 1480 Kc. Power: 5000 Watts
 Owned-Oper. By. Mobile Press Register, Inc.
 Business Address. 304 Government St.
 Phone Number 3-1551
 Air Time. 6 a.m.-M.
 News Service UP
 Transcription Service. World
 Representative Branham Co.
 President. R. B. Chandler
 Executive V.P. W. J. Hearin, Jr.
 Gen. Mgr. Dewey H. Long
 Chief Engineer. William H. Murphree

WALA

MOBILE—1930—NBC

Frequency: 1410 Kc. Power: 5000 Watts
 Owned-Operated By. Pape Bcstg. Co., Inc.
 Bus.-Studio Address. 210 Government St.

THOSE WHO KNOW FAMOUS BRANDS

Says Henry P. Johnston, President of WAPI at Birmingham, Ala.: "From **AP** we get solid coverage backed up by The **AP's** solid prestige."

. . . . **KNOW THE MOST FAMOUS
BRAND IN NEWS IS AP**

Phone Number 3-3756
 Air Time Full Time
 News Service AP
 Transcription Service Standard
 Representative Headley-Reed
 Membership NARTB
 President W. O. Pape
 Exec. Vice-Pres. H. K. Martin
 General Manager H. K. Martin
 Local Commercial Manager. . . . A. Treadway
 Pgm., Pub. Dir. Al Homan
 Chief Engineer R. B. Hurley

WKAB
 MOBILE—1947

Frequency: 840 Kc. Power: 1000 Watts d.
 Owned-Operated By Pursley Bcstg. Service
 Business-Studio Address. Box 1306
 Phone Number 7-6345
 Air Time Local sunrise-local sunset
 Transcription Service. SESAC, Langworth
 Representative Forjoe, Dora Clayton
 News Service AP
 Membership NARTB
 General Manager Louise P. Pursley
 Sta. Mgr., Pub. Dir. R. H. Moore
 Com. Mgr. Herbert Johnson
 Sales Prom. Mgr. Jim Smith
 Program Director John T. Jackson
 Chief Engineer Gene Miller

WKRG
 MOBILE—1946—CBS

Frequency: 710 Kc. Power: 1000 Watts
 Owned-Operated By Giddens & Rester
 Bus-Studio-Trans. Address. Telegraph Rd.
 Phone Number 2-6789
 Air Time Unlimited
 News Service AP
 Transcription Service Langworth
 Representative Adam J. Young, Jr.
 Membership BAB, NARTB
 President Kenneth R. Giddens
 Gen., Sta. Mgr. Frank Conwell
 Sales Manager Carl Haug
 Program Director Richard McMullen
 Publicity Director Shirley Rester
 Chief Engineer F. E. Couey

WMOZ
 MOBILE—1952

Frequency: 960 Kc. Power: 1000 Watts d.
 Owned-Oper. By Gasden Radio Co.
 Phone Number 6-9201
 Representative John E. Pearson
 President Edwin Estes
 Partner C. L. Graham
 General Mgr. Walter V. Turner
 Chief Engineer Vernon Floyd

WMFC
 MONROEVILLE—1952

Frequency: 1220 Kc. Power: 250 Watts d.
 Owned-Oper. By Monroe Bdcstg. Co.

Phone Number 1220
 News Service AP
 Transcription Service World
 Gen. Mgr. George T. Shurden
 Program Director Jim Aycock
 Chief Engineer Chuck Smith

WAPX
 MONTGOMERY—1947—ABC

Frequency: 1600 Kc. Power: 1000 Watts
 Owned-Operated By United Bcstg. Co.
 Business, Studio Address. 116 Catoma St.
 Phone Number 3-7569
 News Service AP
 Transcription Service Standard
 Representative Walker Co.
 Pres., Gen. Mgr. Thomas E. Martin
 Station, Commercial Manager. . . . Hoke Williford
 Sales Promotion Manager. Frank Dudley
 Program Director Lee Stuckfelt
 Chief Engineer Owen Lehr

WBAM
 MONTGOMERY—1953

Frequency: 740 Kw. Power: 50,000 Watts d.
 Owned-Oper. By Deep South Bcstg. Co.
 Phone Number 2-3851
 President Mrs. J. F. Richardson
 General Manager W. J. Brennan
 Program Director Fred U. Wamble
 Chief Engineer Cyril G. Brennan

WCOV
 MONTGOMERY—1938—CBS

Frequency: 1240Kc. Power: 250 Watts
 Owned-Oper. By Capitol Bcstg. Co.
 Business-Studio Address. Exchange Hotel
 Phone Number 2-5781
 News Service UP
 Representative O. L. Taylor
 Membership NARTB
 President Oscar P. Covington
 General Manager Hugh M. Smith
 Station Manager Joe Petranka
 Sales Prom. Mgr. O. M. Teate
 Program Director Walter Spiro
 Chief Engineer W. D. Weatherly

WJJJ
 MONTGOMERY—1948—MBS

Frequency: 1170 Kc. Power: 10,000 Watts d.,
 1000 n.
 Owned-Oper. By Southern Bcstg. Co., Inc.
 Business-Studio Address. 135 Commerce St.
 Transcription Service Thesaurus
 Representative Weed
 President Joseph G. Mathews
 Chief Engineer A. Fred Wright

WMGY
 MONTGOMERY—1946

Frequency: 800 Kc. Power: 1000 Watts d.
 Owned-Operated By Dixie Bcstg. Co.

Business Studio Address 4 S. Perry St.
Phone 2-5245
News Service UP
Representative Forjoe & Co.
Membership BAB
President Dr. S. D. Suggs
Gen.-Comm. Manager Thomas W. Sewell
Sales Prom. Mgr. C. L. Brown
Chief Engineer John D. Lamar

Phone Number 712, 713
News Service UP
Transcription Service World
Representative Indie Sales, Inc.
Membership NARTB, BAB
Station Manager John C. Cooper, Jr.
Commercial Manager E. Turk
Sls. Prom. Mgr. G. E. Snyder
Chief Engineer John E. Smollon

WRMA

MONTGOMERY—1953

Frequency: 950 Kw Power: 1000 Watts d.
Owned-Oper. By Southland Bcstg. Co.
Business Address 26 North Lawrence St.
Phone Number 2-1475
Transcription Service Associated
Representative McGillvra
Partner & Gen. Mgr. Rolph M. Allgood
Partner Grover Wise
Chief Engineer Walter B. Stevenson

WAMI

OPP—1952

Frequency: 860 Kw Power: 1000 Watts d.
Owned-Oper. By Opp Bcstg. Co.
Business Address Box 169
Phone Number 659
News Service UP
President H. N. Lee
Gen. Com. Mgr. Beri Moore
Chief Engineer Joe Osgatharp

WSFA

MONTGOMERY—1930—NBC

Frequency: 1440 Kc. Power: 5000 Watts d.;
 1000 Watts n.
Owned Oper. By Montgomery Bcstg. Co., Inc.
Business Address P. O. Box 1031
Phone 8361
News Service AP
Representative Headley-Reed
Membership NARTB, BAB
President David E. Dunn
General Manager Lionel Baxter
Nat. Sales Mgr. Julia Looney
Commercial Mgr. Travis Williams

WOZK

OZARK—1953

Frequency: 950 Kw. Power: 1030 Watts d.
Owned-Oper. By Ozark Bcstg. Corp.

WPNX

PHENIX CITY—1952

Frequency: 1460 Kc. Power: 1030 Watts d.
Owned-Oper. By Community Bdcstg. Co.
Address Phenix Guard Bank Bldg.
Phone Number 8-8787
News Service AP
President Ray M. Greene
Comm. Mgr. Don C. Price
Prog. Dir., Chief Engneer Jay H. Lamb

WLAY

MUSCLE SHOALS—1933—MBS

Frequency: 1450 Kc. Power: 250 Watts
Owned Oper. By Muscle Shoals Bcstg. Corp.
Business Address P. O. Box 230, Sheffield
News Service UP
Representative Devney & Co.
Membership NARTB, BAB
President Frank M. Farris, Jr.
General Manager E. O. Whitehead
Program Director George Manush
Chief Engineer Lynn V. McMoran

WPID

PIEDMONT—1953

Frequency: 1200 Kw Power: 1000 watts d.
Owned-Oper. By Piedmont Radio Station
Phone Number 2231
President C. L. Graham
General Manager Curt Blair
Program Director Frances Kerns
Prom. Mgr. J. D. Carter
Chief Engineer Hamilton Masters

WCRL

ONEONTA—1952

Frequency: 1570 Kc. Power: 250 Watts d.
Owned-Oper. By Blount County Bcstg. Serv.
Phone Number 4871
News Service AP
Transcription Service Capitol
Gen. Mgr. E. Glenn Abercrombie

WELR

ROANOKE—1950—KBS

Frequency: 1360 Kc. Power: 1000 Watts d.
Owned-Operated By J. W. Buttram
Address 801 N. Main St.
Phone 3811
Pres., Gen., Com. Mgr. J. W. Buttram
Program Director John Hodges
Chief Engineer Leverne Foster

WJHO

OPELIKA—1940—MBS-KBS

Frequency: 1400 Kc. Power: 250 Watts
Owned Oper. By Opelika-Auburn Bcstg. Co.

WWWR

RUSSELLVILLE—1949

Frequency: 920 Kc. Power: 1000 Watts d.
Owned-Oper. By Bankhead Bcstg. Co., Inc.

Address... Bankhead-Long Bldg., Jasper, Ala.
 Phone Number 647
 News Service UP
 Transcription Service SESAC
 Representative Southern Radio
 President..... Walter W. Bankhead
 Gen. Mgr..... Hal Kirby
 Pgm. Dir., Chief Engineer... Carl Van Sittert

WCRI
 SCOTTSBORO—1950

Frequency: 1050 Kc..... Power: 250 Watts d.
 Owned-Operated By..... Pat M. Courington
 Phone 123
 News Service AP
 Gen. Mgr..... Pat M. Courington
 Station Mgr..... Eaton P. Govan, Jr.
 Program Director..... Jack Wilhelm
 Chief Engineer..... James G. Wallace

WROS
 SCOTTSBORO—1952

Frequency: 1330 Kw... Power: 1000 Watts d.
 Owned-Oper. By..... Scottsboro Bcstg. Co.
 Business Address..... 717 Scott St.
 Phone Number 156
 President..... Hugh T. Kirby
 Gen., Com. Mgr..... Rose M. Kirby
 Program Dir..... Clyd R. Varner
 Chief Engr..... Bill Prickett

WGWC
 SELMA—1946—CBS

Frequency: 1340 Kc..... Power: 250 Watts
 Owned-Oper. By..... Dallas Broadcasters, Mc.
 Address..... P. O. Box 686
 Phone Number..... TRinity 4-6687
 Air Time..... Full Time
 Station Representative..... Hal Holman
 Membership NARTB
 President Oscar Covington
 Gen. Mgr. & Chief Engr... John F. Townshend
 Commercial Manager..... John Frazier

WHBB
 SELMA—1935—NBC

Frequency: 1490 Kc..... Power: 250 Watts
 Owned-Operated By..... Selma Bcstg., Inc.
 Business Address..... 209 Washington St.
 Phone Number..... TR 4-8861
 President..... B. H. Hopson
 Gen., Sta., Comm. Mgr..... Julien Smith, Jr.
 Program Director..... Mrs. Douglas Reynolds
 Chief Engineer..... W. D. Powers, Jr.

WFEB

SYLACAUGA—1945—MBS-KBS

Frequency: 1340 Kc..... Power: 250 Watts
 Owned-Operated By..... Alabama Bcstg. Co.
 Business-Studio Address..... P. O. Box 358
 Phone Number 2-3281
 News Service UP

Air Time..... Full Time
 President..... E. E. Forbes, Sr.
 Comm., Sta. Mgr..... George W. Carr
 Chief Engineer..... Conrad Pickren

WMLS
 SYLACAUGA—1948—ABS

Frequency: 1290 Kc..... Power: 1000 Watts d.
 Owned-Oper. By... Marble City Bcstg. Co., Inc.
 Business Address..... Box 511
 Phone Number 2-4354
 Air Time 5:45 a.m.—Sunset
 News Service AP
 Pres., Gen. Manager..... Curtis O. Liles, Jr.
 Commercial Manager..... Marion W. McEwen
 Prog., Pub. Dir..... Robert M. Duck
 Chief Engineer..... Walter Welch

WHTB
 TALLADEGA—1945—MBS-KBS-ABS

Frequency: 1230 Kc..... Power: 250 Watts
 Owned-Operated By... Voice of Talladega, Inc.
 Address Bemiston Highway
 Phone Number 2205
 Air Time..... Full Time
 News Service..... AP
 Transcription Service World
 Representative Continental
 Pres., Gen. Sta. Mgr..... R. A. Davidson
 Commercial Manager..... Myron T. Snoddy
 Program Director..... W. B. Dorriety
 Chief Engineer..... David Andrews

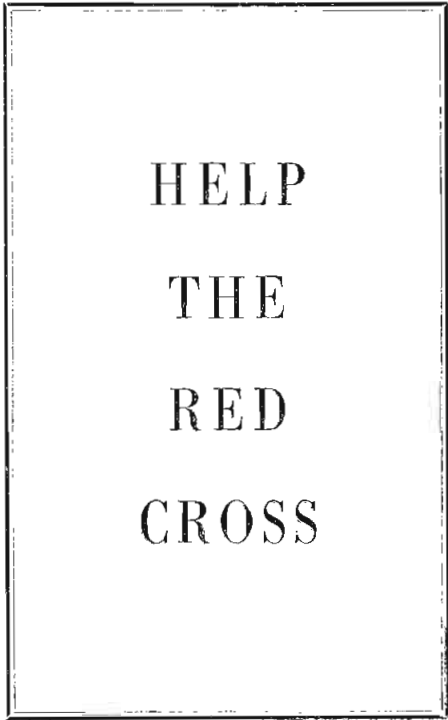

WTBF

TROY—1947—MBS-KBS

Frequency: 1490 Kc. Power: 250 Watts
 Owned-Operated By: Troy Bcstg. Corp.
 Address: College Drive
 Phone Number: 980-1
 News Service: AP
 Transcription Service: World
 Membership: NARTB
 President: Roy Crow
 Gen. Mgr.: Jess Jordan
 Commercial Mgr.: Robert Tolbert
 Chief Engineer: Joe W. Gilchrist

WJRD

TUSCALOOSA—1936—NBC

Frequency: 1150 Kc. Power: 5000 Watts c.;
 1000 Watts n.
 Owned-Oper. By: Wilhelmina (Doss) Echols
 Business-Studio Address: 2316 Broad St.
 Phone Number: 4464
 Air Time: 5:30 a.m.-M.
 News Service: UP
 Transcription Service: World
 Representative: Rambeau, Clayton, Southeast
 Membership: NARTB
 Gen., Sta. Mgr.: Gene Tibbett
 Comm. Mgr.: Lehman Mayer
 Prog. Dir.: Roy McAllister
 Chief Engineer: Dave Livingston

WNPT

TUSCALOOSA—1951

Frequency: 128J Kc. Power: 1000 Watts d.
 Owned-Oper. By: W. Alabama Bdcstg. Co.
 Address: P. O. Box 181
 Phone Number: 3311
 Representative: Indie Sales
 President: W. P. Thielens
 Gen. Mgr.: T. H. Todd
 Program Director: Wm. G. Harris
 Chief Engineer: Keith Barze

WTBC

TUSCALOOSA—1946—MBS-KBS

Frequency: 1230 Kc. Power: 250 Watts
 Owned By: Tuscaloosa Bcstg. Co.
 Business-Studio Address: City Hall Bldg.
 Phone Number: 5523
 Representative: Sears & Ayer
 General Manager: Bert Bank

WTUS

TUSKEGEE—1952—KBS

Frequency: 580 Kc. Power: 500 Watts d.
 Owned-Oper. By: Radio Tuskegee, Inc.
 News Service: UP
 General Manager: James Honey
 Program Director: G. B. White
 Commercial Mgr.: J. A. Bowers
 Chief Engineer: Julian A. Duncan

ARIZONA

Pop. Feb. 1, 1954 (Est.) 816,000 — Families 296,000 — Radio Homes
 277,000 — TV Homes 108,000 — Stations in State — 29

KSUN

BISBEE—1933—MBS
 ARIZONA NETWORK

Frequency: 1230 Kc. Power: 250 Watts
 Owned-Operated By: Carleton W. Morris
 Address: P. O. Drawer C, Lowell Station
 Phone Number: 9
 Transcription Service: World, SESAC
 News Service: UP
 Representative: Blair & Co.
 President: Carleton W. Morris
 Gen., Comm. Mgr.: Arlo Woolery
 Sales Promotion Manager: Leo Bernard
 Program Director: Ray Helgesen
 Chief Engineer: John Harris

KCLF

CLIFTON—1950

Frequency: 1400 Kc. Power: 250 Watts
 Owned-Oper. By: Saguaro Bdcstg. Co.
 Address: Box 528
 Phone Number: 321
 News Service: UP

President: Dwight Hatkins
 Gen. Mgr.: Harl Barnett
 Chief Engineer: Odorisio Pannozzo

KCKY

COOLIDGE—1948—CBS
 ARIZONA NETWORK

Frequency: 1150 Kc. Power: 1,000 Watts
 Owned-Oper. By: Gila Bcstg. Co., Inc.
 Address: Roosevelt & Main Streets
 Phone Number: 4451
 Transcription Service: Langworth
 Representative: Forioe & Co.
 President: Louis F. Long
 Station Manager: Bill Parady
 Comm. Mgr., Pgm. Dir.: Jim Murdock
 Publicity Director: Bob Ehrlich
 Chief Engineer: Jeff Lapping

KAWT

DOUGLAS—1946—NBC
 ARIZONA NETWORK

Frequency: 1450 Kc. Power: 250 Watts

Owned-Operated By.....Carleton W. Morris
 Phone Number173
 Transcription Service.....Langworth, MacGregor
 MembershipNARTB
 Gen., Sta., Comm. Mgr.....Robert L. Whitaker
 Program Director.....Sidney Manette
 Publicity Director.....James Bruns
 Chief Engineer.....Oliver Grieve

KCLS

FLAGSTAFF—1950—MBS
 DON LEE—ARIZONA

Frequency: 1360 Kc.....Power: 5000 Watts d.
 Owned-Operated By.....Saunders Bcstg. Co.
 AddressBox 1677
 Phone Number946
 Owner, Gen. Mgr.....Charles J. Saunders
 Commercial Mgr.....Harry Becker
 Chief Engineer.....Len Benson

KGPH

FLAGSTAFF—1950

Frequency: 690 Kc.....1000 Watts d.;
 500 Watts n.
 Owned-Operated By.....Frontier Bcstg. Co.
 AddressWeatherford Hotel
 Phone Number51 or 65
 News ServiceAP
 Transcription ServiceLangworth
 Representative...John Hershey McGillvra, Inc.
 MembershipNARTB
 Pres., Chief Engineer.....E. C. Phillippi
 General, Station Manager.....A. S. Holm
 Commercial Mgr.....Clair Hill
 Prog., Publ. Dir.....Mary Jane Phillippi

KWJB

GLOBE—1938—NBC-ABS

Frequency: 1240 Kc.....Power: 250 Watts
 Owned-Operated By...Gila Bcstg. Co., Inc.
 AddressP. O. Box 2343
 Phone Number41
 News ServiceAP
 Transcription ServiceThesaurus
 Representative.....Paul H. Raymer
 President.....Louis F. Long
 General Manager.....Paul Merrill
 Station Manager.....Willard Shoecraft
 Prog. Dir., Comm Mgr.....Eric Manola

KGAN

KINGMAN—1949

Frequency: 1230 Kc.....Power: 250 Watts
 Owned-Operated By.....J. James Glancy
 Business Address.....P. O. Box 1208
 Phone NumberBlue 462
 President.....J. J. Glancy
 Chief Engineer.....Leroy O'Loughlin

KTYL

MESA—1947

Frequency: 1310 Kc.....Power: 1000 Watts d.,
 500 Watts n.

Owned-Oper. By.....Harkins Bdcstg. Co.
 Address.....P. O. Box 885
 Phone Number.....Woodland 4-5737
 News ServiceUP
 Transcription ServiceStandard
 MembershipNARTB
 President.....Harry L. Nace, Jr.
 Gen. Mgr.....Dwight Harkins
 Commercial Manager....Lorenzo K. Lisonbee
 Program Director.....Jack Harris
 Publicity Director.....Dick Gilbert
 Chief Engineer.....Ben Smith

KNOG

NOGALES—1948—CBS

Frequency: 1340 Kc.....Power: 250 Watts
 Owned-Oper. By.....Old Pueblo Bcstg. Co.
 AddressRancho Grande Hotel
 Phone Number770
 Representative.....Forjoe & Co.
 President.....Harold C. Tovrea
 General Managers.....E. S. Mittendorf,
 Jack Martin
 Station Mgr.....Dorothy deRivera
 Program Dir.....Nancy M. Soto
 Chief Engineer.....Peter Hamilton

KOOL

PHOENIX—1947
 CBS—RNA

Frequency: 960 Kc.....Power: 5000 Watts
 Owned-Operated By...Maricopa Bcsters., Inc.
 Business-Studio Address.....Adams Hotel
 Phone Number.....Alpine 8-6421
 Air Time.....6 a.m.-M.
 News ServiceUP
 Transcription ServiceStandard
 Representative.....George P. Hollingbery
 MembershipNARTB
 PresidentGene Autry
 General Manager.....Charles H. Garland
 Commercial Manager.....William Connelly
 Station Manager.....Thos. Kelland
 Program Director.....Homer Lane
 Chief Engineer.....Miles Shepherd

KIFN

PHOENIX—1949

Frequency: 860 Kc.....Power: 1000 Watts d.
 Owned-Operated By.....Western Bcstg. Co.
 Address.....1975 S. Central Ave.
 Phone Number.....ALPINE 3-6155
 News ServiceUP
 Transcription ServiceSESAC
 Station Representative.....Harlan Oakes
 Pres., Gen. Mgr.....Frank P. Redfield
 Prog. Dir.....Joe D. Alvarado
 Chief Engineer.....Edgar B. Pool

KOY

PHOENIX—1922—MBS, Don Lee

Frequency: 550 Kc.....Power: 5000 d.; 1000 n.
 Owned-Oper. By.....KOY Bcstg. Co.

Address..... 840 N. Central Ave., P. O. Box
2671
Phone Number..... Alpine 4-4144
Air Time..... 24 hrs. wk. d.; 17 hrs. Sun.
News Service..... UP
Transcription Service..... World
Representative..... John Blair
Membership..... NARTB, BAB
Pres., Comm. Mgr..... John L. Hogg
Gen.-Station Mgr..... Albert D. Johnson
Prog., Pub. Director..... John R. Williams
Chief Engineer..... Edward R. Janney

KPHO

PHOENIX—1940—ABC

Frequency: 910 Kc.....Power: 5000 Watts
Owned-Operated By
Meredith Publishing Co., Inc., Des Moines
Phone Number.....ALpine 8-4511
News Service.....AP
Representative.....Katz
Membership.....NARTB, BAB
President.....E. T. Meredith, Jr.
Commercial Manager.....Charles Schlueter
Program Director.....Gene Spry
Publicity Director.....Dan Schwartz
Chief Engineer.....George L. McClanathan

KRIZ

PHOENIX—1950—KBS

Frequency: 1230 Kc.....Power: 250 Watts
Owned-Operated By.....Howard M. Loeb
Address-Trans. Loc.....2345 Westward Blvd.
Phone Number.....4-8436
Air Time.....6:00 a.m.-12 M.
News Service.....UP
Station Representative.....Burn-Smith
Membership.....NARTB
Gen., Sta. Manager.....Howard M. Loeb
Comm., Prom. Mgr.....Sheldon Engel
Chief Engineer.....James E. Groll

KRUX

PHOENIX—1947

Frequency: 1340 Kc.....Power: 250 Watts
Owned-Operated By.....Radio Arizona Inc.
Bus.-Studio Address.....Goodrich Bldg.
Phone Number.....ALp'ne 2-2371
President.....Stanley Schultz
General Manager.....Stan Norman
Comm. Mgr.....Frank Barc
Program Dir.....Timothy Sparkman
Chief Engineer.....Gene Boos

KTAR

PHOENIX—1922—NBC-ARIZ. BCSTG.

Frequency: 620 Kc.....Power: 5000 Watts
Owned-Operated By.....KTAR Bcstg. Co.
Business Studio Address.....1101 North Central
Phone Number.....AL 4-4161
Air Time.....6 a.m.-M.
News Service.....AP
Trans. Ser.....Thesaurus Standard, Capitol

Representative.....Paul H. Raymer
Membership.....NARTB
Ch. of Bd.....John J. Louis
Pres., Gen. Mgr.....Richard O. Lewis
Commercial Manager.....E. W. Harvey
Public Serv. in.....Ted Edwards
Program Director.....Rol Laughner
Chief Engineer.....A. C. Anderson

KYCA

PRESCOTT—1940
NBC-ARIZ. BCSTG.

Frequency: 1490 Kc.....Power: 250 Watts
Owned-Oper. By.....Southwest Bcstg. Co.
Business-Studio Address.....P. O. Box 1631
Phone Number.....244
News Service.....AP
Transcription Service.....Thesaurus, Capitol
Representative.....Paul H. Raymer
Pres., Gen. Mg.....Harold Ritter
Program Director.....Hollis Hill
Chief Engineer.....George Eitel

KGLU

SAFFORD—1938—NBC-ABS

Frequency: 1480 Kc.....Power: 1000 Watts
Owned-Operated By.....Gila Bcstg. Co.
Business-Studio Address.....520 Main St.
Phone Number.....15
Air Time.....Unlimited
News Service.....AP, UP
Transcription Service.....World & Thesaurus
Representative.....Paul H. Raymer
President.....Louis F. Long
General Manager.....Paul Merrill
Pgm., Prod. Dir.....Lester McBride
Comm. Mgr.....Edward E. Furman
Chief Engineer.....John E. Hickman

KCNA

TUCSON—1946—ABC

Frequency: 580 Kc.....Power: 5000 W. d.:
500 W. n.
Owned-Operated By.....Catalina Bcstg. Co.
Business-Studio Address.....Box 2348
Phone Number.....2-4664
Air Time.....5 a.m.-1 a.m.
News Service.....AP
Transcription Service.....Lang-Worth
Representative.....Hollingbery
Membership.....NARTB, BAB
President.....Erskine Caldwell
Gen., Sta. Manager.....Wayne Sanders
Sales Manager.....Harry Chambers
Chief Engineer.....Tom Epperson

KEVT

TUCSON—1953

Frequency: 690 Kw.....Power: 250 Watts d.
Owned-Oper. By.....Tucson Radio Inc.
Business Address.....503 N. Shawnee
Phone Number.....4-5588
Representative.....Oakes

Pres., Gen. Mgr. Peter Trowbridge
 Vice Pres. Helen Wray
 Comm. Mgr. De Witt Wray
 Program Dir. Hector Le Desma

Program Director Ben L. Slack, Jr.
 Chief Engineer Ray H. Holsclaw

KOPO

TUCSON—1947—CBS

Frequency: 1450 Kc. Power: 250 Watts
 Owned-Operated By Old Pueblo Bcstg. Co.
 Business-Studio Add. 115 W. Drachman St.
 Phone Number 4-2511
 Air Time 5 a.m.-1 a.m.
 News Service AP
 Representative Forjoe & Co.
 Membership NARTB, BAB
 President Harold C. Tovrea
 General Manager E. S. Mittendorf
 Commercial Manager S. J. Kossack, Jr.
 Sales Prom. Mgr. Paul Plunkett
 Publicity Director Joe Crystall
 Chief Engineer Vernard Cimmiyotti

KTKT

TUCSON—1949

Frequency: 1490 Kc. Power: 250 Watts
 Owned-Operated By Thomas J. Wallace
 Business-Studio Transmitter Add. 500 W. Elm
 Phone Number 4-1777
 Transcription Service SESAC
 Owner Thomas J. Wallace
 Chief Eng., Asst. Mgr. Thomas J. Wallace, Jr.

KTUC

TUCSON—1929—MBS-ARIZ. NET.

Frequency: 1400 Kc. Power: 250 Watts
 Owned-Oper. By Tucson Bcstg. Co.
 Business-Studio Address 900 E. Broadway
 Phone Number 2-3344
 Air Time 6 a.m.-M.
 News Service UP
 Transcription Service World
 Associated
 Representative John Blair
 Membership NARTB, BAB
 Pres. & General Manager Lee Little
 Business Manager Mac C. Matheson
 Commercial Mgr. George Bradley
 Program Director Pete Tufts
 Chief Engineer Cliff Livingston

KVOA

TUCSON—1929—NBC-ARIZ. BCSTG.

Frequency: 1290 Kc. Power: 1000 Watts
 Owned-Operated By Arizona Bcstg. Co., Inc.
 Business-Studio Address 209 W. Elm
 Phone Number 3-2557
 Air Time Full Time
 News Service AP
 Transcription Service Thesaurus, Capitol
 Representative Paul H. Raymer
 Membership NARTB
 General Manager R. B. Williams
 Business Mgr. Harper M. Phillips
 Commercial Mgr. John C. Underwood, Jr.

KVNC

WINSLOW—1952

Frequency: 1010 Kc. Power: 1000 Watts d.
 500 Watts n.
 Owned-Oper. By Gila Bdcstg. Co.
 Address P. O. Box 373
 News Service AP, INS
 Transcription Service
 Thesaurus, Standard, World
 President L. F. Long
 Gen. Mgr. O. E. Whelan
 Chief Engineer R. W. Wiseman

KOLD

YUMA—1953—CBS

Frequency: 1240 Kc. Power: 250 Watts
 Owned-Operated By Southwestern Bcstg. Co.
 Address P. O. Box 1430
 Phone Number Sunset 3-8341
 News Service UP
 Transcription Service Standard
 Representative Hollingbery
 Membership NARTB
 President Gene Autry
 General Manager Charles H. Garland
 Station Manager Robert C. Garland
 Chief Engineer Donald Peltz

KYMA

YUMA—1950—MBS—ARIZ. NET.

Frequency: 1400 Kc. Power: 250 Watts
 Owned-Oper. By KYMA-Yuma, Inc.
 Address P. O. Box 671
 Phone 37841
 Air Time Full Time
 Transcription Service World
 Representative John Blair
 Membership NARTB, BAB
 Pres., Gen., Sta. Mgr. William B. Lindsey
 Commercial Mgr. Carl Paige
 Program Director Jack La Marca
 Chief Engineer Neil Weidner

KYUM

YUMA—1940—NBC-ABS

Frequency: 560 Kc. Power: 1000 Watts
 Owned-Operated By Yuma Bcstg. Co.
 Business Address 1901 E. 1st St.
 Phone Number 3-3305
 Air Time 5:30 a.m.-M.
 News Service AP, UP, INS
 Transcription Service Thesaurus & Standard
 Representative Paul H. Raymer
 Membership NARTB
 Pres., Gen., Sta. Mgr. Ray C. Smucker
 Commercial Manager Roy L. Jorgensen
 Sales Prom. Mgr. Hank Olcott
 Program Director Bob Hansen
 Publicity Director Russ Siner
 Chief Engineer Leavenworth Wheeler

ARKANSAS

Pop. Feb. 1, 1954 (Est.) 2,000,000 — Families 580,000 — Radio Homes
487,000 — TV Homes 102,000 — Stations in State — 51

KVRC

ARKADELPHIA—1947—MBS-KBS

Frequency: 1240 Kc. Power: 250 Watts
Owned-Operated By: Arkadelphia Bcstg. Co.
Business Studio Address: 506 Main St.
Phone Number: 789
Air Time: 6 a.m.-11 p.m.
News Service: AP
Representative: Hil F. Best
President: Cecil W. Cupp
Gen., Sta., Comm. Mgr.: J. M. Moore
Pgm., Prod. Pub. Dir.: Bill Deaton
Chief Engineer: Ray Burns

KBTA

BATESVILLE—1950—MBS-KBS

Frequency: 1340 Kc. Power: 250 Watts
Owned-Oper. By: White River Valley
Broadcasters, Inc.
Bus., Studio, Transmitter Address: Glenn St.
& Lock & Dam Road
Phone: 1112-1113
Air Time: 6 a.m.-11 p.m. (7 a.m.-11 p.m. Sun.)
News Service: AP
Transcription Service: Thesaurus
President: J. F. Higginbottom
Comm. Mgr.: F. W. Griffin
Program Director: Bill Clark
Chief Engineer: Morris Colfer

KBBA

BENTON—1953

Frequency: 690 Kw. Power: 250 Watts d.
Owned-Oper. By: Benton Bcstg. Service
Business Address: Box 294
Phone Number: 2-690
Pres., Gen. Mgr.: W. R. Tuck Jr.
Comm. Mgr., Prod. Dir.: Lavelle Langley
Chief Engineer: Preston Bridges

KLCN

BLYTHEVILLE—1922

Frequency: 910 Kc. Power: 5000 Watts d.
Owned-Operated By: Harold L. Sudbury
Phone Number: 2093
News Service: AP
Station Representative: John E. Pearson
Gen., Comm. Mgr.: Harold L. Sudbury
Sales Promotion Manager: J. T. Sudbury
Program Director: Carl Frame
Chief Engineer: Joe Nearns

KAMD

CAMDEN—1946—MBS-KBS
RAZORBACK

Frequency: 1450 Kc. Power: 250 Watts
Owned-Operated By: Camden Radio Inc.

Address: P. O. Box 5859
Phone Number: 6-5091-2
Air Time: Full Time
News Service: AP
Membership: NARTB
President: Walter E. Hussman
General Manager: Frank O. Myers
Commercial Manager: Donald Cathey
Sales Prom., Prog. Dir.: Callis Carter
Chief Engineer: Dorris C. Hunter

KPLN

CAMDEN—1953

Frequency: 1370 Kw. Power: 1000 Watts d.
Owned-Oper. By: D. R. James Jr.
Business Address: Stephens Rd.
Phone Number: 6-9334
President: D. R. James Jr.
Gen. Mgr.: C. T. Mullins
Program Director: J. Andrew Wright
Comm. Mgr.: L. J. Smith

KCON

CONWAY—1950—KBS

Owned-Operated By: Conway Bcstg. Co.
Frequency: 1230 Kc. Power: 250 Watts
Address: 903½ Front St.
Phone Number: 189
Air Time: 6 a.m.-11 p.m.
Transcription Service: SESAC, World
News Service: UP
Pres., Gen., Sta. Mgr.: James E. Clayton
Sales Promotion Mgr.: Charles Buice
Program Director: Muriel Cobb
Chief Engineer: Herman G. Stermer

KAGH

CROSSETT—1951—NBC-KBS

Frequency: 1340 Kc. Power: 250 Watts
Owned-Operated By: Julian Haas
Address: 900 Main St.
Phone Number: 750
News Service: AP
Representative: Best-Melville
General Manager: Julian Haas
Chief Engineer: Charles Bucie

KDMS

EL DORADO—1950—KBS

Frequency: 1290 Kc. Power: 1,000 Watts d.
Owned-Operated By: KDMS, Inc.
Address: Randolph Hotel
Phone Number: 3-9190
News Service: UP
Transcription Service: Lang-Worth
Representative: Devney
Pres., Gen. Mgr.: David M. Segal
Station Manager: Virgil E. Stone

Commercial Manager.....Paul E. Norton
Chief Engineer.....E. C. Gresham

KELD

EL DORADO—1935—ABC

Frequency: 1400 Kc.....Power: 250 Watts
Owned-Operated By...Radio Enterprises, Inc.
Business-Studio Address...Radio Center Bldg.
Phone Number.....UNION 3-6126
Air Time.....Full Time
News Service.....AP
Transcription Service.....World
Membership.....NARTB
Pres., Gen., Sta. Mgr.....W. N. McKinney
Program Director.....Mrs. D. Pondrom
Chief Engineer.....John Long

KGRH

FAYETTEVILLE—1946—MBS-KBS

Frequency: 1450 Kc.....Power: 250 Watts
Owned-Oper. By...Fayetteville Bcstg. Co., Inc.
Business-Studio Address...922 Leverett St.
Phone Number.....2-2322
Air Time.....5:30 a.m.-11:30 p.m.
News Service.....AP
Representative.....Walker
Membership.....NARTB
President.....Hayden McIlroy
Gen. Sta. Mgr.....Fred J. Stevenson
Commercial Mgr.....Ed. Gideon
Program Director.....Wallie Ingalls
Chief Engineer.....Harold Lindsey

KXJK

FORREST CITY—1949—KBS

Frequency: 950 Kc.....Power: 1000 Watts
Owned-Operated By...Forrest City Bcstg. Co., Inc.
Address...Natl. Bank of East. Arkansas Bldg.
Phone Number.....950
Air Time.....Daytime
News Service.....AP
Transcription Service.....World
Pres., Gen. Mgr.....William Fogg
Commercial Manager.....James Pearson
Program Director.....Lloyd Denney
Chief Engineer.....Walter Smith

KFPW

FORT SMITH—1930—CBS

Frequency: 1230 Kc.....Power: 250 Watts
Owned-Oper. By...Tulsa Bcstg. Co.
Business Address...2401 N. Albert Pike Rd.
Phone Number.....34105
News Service.....UP
Transcription Service.....World
Representative.....Avery-Knodel
Membership.....BAB, NARTB
President.....John T. Griffin
General Manager.....L. A. Blust
Station Manager.....J. Paul McCaslin
Commercial Manager.....William D. Swanson
Gen. Prom. Mgr.....George Ketcham
Program Director.....Harlan Judkins
Chief Engineer.....Gene Gregory

KFSA

FORT SMITH—1947—ABC

Frequency: 950 Kc.....Power: 1000 Watts d.,
500 Watts n.
Owned-Oper. By.....Southwestern Pub. Co.
Business-Studio Address...920 Rogers Ave.
Phone Number.....29126
Air Time.....5:30 a.m.-11 p.m.
News Service.....AP
Representative.....John E. Pearson
President.....Donald W. Reynolds
Gen., Sta., Comm. Mgr.....Weldon Stamps
Program Director.....Pat Porta
Chief Engineer.....Robert W. Platt

KWHN

FT. SMITH—1947

Frequency: 1320 Kc.....Power: 5000 Watts
Owned-Operated By...KWHN Bcstg. Co., Inc.
Business-Studio Add...421-423 Garrison Ave.
Phone Number.....3-8967
Air Time.....Full Time
News Service.....AP
Representative.....Rumbeau
Gen. Mgr., Sec.-Treas.....H. S. Nakdimen
Sta. Dir., Comm. Mgr.....Parkman R. Feezor
Program Director.....Glenn O'Neal
Chief Engineer.....Bruce Dennis

KHOZ

HARRISON—1946—KBS
MBS-RAZORBACK-OZARK-ARK.

Frequency: 1240 Kc.....Power: 250 Watts
Owned-Operated By...Harrison Bcstg. Corp.
Bus.-Studio Address...Radio City Addition
Phone Number.....1240
Air Time.....Full Time
News Service.....UP
Transcription Service...Thesaurus, Keystone
President.....Betty Lou Wheeler
Gen., Sta. Mgr.....R. S. Wheeler, Jr.
Comm. Mgr.....Mel Lymbery
Program Director.....Pat Goolsby
Chief Engineer.....Fred E. Ward

KFFA

HELENA—1941—KBS—MBS

Frequency: 1360 Kc.....Power: 1,000 Watts
Owned-Operated By.....Helena Bcstg. Co.
Address.....215 York St.
Phone Number.....4-2361
News Service.....AP
Transcription Service.....World
Representative.....Best
Comm. Mgr.....George Caven
General Manager.....Sam W. Anderson
Program Director.....Larry Parker
Chief Engineer.....Earl Hodges

KXAR

HOPE—1948—MBS-KBS

Frequency: 1490 Kc.....Power: 250 Watts

Owned-Operated By.....Hope Bcstg. Co.
 Phone NumberPR 7-3601
 News ServiceAP
 President.....A. H. Washburn
 Gen. Mgr., Chief Engineer.....L. B. Tooley
 Program Director.....Carroll A. Winn

KBHS

HOT SPRINGS—1953

Frequency: 590 Kc. Power: 1000 Watts d.
 Owned-Oper. By.....Resort Bdcstg. Co., Inc.
 Address.....113 Third St.
 Phone Number.....3888
 News Service.....UP
 Transcription Service.....World
 President.....I. A. Cain
 Gen. Mgr.....Marvin Hull
 Chief Eng.....Clint Norman

KBLO

HOT SPRINGS—1953

Frequency: 1470 Kw. Power: 1000 Watts d.
 Owned-Oper. By.....National Park Bcstg. Co.
 Address.....1011 Central Ave.
 Phone Number.....5365
 Co-Owner, Gen. Mgr.....R. S. Bielow
 Co-Owner.....J. W. Bowie
 Comm. Mgr.....Jesse Pate
 Program Director.....Jack Nash
 Chief Engineer.....R. G. King

KRCH

HOT SPRINGS—1953—KBS

Frequency: 1270 Kw. Power: 1000 Watts d.
 Owned-Oper. By.....Garland Radio & TV Corp.
 Address.....873 1/2 Park Ave.
 Phone Number.....2102
 President.....Leonard P. Frankel
 General Manager.....Randall L. McCarrell
 Comm., Prom. Mgr.....A. E. Simmons
 Program Director.....Dorothy E. Foley
 Chief Engineer.....A. R. Garrett

KWFC

HOT SPRINGS—1941—MBS

Frequency: 1340 Kc. Power: 250 Watts
 Owned-Operated By.....Spa Bcstg. Co., Inc.
 Business-Studio Address.....819 1/2 Central Ave.
 Phone Number.....412-3
 News Service.....AP
 Membership.....NARTB
 Transcription Service.....Thesaurus
 Representative.....Gill-Perna
 President.....Walter E. Hussman
 Gen. Sta. Mgr.....C. J. Dickson
 Commercial Manager.....Jack Wolever
 Prog., Pub. Dir.....Larry Higgins
 Chief Engineer.....William A. Carr

KBTM

JONESBORO—1930—MBS-KBS

Frequency: 1230 Kc. Power: 250 Watts
 Owned-Operated By.....Regional Bcstg. Co.

Address.....603 Madison St.
 Phone Number.....WEBster 5-5597
 Air Time.....Full Time
 News Service.....AP
 Transcription Service.....World
 Pres., Gen., Sta. Mgr.....Jay P. Beard

KNEA

JONESBORO—1950

Frequency: 970 Kc. Power: 1000 Watts d.
 Owned-Operated By.....Radio Jonesboro, Inc.
 Address.....Hotel Noble
 Phone Number.....WE 2-8381
 News Service.....UP
 Transcription Service.....Thesaurus
 Representative.....Perna, Inc.
 President.....Ernest Farabee
 General, Station Manager.....Dick Crane
 Commercial Manager.....Harold Gregson
 Program Director.....Chad Lassiter
 Sales Promotion Manager.....Charles Quinton
 Chief Engineer.....Wesley Bell

KARK

LITTLE ROCK—1928—NBC

Frequency: 920 Kc. Power: 5000 Watts
 Owned-Oper. By.....Arkansas Radio & Equip. Co.
 Address.....Radio Ctr., 114 E. Capitol Ave.
 Phone Number.....LD 99
 Air Time.....Full Time
 News Service.....AP, UP
 Transcription Service.....World
 Representative.....Edward Petry
 Membership.....NARTB, BAB
 President.....T. H. Barton
 Station Manager.....Douglas J. Romine
 Commercial Mgr.....A. C. Dowden
 Sales Prcm. Mgr.....Carol Vinson
 Program Director.....Ernest M. Howard
 Chief Engineer.....Dan L. Winn

KGHI

LITTLE ROCK—1927—ABC

Frequency: 1250 Kc. Power: 1,000 Watts a.
 500 Watts n.
 Owned-Operated By.....KGHI Bcstg. Service
 Address.....308 1/2 W. 3rd St.
 Phone Number.....Franklin 2-0166
 Air Time.....Unlimited
 Station Representative George P. Hallingbery
 General Manager.....S. C. Vinsonhaler
 Commercial Mgr.....Kermit L. Richardson
 Program Director.....Betty Jo McNealy
 Chief Engineer.....V. O. Vandusen

KLRA

LITTLE ROCK—1927—CBS

Frequency: 1310 Kc. Power: 10,000 Watts d.
 5,000 Watts n.
 Owned-Oper. By.....Arkansas Bcstg. Co.
 Business-Studio Address.....Gazette Bldg.
 Phone Number.....2-5427
 Air Time.....Full Time
 Newspaper Affiliation.....Arkansas Gazette

News Service.....AP, UP
Transcription Service.....Standard, SESAC
Representative.....Paul Raymer
President.....J. N. Heiskell
General Manager.....W. V. Hutt
Sales Prom. Mgr......R. J. Myers
Prog., Prod. Dir......Harris Owen
Chief Engineer.....Kermit F. Tracy

K T H S

LITTLE ROCK—1924—CBS

Frequency: 1090 Kc. **Power:** 50,000 Watts
Owned By: Times Pub. Co., Ltd., Shreveport, La.

Operated By:.....Radio Broadcasting, Inc.
Business-Studio Address:.....313 Main St.
Phone Number.....4-2293
Air Time.....5 a.m.-M.
News Service.....UP, AP
Transcription Service.....Lang-Worth
Representative.....Branham
Membership.....NARTB, BAB
President.....W. H. Bronson
General Manager.....B. G. Robertson
Program Director.....Cecil Bland
Chief Engineer.....Cecil L. Suitt

K V L C

LITTLE ROCK—1948

Frequency: 1050 Kc. **Power:** 1000 Watts d.
Owned-Operated By: Southwestern Bcstg. Co.
Business-Studio

Address: Southern Natl. Insurance Bldg...
News Service.....UP
Representative.....McGillvra
Membership.....BAB
President.....R. M. Saxon
General Manager.....Leonard Coe
Station Manager.....Ray Dexter
Commercial Mgr......Wally Geiger
Chief Engineer.....Dale Mahurin

K X L R

LITTLE ROCK—1946
MBS-RAZORBACK

Frequency: 1150 Kc. **Power:** 5000 Watts d.
 1000 Watts n.

Owned-Oper. By:.....Ark. Airwaves Co.
Business Address.....217 E. Third St.
Phone Number.....2-2155
News Service.....UP
Transcription Service.....Rambeau, Thesaurus
Representative.....Pearson
President.....John F. Wells
Gen., Sta. Manager.....Emil J. Pouzar
Commercial Mgr......Melton Lancaster
Program Director.....Roy Nichols
Chief Engineer.....Earl H. Butler

K V M A

MAGNOLIA—1948—MBS

Frequency: 630 Kc. **Power:** 1000 Watts d.
Owned-Oper. By:.....Magnolia Bcstg. Co.

Business-Studio Address: 212 N. Jefferson St.
Phone Number.....630
News Service.....AP
Transcription Service.....World
President.....Joe F. Rushton
Gen., Sta., Comm. Mgr......William M. Bigley
Chief Engineer.....Ray Wells

K D A S

MALVERN—1951

Frequency: 1420 Kc. **Power:** 1000 Watts d.
Owned-Operated By:.....Malvern Bcstg. Co.
Address:.....Young Insurance Bldg.
Phone Number.....1584

Transcription Service.....World
Representative.....Devney, Melville
Pres., Gen. Mgr......Thomas Alford
Program Director.....Jim Faulkner
Chief Engineer.....John R. Williams

K V S A

McGEHEE—1953—KBS

Frequency: 1220 Kw. **Power:** 1000 Watts d.
Owned-Oper. By:.....S. E. Arkansas Bcstrs. Inc.
Address.....Box 1220
Phone Number.....20

News Service.....AP
Transcription Service.....Capitol
Representative.....Best
Pres., Gen. Mgr......Abbott F. Kinney
Sales Manager.....Frank H. Ross
Program Director.....H. E. Parent
Chief Engineer.....Thomas O. Graves

K E N A

MENA—1950—MBS-KBS

Frequency: 1450 Kc. **Power:** 250 Watts
Owned-Operated By:.....R. B. Bell
Address.....S. Rene St.
Phone.....878
Transcription Service.....Standard
News Service.....UP
Owner Manager.....R. B. Bell
Program Director.....Bernice Bell
Chief Engineer.....O. D. Frederlck

K V O M

MORRILTON—1953

Frequency: 800 Kw. **Power:** 250 Watts d.
Owned-Oper. By:.....Morrilton Bcstg. Co.
Address:.....c/o C. R. Horne, Station KXRJ,
 Russellville, Ark.

K T L O

MOUNTAIN HOME—1953—MBS

Frequency: 1490 Kw. **Power:** 250 Watts
Owned-Oper. By:.....Mountain Home Bcstg. Corp.
Address.....Box 1471
Phone Number.....1490
President.....Robert S. Wheeler Jr.
General Manager.....Bruce C. Washburn
Commercial Mgr......Everett Horton
Chief Engineer.....Fred E. Ward

KNBY

NEWPORT—1949

Frequency: 1280 Kc. Power: 1000 Watts d.
 Owned-Operated By: Newport Bcstg. Co.
 Business Address: Box 218
 Phone Number: 749
 News Service: UP
 President: Harold Sudbury
 Commercial Mgr.: Gene Howe
 Chief Engineer: Anson Clark

KOSE

OSCEOLA—1949—KBS

Frequency: 860 Kc. Power: 1000 Watts d.
 Owned-Oper. By: Osceola Bcstg. Corp.
 Business Address: P. O. Box 311
 Phone Number: 860
 News Service: AP
 Transcription Service: World
 Membership: NARTB
 Representative: Hil F. Best
 President: H. F. Ohlendorf
 General Manager: Ted Woods
 Commercial Manager: Betty G. Woods
 Program Director: Hobson Daws
 Chief Engineer: H. M. Jones

KDRS

PARAGOULD—1947—KBS

Frequency: 1490 Kc. Power: 250 Watts
 Owned-Oper. By: Progressive Bcstg. Co.
 Business Address: Box 491
 Phone Number: Cedar 2-7627
 Air Time: Full Time
 News Service: AP
 General Manager: Ted Rand
 Commercial Manager: Doyne F. Bateman
 Business Manager: T. M. Self
 Chief Engineer: Russell Schwamb

KCLA

PINE BLUFF—1947

Frequency: 1400 Kc. Power: 250 Watts
 Owned-Oper. By: Radio Engineering Service
 Business-Studio Address: 2900 W. 28th St.
 Phone Number: 1900
 Air Time: 6 a.m.-11 p.m.
 News Service: AP
 General Mgr.: Kenneth Kesterson
 Commercial Manager: Clyde Martin
 Pgm. Dir., Chief Engineer: Charles Penix

KOTN

PINE BLUFF—1934—MBS-KBS

Frequency: 1490 Kc. Power: 250 Watts
 Owned-Operated By: Universal Bcstg. Corp.
 Address: P. O. Box 957
 Phone Number: 721
 News Service: AP
 Transcription Service: Thesaurus
 Pres., Gen. Mgr., Chief Engr.: B. J. Parrish
 Prom. Mgr.: R. W. Etter
 Program Director: Lois Palmer

KPOC

POCAHONTAS—1950

Frequency: 1420 Kc. Power: 1,000 Watts d.
 Owned-Operated By: Pocahontas Radio, Inc.
 Address: P. O. Box 250
 Phone: 500
 News Service: AP
 Transcription Service: World
 President: A. J. Baltz
 Gen. Mgr.: Adrian L. White
 Com. Mgr.: Hiram Mayo
 Prog. Dir.: Bill Nicholson
 Chief Engineer: Jack Wilson

KXRJ

RUSSELLVILLE—1947—MBS-KBS

Frequency: 1490 Kc. Power: 250 Watts
 Owned-Oper. By: Valley Broadcasters, Inc.
 Address: Fine Arts Bldg.
 Phone Number: 299
 News Service: AP
 Owner, Gen., Sta. Mgr.: C. R. Horne
 Commercial Manager: L. L. Bryan
 Sales Prom. Mgr.: Don Sammons
 Pgm. Dir., Chf. Engr.: W. C. McKenney

KWCB

SEARCY—1951

Frequency: 1300 Kc. Power: 1000 Watts d.
 Owned-Operated By: White County Bcstg. Co., Inc.
 Address: P. O. Box 95
 Phone Number: 1281
 News Service: AP
 Transcription Service: SESAC
 Representative: Hil F. Best
 Membership: NARTB
 Pres., Gen. Mgr.: Carl N. Dodd
 Sales Prom. Manager: Don P. Jones
 Chief Engineer: Homer Harris

KUOA

SILOAM SPRINGS—1923—MBS

Frequency: 1290 Kc. Power: 5,000 Watts d.
 Owned-Operated By: KUOA, Inc.
 Business-Studio Address: Siloam Springs
 Phone Number: 777
 News Service: UP
 Transcription Service: Thesaurus
 President: John E. Brown, Sr.
 Program Director: Ralph Kennedy
 Chief Engineer: Cecil E. Smith

KBRS

SPRINGDALE—1949—ABC

Frequency: 1340 Kc. Power: 250 Watts
 Owned-Operated By: Southwest Pub. Co.
 Address: Box 29
 Phone Number: 675
 Air Time: 5:30 a.m.-11 p.m.
 News Service: AP
 Representative: Pearson
 President: Donald W. Reynolds

General Manager.....Roy J. Bowman
 Chief Engineer.....Bill Ussery

K W A K

STUTT GART—1948—MBS-KBS

Frequency: 1240 Kc.....Power: 250 Watts
 Owned-Operated By....Stuttgart Bcstg. Corp.
 Business AddressStuttgart
 Phone Number25212
 Air Time.....Full Time
 News Service.....UP
 Transcription Service.....Standard, World
 Representative.....Hil F. Best
 Membership.....NARTB
 President.....Beloit Taylor
 Gen.-Station Manager.....Melvin P. Spann
 Commercial Mgr.....Norman Biddulph
 Program Dir.....June Spann
 Chief Engineer.....Marvin Heffington

K O S Y

TEXARKANA—1951—MBS

Frequency: 790 Kc.....Power: 1000 Watts d.;
 500 Watts n.
 Owned-Operated By.....Gateway Bcstg. Co.
 Address.....P. O. Box 1318
 News Service.....AP
 Transcription Service.....Thesaurus
 Partners....Dr. W. Decker Smith, A. L. Davis
 General Manager.....Tom E. Dillahunt
 Commercial Manager.....Herman Cecil
 Program Director.....Bill Mitchell
 Chief Engineer.....Chas. Mathis

K R L W

WALNUT RIDGE—1951
 RAZORBACK

Frequency: 1320 Kc.....Power: 1000 Watts d.
 Owned-Operated By...Southern Baptist College
 Address.....Box 30
 Phone Number980
 Representative.....Best
 President.....Dr. H. E. Williams
 General Manager.....Neal B. Bunn
 Program Director.....Bill Thornton
 Chief Engineer.....Leonard Ringle

K W R F

WARREN—1953

Frequency: 860 Kw.....Power: 250 Watts d.
 Owned-Oper. By.....Pines Bcstg. Co.
 Address.....Box 480
 Phone Number353
 Partners.....Paul Fiser, John Rye
 General Manager.....Lee Reeves
 Commercial Mgr.....Deno Nichols
 Chief Engineer.....Norman Jones

K W E M

WEST MEMPHIS—1947

Frequency: 990 Kc.....Power: 1000 Watts d.
 Owned-Oper. By.....KWEM Inc.
 Business-Studio Address.....Box 855
 Phone Number463
 President.....E. D. Rivers, Jr.
 Com. Mgr.....Spencer Bedsole
 Chief Engineer.....Ed Beck

THOSE WHO KNOW FAMOUS BRANDS

Says a locker plant president: "Through daily use of this **AP** program I have found my business has increased to maximum present capacity. The coverage of The **AP** and its completeness has made it possible."

. . . . KNOW THE MOST FAMOUS
 BRAND IN NEWS IS **AP**



DON LEE

Is

PACIFIC COAST RADIO*

With 45 stations located within each of the 45 important marketing areas, Don Lee is the only network to reach Pacific Coast people where they live and buy.

And remember . . . on Don Lee low, low daytime rates apply to nighttime, too.

Two reasons why Don Lee is *STILL* the best, the most economical, the most effective medium to reach the nearly 16 million responsive people on the Pacific Coast.

** The Nation's Greatest
Regional Network*

DON LEE BROADCASTING SYSTEM

Mutual
DON LEE
RADIO

*Represented Nationally by
H-R Representatives, Inc.*

HOLLYWOOD 28, CALIF.

CALIFORNIA

Pop. Feb. 1, 1954 (Est.) 12,479,000 — Families 4,300,000 — Radio Homes 4,223,000 — TV Homes 2,846,500 — Stations in State — 145

KCNO

ALTURAS—1951

Frequency: 570 Kc. Power: 1000 Watts d.
Owned-Operated By.....CONR Inc.
Address.....P. O. Box 207
Phone Number.....2531
News Service.....UP
Transcription Service.....Standard, Capitol,
SESAC

Representative.....Forjoe
Membership.....NARTB
President.....Rowland H. Dow
Comm., Prom. Mgr.....Philip N. Good
Chief Engineer.....Wayne Powers

KDIA

AUBURN—1950—KBS

Frequency: 1490 Kc. Power: 250 Watts
Owned-Oper. By.....Charles E. Halstead
business Address.....P. O. Box 992
Phone.....1078
Air Time.....Full Time
Representative.....Ayres
Pres., Gen. Mgr.,
Chief Engr.....Charles E. Halstead, Jr.

KBIG

AVALON—1952

Frequency: 740 Kc. Power: 10,000 Watts
Owned-Operated By.....John Poole Bcstg. Co.
Address.....6540 Sunset Blvd., Hollywood
Phone Number.....Hollywood 3-3205
Air Time.....Daytime
News Service.....UP
Transcription Service.....Capitol
Representative.....Robert Meeke Associates
Membership.....NARTB, BAB
Pres., Gen., Sta. Mgr., Chf. Engr.....John Poole
Comm., Prom. Mgr.....Robert J. McAndrews
Operations Manager.....Cliff Gill
Program Director.....Alan Lisser

(See Page 338)

KBAK

BAKERSFIELD—1946—MBS-DON LEE

Frequency: 550 Kc. Power: 1000 Watts
Owned-Operated By.....Bakersfield Bcstg. Co.
Business-Studio Address.....2013 Chester Ave.
Phone Number.....4-6421
News Service.....UP
Transcription Service.....Capitol
Representative.....Forjoe
Membership.....NARTB
President.....Harold P. See
Station Manager.....Naum Healy
Sales Prom. Mgr.....Bea Waldon
Program Director.....Joe Kinsler
Chief Engineer.....James Garner

KBIS

BAKERSFIELD—1950

Frequency: 970 Kc. Power: 1000 Watts
Owned-Oper. By.....Marmat Bcstg. Co.
Studio Address.....957 Oak St.
Phone.....4-6093
Air Time.....Full Time
Transcription Service.....Associated
SESAC

News Service.....AP
Representative.....Grant
Pres., Mgr.....Hal Brown
Commercial Mgr.....Franklin H. Wilbur
Director of News.....Bob Elias
Chief Engineer.....Jack Duemler

KERN

BAKERSFIELD—1938—CBS

Frequency: 1410 Kc. Power: 1000 Watts
Owned-Operated By.....McClatchy Bcstg. Co.
Business-Studio Address.....Elk's Club Building
Phone Number.....8-8431
Air Time.....6 a.m.-12 M.
News Service.....AP
Transcription Service.....Capitol
Representative.....Paul H. Raymer
President.....Eleanor McClatchy
Station Manager.....Walter Baziuk
Chief Engineer.....Luverne Shatto

KERO

BAKERSFIELD—1946—NBC

Frequency: 1230 Kc. Power: 250 Watts
Owned-Oper. By.....Kern County Bcstrs., Inc.
Business-Studio Address.....1420 Truxton Ave.
Phone Number.....44548
News Service.....UP
Air Time.....Full Time
Transcription Service.....World
Representative.....Avery Knodel
Membership.....NARTB, BAB
Pres., Gen. Mgr.....Gene De Young
Gen. Sales Mgr.....Ed Urner
Program Director.....Leslyn Day
Publicity Director.....J. Towerlin
Chief Engineer.....Edwin Andrews

KPMC

BAKERSFIELD—1932—ABC

Frequency: 1560 Kc. Power: 1000 Watts
Owned-Oper. By.....Pioneer Mercantile Co.
Address.....P. O. Bin 1709
Phone Number.....8-8157
News Service.....UP
Transcription Service.....Thesaurus
Station Representative.....George P. Hollingbery
Membership.....NARTB
President.....F. G. R. Schamblin

240

This is the "high-traffic" point on the dial where advertisers and listeners meet. The powerful KBIG signal is boomed from Catalina Island across salt water (best conductor of radio waves) to reach all Southern California... Los Angeles, San Diego, Long Beach, Pasadena and 103 other incorporated cities PLUS the vast rural populations of 8 big counties. This is truly the Giant Economy Package of Southern California Radio.

John Poole
Broadcasting Co.
KBIG KBIF KBID-TV
KBIC-TV

6540 Sunset Boulevard
Hollywood 28
Hollywood 3-3205

I ncrease your sales in ALL Southern California.



Reach America's Third Market with the KBIG 10,000 watt signal from Catalina.

Good Availabilities do go fast!



Call your KBIG sales representative or Robert Meeker Associates, Inc., for costs and schedules.

K eep your eye on KBIG!



Our advertisers report sales increases, which are reflected in increased schedules.

B usiness is Good!



KBIG last quarter sales were 72% more than same period last year.

REACH
AMERICA'S
RICHEST AGRICULTURAL
VALLEY
WITH
KBIF 900 KC
Center of the Dial

Advertisers use KBIF independently or in combination with KBIG to reach Fresno County and its adjoining counties—KINGS, MADERA, MERCED and TULARE—all in the prosperous San Joaquin Valley of Central California.

Gen., Sta. Mgr. L. A. Schamblin
 Sales Prom., Comm. Mgr. C. C. Sturm
 Publicity Director P. R. Biermann
 Chief Engineer L. P. Jarvis

K P A S

BANNING—1947

Frequency: 1490 Kw. Power: 250 Watts
 Owned-Oper. By Darwin Bstg. Co.
 Address Box 1394
 Phone Number Banning 515
 Pres., Gen. Mgr. Chet Darwin
 Program Director Jack Campbell
 Chief Engineer Drew Walker

K W T C

BARSTOW—1947

Frequency: 1230 Kc. Power: 250 Watts
 Owned-Operated By Mojave Valley Bcstg. Co.
 Business Address Box 697
 Phone Number 4001
 Air Time Full Time
 News Service UP
 Transcription Service World
 Representative Donald Cooke
 President W. T. Brown
 Sta., Com. Mgr. Harry S. White
 Program Director Jim Harvey
 Chief Engineer Don Hetzel

K R E

BERKELEY—1923

Frequency: 1400 Kc. Power: 250 Watts
 Owned-Oper. By Central Calif. Bcstrs., Inc
 Address-Trans. 601 Ashby Avenue
 Phone Number Ashberry 3-7715
 Air Time 6 a.m.-12M.
 News Service AP
 Membership NARTB
 Pres., Gen. Sta. Mgr. Arthur Westlund
 Comm., Prom. Mgr. Don Hambly
 Program Director Les Avery

K I B S

BISHOP—1953

Frequency: 1230 Kw. Power: 250 Watts
 Owned-Oper. By Inyo Bcstg. Co.
 Address Box 757
 Phone Number Bishop 4411
 General Manager James R. Oliver
 Partner S. A. Cisler
 Commercial Mgr. R. S. Deming
 Program Director John Drozd
 Chief Engineer Alva Wilt

K Y O R

BLYTHE—1948—ABC

Frequency: 1450 Kc. Power: 250 Watts
 Owned-Operated Bcstg. Corp. of America
 Business-Studio Address Box 668
 Phone Number 2231
 General Manager Paul Nelson
 Chief Engineer Bill Blaisey

K R O P

BRAWLEY—1948—ABC

Frequency: 1300 Kc. 1000 Watts d., 500 n.
 Owned-Oper. By Bcstg. Corp. of America
 Address Box 987
 Phone Number 6290
 Representative John E. Pearson Co.
 Station Manager Bill E. Williams
 Program Director Carol Williams
 Chief Engineer Don Peterson

K B L A

BURBANK—1952

Frequency: 1490 Kc. Power: 250 Watts
 Owned-Oper. By Bcstrs. of Burbank
 Address 11516 Oxnard St.
 Phone Number Sunset 2-1195
 News Service UP
 Transcription Service Lang-Worth
 President Gordon A. Rogers
 Gen. Mgr. Robert S. Marshall
 Chief Engineer William Robinson

K I C O

CALEXICO—1947

Frequency: 1490 Kc. Power: 250 Watts
 Owned-Operated By Charles R. Love
 Business Address 722 Main St.
 Phone Number 3250
 News Service AP
 President Charles R. Love
 General Mgr. W. A. Geddes
 Comm. Mgr. Don Gillette
 Chief Engineer Hub Herbert

K H S L

CHICO—1935—CBS

Frequency: 1290 Kc. Power: 5000 Watts
 Owned-Operated Golden Empire Bcstg. Co.
 Address 336 Broadway
 Phone Number FI 2-0141
 News Service UP
 Representative W. S. Grant
 Membership NARTB
 Pres., Gen. Mgr. Mickey McClung
 Station Manager M. F. Woodling
 Commercial Manager J. A. Pero
 Program Director Ed Parker
 Publicity Director Tommy Nelson
 Chief Engineer Russell B. Pope

K X O C

CHICO—1949—MBS

Frequency: 1060 Kc. Power: 10,000 Watts
 Owned-Oper. By **KXOC, Inc.**
 Address-Trans. Box 571
 Phone Number FI 2-4211
 Air Time Full Time
 News Service UP
 Transcription Service Standard
 Representative Pearson
 Membership **BAB**

PresidentLincoln Dellar
 Gen., Sta., Comm. Mgr..... Jack L. Powell
 Prog., Prod., Pub. Dir.....Neil McIntyre
 Chief Engineer.....E. W. Berger

K B M X

COALINGA—1950—KBS

Frequency: 1470 Kc.....Power: 500 d.
 Owned-Oper. By. Pleasant Valley Radio Co.
 AddressBox 715
 Phone136
 Transcription Service SESAC, Langworth
 News ServiceUP
 President..... Benjamin M. Bowman
 Gen., Sta. Mgr.Fea B. Bowman

K B U C

CORONA—1948

Frequency: 1370 Kc. Power: 1000 Watts d.
 Owned Radio Broadcasting, Inc.
 Business AddressBox 368
 Phone Number..... 1370-12
 News ServiceUP
 RepresentativeMcGillvra
 Pres., Gen. Mgr.Elmer J. Bucknum
 Station Manager Mary Bucknum
 Promotion Mgr.Chuck Ferguson
 Chief EngineerCharles Billyew

K C R E

CRESCENT CITY—1950

Frequency: 1400 Kc. Power: 250 Watts
 Owned-Operated By. Del Norte Bcstg. Co.
 AddressBox 248
 Phone Number.....3061
 News ServiceAP, INS
 RepresentativeAyres
 Transcription Service Standard, SESAC.
 World
 Pres., Gen. Mgr., Pgm. Dir. .. Robert E. Grey
 Business Mgr.Peggy Burke Grey

K C H J

DELANO—1951

Frequency: 1010 Kc.....Power: 1000 Watts
 d.
 Owned-Oper. By.Charles Herman Johnes
 AddressCity, Line Rd.
 Phone8676
 Transcription ServiceSESAC
 News ServiceUP
 Pres., Gen. Mgr., Chief Eng.Charle H. Johnes
 Program Director.....Jean J. Johnes

K R D U

DINUBA—1946

Frequency: 1240 Kc.....Power: 250 Watts
 Owned-Operated By.....Radio Dinuba Co.
 Business-Studio AddressBox 157
 Phone NumberDI 500
 News ServiceAP
 Transcription ServiceWorld
 Pres., Gen., Sta. Mgr.Egon A. Hofer

Program DirectorHarold Sparks
 Chief EngineerWarren Nystrom

K X O

EL CENTRO—1927—MBS

Frequency: 1230 Kc.....Power: 250 Watts
 Owned-Operated By.....Valradio Inc.
 Business AddressBox 140
 Phone Number1100
 Air Time..... Full Time
 News ServiceUP
 Transcription Service Capitol, SESAC
 Representative.....Paul H. Raymer
 President.....Paul A. Jenkins
 General ManagerRiley R. Gibson
 Commercial Manager.....Belle Hovey

K H U M

EUREKA—1947—CBS

Frequency: 1240 Kc. Power: 250 Watts
 Owned-Oper. By.....Carroll R. Hauser
 AddressBox 1015
 Phone Number Hillside 2-5744
 Air Time.....6 a.m.-12M.
 News ServiceAP
 Transcription ServiceCapitol
 Representative.Pearson, MacGavren
 MembershipNARTB
 Gen., Sta. Mgr.Carroll R. Hauser
 Commercial Mgr.....Frank M. Smith
 Pgm., Pub. DirectorBill Kelso
 Chief EngineerDean Elliott

K I E M

EUREKA—1933—MBS

Frequency: 1430 Kc. Power: 5000 Watts
 Owned Opr. By. Redwood Bdcstg. Co., Inc.
 AddressBox 1021
 Phone Number Hillside 3-1621
 News ServiceUP
 RepresentativeJohn Blair
 President, Manager.....Wm. B. Smullin
 General ManagerDon Telford
 Commercial Mgr.Robert Stach
 Program DirectorPearl Jacobsen
 Chief EngineerLarry King

K D A C

FORT BRAGG—1948

Frequency: 1230 Kc.....Power: 250 Watts
 Owned-Oper. By.Edward Mertle
 AddressBox 616
 Phone Number3251
 Air Time7 a.m.-10 p.m.
 News ServiceAP
 RepresentativeForjoe
 OwnerEdward Mertle
 Gen. Mgr., Chief Eng..... Craig N. Smith

K A R M

FRESNO—1938—ABC

Frequency: 1430 Kc. Power: 5000 Watts
 Owned-Oper. By.KARM

Business-Studio Address...1333 Van Ness Ave.
 Phone Number4-2966
 News Service.....AP, INS
 Transcription ServiceStandard
 RepresentativeBolling
 PresidentHattie Harm
 General-Station Manager...Clyde F. Coombs
 Program Director.....Lou Lampe
 Chief Engineer.....Elbert Dean

K F R E

FRESNO—1937—CBS

Frequency: 940 Kc.....Power: 50,000 Watts
 Owned-Oper. By.....Calif. Inland Bcstg. Co.
 Business-Studio Address..T. W. Patterson Bldg.
 Phone Number4-5001
 Air Time.....Full Time
 News ServiceUP
 Transcription ServiceWorld
 RepresentativeAvery-Knodel
 MembershipNARTB, BAB
 Pres., Gen. Mgr.....Paul R. Bartlett
 Asst. Mgr., Chief Engr.....Keith L. Mealey
 Sales Manager.....Frank D. Woody
 Director of Sls. Svce.....Harry H. Burum
 Program Director.....Ed J. Fréch

K G S T

FRESNO—1949

Frequency: 1600 Kc.....Power: 1000 Watts d.
 Owned-Operated By.....Delle Broadcasting Co.
 Address.....Plaza Shopping Center
 Phone Number.....6-6526 and 4-5459
 Air Time.....6 a.h.-Sunset
 News ServiceUP
 Station RepresentativeRambeau
 MembershipNARTB, BAB
 Commercial Manager.....Morris Mindel
 Program Director.....Jeanne Bacher

K M A K

FRESNO—1953

Frequency: 1340 Kw.....Power: 250 Watts
 Owned-Oper. By.....McMahan Bcstg. Co.
 Address.....2020 McKinley
 Phone Number6-9448
 RepresentativeGrant
 President.....R. O. McMahan
 General Manager.....Coyle Chambers
 Chief Engineer.....Ed Nickels

K M J

FRESNO—1925—NBC

Frequency: 580 Kc.....Power: 5000 Watts
 Owned-Operated By.....McClatchy Bcstg. Co.
 Business-Studio Address..1515 Van Ness Ave.
 Phone Number3-6277
 Air Time.....Full Time
 News Service.....AP, UP
 Transcription ServiceAssociated
 RepresentativePaul H. Raymer
 PresidentEleanor McClatchy
 Station Manager.....David T. Harris
 Commercial Manager.....Roy Swanson

Sales Promotion Dir.....Richard Ebbert
 Chief Engineer.....William N. Wallace

K Y N O

FRESNO—1947—MBS

Frequency: 1300 Kc.....Power: 1000 Watts
 Owned-Oper. By.....Radio KYNO
 AddressHotel Fresno
 Phone Number2-4163
 Air Time.....5 a.m.-12M.
 News ServiceUP
 RepresentativeHollingbery
 Transcription ServiceThesaurus
 MembershipNARTB, BAB
 General, Sta. Manager.....L. E. Chenault
 Commercial Manager.....Leslie Daggett
 Program Director.....Leo Goldman
 Publicity Director.....Virginia Wilson
 Chief Engineer.....Bert Williamsor

K I E V

GLENDALE—1933

Frequency: 870 Kc.....Power: 250 Watts d.
 Owned-Operated By.....Cannon System, Ltd.
 Address.....102 N. Glendale Ave.
 Phone Number.....Citrus 1-1133
 News ServiceUP
 President.....David H. Cannon
 General Mgr.....Cal Cannon
 Chief Engineer.....Charles N. Whitten, Jr.

K N G S

HANFORD—1948

Frequency: 620 Kc.....Power: 1000 Watts
 Owned-Oper. By.....Hanford Bcstg.
 Business Address.....P. O. Box 620
 Phone Number620
 Newspaper Affiliation.....Hanford Sentinel,
 Hanford Journal
 Air Time.....24 hrs. daily
 News ServiceINS, UP
 RepresentativeO'Connell
 MembershipNARTB, BAB
 President.....Earl J. Fenston
 Sta. Mgr., Chief Engr.....Don C. Reeves
 Commercial Manager.....John Haslam
 Program Director.....Lloyd Chappel

K F W B

HOLLYWOOD—1926

Frequency: 980 Kc.....Power: 5000 Watts
 Owned-Oper. By.....KFWB Broadcasting Corp.
 Business-Studio Add...6419 Hollywood Blvd.
 Phone NumberHO 3-5151
 Air Time.....Unlimited
 News ServiceUP, INS
 Transcription ServiceSESAC
 Station RepresentativeBranham
 Pres., Gen., Sta. Mgr.....Harry Maizlish
 Commercial Manager.....Morton Ridley
 Special Events Dir.....Dan Sussell
 Program Director.....Sydney Yallen
 Chief Engineer.....Harry Meyers

K G F J

HOLLYWOOD—1926

Frequency: 1230 Kc. Power: 250 Watts
 Owned-Operated By: Ben S. McGlashan
 Business-Studio Address: 6314 Sunset Blvd.
 Phone Number: HO 4-0201
 News Service: UP
 Transcription Service: Associated
 Owner: Ben S. McGlashan
 General Manager: Thelma Kirchner
 Chief Engineer: Homer Obuchon

KLAC

HOLLYWOOD—1928

Frequency: 570 Kc. Power: 5000 Watts d.,
 1000 Watts n.
 Owned-Operated By: KMTR Radio Corp.
 Address: 1000 Cahuenga Blvd.
 Phone Number: Hollywood 2-7311
 News Service: INS, UP
 Representative: Adam J. Young, Jr.
 President: M. W. Hall
 Commercial Manager: Larry Buskett
 Program Director: R. F. Horgan

KREO

INDIO—1946

Frequency: 1400 Kc. Power: 250 Watts
 Owned-Oper. By: Bcstg. Corp. of America
 Address: Box 697
 Phone Number: Indio 7-3403
 Representative: Pearson
 General Manager: R. T. Sampson

KAVL

LANCASTER—1930

Frequency: 1340 Kc. Power: 250 Watts
 Owned-Oper. By: Antelope Bcstg. Co.
 Address: P. O. Box 1192
 Phone: 1000
 Air Time: Full Time
 Transcription Service: World, SESAC
 News Service: UP
 Pres., Gen. Mgr.: W. B. Carter
 Commercial Mgr.: H. L. Comstock
 Chief Engineer: James French

KCVR

LODI—1946—KBS

Frequency: 1570 Kc. Power: 1000 Watts d.
 Owned-Operated By: Central Valley Radio
 Business Address: P. O. Box 600
 Phone Number: Lodi 8-0628
 News Service: UP
 Co-owners: Herbert W. Brown, D. A. Brown
 Program Director: D. M. Corlett
 Chief Engineer: George Sampson

KFOX

LONG BEACH—1924

Frequency: 1280 Kc. Power: 1000 Watts
 Owned-Operated By: Nichols & Warinner, Inc.

Address: 220 E. Anaheim Street
 Phone Number: Long Beach 6-7281
 News Service: UP
 Transcription Service: Lang-Worth, World
 Representative: Burn-Smith
 Membership: NARTB, BAB
 Gen., Sta. Mgr.: Hal G. Nichols
 Pub., Prom. Mgr.: Robert Lamb
 Program Director: L. W. McDowell
 Technical Advisor: Al Mutter

KGER

LONG BEACH—1926

Frequency: 1390 Kc. Power: 5,000 Watts
 Owned By: John Brown Schools of Calif., Inc.
 Business-Studio Address: 3745 Atlantic
 Phone Number: 40-7907
 News Service: AP
 Transcription Service: Thesaurus
 Representative: Gill-Perna
 Membership: NARTB
 President: Dr. John E. Brown
 Gen., Sta., Comm. Mgr., Pgm. Dir.:
 Clinton H. Fowler
 Chief Engineer: Luther Crumbaugh

KABC

LOS ANGELES—1929—ABC

Frequency: 790 Kc. Power: 5000 Watts
 Owned-Oper. By: American Bcstg. Co., Inc.
 Address: 1539 N. Vine St., Hollywood 28, Cal.
 Phone Number: HO 2-3141
 Air Time: Unlimited
 News Service: AP, UP
 Representative: Edward Petry
 President: Robert E. Kintner
 General Manager: W. Phillipson
 Commercial Mgr.: Amos T. Baron
 Promotion Manager: Jon Barkhurst
 Program Director: Dresser Dahlstead
 Chief Engineer: Phillip Caldwell

KFAC

LOS ANGELES—1931

Frequency: 1330 Kc. Power: 5000 Watts
 Owned-Oper. By: Los Angeles Bcstg. Co., Inc.
 Bus.-Studio Address: 5773 Wilshire Blvd.
 Phone Number: Webster 0161
 Air Time: Full Time
 News Service: AP
 Representative: Bolling
 Membership: NARTB
 Pres.-Gen.-Sta. Mgr.: Calvin J. Smith
 Program Director: Howard Rhines
 Publicity Director: Tom Dixon
 Chief Engineer: Ron Oakley

KFI

LOS ANGELES—1922—NBC

Frequency: 640 Kc. Power: 50,000 Watts
 Owned-Operated By: Earle C. Anthony, Inc.
 Business-Studio Address: 141 N. Vermont Ave.
 Phone Number: Dunkirk 2-2121
 News Service: AP, UP

Transcription Service.....Capitol, World Representative.....Henry I. Christal
Pres., Gen. Mgr......Earle C. Anthony
Sales Prom. Mgr......Ronnie Manders
Asst. to President.....Charles E. Hamilton
Program Director.....Pat Kelly
Co-Chief Engineers.....H. L. Blatterman, Curtis W. Mason

K F V D

LOS ANGELES—1925

Frequency: 1020 Kc.....**Power:** 5,000 Watts
Owned-Operated By.....Standard Bcstg. Co.
Business-Studio Add......338 S. Western Ave.
Phone Number.....Dunkirk 8-2345
Air Time.....Daytime
News Service.....AP, UP
Transcription Service.....Langworth
Representative.....McGillvra
Membership.....BAB, NARTB
Pres., Gen. Mgr......Frank Burke, Jr.
Comm., Sta. Manager.....Vern Lindblade
Pgm., Pub. Dir......Carl Brewster
Chief Engineer.....Leonard Reeves

K H J

LOS ANGELES—1922
MBS-DON LEE

Frequency: 930 Kc.....**Power:** 5,000 Watts
Owned-Oper. By.....General Teleradio, Inc.
Address.....1313 N. Vine St., Hollywood
Phone Number.....Hollywood 2-2133
Air Time.....6 a.m.-M.
News Service.....AP, UP
Representative.....H-R
Membership.....NARTB, BAB
Pres., Gen. Mgr......Willet H. Brown
Exec. Vice-Pres......Ward D. Ingram
Vice Pres., Sales.....Norman Boggs
Sales Promotion Mgr......Robert Light
Program Director.....A. J. LaFrano
Publicity Director.....Bud Coulson
Chief Engineer.....Robert Arne

K M P C

LOS ANGELES—1927

Frequency: 710 Kc.....**Power:** 50,000 Watts d.; 10,000 Watts n.
Owned-Oper. By.....KMPC, Inc.
Address.....5939 Sunset Boulevard
Phone Number.....Hollywood 9-5341
Air Time.....5:45 a.m.-1:00 a.m.
News Service.....INS, UP
Representative.....AM Radio Sales
Membership.....BAB
President.....Gene Autry
Gen. Mgr. & V.P......Robert O. Reynolds
V.P. & Asst. Gen. Mgr......Lloyd C. Sigmon
Nat. Sales Mgr......Charles Cowling
Director of Bcstg......Mark Haas
Chief Engineer.....L. C. Sigmon

K P O L

LOS ANGELES—1952

Frequency: 1540 Kc...**Power:** 10,000 Watts d.
Owned-Oper. By....Coast Radio Bdcstg. Corp.
Address.....5087 Huntington Dr.
Phone Number.....Capitol 1-6101
News Service.....AP
Transcription Service.....SESAC
Representative.....Keller
Membership.....NARTB
President.....Hugh R. Murchison
Station Manager.....Frederick Custer
Chief Engineer.....Floyd Hall
Program Director.....R. Scott

K R K D

LOS ANGELES—1927

Frequency: 1150 Kc...**Power:** 5000 d.; 1000 n.
Owned-Oper. By.....Radio Bctrs., Inc.
Business-Studio Address....541 So. Spring St.
Phone Number.....Madison 2121
News Service.....AP, INS
Transcription Service.....World, SESAC, Associated
Membership.....NARTB
General Manager.....Ned Connor
Pgm. Dir.-Chief Announcer...Charles Clifton
Chief Engineer.....Willis O. Freltag

YOU AREN'T REACHING

LOS ANGELES' MAJOR

Negro Audience

unless you're buying
 Hunter Hancock's

"HARLEMATINEE"

THIS TIME

Check
KFVD

LOS ANGELES

Represented by
Joseph Hershey McGillvra, Inc.

KNX IS CBS RADIO IN LOS ANGELES

- CHRISTOPHER ALBERT
- PAUL ANDERSON
- OTHELIA ALLEN
- GENE ALTHEY
- LAUREY LAMBERT
- MELBA ANDERSON
- BOB BAILEY
- LEONEL BARRERA
- JACK BENNY
- DEAN BURTON
- BARBARA BLETCHEN
- CHARLES COLINGWOOD
- BOB CONRAD
- DWIGHT COOPER
- CLAYTON COOPER
- BOB COSBY
- BOB COHEN
- PAUL COHEN
- LEONARD COHEN
- JOSEPH COOPER
- EDWARD DENNING
- RICHARD DENNING
- MARSHALL DORTCH
- BOB DOUGLAS
- BOB DOWNS
- CHARLES FARRAR
- BOB FEERES
- GASTON FISCHER
- GEORGE FISHER
- BILL FORDMAN
- CHILDSY FOX
- ALBERT G. GIBBY
- GARY GORDON
- EDWARD GOSMAN
- FRANK GOSS
- TOM HANSON
- TOM HARMON
- PAUL HART
- BOB HEARD
- HAN HERSHOLT
- BOB HUNTER
- BOB JOY
- WILLIAM KENNEDY
- HARRY KOPAN
- CATY LEWIS
- LEON LEWIS
- ROBERT O. LEWIS
- ART LINKLETTER
- MARY LIVINGSTONE
- JOHN LUND
- ROBERTA LIND
- CURT MASSEY
- DUKE MARTIN
- JAMES MATTHEWS
- MERCEDES McCAMBRIDGE
- JOHNNY MERCER
- RAY MILLAND
- VAGGIN MONIGOT
- EDWARD P. MURROW
- WENDEL NOBLE
- PHILIP NORMAN
- WALTER O'KEEFE
- LOUELLA PARSONS
- MAN ROBY
- WILL ROGERS, JR.
- BILL SHADEL
- DAVE SHOWALTER
- HERB SHRINFEL
- HOWARD K. SMITH
- GALE STORM
- RALPH STORRY
- BILL STOUT
- LOWELL THOMAS
- SHIRLEY THOMAS
- LARRY THOR
- MARTHA TILTON
- ROBERT TROUT
- DAVID VAILE
- ELINA VERDUGO
- JIMMY WARELY
- JOE WALTERS
- MAURIE WEISBERG
- BARBARA WHITING

Los Angeles' Most Listened-to Station
DUPLICATE 1070

KNX

LOS ANGELES—1922—CBS (RADIO)
COLUMBIA PACIFIC

Frequency: 1070 Kc. Power: 50,000 Watts
Owned By Columbia Bcstg. System, Inc.
Operated By CBS Radio Division
Business-Studio Address 6121 Sunset Blvd.
Phone Number HOLlywood 9-1212
Air Time 5:25 a.m.-1:05 a.m.
News Service AP, UP
Representative Radio Spot Sales, CBS
General Manager William D. Shaw
Sales Promotion Mgr. J. W. Frost
Program Director Robert Sutton
Chief Engineer Les Bowman

KMYC

MARYSVILLE—1940—MBS

Frequency: 1410 Kc. Power: 1,000 Watts
Owner-Oper. Marysville-Yuba City Bcstrs., Inc.
Business Address P. O. Box 631
Phone Number 2-2396
Air Time Full Time
News Service AP
Transcription Service World
Representative W. S. Grant
Membership NARTB, BAB
President H. E. Thomas
Gen.-Station Manager Joe D. Carroll
Program Director W. R. Cleveland
Chief Engineer Loyd McQuary

KYOS

MERCED—1936—MBS-DON LEE

Frequency: 1480 Kc. Power: 5000 Watts
Owned-Operated By Merced Bcstg. Co.
Business Address P. O. Box 717
Phone Number RAndolph 2-6251
Air Time Full Time
News Service UP
Representative W. S. Grant, McClung
Membership NARTB
Pres., Gen. Mgr. Mrs. Hugh McClung
Station Manager Charles H. Kinsley, Jr.
Commercial Manager Edward Blakesley
Program Director Stan Evans
Publicity Director Wilma Belloli
Chief Engineer Russel Pope

KBOX

MODESTO—1951

Frequency: 970 Kc. Power: 1000 Watts
Owned-Operated By Stanislaus County
Bcstrs, Inc
Address 1507 10th St.
Phone Number 3-7756
News Service AP
Transcription Service Lang-Worth
Representative Rambeau
Membership NARTB, BAB
Pres., Gen., Sta., Comm. Mgr. Milton Hibdon
Sales Prom. Mgr. Dave Jacobs
Program Director Norma Alamshau

One of Los Angeles'
MORE IMPORTANT

Radio
Stations

KOWL

REACHING AND SELLING:

- **NEGRO MARKET (350,000)** — Joe Adams (D.J.), "Sharing Secrets" (housewife show), news (Negro appeal).
- **MEXICAN AND MEXICAN AMERICAN MARKET (400,000)** — "Chico" (Latin flavor d.j.), Elena Salinas (Spanish language family program), news (Spanish language).
- **PLUS** Jewish and eight other language markets.



1580 kc.

NOW 10,000 WATTS
— the most powerful station
of its kind in the United States!

(See Santa Monica listing)

Publicity Director.....Fran Abell
 Chief Engineer.....Paul Ferrelle

KMOD

MODESTO—1950—ABC

Frequency: 1360 Kc.....Power: 1000 Watts
 Owned-Operated By.....Radio Modesto, Inc.
 Address.....P. O. Box 941
 Phone.....2-1051
 Air Time.....Full Time
 News Service.....AP
 Transcription Service.....World
 Representative.....Meeker (N. Y.), Moore
 (L.A.), McGavern (San. Fran.)
 President.....John Griffin
 Membership.....NARTB
 Gen., Sta. Mgr.....John H. Schacht
 Sales Prom. Mgr.....Judd Sturtevant
 Publicity Director.....Arnold Green
 Chief Engineer.....Pete Onnigian

KTRB

MODESTO—1933

Frequency: 860 Kc. Power: 10,000 d.; 1000 n.
 Owned-Operated By.....KTRB Bcstg. Co., Inc.
 Address.....Box 593
 Phone Number.....3-0737
 News Service.....INS, UP
 Transcription Service.....Cole, Standard
 Representative.....W. S. Grant
 Pres.-Gen.-Station Mgr.....William H. Bates, Jr.
 Commercial Mgr.....Lee Roddy
 Prog. Dir.....Don E. Lapan
 News Director.....Charlie McEwen
 Chief Engineer.....William H. Bates, Jr.

KMBY

MONTEREY—1939

Frequency: 1240 Kc.....Power: 250 Watts
 Owned-Oper. By.....Monterey Radio-TV Co.
 Business Address.....468 Calle Principal
 Phone Number.....2-4541
 President.....Kenyon Brown

KXXL

MONTEREY—1952

Frequency: 630 Kw.....Power: 1000 Watts
 Owned-Oper. By.....S. A. Cisler
 Address.....546 Hartnell Plaza
 Transcription Service.....Standard, Thesaurus
 President.....S. A. Cisler
 Gen. Mgr.....James Oliver

KWSD

MT. SHASTA—1947

Frequency: 1340 Kc. Power: 250 Watts
 Owned-Oper. By.....Shasta Cascade Bcstg. Corp.
 Address.....E. Alma Street
 Phone Number.....Mt. Shasta 2124
 Air Time.....Full Time
 News Service.....AP
 Representative.....Continental, McGavern

Membership.....NARTB
 General Manager.....Arthur Adler
 Sta. Mgr., Chief Eng.....David H. Rees
 Program Director.....Iola Huntingdon

KVON

NAPA—1947

Frequency: 1440 Kc.....Power: 500 Watts
 Owned-Oper. By.....Gibson Radio & Pub. Co.
 Address.....P. O. Box 911
 Phone Number.....Napa 6-2023
 Air Time.....6:45 a.m.-10:45 p.m.
 News Service.....UP
 Transcription Service.....World
 Representative.....Wm. Ayres
 Pres., Gen. Mgr.....Luther E. Gibson
 Sta., Comm. Mgr.....Elmer L. Gibson
 Program Director.....Nolan Cruise
 Chief Engineer.....Dave Wortman

KSFE

NEEDLES—1952—KBS

Frequency: 1340 Kc.....Power: 250 Watts
 Owned-Oper. By.....Needles Bdcstg. Co.
 Address.....P. O. Box C-2
 Phone Number.....1234
 News Service.....INS
 Transcription Service.....Thesaurus
 Partners.....B. J. Fitzpatrick and
 L. A. Newsome, Jr.
 Chief Eng.....Albert Lincoln

KLX

OAKLAND—1922

Frequency: 910 Kc.....Power: 5000 Watts
 Owned-Operated By.....Tribuna Building Co.
 Business Studio Address.....401 13th St.
 Phone Number.....GLencourt 1-0660
 Air Time.....6 a.m.-M.
 Newspaper Affiliation.....Oakland Tribune
 News Service.....AP
 Transcription Service.....Standard, Thesaurus
 Representative.....Burn-Smith
 Membership.....NARTB, BAB
 President.....J. R. Knowland, Jr.
 General Manager.....Milton L. Levy
 Publicity Director.....Jean Williams
 Chief Engineer.....Roswell S. Smith

KROW

OAKLAND—1925

Frequency: 960 Kc.....Power: 1000 Watts
 Owned-Operated By.....KROW, Inc.
 Address.....464 19th St.
 Phone Number.....TWinoaks 3-9600
 Air Time.....Full Time
 News Service.....UP
 Transcription Service.....Standard
 Representative.....Raymer
 Membership.....NARTB, BAB
 President.....Sheldon F. Sackett
 General Manager.....J. G. Paltridge
 Commercial Manager.....Jack Grant
 Program Director.....Russ Coughlan

Publicity Director.....Phyllis Diller
Chief Engineer.....A. Pattison

K W B R
OAKLAND—1920

Frequency: 1310 Kc.....Power: 1000 Watts
Owned-Operated By...Warner Bros. Radio, Inc.
Business-Studio Address.....327 22nd St.
Phone Number.....Higate 4-1212
Air Time.....Unlimited
News Service.....UP
Representative.....Forjoe
General Manager.....S. W. Warner
Station Manager.....F. Wellington Morse
Program Director.....Jeane K. Fisher
Chief Engineer.....Paul Gregg

K O C S
ONTARIO—1947

Frequency: 1510 Kc.....Power 250 Watts
Owned-Operated By...The Daily Report Co.
Business-Studio Address.....222 East "B" St.
Phone Number.....627-54
News Service.....UP
Transcription Service.....Capitol, SESAC
Representative.....O'Connell
Gen., Comm. Mgr.....Harry Allen
Chief Engineer.....Glenn Clark

K M O R
OROVILLE—1948

Frequency: 1340 Kc.....Power: 250 Watts
Owned-Operated By.....Oroville Bcstrs.
Address.....P. O. Box 1032
Phone Number.....1340
News Service.....UP
Transcription Service.....Thesaurus
Representative.....Ayres (S.F.)
President.....Joy C. Fearhead
Gen., Sta., Comm. Mgr.....J. R. Bird
Program Director.....Louis Coppola

K C M J
PALM SPRINGS—1946—CBS

Frequency: 1340 Kc.....Power: 250 Watts
Owned-Operated By..Palm Springs Bcstg. Co.
Business Address.....Box KK
Phone Number.....2253
Air Time.....Full Time
News Service.....UP
Representative.....O'Connell, McGavren
Membership.....NARTB, BAB
Pres., Gen. Mgr.....Joseph E. Gamble
Commercial Manager.....Norman Loftus
Program Director.....Thelma Roberts
Chief Engineer.....N. Vincent Parsons

K I B E
PALO ALTO—1949

Frequency: 1220 Kc.....Power: 1,000 Watts d.
Owned-Oper. By.....Sundial Bcstg. Corp.
Address.....Box 1151
Phone Number.....Davenport 3-1341
Air Time.....Daytime

News Service.....UP
Transcription Service Standard, World, London
Representative.....Grant, Best
Membership.....NARTB
President.....William R. Crocker
General Mgr.....Edward Davis
Sta., Comm., Sales Mgr.....Peter A. Cuneo
Program Director.....Claire Barskey
Chief Engineer.....Ben K. Wright

K A L I
PASADENA—1950

Frequency 1430 Kc.....Power: 5000 Watts d.
Owned-Operated By...Consolidated Bcstg. Co.
Business-Studio Address.....758 E. Colorado
Phone Number.....RY 1-7149
News Service.....UP
Transcription Service.....Associated
Pres., Gen. Mgr.....Henry Fritzen
Chief Engineer.....Harvey Fritch

K W K W
PASADENA—1942

Frequency: 1300 Kc.....Power: 1000 Watts
Owned-Oper. By...Southern Calif. Bcstg. Corp.
Address.....800 Sierra Madre Villa
Phone Number.....Ryan 1-6744
Air Time.....Unlimited
News Service.....UP
Representative.....O'Connell
Membership.....NARTB, BAB
General Partner.....Marshall S. Neal
Gen.-Station-Comm. Mgr.....William J. Beaton
Pgm. Dir., Chief Anncr.....Bill Garr
Chief Engineer.....Paul W. Spargo

K X L A
PASADENA—1942

Frequency: 1110 Kc.....Power: 10,000 Watts
Owned-Operated By..Pacific Coast Bcstg. Co.
Business Address...1401 So. Oak Knoll Ave.
Phone Number.....RYan 1-6991
News Service.....AP
Transcription Service.....World
President-Gen. Sta. Mgr.....Loyal K. King
Director of News.....Carl Saunders
Program Director.....Marian Atkinson
Chief Engineer.....Jack Reeder

K P R L
PASO ROBLES—1946—MBS-KBS

Frequency: 1230 Kc.....Power: 250 Watts
Owned-Oper. By.....D. J. & Bernard Schwartz
Business-Studio Address.....32nd & Oak Sts.
Phone Number.....204
News Service.....AP
Representative.....W. S. Grant
Pgm., Comm. Dir.....Bernard Schwartz
Commercial Mgr.....Dorothy Schwartz
Gen. Mgr., Chief Engineer...Dale Schwartz

K A F P
PETALUMA—1950

Frequency: 1490 Kc.....Power: 250 Watts
Owned-Oper. By.....Warner Bros.

Address Box 590
 Phone Number 2-9787
 Transcription Service World, Capitol
 News Service UP
 President S. W. Warner
 Gen. Mgr. Wellington Morse
 Sta., Comm. Mgr. Ted Kenessey
 Program Director Jack Goforth

K E C C

PITTSBURG—1949

Frequency: 990 Kc. Power: 1000 Watts
 Owned-Operated By KECC, Inc.
 Business Address 235 Railroad Ave.
 Phone Number 2-2964
 News Service UP
 Transcription Service World, Lang-Worth
 Representative W. S. Grant
 General Mgr. Mel D. Marshall
 Commercial Mgr. John C. McFarland
 Chief Engineer M. R. Scott

K P M O

POMONA—1947

Frequency: 1600 Kc. Power: 500 Watts
 Owned-Oper. By Valley Bdstg. Co.
 Business-Studio Address 1240 E. Holt St.
 Phone Number Lycoming 2-1293
 News Service UP
 Partner, Comm. Mgr. Deon H. Wickstrom
 Prog. Dir. Florence E. Wickstrom
 Chief Engineer Buck Rogers

K T I P

PORTERVILLE—1946

Frequency: 1450 Kc. Power: 250 Watts
 Owned-Operated By J. F. Tighe
 Business-Studio Address Box 1312
 Phone Number PO 1450
 Air Time Unlimited
 News Service UP
 Transcription Service Thesaurus
 Representative Cook, Grant
 Membership NARTB
 President J. F. Tighe
 Gen., Sta. Mgr. Frank Robinson Brown
 Comm., Prog. Dir. Jean Snowden
 Chief Engineer Alan Snowden

K B L F

RED BLUFF—1946—KBS

Frequency: 1490 Kc. Power: 250 Watts
 Owned-Oper. By Hal K. Shade
 Address 737 Main St.
 Phone Number 880
 Gen. Mgr. Bill Baumgarten
 Chief Engineer Harry Shelby

K V C V

REDDING—1936—CBS

Frequency: 600 Kc. Power: 1000 Watts
 Owned-Oper. By Golden Empire Bcstg. Co.
 Address Box 717, Merced
 Phone Number 1646
 Air Time Full Time

News Service UP
 Transcription Service Standard
 Representative W. S. Grant Co.
 Pres., Gen. Mgr. Mrs. Hugh McClung
 Station Manager Fred M. Stuelpnagel
 Commercial Manager H. E. McCarty
 Sales Prom. Mgr. Ted Dooley
 Pgm., Prod. Dir. Lyle Mathys
 Publicity Director Charles Castor
 Chief Engineer Russ Pope

K P R O

RIVERSIDE—1941

Frequency: 1440 Kc. Power: 1000 Watts
 Owned-Oper. By Broadcasting Corp. of
 America
 Business Address P.O. Box 987
 Phone Number Riverside 6290
 News Service AP
 Representative Pearson
 President Fred E. Carr
 Gen., Sta. Mgr. D. R. Peterson

K C R A

SACRAMENTO—1945—NBC

Frequency: 1320 Kc. Power: 5000 W. d.;
 1000 W. n.
 Owned-Oper. By KCRA, Inc.
 Business Studio Address 1010 11th St.
 Phone Number Gilbert 2-0758
 Air Time 6 a.m.-12M.
 News Service UP
 Transcription Service World
 Representative Robert Meeker
 Membership BAB, NARTB
 President-General Mgr. Ewing C. Kelly
 Commercial Manager F. C. Beckwith
 Station Mgr. Howard J. Smiley
 Publicity Director Irma Davis
 Program Dir. John Kuhlman
 Chief Engineer W. Herbert Hartman

K F B K

SACRAMENTO—1922—ABC

Frequency: 1530 Kc. Power: 50,000 Watts
 Owned-Operated By McClatchy Bcstg. Co.
 Business Studio Address 708 Eye St.
 Phone Number Gilbert 3-1745
 Air Time Full Time
 Newspaper Affiliation Sacramento Bee
 News Service UP, AP
 Transcription Service Thesaurus
 Representative Paul H. Raymer
 Membership BAB, NARTB
 President Eleanor McClatchy
 Gen., Sta. Mgr. Keith B. Collins
 Comm., Sales Prom. Mgr. A. C. Williams
 Program Director Harry Warren
 Chief Engineer Stam Sronce

K G M S

SACRAMENTO—1952

Frequency: 1380 Kc. Power: 1000 Watts d.
 Owned-Oper. By Capitol Radio Enterprises

Address Hotel Senator
 Phone Number Hudson 1-3133
 News Service AP
 Transcription Service Langworth
 General Manager Irving J. Schwartz
 Station Manager J. Matranga
 Commercial Manager S. George
 Chief Engineer Richard Hinz

KROY

SACRAMENTO—1937—CBS

Frequency: 1240 Kc. Power: 250 Watts
 Owned-Oper. By KROY, Inc.
 Business-Studio Address Hotel Sacramento
 Phone Number Gilbert 3-2525
 News Service UP
 Transcription Service Langworth
 Representative Avery-Knodel
 Membership NARTB
 Pres., Gen. Mgr. C. L. McCarthy
 Program Director John Z. Ickes
 Chief Engineer William Karpisek

KXOA

SACRAMENTO—1945—MBS

LON LEE

Frequency: 1470 Kc. Power: 1000 Watts
 Owned-Oper. By Sacramento Bcstrs., Inc.
 Business Address P. O. Box 94
 Phone Number Wabash 5-2717
 News Service UP
 Representative J. E. Pearson, McGovern
 Membership NARTB, BAB
 Transcription Service Standard
 President Lincoln Dellar
 General Manager Robert W. Dumon
 Program Director Dean Serton
 Chief Engineer Ewald Berger

KDON

SALINAS—1935

Frequency: 1460 Kc. Power: 5000 Watts
 Owned-Oper. By Charles Blackwood Grant
 Business Address Box 1490, Salinas
 Phone Number 2-6464
 Air Time Full Time
 News Service UP
 Transcription Service World, Capitol
 Representative Weed & Co.
 Membership NARTB, BAB
 Gen. Mgr. Charles B. Grant
 Commercial Mgr. Ann Knowlton
 Program Director J. L. Lyons
 Chief Engineer Omer Wright

KSBW

SALINAS—1946—MBS

Frequency: 1380 Kc. Power: 1,000 Watts
 Owned-Operated By Salinas Bcstg. Corp.
 Business Address P.O. Box 1651
 Phone Number 8071
 News Service AP
 Transcription Service Langworth
 Representative Forjoe
 Membership NARTB, BAB

Gen., Sta. Manager John C. Cohan
 Commercial Manager W. M. Oates
 Program Director Neal Edmondson
 Chief Engineer Charles Haight

KCSB

SAN BERNARDINO—1947

Frequency: 1350 Kc. Power: 500 Watts
 Owned-Oper. By Fred P. D'Angelo
 Business Address 770 Mill St.
 Phone Number 8-2245
 News Service UP
 Transcription Service Thesaurus
 Representative Forjoe
 President, Gen. Mgr. Fred P. A'Angelo
 Pgm., Pub. Dir. Ed Mundy, Jr.
 Sta. Mgr., Pgm. Dir., Chief Eng. Jim Tracewell

KFXM

SAN BERNARDINO—1929—MBS

Frequency: 590 Kc. Power: 1000 Watts
 Owned-Operated By Lee Bros. Bcstg. Corp.
 Business-Studio Address 512 Fifth St.
 Phone Number 4761
 News Service UP
 Transcription Service World
 Representative John Blair
 President J. Clifford Lee
 General Manager E. W. Lee
 Commercial Mgr. Paul H. Martin
 Program Director Gene Lee
 Chief Engineer George Ewing

KITO

SAN BERNARDINO—1947—ABC

Frequency: 1290 Kc. Power: 5000 Watts
 Owned-Operated By KITO, Inc.
 Address 569 Fourth St.
 Phone Number 7807
 Air Time Unlimited
 News Service UP
 Representative Hollingbery
 Pres., Gen., Sta. Mgr. J. J. Flanigan
 Commercial Manager Arnold Benum
 Program Director Fred Reinhardt
 Chief Engineer Richard Klitzing

KRNO

SAN BERNARDINO—1948

Frequency: 1240 Kc. Power: 250 Watts
 Owned-Oper. By Western Empire Bcstrs., Inc.
 Address 990 Colton Ave
 Phone Number 8-2771
 Air Time Full Time
 News Service AP
 Representative Donald Cooke
 Pres., Gen. Mgr. Norman H. Rogers
 Program Director Chuck Palmer
 Chief Engineer George W. Brock

KCBQ

SAN DIEGO—1946-ABC

Frequency: 1170 Kc. Power: 5000 Watts d.,
 1000 Watts n.

Owned-Operated By.....Charles E. Salik
 Bus. Studio Address.....P. O. Box 1629
 Phone Number.....Cypress 5-4103
 Air Time.....Unlimited
 News Service.....UP
 Representative.....Avery-Knodel
 Membership.....NARTB
 Pres., Gen. Mgr.....Charles E. Salik
 Commercial Mgr.....Graham H. Moore
 Prog., Pub. Dir.....Robert Regan
 Chief Engineer.....Charles J. Sherbourne

K F M B
 SAN DIEGO—1941—CBS

Frequency: 550 Kc.....Power: 1000 Watts
 Owned-Oper. By.....Jack Wrather and
 Helen Alvarez
 Bus. Studio Address.....Fifth & Ash Sts.
 Phone Number.....Main 2114
 Air Time.....6 a.m.-1 a.m.
 News Service.....AP, UP
 Transcription Service.....Capitol, SESAC
 Representative.....Petry
 Membership.....BAB, NARTB
 President.....J. D. Wrather
 Vice President.....Maria Helen Alvarez
 General Manager.....George Whitney
 Station Manager.....Hobby Myers
 Executive Editor.....Paul W. White
 Program Director.....Jerry Lee Pechl
 Chief Engineer.....Charles F. Abel

K F S D
 SAN DIEGO—1926—NBC

Frequency: 600 Kc.....Power: 5000 Watts
 Owned-Operated By.....Airlan Radio Corp. Ltd.
 Business Studio Address.....U. S. Grant Hotel
 Phone Number.....Belmont 3-6353
 Air Time.....6 a.m.-M.
 News Service.....INS, AP
 Representative.....Katz Agency
 Membership.....NARTB
 Pres., Gen. Mgr.....Thomas E. Sharp
 Station Manager.....John C. Merino
 Program Director.....Peter Murphy
 Chief Engineer.....Leroy Bellwood

K G B
 SAN DIEGO—1926—MBS-DON LEE

Frequency: 1360 Kc.....Power: 1000 Watts
 Owned-Operated By.....Don Lee Ecstg. Syst.
 Address.....1017 First Ave.
 Phone Number.....BE 3-6151
 Air Time.....6 a.m.-M.
 News Service.....UP
 Membership.....BAB
 President.....Willet H. Brown
 Sta., Gen. Mgr.....Marion R. Harris
 Program Director.....Matt Long
 Chief Engineer.....Joe Kline

To completely cover
 isolated SAN DIEGO,

*(America's Fastest Growing-
 Billion Dollar Market)*

You Must Buy
KFMB-Radio
-CBS-

**SAN DIEGO'S MOST LISTENED-TO
 RADIO STATION!**

KSDO
SAN DIEGO—1947

Frequency: 1130 Kc....Power: 5000 Watts d.;
1000 Watts n.
Owned-Operated By...San Diego Bcstg. Co.
Bus. Studio Address...U. S. Natl. Bank Bldg.
Phone Number.....Main 2041
Air Time.....Full Time
News Service.....AP, UP
Representative.....Pearson
Vice-Pres., Gen. Mgr.....Jack Heintz
Commercial Manager.....Norman Kay
Station Manager.....W. Edwards
Chief Engineer.....Vern Milton

KSON
SAN DIEGO—1947

Frequency: 1240 Kc.....Power: 250 Watts
Owned-Oper. By.....Fred & Dorothy Rabell
Business Studio Address.....630 F St.
Phone Number.....Franklin 5175
News Service.....AP
Transcription Service.....Associated
Representative.....Bolling
General Manager.....Fred Rabell
Program Director.....Dorothy Rabell
Chief Engineer.....Charles Mowatt

KGIL
SAN FERNANDO—1947

Frequency: 1260 Kc....Power: 1000 Watts d.

Owned-Oper. By..San Fernando Va. Bcstg. Co.
Business Address.....4919 Van Nuys Blvd.
Phone Number.....State 4-6291
Air Time.....Full Time
News Service.....AP
Transcription Service.....Capitol
President.....E. P. Franklin
Commercial Manager.....Howard P. Gray
Program Director.....Allan McKee
Chief Engineer.....Jay Rice

KCBS
SAN FRANCISCO—1912—CBS

Frequency: 740 Kc.....Power: 50,000 Watts
Owned-Operated By...CBS Radio Division Inc.
Address.....Palace Hotel
Phone Number.....YUkon 2-7000
News Service.....AP, UP, INS
Representative.....CBS Radio Spot Sales
Membership.....BAB
President (CBS).....Frank Stanton
Gen., Sta. Mgr.....Arthur Hull Hayes
Promotion Mgr.....Evelyn Clark
Program Director.....Pede Worth
Publicity Director.....William Cullenward
Chief Engineer.....Alan Cormack

KEAR
SAN FRANCISCO—1948

Frequency: 1550 Kc.....Power: 10,000 Watts
Owned-Operated By.....Bay Radio, Inc.

**THOSE WHO KNOW
FAMOUS BRANDS**

A radio news man reports: "This station offers 20 **AP** news shots a day. **The Associated Press** 5-minute summaries are the station's favorites. Listeners appreciate the terse, concise, crisp presentations."

**. . . . KNOW THE MOST FAMOUS
BRAND IN NEWS IS AP**

Business-Studio Address 3 W. 37th Ave.
 Phone Number Fireside 5-4837
 News Service AP
 Transcription Service Associated, Standard
 Representative Bolling
 President Stephen F. Cisler
 General Manager George C. Atkinson
 Chief Engineer Douglas F. Mariska

K F R C

SAN FRANCISCO—1924—MBS

Frequency: 610 Kc. Power: 5030 Watts
 Owned-Oper. By General Teleradio
 Business-Studio Address 1000 Van Ness Ave.
 Phone Number Prospect 6-0500
 Air Time 6 a.m.-M.
 News Service AP, UP
 Representative H.R. Representatives
 Membership BAB, NARTB
 General Manager William D. Pabst
 Commercial Manager Merwyn L. McCabe
 Sales Prom. Mgr. Pub. Dir. Dink Templeton
 Program Director Mel Venter
 Chief Engineer E. G. Underwood

K G O

SAN FRANCISCO—1924—ABC

Frequency: 810 Kc. Power: 50,000 Watts
 Owned-Oper. By ABC-PT
 Business Address 420 Taylor St.
 Phone Number Graystone 4-6555
 Air Time Full Time
 News Service AP, INS, UP
 Transcription Service Langworth
 Representative Edward Petry
 Membership BAB, NARTB
 President (ABC) Robert E. Kintner
 General Manager James H. Connolly
 Station Manager Paul T. Scheiner
 Sales Manager John Hansen
 Program Director Victor P. Reed
 Chief Engineer A. E. Evans

K J B S

SAN FRANCISCO—1924

Frequency: 1100 Kc. Power: 1000 Watts d
 Owned-Operated By KJBS Bcstrs.
 Business Studio Address 1470 Pine St.
 Phone Number Ordway 3-4148
 Air Time 5 a.m.-Local Sunset
 News Service AP, INS
 Representative Avery-Knodel
 Membership NARTB, BAR
 Gen. Mgr.-Sta. Mgr. Edwin P. Franklin
 Comm. Mgr. Stanley G. Breyer
 Pgm. Dir.-Prod.-Pub. Mgr. Charles F. Pendleton
 Chief Engineer Roger Roberts

KNBC

SAN FRANCISCO—1922—NBC

Frequency: 680 Kc. Power: 50,000 Watts
 Owned-Operated By National Bcslg. Co.
 Address 420 Taylor St.
 Phone Number Graystone 4-8700
 Air Time Unlimited

News Service AP, INS, UP
 Transcription Service Thesaurus
 Representative NBC Spot Sales
 Membership NARTB, BAB
 President (NBC) S. L. Weaver, Jr.
 Gen. Sta. Mgr. George Greaves
 Commercial Mgr. W. K. McDaniel
 Sales Promotion Mgr. Dean Moxley
 Program Director John Thompson
 Chief Engineer Curtis Peck

(See Page 351)

K S A N

SAN FRANCISCO—1922

Frequency: 1450 Kc. Power: 250 Watts
 Owned-Oper. By Golden Gate Bcslg. Corp.
 Business Address 1355 Market St.
 Phone Number Market 1-8171
 Air Time 6 a.m.-1 a.m.
 News Service P
 Representative McGillvra
 Membership NARTB
 President S. H. Patterson
 Gen. Mgr. Richard P. Bolt
 Pgm. Dir. Susan Alex
 Sales Mgr. Ralph Sacks
 Chief Engineer Norwood Patterson

K S F O

SAN FRANCISCO—1925

Frequency: 560 Kc. Power: 5000 Watts d.,
 1000 Watts n.
 Owned-Oper. By The Associated Bcstrs., Inc.
 Bus.-Studio Address Van Ness at Greenwith
 Phone Number Prospect 6-5100
 Air Time 6:15 a.m.-12:15 a.m.
 News Service INS, UP
 Transcription Service Standard; World
 Representative Headley-Reed
 Membership NARTB, BAB
 President Wesley I. Dumm
 Gen. Sta. Mgr. Alan L. Torbet
 Ccm. Mgr. Gary Garland
 Prom. Pub. Mgr. Gene DeAlessi
 Program Dir. Robert Hansen
 Dir. of Engineering A. E. Towne

K Y A

SAN FRANCISCO—1926

Frequency: 1260 Kc. Power: 5000 Watts d.,
 1000 Watts n.
 Owned-Operated By KYA, Inc.
 Business Studio Address Fairmont Hotel
 Phone Number Douglas 2-2536
 News Service UP
 Representative George W. Clark
 Membership BAB
 President J. Elroy McCaw
 General Manager H. G. Fearnhead
 Commercial Manager Ken Hildebrandt
 Chief Engineer Paul Beck

KBIF

SANGER—1947

Frequency: 900 Kc. Power: 1000 Watts d.

. . . finest radio-TV facilities in northern California!

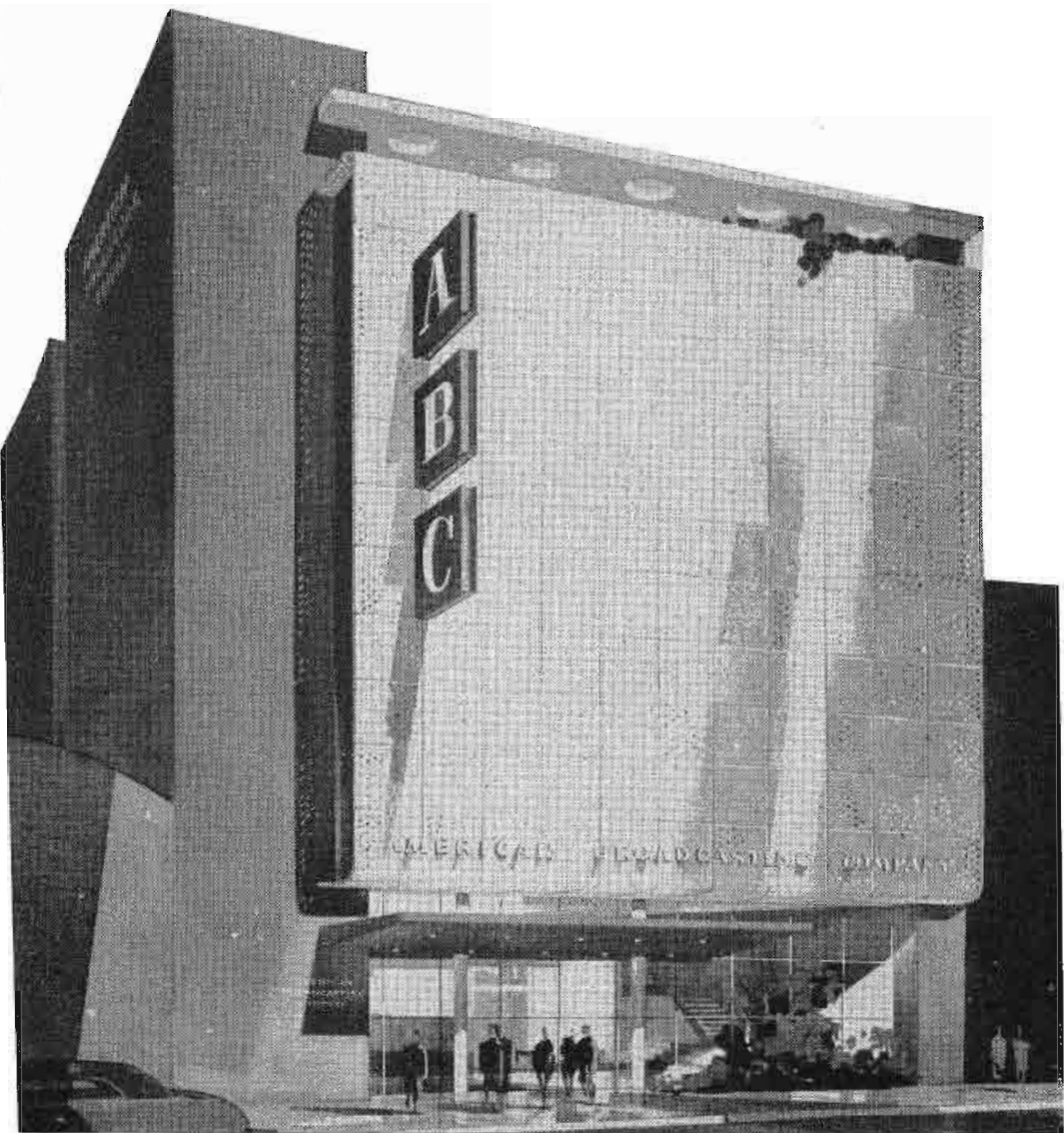

This is ABC Radio-TV Center in San Francisco . . . *new* home for ABC's owned stations, KGO and KGO-TV. Just completed, this ultra-modern center, costing in excess of a million dollars, provides KGO and KGO-TV with broadcasting-telecasting facilities *superior to any* in the important San Francisco-Oakland Bay Area market. Better facilities mean better service to listeners and advertisers . . . bigger audiences for KGO and KGO-TV advertisers.

KGO-Radio

dial 810
50,000 watts

San Francisco

KGO-TV

channel 7
now, 160,000 watts
soon—316,000 watts

Picture



DOUG PLEDGER

sensation of morning radio

and other topflight participating personalities:

**MARJORIE KING, CLARENCE LEISURE,
JOE GILLESPIE, HAL WOLF, BILL GUYMAN,
BUDD HEYDE, IRA BLUE.**

only on

Owned by National Broadcasting Company
Represented nationally by NBC Spot Sales

50,000 watts—clear channel

KABC

San Francisco—680

Owned-Oper. By.....John Poole Bdcstg. Co.
 Business Address.....1412 Fulton St., Fresno
 Phone Number.....6-4702
 News Service.....UP
 Representative.....Meeker
 Membership.....BAB, NARTB
 President.....John H. Poole
 Gen., Comm., Mgr.....George Nickson
 Prog. Dir.....Walter K. Novell
 Chief Engineer.....Russell C. Friend

K E E N
SAN JOSE—1947

Frequency 1370 Kc.....Power 1000 Watts
 Owned-Operated By.....United Bcstg. Co.
 Business Studio Address.....Hotel De Anza
 Phone Number.....Cypress 4-0344
 Air Time.....Full Time
 News Service.....UP
 Representative.....W. S. Grant
 Membership.....NARTB
 President.....George M. Mardikian
 Genl. Mgr.....Floyd Farr
 Commercial Mgr.....Bob Blum
 Program Dir.....George Snell
 Chief Engineer.....Bill Green

K L O K
SAN JOSE—1946

Frequency: 1170 Kc....Power: 5000 Watts d.
 Owned-Operated By.....Valley Bcstg Co.
 Business Address.....P. O. Box 967
 Phone Number.....Cypress 3-3445
 News Service.....AP
 Representative.....Pearson
 President-Gen. Mgr.....E. L. Barker
 Commercial Mgr.....Richard E. Ryan
 Program Director.....Ruth Poindexter
 Chief Engineer.....Bill Cunningham

K S J O
SAN JOSE—1946

Frequency: 1590 Kc...Power: 1000 Watts d.,
 500 Watts n.
 Owned-Operated By..Santa Clara Bcstg. Co.
 Business Address.....P. O. Box 995
 Phone Number.....Cypress 3-8030
 Air Time.....Unlimited
 Newspaper Affiliation.....Les Gatos Times,
 Gilroy Dispatch
 News Service.....UP
 Transcription Service.....Standard
 Representative.....Rambeau
 Membership.....BAB, NARTB
 President.....Patrick H. Peabody
 Gen., Sta. Mgr.....Charles F. Mallory
 Program Director.....Norman Paul
 Chief Engineer.....Edward W. Meece

K X R X
SAN JOSE—1948

Frequency: 1500 Kc.....Power: 1000 Watts
 Owned-Operated By.....San Jose Bcstg. Co.
 Address.....Box 187
 Phone Number.....Cypress 2-5080

Air Time.....24 hrs.
 News Service.....UP
 Representative.....McGavren, Tracy Moore
 President-Gen. Mgr.....Joe E. Levitt
 Sta., Commercial Mgr.....Gordon Graham
 Program Director.....Frank G. Kilpatrick
 Chief Engineer.....Frank Glass

K A T Y

SAN LUIS OBISPO—1949—ABC

Frequency: 1340 Kc.....Power: 250 Watts
 Owned-Operated By.....KATY
 Address.....P. O. Box 700
 Phone Number.....3171
 News Service.....UP
 Representative.....Meeker
 Membership.....NARTB
 President.....Maynard Marquardt
 Sta., Comm. Mgr.....D. D. MacLeod
 Sales Prom. Mgr.....Gloria Heinz
 Program Director.....Barbara Brydia
 Publicity Director.....Don Bowden
 Chief Engineer.....Clay Coldwell

K V E C

SAN LUIS OBISPO—1937
MBS-DON LEE-KBS

Frequency: 920 Kc.....Power: 1000 Watts d.;
 500 Watts n.
 Owned-Oper. By.....Alley Electric-Jacobson
 Business Address.....787 Higuera St.
 Phone Number.....1100
 Air Time.....Full Time
 News Service.....AP
 Transcription Service.....Standard
 Representative.....W. S. Grant
 Membership.....NARTB
 Pres.-Owner.....Christina M. Jacobson
 Gen., Sta. Mgr.....Les Hacker
 Commercial Manager.....Jack Wasson
 Program Director.....Arthur Hapgood
 Chief Engineer.....E. W. Franklin

K E A R

SAN MATEO—1948

Frequency: 1550 Kw.....Power: 1000 Watts
 Owned-Oper. By.....Bay Radio Inc.
 Address.....3 West 37th Ave.
 Phone Number.....Fireside 5-4837
 Transcription Service...Associated, Standard
 News Service.....AP
 Representative.....Bolling
 President.....Stephen A. Cisler
 Commercial Mgr.....George C. Atkinson
 Program Director.....William Agee
 Promotion Dir.....Charles Lynn
 Chief Engineer.....D. F. Mariska

K V S M

SAN MATEO—1946

Frequency: 1050 Kc.....Power: 1000 Watts d.
 Owned-Oper. By.....Hugh H. Smith
 Business Studio Address...279 Baldwin Ave.
 Phone Number.....Diamond 4-2541

Air Time.....Local sunrise-local sunset
 News Service.....INS, UP
 Transcription Service.....Cole
 Representative.....Walker
 President.....Hugh H. Smith
 General Manager.....Gilbert L. Bond
 Chief Engineer.....Merwyn F. Planting

K T I M

SAN RAFAEL—1947

Frequency: 1510 Kc.....Power: 1000 Watts d.
 Owned-Operated By.....Marin Bcstg. Co., Inc.
 Business Address.....1117 Fifth St.
 Phone Number.....Glenwood 3-6880
 Newspaper Affiliation.....S. R. Independent
 Journal
 News Service.....UP
 President.....Roy A. Brown
 Gen. Mgr., Prog. Dir.....Hugh E. Turner
 Publicity Director.....Kitty Oppenheimer
 Chief Engineer.....Edward Ohmstead

K V O E

SANTA ANA—1926

Frequency: 1480 Kc.....Power: 1000 Watts
 Owned-Operated By.....The Voice of the Orange
 Empire, Inc., Ltd.
 Business Address.....105 E. 5th St.
 Phone Number.....Kimberly 3-8321
 Air Time.....Unlimited
 News Service.....UP
 Transcription Service.....MacGregor
 Representative.....Pearson
 Pres., Gen. Mgr.....Ernest L. Spencer
 Station Manager.....Hal Davis
 Commercial Mgr.....Donner P. Spencer
 Program Director.....Dean S. Long
 Chief Engineer.....Stanley G. Guenther

K D B

SANTA BARBARA—1921—MBS
 DON LEE

Frequency: 1490 Kc.....Power: 250 Watts
 Owned-Oper. By.....F. Robert Bauer
 Business-Studio-Transmitter.....Radio Square
 Phone Number.....4131
 Air Time.....Unlimited
 News Service.....UP
 Representative.....Pearson
 President.....F. Robert Bauer
 General Manager.....Harry Butcher
 Program Director.....Joe Benes
 Chief Engineer.....Robert Carter

K I S T

SANTA BARBARA—1946—NBC

Frequency: 1340 Kc.....Power: 250 Watts
 Owned-Operated By.....Radio KIST, Inc.
 Business-Studio Address.....Balboa Bldg.
 Phone Number.....3981
 Air Time.....Full Time
 News Service.....UP
 Transcription Service.....Thesaurus

Representative.....George P. Hollingbery
 Membership.....BAB
 Pres., Gen., Sta., Pub. Mgr.....Harry C. Butcher
 Vice President.....M. J. McKeogh
 Commercial Manager.....James Blomfield
 Sales Promotion Mgr.....Michael J. McKeogh
 Program Director.....Darleen Levinson
 Chief Engineer.....Gene Fossell

K T M S

SANTA BARBARA—1937—ABC

Frequency: 1250 Kc.....Power: 1000 Watts
 Owned-Oper. By.....News-Press Publishing Co.
 Business-Studio Address.....de la Guerra Plaza
 Phone Number.....3911
 Air Time.....Full Time
 Newspaper Affil.....Santa Barbara News-Press
 News Service.....AP
 Transcription Service.....SESAC
 Representative.....Paul H. Raymer
 President.....Thomas M. Storke
 Gen., Sta. Mgr.....Charles A. Storke
 Commercial Mgr.....Jo Benes
 Program Director.....Gordon Phillips
 Chief Engineer.....Leo De Connick

K S C O

SANTA CRUZ—1947

Frequency: 1080 Kc.....Power: 1000 d.; 500 n.
 Owned-Operated By.....Radio Santa Cruz
 Business Address.....P. O. Box 1080
 Phone Number.....1080
 News Service.....AP
 Membership.....NARTB, BAB
 Transcription Service.....Standard, Thesaurus
 Pres., Gen. Mgr., Chief Engr.
 Charles Vernon Berlin

K C O Y

SANTA MARIA—1947—ABC

Frequency: 1400 Kc.....Power: 250 Watts
 Owned-Oper. By.....News-Press Publishing Co.
 Business-Studio Address.....114 W. Cook St.
 Phone Number.....5-2644
 Newspaper Affiliation.....Santa Barbara News
 Press
 News Service.....AP
 Transcription Service.....SESAC
 Representative.....Paul H. Raymer
 Station Manager.....W. A. Cook
 Program Director.....Louise Hapgood
 Chief Engineer.....John D. Clowes, Jr.

K S M A

SANTA MARIA—1945—KBS

Frequency: 1240 Kc.....Power: 250 Watts
 Owned-Oper. By.....Hagerman, Groom
 Address.....510 W. Morrison
 Phone Number.....5-2582
 News Service.....UP
 Transcription Service.....World
 Partners.....James M. Hagerman, John I. Groom
 Program Dir.....Anthony Kent
 Chief Eng.....Gale Brady

KOWL

SANTA MONICA—1947

Frequency: 1580 Kc. Power: 10,000 Watts, d.
 Owned-Operated By.....KOWL, Inc.
 Address.....Pico at Ocean
 Phone Number.....Exbrook 4-6761
 Air Time.....Daytime
 Representative.....George W. Clark,
 McGavren, Clayton
 President.....J. D. Funk
 General Manager.....G. A. Baron
 Promotion Director.....Paul Compton
 Chief Engineer.....Robert Dye

KSPA

SANTA PAULA—1948—KBS

Frequency: 1400 Kc. Power: 250 Watts
 Owned-Operated By.....Santa Paula Bcstrs. Inc.
 Business-Studio Address.....Santa Paula
 Phone Number.....940
 Pres., Gen. Mgr., Ch. Eng.....C. Harvey Haas
 Prom., Comm. Mgr.....Chas. Martin

KSRO

SANTA ROSA—1937

Frequency: 1350 Kc. Power: 1000 Watts
 Owned-Oper. By.....Finley Bcstg. Co.
 Bus.-Studio Address.....Corner Fresno & Finley
 Phone Number.....110
 Air Time.....Full Time
 Representative.....W. S. Grant
 President.....Mrs. Ruth Finley
 General-Station Manager.....Charles P. Scott
 Program Director.....Al Pearson
 Chief Engineer.....Hilmar Cann

KROG

SONORA—1949—KBS

Frequency: 1450 Kc. Power: 250 Watts
 Owned-Oper. By.....Brewster E. Ferrel
 Business-Studio Address.....P. O. Box 996
 Phone Number.....Jefferson 2-7898
 Air Time.....Full Time
 News Service.....AP
 Transcription Service.....Standard, SESAC
 Owner, Gen. Mgr.....Brewster E. Ferrel
 Chief Engineer.....C. W. Mitchell

KGDM

STOCKTON—1926—CBS

Frequency: 1140 Kc. Power: 5000 Watts
 Owned-Operated By.....E. F. Peffer
 Business-Studio Address.....519 E. Market St.
 Phone Number.....4-4551
 Air Time.....6 a.m.-M.
 News Service.....UP
 Transcription Service.....World
 Representative.....John Blair
 President.....E. F. Peffer
 Gen., Comm. Mgr.....E. Smith
 Program Director.....M. Humphreys
 Promotion Director.....A. Stover
 Chief Engineer.....J. Tyron Kelley

KSTN

STOCKTON—1949

Frequency: 1420 Kc. Power: 1000 Watts
 Owned-Operated By.....San Joaquin Bcstg. Co.
 Business Address.....Hotel Clark
 Phone Number.....4-7338
 Air Time.....Unlimited
 News Service.....UP
 Representative.....Hollingbery
 President.....Knox La Rue
 Gen., Sta., Com. Mgr.....D. T. Ralph
 Program Director.....Ellis Lind
 Chief Engineer.....Carl McGee

KWG

STOCKTON—1921—ABC

Frequency: 1230 Kc. Power: 250 Watts
 Owned-Operated By.....McClatchy Bcstg. Co.
 Bus.-Studio Address.....612 E. Market St.
 Phone Number.....5-5728
 Newspaper Affiliation.....McClatchy
 Air Time.....Full Time
 News Service.....AP
 Transcription Service.....Thesaurus
 Representative.....Paul H. Raymer
 Membership.....NARTB, BAB
 President.....Eleanor McClatchy
 Station Manager.....James H. Ranger
 Program Manager.....James E. Longe
 Chief Engineer.....Frank Nesmith

KXOB

STOCKTON—1947—MBS-DON LEE

Frequency: 1280 Kc. Power: 1000 Watts
 Owned-Oper. By.....KXOB, Inc.
 Business-Studio Address.....Hotel Stockton
 Phone Number.....4-7313
 Air Time.....6 a.m.-M.
 News Service.....UP
 Representative.....Pearson, McGavren, etc.
 Membership.....NARTB, BAB
 President.....J. E. Gamble
 Gen., Sta., Comm. Mgr.....Ort Lothus
 Program Director.....Homer Van Derwerker
 Publicity Director.....Carolyn Prybil
 Chief Engineer.....James L. Johnson

KSUE

SUSANVILLE—1948

Frequency: 1240 Kc. Power: 250 Watts
 Owned-Oper. By.....Nolan Hollowell,
 James E. McKahan
 Phone Number.....2020
 Air Time.....Full Time
 News Service.....UP
 Transcription Service.....Capitol, Standard
 Representative.....Tracy Moore
 Membership.....NARTB
 Gen., Sta. Mgr.....Nolan Hollowell
 Commercial Manager.....Frank Rondas
 Program Director.....Gerald Oliver
 Chief Engineer.....Harold C. Houston

KTKR

TAFT—1948—KBS

Frequency: 1310 Kc. Power: 500 Watts d.
 Owned-Operated By: Taft Bcstg. Co.
 Business Address: P.O. Box "WW"
 Phone Number: 5-3101
 Air Time: Day Time
 News Service: UP
 Pres., Gen. Mgr.: Kenneth Aitken
 Station Manager: George J. Tchumy, Jr.
 Commercial Manager: Jack Smith
 Chief Engineer: Kenneth Aitken

KCOK

TULARE—1945—MBS-CCN

Frequency: 1270 Kc. Power: 1000 Watts
 Owned-Oper. By: Sheldon Anderson
 Business Address: P. O. Box 119
 Phone Number: 6-2866
 Air Time: Full Time
 News Service: UP
 Representative: Forjoe
 Membership: NARTB, BAB
 Pres., Gen. Mgr.: Sheldon Anderson
 Sta., Sales Prom. Mgr.: Don Weldon
 Program Director: Bob Lee
 Chief Engineer: Don Ferguson

KTUR

TURLOCK—1949—KBS

Frequency: 1390 Kc. Power: 1000 Watts
 Owned-Operated By: Turlock Bcstg. Corp.
 Address: P. O. Box 526
 Phone Number: Turlock 43430, 45827
 News Service: UP
 Representative: O'Connell
 President: Wallace Lindskoog
 General Manager: H. Ansell McMillen
 Program Director: B. McMillen
 Chief Engineer: Maxon Sayre

KUKI

UKIAH—1950

Frequency: 1400 Kc. Power: 250 Watts
 Owned-Oper. By: M. E. Sims
 Address: P. O. Box 638
 Phone: Homestead 2-4771
 Air Time: Unlimited
 Representative: McGavren
 Transcription Service: Standard
 News Service: AP
 Pres., Gen. Mgr.: M. E. Sims
 Commercial Mgr.: Louis DuMoulin
 Program Director: John Franklin
 Chief Engineer: Stanley Ryno

KGYW

VALLEJO—1947

Frequency: 1190 Kc. Power: 250 Watts d.
 Owned-Oper. By: Vallejo Bcstg. Co.
 Business-Studio Address: 3267 Sonoma Blvd.
 Phone Number: Vallejo 8-8944
 News Service: UP

Representative: McGavren
 Co-Managers: Ellsworth Peck, A. J. Krisik
 Program Director: Ellsworth Peck
 Publicity Director: Robert Wade
 Chief Engineer: William Roberts

KVEN

VENTURA—1948

Frequency: 1450 Kc. Power: 250 Watts
 Owned-Operated By: Coast Ventura Co.
 Address: Box 1611
 Phone Number: Miller 3-8675
 News Service: UP
 Representative: McGavren, Webb
 Pres., Gen. Mgr.: Harry M. Engel
 General Manager: Sydney Held
 Program Director: Fred Hall
 Chief Engineer: Frank Haines

KVVC

VENTURA—1947

Frequency: 1590 Kc. Power: 1000 Watts
 Owned-Oper. By: Voice of Ventura County
 Business Address: P.O. Box 1411
 Phone Number: Miller 3-6185
 Air Time: 6 a.m.-M.
 Representative: Walker
 Transcription Service: Langworth
 President: Wm. H. Haupt
 Station Manager: Karl A. Rembe
 Sales Prom., Comm. Mgr.: Bob Brown
 Chief Engineer: Charles Farmer

KONG

VISALIA—1948

Frequency: 1400 Kc. Power: 250 Watts
 Owned-Operated By: Tulare County Bcstg.
 Address: Rt. 6, Box 205
 Phone Number: 4-5811
 Air Time: Full Time
 News Service: AP
 Representative: Hollingbery
 President: Knox La Rue
 General Manager: Jim Carroll
 Program Manager: Mike Kirmeyer
 Chief Engineer: Gorman Brown

KWSO

WASCO—1950

Frequency: 1050 Kc. Power: 1000 Watts d.
 Owned-Operated By: Maple Leaf Bcstg. Co.
 Address: P. O. Box 366
 Phone: 2145
 Air Time: Daytime
 Transcription Service: Lang-Worth, SESAC
 News Service: UP
 Membership: NARTB
 President: E. J. Peters
 Gen., Sta. Mgr.: Theodore G. Heinrichs
 Comm., Sale Prom. Mgr.: Jim Hodges
 Chief Engineer: Bob Robertson
 Pgm., Pub. Dir.: Bob Bann

K H U B

WATSONVILLE—1937

Frequency: 1340 Kc.....Power: 250 Watts
 Owned-Operated By.....Patrick H. Peabody
 Business Address.....P. O. Box 349
 Phone.....4-5641
 Air Time.....Full Time
 News Service.....UP
 Representative.....Rambeau
 Membership.....NARTB
 President.....Patrick H. Peabody
 Gen., Sta., Comm. Mgr.....Hal E. Chase
 Program Director.....Tom Martin
 Chief Engineer.....Merle Rossman

K S Y C

YREKA—1947

Frequency: 1490 Kc.....Power: 250 Watts
 Owned-Oper. By.....Siskiyou Cty. Bcstg. Co., Inc.
 Address.....Lawrence Lane & S. Oregon St.
 Phone Number.....624
 Air Time.....Full Time

News Service.....AP
 Membership.....NARTB
 President.....E. G. Millbourn
 General Manager.....D. C. Holfinger
 Station Manager.....Jack A. Mitchell
 Assistant Manager.....D. M. Comstock
 Chief Engineer.....Bill Maginnis

K U B A

YUBA CITY—1947

Frequency: 1600 Kc...Power: 1000 Watts d.:
 500 Watts n.
 Owned-Operated By..Peachbowl Bcstrs., Inc.
 Business Address.....Hotel Marysville
 Phone Number.....3-7309
 News Service.....AP
 Transcription Service.....Thesaurus
 Representative.....Ayers, O'Connell
 President.....Chester V. Ullom
 Gen., Station Manager.....Roger R. Hunt
 Commercial Manager.....Lloyd Klemp
 Sales Promotion Mgr.....Ray Davenport
 Pgm., Pub. Dir.....Ric Ryan
 Chief Engineer.....John J. Rolih

COLORADO

*Pop. Feb. 1, 1954 (Est.) 1,558,000 — Families 461,000
 Radio Homes 446,000 — TV Homes 199,500 — Stations in State 33*

K G I W

ALAMOSA—1929

Frequency: 1450 Kc.....Power: 250 Watts
 Owned-Operated By.....E. L. Allen
 Phone Number.....26
 News Service.....UP
 Transcription Service.....SESAC
 President.....E. L. Allen
 General Manager.....D. L. Allen
 Director of News.....Charles Dynes

Air Time.....7 a.m.-7 p.m.
 News Service.....UP
 Transcription Service.....Keystone, Cole
 Pres., Gen., Sta., Mgr.....Ray M. Beckner
 Chief Engineer.....Ed Wood

K B O L

BOULDER—1946—COLUMBINE

Frequency: 1490 Kc.....Power: 250 Watts
 Owned-Oper. By....Boulder Radio KBOL, Inc.
 Address.....1617 Pearl
 Air Time.....7 a.m.-11:05 p.m.
 News Service.....UP
 Transcription Service.....Standard, Thesaurus
 Membership.....NARTB, BAB
 Pres., Gen. Mgr.....Russel Shaffer
 Commercial Manager.....Gene Palm
 Chief Engineer.....Blair Dobbins

K R D O

COLORADO SPRINGS—1947

Frequency: 1240 Kc.....Power: 250 Watts
 Owned-Operated By....Pikes Peak Bcstg. Co.
 Business-Studio Address.....399 S. 8th St.
 Phone Number.....Melrose 2-1515
 Air Time.....6:00 a.m.-M.
 News Service.....AP
 Transcription Service...Standard, Langworth,
 Thesaurus
 Representative.....McGillvra
 Pres., Gen. Mgr.....Joseph H. Rohrer
 Business Manager.....Paul Crozier
 Commercial Manager.....Harry Hoth
 Program Director.....Jean Gitz
 Chief Engineer.....Herbert Schubarth

K R L N

CANON CITY—1946—KBS

Frequency: 1400 Kc.....Power: 250 Watts
 Owned-Oper. By....Royal Gorge Bcstrs., Inc.
 Business-Studio Address...1615 Central Ave.
 Phone Number.....1100

K V O R

COLORADO SPRINGS—1924—CBS

Frequency: 1300 Kc.....Power: 1000 Watts
 Owned-Oper. By....Voice of the Rockies, Inc.
 Address.....512 So. Tejon
 Phone Number.....Melrose 4-2844
 Air Time.....Unlimited
 News Service.....UP

Transcription Service World
 Representative Hollingbery
 Membership NARTB, BAB
 Pres., Gen. Mgr. J. D. Russell
 Sta. Mgr., Prog. Dir. Isabelle McClung
 Publicity Director Betty Demarest
 Chief Engineer H. Cozine Strang

KRAI

CRAIG—1949—KBS

Frequency: 1230 Kc. Power: 250 Watts
 Owned-Oper. By No. Western Colo. Bcstg. Co.
 Business Address Craig
 Phone Number 707-8
 Air Time Full Time
 News Service UP
 Transcription Service Thesaurus
 Membership BAB, NARTB
 President Miles Barrett
 General Manager George Cory
 Station Manager Gene Wilburn
 Comm., Sales Prom. Mgr. Carr Pecknold
 Program, Pub. Dir. William M. Jack, Jr.
 Chief Engineer Norman Davis

KFEL

DENVER—1923—MBS

Frequency: 950 Kc. Power: 5,000 Watts
 Owned-Operated By Eugene P. O'Fallon, Inc.
 Business-Studio Address Albany Hotel
 Phone Number Alpine 4681
 Air Time 24 hrs.
 News Service INS
 Transcription Service Associated
 Representative John Blair
 Membership NARTB, BAB
 General Manager Gene O'Fallon
 Managing Director Frank Bishop
 Commercial Mgr. John McEniry
 Prom. Mgr., Publ. Dir. Gene O'Fallon, Jr.
 Program Director Dale Morgan
 Chief Engineer Rhea Cunningham

KLIR

DENVER—1953

Frequency: 990 Kw. Power: 1000 Watts d.
 Owned-Oper. By Denver Bcstg. Co.
 Address 6535 W. Jewell
 Phone Number Westwood 1313
 Owner-Gen. Mgr. F. Donald Hall
 Commercial Mgr. L. L. Tracy
 Program Director Ernest E. Mark
 Chief Engineer Lloyd L. Wilson

KLZ

DENVER—1922—CBS

Frequency: 560 Kc. Power: 5000 Watts
 Owned-Operated By Aladdin Radio & TV, Inc.
 Business-Studio Address 131 Speer Blvd.
 Phone Number MAin 4271
 Air Time 5:30 a.m.-M.
 News Service AP, INS.
 Transcription Serv. Standard, Capitol, World
 Representative Katz

Membership NARTB, BAB
 Pres., Gen. Sta. Mgr. Hugh B. Terry
 Commercial Manager Dudley Tichenor
 Sales Prom. Mgr. Bill Day
 Program Director Charles C. Roberts
 Chief Engineer Harvey E. Wehrman

KMYR

DENVER—1941—COLUMBINE

Frequency: 1340 Kc. Power: 250 Watts
 Owned-Operated By KMYR Bcstg. Co.
 Address Security Life Bldg.
 Phone Number MAin 4161
 Air Time Unlimited
 News Service AP
 Station Representative Forjoe & Co.
 Membership NARTB
 Pres., Gen. Mgr. F. W. Meyer
 Station Manager A. G. Meyer
 Commercial Manager Ed Koepke
 Pgm., Prod. Dir. Lowell Switzer
 Chief Engineer Walt Wilson

KOA

DENVER—1924—NBC

Frequency: 850 Kc. Power: 50,000 Watts
 Owned-Oper. By KOA, Inc.
 Business-Studio Address 1625 California St.
 Phone Number Main 6211
 Air Time Full Time
 News Service AP, INS
 Transcription Service Thesaurus & Associated
 Representative Edward Petry & Co.
 Membership NARTB, BAB
 President William W. Grant
 Gen., Sta. Mgr. Don Searle
 Sales Promotion Manager Dick Harris
 Program Director Jim Atkins
 Publicity Director Ralph Radetsley
 Chief Engineer Robert H. Owen

KTLN

DENVER—1948

Frequency: 1150 Kc. Power: 1000 Watts d.
 Owned-Oper. By Radio Station KTLN
 Address 431 W. Colfax
 Phone Number Acoma 4811
 Air Time 4:30 a.m.-Sunset
 News Service UP
 Transcription Service Capitol
 Representative Radio Reps., Inc.
 Owner Leonard Coe
 General Manager John L. Buchanan
 Commercial Manager Dean Jarvis
 Sales Promotion Mgr. Del Wood
 Program Director Jack Helling
 Chief Engineer O. E. Kelly

KVOD

DENVER—1925—ABC

Frequency: 630 Kc. Power: 5000 Watts
 Owned-Operated By Colorado Radio Corp.
 Business-Studio Add. Midland Savings Bldg.

Phone Number.....Tabor 2291
 Air Time.....Full Time
 News Service.....UP
 Transcription Service..Lang-Worth, Associated
 Representative.....Free & Peters
 Membership.....NARTB
 President-Gen. Mgr.....William D. Pyle
 Station Manager.....T. C. Ekrem
 Commercial Manager.....Con Hecker
 Program Director.....V. W. Corbett
 Publicity Director.....Ben H. Stanton
 Chief Engineers.....W. D. Pyle, T. C. Ekrem

KIUP

DURANGO—1935—MBS

Frequency: 930 Kc.....Power: 1000 Watts
 Owned-Operated By....San Juan Bcstg. Co.
 Address.....P. O. Box 641
 Phone Number.....117
 News Service.....UP
 Transcription Service.....SESAC, Thesaurus,
 World
 Representative.....Holman Co.
 President.....Mike Cummins
 General Manager.....R. E. O'Brien
 Comm., Prom. Mgr.....Lindsey Becker
 Program Director.....Clayton Holm
 Publicity Director.....Frank Toomey
 Chief Engineer.....Henry Pollman

K G M C

ENGLEWOOD—1952

Frequency: 1220 Kc....Power: 1000 Watts d.
 Owned-Oper. By....Grady Franklin Maples,
 P. B. McAlister
 Address.....3355 S. Broadway
 Phone Number.....Sunset 1-4481
 News Service.....UP
 Co-owner, Gen. Mgr.....Grady F. Maples
 Co-owner, Prog. Dir., Prom. Mgr..R. B. McAlister
 Chief Engineer.....D. F. White, Jr.

K C O L

FT. COLLINS—1947—COLUMBINE INTERMOUNTAIN

Frequency: 1410 Kc.....Power: 1000 Watts
 Owned-Oper. By....Northern Colo. Bcstg. Co.
 Business-Studio Address..1600 La. Porte Ave.
 Phone Number.....2600
 Air Time.....Unlimited
 News Service.....UP
 Transcription Service.....Thesaurus
 Membership.....NARTB, BAB
 President.....Herb Hollister
 General Manager.....Ellis Atteberry
 Commercial Manager.....Bob McClary
 Program Director.....Hollis Hoff
 Chief Engineer.....Dan Coltrane

K F T M

FORT MORGAN—1949—KBS

Frequency: 1260 Kc....Power: 500 Watts d.
 Owned-Oper. By....Morgan County Bcstg. Co.
 Address.....P. O. Box 431

Phone Number.....1000
 Air Time.....Daytime
 News Service.....UP
 Transcription Service.....Capitol
 General Manager.....Donnell K. Smith
 Program Director.....Johanna Hanson
 Chief Engineer.....Richard Oldfield

K G L N

GLENWOOD SPRINGS—1950—MBS WESTERN SLOPE

Frequency: 1340 Kc.....Power: 250 Watts
 Owned-Oper. By.....KGLN, Inc.
 Address.....P. O. Box C
 Phone Number.....777
 Representative.....Holman
 News Service.....UP
 President.....Rex Howell
 Co-owner, Gen. Mgr.....Jerry Fitch
 Program Director.....Gene Curtis
 Chief Engineer.....Bonner Z. Baker

K E X O

GRAND JUNCTION—1948 COLUMBINE

Frequency: 1230 Kc.....Power: 250 Watts
 Owned-Oper. By..Voice of Western Colo., Inc.
 Address.....2508 North Ave.
 Phone Number.....1230
 Air Time.....6 a.m.-12M.
 News Service.....INS
 Transcription Service....Capitol, Thesaurus
 Representative.....Harlan Oakes
 Membership.....NARTB, BAB
 President.....D. Spencer Grow
 Gen., Sta. Mgr.....Abbott Tessman
 Program Director.....Robert Collins
 Publicity Director.....Mildred Fuller
 Chief Engineer.....D. E. Towne

K F X J

GRAND JUNCTION—1926—MBS WESTERN SLOPE-INTERMOUNTAIN

Frequency: 920 Kc....Power: 1000 Watts d;
 500 Watts n.
 Owned-Oper. By....Western Slope Bcstg. Co.
 Business-Studio Address.....Box 30
 Phone Number.....1300
 Air Time.....6 a.m.-M.
 News Service.....UP
 Transcription Service.....Standard
 Representative.....Hal Holman
 Membership.....NARTB
 Pres., Gen. Mgr.....Rex Howell
 Sta., Comm. Mgr.....E. Anson Thomas
 Program Director.....Ed Lewis
 Chief Engineer.....Cecil Whitchurch

K F K A

GREELEY—1921

Frequency: 1310 Kc.....Power: 1000 Watts
 Owned-Oper. By....Mid-Western Bcstg. Co., Inc.
 Business-Studio Address.....620—8th Ave.
 Phone Number.....450-1

Air Time Full Time
 Representative Hal Holman
 News Service UP
 Transcription Service Thesaurus
 Pres., Gen. Mgr. H. E. Green
 Sta., Comm. Mgr. William G. Stewart
 Program Director Jack Redus
 Chief Engineer Harry Brewer

Representative Clark
 President M. S. Morrison
 Gen., Sta. Mgr. R. D. Gerkin
 Comm. Mgr., Chief Eng. R. D. McGregor
 Program Director Dorene Brown

KYOU

GREELEY—1948—KBS-COLUMBINE

Frequency: 1450 Kc. Power: 250 Watts
 Owned-Oper. By Meroco Bcstg. Co.
 Phone Number 3275
 Air Time Unlimited
 News Service AP
 Representative McGillvra, Inc.
 Transcription Service World
 President, Gen. Mgr. Elwood H. Meyer
 Sta. Mgr. Chief Engr. John T. Roscoe

KBNZ

LA JUNTA—1937—MBS-KBS

Frequency: 1400 Kc. Power: 250 Watts
 Owned-Oper. By Otero Broadcasting Co.
 Address Radio Building
 Phone 42
 Air Time 6:00 a.m.-12M.
 News Service UP

KLMR

LAMAR—1948

Frequency: 1340 Kc. Power: 250 Watts
 Owned-Oper. By SE Colorado Bcstg. Co.
 Address Lamar, Colorado
 Phone Number 804
 News Service AP
 Transcription Service World
 Representative Continental
 President Ralph Eaton
 Gen., Sta. Mgr. Everett Shupe
 Comm., Prom. Mgr. Dennis Behan
 Program Director Claire Behan
 Chief Engineer Kenneth Roberts

KLVC

LEADVILLE—1951—KBS
 COLUMBINE

Frequency: 1230 Kc. Power: 250 Watts
 Owned-Operated By Leadville's Top of the
 Nation Station, Inc.
 Address 520 W. 6th St.

THOSE WHO KNOW FAMOUS BRANDS

Short and sweet, from a commercial manager: "Sponsor was 100% satisfied . . . said he was more than pleased with the AP's material . . . declared this was one of their best promotions."

. . . . KNOW THE MOST FAMOUS
 BRAND IN NEWS IS **AP**

Phone Number70
 RepresentativeClark
 President.....Vir N. James
 General Manager.....J. L. Littlejohn

President-Gen. Mgr.....Dee B. Crouch
 Sales Prom. Manager.....Bill Beck
 Chief Engineer.....William Willig

K L M O

LONGMONT—1949—KBS

Frequency: 1050 Kc.....Power: 250 Watts d.
 Owned-Operated By.....Longmont Bcstg. Co.
 Phone Number1050
 News ServiceUP
 Transcription ServiceLang-Worth
 Pres., Gen. Mgr.....Irving Ludlow
 Program Director.....Dick Lee
 Chief Engineer.....Walter Robinson

K U B C

MONTROSE—1947—KBS
 INTERMOUNTAIN

Frequency: 1260 Kc.....1000 Watts d.;
 500 Watts n.
 Owned-Operated By..Uncompaghe Bcstg. Co.
 Business-Studio Address.....P. O. Box 279
 Phone Number199
 Air Time.....6 a.m.-10:30 p.m.
 News ServiceUP
 Transcription Service.....Thesaurus
 MembershipNARTB, BAB
 President.....F. J. Hartman
 Gen., Sta. Mgr.....Geo. Cory
 Sales Prom. Mgr.....Dale G. Moore
 Program Director.....Ed DeJulio
 Chief Engineer.....Tom Weir

K C S J

PUEBLO—1947—MBS
 INTERMOUNTAIN

Frequency: 590 Kc.....Power: 1000 Watts
 Owned-Oper. By.....Star Bcstg. Co., Inc.
 Address.....211 W. 5th St.
 Phone Number8522
 Air Time.....6 a.m.-M.
 News ServiceAP
 Transcription ServiceThesaurus
 Representative.....Avery-Knodel, Inc.
 Pres., Gen. Mgr.....Douglas Kahle
 Commercial Mgr.....Bob Clinton
 Program Director.....Larry Gordon
 Chief Engineer.....Dale Redlingshafer

K D Z A

PUEBLO—1947

Frequency: 1230 Kc.....Power: 250 Watts
 Owned-Operated By.....Pueblo Radio Co.
 Address3011 Elizabeth
 Phone Number1255
 News ServiceAP
 Transcription Service.....Lang-Worth
 RepresentativeMcGillvra

K G H F

PUEBLO—1928—ABC

Frequency: 1350 Kc..Power: 5000 d.; 1000 n.
 Owned-Operated By..Colorado Bcstg. Co., Inc.
 AddressBox 293
 Phone Number3877
 Air Time.....6 a.m.-M.
 News ServiceUP
 Transcription Service.....World, SESAC
 Representative.....Gill-Perna, Inc.
 PresidentGifford Phillips
 General Manager.....Robert D. Ellis
 Commercial Manager.....Bill Mahoney
 Station Manager.....J. H. McGill
 Chief Engineer.....Willis C. Shanks

K V R H

SALIDA—1948—KBS
 COLUMBINE-INTERMOUNTAIN

Frequency: 1340 Kc.....Power: 250 Watts
 Owned-Operated By.....Vir N. James
 Phone Number30
 News ServiceINS
 RepresentativeClerk
 Sta., Chief Eng., Gen., Comm. Mgr.
 Vir N. James
 Program Director.....Jack Diehl
 Chief Engineer.....Philip Parmelee

K G E K

STERLING—1925

Frequency: 1230 Kc.....Power: 250 Watts d.
 Owned-Operated By.....Elmer G. Beehler
 Address.....Fleming Rd.
 Phone Number679
 News ServiceUP
 Owner, Gen. Mgr.....Elmer G. Beehler

K C R T

TRINIDAD—1947—MBS-KBS

Frequency: 1240 Kc.....Power: 250 Watts
 Owned-Oper. By.....KCRT, Inc.
 AddressBox 772
 Phone Number338
 News ServiceUP
 Transcription Service.....World, Langworth
 Pres., Gen. Mgr.....E. M. Cooper
 Commercial Mgr.....Bob Loehr
 Program Director.....Vince Brascia
 Pgm., Publ. Dir.....Martin Mendine



50,000 WHATS ?

Station power by itself is only part of the story, and the fact that WTIC is the most powerful station in Southern New England would not interest an advertiser were it not for the confidence and loyalty of our listeners. Over the years, WTIC's policy of careful screening of advertisers, high standards of entertainment and public service has made our programs unexcelled backgrounds for messages that sell.

FOR YOUR SELLING . . .
USE **WTIC**

WTIC DOMINATES THE PROSPEROUS
SOUTHERN NEW ENGLAND MARKET

CONNECTICUT

Pop. Feb. 1, 1954 (Est.) 2,097,000 — Families 639,000
Radio Homes 630,000 — TV Homes 485,000 — Stations in State 26

W I C C

BRIDGEPORT—1926—MBS-YANKEE

Frequency: 600 Kc. Power: 1000 Watts d.
500 Watts n.
Owned-Oper. By. Bridgeport Bcstg. Co.
Address Box 9140
Air Time 24 hrs.
News Service AP
Phone Number Tr 8-1601
Transcription Service Thesaurus
Representative Adam Young & Co.
Membership BAB
Pres., Gen., Sta. Mgr. Philip Merryman
Commercial Manager Manning Slater
Sales Promotion Manager Joan Fisher
Program Director Bob Crane
Chief Engineer Pat Uliano

W N A B

BRIDGEPORT—1941 ABC-CONN. STATE

Frequency: 1450 Kc. Power: 250 Watts
Owned-Operated By. WNAB, Inc.
Business-Studio Address 991 Broad St.
Phone Number 3-3112
Air Time Full Time
News Service UP
Representative Rambeau, Bannan
President-Chief Engineer Harold Thomas
Commercial Manager Ray Colonari
Program Director Jack Dahlby
Publicity Director Grace Kaltenbach

W B I S

BRISTOL—1948

Frequency: 1440 Kc. Power: 500 Watts d.
Owned-Oper. By. The Bristol Bcstg. Corp.
Business-Studio Address 183 Main St.
Phone Number 9265
Air Time Daytime
News Service UP
Representative McGillvra
Transcription Service Associated, World
President Frederick W. Beach
Gen., Sta. Mgr. R. H. Gillespie
Comm., Sales, Prom. Mgr. Amleto Ciccarelli
Chief Engineer Richard L. Ricci

W L A D

DANBURY—1947

Frequency: 800 Kc. Power: 250 Watts d.
Owned-Operated By. Berkshire Bcstg. Corp.
Business-Studio Address 207 Main St.
Phone Number 8-3565
Air Time Daytime
News Service AP
Transcription Service World, SESAC
Representative Indie Sales

President John P. Previdi
Gen., Comm. Mgr., Pub. Dir. Sol Robinson
Program Director Eleanor Kemble
Chief Engineer Rudolph Cehak

W C C C

HARTFORD—1947

Frequency: 1290 Kc. Power: 500 Watts d.
Owned-Oper. By. Greater Hartford Bcstg Corp.
Address Hotel Bond
Phone Number Jackson 5-6648
Air Time Local sunrise-local sunset
News Service UP
President William M. Savitt
Sec't. Treas. M. Savitt
Sta., Comm. Mgr. R. H. Klein
Program Director B. LaCoe
Publicity Director E. Seltzer
Chief Engineer Michael Cookish

W D R C

HARTFORD—1922—CBS

Frequency: 1360 Kc. Power: 5000 Watts
Owned-Oper. By. The Connecticut Bcstg. Co.
Business-Studio Address 750 Main St.
Phone Number 7-1188

W E

C R E A T E

C A S H

C U S T O M E R S

HARTFORD'S
ONLY
INDEPENDENT
STATION —
OFFERING
MUSIC
AND NEWS
ALL DAY;
EVERY DAY.

"THERE'S T.N.T. ON WCCC"

(Time, news, temperature, including
weather every 15 minutes)

Representatives: Walker
Kettell-Carter

1290 KC

500 WATTS

Air Time.....Full Time
 News Service.....UP
 Representative.....Paul H. Raymer
 Membership.....NARTB
 Transcription Service.....SESAC
 President.....Franklin M. Doolittle
 General Manager.....Walter B. Haase
 Comm., Sales Prom. Mgr.....William F. Malo
 Program, News Dir.....Harvey H. Olson
 Chief Engineer.....Henry M. Broderick, Jr.

Phone Number.....5-5747
 Air Time.....Daytime
 News Service.....UP
 President.....C. A. Schultz
 General Manager.....G. A. Kruttschnitt
 Program Director.....Leo Finn
 Chief Engineer.....John Roache

WGTH

HARTFORD—1935—MBS

Frequency: 1410 Kc.....Power: 5,000 Watts
 Owned-Oper. By.....Gen. Times Television Corp.
 Business-Studio Address.....54 Pratt St.
 Phone Number.....Hartford 7-9131
 Air Time.....Full Time
 News Service.....UP
 Representative.....H-R Reps. Inc.
 President.....Thomas F. O'Neil
 General Manager.....F. W. Wagenvoord
 Commercial Manager.....Cy Kaplan
 Program Director.....John Downey
 Chief Engineer.....Rogers Holt

WTHT

**HARTFORD—1936
 ABC-CONN. STATE**

Frequency: 1230 Kc.....Power: 250 Watts
 Owned-Operated By.....The Hartford Times, Inc.
 Business Address.....555 Asylum St.
 Phone Number.....2-0237
 Air Time.....Full Time
 News Service.....AP
 Representative.....Everett McKinney, Bannan
 General Manager.....C. Glover DeLaney
 Assistant Manager.....R. K. Blackburn
 Commercial Manager.....Leonard R. Schoenfeld
 Program Director.....Mitchell Betters
 Chief Engineer.....Charles S. Masini

WTIC

HARTFORD—1925

Frequency: 1080 Kc.....Power: 50,000 Watts
 Owned-Oper. By.....Travelers Bcstg. Service
 Business-Studio Address.....26 Grove St.
 Phone Number.....5-0801
 Air Time.....Full Time
 News Service.....AP, INS
 Transcription Service.....Lang-Worth SESAC
 Representative.....Christal
 General Manager.....Paul W. Morency
 Commercial Mgr.....Walter Johnson
 Asst. Sales Mgr.....Irwin Cowper
 Program Director.....Leonard J. Patricelli
 Promotion Mgr.....Bernard Mullins
 (See Page 361)

WMWW

MERIDEN—1947

Frequency: 1470 Kc.....Power: 1000 Watts d.
 Owned-Operated By.....Silver City Crystal Co.
 Business-Studio Address.....8 W. Main St.

WCNX
MIDDLETOWN—1948

Frequency: 1150 Kc.....Power: 500 Watts d.
 Owned-Oper. By.....Middlesex Bcstg. Co.
 Business-Studio Address.....460 Main St.
 Phone Number.....Diamond 7-2565
 President.....R. J. O'Brien
 General Manager.....Wm. J. O'Brien, Jr.
 Program Director.....Wm. J. Glynn
 Chief Engineer.....Kenneth A. F. Bishop

WHAY

**NEW BRITAIN—1949
 CONNECTICUT STATE
 FOREIGN LANGUAGE**

Frequency: 910 Kc.....Power: 5000 Watts
 Owned-Operated By.....Central Conn. Bcstg. Co.
 Business Address.....22 Grove Hill
 Phone Number.....3-2721
 Air Time.....Unlimited
 News Service.....UP
 Representative.....Adam Young, Bannan
 President.....Patrick Goode
 Exec. Vice-Pres.....Edward D. Taddei
 Secretary-Treasurer.....Aldo DeDominicis
 Station Manager.....Leo Borin
 Commercial Manager.....Charles Bell
 Program Director.....Pete Stoner
 Chief Engineer.....Hillis W. Holt

WKNB

NEW BRITAIN—1946

Frequency: 840 Kc.....Power: 1000 Watts d.
 Owned-Oper. By.....New Britain Bcstg. Co.
 Address.....213 Main St.
 Phone Number.....Baldwin 3-3603
 Air Time.....Daytime
 News Service.....AP
 Representative.....Bolling
 Membership.....NARTB
 President.....Julian Gross
 General Manager.....Peter B. Kenney
 Commercial Manager.....Gustave Nathan
 Program Director.....Robert Andrews
 Publicity Director.....Dean Bafford
 Chief Engineer.....John Shipley

WAVZ

NEW HAVEN—1947

Frequency: 1260 Kc.....Power: 1000 Watts d.
 Owned-Operated By.....WAVZ Bcstg. Corp.
 Business-Studio Address.....152 Temple St.
 Phone Number.....SPruce 7-4761
 Air Time.....Local sunrise-local sunset
 News Service.....AP

Representative.....Forjoe, Kettell, Carter
 Membership.....BAB
 President.....Victor W. Knauth
 V.P., Gen., Sta. Mgr.....Daniel W. Kops
 Program Director.....E. J. Markle
 Publicity Director.....S. L. Barstein
 Chief Engineer.....Ralph Carrano

WELI

NEW HAVEN—1935—ABC

Frequency: 960 Kc.....Power: 1000 Watts
 Owned-Operated By...Conn. Radio Founda-
 tion, Inc.
 Business-Studio Address.....221 Orange St.
 Phone Number.....UNiversity 5-1133
 Air Time.....Full Time
 News Service.....UP
 Representative.....Headley-Reed
 Pres., Gen. Mgr.....Richard W. Davis
 Commercial Mgr.....Edwin H. Schweitzer
 Publicity Director.....Rudy Frank
 Program Director.....Charles H. Wright
 Chief Engineer.....Fred King

WNHC

NEW HAVEN—1944—CONN. STATE

Frequency: 1340 Kc.....Power: 250 Watts
 Owned-Operated By...Elm City Bcstg. Corp.
 Business-Studio Address.....1110 Chapel St.
 Phone Number.....SP 7-3611
 Air Time.....Full Time
 News Service.....AP, INS
 Representative.....Katz Agency
 Membership.....NARTB
 President.....Patrick J. Goode
 General Manager.....Aldo DeDominicis
 Exec. Vice-Pres.....Edward D. Taddei
 Commercial Manager.....J. Vincent Callanan
 Station Manager.....Edward C. Obrist
 Prom. Mgr., Publ. Dir.....James W. Evans
 Chief Engineer.....Vinnie DeLaurentis

WNLC

**NEW LONDON—1936 — MBS
 YANKEE, CONN. ST.**

Frequency: 1490 Kc.....Power: 250 Watts
 Owned-Operated By...The Thames Bcstg. Corp.
 Business-Studio Address.....281 State St.
 Phone Number.....2-4365
 Air Time.....Unlimited
 News Service.....UP
 President-Gen. Sta. Mgr.....Gerald J. Morey
 Comm.-Sales Prom. Mgr.....Leo B. Keeagan
 Prog., Publ. Dir.....Nelson Brown
 Chief Engineer.....Randolph Barrett

WNLK

NORWALK—1948

Frequency: 1350 Kc.....Power: 500 Watts
 Owned-Operated By...Norwalk Bcstg. Co., Inc.
 Business-Studio Address...Main & Wall Sts.
 Phone Number.....Temple 8-5566
 Air Time.....Full Time

News Service.....UP
 Transcription Service.....World
 Representative.....McGillvra
 Pres., Gen. Mgr.....James Stolcz
 Program Director.....John Naylor
 Chief Engineer.....Russ Bassett

WICH

NORWICH—1946

Frequency: 1400 Kc.....Power: 250 Watts
 Owned-Oper. By.....Eastern Conn Bcstg. Co.
 Business-Studio Address.....Cuprak Rd.
 Phone Number.....Turner 7-1613
 Air Time.....Full Time
 News Service.....UP
 Transcription Service.....World
 President.....J. K. Lasser
 Promotion Dir.....Edward Adler
 Chief Engineer.....Alexander Dubenetsky

WPCT

PUTNAM—1953

Frequency: 1350 Kw.....Power: 500 Watts d.
 Owned-Oper. By...Israel Putnam Bcstg. Co.
 Address.....42 Main St.
 Phone Number.....8-2721
 President.....Roland A. Gayette
 General Manager.....Daniel J. Hyland
 Program Director.....William Winne
 Chief Engineer.....James Bonney

WSTC

STAMFORD—1941—ABC

Frequency: 1400 Kc.....Power: 250 Watts
 Owned-Oper. By.....W. Conn. Bcstg. Co.
 Business-Studio Address.....270 Atlantic St.
 Phone Number.....4-7575
 Air Time.....6:30 a.m.-M.
 Newspaper Affiliation...Stamford Advocate
 News Service.....UP
 Transcription Service.....Lang-Worth
 Representative.....Everett-McKinney
 Membership.....NARTB
 President.....Kingsley Gillesph
 Gen.-Sta. Manager.....Julian Schwartz
 Program Director.....Walter Dibble
 Acting Chief Engineer.....Alex Kiselewich

WLCR

TORRINGTON—1947

Frequency: 990 Kc.....Power: 1000 Watts d.
 Owned-Oper. By...Litchfield Cty. Radio Corp.
 Business-Studio Address.....23 Main St.
 Phone Number.....4173
 Air Time.....Local sunrise-local sunset
 News Service.....UP
 Transcription Service.....World
 Representative.....Sears & Ayer
 Membership.....BAB
 Pres., Gen. Mgr.....Charles O. Scott
 Comm., Sales Prom. Mgr.....Joe Storm
 Program Director.....Ken Mudgett
 Chief Engineer.....Alfred Pollakot

W T O R

TORRINGTON—1948
CONN. STATE—ABC

Frequency: 1490 Kc. Power: 250 Watts
Owned-Oper. By... Torrington Bcstg. Co., Inc.
Business-Studio Address... 93 Perkins St.
Phone Number... 4181
Air Time... Full Time
News Service... AP
Representative... Rambeau
President... Harold Thomas
Gen., Sta. Mgr... Edmund Waller
Sales Prom., Comm. Mgr... John J. Morris
Program Director... Richard C. Kilbourn
Chief Engineer... Edwin Michalski

W A T R

WATERBURY—1934
ABC-CONN. STATE

Frequency: 1320 Kc. Power: 1000 Watts
Owned-Oper. By... The WATR Co., Inc.
Business-Studio Address... 440 Meadow St.
Phone Number... 5-1121
Air Time... 7 a.m.-M.
News Service... UP
Representative... Rambeau, Bannon
Membership... NARTB
President-Gen. Mgr... Harold Thomas
Sta.-Comm. Mgr... Sam Elman
Sales Prom. Mgr... Wallace Gordon
Program Director... Wally King
Publicity Director... Phil Corvo
Chief Engineer... Russell Jensen

W B R Y

WATERBURY—1934—CBS

Frequency: 1590 Kc. Power: 5000 Watts
Owned-Oper. By... American-Republican, Inc.
Business-Studio Address... P. O. Box 1627
Phone Number... 3-1125
Air Time... 6:55 a.m.-12:05 a.m.
News Service... AP
Transcription Service... World
Representative... Avery-Knodel,
Kettel-Carter (Boston)
Membership... NARTB
President... William J. Pape
Commercial Manager... Harry A. DeVorken
Gen., Sta. Mgr... J. Maxim Ryder
Sales Promotion Mgr... Robert Holczer
Program Director... Walter O. Howard
Chief Engineer... Frank B. Hales

W W C O

WATERBURY—1946
MBS-YANKEE

Frequency: 1240 Kc. Power: 250 Watts
Owned-Operated By Mattatuck Bcstg. Co., Inc.
Business-Studio Address... 119 W. Main St.
Phone Number... 4-5141
Air Time... Full Time
News Service... AP
Representative... McGillvra
President... William G. Wells
Commercial Manager... Al Simmons
Program Director... Robert C. Crager
Chief Engineer... Wm. Goldstein

DELAWARE

Pop. Feb. 1, 1954 (Est.) 324,000 — Families 91,000
Radio Homes 87,000 — TV Homes 76,000 — Stations in State 7

W D O V

DOVER—1948

Frequency: 1410 Kc. Power: 1000 Watts d.
Owned-Oper. By... Del. State Capital
Bcstg. Corp.
Business Address... Denny's Rd.
Phone Number... 5816
Air Time... 6:30 a.m.-Sunset
News Service... AP
Transcription Service... World
Representative... Rambeau
Membership... BAB
President... Dr. C. F. Freed
General Manager... Cliff Goodman
Commercial Manager... William S. Freed
Chief Engineer... B. Brownell

W J W L

GEORGETOWN—1951

Frequency: 900 Kc. Power: 1000 Watts d.
Owned-Operated By... Rollins Bcstg., Inc.

Address... DuPont Highway
Phone Number... 2567
Air Time... 6:00 a.m.-12:30 a.m.
News Service... AP
Transcription Service... Thesaurus
Representative... Pearson
President... John W. Rollins
Gen., Comm. Manager... Norman M. Glenn
Program Director... Bill Jaeger
Chief Engineer... Edward Marzoc

W K S B

MILFORD—1953

Frequency: 930 Kc. Power: 500 Watts d.
Owned-Oper. By... Kent-Sussex Bcstg. Co.
Address... Box 444
Phone Number... Milford 8881
News Service... UP
Transcription Service... Langworth
Co-owner, Comm. Mgr... H. M. Griffith Jr.
Co-owner, Chief Engineer... C. V. Lundsledt
Program Director... Borden E. Smith

WAMS

WILMINGTON—1948—MBS

Frequency: 1380 Kc. Power: 1000 Watts
 Owned-Oper. By. Wilmington Tri-State Bcst.
 Co., Inc.
 Bus.-Studio Address. 321 Delaware Ave.
 Phone Number 4-8882
 Air Time 6:00 a.m.-12:30 a.m.
 News Service AP
 Transcription Service Associated
 Representative Hollingberry
 President. Frank S. Carrow
 General Manager. Edwin A. McKeon
 Comm. Mgr. William S. Ewing
 Program Director. Tim Crow
 Chief Engineer. Perley Tribou

WDEL

WILMINGTON—1922—NBC

Frequency: 1150 Kc. Power: 5000 Watts
 Owned-Operated By. WDEL, Inc.
 Business-Studio Address. 10th & King Sts.
 Phone Number 7268
 Air Time 6:00 a.m.-1 a.m.
 News Service UP
 Transcription Service World
 Representative Robert Meeker
 Membership NARTB, BAB
 Station Executive. Clair R. McCollough
 Station Manager. Harvey C. Smith
 National Sales Manager. J. Robert Gulck
 Program Director. R. V. Aydelotte

WILM

WILMINGTON—1922—ABC

Frequency: 1450 Kc. Power: 250 Watts
 Owned-Operated By. Delaware Bcstg. Co.
 Business-Studio Address. 920 King St.
 Phone Number 4-7771
 Air Time Full Time
 News Service UP
 Transcription Service World
 Representative Bolling Co.
 Membership NARTB, BAB
 Pres., Gen. Mgr. Ewing B. Hawkins
 Sta., Comm. Mgr. Jackson F. Lee
 Program Director. Warren Keyser
 Chief Engineer. H. Edwin Kennedy

WTUX

WILMINGTON—1947

Frequency: 1290 Kc. Power: 500 Watts d.
 Owned-Oper. By. Port Frere Bcstg. Co., Inc.
 Business-Studio Address. 1326 Market St.
 Phone Number. Wilmington 5-8821
 Air Time Local sunrise-local sunset
 News Service AP
 Transcription Service Thesaurus
 Representative. Indie Sales, Inc.
 Membership NARTB, BAB
 Pres.-Sta. Mgr. Gordon K. MacIntosh
 General Mgr. Howard Robinson
 Commercial Mgr. John M. Talley
 Program Director. William H. Gehlert
 Publicity Director. Justina Spagnolo
 Chief Engineer. Seymour Toberisky

**THOSE WHO KNOW
 FAMOUS BRANDS**

Says a station executive, speaking of a Cadillac dealer's program: "Our sponsor believes Cadillac is the ultimate in automobile quality. We at the station believe just as firmly that the ultimate in news is **AP**. The marriage, you might say, was inevitable."

**. . . . KNOW THE MOST FAMOUS
 BRAND IN NEWS IS AP**

DISTRICT OF COLUMBIA

Pop. Feb. 1, 1954 (Est.) 834,400 — Families 271,000
 Radio Homes 262,000 — TV Homes 201,500 — Stations in State 7

W G M S

WASHINGTON, D. C.—1947

Frequency: 570 Kc.....Power: 1000 Watts d.
 Owned-Oper. By...The Good Music Station, Inc.
 AddressHotel Harrington
 Phone Number.....Executive 3-8676
 Transcription ServiceAssociated
 News ServiceAP
 Air Time.....6:30 a.m. to Sunset
 RepresentativeGood Music Bcstrs.
 Pres., Gen. Mgr.....M. Robert Rogers
 Commercial Mgr.....Dan Cavalier
 Program Director.....Pierson Underwood
 Chief Engineer.....Nick Chaconas

Owned-Operated By.....The Evening Star
 Bcstg. Co., Inc.

Bus. Studio Add. 4461 Connecticut Ave., N.W.
 Phone Number.....Kellogg 7-1100
 Air Time.....Full Time
 News ServiceAP
 Transcription ServiceSESAC
 Newspaper Affiliation.....Evening Star
 Representative.....The Katz Agency
 MembershipNARTB
 President.....S. H. Kauffmann
 V.P., General Manager.....K. H. Berkeley
 Sales Prom., Pub. Dir.....Haywood Meeks
 Commercial Mgr.....Robert Jonscher
 Program Director.....Charles Bishop
 Chief Engineer.....Frank Harvey

W M A L

WASHINGTON, D. C.—1926—ABC

Frequency: 630 Kc.....Power: 5000 Watts

W O L

WASHINGTON, D. C.—1924

Frequency: 1450 Kc.....Power: 250 Watts

**CHAIN LIGHTNING
 WORKS FOR
 WRC CUSTOMERS!**

Attractive, effective
 displays as shown here
 can be yours in scores
 of leading food stores
 throughout metropolitan
 Washington.

● Contact WRC or your
 NBC Spot Sales office for
 complete Chain Lightning
 information.

WRC
 NBC in Washington



Owned-Oper. By.....Wash. Bcstg. Corp.
 Address.....1000 Connecticut Ave.
 Phone.....METropolitan 8-0010
 Air Time.....Full Time
 Transcription Service.....SESAC
 News Service.....UP
 President.....Henry Rau
 General Manager.....Charles Dillon
 Comm. Mgr., Prog. Dir.....Maxwell Marvin
 Publicity Director.....Joan R. Dorf
 Chief Engineer.....Lloyd Smith

W O O K

WASHINGTON, D. C.—1940

Frequency: 1340 Kc.....Power: 250 Watts
 Owned-Operated By.....United Bcstg. Co.
 Business-Studio.....8th & I Sts., N.W.
 Phone Number.....Republic 7-8000
 News Service.....UP
 Pres., Gen. Mgr.....Richard Eaton
 Comm., Sta. Mgr.....Arthur A. Snowberger

W R C

WASHINGTON, D. C.—1923—NBC

Frequency: 980 Kc.....Power: 5000 Watts
 Owned-Operated By.....National Bcstg. Co., Inc.
 Business-Studio Address.....Sheraton Park Hotel
 Phone Number.....Adams 4-5400
 News Service.....AP, INS, UP
 Representative.....NBC Spot Sales
 President (NBC).....Sylvester L. Weaver Jr.
 Exec. Vice-Pres. (NBC).....Robert Sarnoff
 Vice-Pres. (Wash.).....Frank Russell
 General Manager.....Carlton D. Smith
 Program Director.....James E. Kovach
 Sales Prom. Mgr.....Robert Adams
 Chief Engineer.....John Rodgers

W T O P

WASHINGTON, D. C.—1927—CBS

Frequency: 1500 Kc.....Power: 50,000 Watts
 Owned-Operated By.....WTOP Inc.
 Business-Studio Address.....Broadcast House
 Phone Number.....Emerson 2-9300
 Air Time.....Full Time
 News Service.....AP, UP, INS
 Representative.....CBS Radio Spot Sales
 President, Gen. Mgr.....John S. Hayes

V.P., Comm. Mgr.....George Hartford
 V.P., Program Director.....Lloyd Dennis
 Sales Promotion Mgr.....Warren Boorum
 Publicity Director.....Cody Pfanstiehl
 V.P., Chief Engr.....Clyde Hunt

W W D C

WASHINGTON, D. C.—1941—MBS

Frequency: 1260 Kc.....Power: 5000 Watts
 Owned-Oper. By.....WWDC, Inc.
 Business-Studio Address.....1627 K St., N.W.
 Phone Number.....Sterling 3-3800
 Air Time.....Full Time
 News Service.....AP, UP
 Transcription Service.....Standard
 Representative.....Blair
 Membership.....NARTB, BAB
 President.....Joseph Katz
 General Manager.....Ben Strouse
 Comm. Manager.....Herman Paris
 Program Director.....Norman Reed
 Sls. Prom., Pub. Dir.....Irving Lichtenstein
 Chief Engineer.....Ross H. Beville

Washington's

BEST

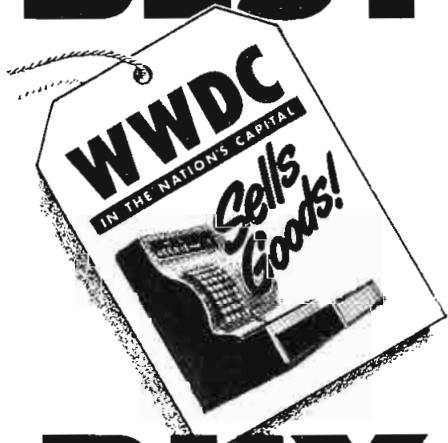

BUY

Ask your John Blair man for the WWDC story!

FLORIDA

Pop. Feb. 1, 1954 (Est.) 3,192,000 — Families 1,041,000
Radio Homes 905,000 — TV Homes 397,500 — Stations in State 80

W B A R

BARTOW—1953

Frequency: 1460 Kc. Power: 1000 Watts d.
Owned-Oper. By William Avera Wynne
Address Box 820, Lakeland Hwy.
Phone Number 3-5111
President W. A. Wynne
General Manager Ted Leeper
Commercial Mgr. John Burgreen
Chief Engineer Edward St. Clair

W S W N

BELLE GLADE—1947

Frequency: 900 Kc. Power: 1000 Watts d.
Owned-Operated By Seminole Bcstg. Co.
Business Address P. O. Box 8
Phone Number 2063
Air Time Daytime
News Service UP
Transcription Service Thesaurus, SESAC,
World
Membership BAB, NARTB
President Dr. R. G. Nelson
V.P., Gen. Mgr. Mrs. Mary Foy
Sales Manager Marvin Smith
Chief Engineer C. S. Clemans

W T R L

BRADENTOWN—1946—KBS

Frequency: 1490 Kc. Power: 250 Watts
Owned-Operated By Trail Bcstg. Corp.
Business Address Memorial Pier
Phone Number 3-1531
Air Time Full Time
News Service AP
Representative Hil Best
Transcription Service World, Standard
Exec. Vice-Pres. Howard A. Donahoe
Station Mgr. George W. Manning
Dir. of Operations Don McKellar
Chief Engineer Gerald McGougan

W T A N

CLEARWATER—1948—KBS

Frequency: 1340 Kc. Power: 250 Watts
Owned-Oper. By Clearwater Ra. Bcstrs., Inc.
Business Address 200 Pierce Blvd.
Phone Number 33084
Air Time 6:00 a.m.-12 M.
News Service UP
Transcription Service World
Representative McGillvra
Membership NARTB
President Otis E. Pruitt
General, Station Manager H. D. Parker
Commercial Manager F. L. Parker
Program Director L. H. Falconnier
Chief Engineer John D. Callan

W K K O

COCOA—1953—KBS

Frequency: 860 Kc. Power: 250 Watts d.
Owned-Operated By Brevard Bcstg. Co.
Address Box 387
News Service UP
Transcription Service Standard, SESAC
Representative Hil F. Best
Membership BAB, NARTB
General Manager Emerson W. Browne
Comm. Mgr., Prog. Dir. Carl G. Collins, Jr.
Chief Engineer Davis E. Wilson

W V C G

CORAL GABLES—1948

Frequency: 1070 Kc. Power: 1000 Watts d.
Owned-Operated By Peninsular Bcstg. Corp.
Business Address 223 Aragon Ave.
Phone Number 48-7411
Air Time Sunrise to sunset
News Service AP
Transcription Service Associated
Representative Clark
Membership BAB, NARTB
President-General Mgr. George W. Thorpe
Commercial Manager T. Hooke McCallie
Program Director Robert S. Stevens
Chief Engineer Thomas Middleton

W C N U

CRESTVIEW—1948—KBS

Frequency: 1010 Kc. Power: 1000 Watts d.
Owned-Operated By Gulfshores Bcstg. Co.
Business-Studio Address Box 518
Phone Number 3511
News Service AP
Transcription Service World, SESAC
President D. Grady O'Neal
Program Director Vernon Cooper
General Manager Sam F. Townsend

W M F J

DAYTONA BEACH—1935—ABC

Frequency: 1450 Kc. Power: 250 Watts
Owned-Operated By W. Wright Esch
Business Studio Address 444 N. Beach St.
Phone Number 6491
Air Time 6:30 a.m.-12 M.
News Service UP
Transcription Service SESAC
Representative Joseph Hershey McGillvra
Station Manager Ray Clancy
Commercial Manager John S. Pitts
Program Director Mildred Mullins
Chief Engineer Webster K. Ellenwood

WNDB

DAYTONA BEACH—1948—MBS

Frequency: 1150 Kc. Power: 1,000 Watts
 Owned-Operated By: News-Journal Corp.
 Business-Studio Address: Daytona Beach, Fla.
 Phone Number: 2-0531
 Air Time: Full Time
 News Service: AP
 Representative: John H. Perry
 Membership: BAB, NARTB
 Gen. Sta. Mgr.: Jerry Stone
 Comm., Prom. Mgr.: R. Y. Huffman
 Prog., Publ. Dir.: William R. Steadman
 Chief Engineer: F. A. Scott

WROD

DAYTONA BEACH—1947—NBC

Frequency: 1340 Kc. Power: 250 Watts
 Owned-Operated By: Daytona Beach Bcstg. Corp.
 Bus. Address: Wilder Blvd. & S. Beach St.
 Phone Number: 4626
 Air Time: Full Time
 News Service: UP
 Transcription Service: Thesaurus
 Representative: Rambeau
 Pres.-Gen. Mgr.: E. J. Sperry
 Pgm. Dir., Chief Engr.: W. C. Collier

WJBS

DELAND—1948—NBC

Frequency: 1490 Kc. Power: 250 Watts
 Owned-Oper. By: John B. Stetson Univ.
 Address: 220 East Hubbard Ave.
 Phone Number: 1490
 News Service: AP
 Transcription Service: Associated
 Membership: NARTB
 Gen. Mgr., Prog. Dir.: C. L. Menser
 Comm., Prom. Mgr.: Robert Walton
 Chief Engineer: James Miller

WBRD

FT. LAUDERDALE—1950—KBS

Frequency: 1580 Kc. Power: 250 Watts d.
 Owned-Operated By: Broward Bcstg. Co.
 Address: P. O. Box 78
 Phone Number: 2-2563
 News Service: UP
 Representative: Hil F. Best
 President: Myles Johns
 Gen., Sta. Mgr.: Ted Nelson
 Program Director: Betty Phillips
 Chief Engineer: Sam Dudas

WFTL

FORT LAUDERDALE—1946

Frequency: 1400 Kc. Power: 250 Watts
 Owned-Oper. By: Tri-County Bcstg. Co.
 Bus. Studio Address: Box 131
 Phone Number: 3-2511

Air Time: Full Time
 News Service: AP
 Transcription Service: World, Langworth
 Representative: Sears & Ayer
 President: J. W. Dickey
 Gen., Sta., Comm. Mgr.: R. L. Bowles
 Program Director: Jack W. Swart
 Chief Engineer: Richard P. Northey

WINK

FT. MYERS—1939—CBS

Frequency: 1240 Kc. Power: 250 Watts
 Owned-Oper. By: Ft. Myers Bcstg. Co., Inc.
 Address: 54 E. First St.
 Phone Number: 4-1341
 News Service: AP
 Representative: Donald-Cooke
 President: Daniel Sherby
 General Manager: A. J. Bauer
 Program Director: Frank Nodine
 Chief Engineer: James Lacy

WMYR

FT. MYERS—1952

Frequency: 1410 Kc. Power: 1000 Watts d.
 Owned-Operated By: Robert Hecksher
 Address: 33 East Hanson St.
 Phone Number: 5-1175
 Transcription Service: Lang-Worth
 News Service: UP
 Commercial Manager: Kenneth M. Parke

WARN

FORT PIERCE—1952—ABC-KBS

Frequency: 1330 Kw. Power: 1000 Watts d.
 Owned-Oper. By: Hurricane Bcstg. Co.
 Address: Box 1343
 Phone Number: 1330
 Co-owner, Gen. Mgr.: Murray C. Tillman
 Co-owner, Prom. Mgr.: C. C. Tillman Jr.
 Commercial Mgr.: E. Fisher Darden
 Program Director: Willis M. Shawver Jr.
 Chief Engineer: John E. Palmer

WIRA

FORT PIERCE—1946—MBS-NBC

Frequency: 1400 Kc. Power: 250 Watts
 Owned-Operated By: Indian River Bcstg. Co.
 Business Address: Melody Lane
 Phone Number: 1400
 Air Time: 6:30 a.m.-11:15 p.m.
 News Service: UP
 Membership: NARTB
 Transcription Service: World
 Pres., Gen., Sta. Mgr.: James L. Howe
 Program Director: Anne Wilder
 Commercial Manager: J. Kingsley Butt
 Chief Engineer: James Sowinski

WGGG

GAINESVILLE—1948—ABC

Frequency: 1230 Kc. Power: 250 Watts

Owned-Operated By.....Alachua County
Broadcasting Co., Inc.
Business-Studio.....1230 Waldo Rd.
Phone Number.....5791
News Service.....AP
Transcription Service.....World
Representative.....Best
Pres., Gen. Mgr., Ch. Eng., R. M. Chamberlin
Commercial Manager.....Leon E. Mims
Program Director.....Pierre A. Bejano
Promotion Manager.....Scott Sulton

WRUF

GAINESVILLE—1928—MBS

Frequency: 850 Kc.....Power: 5000 Watts
Owned-Operated By.....Univ. of Fla.
Business-Studio Address.....Campus, Univ. of Fla.
Phone Number.....3261, Ext. 466-7-8
Air Time.....Full Time
News Service.....AP
Transcription Service.....Langworth, Thesaurus
Representative.....Burn-Smith
Membership.....NARTB
General Manager.....Garland Powell
Commercial Manager.....John Dunnivant
Station Manager.....Ray Dantzler
Chief Engineer.....Bertram McNamara

WHWD

HOLLYWOOD—1953

Frequency: 1320 Kw.....Power: 500 Watts d.
Owned-Oper. By.....Circle Bcstg. Co.
Address.....First Ntl. Bank Bldg.
Phone Number.....2-2969
News Service.....UP
Transcription Service.....Capitol
Representative.....McGillvra
Owner.....Roy M. Greene
General Manager.....Robert L. Bowles
Chief Engineer.....George Ralston

WIVY

JACKSONVILLE—1948

Frequency: 1050 Kc.....Power: 1000 Watts d.
Owned-Oper. By.....Edward J. Oberle
Business-Studio Address.....Rt. 9, Box 228A
Phone Number.....4-7722
News Service.....INS
Representative.....Thomas F. Clark
Pres., Gen. Mgr.....Edward J. Oberle
Commercial Manager.....Arman Reinke
Program Director.....Richard Webb
Chief Engineer.....James Stephens

WJAX

JACKSONVILLE—1925—NBC

Frequency: 930 Kc.....Power: 5,000 Watts
Owned-Operated By.....City of Jacksonville, Fla.
Business-Studio Address.....1 Broadcast Pl.
Phone Number.....4-1681
Air Time.....Full Time
Transcription Service.....MUSAC
Representative.....John Blair; Harry E. Cummings
Commissioner in Charge.....J. D. Kennedy

Sta. Mgr., Chief Engr.....John T. Hopkins, III
Program Director.....Marion D. Trowell
Commercial Manager.....J. W. Douglass

WJHP

JACKSONVILLE—1940—MBS

Frequency: 1320 Kc.....Power: 5000 Watts
Owned-Operated By.....Jacksonville Journal Co.
Bus.-Studio Address.....4038 Phillips Highway
Phone Number.....4-7711
Air Time.....6 a.m.-12M.
News Service.....AP
Transcription Service.....Lang-Worth
Representative.....John H. Perry Associates
Membership.....NARTB
President.....John H. Perry, Jr.
Gen., Sta. Mgr.....T. S. Gilchrist, Jr.
Chief Engineer.....Beecher Hayford

WOBS

JACKSONVILLE—1948

Frequency: 1360 Kc.....Power: 1000 Watts d.
Owned-Oper. By.....So. Radio and Equip. Co.
Business-Studio Address.....1036 Mary St.
Phone Number.....98-3411
Air Time.....Sunrise to sunset
Station Representative.....Stars
President.....E. D. Rivers, Sr.
General Manager.....Jim Macri
Chief Engineer.....W. F. Askew

WMBR

JACKSONVILLE—1933—CBS

Frequency: 1460 Kc.....Power: 5000 Watts
Owned-Oper. By.....Washington Post Co.
Business-Studio Address.....605 Main St. S.
Phone Number.....9-4475
Air Time.....Full Time
News Service.....UP
Representative.....CBS Radio Spot Sales
President.....Philip Graham
Vice President.....John S. Hayes
Comm. Mgr.....Charles M. Stone
Program Director.....Dave Booher
Chief Engineer.....Ernest B. Vordermark

WPDQ

JACKSONVILLE—1942—ABC

Frequency: 800 Kc.....Power: 5000 Watts
Owned-Operated By.....Jacksonville Bcstg. Corp.
Phone Number.....4-4421
Studio Address.....Gulf Life Bldg.
Air Time.....5:30 a.m.-1:00 a.m.
News Service.....AP
Transcription Service.....World
Station Representative.....O. L. Taylor
President.....James R. Stockton
General-Station Manager.....Robert R. Feagin
Commercial Mgr.....Kenneth F. Small
Sales Prom. Mgr.....Madeleine Osborne
Program Director.....Charles E. Edwards
Chief Engineer.....James R. Donavan

WRHC
JACKSONVILLE—1950

Frequency: 1400 Kc.....Power: 250 Watts
Owned-Operated By.....WRHC, Inc.
Address.....247 Margaret St.
Phone.....6-0461
Air Time.....6 a.m.-M.
Transcription Service.....Lang-Worth
Membership.....NARTB
Representative, Interstate United Newspapers
Pres., Prom. Mgr.....Harold S. Cohn
General Manager.....Harold Cohn, II
P.ogram Directors.....E. Cohn.
A. Kenneth Knight
Chief Engineer.....William Johnson

WJVB
JACKSONVILLE BEACH—1947—KBS

Frequency: 1010 Kc.....Power: 1000 Watts d.
Owned-Oper. By.....Jacksonville Beach Bcstg. Co.
Phone Number.....5-3674
Representative.....Hil F. Best
Membership.....NARTB
Air Time.....Daytime
News Service.....AP
Pres., Gen., Sta. Mgr.....J. Lyle Williams, Jr.
Program Director.....Ted Booth
Chief Engineer.....Daniel M. Long

WKWF

KEY WEST—1945—MBS

Frequency: 1600 Kc.....Power: 500 Watts
Owned-Operated By.....John M. Spottswood
Address.....Stock Island
Phone Number.....2-7777
Pres., Gen. Comm., Mgr.....John M. Spottswood
Station Manager.....Kermit Lewin
Chief Engineer.....Charles Lowe

WDSR
LAKE CITY—1946

Frequency: 1340 Kc.....Power: 250 Watts
Owned-Operated By.....Deep South Radioways
Business-Studio Address.....126 No. Marion St.
Phone Number.....525
News Service.....UP
Transcription Service.....Associated
General Manager.....Alfred H. Temple
Chief Engineer.....Richard Dyer

WLAK

LAKELAND—1936—NBC

Frequency: 1430 Kc.....Power: 1000 Watts
Owned-Operated By.....Lakeland Bcstg. Corp.
Business Address.....P. O. Box 1211
Phone Number.....MU 2127
Air Time.....Full Time
News Service.....UP
Transcription Service.....Associated, World, Sid.
Station Representative.....John E. Pearson
Membership.....BAB, NARTB
Pres., Gen. Mgr.....S. O. Ward
Sta. Mgr., Chief Engr.....William P. Lee

Commercial Manager.....Powell Adams
Program Director.....Maxine Tyner

WONN

LAKELAND—1949—MBS

Frequency: 1230 Kc.....Power: 250 Watts
Owned-Operated By.....Coastal Bcstg. Co.
Business Address.....Lake Hunter Drive
Phone Number.....MU 5117
Air Time.....Full Time
News Service.....AP
Transcription Service.....Gates
Representative.....Donald Cooke, Inc.
Pres., Gen., Sta. Mgr.....Robert S. Taylor
Commercial Mgr.....Tom Barber
Program Dir.....Ted Covington
Chief Engineer.....Duane McConnell

WIPC

LAKE WALES—1951—KBS

Frequency: 1280 Kc.....Power: 1000 Watts d.
Owned-Operated By.....Imperial Polk Bcstg.
Corp.
Address.....P. O. Box 712
Phone Number.....2-9831
News Service.....AP
Transcription Service.....World
Membership.....BAB, NARTB
President.....Sarkes Tarzian
Gen. Mgr., Chf. Engr.....G. Max Kimbrel
Publicity Director.....John Haughee

WEAT

LAKE WORTH-W. PALM BEACH
1948—NBC

Frequency: 1490 Kc.....Power: 250 Watts
Owned-Operated By.....James R. Meachem
Business Address.....422 North Dixie Hwy.
Phone Number.....Lcke Worth 4422
Air Time.....6:30 a.m.-12:05 a.m.
News Service.....AP
Transcription Service.....Capitol
Representative.....Walker
General Manager.....James R. Meachem
Commercial Manager.....Clifford H. Glick
Program Director.....Bill Gordon
Chief Engineer.....Wayne Stump

WLBE

LEESBURG—1949—MBS

Frequency: 790 Kc.....Power: 1000 Watts
Owned-Operated By.....WLBE, Inc.
Business-Studio Address.....Box 297
Phone Number.....Leesburg 552
News Service.....UP
Transcription Service.....World
President.....Paul A. Husebo
General Manager.....Wendel F. Husebo
Program Director.....Richard R. Coleman
Chief Engineer.....J. Allen Brimmer

WNER

LIVE OAK—1949—KBS-FLA. STATE
Frequency: 1450 Kc.....Power: 250 Watts

Owned-Oper. By.....Norman O. Protsman
 Business Address.....P. O. Box 655
 Phone Number.....1450
 Air Time.....Full Time
 News Service.....UP
 Commercial Mgr.....John Lee Alford
 Program Director.....Faith Protsman
 Chief Engineer.....C. S. Parker

WTYS

MARIANNA—1948—MBS

Frequency: 1340 Kc.....Power: 250 Watts
 Owned-Oper. By...John H. Phipps Radio Stas.
 Address.....Box 565
 Phone Number.....650
 Air Time.....Full Time
 News Service.....AP
 Representative.....Cummings
 President.....John H. Phipps
 General Manager.....L. H. Graves
 Station Manager.....Guy Hamilton
 Chief Engineer.....Wm. A. Snowden, Jr.

WMMB

MELBOURNE—1948—MBS

Frequency: 1240 Kc.....Power: 250 Watts
 Owned-Operated By...Melbourne Bcstg. Corp.
 Business-Studio Address.....Drawer 790
 Phone Numbers.....574-5
 Air Time.....6 a.m.-12 M.
 News Service.....UP
 Transcription Service.....SESAC, World
 Membership.....NARTB
 President.....Henry G. Dravneek
 General Manager.....Austin V. Catterton
 Commercial Mgr.....Victoria C. Martin
 Program Director.....Joy Jorgensen
 Chief Engineer.....Hugh Tyler

WFEC

MIAMI—1949

Frequency: 1220 Kc.....Power: 250 Watts
 Owned-Oper. By.....David Haber
 Trans-Address.....350 N.E. 71st St.
 Phone Number.....89-7534
 Air Time.....Daytime
 News Service.....UP
 Representative...Interstate United Newspapers
 Pres., Gen., Comm. Mgr.....Herbert Schorr
 Program Director.....Milton Oshins
 Chief Engineer.....William Reeder

WGBS

MIAMI—1944—CBS

Frequency: 710 Kc.....Power: 50,000 Watts d.,
 10,000 Watts n.
 Owned-Oper. By.....Storer Bcstg. Co.
 Address.....1005 Kane Concourse,
 Miami Beach, 41
 Phone Number.....86-0331
 Air Time.....Full Time
 News Service.....UP
 Transcription Service.....Langworth
 Station Representative...The Katz Agency Inc.

Membership.....NARTB, BAB
 President.....George B. Storer
 Gen., Sta. Mgr.....Miller N. Babcock
 Commercial Manager.....Francis J. Riordan
 Program Director.....Ewald Kockritz
 Chief Engineer.....Edward C. Lockwood

WINZ

MIAMI—1946

Frequency: 940 Kc.....Power: 50,000 Watts d.,
 10,000 Watts n.
 Owned-Operated By.....Hollywood Bcstg.
 Business Address.....Biscayne Terrace Hotel
 Phone Number.....82-6641-3
 News Service.....AP, INS
 Representative.....Paul Raymer
 Membership.....NARTB
 Pres., Gen. Mgr.....Rex Rand
 Chief Engineer.....James Sawyer

WIOD

MIAMI—1926—NBC

Frequency: 610 Kc.....Power: 5,000 Watts
 Owned-Oper. By...Isle of Dreams Bcstg. Corp.
 Business-Studio Address...600 Biscayne Blvd.
 Phone Number.....3-6444
 Air Time.....Full Time
 News Service.....AP, INS, UP
 Transcription Service.....RCA, Thesaurus
 Representative.....Hollingbery
 President.....Daniel J. Mahoney
 General Manager.....James M. LeGate
 Commercial Manager.....Robert L. Fidler
 Program Director.....Scott Bishop
 Publicity Director.....Martha Henriquez
 Chief Engineer.....M. C. Scott

WMIE

MIAMI—1948

Frequency: 1140 Kc...Power: 10,000 Watts, d.,
 5,000 Watts, n.
 Owned-Operated By...Sun Coast Bcstg. Corp.
 Business Address.....Everglades Hotel
 Phone Number.....3-5556
 Air Time.....Full Time
 News Service.....INS
 Representative.....Stars Natl., Inc.
 President.....E. D. Rivers, Sr.
 Gen., Sta. Mgr.....Kurt Meer
 Commercial Manager.....Bud Dailey
 Program Director.....Julian Silver
 Chief Engineer.....Russell Bennett

WQAM

MIAMI—1921—ABC

Frequency: 560 Kc.....Power: 5,000 Watts, d.,
 1,000 Watts, n.
 Owned-Operated By.....Miami Bcstg. Co.
 Business-Studio Address.....duPont Bldg.
 Phone Number.....2-6121
 News Service.....AP
 Transcription Service.....World
 Representative.....John Blair
 Membership.....NARTB, BAB

President.....John S. Knight
 Gen., Sta., Comm. Mgr.....Owen F. Uridge
 Sales Prom., Pub. Dir.....Ruth Tanksley
 Chief Engineer.....Gene Rider

W W P B

MIAMI—1947—KEYSTONE

Frequency: 1450 Kc.....Power: 250 Watts
 Owned-Operated By.....Paul Brake
 Business-Studio Address.....414 S.W. 2nd Ave.
 Phone Number.....3-7405
 Air Time.....24 hrs.
 News Service.....AP
 Representative.....Walker
 Pres., Gen., Sta. Mgr.....Paul Brake
 Program Director.....Peggy Newmay
 Publicity Director.....Bert Y. Johnson
 Chief Engineer.....Jack Wilson

W K A T

MIAMI BEACH—1937—MBS

Frequency: 1360 Kc.....Power: 5000 Watts d.
 1000 Watts n.
 Owned-Operated By.....WKAT, Inc.
 Trans.-Address.....1759 Bay Road
 Phone Number.....5-5711
 News Service.....UP
 Transcription Service.....Standard, Cole
 Representative.....Headley-Reed
 President.....A. Frank Katzentine
 General Manager.....John I. Prosser
 Sales Prom. Mgr.....Walter A. Callahan
 Commercial Mgr.....C. A. Wamper
 Chief Engineer.....Arthur Smith

W M B M

MIAMI BEACH—1947

Frequency: 800 Kc.....Power: 1000 Watts d.
 Owned-Oper. By.....R. W. Rounsaville
 Address.....c/o WQXI, Atlanta Ga.
 Phone Number.....5-5586
 News Service.....UP
 Representatives.....Dora, Clayton, Forjoe
 Station Manager.....J. E. Vaughn
 Program Director.....Ed. Cook
 Commercial Mgr.....Arnold Kaufman
 Chief Engineer.....Charles A. Hartwick, Jr.

W S B B

NEW SMYRNA BEACH—1951

Frequency: 1230 Kc.....Power: 250 Watts
 Owned-Operated By.....Beach Bcstg. Co.
 Address.....760
 News Service.....UP
 Transcription Service.....Thesaurus
 Gen., Comm. Mgr.....Walter T. Slattery
 Program Director.....James D. King
 Chief Engineer.....Roland W. Jordan

W T M C

OCALA—1939—NBC

Frequency: 1290 Kc.....Power: 1000 Watts
 Owned-Operated By...Ocala Bcstng. Co. Inc

Address.....14 S. Magnolia
 Phone Number.....MA 2-4127
 Air Time.....Full Time
 Newspaper Affiliation.....Perry Newspapers
 News Service.....AP
 Transcription Service.....Lang-Worth
 President.....John H. Perry, Jr.
 Gen., Prom. Mgr.....Thomas S. Gilchrist, Jr.
 Commercial Manager.....T. S. Catalano
 Station Manager.....James B. Smith
 Publicity Director.....Ken Brown
 Chief Engineer.....William P. Callahan

W D B O

ORLANDO—1924—CBS-FRN

Frequency: 589 Kc.....Power: 5000 Watts
 Owned-Operated By...Orlando Bcstg. Co., Inc.
 Business-Studio Address.....P. O. Box 3707,
 30 S. Ivanhoe Blvd.
 Phone Number.....6181
 Air Time.....Full Time
 News Service.....AP, UP
 Transcription Service.....World, Thesaurus,
 Associated
 Representative....John Blair, Harry Cummings
 Membreship.....NARTB, BAB
 Pres., Gen. Mgr.....Harold P. Danforth
 Sales Dir.....W. G. McBride
 Program Director.....Rosalind Boggs
 Chief Engineer.....J. E. Yarbrough

W H O O

ORLANDO—1947—ABC

Frequency: 990 Kc.....Power: 10,000 Watts d.;
 5000 Watts n.
 Owned-Oper. By.....WHOO, Inc.
 Address.....Fort Gatlin Hotel
 Phone Number.....9900
 Air Time.....Full Time
 News Service.....AP
 Transcription Service.....Standard, World
 Representative.....Avery-Knodel
 President.....Edward Lamb
 Gen., Sta., Comm. Mgr.....Carl Hallberg
 Program Director.....Walter E. Sickles
 Sales Prom. Mgr.....Tom Sawyer
 Chief Engineer.....Don Compton

W L O F

ORLANDO—1940—MBS

Frequency: 950 Kc.....Power: 5000 Watts
 Owned-Operated By.....Hazelwood, Inc.
 Business-Studio Address.....Box 1991
 Phone Number.....8163
 Air Time.....4:55 a.m.-1:00 a.m.
 News Service.....UP
 Transcription Service.....Langworth
 President.....J. L. Brechner
 General Manager.....Donn R. Collee
 Commercial Mgr.....Thomas H. Donohue
 Program Director.....Ernest Legge
 Promotion Dir.....Freda M. Hilton
 Chief Engineer.....W. Dodd Daniel

W O R Z

ORLANDO—1947—NBC

Frequency: 740 Kc. Power: 5000 Watts d.;
1000 Watts n.

Owned-Oper. By... Central Florida Bcstg. Co.
Bus. Studio Address... 790 N. Orange Ave.
Phone Number... 2-2451
Air Time... Full Time
News Service... AP
Transcription Service... Capitol
Representative... Taylor
President... Naomi Murrell
Gen. Comm. Mgr... John E. Surrick
Promotion Dir... Harry Gaines
Program Director... Happy Ison
Chief Engineer... Jim Moore

W W P F

PALATKA—1947—KBS

Frequency: 1260 Kc. Power: 500 Watts
Owned-Operated By... Palatka Bcstg. Co.
Address... Box 86
Phone Number... EA 54555
Air Time... Full Time
News Service... UP
Transcription Service... World, Langworth
Gen. Mgr., Chief Engr... L. C. McCall
Partner... J. E. Massey
Commercial Manager... Herb Young
Program Director... Johnny Gillis

W W P G

PALM BEACH—1941

Frequency: 1340 Kc. Power: 250 Watts
Owned-Operated By... Palm Beach Bcstg. Co.
Business Address... 3000 South Ocean Blvd.
Phone Number... 2-1515
News Service... UP
Transcription Service... Thesaurus, Langworth
President, Gen. Mgr... Charles E. Davis
Program Director... Florence Hicks
Chief Engineer... Clyde L. Walkden

W D L P

PANAMA CITY—1940—NBC-KBS

Frequency: 590 Kc. Power: 1000 Watts
Owned-Oper. By... Panama City Bcstg. Co., Inc.
Business-Studio Address... West Beach Dr.
Phone Number... Poplar 3-1777
News Service... AP
Transcription Service... Lang-Worth
Representative... Perry Associates
President... John H. Perry
General Manager... C. B. Kelly
Sta., Comm. Mgr., Pgm. Dir... Byron Hayford

W P C F

PANAMA CITY—1943—ABC-MBS

Frequency: 1400 Kc. Power: 250 Watts
Owned-Operated By... Bay County Bcstg. Co.
Trans-Address... 300 E. 15th St.
Phone Number... Sunset 5-6176

Transcription Service... Thesaurus
Representative... Devney, Dora-Clayton
Pres., Gen. Mgr... E. L. DuKate
Sta. Mgr., Prog. Dir... W. D. Lanier

W B S R

PENSACOLA—1946—CBS

Frequency: 1450 Kc. Power: 250 Watts
Owned-Oper. By... WBSR, Inc.
Business Address... WBSR Bldg.
Phone Number... 6173
News Service... AP
Transcription Service... World
Representative... Taylor
President... Patt McDonald
Sta., Gen. Mgr... Don J. Lynch
Commercial Manager... Bo Mitchell
Program Director... Tony Chastain
Chief Engineer... Glenn Nichols

W C O A

PENSACOLA—1926—NBC

Frequency: 1370 Kc. Power: 5000 Watts
Owned-Operated By... WCOA, Inc.
Business-Studio Address... 118 E.
Intendencia St.
Phone Number... 4111
Air Time... Full Time
Newspaper Affiliation... News-Journal
News Service... AP
Transcription Service... Lang-Worth
Representative... John H. Perry Associates
President... John H. Perry, Jr.
General Manager... J. Holliday Veal
Commercial Manager... Irving Welch
Program Director... Roland Wolf
Chief Engineer... Harold Heath

W E A R

PENSACOLA—1947—MBS-ABC

Frequency: 1230 Kc. Power: 250 Watts
Owned-Oper. By... Gulfport Bcstg. Co.
Address... 2nd & Hyer St.
Phone... 8-4449
Air Time... Full Time
News Service... AP
Membership... BAB
Pres., Gen., Sta. Mgr... Mel Wheeler
Pgm., Pub. Dir... Jerry Williams
Chief Engineer... Jim Smith

W P L A

PLANT CITY—1949

Frequency: 1570 Power: 250 Watts d.
Owned-Operated By... W. A. Smith
Address... P. O. Box 1588
Phone Number... 526
Air Time... Sunrise-Sunset
News Service... UP
Station Representative... Best
President... W. A. Smith
Gen., Sta., Comm. Mgr... George Friend
Program Director... Miss Frankie Blackwelder

Publicity Director.....Joseph J. Wilson
Chief Engineer.....James L. Derrick

WCNH
QUINCY—1948—MBS

Frequency: 1230 Kc.....Power: 250 Watts
Owned-Operated By.....Quincy Bcstg. Corp.
Business Address.....Quincy
Phone Number.....Main 7-6700
News Service.....UP
Transcription Service.....Thesaurus
Membership.....NARTB
Pres., Gen. Mgr.....A. B. Letson
Comm., Sta. Mgr.....Jerry Melvin
Program Director.....Dewey C. Newton
Chief Engineer.....A. B. Letson

WFOY

ST. AUGUSTINE—1936—CBS

Frequency: 1240 Kc.....Power: 250 Watts
Owned-Operated By.....Fountain of Youth
Broadcasting Co.
Address.....Magnolia Ave.
Phone Number.....1622
Air Time.....Full Time
News Service.....UP
Membership.....NARTB
President.....Mrs. Mary E. Bell
Gen., Sta. Mgr.....John E. Bernhard, Jr.
Prog., Pub. Dir.....Mrs. Frankie C. Walker
Chief Eng., Farm Editor.....Ernest Raistrick

WPIN

ST. PETERSEURG—1947

Frequency: 680 Kc.....Power: 1000 Watts
Owned-Oper. By.....Fla. W. Coast Bcstrs., Inc
Address.....Royal Palm Hotel
Phone Number.....Petersburg 7-0511;
Air Time.....Daytime
News Service.....AP
Station Representative.....Indie Sales
Membership.....BAB
President.....Dr. Charles Farrington
Gen., Comm. Mgr.....Arthur Mundorf
Station Manager.....Bob Clayton
Promotion Manager.....Marjorie Blank
Program Director.....James Carley
Publicity Director.....Bill Wright
Chief Engineer.....Manley St. Jean

WSUN

ST. PETERSBURG—1928—ABC

Frequency: 620 Kc.....Power: 5000 Watts
Owned-Operated By.....City of St. Petersburg
Business Address.....Recreation Pier
Phone Number.....7-4747-8
News Service.....UP
Transcription Service.....Associated
Representative.....Weed
General Manager.....George D. Robinson
Commercial Manager.....Vera New
Program Director.....Louis J. Link

WTSP

ST. PETERSBURG—1939—MBS

Frequency: 1380 Kc.....Power: 5000 Watts
Owned-Operated By.....Pinellas Bcstg. Co.
Business-Studio Address.....Box 691
Phone Number.....7-8108
News Service.....UP
Transcription Service.....Standard
Representative.....H-R
Membership.....NARTB, BAB
President.....Nelson Poynter
General Manager.....F. J. Kelly
Comm. Mgr.....L. L. Wildman
Prom., Prog. Dir.....Jack Faulkner
Chief Engineer.....William D. Mangold

WTRR

SANFORD—1947—KBS

Frequency: 1400 Kc.....Power: 250 Watts
Owned-Operated By.....Myron A. Reck
Business Address.....Box 1541
Phone Number.....999
Air Time.....Full Time
Representative.....Hil Best
News Service.....UP
Gen., Sta. Mgr.....Myron A. Reck
Commercial Manager.....Roy D. Green
Program Director.....J. Marion Harman, Sr.
Chief Engineer.....James S. Williamson, Jr.

WKXY

SARASOTA—1949—KBS

Frequency: 1540 Kc.....Power: 1000 Watts d.
Owned-Operated By.....Sarasota Bcstg. Co.
Business Address.....P. O. Box 2431
Phone Number.....Ringling 66651
Representative.....Hil Best
News Service.....AP
Transcription Service.....Lang-Worth, World
Pres., Gen. Mgr.....A. G. Fernandez

WSPB

SARASOTA—1939—CBS

Frequency: 1450 Kc.....Power: 250 Watts
Owned-Operated By.....WSPB, Inc.
Business Address.....City Island
Phone.....Ringling 8-1811
Air Time.....6:30 a.m.-12:05 a.m.
News Service.....UP
Transcription Service.....Thesaurus
Representative.....John E. Pearson
Membership.....NARTB, BAB
President.....Robert C. Jones, Jr.
General Manager.....John B. Browning
Commercial Manager.....J. M. Miller
Program Director.....David Hale
Chief Engineer.....James E. Grant

WJCM

SEBRING—1950—MBS-KBS

Frequency: 1340 Kc.....Power: 250 Watts
Owned-Operated By.....Clearfield Bcstrs., Inc.

Business Address.....P. O. Box 233
 Phone Number.....Sebring 81811
 Transcription Service.....Lang-Worth
 News Service.....UP
 President.....W. K. Ulerich
 Gen. Mgr.....William J. Thomas
 Sta., Comm. Mgr.....Al Frank
 Program Director.....Betty Frank
 Chief Engineer.....Robert Goshorn

WTAL

TALLAHASSEE—1935—CBS

Frequency: 1270 Kc.....Power: 5000 Watts
 Owned-Oper. By.....John H. Phipps Radio
 Stations
 Business Address.....Box 989
 Phone Number.....2-1270
 News Service.....AP
 Representatives.....Meeker, Cummings
 President.....John H. Phipps
 General Manager.....L. Herschel Graves
 Program Director.....Joe Hosford
 Chief Engineer.....W. A. Snowden, Jr.

WTNT

TALLAHASSEE—1946—ABC

Frequency: 1450 Kc.....Power: 250 Watts
 Owned-Oper. By.....Tallahassee Appli. Corp.
 Business-Studio Address.....Duval Hotel
 Phone Number.....2-1450
 News Service.....UP
 Transcription Service.....Thesaurus
 Representative.....Dora-Clayton
 Pres., Gen. Mgr.....Frank W. Hazleton
 Vice-President.....Emanuel Joanos
 Chief Engineer.....Charles Clifton

WALT

TAMPA—1946

Frequency: 1110 Kc.....Power: 1000 Watts d.
 Owned-Operated By.....W. Walter Tison tr/as
 Tampa Broadcasting Company
 Address.....401 W. Tyler St.
 Phone.....2-7921
 News Service.....AP
 Transcription Service.....Langworth
 Station Representative.....Pearson
 Membership.....NARTB
 Pres., Gen., Sta., Comm. Mgr. W. Walter Tison
 Program Dir.....C. W. Geer
 Chief Engineer.....J. B. Tison

WDAE

TAMPA—1922—CBS

Frequency: 1250 Kc.....Power: 5000 Watts
 Owned-Operated By.....Tampa Times Co.
 Business Address.....14 N. Franklin St.
 Phone Number.....2-2911
 Air Time.....Full Time
 News Service.....AP
 Transcription Service.....Associated
 Representative.....Katz
 President.....David E. Smiley
 Gen., Comm. Mgr.....L. Spencer Mitchell

Program Director.....Kenneth W. Skelton
 Chief Engineer.....William Pharr Moore

WEBK

TAMPA—1950

Frequency: 1590 Kc...Power: 1000 Watts d.
 Owned-Operated By.....Hillsboro Bcstg. Co.
 Address.....1521 E. Broadway
 Phone Number.....4-4177
 News Service.....INS
 Gen. Mgr., Chf. Engr.....Elmo B. Kitts
 Program Director.....Bob Chambers

WFLA

TAMPA—1925—NBC

Frequency: 970 Kc.....Power: 5000 Watts
 Owned-Operated By.....Tribune Co.
 Business Address.....P. O. Box 1410
 Phone Number.....2-4747
 Air Time.....6 a.m.-12:05 a.m.
 News Service.....UP
 Transcription Service.....Thesaurus
 Representative.....John Blair, Harry E. Cummings
 Membership.....NARTB
 President.....John C. Council
 Sta.-Gen. Mgr.....George W. Harvey
 Sales Prom. Mgr., Pub. Dir.....Tom Matthews
 Prog. Director.....Paul M. Jones
 Commercial Mgr.....Melvin E. Myer
 Chief Engineer.....Joseph Mitchell

*Serving the fast-growing
 Palm Beach County Area
 for 18 years . . .*

WJNO

"The Voice of the Palm Beaches"
 West Palm Beach, Florida

1230 Kc
 AFFILIATE OF THE
CBS RADIO NETWORK

National Representative
ROBERT MEEKER ASSOCIATES, INC.
 NEW YORK CITY CHICAGO

WHBO

TAMPA—1948

Frequency: 1050 Kc. Power: 250 Watts d.
 Owned-Operated By. . . Sulphur Springs Bcstrs.,
 Inc.
 Business Address. 11,011 Florida Ave.
 Phone Number 911711
 Air Time Daytime
 Membership BAB
 News Service AP
 Pres., Gen. Mgr. Harold A. Dunlap
 Sta., Comm. Mgr. Paul Hayes

WJNO

WEST PALM BEACH—1936—CBS

Frequency: 1230 Kc. Power: 250 Watts
 Owned-Operated By. WJNO, Inc.
 Business-Studio Address. Box 189
 Phone Number 2-3838
 Air Time Full Time
 News Service AP
 Transcription Service World
 Representative Robert Meeker
 Membership NARTB
 President. S. K. Russell
 Gen.-Sta. Mgr. H. V. McMillan
 Program Director. Vernon Crawford
 Chief Engineer. Warren Spencer

WIRK

WEST PALM BEACH—1947—MBS

Frequency: 1290 Kc. Power: 5000 d.;
 1000 n.
 Owned-Operated By. Ken-Sell, Inc.
 Business Address. 715 S. Flagler Drive
 Phone Number 2-1744
 Air Time Full Time
 News Service AP
 Transcription Service. Associated
 Representative Cooke
 Pres., Gen., Sta. Mgr. Joseph S. Field, Jr.
 Program Director. Rome Hartman
 Chief Engineer. William P. Heitzman

WSIR

WINTER HAVEN—1947—MBS

Frequency: 1490 Kc. Power: 250 Watts
 Owned-Oper. By. Citrus Belt Bcstrs., Inc.
 Business Address. P. O. Box 633
 Phone Number. 32-561
 Air Time. Full Time
 News Service UP
 Representative. Devney & Co.
 President. Frederick L. Allman
 Gen., Sta. Manager. Larry Rollins
 Commercial Manager. Earl Sturgeon
 Program Director. Richard Eyריך
 Chief Engineer. L. Orden Craig

GEORGIA

Pop. Feb. 1, 1954 (Est.) 3,890,000 — Families 963,000
 Radio Homes — 802,000 — TV Homes 392,500 — Stations in State 85

WALB

ALBANY—1941—MBS

Frequency: 1590 Kc. Power: 1000 Watts
 Owned-Operated By. . . Herald Publishing Co.
 Address. 138 Pine Ave.
 Phone Number. Hemlock 5-4511
 News Service UP
 Transcription Service. World
 Representative Burn-Smith
 Membership NARTB
 President. James H. Gray
 General Manager. Tom Stillwagon
 Program Director. Jack Mayer
 Publicity Director. Bill Bowick
 Chief Engineer. E. nest Gay

President. J. W. Woodruff
 Executive Manager. J. W. Woodruff, Jr.
 Sta., Comm., Sls., Prom., Pub. Dir. . . L. M. George
 Program Director. Walter H. Flint
 Chief Engineer. Asa Tift

WJAZ

ALBANY—1952

Frequency: 1050 Kc. Power: 250 Watts d.
 Owned-Oper. By. . . Southeastern Bcstg. System
 Representative Dora-Clayton
 News Service UP
 President. James S. Rivers
 General Manager. Richard B. Smith
 Sta., Comm. Mgr. R. V. Rogers

WGPC

ALBANY—1933—CBS

Frequency: 1450 Kc. Power: 250 Watts
 Owned-Operated By. Albany Bdcstg. Co.
 Business-Studio Address. New Albany Hotel
 Phone Number. Hemlock 21277
 Air Time Full Time
 News Service UP
 Representative. George P. Hollingbery
 Membership NARTB, BAB

WDEC

AMERICUS—1947—MBS-KBS

Frequency: 1280 Kc. Power: 250 Watts
 Owned-Operated By. . . The Americus Bdcstg. Co.
 Business-Studio Address. . . 109½ Windsor Ave.
 Phone Number. 3681-3682
 Air Time. 6 a.m.-M.
 News Service. AP
 Transcription Service World
 Representative. Dora-Clayton, Indie Sales



If you're looking for coverage which umbrella would you choose?

Measure dollars expended. Measure audience obtained. POWER is radio's *only* successful answer to the competition of television.

In Georgia, Atlanta's WSB is your clear channel 50,000-watt voice. This one *power* station gives you the major share of the Atlanta audience; it delivers for you a worthwhile audience in Georgia's secondary markets—and a tremendous number of listeners elsewhere.

No other Georgia station or combination of Georgia stations gives you as many listeners per dollar as you can get on WSB.

Clear channel *power* alone gives you this complete, low cost umbrella-type coverage.

Get more for your radio dollar in Georgia . . . *get on WSB*. One rate, day and night, 7 a.m. to 11 p.m., class B all other.

wsb

The Voice of the South

*Georgia's only 50,000 watt
clear channel station
Atlanta, Georgia*

MembershipNARTB
 Vice-Pres., Gen., Sta. Mgr....Charles C. Smith
 Chief Engineer.....John Rivard

WGAU

ATHENS—1938—CBS-KBS

Frequency: 1340 Kc.....Power: 250 Watts
 Owned-Operated By...J. K. Patrick & Company
 Business-Studio Address....Bobbin Mill Road
 Phone Number1741-2
 Newspaper AffiliationBanner-Herald
 Air Time.....Full Time
 News ServiceAP
 President.....C. A. Rowland, Sr.
 Gen., Sta. Mgr.....R. Lewis Doster
 Commercial Manager.....Burl Womack
 Program Dir.....Mary L Betts
 Chief Engineer.....Bill Evans

WRFC

ATHENS—1948

Frequency: 960 Kc.....Power: 1000 Watts d.;
 500 Watts n.
 Owned-Operated By.....Radio Athens, Inc.
 Business-Studio Add.....279½ N. Lumpkin St.
 Phone Number.....446-7
 Air Time.....Full Time
 News Service.....UP
 Transcription ServiceWorld
 MembershipBAB, NARTB
 Pres., Gen., Sta. Mgr.....L. H. Christian
 Comm., Sales Prom. Mgr...Charles A. McClure
 Program Director.....Mary Anne Martin
 Publicity Director.....Ed Thilenius
 Chief Engineer.....L. D. Drewry

WAGA

ATLANTA—1937—CBS

Frequency: 590 Kc.....Power: 5000 Watts
 Owned-Operated By.....Storer Bcstg. Co.
 Bus.-Studio Address....1018 W. Peachtree St.
 Phone Number.....Vernon 3553
 Air Time.....Full Time
 News ServiceAP
 Transcription ServiceThesaurus
 RepresentativeKatz
 MembershipNARTB, BAB
 President.....George B. Storer, Sr.
 General Manager.....G. C. Jackson
 Commercial Manager.....Claude H. Frazier
 Promotion Manager.....Charles E. Trainor
 Program Director.....Don Naylor
 Chief Engineer.....Hugo Bondy

WATL

ATLANTA—1931—MBS

Frequency: 1380 Kc.....Power: 5000 Watts
 Owned-Operated By.....Atlanta Bcstg. Co.
 Business Address.....201 Henry Grady Bldg.
 Phone Number.....Alpine 1515
 Air Time.....Full Time
 News ServiceUP
 RepresentativeWalker
 President.....J. W. Woodruff, Sr.
 General Manager.....G. C. Livingston Jr.

Comm. Mgr., Prog. Dir.....Lee Nance
 Chief Engineer.....G. C. Livingston, Jr.

WBGE

ATLANTA—1947

Frequency: 1340 Kc.....Power: 250 Watts
 Owned-Operated By.....General Bcstg. Co.
 Bus.-Studio Address....Georgian Terrace Hotel
 Phone Number.....Vernon 1194
 Air Time.....Full Time
 News ServiceAP
 MembershipBAB
 Pres., Comm. Mgr.....Robert N. Pinkerton
 Gen., Sta. Mgr.....H. W. Lanham
 Program Director.....R. O. Davidson
 Chief Engineer.....Howard J. Parrish

WERD

ATLANTA—1949

Frequency: 860 Kc.....Power: 1000 Watts d.
 Owned-Operated By.....Radio Atlanta, Inc.
 Business-Studio Add...274½ Auburn Ave., NE
 Phone Number.....Lamar 0666-7-8
 Representative.....Interstate, Dora-Clayton
 MembershipNARTB, BAB
 President.....J. B. Blayton, Sr.
 Gen. & Sta. Mgr.....J. B. Blayton, Jr.
 Commercial Mgr.....Albert H. Saddler
 Program Director.....R. H. Brisendine
 Chief Engineer.....William F. Kennedy

WGST

ATLANTA—1923—ABC

Frequency: 520 Kc.....Power: 5000 Watts d.;
 1000 n.
 Owned-Operated By....Board of Regents, Uni-
 versity System of Ga.
 Bus.-Studio Address.....900 Forsyth Bldg.
 Phone Number.....Walnut 8441
 Air Time.....Full Time
 News Service.....AP
 RepresentativeBlair
 General Manager.....Ben Ackerman
 Commercial Mgr.....Jim Hicks
 Program Director.....Jack Kelly
 Chief Engineer.....Ivan Miles

WSB

ATLANTA—1922—NBC

Frequency: 750 Kc.....Power: 50,000 Watts
 Owned-Oper. By....Atlanta Newspapers, Inc.
 Phone Number.....ELgin 6711
 Newspaper Affiliation...Journal, Constitution
 Air Time.....Full Time
 News ServiceAP
 Transcription Service...Associated, Standard
 RepresentativeEdward Petry
 MembershipNARTB, BAB
 Managing Director.....J. Leonard Reinsch
 General Manager.....John M. Outler, Jr.
 Station Manager.....Frank Gaither
 Sales Promotion Mgr.....Walter Paschall
 Program Director.....Elmo Ellis
 Publicity Director.....Wayne L. Anderson
 Chief Engineer.....C. F. Daugherty

WQXI

ATLANTA—1948—MBS

Frequency: 790 Kc. Power: 5000 Watts d.:
1000 Watts n.
Owned-Operated By: R. W. Rounsaville
Bus-Studio Address: 3165 Mathieson Dr., N.E.
Phone Number: Cherokee 2196
Air Time: Full Time
News Service: UP
Transcription Service: Standard
Station Representative: Hollingbery
Membership: NARTB
Owner: R. W. Rounsaville
Station Manager: John Fulton
Commercial Mgr.: Den Mitchell
Program Dir.: Bob Corley
Chief Engineer: Elton B. Chick
Technical Director: Paul Cram

WAUG

AUGUSTA—1951

Frequency: 1050 Kc. Power: 250 Watts d.
Owned-Operated By: Garden City Bcstg. Co.
Address: Bon Air Hotel
Phone Number: 3-4441
News Service: AP
General Manager: T. L. Morgan
Commercial Mgr.: Gordon Anderson
Chief Engineer: J. W. Faulkner

WBBQ

AUGUSTA—1946—MBS

Frequency: 1340 Kc. Power: 250 Watts
Owner: Savannah Valley Bdcstg. Co.
Address: 515 Jefferson Davis Avenue
Phone Number: 4-5441
Air Time: Full Time
News Service: AP
Representative: Walker, Dora Clayton
Membership: BAB
President: George G. Weiss
Gen., Sta., Comm. Mgr.: John W. Watkins
Prod., Prom. Mgr.: John G. Lyon
Program Director: Edward H. Dunbar
Chief Engineer: Marvin Tarpley

WGAC

AUGUSTA—1940—ABC

Frequency: 580 Kc. Power: 5000 Watts d.:
1000 Watts n.
Owned-Oper. By: The Twin States Bcstg. Co.
Business-Studio Address: P. O. Box 1131
Phone Number: 2-2692
Air Time: Full Time
News Service: UP
Transcription Service: Thesaurus
Representative: Avery-Knodel
Membership: NARTB, BAB
Pres., Gen. Mgr.: A. D. Willard, Jr.
Station Mgr.: Donald MacDonald
Commercial Mgr.: Martin E. White
Program Dir.: Warren Hiles
Chief Engineer: William Atkinson

THE ROUNSAVILLE CHAIN

Your key to some of the nation's most concentrated . . . most profitable markets! Backed by years of successful operation, they're your best bet for high profits on low-cost-per-thousand listeners!

3 TV STATIONS

Now Under Construction!

- WCIN-TV Cincinnati, Ohio
- WLOU-TV Louisville, Kentucky
- WQXI-TV Atlanta, Georgia

3 NETWORK STATIONS

- WQXI Mutual Atlanta, Georgia
- WBAC Mutual Cleveland, Tenn.
- WBEJ Mutual Elizabethton-Johnson City, Tennessee

3 NEGRO-PROGRAMMED STATIONS

- WCIN Cincinnati, Ohio
- WLOU Louisville, Kentucky
- WMBM Miami Beach, Florida

ROUNSAVILLE Radio Stations
Peachtree at Mathieson Dr., Atlanta, Ga.

National Reps.: Gen. P. Hollingbery (WQXI)
National Reps.: Forjoe and Company (WCIN - WLOU - WMBM)
Southeastern: Dora-Clayton Agency (All Stations)

W J B F

AUGUSTA—1945—NBC

Frequency: 1230 Kc.....Power: 250 Watts
 Owned-Oper. By...Georgia-Carolina Bcstg. Co.
 AddressWJBF B'dg.
 Phone Number.....4-2421
 Air Time.....Full Time
 News Service.....UP
 RepresentativeHollingbery
 MembershipNARTB, BAB
 Pres., Gen. Mgr.....J. B. Fuqua
 Station Mgr.....D. M. Kelly, Jr.
 Comm., Sales Prom. Mgr....Steve Manderson

WRDW

AUGUSTA—1930—CBS

Frequency: 1480 Kc.....Power: 5000 Watts
 Owned-Operated By.....Radio Augusta, Inc.
 Business-Studio Address...Eighth & Broad S's.
 Phone Number2-8805
 News ServiceAP
 Transcription ServiceWorld
 RepresentativeHeadley-Reed
 MembershipBAB, NARTB
 President.....Grover C. Maxwell
 General, Sta. Mgr.....W. R. Ringson
 Sales Manager.....M. C. Gregory
 Program Director.....Richard Warner
 Chief Engineer.....Rabun F. Bobo

WMGR

BAINBRIDGE—1946—MBS-KBS

Frequency: 1490 Kc.....Power: 250 Watts
 Owned-Operated By.....Decatur Bcstg. Co.
 AddressBox 375
 Phone Number777
 Representative.....Southern Radio Sales
 Transcription ServiceWorld
 General Manager.....Thomas R. Hanssen
 Commercial Mgr.....Charles W. Dowdy
 Program Director.....Joe Hill
 Chief Engineer.....Thomas R. Hanssen

WGIG

BRUNSWICK—1949—ABC

Frequency: 1440 Kc.....Power: 1,000 Watts
 Owned-Operated By...Brunswick Bcstg. Corp.
 Business-Studio Address.....1514 Union St.
 Phone Number2714
 News ServiceAP
 RepresentativeMcGillvra
 General Manager.....Hugh K. Tollison
 Commercial Manager.....John Lane
 Program Director.....John Harmon
 Promotion Director.....Marvin Massay
 Chief Engineer.....Herman Lange

WMOG

BRUNSWICK—1940—MBS-KBS

Frequency: 1490 Kc.....Power: 250 Watts
 Owned-Oper. By.....Radio Brunswick Inc.
 Address.....St. Simons Causeway

Phone Number.....1500
 RepresentativeDora-Clayton
 President.....Allen M. Woodall
 General Manager.....Albert H. Haack Jr.
 Commercial Mgr.....Ben R. Willis
 Program Director.....Lew Carter
 Chief Engineer.....Cecil Tankersly

WGRA

CAIRO—1950—ABC-KBS-GALS

Frequency: 790 Kc....Power: 1000 Watts d.
 Owned-Oper. By...Grady Mitchell Bcstg. Co.
 AddressBainbridge Rd.
 Phone Number2-4392
 Transcription ServiceStandard
 News ServiceUP
 PresidentEd Stevens
 General Manager.....Jim Honey
 Program Director.....Sara Crew
 Chief Engineer.....Gregg Strang

WCGA

CALHOUN—1953

Frequency: 900 Kw.....Power: 1000 Watts d.
 Owned-Oper. By.....Gordon Cty. Bcstg. Co.
 Address.....Box 312, West Point, Ga.

WLBB

CARROLLTON—1947—KBS

Frequency: 1100 Kc.....Power: 250 Watts d.
 Owned-Oper. By.....Carroll Bcstg. Co., Inc.
 Business-Studio Address.....P. O. Box 569
 Phone Number980
 Transcription ServiceWorld
 MembershipNARTB
 Pres., Gen., Sta. Mgr.....Thomas K. Vassy
 Comm. Sales Prom. Mgr.....J. D. Norton Jr.
 Program Director.....Chuck Angley
 Chief Engineer.....Chessley Hooper

WBHF

CARTERSVILLE—1946—MBS-KBS

Frequency: 1450 Kc.....Power: 250 Watts
 Owned-Operated By.....W. R. Frier
 Phone Number1200
 News ServiceUP
 Transcription ServiceThesaurus
 Station Manager.....W. Ryan Frier
 Program Director.....Martha Sullins
 Chief Engineer.....H. E. Bridges

WGAA

CEDARTOWN—1941—ABC

Frequency: 1340 Kc.....Power: 250 Watts
 Owned-Operated By.....Timm Inc.
 Business-Studio Address.....P. O. Box 807
 Phone Number.....Cedartown 777
 News ServiceAP
 Representative.....Southern Radio Prod.
 General Manager.....John R. Barlett
 Chief Engineer.....James E. Schleistett

W D A K
COLUMBUS—1943—NBC

Frequency: 1340 Kc. Power: 250 Watts
Owned-Operated By Radio Columbus, Inc.
Business-Studio Address Martin Bldg.
Phone Number 5447
Air Time Full Time
News Service AP
Transcription Service World
Station Representative Headley Reed
Membership NARTB, BAB
President Allen M. Woodall
Sta., Sales Prom. Mgr. Miles H. Ferguson
Commercial Manager William Massie
Program Director Joe Byars
Chief Engineer Max F. Harper

W G B A
COLUMBUS—1947

Frequency: 1270 Kc. Power: 1000 Watts d.
Owned-Oper. By Christian and McClure
Business-Studio Address 1213 1/2 Broadway
Phone Number 3-3603
Air Time Day Time
News Service UP, AP
Transcription Service Standard
Representative J. S. Ayers
Membership BAB
President L. H. Christian
Gen., Sta. Mgr. C. M. McClure

Sales Prom. Mgr. Ralph Burgess
Program Director Rhett Turnipseed
Publicity Director Carmen Neill
Chief Engineer F. Keith Brown

W R B L
COLUMBUS—1928—CBS

Frequency: 1420 Kc. Power: 5000 Watts
Owned-Operated By Columbus Bdcstg. Co.
Business-Studio Address 1350 - 13th St.
Phone Number 2-0601
Air Time Full Time
News Service INS, UP
Transcription Service Associated
Pres., Gen. Mgr. J. W. Woodruff Jr.
Commercial Mgr. Walter Graham
Program Director Bill Gramer
Chief Engineer Noel Moore

W M J M
CORDELE—1940—MBS

Frequency: 1490 Kc. Power: 250 Watts
Owned-Oper. By Southeastern Bcstg. System
Business-Studio Address 20th Ave. & B St.
Phone Number 666
News Service UP
President James S. Rivers
General Mgr. William E. Blizzard, Jr.
Sales Prom. Manager O. Grady Cooper
Program Director Clark Standard
Chief Engineer Freddie Albert

AM
5000 WATTS



FM
48000 WATTS

WRBL

COLUMBUS, GEORGIA

1ST STATION IN GEORGIA'S
2ND MARKET!

Call Hollingbery

WCON

CORNELIA—1953—ABC

Frequency: 1450 Kw. Power: 250 Watts
 Owned-Oper. By: Habersham Bcstg. Co.
 Address: 1 Burrell St.
 Phone Number: 1450
 News Service: AP
 General Manager: Jack Bradley
 Commercial Mgr.: Bob Kilgore
 Program Director: Hoyt Dillard
 Promotion Mgr.: S. Y. Sosbee
 Chief Engineer: Warren G. Gilpin

WMOC

COVINGTON—1946

Frequency: 1430 Kw. Power: 1000 Watts d.
 Owned-Oper. By: Georgia Bcstg. Svc. Inc.
 Phone Number: 2275
 News Service: UP
 Transcription Service: World, SESAC
 President: George Mooney
 General Manager: Wm. P. Williams
 Commercial Mgr.: Derel Morris
 Program Director: Lew Banks
 Chief Engineer: Russell Caldwell

WBLJ

DALTON—1940—MBS-KEYSTONE

Frequency: 1230 Kc. Power: 250 Watts
 Owned-Operated By: Dalton Bdcstg. Corp.
 Business-Studio Address: 111 South Pentz St.
 Phone Number: 1180
 Air Time: 6 a.m.-11:15 p.m.
 News Service: AP
 Transcription Service: Thesaurus
 Membership: NARTB, BAB
 President: H. C. Kenemer
 General Manager: William B. Davies
 Commercial Manager: Olin H. Kenemer
 Chief Engineer: John S. Andrews

WDWD

DAWSON—1948—ABC-KBS

Frequency: 990 Kc. Power: 1000 Watts D.
 Owned-Operated By: Dawson Bdcstg. Co.
 Trans.-Bus.-Studio Address: Parrott Road
 Phone Number: 416
 News Service: UP
 Representative: Indie Sales
 President: Ed Stevens
 General Manager: W. C. Woodall, Jr.
 Program Director: O. W. Parnacott
 Chief Engineer: Joe Stephens

WEAS

DECATUR—1947

Frequency: 1010 Kc. Power: 10,000 Watts d.
 Owned-Oper. By: WEAS, Inc.
 Address: 217 W. Ponce de Leon Ave.
 Phone Number: Dearborn 2521
 News Service: INS
 Representative: Stars National, Inc.

Membership: BAB
 Chairman of Board: E. D. Rivers, Jr.
 President: W. H. Keller, Jr.
 Station Director: Warren Roberts
 Commercial Mgr.: Joe Robkin
 Publicity Director: Imogene Jones
 Program Director: Ned Lukens
 Chief Engineer: Les Gradick

WGLS

DECATUR—1949—KEYSTONE

Frequency: 970 Kc. Power: 1000 Watts d.
 Owned-Oper. By: DeKalb Bcstg. Co.
 Business-Studio Address: 526 Church St.
 Phone Number: Crescent 6471
 Newspaper Affiliation: "New Era"
 News Service: UP
 Transcription Service: Standard
 Representative: Rambeau
 President: Guy W. Rutland, Sr.
 Gen., Sta. Mgr.: Sam W. Kane
 Comm. Sales Prom. Mgr.: Al Ciraldo
 Chief Engineer: Lawrson Leake

WDMG

DOUGLAS—1947

Frequency: 860 Kc. Power 1000 Watts D.
 Owned-Operated By: WDMG, Inc.
 Business-Studio Address: Box 590
 Phone Number: 584
 Air Time: Sunrise-sunset
 News Service: UP
 Transcription Service: World
 Representative: Dora-Clayton
 President: B. F. J. Timm
 General Mgr.: Mary Jarrard
 News Director: Edw. Lund
 Chief Engr., Prog. Dir.: S. H. Strickland

WMLT

DUBLIN—1945—MBS-KBS

Frequency: 1340 Kc. Power: 250 Watts
 Owned-Operated By: Dublin Bdcstg. Co.
 Business Address: Dublin
 Phone Number: 871
 News Service: AP
 Transcription Service: World
 Membership: BAB
 President: George T. Morris
 General Manager: W. Newton Morris
 Commercial Mgr.: Sarah Orr Williams
 Sales Prom. Mgr.: W. C. Courson
 Program Director: George Tellmann
 Chief Engineer: Lawrence L. Henry

WTJH

EAST POINT—1949—KBS

Frequency: 1260 Kc. Power: 5000 Watts d.
 Owned-Oper. By: J. S. & D. R. Rivers
 Address: Dodson Drive
 Phone Number: Franklin 1473
 News Service: UP
 President: James S. Rivers
 Gen. Mgr., Chief Engr.: Wm. B. Hill

W S G C

ELBERTON—1946

Frequency: 1400 Kc. Power: 250 Watts
 Owned-Oper. By Elberton Bcstg. Co.
 Address Elberton
 Manager Melvin C. Gorman

W B H B

FITZGERALD—1946—MBS-KBS

Frequency: 1240 Kc. Power: 250 Watts
 Owned-Operated By Ben Hill Bdcstg. Corp.
 Address 601 Roanoke Dr.
 Phone Number 2077-8
 Air Time Full Time
 News Service AP
 Transcription Service World
 Representative Evans
 President Otto Oriner
 Gen., Sta., Comm. Mgr. Al H. Evans
 Program Director Duphine Newsome
 Chief Engineer Ed Durham

W F P M

FORT VALLEY—1951—KBS

Frequency: 1150 Kc. Power: 1000 Watts d.
 Owned-Operated By Peach Belt Bcstg. Co.
 Phone Number 84
 News Service UP
 Representative Indie Sales
 President Ed Stevens
 General Manager Hugh Birdsong
 Commercial Manager Kenneth Flynn
 Program Director Lee Mathis

W D U N

GAINESVILLE—1949—ABC

Frequency: 1240 Kc. Power: 250 Watts
 Owned-Operated By Northeast Ga. Bdcstg. Co.
 Business-Studio Address 217½ S. Main St.
 Phone Number Lenor 4-7331
 Air Time Full Time
 News Service AP
 Transcription Service World
 Representative Indie Sales
 Membership BAB
 Pres., Gen. Manager John W. Jacobs, Jr.
 Station Manager J. A. Hartley
 Commercial Manager Doris Smith
 Program Director Julius Still
 Chief Engineer Les Brooks

W G G A

GAINESVILLE—1941—MBS-KBS

Frequency: 550 Kc. Power: 5000 Watts d.;
 500 Watts n.
 Owned-Operated By Blue Ridge Bdcstg. Co.
 Business Address Press-Radio Center
 Phone Number LE 2-6211
 Air Time Full Time
 News Service UP
 Representative Dora Clayton Agency
 President Charles A. Smithgall

General Manager Robert O. Horan
 Commercial Manager Robert Schwab
 Program Director Billy Kinsey
 Production Mgr. Eric Bruton
 Chief Engineer F. Keith Brown

W K E U

GRIFFIN—1933—MBS-KBS

Frequency: 1450 Kc. Power: 250 Watts
 Owned-Oper. By Radio Station WKEU
 Address P. O. Box 155
 Phone Number 5507
 Air Time Full Time
 News Service AP
 Transcription Service Lang-Worth
 President, General Mgr. A. W. Marshall, Jr.
 Chief Engineer W. F. Westmoreland

W R H T

GRIFFIN—1952

Frequency: 1320 Kw. Power: 1000 Watts d.
 Owned-Oper. By Griffin Bcstg. System
 Address Cherokee Rd.
 Phone Number 9451
 News Service UP
 Transcription Service World
 Representative Dora-Clayton
 Owner, Gen. Mgr. R. H. Thompson, Sr.
 Station Manager James Watson
 Commercial Mgr. Johnny Williams
 Program Director R. H. Thompson, Jr.
 Chief Engineer Charles Player

W K L Y

HARTWELL—1947

Frequency: 980 Kc. Power: 1000 Watts d.
 Owned-Operated By Louie L. Morris
 Business Address Box 189, Hartwell
 Phone Number 71
 News Service UP
 Transcription Service Capitol, World
 President Louie L. Morris
 Exec. Vice-Pres. Max G. Pfander
 Chief Engineer Eugene Holden

W C E H

HAWKINSVILLE—1952—KBS

Frequency: 610 Kw. Power: 500 Watts d.
 Owned-Oper. By Tri-County Bcstg. Co.
 Address Box 184
 Phone Number 498
 President R. T. Ragan
 Vice-President Henry Griffin
 General Manager Paul E. Reid
 Program Director James Popwell
 Chief Engineer Mike Pelton

W B G R

JESSUP—1949—KBS

Frequency: 1370 Kc. Power: 1000 Watts d.
 Owned-Operated By Altamaha Bcstg. Co.
 Address P. O. Box 147
 Phone Number 2444

Air Time.....Day Time
 News Service.....UP
 Transcription Service.....Capitol
 Representative.....Dora-Clayton
 Pres., Gen. Mgr.....W. G. Thomas, Sr.
 Sta., Comm. Mgr.....Dennis N. Brown
 Pgm., Prom. Dir.....T. N. Oglesby
 Publicity Director.....Elwood Harper
 Chief Engineer.....Arthur L. Manning

W L A G

LA GRANGE—1941—MBS-KBS

Frequency: 1240 Kc.....Power: 250 Watts
 Owned-Operated By.....LaGrange Bdcstg. Co.
 Business-Studio Address.....305-307 Broome St.
 Phone Number.....2-3505
 Newspaper Affiliation....."Daily News"
 Air Time.....6 am.-M.
 News Service.....UP
 Transcription Service.....World, Associated
 Representative.....Indie Sales, Dora-Clayton
 President.....Roy C. Swank
 General-Station-Commercial
 Manager.....Edwin Mullinax
 Sales Promotion Mgr.....Patricia Smith
 Program Director.....John Bogges
 Publicity Director.....Linda McKee
 Chief Engineer.....James McKay

W T R P

LaGRANGE—1953

Frequency: 620 Kw.....Power: 500 Watts d.
 Owned-Oper. By.....Chattahooche Bcstg. Co.,
 Ltd.
 Address.....Hammett Bldg.
 News Service.....AP
 Transcription Service.....Thesaurus
 Partner, Gen. Mgr.....Byron H. Hurst
 Partner.....Ralph C. Freeman
 Partner.....Cecil Crew
 Commercial Mgr. Prog. Dir.....Jim Martin
 Chief Engineer.....Ray Relihan

W B M L

MACON—1940—NBC

Frequency: 1240 Kc.....Power: 250 Watts
 Owned-Operated By.....Middle Georgia Bdcstg.
 Co.
 Business-Studio Address.....230 Second St.
 Phone Number.....3-5454
 Air Time.....Full Time
 News Service.....AP
 Transcription Service.....World
 Representative.....Headley-Reed
 Membership.....NARTB, BAB
 President.....Allen M. Woodall
 General Manager.....E. F. MacLeod
 Commercial Mgr.....George W. Patton
 Traffic Manager.....Bernice Johnson
 Chief Engineer.....James M. Wilder

W I B B

MACON—1948

Frequency: 1280 Kc.....Power: 1000 Watts d.

Owned-Oper. By...Peach State Bcstg. Co., Inc.
 Business-Studio Address...Professional Bldg.
 Phone Number.....2-2505
 Air Time.....Daytime
 News Service.....AP
 Representative.....Walker, Dora-Clayton
 Membership.....NARTB
 Pres., Gen. Mgr.....Thomas H. Maxwell
 Commercial Manager.....Donald C. Frost
 Program Director.....Gordon Price

W M A Z

MACON—1922—CBS

Frequency: 940 Kc.....Power: 10,000 Watts
 Owned-Oper. By.....Southeastern Bcstg. Co.
 Address.....Bankers Insurance Bldg.
 Phone Number.....2-7373
 Air Time.....Full Time
 News Service.....UP
 Transcription Service.....Lang-Worth
 Representative.....Katz
 Pres., Chief Engineer.....George P. Rankin
 General Manager.....Wilton E. Cobb
 Commercial Mgr.....Frank Crowther
 Publicity Director.....Ed Pendleton
 Chief Engineer.....George P. Rankin

W N E X

MACON—1945—MBS-ABC

Frequency: 1400 Kc.....Power: 250 Watts
 Owned-Operated By.....Macon Bcstg. Co.
 Business-Studio Address.....Bibb Bldg.
 Phone Number.....5-3301
 News Service.....AP
 Transcription Service.....Thesaurus
 Representative.....Branham
 President.....Ed Lowe
 General Manager.....Alfred Lowe
 Business Manager.....Emory G. Stroberg
 Commercial Manager.....Marion Bragg
 Program Director.....Mrs. Billie Edwards
 Chief Engineer.....Emanuel Farber

W F O M

MARIETTA—1946

Frequency: 1230 Kc.....Power: 250 Watts
 Owned-Oper. By.....F. Wilson & A. Jones
 Address.....P. O. Box 131
 Phone Number.....8-3396
 News Service.....UP
 Transcription Service.....Thesaurus
 General Manager.....Albert L. Jones
 Prog. Dir., Chief Engr.....Chuck Strauss

W M V G

MILLEDGEVILLE—1946—MBS-KBS

Frequency: 1450 Kc.....Power: 250 Watts
 Owned-Operated By.....Jere N. Moore
 Business-Studio Address.....Milledgeville, Ga.
 Phone Number.....250
 Newspaper Affiliation....."Union Recorder"
 Air Time.....Full Time
 Transcription Service.....Langworth
 Representative.....Hazel Griffith
 Membership.....NARTB
 General Manager.....Michael T. Landy

Program Director Josephine Ragsdale
 Chief Engineer Robbie O. Hattaway

W M G A

MOULTRIE—1939—ABC-KBS

Frequency: 1400 Kc. Power: 250 Watts
 Owned-Operated By John F. Pidcock
 Business-Studio Address Box 310
 Phone Number 999
 Air Time Full Time
 News Service UP
 Representative Everett-McKinney, Ayres
 Owner, Gen. Mgr. John F. Pidcock
 Station, Comm. Mgr. Roy F. Zess
 Pgm., Publ. Dir. Robert Lenihan
 Chief Engineer Homer Sloan

W C O H

NEWMAN—1947—MBS

Frequency: 1400 Kc. Power: 250 Watts
 Owned-Operated By Newman Bcstg. Co.
 Bus.-Studio Address P. O. Box 581
 Phone Number 1400
 News Service AP
 Transcription Service Thesaurus
 Representative Richard N. Hunter
 Pres., Gen., Sta., Comm. Mgr. J. O. Hardin, Jr.
 Chief Engineer William E. Davis, Jr.

W L A Q

ROME—1947—ABC

Frequency: 1410 Kc. Power: 1000 Watts
 Owned-Operated By News Publishing Co.

Address 209 Broad St.
 Phone Number 7767
 Newspaper Affiliation "News Tribune"
 News Service AP, INS, UP
 Transcription Service World
 Membership BAB, NARTB
 President Mrs. B. H. Mooney, Sr.
 General Manager J. F. Mann
 Station Manager Lee Mowry
 Commercial Manager Martha Daniel
 Program Director Elizabeth Hardin
 Chief Engineer Dan Scott

W R G A

ROME—1929—MBS-WGN

Frequency: 1470 Kc. Power: 5000 Watts
 Owned-Operated By Rome Bcstg. Corp.
 Bus.-Studio Address 501 Broad St.
 Phone Number 2-2411
 Air Time Full Time
 News Service UP
 Transcription Service Lang-Worth
 Representative Walker, Dora-Clayton
 Pres. and Gen. Mgr. Mather Payne
 Secretary-treasurer Charles Smithgall
 Commercial Manager L. B. Talley
 Sales Prom. Mgr. Clarence Salmon
 Program Director Jim Roberts
 Chief Engineer R. A. Starr

W R O M

ROME—1946

Frequency: 710 Kc. Power: 1000 Watts d.

**THOSE WHO KNOW
 FAMOUS BRANDS**

Says George W. Patton, Commercial Manager, WBML, Macon, Ga.: "Sales obstacles are lessened when you offer **AP** news. Ideas and quality seem to make a powerful sales combination."

**. . . . KNOW THE MOST FAMOUS
 BRAND IN NEWS IS AP**

Owned-Oper. By.....Coosa Valley Radio Co.
 Business-Studio Address.....121½ Broad St.
 Phone Number.....2-0833
 Air Time.....Sunrise-sunset
 News Service.....AP
 Representative.....Southern
 President.....Dean Covington
 Gen. Mgr.....Edward N. McKay
 Program Director.....Charlie Doss
 Chief Engineer.....Thomas Robertson

WCCP

SAVANNAH—1946—MBS

Frequency: 1450 Kc.....Power: 250 Watts
 Owned-Operated by.....Dixie Bcstg. Co.
 Business-Studio Address.....P. O. Box 943
 Phone Number.....2-4182
 Air Time.....Full Time
 News Service.....UP
 Representative.....Walker
 Membership.....NARTB
 Pres., Gen. Mgr.....Carter C. Peterson
 Sta., Comm. Mgr.....Weldon Herrin
 Program Director.....Charles Beresford
 Publicity Director.....Jesse Mooney
 Chief Engineer.....William Moats

WDAR

SAVANNAH—1946

Frequency: 1400 Kc.....Power: 250 Watts
 Owned-Operated By.....WDAR, Inc.
 Business-Studio Address.....34 E. Bryan St.
 Phone Number.....3-8807
 Air Time.....Full Time
 News Service.....AP
 Transcription Service.....World
 Representative.....Pearson
 Membership.....NARTB-BAB
 Pres., Gen. Mgr.....H. Blair Minick
 Commercial Manager.....Bill Miller
 Program Director.....Ray G. Clark
 Chief Engineer.....Joseph Testo

WFRP

SAVANNAH—1946—ABC

Frequency: 1230 Kc.....Power: 250 Watts
 Owned-Operated By.....Georgia Bcstg. Co.
 Business-Studio Address.....219 E. Charlton St.
 Phone Number.....3-9642
 Air Time.....6 a.m.-M.
 News Service.....AP
 Representative.....McKinney-Ayres
 Pres., Gen. Sta. Mgr., Pgm. Dir., John F. Pidcock
 Comm., Sls. Prom., Pub. Mgr., John Williams
 Chief Engineer.....B. M. McKnight

WJIV

SAVANNAH—1950

Frequency: 900 Kc.....Power: 1000 Watts d.
 Owned-Oper. By.....WJIV, Inc.
 Bus. Address.....128 W. Taylor St.
 Phone.....4-7264
 News Service.....AP
 Representative.....Stars' Nail.

President.....W. H. Keller, Jr.
 Commercial Manager.....Abe Eisenman
 General Manager.....J. L. Woods
 Sls. Prom. Mgr.....Frank Freeman
 Chief Engineer.....Heyward Tuten

WSAV

SAVANNAH—1939—NBC

Frequency: 630 Kc.....Power: 5000 Watts
 Owned-Operated By.....WSAV, Inc.
 Bus-Studio Address.....Liberty Natl. Bank Bldg.
 Phone Number.....3-0234
 Air Time.....Full Time
 News Service.....AP
 Transcription Service.....Thesaurus
 Representative.....Blair
 Pres., Gen. Sta. Mgr.....Harben Daniel
 Comm., Sales Prom. Mgr.....Don Jones
 Program Director.....Duane A. Hatch
 Publicity Director.....Susan Perry
 Chief Engineer.....M. E. Thompson

WTOC

SAVANNAH—1929—CBS

Frequency: 1290 Kc.....Power: 5000 Watts
 Owned-Operated By.....Savannah Bcstg. Co.
 Business-Studio Address.....516 Abercorn St.
 Phone Number.....2-0127
 Air Time.....Full Time
 News Service.....UP
 Transcription Service.....Lang-Worth
 Representative.....Katz
 Membership.....NARTB
 Pres., Gen. Mgr.....William T. Knight, Jr.
 Commercial Manager.....Ben Williams
 Program Director.....Dwight J. Bruce
 Publicity Director.....Courtenay Knight
 Chief Engineer.....Kyle E. Goodman

WWNS

STATESBORO—1947—MBS-KBS

Frequency: 1490 Kc.....Power: 250 Watts
 Owned-Operated By.....Statesboro Bcstg. System
 P. O. Box 146
 Phone Number.....502
 Air Time.....Full Time
 News Service.....UP
 Transcription Service.....World
 Pres., Gen. Mgr.....R. H. Thompson
 Sta., Comm. Mgr.....Edwin Bass
 Program Director.....Shirley Dyer

WGTA

SUMMERVILLE—1950

Frequency: 950 Kc.....Power: 1000 Watts d.
 Owned-Oper. By.....Tri-State Bcstg. Co.
 Address.....Box 213
 Phone Number.....295
 News Service.....UP
 Transcription Service.....Capitol
 President.....E. C. Pesterfield
 General Manager.....William B. Farrar
 Program Director.....Laurence Keown
 Chief Engineer.....Charles M. Lowry, Jr.

WJAT
SWAINSBORO—1950

Frequency: 800 Kc. Power: 1000 Watts d.
Owned-Oper. By Jack & Nancy M. Thompson
Address P. O. Box 371
Phone Number 2011
Transcription Service Langworth, Capitol,
World
News Service UP
Membership NARTB
General Manager Jack A. Thompson
Sta. Mgr., Chief Engr. John H. (Jack) Wiseley
Program Director Doris Lewis

WSFT
THOMASTON—1947—MBS-KBS

Frequency: 1220 Kc. Power: 250 Watts d.
Owned-Oper. By Thomaston Bcstg. Co.
Business-Studio Address P. O. Box 689
Phone Number 2187
Newspaper Affiliation "Times" and
"Free Press"
Air Time Daytime
Transcription Service World
News Service AP
Membership BAB, NARTB
President J. B. Hardy
Gen., Sta. Mgr. S. J. Carswell
Comm., Sales Prom. Mgr. C. D. Thames
Program Director Bill Heule

WKTG
THOMASVILLE—1947

Frequency: 730 Kc. Power: 1000 Watts d.
Owned-Oper. By Southern Bcstg. System, Inc.
Address Bank of Thomas County Bldg.
Phone Number 1501
News Service AP
Air Time Daytime
Transcription Service World, Thesaurus
Representative Clark, Dora-Clayton
Pres., Gen. Mgr. W. F. Scott, Jr.
Sta., Comm. Manager L. T. Porter
Program Director Roger Mansfield
Chief Engineer Bruce E. Singleton

WPAX
THOMASVILLE—1934

Frequency: 1240 Kc. Power: 250 Watts
Owned-Operated By H. Wimpy
Business-Studio Address 117 Remington Ave
Phone Number 909
News Service UP
Transcription Service Capitol
Owner, Gen. Mgr. H. Wimpy
Commercial Manager Al Feinberg
Chief Engineer James Poole

WTWA
THOMSON—1947—MBS-KBS

Frequency: 1240 Kc. Power: 250 Watts
Owned-Oper. By Hickory Hill Bcstg. Co., Inc.
Business Address 127 Journal St.

Phone Number 777
Air Time Full Time
News Service UP
Transcription Service World
Representative Southern Radio
Membership NARTB, BAB
President Edgar H. Kobak
General Manager Frank F. Hash
Commercial Mgr. Richard J. Roche
Chief Engineer W. P. Dickson

WWGS
TIFTON—1947—MBS

Frequency: 1340 Kc. Power: 250 Watts
Owned-Oper. By Tifton Bcstg. Corp.
Address Box 34
Phone Number 921
Air Time Full Time
News Service UP
Transcription Service World
Representative Thomas F. Clark
President W. A. Graham
Gen., Comm. Mgr. Carl Wendell
Program Director William Crutchley
Chief Engineer Frank Proctor

WLET
TOCCOA—1941—MBS-KBS

Frequency: 1420 Kc. Power: 5000 Watts d.
Owned-Oper. By R. G. LeTourneau
Address 423 Prather Bridge Rd.
Phone Number 544
Air Time Day Time
News Service UP
Transcription Service Thesaurus
Representative Thomas F. Clark
Membership NARTB
President R. G. LeTourneau
Sta. Mgr., Prog. Dir. Virgle E. Craig
Comm., Sls. Prom. Mgr. Roy Gaines
Prog., Publ. Dir. Charles H. Gaines
Chief Engineer C. H. Sutton

WGAF
VALDOSTA—1951—ABC

Frequency: 910 Kc. Power: 5000 Watts
Owned-Operated By Valdosta Bcstg. Co.
Address 116 W. Hill Ave.
Phone Number 910
News Service AP
Transcription Service Thesaurus
Representative John E. Pearson, Dora-Clayton
Membership NARTB
Pres., Gen. Mgr. George B. Cook
Program Director Willard Belote
Publicity Director Mary V. McDonald
Chief Engineer E. W. Greene

WGOV
VALDOSTA—1940—MBS

Frequency: 950 Kc. Power: 5000 Watts d.;
1000 Watts n.
Owned-Operated By WGOV, Inc.
Address Daniel Ashby Hotel
Phone Number 1420

Air Time.....6 a.m.-12 M.
News Service**UP**
 Chairman of Board.....Ed Rivers
 President.....Wm. H. Keller, Jr.
 General Mgr.....A. B. Smith
 Program Director.....Vince Randolph
 Chief Engineer.....Lester Q. Hall

WVOP

VIDALIA—1946—MBS

Frequency: 970 Kc.....Power: 1000 Watts
 Owned-Operated By.....Vidalia Bcstg. Co.
 Address.....Highway 280
 Phone Number.....3029
 Air Time.....Daytime
News Service**UP**
 Transcription Service.....Cole
 Membership.....NARTB, BAB
 Pres., Gen. Mgr.....Howard C. Gilreath
 Program Director.....Ruby Bryant
 Publicity Director.....R. E. Ledford
 Chief Engineer.....Loren Dorough

WACL

WAYCROSS—1951

Frequency: 570 Kc.....Power: 1000 Watts d.
 Owned-Operated By.....Teletronics Inc.
 Address.....Memorial Drive
 Phone Number.....3068
News Service**AP**
 Transcription Service.....Lang-Worth
 Membership.....BAB
 President.....James S. Rivers
 General Manager.....L. H. Thesmar
 Station Manager.....Robert C. Lay
 Chief Engineer.....Lloyd E. McKinney

WAYX

WAYCROSS—1936—MBS-KBS-GALS

Frequency: 1230 Kc.....Power: 250 Watts
 Owned-Operated By.....Jack Williams
 Business-Studio Address...1600 Carswell Ave.
 Phone Number.....965
 Air Time.....6:30 a.m.-M.
News Service**UP**
 Transcription Service.....World, Capitol
 Representative.....Hal Holman
 President.....Jack Williams
 Commercial Mgr.....John J. Tobola
 Chief Engineer.....Curtis Frazier

WBRO

WAYNESBORO—1953

Frequency: 1310 Kc.....Power: 1000 Watts d.
 Owned-Oper. By...Burke County Broadcasting
 Co.
 Address.....Highway 56, McBean Road
 Phone Number.....3373
 Air Time.....Daytime
News Service.....**INS**
 President.....R. F. Chaiker
 General Manager.....Jim Martin
 Chief Engineer.....Billy Fulghum

WRLD

WEST POINT—1941—ABC-KBS

Frequency: 1490 Kc.....Power: 250 Watts
 Owned-Oper. By.....Valley Bcstg. Co., Inc.
 Business Address.....P. O. Box 312
 Phone Number.....2-2771
 Newspaper Affiliation.....Valley Daily
 Times News

Air Time.....6 a.m.-11 p.m.
News Service**AP**
 Transcription Service.....Thesaurus
 Representative.....Joseph H. McGillvra
 Membership.....BAB, NARTB
 President.....J. C. Henderson
 Sales Promotion Mgr.....Dorothy Forrester
 General Manager.....Jim Murphy
 Program Director.....Aileen Love
 Chief Engineer.....Al Stancil

WIMO

WINDER—1952—KBS

Frequency: 1300 Kc...Power: 1000 Watts d.
 Owned-Operated By...Winder-Monroe Bcstg.
 Business Address.....P. O. Box 526
 Phone Number.....4831
News Service**UP**
 President.....W. C. Woodall, Jr.
 Gen., Comm. Mgr.....C. H. Grider
 Program Director.....Orson G. Swindle, Jr.
 Publicity Director.....R. A. Jones
 Chief Engineer.....W. R. Powell

THOSE WHO KNOW
 FAMOUS BRANDS . . .

Enthusiasm from an appliance
 dealer: "We like **AP** news.
 These newscasts are the best
 thing we've ever had."

. . . . KNOW THE MOST FAMOUS
 BRAND IN NEWS IS **AP**

IDAHO

Pop. Feb. 1, 1954 (Est.) 600,000 — Families 180,000
Radio Homes 176,000 — TV Homes 27,500 — Stations in State 24

KBLI

BLACKFOOT—1951

Frequency: 1490 Kc. Power: 250 Watts
Owned-Operated By: William I. Palmer
Address: Yellowstone Ave.
Phone Number: 780
Comm. Sta. Manager: Carl Winther
Program Director: Vannie Winther
Chief Engineer: Donald R. Clark

KDSH

BOISE—1947—CBS

Frequency: 950 Kc. Power: 5000 Watts
Owned-Operated By: Boise Valley Bcstrs., Inc.
Business-Studio Address: 311 N. 10th St.
Phone Number: 3-2511
Air Time: 6 a.m.—M.
News Service: UP
Transcription Service: World
Representative: Free & Peters
Membership: BAB
Pres., Gen. Mgr.: H. Westerman Whillock
Commercial Mgr.: Earl Glade Jr.
Station Manager: George Ganz Jr.
Chief Engineer: James Johnitz Jr.

KGEM

BOISE—1946—ABC

Frequency: 1140 Kc. Power: 10,000 Watts
Owned-Oper. By: Idaho Bcstg. & Telev. Co.
Business-Studio Address: 5601 Cassia
Phone Number: 4-3511
Air Time: 6 a.m.—1 a.m.
News Service: UP
Transcription Service: Langworth
Representative: Avery-Kncdel
Membership: BAB, NARTB
President: Frank C. Carman
General Manager: Milo J. Petersen
Chief Engineer: Howard McDonald

KIDO

BOISE—1928—NBC

Frequency: 630 Kc. Power: 5000 Watts
Owned-Operated By: KIDO, Inc.
Business-Studio Address: Chamber of Comm. Bldg.
Phone Number: 2-4611
Air Time: 6 a.m.—12M.
News Service: UP
Transcription Service: Thesaurus
Representative: John Blair
Membership: NARTB, BAB
President: Georgia M. Davidson
General Mgr.: Walter E. Wagstaff
Commercial Mgr.: John Young
Program Director: George Walton
Chief Engineer: Harold W. Toedtemeir

KBAR

BURLEY—1946—ABC

Frequency: 1230 Kc. Power: 250 Watts
Owned-Oper. By: KBAR, Inc.
Business-Studio Address: P. O. Box 461
Phone Number: 10
News Service: UP
Transcription Service: World
Representative: Donald S. Cooke
President: Jessica L. Longston
Commercial Mgr.: Dee Carter
Gen. Sta. Mgr.: K. Clark
Program Director: E. Joan Walleri
Chief Engineer: Donald Lockwood

KCID

CALDWELL—1947

Frequency: 1490 Kc. Power: 250 Watts
Owned-Operated By: Caldwell Bcstg. Co.
Business-Studio Address: 520 So. Kimball
Phone Number: 9-7444
Air Time: 6:30 a.m.—10:30 p.m.
News Service: UP
Transcription Service: Capitol
Pres., Comm. Mgr.: Clair B. Hull
Sta. Mgr., Prog. Dir.: F. H. Borton
Chief Engineer: Richard Lewis

KVNI

COEUR D'ALENE—1946—MBS

DON LEE

Frequency: 1240 Kc. Power: 250 Watts
Owned-Oper. By: Coeur d'Alene Bcstg. Co.
Business-Studio Address: Blackwell Island
Phone Number: 1250
Air Time: 6 a.m.—11 p.m.
President: Burl C. Hagadone
Sta. Comm. Mgr.: Wayne E. Olsen
Pgm., Pub. Dir.: Bernard V. Merriman
Chief Engineer: Don Schafer

KID

IDAHO FALLS—1928—CBS

Frequency: 590 Kc. Power: 5000 Watts d.,
1000 Watts n.
Owned-Operated By: Idaho Radio Corp.
Business-Studio Address: Box 701
Phone Number: 4
Air Time: Unlimited
News Service: UP
Transcription Service: World
Membership: NARTB
President: A. W. Schweider
General-Station Manager: C. N. Layne
Commercial Manager: Leonard Warden
Program Director: Leo Higham
Chief Engineer: Carroll Secrist

KIFI

IDAHO FALLS—1947—ABC-MBS INTERMOUNTAIN

Frequency: 1400 Kc. Power: 250 Watts
 Owned-Oper. By Eastern Idaho Bcstg. &
 Television Co.
 Business-Studio Address Box 581
 Phone Number 1054
 Air Time Unlimited
 News Service AP
 Transcription Service Standard
 Representative Avery-Knodel
 Membership BAB
 Pres., Gen. Mgr. J. M. Brady
 Program Director Hal Simmons
 Publicity Director Wayne Davis
 Chief Engineer George Stone

KLER

LEWISTON—1953

Frequency: 740 Kw. Power: 250 Watts d.
 Owned-Oper. By Cole E. Wylie
 Address 2829 Country Club Dr.
 Phone Number 3-5558
 President Cole E. Wylie
 General Manager William C. Rhodes
 Program Director Robert O. Edwards
 Chief Engineer Gene Wilson

KRLC

LEWISTON—1935—MBS-DON LEE

Frequency: 1350 Kc. Power: 1000 Watts
 Owned-Operated By H. E. Studebaker
 Business-Studio Address Lewis-Clark Hotel
 Phone Number 3-1551
 Air Time Full Time
 News Service UP
 Transcription Service Thesaurus
 Representative Weed, Moore-Lund
 Membership NARTB, BAB
 General Manager H. E. Studebaker
 Station Manager Donald Thomas
 Commercial Manager Thomas Decker
 Program Director Alben Nelson
 Chief Engineer William Neuman

KRPL

MOSCOW—1947—KBS

Frequency: 1400 Kc. Power: 250 Watts
 Owned-Oper. By Latah County Bcstrs.
 Business Address P. O. Box 396
 Phone Number Moscow 2283
 News Service AP
 Transcription Service SESAC
 Owner Roy Anderson
 General Manager Bert McAllister
 Chief Engineer Herbert D. Young

KFXD

NAMPA—1930—MBS INTERMOUNTAIN

Frequency: 580 Kc. Power: 5000 Watts
 Owned-Oper. By Frank E. Hurt & Son

Business Address Box 891
 Phone Number 6-4611
 Air Time 6 a.m.-11 p.m.
 News Service UP
 Transcription Service Langworth
 Representative Avery-Knodel
 Membership BAB
 President Edward P. Hurt
 Sta., Comm. Mgr. Doyle Cain
 Program Director Shirl Black
 Chief Engineer G. M. Rose

KJRL

POCATELLO—1946—CBS

Frequency: 1240 Kc. Power: 250 Watts
 Owned-Oper. By Radio & Telev. Corp. of
 Idaho
 Address 1140 Yellowstone Ave.
 Phone Number 1240
 Transcription Service Capitol
 Representative CBS Radio Spot Sales
 President Burt C. Hagadone
 Sta., Comm. Mgr. Roger L. Hagadone
 Program Director Dick Wright
 Chief Engineer Julian Dennis

KSEI

POCATELLO—1926—NBC

Frequency: 930 Kc. Power: 5000 Watts
 Owned-Operated By Radio Service Corp.
 Business-Studio Address Box 31
 Phone Number 4000
 Air Time 6 a.m.-12M.
 News Service UP
 Transcription Standard, Lang-Worth, Thesaurus
 Representative Weed and Co.
 Membership NARTB, BAB
 Pres., Gen., Comm. Mgr. Henry H. Fletcher
 Publicity Dir. Olive M. Leoney
 Program Director Ruthe A. Fletcher
 Chief Engineer Ellis W. Call

KWIK

POCATELLO—1946—ABC-MBS INTERMOUNTAIN

Frequency: 1440 Kc. Power: 1000 Watts
 Owned By Eastern Idaho Bcstg. & TV Co.
 Business-Studio Address Hotel Bannock
 Phone Number 3400
 News Service AP
 Transcription Service World
 Representative Avery-Knodel
 Membership NARTB, BAB
 President James M. Brady
 Gen., Sta. Mgr. John R. Taylor
 Commercial Manager Don W. Burden
 Program Director Robert Weggeland
 Chief Engineer Dean McCurdy

KPST

PRESTON—1948—KBS

Frequency: 1340 Kc. Power: 250 Watts
 Owned-Oper. By Voice of The Rockies, Inc.
 Business-Studio Address Box 192

Phone Number 600
 Transcription Service Associated
 President Leon Smith
 Gen. Sta. Mgr. Rulon Dunn
 Commercial Mgr. M. S. Stocking
 Chief Engineer D. A. Nash, Jr.

K R X K

REXBURG—1950

Frequency: 1230 Kc. Power: 250 Watts
 Owned-Operated By Snake River Radio &
 TV Co., Inc.
 Address 445 S. 2nd East
 Phone Number 700, 701
 News Service AP
 Transcription Service Capitol, Thesaurus
 President Dr. M. F. Rigby
 General Manager Merrill Skinner
 Program Director James G. Clawson

K S P T

SANDPOINT—1949—KBS

Frequency: 1400 Kc. Power: 250 Watts
 Owned-Operated By Bauer Bcstg. Co.
 Phone Number 555
 News Service UP
 Transcription Service Standard
 Pres., Gen. Mgr. Norman Bauer
 Program Director Watt Moreland Jr.
 Chief Engineer William Frey

K E E P

TWIN FALLS—1945—CBS

Frequency: 1450 Kc. Power: 250 Watts
 Owned-Operated By Radio Sales Corp.
 Business Address Blue Lakes Blvd.
 Phone Number 3002
 Air Time 6 a.m.-12M.
 News Service UP
 President H. W. Ireland
 Commercial Mgr. Ken Montgomery
 Program Director Paul Droubay

K L I X

TWIN FALLS—1946—MBS-ABC

Frequency: 1310 Kc. Power: 1000 Watts
 Owned-Operated By Southern Idaho Bcstg.
 & Television Co.
 Business-Studio Address Elizabeth Blvd.
 Phone Number 206
 Air Time 4:30 a.m.-1:00 a.m.
 News Service AP
 Transcription Service Capitol, MacGregor,
 Associated
 Representative Avery-Knodel, Moore-Lund,
 N. W.
 Membership NARTB, BAB
 V.P., Gen. Sta. Mgr. Frank C. McIntyre
 Commercial Mgr. Juneau H. Shinn
 Program Director Des Barker
 Sales Prom. Mgr. Dale Kassel
 Chief Engineer Don Cedarstrom

K T F I

TWIN FALLS—1928—NBC

Frequency: 1270 Kc. Power: 5000 d., 1000 n.
 Owned-Operated By Radio Bcstg. Corp.
 Business-Studio Address 241 Main Ave. W.
 Phone Number 2400
 Air Time 6 a.m.-12M.
 News Service UP
 Transcription Service Standard, Lang-Worth
 Representative Weed
 Membership NARTB, BAB
 President O. P. Soule
 Gen.-Station-Comm. Manager F. M. Gardner
 Sales Prom. Mgr. F. M. Gardner
 Program Director Jack Farrar
 Chief Engineer Marvin Hartley

K W A L

WALLACE—1938—MBS

Frequency: 620 Kc. Power: 1000 Watts
 Owned-Operated By Silver Bcstg. Co.
 Business-Studio Address Box 930
 Phone Number 8-2111
 Transcription Service World
 Representative Hal Holman
 President R. Lee Black
 Program Director George Shreve
 Promotion Dir. Geraldine Black
 Chief Engineer Ralph S. Click

K W E I

WEISER—1947

Frequency: 1240 Kc. Power: 250 Watts
 Owned-Operated By Inland Bcst. Co.
 Business-Studio Address Box 791
 Phone Number 700
 News Service AP
 Transcription Service Capitol
 Membership BAB
 Pres., Gen. Sta. Mgr. M. V. Ling
 Sales Prom. Mgr., Ch. Eng. Edwin C. Miller
 Program Director Marilyn Potter

ESTIMATED
 FAMILIES
 FOR
 1954
 SEE PAGE 296

ILLINOIS

Pop. Feb. 1, 1954 (Est.) 9,273,000 — Families 2,858,000
Radio Homes 2,787,000 — TV Homes 1,962,000 — Stations in State 81

WOKZ

ALTON—1948—KBS

Frequency: 1570 Kc. Power 1000 Watts
Owned-Oper. By..... Edward N. Palen
Address Hotel Stratford
Phone Number 3-5506
Air Time Daytime
News Service UP
Pres., Gen. Mgr..... Edward N. Palen
Sta., Comm. Mgr..... W. Eccles Huff
Prom. Mgr., Pub. Dir..... Lloyd Smith
Program Director..... Clyde Wiseman
Chief Engineer..... Ben Ruyle

WMRO

AURORA—1938

Frequency: 1280 Kc. Power: 250 Watts, d.
Owned-Operated By..... Martin R. O'Brien
Business-Studio Address..... 184 S. River
Phone Number 4215
News Service INS
Transcription Service Lang-Worth
Pres., Gen., Sta. Mgr..... Martin R. O'Brien
Comm., Sales Prom. Mgr..... Vincent G. Coffey
Prog., Publ. Dir..... Jeanne M. Doran
Chief Engineer..... John Kitner

WIBV

BELLEVILLE—1947

Frequency: 1060 Kc. Power: 250 Watts, d.
Owned-Operated By..... Belleville Bcstg. Co.
Bus.-Studio-Transmitter Address... 2100 W. Main
Phone Number BE 5000
News Service AP
Representative Indie Sales
President..... John W. Lewis
Program Director..... Wm. C. Bailey
Comm., Prom. Mgr..... Clarence Keller
Chief Engineer..... Marvin Mollring

WJBC

BLOOMINGTON—1924—ABC

Frequency: 1230 Kc. Power: 250 Watts
Owned-Oper. By..... Bloomington Bcstg. Corp.
Address..... 209 E. Washington
Phone Number 5281
Air Time Full Time
News Service UP
Transcription Service..... Thesaurus, World
Representative Rambeau
Membership NARTB, BAB
President..... Loring C. Merwin
General Sta., Manager... Warner C. Tidemann
Commercial Manager..... Harry Swift
Program Director..... Fred Muxifield
News Director..... Keith Bright
Chief Engineer..... Fred L. Bailey

WKRO

CAIRO—1942—MBS

Frequency: 1490 Kc. Power: 250 Watts
Owned-Operated By..... Oscar C. Hirsch
Business Address..... Box 311
Phone Number 1490
Air Time Full Time
News Service UP
Representative John E. Pearson
Membership NARTB, BAB
Owner-Chief Engr..... Oscar C. Hirsch
Gen.-Station-Comm. Mgr..... Merrill C. Currier

WBYS

CANTON—1947—KBS

Frequency: 1560 Kc. Power: 250 Watts, d.
Owned-Operated By..... Fulton Co. Bcstg. Co.
Business-Studio-Transmitter... East Linn Limits
Phone Number 1877
Air Time Sunrise-Sunset
News Service AP
Transcription Service World
Owner, Gen. Mgr..... D. S. Phares

WCIL

CARBONDALE—1946

Frequency: 1020 Kc. Power: 1000 Watts, d.
Owned-Operated By... Southern Illinois Bcstg.
Business-Studio Address.... 218 W. Main St.
Phone Number 167
News Service AP
Transcription Service Thesaurus
Membership NARTB, BAB
Gen., Sta. Mgr., Chf. Engr..... Paul F. McRoy
Commercial Manager..... Walter Schafer

WROY

CARMI—1948—KEYSTONE

Frequency: 1460 Kc. Power: 1000 Watts d.
Owned-Oper. By Carmi Bdcstg Co.
Address 101 South Walnut Street
Phone Number 4161
News Service UP
Transcription Service..... Lang-Worth, SESAC
Representative Sears & Ayer, Inc.
President Roy Clippinger
General Manager..... Howard M. Reedy
Commercial Manager..... Jack Wiedemann
Program Director..... William Baker
Chief Engineer..... John Greenwood

WC AZ

CARTHAGE—1921

Frequency: 990 Kc. Power: 1000 Watts d.
Owned-Oper. By... Superior Bcstg. Service, Inc.
Business-Studio Address..... 502 Wabash Ave.
Phone Number 520

94% of Illinois' Retail Sales
92% of Illinois' Food Store Sales
94% of Illinois' Drug Store Sales
92% of Illinois' Automotive Sales

in

WGN's COVERAGE AREA

**WGN...reaching more homes per week
than any other Chicago station**

*Sales Management Survey of Buying Power
Nielsen Coverage Service*

The logo for WGN, featuring the letters 'W', 'G', and 'N' in a stylized, overlapping arrangement. The 'W' and 'G' are connected at the top, and the 'N' is positioned below them.

**Chicago 11
Illinois**
50,000 Watts
720
On Your Dial



441 North Michigan Avenue

Eastern Sales Office: 220 E. 42nd Street, New York 17, N.Y. for New York City, Philadelphia and Boston

Geo. P. Hollingbery Co.

Advertising Solicitors for All Other Cities

Los Angeles—411 W. 5th Street • New York—500 5th Avenue • Atlanta—223 Peachtree Street
Chicago—307 N. Michigan Avenue • San Francisco—625 Market Street

Air Time Daytime
 President Zola Compton

WCNT
CENTRALIA—1946

Frequency: 1210 Kc. Power: 1000 Watts, d.
 Owned-Operated By Southern Illinois
 Broadcasting Corp.
 Address Box 428
 Phone Number 5151
 News Service UP
 Transcription Service Standard, Thesaurus
 President C. W. Rodgers
 General Manager Merle G. Rogers
 Publicity Director Don Brown
 Chief Engineer C. G. Swanzy

WDWS
CHAMPAIGN—1937—CBS

Frequency: 1400 Kc. Power: 250 Watts
 Owner The Champaign News Gazette, Inc.
 Business Address 48 Main St.
 Phone Number 6-1855
 Air Time 7 a.m. M.
 News Service UP
 Transcription Service World
 Representative Robert Meeker & Associates
 Membership NARTB
 President Mrs. Helen M. Stevick
 General Manager J. A. McDermott
 Station Manager Larry Stewart
 Chief Engineer Robert Brown

WAFF
CHICAGO—1922

Frequency: 950 Kc. Power: 1000 Watts, d.
 Owned-Operated By Corn Belt Pub., Inc.
 Business Address 221 N. LaSalle St.
 Phone Number Randolph 6-1932
 News Service UP
 Transcription Service Standard
 Representative Rambeau
 President Ward A. Neff
 Vice-President W. E. Hulchinson
 Sta., Comm., Prom. Mgr. Thomas L. Davis
 Prog., Publ. Director Bill Bauer
 Chief Engineer Carl W. Ulrich

WAIT
CHICAGO—1941

Frequency: 820 Kc. Power: 5000 Watts
 Owned-Operated By Radio Station WAIT
 Bus.-Studio Address 75 E. Wacker Dr.
 Phone Number Franklin 2-0660
 News Service UP
 Transcription Service Standard
 Representative Forjoe
 President Gene T. Dyer
 General Manager Earl Withrow
 Program Director Rosemary Petru
 Chief Engineer Edward W. Jacker

WBBM
CHICAGO—1923—CBS

Frequency: 780 Kc. Power: 50,000 Watts

Owned By CBS, Inc.
 Operated By CBS Radio Division
 Address 410 N. Michigan Ave.
 Phone Number Whitehall 4-6000
 Air Time Full Time
 News Service AP, UP
 Transcription Service Associated
 Vice-Pres., Gen. Mgr. H. Leslie Atlass
 Asst. Gen. Mgr. E. H. Shomo
 Commercial Mgr. Wm. F. Miller
 Program Director Al Bland
 Sales Prom. Mgr. C. W. Doebler
 Chief Engineer J. F. Novy

WCBD
CHICAGO-ZION—1947

Frequency: 820 Kc. Power: 5000 Watts
 Owned-Oper. By Michael J. Mintern
 Business Address 2714 Enoch Ave., Zion
 Phone Number 521
 Managing Director Michael J. Mintern
 Commercial Manager Carl G. Lee

WCFL
CHICAGO—1926—ABC

Frequency: 1000 Kc. Power: 50,000 Watts
 Owned-Operated By Chicago Federation of
 Labor
 Business-Studio Address 666 Lake Shore Dr.
 Phone Number MOhawk 4-2400
 Air Time Unlimited
 News Service UP, AP
 Transcription Service Standard
 Representative Radio-TV Reps., Inc.
 General Manager Martin F. Hogan
 Commercial Mgr. Thomas E. Haviland
 Program Director L. J. Ronder, Jr.
 Chief Engineer Charles E. Willett

WCRW
CHICAGO—1926

Frequency: 1240 Kc. Power: 100 Watts
 Owned-Operated By Clinton R. White
 Address 2756 Pine Grove Ave.
 Phone Number EAstgate 7-6860
 General Manager J. A. White

WEDC
CHICAGO—1926

Frequency: 1240 Kc. Power: 250 Watts
 Owned-Operated By Emil Denmark, Inc.
 Address 3860 W. Ogden Ave.
 Phone Number CRawford 7-4100
 Air Time Full Time
 News Service UP
 President Emil Denmark
 Gen.-Station-Comm. Mgr. Frank J. Kotnour
 Program, Publicity Director Bill Mack

WGN
CHICAGO—1924—MBS

Frequency: 720 Kc. Power: 50,000 Watts
 Owned-Operated By WGN, Inc.
 Bus.-Studio Address 441 N. Michigan Ave.

*The Purpose of Advertising
is to get*

RESULTS

Evidence of WLS position as a result producing medium for advertising is found in the impressive group of advertisers who, like those listed below, use the station consistently year after year. They and many others have found that listener loyalty to WLS extends to the station's advertisers —and that midwest people *buy* the products they hear about on WLS.

Listener loyalty produces advertising results.

Bristol-Myers	10 years	Carter Medicine Co.	16 years
De Kalb Agric Assoc	17 years	Flex-O-Glass	17 years
Allied Mills	15 years	Lever Bros	9 years
Block Drugs	10 years	Hulman & Co	14 years
Campbell Cereal Co	24 years	Little Crow Milling Co	15 years
Consolidated Products	13 years	Colgate-Palmolive-Pect	11 years
Phillips Petroleum	10 years	Vick Chemical Co.	15 years
General Foods	10 years	Murphy Products Co.	22 years
Standard Brands	8 years	Grove Laboratories, Inc	11 years
Pioneer Hi-Bred Corn Co.	17 years	Sterling Drug	10 years
Chrysler Corp	9 years	Keystone Steel & Wire Co.	22 years
Oshkosh Overall Co	17 years	Metropolitan Life Ins	9 years
Procter & Gombic	17 years		

50,000 WATTS
CLEAR CHANNEL



ABC NETWORK
890 KILOCYCLES

**The
PRAIRIE
FARMER
STATION**

CHICAGO 7

REPRESENTED BY JOHN BLAIR & CO.

Phone NumberSU 7-0100
 Newspaper Affiliation...The Chicago Tribune
 Air Time.....Full Time
 News Service.....AP, INS, UP
 Transcription Service.....Standard
 Representative.....Hollingberry
 Membership.....NARTB, BAB
 President.....Col. Robert R. McCormick
 General Sta. Manager.....Frank P. Schreiber
 Commercial Manager...William A. McGuineas
 Sales Promotion Manager...Charles A. Wilson
 Program Director.....Bruce Dennis
 Publicity Director.....James Hanlon
 Dir. of Engineering.....Carl J. Meyers

WGES
 CHICAGO—1924

Frequency: 1390 Kc.....Power: 5000 Watts
 Owned-Operated By...Radio Station WGES
 Business-Studio Address...2708 Wash. Blvd.
 Phone Number.....Sacramento 2-1700
 News Service.....UP
 Transcription Service.....Associated
 General, Station Manager.....John A. Dyer
 Commercial Mgr.....Elizabeth M. Hinzman
 Sales Promotion Manager.....K. P. Freda
 Program Director.....Herbert Rudolph
 Chief Engineer.....William Shunk

WHFC
 CHICAGO—1926

Frequency: 1450 Kc. Power: 250 Watts
 Owned-Operated By.....WHFC, Inc.
 Address...3350 S. Kedzie Ave., Chicago 23, Ill.
 Phone Number.....Townhall 3-6305
 Air Time.....Full Time
 News Service.....AP
 General Manager.....Richard W. Hoffman

WIND
 CHICAGO—1926

Frequency: 560 Kc.....Power: 5000 Watts
 Owned-Oper. By.....WIND, Inc.
 Bus.-Studio Address...400 N. Michigan Blvd.
 Phone Number.....Whitehall 4-2170
 Transcription Service.....Standard
 Air Time.....Unlimited
 News Service.....AP, UP
 Representative.....AM Radio Sales
 Membership.....BAB
 President, General Manager...Ralph L. Atlass
 Commercial Manager.....John T. Carey
 Program Director.....H. Leslie Atlass, Jr.
 Sales Promotion Manager...Robert D. Peel
 Chief Engineer.....Kenneth C. Shirk

WJJD
 CHICAGO—1934

Frequency: 1160 Kc.....Power: 50,000 Watts
 Owned-Oper. By.....Plough Bcstg. Co.
 Bus.-Studio Address...230 N. Michigan Ave.
 Phone Number.....State 2-5466
 Air Time.....4 a.m.-sundown
 News Service.....UP
 Transcription Service...Standard, Capitol, RCA

Representative..Radio-TV Representatives, Inc.
 President.....Abe Plough
 Gen., Sta. Mgr.....Frederick G. Harm
 Sales Prom. Mgr.....George Rice
 Program Director.....Jeanne Spangler
 Publicity Director.....Ed Short
 Chief Engineer.....Walter F. Myers

WLS

CHICAGO—1924—ABC

Frequency: 890 Kc.....Power: 50,000 Watts
 Owned-Oper. By.....WLS, Inc.
 Business Address...1230 Washington Blvd.
 Phone Number.....MO 6-9700
 News Service.....AP, UP
 Transcription Service.....Standard
 Representative.....John Blair
 President.....James E. Edwards
 General Manager.....Glenn Synder
 Commercial Manager...Charles M. Freeman
 Sales Prom. Mgr.....Betty Howard
 Program Director.....Harold Safford
 Chief Engineer.....Thomas Rowe

WMAQ

CHICAGO—1922—NBC

Frequency: 670 Kc.....Power: 50,000 Watts
 Owned-Operated By...National Bcstg. Co., Inc.
 Business-Studio Address...Merchandise Mart
 Phone Number.....Superior 7-8300
 Air Time.....Full Time
 News Service.....AP, INS, UP
 Transcription Service.....Thesaurus
 Representative.....National Spot Sales
 Membership.....NARTB
 President.....Brig. Gen. David Sarnoff
 V.P.-General Manager.....Harry Kopf
 Sales Manager.....Rudi Neubauer
 Sales Promotion Manager...John Keys
 Program Director.....George Heineman
 Publicity Director.....Chet Campbell
 Chief Engineer.....Howard Lutgens

WSBC

CHICAGO—1925

Frequency: 1240 Kc.....Power: 250 Watts
 Owned-Operated By...Radio Station WSBC
 Business-Studio Address...2400 W. Madison St.
 Phone Number.....Monroe 6-9060
 News Service.....YP
 Transcription Service.....SESAC
 Representative.....Stars Nat'l, Inc.
 Gen., Sta. Mgr., Pgm. Dir....Robert O. Miller
 Commercial Manager.....Julius Miller

WHOW

CLINTON—1947—LINCOLN NET

Frequency: 1520 Kc.....Power: 1000 Watts d.
 Owned-Operated By...Cornbelt Bcstg. Co.
 Business Address...401½ S. Side Sq.
 Phone Number.....305
 Representative.....Holman
 Transcription Service.....SESAC
 News Service.....AP

President J. R. Livesay
 V.P., Gen., Sta. Mgr. Rolland O. Looper
 Comm., Prom. Manager James Williams
 Program Director Frank C. Jennings
 Chief Engineer R. O. Looper

W D A N

DANVILLE—1938—CBS

Frequency: 1490 Kc. Power: 250 Watts
 Owned-Operated By Northwestern Pub. Co.
 Address 1500 N. Washington
 Phone Number 1700
 Air Time Full Time
 News Service AP
 Transcription Service Thesaurus
 Representative Everett-McKinney, Inc
 Membership NARTB, BAB
 Gen., Sta., Comm., Prom. Mgr. Robert J. Burow
 Program, Publicity Dir. Honore E. Ronan
 Chief Engineer T. G. Magin

W I T Y

DANVILLE—1953

Frequency: 980 Kw. Power: 1000 Watts
 Owned-Oper. By Vermilion Bcstg. Corp.
 Address Box 551
 Phone Number 1312
 President G. E. Metzger
 General Manager F. A. Higgins
 Commercial Mgr. Ward White
 Program Director Ken Early
 Chief Engineer Jack Brookhank

W D Z

DECATUR—1921

Frequency: 1050 Kc. Power: 1000 Watts d.
 Owned-Operated By W D Z Bcstg. Co.
 Business-Studio Address 265 S. Park St
 Phone Number 3-9744
 News Service UP
 Transcription Service Thesaurus
 Representative Free & Peters
 Membership NARTB, BAB
 President Charles C. Caley
 Gen., Sta. Mgr. Frank C. Schroeder, Jr.
 Commercial Manager Howard G. Bill
 Program Director William F. Miller
 Chief Engineer A. James Ebel

W S O Y

DECATUR—1925—CBS

Frequency: 1340 Kc. Power: 250 Watts
 Owned-Operated By Illinois Bcstg. Co.
 Address Rt. 48 at N. Jasper St.
 Phone Number 5371
 Air Time 5:30 a.m.-12:05 a.m.
 News Service AP
 Transcription Service Standard, Cole
 Representative Weed
 Membership NARTB, BAB
 President Frederick W. Schaub
 General Manager Merrill Lindsay
 Prom., Comm. Mgr. Charles F. Bruce
 Chief Engineer Allan Doyle

W L B K

DE KALB—1947

Frequency: 1360 Kc. Power: 500 Watts d.
 Owned-Oper. By DeKalb Radio Studios, Inc.
 Business-Studio Address 153 1/2 N. Third St.
 Phone Number 2677
 News Service AP
 Transcription Service Capitol
 Pres., Gen. Mgr. George C. Biggar
 General Manager R. C. Brown
 Commercial Manager Richard Meier
 Program Director R. C. Brown
 Chief Engineer Robert Zirk

W D Q N

DJ QUION—1951

Frequency: 1580 Kc. Power: 250 Watts
 Owned-Operated By Johnson & Johnson
 Address 30 1/2 W. Main St.
 Phone Number 1399
 News Service UP
 Transcription Service SESAC
 Co-owner, Prom. Mgr. Leonard M. Johnson
 Co-owner, Gen. Mgr. Leonard F. Johnson
 Chief Engineer Julian Emlen

W T M V

EAST ST. LOUIS—1935

Frequency: 1490 Kc. Power: 250 Watts
 Owned By-Operated By On the Air, Inc.
 Business-Studio Address Broadview Hotel
 Phone Number Bridge 4625
 News Service UP
 Transcription Service SESAC
 Representative Sears & Ayer
 General Manager Frank J. Prendergast
 Promotion Mgr. Elmer Willrich
 Program Director R. S. Holcomb
 Chief Engineer Erle E. White

W C R A

EFFINGHAM—1947

Frequency: 1090 Kc. Power: 250 Watts, d.
 Owned-Operated By Effingham Bcstg. Co.
 Business-Studio Address 110 N. Banker St.
 Phone Number 1090
 Air Time Daytime
 News Service UP
 President Joseph E. McNaughton
 General Manager Jack Armel
 Program Director Lee Hayward
 Chief Engineer G. S. Kregotis

W R M N

ELGIN—1949

Frequency: 1410 Kc. Power: 500 Watts
 Owned-Oper. By The Elgin Bdcstg Co.
 Address 156 Division St.
 Phone Number 7700-1
 News Service UP
 Representative Joseph Hershey MvGillvra
 President Joseph E. McNaughton

Gen., Sta., Comm. Mgr. Dick Sutter
 Prog. Dir., Chf. Engr. George J. Merker
 Publicity Director. J. Richard Sutter

W N M P

EVANSTON—1948

Frequency: 1590 Kc. Power: 1000 Watts d.
 Owned-Operated By Evanston Bcstg. Co.
 Business-Studio-Transmitter... 2201 Oakton St.
 Phone Number Greenleaf 5-1590
 Air Time Sunrise-sunset
 News Service INS
 Transcription Capitol, SESAC
 Membership NARTB, BAB
 President. Fred S. Newton
 General Manager. Angus D. Pfaff
 Production Dir. J. W. Horton
 Chief Engineer. Albert Griffin

W F I W

FAIRFIELD—1953

Frequency: 1390 Kw. Power: 500 Watts d.
 Owned-Oper. By... Wayne County Bcstg. Co.
 Address Box 148
 Phone Number Fairfield 2159
 Co-Owner, Gen. Mgr. Thomas S. Land
 Co-Owner, Prog. Dir. Bryan Davidson
 Commercial Mgr. Garnet Williams

W F R L

FREEPORT—1947

Frequency: 1570 Kc. Power: 1000 Watts d.
 Owned-Operated By... Freeport Bcstg. Co., Inc.
 Business-Studio Address... 9 N. Chicago Ave.
 Phone Number State 436
 News Service AP
 Representative. Sears & Ayer
 Pres., Gen. Mgr., Ch. Engr. Vincent S. Barker
 Commercial Manager. Dave Taylor
 Program Director. Ralph Reynolds

W G I L

GALESBURG—1936

Frequency: 1400 Kc. Power: 250 Watts
 Owned-Oper. By... Galesburg Bcstg. Co., Inc.
 Business Address... 312 Hill Arcade
 Phone Number 4626
 Newspaper Affiliation. "Daily Register Mail"
 Air Time 6 a.m.-M.
 News Service AP
 Membership BAB
 Representative Wm. G. Rambeau
 President Mrs. O. N. Custer
 General Manager. Robert W. Frudeges
 Commercial Mgr. Roger L. Hoffman
 Program Director. G. F. Thoma
 Chief Engineer. H. H. Frederick

W E B Q

HARRISBURG—1923—KBS

Frequency: 1240 Kc. Power: 250 Watts
 Owned-Oper. By... Harrisburg Bcstg. Co.
 Business-Studio-Transmitter... 100 E. Poplar St.

Phone Number 2-8
 Air Time Full Time
 News Service UP
 Gen.-Station-Comm. Mgr. Inglls M. Taylor
 Sales Prom. Mgr. Ken Hamilton
 Program Director. Dorice Turner
 Publicity Director. Eddie Wise
 Chief Engineer. Elmer L. Gladson

W J P F

HERRIN—1940—MBS-KBS

Frequency: 1340 Kc. Power: 250 Watts
 Owned-Operated By Orville W. Lyerla
 Business-Studio Address... P. O. Box 179
 Phone Number 382
 Air Time Full Time
 News Service UP
 Transcription Service World
 Representative. John E. Pearson
 Membership NARTB, BAB
 President. Orville W. Lyerla
 General Manager. Charles R. Cook
 Sales Promotion Manager. Fred Simmons
 Chief Engineer. Ben Orf

W L D S

JACKSONVILLE—1941

Frequency: 1180 Kc. Power: 1000 Watts d.
 Owned-Operated By... Jacksonville Radio &
 TV B'csting Corp.
 Business-Studio... Fox-Illinois Theater Bldg.
 Phone Number 1180
 Air Time Sunrise-sunset
 News Service AP
 Transcription Service World
 Newspaper Affiliation "Journal-Courier"
 Representative Hal Holman
 Membership NARTB, BAB
 President. Robert A. Fay
 V.-P., Gen., Sta. Mgr. R. Karl Baker
 Program Director. T. J. Fairburn
 Chief Engineer. G. J. Cassens

W J O L

JOLIET—1926

Frequency: 1340 Kc. Power: 250 Watts
 Owned-Operated By... Joliet Bcstg. Co.
 Business-Studio-Transmitter... 601 Walnut St.
 Phone Number JO 4761
 Air Time 7 a.m.-11 p.m.
 News Service UP
 Transcription Service Thesaurus
 Representative Holman
 Membership BAB
 President Calvin Wilson
 Gen., Sta. Mgr. Joseph J. Garvey
 Promotion Manager. Marion Philburn
 Program Director. Eileen Caron
 Chief Engineer. Lester DeCosta

W K A N

KANKAKEE—1947

Frequency: 1320 Kc. Power: 1000 Watts d.
 Owned-Oper. By... Kankakee Daily Journal Co.
 Business-Studio Address... 183 N. Schuyler Ave.

Phone Number 3-6633
 Air Time Daytime
 News Service AP
 Transcription Service Standard
 Representative Sears-Ayer
 Membership NARTB
 President..... Leslie C. Small
 General Manager..... Burrell Small
 Station Manager..... Bruce Brown
 Asst. Station Manager..... Robert Hawkins
 Program Director..... Orren Allain
 Chief Engineer..... Richard Eckels

Commercial Manager Saunders Devine
 Sales Prom. Mgr..... John H. Deal
 Program Director..... William H. Brady
 Publicity Director..... Earle W. Layman
 Chief Engineer..... Donald Thompson

WKEI
 KEWANEE—1952

Frequency: 1450 Kc. Power: 100 Watts
 Owned-Operated By Kee Bcstg. Co.
 Address..... 207 Baker Bldg.
 Phone Number 4471
 News Service AP
 Transcription Service Lang-Worth
 Pres., Gen. Mgr., Chf. Engr..... E. D. Scandrett
 Prog., Pub. Dir..... Paul Messplam

WSMI
 LITCHFIELD—1950
 Frequency: 1540 Kc. Power: 1000 Watts d.
 Owned-Oper. By..... Mid-Illinois Bcstg. Co.
 Address Box 72
 Phone Number 100
 News Service AP
 Air Time Daytime
 Representative Hi'best
 Membership BAB
 Pres., Gen. Mgr..... Hayward L. Talley

WTAQ
 LA GRANGE—1950

Frequency: 1300 Kc. Power: 500 Watts d.
 Owned-Oper. By..... The La Grange Bcstg. Co.
 Address Box 408
 Phone Number..... FL 2-1300
 Air Time Daytime
 President Charles Sebastian
 Partner..... W. A. Murphy
 Gen., Sta. Mgr., Chief Engr..... Russ Salter
 Commercial Manager..... Ralph Faucher

WKAI
 MACOMB—1947
 Frequency: 1510 Kc. Power: 250 Watts d.
 Owned-Oper. By..... The Macomb Bcstg. Co.
 Business-Studio Address..... 113 E. Carroll St.
 Phone Number 1350
 Air Time Daytime
 News Service UP
 Transcription Service Langworth, World
 Membership NARTB
 Pres., Gen. Mgr..... Wm. E. Schons
 Sta., Comm. Mgr..... Allan Fobes
 Sales Promotion Mgr..... Don Vallier
 Chief Engineer Howard Welly

WLPO
 LA SALLE—1947

Frequency: 1220 Kc. Power: 250 Watts d.
 Owned-Oper. By..... La Salle County Bcstg. Co.
 Bus. Ad..... P. O. Box 215
 Phone Number 3100
 Air Time Daytime
 News Service AP
 Transcription Service..... RCA, Thesaurus
 Membership NARTB, BAB
 President Peter Miller
 General Manager..... William Helm
 Program Director..... Donald Frost
 Publicity Director..... Laverne Waltman
 Chief Engineer..... Lawrence McCann

WGGH
 MARION—1949
 Frequency: 1150 Kc. Power: 500 Watts d.
 Owned-Operated By..... George W. Dodds
 Business Address..... P. O. Box 331
 Phone Number 824
 News Service AP
 Transcription Service Associated
 Representative Sears & Ayer
 Membership BAB
 Pres., Gen. Manager..... George W. Dodds
 Commercial Manager..... Raymond L. Halley
 Prog. Dir., Sta. Mgr..... James W. Duncan
 Chief Engineer..... Orville D. Jackson

WPRC
 LINCOLN—1947—KBS

Frequency: 1370 Kc. Power: 500 Watts d.
 Owned-Oper. By Prairie Radio Corp.
 Address..... RT. 66 Bypass
 Phone Number 1370
 Air Time Daytime
 News Service AP
 Transcription Service Lang-Worth
 Representative Rambeau
 Membership NARTB
 Pres., Gen. Sta. Mgr..... Ray F. Knochel

WLBH
 MATTOON—1946
 Frequency: 1170 Kc. Power: 250 Watts d.
 Owned-Operated By..... Mattoon Bcstg. Co.
 Bus.-Studio Address..... 17th & Broadway Ave.
 Phone Number 6464
 Air Time..... Local sunrise-local sunset
 News Service AP
 Transcription Service Standard
 Representative Holman
 Membership NARTB, BAB
 President, Gen.-Station Mgr..... J. R. Livesay
 Commercial Manager..... Ken Wooddell
 Sales Promotion Manager..... Dwain Bower
 Program Director..... Robert Gwess
 Chief Engineer..... Roy Livesay

WMOK

METROPOLIS—1951—KBS

Frequency: 920 Kc. Power: 500 Watts d.
 Owned-Oper. By Fort Massac Bcstg. Co.
 Address Nat'l State Bank Bldg.
 Phone Numbers 2106
 Transcription Service Thesaurus
 News Service UP
 Representative Indie Sales, Inc.
 Membership NARTB, BAB
 Gen., Sta., Comm. Mgr. James H. Firmin
 Program Director J. R. Wetherington
 Chief Engineer Carlos Steel

WQUA

MOLINE—1946—ABC

Frequency: 1230 Kc. Power: 250 Watts
 Owned-Oper. By Quad-City Bcstg. Corporation
 Address 1319 Fifth Ave.
 Phone Number 4-6727
 Air Time Full Time
 News Service AP
 Representative Geo. P. Hollingberry Co.
 President Dalton A. LeMasurier
 V. Pres., Gen. Mgr. G. LaVerne Flambo
 Promotion Mgr. Ann Glewwe
 Program Director Benne Alter
 Chief Engineer Harold Higby

WVMC

MOUNT CARMEL—1948—KBS

Frequency: 1360 Kc. Power: 500 Watts d.
 Owned-Oper. By WVMC
 Address M. T. Carmel
 Phone Number 1360
 Air Time Daytime
 News Service UP
 Membership NARTB
 General Manager Stephen P. Bellingier
 Program Director Gil Wallace
 Chief Engineer Eugene D. Garrett

WMIX

MT. VERNON—1947

Frequency: 940 Kc. Power: 1000 Watts d.
 Owned-Oper. By Mt. Vernon Radio & Tel. Co.
 Address No. 2 Radio Center
 Phone Number 3500
 Air Time Daytime
 News Service AP
 Transcription Service World
 Representative John E. Pearson Co.
 President John Russell Mitchell
 General Manager R. J. Cheney
 Chief Engineer Alva Hulbert

WOPA

OAK PARK—1950

Frequency: 1490 Kc. Power: 250 Watts
 Owned-Oper. By Village Bcstg. Co.
 Address 408 S. Oak Park Ave.
 Phone Number VI 8-5760

Transcription Service Standard
 News Service UP
 Pres., Sta., Gen. Mgr. Egmont Sonderling
 Program Director Martin Bouhan
 Publicity Director Marylou Kelley
 Chief Engineer Sidney Schneider

WVLN

OLNEY—1947—KBS

Frequency: 740 Kc. Power: 250 Watts d.
 Owned-Operated By Olney Bcstg. Co.
 Business-Studio Address Olney
 Phone Number 2156
 Air Time Daytime
 News Service AP
 Transcription Service SESAC
 Representative Hal Holman
 Pres., Gen., Sta. Mgr. Marshall H. Poole
 Prom. Mgr., Prog. Dir. Bert DeBarr
 Chief Engineer Paul Hartsey

WCMY

OTTAWA—1952

Frequency: 1430 Kc. Power: 500 Watts d.
 Owned-Operated By Carl H. Meyer
 Address P. O. Box 687
 Phone Number 551
 News Service UP
 Transcription Service SESAC
 Representative Sears & Ayer
 Pres., Gen. Mgr. Carl H. Meyer

WPRS

PARIS—1951

Frequency: 1440 Kc. Power: 500 Watts d.
 Owned-Operated By Paris Bcstg. Corp.
 Address 2 Mi. W. Paris on State Rd. 133
 Phone 3-1440
 News Service AP
 Transcription Service Capitol
 Pres., Gen., Sta., Comm. Mgr. Adlai C. Ferguson Jr.
 Program Director Carl E. Sunkel

WSIV

PEKIN—1945—MBN

Frequency: 1140 Kc. Power: 1000 Watts d.
 Owned-Operated By Pekin Bcstg. Co., Inc.
 Business-Studio Address 15 S. Capitol St.
 Phone Numbers 3400-01
 Air Time Daytime
 News Service AP
 Representative Rambeau
 Pres., Gen. Mgr. W. Kenneth Patterson
 Commercial Manager James T. Butler
 Promotion Dir. George Udry
 Program Director Robert R. Snow

WEEK

PEORIA—1946—NBC

Frequency: 1350 Kc. Power: 1000 Watts
 Owned-Operated By West Central Bcstg. Co.

Address.....Commercial Natl. Bank Bldg.
 Phone Number.....3-3688
 Air Time.....6 a.m.-M.
 News Service.....AP
 Transcription Service.....Langworth
 Representative.....Headley-Reed
 Membership.....NARTB, BAB
 President.....Sen. Robert S. Kerr
 Gen. Mgr.....Fred C. Mueller
 Sta., Comm. Mgr.....Don Kynaston
 Publicity Director.....F. R. Oakley
 Chief Engineer.....Wayne Lovely

WIRL

PEORIA—1948—ABC—MBS

Frequency: 1290 Kc.....Power: 5000 Watts
 Owned-Oper. By.....Illinois Valley Bcstg. Co.
 Business-Studio Address.....115 N. Jefferson Ave.
 Phone Number.....4-9239
 Air Time.....Full Time
 News Service.....UP
 Representative.....Avery-Knodel
 Membership.....NARTB
 President.....Timothy W. Swain
 General, Station Manager.....Tom Gavin
 Commercial Manager.....Joe Faulkner
 Prog., Prom., Publ. Dir.....Lloyd Harvey
 Chief Engineer.....Rudolph Luukinen

WMBD

PEORIA—1927—CBS

Frequency: 1470 Kc.....Power 5000 Watts
 Owned-Oper. By.....WMBD, Inc.
 Address.....212 South Jefferson Street
 Phone Number.....6-0711
 Air Time.....Full Time
 News Service.....AP, UP
 Transcription Service.....Thesaurus
 Representatives.....Free & Pelters
 Pres., Gen. Mgr.....Charles C. Caley
 Commercial Manager.....Harold V. Phillips
 Promotion Mgr.....Robert M. Riley, Jr.
 Program Director.....Marvin H. Hult
 Chief Engineer.....A. James Ebel

WPEO

PEORIA—1950

Frequency: 1020 Kc.....Power: 1000 Watts d.
 Owned-Oper. By.....WPEO, Inc.
 Address.....225 Main St.
 News Service.....UP
 Membership.....NARTB
 Pres., Gen., Sta. Mgr.....John R. Livingston
 Sales Prom., Pub. Dir.....Bill Rogers
 Program Director.....Ken Scott
 Chief Engineer.....Gerry De Vore

WTVH

PEORIA—1952

Frequency: 1590 Kc.....Power: 1000 Watts
 Owned-Operated By.....Hilltop Bcstg. Co.
 Address.....410 Fayette St.

Phone Number.....6-8771
 Air Time.....Full Time
 News Service.....AP
 Transcription Service.....Cole
 Representative.....Sears & Fyer
 Pres., Gen. Mgr.....Hugh R. Norman
 Sta., Comm. Mgr.....O. H. Duewall
 Sales Prom. Mgr.....Dorris Duewall
 Prog., Publ. Dir.....George B. Norman
 Chief Engineer.....Wallace Wurz

WGEM

QUINCY—1948—ABC

Frequency: 1440 Kc.....Power: 1000 Watts
 Owned-Operated By.....Quincy Bcstg. Co.
 Business-Studio Address.....Hotel Quincy
 Phone Number.....6840
 Air Time.....Full Time
 Newspaper Affiliation.....Quincy Herald Whig
 News Service.....UP
 Transcription Service.....World
 Representative.....Walker
 Membership.....NARTB, BAB
 President.....T. C. Oakley
 General Manager.....Joseph S. Bonansinga
 Program Dir.....Paul McClelland
 Chief Engineer.....Frank E. Laughlin

WTAD

QUINCY—1927—CBS

Frequency: 930 Kc.....Power: 5000 d.:
 1000 n.
 Owned-Operated By.....Leo Bcstg., Inc.
 Business-Studio Address.....510 Maine St.
 Phone Number.....6200
 Air Time.....Full Time
 News Service.....AP, UP
 Representative.....Weed & Co.
 Membership.....NARTB, BAB
 President.....Leo P. Loomis
 General Manager.....Waller Rothschild
 Sales Promotion Mgr.....Gene Terry
 Program Dir.....Merritt Milligan
 Chief Engineer.....J. E. Gray

WROK

ROCKFORD—1929—ABC

Frequency: 1440 Kc.....Power: 1000 Watts d.:
 500 Watts n.
 Owned-Operated By.....Winnebago
 Newspapers, Inc.
 Bus-Studio Address.....Rockford Newstower
 Phone Number.....2-6621
 Air Time.....Full Time
 News Service.....AP
 Transcription Service.....Thesaurus
 Representative.....Headley-Reed
 President.....E. K. Todd
 General Manager.....Walter M. Koessler
 Commercial Manager.....John J. Dixon
 Publicity Dir.....Betty L. Thro
 Program Director.....Maurice P. Owens
 Chief Engineer.....Morey Nelson

W H B F

ROCK ISLAND—1925—CBS

Frequency: 1270 Kc.....Power: 5000 Watts
 Owned-Operated By.....Rock Island Bcastg. Co.
 Business-Studio Address.....231 18th St.
 Phone Number.....6-5441
 Air Time.....Full Time
 News Service.....UP
 Transcription Service.....Standard, World
 Representative.....Avery-Knodel
 Membership.....NARTB, BAB
 President.....Ben H. Potter
 Gen. Sta. Mgr.....Leslie C. Johnson
 Commercial Mgr.....Maurice Corken
 Program Director.....Frank S. Hicks
 Sales Prom., Pub. Dir.....Fern R. Hawks
 Chief Engineer.....Robert J. Sinnett

W C V S

SPRINGFIELD—1924—MBS

Frequency: 1450 Kc.....Power: 250 Watts
 Owned-Operated By.....WCBS, Inc.
 Business-Studio Address.....523 E. Capitol Ave.
 Phone Number.....9855
 Air Time.....Full Time
 News Service.....AP
 Representative.....Sears & Ayer
 President.....H. L. Dewing
 Comm., Prom., Gen. Mgr.....C. W. Neeld
 Program Director.....John Geil
 Chief Engineer.....R. Ashenfelter

W M A Y

SPRINGFIELD—1950—NBC

Frequency: 970 Kc.....Power: 1000 Watts d.,
 500 Watts n.
 Owned-Oper. By.....Lincoln Bcastg. Corp.
 Address.....711 Myers Bldg.
 Phone Number.....6963
 Air Time.....Full Time
 News Service.....UP
 Representative.....John E. Pearson
 Membership.....NARTB
 Pres., Gen., Sta., Comm. Mgr. Gordon Sherman
 Program Director.....Syl Binkin
 Prom., Publ. Dir.....Mel Kempe
 Chief Engineer.....Melvin Feldman

W T A X

SPRINGFIELD—1930—CBS

Frequency: 1240 Kc.....Power: 250 Watts
 Owned-Operated By.....WTAX, Inc.
 Address.....Route 66 & E. Cook St.
 Phone Number.....2-4441
 Air Time.....Full Time
 News Service.....AP
 Representative.....Weed
 Membership.....NARTB, BAB
 Pres., Gen. Mgr.....Oliver J. Keller
 Commercial Manager.....O. J. Keller, Jr.
 Sales Promotion Manager.....Bill Miller
 Program Director.....John W. Midgely
 Chief Engineer.....E. C. Swaringen

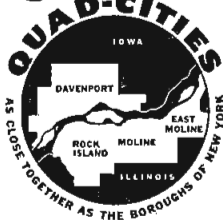

In the 10 Iowa-Illinois Counties circling the Quad-Cities there are:

21,220 FARMS

with an average acreage of
160 ACRES per FARM

and a gross cash farm income of
\$14,400 per FARM

- Three of these counties were among the nation's top ten for hog raising.
- Four of these counties were among the nation's 100 leading counties in Gross Cash Farm Income.
- And in all 10 counties that circle the Quad-Cities the farmers who live there averaged over \$14,000 a year income.
- Huge acreages of grain and hay crops as well as top production of cattle, hogs, and sheep bring in the money.
- Figures from Sales Management and U. S. Census.

Sell this good Quad-City Farm Market with →

Quad-Cities' favorite
WHBF AM FM TV
 TELCO BUILDING, ROCK ISLAND, ILLINOIS
 Represented by Avery-Knodel Inc.

WSDR

STERLING—1949

Frequency: 1240 Kc. Power 100 Watts
 Owned-Oper. By Blackhawk Bdstg. Co.
 Address 218 1st Ave.
 Phone Number Main 3400
 News Service AP
 Transcription Service Capitol, Lang-Worth
 Pres., Gen. Mgr. Sam Bartlett
 Comm. Mgr. Lillian Bartlett
 Program Director John Rohwer
 Chief Engineer Ed Fisher

WIZZ

STREATOR—1953

Frequency: 1250 Kw. Power: 500 Watts d.
 Owned-Oper. By Streator Bcstg. Co.
 Address Highway 23 North
 Phone Number 4147
 Representative Best
 General Manager Vernon R. Nunn
 Partner Stephen P. Bellinger
 Commercial Mgr. Jack A. Dill
 Chief Engineer Harold I. Peters

WTIM

TAYLORVILLE—1952

Frequency: 1410 Kc. Power: 1000 Watts d.
 Owned-Operated By Moyer Bcstg. Co.
 Phone Number 1410
 Transcription Service Standard, Thesaurus
 Representative Continental
 Co-Owners Russell Armentrout, Roger Moyer
 Exec. Vice-Pres. Keith Moyer
 General Manager James C. Hilderbrand
 Chief Engineer Tom Mathis

WKID

URBANA—1948

Frequency: 1580 Kc. Power 250 Watts d.
 Owned-Operated By Sterling Bcstg. Co.
 Address P. O. Box 192

Phone Number 75431
 Air Time Daytime
 News Service UP
 Representative Joseph Hershey, McGillvra
 Partner, Comm. Mgr. R. E. J. Snyder
 Partner, Prog. Dir. G. W. Phillippe

WKRS

WAUKEGAN—1949

Frequency: 1220 Kc. Power: 1000 Watts d.
 Owned-Operated By News-Sun Bcstg. Co.
 Business Address P. O. Box 500
 Phone Number Delta 6-7900
 News Service AP
 Transcription Service Thesaurus
 Representative McGillvra
 President F. Ward Just
 Gen., Comm. Mgr. Joseph B. Kirby
 Program Director A. F. Sorenson
 Chief Engineer Stanley G. Chadwick

WFRX

WEST FRANKFORT—1951

Frequency: 1300 Kc. Power: 1000 Watts d.
 Owned-Oper. By Pyramid Radio Bcstg. &
 TV Co.
 Address S. Logan St.
 Phone Number 1300
 News Service UP
 Transcription Service Thesaurus
 President Guy Lambert
 Station Manager Robert O. Veach
 Program Director Billy Spangler
 Chief Engineer Everett Kennedy

WCBD

ZION—1947

Frequency: 820 Kw. Power: 5000 Watts d.
 Owned-Oper. By Michael J. Mintern
 Address 2714 Enoch Ave.
 Phone Number 521
 Managing Director M. J. Mintern
 Commercial Mgr. Carl Q. Lee

INDIANA

*Pop. Feb. 1, 1954 (Est.) 4,252,000 — Families 1,350,000
 Radio Homes 1,303,000 — TV Homes 830,000 — Stations in State 48*

WCBC

ANDERSON—1947

Frequency: 1470 Kc. Power: 1000 Watts d.
 Owned-Operated By Civic Bcstg Corp.
 Address 204 Tower Bldg.
 Phone Number 3-5321
 News Service UP
 Transcription Service World, SESAC
 Membership BAB
 President Paul E. Billheimer
 General Manager Worth S. Rough
 Program Director John Snider
 Chief Engineer Burl Dixon

WHBU

ANDERSON—1923—CBS-ABC

Frequency: 1240 Kc. Power: 250 Watts
 Owned-Operated By Anderson Bcstg. Corp.
 Business-Studio 640 Citizens Bank Bldg.
 Phone Number 7791
 News Service AP
 Transcription Service NBC Thesaurus,
 Standard
 Representative Bolling Co.
 Membership BAB, NARTB
 President C. Bruce McConnell
 General Manager John R. Atkinson

WBIW

BEDFORD—1948—MBS

Frequency: 1340 Kc. Power: 250 Watts
 Owned-Oper. By Radio Bedford, Inc.
 Address Radio Farm, P. O. Drawer 472
 Phone Number 4421-4422
 Air Time Full Time
 News Service AP, INS
 Transcription Service Langworth, Thesaurus
 Representative W. S. Grant
 Pres., Gen. Mgr. William C. Smith, Jr.
 Program Director Claude Parsons
 Chief Engineer Carl J. Finger

WTTS

BLOOMINGTON—1949—ABC

Frequency: 1370 Kc. Power 5000 Watts d.:
 500 Watts n.
 Owned-Oper. By Sarkes Tarzian, Inc.
 Business-Studio Address 535 S. Walnut St.
 Phone Number 2-3366
 Air Time Full Time
 News Service AP
 Representative Robert Meeker Associates
 Membership BAB
 President Sarkes Tarzian
 Station Manager Glenn Van Horn
 Commercial Mgr. Ray Bartlett
 Chief Engineer Morton Weigel

WBNL

BOONVILLE—1950—KBS

Frequency: 1540 Kc. Power: 250 Watts d.
 Owned-Oper. By Boonville Bcstg. Co.
 Address Lynville Rd.
 Phone Number 980
 News Service UP
 Transcription Service Cole
 Co-O., Gen., Comm. Mgr., Chi. Engr.
 H. C. Sanders
 Co-O., Asst. Mgr., Pgm. Dir. Norman Hall

WCST

COLUMBUS—1950

Frequency: 1010 Kc. Power: 250 Watts d.
 Owned-Oper. By Syndicate Theatres, Inc.
 Address 55½ E. Court St.
 Phone Number 1057
 Transcription Service Associated, Thesaurus
 Membership BAB
 News Service AP
 President Joseph Finneran
 General Manager Dick Jewell
 Chief Engineer Phil Hurlbut

WCNB

CONNERSVILLE—1948

Frequency: 1580 Kc. Power: 250 Watts d.
 Owned-Operated By News Examiner Co.
 Business-Studio Address 406 Central Ave.
 Phone Number 1950
 News Service UP

Transcription Service World
 Representative Gill-Perna
 Secretary G. S. Tatman
 Gen., Sta., Comm. Mgr. E. M. Jackson
 Program Director Ralph T. Underwood
 Chief Engineer Earl Thompson

WTRC

ELKHART—1931—NBC

Frequency: 1340 Kc. Power: 250 Watts
 Owner-Oper. By Truth Publishing Corp.
 Business-Studio Address 116 S. Second St.
 Phone Number 3-1960
 Air Time 6 a.m.-M.
 News Service UP
 Representative John E. Pearson Co.
 President John F. Dille, Jr.
 General Manager Donald McFall
 Commercial Mgr. Don Freed
 Program Director Jerry Maloney
 Chief Engineer Lester Zellmer

WEOA

EVANSVILLE—1936—CBS

Frequency: 1400 Kc. Power: 250 Watts
 Owned-Operated By WFBS, Inc.
 Business-Studio Address 24 N.W. 3rd St.
 Phone Number 4-9215
 Air Time Full Time
 News Service AP
 Transcription Service Lang-Worth
 Representative Katz
 President Harry M. Bitner, Jr.
 General-Station-Commercial Mgr. Don Menke
 Program Director Michael Finn
 Chief Engineer William Schultz

WGBF

EVANSVILLE—1923—NBC

Frequency: 1280 Kc. Power: 5000 Watts d.:
 1000 Watts n.
 Owned-Operated By On The Air, Inc.
 Business-Studio Ad. 1001 Diamond Ave.
 Phone Number 21171
 Representative Weed & Co.
 Air Time Full Time
 News Service UP
 Membership NARTB
 President Alvin Q. Eades
 General, Station Manager Martin L. Leich
 Sales Prom., Pub. Dir. Del Greenwood
 Program Director Mrs. Pat Roper
 Chief Engineer Erwin P. Schoeny

WIKY

EVANSVILLE—1947

Frequency: 820 Kc. Power: 250 Watts d.
 Owned-Oper. By South Central Bcstg. Corp.
 Address P. O. Box 148
 Phone Number 4-8284
 Air Time Daytime
 News Service AP
 Transcription Service Thesaurus, Capitol
 Representative John E. Pearson Co.

Pres., Gen. Sta. Mgr. John A. Engelbrecht
 Chief Engineer George F. Stoltz

WJPS

EVANSVILLE—1948—ABC

Frequency: 1330 Kc. Power: 5000 Watts d.;
 1000 Watts n.
 Owned-Operated By WJPS, Inc.
 Business-Studio Address 206 Main St.
 Phone Number 5-2221
 Air Time Unlimited
 News Service AP
 Transcription Service Standard, World
 Representative George P. Hollingbery
 Membership NARTB
 President Robert S. Davis
 Gen., Sta. Mgr. Robert J. McIntosh
 Pub. Dir., Comm. Mgr. Jack McLean
 Sales Prom. Mgr., Pub. Dir. Phillip Landman
 Chief Engineer James Jared

WANE

FT. WAYNE—1948—CBS

Frequency: 1450 Kc. Power: 250 Watts
 Owned-Operated By Radio Fort Wayne, Inc.
 Address Fort Wayne Nat'l Bank Bldg.
 Phone Number Anthony 6212
 Air Time Full Time
 News Service AP
 Transcription Service Standard
 Representative Boiling
 President C. Bruce McConnell
 General Manager Robert McConnell
 Station Manager Charles E. Kennedy
 Local Commercial Manager Merlin Smith
 Program Director Robert Hill
 Chief Engineer Eugene Humphrey

WGL

FT. WAYNE—1924—ABC

Frequency: 1250 Kc. Power: 1000 Watts
 Owned-Oper. By News-Sentinel Bcstg. Co., Inc.
 Business-Studio Address 201 W. Jefferson St.
 Phone Number Eastbrook 3366
 Air Time Full Time
 Newspaper Affiliation News-Sentinel
 News Service UP
 Transcription Service Langworth
 Representative Headley-Reed
 Membership BAB
 President Helen R. Foellinger
 Gen., Sta., Comm. Mgr. Merrill C. Johnson
 Prom. Mgr., Pub. Dir. Dorsey M. Roth
 Program Director Norman Widenhofer
 Chief Engineer Damon Wilson

WKJG

FT. WAYNE—1947—MBS

Frequency: 1380 Kc. Power: 5000 Watts
 Owner Northeastern Indiana Bcstg. Co., Inc.
 Business-Studio Add. 220 E. Jefferson St.
 Phone Number Anthony 2295
 News Service UP
 Transcription Service World
 Representative Raymer

President Clarence L. Schust
 General Manager Edward G. Thoms
 Asst. to Mgr. Hilliard Gates
 Commercial Manager Carl B. Evans
 Program Dir. Calo O. Mahlock

WOWO

FT. WAYNE—1925—NBC

Frequency: 1190 Kc. Power: 10,000 Watts
 Owner Westinghouse Radio Stations, Inc.
 Bus. Studio Address 124 W. Washington Blvd.
 Phone Number Anthony 2136
 Air Time Unlimited
 News Service UP
 Transcription Service RCA Thesaurus
 Representative Free & Peters
 Membership BAB
 President Chris J. Witting
 General Manager J. E. Baudino
 Commercial Manager Tom Longworth
 Sales Prom. Mgr. G. H. Abels
 Sales Service Director Hilda C. Wohrmeyer
 Sta. Mgr. Carl Vandagriff
 Program Director Guy Harris
 Chief Engineer Bruce H. Ratts

WGRY

GARY—1950

Frequency: 1370 Kc. Power: 500 Watts d.
 Owned-Oper. By WGRY, Inc.
 Address 734 Washington St.
 Phone Number 5-5151
 News Service UP
 Transcription Service SESAC
 Pres., Gen. Mgr. George Whitney
 Program Director Robert Dietz

WWCA

GARY—1949

Frequency: 1270 Kc. Power: 1000 Watts
 Owned-Operated By Lake Bdcstg Co., Inc.
 Address Hotel Gary
 Phone Number Gary 9171
 Air Time Unlimited
 News Service AP
 Membership BAB
 Pres., Gen., Sta. Mgr. Dee O. Coe
 Comm., Sls., Prom. Mgr. Joe Fife
 Program, Publicity Director Todd Branson
 Chief Engineer Victor Voss

WJOB

HAMMOND—1928

Frequency: 1230 Kc. Power: 250 Watts
 Owned-Oper. By South Shore Bcstg. Corp.
 Business-Studio Address 449 State St.
 Phone Number Sheffield 8400
 News Service UP
 Representative Joseph Hershey McGillvra
 Pres., Gen. Mgr. R. C. Adair
 Commercial Manager Ed Rozhon
 Program Director Bill Wobus
 Chief Engineer Jess Peters

W F B M

INDIANAPOLIS—1926—CBS

Frequency: 1260 Kc. Power: 5000 Watts
 Owned-Operated By.....WFBM, Inc.
 Business-Studio Address...1330 N. Meridian St.
 Phone Number.....Lincoln 8521
 News Service.....AP, INS
 Representative.....Katz
 Membership.....NARTB, BAB
 Pres., Gen., Sta. Mgr.....Harry M. Bitner, Jr.
 Commercial Manager.....William F. Kiley
 Prom. Mgr., Pub. Dir.....Bernard W. Carney
 Program Dir.....Frank O. Sharp
 Chief Engineer.....Harold Holland

W I B C

INDIANAPOLIS—1938—MBS

Frequency: 1070 Kc. Power: 50,000 d.;
 10,000 n.
 Owned-Operated By.....WIBC, Inc.
 Business-Studio Address. 30 W. Washington St.
 Phone Number.....Lincoln 2305
 Air Time.....Full Time
 News Service.....AP, UP
 Transcription Service.....SESAC
 Representative.....John Blair
 Membership.....NARTB
 President, Gen. Mgr.....Richard M. Fairbanks
 Commercial Manager.....Gilbert I. Berry
 Sales Prom., Pgm. Dir.....William L. Dean
 Chief Engineer.....Robert W. Minton

W I R E

INDIANAPOLIS—1924—NBC

Frequency: 1430 Kc. Power: 5000 Watts d.
 Owned-Oper. By.....Indianapolis Bcstg., Inc.
 Business-Studio Add...307 N. Pennsylvania St.
 Phone Number.....Plaza 1541
 Newspaper Affiliation....Central Newspaper
 News Service.....AP
 Transcription Service.....Langworth
 Representative.....Free & Peters
 Membership.....BAB
 President.....Eugene C. Pulliam
 General Manager.....Willard C. Worcester
 Commercial Manager.....Daniel C. Park
 Prom. Mgr., Pub. Dir.....Richard Higgs
 Program Director.....M. Wayland Fullington
 Chief Engineer.....Eugene E. Alden

W I S H

INDIANAPOLIS—1941—ABC

Frequency: 1310 Kc. Power: 5000 Watts d.;
 1000 n.
 Owned-Oper. By.....Universal Bcstg. Co., Inc.
 Business-Studio Address. 1440 N. Meridian St.
 Phone Number.....Plaza 4595
 Air Time.....6 a.m.-M.
 News Service.....AP
 Transcription Service.....Thesaurus
 Representative.....Bolling
 Membership.....BAB, NARTB
 President.....C. Bruce McConnell
 V. Pres.....Robert B. McConnell

Sales Prom. Mgr., Pub. Dir.....Reid Chapman
 Station Manager.....William H. Spencer
 Program Director.....William E. Frosch
 Chief Engineer.....Stokes Gresham, Jr.

W X L W

INDIANAPOLIS—1948

Frequency: 1590 Kc. Power: 1000 Watts d.
 Owned-Oper. By.....Radio Indianapolis, Inc.
 Phone Number.....Hickory 6494
 News Service.....UP
 Representative.....John Pearson Co.
 Membership.....BAB, NARTB
 P. resident.....Lyman S. Ayres
 General Manager.....Robert D. Enoch
 Program Director.....G. A. Smith, Jr.
 Chief Engineer.....Bert Goetzinger

W I T Z

JASPER—1948

Frequency: 990 Kc. Power: 1000 Watts d.
 Owned-Operated By ..Jasper on the Air Inc.
 Address.....P. O. Box 167
 Phone Number.....Jasper 678
 Air Time.....Sunrise-Sunset
 News Service.....UP
 Transcription Service.....World
 President.....Dr. Gilbert E. Metzger
 Gen., Sta. Mgr.....Dennis Keller
 Commercial Manager.....Richard Witty
 Sales Prom. Mgr.....Joe Salvi
 Publicity Director.....James Young
 Program Director.....Rick Foster
 Chief Engineer.....Peter Russo

W I O U

KOKOMO—1948—CBS

Frequency: 1350 Kc. Power: 1000 Watts
 Owner.....North Central Indiana Bcstg. Corp.
 Business-Studio Address....State Rd. No. 26
 Phone Number.....6194
 Air Time.....Unlimited
 News Service.....AP
 Transcription Service.....Thesaurus
 Representative.....Weed
 Membreship.....NARTB, BAB
 President.....Richard Blacklidge
 V.P., Gen., Sta. Mgr.....John Carl Jeffrey
 Program Director.....William R. Cox
 Chief Engineer.....Chester Rector

W A S K

LAFAYETTE—1942—MBS

Frequency: 1450 Kc. Power: 250 watts
 Owned-Operated By.....WFAM, Inc.
 Business-Studio Address.....McCarty Lane
 Phone Number.....4300
 Air Time.....Full Time
 News Service.....UP
 Representative.....Wm. G. Rambeau
 Membership.....BAB
 President.....O. E. Richardson
 Sta., Comm. Mgr.....David Milligan
 Program Director.....Richard W. Long
 Chief Engineer.....Richard Cochran

WLOI

LA PORTE—1948

Frequency: 1540 Kc. Power: 250 Watts d.
 Owned-Oper. By La Porte Bcstg. Co.
 Business-Studio Address Rumely Hotel
 Phone Number 3734
 News Service AP
 Transcription Service Capitol
 President, Sta. Mgr. Hoyt H. Scott

WBTO

LINTON—1953

Frequency: 1600 Kw. Power: 500 Watts d.
 Owned-Oper. By The Linton Bcstg. Co.
 Address c/o WBNL, Boonville, Ind.
 Owner Henry C. Sanders

WSALLOGANSPOBT—1949—MBS
KEYSTONE

Frequency: 1230 Kc. Power: 250 Watts
 Owned-Operated By Logansport Bdg. Corp.
 Address P. O. Box 399
 Phone Number 4261
 Air Time 6 a.m.-M.
 News Service AP
 Membership NARTB, BAB
 General Manager Raymond W. Baker
 Program Director Ira McCormack
 Chief Engineer Raymond A. Olson

WBAT

MARION—1947—CBS

Frequency: 1400 Kc. Power: 250 Watts
 Owned-Operated By Marlon Radio Corp.
 Business-Studio Address 303½ S. Adams St.
 Phone Number 5500
 Air Time Full Time
 News Service AP
 Transcription Service Standard
 Representative Rambeau
 Membership NARTB
 President John Ramp
 Station Manager William Fowler
 Commercial Mgr. Wm. J. Emard
 Chief Engineer Walter E. Johnson

WIMS

MICHIGAN CITY—1947

Frequency: 1420 Kc. Power: 1000 Watts d.;
 500 n.
 Owned-Oper. By Northern Indiana Bcsters.,
 Inc.
 Business-Studio Address 415 Frankln St.
 Phone Number 5-5245
 News Service UP
 Station Representative Wm. G. Rambeau
 Pres., Gen. Mgr. William N. Udell
 Commercial Managers Al Halus, Jay Schoff
 Program Director Richard Olson
 Chief Engineer Robert J. Schilling

WLBC

MUNCIE—1926—CBS

Frequency: 1340 Kc. Power: 250 Watts
 Owned-Operated By Tri City Radio Corp.
 Business Address Hwy. No. 35
 Phone Number 4403
 Air Time Full Time
 News Service AP
 Transcription Service Standard, World
 Representative Walker, Hal Holman
 Pres., Gen. Sta. Mgr. D. A. Burton
 Commercial Manager W. F. Crain
 Program Director Lee Allerton
 Chief Engineer M. M. Crain

WLRP

NEW ALBANY—1949

Frequency: 1570 Kc. Power: 1000 Watts d.
 Owned-Operated By Ohio Valley Bcstg., Inc.
 Address Box 285
 Phone Number 4-2235
 Air Time Sunrise-Sunset
 News Service UP
 Transcription Service Lang-Worth
 Pres., Gen. Sta. Mgr. Roy L. Hickox
 Comm., Sales Prom. Mgr. Milton Lamm
 Program Director Keith Reising
 Publicity Director Joe Gillum
 Chief Engineer Eugene A. Fischer

WPGW

PORTLAND—1951

Frequency: 1440 Kc. Power: 500 Watts d.
 Owned-Oper. By Glenn West
 Address Box 608
 Phone Number 1094
 Transcription Service SESAC, World
 Owner, Gen. Mgr. Glenn West
 Program Director Ron Miller

WRAY

PRINCETON—1950

Frequency: 1250 Kc. Power: 1000 Watts d.
 Owned-Oper. By Princeton Bcstg. Co.
 Address Box 8
 Phone Number 1250
 News Service AP
 Transcription Service Lang-Worth
 Station Representative Walker
 President M. R. Lankford
 Station Manager Gene Peterson
 Commercial Mgr. D. T. Critchfield
 Chief Engineer Ray Shigley

WKBV

RICHMOND—1926—ABC

Frequency: 1490 Kc. Power: 250 Watts
 Owned-Operated By Central Bcstg. Corp.
 Bus.-Studio-Transmitter Address Richmond
 Phone Number 2-1156
 Air Time 5:45 a.m.-M.

News ServiceUP
Transcription Service.....Thesaurus
Representative Robert Meeker
Membership NARTB, BAB
President.....Paul R. Quigg
Gen., Sta. Mgr......Lester G. Spencer
Comm. Sis. Prom. Mgr......Roland L. Nusbaum
Program Director.....Charles L. Mitchell
Chief Engineer.....L. J. Duning

W S L M

SALEM—1953—KBS

Frequency: 1220 Kw. **Power:** 250 Watts d.
Owned-Oper. By.....Don H. Martin
Address Radio Ridge
Phone Number 700
News Service AP
Transcription Service.....Thesaurus, MacGregor
Representative Continental
Pres., Gen. Mgr......Don H. Martin
Commercial Mgr......Herbert L. Arms
Program Director.....Margaret Martin
Chief Engineer.....Darrell Dixon

W J C D

SEYMOUR—1949—KBS

Frequency: 1390 Kc. **Power:** 500 Watts d.
Owned-Operated By.....Dr. Azra C. Baker
Address.....1534 Ewing St.
Phone Number 1212
News Service AP
Air Time Daytime
Transcription Service.....World, Capitol
General Manager.....Azra C. Baker
Commercial Manager Robert E. Shippee
Program Director.....Roge: W. Bradley
Chief Engineer.....Arnold Haun

W H O T

SOUTH BEND—1944—ABC

Frequency: 1490 Kc **Power:** 250 Watts
Owned-Operated By South Bend Bcstg. Corp.
Address.....434 S. St. Joseph St.
Phone Number 7-1566
Air Time.....Full Time
News Service AP
Transcription Service Associated
Representative Bolling
President C. Bruce McConnell
General Manager.....Frank Crosiar
Commercial Manager.....C. J. Pajakowski
Program Director.....Bill Etherton
Chief Engineer.....Ira D. Kealy

W J V A

SOUTH BEND—1947—KBS

Frequency: 1580 Kc. **Power:** 250 Watts d.
Owned-Oper. By St. Joseph Valley Bdsg. Corp.
Address Box 179
Phone Number 4-1111
Air Time Sunrise-Sunset
News Service UP
Representative Burn-Smith
Pres., Gen. Mgr. F. R. Householder

Program Director.....Owen Lackey Jr.
Commercial Mgr......Vince Doyle
Chief Engineer.....Francis J. Bock

W S B T

SOUTH BEND—1922—CBS

Frequency: 960 Kc. **Power:** 5000 Watts
Owned-Operated By The South Bend Tribune
Bus.-Studio Address.....225 W. Colfax Ave.
Phone Number 3-6161
Newspaper Affiliation.....South Bend Tribune
News Service UP, INS
Transcrip. Serv. ... RCA Thesaurus, Standard
Representative.....Paul H. Raymer
Membership NARTB, BAB
President F. A. Miller
General Manager.....Neal B. Welch
Publicity Director.....Robert H. Swintz
Program Director Robert J. Drain
Chief Engineer.....Arthur R. O'Neill

W T C J

TELL CITY—1948

Frequency: 1230 Kc **Power:** 250 Watts
Owned-Operated By.....Tell City Bcstg. Co.
Phone Number 740
Owner, Manager.....James R. Brewer

W B O W

TERRE HAUTE—1927—NBC

Frequency: 1230 Kc **Power:** 250 Watts
Owned-Operated By Banks of the Wabash, Inc.
Business-Studio Address 303 S. Sixth St.
Phone Number Crawford 5034
Air Time Full Time
News Service UP
Transcription Service Thesaurus
Representative Weed
Membership NARTB
President Alvin Eades
Comm., Gen., Sta. Mgr. ... William F. Rippetoe
Sales Prom. Manager.....Bob Rhoads
Program Director.....Harry Frey
Publicity Director.....Ralph McHargue
Chief Engineer.....Howard Stewart

W T H I

TERRE HAUTE—1947—CBS

Frequency: 1480 Kc. **Power:** 1000 Watts
Owned-Oper. By Wabash Valley Bdg. Corp.
Address 120 South 7th Street
Phone Number Crawford 9481
Air Time 6 a.m.-M.
News Service UP
Transcription Service Langworth
Representation.....Bolling Co., Inc.
Membership NARTB, BAB
President Anton Hulman, Jr.
Gen., Sta. Mgr......Joseph M. Higgins
Sales Promotion Mgr......Robert F. Cranford
Program Director Ben Falber, Jr.
Chief Engineer.....Don Pettit

W A O V

VINCENNES—1940—MBS

Frequency: 1450 Kc. Power: 250 Watts
 Owned-Operated By: Vincennes Sun Co.
 Business Address: Grand Hotel
 Phone Number: 787
 News Service: UP
 Transcription Service: World
 Representative: Free & Peters
 President: Eugene C. Pulliam
 Gen., Comm. Mgr.: A. C. Bernstein
 Program Director: Neal Spencer
 Chief Technician: Ralph Baldwin
 Prom. Mgr.: Roy Stanley

W K A M

WARSAW—1949—KBS

Frequency: 1220 Kc. Power: 250 Watts d.
 Owned-Operated By: Kosciusko Bcstg. Corp.

Address: R.F.D. No. 1
 Phone Number: 65
 News Service: AP
 Representative: Hal Holman Co.
 President: J. W. Autenrieth, Jr.
 Chief Engineer: Howard Wheelock

W R S W

WARSAW—1952

Frequency: 1480 Kc. Power: 500 Watts
 Owned-Oper. By: Reub Williams & Sons, Inc.
 Address: Times Building
 Phone Number: 155
 News Service: UP
 Trans. Service: Capitol, Lang-Worth, World
 President: Raymond B. Williams
 General Manager: C. Reuben Williams
 Comm., Bus. Mgr.: William Mollenhour
 Program Director: Marie Snyder
 Prom. Mgr.: Jack Essenberg
 Chief Engineer: Fred Grosso

IOWA

*Pop. Feb. 1, 1954 (Est.) 2,647,000 — Families 872,000
 Radio Homes 847,000 — TV Homes 422,000 — Stations in State 50*

K A S I

AMES—1948—KBS

Frequency: 1430 Kc. Power: 1000 Watts d.
 Owned-Operated By: Ames Bcstg. Co.
 Business-Studio Address: 328½ Main St.
 Phone Number: 3460
 Air Time: Daytime
 News Service: UP
 Transcription Service: Thesaurus
 President: W. S. Rupe
 Gen., Comm. Mgr.: Arthur A. Skinner
 Program Director: R. B. Tillerson
 Chief Engineer: Doyle D. Kelso

Transcription Service: World, Thesaurus
 News Service: UP, INS
 Representative: John E. Pearson
 President: Mary G. Garvey
 General Manager: Paul E. Millex
 Commercial Manager: Robert Erickson
 Chief Engineer: Dan Garretson

K B U R

BURLINGTON—1941—ABC

Frequency: 1490. Power: 250 Watts
 Owned-Operated By: Burlington Bcstg. Co.
 Business-Studio Address: Roosevelt Ave.
 Phone Number: 7660
 Air Time: Full Time
 News Service: AP
 Transcription Service: Standard
 Representative: Taylor
 Membership: BAB
 Pres., Gen., Sta. Mgr.: Gerard B. McDermott
 Prom., Comm. Mgr.: David H. Steidle
 Program Director: Richard Mosena
 Chief Engineer: John Gallino

K J A N

ATLANTIC—1950—KBS

Frequency: 1220 Kc. Power: 250 Watts d.
 Owned-Operated By: Nishna Valley Bcstg. Co.
 Phone Number: 1717
 News Service: AP
 Transcription Service: World
 Representative: Continental, Biddick
 President: Al Hansen
 Gen., Sta. Mgr.: Franklin G. Miller
 Comm., Prom. Mgr.: H. A. Preston
 Chief Engineer: Henry L. Ankeny

K C I M

CARROLL—1950

Frequency: 1380 Kc. Power: 1000 Watts
 Owned-Oper. By: Carroll Broadcasting Co.
 Address: 520 N. Adams St.
 Phone Number: 3586
 Transcription Service: Thesaurus
 News Service: AP
 Representative: Pearson
 Membership: NARTB
 General Manager: M. W. McPherson
 Chief Engineer: Eugene Reiff

K W B G

BOONE—1950

Frequency: 1590 Kc. Power: 1000 Watts d.,
 500 Watts n.
 Owned-Operated By: Boone Bcstg. Co.
 Address: P. O. Box 36
 Phone Number: 1590

K C R I**CEDAR RAPIDS—1947—MBS**

Frequency: 1600 Kc. Power 5000 Watts
 Owned-Oper. By Cedar Rapids TV Co.
 Business-Studio Address 1st St. & 1st Ave.
 Phone Number 4-4194
 News Service AP, INS
 Transcription Service World
 Representative Burn-Smith
 President Sutherland Dows
 Gen., Comm. Mgr. W. S. Patterson
 Program Director Ralph D. Willey
 Promotion Mgr. Edna Herbst
 Chief Engineer Carl Rollert

K P I G**CEDAR RAPIDS—1949—TALL CORN**

Frequency: 1450 Kc. Power: 250 Watts
 Owned-Oper. By Cedar Rapids Bcstg.
 Business Address 211 1st St., S.W.
 Phone Number 3-8265
 News Service UP
 Transcription Service Capitol
 Representative Pearson
 Gen., Comm. Mgr. Allen H. Embury
 Program Director Don Ramsell
 Chief Engineer Al Morse

W M T**CEDAR RAPIDS—1922—CBS**

Frequency: 600 Kc. Power: 5000 Watts
 Owned-Operated By American Bcstg.
 Stations, Inc.
 Bus.-Studio Address Paramount Theater Bldg.
 Phone Number 6127
 Air Time Full Time
 News Service AP, INS, UP
 Transcription Service RCA, Lang-Worth
 Representative Katz
 Membership NARTB, BAB
 President William B. Dolph
 General Manager William B. Quarton
 Sales Manager Lew Van Nostrand
 Prom., Pub. Dir. Leo F. Cole
 Program Manager Douglas B. Grant
 Chief Engineer George Hixenbaugh

K C O G**CENTERVILLE—1949**

Frequency: 1400 Kc. Power: 100 Watts
 Owned-Operated By Centerville Bdcstg Co.
 Address 1910 South Main St.
 Phone Number 131, 407
 Air Time Unlimited
 News Service AP
 Transcription Service Thesaurus
 Representative McGillvra
 Membership NARTB
 President R. K. Beck
 Gen., Sta., Comm., Mgr. A. M. Farber
 Program Director Margaret Ashby
 Chief Engineer Walter H. Lemen

K C H A**CHARLES CITY—1949—KBS**

Frequency: 1580 Kc. Power: 250 Watts d.
 Owned-Oper. By Radio Incorporated
 Business Address 300Y2 N. Main St.
 Phone Number 787
 Air Time Daytime
 News Service UP
 Transcription Service World
 Representative Orville Lawson
 President Charles J. Ellis
 General Manager C. E. Wright
 Commercial Mgr. Vern Bromberg
 Program Director Wayne Mack
 Publicity Director Doris LaBounty
 Chief Engineer Loren Koesling

K C H E**CHEROKEE—1953**

Frequency: 1440 Kc. Power: 500 Watts d.
 Owned-Operated By Cherokee Bcstg. Co.
 Address 219½ W. Main St.
 Phone Number 51
 News Service AP
 Transcription Service Thesaurus, Langworth
 Membership NARTB
 Gen., Comm. Mgr. Russell A. Hickmon
 Prom. Mgr., Prog. Dir. Charles Resnikov
 Chief Engineer Sterling H. Heil

K R O S**CLINTON—1941—MBS-TALL CORN**

Frequency: 1340 Kc. Power: 250 Watts
 Owned-Operated By Clinton Bdcstg Corp.
 Address 246 Fifth Avenue South
 Phone Number 448
 Air Time Full Time
 News Service UP
 Transcription Service World
 Representative Pearson
 Membership NARTB, BAB
 President W. S. Jacobsen
 General Manager B. M. Jacobson
 Commercial Mgr. Darline Gordon
 Program Director Ralph Stoeckel
 Chief Engineer Gerald Parker

K S W I**COUNCIL BLUFFS—1947**

Frequency: 1560 Kc. Power: 500 Watts d.
 Owned-Operated By Nonpareil Bdcstg. Co.
 Address 120 S. Main
 Phone Number Co. Bluffs 4041, Omaha,
 Jackson 7736
 Air Time Day Time
 News Service AP
 Transcription Service Thesaurus
 Representative Arthur Hagg & Assoc.
 Membership NARTB
 President Robert R. O'Brien
 Gen., Sta. Mgr., Chief Eng. Robert H. O'Brien
 Commercial Manager Had Hughes
 Sales Promotion Mgr. Harold Abramson
 Program Director R. M. Hallgren
 Publicity Director Marge Morris

KSIB**CRESTON—1946—TALL CORN**

Frequency: 1520 Kc. Power: 1000 Watts d.
 Owned-Oper. By Southwest Iowa Bcstg. Co.
 Address Creston
 Phone Number
 News Service INS
 Transcription Service Thesaurus
 Representative Pearson
 President Arden D. McKee
 Gen., Sta., Comm. Mgr. E. M. Hoening
 Publicity Director Jack Mills
 Chief Engineer William Zollman

KFMA**DAVENPORT—1952**

Frequency: 1580 Kc. Power: 250 Watts d.
 Owned-Operated By KFMA Bcstg. Co.
 Address 415 Perry St.
 Phone Number 6-4407
 News Service UP
 Transcription Service Capitol, Standard
 Pres., Gen., Comm. Mgr. A. D. Pierce
 Promotion Mgr. Doris Hanner
 Pgm., Pub. Dir. Eugene Larsen
 Chief Engineer Francis B. Shawver

KSTT**DAVENPORT—1946—MBS**

Frequency: 1170 Kc. Power: 1000 Watts
 Owned-Operated By Davenport Bcstg. Co. Inc.
 Bus. Studio Address 310 Harrison St.
 Phone Number 6-2541
 Air Time Full Time
 News Service INS
 Transcription Service C. P. MacGregor
 Representative Sears & Aye
 President Hugh R. Norman
 General Manager Jerry Dunphy
 Commercial Mgr. Neil Conklin
 Nat'l Sales Mgr. Lois Snively
 Program Director Bruno Olson
 Publicity Director I. F. Whalen
 Chief Engineer A. M. McGregoo

WOC**DAVENPORT—1922—NBC**

Frequency: 1420 Kc. Power: 5000 Watts
 Owned-Operated By Tri-City Bcstg. Co.
 Address 805 Brady Street
 Phone Number 3-3661
 Air Time Full Time
 News Service UP
 Transcription Service Thesaurus
 Representatives Free & Peters, Inc.
 Membership NARTB, BAB
 President Col. B. J. Palmer
 V.P. & Treasurer D. D. Palmer
 Exec. Vice-Pres. Ralph Evans
 Secretary Wm. D. Wagner
 Manager Ernest C. Sanders
 Sales Manager Mark Wodlinger
 Program Director Warren Vasen
 Asst. Mgr. Fred A. Reed

Publicity Director Paul Ives
 Chief Engineer Paul Arvidson

KDEC**DECORAH—1947—MBS-TALL CORN**

Frequency: 1240 Kc. Power: 250 Watts
 Owned-Operated By Scenic Bcstg. Co.
 Business-Studio Address State Road
 Phone Number 1240
 News Service AP
 Transcription Service Thesaurus
 Representative Pearson
 Membership NARTB
 Pres., Gen. Co-Mgr. Verne Koenig
 Gen. Co-Mgr., Comm. Mgr. Kenneth Bjerke
 Sales Prom. Mgr. John Hansen
 Chief Engineer Arnie Zaruba

KCBC**DES MOINES—1947**

Frequency: 1390 Kc. Power: 1000 Watts
 Owned-Oper. By Majestic Bcstg. Co.
 Business-Studio Address 3512 Ingersoll
 Phone Number 7-4483
 News Service INS
 President Karl Peters
 General Manager Rollo H. Bergeson
 Chief Engineer Bob Brown

KIOA**DES MOINES—1948—MBS**

Frequency: 940 Kc. Power: 10,000 Watts d.
 5,000 Watts n.
 Owned-Oper. By Independent Bcstg. Co.
 Address 10th & Mulberry
 Phone Number 2-9191
 Air Time Full Time
 News Service INS, UP
 Transcription Service World
 Representative A. M. Radio Sales Co.
 President Ralph L. Atlass
 General Manager Harold W. Cassill
 Program Director Lee L. Harris
 Chief Engineer Lyle Nolan

KRNT**DES MOINES—1935—CBS**

Frequency: 1350 Kc. Power: 5000 Watts
 Owned-Operated By Cowles Bcstg. Co.
 Business-Studio Address Register & Tribune
 Bldg.
 Phone Number 3-2111
 Newspaper Affiliation Register-Tribune
 Air Time Full Time
 News Service AP, UP
 Transcription Service Standard
 Station Representative The Katz Agency
 Membership NARTB
 President Gardner Cowles
 General-Station Manager Bob Dillon
 Commercial Manager Paul Elliott
 Sales Prom. Mgr., Pub. Dir. Joe Hudgens
 Program Director Dick Covey
 Chief Engineer Charles Quentin

K S O**DES MOINES—1921—ABC**

Frequency: 1460 Kc. Power: 5000 Watts
 Owned-Operated By: Murphy Bcstg. Co.
 Business-Studio Address: 800 Farm Bldg.
 Phone Number: 3-0571
 News Service: AP, INS
 Transcription Service: Capitol
 Representative: Avery-Knodel
 Membership: NARTB
 President: Kingsley H. Murphy
 Commercial Mgr.: Gene Shumate
 Pub., Pgm. Dir.: B. C. Baldwin
 Chief Engineer: F. E. Bartlett

K W D M**DES MOINES—1948**

Frequency: 1150 Kc. Power: 1000 Watts
 Owned-Operated By: Des Moines Bcstg. Corp.
 Business-Studio Address: 407 Fifth Ave.
 Phone Number: 2-8363
 Air Time: Full Time
 News Service: INS
 Transcription Service: Cole, SESAC, Associated
 Pres., Comm. Mgr.: George W. Webber
 Gen., Sta. Mgr.: Robert L. Webber
 Program Director: Edith L. Webber
 Sales Prom. Mgr.: Les Gates
 Chief Engineer: Werner Schwarz

W H O**DES MOINES—1924—NBC**

Frequency: 1040 Kc. Power: 50,000 Watts
 Owned-Operated By: Central Bcsta. Co.
 Business-Studio Address: 914 Walnut St.
 Phone Number: 3-7147
 Air Time: Full Time
 News Service: AP, INS, UP
 Transcription Service: Thesaurus, SESAC
 Station Representative: Free & Peters
 Membership: NARTB, BAB
 President: Col. B. J. Palmer
 Vice-Pres. & Treas.: D. D. Palmer
 V. Pres. & Resident Mgr.: Paul A. Loyel
 Exec. V. Pres.: Ralph Evans
 Sales Manager: Harold Fulton
 Sales Promotion: John Schweiker
 Program Director: Jack Kerrigan
 Production Director: Kenneth Gfeller
 News Bureau Manager: Jack D. Shelley
 Chief Engineer: Reed E. Snyder

K D T H**DUBUQUE—1941—NBC
TALL CORN**

Frequency: 1370 Kc. Power: 1000 Watts
 Owner: Dubuque Telegraph-Herald
 Bus-Studio Address: Eighth Ave. & Bluff St.
 Phone Number: 3-7351
 Newspaper Affiliation: Telegraph-Herald
 News Service: AP
 Transcription Service: World
 Station Representative: Pearson

Membership: NARTB
 President: Fred Woodward
 General-Station Manager: K. S. Gordon
 Commercial Manager: A. C. Newburgh
 Program Director: George Freund
 Publicity Director: Gerald McAleece
 Chief Engineer: Robert I. Hancock

W D B Q**DUBUQUE—1933—MBS-ABC**

Frequency: 1490 Kc. Power: 250 Watts
 Owned-Operated By: Dubuque Bcstg. Co.
 Business-Studio Address: 505 Main St.
 Phone Number: 3-8241
 Air Time: Full Time
 News Service: UP
 Transcription Service: Thesaurus
 Representative: Robert Meeker
 Membership: NARTB
 Exec. V.P., Gen. Sta. Mgr.: James D. Carpenter
 Commercial Mgr.: Harry Hatzenbuehler
 Program Director: Gleason Kisteler
 Publicity Director: R. E. Carpenter
 Chief Engineer: Barker-Heim

K L I L**ESTERVILLE—1952—ABC**

Frequency: 1340 Kc. Power: 100 Watts
 Owned-Operated By: Esterville Bcstg. Co.
 Address: Box 173
 Phone Number: 1800
 News Service: AP
 Transcription Service: Lang-Worth, SESAC
 Pres., Gen. Mgr.: Wm. E. Schons
 Commercial Mgr.: Jack Turnbull
 Program Director: Gene Randolph

K F A D**FAIRFIELD—1953—KBS**

Frequency: 1570 Kw. Power: 250 Watts d.
 Owned-Oper. By: Fairfield Bcstg. & TV Corp.
 Address: Highway 34 W.
 Phone Number: 345
 President: Carl D. Boyer
 Vice-Pres., Gen. Mgr.: James D. Mortwedt
 Program Director: Don Mortwedt
 Commercial Mgr.: Eugene Spiker
 Chief Engineer: Tom Kleckner

K V F D**FT. DODGE—1939—MBS
TALL CORN**

Frequency: 1400 Kc. Power: 250 Watts
 Owned-Operated By: Northwest Bcstg. Co.
 Business-Studio Address: Warden Bldg.
 Phone Number: Walnut 3761
 Air Time: Full Time
 News Service: UP, INS
 Transcription Service: Thesaurus
 Representative: Pearson
 Membership: NARTB, BAB
 President, General Manager: Edward Breen
 Commercial Manager: Max E. Landes
 Program Director: Drexel Peterson
 Chief Engineer: David G. Sinclair

KXGI

FT. MADISON—1948

Frequency: 1360 Kc. Power: 500 Watts d.
 Owned-Oper. By: KXGI, Inc.
 Business-Studio Address: Marquette Bldg.
 Phone Number: 1360
 Air Time: Day Time
 News Service: UP
 Transcription Service: Standard
 Representative: Hal Holman
 President: W. E. Walker
 Gen., Sta., Prom. Mgr.: Greg Rouleau
 Commercial Mgr.: Paul Oye
 Pgm., Pub. Dir.: Lloyd Mallette
 Chief Engineer: Harold Hackbarth

KXIC

IOWA CITY—1948

Frequency: 800 Kc. Power: 1000 Watts d.
 Owned-Oper. By: Johnson County Bcstg. Corp.
 Bus.-Studio Address: 108½ E. Washington St.
 Phone Number: 8-1181
 News Service: INS
 Representative: Pearson
 Membership: BAB, NARTB
 President: Scott Swisher
 Gen., Comm. Mgr.: Gene Claussen
 Sales Prom. Mgr.: F. M. Broeders
 Chief Engineer: Elliott Full

KOKX

KEOKUK—1948

Frequency: 1310 Kc. Power: 1000 Watts d.
 500 Watts n.
 Owned-Operated By: Keokuk Bcstg. Co.
 Address: 4 So. 5th St.
 Phone Number: 235
 Air Time: Unlimited
 News Service: AP
 Transcription Service: World, Capitol
 President: H. W. Stadler
 Gen., Comm., Prom. Mgr.: Herb Nelson
 Program Director: Virgil Fortner
 Chief Engineer: James L. Mott

KFJB

MARSHALLTOWN—1923—MBS

TALL CORN

Frequency: 1230 Kc. Power: 250 Watts
 Operated By: Marshall Electric Co.
 Business-Studio Address: 133 E. Main St.
 Phone Number: 3361
 Air Time: Full Time
 News Service: UP
 Transcription Service: Thesaurus
 Representative: Pearson
 General Manager: William P. White
 Commercial Manager: William C. Doll
 Prom. Mgr., Prog. Dir.: Allan N. Schrock
 Chief Engineer: Herbert G. Anderson

KGLO

MASON CITY—1937—CBS

Frequency: 1300 Kc. Power: 5000 Watts

Owned-Operated By: Lee Radio, Inc.
 Bus.-Studio Address: 2nd & Pennsylvania
 Phone Number: 2800
 Air Time: Full Time
 News Service: AP, UP
 Transcription Service: World
 Representative: Weed
 Membership: NARTB, BAB
 President: Lee P. Loomis
 Exec. V.P., Gen. Mgr.: Herbert R. Ohrt
 Comm., Prom. Mgr.: Lloyd D. Loers
 Publicity Director: Donald Harrer
 Program Director: William G. Suter
 Chief Engineer: Roger E. Sawyer

KRIB

MASON CITY—1948—MBS

Frequency: 1490 Kc. Power: 250 Watts
 Owned-Oper. By: Mason City Bcstg. Co.
 Address: Box 885
 Phone Number: 5400
 Representative: Pearson
 Transcription Service: Thesaurus
 News Service: AP
 President: W. G. Kelly
 General Manager: Marlin T. Obie
 Commercial Mgr.: Donald Obie
 Program Director: Bob Cavanaugh
 Chief Engineer: Paul Dominguez

KSMN

MASON CITY—1947

Frequency: 1010 Kc. Power: 1000 Watts d.
 Owned-Operated By: Mohawk Bcstg. Co.
 Business-Studio Address: Weir Bldg.
 Phone Number: 5420
 Air Time: Sunrise-Sunset
 News Service: UP
 Transcription Service: Associated
 Pres., Gen. Mgr.: Robert M. Carson
 Commercial Mgr.: Steve M. Hoft
 Program Director: Milton H. Cohen
 Chief Engineer: Hubert J. Marshall

KWPC

MUSCATINE—1947

Frequency: 860 Kc. Power: 250 Watts d.
 Owned-Operated By: Muscatine Bcstg. Co.
 Phone Number: 860
 Air Time: Day Time
 News Service: UP
 Transcription Service: World
 Representative: Pearson
 Membership: NARTB, BAB
 Comm., Gen., Sta. Mgr.: George J. Volger
 Program Director: Marion Templeman
 Chief Engineer: Darrell Dorsey

KOEL

OELWEIN—1950—TALL CORN

Frequency: 950 Kc. Power: 500 Watts
 Owned-Oper. By: Northeast Iowa Radio Corp.
 Address: 4½ W. Charles St.
 Phone Number: 120-1
 Air Time: Full Time

Representative Pearson
 Transcription Service.....Thesaurus, SESAC
 News Service.....INS, UP
 Membership.....NARTB, BAB
 President.....C. W. Crahan
 Gen., Sta. Mgr.....W. J. Teich
 Comm., Prom. Mgr.....Donald McKee
 Prog. Dir.....Ed Jenkins
 Publicity Director.....Len Bjella
 Chief Engineer.....Burt Murphy

K B O E

OSKALOOSA—1950—TALL CORN
 Frequency: 740 Kc.....Power: 250 Watts d.
 Owned-Oper. By.....Oskaloosa Bcstg. Co.
 Address.....Highway 63, N. of Oskaloosa
 Phone Number.....3-3493
 Transcription Service.....Thesaurus
 News Service.....AP
 Representative.....Pearson
 Membership.....NARTB
 President.....E. G. Wenrick
 General Manager.....Ken Kilmer
 Commercial Mgr.....G. L. Stanley
 Program Director.....Bob Henry
 Chief Engineer.....Robert W. Moore

K B I Z

OTTUMWA—1941—MBS

Frequency: 1240 Kc.....Power: 250 Watts
 Owned-Operated By.....KBIZ, Inc.
 Address.....2513 N. Court Rd.
 Phone Number.....2422
 News Service.....AP
 Transcription Service.....World
 Membership.....NARTB
 President, General Mgr.....James J. Conroy
 Station Manager.....Alice E. Fisher
 Program Director.....Larry Shepard
 Chief Engineer.....Lloyd Hanson

K F N F

SHENANDOAH—1924—MBS

Frequency: 920 Kc.....Power: 1000 Watts d.;
 500 Watts n.
 Owned-Operated By.....Capital Bcstg. Co.
 Address.....Shenandoah
 Phone Number.....1302
 News Service.....AP, INS
 Transcription Service.....World, SESAC
 Representative.....Pearson
 Membership.....NARTB, BAB
 President.....C. J. Abbott
 Gen., Comm. Manager.....C. Earl Williams
 Program Director.....Earl Blakesley
 Chief Engineer.....Franz Cherny

K M A

SHENANDOAH—1925—ABC

Frequency: 960 Kc.....Power: 5000 Watts
 Owned-Operated By.....May Bcstg. Co.
 Phone Number.....192
 Air Time.....Unlimited
 News Service.....AP, UP
 Transcription Service.....Capitol, SESAC

RepresentativeEdward Petry
 Membership.....NARTB
 President.....Edward W. May
 General Manager.....Owen Saddler
 Station Manager.....Anthony Koelker
 Commercial Mgr.....Arden Swisher
 Pub. Dir., Sales Prom. Mgr.....Joe Baker
 Program Director.....Warren Nielson
 Chief Engineer.....R. J. Schroeder

K C O M

SIOUX CITY—1949—TALL CORN

Frequency: 620 Kc.....Power: 1000 Watts
 Owned-Operated By.....KCOM Bcstg. Co.
 Address.....620 Insurance Exchange Bldg.
 Phone Number.....8-0628
 Air Time.....Unlimited
 News Service.....UP
 Transcription Service.....Standard
 Representative.....Pearson
 Membership.....NARTB, BAB
 President & Manager.....Dietrich Dirks
 Sales, Prom. Mgr.....Hap Burgess
 Program Director.....Dean Murray
 Prog. Dir., Chief Eng.....Al Smith

K S C J

SIOUX CITY—1927—ABC

Frequency: 1360 Kc.....Power: 5000 Watts
 Owned-Operated By.....Perkins Bros. Co.
 Business-Studio Address.....415 Douglas St.
 Phone Number.....5-7993
 News Service.....AP
 Transcription Service.....Lang-Worth, World
 Representative.....George P. Hollingbery
 Membership.....NARTB
 President.....W. R. Perkins
 Manager.....E. T. Flaherty
 Program Director.....Elizabeth Sammons
 Publicity Director.....Jean Harrady
 Chief Engineer.....Ernest Kruger

K T R I

SIOUX CITY—1938—MBS

Frequency: 1470 Kc.....Power: 5000 Watts
 Owned-Operated By.....Sioux City Bcstg. Co.
 Business-Studio Address.....400 Commerce Bldg.
 Phone Number.....8-0165
 News Service.....UP
 Transcription Service.....Thesaurus
 Representative.....Venard
 President.....John C. Kelly
 General Manager.....James Mitchell
 Sales Prom. Dir.....Harry Bulow Jr.
 Program Director.....Bob Hansen
 Chief Engineer.....Sam Seldon

K I C D

**SPENCER—1941—MBS
 TALL CORN**

Frequency: 1240 Kc.....Power: 250 Watts
 Owned-Oper. By.....Iowa Great Lakes Bcstg. Co.
 Address.....Spencer
 Phone Number.....1240
 News Service.....AP

Transcription Service. Standard, Thesaurus
 Representative Pearson
 Membership BAB, NARTB
 Pres., Gen., Sta. Mgr. Ben B. Sanders
 Comm., Prom. Mgr. Kenneth Black
 Program Director Mason Dixon
 Publicity Director Tom Shumate
 Chief Engineer Eldon Kanago

KAYL

STORM LAKE—1948

Frequency: 990 Kc. Power: 250 Watts d.
 Owned-Operated By Cornbelt Bcstg. Co.
 Address Park Building
 Phone Number 1490-1
 News Service AP
 Transcription Service. World, Standard
 Membership NARTB, BAB
 President O. J. Grau
 Gen., Sta., Comm. Mgr. Gene P. Loffler
 Program Director P. R. Benson
 Chief Engineer Paul Tarrant

KWWL

WATERLOO—1947—MBS

Frequency: 1330 Kc. Power: 5000 Watts d.,
 1000 Watts n.
 Owned-Operated By Black Hawk Bdcstg Co.
 Address Hotel Russell Lamson
 Phone Number 4404
 News Service AP
 Representative Headley-Reed
 Membership NARTB, BAB

Pres., Gen., Sta. Mgr. Ralph J. McElroy
 Commercial Manager Donald E. Inman
 Sales Prom. Mgr. Virgil D. Clark
 Program Manager Charles Freburg
 Publicity Dir. Raymond C. Starr
 Chief Engineer Gerald McCasland

KXEL

WATERLOO—1942—ABC

Frequency: 1540 Kc. Power: 50,000 Watts
 Owned-Oper. By Josh Higgins Bcstg. Co.
 Address Highway 20 East
 Phone Number 3-3371, 3-3372
 News Service INS
 Transcription Service SESAC
 Representative Avery-Knodel
 Pres., Gen. Mgr. Joe DuMond
 Commercial Mgr. A. J. DuMond
 Program Dir. Emyln Owen
 Chief Engineer Don Kassner

KJFJ

WEBSTER CITY—1950—KBS

Frequency: 1570 Kc. Power: 250 Watts d.
 Owned-Oper. By Land O'Corn Bcstg. Co.
 Address Box 222
 Phone Number 1500
 News Service AP
 Transcription Service Thesaurus, Capitol
 President Charles V. Warren
 General Manager Ray Malmberg
 Pgm. Dir. G. D. Warland
 Chief Engineer Cecil C. Segar

THOSE WHO KNOW FAMOUS BRANDS

Says a sales-minded station executive: "We buy news for re-sale. We find **AP** news is not only favored by our sponsors, but **AP's** complete coverage gives us a gratifying revenue potential because of the variety of packages we can make of it."

. . . . KNOW THE MOST FAMOUS
 BRAND IN NEWS IS **AP**

KANSAS

Pop. Feb. 1, 1954 (Est.) 1,943,000 — Families 583,000
Radio Homes 554,000 — TV Homes 215,500 — Stations in State 40

KSOK

ARKANSAS CITY—1947—KBS

Frequency: 1280 Kc. Power: 1000 Watts d.
Owned-Operated By The KSOK Bdcstg. Co.
Address Box 455
Phone Number 2666
News Service AP
Transcription Service Lang-Worth
President Oscar S. Stauffer
General Manager S. C. Thompson
Program Director Richard Moore
Commercial Mgr. C. E. Archer
Chief Engineer Edward H. Howe

KARE

ATCHISON-ST. JOSEPH—1939

Frequency: 1470 Kc. Power: 1000 Watts
Owned-Oper. By Griffith-Buening Bdstg. Co.
Address Fifth & Kansas Ave., Atchison
Phone Number 2447
Air Time 5:45 a.m.-12 M.
News Service AP
Representative Sears & Ayre
Transcription Service Standard
General Manager J. M. Griffith
Station Manager Paul H. Buening
Comm. Mgr. Robert Nelson
Publicity Director Edna Shelly
Chief Engineer L. H. Winegardner

KCRB

CHANUTE—1952—KBS

Frequency: 1460 Kc. Power: 1000 Watts d.
Owned-Operated By Cecil W. Roberts
Address Box 132
Phone Number 434
News Service UP
Representative H.I. F. Best
President Cecil W. Roberts
Gen. Mgr., Chief Engr. D. W. Hoisington
Program Director Joe Young

KGGF

COFFEYVILLE—1930—ABC

Frequency: 690 Kc. Power: 10,000 Watts d.,
5000 Watts n.
Owned-Oper. By The Midwest Bcstg. Co., Inc.
Business-Studio Address 8th & Elm
Phone Number 1843-4
Air Time 6 a.m.-12 M.
News Service AP, INS
Transcription Service World
Representative Weed
Membership NARTB
President Richard M. Seaton
Gen., Sales Prom. Mgr.,
Pub. Dir. Robert L. Pratt
Commercial Manager E. B. Spoonamore

Program Dir. Richard S. Embody
Chief Engineer J. S. Jaminet

KXXX

COLBY—1947

Frequency: 790 Kc. Power: 5000 Watts d.
Owned-Oper. By Western Plains Bcstg. Co.
Address 380 W. 4th St.
Phone Number 790
Air Time Daytime
News Service UP
Transcription Service RCA
Representative Headley-Reed
President Don Searle
V.P., Mgr. Ed Mason
Commercial Mgr. William A. Martin
Promotion Mgr. Quinl McCredie
Chief Engineer V. L. Lynch

KFRM

CONCORDIA—1948—CBS

Frequency: 550 Kc. Power: 5000 Watts d.
Owned-Oper. By Midland Bcstg. Co.
Address KMBC Bldg., Kans. City, Mo.
Phone Number Harrison 2650
News Service AP, UP
Transcription Service Langworth
Representative Free & Peters
President Arthur B. Church
Vice-Pres., Gen. Mgr. George J. Higgins
Program Director Roderick B. Cupp
Promotion Mgr. Harold W. Storm
Chief Engineer C. E. Moler

KGNO

DODGE CITY—1930

Frequency: 1370 Kc. Power: 5000 Watts d.;
1000 Watts n.
Owned-Oper. By Dodge City Bcstg. Co.
Business Address 705 Second St.
Phone Number 1370
Air Time 6 a.m.-11 p.m.
Newspaper Affiliation Dodge City Daily Globe
News Service AP
Representative Art Hagg
Membership NARTB, BAB
President J. C. Denious
Gen., Sta. Mgr. W. Elliott
Program Director Herschel Holland
Chief Engineer Frank Miller
Sales Prom. Mgr. Ruth Peterson

KBTO

EL DORADO—1953

Frequency: 1360 Kw. Power: 500 Watts d.
Owned-Oper. By C. A. Tedrick
Address Box 168
Phone Number 130
Owner O. A. Tedrick

General Manager..... B. E. Brown
 Chief Engineer..... Jay H. Williams

K T S W

EMPORIA—1939—MBS

Frequency: 1400 Kc.....Power: 250 Watts
 Owned-Oper. By..... Emporia Bcstg. Co., Inc.
 Business Address..... Soden's Grove
 Phone Number..... 153
 Air Time..... Unlimited
 News Service..... AP
 Transcription Service..... Thesaurus
 Representative..... Gill-Perna, W. C.
 President..... G. F. Reed
 Commercial Manager..... Harold Servey
 Program Director..... Wilma Slattery
 Chief Engineer..... Everett Thompkins

K G A R

GARDEN CITY—1948

Frequency: 1050 Kc.....Power: 1000 Watts d.
 Owned-Oper. By..... Ark Valley Bcstg. Co., Inc.
 Business-Studio Address..... R.R. No. 1
 Phone Number..... 3041
 News Service..... UP
 Transcription Service..... Associated
 Representative..... Hal Holman Co.
 President..... Ellsworth Sherman
 General Manager..... M. R. Pearce
 Program Director..... Lo raine L. Pearce
 Chief Engineer..... Robert Breeding

K I U L

GARDEN CITY—1935—MBS

Frequency: 1240 Kc.....Power: 250 Watts
 Owned-Oper. By..... KIUL, Inc.
 Business-Studio Address..... 509½ N. Main
 Phone Number..... 3251
 News Service..... AP
 Transcription Service..... World
 Pres., Gen., Sta. Mgr..... Robert Wells
 Commercial Manager..... Bob Emery
 Program Director..... Tony Jewell
 Promotion Director..... Ann Conrad
 Chief Engineer..... Joe Tennesen

K W G B

GOODLAND—1947—MBS-KBS

Frequency: 730 Kc.....Power: 1000 Watts d.
 Owner-Oper. By..... Goodland Bcstg. Co.
 Address..... Hotel Howard
 Phone Number..... 331
 News Service..... UP
 Transcription Service..... Capitol, Cole
 Owner, General Mgr..... James E. Blair
 Commercial Mgr..... Bert Blair
 Chief Engineer..... Lyle Fick

K V G B

GREAT BEND—1937—NBC

Frequency: 1590 Kc.....Power: 5000 Watts
 Owned-Operated By..... KVGB, Inc.

Business-Studio Address..... 2103 Forest
 Phone Number..... 4317
 Air Time..... Full Time
 News Service..... AP
 Newspaper Affiliation..... "Daily Tribune"
 Transcription Service..... Thesaurus
 Representative..... John E. Pearson
 Membership..... NARTB
 President..... Helen T. Coogan
 V.P., Gen., Sta. Mgr..... Grover C. Cobb
 Asst. Mgr..... Sherwood R. Parks
 Sales Manager..... Bill J. Jarvis
 Program Director..... Ray H. Beals
 Chief Engineer..... Gilbert Hanzlicek

K A Y S

HAYS—1948—KBS

Frequency: 1400 Kc.....Power: 250 Watts
 Owned-Operated By..... KAYS, Inc.
 Phone Number..... 4-2578
 Address..... 2450 Hall St.
 Air Time..... Full Time
 Newspaper Affiliation..... Hays Daily News
 News Service..... AP
 Transcription Service..... Langworth
 Membership..... NARTB, BAB
 President..... Frank Motz
 Gen., Sta., Comm. Mgr..... Bob Schmidt
 Program Director..... Max Bicknell
 Publicity Director..... Janie Roth
 Promotion Manager..... Bud Ryan
 Chief Engineer..... Glen Barnett

K W B W

HUTCHINSON—1935—NBC

Frequency: 1450 Kc.....Power: 250 Watts
 Owned-Oper. By..... Nation's Center Bcstg. Co.
 Business-Studio Address..... Box 1026
 Phone Number..... 24486
 Air Time..... Full Time
 News Service..... AP
 Transcription Service..... World
 Representative..... Taylor
 Membership..... NARTB
 President..... Bess Marsh Wyse
 General Manager..... Harold E. King
 Commercial Manager..... Kainor Carson
 Program Director..... Edward Welch
 Publicity Director..... Marguerite MacMorris
 Chief Engineer..... Bill Hart

K W H K

HUTCHINSON—1946

Frequency: 1260 Kc.....Power: 1000 Watts d.:
 500 n.
 Owned-Operated By..... KWHK Bcstg. Co., Inc.
 Business-Studio Address..... 18 W. 5th St.
 Phone Number..... 5-461
 Air Time..... Full Time
 News Service..... AP
 Transcription Service..... Thesaurus
 Representative..... Everett-McKinney
 President..... James E. Murray
 General Manager..... Vern Minor

Program Director.....Jim Murray, Jr.
 Chief Engineer.....Millard Clary

KIND
 INDEPENDENCE—1947

Frequency: 1010 Kc.....Power: 250 Watts d.
 Owned-Operated By.....Central Bcstg., Inc.
 Bus.-Studio-Transmitter.....Professional Bldg.
 Phone Number.....1010
 News Service.....AP
 Membership.....BAB
 Pres., Gen. Mgr.....J. Nelson Rupard
 Chief Engineer.....James Teats

KJCK
 JUNCTION CITY—1949

Frequency: 1420 Kc...Power: 1000 Watts d.
 Owner-Oper. By.....Junction City Bcstg. Co.
 Address.....724½ No. Washington St.
 Phone Number.....18-3165
 Air Time.....Daytime
 News Service.....UP
 Transcription Service.....World
 Pres., General Manager.....R. L. Weir, Jr.
 Commercial Mgr.....James Platt
 Program Director.....Jack Horner

KCKN
 KANSAS CITY—1930

Frequency: 1340 Kc.....Power: 250 Watts
 Owned-Operated By.....KCKN Bcstg. Co.
 Business Address.....300 Walltower Bldg.
 Phone Number.....Victor 3884
 Air Time.....Full Time
 News Service.....AP, UP
 Transcription Service.....Lang-Worth, Standard
 Representative.....Capper Publications
 President.....W. A. Bailey
 General Manager.....Ben Ludy
 Program Director.....George Stump
 Chief Engineer.....Louis Dickensheets

KLWN
 LAWRENCE—1951

Frequency: 1320 Kc.....Power: 500 Watts d.
 Owned-Operated By.....Lawrence Bcstrs. Inc.
 Address.....Lawrence
 Phone Number.....3431
 News Service.....UP
 Transcription Service.....Thesaurus
 Representative.....W. S. Grant
 Membership.....NARTB, BAB
 President.....R. E. Graber
 Gen., Sta. Mgr.....Arden Booth
 Program Director.....Ed Hundley
 Chief Engineer.....Hal Carlson

KCLO
 LEAVENWORTH—1948—KBS

Frequency: 1410 Kc.....Power: 500 Watts d.
 Owned-Oper. By.....Midwest Bcstg. Sys.
 Address.....Farmington

Phone Number.....3620
 Air Time.....Day Time
 News Service.....UP
 Representative.....Hil F. Best
 President.....Cecil W. Roberts
 Station Manager.....Chet B. Kozak
 Commercial Mgr.....Jack Campbell
 Chief Engineer.....Del Rush

KSCB
 LIBERAL—1948

Frequency: 1270 Kc....Power: 1000 Watts d.
 Owned-Oper. By...Seward County Bcstg. Co.
 Business Address.....P. O. Box 311
 Phone Number.....3891
 Air Time.....Day Time
 News Service.....UP
 Transcription Service.....Lang-Worth
 Representative.....Hil F. Best
 Membership.....NARTB, BAB
 President.....Alf M. Landon
 General Manager.....Leon S. Salathiel
 Commercial Manager.....Roy Pearce
 Program Director.....Bill Scott
 Chief Engineer.....J. A. Seegars

KMAN
 MANHATTAN—1950

Frequency: 1350 Kc.....Power: 500 Watts d.
 Owned-Oper. By.....Manhattan Bcstg. Co.
 Address.....114 No. 4th St.
 Phone Number.....PR 8-4451
 Transcription Library.....Thesaurus, SESAC
 Newspaper Affil...."Daily Mercury-Chronicle"
 News Service.....AP
 President.....Fred A. Seaton
 Gen., Sta. Manager.....Warren L. Mowder
 Commercial Mgr.....Paulson E. Leighton
 Program Director.....Sam Blessing
 Chief Engineer.....Herbert P. Lavin

KNEX
 McPHERSON—1949—KBS

Frequency: 1540 Kc.....Power: 250 Watts d.
 Owned-Operated By.....McPherson Bcstg. Co.
 Phone Number.....1540
 News Service.....AP
 Transcription Service.....Thesaurus
 Membership.....BAB
 General Manager.....Henry Dais
 Chief Engineer.....Claude Hughes

KJRG
 NEWTON—1953

Frequency: 950 Kw.....Power: 500 Watts d.
 Owned-Oper. By.....Geo. Basil Anderson
 Phone Number.....3240
 Representative.....Continental, Biddick
 Owner.....Geo. Basil Anderson
 General Manager.....Robert Kent
 Commercial Mgr.....William Fellner
 Program Director.....Ken Stobaugh

KOFO

OTTAWA—1949

Frequency: 1220 Kc. Power: 250 Watts d.
 Owned-Operated By: Ottawa Bcstg. Co.
 Address: 20th & S. Main
 Phone Number: 1045
 Air Time: Daytime
 News Service: UP
 Transcription Service: Capitol. Lang-Worth
 Partner, Gen. Mgr.: J. N. Jobs
 Partner: Herbert M. Jobs
 Commercial Mgr.: Thomas F. Ruble

KLKC

PARSONS—1948

Frequency: 1540 Kc. Power: 250 Watts d.
 Owned-Oper. By: Community Bcstg. Co.
 Business-Studio Address: 1904 Broadway
 Phone Number: 4050
 Air Time: Sunrise-Sunset
 News Service: AP
 Transcription Service: Thesaurus. Associated
 President: Clyde M. Reed, Jr.
 General Manager: Raeburn D. Drenner
 Chief Engineer: Charles Neer

KOAM

PITTSBURG—1937—NBC

Frequency: 860 Kc. Power: 10,000 Watts d.,
 5,000 n.
 Owned-Oper. By: The Pittsburg Bcstg. Co., Inc.
 Phone Number: 2165
 Air Time: 5:45 a.m.-M.
 News Service: AP
 Representative: John E. Pearson
 Membership: NARTB
 Pres., Gen., Sta. Mgr.: E. V. Baxter
 Sales Prom. Mgr.: Paul Hudson
 Chief Engineer: Lea Stafford

KSEK

PITTSBURG—1947

Frequency: 1340 Kc. Power: 250 Watts
 Owned-Oper. By: KSEK Bcstg. Co., Inc.
 Business-Studio Address: 1340 E. Quincy
 Phone Number: 742
 Air Time: Full Time
 News Service: AP
 Transcription Service: Thesaurus
 Representative: Cooke
 President: O. S. Stauffer
 General Manager: Thad M. Sandstrom
 Chief Engineer: Paul A. Winders

KWSK

PRATT—1952

Frequency: 1570 Kc. Power: 250 Watts d.
 Owned-Operated By: Pratt Bcstg. Co.
 Address: 207 1/2 Main St.
 Phone Number: 1570
 General Manager: Clem Morgan
 Commercial Mgr.: John Wright

Promotion Mgr.: Bud Pratt
 Chief Engineer: Clarence Evans

KSAL

SALINA—1937—MBS

Frequency: 1150 Kc. Power: 5000 Watts
 Owned-Operated By: KSAL, Inc.
 Bus-Studio Address: 201 W. Iron Ave.
 Phone Number: 3701
 Air Time: Unlimited
 News Service: AP
 Transcription Service: Lang-Worth, Standard
 Representative: John E. Pearson
 Membership: NARTB, BAB
 President: R. J. Laubengayer
 Station Mgr.: R. V. Jensen
 Prom. Mgr., Publ. Dir.: C. R. Lamer
 Program Director: Al Thompson
 Chief Engineer: Donald Engelhardt

KJAY

TOPEKA—1949

Frequency: 1440 Kc. Power: 5000 Watts d.,
 1000 Watts n.
 Owned-Oper. By: S. H. Patterson
 Address: 908 Kansas Ave.
 Phone Number: 3-1336
 Air Time: Full Time
 News Service: INS
 Representative: McGillvra
 President: S. H. Patterson
 General Manager: Norwood J. Patterson
 Program Director: Hal McWilliams
 Commercial Mgr.: A. J. Stewart

KTOP

TOPEKA—1947—MBS

Frequency: 1490 Kc. Power: 250 Watts
 Owned-Operated By: Charles B. Axton
 Address: Box 538
 Phone Number: 4-3444
 Air Time: Full Time
 News Service: AP
 Transcription Service: Associated
 Representative: John E. Pearson Co.
 Owner, Gen., Sta. Mgr.: C. B. Axton
 Commercial Manager: Allan Curnutt
 Asst. Manager: Marie M. McKinney
 Program Director: Jack Warren Ostrode
 Chief Engineer: Floyd A. Griffiths

WIBW

TOPEKA—1926—CBS

Frequency: 580 Kc. Power: 5000 Watts
 Owned By: Capper Publications, Inc.
 Business-Studio Address: 1035 Topeka Blvd.
 Phone Number: 3-2377
 News Service: AP, UP
 Transcription Service: Lang Worth, Standard
 Membership: NARTB
 President: H. S. Blake
 General-Station Manager: Ben Ludy
 Commercial Manager: Hilton Hodges

Program Director.....Maude Carlson
 Chief Engineer.....Lewis Dickensheets

WREN

TOPEKA—1926—ABC

Frequency: 1250 Kc.....Power: 5000 Watts
 Owned-Operated By...WREN, Edcstg. Co., Inc.
 Business-Studio Address.....411 W. 10th St.
 Phone Number.....2-0505
 Air Time.....Full Time
 News Service.....UP
 Transcription Service.....World
 Representative.....Weed
 Membership.....NARTB, BAB
 President.....Alf M. Landon
 Business Manager.....Fred L. Conger
 Sales Promotion Manager...Gerald K. Barker
 Program Director.....Max Falkenstein
 Technical Spvsr.....Albert J. Meyer

KAKE

WICHITA—1947—MBS

Frequency: 1240 Kc.....Power: 250 Watts
 Owned-Operated By...KAKE Bcstg. Co., Inc.
 Bus-Studio Address.....418 W. Douglz Ave.
 Phone Number.....4-9369
 News Service.....AP
 Transcription Service.....World
 Representative.....Radio Reps. Inc.
 V.P., General Manager.....Jack Todd
 Commercial Manager.....Martin Bass
 Program Director.....Graeme Fletcher
 Chief Engineer.....Harold Newby

KANS

WICHITA—1936—NBC

Frequency: 1480 Kc.....Power: 5000 Watts d.;
 1000 Watts n.
 Owned-Operated By.....Taylor Radio & TV
 Business-Studio Address.....1015 N. Broadway
 Phone Number.....4-2387
 Air Time.....Full Time
 News Service.....AP, UP
 Transcription Service.....Associated
 Representative.....O. L. Taylor Co.
 Membership.....NARTB
 President.....O. L. Ted Taylor
 General Manager.....Archie J. Taylor
 Sales Promotion Manager...Russell L. Lowe
 Program Director.....Vernon Reed
 Chief Engineer.....Ted Hei'hecker

KFBI

WICHITA—1922—ABC

Frequency: 1070 Kc..Power: 10,000 Watts d.;
 1000 Watts n.
 Owned-Operated By.....KFBI, Inc.
 Business-Studio Address.....Box 1402
 Phone Number.....Temple 8-3377
 Air Time.....6 a.m.-M.
 News Service.....AP
 Transcription Service.....World
 Representative.....Avery-Knodel
 Membership.....NARTB, BAB

President.....Howard Lane
 Gen., Sta. Mgr.....Hale Bondurant
 Commercial Mgr.....Clarence Sewell
 Program Di.....George Wells
 Publicity Director.....Marie MacDonald
 Chief Engineer.....K. W. Pyle

KFH

WICHITA—1922—CBS

Frequency: 1330 Kc.....Power: 5000 Watts
 Owned-Operated By...Radio Station KFH Co.
 Business-Studio Address.....KFH Bldg.
 Phone Number.....2-4491
 Air Time.....Full Time
 Newspaper Affiliation....."Eagle"
 News Service.....UP, AP
 Transcription Service.....Capitol
 Representative.....Blair
 Membership.....NARTB
 President.....John Rigby
 V.P., Gen. Mgr.....Frank V. Webb
 Sales Promotion Manager...Beulah Roth
 Program Director.....Thomas Bashaw
 Chief Engineer.....Virgil Hinshaw

KWBB

WICHITA—1950

Frequency: 1410 Kc.....Power: 1000 Watts
 Owned-Oper. By...Wichita Beacon Bcstg. Co.
 Address.....2829 Salina Ave.
 Phone Number.....8-3331
 Air Time.....6 a.m.-M.
 Transcription Service.....Thesaurus
 News Service.....AP
 Representative.....Clark
 Membership.....NARTB, BAB
 President.....O. E. Bradley
 General Manager.....J. Milton Hall
 Commercial Mgr.....John Merrell
 Program Director.....W. Welch
 Chief Engineer.....Gene Williams

COMPLETE
 EDITORIAL
 INDEX
 STARTS ON
 PAGE 5

KENTUCKY

Pop. Feb. 1, 1954 (Est.) 3,004,000 — Families 770,000
Radio Homes 684,000 — TV Homes 359,500 — Stations in State 50

W C M I

ASHLAND—1935—CBS

Frequency: 1340 Kc. Power: 250 Watts
Owned-Oper. By Ashland Bdcstg. Co., Inc.
Address 120 20th Street
Phone Number Main 3010
Air Time 6 a.m.-12:05 a.m.
News Service UP
Trans. Service World. Thesaurus. SESAC
Representative H-R Reps
President Charles Sawyer
Exec. Vice-President J. P. Williams
General Manager Adna H. Karns
Sta., Comm. Mgr. W. R. Martin
Program Director J. B. Sowards
Chief Engineer Clarence W. Weaver

W K C T

BOWLING GREEN—1947—ABC

Frequency: 930 Kc. Power: 1000 Watts d.
500 Watts n.
Owned-Oper. By Daily News Bdcstg. Co.
Address Box 727
Phone Number BO 4325
Air Time 5:30 a.m.-12 M.
News Service UP
Newspaper Affiliation Park City Daily News
Transcription Service Thesaurus
Representative Pearson
President J. Ray Gaines
Sta., Gen. Mgr. Al Temple
Comm., Prom. Mgr. Jeff Wright
Program Director Jack Eversole
Publicity Director Alvis Temple
Chief Engineer Haro Durham

W L B J

BOWLING GREEN—1938—MBS-KBS

Frequency: 1410 Kc. Power: 5000 Watts d.
1000 Watts n.
Owned-Oper. By Bowling Green Bcstg. Co.
Address 901 Fairview
Phone Number 3212
Air Time Full Time
News Service AP
Transcription Service World
Representative Burn-Smith
Membership BAB, NARTB
Pres., Gen. Sta. Mgr. Ken D. Given
Commercial Manager Robert Proctor
Sales Prom. Mgr. Bill Kuznitsol
Publicity Director Georgia Bates
Program Director Helen Given
Chief Engineer Tom Smith

W L C K

CAMPBELLSVILLE—1951

Frequency: 1450 Kc. Power: 250 Watts

Owned-Operated By Taylor Bcstg. Co.
Address P. O. Box 248
Phone Number 380
News Service UP
Transcription Service Cole
Pres., Gen. Mgr. Redman Turner
Commercial Manager Lindsey Harden
Program Director Tommie Kerr
Chief Engineer James B. Crawley

W T C O

CAMPBELLSVILLE—1948—KBS

Frequency: 1150 Kc. Power: 1000 Watts d.
Owned-Oper. By South Central Kentucky
Bcstg. Co., Inc.
Business-Studio Address 203 E. Main St.
Phone Number 250
Air Time Daytime
News Service UP
Transcription Service World. SESAC
President H. T. Parrott
Gen., Sta., Comm. Mgr. James Shacklette
Sales Promotion Mgr. Frank Hayden
Chief Engineer Harvey Kingsbury

W A I N

COLUMBIA—1951

Frequency: 1270 Kc. Power: 1000 Watts d.
Owned-Oper. By Tri-County Bcstg. Corp.
Address Columbia
Phone Number 4111
News Service UP
Trans. Ser. MacGregor, Thesaurus
Pres., Gen. Mgr. S. C. Bybee
Commercial Mgr. Lanier Burchett
Chief Engineer Lewis Owens

W C T T

CORBIN—1947—MBS

Frequency: 680 Kc. Power: 1000 Watts
Owned-Oper. By Corbin Times-Tribune, Inc.
Phone Number 123-4
Air Time 6 a.m.-M.
News Service AP
Transcription Service World
President J. Springer Robinson
General Manager John L. Crawford
Station Manager Kenneth Turner
Commercial Manager S. G. Hembree
Chief Engineer C. R. Austin

W Z I P

COVINGTON—1947—KBS

Frequency: 1050 Kc. Power: 250 Watts d.
Owned-Operated By WZIP, Inc.
Bus. Studio Address Sixth & Madison Aves.
Phone Number Juniper 5300
Air Time Daytime

News Service AP
Representative Indies, Inc.
Membership NARTB, BAB
Pres., Gen., Comm. Mgr. Arthur L. Eilerman
Publicity Director Walter Rehbaum
Chief Engineer Robert G. Staab

WCPM

CUMBERLAND—1950—MBS

Frequency: 1490 Kc. **Power:** 250 Watts
Owned-Operated By Blanfox Radio Co.
Address Harlan, Ky.
Pres., Gen., Sta. Mgr. R. B. Helms
Commercial Mgr. Lew Boehm
Program Director Charles Esposito
Chief Engineer J. Francke Fox

WHIR

DANVILLE—1947—MBS

Frequency: 1230 Kc. **Power:** 250 Watts
Owned-Oper. By Commonwealth Bcstg. Corp.
Address P. O. Box 234
Phone Number Danville 1230
Air Time Full Time
News Service UP
Transcription Service World
Representative Hal Holman Co.
Membership NARTB, BAB
Pres., Comm. Mgr. W. T. Isaac
V.P., Pgm. Dir. David B. Highbaugh
Chief Engineer Henry C. Lovell

WIEL

ELIZABETHTOWN—1950

Frequency: 1400 Kc. **Power:** 250 Watts
Owned-Oper. By Elizabethtown Bcstg. Co.
Phone Number 5151
Air Time Full Time
Transcription Service RCA Thesaurus
News Service UP
Membership NARTB, BAB
President J. W. Hodges
Gen., Sta. Mgr. Dee Huddleston
Chief Engineer Thomas Moore Baldwin

WFKY

FRANKFORT—1946—MBS-KBS

Frequency: 1490 Kc. **Power:** 250 Watts
Owned-Operated By Frankfort Bcstg. Co., Inc.
Phone Number 48281
Air Time 5 a.m.-11 p.m.
News Service UP
Representative Burn-Smith
Pres., Gen. Mgr. Ken Hart
Prog. Dir. Robert Beasley
Comm., Sales Prom. Mgr. Charles Drew
Chief Engineer Wally Roach

WFUL

FULTON—1951

Frequency: 1270 Kc. **Power:** 1000 Watts d.
Owned-Operated By Ken-Tenn Bcstg. Corp.
Phone Number 1270
News Service UP

Transcription Service Thesaurus, SESAC
President Dr. R. W. Bushart
Gen. Mgr., Pgm. Dir. J. O. Lewis
Gen. Mgr., Chief Engr. John Latham

WKAY

GLASGOW—1946

Frequency: 1490 Kc. **Power:** 250 Watts
Owned-Oper. By Glasgow Bcstg. Co., Inc.
Phone Number 2141
News Service UP
Transcription Service SESAC
President Jack Pedigo
Gen., Sta. Mgr., Chief Eng. Clovis Sadler
Sales Prom. Mgr. J. M. Barrick
Mgr. Freeman Cherry
Program Director Caroline Biggers
Chief Engineer C. H. Hulse

WHLN

HARLAN—1941—MBS

Frequency: 1230 Kc. **Power:** 250 Watts
Owned-Operated By Blanfox Radio Co., Inc.
Phone Number 625
Air Time Full Time
News Service UP
Transcription Service Thesaurus, World
Representative Burn-Smith
Membership BAB
President, Gen. Mgr. R. B. Helms
Program Director Nell Bradford
Commercial Mgr. J. T. Morgan
Chief Engineer J. Francke Fox, Jr.

THOSE WHO KNOW FAMOUS BRANDS . . .

Says WLBj's Commercial Manager
 Bob Proctor at Bowling Green, Ky.:
 "Our merchants — like merchants
 everywhere — are brand conscious.
 When we offer them AP, they know
 they're getting the best brand in
 news."

. . . KNOW THE MOST FAMOUS
 BRAND IN NEWS IS AP

WKIC

HAZARD—1947—MBS

Frequency: 1340 Kc. Power: 250 Watts
 Owned-Operated By: BMG Bcstg. Corp.
 Address: Peoples Bank Building
 Phone Number: 720
 Air Time: Full Time
 News Service: AP
 Transcription Service: World
 Representative: Hil F. Best
 President: Fred B. Bullard
 General Manager: Richard H. Goodlette
 Chief Engineer: Marvin E. Young
 News Director: Charles W. Metcalf
 Comm. Prom. Manager: Bob Mansfield

WSON

HENDERSON—1941—MBS-KBS

Frequency: 860 Kc. Power: 500 Watts d.
 Owned-Oper. By: Henderson Bcstg. Co., Inc.
 Bus. Studio Address: Zion Rd.
 Phone Number: 3923
 News Service: UP
 Transcription Service: World
 Representative: Meeker
 Membership: NARTB, BAB
 Pres., Gen. Sta. Mgr.: Hecht S. Lackey
 Program Director: Martin E. Schaeffer
 Chief Engineer: Orville D. Jackson

WHOP

HOPKINSVILLE—1940—CBS

Frequency: 1230 Kc. Power: 250 Watts
 Owned-Oper. By: Hopkinsville Bcstg. Co., Inc.
 Phone Number: TV 5-5331
 Studio-Transmitter Location: Cadiz Rd.
 Air Time: 5 a.m.-11:05 p.m.
 News Service: UP
 Transcription Service: RCA
 Representative: Meeker
 Membership: NARTB, BAB
 Pres., Gen. Sta. Mgr.: F. E. Lackey
 Commercial Manager: Katherine Peden
 Program Director: Margaret Wyatt
 Chief Engineer: Leo Y. Wilson

WLBN

LEBANON—1953

Frequency: 1590 Kw. Power: 500 Watts d.
 Owned-Oper. By: Lebanon-Springfield Bcstg. Co.
 Address: Box 647
 Co-Owner, Gen. Mgr.: C. H. Hulse
 Co-Owner, Prog. Dir.: Charles Shuffett

WLAP

LEXINGTON—1922—ABC

Frequency: 630 Kc. Power: 5000 Watts d., 1000 n.
 Owned-Operated By: American Bcstg. Corp. (Not ABC)
 Business-Studio Address: Radio Bldg.
 Phone Number: 3-2727

Air Time: Full Time
 News Service: UP
 Transcription Service: World
 Representative: John E. Pearson
 Membership: NARTB, BAB
 President: Gilmore N. Nunn
 V.P.-General Manager: J. E. Willis
 Program Director: Jack Brooks
 Publicity Director: Joe DeLong
 Chief Engineer: Henry C. Locklar

WLEX

LEXINGTON—1946—KBS

Frequency: 1300 Kc. Power: 1000 Watts
 Owned-Oper. By: Central Ky. Bcstg. Co.
 Business Address: Campbell House
 Phone Number: 3-0433
 Air Time: Unlimited
 Trans. Service: Lang-Worth, MacGregor
 Representative: Forjoe
 News Service: AP
 President: J. D. Gay, Jr.
 Secy.-Treas.: Guthrie Bell
 Gen. Com. Mgr.: J. L. Brownell, Sr.
 Chief Engineer: William Yount

WVLK

LEXINGTON—1947—MBS

Frequency: 590 Kc. Power: 1000 Watts
 Owned-Oper. By: Bluegrass Bcstg. Co., Inc.
 Address: Phoenix Hotel
 Phone Number: 4-6470
 News Service: AP
 Transcription Service: Thesaurus
 Representative: Burn-Smith
 President: Donald J. Horton
 V. Pres., Gen. Mgr.: Ted Grizzard
 Secy., Sta. Dir.: Ted Grizzard
 Commercial Manager: Lynn E. Knox
 Promotion Manager: George T. Webb
 Program Director: O. C. Halyard, Jr.
 Chief Engineer: Paul Dunbar

WAVE

LOUISVILLE—1933—NBC

Frequency: 970 Kc. Power: 5000 Watts
 Owned-Operated By: WAVE, Inc.
 Business Address: 334 E. Broadway
 Phone Number: Wabash 2201
 Air Time: Unlimited
 Transcription Service: Thesaurus, Standard
 Representative: Free & Peters
 Membership: NARTB, BAB
 President: George W. Norton, Jr.
 General Station Manager: Nathan Lord
 Commercial Manager: Le Vel Waltman
 Sales Prom. Mgr.: Charles Hill
 Program Director: James Caldwell
 Chief Engineer: Wilbur Hudson

WGRC

LOUISVILLE—1936

Frequency: 790 Kc. Power: 5000 d., 1000 n.
 Owned-Operated By: Northside Bcstg. Corp.

Bus.-Studio Address... Ky. Home Life Bcstg.
 Phone Number... Wabash 8871
 Air Time... Full Time
 News Service... UP
 Transcription Service... Lang-Worth
 Representative... Walker
 Pres., Comm. Mgr... J. Porter Smith
 Gen. Mgr... Charles L. Harris
 Pgm. Dir... Ward Hatcher
 Chief Engineer... W. J. Morrison

WHAS

LOUISVILLE—1922—CBS

Frequency: 840 Kc. Power: 50,000 Watts
 Owned-Oper. By... WHAS, Inc.
 Address... 525 W. Broadway
 Phone Number... WABash 2211
 Air Time... Full Time
 News Service... AP
 Newspaper Affil... Courier-Journal, "Times"
 Transcription Service... Lang-Worth
 Representative... Henry I. Christal Co.
 President... Barry Bingham
 V. Pres., Dir... Victor A. Sholis
 Station Manager... Neil D. Cline
 Sales Director... John M. Fouts
 Publicity Director... William Loader
 Chief Engineer... Orrin W. Towner
 Program Director... Sam Gifford

WINN

LOUISVILLE—1940

Frequency: 1240 Kc. Power: 250 Watts
 Owned-Oper. By... Kentucky Bcstg. Corp., Inc.
 Bus.-Studio Address... Earle Hotel
 Phone Number... WABash 5148
 Air Time... 7 a.m.-M.
 News Service... UP
 Transcription Service... World
 Representative... R-TV, Rep., Scott
 Pres., Gen. Sta. Mgr... Harry McTigue
 Commercial Manager... Chas. A. Schacht, Jr.
 Program Director... George Partridge
 Chief Engineer... Melvin Scarsdale

WKLO

LOUISVILLE—1948—ABC

Frequency: 1080 Kc. Power: 5000 Watts d.;
 1000 Watts n.
 Owned-Oper. By... Mid-America Bcstg. Corp.
 Business-Studio Address... Henry Clay Hotel
 Phone Number... Clay 4441
 Air Time... Full Time
 Representative... John Blair & Co.
 Membership... BAB
 News Service... UP
 Pres. Gen. Mgr... Joe Eaton
 Commercial Manager... Russell J. Pirkey
 Program Director... Mary Louise Moore
 Chief Engineer... D. C. Summerford

WKYW

LOUISVILLE—1947

Frequency: 900 Kc. Power: 1000 Watts d.

Owned-Oper. By... Radio Kentucky, Inc.
 Bus.-Studio Address... 431 W. Jefferson St.
 Phone Number... CLay 4811
 Air Time... Daytime
 News Service... AP
 Transcription Service... Standard, Capitol
 Representative... Burn-Smith
 Membership... BAB
 President... F. Eugene Sandford
 Sta. Manager... Edwin E. S. Weldon
 Commercial Manager... H. Parker Smith

WLOU

LOUISVILLE—1948

Frequency: 1350 Kc. Power: 1000 Watts d.
 Owned-Operated By... Robert W. Rounsaville
 Business-Studio Address... 2549 S. Third St.
 Phone Number... Calhoun 3680
 Air Time... Daytime
 News Service... AP
 Representative... Forjoe, Dora-Clayton
 President, Gen. Mgr... R. W. Rounsaville
 Station Manager... Lee Smith
 Commercial Mgr... Joe Starr
 Chief Engineer... Steve Dawson

WFMW

MADISONVILLE—1948—KBS

Frequency: 730 Kc. Power: 250 Watts d.
 Owned-Oper. By Messenger Bcstg. Co., Inc.
 Address... Box 387
 Phone Number... 1885
 Air Time... Sunrise-Sunset
 Newspaper Affiliation... Madison Publishing
 News Service... UP
 Trans. Service... Capitol, Thesaurus, Standard
 Representative... Continental
 President... Edgar Arnold, Sr.
 Sta., Gen. Mgr... H. W. Wells
 Prom., Comm. Mgr... Elmer L. Kelley, Jr.
 Program Director... Richard T. Harris
 Chief Engineer... Evers Mick

WKT M

MAYFIELD—1946—MBS

Frequency: 1050 Kc. Power: 1000 Watts d.
 Owned-Oper. By... Mayfield Bcstg. Co.
 Phone Number... 48
 Studio Address... Mayfield Hotel
 Air Time... Sunrise-sunset
 News Service... UP
 Transcription Service... Thesaurus
 Representative... Best
 President... Mike Layman
 Gen., Sta., Comm. Mgr... Wayne Morgan
 Program Director... Joe McNeilly
 Chief Engineer... Joseph M. Hargrove

WNGO

MAYFIELD—1947

Frequency: 1320 Kc. Power: 1000 Watts d.
 Owned-Oper. By... West Ky. Bcstg. Co., Inc.
 Phone Number... 1597
 Air Time... Full Time
 News Service... AP

Transcription ServiceCapitol
 President.....H. M. Suthard
 General Mgr.....T. E. Brewer
 Program Director.....O. L. Davis
 Promotion Mgr.....Bob Lee
 Chief Engineer.....Ben Dixon

WFTM
 MAYSVILLE—1948—MBS

Frequency: 1240 Kc.Power: 250 Watts
 Owned-Oper. By...Standard Tobacco Co., Inc.
 Bus. Address.....626 Forest Ave.
 Phone Number.....1400
 Air Time.....6 a.m.-M.
 News Service.....UP
 Transcription Service.....World
 Membership.....NARTB, BAB
 President.....Charles P. Clarke
 General Mgr.....John W. Betts
 Commercial Mgr.....James Newhart
 Program Director.....Gene Waters
 Chief Engineer.....Harvey Cross

WMIK
 MIDDLESBORO—1948

Frequency: 560 Kc.Power: 500 Watts d.
 Owned-Oper. By.....Cumberland Gap Bcstg.
 Phone Number.....980
 Air Time.....Day Time
 Representative.....Holman
 Transcription Service.....Thesaurus
 News Service.....UP
 Membership.....BAB
 President.....Dr. U. G. Brummett
 Gen., Sta., Comm. Mgr.....Maurice K. Henry

WNBS
 MURRAY—1948

Frequency: 1340 Kc.Power: 250 Watts
 Owned-Operated By.....Murray Bcstg. Co.
 Address.....P. O. Box 548
 Phone Number.....1340
 News Service.....AP
 President.....H. T. Waldrop
 Manager.....Edward Griffin
 Comm. Mgr., Prog. Dir.....Troy Glidwell
 Chief Engineer.....Olis Cohoon

WNOP
 NEWPORT—1948

Frequency: 740 Kc.Power: 1000 Watts d.
 Owned-Operated By.....Tri-City Bcstg. Co.
 Business-Studio Address.....606 Monmouth St.
 Phone Number.....Juniper 7100
 Air Time.....Sunrise-sunset
 News Service.....UP
 President, Comm. Mgr.....James G. Lang
 Station Manager.....Ann Rolles Lang
 Chief Engineer.....Joseph M. Rice

WOMI
 OWENSBORO—1938—MBS-KBS

Frequency: 1490 Kc.Power: 250 Watts

Owned-Oper. By...Owensboro Bcstg. Co., Inc.
 Phone Number.....3-1558
 Air Time.....6 a.m.-M.
 News Service.....AP
 Newspaper Affiliations...Messenger, Inquirer
 Transcription Service.....Thesaurus
 Representative.....Burn-Smith
 Membership.....NARTB, BAB
 President.....Lawrence W. Hager
 Gen.-Sta. Mgr.....Hugh O. Potter
 Program Director.....Cliffordean Potter
 Chief Engineer.....Harold I. Peters

WVJS
 OWENSBORO—1946

Frequency: 1420 Kc.Power: 1000 Watts
 Owned-Oper. By...Owensboro On The Air, Inc.
 Business-Studio Address.....324 Allen St.
 Phone Number.....3-3521
 News Service.....UP
 Transcription Service.....World
 Representative.....William G. Rambeau
 Membership.....NARTB
 President.....V. J. Steele
 General Manager.....Malcolm Greep
 Commercial Manager.....John T. Rutledge
 Program Director.....Larry Adams
 Chief Engineer.....Robert Earl Jaqoe

WKYB

PADUCAH—1946—NBC

Frequency 570 Kc.Power: 1000 Watts d.,
 500 n.
 Owned-Oper. By.....WKYB, Inc.
 Business-Studio Address.....Box 931
 Phone Number.....2-1678
 Air Time.....Full Time
 News Service.....AP
 Transcription Service.....World
 Representative.....Pearson
 Membership.....NARTB, BAB
 Pres., Gen. Mgr.....E. J. Paxton, Jr.
 Commercial Manager.....S. Livingston
 Program Dir.....Joe P. Knight
 Chief Engineer.....E. J. Pell

WPAD

PADUCAH—1930—CBS

Frequency: 1450 Kc.Power: 250 Watts
 Owned-Oper. By...Paducah Bdcstg. Co., Inc.
 Address.....4th & Bway—Taylor Bldg.
 Phone Number.....2-8231
 Air Time.....5 a.m.-12 M.
 News Service.....UP
 Trans. Serv.....Lang-Work
 Representative.....Meeker
 Membership.....NARTB, BAB
 Pres., Gen., Sta. Mgr.....Pierce E. Lackey
 Prog., Pub. Dir.....Ray Mofield
 Chief Engineer.....U. C. Morris

WSIP

PAINTSVILLE—1949—MBS

Frequency: 1490 Kc.Power: 250 Watts

Owned-Oper. By.....Big Sandy Bcstg. Co.
 AddressMeade Bldg.
 Phone Number1186
 News ServiceAP
 Transcription ServiceThesaurus
 General Manager.....Ted Arnold Silvers
 Station Manager.....Jack Welch
 Chief Engineer.....Eugene Baldrige

WLSI

PIKEVILLE—1949

Frequency: 900 Kc.....Power: 1000 Watts d.
 Owned-Operated By.....Cumberland Pub. Co.
 AddressPikeville
 Phone Number456
 Air Time.....Day Time
 Newspaper Affiliation.....Daily News
 News ServiceUP
 Transcription Service..Lang-Worth, Thesaurus
 President.....Mrs. W. J. Ward
 Gen., Comm. Mgr.....Ray E. Alexander

WPKE

PIKEVILLE—1949—MBS-KBS

Frequency: 1240 Kc.....Power: 250 Watts
 Owned-Oper. ByE. Ky. Bdcstg. Corp.
 Phone Number1280
 News ServiceAP
 Transcription Service.....SESAC, World
 MembershipNARTB
 President.....Clyde Childers Jr.
 Program Director.....Al Kahn
 Chief Engineer.....Edwin Meek

WPRT

PRESTONBURG—1953

Frequency: 960 Kc.....Power: 1000 Watts d.
 Owned-Oper. By.....Kentucky Mt. Bcstg. Co.
 News ServiceUP
 Transcription ServiceMacGregar
 President.....D. C. Stephens
 Gen., Prom. Mgr.....Rex Osborne
 Chief Engineer.....Wm. E. Rumble

WPKY

PRINCETON—1950—MBS-KBS

Frequency: 1580 Kc.....Power: 250 Watts d.
 Owned-Operated By.....Princeton Bcstg. Co.
 AddressBox 478
 Phone2072
 News ServiceAP
 Owner, Gen. Mgr.....Leslie Goodaker
 Program Dir.....Mrs. Leslie Goodaker
 Commercial Manager.....James H. Johnson
 Chief Engineer.....Marvin Mahoney

WEKY

RICHMOND—1953—MBS

Frequency: 1340 Kc.....Power: 250 Watts
 Owned-Oper. By.....Dages I. Boyle
 AddressMcKee Bldg.
 Phone Number1340
 Owner.....Dages I. Boyle
 General Manager.....O. C. Halyard Jr.
 Commercial Mgr.....Jack Parrish
 Program Director.....Bob Doll
 Promotion Mgr.....Jay Waters
 Chief Engineer.....Reed Anderson

WRWS

RUSSELLVILLE—1953

Frequency: 800 Kc.....Power: 1000 Watts d.
 Owned-Oper. By.....Southern Ky. Bcstg. Co.

WSFC

SOMERSET—1947—MBS

Frequency: 1240 Kc.....Power: 250 Watts
 Owned-Oper. By.....Southeastern Bcstg. Corp.
 AddressStanford Rd.
 Phone Number1240-41
 Air Time.....Full Time
 News ServiceUP
 Transcription Service.....Thesaurus
 Representative.....Hill F. Best
 Pres., Gen., Sta. Mgr.....Mike Layman
 Commercial ManagerDonald Orwin
 Program Director.....John A. Hartnett
 Chief Engineer.....Johnny Agostine

WMTC

VANCLEVE—1948

Frequency: 730 Kc.....Power: 1000 Watts d.
 Owned-Oper. By.....Kentucky Mt. Holiness Assn.
 Bus-Studio AddressVancleve
 Phone Number.....Vancleve 3 (Jackson exch.)
 Air TimeDaytime
 News ServiceAP
 RepresentativeContinental
 President.....Dr. Lela G. McConnell
 General-Station-Comm. Mgr.....Wilfred Fisher
 Chief Engineer.....Kenneth Amspaugh

WTCW

WHITESBURG—1953

Frequency: 920 Kc.....Power: 1000 Watts d.
 Owned-Oper. By.....Ky.-Va. Bcstg. Corp.
 AddressWhitesburg
 Phone Number2711
 News ServiceUP
 Pres., Gen. Mgr.....Kenneth J. Crosthwait
 Commercial Mgr.....Frank L. Jones
 Program Director.....Aubrey Garber
 Chief Engineer.....David B. Jordan

LOUISIANA

Pop. Feb. 1, 1954 (Est.) 2,738,000 — Families 715,000
Radio Homes 602,000 — TV Homes 281,500 — Stations in State 49

KROF

ABBEVILLE—1948

Frequency: 960 Kc. Power: 1000 Watts d.
Owned-Oper. By Abbeville Bcstg. Serv. Inc.
Business Address P. O. Box 620
Phone Number90
Transcription ServiceWorld
General ManagerGeorge P. Martin
Program DirectorEbba Lou Martin
Chief EngineerGeorge P. Martin

KALB

ALEXANDRIA—1935—ABC

Frequency: 580 Kc. Power: 5,000 Watts d.
1,000 Watts n.
Owned-Oper. By Alexandria Bcstg. Co., Inc.
Address6th and Johnston
Phone Number3-2543
News ServiceAP, UP
Transcription ServiceWorld, MacGrego;
RepresentativeWeed & Co.
PresidentWalter H. Allen
Gen. Mgr.Willard L. Cobb
Commercial ManagerWalter D. Melson
Promotion Mgr.Vivian Close
Prog. Dir.Alex Marchand
Chief EngineerJesse R. Sexton

KSYL

ALEXANDRIA—1947—NBC

Frequency: 970 Kc. Power: 1000 Watts
Owned-Oper. ByKSYL, Inc.
AddressBox 1489
Phone Number6611-12
Air TimeFull Time
News ServiceAP
Transcription ServiceLang-Worth
RepresentativeEverett-McKinney
Pres., Comm. Mgr.Milton Fox
General ManagerVirgil G. Evans
Program DirectorBruce Rainey
Chief EngineerThomas Marhelka

KTRY

BASTROP—1948—KBS

Frequency: 730 Kc. Power: 250 Watts d.
Owned-Oper. ByMorehouse Bcstg. Co.
Business-Studio AddressBox 193
Phone Number1400
News ServiceUP
Transcription ServiceWorld, Associated
General ManagerBill Davis
Commercial ManagerG. I. Johnson
Chief EngineerHarry Howard

WAFB

BATON ROUGE—1948—MBS

Frequency: 1460 Kc. Power: 5000 Watts d.
1000 Watts n.
Owned-Oper. ByModern Bcstg. Co.
Address929 Government St.
Phone Number4-8571
Air TimeFull Time
News ServiceAP
Transcription ServiceThesaurus
RepresentativeAdam Young
MembershipNARTB, BAB
PresidentJack S. Burk
V.P., Gen. Mgr.T. E. Gibbons
Commercial Mgr.Ron Litteral
Program DirectorCharlie Arnold
Chief EngineerDonald K. Allom

WIBR

BATON ROUGE—1948

Frequency: 1300 Kc. Power: 1000 Watts
Owned-Oper. ByCommunity Bcstg. Co.
AddressP. O. Box 1226
Phone Number49493
News ServiceUP
Trans. Serv.Lang-Worth & Standard
RepresentativeWalker
PresidentG. T. Owen
Gen. Mgr.Robert Earle
Commercial ManagerRoger Davison
Chief EngineerE. E. Case

WJBO

BATON ROUGE—1934

NBC-LA. NET

Frequency: 1150 Kc. Power: 5000 Watts
Owned-Oper. ByBaton Rouge Bcstg. Co., Inc.
Business-Studio Address444 Florida St.
Phone Number2-5271
Air TimeUnlimited
News, Affil.State Times, Morning Advocate
News ServiceAP, UP
Transcription ServiceWorld
RepresentativeGeorge P. Hollingbery
MembershipBAB, NARTB
PresidentDouglas L. Manship
V.P., General Mgr.J. Roy Dabodie
Sales ManagerCharles C. Garvey
Program DirectorDon Perrie
Chief EngineerPat Weathersby

WLCS

BATON ROUGE—1946—ABC

Frequency: 910 Kc. Power: 1000 Watts
Owned-Operated ByAir Waves, Inc.
Business Address204 North St.
Phone Number24411
Air TimeFull Time
News ServiceAP, INS
Transcription ServiceAssociated

Representative Wm. G. Rambeau
 Membership NARTB, BAB
 President R. F. Cangelosi
 Gen., Sta. Mgr. Earl Smith
 Commercial Manager..... Lamar Simmons
 Prog. Dir. Herman Nelson
 Chief Engineer..... Edward Van Valkenburg

WXOK

BATON ROUGE—1953

Frequency: 1260 Kc. Power: 1000 Watts d.
 Owned-Oper. By..... WXOK, Inc.
 Address..... 243 Convention St.
 Phone Number 4-7604
 News Service AP
 Transcription Service World
 Representative Forjoe
 Co-Owners Jules Paglin.
 Stanley W. Ray Jr.
 General Manager..... Herb Pearson
 Program Director..... Ed Bishop
 Chief Engineer..... Charles Hoque

WIKC

BOGALUSA—1947

Frequency: 1490 Kc. Power: 250 Watts
 Owned-Operated By..... Enterprise Publishing Co.
 Business Address..... 605 N. Rio Grande St.
 Phone Number 1490
 General Manager..... Curt Siegelin

WARB

COVINGTON—1953

Frequency: 730 Kc. Power: 250 Watts d.
 Owned-Oper. By..... A. R. Blossman, Inc.
 Address Box 568
 Phone Number 1600
 President..... A. R. Blossman
 Gen. Mgr., Chief Engr. William H. Bland Jr.
 Commercial Mgr. Roy Hebert
 Program Director..... Winford McDaniel
 Promotion Dir. Mildred Bland

KSIG

CROWLEY—1947

Frequency: 1450 Kc. Power: 250 Watts
 Owned-Operated By..... Acadia Bcstg. Co.
 Bus.-Studio Address..... 101 N. Parkerson Ave.
 Phone Number 1450-1
 News Service AP
 President Max Thomas
 Commercial Manager..... Dan Harper
 Chief Engineer..... C. P. Ruffner

KDLA

DeRIDDER—1950—KBS

Frequency: 1010 Kc. Power: 1000 Watts d.
 Owned-Operated By..... Sabine Bcstg. Co.
 Address Box 46
 Phone Number 7600
 News Service UP
 President..... Cyril W. Reddoch
 Commercial Manager..... Ralph L. Hooks
 Program Director..... Ted Thompson

KEUN

EUNICE—1952—MBS

Frequency: 1490 Kc. Power: 250 Watts
 Owned-Operated By..... Tri-Parish Bcstg. Co.
 Address Box 789
 Phone Number 3041
 News Service AP
 Transcription Service World
 President Vincent Riehl
 General Manager..... John A. Chauvin
 Publicity Director..... Milton S. David
 Chief Engineer..... J. L. Sylvester

WIHL

HAMMOND—1947—KBS

Frequency: 1400 Kc. Power: 250 Watts
 Owned-Oper. By..... Cefalu Radio Station
 Business-Studio Address..... Box 432
 Phone Number 960
 News Service AP
 President Nicholas Cefalu
 Gen., Comm. Mgr. J. K. Ferris
 Sta. Mgr., Pgm. Dir. George Bonnell
 Chief Engineer..... Warren Adams

KCIL

HOUMA—1946—NBC

Frequency: 1490 Kc. Power: 250 Watts
 Owned-Oper. By..... KCIL Inc.
 Business Address..... Bayou Black Dr.
 News Service AP
 Transcription Service World, SESAC
 President..... D. T. Brannen
 General Manager..... P. T. Hayes

KJEF

JENNINGS—1950

Frequency: 1290 Kc. Power: 500 Watts d.
 Owned-Oper. By..... Jennings Bcstg. Co., Inc.
 Address 1521 Lake Arthur Ave.
 Phone Number 1155
 News Service UP
 Transcription Service Thesaurus
 Pres., Gen. Mgr. Clovis L. Bailey
 Comm. Mgr. Gerald Dugas
 Chief Engineer..... Edgar E. Barton, Jr.

KLFY

LAFAYETTE—1950—ABC

Frequency: 1420 Kc. Power: 1000 Watts d.
 500 W. n.
 Owned-Oper. By..... Camellia Bcstg. Co.
 Address P. O. Box 367
 Phone Number 8-9494
 Transcription Service World
 News Service UP
 Membership NARTB, BAB
 President..... Paul H. De Clouet
 General Manager..... William A. Patton
 Program Director..... Bob Castellon
 Publicity Director..... Virginia Boulanger
 Chief Engineer..... Carroll Crew

KVOL

LAFAYETTE—1935—NBC

Frequency: 1330 Kc. Power: 1000 Watts
 Owned-Oper. By. Evangeline Bcstg. Co., Inc.
 Business-Studio Address. P. O. Box 1070
 Phone Number 5-6426-7
 Newspaper Affiliation "Daily Advertiser"
 Air Time 6 a.m.-M.
 News Service AP
 Transcription Service Lang-Worth
 Representative Meeker
 Membership NARTB, BAB
 General Manager George H. Thomas
 Sta. Mgr. Evan H. Hughes
 Commercial Manager Thomas G. Pears
 Prog. Dir. Don Metz
 Chief Engineer Louis Pilcher

KAOK

LAKE CHARLES—1947—MBS

Frequency: 1400 Kc. Power: 250 Watts
 Owned-Operated By KAOK, Inc.
 Address P. O. Box 1399
 Phone Number 6-7541
 News Service UP
 Representative Forjoe
 President Jules J. Paglin
 Co-Manager Tom Gresham
 Co-Mgr., Prog. Dir. Roy Rhodes
 Station Director Stanley W. Ray, Jr.
 Chief Engineer Walter Jones

KLOU

LAKE CHARLES—1947—CBS

Frequency: 1580 Kc. Power: 1000 Watts
 Owned-Oper. By. The Pelican Bcstg. Co., Inc.
 Bus. Studio Address 203 W. Clarence St.
 Phone Number 6-7277
 Air Time 6 a.m.-M.
 News Service AP
 Representative Pearson
 Owner Sara M. Anderson
 General Manager John L. Vath
 Commercial Mgr. Harper L. Clark
 Program Director Sid Morse
 Chief Engineer Ernest J. Vincent

KPLC

LAKE CHARLES—1935—NBC

Frequency: 1470 Kc. Power: 5000 Watts
 Owned-Oper. By. Calcasieu Bcstg. Co.
 Business Address P. O. Box 1521
 Phone Number 2713
 Air Time 5:30 a.m.-M.
 News Service AP
 Transcription Service World
 Representative Weed
 President T. B. Lanford
 Gen., Sta. Mgr. David Wilson
 Commercial Manager P. E. Mills, Jr.
 Sales Prom. Mgr. Lucille Storer
 Program Director Robert P. Thompson
 Publicity Director Verna Eady
 Chief Engineer A. B. Craft

KAPK

MINDEN—1952

Frequency: 1240 Kc. Power: 100 Watts
 Owned-Operated By Parish Bcstg. Co.
 Address Box 821
 Phone Number 1985
 News Service UP
 Pres., Gen. Sta. Mgr. Martin Kirsch, Jr.
 Commercial Mgr. Reggie Ward
 Chief Engineer Carl W. Goulden

KLIC

MONROE—1950—MBS-KBS

Frequency: 1230 Kc. Power: 250 Watts
 Owned-Oper. By. Dr. Frank Cerniglia
 Address Strauss Bldg
 Phone Number 3-4617
 News Service UP
 President, Manager Dr. Frank Cerniglia
 Commercial Mgr. Robert Fowlikes
 Program Director John Lacy

KMLB

MONROE—1930—ABC

Frequency: 1440 Kc. Power: 5000 d.; 1000 n.
 Owned-Oper. By. Liner's Bcstg. Station, Inc.
 Business Address Hotel Frances
 Phone Number 7161
 News Service AP
 Transcription Service Thesaurus
 Representative O. L. Taylor
 President Mrs. Robert Gaston, Jr.
 Gen., Sta. Mgr. Charles Price
 Comm., Prog. Mgr. James Plaisance
 Publicity Director Jackie Voorhees
 Chief Engineer O. L. Morgan

KNOE

MONROE—1944—NBC

Frequency: 1390 Kc. Power: 5000 Watts
 Owned-Operated By James A. Noe
 Business-Studio Address Knoe Road
 Phone Number 8155
 Air Time Full Time
 News Service AP
 Transcription Service World
 Representative H-R Reps
 Membership NARTB, BAB
 President James A. Noe
 General Manager Paul H. Goldman
 Commercial Mgr. John H. Allen Jr.
 Program Director Harry Arthur
 Chief Engineer Jack Ratliff

KWCJ

NATCHITOCHE—1947

Frequency: 1450 Kc. Power: 250 Watts
 Owned-Oper. By Natchitoches Bcstg. Co.
 Business-Studio Address Box 232
 Phone Number 2353
 President Dr. William H. Pierson

KANE

NEW IBERIA—1946—ABC

Frequency: 1240 Kc. Power: 250 Watts
 Owned-Operated By... New Iberia Bcstg. Co.
 Address... 101 West St., Peter St.
 Phone Number... 2-6726
 News Service... AP
 Transcription Service... World
 General Manager... George H. Thomas
 Station Manager... Dierrell Hamm
 Sales Prom., Pgm. Dir... Al Viguierie
 Commercial Mgr... Donald Bonin
 Chief Engineer... Merle Case

KVIM

NEW IBERIA—1951

Frequency: 1360 Kc. Power: 1000 Watts d.
 Owned-Oper. By... Queen City Bcstg. Co.
 Address... P. O. Box 50
 Phone Number... 2-5826
 Transcription Service... Associated
 President... P. M. Cochran
 General Manager... John H. Coco
 Sales Prom. Mgr... Jim Drake
 Chief Engineer... Lynn Hargreaves

WBOK

NEW ORLEANS—1951

Frequency: 800 Kc. Power: 1000 Watts d.
 Owned-Operated By... WBOK, Inc.
 Address... 505 Baronne St.
 Phone Number... Tulane 5363
 News Service... UP
 Representative... Forjoe
 President... Jules J. Paglin
 Gen., Sta. Mgr... Stanley W. Ray, Jr.
 Comm. Mgr... Fred Schwarz
 Chief Engineer... John Rhode

WDSU

NEW ORLEANS—1923—NBC

Frequency: 1280 Kc. Power: 5000 Watts
 Owned-Operated By... WDSU Bcstg. Corp.
 Business-Studio Address... 520 Royal St.
 Phone Number... Tulane 4371
 Air Time... 6 a.m.-12:30 a.m.
 News Service... AP, UP
 Transcription Service... Capitol, World
 Representative... John Blair
 Membership... NARTB, BAB
 President... Edgar B. Stern, Jr.
 Exec. V.P. & Gen. Mgr... Robert Swezey
 V.P. & Comm. Mgr... Louis Read
 Program Director... Don Howell
 Prom. Dir... Marion Annenberg
 Chief Engineer... Lindsey Riddle

WJBW

NEW ORLEANS—1926

Frequency: 1230 Kc. Power: 250 Watts
 Owned-Operated By... Louise C. Carlson
 Business-Studio Address... Cigali Bldg.
 Phone Number... Ma. 3488

Air Time... Unlimited
 News Service... AP
 Representative... W. G. Rambeau
 Membership... NARTB
 Pres., Gen. Mgr... Louise C. Carlson
 Commercial Mgr... Ed. Carlson
 Prom. Mgr... George Stimmel
 Program Director... Johnny Nickols
 Chief Engineer... Frank J. Recely

WJMR

NEW ORLEANS—1945

Frequency: 990 Kc. Power: 250 Watts d.
 Owned-Operated By... Supreme Bcstg Co., Inc.
 Address... Jung Hotel, 1500 Canal Street
 Phone Number... Canal 0356-0357
 Air Time... Sunrise-Sunset
 News Service... UP
 Representative... Bolling
 Membership... NARTB, BAB
 President... Chester Owens
 Exec. V.P... George A. Mayoral
 V.P. & Gen. Mgr... James E. Gordon
 Commercial Mgr... Patrick J. Shannon
 Program Dir... Tom Abbott
 Chief Engineer... Jack Petrik

WMRY

NEW ORLEANS—1950

Frequency: 600 Kc. Power: 500 Watts d.
 Owned-Oper. By... Southland Bcstg. Co.
 Address... 2107 Dryades St.
 Phone Number... Tulane 4841
 Representative... Gill-Perna
 News Service... UP
 Membership... BAB
 President... Lester Kamin
 General Manager... Mort Silverman
 Chief Engineer... Samuel Perkins

WNOE

NEW ORLEANS—1925—MBS

Frequency: 1060 Kc. Power: 50,000 d.; 5000 n.
 Owned-Operated By... James A. Noe
 Business-Studio Address... St. Charles Hotel
 Phone Number... Express 2173
 Air Time... Unlimited
 News Service... UP
 Transcription Service... SESAC
 Representative... H-R
 Membership... NARTB, BAB
 Owner... James A. Noe
 Gen., Sta. Mgr... Benton Paschall
 Commercial Mgr... Paul Beville
 Prog. Dir... Eldon Durand
 Publicity Dir... Bill Elliott
 Chief Engineer... A. J. Bourgeois

WSMB

NEW ORLEANS—1925—ABC

Frequency: 1350 Kc. Power: 5000 Watts
 Owned-Operated By... WSMB, Inc.
 Business-Studio Address... Maison Blanche Bldg.
 Phone Number... Magnolia 5921

President.....Gaston Dureav
 General Manager.....Jack O'Meallie

WTIX

NEW ORLEANS—1951

Frequency: 1450 Kc. Power: 250 Watts
 Owned-Oper. By Mid-Continent Bcstg. Corp.
 Address.....624 Canal St.
 Phone Number.....MAGnolia 3211
 Air Time.....Full Time
 News Service.....UP
 Membership.....NARTB, BAB
 President.....Robert H. Storz
 Exec. Vice-President.....Todd Storz
 Vice-Pres., Gen. Mgr. George W. Armstrong
 Commercial Mgr. Fred Berthelson
 Program Director.....Larry Wilson
 Chief Engineer Morris E. Jones

WTPS

NEW ORLEANS—1948

Frequency: 940 Kc. Power: 1000 d.; 500 n.
 Owned-Oper. By The Times Picayune
 Business Address 615 Howard Ave.
 Phone Number.....Canal 5561
 Transcription Service.....Associated
 Representative.....Branham
 President.....John F. Tims
 General Mgr. H. F. Wehrmann
 Prog. Dir. Robert Smith
 Prom. Mgr. Martin Burke
 Chief Engineer George DeBlieux

WWEZ

NEW ORLEANS—1947

Frequency: 690 Kc. Power: 5000 Watts
 Owned-Operated By WWEZ Radio Inc.
 Bus.-Studio Address Hotel New Orleans
 Phone Number.....Canal 3521
 News Service.....UP
 Representative.....Hollingbery
 President.....A. J. Chilton
 General Manager Joe A. Oswald
 Program Dir. Ken Elliott
 Chief Engineer Harrison Mondy

WWL

NEW ORLEANS—1922—CBS

Frequency: 870 Kc. Power: 50,000 Watts
 Owned-Operated By Loyola University
 Address.....Roosevelt Hotel
 Phone Number.....Raymond 2194
 News Service.....UP, AP
 Transcription Service Standard, Thesaurus
 Representative.....Katz
 Membership.....NARTB
 President.....Rev. Patrick Donnelly
 General Manager W. H. Summerville
 Comm. Manager.....Larry Balrd
 Sales Prom., Pub. Mgr. Ray Liuzza
 Program Director.....E. M. Hoerner
 Chief Engineer J. D. Bloom, Jr.

KREH

OAKDALE—1953—KBS

Frequency: 900 Kc. Power: 250 Watts d.
 Owned-Oper. By Louisiana Bcstg. Service
 Phone Number.....900
 President.....Cyril W. Reddoch
 General Manager Ralph L. Hooks
 Commercial Mgr. La Vance Carson

KSLO

OPELOUSAS—1947—ABC-KBS

Frequency: 1230 Kc. Power: 250 Watts
 Owned-Operated By KSLO Bcstg. Co.
 Studio Address.....Box 392
 Phone Number.....2633
 News Service.....UP
 Transcription Service.....World
 Representative.....Sears & Ayer
 Pres., Gen. Mgr. W. Eugene Jones
 Commercial Mgr. A. B. Reed Jr.
 Program Director Wandell Allegood
 Chief Engineer Richard M. Cole

KRUS

RUSTON—1947—MBS-KBS

Frequency: 1490 Kc. Power: 250 Watts
 Owned-Oper. By Ruston Bcstg. Co.
 Bus.-Studio Address 105 E. N. Railroad Ave.
 Phone Number.....1490
 Air Time.....Full Time
 News Service.....UP
 Newspaper Affiliation "Daily Leader"
 President.....C. E. Faulk, Jr.
 Station Manager Kenneth L. Whitaker
 Program Director Bill Carter
 Chief Engineer Charles Gandy

KCIJ

SHREVEPORT—1950

Frequency: 980 Kc. Power: 5000 Watts d.
 Owned-Oper. By Southland Bcstg. Co.
 Address.....205 Milam St.
 Representative.....Young
 President Lester Kamin
 Gen. Comm. Mgr. John H. Pace
 Chief Engineer N. L. Keys

KENT

SHREVEPORT—1947—MBS

Frequency: 1550 Kc. Power: 1000 Watts d.;
 500 Watts n.
 Owned-Operated By Frank H. Ford
 Business-Studio Address 311 Milam Bldg.
 Phone Number.....3-3681
 Air Time.....Full Time
 News Service.....AP
 Transcription Service Standard
 Representative Walker
 Membership.....NARTB
 Pres., Gen. Mgr. Frank H. Ford
 Sta., Comm. Mgr. Frank H. Ford, Jr.
 Prom., Pub. Dir. Bill Monroe

K R M D

SHREVEPORT—1928—ABC

Frequency: 1340 Kc. Power: 250 Watts
 Owned-Operated By... Radio Station KRMD
 Bus. Studio Address... New Jefferson Hotel
 Representative... Weed
 President... T. B. Lanford
 Manager... G. V. Wilson
 Program Director... Elizabeth V. Alford
 Chief Engineer... Carl W. Goulden

K T B S

SHREVEPORT—1922—NBC

Frequency: 710 Kc. Power: 10,000 Watts d.,
 5,000 Watts n.
 Owned-Oper. By... Radio Station KTBS, Inc.
 Address... 312 East Kings Hwy
 Phone Number... 7-3644
 Air Time... 5 a.m.-12 M.
 News Service... AP, UP
 Representative... Petry
 Transcription Service... Associated
 Membership... BAB, NARTB
 Pres., Gen. Mgr... E. Newton Wray
 Business Manager... Patrick White
 Pub., Prom. Mgr... Dorothy Goldsworthy
 Program Director... Michael Roppolo
 Chief Engineer... C. H. Maddox

K W K H

SHREVEPORT—1925—CBS

Frequency: 1130 Kc. Power: 50,000 Watts
 Owned-Operated By... International Bcstg. Corp.
 Business-Studio Address... Box 1387
 Phone Number... 2-3711
 Newspaper Affiliation... Shreveport Times
 Air Time... Unlimited
 News Service... AP, UP
 Transcription Service... Standard
 Representative... Branham
 Membership... NARTB, BAB
 President... William H. Bronson
 Exec. V.P., Gen. Mgr... Henry B. Clay
 Commercial Manager... Fred Watkins, Jr.
 Prom. Mgr., Pub. Dir... James T. Briggs
 Program Director... Horace Logan
 Chief Engineer... O. S. Droke

K V P I

VILLE PLATTE—1953

Frequency: 1050 Kc. Power: 250 Watts d.
 Owned-Oper. By... Ville Platte Bcstg. Co.
 Address... Box 566
 Phone Number... 5888
 President... Lionel B. Deville
 General Manager... Chris Duplechain
 Program Director... J. S. Fontenot

MAINE

Pop. Feb. 1, 1954 (Est.) 922,000 — Families 287,000
 Radio Homes 273,000 — TV Homes 69,000 — Stations in State 16

W F A U

AUGUSTA—1946—MBS-YANKEE

Frequency: 1340 Kc. Power: 250 Watts
 Owned-Oper. By... Twin City Bcstg. Co., Inc.
 Address... 160 Bangor St.
 Phone Number... 3-3878
 Air Time... Full Time
 News Service... AP
 Transcription Service... Standard, World
 Representative... O'Connell, Borgatti
 President... Faust Couture
 General Manager... Norman G. Gallani
 Comm. Mgr... Harry Simons
 Program Director... Mona Hixon
 Publicity Director... Gregory Evans
 Chief Engineer... Paul Graves

W R D O

AUGUSTA—1932—NBC

Frequency: 1400 Kc. Power: 250 Watts
 Owned-Oper. By... WRDO, Inc.
 Address... 175 Water Street
 Phone Number... 3-4735
 Air Time... 6 a.m.-12 M.
 News Service... UP
 Transcription Service... Thesaurus

Representative... Weed, Bannan
 Membership... NARTB, BAB
 President... Adeline B. Rines
 Sta., Comm. Mgr... Donald K. Powers
 Sales Prom. Mgr... Lawrence Cloutier
 Publ. Pgm. Dir... Leslie R. Hubley
 Chief Engineer... Harold T. Dinsmore

W A B I

BANGOR—1924—ABC-MBS

Frequency: 910 Kc. Power: 5000 Watts
 Owned-Oper. By... Community Bcstg. Service
 Business-Studio Address... 57 State St.
 Phone Number... 6446
 Air Time... Full Time
 News Service... AP
 Representative... Everett-McKinney, Kettell-Carter
 Co.-O., President... Horace E. Hildreth
 Gen., Sta., Comm. Mgr... Leon Gorman
 Program Dir... Richard Bronson
 Chief Engineer... Walter Dickson

W G U Y

BANGOR—1947—CBS

Frequency: 1230 Kc. Power: 250 Watts
 Owned-Oper. By... Guy Gannett Bcstg. System

Address..... P. O. Box 732
 Phone Number..... 7354
 Air Time..... 6:30 a.m.-12 M.
 News Service..... UP
 Representative..... Avery-Knodel
 President..... Guy P. Gannett
 General Manager..... Creighton E. Gatchell
 Station Manager..... Samuel G. Henderson, Jr.
 Program Director..... Clifton E. Reynolds
 Chief Engineer..... Roger W. Hodgkins

W L B Z

BANGOR—1926—NBC-NERN

Frequency: 620 Kc..... Power: 5000 Watts
 Owned-Operated By..... Maine Bcstg. Co.
 Business-Studio Address..... 100 Main St.
 Phone Number..... Bangor 2-4656
 Air Time..... Unlimited
 News Service..... UP
 Transcription Service..... Thesaurus
 Representative..... Weed, Bertha Bannan
 Membership..... NARTB, BAB
 President..... Adeline Rines
 General Manager..... Edward E. Guernsey
 Program Director..... Irving S. Hunter
 Publicity Manager..... George Chapman
 Chief Engineer..... John Wibby

W I D E

BIDDEFORD—1948—MBS-YANKEE

Frequency: 1400 Kc..... Power: 250 Watts

Owned-Oper. By..... Biddeford Bdcstg. Corp.
 Address..... 234 Main St.
 Phone Number..... 4-4566
 Air Time..... Full Time
 News Service..... AP
 Transcription Service..... World
 Membership..... NARTB
 President..... Victor C. Diehm
 Gen., Sta., Comm. Mgr..... Arthur Deters
 Asst. Sta. Mgr..... Chris Drivas

W A B M

HOULTON—1950—MBS

Frequency: 1340 Kc..... Power: 250 Watts
 Owned-Oper. By..... Aroostook Bdcstg. Corp.
 Phone Number..... 2257
 Air Time..... Full Time
 News Service..... AP
 Transcription Service..... Thesaurus
 President..... Harry E. Umphrey
 General Manager..... Harold D. Glidden
 Station Manager..... Ted Coffin
 Chief Engineer..... Robert W. MacIntosh

W C O U

LEWISTON—1938—MBS-YANKEE

Frequency: 1240 Kc..... Power: 250 Watts
 Owned-Oper. By..... Twin City Bcstg. Co., Inc.
 Business-Studio Address..... 223 Lisbon St.
 Phone Number..... 4-6921
 Air Time..... 18 Hours
 News Service..... AP
 Transcription Serv..... Standard, SESAC, World
 Representative..... O'Connell, Borgatti
 President..... Faust Couture
 General Station Mgr..... John C. Libby
 Comm. Mgr..... Oscar J. Normand
 Pgm., Pub. Dir..... Herb Fontaine
 Chief Engineer..... Herbert Wiles

W L A M

LEWISTON—1947—ABC

Frequency: 1470 Kc..... Power: 5000 Watts
 Owned-Oper. By..... Lewiston-Auburn Bcstg.
 Business-Studio Address..... 129 Lisbon St.
 Phone Number..... 4-5401
 Air Time..... 6 a.m.-12 M.
 News Service..... AP
 Transcription Service..... Thesaurus
 Representative..... Everett-McKinney
 President, Station Mgr..... Elden H. Shute, Jr.
 General Manager..... Frank S. Hoy
 Comm., Sales Prom. Mgr..... Gerald T. Higgins
 Program Director..... Harold W. Dutch
 Chief Engineer..... Henry Root

W C S H

**PORTLAND—1925
 NBC-NERN-ME.**

Frequency: 970 Kc..... Power: 5000 Watts
 Owned-Oper. By..... Congress Square Hotel Co.
 Business-Studio Address..... 157 High St.
 Phone Number..... 2-0181
 Air Time..... Unlimited



W I D E

**BIDDEFORD-SACO, ME.
 MBS-YANKEE**

Since it went on the air November 6, 1948, it has been growing steadily in acceptance as a proven sales medium in this industrial recreational marketing area. WIDE's proven daytime service area covers a population of 201,781. During the spring and summer months the population increases immensely because WIDE is located in the heart of Maine's richest resort area—Old Orchard Beach, Kennebunk Beach, Pine Point and many others. Here, too, are located the famous textile plants of Pepperell, Bates and Saco-Lowell with large year-round pay-rolls.

Together with WIDE, WAZL, WHOL, WHLM and WVDA are under the supervision of Victor C. Diehm, radio pioneer and executive.

**ARTHUR A. DETERS
 President and Gen. Mgr.**

News Service.....AP, UP
 Transcription Service.....Thesaurus
 Representative.....Weed, Bertha Bannan
 Membership.....NARTB, BAB
 President.....Adeline B. Rines
 General Manager.....William H. Rines
 Station Manager.....Linwood T. Pitman
 Commercial Manager.....Albert W. Smith
 Prog. Dir.....Arthur Owens
 Chief Engineer.....Daniel B. Smith

WGAN

PORTLAND—1938—CBS

Frequency: 560 Kc.....Power: 5000 Watts
 Owned-Oper. By...Guy Gannett Bcstg. Services
 Business-Studio Address....390 Congress St.
 Phone Number.....2-7423
 Air Time.....6 a.m.-12:05 a.m.
 News Service.....AP, UP
 Representative.....Avery-Knodel
 Membership.....NARTB
 President.....Guy P. Gannett
 General Manager.....Creighton E. Gatchell
 Commercial Manager.....Richard E. Bates
 Pgm., Pub. Dir.....Francis H. Farnum, Jr.
 Chief Engineer.....Roger W. Hodgkins

WPOR

PORTLAND—1946—ABC-YANKEE
 MBS

Frequency: 1490 Kc.....Power: 250 Watts

Owned-Operated By.....Oliver Bcstg. Corp.
 Business-Studio Address....477 Congress St.
 Phone Number.....3-8111
 Air Time.....Full Time
 News Service.....AP
 Representative.....O'Connell, Borgatti
 Membership.....BAB, NARTB
 Pres., Sta., Gen. Mgr.....Harold H. Meyer
 Commercial Manager.....William J. Mullen
 Sales Prom. Mgr.....Robert Maynard
 Pgm., Pub. Dir.....Raymond Mercier
 Chief Engineer.....Roger S. Perry

WAGM

PRESQUE ISLE—1931—MBS
 YANKEE—M.E.B.S.

Frequency: 1450 Kc.....Power: 250 Watts
 Owned-Operated By...Aroostook Bcstg. Corp.
 Phone Number.....8821
 Air Time.....Unlimited
 News Service.....AP
 Transcription Service.....Thesaurus
 President.....Harry Umphrey
 Gen., Sta. Mgr.....Harold D. Glidden
 Pgm., Comm. Dir.....Richard B. Marshall
 Chief Engineer.....Lester E. Hughes

WRKD

ROCKLAND—1952—ABC

Frequency: 1460 Kc.....Power: 250 Watts
 Owned-Oper. By.....Knox Bcstg. Co.



AMERICAN BROADCASTING COMPANY
 YANKEE NETWORK
 MUTUAL BROADCASTING SYSTEM
 LOBSTER NETWORK

WPORTLAND

1. 25.5% of States' population
2. 37.9% of States' retail sales
3. WPOR is strong on local impact, news, weather, music, sports
4. Growing acceptance — WPOR local business up 106% — national business up 238%

PORTLAND, MAINE

Represented by
 NEW YORK — Richard O'Connell
 BOSTON — Lou Borgatti
 CHICAGO — Hal Holman
 PACIFIC COAST — Duncan Scott
 HAL MEYER, President

Portland's Favorite Station —
Ask Anyone!

YOU GET MORE

COVERAGE

38,000 Square Miles! 496,810 Radio families!

WHEN YOU BUY

RADIO BALTIMORE

WBAL

50,000 Watts • NBC in Maryland

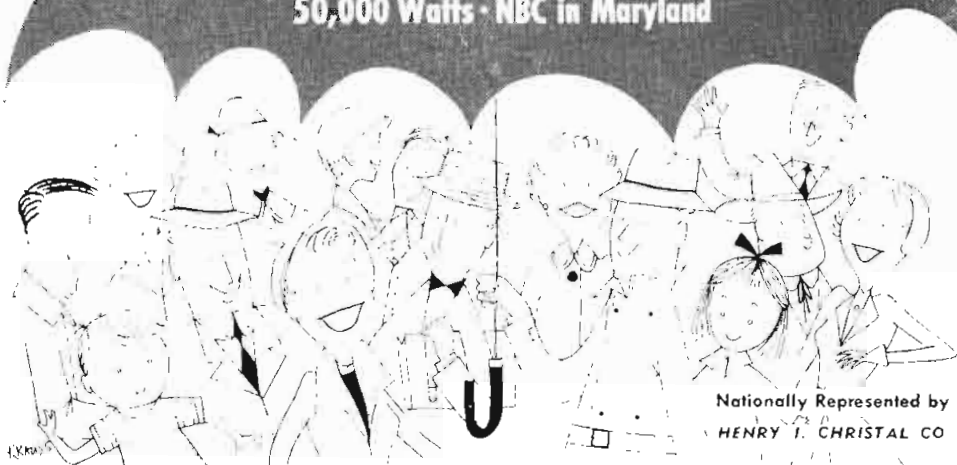

**Nationally Represented by
HENRY I. CRISTAL CO**

◆ ◆ ◆ MAINE - MARYLAND ◆ ◆ ◆

Address.....493 Main St.
Phone Number.....1600
Air Time.....Full Time
News Service.....UP
Transcription Service.....Standard
Representative.....O'Connell, Borgatti
President.....Carleton D. Brown
Station Manager.....Paul R. Huber
Commercial Mgr.....Vere B. Crockett
Chief Engineer.....Donald S. Winslow

WRUM

RUMFORD—1953—KBS

Frequency: 1450 Kc.....Power: 250 Watts
Owned-Oper. By.....Rumford Publ. Co.
Address.....Prospect Ave.
Phone Number.....1057
Representative.....O'Connell
President.....Melvin L. Stone

Gen. Mgr., Prog. Dir.....Ken J. Ellis
Commercial Mgr.....G. B. Cunningham
Chief Engineer.....E. J. Tremblay

WTVL

WATERVILLE—1946—ABC

Frequency: 1490 Kc.....Power: 250 Watts
Owned-Operated By.....Kennebec Bcstg. Co.
Business-Studio Address.....36 Silver St.
Phone Number.....2700-1
Air Time.....6 a.m.-M.
News Service.....AP
Transcription Service.....Standard
Representative.....O'Connell, Kettell-Carter
Membership.....NARTB, BAB
Pres., Gen.-Station Mgr.....Carleton D. Brown
Commercial Mgr.....Harold L. Vique
Program Director.....Fred Preble
Chief Engineer.....Don Sutherland

MARYLAND

*Pop. Feb. 1, 1954 (Est.) 2,366,000 — Families 640,000
Radio Homes 612,000 — TV Homes 601,500 — Stations in State 27*

WANN

ANNAPOLIS—1946

Frequency: 1190 Kc.....Power: 1000 Watts d.
Owned-Operated By.....Annapolis Bcstg. Corp.
Business-Studio Address.....Box 749
Phone Number.....Colonial 3-2500
News Service.....UP
Representative.....Pearson, Dora-Clayton
President, General Mgr.....Morris H. Blum
Chief Engineer.....Arthur P. Dietz

WASL

ANNAPOLIS—1946

Frequency: 810 Kc.....Power: 250 Watts d.
Owned-Oper. By.....Chesapeake Radio Corp.
Business Address.....Truxton Heights
Phone Number.....Colonial 3-3211
News Service.....AP
Transcription Service.....World
Pres., Gen. Mgr.....Robert L. Blalock
Program Director.....M. E. Blalock
Chief Engineer.....Stanley C. Leck

WNAV

ANNAPOLIS—1949—KBS

Frequency: 1430 Kc.....Power: 1000 Watts
Owned-Oper. By.....The Capital Bdcstg. Co.
Phone Number.....Colonial 3-2639
News Service.....AP
Transcription Service.....Thesaurus
Representative.....McGillvra
President.....Albert H. MacCarthy
Station Manager.....Norman Bergholm
Program Director.....Helga Pfefferman
Chief Engineer.....Alan B. Laifler

WBAL

BALTIMORE—1925—NBC

Frequency: 1090 Kc.....Power: 50,000 Watts
Owned-Oper. By.....Hearst Corp. (Radio & TV Div.)
Address.....2610 North Charles St.
Phone Number.....Hopkins 7-3000
Air Time.....Unlimited
News Service.....AP, INS, UP
Transcription Service.....Thesaurus, SESAC
Representative.....Christal
V.P. and Exec. Dir.....Charles B. McCabe
V.P. & Gen. Mgr.....D. L. Provost
V.P. (Engineering).....John Wilner
Station Manager.....Leslie H. Peard, Jr.
Dir. Pub. Affairs & Educ.....Arnold Wilkes
Program Director.....Victor F. Campbell
Program Manager.....William N. Rock
Local Sales Manager.....J. M. Kennedy
Pub. Mgr.....Thomas J. White, Jr.
Chief Engineer.....William C. Bareham

WBMD

BALTIMORE—1947

Frequency: 750 Kc.....Power: 1000 Watts d.
Owned-Operated By.....Key Bcstg. Corp.
Business-Studio Address.....879 Park Ave.
Phone Number.....Mulberry 5-7095
News Service.....AP
President.....George E. Hull
Gen., Sta., Comm. Mgr.....H. Shelton Earp, Jr.
Chief Engineer.....Russell H. Morgan

WCAO

BALTIMORE—1922—CBS

Frequency: 600 Kc.....Power: 5000 Watts

Owned-Oper. By..... Monumental Radio Co.
 Business-Studio Address... 1102 N. Charles St.
 Phone Number..... Mulberry 5-0600
 Air Time..... Unlimited
 News Service..... AP
 Representative..... Paul H. Raymer
 Membership..... NARTB
 Pres., Sta., Gen. Mgr..... L. W. Milbourne
 Comm., Prom. Mgr..... Robert M. Richmond
 Program Dir..... George L. Filling
 Chief Engineer..... Martin L. Jones

W C B M

BALTIMORE—1924—MBS

Frequency: 680 Kc. Power: 10,000 d.; 5000 n.
 Owned-Oper. By..... Baltimore Bcstg. Corp.
 Bus.-Studio Address... Harford & North Aves.
 Phone Number..... Belmont 5-8400
 Air Time..... Full Time
 News Service..... AP, INS
 Representative..... Taylor
 Membership..... NARTB
 President, Comm. Manager..... John Elmer
 Gen., Sta., Comm. Mgr..... G. H. Roeder
 Chief Engineer..... G. Porter Houston

W F B R

BALTIMORE—1922—ABC

Frequency: 1300 Kc. Power: 5000 Watts
 Owned-Oper. By... The Baltimore Radio Show
 Address..... 10 E. No. Ave.
 Phone Number..... Mulberry 5-1300
 Air Time..... 6 a.m.-12 M.
 News Service..... AP, UP
 Representative..... John Blair & Co.
 Membership..... BAB, NARTB
 President..... Robert S. Maslin
 V.P. & Gen. Mgr..... Robert B. Jones
 V.P. & Treasurer..... J. H. L. Trautfelter
 V.P. Charge of Adv..... Robert S. Maslin, Jr.
 Dir. of Sales, Comm. Mgr..... Wm. S. Pirie, Jr.
 Program Dir..... Bert Hanauer
 Chief Engineer..... William Q. Ranft

W I T H

BALTIMORE—1941

Frequency: 1230 Kc. Power: 250 Watts
 Owned-Operated By... Maryland Bcstg. Corp.
 Business-Studio Address... 7 E. Lexington St.
 Phone Number..... Lexington 9-7808
 Air Time..... 24 Hrs.
 News Service..... AP
 Transcription Service..... Standard
 Representative..... Forjoe
 Membership..... BAB
 Pres., Gen. Mgr..... Thomas G. Tinsley, Jr.
 Comm., Sales Prom. Mgr..... Robert C. Embry
 Program Director..... Ellen J. Stoutenberg
 Chief Engineer..... James S. Duff

W S I D

BALTIMORE—1947

Frequency: 1010 Kc. Power: 1000 Watts, d.
 Owned-Operated By..... United Bcstg. Co.

Business-Studio Address... 912 N. Charles St.
 Phone Number..... Saratoga 8250
 News Service..... UP
 President..... Richard Eaton
 Gen., Sta. Mgr..... Marvin Mirvis
 Program Director..... He'len Wherley
 Chief Engineer..... Cliff Inman

W W I N

BALTIMORE—1951

Frequency: 1400 Kc. Power: 250 Watts
 Owned-Oper. By..... Belvedere Bcstg. Co.
 Address..... 1119 N. Charles St.
 Phone Number..... Saratoga 7-3555
 News Service..... AP
 Transcription Service..... Associated
 Representative..... Indie Sales
 Pres., Gen. Mgr..... Thomasc F. McNulty
 Station Manager..... Lenore Feldman
 Chief Engineer..... Joseph Sporney

W U S T

WASHINGTON—1951

Frequency: 1120 Kc. Power: 250 Watts d.
 Owned-Oper. By... Broadcast Management, Inc.
 Address..... 1343 You St., Wash., D. C.
 Phone Number..... HO 2-0011
 News Service..... AP
 Representative..... Interstate United Newspapers
 Pres., Gen. Mgr..... Harold E. Sheffers
 Comm., Prom., Pub. Mgr..... Vernon L. Ward
 Chief Engineer..... Robert Carnine

W C E M

CAMBRIDGE—1947—MBS

Frequency: 1240 Kc. Power: 100 Watts
 Owned-Oper. By..... The Shore Bcstg Co.
 Phone Number..... 1580
 News Service..... AP
 Transcription Service..... World
 Pres., Gen. Mgr..... G. P. Richards
 Commercial Mgr..... Stam Cannon
 Station Manager..... Thomas H. Maquire, Jr.
 Promotion Mgr..... Anna Flowers
 Prog. Dir..... Bette B. Robbins
 Chief Engineer..... Arthur Coburn

W C U M

CUMBERLAND—1948—CBS

Frequency: 1490 Kc. Power: 250 Watts
 Owned-Oper. By..... The Tower Realty Co.
 Address..... Willam Rd., East of City Line
 Phone Number..... 5400-1
 Air Time..... 6:30 a.m.-11:30 p.m.
 News Service..... AP
 Representative..... Forjoe
 President..... Karl F. Stelmann
 Gen., Sta. Mgr..... M. Campbell, Jr.
 Commercial Manager..... Roy S. Knotts
 Sales Prom. Mgr..... Eldred Steinmann
 Chief Engineer..... Paul E. Custer

WDYK

CUMBERLAND—1949—ABC—MBS

Frequency: 1230 Kc. Power: 250 Watts
 Owned-Operated By: Western Md. Bcstg.
 Address: 450 Byrd Avenue
 Phone Number: 5001
 Air Time: Full Time
 News Service: UP
 Transcription Service: Standard
 Representative: Radio Representatives, Inc.
 President: Richard A. Raese
 General Manager: James M. Martinson
 Commercial Manager: Floyd V. Cozad
 Pgm., Pub. Dir.: Edwin Meyer
 Chief Engineer: George Sokol, Jr.

WTBO

CUMBERLAND—1928—NBC

Frequency: 1450 Kc. Power: 250 Watts
 Owned-Operated By: Maryland Radio Corp.
 Address: 31 Frederick St.
 Phone Number: 299
 Air Time: 6 a.m.-M.
 News Service: UP
 Transcription Service: World
 Representative: Branham
 Membership: NARTB, BAB
 Pres., Gen. Sta. Mgr.: Charles E. Smith
 Sales Prom. Mgr.: Ray Miller
 Pgm. Dir.: Michael Hurst
 Publicity Director: Helen Fike
 Chief Engineer: David W. Jelferies

WFMD

FREDERICK—1936—CBS

Frequency: 930 Kc. Power: 1000 Watts
 Owned-Operated By: Monocacy Bcstg. Co.
 Business-Studio Address: West Seventh St.
 Phone Number: MONument 3-4181
 Air Time: 5 a.m.-M.
 News Service: AP
 President: Laurence Leonard
 General Manager: Alan W. Long
 Program Director: Evelyn Leonard
 Sales Prom. Mgr.: Harold Keats
 Chief Engineer: Howard Fisher

WARK

HAGERSTOWN—1947—ABC

Frequency: 1490 Kc. Power: 250 Watts
 Owned-Oper. By: United Bcstg. Co., Inc.
 Business-Studio Address: 128 S. Prospect St.
 Phone Number: 4500
 News Service: UP
 President: Richard Eaton
 General Manager: Samuel E. Phillips, Jr.
 Prog. Dir., Farm Editor: Hunter Reams
 Chief Engineer: G. Harold Brewer

WJEJ

HAGERSTOWN—1932—MBS-ABC

Frequency: 1240 Kc. Power: 250 Watts
 Owned-Oper. By: Hagerstown Bcstg. Co., Inc.

Business-Studio Address: Franklin Court
 Phone Number: 2323
 Air Time: 6 a.m.-12:05 a.m.
 News Service: AP
 Transcription Service: Thesaurus
 Representative: Walker
 Membership: NARTB
 Pres., Gen. Mgr.: Grover C. Crilley
 Sta., Comm. Mgr.: William H. Paulsgrove
 Sales Prom., Pgm. Dir.: Robert Leshner
 Chief Engineer: George McIntire

WASA

HAVRE DE GRACE—1948

Frequency: 1330 Kc. Power: 1000 Watts d.
 Owned-Oper. By: Chesapeake Bcstg. Corp.
 Address: P. O. Box 97
 Phone Number: Havre De Grace 800
 Air Time: Local sunrise-local sunset
 News Service: AP
 Transcription Service: Standard
 President, General-Station Mgr.: Jason T. Pate
 Comm. Sales Prom. Mgr.: Charles W. Irwin
 Pgm., Pub. Dir.: Bob Gray
 Chief Engineer: Gerald D. Johnson

WKIK

LEONARDTOWN—1953

Frequency: 1370 Kc. Power: 1000 Watts d.
 Owned-Oper. By: Southern Md. Bcstrs. Inc.
 Phone Number: Greenwood 5-2211
 President: C. E. Springer
 General Manager: J. L. Bittner
 Commercial Mgr.: W. C. Redd

WPTX

LEXINGTON PARK—1953—KBS

Frequency: 1570 Kc. Power: 1000 Watts d.
 Owned-Oper. By: Patuxent Radio Inc.
 Address: Great Mills Rd.
 Phone Number: Great Mills 2-1031
 President: Harry J. Daly
 General Manager: J. M. Naylor
 Program Director: Lou Douglas

WINX

ROCKVILLE—1948

Frequency: 1600 Kc. Power: 1000 Watts d.
 Owned-Oper. By: Montgomery Cty. Bcstg. Co.
 Phone Number: Poplar 2-4357
 News Service: UP
 General Manager: Richard Eaten
 Program Director: Gene Andrews
 Chief Engineer: Arthur A. Snowberger

WBOC

SALISBURY—1940—MBS

Frequency: 960 Kc. Power: 1000 Watts
 Owned-Oper. By: The Peninsula Bcstg. Co.
 Bus.-Studio Address: Radio Park
 Phone Number: 8131
 Air Time: 6 a.m.-12:30 a.m.
 News Service: AP
 Transcription Service: World

Representative Burn-Smith
President John W. Downing
Gen., Sta., Comm. Mgr. Charles J. Truitt
Program Director John W. Downing, Jr.
Chief Engineer Jack W. Ward

WGAY

SILVER SPRING—1946

Frequency: 1050 Kc. **Power:** 1000 Watts d.
Owned-Oper. By Tri-Suburban Bcstg. Corp.
Business Address 11306 Kemp Mill Rd.
Phone Number Juniper 9-1050
News Service AP
Representative Indie Sales
Membership NARTB, BAB
President John W. Kluge
Gen.-Sta. Mgr. Joseph L. Brechner
Comm., Sales, Prom. Mgr. Ernest Tannen
Chief Engineer Arthur McDougall

WTTR

WESTMINSTER—1953

Frequency: 1470 Kc. **Power:** 1000 Watts d.
Owned-Oper. By Carroll County Bcstg. Corp.
Address Uniontown Road
Phone Number 1171
Vice-Pres., Gen. Mgr. R. H. Morgan
Commercial Mgr. E. E. Divers
Chief Engineer Charles T. Buffington

W DON

WHEATON—1953

Frequency: 1540 Kc. **Power:** 250 Watts d.
Owned-Oper. By Commercial Radio Equip.
Address 1319 F. St., N.W., Washington, D. C.
Phone Number District 7-1319
Pres., Gen. Mgr. E. L. Dillard
Commercial Mgr. James G. Gustafson
Chief Engineer E. V. Juraski

MASSACHUSETTS

Pop., Feb. 1, 1954 (Est.) 4,738,000 — Families 1,425,000
Radio Homes 1,409,000 — TV Homes 1,190,500 — Stations in State 51

WARA

ATTLEBORO—1950

Frequency: 1320 Kc. **Power:** 1000 Watts
Owned-Oper. By Attleboro Radio Assn.
Address 8 N. Main St.
Phone Number AT 1-1320
Representative Bannan, Walker
News Service UP
General Manager Keith S. Field
Commercial Mgr. William A. Dawson, Jr.
Program Director David P. Mohr
Chief Engineer Charles Lynch

Phone Number ALgonquin 4-5670
News Service AP, UP, INS
Transcription Service Thesaurus
Membership BAB
Representative Free & Peters
President Chris J. Witting
Exec. Vice Pres. J. E. Baudino
Station Manager P. E. Mills
Sales Manager C. M. Meehan
Promotion Manager C. Lud Richards
Program Manager Avner Rakov
Chief Engineer W. H. Hauer
Publicity Director Joseph Cullinane

WBMS

BOSTON—1946

Frequency: 1090 Kc. **Power:** 1000 Watts d.
Owned-Oper. By WBMS, Inc.
Business-Studio Address Hotel Shelton
Phone Number Copley 7-3005
News Service UP
Representative Wm. G. Rabeau Co.
President John Laux
General Manager Norman Furman
Chief Engineer Donald Snider

WCOP

BOSTON—1935

Frequency: 1150 Kc. **Power:** 5000 Watts
Owned-Oper. By WCOP Bdcstg. Co.
Business-Studio Address 485 Boylston St.
Phone Number Copley 7-0123
News Service AP, INS
Transcription Service World
Representative Bolling
Pres., Gen., Sta. Mgr. Roy V. Whisnand
Commercial Mgr. A. N. Armstrong, Jr.
Chief Engineer Roland C. Hale

WBZ - WBZA

(Synchronous Operation)

BOSTON-SPRINGFIELD—1921

NBC-NERN

Frequency: 1030 Kc. **Power:** WBZ, 50,000
 Watts; WBZA, 1000 Watts
Owned-Oper. By Westinghouse Radio Sta-
 tions, Inc. (Synchronous Operation)
Business-Studio Address 1170 Soldiers Field Rd.

WEEI

BOSTON—1924—CBS-RADIO

Frequency: 590 Kc. **Power:** 5000 Watts
Owned-Oper. By CBS Radio Division
Business-Studio Address 182 Tremont St.
Phone Number Hubbard 2-2323
Air Time Full Time
News Service AP, UP
Transcription Service Lang-Worth
Representative CBS Radio Spot Sales

MembershipBAB
 General Manager.....Harvey J. Struthers
 Commercial Mgr.....Emmett J. Heerd, Jr.
 Sales Prom. Mgr.....John T. Curry, Jr.
 Program Director.....Eugene M. King
 Publicity Director.....Marie H. Houlahan
 Chief Engineer.....Harold A. Dorschug

WHDH
 BOSTON—1926

Frequency: 850 Kc.....Power: 50,000 Watts
 Owned-Oper. By.....Matheson Radio Co.
 Bus-Studio Address.....6 St. James Ave.
 Phone Number.....HAncock 6-5500
 News ServiceAP
 RepresentativeJohn Blair
 MembershipNARTB, BAB
 President.....Robert B. Choate
 Managing Director.....William B. McGrath
 Commercial Manager.....Alexander M. Tanger
 Program Director.....George M. Perkins
 Sales Prom. Mgr., Pub. Dir...William E. Shea
 Chief Engineer.....Philip K. Baldwin

WMEX
 BOSTON—1934

Frequency: 1510 Kc.....Power: 5000 Watts
 Owned-Oper. By.....The Northern Corp.
 Business-Studio Address...70 Brookline Ave.
 Phone Number.....Commonwealth 6-3900
 Air Time.....Full Time
 News ServiceINS
 Transcription Service....Lang-Worth, SESAC
 Pres., Prog. Dir.....John E. Reilly
 General Manager.....William S. Pate
 Commercial Manager.....Lawrence Flynn
 Sales Promotion Manager...Marie Mason
 Chief Engineer.....William Ferruzzi

WNAC

BOSTON—1937—MBS-YANKEE

Frequency: 680 Kc.....Power: 5000 Watts
 Owned-Oper. By...Yankee Net. Div., General
 Teleradio, Inc.
 Bus-Studio Address.....21 Brookline Ave.
 News Service.....INS, UP
 RepresentativeH.R. Reps.
 PresidentTom O'Neil
 Exec. V.P., Gen. Mgr.....Linus Travers
 Vice President.....George Steffy
 Commercial Manager.....Tom Bateson
 Sales Prom. Mgr.....George Hallberg
 Program Director.....John D. Maloy
 Chief Engineer.....L. B. Robinson

WORL
 BOSTON—1950

Frequency: 950 Kc.....Power: 5000 Watts d.
 Owned-Oper. By.....Pilgrim Bcstg. Co.
 Address.....92 State St.
 Phone Number.....Lafayette 3-4000
 Air Time.....Day Time
 News ServiceAP
 Representative.....Headley Reed Co.
 President.....Joseph A. Dunn

Gen., Sta., Comm. Mgr.....Arthur E. Haley
 Program Director.....Norm Prescott
 Chief Engineer.....John Parker

WVDA

BOSTON—1953—ABC

Frequency: 1260 Kc.....Power: 5000 Watts
 Owned-Oper. By.....Vic Diehm Assoc. Inc.
 AddressHotel Bradford
 Phone Number.....Hancock 6-1122
 RepresentativeRaymer
 PresidentVic Diehm
 General Manager.....Lambert Beuwkes
 Program Director.....Charles Tarkinson
 Promotion Mgr.....Gay Swankin
 Chief Engineer.....Kenneth Smith

WVOM

BOSTON-BROOKLINE—1948—KBS

Frequency: 1600 Kc.....Power: 5000 Watts
 Owned-Oper. By.....The Boston Bcstg. Corp.
 Address.....790 Commonwealth Ave.
 Phone NumberBeacon 2-5650
 Air Time.....Full Time
 Transcription Service.....Thesaurus
 RepresentativeRobert Keller
 News ServiceUP
 V.P., Gen. Mgr.....Benjamin Bartzoff
 Commercial Manager.....Ken Strong
 Program Director.....James A. Fitzgerald, Jr.
 Chief Engineer.....Jerome Bartzoff



WVDA

BOSTON, MASS. ABC

WVDA gives three times the news coverage of any other Boston station and the high calibre reporting of the news is reflective on all stations in the Vic Diehm group.

Together with WVDA, WAZL, WHOL, WHLM, and WIDE are under the supervision of Victor C. Diehm, radio pioneer and executive.

VICTOR C. DIEHM
 President

Rep. PAUL H. RAYMER CO.

WBET

BROCKTON—1946

Frequency: 1460 Kc. Power: 1000 Watts d.
 Owned-Oper. By... Enterprise Publishing Co.
 Business-Studio Address... 60 Main St.
 Phone Number... Brockton 7062
 News Service... AP
 Transcription Service... Thesaurus
 Representative... Bannan, Colton
 Membership... NARTB, BAB
 General Manager... Charles A. Fuller
 Commercial Mgr... Earle G. Clement
 Program Director... William W. Pierce, III
 Chief Engineer... Charles Nowell

WTAO

CAMBRIDGE—1946

Frequency: 740 Kc. Power: 250 Watts d.
 Owned-Oper. By... Middlesex Bcstg. Corp.
 Address... 439 Concord Ave.
 Phone Number... Eliot 4-0500
 News Service... AP
 Representative... Indie Sales
 President... Frank J. Lyman, Jr.
 General Manager... F. S. Bailey
 Commercial Mgr... John H. Kimball
 Program Director... Edward Penney

WACE

CHICOPEE-SPRINGFIELD—1946

Frequency: 730 Kc. Power: 1000 Watts d.
 Owned-Operated By... Regional Bcstg. Co.
 Business Address... Hotel Bridgeway
 Phone Number... 6-1323
 News Service... INS
 Representative... Indie Sales, Kettell Carter
 Membership... NARTB, BAB
 President... David Hayes
 Sta., Comm. Gen. Mgr... Ralph J. Robinson
 Chief Engineer... H. R. Glinka

WALE

FALL RIVER—1948—MBS-YANKEE

Frequency: 1400 Kc. Power: 250 Watts
 Owned-Oper. By... Narragansett Bcstg. Co.
 Address... 374 Central St.
 Phone Number... 4-1400
 News Service... UP
 Transcription Service... World
 Representative... Walker, Bannan
 Membership... BAB
 Pres., Gen. Mgr... George L. Sisson, Jr.
 Commercial Mgr... Madeleine Hamel
 Sales Prom. Mgr... J. Roger Sisson
 Program Director... Ann Kenney
 Publicity Director... Walter Johnson
 Chief Engineer... Roland Berube

WSAR

FALL RIVER—1921—ABC

Frequency: 1480 Kc. Power: 5000 Watts
 Owned-Oper. By... Fall River Bcstg. Co., Inc.
 Business-Studio Address... Academy Bldg.

Phone Number... 7-9477
 Newspaper Affiliation... Herald News, Inc.
 Air Time... Full Time
 News Service... UP
 Transcription Service... Thesaurus
 Representative... Headley-Reed, Kettell-Carter
 Membership... NARTB
 President... Frank W. Miller, Jr.
 General Manager... Lincoln W. N. Pratt
 Commercial Manager... Cornelius Sullivan
 Program Director... Joseph Welch
 Chief Engineer... John Pavao

WEIM

FITCHBURG—1941—MBS-YANKEE

Frequency: 1280 Kc. Power: 1000 Watts
 Owned-Oper. By... WEIM, Fitchburg, Inc.
 Business-Studio Address... 717 Main St.
 Phone Number... Fitchburg 3-3766
 Air Time... Unlimited
 News Service... UP
 Representative... Walker
 President... Henry G. Molina, Jr.
 Commercial Mgr... James W. Chalmers
 Chief Engineer... Ted Kalib

WFGM

FITCHBURG—1950

Frequency: 1580 Kc. Power: 1000 Watts d.
 Owned-Oper. By... Wachusett Bcstg. Co.
 Address... 455 Main St.
 Phone Number... 3-4897
 Representative... Rambeau, Bannan
 News Service... UP
 Transcription Service... SESAC
 President... Francis D. Edes
 General Manager... David M. Myers
 Sales Prom. Mgr... Joseph R. Rich
 Program Director... Tal Hood
 Chief Engineer... Donald L. Coleman

WKOX

FRAMINGHAM—1947

Frequency: 1190 Kc. Power: 1000 Watts d.
 Owned-Operated By... WKOX, Inc.
 Bus.-Studio Address... Mt. Wayte Ave.
 Phone Number... Framingham 7409
 News Service... UP
 Transcription Service... World
 Representative... Kettell-Carter, Grant Webb
 General Manager... Richard E. Adams
 Commercial Manager... Lewis F. Sargent
 Chief Engineer... Francis Bartol

WGAW

GARDNER—1953—ABC

Frequency: 1490 Kc. Power: 250 Watts
 Owned-Oper. By... KBR Stations of N. E.
 Business Number... 3 Pleasant St.
 Phone Number... 1490
 Air Time... Full Time
 News Service... UP
 Representative... Borgatti, Inc.

President.....W. J. Barkley
 General Manager.....Wm. Rust, Jr.
 Sta., Comm., Prom. Mgr.....William C. Engel
 Chief Engineer.....William Martin

W H A I

GREENFIELD—1938—MBS-YANKEE

Frequency: 1240 Kc.....Power: 250 Watts
 Owned-Operated By.....John W. Haigis
 Business-Studio Address.....354 Main St.
 Phone Number.....4301-2
 Air Time.....Full Time
 News Service.....AP
 Representative.....Bertha Bannan, Walker
 Membership.....BAB, NARTB
 President.....John W. Haigis, Sr.
 Gen., Sta. Mgr.....John W. Haigis, Jr.
 Commercial Manager.....H. W. Nichols
 Sales Prom. Mgr., Pub. Dir.....Thomas J. Kelly
 Program Director.....Ira I. Hewey
 Chief Engineer.....Leland F. Wheeler

W H A V

HAVERHILL—1947

Frequency: 1490 Kc.....Power: 250 Watts
 Owned-Oper. By.....Haverhill Gazette Co.
 Business-Studio Address.....30 How St.
 Phone Number.....Haverhill 4-4733
 Newspaper Affiliation...Haverhill Gazette Co.
 News Service.....UP
 Representative.....Kettell-Carter
 Membership.....BAB
 Pres., Gen. Mgr.....John T. Russ
 Station Manager.....Robert I. Kimel
 Commercial Mgr.....John J. Kirby
 Program Director.....Kenneth Ash
 Chief Engineer.....David Cate

W H Y N

**HOLYOKE-SPRINGFIELD—1941
 CBS**

Frequency: 560 Kc.....Power: 1000 Watts
 Owned-Oper. By...Hampden—Hamshire Corp.
 Address.....1300 Liberty St., Springfield
 Phone Number.....Springfield 4-1126
 News Service.....UP
 Transcription Service.....Lang-Worth
 Representative.....Branham, Weed
 Membership.....NARTB, BAB
 General Manager.....Charles N. DeRose
 Commercial Manager...Patrick J. Montague
 Chief Engineer.....Alexander Paley

W R E B

HOLYOKE—1948

Frequency: 930 Kc.....Power: 500 Watts d.
 Owned-Oper. By.....Valley Bcstg. Corp.
 Address.....323 High St.
 Phone Number.....2-3296
 Transcription Service.....SESAC
 News Service.....AP
 Representative.....Lionel Colton
 President.....Sigward Holmes
 Sta., Pgm. Mgr.....John H. Vondell, Jr.
 Commercial Mgr.....Emil R. Werner

News Director.....Warren F. Craig
 Chief Engineer.....Dr. Albert King

W C C M

LAWRENCE—1947

Frequency: 800 Kc....Power: 1000 Watts d.
 Owned-Oper. By.....Lawrence Bdcstg. Co.
 Address.....278 Essex Street
 Phone Number.....Lawrence 3-7171-2
 News Service.....AP
 Representative.....Foster, Indie Sales
 Pres., Gen. Mgr.....Geo. H. Jaspert
 Comm., Sta. Mgr.....Daniel Ruggles, III
 Program Director.....Pete Ward
 Chief Engineer.....John David Bodel

W C A P

LOWELL—1951

Frequency: 980 Kc.....Power: 1000 Watts d.
 Owned-Operated By.....Northeast Radio Inc.
 Address.....243 Central St.
 Phone Number.....4-0404
 News Service.....UP
 Representative.....Kettell-Carter
 President.....Israel Cohen
 Gen., Sta. Mgr.....William J. Warren
 Chief Engineer.....Theodore Cohen

W L L H

**LOWELL-LAWRENCE—1934
 MBS-YANKEE**

Frequency: 1400 Kc.....Power: 250 Watts
 Owned-Oper. By.....Merrimac Bdcstg. Co.
 Address.....39 Kearney Sq., Lowell;
 Cregg Bldg., Lawrence
 Phone Number...Lowell 8715, Lawrence 2-2148
 Air Time.....Full Time
 News Service.....UP
 Representative.....Bloomberg
 President.....Gerald Harrison
 Sta. Mgr.....Dana W. Fitzgerald
 Program Director.....Tom Clayton
 Commercial Manager...Haskell Bloomberg
 Chief Engineer.....Anthony G. Michaels

W L Y N

LYNN—1947

Frequency: 1360 Kc.....Power: 1000 Watts d.
 Owned-Oper. By.....Purltan Bcst. Service, Inc.
 Business-Studio Address.....7 Willow St.
 Phone Number.....LY. 5-6200
 News Service.....UP
 President.....Theodore Feinstein
 General Manager.....Hank Forbes
 Chief Engineer.....Russell Bassett

W H I L

MEDFORD—1952

Frequency: 1430 Kc.....Power: 500 Watts d.
 Owned-Operated By.....Conant Bcstg. Co.
 Address.....99 Revere Beach Pkwy.
 Phone Number.....Mystic 8-2250
 News Service.....UP

Pres., Gen., Sta. Mgr. Sherwood J. Tarlow
 Commercial Mgr. Joseph Kruger
 Sales Prom. Mgr. Allan Roberts
 Chief Engineer. Sal Fulchino

W B S M

NEW BEDFORD—1949

Frequency: 1230 Kc. Power: 100 Watts
 Owned-Oper. By. Bay State Bcstg. Co.
 Address Pope's Island
 Phone Number 3-1767
 Representative The Bolling Co.
 Membership NARTB
 News Service UP
 President. Joseph P. Duchaine
 General Manager Otto F. A. Arnold
 Commercial Manager Richard G. Evans
 Chief Engineer Brownell Brightman

W N B H

**NEW BEDFORD—1921—MBS
 YANKEE**

Frequency: 1340 Kc. Power: 250 Watts
 Owned-Oper. By E. Anthony & Sons, Inc.
 Business-Studio Address 432 County Sts.
 Phone Number 8-5228
 Air Time Full Time
 News Service AP
 Newspaper Affiliation Standard-Times
 Representative. Walker Co., Bertha Bannan
 Station Manager J. Thomas Mathers
 Commercial Manager Arnold Briden
 Program Director. James Gleason
 Publicity Director. Robert Sayre

W M N B

NORTH ADAMS—1947

Frequency: 1230 Kc. Power: 250 Watts
 Owned-Oper. By. Northern Berkshire Bcstg. Co.
 Bus.-Studio-Transmitter Address 466 Curran
 Phone Number. MOhawk 3-6567
 News Service AP
 Transcription Service. Thesaurus
 Representative McGillvra
 Membership NARTB
 Pres., Gen. Mgr. J. Gordon Keyworth
 Chief Engineer. J. Gordon Keyworth

W N A W

NORTH ADAMS—1949

Frequency: 860 Kc. Power: 250 Watts d.
 Owned-Operated By Cecil F. Clifton
 Address 20 State Street
 Phone Number MOhawk 3-5356
 News Service UP
 Transcription Service. Associated, Cole
 General Manager Robert E. Dain
 Chief Engineer. Ralph Haneman

W H M P

NORTHAMPTON—1950

Frequency: 1400 Kc. Power: 250 Watts
 Owned-Oper. By Pioneer Valley Bcstg. Co.

Address. 78 Main St.
 News Service UP
 Representative Louis Borgatti
 President. John H. Williams
 Gen., Sta., Comm.
 Prom. Mgr. Alexander W. Milne
 Program Director Joseph T. Fennessey
 Chief Engineer. Harold Schumacher

W B E C

PITTSFIELD—1947—ABC

Frequency: 1490 Kc. Power: 250 Watts
 Owned-Oper. By. Western Mass. Bcstg. Co.
 Business-Studio Address. 30 Eagle St.
 Phone Number 8292
 News Service AP
 Transcription Service Capitol
 Representative Everett-McKinney, Kettell-Carter
 President. L. K. Miller
 Gen., Comm., Prom. Mgr. W. Wendell Budrow
 Program Director. Robert Henaberry
 Chief Engineer. Walton Ayer

W B R K

PITTSFIELD—1938—MBS-YANKEE

Frequency: 1340 Kc. Power: 250 Watts
 Owned-Operated By. Greylock Bcstg. Co.
 Business-Studio Address. 8 Bank Row
 Phone Number 2-1553
 Air Time Full Time
 News Service UP
 Representative Walker, Borgatti
 Membership NARTB, BAB
 President Leon Podolsky
 General Manager. Walter Kearsey
 Sales Promotion Manager. Robert H. Burbank
 Pub., Pgm. Dir. Edward Merritt
 Chief Engineer. Edward Taffett

W J D A

QUINCY—1947

Frequency: 1300 Kc. Power: 1000 Watts d.
 Owned-Oper. By. South Shore Bcstg. Co., Inc.
 Business-Studio Address Box 373
 Phone Number. Mayflower 9-1300
 News Service UP
 Transcription Service World
 Representative Grant Webb
 Pres., Gen., Sta. Mgr. James D. Asher
 Commercial Mgr. James Lee
 Chief Engineer Fred Lane

W E S X

SALEM—1939

Frequency: 1230 Kc. Power: 250 Watts
 Owned-Oper. By. North Shore Bcstg. Co.
 Business-Studio Address. 49 Washington St.
 Phone Number Salem 5670
 Owner, Comm. Mgr. J. D. Asher
 P es., Gen., Sta. Mgr. William C. Asher
 Program Director Norman Durkee

WBZA-WBZ

(Synchronous Operation)
 SPRINGFIELD-BOSTON—1921
 NBC-NERN
 (See Boston Listing)

WJKO

SPRINGFIELD—1949

Frequency: 1600 Kc. Power: 5000 Watts d.
 Owned-Oper. By Springfield Bdcstg. Co.
 Address 137 State St.
 Phone Number 2-7487
 News Service UP
 Representative Gill, Perna
 Gen. Mgr., Pgm. Dir. C. M. Manitsas

WMAS

SPRINGFIELD—1932—MBS
 YANKEE

Frequency: 1450 Kc. Power: 250 Watts
 Owned-Operated By WMAS, Inc.
 Business-Studio Address 101 West St.
 Phone Number Springfield 7-1414
 News Service UP
 Representative H-R Reps
 Membership NARTB
 President Gerald Harrison
 Sta., Comm. Mgr. Robert Donahue
 Pgm., Pub. Dir. Paul Peltier
 Chief Engineer John Michnovcz

WSPR

SPRINGFIELD—1936—ABC

Frequency: 1270 Kc. Power: 1000 Watts
 Owned-Operated By WSPR, Inc.
 Business Address 63 Chestnut St.
 Phone Number 2-4181
 Air Time Full Time
 News Service AP
 Representative George P. Hollingbery
 Membership NARTB
 Pres., Gen. Mgr. Alan C. Tindal
 Commercial Manager J. H. Ferguson, Jr.
 Sales Prom. Mgr., Prog. Dir. Milton R. Slater
 Chief Engineer George Townsend

WPEP

TAUNTON—1949

Frequency: 1570 Kc. Power: 1000 Watts d.
 Owned-Oper. By Silver City Bcstg. Co.
 Address 174 Broadway
 Phone Number 4-7528
 News Service UP
 President J. Marshall McGregor
 General Manager James Milton Hammond
 Sta. Mgr., Prog. Dir. Joseph G. Quill
 Chief Engineer Lawrence Prado

WCRB

WALTHAM—1948

Frequency: 1330 Kc. Power: 1000 Watts d.

Owned-Oper. By Charles River Bcstg. Co.
 Business-Studio Address 834 Main St.
 Phone Number WA 5-7080
 News Service UP
 Representative Bannan
 Membership BAB
 President, Gen. Mgr. Theodore Jones
 Sales Prom. Mgr. William J. Fitzpatrick
 Program Director David B. Tucker
 Chief Engineer Thomas J. Shea

WARE

WARE—1945

Frequency: 1250 Kc. Power: 1000 Watts d.
 Owned-Oper. By Central Bdcstg. Co.
 Business-Studio Address Ware
 Phone Number Ware 1250
 Air Time Daytime
 News Service AP
 Transcription Service Lang-Worth
 President John B. Poor
 General Manager William R. Sweeney
 Chief Engineer David R. Pryce

WTXL

WEST SPRINGFIELD—1949

Frequency: 1490 Kc. Power: 250 Watts
 Owned-Operated By Telecolor Corp.
 Address 34 Sylvan St.
 News Service INS
 Transcription Service World
 Representative Walker
 Pres., Gen. Mgr. L. A. Reilly
 Commercial Manager Holland D. Cameron
 Oper., Mgr., Chief Engr. J. L. Spates

WOCB

WEST YARMOUTH—1940
 MBS-YANKEE

Frequency: 1240 Kc. Power: 250 Watts
 Owned-Oper. By E. Anthony & Sons
 Address South Sea Avenue
 Phone Number Hyannis 502
 Representative Walker, Bertha Bannan
 President Basil Brewer
 Commercial Mgr. Paul Stiles
 Program Director Joyce Johnson
 Chief Engineer Frank L. Lynch

WAAB

WORCESTER—1931—MBS-YANKEE

Frequency: 1440 Kc. Power: 5000 Watts
 Owned by WAAB, Inc.
 Business-Studio Address 34 Mechanic St.
 Phone Number 2-5811
 Air Time Full Time
 News Service AP
 Representative George P. Hollingbery
 Membership NARTB
 Pres., Gen. Mgr. Gorge F. Wilson
 Commercial Mgr. Wayne Teeter
 Sales Prom. Mgr. Robert Krieger
 Program Dir. Don Stevens
 Chief Engineer George Capalbo

This Is What WWJ Coverage Of The Detroit Market Means:



WWJ Primary Listening Area covers 1,190,000 radio homes, and 5,330,000 people who spend \$6,031,000,000 annually in retail stores.

WWJ Today covers 125,000 more people than in 1951 . . . 227,500 more radio homes . . . and an area that does \$1,257,000,000 more retail business.

WWJ covers 69% of Michigan's total population and total retail sales . . . and centers its sales efforts on a market that is first among the nation's major markets in retail sales per family, in factory wage rates, in drug and automotive sales per family.

WWJ covers the world's greatest car-radio audience . . . nearly one million passenger cars that are driven a total of 15 million miles, to and from work EACH DAY, within Metropolitan Detroit.

WWJ covers 33 years of broadcasting, during which it has received radio's highest merit awards. Its programming leadership and community prestige make WWJ the ACCEPTED station of the nation's selective advertisers, in the richest market concentration of family buying power.

**The time to sell Detroit is now . . .
the station is . . .**



Associate Television Station WWJ-TV

AM - 1450 KILBOURN ST. DETROIT
FM - CHANNEL 56 (97.1 MEGAHERTZ)

WNEB

WORCESTER—1946

Frequency: 1230 Kc. Power: 250 Watts
 Owned-Oper. By New England Bcstg. Co.
 Address 405 Main St.
 Phone Number 6-4672
 News Service UP
 Representative Bolling
 President Paul C. Lytle
 Gen. Mgr. John J. Hurley
 Commercial Mgr. Edward T. McCann, Jr.
 Program Director Thomas J. Decker
 Chief Engineer Vernon P. Wilson

WORC

WORCESTER—1925—ABC

Frequency: 1310 Kc. Power: 1000 Watts
 Owned-Operated By Radio Worcester
 Business-Studio Address 4 Walnut St.
 Phone Number 5-3101
 Representative Headley-Reed
 President C. George Taylor

General Manager Kenneth M. Cooper
 Comm. Mgr. Thomas M. Donlin
 Chief Engineer Carroll Philbrook

WTAG

WORCESTER—1924—CBS

Frequency: 580 Kc. Power: 5000 Watts
 Owned-Operated By WTAG, Inc.
 Business-Studio Address 18 Franklin St.
 Phone Number 5-4321
 Air Time Full Time
 Newspaper Affiliation Telegram & Evening Gazette
 News Service AP
 Transcription Service Associated
 Representative Henry L. Christal Co.
 Membership NARTB, BAB
 Vice-Pres., Gen. Mgr. Robert W. Booth
 Vice Pres., Sta. Mgr. Herbert L. Krueger
 Commercial Manager Robert J. Brown
 Sales Promotion Manager Bernard J. La Plante
 Prod., Pgm. Dir. A. J. Brissette
 Publicity Director John Hiser
 Chief Engineer E. A. Browning

MICHIGAN

*Pop. Feb. 1, 1954 (Est.) 6,700,000 — Families 1,920,000
 Radio Homes 1,916,000 — TV Homes 1,427,500 — Stations in State 70*

WABJ

ADRIAN—1947

Frequency: 1500 Kc. Power: 250 Watts d.
 Owned-Oper. By Gerity Bcstg. Co.
 Address 2982 Treat Rd.
 Phone Number 9000
 News Service UP
 Transcription Service Thesaurus
 Membership NARTB, BAB
 Owner James Gerity, Jr.
 General Manager O. Wm. Myers
 Commercial Manager David L. Norton
 News, Pgm. Dir. Larry Payne
 Chief Engineer Elwood Brown

Phone Number 157
 News Service UP
 Trans. Service Lang-Worth, World
 President L. R. Kamperman
 V.P., Gen. Mgr. Robert W. Cessna
 Chief Engineer Harold Frisby

WATZ

ALPENA—1946—MBS

Frequency: 1450 Kc. Power: 250 Watts
 Owned-Oper. By Midwestern Bcstg. Co.
 Business Address Alpena
 Phone Number 1049
 Air Time 7 a.m.-11 p.m.
 News Service AP
 Representative Hal Holman
 General Manager Les Biederman
 Station Manager Drew McClay
 Chief Engineer William Kiker

WALM

ALBION—1952

Frequency: 1540 Kc. Power: 250 Watts d.
 Owned-Oper. By Calhoun Bcstg. Co.
 Address Hawes Bldg.
 Phone Number 5065
 News Service UP
 Transcription Service Thesaurus
 Representative Hil F. Best
 President J. C. Biedier
 General Manager M. H. Wirth
 Program Director Lewis Shroyer

WHRV

ANN ARBOR—1947—ABC

Frequency: 1600 Kc. Power: 1000 Watts
 Owned-Oper. By Huron Valley Bcstrs., Inc.
 Business Address 4230 Packard Rd.
 Phone Number 2-4573
 News Service AP
 Transcription Service World
 Representative Walker
 Membership NARTB, BAB
 President J. F. Hopkins
 General Manager Steve Filipiak
 Com. Mgr. James H. Hopkins
 Chief Engineer James Allen

WFYC

ALMA—1948

Frequency: 1280 Kc. Power: 1000 Watts d.
 Owned-Oper. By WFYC, Inc.

MUTUAL

CKLW

**LOWEST COST
MAJOR
STATION BUY
IN THE
DETROIT AREA**

COMPARE the Coverage
with the Cost and you'll discover why
this greater "dollar distance" buy
is ringing more cash registers
than ever before for
advertisers.

**SOON
CHANNEL 9**

This Region's Most
Powerful TV Station
325,000 Watts

CKLW covers a 15,
000,000 population
area in five important
states!

**50,000
WATTS
800 KC.**

Adam J. Young Jr., Inc.
National Representative

Guardian Building

Detroit 26, Mich.

J. E. Campeau, Pres.

W P A G

ANN ARBOR—1945

Frequency: 1050 Kc. Power: 1,000 Watts d.
 Owned-Operated By... Washtenaw Bcstg. Co.
 Bus. Studio Address... 3rd Floor, Hutzel Bldg.
 Phone Number 2-5517
 News Service AP
 Transcription Service..... Thesaurus
 Representative McGillvra
 Membership NARTB
 President..... Arthur E. Greene
 Gen. Sta. Manager..... Edward F. Baughn
 Commercial Manager..... Kenneth MacDonald
 Chief Engineer..... D. N. Bowdish

W L E W

BAD AXE—1950

Frequency: 1540 Kc. Power: 250 Watts d.
 Owned-Operated By... Port Huron Bdcstg. Co.
 Address..... 935 S. Van Dyke Rd.
 Phone Number 1010
 Representative Gill, Perna
 Transcription Service Standard
 News Service UP
 Gen. Mgr..... John Wismer
 Station Manager..... Jim Muehlenbeck
 Prog. Dir..... Dick Estell
 Chief Engineer..... Don Clotier

W B C K

BATTLE CREEK—1348—MBS

Frequency: 930 Kc. Power: 1000 Watts
 Owned-Operated By... Michigan Bcstg. Co.
 Address..... 402 Security Natl. Bank Bldg.
 Phone Number..... WO 3-5555
 Air Time 6 a.m.-12 M.
 News Service UP
 Transcription Service World
 Representative Headley-Reed
 P es., General Manager..... Robert H. Holmes
 Program Director..... E. F. Cahill
 Chief Engineer..... Robert Willbur

W E L L

BATTLE CREEK—1925—ABC

Frequency: 1400 Kc. Power: 250 Watts
 Owned-Oper. By... Federated Publications, Inc.
 Bus. Studio-Transmitter Address..... Michigan
 National Bank Bldg.
 Phone Number..... Woodward 4-7173
 Air Time 6 a.m.-11:30 p.m.
 News Service AP
 Transcription Service Thesaurus
 Representative McGillvra
 Membership NARTB, BAB
 General Manager..... Dan E. Jayne
 Comm. Mgr., Pgm. Dir..... Forrest F. Owen
 Chief Engineer..... Earl J. Stone

W B C M

BAY CITY—1928—ABC

Frequency: 1440 Kc. Power: 1000 Watts d.
 500 Watts n.

Owned-Operated By..... Bay Bcstg. Co., Inc.
 Business-Studio Address..... Wenonah Hotel
 Phone Number 7551-2
 Air Time..... 6 a.m.-M.
 News Service UP
 Transcription Service World
 Representative..... George P. Hollingbery
 Membership BAB
 President..... Harley D. Peet
 Gen. Station-Comm. Mgr..... Hugh A Giesel
 Program Director..... Charles E. Anthony
 Chief Engineer..... Ralph H. Carpenter

W H F B

BENTON HARBOR—1947

Frequency: 1060 Kc. Power: 1000 Watts d.
 Owned-Oper. By Palladium Publ. Co.
 Address Fairplain Ave.
 Phone Number 5-2113
 News Service AP
 Transcription Service..... World, Thesaurus
 Representative Hal Holman
 Membership NARTB
 President Stanley R. Banyon
 Gen., Sta. Mgr..... J. P. Scherer
 Commercial Manager Ted Vernasco
 Program Director John Pershing Chase
 Chief Engineer Munson Robinson

W B R N

BIG RAPIDS—1953

Frequency: 1460 Kc. Power: 500 Watts d.

W E L L

BATTLE CREEK

*Battle Creek's
top-rated station*

and the best buy because...

- 28 years of making friends — and sales
- Covers retail trading area of 198,299
- Affiliated with American Bcstg. Company

Represented nationally by

**ROBERT MEEKER
ASSOCIATES, INC.**

521 — 5th Avenue
New York City

250W • 1400

W E L L

**MICHIGAN'S
MOST POWERFUL
TELEVISION
STATION**

American
Broadcasting
Company

wxyz·tv

CHANNEL **7**
DETROIT

represented
nationally
by Blair-TV

**THE RADIO STATION OF
SALES PERSONALITIES**

American
Broadcasting
Company

wxyz·radio

1270 KC.
DETROIT

represented by
John Blair & Co.

Owned-Oper. By.....Paul A. Brandt
 Address.....13804 Northland
 Phone Number.....648
 News Service.....AP
 Transcription Service.....Langworth, SESAC
 Representative.....Holman
 Gen., Comm. Mgr.....Spencer Denison

W A T T

CADILLAC—1945—MBS

Frequency: 1240 Kc.....Power: 2000 Watts
 Owned-Operated By.....Midwestern Bcstg. Co.
 Business-Studio Address.....P. O. Box 219
 Phone Number.....PR 5-7831
 News Service.....AP
 Transcription Service.....SESAC, KBS
 Representative.....Hal Holman
 President.....Les Biederman
 Station Manager.....Art Nyhus
 Sales Manager.....M. L. Chandler
 Chief Engineer.....Bill Kiker

W T V B

COLDWATER—1949

Frequency: 1590 Kc.....Power: 5000 Watts
 Owned-Oper. By.....Twin Valley Bdcstrs, Inc.
 Address.....Box 32
 Phone Number.....1230
 News Service.....AP
 Trans. Service.....World, Thesaurus, Cole
 Representative.....Hil F. Best
 Membership.....BAB
 President.....George Hosek
 Gen., Stat. Mgr., Chief Eng., E. Harold Munn, Jr.
 Somm., Sales Prom. Mgr., James C. Macklem

C K L W

DETROIT-WINDSOR—1932—MBS

Frequency: 800 Kc.....Power: 50,000 Watts
 Owned-Oper. By.....Western Ontario Bcstg. Co.,
 Ltd., Essex Bcstrs., Inc.
 Business Address.....3300 Guardian Bldg., Det.
 Phone Number.....Woodward 1-7200
 Air Time.....24 Hrs.
 News Service.....INS, UP
 Transcription Service.....World, Thesaurus
 Representative.....All Canada Facilities,
 Adam J. Young, Jr.
 Membership.....NARTB
 President, General Mgr.....J. E. Campeau
 Commercial Manager.....E. Wilson Wardell
 Program Director.....S. C. Ritchie
 Publicity Director.....Art Gloster
 Chief Engineer.....W. J. Carter
 (See Page 452)

W J B K

DETROIT—1926

Frequency: 1490 Kc.....Power: 250 Watts
 Owned-Operated By.....Storer Bcstg. Co.
 Business-Studio Address.....500 Temple Ave.
 Phone Number.....TEmpLe 3-7900
 Air Time.....24 Hours
 News Service.....INS
 Representative.....Katz Agency
 Membership.....NARTB, BAB

President.....George B. Storer
 Vice-Pres., Managing Dir.....Gayle V. Grubb
 Commercial Manager.....Harry Lipson
 Sales Prom. Mgr.....Kenneth H. Boehmer
 Program Director.....Richard Fischer
 Chief Engineer.....Paul O. Frincke

W J R

DETROIT—1926—CBS

Frequency: 760 Kc.....Power: 50,000 Watts
 Owned-Oper. By. WJR, The Goodwill Sta., Inc.
 Address.....Fisher Bldg.
 Phone Number.....Trinity 5-4440
 Air Time.....24 Hours
 News Service.....AP, INS, UP
 Trans. Service.....Thesaurus, World
 Representative.....Christal, Radio Time Sales
 Membership.....NARTB, BAB
 President.....John F. Patt
 V.P., & Gen. Mgr.....Worth Kramer
 Sec'y-Treas.....William G. Siebert
 Advt. & Pub. Rel. Dir.....James Quello
 Sales Manager.....Elmer O. Wayne
 Program Director.....Franklin Mitchell
 V.P. in charge of News.....George Cushing
 V.P. in chge of Engr.....George Leydorf

W W J

DETROIT—1920—NBC

Frequency: 950 Kc.....Power: 5000 Watts
 Owned-Oper. By.....The Evening News Assn.
 Address.....615 W. Lafayette
 Phone Number.....W00dward 2-2000
 Newspaper Affiliation....."Detroit News"
 Air Time.....5:30 a.m.-1 a.m.
 News Service.....AP, UP
 Trans. Serv.....Lang-Worth & Thesaurus
 Representative.....George P. Hollingberry Co.
 Membership.....NARTB
 General Manager.....Edwin K. Wheeler
 Asst. Gen. Mgr.....Don DeGroot
 General Program Mgr.....M. C. Wissman
 Public Affairs Manager.....James Eberle
 Commercial Mgr.....Thomas Warner
 Business Mgr.....Henry C. Rogers
 Chief Engineer.....E. J. Love
 (See Page 450)

W X Y Z

DETROIT—1925—ABC

Frequency: 1270 Kc.....Power: 5000 Watts
 Owned-Oper. By.....WXYZ, Inc.
 Business Address.....1700 Mutual Bldg.
 Phone Number.....W00dward 3-8321
 Air Time.....6:30 a.m.-1 a.m.
 News Service.....AP, INS
 Representative.....John Blair
 President.....James G. Riddell
 Commercial Manager.....Harold Christian
 Sales Prom. Mgr.....Robert Baldrice
 Chief Engineer.....Charles Kocher

W J L B

DETROIT—1926

Frequency: 1400 Kc.....Power: 250 Watts
 Owned-Oper. By.....Booth Radio & TV Stas.

Business Address..... Broderick Tower
 Phone Number..... Woodward 5-2000
 News Service..... AP
 Membership..... BAB, NARTB
 Representative..... Forjoe
 Pres., Gen. Mgr..... John L. Booth
 Commercial Mgr..... Eric V. Hay
 Chief Engineer..... Edward H. Clark

W K M H
 DETROIT—1946

Frequency: 1310 Kc..... Power 5000 Watts d.,
 1000 n.
 Owned-Operated By..... WKMh, Inc.
 Address..... WKMh Bldg.
 Phone Number..... Tiffany 6-8500
 News Service..... UP
 Transcription Service..... Lang-Worth
 Representative..... Headley-Reed
 Membership..... NARTB, BAB
 Pres., Sta., Gen. Mgr..... Fred A. Knorr
 Commercial Mgr..... George M. Miller
 Chief Engineer..... Jerrold Martin

W D B C

ESCANABA—1941—MBS

Frequency: 680 Kc..... Power: 1000 Watts
 Owned-Operated By..... Delta Bcstg. Co.
 Business-Studio Address..... P. O. Box 419
 Phone Number..... 3190-1
 Air Time..... 6:30 a.m.-11:30 p.m.
 News Service..... AP
 Transcription Service..... Thesaurus
 Representative..... Walker
 P.es., Gen. Mgr..... George D. Lindenthal
 Station Manager..... Robert Wagner
 Sales Prom., Pub. Dir..... Wm. J. Duchawe
 Chief Engineer..... Henry C. Olsen

W E S K

ESCANABA—1953—NBC

Frequency: 1490 Kc..... Power: 250 Watts
 Owned-Oper. By..... 712½ Ludington St.
 Phone Number..... 3750
 News Service..... UP
 Representative..... Clark
 President..... William E. Walker
 General Manager..... Barclay Conley
 Commercial Manager..... Lee Morrison
 Program Director..... Paul Ryan
 Chief Engineer..... Alister Alexander

W B B C

FLINT—1947—MBS

Frequency: 1330 Kc..... Power: 1000 Watts
 Owned-Oper. By..... Booth Radio & TV Stations.
 Bus.-Studio Address..... 3076 E. Bristol Rd.
 Phone Number..... Detroit, Woodward 2-0220;
 Flint, 9-8686
 Air Time..... 6 a.m.-12 M.
 News Service..... AP
 Representative..... Weed
 Membership..... BAB

President..... John Lord Booth
 Gen., Comm. Mgr..... W. Gerard Schroeder
 Program Director..... Edward Berryman
 Chief Engineer..... G. Elwood Ryan

W F D F

FLINT—1922—NBC

Frequency: 910 Kc..... Power: 1000 Watts
 Owned-Operated By..... The Trebit Corp.
 Address..... Garland at First Ave.
 Phone Number..... 2-7158
 Air Time..... Full Time
 News Service..... AP
 Transcription Service..... Standard, Thesaurus
 Representative..... Katz
 Membership..... NARTB, BAB
 President..... Harry M. Bitner, Sr.
 Gen., Sta. Mgr..... Lester W. Lindow
 Sales Prom. Mgr..... Marvin Levey
 Program Director..... Elmer A. Knopf
 Publicity Director..... Donald Wyant
 Chief Engineer..... Gerald Wolpert

W K M F

FLINT—1952

Frequency: 1470 Kc..... Power: 1000 Watts
 Owned Oper. By..... WKMF, Inc.
 Address..... 1623 Utica Ave., Tulsa, Okla.

W M R P

FLINT—1946—KBS

Frequency: 1510 Kc..... Power: 250 Watts d.
 Owned-Oper. By..... Methodist Radio Parish, Inc.
 Address..... 3217 Lapeer St.
 Phone Number..... 3-5112
 Air Time..... Daytime
 Representative..... Best
 President..... Herbe t Hausser
 General Manager..... William H. Morford
 Commercial Manager..... Richard Carter
 Chief Engineer..... Homer Blumerich

W T A C

FLINT—1946—ABC

Frequency: 600 Kc..... Power: 1000 Watts d.:
 500 Watts n.
 Owned-Oper. By..... Trendle-Campbell Bcstg.
 Business-Studio Address..... 2332 Lapeer St.
 Phone Number..... 2-1136
 Air Time..... Unlimited
 News Service..... UP
 Transcription Service..... Lang-Worth
 Representative..... Paul H. Raymer
 Membership..... BAB
 President..... George W. Trendle
 General Mgr..... H. Allen Campbell
 Station Manager..... J. R. McKinley
 Program Dir..... Laurence Arnold
 Chief Engineer..... James A. Gimbel

W A T C

GAYLORD—1950—BUNYAN

Frequency: 900 Kc..... Power: 1000 Watts d.

Owned-Oper. By.....Midwestern Bcstg. Co.
 Address...Paul Bunyan Bldg., Traverse City
 Phone Number.....Traverse City 2700
 Representative.....Holman
 News Service.....AP
 Pres., Gen. Mgr.....Les Biederman
 Station Manager.....C. O. Rsed
 Commercial Mgr.....Robert Fritz
 Program Director.....Kenn Haven
 Chief Engineer.....William Kiker

W F U R

GRAND RAPIDS—1947

Frequency: 1570 Kc.....Power: 1000 Watts d.
 Owned-Oper. By...Furniture City Bcstg. Corp.
 Address.....399 Gafield Ave., S.W.
 Phone Number.....Gl. 6-9541
 Air Time.....Sunrise-sunset
 News Service.....UP
 Representative.....McGillvra
 Pres., Gen., Sta. Mgr.....William Kuiper
 Commercial Manager.....H. J. Swierenga
 Program Director.....H. Van Dyke
 Chief Engineer.....Jack Timmer

W G R D

GRAND RAPIDS—1947

Frequency: 1410 Kc.....Power: 1000 Watts
 Owned-Operated By.....Music Bcstg. Co.
 Business-Studio Add..35 Lafayette Ave., N.E.
 Phone Number.....9-4111
 Air Time.....6 a.m.-local sunset
 News Service.....AP
 Representative.....Gill Perna
 Pres., Gen. Mgr.....Paul F. Eichhorn
 Sales Prom., Prog. Dir.....Glenn LePard
 Chief Engineer.....Richard Groenevelt

W J E F

GRAND RAPIDS—1945—CBS

Frequency: 1230 Kc.....Power: 250 Watts
 Owned-Oper. By.....Fetzer Bcstg. Co.
 Address.....Pantlind Hotel
 Phone Number.....Glendale 6-8512
 Air Time.....Full Time
 News Service.....AP
 Transcription Service.....Thesaurus
 Representative.....Avery-Knodel, Inc.
 Membership.....NARTB, BAB
 President.....John E. Fetzer
 Sta., Comm. Mgr.....Martin Giaimo
 Managing Director.....Carl E. Lee
 Dir. of Public Affairs.....Dr. Willis F. Dunbar
 Chief Engineer.....Bruce Glycadgis

W L A V

GRAND RAPIDS—1940—ABC

Frequency: 1340 Kc.....Power: 250 Watts
 Owned-Operated By.....Versluis Radio &
 Television, Inc.
 Address.....6 Fountain St., N.E.
 Phone Number.....Glendale 6-5461
 Air Time.....6:30 a.m.-1 a.m.

News Service.....UP
 Transcription Service.....Standard
 Representative.....John E. Pearson
 Membership.....BAB
 President.....Leonard A. Versluis
 Vice-Pres. & Gen. Mgr.....Hy M. Steed
 Chief Engineer.....Lee Stevens

W O O D

GRAND RAPIDS—1924—NBC

Frequency: 1300 Kc.....Power: 5000 Watts
 Owned-Oper. By...Grandwood Bcstg. Co.
 Address..1408 Grand Rapids Natl. Bank Bldg.
 Phone Number.....9-4125
 Air Time.....5:30 a.m.-1 a.m.
 News Service.....AP
 Representative.....Katz Agency
 Membership.....NARTB, BAB
 President.....H. M. Bitner, Sr.
 Gen., Sta. Mgr.....Willard Schrosder
 Commercial Mgr.....Arthur M. Swift
 Program Director.....Frank Sisson
 Publicity Director.....John Dragomier
 Chief Engineer.....Louis Bergenroth

W H T C

HOLLAND—1948

Frequency: 1450 Kc.....Power: 250 Watts
 Owned-Operated By.....Holland Bcstg. Co.
 Business-Studio Address..Hotel Warm Friend
 Tavern
 Phone Number.....9482
 Air Time.....Full Time
 News Service.....AP
 Transc. Serv...World, Lang-Worth, Thesaurus
 Representative.....Best
 President.....W. A. Butler
 General Manager.....Sandy Meek
 Program Director.....William Gargano
 Chief Engineer.....John Klungle

W H D F

HOUGHTON—1929—NBC

Frequency: 1400 Kc.....Power: 250 Watts
 Owned-Oper. By...Upper Michigan Bcstg. Co.
 Address.....Douglass Hotel
 Phone Number.....Houghton 1
 Air Time.....7 a.m.-11:15 p.m.
 News Service.....AP
 Transcription Service.....World
 Representative.....Walker
 Membership.....NARTB
 Chief Owner.....G. L. Burgan
 General Manager.....Albert W. Payne
 Pgm. Pub. Dir.....Earl Norten
 Chief Engineer.....George L. Burgan

W I O N

IONIA—1953

Frequency: 1430 Kc.....Power: 5000 Watts d.
 Owned-Oper. By.....Ionia Bcstg. Co.
 Address.....Box 143
 Phone Number.....1537
 News Service.....AP

Representative Best
 Transcription Service Thesaurus
 Owner Monroe MacPherson
 Gen. Comm. Mgr. Al La Guire
 Program Director. W. M. MacPherson
 Promotion Mgr. Donald Seaman
 Chief Engineer J. Irving Grove

WMIQ

IRON MOUNTAIN—1947
 ABC-NORTHERN

Frequency: 1450 Kc. Power: 250 Watts
 Owned-Oper. By Iron Mountain-Kingsford
 Bcstg. Co.
 Business-Studio Address. 211 E. Ludington St.
 Phone Number 2031
 President. Frank J. Russell
 General Manager. Russell J. Stafford
 Commercial Manager. William C. Johnson
 Chief Engineer. Paul F. Anick

WIKB

IRON RIVER—1949—MBS—KBS

Frequency: 1230 Kc. Power: 250 Watts
 Owned By WIKB, Inc.
 Phone Number 102-3
 Transcription Service Thesaurus
 Representative Walker
 President. H. H. Frailing
 General Manager. James F. Kauper
 Program Director. Len Johnson
 Chief Engineer. Lester Patten

WJMS

IRONWOOD—1931—MBS

Frequency: 630 Kc. Power: 1000 Watts
 Owned-Oper. By Upper Michigan-Wisconsin
 Bcstg. Co., Inc.
 Business-Studio Address. 124 E. McLeod Ave.
 Phone Number 20
 Air Time 7 a.m.-M.
 News Service UP
 Transcription Service Thesaurus
 Representative Walker
 President. William L. Johnson
 Station Manager. Donald R. Hoover
 Program Director. Laura Johnson
 Chief Engineer. Arne Dahlbacka

WJPD

ISHPEMING—1947—PBN-GOEBEL
 KBS

Frequency: 1240 Kc. Power: 250 Watts
 Owned-Operated By Ishpeming Bcstg. Co.
 Business-Studio Address Jenks Block
 Phone Number 1892
 Air Time 7 a.m.-10:30 p.m.
 News Service AP
 Transcription Service World
 Pres., Gen., Sta. Mgr. J. P. Deegan
 Program Director Paul C. Crowley
 Chief Engineer. Bernard R. Maloney

WIBM

JACKSON—1927—ABC

Frequency: 1450 Kc. Power: 250 Watts
 Owned By WIBM, Inc.
 Address. 2511 Kibby Road
 Phone Number 6121
 Air Time 6:30 a.m.-M.
 News Service AP
 Representative Forjoe
 Transcription Service. Thesaurus. Lang-Worth
 President Roy Radner
 Station Manager. William Cizek
 Prog. Dir., Chief Announcer. Jack Underwood
 Chief Engineer. Charles Wirtanen

WKHM

JACKSON—1951—MBS

Frequency: 970 Kc. Power: 1000 Watts
 Owned-Operated By Jackson Bcstg. & Tele.
 Corp.
 Address 441 Wildwood
 Phone 4-7181
 Air Time 6 a.m.-1 a.m.
 News Service UP
 Transcription Service World
 Representative Headley-Reed
 Pres., Gen. Mgr. Fred A. Knorr
 Station Manager. Walter Patterson
 Sales Prom. Mgr. John O. Gilbert
 Program Director. Richard Schueler
 Chief Engineer. Paul Wright

WKMI

KALAMAZOO—1947

Frequency: 1360 Kc. Power: 1000 Watts
 Owned-Oper. By Steere Bcstg. Co.
 Business-Studio Address. State Theatre Bldg.
 Phone Number 4-0111
 News Service UP
 Representative. Young, Mich. Spot Sales
 Pres., Comm. Mgr. Howard D. Steere
 Station Manager. Emil J. Popke, Jr.
 Chief Engineer. Carl Stephens

WKZO

KALAMAZOO—1923—CBS

Frequency: 590 Kc. Power: 5000 Watts
 Owned-Operated By Fetzer Bcstg. Co.
 Business Address. 124 W. Michigan Ave.
 Phone Number 3-1223
 Air Time 6 a.m.-12:05 a.m.
 News Service AP
 Transcription Service Thesaurus
 Representative Avery-Knodel
 Membership NARTB, BAB
 President, Gen. Mgr. John E. Fetzer
 Sales Service Director. John W. O'Harrow
 Program Director. Charles T. Lynch
 Managing Director. Carl E. Lee
 Chief Engineer Arthur E. Covell

WILS

LANSING—1946

Frequency: 1320 Kc....Power: 5000 Watts d-1000 Watts n.

Owned-Operated By.....Lansing Bcstg. Co.
 Bus. Studio Address.....407 N. Washington
 Phone Number.....2-1655
 News Service.....AP
 Transcription Service.....Langworth
 Representative.....O. L. Taylor
 Membership.....NARTB
 Pres., Gen. Mgr.....W. A. Pomeroy
 Asst. Mgr., Chief Eng.....John C. Pomeroy
 Commercial Manager.....Walter L. Dennis
 Sales Prom. Mgr., Publ. Dir....Walter Braeger
 Program Director.....James Pollock

WJIM

LANSING—1934—ABC

Frequency: 1240 Kc.....Power: 250 Watts
 Owned-Oper. By.....WJIM, Inc.
 Bus. Studio Address...Bank of Lansing Bldg.
 Phone Number.....2-1333
 Air Time.....Full Time
 News Service.....UP
 Representative.....H-R Reprs., Inc.
 Membership.....NARTB
 Pres., Gen. Mgr.....Harold F. Gross
 V.P., Gen. Mgr.....Willard E. Walbridge
 V.P., Prog. Dir.....Howard K. Finch
 Chief Engineer.....C. E. Wallace

WKLA

LUDINGTON—1944—ABC-KBS

Frequency: 1450 Kc.....Power: 250 Watts
 Owned-Oper. By.....Ludington Bcstg. Co.
 Address.....204 East Ludington Ave.
 Phone Number.....1450
 Transcription Service.....UP
 Representative.....Burn-Smith
 Pres., Gen. Mgr.....Raymond A. Plank
 Commercial Mgr.....Don Hack
 Program Director.....C. J. Hagerman

WMTE

MANISTEE—1951

Frequency: 1340 Kc.....Power: 250 Watts
 Owned-Operated By....Manistee Radio Corp.
 Address.....Box 332
 Phone Number.....1340
 News Service.....AP
 Transcription Service.....Lang-Worth
 Representative.....Best
 President.....Dr. T. H. Manwell
 General Manager.....Stephen Cole
 Commercial Manager.....Edward Owens
 Sales Prom. Mgr.....Mush Hansen
 Program Director.....Lucille Blake

WDOG

MARINE CITY—1950

Frequency: 1590 Kc.....Power: 1000 Watts d.

Owned-Operated By.....Radio St. Clair, Inc.
 Address.....5300 Marine City Hwy.
 Phone Number.....Rockwell 2-1111
 News Service.....INS
 President.....Jerry Coughlin
 General Manager.....Jack Hazlett
 Sales Prom., Pub. Dir.....Harry Coughlin
 Chief Engineer.....J. R. Duryea

WDMJ

MARQUETTE—1931—MBS

KBS—NORTHERN

Frequency: 1320 Kc.....Power: 1000 Watts
 Owned-Oper. By..Lake Superior Bcstg. Co., Inc.
 Business-Studio Address....Mining Jnl. Bldg.
 Phone Number.....616
 News Service.....UP
 Transcription Service.....Thesaurus
 General Manager.....Leo G. Brott
 Station Manager.....E. W. Wallace
 Commercial Manager.....Robert Luke
 Chief Engineer.....Gordon Brozek

WMAW

MENOMINEE—1952—ABC

Frequency: 1340 Kc.....Power: 100 Watts
 Owned-Oper. By.....Green Bay Bcstg. Co.
 Address.....960 1st St.
 Phone Number.....4651
 News Service.....UP
 Transcription Service...Langworth, Thesaurus
 Representative.....Pearson
 General Manager.....Martin Geertz
 Chief Engineer.....Robert Reimers

WMDN

MIDLAND—1948

Frequency: 1490 Kc.....Power: 250 Watts
 Owned-Oper. By.....Rich Publ. House, Inc.
 Transmitter Address.....298 S. Sweede Rd.
 Phone Number.....Temple 9-9988
 News Service.....AP
 Transcription Service...Lang-Worth, Thesaurus
 President.....Phillip T. Ritch
 Gen., Comm. Mgr.....Jerry Breen
 Program Director.....Tom Matthews
 Chief Engineer.....Peter A. Wolf

WCEN

MT. PLEASANT—1949

Frequency: 1150 Kc.....Power: 1000 Watts d.,
 500 Watts n.
 Owned-Oper. By.....Paul A. Brandt
 Address.....112½ E. Bway
 Phone Number.....33-171, 21-501
 News Service.....AP
 Trans. Serv.....SESAC, Standard
 President.....Paul A. Brandt
 Program Director.....Jim Bailey
 Chief Engineer.....Peter Fronezak

W K B Z

MUSKEGON—1926—ABC

Frequency: 850 Kc. Power: 1000 Watts
 Owned-Oper. By Ashbacker Radio Corp.
 Business-Studio Address 432 Apple Ave.
 Phone Number 2-6051
 Air Time 5:30 a.m.
 News Service AP
 Trans. Serv. Thesaurus
 Representative Meeke
 Membership NARTB
 Pres., Gen. Mgr. Arch Shawd
 Program Director W. L. Trap
 Publicity Director B. L. Bennett
 Chief Engineer George Krivitzky

W K N K

MUSKEGON—1949—MBS

Frequency: 1600 Kc. Power: 5000 Watts
 Owned-Oper. By Nicholas W. Kuris
 Address Federal Square
 Phone Number 32126
 News Service UP
 Representative Best
 President Nicholas W. Kuris
 Program Director Evelyn Johnson
 Chief Engineer P. L. Reynolds

W M U S

MUSKEGON—1947

Frequency: 1090 Kc. Power: 1000 Watts d.
 Owned-Oper. Greater Muskegon Bcstrs., Inc.
 Business-Studio Address 517 W. Giles Rd.
 Phone Number 4-1672
 Air Time Daytime
 News Service AP
 President R. Bunker Rogoski
 Station Manager Harley Lucas
 Program Director Bob McKendrick
 Chief Engineer Sam Lombardi

W O A P

OWOSSO—1948

Frequency: 1090 Kc. Power: 250 Watts d.
 Owned-Operated By Owosso Bcstg. Co.
 Phone Number 980
 News Service AP
 Transcription Service Thesaurus
 Representative Joseph Hershey McGillvra
 President J. E. Campbell
 General Manager M. H. Wirth
 Sta., Comm. Prog. Mgr. Merrill Walker
 Chief Engineer Fran Bowles

W M B N

PETOSKEY—1946—MBS-BUNYAN

Frequency: 1340 Kc. Power: 250 Watts
 Owned-Oper. By Midwestern Bcstg. Co.
 Bus.-Studio Address Traverse City
 President Les Biederman
 Station Manager Ralph Pierson
 Commercial Mgr. Merton Carter

Program Director Kenn Haven
 Chief Engineer William Kiker

W C A R

PONTIAC—1939

Frequency: 1130 Kc. Power: 1000 Watts d.
 Owned-Operated By WCAR, Inc.
 Address 2146 S. Telegraph Rd.
 Phone Number Federal 3-7141
 News Service AP, INS
 Transcription Service Associated
 Representative John E. Pearson
 Pres., Gen. Mgr. H. Y. Levinson
 Commercial Manager William G. Lenhard
 Chief Engineer Wayne N. Cook

W H L S

PORT HURON—1938—MBS

Frequency: 1450 Kc. Power: 250 Watts
 Owned-Oper. By Port Huron Bcstg. Co.
 Address 932 Military St.
 Phone Number Yukon 28536
 Air Time 6 a.m.-1 a.m.
 News Service AP
 Transcription Service World, Standard,
 Langworth
 Representative Gill-Perna
 Membership NARTB
 Gen., Sta., Comm. Mgr. John F. Wismer
 Comm., Prom. Mgr. John L. Shepard
 Program Director Ned S. Hubbell

W T T H

PORT HURON—1947—ABC

Frequency: 1380 Kc. Power: 1000 Watts
 Owned-Oper. By The Times Herald Co.
 Address 606 Water St.
 Phone Number Yukon 5-5171
 News Service AP
 Trans. Serv. Standard, Thesaurus
 Representative Weed & Company
 General Manager Wm. L. Weil
 Commercial Manager Gaylord H. Forbes
 Program Director Dick Sommerville
 Chief Engineer Kenneth Kunze

W H A K

ROGERS CITY—1949

Frequency: 960 Kc. Power: 5000 Watts d.
 Owned-Operated By Rogers City Bcstg. Co.
 Address Mollie Dr.
 Phone Number 7751
 News Service UP
 Transcription Service Lang-Worth
 Pres., Gen., Mgr., Chief Engr. Harvey A. Klann
 Prom., Comm. Mgr. Albert Klann
 Program Director H. E. Bregé

W E X L

ROYAL OAK—1923

Frequency: 1340 Kc. Power: 250 Watts
 Owned-Operated By Royal Oak Bcstg. Co.
 Business Address 212 W. Sixth St.

Phone Number.....Jordan 4-6523
 News Service.....AP, INS
 Pres., Gen. Mgr.....Jacob B. Sparks
 Program Director.....Gordon A. Sparks
 Sales Manager.....Ernest Holder
 Chief Engineer.....Garnet G. Sparks

W K N X

SAGINAW—1947

Frequency: 1210 Kc.Power: 1000 Watts d.
 Owned-Oper. ByLake Huron Bdcstg. Corp.
 Address221 So. Wash. Ave.
 Phone Number3-4471
 News ServiceUP
 RepresentativeGill-Perna
 Pres., Gen. Mgr.....William J. Edwards
 Vice-President.....Alvin M. Bentley
 Station Manager.....Howard H. Wolfe
 Sales Prom. Mgr.....Henry Scott
 Program Director.....Robert Dyer
 Chief Engineer.....Max W. Thomas

W S A M

SAGINAW—1940—NBC

Frequency: 1400 Kc.Power: 250 Watts
 Owned-Oper. BySaginaw Bdcstg. Co.
 Address2435 Holland Ave.
 Phone Number2-8161
 Air Time6:30 a.m.-1 a.m.
 News ServiceAP
 Transcription ServiceStandard Radio
 RepresentativeHeadley-Reed Co.
 MembershipNARTB
 PresidentMilton L. Greenebaum
 Commercial Mgr.....William Lofback
 Program Director.....Richard Hallwood
 Chief Engineer.....Orin Nordenskjold

W S G W

SAGINAW—1950—MBS

Frequency: 790 Kc.Power: 1000 Watts
 Owned-Oper. ByBooth Radio & TV Stations
 Address700 Buhl Bldg., Detroit
 Phone Number3-4456
 RepresentativePearson
 Transcription ServiceNBC Thesaurus
 News ServiceAP
 Pres., Mngng. Dir.....John L. Booth
 Vice-Pres. & Gen. Mgr.....Robert W. Phillips
 Prog., Pub. Director.....Fred Krell
 Chief Engineer.....Harold Volz, Jr.

W S O O

**SAULT STE. MARIE—1940
 ABC-NORTHERN**

Frequency: 1230 Kc.Power: 250 Watts d.:
 100 Watts n.
 Owned-Operated ByHiawathaland Bcstg. Co.
 Business-Studio Address208 Ashmun St.
 Phone NumberMelrose 2-2231
 News ServiceAP
 Transcription ServiceThesaurus, SESAC
 President, General ManagerStanley R. Pratt

Commercial Mgr.....Richard Y. Burnett
 Program Director.....Ed Krieger
 Chief Engineer.....William F. Morris

W S T R

STURGIS—1951

Frequency: 1460 Kc.Power: 500 Watts d.
 Owned-Operated ByWSTR, Inc.
 AddressP. O. Box 67
 Phone Number1199
 News ServiceAP
 Transcription ServiceThesaurus
 RepresentativeHil B. Best
 MembershipBAB
 PresidentDr. Clarence H. Snyder
 General ManagerE. Harold Munn Jr.
 Chief Engineer.....William S. Miller

W T C M

**TRAVERSE CITY—1941
 MBS—BUNYAN**

Frequency: 1400 Kc.Power: 250 Watts
 Owned-Oper. ByMidwestern Bdcstg. Co.
 AddressPaul Bunyan Bldg.
 Phone Number2700-1
 RepresentativeHal Holman Co.
 General Manager.....Les Biederman
 Commercial Manager.....R. E. Detwiler
 Program Director.....Kenn Haven
 Chief Engineer.....W. H. Kiker

COMPLETE
 ADVERTISING
 INDEX
 STARTS ON
 PAGE 25

MINNESOTA

Pop. Feb. 1, 1954 (Est.) 3,127,000 — Families 940,000
Radio Homes 917,000 — TV Homes 439,000 — Stations in State 47

K A S M

ALBANY—1950

Frequency: 1150 Kc. Power: 500 Watts d.
Owned-Oper. By Stearns Co. Bcstg. Co.
Phone Number 1150
News Service UP
President William Blattner
General, Sta. Manager Urban J. Keppers
Commercial Mgr. Arthur Boss
Chief Engineer Dale Howard

K A T E

ALBERT LEA—1937—ABC

Frequency: 1450 Kc. Power: 250 Watts
Owner Albert Lea-Austin Bdcstg. Co., Inc.
Address 332 South Broadway
Phone Number 2338
News Service UP
Transcription Service Thesaurus
Representative Meeker
Membership NARTB, BAB
President Bennett O. Knudson
General Manager Anson Van Alstyne
Program Director Marie Prosecc
Chief Engineer Robert Holt

K X R A

ALEXANDER—1949

Frequency: 1490 Kc. Power: 250 Watts
Owned-Operated By Alexandria Bcstg. Co.
Phone Number 1000
News Service UP
Transcription Service Thesaurus
Representative Lawson
General Manager R. C. Brown
Commercial Manager Everette Q. Walters
Chief Engineer Kenneth Olson

K A U S

AUSTIN—1948—MBS

Frequency: 1480 Kc. Power: 1000 Watts
Owned-Oper. By Cedar Valley Bcstg. Co., Inc.
Business-Studio Address 405A N. Main St.
Phone Number 8836
Air Time 6 a.m.-M.
News Service AP
Transcription Service World
Representative Pearson
Membership NARTB
President Harry Smith
Gen., Sta. Mgr. L. L. McCurnin
Program Director Tom Steensland
Sales Prom. Mgr. Ken Soderberg
Chief Engineer Glen Klein

K B U N

BEMIDI—1946—MBS-KBS

Frequency: 1450 Kc. Power: 250 Watts
Owned-Operated By Butler Bcstg. Co., Inc.
Business-Studio Address 419½ Bellrami Ave.
Phone Number 1900
News Service UP
Transcription Service SESAC
Representative Lawson
Pres., Gen. Mgr. Edward W. Butler
Pgm., Prod. Dir. Gwenyth Butler
Chief Engineer Delwyn Grage

K L I Z

BRAINERD—1946—MBS

Frequency: 1400 Kc. Power: 250 Watts
Owned-Operated By Brainerd Bcstg. Co.
Business Address E. Oak St.
Phone Number 2853
News Service AP
Transcription Service Capitol
Representative Walker
President, General Manager E. T. O'Brien
Sta., Comm., Prom. Mgr. Earl R. Johnsen
Chief Engineer James Peterson

K B M W

BRECKENRIDGE—1948—KBS

Frequency: 1450 Kc. Power: 250 Watts
Owned-Oper. By Interstate Bdcstg. Corp.
Address 519 Dakota Ave., Wahpeton, N. D.
Phone Number 2-5567-8
News Service UP
Transcription Service Standard
General Manager H. M. Griffith
Commercial Manager Geo. Kaufman
Program Director Clayton Kulseth
Chief Engineer Harold Unkenholz

W K L K

CLOQUET—1950—KBS

Frequency: 1230 Kc. Power: 250 Watts
Owned-Operated By Cloquet Bcstg. Co.
Address 124½ Ave. C.
Phone Number 1450
News Service UP
Transcription Service Lang-Worth
General Manager Dale R. Peterson
Commercial Manager Richard A. Rall
Sales Promotion Manager Beverly Norgren
Chief Engineer Darrel Gander

K R O X

CROOKSTON—1948

Frequency: 1260 Kc. Power: 1000 Watts d.
500 Watts n.
Owned-Operated By Crookston Bcstg. Co.
Business-Studio Address Eagles Bldg.

Phone Number 1050
 News Service UP
 Transcription Service.....Thesaurus, World
 Representatives ..Donald Cook, Gene Grant,
 Lawson & Assoc.
 President.....Jerome A. Dahlberg
 General Manager.....William J. Kiewel

K D L M

DETROIT LAKES—1951

Frequency: 1360 Kc.....Power: 1000 Watts d.
 Owned-Oper. By.....Detroit Lakes Bcstg. Corp.
 Address.....1360 Richwood Rd.
 Phone Number1100
 News Service AP
 Transcription Service World
 Representative Lawson
 President..... R. C. Brown
 General Manager.....Gordon Hutton
 Commercial Manager.....Phil Solberg
 Chief Engineer.....Eric Munro

K D A L

DULUTH—1936—CBS

Frequency: 610 Kc.....Power: 5000 Watts
 Owned-Oper. By....Red River Bcstg. Co., Inc.
 Business-Studio Address...218 Bradley Bldg.
 Phone Number2-2628
 Air Time24 Hours
 News ServiceAP
 Transcription ServiceLang-Worth
 RepresentativeAvery-Knodel
 MembershipNARTB, BAB
 Pres., Gen. Mgr.Dalton Le Masurier
 Sta., Comm. Manager.....Odin S. Ramsland
 Sales Prom. Mgr.....Dale Cowle
 Program Director.....Jack Gordon
 Chief Engineer.....Robert A. Dettman

W E B C

**DULUTH—1924
 NBC-ARROWHEAD**

Frequency: 1320 Kc.....Power: 5000 Watts
 Owned-Oper. By. .Head of the Lakes Bcstg. Co.
 Business-Studio Address.....WEBC Bldg.
 Phone Number2-2873
 News Service UP
 Transcription Service.....SESAC, World
 RepresentativeHollingbery
 PresidentMorgan Murphy
 General Manager.....W. C. Bridges
 Station Manager.....Clifford J. Lue
 Program Director.....Michael J. Flaherty
 Chief Engineer.....Norman Gill

W E V E

EVELETH—1947—MBS-KBS

Frequency: 1340 Kc.....Power: 250 Watts
 Owned-Oper. By.....Carl Bloomquist
 Phone Number1340
 Transcription ServiceStandard
 RepresentativeOrville Lawson
 PresidentCarl Bloomquist
 General ManagerArthur F. Nelson

Program Director.....Robert Daniels
 Chief Engineer.....Joe Cerar

K S U M

FAIRMONT—1949—MBS

Frequency: 1370 Kc.....Power: 1000 Watts d.
 Owned-Oper. ByFairmont Bdcstg. Co.
 Address306 North Park St.
 Phone Number1370
 News ServiceAP
 RepresentativeRambeau
 Trans. Serv.Thesaurus
 PresidentLeo J. Seifert
 General ManagerFrank Endersbe
 Program Director.....James L. Barkley
 Chief Engineer.....Lawrence Lawson

K D H L

FARIBAULT—1948

Frequency: 920 Kc.....Power: 1000 Watts
 Owned-Oper. ByKDHL Bdcstg. Co.
 Business-Studio Address...213 Central Ave.
 Phone Number2312
 News ServiceAP
 Transcription ServiceCapitol
 General Mgr.....Herbert H. Lee
 Commercial Mgr.....Palmer Dragsten
 Chief Engineer.....John E. Hyde, Jr.

K G D E

**FERGUS FALLS—1926
 MBS-GREAT NORTHERN**

Frequency: 1250 Kc.....Power: 1000 Watts d.;
 500 Watts n.
 Owned-Operated By.....Fergus Radio Corp.
 Business-Studio Address.....Fergus Falls
 Phone Number6996
 Air Time.....6 a.m.-M.
 News ServiceAP
 RepresentativeWalker
 MembershipNARTB
 Secy.-Treas., Gen. Mgr.....Harold L. Dell
 Station Manager.....N. C. Haagenson
 Asst. Mgr.....Frederic T. Dell
 Chief Engineer.....Harold E. Allen

K B Z Y

GRAND RAPIDS—1948—MBS

Frequency: 1490 Kc.....Power: 250 Watts
 Owned-Operated ByItasca Bcstg. Co.
 Phone Number198
 Air Time.....6:30 a.m.-11 p.m.
 MembershipBAB, NARTB
 Pres., General Manager...Robert D. Kennedy
 Program Director.....Bud Germ
 Chief Engineer.....Ross A. Fessenmeyer

W M F G

HIBBING—1935—NBC-ARROWHEAD

Frequency: 1240 Kc.....Power: 250 Watts
 Owned-Oper. By. .Head of the Lakes Bcstg. Co.
 Business-Studio Address.....5th & Howard
 Phone Number3-7531

News ServiceUP
 Transcription Service..... World, SESAC
 Representative.....George P. Hollingbery
 President.....Morgan Murphy
 General Manager.....W. C. Bridges
 Commercial Mgr..... Oscar H. Peterson
 Program Director..... Ruth E. Coe
 Chief Engineer.....Norman Gill

Publicity DirectorBob Cosgrove
 Chief Engineer..... James Houts

K D U Z

HUTCHINSON—1953

Frequency: 1260 Kc.Power: 1000 Watts d.
 Owned-Oper. By... McLeod County Bbstg. Co.
 AddressRadio City
 Phone Number1555
 General Manager.....Albert Tedesco
 Partners.....Victor Tedesco,
 Nicholas Tedesco
 Commercial Mgr.....Hienz Fruck
 Program Director.....Ted Hanson
 Promotion Mgr.....Howard Nordine
 Chief Engineer.....Darrel Gander

K L T F

LITTLE FALLS—1950—KBS

Frequency: 960 Kc.Power: 500 Watts d.
 Owned-Oper. By.....Little Falls Bcstg. Co.
 Address.....105½ Broadway E.
 Phone Number367
 News ServiceUP
 Transcription Service World
 Pres., Gen. Mgr.....John H. Lemme
 Station Manager.....Jack I. Nugent
 Commercial Manager.....Richard J. Rudeck
 Program Director.....Sumner Sabean

K T O E

MANKATO—1950—ABC

Frequency: 1420 Kc.Power: 5000 Watts
 Owned-Oper. By... Minnesota Valley Bcstg. Co.
 AddressBox 550
 Phone Number4537
 Air Time Full Time
 News ServiceUP
 Representative Pearson
 President.....H. W. Linder
 Gen., Sta. Manager.....D. O. Linder
 Chief Engineer.....Steve Wolf

K Y S M

MANKATO—1938
 NBC-NORTHWEST

Frequency: 1230 Kc.Power: 250 Watts
 Owned-Oper. By.....F. B. Clements & Co.
 Phone Number4673
 Air Time6 a.m.-1 a.m.
 News ServiceAP
 Transcription ServiceThesaurus
 RepresentativeMeeker
 MembershipNARTB, BAB
 Gen.-Station-Comm. Mgr.....John F. Meagher
 Sales Promotion Manager.....Bob DeHaven
 Program Director.....Gene Bouchier

K M H L

MARSHALL—1946—ABC

Frequency: 1400 Kc.Power: 250 Watts
 Owned-Operated By.....Harry W. Linder
 Business-Studio Address.....KMHL Bldg.
 Phone Number2282
 Air Time6 a.m.-M.
 News ServiceUP
 Representative.....John E. Pearson
 Owner.....Harry W. Linder
 General Manager.....Gilmore F. Frayseth
 Program DirectorBen Dickmeyer
 Chief Engineer.....Russ Nelson

KEYD

MINNEAPOLIS—1948

Frequency: 1440 Kc.Power: 5000 Watts d.
 Owned-Operated By..... Family Bcstg. Corp.
 Business-Studio Address.....15 N. Ninth St.
 Phone NumberLincoln 8451
 News ServiceAP
 Transcription ServiceStandard
 RepresentativeRambeau
 MembershipNARTB, BAB
 PresidentHenry Klages
 Sta., Gen. Mgr.....Lee L. Whiting
 Chief Engineer.....Harvey V. Headen

W C C O

MINNEAPOLIS—1924
 CBS Radio

Frequency: 830 Kc.Power: 50,000 Watts
 Owned By.....Midwest Radio-Television, Inc.
 Business-Studio Address.....625 Second Ave. S.
 Phone Number.....Main 1202
 Air Time5 a.m.-1 a.m.
 News Service.....AP, UP, INS
 Transcription ServiceLang-Worth
 Representative.....CBS Radio Spot Sales
 MembershipBAB
 President.....F. von Konyenburg
 General Manager.....Larry Hoeg
 Sales Manager.....Phil Lewis
 Sales Prom., Mgr.....C. H. Smith
 Program Director.....Bob McKinsey
 Publicity Director.....Fred Heywood
 Chief Engineer.....J. J. Beloungy

W D G Y

MINNEAPOLIS—1923

Frequency: 1130 Kc.Power: 50,000 Watts d.;
 25,000 Watts n.
 Owned-Oper. By.....Twin Cities Bcstg. Corp.
 Business-Studio Address.....Hotel Nicollet
 Phone Number.....Bridgeport 2271
 News ServiceUP
 RepresentativeAvery-Knodel
 MembershipNARTB
 Pres., Gen., Sta. Mgr.....Clarence T. Hagman
 Commercial Manager.....Samuel N. Nemer

Program Director.....Don O'Brien
 Chief Engineers.....Kenneth Olson,
 Kenneth Larson

Commercial Mgr.....Bill Farrell
 Chief Engineer.....Richard Beekman

W L O L

MINNEAPOLIS—1940—MBS

Frequency: 1330 Kc.....Power: 5000 Watts
 Owned-Oper. By ..Independent Bdcstg. Co.
 Business-Studio Address..1730 Hennepin Ave.
 Phone Number...Atlantic 0406, Midway 4043
 Air TimeUnlimited
 News ServiceUP
 Representative.....A. M. Radio Sales
 President.....Ralph L. Atlas
 Gen., Sta. Mgr.....Marvin L. Rosene
 Commercial Mgr.....Wayne "Red" Williams
 Prom., Pgm. Dir.....Edward L. Wiebe
 Publicity Director.....Kay Runyon
 Studio Engineer.....Gene Brautigam
 Transmitter Engineer.....Merle Bjork

W P B C

MINNEAPOLIS—1949

Frequency: 980 Kc.....Power: 1000 Watts d.
 Owned-Oper. By ..People's Bdcstg. Co.
 Address1133 Stinson Blvd
 Phone Number ..Granville 4356, Prior 3181
 Air TimeDaytime
 News ServiceUP
 Transcription ServiceLang-Worth
 RepresentativeSears & Ayer, Inc.
 Pres., Gen., Sta. Mgr.....W. V. Stewart
 Commercial Manager.....Merle Forland
 Pgm., Pub. Dir.....Becky Ann Stewart
 Chief Engineer.....Clinton Barstad

W T C N

**MINNEAPOLIS-ST. PAUL—1935
 ABC**

Frequency: 1280 Kc.....Power: 5000 Watts d.;
 1000 Watts n.
 Owned-Oper. By.....Minnesota Television
 Public Service Corp.
 Business-Studio Address....2925 Dean Blvd.
 Phone Number.....Mohawk 9-6771
 News Service.....AP, UP
 Transcription ServiceAssociated
 RepresentativeBlair
 President.....Robert Butler
 General Manager.....Edward G. Smith
 Commercial Manager.....Kendall M. Light
 Program Director.....Judy Bryson
 Chief Engineer.....Myron N. Fleming

K D M A

MONTEVIDEO—1952—ABC

Frequency: 1450 Kc.....Power: 100 Watts
 Owned-Operated By....Midwest Bcstg. Corp.
 Address.....West Hway. 212
 Phone8891
 Air TimeUnlimited
 RepresentativePearson
 Pres., Gen. Mgr.....H. Willard Linder

K V O X

**MOORHEAD—1937
 MBS-GREAT NORTHERN**

Frequency: 1340 Kc.....Power: 250 Watts
 Owned-Operated By.....KVOX Bcstg. Co.
 Bus.-Studio Address.....403 Center Ave.
 Phone Number3-1522
 Air Time6:30 a.m.-M.
 News ServiceUP
 RepresentativeWalker, Lawson
 MembershipNARTB
 PresidentE. J. McKellar
 General Manager.....M. M. Marget
 Comm., Sls. Prom. Mgr.....Robert L. Owens
 Program Director.....Dewey Bergquist
 Chief Engineer.....Don Geiken

K N U J

NEW ULM—1949—KBS

Frequency: 860 Kc.....Power: 1000 Watts d.
 Owned-Oper. ByKNUJ, Inc.
 Address.....304½ N. Minn. St.
 Phone Number905
 Air TimeDaytime
 News ServiceAP
 Transcription Service.....Lang-Worth, World,
 MembershipBAB
 President.....W. K. Mickelson
 Gen. Mgr., Chief Engr.....Jack H. Duncan

K O B K

OWATONNA—1950—KBS

Frequency: 1390 Kc.....Power: 500 Watts d.
 Owned-Operated By....Owatonna Bcstg. Co.
 Address.....307 Vesterby Bldg.
 Phone Number2359
 News ServiceUP
 MembershipBAB
 President.....Myles H. Johns
 Station Manager.....Robert Frye
 Chief Engineer.....Jerome Dvorachek

K A A A

RED WING—1949

Frequency: 1250 Kc. ..Power: 1000 Watts d.
 Owned-Oper. ByRed Wing Bdcstg. Co.
 News ServiceAP
 Transcription Service.....Assoc., Capitol
 General Manager.....Maxine Jacobs
 Program Director.....Peter Lyman
 News Director.....Donald Willie

K R O C

ROCHESTER—1935—NBC

Frequency: 1340 Kc.....Power: 250 Watts
 Owned-Oper. By.....Southern Minnesota
 Bcstg. Co.
 Business-Studio Address...100 1st Ave. Bldg.
 Phone Number3924

Air Time.....6 a.m.-M.
 News Service.....UP
 Transcription Service.....Thesaurus
 Representative.....Meeker
 Membership.....NARTB, BAB
 President.....Mrs. G. P. Gentling
 Gen., Comm. Mgr.....G. David Gentling
 Sta. Mgr., Pgm. Dir.....Cal Smith
 Sales Prom., Pub. Dir.....Warren Miller
 Program Director.....Carl Smith
 Chief Engineer.....Bob Cross

K F A M

ST. CLOUD—1937—NBC

Frequency: 1450 Kc.....Power: 250 Watts
 Owned-Operated By.....Times Publ. Co.
 Address.....Weber Bldg.
 Phone Number.....3330, 3331
 Air Time.....6 a.m.-12 M.
 News Service.....AP
 Transcription Service.....Thesaurus
 Representative.....Pearson
 Membership.....NARTB, BAB
 Pres., Gen. Mgr.....Frederick C. Schilplin
 Sales P.om., Pub., Comm. Mgr.....Donald J. Orth
 Program Director.....Betty May
 Chief Engineer.....Robert Witschen

W J O N

ST. CLOUD—1950—ABC

Frequency: 1240 Kc.....Power: 250 Watts
 Owned-Oper. By.....Granite City Bcstg. Co.
 Address.....St. Cloud Hotel
 Phone Number.....1240
 Representative.....Rambeau
 Transcription Service.....World
 News Service.....UP
 President.....Max H. Lavine
 Program Director.....Wallace MacBriar
 General Manager.....Herm Schneider
 Chief Engineer.....Charles Willms

K S T P

ST. PAUL-MINNEAPOLIS—1928-NBC
 NORTHWEST

Frequency: 1500 Kc.....Power: 50,000 Watts
 Owned By.....KSTP, Inc.
 Bus. Studio Address.....3415 University Ave.
 Phone Number.....Prior 2717
 Air Time.....6 a.m.-1 a.m.
 News Service.....AP, UP
 Transcription Service.....Thesaurus, SESAC, Cole
 Representative.....Edward Petry
 Membership.....NARTB
 President, Gen. Mgr.....Stanley E. Hubbard
 Nat. Sales Mgr.....Karl A. Plain
 Exec. V.P., Treas.....K. M. Hance
 Program Director.....D. Brooks Henderson
 Promotion-Publicity Director.....Joe Cook
 Chief Engineer.....William S. Sadler

W M I N

ST. PAUL—1936

Frequency: 1400 Kc.....Power: 250 Watts

Owned-Operated By.....WMIN Bcstg. Co.
 Business-Studio Address, 611 Frontenac Place
 Phone Number.....Prior 7757
 News Service.....AP
 Representative.....Clark
 Pres., Gen. Mgr.....N. L. Bentson
 Commercial Mgr.....Frank M. Devaney
 Program Director.....Norman Page
 Chief Engineer.....Warren B. Fritze

W C O W

SOUTH ST. PAUL—1951

Frequency: 1590 Kc.....Power: 5000 Watts d.
 Owned-Oper. By.....South St. Paul Bcstg. Co.
 Address.....8 W. 9th St.
 Phone Number.....Garfield 4717
 News Service.....UP
 Transcription Service.....SESAC
 General Manager.....Victor J. Tedesco
 Commercial Mgr.....Arne Peterson
 Program Director.....Jack Douglas
 Chief Engineer.....Larry Lennette

W S H B

STILLWATER—1949

Frequency: 1220 Kc.....Power: 250 Watts d.
 Owned-Operated By.....St. Croix Bcstg. Co.
 Address.....126 S. Main St.
 Phone Number.....46, 47
 News Service.....UP
 Transcription Service.....Lang-Worth
 Representative.....Donald Cook, Inc.
 President.....William F. Johns, Jr.
 General Manager.....Richard Power
 Commercial Manager.....James McLaughlin
 Chief Engineer.....Elmer Christenson

K T R F

THIEF RIVER FALLS—1946

Frequency: 1230 Kc.....Power: 250 Watts
 Owned-Oper. By.....Henry K. Arneson
 Transcription Service.....World
 Representative.....Bulmer & Johnson, Inc.
 Membership.....BAB
 General Manager.....Don Olson
 Sales Prom. Mgr.....Ormond Johnson
 Chief Engineer.....Henry J. Bothman

W H L B

VIRGINIA—1936—NBC

ARROWHEAD, NORTHWEST

Frequency: 1400 Kc.....Power: 250 Watts
 Owned-Oper. By.....Head of the Lakes Bcstg.
 Phone Number.....2000
 News Service.....UP
 Transcription Service.....World, SESAC
 Representative.....Hollingsbery
 President.....J. Morgan Murphy
 General Manager.....Walter Bridges
 Station Manager.....H. J. Parise
 Chief Engineer.....Norman Gill

K W A D

WADENA—1948—MBS

Frequency: 920 Kc. Power: 1000 Watts
 Owned-Oper. By. Associated Bcstrs., Inc.
 Bus. Studio Address. First Natl. Bank Bldg.
 Phone Number. 920-1
 Transcription. World
 Representatives. Bulmer & Johnson
 General Manager. Carl E. Holt
 Program Director. Jim Buchan
 Chief Engineer. Milton La Due

K W L M

WILLMAR—1940—ABC

Frequency: 1340 Kc. Power: 250 Watts
 Owned-Oper. By. Lakeland Bcstg. Co.
 Business-Studio Address. 1340 N. 7th St.
 Phone Number. 1340
 Air Time. 6 a.m.-M.
 News Service. UP
 Transcription Service. Cole
 Representative. John E. Pearson
 Membership. NARTE, BAB
 President, Gen. Mgr. H. W. Linder
 Commercial Manager. Jack Lynch
 Program Director. Joe Martinson
 Chief Engineer. Francois Peterson

K W N O

WINONA—1938—ABC

Frequency: 1230 Kc. Power: 250 Watts
 Owned-Operated By. Winona Radio Service
 Business-Studio Address. 216 Center St.
 Phone Number. 3314
 News Service. AP
 Transcription Service. Standard
 Representative. John E. Pearson
 President. M. H. White
 General Manager. Ken Marsh
 Commercial Manager. H. Rod Hurd
 Chief Engineer. Lewis Denes

K W O A

WORTHINGTON—1947

Frequency: 730 Kc. Power: 1000 Watts d.
 Owned-Oper. By. Worthington Bcstg. Co., Inc.
 Address. Hotel Thompson
 Representative. Bulmer & Johnson
 Transcription Service. Langworth, Thesaurus
 Membership. NARTB
 President. R. W. Olson
 General Manager. R. E. Shepard
 Commercial Manager. Arne Karhu

MISSISSIPPI

Pop. Feb. 1, 1954 (Est.) 2,200,000 — Families 580,000
Radio Homes 463,000 — TV Homes 120,000 — Stations in State 51

W M P A

ABERDEEN—1952—KBS

Frequency: 1240 Kc. Power: 250 Watts
 Owned-Oper. By. Prairie Bcstg. Co.
 Address. P. O. Box 402
 Phone Number. 1050
 News Service. UP
 Representative. McGillvra
 Transcription Service. Lang-Worth
 President. T. A. Richardson
 Gen., Sta., Comm. Mgr. William Felton
 Pgm., Pub. Dir. Grace Felton
 Chief Engineer. Eddie Lane

W B L E

BATESVILLE—1953

Frequency: 1290 Kc. Power: 1000 Watts d.
 Owned-Oper. By. Panola Bcstg. Co.
 Address. Box 247
 Co-Owner, Gen. Mgr. Harold B. McCarley
 Co-Owners. Travis A. Palmer,
 James E. Hartness

W L O X

BILOXI—GULFPORT—1948—MBS

Frequency: 1490 Kc. Power: 250 Watts
 Owned-Operated By. WLOX Bcstg. Co.

Address. Buena Vista Hotel
 Phone Number. 5581-2
 News Service. UP
 Representative. William G. Rambeau
 President. James S. Love, Jr.
 General Manager. Ray Butterfield
 Commercial Manager. Thomas B. Majure
 Program Director. Hugh Smith

W W M I

BILOXI—1950

Frequency: 570 Kc. Power: 1000 Watts d.
 Owned-Oper. By. Radio Associates
 Address. P. O. Box 152
 Phone Number. 6961
 Representatives. Natl. Time Sales, Dora
 Clayton
 Transcription Service. Thesaurus, SESAC
 Membership. BAB, NARTB
 News Service. UP
 Pres., Gen., Sta. Mgr. Odes E. Robinson
 Sales Prom., Comm. Mgr. Chauncey T. Hinman
 Program Director. Earl B. Blessey

W B I P

BOONEVILLE—1950—KBS

Frequency: 1400 Kc. Power: 250 Watts
 Owned-Oper. By. Booneville Bcstg. Co.

Address.....Highway No. 45-S
 Phone Number.....678
 Air Time.....Full Time
 Newspaper Affiliation.....The Independent
 News Service.....UP
 Representative.....Continental Radio Sales
 President, Gen. Mgr.....E. O. Roden
 Sta. Comm., Sales Prom. Mgr.....V. K. Wroten
 Program Director.....Wynex Wroten

W J M B

BROOKHAVEN—1949

Frequency: 1340 Kc.....Power: 250 Watts
 Owned-Operated By.....Brookhaven Bcstg. Co.
 Address.....W. Chicksaw St.
 Phone Number.....1298
 News Service.....AP
 Transcription Service.....World
 Pres., Gen. Mgr.....Tullius Brady

W D O B

CANTON—1953—KBS

Frequency: 1370 Kc.....Power: 500 Watts d.
 Owned-Oper. By.....Madison County Bcstg. Co.
 Address.....Box 182
 Phone Number.....1370
 News Service.....UP
 Transcription Service.....Thesaurus
 Representative.....Dorac-Clayton
 Co-Owners.....J. D. Bishop.
 J. T. Ownby, Anne Lee Davis
 General Manager.....R. L. Statham
 Commercial Manager.....Harold Harris
 Program Director.....Ozella Westbrook

W G L C

CENTREVILLE—1951—KBS

Frequency: 1580 Kc.....Power: 250 Watts d.
 Owned-Oper. By.....Southern Bdcstg. Co.
 News Service.....UP
 Transcription Service.....Capitol
 Phone Number.....4001
 President.....A. Sansing
 General Manager.....P. Simpkins
 Chief Engineer.....Bob Bassett

W R O X

CLARKSDALE—1943—MBS

Frequency: 1450 Kc.....Power: 250 Watts
 Owned-Oper. By.....Birney Imes, Jr.
 Address.....Delta Ave.
 Phone Number.....1566
 Air Time.....Full Time
 News Service.....AP
 Transcription Service.....RCA Thesaurus
 General Manager.....Bob McRaney
 Program Director.....Jack Cristil
 Station Manager.....P. B. Hinman
 Chief Engineer.....C. D. Graves

W C L D

CLEVELAND—1949

Frequency: 1490 Kc.....Power: 250 Watts
 Owned-Operated By.....Cleveland Bcstg. Co., Inc.

Address Trans.....Box 1030
 Phone Number.....990
 News Service.....AP
 Station Representative.....McGillvra
 President.....Lowry Tims
 Gen., Sta., Comm. Mgr.....C. W. Capps
 Program Director.....Elizabeth Bradley
 Chief Engineer.....Richard Bullock

W C J U

COLUMBIA—1946—KBS-MBS

Frequency: 1450 Kc.....Power: 250 Watts
 Owned-Oper. By.....Lester Williams, WCJU, Inc.
 Address.....P. O. Box 472
 Phone Number.....755
 Air Time.....Full Time
 Newspaper Affiliation.....The Progress
 News Service.....AP
 Transcription Service.....World
 Pres., Gen. Manager.....Lester Williams
 Station Manager.....Charles E. Newman, Jr.
 Program Director.....Bill Barrett
 Chief Engineer.....Ray Tolar

W A C R

COLUMBUS—1950—MBS

Frequency: 1050 Kc.....Power: 250 Watts d.
 Owned-Oper. By.....Miss. Bcstg. Co.
 Address.....WACR Bldg.
 Phone.....768
 Air Time.....Sunrise-Sunset
 News Service.....UP
 Pres., Gen. Mgr.....Withers Gavin

W C B I

**COLUMBUS—1940
 MBS—KBS-MID SOUTH**

Frequency: 1340 Kc.....Power: 250 Watts
 Owned-Operated By.....Birney Imes, Jr.
 Business-Studio Address.....Columbus
 Phone Number.....1430
 News Service.....AP
 Transcription Service.....Thesaurus
 Representative.....McGillvra
 President.....Birney Imes, Jr.
 Gen., Sales Prom. Mgr.....Bob McRaney
 Station Manager.....James Eatherton
 Program Director.....Martha Puckett
 Chief Engineer.....Thomas McFerrin

W C M A

CORINTH—1945—MBS-KBS

Frequency: 1230 Kc.....Power: 250 Watts
 Owned-Operated By.....Corinth Bcstg. Co., Inc.
 Business-Studio Address.....Ray Bldg.
 Phone Number.....5575
 News Service.....UP
 Transcription Service.....World
 Representative.....Burn-Smith
 President.....Dr. Frank M. Davis
 General Manager.....Aaron B. Robinson
 Station Manager.....John E. Bell
 Program Director.....Vincent Lawrence
 Commercial Manager.....Joe P. Van Dyke
 Chief Engineer.....James D. Anderson

WGVM

GREENVILLE—1948

Frequency: 1260 Kc. Power: 1000 Watts d.
 Owned-Operated By... Cotton Belt Beasting Co.
 Bus.-Studio Address... 118 So. B'way
 Phone Number... 4559
 Air Time... 6 a.m.-Sunset
 News Service... UP
 Transcription Service... Lang-Worth
 Representative... Devney, Melville
 Pres., General Manager... David M. Segal
 Station Manager... E. M. Guss
 Prom., Sta. Mgr... Jack Stull
 Program Director... Wallace D. Hoy
 Chief Engineer... W. McChristian

WJPR

GREENVILLE—1939—MBS-KBS

Frequency: 1330 Kc. Power: 1000 Watts d.-
 500 Watts n.
 Owned-Oper. By... Radio Services Co.
 Business-Studio Address... 120 So. Poplar St.
 Phone Number... 9040-9049
 News Service... AP
 Transcription Service... World
 Representative... Sears & Ayer
 Membership... NARTB
 Gen. Sta. Mgr... Emmett H. McMurry
 Commercial Manager... Frank W. Baldwin
 Program Director... Thomas Tiller
 Chief Engineer... Percy L. Kuhn

WABG

GREENWOOD—1950

Frequency: 960 Kc. Power: 1000 Watts d.:
 500 Watts n.
 Owned-Oper. By... Greenwood Bcstg. Co.
 Address... Howard St.
 Phone... 3010
 News Service... AP
 Transcription Service... World
 President... Cy Bahakel
 Manager... Tom Reardon
 Chief Engineer... Clifford Greene

WGRM

GREENWOOD—1937—NBC-KBS

Frequency: 1240 Kc. Power: 250 Watts
 Operated By... P. K. Ewing
 Phone Number... 1900-1
 Studio-Transmitter Location... Walnut St.
 Air Time... 6 a.m.-12 M.
 News Service... UP
 President... P. K. Ewing
 General Manager... F. C. Ewing
 Commercial Manager... Don Neil
 Chief Engineer... Louis Pierce

WNA G

GRENADA—1949—MBS
 MID-SOUTH

Frequency: 1400 Kc. Power: 250 Watts

Owned-Operated By... Birney Imes, Jr.
 Phone Number... 1400
 President... Birney Imes, Jr.
 General Manager... Bob McRamey
 Sta., Comm. Mgr... Monroe Looney
 Chief Engineer... Jimmie Pinnix

WGCM

GULFPORT—1929—ABC
 AND KEYSTONE

Frequency: 1240 Kc. Power: 250 Watts
 Owned-Operated By... WGCM Bcstg. Co.
 Address... Hewes-Martin Bldg.
 Phone Number... 1110
 Air Time... 6 a.m.-M.
 News Service... AP
 Transcription Service... World
 Station Representative... Sears & Ayer, Inc.
 Owner & Gen. Mgr... Hugh O. Jones
 Station Manager... C. Edwin Vann
 Commercial Manager... Mrs. O. L. Owens
 Publicity Director... W. Trautman
 Chief Engineer... Charles T. Hook

WFOR

HATTIESBURG—1925
 NBC-KBS-REBEL

Frequency: 1400 Kc. Power: 250 Watts
 Owned-Operated By... Forrest Bcstg. Co.
 Address... 302 Hemphill St.
 Phone Number... Juniper 4-5432
 Air Time... 5:30 a.m.-11:05 p.m.
 News Service... UP
 Station Rep... George P. Hollingbery Co.
 President... C. J. Wright, Sr.
 General, Station Manager... C. J. Wright, Jr.
 Program Director... David L. Waite
 Commercial Mgr... E. M. Jenkins
 Chief Engineer... B. B. McLemore

WHSY

HATTIESBURG—1948—ABC-MBS

Frequency: 1230 Kc. Power: 250 Watts
 Owned-Operated By... Hub City Bcstg. Co. Inc.
 Address... Box 1008
 Phone Number... Juniper 3-1741
 News Service... AP
 Station Representative... Wm. G. Rambeau
 Membership... NARTB, BAB
 President, Gen. Mgr... Charles W. Holt
 Comm., Sales Prom. Mgr... Bob Robinson
 Station Manager... Connie Holt
 Program Director... Keith Andre
 Publicity Director... Olga Hagler
 Chief Engineer... Charles Sharpling

WMDC

HAZLEHURST—1953—KBS

Frequency: 1220 Kc. Power: 250 Watts d.
 Owned-Oper. By... Southwestern Bcstg. Co.
 of Miss.
 Phone Number... 869
 General Manager... Louis Altford

Sta. Mgr., Chief Engr. A. M. Smith
 Commercial Mgr. Lowery Collins
 Program Director Malcolm Jones

W N L A

INDIANOLA—1953

Frequency: 1380 Kc. Power: 500 Watts d.
 Owned Oper. By Central Delta Bcstg. Co.
 Address Box 575
 Phone Number Indianola 500
 Partners W. L. Kent.
 J. M. McClendon
 General Manager Chuck Allen
 Program Director Paul Artman
 Promotion Mgr. J. Stuart Hough
 Chief Engineer Robert Meador

W J D X

JACKSON—1929—NBC

Frequency: 620 Kc. Power: 5000 Watts d.:
 1000 Watts n.
 Owned-Oper. By Lamar Life Ins. Co.
 Business Address P. O. Box 2171
 Phone Number 2-1183
 News Service UP
 Transcription Service Cole, Capitol, World
 Representative George P. Hollingbery
 General Manager Fred L. Beard
 Commercial Manager Frank Gentry
 Program Director Howard Langlitt
 Chief Engineer Percy G. Root

W J Q S

JACKSON—1947—CBS-MISS.

Frequency: 1400 Kc. Power: 250 Watts
 Owned-Oper. By Mississippi Bcstg. Co., Inc.
 Business-Studio Address Edwards Hotel
 Phone Number 3-9681
 News Service UP
 Transcription Service Standard
 President, General Manager Withers Gavlin

W J X N

JACKSON—1945

Frequency: 1450 Kc. Power: 250 Watts
 Owned-Oper. By Jackson Bcstg. Co.
 Address 916 Foley St.—Radio Ranch
 Phone Number 2-6673
 Pres., Gen. Mgr. James T. Ownby

W R B C

JACKSON—1947—MBS

Frequency: 1300 Kc. Power: 5000 Watts d.:
 1000 Watts n.
 Owned-Operated By Rebel Bcstg. Co., Inc.
 Business-Studio Address 125 So. Lamar
 Phone Number 5-1562
 Air Time Full Time
 News Service AP
 Transcription Service Associated
 Representative Branham
 General Manager J. W. Carlier
 Program Director A. C. Leonard
 Chief Engineer G. G. Benson

W S L I

JACKSON—1938—ABC

Frequency: 930 Kc. Power: 5000 Watts
 Owned Oper. By Standard Life Bcstg. Co., Inc.
 Business Address P. O. Box 1847
 Phone Number 2-3230
 Air Time 5:30 a.m.—12 M.
 News Service AP
 Transcription Service World
 Representative Weed
 Membership NARTB, BAB
 President W. R. Newman
 General Station Manager L. M. Sepaugh
 Commercial Manager F. E. Wilkerson, Jr.
 Program Director B. K. Smith
 Chief Engineer C. A. Perkins

W K O Z

KOSCIUSKO—1947—KBS

Frequency: 1340 Kc. Power: 250 Watts
 Owned-Operated By Cy N. Bahakel
 Business Address P. O. Box 392
 Phone Number 782
 Air Time Full Time
 News Service INS
 Representative McGillvra
 Membership NARTB
 General Manager Cy N. Bahakel
 Program Director Erlene Leach
 Comm. Mgr., Prog. Dir. Mims Boswell, Jr.
 Chief Engineer Wayne A. Oliver

W A M L

LAUREL—1932—NBC-KBS-REBEL

Frequency: 1340 Kc. Power: 250 Watts
 Owned-Oper. By New Laurel Radio Station
 Bus. Studio Address 442 6th Ave.
 Phone Number 5601
 News Service AP
 Transcription Service World
 Representative George P. Hollingbery
 Membership NARTB, BAB
 President Harold Matison
 Gen., Sta. Mgr. Granville Walliers
 Commercial Manager M. M. Caver
 Program Director Stanley Walters
 Chief Engineer Clyde Graves

W L A U

LAUREL—1946—ABC-MBS

Frequency: 1490 Kc. Power: 250 Watts
 Owned-Operated By Southland Bcstg. Co.
 Phone Number 8-7227
 Air Time Full Time
 News Service UP
 Representative McGillvra
 Membership BAB
 President C. T. McCallum
 Gen., Sta. Mgr. Norma H. Leggett
 Comm., Sales Prom. Mgr. Teck Jones
 Pgm., Pub. Dir. David Kane
 Chief Engineer W. B. Carter

WLSM

LOUISVILLE—1953

Frequency: 1270 Kc. Power: 1000 Watts d.
 Owned-Oper. By... Louisville Bcstg. Corp.
 Address... Box 111
 Phone Number... 1000
 Station Manager... William R. Parkes
 Chief Engineer... Herb Guthrie

WMBC

MACON—1947—MISS.

Frequency: 1400 Kc. Power: 250 Watts
 Owned-Oper. By... Mississippi Bcstg. Co., Inc.
 Address... MBC Bldg.
 Phone Number... 310
 News Service... UP
 President, General Manager... Withers Gavin

WAPF

McCOMB—1948—KBS

Frequency: 1010 Kc. Power: 1000 Watts d.
 Owned-Operated By... S. W. Bcstg. Co. of Miss.
 Address... Pike Hotel
 Phone Number... 1884
 News Service... UP
 Transcription Service... Langworth, World
 President... Louis Alford
 Commercial Mgr... Ollie Bales
 Sales Prom. Mgr... Cindy Gardner
 Program Director... Carl Austin
 General Manager... Phillip Brady

WSKB

McCOMB—1939

Frequency: 1250 Kc. Power: 5000 Watts d.:
 500 Watts n.
 Owned-Operated By... WSKB, Inc.
 Address... P. O. Box 111
 Phone Number... 2080
 News Service... AP
 Transcription Service... SESAC
 Representative... Dora Clayton, Rambeau
 General Manager... Lester Williams
 Station Manager... Jack Sanders
 Commercial Manager... Bill Tyler
 Chief Engineer... Robert L. Sanders

WCOC

MERIDIAN—1926—CBS-MISS.

Frequency: 910 Kc. Power: 5000 Watts d.:
 1000 Watts n.
 Owned-Oper. By... Mississippi Bcstg. Co., Inc.
 Business-Studio Address... Threefoot Bldg.
 Phone Number... 7714
 Air Time... 5:50 a.m.-12:10 a.m.
 News Service... UP
 Transcription Service... Standard
 President, General Manager... Withers Gavin

WMOX

MERIDIAN—1946—MIDSOUTH

Frequency: 1240 Kc. Power: 250 Watts

Owned-Operated By... Birney Imes, Jr.
 Phone Number... 2-0171
 News Service... AP
 Representative... McGillvra
 President... Birney Imes, Jr.
 General Manager... Bob McRaney
 Station Manager... Joseph W. Carson
 Comm. Mgr., Prog. Dir... Eddie Holladay
 Chief Engineer... Winton Beaver

WTOK

MERIDIAN—1946—ABC

Frequency: 1450 Kc. Power: 250 Watts
 Owned-Oper. By... Southern TV Corp.
 Address... Southern Bldg.
 Phone Number... 3-1441
 News Service... INS
 Transcription Service... SESAC
 Representative... Headley-Reed Co.
 Pres., Gen. Mgr... Robert F. Wright
 Commercial Mgr... William B. Crooks
 Program Director... Cecil Germany
 Chief Engineer... Joe H. Saxon

WMIS

NATCHEZ—1941—NBC-KBS

Frequency: 1240 Kc. Power: 250 Watts
 Owned-Operated By... Natchez Bcstg. Co.
 Business-Studio Address... City Bank Bldg.
 Phone Number... 8211
 President... P. K. Ewing
 General Manager... P. K. Ewing, Jr.
 Commercial Mgr... Ervin Parks
 Program Director... Hoyle Littlejohn
 Chief Engineer... George W. Wilson

WNAT

NATCHEZ—1949—ABC

Frequency: 1450 Kc. Power: 250 Watts
 Owned-Operated By... Old South Bcstg. Co.
 Phone Number... 4621
 News Service... UP
 President... Mrs. Laurie G. Ratcliffe
 General Manager... Paul Schilling
 Commercial Mgr... Eddie Phelan
 Chief Engineer... Martin Tyronne

WPMP

PASCAGOULA—1951—KBS

Frequency: 1580 Kc. Power: 250 Watts d.
 Owned-Operated By... Crest Bcstg. Co., Inc.
 Address... P. O. Box 348
 Phone Number... 83
 News Service... UP
 Transcription Service... World
 Pres., Gen. Mgr... William R. Guest, Jr.
 Sta., Comm. Mgr... Floyd W. Hess
 Program Director... Morris Grenthner
 Chief Engineer... Fred Strother

WHOC

PHILADELPHIA—1948—KBS

Frequency: 1490 Kc. Power: 250 Watts
 Owned-Oper. By... William Howard Cole

Address P. O. Box 26
 Phone Number 740
 News Service UP
 Transcription Service Capitol
 President, Manager William Howard Cole
 Program Director Mrs. Wm. H. Cole

WRJW

PICAYUNE—1949—KBS

Frequency: 1320 Kc. Power: 5000 d.
 Owned-Oper. By Tung Bcstg. Co.
 Address Picayune
 Phone Number 510
 Air Time Daytime
 News Service AP
 Transcription Service SESAC
 Gen., Sta. Mgr. Jimmie Willson
 Prog. Dir., Chief Eng. Archie Rushing, Jr.

WSSO

STARKVILLE—1949—KBS

MID SOUTH

Frequency: 1230 Kc. Power: 250 Watts
 Owned-Oper. By Starkville Bcstg. Co.
 Business-Studio Address Starkville
 Phone Number 1230
 News Service AP
 Transcription Service Capitol
 Pres., Gen., Comm. Mgr. Joe Phillips
 Program Director Martha L. Pearson

WELO

TUPELO—1944—MBS-MID SOUTH

Frequency: 1490 Kc. Power: 250 Watts
 Owned-Operated By Tupelo Bcstg. Co.
 Business-Studio Address Welo Bldg.
 Phone Number 1400
 Air Time Full Time
 News Service AP
 Transcription Service Capitol, Thesaurus
 Station Manager Bob Evans
 Commercial Manager E. L. Bowen, Jr.
 Chief Engineer LeRoy Green

WTUP

TUPELO—1953

Frequency: 1380 Kc. Power: 1000 Watts d.
 Owned-Oper. By Lee Bcstg. Co.
 Address Box 612
 Phone Number 3111
 Partner E. O. Roden
 General Manager Richard F. Crans
 Commercial Mgr. Hal Benson
 Chief Engineer Keith Wroten

WQBC

VICKSBURG—1931—MBS-KBS

Frequency: 1420 Kc. Power: 1000 Watts d.;
 500 Watts n.
 Owned-Operated By Delta Bcstg. Co., Inc.
 Business-Studio Address Post-Herald Bldg.
 Phone Number 312
 Newspaper Affiliation Post, Herald
 News Service AP

Transcription Service SESAC
 Representative Sears & Ayer
 Membership NARTB
 President L. P. Cashman
 General-Station Mgr. Mary-Van Cashman
 Commercial Manager L. L. Miller
 Program Director Charlotte Kahn
 Chief Engineer Waverley Conway

WVIM

VICKSBERG—1948

Frequency: 1490 Kc. Power: 250 Watts
 Owned-Operated By Radio Miss., Inc.
 Business-Studio Address Box 76
 Phone Number 3901
 Transcription Service Thesaurus
 Representative Indie Sales, Dora-Clayton
 President James T. Ownby
 General Manager Frank Holifield
 Commercial Manager Virginia Hatrell
 Chief Engineer Winston Hayes

WROB

WEST POINT—1947—MBS

Frequency: 1450 Kc. Power: 250 Watts
 Owned-Operated By Bob McRaney, Sr.
 Phone Number 1450
 Pres., Gen. Mgr. Bob McRaney Sr.

WAZF

YAZOO CITY—1947—MBS

Frequency: 1230 Kc. Power: 250 Watts
 Owned-Operated By WAZF, Inc.
 Phone Number 1300-1
 News Service UP
 Pres., Gen. Sta. Mgr. Guy Corley
 Commercial Manager Jim Bonnette
 Program Director Hal Webber
 Chief Engineer C. M. Leshe

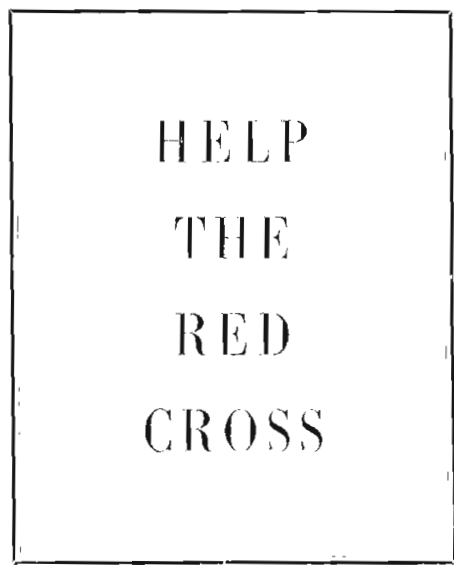

MISSOURI

Pop Feb. 1, 1954 (Est.) 4,034,000 — Families 1,215,000
Radio Homes 1,146,000 — TV Homes 681,500 — Stations in State 61

K F V S

CAPE GIRARDEAU—1925—MBS

Frequency: 960 Kc. Power: 1000 Watts d.;
500 Watts n.

Owned-Operated By Hirsch Bcstg. Co.
Business-Studio Address 324 Broadway
Phone Number 5-5511
Air Time Full Time
News Service UP
Representative John E. Pearson
President Oscar C. Hirsch
Station Manager Ralph L. Hirsch

K G M O

CAPE GIRARDEAU—1952

Frequency: 1220 Kc. Power: 250 Watts d.
Owned-Oper. By KGMO Radio-TV Inc.
Address Box 63
Phone Number 5-8228
Pres., Prog. Dir. William C. Brandt
General Manager Richard C. Brandt
Chief Engineer William M. Bryan

K D M O

CARTHAGE—1947—KBS

Frequency: 1490 Kc. Power: 250 Watts
Owned-Oper. By Carthage Bcstg. Co.
Address 1201 E. Chestnut
Phone Number 2648, 2623
Air Time Full Time
News Service AP
Transcription Service Langworth
Membership NARTB
General Manager L. C. McKenney
Commercial Manager J. I. Dalw
Sales Promotion Manager Edith Snyder
Program Director Leon Crocker
Chief Engineer George Province

K C R V

CARUTHERSVILLE—1950

Frequency: 1370 Kc. Power: 1000 Watts d.
Owned-Oper. By Pemiscot Bcstg. Co.
Address 106 W. 3rd St.
Phone Number 965
Transcription Service Thesaurus, World
News Service UP
President J. E. Taylor
General Manager Robert L. Harrison
Commercial Manager Ed Dyer
Program Director Harry A. Moreland
Chief Engineer O. V. Bennet

K C H R

CHARLESTON—1953—KBS

Frequency: 1350 Kc. Power: 500 Watts d.
Owned-Oper. By South Mo. Bcstg. Co.
Phone Number 4451

Representative Continental
Co-Owner, Gen. Mgr. Kermit Barker
Co-Owner Charles W. Hobbs
Program Director James L. Byrd IIIrd

K C H I

CHILLICOTHE—1950—KBS

Frequency: 1010 Kc. Power: 250 Watts d.
Owned-Oper. By Cecil W. Roberts
Address Farmington, Mo.
Phone Number 710
News Service UP
Representative Hil F. Best
President Cecil W. Roberts
General Manager Howard G. Rion
Commercial Mgr. Jerry Wilson
Chief Engineer Donald P. O'Brien

K D K D

CLINTON—1951

Frequency: 1280 Kc. Power: 1000 Watts d.
Owned-Operated By Clinton Bcstg. Co., Inc.
Address P. O. Box 113
Phone Number 233
News Service UP
Transcription Service World
Representative Devney
President David M. Segal
General Manager Lee Baker
Commercial Mgr. Joe Potts
Chief Engineer Dean Clayton

K F R U

COLUMBIA—1925—ABC-MSN

Frequency: 1400 Kc. Power: 250 Watts
Owned-Operated By KFRU, Inc.
Business Address Box 89
Phone Number 4141
Air Time 6:30 a.m.-M.
News Service AP, INS
Transcription Service Lang-Worth, World
Membership NARTB, BAB
President H. J. Waters, Jr.
General Manager Mahlon R. Aldridge, Jr.
Commercial Mgr. F. J. LeGrand
Program Director Shirley Bauderer
Chief Engineer Robert Halgh

K R E I

FARMINGTON—1947—KBS

Frequency: 800 Kc. Power: 1000 Watts d.
Owned-Oper. By Midwest Bcstg. System
Phone Number 710
Studio Burks Rd. & Webster St.
Air Time Sunrise-sunset
News Service UP
President Cecil W. Roberts
Station Manager Earl L. Whitener
Chief Engineer Bill Westbrook

K J C F

FESTUS—1951

Frequency: 1010 Kc. Power: 250 Watts d.
 Owned-Operated By: Jefferson County Radio
 & TV Co.
 News Service UP
 General Manager: Donald M. Donze
 Chief Engineer: Russell Seals, Jr.

K F M O

**FLAT RIVER—1947—MBS
 GRIESE DIECK**

Frequency: 1240 Kc. Power: 250 Watts
 Owned-Operated By: Lead Belt Bcstg. Corp.
 Business-Studio Address: Flat River
 Phone Number: 1000
 Air Time: Full Time
 News Service UP
 Representative: John E. Pearson
 Membership: BAB
 President, General Manager: Oscar C. Hirsch
 Station Comm. Mgr.: James F. Collins
 Program, Publicity Director: Virginia Collins
 Chief Engineer: Gilbert Collins

K F A L

FULTON—1950

Frequency: 900 Kc. Power: 1000 Watts d.
 Owned-Oper. By: Mo. Central Bcstrs.

Address: 5th and Market
 Phone Number: 1400
 News Service UP
 Transcription Service Standard
 Membership NARTB, BAB
 General Manager: Robert W. Nickles
 Comm. Prom. Mgr.: L. Reed Holt
 Chief Engineer: J. J. Patterson

K H M O

HANNIBAL—1941—MBS

Frequency: 1070 Kc. Power: 5000 Watts d.;
 1000 Watts n.
 Owned-Oper. By: Bolling Bcstg. Co.
 Business-Studio Address: 102½ S. Main St.
 Phone Number: HA 3450
 Air Time: 5:30 a.m.—12 M.
 News Service AP
 Transcription Service Thesaurus
 Representative: John E. Pearson
 Membership: NARTB, BAB
 Partners: James and Ada Bolling
 General Manager: William H. Shaw
 Sales Prom. Mgr.: Gene Hoenes
 Chief Engineer: Ben Parrish

K I M O

INDEPENDENCE—1947

Frequency: 1510 Kc. Power: 1000 Watts d.
 Owned-Oper. By: Craig Siegfried
 Business-Studio Address: 310 N. Osage

**THOSE WHO KNOW
 FAMOUS BRANDS**

Says Commercial Manager (AM) J. Ted Branson of
 KFEQ at St. Joseph, Mo.: "Prospects have high regard
 for The **AP** . . . and therefore you have the advantage
 of a sympathetic climate for your offer."

**. . . . KNOW THE MOST FAMOUS
 BRAND IN NEWS IS **AP****

Phone Number.....CL. 9815
 News Service.....AP
 General Manager.....Wayne Hackett
 Commercial Mgr.....Don Angel
 Chief Engineer.....Robert Atkinson

KLIK

JEFFERSON CITY—1953

Frequency: 950 Kc.....Power: 5000 Watts d.
 Owned-Oper. By.....Empire Bcstg. Co.
 Address.....410 E. Capitol
 Phone Number.....6-3191
 Station Manager.....Jack Adams
 Program Director.....Dean Leupke
 Chief Engineer.....Ted Porter

KWOS

JEFFERSON CITY—1937—MBS-KBS

Frequency: 1240 Kc.....Power: 250 Watts
 Owned-Operated By.....Capital Bcstg. Co.
 Business-Studio Address.....210 Monroe St.
 Phone Number.....6-3137
 Air Time.....Full Time
 Newspaper Affiliation.....News Tribune Co.
 News Service.....AP
 Transcription Service.....Thesaurus
 President.....Mrs. L. R. Goshorn
 Gen., Sta. Comm. Mgr.....Catherine Roer
 Program Director.....Ralph L. Rose
 Chief Engineer.....Leroy S. Hackmann

KFSB

JOPLIN—1948

Frequency: 1310 Kc.....Power: 5000 Watts d.
 1000 Watts n.
 Owned-Oper. By.....Four States Bcsters, Inc.
 Business-Studio Address.....1027 Main
 Phone Number.....1310
 News Service.....UP
 Transcription Service.....World
 Representative.....Meeker
 Membership.....NARTB
 President.....Harry Easley
 V.P., Gen. Mgr.....W. H. Clark
 Chief Engineer.....Ralph Meador

KSWM

JOPLIN—1946—CBS

Frequency: 1230 Kc.....Power: 250 Watts
 Owned-Operated By.....Air Time, Inc.
 Address.....1928 W. 13 St.
 Phone Number.....7260
 News Service.....UP
 Representative.....William G. Rambeau
 Membership.....NARTB
 Pres., Gen. Mgr., Chf. Engr.

Austin A. Harrison

Sta. Mgr., Pgm. Dir.....Ronald Robson
 Commercial Mgr.....D. T. Knight Jr.

WMBH

JOPLIN—1934—MBS

Frequency: 1450 Kc.....Power: 250 Watts
 Owned-Operated By.....Joplin Bcstg. Co.

Business-Studio Address.....Frisco Bldg.
 Phone Number.....330
 Air Time.....Full Time
 News Service.....AP
 Transcription Service.....Thesaurus
 Representative.....Sears & Ayer
 Membership.....NARTB
 Pres., Gen., Sta. Mgr.....D. J. Poynor
 Comm. Mgr.....M. E. Dunn
 Program Director.....Golda Shauce
 Chief Engineer.....Jack Langford

KCKN

KANSAS CITY—1925

Frequency: 1340 Kc.....Power: 250 Watts
 Owned-Operated By.....KCKN Bcstg., Inc.
 Business-Studio Address.....300 Waltower Bldg.
 Phone Number.....Victor 3864
 News Service.....AP, UP
 Transcription Service.....Langworth, Standard
 Representative.....Capper Publications, Inc.
 President.....W. A. Bailey
 General Manager.....Ben Ludy
 Commercial Manager.....Joe Story
 Chief Engineer.....Lewis Dickensheets

KCMO

KANSAS CITY—1936—ABC

Frequency: 810 Kc.....Power: 50,000 Watts d.
 10,000 Watts n.
 Owned-Operated By.....KCMO Bcstg. Co.
 Address.....125 E. 31st St.
 Phone Number.....Jefferson 6789
 Air Time.....Full Time
 News Service.....AP
 Transcription Service.....Thesaurus, Associated
 Representative.....Katz
 Membership.....NARTB, BAB
 President.....E. T. Meredith
 General Manager.....E. K. Hartenbower
 Asst. Manager.....C. E. Breazeal
 Commercial Manager.....R. W. Evans
 Sales Prom., Pub. Dir.....F. C. Strawn
 Program Director.....S. B. Tremble
 Chief Engineer.....Karl Troeglen

KFRM

KANSAS CITY—1947

Frequency: 550 Kc.....Power: 5000 Watts d.
 Owned-Operated By.....Midland Bcstg. Co.
 Business-Studio Address.....222 W. 11th St.
 Phone Number.....HA. 2650
 Air Time.....Daytime
 News Service.....AP, UP
 Transcription Service.....World, Lang-Worth
 Representative.....Free & Peters
 Membership.....NARTB, BAB
 President.....Arthur B. Church
 V.P., Managing Dir.....George J. Higgins
 Sales Promotion Manager.....Harold W. Storm
 Chief Engineer.....Ray Moler

KMBC

KANSAS CITY—1921—CBS

Frequency: 980 Kc.....Power: 5000 Watts

Owned-Operated By.....Midland Bcstg. Co.
 Address.....222 W. 11th St.
 Phone Number.....HARRISON 2650
 ½ Time.....5:55 a.m.-12:05 a.m.
 News Service.....AP, UP
 Transcription Service.....World
 Representative.....Free & Peters
 Membership.....NARTB, BAB
 President.....Arthur B. Church
 V.P., Managing Director.....George J. Higgins
 Sales Promotion Mgr.....Harold W. Storm
 Program Director.....Rod Cupp
 Chief Engineer.....Ray Moler

KPRS

KANSAS CITY—1952

Frequency: 1590 Kc.....Power: 1000 Watts d.
 Owned-Oper. By.....Twin City Adv. Agency
 Address.....2814 E. 23rd St.
 Phone Number.....Humbolt 3100
 News Service.....AP
 General Manager.....Edward H. Pate
 Commercial Mgr., Chief Engr.....Andrew Carter
 Program Director.....Eugenia Pate

WDAF

KANSAS CITY—1922—NBC

Frequency: 610 Kc.....Power: 5000 Watts
 Owned-Oper. By.....The Kansas City Star Co.
 Business-Studio Address.....1729 Grand Ave.
 Phone Number.....HARRISON 1200
 Air Time.....Full Time
 News Service.....AP
 Transcription Service.....Standard, Thesaurus
 Representative.....H. I. Christal
 Managing Director.....H. Dean Fitzer
 Station Manager.....V. S. Batton
 Commercial Manager.....E. Manne Russo
 Pgm., Publ. Dir.....Harry J. Kaufmann
 Chief Engineer.....J. A. Flaherty

WHB

KANSAS CITY—1922—MBS

Frequency: 710 Kc.....Power: 10,000 Watts d.;
 5,000 Watts n.
 Owned-Operated By.....WHB Bcstg. Co.
 Business-Studio Address.....Scarritt Bldg.
 Phone Number.....Baltimore 7109
 News Service.....AP
 Transcription Service.....Associated
 Representative.....John Blair & Co.
 Pres., Comm. Mgr.....Donald Dwight Davis
 General Manager.....John T. Schilling
 Promotion Mgr.....Ed Schulz
 Station Director.....Richard Smith
 Chief Engineer.....Henry Goldenberg

KWDL

KANSAS CITY—1953

Frequency: 1380 Kc.....Power: 1000 Watts d.
 Owned-Oper. By.....David M. Segal
 Address.....409½ State Line Ave., Texarkana

KBOA

KENNETT—1947

Frequency: 830 Kc.....Power: 1000 Watts a.
 Owned-Operated By.....Kennett Bcstg. Corp.
 Business-Studio.....Kennett
 Phone Number.....8-4616
 News Service.....AP
 Transcription Service.....Langworth
 Membership.....NARTB
 President, General Manager.....Paul C. Jones
 Station Manager.....C. H. Harrison
 Commercial Manager.....Joe Bankhead
 Chief Engineer.....Robert H. Conner

KIRX

KIRKSVILLE—1947

Frequency: 1450 Kc.....Power: 250 Watts
 Owned-Operated By.....North Mo. Bcstg. Co.
 Business-Studio Address.....KIRX Bldg.
 Phone Number.....5-3781
 News Service.....AP
 Transcription Service.....Thesaurus
 Gen., Sta. Mgr.....Samuel A. Burk
 Comm., Sales Prom. Mgr.....James J. Dougherty
 Chief Engineer.....Ralph Neely

KLWT

LEBANON—1948—MBS

Frequency 1230 Kc.....Power: 250 Watts
 Owned-Operated By.....Lebanon Bcstg. Co.
 Bus.-Studio Address.....221 E. Commercial St.
 Phone Number.....1015
 News Service.....UP
 Transcription Service.....Lang-Worth
 President.....Robert C. Fields
 General Manager.....O. R. Wright
 Commercial Manager.....Jack A. Sellers
 Program Director.....Thomas H. Miller
 Chief Engineer.....E. L. Hendry

KMMO

MARSHALL—1949

Frequency: 1300 Kc.....Power: 1000 Watts d.
 Owned-Operated By.....KMMO, Inc.
 Address.....Marshall
 Phone Number.....40
 News Service.....UP
 Transcription Service.....Thesaurus, World
 General Manager.....J. M. Silvey
 Sta., Comm., Prom. Mgr.....Harold Douglas
 Program Director.....Don Clem
 Chief Engineer.....Bill Williams

KNIM

MARYVILLE—1953—KBS

Frequency: 1580 Kc.....Power: 250 Watts d.
 Owned-Oper. By.....Maryville Radio-TV Inc.
 Phone Number.....730
 News Service.....AP
 President.....R. W. Wilson
 General Manager.....J. L. Jaquay
 Commercial Mgr.....Gilbert Poesse
 Chief Engineer.....Arnold Wilson

KXEO

MEXICO—1948—MBS

Frequency: 1340 Kc. Power: 250 Watts
 Owned-Operated By...Audrain Bcstg. Corp.
 Phone Number2340-1
 AddressBox 260
 Air Time6:00 a.m.-12 M.
 News ServiceAP
 MembershipNARTB, BAB
 PresidentJohn Badaracco
 Gen., Sta. Mgr.W. Earl Dougherty
 Sales Prom. Mgr.....Dick Harris
 Chief Engineer.....Gene Clay

KNCM

MOBERLY—1950

Frequency: 1230 Kc. Power: 250 Watts
 Owned-Oper. By.....Moberly Bcstg. Co.
 Phone Number1600
 RepresentativeConwell
 Transcription Service...Lang-Worth, Thesaurus
 News ServiceAP
 Owner.....Jerrill A. Shepherd
 General Manager.....Lynn Bickett
 Program Director.....James Lipsey
 Chief Engineer.....John Halligan

KRMO

MONETT—1950—KBS

Frequency: 990 Kc. Power: 250 Watts d.
 Owned-Oper. By.....Carthage Bcstg. Co.
 Phone Number990
 News ServiceAP
 General Manager.....L. C. McKenney
 Partner.....J. J. Daly
 Program Director.....Floyd Stewart
 Commercial Mgr.....Marion Pilant
 Chief Engineer.....George Province

KNEM

NEVADA—1949—KBS

Frequency: 1240 Kc. Power: 250 Watts
 Owned-Oper. By.....Radio KNEM
 News ServiceUP
 Transcription ServiceSESAC
 President.....Cecil W. Roberts
 Gen., Comm. Mgr.....Duane W. Hoisington
 Chief Engineer.....Bob McKune

KRMS

OSAGE BEACH—1952

Frequency: 1150 Kc. Power: 1000 Watts d.
 Owner, President.....Robert M. Smith
 News ServiceAP
 Transcription ServiceLang-Worth
 General Manager.....James Von Greppe
 Program Director.....V. L. Smith
 Chief Engineer.....Emerson Allee

KWOC

POPLAR BLUFF—1938

Frequency: 930 Kc. Power: 1000 Watts

Owned-Oper. By...Poplar Bluff Bcstg. Co., Inc.
 Transmitter Address.....428 Vine St.
 Phone Number3922
 News ServiceUP
 Transcription Service.....SESAC, World
 RepresentativeJohn E. Pearson
 General Manager.....A. L. McCarthy
 Production Dir.....Ted Pyle
 Chief EngineerDonald M. Lidenton

KTTR

ROLLA—1947—KBS

Frequency: 1490 Kc. Power: 250 Watts
 Owned-Oper By....."Show-Me" Bcstg. Co.
 AddressP. O. Box 567
 Phone Number380
 News ServiceAP
 Transcription ServiceWorld
 Gen., Sta. Mgr.....Luther W. Martin
 Promotion Mgr.....Wilson C. Burkhead
 Chief Engineer.....Martin M. Mitchum

KSMO

SALEM—1953—KBS

Frequency: 1340 Kc. Power: 250 Watts
 Owned-Oper. By....."Show-Me" Bcstg. Co.
 AddressBox 71
 General Manager.....Luther W. Martin
 Promotion Mgr.....William C. Burkhead
 Station Manager.....Mel Lee
 Chief Engineer.....Martin M. Mitchum

KFEQ

ST. JOSEPH—1923—MBS

Frequency: 680 Kc. Power: 5000 Watts
 Owned-Operated By.....KFEQ, Inc.
 Business-StudioKFEQ Bldg.
 Phone Number3-2528
 Air Time5:30 a.m.-12 M.
 News ServiceAP
 Transcription ServiceWorld
 RepresentativeHeadley-Reed
 MembershipNARTB
 Pres., Gen. Mgr.....Barton Pitts
 Commercial Mgr.....J. Ted Branson
 Program Director.....E. C. Schirmer
 Chief Engineer.....J. Wesley Koch

KRES

ST. JOSEPH—1946

Frequency: 1550 Kc. Power: 5000 Watts
 Owned-Oper. By...Missouri Valley Bcstg. Corp.
 Business-Studio Address.....113 S. 7th St.
 Phone Number4-8346
 News ServiceAP
 RepresentativePearson
 MembershipNARTB, BAB
 PresidentBasil L. Kaufmann
 General Manager.....John W. Powell
 Production Director.....Gerry Henson
 Chief Engineer.....H. B. Greene

K M O X

ST. LOUIS—1925—CBS

Frequency: 1120 Kc. Power: 50,000 Watts
 Owned By: Columbia Bcstg. System, Inc.
 Operated By: CBS Radio Division
 Business-Studio Address: 401 So. 12th St.
 Phone Number: Central 8240
 Air Time: Full Time
 News Service: AP, UP
 Transcription Service: Associated
 Representative: CBS Radio Spot Sales
 Membership: BAB
 General Manager: Gene Wilkey
 Commercial Manager: Robert Hyland, Jr.
 Sales Prom. Pub. Mgr.: Foster Brown
 Program Director: Mark Russell
 Chief Engineer: Harry Harvey

K S D

ST. LOUIS—1922—NBC

Frequency: 550 Kc. Power: 5000 Watts
 Owned-Oper. By: The Pulitzer Publishing Co.
 Business-Studio Address: 1111 Olive St.
 Phone Number: Main 1111
 News Service: AP
 Transcription Service: World, Thesaurus
 Representative: NBC Spot Sales
 Membership: NARTB
 President: Joseph Pulitzer
 General Manager: George M. Burbach
 Sales Manager: Arthur J. Casey
 Program Director: Harold Grams
 Promotion Manager: David Pasternak
 Chief Engineer: J. E. Risk

K S T L

ST. LOUIS—1948

Frequency: 890 Kc. Power: 1000 Watts d.
 Owned-Operated By: Radio St. Louis, Inc.
 Address: 626 Buder Bldg.
 Phone Number: MAin 0603
 Air Time: Daytime
 Representative: ForJoe
 Station Manager: Dick J. Kasten
 Commercial Manager: William A. Knight
 Program Director: Tony Glenn
 Sales Prom. Mgr.: James D. Neiswander
 Publicity Director: Norman Edwards
 Chief Engineer: Ira E. Pollock

K W K

ST. LOUIS—1927—MBS

Frequency: 1380 Kc. Power: 5000 Watts
 Owned-Operated By: KWK, Inc.
 Bus-Studio Address: 12th & Cole St.
 Phone Number: Main 9100
 Air Time: 5:30 a.m.-M.
 Newspaper Affiliation: St. Louis Globe-Democrat
 News Service: AP
 Representative: Katz
 President, General Mgr.: Robert T. Convey
 Station Manager: Ray E. Dady
 Commercial Manager: V. E. Carmichael

Program Director: John W. Tinnea
 Prom., Publ. Director: Fred J. Mueller
 Chief Engineer: N. J. Zehr

K X L W

ST. LOUIS—1947

Frequency: 1320 Kc. Power: 1000 Watts d.
 Owned-Oper. By: St. Louis County Bcstg. Co.
 Bus-Studio Address: 2735 Bonaparte Ave.
 Phone Number: Sterling 4805
 Representative: Pearson
 President: John W. Kluge
 General Manager: Les Ware
 Commercial Manager: Edward W. Pape
 Program Director: Norb Wood
 Chief Engineer: James F. Mitchell

K X O K

ST. LOUIS—1938—ABC

Frequency: 630 Kc. Power: 5000 Watts
 Owned-Oper. By: KXOX, Inc.
 Business-Studio Address: 12th & Delmar
 Phone Number: CHestnut 6000
 News Service: AP, UP
 Transcription Service: Associated
 Representative: John Blair
 Membership: NARTB
 President: E. M. Roberts
 General Manager: C. L. Thomas
 Asst. to Gen. Mgr.: Bruce Barrington
 Program Director: Elmer Muschany
 Publicity Director: Mary Williamson
 Chief Engineer: Arthur F. Rekart

W E W

ST. LOUIS—1921

Frequency: 770 Kc. Power: 1000 Watts d.
 Owned-Oper. By: The St. Louis University
 Address: 3642 Lindell Blvd.
 Phone Number: FRanklin 5665
 Transcription Service: Lang-Worth
 Representative: Gill Perna
 President (St. Louis U.):
 Very Rev. Paul C. Reinert, S.J.
 General Manager: Geo. A. Volz
 Commercial Manager: Ray Korpowicz
 Program Director: Lambert Kaiman
 Chief Engineer: Charles C. Casey

W I L

ST. LOUIS—1922

Frequency: 1430 Kc. Power: 5000 Watts
 Owned-Operated By: Missouri Bcstg. Corp.
 Business-Studio Address: Hotel Chase
 Phone Number: Rosedale 6200
 News Service: AP
 Transcription Service: Lang-Worth
 Representative: Young
 Pres., Gen. Mgr.: L. A. Benson
 Vice-Pres., Sales Mgr.: R. M. Hetherington
 Commercial Manager: Nick Pagliara
 Program Director: Edward M. Galloway

KSGM

STE. GENEVIEVE—1947—KBS

Frequency: 980 Kc. Power: 500 Watts
 Owned-Oper. By Donze Enterprises, nc.
 Bus.-Studio Address 410 Merchant St.
 Phone Number 580
 Air Time 6 a.m.-10 p.m.
 News Service UP
 President, General Manager Elmer L. Donze
 Chief Engineer Murel L. Rose

KDRO

SEDALIA—1939—MBS

Frequency: 1490 Kc. Power: 250 Watts
 Owned-Oper. By Milton J. Hinlein
 Bus.-Studio Address 2100 W. Broadway
 Phone Number 4004
 Representative For Joe
 President Milton J. Hinlein
 General Manager Herbert W. Brandes
 Commercial Manager James F. Glenn

KSIM

SIKESTON—1948

Frequency: 1400 Kc. Power: 250 Watts
 Owner-Oper. Sikeston Community Bcstg. Co.
 Bus.-Studio-Transmitter Address Hw. 60 W.
 Phone Number 1
 News Service AP
 President Lyman R. Bowman, Jr.
 Sta., Comm. Mgr. Richard L. Watkins, Jr.
 Program Director James Palmer

KGBX

SPRINGFIELD—1926—NBC

Frequency: 1260 Kc. Power: 5000 Watts
 Owned-Operated By Springfield Bcstg. Co.
 Bus.-Studio Address 605 Boonville Ave.
 Phone Number 4-2822
 Air Time Full Time
 News Service AP
 Transcription Service Thesaurus
 Representative George P. Hollingbery
 Membership NARTB
 President T. W. Duvall
 Gen., Sta. Mgr. K. G. Wells
 Commercial Mgr. Robert L. Wheat
 Program Director Francis Uhlis
 Pub., Prom. Dir. Dudley Morris
 Chief Engineer Richard Bowman

KICK

SPRINGFIELD—1949—MBS

Frequency: 1490 Kc. Power: 250 Watts
 Owned-Oper. By Kickapoo Prairie Bcstg. Co.
 Address 610 College St.
 Phone Number 4-1561
 Air Time Full Time
 News Service UP
 Transcription Service Standard, SESAC
 Representative McGillvra

Membership BAB
 President Floyd W. Jones
 General Manager L. C. McKenney
 Commercial Manager Richard Bradley
 Asst. Mgr., Pgm. Dir. Welcome Stanton
 Sales Prom. Mgr. Robert Vinyard
 Publicity Director Richard Hainline
 Chief Engineer Charles Grayston

KTTS

SPRINGFIELD—1941—CBS

Frequency: 1400 Kc. Power: 250 Watts
 Owned-Operated By Independent Bcstg. Co.
 Address P. O. Box 1716 S. S. S.
 Phone Number 2-7474
 Air Time Full Time
 News Service AP
 Transcription Service World
 Representative Sears & Ayer
 Membership NARTB
 President J. H. G. Cooper
 General Manager G. Pearson Ward
 Commercial Manager Bob Burke
 Program Director Wendel Smith
 Chief Engineer William F. Curry

KWTO

SPRINGFIELD—1933—ABC

Frequency: 560 Kc. Power: 5000 Watts
 Owned-Operated By Ozarks Bcstg. Co.
 Business-Studio Address 606 St. Louis St.
 Phone Number 2-4422
 Air Time 5 a.m.-M.
 News Service UP
 Transcription Service Lang-Worth
 Representative John E. Pearson
 Membership NARTB
 Pres., Gen. Mgr. Ralph D. Foster
 Asst. Gen. Mgr. Leslie L. Kennon
 Commercial Manager Raymond M. Keltner
 Program Director Joe Slattery
 Prom., Pub. Dir. Bill Bailey
 Chief Engineer Fritz Bauer

KALM

THAYER—1953

Frequency: 1290 Kc. Power: 1000 Watts d.
 Owned-Oper. By Robert Neathery
 Address N. Hgwy. 63
 President Robert Neathery

KOKO

WARRENSBURG—1953—KBS

Frequency: 1450 Kc. Power: 250 Watts
 Owned-Oper. By Clinton Bcstg. Co. Inc.
 Address Box 395
 News Service AP
 Transcription Service Thesaurus
 President David M. Segal
 General Manager Lee E. Baker
 Commercial Manager C. L. Parks
 Program Director Lonnie Licata

K W R E

WARRENTON—1949—KBS

Frequency: 730 Kc. Power: 500 Watts d.
 Owned-Operated By: W. T. Zimmerman
 Address: Warrenton
 Phone Number: 398
 News Service: UP
 Transcription Service: Thesaurus
 Representative: Continental, Radio Sales
 General Manager: W. T. Zimmerman
 Commercial Manager: Leo Waters
 Chief Engineer: Murray Phillips

K W P M

WEST PLAINS—1947—KBS

Frequency: 1450 Kc. Power: 250 Watts
 Owned-Operated By: Robert F. Neathery
 Address: E. Abe Taylor Blvd.
 Phone Number: 700
 News Service: AP
 Transcription Service: Standard
 Pres., Gen. Mgr.: Robert F. Neathery
 Commercial Manager: Fritze Williams Dixon
 Program Director: John Billingsley

MONTANA

Pop. Feb. 1, 1954 (Est.) 597,000 — Families 181,000
 Radio Homes 176,000 — TV Homes 10,500 — Stations in State 25

K A N A

ANACONDA—1946

Frequency: 1230 Kc. Power: 250 Watts d.
 Owned-Oper. By: Anaconda Bcstg. Co.
 Phone Number: 136
 News Service: UP
 Transcription Service: Lang-Worth
 President: A. J. Mosby
 Program Director: Helen M. Ryan
 Comm. Mgr., Ch. Engr.: E. G. Rinn

K B M Y

BILLINGS—1946

MBS-INTERMOUNTAIN

Frequency: 1240 Kc. Power: 250 Watts
 Owned-Operated By: Billings Bcstg. Co.
 Business Address: Box 2124
 Phone Number: 3-3838
 Air Time: 6 a.m.-12 M.
 News Service: AP
 Transcription Service: Associated
 Representative: Avery-Knodel
 Membership: NARTB, BAB
 President: Rockwood Brown
 General Manager: Ken Nybo
 Comm., Sales, Prom. Mgr.: Warren Marshall
 Pgm., Pub. Dir.: Charles G. du Bois
 Chief Engineer: Theodore Hildebrand

K G H L

BILLINGS—1928—NBC

Frequency: 790 Kc. Power: 5000 Watts
 Owned-Oper. By: Northwestern Industries, Inc.
 Business-Studio Address: 5th & N. B'way
 Phone Number: 2-2222
 News Service: UP
 Transcription Service: Standard, SESAC
 Representative: Katz
 Membership: BAB
 President: Col. Walter E. Schott
 Gen., Comm. Mgr.: Edward Yocum
 Sta., Mgr., Prog. Dir.: V. Braunberger
 Chief Engineer: Jeff A. Kiichli

K O O K

BILLINGS—1951—CBS

Frequency: 970 Kc. Power: 5000 Watts
 Owned-Oper. By: The Montana Network
 Address: P. O. Box 1498
 Phone Number: 9-5970
 News Service: AP
 Transcription Service: World
 Representative: Weed
 Membership: NARTB
 President: C. L. Crist
 Station Manager: V. V. "Bud" Clark
 Commercial Manager: Lloyd Larsen
 Program Director: Cliff Ewing
 Chief Engineer: Grant French

K B M N

BOZEMAN—1950

Frequency: 1230 Kc. Power: 250 Watts
 Owned-Oper. By: Penn Engrg. Co.
 Address: Box 691
 Phone Number: 2105
 News Service: UP
 Representative: Gill-Perna
 President: Mrs. Lura B. Penwell
 General Manager: G. Norman Penwell
 Station Manager: Dan Snyder
 Chief Engineer: Ben Hespern

K X L Q

BOZEMAN—1939—NBC

Frequency: 1450 Kc. Power: 250 Watts
 Owned-Operated By: KRBM Bcsters, Inc.
 Business Address: Bozeman
 Phone Number: 1420
 News Service: AP, UP
 Representative: Walker
 President: E. B. Craney
 General Manager: Ernest A. Noath
 Commercial Mgr.: Ernest Seccomb
 Program Director: Beverly Coulston
 Chief Engineer: Dick Smiley

K B O W
BUTTE—1946

Frequency: 1490 Kc. Power: 250 Watts
Owned-Oper. By. Copper City Radio Co.
Address. 720 Yale Ave.
Phone Number 7429
President Frank Reardon

K O P R
BUTTE—1948—ABC-MBS
INTERMOUNTAIN

Frequency: 550 Kc. Power: 1000 Watts
Owned-Operated By. Copper Bcstg. Co.
Business-Studio Address. Hotel Finlen
Phone Number 6546
Air Time 6 a.m.-11:30 p.m.
News Service UP
Representative Avery-Knodell
President Frank C. Carman
General Manager Ed Cooney
Commercial Manager G. W. Chance
Program Director Jim Harrold
Chief Engineer John Gort

K X L F
BUTTE—1929—NBC

Frequency: 1370 Kc. Power: 5000 Watts
Owned-Operated By. KGIR, Inc.
Address Box 1956
Phone Number 2-2344
News Service AP, UP
Transcription Service Standard, SESAC
Representative Walker; Pacific No. West
Pres., Gen. Mgr. E. B. Craney
Station Manager Ame E. Anzjon
Commercial Mgr. Frank Field
Program Director Paul Hatton
Prom. Mgr., Pub. Dir. Vern Tolten
Chief Engineer W. J. Provis

K X G N
GLENDALE—1948

Frequency: 1400 Kc. Power: 250 Watts
Owned-Oper. By. Glendive Bcstg. Co.
Address Box 200
Phone Number EM 5-3111
News Service UP
Transcription Service Standard
President Lewis Wiles Moore
General Manager Daniel C. Palen
Commercial Mgr. Marvin Wadley
Chief Engineer Don Powers

K F B B

GREAT FALLS—1922—CBS

Frequency: 1310 Kc. Power: 5000 Watts
Owned-Oper. By. Buttrey Bcst., Inc.
Bus.-Studio Address. 607 First Natl. Bank Bldg.
Phone Number 4-4377
News Service UP
Transcription Service World
Membership NARTB, BAB
President J. P. Wilkins

Commercial Manager W. C. Blanchette
Program Director J. R. Kelley
Chief Engineer Wilbur L. Myhre

K M O N

GREAT FALLS—1947—MBS
ABC-INTERMOUNTAIN

Frequency: 560 Kc. Power: 5000 Watts
Owned-Oper. By. Montana Farmer Bcstg. Co.
Business Address Tribune Bldg.
Phone Number 4-4382
Air Time Full Time
News Service AP
Transcription Service Lang-Worth
Representative Avery-Knodell
President Lester Cole
General Manager Robert H. Warner
Commercial Manager Frank W. Kaull
Program Director Mel Hallock
Chief Engineer Eugene B. Bunker, Ben Rush

K X L K

GREAT FALLS—1947—NBC-Z NET

Frequency: 1400 Kc. Power: 250 Watts
Owned-Operated By. Great Falls Bcstg. Co.
Bus.-Studio-Transmitter Add. P. O. Box 2072
Phone Number 2-2453
News Service AP, UP
Representative Walker
President Barclay Craighead
Gen., Sta., Comm. Mgr. T. L. Frayling
Program Director Jaunita Loucks
Prom. Mgr., Chief Eng. Eugene Kukkola

K O J M

HAVRE—1947—MBS-KBS

Frequency: 610 Kc. Power: 1000 Watts
Owned-Operated By. No. Montana Bcstg. Co.
Business-Studio Address Box 70
Phone Number 1096-7
Air Time Full Time
News Service UP
Transcription Service Associated
Representative Cooke, Inc., Avery-Knodell
President O. R. Rubie
General Manager Charlotte H. Brader
Commercial Manager Lyle Leeds
Program Director James R. Saenger
Publicity Director Stan G. Stephens
Chief Engineer George H. Bauer

K C A P

HELENA—1949—MBS-KBS

Frequency: 1340 Kc. Power: 250 Watts
Owned-Oper. By. Lewis & Clark Bcstg. Corp.
Address 1705 Jerome Pl.
Phone Number 4030
News Service UP
President James M. Flinn
General Manager K. O. MacPherson
Commercial Manager C. E. Sullivan
Chief Engineer Dean Mack

KXLJ

HELENA—1937—NBC-Z BAR

Frequency: 1240 Kc. Power: 250 Watts
 Owned-Oper. By Peoples Forum of the Air
 Address 1306 Eleventh Ave.
 Phone Number 1240
 News Service UP, AP
 Representative Walker, Moore
 President A. T. Hibbard
 Gen. Sta. Mgr. Barclay Craighead
 Commercial Mgr. Gene Hogan
 Sales Prom. Mgr. George Wenstrum
 Program Director Harris Jensen
 Chief Engineer Glenn Breech

KGEZ

KALISPELL—1927
 MBS-INTERMOUNTAIN

Frequency: 600 Kc. Power: 1000 Watts
 Owned-Operated By Donald C. Treloar
 Bus.-Studio Address 1236 4th Ave. E.
 Phone Number 4143
 Air Time Full Time
 News Service UP
 Transcription Service World, SESAC, Standard
 Membership NARTB, BAB
 Pres., Gen. Sta. Mgr. Donald C. Treloar
 Sales Prom. Mgr. Robert Bennett
 Program Director Norm Fisher
 Chief Engineer Paul Johnston

KXLO

LEWISTOWN—1947—MBS
 INTERMTN. NET

Frequency: 1230 Kc. Power: 250 Watts
 Owned-Operated By W. G. Kelly
 Bus.-Studio-Transmitter Address E. Main St.
 Phone Number 1210
 News Service UP
 Transcription Service World
 Representative William G. Kelly
 President William G. Kelly
 General Manager Marlin T. Obie
 Chief Engineer David Sather

KLCB

LIBBY—1950

Frequency: 1230 Kc. Power: 250 Watts
 Owned-Oper. By Lincoln County Bcstrs. Inc.
 Address Hafferman Shopping Center
 Phone Number 410
 News Service UP
 Transcription Service SESAC, MacGregor
 Membership NARTB
 President Smith McNeill
 Station Manager William F. Hafferman
 Prog., Pub. Dir. Patrick J. Owens
 Chief Engineer Jim L. McLaughlin

KPRK

LIVINGSTON—1947—MBS
 INTERMTN.

Frequency: 1340 Kc. Power: 250 Watts
 Owned-Oper. By Yellowstone Amuse. Co.
 Business Address Box 691
 Transcription Service World
 Pres., Gen. Mgr. Paul B. McAdam
 Commercial Manager Jack Hinman
 Program Director Jim Edmonds
 Chief Engineer Duke Long

KRJF

MILES CITY—1941—KBS
 MBS-INTERMOUNTAIN

Frequency: 1340 Kc. Power: 250 Watts
 Owned-Operated By Star Printing Co.
 Business Address Miles City
 Phone Number 1340
 Newspaper Affiliation "Daily Star"
 News Service UP
 Transcription Service Thesaurus
 Representative Avery-Knodel
 Membership NARTB, BAB
 Gen. Sta. Mgr. Ian A. Elliot
 Commercial Manager Fred B. Hunnes
 Sales Prom. Mgr. Norval B. Davis
 Program Director T. J. Biedrzycki
 Publicity Director Donald Kern
 Chief Engineer Philip E. Hilt

KGVO

MISSOULA—1931—CBS

Frequency: 1290 Kc. Power: 5000 Watts
 Owned-Operated By Mosby's, Inc.
 Business-Studio Address 127 E. Main St.
 Phone Number 2-2155
 Air Time Full Time
 News Service UP
 Transcription Service Lang-Worth
 Representative Gill Perna
 Membership NARTB, BAB
 Pres., Gen.-Sta. Mgr. A. J. Mosby
 Commercial Mgr. A. T. Christensen
 Prom. Mgr., Prog. Dir. Don Bradley
 Chief Engineer Leo Stewart

KXLL

MISSOULA—1948—NBC-Z NET-PNB

Frequency: 1450 Kc. Power: 250 Watts
 Owned-Oper. By Western Montana Assoc.
 Business Address Box 1503
 Phone Number 4-4114
 Air Time Full Time
 News Service AP, UP
 Representative Walker, Moore
 Pres., Gen., Sta. Mgr. Pat M. Goodover
 Comm., Prom. Mgr. Bob Gillis
 Program Director Bill Strothman
 Publicity Director John Campbell
 Chief Engineer Ray Lee

KIYI

SHELBY—1947—KBS-MBS

Frequency: 1230 Kc. Power: 250 Watts
 Owned-Operated By: Tri County Radio Corp.
 Phone Number: 5541
 Representative: Cooke
 Membership: NARTB
 President: John Lyon
 Sec.-Treas.: Frank Krshka
 Program Director: Don Redfield
 Chief Engineer: George Potter

KGCX

SIDNEY—1926—MBS

Frequency: 1480 Kc. Power: 5000 Watts
 Owned-Operated By: E. E. Krebsbach
 Address: 109 S. Central
 Phone Number: 408
 News Service: AP, UP
 Transcription Service: Capitol
 Representative: Lawson
 General Manager: E. E. Krebsbach
 Commercial Mgr.: Keith Krebsbach
 Sales Prom. Mgr.: Don Cole
 Chief Engineer: O. H. Halvorson

NEBRASKA

Pop. Feb. 1, 1954 (Est.) 1,353,000 — Families 426,000
 Radio Homes 408,000 — TV Homes 181,500 — Stations in State 25

KCOW

ALLIANCE—1949—KBS

Frequency: 1400 Kc. Power: 250 Watts
 Owned-Operated By: Sandhills Bcstg. Corp.
 Trans. Address: 1100 West 10th St.
 Phone Number: 1300
 Air Time: 6:30 a.m.-10:30 p.m.
 News Service: UP
 Transcription Service: World
 Representative: McGillvra
 Membership: NARTB
 President: Hansford Jagers
 General Manager: Gene Ackerley
 Program Director: Erv Jensen
 Chief Engineer: George Vogel

KJSK

COLUMBUS—1948—KBS

Frequency: 900 Kc. Power: 1000 Watts d.
 Owned-Oper. By: George Basil Anderson
 Business Address: Box 460
 Phone Number: 5154
 Air Time: Sunrise-sunset
 News Service: AP
 Representative: Biddick, Continental
 Transcription Service: World, SESAC,
 Thesaurus
 Pres., Gen. Sta. Mgr.: George Basil Anderson
 Commercial Manager: Milo Kincaid
 Program Director: Florence L. Anderson
 Chief Engineer: Max Reeves

KWBE

BEATRICE—1949—MBS

Frequency: 1450 Kc. Power: 250 Watts
 Owned-Oper. By: Blue Valley Bcstg. Co.
 Address: Box 567
 Phone Number: 1245
 News Service: AP
 Transcription Service: Thesaurus
 Representative: Gill-Perna
 Membership: NARTB
 President: Merle G. Jones
 General Manager: Bud Pentz
 Commercial Mgr.: William Boyce
 Program Director: Madge McGavren

KFGT

FREMONT—1939—MBS

Frequency: 1340 Kc. Power: 100 Watts
 Owned-Oper. By: Walker Radio, Inc.
 Business-Studio Address: 118 E. 5 St.
 Phone Number: 1060
 Membership: NARTB
 Pres., Gen. Mgr.: Lester A. Walker
 Station Manager: Robert L. Johnson
 Program Director: Ken Headrick
 Chief Engineer: Harry Snyder

KCNI

BROKEN BOW—1949

Frequency: 1280 Kc. Power: 1000 Watts d.
 Owned-Oper. By: Custer County Bstg. Co.
 Address: Box 561
 Phone Number: 611
 Gen. Mgr., Chief Engr.: Bud Crawford
 Commercial Mgr.: Joe Grieser

KMMJ

GRAND ISLAND—1925—ABC

Frequency: 750 Kc. Power: 1000 Watts d.
 Owned-Oper. By: Town & Farm Co., Inc.
 Business-Studio Address: Division at Cedar
 Phone Number: 703-4
 Air Time: Daytime
 News Service: UP
 Transcription Service: Thesaurus
 Representative: H-R
 President: Don Searle
 V.P. & General Manager: Bill Martin
 V.P. & Regional Sales Mgr.: Rex Lathen

Program DirectorEd. Meyer
 Sales Promotion Manager...Quintin McCredie
 Chief Engineer.....U. L. Lynch

K R G I

GRAND ISLAND—1953

Frequency: 1430 Kc.Power: 1000 Watts
 Owned-Oper. By.....Grand Island Bcstg. Co.
 Address315 South Locust
 Phone Number5181
 News ServiceAP
 Representative.....Sears & Ayer
 President.....Robert L. Lester
 General Manager.....Wick Heath
 Comm. Mgr., Prog. Dir.....Ray Kozak
 Chief Engineer.....Don Campbell

K H A S

HASTINGS—1940—MBS-KBS

Frequency: 1230 Kc.Power: 250 Watts
 Owned-Operated By.....Nebraska Bcstg. Co.
 Transmitter Address.....906½ W. Second St.
 Phone Number2-5101
 Air Time6 a.m.-12 M.
 News ServiceINS
 Transcription ServiceThesaurus
 RepresentativeGill-Perna
 MembershipNARTB
 PresidentFred A. Seaton
 Gen., Sta. Mgr.....James Pickett
 Commercial Manager...Raymond Bartlett
 Pub., Prog. Dir.....Lloyd O. Thomas
 Chief EngineerDuane B. Allison

THOSE WHO KNOW
 FAMOUS BRANDS....

Says Promotion Director Evans
 G. Meier of WJAG, Norfolk,
 Nebr.: "I figure AP news is
 easier to sell sponsors because
 they already know AP."

.... KNOW THE MOST FAMOUS
 BRAND IN NEWS IS AP

K G F W

KEARNEY—1930—MBS-KBS

Frequency: 1340 Kc.Power: 250 Watts
 Owned-Oper. By.....Central Neb. Bcstg. Corp.
 Business-Studio Address...Federal Annex Bldg.
 Phone Number.....Business, 2-3541
 News ServiceUP
 Transcription ServiceWorld
 Representative.....Hal Holman
 Pres., Gen., Sta. Mgr.....John W. Yeager, Jr.
 Comm., Sales Prom. Mgr....Ly'e Richardson
 Pgm., Pub. Dir.....Robert Rudy
 Chief Engineer.....Howard Harrington

K R V N

LEXINGTON—1950

Frequency: 1010 Kc.Power: 25,000 Watts d.
 Owned-Oper. By.....Nebraska Rural Radio
 Address.....104 W. 8th St.
 Phone Number716
 Transcription ServiceStandard
 News ServiceAP
 President.....Jay A. Person
 General Manager.....Max Brown
 Commercial Manager.....Dan Bellus
 Program Director.....G. W. Embree
 Chief Engineer.....Robert Bitner

K F O R

LINCOLN—1924—ABC

Frequency: 1240 Kc.Power: 250 Watts
 Owned-Operated By.....Cornbelt Bcstg. Corp.
 Business-Studio Address...48th and Vine Sts.
 Phone Number2-6965
 Air TimeUnlimited
 News ServiceAP
 Transcription ServiceThesaurus
 RepresentativePaul Raymer
 MembershipNARTB, BAB
 PresidentJames Stuart
 Gen., Sta. Mgr.....George X. Smith
 Commercial Manager...Richard Chapin
 Prom., Pub. Dir.....Ruth Thone
 Program Director.....Avrun Bondarin
 Chief Engineer.....Charles W. Winkler

K L M S

LINCOLN—1949

Frequency: 1480 Kc.Power: 1000 Watts
 Owned-Operated By.....Lincoln Bcstg. Corp.
 Address.....130 N. 16th St.
 Phone Number2-7579
 President.....Howard A. Shuman
 General Manager.....J. Russell Joynl
 Sta., Comm. Mgr.....Frank Stubbs

K O L N

LINCOLN—1947—MBS

Frequency: 1400 Kc.Power: 250 Watts
 Owned-Oper. By.....Cornhusker Radio &
 Television Corp.
 Business-Studio Address...40th and W Sts.

Phone Number2-7218
 Air Time 6 a.m.-M.
 News ServiceAP
 Transcription ServiceWorld
 RepresentativeWeed
 MembershipBAB, NARTB
 President John E. Fetzer
 General Manager Harold E. Anderson
 Commercial Mgr. Otis H. Seegler
 Program Director William L. Lucas
 Publicity Director Louise Nyland
 Chief Engineer Ray Taylor

K B R L

McCOOK—1947—MBS

Frequency: 1450 Kc. Power: 250 Watts
 Owned-Oper. By The McCook Bcstg. Co.
 Phone Number 1450
 News Service AP
 Representative McGillvra
 Pres., Gen. Mgr. and Chief Engineer
 Le Roy W. Lenwell
 Program Director Gilbert Mitchell

W J A G

NORFOLK—1922

Frequency: 780 Kc. Power: 1000 Watts d.
 Owned-Oper. By Huse Publ. Co.
 Phone Number 432
 News Service AP
 Transcription Service Standard
 Representative Walker
 Membership NARTB, BAB
 President Gen. Huse
 General Manager Jerry Huse
 Station Manager Bob Thomas
 Commercial Manager Vernon Stedry
 Program Director Glen Hixson
 Chief Engineer Frank Wiedenbach

K N B R

NORTH PLATTE—1952

Frequency: 970 Kc. Power: 1000 Watts
 Owned-Oper. By John Townsend
 Phone Number 3528
 News Service UP
 Transcription Service Thesaurus, SESAC
 Representative Indie Sales
 Owner John Townsend
 Gen., Comm. Mgr., Prog. Dir. Joe Stavas
 Chief Engineer Herb Zimmerman

K O D Y

NORTH PLATTE—1930—NBC-KBS

Frequency: 1240 Kc. Power: 250 Watts
 Owned-Oper. By Radio Station KODY
 Bus.-Studio-Transmitter Address. 1521 W. 12th
 Phone Number 382
 Air Time 6 a.m.-12 M.
 News Service AP
 Transcription Service Lang-Worth, World
 Representative Meeker
 Membership NARTB
 Gen., Sta. Mgr. John Alexander
 Program Director Bill Wood

Commercial Manager Joe di Natale
 Chief Engineer Jay Blakesley

K B O N

OMAHA—1942—MBS

Frequency: 1490 Kc. Power: 250 Watts
 Owned-Operated By Inland Bcstg. Co.
 Business-Studio Add. 676 World Ins. Bldg.
 Phone Number Jackson 8282
 Air Time 6:30 a.m.-12 M
 News Service AP
 Transcription Service Thesaurus
 Representative Pearson
 Membership NARTB, BAB
 Pres., Gen. Mgr. Paul R. Fry
 Commercial Manager Ernest S. Priesman
 Chief Engineer Richard E. Welna

K F A B

OMAHA—1924—CBS

Frequency: 1110 Kc. Power: 50,000 Watts
 Owned-Operated By KFAB Bcstg. Co.
 Business-Studio Address. 620 Farnam Bldg.
 Phone Number Ja. 3420
 Newspaper Affiliation "Journal & Star"
 (Lincoln)
 Air Time 24 Hrs.
 News Service AP
 Transcription Service SESAC
 Representative Free & Peters
 Membership NARTB
 Chairman of Board Joe W. Seacrest
 President Fred S. Sidles
 Gen., Sta. Mgr. Harry Burke
 Commercial Mgr. Harold Soderlund
 Prom., Pub. Mgr. Don Shoemaker
 Program Director Lyell Bremser
 Chief Engineer Art Stewart
 News Director Carl Uhlarik
 Musical Director Wm. J. Granville
 Transmitter Engineer Art Stewart
 Farm Editor W. E. Macdonald
 Consulting Engineer George Davis

K O I L

OMAHA—1925—ABC

Frequency: 1290 Kc. Power: 5000 Watts
 Owned-Oper. By Central States Bcstg. Co.
 Business-Studio Address. 511 So. 17th St.
 Phone Number Jackson 7626
 Air Time Full Time
 News Service AP, INS
 Transcription Service Capitol, Standard
 Representative Paul H. Raymer
 Membership NARTB, BAB
 President James Stuart
 Commercial Mgr. Don W. Burden
 Program Director Chic Crabtree

K O W H

OMAHA—1922

Frequency: 660 Kc. Power: 500 Watts d.
 Owned-Oper. By Mid-Continent Bcstg. Co.
 Business-Studio Address. 15th & Farnam
 Phone Number Atlantic 2228

News Service AP, INS, UP
 Transcription Service Lang-Worth
 Representative Bolling
 Membership NARTB
 President Robert H. Storz
 Sta., Gen. Manager Todd Storz
 Prom. Mgr., Pgm. Dir. Virgil Sharpe
 Chief Engineer Dale Moudy

WOW

OMAHA—1923—NBC

Frequency: 590 Kc. Power: 5000 Watts
 Owned-Operated By Meredith WOW, Inc.
 Business-Studio Address 280 Insurance Bldg.
 Phone Number Webster 3400
 Air Time Unlimited
 News Service INS, UP
 Transcription Service Standard, SESAC
 Representative John Blair
 Membership NARTB
 Chariman of Board Fred Mohen
 President E. T. Meredith, Jr.
 General Manager Frank P. Fogarty
 Sales Manager Bill Wiseman
 Program Director Ray Olson
 Chief Engineer William J. Kotera

KNEB

SCOTTSBLUFF—1948—MBS
 INTERMOUNTAIN

Frequency: 960 Kc. Power: 1000 Watts d.
 500 Watts n.
 Owned-Oper. By Platte Valley Bcstg. Corp.
 Business-Studio Address Golden Rule Bldg.
 Phone Number 1620
 Air Time 5:30 a.m.-12:30 a.m.

News Service AP
 Transcription Service Capitol, Lang-Worth
 Representative Hal Holman
 Membership NARTB
 President John R. Jrdon
 General-Station Mgr. Russ M. Stewart
 Commercial Mgr. Byron Joachim
 Program Director Wayne McIntosh
 Publicity Director Fred Walgren
 Chief Engineer Leslie A. Proctor

KOLT

SCOTTSBLUFF—1930—CBS

Frequency: 1320 Kc. Power: 5000 d., 1000 n.
 Owned-Operated By The Hilliard Co.
 Address 1517½ Bway
 Phone Number 858
 News Service UP
 Representative Gill-Perna
 Pres., Gen.-Sta. Mgr. L. L. Hilliard
 Commercial Manager Tony Kehl
 Program Director A. W. Taylor
 Chief Engineer Harland A. Morrison

KSID

SIDNEY—1952—ABC

Frequency: 1340 Kc. Power: 250 Watts
 Owned-Oper. By Sidney Bcstg. Co.
 Address Legion Park
 Phone Number 5503
 News Service UP
 Representative McGillvra
 Pres., Chief Eng. W. C. Grove
 Gen., Com. Mgr. Max Young
 Program Director Edith Sanks

NEVADA

*Pop. Feb. 1, 1954 (Est.) 176,000 — Families 66,000
 Radio Homes 64,000 — TV Homes 12,500 — Stations in State 10*

KELK

ELKO—1948—MBS

Frequency: 1240 Kc. Power: 250 Watts
 Owned-Operated By Elko Bcstg. Co.
 Address P. O. Box 790
 Phone Number 260
 News Service UP
 President Chris Sheerin
 General Manager John J. Gammick
 Program Director Bob Vizina
 Chief Engineer Roy Gallagher

KELY

ELY—1950

Frequency: 1230 Kc. Power: 250 Watts
 Owned-Oper. By White Pine Bcstg. Co.
 Address Box 1088
 Phone Number 2077
 Transcription Service World

News Service INS
 Co-Manager D. I. Hansen
 Co-Manager D. V. Bradley

KENO

LAS VEGAS—1940—ABC

Frequency: 1460 Kc. Power: 1000 Watts
 Owned-Operated By Nevada Bcstg. Co.
 Business Address Box 1310
 Phone Number 1400
 Air Time Full Time
 News Service INS
 Representative W. S. Grant
 Pres., Gen.-Sta. Manager Maxwell Kelch
 Commercial Mgr. Thompson Magowan
 Pgm., Pub. Dir. Ken O'Connell
 Chief Engineer R. O. Dow

KLAS

LAS VEGAS—1948—CBS

Frequency: 1230 Kc. Power: 250 Watts

Owned-Oper. By.....Las Vegas Bctrs., Inc.
AddressDesert Inn, P. O. Box 1510
Phone Number4646
Air Time.....Full Time
Transcription ServiceStandard
Representative.....Weed & Co.
Membership.....BAB
President.....Fred Stoye
General Manager.....Tom Ivory
Commercial Manager.....Bill Pursel
Program Director.....James Hart
Publicity Director.....Flo Brummel
Chief Engineer.....Greg Gelhart

KORK

LAS VEGAS—1951—NBC

Frequency: 1340 Kc.....Power: 250 Watts
Owned-Oper. By.....Vegas Valley Bcstg. Co.
AddressHotel Thunderbird
Phone Number6500
News Service.....UP
Representative.....Geo. P. Hollingbery
Membership.....BAB
Pres., Gen. Mgr.....David McKay
Station Manager.....Roland B. Vaile
Program Director.....Robert Baker
Chief Engineer.....Bill Binford

KRAM

**LAS VEGAS—1947—MBS-KBS
 INTERMOUNTAIN**

Frequency: 920 Kc.....Power: 1000 Watts
Owned-Oper. By.....Boulder City Bcstg. Co.
Address.....P. O. Box 1712
Phone Number920
Air Time.....Full Time
News Service.....UP
Transcription ServiceThesaurus
Station Representative.....Avery-Knodel
President.....Edward J. Jansen
Commercial Manager.....Lester Seiffer
Program Director.....Martin Black
Chief Engineer.....Fred Young

KATO

RENO—1946—MBS-DON LEE

Frequency: 1340 Kc.....Power: 250 Watts
Owned-Operated By.....Sierra Bcstg. Co.
Business-Studio Address.....Box 2231
Phone Number2-4501
Air Time.....Full Time
Representative.....Walker, McGavren
Transcription ServiceLangworth
Membership.....NARTB
Pres., Gen. Mgr.....R. L. Stoddard
Commercial Manager.....Robert S. Hughes
Program Director.....Betty Stoddard
Chief Engineer.....Al Glass

KOH

RENO—1928—NBC

**Frequency: 630 Kc.....Power: 5000 Watts d.,
 1000 n.**
Owner.....McClatchy Bcstg. Co.

Business-Studio Address.....143 Stevenson St.
Phone Number3-5106
News Service.....UP
Transcription ServiceCapitol
Representative.....Paul H. Raymer
President.....Eleanor McClatchy
Manager.....Hewitt Kees
Program Director.....Bruce Branson
Chief Engineer.....Wesley Craig

KOLO

RENO—1946—CBS

Frequency: 920 Kc.....Power: 1000 Watts
Owned-Operated By.....Reno Bcstg. Co.
Business-Studio Address.....33 Sierra St.
Phone Number2-4516
Air Time.....Full Time
News Service.....UP
Representative.....George P. Hollingbery
Membership.....NARTB, BAB
President.....Dave McKay
General-Station Manager.....H. G. Wells
Commercial Manager.....Howard Doyle, Jr.
Sales Prom. Mgr.....Gene McKenna
Program Director.....Dave Niles
Publicity Director.....Pat Welty
Chief Engineer.....Merle Peterson

KWRN

RENO—1947—ABC

Frequency: 1230 Kc.....Power: 250 Watts
Owned-Operated By.....KWRN, Inc.
Business-Studio Address.....Box 76
Phone Number3-6156
Air Time.....Full Time
News Service.....AP
Membership.....BAB, NARTB
Transcription Service.....Thesaurus, Standard
Pres., Gen. Mgr.....Franz J. Robischon
Commercial Mgr.....W. V. Leroy Swecker
Chief Engineer.....Walt Rees

FOR
 NEW YORK
 TELEPHONE
 NUMBERS
 SEE PAGE
 100

NEW HAMPSHIRE

Pop. Feb. 1, 1954 (Est.) 554,000 — Families 160,000
Radio Homes 155,000 — TV Homes 86,500 — Stations in State 12

W M O U

BERLIN—1946—KBS

Frequency: 1230 Kc. Power: 250 Watts
Owned-Oper. White Mtns., Bcstg. Co.
Address 27 Green Square
Phone Number 1797-8
Air Time Unlimited
News Service AP
Transcription Service Langworth
Representative Kettell-Carter, Radio Reps.
Membership NARTB, BAB
President John W. Guider
General Manager Wendell C. MacKenzie
Chief Engineer Herschel M. Howe

W T S V

CLAREMONT—1948

Frequency: 1230 Kc. Power: 250 Watts
Owned-Oper. By Grandview Inc.
Trans. Address 155 Front St., Manchester
Phone Number 4-4075
President William J. Barkley
General Manager W. J. Rust Jr.
Comm. Sta. Mgr. C. Stearns Jr.

W K X L

CONCORD—1946—CBS

Frequency: 1450 Kc. Power: 250 Watts
Owned-Operated By Capitol Bcstg. Co.
Business-Studio Address Eagle Hotel
Phone Number 4180
Air Time Full Time
News Service AP
Representative Adam Young, Kettell-Carter
President Henry R. Silver
General Manager Tom Frank
Commercial Mgr. Saul Gross
Sales Prom. Mgr. Al Englehardt
Chief Engineer Robert Wright

W T S L

HANOVER-LEBANON—1950
GRANITE

Frequency: 1400 Kc. Power: 250 Watts
Owned-Oper. By WTSL Inc.
Address 155 Front St.
Phone Number 4-4075
President William J. Barkley
General Manager Ralph Gottlieb
Chief Engineer Al Davis

W K N E

KEENE—1926—CBS

Frequency: 1290 Kc. Power: 5000 Watts
Owned-Oper. By WKNE Corp.
Address 17 Dunbar St.
Phone Number 2080
Air Time Full Time

News Service AP
Transcription Service Thesaurus
Representative Meeker, Kettell-Carter
Membership NARTB, BAB
President Joseph K. Close
Gen. Sta. Comm. Mgr. Frank B. Estes
Sales Prom. Mgr., Pub. Dir. Ted B. Sawyer
Chief Engineer Ernest Roberge

W L N H

LACONIA—1922—ABC-KBS
YANKEE

Frequency: 1340 Kc. Power: 250 Watts
Owned-Oper. By Northern Bcstg. Corp.
Business-Studio Address 653 Main St.
Phone Number 2-300
Air Time Unlimited
News Service AP
Representative Kettell-Carter, Grant
Transcription Service Langworth
President Genevieve Wingate
Gen. Sta. Mgr. Arthur Rothafel
Commercial Manager Sydney Clarke
Program Director Irving W. Kaizer
Chief Engineer Walter Avery

W F E A

MANCHESTER—1932—CBS

Frequency: 1370 Kc. Power: 5000 Watts
Owned-Operated By N. H. Bcstg., Inc.
Business-Studio Address 286 Franklin St.
Phone Number 5-5491
Air Time Full Time
News Service AP
Transcription Service Thesaurus
Representative Adam J. Young, Jr.
Kettell-Carter
President Morris Silver
Gen. Sta. Mgr. Warren H. Jounray
Commercial Manager Saul Gross
Program Director Frank Finning
Chief Engineer Reginald Schow

W K B R

MANCHESTER—1945
GRANITE STATE

Frequency: 1240 Kc. Power: 250 Watts
Owned-Oper. By Granite State Bcstg., Inc.
Address 155 Front St.
Phone Number 44075
Air Time 6 a.m.-11:30 p.m.
President W. J. Barkley
Program Director Perry White
Chief Engineer Royston Phillips

W M U R

MANCHESTER—1941—CBS

Frequency: 610 Kc. Power: 5000 Watts d.,
1000 Watts n.

Owned-Operated By.....The Radio Voice of
New Hampshire, Inc.
Business-Studio Address.....1819 Elm St.
Phone Number.....5-5788
News Service.....UP
Air Time.....Full Time
Transcription Service.....World
Representative.....Weed
Membership.....NARTB, BAB
President.....Hon. Francis P. Murphy
General Manager.....Wallace A. Walker
Program Director.....Bernie Mack
Chief Engineer.....Vincent Chandler

WOTW
NASHUA—1947

Frequency: 900 Kc. Power: 1000 Watts d.
Owned-Operated By.....Nashua Bcstg. Corp.
Bus.-Studio-Transmitter Location.....Lund Rd.
Phone Number.....5000
News Service.....UP
Transcription Service.....World
Representative.....Bertha Bannan, Walker
Membership.....BAB
Pres., Gen. Mgr.....Arthur A. Newcomb
Program Director.....Aldo Cretarolo
Chief Engineer.....Harry Handfield

WHEB
PORTSMOUTH—1932—MBS

Frequency: 750 Kc. Power: 1000 Watts d.
Owned-Operated By.....WHEB, Inc.
Phone Number.....4080
Air Time.....Daytime
News Service.....AP
Transcription Service.....World
Representative.....Kettel-Carter, Walker
President.....Charles M. Dale
Gen., Comm., Prom. Mgr.....Thomas M. Dale
Program Dir.....Lucien Dumont
Chief Engineer.....Anthony Vaccaro

WVNH
ROCHESTER—1948
GRANITE STATE

Frequency: 930 Kc. Power: 1000 Watts d.
Owned-Operated By.....Strafford Bcstg. Corp.
Address.....Rochester Hill Rd.
Phone Number.....1400-1
News Service.....UP
Representative.....Borgati, Webb
Membership.....BAB, NARTB
Pres., Gen. Mgr.....A. J. K. Malin
Commercial Mgr.....M. C. Ball
Station Manager.....H. Martin
Chief Engineer.....F. De Falco

NEW JERSEY

Pop. Feb. 1, 1954 (Est.) 5,228,000 — Families 1,547,000
Radio Homes 1,493,000 — TV Homes 1,375,000 — Stations in State 20

WJLK
ASBURY PARK—1926

Frequency: 1310 Kc. Power: 250 Watts
Owned-Operated By.....Asbury Park Press, Inc.
Address.....Press Plaza
Phone Number.....Asbury Park 2-3000
News Service.....AP
Transcription Service.....Associated
President.....Wayne D. McMurray
Station Manager.....Everett Rudloff
Commercial Manager.....Margaret Curtis
Program Director.....Frank Huber

WFPG
ATLANTIC CITY—1940—CBS

Frequency: 1450 Kc. Power: 250 Watts
Owned-Operated By.....Neptune Bcstg. Corp.
Business Address.....Steel Pier
Phone Number.....5-2188
News Service.....UP
Representative.....John E. Pearson
President.....Fred Weber
Director of Operations.....Blair Thron
Commercial Mgr.....R. E. Truex
Office Manager.....Pearl Kogen

Program Dir.....Ed Davis
Chief Engineer.....Earle Godfrey

WMID
ATLANTIC CITY—1947—ABC-MBS

Frequency: 1340 Kc. Power: 250 Watts
Owned-Oper. By.....Mid-Atlantic Bcstg. Co., Inc.
Business-Studio Address.....Box 1016
Phone Number.....4-1340
Air Time.....7 a.m.-2 a.m.
News Service.....AP
Transcription Service.....Associated, World
Representative.....Stars Nati.
Gen., Sta. Mgr.....David H. Freedman
Program Director.....Vincent Lindner

WSNJ
BRIDGETON—1937

Frequency: 1240 Kc. Power: 250 Watts
Owned-Oper. By.....Eastern States Bcstg. Corp.
Phone Number.....BR 2930
Transcription Service.....Thesaurus
Station Representative.....Clark
President.....Russell S. Henderson
Vice-Pres., Gen. Mgr.....Paul Alger
Commercial Manager.....Jerry Aldan
Chief Engineer.....Ed Bold

WCAM

CAMDEN—1922

Frequency: 1310 Kc. Power: 250 Watts
 Owned-Oper. By City of Camden
 Business Address City Hall
 Phone Number Emerson 5-5600
 Air Time 24 hours
 Transcription Service Standard
 Membership NARTB
 General Manager John Cleary
 Sales Prom. Mgr. Joseph Hale
 Program Director Jack La Mar
 Publicity Director Gilbert Whiting
 Chief Engineer John Zander

WKDN

CAMDEN—1948

Frequency: 800 Kc. Power: 1000 Watts d.
 Owned-Oper. By South Jersey Bcstg. Co.
 Business-Studio Address 2881 Mt. Ephraim Ave.
 Phone Number Emerson 5-7200
 Air Time Daytime
 Representative Keller
 Membership NARTB
 President Ranull Compton
 General Manager Gordon Gillen
 Sales Prom. Mgr. William Murphy
 Program Director Harvey Husten
 Chief Engineer Robert Houston

THOSE WHO KNOW

FAMOUS BRANDS

Says a sponsor of WCTC, New Brunswick, N. J.: "The worldwide coverage of **The Associated Press**, which we use in our news-cast, is excellent."

. . . . **KNOW THE MOST FAMOUS**

BRAND IN NEWS IS AP

WMTR

MORRISTOWN—1948—ABC

Frequency: 1250 Kc. Power: 1000 Watts d.
 Owned-Operated By Morristown Bcstg. Co.
 Address Box 345
 Phone Number MO 4-5700
 Transcription Service Associated
 President George S. Croy
 General Manager Kenneth A. Croy
 Commercial Mgr. Henry Behre
 Program Director Bob Vesel
 Chief Engineer Rudolph C. Prow

WAAT

NEWARK—1921

Frequency: 970 Kc. Power: 5000 d., 1000 n.
 Owned-Operated By Bremer Bcstg. Corp.
 Business-Studio Address 1020 Broad St.
 Phone Mitchell 2-6400; Barclay 7-3260 (N. Y.)
 News Service AP
 Transcription Service Associated, SESAC
 Representative Weed
 Membership NARTB
 President, Gen. Mgr. Irving R. Rosenhaus
 V.P., National Sales E. S. Lennon
 Publicity Director Elizabeth C. Butterfield
 V.P., Engineering Frank V. Bremer

WHBI

NEWARK—1922

Frequency: 1280 Kc. Power: 2500 Watts d.;
 1000 Watts n.
 Owned-Operated By May Radio Bcst. Corp.
 Business-Studio Address 100 Shipman St.
 Phone Number Mitchell 2-7354
 President James L. Shearer
 General Manager William Masi
 Chief Engineer Harold Michaels

WNJR

NEWARK—1947

Frequency: 1430 Kc. Power: 5000 Watts
 Owned-Oper. By Rollins Bcstg. Co.
 Business-Studio Address Route 22
 Phone Number Market 3-2700
 News Service UP
 Transcription Service Standard
 General Manager A. R. Lanthear

WVNJ

NEWARK—1948

Frequency: 620 Kc. Power: 5000 Watts
 Owned-Operated By Newark Bcstg. Corp.
 Business-Studio Address 91 Halsey St.
 Phone Number Mitchell 3-7600
 News Service UP
 Transcription Service World
 President Edward W. Scudder, Jr.
 Gen. Sta. Mgr. Harry D. Goodwin
 Commercial Mgr. Ivon B. Newman
 Chief Engineer Peter Testan

WCTC

NEW BRUNSWICK—1946

Frequency: 1450 Kc. Power: 250 Watts
 Owned-Operated By... Chanticleer Bcstg. Co.
 Business-Studio Address... 385 George St.
 Phone Number... Charter 7-1450
 News Service... AP
 Transcription Service... Langworth
 Membership... NARTB
 President... James L. Howe
 Station Manager... Robert Williams
 Commercial Manager... James M. Vogdes, Jr.
 Chief Engineer... Victor Takach

WNNJ

NEWTON—1953

Frequency: 1360 Kc. Power: 500 Watts d.
 Owned-Oper. By... Sussex County Bcstrs.
 Address... Andover Township
 General Manager... William Fairclough
 Comm. Mgr., Chief Engr... Simon Geller
 Program Director... Robert Mensel

WPAT

PATERSON—1941

Frequency: 930 Kc. Power: 5000 Watts
 Owned-Oper. By... North Jersey Bcstg. Co., Inc.
 Business-Studio Address... 66 Hamilton St.
 Phones... Armory 4-3400, PE. 6-2945 (N. Y.)
 Newspaper Affiliation... Passaic Daily News

News Service... AP, UP
 Transcription Service... Associated, Thesaurus
 Lang-Worth
 President... Richard Drukker
 General Manager... D. J. Wright
 Business Manager... Charles W. Parker
 Chief Engineer... Earl F. Lucas

WOND

PLEASANTVILLE—1950

Frequency: 1400 Kc. Power: 250 Watts
 Owned-Oper. By... Pioneer Bcstrs., Inc.
 Address... Old Turnpike
 Phone Number... Pleasantville 3971
 Transcription Service... Standard, Thesaurus
 News Service... AP
 Membership... NARTB, BAB
 President... Charles Rupp
 General Manager... John Struckell
 Chief Engineer... Milton Thurlow

WBUD

TRENTON—1947

Frequency: 1260 Kc. Power: 1000 Watts
 Owned-Operated By... Morrisville Bcstg. Co.
 Address... 108 N. Broad St.
 Phone Number... 4-7191
 News Service... AP
 Transcription Service... World
 President... Verna S. Hardin
 General Manager... Richard M. Hardin
 Chief Engineer... William A. Brewer

Stolen From a Time Buyer's Memo:

31

DECEMBER

Su	Mo	Tu	We	Th	Fr	Sa	Su	Mo	Tu	We	Th	Fr	Sa
	1	2	3	4	5		3	4	5	6	7	8	9
6	7	8	9	10	11	12	10	11	12	13	14	15	16
13	14	15	16	17	18	19	17	18	19	20	21	22	23
20	21	22	23	24	25	26	24	25	26	27	28	29	30
27	28	29	30	31			31						

Use WCTC, New Brunswick, N. J., in '54! Scuttlebutt rates WCTC tops in Music and Local News. Covers Central Jersey (Middlesex and Somerset Ctys.) — Pop. 371,000. \$359 million dollar market. Every indication of rapidly expanding market and audience. Contact: Sales Mgr. at Charter 7-1450, New Brunswick, N. J.

365 THURSDAY, DECEMBER 31, 1953 D

WCTC 98.3 FM

In ATLANTIC CITY

it's the

WONDerful music station

for sensational

RESULTS

More People Listen to WOND
 Than Any Other Station

WOND

It's listener loyalty to top personalities on programs of music, news and sports geared to local tastes. That's why most Atlantic advertisers and more national sponsors are using

WOND

Studios—Pleasantville, N. J.
 John G. Struckell, Gen. Mgr.

* Advertest Research

WTNJ

TRENTON—1928

Frequency: 1300 Kc. Power: 250 Watts d.
 Owned-Operated By: WOAX, Inc.
 Address: 416 Bellevue Ave.
 Phone Number: 3-4281
 President: Dick Delreitas
 General Manager: Leonard H. Levitt
 Chief Engineer: Nicholas Delassandro

WTTM

TRENTON—1941—NBC

Frequency: 920 Kc. Power: 1000 Watts
 Owned-Operated By: Peoples Bcst. Corp.
 Business-Studio Address: 541 E. State St.
 Phone Number: 5-8515
 Air Time: 7 a.m.-12:05 a.m.
 News Service: AP
 Representative: For Joe
 Membership: NARTB, BAB
 President: M. D. Lincoln
 General Manager: F. L. Bernstein
 Publicity Director: Fred Walker
 Chief Engineer: Chester Sunderland

WWBZ

VINELAND—1946

Frequency: 1360 Kc. Power: 1000 Watts
 Owned-Operated By: Community Bcstg. Serv.
 Address: 633 Wood St.
 Phone Number: Vineland 7-1360
 News Service: UP
 Transcription Service: World
 Representative: Gill, Perna
 President: Joseph M. Bullock
 Gen., Sta., Prom. Mgr.: Fred M. Wood
 Commercial Manager: John Serra
 Chief Engineer: Saul Altzman

WCMC

WILDWOOD—1951

Frequency: 1230 Kc. Power: 100 Watts
 Owned-Operated By: Francis J. Matrangola
 Phone Number: 2-7751
 Transcription Service: Capitol
 Owner, Gen. Mgr.: Francis J. Matrangola
 Comm. Mgr., Prog. Dir.: George M. Hart
 Chief Engineer: Carlton S. Owen

NEW MEXICO

Pop. Feb. 1, 1954 (Est.) 760,000 — Families 195,000
 Radio Homes 181,000 — TV Homes 51,000 — Stations in State 29

KALG

ALAMOGORDO—1950

Frequency: 1230 Kc. Power: 250 Watts
 Owned-Oper. By: William Wayne Phelps
 Address: Box 268
 Phone Number: 211
 Air Time: Full Time
 News Service: UP
 Membership: NARTB, BAB
 Gen., Sta. Mgr.: Wayne Phelps
 Chief Engineer: Harry Albers

KDEF

ALBUQUERQUE—1953

Frequency: 1280 Kc. Power: 1000 Watts d.
 Owned-Oper. By: Frank Quinn
 Address: 506 2d N.W.
 Phone Number: 3-7813
 Pres., Gen. Mgr.: Frank Quinn
 Commercial Mgr.: Lee Govan
 Program Director: Jerry Nesler
 Promotion Mgr.: Bill Prevetti
 Chief Engineer: Bob Easley

KABQ

ALBUQUERQUE—1947—MBS
INTERMOUNTAIN

Frequency: 1340 Kc. Power: 250 Watts
 Owned-Oper. By: KABQ Bcstg. Co.
 Address: 317 N. Broadway, Box 1388
 Phone Number: 3-1744
 Air Time: 5 a.m.-M.
 Transcription Service: Thesaurus
 News Service: AP
 Representative: Richard O'Connell
 Membership: BAB
 Pres., Prom. Mgr.: Helen A. Price
 V.P., Gen., Comm. Mgr.: Bert Arnold
 Program Director: Don Husted
 Chief Engineer: John Morrison

KGGM

ALBUQUERQUE—1927—CBS

Frequency: 610 Kc. Power: 5000 Watts
 Owned-Oper. By: New Mexico Bcstg. Co.
 Business Address: 1414 Coal St., S.W.
 Phone Number: 3-4543
 Air Time: Full Time
 Representative: Weed & Co.
 President: A. R. Hebenstreit
 Station Manager: E. Jonny Graff
 Program Director: Robert Vandriel
 Chief Engineer: Leonard F. Dodds

KOAT

ALBUQUERQUE—1946—ABC

Frequency: 1240 Kc. Power: 250 Watts
 Owned-Oper. By: Alvarado Bcstg. Co., Inc.

Business-Studio Address.....122 S. Tulane
 Phone Number.....5-7501
 News Service.....UP
 Trans. Service.....Associated, Lang-Worth
 Representative.....Rambau
 President.....Herbert W. Wimberly
 General Manager.....A. M. Caldwell
 Chief Engineer.....Donald Delaney

K O B

ALBUQUERQUE—1920—NBC

Frequency: 770 Kc....Power: 50,000 Watts d.;
 25,000 Watts n.
 Owned-Oper. By.....Albuquerque Bcstg. Co.
 Bus.-Studio Address.....234 Fifth St., S.W.
 Phone Number.....3-4411
 Air Time.....Full Time
 News Service.....AP, UP
 Transcription Service.....SESAC
 Representative.....Branham
 Membership.....BAB
 Pres., Gen. Mgr.....Wayne Coy
 General Manager.....J. I. Meyerson
 Commercial Manager.....Rolf Nielson
 Sales Prom. Mgr.....A. E. Mickel
 Program Director.....Michael Dillon
 Chief Engineer.....George S. Johnson

K S V P

**ARTESIA—1946—KBS-MBS
 INTERMOUNTAIN**

Frequency: 990 Kc....Power: 1000 Watts d.,
 250 n.
 Owned-Operated By ..Artesia Bcstg. Corp.
 Business-Studio Address.....Box 38
 Phone Number.....650
 News Service.....UP
 Representative.....Avery Knodel
 President.....Martin Yates III
 General Manager.....David M. Button
 Chief Engineer.....Ronald Austin

K A V E

CARLSBAD—1936—CBS-SWN

Frequency: 1240 Kc....Power: 250 Watts
 Owned-Operated By ..Carlsbad Bcstg. Corp.
 Business-Studio Address.....601 No. Canal St.
 Phone Number.....5-4101
 Air Time.....6 a.m.-M.
 News Service.....AP
 Representative.....Taylor Co.
 President.....Val Lawrence
 General-Station Mgr.....Norman R. Loose
 Commercial Manager.....Richard E. Doyle
 Sales Prom. Mgr.....Richard Miner
 Program Director.....Alexander Pitcaithley
 Chief Engineer.....Harland Nilong

K P B M

CARLSBAD—1950

Frequency: 740 Kc....Power: 1000 Watts d.
 Owned-Operated By ..Coronado Bcstg. Co.
 Address.....313 W. Mermod
 Phone Number.....5-5373
 Transcription Service.....Lang-Worth

Representative.....McGillvra
 Membership.....BAB, NARTB
 Pres., Gen. Mgr.....Maurice F. McEvoy
 Sta., Comm. Mgr.....Darrell A. Swayze
 Chief Engineer.....Vic Daley

K L M X

CLAYTON—1949

Frequency: 1450 Kc....Power: 250 Watts
 Owned-Oper By.....Ari-Ne-Mix Bcstg.
 Address.....Box 7, Fair Grounds
 Phone Number.....616
 Transcription Service.....Thesaurus
 News Service.....UP
 Representative.....Best, Palmer
 President.....Arthur Jernigan
 Gen., Sta., Comm. Mgr.....Frank Vale
 Chief Engineer.....Robert Waters

K C L V

CLOVIS—1952—ABC

Frequency: 1240 Kc....Power: 250 Watts
 Owned-Oper. By.....New-Tex Bdcstg.
 Address.....Box 866
 Phone Number.....4401
 News Service.....UP
 Transcription Service.....Capitol
 Representative.....Pearson
 President.....Odus L. Echols
 Commercial Mgr.....Evelyn Ganter
 Chief Engineer.....Clayton Fuchs

K I C A

CLOVIS—1931—MBS

Frequency: 980 Kc....Power: 1000 Watts
 Owned-Oper. By.....Hugh DeWitt Landis
 Address.....519 Piles St.
 Phone Number.....5511
 Air Time.....Full Time
 News Service.....UP
 Transcription Service.....World
 Station Representative.....Hal Holman
 Membership.....BAB, NARTB
 Gen., Sta. Mgr.....DeWitt Landis
 Commercial Manager.....C. O. Kendrick
 Pgm., Pub. Dir.....Harold Cook
 Chief Engineer.....M. S. Digger O'Dell

K V B C

FARMINGTON—1951—KBS

Frequency: 1240 Kc....Power: 250 Watts
 Owned-Operated By.....Valley Bcstg. Co.
 Address.....Box 1117
 Phone Number.....789
 News Service.....UP
 Transcription Service.....World
 Pres., Gen. Mgr.....Marvin E. Bowles
 Commercial Mgr.....James Montgomery

K G A K

GALLUP—1946—KBS

Frequency: 1230 Kc....Power: 250 Watts
 Owned-Oper. By.....Thunderbird Bcstg. Co.
 Address.....E. of Gallup

Phone Number1300
 News ServiceUP
 Transcription ServiceLang-Worth
 Station RepresentativeMcGillvra
 Pres., Gen. Mgr.Merle H. Tucker
 Chief Engineer.....Robert Adamson

KWEW

HOBBS—1938
 MBS-KBS-SOUTHWEST

Frequency: 1490 Kc.Power: 250 Watts
 Owned-Operated By.....KWEW, Inc.
 Business-Studio Address...116 E. Dunnam
 Phone Number3-3137
 News ServiceUP
 Transcription Service...MacGregor, Lang-Worth
 RepresentativeTaylor
 President.....Mrs. Theresa Whitmore
 General ManagerHarry McAdams
 Commercial Manager.....Phil McGee
 Chief Engineer.....Roy Evans

KOBE

LAS CRUCES—1947—MBS

Frequency: 1450 Kc.Power: 250 Watts
 Owned-Oper. By.....Mesilla Valley Bcstg. Co.
 Bus.-Studio Address902 N. Main St.
 Phone Number1121
 News ServiceUP
 President.....M. B. Thompson
 General ManagerL. S. Sleppy
 Chief Engineer.....Bruce Pedersen

KFUN

LAS VEGAS—1941—MBS

Frequency: 1230 Kc.Power: 250 Watts
 Owned-Operated By...Southwest Bcsters, Inc.
 Business AddressBox 710
 Phone Number12
 News ServiceUP
 Transcription ServiceStandard
 Representative.....Hil F. Best
 Pres., Comm. Mgr.Ernest N. Thwaites
 Chief Engineer.....A. F. Schultz

KRSN

LOS ALAMOS—1949—ABC

Frequency: 1490 Kc.Power: 250 Watts
 Owned-Oper. By.....Alvarado Bcstg. Co.
 AddressCommunity Center
 Phone Number2-4422
 Air TimeFull Time
 Representative.....George P. Hollingbery
 Transcription ServiceAssociated
 News ServiceUP
 MembershipBAB
 President.....H. W. Wimberly
 General Manager.....A. M. Cadwell
 Sta., Comm. Mgr.Bob Porton
 Pgm. Dir., Sls. Prom. Mgr. William Spack, Jr.
 Publicity Director.....Jack N. Hardwick
 Chief EngineerJohn L. Lockhart

KLEA

LOVINGTON—1952

Frequency: 1050 Kc.Power: 250 Watts
 Owned-Oper. By...Prosperity Land Bcstg. Co.
 Address.....P. O. Drawer 865
 Phone Number8911
 News ServiceUP
 Transcription ServiceStandard
 RepresentativeClyde Melville
 MembershipBAB, NARTB
 Owner, Gen. Mgr.David R. Worley
 Sta., Comm., Prom. Mgr.Butler A. Summer
 Program Director.....Jack Healon
 Chief Engineer.....Francis Clements

KENM

PORTALES—1950

Frequency: 1450 Kc.Power: 250 Watts
 Owned-Operated By.....Plains Bcstg. Co.
 Address.....Box 447, Roswell
 Phone Number600
 News ServiceUP
 Transcription Service...Lang-Worth, MacGregor
 PresidentTheresa Whitmore
 Commercial Manager.....Ed Fitzpatrick
 Chief EngineerRoy Simmons

KRTN

RATON—1948—MBS
 INTERMOUNTAIN

Frequency: 1490 Kc.Power: 250 Watts
 Owned-Operated By...Southwest Bcsters, Inc.
 Business AddressBox 767
 Phone Number875
 Air TimeFull Time
 News ServiceUP, INS
 Transcription ServiceStandard
 MembershipBAB
 Pres., Gen. Manager.....Ernest N. Thwaites
 Sta., Comm., Prom. Mgr.Ray Birch
 Chief Engineer.....A. F. Schultz

KBIM

ROSWELL—1953—KBS

Frequency: 910 Kc.Power: 1000 Watts d.
 Owned-Oper. By.....Taylor Bcstg. Co.
 AddressBox 525
 Phone Number4848
 RepresentativeClark
 President.....William C. Taylor

KGFL

ROSWELL—1927—MBS

Frequency: 1400 Kc.Power: 250 Watts
 Owned-Operated By.....KGFL, Inc.
 Business-Studio Address...310 N. Robertson
 Phone Number2000
 News ServiceUP
 Transcription Service...Langworth, World
 RepresentativeTaylor Co.
 President.....Mrs. Theresa Whitmore
 Sec'y-Treas.....W. E. Whitmore, Jr.

General Manager.....G. F. Roberts
 Chief Engineer.....E. C. Rader

Gen., Comm. Mgr.....Ivan R. Head
 Chief Engineer.....E. J. Vanderwood

K S W S
 ROSWELL—1947—ABC

Frequency: 1230 Kc.....Power: 250 Watts
 Owned-Oper. By.....John A. Barnett
 Business-Studio Address.....1723 W. Second
 Phone Number.....3737
 News Service.....AP
 Transcription Service.....Thesaurus
 Representative.....Meeker, Melville
 Owner.....John A. Barnett
 General Manager.....J. C. Porter
 Station Manager.....John Anderson
 Commercial Manager.....Paul B. McEvoy
 Chief Engineer.....Ray R. Summersgill

K S I L
 SILVER CITY—1946—CBS-KBS

Frequency: 1340 Kc.....Power: 250 Watts
 Owned-Oper. By.....James H. Duncan
 Bus.-Studio-Transmitter Address..17th & Cactus
 News Service.....AP
 Representative.....Taylor
 Pres., Gen. Mgr.....J. H. Duncan
 Chief Engineer.....Wm. Rider

K T R C
 SANTA FE—1946—ABC

Frequency: 1400 Kc.....Power: 250 Watts
 Owned-Oper. By.....J. Gibbs & Bayne A. Spring
 Address.....210 E. Marcy St.
 Phone Number.....3-6335
 News Service.....UP
 Transcription Service.....Associated
 Representative.....McGillvra
 Membership.....NARTB
 President.....J. Gibbs Spring
 Commercial Mgr.....S. C. Horn
 Chief Engineer.....Lloyd Storr

K C H S
 TRUTH OR CONSEQUENCES—1946
 KBS

Frequency: 1400 Kc.....Power: 250 Watts
 Owned-Oper. By.....O. L. and Gladyce P. Dennis
 Address.....401 Broadway
 Phone Number.....161
 News Service.....UP
 Representative.....Continental Radio Sales
 General Manager.....O. L. Dennis
 Program Director.....Gladyce P. Dennis
 Chief Engineer.....S. J. Woodworth

K V S F
 SANTA FE—1935—CBS

Frequency: 1260 Kc.....Power: 1000 Watts
 Owned-Oper. By.....Sante Fe Bcstg. Co.
 Business-Studio Address.....759 Cerrillos Rd.
 Phone Number.....3-7319
 Transcription Service.....World
 Representative.....Weed
 President.....A. R. Hebenstreit

K T N M
 TUCUMCARI—1941—MBS

Frequency: 1400 Kc.....Power: 250 Watts
 Owned-Operated By.....Quay County Bcstg. Co.
 Business Address.....Box 668
 Phone Number.....100
 Air Time.....6 a.m.-10:30 p.m.
 News Service.....UP
 Transcription Service.....World
 Representative.....Melville
 Membership.....NARTB
 Gen., Sta. Mgr.....Lloyd Hawkins
 Commercial Mgr.....Richard S. Fox
 Program Director.....Jack Crandall

NEW YORK

Pop. Feb. 1, 1954 (Est.) 15,872,000 — Families 4,771,000
 Radio Homes 4,618,000 — TV Homes 3,912,000 — Stations in State 99

W A B Y
 ALBANY—1933

Frequency: 1400 Kc.....Power: 250 Watts
 Owned-Oper. By.....Eastern N. Y. Bcstg.
 Business-Studio.....80 Braintree St.
 Phone Number.....2-3353
 News Service.....UP
 Representative.....Rambeau
 President.....David Kyle
 Gen., Sta. Mgr.....Edward L. Trudeau
 Comm., Sales Prom. Mgr.....Alix Blake
 Chief Engineer.....Tom Stapleton

W O K O
 ALBANY—1925—UBS

Frequency: 1460 Kc.....Power: 5000 Watts
 Owned-Oper. By.....Gov. Dongan Bcstg. Corp.
 Business-Studio Address.....136 State St.
 Phone Number.....3-6638
 News Service.....AP
 Representative.....McGillvra
 President, General Mgr.....James T. Healey
 Commercial Manager.....Eugene Fitzpatrick
 Chief Engineer.....Al Sardi

W P T R

ALBANY—1948

Frequency: 1540 Kc. Power: 50,000 Watts
 Owned-Oper. By: Patroon Brcdstg. Co., Inc.
 Address: Hotel Ten Eyck
 Phone Number: 5-3345
 News Service: AP, UP
 Transcr. Service: Associated, SESAC, World
 Station Representative: Weed and Co.
 Membership: BAB
 President: J. Myer Schine
 General Manager: Stephen R. Rintoul
 Chief Engineer: W. Russell David

W R O W

ALBANY—1947—ABC

Frequency: 590 Kc. Power: 5,000 Watts d.:
 1,000 Watts n.
 Owned-Oper. By: Hudson Valley Br. Co., Inc.
 Address: North Greenbush
 Phone Number: 9-2225
 News Service: UP
 Transcription Service: Thesaurus
 Station Representative: The Bolling Co.
 Membership: NARTB, BAB
 General Manager: Harry L. Goldman
 Station Manager: Isabella Arden
 Commercial Manager: Leo Rosen
 Chief Engineer: Charles Heisler

W C S S

AMSTERDAM—1947

Frequency: 1490 Kc. Power: 250 Watts
 Owned-Oper. By: Community Service Bst.
 Business-Studio Address: Upper Locust Ave.
 Phone Number: 4000
 News Service: UP
 Transcription Service: World
 Representative: McGillvra
 Membership: BAB, NARTB
 President: Alphonse Di Merza
 General Manager: Alex Sherwood
 Chief Engineer: Barry Frank

W M B O

AUBURN—1926—MBS

Frequency: 1340 Kc. Power: 250 Watts
 Owned-Operated By: WMBO, Inc.
 Business-Studio Address: 141 Genesee St.
 Phone Number: 2-3511
 Newspaper Affiliation: "Advertiser"
 News Service: AP
 Transcription Service: World
 Representative: Thomas F. Clark
 Membership: NARTB, BAB
 President: William O. Dapping
 General Manager: Frederick L. Keese
 Chief Engineer: Herbert House

W B T A

BATAVIA—1941—MBS

Frequency: 1490 Kc. Power: 250 Watts

Owned-Operated By: Batavia Bcstg. Corp.
 Business-Studio Address: 218 East Main St.
 Phone Number: 715
 News Service: AP
 Transcription Service: World
 Pres., Gen. Mgr.: Edmund R. Gamble
 Sales Prom. Mgr.: Charles L. Snow
 Program Director: Jan Danielson
 Chief Engineer: Fred Callendar

W E N E

BINGHAMTON—ENDICOTT—1947

ABC

Frequency: 1430 Kc. Power 5000 Watts

AN UNBEATABLE COMBINATION!

MBS

NETWORK + 50,000 WATTS

IN THE 31st MARKET

PLUS
UPSTATE, N. Y.

SELLS ALBANY-TROY-SCHENECTADY

ALBANY, NEW YORK

W P T R

Owned-Oper. By.....Ottaway Stations, Inc.
 Business-Studio Address.....909 E. Main
 Phone Number.....5-3351
 Air Time.....6 a.m.-12:05 a.m.
 News Service.....UP
 Transcription Service.....Associated
 Representative.....Radio Reps. Inc.
 Membership.....NARTB, BAB
 President.....James H. Ottaway
 Managing Director.....F. H. Brinkley
 Station Manager.....S. W. Ryder
 Sales Prom., Comm. Mgr.....Norman F. Flynn
 Program Director.....Len Hathaway
 Chief Engineer.....Sheldon W. Weyland

WINR

BINGHAMTON—1946—NBC

Frequency: 680 Kc.....Power: 1000 Watts d.,
 500 Watts n.
 Owned-Oper. By.....Southern Tier Radio Service
 Business-Studio Address.....Court House Square
 Phone Number.....4-4318
 News Service.....UP
 Transcription Service.....Lang-Worth
 Representative.....George P. Hollingbery
 President.....Donald Kramer
 General Manager.....George J. O'Connor
 Commercial Manager.....H. R. Nicholson
 Pgm., Prom. Dir.....Charles Bishara
 Chief Engineer.....A. A. Kelley

WKOP

BINGHAMTON—1947—MBS

Freq.: 1360 Kc.....Power: 100 Watts d.; 500 n.
 Owned-Oper. By.....The Binghamton Bcstrs., Inc.
 Business-Studio Address.....34 Chenango St.
 Phone Number.....2-3437
 Air Time.....5:30 a.m.-1 a.m.
 News Service.....AP
 Transcription Service.....World
 Representative.....Headley-Reed
 Membership.....NARTB, BAB
 Pres., Gen.-Sta. Mgr.....Andrew Jarema
 Commercial Mgr.....Thomas Riley
 Program Director.....Wally Buman
 Chief Engineer.....Charles Hallinan

WNBF

BINGHAMTON—1927—CBS

Frequency: 1290 Kc.....Power: 5000 Watts
 Owned-Operated By.....Clark Associates, Inc.
 Business Address.....40 Wall St.
 Phone Number.....Binghamton 3-7311
 News Service.....UP
 Transcription Service.....Thesaurus
 Representative.....Bolling
 Membership.....NARTB, BAB
 General Manager.....Cecil D. Mastin
 Commercial Manager.....S. N. Heslop
 Sales Prom. Mgr., Pub. Dir.....John Turner
 Program Director.....E. M. Scala
 Comptroller.....E. W. Farneli
 Chief Engineer.....L. H. Stantz

WBEN

BUFFALO—1930—NBC

Frequency: 930 Kc.....Power: 5000 Watts
 Owned-Operated By.....WBEN, Inc.
 Phone Number.....MOhawk 0930
 Newspaper Affiliation.....Buffalo Evening News
 Air Time.....5:30 a.m.-1 a.m.
 News Service.....AP, INS, UP
 Transcription Service.....Thesaurus, Lang-Worth
 Representative.....Henry I. Christal
 Membership.....NARTB, BAB
 President.....Edward H. Butler
 Vice-President.....A. H. Kirchhofer
 General Manager.....C. Robert Thompson
 Station Manager.....Frank W. Kelly
 Sales Manager.....C. E. Daly
 Program Director.....Carl Erickson
 Publicity Director.....Joseph A. Haeffner
 Chief Engineer.....Ralph J. Kingsley

WBNY

BUFFALO—1935

Frequency: 1400 Kc.....Power: 250 Watts
 Owned-Operated By.....Roy L. Albertson
 Business-Studio Address.....485 Main St.
 Phone Number.....Mohawk 1400
 News Service.....AP, UP
 Pres., Gen. Mgr.....Roy L. Albertson
 Chief Engineer.....Thomas L. Vines

WEBR

BUFFALO—1924—MBS

Frequency: 970 Kc.....Power: 5000 Watts
 Owned-Operated By.....WEBR, Inc.
 Business-Studio Address.....23 North St.
 Phone Number.....Lincoln 7133
 Newspaper Affiliation....."Courier-Express"
 Air Time.....5:30 a.m.-2 a.m.
 News Service.....AP, INS, UP
 Transcription Service.....Thesaurus, Standard,
 SESAC
 Representative.....Katz
 Membership.....NARTB
 President.....William J. Conners, III
 General Manager.....William Doerr
 Commercial Manager.....Carl J. Kirchhofer
 Pgm., Prom. Mgr.....Wm. Schweitzer
 Chief Engineer.....Frank B. Ridgeway

WGR

BUFFALO—1922—CBS

Frequency: 550 Kc.....Power: 5000 Watts
 Owned-Operated By.....WGR Bcstg. Corp.
 Business-Studio Address.....Rand Bldg.
 Phone Number.....Washington 3100
 Air Time.....5:50 a.m.-1:05 a.m.
 News Service.....UP
 Representative.....Free & Peters
 Membership.....NARTB, BAB
 Chairman of Board.....Leo J. Fitzpatrick
 Pres., Gen. Mgr.....I. R. Lounsberry
 Vice President.....Karl Hoffmann
 Commercial Manager.....Nat Cohen
 Sales Promotion Manager.....R. McPherson
 Program Director.....Robert Strigl

SATURATION

**GIVES YOU
ALL
THE AUDIENCE**

IN BUFFALO and WESTERN NEW YORK

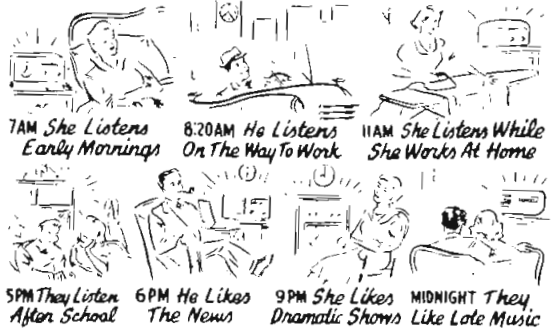

SO Pitch your sales message at ALL hours

. . . NOT once a week; NOT five times a week . . .

BUT 26 TIMES A WEEK!

WKBW offers alert advertisers SATURATION!

The most successful advertising technique is "Telling your sales story to as many people, as many times as you can, within the limits of a sound budget." This is the WKBW SATURATION FORMULA which is bringing increased sales results for WKBW advertisers; and we have the renewals to prove it. Call Avery-Knodel or WKBW.

WKBW offers you MORE THAN TWICE AS MANY LISTENERS FOR YOUR DOLLAR!

No matter what your yardstick is for buying radio time . . . Nielsen . . . Pulse . . . coverage maps . . . or special local surveys, you'll find a WKBW SATURATION CAMPAIGN gives you MORE THAN TWICE AS MANY LISTENERS for your advertising dollar. That's why your sales results will be MORE THAN TWICE AS GOOD! For details about this and other WKBW saturation campaigns call Avery-Knodel or WKBW.

50,000 WATTS
AVERY-KNODEL, INC.
National Representatives

WKBW

BUFFALO'S MOST POWERFUL STATION

BASIC ABC
CLINTON H. CHURCHILL
Founder, President
and General Manager

W K B W

BUFFALO—1925—ABC

Frequency: 1520 Kc. Power: 50,000 Watts
 Owned-Operated By: WKBW, Inc.
 Business Address: Radio Center, 1430 Main St.
 Phone Number: Grant 5101
 Air Time: 5:30 a.m.-2 a.m.
 News Service: UP
 Transcription Service: World
 Representative: Avery-Knodel
 Pres., Gen. Mgr.: Clinton H. Churchill
 Sales Prom., Pub. Dir.: Dorothy L. Ireland
 Sta., Comm. Mgr.: Alfred E. Anscombe
 Program Director: James McGrath
 Chief Engineer: Leroy Fiedler

W W O L

BUFFALO—1947

Frequency: 1120 Kc. Power: 1000 Watts d.
 Owned-Operated By: Greater Erie Broad. Co.
 Address: 315 Main St.
 Phone Number: MO 1200
 News Service: INS, UP
 Representative: Forjoe
 Owner: Leon Wyszatycki
 General Manager: Ted Wyszatycki
 Commercial Manager: Jack Greenfield
 Chief Engineer: Walter Williams Jr.

W X R A

BUFFALO—KENMORE—1948

Frequency: 1080 Kc. Power: 1000 Watts d.
 Owned-Operated By: W. New York Broad. Co.
 Address: Box 85
 Phone Number: AMherst 1160
 News Service: AP
 Station Representative: Wm. G. Rambeau
 Gen., Comm. Mgr.: Thaddeus Podbielniak
 Sales Prom., Pub. Dir.: Bradley D. Steiger
 Program Director: James J. Frieling
 Chief Engineer: Roger W. Fleming

W C B A

CORNING—1948

Frequency: 1350 Kc. Power: 1000Watts d.
 Owned-Operated By: Wellsboro Corning Broad. Adv. Inc.
 Address: Davis Road
 Phone Number: 6-6442
 News Service: AP, World
 Representative: McGillvra, Inc.
 Pres., Gen. Mgr.: Paul L. Carpenter
 Program Director: Gerry Wells
 Chief Engineer: Charles Charnesky

W C L I

CORNING—1947—ABC

Frequency: 1450 Kc. Power: 250 Watts
 Owned-Oper. By: Radio Corning, Inc.
 Address: Box 100
 Phone Number: 6-5421
 Transcription Service: Thesaurus

Station Representative: Meeker
 News Service: AP
 Pres., Gen. Mgr.: Gordon M. Jenkins
 Sta. Mgr., Prog. Dir.: George P. Droelle
 Chief Engineer: Frank Saia

W K R T

CORTLAND—1947

Frequency: 920 Kc. Power: 1000 Watts d.,
 500 n.
 Owned-Operated By: Radio Cortland, Inc.
 Bus. Studio Address: State Theatre Bldg.
 Phone Number: 2990
 News Service: UP
 Transcription Service: Lang-Worth
 Representative: Gill, Perna
 Membership: BAB
 President: Leighton A. Hope
 General Manager: William L. Thompson
 Chief Engineer: William Barron

W F C B

DUNKIRK—1949

Frequency: 1410 Kc. Power: 500 Watts
 Owned-Operated By: Dunkirk Broad. Corp.
 Address: 316 Main St.
 Phone Number: 7756-7-8
 News Service: UP
 Transcription Service: Thesaurus, World
 Station Representative: Walker
 Membership: NARTB, BAB
 Pres., Gen. Mgr., Sta. Mgr.: Alois A. Schmidt
 Commercial Manager: B. F. Goodrich
 Program Director: Tiny Hamrick
 Chief Engineer: J. T. Grace

W E L M

ELMIRA—1947—CBS-ABC

Frequency: 1400 Kc. Power: 250 Watts
 Owner: Radio Elmira, Inc.
 Business-Studio Address: 222 E. Market St.
 Phone Number: 3-5626
 Air Time: 6 a.m.-M.
 News Service: AP
 Transcription Service: Thesaurus
 Station Representative: Meeker
 Membership: NARTB
 President: John S. Riggs
 Vice Pres. (Sales): Keith W. Horton
 Vice Pres. (Bcstg.): Phil Cameron
 Program Director: William Griffiths
 Chief Engineer: Arthur French

W E N Y

ELMIRA—1939—NBC-MBS

Frequency: 1230 Kc. Power: 250 Watts
 Owned-Operated By: Elmira Star-Gazette, Inc.
 Bus. Studio Address: Mark Twain Hotel
 Phone Number: 5181
 Air Time: 6 a.m.-1 a.m.
 News Service: AP
 Transcription Service: World
 Representative: Everett & McKinney
 Membership: NARTB, BAB
 General Manager: Dale L. Taylor



Strong LOCAL Programming

Gives Audience Domination to WHLI

In the Major Long Island Market

- Familiar good music Long Islanders prefer
- LOCAL Long Island—national—international news
- Railroad—bus—school and industrial plant information
- LOCAL special events—editorial leadership in Long Island issues
- Long Island traffic and complete highway condition information
- Long Island weather—boating—fishing—beach and garden reports

WHLI "THE VOICE OF LONG ISLAND" has a larger daytime audience in the big booming major Long Island Market than any network or combination of independents . . . (Conlan)

WHLI

A M 1100

F M 98.3

HEMPSTEAD
LONG ISLAND, N. Y.

Paul Godofsky, Pres.

Represented by Rambeau

*the voice of
long island*

Sales Manager..... Ellis Erdman
 Program Director..... Ted Hodge
 Chief Engineer..... Thurlow A. Greene

W G B B
FREEPORT—1924

Frequency: 1240 Kc..... Power: 100 Watts
 Owned-Operated By..... Harry H. Carman
 Business-Studio Address..... 44 So. Grove St.
 Phone Number..... Freeport 9-1400
 News Service..... AP
 Transcription Service..... Lang-Worth
 Pres., Gen., Sta. Mgr. & Chief Engineer

Harry H. Carman
 Commercial Manager..... Murray C. Evans
 Program Director..... A. Cheesman
 Promotion Mgr..... Herbert Clock

W O S C
FULTON—1949

Frequency: 1300 Kc..... Power: 1000 Watts d.
 Owned-Oper. By..... Cassill Radio Corp.
 Address..... Pontiac Hotel, Oswego
 Phone Number..... Fulton 2-2255
 News Service..... UP
 Transcription Service..... Thesaurus
 Membership..... NARTB
 Station Representative..... Devney
 Pres., Gen. Mgr..... A. L. Richardson
 Station Manager..... N. A. Dukes
 Program Director..... Edward Reich
 Chief Engineer..... Robert N. Blair

W G V A
GENEVA—1947—ABC

Frequency: 1240 Kc..... Power: 250 Watts
 Owned-Operated By..... Star Bcstg. Co., Inc.
 Address..... Geneva Federal Savings Bldg.
 Phone Number..... 6691
 Air Time..... Full Time
 News Service..... AP
 Representative..... Cooke
 Transcription Service..... Lang-Worth
 Membership..... BAB
 President..... M. R. Forman
 General Manager..... Thomas L. Brown
 Program Director..... Alex Lamutis
 Chief Engineer..... R. Carleton Greene

W W S C
GLENS FALLS—1946—ABC

Frequency: 1450 Kc..... Power: 250 Watts
 Owned-Operated By..... Gt. Northern Radio Co.
 Address..... 13 Warren St.
 Phone Number..... 2-6518
 Air Time..... 6 a.m.-M.
 News Service..... AP
 Transcription Service..... Thesaurus
 Membership..... BAB
 President..... Louis Brown
 Gen., Comm. Mgr..... Martin Karig
 Program Director..... Carl Mattison
 Chief Engineer..... Joseph Thomas

W E N T

GLOVERSVILLE—1944—CBS

Frequency: 1340 Kc..... Power: 250 Watts
 Owned-Oper. By..... Sacandaga Bcstg. Corp.
 Business-Studio Address..... 8 W. Fulton St.
 Phone Number..... 4-7175
 News Service..... UP
 Transcription Service..... Thesaurus
 Representative..... Gill, Perna
 President..... George Bissell
 General Manager..... J. L. Brownell, Jr.
 Program Director..... Lloyd Howell
 Chief Engineer..... Richard Stewart

W H L I

HEMPSTEAD—1947

Frequency: 1100 Kc..... Power: 250 Watts d.
 Owned-Oper. By..... FM Bcstg. Corp.
 Business-Studio Address..... 245 Baldwin Rd.
 Phone Number..... Hempstead 2-8000
 News Service..... UP
 Transcription Service..... Associated. World.
 Thesaurus
 Representative..... Rambeau
 Membership..... BAB
 Pres., Gen. Mgr..... Paul Godofsky
 V.P., Sales..... Joseph A. Lenn
 Publicity Director..... George Ball
 V.P., Chief Engineer..... Frank E. Knaack

W L E A

HORNELL—1951—MBS

Frequency: 1480 Kc..... Power: 1000 Watts d.
 Owned-Oper. By..... Hornell Bcstng. Corp.
 Business-Studio Address..... P. O. Box 450
 Phone Number..... 1420
 News Service..... UP
 Transcription Service..... Capitol
 Representative..... Gill, Perna
 Membership..... BAB
 Pres., Gen. Mgr..... Charles D. Henderson
 Publicity Director..... Blanche Stuart Scott
 Chief Engineer..... George W. Stidstone

W W H G

HORNELL—1949

Frequency: 1320 Kc..... Power: 1000 Watts
 Owned-Operated By..... W. H. Greenhow Co.
 Address..... 85 Canisteo St.
 News Service..... AP
 Transcription Service..... Thesaurus
 Representative..... McGillvra
 Pres., Gen. Mgr..... Louis G. Buisch
 Station Manager..... Donald J. Curran
 Chief Engineer..... Howard Huff

W H U C

HUDSON—1947

Frequency: 1230 Kc..... Power: 250 Watts
 Owned-Oper. By..... Colgren Bcstg. Co.
 Address..... Union Turnpike
 Phone Number..... HU 8-3341
 News Service..... UP

Transcription Service World
 Representative McGillvra
 Membership NARTB
 General Manager John Kearney
 Commercial Manager Robert Strakos
 Chief Engineer Charles Weiler

W G S M

HUNTINGTON—1951

Frequency: 740 Kc. Power: 1000 Watts d.
 Owned-Oper. By Huntington-Montauk Bcstg.
 Co., Inc.
 Address 379 New York Ave.
 Phone Number Huntington 4-6740
 News Service UP
 Station Representative Robert Keller
 Transcription Service World
 Membership BAB
 President Byron T. Sammis
 Gen., Sta. Mgr. Edward J. Fitzgerald
 Program Director Don Daily
 Publicity Director Estelle Sammis
 Chief Engineer William Naramore

W H C U

ITHACA—1940—CBS

Frequency: 870 Kc. Power: 1000 Watts d.
 Owned-Operated By Cornell University
 Business-Studio Address Savings Bank Bldg.
 Phone Number 4-6301
 Air Time Sunrise-sunset
 News Service UP
 Transcription Service Associated
 Membership NARTB, BAB
 Gen., Sta. Mgr. Michael R. Hanna
 Commercial Mgr. Earl S. Cobey
 Program Director Joseph A. Short
 Publicity Director Sam Woodside
 Chief Engineer True McLean

W J O C

JAMESTOWN—1948—MBS

Frequency: 1340 Kc. Power: 250 Watts d.
 Owned-Operated By Air Waves, Inc.
 Trans.-Bus.-Studio Address 415 W. Fourth St.
 Phone Number 5-108
 Air Time 5:55 a.m.-12 M.
 News Service AP
 Representative Gill-Perna
 Transcription Service World
 Membership NARTB, BAB
 Pres., Gen. Sta. Mgr. Harold P. Kane
 Program Director William Winn
 Commercial Manager Richard F. Rose
 Chief Engineer Burlon O. Waterman

W J T N

JAMESTOWN—1924—ABC

Frequency: 1240 Kc. Power: 250 Watts
 Owned-Operated By James Bcstg. Co., Inc.
 Bus.-Studio Address Hotel Jamestown
 Phone Number 7-151
 Air Time 6 a.m.-M.
 News Service UP

Transcription Service... Associated, McGregor
 Representative Taylor
 Membership NARTB, BAB
 President Jay E. Mason
 Gen.-Sta., Comm. Simon Goldman
 Program Director George Pileeger
 Publicity Dir. Jess Price
 Chief Engineer Harold J. Kratzert

W K N Y

KINGSTON—1939—MBS

Frequency: 1490 Kc. Power: 250 Watts
 Owned-Oper. By Kingston Bcstg. Corp.
 Business-Studio Address 601 Broadway
 Phone Number Kingston 4500
 Air Time Full Time
 News Service UP
 Representative Meeker
 Membership BAB, NARTB
 President Joseph K. Close
 General, Station Mgr. Robert M. Peebles
 Program Director Ernest Ward
 Publicity Director Richard McCarthy
 Chief Engineer Carl Egoli

W V O S

LIBERTY—1947

Frequency: 1240 Kc. Power: 250 Watts
 Owned-Oper. By Sullivan County Bcstg. Co.
 Phone Number 1680-1
 Air Time 6:58 a.m.-12 M.
 News Service UP
 Pres., Gen. Mgr. S. D. Lubin
 Commercial Mgr. H. G. Borwick
 Chief Engineer Robert Gessner

W L F H

LITTLE FALLS—1952—MBS

Frequency: 1230 Kc. Power: 250 Watts
 Owned-Oper. By Radio City Bcstrs.
 Address S. 2nd St.
 Phone Number 654
 News Service AP
 Representative McGillvra
 President Arthur Feldman
 Vice-President Robert Feldman
 Gen. Mgr., Comm. Mgr. James M. Bryant
 Chief Engineer Henry Darco

W U S J

LOCKPORT—1949

Frequency: 1340 Kc. Power: 250 Watts
 Owned-Oper. By Union-Sun & Journal, Inc.
 Trans.-Address 320 Michigan St.
 Phone Number 3-5944
 News Service AP
 Transcription Service World
 Newspaper Affil. "Union Sun & Journal"
 Representative Gill, Perna
 Membership NARTB
 President Egbert D. Corson
 Gen., Sta. Mgr. Jack Gelzer
 Chief Engineer Richard Weatherbee

WICY

MALONE—1946—MBS-KBS

Frequency: 1490 Kc. Power: 250 Watts
 Owned-Oper. By... North Country Bcstg. Co.
 Trans. Address... Malone Radio Center
 Phone Number... 187
 Air Time... 7 a.m.-11:15 p.m.
 News Service... UP
 Pres., Gen. Sta. Mgr... Mitchell C. Tackley
 Commercial Manager... Alice M. Tackley
 Program Director... Donald J. Payo
 Chief Engineer... John Gilchreist

WMSA

MASSENA—1945—ABC

Frequency: 1340 Kc. Power: 250 Watts
 Owned-Operated By... The Brockway Co.
 Business Address... Central Bldg.
 Phone Number... 990
 Air Time... 6:15 a.m.-12:05 a.m.
 News Service... UP
 Transcription Service... Thesaurus
 Representative... Weed
 Membership... NARTB, BAB
 President... John B. Johnson
 General Manager... Louis Saiff, Jr.
 Station Manager... Thomas R. McHugh
 Program Director... James H. Nash
 Chief Engineer... Michael Tarkulich

WALL

MIDDLETOWN—1942

Frequency: 1340 Kc. Power: 250 Watts
 Owned-Oper. By... The Community Bcstg. Corp.
 Business-Studio Address... 62 North St.
 Phone Number... Middletown 3119
 News Service... AP
 Pres., Gen., Comm. Mgr... James M. Patt
 Program Director... Jerry Wax
 Chief Engineer... Charles E. Lissner

WGN Y

NEWBURGH—1933

Frequency: 1220 Kc. Power: 1000 Watts d.
 Owned-Oper. By... Orange County Bcstg. Co.,
 Inc.
 Business-Studio Address... 161 Broadway
 Phone Number... Newburgh 4600
 News Service... AP
 Membership... BAB
 Pres., Gen. Mgr... George W. Bingham
 Commercial Manager... Joseph Rake
 Chief Engineer... Marvin S. Seimes

WNRC

NEW ROCHELLE—1953

Frequency: 1460 Kc. Power: 500 Watts d.

Owned-Oper. By... Radio New Rochelle, Inc.
 Address... 411 Fifth Ave.
 Phone Number... New Rochelle 6-0800
 News Service... AP
 President... James A. Iodice
 Sta. Mgr., Chief Eng... Morton Morrison
 Program Director... Kenneth Johnston

WABC

NEW YORK—1921—ABC

Frequency: 770 Kc. Power: 50,000 Watts
 Owned-Oper. By... American Bcstg. Co., Inc.
 Business Address... 7 West 66th St.
 Phone Number... SU 7-5000
 Air Time... 24 hours
 News Service... AP, INS
 Representative... Edward Pety & Co.
 President... Robert E. Kintner
 Vice-Pres., Gen. Mgr... Ted Oberfelder
 Commercial Manager... Mike Renault
 Publicity Director... Miles Eiten
 Program Manager... Myrtle Tower
 Sales Prom. Mgr... Willis Parsons
 Chief Engineer... John Bourcier

WBNX

NEW YORK—1927

Frequency: 1380 Kc. Power: 5000 Watts
 Owned-Operated By... WBNX Bcstg. Co., Inc.
 Bus.-Studio Address... 260 E. 161st St., Bronx
 Phone Number... MELrose 5-0333
 News Service... AP
 Transcription Service... SESAC
 Representative... King
 President... A. L. Haskell
 V.P., Sta.-Gen. Manager... William I. Moore
 Production Director... Frank Johnson

WCBS

**NEW YORK—1924—CBS
 RADIO**

Frequency: 880 Kc. Power: 50,000 Watts
 Owned By... Columbia Bcstg. System, Inc.
 Operated By... CBS Radio Division
 General Studio Address... 485 Madison Ave.
 Phone Number... PLaza 1-2345
 Air Time... Unlimited
 News Service... AP, INS, UP
 Transcription Service... Capitol
 Representative... CBS Radio Spot Sales
 Membership... BAB
 President of CBS... Frank Stanton
 General Manager... Carl Ward
 Sales Manager... Henry Untermyer
 Sales Service Manager... Mike Campbell
 Sales Prom. Mgr... Don Foley
 Program Director... Sam Slate
 Public Affairs Dir... D. Gordon Graham
 Publicity Director... Milton Rich



**W
H
O
M**

NOW 8 HOURS IN SPANISH

**ALL THE STARS
ARE ON WHOM
NEW YORK'S FOREMOST
FOREIGN LANGUAGE
STATION**



The El Progreso Station

**ATLANTIC BROADCASTING COMPANY, INC.
136 WEST 52nd STREET, NEW YORK 19, N. Y.**

WEVD

NEW YORK—1927

Frequency: 1330 Kc. Power: 5000 Watts
 Owned-Oper. By. Debs Memorial Radio Fund
 Business-Studio Address. 117 W. 46th St.
 Phone Number. Plaza 7-0880
 News Service AP
 President Adolph Held
 Gen. Sta. Comm. Mgr. Henry Greenfield
 Program Director George Field
 Chief Engineer Charles Brown

WHOM

NEW YORK—1930

Frequency: 1480 Kc. Power: 5000 Watts
 Owned-Oper. By. Atlantic Bcstg. Co., Inc.
 Business Address. 136 W. 52nd St.
 Phone Number. Circle 6-3900
 News Service UP
 President Fortune Pope
 V.P. Chge. Sales Charles Baltin
 Program Director Ralph Constantino
 Chief Engineer George Steiger

WINS

NEW YORK—1926

Frequency: 1010 Kc. Power: 50,000 Wtts
 Owned-Oper. By. Gotham Bcstg. Corp.
 Address. 28 W. 44th St.
 Phone Number. BRyant 9-6000
 News Service INS, UP
 Transcription Service Associated
 President J. Elroy McCaw
 Gen. Mgr. Robert Leder
 Commercial Mgr. Harry G. Kirwan
 Program Director Robert Smith
 Chief Engineer Paul von Kunitz

WLIB

NEW YORK—1942

Frequency: 1190 Kc. Power: 1000 Watts d.
 Owned-Operated By. New Bcstg. Co., Inc.
 Business-Studio Address. 207 E. 30th St.
 Phone Number. ORegon 9-2720
 News Service AP
 Representative Forjoe
 President Morris S. Novik
 Gen. Sta. Mgr. Harry Novik
 Program Director Nat Rudich
 Chief Engineer John J. Bubbers

(See Page 508)

WMCA

NEW YORK—1925

Frequency: 570 Kc. Power: 5000 Watts
 Owned-Operated By. WMCA, Inc.
 Business-Studio Address. 1657 Broadway
 Phone Number. Circle 6-2200
 News Service AP
 Transcription Service World
 Representative AM Radio Sales
 President Nathan Straus

General Manager. M. M. Fleischl
 Program Director. Leon Goldstein
 Sales Mgr. John J. McSweeney
 Chief Engineer. James McCafferty

WMGM

NEW YORK—1922

Frequency: 1050 Kc. Power: 50,000 Watts
 Owned-Oper. By. Marcus Loew Booking Agcy.
 Business-Studio Address. 711 Fifth Ave.
 Phone Number. MUrray Hill 8-1000
 News Service UP, AP
 Representative Radio Reprs.
 Director. Bertram Lebharr, Jr.
 General Manager. Frank Roehrenbeck
 Sales Manager. Arthur M. Tolchin
 Program Director. Raymond Katz
 Chief Engineer. Paul Fuelling

WNBC

NEW YORK—1922—NBC

Frequency: 660 Kc. Power: 50,000 Watts
 Owned-Oper. By. National Bcstg. Co., Inc.
 Bus. Studio Address. 30 Rockefeller Plaza
 Phone Number. Circle 7-8300
 Transmitter Location. Port Washington
 News Service AP, INS, UP
 Transcription Service Thesaurus
 Representative. NBC Spot Sales
 Membership NARTB, BAB
 President Sylvester Weaver
 General Manager. Hamilton Shea

WHY ADVERTISERS RENEW CONTRACTS

with

WEVD AM 1330 K.C. 5 K.W.
 FM 97.9 20 K.W.

For more than twenty years some of the foremost national and local advertisers have renewed their contracts with WEVD to reach the Jewish population of the New York Metropolitan area.

Here they find an amazing market of vast buying power, represented by more than 600,000 families with a population exceeding 3,000,000.

To this adult listening audience WEVD's selected cultural, educational and entertainment features in Jewish and in English are an eager "must" on the dial.

Through the years advertisers have proved the loyalty of WEVD's unique audience . . . it stays tuned to WEVD . . . it responds quickly to quality . . . it has the means to buy.

That is the ONLY reason why sponsors renew their WEVD contracts year after year.

Advertisers who wish to cover the Metropolitan New York area need the voice of WEVD. Send for Your copy of the distinguished roster of

WHO'S WHO AMONG WEVD's SPONSORS

All Programs Broadcast on
 AM and FM Simultaneously

Henry Greenfield, Managing Director

WEVD 117-119 West 46th Street
 New York 36, N. Y.

A carbon copy is never quite as good as the ORIGINAL

A carbon copy is never quite as good as the ORIGINAL

the original...

WNEW

1130 | ON YOUR DIAL

565 Fifth Avenue, New York 17, N. Y.

Commercial Manager.....George Stevens
 Promotion Mgr.....John Hurlbut
 Program Director.....Richard Pack
 Publicity Mgr.....Bill Anderson
 Chief Engineer.....Gerald Sellar

Co-ordinator of Operations.....John Jaeger
 Chief Engineer.....Max Welner

W N E W
NEW YORK—1934

Frequency: 1130 Kc....Power: 50,000 Watts d.;
 10,000 Watts n.
 Owned-Operated By.....WNEW, Inc.
 Business-Studio Address.....565 Fifth Ave.
 Phone Number.....PLaza 3-3300
 Air Time.....24 Hours
 Transcription Service.....Lang-Worth
 Representative.....John Blair
 President.....William S. Cherry, Jr.
 Exec. V.P., Gen. Mgr.....Bernice Judis
 V.P., Sales Director.....Ira Herbert
 Promotion Manager.....Kenneth Klein
 Program Director.....William Kaland

W O R

NEW YORK—1922—MBS

Frequency: 710 Kc.....Power: 50,000 Watts
 Owned-Oper. By.....General Teleradio, Inc.
 Business-Studio Address.....1440 Broadway
 Phone Number.....LOngacre 4-8000
 Air Time.....Full Time
 News Service.....AP, UP
 Transcription Service.....Associated
 Representative.....H-R Reps.
 Membership.....NARTB, BAB
 President.....Thomas F. O'Neil
 General Manager.....Gordon Gray
 Director of Sales.....Robert Mayo
 Sales Prom. Mgr.....Robert Sullivan
 Program Director.....Lawrence Menkin
 Publicity Manager.....Richard Jackson
 Chief Engineer.....Charles Singer

(See Page 298)

The Red Cross Needs

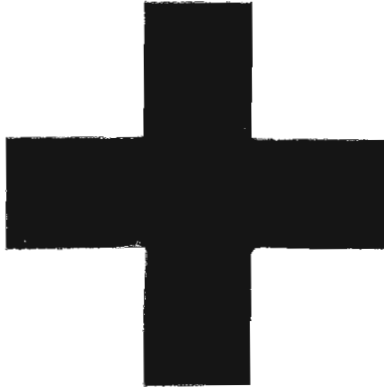

Your Unstinting Assistance

GIVE!

WLIB

1000 WATTS "1190 ON THE DIAL"

THE ONLY STATION IN
N. Y. WITH STUDIOS IN
HARLEM.

MORE NEGRO LISTENERS
IN A.M. THAN ANY OTHER
N. Y. STATION—PULSE

PROGRAM

NEGRO TIME (6:30 A.M. to 12 Noon
) 5:30 P.M. to sign off

RHYTHM AND BLUES • SPIRITUALS
32 COMMUNITY NEWS PROGRAMS
SPECIAL EVENTS, JAZZ, POPS, ETC.

ANGLO-JEWISH TIME — 4 to 5:30 P.M.

WLIB

"1190 ON THE DIAL"

POWERFUL NEW TRANSMITTER
ON AIR FEBRUARY 15, 1954
WALTER WHITE SHOW
SYNDICATED NATIONALLY

NEGRO POPULATION OF GREATER
NEW YORK IS 1,012,883—CENSUS

WLIB

"1190 ON THE DIAL"

ALSO SERVING 700,000
ENGLISH-SPEAKING JEWISH
FAMILIES — COST 7½ CENTS
PER 1000 LISTENERS — PULSE

— STARRING —

LLOYD WILLIAMS

HAL JACKSON

"HARLEM SERENADE"
LARRY FULLER

"HOUSE THAT
JACK BUILT"
CHAS CAMPBELL

"GOSPEL TRAIN"
"COMMUNITY NEWS"

— STARRING —

THE BOWSERS

BUDDY and SARA LOU

NEWS

NEWS

G. JAMES FLEMING

WALTER WHITE

HARRY NOVIK

General Manager — 207 East 30 St., N. Y. 17, N. Y.

PHONE: ORegon 9-2720

See pages 100-101 for

LISTING OF NEW YORK PHONE NUMBERS



NETWORKS



PUBLICATIONS



ORGANIZATIONS



TALENT AGENCIES



FM RADIO STATIONS



AM RADIO STATIONS



NEWS ASSOCIATIONS



TELEVISION STATIONS



PROGRAM PRODUCERS



RECORDING COMPANIES



ADVERTISING AGENCIES



TRANSCRIPTION COMPANIES



STATION REPRESENTATIVES



The Italian Influence

In every phase of American life, Italian creativeness plays a leading role in satisfying our demands for better living. From music to motor cars, from fashions and furniture to films and food, we eagerly accept the good things the Italian Influence brings us. Here in New York, with more than two million Americans of Italian origin, the Italian influence makes its most penetrating impact. Let WOV show you how to direct this influence to the profit of the product you advertise.

One of America's Important Stations
WOV
NEW YORK
5000 WATTS

Representatives:
John E. Pearson Co.

730 FIFTH AVE., NEW YORK 19 • ROME STUDIOS: VIA di PORTA PINCIANA 4

W O V**NEW YORK—1926**

Frequency: 1280 Kc.....Power: 5000 Watts
 Owned-Operated By.....Wodaam Corp.
 Business-Studio Address.....730 Fifth Ave.
 Phone Number.....Circle 5-7979
 Air Time21 hrs.

News ServiceAP
 Transcription Service Standard...MacGregor
 RepresentativePearson
 President.....Richard E. O'Dea
 General Manager.....Ralph N. Well
 Commercial Manager.....Joseph N. Curl
 Sales Promotion Mgr.....Carroll Forbes
 Program Director.....Arnold Hartley
 Chief Engineer.....Emile Hill

FOR THE

WHLI Story

AND

PERSONNEL ROSTER

SEE

PAGES 500-501

Why WQXR is more than a radio station to 600,000 families

It's because WQXR means something very special and personal to its listeners.



It's because WQXR provides New York's *only* consistent source of good music. It's because WQXR's listeners tune to it as a *station*, not just for a special program.

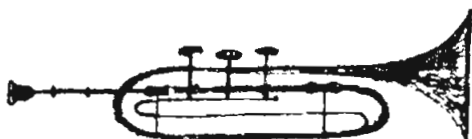

It's all summed up by the reaction you get whenever you mention WQXR: "Oh, that's my *favorite station!*"



This very personal listener loyalty brings very generous results to WQXR advertisers. This year nearly 300 of them have found out how the nation's No. 1 good music station in the nation's No. 1 market pays off in more sales for them. Let us tell you more!

WQXR AM • FM

The Radio Station of The New York Times

"Always the Best in Music"

229 West 43 Street • New York 36, N. Y. • LA 4-1100

W Q X R
NEW YORK—1936

Frequency: 1560 Kc. Power: 50,000 Watts
Owned-Operated By..... Interstate Bcstg. Co.
Business-Studio Address..... 229 W. 43rd St.
Phone Number..... LA. 4-1100
News Service..... N. Y. Times (Owner)
Transcription Service..... Associated, SESAC
Representative..... Paul H. Raymer
President..... Arthur Hays Sulzberger
Exec. V.P., Gen. Mgr..... Elliott M. Sanger
V.P. Sales Mgr..... Norman S. McGee
Sales Prom. Dir..... Mary Rice Anderson
Program Director..... Eleanor N. Sanger
Chief Engineer..... L. J. Kleinklaus

W H L D

NIAGARA FALLS—1940—RRN

Frequency: 1270 Kc. Power: 5000 Watts d.
Owned-Oper. By..... The Niagara Falls Gazette
Publishing Co.
Business-Studio Address..... Hotel Niagara
Phone Number..... 8421
News Service..... UP
Transcription Service..... Associated, Standard
Representative..... Headley-Reed
Membership..... NARTB
V.P., Gen. Station Mgr..... Earl C. Hull
Commercial Manager..... Richard G. Robbins
Chief Engineer..... Robert Wilson

W J J L

NIAGARA FALLS—1947

Frequency: 1440 Kc. Power: 1000 Watts d.
Owned-Oper. By..... John J. Laux
Phone Number..... 5266
News Service..... UP
Transcription Service..... SESAC
Representative..... Pearson
Gen., Comm. Mgr..... Tom W. Talbot
Program Director..... Helen Tubbs
Chief Engineer..... Gustav Czaplak

W C H N

NORWICH—1952

Frequency: 970 Kc. Power: 500 Watts d.
Owned-Oper. By..... Radio Norwich, Inc.
Address..... 14 S. Broad St.
Phone Number..... 4-2218
News Service..... UP
Pres., Gen. Mgr..... William J. Hall
Pub. Dir., Comm. Mgr..... G. R. Perkins
Chief Engineer..... William M. Bush

W S L B

OGDENSBURG—1940—MBS-KBS

Frequency: 1400 Kc. Power: 250 Watts
Owned-Oper. By..... St. Lawrence Bcstg. Corp.
Address..... 2315 Knox St.
Phone Number..... 500
News Service..... UP
President..... Joseph R. Brandy

General Manager..... Harold J. Frank
Program Director..... Hal Gilman
Chief Engineer..... Ellsworth Hall

W H D L
OLEAN—1929—ABC

Frequency: 1450 Kc. Power: 250 Watts
Owned-Operated By..... WHDL, Inc.
Address..... 3219 State St.
Phone Number..... 4149
Newspaper Affiliation..... Times Herald
News Service..... AP
Transcription Service..... Associated
Representative..... Everett & McKinney
Membership..... NARTB, BAB
Pres., Gen. Sta. Mgr..... John R. Henzel
Commercial Manager..... James F. Hastings
Program Director..... Donald W. Merriman
Chief Engineer..... Parker H. Vincent

W D O S

ONEONTA—1947—MBS

Frequency: 1400 Kc. Power: 250 Watts
Owned-Oper. By..... Ottoway Stations, Inc.
Bus. Studio Address..... 104 Chestnut St.
Phone Number..... 2470
Air Time..... 6 a.m.-M.
News Service..... UP
Newspaper Affiliation..... Daily Star
Transcription Service..... Associated
Representative..... Radio Reps.
Membership..... BAB
President..... James H. Ottaway
Managing Director..... Francis H. Brinkley
Station Manager..... Harold E. Graves
Program Director..... Howard Atwell
Chief Engineer..... Wiley Bates

W K B S

OYSTER BAY—1948

Frequency: 1520 Kc. Power: 250 Watts d.
Owned-Oper. By..... Key Bcstg. System Inc.
Phone Number..... Oyster Bay 6-2500
News Service..... UP
Transcription Service..... MacGregor
Pres., Gen. Mgr., Chief Engr.
R. Lee Hollingsworth

W A L K

PATCHOGUE—1952

Frequency: 1370 Kc. Power: 500 Watts d.
Owned-Oper. By..... Suffolk Bcstg. Corp.
Address..... P. O. Box 230
Phone Number..... Patchogue 3-0408
News Service..... AP
Newspaper Affiliation..... Suffolk Cons. Press
Transcription Service..... Associated, Capitol
Membership..... NARTB
Pres., Gen. Mgr..... Nils E. Segerdahl
Vice-President..... W. K. Macy, Jr.
Chief Engineer..... George Chandler

WPAC

PATCHOQUE—1951

Frequency: 1580 Kc. Power: 250 Watts d.
 Owned-Oper. By: Patchogue Bcstg. Co.
 Address: 2 E. Main St.
 Phone Number: Patchogue 3-4600
 News Service: UP
 Pres., Gen. Mgr.: Lee Morrison
 Sta., Comm. Mgr.: Herbert Morrison
 Sales Prom. Mgr.: Don Lombardy
 Program Director: Stan Allan
 Chief Engineer: Morton Morrison

WLNA

PEEKSKILL—1948

Frequency: 1420 Kc. Power: 1000 Walls d.
 Owned-Oper. By: Highland Bcstg. Corp.
 Trans. Address: Radio Terrace
 Phone Number: Peekskill 7-1124
 News Service: UP
 Transcription Service: SESAC, World
 Membership: NARTB
 President: Peter C. Housekeeper
 General Manager: Irving E. Cottrell
 Comm., Sales Prom. Mgr.: Francis Lough

WEAV

PLATTSBURG—1935—ABC

Frequency: 960 Kc. Power: 1000 Watts
 Owned-Oper. By: Plattsburg Bcstg. Corp.
 Studio Address: 153 Margaret St.
 Phone Number: 1600
 News Service: UP
 Transcription Service: World
 Representative: Gill-Perna
 Membership: NARTB, BAB
 Pres., Gen. Mgr.: George F. Bissell
 Program Director: Ray Turner
 Commercial Mgr.: Jack Charles
 Chief Engineer: Larry Lapanne

WIRY

PLATTSBURG—1950—MBS-KBS

Frequency: 1340 Kc. Power: 250 Watts
 Owned-Oper. By: Clinton Cty. Bcstg. Corp.
 Trans. Loca. Address: 301 03 Cornelia St.
 Phone Number: Plattsburg 2800
 Air Time: 6:30 a.m.-12:05 a.m.
 News Service: AP
 Transcription Service: Associated
 Representative: W. S. Grant Co., Inc.
 Membership: NARTB, BAB
 Pres., Gen., Comm. Mgr.: Joel H. Scheier
 Sales Prom. Mgr.: Martin D. Mannix
 Program Director: Betty Kraus
 Chief Engineer: John M. Nazak

WDLC

PORT JERVIS—1953

Frequency: 1490 Kc. Power: 100 Watts
 Owned-Oper. By: Port Jervis Bcstg. Co.
 Address: Horn Road
 Phone Number: 3-3311
 Representative: Cooke
 President: William H. Ware
 General Manager: Ernest C. Walker
 Commercial Mgr.: Oscar Wein
 Program Director: Henry Schwartz
 Chief Engineer: Herbert Stein

WEOK

POUGHKEEPSIE—1949

Frequency: 1390 Kc. Power: 1000 Watts, d.
 Owned-Operated By: Mid-Hudson Bcsts. Inc.
 Business-Studio Address: 385 Main St.
 Phone Number: 8300
 News Service: UP
 Transcription Service: Thesaurus
 Representative: Everett-McKinney
 Membership: NARTB, BAB
 Pres., Gen. Mgr.: Arthur J. Barry, Jr.
 Chief Engineer: John P. Burke

WKIP

POUGHKEEPSIE—1940—ABC

Frequency: 1450 Kc. Power: 250 Watts
 Owned-Oper. By: Dutchess County
 Broadcasting Corp.

1000 W WEAV 960 KC

ABC • PLATTSBURG, N. Y.

SELLS THE RICH Champlain Valley, including rich
 Clinton, Essex, and Franklin Counties . . .
 . . . a fast growing, fertile market for your
 product's soles.
 . . . a natural test market.

Retail Sales Almost Tripled in 10 Years

250 W WENT 1340 KC

GBS • GLOVERSVILLE-JOHNSTOWN, N. Y.

The 'Local', 'Most Popular' Station Throughout
 rich Fulton and Montgomery Counties. Has
 dominated listening in Gloversville-Johnstown
 and surrounding area. Throughout the week more
 families in this area listen to WENT . . . making
 WENT a natural for your sales messages beamed
 to the prosperous families in this rich 2-county
 market.

*WENT means consistently high listenerhip and
 best results for advertisers.*

*WENT can sell the rich Gloversville-Johnstown
 area for you.*

GILL-PERNA, INC.

National Representative

Business-Studio Address.....Box 889
 Phone Number.....6800
 Air Time.....Full Time
 News Service.....AP
 Transcription Service.....Associated
 Membership.....NARTB, BAB
 Pres., Gen. Mgr.....George W. Bingham
 Commercial Manager.....Richard A. Dwelley
 Program Director.....John Kuhn
 Chief Engineer.....Marvin S. Seimes

W B B F

ROCHESTER—1947—MBS

Frequency: 950 Kc.....Power: 1000 Watts
 Owned-Oper. By.....WBBF, Inc.
 Bus-Studio Address.....Sheraton Hotel
 Phone Number.....HAMilton 8920
 Air Time.....Full Time
 News Service.....AP
 Representative.....Cooke
 Transcription Service.....Thesaurus
 President.....Thomas L. Brown
 Commercial Mgr.....Lloyd B. Gibson
 Sales Prom. Mgr.....Claude Johnstone
 Program Director.....Nick Nickson
 Chief Engineer.....Vincent Lopopolo

W H A M

ROCHESTER—1922—NBC

Frequency: 1180 Kc.....Power: 50,000 Watts
 Owned-Operated By.....Stromberg-Carlson Co.
 Business Address.....201 Humboldt St.
 Phone Number.....Culver 7240
 Air Time.....Full Time
 News Service.....UP
 Transcription Service.....World
 Representative.....George P. Hollingbery
 Membership.....NARTB
 Sta., Gen. Mgr.....William Fay
 Commercial Manager.....John W. Kennedy, Jr.
 Program Director.....Charles W. Siverson
 Publicity Director.....Terry David
 Chief Engineer.....Kenneth Gardner

W H E C

ROCHESTER—1925—CBS

Frequency: 1460 Kc.....Power: 5000 Watts
 Owned-Operated By.....WHEC, Inc.
 Business-Studio Address.....40 Franklin St.
 Phone Number.....Baker 6740
 News Service.....AP
 Representative.....Everett McKinney
 Membership.....NARTB, BAB
 President.....Frank E. Gannett
 General Manager.....Glover Delaney
 Commercial Manager.....Le Moine C. Wheeler
 Program Director.....William J. Adams
 Chief Engineer.....Bern C. O'Brien

WRNY

ROCHESTER—1947

Frequency: 680 Kc.....Power: 250 Watts d.
 Owned-Oper. By.....Rochester Bcstg. Co., Inc.
 Business-Studio Address.....191 East Ave.

Phone Number.....Hamilton 9775
 News Service.....AP
 Transcription Service.....Associated, etc.
 Representative.....Stars Natl.
 Membership.....NARTB, BAB
 President.....S. J. Bachman
 Gen., Sta. Mgr.....J. A. Shefrin
 Program Director.....Fred Bethel
 Chief Engineer.....H. E. Kane

W S A Y

ROCHESTER—1936

Frequency: 1370 Kc.....Power: 1000 Watts
 Owned-Oper. By.....Federal Bcstg. System, Inc.
 Business-Studio Address.....328 Main St. E.
 Phone Number.....Baker 4870
 News Service.....INS
 Representative.....Walker
 Pres., Gen. Mgr.....Gordon P. Brown
 Station Director.....John Hill

W V E T

ROCHESTER—1947—ABC

Frequency: 1280 Kc.....Power: 5000 Watts
 Owned-Oper. By.....Veterans Bdcstg. Inc.
 Address.....17 Clinton Ave So.
 Phone Number.....HAMilton 4820
 Air Time.....Unlimited
 News Service.....UP
 Transcription Service.....Associated
 Representative.....The Bolling Co., Inc.
 Pres., Gen. Mgr., Chf. Engr.....Ervin F. Lyke



ROCHESTER, NEW YORK

THE BEST IN MUSIC

AM — All Day Long
 FM — All Day & Evening

5 MUSIC LIBRARIES

1. Thesaurus
2. Standard
3. Associated
4. Sescac
5. Capitol

Jack Shefrin Fred Bethel
 General Manager Program Director

A BACHMAN ENTERPRISE

"Rochester's Prestige Station"

Nationally Represented By STARS NATIONAL, INC.

In this 5-Station Market,

WSYR is FIRST

Any way you look at it

PULSE OF SYRACUSE
April, 1953

72 15-Min. Periods, 6 a.m. to Midnight
WSYR FIRST ... in 50 periods
WSYR SECOND in 22 periods
72
(that's all there is!)

NIELSEN 1952

WSYR FIRST
by 47% to 212%

SAMS 1952

WSYR FIRST
by 29.8% to 239%

WSYR ACUSE
570 KC

NBC Affiliate • Write, Wire, Phone or
Ask Headley-Reed

WSYR-AM-FM-TV — the Only Complete Broadcast Institution in Central New York

Radio Sales Mgr. Elmer J. Walz
 Gen. Sales Mgr. Arthur Murrellwright
 Program Director Paul C. Louther

WKAL

ROME—1946—MBS

Frequency: 1450 Kc. Power: 250 Watts
 Owned-Oper. By Copper City Bcstg. Corp.
 Business-Studio Address Capitol Theatre Bldg.
 Phone Number 3616-7
 Air Time 6:30 a.m.—12 M.
 News Service UP
 Transcription Service Lang-Worth
 Representative Rambeau
 Membership BAB
 President Myron J. Kallet
 General Manager Charles King
 Commercial Manager Joseph Trela
 Program Director Louis Barile
 Chief Engineer James Delaney

WNBZ

SARANAC LAKE—1927—ABC

Frequency: 1450 Kc. Power: 250 Watts
 Owned-Operated By Upstate Bcstg. Corp.
 Business-Studio Address 88 Main St.
 Phone Number 1320
 Air Time 7:15 a.m.—11:15 p.m.
 News Service AP
 Transcription Service World
 Representative Wm. G. Rombeau
 Membership NARTB, BAB
 Pres., Gen. Mgr. Jacques DeMattos
 Chief Engineer H. Berwind Williams

WGY

SCHENECTADY—1922—NBC

Frequency: 810 Kc. Power: 50,000 Watts
 Owned-Oper. By General Electric Co.
 Business-Studio Address 1 River Rd.
 Phone Number Schenectady 7-2261
 Air Time Unlimited
 News Service AP, UP
 Transcription Service Thesaurus
 Representative Henry I. Christal
 Membership NARTB, BAB
 General Manager R. B. Hanna, Jr.
 Station Operations Mgr. R. W. Welpott
 Supervisor of Sales Robert F. Reid
 Promotion Mgr. James Cobb
 Spvr. of Programs A. G. Zink
 Mgr. of Engineering W. J. Purcell

WSNY

SCHENECTADY—1942

Frequency: 1240 Kc. Power: 250 Watts
 Owned-Oper. By Western Gateway Bcstg.
 Business-Studio Address 619 State St.
 Phone Number 3-3622
 News Service AP
 Transcription Service Lang-Worth
 Membership BAB
 President, Gen. Mgr. Winslow Leighton
 Comm., Sls. Prom. Mgr. Thomas Seeley
 Chief Engineer Irving P. Beck

WAGE

SYRACUSE—1941—ABC

Frequency: 620 Kc. Power: 5000 Watts d.,
 1000 Watts n.
 Owned-Operated By WAGE, Inc.
 Business-Studio Address Loew Bldg.
 Phone Number 2-0277
 Air Time Full Time
 News Service AP
 Representative O. L. Taylor
 Pres., Gen. Mgr. Frank G. Revoir
 Commercial Mgr. L. N. Parmentier
 Program Director George Drisko
 Chief Engineer Donald F. Langham

WFBL

SYRACUSE—1922—CBS

Frequency: 1390 Kc. Power: 5000 Watts
 Owned-Oper. By Onondaga Radio Bcstg.
 Bus.-Studio Address 433 S. Warren St.
 Phone Number 2-1147
 Air Time Full Time
 News Service UP
 Representative Free & Peters
 Membership NARTB, BAB
 President Oscar F. Soule
 General Manager Samuel Woodworth
 Commercial Mgr. Charles Phillips
 Sales Prom. Mgr. Lennox White

WNDR

SYRACUSE—1946

Frequency: 1260 Kc. Power: 5000 Watts
 Owned-Oper. By Syracuse Bcstg. Corp.
 Address Box 1212
 Phone Number 72-3366
 Gen., Sta. Mgr. Arthur C. Kyle, Jr.
 Comm., Prom. Mgr. Melvyn Silvieus

WOLF

SYRACUSE—1940

Frequency: 1490 Kc. Power: 250 Watts
 Owned-Operated By Civic Bcstg. Corp.
 Bus.-Studio Address Kirkpatrick & Van
 Rensselaer Sts.
 Phone Number 2-7211
 Air Time Full Time
 Transcription Service Standard
 Representative Walker
 President, General Mgr. T. Sherman Marshall
 Sta. Mgr., Prog. Dir. Hamilton M. Woodle
 Chief Engineer Don Muir

WSYR

SYRACUSE—1926—NBC

Frequency: 570 Kc. Power: 5000 Watts
 Owned-Operated By Central N. Y. Bcstg.
 Phone Number SY 3-7111
 Bus.-Studio Address 224 Harrison St.
 Air Time 5 a.m.—M.
 News Service UP
 Transcription Service Lang-Worth
 Representative Headley-Reed

Membership NARTB, BAB
 Pres., Gen. Mgr. E. R. Vadeboncoeur
 Director of Sales W. R. Allford, Jr.
 Sales Prom. Mgr. Thomas McCollum
 V.P., Pgm. Dir. Bill Rothrum
 V.P., Chief Engineer Armand Bell Isle

WTRY

TROY—1940—CBS

Frequency: 980 Kc. Power: 5000 Watts
 Owned-Oper. By Troy Bcstg. Co., Inc.
 Business-Studio Address 92 Fourth St.
 Phone No. Albany 4-2500, Ashley 4-1100
 Air Time 6 a.m.-1 a.m.
 News Service UP
 Transcription Service Capitol
 Representative Headley-Reed
 Membership NARTB, BAB
 President H. C. Wilder
 General Manager W. W. Carter
 Commercial Manager E. M. Sleighel
 Sales Prom. Mgr., Pub. Dir. James F. Baker, Jr.
 Program Director Randolph English
 Chief Engineer A. H. Chismark

WGAT

UTICA—1947

Frequency: 1310 Kc. Power: 1000 Watts d.:
 500 Watts n.
 Owned-Operated By Central Bcstg. Co.
 Phone Number 2-9231

President J. Eric Williams
 General Manager John C. Davies
 Chief Engineer William Routh

WIBX

UTICA—1925—CBS

Frequency: 950 Kc. Power: 5000 Watts
 Owned-Oper. By WIBX, Inc.
 Address First Bank Bldg.
 Phone Number 2-2101
 News Service UP
 Transcription Service World
 Reps. Colton, Bannan, Biddick, Clark
 Membership NARTB, BAB
 Pres., Gen. Mgr. Mrs. Margaret B. Stevens
 Exec. V.P., Sta. Mgr., Pgm. Dir. Elliott Stewart
 Production Director Betty Cushing Griffin
 Comm. Mgr., Pub. Dir. Nathan W. Cook
 Merchandising Mgr. F. C. Bowen
 V.P., Secretary Gladys P. Moore
 Chief Engineer John T. Dowdell

WRUN

UTICA—ROME—1948—ABC

Frequency: 1150 Kc. Power: 5000 Watts d.:
 1000 Watts n.
 Owned-Oper. By The Rome Sentinel Co.
 Business-Studio Address 136 N. James St.
 Phone Number 4-2245
 Representative Avery-Knodel
 President Bradley C. Barnard
 General Manager Fritz S. Uptdike

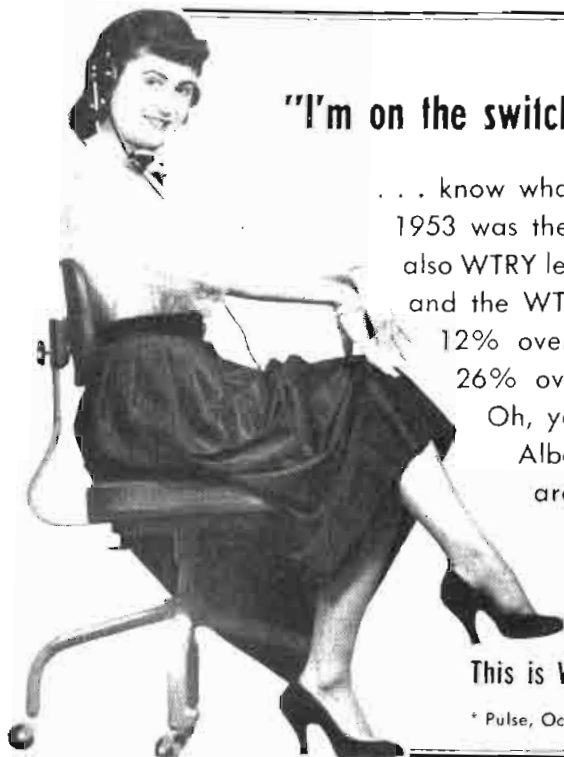

"I'm on the switchboard at Station WTRY

... know what they're all talking about?
 1953 was the best year for WTRY sales,
 also WTRY leads 45 of 72 daily ¼ hours,*
 and the WTRY audience has increased:
 12% over 1952 in the daytime,
 26% over 1952 in the night time.
 Oh, yes! Retail sales per home in
 Albany, Troy and Schenectady
 are over 50% above national
 average . . .

Worth talking about, isn't it?

This is WTRY, the CBS Radio Network"

* Pulse, Oct. '53

Program Director..... Edward M. Stemmler
 Sta., Comm. Mgr..... Richard A. Clark
 Chief Engineer..... George S. Woods

WDLA
WALTON—1951

Frequency: 1270 Kc..... Power: 1000 Watts d.
 Owned-Oper. By..... Delaware County Bcstg.
 Address..... Bear Spring Mt.
 Phone Number..... 1270
 Representative..... Rambeau
 Pres., Gen. Mgr..... E. Ogden Bush
 Chief Engineer..... Robert Devine

WATN
WATERTOWN—1941—MBS

Frequency: 1240 Kc..... Power: 250 Watts
 Owned-Oper. By..... Watertown Bcstg. Corp.
 Bus. Studio Location..... 118 Washington St.
 Phone Number..... 2424
 Transcription Service..... Standard, SESAC
 Membership..... NARTB
 Pres., Gen. Mgr..... G. Harry Righter

W W N Y
WATERTOWN—1941—CBS

Frequency: 790 Kc..... Power: 1000 Watts
 Owned-Operated By..... The Brockway Co.
 Phone Number..... 4120
 News Service..... UP
 Transcription Service..... World, Thesaurus
 Representative..... Weed
 Membership..... NARTB, BAB

President..... John B. Johnson
 General-Comm. Mgr..... Louis Saffi, Jr.
 Chief Engineer..... M. B. Davis

WFAS
WHITE PLAINS—1932

Frequency: 1230 Kc..... Power: 250 Watts
 Owned-Oper. By..... Westchester Bcstg. Corp.
 Bus. Studio Address..... 8 Church St.
 Phone Number..... White Plains 9-6400
 Air Time..... Unlimited
 News Service..... AP
 Trans. Service..... Associated, Capitol, SESAC
 Representative..... Headley-Reed
 Membership..... NARTB
 President..... Valentine E. Macy, Jr.
 Gen. Sta. Mgr., Chief Engineer..... Frank A. Seitz
 Program Director..... Randall Kaler

W W R L
WOODSIDE—1926

Frequency: 1600 Kc..... Power: 5000 Watts
 Owned-Oper. By..... Long Island Bcstg. Corp.
 Bus. Studio-Transmitter Address..... 41-30 58th St.
 Phone Number..... DE 5-1600
 Air Time..... Full Time
 News Service..... AP
 Transcription Service..... Associated, SESAC
 President..... W. H. Reuman
 Gen. Sta. Mgr..... Edith Dick
 Sales Prom. Mgr..... Selvin Donnison
 Program Director..... Fred Barr
 Chief Engineer..... Benton R. Bartlett

In **WESTCHESTER**

a \$¾ billion market
 equivalent to the
 37th state

Agency-placed business on
 WFAS increased

214%
 in '53 over '52.

The answer is proven audience
 penetration. Ask for a copy
 of current surveys.

WFAS and WFAS-FM
 8 Church Street
 White Plains, N. Y.

Represented by
Headley-Reed Company

WWRL

New York
5,000 WATTS

Powerfully Selling America's Greatest
 Market at the Lowest Cost

• • •

TOPS in New York
 for the
NEGRO MARKET

SPANISH
GERMAN

• • •

1600 Kc DEFender 5-1600

NORTH CAROLINA

Pop. Feb. 1, 1954 (Est.) 4,224,000 — Families 1,130,000
Radio Homes 984,000 — TV Homes 398,000 — Stations in State 107

WRCS

AHOSKIE—1948—KBS

Frequency: 970 Kc. Power: 1000 Watts d.
Owned-Oper. By: Roanoke-Chowan Bcstg.
Co., Inc.
Business Address: P. O. Box 89
Phone Number: 3101
News Service: UP
Transcription Service: World
President: Charles H. Jenkins
Gen., Comm. Mgr.: P. G. Sewell
Program Director: Bill Smith
Chief Engineer: W. G. Barnes

WABZ

ALBEMARLE—1947—KBS

Frequency: 1010 Kc. Power: 1000 Watts d.
Owned-Oper. By: Radio Station WABZ, Inc.
Business-Studio Address: Box 226
Phone Number: 1100
News Service: AP
Representative: Dodson
President: S. R. Williams
General Manager: W. J. Page
Commercial Manager: J. T. Newman
Program Director: L. W. Kinard
Chief Engineer: J. D. Brooks

WGWR

ASHEBORO—1947

Frequency: 1260 Kc. Power: 1000 Watts d.
Owned-Oper. By: Asheboro Bcstg. Co., Inc.
Business-Studio Address: 303 E. Salisbury St.
Phone Number: 2187
News Service: UP
Transcription Service: Thesaurus
Membership: BAB
President: Roy Cox
Gen., Sta., Comm., Prom. Mgr.: J. R. Marlowe
Program Director: A. B. Brown
Chief Engineer: W. H. Trogdon

WISE

ASHEVILLE—1939—NBC

Frequency: 1310 Kc. Power: 5000 W. d.
1000 n.
Owned-Operated By: Radio Station WISE, Inc.
Address: 100 College St.
Phone Number: 3-5381-3
Air Time: Unlimited
News Service: AP
Representative: Bolling Co.
Pres., Gen. Sta. Mgr.: Harold H. Thoms
Commercial Mgr.: Loyd B. Leonard
Program Director: Dick Harshaw
Publicity Dir.: Skeeter Moore
Chief Engineer: John Randolph

WLOS

ASHEVILLE—1947—ABC

Frequency: 1380 Kc. Power: 5000 Watts d.
1000 Watts n.
Owned-Operated By: Skyway Bcstg. Co.
Business-Studio Address: Battery Park Hotel
Phone Number: 2-2431
Air Time: Full Time
News Service: UP
Transcription Service: World
Representative: Venard, Inc.
Executive Vice President: Charles B. Britt
Production Mgr.: Charles E. Newcomb
Commercial Mgr.: Bradley H. Roberts
Program Director: R. Fred Brown Jr.
Chief Engineer: C. Sumner

WSKY

ASHEVILLE—1947

Frequency: 1230 Kc. Power: 250 Watts
Owned-Operated By: Radio Asheville, Inc.
Business-Studio Address: 12 Church St.
Phone Number: 3-4451
Air Time: 5:30 a.m.-M.
News Service: AP
Representative: Rambeau
Pres., Gen., Sta. Mgr.: Zeb Lee
Commercial Manager: Hal Edwards
Sls. Prom. Mgr., Pub. Dir.: J. W. Young
Chief Announcer: Henry Varner
Chief Engineer: Bill Clements

WWNC

ASHEVILLE—1927—CBS

Frequency: 570 Kc. Power: 5000 Watts
Owned-Oper. By: Asheville Citizen-Times Co.
Business-Studio Address: 14 O'Henry Ave.
Phone Number: 5611
Air Time: Full Time
Newspaper Affiliation: Asheville Citizen-
Times
News Service: AP, UP
Transcription Service: Associated, Thesaurus
Representative: Headley-Reed
Membership: NARTB, BAB
President: Don S. Elias
Gen., Sta., Prom. Mgr.: Cecil B. Hoskins
Program Director: William F. Melia
Chief Engineer: William H. Hamrick

WATA

BOONE—1950—MBS

Frequency: 1450 Kc. Power: 250 Watts
Owned-Oper. By: Wilkes Bcstg. Co.
Phone Number: 467
News Service: AP
President: Doris B. Brown
General Manager: Roland Potter
Commercial Manager: Ralph Tugman

Program Director.....Dwight Larick
 Chief Engineer.....Bob Daugherty

W P N F

BREVARD—1950—NBC

Frequency: 1240 Kc.....Power: 250 Watts
 Owned-Oper. By.....Pisgah Bcstg. Co., Inc.
 Phone Number.....3-2611
 News Service.....AP
 News. Affil....."Transylvania Times"
 Representative.....Continental Radio Sls.
 President.....Ed M. Anderson
 Gen., Comm. Mgr.....Jack Hammette
 Sales Prom. Mgr.....John Dellinger
 Chief Engineer.....William Pascal

W B B B

BURLINGTON—1941—MBS-KBS

Frequency: 920 Kc.....Power: 500 Watts d.
 Owned-Operated By.....Alamance Bcsta. Co., Inc.
 Business-Studio Address.....318½ S. Main St.
 Phone Number.....6-6376
 News Service.....AP
 Transcription Service.....Associated
 Membership.....NARTB
 General Manager.....E. Z. Jones
 Commercial Manager.....Robert Ray
 Program Director.....Ed Brooks
 Chief Engineer.....Berry Tysor

W F N S

BURLINGTON—1946—TOBACCO

Frequency: 1150.....Power: 1000 Watts d.
 Owned-Oper. By Burlington-Graham Bdcstg Co.
 Address.....113 W. Andrews St.
 Phone Number.....4261
 News Service.....UP
 Transcription Service.....World
 Representatives.....Sears & Ayer, Clayton
 President.....L. E. Neese
 Gen., Sta. Mgr.....G. C. Starnes
 Comm., Prom. Mgr.....Wally Mack
 Program Director.....Frank Candelario
 Chief Engineer.....Charles D. Chandler

W C H L

CHAPEL HILL—1953

Frequency: 1360 Kc.....Power: 1000 Watts d.
 Owned-Oper. By.....Village Bcstg. Co.
 Address.....Box 338
 Phone Number.....9-2261
 News Service.....AP
 Transcription Service.....Langworth. SESAC
 Pres., Gen. Mgr.....R. McClamroch, Jr.
 Commercial Mgr.....Harold L. Nail
 Program Director.....C. Scott Jarrett
 Chief Engineer.....Fritz Thurston

W A Y S

CHARLOTTE—1942—ABC

Frequency: 610 Kc.....Power: 5000 Watts d.;
 1000 Watts n.
 Owned-Oper. By.....Inter-City Advertising Co.

Business-Studio Address.....3229 S. Blvd.
 Phone Number.....3-7173
 Air Time.....Full Time
 News Service.....UP
 Representative.....Bolling Co.
 Membership.....NARTB
 President.....George W. Dowdy
 Gen., Sta. Mgr.....J. P. Poston
 Sales Prom., Pub. Dir.....Don Matney
 Chief Engineer.....B. C. Stewart

W B T

CHARLOTTE—1922—CBS

Frequency: 1110 Kc.....Power: 50,000 Watts
 Owned-Oper. By.....Jefferson Standard Bdcstg.
 Address.....Wilder Building
 Phone Number.....3-8833
 Air Time.....Full Time
 News Service.....AP, UP
 Transcription Service.....World
 Representative.....CBS Radio Spot Sales
 Membership.....NARTB, BAB
 President.....J. M. Bryan
 General Manager.....Charles H. Crutchfield
 Asst. Vice-President.....Robert Covington
 Program Director.....William Melson
 Publicity Director.....Nelson Benton
 Chief Engineer.....M. J. Minor

W G I V

CHARLOTTE—1947

Frequency: 1600 Kc.....Power: 1000 Watts d.
 Owned-Oper. By.....Charlotte Radio & TV Corp.
 Business Address.....2520 Toomey Ave.
 Phone Number.....2-6669, 5-4829
 News Service.....AP
 Representative.....Forjoe
 Membership.....NARTB, BAB
 Pres., Gen. Mr.....Francis M. Fitzgerald
 Promotion Manager.....John G. Surratt
 Commercial Mgr.....Ray Ervin
 Program Director.....C. E. Friar
 Sales Promotion Mgr.....James Fokes
 Chief Engineer.....S. K. Lineberger

W I S T

CHARLOTTE—1951—MBS

Frequency: 930 Kc.....Power: 5000 d; 1000 n.
 Owned-Oper. By.....Bcstg. Co. of South
 Address.....Liberty Life Bldg.
 Phone Number.....8-3511
 News Service.....AP
 Transcription Service.....Thesaurus
 Representative.....Free & Peters
 President.....B. C. Hipp
 General Manager.....G. R. Shafto
 Managing Director.....Guy Vaughan
 Program Director.....Fred Vinroot
 Chief Engineer.....John N. Parker

W S O C

CHARLOTTE—1933—NBC

Frequency: 1240 Kc.....Power: 250 Watts
 Owned-Oper. By.....Radio Station WSOC, Inc.
 Address.....1925 N. Tryon St.

Phone Number 2-7138
 News Service AP
 Representative H.R. Reys
 Membership NARTB, BAB
 Pres., Gen. Sta. Mgr. E. J. Gluck
 Commercial Mgr. Bomar A. Lowrance
 Sls. Prom. Mgr., Pub. Dir. . . Charles M. Marshall
 Program Director Armand F. Bodie
 Chief Engineer L. L. Caudle, Jr.

WRRZ
 CLINTON—1947

Frequency: 880 Kc. Power: 1000 Watts d.
 Owned-Oper. By Radio Station WRRZ, Inc.
 Bus. Studio Address Butler Bldg.
 Phone Number 2354
 President W. R. Roberson, Sr.

WEGO
 CONCORD—1943

Frequency: 1410 Kc. Power: 1000 Watts d.
 Own-Oper. By Cabarrus Bdcstg. Co.
 Business Studio Address P. O. 527
 Phone Number 2-6000
 News Service AP
 President A. W. Huckle
 General Manager Elizabeth Huckle
 Pgm., Comm. Dir. Howard McCurry
 Chief Engineer Kenneth R. Kennedy

WCKB
 DUNN—1946—KBS

Frequency: 780 Kc. Power: 1000 Watts d.
 Owned-Oper. By No. Car. Cent. Bcstrs.
 Business Address Box 431
 Phone Number 3133-4
 Air Time Daytime
 News Service UP
 Transcription Service Lang-Worth
 Membership BAB
 President Lelton A. Tart, Sr.
 Sta., Gen. Mgr. A. Lincoln Faulk
 Commercial Manager Carl Lamm
 Sales Prom. Mgr. John Ciccone
 Program Director E. L. Burwell
 Publicity Director Hershell Barbour
 Chief Engineer Joseph Koltas

WDNC
 DURHAM—1934—CBS

Frequency: 620 Kc. Power: 5000 Watts d.;
 1000 Watts n.
 Owned-Oper. By The Durham Radio Corp.
 Bus. Studio Address 138½ E. Chapel Hill St.
 Phone Number 6155
 Air Time Full Time
 News Service UP
 Transcription Service Associated
 Representative Paul H. Raymer
 Membership NARTB, BAB
 President C. C. Council
 V.P., Gen. Mgr. J. Frank Jarman
 Office Manager Sue Germino
 Commercial Manager C. James Woodhouse

Program Director E. R. Higgins, Jr.
 Chief Engineer G. W. Bartlett

WSSB
 DURHAM—1948—MBS

Frequency: 1490 Kc. Power: 250 Watts
 Owned-Oper. By Public Information Corp.
 Address Box 1168
 Phone Number 6919-6910
 Air Time 6 a.m.-12 M.
 News Service INS
 Transcription Service Capitol
 President Tom Sawyer
 General Manager Wm. Kirby
 Program Director C. Cook
 Chief Engineer Edward Norman

WTIK
 DURHAM—1946—ABC

Frequency: 1310 Kc. Power: 1000 Watts d.,
 500 Watts n.
 Owned-Oper. By Durham Bcstg Enter., Inc.
 Address 205½ W. Main St.
 Phone Number 6101
 News Service AP
 Representative Headley-Reed
 Membership NARTB, BAB
 Pres., Gen. Mgr. H. L. Duncan
 Station Manager Floyd Fletcher
 Commercial Mgr. Mike Thompson
 Program Director Ed Coles
 Chief Engineer Arlis White

WCNC
 ELIZABETH CITY—1939

Frequency: 1240 Kc. Power: 250 Watts
 Owned-Oper. By Albemarle Bcstg. Co., Inc.
 Address E. Colonial Ave.
 Phone Number 4370
 President Joseph A. Gill

WGAI
 ELIZABETH CITY—1947

Frequency: 560 Kc. Power: 1000 Watts d.,
 500 Watts n.
 Owned-Operated By WGAI Radio Co., Inc.
 Business-Studio Address Box 426
 Phone Number 4371-2
 Air Time 6 a.m.-11 p.m.
 News Service AP
 Transcription Service World
 Membership BAB
 President C. Alden Baker
 Commercial Mgr. Ray Jones, Jr.
 Prom., Pub. Dir. Don Owens
 Program Director Gene Marshall
 Chief Engineer Goodrich Williams

WIFM
 ELKIN—1949—MBS

Frequency: 1540 Kc. Power: 250 Watts d.
 Owned-Oper. By James B. Childress
 Address 1141 Elk Spur St.

Phone Number739
 Air Time.....Daytime
 News Service.....UP
 Transcription Service.....Langworth
 Representative.....Continental
 President.....John A. Hinshaw
 Program Director.....Claude White

W F M O

FAIRMONT—1953

Frequency: 860 Kc.....Power: 1000 Watts d.
 Owned-Oper. By.....Carolinas Bcstg. Corp.
 Address.....Box 125
 Phone Number.....4781
 President.....Cutlar Moore
 General Manager.....Allen N. Vause
 Commercial Mgr.....Billy Hodges
 Program Director.....Ray Godwin
 Chief Engineer.....J. F. Milazzo

W F A I

FAYETTEVILLE—1951—CBS

Frequency: 1230 Kc.....Power: 250 Watts
 Owned-Operated By.....Rollins Bcstg., Inc.
 Bus-Studio Add.....Huske Bldg.
 Phone Number.....2-8131
 Air Timec.....Full Time
 News Service.....AP
 Transcription Service.....RCA Thesaurus
 Representative.....Thomas F. Clark
 President.....O. Wayne Rollins
 General Manager.....James H. Mayes, Jr.
 Publicity Director.....Winnie Stevenson
 Program Director.....Dick Perry
 Chief Engineer.....Bob Money

W F L B

FAYETTEVILLE—1948—ABC

Frequency: 1490 Kc.....Power: 250 Watts
 Owned-Oper. By.....Fayetteville Bcstrs., Inc.
 Address.....P. O. Box 512
 Phone Number.....2-7136
 Air Time.....5:30 a.m.-M.
 News Service.....AP
 Representative.....Burn-Smith
 Membership.....NARTB, BAB
 General Manager.....L. W. Allen
 Commercial Manager.....W. D. Bailey
 Sales Prom. Mgr.....W. B. Belche
 Chief Engineer.....Richard Madson

W F N C

**FAYETTEVILLE—1940
 MBS—TOBACCO NET**

Frequency: 1390 Kc.....Power: 5000 W. d.-
 1000 W. n.
 Owned-Oper. By.....Cape Fear Bcstg. Co.
 Business-Studio Address.....Box 1230
 Phone Number.....2-4848
 Air Time.....Full Time
 News Service.....UP
 Representative.....Walker
 Membership.....BAB
 Pres., Gen. Mgr.....Victor W. Dawson
 Commercial Manager.....Tom Harrell

Program Director.....Mac Stamps
 Chief Engineer.....John Ikner

W B B O

FOREST CITY—1947

Frequency: 780 Kc.....Power: 1000 Watts d.
 Owned-Oper. By.....Rutherford County Radio
 Co., Inc.
 Address.....Forest City
 Phone Number.....3205
 News Service.....AP
 Transcription Service.....Thesaurus
 Pres., Gen. Mgr.....Ed M. Anderson
 Sta., Comm. Mgr.....Fred Blanton
 Sales Prom. Mgr., Prog. Dr.....Jane Smith
 Chief Engineer.....Merton Iwerks

W F V G

FUQUAY SPRINGS—1949—KBS

Frequency: 1460 Kc.....Power: 1000 Watts a.
 Owned-Oper. By.....WFVG Bdcstg. Co.
 Business-Studio Address.....Box 1230
 Phone Number.....333
 News Service.....UP
 President.....J. M. Stephenson
 Gen., Sta. Mgr.....Robert E. Stephenson
 Comm., Prom. Mgr.....Rupert Weathers
 Chief Engineer.....Harry Stephenson

W G N C

GASTONIA—1939—ABC

Frequency: 1450 Kc.....Power: 250 Watts
 Owned-Operated By.....Catherine T. McSwain
 Phone Number.....8501
 News Service.....UP
 Transcription Service.....Lang-Worth
 Representative.....Continental Radio Sales
 Owner.....Catherine T. McSwain
 General Manager.....Pat McSwain
 Commercial Manager.....F. C. Abernathy
 Program Director.....Fred Gray
 Chief Engineer.....W. C. Groves, Jr.

W L T C

GASTONIA—1948—KBS

Frequency: 1370 Kc.....Power: 1000 Watts d.
 Owned-Oper. By.....Gastonia Bcstg. Serv., Inc.
 Address.....P. O. Box 1010
 Phone Number.....5-1280
 News Service.....UP
 Transcription Service.....World
 Representative.....Thomas F. Clark
 Pres., Gen. Mgr.....James B. Petty
 Commercial Manager.....Boyce C. Morrow
 Chief Engineer.....Don Voigt

W F M C

GOLDSBORO—1951—KBS

Frequency: 730 Kc.....Power: 1000 Watts d.
 Owned-Oper. By.....Southern Radio & TV Corp.
 Address.....Box 655
 Phone Number.....Trucklane 117
 News Service.....UP
 President.....Hayden Stuart

General Manager Charles S. Carter
 Chief Engineer William W. Bridges

Program Director H. Marie Craven
 Chief Engineer Fred S. Smith

W G B R

GOLDSBORO—1938—ABC

Frequency: 1150 Kc. Power: 1000 Watts
 Owned-Oper. By E. Carolina Bdcstg. Co., Inc.
 Address P. O. Box 1924
 Phone Number 3730
 Air Time Full Time
 News Service AP
 Transcription Service Assoc.
 President A. T. Hawkins
 General Manager V. Gerald Balkcum
 Chief Engineer Daniel B. Trueblood
 Commercial Manager Nat. Royster
 Program Director Norman D. Satterthwaite

W B I G

GREENSBORO—1926—CBS

Frequency: 1470 Kc. Power: 5000 Watts
 Owned-Oper. By North Carolina Bcstg. Co.
 Phone Number 2-6125
 Studio Address O. Henry Hotel Bldg.
 Air Time Full Time
 News Service AP
 Transcription Service World
 Representative George P. Hollingbery
 Membership NARTB
 Gen., Prom., Sta. Mgr. Allen Wannamaker
 Commercial Mgr. William P. Mitchell
 Publicity Director Virginia Neese
 Program Director Dan Griffin
 Chief Engineer William H. Malone

W C O G

GREENSBORO—1948—ABC

Frequency: 1320 Kc. Power: 1000 Watts
 Owned-Oper. By Inter-City Adv. Co., Inc.
 Business-Studio Address 314 S. Greene St.
 Phone Number 3-6925
 Air Time Full Time
 News Service UP
 Representative The Bolling Co.
 Membership NARTB, BAB
 President George W. Dowdy
 General Manager Gilbert M. Hutchison
 Commercial Manager Jack Rimmer
 Prog., Pub. Dir. John E. Parker
 Chief Engineer Joseph L. Lamb, Jr.

W G B G

GREENSBORO—1942—MBS

Frequency: 1400 Kc. Power: 250 Watts
 Owned-Oper. By Greensboro Bcstg. Co., Inc.
 Business-Studio Address P. O. Box 2280
 Phone Number 3-3631
 Air Time Full Time
 News Service UP
 Transcription Service Lang-Worth
 Representative Burn-Smith
 Pres., Gen., Sta. Mgr. Ralph M. Lambeth
 Commercial Mgr. B. George Barber, Jr.
 Publicity Director Earl O. Sullivan

W G T C

**GREENVILLE—1940
 TOBACCO—MBS**

Frequency: 1590 Kc. Power: 5000 Watts d.,
 1000 Watts n.
 Owned-Oper. By Carolina Bdcstg. Sys., Inc.
 Address P. O. Box 898
 Phone Number 6181
 News Service UP
 Transcription Service World,
 Capitol Associated
 Representative John E. Pearson Co.
 President Earl Westbrook
 General Manager A. Hartwell Campbell
 Commercial Manager John G. Clark, Jr.
 Program Director Bill Durwell
 Chief Engineer Hank Tribbley

W H N C

HENDERSON—1945—MBS

Frequency: 890 Kc. Power: 1000 Watts d.
 Owned-Oper. By Henderson Radio Corp.
 Bus.-Studio Address Nolana Road
 Phone Number 7136
 Air Time Daytime
 News Service AP
 Transcription Service Thesaurus, World,
 Langworth
 Pres., Gen., Prom., Comm. Mgr. Nathan Frank
 Program Director Tommy Powell
 Publicity Director Bob Harrison
 Chief Engineer James Mayo

W H K P

HENDERSONVILLE—1946—ABC-KBS

Frequency: 1450 Kc. Power: 250 Watts
 Owned-Oper. By Radio Hendersonville, Inc.
 Address Chimney Rock Road
 Phone Number 9061
 Air Time 5:45 a.m.-M.
 News Service UP
 Transcription Service McGregor, Keystone,
 Standard
 Representative Donald Cooke
 President Beverly Middleton
 Station Manager Kermit Edney
 Commercial Manager Robert Smith
 Chief Engineer Charles Renfrow

W H K Y

HICKORY—1939—ABC

Frequency: 1290 Kc. Power: 5000 Watts d.,
 1000 Watts n.
 Owned-Oper. By Catawba Valley Bcstg. Co.
 Address Radio Bldg.
 Phone Number 2294
 Representative Walker
 Transcription Service World
 News, Affil. "Daily Record"
 Membership NARTB
 News Service UP

President.....Carl V. Cline
 General Manager.....Edmund S. Long
 Comm. Prom. Mgr.....James W. Batts
 Program Director.....Stowe W. Hoyle
 Publicity Director.....Laura Hall
 Chief Engineer.....Thomas E. Long

WIRC

HICKORY—1948—TOBACCO NET

Frequency: 630 Kc.Power: 1000 Watts d.
 Owned-Oper. ByFoothills Bdcstg., Inc.
 Address 329 1st Ave.
 Phone Number 2124
 News Service AP
 Transcription Service.....Lang-Worth
 Representative.....John E. Pearson
 Membership NARTB
 President.....Margaret A. Smith
 General Manager.....E. H. Smith, Jr.
 Sta. Mgr., Chief Engr.....Elmer Troutman
 Commercial ManagerLee Douglas
 Program Director.....Mattie I. Padgett

WHPE

HIGH POINT—1946—KBS

Frequency: 1070 Kc.Power: 1000 Watts d.
 Owned-Oper. By .High Point Enterprise, Inc.
 Business-Studio Address.....307 N. Main St.
 Phone Number 4560
 News Service AP
 Transcription Service World
 Membership NARTB
 President.....R. B. Terry
 Sec'y & Treas., Comm. Mgr.....Walter Hester
 Chief Engineer.....Robert Moore

WMFR

HIGH POINT—1935—ABC

Frequency: 1230 Kc.Power: 250 Watts
 Owned-Oper. By ...Radio Station WMFR, Inc.
 Business Studio Address.....164 S. Main
 Phone Number 4593
 Air Time Full Time
 News Service UP
 Transcription ServiceLang-Worth
 RepresentativeBurn-Smith
 Membership BAB
 Pres., Gen. Station Mgr.....Frank S. Lambeth
 Commercial Manager.....Frank Smith
 Prom., Publ. Dir.....Gerald D. Sullivan
 Program Director.....Max Meeks
 Publicity Director.....Bill Smith
 Chief Engineer.....Robert P. Boyd

WNOS

HIGH POINT—1953

Frequency: 1590 Kc.Power: 1000 Watts d.
 Owned-Oper. ByNorth State Bcstg. Co.
 Address Box 1448
 Phone Number 8900
 Pres., Gen. Mgr.....W. H. Currie
 Commercial Mgr.....Clayton Steele
 Program Director.....Harold Craven
 Chief Engineer.....J. M. Stewart

WJNC

**JACKSONVILLE—1945
 MBS-TOBACCO**

Frequency: 1240 Kc.Power: 250 Watts
 Owned-Oper. ByLester L. Gould
 Address Box "E"
 Phone Number 7707-7708
 Air Time Full Time
 News Service UP, AP
 Transcription Service World
 Membership NARTB, BAB
 Pres., Gen. Mgr.....Lester L. Gould
 Sta., Comm. Mgr.....Rodric L. Jones
 Pub., Sales Prom. Mgr.....Myron Zabner
 Program Director.....Dorothy R. Gould
 Chief Engineer.....Rod O. Dorsey

WGTL

KANNAPOLIS—1946

Frequency: 870 Kc.Power: 1000 Watts d.
 Owned-Oper. By.....Fred H. Whitley, Inc.
 Address Box 997
 Phone Number Kannapolis 8700
 News Service UP
 Transcription Service.....Lang-Worth, World
 Membership NARTB
 Pres., Gen. Mgr.....Fred H. Whitley
 Chief Engineer.....Foy Hinson

WKMT

KINGS MOUNTAIN—1953

Frequency: 1220 Kc.Power: 500 Watts d.
 Owned-Oper. By...Southern Radiocasting Co.
 Address Box 822
 Phone Number 999
 RepresentativeDora-Clayton
 Partner, Gen. Mgr.....John C. Greene Jr.
 Partner.....R. H. Whiteside
 Commercial Mgr.....J. K. Willis Jr.
 Promotion Mgr.....Helen R. Greene
 Chief Engineer.....George E. Webb

WELS

KINSTON—1950—KBS

Frequency: 1010 Kc.Power: 1000 Watts d.
 Owned-Oper. By...Farmers Bstg. Service, Inc.
 Address 1400 W. Vernon Ave.
 Phone Number 5151
 News Service UP
 Transcription Service.....Thesaurus
 RepresentativeDevney
 Membership BAB
 President.....E. L. Scott
 General Manager.....Jack P. Hankins
 Commercial Manager.....Glen Harman
 Chief Engineer.....Ed Landry

WFTC

KINSTON—1937—ABC-CBS

Frequency: 960 Kc.Power: 5000 d.; 1000 n.
 Owned-Operated By.....Kinston Bcstg. Co.
 Address.....204 East King St.

Phone Number4111
 Air Time Full Time
 News Service AP
 Transcription Service Lang-Worth
 Representative Bum-Smith
 Membership BAB
 Pres., Gen., Sta. Mgr. William S. Page
 Commercial Mgr. J. Harold Vester
 Publicity Director Carl B. Caudill, Jr.
 Chief Engineer.....David E. Hardison

WISP

KINSTON—1953—MBS

Frequency: 1230 Kc. Power: 100 Watts
 Owned-Oper. By E. J. Schuffman
 Address Oasis Bldg.
 Phone Number 6181
 Pres., Gen. Mgr. E. J. Schuffman
 Commercial Mgr. J. L. Moseley
 Program Director Robert E. Mongold
 Chief Engineer S. Bruce Petteway

WEWO

LAURINBURG—1947—KBS

Frequency: 1080 Kc. Power: 1000 Watts d.
 Owned-Oper. By Scotland Bcstg. Co
 Bus. Studio Address State Bank Bldg.
 Phone Number 770
 News Service..... AP, UP
 Transcription Service Thesaurus
 Membership NARTB, BAB
 President Edwin Pate
 General Manager..... J. R. Dalrymple, Jr.
 Commercial Manager Bill Hogan
 Program Director..... C. W. Hagan
 Chief Engineer..... Truman N. Brock

WLOE

LEAKSVILLE—1946—MBS-KBS

Frequency: 1490 Kc. Power: 250 Watts
 Owned-Operated By WLOE, Inc.
 Address Box L, Blvd. St.
 Phone Number 701-2
 Air Time Full Time
 News Service AP
 Transcription Service World
 Membership NARTB, BAB
 Pres., Gen., Sta. Mgr. Douglas L. Craddock
 Program Director Madeline Smart
 Chief Engineer..... Eldred Winn

WJRI

LENOIR—1947—MBS-KBS-TOBACCO

Frequency: 1340 Kc. Power: 250 Watts
 Owned-Operated By John P. Rabb
 Address 107 West Ave.
 Phone Number 4-5361
 News Service UP
 Transcription Service Lang-Worth
 Pres., Gen. Mgr. John P. Rabb
 Commercial Manager F. Kent Atwater
 Program Director K. Rabb
 Chief Engineer..... James B. Hemphill

WBUY

LEXINGTON—1946—KBS

Frequency: 1450 Kc. Power: 250 Watts
 Owned-Oper. By Davidson County Bcstg. Co.
 Business Address P. O. Box 359
 Phone Number 2716
 News Service AP
 Transmitter Service..... Thesaurus
 Membership BAB
 General Manager..... Omar G. Hilton
 Station Manager..... John T. Cashion
 Commercial Mgr. Greely N. Hilton
 Program Director James Odom
 Chief Engineer Fred Honeycutt

WLON

LINCOLNTON—1953

Frequency: 1270 Kc. Power: 500 Watts d.
 Owned-Oper. By Lincoln County Bcstg. Co.
 Address Startown Rd.
 Phone Number 5-2359
 President..... J. A. Polhill
 Vice-Pres., Gen. Mgr. Earl Holder
 Commercial Manager Jack Brown
 Chief Engineer..... Dennis Long

WTSB

LUMBERTON—1946—MBS

Frequency: 1340 Kc. Power: 250 Watts
 Owned-Operated By Robeson Bcstg. Corp.
 Business-Studio Address 112 W. Fifth St.
 Phone Number 6056
 News Service AP
 Transcription Service World
 Representative..... Continental Radio Sales
 General Manager..... James MacNeil

WBRM

MARION—1949

Frequency: 1250 Kc. Power: 1000 Watts d.
 Owned-Operated By Lake City Bcstg. Corp.
 Address 13½ W. Court St.
 Phone Number 7221
 News Service UP
 Pres., Gen. Mgr. W. P. Erwin
 Commercial Mgr. J. C. Pleasant
 Program Director J. L. Reynolds, Jr.
 Chief Engineer Hubert C. Martin

WMAP

MONROE—1947—KBS

Frequency: 1060 Kc. Power: 250 Watts d.
 Owned-Operated By Union Bcstg. Corp.
 Business Address P. O. Box 382
 Phone Number 1060
 News Service UP
 President Dick Marable
 Chief Engineer Robert I. Smith

WHIP

MOORESVILLE—1950—KBS

Frequency: 1350 Kc. Power: 1000 Watts d.

Owned-Operated By.....Wayne M. Nelson
 Address.....Mooresville, N. C.
 Phone Number.....3-4301
 News Service.....UP
 Transcription Service.....Capitol
 Pres., Gen., Sta. Mgr.....Wayne M. Nelson
 Chief Engineer.....E. M. Stanton, Jr.

Phone Number.....4450-4024
 News Service.....UP
 Transcription Service.....Lang-Worth
 Representative.....John E. Pearson
 Membership.....BAB
 Gen.-Sta.-Comm. Mgr.....Ray D. Williams
 Sales Prom. Mgr.....William Banks
 Program Director.....George Nelson
 Chief Engineer.....Stuart Hill

W M B L

MOREHEAD CITY—1947

Frequency: 740 Kc.....Power: 1000 Watts d.
 Owned-Oper. By.....Carteret Bcstg. Co., Inc.
 Address.....Box 432
 Phone Number.....6-3188
 News Service.....UP
 Transcription Service.....World
 Representative.....McGillvra
 Pres., Gen. Mgr.....Grover C. Munden
 Sales Prom. Mgr.....Charles Markey
 Commercial Manager.....Jimmy Wallace
 Prog. Dir., Chf. Engr.....Ray Cummins

W O O W

NEW BERN—1953

Frequency: 1490 Kc.....Power: 250 Watts
 Owned-Oper. By.....Craven Bcstg. Co.
 Address.....Glenburnie Gardens
 Phone Number.....3311
 Co-Owners.....L. T. Grantham,
 L. H. Wetherington
 General Manager.....Lester L. Williams
 Commercial Mgr.....James C. Clark
 Program Director.....Roy Williamson
 Chief Engineer.....Billy Haire

W M N C

MORGANTON—1947—NBC

Frequency: 1490 Kc.....Power: 250 Watts
 Owned-Operated By.....Nathan J. Cooper
 Phone Number.....Box 698
 Air Time.....Full Time
 News Service.....AP
 Pres., Gen. Mgr.....Nathan J. Cooper
 Com. Mgr., Chf. Eng.....Frank A. Ballew
 Program Director.....Madelyn V. Patton

W N N C

NEWTON—1948

Frequency: 1230 Kc.....Power: 250 Watts
 Owned-Oper. By.....Southern Radiocasting
 Business Address.....Box 148
 Phone Number.....930
 Transcription Service.....SESAC
 News Service.....UP
 General Manager.....J. C. Greene Jr.
 Partner.....R. H. Whitesides
 Program Director.....Jonas Bridges
 Chief Engineer.....George Webb

W P A Q

MT. AIRY—1948—KBS

Frequency: 740 Kc.....Power: 1000 Watts d.
 Owned-Operated By.....Ralph D. Epperson
 Phone Number.....1400-1
 News Service.....AP
 Representative.....Thomas Clark
 Membership.....NARTB
 Pres., Gen.-Sta. Mgr.....Ralph D. Epperson
 Commercial Manager.....Lucy Bowman
 Sales Prom. Mgr.....Bill Belton
 Program Director.....Olive P. Epperson
 Chief Engineer.....Harry A. Epperson, Jr.

W K B C

NORTH WILKESBORO—1947—KBS

Frequency: 810 Kc.....Power: 1000 Watts d.
 Owned-Oper. By.....Wilkes Bcstg. Co.
 Phone Number.....633
 News Service.....AP
 Transcription Service.....Thesaurus
 Pres., Gen. Mgr.....Doris B. Brown
 Comm.-Sales Prom. Mgr.....Roland B. Potter
 Chief Engineer.....Walter Harrold

W S Y D

MOUNT AIRY—1951—MBS

Frequency: 1240 Kc.....Power: 250 Watts
 Owned-Oper. By.....Mount Airy Bcstrs., Inc.
 Address.....P. O. Box 209
 Phone Number.....581
 Pres., Gen. Mgr., Chief Engineer
 Robert H. Epperson
 Commercial Manager.....Erastus F. Poore
 Program Director.....Jim Harrelson

W O X F

OXFORD—1949

Frequency: 1340 Kc.....Power: 250 Watts
 Owned-Operated By.....Oxford Bcstg. Corp.
 Address.....P. O. Box 1111
 Phone Number.....4167
 Transcription Service.....Capitol
 News Service.....UP
 President.....Charles Allen
 General Manager.....James F. Flanagan
 Promotion Manager.....Bob Smith
 Chief Engineer.....Howard Harrell

W H I T

NEW BERN—1942—MBS-TOBACCO

Frequency: 1450 Kc.....Power: 250 Watts
 Owned-Oper. By.....Radio Station WHIT
 Address.....P. O. Box 551

W N A O

RALEIGH—1948—ABC

Frequency: 850 Kc.....Power: 10,000 Watts d.,
 5000 Watts n.

Owened-Oper. By Sir Walter Television Co.
 Address 219 So. McDowell St.
 Phone Number 2-0321
 Air Time Full Time
 News Service AP
 Transcription Service World
 Representative Avery-Knodel
 Membership NARTB
 President John W. English
 Gen., Sta. Mgr. Charles G. Baskerville
 Commercial Mgr. James Simpson
 Program Director Byron Davidson
 Chief Engineer Pete Miller

WPTF

RALEIGH—1924—NBC

Frequency: 680 Kc. Power: 50,000 Watts
 Owened-Oper. By WPTF Radio Co.
 Business-Studio Address Insurance Bldg.
 Phone Number 8311
 Air Time 5:30 a.m.-12:05 a.m.
 News Service AP, UP
 Transcription Service Thesaurus
 Representative Free & Peters
 Membership NARTB
 Pres., Gen. Mgr. Richard H. Mason
 Commercial Mgr. R. W. Youngsteadt
 Program Manager Graham B. Poyner
 Publicity Director Henry T. Vaden
 Chief Engineer Henry Hulick, Jr.

WRAL

RALEIGH—1939—MBS-TOBACCO

Frequency: 1240 Kc. Power: 250 Watts
 Owened-Operated By Capitol Bcstg. Co., Inc.
 Bus.-Studio Address 130 S. Salisbury St.
 Phone Number 6411
 Air Time Full Time
 News Service AP
 Representative Forjoe & Co.
 Membership NARTB, BAB
 President A. J. Fletcher
 General Manager Fred Fletche
 Commercial Mgr. N. Fletcher Turner, Jr.
 Sales Prom. Mgr. Jim Thomas
 Program Director George Ha'l
 Chief Engineer Virgil D. Duncan

WFRC

REIDSVILLE—1947—KBS-ABC

Frequency: 1600 Kc. Power: 1000 Watts
 Owened-Oper. By Piedmont Carolina Bcstg.
 Business-Studio Address Box 990, Gilmer St.
 Phone Number 4361-2
 Air Time Full Time
 News Service AP
 Transcription Service Thesaurus
 Membership NARTB
 President H. T. Williams
 Gen., Sta. Mgr. Stephen F. Woodson
 Sales Prom. Mgr. Page Smith
 Program Director Alfred Nelson
 Publicity Director Joan Smith
 Chief Engineer Sam Sexton

WREV

REIDSVILLE—1948

Frequency: 1220 Kc. Power: 250 Watts d.
 Owened-Oper. By Reidsville Bcstg. Co.
 Address P. O. Box 725
 Phone Number 7051
 Transcription Library Standard
 News Service UP
 Representative Continental
 Pres., Gen., Sta., Comm., Prom. Mgr.
 William M. Oliver, Sr.
 Chief Engineer William M. Oliver, Jr.

WCBT

ROANOKE RAPIDS—1939—MBS-KBS

Frequency: 1230 Kc. Power: 250 Watts
 Owened-Oper. By WCBT, Inc.
 Address 251 Roanoke Ave.
 Phone Number 7-2545
 News Service UP
 Transcription Service Lang-Worth, SESAC
 Pres., Mgr. J. Winfield Crew, Jr.
 Station Manager Jerry Elliott
 Commercial Mgr. Donald O. Collins
 Chief Engineer Ed. McLeod

WAYN

ROCKINGHAM—1946

Frequency: 900 Kc. Power: 1000 Watts a.
 Owened-Operated By WAYN, Inc.
 Bus.-Studio-Trans. Address Rockingham
 Phone Number 4041
 News Service UP
 Transcription Service Capitol, World
 Pres., Gen. Mgr. Wayne M. Nelson
 Chief Engineer William Henley

WCEC

ROCKY MOUNT—1947

Frequency: 810 Kc. Power: 1000 Watts d.
 Owened-Operated By E. Caro. Elec.
 Bus.-Studio Address 115 N. Church St.
 Phone Number 23108
 News Service AP
 Transcription Service Associated
 Representative Pearson
 President Josh L. Horne
 General Manager Mel Warner
 Commercial Manager Ray Thompson
 Program Director Ray Wilkinson
 Chief Engineer Grover Taylor

WEED

ROCKY MOUNT—1933—ABC

Frequency: 1390 Kc. Power: 1000 Watts
 Owened-Operated By W. A. Wynne
 Address Box 752
 Phone Number 2-6149
 Air Time Full Time
 News Service AP
 Transcription Service RCA Thesaurus
 Representative Burn-Smith
 Gen.-Sta. Manager W. A. Wayne

Commercial Mgr.....R. E. Horner
 Program Dir.....Eunice Snipes
 Chief Engineer.....Joe R. Morris

WRXO

ROXBORO—1949

Frequency: 1430.....Power: 1000 Watts d.
 Owned-Operated By.....Roxboro Bcstg. Co.
 Address.....Box 130
 Phone Number.....6013
 News Service.....UP
 President.....H. S. Taylor
 Program Director.....John Mauti
 Chief Engineer.....Lloyd Perkins

WSAT

SALISBURY—1947—ABC

Frequency: 1280 Kc.....Power: 1000 Watts
 Owned-Oper. By.....Mid-Carolina Bcstg. Co.
 Business-Address.....Drawer 99
 Phone Number.....276
 Air Time.....Full Time
 News Service.....UP
 Representative.....McGillvra
 Membership.....NARTB
 President.....Charles H. Wentz
 Gen., Sta. Mgr.....Harry L. Welch
 Program Director.....Johnny L. Joyce
 Chief Engineer.....Elbert Sherman

WSTP

SALISBURY—1939—MBS

Frequency: 1490 Kc.....Power: 250 Watts
 Owned-Oper. By.....Piedmont Bcstg. Corp.
 Bus.-Studio Address.....Center Theatre Bldg.
 Phone Number.....2121
 Air Time.....6 a.m.-M.
 News Service.....AP
 Representative.....Burn-Smith
 Membership.....NARTB
 President.....Bryce P. Beard, Sr.
 General Mgr.....Robert Wallace
 Pgm., Publicity Dir.....Russ McIntire
 Comm. Mgr.....Katherine F. Murphy
 Chief Engineer.....Carl B. Watson

WEYE

SANFORD—1952

Frequency: 1290 Kc.....Power: 1000 Watts d.
 Owned-Oper. By.....Lee Bcstg. Corp.
 Address.....519 Cross St.
 Phone Number.....1269
 News Service.....AP
 Transcription Service.....Associated, SESAC
 General Manager.....W. W. Primm
 Program Director.....W. M. Primm

WWGP

SANFORD—1946—KBS

Frequency: 1050 Kc.....Power: 1000 Watts d.
 Owned-Oper. By.....Sandhills Bcstg. Corp.

Address.....137 So. Steele, Box 651
 Phone Number.....860
 News Service.....UP
 Transcription Service.....World
 President.....J. C. McIver
 Gen., Sta., Prom., Pub. Mgr.

Harry C. Barfield
 Chief Engr.Edward O. Koprivier

WOHS

SHELBY—1946—MBS-KBS

Frequency: 730 Kc.....Power: 250 Watts
 Owned-Oper. By.....Western Carolina Radio
 Business Address.....Box 1401, Shelby
 Phone Number.....6313
 Air Time.....Daytime
 News Service.....UP
 Transcription Service.....SESAC
 Membership.....NARTB
 Pres., Gen., Sta. Mgr.....Robert M. Wallace
 Comm., Prom. Mgr.....Max P. Butler
 Program Director.....Hugh Dover
 Chief Engineer.....Edwin Patterson

WNCA

SILER CITY—1952

Frequency: 1570 Kc.....Power: 1000 Watts d.
 Owned-Operated By.....Chatam Bdcstg. Co.
 Address.....P. O. Box 212
 Phone Number.....616
 News Service.....UP
 Transcription Service.....Lang-Worth, SESAC
 General Manager.....H. Tom Morris
 Chief Engineer.....W. B. Medlin

WMPM

SMITHFIELD—1950

Frequency: 1270 Kc.....Power: 1000 Watts d.
 Owned-Oper. By.....Selma-Smithfield Bcstg. Co.
 Address.....Buffalo Rd.
 Phone Number.....2434
 News Service.....UP
 Transcription Service.....Capitol
 Co-own., Gen. Mgr.....John S. Townsend
 Co-Owner.....J. Fred Horton
 Commercial Manager.....C. I. Parrish

WEEB

SOUTHERN PINES—1947—MBS

Frequency: 990 Kc.....Power: 1000 Watts d.
 Owned-Oper. By.....The Sandhill Community
 Bcstrs., Inc.
 Business Address.....113-115 E. Broad St.
 Phone Numbers.....2-2942, 2-8171
 News Service.....AP
 Transcription Service.....Associated
 Membership.....NARTB, BAB
 Pres., Gen. Mgr.....Jack S. Younts
 Commercial Mgr.....Joe A. Warren
 Program Director.....Elizabeth M. Younts
 Chief Engineer.....Melvin Kushner

WSIC

STATESVILLE—1947—MBS
TOBACCO

Frequency: 1400 Kc. Power: 250 Watts
Owned-Oper. By Statesville Bcstg. Co.
Address Box 1189
Phone Number 9078
Air Time Full Time
News Service AP
Transcription Service World
Representative Southern Radio Reps
Membership NARTB, BAB
Gen. Comm. Mgr. Charles D. Mellon
Sales Prom. Mgr. Garrett Allen
Program Director Tom Lawrence
Chief Engineer T. K. Abernethy

WCPS

TARBORO—1946—TOB. SPORTS

Frequency: 760 Kc. Power: 1000 Watts d.
Owned-Oper. Coastal Plains Bcstg. Co., Inc.
Bus. Studio Address Edgcombe Bank Bldg.
Phone Number 2191.2
News Service AP
Transcription Service World, Thesaurus
Representative Dora-Clayton
Membership NARTB
President V. E. Fountain
Gen. Sta. Mgr. J. T. Snowden, Jr.
Commercial Manager J. Porter MacNair
Program Director Ben F. Mayo
Chief Engineer G. Lee Hodges

WTNC

THOMASVILLE—1947

Frequency: 790 Kc. Power: 1000 Watts d.
Owned By The Thomasville Bcstg. Co.
Address P. O. Box 750
Phone Number 2701
News Service UP
Transcription Service SESAC
Representative Continental
President George W. Lyles, Sr.
Gen. Sta., Comm. Mgr. Harold Harrison
Chief Engineer James McAden

WADE

WADESBORO—1923—KBS

Frequency: 1210 Kc. Power: 1000 Watts d.
Owned-Oper. By R. P. Lyon & Son
Bus. Studio Address Radio Bldg.
Phone Number 620
News Service UP
Transcription Service Capitol
Representative Walker
President R. P. Lyon
General Mgr. J. A. Ballard
Program Director Peggy L. Mitchell
Chief Engineer Kenneth Read

WLSE

WALLACE—1953—MBS-KBS

Frequency: 1400 Kc. Power: 250 Watts

Owned-Oper. By Duplin Bcstg. Co.
Address Box 449
Phone Number 6611
President Harry Kramer
General Manager Lester L. Gould
Sta., Comm. Mgr. Howard Fisher
Chief Engineer Walter Tabler

WHED

WASHINGTON—1948—KBS

Frequency: 1340 Kc. Power: 250 Watts
Owned-Oper. By Beaufort Bcstg. Co.
Phone Number 278
Transcription Service Lang-Worth
Representative Continental
President Lee B. Wynne
General Manager William R. Abeyollnis
Program Director Charlie Yates
Chief Engineer John Wilroy

WRRF

WASHINGTON—1942—ABC

Frequency: 930 Kc. Power: 5000 Watts d.,
1000 Watts n.
Owned-Oper. By Tar Heel Bcstg. System, Inc.
Bus. Studio Address Bank of Washington Bldg.
Phone Number 403
Air Time Full Time
News Service AP
Transcription Service Thesaurus
Representative Walker
Membership NARTB
Pres., Gen. Mgr. W. R. Roberson, Jr.
Station Manager T. H. Patterson
Commercial Mgr. William Abeyounis
Program Manager Merrill Daniels
Sales Prom. Mgr. Dick Stokes
Publicity Director Bob West
Chief Engineer L. E. Hiland

WHCC

WAYNESVILLE—1947—MBS-KBS

Frequency: 1400 Kc. Power: 250 Watts
Owned-Operated By WHCC, Inc.
Business-Studio Address Box 180
Phone Number Glendale 6-4661
Pres., Gen. Mgr. K. D. Fry
Chief Engineer Frank Wilbur

WENC

WHITEVILLE—1946—MBS

Frequency: 1240 Kc. Power: 250 Watts
Owned-Oper. By Whiteville Bcstg. Co., Inc.
Business-Studio Address P. O. Box 700
Phone Number 2133
Transcription Service Langworth, SESAC, etc.
Representative Clark
President Josiah Maultsby
General Manager Ward A. Coleman
Commercial Manager Jerry Honeycutt
Chief Engineer Steve Hart

W I A M

WILLIAMSTON—1951

Frequency: 900 Kc. Power: 1000 Watts d.
 Owned-Oper. By: E. Carolina Bcstg. Co.
 Address: 115 E. Main St.
 Phone Number: 2478
 News Service: UP
 Co.-O., Sta. Mgr., Pgm. Dir.: William H. Farrior
 Co.-O., Gen., Comm., Prom. Mgr.

Charles M. Gaylord
 Chief Engineer: Joseph L. McFarland

W G N I

WILMINGTON—1946—MBS TOBACCO

Frequency: 1340 Kc. Power: 250 Watts
 Owned-Oper. By: New Hanover Bcstg. Corp.
 Business Address: 211 N. 2nd St.
 Phone Number: 2-2493
 News Service: UP
 Representative: Pearson
 President: J. S. Brody
 General Manager: Allen B. Jones
 Commercial Mgr.: A. V. Thompson
 Program Director: Paul Parker
 Chief Engineer: Arthur L. Madeley

W M F D

WILMINGTON—1935—ABC-CBS

Frequency: 630 Kc. Power: 1000 Watts
 Owned-Operated By: R. A. Dunlea
 Phone Number: 4840
 Address: 225 Princess St.
 Air Time: Unlimited
 News Service: UP
 Representative: Burn-Smith
 Membership: NARTB, BAB
 General Manager: R. A. Dunlea
 Station Manager: R. A. Dunlea, Jr.
 Commercial Manager: C. O'Shields
 Asst. to Manager: Julia Mitton
 Chief Engineer: E. I. Herring, Jr.

W G T M

WILSON—1937—CBS

Frequency: 590 Kc. Power: 5000 Watts
 Owned-Oper. By: Watson Industries, Inc.
 Bus.-Studio Address: Herring Ave. Ext.
 Phone Number: 2188-9
 Air Time: Full Time
 News Service: UP
 Transcription Service: Thesaurus
 Representative: Walker
 Membership: NARTB, BAB
 President: Penn Thomas Watson
 General Manager: Henry Sullivan
 Commercial Mgr.: J. Q. Wallace
 Program Director: Bill Bunn
 Chief Engineer: Ernie Pate

W V O T

WILSON—1948—MBS-TOBACCO

Frequency: 1420 Kc. Power: 1000 Watts d.;
 500 Watts n.

Owned-Oper. By: Wilson Radio Co., Inc.
 Address: Wilson
 Phone Number: 5157
 President: H. W. Anderson
 Gen., Sta. Mgr.: Harry Severance
 Commercial Mgr.: P. O. Barnes
 Sales Prom. Mgr.: Lynda Thomas
 Program Director: Joel Lawhon
 Chief Engineer: Dan Williams

W A A A

WINSTON-SALEM—1950

Frequency: 980 Kc. Power: 1000 Watts d.
 Owned-Oper. By: Community Bcstg.
 Service, Inc.
 Address: Box 3119
 Phone Number: 2-4121
 President: Roger Page, Jr.

W A I R

WINSTON-SALEM—1937—ABC

Frequency: 1340 Kc. Power: 250 Watts
 Owned-Oper. By: Radio Winston-Salem, Inc.
 Business-Studio Address: Pepper Bldg.
 Phone Number: 2-1133
 Transcription Service: World
 Representative: Meeker
 Membership: NARTB, BAB
 President: John S. Riggs
 General Manager: Joseph A. Pace
 Comm., Prog. Mgr.: Wallace Voigt
 Program Director: Lawrence Patrick
 Chief Engineer: Lee King

W S J S

WINSTON-SALEM—1930—NBC

Frequency: 600 Kc. Power: 5000 Watts
 Owned-Oper. By: Piedmont Publishing Co.
 Bus.-Studio Address: 419-21 N. Spruce St.
 Phone Number: 5-2311
 Air Time: Full Time
 Transcription Service: Lang-Worth
 Representative: Headley-Reed
 Membership: NARTB, BAB
 President: Gordon Gray
 V.P., Gen. Mgr.: Harold Essex
 Operations Manager: Phil Hedrick
 Sales Manager: Harry B. Shaw
 Program Manager: John Comas
 Publicity Director: Jean Isenhower
 Chief Engineer: Leon Casley

W T O B

WINSTON-SALEM—1947-MBS-CBS

Frequency: 1380 Kc. Power: 1000 Watts
 Owned-Op. By: Winston-Salem Bcstg. Co., Inc.
 Address: 300 S. Stratford
 Phone Number: 34353
 Transcription Service: Thesaurus
 Representative: H-R Reps
 President: James W. Coan
 General Manager: John G. Johnson
 Sales Prom. Manager: Charles Brunt
 Chief Engineer: Hassell Bailey

NORTH DAKOTA

Pop. Feb. 1, 1954 (Est.) 626,000 — Families 169,000
Radio Homes 164,000 — TV Homes 13,500 — Stations in State 13

KFYR

BISMARCK—1925—NBC

Frequency: 550 Kc. Power: 5000 Watts
Owned-Operated By Meyer Bcstg. Co.
Bus. Studio Address 202½ Fourth St.
Phone Number 468
News Service UP
Transcription Service Thesaurus
Representative John Blair
President Mrs. P. G. Meyer
General Manager F. E. Fitzsimonds
Commercial Mgr. R. W. MacLeod
Program Director Cal Culver
Promotion Dir. Jack Swenson
Chief Engineer Ivar Nelson

KDLR

DEVILS LAKE—1925
MBS-GREAT NORTHERN—KBS

Frequency: 1240 Kc. Power: 250 Watts
Owned-Operated By KDLR, Inc.
Business Studio Address 1025 3rd St.
Phone Number 1090
Air Time Unlimited
News Service UP
Transcription Service World, SESAC
Representative Lawson
President, General Manager Bert Wick
Commercial Manager Paul R. Lange
Program Director Wilbur Clemenson
Chief Engineer Richard Moritz

KDIX

DICKINSON—1947—KBS

Frequency: 1230 Kc. Power: 250 Watts
Owned-Oper. By Dickinson Radio Assn.
Bus. Studio Address 119 2d Ave. W.
Phone Number 4113
News Service AP, UP
Trans. Service Standard, SESAC, World
Membership NARTB, BAB
President Dr. P. J. Weir
Gen. Sta. Mgr. Orville F. Burda
Commercial Manager E. A. Spear
Chief Engineer Benjamin G. Lockerd

KFGO

FARGO—1948—ABC

Frequency: 790 Kc. Power: 5000 Watts
Owned-Oper. By Northern States Bcstg. Co.
Business Studio Address Box 1610
Phone Number 2-3291
News Service AP
Transcription Service Standard
Representative Bolling, Inland
President W. R. Haggart
Gen. Sta., Comm. Mgr. Charles G. Burke

Pgm. Pub. Dir. Albert F. Horrigan
Chief Engineer Olaf Gabrielson

WDAY

FARGO—1922—NBC

Frequency: 970 Kc. Power: 5000 Watts
Owned-Operated By WDAY, Inc.
Business Studio Address Black Bldg.
Phone Number 5357
News Service AP, UP
Transcription Service Thesaurus
Representative Free & Peters
President, Gen. Mgr. E. C. Reineke
Station Manager Jack Dunn
Commercial Manager Tom Barnes
Sales Promotion Manager Roy Pedersen
Program Director Ken Kennedy
Technical Director Julius Heiland
Chief Engineer Juline Savold

KILO

GRAND FORKS—1941—CBS

Frequency 1440 Kc. Power: 1000 d.; 500n.
Owned-Oper. By Grand Forks Herald, Inc.
Bus. Studio Address First Natl. Bank Bldg.
Phone Number 4-5321
Air Time Unlimited
News Service AP
Newspaper Affiliation "Herald"
Transcription Service Thesaurus
Representative Avery-Knodel
Membership NARTB
Pres., Gen. Mgr. M. M. Oppegard
Commercial Manager Herman Livingston
Program Director John Doyle
Chief Engineer A. F. Petrich

KNOX

GRAND FORKS—1947—MBS
KBS—GREAT NORTHERN

Frequency: 1400 Kc. Power: 5000 Watts
Owned By Community Radio Corp.
Address Grand Forks
Phone Number 4-4611
News Service UP
Membership NARTB
Representative Lawson, Walker
President Carroll E. Day
Gen. Sta. Mgr. Elmer Hanson
Program Director Robert Whyte
Promotion Manager Jack French
Chief Engineer Clifford Thomforde

KSJB

JAMESTOWN—1937—CBS

Frequency: 600 Kc. Power: 5000 Watts
Owned-Oper. By N. Dak. Bcstg. Co., Inc.
Address 429 S. W. Second St.
Phone Number 1600
News Service UP, AP

Representative.....Weed & Co.
 President.....John W. Boler
 Commercial Manager.....Bob Ingersoll
 Sales Prom. Mgr.....Virgil Cobia
 Program Director.....Donald Kingsley
 Chief Engineer.....Robert E. Ridgway

K G C U

MANDAN—1927—MBS-ABC

Frequency: 1270 Kc....Power: 1000 d.; 250n.
 Owned-Oper. By.....Mandan Radio Assn.
 Bus.-Studio Address.....Mandan
 Phone Number.....MA 561
 Air Time.....6 a.m.-12 p.m.
 News Service.....AP
 Transcription Service.....Lang-Worth, Associated
 Representative.....Walker
 Membership.....NARTE, BAB
 President.....W. S. Russell
 Sta., Comm. Mgr.....Paul C. Gussner
 Program Director.....Merritt Bushee
 Chief Engineer.....Ray Barnett

K C J B

MINOT—1950—CBS-DRN

Frequency: 910 Kc.....Power: 1000 Watts
 Owned-Oper. By.....No. Dakota Bcstg. Co.
 Address.....15-A West Central Ave.
 Phone Number.....51-161
 Representative.....Weed
 Transcription Service.....Associated
 News Service.....UP
 Pres., Gen. Mgr.....John W. Boler
 Sta., Comm. Mgr.....Wm. L. Hurley
 Sales Prom. Mgr.....Casper Putnam
 Program Director.....A. Johnson
 Chief Engineer.....Joseph Main

K L P M

MINOT—1929—ABC-MBS
 GREAT NORTHERN

Frequency: 1390 Kc..Power: 5000 d.; 1000 n.
 Owned-Operated By.....Minot Bcstg. Co.
 Business-Studio Address.....Fairblock, So. Main
 Phone Number.....41-148
 News Service.....AP, UP
 Transcription Service.....World
 Representative.....Walker, Lawson
 General Manager.....John B. Cooley
 Sta. Mgr., Chief Engineer.....C. W. Baker

K O V C

VALLEY CITY—1936—MBS-KBS

Frequency: 1490 Kc.....Power: 250 Watts
 Owned-Operated By.....KOV, Inc.
 Business-Studio Address.....135 Central Ave. S.
 Phone Number.....408-W
 Transcription Service.....Standard
 Pres., Gen., Comm. Mgr.....Robert E. Ingstad
 Program Director.....Russ Kaber
 Publicity Director.....Bob Jensen
 Chief Engineer.....Charles Sjostrom

K W B M

WILLISTON—1948—KBS

Frequency: 1450 Kc.....Power: 250 Watts
 Owned-Oper. By.....KWBM Bcstg. Co.
 Address.....Box 198, Williston
 Phone Number.....35-371
 Transcription Service.....World
 General Manager.....Charles L. Scofield
 Partner.....James C. Carson
 Sales Prom. Mgr.....W. L. Holter
 Chief Engineer.....W. A. Sebastian

OHIO

Pop. Feb. 1, 1954 (Est.) 8,385,000 — Families 2,499,000
 Radio Homes 2,435,000 — TV Homes 2,017,500 — Stations in State 78

W A D C

AKRON—1925—CBS

Frequency: 1350 Kc.....Power: 5000 Watts
 Owned-Operated By.....Allen T. Simmons
 Bus.-Studio Address.....WADC Bldg.
 Phone Number.....JEfferson 5-6185
 Air Time.....5:30 a.m.-1:05 a.m.
 News Service.....UP
 Transcription Service.....Standard, World
 Representative.....George P. Hollingsbery
 Owner-Operator.....Allen T. Simmons
 Assistant Manager.....Robert B. Wilson
 Sales Prom. Mgr.....Doc Williams
 Program Director.....Harold H. Hageman
 Chief Engineer.....Arnold Bock

W A K R

AKRON—1940—ABC

Frequency: 1590 Kc.....Power: 5000 Watts
 Owned By.....Summit Radio Corp.
 Operated By.....WAKR
 Bus.-Studio Address.....First Natl. Tower
 Phone Number.....HEmlock 4-6151
 Newspaper Affiliation.....Beacon Journal
 Air Time.....Full Time
 News Service.....UP
 Representative.....Weed
 President, Gen. Mgr.....S. Bernard Berk
 Station Manager.....Roger G. Berk
 Comm.-Sales Prom. Mgr.....Keith Baldwin
 Pgm., Pub. Dir.....A. R. Cooper
 Chief Engineer.....Irwin L. Knopp

WCUE

AKRON—1949

Frequency: 1150 Kc. Power: 1000 Watts d.
 Owned-Oper. By: Akron Bcstg. Corp.
 Address: 41 S. Main St.
 Phone Number: Fr. 6-7114
 Representative: Forjoe
 News Service: UP
 Transcription Service: Associated
 President, Gen. Mgr.: Tim Elliot
 Sta., Comm. Mgr.: Jack Maurer
 Program Director: Jack Clifton
 Chief Engineer: George V. Paul

WHKK

AKRON—1945—MBS

Frequency: 640 Kc. Power: 1000 Watts
 Owned-Oper. By: WHKK Bcstg. Co.
 Business-Studio Address: 51 W. State St.
 Phone Number: Bl. 7101
 News Service: AP
 Transcription Service: Thesaurus
 Representative: Bolling
 Co-Manager: Philip R. Herbert
 Co-Manager: Jackson B. Maurer
 Program Dir.: B. R. Blake
 Chief Engineer: Henry Neiderkofler

WFAH

ALLIANCE—1953

Frequency: 1310 Kc. Power: 1000 Watts d.
 Owned-Oper. By: The Review Pub.
 Address: 2720 S. Union
 Phone Number: 1-5345
 Representative: Rambeau
 General Manager: D. A. Peterson
 Commercial Mgr.: Frank LaBarba
 Program Director: R. A. Gates
 Chief Engineer: Gene Peterman

WATG

ASHLAND—1947—MBS

Frequency: 1340 Kc. Power: 250 Watts
 Owned-Oper. By: Ashland-Mansfield Rd.
 Phone Number: 2-1573
 Transcription Service: Thesaurus
 Representative: McGillvra
 News Service: AP
 President: Robert S. Burke
 General Manager: Eugene E. Mills
 Station Manager: Don Holzapfel
 Sales Prom. Mgr.: Harlan Cook Jr.
 Program Director: Richard Leidy
 Chief Engineer: Richard Matthes

WICA

ASHTABULA—1937

Frequency: 970 Kc. Power: 5000 Watts d.,
 1000 n.
 Owned-Operated By: WICA, Inc.
 Business-Studio Address: Jefferson Rd.
 Phone Number: 32-126
 News Service: UP
 Transcription Service: World
 Representative: Gill-Perna
 President: D. C. Rowley
 General Manager: John Colin
 Program Director: John C. Strassen
 Chief Engineer: F. N. Barnato

WATH

ATHENS—1950

Frequency: 1540 Kc. Power: 1000 Watts d.
 Owned-Oper. By: Andrew Kovlan & James
 Sinyard
 Address: P. O. Box 502
 Phone Number: 3-1369
 Gen. Mgr., Chief Engr.: Andrew Kovlan
 Comm., Sls. Prom. Mgr.: J. D. Sinyard
 Program Director: Ted Covert

WTRF

BELLAIRE—1947—MBS

Frequency: 1290 Kc. Power: 1000 Watts d.
 Owned-Operated By: The Tri-City Bcstg. Co.
 Bus. Studio-Transmitter Address: The Skyline
 Phone Number: BE 1515
 News Service: AP
 Transcription Service: Associated
 Representative: Hollingberry
 Membership: NARTB, BAB
 President: Thomas Bloch
 V.P., Gen. Manager: Robert W. Ferguson
 Publicity Director: Greg Van Camp
 Program Director: Frank Curtiss
 Sales Prom. Mgr.: William Greaver
 Chief Engineer: Howard Daubenmeyer

WOHP

BELLEFONTAINE—1952—KBS

Frequency: 1390 Kc. Power: 500 Watts d.
 Owned-Oper. By: Lake Erie Radio & TV Corp.
 Phone Number: 6681
 News Service: AP
 President: Ted Nelson
 Vice-President: Pat Shannon
 General Manager: Frank Cummins
 Chief Engineer: Chester Terry

WILE

CAMBRIDGE—1948—KBS

Frequency: 1270 Kc. Power: 1000 Watts a.
 Owned-Oper. By: Land O'Lakes Bcstg. Corp.

Business-Studio Address.....917 Beatty Ave.
 Phone Number4-5605
 News ServiceAP
 Transcription ServiceWorld, Standard
 President.....H. D. McClelland
 Exec. Vice-President.....Howard A. Donahoe
 Comm. Mgr.....Bruce Meighen
 Program Director.....David C. Lorimer
 Chief Engineer.....A. G. Engel

WAND**CANTON—1947**

Frequency: 900 Kc.....Power: 500 Watts d.
 Owned-Oper. By.....P. C. Wilson
 Address106 High Ave. N.W.
 Phone Number68396
 Representative.....Hil F. Best
 President.....P. C. Wilson
 General Manager.....Frank Grosjean

WCMW**CANTON—1947**

Frequency: 1060 Kc.....Power: 1000 Watts d.
 Owned-Operated By.....Stark Bcstg. Corp.
 Bus.-Studio Address.....Hills & Dales Rd.
 Phone Number.....5-9475
 News ServiceINS
 Transcription ServiceThesaurus, World
 RepresentativeMcGillvra
 Pres., Gen. Mgr.....S. L. Huffman
 Station Manager.....Clark L. Dozer
 Chief Engineer.....W. Waechter

WHBC**CANTON—1925—ABC**

Frequency: 1480 Kc.....Power: 5000 Watts
 Owned-Operated By.....Ohio Bcstg. Co.
 Business-Studio Address.....550 S. Market St.
 Phone Number6-7166
 Air Time6 a.m.-1 a.m.
 News ServiceAP
 Newspaper AffiliationBrush-Moore
 Newspapers
 Transcription ServiceAssociated
 RepresentativeTaylor Co.
 MembershipNARTB, BAB
 President.....Roy D. Moore
 General Manager.....Gordon G. Strong
 Director of Radio.....Eugene Carr
 Station Manager.....Robert C. Fehiman
 Commercial Manager.....Paul E. Gilmor
 Sales Prom. Mgr.....Louise Maag
 Program Director.....Robert Breen
 Chief Engineer.....Kenneth L. Sliker

WBEX**CHILICOTHE—1947—ABC-KBS**

Frequency: 1490 Kc.....Power: 250 Watts

Owned-Operated By.....Shawnee Bcstg. Co.
 Business-Studio Address.....27 E. Second St.
 Phone Number3-2244
 Air TimeFull Time
 News ServiceAP
 Representative.....W. S. Grant
 MembershipNARTB
 President.....John Halliday
 General Manager.....Truman Morris
 Sta., Sales Prom. Mgr.....William R. Mnich
 Program Director.....James A. Eldridge
 Chief Engineer.....H. W. Dornhuber

WCIN**CINCINNATI—1953**

Frequency: 1480 Kc.....Power: 1000 Watts d.
 Owned-Oper. By.....Robert W. Rounsaville
 Address.....Radio Station WQXI,
 Atlanta, Ga.
 News ServiceUP
 RepresentativeForjoe, Dorá-Clayton
 General Manager.....Robert W. Rounsaville
 Station Manager.....William R. Wagner
 Commercial Manager.....Ralph B. Johnson
 Sales Prom. Mgr.....Carter Jones
 Program Director.....Larry Dean Faulker
 Publicity Director.....Jimmy Carter
 Chief Engineer.....Joseph McCormick

WCKY**CINCINNATI—1929**

Frequency: 1530 Kc.....Power: 50,000 Watts
 Owned-Operated By.....L. B. Wilson, Inc.
 Bus.-Studio Address.....Hotel Sheraton Gibson
 Phone Number.....Cherry 6565
 News ServiceINS
 Transcription Service.....Standard, Associated
 RepresentativeThomas Welstead
 MembershipBAB
 President, General Manager.....L. B. Wilson
 V.P., Comm. Manager, Chief
 Engineer.....C. H. Topmiller

WCPO**CINCINNATI—1928—MBS**

Frequency: 1230 Kc.....Power: 250 Watts
 Owned-Oper. By.....Scripps-Howard Radio, Inc.
 Phone Number.....Capitol 0777
 Studio Address.....2345 Symmes St.
 News ServiceUP
 RepresentativeBranham
 President.....Jack R. Howard
 General Manager.....M. C. Watters
 Program Director.....Earl Corbett
 Promotion Dir.....Richard Zavon
 Chief Engineer.....Paul Adams

TWO KINGS

in the
Queen City ★

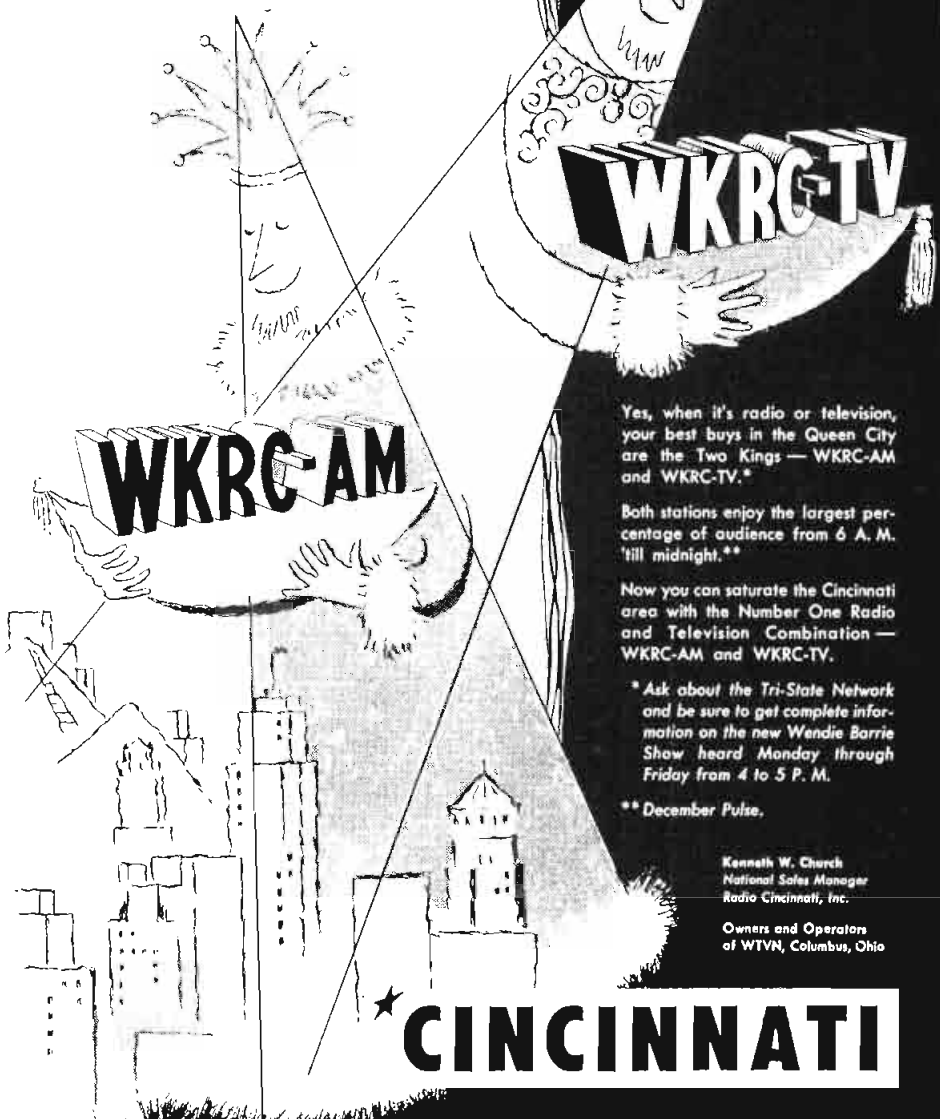

Yes, when it's radio or television, your best buys in the Queen City are the Two Kings — WKRC-AM and WKRC-TV.*

Both stations enjoy the largest percentage of audience from 6 A. M. 'till midnight.**

Now you can saturate the Cincinnati area with the Number One Radio and Television Combination — WKRC-AM and WKRC-TV.

* Ask about the Tri-State Network and be sure to get complete information on the new Wendie Barrie Show heard Monday through Friday from 4 to 5 P. M.

** December Pulse.

Kenneth W. Church
National Sales Manager
Radio Cincinnati, Inc.

Owners and Operators
of WTVN, Columbus, Ohio

★ CINCINNATI

REPRESENTED BY THE KATZ AGENCY • CBS RADIO AND TELEVISION NETWORKS

WKRC**CINCINNATI—1921—CBS**Frequency: 550 Kc. Power: 5000 Watts d.
1000 Watts n.

Owned-Oper. By.....Radio Cincinnati, Inc.
Address-Trans.Hotel Alms
Phone Number.....Woodburn 0550
News Service.....AP
Newspaper Affiliation.....Times-Star
Transcription Service.....SESAC
Representative.....Katz
Membership.....NARTB
President.....Hulbert Taft, Jr.
General Manager.....David Taft
Sales Prom. Mgr.....Lila Lambert
Commercial Manager.....Hubbard Hood
National Sales Mgr.....Kenneth W. Church
Program Director.....Byron Taggart
Chief Engineer.....W. Kennedy

WLW**CINCINNATI—1922—NBC**Frequency: 700 Kc. Power: 50,000 Watts
Owned-Oper. By.....Crosley Bcstg. Corp.
Subs. of Avco Mfg.

Address.....140 W. Ninth St.
Phone Number.....Cherry 1822
Air Time.....Full Time
Pres., General Mgr.....R. E. Dunville
V.P. in Charge Sales.....Harry Mason Smith
Dir. Client Service.....Fred Gregg
Program Director.....Chester Herman
Publicity Director.....Gilbert Kingsbury
Chief Engineer.....R. J. Rockwell

WSAI**CINCINNATI—1923—ABC**

Frequency: 1360 Kc. Power: 5000 Watts
Owned-Oper. By.....Gordon Bcstg. Co.
Bus.-Studio Address.....115 E. Fourth St.
Phone Number.....Main 1068
Air Time.....6 a.m.-M.
News Service.....UP
Transcription Service.....World
Representative.....Avery-Knodel
Membership.....NARTB, BAB
Pres., Gen. Mgr.....Sherwood R. Gordon
Sales Manager.....Tom Thuman
Program Director.....Charles Black
Publicity Director.....Vonne Monsell
Chief Engineer.....Jonas Heiser

*(See Page 538)***WDOK****CLEVELAND—1950**

Frequency: 1260 Kc. Power: 5000 Watts
Owned-Operated By.....Civic Bcstrs., Inc.
Address.....1515 Euclid Ave.
Phone Number.....FL 1-1834
News Service.....UP, INS
Representative.....Everett-McKinney
Transcription Service.....SESAC, World
Membership.....NARTB
Pres., Gen. Mgr.....R. Morris Pierce

Sales Prom., Comm. Mgr.....Frederick Wolf
Prog. Dir., Chief Eng.....Ralph Quay**WERE****CLEVELAND—1948**

Frequency: 1300 Kc. Power: 5000 Watts
Owned-Operated By.....Cleveland Bcstg. Inc.
Address.....1501 Euclid Ave.
Phone Number.....SUpperior 1-9600
News Service.....AP, INS
Transcription Service.....Lang-Worth, World
President.....Ray T. Miller
General Manager.....Richard M. Klaus
Program Director.....Ed Stevens
Chief Engineer.....Harry Dennis

WGAR**CLEVELAND—1930—CBS**

Frequency: 1220 Kc. Power: 50,000 Watts
Owned-Operated By.....WGAR Bcstg. Co.
Address.....Hotel Statler
Phone Number.....Prospect 1-0200
News Service.....INS, UP
Transcription Service.....World
Representative.....Christal, Radio Tim. Sales
Membership.....NARTB, BAB
President.....Herbert L. Evans
General Manager.....Carl E. George
Sect.-Treas.....Elmer Krause
Commercial Manager.....John Garfield
Sales Promotion Manager.....Julius Glass
Program Director.....Reg Merridew
Publicity Director.....Robert Smith
Chief Engineer.....Bob Fox

WHK**CLEVELAND—1921—MBS**

Frequency: 1420 Kc. Power: 5000 Watts
Owned-Operated By.....United Bcstg. Co.
Business-Studio Address.....5000 Euclid Avenue
Phone Number.....Express 1-5000
Air Time.....Unlimited
News Service.....AP
Transcription Service.....BMI, ASCAP
Representative.....Headley-Reed
Membership.....NARTB
President.....H. K. Carpenter
General Manager.....K. K. Hackathorn
Commercial Manager.....W. K. Brusman
Sales Prom. Manager.....John Wyman
Program Director.....C. M. Hunter
Publicity Director.....F. P. Wilhelm
Chief Engineer.....R. H. DeLany

WJMO**CLEVELAND—1947**

Frequency: 1540 Kc. Power: 1000 Watts a.
Owned-Operated By.....Friendly Bcstg. Co.
Address.....2157 Euclid Ave.
Phone Number.....SUpperior 1-4424
News Service.....UP
Transcription Service.....Lang-Worth

SOUND SALES PLANNING INCLUDES

WSAI



The
NEW SOUND
in
Cincinnati!

New Sound ENTERTAINMENT...

from big-time music to local news and homemaker views supplemented by the widest variety of A B C attractions. Smart advertisers are profiting from our happy new balance of audience-pulling entertainment.

New Sound SHOWMANSHIP...

sparked by the fresh new ideas of the Gordon Broadcasting Company, salesmanship is the keynote of our showmanship every personality in our talent shop is a showman ready to sell for you!

New Sound MERCHANDISING..

"follow thru" or point-of-sale means more profit for you. Our complete merchandising planning department is at your service to show you how to make more money out of radio!

SHERWOOD R. GORDON
Pres. and Gen. Mgr.

NATIONAL REPRESENTATIVE: AVERY-KNODEL, INC.

Write, phone or wire for
**MORE SOUND REASONS TO BUY THE
5000 SELLING WATTS OF WSAI**
The New Sound in Cincinnati!

FOR
IMPORTANT
TELEPHONE NUMBERS
IN
NEW YORK, LOS ANGELES, CHICAGO,
WASHINGTON
SEE PAGE 100



You! A Dictator?

Were you the kind of man pictured here, we would refuse to do business with you. The kind of *power* a dictator seeks is an anathema and abomination in the minds of free Americans. But there is *another* kind of *power* you should have . . .

Broadcast power, day and night, is what we sell. Around-the-clock programming with *selling power* is our business. From Cleveland, WTAM saturates a daytime area of more than 1,212,550 radio homes. And at night, 48 states comprise the tremendous WTAM market area. You can't beat that kind of *broadcast power* developed to usefully serve both *audience* and *advertiser* on a mass scale.

When seeking *powerful* results with an advertising message, investigate WTAM *radio power* with its most distinguished record of community service.

NBC BUILDING

Cleveland 14, Ohio

Represented Nationally
by NBC Spot Sales

WTAM

"at your service day and night"

1100 kilocycles

50,000 watts

Class 1a Clear Channel



President Richard Eaton
 Station Manager Paul Nakel
 Comm. Mgr. Leonard B. Fidanis
 Chief Engineer C. C. Courtney

W J W**CLEVELAND—1932—ABC**

Frequency: 850 Kc. Power: 5000 Watts
 Owned-Operated By WJW, Inc.
 Business-Studio Address 1375 Euclid Ave.
 Phone Number Superior 1-0104
 Air Time Full Time
 News Service UP
 Transcription Service Standard
 Representative H-R Representatives, Inc.
 P. President William M. O'Neil
 V.P., Ass't to Pres. John D. Kelly
 Vice-Pres., Gen. Mgr. William Lemmon
 Vice-Pres., Comm. Mgr. Harold W. Waddell
 Sales Prom. Mgr. Virgil Brinnon
 Program Director Bruce MacDonald
 Chief Engineer Gerald G. Roberts

W S R S**CLEVELAND—1947**

Frequency: 1490 Kc. Power: 250 Watts
 Owned-Operated By WSRS, Inc.
 Bus.-Studio-Transmitter Address 2156 Lee Rd.
 Phone Number ERview 1-2005
 News Service AP, INS
 Transcription Service APS, SESAC
 Representative Forjoe & Co.
 Membership NARTB, BAB
 Pres., Gen. Mgr., Pgm. Dir. S. R. Sague
 Commercial Mgr. Will Dougherty
 Chief Engineer Bob Leedham

W T A M**CLEVELAND—1923—NBC**

Frequency: 1100 Kc. Power: 50,000 Watts
 Owned-Oper. By National Bcstg. Co., Inc.
 Bus.-Studio Address 815 Superior Ave.
 Phone Number CHerry 1-0942
 Air Time 5:30 a.m.-2:00 a.m.
 News Service AP, UP
 Transcription Service Thesaurus
 Representative NBC Spot Sales
 Membership NARTB, BAB
 Chairman of the Board David Sarnoff
 General Manager Lloyd E. Yoder
 Program Director Brooke Taylor
 Sales Manager Wm. P. Dix, Jr.
 Adv. & Prom. Mgr. Clement G. Scerback
 Publicity Director Frank Derry
 Engineer-in-Charge S. E. Leonard

W B N S**COLUMBUS—1924—CBS**

Frequency: 1460 Kc. Power: 5000 Watts d.:
 1000 Watts n.
 Owned-Oper. By RadiOhio, Inc.
 Business-Studio Address 33 N. High St.
 Phone Number Ad. 9265
 Air Time Full Time
 News Service AP
 Representative John Blair

Membership NARTB, BAB
 General Manager Richard A. Borel
 Commercial Manager W. I. Orr
 Sales Prom. Director Jim Yeran
 Program Director Geer Parkinson
 Chief Engineer Lester H. Natfzger

W C O L**COLUMBUS—1922—ABC**

Frequency: 1230 Kc. Power: 250 Watts
 Owned-Operated By Air Trails, Inc.
 Business-Studio Address E. Broad & Young St.
 Phone Number MAin 4581
 News Service AP
 Transcription Service World
 Representative H-R Reps., Inc.
 Membership BAB
 President Charles Sawyer
 Exec. V.P. J. P. Williams
 General Manager Adna H. Karns
 Station Manager Charles Reeder
 Program Director Michael Ryan
 Nat'l Sales Manager John Doty
 Publicity Director Mary Hart
 Chief Engineer Harold E. Beard

W H K C**COLUMBUS—1921—MBS**

Frequency: 610 Kc. Power: 5000 Watts
 Owned-Operated By United Bcstg. Co.
 Business-Studio Address 22 East Gay St.
 Phone Number Adams 1101
 Air Time 6 a.m.-1 a.m.

W S R S

1st PLACE
 LOCAL NEWS
 AWARD WINNER

COVERS
 CLEVELAND

W S R S
 COMMUNITY
 INFORMATION

VOICE
 OF
 CLEVELAND

W S R S
 "Best by Test"

Newspaper Affiliation....."Plain Dealer"
 News Service.....INS, UP
 Transcription Service.....Lang-Worth
 Representative.....Paul H. Raymer
 Membership.....NARTB
 President.....Sterling Graham
 Gen., Sta. Mgr.....Carl M. Everson
 Comm.-Sales Prom. Mgr.....H. H. Hoessly
 Program Director.....John B. Moses
 Publicity Director.....Ann Dully
 Chief Engineer.....William C. Minor

WV KO

COLUMBUS—1948—BUCKEYE

Frequency: 1580 Kc..... Power: 1000 Watts d.
 Owned-Oper. By.....Sky Way Bcstg. Corp.
 Address.....274 S. 3rd St.
 Phone Number.....Main 5247
 News Service.....UP
 Transcription Service.....Standard. Capitol
 Representative.....Forjoe
 President.....Gustav Hirsch
 Gen., Sta. Manager.....Bert Charles
 Comm., Sales Prom. Mgr.....Joe Hill
 Chief Engineer.....William Hammett

WTNS

COSHOCTON—1947

Frequency: 1560 Kc..... Power: 1000 Watts d.
 Owned-Oper. By.....Coshocton Bcstg. Co.

Putting our Best
Foot Forward

WV KO
AM - FM

**COLUMBUS
OHIO**

HOOPER
April 1953

PULSE
Sept. Oct. 1953

- * Pulse and Hooper put WV KO in a solid second place in a six station market.
- * The only independent station in Columbus.
- * Lowest cost per thousand radio homes.

Represented nationally by:
Forjoe, Inc.

Business-Studio Address.....114 N. 6th St.
 Phone Number.....1560, 2140
 News Service.....UP
 Pres., Gen. Mgr.....Bruce Wallace
 Commercial Mgr.....James Sigman
 Program Director.....Stanley Robinson
 Chief Engineer.....Elmer Moravecky

WHIO

DAYTON—1935—CBS

Frequency: 1290 Kc..... Power: 5000 Watts
 Owned-Oper. By.....Miami Valley Bcstg. Corp.
 Business-Studio Address.....45 S. Ludlow St.
 Phone Number.....Adams 2261
 News Service.....AP, UP
 Newspaper Affiliation....."Daily News"
 Representative.....Hollingbery
 Membership.....NARTB
 President.....James M. Cox, Jr.
 General Manager.....Robert H. Moody
 Commercial Mgr.....W. E. Wolaver
 Station Manager.....Wade H. Alley
 Publicity Director.....Chuck Gay
 Chief Engineer.....Ernest L. Adams

WING

DAYTON—1924—ABC

Frequency: 1410 Kc..... Power: 5000 Watts
 Owned-Oper. By.....Great Trails Bcstg. Co.
 Business-Studio Address.....121 N. Main St.
 Phone Number.....HEmlock 3773
 Air Time.....5 a.m.-1:30 a.m.
 News Service.....AP
 Transcription Service.....World
 Representative.....H. R. Representative, Inc.
 President.....Charles Sawyer
 Exec. V.P.....John Pattison Williams
 General Manager.....Adna Karns
 Publicity Director.....M. A. Dell
 Chief Engineer.....Howard Ryan

WONE

DAYTON—1949

Frequency: 980 Kc..... Power: 5000 Watts
 Owned-Operated By.....Skyland Bcstg. Corp.
 Address.....380 West First St.
 Phone Number.....Michigan 6501
 News Service.....AP
 Transcription Service.....Capitol
 Representative.....Headley-Reed
 President.....Ronald B. Woodyard
 Nat'l Sales Manager.....C. J. Thornquest
 Commercial Manager.....Louis G. Froelich

WONW

DEFIANCE—1947

Frequency: 1280 Kc..... Power: 500 Watts d.
 Owned-Oper. By.....Tri-State Bcstg. Co.
 Address.....U. S. Route 24
 Phone Number.....32226
 News Service.....AP
 Transcription Service.....Associated
 Representative.....Devney
 President.....Richard W. Crowell

Gen., Comm. Mgr. Glenn R. Thayer
 Program Director Paul R. Murphy

WJER

DOVER—1950

Frequency: 1450 Kc. Power: 250 Watts
 Owned-Oper. By Dover Bcstg. Co., Inc.
 Address 210 Blvd.
 Phone Number 4-2126
 Transcription Service World, Thesaurus
 Representative Hil F. Best
 News Service UP
 President Agnes J. Reeves Greer
 Gen., Sta. Mgr. W. B. Steis
 Commercial Manager John C. Needs
 Chief Engineer Don Graff

WLIO

EAST LIVERPOOL—1948

Frequency: 1570 Kc. Power: 1000 Watts d.
 Owned-Operated By Pottery Bcstg. Co.
 Address 6th and Walnut
 Phone Number Main 5190
 News Service AP
 Representative Schepp-Reiner
 Pres., Gen. Mgr. Paul Bron Saliner
 Sta., Comm. Mgr. Van Lane
 Chief Engineer George T. Kelly

WOHI

EAST LIVERPOOL—1949—ABC

Frequency: 1490 Kc. Power: 250 Watts
 Owned-Oper. By East Liverpool Bcstg. Co.
 Address 516 Market St.
 Phone Number Main 1490
 News Service AP
 Transcription Service World
 President, Gen. Manager Richard V. Beatty
 Comm., Prom. Mgr. George T. Farrall
 Sta. Mgr., Prog. Dir. Bob Metcalfe
 Chief Engineer William Siebenthal

WEOL

ELYRIA—1948

Frequency: 930 Kc. Power: 1000 Watts
 Owned-Oper. By Elyria-Lorain Bcstg. Co.
 Address Elyria Savings and Trust Bldg.
 Phone Number EL 2255
 News Service UP
 President Roy W. Ammel
 General Manager Alex Buchan
 Sales Prom. Mgr. Ronald Barrett
 Program Director Pat Fredericks
 Chief Engineer William Albrecht

WFIN

FINDLAY—1941

Frequency: 1330 Kc. Power: 1000 Watts d.
 Owned-Operated By The Findlay Publ. Co.
 Bus.-Studio Address 500½ South Main St.
 Phone Number 1330
 News Service INS, UP, AP
 Transcription Service Thesaurus

Newspaper Affil. "Republican-Courier"
 Membership NARTB
 Representative McGillvra
 President R. L. Heminger
 Gen., Sta., Comm. Mgr. Harold H. Heminger
 Sls. Prom. Mgr. Allen P. Dudley
 Chief Engineer Edgar C. Smith

WFOB

FOSTORIA—1952—KBS

Frequency: 1430 Kc. Power: 1000 Watts
 Owned-Operated By Seneca Radio Corp.
 Address P. O. Box 589
 Phone Number 5665
 News Service UP
 Transcription Service Capitol, SESAC
 President Andrew Emerine
 General Manager Mel Murray
 Chief Engineer Fa rell Elsea

WFRO

FREMONT—1949

Frequency: 900 Kc. Power: 500 Watts d.
 Owned-Oper. By Wolfe Bcstg. Corp.
 Address 905 W. State St.
 Phone Number FE 2-3951
 Transcription Service Standard
 Representative Hil F. Best
 News Service UP
 Membership NARTB, BAB
 President Robert F. Wolfe
 Sta., Prom., Comm. Mgr. R. C. Force
 Chief Engineer Allen Kaubel

WJEH

GALLIPOLIS—1950—KBS

Frequency: 990 Kc. Power: 250 Watts d.
 Owned-Oper. By Ohio Valley on the Air, Inc.
 Address Box 244
 Phone Number 1160-1
 News Service UP
 Transcription Service Capitol
 Representative Grant
 President John E. Halliday
 General Manager Truman A. Morris
 Station Manager Marianne Campbell
 Sales Prom. Mgr. K. W. Robinson
 Program Director William Watterson, Jr.
 Chief Engineer Edgar Atkins

WMOH

HAMILTON—1944

Frequency: 1450 Kc. Power: 250 Watts
 Owned-Oper. By Fort Hamilton Bcstg. Co.
 Bus.-Studio Address Second Natl. Bank Bldg.
 Phone Number Hamilton 4-6543
 News Service UP
 Transcription Service Lang-Worth
 Representative W. S. Grant
 President Robert J. Briede
 General Manager Robert L. Odson
 Program Director Norm Keller
 Commercial Manager Ray Motley
 Chief Engineer Girard Cain

WIRO

IRONTON—1951—MBS

Frequency: 1230 Kc. Power: 250 Watts
 Owned-Oper. By Iron City Bcstg. Co.
 Address Radio Plaza
 Phone Number 280
 Representative McGillvra
 President T. M. Nelson
 General Manager C. E. McElroy
 Vice-President Patrick Shannon
 Chief Engineer C. A. Baker

WLMJ

JACKSON—1953—KBS

Frequency: 1280 Kc. Power: 1000 Watts d.
 Owned-Oper. By WLMJ Inc.
 Phone Number 850
 President Frances Moore
 General Manager Truman Morris
 Station Manager Don Hughes
 Chief Engineer Hank Dornhuber

WHOK

LANCASTER—1947

Frequency: 1320 Kc. Power: 500 Watts d.
 Owned-Oper. By Hocking Valley Bcstg. Corp.
 Address-Trans. Loc. Memorial Dr.
 Phone Number 4500
 News Service UP
 Transcription Service Thesaurus
 Representative McGillvra
 Membership NARTB
 Pres., Gen. Mgr. Dr. Nelson Embrey
 Station Manager James W. Tidd
 Comm., Prom. Mgr. Roy Stingley
 Chief Engineer Irving Brown

WIMA

LIMA—1948—ABC

Frequency: 1150 Kc. Power: 1000 Watts
 Owned-Oper. By N.W. Ohio Bcstg. Corp.
 Business-Studio Address 223 N. Main St.
 Phone Number 32660
 News Service AP
 Representative Weed
 Membership NARTB
 President G. E. Hamilton
 General Sta. Mgr. R. W. Mack
 Commercial Mgr. C. B. Heller
 Program Dir. Easter Straker
 Chief Engineer A. J. F. Smith

WLOK

LIMA—1936—NBC

Frequency: 1240 Kc. Power: 250 Watts
 Owned-Oper. By WLOK, Inc.
 Business Address 1424 Rice Avenue
 Phone Number 6-3411
 Transcription Service World
 Membership NARTB
 News Service UP

Representative H.R. Reps., Inc.
 President L. A. Pixley
 Station Manager Robert O. Runnerstrom
 Program Director William Huffman
 Commercial Mgr. Lawrence Webb
 Chief Engineer Darrel Hunter

WMAN

MANSFIELD—1939—ABC

Frequency: 1400 Kc. Power: 250 Watts
 Owned-Operated By Richland, Inc.
 Business-Studio Address 144½ Park Ave. W.
 Phone Number 4235-6
 Air Time Full Time
 News Service AP
 Transcription Service World
 Representative The Taylor Co.
 Membership NARTB, BAB
 Pres., Gen. Sta. Comm. Mgr. J. M. O'Hara
 Sales Prom. Manager Carl Kindt
 Prog.-Pub. Dir. Robert James
 Chief Engineer William Morrison

WMOA

MARIETTA—1946—MBS

Frequency: 1490 Kc. Power: 250 Watts
 Owned-Operated By Marietta Bcstg. Co.
 Business Address P. O. Box 201
 Phone Number 1690
 News Service AP
 Transcription Service SESAC
 Representative McGillvra
 Membership NARTB
 President William G. Wells
 General Manager R. Sanford Guyer
 Commercial Manager Fred Reynolds
 Program Director Tom Butscher
 Chief Engineer Charles E. Clark

WMRN

MARION—1940—ABC

Frequency: 1490 Kc. Power: 250 Watts
 Owned-Oper. By The Marion Bcstg. Co.
 Business Address P. O. 518
 Phone Number 2-6666-7
 Air Time 6:30 a.m.-M.
 News Service UP
 Transcription Service Thesaurus
 Representative Harace Stovin, Canada
 Membership NARTB, BAB
 Pres., Gen. Sta. Mgr. Robert T. Mason
 Commercial Manager Arthur L. Martin
 Sls. Prom. Mgr., Pub. Dir. Majorie Williams
 Chief Engineer Francis Joseph Peters

WPFB

MIDDLETOWN—1947

Frequency: 910 Kc. Power 1000 Watts d.
 100 Watts n.
 Owned-Operated By Paul F. Braden
 Address-Trans. Loc. Lebanon-Coles Rd.
 Phone Number 2-3625
 News Service AP

Transcription Service.....Thesaurus
 Membership.....NARTB, BAB
 Pres., Gen., Sta. Mgr.....Paul F. Braden
 Program Director.....Tom Lummis
 Chief Engineer.....Larry Beckwith

WMVO

MT. VERNON—1953

Frequency: 1300 Kc.....Power: 500 Watts d.
 Owned-Oper. By.....Mt. Vernon Bcstg.
 Address.....Coshocton Rd., Box 390
 Phone Number.....2-0946
 President.....Dr. Charles Tramont
 General Manager.....Mrs. C. M. Zelkowitz
 Program Director.....George Bennett
 Chief Engineer.....Eugene Phillips

WCLT

NEWARK—1946

Frequency: 1430 Kc.....Power: 500 Watts d.
 Owned-Operated By...Advocate Printing Co.
 Address.....27 West Main St.
 Phone Number.....4007
 News Service.....AP
 Newspaper Affiliation.....The Advocate
 Transcription Service.....Thesaurus
 Representative.....Meeker Associates
 Membership.....NARTB, BAB
 President.....Frank W. Spencer
 Gen., Sta. Mgr.....Thomas A. Rogers
 Commercial Mgr.....Robert Pricer
 Chief Engineer.....Benjamin Windle

WPTW

PIQUA—1947

Frequency: 1570 Kc.....Power: 250 Watts d.
 Owned-Oper...Miami County Bcstg. Co., Inc.
 Address-Trans.....1625 W. Covington Ave.
 Phone Number.....1420-1
 News Service.....AP
 Transcription Service.....World
 Pres., Gen. Mgr.....Richard E. Hunt
 Sta., Comm. Mgr.....Robert Bubp
 Chief Engineer.....Dallas Davis

WNXT

PORTSMOUTH—1951—ABC

Frequency: 1260 Kc.....Power: 1000 Watts
 Owned-Operated By...Portsmouth Bcstg. Co.
 Address.....Masonic Temple Bldg.
 Phone Number.....2-1961
 Air Time.....Unlimited
 News Service.....UP
 Representative.....Everett-McKinney
 Pres., Gen., Sta., Comm. Mgr..Marshall Rosene
 Program Director.....Phil Phillips
 Publicity Director.....Thelma Henderson
 Chief Engineer.....Russell Newman

WPAY

PORTSMOUTH—1935—CBS

Frequency: 1400 Kc.....Power: 250 Watts

Owned-Oper. By.....The Scioto Bcstg. Co.
 Bus.Studio-Trans. Address....1009 Gallia St.
 Phone Number.....3-2111
 News Service.....AP
 Transcription Service.....Associated
 Representative.....Venard
 President.....Roy D. Moore
 Station Mgr.....Gerald F. Boyd
 Program Director.....E. G. Sheridan
 Chief Engineer.....Maurice L. Myers

WLEC

SANDUSKY—1947—MBS

Frequency: 1450 Kc.....Power: 250 Watts
 Owned-Operated By...Lake Erie Bcstg. Co.
 Address.....Cleveland Rd. & Huntington
 Phone Number.....5170
 News Service.....UP
 Transcription Service.....World, Thesaurus
 Representative.....Hal Holman
 Pres., General-Station Mgr.....Jay Wagner
 Commercial Manager.....Ralph S. Silver, Jr.
 Program Director.....Robert Hinners
 Sales Prom. Mgr.....Kathryn Heiser
 Chief Engineer.....Jay Leibach

WIZE

SPRINGFIELD—1940—ABC

Frequency: 1340 Kc.....Power: 250 Watts
 Owned-Oper. By...Radio Voice of Springfield
 Trans.-Address.....117 W. High St.
 Phone Number.....3-4955
 News Service.....AP
 Transcription Service.....World
 Representative.....H. R. Representative, Inc.
 President.....Charles Sawyer
 General Manager.....Adna Karns
 Program Director.....Rudolph Perez
 Sta., Comm. Mgr.....Virginia Bennett
 Chief Engineer.....Victor L. Bushong

WJEL

SPRINGFIELD—1947

Frequency: 1600 Kc...Power: 1000 Watts d.
 Owned-Oper. By...Champion City Bcstg. Co.
 Business Address.....120 S. Limestone
 Phone Number.....3-4676
 News Service.....INS
 Representative.....McGillvra
 Transcription Service.....Associated
 President.....George R. Walker
 Gen., Sta. Mgr.....Robert Yontz
 Commercial Manager.....Vince Shannon
 Chief Engineer.....Myron Maddex

WWSO

SPRINGFIELD—1947

Frequency: 1210 Kc.....Power: 250 Watts d.
 Owned-Oper. By.....Radio Springfield, Inc.
 Address.....Chamber of Commerce Bldg.
 Phone Number.....3-6488
 News Service.....AP
 Representatives.....Gill-Perna
 President.....Bradley Kincaid

General Manager.....R. K. Wood
Chief Engineer.....Vernon B. Yeich

WSTV

STUEBENVILLE—1940—MBS

Frequency: 1340 Kc.....Power: 250 Watts
Owned-Oper. By.....WSTV, Inc.
Bus. Studio Address.....Exchange Realty Bldg.
Phone Number.....2-6265-6-7
Air Time.....Full Time
News Service.....UP
Transcription Service.....World
Representative.....Avery-Knoedel
V.P., Gen. Mgr.....John J. Laux
Asst. General Manager.....Joseph M. Troesch
Pgm., Pub. Dir.....Roy Briscoe
Chief Engineer.....Charles S. Shepherd

WSPD

TOLEDO—1921—NBC

Frequency: 1370 Kc.....Power: 5000 Watts
Owned-Oper. By.....Storer Broadcasting Co.
Bus. Studio Address.....136 Huron St.
Phone Number.....Adams 3175
News Service.....INS, UP
Transcription Service.....Langworth
Representative.....Katz
President.....George B. Storer
Gen., Sta. Mgr.....Allen L. Haid
Comm. Mgr.....Westford F. Shannon
Program Director.....Emerson Kimble
Chief Engineer.....William M. Stringfellow

WTOD

TOLEDO—1946

Frequency: 1560 Kc.....Power: 1000 Watts d.
Owned-Operated By.....Unity Corp.
Business-Studio Address.....515 Madison Ave.
Phone Number.....Garfield 5551
News Service.....AP
Transcription Service.....Lang-Worth
Representative.....Forjoe
President.....Edward Lamb
General Manager.....Sunne Miller
Program Director.....Richard Rice
Chief Engineer.....Robert Sowers

WTOL

TOLEDO—1938—ABC

Frequency: 1230 Kc.....Power: 250 Watts
Owned-Operated By.....Community Bcstg. Co.
Trans. Address.....Bell Bldg.
Phone Number.....Adams 3291
Air Time.....Full Time
News Service.....AP, UP
Representative.....Paul H. Raymer
Membership.....NARTB
President.....Frazier Reams
Gen. Station Mgr.....Thomas S. Bretherton
Commercial Mgr.....R. H. Edsall
Sales Prom. Mgr., Pub. Dir.....Bob Krieghoff
Program Director.....Robert Krieghoff
Chief Engineer.....Harold Holmes

WHHH

WARREN—1941—MBS

Frequency: 1440 Kc.....Power: 5000 Watts
Owned-Oper. By.....Warren Tribune Radio
Station, Inc.
Business-Studio Address.....108 Main St.
Phone Number.....2212-9
Newspaper Affiliation.....The Tribune Co.
Air Time.....6:45 a.m.-M.
News Service.....AP
Representative.....Rambeau
Transcription Service.....Associated
President.....Helen Hart Hurlbert
General Manager.....Carl J. Raymond
Sales Prom., Pub. Dir.....Peter W. Mesner
Chief Engineer.....Robert E. Hardy

WCHO

WASHINGTON COURT HOUSE— 1952—KBS

Frequency: 1250 Kc.....Power: 500 Watts d.
Owned-Oper. By.....Court House Bdcstg. Co.
Address.....113 1/2 S. Main St.
Phone Number.....5-6211
News Service.....AP
Transcription Service.....Thesaurus. SESAC
Membership.....BAB
President.....W. N. Nungesser
Program Director.....Ron Arnold
Chief Engineer.....Carl Egbert

WKOV

WELLSTON—1952

Frequency: 1570 Kc.....Power: 250 Watts d.
Owned-Operated By.....S. H. Kovalan
Address.....P. O. Box 190
Phone Number.....546
News Service.....UP
President.....Stephen H. Kovalan
General Manager.....Parks Robinson
Program Director.....John E. Wilson

WWST

WOOSTER—1947

Frequency: 960 Kc.....Power: 1000 Watts d.
Owned-Oper. By.....Wooster Republican Ptg. Co.
Phone Number.....760-1
News Service.....AP
Transcription Service.....Thesaurus. SESAC,
World
General Manager.....E. B. Evans
Commercial Mgr.....Quentin W. Welty
Chief Engineer.....Burton L. Bowman

WRFD

WORTHINGTON—1947

Frequency: 880 Kc.....Power: 5000 Watts d.
Owned-Oper. By.....Peoples Bcstg. Corp.
Phone Number.....FR 2-5342
News Service.....AP
Transcription Service.....Thesaurus
Representative.....Geo. W. Clark, Inc.
Membership.....NARTB, BAB

President..... M. D. Lincoln
 General Manager..... Herbert E. Evans
 Sta., Comm. Mgr..... Joseph D. Bradshaw
 Program Director..... Bob Geis
 Chief Engineer..... Harold Schaaf

W B B W

YOUNGSTOWN—1949—ABC

Frequency: 1240 Kc..... Power: 250 Watts
 Owner..... Mahoning Valley Bcstg. Corp.
 Address..... Warner Theatre Bldg.
 Phone Number..... Riverside 44421
 Air Time..... Full Time
 News Service..... AP
 Transcription Service..... Lang-Worth
 Station Representative..... Forjoe & Co.
 Membership..... NARTB
 President, Ch. Eng..... John Cherpach, Jr.
 Vice-Pres., Gen.-Comm. Mgr..... Gene Trace
 Program Director..... Tony Ross
 Publicity Director..... Marilyn Noble

W F M J

YOUNGSTOWN—1939—NBC

Frequency: 1390 Kc..... Power: 5000 Watts
 Owned-Operated By..... WFMJ Bcstg. Co.
 Business-Studio Address..... 101 W. Boardman
 Phone Number..... Riverside 3-4121
 News Service..... AP, UP
 Representative..... Headley-Reed
 Pres., Gen. Mgr..... William F. Maag, Jr.
 Comm., Sales Prom. Mgr..... Leonard E. Nasman
 Program Director..... Ronald W. Richards
 Chief Engineer..... Frank A. Dieringer

W K B N

YOUNGSTOWN—1926—CBS

Frequency: 570 Kc..... Power: 5000 Watts
 Owned-Operated By..... WKBN Bcstg. Corp.
 Phone Number..... Sterling 2-1145
 Air Time..... Full Time
 Address..... 3930 Sunset Blvd.
 News Service..... UP, AP
 Newspaper Affiliation..... Plain Dealer
 Transcription Service..... World, Lang-Worth
 Representative..... Paul H. Raymer
 Membership..... NARTB, BAB
 Pres., Gen. Mgr..... Warren P. Williamson, Jr.
 Station Manager..... J. Lothair Bowden
 Program Director..... Don Brice
 Public Relations Director..... Jim Smith
 Chief Engineer..... B. T. Wilkins

W H I Z

ZANESVILLE—1924—NBC

Frequency: 1240 Kc..... Power: 250 Watts
 Owner..... Southeastern Ohio Bcstg. System, Inc.
 Business-Studio Address..... Lind Arcade Bldg.
 Phone Number..... 2-5431
 Newspaper Affiliation..... Zanesville Publ. Co.
 News Service..... UP
 Representative..... John E. Pearson
 Membership..... NARTB, BAB
 President..... Clay Littick
 Sales Prom. Mgr., Pub. Dir..... Bill Eberle
 Gen., Station Manager..... Vernon A. Nolte
 Dir. of Sales..... Nate Milder
 Chief Engineer..... William A. Hunt

OKLAHOMA

Pop. Feb. 1, 1954 (Est.) 2,280,000 — Families 650,000
 Radio Homes 582,000 — TV Homes 32,000 — Stations in State 46

K A D A

ADA—1934—ABC-KBS

Frequency: 1230 Kc..... Power: 250 Watts
 Owned-Operated By..... KADA Bcstg., Inc.
 Business Address..... Box 642
 Phone Number..... 12-3
 Air Time..... 6 a.m.-12 M.
 News Service..... AP
 Transcription Service..... Standard
 Representative..... The Taylor Co.
 Membership..... NARTB, BAB
 President..... Dr. C. C. Morris
 General Manager..... Billy T. Hoover
 Station Manager..... Brown Morris
 Program Director..... Nadine Mullinax
 Chief Engineer..... George Miller

K W H W

ALTUS—1946—MBS

Frequency: 1450 Kc..... Power: 250 Watts

Owned-Operated By..... Altus Bcstg. Co., Inc.
 Phone Number..... 1405
 Air Time..... 7 a.m.-10 p.m.
 News Service..... AP
 Representative..... Hil F. Best
 Newspaper Affiliation..... "Times-Democrat"
 Membership..... NARTB
 Pres., Gen. Mgr..... Frank E. Wimberly
 Chief Engineer..... Ernest Baucum

K V S O

ARDMORE—1935—ABC

OKLA. NET

Frequency: 1240 Kc..... Power: 250 Watts
 Owned-Operated By..... John F. Easley
 Bus. Studio Address..... 112 N. Washington
 Phone Number..... 3030
 Air Time..... Full Time
 News Service..... AP
 Newspaper Affiliation..... Daily Ardmoreite
 Transcription Service..... World, SESAC

Representative.....The Taylor Co.
 General Manager.....Albert Riesen
 Comm. Mgr.....J. E. Riesen
 Program Director.....Dolly Dutton
 Publicity Director.....Galy Varnell
 Chief Engineer.....William E. Kolb

KWON

BARTLESVILLE—1941—MBS

Frequency: 1400 Kc.....Power: 250 Watts
 Owned-Operated By...Bartlesville Bcstg. Co.
 Business-Studio Address...Dewey Rd.
 Phone Number.....1400
 News Service.....AP
 President, Gen. Sta. Mgr.....J. Fred Case
 Commercial Mgr.....John Collins
 Chief Engineer.....Cecil Tanner

KBWL

BLACKWELL—1952

Frequency: 1580 Kc.....Power: 250 Watts d.
 Owned-Operated By...Star Bcstg. Co., Inc.
 Phone Number.....309
 News Service.....AP
 Transcription Service.....Thesaurus
 General Manager.....R. L. McCarrell
 Chief Engineer.....Charles Hobbs

KWCO

CHICKASHA—1946—MBS-KBS

Frequency: 1500 Kc.....Power: 1000 Watts d.:
 250 Watts n.
 Owned-Oper. By...Washita Valley Bcstg. Corp.
 Address.....KWCO Bldg.
 Phone Number.....2898
 News Service.....AP
 Co-Owner, Gen. Mgr.....P. D. Jackson
 Commercial Manager.....Hoyt Caldwell
 Program Director.....Lorine Null
 Chief Engineer.....Neal M. Allen

KWOE

CLINTON—1949

Frequency: 1320 Kc.....Power: 1000 Watts d.
 Owned-Operated By...Western Okla. Bcstg. Co.
 Address.....Box 558
 Phone Number.....617
 News Service.....UP
 Transcription Service.....SESAC
 Station Representative.....Hil F. Best
 General Manager.....V. M. Preston
 Commercial Mgr.....Leo Tremblay
 Chief Engineer.....Hubert Gaston

KWHP

CUSHING—1952

Frequency: 1600 Kc.....Power: 1000 Watts d.
 Owned-Operated By...W. H. Payne
 Address.....Box 791
 Phone Number.....922
 News Service.....AP
 Representative.....Hil F. Best

Transcription Service.....Thesaurus
 General Manager.....William H. Payne
 Commercial Manager.....James Kirkpatrick
 Program Director.....Jim Waites
 Chief Engineer.....Charles F. Hebard

KRHD

DUNCAN—1947—MBS-KBS

Frequency: 1350 Kc.....Power: 250 Watts d.,
 100 n.
 Owned-Operated By...Duncan Bcstg. Co.
 Address.....Box 1192
 Phone Number.....1350
 Air Time.....Unlimited
 News Service.....UP
 Transcription Service.....World
 Representative.....Hil F. Best
 Membership.....NARTB
 President.....R. H. Drury
 Gen., Sta. Mgr.....W. M. Brubaker
 Comm. Sales Prom. Mgr.....Lester Agee
 Program Director.....Tommy Richardson
 Publicity Dir.....John Moen

KSEO

DURANT—1947

Frequency: 750 Kc.....Power: 250 Watts d.
 Owned-Operated By...Democrat Printing Co.
 Address.....Democrat Bldg.
 Phone Number.....2200
 News Service.....AP
 Transcription Service.....Standard
 Partners.....R. F. Story, Bennett Story
 General Manager.....Leroy Moses
 Chief Engineer.....Leonard Brown

KASA

ELK CITY—1932—MBS

Frequency: 1240 Kc.....Power: 250 Watts
 Owned-Oper. By...Southwest Bcstg. Co.
 Address.....North Randall St.
 Phone Number.....730
 Manager.....Lonnie J. Preston
 Program Director.....Alice Howenstine
 Chief Engineer.....Robert Hemphill

KCRC

ENID—1929—ABC-OKLA. NET

Frequency: 1390 Kc.....Power: 1000 Watts
 Owned-Oper. By...Enid Radiophone Co.
 Bus. Studio Address.....Broadway Tower
 Phone Number.....447
 Air Time.....6 a.m.-M.
 News Service.....AP
 Transcription Service.....World
 News. Affil. "Morning News," "Daily Eagle"
 Representative.....O. L. Taylor Co.
 Membership.....NARTB
 President.....Milton B. Garber
 General Manager.....Guy B. Farnsworth
 Commercial Mgr.....H. P. Hale
 Program Director.....B. Napier
 Chief Engineer.....Murray D. Coleman

KGWA

ENID—1949—MBS

Frequency: 860 Kc. Power: 1000 Watts
 Owned-Oper. By... Public Bcstg. Service, Inc.
 Address... 115½ E. Broadway
 Phone Number... 4230
 News Service... UP
 Transcription Service... Standard
 Representative... Pearson
 President... George E. Failing
 General Manager... H. J. Godschalk
 Sta., Comm. Mgr... Tom Belcher
 Chief Engineer... William Teitzel Jr.

KTAT

FREDERICK—1948—KBS

Frequency: 1570 Kc. Power: 250 Watts d.
 Owned-Operated By... Frederick Bcstg. Co.
 Address... Main & Grand
 Phone Number... 1010
 News Service... UP
 Transcription Service... Capitol
 Representative... Hil F. Best
 General Manager... J. D. Jones, Jr.
 Partner... Ronald W. Wheeler
 Program Director... Mary Wheeler

KGYN

GUYMON—1948

Frequency: 1220 Kc. Power: 1000 Watts d.
 Owned-Operated By... Plains Bcstg. Co.
 Business-Studio Address... P. O. Box 38
 Phone Number... 888
 News Service... UP
 Transcription Service... World, Thesaurus
 Representative... Hil F. Best
 President, Gen. Mgr... T. M. Raburn, Jr.
 Chief Engineer... Herbert L. Noyes

KTJS

HOBART—1947—KBS

Frequency: 1420 Kc. Power: 250 Watts d.
 Owned-Operated By... T. J. Shriner
 Address... 315 E. 11th St.
 Phone Number... 1070
 News Service... AP
 President, Ch. Eng... T. J. Shriner
 Promotion Dir... May Jo Shriner

KIHN

HUGO—1948

Frequency: 1340 Kc. Power: 250 Watts
 Owned-Oper. By... Little Dixie Bcstg. Co.
 Address... P. O. Box 248
 Phone Number... 1140
 News Service... AP
 Transcription Service... SESAC
 President... George Malone
 Co-Manager... James Gerity Jr.
 Chief Engineer... Dalton E. Jones

KBEL

IDABEL—1953

Frequency: 1240 Kc. Power: 250 Watts
 Owned-Oper. By... Idabel Bcstg. Co.
 Address... Box 1072
 Phone Number... 892
 Pres., Gen. Mgr... Winston O. Ward
 Commercial Mgr... J. P. Stanley
 Program Director... Lee Mars
 Chief Engineer... Cliff Taylor

KSWO

LAWTON—1941

ABC-OKLA. NET

Frequency: 1380 Kc. Power: 1000 Watts
 Owned-Oper. By... Okla. Quality Bcstg. Co.
 Bus-Studio Address... 406½ D Ave.
 Phone Number... 1380
 Air Time... Unlimited
 News Service... UP
 Transcription Service... World
 Representative... The Taylor Co.
 Membership... NARTB, BAB
 President... R. H. Drewry
 Gen. Sta. Mgr... Leo R. Morris
 Prom. Mgr., Pub. Dir... Mrs. L. B. Goochey
 Program Director... Lyle Gaston
 Chief Engineer... Willard Cochran

THOSE WHO KNOW FAMOUS BRANDS . . .

Says KHGB Manager John
 Whitt at Okmulgee, Okla.:
 "Sponsors and prospects know
The Associated Press—and
 know it well, and favorably."

. . . KNOW THE MOST FAMOUS
 BRAND IN NEWS IS **AP**

KNED

McALESTER—1950

Frequency: 1150 Kc. Power: 1000 Watts d.
 Owned-Operated By: Pittsburg Bcstg. Co., Inc.
 Address: Box 73
 Phone Number: 1460
 News Service: UP
 Transcription Service: World, Thesaurus
 Representative: Pearson
 Pres., Gen. Mgr.: Ray Van Hooser
 Commercial Manager: Phil Reed
 Chief Engineer: Dexter Ferry

KTMC

McALESTER—1946—ABC-OKLA.

Frequency: 1400 Kc. Power: 250 Watts
 Owned-Operated By: McAlester Bcstg. Co.
 Business-Studio Address: Box 157
 Phone Number: 2411
 News Service: AP
 Representative: The Taylor Co.
 Membership: NARTB, BAB
 President: William Young
 Gen., Sta. Mgr.: Bob Baggett
 Program Director: Walter Freeman
 Chief Engineer: Harold Duncan

KGLC

MIAMI—1948—KBS

Frequency: 910 Kc. Power: 1000 Watts
 Owned-Operated By: Miami Bcstg. Co.
 Address: Box 511
 Phone Number: 3303
 News Service: AP
 Representative: Adam Young
 President: Kenyon Brown
 General Manager: Charles L. Unger, Jr.
 Chief Engineer: Louis Stone

KBIX

MUSKOGEE—1936—ABC

Frequency: 1490 Kc. Power: 250 Watts
 Owned-Oper. By: Okla. Press Pub. Co.
 Address: 214-216 Wall St.
 Phone Number: MU 2-1331
 News Service: UP
 Transcription Service: Thesaurus
 Representative: Venard
 President: Tams Bixby, Jr.
 General Manager: Walter W. Weber
 Commercial Mgr.: George Lanham
 Program Director: Howard Whitely
 Chief Engineer: Eugene Edwards

KMUS

MUSKOGEE—1948—GRASS ROOTS

Frequency: 1380 Kc. Power: 1000 d., 500 n.
 Owned-Oper. By: Eastern Okla. Bcstg. Corp.
 Business-Studio Address: 412½ Court St.
 Phone Number: MU 2-3341
 News Service: UP
 Transcription Service: World

Representative: Pearson
 President: R. M. Mountcastle
 Gen., Station Mgr.: Jimmie Barry
 Program Director: George Overton
 Chief Engineer: James Keitel

KNOR

NORMAN—1949

Frequency: 1400 Kc. Power: 250 Watts
 Owned-Operated By: Cleveland County
 Bcstg. Co.
 Address: P. O. Box 542
 Phone Number: 474
 News Service: UP
 Transcription Service: World
 Gen. Mgr. (Ptnr.): William S. Morgan
 President: Tol Dickenson
 Program Director: Gene Stansberry
 Chief Engineer: Gene Morris

KBYE

OKLAHOMA CITY—1947

Frequency: 890 Kc. Power: 1000 Watts d.
 Owned-Operated By: State Bcstg. Co.
 Bus.-Studio Address: 108 N.W. 9th
 Phone Number: FO 5-2323
 News Service: UP
 Membership: NARTB, BAB
 President: A. Earl Cullum
 Chief Engineer: Charles Shaeffer

KLPR

OKLAHOMA CITY—1947

Frequency: 1140 Kc. Power: 1000 Watts d.
 Owned-Oper. By: Okla. City Bcstg. Co.
 Business Address: 128½ W. Commerce St.
 Phone Number: Central 2-1341
 News Service: AP
 Owner, Pres., Gen. Mgr.: Byrne Ross
 Promotion Mgr.: Grant Ladd
 Program Director: Mrs. Kathleen Burkett
 Chief Engineer: Jay Davis

KOCY

OKLAHOMA CITY—1938—MBS

Frequency: 1340 Kc. Power: 250 Watts
 Owned-Oper. By: Plaza Court Bcstg. Co.
 Business-Studio Address: Plaza Court Bldg.
 Phone Number: Forest 5-4333
 Air Time: 6 a.m.-M.
 News Service: AP
 Transcription Service: Standard
 Representative: Pearson
 Membership: NARTB, BAB
 Pres., Gen. Mgr.: M. H. Bcnebrake
 Sta., Comm. Mgr.: George Collisson
 Program Director: I. L. Marquiss
 Chief Engineer: J. S. Merryman

KOMA

OKLAHOMA CITY—1931—CBS

Frequency: 1520 Kc. Power: 50,000 Watts
 Owned-Operated By: KOMA, Inc.
 Business-Studio Address: 7300 Lincoln Blvd.

Phone Number.....Victor 3-6641
 Air Time.....5:30 a.m.-12:30 a.m.
 News Service.....AP
 Transcription Service.....Standard, Lang-Worth
 Representative.....Avery-Knodel
 Membership.....NARTB
 President.....John Toole Griffin
 General-Station Mgr.....Edgar T. Bell
 Comm. Asst. Mgr.....Ben H. Holmes
 Program Director.....Mack Fuller
 Chief Engineer.....M. W. Thomas

K T O K

OKLAHOMA CITY—1927—ABC

Frequency: 1000 Kc.....Power: 5000 Watts
 Owned-Operated By.....KTOK, Inc.
 Business-Studio Address.....1800 W. Main
 Phone Number.....FO 5-8352
 Air Time.....6 a.m.-M.
 News Service.....UP
 Transcription Service.....World
 Representative.....Paul H. Raymer
 Membership.....BAB
 President.....Wendell Mayes
 Gen., Sta. Mgr.....John Hopkins
 Commercial Mgr.....Tom Johnson
 Chief Engineer.....Clifford Easum

K T O W

OKLAHOMA CITY—1948

Frequency: 800 Kc.....Power: 250 Watts d.
 Owned-Operated By.....Sooner Bcstg. Co.
 Business-Studio Address.....Liberty Bank Bldg.
 Phone Number.....CE 2-6367
 News Service.....AP
 Representative.....Rambeau
 Membership.....NARTB
 President.....Ralph Ball
 Gen., Sta. Mgr.....Rex M. Lester, Jr.
 Chief Engineer.....Thomas F. Lindsey

W K Y

OKLAHOMA CITY—1920—NBC

Frequency: 930 Kc.....Power: 5000 Watts
 Owned-Oper. By.....WKY Radiophone Co.
 Business-Studio Address.....Box 8668
 Phone Number.....Trinity 8-2161
 Air Time.....Unlimited
 News Service.....UP
 Newspaper Affiliation.....Oklahoman, Times
 Transcription Service.....Standard
 Representative.....Katz
 Membership.....NARTB
 President.....E. K. Gaylord
 Manager.....P. A. Sugg
 Commercial Manager.....Robert E. Chapman
 Program Director.....Paul Brawner
 Public Relations Mgr.....Wally Kinnan
 Chief Engineer.....H. J. Lovell

K H B G

OKMULGEE—1937—MBS

Frequency: 1240 Kc.....Power: 250 Watts
 Owned-Oper. By.....Okmulgee Bcstg. Corp.

Business Address.....Times Bldg.
 Phone Number.....3646
 News Service.....AP
 Representative.....Pearson
 President.....Don Reynolds
 Station Manager.....John R. Trotter
 Program Director.....Gladys LeGrand
 Chief Engineer.....John Brennerman

K V L H

PAULS VALLEY—1947—KBS

Frequency: 1470 Kc.....Power: 250 Watts d.
 Owned-Operated By.....KVLH Bcstg. Co.
 Business Trans. Address.....P. O. Box 610
 Phone Number.....1470
 News Service.....UP
 Transcription Service.....Langworth
 Representative.....Hil F. Best
 President.....James T. Jackson
 General Manager.....Phil Crenshaw
 Chief Engineer.....George Rountree

W B B Z

PONCA CITY—1928—MBS

Frequency: 1230 Kc.....Power: 250 Watts
 Owned-Oper. By.....The Ponca City News
 Address.....3rd & Cleveland
 Phone Number.....RO 5-3311
 Air Time.....Full Time
 Newspaper Affiliation.....The News
 News Service.....AP
 Transcription Service.....World
 Membership.....NARTB, BAB
 President.....Clyde E. Muchmore
 Sta., Gen. Mgr.....Cy Casper
 Commercial Mgr.....Larry Nolan
 Prom., Pub., Pgm. Wir.....William G. Mangans
 Chief Engineer.....Chuck Chaney

K O L S

PRYOR—1950—KBS

Frequency: 1570 Kc.....Power: 250 Watts d.
 Owned-Oper. By.....Lakes Area Bcstg. Co.
 Address.....Fifth & S. Mill Sts.
 Phone Number.....1263
 Transcription Service.....SESAC
 News Service.....AP
 Representative.....Continental
 General Manager.....L. L. Gaffaney
 Commercial Manager.....Mrs. L. L. Gaffaney
 Program Director.....Merle Caldwell

K G F F

SHAWNEE—1930

Frequency: 1450 Kc.....Power: 250 Watts
 Owned-Operated By.....KGFF Bcstg. Co., Inc.
 Address.....Hotel Aldridge
 Phone Number.....4390
 News Service.....AP
 Newspaper Affiliation.....Stauffer Publ., Inc.
 Transcription Service.....World
 President.....Oscar S. Stauffer
 Gen., Sta. Manager.....Wilford C. Dickson
 Chief Engineer.....Earl R. Ward

KSPI

STILLWATER—1947—MBS

Frequency: 780 Kc. Power: 250 Watts d.
 Owned-Oper. By... Stillwater Publishing Co.
 Business Address... P. O. Box 231
 Phone Number... 311
 Newspaper Affiliation... News-Press
 Transcription Service... Standard
 General Manager... L. F. Bellatti
 Program Director... J. R. Bellatti
 Chief Engineer... Paul McCollum

KAKC

TULSA—1946

Frequency: 970 Kc. Power: 1000 Watts d.
 500 n.
 Owned-Oper. By... Public Radio Corp.
 Bus.-Studio Address... American Airlines Bldg.
 Phone Number... 4-2401
 News Service... AP
 Representative... Walker
 President-Treas... S. E. Avey
 V.P., General Manager... James L. Neal
 Commercial Mgr... John B. Wheeler
 Program Director... Rusty Kirk
 Chief Engineer... M. M. Donley

KFMJ

TULSA—1946—MBS

Frequency: 1050 Kc. Power: 1000 Watts d.
 Owned-Operated By... Fred Jones Bcstg. Co.
 Business-Studio Address... 13th & Boston
 Phone Number... 5-5555
 News Service... UP
 Representative... Bolling
 President... Fred Jones
 General Manager... Lawson Taylor

KOME

TULSA—1938

Frequency: 1300 Kc. Power: 5000 d., 1000 n.
 Owned-Oper. By... Oil Capital Sales Corp.
 Business-Studio Address... Kome Bldg.
 Phone Number... 3-4121
 News Service... AP
 Transcription Service... Associated
 Representative... Gill-Perno
 President... John E. Brown Jr.
 General Manager... Charles W. Grim, Jr.
 Chief Engineer... Roy Brown

KRMG

TULSA—1949—ABC

Frequency: 740 Kc. Power: 50,000 Watts d.
 25,000 n.
 Owned-Operated By... All Oklahoma Bcstg. Co.
 Business-Studio Address... 311 So. Denver Ave.
 Phone Number... 54-4291
 Representative... John Blair
 News Service... AP
 Membership... NARTB, BAB
 President... Robert S. Kerr
 General Manager... Frank S. Lane

Program Director... Keith Bretz
 Chief Engineer... William H. Bradley

KTUL

TULSA—1934—CBS

Frequency: 1430 Kc. Power: 5000 Watts
 Owned-Operated By... Tulsa Bcstg. Co.
 Business Address... Boulder-on-the-Park
 Phone Number... 2-3191
 News Service... UP
 Transcription Service... World
 Representative... Avery-Knodel
 President... John T. Griffin
 V.P. & Gen. Mgr... L. A. Blust, Jr.
 Commercial Mgr... William D. Swanson
 Sales Prom. Mgr... George Ketcham
 Program Director... Karl Janssen
 Chief Engineer... Robert Snider

KVOO

TULSA—1925—NBC

Frequency: 1170 Kc. Power: 50,000 Watts
 Owned-Oper. By... Southwestern Sales Corp.
 Bus.-Studio Address... Philltower Bldg.
 Phone Number... 2-3281
 Transcription Service... Standard, World
 Representative... Edward Petry
 President... W. G. Skelly
 V.P., General Mgr... William B. Way
 Commercial Manager... Gustav K. Brandborg
 Sales Prom. Mgr... W. T. McClarin
 Program Director... Sam Schneider
 Chief Engineer... John Bushnell

KWSH

WEWAKA—1951—ABC-KBS

Frequency: 1260 Kc. Power: 1,000 Watts
 Owned-Operated By... Tri Cities Bcstg. Co., Inc.
 Address... Box 1260
 Phone Number... 1260-1261
 Air Time... 6 a.m.-M.
 News Service... AP
 Transcription Service... Standard
 Representative... Taylor
 President... Dr. C. C. Morris
 General Manager... Bill Hoover
 Station Manager... Pat Murphy
 Commercial Manager... Roy Judge
 Sales Prom. Mgr... Gladys Williams
 Publicity Director... Jay Harmon
 Prog. Dir., Chief Engr... Warren W. Abbott

KSIW

WOODWARD—1947—MBS-KBS

Frequency: 1450 Kc. Power: 250 Watts
 Owned-Oper. By... Woodward Bcstg. Co.
 Address Trans. Loc... 22 & Cedar Sts.
 Phone Number... 1450
 News Service... AP
 Transcription Service... Capitol, Thesaurus
 Representative... Hil F. Best
 Pres., Gen. Mgr... Edward A. Ryan
 Program Director... Lenora W. Ryan
 Chief Engineer... George Archer

OREGON

Pop. Feb. 1, 1954 (Est.) 1,854,000 — Families 620,000
Radio Homes 604,000 — TV Homes 187,000 — Stations in State 47

KWIL

ALBANY—1941—MBS-DON LEE

Frequency: 790 Kc. Power: 1000 Watts
Owned-Oper. By... Central Willamette Bcstg.
Bus.-Studio-Trans. Loc.... Queen Ave. & Elm
Phone Number 1234-5
Air Time 6 a.m.-M.
News Service AP
Transcription Service World
Newspaper Affiliation.... "Democrat Herald"
Representative Moore-Lund, Ayers
Membership NARTB, BAB
President..... R. R. Cronise
General Manager..... Chet Wheeler
Commercial Manager..... Johnny Birrel
Station Manager..... Warren Stoffer
Sales Prom. Mgr..... Mal Waltman
Program Director..... LeRoy Jolley
Publicity Director..... Ken McCoy
Chief Engineer, Farm Editor. Herbert Davidson

KWIN

ASHLAND—1946—MBS-DON LEE

Frequency: 1400 Kc. Power: 250 Watts
Owned-Oper. By.... Rogue Valley Bcstg. Co.
Address..... 1160 Helman Rd.
Phone Number 2-4381
Air Time..... 6:30 a.m.-11 p.m.
President..... Dick Maguire
Station Manager..... Alan Abner
Chief Engineer..... Don Smith

KAST

ASTORIA—1936—MBS-KBS
DON LEE

Frequency: 1370 Kc. Power: 1000 Watts
Owned-Operated By..... Astoria Bcstg. Co.
Bus.-Studio Address..... 1006 Taylor Ave.
Phone Number 95
News Service UP
Transcription Service Standard
Representative Moore-Lund, Ayers
Membership BAB, NARTB
President..... Robert B. Chessman
Gen., Sta. Mgr..... R. D. Holmes
Program Director..... Mrs. Mary Ristola
Commercial Manager..... Irving Steinbock
Chief Engineer..... Jay Bruce Whitwell

KVAS

ASTORIA—1950

Frequency: 1230 Kc. Power: 250 Watts
Owned-Oper. By..... Wm. Ohlmann
Address..... 812 Commercial St.
Phone Number 41
Representative Moore

Transcription Service World
News Service UP
Receiver Wm. Ohlmann

KBKR

BAKER—1939—KBS

Frequency: 1490 Kc. Power: 250 Watts
Owned-Oper. By..... Inland Radio, Inc.
Bus.-Studio Address..... 2030 Auburn Sts.
Phone Number 140
News Service UP
Transcription Service World
Gen., Comm. Mgr..... Kenneth B. Lockwood
Program Dir..... Kenneth Holden
Chief Engineer..... Charles Harland

KBND

BEND—1937—MBS-DON LEE

Frequency: 1110 Kc. Power: 1000 Watts
Owned-Oper. By.... Central Oregon Bcstg. Co.
Bus.-Studio Address..... Coble Bldg.
Phone Number 848
Air Time..... 6 a.m.-11 p.m.
News Service UP
Transcription Service World
Representative..... W. S. Grant, Moore-Lund
Membership NARTB
Pres., Gen., Sta. Mgr..... Frank H. Loggan
Comm. Mgr..... Doug Gaines
Pgm. Dir..... Kessler Cannon
Chief Engineer..... Robert Dickinson

KOOS

COOS BAY—1928—MBS

Frequency: 1230 Kc. Power: 250 Watts
Owned-Operated By..... KOOS, Inc.
Address Box 777
Phone Number..... Congress 7-2121
Air Time..... Day Time
News Service UP
Representative Moore-Lund
President..... Sheldon F. Sackett
General Manager..... Fred F. Chitty
Station Manager..... Phil Waters

KWRO

COQUILLE—1948

Frequency: 1450 Kc. Power: 250 Watts
Owned-Operated By..... KWRO, Inc.
Address P. O. Box 396
Phone Number 3961
News Service AP
Transcription Service..... Capitol, World
Membership NARTB
Sect.-Treas..... W. E. Walsh
General Manager..... Lynn C. Thomas
Program Director..... Robert Eubanks

KRUL
CORVALLIS—1947

Frequency: 1340 Kc. Power: 250 Watts
Owned-Oper. By Pacific States Radio Co.
Address Trans. Lot 1221 So. 15th St.
Phone Number 3-3322
News Service AP
Transcription Service Capitol. SESAC
Representative Keystone
Membership NARTB, BAB
President J. C. Haley
Gen., Sta. Mgr. Loyal H. Vickers
Sales Prom. Mgr. Jack Gallant
Program Director Ted C. Carlson
Chief Engineer Wm. C. Martin

KSGA
COTTAGE GROVE—1953

Frequency: 1400 Kc. Power: 250 Watts
Owned-Oper. By Coast Fork Broad Co.
Phone Number 1285
President W. Gordon Allen
General Manager Anthony Maucione
Program Director Jack Vaughn
Promotion Mgr. Walter Dodd
Chief Engineer Bob Kennedy

KODL
THE DALLAS—1947—ABC

Frequency: 1230 Kc. Power: 250 d. 100 n.
Owned-Oper. By Western Radio Corp.
Address Kodl Bldg.
Phone Number 2300
News Service UP
Transcription Service MacGregor
Pres., General Manager V. B. Kenworthy
Station Manager Paul E. Walden
Promotion Director Montle DeVon
Chief Engineer Bruce Elliott

KASH
EUGENE—1947—ABC-KBS

Frequency: 1600 Kc. Power: 1000 Watts
Owned-Oper. By Radio Air Ways, Inc.
Address P. O. Box 1600
Phone Number 5-3357
Air Time 5:30 a.m.-12:30 a.m.
News Service UP
Transcription Service Capitol
Representative Donald Cooke
Pres., Gen. Mgr. E. L. Kincaid
Commercial Manager Paul N. Plank
Program Director Laura Plank
Asst. Mgr., Pub. Dir. Clare Mattingly
Chief Engineer Norville M. Packard

KERG
EUGENE—1949—CBS

Frequency: 1280 Kc. Power: 1000 Watts
Owned-Operated By Guard Pub. Co.
Address P. O. Box 506
Phone Number 5-4304

Air Time 6 a.m.-M.
News Service AP
Newspaper Affiliation "Register-Guard"
Transcription Service Standard
Representative Weed & Co.
Membership NARTB, BAB
President Alton F. Baker
Gen., Sta. Mgr. L. W. Trommlitz
Commercial Manager Herb Michael
Publicity Director Jack Craig
Prom. Mgr., Prog. Dir. Robert Fulton
Chief Engineer Calvert Applegate

KORE
EUGENE—1927—MBS-DON LEE

Frequency: 1450 Kc. Power: 250 Watts
Owned-Operated By Lane Bcastg. Co.
Business Address P. O. Box 1032
Phone Number 4-4214
Air Time 6 a.m.-M.
News Service UP
Transcription Service World
Representative Everett-McKinney
Membership NARTB, BAB
Pres., Gen. Mgr. Lee Bishop
Commercial Mgr. Virgil Parker
Program Director Harry Kirk
Publicity Director Bob Davis
Chief Engineer Floyd Vikon

KUGN
EUGENE—1946—NBC

Frequency: 590 Kc. Power: 1000 Watts d.;
1000 Watts n.
Owned-Operated By KUGN, Inc.
Business Address P. O. Box 112
Phone Number 4-6216
Air Time 6 a.m.-M.
News Service AP
Representative Meeker
Membership NARTB
Pres., Gen., Sta. Mgr. C. O. Fisher
Commercial Manager E. W. Karl
Program Director Reg Roos
Chief Engineer George Hathaway

KRWC
FOREST GROVE—1950

Frequency: 1570 Kc. Power: 250 Watts d.
Owned-Oper. By Irving G. Schmidtke
Address Rt. 2, Box 245
Phone Number Forest Grove 6091
Representative Wm. Ayres
Transcription Service Standard, SESAC
News Service AP
Pres., Gen. Mgr. Irving V. Schmidtke
Commercial Mgr. James Forsythe

KUIN
GRANTS PASS—1939—MBS
DON LEE

Frequency: 1340 Kc. Power: 250 Watts
Owned-Oper. By Southern Oregon Bcastg. Co.

Business Address..... Redwood Hwy.
 Phone Number 4477
 News Service AP
 Transcription Service..... World, McGregor
 Representative..... W. S. Grant
 Membership NARTB, BAB
 President..... A. E. Voorhies
 General Manager..... E. A. Malone
 Commercial Mgr..... M. K. Ball
 Program Director..... Dave Allen
 Chief Engineer..... N. L. Williams

K I H R

HOOD RIVER—1950

Frequency: 1340 Kc.....Power: 250 Watts
 Owned-Oper. By..... Ore.-Wash. Bcstrs.
 Address..... P. O. Box 207
 Phone Number 8561
 President..... C. H. Fisher
 Station Manager..... Don McCutcheon
 Chief Engineer..... James H. Platz

K F J I

KLAMATH FALLS—1923—MBS
 DON LEE

Frequency: 1150 Kc....Power: 5000 d., 1000 n.
 Owned-Oper. By..... KFJI Bcstrs., Inc.
 Address..... P. O. Box 692
 Phone Number 22551
 Air Time..... 6 a.m.-12 M.
 News Service UP
 Transcription Service..... Thesaurus
 Representative..... W. S. Grant, Moore-Lund
 Membership NARTB
 President..... W. D. Miller
 Gen., Sta. Mgr..... Dick Maguire
 Comm. Mgr., Pgm. Dir..... Bob McVay

K F L W

KLAMATH FALLS—1946—ABC-CBS

Frequency: 1450 Kc.....Power: 250 Watts
 Owned-Operated By..... Herald Publ. Co.
 Address..... P. O. Box 941
 Phone Number 8115
 Air Time..... 6 a.m.-M.
 News Service AP
 Transcription Service Standard
 Representative Everett-McKinney
 Membership NARTB, BAB
 President Frank Jenkins
 General Manager..... Bud Chandler
 Commercial Manager..... Aaron Boe
 Chief Engineer..... Bill Grimes

K L B M

LA GRANDE—1938

Frequency: 1450 Kc.....Power: 250 Watts
 Owned-Oper. By..... Inland Radio, Inc.
 Phone Number 2201
 News Service UP
 Transcription Service..... Standard
 Representative..... Moore & Lund
 Membership NARTB, BAB
 Gen., Comm. Manager..... Ken Lillard
 Program Director..... Judy Holman
 Chief Engineer..... Len Serdar

K G A L

LEBANON—1950

Frequency: 920 Kc.....Power: 1000 Watts d.
 Owned-Oper. By..... Linn County Bcstrs., Inc.
 Address..... P. O. Box 341
 Phone Number 8631
 News Service..... AP, INS
 Transcription Service..... Langworth, SESAC
 President, Gen. Mgr..... W. Gordon Allen
 Station Manager..... John Trunan
 Commercial Manager..... Don Wellman
 Program Director..... Nate Bridges
 Chief Engineer..... Danny Bridges

K M C M

McMINNVILLE—1949—KBS

Frequency: 1260 Kc.....Power: 1000 Watts
 Owned-Oper. By..... Yamhill Bcstrs.
 Address..... P. O. Box 207
 Phone Number 3811
 Transcription Service World
 News Service AP
 President..... Jack B. Bladine
 Gen., Comm. Mgr..... Glasco Branson
 Chief Engineer..... Jack Adkins

K M E D

MEDFORD—1922—NBC

Frequency: 1440 Kc.....Power: 5000 Watts d.
 1000 Watts n.
 Owned-Operated By..... Radio Medford, Inc.
 Address..... P. O. Box 1306
 Phone Number 2-4000
 News Service UP
 Transcription Service... Thesaurus, MacGregor
 Station Representative..... Meeker Assoc.
 President Vern Robinson
 General, Sta. Manager..... Jennings Pierce
 Commercial Manager..... Bill Hansen
 Sales Prom. Mgr..... Norm Oberst
 Program Director..... Russ Jamison
 Chief Engineer..... Ray Johnson

In the
prosperous Pacific Northwest

KGW

is your best buy

•

Portland, Oregon Affiliated with NBC

Represented nationally by Edward Petry & Co.

KYJC

MEDFORD—1947—ABC-CBS

Frequency: 1230 Kc. Power: 250 Watts
 Owned-Operated By Medford Printing Co.
 Trans. Address 27 North Fir St.
 Phone Number 2-5277
 News Service UP
 Newspaper Affiliation Mail Tribune
 Representative Grant
 Transcription Service Langworth
 President Robert W. Ruhl
 Gen., Sta. Mgr. Jimmy Dunlevy
 Comm., Sales Prom. Mgr. Tom MacLeod
 Pgm. Dir. John Ahern
 Chief Engineer Dick Woods

KNPT

NEWPORT—1948

Frequency: 1310 Kc. Power: 1000 Watts
 Owned-Oper. By Yaquina Radio, Inc.
 Business Address Box 276
 Phone Number 560
 News Service AP
 Transcription Service World
 Representative Wm. A. Ayres
 Pres., Gen. Mgr. Tom R. Becker
 Commercial Manager Dan Kirch
 Sales Prom. Mgr., Prog. Dir. Ed Warmoth

KFIR

NORTH BEND—1951—CBS

Frequency: 1340 Kc. Power: 250 Watts
 Owned-Operated By Bay Bcstg. Co.
 Address Box 905
 Phone Number SK 9-7351
 Air Time Full Time
 News Service AP
 Transcription Service Standard
 Representative W. S. Grant,
 Keating, Natl. Rep
 Pres., Gen. Mgr. Josephine Edwards
 Station Manager Glenn Nickell
 Sales Prom. Mgr. Charles Lee
 Chief Engineer Arthur Schuldt

KSRV

ONTARIO—1946

Frequency: 1380 Kc. Power: 1000 Watts
 Owned-Operated By Inland Radio, Inc.
 Address Box 540
 Phone Number 212
 News Service UP
 Representative Pac. Northwest, Moore-Lund
 Transcription Service Standard
 Membership NARTB
 General Manager Gordon L. Capps
 Commercial Manager Robert Humphreys
 Chief Engineer Charles E. Harland

KGON

OREGON CITY-PORTLAND—1947

Frequency: 1230 Kc. Power: 250 Watts
 Owned-Operated By Clackamas Bcstrs.

Business Address Box 391
 Phone Number OR 5249
 News Service AP
 Transcription Service World, Associated
 Representative Robt. Meeker
 President Dr. John H. Fitzgibbon
 Comm., Prom., Gen. Mgr. Irwin S. Adams
 Chief Engineer Edward G. Saxe

KWRC

PENDLETON—1941—ABC

Frequency: 1240 Kc. Power: 250 Watts
 Owned-Oper. By Western Radio Corp.
 Business Address P. O. Box 178
 Phone Number 1425
 News Service UP
 Pres., Gen. Mgr. V. B. Kenworthy
 Station Manager Lea Phillips
 Program Director Denmane Dayton
 Chief Engineer Douglas Whipple

KGW

PORTLAND—1922—NBC

Frequency: 620 Kc. Power: 5000 Watts
 Owned-Oper. Pioneer Bcstrs. Inc.
 Bus.-Studio Address 1320 S.W. Broadway
 Phone Number BEacon 6364
 Air Time 6 a.m.-12 M.
 News Service AP
 Representative Edward Petry
 Membership NARTB
 President George Orput

MORE

Local Advertisers

MORE

Network Programs

MORE

For Your Money

ON

KYJC

Favorite Station

Oregon's 4th Market

CBS

ABC

Represented by

W. S. GRANT INC.

NEW YORK — CHICAGO
 SAN FRANCISCO — LOS ANGELES

General Manager.....H. Quenton Cox
 Program Director.....Donald Whitman
 Chief Engineer.....Harold C. Singleton

KEX

PORTLAND—1926—ABC

Frequency: 1190 Kc.....Power: 50,000 Watts
 Owned-Operated By.....Westinghouse Radio
 Address.....1230 SW Main St.
 Phone Number.....Capital 1881
 Air Time.....5:30 a.m.-2:00 a.m.
 News Service.....UP, INS
 Transcription Service.....Associated
 Membership.....BAB
 Station Representative.....Free & Peters Inc.
 President.....Chris Witting
 General Manager.....Joseph E. Baudino
 Station Manager.....J. B. Conley
 Commercial Manager.....Robert H. Prigmore
 Sales Promotion Manager.....Charles L. Burrow
 Program Director.....Mel Bailey
 Chief Engineer.....Tom Ely

KLIQ

PORTLAND—1948

Frequency: 1290 Kc.....Power: 1000 Watts d.
 Owned-Operated By.....Mercury Bdcstg. Co.
 Address.....3908 N.E. Sandy Blvd.
 Phone Number.....Webster 1290
 Pres., Gen. Mgr.....
 Prog. Dir.....Gordon E. Bambricks

KOIN

PORTLAND—1925—CBS

Frequency: 970 Kc.....Power: 5000 Watts
 Owned-Oper. By.....Mt. Hood Radio-TV Bcstg.
 Corp.
 Business Address.....P. O. Box 1031
 Phone Number.....ATwater 3333
 Air Time.....6 a.m.-M.
 News Service.....AP, INS, UP
 Transcription Service.....World, Standard
 Representative.....Avery-Knodel
 Membership.....NARTB, BAB
 President.....Ted Gamble
 Vice President.....C. H. Lane
 Gen. Mgr.....Harry H. Buckendahl
 Promotion Director.....George Wann
 Program Manager.....Willard Mears
 Nat'l Adv. Mgr.....J. L. Palmer
 Dir. of Engineering.....Louis S. Bookwalter

KPAM

PORTLAND—1951

Frequency: 1410 Kc.....Power: 1000 Watts d.
 Owned-Operated By.....Bcstrs. Oregon Ltd.
 Address.....P. O. Box 1230
 Phone Number.....ATwater 0106
 News Service.....AP
 Membership.....NARTB
 Transcription Service.....Associated, World
 Pres., Comm. Gen. Mgr.....Stanley M. Goad
 Program Director.....Douglas Ducklow
 Chief Engineer.....Charles K. Dickson

KPDQ

PORTLAND—1947

Frequency: 800 Kc.....Power: 1000 Watts d.
 Bus. Studio-Trans. Address. 1008 S.W. 6th Ave.
 Phone Number.....CA 9209
 News Service.....AP
 Pres., Gen. Mgr.....Jack W. Davis
 Commercial Manager.....Dave Jack
 Program Director.....Hal Starr
 Chief Engineer.....Bob Beattie

KPOJ

PORTLAND—1932—DON LEE

Frequency: 1330 Kc.....Power: 5000 Watts
 Owned-Oper. By.....Journal Publ. Co.
 Phone Number.....Broadway 3484
 Studio Address.....1019 S.W. 10th
 News Service.....UP
 Newspaper Affiliation.....Oregon Journal
 Transcription Service.....Thesaurus
 Representative.....John Blair
 Membership.....NARTB, BAB
 President.....Wm. W. Knight
 General-Station Manager.....R. M. Brown
 Commercial Manager.....Robert C. La Bonte
 Program Director.....Jack Moys
 Chief Engineer.....Richard R. Pooley

KWJJ

PORTLAND—1925

Frequency: 1080 Kc.....Power: 10,000 Watts
 Owned-Oper. By.....Rodney F. Johnson
 Bus. Studio Address.....1011 S.W. 6th Ave.
 Phone Number.....Atwater 4393
 News Service.....INS
 Representative.....Burn-Smith
 Membership.....NARTB
 Pres., Gen. Sta. Mgr.....Rod F. Johnson
 Prog. Dir.....Jerry Speerstra
 Chief Engineer.....Les Windes

KXL

PORTLAND—1926

Frequency: 750 Kc.....Power: 10,000 Watts
 Owned-Operated By.....KXL Bcstrs.
 Business-Studio Address.....Box 5886
 Phone Number.....BR. 6451
 News Service.....UP, AP
 Transcription Service.....Associated
 Representative.....Walker, Pacific Northwest
 Pres., Gen. Comm. Mgr.....H. S. Jacobson
 Program Director.....Ric Thomas
 Chief Engineer.....Len Garrett

KRCO

PRINEVILLE—1950

Frequency: 690 Kc.....Power: 1000 Watts d.
 Owned-Oper. By.....Radio Central Oregon
 Address.....P. O. Box 188
 Phone Number.....6-239
 Representative.....Grant, Best, Keating
 News Service.....UP

Pres., Gen. Mgr. Norbert A. Miksche
Comm. Mgr., Chief Engr. C. R. Matheny

KJUN

REDMOND—1952—ABC

Frequency: 1240 Kc. Power: 250 Watts
Owned-Oper. By Juniper Bcstrs., Inc.
Address P. O. Box 1240
Representative McGillvra
President Harold Singleton
General Manager F. G. Lieser
Sales Prom. Mgr. Jack Leutjen
Chief Engineer Don Gay

KRNR

ROSEBURG—1935—CBS

Frequency: 1490 Kc. Power: 250 Watts
Owned-Oper. By News Review Co.
Address 134 N. Jackson
Phone Number 3-5551
News Service AP
Transcription Service Standard
Newspaper Affiliation News Review Co.
Representatives Keating, Grant
Membership NARTB, BAB
President Frank Jenkins
Gen., Sta. Mgr. Leroy Hiatt
Commercial Mgr. Warren Ward
Program Director Lyle Fenner
Chief Engineer Max Dick

KRXL

ROSEBURG—1950—MBS

Frequency: 1240 Kc. Power: 250 Watts
Owned-Oper. By Umpqua Bcstrs., Inc.
Address 1640 Medford St.
Phone Number 3-4464
President Donn Radabaugh
General Manager Iris Rice Helliwell
Commercial Manager Lon D. Hunt
Chief Engineer Leo Reetz

KGAE

SALEM—1951

Frequency: 1430 Kc. Power: 1000 Watts d.
Owned-Operated By KGAE, Inc.
Address Box 768
Phone Number 3-7121
News Service AP
President W. Gordon Allen
General Manager Robert Bruce
Program Director Jean McLean
Chief Engineer John Truhan

KOCO

SALEM—1947

Frequency: 1490 Kc. Power: 250 Watts
Owned-Oper. By Loring Schmidt
Address Trans. Loca. 1426 Edgewater St.
Phone Number 3-3108
News Service UP
Transcription Service Standard, Associated
Representative William G. Rambeau

Pres., Gen. Mgr. Loring Schmidt
Program Director Carl Ritchie
Commercial Manager Seth Smith
Chief Engineer Robert Suing

KSLM

SALEM—1934—MBS—DON LEE

Frequency: 1390 Kc. Power: 1000 Watts
Owned-Operated By Oregon Radio, Inc.
Business Address P. O. Box 631
Phone Number 3-4831
Representative Everett, McKinney
Air Time 24 Hours
News Service UP
Transcription Service World, Lang-Worth
Membership NARTB, BAB
President, Gen. Mgr. Glenn McCormick
Sales Prom., Sta. Mgr. Dave Hoss
Commercial Manager Bruce Brown
Publicity Director D. S. Hoss
Chief Engineer Clyde Carlton

KTIL

TILLAMOOK—1947

Frequency: 1590 Kc. Power: 250 Watts
Owned-Oper. By Tillamook Bcstg. Co., Inc.
Business Address Box 227
Phone Number Victor 2-4422
Representative Continental
President F. H. Guyton
Manager Tom Hoover
Chief Engineer Larry Brunen

NOW THAT
YOU CAN
HAVE THE
BEST,
WHY BE
SATISFIED WITH
LESS?

AP

PENNSYLVANIA

Pop. Feb. 1, 1954 (Est.) 11,223,000 — Families 3,145,600
Radio Homes 3,001,000 — TV Homes 2,375,000 — Stations in State 117

W A E B

ALLENTOWN—1948—ABC

Frequency: 790 Kc. Power: 500 Watts d.;
1000 Watts n.
Owned-Oper. By: WAEB, Inc.
Address: Center Square
Phone Number: Hemlock 4-9364
News Service: UP
Representative: George P. Hollingsbery Co.
President: Howard Wasserman
Commercial Mgr.: P. Robert Ackley
Chief Engineer: William Gottshall

W H O L

ALLENTOWN—1948—CBS

Frequency: 1230 Kc. Power: 250 Watts
Owned-Operated By: Allentown Bcstg. Corp.
Phone Number: HE 4-4801
Air Time: 7 a.m.-M.
News Service: UP
Transcription: Thesaurus
Representative: Robert Meeker
Membership: NARTB, BAB
President: Charles G. Helwig
Sta. Mgr., Pgm. Dir.: J. F. Chambers
Publicity Director: Syd Paul
Chief Engineer: Gerald B. Werst

W K A P

ALLENTOWN—1947

Frequency: 1320 Kc. Power: 1000 Watts
Operated By: WKAP, Inc.
Bus. Studio Address: P. O. Box 689
Phone Number: Hemlock 3-3166
News Service: AP
Transcription Service: Associated
Representative: Weed
President: N. Joe Rahall
Sta., Gen. Mgr.: O. R. Davies
Chief Engineer: C. Frank Cordaro

W S A N

ALLENTOWN—1923—NBC

Frequency: 1470 Kc. Power: 5000 Watts
Owned-Oper. By: Lehigh Valley Bcstg. Co.
Bus. Studio Address: 39-41 N. Tenth St.
Phone Number: Hemlock 4-9511
Air Time: 6:30 a.m.-12:05 a.m.
News Service: AP
Transcription Service: World
Representative: Headley Reed
General Manager: B. Bryan Musselman
Sta., Comm. Mgr.: Olivia M. Barnes
Dir. of Programs: George Y. Snyder
Chief Engineer: Revel H. Musselman

W F B G

ALTOONA—1924—NBC

Frequency: 1340 Kc. Power: 250 Watts
Owned-Operated By: Gable Bcstg. Co.
Phone Number: 6467
Air Time: Full Time
News Service: AP
Transcription Service: World
Representative: H.R. Repp, Inc.
Membership: NARTB
President: George P. Gable
General Manager: John M. Snyder
Sta., Sales Prom. Mgr.: James R. Gates
Chief Engineer: George Burgoon

W R T A

ALTOONA—1947—ABC-MBS

Frequency: 1240 Kc. Power: 250 Watts
Owned-Operated By: Thompson Bcstg. Co.
Address: 1421 12th Ave.
Phone Number: 6646
Air Time: Full Time
News Service: UP
Transcription Service: Associated
Representative: Robert Meeker
Membership: NARTB



WHOL

ALLENTOWN, PA. CBS

Serving a progressive and prosperous area of diversified manufacturing plants; rich farms and splendid educational institutions; WHOL should definitely be your choice in the Allentown-Bethlehem market . . . 2nd in Pennsylvania . . . 12nd in the Nation.
The last census showed approximately 103,000 residents in the area served by WHOL. Retail sales in 1951 amounted to more than \$30,000,000 . . . and farm dollars exceeded \$28,000,000. You certainly want some of this business for your client's products, and WHOL can deliver it to you.
Together with WHOL, WAZL, WHLM, WIDE and WYDA are under the supervision of Victor C. Diehm, radio pioneer and executive.

CHAS. G. HELWIG, Esq.
President
Rep. ROBERT MEEKER

Pres., Gen. Mgr. Roy T. Thompson
 Sta., Comm., Prom. Mgr. William Clear
 Program Director Dorothy M. Thompson
 Publicity Director Dave Deniston
 Chief Engineer George Shaffer

W V A M

ALTOONA—1948—CBS

Frequency: 1430 Kc. Power: 1000 Watts
 Owned-Oper. By General Bcstg. Corp.
 Address 2727 W. Albert Dr.
 Phone Number 8127
 News Service UP
 Transcription Service Standard
 Representative Weed & Co.
 President Emanuel S. Leopold
 Manager Will Ketner
 Comm., Prom. Mgr. Will Union
 Chief Engineer Bernard Bopp

W A V L

APOLLO—1947

Frequency: 910 Kc. Power: 1000 Watts, d.
 Owned-Oper. By Tri-Borough Bcstg. Co.
 News Service UP
 General Manager Cecil F. Clifton
 Chief Engineer H. E. Smith

W N C C

BARNSBORO—1950—KBS

Frequency 950 Kc. Power: 500 Watts d.



WHLM BLOOMSBURG, PA.

The 1951 retail sales in the area serviced by WHLM amounted to \$147,346,000. Add to this \$21,847,000 of farming dollars and you get a pretty fair idea why we say, "Time Buyers, you can't afford to pass up the selling power of WHLM."

Located in WHLM's primary coverage area are the famous Magee Carpet Company, American Car & Foundry, Wise Potato Chips and Merck Drug Company, to mention just a few with good, big payrolls. Together with WHLM, WAZL, WHOL, WIDE and WDVA are under the supervision of Victor C. Diehn, radio pioneer and executive.

HARRY L. MAGEE
Owner and Operator

Owned-Oper. By No. Cambria Bcstrs.
 Phone Number 1010
 Transcription Service Thesaurus, World
 News Service UP
 Pres., Pub. Mgr. Harris G. Breth
 General Manager W. J. Thomas
 Program Director William R. Raihall
 Chief Engineer Dyle Miller

W B V P

BEAVER FALLS—1948

Frequency: 1230 Kc. Power: 250 Watts
 Owned-Operated By WBVP, Inc.
 Business-Studio Address 1216 Seventh Ave.
 Phone Number 4100
 News Service UP, AP
 Transcription Service Standard, World
 Pres., Gen. Mgr. Frank R. Smith, Jr.
 Commercial Mgr. Thomas B. Price
 Program Director Charles H. Wilson
 Chief Engineer Frank W. Schaefer

W G P A

BETHLEHEM—1946

Frequency: 1100 Kc. Power: 250 Watts d.
 Owned-Oper. By The Bethlehems' Globe
 Bus.-Studio Address 426 Brodhead Ave.
 Phone Number University 6-8074-5
 News Service UP
 Transcription Service Capitol, Thesaurus
 Membership NARTB
 President Rolland L. Adams
 General Manager Ellis Service
 Station Manager Arthur C. McCracken
 Comm., Sales Prom. Mgr. Frank Collie
 Chief Engineer Edwin L. Hybak

W C N R

BLOOMSBURG—1946

Frequency: 930 Kc. Power: 1000 Watts d.
 Owned-Oper. By The Columbia-Montour
 Bcstg. Corp.
 Bus.-Studio Address 38 W. Main St.
 Phone Number 1700
 News Service AP
 Gen. Mgr. Ed Darlington
 Chief Engineer Robert Fulton

W H L M

BLOOMSBURG—1948

Frequency: 690 kc. Power: 1000 Watts a.
 Owned-Oper. By Harry L. Magee
 Address Hotel Magee
 Phone Number 1800-1
 News Service AP
 President Harry Magee
 General Manager Robert R. Williams
 Commercial Mgr. Pat Campbell
 Sales Prom. Mgr. Ray Calabrese
 Prog. Dir. James K. Stock
 Chief Engineer Anthony Hogg

WLOA

BRADDOCK—1947

Frequency: 1550 Kc. Power: 1000 Watts d.
 Owned-Operated By: Matta Bcstg. Co.
 Business-Studio Address: 1233 Braddock Ave.
 Phone Number: Electric 1-1100
 News Service: UP
 President: William G. Matta
 Commercial Manager: George Matta
 Chief Engineer: Elmer L. Heess

WESB

BRADFORD—1947—MBS

Frequency: 1490 Kc. Power: 250 Watts
 Owned-Oper. By: WESB
 Business Address: 43 Main St.
 Phone Number: 3173
 Air Time: 7 a.m.-12 M. (8 a.m.-12 M.-Sun.)
 News Service: AP
 Transcription Service: Thesaurus
 Representative: Burn-Smith
 Membership: NARTB
 Gen. Mgr., Sls. Prom., Pub. Dir.: J. M. Cleary
 Commercial Manager: Frederick P. Tascone
 Program Dir.: Lloyd P. Gordon
 Chief Engineer: Dean Merry

WBUT

BUTLER—1949

Frequency: 1580 Kc. Power: 500 Watts d.
 Owned-Oper. By: J. Patrick Beacom
 Phone Number: 75-778
 News Service: AP
 President: J. Patrick Beacom
 Gen., Comm. Mgr.: Kenneth E. White
 Program Director: Rick Hanna
 Chief Engineer: Gerald L. Coleman

WISR

BUTLER—1941—TRI-STATE

Frequency: 680 Kc. Power: 250 Watts d.
 Owned-Oper. By: The Butler Bcstg. Co., Inc.
 Business-Studio Address: 357 N. Main St.
 Phone Number: Butler 4701-2
 Air Time: 6:30 a.m.-Sunset
 Membership: PAB
 News Service: UP
 President: Joel W. Rosenblum
 General Manager: Robert Kaufman
 Program Director: Warren Ihlenfeld
 Chief Engineer: Paul Rex

WCDL

CARBONDALE—1950—KBS

Frequency: 1230 Kc. Power: 250 Watts
 Owned-Oper. By: Carbondale Bcstg. Co., Inc.
 Address: 127 Salem Rd.
 Phone Number: Carbon. 1230
 News Service: UP
 Transcription Service: World
 Representative: Donald Cooke, Inc.
 Membership: NARTB
 President: William H. Ware

General Manager: John R. Kreiger
 Comm. Mgr.: Frank T. Bailey
 Chief Engineer: Walter F. Rude

WHYL

CARLISLE—1952

Frequency: 960 Kc. Power: 1000 Watts d.
 Owned-Oper. By: Richard Field Lewis, Jr.
 Business Address: Holly Pike
 Phone Number: 1785
 News Service: UP
 President: Richard F. Lewis, Jr.
 General Mgr.: Winslow T. Porter
 Chief Engineer: Jack Simmons

WCHA

CHAMBERSBURG—1946

Frequency: 800 Kc. Power: 1000 Watts d.
 Owned-Oper. By: Chambersburg Bcstg. Co.
 Bus. Studio Address: Craft Press Bldg.
 Phone Number: 1110
 News Service: AP
 Transcription Service: Thesaurus, Standard
 Representative: Forjoe
 Membership: NARTB, BAB
 President: C. M. Cassell
 General Manager: John S. Booth
 Sta., Comm. Mgr.: Earl P. Strine
 Chief Engineer: James McCurdy

WESA

CHARLEROI—1947—KBS

Frequency: 940 Kc. Power: 250 Watts d.
 Owned-Oper. By: Monongahela Valley Bcstg.
 Business-Studio Address: Fifth St.
 Phone Number: Charleroi 3-6551
 Air Time: Local sunrise-local sunset
 News Service: AP
 Transcription Service: Thesaurus
 President: Dr. A. S. Sickman
 Gen. Mgr.: C. R. Duvall
 Program Dir.: George Gailey
 Chief Engineer: Sylvio Garlolo

WPWA

CHESTER—1947

Frequency: 1590 Kc. Power: 1000 Watts
 Owned-Operated By: Lou Poller
 Business Address: 3500 Edgmont Ave.
 Phone Number: 4-4321
 News Service: UP
 Membership: NARTB, BAB
 Gen., Sta. Mgr.: Lou Poller
 Commercial Manager: Cy Swingle
 Chief Engineer: Harry Simmington

WVCH

CHESTER—1948

Frequency: 740 Kc. Power: 250 Watts d.
 Owned-Operated By: James M. Tisdale
 Bus. Studio Address: Wolf Bldg., Market Sq.
 Phone Number: Chester 2-8861
 News Service: UP
 Pres., Gen., Comm. Mgr.: James M. Tisdale
 Program Director: Robert A. Hibbert, Jr.

WCPA
CLEARFIELD—1947

Frequency: 900 Kc. Power: 1000 Watts d.
Owned-Oper. By Clearfield Bcstrs, Inc.
Address 215 Church St.
Phone Number 5-5541
Newspaper Affiliation Clearfield Progress
News Service UP
Transcription Service Thesaurus, Lang-Worth
Membership NARTB, BAB
President W. K. Ulerich
General Manager W. J. Thomas
Sta., Comm. Mgr. Joseph Milsof
Chief Engineer Lewellyn Duck

WCOJ
COATESVILLE—1949—QUAKER

Frequency: 1420 Kc. Power: 1000 Watts d.
Owned-Oper. By Chester Co. Bcstg. Co.
Address 703 E. Chestnut St.
Phone Number 2100
Transcription Service SESAC
News Service UP
Representative Grant Webb
Membership NARTB
Pres., Gen. Mgr. William S. Halpern
Comm., Prom. Mgr. Donald Kimes
Sta. Mgr., Secy., Chief Eng. Louis N. Seltzer

WCVI
CONNELLSVILLE—1947

Frequency: 1340 Kc. Power: 250 Watts
Owned-Oper. By Connelville Bcstrs., Inc.
Bus.-Studio Address 126 W. Crawford Ave.
Phone Number Connelville 2700
News Service UP
Transcription Service SESAC, World
President Raymond Galiardi
Gen., Sta. Mgr. Jack Craddock
Chief Engineer Paul Queer

WFRM
COUDERSPORT—1953

Frequency: 600 Kc. Power: 500 Watts d.
Owned-Oper. By Farm & Home Bcstg. Co.
Address 9 N. Main St.
Phone Number 611
President C. H. Simpson
Vice-Pres., Gen. Mgr. John A. Fay
Sales Manager George A. Clark
Commercial Mgr. David W. Hammond
Chief Engineer Maurice Sherman

WBUX
DOYLESTOWN—1948—KBS

Frequency: 1570 Kc. Power: 250 Watts d.
Owned-Operated By Charles M. Meredith
Business-Studio Address Hart Bldg.
Phone Number 220
News Service AP
Transcription Service World
Representative Indie Sales, Inc.
President Charles M. Meredith

Gen., Sta., Comm. Mgr. William A. Lynch
Program Director Robert Fretz
Chief Engineer P. Robert Wright

WCED
DUBOIS—1941—CBS

Frequency: 1230 Kc. Power: 250 Watts
Owned-Oper. By Tri-County Bcstg. Co.
Business-Studio Address 80 N. Park Pl.
Phone Number 1700
News Service UP
Transcription Service SESAC
Representative McGillvra
President Harold Gray
General Mgr. Jason S. Gray
Commercial Manager George Williams
Promotion Mgr. Ken Johnson
Chief Engineer Bernard Guewich

WEST
EASTON—1936—NBC

Frequency: 1400 Kc. Power: 250 Watts
Owned-Oper. By Associated Bcstrs., Inc.
Bus.-Studio Address 516 Northampton St.
Phone Number 6131
Air Time Full Time
News Service UP
Transcription Service World
Representative Robert Meeker
Membership NARTB, BAB
Station Executive Clair R. McCollough
Station Manager Theodore W. Pierce
Natl. Sales Manager J. Robert Gulick
Program Director Eugene Bethman
Technical Director J. E. Mathiot

WIKK
ERIE—1949—ABC

Frequency: 1330 Kc. Power: 5000 Watts
Owned-Oper. By Community Service Bcstg.
Bus.-Studio Address 1021 State St.
Phone Number 23-248
News Service AP
Transcription Service World
President Edward Lamb
Gen., Sta. Mgr. Charles R. Kinney
Commercial Mgr. William George
Promotion Director Jack Shumaker
Program Director James Hurley
Chief Engineer Ken Husband

WJET
ERIE—1951

Frequency: 1570 Kc. Power: 250 Watts d.
Owned-Operated By Jet Bcstg. Co.
Address 1635 Ash St.
Phone Number 4-6013
News Service AP
Transcription Service Standard
Representative Forje
Membership NARTB
Pres., Gen., Sta. Mgr. Myron Jones
Commercial Manager Lou Skelly
Chief Engineer William Fleckenstein

W E R C

ERIE—1941—NBC-QUAKER

Frequency: 1260 Kc. Power: 5000 Watts
Owned-Oper. By..... Presque Isle Bcstg. Co.
Bus. Studio Address 121 W. 10 St.
Phone Number 46367
News Service UP
Representative Weed
President..... Jacob A. Young
General Manager..... Arthur M. Ingram
Program Director..... J. Jacob Young
Chief Engineer..... Ken Hestor

W L E U

ERIE—1933

MBS-QUAKER-KEYSTONE

Frequency: 1450 Kc. Power: 250 Watts
Owned-Oper. By..... Commodore Perry
Bcstg. Service, Inc.
Bus. Studio-Trans. Add.... 212 Commerce Bldg.
Phone Number..... 23-327, 22-129
Air Time..... Full Time
News Service AP
Representative..... Adams J. Young Jr.
President..... Owen K. Murphy
General Manager..... Philip B. Hirsch
Chief Engineer..... William P. Sepenick

NOW THAT
YOU CAN
HAVE THE
BEST,
WHY BE
SATISFIED WITH
LESS?

PA

W E R C
ERIE PENNSYLVANIA'S
LEADING REGIONAL STATION
GIVES YOU OUTSTANDING
MERCHANDISING

Pluses

- BUS CARDS
- TAXI POSTERS
- DIRECT MAIL
- POINT OF SALE
- POSTERS
- THEATER SCREEN
- PROMOTION



5000 WATTS
1260 KC

Represented by
WEED & CO.

WGET

GETTYSBURG—1950—KBS
QUAKER

Frequency: 1450 Kc. Power: 250 Watts
Owned-Oper. By: Times & News Pub. Co.
Address: P. O. Box 28
Phone Number: 850
News Service: AP
Transcription Service: World
Gen., Sta., Comm., Prom. Mgr.: Murray L. Goldsborough
Program Director: C. W. Baker, III
Chief Engineer: Lester Blair

WHJB

GREENSBURG—1934

Frequency: 620 Kc. Power: 1000 Watts d., 500 n.
Owned-Oper. By: Pittsburgh Radio Supply House
Business-Studio Address: 128 N. Penn Ave.
Phone Number: Greensburg 3740
News Service: UP
Transcription Service: Lang-Worth
President: H. Kenneth Brennen
General-Comm. Mgr.: G. J. Podeyn
Chief Engineer: L. L. Allen

WHVR

HANOVER—1948—MBS

Frequency: 1280 Kc. Power: 1000 Watts d., 500 Watts n.
Owned-Operated By: Radio Hanover, Inc.
Address: Hanover Rd.
Phone Number: 3831
Air Time: Full Time
News Service: UP
Transcription Service: World
Pres., Sta. Gen. Mgr.: John D. Bare
Program Director: Ned Rutledge
Publicity Director: Ed John
Chief Engineer: Philip Rohrbaugh

WCMB

HARRISBURG—1948—MBS

Frequency: 1460 Kc. Power: 5000 Watts
Owned-Oper. By: Rossmoyne Corp.
Business-Studio Address: 228 Court St.
Phone Number: 4-3005
Air Time: 24 Hours
News Service: AP
Transcription Service: Thesaurus
Representative: Donald Cooke, Inc.
Membership: NARTB
President: Edgar T. Shepard, Jr.
General Manager: Ed K. Smith
Commercial Mgr.: Rudolph O. Marvoux
Sales Prom. Mgr.: Gilbert Brown
Program Director: John Archer
Chief Engineer: J. Howard Bair

WCMB

means BUSINESS in
HARRISBURG

POWER 5000 watts day and night covers the ENTIRE Harrisburg Market.

PROGRAMS Top News, Sports, Local and MBS Features.

PROMOTION Window displays, bus cards, theater screens, etc.

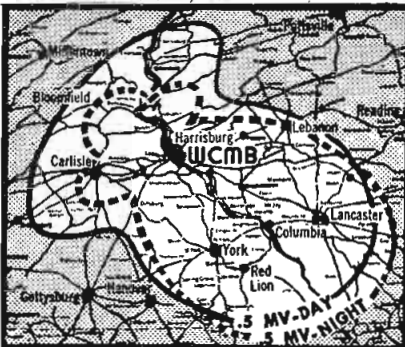

MUTUAL FOR HARRISBURG
5000 WATTS 24 HOURS DAILY

AND NOW TELEVISION

ON WCMB-TV

Following the successful formula of WCMB-Radio with selected specialty shows from a quality talent roster.

Priced less than you'd expect for the companion station to one of the nation's most alert and progressive radio operations.

HARRISBURG WCMB-TV

Harrisburg—

Pennsylvania's Best LARGE Market

WHP & WHP-TV

Best Buy In Pennsylvania's Capital City.

The most powerful advertising medium for tapping this high Per Capita income market, plus the rich South Central Pennsylvania area.

It gives you the insurance of a well established audience for your sales message. The staff of WHP and WHP-TV has the showmanship and experience to present your sales story in the most effective way possible in this top quality market of Pennsylvania. The stability gained through 30 years of service to the Harrisburg area makes this the outstanding medium for making sales.

The same audience loyalty which WHP has enjoyed through the past 30 years also prevails in television — and the results of the two mediums tied together are inevitable.

The tested medium for selling Harrisburg and the South Central Pennsylvania area is WHP and WHP-TV. It's your best buy.

WHP
AND
WHP-TV

Key Stations of the
Keystone State

Harrisburg, Pa.

Represented by The Bolling Co.

CBS Radio and Television Affiliates

W H G B

HARRISBURG—1945—ABC

Frequency: 1400 Kc.....Power: 250 Watts
 Owned-Oper. By.....Kendrick Bcstg. Co., Inc.
 Bus.Studio-Trans. Address.....112 Market St.
 Phone Number.....4-4988
 Air Time.....6 a.m.-1 a.m.
 News Service.....AP
 Transcription Service.....Capitol
 Representative.....Weed
 Membership.....NARTB, BAB
 Pres., Gen. Mgr.....Herbert Kendrick
 Station Manager.....Jack Hooper
 Pub. Dir.....Red McCarthy
 Chief Engineer.....William Kuntz

W H P

HARRISBURG—1924—CBS

Frequency: 580 Kc.....Power: 5000 Watts
 Owned-Operated By.....WHP, Inc.
 Business-Studio Address.....216 Locust St.
 Phone Number.....4-3211
 Air Time.....Unlimited
 News Service.....AP, UP
 Transcription Service.....Standard, Associated
 Representative.....The Bolling Co.
 Membership.....NARTB
 Gen.-Sta.-Comm. Mgr.....A. K. Redmond
 Sales Prom. Mgr.....Beatrice Pottelger
 Program Director.....Dick Redmond
 Publicity Dir.....John Price
 Chief Engineer.....E. Daniel Leibensperger

W K B O

HARRISBURG—1922—NBC

Frequency: 1230 Kc.....Power: 250 Watts
 Owned-Oper. By.....Keystone Bcstg. Corp.
 Bus.Studio Address.....31 N. Second St.
 Phone Number.....4-0191
 Air Time.....Full Time
 News Service.....UP
 Transcription Service.....World
 Representative.....Robert Meeker
 Membership.....NARTB, BAB
 Station Executive.....Clair R. McCollough
 Station Manager.....Henry M. Traugh
 Natl. Sales Mgr.....J. Robert Gullick
 Program Director.....Seibert D. Eberly
 Technical Director.....J. E. Mathiot

W A Z L

HAZLETON—1932—NBC-MBS

Frequency: 1490 Kc.....Power: 250 Watts
 Owned-Operated By.....Hazleton Bcstg. Co.
 Bus.Studio Address.....708 Hazleton Natl.
 Bank Bldg.
 Phone Number.....Gladstone 4-3511
 Air Time.....Unlimited
 News Service.....AP
 Transcription Service.....World
 Representative.....Robert Meeker
 Membership.....NARTB, BAB
 Pres., Gen., Sta. Mgr.....Victor C. Diehm
 Sales Prom. Mgr.....Thomas Tito

Program Director.....Bill Graham
 Publicity Dir.....Betty Mulligan
 Chief Engineer.....Elwood Tito

W H O D

HOMESTEAD—1948

Frequency: 860 Kc.....Power: 250 Watts d.
 Owned-Operated By.....Steel City Bcstg. Corp.
 Bus.Studio Address.....105 E. Eighth Ave.
 Phone Number.....HO 1-0172
 News Service.....UP
 Representative.....Forjoe
 General Manager.....Roy Ferres
 Station Mgr.....Leonard Walk
 Promotion Dir.....Sid Dickler
 Chief Engineer.....James Herbert

W H U N

HUNTINGDON—1947—KBS

Frequency: 1150 Kc.....Power: 500 Watts
 Owned-Oper. By.....Joseph F. Biddle Publ. Co.
 Bus.Studio Address.....400 Washington St.
 Phone Number.....1291
 Newspaper Affiliation....."Daily News"
 News Service.....UP
 Transcription Service.....SESAC, World
 Representative.....Indie Sales
 President.....John H. Biddle
 General Manager.....William E. Germann
 Chief Engineer.....Ernest A. Craig



W A Z L

HAZLETON, PA. NBC-MBS

WAZL is uniquely located at the southern end of Luzerne County and its coverage reaches into Carbon, Schuylkill and Columbia counties. This brings Hazleton's metropolitan buying population to 127,000. Hazleton enjoys the rare distinction of having a higher effective buying income per family than the U. S. average . . . \$6,370.00 per family and they use it to buy the products advertised on WAZL. Here is a station that will deliver to you 70% of the radio listening audience from 8:00 in the morning until 10:30 at night. Together with WAZL, WHOL, WIDE, WHLM and WVDA are under the supervision of Victor C. Diehm, radio pioneer and executive.

VICTOR C. DIEHM
 President and Gen. Mgr.
 Rep. ROBERT MEEKER

WDAD

INDIANA—1945—CBS-KBS

Frequency: 1450 Kc. Power: 250 Watts
 Owned-Oper. By: WDAD Inc.
 Address: 673 Philadelphia St.
 Phone Number: 5-5511
 News Service: UP
 President: W. K. Ulerich
 General Manager: Winsor Brown
 Commercial Mgr.: Jonas Termin
 Chief Engineer: Stanley Graziadio

WARD

JOHNSTOWN—1946—CBS

Frequency: 1490 Kc. Power: 250 Watts
 Owned-Oper. By: Central Bcstg. Co., Inc.
 Business-Studio Address: Porch Bldg.
 Phone Number: 81-216
 News Service: UP
 Transcription Service: World
 Representative: Weed
 President: Paul Short
 General Manager: George D. Gartland
 Station Manager: Robert R. Nelson
 Chief Engineer: Millard C. Coleman

WCRO

**JOHNSTOWN—1947—ABC-MBS
 QUAKER**

Frequency: 1230 Kc. Power: 250 Watts
 Owned-Oper. By: Century Bcstg. Corp.
 Bus.-Studio Address: Fort Stanwix Hotel
 Phone Number: 9-1187
 Air Time: 6 a.m.-1 a.m.
 News Service: INS
 Representative: Radio-TV Reps
 President: John J. Keel
 General Manager: Stewart W. Phillips
 Asst. to Manager: Jane Smith
 Chief Engineer: Earl Castine

WJAC

JOHNSTOWN—1925—NBC

Frequency: 1400 Kc. Power: 250 Watts
 Owned-Operated By: WJAC, Inc.
 Bus.-Studio Address: 329 Main St.
 Phone Number: 4-1267
 Newspaper Affiliation: Tribune-Democrat
 News Service: AP
 Transcription Service: Lang-Worth
 Representative: Young
 Membership: NARTB
 President: W. W. Krebs
 Station Manager: John P. Foster
 Comm. Mgr.: Park Claycomb
 Publicity Director: Edward T. Bunn
 Chief Engineer: Theodore E. Campbell

WACB

KITTANNING—1948

Frequency: 1380 Kc. Power: 1000 Watts d.
 Owned-Oper. By: The Armstrong County
 Bcstg. Corp.
 Bus.-Studio Address: 325 Market St.

Phone Number: 43-1381
 News Service: AP
 Transcription Service: Thesaurus
 President: J. B. Moore
 General Manager: Edward J. Hirshberg
 Station Manager: Clyde W. Cranmer
 Commercial Mgr.: Albert Dame
 Chief Engineer: Joseph Pelletier

WGAL

LANCASTER—1922—NBC

Frequency: 1490 Kc. Power: 250 Watts
 Owned-Operated By: WGAL, Inc.
 Business-Studio Address: 8 W. King St.
 Phone Number: 5251
 News Service: UP
 Transcription Service: World
 Representative: Robert Meeker
 President: Clair R. McCollough
 Station Manager: Maynard W. Thomas
 Nat. Sales Mgr.: J. Robert Gulick
 Program Mgr.: Kenneth Kreider
 Technical Director: J. E. Mathiot

WLAN

**LANCASTER—1946
 ABC—QUAKER**

Frequency: 1390 Kc. Power: 1000 Watts
 Owned-Oper. By: The Peoples Bcstg. Co.
 Bus.-Studio Address: 252 N. Queen St.
 Phone Number: 7261
 News Service: AP
 Transcription Service: Lang-Worth, Capitol
 Representative: Headley-Reed
 Pres., Gen. Mgr.: Frank H. Altdoerffer
 Vice-President: S. M. Altdoerffer
 Commercial Mgr.: Stanley Baker
 Promotion Dir.: Bernie De Paul
 Program Dir.: Ted Pollack

WLSH

LANSFORD—1952

Frequency: 1410 Kc. Power: 1000 Watts d.
 Owned-Oper. By: Miners Bcstg. Service, Inc.
 Address: P. O. Box D
 Phone Number: 1440
 News Service: UP
 Transcription Service: Associated, Thesaurus
 Representative: Everett-McKinney
 President: Joseph L. Maquire
 Station Manager: John W. Angst
 Commercial Manager: J. C. Lindvay
 Program Director: Bud Angst
 Chief Engineer: Milton W. Seltzer

WAKU

LATROBE—1951

Frequency: 1570 Kc. Power: 250 Watts d.
 Owned-Operated By: Clearfield Bcstrs. Inc.
 Address: Depot St.
 Phone Number: 2348
 Transcription Service: Thesaurus, World
 President: W. K. Ulerick
 General Manager: W. J. Thomas
 Chief Engineer: Bernard Guidos

W L B R
LEBANON—1946

Frequency: 1270 Kc. Power: 1000 Watts d.
Owned-Operated By.....Lebanon Bcstg. Co.
Bus.-Studio Address.....8th & Cumberland Sts.
Phone Number2-7651
News ServiceAP
Transcription ServiceWorld
RepresentativeBurn-Smith
President.....H. Raymond Stadiem
Prog. Dir.....Henry Homan
Chief Engineer.....M. Leonard Savage

W K V A

LEWISTOWN—1949—ABC

Frequency: 920 Kc. Power: 1000 Watts a.
Owned-Operated By.....Central Pa. Bcstg. Co.
Address.....19 S. Wayne St.
Phone Number6771
News ServiceUP
RepresentativeGill-Perna
Pres., Sta., Gen. Mgr.....Robert L. Wilson
Pgm. Dir.....Lynn Bloom
Promotion Dir.....Reed Gray
Sales Prom. Mgr.....Robert Hyle
Chief Engineer.....Robert Steltzer

W M R F

LEWISTOWN—1941—NBC

Frequency: 1490 Kc. Power: 250 Watts
Owned-Operated By.....Lewistown Bcstg. Co.
Business-Studio Address.....Monument Square
Phone Number6757
Air Time.....6 a.m.-M.
News ServiceAP
RepresentativeBurn-Smith
MembershipNARTB
President.....J. S. Woods
General Manager.....T. W. Metzger
Commercial Manager.....Ralph Parker
Prom., Pub. Director.....James Keyes
Chief Engineer.....Kenneth Callahan

W B P Z

LOCK HAVEN—1946—MBS

Frequency: 1230 Kc. Power: 250 Watts
Owned-Oper. By.....Lock Haven Bcstg. Corp.
Bus.-Studio Address.....132½ E. Main St.
Phone Number4038
Air Time.....Full Time
News Service.....AP, UP
Transcription Service.....Thesaurus, Langworth
Representative.....Joseph Hershey McGillvra
MembershipNARTB, BAB
President.....Donald C. Welch
General-Station Manager.....Harris Lipetz
Prog., Publ. Director.....Dave King
Chief Engineer.....Kenneth C. Caum

W E D O

McKEESPORT—1946

Frequency: 810 Kc. Power: 1000 Watts d.

Owned-Operated By.....Tri-City Bcstg. Co.
Business-Studio AddressBox 810
Phone NumberMcKeesport 4-7167,
Homestead 1-3113

News ServiceAP
Trans. ServiceThesaurus
Pres., Gen. Mgr.....Edward J. Hirshberg
Sta. Mgr.....Robert E. Badger
Chief Engineer.....Wilkes E. Hurley

W M C K

McKEESPORT—1946

Frequency: 1360 Kc. Power: 1000 Watts
Owned-Oper. By.....Mon-Yough Bcstg. Co.
Business-Studio Address.....516 Market St.
Phone Number8-8888
News ServiceUP
Transcription Service.....Lang-Worth, World
PresidentRobert M. Cox
Gen., Prom. Mgr.....Gene Kline
Station Manager.....Sam Vidnovic
Chief Engineer.....Charles White

W M G W

MEADVILLE—1947—ABC

Frequency: 1490 Kc. Power: 250 Watts
Owned-Oper. By.....Meadville Bdcstg. Serv., Inc.
Address1st National Bank Bldg.
Phone Number46-723
Air Time.....6:30 a.m.-12 M.
News ServiceUP
Transcriptoin ServiceWorld
MembershipNARTB, BAB
PresidentH. C. Winslow
Station Manager.....Robert Trace
Commercial Manager.....Douglas M. Rose
Program Director.....James Strickler
Chief Engineer.....Jack Harvey

W P E L

MONTROSE—1953

Frequency: 1250 Kc. Power: 1000 Watts d.
Owned-Oper. By.....Montrose Bcstg.
Address.....Lake & Locust St.
Phone Number397
President.....W. Douglas Roe
General Manager.....Loren F. Bridges
Chief Engineer.....Chales Hallinan

W H W L

NANTICOKE—1947

Frequency: 730 Kc. Power: 1000 Watts d.
Owned-Oper. By.....Radio Anthracite, Inc.
Business-Studio Address.....38 E. Main St.
Phone Number.....Nanticoke 1332
News ServiceUP
Transcription ServiceCapitol
RepresentativeForjoe
President.....Henry W. Lark
General Manager.....Jones Evans



In
 WFIL-adelphia
 ONE POINT
 OF SALE FOR

7,407,400
 Good Customers

WFIL is the station that increases the dimensions of the Philadelphia Market—gives you the greatest one-medium coverage of a 4-state area almost **TWICE THE SIZE** of the Philadelphia Retail Trading Zone.

WFIL-adelphia is the area—37 counties in Pennsylvania, New Jersey, Delaware, New York—where a population of 7½-million annually has \$13-billion to spend.

For Philadelphia's top radio coverage . . . most effective promotion . . . most complete merchandising—Philadelphia advertisers place more spot advertising with WFIL than any other station.

◀ Source:
 Broadcast Advertisers
 Report, Sept. '53

WFIL

The Philadelphia Inquirer Station

ABC AFFILIATE • Represented by JOHN BLAIR & COMPANY

WKST

NEW CASTLE—1938—MBS-QUAKER

Frequency: 1280 Kc. Power: 1000 Watts
 Owned-Operated By: WKST, Inc.
 Business-Studio Address: Lincoln Ave.
 Phone Number: Oliver 4-5501
 Air Time: Full Time
 News Service: UP
 Representative: Everett-McKinley
 President, General Mgr.: S. W. Townsend
 Station Manager: A. W. Graham
 Comm., Sales Prom. Mgr.: I. A. Eubanks
 Program Dir.: Harry Reith
 Publicity Dir.: Al Francis
 Chief Engineer: Donald Dout

WKPA

NEW KENSINGTON—1940

Frequency: 1150 Kc. Power: 250 Watts d.
 Owned-Oper. By: Allegheny-Kiski Bcstg. Co.
 Business-Studio Address: 810 Fifth Ave.
 Phone Number: Edison 7-3588
 News Service: AP
 Transcription Service: World
 Representative: Continental Radio Sales
 President: C. R. Cooper
 Gen., Sta. Mgr.: E. J. Kroen
 Commercial Manager: Melvin Goldberg
 Chief Engineer: W. W. Neely

WNAR

NORRISTOWN—1946

Frequency: 1110 Kc. Power: 500 Watts d.
 Owned-Operated By: Norristown Bcstg. Co.
 Bus.-Studio Address: 115 W. Main St.
 Phone Number: Norristown 8-7600
 News Service: AP
 Transcription Service: SESAC
 Membership: NARTB
 President: N. Joe Rahall
 Gen. Mgr.: Ogden R. Davies
 Station Manager: John M. Banzhoff
 Chief Engineer: Julius Kosik

WKRZ

OIL CITY—1946—MBS-KBS

Frequency: 1340 Kc. Power: 250 Watts
 Owned-Operated By: WKRZ, Inc.
 Business-Studio Address: 201 Fair Bldg.
 Phone Number: 4-1269
 News Service: UP
 Transcription Service: World
 Pres., Gen. Mgr.: Kenneth E. Rennekamp
 Commercial Mgr.: Catherine McLaughlin
 Promotion Mgr.: Mary Freed
 Program Director: Ruth Siembadi
 Chief Engineer: David McElhatten
 Publicity Director: Patrick Nuhfer

KYW

PHILADELPHIA—1921—NBC

Frequency: 1060 Kc. Power: 50,000 Watts

Owned-Oper. By: Westinghouse Radio Stations, Inc.

Business-Studio Address: 1625 "K" Street, N.W.
 Phone Number: Sterling 3-0903
 Air Time: Full Time
 News Service: INS, UP
 Transcription Service: Thesaurus
 Representative: Free & Peters
 Membership: BAB
 President: Chris J. Witting
 General Manager: Joe Baudino
 Station Manager: Franklin A. Tooke
 Commercial Manager: R. H. Teter
 Prom. Mgr., Publ. Dir.: Paul I. Woodland
 Program Director: Gordon Davis
 Chief Engineer: I. N. Eney

WCAU

PHILADELPHIA—1922—CBS

Frequency: 1210 Kc. Power: 50,000 Watts
 Owned-Oper. By: WCAU, Inc.
 Address: City & Monument Ave.
 Phone Number: Greenwood 7-8300
 Air Time: Unlimited
 News Service: AP, INS
 Transcription Service: Lang-Worth
 Representative: CBS Radio Spot Sales
 Pres., Gen. Mgr.: Donald W. Thornburgh
 Exec. Vice-President: Jos. L. Tinney
 Commercial Manager: John S. DeRussy
 V.P., Prog. Director: Jos. T. Connolly
 V.P., Prom. Dir.: Robert N. Pryor
 V.P., Director of Engr.: John G. Leitch

WDAS

PHILADELPHIA—1924

Frequency: 1400 Kc. Power: 250 Watts
 Owned-Oper. By: Max M. Leon, Inc.
 Business-Studio Address: 223 Arch St.
 Phone Number: Market 7-8484
 News Service: AP
 Representative: Forjoe
 Membership: NARTB
 President: Max M. Leon
 Gen., Comm. Mgr.: Robert A. Klein
 Program Director: Fred H. Greene
 Prom. Mgr.: Louis Palens
 Chief Engineer: Frank W. Unterberger

WFIL

PHILADELPHIA—1922

ABC-QUAKER

Frequency: 560 Kc. Power: 5000 Watts
 Owned-Oper. By: Philadelphia Inquirer Div. of Triangle Publications, Inc.
 Business-Studio Address: 46th & Market
 Phone Number: Evergreen 2-4700
 Air Time: Unlimited
 News Service: UP
 Transcription Service: Associated, World
 Representative: Katz
 Membership: NARTB
 General Manager: Roger W. Clipp
 Operations Asst. to Gen. Mgr.: John D. Scheuer, Jr.
 Executive Assistant: George A. Koehler

how do you measure a radio station?

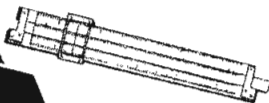

Our advertisers measure by
results!

That's why more advertis-
ers use WIP than any
other Philadelphia net-
work radio station, to
sell their products
and services.

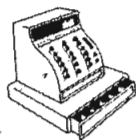

National Representatives
EDWARD PETRY & CO., INC.

WIP

610 KC

PHILADELPHIA 7, PA.

PHILADELPHIA'S PIONEER VOICE

Promotion Mgr.....Joe Zimmermann
 Program Dir.....Felix Meyer
 Publicity Dir.....John J. Hyland
 Chief Engineer.....Henry Rhea

W H A T
 PHILADELPHIA—1929

Frequency: 1340 Kc.Power: 250 Watts
 Owned-Oper. By...Independence Bcstg. Co.
 Business-Studio Address.....1505 Walnut St.
 Phone Number.....Rittenhouse 6-2058
 RepresentativeIndie Sales
 Pres., Gen., Comm. Mgr. .William A. Banks
 Prom., Sta. Mgr.Dolly Banks
 Chief Engineer.....Charles Lehmann

W I B G
 PHILADELPHIA—1925

Frequency: 990 Kc.....Power: 10,000 Watts
 Owned-Oper. By.....Seaboard Radio Bcstg.
 Corp.
 Business-Studio Address.....1425 Walnut St.
 Phone Number.....Rittenhouse 6-2300
 News ServiceUP
 RepresentativeRadio Reps.
 President.....Paul F. Harron
 Vice-Pres.Joseph Lang
 Gen.-Sta.-Comm. Mgr.....Edward D. Clery
 Sales Prom., Publ. Dir.....Rupe Werling
 Technical DirectorJohn H. Henninger
 Chief EngineerGeorge Hooper

W I P

PHILADELPHIA—1922—MBS

Frequency: 610 Kc.....Power: 5000 Watts
 Owned-Oper. By.....Pennsylvania Bcstg. Co.
 Business-Studio Address.....35 S. 9th St.
 Phone Number.....Walnut 2-6800
 Air TimeUnlimited
 News Service.....AP, UP
 Transcription ServiceWorld
 RepresentativeEdward Petry
 MembershipBAB
 Pres., Gen., Sta. Mgr.....Benedict Gimbel, Jr.
 Dir. of Sales.....Ralph Brent
 Loc. Sales Mgr.....Clyde Spitzner
 Program Director.....Varner Paulsen
 Prom. Mgr., Pub. Dir.....Edward Wallis
 Technical DirectorClifford C. Harris

W J M J

PHILADELPHIA—1948

Frequency: 1540 Kc.....Power: 1000 Watts d.
 Owned-Operated By.....Patrick J. Stanton
 Business-Studio Address.....2043 Locust St.
 Phone Number.....LOcust 4-2300
 News ServiceAP
 Transcription ServiceSESAC
 RepresentativeMcGillvra
 Gen., Sta. Mgr.....Patrick J. Stanton
 Commercial Mgr.....Charles Stahl
 Prog. Dir.....Michael Deegan
 Chief Engineer.....Alec Felton Iles

WIBG

PHILADELPHIA

RUPE:
 WE DID IT AGAIN,
 SO RUN THIS SAME
 AD AGAIN. E. D. C.

CARRIED MORE NATIONAL SPOT BUSI-
 NESS IN THE PAST YEAR THAN EVER
 BEFORE IN OUR HISTORY — AND WE
 STARTED BACK IN '25.

10,000 WATTS OF SPORTS, NEWS AND MUSIC
 NATIONAL REPRESENTATIVE — RADIO-TV REPRESENTATIVES

W P E N

PHILADELPHIA—1929

Frequency: 950 Kc. Power: 5000 Watts
 Owned-Oper. By William Penn Bcstg. Co.
 Business-Studio Address 2212 Walnut St.
 Phone Number LOcust 4-6000
 News Service AP, UP
 Representative Gill-Perna
 Membership BAB
 President William Sytk
 Gen., Sta. Mgr. William B. Caskey
 Asst. Sta. Mgr. Murray Arnold
 Commercial Mgr. Erwin Rosner
 Chief Engineer Charles W. Burtis

W T E L

PHILADELPHIA—1925

Frequency: 860 Kc. Power: 250 Watts d.
 Owned-Oper. By Foulkrod Radio Engineering Co.
 Business-Studio Address 4312 N. Broad St.
 Phone Number Davenport 4-4310
 Pres., Pgm. Dir. E. Douglass Hibbs
 General Manager Henry N. Cocker
 Chief Engineer John Field

K D K A

PITTSBURGH—1920—NBC

Frequency: 1020 Kc. Power: 50,000 Watts
 Owned-Oper. By Westinghouse Radio Stations, Inc.
 Business-Studio Address Grant Bldg.
 Phone Number Grant 1-4200
 Air Time Unlimited
 News Service AP, UP
 Representative Free & Peters
 Membership BAB
 President Chris J. Witting
 V.P., General Manager Joseph E. Baudino
 Station Manager L. R. Rawlins
 Commercial Manager John Stilli
 Promotion Manager David N. Lewis
 Program Manager Robert E. White
 Publicity Manager Lee Curran
 Chief Engineer Theodore C. Kenney

K Q V

PITTSBURGH—1919—CBS

Frequency: 1410 Kc. Power: 5000 Watts
 Owned-Oper. By Allegheny Bcstg. Corp.
 Bus. Studio Address 800 Chamber of Commerce Bldg.
 Phone Number Atlantic 1-9100
 Air Time Unlimited
 News Service UP
 Representative Weed
 Exec. Vice President Gunnar O. Wiig
 Gen., Sta. Mgr. J. F. Murray
 Comm. Mgr. Chris Salmon
 Prom., Pub. Dir. Owen Simon
 Program Dir. John Gibbs
 Chief Engineer James J. Schultz

W C A E

PITTSBURGH—1922—ABC

Frequency: 1250 Kc. Power: 5000 Watts
 Owned-Operated By WCAE, Inc.
 Bus. Studio Address Carlton House
 Phone Number Atlantic 1-6900
 Air Time 5:45 a.m.-1 a.m.
 News Service INS
 Representative Katz
 Membership NARTB, BAB
 Pres., General Manager Leonard Kapner
 Gen., Sta. Mgr., Prog. Dir. R. Clifton Daniel
 Commercial Manager Carl M. Dozer
 Prom. Mgr., Pub. Dir. William Thieman
 Chief Engineer James Greenwood

W J A S

PITTSBURGH—1921—MBS

Frequency: 1320 Kc. Power: 5000 Watts
 Owned-Oper. By Pittsburgh Radio Supply House, Inc.
 Bus. Studio Address 411 Seventh Ave.
 Phone Number Grant 1-4860
 Air Time 6 a.m.-12:30 a.m.
 News Service UP
 Transcription Service Lang-Worth
 Representative Hollingbery
 Pres., Gen. Mgr. H. K. Brennen
 Comm.-Sales Prom. Mgr. John H. Buchhelt
 Program Director William Babcock
 Publicity Director Caley E. Augustine
 Chief Engineer Walter W. McCoy

W P G H

PITTSBURGH—1947

Frequency: 1080 Kc. Power: 1000 Watts d.
 Owned-Operated By Pittsburgh Bcstg. Co.
 Bus. Studio Address 220 N. Highland Ave.
 Phone Number EMerson 1-5000
 News Service AP
 Transcription Service Lang-Worth
 President George M. Harton
 General Manager Howard Lazarus
 Chief Engineer Ralph L. Ketterer

W P I T

PITTSBURGH—1947

Frequency: 730 Kc. Power: 1000 Watts d
 Owned-Operated By WPIT, Inc.
 Business-Studio Address 213 Smithfield St.
 Phone Number Atlantic 1-1900
 News Service UP
 Representative Forjoe
 President John J. Laux
 V.P., Gen., Sta., Comm. Mgr. Don Isotek
 Chief Engineer Mike Komichak

W W S W

PITTSBURGH—1932

Frequency: 970 Kc. Power: 5000 Watts
 Owned-Oper. By WWSW, Inc.
 Bus. Studio Address Sheraton Hotel

Phone Number.....GRant 1-5200
 News ServiceUP
 RepresentativeJohn Blair
 MembershipNARTB
 President, Gen. Manager.....O. M. Schloss
 Station Manager.....Ben W. Muros
 Chief Engineer.....Henry R. Kaiser

WPAZ

POTTSTOWN—1951

Frequency: 1370 Kc.....Power: 1000 Watts d.
 Owned-Operated By.....Pottstown Bcstg. Co.
 Address.....247 High St.
 Phone Number5000
 News ServiceUP
 RepresentativeIndie Sales
 MembershipBAB
 Pres., Gen. Mgr.....Herbert Scott
 Commercial Manager.....Clifford M. Chafey
 Chief Engineer.....Ralph E. P. Mellon

WPAM

POTTSVILLE—1947—MBS-KBS

QUAKER

Frequency: 1450 Kc.....Power: 250 Watts
 Owned-Oper. By.....Miners Bcstg. Serv., Inc.
 Business-Studio Address.....Box 629
 Phone Number.....Pottsville 5050
 News ServiceUP
 Transcription ServiceAssociated
 RepresentativeEverett-McKinney

President.....Joseph L. Maquire
 General Mgr.....Louis H. Murray
 Comm. Mgr.....Frank L. Tamulonis
 Program Director.....Horace Richards
 Chief EngineerMilton Seltzer

WPPA

POTTSVILLE—1946

Frequency: 1360 Kc.....Power: 1000 Watts d.;
 500 Watts n.
 Owned-Oper. By.....Pottsville Bcstg. Co.
 Bus.-Studio Address.....8 So. Second St.
 Phone NumberPottsville 4744
 News ServiceAP
 Transcription ServiceWorld
 MembershipNARTB
 Owner, Gen. Mgr.....A. V. Tidmore
 Commercial Manager.....Ralph L. Price, Jr.
 Chief Engineer.....A. V. Tidmore

WPME

PUNXSUTAWNEY—1953

Frequency: 1540 Kc.....Power: 1000 Watts d.
 Owned-Oper. By.....Punxsutawney Bcstg Co.
 Address.....103 N. Gilpin St.
 Phone Number1221
 PresidentSheridan Pruett
 Vice-Pres., Gen. Mgr.....C. M. Erhard Jr.
 Commercial Mgr.....Michael Catanzarito
 Program Director.....C. Robert Shaw
 Chief Engineer.....Joseph Pelletier

THOSE WHO KNOW FAMOUS BRANDS

Says General Manager Harris Lipez, WBPZ, Lock Haven,
 Pa.: "Associated Press makes it easier to offer a
 salable program to any sponsor."

. . . . KNOW THE MOST FAMOUS
 BRAND IN NEWS IS AP

WPXY

PUNXSUTAWNEY—1953—MBS

Frequency: 1300 Kc. Power: 1000 Watts d.
 Owned-Oper. By: Jefferson Bcstg.
 Address: 110 N. Findley
 Phone Number: 2080
 Representative: McGillvra
 President: C. H. Simpson
 Gen., Comm. Mgr.: Richard Bower
 Program Director: Jim Crummy
 Chief Engineer: Kenneth Bowers

WEEU

**READING—1932
 ABC—QUAKER**

Frequency: 850 Kc. Power: 1000 Watts
 Owned By: Hawley Bcstg. Co.
 Business-Studio Address: 433 Penn St.
 Phone Number: 6-7335
 Air Time: 6:15 a.m.-12 M.
 Newspaper Affiliation: "Eagle Times"
 News Service: UP
 Transcription Service: Associated
 Representative: Headley-Reed
 Membership: NARTB, BAB
 President: Hawley Quier
 General Manager: Thomas Martin
 Commercial Mgr.: K. Richard Creftz
 Program Director: George Carroll
 Chief Engineer: David J. Miller, Jr.

WHUM

READING—1946—CBS

Frequency: 1340 Kc. Power: 250 Watts
 Owned-Oper. By: Eastern Radio Corp.
 Business-Studio Address: Berkshire Hotel
 Phone Number: Reading 4-4805
 News Service: AP
 Representative: H.R. Repts.
 Pres., Gen., Sta. Mgr.: Humboldt J. Greig
 Sales Mgr.: Dick Paisley
 Program Director: Alan Lane
 Chief Engineer: Louis Littlejohn

WRAW

READING—1922—NBC

Frequency: 1340 Kc. Power: 250 Watts
 Owned-Oper. By: Reading Bcstg. Co., Inc.
 Business-Studio Address: 19 N. Fifth St.
 Phone Number: Reading 7173
 News Service: UP
 Transcription Service: World
 Representative: Robert Meeker
 Station Executive: Clair R. McCollough
 Station Manager: Frank J. Voss
 Natl. Sales Mgr.: J. Robert Gulick
 Program Director: Saul Miller
 Technical Director: J. E. Mathlot

WGCB

RED LION—1950

Frequency: 1440 Kc. Power: 1000 Watts d.
 Owned-Oper. By: Red Lion Bcstg. Co.

Phone Number: 3-3471
 Address: Box 88
 News Service: UP
 President: Rev. John M. Norris
 Gen., Sta. Mgr.: John H. Norris
 Commercial Mgr.: Vincent A. Freeman
 Chief Engineer: Geary Russel

WKBI

ST. MARYS—1950—MBS

Frequency: 1400 Kc. Power: 250 Watts
 Owned-Oper. By: Elk Cameron Bcstg. Co.
 Address: 41 Erie Ave.
 Phone Number: 4-2821
 Transcription Service: Standard
 News Service: AP
 Membership: NARTB, BAB
 General Manager: C. H. Simpson
 Commercial Manager: R. H. Knouse
 Program Director: John A. Fay
 Promotion Manager: Herbie Martin
 Chief Engineer: Gilbert H. Wogan

WATS

SAYRE—1950—KBS

Frequency: 960 Kc. Power: 1000 Watts d.
 Owned-Oper. By: Susquehanna Val. Bcstg. Co.
 Address: 110 N. Elmer Ave.
 Phone Number: Turner 2-2401
 Transcription Service: Thesaurus, World
 Representative: Indie Sales
 Membership: NARTB, BAB
 News Service: UP
 Owner: T. K. Cassel
 General Manager: Walter D. Knowles
 Program Director: William J. Miller
 Chief Engineer: Benjamin A. Franklin

WARM

SCRANTON—1939—ABC

Frequency: 590 Kc. Power: 5000 Watts
 Owned-Oper. By: Union Bcst. Co.
 Address: Bowman Bldg.
 Phone Number: 4-1148
 Air Time: 6 a.m.-1 a.m.
 News Service: UP
 Representative: Hollingbery Co.
 Transcription Service: Thesaurus
 Membership: BAB
 President: Martin F. Memolo
 Gen., Sta. Manager: William M. Dawson
 Sales Prom. Mgr., Pub. Dir.: Donald S. Preven
 Program Director: Joseph H. Salsburg
 Chief Engineer: Roswell J. Parker

WGBI

SCRANTON—1925—CBS

Frequency: 910 Kc. Power: 1000 Watts d.;
 500 Watts n.
 Owned-Oper. By: Scranton Bcstrs., Inc.
 Business-Studio Address: 1000 Wyoming Ave.
 Phone Number: SC 2-0296
 Air Time: 6 a.m.-1:05 a.m.
 News Service: AP
 Representative: John Blair

Membership **NARTB**
President **Mrs. M. E. Megargee**
Vice-President **Mrs. Douglas Holcomb**
Gen., Comm., Sales Prom. Mgr.
 George D. Coleman
Station Manager **Robert E. McDowell**
Program Director **Frank Monaghan**
Chief Engineer **Kenneth R. Cooke**

WQAN
SCRANTON—1923

Frequency: 630 Kc. **Power:** 500 Watts d.
Owned-Oper. By **The Scranton Times**
Address Trans. Loca. **149 Penn Ave.**
Phone Number **2-9151**
News Service **UP, AP**
Transcription Service **Standard, Langworth**
Membership **NARTB, BAB**
Gen., Sta., Prom. Mgr. **Cecil Woodland**
Comm. Mgr. **Frank McCaffery**
Program Director **Hugh Connor**
Chief Engineer **Guy Rauer**

WSCR

SCRANTON—1947—NBC

Frequency: 1320 Kc. **Power:** 1000 Watts d.,
 500 Watts n.
Owned-Oper. By .. **Lackawanna Valley Bcstg.**
Co.
Business-Studio Address **116 Adams Ave.**
Phone Number **7-3388**
Air Time **Full Time**

News Service **AP**
Transcription Service **Lang-Worth**
Representative **Headley-Reed**
Pres., Gen., Comm. Mgr. **David M. Baltimore**
Program Director **Barry Sherman**
Chief Engineer **Willard Shimsky**

WISL
SHAMOKIN—1947—MBS

Frequency: 1480 Kc. **Power:** 1000 Watts
Owned-Oper. By **Radio Anthracite, Inc.**
Bus-Studio Address **Rock & Sunbury Sts.**
Phone Number **8-6831**
Air Time **6 a.m.-M.**
News Service **AP**
Transcription Service **Lang-Worth**
Representative **Forjoe**
Membership **NARTB**
President **Henry W. Lark**
General Manager **Charles R. Petrie**
Program Director **Dick Owens**
Chief Engineer **Ray Williard**

WPIC

SHARON—1938

Frequency: 790 Kc. **Power:** 1000 Watts d.
Owned-Oper. By **Sharon Herald Bcstg. Co.**
Business Address **P. O. Box 541**
Phone Number **4113**
News Service **UP**
Transcription Service **Associated, World**
Representative **Adam J. Young, Jr.**
Pres., Gen. Mgr. **John Fahline, Jr.**

ECONOMY COVERAGE OF PENNSYLVANIA'S ANTHRACITE REGION

COUNTIES: Luzerne, Lackawanna, Wyoming, Carbon, Northumberland, Schuylkill, Columbia, Monroe, Sullivan.

Total Retail Sales	Radio Families	Population
\$1,034,174,000	276,470	1,172,900
— Data from 1953 Consumer Markets - SRDS —		
FOOD	\$247,722,000	FILLING STATIONS 38,581,000
GENERAL MERCHANDISE	101,169,000	BUILDING MATERIALS- HARDWARE
APPAREL	72,815,000	EAT-DRINK
HOME FURNISHINGS	55,657,000	DRUG
AUTOMOTIVE	146,815,000	FARM INCOME

TWO stations could not conform to a particular region more perfectly than WHWL and WISL! In combination they offer complete coverage of Pennsylvania's rich Anthracite region with rates based on an exceptionally low cost-per-thousand families. It PROVES that the combination of WHWL and WISL is your BEST BUY in the Pennsylvania Anthracite Region. TWO 1,000-watt stations driving into this region from their strategic north and south locations, are sure to deliver through programming of definite local interest.

S E E
 FORJOE & COMPANY

New York — Chicago — Atlanta — Los Angeles — San Francisco

WISL

RADIO ANTHRACITE, INC.

WHWL

1000 W ... 1480 Kc
 Full Time ... Mutual

Rock and Sunbury Sts.
 Shamokin, Penna.

1000 W ... 730 Kc
 Day Time ... Independent

Program Director..... Marc McCulloch
 Chief Engineer..... A. C. Heck

WVSC

SOMERSET—1951—KBS

Frequency: 990 Kc..... Power: 250 Watts d.
 Owned-Operated By..... Somerset Bcstg. Co.
 Address..... P. O. Box 231
 Phone Number..... 4186
 News Service..... UP
 Transcription Service..... Standard
 Representative..... Indie Sales
 Gen. Comm. Mgr..... T. H. Oppegard
 Station Mgr..... Carl R. Lee
 Chief Engr., Sta. Mgr..... Carl R. Lee

WMAJ

STATE COLLEGE—1945—MBS-KBS

Frequency: 1450 Kc..... Power: 250 Watts
 Owned-Operated By..... Centre Bcstg., Inc.
 Bus.-Studio Address..... P. O. Box 888
 News Service..... AP
 Transcription Service..... World
 Co-Owner..... R. J. Kennard
 Co-Owner..... W. K. Ulerich
 Commercial Manager..... Miriam Krebs
 Program Director..... W. J. Morris
 Chief Engineer..... Douglas Beman

WVPO

STROUDSBURG—1948

Frequency: 840 Kc..... Power: 250 Watts d.
 Owned-Operated By..... Pocono Bcstg., Inc.
 Business-Studio Address..... 578 Main St.
 Phone Number..... Stroudsburg 1102
 News Service..... UP
 Transcription Service..... Associated
 Representative..... Radio Reps.
 President..... James H. Ottaway
 General Manager..... Merle C. Ostrom
 Comm. Mgr..... Chester S. Miller
 Station Manager..... Elton Hall
 Managing Director..... Francis H. Brinkley
 Chief Engineer..... Ernest Transue

WKOK

SUNBURY—1933—CBS-QUAKER

Frequency: 1240 Kc..... Power: 250 Watts
 Owned-Operated By..... Sunbury Bcstg. Corp.
 Bus.-Studio-Transmitter..... 1150 N. Front St.
 Phone Number..... Sunbury 1325-6
 News Service..... AP
 President..... Harry H. Haddon
 Gen., Sta. Manager..... Homer R. Smith
 Commercial Manager..... C. Donald Walther
 Program Director..... Michael J. Kane
 Publicity Director..... Malcolm E. Arter
 Chief Engineer..... John W. Keller

WMBS

UNIONTOWN—1936
 CBS—QUAKER

Frequency: 590 Kc..... Power: 1000 Watts
 Owned-Oper. By..... Fayette Bcstg. Corp.

Address..... F. Natl Bldg.
 Phone Number..... 8-3900, 8-3909
 Air Time..... 7 a.m.-12:05 a.m.
 News Service..... UP
 Transcription Service..... SESAC
 Representative..... Meeker Asso., Inc.
 Pres., Gen. Mgr..... J. C. Burwell
 Station Manager..... James Gismondi
 Prom., Pgm. Dir..... C. H. Underwood
 Publicity Director..... Anne Kovar
 Chief Engineer..... William Henzly

WNAE

WARREN—1946

Frequency: 1310 Kc..... Power: 1000 Watts d.
 Owned-Oper. By..... N. Allegheny Bcstg. Co.
 Address..... First Natl. Bank Bldg.
 Phone Number..... 3032
 News Service..... AP
 Transcription Service..... Thesaurus
 Pres., Gen. Mgr..... David Potter
 Commercial Manager..... James W. Potter
 Program Director..... Leroy Schneck
 Chief Engineer..... Homer M. Haines

WJPA

WASHINGTON—1942—MBS

Frequency: 1450 Kc..... Power: 250 Watts
 Owned-Oper. By..... Washington Bcstg. Co.
 Bus. Address..... George Washington Hotel
 Phone Number..... 4870
 News Service..... UP
 Transcription Service..... World
 Representative..... Joseph Hershey McGillvra
 Managing Director..... A. Boyd Siegel
 Gen., Prom. Manager..... John L. Merdian
 Commercial Mgr..... Peter Stanton
 Program Director..... G. Robert Johnson
 Chief Engineer..... Chris E. Langhurst

WAYZ

WAYNESBORO—1953

Frequency: 1380 Kc..... Power: 1000 Watts d.
 Owned-Oper. By..... Richard Field Lewis Jr.
 Address..... 21 W. Main St.
 Phone Number..... 1900
 President..... Richard Field Lewis Jr.
 General Manager..... Sam Hanshaw
 Program Director..... John Geiger
 Chief Engineer..... Fred Brabandt

WBAX

WILKES-BARRE—1922—MBS

Frequency: 1240 Kc..... Power: 250 Watts
 Owned-Oper. By..... Anna Stenger
 Business-Studio Address..... 85 W. Union St.
 Phone Number..... VA 3-0198
 Air Time..... 6:45 a.m.-M.
 News Service..... UP
 Transcription Service..... Associated
 Representative..... Burn-Smith
 Licensee..... Anna Stenger
 General Manager..... John H. Stenger, III
 Program Director..... Ed Kuzma
 Chief Engineer..... Milan Krupa

W B R E

WILKES-BARRE—1924—NBC

Frequency: 1340 Kc.....Power: 250 Watts
 Owned-Oper. By.....Louis G. Baltimore
 Bus.-Studio Address.....62 S. Franklin St.
 Phone Number.....Valley 3-3101
 Air Time.....6:30 a.m.-1 a.m.
 News Service.....AP
 Transportation Service.....Langworth
 Representative.....Headley-Reed
 Membership.....NARTB, BAB
 Owner.....Louis G. Baltimore
 General Manager.....David M. Baltimore
 Operations Director.....Franklin D. Coslett
 Chief Engineer.....Charles Sakoski, Sr.

W I L K

WILKES-BARRE—1947

ABC-QUAKER

Frequency: 980 Kc.....Power: 5000 Watts d.,
 1000 Watts n.
 Owned-Oper. By..Wyoming Valley Bcstg. Co.
 Bus.-Studio Address.....88 No. Franklin St.
 Phone Number.....VA 4-4666
 Air Time.....Full Time
 News Service.....AP
 Transcription Service..Lang-Worth, Thesaurus
 Representative.....Avery-Knodel
 Membership.....NARTB, BAB
 President.....Mitchell Jenkins
 Exec. V.P., Gen. Mgr.....Roy E. Morgan
 Treasurer.....Thomas P. Shelburne

Commercial Manager.....Luther Strittmatter
 Program Director.....Tom Bigler
 Chief Engineer.....Theodore French

W L Y C

WILLIAMSPORT—1949

Frequency: 1050 Kc.....Power: 1,000 Watts d.
 Owned-Operated By.....Lycoming Bcstg. Co.
 Address.....331 Pine St.
 Phone Number.....24676
 Transcription Service.....Thesaurus
 President.....John T. Keliher
 Gen., Sta. Mgr.....W. Richard Carlson
 Promotion Manager.....Harry Wagner

W R A K

WILLIAMSPORT—1930—NBC

Frequency: 1400 Kc.....Power: 250 Watts
 Owned-Oper. By.....WRAC, Inc.
 Address.....244 West 4th St.
 Phone Number.....2-6116
 Air Time.....6:30 a.m.-12:05 a.m.
 News Service.....AP
 Transcription Service.....Associated
 Representative.....Everett McKinney
 Membership.....NARTB, BAB
 Pres., Gen. Mgr.....George E. Joy
 Comm. Mgr.....J. Wright Mackey
 Pgm. Mgr.....Leon E. Kelly
 Production Mgr.....Irving Berndt
 Promotion Manager.....Everett W. Rubendall
 Chief Engineer.....Glen L. Sherman

IN NORTH CENTRAL PENNA.

The right combination for a
REAL selling campaign in the
 Williamsport market.



NATIONAL REPRESENTATIVE
 EVERETT-McKINNEY, INC.
 NEW YORK · CHICAGO
 LOS ANGELES

Since 1930, The Pioneer Broadcasters in Williamsport

COVERAGE

5000 watts (full time) on 630 kc, blanketing NEW ENGLAND'S SECOND LARGEST MARKET, and also covering the rich Fall River - New Bedford, Mass., marketing area with a signal greater than 2 mv.

AUDIENCE

An "active" audience responsive to a rich variety of TOP-RATED local and CBS-Radio programs — RESULT-FUL programs consistently hitting the mark of PRIMARY listening attention. Listeners who LISTEN are buyers who BUY!

IN NEW ENGLAND
MORE PEOPLE LISTEN
TO WPRO THAN ANY
OTHER RHODE ISLAND
STATION.

*to reach the
most buyers...*

BUY BASIC...



WPRO AM
& FM

PROVIDENCE · 630 KC · 5000 W

Represented by John BLAIR & COMPANY

W W P A

WILLIAMSPORT—1949—CBS

Frequency: 1340 Kc. Power: 250 Watts
 Owned-Oper. By... Williamsport Radio Bcstg. Assoc., Inc.
 Address..... 330 Government Pl
 Phone Number 7119
 Air Time 6:30 a.m.-12:05 a.m.
 News Service UP
 Transcription Service World
 Representative Burn-Smith
 Membership NARTB, BAB
 President..... Harry J. W. Kiessling
 Gen. Sta. Manager..... Woodrow W. Ott
 Program Director..... Louis C. Cate
 Sales Prom. Mgr..... Phil Lane
 Publicity Director..... John B. Willmann
 Chief Engineer..... Carl Steinbacher

W N O W

YORK—1948—KBS

Frequency: 1250 Kc. Power: 1000 Watts d.
 Owned-Operated By..... Helm Coal Co.
 Business-Studio Address..... 25 S. Duke St.
 Phone Number..... 8-2911, 8-2952
 News Service AP
 Transcription Service Associated
 General Manager Lowell W. Williams
 Commercial Manager John O. Border
 Program Director..... H. E. Daugherty

Sales Promotion Manager..... Edwin L. Jay
 Chief Engineer..... Glenn Winter

W O R K

YORK—1932—NBC-MBS

Frequency: 1350 Kc. Power: 5000 d.; 1000 n.
 Owned-Operated By..... York Bcstg. Co.
 Business-Studio Address..... 13 S. Beaver St.
 Phone Number 6629
 News Service UP
 Transcripion Service Thesaurus
 Representative Robert Meeker
 Station Executive..... Clair R. McCollough
 Station Manager..... Clare I. Miller
 Natl. Sales Mgr..... J. Robert Gulick
 Program Director..... Glenn M. Brillhart
 Technical Director..... J. E. Mathlot

W S B A

YORK—1942—ABC—QUAKER

Frequency: 910 Kc. Power: 1000 Watts
 Owned-Oper. By... Susquehanna Bcstg. Co.
 Address..... 53 N. Duke St.
 Phone Number..... YO 82678 - 81308
 News Service UP
 Transcription Service World
 Representative Radio Reps. Inc.
 Membership NARTB, BAB
 President..... Louis J. Appell
 Comm. Sales Prom. Mgr. Philip K. Eberly
 Chief Engineer..... Llewellyn Jones

RHODE ISLAND

Pop. Feb. 1, 1954 Est.) 816,000 — Families 303,000
Radio Homes 299,000 — TV Homes 230,000 — Stations in State 11

W A D K

NEWPORT—1948—KBS

Frequency: 1540 Kc. Power: 1000 Watts d.
 Owned-Oper. By... The Aquidneck Bcstg. Corp.
 Business-Studio Address..... 217 Reservoir Rd.
 Phone Number 4673
 News Service AP
 Transcription Service World
 Representative Deveny & Co.
 Pres., Gen. Mgr..... Milton E. Miller
 Chief Engineer..... Jos. Britto

W P A W

PAWTUCKET—1950—KBS

Frequency: 550 Kc. Power: 1000 Watts d.
 Owned-Oper. By... Roger Williams Bcstg. Co.
 Address..... 34 N. Union St.
 Phone Number..... PA 5-9000
 Transcription Service MacGregor
 News Service UP
 Representative Rambeau
 President Dominick Hysko
 Gen. Comm. Mgr..... Allen Jones
 Chief Engineer..... James Bonney

W E A N

PROVIDENCE—1922—MBS-YANKEE

Frequency: 790 Kc. Power: 5000 Watts
 Owned-Oper. By..... General Teleradio, Inc.
 Business-Studio Address..... Crown Hotel
 Phone Number..... Temple 1-0800
 Air Time..... Full Time
 News Service UP
 Transcription Service Associated
 Representative H-R Reps.
 President William O'Neil
 General Manager..... Mowry Lowe
 Asst. Sta. Mgr..... Tod Williams
 Program Director..... Nancy Hogan
 Chief Engineer..... Harry Tilley

W H I M

PROVIDENCE—1947

Frequency: 1110 Kc. Power: 1000 Watts d.
 Owned-Oper. By..... Intercity Bcstg. Co.
 Business-Studio Address..... 144 Westminster St.
 Phone Number Union 1-4211
 News Service AP

Representative... Headley Reed, Kettel-Carter
 President, Gen. Sta. Mgr. Robert T. Engles
 Chief Engineer.....Carroll Philbrook

WICE

PROVIDENCE—1947

Frequency: 1290 Kc.Power: 500 Watts d.
 Owned-Oper. ByNarragansett Bay B. Co.
 Address.....1111 N. Main St.
 Phone NumberJackson 1-6565
 News ServiceUP
 TranscriptionSESAC
 RepresentativeRambeau
 President.....Louis A. R. Pieri
 Gen., Sta. Mgr.....Sumner Pearl
 Sales Prom., Comm. Mgr.....John F. Crohan
 Chief Engineer.....Oliver R. Adams

WJAR

PROVIDENCE—1922—NBC

Frequency: 920 Kc.Power: 5000 Watts
 Owned-Operated By.....The Outlet Co.
 Business-Studio Address....176 Weybosset St.
 Phone NumberGaspee 1-8521
 Air Time.....Full Time
 Transcription ServiceWorld
 News Service.....AP, INS
 RepresentativeWeed, Bannan
 MembershipNARTB
 Vice Pres., Treas.....George O. Griffith
 General Mgr.....John J. Boyle
 Station Manager.....Sothern Abbott
 Chief Engineer.....Thomas C. J. Prior

WPJB

PROVIDENCE—1941—ABC

Frequency: 1420 Kc.Power: 5000 Watts
 Owned.....Providence Journal Co.
 Address.....75 Fountain St.
 Phone Number.....Dexter 1-0600
 Station RepresentativeBorgatti
 President.....George P. Metcalf
 General Manager.....H. William Koster
 Sales Promotion Manager...Arthur E. Lathrop
 Program Director.....Don Morton
 Chief Engineer.....George W. Sharpe

WPRO

PROVIDENCE—1924—CBS

Frequency: 630 Kc.Power: 5000 Watts
 Owned-Oper. ByCherry & Webb Bcstg. Co.
 Bus-Stud. Add.24 Mason St., WPRO Bldg.

Phone Number.....Plantations 1-9776
 Air Time.....Full Time
 News Service.....AP, UP
 RepresentativeBlair
 MembershipNARTB
 President.....William S. Cherry, Jr.
 General Manager.....Arnold F. Schoen, Jr.
 Commercial Mgr.....Kenneth Curto
 Program Director.....John A. Owen
 Chief Engineer.....John V. Ferri
 (See Page 580)

WRIB

PROVIDENCE—1947

Frequency: 1220 Kc.Power: 1000 Watts d.
 Owned-Oper. ByR. I. Bcstg. Co.
 Bus-Studio Address.....Narragansett Hotel
 Phone Number.....Union 1-4512
 News ServiceUP
 Transcription ServiceAssociated
 RepresentativeForjoe
 President.....Frank Rao
 General Manager.....Nicholas Ruggieri
 Chief Engineer.....Fred Weiss

WERI

WESTERLY—1949—ABC-KBS

Frequency: 1230 Kc.Power: 250 Watts
 Owned Oper. ByRadio Westerly, Inc.
 Address.....34 Main St.
 Phone Number.....WE 2263
 Air Time.....Full Time
 News ServiceUP
 Transcription ServiceLang-Worth
 RepresentativeWalker, Bannan
 President.....Richard G. Moore
 Gen., Sta. Mgr.....Warren M. Greenwood
 Commercial Mgr.....Melvin H. Lahr
 Prog., Publ. Director.....Brud Warren
 Chief Engineer.....Anibal Martins

WWON

WOONSOCKET—1946—MBS

Frequency: 1240 Kc.Power: 250 Watts
 Owned-Oper. ByWoonsocket Bcstg. Co.
 Business-Studio Address....99 Main St.
 Phone Number1240
 News ServiceAP
 Transcription ServiceWorld
 President.....Mrs. Andrew P. Palmer
 General Manager.....Mitchell F. Stanley
 Program Director.....Eugene C. Rousscau
 Chief Engineer.....Harold Belknap

HELP THE RED CROSS

SOUTH CAROLINA

Pop. Feb. 1, 1954 (Est.) 2,181,000 — Families 530,000
Radio Homes 441,000 — TV Homes 195,000 — Stations in State 51

WAKN

AIKEN—1952

Frequency: 990 Kc. Power: 1000 Watts d.
Owned-Oper. By Aiken Electronics Adv. Corp.
Address Box 811
Phone Number 774242
News Service AP
Transcription Service World, Capitol
Membership NARTB, BAB
President B. T. Whitmire
General Manager John Mare
Station Manager Randy Davidson
Chief Engineer Allen Askins

WAIM

ANDERSON—1935—CBS
PALMETTO NET

Frequency: 1230 Kc. Power: 250 Watts
Owned-Operated By Wilton E. Hall
Address-Trans. Loca. 1 Martin St.
Phone Number 3800-1
Air Time Full Time
News Service INS
Newspaper Affiliation Independent, Daily
Mail
Transcription Service World, Lang-Worth
Representative Burn-Smith
President Wilton E. Hall
General Manager Glenn P. Warnock
Commercial Mgr. G. P. Browne
Sales Prom. Mgr. V. Barath
Program Director Marshall Gaillard
Chief Engineer John Willis

WANS

ANDERSON—1949—MBS

Frequency: 1280 Kc. Power: 1000 Watts
Owned-Operated By Carolina Bcstrs.
Address Box 211
Phone Number 3262
Transcription Service Standard
Representative Devney
News Service UP
President C. R. Johnson
General Manager R. E. Liverance
Commercial Mgr. Robert S. Fant
Chief Engineer Alfred W. Pratt

WBAW

BARNWELL—1953

Frequency: 740 Kc. Power: 250 Watts d.
Owned-Oper. By Blue Ridge Bcstg. Co. Inc.
Address Jackson St. Ext.
Phone Number 3507
News Service UP
Transcription Service Thesaurus
President J. A. Gallimore
Comm. Sta. Mgr. Joe Wilder
Program Director Frank Harmon
Chief Engineer Marion P. Jones

WBSC

BENNETTSVILLE—1947—MBS

Frequency: 1550 Kc. Power: 10,000 Watts d.;
5,000 Watts n.
Owned-Oper. By Bennettsville Bcstg. Co.
Business-Studio Address Box 639
Phone Number 1080
Air Time Full Time
News Service AP
Representative Joseph Hershey McGillvra
President John W. Orvin
General Manager Malcolm A. Young
Prog., Publ. Director Neil Terrell
Chief Engineer John Gronert

WACA

CAMDEN—1948

Frequency: 1590 Kc. Power: 1000 Watts d.
Owned-Operated By Camden Bcstg. Co.
Address Camden
Phone Number 80
News Service UP
Transcription Service World
President Haygood S. Bowden
General Manager Tom Richards
Chief Engineer Angelo Amodio

WCSC

CHARLESTON—1930—CBS

Frequency: 1390 Kc. Power: 5000 Watts
Owned-Oper. By WCSC, Inc.
Address Francis Marion Hotel
Phone 2-7611
News Service UP
Transcription Service World
Representative Free & Peters
Membership NARTB, BAB
Pres., Gen. Sta. Mgr. John M. Rivers
Program Director Robert Tambllyn
Sales Prom. Pub. Dir. Alma D. Davis
Chief Engineer Wilbur Albee

WHAN

CHARLESTON—1946—ABC

Frequency: 1340 Kc. Power: 250 Watts
Owned-Oper. By Charleston Bcstg. Co.
Business Address 152 Market St.
Phone Number 3-1643
News Service UP
Transcription Service Capitol
Representative Headley-Reed
General Manager E. H. Keown
Commercial Manager G. R. Connor
Chief Engineer William P. Birchfield

WPAL

CHARLESTON—1947

Frequency: 730 Kc. Power: 1000 Watts d.
Owned-Oper. By Palmetto Bcstrs., Inc.
Business-Studio Address 149 Wentworth St.

Phone Number 3-6428-9
 Representative Forjoe, Dora-Clayton
 President George G. Weiss
 General Manager Laurens Moore
 Commercial Mgr. Bob Chrystie
 Program Director Louise Withrock
 Chief Engineer Gunnar Sundeen

WTMA
CHARLESTON—1939—NBC

Frequency: 1250 Kc. Power: 5000 d.; 1000 n.
 Owned-Oper. By Atlantic Coast Bcstg. Co.
 Business Address 133 Church St.
 Phone Number 2-2961
 Air Time Full Time
 News Service AP
 News Affil. Evening Post, News & Courier
 Transcription Service Thesaurus
 Representative Hollingbery
 Membership NARTB
 President Edward Manigault
 Gen., Sta. Mgr. Douglass M. Bradham
 Comm. Mgr. Grange S. Cuthbert, Jr.
 Program Director Newton S. Smyth
 Chief Engineer Gordon Knight

WUSN
CHARLESTON—1948—MBS

Frequency: 1450 Kc. Power: 250 Watts
 Owned-Operated By Southern Bcstg. Co.
 Address Box 154
 Phone Number 2-2652
 News Service UP
 Air Time 6 a.m.-M.
 Transcription Service Standard
 Representative Interstate
 Pres., Gen., Sta., Comm. Mgr. J. Drayton Hastie

Promotion Manager Dean Callahan
 Program Director Henry Hoppe
 Publicity Director Edith Crosby
 Chief Engineer Walter Nelson

WCRE
CHERAW—1953

Frequency: 1420 Kc. Power: 500 Watts d.
 Owned-Oper. By Chesterfield Bcstg. Co. Inc.
 Phone Number 7500
 Representative Sherman
 President Dr. R. D. Baxley
 Gen., Comm. Mgr. D. A. Baxley
 Vice-President R. D. Meisheimer
 Program Director Frank Martin
 Chief Engineer W. L. Hipp

WGCD
CHESTER—1948—MBS—KBS

Frequency: 1490 Kc. Power: 250 Watts
 Owned-Oper. By Craig Bcstg. Co.
 Address 128 Main St.
 Phone Number 2171
 News Service AP
 President Morgan J. Craig
 Gen., Sta., Comm. Mgr. George P. Cobb
 Promotion Director James Kennedy

WCOS
COLUMBIA—1939—ABC

Frequency: 1400 Kc. Power: 250 Watts
 Owned-Operated By Radio Columbia
 Address Cornel Arms Bldg.
 Phone Number 2-2177
 Air Time Full Time
 News Service AP
 Transcription Service World
 Representative Headley-Reed
 Membership NARTB, BAB
 Pres., Gen. Mgr. Charles W. Pittman
 Commercial Manager Law Epps
 Program Director John Ropp
 Chief Engineer Robert D. Lambert, Jr.

WIS
COLUMBIA—1930—NBC

Frequency: 560 Kc. Power: 5000 Watts
 Owned-Oper. By Bcstg. Co. of the South
 Business-Studio Address 1111 Bull St.
 Phone Number 3-6431
 Air Time Full Time
 News Service AP, UP
 Transcription Service SESAC, Thesaurus
 Representative Free & Peters
 Membership NARTB, BAB
 President B. Calhoun Hipp
 General Manager G. Richard Shafto
 Station Manager J. Dudley Saumenig
 Local Sales Mgr. W. Miller Montgomery
 Program Director Frank Harden
 Chief Engineer Herbert G. Eidson, Jr.

WMSC
COLUMBIA—1945—CBS

Frequency: 1320 Kc. Power: 1000 Watts
 Owned-Oper. By WMSC Radio, Inc.
 Business-Studio Address 1127 Lady St.
 Phone Number 2-8659
 News Service UP
 Transcription Service Lang-Worth, Associated
 Representative H-R Representatives
 Membership NARTB, BAB
 Pres., Gen., Sta., Comm. Mgr. C. Wallace Martin
 Prog., Pub. Dir. Charles Wickensberg
 Chief Engineer C. E. Stone

WNOK
COLUMBIA—1947—MBS

Frequency: 1230 Kc. Power: 250 Watts
 Owned-Oper. By Palmetto Radio Corp.
 Address 1811 Main St., Box 5307
 Phone Number 39401
 News Service AP
 Representative Raymer
 Membership NARTB
 General Manager H. Moody McElveen
 Commercial Manager W. C. Bochman
 Program Director David Campbell
 Chief Engineer Don Willoughby

W L A T
CONWAY—1945—MBS

Frequency: 1490 Kc. Power: 250 Watts
Owned-Oper. By Coastal Bcstg. Co.
Business-Studio Address P. O. Box 497
Phone Number 340
Representative Joseph Hershey McGillvra

W D S C
DILLON—1946—ABC

Frequency: 800 Kc. Power: 1000 Watts d.
Owned-Oper. By Border Bcstg. Co., Inc.
Address Box 231
Phone Number 470-1
Air Time Sunrise-Sunset
News Service UP
Transcription Service Thesaurus
Membership NARTB
Pres., Gen. Sta. Mgr. Joseph Martin
Commercial Manager Adelaide C. Monroe
Prog., Sales Prom. Mgr. Lee Lumpkin
Publicity Director Johnny Quick
Chief Engineer Ray Allen

W E L P
EASLEY—1951—KBS

Frequency: 1360 Kc. Power: 1000 Watts d.
Owned-Operated By Pickens County Bcstg. Co.
Address Box 522
Phone Number 9388
News Service UP
Representative Indie Sales
Membership BAB
Pres., Gen. Mgr. Cleatus Brazzell
Chief Engineer H. O. McDonald, Jr.

W J M X
FLORENCE—1947—ABC

Frequency: 970 Kc. Power: 5000 Watts d.,
1000 Watts n.
Owned-Oper. By Atlantic Bcstg. Co., Inc.
Business Address P. O. Box 1211
Phone Number 6351
Air Time Full Time
News Service UP
Transcription Service World, Thesaurus
Representative Walker
President Eugene E. Stone
Gen., Sta. Mgr. Paul H. Benson, Jr.
Chief Engineer Frank Jenne

W O L S
FLORENCE—1937—KBS

Frequency: 1230 Kc. Power: 250 Watts
Owned-Oper. By Florence Bcstg. Co., Inc.
Business-Studio Address 151 S. Dargan St.
Phone Number 3271-2
News Service UP
Transcription Service SESAC
Representative Southern Radio Rep
Pres., Gen. Mgr. Melvin Purvis
Sta., Comm. Mgr. A. P. Skinner

Program Director Don Gray
Chief Engineer W. A. Pritchett

W F G N
GAFFNEY—1948

Frequency: 1570 Kc. Power: 250 Watts d.
Owned-Oper. By Cherokee Radio Co., Inc.
Address P. O. Box 759
Phone Number 4795-6
News Service UP
Transcription Service Lang-Worth, SESAC
President A. Ray Godshall
Gen., Sta. Mgr. Morton E. Green
Promotion Mgr. Mrs. E. Stacy
Program Director B. Gibbons
Chief Engineer J. E. Parker

W G T N
GEORGETOWN—1949—MBS

Frequency: 1400 Kc. Power: 250 Watts
Owned-Operated By Georgetown Bcstg. Co.
Address, Trans. Loc. 216 Fraser St.
Phone Number 3-3421
Pres., Gen. Manager J. B. Delzell
Commercial Manager Al Webster
Chief Engineer A. D. Nix

W A K E
GREENVILLE—1950—CBS

Frequency: 1440 Kc. Power: 500 Watts DA 2
Owned-Oper. By Piedmont Bcstg. Co., Inc.
Address 3 College St.
Phone Number 5-7406
Air Time Full Time
News Service UP
Transcription Service Associated
Representative Pearson
President V. D. Ramseur
Gen. Mgr., Prog. Dir. J. F. McDonough
Traffic Director Inez Anders
Sales Mgr. John Westbrook
Chief Engineer H. A. Morris

W E S C
GREENVILLE—1947

Frequency: 660 Kc. Power: 5000 Watts d.
Owned-Operated By Greenville Bcstg. Co.
Business-Studio Address 1 College St.
Phone Number 2-8241
News Service AP
Transcription Service Lang-Worth
Representative Rambeau, Dora-Clayton
President (Mrs.) James Meade
General Manager Buddy E. Starcher
Commercial Manager James G. Meade
Chief Engineer F. B. Bailey

W F B C
GREENVILLE—1933—NBC

Frequency: 1330 Kc. Power: 5000 Watts
Owned-Oper. By WMRC, Inc.
Business-Studio Address Poinsett Hotel
Phone Number 5-8525
Air Time Full Time

News Service UP
 Transcription Service Thesaurus
 Representative Avery-Knodel
 Membership NARTB, BAB
 President R. A. Jolley, Sr.
 Gen., Sta., Comm. Mgr. Kenneth Beachboard
 Sales Prom. Mgr. Keener Garrett
 Program Director William T. Arrington
 Publicity Director Lidie Walters
 Chief Engineer Burton T. Anderson

WMUU
 GREENVILLE—1949

Frequency: 1260 Kc. Power: 1000 Watts d.
 Owned-Oper. By Bob Jones Univ.
 Address Greenville
 Phone Number GR 2-6711
 Air Time Day Time
 News Service AP, INS
 Transcription Service SESAC, Associated
 Membership BAB
 President Dr. Bob Jones, Jr.
 General Manager R. K. Johnson
 Station Manager Jim Ryerson
 Commercial Manager Glen Schunk
 Sales Prom. Mgrs. D. Yearick, J. Baehre
 Program Director Paul Schultz
 Publicity Director Virginia Patterson
 Chief Engineer Paul Mathew

WCRS
 GREENWOOD—1941—NBC

Frequency: 1450 Kc. Power: 250 Watts
 Owned-Operated By Grenco, Inc.
 Address P. O. Box 868
 Phone Number 4300
 News Service AP
 Transcription Service, Thesaurus, Associated,
 World
 Representative Thomas Clark, Ayers
 Membership NARTB, BAB
 President Douglas Featherstone
 General Manager Dan Crosland
 Commercial Manager Ralph Norman
 Chief Engineer Charlie Sparks

WGSW
 GREENWOOD—1953—MBS

Frequency: 1350 Kc. Power: 1000 Watts d.
 Owned-Oper. By Radio Greenwood Inc.
 Address Edward Arms Bldg.
 Phone Number 9-7372
 News Service UP
 Representative Indie
 President W. C. Woodall Jr.
 General Manager C. H. Grider
 Commercial Mgr. Vernon C. McCarthy
 Station Manager Olyn L. Gee
 Chief Engineer Eddie Rose

WEAB
 GREER—1949—KBS

Frequency: 800 Kc. Power: 250 Watts d.

Owned-Oper. By Greer Bcstg. Co.
 Address P. O. Box 151
 Phone Number 1057-8
 News Service UP
 Transcription Service Lang-Worth
 Co.-O., Gen., Comm. Mgr. E. A. Burch
 Co-Owner W. Ryan Frier
 Program Director Betty Beers
 Chief Engineer Joe Cole

WHSC
 HARTSVILLE—1946—MBS-KBS

Frequency: 1450 Kc. Power: 250 Watts
 Owned-Oper. By Hartsville Bcstg. Co., Inc.
 Business-Studio Address College Ave.
 Phone Number 1450
 Air Time Full Time
 News Service AP
 Transcription Service Capitol
 President Charles H. Campbell
 General Manager Raymond Caddell
 Commercial Manager George Brandon
 Program Director Earl Caton
 Chief Engineer Donald A. Brienen

WDKD
 KINGSTREE—1949

Frequency: 1300 Kc. Power: 1000 Watts d.
 Owned-Operated By Palmetto Bcstg. Co.
 Address Kingstree
 Phone Number 6761
 News Service AP
 Transcription Service World
 General Manager E. G. Robinson, Jr.
 Program Director Carroll Godwin
 Chief Engineer Dan Owen

WJOT
 LAKE CITY—1953

Frequency: 1260 Kc. Power: 1000 Watts d.
 Owned-Oper. By Lake Bcstg. Corp.
 Address 10 S. Acline Ave.
 Phone Number 7631
 President James Olin Tice Jr.
 General Manager J. O. Tice Sr.
 Commercial Mgr. Wolford McCutcheon
 Program Director Ralph Bramlett
 Chief Engineer Walter Turner

WLCM
 LANCASTER—1951

Frequency: 1360 Kc. Power: 1000 Watts d.
 Owned-Operated By Royal Bcstg. Co.
 Address 103 S. Catawba St.
 Phone Number 2051
 News Service AP
 Transcription Service Thesaurus, World
 President Charles Connelly
 General Manager William Coble
 Program Director Joann McManus
 Chief Engineer Robert Shikenjanski

WLBG

LAURENS—1948—KBS

Frequency: 860 Kc. Power: 250 Watts d.
 Owned-Operated By.....WLBG, Inc.
 Business Address.....Box 842, Laurens
 Phone Number.....2-2331
 News Service.....UP
 Transcription Service.....World
 President.....James C. Todd
 General Manager.....Richards Todd
 Program Director.....Carrol Sexton
 Chief Engineer.....Jack Taylor

WJAY

MULLINS—1949—KBS

Frequency: 1280 Kc. Power: 1000 Watts d.
 Owned-Oper. By..Mullins & Marion Bcstg. Co.
 Address.....Box 41
 Phone Number.....3901
 News Service.....UP
 Transcription Service.....Langworth
 President.....W. G. Smith
 Gen., Sta., Comm. Mgr.James F. Ramsey
 Chief Engineer.....George Magera

WMRA

MYRTLE BEACH—1948

Frequency: 1450 Kc. Power: 250 Watts
 Owned-Oper. By.....Elizabeth Evans
 Address.....Ocean Forest Hotel
 Phone Number.....5061
 Pres., Gen. Mgr.....Elizabeth Evans
 Commercial Manager.....S. W. Monroe
 Program Director.....Crosby Brunson
 Chief Engineer.....W. C. Evans

WKDK

NEWBERRY—1946—MBS-KBS

Frequency: 1240 Kc. Power: 250 Watts
 Owned-Oper. By...Newberry Bcstg. Co., Inc.
 Address, Trans.....11 Radio Dr., Box 211
 Phone Number.....143
 News Service.....AP
 Transcription Service.....Thesaurus
 Pres., Gen., Sta. Mgr.....James F. Coggins
 Commercial Mgr.....Emory Bedenbaugh
 Chief Engineer.....Ray Gilliam

WDIX

**ORANGEBURG—1946—ABC
 MBS-KBS**

Frequency: 1450 Kc. Power: 250 Watts
 Owned-Oper. By.....WDIX, Inc.
 Bus. Addr.-Trans. Loc.Orangeburg, S. C.
 Phone Number.....1420
 Air Time.....Unlimited
 News Service.....AP
 Membership.....BAB
 President.....Charles S. Henery
 General Manager.....Frank B. Best
 Asst. Manager.....Frank Best, Jr.
 Program Director.....Joe Phillips
 Commercial Mgr.....Norman M. Matthews
 Chief Engineer.....Gus Browning

WTND

ORANGEBURG—1948

Frequency: 920 Kc. Power: 1000 Watts d.
 Owned-Operated By.....WTND, Inc.
 Phone Number.....1600
 Transcription Service.....World
 Representative...Thos. F. Clar., Dora-Clayton
 Gen., Sta. Mgr., Pres.....J. I. Sims
 Program Director.....Richard R. Rhame
 Chief Engineers.....Larry W. Styles,
 Perry Herrington

WRHI

ROCK HILL—1944—MBS

Frequency: 1340 Kc. Power: 250 Watts
 Owned-Oper. By.....York Co. Brcdg. Co.
 Address.....Rock Hill Nat. Bk. Bldg.
 Phone No.....2085
 Transcription Service.....World
 Representative.....McGillvra
 Gen. Mgr., Chf. Eng.....James S. Beaty, Jr.
 Sta. Mgr., Prog. Dir.....Wm. C. Beaty
 Commercial Manager.....Harper S. Gault

WTYC

ROCK HILL—1948

Frequency: 1150 Kc. Power: 1000 Watts d.
 Owned-Oper. By.....Trl-County Bcstg. Co.
 Bus.-Studio Address.....Box 1091
 Phone Number.....3175
 President.....T. Lamar Simmons
 Gen., Sta. Mgr.....Marshall T. Pack
 Chief Engineer.....Robert Bolin

WSNW

SENECA—1949—KBS

Frequency: 1150 Kc. Power: 1000 Watts d.
 Owned-Oper. By..Blue Ridge Bcstg. Co., Inc.
 Address.....Seneca
 Phone Number.....8234
 News Service.....UP
 Transcription Service.....Lang-Worth, World
 Pres., Gen. Mgr.....J. A. Gallimore
 Program Director.....Virginia Gallimore
 Commercial Mgr.....Chet Munson
 Chief Engineer.....Herbert Hosea

WJAN

SPARTANBURG—1953—ABC-MBS

Frequency: 1400 Kc. Power: 250 Watts
 Owned-Oper. By.....Spartanburg Bcstg. Co.
 Address.....101 Schuyler Bldg.
 Phone Number.....3-1400
 News Service.....AP
 Owner, Gen. Mgr.....W. Ennis Bray
 Commercial Mgr.....Charles Goodyear
 Program Director.....Bob Way
 Chief Engineer.....James Tate

WORD

SPARTANBURG—1940—NBC

Frequency: 910 Kc. Power: 1000 Watts

Owned-Oper. By. The Spartan Radiocstg. Co.
 Business-Studio Address..... 291 E. Main St.
 Phone Number 3-2711
 Air Time Full Time
 News Service AP
 Representative Hollingbery
 Membership NARTB, BAB
 Transcription Service Thesaurus
 President Walter J. Brown
 Manager John W. Kirkpatrick
 Commercial Mgr. J. H. Callaway
 Program Director..... Oles C. Womick
 Chief Engineer..... Clyde J. Burdette

WSPA

SPARTANBURG—1930—CBS

Frequency: 950 Kc..... Power: 5000 Watts
 Owned-Operated By. Bcsting. Co. of the So.
 Business-Studio Address..... 224 E. Main St.
 Phone Number 33621
 News Service UP
 Transcription Service Standard
 Representative Blair, Cummings
 Managing Director..... Roger A. Shaffer
 Commercial Manager..... Ross M. Holmes
 Program Director..... Ed McGrath
 Chief Engineer..... H. R. Beckholt

WFIG

SUMTER—1940—MBS

Frequency: 1340 Kc..... Power: 250 Watts
 Owned-Oper. By. Radio Station WFIG, Inc.
 Business-Studio Address Box 30
 Phone Number 1340
 News Service AP
 Transcription Service World
 Representative Joseph Hershey McGillvra
 Pres., Comm. Mgr..... Fulton B. Creech
 General Manager..... T. Doug Youngblood
 Commercial Mgr..... Fulton B. Creech, Jr.

Program Director..... Paul Reidy
 Chief Engineer..... Richard Elam

WSSC

SUMTER—1953—ABC

Frequency: 1240 Kc..... Power: 100 Watts
 Owned-Oper. By. Radio Sumter
 Address E. Calhoun Ext.
 Phone Number 1498
 President..... J. A. Gallimore
 General Manager..... Ed Damron
 Commercial Manager..... Hiram Bray
 Program Director..... Ann Davidson
 Promotion Manager..... Harry Fowler
 Chief Engineer..... Leon Webb

WBCU

UNION—1949—MBS

Frequency: 1460 Kc..... Power: 1000 Watts
 Owned-Oper. By. Bcstg. Co. of Union, Inc.
 Address 210 East Main St.
 Phone Number 1200
 Air Time 6:00 a.m. to 12:00 M.
 News Service UP
 Transcription Service World
 Station Repr. Keystone
 Pres., Gen. Mgr..... Edward L. B. Osborne
 Program Director..... Noel Belue
 Chief Engineer T. W. Weathers

WALD

WALTERBORO—1947—MBS

Frequency: 1490 Kc..... Power: 250 Watts
 Owned-Oper. By. Walterboro Bcstg. Co.
 Studio Address Box 12
 Phone Number 6262
 News Service AP
 President..... R. M. Jefferies
 General Manager..... Louis M. Neale, Jr.
 Program Director..... Peggy Ballentine

SOUTH DAKOTA

Pop. Feb. 1, 1954 (Est.) 666,000 — Families 231,000
 Radio Homes 221,000 — TV Homes 18,500 — Stations in State 14

KABR

ABERDEEN—1952

Frequency: 1220 Kc..... Power: 250 Watts d.
 Owned-Operated By. Aberdeen Bcstg. Svc.
 Address Hwya. No. 281 N.
 Phone 2686
 News Service UP
 Pres., Gen. Mgr., Chief Eng..... D. T. Hunt

KSDN

ABERDEEN—1948—ABC

Frequency: 930 Kc..... Power: 1000 Watts
 Owned-Oper. By. Aberdeen News Co.
 Phone Number 4573

Air Time 6 a.m.-12 M.
 News Service AP
 Representative Weed
 Membership NARTB
 President..... Henry J. Schmitt
 Sta. Gen. Manager Byron McElligott
 Commercial Manager..... Russa Osborne
 Program Director..... E. C. Pieplow
 Chief Engineer..... George Crocker

KDSJ

DEADWOOD—1947—MBS

Frequency: 980 Kc..... Power: 1000 Watts
 Owned-Oper. By. Heart of the Black Hills Sta.
 Address 745 Main

Phone Number186
 Transcription ServiceWorld
 News ServiceUP
 Gen. Mgr., Chief Engr.Eli Daniels
 Commercial ManagerHarry Daniels
 Program DirectorBonnie Laughlin

Address816 Kansas City St.
 Phone Number6050
 News ServiceUP
 PresidentJohn Daniels
 General ManagerEli Daniels
 Commercial ManagerStan Lieberman
 Program DirectorTruman Walrod

KIJV

HURON—1947—NBC-KBS

Frequency: 1340 Kc.Power: 250 Watts
 Owned-Oper. By. James Valley Bcstg. Co., Inc.
 Bus.-Studio Address1726 Dakota Ave., S.
 Phone Number765
 Transcription ServiceThesaurus
 Pres., Gen. Mgr.Max F. Staley
 Comm. Mgr.Dwight Coursey
 Program Dir.Dale Larson

KORN

MITCHELL—1947—MBS

Frequency: 1490 Kc.Power: 250 Watts
 Owned-Oper. By. Mitchell Bcstg. Assn.
 Bus.-Studio Address217-219 N. Main
 Phone Number621
 Air Time6 a.m.-M.
 News ServiceUP
 Transcription ServiceLang-Worth
 MembershipNARTB
 Gen., Sta. Mgr.Raymond V. Eppel
 Comm., Sales Prom. Mgr.M. Johnson
 Chief EngineerJ. R. Doherty

KGF X

PIERRE—1916—KBS

Frequency: 630 Kc.Power: 200 Watts d.
 Owned-Oper. By. Estate of Dana McNeil
 Bus.-Studio Address203 W. Summit Ave.
 Phone Number2351
 Air Time9:30 a.m.-sunset
 News ServiceUP
 RepresentativeLarson
 PresidentIda A. McNeil

KOTA

RAPID CITY—1936—CBS

Frequency: 1380 Kc.Power: 5000 Watts
 Owned-Oper. By. Black Hills Bcstg. Co. of
 Rapid City
 Business Address1819 W. St. Joe St.
 Phone Number2000
 Air TimeFull Time
 News ServiceUP
 RepresentativeHeadley-Reed, Bulmer &
 Johnson
 Transcription ServiceWorld, Capitol
 MembershipNARTB, BAB
 PresidentRobert J. Dean
 Gen., Sta., Comm. Mgr.Abner H. George
 Chief EngineerRobert Mustfeldt

KRS D

RAPID CITY—1953—MBS

Frequency: 1340 Kc.Power: 250 Watts
 Owned-Oper. By. Heart of the Black Hills Sta.

KELO

SIOUX FALLS—1937—NBC

Frequency: 1320 Kc.Power: 5000 Watts
 Owned-Oper. By. Midcontinent Bcstg. Co.
 Bus.-Studio AddressPhillips Ave.—8th St.
 Phone Number4-5841
 Air Time5:45 a.m.-1 a.m.
 News ServiceUP
 Transcription ServiceCapitol, Standard
 RepresentativeTaylor
 President, Gen. Mgr.Joe Floyd
 Station ManagerEvans Nord
 Program DirectorWip Robinson III
 Publicity DirectorJulie Wilds
 Chief EngineerLester Froke

KIHO

SIOUX FALLS—1948—MBS

Frequency: 1270 Kc.Power: 1000 Watts
 Owned-Oper. By. Big Sioux Bcstg. Co., Inc.
 Address218 South Main Ave.
 Phone Number4-7736
 News ServiceUP
 RepresentativePaul H. Raymer Co.
 PresidentDr. J. D. Conner
 General ManagerDavid J. Kempkes
 Commercial ManagerRichard C. Morenus
 Program DirectorFred W. Schweikher

KIS D

SIOUX FALLS—1948—KBS

Frequency: 1230 Kc.Power: 250 Watts
 Owned-Operated By. KISD, Inc.
 Bus.-Studio AddressKISD Bldg., W. 12th
 Phone Number4-5571
 News ServiceAP
 PresidentH. R. Alton
 Gen. Mgr., Prog. Dir.Verl Thomson
 Commercial ManagerGabe Caffrey
 Sales Prom. Mgr.Bob Printup
 Chief EngineerJohn Vick

KSOO

SIOUX FALLS—1927

Frequency: 1140 Kc.Power: 10,000 Watts d.;
 5,000 Watts n.
 Owned-Oper. By. Sioux Falls Bcstg. Asso., Inc.
 Address317 S. Phillips Ave.
 Phone Number4-5601
 News ServiceAP
 Transcr. ServiceRCA, Thesaurus
 Station RepresentativeAvery-Knodel, Inc.
 PresidentMorton Henkin
 Vice Pres., Gen. Mgr.George R. Hahn
 Station ManagerGeorge "Bill" Rohn
 Commercial ManagerRollie R. Williams
 Chief EngineerMax Pierce

KWAT

WATERTOWN—1926—KBS

Frequency: 950 Kc. Power: 1000 Watts
 Owned-Oper. By Midland Natl. Life Ins. Co.
 Address Watertown
 Phone Number 777
 News Service AP
 Transcr. Service Standard
 Representative Walker
 Membership NARTB, BAB
 President John Ehrstrom
 General Manager Ross E. Case
 Sales Prom. Mgr. Bernard Kinney
 Chief Engineer Francis Alwin

WNAX

YANKTON—1923—CBS

Frequency: 570 Kc. Power: 5000 Watts
 Owned-Operated By Cowles Bcstg. Co.
 Bus.-Studio Address WNAX Bldg.
 Phone Number YA 442
 Air Time 5:30 a.m.-M.
 News Service AP, UP
 Transcription Service Capitol
 Representative Katz
 Membership NARTB, BAB
 President Gardner Cowles
 General Manager Robert R. Tinchler
 Advertising Director Donald D. Sullivan
 Promotion Mgr. Larry Butler
 Program Director Roland Peterson
 Chief Engineer Clifton M. Todd

TENNESSEE

Pop. Feb. 1, 1954 (Est.) 3,424,000 — Families 884,000
 Radio Homes 768,000 — TV Homes 391,000 — Stations in State 65

WLAR

ATHENS—1946—KBS-MBS

Frequency: 1450 Kc. Power: 250 Watts
 Owned-Operated By Athens Bcstg. Co.
 Business-Studio Address N. Jackson St.
 Phone Number 1450
 News Service UP
 Transcription Service Thesaurus
 President Lowell F. Arterburn
 General Manager Buell J. Charles
 Program Director E. Max Robinette
 Commercial Manager Leonard Dawson
 Chief Engineer J. W. Turner

Phone Number 7-1128
 Air Time 5:55 a.m. to 12 M.
 News Service AP
 Transcription Service Langworth
 Representative Walker
 General Manager Vann Campbell
 Comm. Mgr. Cliff Bowers
 Program Director Bill Giddens
 Chief Engineer George McMurtrie

WOPI

BRISTOL—1929—NBC

(See Also Bristol, Va.)

Frequency: 1490 Kc. Power: 250 Watts
 Owned-Oper. By Radiophone Bcstg. Station,
 WOPI, Inc.
 Business-Studio Address 310 State St.
 Phone Number South 3730
 Air Time 5:30 a.m.-12:05 a.m.
 News Service AP
 Transcription Service Lang-Worth
 Representative Burn-Smith
 Membership NARTB, BAB
 Pres., Gen., Sta. Mgr. W. A. Wilson
 Commercial Mgr. James C. Wilson
 Publicity Director Margaret Lewis
 Chief Engineer George Guertin

W A P O

CHATTANOOGA—1936—NBC

Frequency: 1150 Kc. Power: 5000 Watts d.;
 1000 Watts n.
 Owned-Oper. By WAPO Bcstg. Service
 Business-Studio Address Read House
 Phone Number 6-6141
 Air Time 5:00 a.m.-12M.
 News Service AP
 Transcription Service Thesaurus
 Representative Avery-Knodel
 Membership NARTB
 Pres., Gen., Sta. Mgr. R. G. Patterson
 Program Director Frances Harley
 Prom., Pub. Dir. Helen Patterson
 Chief Engineer B. B. Barnes

W D E F

CHATTANOOGA—1941—NBC

Frequency: 1370 Kc. Power: 5000 Watts
 Owned-Oper. By WDEF Bcstg. Co.
 Bus.-Studio Address 420 Volunteer Bldg.
 Phone Number 6-5664
 Air Time 5:00 a.m.-M.
 News Service UP
 Transcription Service Capitol
 Representative Branham
 Membership NARTB

WAGC

CHATTANOOGA—1945—MBS

Frequency: 1450 Kc. Power: 250 Watts
 Owned-Oper. By Tenn. Valley Bcstg. Co.
 Address Hotel Patten

President.....Carter M. Parham
 General Manager.....Ken Flenniken
 Sales Prom. Mgr.....Warren Herring
 Program Director.....Morris Quave
 Chief Engineer.....B. C. Baker

W D O D

CHATTANOOGA—1925—CBS

Frequency: 1310 Kc.....Power: 5000 Watts
 Owned-Oper. By.....WDOD Bcstg. Corp.
 Address.....Hamilton Natl. Bank Bldg.
 Phone Number.....6-5117
 Air Time.....5:30 a.m.-12:30 a.m.
 News Service.....AP
 Transcription Service.....Standard, World
 Representative.....Paul H. Raymer
 Membership.....NARTB
 Pres., Gen., Sta. Mgr.....Earl W. Winger
 Commercial Manager.....Norman A. Thomas
 Publicity Director.....Byron J. Bush
 Program Director.....Frank F. Hubbs
 Chief Engineer.....James E. Walker

W D X B

CHATTANOOGA—1948

Frequency: 1490 Kc.....Power: 250 Watts
 Owned-Oper. By.....WDXB, Inc.
 Address.....Dome Bldg.
 Phone Number.....6-1114
 Representative.....Forjoe
 Transcription Service.....SESAC
 Membership.....NARTB, BAB
 News Service.....AP, UP
 President.....Joseph Bloom
 General Manager.....B. E. Fincher
 Commercial Mgr.....Carl Harden
 General Manager.....J. M. Brown
 Chief Engineer.....E. E. East

W M F S

CHATTANOOGA—1951

Frequency: 1260 Kc.....Power: 1000 Watts d.
 Owned-Operated By.....WMFS, Inc.
 Address.....215 W. Ninth St.
 Phone Number.....6-4145
 News Service.....AP
 Representative.....Pearson
 Pres., Gen. Sta. Mgr.....Brody Timm
 Program Director.....Fred Webb

W J Z M

CLARKSVILLE—1941—MBS-KBS

Frequency: 1400 Kc.....Power: 250 Watts
 Owned-Oper. By.....Campbell & Sheftall
 Business-Studio Address.....411 Madison St.
 Phone Number.....6414
 News Service.....AP
 Transcription Service.....Thesaurus
 Membership.....NARTB, BAB
 Pres., Gen.-Sta. Mgr.....E. T. Campbell
 Commercial Manager.....Parry Sheftall
 Prom. Mgr., Pgm. Dir.....Clay Cline, Jr.

Publicity Dir.....David J. Muhlstein
 Chief Engineer.....John Bailey

W B A C

CLEVELAND—1945—MBS

Frequency: 1340 Kc.....Power: 250 Watts
 Owned-Oper. By.....Robert W. Rounsaville
 Business-Studio Address.....Box 677
 Phone Number.....62
 Air Time.....6:00 a.m.-10:30 p.m.
 News Service.....UP
 General Manager.....R. W. Rounsaville
 Station Manager.....Thad F. Fitch
 Program Director.....Paul Kirksey
 Chief Engineer.....William D. Stuart

W K R M

COLUMBIA—1946—MBS-KBS

Frequency: 1340 Kc.....Power: 250 Watts
 Owned-Oper. By.....The Middle Tennessee
 Bcstg. Co., Inc.
 Bus.-Studio-Transmitter Address..P. O. Box 71
 Phone Number.....1340
 News Service.....AP
 Transcription Service.....World
 Pres., Gen.-Sta.-Comm. Mgr...R. M. McKay, Jr.
 Sales Prom. Mgr.....Mel Dugger
 Program Director.....Al Knott
 Chief Engineer.....Cameron McKay

W H U B

COOKEVILLE—1940—CBS-KBS

Frequency: 1400 Kc.....Power: 250 Watts
 Owned-Operated By.....WHUB, Inc.
 Bus.-Studio Address.....315 E. Spring St.
 Phone Number.....789
 News Service.....UP
 Representative.....Continental Radio Sales
 Membership.....NARTB, BAB
 General Manager.....M. L. Medley
 Station Director.....Joe Mabry
 Publicity Director.....Stacey Mott
 Chief Engineer.....Claude Haston

W A E W

CROSSVILLE—1953

Frequency: 1340 Kc.....Power: 100 Watts
 Owned-Oper. By.....WAEW, Inc.
 Address.....10th & School Sts.
 Phone Number.....334
 News Service.....UP
 President.....Arthur Wilkerson

W D S G

DYERSBURG—1946—MBS

Frequency: 1450 Kc.....Power: 250 Watts
 Owned-Oper. By.....State Gazette Bcstg. Co., Inc.
 Address.....Box 58
 Phone Number.....77
 Transcription Service.....World
 News Service.....AP
 General Manager.....Frank Armstrong

Commercial Manager... Wendell Vaughan
 Program Dir..... Bill Ward
 Chief Engineer..... Dave Ross

WBEJ

ELIZABETHTON—1946—MBS

Frequency: 1240 Kc..... Power: 250 Watts
 Owned-Oper. By..... Robert Rounsaville &
 George Clark
 Business-Studio Address..... Elk Ave.
 Phone Number..... 2-1241
 News Service..... UP
 Senior Partner & Mgr..... R. W. Rounsaville
 Station Manager..... Frazier Cochrane
 Commercial Mgr..... Frank Ryan
 Program Director..... Bill Hale
 Chief Engineer..... M. C. Bowers, Jr.

WEKR

FAYETTEVILLE—1948—MBS-KBS

Frequency: 1240 Kc..... Power: 250 Watts
 Owned-Oper. By..... Fayetteville Bcstg. Co.
 Business-Studio Address..... Box 625
 Phone Number..... 1240
 President..... John R. Crowder
 General Manager..... James Porter Clark
 Station Manager..... Jim Tate
 Program Director..... Teddy Barnes
 Chief Engineer..... Ernest Tucker

WAGG

FRANKLIN—1953

Frequency: 950 Kc..... Power: 1000 Watts d.
 Owned-Oper. By..... Williamson County Bcstg.
 Address..... Mallory Rd.
 Phone Number..... 982
 Representative..... Best
 Pres., Gen. Mgr..... William Ormes
 Commercial Mgr..... A. B. Thomas
 Program Director..... Bob Holland
 Promotion Mgr..... Ralph Emery
 Chief Engineer..... Ellis F. Jones Jr.

WHIN

GALLATIN—1948—KBS

Frequency: 1010 Kc..... Power: 1000 Watts d.
 Owned-Oper. By..... Sumner County Bcstg. Co.
 Address..... Box 811
 Phone Number..... 1010
 News Service..... UP
 President..... A. B. Perkins
 Gen., Sta., Prog. Mgr..... J. B. Thomas
 Commercial Manager..... Charles Brewer
 Chief Engineer..... Lee Raines Jr.

WGRV

GREENEVILLE—1946—MBS

Frequency: 1340 Kc..... Power: 250 Watts
 Owned-Oper. By..... Radio Greeneville, Inc.
 Address..... Depot St.
 Phone Number..... 4147
 News Service..... UP
 Transcription Service..... Capitol

Pres., Gen. Mgr..... Paul Metcalfe
 Commercial Manager..... Hugh Pickel
 Program Director..... Bill Moore
 Chief Engineer..... Laile Hampton

WHBT

HARRIMAN—1947—MBS-KBS

Frequency: 1230 Kc..... Power: 250 Watts
 Owned-Oper. By..... The Harriman Bcstg. Co.,
 Inc.
 Bus.-Studio Address..... Harriman
 Phone Number..... 661
 Air Time..... 6:15 a.m.-11:15 p.m.
 News Service..... UP
 Transcription Service..... World
 Representative..... Continental
 Membership..... BAB
 Owner, Gen. Mgr..... F. L. Crowder
 Comm., Sales Prom. Mgr..... Walter Scarbrough
 Pgm. Dir., Chief Ann..... Carl Williams
 Chief Engineer..... Reggie Honey

WIRJ

HUMBOLDT—1949—MID-SOUTH
 KBS

Frequency: 740 Kc..... Power: 250 Watts d.
 Owned-Oper. By..... Gibson Co. Bcstg. Co., Inc.
 Address..... 210 N. 22nd Ave.
 Phone Number..... 740
 News Service..... UP
 Transcription Service..... Thesaurus
 President..... J. F. Warmath
 Gen., Sta. Mr..... Howard E. Byrum
 Chief Engineer..... Gerald Hicks

WDXI

JACKSON—1948—MBS—KBS

Frequency: 1310 Kc..... Power: 5000 Watts d.,
 1000 n.
 Owned-Operated By..... Dixie Bcstg. Co.
 Business-Studio Address..... Williams Bldg.
 Phone Number..... 7-9611
 Air Time..... Unlimited
 News Service..... UP
 Transcription Service..... World
 Representative..... Burn-Smith, Dora-Clayton
 Membership..... NARTB, BAB
 Pres., Gen. Mgr..... Aaron B. Robinson
 Station Manager..... Bill Winsell
 Commercial Mgr..... Jack Murphy
 Program Director..... Larry Crenshaw
 Publicity Director..... Al Craven
 Chief Engineer..... James S. Thomas

WTJS

JACKSON—1931—ABC-MID-SOUTH

Frequency: 1390 Kc..... Power: 1000 Watts
 Owned-Oper. By..... The Sun Publishing Co.
 Bus.-Studio Address..... Jackson
 Phone Number..... 7-3316
 Air Time..... 5 a.m.-M.
 News Service..... AP
 Transcription Service..... World, Thesaurus

Representative Branham
 Membership NARTB, BAB
 Exec. V.P., Gen. Mgr. A. A. Stone
 Station Manager Frank S. Proctor
 Publicity Dir. Peggy McKinnie
 Program Director Douglas Maxwell
 Chief Engineer Robert M. Gordon

WJHL

JOHNSON CITY—1938—ABC

Frequency: 910 Kc. Power: 5000 Watts d.;
 1000 Watts n.
 C. med-Operated By WJHL, Inc.
 Business-Studio Address 145 W. Main St.
 Phone Number 2780
 Air Time 6 a.m.-M.
 News Service AP, UP
 Transcription Service Lang-Worth
 Representative John E. Pearson
 Membership NARTB
 President W. H. Lancaster, Sr.
 General Manager W. H. Lancaster, Jr.
 Publicity Director W. K. Matthews
 Program Director William Shell
 Chief Engineer O. K. Garland

WETB

JOHNSON CITY—1947

Frequency: 790 Kc. Power: 1000 Watts d.
 Owned-Oper. By Press, Inc.
 Business Address Main St.
 Phone Number 2993
 News Service AP
 Representative McGillvra
 Transcription Service World
 President Carl A. Jones
 General Manager Arthur Kelsey
 Program Director Bernard Burleson
 Chief Engineer U. G. Jones

WKIN

KINGSPORT—1951

Frequency: 1320 Kc. Power: 1000 Watts d.
 Owned-Oper. By WKIN, Inc.
 Address Wexler & E. Mkt. Sts.
 Pres., Gen. Mgr. Cy N. Bahakel
 Sta. Mgr., Chief Eng. John Strong

WKPT

KINGSPORT—1940—NBC

Frequency: 1400 Kc. Power: 250 Watts
 Owned-Oper. By Kingsport Bcstg. Co., Inc.
 Business-Studio Address 222 Commerce St.
 Phone Number Circle 5-4161
 Transcription Service Thesaurus
 Representative Burn-Smith, Dora-Clayton
 Membership NARTB, BAB
 President C. P. Edwards, Jr.
 Gen., Sta. Manager Paul L. Overbay
 Commercial Mgr. Phil Weaver
 Program Dir. Martin Karant
 Publicity Dir. Jim Davis
 Chief Engineer Thomas Phillips

WBIR

KNOXVILLE—1941—ABC

Frequency: 1240 Kc. Power: 250 Watts
 Owned-Oper. By Radio Station WBIR, Inc.
 Business-Studio Address 618 S. Gay St.
 Phone Number 4-3321
 Air Time 5:30 a.m.-M.
 Transcription Service Thesaurus
 Representative Bolling
 Membership NARTB, BAB
 Pres., Gen. Mgr. John P. Hart
 Program Director Neal Branch
 Publicity Director Ted Brosseau
 Chief Engineer J. Rex Horton

WIVK

KNOXVILLE—1953

Frequency: 860 Kc. Power: 1000 Watts d.
 Owned-Oper. By Kick Bcstg. Co.
 Co-Owners James M. Dick,
 Marilyn M. Dick

WKGN

KNOXVILLE—1947—MBS

Frequency: 1340 Kc. Power: 250 Watts
 Owned-Operated By WKGN Bcstg. Co.
 Bus.-Studio Address Park Natl. Bank Bldg.
 Phone Number 4-0766
 Air Time 6 a.m.-M.
 News Service AP
 Transcription Service Lang-Worth
 Membership NARTB
 Pres., Gen., Sta. Mgr. Clarence Beaman
 Commercial Mgr. J. Horton Davis
 Program Director John Ward
 Chief Engineer Milton L. Jones

WNOX

KNOXVILLE—1921—CBS

Frequency: 990 Kc. Power: 10,000 Watts
 Owned-Oper. By Scripps-Howard Radio, Inc.
 Business-Studio Address 110 S. Gay St.
 Phone Number 3-3171
 Air Time 5 a.m.-1:05 a.m.
 Newspaper Affiliation "News Sentinel"
 News Service UP
 Transcription Service Standard
 Representative Branham
 President Jack R. Howard
 General Manager R. B. Westergaard
 Comm.-Sales Prom. Mgr. O. L. Smith
 Program Dir. C. A. McMahon
 Chief Engineer Ray Evans

WROL

KNOXVILLE—1927—NBC

Frequency: 620 Kc. Power: 5000 Watts
 Owned-Operated By Mountcastle Bcstg. Co.
 Business-Studio Address 612 Gay St.
 Phone Number 2-7111
 Air Time Full Time
 News Service UP
 Transcription Service World

Representative Avery Knodel
 Membership NARTB, BAB
 President Paul Mounycastle
 Gen., Sta. Mgr. W. H. Linebaugh
 Commercial Manager..... J. T. McCloud
 Program Dir. J. H. Reese
 Prom., Pub. Dir. H. W. Hudson
 Chief Engineer..... Fred Andrews

W D X E

LAWRENCEBURG—1951—MBS
 KEYSTONE

Frequency: 1370 Kc. Power: 1000 Watts d.
 Owned-Oper. By Lawrenceburg Bcstg. Co.
 Address Locke Bldg.
 Phone Number 4462
 News Service UP
 Transcription Service..... SESAC, World
 Representative Burn-Smith
 President..... Aaron B. Robinson
 General Manager..... George Eubanks
 Program Director..... Ken Marston
 Promotion Manager..... Bud Sawyer
 Chief Engineer..... Phillip Kemper

W C O R

LEBANON—1949—KBS

Frequency: 900 Kc. Power: 250 Watts d.
 Owned-Operated By... Lebanon Bcstg. Co., Inc.
 Address..... 106½ S. Cumberland Ave.
 Phone Number 1540
 News Service AP
 Pres., Gen. Mgr. Theo. F. Exell, Jr.
 Comm. Mgr. Michael R. Freeland
 Chief Engineer..... William Johnston

W L I L

LENOIR CITY—1950

Frequency: 730 Kc. Power: 1000 Watts d.
 Owner WLIL, Inc.
 Address..... 406 E. Broadway
 Phone Number 1095
 Membership NARTB, BAB
 News Service UP
 Pres., Gen. Mgr. Arthur Wilkerson
 Chief Engineer..... Allen Breazeale

W J J M

LEWISBURG—1947—MBS-KBS

Frequency: 1490 Kc. Power: 250 Watts
 Owned-Oper. By... Estate of James J. Murray
 Address Box 20
 Phone Number 780
 News Service AP
 General Manager..... Louis D. Lingner
 Chief Engineer..... J. E. Sowell

W G A P

MARYVILLE—1947

Frequency: 1400 Kc. Power: 250 Watts
 Owned By Aluminum Cities Bcstg. Co.
 Address..... Blount Natl. Bank Bldg.
 Phone Number 2490

Membership NARTB, BAB
 News Service AP
 Transcription Service Thesaurus
 Co-owners F. H. Corbett, H. C. Weaver
 General Manager F. H. Corbett
 Commercial Manager..... Horace McGill
 Chief Engineer..... Mark Murphy

W M M T

McMINNVILLE—1947—MBS
 KEYSTONE

Frequency: 1230 Kc. Power: 250 Watts
 Owned-Oper. By... McMinnville Brdg. Co., Inc.
 Address McMinnville
 Phone Number 401
 President..... Dr. Sam J. Albritton

W D I A

MEMPHIS—1947

Frequency: 730 Kc. Power: 250 Watts d.
 Owned By Bluff City Bcstg. Co.
 Operated By... John Pepper, Bert Ferguson
 Business-Studio Address..... 2074 Union Ave.
 Phone Number 36-2703
 News Service UP
 Representative Pearson, Dora-Clayton
 Membership NARTB, BAB
 Gen. Mgr. Bert Ferguson
 Commercial Manager..... Harold F. Walker
 Chief Engineer..... Henry N. Fones

W C B R

MEMPHIS—1952

Frequency: 1480 Kc. Power: 1000 Watts d.
 Owned-Oper. By Chickasaw Bcstg. Co.
 Address Exchange Building
 Phone 5-7545
 Representative Gill-Perna
 General Manager..... Charles DeVois

W H B Q

MEMPHIS—1925—MBS

Frequency: 560 Kc. Power: 5000 Watts
 Owned-Oper. By Harding College
 Bus.-Studio Address..... Hotel Chisca
 Phone Number 8-6868
 Air Time Full Time
 News Service UP
 Transcription Service Associated
 Representative John Blair
 Membership NARTB, BAB
 President..... Dr. George S. Benson
 Gen., Sta. Mgr. John Cleghorn
 Commercial Mgr. Tom W. Ragland
 Program Director..... Lee N. McEachern
 Sales Prom. Mgr. Tom W. Ragland
 Publicity Director..... Leslie Birchfield
 Chief Engineer..... Welton Roy

W H H M

MEMPHIS—1946

Frequency: 1340 Kc. Power: 250 Watts
 Owned-Oper. By Mid-South Bcstg. Corp.

Business-Studio Address.....433 Sterick Bldg.
 Phone Number37-4422
 News ServiceUP
 Representative.....O. L. Taylor
 Membership.....NARTB
 President.....P. E. Furlow
 Gen., Sta. Mgr.....C. K. Beaver
 Commercial Mgr.....Allan Avery
 Chief Engineer.....William Marsh

W M C
MEMPHIS—1923—NBC

Frequency: 790 Kc.....Power: 5000 Watts
 Owned-Oper. By.....Memphis Publishing Co.
 Bus.-Studio Address..Goodwyn Institute Bldg.
 Phone Number8-7464
 News ServiceUP
 Transcription Service..Thesaurus, Lang-Worth
 Representative.....Branham
 Gen., Sta. Mgr.....H. W. Slavick
 Commercial Mgr.....Richard Voorhis
 Program Director.....Ott Roush
 Chief Engineer.....E. C. Frase, Jr.

W M P S
MEMPHIS—1925—ABC

Frequency: 680 Kc....Power: 10,000 Watts d.;
 5000 Watts n.
 Owned-Operated By.....WMPS, Inc.
 Business-Studio Address.....Radio Center
 Phone Number5-2663
 Air Time.....5 a.m.-12:05 a.m.
 News ServiceUP
 Transcription Service.....Standard
 Representative.....Radio Representatives
 Membership.....NARTB
 Pres., Gen. Mgr.....Harold R. Krelstein
 Sales Prom. Mgr.....Brent Roper
 Program Dir.....W. E. Crump
 Chief Engineer.....J. G. Deaderick

W R E C
MEMPHIS—1922—CBS

Frequency: 600 Kc.....Power: 5000 Watts
 Owned-Oper. By.....WREC Bcstg. Service
 Business-Studio Address.....Hotel Peabody
 Phone Number5-1313
 News ServiceUP
 Transcription.....World, Lang-Worth, SESAC
 Representative.....Katz
 Owner, General Manager...Hoyt B. Wooten
 Commercial Manager.....Hollis R. Wooten
 Program Director.....Roy Wooten
 Chief Engineer.....Wilson Raney

W C R K

MORRISTOWN—1947—MBS

Frequency: 1450 Kc.....Power: 250 Watts
 Owned-Oper. By.....Cherokee Bcstg. Corp.
 Bus.-Studio-Transmitter Address..Radio Center
 Phone Number1450
 News ServiceAP
 Transcription Service.....Lang-Worth
 Representative.....Hal Holman
 President.....Herbert S. Walters

General Manager.....Howell Ashford
 Program Director.....John Frank McCrary
 Chief Engineer.....James R. Redden

W G N S

MURFREESBORO—1946—KBS

Frequency: 1450 Kc.....Power: 250 Watts
 Owned-Oper. By.....WGNS, Inc.
 Address.....P. O. Box 456
 Phone Number1450
 News Service.....AP, UP
 Representative.....Holman
 Transcription Service.....World, Langworth
 Pres., Gen. Mgr.....Cecil Elrod, Jr.
 Program Director.....John D. Hood
 Chief Engineer.....Paul Howell

W M T S

MURFREESBORO—1953

Frequency: 860 Kc.....Power: 250 Watts d.
 Owned-Oper. By.....Murfreesboro Bcstg. Co.
 Address.....122 N.W. Broad
 News ServiceUP
 President.....Arthur D. Smith Jr.
 General Manager.....Virgil Trimm
 Commercial Mgr.....Charles Snoddy
 Program Director.....Jim Edwards
 Chief Engineer.....Eugene Covington

W K D A

NASHVILLE—1947

Frequency: 1240 Kc.....Power: 250 Watts
 Owned-Oper. By.....DBA Bcstg. Co.
 Bus.-Studio Address..1st American Natl. Bank
 Bldg.
 Phone Number4-0511
 News ServiceAP
 Transcription Service.....Capitol, Standard
 Representative.....Bolling
 Membership.....NARTB
 (Partners) Owners.....T. B. Baker, Jr. &
 A. G. Beaman
 General Manager.....T. B. Baker, Jr.
 Chief Engineer.....Oscar C. Griffin, Jr.

W L A C

NASHVILLE—1926—CBS

Frequency: 1510 Kc.....Power: 50,000 Watts
 Owned-Oper. By.....Life & Casualty Insurance
 Co. of Tennessee
 Bus.-Studio Address.....Third Natl. Bank Bldg.
 Phone Number6-0161
 Air Time.....5 a.m.-1 a.m.
 News ServiceUP
 Transcription Service.....Thesaurus
 Representative.....Katz
 Membership.....NARTB, BAB
 Gen. Mgr.....F. C. Sowell
 Commercial Manager.....E. G. Blackman
 Promotion Manager.....Frank Gonzales
 Program Director.....Paul Oliphant
 Chief Engineer.....F. D. Binns

WMAK

NASHVILLE—1948—MBS

Frequency: 1300 Kc. Power: 5000 Watts
 Owned-Oper. By Volunteer State Bcstg. Co.
 Address Maxwell House Hotel
 Phone Number 4-3411
 President Frank W. Mayborn
 General Manager George B. Faulder
 Sales Prom. Mgr. Robert Cooper
 Chief Engineer Charles W. Stokely

WNAH

NASHVILLE—1949—KBS-LBS

Frequency: 1360 Kc. Power: 1000 Watts d.
 Owned-Oper. By Hermitage Bcstg. Corp.
 Address James Robertson Hotel
 Phone Number 4-7611
 News Service UP
 Representative Continental
 Pres., Gen., Comm. Mgr. Van T. Irwin, Jr.
 Program Director Donn C. McInturff
 Chief Engineer Harold Woodard

WSIX

NASHVILLE—1927—ABC

Frequency: 980 Kc. Power: 5000 Watts
 Owned-Oper. By Louis B. Draughon
 Address Nashville Trust Building
 Phone Number 5-5431
 Air Time 5:00 a.m. to 12:00 M.
 News Service AP
 Transcription Service World
 Station Representative George P. Hollingbery
 Membership NARTB, BAB
 Gen. Sta. Mgr. Louis R. Draughon
 Comm. Prom. Manager E. S. Tanner
 Program Director Jack Simpson
 Chief Engineer Charles R. Duke

WSM

NASHVILLE—1925—NBC

Frequency: 650 Kc. Power: 50,000 Watts
 Owned-Operated By Nat'l Life & Acc. Ins. Co.
 Bus. Studio Address 301 7th Ave. N.
 Phone Number 6-7181
 News Service AP, INS
 Transcription Service Thesaurus
 Representative Edward Petry
 Membership NARTB, BAB
 Chairman of Board E. W. Craig
 President John H. DeWitt, Jr.
 Commercial Manager Irving C. Waugh
 Dir. of Publicity Wm. R. McDaniel
 Program Director Jack Stapp
 Chief Engineer George A. Reynolds

WSOK

NASHVILLE—1951

Frequency: 1470 Kc. Power: 1000 Watts d.
 Owned-Operated By Nashville Bcstg. Co.
 Address 419 Fourth Ave. N.
 Phone Number 42-0489
 Representative Forjoe

Pres., Gen., Sta. Mgr. H. C. Young, Jr.
 Com., Prom. Mgr. Norman Stewart
 Chief Engineer Arthur Viaches

WATO

OAK RIDGE—1948—MBS

Frequency: 1490 Kc. Power: 250 Watts
 Owned-Operated By WATO, Inc.
 Address Municipal Market Bldg.
 Phone Number Oak Ridge 5-3535
 Air Time Unlimited
 News Service AP
 Transcription Service World
 Representative H-R Representatives
 President Ross Charles
 Gen. Sta. Mgr. Samuel P. Thrower, Jr.
 Program Director Thearon O. Atkins
 Chief Engineer Hal Tompkins

WOKE

OAK RIDGE—1951—KBS

Frequency: 1290 Kc. Power: 1000 Watts d.
 Owned-Oper. By Air Mart Corp.
 Address Box 391
 Phone Number 5-1333
 News Service AP
 Representative Continental
 President Harry C. Weaver
 Commercial Mgr. O. E. O'Bleness
 Program Director William E. Sorrell
 Chief Engineer Henry McDonald

WTPR

PARIS—1947—KBS-MBS

Frequency: 710 Kc. Power: 250 Watts d.
 Owner Paris Bcstg. Co.
 Address Davis Bldg.
 Phone Number 1700
 General Manager J. M. Cecil
 Commercial Manager B. C. Kilgore
 Chief Engineer Don Somerville

WKSR

PULASKI—1947—ABC

Frequency: 1420 Kc. Power: 1000 Watts
 Owned-Oper. By The Richland Bcstg. Co.
 Address Jones Bldg.
 Phone No. 1066-67
 News Service UP
 Transcription Service World, SESAC
 President J. R. Stephens
 Commercial Mgr. Mrs. J. R. Stephens
 Pgm. Dir., Chief Anncr. George Martin
 Chief Engineer N. G. Morgan

WHAL

SHELBYVILLE—1946—MBS

Frequency: 1400 Kc. Power: 250 Watts
 Owned-Oper. By Shelbyville Bcstg. Co., Inc.
 Phone Number 1400
 News Service UP
 V.P., Gen. Mgr. Charles Christian
 Chief Engineer Tim Marsh

W S M T

SPARTA—1953

Frequency: 1050 Kc. Power: 1000 Watts d.
 Owned-Oper. By: Sparta Bcstg. Co. Inc.
 Address: Box O
 Phone Number: 3751
 President: Sam J. Albritton
 General Manager: B. L. Upchurch
 Commercial Mgr.: Van L. Slack
 Program Director: William Round Jr.
 Chief Engineer: I. D. Byars

W D B L

SPRINGFIELD—1950—KBS

Frequency: 1430 Kc. Power: 1000 Watts d.
 Owned-Oper. By: Springfield Bcstg. Co., Inc.
 Address: P. O. Box 464
 Phone Number: 1287
 Transcription Service: World
 News Service: UP
 Gen., Sta. Mgr.: Walter A. Duke
 Comm. Mgr.: Howard M. Peters
 Chief Engineer: Ann Duke

W J I G

TULLAHOMA—1947

Frequency: 740 Kc. Power: 250 Watts d.
 Owned-Oper. By: WJIG Bcstg.
 Business Address: West End Drive
 Phone Number: 2607-8

News Service: UP
 Transcription Service: World
 Pres., Gen. Mgr.: Col. Raymond L. Prescott, Jr.
 Chief Engineer: William Dunn

W E N K

UNION CITY—1946—MBS-KBS

Frequency: 1240 Kc. Power: 250 Watts
 Owned-Operated By: Union City Bcstg. Co.
 Phone Number: 1240-1
 Air Time: 5 a.m.-11 p.m.
 News Service: UP
 Transcription Service: World
 Representative: Burn-Smith
 President: Aaron B. Robinson
 Station Manager: Louis C. Wrather
 Commercial Mgr.: Edwin A. Kallenberg
 Program Director: Virginia L. Osborne
 Chief Engineer: Charles Holland

W C D T

WINCHESTER—1948—MBS

Frequency: 1340 Kc. Power: 250 Watts
 Owned-Oper. By: Arthur D. Smith, Jr.
 Address: Box 1103
 Phone Number: 2201
 News Service: UP
 Pres., Gen. Mgr.: Arthur D. Smith, Jr.
 Commercial Manager: Harry W. Sullivan
 Program Director: Hank Murray
 Chief Engineer: James F. Spencer

**THOSE WHO KNOW
 FAMOUS BRANDS . . .**

Reports Station WDOH at Chattanooga, Tenn.: "AP has shown us that in addition to a superior news report, behind the famous name of **Associated Press** is a store of cooperation and service."

**. . . . KNOW THE MOST FAMOUS
 BRAND IN NEWS IS AP**

TEXAS

Pop. Feb. 1, 1954 (Est.) 8,986,000 — Families 2,793,000
Radio Homes 2,463,000 — TV Homes 1,129,000 — Stations in State 191

K R B C

ABILENE—1936—ABC—TEXAS

Frequency: 1470 Kc. Power: 5000 Watts d.;
1000 Watts n.
Owned-Oper. By Reporter Bcstg. Co.
Business Address Windsor Hotel
Phone Number 4-6255
Air Time 6 a.m.-M.
News Service AP
Transcription Service Associated
Representative John E. Pearson
President Dale Ackers
General Manager Howard Barrett
Comm. Sales Prom. Mgr. Forest Lane
Chief Engineer Troy Mallon

K W K C

ABILENE—1948—MBS

Frequency: 1340 Kc. Power: 250 Watts
Owned-Oper. By Citizens Bcstg. Co.
Bus. Studio Address 2500 Butternut
Phone Number 3-2545
News Service AP, UP
Transcription Service World
Representative Venard
President W. P. Wright
Gen. Prom. Mgr. A. C. Eller
Commercial Manager Tyler Stewart
Program Director Leonard Johnson
Chief Engineer Forrest Tipton

K B K I

ALICE—1947—MBS

Frequency: 1070 Kc. Power: 1000 Watts
Owned-Operated By Alice Bcstg. Co.
Business Address Box 731
Phone Number 4-4324
Air Time Full Time
News Service AP
Transcription Service World
Representative Pearson
Membership NARTB
President E. G. Lloyd, Jr.
Gen. Sta. Mgr. A. C. Lloyd, Jr.
Commercial Manager Bob Grimes
Sales Prom. Mgr. Irma Salas
Program Dir. J. Allen Frye
Publicity Director Gloria Sanchez
Chief Engineer Charles M. Boyd

K V L F

ALPINE—1947—MBS-KBS-CACTUS

Frequency: 1240 Kc. Power: 250 Watts
Owned-Operated By Big Bend Bcstrs.
Business Address P. O. Box 779
Phone Number 2144
News Service UP
Representative Hil F. Best
Transcription Service Thesaurus
President Jack Hawkins

Gen. Sta., Comm. Mgr. Gene Hendryx
Program Director Bill Height
Chief Engineer Sherman Newsom

K A M Q

AMARILLO—1947—MBS

Frequency: 1010 Kc. Power: 1000 Watts d.,
500 Watts n.
Owned-Oper. By Top of Texas Bcstg. Co.
Address 1301 Polk St.
Phone Number 2-6543
Representative Forjoe
Transcription Service Thesaurus
News Service AP
Gen. Sta. Mgr. R. D. Houck
Commercial Manager Jess Richardson
Program Director Webb Smith
Publicity Director Johnny Hathcock
Chief Engineer Stewart Parsons

K F D A

AMARILLO—1939—ABC

Frequency: 1440 Kc. Power: 5000 Watts d.;
1000 Watts n.
Owned Oper. By Amarillo Bcstg. Co., Inc.
Business-Studio Address Box 1400
Phone Number 4-5343
News Service UP
Representative Branhan Co.
Membership BAB
President Wendall Mayes
General Manager Stan Wilson
Commercial Mgr. Ed Moore
Program Director Warren Anderson
Publicity Director Ruth Holt
Chief Engineer W. B. Spiller

K G N C

AMARILLO—1922—NBC-TQN

Frequency: 710 Kc. Power: 10,000 Watts
Owned-Oper. By Plains Radio Bcstg. Co.
Address P. O. Box 751
Phone Number 3-4242
Air Time Full Time
News Service UP, AP
Transcription Service World
Representative Katz
Membership NARTB, BAB
President B. E. Walker
General Manager Tom Kritser
Business Manager Calvin Handy
Sta., Mgr., Prog. Dir. Bob Watson
Prom. Mgr., Pub. Dir. Marianne Johnson
Chief Engineer W. H. Torrey

K L Y N

AMARILLO—1949—CBS

Frequency: 940 Kc. Power: 1000 Watts
Owned-Oper. By Plains Empire Bcstg. Co.
Address 1014 West Seventh

Phone Number2-6773
 Air Time6 a.m.-12 M.
 News ServiceUP
 Transcription ServiceStandard
 RepresentativeJohn Blair & Co.
 MembershipNARTB, BAB
 PresidentR. G. Hughes
 Gen., Comm. Mgr.....Howard Roberson
 Publicity Director.....Mae Dorsey
 Chief EngineerGene Fennimore

KBUD
 ATHENS—1948

Frequency: 1410 Kc.....Power: 250 Watts d.
 Owned-Oper. By..Henderson County Bcstg. Co.
 Business Address.....Box 309
 Phone Number2277
 Transmitter LocationHighway 19
 Transcription Service.....Langworth
 News ServiceUP
 Sta., Gen. Mgr.J. B. McNutt, Jr.
 Consulting Engr.....Merl Saxon

KALT
 ATLANTA—1950

Frequency: 900 Kc.....Power: 1000 Watts d.
 Owned-Oper. By.....Ark-La-Tex Bcstg. Co.
 Phone Number900
 Transcription ServiceWorld
 News ServiceAP
 Representative.....Hill F. Best
 President.....Herman H. Wommack, Jr.
 Gen., Sta. Mgr.....David A. Wommack
 Commercial Manager.....A. N. Dowd
 Chief Engr.....James L. Waites

KNOW
 AUSTIN—1927—ABC-TSN

Frequency: 1490 Kc.....Power: 250 Watts
 Owned-Oper. By.....Pioneer Bcstg. Co., Inc.
 Bus.-Studio Address..Capitol Natl. Bank Bldg.
 Phone Number2-6213
 Air Time.....Full Time
 News ServiceAP
 Transcription ServiceStandard
 RepresentativePearson
 MembershipNARTB, BAB
 President.....Wendell W. Mayes
 Station Manager.....Louis R. Cook
 Commercial Mgr.....Mitt Coleman
 Program Director.....Frank Bissett
 Chief Engineer.....James E. Lewis

KTBC
 AUSTIN—1939—CBS

Frequency: 590 Kc.....Power: 5000 Watts d.;
 1000 Watts n.
 Owned-Oper. By.....Texas Bcstg. Corp.
 Bus.-Studio Address.....P. O. Box 717
 Phone Number2-2424
 News ServiceUP
 Transcription ServiceWorld
 RepresentativeTaylor Co.

President.....Claudia T. Johnson
 Gen., Sta. Mgr.....J. C. Kellam
 Sales Prom. Mgr.....Harry Voelker
 Program Director.....Richard S. Pryor
 Chief Engineer.....A. B. Hearn

KTXN
 AUSTIN—1949

Frequency 1370 Kc. ...Power: 1000 Watts d.
 Owned-Oper. By.....Radio Station KTXN
 Address.....P. O. Box 1102
 Phone Number74476
 Representative...Oakes, Clayton, Nat'l Time
 Sales
 President.....Ed C. James, Sr.
 Gen., Sta. Comm., Manager...Frank Stewart
 Sales Promotion Manager.....Larry Jones
 Chief Engineer.....Paul Lindhorn

KVET
 AUSTIN—1946—MBS

Frequency: 1300 Kc.....Power: 1000 Watts
 Owned-Oper. By.....Austin Bcstg. Co.
 Business-Studio Address.....113 West 8th
 Phone Number8-8521
 Air Time.....Full Time
 News ServiceUP
 RepresentativeForjoe
 MembershipNARTB, BAB
 President.....John B. Connally
 Gen., Sta. Mgr.....Willard Deason
 Commercial Manager.....Charles Howell
 Program Director.....Dave Smith
 Chief Engineer.....Willis Morter

KRUN
 BALLINGER—1947—KBS

Frequency: 1400 Kc.....Power: 250 Watts
 Owned-Oper. By.....Runnels County Bcstg. Co.
 AddressBox 351
 Phone Number3151
 News ServiceAP
 RepresentativeBest
 President.....Walter G. Russell
 Gen., Comm. Mgr.....R. F. McGarvey
 Chief Engineer.....W. C. Kelley

KIOX
 BAY CITY—1947—MBS-KBS

Frequency: 1270 Kc.....Power: 1000 Watts
 Owned-Oper. By.....Bay City Bcstg. Co.
 Business Address.....Box 1391
 Phone Number.....4642-3
 Air Time.....Full Time
 News ServiceUP
 Transcription ServiceWorld
 Representative.....Hil F. Best
 President.....J. G. Long
 General Manager.....Bryan Powell
 Station Manager.....Vernon Townsend
 Commercial Manager.....Boyd Porter
 Chief Engineer.....Sam Sitterlee

KRCT

BAYTOWN—1947—KBS

Frequency: 650 Kc. Power: 250 Watts d.
 Owned-Operated By: Bay Bcstg. Co.
 Address: Box 629
 Phone Number: 8251
 News Service: AP
 President: W. D. Christmas
 Gen. Mgr., Chief Engr.: M. J. Tavary

KREL

BAYTOWN—1947

Frequency: 1360 Kc. Power: 1000 Watts
 Owned-Oper. By: Tri-Cities Bcstg. Co.
 Business Address: Decker Drive
 Phone Number: 8211-2
 News Service: UP
 Transcription Service: World
 Representative: Richard O'Connell
 President: Robert Matherne
 General Manager: Pat McDonald
 Commercial Mgr.: Don Lilly
 Program Director: Jay Shepherd
 Chief Engineer: Mack S. Malpee

KFDM

BEAUMONT—1924—ABC

Frequency: 560 Kc. Power: 5000 Watts
 Owned-Oper. By: Beaumont Bdcstg. Corp.
 Address: P. O. Box 2950
 Phone Number: 2-7758
 Air Time: Full Time
 News Service: UP
 Transcription Service: Lang-Worth
 Representative: Free & Peters, Inc.
 Membership: NARTB
 President: D. A. Cannan
 Gen., Sta., Comm. Mgr.: C. B. Locke
 Program Director: Dave Russell
 Pub. Dir., Sales Prom. Mgr.: H. P. Caldwell
 Chief Engineer: Harold W. Bartlett

KJIM

BEAUMONT—1947

Frequency: 1380 Kc. Power: 1000 Watts d.
 Owned-Oper. By: KPBX Bcstg., Inc.
 Address: 2295 Calder Ave.
 Phone Number: 2-0201
 Representative: Forjoe
 News Service: AP
 Transcription Service: Capitol
 Chairman of Board: Joe B. Carrigan
 Pres., Gen. Mgr.: James King Smith
 V.P., Comm. Mgr.: Les Ryder
 Chief Engineer: Fred Reiner

KRIC

BEAUMONT—1938

Frequency: 1450 Kc. Power: 250 Watts
 Owned-Operated By: The Enterprise Co.
 Bus.-Studio-Trans. Address: 380 Walnut
 Phone Number: 4-3311
 News Service: AP

Transcription Service: World
 Newspaper Affiliation: "Enterprise & Journal"
 Representative: Branham
 Membership: BAB
 President: O. Eugene Davis
 General Mgr.: E. C. Davis
 Commercial Mgr.: Jim Saxon
 Chief Engineer: Marvin J. Easterwood

KTRM

BEAUMONT—1947

Frequency: 990 Kc. Power: 1000 Watts
 Owned-Operated By: KTRM, Inc.
 Business-Studio Address: 230 Orleans St.
 Phone Number: 2-8478
 News Service: UP
 Representative: Adam Young
 Pres., Gen. Mgr.: Jack Neil
 Station Manager: Joseph S. Trum
 Commercial Mgr.: Bill McRae
 Sales Prom. Mgr.: Luther K. Woods
 Chief Engineer: Ben F. Hughes

KIBL

BEEVILLE—1949

Frequency: 1490 Kc. Power: 250 Watts d.,
 250 Watts n.
 Owned-Oper. By: Bee Bdcstg. Co.
 Address: P. O. Box 650
 Phone Number: 1490
 News Service: AP
 Transcription Service: World
 President (Partnership): John D. Rossi,
 V. L. Rossi
 General Manager: John D. Rossi
 Station Manager: James V. Rossi
 Commercial Mgr.: Fred Strong
 Chief Engineer: James Egbert

KBST

**BIG SPRING—1936—ABC
 TEXAS STATE**

Frequency: 1490 Kc. Power: 250 Watts
 Owned-Oper. By: Big Spring Bcstg. Co.
 Bus.-Studio Address: 702 Johnson St.
 Phone Number: 4-6391
 News Service: AP
 Transcription Service: Standard
 Representative: Pearson
 Pres., Gen. Sta. Mgr.: William J. Wallace
 Commercial Manager: William L. Cox
 Pub., Pgm. Dir.: J. N. Young, Jr.
 Chief Engineer: Andrew M. Jones

KTXC

BIG SPRING—1949—KBS

Frequency: 1400 Kc. Power: 100 Watts
 Owned-Oper. By: Big State Bdcstg. Co.
 Address: Big Spring City Park
 Phone Number: 3300
 Transcription Service: World
 News Service: UP
 Representative: Hil F. Best
 Pres., Gen. Mgr.: V. T. Anderson

KFYN

BONHAM—1948

Frequency: 1420 Kc. Power: 250 Watts d.
 Owned-Operated By: Bonham Publ. Co.
 Bus.-Studio Address: 314 N. Center St.
 Phone Number: 915
 News Service: UP
 Transcription Service: World
 Membership: BAB
 President: Clark Bass
 Commercial Mgr.: Leon Patrick
 Chief Engineer: Tommy Tomlinson

KHUZ

BORGER—1947—MBS

Frequency: 1490 Kc. Power: 250 Watts
 Owned-Operated By: KHUZ, Inc.
 Business Address: Box 110
 Phone Number: 1600
 News Service: UP
 Trans. Serv.: World, SESAC
 President: R. G. Hughes
 Manager: Jack Roberts
 Commercial Manager: Louis Roberts
 Chief Engineer: Herman Kreiger

KNEL

BRADY—1935—KBS

Frequency: 1490 Kc. Power: 250 Watts
 Owned-Oper. By: G. L. Burns
 Business-Studio Address: Brady
 Phone Number: 7777
 News Service: AP
 Representative: Hil F. Best
 Pres., Gen. Manager: G. L. Burns
 Commercial Manager: J. S. Sloane
 Chief Engineer: Cecil Nellin

KSTB

BRECKENRIDGE—1947—KBS

Frequency: 1430 Kc. Power: 1000 Watts d.
 Owned-Oper. By: Stephens County Bcstg. Co.
 Business-Studio Address: Miller Bldg.
 Phone Number: 1430
 News Service: AP
 Transcription Service: Lang-Worth
 Representative: Best, Melville
 Pres., Gen. Mgr.: R. W. Chapman
 Chief Engineer: R. E. Smith

KWHI

BRENHAM—1947

Frequency: 1280 Kc. Power: 1000 Watts d.
 Owned-Oper. By: Tom S. Whitehead, Sr.
 Business Address: 108½ Main St.
 Phone Number: 3655
 News Service: UP
 Transcription Service: World
 Pres., Gen., Sta. Mgr.: Tom S. Whitehead, Sr.
 Commercial Manager: J. C. Price
 Chief Engineer: Don Dickson, Jr.

KTFY

BROWNFIELD—1949—KBS

Frequency: 1300 Kc. Power: 1000 Watts d.
 Owned-Oper. By: Terry Cty. Bcstg. Co.
 Address: Drawer 1032
 Phone Number: 2111
 News Service: UP
 Transcription Service: Standard, World, Cap.
 Pres., Sta., Gen., Comm. Mgr.: Mike A. Barrett
 Program Director: Dick Aker
 Chief Engineer: Ivan Anderson

KBOR

BROWNSVILLE—1949—ABC

Frequency: 1600 Kc. Power: 1000 Watts d.
 Owned-Oper. By: Brownsville Bcstg. Co.
 Address: Box 472
 Phone Number: 2-5677
 Air Time: 6 a.m.-12
 News Service: UP
 Trans. Service: World, Thesaurus
 Representative: Best
 Membership: NARTB
 Pres., Gen., Sta. Mgr.: M. J. Wilson
 Commercial Manager: Vance C. Wilson
 Prom. Mgr., Pub. Dir.: Earl Wheeler
 Chief Engineer: Willis A. Wilson

KBWD

BROWNWOOD—1941—MBS

TEXAS STATE

Frequency: 1380 Kc. Power: 1000 Watts d.;
 500 Watts n.
 Owned-Oper. By: Brown County Bcstg. Co.
 Business-Studio Address: 800 Hawkins St.
 Phone Number: 2401
 Air Time: Full Time
 News Service: AP
 Representative: Pearson
 Pres., Gen., Sta. Mgr.: W. Mayes
 Commercial Manager: Joe B. Foster
 Sales Prom. Mgr.: Bill Jamar
 Publicity Director: Barbara Taylor
 Program Director: Wendell Mayes, Jr.
 Chief Engineer: A. W. Stewart

KEAN

BROWNWOOD—1953

Frequency: 1240 Kc. Power: 100 Watts
 Owned-Oper. By: Lyman Brown Enterprises

KORA

BRYAN—1947—MBS

Frequency: 1240 Kc. Power: 250 Watts
 Owned-Oper. By: Bryan Bcstg. Co.
 Bus.-Studio Address: 604 Varisco Bldg.
 Phone Number: 3-1240
 Pres., Gen. Mgr.: David C. Jones, Jr.
 Comm., Prom. Mgr.: Mike Mistovich
 Chief Engineer: James W. Robertson

KDET

CENTER—1949—KBS

Frequency: 930 Kc. Power: 1000 Watts d.
 Owned-Operated By: Center Bcstg. Co., Inc.
 Address: 205 Austin St.
 Phone Number: 1199
 News Service: UP
 Transcription Service: Associated
 Representative: Hil F. Best
 Program Director: Tolbert E. Foster
 Gen., Sta. Mgr.: Tom E. Foster
 Chief Engineer: Harlan Riley

KCTX

CHILDRESS—1947—MBS

Frequency: 1510 Kc. Power: 250 Watts d.
 Owned-Oper. By: Golden West Bcstg. Co., Inc.
 Bus.-Studio. Address: 217½ N. Main
 Phone Number: 1085-6
 Air Time: Local sunrise-sunset
 News Service: AP
 Transcription Service: World
 Representative: Hil F. Best
 President: R. Malone Hagan
 General Manager: George D. Cowan
 Program Director: LeRoy Carter
 Publicity Director: Nelle Carter
 Chief Engineer: William V. Queen

KCLE

CLEBURNE—1947

Frequency: 1120 Kc. Power: 250 Watts d.
 Owned-Oper. By: Marti, Inc.
 Address: 919 N. Main
 Phone Number: 5-6643
 News Service: AP
 Representative: Hil F. Best
 Membership: NARTB, BAB
 Pres., Gen., Sta. Mgr.: George W. Marti
 Commercial Mgr.: John Marti
 Sales Prom. Mgr.: Frank H. Hardgrove
 Program Director: D'Voe Lee
 Chief Engineer: Walter C. Lacy

KSTA

COLEMAN—1947—KBS

Frequency: 1000 Kc. Power: 250 Watts d.
 Owned-Oper. By: Coleman County Bcstg. Co.
 Business Address: Box 432
 Phone Number: 8406
 News Service: UP
 Transcription Service: World
 Membership: BAB
 President: H. H. Jackson
 Gen., Sta. Mgr.: Floyd Shelton
 Comm., Prom. Mgr.: Paul Johnson
 Chief Engineer: J. D. Larson

WTAW

COLLEGE STATION—1922—KBS

Frequency: 1150 Kc. Power: 1000 Watts d.
 Owned-Oper. By: A. & M. College of Tex.

Bus.-Studio Address: College Station
 Phone Number: 66724
 Sta. Mgr.: Richard L. Webb
 Commercial Manager: Elsie Patranello
 Chief Engineer: Jerry Merryman

KVMC

COLORADO CITY—1951

Frequency: 1320 Kc. Power: 500 Watts d.
 Owned-Oper. By: John & Eldon Mahon
 Address: P. O. Box 990
 Phone Number: 1320
 News Service: AP
 Transcription Service: Thesaurus, Capitol
 Representative: Best
 Co-Owners: Eldon & John Mahon
 General Manager: Charles Diegel
 Chief Engineer: Porter Richardson

KMCO

CONROE—1951

Frequency: 900 Kc. Power: 500 Watts d.
 Owned-Oper. By: Montgomery County
 Bcstg. Co.
 Address: P. O. Box 1464
 Phone Number: 1190
 News Service: UP
 Transcription Service: Standard, Thesaurus
 President: Reagan Smith
 Station Manager: James C. Dorrell
 Commercial Manager: David L. Oglesby
 Program Director: Hal H. Coley
 Chief Engineer: John W. Neathery, Jr.

KEYS

CORPUS CHRISTI—1941

Frequency: 1440 Ks. Power: 1000 Watts d.;
 500 Watts n.
 Owned-Operated By: Nueces Bcstg. Co.
 Address: Centre Theatre Bldg.
 Phone Number: 2-7411
 Transcription Service: World
 Representative: O. L. Taylor
 General Manager: Aubrey Jackson
 Program Director: Allan Dale
 Chief Engineer: Harold Griffith

KRIS

CORPUS CHRISTI—1937—NBC-TQN

Frequency: 1360 Kc. Power: 1000 Watts
 Owned-Oper. By: Gulf Coast Bcstg. Co.
 Address: P. O. Box 840
 Phone Number: 4-6354
 Air Time: Full Time
 News Service: AP
 Transcription Service: Standard
 Representative: Free & Peters
 Pres., Gen., Sta. Mgr.: T. Frank Smith
 Commercial Manager: William Eikner
 Program Director: Charles Nethery
 Chief Engineer: Don Morris

KSIX

CORPUS CHRISTI—1947

Frequency: 1230 Kc. Power: 250 Watts
 Owned-Oper. By Corpus Christi Bdstg. Co., Inc.
 Address Show Room Bldg.
 Phone Number 2-9242
 News Service AP
 Transcriptions Service Thesaurus
 Representative ForJoe
 Membership NARTB
 President Vann M. Kennedy
 Commercial Mgr. Charles R. Manning
 Program Director Eugene M. Looper
 Chief Engineer W. K. Bridges

KUNO

CORPUS CHRISTI—1950—MBS

Frequency: 1400 Kc. Power: 250 Watts
 Owned-Oper. By KUNO, Inc.
 Address-Trans. Loca. P. O. Box 4286
 Phone 4-5203
 Air Time Full Time
 Transcription Service Associated
 Representative Everett-McKinney, Inc.
 Membership BAB
 Pres., Gen. Mgr. Leslie C. Smith
 Commercial Mgr. Herb Garrett
 Chief Engineer J. H. Mayberry

KWBU

CORPUS CHRISTI—1944

Frequency: 1030 Kc. Power: 50,000 Watts d.
 Owned-Oper. By Texas Baptist Convention
 Address White-Plaza Hotel
 Representative Branham
 News Service AP
 President Carr P. Collins
 Gen., Comm. Mgr. Harry H. Hayes
 Program Director George Wilcox
 Chief Engineer Nestor Cuesta

KAND

CORSICANA—1937

Frequency: 1340 Kc. Power: 250 Watts
 Owned-Operated By Alto, Inc.
 Bus-Studio Address State Natl. Bank Bldg.
 Phone Number 2486
 News Service UP
 Transcription Service World, Thesaurus
 Representative Branham
 Pres., Gen. Mgr. Luther A. Johnson, Jr.
 V.P., Prog. Dir. Perry Taylor

KIVY

CROCKETT—1949—KBS

Frequency: 1570 Kc. Power: 250 Watts d.
 Owned-Oper. By Pioneer Bcstg. Co.
 Address Box 670
 Phone Number 222
 News Service AP
 Transcription Service World
 Membership NARTB
 Comm., Prom. Mgr., Chief Eng. Bill Carter
 Gen., Sta. Mgr., Prog. Dir. James H. Gibbs

KCFH

CUERO—1949

Frequency: 1600 Kc. Power: 500 Watts d
 Owned-Oper. By A. M. Respondek
 Phone Number 5-3430
 Representative Best
 Pres., Gen. Mgr., Chief Engr. A. M. Respondek
 Commercial Mgr. Frank Notzon

KXIT

DALHART—1948—KBS

Frequency: 1410 Kc. Power: 500 Watts a.
 Owned-Operated By Dalrad Associates
 Address Box 1350
 Phone Number 740
 News Service UP
 Representative Best
 Transcription Service World
 General Manager Ken Bishop
 Chief Engineer Bill Smith

KGKO

DALLAS—1953

Frequency: 1480 Kc. Power: 1000 Watts d.;
 500 Watts n.
 Owned-Oper. By Lakewood Bcstg. Co.
 Address Cliff Tower Hotel
 Phone Number Westbrook 7594
 Representative McGillvra
 News Service UP
 General Manager Leonard Coe
 Commercial Mgr. Bill Morgan
 Program Director Bud Vincent
 Promotion Mgr. Henry Steele
 Chief Engineer Henderson Rogers

KIXL

DALLAS—1947

Frequency: 1040 Kc. Power: 1000 Watts d.
 Owned-Operated By Variety Bcstg. Co., Inc.
 Business-Studio Address 1401 S. Akard St.
 Phone Number Riverside 4521
 News Service AP
 Transcription Service Standard, World,
 Capitol, Associated, McGregor, Thesaurus
 Representative ForJoe
 President Lee Segall
 Gen., Sta. Mgr. T. W. Massey
 Chief Engineer Bob E. Tripp

KLIF

DALLAS—1947

Frequency: 1190 Kc. Power: 5000 Watts d.,
 1000 Watts n.
 Owned-Oper. By Trinity Bcstg. Corp.
 Business-Studio Address 2104 Jackson St.
 Phone Number RAndolph 7121
 News Service UP
 Representative H-R Reps.
 President B. R. McLendon
 General Manager Gordon McLendon
 Sta., Comm. Mgr. Bill Weaver
 Program Director Bill Stewart
 Chief Engineer Glenn Callison

KRLD

DALLAS—1926—CBS

Frequency: 1080 Kc. Power: 50,000 Watts
 Owned-Operated By: KRLD Radio Corp.
 Address: Herold Square
 Phone Number: Randolph 6811
 Air Time: Full Time
 News Service: UP, INS, AP
 Transcription Service: Standard, SESAC
 Newspaper Affiliation: "Times Herald"
 Representative: Branham
 Membership: NARTB, BAB
 President: Clyde W. Remberl
 Commercial Mgr.: William A. Roberts
 Sales Prom. Mgr.: A. J. Putnam
 Program Director: Ted Parrino
 Chief Engineer: Bill B. Honeycutt

KSKY

DALLAS—1941

Frequency: 660 Kc. Power: 1000 Watts d.
 Owned-Operated By: SKY Bcstg. Service
 Business-Studio Address: 2927 Maple
 Phone Number: Randolph 6193
 News Service: UP
 President: A. L. Chilton
 Gen. Prom. Manager: R. G. Terrill
 Commercial Manager: R. L. Kanatzar
 Chief Engineer: Morris M. Ming

WFAA

DALLAS—1922—NBC-ABC
 TEXAS QUALITY

Frequency: 820 Kc. Power: 50,000 Watts
 Frequency: 570 Kc. Power: 5000 Watts
 Owned-Oper. By: A. H. Belo Corp.
 Business-Studio Address: 1122 Jackson St.
 Phone Number: Riverside 9631
 Air Time: Unlimited
 News Service: AP, UP
 Representative: Edward M. Petry
 Membership: NARTB, BAB
 President: E. M. Dealey
 Supervisor: Martin B. Campbell
 Station Manager: Alex Keese
 Commercial Manager: George K. Utley
 Sales Prom. Mgr.: Mrs. Winona Portwood
 Program Director: Karl Lambertz
 Chief Engineer: William C. Ellis

WRR

DALLAS—1920—MBS-TEXAS STATE

Frequency: 1310 Kc. Power: 5000 Watts
 Owned-Oper. By: City of Dallas
 Business Address: Municipal Radio Bldg.
 Phone Number: Tenison 6101
 News Service: AP
 Transcription Service: Associated
 Representative: John Blair
 Membership: NARTB, BAB
 Gen., Comm. Mgr., Chief Engr. Durward Tucker
 Sales Prom. Mgr.: Pete Tedelie
 Program Director: Richard Workman

KDLK

DEL RIO—1945—KBS

Frequency: 1230 Kc. Power: 250 Watts
 Owned-Operated By: Del Rio Bcstg. Co.
 Business Address: P. O. Box 1162
 Phone Number: 1745
 News Service: UP
 Transcription Service: Standard
 General Manager: Don R. Howard
 Program Director: Edward Williams
 Chief Engineer: Pat Jeter

KDSX

DENISON—1948

Frequency: 950 Kc. Power: 500 Watts
 Owned-Oper. By: L. L. Hendrick & B. V. Hammond
 Address: Box 263
 Phone Number: 3400
 News Service: AP
 Transcription Service: Lang-Worth
 Co-Owners: B. V. Hammond, Jr., L. L. Hendrick
 Program Director: Allen Hundley
 Chief Engineer: J. D. Knight

KDNT

DENTON—1938

Frequency: 1440 Kc. Power: 1000 Watts d.;
 500 Watts n.
 Owned-Operated By: Harwell V. Shepard
 Address: Radio Center Bldg.
 Phone Number: Central 4144
 News Service: UP
 Transcription Service: Thesaurus
 Owner & Manager: Harwell V. Shepard

KDDD

DUMAS—1948

Frequency: 800 Kc. Power: 250 Watts d.
 Owned-Oper. By: North Plains Bcstg. Corp.
 Address: Box 337
 Phone Number: 2-5000
 News Service: AP
 Transcription Service: Standard
 Representative: Hil F. Best
 Pres., Gen. Mgr.: Ken Duke
 Promotion Mgr.: Al Tremble
 Program Director: Bill Lask

KERC

EASTLAND—1953

Frequency: 1590 Kc. Power: 500 Watts d.
 Owned-Oper. By: Tri-Cities Bcstg. Co.

KURV

EDINBURG—1947—KBS

Frequency: 710 Kc. Power: 250 Watts d.
 Owned-Oper. By: KURV, Inc.
 Address: P. O. Box 480
 Phone Number: 710

News ServiceUP
 Transcription ServiceMcGregor
 RepresentativeForJoe
 PresidentRogers Kelley
 General Manager.....J. M. McDonald
 Program Director.....Don Mallory
 Chief Engineer.....I. D. Williams

KULP

EL CAMPO—1948

Frequency: 1390 Kc.....Power: 500 Watts d.
 Owned-Oper. By..Wharton County Bcstg. Co.
 Business Address.....Box 1390
 Phone Number1390
 News ServiceUP
 Transcription ServiceLang-Worth
 PresidentCulp Krueger
 General Manager.....Bob Hathway
 Program Director.....Jerry H. Werilla
 Chief Engineer.....Joe Miller

KELP

EL PASO—1947

Frequency: 920 Kc.....Power: 1000 Watts
 Owned-Oper. By.....Trinity Bdcstg. Corp.
 Address.....4530 Delta St.
 Phone Number3-3659
 RepresentativeEverette-McKinney
 President.....B. R. McLendon
 General Manager.....Joe Roddy, Jr.
 Commercial Mgr.....Elmer Allen
 Program Director.....Al Cobb

KEPO

EL PASO—1948—ABC

Frequency: 690 Kc.....Power: 10,000 Watts
 Owned-Oper. By.....KEPO, Inc.
 Address.....2419 N. Piedras St.
 Phone Number5-2731
 Air Time.....Full Time
 News ServiceUP
 Transcription Service...Standard, Lang-Worth
 RepresentativeAvery-Knodel, Inc.
 MembershipNARTE, BAB
 Pres., Gen. Mgr.....Miller C. Robertson
 Sta., Comm. Mgr.....Willard L. Kline
 Prom. Mgr., Prog., Pub. Dir...Arthur B. Davis
 Chief Engineer.....E. L. Gemoets

KROD

EL PASO—1940—CBS

Frequency: 600 Kc.....Power: 5000 Watts
 Owned-Oper. By.....El Paso Times Inc.
 Business-Studio Address...2201 Wyoming St.
 Phone Number2-6551
 News ServiceAP
 Transcription ServiceCapitol
 RepresentativeBranham
 Chairman.....Dorrance D. Roderick
 Pres., Gen., Comm. Mgr.....Val Lawrence
 Promotion Manager.....T. Wiseheart
 Program Director.....Ted Hunt
 Chief Engineer.....Edward P. Talbot

KSET

EL PASO—1949—MBS

Frequency: 1340 Kc.....Power: 250 Watts
 Owned-Oper. By.....Rio Grande Bcstg. Co.
 Address.....904 Magoffin
 Phone Number326-23
 RepresentativeMcGillvra
 Transcription ServiceCapitol
 News ServiceAP
 PresidentFred Hervey
 General Manager.....George R. Thady
 Commercial Manager.....Don Brooks
 Program Director.....Juanita Wells
 Promotion Manager.....Sheldon Turner
 Chief Engineer.....John Sheehan

KTSM

EL PASO—1929—NBC

Frequency: 1380 Kc.Power: 1000 d., 500 n.
 Owned-Oper. By.....Tri-State Bcstg. Co., Inc.
 Bus-Studio Address.....801 N. Oregon St.
 Phone Number2-5423
 Air Time6 a.m.-11:30 p.m.
 News ServiceUP
 Transcription Service.....Thesaurus, World
 Representative.....George P. Hollingbery
 MembershipNARTE
 Pres., Gen. Mgr.....Karl O. Wyler
 Commercial Manager.....Roy T. Capman
 Prom. Mgr., Pub. Dir.....Karl O. Wyler, Jr.
 Program Director.....Jack Chapman
 Chief Engineer.....Kenneth J. Walton

KFLD

FLOYDADA—1950—KBS

Frequency: 900 Kc.....Power: 250 Watts d.
 Owned-Operated By...West Texas Bcstrs. Inc.
 Address.....Ralls Hwy.
 Phone Number900
 News ServiceUP
 Transcription ServiceStandard
 RepresentativeContinental
 PresidentEd Holmes
 Gen., Sta., Comm. Mgr.....W. Robison
 Program Director.....Carl Minor
 Chief Engineer.....Joe Cole

KCNC

FORT WORTH—1947

Frequency: 870 Kc.....Power: 250 Watts d.
 Owned-Oper. By...Blue Bonnet Bcstg. Corp.
 Bus-Studio Address.....2100 East 4th St.
 Phone NumberFortune 7175
 News ServiceUP
 MembershipNARTE
 Pres., Gen., Sta. Mgr.....J. H. Speck
 Commercial Manager.....Herman Clark
 Asst. Mgr., Chf. Engr.....Chester Grubbs

UP!
UP!
UP! goes the
market!

WBAP-TV ALONE covers a \$2½ billion market... add the tremendous power of **WBAP 820 and 570 PLUS** the finest programming
 greatest facilities
 biggest names

*AND... you'll see why the
SMARTEST advertisers turn to...*

WBAP
AM ★ FM ★ TV
820 ★ 570 ★ CHANNEL 5

STAR-TELEGRAM STATIONS • ABC - NBC • FORT WORTH, TEXAS

AMON CARTER Chairman	AMON CARTER, JR. President	HAROLD HOUGH Director	GEORGE CRANSTON Manager	ROY BACUS Commercial Manager
-------------------------	-------------------------------	--------------------------	----------------------------	---------------------------------

FREE & PETERS, INC. — National Representatives



K C U L

FORT WORTH—1946

Frequency: 1540 Kc. Power: 5000 Watts d.,
1000 Watts n.
Owned-Oper. By East-West Bdcstg. Co.
Address 3607 Camp Bowie Blvd.
Phone Number SUNset 6555
Representative Burn-Smith
Transcription Service Thesaurus
Pres., Gen., Sta. Mgr. Jas. G. Ulmer
Commercial Manager Hewel Jones
Sales Promotion Mgr. Jack Reed, Jr.
Program Director Dan Allison
Chief Engineer R. L. McAlister

K F J Z

**FORT WORTH
MBS-TEXAS STATE**

Frequency: 1270 Kc. Power: 5000 Watts
Owned-Oper. By Tarrant Bcstg. Co.
Business-Studio Address 1201 W. Lancaster
Phone Number Ed 3474
News Service AP
Transcription Service Associated
Representative John Blair
Membership BAB
Pres., Gen. Mgr. Gene L. Cagle
Comm. Mgr. Clyde D. Pemberton
Program Director Hczel Riley
Chief Engineer James T. Peterson

K W B C

FORT WORTH 1946

Frequency: 970 Kc. Power: 1000 Watts d.
Owned-Oper. By Assoc. Bcstrs. Inc.
Business-Studio Address 806 Taylor
Phone Number Fortune 8262
News Service UP
Representative Rambeau
President John Flood Jr.
General Manager Joe W. Evans
Chief Engineer Melvin Parsons

K X O L

FORT WORTH—1947

Frequency: 1360 Kc. Power: 1000 Watts
Owned-Oper. By Fort Worth Bcstg. Co., Inc.
Bus-Studio Address 3004 W. Lancaster St.
Phone Number Edison 1448
News Service AP
Representative Forjoe & Co.
Pres., Gen., Sta. Mgr. E. Fletcher
Comm., Prom. Mgr. Ed Bayro
Chief Engineer John R. Crouse

W B A P

**FORT WORTH—1922
NBC-ABC-TQN**

Frequency: 820 Kc. Power: 50,000 Watts
Frequency: 570 Kc. Power: 5000 Watts
Owned-Oper. By Carter Publications, Inc.
Business Address 3900 Barnett St.
Phone Number Ft. Worth LO-1931

Air Time Full Time
News Service AP
Transcription Service Associated, World
Representative Free & Peters
Membership NARTB
Bd. Chairman Amon Carter, Sr.
President Amon Carter, Jr.
Director Harold Hough
General Manager George Cranston
Commercial Manager Roy Bacus
Program Director Ed Lally
Promotion Manager Howard Fisher
Chief Engineer R. C. Stinson

K N A F

FREDERICKSBURG—1947—MBS-KBS

Frequency: 1340 Kc. Power: 250 Watts
Owned-Oper. By Gillespie Bcstg. Co., Inc.
Business-Studio Address P. O. Box 347
Phone Number 311
Air Time Full Time
Representative Hil F. Best
President Arthur Stehling
Chf. Engr., Comm., Gen. Mgr. Norbert A. Fritz

K B R Z

FREEPORT—1952

Frequency: 1460 Kc. Power: 500 Watts d.
Owned-Oper. By Brazosport Bcstg. Co.
Address Box 1077
Phone Number 3-2655
News Service AP
Transcription Service World
President Kelly Bell
General Manager Rex Bodoin
Commercial Manager Jack Howard
Program Director Will Coker
Promotion Manager Charles Dunaway
Chief Engineer Kenneth Ferguson

K G A F

GAINESVILLE—1947—KBS

Frequency: 1580 Kc. Power: 250 Watts d.
Owned-Oper. By Gainesville Bcstg. Co.
Address Box 222
Phone Number 834, 1600
News Service AP
Transcription Service Standard, Ullman
Representative Clyde Melville
President Joe M. Leonard, Sr.
General Manager Joe M. Leonard, Jr.
Comm. Mgr. Earl Leonard
Chief Engineer Cordell Martin

K G B C

GALVESTON—1947

Frequency: 1540 Kc. Power: 1000 Watts d.,
250 n.
Owned-Oper. By The Galveston Bcstg. Co.
Business-Studio Address P. O. Box 1138
Phone Number 3-4329
News Service AP
Transcription Service SESAC
Station Representative John E. Pearson

Membership NARTB, BAB
 Gen., Sta. Mgr. James W. Bradner, Jr.
 Asst. Manager Roger Beane
 Prog. Dir., Chief Eng. Ken Gilmore

KLUF

GALVESTON—1922

Frequency: 1400 Kc. Power: 250 Watts
 Owned-Oper. By The KLUF Bcstg. Co.
 Business-Studio Address 300 Haden Bldg.
 Phone Number 5-6676
 News Service UP
 Representative William G. Rambeau
 Pres., Gen. Mgr. Geo. Roy Clough
 Chief Engineer Lee Clough

KSIJ

GLADEWATER—1949

Frequency: 1430 Kc. Power: 1000 Watts d.
 Owned-Oper. Bq T. W. Lee
 Address Gladewater
 Phone Number 2181
 News Service AP
 Representative Hil F. Best
 Membership NARTB, BAB
 President T. W. Lee
 Gen., Sta., Comm. Mgr. Tom Perryman
 Program Director Dowell Bushnell
 Chief Engineer Lloyd Johnson

KCTI

GONZALES—1947—KBS

Frequency: 1450 Kc. Power: 250 Watts
 Owned-Oper. By Gonzales Bcstg. Co.
 Business Address P. O. Box 158
 Phone Number 770
 News Service AP
 Transcription Service SESAC
 Representative Gene Grant, Cooke
 Gen. Comm. Mgr. Lawrence M. Walshak
 Prom. Mgr., Pgm. Dir., Chief Engr.
 Frank Wilson, Jr.

KSWA

GRAHAM—1948

Frequency: 1330 Kc. Power: 500 Watts d.
 Owned-Oper. By Southwestair, Inc.
 Address Box 1050
 Phone Number 1200
 News Service UP
 President Clay E. Thompson, Jr.
 Gen., Comm. Mgr., Chf. Engr. H. V. Newsom
 Program Director Eugene Turner

KGVL

GREENVILLE—1946
 MBS-TEXAS STATE-KBS

Frequency: 1400 Kc. Power: 250 Watts
 Owned-Operated By Truett Kimzey
 Address Box 1015
 Air Time 18 hrs.
 News Service AP
 Representative Pearson

General Manager Leo Hackney
 Program Director James D. Jones
 Chief Engineer Stafford E. Davis

KCLW

HAMILTON—1948

Frequency: 900 Kc. Power: 250 Watts d.
 Owned-Oper. By Hamilton Bcstg. Co.
 Phone Number 500
 News Service UP
 Transcription Service Thesaurus
 Membership NARTB
 Pres., Gen. Sta. Mgr. Clyde Weatherby
 Comm. Mgr., Prog. Dir. A. B. Scott
 Chief Engineer Carl Knely

KGBS

HARLINGEN—1941—CBS

Frequency: 1530 Kc. Power: 50,000 Watts d.;
 10,000 n.
 Owned-Oper. By Harbenito Bcstg. Co., Inc.
 Address 1519 W. Harrison St.
 Phone Number 2200
 Air Time Full Time
 News Service UP
 Representative Pearson
 President McHenry Tichenor
 Commercial Mgr. I. S. Roberts
 Chief Engineer Harold Jones

KGRI

HENDERSON—1947

Frequency: 1000 Kc. Power: 250 Watts a.
 Owned-Oper. By Henderson Bcstg. Co.
 Business-Studio Address Box 311
 Phone Number 4528
 News Service UP
 Representative Best
 Transcription Service World, SESAC
 President Roy B. Cannon
 General Manager Cliff Crawford
 Chief Engineer John M. Bolin

KPAN

HEREFORD—1948

Frequency: 860 Kc. Power: 250 Watts d.
 Owned-Oper. By Marshall Formby
 Address P. O. Box 868
 Phone Number 860
 Representative Best
 Transcription Service Thesaurus
 News Service UP
 President Marshall Formby
 Gen. Sta. Mgr. Clint Formby
 Commercial Mgr. Tom Hulsey
 Chief Engineer Dennis Surber

KHBR

HILLSBORO—1948

Frequency: 1560 Kc. Power: 250 Watts d.
 Owned-Operated By Hill County Bcstg. Co.
 Phone Number 594
 President Ray J. Williams

KATL

HOUSTON—1947

Frequency: 1590 Kc. Power: 5000 Watts
 Owned-Oper. By Texas Bdcsters., Inc.
 Address 412 Main St.
 Phone Number PReston 3108
 News Service UP
 Transcription Service Lang-Worth
 Representative McGillvra
 President William H. Talbot
 Gen., Sta. Mgr. King H. Robinson
 Program Director Webb Hunt
 Chief Engineer Edward Martin

KCOH

HOUSTON—1948

Frequency: 1430 Kc. Power: 1000 Watts d.
 Owned-Oper. By Call of Houston Inc.
 Business-Studio Address 1 Main St.
 Phone Number Charter 1888
 Representative Clarke
 President William A. Smith
 General Manager Robert C. Meeker
 Program Director Vernon Chambers
 Chief Engineer Harold Weinzel

KLBS

HOUSTON—1948

Frequency: 610 Kc. Power: 5000 Watts
 Owned-Operated By Trinity Bcstg. Corp.
 Bus.-Studio Address 2104 Jackson St.
 Phone Number Preston 1161
 News Service UP
 Transcription Service World
 Representative Everett-McKinney, Inc.
 President B. R. McLendon
 Executive Director Gordon B. McLendon
 Station Manager Glenn Douglas
 Program Director Art Magee
 Chief Engineer Glenn Cook, Jr.

KNUZ

HOUSTON—1948

Frequency: 1230 Kc. Power: 250 Watts
 Owned-Oper. By Veterans Bcstg. Co.
 Business-Studio Address 4701 Caroline St.
 Phone Number Keystone 2581
 News Service UP
 Transcription Service SESAC
 Representative Forjoe
 Membership NARTB
 President Max E. Jacobs
 Gen., Sta. Mgr. David Morris
 Commercial Mgr. Bill Lightfoot
 Program Director Ken Grant
 Chief Engineer O. C. Crossland

KPRC

HOUSTON—1926

NBC—T. Q. N.

Frequency: 950 Kc. Power: 5000 Watts
 Owned-Oper. By The Houston Post Co.

Address P. O. Box 1234
 Phone Number MADison 9271
 News Service AP
 Transcription Service Thesaurus
 Representative Edw. Peiry & Co.
 President W. P. Hobby
 Gen., Sta. Mgr. Jack W. Harris
 Commercial Manager Jack McGrew
 Promotion Manager Kirt Harriss
 Program Director Frank Sullivan
 Publicity Director Sharon Anderson
 Chief Engr. Harvey T. Wheeler

KTHT

HOUSTON—1944—MBS

Frequency: 790 Kc. Power: 5000 Watts
 Owned-Oper. By Texas Radio Corp.
 Bus.-Studio Address 4005 Travis St.
 Phone Number Keystone 5535
 Air Time Full Time
 News Service UP
 Representative H-R Reprs.
 President Robert Straus
 Gen., Comm., Sta. Mgr. Bill Bennett
 Prom., Pub. Dir. Lauri Schutt
 Program Director Tim Osborne
 Chief Engineer O. B. Johnson

KTRH

HOUSTON—1930—CBS-TEXAS

Frequency: 740 Kc. Power: 50,000 Watts
 Owned-Operated By KTRH Bdcstg. Co.
 Address Rice Hotel
 Phone Number Preston 4361
 News Service AP, INS
 News. Affil. The Chronicle
 Transcription Service SESAC
 Representative John Blair
 President B. F. Orr
 Station Manager Ray Herndon
 Sales Manager Ray Bright
 Promotion Mgr. Helen Bender
 Program Director Tom Jacobs
 Engineers Tom Hiner, Lester Mullan

KXYZ

HOUSTON—1930—ABC

Frequency: 1320 Kc. Power: 5000 Watts
 Owned-Oper. By Shamrock Bdcstg.
 Address Gulf Bldg.
 Phone Number CApiitol 6151
 Air Time Full Time
 News Service AP, UP
 Newspaper Affiliation Citizen Newspapers
 Transcription Service World
 Representative Free & Peters, Inc.
 Membership NARTB, BAB
 President Glenn H. McCarthy
 V.P., Gen. Mgr. Fred Nahas
 Sta., Comm. Manager Ted Hills
 Program Director Ken Bagwell
 Prom., Pub. Dir. Wayne E. Thompson
 Chief Engineer Gerald R. Chinski

K S A M

HUNTSVILLE—1938—KBS-MBS

Frequency: 1490 Kc. Power: 250 Watts
 Owned-Oper. By Huntsville Bcstg. Co.
 Address Box 312
 Phone Number 30
 News Service AP
 Transcription Service Capitol, SESAC
 President M. B. Cauthen
 Gen., Sta. Mgr. Ted Lott
 Comm., Sales Prom. Mgr. Roy Greer
 Chief Engineer Jack Nichols

K E B E

JACKSONVILLE—1947—KBS

Frequency: 1400 Kc. Power: 250 Watts
 Owned-Operated By Bill A. Laurie
 Phone Number 2211
 News Service AP
 Transcription Service Lang-Worth
 Gen. Mgr. Bill A. Laurie
 Station Manager Mrs. B. A. Laurie
 Chief Engineer J. W. Kriegel

K T X J

JASPER—1948

Frequency: 1240 Kc. Power: 250 Watts
 Owned-Oper. By Jasper Bcstg. Co.
 Address Texas Theatre Bldg.
 Phone Number 580
 President Joe Fisher

K M B L

JUNCTION—1951

Frequency: 1450 Kc. Power: 250 Watts
 Owned-Operated By Kimble County Bcstg. Co.
 Phone Number 70

K E R B

KERMIT—1950

Frequency: 600 Kc. Power: 1000 Watts d.
 Owned-Oper. By KERB, Inc.
 Address Hwy. 302
 Phone Number 3481
 Transcription Service Thesaurus, SESAC
 News Service UP
 President George H. Cook
 General Manager H. J. Porter
 Program Director Ray Boyd Kilman
 Chief Engineer Bob Shackelford

K E R V

KERRVILLE—1948

Frequency: 1230 Kc. Power: 250 Watts
 Owned-Oper. By Kerrville Bdcstg. Co.
 Address P. O. Box 791
 Phone Number 900 and 999
 News Service AP
 Transcription Service Thesaurus, Capitol
 Membership BAB
 President Hal Peterson

Gen., Sta. Mgr. William G. Feild
 Program Director Carol Woodard
 Chief Engineer Clyde Jones

K O C A

KILGORE—1936—KBS

Frequency: 1240 Kc. Power: 250 Watts
 Owned-Oper. By Radio Sta. KOCA, Inc.
 Address Box 989
 Phone Number 2001
 News Service AP
 Transcription Service World
 President Roy G. Terry
 Gen., Sta. Mgr. H. A. Degner
 Comm., Sales Prom. Mgr. Wayne Douglas
 Chief Engineer George Chase

K I N E

KINGSVILLE—1948

Frequency: 1330 Kc. Power: 1000 Watts d.
 Owned-Oper. By KINE, Inc.
 Address 205 E. King St.
 Phone Number 2-2822
 News Service UP
 Transcription Service Capitol
 Representative Hil F. Best
 Membership NARTB
 President James H. Clement
 General Manager Ben A. Glusing
 Comm., Sta. Mgr. Eston R. Pace
 Chief Engineer R. T. Whitaker

K P E T

LAMESA—1947—KBS

Frequency: 690 Kc. Power: 250 Watts
 Operated By Lamesa Bcstg. Co.
 Business-Address Box 30
 Phone Number 2404
 News Service AP
 Transcription Service World
 Gen., Sta. Mgr. Bob Bradbury
 Commercial Mgr. Clayton Barkhurst
 Program Director Geneva Crutcher
 Chief Engineer Roland Ouelette

K C Y L

LAMPASAS—1952

Frequency: 1450 Kc. Power: 250 Watts
 Owned-Oper. By Lampasas Bcstg. Co.
 Phone Number 1000
 Representative Best
 President V. Dean Turner
 Program Director Albert Mason Jr.

K V O Z

LAREDO—1952—MBS-KBS

Frequency: 1490 Kc. Power: 250 Watts
 Owned-Operated By Border Bcstrs., Inc.
 Address P. O. Box 1498
 Phone Number 3-4396
 News Service UP
 Representative Continental
 President W. J. Harpole

General Manager.....Burney Jones
 Commercial Manager.....Bill Douthitt
 Program Director.....Evelyn Jones
 Chief Engineer.....Frank Manuel

KLVT

LEVELLAND—1949

Frequency: 1230 Kc.....Power: 250 Watts
 Owned-Oper. By.....Herald Bcstg. Co.
 Address.....P. O. Box 866
 Phone Number.....1030
 News Service.....AP
 Transcription Service.....World, Thesaurus,
 SESAC
 Station Representative.....Melville
 President.....Forrest Weimhold
 General Manager.....Jerry Saunders
 Program Director.....Eddie Langill
 Commercial Mgr.....Bobby Garrison
 Chief Engineer.....Gilbert Patschke

KVOW

LITTLEFIELD—1947—KBS

Frequency: 1490 Kc.....Power: 250 Watts
 Owned-Oper. By.....Southwestern Bcstrs.
 Business Address.....Box 192
 Phone Number.....400
 News Service.....AP
 Transcription Service.....SESAC
 Membership.....NARTB
 President.....J. C. Rothwell
 General Manager.....J. B. McShan
 Program Director.....Othell W. Whitson
 Chief Engineer.....Wilton Highfield

KFRO

LONGVIEW—1934
 ABC-KBS-TEX. STATE

Frequency: 1370 Kc.....Power: 1000 Watts
 Owned-Oper. By.....Voice of Longview
 Bus. Studio Address.....Curtis Bldg.,
 P. O. Box 792
 Phone Number.....PLaza 8-8261
 Air Time.....Full Time
 News Service.....AP
 Transcription Service.....Lang-Worth
 Representative.....Donald Cooke
 Membership.....NARTB
 President.....James R. Curtis
 Commercial Mgr.....John Allen
 Program Director.....Howard Kuhn
 Chief Engineer.....Leslie Hellums

KLTI

LONGVIEW—1948

Frequency: 1280 Kc.....Power: 1000 Watts d.
 Owned-Operated By.....LeTourneau Radio Corp.
 Address.....P. O. Box 1866
 Phone Number.....PLaza 8-4496
 News Service.....UP
 Transcription Service.....Associated, Standard
 Representative.....Pearson
 Membership.....NARTB
 President.....R. G. LeTourneau

General Manager.....Allen C. Tyler
 Sales Prom., Sta. Mgr.....Arthur L. Greene
 Commercial Mgr.....Allen E. Vinson
 Chief Engineer.....Ken Maxwell

KCBD

LUBBOCK—1947—NBC

Frequency: 1590 Kc.....Power: 1000 Watts
 Owned-Operated By.....Caprock Bcstg. Co.
 Bus. Studio Address.....56 and Ave. A
 Phone Number.....4-1414
 Air Time.....6 a.m.-12 M.
 News Service.....AP
 Transcription Service.....World
 Representative.....John E. Pearson
 Membership.....NARTB, BAB
 President, General Mgr.....Joe H. Bryant
 Business-Manager.....Robert L. Snyder
 Commercial Manager.....George L. Tarter
 Promotion Director.....Leroy L. Land
 Program Director.....John Devine
 Publicity Director.....Jack Tippit
 Chief Engineer.....Frank Lee

KDAV

LUBBOCK—1953

Frequency: 580 Kc.....Power: 500 Watts d.
 Owned-Oper. By.....Western Bcstg. Co.
 Address.....Box 1319
 Phone Number.....4-4567
 President.....D. P. Pinkston
 Program Director.....W. J. Duncan
 Chief Engineer.....Walter Lawson

KFYO

LUBBOCK—1927—ABC

Frequency: 790 Kc.....Power: 5000 Watts d.,
 1000 Watts n.
 Owned-Oper. By.....Plains Radio Bcstg. Co., Inc.
 Business-Studio Address.....914 Ave. J
 Phone Number.....5-5567
 Air Time.....Full Time
 News Service.....AP, UP
 Trans. Service.....Standard, Thesaurus
 Representative.....Katz
 Membership.....NARTB
 Vice Pres.....Parker F. Prouty
 Gen., Sta. Mgr.....Gordon Thompson
 Sales Prom. Mgr.....Jerry Henderson
 Program Director.....Robert A. Nash
 Comm. Mgr., Pub. Dir.....Leon Harris
 Chief Engineer.....W. S. Bledsoe

KSEL

LUBBOCK—1946—MBS

Frequency: 950 Kc.....Power: 1000 Watts d.;
 500 Watts n.
 Owned-Operated By.....Lubbock Bcstg. Co.
 Business Address.....Box 1524
 Phone Number.....3-0484
 Air Time.....Full Time
 News Service.....AP
 Transcription Service.....Lang-Worth
 Representative.....Wm. G. Rambeau & Co.

Membership NARTB, BAB
President Walter G. Russell
 Gen., Sta. Mgr., Pub. Dir. M. M. Rochester
 Comm., Prom. Mgr. W. H. Kyle
 Program Director Wesley Youngblood
 Chief Engineer Roger Hively

KVSP

LUBBOCK—1953

Frequency: 1460 Kc. Power: 500 Watts d.
 Owned-Oper. By Hub Bcstg. Co.
 Address 52nd & Magnolia
 Phone Number 4-1460
 Representative Indie, Grant
 General Manager Wayne D. Tibbs, Jr.
 Commercial Mgr. Hal Ragan
 Promotion Mgr. Randall Abernathy
 Chief Engineer Don Edwards

KRBA

LUFKIN—1938—KBS-ABC

Frequency: 1340 Kc. Power: 250 Watts
 Owned-Operated By Darrell E. Yates
 Address 110 S. First St.
 Phone Number 3-6661
 Representative Continental Radio Sales
 Owner, Gen. Mgr. Darrel E. Yates
 Chief Engineer Ambrose Maxim

KTRE

LUFKIN—1947—MBS

Frequency: 1420 Kc. Power: 1000 Watts
 Owned-Oper. By Forest Capitol Bcstg. Co.
 Address P. O. Box 701
 Phone Number 3-7771
 Air Time Full Time
 News Service AP
 Transcription Service World
 Representative Taylor Co.
 Membership NARTB
 President R. W. Wortham, Jr.
 Gen., Sta. Mgr. Richman G. Lewin
 Comm., Prom. Mgr. Murphy Martin
 Program Director Royce Christenson
 Publicity Director Ernestene Trahan
 Chief Engineer Fred C. Hill

KMLW

MARLIN—1953

Frequency: 1010 Kc. Power: 250 Watts d.
 Owned-Oper. By Falls County Public Service
 Address Box 335
 Phone Number 6-2551
 News Service AP
 General Manager Hugh McBeath
 Commercial Mgr. Duane W. Ramsey
 Program Director Jerry S. Hughes

KMHT

MARSHALL—1947

MBS—TEX. STATE—KBS

Frequency: 1450 Kc. Power: 250 Watts
 Owned-Oper. By Marshall Bcstg. Co.

Business-Studio Address 109 W. Rusk St.
 Phone Number 5-7826
 Air Time Full Time
 News Service AP
 Pres., Gen. Mgr. Earle Fletcher
 Station Manager Myrl Stein
 Comm. Mgr. John Strength, Jr.
 Program Dir. George Warwick
 Chief Engineer R. L. Clay

KRIO

McALLEN—1947—ABC-MBS-TSN

Frequency: 910 Kc. Power: 1000 Watts
 Owned-Oper. By Frontier Bcstg. Co., Inc.
 Business Address 1201 W. Lancaster Ave.
 Phone Number 6-5454
 Air Time 6 a.m.-11:30 p.m.
 News Service AP
 Representative Weed, Air Waves
 President Gene L. Cagle
 Gen., Sta. Mgr. George Breeding, Jr.
 Program Director Norman Mann
 Chief Engineer Wm. Meiners

KMAE

McKINNEY—1947

Frequency: 1600 Kc. Power: 1000 Watts d.
 Owned-Oper. By McKinney Air Enterprises, Inc.
 Bus. Studio Address 218 E. Virginia St.
 Phone Number 2-2651
 News Service AP
 Transcription Service World
 Pres., Gen. Mgr. George W. Smith, Jr.
 Comm., Sales Prom. Mgr. Melvin Belew

KCRS

MIDLAND—1935—ABC

TEXAS STATE

Frequency: 550 Kc. Power: 5000 Watts d.;
 1000 Watts n.
 Owned-Oper. By Clarence Scharbauer, Jr.,
 Ruth Scharbauer
 Business-Studio Address Box 1072
 Phone Number 2-4393
 Air Time Full Time
 News Service UP
 Transcription Service Thesaurus
 Representative John E. Pearson
 Membership NARTB
 President Clarence Scharbauer, Jr.
 Gen., Sta. Mgr. Wallace R. Jackson
 Comm. Mgr. Eleanor McDonald
 Program Director Dean Baker
 Publicity Director Bob Byron
 Chief Engineer Tom Yates

KJBC

MIDLAND—1950—KBS

Frequency: 1150 Kc. Power: 1000 Watts d.
 Owned-Oper. By Jack Cecil
 Address Box 1658
 Phone Number 4-5152
 News Service UP

Transcription Service.....World, Standard.
Keystone
Pres., Gen. Mgr., Chief Engr.....Jack Cecil
Commercial Mgr.....Naomi Boswell
Sales Prom. Mgr.....Routh Burr
Program Director.....Joe Mainz
Publicity Director.....Keith Ward

KORC

MINERAL WELLS—1946—KBS

Frequency: 1140 Kc.....Power: 250 Watts d.
Owned-Operated By.....J. Elroy McCaw
Address.....1615 S.E. 14th Ave.
Phone Number.....319
News Service.....AP
President.....J. Elroy McCaw
Gen., Comm., Sta. Mgr.....Hary A. Riley, Jr.
Program Director.....Olie Carriker
Chief Engineer.....W. M. McCreary, Jr.

KVKM

MONAHANS—1947—MBS-KBS

Frequency: 1340 Kc.....Power: 250 Watts
Owned-Oper. By.....Monahans Bcstrs., Inc.
Address.....Box 1118
Phone Number.....438
News Service.....UP
Transcription Service.....World
Representative.....Hil F. Best
President.....Doris D. King
General Manager.....J. R. Rucker
Commercial Manager.....Joe Collins
Chief Engineer.....John Rosenberger

KIMP

MOUNT PLEASANT—1948—KBS

Frequency: 960 Kc.....Power: 1000 Watts d.
Owned-Oper. By.....Mt. Pleasant Bcstg. Co.
Business Address.....Box 990
News Service.....AP
Transcription Service.....Thesaurus
Membership.....NARTB, BAB
Pres., Gen., Sta. Mgr.....Winston O. Ward
Program Director.....Ruby Stanley
Chief Engineer.....Brad Redfearn

KOSF

NACOGDOCHES—1947—ABC-KBS

Frequency: 1230 Kc.....Power: 250 Watts
Owned-Operated By.....Kelly Bell
Address.....Box 8
Phone Number.....4-7222
News Service.....UP
Membership.....NARTB, BAB
President.....Kelly Bell
Gen., Comm. Mgr.....J. C. Stallings
Program Director.....R. C. Atherton
Publicity Director.....Ed Rice
Chief Engineer.....Frank Murray

KSFA

NACOGDOCHES—1947

Frequency: 860 Kc.....Power: 1000 Watts d.

Owned-Oper. By...Nacogdoches Br. Co., Inc.
Address.....2107 North St.
Phone Number.....4-3723
News Service.....AP
Transcription Service.....Thesaurus
Pres., Gen., Sta., Comm. Mgr...Wilbur C. Fouts
Program Director.....Sara Jane Moon
Chief Engineer.....T. C. Dobbs

KGNB

NEW BRAUNFELS—1950—KBS

Frequency: 1420 Kc.....Power: 1000 Watts d.
Owned-Oper. By.....Comal Bcstg. Co.
Address.....184 Castell
Phone Number.....1612
Transcription Service.....Thesaurus
News Service.....AP
General Manager.....F. T. Wilson
Pgm., News Dir.....Howard Edwards
Chief Engineer.....Bob Stewart

KECK

ODESSA—1947

Frequency: 920 Kc.....Power: 1000 Watts d.
500 Watts n.
Owned-Operated By...Ector County Bcstg. Co.
Business Address.....120 W. 3d
Phone Number.....6-5791-2
News Service.....AP
Transcription Service.....Standard
Representative.....ForJoe
Owner, Gen., Sta. Mgr., Pub. Dir...Ben Nedow
Commercial Mgr.....Sol Schmerman
Prod., Prg. Director.....Roy Elser
Chief Ann., News Editor.....Tom Rollins
Chief Engineer.....Dave Williams

KOSA

ODESSA—1947—CBS-SOUTHWEST

Frequency: 1230 Kc.....Power: 250 Watts
Owned-Oper. By.....Odessa Bcstg. Corp.
Business-Studio Address.....115 W. 6th
Phone Number.....6-4301
Air Time.....Full Time
News Service.....AP
Transcription Service.....Capitol
Representative.....Taylor Co.
Membership.....NARTB
Pres., General Manager.....Cecil L. Trigg
Commercial Manager.....Ron Smith
Public Relations Dir.....Ed Costello
Program Manager.....John Vacca
Publicity Director.....Jay Mehaffey
Chief Engineer.....James Simpson

KRIG

ODESSA—1946—MBS

Frequency: 1410 Kc.....Power: 1000 Watts
Owned-Oper. By...Oil Center Bcstg. Co., Inc.
Address.....Box 231
Phone Number.....6-6871-2
Air Time.....6 a.m.-M.
News Service.....UP
Transcription Service.....World

Representative.....Hil F. Best
 President.....R. O. Canon
 General Manager.....Jack W. Hawkins
 Commercial Manager.....C.H. Allen
 Station Manager.....Marguerite Larue
 Program Director.....Bob Evans
 Chief Engineer.....Jody Singleton

K O G T

ORANGE—1948—KBS

Frequency: 1600 Kc.....Power: 1000 Watts
 Owned-Oper. By.....Sabine Area Brcstg. Corp.
 Address.....Lucas Bldg.
 Phone Number.....8-9336
 News Service.....UP
 Transcription Service.....Associated
 President.....M. L. Jacobs
 General Manager.....Ed Lovelace
 Commercial Manager.....Frank Dusenbury
 Program Director.....Dean Durham

K N E T

PALESTINE—1936—KBS

Frequency: 1450 Kc.....Power: 250 Watts
 Owned-Operated By.....Palestine Bcstg. Corp.
 Business-Studio Address.....P. O. Box 649
 Phone Number.....8686
 Air Time.....Full Time
 News Service.....UP
 Pres., Gen., Sta. Mgr.....B. A. Laurie
 Program Director.....Don Norton
 Chief Engineer.....George Tabb

K P A T

PAMPA—1951—KBS

Frequency: 1230 Kc.....Power: 250 Watts
 Owned-Operated By.....J. C. Daniels
 Phone Number.....4-2551
 News Service.....UP, INS
 Transcription Service.....Capitol, Standard
 Representative.....Pearson
 President.....J. C. Daniels
 General Manager.....Ed Murphree
 Program Director.....Eibert Goodnight

K P D N

PAMPA—1936—MBS

Frequency: 1340 Kc.....Power: 250 Watts
 Owned-Oper. By.....Top O' Texas Bcstg. Co.
 Address.....Hughes Bldg.
 Phone Number.....4-7461
 Air Time.....Full Time
 News Service.....UP
 Transcription Service.....World
 Membership.....NARIB, BAB
 General Manager.....Coy Palmer
 Sta. Mgr., Prog. Dir.....Warren Hasse
 Comm., Prom. Mgr.....Kay Fancher
 Publicity Director.....Henry Gordon
 Chief Engineer.....John King

K F T V

PARIS—1950

Frequency: 1250 Kc.....Power: 500 Watts d.
 Owned-Operated By.....Lamar Bcstg. Co., Inc.
 Address.....First Nat'l Bank Bldg.
 Phone Number.....4-6676
 News Service.....UP
 Transcription Service.....SESAC
 President.....D. W. Brawner
 Gen., Sta. Mgr.....James F. Hendrix
 Chief Engineer.....Travis Fodge

K P L T

PARIS—1936—ABC—TEXAS STATE

Frequency: 1490 Kc.....Power: 250 Watts
 Owned-Oper. By.....No. Star Bcstg. Co., Inc.
 Phone Number.....3-3311
 Address.....Hwy. 124
 Air Time.....Full Time
 News Service.....AP
 Representative.....John E. Pearson
 Pres., Gen. Sta. Mgr.....Fred Kincaid
 Commercial Manager.....Bob Prichard
 Sales Prom. Mgr.....Richard Eben
 Program Dir.....Bill Davis
 Publicity Director.....Ruby Riley
 Chief Engineer.....Paul H. Daniels

K L V L

PASADENA—1950

Frequency: 1480 Kc.....Power: 1000 Watts d.
 Owned-Oper. By.....Felix H. Morales
 Address.....2903 Canal St., Houston
 Phone Number.....Blackstone 3208-09
 President, Gen. Mgr.....Felix H. Morales
 Station Mgr.....C. B. Rice
 Comm. Mgr.....Alberto Rodriguez
 Program Director.....Joe L. Morales
 Chief Engineer.....Donald Gullihur

K I U N

PECOS—1935—MBS-KBS

Frequency: 1400 Kc.....Power: 250 Watts
 Owned-Oper. By.....Jack Hawkins, Barney Hubbs
 Business-Studio Address.....Box 469
 Phone Number.....999-8
 Air Time.....6:30 a.m.-10:30 p.m.
 News Service.....UP
 Representative.....Hil F. Best
 General Manager.....Jack Hawkins
 Station Manager.....David Martin
 Program Director.....Jack James
 Publicity Dir.....Barney Hubbs
 Consulting Chf. Engr.....Harry W. Boehnemann

K E Y E

PERRYTOWN—1948—MBS

Frequency: 1400 Kc.....Power: 250 Watts
 Owned-Oper. By.....Great Plains Bcstg. Co.
 Phone Number.....5771
 Gen., Sta., Comm. Mgr.....Irvin R. Buchanan
 Sales Prom. Mgr.....G. K. Rupprecht

Program Director.....Kenneth Roller
 Chief Engineer.....Coy Thompson

Gen., Sta. Mgr.....Orville L. Jenkins
 Chief Engineer.....Richard O. Dormier

KVOP

PLAINVIEW—1944—MBS-KBS

Frequency: 1400 Kc.....Power: 250 Watts
 Owned-Oper. By.....KVOP, Inc.
 Business-Studio Address...24th & Kokomo St.
 Phone Number4-2772
 News ServiceAP
 MembershipNARTB
 PresidentW. J. Harpole
 Gen., Sta. Manager.....Kermit Ashby
 Commercial Mgr.....Harold Henegar
 Program Dir.....Doug Sewell
 Chief Engineer.....Hugh Smith

KBOP

PLEASANTON—1951

Frequency: 1380 Kc.....Power: 1000 Watts d.
 Owned-Oper. By.....Ben L. Parker
 Phone Number4871
 Transcription Service.....World, SESAC
 RepresentativeBest
 News ServiceINS
 General Manager.....Ben L. Parker
 Commercial Mgr.....A. Terrell
 Chief Engineer.....Mona Parker

KOLE

PORT ARTHUR—1947

Frequency: 1340 Kc.....Power: 250 Watts
 Owned-Oper. By.....Port Arthur Bcstg. Co.
 Business Address.....P. O. Box 1126
 Phone Number2-9436
 Ptnr., Gen. Mgr., Chf. Engr.....Socs Vratiss

KPAC

PORT ARTHUR—1934—MBS

Frequency: 1250 Kc.....Power: 5000 Watts d.;
 1000 Watts n.
 Owned-Oper. By.....Port Arthur College
 Bus.-Studio Address.....1500 Procter St.
 Phone Number5-7458
 Air Time.....Full Time
 News ServiceAP
 Transcription ServiceStandard
 RepresentativePearson
 MembershipNARTB
 Sta., Gen. Manager.....Marjorie R. Vickers
 Commercial Mgr.....Gordon Baxter, Jr.
 Prom. Mgr., Pub. Dir.....Mack Newberry
 Program Director.....Corinne Enos
 Chief Engineer.....Glenn Boatright

KOLJ

QUANAH—1951—KBS

Frequency: 1150 Kc.....Power: 500 Watts d.
 Owned-Operated By.....Orville L. Jenkins
 Address.....Box 566
 Phone Number654
 News ServiceAP
 Transcription ServiceWorld

KFRD

ROSENBERG—1948

Frequency: 980 Kc.....Power: 1000 Watts d.
 Owned-Oper. By.....Ford Bend Bcstg. Co.
 Business Address.....P. O. Box 832
 Phone Number.....Northfield 2-3776
 News ServiceUP
 Transcription ServiceLang-Worth
 Vice Pres., Gen. Mgr.....Jim Hairgrove
 Chief Engineer.....Frank Wood

KGKL

SAN ANGELO—1928—ABC

Frequency: 960 Kc.....Power: 5000 Watts d.;
 1000 Watts n.
 Owned-Oper. By.....Lewis O. Seibert
 Business-Studio Address.....P. O. Box 850
 Phone Number6715
 Air Time.....Full Time
 News ServiceAP
 Representative.....John E. Pearson
 MembershipNARTB
 General Manager.....Lewis O. Seibert
 Commercial Mgr.....Mark Cooper
 Program Director.....Franklin Rainey
 Chief Engineer.....William Poteet

KTXL

SAN ANGELO—1947

Frequency: 1340 Kc.....Power: 250 Watts
 Owned-Oper. By.....Wes-Tex Bcstg. Co., Inc.
 Bus.-Studio Address.....1901 W. Beauregard
 Phone Number7183
 News ServiceUP
 RepresentativeVenard
 President.....Armistead D. Rust
 General Manager.....Robert McClellan
 News Dir., Comm. Mgr.....Walton Foster
 Chief Engineer.....Robert Benson

KCOR

SAN ANTONIO—1946

Frequency: 1350 Kc.....Power: 5000 Watts d.;
 1000 Watts n.
 Owned-Operated By.....KCOR, Inc.
 Business-Studio Address.....KCOR Bldg.
 Phone Number.....C-21301
 News ServiceUP
 RepresentativeO'Connell
 General Manager.....Kenneth R. Hyman
 Program Director.....Fred Romero
 Chief Engineer.....Marvin L. Fiedler

KGBS

SAN ANTONIO—1926—CBS

Frequency: 680 Kc.....Power: 50,000 Watts d.;
 10,000 Watts n.
 Owned-Oper. By.....San Antonio Television Co.
 Business-Studio Address.....Milam Bldg.
 Phone Number.....Fannin 3126

News ServiceAP
 Representative John Blair
 Managing Director..... George Storer, Jr.
 Station Manager..... Bill Michaels
 Comm. Mgr..... Bill Joeke!
 Promotion Mgr..... Art Forrest
 Chief Engineer..... Bill Jackson

KEXX

SAN ANTONIO—1953

Frequency: 1250 Kc..... Power: 500 Watts d.
 Owned-Oper. By..... Manuel D. Leal
 Address..... 403 N. Flores St.
 Phone Number..... Garfield 6373
 Representative..... McGillvra
 Owner, Gen. Mgr..... Manuel D. Leal
 Commercial Mgr..... M. Davila
 Program Director..... Fidel Cuellar
 Chief Engineer..... Charles Harris

KITE

SAN ANTONIO—1947

Frequency: 930 Kc..... Power: 1000 Watts d.
 Owned-Operated By..... Radio Station KITE
 Business-Studio Address... 310 Transit Tower
 Phone Number..... Fannin 0335
 News Service..... INS, UP
 Representative..... Pearson
 Membership..... BAB
 Pres., Gen. Mgr..... Charles W. Balthrope
 Station Manager..... Alex A. Coe

Commercial Mgr..... Kelly Wofford
 Chief Engineer..... John Siercovich

KIWW

SAN ANTONIO—1948

Frequency: 1540 Kc..... Power: 250 Watts d.
 Owned-Oper. By..... Good Neighbor Bcstg. Co.
 Address..... International Bldg.
 Phone Number..... Fannin 5254
 Representative..... Nat'l Time Sales. Grant
 President..... Joe Olivares
 Station Manager..... L. E. Richards
 Comm. Mgr., Prog. Dir..... Felipe Cantu
 Chief Engineer..... L. E. Richards

KMAC

SAN ANTONIO—1926—MBS

Frequency: 630 Kc..... Power: 5,000 Watts
 Owned-Oper. By..... The Walmac Co.
 Address..... KMAC Bldg.
 Phone Number..... Belmont 3-6211
 Representative..... Walker
 Membership..... NARTB
 Pres., Gen. Sta. Mgr..... Howard W. Davis
 Program Director..... A. S. (Tony) Bessan
 Chief Engineer..... Al Knight

KONO

SAN ANTONIO—1927

Frequency: 860 Kc..... Power: 5000 d., 1000 n.

**THOSE WHO KNOW
 FAMOUS BRANDS**

Quote from a letter: "Our station has consistently found that its new programs are more attractive to listeners and sponsors than any other one category in its program format. Complete **AP** news coverage throughout the broadcast day guarantees our sponsors a loyal and responsive audience."

**. . . . KNOW THE MOST FAMOUS
 BRAND IN NEWS IS AP**

Owned-Operated By.....Mission Bdcstg. Co.
Address.....317 Arden Grove
Phone Number.....Fannin 5171
News Service.....AP
Representative.....ForJoe
Membership.....NARTB, BAB
Pres., Owner.....Eugene J. Roth
General Manager.....James M. Brown
Commercial Manager.....Bob Roth
Program Director.....Robert F. Jenkins
Chief Engineer.....George Ing

KTSA

SAN ANTONIO—1928—CBS

Frequency: 550 Kc.....**Power:** 5000 Watts
Owned-Oper. By.....Express Publishing Co.
Business-Studio Address.....Ave. E. & 3rd St.
Phone Number.....Garfield 1251
News Service.....AP
Transcription Service.....MacGregor
Representative.....Free & Peters
President.....Frank G. Huntress, Jr.
Sta., Prom., Comm. Mgr......Charles D. Lutz
Program Director.....H. H. Carr
Chief Engineer.....W. G. Egerton

WOAI

SAN ANTONIO—1922—NBC-TQN

Frequency: 1200 Kc.; **Power:** 50,000 Watts d.n.
Owned-Oper. By.....Southland Industries, Inc.
Address.....1031 Navarro St.
Phone Number.....Garfield 4221
Air Time.....Unlimited
News Service.....AP, INS, UP
Representative.....Edward Pety & Co., Inc.
President.....Hugh A. L. Halff
General Manager.....James M. Gaines
Commercial Manager.....Rex Prels
Sales Promotion Mgr......Morton Grossman
Publicity Director.....Imogene Stanley
Chief Engineer.....Charles L. Jeffers

KCNY

SAN MARCOS—1948

Frequency: 1470 Kc.....**Power:** 250 Watts d.
Owned-Oper. By.....Central Brcstg. Co.
Address.....P. O. Box 32
Phone Number.....888
Transcription Service.....Lang-Worth
Station Representative.....Hil F. Best
President.....Edw. C. James
General Mgr......Tom C. Fleet
Comm. Mgr......Princess J. Fleet
Chief Engineer.....Ernie Wood

KWED

SEGUIN—1948

Frequency: 1580 Kc. ...**Power:** 1000 Watts d.
Owned-Oper. By.....Seguin Bdcstg. Co.
Business-Studio Address.....200 S. Camp St.
Phone Number.....1580
News Service.....UP

Membership.....NARTB
Representative.....Hil F. Best
President.....Garfield Kiel
Comm., Sta. Mgr......Stan McKenzie
Chief Engineer.....Louis Sowder

KSEY

SEYMOUR—1950

Frequency: 1230 Kc.....**Power:** 100 Watts
Owned-Oper. By.....W. C. Moss, Jr.
Address.....Box 1191
Phone Number.....2525
News Service.....AP
Transcription Service.....Lang-Worth
Pres., Gen., Comm. Mgr......W. C. Moss, Jr.
Program Dir......Elizabeth Moss
Chief Engineer.....Luke M. Stribling

KEVA

SHAMROCK—1949—KBS

Frequency: 1580 Kc.....**Power:** 250 Watts d.
Owned-Oper. By.....Shamrock Tex. Bcstg. Co.
Address.....Box 21
Phone Number.....620
Representative.....Best
General Manager.....James D. Abbott
Comm. Mgr., Chief Eng......Robert J. Beller
Program Director.....Joyce Abbott

The most
 powerful
 advertising
 influence
 in the
 Southwest



Represented Nationally by
 EDWARD PETRY & COMPANY, INC.
 New York • Chicago • St. Louis
 Los Angeles • Dallas • Detroit
 San Francisco

NBC Affiliate
TQN

KRRV

SHERMAN-DENISON—1936
MBS-TEX STATE

Frequency: 910 Kc. Power: 1000 Watts
Owned-Oper. By Red River Valley Bcstg. Corp.
Address Box 94 (Denison)
Box 665 (Sherman)
Phone Number 423 (Denison); 201 (Sherman)
Representative Pearson
Transcription Service Associated
News Service UP
General Manager Tom E. Spellman (Sherman)
Program Director Earl Ellington
Chief Engineer Tom John

KTAN

SHERMAN—1947—KBS

Frequency: 1500 Kc. Power: 250 Watts d.
Owned-Oper. By Howard L. Burris
Bus. Studio Address 2334 S. Mead, Arlington, Va.
Phone Number Otis 47090
News Service AP
Membership BAB
Representative Hil F. Best
Owner Howard L. Burris
General Manager William A. Jaco
Asst. Mgr., Chief Eng. James Shelton

KSNY

SNYDER—1949

Frequency: 1450 Kc. Power: 250 Watts
Owned-Oper. By Snyder Bdcstg. Co.
Address Box 1468
Phone Number 3-5451
News Service UP
Pres., Gen. Mgr. J. T. Hughes
Commercial Mgr. Mel Z. Gilbert

KDWT

STAMFORD—1946—MBS

Frequency: 1400 Kc. Power: 250 Watts
Owned-Oper. By David W. Ratliff
Phone Number 1400
Air Time Full Time
News Service AP
Pres., Gen., Sta. Mgr. David W. Ratliff
Comm., Prom. Mgr. George Morey
Program Director Glenna Giles
Chief Engineer Erick Henske

KSTV

STEPHENVILLE—1947

Frequency: 1510 Kc. Power: 250 Watts d.
Owned-Oper. By Galen O. Gilbert & J. R. Kincaid
Address P. O. Box 102
Phone Number Lindsey 3141
News Service UP
General Manager Galen O. Gilbert
Commercial Mgr. Jack Reeves
Chief Engineer Floyd Jeter

KSST

SULPHUR SPRINGS—1947
MBS-KBS

Frequency: 1230 Kc. Power: 250 Watts
Owned-Oper. By Hopkins County Bcstg. Co.
Business-Studio Address P. O. Box 284
Phone Number 1230
Air Time Full Time
Pres., Gen., Sta. Mgr. William E. Bradford
Comm., Prom. Mgr. Clovis Pinion
Program Director Lona Ruth Long
Chief Engineer Bill Bradford

KXOX

SWEETWATER—1939—MBS-KBS

Frequency: 1240 Kc. Power: 250 Watts
Owned-Oper. By Radio & News, Inc.
Bus. Studio-Transmitter Address Box 570
Phone Number 4655-6
Air Time Full Time
News Service UP
Representative Hil F. Best
President J. S. McBeath
Gen., Sta. Manager J. Harley Hubbard
Commercial Mgr. Elwood Fritch
Chief Engineer J. T. Allen

KTAE

TAYLOR—1948

Frequency: 1260 Kc. Power: 1000 Watts d.
Owned-Oper. By KTAE, Inc.
Business Address Box 191
Phone Number 1260
News Service UP
Transcription Service World
Pres., Gen. Mgr. Graham Gillis Conoley
Commercial Manager John M. Wehby
Prog., Pub. Dir. F. Switzer, Jr.
Chief Engineer Gordon W. Rainey

KTEM

TEMPLE—1936—MBS

Frequency: 1400 Kc. Power: 250 Watts
Owned-Operated By Bell Bcstg. Co., Inc.
Business-Studio Address 17 S. Third St.
Phone Number 3-5252
Air Time 6 a.m.-11 p.m.
News Service UP
Transcription Service Thesaurus
Membership NARTB, BAB
President Frank W. Mayborn
General Manager Burton Bishop
Station Manager Ralph Weedon
Program Director John O'Brien
Chief Engineer Curtis M. Casey

KTER

TERRELL—1950

Frequency: 1570 Kc. Power: 250 Watts d.
Owned-Oper. By Terrell Bcstg. Corp.
Address Walnut & State Sts.

Phone Number 44497
 Transcription Service..... SESAC, Thesaurus
 News Service UP
 Pres., Gen. Mgr..... Paul A. Wnorowski
 Program Director..... Dean Tiller
 Chief Engineer..... Martin Pitte

K C M C
TEXARKANA—1932
ABC-TEX. STATE

Frequency: 1230 Kc..... Power: 250 Watts
 Owned-Oper. By..... KCMC, Inc.
 Business-Studio Address..... 315 Pine St.
 Phone Number 3-6151
 Air Time..... 6 a.m.-M.
 News Service AP, UP
 Transcription Service Langworth
 Representative Taylor
 Membership NARTB, BAB
 President..... C. E. Palmer
 General Manager..... Frank O. Myers
 Program Director..... Donald Myers
 Chief Engineer..... Harvey Robertson

K T F S
TEXARKANA—1946

Frequency: 1400 Kc..... Power: 250 Watts
 Owned-Oper. By..... KTFS, Inc.
 Business-Studio Address..... 4325 N. Stateline
 Phone Number 3-5123
 News Service UP
 Transcription Service World
 Transcription Service Devney
 General Manager..... David M. Segal
 Program Director..... Les Eugene
 Chief Engineer..... J. H. Crawford

K T L W
TEXAS CITY—1948—KBS

Frequency: 920 Kc..... Power: 1000 Watts d.
 Owned-Oper. By..... Long Radio Enterprises
 Business-Studio Address..... Bay City
 News Service UP
 President..... John G. Long
 Gen., Sta. Mgr..... Joe Brown
 Chief Engineer..... Phil Gainor

K G K B
TYLER—1930—MBS

Frequency: 1490 Kc..... Power: 250 Watts
 Owned-Oper. By..... Lucille Lansing
 Bus.-Studio Address..... 115 South College
 Phone Number 23874
 Air Time..... 5:30 a.m.-M.
 Transcription Service AP
 Transcription Service World
 Representative Pearson
 Membership NARTB, BAB
 President..... Lucille Buford
 General Manager..... Gerry Lansing
 Commercial Mgr..... William Peart
 Sales Prom. Mgr..... Sam Matthews
 Program Director..... Edwin Smith
 Chief Engineer..... Hudson C. Collins

K T B B

TYLER—1947—TSN-ABC

Frequency: 600 Kc..... Power: 500 Watts d.
 1000 Watts n.
 Owned-Operated By..... Blackstone Bcstg. Co.
 Business-Studio Address..... Blackstone Hotel
 Phone Number 4-7278
 News. Affil..... "Courier Times Telegraph"
 Air Time..... Full Time
 News Service UP
 Transcription Service Lang-Worth
 Representative Taylor Co.
 Membership NARTB, BAB
 President..... Mrs. C. N. Clyde
 Gen., Sta. Mgr..... M. E. Danbom
 Commercial Mgr..... Oneil Inman
 Comm., Prom. Mgr..... Herbert Golombeck
 Program Dir..... Don Jackson Tausch
 Prom. Mgr., Pub. Dir..... David H. Bothwell
 Chief Engineer..... R. A. Wileman

K V O U

UVALDE—1947—MBS-KBS

Frequency: 1400 Kc..... Power: 250 Watts
 Owned-Oper. By..... E. J. & W. J. Harpole
 Address..... 1450 Batesville Rd.
 Phone Number..... 717
 News Service UP
 Membership BAB
 Pres., Gen. Mgr..... Edward J. Harpole
 Station Mgr..... Bob Hicks
 Commercial Mgr..... Joe Watson, Jr.
 Program Dir..... Sally Adams
 Chief Engineer..... Walter Herbert, Jr.

K V W C

VERNON—1939—MBS

Frequency: 1490 Kc..... Power: 250 Watts
 Owned-Oper. By..... Northwestern Bcstg. Co.
 Business-Studio Address..... 1813 Wilbarger
 General Manager..... James Doyle

K N A L

VICTORIA—1949

Frequency: 1410 Kc..... Power: 500 Watts
 Owned-Operated By..... Victoria Bcstg. Co.
 Address Box 642
 Phone Number 1410
 News Service UP, AP
 Transcription Service..... Thesaurus
 Representative Hil F. Best
 President..... A. B. Alkek
 General Manager..... James A. Traber
 Commercial Mgr..... Warren Dentler
 Program Director..... Jean Wilson
 Chief Engineer..... Douglas Smith

K V I C

VICTORIA—1939—MBS

Frequency: 1340 Kc..... Power: 250 Watts
 Owned-Oper. By..... KVIC Bcstg. Co.
 Business Address..... Box 725
 Phone Number 1106-7

Air Time..... Full Time
 News Service..... UP
 Transcription Service..... World
 Membership..... BAB
 President..... J. G. Long
 Gen., Comm. Mgr..... William C. Burks
 Sales Prom. Mgr..... Hans Felix
 Program Dir..... Wilburn H. Jackson
 Chief Engineer..... Vic Boldt

K W T X

WACO—1946—MBS

Frequency: 1230 Kc..... Power: 250 Watts
 Owned-Operated By..... KWTX Bcstg. Co.
 Business-Studio Address..... P. O. Box 3128
 Phone Number..... 3-7331
 News Service..... AP
 Representative..... Everett McKinney
 Membership..... NARTB
 Gen., Sta. Manager..... M. N. Bostick
 Commercial Manager..... J. M. Brinegar
 Sales Prom. Mgr..... Harry L. Gillam
 Program Director..... Curtis B. Matties
 Chief Engineer..... William Moore

W A C O

WACO—1922—ABC

Frequency: 1460 Kc..... Power: 1000 Watts
 Owned-Operated By..... Frontier Bcstg. Co.
 Business Address..... 3620 Franklin Ave.
 Phone Number..... 2-6571
 Air Time..... 6a.m.-M.
 News Service..... AP
 Representative..... Weed
 Membership..... BAB
 President..... Gene L. Cagle
 General Manager..... R. Lee Glasgow
 Chief Engineer..... Jesse H. Dove

K R G V

WESLACO—1927—NBC-TQN

Frequency: 1290 Kc..... Power: 5000 Watts
 Owned-Oper. By..... Taylor Radio & TV Corp.
 Bus.-Studio-Transmitter Address..... 201 Border St.
 Phone Number..... 375
 News Service..... AP, UP
 Transcription Service..... World, SESAC
 Representative..... Taylor Co.
 President..... O. L. Ted Taylor
 General Manager..... Byron W. Ogle
 Program Director..... James D. Cook
 Chief Engineer..... O. Lewis Hartwig

K F D X

WICHITA FALLS—1947—ABC

Frequency: 990 Kc..... Power: 10,000 Watts d.,
 1,000 Watts n.
 Owned-Oper. By..... Wichtex Radio and Tel. Co.
 Address..... City Natl. Bldg.
 Phone Number..... 2-8668
 Air Time..... Full Time
 News Service..... UP
 Transcription Service..... World
 Station Representative..... Taylor Co.
 Membership..... NARTB, BAB

Pres., Gen. Mgr..... Darrold A. Cannan
 Station Manager..... Howard Fry
 Comm., Prom. Mgr..... Matt M. Johnson
 Program Director..... Warren Silver
 Publicity Director..... Bill Hood
 Chief Engineer..... John Adams

K T R N

WICHITA FALLS—1949—MBS

Frequency: 1290 Kc..... Power: 5000 Watts d.;
 1000 Watts n.
 Owned-Operated By..... Texoma Bcstg. Co.
 Address..... 917½ Scott St.
 Phone Number..... 2-5214
 News Service..... AP
 Representative..... Pearson
 Pres., Gen. Manager..... Boyd Kelley
 Commercial Mgr..... Bob Cain
 Program Director..... Bill Edgar
 Chief Engineer..... Bob Harmon

K W F T

WICHITA FALLS—1939—CBS

Frequency: 620 Kc..... Power: 5000 Watts
 Owned-Operated By..... Rowley-Brown Bcstg. Co.
 Business-Studio Address..... P. O. Box 420
 Phone Number..... 3-4181
 News Service..... UP
 Transcription Service..... Lang-Worth
 President..... Kenyon Brown
 General Manager..... Charles E. Clough
 Sales Prom. Mgr..... A. L. Pierce
 Program Director..... Blaine Cornwell
 Chief Engineer..... Herbert T. Wiley

THOSE WHO KNOW
 FAMOUS BRANDS

WBVP at Beaver Falls, Pa.,
 writes: "Our sponsors are satis-
 fied, our listeners are well in-
 formed—thanks to AP news."

. . . . KNOW THE MOST FAMOUS
 BRAND IN NEWS IS AP

UTAH

Pop. Feb. 1, 1954 (Est.) 724,000 — Families 247,000
Radio Homes 242,000 — TV Homes 121,000 — Stations in State 18

K B U H

BRIGHAM CITY—KBS

Frequency: 800 Kc. Power: 250 Watts d.
Owned-Oper. By Wade Ebeling
Address 948 W. Forrest St.
Phone Number 948
Membership BAB, NARTB
Pres., Gen., Comm. Mgr. Wade Ebeling
Sales Prom. Mgr. Art Fishler
Program Director Melvin Richardson
Chief Engineer Samuel Stevens

K S U B

CEDAR CITY—1937—CBS

Frequency: 590 Kc. Power: 1000 Watts
Owned-Oper. By So. Utah Bcstg. Co.
Address 189 N. Main St.
Phone Number 590
Air Time Full Time
News Service UP
Reps. Bonneville, CBS Spot Sales
Membership NARTB, BAB
President Ivor Sharp
General Manager Arthur Higbee
Commercial Mgr. W. V. Lowe
Asst. Manager Robert Heyborne
Program Director Mauray Payne
Chief Engineer Richard Gunn

K V N U

LOGAN—1938

MBS-INTERMOUNTAIN-KBS

Frequency: 610 Kc. Power: 1000 Watts
Owned-Oper. By Cache Valley Bcstg. Co.
Address 1393 N. Main St.
Phone Number 1400
Air Time 6:00 a.m. to 12:00 p.m.
News Service UP
Transcription Service World
President Herschel Bullen
Gen., Sta. Mgr. Reed Bullen
Comm., Sales Prom. Mgr. W. W. Kirkland
Program Director Morgan White
Chief Engineer Wm. Jones

K M U R

MURRAY—1948

Frequency: 1290 Kc. Power: 250 Watts
Owned-Oper. By Murray Bcstg. Service
Address 4646 So. State St.
Phone Number 9-9822
News Service UP
Transcription Service Lang-Worth
Membership NARTB
President Oral J. Wilkinson
Gen., Sta. Manager Howard Pingree
Chief Engineer Ervin N. Greene

K L O

OGDEN—1925

MBS-INTERMOUNTAIN

Frequency: 1430 Kc. Power: 5000 Watts
Owned-Oper. By Interstate Bcstg. Corp.
Address Hotel Ben Lomond
Phone Number 4-5721
Air Time Full Time
News Service UP
Representative Avery-Knodel
Membership NARTB, BAB
President Edris Glasmann
General Manager A. L. Glasmann
Station Manager Collin W. Lowder
Commercial Manager W. Kimball Ward
Publicity Director Bruce Thornton
Chief Engineer Robert V. Beadles

K O P P

OGDEN—1947—KBS

Frequency: 730 Kc. Power: 1000 Watts d.
Owned-Oper. By KOPP, Inc.
Address W. 12th St.
Transcription Service Lang-Worth
President G. Stanley Brewer
General Manager King Harmon

K V O G

OGDEN—1948

Frequency: 1490 Kc. Power: 250 Watts
Owned-Oper. By United Bcstg. Co.
Business Address 1438 Gibson Ave.
Phone Number 2-7535
Representative Biddick
Transcription Service Capitol
News Service AP
Pres., Gen. Mgr. Arch G. Webb
Chief Engineer James Condrey
Commercial Mgr. David B. Affleck

K O A L

PRICE—1936

MBS-INTERMOUNTAIN—KBS

Frequency: 1230 Kc. Power: 250 Watts
Owned-Oper. By Eastern Utah Bcstg. Co.
Address Box 591
Phone Number Price 200
Representative Avery-Knodel
Pres., Gen. Mgr. Jack Richards
Sls. Prom. Mgr., Pgm. Dir. Carl P. Wolfrom

K C S U

PROVO—1947—ABC

Frequency: 1400 Kc. Power: 250 Watts
Owned-Oper. By Central Utah Bcstg. Co., Inc.
Address P. O. Box 550
Phone Number 2802



RepresentativeHollingsbery
 News ServiceUP
 Co.-owner, Pres., Comm., Prom. Mgr.
 Frank A. Van Wageningen
 Co.-owner, V.P., Gen., Sta. Mgr.
 Harold E. Van Wageningen
 Chief Engineer.....Dallin H. Oaks

Commercial Mgr.....Art Tucker
 Chief Engineer.....Ralph Ross

KEYY

PROVO—1949—KBS

Frequency: 1450 Kc.....Power: 250 Watts
 Owned-Oper. By.....Mid Utah Bcstg. Co.
 Address.....307 So. 17th W.
 Phone Number4060
 Transcription ServiceThesaurus
 President.....Spencer D. Grow
 Commercial Mgr.....Garn Carter
 Program Director.....Hal Parkes
 Chief Engineer.....Ron Bailie

KALL

SALT LAKE CITY—1945
 MBS-INTERMOUNTAIN

Frequency: 910 Kc.....Power: 1000 Watts
 Owned-Oper. By....Salt Lake City Bcstg. Co.
 Business-Studio Address.....146 S. Main St.
 Phone Numbers4-3561
 Air Time.....Full Time
 News ServiceAP
 Representative.....Avery-Knodel, Inc.
 MembershipNARTB, BAB
 President.....George C. Hatch
 Gen., Sta., Comm. Mgr., Thomas H. Anderson
 Publicity Manager.....Florien Wineriter
 Program Director.....Kay Richins
 Chief EngineerW. D'Orr Cozzens

KOVO

PROVO—1939
MBS-INTERMOUNTAIN

Frequency: 960 Kc.....Power: 5000 Watts
 Owned-Operated By.....KOVO Bcstg. Co.
 Business-Studio Address....108 W. Center St.
 Phone Number1680
 Air Time.....6 a.m.-M.
 News ServiceUP
 Transcription ServiceWorld
 RepresentativeAvery-Knodel
 MembershipNARTB, BAB
 President.....Clifton A. Tolboe
 General-Station Mgr.....Arch L. Madsen
 Commercial ManagerL. H. Curtis
 Pgm. Dir.....James H. Lawrence
 Chief Engineer.....Lovell A. Killpack

KDYL

SALT LAKE CITY—1922
 NBC

Frequency: 1320 Kc.....Power: 5000 Watts
 Owned-Oper. By.....Intermountain Bcstg. &
 Telev. Corp.
 Bus.-Studio Address.....128 Social Hall Ave.
 Phone Number5-2991
 Air TimeUnlimited
 News ServiceUP
 RepresentativeJohn Blair
 Pres., Gen. Mgr.G. Bennett Larson
 Program Director.....Alvin G. Pack
 Publicity Dir.....Del Leeson
 Chief Engineer.....Allan Gunderson

KSVC

RICHFIELD—1947
INTERMOUNTAIN

Frequency: 980 Kc.....Power: 1000 Watts d.
 Owned-Operated By..Sevier Valley Bcstg. Co.
 Buiness Address.....980 Tower Lane
 Phone Number620
 News Service.....UP
 Transcription ServiceWorld
 RepresentativeAvery Knodel
 PresidentHomer Bandlely
 Gen., Sta. Mgr.....Frank Peacock

KNAK

SALT LAKE CITY—1945

Frequency: 1280 Kc....Power: 1000 Watts d.:
 500 n.
 Owned-Operated By....Granite District Radio
 Bcstg. Co.
 Business-Studio Address.....1042 So. 6th W.
 Phone Number.....4-3685
 News ServiceUP
 RepresentativeForjoe
 President.....Howard D. Johnson
 General Manager.....Lee Walker
 Program Director.....Wayne Logan
 Chief Engineer.....Jack Jeppson

K S L

SALT LAKE CITY—1922—CBS

Frequency: 1160 Kc.....Power: 50,000 Watts
 Owned-Oper. By..Radio Service Corp. of Utah
 Bus. Studio Address.....10 S. Main St.
 Phone Number5-4641
 News Service.....AP, UP
 Transcription Service.....World, SESAC
 Representative.....CBS Radio Spot Sales
 MembershipNARTB, BAB
 President.....J. Reuben Clark
 Exec. Vice Pres.....Ivor Sharp
 Manager.....Eugene M. Halliday
 Sales Manager.....Frank McLatchy
 Program Director.....Joseph A. Kjar
 Chief Engineer.....Vincent Clayton

K U T A

SALT LAKE CITY—1938—ABC

Frequency: 570 Kc.....Power: 5000 Watts
 Owned-Oper. By.....Utah Bcstg. & Telev. Co.

Business-Studio Address.....179 Motor Ave.
 Phone Number22-2505
 Air Time.....6 a.m.-12 M.
 News ServiceUP
 Transcription Service.....Standard
 RepresentativeHollngbery
 MembershipNARTB, BAB
 President, General Mgr.....Frank C. Carman
 Sta. Mgr., Prog. Dir.....Ray Fadel
 Comm., Sales Prom. Mgr.....Allan Thomas
 Chief Engineer.....C. Wendell Bell

K J A M

VERNAL—1947—KBS

Frequency: 1340 Kc.....Power: 250 Watts
 Owned-Oper. By.....Uintah Bcstg. Co.
 Address120 E. Main St.
 Phone Number494
 News ServiceUP
 President.....James C. Wallentine
 Gen. Mgr., News Dir.....Lee Walker
 Commercial Manager.....Grant E. Parry
 Chief Engineer.....Wallace D. Raker

No trick at all!

For KSL Radio to produce results. We've been doing it for years — because 1/4 million listeners in the Mountain West are tuned to KSL Radio regularly.

Salt Lake City, Utah

CBS Radio Network - 50,000 watts

Represented by CBS Radio Spot Sales

Source: A. C. Nielsen - 1952



VERMONT

Pop. Feb. 1, 1954 (Est.) 386,000 — Families 110,000
Radio Homes 106,000 — TV Homes 26,500 — Stations in State 11

W B T N

BENNINGTON—1953

Frequency: 1370 Kc. Power: 500 Watts d.
Owned-Oper. By: Catamount Bcstrs. Inc.
Address: Harwood Hill
Phone Number: 6321
News Service: UP
Representative: McGillvra
Co-Owner & Treas.: J. Gordon Keyworth
Station Manager: Ben A. Hubley

W T S A

BRATTLEBORO—1950—ABC

Frequency: 1450 Kc. Power: 250 Watts
Owned-Oper. By: Tri-State Area
Address: Box 819
Phone Number: 1700
Representative: Rambeau
President: Theodore Feinstein
Vice-Pres., Gen. Mgr.: Phillips Terhune
Program Director: Loren C. Smith
Chief Engineer: Edward D. Somes

W C A X

BURLINGTON—1927—CBS

Frequency: 620 Kc. Power: 5000 Watts
Owned-Operated By: WCAX Bcstg. Corp.
Business-Studio Address: 135 Main St.
Phone Number: Burlington 3-3437
Air Time: Unlimited
News Service: UP
Transcription Service: SESAC
Representative: Weed
Membership: NARTB, BAB
President, Gen. Mgr.: C. P. Hasbrook
Sta., Comm. Mgr.: J. D. Swan
Program Director: Louis J. Rocke
Chief Engineer: James W. Tierney

W J O Y

BURLINGTON—1946—ABC

Frequency: 1230 Kc. Power: 250 Watts
Owned-Oper. By: Vermont Bcstg. Corp.
Bus. Studio-Transmitter Location: 633 Main St.
Phone Number: 4-5774
Transcription Service: Thesaurus
Air Time: Full Time
News Service: AP
Representative: Brannon, Rambeau
Membership: BAB, NARTB
President: David W. Howe
Prog., Pub. Dir.: Richard Burt
Sta., Comm. Mgr.: Alfred E. Spokes
Chief Engineer: Donald M. Wheatley

W S K I

MONTPELIER-BARRE—1947

Frequency: 1240 Kc. Power: 250 Watts
Owned By: Montpelier-Barre Bcstg. Co.
Business Address: Union Mutual Bldg.
Phone Number: 1740
Air Time: Full Time
News Service: AP
Representatives: Borgatti, W. S. Grant
Pres., Gen., Comm. Mgr.: C. W. Grinnell
Program Director: Robert Bannon
Chief Engineer: Gerald Mareot

W I K E

NEWPORT—1952

Frequency: 1490 Kc. Power: 250 Watts
Owned-Oper. By: Memphremagog Bcstg. Co.
Phone: 832-3
Transcription Service: World
News Service: UP
Reps.: McGillvra, Kettel-Carter
Pres., Gen. Mgr.: E. D. Finney
Prog. Dir., Ch. Eng.: D. A. Thurston

W H W B

RUTLAND—1949

Frequency: 1000 Kc. Power: 1000 Watts
Owned-Oper. By: Central Vt. Bcstg. Corp.
Address: 24½ Center St.
Phone Number: PR 3-3200
News Service: AP
Transcription Service: World
Representative: Kettel-Carter
Pres., Gen., Sta. Mgr.: Vena M. Bates
Program Director: Shirley Neilson
Chief Engineer: Kenneth Pockett

W S Y B

RUTLAND—1930

Frequency: 1380 Kc. Power: 1000 Watts
Owned-Oper. By: Philip Weiss Music Co.
Bus. Studio Address: 35 Washington St.
Phone Number: 1247
Representative: Joseph Hershey McGillvra
Station Manager: J. H. Weiss

W W S R

ST ALBANS—1941—YANKEE

Frequency: 1420 Kc. Power: 1000 Watts d.
Owned-Oper. By: Vermont Radio Corp.
Business-Studio Address: 75 N. Main St.
Phone Number: 1390
News Service: UP
Transcription Service: World

Representative Walker, Bannon
 President-Gen. Mgr. Lloyd Squier
 Sta., Comm., Sales Prom. Mgr. Richard W. Hill
 Program Director Robert Leavitt
 Chief Engineer Theodore Boisvert

W T W N

ST. JOHNSBURY—1949

Frequency: 1340 Kc. Power: 250 Watts
 Owned-Oper. By Twin State Bcstrs. Inc.
 Address Box 662
 Phone Number Pioneer 8-2344
 News Service UP
 Transcription Service Thesaurus, World
 Representative McGillvra, Kettel-Carter
 Pres., Gen. Mgr. E. Dean Finney
 Program Director Guy O. Austin

W D E V

WATERBURY—1931—MBS

Frequency: 550 Kc. Power: 1000 Watts
 Owned-Oper. By Lloyd E. Squier
 Address 8 Stowe St.
 Phone Number 4-7321
 Air Time 6:00 a.m.-12 M.
 News Service UP
 Transcription Service World
 Representative Walker
 Membership NARTB, BAB
 General Manager Lloyd E. Squier
 Comm. Mgr., Pgm. Dir. Craig S. Parker
 Chief Engineer Warren Chase

VIRGINIA

*Pop. Feb. 1, 1954 (Est.) 3,452,000 — Families 830,000
 Radio Homes 738,000 — TV Homes 512,000 — Stations in State 63*

W P I K

ALEXANDRIA—1945

Frequency: 730 Kc. Power: 1000 Watts d.
 Owned-Oper. By Potomac Bcstg. Corp.
 Address Virginia Theatre Bldg.
 Phone Number Overlook 3-3000
 Representative Grant Webb
 Membership NARTB, BAB
 News Service AP
 Pres., Gen. Mgr. Carl L. Lindberg
 Commercial Mgr. Art Kellar
 Chief Engineer Peter Dunckle

Program Director John Cooley
 Chief Engineer William Beresford

W B L T

BEDFORD—1950—MBS

Frequency: 1490 Kc. Power: 250 Watts
 Owned-Operated By Bedford Bcstg. Co.
 Address P. O. Box 406
 Phone Number 8245
 News Service AP
 Transcription Service Thesaurus
 Pres., Gen. Mgr. A. P. Marsh, Jr.
 Commercial Manager R. A. Owen
 Program Director R. A. Scott, Jr.

W A R L

ARLINGTON—1947

Frequency: 780 Kc. Power: 1000 Watts d.
 Owned-Oper. By No. Virginia Bcstrs., Inc.
 Bus-Studio Address 5232 Lee Hwy.
 Phone Number Jackson 7-7800
 News Service UP
 President Lou Poiler
 General Manager Cy Blumenthal
 Program Director Ray Armand
 Chief Engineer Stephen Hart

W L S D

BIG STONE GAP—1953

Frequency: 1220 Kc. Power: 1000 Watts d.
 Owned-Oper. By Gap Bcstg. Co.
 Phone Number 960
 General Manager W. H. Wren Jr.
 Program Director W. R. Holland Jr.
 Promotion Mgr. James E. True Jr.
 Chief Engineer Andrew R. McMaster

W E A M

ARLINGTON—1947

Frequency: 1390 Kc. Power: 5000 Watts
 Owned-Oper. By Arlington Fairfax Bcstg. Co.
 Address 2030 N. 16th St.
 Phone Number Jackson 7-7100
 News Service AP
 President Harold H. Thoms
 General Manager George Oleson

W K L V

BLACKSTONE—1947—MBS-KBS

Frequency: 1490 Kc. Power: 250 watts
 Owned-Oper. By Blackstone Bdcstg. Corp.
 Phone Number 478
 Address Community Bldg.
 Air Time 6 a.m.-11 p.m.
 Transcription Service Langworth
 Representative Colton
 News Service AP
 President H. L. Umstead
 Sta. Mgr., Chief Eng. Cosby A. Cooper, Jr.

WCYB

BRISTOL—1946

(See Also Bristol, Tenn.)

Frequency: 690 Kc. Power: 10,000 Watts d.
 Owned-Oper. By... Appalachian Bcstg. Corp.
 Address... Front & Cumberland Sts.
 Phone Number... North 3560
 Air Time... Daytime
 News Service... AP, UP
 Transcription Service... World. Cole. Associated
 Membership... NARTB, BAB
 President, Gen. Mgr... Robert H. Smith
 V.P., Sales Mgr... J. Fey Rogers
 Chief Engineer... R. V. Robinson

WFHG

BRISTOL—1946—MBS

Frequency: 980 Kc. Power: 1000 Watts
 Owned-Oper. By... Bristol Bcstg. Co.
 Address... Valley Drive
 Phone Number... N-3620
 News Service... UP
 Transcription Service... Thesaurus
 Pres., Gen. Mgr... W. C. Nininger
 Commercial Manager... Jack Martin
 Program Director... David Pursglove
 Chief Engineer... John Hughlett

WCHV

CHARLOTTESVILLE—1933—ABC

Frequency: 1240 Kc. Power: 250 Watts
 Owned-Operated By... Barham & Barham
 Bus-Studio-Transmitter Address... Rose Hill Dr.
 Phone Number... 2-5121
 Air Time... Full Time
 News Service... AP
 Representative... Clark
 Representative... Walker
 Managing Director... Charles Barham, Jr.
 Gen. Comm. Manager... Robert C. Walker
 Prog., Pub. Dir... R. G. Sketchley, Jr.
 Promotion Manager... Charles Smith
 Chief Engineer... Walter W. Gray

WINA

CHARLOTTESVILLE—1949—MBS

Frequency: 1280 Kc. Power: 1000 Watts, d.
 Owned-Oper. By... Charlottesville Bcstg. Corp.
 Address... P. O. Box 1230
 Phone Number... 2-6177
 Air Time... Daytime
 News Service... UP
 Transcription Service... Standard
 Membership... NARTB, BAB
 Pres., Gen. Mgr... Donald G. Heyne
 Station Manager... Charles W. Freeman
 Chief Engineer... Lawrence Kennedy

WCFV

CLIFTON FORGE—1950—MBS

Frequency: 1230 Kc. Power: 250 Watts
 Owned-Oper. By... Clifton Forge Bcstg. Corp.
 Address... Fairview Hts
 Phone Number... 2147
 Transcription Service... Standard
 News Service... AP
 President... Cletus H. Lawler
 General Manager... Grover K. Fulk
 Program Director... Larry Cooper

WKEY

COVINGTON—1941—ABC

Frequency: 1340 Kc. Power: 250 Watts
 Owned-Operated By... Earl M. Key
 Business Address... Box 710
 Phone Number... 8351
 Air Time... 7 a.m.-11:15 p.m.
 News Service... UP
 Representative... Devney
 Transcription Service... Thesaurus
 Membership... NARTB, BAB
 General Manager... Earl M. Key
 Commercial Mgr... Kenneth L. Bryant
 Program Director... John Lee Davis
 Chief Engineer... E. G. Hemingway

WSVS

CREWE—1947

Frequency: 800 Kc. Power: 1000 Watts d.
 Owned-Oper. By... So. Virginia Bcstg. Corp.
 Business Address... 800 Melody Lane

BRISTOL, VA.-TENN.

WCYB

10,000 WATTS 690 KILOCYCLES

**Gets Results for the
 Tri-Cities Market**

Bristol, Va.-Tenn., Johnson City, Tenn.,
 Kingsport, Tenn.

Top RESULTS
Top POWER *Top* FREQUENCY
Top PROGRAMS *Top* FEATURES
Top PERSONALITIES

GIL PERNA, INC., National Representatives

*ask them for the Top story in
 the Virginia-Tennessee Market*

Phone Number 8711
News Service **AP**
 Transcription Service **World**
 Representative **BAB**
 President **Calvin S. Willis**
 General Manager **John E. Sadler**
 Commercial Mgr. **Freeman H. Stewart**
 Chief Engineer **C. E. Wilson**

WCVA

CULPEPER—1949—KBS-MBS

Frequency: 1490 Kc. Power: 250 Watts
 Owned-Operated By **Culpeper Bcstg. Co.**
 Address **Hendricks Ave.**
 Phone Number **8338**
 Air Time **6:30 a.m. to 9:35 p.m.**
 News Service **UP**
 Transcription Service **Standard**
 President **Ira C. Hopkins**
 Gen., Comm. Mgr. **John T. Rogers**
 Program Director **Woody Powell**
 Chief Engineer **Walter Wilkerson**

WBTM

DANVILLE—1930—ABC

Frequency: 1330 Kc. Power: 5000 Watts d.;
 1000 Watts n.
 Owned-Operated By **Piedmont Bcstg. Corp.**
 Bus.-Studio Address **Hotel Danville Bldg.**
 Phone Number **2350**
 Air Time **Full Time**
 News Service **AP**
 Transcription Service **World**
 Representative **George P. Hollingbery**
 Membership **NARTB, BAB**
 President **L. N. Dibrell**
 General Manager **Edward G. Gardner**
 Comm. Mgr. **John Holland**
 Program Director **Milton Adams**
 Chief Engineer **Lyle C. Motley**

WDVA

DANVILLE—1947—MBS

Frequency: 1250 Kc. Power: 5000 Watts d.;
 1000 Watts n.
 Owned-Oper. By **Va.-Carolina Bcstg. Corp.**
 Address **American Natl. Bank Bldg.**
 Phone Number **5300**
 Air Time **Full Time**
 News Service **UP**
 Transcription Service **Lang-Worth**
 Representative **Burn-Smith, Dora-Clayton**
 Membership **NARTB, BAB**
 President **J. D. Pruitt**
 General Manager **Emerson J. Pryor**
 Commercial Mgr. **Stover Morris, Jr.**
 Program Director **Richard Campbell**
 Chief Engineer **Howard Clendenon**

WEVA

EMPORIA—1952

Frequency: 1400 Kc. Power: 250 Watts
 Owned-Operated By **Stone Bdcstg. Co.**
 Address **Washington St. & Florida St.**
 Phone **2133**

Transcription Service **Thesaurus, Standard**
 Membership **BAB**
 News Service **AP**
 Pres., Gen. Mgr. **M. E. Stone**
 Commercial Mgr. **Sally Whitlock**
 Chief Engineer **E. A. Short, Jr.**

WFAX

FALLS CHURCH—1948—KBS

Frequency: 1220 Kc. Power: 500 Watts d.
 Owned-Operated By **Lamar A. Newcomb**
 Address **Box L**
 Phone Number **Jefferson 2-0900**
 News Service **UP**
 Pres., Gen. Mgr. **Lamar A. Newcomb**
 Program Director **Genevieve Main**
 Chief Engineer **Richard Fanning**

WFLO

FARMVILLE—1947

Frequency: 870 Kc. Power: 1000 Watts d.
 Owned-Operated By **Colonial Bcstg. Co.**
 Business Address **Johnson City**
 Phone Number **Farmville 870**
 News Service **UP**
 Transcription Service **Thesaurus**
 Representative **Clark**
 Membership **NARTB, BAB**
 Pres., Gen. Mgr. **Carla B. Keys**
 Station Manager **John D. Wilson**
 Commercial Mgr. **Reginald Speir**
 Program Director **John Calhoun**
 Chief Engineer **Charles K. Chrismon**

WFVA

FREDERICKSBURG—1939—ABC-KBS

Frequency: 1230 Kc. Power: 250 Watts
 Owned-Oper. By **Fredericksburg Bcstg. Corp.**
 Business Address **707 Princess Anne St.**
 Phone Number **1261**
 Exec. Vice-Pres. **Richard Lewis**
 Manager **Walter F. Harris, Jr.**

WFTR

FRONT ROYAL—1948—MBS

Owned-Oper. By **Sky Park Bcstg. Corp.**
 Address **P. O. Box 192**
 Phone Number **750**
 News Service **UP**
 President **E. H. Stokes**
 Gen., Comm. Mgr. **Kenneth Gordon**
 Program, News Director **Tom Gibson**
 Chief Engineer **Claude F. Jones**

WBOB

GALAX—1947—MBS-KBS

Frequency: 1400 Kc. Power: 250 Watts
 Owned-Oper. By **Carroll-Grayson Bcstg. Corp.**
 Address **Poplar Knob Rd.**
 Phone Number **2921**
 News Service **AP**
 President **Robert V. Morris**
 Gen., Sta. Manager **Joseph P. Crockett**

Program Director..... Muriel Bell
 Commercial Manager..... Brice J. Parks
 Chief Engineer..... Edward Boyer

WVEC

HAMPTON—1948—NBC

Frequency: 1490 Kc..... Power: 250 Watts d.
 Owned-Operated By..... Peninsula Bcastg. Co.
 Studio-Trans. Address..... 1490 Pembroke
 Phone Number..... Hampton 6332
 Air Time..... Full Time
 News Service..... AP
 Transcription Service..... World, Standard
 Representative..... Wm. G. Rambeau
 Membership..... NARTB, BAB
 President..... Thomas P. Chisman
 General Manager..... Harrol A. Brauer, Jr.
 Comm. Manager..... Charles L. Coker, Jr.
 Program Director..... Bob Drill
 Chief Engineer..... Wm. C. King, Jr.

WSVA

HARRISONBURG—1935—NBC

Frequency: 550 Kc..... Power: 1000 Watts
 Owner-Oper..... Shenandoah Valley Bcastg. Corp.
 Business-Studio Address..... Rawley Pike
 Phone Number..... 4-4431
 Air Time..... Full Time
 News Service..... UP
 Transcription Service..... World
 Representative (Eastern)..... Devney & Co.
 Membership..... NARTB, BAB
 President..... Frederick L. Allman
 Sales Prom., Comm. Mgr..... Robert B. Harrington
 Program Director..... Richard H. Johnson
 Production Director..... Charles McGinley
 Chief Engineer..... Warren L. Braun

WHAP

HOPEWELL—1949

Frequency: 1340 Kc..... Power: 250 Watts
 Owned-Operated By..... The Hopewell Bcastg. Co.
 Business Address..... City Point Rd.
 Phone Number..... HO 801
 News Service..... UP
 Transcription Service..... Thesaurus
 Pres., Gen. Mgr..... Mort. Hendrickson
 Chief Engineer..... Steve Wolchin

WREL

LEXINGTON—1948—NBC-KBS

Frequency: 1450 Kc..... Power: 250 Watts
 Owned-Operated By..... Rockbridge Bcastg. Co.
 Phone Number..... 6000
 News Service..... AP
 Representative..... Cooke
 Transcription Service..... Thesaurus
 President..... Marshall L. Wilmer
 Gen., Sta., Comm. Mgr..... Milton B. Henson
 Program Director..... Andrew Peterson
 Chief Engineer..... James I. Bray, Jr.

WLVA

LYNCHBURG—1930—ABC

Frequency: 590 Kc..... Power: 1000 Watts
 Owned-Oper. By..... Lynchburg Bcastg. Corp.
 Address..... 925 Church St.
 Phone Number..... 2-1242
 Air Time..... 6:00 a.m.-12 M.
 News Service..... AP
 Transcription Service..... Lang-Worth
 Representative..... George P. Hollingbery
 Membership..... NARTB, BAB
 President..... Edward A. Allen
 Gen., Sta. Manager..... Philip P. Allen
 Commercial Manager..... Joseph F. Wright, Jr.
 Sales Prom. Mgr..... C. A. Larsen
 Prog. Publ. Dir..... Warren Uttal
 Chief Engineer..... John T. Orth

WWOD

LYNCHBURG—1947—MBS

Frequency: 1390 Kc..... Power: 1000 Watts
 Owned-Oper. By..... Old Dominion Bcastg. Corp.
 Address..... P. O. Box 918
 Phone Number..... 2-3441
 Air Time..... Unlimited
 News Service..... AP
 Transcription Service..... Thesaurus
 Representative..... Walker
 Membership..... NARTB
 President..... Dr. Powell G. Dillard
 Gen., Sta. Mgr..... Charles R. Maillet
 Commercial Manager..... Richard E. Gooch
 Chief Engineer..... Forest J. Pinkerton

WMEV

MARION—1948—ABC-KBS

Frequency: 1010 Kc..... Power: 1000 Watts d.
 Owned-Oper. By..... Mountain Empire Bcastg. Corp.
 Address..... Park Boulevard
 Phone Number..... 3-9001
 Air Time..... Daytime
 News Service..... AP
 Transcription Service..... World
 Representative..... Cooke
 Membership..... NARTB, BAB
 V.P., Gen., Sta. Mgr..... Robert C. Wolfenden
 Pgm. Dir..... Mrs. R. C. Wolfenden
 Chief Engineer..... F. M. White, Jr.

WMVA

MARTINSVILLE—1941—NBC-KBS

Frequency: 1450 Kc..... Power: 250 Watts
 Owned-Oper. By..... Martinsville Bcastg. Co., Inc.
 Address..... Chatham Heights
 Phone Number..... Virginia 2152
 News Service..... AP
 President..... S. S. Walker
 General Manager..... Maynard E. Dillaber
 Commercial Mgr..... Charles F. Adams
 Program Director..... Barbara Zimmerman
 Chief Engineer..... B. E. Boyer

WNRV

NARROWS—1953

Frequency: 990 Kc. Power: 1000 Watts d.
 Owned-Oper. By.....Giles Bcstg. Co.
 Phone Number2211
 President.....H. J. Romanus
 General Manager.....H. Tom Hicks
 Commercial Mgr.....R. J. Torquato
 Program Director.....Albert A. Rich
 Chief Engineer.....Washington Elitchko

WGH

NEWPORT NEWS—1928—ABC

Frequency: 1310 Kc. Power: 5000 Watts
 Owned-Oper. By.....Hampton Roads Bcstg. Corp.
 Bus.-Studio Address.....739 Boush St., Norfolk
 Phone NumberNorfolk-2-7031
 News ServiceAP
 News Affil.....Daily Press, Times-Herald
 Transcription ServiceAssociated
 Representative.....Free & Peters
 Membership.....NARTB, BAB
 President.....William R. Van Buren, Sr.
 Gen.-Sta. Manager.....Edward E. Bishop
 Commercial Mgr.....Clyde F. Meades
 Program Director.....Ambert Dail
 Chief Engineer.....Alois Braun

WHYU

NEWPORT NEWS—1947

Frequency: 1270 Kc. Power: 1000 Watts d.
 Owned-Operated By.....Eastern Bcstg. Corp.
 Business-Studio Address.....114 W. 24th St.
 Phone Number.....Newport News 3-1631
 News ServiceUP
 Transcription ServiceCapitol
 President.....John Doley
 General Manager.....Frederic F. Clair
 Program Dir.....Tom Bradshaw, Jr.

WCAV

NORFOLK—1947—MBS

Frequency: 850 Kc. Power: 1000 Watts
 Owned-Operated By.....Cavalier Bcstg. Corp.
 Bus.-Studio Address.....Helena Bldg.
 Phone Number2-3266
 News ServiceUP
 Transcription ServiceCapitol
 Representative.....Indie Sales, Inc.
 Membership.....NARTB
 President.....Mrs. Pauline Light
 General Manager.....William M. Manrov
 Program Director.....Jack Lynn
 Chief Engineer.....Sanford Willis

WLOW

NORFOLK—1946—

Frequency: 1400 Kc. Power: 250 Watts
 Owned-Oper. By.....Commonwealth Bcstg. Corp.
 Bus.-Studio Addr.....21st & Manteo Sts.
 Phone Number4-5677
 News ServiceUP
 RepresentativeForJoe

President.....E. L. Scott
 General Manager.....Robert Wasdon
 Station Manager.....Glenn Harmon
 Tech. Dir., Chf. Engr.....Jack Siegel

WNOR

NORFOLK—1949

Frequency: 1230 Kc. Power: 250 Watts
 Owned-Oper. By.....Norfolk Bcstg. Co.
 Address.....1019 Boissevain Ave.
 Phone Number27071
 News ServiceAP
 Transcription ServiceLang-Worth
 Representative.....Walker
 President.....Louis H. Peterson
 Gen., Comm. Mgr.....Earl Harper
 Program Manager.....Bill Montgomery
 Chief Engineer.....Howard Sheets

WRAP

NORFOLK—1952

Frequency: 1050 Kc. Power: 1000 Watts
 Owned-Operated By.....Rollins Bcstg., Inc.
 Address.....300 Portlock Bldg.
 Phone Number4-8307
 Chairman of Board.....John W. Rollins
 President.....O. Wayne Rollins
 General Manager.....Robert Lyons
 Chief Engineer.....Glen Frazier

WTAR

NORFOLK—1923—CBS

Frequency: 790 Kc. Power: 5000 Watts
 Owned-Oper. By.....WTAR Radio Corp.
 Bus.-Studio Address.....720 Boush St.
 Phone Number56711
 News ServiceAP
 News Affil.....Norfolk Newspapers, Inc.
 Transcription ServiceStandard
 Representative.....Edward Petry
 Pres., Gen. Mgr.....Campbell Arnoux
 Commercial Mgr.....Robert M. Lambe
 Promotion Manager.....Robert A. Davis
 Program Director.....William Johnson
 Publicity Director.....Joel Carlson
 Chief Engineer.....Dick Lindell

WNVA

NORTON—1946—MBS-KBS

Frequency: 1450 Kc. Power: 250 Watts
 Owned-Oper. By.....Blamfox Radio Co., Inc.
 Bus.-Studio Address.....Harlan, Ky.
 News ServiceAP
 Transcription ServiceWorld
 President.....Richard B. Helms
 Gen., Sta. Mgr.....Jack T. Helms
 Comm. Mgr., Pgm. Dir.....Wally Douglass
 Chief Engineer.....Gene Tommerdahl

WJMA

ORANGE—1949—MBS

Frequency: 1340 Kc. Power: 250 Watts

Owned-Oper. By. James Madison Bcstg. Corp.
 Address..... P. O. Box 271
 Phone Number 7263
 Air Time..... Full Time
 News Service UP
 Transcription Service SESAC
 Membership NARTB
 President..... W. A. Sherman, Jr.
 Gen., Comm. Mgr..... Alfred W. Walthall
 Program Director..... Jim Simmons
 Publicity Director..... Ann G. Butler
 Chief Engineer..... Charles F. Brown

WSSV

PETERSBURG—1945—MBS

Frequency: 1240 Kc. Power: 250 Watts
 Owned-Oper. By. Southside Virginia Bcstg.
 Corp.
 Business-Studio Address..... 112 W. Tabb St.
 Phone Number..... RE 3-4567
 Air Time..... 6:30 a.m.-M.
 News Service AP
 Membership NARTB
 President..... Louis H. Peterson
 Station Manager..... Ray L. Moss
 Commercial Mgr..... E. L. Von Nordeck
 Program Director..... N. W. Andrews
 Chief Engineer..... Donald W. Hall

WAVY

PORTSMOUTH—1943

Frequency: 1350 Kc. Power: 5000 Watts

Owned-Oper. By. Portsmouth Radio Corp.
 Bus.-Studio Address..... 205 Professional Bldg.
 Phone Number 7-3488
 News Service UP
 Transcription Service Thesaurus
 Representative Burn-Smith
 President..... Hunter C. Phelan
 Gen., Sta. Mgr..... Carl J. Burkland
 Chief Engineer..... Luther Norris

WPUV

PULASKI—1946—NBC

Frequency: 1230 Kc. Power: 250 Watts
 Owned-Oper. By. Southwest Bcstg. Corp.
 Address Box 351
 Phone Number 3-3931
 News Service AP
 Transcription Service World
 Representative Sears & Ayer
 Pres., Gen. Mgr..... Mason C. Deaver
 Commercial Manager..... Larry Schoenfeld
 Chief Engineer..... John A. Columbus

WRAD

RADFORD—1950

Frequency: 1340 Kc. Power: 250 Watts
 Owned-Oper. By. Rollins Bcstg., Inc.
 Phone Number 2461
 Transcription Service Associated
 Representative Pearson
 News Service AP
 President..... O. Wayne Rollins
 Gen., Comm. Mgr..... Wendell H. Siler
 Sales Prom. Mgr..... Ben Johnston
 Prog. Dir., Chief Engr..... Alfred L. Mills

WRIC

RICHLANDS—1951

Frequency: 1050 Kc. Power: 1000 Watts d.
 Owned-Oper. By. Clinch Valley Bcstg. Corp.
 Address Box 218
 Phone Number 450
 Transcription Service..... Thesaurus, SESAC
 News Service AP
 Gen., Sta. Mgr., Chf. Eng., Max M. Blakemore
 Program Director Lindy Seamon
 Comm., Prom. Mgr..... Joe J. Webb

WANT

RICHMOND—1951

Frequency: 990 Kc. Power: 1000 Watts
 Owned-Oper. By. United Bcstg. Co. of Virginia
 Address..... 513 E. Main St.
 Phone Number 38368
 President Richard Eaton
 General Manager..... Richard Scheele
 Program Manager..... Michael Novello
 Chief Engineer Silas Bell

WLEE

RICHMOND—1945—MBS

Frequency: 1480 Kc. Power: 5000 Watts
 Owned-Operated By. Lee Bcstg. Corp.

DOMINATING

in
**NEWS
 MUSIC
 and
 SPORTS**

Exclusive Station
 for

INTERNATIONAL LEAGUE
 BROADCASTS



WLEE

Richmond, Va.

Business-Studio Address..... Broad St. Road
 Phone Number..... 88-2837
 Air Time..... Full Time
 News Service..... AP
 Representative..... Forjoe
 President..... Thomas G. Tinsley, Jr.
 Sta., Gen.-Comm. Mgr..... Irvin G. Abeloff
 Program Director..... Harvey Hudson
 Chief Engineer..... George W. McGulgan, Jr.

W M B G

RICHMOND—1926—NBC

Frequency: 1380 Kc..... Power: 5000 Watts
 Owned-Oper. By..... Havens & Martin, Inc.
 Bus.-Studio Address..... 3301 W. Broad St.
 Phone Number..... 5-8611
 News Service..... UP
 Air Time..... Full Time
 Representative..... Bolling Co.
 Membership..... BAB
 Pres., Gen. Mgr..... Wilbur M. Havens
 Asst. Gen., Comm. Mgr... Walter A. Bowry, Jr.
 Program Director..... G. Conrad Ranhard, Jr.
 Chief Engineer..... James Kyle

WRNL

RICHMOND—1937—ABC

Frequency: 910 Kc..... Power: 5000 Watts
 Owned-Oper. By... Richmond Newspapers, Inc.
 Business-Studio Address..... 111 N. Fourth St.
 Phone Number..... 3-3436
 Air Time..... Full Time

News Service..... AP
 Transcription Service..... Standard, Thesaurus
 Representative..... Edward Petry
 Membership..... NARTB, BAB
 President..... D. Tennant Bryan
 Station Manager..... E. S. Whitlock
 Sales Manager..... Joseph Sierer
 Program Director..... Howard Hamrick
 Publicity Director..... Grace Braver
 Chief Engineer..... Vincent Wolstenholme

WRVA

RICHMOND—1925—CBS

Frequency: 1140 Kc..... Power: 50,000 Watts
 Owned-Oper. By..... Larus & Brother Co.
 Business Address..... Hotel Richmond
 Phone Number..... 3-6633
 News Service..... UP
 Transcription Service..... World, Lang-Worth
 Representative..... Radio Sales
 Membership..... NARTB, BAB
 General Manager..... C. T. Lucy
 Comm., Business Mgr..... James D. Clark
 Promotion Manager..... Jack Stone
 Program Manager..... Samuel S. Carey
 Production Manager..... Wm. R. Preston
 Business Manager..... Barron Howard
 Chief Engineer..... David C. Woods

WXGI

RICHMOND—1947

Frequency: 950 Kc..... Power: 1000 Watts d.
 Owned-Operated By..... Radio Virginia, Inc.

Proof of SELLING POWER in the RICH VIRGINIA MARKETS

The only yardstick of sales power is results. The proof of direct, immediate, profitable results, is consistent use of WRNL by highly successful advertisers, week after week, for OVER A DECADE. We'd like to tell you about it.

**5000 Watts
 ABC Affiliate
 Richmond, Virginia**

There's
 more
SELL
 on

WRNL
910 ON YOUR DIAL

Edward Petry & Co., Inc., National Representatives

Bus.-Studio Address.....100 W. Franklin St.
 Representative.....Indie Sales
 News Service.....AP
 President.....Douglas H. Robertson
 Gen. Comm. Mgr.....David M. Wilburn
 Chief Engineer.....Paul Kness

W D B J

ROANOKE—1924—CBS

Frequency: 960 Kc.....Power: 5000 Watts
 Owned-Oper. By.....Times-World Corp.
 Address.....124 W. Kirk Ave.
 Phone Number.....8131
 Air Time.....6 a.m.-12:05 a.m.
 News Service.....AP, UP
 News Affil.....Times, World News
 Transcription Service.....World
 Representative.....Free and Peters, Inc.
 Membership.....NARTB, BAB
 President.....J. P. Fishburn
 General Manager.....Ray P. Jordan
 Commercial Manager.....John W. Harkrader
 Program Director.....Paul E. Reynolds
 Production Director.....Charles A. Ballou
 Promotion Director.....Joe B. Grant
 Chief Engineer.....J. Edward Newman

WRIS

ROANOKE—1953

Frequency: 1410 Kc.....Power: 5000 Watts d.
 Owned-Oper. By.....Roanoke Independent
 Bcstrs. Inc.
 Address.....Pythian Bldg.
 Phone Number.....2-3131
 President.....Cy Bahakel
 Manager.....Frank Tirico
 Program Director.....Herman Reavis
 Promotion Manager.....Coleman Austin
 Chief Engineer.....John Strong

WROV

ROANOKE—1946—ABC-MBS

Frequency: 1240 Kc.....Power: 250 Watts
 Owned-Oper. By.....Radio Roanoke, Inc.
 Bus.-Studio Address.....600 Mountain Trust Bldg.
 Phone Number.....3-4444
 Air Time.....Unlimited
 News Service.....UP
 Transcription Service.....Lang-Worth
 Representative.....Burn-Smith
 Membership.....NARTB, BAB
 President.....Leo F. Henebry
 Gen.-Sta.-Comm. Mgr.....Frank E. Koehler
 Program Director.....Lee Garrett
 Chief Engineer.....J. W. Robertson

WSLS

ROANOKE—1940—NBC

Frequency: 610 Kc.....Power: 1000 Watts
 Owned-Oper. By.....Shenandoah Life Stations,
 Inc.
 Business-Studio Address.....Shenandoah Bldg.
 Phone Number.....9227
 Air Time.....Unlimited
 News Service.....AP

Transcription Service.....Thesaurus
 Representative.....Avery-Knodel
 Membership.....NARTB, BAB
 President.....Paul C. Buford
 Exec. Vice President.....James H. Moore
 Chief Engineer.....J. P. Briggs
 Commercial Manager.....Horace Fitzpatrick

WHLF

SOUTH BOSTON—1947—KBS—ABC

Frequency: 1400 Kc.....Power: 250 Watts
 Owned-Operated By.....Halifax Bcstg. Co.
 Address.....Webster St.
 Phone Number.....2-9988
 News Service.....AP
 Transcription Service.....World
 Owner, Comm. Mgr.....John L. Cole, Jr.
 Program Director.....Ella L. Poindexter
 Chief Engineer.....Arthur A. Moran

WJWS

SOUTH HILL—1953

Frequency: 1370 Kc.....Power: 1000 Watts d.
 Owned-Oper. By.....Mecklenburg Bcstg. Corp.
 Address.....Box 669
 Phone Number.....230
 President.....John Shultz
 Vice-Pres., Chief Engr.....Phil Hedrick
 Commercial Mgr.....W. Brown Hofter

WTON

STAUNTON—1945—ABC

Frequency: 1400 Kc.....Power: 250 Watts
 Owned-Operated By.....Charles P. Blackley
 Business-Studio Address.....Morrison Bldg.
 Phone Number.....5-5555
 News Service.....AP
 Transcription Service.....Thesaurus
 Membership.....NARTB
 General-Station Mgr.....Charles P. Blackley
 Comm.-Sales Prom. Mgr.....Charles F. Seebeck
 Program Director.....Fulton A. King
 Chief Engineer.....Rex C. Houser

WLPM

SUFFOLK—1940—ABC-KBS

Frequency: 1450 Kc.....Power: 250 Watts
 Owned-Operated By.....Suffolk Bcstg. Corp.
 Business-Studio Address.....Radio Bldg.
 Phone Number.....2394
 Air Time.....Unlimited
 News Service.....AP
 Transcription Service.....Standard
 Representative.....Sears & Ayer
 Pres., Gen. Manager.....Fred L. Hart
 Commercial Dir.....Earl Hundley
 Publicity Director.....Lee Williams
 Chief Engineer.....Veryl W. Rupp

WNNT

WARSAW—1949—KBS

Frequency: 690 Kc.....Power: 250 Watts d.
 Owned-Oper. By.....No. Neck & Tidewater
 Bcstg. Co.

Address Warsaw
 Phone Number..... WA 690
 News Service UP
 Transcription Service..... Thesaurus
 Pres.-Gen. Mgr..... Grayson Headley
 Commercial Mgr..... Ruth R. Rouzie
 Chief Engineer..... Kenneth Lueck

WAYB

WAYNESBORO—1947—MBS-KBS

Frequency: 1490 Kc..... Power: 250 Watts
 Owned-Oper. By.... Waynesboro Bcstg. Corp.
 Address..... 526 Main St.
 Phone Number 6066
 Air Time..... Full Time
 News Service AP
 Transcription Service World
 Membership NARTB
 President..... Judson T. Phillips
 Gen., Sta., Comm. Mgr..... N. Wilbur Kidd
 Program Director..... Al Charles
 Chief Engineer..... Donald D. Curtis

WINC

WINCHESTER—1941—NBC-KBS

Frequency: 1400 Kc..... Power: 250 Watts

Owned-Oper. By.... Richard Field Lewis, Jr.
 Business Address..... Box 605
 Phone Number 4855
 Air Time..... 6 a.m.-11:30 p.m.
 News Service UP
 Transcription Service Associated
 President... Richard Field Lewis, Jr. (Licensee)
 Pgm., Prod. Dir..... John Morgan
 Chief Engineer..... Phil Whitney

WYVE

WYTHEVILLE—1949—KBS-MBS

Frequency: 1280 Kc.... Power: 1000 Watts d.
 Owned-Oper. By.... Wythe County Bcstg. Co.
 Address..... P. O. Box 534
 Phone Number 840-1
 News Service UP
 Membership NARTB, BAB
 Transcription Service... Langworth, Keystone
 President..... A. M. Gates, M.D.
 General Manager..... A. M. Gates, Jr.
 Chief Engineer..... Jack Fleming

WASHINGTON

Pop. Feb. 1, 1954 (Est.) 2,814,000 — Families 987,000
 Radio Homes 965,000 — TV Homes 411,500 — Stations in State 54

KBKW

ABERDEEN—1948—ABC

Frequency: 1450 Kc..... Power: 250 Watts
 Owned-Oper. By..... KBKW, Inc.
 Address .. 701 E. Heron St., Aberdeen, Wash.
 Phone Number 1015, 1016
 Air Time..... 6 a.m.-11 p.m.
 News Service AP
 Transcription Service..... World, Associated
 Reresentative For Joe
 Membership BAB
 President..... Archie Taft, Jr.
 Gen., Sta. Mgr..... L. H. Davis court
 Program Director..... Francis White
 Chief Engineer..... Jack Fleming

KXRO

ABERDEEN—1927—MBS—DON LEE
 KBS

Frequency: 1320 Kc..... Power: 1000 Watts
 Owned-Oper. By KXRO, Inc.
 Address 207½ E. Market St.
 Phone Number Aberdeen 4098
 Air Time..... 7 a.m.-11:15 p.m.
 News Service UP
 Representative..... Clark, Moore-Lund
 Membership NARTB, BAB
 President..... Harry R. Spence
 Sta., Gen. Mgr..... Fred G. Goddard

Program Director..... Phillip M. Wacker
 Chief Engineer Philip True

KPUG

BELLINGHAM—1948—MBS-KBS
 DON LEE

Frequency: 1170 Kc..... Power: 1000 Watts
 Owned-Operated By..... KPUG, Inc.
 Business Address..... P. O. Box: 655
 Telephone 6200
 News Service UP
 Representative Clark
 President Jessica L. Longston
 Station Mgr..... James Hamstreet
 Comm. Mgr..... Alex DeSchweinitz
 Prom. Mgr..... Dick Rapp
 Program Dir..... Jeanne Smith
 Chief Engineer..... Donald R. Pinney

KVOS

BELLINGHAM—1927—ABC

Frequency: 790 Kc..... Power: 1000 Watts
 Owned-Operated By..... KVOS, Inc.
 Bus.-Studio Address..... 1321 Commercial St.
 Phone Number 790
 News Service UP
 Representative For Joe, Fellis
 Membership NARTB, BAB
 President Rogan Jones

Gen. Sta. Mgr. Jack Clarke
 Sales Prom. Mgr. Mel McKee
 Publicity Director. Dave Mintz
 Chief Engineer. Ernest Harper

KBRO

BREMERTON—1947

Frequency: 1490 Kc. Power: 250 Watts
 Owned-Oper. By. Bremerton Broadcast Co.
 Address Box 1803
 Phone Number 7-3995
 News Service AP
 Transcription Service Standard
 Membership BAB
 Owner & Pres. Bruce Bartley
 Gen. Sta. Mgr. Loren B. Stone
 Commercial Mgr. G. Jacobsen
 Program Director. Al Stewart
 Chief Engineer. Bill Dore

KGIB

BREMERTON—1950

Frequency: 1540 Kc. Power: 1000 Watts d.
 Owned-Oper. By. Kitsap G.I. Bcstrs., Inc.
 Address 124 N. Callow St.
 Phone Number 7-3757

KELA

**CENTRALIA-CHEHALIS—1937-MBS
 KEYSTONE-DON LEE**

Frequency: 1470 Kc. Power: 1000 Watts
 Owned-Oper. By. Central Bcstg. Co.-p.
 Business Address. P. O. Box 720, Centralia;
 P. O. Box 827, Chehalis
 Phone Numbers. Centralia 6-3321,
 Chehalis 8-3321
 News Service UP
 Representative Clark, Moore-Lund
 Membership NARTB, BAB
 President. J. Elroy McCaw
 Sec.-Treas. Mabel A. Gwinn
 Gen., Sta., Comm. Mgr. Joe Chytil
 Program Director. Joe Clement
 Publicity Dir. Robert Cleland
 Chief Engineer. Lloyd Hannah

KCLX

COLFAX—1950—KBS

Frequency: 1450 Kc. Power: 250 Watts
 Owned-Oper. By. Whitman County Bcstrs.
 Address Box 710
 Phone Number 780
 News Service AP
 Membership NARTB
 General Manager. E. Pournelle
 Program Director. Ruth Pournelle
 Chief Engineer. David Dodd

KXLE

ELLENSBURG—1946

Frequency: 1240 Kc. Power: 250 Watts
 Owned-Oper. By. Central Washington Bcstrs.

Bus. Add. Trans. Loc. Box 600
 Phone Number 2-1488
 Air Time 6:30 a.m.-10:30 p.m.
 News Service UP
 Transcription Service. Associated Program
 Representative McGillvra
 Membership BAB
 President. Goodwin Chase, Jr.
 Gen. Sta. Manager. Joe Kendall
 Program Director. Wm. Chase
 Publicity Dir. Ron Forsell
 Chief Engineer. Wm. Hanning

KULE

EPHRATA—1949

Frequency: 730 Kc. Power: 250 Watts d.
 Owned-Oper. By. Columbia Basin Bcstg. Co.
 Phone Number 730
 President. Robert E. Billingsley
 General Manager. Bob Moore
 Commercial Mgr. Bob Osland
 Chief Engineer. Bill McCoy

KRKO

EVERETT—1920—MBS-DON LEE

Frequency: 1380 Kc. Power: 1000 Watts
 Owned-Oper. By. The Everett Bcstg. Co., Inc.
 Address P. O. Box 916
 Phone Number. Cedar 1144
 Air Time 6 a.m.-M.
 News Service AP
 Transcription Service SESAC
 Representative Joseph Hershey McGillvra
 Membership NARTB, BAB
 Pres., Gen. Sta. Mgr. William R. Taft
 Sales Manager Warren Johnson
 Traffic Dir. Nancy Spaeth
 Chief Engineer. Dave Foley

KFDR

GRAND COULEE—1950—KBS

Frequency: 1400 Kc. Power: 250 Watts
 Owned-Oper. By. Columbia River Bcstrs., Inc.
 Address Box 395
 Phone Number 140
 Air Time 15 Hrs.
 News Service UP
 Representative Moore & Lund
 Membership NARTB, BAB
 Pres., Gen. Mgr. J. W. England
 Program Dir. Robert Anderson
 Chief Engineer. John Loudon

KLOG

KELSO—1949

Frequency: 1490 Kc. Power: 250 Watts
 Owned-Oper. By. N.W. Public Services, Inc.
 Address P. O. Box 90
 News Service UP
 President. Roscoe A. Day, Jr.
 General Manager. John Carlson
 Program Director. Lowell Gibson
 Chief Engineer. Bill Vance

KWIE

KENNEWICK—1949

Frequency: 610 Power: 1030 Watts
 Owned-Oper. By KWIE, Inc.
 Address 11 S. Cascade St.
 Phone Number KE 6961
 Air Time 6 a.m.-12 M.
 News Service AP
 Transcription Service Associated
 Representative Moore-Lund, Robert Meeker
 Membership NARTB
 Pres., Sta. Mgr. Harold A. Clark
 Comm. Mgr., Chief Eng. C. J. McCredie
 Program Director Marvin E. Johnston

KRKL

KIRKLAND—1948

Frequency: 1050 Kc. Power: 250 Watts d.
 Owned-Oper. By Eastside Bdcstg. Co.
 Address Trans. Loca. Civic Center
 Phone Number KI 22-1201
 Transcription Service Capitol
 Presidents . . . L. N. Ostrander, W. A. Chamness
 General Manager G. A. Wilson
 Program Director Rosanne Coyle Lomen
 Chief Engineer R. H. Waldron

KWLK

LONGVIEW—1938—MBS

Frequency: 1400 Kc. Power: 250 Watts
 Owned-Oper. By Twin City Bcstg. Corp.
 Bus.-Studio Add., Natl. Bank of Commerce Bldg.
 Phone Number 1500
 Air Time Full Time
 News Service UP
 Transcription Service World
 Representative W. S. Grant, Moore-Lund
 Membership NARTB, BAB
 President, Gen. Mgr. C. O. Chatterton
 Station Mgr. Bob L. Moran
 Program Director Ellen Hammond
 Chief Engineer Ralph Brown

KSEM

MOSES LAKE—1947—KBS

Frequency: 1450 Kc. Power: 250 Watts
 Owned-Operated By KSEM, Inc.
 Address Box 276
 Phone Number 234
 Air Time 6 a.m.-M.
 News Service UP
 Transcription Service Langworth
 Representative Moore-Lund, Donald Cooke
 Membership NARTB, BAB
 President Jessica Longsien
 Gen. Mgr. Robert Pollack
 Station Mgr. Alan Miller
 Program Director Roland Hooper
 Chief Engineer Earl Baynes

KBRC

MOUNT VERNON—1946

Frequency: 1430 Kc. Power: 500 Watts
 Owned-Operated By Beckley Radio Co.
 Bus.-Studio Add.-Trans. Loca. . . P. O. Box 240
 Phone Number 8955
 Air Time 6 a.m.-10 p.m.
 News Service UP
 Representative Moore-Lund, McGillvra
 Membership NARTB, BAB
 Gen., Sta. Mgr. Leo H. Beckley
 Commercial Mgr. Don Usher
 Program Director Tom Haveman
 Chief Engineer John Price

KGY

OLYMPIA—1922—MBS

Frequency: 1240 Kc. Power: 250 Watts
 Owned-Oper. By Tom Olsen
 Address Trans. Loca. . . Rockway Leland Bldg.
 Phone Number 6636
 Air Time 6 a.m.-11 p.m.
 News Service UP
 Transcription Service World, SESAC
 Representative George Clark, Art Moore
 Membership BAB
 General Manager Tom Olsen
 Commercial Mgr. Elmer J. Holmberg
 Program Director Don Jones
 Chief Engineer Charles A. Roark

KOMW

OMAK—1947

Frequency: 680 Kc. Power: 1000 Watts d.
 Owned-Operated By KOMW, Inc.
 Business-Studio Address Box 151
 Air Time Daytime
 News Service AP
 Transcription Service Lang-Worth
 Membership NARTB
 President R. L. McNett
 General Manager Dean Nichols
 Commercial Manager Grover D. Allen
 Program Director Mary Jane Robbins
 Chief Engineer Leonard Fleisher

KPKW

PASCO—1945—ABC

Frequency: 1340 Kc. Power: 250 Watts
 Owned-Oper. By Western Radio Corp.
 Address Chase & "A" Sts.
 Phone Number 3337
 Air Time 6 a.m.-12 M.
 News Service UP
 Transcription Service Capitol
 Pres., Gen. Mgr. V. B. Kennworthy
 Sta., Comm. Mgr. W. J. Hunt
 Program Director Walter Mott
 Chief Engineer Robert Rockne

KONP

PORT ANGELES—1945—KBS

Frequency: 1450 Kc. Power: 250 Watts
 Owned-Operated By: Radio Pacific, Inc.
 Bus.-Studio-Transmitter Address: 313 W. First
 Phone Number: 4200
 Air Time: 6:45 a.m.-10:30 p.m.
 News Service: UP
 Transcription Service: World
 Representative: John Keating
 Pres., General Mgr.: C. N. Webster
 Station Manager: Keith Patterson
 Chief Engineer: Frederick Fields

KOFE

PULLMAN—1950

Frequency: 1150 Kc. Power: 1000 Watts d.
 Owned-Oper. By: Bayton & Hicks
 Address: P. O. Box 356
 Phone Number: 1-5251
 News Service: UP
 Membership: BAB
 Transcription Service: Lang-Worth
 Gen., Sta. Mgr.: J. Ronald Bayton
 Commercial Mgr.: John R. Puckett
 Prom. Mgr., Chief Eng.: B. J. Bayton

KPUY

PUYALLUP—1951—KBS

Frequency: 1450 Kc. Power: 250 Watts
 Owned-Oper. By: Puyallup Valley Bcstg. Co.
 Address: 1510 Linden Drive
 Phone Number: 5-7711
 News Service: UP
 Transcription Service: Associated
 Gen., Comm. Mgr.: Merrill E. Mael
 Program Director: Pete Hansen
 Chief Engineer: George Yeager

KAPA

RAYMOND—1950

Frequency: 1340 Kc. Power: 250 Watts
 Owned-Oper. By: Pacific Bcstg. Corp.
 Address: P. O. Box 626
 Phone Number: 1010
 Air Time: 6 a.m.-12 M.
 News Service: AP
 Station Representative: Clark Moore-Lund
 Membership: NARTB, BAB
 President: Joe Chytil
 Gen., Sta. Mgr.: Hugh MacPherson
 Program Director: Stan Witter
 Chief Engineer: Robert McNamara

KLAN

RENTON—1947

Frequency: 1230 Kc. Power: 250 Watts
 Owned-Oper. By: Interlake Bdcstg. Corp.
 Address Trans. Loca.: N. 7th & Park Ave.
 Phone Number: Renton 5-3424
 Air Time: Full Time (Ex. Sunday)
 News Service: UP
 Transcription Service: Cole. World

Representative: Forjoe
 President, Manager: Ralph Sander
 Station Manager: Clifford H. Hansen
 Program Director: George Edgar
 Chief Engr.: F. C. Cook

KALE

RICHLAND—1950

Frequency: 960 Kc. Power: 1000 Watts
 Owned-Oper. By: KALE, Inc.
 Address: P. O. Box 367
 Phone Number: RI 4-3180
 Representative: George Clark
 Transcription Service: Lang-Worth
 Membership: NARTB, BAB
 News Service: UP
 President: R. S. McCaw
 Gen., Sta. Mgr.: L. G. Dix
 Prog. Dir., Chief Eng.: Joseph Muench

KAYO

SEATTLE—1926

Frequency: 1150 Kc. Power: 1000 Watts
 Owned-Operated By: Wash. Telecasters, Inc.
 Add., Trans. Loca.: 2939 Fourth Ave. So.
 Phone Number: ELiot 2480
 Air Time: Full Time
 News Service: UP
 Membership: NARTB, BAB
 President: Jessica L. Longston
 Gen., Sta. Mgr.: R. E. Pollock
 Sales Prom. Mgr., Pgm. Dir.: Ben H. Harkins
 Chief Engineer: Verle Jones

KING

SEATTLE—1946—ABC

Frequency: 1090 Kc. Power: 50,000 Watts
 Owned-Oper. By: KING Bcstg. Co.
 Address: 320 Aurora Ave.
 Phone Number: Mutual 3555
 Representative: Blair
 News Service: UP
 Membership: NARTB, BAB
 President: Mrs. A. Scott Bullitt
 V.P., Gen. Mgr.: Otto P. Brandt
 Commercial Mgr.: Roger D. Rice
 Program Director: Earl F. Reilly, Jr.
 Publicity Director: Mel Anderson
 Chief Engineer: Arthur A. Shultz

KIRO

SEATTLE—1935—CBS

Frequency: 710 Kc. Power: 50,000 Watts
 Owned-Oper. By: Queen City Bcstg. Co.
 Bus.-Studio Address: 1530 Queen Anne Ave.
 Phone Number: Alder 9800
 News Service: UP
 Transcription Service: Thesaurus
 Membership: BAB
 President: Saul Haas
 Comm. Manager: William F. Tucker
 Program Director: Carroll Foster
 Chief Engineer: James Hatfield

KJR

SEATTLE—1923

Frequency: 950 Kc. Power: 5000 Watts
 Owned-Oper. By Mt. Rainier Radio &
 Television Bcstg. Corp.
 Business-Studio Address Skinner Bldg.
 Phone Number Elliot 5890
 Air Time Unlimited
 News Service UP
 Transcription Service Standard
 Representative Avery-Knodel
 President C. Howard Lane
 Chairman of Board Theodore R. Gamble
 Gen., Prom. Mgr. Mait Jordan
 Pgm. Director Homer Pope
 Chief Engineer Don M. Anderson

KOL

SEATTLE—1922

Frequency: 1300 Kc. Power: 5000 Watts
 Owned-Oper. By Seattle Bcstg. Co.
 Bus.-Studio Address 1100 W. Florida St.
 Phone Number MA. 2312
 Air Time 6 a.m.-M.
 News Service UP, INS
 Transcription Service World
 Representative Bolling
 Membership BAB, NARTB
 President Archie Taft
 Sta., Gen. Mgr. Archie Taft, Jr.
 Comm., Prom. Mgr. Gil Bond
 Program Director Robert Harris
 Chief Engineer Perry Lind

KOMO

SEATTLE—1926—NBC

Frequency: 1000 Kc. Power: 50,000 Watts
 Owned-Oper. By Fisher's Blend Station, Inc.
 Bus.-Studio Address 100 4th Ave. No.
 Phone Number SENECA 6000
 Air Time 18 hrs.
 News Service UP
 Transcription Serv. Associated, Lang-Worth
 Representative Hollingbery
 Membership NARTB, BAB
 President, General Mgr. O. W. Fisher
 V.P., Gen. Mgr. W. W. Warren
 V.P., Com. Manager Ray Baker
 Publicity Director Margaret Frey
 Program Manager F. J. Patterson
 Chief Engineer F. J. Brott

KTW

SEATTLE—1920

Frequency: 1250 Kc. Power: 1000 Watts
 Owned-Oper. By The First Presbyterian
 Church of Seattle, Wash.
 Phone Number Mutual 1250
 President W. T. Whitney
 Station Manager Don Bevilacqua
 Chief Engineer James S. Ross
 Program Dir. A. G. Atworth, Jr.
 Chief Engineer James S. Ross

KVI

SEATTLE—1928—MBS

Frequency: 570 Kc. Power: 5000 Watts
 Owned-Oper. By Puget Sound Bcstg. Co., Inc.
 Business Address Camlin Hotel
 Phone Number SENECA 4848
 Air Time 6 a.m.-12 M.
 News Service AP
 Transcription Service Thesaurus
 Representative H-R Reps.
 Membership NARTB, BAB
 Pres., Gen. Mgr. Vernice Irwin
 Chief Owner Laura M. Doernbecher
 Commercial Mgr. Earl T. Irwin
 Program Dir. Harry Long
 Chief Engineer D. M. McDonough

KXA

SEATTLE—1926

Frequency: 770 Kc. Power: 1000 Watts d.
 Owned-Operated By KXA, Inc.
 Bus.-Studio Address 320 Second Ave., W.
 Phone Number ALDER 8600
 Air Time 5 a.m.-Local Sunset
 News Service AP
 Membership NARTB, BAB
 President Wesley I. Dumm
 General Manager Hugh A. Smith
 Commercial Mgr. John W. Mowbray
 Chief Engineer John Dubuque

KGA

SPOKANE—1926—ABC

Frequency: 1510 Kc. Power: 50,000 Watts
 Owned-Oper. By Bankers Life and Casualty
 Bus.-Stud. Add. 4444 Lawrence Ave., Chicago
 Air Time 6 a.m.-12 M.
 News Service UP
 Transcription Service World
 Representative Clark
 President John MacArthur
 General Manager Kenneth Yeend
 Program Director Rod Klise
 Chief Engineer B. B. Boardman

KHQ

SPOKANE—1922—NBC

Frequency: 590 Kc. Power: 5000 Watts
 Owned-Operated By KHQ, Inc.
 Bus.-Studio Address Radio Central Bldg.
 Phone Number MADISON 5131
 Air Time 19 hrs.
 News Service AP
 Transcription Service Associated
 Representative Katz
 Membership NARTB, BAB
 Pres., Gen. Mgr. Richard O. Dunning
 Station Manager Chas. E. Lohnes
 Program Director R. H. Godon
 Chief Engineer A. G. Sparling

KNEW

SPOKANE—1947—MBS—DON LEE

Frequency: 790 Kc. Power: 5000 Watts
 Owned-Oper. By Inland Empire Bcstg. Co.
 Bus.-Studio Address Sprague at Wall
 Phone Number Riverside 8035
 Representative Weed
 Transcription Service Capital
 Membership NARTB
 Pres., Gen. Mgr. Burl C. Hagadone
 Station Manager C. E. Rodell
 Program Director Paul Crain
 Chief Engineer Vincent L. Hoffart

KREM

SPOKANE—1947

Frequency: 970 Kc. Power: 1000 Watts
 Owned-Operated By Louis Wasmer
 Address South 4103 Regal
 Phone Number Keystone 0466
 Transmitter Location 4101 S. Regal St.
 News Service AP
 Transcription Service Associated
 Representative Bolling
 Pres., Gen. Sta. Mgr. Louis Wasmer
 Manager Robert H. Temple
 Program Director E. A. Moseley
 Chief Engineer William Patterson

KSPO

SPOKANE—1922

Frequency: 1340 Kc. Power: 250 Watts
 Owned-Oper. By Williams and Berthoff
 Address, Trans. Loc. Realty Bldg.
 Phone Number Riverside 8033
 News Service UP
 Co-Owner Delbert Berthoff
 Co-Owner Gene Williams
 Chief Engineer E. P. Antosyn

KXLY

SPOKANE—1922—CBS-PNB

Frequency: 920 Kc. Power: 5000 Watts
 Owned-Operated By Symons Bcstg. Co.
 Address West 315 Sprague
 Phone Number MAin 1218
 Air Time Unlimited
 News Service AP, UP
 Transcription Service MacGregor, SESAC
 Representative Walker, PNB, Moore-Lund
 Pres., Gen. Mgr. E. B. Craney
 Sta., Comm. Mgr. George Morgan
 Program Director Gene Roth
 Chief Engineer George Langford

KREW

SUNNYSIDE—1950

Frequency: 1230 Kc. Power: 250 Watts
 Owned-Oper. By Cole E. Wylie
 Address Outlook Road
 Phone Number 7-2277
 News Service AP

Representative Forjoe
 Membership NARTB, BAB
 President Cole E. Wylie
 General Manager Don G. Bennett
 Program Director Jean Runyan
 Chief Engineer John Berg

KMO

TACOMA—1926

Frequency: 1360 Kc. Power: 5000 Watts
 Owned-Oper. By KMO, Inc.
 Bus.-Studio Address P. O. Box 1651
 Phone Number FU 1581
 Air Time 6 a.m.-12 p.m.
 News Service UP
 Transcription Service Thesaurus, Standard
 Representative Bramham
 Membership NARTB, BAB
 President Carl E. Haymond
 V.P., Gen. Sta. Mgr. Jerry Geehan
 Comm. Mgr. Raymond T. McKenzie
 Prom., Pub. Dir. Eugene W. Dryden
 Program Dir. Richard D. Weeks
 Chief Engineer John Boor

KTAC

TACOMA—1942

Frequency: 810 Kc. Power: 1000 Watts
 Owned-Operated By Tacoma Bcstrs., Inc.
 Address 2715 Center St.
 Phone Number BRoadway 2241
 Air Time 18 hrs.
 News Service UP
 Transcription Service World
 Representative McGillivra, Moore
 Membership NARTB
 President Harold I. Quilliam
 Station Manager T. R. Knighlinger
 Commercial Manager Don Hopkins
 Chief Engineer R. C. Velo

KTNT

TACOMA—1952

Frequency: 1400 Kc. Power: 250 Watts
 Owned-Operated By Tribune Publ. Co.
 Address So. 11th & Grant Sts.
 Phone FU 2561
 Transcription Service Associated
 News Service AP, UP
 Representative Weed
 General Manager Len Higgins
 Commercial Mgr. John Upham
 Program Director Gless Conroy
 Chief Engineer Max H. Bice

KVAN

VANCOUVER—1939

Frequency: 910 Kc. Power: 1000 Watts
 Owned-Oper. By KVAN, Inc.
 Studio Address 707 1/2 Main St.
 Phone TW 7323
 Air Time 6 a.m.-M.
 News Service UP

Transcription Service World
 Representative Bolling
 Membership BAB
 President..... Sheldon F. Sackett
 General-Station Mgr..... Fred F. Chitty
 Comm. Mgr..... Walter P. Rossman
 Sales Prom. Mgr..... Al Bauer
 Prog., Pub. Dir..... George W. Conner
 Chief Engineer..... Leo Erickson

KTEL

WALLA WALLA—1946—ABC

Frequency: 1490 Kc. Power: 250 Watts
 Owned-Oper. By Walla Walla Bdcstg. Co.
 Address Book Nook Bldg.
 Phone Number 4103
 Air Time Unlimited
 News Service AP
 Transcription Service World
 Representative Grant, Keating
 Pres., Gen. Mgr..... Jack Keating
 Commercial Manager..... Don Harris
 Chief Engineer..... Bevin Roth

KUJ

**WALLA WALLA—1928—MBS
 DON LEE**

Frequency: 1420 Kc. Power: 5000 Watts
 Owned-Operated By..... KUJ, Inc.
 Business-Studio Address..... 55 E. Main St.
 Phone Number 1230
 Air Time Full Time
 News Service UP
 Transcription Service Thesaurus
 Representative... Weed, National, Moore-Lund
 Membership NARTB, BAB
 Pres., Gen. Mgr..... H. E. Studebaker
 Sta. Comm. Mgr..... Don Wike
 Program Director..... John Sherman
 Chief Engineer..... M. L. MacLafferty

KPQ

WENATCHEE—1929—ABC

Frequency: 560 Kc. Power: 5000 Watts
 Owned-Oper. By Westcoast Bcstg. Co., Inc.
 Bus.-Studio Address..... 2nd & Columbia Sts.
 Phone Number 2757
 Air Time 6 a.m.-M.
 News Service UP
 Transcription Service World
 Representative Forjoe
 Membership BAB
 President Rogan Jones
 Sta., Gen. Mgr..... James W. Wallace
 Prom., Comm. Mgr. Pat O'Halloran
 Program Director..... Emerson Elder
 Publicity Director..... Laura Murphey
 Chief Engineer..... George Frese

KWNW

WENATCHEE—1948—MBS

Frequency: 1340 Kc. Power: 250 Watts
 Owned-Oper. By Wenatchee Broadcasters
 Address P. O. Box 1510
 Phone Number 2468-2469
 Air Time 6 a.m.-12 M.
 Representative.... McGillvra, Moore & Lund
 General Mgr..... Stuart S. Maus
 Sta., Comm. Mgr..... Mark A. Sorley
 Chief Engineer..... Warren Brown

KIMA

YAKIMA—1944—CBS

Frequency: 1460 Kc. Power: 5000 Watts
 Owned-Oper. By Cascade Bdcstg. Co.
 Address P. O. Box 702
 Phone Number 6104
 News Service AP
 Transcription Service..... Langworth, SESAC
 Representative.... Weed & Co.
 Membership NARTB, BAB
 President A. W. Talbot
 General Manager..... R. Lee Black
 Station Manager..... Frank G. Mitchell
 Commercial Mgr..... W. B. Hansen
 Chief Engineer..... J. Barry Watkinson

KIT

YAKIMA—1929—ABC—NBC

Frequency: 1280 Kc. Power: 5000 Watts d.,
 1000 Watts n.
 Owned-Operated By..... KIT, Inc.
 Business-Studio Address. 414 E. Yakima Ave.
 Phone Number 8115
 Air Time 6 a.m.-12 M.
 News Service UP
 Representative Branham
 Membership BAB
 President Carl E. Haymond
 Gen., Sta. Mgr..... James A. Murphy
 Com., Prom. Mgr..... Jack H. Goetz
 Chief Engineer..... H. B. Murphy

KYAK

YAKIMA—1947—MBS

Frequency: 1400 Kc. Power: 250 Watts
 Owned-Oper. By..... Yakima Bcstg. Co.
 Address P. O. Box 172
 Phone Number 2-7143
 Transcription World
 News Service UP
 Membership NARTB, BAB
 President..... Robert S. McCaw
 Station Manager..... W. W. Boone
 Commercial Manager..... Leroy T. Desilet
 Program Director..... Gerald Webb
 Chief Engineer..... Donald E. Gardner

WEST VIRGINIA

Pop. Feb. 1, 1954 (Est.) 2,086,000 — Families 502,000
Radio Homes 461,000 — TV Homes 233,500 — Stations in State 41

WJLS

BECKLEY—1939—CBS

Frequency: 560 Kc. Power: 5000 Watts d.
500 Watts n.
Owned-Oper. By Joe L. Smith, Jr., Inc.
Bus.-Studio Address WJLS Building
Phone Number 7311
Air Time Unlimited
News Service UP
Representative Weed
Membership NARTB
Pres., Gen. Mgr. Joe L. Smith, Jr.
Station Manager Virginia N. Cooper
Sales Prom. Mgr., Pub. Dir. W. R. Barrett
Program Director R. R. Brown
Chief Engineer Al J. Ginkel

WWR

BECKLEY—1946—MBS

Frequency: 620 Kc. Power: 1000 Watts d.
500 Watts n.
Owned-Operated By Rahall Bcstg. Co.
Business-Studio Address 1565 Harper Rd.
Phone Number 9309
Air Time Full Time
News Service AP
Representative Everett-McKinney
President N. Joe Rahall
General Manager R. H. Booth
Chief Engineer Robert Ramsey

WHIS

BLUEFIELD—1928—NBC-KBS

Frequency: 1440 Kc. Power: 5000 Watts
Owned-Oper. By Daily Telegraph Prtg. Co.
Business-Studio Address 623 Commerce St.
Phone Number 7114
Air Time Unlimited
News Service AP
Transcription Service World. Cole
Representative Katz
Vice President Hugh I. Shott, Jr.
Gen. Mgr., Chief Eng. P. T. Flanagan
Program Director William Hostetter

WKOY

BLUEFIELD—1948—MBS

Frequency: 1240 Kc. Power: 250 Watts
Owned-Oper. By WKOY, Inc.
Address West Virginian Hotel
Phone Number 7405
Air Time 6 a.m.-12 M.
News Service UP
Representative Devney & Co.
Pres., Gen., Sta. Mgr. J. Lindsley Alley
Program Director Emma Sue Phelps
Chief Engineer Roy Yost

WCAW

CHARLESTON—1947

Frequency: 1400 Kc. Power: 250 Watts
Owned-Oper. By Capitol Bcstg. Corp.
Business Address 16th St. at McCarkle Ave.
Phone Number 2-7503
Transcription Service Lang-Worth
Representative McGilvra
Pres., Gen. Mgr. Garland F. Wilkinson
Commercial Manager James H. Tomblin
Program Director Al Walker
Chief Engineer William Stone

WCHS

CHARLESTON—1927—CBS

Frequency: 580 Kc. Power: 5000 Watts
Owned-Oper. By The Tierney Co.
Address 1111 Virginia St. E.
Phone Number 28-131
Air Time Full Time
News Service AP, UP
Representative Branham
Membership NARTB, BAB
President Lewis C. Tierney
V.P., Gen. Mgr. John T. Gelder, Jr.
Comm. Mgr. John L. Sinclair, Jr.
Prom., Pub. Dir. Frank E. Shaffer
Program Director Morton S. Cohn
Chief Engineer William E. Dixon

WGKV

CHARLESTON—1939—NBC

Frequency: 1490 Kc. Power: 250 Watts
Owned-Oper. By The Kanawha Valley
Bcstg. Co.
Address Box 953
Phone Number 3-7541
Air Time Full Time
News Service AP
Transcription Service SESAC
Representative Robert Meeker Assos., Inc.
Pres., Gen. Mgr. R. M. Venable
Program Director Joe Farris
Publicity Director Bill Richards
Chief Engineer Harry R. Bowen

WKNA

CHARLESTON—1946

Frequency: 950 Kc. Power: 5000 d., 1000 n.
Owned-Oper. By Joe L. Smith, Jr., Inc.
Bus.-Studio Address 804¹/₂ Kanawha Blvd.
Phone Number 39-971
Air Time 5:30 a.m.-12 M.
News Service UP
Representative Weed
President Joe L. Smith, Jr.
Station Manager C. P. Vogel, Jr.
Chief Engineer A. J. Ginkel

WTIP

CHARLESTON—1946—MBS

Frequency: 1240 Kc. Power: 250 Watts
 Owned-Oper. By... Chemical City Bcstg. Co.
 Bus.-Studio Address... Capitol & Fife
 Phone Number... 23-136
 Air Time... 6 a.m.-12 M.
 News Service... UP
 Transcription Service... Thesaurus
 Representative... Forjoe
 Membership... NARTB
 President... Gus Zaharis
 Gen., Sta. Mgr... Berton Sonis
 Comm. Mgr... Mel S. Burka
 Program Director... Bob Bower
 Chief Engineer... Paul Sullivan

WBLK

CLARKSBURG—1937—NBC

Frequency: 1400 Kc. Power: 250 Watts
 Owned-Oper. By... Ohio Valley Bcstg. Corp.
 Address... 444½ W. Pike St.
 Phone Number... 4-7571
 News Service... UP
 Transcription Service... Thesaurus
 Representative... Branham
 Membership... BAB, NARTB
 President... Austin Wood
 General Manager... George H. Clinton
 Station Manager... Carl Loose
 Program Manager... James L. Harper
 Chief Engineer... Harry S. Brown

WHAR

**CLARKSBURG—1946—MBS-KBS
 ABC**

Frequency: 1340 Kc. Power: 250 Watts
 Owned-Oper. By... Mountain State Bcstg. Co.
 Address Trans. Loca... Radio Plaza
 Phone Number... 4-5525-6
 News Service... UP
 Representative... McGillivra
 Membership... NARTB
 Pres., Gen., Mgr... Glacus G. Merrill
 Commercial Manager... F. T. Gregg
 Program Director... Joe McQuay
 Publicity Dir... Robert Edge
 Chief Engineer... Beryl Snyder

WPDX

CLARKSBURG—1947

Frequency: 750 Kc. Power: 1000 Watts d.
 Owned-Oper. By... Clarksburg Bcstg. Corp.
 Business-Studio Address... 339 W. Main St.
 Phone Number... 4-6425
 News Service... AP
 Transcription Service... World
 President... O. L. Billingsley
 Gen., Sta. Mgr... R. C. Warden
 Comm., Sales Prom. Mgr... Joe M. Larosa
 Prog., Pub. Dir... Dewitt Wyatt
 Chief Engineer... R. D. Hough

WDNE

ELKINS—1948—MBS-KBS

Frequency: 1240 Kc. Power: 250 Watts
 Owned-Oper. By... W. Va. Radio Corp.
 Address... P. O. Box 967, Elkins
 Phone Number... 1300
 Air Time... Full Time
 News Service... UP
 Transcription Service... World
 President... Mrs. A. J. R. Greer
 Sta., Comm. Mgr... Edward F. Libby
 Program Director... Richard Rhodes

WMMN

FAIRMONT—1928—CBS

Frequency: 920 Kc. Power: 5000 Watts
 Owned-Oper. By... Storer Bcstg. Co.
 Address... 208 Adams Street
 Phone Number... 3100
 Air Time... 5 a.m.-12:05 a.m.
 News Service... UP
 Transcription Service... Standard
 Representative... H.R. Reps
 Membership... NARTB, BAB
 President... Herbert Evans
 Station Manager... A. G. Ferrise
 Program Director... Francis Lauzau
 Chief Engineer... Harry W. Jackson

WVWV

FAIRMONT—1946—ABC

Frequency: 1490 Kc. Power: 250 Watts
 Owned-Oper. By... Fairmont Bcstg. Co., Inc.
 Bus.-Studio Address... 108 Gaston Ave.
 Phone Number... 5000
 Air Time... 6:45 a.m.-1:15 a.m.
 News Service... AP, INS
 Transcription Service... Standard
 President... J. Patrick Beacom
 General Manager... Robert Drummond
 Comm., Prom. Mgr... J. F. Watkins
 Program Director... Richard Frazier
 Chief Engineer... Richard McBride

WHTN

HUNTINGTON—1947

Frequency: 800 Kc. Power: 1000 Watts d.
 Owned-Oper... Greater Huntington Radio Corp.
 Business-Studio Address... 1112½ Fourth Ave.
 Phone Number... 3-3453
 Air Time... Daytime
 News Service... UP
 Transcription Service... Thesaurus
 President... A. B. Hyman
 General Manager... John S. Phillips
 Program Director... George Hutchinson
 Chief Engineer... Harold F. Sturm

WPLH

HUNTINGTON—1946—MBS

Frequency: 1450 Kc. Power: 250 Watts
 Owned-Oper. By... Huntington Bcstg. Corp.

Business-Studio Address.....1105 Fourth Ave.
 Phone Number3-3421
 Air Time 6 a.m.-12 M.
 News Service AP
 Transcription Service Capitol
 Representative Walker
 Membership NARTB
 President..... E. A. Marshall
 Gen., Sta. Mgr..... F. J. Evans
 Program Director..... Naseeb Tweel
 Sales Prom. Mgr..... Charles Oppenheimer
 Chief Engineer..... Alvin V. Jayne

W S A Z

HUNTINGTON—1923—ABC-KBS

Frequency: 930 Kc.... Power: 5000 Watts d.:
 1000 Watts n.
 Owned-Operated By..... WSAZ, Inc.
 Business-Studio Address.....201 Ninth St.
 Phone Number38-401
 Air Time6 a.m.-1 a.m.
 News Service AP
 Transcription Service Lang-Worth
 Representative Katz
 Membership NARTB. BAB
 President..... Col. J. H. Long
 General Manager..... Lawrence H. Rogers
 Station Manager..... C. T. Garten
 Prom., Pub. Dir..... Charles Dinkins
 Program Director..... C. Bosworth Johnson
 Chief Engineer..... Leroy Kilpatrick

W K Y R

KEYSER—1952

Frequency: 1270 Kc.... Power: 1000 Watts d.
 Owned-Oper. By. . . . Potomac State Bcstg. Co.,
 Inc.
 Address Radio Plaza
 Representative McGillvra
 President Glacus G. Merrill

W L O G

LOGAN—1940—MBS

Frequency: 1230 Kc.... Power: 250 Watts
 Owned-Oper. By. . . . C. H. Frey, R. O. Greever
 Address.....445 Stratton St.
 Phone Number540
 Transcription Service World
 News Service UP
 Partner..... Clarence H. Frey
 Partner..... Robert O. Greever

W V O W

LOGAN—1951—KBS

Frequency: 1290 Kc.... Power: 5000 Watts d.:
 1000 Watts n.
 Owned-Operated By..... Logan Bcstg. Corp.
 Address.....Consolidated Bus Terminal Bldg.
 Phone2356
 Transcription Service Lang-Worth
 News Service UP
 Representative McGillvra
 President..... C. M. Browning
 Gen., Comm. Mgr..... H. V. Diefenbach

Program Director..... Audie Albright
 Promotion Manager..... Lila Abrahams
 Chief Engineer..... Lew J. Frye

W E P M

MARTINSBURG—1946—MBS

Frequency: 1340 Kc.... Power: 250 Watts
 Owned-Oper. By..... Martinsburg Bcstg. Co.
 Business Address..... Peoples Trust Co. Bldg.
 Phone Number5252
 Air Time17 hrs.
 News Service AP
 Transcription Service World
 Representative McGillvra
 Membership NARTB
 Gen., Sta. Mgr..... C. Leslie Golliday
 Program Director..... Eunice J. Schneider
 Sales Prom. Mgr..... C. Rodig
 Chief Engineer..... Clinton Lewis

W H J C

MATEWAN—1951—KBS

Frequency: 1360 Kc.... Power: 1000 Watts d.
 Owned-Operated By. . . Three State Bcstg. Co.
 Phone Number..... MC 4771
 Air Time Daytime
 News Service UP
 Transcription Service SESAC, Standard
 Membership NARTB
 President Fred Morningstar
 General Manager..... Fred Staples
 Chief Engineer..... Leonard Dykema

W M O N

MONTGOMERY—1946—MBS

Frequency: 1340 Kc.... Power: 250 Watts
 Owned-Oper. By..... Fayette Associates, Inc.
 Address.....1028 1st Ave.
 Phone Number..... HE 2-2191
 Air Time6 a.m.-M.
 News Service AP
 Transcription Service World
 President..... Arnold M. Vickers
 Station Manager..... Andrew W. Vickers
 Chief Engineer..... J. C. Craver

W A J R

MORGANTOWN—1941—MBS

Frequency: 1230 Kc.... Power: 250 Watts
 Owned-Oper. By. . . West Virginia Radio Corp.
 Business-Studio Address.....446 Spruce St.
 Phone Number9488
 News Service UP
 Transcription Service World
 Membership NARTB
 President Agnes J. Reeves Greer
 General Manager..... John W. Johns
 Comm., Prom. Mgr..... George J. Shean
 Publicity Director..... Jack Fleming
 Chief Engineer..... Al Novak

W M O D

MOUNDSVILLE—1950—KBS

Frequency: 1370 Kc.... Power: 1000 Watts d.

Owned-Oper. By.....Radio Moundsville
 Address P. O. Box 308
 Phone Number1730
 News ServiceUP
 President.....Robert W. Munn
 Gen., Prom. Manager.....John T. Taylor
 Program Dir.....George W. Wright
 Chief Engineer.....J. W. Jones

WETZ

NEW MARINSVILLE—1953—ABC

Frequency: 1330 Kc.....Power: 1000 Watts d.
 Owned-Oper. By...Magnolia Broadcasting Co.
 Address.....3rd St. Ext.
 Phone Number1000
 RepresentativeGill-Perna
 President.....J. Patrick Beacom
 General Manager.....Owen Deitz, Jr.
 Comm., Prom. Mgr.....Nelson Parks
 Chief Engineer.....Eugene Vinsen

WOAY

OAK HILL—1947

Frequency: 860 Kc.....Power: 5000 Watts d.
 Owned-Oper. By.....Robert R. Thomas, Jr.
 Business Address.....Oak Hill
 Phone Number651
 News ServiceAP
 Transcription Service.....Capital, Thesaurus
 MembershipNARTB
 Pres., Gen. Mgr.....Robert R. Thomas, Jr.
 Chief Engineer.....Curtis Horton

WCOM

PARKERSBURG—1947—ABC

Frequency: 1230 Kc.....Power: 250 Watts
 Owned-Oper. By.....Parkersburg Bdcstg. Co.
 Address.....317 Ninth St.
 Phone Number7-4491
 News ServiceAP
 Transcription ServiceWorld
 RepresentativeMcGillvra
 President.....Joseph M. Handlan
 Gen., Sta., Mgr.....A. N. Archer
 Chief Engineer.....William Collins

WPAR

PARKERSBURG—1935—CBS

Frequency: 1450 Kc.....Power: 250 Watts
 Owned-Oper. By.....Ohio Valley Bcstg. Corp.
 Business-Studio Address211½ 5th St.
 Phone Number7-5475
 News ServiceUP
 Transcription ServiceThesaurus
 RepresentativeBranham
 MembershipNARTB, BAB
 President.....Austin V. Wood
 Gen., Sta., Comm. Mgr.....George H. Clinton
 Sales Prom. Mgr.....Lawrence V. Murphy
 Program Dir.....Sherman Grimm
 Publicity Director.....Hazel N. Mercer
 Chief Engineer.....V. G. Brooks

WVYO

PINEVILLE—1949

Frequency: 970 Kc.....Power: 1000 Watts d.
 Owned-Oper. By ..Wyoming Bdcstg. Co., Inc.
 AddressBox 184
 Phone Number2711
 Air Time.....6 a.m.-Sunset
 News ServiceUP
 Transcription Service.....Langworth
 President.....R. D. Bailey
 Sta., Com. Mgr.....Edward Hawley
 Program Director.....Al Dougherty
 Chief Engineer.....William D. Stone

WLOH

PRINCETON—1947—ABC
 W. VA. NET

Frequency: 1490 Kc.....Power: 250 Watts
 Owned-Oper. By.....Mountain Bcstg. Service
 Phone Number2151
 Studio-Trans. Loca.....Lilly Grove
 Air TimeUnlimited
 News ServiceUP
 Transcription ServiceLang-Worth
 MembershipNARTB
 President.....E. E. Bailey
 Gen., Sta. Mgr.....Melvin F. Barnett
 Commercial Manager.....James M. Angel
 Chief Engineer.....Earl H. Graham

WRON

RONCEVERTE—1947—NBC

Frequency: 1400 Kc.....Power: 250 Watts
 Owned-Oper. By.....Blake Bcstg. Co.
 AddressFranklin Bldg.
 Phone Number300
 News ServiceAP
 Transcription ServiceLangworth
 RepresentativeJoseph Hershey McGillvra
 MembershipNARTB
 Pres., Gen. Mgr.....William E. Blake
 Chief Engineer.....Hugh I. Shott II

WEIR

WEIRTON—1950

Frequency: 1430 Kc.....Power: 1000 Watts
 Owned-Oper. By.....Tri-State Bcstg. Co.
 AddressProfessional Bldg.
 Phone NumberWE 2815
 Transcription ServiceThesaurus
 News ServiceAP
 RepresentativeRambeau
 President.....Thomas E. Millsop
 General Manager.....Edward J. Hirschberg
 Station Manager.....Robert E. Badger
 Program Director.....Marshall Fatkin
 Chief Engineer.....James Mark

WBRW

WELCH—1940—MBS—KBS

Frequency: 1340 Kc.....Power: 250 Watts
 Owned-Operated By.....McDowell Service Co.

Address.....10 Riverside Drive
 Phone Number.....818
 News Service.....AP
 Transcription Service.....Thesaurus
 Membership.....NARTB
 President.....J. G. Hunt
 General Manager.....Paul Wm. Marlowe
 Chief Engineer.....Willis Seaman

WELC
WELCH—1950

Frequency: 1150 Kc...Power: 1000 Watts d.
 Owned-Oper. By.....Pocahontas Bcstg. Co.
 Address.....Box 1032
 Phone Number.....1150
 News Service.....UP
 Representative.....McGillvra
 Transcription Service.....World
 Membership.....NARTB
 President.....Sam Sidote
 Asst. Sta. Mgr.....John Villani
 Chief Engineer.....Howard R. King

WHAW

WESTON—1948—KBS-MBS

Frequency: 1450 Kc...Power: 250 Watts
 Owned-Oper. By.....Lewis Service Corp.
 Address.....P. O. Box 431
 Phone Number.....1555
 News Service.....AP
 Transcription Service.....Associated
 Representative.....Donald Cooke, Inc.

**THOSE WHO KNOW
 FAMOUS BRANDS....**

Says WQAN General Manager
 Cecil Woodland at Scranton, Pa.:
 "By presenting news programs over
 WQAN that bear a famous label
 — AP — our sponsor is able to at-
 tract an effective audience."

**.... KNOW THE MOST FAMOUS
 BRAND IN NEWS IS AP**

Pres., Gen. Mgr.Harold McWhorter
 Sta., Comm. Mgr.George Yazell
 Program Director.....Don McWhorter
 Chief Engineer.....James McEwen

WHLL
WHEELING—1949

Frequency: 1600 Kc...Power: 5000 Watts d.
 Owned-Operated By.....Wheeling Bcstg. Co.
 Address.....Box 989
 Phone Number.....Wheeling 6700
 News Service.....UP
 Transcription Service.....Standard
 Pres., Gen. Mgr.....K. H. Forney
 Commercial Manager.....Paul Miles
 Program Director.....James Smith

WKWK

WHEELING—1941—ABC

Frequency: 1400 Kc...Power: 250 Watts
 Owned-Oper. By.....Community Bcstg., Inc.
 Trans. Add. . .Pythian Bldg. 16th & Market Sts.
 Phone Number.....WH 5320
 News Service.....UP
 Station Representative.....Weed
 Pres., Gen. Manager.....John B. Reynolds
 Commercial Mgr.....Elsie M. Cook
 Program Director.....Irene Goddard
 Chief Engineer.....Richard B. Todd

WWVA

WHEELING—1926—CBS

Frequency: 1170 Kc...Power: 50,000 Watts
 Owned-Oper. By.....Storer Broadcasting Co.
 Address.....Hawley Bldg.
 Phone Number.....Wheeling 5383
 Air Time.....Full time
 News Service.....AP
 Transcription Service.....Lang-Worth
 Representative.....John Blair
 Membership.....NARTB, BAB
 President.....George B. Storer
 General Manager.....Lee B. Wailles
 Station Manager.....Paul J. Miller
 Program Director.....Paul A. Myers
 Chief Engineer.....Edwin L. Keim

WBTH

WILLIAMSON—1939—MBS

Frequency: 1400 Kc...Power: 250 Watts
 Owned-Oper. By.....Williamson Bcstg. Corp.
 Business Address.....Williamson
 Phone Number.....1241
 Air Time.....Unlimited
 News Service.....UP
 Membership.....NARTB, BAB
 President.....Clarence Lovitch
 Gen., Comm. Mgr.....Alice Shein
 Program Director.....John T. Blair, Jr.
 Chief Engineer.....Robert W. Bullico

WISCONSIN

Pop. Feb. 1, 1954 (Est.) 3,607,000 — Families 1,063,000
Radio Homes 1,037,000 — TV Homes 568,500 — Stations in State 65

WATK

ANTIGO—1948—WISCONSIN

Frequency: 900 Kc. Power: 250 Watts d.
Owned-Oper. By Antigo Bcstg. Co.
Business-Studio Address 936 Superior St.
Phone Number 3-4124
Transcription Service Thesaurus
News Service UP
President Artemas F. Burner
Chief Engineer Robert Fowler

Owned-Operated By Beaver Dam Bcstg. Co.
Address Radio Park
Phone Number 4444
News Service UP
Transcription Service Thesaurus
Membership NARTB, BAB
President William E. Walker
General Mgr. Charles R. Dickoff
Comm. Mgr. W. B. Walker
Chief Engineer Alister Alexander

WAPL

APPLETON—1952

Frequency: 1570 Kw. Power: 1000 Watts d.
Owned-Oper. By Bartell Broadcaster
Address Balliet Hotel
Phone Number 4-2609
President Gerald A. Bartell
Program Director Rex Munger
Chief Engineer L. A. Bauernfeind

WBEL

BELOIT—1948

Frequency: 1380 Kc. Power: 1000 Watts d.
Owned-Oper. By Beloit Bcstrs., Inc.
Business-Studio Address 335 E. Grand Ave.
Phone Number College 1380
Air Time 5:30 a.m.-Local Sunset
News Service AP
Transcription Service Thesaurus
President Lloyd Burlingham
General Mgr. L. O. Fitzgibbons
Assistant Manager Warren A. Anderson
Commercial Manager Joe Moen
Publicity Director Mrs. Christie Thomsen
Chief Engineer Leo Wilson

WHBY

APPLETON—1924—MBS
WISCONSIN

Frequency: 1230 Kc. Power: 250 Watts
Owned-Operated By WHBY, Inc.
Bus.-Studio Address 600 So. Lawe St.
Phone Number 3-6639
Air Time 5:30 a.m.-M.
News Service AP
Transcription Service World
Representative Meeker
Comm., Gen., Sta. Mgr. Earl H. Huth
Sales Prom. Mgr. Earl McRoberts
Program Director Greg McElrone
Publicity Director Lewis Process
Chief Engineer George Merkl

WGEZ

BELOIT—1948—MBS-WISCONSIN

Frequency: 1490 Kc. Power: 250 Watts
Owned-Oper. By Beloit Bcstg. Co.
Business-Studio Address Hotel Hilton
Phone Number College 6024
Air Time 6 a.m.-11 p.m.
News Service AP
Transcription Service World
Representative George W. Clark
President Sidney H. Bliss
General Manager Robert J. Bodden
Commercial Manager Gene Steinhorst
Chief Engineer Stanley Holmes

WATW

ASHLAND—1940—MBS-KBS

Frequency: 1400 Kc. Power: 250 Watts
Owned-Oper. By Upper Michigan-Wisconsin
Broadcasting System, Inc.
Address No. State Bank Bldg.
Phone Number 1680
Air Time 5:55 a.m.-11:55 p.m.
Transcription Service Thesaurus
Representative Walker
Membership NARTB
President William L. Johnson
Station Manager Todd Hogan
Publicity Director Arnold Peterson
Program Director Mary Jean Anne
Chief Engineer Otto Link

WBIZ

EAU CLAIRE—1947—MBS

Frequency: 1400 Kc. Power: 250 Watts
Owned-Operated By WBIZ, Inc.
Bus.-Studio-Transmitter Address 609 Cameron
St.
Phone Number 5111-2
Air Time 6:30 a.m.-12 M.
News Service UP
Representative McGillivray
President, General Mgr. James J. Conroy
Station Manager Stan Torgerson
Program Dir. Dean Osmundson
Chief Engineer Don Roering

WBEV

BEAVER DAM—1951

Frequency: 1430 Kc. Power: 1000 Watts d.

WEAU

EAU CLAIRE—1937—NBC

Frequency: 790 Kc. Power: 5000 Watts

Owned-Operated By.....Central Bcstg. Co.
 Business-Studio Add.....2415 So. Hastings
 Phone Number.....8149
 News Service.....UP
 Transcription Service.....Thesaurus
 Representative.....Hollingbery
 Membership.....NARTB, BAB
 President.....W. C. Bridges
 General Manager.....Harry S. Hyett
 Sta., Comm. Mgr.....Robert E. Nelson
 Chief Engineer.....T. O. Jorgenson

W R F W

EAU CLAIRE—1948

Frequency: 1050 Kc.....Power: 1000 Watts d.
 Owned-Oper. By.....Chippewa Valley Radio &
 Telev. Corp.
 Bus.-Studio-Transmlttr Address...Rudolph Rd.
 Phone Number.....2-1629
 Air Time.....Daytime
 News Service.....AP
 Transcription Service.....Capitol, Standard
 President.....Thomas K. Werner
 General Manager.....Jack Kelly
 Commercial Manager.....Richard Werner
 Chief Engineer.....Wm. Hill

K F I Z

FOND DU LAC—1922
MBS-WISCONSIN

Frequency: 1450 Kc.....Power: 250 Watts
 Owned-Operated By.....KFIZ Bcstg. Co.
 Bus.-Studio-Transmitter Address...18 W. First St.
 Phone Number.....356
 Air Time.....8:30 a.m.-10 p.m.
 News Service.....UP
 Transcription Service.....World
 Membership.....NARTB
 Exec. Vice Pres.....Emery W. Martin
 General Manager.....Lynn N. Fairbanks
 Program Director.....Lucille Fairbanks
 Chief Engineer.....Wendell S. Meyers

W B A Y

GREEN BAY—1925—CBS

Frequency: 1360 Kc.....Power: 5000 Watts
 Owned-Operated By.....Norbertine Fathers
 Phone Number.....Hemlock 2-3331
 News Service.....AP
 Representative.....Weed
 Managing Director.....Rev. M. J. Beemster
 General Manager.....Haydn R. Evans
 Sales Prom. Manager.....Lee Stinson
 Program Director.....Rodger Mueller
 Chief Engineer.....Wallace Stangel

W D U Z

GREEN BAY—1947—ABC

Frequency: 1400 Kc.....Power: 250 Watts
 Owned-Oper. By.....Green Bay Bcstg. Co.
 Business-Studio Address.....225 N. Adams St.
 Phone Number.....HE 5-5331
 Air Time.....6 a.m.-M.

News Service.....UP
 Transcription Service.....World
 Representative.....John E. Pearson
 Membership.....NARTB, BAB
 Pres., Gen. Mgr.....Ben A. Laird
 Sta. Mgr., Prog. Dir.....Don Arthur
 Commercial Manager...Robert A. Vandersteen
 Chief Engineer.....Leo Westerman

W J P G

GREEN BAY—1947--WISCONSIN

Frequency: 1440 Kc.....Power: 1000 Watts d.;
 500 Watta n.
 Owned-Oper. By....Green Bay Newspaper Co.
 Business Address.....P. O. Box 620
 Phone Number.....Hemlock 5-7575
 Air Time.....6 a.m.-12 M.
 Newspaper Affiliation....."Press-Gazette"
 News Service.....AP
 Transcription Service.....Standard, Thesaurus
 Representative.....McGillvra
 Membership.....NARTB
 President.....V. I. Minahan
 General Manager.....Joseph Horner, Jr.
 Station Manager.....John M. Walter
 Commercial Manager.....Glen R. Holznecht
 Program Dir.....Jack Stelling
 Publicity Director.....John B. Torinus
 Chief Engineer.....Elmo Reed

W T K M

HARTFORD—1951

Frequency: 1540 Kc.....Power: 500 Watts d.
 Owned-Operated By.Kettle Moraine Bcstg. Co.
 Address.....R R No. 1
 Phone Number.....61
 Transcription Service.....SESAC
 News Service.....UP
 Membership.....NARTB
 Pres., Gen. Mgr.....Waller Zastrow
 Sta., Prom., Pub. Dir.....Don Zastrow
 Program Director.....Redd Hall
 Chief Engineer.....Herbert Jordan

W C L O

JANESVILLE—1930
MBS-WISCONSIN

Frequency: 1230 Kc.....Power: 250 Watts
 Owned-Oper. By.....Southern Wisconsin Radio,
 Inc.
 Business-Studio Address...200 E. Milwaukee St.
 Phone Number.....3316
 Air Time.....6 a.m.-11 p.m.
 News Service.....AP
 Transcription Service.....World
 Newspaper Affiliation....."Daily Gazette"
 Representative.....George W. Clark, Inc.
 Membership.....NARTB, BAB
 President.....Sidney H. Bliss
 Gen., Sta. Mgr.....V. W. Williams
 Commercial Manager....Charles W. Bessire
 Prom., Pgm., Pub. Dir.....Ralph Schroeder
 Chief Engineer.....Wayne Clay

WLIP

KENOSHA—1947

Frequency: 1050 Kc. Power: 250 Watts
 Owned-Oper. By: William L. Lipman
 Bus.-Studio-Transmitter Address: 625 57th St.
 Phone Number: 6162
 Air Time: Sunrise-Sunset
 News Service: AP
 Transcription Service: Thesaurus
 Representative: Everett-McKinney
 Membership: BAB, NARTB
 General Manager: William L. Lipman
 Station Manager: Hugh Gately
 Program Director: Jerome Golden
 Chief Engineer: Casimir Lubinski

WKBH

LA CROSSE—1923—NBC

Frequency: 1410 Kc. Power: 5000 Watts
 Owned-Operated By: WKBH, Inc.
 Business-Studio Address: 409 Main St.
 Phone Number: 2-4678
 Air Time: 6 a.m.-M.
 News Service: AP
 Transcription Service: World
 Representative: Paul H. Raymer Co.
 Membership: NARTB, BAB
 President, Station Mgr.: Howard Dahl
 Program Director: Berneice Callaway
 Chief Engineer: Al Leeman

WKTY

LA CROSSE—1948—ABC

Frequency: 580 Kc. Power: 1000 Watts
 Owned-Oper. By: La Crosse Bcstg. Co.
 Business-Studio Address: 112 N. 4th St.
 Phone Number: 2-6042
 Air Time: 6 a.m.-M.
 News Service: UP
 Transcription Service: Thesaurus
 Representative: Everett-McKinney
 Membership: NARTB
 V. P., Gen. Mgr.: Verl Bratton
 Prom., Prog. Dir.: John Bondeson
 Chief Engineer: George W. Egli

WLCX

LA CROSSE—1947—MBS

Frequency: 1490 Kc. Power: 250 Watts
 Owned-Operated By: Bermac Radio, Inc.
 Business-Studio Address: State Bank Bldg.
 Phone Number: 4-4521
 Air Time: 6 a.m.-12 M.
 News Service: UP
 Representative: McGillvra
 President: James J. Conroy
 Station Manager: Milo G. Knutson
 Comm. Mgr.: Roy E. Nicholson
 Publicity Director: Catherine Guillaume
 Program Dir.: Rosemary Castor
 Chief Engineer: William Bruring

WLDY

LADYSMITH—1948—KBS

Frequency: 1340 Kc. Power: 250 Watts
 Owned-Operated By: Flambeau Bcstg. Co.
 Phone Number: 584
 Air Time: 6 a.m.-12 M.
 News Service: AP
 Transcription Service: World
 Representative: Thomas Clark
 Membership: NARTB, BAB
 President: O. J. Falge
 Gen., Sta., Comm. Mgr.: A. T. Shields
 Pub. Dir.: Corinne Kopp
 Program Dir.: Joseph Dahlwig
 Chief Engineer: Jeff Evans

WIBA

MADISON—1925—NBC

Frequency: 1310 Kc. Power: 5000 Watts
 Owned-Operated By: Badger Bcstg. Co.
 Business-Studio Address: 3800 Regent St.
 Phone Number: 3-5311
 Transmitter Location: Fitchburg
 News Service: AP
 Transcription Service: Thesaurus
 News. Affil.: "Capital Times," "Wisc. State Journal"
 Representative: Avery-Knodel
 Membership: NARTB
 President: William T. Evjue
 General Manager: Kenneth F. Schmitt
 Commercial Manager: Howard A. Johnson
 Program Director: Robert N. Dick
 Chief Engineer: Norman Hahn

WISC

MADISON—1948—MBS-ABC

Frequency: 1480 Kc. Power: 1000 Watts
 Owned-Oper. By: Radio Wisconsin, Inc.
 Address: Comm. State Bank Bldg.
 Phone Number: 7-2588
 Air Time: 6 a.m.-12 M.
 News Service: UP
 Transcription Service: World
 Representative: George P. Hollingsbery
 President: Ralph M. Immell
 General Manager: Ralph O'Connor
 Promotion Mgr.: Richard S. Nickeson
 Program Director: Beverly White
 Publicity Director: Lee Wesner
 Chief Engineer: W. M. Greely

WKOW

MADISON—1948—CBS

Frequency: 1070 Kc. Power: 10,000 Watts d.,
 5,000 Watts n.
 Owned-Oper. By: Monona Bcstg. Co.
 Address: 215 W. Washington Ave.
 Phone Number: 7-2261
 Air Time: Full Time
 News Service: UP
 Transcription Service: Langworth
 Representative: Headley Reed
 President: Stewart Watson

General Manager.....Michael Henry
 Program Director.....Lu Baitinger
 Chief Engineer.....Bob Wickhem

W O M T

MANITOWOC—1926—MBS-WISC.
 Frequency: 1240 Kc.....Power: 250 Watts
 Owned-Operated By.....Francis M. Kadow
 Business-Studio Address.....Radio Bldg.
 Phone Number.....5015
 Air Time.....Full Time
 News Service.....UP
 Transcription Service.....World
 Representative.....Holman
 Membership.....NARTB
 President, Gen. Mgr.....Francis M. Kadow
 Program Director.....George H. Erdman
 Promotion Mgr.....L. J. Splitt
 Chief Engineer.....Hubert Willis

W W O C

MANITOWOC—1952
 Frequency: 980 Kc. Power: 1000 Watts d.
 Owned-Operated By.....Manitowoc Bcstg. Co.
 Address.....Box 101
 Phone.....7763
 News Service.....AP
 Transcription Service.....Thesaurus
 Representative.....McGillvra
 Ptnr., Gen. Mgr.....Edward Allen, Jr.
 Ptnr., Chief Engineer.....Edward Jacker

W M A M

MARINETTE—1939—NBC
 Frequency: 570 Kc.....Power: 250 Watts d.;
 100 Watts n.
 Owned-Oper. By.....M. & M. Bcstg. Co., Inc.
 Bus. Studio-Transmitter Address.....Radio Park
 Phone Number.....2-6631
 Air Time.....Unlimited
 News Service.....UP
 Representative.....George W. Clark
 Membership.....BAB
 President.....William E. Walker
 General Manager.....Joseph D. Mackin
 Commercial Manager.....Howard L. Emich
 Sales Prom. Mgr.....Ed Maxwell
 Program Director.....Pat Kehoe
 Chief Engineer.....Al Alexander

W D L B

MARSHFIELD—1946—KBS
 Frequency: 1450 Kc.....Power: 250 Watts
 Own-Oper. By Dairyland's Bcstg. Serv., Inc.
 Add. Trans. Loca.....1710 N. Central Ave.
 Phone Number.....1450
 Air Time.....6:30 a.m.-11 p.m.
 News Service.....UP
 Transcription Service.....Thesaurus
 Membership.....NARTB, BAB
 President.....Lloyd L. Felker
 Gen., Sta. Mgr., Pub. Dir.....Robert W. Behling
 Comm. Mgr.....Roger Thomsen
 Sales Prom. Mgr.....Ron Smith

Program Director.....Howard Sturtz, Jr.
 Chief Engineer.....Jerry Boos

W I G M

MEDFORD—1941—MBS-KBS
 Frequency: 1490 Kc.....Power: 250 Watts
 Owned-Oper. By.....Murphy-Nelson Bcstg. Co.,
 Inc.
 Business-Studio Address.....Box 59
 Phone Number.....5147
 News Service.....UP
 Representative.....Continental
 Pres., Gen. Mgr.....Charles H. Nelson
 Program Director.....Richard Johnson
 Chief Engineer.....Ray Bohnert

W M N E

MENOMONIE—1951—KBS
 Frequency: 1360 Kc.....Power: 500 Watts d.
 Owned-Oper. By.....Menomonie Bcstg. Co.
 Address.....603½ Broadway
 Phone Number.....1156
 Transcription Service.....Lang-Worth
 News Service.....UP
 General Manager.....Dr. Wendell Hansen
 Sta., Comm. Mgr.....Douglas Weikley
 Chief Engineer.....Everette Lindgren

W C A N

MILWAUKEE—1948—ABC
 Frequency: 1250 Kc.....Power: 5000 Watts
 Owned-Oper. By.....Midwest Bcstg. Co.
 Business-Studio Address.....808 N. Third St.
 Phone Number.....Broadway 6-2154
 Air Time.....18 hrs.
 News Service.....UP
 Representative.....Rosenman
 President.....Lou Poller
 Gen., Sta. Mgr.....Burton L. Levine
 Chief Engineer.....Wally Wesley

W E M P

MILWAUKEE—1935
 Frequency: 1340 Kc.....Power: 250 Watts
 Owned-Oper. By.....Milwaukee Bcstg. Co.
 Bus.-Address.....710 N. Plankinton Ave.
 Phone Number.....Broadway 1-7722
 News Service.....UP
 Representative.....Headley Reed
 Membership.....NARTB, BAB
 President.....A. M. Spheeris
 General Manager.....Hugh K. Boice, Jr.
 Commercial Manager.....John C. Gagliano
 Publicity Director.....Lou Riepenhoff
 Program Director.....Tom Shanahan
 Chief Engineer.....Rolland Paske

W F O X

MILWAUKEE—1946
 Frequency: 860 Kc.....Power: 250 Watts d.
 Owned-Oper. By.....Wisconsin Bcstg. System,
 Inc.

Address.....208 E. Wisconsin Ave.
 Phone Number.....Broadway 2-1272
 News Service.....AP
 Representative.....George Clark, Inc.
 Pres., Gen. Mgr.....Charles J. Lanphier
 Publicity Director.....Jim Wallace
 Program Director.....Charles La Force
 Chief Engineer.....George Dodge

WISN

MILWAUKEE—1922—CBS

Frequency: 1150 Kc....Power: 5,000 Watts
 Owned-Oper. By.....Hearst Corporation
 Address.....540 N. Plankinton Ave.
 Phone Number.....Division 2-3000
 Air Time.....6 a.m.-12 M.
 Transcription Service.....World
 Representative.....The Katz Agency
 Membership.....NARTB
 General Manager.....Harry D. Peck
 Comm. Mgr.....R. E. Shireman
 Sales Prom. Mgr.....J. D. Hill
 Program Director.....Leslie F. Biehl
 Chief Engineer.....Donald A. Weller

WMIL

MILWAUKEE—1947

Frequency: 1290 Kc....Power: 1000 Watts d.
 Owned-Oper. By...Cream City Bcstg. Co., Inc.
 Bus.-Studio Address..2625 W. Wisconsin Ave.
 Phone Number.....West 3-1290
 Air Time.....Day Time
 News Service.....UP
 Transcription Service.....SESAC, Cole
 Membership.....NARTB, BAB
 President.....Gene Posner
 Gen. Mgr.....Jerome Sill
 Program Director.....Arthur H. Vogel
 Chief Engineer.....Gino Monaco

WOKY

MILWAUKEE—1950

Frequency: 920 Kc....Power: 1000 Watts d.
 Owned-Oper. By.....Bartell Bdcsters, Inc.
 Bus.-Studio Address..704 W. Wisconsin Ave.
 Phone Number.....Broadway 1-8480
 President.....Gerald A. Bartell
 Chief Engineer.....Ralph Evans

WTMJ

MILWAUKEE—1927—NBC

Frequency: 620 Kc....Power: 5000 Watts
 Owned-Oper. By.....The Journal Co.
 Business Address.....720 E. Capitol Dr.
 Phone Number.....Broadway 1-6000
 Air Time.....19½ hrs.
 News Service.....AP
 Representative.....Crystal
 V.P., General Mgr.....Walter J. Damm
 Asst. Gen. Mgr.....R. G. Winnie
 Station Manager.....George Comte
 Research & Devel. Co-ordinator..L. W. Herzog
 Sales Manager.....Necle V. Bakke

Mgr., Engineering.....Philip B. Laeser
 Mgr., Pub. Serv. & Prom.....Bruce Wallace
 Chief Engineer.....William Hebal

WEKZ

MONROE—1951

Frequency: 1260 Kc....Power: 500 Watts d.
 Owned-Operated By...Green County Bcstg. Co.
 Phone Number.....1260
 News Service.....AP
 President.....Kenneth Stuart
 Gen., Sta. Mgr.....Grant A. Ritter
 Program Director.....Stan Neuberger
 Chief Engineer.....Rex Eyler

WNAM

NEENAH—MENASHA—1947

Frequency: 1280 Kc....Power: 1,000 Watts
 Owner.....Neenah-Menasha Bcstg. Co.
 Bus.-Studio Address...Radio-Television Park
 Phone Number.....2-6471
 Air Time.....6 a.m.-12 M.
 News Service.....UP
 V. P., General Manager.....Don C. Wirth
 Station Manager.....W. C. Porson
 Chief Engineer.....Harry Hill

WOSH

OSHKOSH—1941—ABC

Frequency: 1490 Kc....Power: 250 Watts
 Owned-Oper. By.....Oshkosh Bcstg. Co.
 Transmitter Location.....1235 Bowen St.
 Phone Number.....Stanley 4580
 Transcription Service.....Capitol
 Representative.....Pearson
 Pres., Pgm. Dir.....Wm. F. H. Johns, Jr.
 General Manager.....Robert J. Flynn
 Chief Engineer.....Don Zuehike

WPFP

PARK FALLS—1953—KBS

Frequency: 1450 Kc....Power: 100 Watts
 Owned-Oper. By.....M & N Bcstg. Co., Inc.
 Phone Number.....262
 Pres., Gen. Mgr.....Chas. H. Nelson
 Station Manager.....Albert J. Michela
 Program Manager.....Paul Olson
 Chief Engineer.....Raymond Bohner

WPDR

PORTAGE—1952

Frequency: 1350 Kc....Power: 1000 Watts d.
 Owned-Operated By.....Portage Bcstg. Co.
 Address.....Box 142
 Phone.....1200
 Transcription Service.....Thesaurus
 President.....W. T. Comstock
 General Manager.....John Haerle
 Commercial Manager.....Berwyn Ableman
 Program Director.....Keith Pettack
 Chief Engineer.....Garth Bowker

WIBU

POYNETTE—1925—KBS-WISC.

Frequency: 1240 Kc. Power: 250 Watts
 Owned-Oper. By William C. Forrest
 Bus.-Transmitter Address Poynette
 Phone Number Poynette 98
 News Service UP
 Transcription Service Standard, SESAC
 Pres., Gen., Sta. Mgr. William C. Forrest
 Program Dir. Sarah A. Forrest
 Chief Engineer L. Stanley Sadler

WPRE

PRARIE DU CHIEN—1952

Frequency: 1280 Kc. Power: 500 Watts d.
 Owned-Operated By Prarie Bcstg. Co.
 Address Box 36
 Phone 637
 News Service UP
 General Manager W. C. Schlaugat, Jr.
 Program Director J. W. Hassebrook
 Chief Engineer Willis Schultz

WRAC

RACINE—1950

Frequency: 1460 Kc. Power: 500 Watts d.
 Owned-Oper. By WRAC, Inc.
 Address Arcade Bldg.
 Phone Number 2-1627
 News Service UP
 Representative Sears & Ayer
 President James S. Allen
 Sta., Prog. Mgr. Bob Martin
 Commercial Mgr. Al Gale
 Publicity Dir. Dick Fitzgerald
 Chief Engineer Ray Doane

WRJN

RACINE—1926—ABC

Frequency: 1400 Kc. Power: 250 Watts
 Owned-Oper. By Racine Bcstg. Corp.
 Business Address American Bank Bldg.
 Phone Number 4-3311
 News Service AP
 Representative Walker
 Newspaper Affiliation "Journal-Times"
 Membership NARTB, BAB
 President J. D. McMurray
 General Manager Harry R. LePoidevin
 Station Manager Harold J. Newcomb
 Commercial Manager Gerald D. Nelson
 Program Director Lyman Merens
 Publicity Director Amelia French
 Chief Engineer F. Lee Dechant

WRDB

REEDSBURG—1952

Frequency: 1400 Kc. Power: 250 Watts
 Owned-Operated By William C. Forrest
 Address Poynette
 News Service UP
 Transcription Service Standard, SESAC
 General Manager Wallace Morton

WOBT

RHINELANDER—1947—MBS-WISC.

Frequency: 1240 Kc. Power: 250 Watts
 Owned-Operated By Onelda Bcstg. Co.
 Business Address Highway 8—East
 Phone Number 1240
 News Service UP
 Representative McGillvra
 Transcription Service World
 President James Cleary
 Gen. Mgr., Prog. Dir. Bruce G. Beicht
 Commercial Mgr. Robert Frye
 Program Director John Wadd
 Chief Engineer Charles Marvin

WJMC

RICE LAKE—1938—MBS

Frequency: 1240 Kc. Power: 250 Watts
 Owned-Oper. By WJMC, Inc.
 Address Trans. Loca. Route No. 2
 Phone Number 550
 News Service UP
 Transcription Service World, SESAC
 Representative Hollingbery, Bulmer-Johnson
 President W. C. Bridges
 Commercial Manager Russell J. Brown
 Program Director Carl N. Klauss
 Chief Engineer Robert Kolsky

WRCO

RICHLAND CENTER—1949

Frequency: 1450 Kc. Power: 250 Watts
 Owned-Operated By Richland Bcstg. Co.
 Address P. O. Box 192
 Phone Number 20
 News Service UP
 Transcription Service Thesaurus
 Membership NARTB, BAB
 President Arthur Overgaard
 General Manager T. R. Kelly
 Chief Engineer Pete Athanas

WTCH

SHAWANO—1948

Frequency: 960 Kc. Power: 1,000 Watts d.
 Owner Shawano County Leader Pub. Co.
 Business-Studio Address 107 E. Green Bay St.
 Telephone Number 666
 Representative Lawson
 News Service UP
 Transcription Service Capitol
 General Manager Mrs. Jeanne Donald
 Station Manager Ray Gruetzmacher

WHBL

SHEBOYGAN—1924—ABC-WIS.

Frequency: 1330 Kc. Power: 1000 Watts d.;
 250 Watts n.
 Owned-Operated By WHBL, Inc.
 Bus.-Studio Address P. O. Box 27
 Phone Number 4844-5
 Air Time 7 a.m.-11 p.m.
 News Service AP

Transcription Service Associated
 President..... C. E. Broughton
 General Manager..... Ben F. Hovel
 Comm. Mgr..... John Harvey
 Program Director..... Glen James
 Chief Engineer..... Herbert J. Mayer

W K L J

SPARTA—1951—KBS-Mid.

Frequency: 990 Kc..... Power: 250 Watts d.
 Owned-Oper. By... Sparta-Tomah Bcstg. Co.
 Address..... 124 S. Water St.
 Phone Number 3307
 Transcription Service..... SESAC, Associated
 News Service UP
 Membership NARTB
 Pres., Gen. Mgr..... Jon F. Lohmer
 Program Director..... Orion Samuelson
 Chief Engineer..... Warner Stenslund

W S P T

STEVENS POINT—1948

Frequency: 1010 Kc..... Power: 250 Watts d.;
 Owned-Oper. By..... Stevens Pt. Bcstg. Co.
 Business-Studio Address..... 414½ Main St.
 Phone Number 2744
 News Service UP
 Transcription Service SESAC
 Representative Hal Holman
 President..... W. F. Johns, Sr.
 General Manager..... A. L. Mayer
 Program Director..... Thomas Lund
 Chief Engineer..... R. Tellekson

W D O R

STURGEON BAY—1952

Frequency: 910 Kc..... Power: 500 Watts d.
 Owned-Oper. By... Door County Bcstg. Co. Inc.
 Address..... 15th & Utah
 Phone Number..... ST 593
 Transcription Service Thesaurus
 News Service AP
 Pres., Gen. Mgr..... Edward Allen, Jr.
 Commercial Manager... William O. Warnkey
 Program Director..... Dolores Allen
 Chief Engineer..... Joseph Genovese

W O K W

STURGEON BAY—1951

Frequency: 1050 Kc..... Power: 250 Watts d.
 Owned-Operated By... Door County Radio Co.
 Address Box 538
 Phone Number 1050
 News Service UP
 President..... Chandler F. Harris
 Gen., Sta. Mgr..... Herbert H. Graefe
 Chief Engineer..... G. Robert Egeland

W D S M

SUPERIOR—1939—ABC-MBS

Frequency: 710 Kc..... Power: 5000 Watts
 Owned-Oper. By..... WDSM, Inc.

Business Address..... 921 Tower Ave.
 Phone Number..... Superior: 4451
 News Service UP
 News. Affil..... "Herald & News Tribune"
 Representative..... Free & Peters
 Membership NARTB
 President Robert Ridder
 General Manager..... Rodney A. Quick
 Commercial Mgr..... Ralph Nelson
 Program Director..... Lew Martin
 Chief Engineer..... Melvin Laskey

W T R W

TWO RIVERS—1951—KBS

Frequency: 1590 Kc..... Power: 500 Watts d.
 Owned-Operated By... Two Rivers Bcstg. Co.
 Address 1817 Washington
 Phone Number 324
 Transcription Service Standard
 News Service UP
 President Wendell Hansen
 General Manager..... Howard Luebke
 Commercial Mgr..... Stanley Greene
 Chief Engineer..... Elmer Johnson

W T T N

WATERTOWN—1950—KBS

Frequency: 1580 Kc..... Power: 250 Watts d.
 Owned-Oper. By... Watertown Radio, Inc.
 Address..... 104 W. Main St.
 Phone Number 2215
 Transcription Service Thesaurus
 Membership NARTB, BAB
 Pres., Gen. Mgr..... Carl V. Kolata
 Program Director..... Arnold Kaine
 Chief Engineer..... Harold Winkenwerder

W A U X

WAUKESHA—1947

Frequency: 1510 Kc..... Power: 250 Watts d.
 Owned-Operated By... Waukesha Bcstg. Co.
 Business-Studio Address..... 319 W. Main St.
 Phone Number 6636
 Air Time Sunrise-sunset
 News Service AP
 Transcription Service Langworth
 Representative Holman
 Membership NARTB, BAB
 Gen., Sta. Mgr..... Mig Figi
 Commercial Manager... Charles E. Williams
 Prog. Dir..... Donald Froehlich
 Chief Engineer..... Adin Randall

W H V F

WAUSAU—1953

Frequency: 1230 Kc..... Power: 250 Watts
 Owned-Oper. By..... Lakeland Bcstg. Co.
 Address..... 1110 Wausau Ave.
 Phone Number 2-1188
 Pres., Chief Engr..... Hilding V. Foreen
 Gen., Prom. Mgr..... R. J. Topinka

W O S A

WAUSAU—1947—MBS

Frequency: 550 Kc. Power: 5000 Watts
 Owned-Operated By: Alvin E. O'Konski
 Address: Lake Road, Merrill, Wis.
 Phone Number: 1444-5
 Representative: Rambeau
 Transcription Service: Capitol, Standard, Cole
 News Service: AP, UP
 General Manager: Alvin O'Konski
 Commercial Manager: Danworth Turner
 Program Director: Jack Larkin
 Promotion Manager: Leon Gabriel
 Chief Engineer: Russell Grambsch

W S A U

WAUSAU—1937—NBC

Frequency: 1400 Kc. Power: 250 Watts
 Owned-Oper. By: WSAU, Inc.
 Business-Studio Address: 714 Fifth St.
 Phone Number: 6521
 Air Time: 17 hrs.
 News Service: AP
 Transcription Service: Thesaurus
 Representative: Meeker
 President: John R. Tomek
 General Manager: Richard R. Dudley
 Sales Prom. Mgr.: James Frey
 Program Director: George Bundner
 Chief Engineer: Roland W. Richardt

W B K V

WEST BEND—1950

Frequency: 1470 Kc. Power: 500 Watts d.
 Owned-Oper. By: West Bend Bcstg. Co.
 Address: Box 59, Decorah Rd.
 Phone Number: 1640
 Transcription Service: Thesaurus
 News Service: UP
 President: Carl H. Rhode
 Gen. Mgr.: August C. Berkholtz
 Commercial Mgr.: Paul J. Mueller
 Program Director: Roy Ambrose
 Chief Engineer: Paul J. Ripple

W F H R

WISCONSIN RAPIDS—1940
 MBS-WIS.

Frequency: 1340 Kc. Power: 250 Watts
 Owned-Oper. By: William F. Huffman Radio
 Business Address: 141 W. Grand Ave.
 Phone Number: 1340
 Air Time: 6:30 a.m.-10:30 p.m.
 News Service: AP
 Transcription Service: World
 Representative: Devney & Son
 Membership: NARTB, BAB
 President: Louise F. Huffman
 Gen., Sta., Mgr., Prom. Dir.: Geo. T. Frechette
 Commercial Manager: L. J. Zurawski
 Prog., Pub. Dir.: James Tighe
 Chief Engineer: Gordon Miller

THOSE WHO KNOW FAMOUS BRANDS

Says WBEL Manager Joseph E. Moen at Beloit, Wisc.:
 "As always, a sale's easier to consummate when it's an
AP news program you offer the prospect. He knows
AP and believes in its audience appeal."

. . . . KNOW THE MOST FAMOUS
 BRAND IN NEWS IS **AP**

WYOMING

Pop. Feb. 1, 1954 (Est.) 308,000 — Families 93,000
Radio Homes 90,000 — TV Homes 7,500 — Stations in State 16

KSPR

CASPER—1930
MBS-INTERMOUNTAIN

Frequency: 1470 Kc. Power: 1000 Watts
Owned-Operated By Donald L. Hathaway
Business Address Box 930
Phone Number 3-5777
Air Time Full Time
News Service UP
Transcription Service World, Associated
Representative Sears & Ayer
Membership NARTB, BAB
Owner, Pres., Mgr. Donald L. Hathaway
Asst. Station Manager Marcus R. Nichols
Chief Engineer John Cheatham, Jr.

KVOC

CASPER—1946—ABC

Frequency: 1470 Kc. Power: 250 Watts
Owned-Operated By KVOC Bcstg. Co.
Bus.-Studio-Transmitter Address Box 2090
Phone Number 2-24512
Air Time Full Time
News Service AP
Transcription Service Lang-Worth
Representative McGillvra
Membership NARTB, BAB
President Duane Simons
Gen., Sta. Mgr. William F. Shutts
Commercial Manager I. E. Shahan
Program Director Jim Baker

KFBC

CHEYENNE—1940—ABC

Frequency: 1240 Kc. Power: 250 Watts
Owned-Operated By Frontier Bcstg. Co.
Bus.-Studio Address 2923 East Lincolnway
Phone Number 4-4461
Air Time Full Time
News Service UP
Representative McGillvra
Membership NARTB, BAB
News, Affil. Wyoming Eagle, Wyoming State
Tribune
President Robert S. McCracken
Gen., Sta. Mgr. William C. Grove
Commercial Manager Charles Cahill
Sales Prom. Mgr. Dave Young
Program Director Mae Sunada
Publicity Director Margaret O'Brien
Chief Engineer R. C. Pfannanschmid

KODI

CODY—1947—ABC

Frequency: 1400 Kc. Power: 250 Watts
Owned-Operated By Absaroka Bcstg. Co.
Address P. O. Box 762
Phone Number 444

News Service AP
Transcription Service World
Representative McGillvra
Newspaper Affiliate The "Enterprise"
Membership NARTB, BAB
President William L. Simpson
General Manager Chuck Shaw
Station Manager C. Owen Allen
Program Director Bert Frendrich
Chief Engineer Hal Bowen

KVWO

CHEYENNE—1952—MBS
INTERMOUNTAIN

Frequency: 1370 Kc. Power: 1000 Watts d.
Owned-Operated By Great West Co.
Address Box 926
Phone 2-6433
Transcription Service Lang-Worth
News Service AP
Representative Avery-Knodel
President Wm. T. Kemp
V.P., Gen. Mgr. Bill Harrell
Station Manager Bert Godfrey
Commercial Mgr. Ruth Dorr
Sales Prom. Mgr. Peter Dunne
Program Director Eugene Gelhaar
Chief Engineer Bud Roberts

KLUK

EVANSTON—1953—MBS-KBS
INTERMOUNTAIN

Frequency: 1240 Kc. Power: 250 Watts
Owned-Oper. By Advertising Enterprises Ltd.
Address P. O. Box 198
Phone Number 700
News Service UP
Transcription Service Thesaurus
Representative Avery-Knodel
Owner, Gen. Mgr. Edwin L. Bullis
Program Director Bob Collins
Chief Engineer C. W. Brokaw

KOVE

LANDER—1948—KBS—MBS
INTERMOUNTAIN

Frequency: 1230 Kc. Power: 250 Watts
Owned-Operated By Edward J. Breece
Business Address P. O. Box 436
Phone Number 488
News Service UP
News, Affil. Wyoming State Journal
Representative Continental
Owner Edward J. Breece
Sta., Gen. Mgr. Jack L. Breece
Comm., Prom. Mgr. Dorothy L. Reed
Publicity Director Louise York
Chief Engineer Gary Fehlauer

KOWB

LARAMIE—1948—ABC
WYO. COWBOY

Frequency: 1340 Kc. Power: 250 Watts d.
Own. Oper. By Snowy Range Bdstg. Co., Inc.
Address Box 972
Phone Number 4888
Air Time Full Time
News Service AP
Representative McGillvra
President F. O. Rice
General Manager Carroll Mohr
Chief Engr., Pgm. Dir. L. O. Smith
Comm., Sales Prom. Mgr. J. C. Steele

KASL

NEWCASTLE—1953—ABC
WYO. COWBOY

Frequency: 1240 Kc. Power: 250 Watts
Owned-Oper. By Newcastle Bdstg. Co.
Address Newcastle
Phone Number 700
President Joe Aimonetto
General Manager Floyd L. Sparks
Chief Engineer C. E. Warford

KPOW

POWELL—1941
MBS-KBS-INTERMOUNTAIN

Frequency: 1260 Kc. Power: 5000 Watts d.
1000 Watts n.
Owned-Operated By A. J. Meyer
Address Elder Bldg.
Phone Number 222
Air Time Full Time
News Service UP
Transcription Service Associated, Cole
Representative Avery-Knodel
Gen., Sta. Mgr., Chief Engr. Al Meyer
Program Director Agnes Fields

KRAL

RAWLINS—1947—ABC
WYO. COWBOY

Frequency: 1240 Kc. Power: 250 Watts
Owned-Operated By Rawlins Bdstg. Co.
Address Rawlins
Phone Number 1003
Air Time Full Time
News Service AP
Representative Joseph Hershey McGillvra
Membership NARTB
President Tracy S. McCracken
Gen., Sta., Comm. Mgr. Jack C. Vagner
Program Director Anita Phisterer
Chief Engineer Robert S. Williams

KWRL

RIVERTON—1948—ABC

Frequency: 1450 Kc. Power: 250 Watts
Owned-Operated By Joseph P. Ernst

Address 1314 Charles St., Worland
Phone Number 760
Representative Joseph Hershey McGillvra
News Service AP
President, Ch. Eng. Joseph P. Ernst
General Manager Mrs. Mildred Ernst
Station Manager Mrs. Cleo Berry
Commercial Manager Bud Moore
Program Director Bob Lee

KVRS

ROCK SPRINGS—1938
MBS-INTERMOUNTAIN-KBS

Frequency: 1360 Kc. Power: 1000 Watts d.;
500 Watts n.
Owned-Oper. By Wyoming Bdstg. Co.
Address Box 1067
Phone Number 93
Representative Avery-Knodel
News Service AP
Transcription Service Standard
President D. G. Richardson
General Manager Dwight Fisher
Commercial Manager Laurel Moseby
Program Director Imogene Parr
Chief Engineer Dave Wood

KWYO

SHERDAN—1934—MBS
INTERMOUNTAIN

Frequency: 1410 Kc. Power: 1000 d., 500 n.
Owned-Operated By Bighorn Bdstg. Co.
Business-Studio Address 21 N. Main
Phone Number 601
News Service UP
Transcription Service Lang-Worth
Representative Avery-Knodel
Pres., Gen. Mgr. Jim Carroll
Commercial Mgr. Don Tannehill
Program Director Bob Wilson
Chief Engineer Bob Crosthwaite

KGOS

TORRINGTON—1950—ABC

Frequency: 1490 Kc. Power: 250 Watts
Owned-Oper. By Joseph P. Ernst
Address Box 271
Phone Number 567
News Service UP
Representative McGillvra
President Joseph P. Ernst
Gen., Comm. Mgr. Alice Grange
Chief Engineer Lester R. Rash

KWOR

WORLAND—1946—ABC

Frequency: 1490 Kc. Power: 250 Watts
Owned-Operated By Joseph P. Ernst
Phone Number 733
Representative McGillvra
Pres., Prom. Mgr. Joseph P. Ernst
Gen., Comm. Manager Mildred V. Ernst
Program Director Karl Kertson
Chief Engineer Joe C. Henry

TERRITORIES AND POSSESSIONS



ALASKA

KBYR

ANCHORAGE—1948

Frequency: 1240 Kc. Power: 250 Watts
Owned-Oper. By.....Aleutian Bcstrs.
Business-Studio Address.....P. O. Box 1960
Phone Number3-4433

KENI

ANCHORAGE—1939-MBS-ABC-NBC

Frequency: 550 Kc. Power: 5000 Watts
Owned-Oper. By.....Midnight Sun Bcstg. Co.
Business Address.....Box 879
Phone Number20301
Air Time.....6:15 a.m.-12 M.
News Service.....AP
Transcription Service.....Associated
Representative.....Wellington Fletcher
Membership.....NARTB
President.....Miriam Kinsey
Gen., Sta. Mgr.....Claire O. Banks
Commercial Manager.....William Stewart
Program Director.....Harold Knutson
Publicity Director.....Phyllis Bock
Chief Engineer.....Ralph Walker

KFQD

ANCHORAGE—1924—CBS

Frequency: 600 Kc. Power: 5000 Watts
Owned-Oper. By.....W. J. Wagner
Address.....830 Securities Bldg., Seattle
Phone Number.....Seneca 6333
Air Time.....Unlimited
News Service.....AP
Transcription Service.....Langworth
Representative.....Alaska Radio Sales; Scott
Pres., Gen. Mgr.....Wm. J. Wagner
Station Manager.....George Ernsi
Commercial Mgr.....Don Kopf
Program Director.....Gerald Mathis
Promotion Mgr.....John Funk

KFAR

FAIRBANKS—1939—MBS-NBC-ABC

DON LEE

Frequency: 660 Kc. Power: 10,000 Watts
Owned-Operated By.....Midnight Sun Bcstg. Co.
Business-Studio Address.....Box 90
Phone Number.....2125
News Services.....AP and UP

Representative.....Fletcher, Wellington
President.....Mrs. Robert Kinsey
General Manager.....Alvin O. Bramstedt
Commercial Manager.....Robert Wells
Program Director.....Richard Greuel
Promotion Manager.....Jay Greuel
Chief Engineer.....Richard Shoup

KFRB

FAIRBANKS—1948—CBS

Frequency: 790 Kc. Power: 5000 Watts
Owned-Oper. By.....W. J. Wagner
Address.....830 Securities Bldg., Seattle
Phone Number.....Seneca 6333
News Service.....AP
Transcription Service.....Langworth
Representative.....Alaska Radio Sales; Scott
Pres., Gen. Mgr.....Wm. J. Wagner
Station Manager.....Jack Hauser
Commercial Mgr.....Henry Whitson
Program Dir.....Dale Haviland
Promotion Mgr.....John Funk
Chief Engineer.....Murray Durham

KINY

JUNEAU—1935—CBS

Frequency: 1290 Kc. Power: 5000 Watts
Owned-Oper. By.....W. J. Wagner
Address.....830 Securities Bldg., Seattle
Phone Number.....Seneca 6333
Air Time.....Unlimited
News Service.....AP
Transcription Service.....Langworth, Thesaurus
Representative.....Alaska Radio Sales; Scott
Pres., Gen. Mgr.....Wm. J. Wagner
Program Manager.....Richard Peter
Sta., Comm. Mgr.....James B. Lawson
Chief Engineer.....Gordon Burnett

KJNO

JUNEAU—1952—ABC-MBS-NBC

Frequency: 630 Kc. Power: 1000 Watts d.;
500 Watts n.
Owned-Operated By.....Aurora Bcstrs., Inc.
Address.....123 Third St.
Phone.....508
Transcription Service.....Associated
News Service.....AP
Representative.....Wellington, Fletcher

President Austin Cooley
 Gen. Sta. Mgr. Del Day
 Publicity Director Norma Weeks
 Chief Engineer Royal O'Reilly

Station Manager Robert Mehan
 Program Director Thelma Alden
 Chief Engineer James Kemp

KABI

KETCHIKAN—1952—ABC-MBS-NBC

Frequency: 580 Kc. Power: 1000 Watts d.;
 500 Watts n.
 Owned-Operated By Aurora Bcstrs., Inc.
 Address 211 Heckman Bldg.
 Phone 3124
 Transcription Service Associated
 News Service AP
 Representative Wellington, Fletcher
 President Austin G. Cooley
 General Manager Jack D. Ellison
 Commercial Manager John C. Gunn
 Program Director Tom Sawyer
 Chief Engineer Dick Nicholas

KIBH

SEWARD—1948—CBS

Frequency: 1340 Kc. Power: 250 Watts
 Owned-Operated By William J. Wagner
 Address 830 Securities Bldg., Seattle
 Phone Number Seneca 6333
 News Service AP
 Transcription Service Langworth
 Representative Alaska, Scott
 Pres., Gen. Mgr. William J. Wagner
 Station Manager Joel Buffington
 Program Dir. Allen Hendricks
 Promotion Mgr. John Funk
 Chief Engineer David Hassinger

KTKN

KETCHIKAN—1935—CBS

Frequency: 930 Kc. Power: 1000 Watts
 Owned-Oper. By William J. Wagner
 Address 830 Securities Bldg., Seattle
 Phone Number Seneca 6333
 News Service AP
 Air Time Full Time
 Transcription Service Langworth, Thesaurus
 Representative Alaska Radio Sales; Scott
 Pres., Gen. Mgr. William J. Wagner

KIFW

SITKA—1949—CBS

Frequency: 1230 Kc. Power: 250 Watts
 Owned-Operated By William J. Wagner
 Address 830 Securities Bldg., Seattle
 Phone Number Seneca 6333
 News Service AP
 Air Time 12N.-12M.
 Transcription Service Langworth, Thesaurus
 Representative Alaska Radio Sales; Scott
 Pres., Gen. Mgr. William J. Wagner
 Pgm. Dir., Sta. Mgr. Harry Lanz
 Chief Engineer DeWayne Sharp

GUAM

KUAM

AGANA—1953—NBC

Frequency: 610 Kc. Power: 1000 Watts
 Owned-Oper. By Radio Guam
 Address Post Office Box 68, Agana, Guam

Air Time Full Time
 News Service AP, UP
 Representative Young
 President Harry M. Engel
 Program Director Richard Station
 Publicity Director Wallace George
 Chief Engineer Don Brown

HAWAII

KHBC

HILO—1936—CBS

Frequency: 970 Kc. Power: 1000 Watts
 Owned-Oper. By Hawaiian Bcstg. System, Ltd.
 Business Address P. O. Box 1476
 Phone Number 4618
 Newspaper Affiliation Honolulu Star Bulletin
 Representative Free & Peters
 President J. Howard Worrall
 Vice-Pres., Gen. Mgr. C. R. Evans

Station Manager Meg Thompson
 Program Director Roger H. Coryell
 Chief Engineer Harold L. Marques

KILA

HILO—1951—MBS

Frequency: 850 Kc. Power: 1000 Watts
 Owned-Operated By Island Bcstg. Co.
 Address Box 1595
 Phone Number 5-4913

Air Time.....3.30 p.m.-12 M.
 Representative.....Hollingbery
 News Service.....UP
 General Manager.....James E. Jaeger
 Program Dir.....Mickey Abe
 Sales Prom. Mgr.....William Myers
 Program Director.....Miss Bey Kodma
 Chief Engineer.....Rikio Dol

KIPA

HILO—1947

Frequency: 1110 Kc.....Power: 1,000 Watts
 Owned-Oper. By.....Big Island Bcstg. Co., Ltd.
 Business-Studio Address.....140 Iaili St.
 Phone Number.....2177
 President, Manager.....A. H. Green

K G M B

HONOLULU—1930—CBS

Frequency: 590 Kc.....Power: 5000 Watts
 Owned-Oper. By.....Hawaiian Bcstg. System,
 Ltd.
 Address.....1534 Kapiolani Blvd.
 Phone Number.....9-2011
 Air Time.....Full Time
 News Service.....UP
 Transcription Service.....Capitol
 Newspaper Affiliation....."Star-Bulletin"
 Representative.....Free & Peters
 President.....J. Howard Worrall
 V.;P., Gen. Mgr.....C. R. Evans
 Station Manager.....Melvin B. Wright

Program Director.....Arthur Hansen
 Promotion Mgr.....Faye Johnson
 Chief Engineer.....Daniel Hunter

KGU

HONOLULU—1922—NBC

Frequency: 780 Kc.....Power: 2,500 Watts
 Owned-Operated By.....Advertiser Pub. Co., Ltd.
 Phone Number.....5-2977
 Air Time.....6 a.m.-11 p.m.
 News Service.....UP
 Representative.....NBC Spot Sales
 Membership.....NARTB
 President.....Lorin P. Thurston
 General Mgr.....William O. Paine
 Sales Prom. Mgr.....George C. Mansfield
 Commercial Dir.....Lee D. Hirschland
 Program Director.....Gene Good
 Chief Engineer.....M. A. Mulronv

KHON

HONOLULU—1946
 ALOHA NETWORK

Frequency: 1380 Kc.....Power: 5,000 Watts
 Owned-Operated By.....Aloha Bcstg. Co., Ltd.
 Business Address.....P. O. Box 1380
 Phone Number.....9-5295
 News Service.....UP
 Trans. Serv.....Capitol, Lang-Worth
 Representative.....Grant
 President.....R. M. Fitkin
 Chief Engr., Sta. Mgr.....Ira G. Mercer
 Commercial Mgr.....Hal Lewis
 Natl. Sales Director.....John D. Allison
 Program Dir.....Wright Esser
 Promotion Mgr.....Buck Buchwach

KIKI

HONOLULU—1951—MBS

Frequency: 860 Kc.....Power: 250 Watts
 Owned-Oper. By.....KIKI, Ltd.
 Address.....320 Ward Ave.
 Phone Number.....63456
 Representative.....Rambeau
 Transcription Service.....Lang-Worth
 News Service.....INS
 President.....Royal V. Howard
 General Manager.....Robert W. Denison
 Station Manager.....Wil Silva
 Chief Engineer.....Kurt Shoemaker

KPOA

HONOLULU—1946—MBS

Frequency: 630 Kc.....Power: 5000 Watts
 Owned-Operated By.....Island Bcstg. Co.
 Business-Studio Address.....575 Kamoku St.
 Phone Number.....95236
 News Service.....UP
 Representative.....George P. Hollingbery
 Owners.....J. Elroy McCaw, John D. Keating
 General Manager.....Fin Hollinger
 Prog., Pub. Dir.....Carlos Rivas
 Chief Engineer.....John R. Sanders
 Sales Prom. Mgr.....Barbara Bishop

EVERYBODY HAS TO

Listen to **KUAM**
on GUAM!

70,000 PEOPLE MUST LISTEN TO
 RADIO STATION KUAM BECAUSE
 THERE IS NO OTHER STATION.
 • KUAM COVERS THE MARIANNAS
 WITH 1,000 WATTS AT 610 ON
 THE DIAL. • NBC AFFILIATED

KUAM

Adam Young, Radio Representative

NEW YORK — 22 EAST 40th STREET
 MURRAY HILL 9-0006
 CHICAGO 2 — 55 E. WASHINGTON STREET
 ANDOVER 3-5448
 ST. LOUIS — 6 NO. SEVENTH STREET
 MAINE 5020
 HOLLYWOOD—ROOM 422, GUARANTY BLDG.
 6331 HOLLYWOOD BLVD.
 HOLLYWOOD 9-0963

in
PUERTO RICO
it's

Cadena Azul

(The BLUE Network)

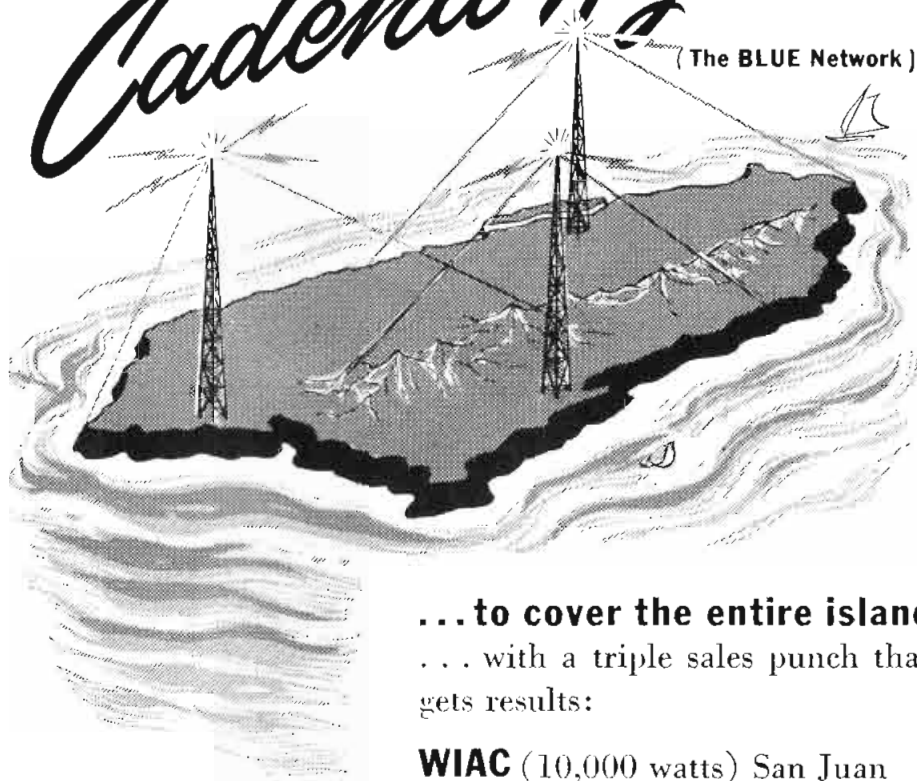

... to cover the entire island
... with a triple sales punch that
gets results:

WIAC (10,000 watts) San Juan

WPRP (5,000 watts) Ponce

WORA (1,000 watts) Mayagüez

*Exclusive United States and
Canadian Representatives:*

MELCHOR GUZMAN CO., INC.

45 Rockefeller Plaza, N. Y. C. 20, N. Y.

Circle 7-0624

*Don't miss out on the
P. R. boom!*

*Hit it... but good...
with the "BLUE"!*

KULA

HONOLULU—1947—ABC

Frequency: 690 Kc. Power: 10,000 Watts
Owned-Oper. By Pacific Frontier Bdcstg. Co., Ltd.

Address 1290 Ala Moana Blvd.
Air Time 18 hrs.
News Service UP
Representative Headley-Reed
Transcription Service World.
Associated, Standard

President H. L. Pettey
General Manager Jack A. Burnett
Station Manager Ted R. Scott
Publicity Director Gordon Burke
Chief Engineer Ronald Miyahira

KANI

KANEOHE, OAHU—1953

Frequency: 1150 Kc. Power: 1000 Watts
Owned-Oper. By Windward Bcstg. Co., Ltd.
Address P. O. Box 227
Phone Number 243882
President Judge Calvin C. McGregor
Vice-Pres., Gen. Mgr. J. Robert Jensen
Chief Engineer Leonard E. Grothe

KTOH

LIHUE, KAUAI—1940—NBC

Frequency: 1490 Kc. Power: 250 Watts
Owned-Oper. By Garden Island Publ., Ltd.
Phone Number Kauai 381

Representative NBC Spot Sales
President Charles J. Fern
Manager Martin H. Sebastian, Jr.
Program Director Raymond K. Sasaki
Chief Engineer Katashi Nose

KMVI

WAILUKU-MAUI—1946—ALOHA

Frequency: 550 Kc. Power: 1000 Watts
Owned-Oper. By Maui Publ. Co., Ltd.
Address Trans. Loca. Wailuku-Maui, Box 374
Phone Number 981
Air Time 5 a.m.-M.
News Service UP
Transcription Service Thesaurus
Representative NBC Spot Sales
Membership NARTB
President J. Walter Cameron
General Manager Ezra J. Crane
Station Manager Richard E. Mawson
Commercial Manager Frank Kovacic
Chief Engineer Neil Arveschoug

KAHU

WAIPAHU—1950

Frequency: 920 Kc. Power: 1000 Watts
Owned-Oper. By Rural Bcstg. Co., Ltd.
Address P. O. Box 1007
Phone Number Honolulu 41-2835
Representative Devney
President Dr. Timothy I. Wee
General Manager Harry En Chu
Station Manager Curt Butler
Chief Engineer Robert Pearson

PUERTO RICO

WABA

AQUADILLA—1951

Frequency: 1240 Kc. Power: 250 Watts
Owned-Operated By L. Hector Reichard
Address Box 188
Phone Number 242
President L. Hector Reichard
General Manager F. Bonnet Velez
Commercial Manager Wilfredo Almodovar
Program Director Ricardo Vega
Chief Engineer Antolin Jimenez

WCMN

ARECIBO—1947

Frequency: 1280 Kc. Power: 1000 Watts
Owned-Oper. By Caribbean Bdcstg Corp.
Address Box 755
Phone Number (Studios) 589
Membership NARTB
President Aristides Santoni Ledesma
General Manager Nabal Barreto
Commercial Mgr. Francisco Lopez Oronoz
Program Dir. Degna Olivero Pabon
Chief Engineer José Soler

WENA

BAYAMON—1947

Frequency: 1560 Kc. Power: 250 Watts
Owned-Operated By Bayamon Bcstg. Co.
Address Box 157
Phone Number Bayamon 161
President Dr. A. Diaz Atilas
General Manager D. Diaz Alejandro

WJFR

CAGUAS—1953

Frequency: 1240 Kc. Power: 250 Watts
Owner Jorama Fer-Radio Corp.
Address 17 Gautier Benitez St.
Phone Number 3240
Pres., Gen. Mgr. Jose M. Fernandez
Comm., Prod. Mgr. Manuel Iglesias

WRIA

CAGUAS—1947

Frequency: 1450 Kc. Power: 250 Watts
Owner Inter-American Radio Corp.
Phone Number 678

TOPS
to deliver your
selling message

in
Puerto Rico
W A P A

on TV: Channel **4**

Affiliated with N. B. C. and Dumont

on Radio: **680 Kcs.**
(10,000 watts)



U. S. A. and Canadian Sales Office:

CARIBBEAN NETWORKS, Inc.

200 West 57 St., New York City 19, N. Y. Circle 5-7433

WVJP

CAGUAS—1947

Frequency: 1110 Kc. Power: 250 Watts
 Owned-Oper. By Borinquen Bdcstg. Co.
 Address P. O. Box 207
 Phone Number 789

WMDD

FAJARDO—1947

Frequency: 1490 Kc. Power: 250 Watts
 Owned-Oper. By Madrazo & Diaz
 Address P. O. Box 187
 Phone Number 132

WXRF

GUAYAMA—1948

Frequency: 1590 Kc. Power: 1,000 Watts
 Owned-Operated By Rafael Fuster
 Business-Studio Address Calle Hostos No. 42
 Phone Number 243
 President Rafael Fuster
 Gen., Comm. Mgr. Charles L. Cordero

WAEL

MAYAGUEZ—1948

Frequency: 1400 Kc. Power: 250 Watts
 Owned-Operated By Mario Acosta
 Business Address Iglesia No. 12
 Phone Number 799
 Owner-Manager Mario Acosta

WKJB

MAYAGUEZ—1946

Frequency: 710 Kc. Power: 1000 d.; 500 n.
 Owned-Operated By Jose A. Bechara, Jr.
 Business Address Minerva St. 54
 Phone Number 983
 President Jose A. Bechara

WORA

MAYAGUEZ—1946

Frequency: 1150 Kc. Power: 1000 Watts
 Owned-Oper. By Radio Americas Corp.
 Phone Number 1150
 Studio Address 1150 Guanajibo Ave.
 Pres., Gen. Mgr. Alfred R. de Arellano, Jr.
 Sta., Comm. Mgr. Reinaldo Dupont

WPRA

MAYAGUEZ—1937

Frequency: 990 Kc. Power: 10,000 Watts
 Owned-Oper. By Puerto Rico Adv. Co.
 Address Box 869
 Phone Number 869
 President Andres Camara

WTIL

MAYAGUEZ—1950

Frequency: 1300 Kc. Power: 1000 Watts

Owned-Operated By Mayaguez Radio Corp.
 Address Post & Palmer Sts.
 Phone Number 1290
 President Alberto Sanabria
 Commercial Manager Gilbert Mamary
 Chief Engineer Aristides Zapata

WISO

PONCE—1953

Frequency: 1260 Kc. Power: 1000 Watts
 Owned-Oper. By South P. R. Bcstg. Corp.
 Address Box 2023
 Phone Number 137
 Pres., Gen. Mgr. Luis E. Freyre

WPAB

PONCE—1940

Frequency: 550 Kc. Power: 5000 Watts d.;
 1000 Watts n.
 Owned-Operated By
 Portorican American Bcstg. Co., Inc.
 Bus-Studio Add. P. O. Box 786, 164 Villa St.
 Phone Number 783, 1177
 Representative Inter-American Pub'l., Inc.
 Pres., Gen. Mgr. A. Gimenez-Aguayo
 Commercial Manager Radames Mayoral
 Program Director Eliseo Borrero
 Chief Engineer Pedro E. Conesa

WPRP

PONCE—1936

Frequency: 910 Kc. Power: 5000 Watts
 Owned-Oper. By Voice of Puerto Rico, Inc.
 Business Address Box 430
 Phone Number 1015, 1752, 1821
 Representative Guzman, Co., Inc.
 President Alfredo Ramirez de Arellano
 General Manager Roberto Muniz
 Commercial Manager Antonio Miro
 Chief Engineer Julio M. Conesa

WRIO

RIO PIEDRAS—1949

Frequency: 1320 Kc. Power: 1000 Watts
 Owned-Oper. By The Master Bdcstg. Corp.
 Address P. O. Box 335—Hato Rey
 Phone Number Hato Rey 1096
 President Isidro Quinanes Vidal

WWW

RIO PIEDRAS—1949

Frequency: 1520 Kc. Power: 250 Watts
 Owned-Oper. By Frank A. Gaudia
 Address P. O. Box 935
 Phone Number 1098
 Owner Frank A. Gaudia

WAPA

SAN JUAN—1947—ABC-MBS

Frequency: 680 Kc. Power: 10,000 Watts
 Owned-Oper. By José Ramón Quiñones
 Bus-Studio Address 357 Ponce de León Ave.

Phone Number3-3000
MembershipNARTB
PresidentJosé Ramón Quiñones
General Manager.....Ary R. Moll
Commercial Manager...Segismundo Quiñones
Program Director..... Jose E. Franco
Chief Engineer..... Jose Arzuaga

W I A C

SAN JUAN—1947

Frequency: 740 Kc.....Power: 10,000 Watts
Owned-Oper. By.....Radio Station WIAC
Address.....P. O. Box 4504
Phone Number.....2-0014
Gen., Sta. Mgr.....Tomas Muniz
Commercial Manager.....Nestor Muniz
Program Director.....Roberto Perez Navarro

W I T A

SAN JUAN—1948

Frequency: 1400 Kc.....Power: 250 Watts
Owned-Oper. By...Electronic Enterprises, Inc.
Address.....P. O. Box 2692
Phone Number2-4756
PresidentAntonio Valdivieso
Chief Engineer.....Luis Martorell

W K A Q

SAN JUAN—1922—CBS

Frequency: 580 Kc.....Power: 5000 Watts

Owned-Oper. By.....El Mundo Bcstg. Corp.
Business Address.....P. O. Box 9007
Phone Number2-2023
Newspaper Affiliation....."El Mundo"
Air Time.....6 a.m.-11 p.m.
Transcription ServiceAssociated
News ServiceUP
Representatives.....Inter-American Pub'l. Inc.
MembershipNARTB
Pres., Gen. Mgr.....Angel Ramos
Comm. Mgr.....V. Lamas, Jr.
Program Director.....Esther Pales
Chief Engineer Angel Del Valle

W K V M

SAN JUAN—1951

Frequency: 1070 Kc...Power: 25,000 Watts d.:
5000 n.
Address.....1000 Ponce de Leon Ave.
Phone3-0840
Pres., Gen. Mgr.....R. P. Perry

W N E L

SAN JUAN—1934

Frequency: 860 Kc.....Power: 5000 Watts
Owned-Oper. By.....WNEL, Inc.
Address.....960 Ponce de Leon Ave.
Phone Number2-1300
Pres., Gen. Mgr.....Juan Piza

WHY IS AP THE BEST?

BECAUSE—AP is faster, more complete, more accurate than any other news service.

STATE BROADCASTER ASSOCIATIONS

Alabama Broadcasters Association

P. O. Box 477, University, Alabama
 Meetings: Semi-annual (March and October)
 Elections: March meeting
 Members: 69
 Pres.....Malcolm Street, WHMA, Anniston
 Vice-Pres...J. Dige Bishop, WCTA, Andalusia
 Secy.-Treas...Dick Biddle, WOWL, Florence

Arizona Broadcasters Association

P. O. Box 2671, Phoenix, Arizona
 Meetings: Annual (January)
 Elections: January
 Members: 21
 President....Albert Johnson, KOY, Phoenix
 Vice-Pres.....Carl Morris, KSUN, Bisbee
 Secy.-Treas...Frank Redfield, KIFN, Phoenix
 Legislative Chmn.....Richard O. Lewis, KTAR, Phoenix

Arkansas Broadcasters Association

P. O. Box 550, Little Rock, Arkansas
 Meetings: Semi-annual
 Elections: March
 Members: 37
 President.....William V. Hutt, KLRA, Little Rock
 Vice-President.....W. N. McKinney, KELD, El Dorado
 Secy.-Treas.....Ted Woods, KOSE, Osceola
 Legislative Chmn.....Jay P. Beard, KBTM, Jonesboro

California State Radio and Television Broadcasters Association

T. W. Patterson Bldg., Fresno 21, California
 Meetings: Annual
 Elections: November
 Members: 97
 President...Arthur Westlund, KRE, Berkeley
 Vice-Pres.....Wm. J. Beaton, KWKW, Pasadena
 Secy.-Treas...Paul R. Bartlett, KFRE, Fresno
 Leg. Chm.....C. L. McCarthy, KROY, Sacramento

Colorado Broadcasters Association

Care of Pres. or Secy.
 Meetings: Semi-annual

Elections: March
 Members: 34
 President....Russell Shaffer, KBOL, Boulder
 Vice Pres.....Vir N. James, KVRH, Salida
 Secy.-Treas.....Joseph Rohrer, KRDO, Colorado Springs
 Legis. Chmn...Robert Ellis, KGHF, Pueblo

Florida Association of Broadcasters, Inc.

Care of Pres. or Secy.
 Meetings: Semi-Annual
 Elections: June
 Members: 76
 President.....Hershel Graves, WTAL, Tallahassee
 Vice-Pres....John Browning, WSPB, Sarasota
 Vice-Pres.....T. S. Gilchrist, WTMC, Ocala
 Secy.-Treas....A. B. Letson, WCNH, Quincy

Georgia Association of Broadcasters

Care of Pres. or Secy.
 Meetings: Three times a year
 Elections: Spring meeting (April or May)
 President...S. J. Carswell, WSFT, Thomaston
 Vice-Pres....E. F. MacLeod, WBML, Macon
 Secy.-Treas....Glen Jackson, WAGA, Atlanta
 Legis. Chmn...Ben Chatfield, WMAZ, Macon

Hawaiian Association of Radio and TV Broadcasters

P. O. Box 1380, Honolulu, T. H.
 Meetings: On Call
 Elections: May
 Members: 18
 President...Fin Hollinger, KPOA, Honolulu
 Vice-Pres.....Ez Crane, KMVI, Waluku
 Secy.-Treas....Ira Mercer, KHON, Honolulu

Idaho Broadcasters Association

Box 31, Boise, Idaho
 Meetings: Semi-annual (May and November)
 Elections: November
 Members: 21
 President...Edward P. Hurt, KFXD, Nampa
 Vice-Pres....Donald A. Thomas, KRLC, Lewis
 Vice-Pres.....Donald A. Thomas, KRLC, Lewiston
 Secy.-Treas.....Florence Gardner, KTFI, Twin Falls
 Legislative Chmn.....Walt Wagstaff, KIDO, Boise

Illinois Broadcasters Association

care of Pres. or Secy-Treas.

Meetings: Semi-annual
 Elections: February
 Members: 65
 Pres. Robert J. Burow, WDAN, Danville
 Vice-Pres. Harold L. Dewing,
 WCVS, Springfield
 Secy. Treas. R. Karl Baker,
 WLOS, Jacksonville
 Leg. Chmn. Ray Livesay, WLBH, Mattoon

Indiana Broadcasters Association, Inc.

Box 89, Washington, Ind.

Meetings: Four times a year
 Elections: March
 Members: 49
 President. Dee W. Coe, WWCN, Gary
 Vice-Pres. Farrell Rippetoe,
 WBOW, Terre Haute
 Vice-Pres. (FM) E. D. Ogborne,
 WCTW, New Castle
 Vice-Pres. (TV) Harry Bitner, Jr.,
 WFBMTA
 Secy. Treas. Robert E. William,
 WFML, Washington
 Asst. Secy. Robert D. Enoch,
 WXLW, Indianapolis
 Asst. Treas. Ronnie Householder,
 WJVA, South Bend
 Leg. Chmn. C. Bruce McConnell,
 WISH, Indianapolis

Iowa Broadcasters Association

c/o President

Meetings: Annual (July or August) or more
 Elections: Annual meeting
 Members: 35
 President. Ben Sanders, KIGD, Spencer
 Vice-Pres. Ken Gordon, KDTH, Dubuque
 Secy. Treas. W. W. Woods,
 WHO, Des Moines
 Director Herbert Ohrt,
 KGLD, Mason City

Kansas Association of Radio Broadcasters

KSAL, Salina, Kansas

Meetings: Annual
 Elections: Annual meetings
 Members: 37
 President. Roy A. Jensen, KSAL
 Vice-Pres. Fred Conger, WREN
 Secy. Treas. Grover Cobb, KVGB
 Legislative Chmn. Wendell Elliot, KGNO

Kentucky Broadcasters Association

c/o Secy. Treas.

Meetings: Semi-annual
 Elections: Fall meeting
 Members: 38
 President. Mike Layman, WSEC, Somerset
 Vice-Pres. Sam Livingston, WKYB, Paducah
 Vice-Pres. Gibmore Nunn, WLAP, Lexington
 Secy. Treas. Hugh O. Potter
 WOMH, Owensboro
 Legislative Chmn. J. W. Betts,
 WFTM, Maysville

Louisiana Association of Broadcasters

P. O. Box 4218, Shreveport, Louisiana

Meetings: Semi-annual
 Elections: Fall
 Members: 40
 Pres. Willard Cobb, KALB, Alexandria
 Vice-Pres. Frank Ford, Jr.,
 KENT, Shreveport
 Secy. Treas. Jerry Hamon, KANE, New Iberia

Maine Broadcasters Association

c/o WPOR, Portland

Meetings: October
 Elections: October
 Members: 15
 Pres. Harold H. Meyer, WPOR, Portland
 Vice-Pres. Harold Glidden,
 WAGM, Presque Isle
 Secy. Treas. Francis H. Farnham,
 WGAN, Portland
 Legislative Chmn. Frank Hoy,
 WLAM, Lewiston

Maryland-D.C. Radio and Television Broadcasters Association

c/o President

Meetings: Semi-annual
 Elections: Fall meeting
 Members: 29
 President. Charles E. Smith,
 WTBO, Cumberland
 Vice-Pres. Joseph L. Brechner,
 WGAY, Silver Springs
 Secy. Treas. Les Peard, WBAL, Baltimore

Michigan Association of Broadcasters

c/o President

Meetings: Semi-annual
 Elections: November meeting
 Members: 68
 Pres. W. A. Pomeroy, WILS, Lansing
 Vice-Pres. W. J. Edwards, WKNX, Saginaw
 Secy. Treas. Gayle Grubb, WJBK, Detroit
 Legislative Chmn. Walter Patterson,
 WKMH, Jackson

Minnesota Broadcasters Association

WDGY, Nicollet Hotel, Minneapolis

Meetings: September
Elections: September
Members: 30

President.....C. T. Hagman,
WDGY, Minneapolis
Vice-Pres.....Lee L. Whiting,
KEYD, Minneapolis
Secy.-Treas..M. M. Marget, KVOX, Moorhead
Legislative Chmn.....C. T. Hagman,
WDGY, Minneapolis

Mississippi Broadcasters Association

c/o President

Meetings: Annual
Elections: Annual meeting
Members: 46

President.....Bob C. J. Wright, Jr.,
WFOR, Hattiesburg
Vice-Pres.....Bob Evans, WELO, Tupelo
Secy.-Treas.Granville Walters,
WAML, Laurel
Legislative Chmn.....Fred Beard
WJDX, Jackson

Missouri Broadcasters Association

P. O. Box 1716, S.S.S., Springfield, Missouri

Meetings: Semi-annual
Elections: Fall meeting
Members: 40

President.....G. Pearson Ward,
KTTS, Springfield
Vice-Pres.....Robt. Neathery, KWPM, Alton
Secy.-Treas.Catherine Roer,
KWOS, Jefferson City
Legislative Chmn.....Bruce Barrington,
KXOK, St. Louis

Montana Radio Stations, Inc.

P. O. Box 2124, KBMY, Billings

Meetings: Annual
Elections: January
Members: 25

President.....Ken Nybo, KBMY, Billings
Vice-Pres.....Ian Elliot, KRJF, Miles City
Secy.-Treas.Norman Penwell,
KBMN, Bozeman
Legislative Chmn.....Paul MacAdam
KPRK, Livingston

Nebraska Broadcasters Association

WJAG, Norfolk, Nebraska

Meetings: Annual
Elections: Annual
Members: 28

President.....R. E. Thomas,
WJAG, Norfolk
Vice-Pres.....L. L. Hilliard,
KOLT, Scottsbluff
Secy.-Treas.Gene Ackerley,
KCOW, Alliance

Nevada State Broadcasters Association

P. O. Box 821, Reno, Nevada

Meetings: Annual
Elections: Annual
Members: 12

President.....H. G. Wells, KOLO, Reno
Vice-Pres.....Fred Stoye, KLAS, Las Vegas
Secy.-Treas...Robert Stoddard, KATO, Reno
Legislative Chmn..H. G. Wells, KOLO, Reno

New Jersey Broadcasters Association

P. O. Box 166, Bridgeton, New Jersey

Meetings: Semi-annual (May and October)
Elections: October
Members: 17

President.....Everett Rudloff,
WJLK, Asbury Park
Vice-Pres....Gordon Giffin, WKDN, Camden
Secy.-Treas..Jerry McCarthy, WTOA, Trenton
Legislative Chmn.....Fred Bernstein,
WTTM, Trenton

New Mexico Broadcasters Association

759 Cerrillos Road, Santa Fe

Meetings: September and April
Elections: April
Members: 18

President.....Ivan R. Hcad, KVSF, Santa Fe
Vice-Pres....E. N. Thwaites, KRTN, Raton
Secy.-Treas.....Lydia S. Sleppy,
KOBE, Las Cruces
Legislative Chmn.....W. E. Whitmore, Jr.,
KEMN, Portales

North Carolina Association of Broadcasters, Inc.

c/o Secretary

Meetings: Semi-annual
Elections: Fall meeting
Members: 96

President.....James McNeil,
WTSB, Lumberton
Vice-Pres.....Wm. S. Page, WFTC, Kinston
Secy.-Treas...J. T. Snowden, WCPS, Tarboro

North Dakota Broadcasters Association

KNOX, Grand Forks, N. D.

Meetings: October

Elections: October
 Members: 14
 President..... E. E. Fitzsimmonds,
 KFYR, Bismarck
 Vice-Pres. Elmer Hanson,
 KNOX, Grand Forks
 Legislative Chmn..... John Cooley,
 KLPN, Minot

**Ohio Association of Radio and
 Television Broadcasters**

44 East Broad, Columbus 15, Ohio
 Meetings: Semi-annual
 Elections: Spring meeting
 Members: 66
 President..... Adna Karns, WING, Dayton
 Vice-Pres.. Robert Ferguson, WTRF, Bellaire
 Secy.-Treas..... L. A. Pixley, WLOK, Lima
 Legislative Chmn..... Adna Karns,
 WING, Dayton

**Oklahoma Radio
 Broadcasters Association**

P. O. Box 588, Ponca City, Oklahoma
 Meetings: Semi-annual (or more)
 Elections: January
 Members: 36
 President..... Cy Casper, WBBZ, Ponca City
 Vice-Pres..... J. J. Bernard,
 KOMA, Oklahoma City
 Secy. Treasurer..... Guy Farnsworth,
 KCRC, Enid
 Legislative Chmn..... Bill Hoover,
 KADA, Ada

**Oregon State Broadcasters
 Association**

R. E. Summers, Journalism Bldg.,
 U. of Oregon, Eugene
 Meetings: Semi-annual
 Elections: Annual
 Members: 48
 President... S. W. McCready, KUGN, Eugene
 Vice-Pres... Paul Walden, KODL, The Dalles
 Secy.-Treas... Joe Schertler, KEX, Portland
 Legislative Chmn..... Dick Brown,
 KPOJ, Portland

**Pennsylvania Association
 of Broadcasters**

WCPA, 215 Church St., Clearfield
 Meetings: Annual
 Elections: May
 Members: 108
 President..... W. J. Thomas,
 WCPA, Clearfield
 Vice-Pres. Frank Altdoerfer,
 WI AN, Lancaster

Vice-Pres. and Treas..... James Murray,
 KQV, Pittsburgh
 Treasurer... James Murray, KQV, Pittsburgh
 Secretary..... Joseph T. Connolly,
 WCAU, Philadelphia
 Legislative Chmn..... Roy E. Morgan,
 WIIK, Wilkes-Barre

**Puerto Rican Association of
 Broadcasters**

Box 4504, San Juan, Puerto Rico
 Meetings: Monthly
 Elections: July
 Members: 19
 President..... Alfonso Gimenez Aguayo
 WPAB, Ponce
 Vice-Pres..... Tomas Muniz Souffront,
 WIAC, Santurce
 Secretary..... Frederico E. Virella,
 WWJP, Caguas
 Treasurer... Gustavo Dias, WENA, Bayamon

**Rhode Island Radio &
 Television Broadcasters
 Association**

c/o President
 Meetings: June
 Elections: June
 Members: 12
 President... Mowry Lowe, WEAN, Providence
 Vice-Pres..... Mitchell Stanley,
 WWON, Woonsocket
 Secy.-Treas. Norm Gittelson,
 WJAR-TV, Providence

**South Carolina Broadcasters
 Association**

c/o Secretary
 Meetings: January
 Elections: January meeting
 Members: 36
 President..... Walter J. Brown,
 WORD, Spartanburg
 Vice-Pres..... James F. Coggins,
 WKDK, Newberry
 Secy.-Treas..... T. Doug Youngblood,
 WFIG, Sumter
 Legislative Chmn..... H. Moody McElyeen,
 WNOK, Columbia

**Southern California
 Broadcasters Association**

6047 Hollywood Blvd., Hollywood 28
 Meetings: Monthly
 Elections: May
 Members: 64

President.....Frank Burke, Jr.,
 KFVD, Los Angeles
 Vice-Pres.....Norman Osthy,
 KHJ, Los Angeles
 Secy.-Treas.Thelma Kirchner,
 KGEJ, Hollywood
 Managing Director.....Norman Nelson

South Dakota Broadcasters Association

c/o Secretary

Meetings: Semi-annual
 Elections: April
 Members: 14
 President.....Max Staley, KIJV, Huron
 Vice-Pres....Ross Case, KWAT, Watertown
 Secy.-Treas.Keith Nighbert,
 KUSD, Vermillion
 Legislative Chmn.....Morton Henkin,
 KSOO, Sioux Falls

Tennessee Association of Broadcasters

407 Chamber of Commerce Bldg.,
 Nashville, Tennessee

Meetings: Semi-annual
 Elections: December meeting
 Members: 46
 President.....Earl W. Winger,
 WDOJ, Chattanooga
 Vice-Pres.....John Hart, WBIR, Knoxville
 Secy.-Treas.....Mrs. Drue Smith,
 WAPO, Chattanooga
 Legislative Chmn.....F. C. Sowell,
 WLAC, Nashville

Texas Association of Broadcasters

c/o Secretary

Meetings: Semi Annual
 Elections: October
 Members: 112
 President...Willard Deason, KVET, Austin
 Vice-Pres....Louis R. Cook, KNOW, Austin
 Secy.-Treas....Richard Lewin, KTRE, Lufkin

Utah Broadcasters Association

c/o President

Meetings: Semi-Annual
 Elections: January
 Members: 19
 President Arch Madsen,
 KOVO, Provo
 Vice-PresidentGeorge Hatch,
 KALL, Salt Lake City
 Vice-President....Reed Bullen, KLO, Ogden

Secy.-Treas.....Arch Webb, KVOC, Ogden
 Legislative Chmn.....Oral Wilkinson,
 KMUR, Murray

Virginia Association of Broadcasters, Inc.

c/o President

Meetings: Annual
 Elections: Annual meeting
 Members: 42
 President...Robert H. Smith, WCYB, Bristol
 Vice-Pres.....Frank E. Koehler,
 WROV, Roanoke
 Secy.-Treas.Chas. Maillett,
 WWOOD, Lynchbnrg
 Legislative Chmn.....C. T. Lucy,
 WRVA, Richmond

Washington State Association of Broadcasters

Carl Downing, Manager, Legislative Bldg.,
 Olympia, Washington

Meetings: Semi-annual
 Elections: Spring
 Members: 44
 President.....Leo H. Beckley,
 KBRC, Mount Vernon
 Vice-Pres....Loren Stone, KBRO, Bremerton
 Secy.-Treas....Allen Miller, KWCS, Pullman

West Virginia Broadcasters Association

c/o Secretary

Meetings: Semi-annual
 Elections: Spring
 Members: 34
 PresidentAlice Shein,
 WBTH, Williamson
 Vice-Pres..Paul A. Myers, WWVA, Wheeling
 Secy.-Treas.....John S. Phillips,
 WHTN, Huntington
 Legislative Chmn.....Harry Brawley,
 WCHS, Charleston

Wisconsin Broadcasters Association

Nicolet Bldg., Green Bay, Wisconsin

Meetings: Annual
 Elections: First Tuesday in October
 Members: 46
 President..Harry D. Peck, WISN, Milwaukee
 Vice-Pres.....Wm. E. Walker,
 WMAM, Marinette
 Secretary....Verl Bratton, WKTY, LaCrosse
 Treasurer.....Mig Figi, WAUX, Waukesha

IN CANADA

more people listen regularly to*

CFRB Toronto

*than to any other
station . . .*

★ The 1952 BBM figures show CFRB's coverage as 619,430 daytime and 639,720 night time — more than one-fifth of the homes in Canada, concentrated in the market which accounts for 40% of the Dominion's retail sales.

CFRB

Representatives

UNITED STATES

Adam J. Young Jr. Incorporated

CANADA

All-Canada Radio Facilities Limited

Canada

•

CARTB

•

CBC

•

**ALPHABETICAL INDEX
BY CALL LETTERS**

•

STATIONS

•

NETWORKS

CANADA

is boom country

... want a share?

Just speak up!

The Canadian is listening for you at his radio. He's listening in Alberta, where the oil's coming up richer and thicker than ever. In Saskatchewan, where uranium, oil and bumper crops are swelling the coffers. In Labrador, on top a new wealth of iron ore. In Quebec and Ontario, where heavy industry keeps getting heavier and light industry expands by leaps and bounds.

The Canadian is listening in every city, town and village . . . to a voice he already knows and trusts, the voice of his local radio station. The wife is listening — the youngsters, too. Millions upon millions of Canadians, with more money than ever to spend . . . and wanting to know what to spend it on.

Speak up. You'll be heard in 95% of all the homes in Canada . . . in the language familiar to each home, English or French. You'll be heard in the best of company — the big network shows *plus* the friendly entertainment,

news and services that only local radio can provide for its community.

Local radio in Canada is welcome, intimate, persuasive. It's *everywhere*, in a country where only 38% of the population lives in cities of 30,000 or over. It combines penetration, effectiveness and economy as no other advertising medium in Canada can. That's hard fact.

Purchasing power is booming. Canadians spent 10½ billion dollars in 1951, just in the retail stores . . . over 11½ billion dollars in 1952. And the Canadian buys more U. S. goods than any country other than your own. With cash — the stuff that's straining every billfold in the nation.

Want a share? Canada is waiting by the radio. Just speak up.

"In Canada you sell 'em when you tell 'em!"

A message from the 120 member stations of the Canadian Association of Radio and Television Broadcasters — whose voices are invited into over 3 million Canadian homes every day.

Canadian Association of Radio and Television Broadcasters

108 SPARKS ST., OTTAWA 4, CANADA • 373 CHURCH ST., TORONTO, ONTARIO

CANADIAN ASSOCIATION OF RADIO-TELEVISION BROADCASTERS

OFFICES

Head Office—108 Sparks St., Ottawa, Ont.
Phone: 3-4036

Sales Offices—373 Church St., Toronto, Ont.
Phone: Empire 4-8244



Officers

President.....	F. H. Elphicke
Vice-President.....	E. Finlay MacDonald
Executive Vice-President.....	T. J. Allard
Secretary-Treasurer	Flora Love
Director of Sales and Research.....	A. F. P. Freeman



Directors

William Rea, New Westminster, B. C.; G. C. Gaetz, Edmonton, Alta.; H. A. Crittenden, Regina, Sask.; John Craig, Brandon, Man.; J. E. Campeau, Windsor, Ont.; F. B. Ricard, Sudbury, Ont.; Wallace Slatter, Guelph, Ont.; J. M. Davidson, Toronto, Ont.; J. P. Lemire, Hull, P. Q.; J. A. Dupont, Montreal, P. Q.; Henri Lepage, Quebec City, P. Q.; D. Malcolm Neill, Fredericton, N. B.



Functions

The Canadian Association of Radio and Television Broadcasters is a voluntary trade organization of 115 privately owned (independent) broadcasting stations in Canada.

CANADIAN BROADCASTING CORP.

OFFICES

Head Office—P. O. Box 806, 140 Wellington St., Ottawa, Ont.
Administration—P. O. Box 6000, Montreal, Que.
Commercial Division—P. O. Box 500, 354 Jarvis St., Toronto 5, Ont.
New York Office c/o United Nations

EXECUTIVES and STAFF

Board of Governors

A. Davidson Dunton, Ottawa, Ont., Chairman
Rene Morin, Montreal, Que., Vice-Chairman
Dcan Adrien Pouliot, Laval University, Quebec
F. J. Crawford, Toronto, Ont.
G. D. Steel, Charlottetown, P.E.I.
W. H. Phillips, Ottawa, Ont.
J. A. Corry, Queen's University, Kingston
Mr. Mary E. Farr, Victoria, B. C.
Jesse P. Tripp, Oxbow, Sask.
Gordon A. Winter, St. Johns, Nfld.
Roy J. Fry, Winnipeg, Man.

Ottawa

HEAD OFFICE

J. A. Ouimet, General Manager
E. L. Bushnell, Ass't. Gen. Mgr. and Co-ordinator of TV
J. P. Gilmore, Assistant to Co-ordinator of TV
D. C. McArthur, Executive Assistant
G. W. Richardson, Executive Assistant
Harry Bramah, Treasurer
Charles Jennings, Director of Programs
Marcel Ouimet, Assistant Director of Programs
J. M. Beaudet, Director of Program Planning and Production
W. G. Richardson, Director of Engineering
Marcel Carter, Director of Personnel and Administrative Services
C. E. Stiles, Asst. Dir. of Personnel and Adm. Services
H. G. Walker, Director of Network Co-ordination
George Young, Dir. of Station Relations and Broadcast Regulations
R. C. Fraser, Director of Press and Information Services
F. W. Savignac, Executive Assistant—Legal
R. E. Keady, Sec'y to Board of Governors

Montreal

RADIO CANADA BUILDING

R. P. Landry, Director for the Province of Quebec
Aurele Sequin, Director of Programs, Quebec
J. St.-Georges, Director of Radio, Montreal
Andre Ouimet, Director of Television, Montreal
J. E. Hayes, Chief Engineer
W. A. Nichols, Assistant Chief Engineer
E. C. Stewart, Co-ordinator of Engineering Projects and Services
R. E. Santo, Transmission and Development
J. Carlisle, Plant Engineer
N. R. Olding, Operations Engineer
D. G. McKinstry, Chief Architect
M. D. Peterkin, Purchasing Agent
G. G. Yull, Supervisor of Stores

Toronto

NATIONAL PROGRAM OFFICE

Ira Dilworth, Director for the Province of Ontario
H. J. Boyle, Director of Programs, Ontario
R. W. McCall, Director of Radio, Toronto
Fergus Mutrie, Director of Television, Toronto
Frank Peers, Supervisor of Talks and Public Affairs
W. H. Hogg, Chief News Editor
R. S. Lambert, Supervisor of School Broadcasts
W. J. Dunlop, Supervisor of International Exchange and Institutional Broadcasts
W. C. Anderson, Supervisor of Program Clearance
E. W. Jackson, Traffic Manager
W. E. Powell, Commercial Manager
W. R. Johnston, Assistant Commercial Manager

STATIONS OF CANADA

The following list of stations is arranged in call letter alphabetical order giving page number for complete station data.

Call Letters	City	See Page	Call Letters	City	See Page
CBA . . .	Sackville, N. B.	680	CFRN . . .	Edmonton, Alta.	675
CBE . . .	Windsor, Ont.	687	CHAB . . .	Moose Jaw, Sask.	692
CBF . . .	Montreal, Que.	689	CHAD . . .	Amos, Que.	688
CBG . . .	Gander, Nfld.	680	CHAT . . .	Medicine Hat, Alta.	676
CBH . . .	Halifax, N. S.	681	CHEF . . .	Granby, Que.	688
CBI . . .	Sydney, N. S.	682	CHEX . . .	Peterborough, Ont.	685
CBJ . . .	Chicoutimi, Que.	688	CHFA . . .	Edmonton, Alta.	675
CBK . . .	Winnipeg, Man.	679	CHGB . . .	Ste. Anne de la Pocatiere.	691
CBL . . .	Toronto, Ont.	687	CHLN . . .	Three Rivers, Que.	691
CBM . . .	Montreal, Que.	689	CHLO . . .	St. Thomas, Ont.	686
CBN . . .	St. John's, Nfld.	680	CHLP . . .	Montreal, Que.	689
CBO . . .	Ottawa, Ont.	685	CHLT . . .	Sherbrooke, Que.	691
CBT . . .	Grand Falls, Nfld.	680	CHML . . .	Hamilton, Ont.	683
CBU . . .	Vancouver, B. C.	677	CHNC . . .	New Carlisle, Que.	690
CBV . . .	Quebec City, Que.	690	CHNO . . .	Sudbury, Ont.	686
CBW . . .	Winnipeg, Man.	679	CHNS . . .	Halifax, N. S.	681
CBX . . .	Edmonton, Alta.	675	CHOK . . .	Sarnia, Ont.	686
CBY . . .	Corner Brook, Nfld.	680	CHOV . . .	Pembroke, Ont.	685
CFAB . . .	Windsor, N. S.	682	CHRC . . .	Quebec City, Que.	690
CFAC . . .	Calgary, Alta.	675	CHRL . . .	Roberval, Que.	691
CFAR . . .	Flin Flon, Man.	678	CHSJ . . .	Saint John, N. B.	680
CFBC . . .	Saint John, N. B.	680	CHUB . . .	Nanaimo, B. C.	676
CFCF . . .	Montreal, Que.	689	CHUM . . .	Toronto, Ont.	687
CFCH . . .	North Bay, Ont.	684	CHVC . . .	Niagara Falls-Welland, Ont.	684
CFCL . . .	Timmins, Ont.	686	CHWK . . .	Chilliwack, B. C.	676
CFCN . . .	Calgary, Alta.	675	CJAD . . .	Montreal, Que.	689
CFCO . . .	Chatham, Ont.	683	CJAT . . .	Trail, B. C.	677
CFCY . . .	Charlottetown, P.E.I.	688	CJAV . . .	Port Alberni, B. C.	677
CFGP . . .	Grande Prairie, Alta.	675	CJBC . . .	Toronto, Ont.	687
CFJC . . .	Kamloops, B. C.	676	CJBQ . . .	Belleville, Ont.	682
CFJR . . .	Brockville, Ont.	683	CJBR . . .	Rimouski, Que.	690
CFNB . . .	Fredericton, N. B.	679	CJCA . . .	Edmonton, Alta.	675
CFNS . . .	Saskatoon, Sask.	692	CJCB . . .	Sydney, N. S.	682
CFOR . . .	Orillia, Ont.	684	CJCH . . .	Halifax, N. S.	681
CFOS . . .	Owen Sound, Ont.	685	CJCS . . .	Stratford, Ont.	686
CFPA . . .	Port Arthur, Ont.	685	CJDC . . .	Dawson Creek, B. C.	676
CFPL . . .	London, Ont.	684	CJEM . . .	Edmundston, N. B.	679
CFPR . . .	Prince Rupert, B. C.	677	CJFP . . .	Riviere—Du-Loup, Que.	690
CFQC . . .	Saskatoon, Sask.	693	CJFX . . .	Antigonish, N. S.	681
CFRA . . .	Ottawa, Ont.	685	CJGX . . .	Yorkton, Sask.	693
CFRB . . .	Toronto, Ont.	687	CJIB . . .	Vernon, B. C.	678
CFRG . . .	Gravelbourg, Sask.	692	CJIC . . .	Sault Ste. Marie, Ont.	686

Call Letters	City	See Page
CJKL	Kirkland Lake, Ont.	684
CJLS	Yarmouth, N. S.	682
CJMS	Montreal, Que.	690
CJNB	North Battleford, Sask.	692
CJOB	Winnipeg, Man.	679
CJOC	Lethbridge, Alta.	676
CJON	St. John's, Nfld.	681
CJOR	Vancouver, B. C.	677
CJOY	Guelph, Ont.	683
CJQC	Quebec City, Que.	690
CJRL	Kenora, Ont.	684
CJRW	Summerside, P.E.I.	668
CJSO	Sorel, Que.	691
CJVI	Victoria, B. C.	678
CKAC	Montreal, Que.	690
CKBB	Barrie, Ont.	682
CKBI	Prince Albert, Sask.	692
CKBL	Matane, Que.	689
CKBW	Bridewater, N. S.	681
CKCH	Hull, Que.	688
CKCK	Regina, Sask.	692
CKCL	Truro, N. S.	682
CKCR	Kitchener, Ont.	684
CKCV	Quebec City, Que.	690
CKCW	Moncton, N. B.	680
CKDA	Victoria, B. C.	678
CKDM	Dauphin, B. C.	678
CKEN	Kentville, N. S.	682
CKEY	Toronto, Ont.	687
CKFH	Toronto, Ont.	687
CKFI	Fort Frances, Ont.	683
CKGB	Timmins, Ont.	687
CKLB	Oshawa, Ont.	685
CKLN	Nelson, B. C.	676
CKLS	La Sarre, Que.	689
CKLW	Windsor, Ont.	687
CKMO	Vancouver, B. C.	677
CKMR	New Castle, N. B.	680
CKNB	Campbellton, N. B.	679
CKNW	New Westminster, B. C.	677
CKNX	Wingham, Ont.	688
CKOC	Hamilton, Ont.	683
CKOK	Penticton, B. C.	677
CKOM	Saskatoon, Sask.	693
CKOV	Kelowna, B. C.	676
CKOX	Woodstock, Ont.	688
CKOY	Ottawa, Ont.	685

Call Letters	City	See Page
CKPC	Brantford, Ont.	682
CKPG	Prince George, B. C.	677
CKPR	Fort William, Ont.	683
CKRC	Winnipeg, Man.	679
CKRD	Red Deer, Alta.	676
CKRM	Regina, Sask.	692
CKRN	Rouyn, Que.	691
CKRS	Jonquiere, Que.	689
CKSB	St. Boniface, Man.	678
CKSF	Cornwall, Ont.	683
CKSM	Shawinigan Falls, Que.	691
CKSO	Sudbury, Ont.	686
CKTB	St. Catharines, Ont.	686
CKTS	Sherbrooke, Que.	691
CKVD	Val D'Or, Que.	691
CKVL	Verdun, Que.	691
CKWS	Kingston, Ont.	684
CKWX	Vancouver, B. C.	678
CKY	Winnipeg, Man.	679
CKX	Brandon, Man.	678
CKXL	Calgary, Alta.	675
VOAR	St. John's, Nfld.	681
VOCM	St. John's, Nfld.	681

ALL-CANADA RADIO FACILITIES LIMITED

Canada's Foremost
Radio Organization

Representing
29 Key Canadian
Radio Stations
Coast to Coast



Largest Canadian
Distributors
of Packaged Shows

Toronto • Montreal
Vancouver • Calgary • Winnipeg

ALBERTA

CFAC

CALGARY—1922—CBC,
TRANS-CANADA

Frequency: 960 Kc. Power: 5000 Watts
Owned-Oper. By... Calgary Bcstg. Co., Ltd.
Bus. Studio Address... 1000 Greyhound Bldg.
Phone Number 6-1036
Air Time..... 19 hrs.
News Service..... PN, PUB, CP
Transcription Service..... Thesaurus, World,
Associated
Representative All-Canada, Weed
Membership CARTB
President..... John D. Southam
Manager..... A. M. Cairns
Commercial Manager..... D. H. Hartford
Program Director..... G. A. Brown
Promotion Manager..... R. J. Tregillus
Chief Engineer..... E. C. Connor

CFCN

CALGARY—1922—CBC

Frequency: 1060 Kc. Power: 10,000 Watts
Owned-Oper. By... The Voice of the Prairies, Ltd.
Bus. Studio Address... 12th Ave. & 6th St., East
Phone Number 2-1161
Air Time..... Full Time
News Service..... Can Press
Transcription..... SESAC, Langworth, Capitol
Representative..... Adam J. Young, Jr.
Membership CAB, WAB
Pres., Gen. Mgr..... H. G. Love
Commercial Manager..... E. H. McGuire
Pgm. Director..... James A. Love
Chief Engineer..... Robert Lamb

CKXL

CALGARY—1950

Frequency: 1140 Kc. Power: 1000 Watts
Owned-Oper. By... Albertan Bcstg. Co.
Address..... 210 9th Ave. W.
Phone Number 63026
Representative..... H. C. Stovin
News Service..... BUP, CP
Membership CAB, BBM
President..... C. E. Chesher
Station Manager..... Frederick R. Shaw
Commercial Manager..... Bruce D. Alloway
Prom. Mgr., Pub. Dir..... Pearl Borgal
Program Director..... Jack Stewart
Chief Engineer..... Ross Craig

CBX

EDMONTON—1948—CBC

Frequency: 1010 Kc. Power: 50,000 Watts
Owned-Oper. By... Canadian Bcstg. Corp.
Bus. Studio Address... 713 MacDonald Hotel
General Manager..... J. Alphonse Oumet
Commercial Manager..... W. E. Powell
Chief Engineer..... G. W. Oliver

CFRN

EDMONTON—1934—CBC

Frequency: 1260 Kc. Power: 5000 Watts
Owned-Oper. By... Sunwapta Bcstg. Co., Ltd.
Business Studio Address... 109 CPR Bldg.
Phone Number 22101
News Service..... BUP, PN
Transcription Service Lang-Worth
Representative..... Radio Representatives,
Adam J. Young, Jr., Harlan G. Oakes
Membership CARTB
Pres., Gen., Sta. Mgr..... G. R. A. Rice
Commercial Mgr..... A. J. Hoppe
Program Director..... George A. Duffield
Publicity Director..... Isobel McDonald
Chief Engineer..... Frank G. Makepeace

CHFA

EDMONTON—1949—CBC

Frequency: 680 Kc. Power: 5000 Watts
Owned-Operated By... Radio Edmonton, Ltd.
Business Address... 10012 109th St.
Phone Number 42157
News Service..... BUP
Representative..... Omer Renaud Co., Hunt
President P. Mousseau
Gen., Sta. Mgr..... Leo Remillard
Chief Engineer..... Robert D. Guy

CJCA

EDMONTON—1922—CBC

Frequency: 930 Kc. Power: 5000 Watts
Owned-Oper. By... Edmonton Bcstg. Co., Ltd.
Bus. Studio Address... 452 Birks Bldg.
Phone Number PBX 44131
Air Time..... Full Time
News Service..... PN, BUP, CP
Trans. Serv..... Thesaurus, World, Standard
Representative All-Canada, Weed
Membership CARTB, BMB
Station Manager..... Gerry Gaetz
Asst. Sta. Mgr..... Rolfe Barnes
Commercial Manager..... Joe MacKenzie
Production Director..... Dalt Elton
Promotion Manager..... Miss Win Sutton
Chief Engineer..... Frank Hollingsworth

CFGP

GRANDE PRAIRIE—1937—CBC

Frequency: 1050 Kc. Power: 1000 Watts
Owned By... Northern Bcstg. Corp., Ltd.
Phone Number 2311
Air Time..... 6 a.m.-M.
News Service..... CP
Transcription Service World
Representative All-Canada, Weed
Membership CARTB
President..... J. E. Thomson
Station Manager..... Arthur J. Balfour
Commercial Manager..... Jack E. Soars
Program Director..... John Wilson
Chief Engineer..... Jim de Roaldes

CJOC

LETHBRIDGE—1926

Frequency: 1220 Kc. Power: 5000 Watts
 Owned-Oper. By: Lethbridge Bcstg., Ltd.
 Address: 1015 Third Ave. E.
 Phone Number: 3161
 Air Time: 5:30 a.m.-1 a.m.
 News Service: PN, BUP, CP
 Transcription Service: Assoc. Thesaurus
 Representative: Weed, All-Canada
 Membership: CAB, BBM, WAB
 Pres. & Gen. Mgr.: H. R. Carson
 Station Manager: N. Botterill
 Sls. Prom. Mgr., Pub. Dir.: Francis Hushagen
 Commercial Manager: J. Budd
 Program Director: Bob Reagh
 Chief Engineer: Doug Card

CHAT

MEDICINE HAT—1946—CBC

Frequency: 1270 Kc. Power: 1000 Watts

Owned-Oper. By: Monarch Bcstg. Co., Ltd.
 Address: 520 First St.
 Phone Number: 2821
 Representative: Weed, All-Canada
 Transcription Library: World
 President: J. H. Yuill
 Gen. Sta. Mgr.: R. J. Buss
 Chief Engineer: Ian Carson

CKRD

RED DEER—1949—CBC

Frequency: 1230 Kc. Power: 250 Watts
 Owned-Oper. By: Central Alberta Bcstg. Co.
 Business Address: Foster Block
 Phone Number: 2083
 Air Time: 17½ hrs.
 News Service: BUP
 Representative: Radio Reps., Young
 Membership: CARTB
 Pres., Gen. Sta. Mgr.: Gordon S. Henry
 Commercial Mgr.: Ned Corrigan
 Program Director: John Barton
 Chief Engineer: Ken L. Martin

BRITISH COLUMBIA

CHWK

CHILLIWACK—1927—CBC

Frequency: 1270 Kc. Power: 1000 Watts
 Owned-Oper. By: Fraser Valley Bcstrs., Ltd.
 Business-Studio Address: 50 Yale Rd. E.
 Phone Number: 7511-21
 Air Time: 6:30 a.m.-M.
 News Service: BUP
 Representative: All-Canada, Weed
 President: C. Casey Wells
 Gen. Mgr., Chief Engr.: Jack Pilling
 Commercial Manager: W. G. Teetzel
 Production Mgr.: J. M. MacLachlan

CKOV

KELOWNA—1931—CBC

Frequency: 630 Kc. Power: 1000 Watts
 Owned-Oper. By: Okanagan Bcstrs., Ltd.
 Business-Studio Address: Box 1481
 Phone Number: 3331
 News Service: PN
 Transcription Service: World
 Representative: All-Canada, Weed
 Membership: CARTB
 General Manager: J. W. B. Browne
 Station Manager: D. Reid
 Promotion Mgr.: Freda Woodhouse
 Chief Engineer: J. Fred Weber

CJDC

DAWSON CREEK—1947—CBC

Frequency: 1350 Kc. Power: 1000 Watts
 Owned-Operated By: Radio Station CJDC, Ltd.
 Business Address: 102nd Ave. & 9th St.
 Phone Number: 215
 News Service: Broadcast News
 Transcription Service: Associated
 Representative: Radio Representatives, Cooke
 Membership: CARTB
 President: W. B. Michaud
 General Manager: Lewis R. Roskin
 Program Director: Michael Laverne
 Publicity Director: Ethyl Emes
 Chief Engineer: John Pringle

CHUB

NANAIMO—1949

Frequency: 1570 Kc. Power: 1000 Watts
 Owned-Operated By: Standard Bcstg. Co.
 Business Address: Malaspina Hotel
 Air Time: Full Time
 News Service: BUP
 Transcription Service: World, Standard
 Representative: Natl. Bcstg. Sales, Hunt, Cooke
 Station Manager: C. J. Rudd
 Commercial Mgr.: Sheila Hassell
 Program Director: Tom Koch
 Chief Engineer: E. Ross MacIntyre

CFJC

KAMLOOPS—1927—CBC

Frequency: 910 Kc. Power: 1000 Watts
 Owned-Oper. By: Ian G. Clark Ltd.
 Business-Studio Address: 310 St. Paul St.
 Phone Number: 1021

CKLN

NELSON—1939—CBC

Frequency: 1240 Kc. Power: 250 Watts
 Owned-Oper. By: News Publishing Co., Ltd.
 Address: 266 Baker St.
 Phone Number: 19
 Air Time: Full Time

Newspaper Affiliation.....Nelson Daily News
 News ServicePN
 RepresentativeStovin, Young
 Membership.....CARTB, WAB, BCAB
 President.....Maj. R. H. Green
 General Manager.....C. W. Ramsden
 Station Mgr., Chief Engineer....A. R. Ramsden

CKNW

NEW WESTMINSTER—1944

Frequency: 1320 Kc.....Power: 1000 Watts
 Owned By.....Bill Rea
 Business-Studio Address.....227 Columbia St.
 Phone Number.....New Westminster 3000
 News Service.....UP, AP
 Transcription.....Associated, Standard, Cole
 Representative.....Forjoe, Nat. Bcstg. Sales
 Membership.....BAB
 Pres., Gen. Sta. Mgr.....William Rea, Jr.
 Assistant Manager.....Phil Baldwin
 Prod. Manager.....Hal Davis
 Chief Engineer.....Clare Purvis

CKOK

PENTICTON—1948

Frequency: 800 Kc.....Power: 1000 Watts d.;
 500 Watts n.
 Owned-Operated By.....CKOK, Ltd.
 Business-Studio Address...125 Nanaimo Ave.
 Phone Number.....2800, 2850
 News ServiceCP
 Transcription ServiceStandard
 Representative.....Mulvihill, Cooke, Hunt
 Membership.....BBM, CAB, BCAB, WAB
 President.....Maurice P. Finnerty
 Station Manager.....Roy G. Chapman

CJAV

PORT ALBERNI—1946

Frequency: 1240 Kc.....Power: 250 Watts
 Owned-Operated By.....CJAV, Ltd.
 Address.....735 Third Ave., N.
 Phone Number604
 Air Time.....6 a.m.-12 M.
 News Service.....AP, PN, Reuters
 Transcription.....Lang-Worth, Cole, Capitol
 Membership.....CAB
 Managing Dir.....Kenneth Hutcheson
 Comm. Mgr.....J. Geoffrey Holmes
 Program Dir.....Thomas A. Rannie
 Publicity Dir.....Lyall Feltham
 Chief Engineer.....Ross McIntyre

CKPG

PRINCE GEORGE—1946—CBC

Frequency: 550 Kc.....Power: 250 Watts
 Owned-Oper. By...Radio Station CKPG, Ltd.
 Address.....1220 Sixth Ave.
 Phone Number140
 RepresentativeAll-Canada, Weed
 Membership.....CARTB, BBM
 President.....Frank H. Elphicke
 General Manager.....Cecil G. Elphicke
 Commercial Manager.....Jack Carbutt
 Production Mgr.....Chuck Cawdell

CFPR

PRINCE RUPERT—1938—CBC

Frequency: 1240 Kc.....Power: 250 Watts
 Owned By.....Canadian Broadcasting Corp.
 Studio Address.....140 Wellington St., Ottawa
 RepresentativeStovin
 General Manager (CBC).....J. A. Ouimet

CJAT

TRAIL—1932—CBC

Frequency: 610 Kc.....Power: 1000 Watts
 Owned-Oper. By.....Kootenay Bcstg. Co., Ltd.
 Business-Studio Address.....815 Victoria St.
 Phone Number1840
 News ServiceAP
 RepresentativeWeed
 President.....A. S. Mawdsley
 Station Manager.....John W. Loader
 Commercial Manager.....Lorne V. McLeod
 Program Director.....J. P. Kobluk
 Chief Engineer.....John D. Hepburn

CBU

VANCOUVER—1936—CBC

Frequency: 690 Kc.....Power: 10,000 Watts
 Owned-Oper. By.....Canadian Bcstg. Corp.
 Address.....701 Hornby St.
 Phone NumberMarine 6121
 News Service.....BUP, R, CP
 General Manager (CBC)...J. Alphonse Ouimet
 Commercial Mgr. (CBC).....Walter E. Powell
 Regional Representative.....Kenneth Caple
 Program Director.....Doug Nixon
 Publicity Director.....W. Gilmour Clark
 Chief Engineer.....W. G. Richardson

CJOR

VANCOUVER—1926—CBC

Frequency: 600 Kc.....Power: 5000 Watts
 Owned-Operated By.....CJOR, Ltd.
 Business-Studio Address.....846 Howe St.
 Phone Number.....MARine 6464
 News Service.....BUP, UP, CP
 Transcription Service.....Thesaurus
 Representative.....Stovin, Young
 Membership.....CAB
 Pres., Gen. Mgr.....George C. Chandler
 Exec. Assistant.....F. W. H. Wellwood
 Chief Engineer.....Art Chandler
 Commercial Mgr.....Don Laws

CKMO

VANCOUVER—1920

Frequency: 1410 Kc.....Power: 1000 Watts
 Owned-Oper. By.....B. C. Bcstg. System, Ltd.
 Address.....812 Robson St.
 Phone Number.....MARine 1271
 Transcription Service.....Associated, SESAC
 RepresentativeCooke, Renaud
 President.....Mrs. R. J. Sprott
 Managing Director.....Mrs. K. M. Willis
 Chief Engineer.....D. Rogers

CKWX

VANCOUVER—1923—MBS

Frequency: 980 Kc. Power: 5000 Watts
 Business-Studio Address: 543 Seymour St.
 Phone Number: TAlow 5131
 News Service: CP, BUP
 Transcription Service: Lang-Worth, World
 Representative: All-Canada, Weed
 President: Arthur Holstead
 Vice-Pres., Gen. Mgr.: Frank H. Elphicke
 Commercial Manager: John L. Sayers
 Program Director: John Ansell
 Sales Promotion Mgr.: Ken Hughes
 Chief Engineer: Charles Smith

CJIB

VERNON—1947—CBC-DOMINION

Frequency: 940 Kc. Power: 1000 Watts
 Owned-Operated By: Interior Bcstrs., Ltd.
 Business Address: 3330 Barnard Ave. W.
 Phone Number: 3900
 Air Time: Full Time
 News Service: PN
 Representative: Radia Representatives
 General Manager: A. G. Seabrook
 Commercial Mgr.: Larry Scott
 Program Dir.: Don McGibbon
 Publicity Dir.: Dave Lilwall
 Chief Engineer: Loren Merriman

CJVI

VICTORIA—1941—CBC

Frequency: 900 Kc. Power: 1000 Watts
 Owned-Oper. By: Island Bcstg. Co., Ltd.
 Business-Studio Address: 817 Fort Street
 Phone Number: Beacon 8221
 News Service: CP
 Transcription Service: Thesaurus
 Newspaper Affiliation: "Daily Colonist"
 Representative: Weed, All-Canada
 Membership: CAB
 President: J. M. Taylor
 General Manager: W. M. Guild
 Commercial Manager: Lee F. Hallberg
 Sales Prom. Mgr.: James S. Crawford
 Program Director: Vern Groves
 Chief Engineer: Joe Sommers

CKDA

VICTORIA—1950

Frequency: 1340 Kc. Power: 250 Watts
 Owned-Oper. By: Capital Bcstg. System
 Address: 1450 Douglas St.
 Phone Number: Garden 9311
 News Service: BUP
 Transcription Service: Standard, SESAC
 Representative: Forje Radio Reps.
 Pres., Gen. Mgr.: David M. Armstrong
 Commercial Mgr.: Gordon M. Reid
 Production Mgr.: David G. Hill
 Program Dir.: C. Edward Farey
 Publicity Director: Donald MacDonald

MANITOBA

CKX

BRANDON—1928—CBC DOMINION

Frequency: 1150 Kc. Power: 1000 Watts
 Owned-Oper. By: Western Manitoba Bcstrs.
 Address: 8th St. & Princess Ave.
 Phone Number: 4532
 Transcription Service: Thesaurus
 Representative: Radio Representatives, Young
 News Service: BUP, CP
 Managing Director: J. B. Craig
 Commercial Manager: E. D. Holland
 Program Director: Eric Davies
 Publicity Director: Archie Olson
 Chief Engineer: Humphrey Davies

CFAR

FLIN FLON—1937—CBC

Frequency: 590 Kc. Power: 1000 Watts
 Owned-Oper. By: Arctic Radio Corp., Ltd.
 Address: 75 Hill St.
 Phone Number: 4422
 News Service: PN
 Transcription Service: SESAC
 Representative: Stovin, Young
 Membership: CAB, WAB
 Station Manager: C. H. Witney
 Commercial Manager: M. Cambell
 Program Director: E. Smallwood

CKDM

DAUPHIN—1951

Frequency: 1230 Kc. Power: 250 Watts d.
 Owned-Operated By: Dauphin Bcstg. Co., Ltd.
 Phone: 22
 Transcription Service: Thesaurus
 News Service: PN
 President: Dr. M. Poloski
 General Manager: D. M. Hughes
 Chief Engineer: G. Shave

CKSB

ST. BONIFACE—1946

Frequency: 1250 Kc. Power: 1000 Watts
 Owned-Oper. By: Radio St. Boniface, Ltd.
 Address: 607 Langevin St.
 Phone Number: 204-865
 Representative: McGillvra
 President: Celestin Champagne
 Gen., Comm., Sta., Prom. Mgr.: Roland Couture
 Program Director: Denis Belair
 Chief Engineer: Yves Savignac

CBK

WINNIPEG—1939—CBC

Frequency: 540 Kc. Power: 50,000 Watts
 Owned-Oper. By: Canadian Bcstg. Corp.
 Business-Studio Address: 541 Portage Ave.,
 Winnipeg, Man.

Phone Numbers: 74-2541
 News Service: PN, BUP
 Chairman: A. D. Dunton
 General Manager (CBC): J. A. Ouimet
 Station Manager: J. N. Mogridge
 Commercial Manager (CBC): W. E. Powell
 Program Director: Dan Cameron
 Publicity Director: C. E. L'Ami
 Chief Engineer: R. D. Cahoon

CBW

WINNIPEG—1948—CBC

Frequency: 990 Kc. Power: 50,000 Watts
 Owned-Operated By: Canadian Bcstg. Corp.
 Business Address: 541 Portage Ave.
 Phone Number: 74-2541

Regional Representative: J. R. Finlay
 General Manager: J. Alphonse Ouimet
 Station Manager (CBC) Winnipeg:

J. N. Mogridge
 Commercial Mgr.: R. Horley
 Publicity Director: C. E. L'Ami
 Chief Engineer: R. O. Cahoon

CJOB

WINNIPEG—1946

Frequency: 1340 Kc. Power: 250 Watts
 Owned-Operated By: Blick Bcstg., Ltd.
 Business-Studio Address: Lindsay Bldg.
 Phone Number: 926, 374

News Service: CP, BUP
 Transcription Service: World, Thesaurus,
 Associated, Standard, Lang-Worth
 Membership: CAB

President, General Manager: J. O. Blick
 Commercial Manager: A. J. Messner
 Sales Prom. Mgr.: H. J. Gibson
 Program Director: George C. Davies
 Chief Engineer: R. V. Durie

CKRC

WINNIPEG—1934—CBC DOMINION

Frequency: 630 Kc. Power: 5000 Watts
 Owned-Oper. By: Transcanada Communica-
 tions, Ltd.

Bus. Studio Address: 300 Carlton St.
 Phone Number: 92-2266
 Air Time: Day Time
 News Service: BUP, AP, CP
 Transcription Service: Lang-Worth, Standard
 Representative: Weed, All-Canada
 President: V. Sifton
 Gen. Sta. Mgr.: William A. Speers
 Commercial Manager: B. M. Pirie
 Prom., Pub. Mgr.: F. M. Desourdy
 Program Director: J. M. Hill
 Chief Engineer: A. W. Hooper

CKY

WINNIPEG—1950

Frequency: 580 Kc. Power: 5000 Watts
 Owned-Oper. By: Station CKY, Ltd.
 Business Address: 432 Main St.
 Phone: 931, 531
 Air Time: 5:50 a.m.-1 a.m.

Transcription Service: Capitol, SESAC,
 Associated
 Representative: Stovin, Cooke
 Membership: CARTB, WAB
 President: Lloyd E. Moffatt
 General Manager: A. R. Mackenzie
 Adv. Sales Mgr.: W. E. Collier
 Local Sales Mgr.: C. F. Hawkins
 Sales Prom. Mgr.: Harry O. Watts
 Program Director: Jack R. Stewart
 Chief Engineer: A. Melowanchuck

NEW BRUNSWICK

CKNB

CAMPBELLTON—1939—CBC

Frequency: 950 Kc. Power: 1000 Watts
 Owned-Oper. By: Restigouche Bcstg. Co., Ltd.
 Business Address: 110 Water St.
 Phone Number: 8

Air Time: 7:50 a.m.-12:10 a.m.
 Representative: Hardy, Weed
 Membership: CARTB, BBM
 President: J. Wesley MacDonald
 General Manager: Dr. Charles H. Houde
 Station Manager: Stan Chapman
 Program Director: Bob Richards
 Chief Engineer: Phil Paquet

Owned-Oper. By: Edmundston Radio, Ltd.
 Business-Studio Address: 91 Canada Rd.
 Phone Number: 880
 Air Time: 7:00 a.m.-12:15 a.m.
 Transcription Service: SESAC
 News Service: PN
 Representative: Stovin, Young
 President: George Michaud
 Station Manager: Maurice Lacasse
 Comm., Prom. Mgr.: Georges Guerrette
 Program Director: Raynald Teasdale
 Chief Engineer: Yvon Roy

CFNB

FREDERICTON—1923—CBC

Frequency: 550 Kc. Power: 5000 Watts
 Owned-Oper. By: James S. Neill & Sons, Ltd.
 Business-Studio Address: York St.
 Phone Number: 5501

CJEM

EDMUNDSTON—1944—CBC

Frequency: 1380 Kc. Power: 1000 Watts

Air Time Full Time
 News Service..... BUP, RP
 Transcription Service..... Thesaurus, Standard
 Representative All-Canada, Weed
 Membership CARTB
 Gen., Sta. Mgr..... Dr. Malcolm Neill
 Comm., Prom. Mgr..... H. L. McFee
 Program Director..... J. T. H. Fenety
 Chief Engineer..... Glenn D. Love

CKCW

MONCTON—1934—CBC

Frequency: 1220 Kc..... Power: 5000 Watts
 Owned-Oper. By..... Moncton Bcstg., Ltd.
 Business-Studio Address..... K. of P. Bldg.
 Phone Number 9111
 Air Time 6:30 a.m.-1 a.m.
 News Service..... BUP, RP
 Transcription Service Langworth
 Representative Young, Stovin
 Membership CARTB
 Pres., Gen. Mgr..... F. A. Lynds
 Commercial Manager..... T. Tonner
 Program Director..... C. R. Tabor
 Chief Engineer..... Arnold Brewster

CKMR

NEW CASTLE—1949—CBC

Frequency: 1340 Kc..... Power: 250 Watts
 Owned-Oper. By..... Miramichi Bcstg. Co., Ltd.
 Business Address..... Castle St.
 Phone Number 690
 President..... L. W. Fleet

CBA

SACKVILLE—1939—CBC

Frequency: 1070 Kc..... Power: 50,000 Watts
 Owned-Oper. By..... Canadian Bcstg. Corp.
 Bus.-Studio Address..... 100 Sackville St.
 Halifax, N. S.

Phone Number 3-6188
 News Service..... BUP, CP, R
 Regional Representative..... W. E. S. Briggs
 General Manager (CBC)..... J. Alphonse Ouimet
 Station Manager..... S. R.
 Program Director..... H. J. Boyle
 Publicity Director..... R. C. Fraser
 Chief Engineer..... G. W. Olive

CFBC

SAINT JOHN—1946—CBC

Frequency: 930 Kc..... Power: 5000 Watts
 Owned-Operated By..... Fundy Bcstg. Co., Ltd.
 Business-Studio Address..... 38 Carleton St.
 Phone Number 2-3301
 Air Time 6 a.m.-1 a.m.
 News Service..... RP, BUP
 Transcription Service Thesaurus
 Representative Weed, Hunt, Nat'l Bcst. Sales
 Membership CARTB
 President..... A. M. A. McLean
 General Manager..... Robert T. Bowman
 Commercial Manager..... C. F. Bedford
 Program Director..... Wm. Tonner
 Prom. Mgr., Publ. Dir..... R. J. Gallagher
 Chief Engineer..... H. M. Stout

CHSJ

SAINT JOHN—1934—CBC

Frequency: 1150 Kc..... Power: 5000 Watts
 Owned-Oper. By..... New Brunswick Bcstg. Co.
 Business-Studio Address..... 14 Church St.
 Phone Number 3-3304
 Air Time Unlimited
 News Service CP
 Transcription Service..... World, Langworth
 Representative Stovin, Young
 Membership CARTB
 Station Manager..... George A. Cromwell
 Program Director..... Cleve G. Stillwell
 Station Manager..... Earl McCarron
 Chief Engineer..... J. J. Bishop

NEWFOUNDLAND

CBY

CORNER BROOK—1949—CBC

Frequency: 790 Kc..... Power: 1000 Watts
 Owned-Operated By..... Canadian Bcstg. Corp.
 Address..... Corner Brook
 News Service..... CP, BUP, Reuters
 Representative CBC
 Gen. Mgr. (CBC)..... J. Alphonse Ouimet
 Station Manager..... C. V. Hierlihy

CBG

GANDER—1949—CBC

Frequency: 1450 Kc..... Power: 250 Watts
 Owned-Operated By..... Canadian Bcstg. Corp.
 Address..... P. O. Drawer 32
 Phone Number 349
 News Service..... CP, BUP, Reuters, PN
 Station Manager..... A. Barrett

CBT

GRAND FALLS—1949—CBC

Frequency: 1350 Kc..... Power: 1000 Watts
 Owned-Operated By..... Canadian Bcstg. Corp.
 Address..... Munro Bldg.
 Phone Number 2102
 Air Time 16½ hrs.
 Gen. Mgr. (CBC)..... J. Alphonse Ouimet
 Station Manager..... John J. Grace
 Publ. Director (CBC)..... Ron C. Fraser

CBN

ST. JOHN'S—1949—CBC

Frequency: 640 Kc..... Power: 10,000 Watts
 Owned-Operated By..... Canadian Bcstg. Corp.
 Address..... St. John's
 Air Time..... 16½ hrs.

News Service.....CP, Reuters
 Representative.....CBC
 General Manager (CBC)...J. Alphonse Oumiet
 Commercial Mgr. (CBC).....W. E. Powell
 Publ. Director (CBC).....Ron C. Fraser
 Chief Engineer (CBC).....C. W. Olive

CJON
 ST. JOHN'S—1951

Frequency: 930 Kc.....Power: 5000 Watts
 Owned-Oper. By.....Nfld. Bcstg. Co., Ltd.
 Address.....Prince of Wales St.
 Phone.....7106
 Ai. Time.....Full Time
 News Service.....AP
 Transcription Service...Lang-Worth, SESAC
 Reprs.....All-Canada Radio, Weed
 Membership.....CARTB, BBM
 Pres., Gen. Mgr.....Geoffrey W. Stirling
 Station Manager.....Don Jamieson
 Commercial Manager.....F. Dawe
 Sales Prom. Mgr.....Jack Baird
 Program Director.....Art Hartnett
 Publicity Director.....M. Carter
 Chief Engineer.....Oscar Hierlihy

VOAR
 ST. JOHN'S—1931

Frequency: 1230 Kc.....Power: 100 Watts d.
 Owned-Oper. By.....Station VOAR
 Address.....106 Freshwater Rd.
 Phone.....6760
 Pres., Gen. Mgr.....Philip Moores

VOCM
 ST. JOHN'S—1936

Frequency: 590 Kc.....Power: 1000 Watts
 Owned-Operated By...Colonial Bcstg. System
 Business Address...Water at McBride's Hill
 Phone.....3148-9
 News Service.....CP, PN, BUP
 Transcription Service...Thesaurus, World
 Membership.....CARTB, AAB
 Representative.....Stovin, Young
 Mng. Director.....J. L. Butler
 Sta., Comm., Pro. Mgr.....M. Shulman
 Program Director.....Denys Ferry
 Chief Engineer.....W. B. Williams

NOVA SCOTIA

CJFX

ANTIGONISH—1943—CBC

Frequency: 580 Kc.....Power: 5000 Watts
 Owned-Operated By.....Atlantic Bcstrs., Ltd.
 Address.....Box 280
 Phone.....580
 Transcription Service...SESAC, Lang-Worth
 Representative.....Mulvihill
 News Service.....BUP
 General Manager.....J. Clyde Nunn
 Commercial Manager.....R. J. Ricketts
 Program Director.....Charles O'Brien
 Chief Engineer.....G. C. MacDougall

CKBW

BRIDEWATER—1947

Frequency: 1000 Kc.....Power: 1000 Watts
 Owned-Oper. By.....Acadia Bcstg. Co., Ltd.
 Address.....399 King St.
 Phone Number.....1030
 News Service.....BAP
 Transcription Service...Associated
 Representative.....Radio Representative Ltd.,
 Cooke
 President.....C. J. Morrow
 General Manager.....John F. Hirtle
 Station Manager.....James A. MacLeod
 Sales Prom. Mgr.....Lester L. Rogers
 Program Director.....A. Maxwell Ramey
 Publicity Director.....Donald E. Nicolle
 Chief Engineer.....Douglas B. Hirtle

CBH

HALIFAX—1944—CBC

Frequency: 1330 Kc.....Power: 100 Watts

Owned-Operated By...Canadian Bcstg. Corp.
 Business-Studio Address.....100 Sackville St.
 Phone Number.....3-6188
 News Service.....BUP, PN, Reuters, CP
 General Manager.....J. Alphonse Oumiet
 Station Manager.....S. R. Kennedy
 Publicity Director.....Ron Fraser

CHNS

HALIFAX—1926—CBC

Frequency: 960 Kc.....Power: 5000 Watts
 Owned-Oper. By...Maritime Bcstg. Corp., Ltd.
 Bus.-Studio Address.....10 Tobin St.
 Phone Number.....3-8318
 Air Time.....6:45 a.m.-12:15 a.m.
 News Service.....BAP, BUP
 Transcription Service...Thesaurus, Lang-Worth
 Representative.....All-Canada, Weed
 President.....Graham W. Dennis
 Station Manager.....Gerald Redmond
 Commercial Manager.....Douglas Grant
 Chief Engineer.....Arthur H. Greig

CJCH

HALIFAX—1944

Frequency: 920 Kc.....Power: 5000 Watts
 Owned-Operated By.....Chronicle Co., Ltd.
 Bus.-Studio Address.....741 Robie St.
 Phone Number.....5-5443
 Air Time.....Full Time
 News Service.....PN
 Transcription Service...World, Associated
 Representative.....Mulvihill
 Managing Director.....B. P. McCurdy
 Station Manager.....E. Finlay MacDonald
 Commercial Mgr.....C. L. Chambers
 Chief Engineer.....A. Reginald MacWilliams

CKEN

KENTVILLE—1948

Frequency: 1490 Kc. Power: 250 Watts
 Owned-Oper. By: Evangeline Bcstg. Co., Ltd.
 Business-Studio Address: Radio Center
 Phone Number: Kentville 2111
 Air Time: 7 a.m.-10:20 p.m.
 News Service: PN
 Transcription Service: Lang-Worth
 Representative: Alexander
 Membership: CAB
 President: George Wilson

Owned-Operated By: Colchester Bcstg. Co. Ltd.
 Business Address: 7 Pleasant St.
 Phone Number: 491
 Air Time: 7 a.m.-11 p.m.
 News Service: BUP
 Transcription Service: Associated
 Representative: Omer Renaud
 President, General Mgr.: J. Arthur Manning
 Program Director: Lloyd Cavanagh
 Chief Engineer: Sidney Bernasconi

CBI

SYDNFY—1948—CBC

Frequency: 1570 Kc. Power: 1000 Watts
 Owned-Operated By: Canadian Bcstg. Corp.
 Business-Studio Address: 247 Charlotte St.
 News Service: BUP, Reuters, CP
 Station Manager: Barry MacDonald

CFAB

WINDSOR—1946

Frequency: 1450 Kc. Power: 250 Watts
 Owned-Oper. By: Evangeline Bcstg. Co., Ltd.
 Address: Radio Centre
 Phone Number: 2111
 Air Time: Full Time
 News Service: PN
 Transcription Service: Lang-Worth
 Representative: Alexander
 Membership: CAB, BBM
 President: George Wilson
 General Manager: J. A. C. Lewis
 Promotion Mgr.: Bernard Butler-Gray
 Program Director: Willard A. Bishop

CJCB

SYDNEY—1929—CBC

Frequency: 1270 Kc. Power: 5000 d.,
 1000 Watts n.
 Owned-Oper. By: Cape Breton Bcstrs., Ltd.
 Business-Studio Address: Radio Bldg.
 Phone Number: 5596-7
 Air Time: Full Time
 News Service: PN
 Transcription Service: Thesaurus, Lang-Worth
 Representative: All-Canada, Weed
 General Manager: J. Marven Nathanson
 Commercial Manager: R. M. Burchell
 Sales Prom. Mgr.: M. C. MacQuarrie
 Program Director: T. C. Robertson
 Chief Engineer: A. E. Vernon

CJLS

YARMOUTH—1934—CBC

Frequency: 1340 Kc. Power: 250 Watts
 Owned-Oper. By: Gateway Bcstg. Co., Ltd.
 Address: 222 Main St.
 Phone Number: 500
 Air Time: 7:45 a.m.-12:10 a.m.
 News Service: CP
 Transcription Service: All-Canada, MGM
 Library
 Representative: All-Canada, Weed
 Pres., Gen., Comm. Mgr., Chf. Eng.: D. L. Smith
 Program Director: Denny J. Comeau
 Publicity Director: William Singer

CKCL

TRURO—1947

Frequency: 1400 Kc. Power: 250 Watts

ONTARIO

CKBB

BARRIE—1949

Frequency: 1230 Kc. Power: 250 Watts
 Owned-Oper. By: Barrie Bcstg. Co. Ltd.
 Address: 26 Elizabeth St.
 Phone Number: 5585
 Representative: Young, Mulvihill
 News Service: AP
 Pres., Gen. Mgr.: Ralph T. Snelgrove

Phone Number: 3200
 Air Time: Full Time
 News Service: BN
 Transcription Service: World, Thesaurus
 Representative: Stovin, Young
 Membership: CARTB, BBN
 President: A. McLean Haig
 Station Manager: W. H. Stovin
 Commercial Manager: J. H. MacDonald
 Program Director: P. R. Flagler
 Chief Engineer: I. B. Buchanan

CJBQ

BELLEVILLE—1946—CBC

Frequency: 1230 Kc. Power: 250 Watts
 Owned-Operated By: Quinte Bcstg. Co., Ltd.
 Business-Studio Address: 11 Victoria Ave.

CKPC

BRANTFORD—1923—CBC

Frequency: 1380 Kc. Power: 1000 Watts
 Owned-Oper. By: Telephone City Bcst., Ltd.
 Address: 525 Colborne St.

Phone Number 3-2664
 Transcription Service World
 News Service BUP
 Transcription Service World, Capitol
 Representative J. L. Alexander
 Pres., Gen. Mgr. Mrs. F. M. Buchanan
 Station Manager Hugh Bremner
 Program Director Richard Buchanan
 Publicity Director Jack Willkinson
 Chief Engineer Don Williamson

CFJR

BROCKVILLE—1943—CBC

Frequency: 1450 Kc. Power: 250 Watts
 Owned By Eastern Ontario Bcstg. Co., Ltd.
 Business-Studio Address 17 King St. West
 Phone Number 4628
 Air Time Full Time
 News Service BUP
 Representative Stovin, Young
 Membership CARTB, CCBA, BBM
 Pres., Gen. Sta., Comm. Mgr. Jack R. Radford
 Program Director Jim Chapman
 Chief Engineer Sid Penstone

CFCO

**CHATHAM—1926—CBC—
 DOMINION**

Frequency: 630 Kc. Power: 1000 Watts d.
 Owned-Operated By John Beardall
 Business address 42 King St. W.
 Phone Number 2626
 News Service BUP
 Transcription Service Cole, Lang-Worth
 Pres., Gen. Manager John Beardall
 Commercial Manager Peter Kirkey

CKSF

CORNWALL—1945—CBC

Frequency: 1230 Kc. Power: 250 Watts
 Owned-Operated By Standard-Freeholder, Ltd.
 Business-Studio Address 36 Pitt St.
 Phone Number 4800-01
 Air Time 6:45 a.m.-11:45 p.m.
 News Service CBN
 Transcription Service Thesaurus
 Representative Stovin, McGillivra
 Membership CARTB
 Station Manager Fred H. Pemberton
 Publicity Director Alma Larocque
 Program Director Carl Fisher
 Chief Engineer Mahlon Clark

CKFI

FORT FRANCES—1944—CBC-KBS

Frequency: 800 Kc. Power: 1000 Watts d.
 1000 Watts n.
 Owned By Radio Station CKFI
 Business-Studio Address 242 Scott St.
 Phone Number 200
 Air Time 6:55 a.m.-11 p.m.
 News Service PN
 Transcription Service Keystone
 Representative Radio Reprs., Cooke

Pres., Gen. Mgr. J. G. McLaren
 Station Manager Gordon McBride
 Commercial Mgr. W. H. McLellan
 Chief Engineer Dick Endseth

CKPR

FORT WILLIAM—1931—CBC

Frequency: 580 Kc. Power: 1000 Watts
 Owned-Oper. By H. F. Dougall Co., Ltd.
 Bus.-Studio Address Victoria Ave.
 Phone Number 33477
 Air Time Full Time
 News Service CP
 Transcription Service Thesaurus, United
 Representative. . . Stovin, Radio Representatives,
 Young, All-Canada
 Membership BBM, CARTB
 Pres., Gen. Mgr. H. F. Dougall
 Commercial Manager George Jeffrey
 Program Director J. P. Friesen
 Chief Engineer W. T. Ross

CJOY

GUELPH—1948

Frequency: 1450 Kc. Power: 1000 Watts
 Owned-Operated By CJOY, Ltd.
 Business Address Bond Bldg.
 Phone Number 5500
 Air Time 6:30 a.m.-12:30 a.m.
 News Service PN
 Transcription Service Associated
 Representative Radio Reprs., Cooke
 Pres., Sta. Mgr. Wallace Slatter
 Commercial Mgr. Frederick T. Metcalf
 Program Director Don LeBlanc
 Chief Engineer J. Milligan

CHML

HAMILTON—1927—CBC

Frequency: 900 Kc. Power: 5000 Watts
 Owned-Oper. By Maple Leaf Bcstg. Co., Ltd.
 Business-Studio Address 848 Main St., E.
 Phone Number 9-2411
 Air Time Full Time
 News Service PN
 Representative. . . Stephens & Tondrow, Young
 Transcription Service Standard
 Membership CARTB
 President. Kenneth D. Soble
 Station Manager Tom Darling
 Commercial Manager W. D. Whitaker
 Sales Prom. Mgr. Stafford Habberfield
 Program Director Russel J. Eastcott
 Chief Engineer Hugh Potter

CKOC

HAMILTON—1922—CBC

Frequency: 1150 Kc. Power: 5000 Watts
 Owned-Oper. By Wentworth Radio Bcstg.
 Co., Ltd.
 Business-Studio Address 32 John St.
 Phone Number 7-4483
 Air Time 5:45 a.m.-1:05 a.m.
 News Service BUP
 Transcription Service Thesaurus, World

Representative All-Canada, Weed
Membership CARTB, CCBA
President H. R. Carson
General Manager W. T. Cranston
Commercial Manager L. A. Westmoreland
Promotion Mgr. Mary A. Hill
Program Director H. Gibson
Chief Engineer Leslie Horton

CJRL

KENORA—1938—CBC

Frequency: 1220 Kc. **Power:** 1000 Watts
Owned-Oper. By C. W. Johnson
Address Johnson Block
Phone Number 8921
Air Time 17 hrs.
News Service CP, BUP
Representative Stovin, Cooke
Membership BBM, WAB, CARTB
General Manager C. W. Johnson
Station Manager J. Thom
Sales Prom. Mgr. George Balcaen
Chief Engineer J. Edwards

CKWS

KINGSTON—1942—CBC

Frequency: 960 Kc. **Power:** 5000 Watts
Owned-Operated By Brookland Co., Ltd.
Address King St.
Phone Number 4405
Air Time Full Time
News Service PN
News, Affil. Whig-Standard
Transcription Service Langworth, Thesaurus
Representative Natl. Bcst. Sales
Membership CARTB
President Senator W. R. Davies
Station Manager Roy W. Hoistetter
Commercial Manager E. Jones
Program Manager W. Luxton
Chief Engineer Burt Cobb

CJKL

KIRKLAND LAKE—1933—CBC

Frequency: 580 Kc. **Power:** 5000 Watts
Owned-Oper. By No. Bcstg. Co., Ltd.
Address 44 King St. West
News Service PN
Transcription Service Thesaurus, Lang-Worth
Representative Natl. Bcst. Sales, Cooke
President Roy H. Thompson
General Manager J. M. Davidson
Station Manager Gord Burnett
Commercial Manager J. Weatherwax
Sales Prom. Mgr. Ralph Nelson
Program Director Jesse French
Chief Engineer C. L. Spence

CKCR

KITCHENER—1930—CBC

Frequency: 1490 Kc. **Power:** 250 Watts
Owned-Oper. By K-W. Bcstg. Co., Ltd.
Business-Studio Address 125 King St. W.
Phone Number 3-3628
Air Time Full Time

News Service AP
Transcription Service Associated
Representative Renaud, Young
Pres., Gen. Mgr. G. Liddle
Publ. Dir., Comm. Mgr. James C. Mitchell
Program Director Stu Monroe
Chief Engineer Ion Hartman

CFPL

LONDON—1933—CBC

Frequency: 980 Kc. **Power:** 5000 Watts
Owned-Oper. London Free Press Printing Co.
Address 442 Richmond St.
Phone Number 2-5201
Air Time 6:00 a.m.-1:00 a.m.
News Service PN
News, Affil. Free Press
Transcription Langworth, World
Representative Weed, All-Canada
Membership CARTB, BMI, BBM
President Walter J. Blackburn
Station Manager Murray T. Brown
Production Mgr. J. N. Illman
Chief Engineer Glen A. Robitaille

CHVC

NIAGARA FALLS-WELLAND—1947

Frequency: 1600 Kc. **Power:** 5000 Watts d.;
 5000 Watts n.
Owned-Oper. By Radio Station CHVC, Ltd.
Business Address Rainbow Bridge, Niagara
 Falls—76 Division St., Welland
Phone NI 4110, WE 7269
Air Time Full Time
News Service BUP
Transcription Service Thesaurus
Representative Cooke, Alexander
President B. Howard Bedford
General Manager A. W. Blakely
Commercial Manager R. H. Hamilton
Promotion Mgr. Jack Burghardt
Publicity Director George McLean
Chief Engineer L. H. Rook

CFCH

NORTH BAY—1932—CBC

Frequency: 600 Kc. **Power:** 1000 Watts
Owned-Oper. By Northern Bcstg. Co., Ltd.
Address Bank of Nova Scotia Bldg., Toronto
Phone Number EM 3-8894
Air Time Full Time
News Service CP
Transcription Service Lang-Worth, Thesaurus
Representative Natl. Bcst. Sales
Membership CARTB, CCAB
President Roy H. Thomson
General Manager H. Freeman
Station Manager Keith Packer
Commercial Manager Bill King
Program Director G. Shale
Chief Engineer Jack Barnaby

CFOR

ORILLIA—1945—CBC

Frequency: 1570 Kc. **Power:** 1000 Watts

Owned-Oper. By.....Gordon E. Smith
 Bus.-Studio Address.....R. R. No. 3
 Phone Number.....3246
 News Service.....BUP
 Transcription Service.....World, Cole
 Representative.....Stovin
 Membership.....CARTB, BBM
 President, General Mgr.....Gordon E. Smith
 Program Director.....Pete McGarvey
 Commercial Manager.....Alex Gilmour
 Promotion Manager.....Russ Waters
 Chief Engineer.....George Slinn

CKLB
OSHAWA—1949

Frequency: 1240 Kc.....Power: 250 Watts
 Owned-Oper. By...Lakeland Bcstg. Co., Ltd.
 Business-Studio Address.....16 Centre St.
 Phone Number.....3-3415
 Air Time.....19 hrs.
 Representative.....Alexander, McGillvra
 Pres., Gen. Mgr.....Alfred H. Collins
 Comm., Sta. Mgr.....Gordon G. Garrison
 Program Director.....John Wacku
 Publicity Director.....Paul Summerville

CBO
OTTAWA—1924—CBC

Frequency: 910 Kc.....Power: 1000 Watts
 Owned-Oper. By.....Canadian Bcstg. Corp.
 Bus.-Studio Address...Chateau Laurier Hotel
 Phone Number.....2-1151
 Station Manager.....Charles P. Wright

CFRA
OTTAWA—1947

Frequency: 560 Kc.....Power: 5000 Watts
 Owned-Operated By.....Radio Station CFRA
 Business Address.....Ryan Auditorium
 Phone Number.....3-8241
 Transcription Service...Standard, Lang-Worth,
 Capitol
 Representative...Stephens-Towndrow, Weed
 President, General Mgr.....Frank Ryan

CKOY
OTTAWA—1949—CBC

Frequency: 1310 Kc....Power: 5000 Watts d.;
 1000 Watts n.
 Owned-Operated By.....CKOY, Ltd.
 Address.....272 Somerset St., W.
 Phone Number.....2-2641
 Air Time.....Full Time
 News Service.....AP
 Transcription Service.....Capitol, Thesaurus
 Representative.....Cooke, Natl. Bcst. Sales
 President.....Duncan K. MacTavish
 General Manager.....Dan V. Carr
 Commercial Manager.....Jack Thompson
 Program Director.....Keith Sterling
 Publicity Director.....Allan Chrysler
 Chief Engineer.....Ken Puttock

CFOS

OWEN SOUND—1940—CBC

Frequency: 1470 Kc.....Power: 1000 Watts
 Owned-Oper. By....Grey & Bruce Bcstg. Co.,
 Ltd.
 Address.....270 9th St. E.
 Phone Number.....1940
 Air Time.....Full Time
 News Service.....PN
 Transcription Service.....World
 Representative.....Stovin, Young
 President.....Howard Fleming
 General Manager.....William N. Hawkins
 Commercial Manager.....R. Tomlinson
 Program Director.....E. Smith
 Publicity Director.....B. Masters
 Chief Engineer.....R. Turnpenny

CHOV

PEMBROKE—1942—CBC

Frequency: 1350 Kc.....Power: 1000 Watts
 Owned-Oper. By....Ottawa Valley Bcstg. Co.
 Address.....197 Albert St.
 Phone Number.....1350
 News Service.....BUP
 Transcription Service.....Thesaurus, SESAC
 Representative.....Stovin, Young
 Pres., Gen. Mgr.....E. G. Archibald
 Program Director.....Bill Kutschke
 Comm., Prom. Manager...Ramsay F. Garrow
 Chief Engineer.....W. E. Schmidt

CHEX

PETERBOROUGH—1942—CBC

Frequency: 1430 Kc.....Power: 1000 Watts
 Owned-Oper. By.....Brookland Co., Ltd.
 Bus.-Studio Address.....Hunter & Water Sts.
 Phone Number.....2-0451
 Air Time.....6 a.m.-12 M.
 News Service.....CPN
 News, Affil.....The Examiner
 Transcription Service.....Lang-Worth
 Representative.....Natl. Bcst. Sales, Cooke
 Membership.....CARTB, CCBA, BMI
 President.....W. R. Davies
 General Manager.....J. Davidson
 Station Manager.....D. R. Lawrie
 Commercial Manager.....G. Grady
 Program Director.....Wm. Stratton
 Chief Engineer.....Allan Taylor

CFPA

PORT ARTHUR—1944—CBC

Frequency: 1230 Kc.....Power: 250 Watts
 Owned-Operated By.....Ralph H. Parker
 Bus.-Studio Address.....Public Utilities Bldg.
 Phone Number.....5-7851
 Air Time.....Full Time
 News Service.....PN
 Transcription Service.....Standard
 Representative...Broadcast Representatives,
 Alexander, Weed
 Membership.....CARTB, BBM, CCBA



Pres., Sta., Gen. Mgr. Ralph H. Parker
Commercial Manager R. P. MacGowan
Program Director Ken MacGray

CKTB

ST. CATHARINES—1933—CBC

Frequency: 620 Kc. Power: 1000 Watts
Owned-Oper. By The Niagara District Bcstg. Co., Ltd.

Business-Studio Address 12 Yates St.
Phone Number MUtuol 4-1174
News Service PN
Air Time Full Time
Transcription Service Standard
Representative McGillvra, P. Mulvihill
Membership CARTB, BBM, CCBA
President W. B. C. Burgayne
General Manager Mary C. Burgoyne
Commercial Manager V. A. Lococo
Sta., Prom. Mgr., Pgm. Dir. W. C. Wingrove
Program Director Jack Dawson
Chief Engineer W. H. Allen

CHLO

ST. THOMAS—1948—CBC

Frequency: 680 Kc. Power: 1000 Watts
Owner Station CHLO, Ltd.
Bus. Studio Address Curtis & Mondamin Sts.
Phone Number 3696
Air Time 6 a.m.-1 a.m.
News Service AP
Transcription Service Langworth, SESAC
Representative Radio Reps., Cooke
President G. C. Nichols
General Manager F. A. Bestall
Asst. Manager Doug Cole
Commercial Mgr. Ken Deas
Program Director P. K. Dickens
Chief Engineer Gord Barber

CHOK

SARNIA—1946—CBC

Frequency: 1070 Kc. Power: 5000 Watts d.:
1000 Watts n.
Owned-Oper. By Sarnia Bcstg. Co., Ltd.
Address 148½ Front St. N.
Phone Number Digby 1121
Air Time Full Time
Transcription Service Lang-Worth
Representative Cooke, Mulvihill
Pres., Gen. Mgr. Claude R. Irvine
Station Manager Karl E. Monk
Commercial Manager Arthur H. J. O'Hagan
Production Mgr. Phil Clayton
Program Director Frank P. Stalley
Chief Engineer Robert F. Cooke

CJIC

SAULT STE. MARIE—1934—CBC

Frequency: 1490 Kc. Power: 250 Watts
Owned-Operated By J. G. Hyland
Address P. O. Box 218
Phone Number Algoma 31121

News Service PN
Representative J. L. Alexander, McGillvra
Pres., Gen. Mgr. J. G. Hyland
Commercial Manager E. Vance
Chief Engineer D. N. Irwin

CJCS

STRATFORD—1927—CBC
DOMINION

Frequency: 1240 Kc. Power: 250 Watts
Owned-Oper. By Frank M. Squires
Address 125 Ontario St.
Phone Number 1675
News Service BUP
Transcription Service World
Representative All Canada, Weed
Membership CAB
Sta., Gen. Manager Frank M. Squires
Sta., Comm. Mgr. S. E. Tapley
Sts. Prom. Mgr., Pub. Dir. John E. Phillips
Program Director Alex L. Smith
Chief Engineer John Grigg

CHNO

SUDBURY 1947—CBC

Frequency: 1440 Kc. Power: 1000 Watts
Owned-Oper. By Sudbury Bcstg. Co., Ltd.
Business Address 166 Elm St., W.
Phone Number 6-6416
Air Time Full Time
News Service PN
Representative Renaud, Hunt, Young
President, General Mgr. F. B. Ricard
Station Commercial Manager R. Riel
Program Director Wilf Davidson
Chief Engineer Henry Albert

CKSO

SUDBURY—1935—CBC

Frequency: 790 Kc. Power: 5000 Watts
Owned-Operated By CKSO, Radio, Ltd.
Business-Studio Address 21 Elgin St., N.
Phone Number 77-505
News Service PN
Transcription Service Thesaurus
Representative All-Canada, Weed
President G. M. Miller, Q.C.
General Manager W. J. Woodill
Station Manager K. Dobson
Program Director Basil Scully
Chief Engineer J. McRae

CFCL

TIMMINS—1951

Frequency: 560 Kc. Power: 1000 Watts
Owned-Oper. By J. Conrad Lavigne
Address 175 3rd Ave.
Phone 577
Transcription Service SESAC
News Service BUP
President J. Conrad Lavigne
General Manager Rene Barrette

CKGB

TIMMINS—1933—CBC

Frequency: 680 Kc. Power: 5000 Watts
 Owned-Oper. By Northern Bcstg. Co., Ltd.
 Bus.-Studio Address Thomson Bldg.
 Phone Number 1-500
 Air Time Full Time
 News Service PN
 News, Affil. Daily Press
 Transcription Service Lang-Worth
 Representative Natl. Bcst. Sales, Cooke
 Membership CARTB
 President R. H. Thomson
 General Manager J. M. Davidson
 Station Manager J. W. Pollie
 Commercial Manager Wally Rewegan
 Sales Prom. Mgr. Gerry Hall
 Program Director Bill Nadeau
 Chief Engineer Ernie Mott

CBL

TORONTO—1927—CBC

Frequency: 740 Kc. Power: 50,000 Watts
 Owned-Oper. By Canadian Bcstg. Corp.
 Business-Studio Address 354 Jarvis St.
 Phone Number Midway 5481
 News Service BUP, Reuters, CP
 Transcription Service Lang-Worth
 Representative CBC
 General Manager (CBC) J. Alphonse Ouimet
 Commercial Manager (CBC) W. E. Powell
 Program Director E. L. Bushnell

CFRB

TORONTO—1927—CBS

Frequency: 1010 Kc. Power: 50,000 Watts
 Owned-Oper. By Rogers Radio Bcstg. Co., Ltd.
 Business-Studio Address 37 Bloor St. W.
 Phone Number Princess 5711
 Air Time Full Time
 News Service BUP, PN
 Transcription Service Thesaurus, World
 Representative Young, All-Canada
 Membership BEM
 President Harry Sedgwick
 Station Manager Lloyd Moore
 Commercial Manager Waldo Holden
 Program Director Wes McKnight
 Publicity Director Ken Marsden
 Chief Engineer Clive Eastwood

CHUM

TORONTO—1945

Frequency: 1050 Kc. Power: 1000 Watts d.
 Owned-Oper. By York Bcstrs., Ltd.
 Address 225 Mutual St.
 Phone Number EM 44271
 Air Time Sunrise-sunset
 News Service BUP
 Transcription Service Lang-Worth, Capitol
 Representative McGillvra, Renaud
 President John H. Part
 General Manager Robert L. Lee
 Commercial Manager John Pritchard

Program Director Leigh Lee
 Chief Engineer George Jones

CJBC

TORONTO—1936—CBC

Frequency: 860 Kc. Power: 50,000 Watts
 Owned-Oper. By Canadian Bcstg. Corp.
 Business-Studio Address 354 Jarvis St.
 Phone Number Midway 5481
 Air Time 17 hrs.
 News Service BUP, Reuters, PN
 General Manager (CBC) J. Alphonse Ouimet
 Program Director H. G. Walker
 Commercial Manager (CBC) W. E. Powell
 Chief Engineer (CBC) G. W. Olive

CKEY

TORONTO—1944

Frequency: 580 Kc. Power: 5000 Watts d.;
 1000 Watts n.
 Owned By Toronto Bcstg. Co., Ltd.
 Bus.-Studio Address 444 University Ave.
 Phone Number Waverly 3881
 Air Time Full Time
 News Service CP, BUP
 Transcription Service World, Lang-Worth,
 Standard, Associated
 Representative Natl. Bcst. Sales
 President Jack K. Cooke
 Gen., Sta. Manager Hal Cooke
 Commercial Manager Jack Turrall
 Program Director Don Inasley
 Publicity Director Marietta Pukara
 Chief Engineer Allan Taylor

CKFH

TORONTO—1951

Frequency: 1400 Kc. Power: 250 Watts
 Owned-Oper. By Foster Hewitt Bcstg., Ltd.
 Address 1 Greenville St.
 President Foster Hewitt
 Station Manager Howard C. Caine
 National Sales Mgr. Keith Davey
 Publicity Director Frank Somerville
 Program Director D. Robert Pugh
 Chief Engineer G. A. Wilson

CBE

WINDSOR—1950—CBC

Frequency: 1550 Kc. Power: 10,000 Watts d.
 Owned-Oper. By Canadian Bcstg. Corp.
 Address Security Bldg.
 News Service CP, BUP, R.
 General Mgr. (CBC) J. Alphonse Ouimet
 Station Manager M. L. Poole
 Promotion Manager Ron C. Fraser
 Commercial Manager (CBC) W. E. Powell
 Chief Engineer (CBC) G. W. Olive

CKLW

WINDSOR—CBC

(See U. S. Listing, Detroit, Mich.)

CKNX

WINGHAM—1926—CBC

Frequency: 920 Kc. Power: 1000 Watts
 Owned and Operated By: Radio Station
 CKNX, Ltd.
 Business-Studio Address: Josephine St.
 Phone Number: 158
 News Service: BUP
 Transcription Service: Thesaurus
 Representative: Alexander, Young
 Membership: CARTB
 President, General Mgr.: W. T. Cruickshank
 Sta., Comm. Manager: J. I. Cruickshank
 Promotion Manager: V. Dittmer
 Publicity Director: Don Hildebrand
 Chief Engineer: S. C. Reid

CKOX

WOODSTOCK—1947

Frequency: 1340 Kc. Power: 250 Watts
 Owned-Operated By: Oxford Bcstg. Co., Ltd.
 Business Address: P. O. Box 100
 Phone Number: 2400
 Air Time: Unlimited
 News Service: BUP
 Transcription Service: Langworth
 Representative: Omer Renaud
 Membership: CARTB
 President, Gen. Station Mgr.: Monty J. Werry
 Comm.-Sales Prom. Mgr.: G. Lewis
 Program Director: William Holmes
 Chief Engineer: Gordon Ballantyne

PRINCE EDWARD ISLAND

CFCY

CHARLOTTETOWN—1924—CBC

Frequency: 630 Kc. Power: 5000 Watts
 Owned-Oper. By: Island Radio Bcstg. Co.
 Business-Studio Address: 85 Kent St.
 Phone Number: 7347
 News Service: PN
 Transcription Service: SESAC
 Representative: All-Canada, Weed
 Membership: CARTB
 Pres., Managing Dir.: Lt. Col. K. S. Rogers
 Station Manager: R. F. Large
 Promotion Manager: M. E. Large

CJRW

SUMMERSIDE—1948

Frequency: 1240 Kc. Power: 250 Watts
 Owned-Operated By: Gulf Bcstg. Co., Ltd.
 Business-Studio Address: 218 Water St.
 Phone Number: 2201-2
 Air Time: 6 a.m.-12 M.
 Representative: Radio Reps.
 Membership: CAB, BBM
 President: J. K. Curran
 General Manager: R. C. Schurman
 Chief Engineer: H. Huestis

QUEBEC

CHAD

AMOS—1942

Frequency: 1340 Kc. Power: 250 Watts
 Owned-Operated By: Northern Radio Inc.
 Business Address: 70 Gamble St. W., Rouyn
 Representative: Weed & Co.
 Pres., Gen. Mgr.: David A. Gourd
 Chief Eng., Asst. Mgr.: Jean Senecal

CBJ

CHICOUTIMI—1933—CBC

Frequency: 1580 Kc. Power: 10,000 Watts
 Owned-Oper. By: Canadian Bcstg. Corp.
 News Service: CP, BUP, R. PN
 Representative: Fortin
 President: A. D. Dunton
 General Manager: J. A. Ouimet
 Station Manager: V. Fortin
 Comm. Mgr.: M. Valiquette
 Program Director: Aurele Seguin
 Publicity Director: Robert Elie
 Chief Engineer: J. Roberts

CHEF

GRANBY—1945

Frequency: 1450 Kc. Power: 250 Watts
 Owned-Oper. By: Granby Bcstg. Co., Ltd.
 Address: Hains Bldg., 13 Centre
 Phone Number: 6611
 News Service: BUP
 Representative: Radio & TV Sales
 Membership: CARTB
 President: R. Chaput
 Gen., Sta. Mgr.: G. Laliberte
 Comm., Prom. Mgr.: F. Normandin
 Program Director: R. M. Dube
 Publicity Director: Bernard Papineau

CKCH

HULL—1933—CBC

Frequency: 970 Kc. Power: 1000 Watts
 Owned-Oper. By: Syndicats d'Oeuvres Sociales
 Ltée.
 Business Studio Address: 121 Notre-Dame St.
 Phone Number: Pr 7-2771

Air Time Unlimited
 News Service BUP
 News. Affil. Le Droit
 Transcription SESAC
 Representative Renaud, McGillvra
 President L. J. Billy
 General Mgr. A. Gratton
 Station Manager J. P. Lemire
 Sales Promotion Manager Henry Allard
 Publicity Director Y. Dufour
 Chief Engineer J. L. Champagne

CKRS

JONQUIERE—1947

Frequency: 590 Kc. Power: 1000 Watts
 Owned-Oper. By Radio Saguenay, Ltd.
 Address 359 St. Dominique St.
 Phone Number 2-3551
 News Service BUP
 Representative Trans-Quebec, Hardy, Young
 General Manager Tom Burham
 Chief Engineer Gerard Lemieux

CKLS

LA SARRÉ—1950

Frequency: 1240 Kc. Power: 250 Watts
 Owner Radio La Sarre, Inc.
 Operated By Northern Radio-Radio Nord, Inc.
 Representative Renaud, Weed
 Pres., Gen. Mgr. David Armand Gourd

CKBL

MATANE—1949

Frequency: 1250 Kc. Power: 1000 Watts
 Owned-Oper. By La Cie de Radiodiffusion
 Address 144 Ave. St. Jerome
 Phone Number 355
 Air Time Full Time
 News Service BUP
 Transcription Service Associated
 Representative Jos. A. Hardy & Co., Ltd.
 Membership CAB
 Pres., Gen., Sta. Mgr. Rene Lapointe
 Commercial Manager Octave Lapointe
 Pub. Dir., Prom. Mgr. Jean Daigle
 Pgm., Prod. Dir. Marcel Houle
 Chief Engineer Yvan Fortier

CBF

MONTREAL—1937—CBC-ABC-MBS
 NBC

Frequency: 690 Kc. Power: 50,000 Watts
 Owned-Oper. By Canadian Bcstg. Corp.
 Bus.-Studio Address Radio Canada Bldg.
 Phone Number UN 6-2571
 Air Time 7 a.m.-M.
 News Service BUP
 Membership BBM
 Manager Jean St. Georges
 Commercial Manager M. Valiquette
 Program Director Robert Elie
 Chief Engineer Joseph Marcotte

CBM

MONTREAL—1936—CBC

Frequency: 940 Kc. Power: 50,000 Watts
 Owned-Oper. By Canadian Bcstg. Corp.
 Bus.-Studio Address Radio Canada Bldg.
 Phone Number University 62571
 News Service CP, BUP, AFP
 Representative McGill
 President A. D. Dunton
 Gen. Mgr. (CBC) J. Alphonse Ouimet
 Commercial Mgr. (CBC) M. Valiquette
 Publicity Director (CBC) R. Elie
 Chief Engineer (CBC) Jos. Marcotte

CFCF

MONTREAL—1919—ABC-CBC

Frequency: 600 Kc. Power: 5000 Watts
 Owned-Oper. By Canadian Marconi Co.
 Bus.-Studio Address 4824 Cote des Neiges Rd.
 Phone Number EX-1184
 Air Time 6 a.m.-12:30 a.m.
 News Service BUP
 Transcription Service Standard
 Representative Weed, All-Canada
 Membership CARTB, BBM
 Bcstg. Manager W. Victor George
 Station Manager J. Allan Hammond
 Commercial Manager T. J. Quigley
 Program Director J. Howlett
 Chief Engineer J. Creighton Douglas

CHLP

MONTREAL—1933

Frequency: 1410 Kc. Power: 1000 Watts
 Owned-Oper. By La Comp. de Publ. "La
 Patrie" Ltée
 Address Sun Life Bldg.
 Phone Number University 6-6611
 Air Time 18 hrs.
 News Service BUP, CP
 Transcription Service Associated
 Representative Alexander, McGillvra
 Pres., Gen. Mgr. Sen. P. R. DuTremblay
 Sales. Sta. Comm. Mar. Flavius M. Daniel

CJAD

MONTREAL—1945—CBS

Frequency: 800 Kc. Power: 5000 Watts
 Owned-Operated By CJAD, Ltd.
 Business-Studio Address 1191 Mountain St.
 Phone Number University 6-6821
 Air Time 6:05 a.m.-12:35 a.m.
 News Service BUP, CP
 Transcription Service Lang-Worth,
 World, Associated, Thesaurus, Capitol
 Representative Young, Radio Time Sales
 Membership CARTB
 Pres., Gen. Mgr. J. Art Dupont
 Station Manager James A. Tapp
 Comm., Prom. Manager R. L. Laurion
 Program Director H. T. McCurdy
 Chief Engineer Maurice Rousseau

CJMS

MONTREAL—1953

Frequency: 1280 Kc. Power: 5000 Watts

CKAC

MONTREAL—1922—CBC

Frequency: 730 Kc. Power: 10,000 Watts n. 5000 d.

Owned-Oper. By: La Cie. De Publication, La Presse, Ltée.

Phone Number: University 6-7301
 Studio Address: 980 St. Catherine St. W.
 Air Time: 19 hrs.
 News Service: BUP, PN, CP, FP
 Transcription Service: Associated, Lang-Worth
 Representative: Young, Renaud
 Pres., Gen. Mgr.: Hon. Sen. P. R. Du Tremblay
 Sta. Manager: Phil Lalonde
 Program Director: Ferdinand Bionde
 Chief Engineer: Leonard Spencer

CHNC

NEW CARLISLE—1933—CBC

Frequency: 610 Kc. Power: 5000 Watts

Owned-Oper. By: Gaspesia Radio Bcstg. Co.

Business-Studio Address: New Carlisle
 Phone Number: 64
 Representative: Hardy, Young
 Membership: BUP, CAB
 Representatives: Hardy, Young
 President: Dr. Charles A. Dumont
 General Mgr.: Dr. Charles Houde
 Sta., Comm. Manager: Viateur Bernard
 Chief Engineer: Gordon S. Coleman

CBV

QUEBEC CITY—1939—CBC

Frequency: 980 Kc. Power: 1000 Watts

Owned-Oper. By: Canadian Bcstg. Corp.

Business Studio Address: Palais Montcalm
 Phone Number: 5-8155
 Air Time: 7:30 a.m.-M.
 Station Manager: Guy Dumais

CHRC

QUEBEC CITY—1926

Frequency: 800 Kc. Power: 5000 Watts

Owned-Operated By: CHRC, Limitée

Business-Studio Address: 39 St. John St.
 Phone Number: 2-8177
 Air Time: 6 a.m.-12:30 a.m.

News Service: AP, UP, BUP
 Representative: Young, Hardy
 President: Herve Baribeau
 General Manager: Henri Lepage
 Commercial Manager: Aurele Pelletier
 Program Director: Mr. Magella Alain
 Chief Engineer: Arsene Nadeau

CJQC

QUEBEC CITY—1949—CBC

Frequency: 1340 Kc. Power: 250 Watts
 Owned-Oper. By: The Goodwill Bcstrs. of Quebec, Inc.

Address: 405 Hamel Blvd.
 Phone Number: MU 3-4931
 Transcription Service: SESAC, Lang-Worth
 Representative: Radio Time Sales, Young
 President: G. Howard Wert
 Vice President: Peter Nesbitt Thomson

CKCV

QUEBEC CITY—1926—CBC

Frequency: 1280 Kc. Power: 1000 Watts

Owned-Operated By: CKCV, Ltd.

Business-Studio Address: 142 St. John St.
 Phone Number: 2-1585
 Air Time: Full Time

News Service: PN
 Transcription Service: World
 Representative: Renaud, Weed
 Membership: CARTB
 President: Gaston Pratte
 Gen., Sta., Comm. Mgr.: Paul Lepage
 Pgm. Prod. Dir., Chf. Ann.: Marcel Leboeuf
 Publicity Director: Pierre Hudon
 Chief Engineer: Albert DuBerger

CJBR

RIMOUSKI—1937—CBC

Frequency: 900 Kc. Power: 5000 Watts
 Owned-Oper. By: The Central Public Service Corp., Ltd.

Address: 1 St. John St.
 Phone Number: 2217

News Service: PN
 Transcription Service: SESAC, Standard

News Service: PN
 Membership: CAB

Representative: Stovin, Young
 President: Hon. J. A. Brillant

Station Manager: André Lecomte
 Commercial Manager: Rosario Levesque

Sales Prom. Mgr., Pub. Dir.: Guy Ross
 Program Director: Francois Raymond
 Chief Engineer: Cecil Daok

CJFP

RIVIERE-DU-LOUP—1947—CBC

Frequency: 1400 Kc. Power: 250 Watts

Owned-Oper. By: Radio-Temisouata Ltée

Address: 322 rue Lafontaine
 Phone Number: 2727
 Transmitter Location: La Pointe

Air Time: Full Time
 News Service: BUP

Newspaper Affiliation: Le St. Laurent
 Representative: Renaud

Pres., Gen. Mgr.: Armand Belle
 Sta. Mgr., Pub. Dir.: Henri Bourdeau
 Commercial Manager: Yves Marchand

Sales Prom. Mgr. Luc Simard
 Program Director.....Raoul Savard
 Chief Engineer.....Raymond Lavoie

CHRL

ROBERVAL—1949

Frequency: 1340 Kc.Power: 250 Watts
 Owned-Operated By.....Radio Roberval Inc.
 Address.....Hotel Maison Blanche
 Phone450-1
 Air Time.....7:00 a.m.-M.
 News ServiceUP
 RepresentativeRenaud
 MembershipCAB
 PresidentGeorges Gagnon
 General Manager.....L. Morin
 Chief Engineer.....R. Lacombe

CKRN

ROUYN—1939—CBC

Frequency: 1400 Kc.Power: 250 Watts
 Owned-Oper. By.....Northern Radio, Inc.
 Bus.-Studio Address.....70 Gamble St. W.
 News ServiceBUP
 RepresentativeCBC, Renaud

CHGB

STE. ANNE DE LA POCATIERE—1938

Frequency: 570 Kc.Power: 1000 Watts
 Owned-Oper. By.....G. Thomas Desjardins
 AddressMain St.
 Phone Number101

CKSM

SHAWINIGAN FALLS—1951—CBC

Frequency: 1220 Kc.Power: 1000 Watts
 Owned-Operated By.....Shawinigan Falls
 Broadcasting Co.
 Address.....City Hall Bldg.
 Phone Number4494
 Transcription ServiceThesaurus
 News ServiceBUP
 RepresentativeRenaud
 MembershipCARTB
 General Manager.....Allen Rogerson
 Program Director.....Gaston Tessier
 Chief Engineer.....Ernest Brunelle

CHLT

SHERBROOKE—1937—CBC

Frequency: 900 Kc.Power: 1000 Watts
 Owned-Oper. By.....La Tribune Ltee.
 Business-Studio Address.....221 Dufferin St.
 Phone Number3-2525
 Air Time.....Full Time
 Transcription Service.....Thesaurus, SESAC
 News ServiceCP
 RepresentativeHardy, Young
 President.....Sen. Jacob Nicol
 General Manager.....A. Gauthier
 Station Manager.....Jean Louis Gauthier
 Program Director.....Rene Caron
 Chief Engineer.....Romeo Paquette

CKTS

SHERBROOKE—1946—CBC

Frequency: 1240 Kc.Power: 250 Watts
 Owned-Oper. By.....Sherbrooke Telegram
 Business-Studio Address.....221 Dufferin St.
 Phone Number3-2525
 Transcription Service.....Thesaurus, SESAC
 Representative.....Radio Time Sales
 President.....Hon. C. B. Howard
 General Manager.....A. Gauthier
 Commercial Manager.....Jeanne Tremblay

CJSO

SOREL—1945—FRA

Frequency: 1320 Kc.Power: 1000 Watts
 Owned-Oper. By.....Radio Richelieu, Ltee
 Business Studio Address.....72 Rue Du Roi
 Air Time.....6:55 a.m.-11 p.m.
 News ServiceBUP
 Representative.....Radio & TV Sales
 Pres., Elec. Engr.....J. Arthur Villeneuve
 General Manager.....Henri Olivier
 Station Manager.....Maurice Boulianne
 Sales Prom. Mgr.....Maurice Berube
 Program Director.....Claude Rochon
 Chief Engineer.....Joseph Cardin

CHLN

THREE RIVERS—1937

Frequency: 550 Kc.Power: 1000 Watts
 Owned-Oper. By.....Radio Trois-Rivieres, Inc.
 Bus.-Studio Address.....522 Bonaventure St.
 Phone Number4-3556
 Air Time.....6:50 a.m.-M.
 News ServicePN
 Transcription ServiceSESAC
 RepresentativeRenaud
 President.....Honoré Dansereau
 Station Manager.....Léon Trépanier
 Commercial Manager.....Maurice Dansereau
 Program Director.....André Cartier
 Chief Engineer.....Oric Lefebvre

CKVD

VAL D'OR—1939

Frequency: 1230 Kc.Power: 100 Watts
 Owned-Oper. By.....Northern Radio, Inc.
 Address.....70 Gamble St. W., Rouyn
 Pres., Gen. Mgr.....David A. Gourd

CKVL

VERDUN—1946

Frequency: 980 Kc.Power: 1000 Watts
 Owned-Operated By.....J. Teitlman
 Business Studio Address.....211 Gordon Ave.
 Phone Number.....PO 6-2311
 Air Time.....24 hrs.
 Representative...Cooke, Radio & TV Sales Inc.
 Managing Dir.....Jack Tietolman
 Pub. Dir., Sta. Manager.....Corey Thomson
 Commercial Manager.....Judah Tietolman

SASKATCHEWAN

CFRG

GRAVELBOURG—1952—CBC

Frequency: 1230 Kc. Power: 250 Watts
Owned-Oper. By: Radio Gravelbourg, Ltd.
Phone: 155
News Service: BUP
President: Dr. R. Morin
Gen. Prom. Mgr.: Dumont LePage
Chief Engineer: Marc Riou

CHAB

MOOSE JAW—1922—CBC

Frequency: 800 Kc. Power: 5000 Watts
Owned-Operated By: CHAB, Ltd.
Bus. Studio Address: 127 Main N.
Phone Number: 6464
Air Time: 6:30 a.m.—12 M.
News Service: BUP
Representative: Stovin. Weed
Membership: CARTB
President: W. L. Davis
General Manager: J. S. Boyling
Commercial Manager: N. Skingle
Program Director: R. D. Giles
Chief Engineer: M. Pickford

CJNB

NORTH BATTLEFORD—1947

Frequency: 1460 Kc. Power: 1000 Watts
Owned-Oper. By: Northwestern Bcstg. Co., Ltd.
Business Address: 66 E. 1st Ave.
Phone Number: 2477-8
Air Time: 6:30 a.m.—12 M.
News Service: BUP
Transcription Service: Associated
Representative: Stovin
Membership: CAB, WAB, BBM
General, Station Manager: Hume A. Lethbridge
Program Director: Thomas O. Nelson
Chief Engineer: A. Clint Nichol

CKBI

PRINCE ALBERT—1932—CBC
DOMINION

Frequency: 900 Kc. Power: 5000 Watts
Owned-Oper. By: Central Bcstg. Co., Ltd.
Bus. Studio Address: Sanderson Bldg.
Phone Number: 2621
Air Time: 19 hrs.
News Service: PN

Transcription Service: Thesaurus
Representative: All-Canada. Weed
Membership: CAB
General Manager: E. A. Rawlinson
Commercial Manager: Gerald Prest
Sales Prom. Mgr.: J. J. Cennon
Chief Engineer: Tom Van Nes

CKCK

REGINA—1922—CBC

Frequency: 620 Kc. Power: 5000 Watts
Owned-Oper. By: Trans Canada
Communications Ltd.
Phone Number: 8525
Air Time: Full Time
News Service: BUP, PN
Transcription Service: World
Membership: CARTB, WAB, BBM, SAB
Representative: All-Canada. Weed
President: Victor M. Sifton
General Manager: Harold A. Crittenden
Commercial Manager: Roy Malone
Sls. Prom. Mgr.: Allan Edwardson
Chief Engineer: E. A. Strong

CKRM

REGINA—1926—CBC

Frequency: 980 Kc. Power: 5000 Watts
Owned-Oper. By: Western Communications
Business Studio Address: 2060 Halifax St.
Phone Number: 3-5661
Air Time: Unlimited
Membership: CARTB, BBM
Representative: Radio Reps., Young
Membership: CAB, BBM
President: Dr. E. A. McCusker
Station Manager: D. J. Oaks
Commercial Manager: H. C. Dane
Sales Prom. Mgr.: W. A. Smith
Program Director: B. R. Hill
Chief Engineer: William MacDonald

CFNS

SASKATOON—1953—CBC

Frequency: 1170 Kc. Power: 1000 Watts
Owned-Oper. By: Radio-Prairies-Nord, Ltd.
Address: 1902 Broadway
Phone: 93-766
President: Father J. A. Beaulac
Gen., Comm. Mgr.: Theodore Prefontaine
Program Director: F. Ippersiel
Chief Engineer: E. O. Drouin

CFQC

SASKATOON—1923—CBC

Frequency: 600 Kc.....Power: 5000 Watts
 Owned-Oper. By....A. A. Murphy & Sons, Ltd.
 Bus.-Studio Address.....216 1st Ave., N.
 Phone Number7917
 Air Time.....Full Time
 Representative...Radio Reps., Young, Oakes
 News Service.....PN, BUP
 President.....A. A. Murphy
 Station Manager.....Vernon Dallin
 Commercial Manager.....Blair Nelson
 Program Director.....Roy Currie
 Chief Engineer.....Lyn Hoskins

CKOM

SASKATOON—1951

Frequency 1420 Kc.....Power: 5000 Watts
 Owned-Oper. By..Saskatoon Community Bcstg.
 Co., Ltd.
 AddressEmpire Hotel

Phone2-1271
 News Service.....Broadcast News
 Pres., Gen. Mgr.....R. A. Hosie
 Commercial Mgr.....G. D. Tunnicliffe
 Program Director.....G. E. Walburn
 Chief Engineer.....William Forsi

CJGX

YORKTON—1927—CBC

Frequency: 940 Kc.....Power: 1000 Watts
 Owned-Oper. By.....Yorkton Bcstg. Co., Ltd.
 Phone Number2258-9
 Air Time.....6:30 a.m.-11:30 p.m.
 News ServiceCP
 Transcription ServiceLang-Worth
 RepresentativeStovin, Young
 MembershipCBA
 PresidentDawson Richardson
 Gen., Sta. Mgr.....J. M. Shortreed
 Sales Prom. Mgr.....J. C. Goodman
 Commercial Mgr.....Geo. Gallagher
 Chief Engineer.....M. McRae

**THOSE WHO KNOW
 FAMOUS BRANDS**

Says Everett Rudloff, Manager, WJLK, at Asbury Park, N. J., of his own program *As I See It*: "Judging from the reactions of my listeners, the result of using **Associated Press** material has been to give 'As I See It' an authority and impact that attracts regular listenership."

**. . . . KNOW THE MOST FAMOUS
 BRAND IN NEWS IS AP**

here's a market for you!



WE COVER
THE
WHOLE COUNTRY
WITH THE **100**
MOST IMPORTANT
STATIONS
IN MEXICO

RCN

RADIO CADENA NACIONAL S.A.

Vallarta N° 1 • Tel. 10-39-09 • México, D. F.

I *nternational*

•

**AM STATIONS OF MEXICO,
CUBA, HAITI, DOMINICAN
REPUBLIC, BAHAMAS AND
JAMAICA**

•

**RADIO PROGRAMAS
de MEXICO, S.A.**

•

**RADIO CADENA NACIONAL, S.A.
MEMBER STATIONS**

•

**INTERNATIONAL BROADCAST
STATIONS OF U. S. AND CANADA**

NOW

THE NEW 50,000 WATTS

XERCN

IN MEXICO CITY

AND RCN

100 STATIONS

NETWORK,

COVER

A THIRTY MILLION

POTENTIAL MARKET

IN MEXICO

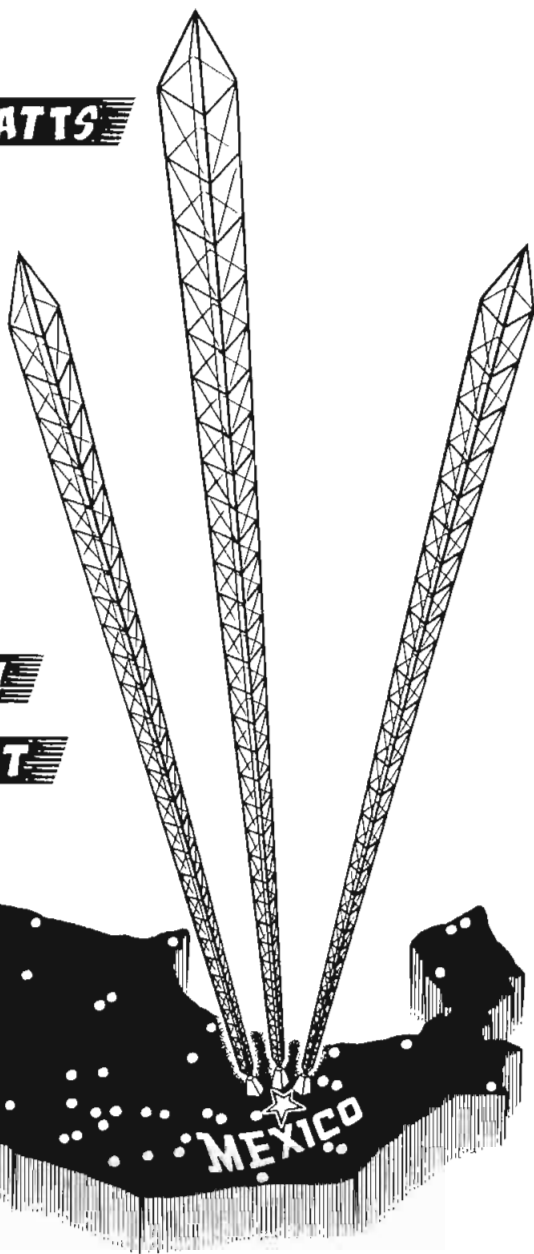

RCN

RADIO CADENA NACIONAL S.A.

Vallarta 711 • 6th. Floor • Mexico, D.F.

STATIONS OF MEXICO



<i>Location</i>	<i>Call Letters</i>	<i>Frequency</i>	<i>Owner</i>
Acambaro, Gto.	XEGW	1270	
Acapulco, Gro.	XEBB	600	
Acapulco, Gro.	XECI	1340	
Acapulco, Gro.	XEDO	1600	Heriberto Guizar Castro
Acapulco, Gro.	XEKJ	1400	Ramon Ortego Escobedo
Agua Prieta, Son.	XEAQ	1490	Manuel Rodriguez
Agua Prieta, Son.	XEFG	1310	Jesus Rodriguez Verdugo
Aguascalientes, Ags.	XEBI	790	Pedro C. Rivas
Aguascalientes, Ags.	XEDC	1560	
Aguascalientes, Ags.	XEII	1170	
Aguascalientes, Ags.	XERO	1490	Radio Hidrotermopolitana
Aguascalientes, Ags.	XEYZ	1450	Luis Chavez Calvillo
Apatzingan, Mich.	XECJ	1340	
Apatzingan, Mich.	XEGV	1240	
Boca del Rio, Ver.	XEOD	1090	
Campeche, Camp.	XEA	1370	Casanova Brito
Cananea, Son.	XEFQ	980	Pedro L. Diaz
Celaya, Gto.	XENC	1540	El Heraldo del Bajio
Celaya, Gto.	XEY	1360	
Chetumal, Q.R.	XEOS	960	
Chihuahua, Chih.	XEBU	620	Roberto O. Stevenson
Chihuahua, Chih.	XEBW	1280	Radioemisora del Norte
Chihuahua, Chih.	XEFI	1440	Pregon, Del Est. de Chih.
Chihuahua, Chih.	XEM	1390	Pedro Meneses, Jr.
Chihuahua, Chih.	XERA	1490	Red Nacional Radiomisora, S.A.
Ciudad Acuma, Coah.	XEKD	1010	
Ciudad Camargo, Chih.	XEHA	570	Hugo Pinera Limas
Ciudad Camargo, Chih.	XEOH	1270	
Ciudad Cuauhtemoc, Chih.	XEQZ	1560	
Ciudad Cuauhtemoc, Chih.	XEPL	560	
Ciudad Cuauhtemoc, Chih.	XEER	990	
Ciudad del Carmen, Cam.	XEUJ	1460	
Ciudad Delicia, Chih.	XEAY	660	
Ciudad Delicias, Chih.	XEBN	1240	
Ciudad Delicias	XEJK	1340	Amador Ronquillo Reza
Ciudad Guzman	XEBC	1430	Roberto Chavez Gonzalez
Ciudad Jimenez, Chih.	XEJZ	1320	
Ciudad Juarez, Chih.	XEFV	1240	Dario Cordo Rocha
Ciudad Juarez, Chih.	XEF	1420	Jose Carlos Amaya
Ciudad Juarez, Chih.	XEJ	970	Pedro Meneses, Jr.
Ciudad Juarez, Chih.	XELO	800	Cia Radio de Piedras Negras
Ciudad Juarez, Chih.	XEWG	1490	Carlos Mendez
Ciudad Juarez, Chih.	XEYC	1460	Ysela Fern. Caball. de Yanez
Ciudad Juarez, Chih.	XEP	1300	
Ciudad Ixtepec, Oax.	XECA	1480	
Ciudad, Lerdo	XENQ	960	
Ciudad Lerdo, Dur.	XEGZ	670	
Ciudad Mante, Tam.	XECM	1450	
Ciudad Miguel Aleman, Tam.	XEHD	1430	
Ciudad Miguel Aleman, Tam.	XEHI	1470	
Ciudad Obregon, Son.	XESO	1150	
Ciudad Obregon, Son.	XEAP	1290	Emillo Manzanilla
Ciudad Obregon, Son.	XEHX	1460	
Ciudad Obregon, Son.	XEOX	1430	Felipe G. de Leon
Ciudad Reynosa, Tam.	XERU	810	
Ciudad Valles, S.L.P.	XETR	1120	Tomas Oliva Banuelos
Ciudad Victoria, Tam.	XECP	1450	
Ciudad Victoria, Tam.	XEBJ	1340	Fernando Elizalde
Coatzacoalcos, Ver.	XEGB	840	
Coatzacoalcos, Ver.	XEOM	1340	Daniel Schact Perez
Colima, Col.	XERL	1280	J. Roberto Levy
Colima	XEUT	1280	

STATIONS OF MEXICO

<i>Location</i>	<i>Call Letters</i>	<i>Frequency</i>	<i>Owner</i>
Cordoba, Ver.	XEAG	1280	Luz Maria Zuniga de Miguel
Cordoba, Ver.	XEDZ	570	
Cordoba, Ver.	XEJD	820	J. Jac. Vda. de Zuniga
Cosamaloapan, Ver.	XEFU	630	
Guassave, Sm.	XEGS	1490	Radio Guassave S.A.
Cuatlla, Mor.	XEWF	1400	Fernando Diaz Enriquez
Cuernavaca, Mor.	XEFS	1420	
Cuernavaca, Mor.	XEJC	980	Ed. Jimenez de la Cuesta
Cuernavaca, Mor.	XEJC	1420	Miguel Angel T. Benitez
Culiacan, Sin.	XEBL	1260	Enrique Maxim Gomez Blanco
Culiacan, Sin.	XECQ	1300	Radio Culiacan, S.A.
Culiacan, Sin.	XEGF	1450	
Culiacan, Sin.	XESA	1360	Pablos y Elizalde
Durango, Dgo.	XECK	1340	
Durango, Dgo.	XEDU	1400	Carlos C. Armas
Durango, Dgo.	XEE	1280	Jose Valenzuela
Durango, Dur.	XEDU	860	Carlos C. Armas
El Sauzal, B.C.	XEDX	1010	
Ensendada, B.C.	XEFY	1450	
Ensendada, B.C.	XEPF	1400	Luis Enrique Encisco
Empalme, Son.	XEBQ	1240	Roberto Gonzalex Mata.
Fresnillo, Zac.	XEMA	1340	Jose Miguel Acevedo Moya
Gomez Palacio, Dur.	XEMD	920	
Gomez Palacio, Dur.	XERS	1400	
Gomez Palacio, Dur.	XEPA	790	
Guadalajara, Jal.	XEAD	1150	Alejandro Diaz
Guadalajara, Jal.	XEAV	570	Manuel Lopez Diaz
Guadalajara, Jal.	XEBA	840	Jesus D. Gonzales
Guadalajara, Jal.	XEDG	1370	
Guadalajara, Jal.	XEDK	1250	Manuel Lopez Diaz
Guadalajara, Jal.	XEGJ	1280	Quirino Francisco Gonzalez
Guadalajara, Jal.	XEHK	960	Francisco E. Fregoso
Guadalajara, Jal.	XEHL	1010	Radiodif de Occidente, S.A.
Guadalajara, Jal.	XEJB	630	State Government
Guadalajara, Jal.	XEJE	1310	Difusoras de Occidente, S.A.
Guadalajara, Jal.	XELT	970	Eduardo Reynoso Gonzalez
Guadalajara, Jal.	XELW	1340	Salvador Galindo de la Torre
Guadalajara, Jal.	XELT	920	Eduardo Reynoso Gonzalez
Guadalajara, Jal.	XERP	1190	
Guanajuato, Gto.	XEWZ	610	Gonzalo Sanchez Gomez
Guasave, Sin.	XECV	1490	
Guasave, Sin.	XEGS	610	
Guaymas, Son.	XEDR	1490	Sucrs. de Modesto Ortega
Hermosillo, Son.	XEBH	920	Carlos Balderrama
Hermosillo, Son.	XEDL	1250	Eufemia Esquer de Vidal
Hermosillo, Son.	XEDM	1580	Radio Pacifico
Hermosillo, Son.	XEHQ	590	Radio Hermosillo
Hermosillo, Son.	XEOP	960	
Hermosillo, Son.	XEQN	1540	
Hidalgo del Parral, Chih.	XEAT	1250	Sucrs. de Jorge Perez
Hidalgo del Parral, Chih.	XEGD	1520	
Hidalgo, del Parral, Chih.	XEJR	1490	
Hidalgo del Parral, Chih.	XEJS	1150	Olfonso Perez Porras
Huamantla, Tlax.	XEHT	1520	Alf. Macias y Mario Pardo S.
Huauchimango, Puebla	XEGU	1490	
Iguala, Gro.	XEKF	1360	Rafael Campos Marquina
Irapuato, Gto.	XEBO	1330	Alfonso Martinez
Irapuato, Gto.	XEHE	970	
Irapuato, Gto.	XEWE	1420	Felipe Gallardo
Jalapa, Ver.	XEFA	1340	Adolfo Alvarez
Jalapa, Ver.	XEJA	610	
Jalapa, Ver.	XEJA	1400	Adolfo Alvarez
Jalapa, Ver.	XEJW	1130	Mariano Caraza
Jalapa, Ver.	XEXB	1400	
Jalapa, Ver.	XEKI	550	Carlos Ferraez Matos.
Jiquippan, Mich.	XEIX	1290	

◆ ◆ ◆ STATIONS OF MEXICO ◆ ◆ ◆

<i>Location</i>	<i>Call Letters</i>	<i>Frequency</i>	<i>Owner</i>
La Barca, Jal.	XELB	1090	Ramon Alvarez Lopez
La Paz, B.C.	XEAL	1310	
La Paz, B.C.	XENT	790	
La Paz, B.C.	XEPX	550	
La Piedad, Mich.	XELC		
Leon, Gto.	XEFM	1270	
Leon, Gto.	XELG	680	Radio Impuls. del Centro S.A.
Leon, Gto.	XERW	1390	Augustin Obregon Padilla
Leon, Gto.	XERZ	1240	Carlos Obregon Padilla
Linares, N.L.	XER	1260	Radio Linares, S.A.
Los Mochis, Sin.	XECF	1410	Francisco Perez H.
Los Mochis, Sin.	XECU	1470	Luis Perez Gomez
Magdalena, Son.	XEDJ	1450	Jesus L. Rochin
Magdalena, Son.	XESY	1320	
Manzanillo, Col.	XECS	1400	
Matamoros, Tam.	XEAM	1450	Manuel L. Salinas
Matamoros, Tam.	XEMS	1420	
Matamoros, Tam.	XEMT	1340	Severo Garza Saenz
Matamoros, Tam.	XEO	970	Can. Maria Gonzalez
Matehuala, S.L.P.	XEFF	1490	
Mazatlan, Sin.	XEDS	1420	Alexjandro A. Schober
Mazatlan, Sin.	XERJ	1320	Oscar Perez E.
Mazatlan, Sin.	XETK	1390	Radio Emisors de Occidente
Mazatlan, Sin.	XEEC	1270	
Merida, Yuc.	XERY	1150	
Merida, Yuc.	XEDY	1450	
Merida, Yuc.	XEFC	1330	Rafael Rivas Franco
Merida, Yuc.	XEME	1270	
Merida, Yuc.	XEMH	1400	Man, Arango Echverria
Merida, Yuc.	XEMH	1490	Alvaro Barquet Y
Merida, Yuc.	XEMQ	1240	Lazaro Achurra Suarez
Merida, Yuc.	XEQW	550	
Merida, Yuc.	XEZ	600	Jorge L. Palomeque
Mexicali, B.C.	XECL	990	Alfonso A. Lacarra
Mexicali, B.C.	XEAA	1340	Consuelo Tonnella King
Mexicali, B.C.	XEAO	910	Juan C. Chavez
Mexicali, B.C.	XEBF	940	
Mexicali, B.C.	XED	1050	Carlos Blando
Mexicali, B.C.	XEGE	1570	
Mexicali, B.C.	XESU	790	
Mexico, D.F.	XENP	760	
Mexico, D.F.	XEB	1220	El Buen Tono S.A.
Mexico, D.F.	XEAI	1320	G.N. Medina y Loc. Ag. Ramos
Mexico, D.F.	XEBS	1410	Hispano Mexicano S.A.
Mexico, D.F.	XEBZ	660	Vocero Mexicano S.A.
Mexico, D.F.	XEDA	1290	Publ. Com. de Mexico, S.A.
Mexico, D.F.	XEDP	1060	Radio Gobernacion
Mexico, D.F.	XEFR	1180	
Mexico, D.F.	XEJP	1150	Radio America, S.A.
Monterrey, N.L.	XEJO	1150	
Mexico, D.F.	XEK	970	Arturo Martinez
Mexico, D.F.	XEL	1260	Herdez S.A.
Mexico, D.F.	XELA	830	Radio Metropolitan S.A.
Mexico, D.F.	XELZ	1440	Maria Cardena de Zetina
Mexico, D.F.	XEMC	1590	Dol. G. Estrada de Ferreiro
Mexico, D.F.	XEML	1550	Roberto Valeggi Esparza
Mexico, D.F.	XEMX	1380	Publ. Com. de Mexico S.A.
Mexico, D.F.	XEN	690	Guillermina P. de Del Conde
Mexico, D.F.	XENK	620	Gral. Brig. P.A.F. Proal Pardo
Mexico, D.F.	XEOF	560	
Mexico, D.F.	XEOY	1000	Fomento de Radio, S.A.
Mexico, D.F.	XEPH	590	Cia. Mexico de Radiodif. S.A.
Mexico, D.F.	XEQK	1350	Guillermo Morales B.
Mexico, D.F.	XEQR	1030	Corp. Mexicana de Radio, S.A.
Mexico, D.F.	XESM	1470	Salvador San Martin
Mexico, D.F.	XEQ	940	Radio Panamericana, S.A.

STATIONS OF MEXICO

<i>Location</i>	<i>Call Letters</i>	<i>Frequency</i>	<i>Owner</i>
Mexico, D.F.	XEQB	1110	Radio Central de Mexico
Mexico, D.F.	XERC	790	Radio Popular de Mexico
Mexico, D.F.	XERH	1500	"A.R.S.E." S.A.
Mexico, D.F.	XESM	1490	Salvador San Martin
Mexico, D.F.	XEUN	860	Universidad Nacional de Mexico
Mexico, D.F.	XEW	900	Cadena Radiodifusora, S.A.
Mexico, D.F.	XEX	730	Radio de Mexico, S.A. de C.V.
Minatitlan, Ver.	XEDW	1260	Ouers de Hector Silva Canto
Monclova, Coah.	XEKN	1390	
Monclova, Coah.	XEMF	1260	Alfonso L. Bres.
Monclova, Coah.	XEMW	910	
Monterrey, N.L.	XEAR	1480	Alfonso Flores Lopez
Monterrey, N.L.	XEAW	1280	Jesus D. Gonzalez
Monterrey, N.L.	XEDD	1560	
Monterrey, N.L.	XEFB	630	Emis. Inc. de Monterrey, S.A.
Monterrey, N.L.	XEPZ	1140	
Monterrey, N.L.	XEG	1050	La Voz de Norte-America, S.A.
Monterrey, N.L.	XEGQ	1590	
Monterrey, N.L.	XEH	1420	Radio Taranava, S. de R.L.
Monterrey, N.L.	XERR	570	
Monterrey, N.L.	XEJM	1450	
Monterrey, N.L.	XEMR	1370	Enrique Serna Martinez
Monterrey, N.L.	XENL	860	
Monterrey, N.L.	XEOK	920	Carlos Roa Montes De Oca
Monterrey, N.L.	XET	990	El Pregonero del Norte
Morelia, Mich.	XECR	1340	
Morelia, Mich.	XELQ	570	Francisco Laris Iturbide
Morelia, Mich.	XEGP	1580	
Morelia, Mich.	XESF	1300	Jose Martinez Ramirez
Morelia, Mich.	XEI	1400	Tiburcio Ponce
N. Casas Grandes, Chih.	XETX	1400	Laureano Molinar Contreras
Naco, Son.	XETM	1350	Jesus Manuel Franco
Navajoa, Son.	XEAJ	1400	
Navajoa, Son.	XEGL	1270	Fausto M. Gomez
Navajoa, Son.	XEHG	980	
Nogales, Son.	XECG	1240	
Nogales, Son.	XEHF	1370	Gaston Mascareñas
Nogales, Son.	XENS	1590	
Nuevo Casas Grandes, Chih.	XETX	1010	Laureano Molinar Contreras
Nueva Laredo, N.L.	XEXO	1550	
Nuevo Laredo, Tam.	XEAS	1410	Jose Maria Villarreal
Nuevo Laredo, Tam.	XEFE	790	Ruberto Villarreal
Nuevo Laredo, Tam.	XERG	1090	Reynoldo Garza Alvarez
Nuevo Laredo, Tam.	XEBK	1340	Juan Manuel Cortes
Nuevo Laredo, Tam.	XEDF	960	Rafael Tijerina Carranza
Nuevo Laredo, Tam.	XEXO	1140	Julio Santo Coy
Nuevo Laredo, Tam.	XENU	1370	
Nuevo Rosita, Coah.	XEJF	1400	
Nueva Rosita, Coah.	XELF	1380	
Nueva Rosita, Coah.	XERN	1430	
Oaxaca, Oax.	XEAX	1270	Delia Rodriguez de Marquez
Oaxaca, Oax.	XECE	1240	
Ocotlan, Jal.	XEAN	800	Radio Ocotlan S. de R.L.
Ojinaga, Chih.	XECT	1450	
Orizaba, Ver.	XEPP	1450	Radio Impulsora de Orizaba
Orizaba, Ver.	XETQ	1370	Suers de Francisco Campos H.
Pachuca, Hgo.	XETK	1420	
Pachuca, Hgo.	XEPK	1180	Radio Publ. de Pachuca
Papantla, Ver.	XEGK	920	
Piedras Negras, Coah.	XEMJ	920	Jesus L. Elizondo
Piedras Negras, Coah.	XEMU	570	Alfonso L. Bres
Poza Rica, Ver.	XEFO	1480	
Progreso, Yuc.	XEGO	620	
Progreso, Yuc.	XECN	1400	
Puebla, Pue.	XECD	1170	Roberto Canedo
Pueblo, Pue.	XEHR	1090	Manuel R. Canale

STATIONS OF MEXICO

Location	Call Letters	Frequency	Owner
Queretaro, Qro.	XEJX	1450	Radio Emisora Queretaro
Queretaro, Qro.	XEJX	1520	Radio Emisora Queretana
Queretaro, Qro.	XENA	1450	Ramon Rodriguez Familiar
Queretaro, Qro.	XENA	1520	Ramon Rodriguez Familiar
Quertaro, Que.	XEDI	1570	
Reynosa, Tam.	XEFP	1240	
Reynosa, Tam.	XEGH	620	
Reynosa, Tam.	XEOR	1390	Cond. S. Vda. de Gonzalez
Reynosa, Tam.	XERT	590	Ignacio Magallon
Rio Bravo, Tam.	XEFD	1170	
Rio Bravo, Tam.	XEFL	1110	
Rosarioto, B.C.	XERB	1090	Interamericana de Radio, S.A.
Sabinas, Coah.	XEBX	610	Radiodif. Coahuila, S.A.
Sabinas, Coah.	XESH	1460	
Saguayo, Mich.	XEGC	1450	Alberto Barragan Degollado
Salamanca, Gto.	XENP	1430	
Salamanca, Gto.	XERX	1560	Ernesto Bravo Vargas
Salina Cruz, Oax.	XEEA	1330	
Saltillo, Coah.	XEDE	1400	Enrique Martinez y Martinez
Saltillo, Coah.	XESJ	1250	Froylan Mier Narro
Saltillo, Coah.	XEXU	1490	
San Andres Tuxtla, Ver.	XEPA	980	
San Andres Tuxtla, Ver.	XERM	1370	
San Andres Tuxtla, Ver.	XELN	1510	
San Andres Tuxtla, Ver.	XEDQ	1400	
San Andres Tuxtla, Ver.	XEGA	1300	
San Miguel Allende, Gto.	XESQ	1280	
San Luis Potosi, S.L.P.	XEBM	920	Benjamin Briones
San Luis Potosi, S.L.P.	XECZ	1430	Radiodif, Mexicano
San Luis Potosi, S.L.P.	XEPO	1260	Alejandro Espinosa Pitman
San Luis Potosi	XEPO	1400	Alejandro Espinosa Pitman
San Luis Potosi	XEWA	540	Cadena Radiodif. Mex. S.A.
San Luis Potosi, S.L.P.	XEXQ	1460	
San Luis Potosi, S.L.P.	XESL	1340	Guadalupe Delgado Ramirez
San Luis Rio Colorado, Son.	XECB	1450	Carlos Flandoc
San Pedro Tia Quepaque, Jal.	XESP	1400	Hermanio Macias Alonso
Santa Ana, Son.	XEAB	1400	Alfredo Marin Castro
San Francisco del Oro, Chih.	XEHB	770	
Santa Barbara, Chih.	XESB	1400	Domingo Salayandia Najera
Santa Rosalia, B.C.	XEAH	560	
Santa Rosalia, B.C.	XESR	1320	
Santiago Ixcuintla, Hay.	XEEF	620	
Satillo, Coah.	XEKS	1330	Elfrain Lopez
Tala, Jal.	XEAF	550	
Tampico, Tam.	XECA	1460	Difusora Portena S. de R.L.
Tampico, Tam.	XEFW	810	Flores y Martinez
Tampico, Tam.	XES	1240	Radio Televisora de Tampico
Tampico, Tam.	XETO	1370	Radio Tiempo S. de R.L. de C.V.
Tampico, Tam.	XETO	1400	Radio Tiempo S. de R.L. de C.V.
Tampico, Tam.	XETU	980	Impuls. Moderna Del Radio, S.A.
Tampico, Tam.	XETU	1460	Impuls. Moderna del Radio
Tampico, Tam.	XELE	1300	
Teapa, Tab.	XEUI	1320	
Tapachula, Chis.	XETS	630	Napolean Correa
Tecate, B.C.	XEAK	560	
Tecate, B.C.	XEKT	1590	
Tecuala, Nay.	XEFG	1450	
Tehuacan, Pue.	XEDB	1520	
Tehuacan, Pue.	XEWJ	1420	Jaime Retif Del Morel
Tehuacan, Pue.	XEGY	1080	
Tepic, Nay.	XERK	1380	Dario Mondragon
Tepic, Nay.	XERK	1450	Dario Mondragon
Tepic, Nay.	XEXT	980	State Government
Tuxtla, Gutierrez, Chia.	XEON	710	Enrique Valero Arambula
Teziutlan, Pue.	XEFJ	680	
Tijuana, B.C.	XEAC	690	Jorge I. Rivera

STATIONS OF MEXICO—CUBA

<i>Location</i>	<i>Call Letters</i>	<i>Frequency</i>	<i>Owner</i>
Tijuana, B.C.	XEAU	1470	Manuel Acuna Varela
Tijuana, B.C.	XEAZ	1270	Fernando Sanchez Mayans
Tijuana, B.C.	XEBE	800	
Tijuana, B.C.	XEBG	1550	Octavio B. Lelexier
Tijuana, B.C.	XEC	1310	Luis Enrique Encisco
Tijuana, B.C.	XEGM	950	Gustavo Faust Fernandez
Tijuana, B.C.	XEMO	860	Fernando Frederico Ferreira
Tijuana, B.C.	XEXX	1420	Jose J. Clark, Fern. Fed. Ferret
Toluca, Mex.	XECH	1490	Rodolfo Llamas
Torreón, Coah.	XEBP	1310	La Voz de la Laguna S.A.
Torreón, Coah.	XEDN	600	Difusora del Norte, S.A.
Torreón, Coah.	XETB	1350	Radio Laguna, S.A.
Torreón, Leon	XEOB	1490	
Torreón, Coah.	XETC	1240	
Tuxpan, Nay.	XEUN	1340	Salvador Hrena Benítez
Tuxpan, Ver.	XETL	1390	Calixte Abmazan
Tuxtla Gutierrez	XEON	710	Enrique Balero Arambula
Tuxtla Gutierrez, Chi.	XEUE	1360	
Uruapan, Mich.	XEFN	1130	
Uruapan, Mich.	XEUF	550	Ignacio Navarro
Uruapan, Mich.	XEUF	610	Ignacio Navarro
Valle Hermosa, Tam.	XEVH	1310	
Veracruz, Ver.	XECW	1490	
Veracruz, Ver.	XEHV	1310	Suers de Juan A. Palavicini
Veracruz, Ver.	XELL	1430	Carlos Fernandez Matos
Veracruz, Ver.	XEJR	610	
Veracruz, Ver.	XETF	1250	Sucr. de Jose Rodr. Lopez
Veracruz, Ver.	XEU	960	Fernado Pazos SOSA
Villa Acuna, Coah.	XEAE	1600	
Villa Acuna, Coah.	XEDH	1340	Oscar Gonzalez Galindo
Villa Acuna, Coah.	XERF	1570	Cia Radio-Dif. de Coahuila, SA
Villahermosa, Tab.	XEUS	1080	
Villahermosa, Tab.	XETZ	1330	
Villahermosa, Tab.	XEUH	1500	
Villahermosa, Tab.	XEVV	970	
Zacapu, Mich.	XEZU	1270	Guillermo Calzada Cervantes
Zacatecas, Zac.	XELK	1230	Macia y Acevedo
Zacatecas, Zac.	XEXZ	1450	Manuel Llamas Felix
Zamora, Mich.	XEGT	1490	Radio Zamora S. de R.L.
Zamora, Mich.	XEZM	650	La Voz del Comercio de Zamora
Zapopan, Jal.	XECO	760	
Zapopan, Jal.	XEDV	700	
Zihuatanejo, Gro.	XESZ	1450	
Zitacuaro, Mich.	XELX	1460	
Zitacuaro, Mich.	XETA	810	Gabriel Saenz Gutierrez

STATIONS OF CUBA

<i>Location</i>	<i>Call Letters</i>	<i>Frequency</i>	<i>Owner</i>
Artemisa	CMAD	1240	Manuel Domingues Motolongo
Artemisa	CMAR	1170	Manuel Diaz Autran
Bayamo	CMKX	1390	Astides Gervet Villafane
Cabaiguan	CMHP	1250	Borges Enriquez
Camaguey	CMJE	680	Satellite CMBC Havana
Camaguey	CMJF	1340	Radio Camaguey
Camaguey	CMJC	1270	Cadena Camagueyana de Radio
Camaguey	CMJW	1440	Andres Moran Cisneros
Camaguey	CMJA	1060	Rafael Valdes Jimenez

STATIONS OF CUBA

<i>Location</i>	<i>Call Letters</i>	<i>Frequency</i>	<i>Owner</i>
Camaguey	CMJR	1030	Org. Insular de Radio S.A.
Camajuani	CMHF	1020	Jose Fernandez Aleman
Camaguey	CMJG	1000	Cadena Oriental de Radio S.A.
Camaguey	CMJN	960	RHC Cadena Azul S.A.
Camaguey	CMJB	880	Union Radio S.A.
Camaguey	CMJB	850	Union Radio S.A.
Camaguey	CMJK	1160	Jones, Castrillon y Cia
Cardenas	CMGE	1470	Genaro Sabater Fox
Ciego de Avila	CMJH	1370	Luis Marauri Mendoza
Ciego de Avila	CMJD	1190	Union Radio S.A.
Ciego de Avila	CMJY	800	Simeon Ferro Martinez
Ciego de Avila	CMJY	760	Cadena Oriental de Radio S.A.
Ciego de Avila	CMJP	580	
Ciego de Avila	CMJM	1080	RHC Cadena Azul S.A.
Ciego de Avila	CMJS	1580	
Ciego de Avila	CMJO	1470	Bonifacio Idelfonso Morales
Cienfuegos	CMHU	720	Modesto Vasquez Gonzales
Cienfuegos	CMHU	1130	Modesto Vasquez Gonzales
Cienfuegos	CMHJ	1350	Union Radio S.A.
Cienfuegos	CMHX	1480	Eugenio Perez Mena
Colon	CMGM	1440	
Cruces	CMHK	1220	Virgilio Villanueva Bravo
Cruces	CMHK	1210	Virgilio Villanueva Bravo
Encrucijada	CMHE	1090	Virgilio R. Diaz Quintanilla
Florida	CMJI	1400	Dr. Osvaldo Moran Artega
Guantanamo	CMKA	1250	Cadena Oriental de Radio S.A.
Guantanamo	CMKH	1140	Cadena Oriental de Radio S.A.
Guantanamo	CMKH	1130	Luis Coronado Estrada
Guantanamo	CMKI	1110	Union Radio S.A.
Guantanamo	CMKS	1070	Union Radio S.A.
Guantanamo	CMKS	900	Candido S. von Suarez
Guanabacoa	CMBC	690	Radiodif Progreso S.A.
Havana	CMOA	1590	Juan Fernandez Duran
Havana	CMZ	1560	Ministry of Education
Havana	CMOX	1360	
Havana	CMCM	1460	Cia. Transradio Columbia S.A.
Havana	CMCQ	1420	Andres Martinez
Havana	CMBX	1390	Alberto Alvarez Ferrera
Havana	CMBG	1490	
Havana	CMCB	1330	Radio Reloj S.A.
Havana	CMCO	1230	Edelberto Perez Rubio
Havana	CMK	1190	Faust Montiel
Havana	CMCA	1150	Radio Publicidad Tropico S.A.
Havana	CMBY	1120	Pages y Cia.
Havana	CMBS	1090	Enrique Artalejo Fernandez
Havana	CMCI	1260	Cadena Oriental de Radio S.A.
Havana	CMCX	1060	Circuito Occidental de Radio S.A.
Havana	CMBQ	1010	Radio Continental CMBQ S.A.
Havana	CMCK	980	Cia. Radiodif. COCO y CMCK S.A.
Havana	CMGN	960	RHC Cadena Azul S.A.
Havana	CMBF	950	Radio Universal S.A.
Havana	CMJL	920	Circuito CMQ S.A.
Havana	CMAQ	920	Circuito CMQ S.A.
Havana	CMCF	910	J. Ulloa y Cia.
Havana	CMHD	890	Union Radio S.A.
Havana	CMBL	860	Radio Cadena Suaritos
Havana	CMAN	840	RHC Cadena Azul S.A.
Havana	CMBZ	830	Manuel y Guillermo Salas
Havana	CMCH	790	Radio Cadena Habana S.A.
Havana	CMHB	780	Union Radio S.A.
Havana	CMCD	760	La Voz del Aire
Havana	CMKJ	740	Circuito CMQ S.A.
Havana	CMCD	740	La Voz del Aire
Havana	CMCA	730	Radio Publicidad Tropico S.A.
Havana	CMW	550	A. Gil y M. Troncoso
Havana	CMCY	590	RHC Cadena Azul S.A.

STATIONS OF CUBA

<i>Location</i>	<i>Call Letters</i>	<i>Frequency</i>	<i>Owner</i>
Havana	CMQ	630	Cirquito CMQ S.A.
Havana	CMCW	1290	Gilb. y Mario Lavín Dominguez
Havana	CMCU	660	Radio Garcia Serra S.A.
Havana	CMJM	840	
Holguín	CMDL	1150	
Holguín	CMKT	1400	
Holguín	CMDC	1290	Cadena Oriental de Radio S.A.
Holguín	CMKO	1220	Manuel Angulo Ferran
Holguín	CMKF	1050	Manuel J. de Gongova
Holguín	CMKD	970	Cadena Oriental de Radio
Holguín	CMKJ	730	Cirquito CMQ S.A.
Holguín	CMKP	670	Satellite CMBC Havana
Holguín	CMKV	600	RHC Cadena Azul S.A.
Holguín	CMKM	560	Union Radio S.A.
Mantanzas	CMGF	930	Manuel Domingues Motolongo
Manzanillo	CMDF	1590	
Marianao	CMBD	1520	Luis Perez Garcia
Matanzas	CMGW	1100	Ramon A. de Zayas Lopez
Matanzas	CMGF	1240	RHC Cadena Azul S.A.
Matanzas	CMGW	1100	Ramon A. de Zayas Lopez
Matanzas	CMGU	1340	Cadena Oriental de Radio S.A.
Matanzas	CMGL	1400	Cadena Oriental de Radio S.A.
Moron	CMJX	1230	Dr. Pable Castellanos Caballero
Nuevitas	CMJQ	1300	Juan Filiguieras Cabaleiro
Palma Soriano	CMKZ	1430	Maria Dominguez Dousseu
Pinar del Rio	CMAB	1070	Simeon Ferro Martinez
Pinar del Rio	CMAN	1300	RHC Cadena Azul S.A.
Pinar del Rio	CMAL	1340	Radiocidenta S.A.
Pinar del Rio	CMAW	990	Pedro Redondo Fernandez
Pinar del Rio	CMAW	800	Pedro Redondo Fernandez
Pinar del Rio	CMAB	760	Simeon Ferro Martinez
Puerto Padre	CMKY	1350	Pedro Zacca Cheda
Sagua La Grande	CMHR	1560	
Sancti Spiritus	CMHT	990	Juan B. Santana Padron
Sancti Spiritus	CMHB	1050	Union Radio S.A.
San Luis	CMKQ	1400	Raul de Arms Trompeta
Santiago de Cuba	CMDE	680	Synchronized with CMBC Camaguey
Santiago de Cuba	CMKC	770	Radio Orientale S.A.
Santiago de Cuba	CMKL	800	Cadena Oriental de Radio S.A.
Santiago de Cuba	CMKU	850	Cirquito CMQ S.A.
Santiago de Cuba	CMKU	900	Cirquito CMQ S.A.
Santiago de Cuba	CMKN	930	RHC Cadena Azul S.A.
Santiago de Cuba	CMKW	1000	Reloj Del Aire S.A.
Santiago de Cuba	CMKR	1090	Jaime Nadal
Santiago de Cuba	CMKB	1170	Union Radio S.A.
Santiago de Cuba	CMKC	1290	Radio Oriente S.A.
Sagua la Grande	CMHA	1280	Justiniano Valdes Aguado
Santiago de Cuba	CMDA	1320	
Santiago de Cuba	CMDC	1360	Cadena Oriental de Radio S.A.
Santa Clara	CMHO	1310	Org. Insular de Radio
Santa Clara	CMHI	570	RHC Cadena Azul S.A.
Santa Clara	CMHQ	640	Cirquito CMQ S.A.
Santa Clara	CMHG	680	Synchronized with Camaguey
Santa Clara	CMHD	730	Union Radio S.A.
Santa Clara	CMHW	810	RHC Cadena Azul S.A.
Santa Clara	CMHM	970	Cadena Oriental de Radio S.A.
Santa Clara	CMHF	1040	Jose Fernandez Aleman
Santa Clara	CMHM	1130	Cadena Oriental de Radio S.A.
Santa Clara	CMHC	1410	
Santa Clara	CMHC	1480	
San Cristobal	CMAC	1030	Guillermo Garcia Ovies
Sancti Spiritus	CMHL	1450	
Victoria de las Tunas	CMKG	1490	Ramon Esquivosa Perez
Victoria de las Tunas	CMDQ	540	
Victoria de las Tunas	CMGW	1240	Humberto Anteres Pena
Victoria de las Tunas	CMKT	1520	Alfr. O. Sanchez Morejon

STATIONS OF HAITI



<i>Location</i>	<i>Call Letters</i>	<i>Frequency</i>	<i>Owner</i>
Port-au-Prince	4VW	1300	Ricardo Widmaier
Port-au-Prince ..	4VGM	1470	Frank C. Magloire

STATIONS OF DOMINICAN REPUBLIC



<i>Location</i>	<i>Call Letters</i>	<i>Frequency</i>	<i>Owner</i>
Bani	H13V	1310	Manuel Bello Hijo
Barahona	H15K	1360	
Ciudad Trujillo	H1T	1400	Francisco A. Sanabia
Ciudad Trujillo	H1Z	1350	Frank Hatton
Ciudad Trujillo	H12H	1490	Raf. E. Tavarez L.
Ciudad Trujillo	H1N	1220	Partido Dominicano
Ciudad Trujillo	H1G	950	Andres Cordero Puello
Ciudad Trujillo	H1L	790	Joaquin C. Pellicer
Ciudad Trujillo	H13T	620	J. Arismendi Trujillo
Puerto Plata	H19U	1240	Luis A. Pelegrin
San Cristobal	H12R	1440	Luis Alberti
San Francisco de Macoris	H14F	1440	
San Francisco de Macoris	H14C	1250	Manuel R. Peralta
San Pedro de Macoris	H13J	610	
Santiago	H14B	1330	Abraham Vanderhorst
Santiago	H13A	1400	Expedi Pou
Santiago	H16T	1380	
Santiago	H18B	1050	
Santiago	H19Z	820	Luis F. Moscoso C.
Santiago	H11L	1230	Joaquin C. Pellicer

STATIONS OF BAHAMAS & JAMAICA



<i>Location</i>	<i>Call Letters</i>	<i>Frequency</i>	<i>Owner</i>
BAHAMAS			
Nassau	ZNS	1540	Bahamas Government
JAMAICA			
Kingston	ZQI	880	Jamaica Bestg. Co.
Montego Bay		1180	

Radio Programas de Mexico, S.A.

Head & General Offices: Bucareli 109

Phones:

Head Office: 35-13-73—12-72-34

General Offices: 36-29-01—12-65-44—13-91-14

P. O. Box 1324

Mexico City, Mexico

— PERSONNEL —

President & General Manager	Clemente Serna Martinez
Vice President	Antonio Eufrazio Ontiveros
Vice President	H. Nino M.
Publicity Manager	H. Rios D.

Radio Cadena Nacional, S.A.

Head Office: Vallarta #1

General Offices: Vallarta #1

Phones:

Head Office: 21-01-78—36-84-68

General Offices: 10-39-09—21-38-62

P. O. Box 7892

Mexico City, Mexico

— PERSONNEL —

President and General Manager	Rafael Cutberto Navarro
Commercial Manager	José Horacio Septién
General Auditor	Eduardo Martínez Celis
Control Manager	Jesús Amor D.
Sales and Recording Manager	Héctor Ventura de Castro
Accounting	Raquel Burgos Romero
International Division	Gloria Barton

Radio Cadena Nacional, S.A.

Member Stations



<i>Location</i>	<i>Call Letters</i>	<i>Frequency Kcs.</i>	<i>Location</i>	<i>Call Letters</i>	<i>Frequency Kcs.</i>
Acapulco, Gro.	XEBB	600	Merida, Yuc.	XEZ	600
Acapulco, Gro.	XEKJ	1400	Merida, Yuc.	XEMQ	1240
Aguascalientes, Ags.	XERO	1490	Merida, Yuc.	XEMH	1400
Agua Prieta, Son.	XEFH	1310	Mexicali, B. C.	XED	1050
Agua Prieta, Son.	XEAQ	1490	Monterrey, N.L.	XET	990
Apatzingan, Mich.	XECJ	1340	Monterrey, N.L.	XEH	1420
Celaya, Gto.	XEY	1360	Monterrey, N.L.	XEAW	1280
Cd. Acuna, Coah.	XERF	1570	Monterrey, N.L.	XEG	1050
Cd. Camargo, Chih.	XEHA	580	Morelia, Mich.	XESF	1300
Ciudad Juarez, Chih.	XEJ	970	Nogales, Arizona	XNOG	1340
Ciudad Juarez, Chih.	XEWG	1490	Nuevo Casas Grandes, Chih.	XETX	1400
Ciudad Juarez, Chih.	XEF	1420	Nuevo Laredo, Tamps.	XEDF	960
Ciudad Juarez, Chih.	XEFV	1240	Nuevo Laredo, Tamps.	XERG	1090
Ciudad Mante, Tamps.	XECM	1450	Parral, Chih.	XEJS	1150
Cd. Miguel Aleman, Tamps.	XEHI	1470	Parral, Chih.	XEGD	1520
Ciudad Obregon, Son.	XEAP	1290	Piedras Negras, Coah.	XEMJ	920
Cd. Obregon, Son.	XEHX	1460	Poza Rica, Ver.	XEPR	1480
Coatzacoalcos, Ver.	XEGB	840	Puebla, Pue.	XECD	1170
Cordoba, Ver.	XEDZ	580	Reynosa, Tamps.	XEOR	1390
Cuautlan, Mor.	XEWZ	1400	Sahuayo, Mich.	XEGC	1450
Culiacan, Sin.	XECQ	1300	Salamanca, Gro.	XERX	1560
Chihuahua, Chih.	XEBW	1280	San Luis Potosi, S.L.P.	XEPO	1310
Chihuahua, Chih.	XEM	1390	San Luis Potosi, S.L.P.	XESL	1340
Delicias, Chih.	XEJK	1340	San Luis Rio Colorado, Son.	XECB	1450
Durango, Dgo.	XEDU	860	Santa Ana, Son.	XEAB	1400
Empalme, Son.	XEBQ	1240	Santa Barbara, Chih.	XESB	1400
Gomez Palacio, Dgo.	XERS	1400	Tampico, Tamps.	XEFW	810
Guadalajara, Jal.	XEHL	1010	Tampico, Tamps.	XETO	1370
Guadalajara, Jal.	XESP	1400	Tepic, Nay.	XEXT	980
Guadalajara, Jal.	XEBA	840	Tijuana, B.C.	XEBG	1550
Guadalajara, Jal.	XEJE	1310	Tijuana, B. C.	XEAU	1470
Guadalajara, Jal.	XEAD	1150	Tijuana, B.C.	XEXX	1420
Hermosillo, Son.	XEDL	1250	Tlaquepaque, Jal.	XESP	1400
Hermosillo, Son.	XEDM	1580	Torreon, Coah.	XETB	1350
Iguala, Gro.	XEKF	1360	Torreon, Coah.	XEOB	1490
Irapuato, Gto.	XEYA	970	Uruapan, Mich.	XEFN	1130
Jalapa, Ver.	XEJW	1270	Veracruz, Ver.	XETF	1250
Jimenez, Chih.	XEJZ	1320	Veracruz, Ver.	XELL	1430
Leon, Gto.	XERZ	1240	Zacatecas, Zac.	XEXZ	1450
Los Mochis, Sin.	XECU	1470	Zacapu, Mich.	XEZU	1270
Magdalena, Son.	XEDJ	1450	Zamora, Mich.	XEZM	650
Manzanillo, Col.	XECS	1400	Zamora, Mich.	XEGT	1490
Matamoros, Tamps.	XEO	970	Zapopan, Jal.	XEDV	700
Matamoros, Tamps.	XEMT	1340	Zihuatanejo, Gro.	XESZ	1450
Matehuala, S.L.P.	XEFF	1490	Leon, Gto.	XELG	680
Mazatlan, Sin.	XERJ	1320			

INTERNATIONAL STATIONS IN THE UNITED STATES AND CANADA

<i>Licensee and Location</i>	<i>Call Letters</i>	<i>Power</i>
The Associated Broadcasters, Inc., San Francisco, Calif.	KWID-1	100 kw
	-2	50 kw
Columbia Broadcasting System, Inc., Brentwood, L. I., N. Y.	WDSI-1	50 kw
	-2	50 kw
	-3	50 kw
	-4	10 kw
Columbia Broadcasting System, Inc., Wayne, N. J.	WDSI-5	50 kw.
	-6	50 kw
Columbia Broadcasting System, Inc., Delano, Calif.	KCBR-1	200 kw
	-2	50 kw.
	-3	50 kw
	-4	100 kw.
	-5	100 kw
The Crosley Corporation, Mason, Ohio	WLWO-1	75 kw.
	-2	50 kw.
The Crosley Corporation, Bethany, Ohio	WLWO-3	200 kw.
The Crosley Corp., Cincinnati, O.	KQ2XAU	1 kw.
	-4	200 kw
	-5	200 kw
	-6	200 kw.
	-7	200 kw
	-8	200 kw
General Electric Company, Schenectady, N. Y.	WGEO-1	100 kw.
	-2	50 kw.
	-3	25 kw
General Electric Company, Belmont, Calif.	KGET-1	50 kw
	-2	100 kw.
National Broadcasting Co., Inc., Bound Brook, N. J.	WRCA-1	50 kw.
	-2	50 kw.
	-3	50 kw
	-4	50 kw.
	-5	50 kw.
	-6	50 kw.
National Broadcasting Co., Inc., Dixon, Calif.	KRCA-1	50 kw
	-2	50 kw.
	-3	200 kw
	-4	100 kw.
	-5	100 kw.
World Wide Broadcasting Corp., Scituate, Mass.	WRUL-1	50 kw
	-2	50 kw.
	-3	50 kw.
	-4	20 kw.
	-5	7 kw.

CANADIAN INTERNATIONAL STATIONS

<i>Licensee and Location</i>	<i>Call Letters</i>	<i>Power in Watts</i>
Canadian Marconi Co., Montreal, Que.	CFCX	75
Rogers Radio Broadcasting Co. Ltd., Toronto	CFRX	1,000
Voice of the Prairies Ltd., Calgary, Alta.	CFVP	100
Maritime Broadcasting Co. Ltd., Halifax, N. S.	CHNX	500
Eastern Broadcasters Ltd., Sydney, N. S.	CJCX	1,000
Transcanada Communications Ltd., Winnipeg, Man.	CKRO	2,000
Transcanada Communications Ltd., Winnipeg, Man.	CKRX	2,000
Western Broadcasting Co. Ltd., Vancouver, B. C.	CKFX	10
Edmonton Journal Ltd., Edmonton, Alta.	VE9AI	200



Video in Latin America: The Outlook for 1954

By FRANK FOUCE

President

Pan American Television Corporation

TELEVISION while in existence some three and a half years now, can, nevertheless, be considered as being in its infancy in Latin America. At the present time there are six stations operating in three markets in Mexico; eight stations operating in five markets in Cuba; one station in the Dominion Republic; two stations in Venezuela; five stations operating in three markets in Brazil; one station in Argentina and C.P.'s issued for several of the other countries in Latin America.

motion picture producers in Latin America all of their backlog together with their current and future production, guaranteeing them ample protection for their theatrical playdates. At the present time our catalogue shows many thousands of hours of feature productions. In addition, we are constantly receiving short subjects and complete series in Spanish for the Stations.

For the present, it is not economically feasible to dub English product into Spanish, unless a Sponsor demands it and is willing to contract for a sufficient number of stations to cover the cost involved.

The reason for so few stations is due to the fact that receiving sets are not being delivered as yet in sufficient quantities to allow existing stations to raise their basic time rates, and since these stations form the nucleus for further expansion, they must obviously be on a paying basis in order for the other principal cities in each country to obtain stations. The chief difficulty at the present time is that receiving sets cost a great deal more than they do in the United States, due to such factors as freight, duties, and so forth, combined with the fact that the per capita income in these countries, in most instances, is much less than in the United States or Great Britain, where sets are manufactured.

For the present only Cuba can afford a micro-wave relay network system and it is highly doubtful that any other country will have such facilities, at least on a national basis, for many years to come.

With these thoughts in mind, Pan American Television Corporation was formed to supply filmed and kinescoped programs throughout Latin America. We have arranged to obtain from the leading

With the interchange of programming between the various countries, I feel certain that each country's culture will be much more easily assimilated by other countries than in the past, resulting in a greater understanding of each other's problems. However, most countries rely on the local type comic for their comedy and variety formats.

The future of live television in Latin America is dependent upon the technical advances made by the Scientists of the industry in devising some means of long distance transmission such as we now have in AM radio. Of course, this is the answer to world-wide television and we find ourselves in the same position exactly as almost all other countries with the possible exception of the United States, insofar as national or regional telecasting is concerned.

In conclusion, our major problems then can be met by lowering the price of the receiving sets to the ultimate consumer and by the technical advancements of long distance transmissions or relay and faith in the future of our markets.

GERRY GROSS-NORMAN BAER
PRODUCTIONS

4 West 58th Street
New York, New York
MU 8-8882

1680 North Vine Street
Hollywood 28, California
HO 2-6343

*P*roduction
Radio and
Television

•

PROGRAM PRODUCERS

•

TRANSCRIPTION COMPANIES

GEORGE F. FOLEY, INC.



Television
and
Motion Picture
Producer

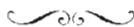

625 MADISON AVE., NEW YORK 22, N. Y.
PLAZA 1-1860

RADIO-TELEVISION PROGRAM PRODUCERS



ADVANCE TELEVISION PICTURE SERVICE, INC.

729 Seventh Ave., New York 19, N. Y.
Phone: CIRCLE 5-6873

President.....Charles A. Alicoate
Secy. & Treas.....F. E. Miles
Services Offered: Producers and distributors of films, features, shorts and package films for TV. Stock Shots Film, Private Projection Theaters, Cutting and Editing.

AFFILIATED PROGRAM SERVICE INC.

535 Fifth Ave., New York 17, N. Y.
Phone: MURRAY Hill 7-1881

President.....Paul F. Adler
Services Offered: Syndicated films, animated spots.

NICHOLAS T. AGNETA

1270 6th Ave., New York 19, N. Y.
Phone: COLUMBUS 5-0232

Manager.....Nicholas T. Agneta
Services Offered: Recording, Production, Scripts, Talent.

AIR FEATURES, INC.

347 Madison Ave., New York 17, N. Y.
Phone MURRAY Hill 9-5900

President.....I. S. Becker
Sales Mgr.....Gil Johnston
Comptroller.....Andy Subbiondo
Services Offered: Radio-TV packaged programs, live, film and transcribed.
Current Productions: Mr. Keen, Helen Trent, Our Gal Sunday, Backstage Wife, Just Plain Bill, Front Page Farrell, Young Widder Brown, Stella Dallas, Lorenzo Jones.

ALTON ALEXANDER RADIO- TELEVISION PRODUCTIONS

825 W. 187th St., New York 33, N. Y.
Phone LORRAINE 8-3100

Manager.....Lottie Ritter
Services Offered: Recording, Scripts, Package Programs, Production.

AMERICAN INSTITUTE OF FOOD PRODUCTS, INC.

608 Fifth Ave., New York 20, N. Y.
Phone: JU 6-7600

General Manager.....Robert A. Bories
Services Offered: Production, scripts, talent for food merchandising.

AMERICAN NATIONAL VIDEO PRODUCTIONS, INC.

17 N. Wabash Ave., Chicago 2, Ill.
Phone: FINANCIAL 6-2255

Pres. & Gen. Mgr.....Thomas J. O'Brien, Jr.

Asso. Producer.....Jean Gendon
Asso. Producer.....Phyllis F. O'Brien
Admin. Asst.Allis Allen
Admin. Asst.Dan D. O'Brien
Services Offered: Live, film shows & commercials.

AMERICAN SALES & SERVICING AGENCY (RADIO LUXEMBOURG)

17 East 42nd St., New York 17, N. Y.
Phone MURRAY Hill 2-0810

President.....Guy Bolam
Services Offered: Sales agency for Radio Luxembourg.

CHARLES R. ANDREWS AFFILIATES, INC.

19 E. 53rd St., New York 22, N. Y.
Phone: MU 8-7589

President.....Charles R. Andrews
Sect.-Treas.Marjorie Warner
Services Offered: Package shows.
Productions: "Jolly Gene and his Fun Machine."

PETER ARNELL PRODUCTIONS, INC.

750 Park Ave., New York 21, N. Y.
Phone: PLaza 5-2145

ASSOCIATED BROADCAST ADVERTISING CO.

1001 No. Western Ave., Los Angeles 29, Calif.
Phone: HO 5-0580

Partner, Adv. Mgr. & Publicity
Dir.....Irwin T. Porter
Partner, Program Mgr. & Dir. Research
Dept.....Gertrude T. Porter
Script Dept.....Jean Norab
Services Offered: Scripts created, for any business, ranging from miniature 5-minute programs to half hour or more shows—also spot announcements, and jingles. Promotion, programming, production, and merchandising. Several participation (quiz) and other shows available.

ASSOCIATED PRESS

50 Rockefeller Plaza, New York 20, N. Y.
Phone: PLaza 7-1111

General Manager.....Frank J. Starzel
Asst. General ManagerOliver Granling
Services Offered: 24-hour news coverage, hourly news summaries, daily & weekly feature coverage for TV & radio.

A-V TAPE LIBRARIES, INC.

730 Fifth Ave., New York 19, N. Y.
Phone: PLaza 7-3091

President.....Charles E. Rynd

ROCKHILL PRODUCTIONS, INC.

STANLEY J. WOLF — EXECUTIVE PRODUCER

- COMPLETE ★ RADIO,
- ★ TELEVISION AND
- ★ FILM PACKAGES

RECORDING DEPARTMENT
COMPLETE RECORDING FACILITIES
☆☆☆
TRANSCRIPTIONS
☆☆☆
"ON LOCATION" - REMOTE RECORDINGS

In the Heart of Radio Center

WINS
WJEW
NBC
WMCA
WJGM
CBS

MADISON AVENUE
51ST STREET
52ND STREET
53RD STREET

Rockhill Productions, Inc.

**18 East 50th
PLaza 9-7979**

Vice-Pres.....Joseph F. Hards
 V. P.-Treas.....Richard S. Rynd
Services Offered: Music on tape for commercial use, available for dealers and distributors. Program material on tape created and produced for specialty uses.

ANN BARBINEL

54 Riverside Dr., New York 24, N. Y.
 Phone: ENdicott 2-4351

PresidentAnn Barbinel
Services Offered: Creating - producing - directing custom built package shows for radio and TV.

BARRY, ENRIGHT & FRIENDLY PRODUCTIONS, INC.

667 Madison Avenue, New York, N. Y.
 Phone: TEmpleton 2-8600

PresidentJack Barry
 Vice-PresidentDan Enright
 V.-P. in Chg. Sales....Edwin S. Friendly, Jr.
 Executive Producer....Myron Oppenheimer
 Producers.....Ann Lawton,
 Jack Farrem, Fred Settner
Services Offered: Package producers of live and transcribed radio shows and live and filmed TV shows.

Productions: Juvenile Jury, Winky Dink and You, Life Begins At 80, Back That Fact, Oh, Baby.

BASCH RADIO & TELEVISION PRODUCTIONS

17 E. 45 St., New York 17, N. Y.
 Phone: MURray Hill 2-8877

Sales Manager.....Charles J. Basch, Jr.
Services Offered: Complete program building service; ideas, scripts, talent and production on live and transcribed programs; custom and syndicated recordings; TV programs and commercial spots, live and film.

ZACH BAYM FILMS

13 E. 37 St., New York 16, N. Y.
 Phone: MURray Hill 9-4175

Owner.....Zach Baym
Services Offered: Distribution of films for TV. 1-hour features & westerns; half, quarter-hour documentary-travel series; baseball series; animated cartoon series; Christmas films.

IRENE BEASLEY RADIO PRODUCTION SERVICE

501 Madison Ave., New York 22, N. Y.
 Phone: PL aza 3-8940

Owner.....Irene Beasley
Services Offered: Program production; package programs.

V. S. BECKER PRODUCTIONS

562 Fifth Ave., New York 36, N. Y.
 Phone: LUXemburg 2-1040

Owner.....Viola S. Becker
Services Offered: Production of package shows and commercials for Radio, Television

programs, live and film. Distributors of film; representatives of talent & ideas for Radio, TV, film, sales promotion.

GEORGE R. BENTEL & ASSOCIATES

5617 Hollywood Blvd., Hollywood 28, Calif.
 Phone: HOLlywood 7-8608

DirectorCarl Coolidge
Services Offered: Scripts.

WALTER BIDDICK CO. (Radio Programs Div.)

1151 S. Bway., Los Angeles 15, Calif.
 Phone: RI 6184

ManagerGuy Biddick
 Asst. Mgr.....Mildred Biddick
 Traveling Rep.....Glenn Biddick
Services Offered: Preparing and recording commercial announcements for your own individual requirements. Packaged 1/2-min. transcribed announcements already prepared for various type businesses. Packaged quarter-hour transcribed radio programs. Transcribed sacred music libraries sold outright.

ALBERT BLACK TELEVISION PRODUCTS

1270 Sixth Ave., New York 20, N. Y.
 Phone: COlumbus 5-2760

PresidentAlbert Black
 V.P., Secy., Treas.....Michael Lippert
 Exec. Director.....Julien Roffman
Services Offered: Live and film package shows; commercials for television; radio shows, transcriptions.

FORD BOND RADIO PRODUCTIONS, INC.

810 RCA Bldg., W., New York 20, N. Y.
 Phone: CIrele 7-2236

PresidentFord Bond
Services Offered: Specializing in open-and transcribed programs. Development of program ideas and advice on radio production. Counselor on radio and TV presentation.

THE BORIES ORGANIZATION

608 Fifth Ave., New York, N. Y.
 Phone: JU 6-7600

PresidentBob Bories
Services Offered: Radio and TV package producer.

BROADCASTING PROGRAM SERVICE

17 E. 45th St., New York 17, N. Y.
 Phone: OXFord 7-0725

PresidentHerbert Rosen
Services Offered: Transcription service, musical programs on tape, sound effects records, mood and bridge music library, TV programs on films.

WILLIAM F. BROIDY PRODUCTIONS, INC.

5545 Sunset Blvd., Hollywood 28, Cal.
 Phone: HEmpstead 6844

President William F. Broidy
 V.P. & Secy..... Edward J. Kay
 Production Mgr..... A. R. Milton
 Adv. Dir..... J. L. Kaufman
Services Offered: Studios for rental. Package shows.

BYRON PRODUCTIONS

8 E. 52nd St., New York 22, N. Y.
 Phone: PLaza 3-6930
 President..... Edward A. Byron
Services Offered: Package programs.

BRUCE CHAPMAN COMPANY

55 West 42nd St., New York 36, N. Y.
 Phone: WIsconsin 7-9214
 President Bruce Chapman
 V.P.-Treas..... Edna Chapman
 Branch Offices:
 30 rue de Gramont, Paris 2, France
 Phone: Richelieu 80-01
 Director Dan Morley
 Assoc. Dir..... Michael Alexander
 22 Davies St., London W. 1, England
 Phone: MAnyfair 1037
 Manager..... Frank Byer
 9-10 am Park, Berlin, Schoneberg, Germany
 Phone: 71-61-69
 Manager Rolf Brede
Services Offered: Production of radio & TV programs in U. S. and Europe.

CHESHIRE & ASSOCIATES
 6533 Hollywood Blvd., Hollywood 28, Calif.
 Phone: HOllywood 9-4580
 General Manager Bob Reichenbach
 President Harry V. Cheshire
Services Offered: Transcribed program and television film producers and distributors. Open-end and custom features.

CINEFFECTS, INC.

(For complete listing see TV Film Producers)

TED COLLINS CORP.

500 Fifth Ave., New York, N. Y.
 Manager Ted Collins
Services Offered: Talent, Production.

COMMODORE PRODUCTIONS & ARTISTS, INC.

971 N. LaCienega Blvd., Hollywood 46, Calif.
 Phone: CRestview 4-2023
 Pres. & Excc. Prod..... Walter White, Jr.
Services Offered: Program production, syndicated transcriptions, scripts, package programs, talent.

FRANK COOPER ASSOCIATES AGENCY

6277 Selma Ave., Hollywood 28, Calif.
 Phone: HO 4-7258
 N. Y. Phone: VAnderbile 6-5661
 President Frank Cooper

GOODSON-TODMAN PRODUCTIONS

Creative Programming For Radio, Television and Television Films

41 East 57th Street
 New York 22, N. Y.

MARK GOODSON

BILL TODMAN

PROGRAM PRODUCERS

V.P. Chge. of N. Y. Office.....Sy Fischer
 Head of Sales—Calif. Off...Martin Sperber
 Executive Secretary.....Gloria Farrier
Services Offered: Packagers and sales representatives of radio and television programs. Representatives of writers and talent.
Productions: Man Against Crime, Strike It Rich, First Nighter, The Chase, Second Chance, Wanted By Washington, Those Manning Girls, Glamour Girl.

LOUIS G. COWAN, INC.

575 Madison Ave., New York 22, N. Y.
 Phone: PLaza 9-3700

President.....Louis G. Cowan
 Vice-President.....Harry Fleischman
 Treasurer.....J. Kyle Faber
 8 S. Michigan Ave., Chicago 3, Ill.
 Phone: RAndolph 6-2022
 Vice-Pres.in-ChargeJohn Lewellen
 Vice-Pres.....R. D. Michels
Services Offered: AM-TV Productions-Network Programs (Package); Production-Transcription Programs; Program Consultants.

DAMON RECORDING STUDIOS, INC.

117 W. 14th St., Kansas City 6, Mo.
 Phone: VICTor 2585

PresidentVic Damon
 Vice President.....Robert Damon
 TreasurerAlice Damon

Secretary.....Harry A. Morris
 Chief Engineer.....Roger Webb
Services Offered: Commercial, personal and audition recordings on tape, discs at all speeds, Radio-TV shows, spots TV film sound track, air checks; masters, portable recordings. Public address installations, sales-rental service.

FREDERIC DAMRAU, M. D.

247 Park Ave., New York 17, N. Y.
 Phone: PLaza 5-3638

Director.....Frederic Damrau, M. D.
 AFTRA Associate.....Adeline Maneery
 Business Manager.....Mary L. Davis
Services Offered: Educational and dramatized programs relating to health, for both radio and TV.

MAC DAVIS FEATURES

1 Montgomery Place, Brooklyn (15), N. Y.
 Phone: Nevins 8-4374

DirectorMac Davis
Services Offered: Sport shows created, written and produced for television and radio presentation. Also special scripts and ideas furnished for all types of sport programs for local, regional or network presentation.

GORDON M. DAY PRODUCTIONS

108 E. 30th St., New York 16, N. Y.
 Phone: ORegon 9-3595

Writer, ComposerGordon M. Day
 DirectorCarol Bulkley

FOUR OF OUR TOPS

TV

BREAK THE BANK

STARRING

BERT PARKS

FOR

DODGE DIVISION OF CHRYSLER CORP.

ABC-TV SUNDAY 10:00 PM EST.

RADIO

HILLTOP HOUSE

STARRING

JAN MINER

FOR

ALKA-SELTZER

CBS RADIO MON. THRU FRI. 3-3:15 PM EST.

MASQUERADE PARTY

STARRING

DOUG EDWARDS

FOR

INSTANT MAXWELL HOUSE COFFEE

CBS-TV MONDAY 9:30 PM EST.

BREAK THE BANK

STARRING

BUD COLLYER

FOR

MILES LABORATORIES

NBC RADIO MON. THRU FRI. 10:45-11 AM EST.

WOLF PRODUCTIONS

WOLF ASSOCIATES

420 MADISON AVENUE, NEW YORK, N. Y.

WILBUR STARK- JERRY LAYTON,

INC.

Radio and Television Productions
270 Park Avenue, New York

CURRENT

— TV —

"ROCKY KING DETECTIVE"

Starring ROSCOE KARNS
Featuring TODD KARNS

"COLONEL HUMPHREY FLACK"

Starring ALAN MOWBRAY
Featuring FRANK JENKS

— RADIO —

"MODERN ROMANCES" "HOLLYWOOD STARWAY"

— AVAILABLE —

Dramatic

"ROOKIE COP"
"THE SERGEANT AND THE LADY"
"MISTER FEATHERS"
"AMAZING MRS. TUPPER"
"RENDEZVOUS"
"WOMAN'S DECISION"

Daytime Series

"LADIES CHOICE"

Panel

"WHAT'S THE GAG"

Audience Participation

"WIN FOR HIM"
"THREE TO WIN"
"SPIN THE PICTURE"

◆◆ PROGRAM PRODUCERS ◆◆

Production Mgr. Edith Adelson
Treasurer Leo L. Reich
Services Offered: Package programs, radio-TV department service to advertising agencies, creating and producing custom-built musical jingles and spots of all kind.

DEMBY PRODUCTIONS, INC.

34 E. 51 St., New York 22, N. Y.
Phone: PLaza 9-2495

President Emanuel Demby
Program Supervisor... Alexander Marsbaek
Script Editor..... Allen Swift
Women & Fashions Editor... Mildred Demby
Client Relations..... Hunter Smith
Services Offered: Radio and TV programming, spot announcements, Public relations and merchandising for radio and TV shows, Asian and Latin-American representation for films and press, Films for TV, sales training and public relations.

JERRY DEVINE PRODUCTIONS

6331 Hollywood Blvd., Hollywood 28, Calif.
Phone: HU 2-1228

Owner Jerry Devine
Services Offered: Packaged radio programs.

ALFRED DIXON PRODUCTIONS

109 E. 39th St., New York, N. Y.
Phone: MFCray HBl 5-6115

President-Owner..... Alfred Dixon
Casting and production..... Lynn Masters
Asst. Dir. and Coaching..... Norma Burton
Services Offered: Radio, stage, film, TV productions.

HARRY S. DUBE

10 Rockefeller Plaza, New York 20, N. Y.
Phone: COlumbus 5-7035

Manager J. Knight
Services Offered: Live Talent, package shows and transcriptions.

DYNAMIC FILMS INC.

112 W. 89th St., New York 24, N. Y.
Phone: TRafalgar 3-6221

President Henry Morley
Treasurer Nathan Zucker
Exec. Pro. Lee R. Bobker
Editorial Chief..... Lester Becker
Sound Engineer..... John De Blau
Film Dist..... M. Pfeiffer
Services Offered: Film producer—open end films and commercials made specifically for TV; amusement and dramatic shorts; educational and industrial shorts; marionette shorts; spot news and special event coverage; video transcriptions; complete sound recording and sound stage facilities; film consultants.

W. M. ELLSWORTH

Suite 203, 159 E. Chicago
Phone: MOhawk 4-7050

Owner..... W. M. Ellsworth

Services Offered: Folk artists, entertainers for radio-TV-records and transcriptions.

EMPIRE BROADCASTING CORP.

480 Lexington Ave., New York 17, N. Y.
Phone: PLaza 9-4500

President.....Helen D. Kelleher
Services Offered: All types of recording namely: tape-disc, studios, air-line checks, AM-FM-TV portable jobs, film synchronization.

ENDORSEMENTS, INC.

500 Fifth Ave., New York 36, N. Y.
Phone: CHickering 4-7257

President.....Jules Alberti
Vice-Pres.....Dr. Harold S. Wadro
Sec.-Treas.....Hazel F. McCabe
Chg. Production.....F. Richard Mansfield
Services Offered: Endorsements and testimonials live and film for TV.

ESTES NEWS AND FEATURE SERVICE

6 Peter Cooper Rd., New York 10, N. Y.
Phone: SPring 7-5766

President.....Bernard Estes
Secretary-Treasurer.....Hazel Estes
Associate Producer.....Jack Sheldon
Services Offered: Live and transcribed package shows produced. Specializing in news and feature programs designed for public relations impact, AM, Video, News and camera correspondents throughout U. S., Latin America, Europe, Far East.

FADIMAN ASSOCIATES, LTD.

1501 Broadway, New York 36, N. Y.
Phone: LAckawanna 4-3544

Manager.....Edwin Fadiman
Services Offered: Production, Package Shows.

FILM ASSOCIATES, INC.

4600 S. Dixie Ave., Dayton 9, O.
Phone: WALnut 2164

President-Treasurer....E. Raymond Arn, Jr.
Vice-President.....Mildred G. Arn
Secretary.....Clement V. Jacobs
General Manager.....Edward R. Lang
Office Manager.....Becky Ann Howe
Services Offered: Producers of TV "Tele-skits" packaged complete fill in shorts of vaudeville character. Advertising trailers, newsreels. Complete facilities for TV film productions. Slides for TV, station breaks, electrical transcription facilities. Complete laboratory service for producers. Model agency.

FISHER PRODUCTIONS

347 East 52nd St., New York, N. Y.
Phone: PLaza 3-5443

Owner.....Maggy Fisher
Assistant.....Marion Mullen
Services Offered: Packaging, writing, directing TV and radio shows.

GEORGE F. FOLEY, INC.

625 Madison Ave., New York 22, N. Y.
President.....G. F. Foley
Services Offered: Package programs, talent representative, production consultant.

WALT FRAMER PRODUCTIONS

1150 Avenue of the Americas
New York 36, New York
OXford 7-3322

Producer.....Walt Framer
Associate Producers.....Joe Gottlieb, Joe Cates, Art Stark, Gary Stevens
Production Supervisors....Mervyn Framer, Production Supervisors...Mervyn Framer, Sid Tamber, Estelle Citron, Paul Kaczander, Vivian Roberts
Business Manager.....Henry Schmerzer
Services Offered: Specializing audience participation and quiz shows; packages, production, question research, contestant screening.
Current Productions: Strike It Rich, The Big Payoff, Double or Nothing.

FREMANTLE OVERSEAS RADIO, INC.

366 Madison Ave., New York 17, N. Y.
Phone: MUrray Hill 7-4344

President.....Paul Talbot
Asst. to Pres.....Lee Volker
Mgr. (Mexico City).....Rene Anselmo
Services Offered: Producers of transcribed radio programs for Spanish audiences. Producers of live radio and TV programs in Mexico. Exclusive TV rights to the Davis Cup tennis matches.

ALLEN A. FUNT PRODUCTIONS

100 Central Park South, Room 11-C,
New York 19, N. Y.
Phone: JUdson 6-5227

President.....Allen A. Funt
Production.....Al Slep
Services Offered: Network, live, transcribed and syndicated programs and eandid commercials.

GAINSBOROUGH ASSOCIATES

207 East 30th St., New York 16, N. Y.
Phone: ORegon 9-2720

President.....Mitchell Jablons
VP and Gen. Mgr.....Josephine Sacoca
VP in chg. Sales.....Martin Seligson
Casting Director.....Arlene Shelley Gaines
Publicity Director.....Shirley Graf
Director of Media Research....Aaron Settle
NY Office Mgr.....Susan M. Gaines
Offices

7200 Santa Monica Blvd., Hollywood, 28, Cal.
Office Manager.....Chas. B. Rogers
Services Offered: Radio & TV package producers. Program consultants to new and existing radio and TV stations. Fnnnd raising campaigns on radio and TV. Talent management and personal representation.

Current Productions: "The Editors Speak,"
 "Harlem Serenade," "Buddy Rogers Show,"
 "Revistas del Mediodia."

GALE, INC.

48 W. 48th St., New York 19, N. Y.
 Phone: PLaza 7-7100

President Moe Gale
 Services Offered: Talent, management and
 production.

**GBA-GALLUCCI BROS. &
 ASSOCIATES**

727 Meriden Rd., Waterbury 63, Conn.
 Phone: Waterbury 3-5272

President Joe Gallucci
 Box 1224, Denver, Colo.
 General Manager N. T. Gallucci
 Services Offered: Package programs.

**HAROLD R. GINGRICH,
 PRODUCTIONS**

333 N. Michigan Ave., Chicago 1, Ill.
 Phone: FRanklin 2-1022

Director Harold R. Gingrich
 Musical Director Jack Wonnell
 Research Director Jessica Petrie
 Services Offered: Transcriptions and films,
 package program and counsellor service.

GENERAL ARTISTS CORP.

1270 Sixth Ave., New York 20, N. Y.
 Phone: Circle 7-7543

President Thomas G. Rockwell
 V.P., Chg. Radio-TV Dept. Milton W. Krasny
 V.P., Chge. Prod. Harry Auger
 Services Offered: Program production,
 package shows, artists' representatives.

JOHN E. GIBBS & CO., INC.

30 Rockefeller Plaza, New York 20, N. Y.
 Phone: PLaza 7-5959

President John Gibbs
 Writers Department Francis Head
 Talent Department Bob Ferres
 Services Offered: Radio and TV produc-
 tion. Talent representation.

**GRACE GIBSON RADIO
 PRODUCTIONS**

6533 Hollywood Blvd., Hollywood 28, Calif.
 Phone: HOLlywood 9-4580

General Manager Bob Reichenbach
 Executive Producer Grace Gibson Parr
 Services Offered: Production and distribu-
 tion of transcribed dramatic programs for
 general or specific sponsorship.

**HARRY S. GOODMAN
 PRODUCTIONS**

19 E. 53rd St., New York 22, N. Y.
 President-Gen. Mgr. Harry S. Goodman

We asked these people to . . .



Licia Albanese
 Leroy Anderson
 Edna Best
 James J. Braddock
 Dick Button
 Ilka Chase
 Melville Cooper
 Bill Corum
 Lily Dache
 Denise Darcel

Frank Farrell
 F. Hugh Herbert
 Harry Hirschfield
 Edward Everett Horton
 Fannie Hurst
 Nick Kenny
 Ralph Meeker
 Mrs. Kathryn Murray
 Ogden Nash
 John Robert Powers

Georgie Price
 Vincent Price
 Grantland Rice
 Pat Rooney
 Zachary Scott
 Dorothy Thompson
 Lawrence Tibbett
 Amy Vanderbilt
 Harriet Van Horne
 Earl Wilson

We thank them and all the other wonderful people that space prevents us listing,
 and the Continental Baking Company, the Ted Bates Agency, and CBS for making
 up their minds about this top-rated program created and produced by

Arthur Henley Productions

Shelton Hotel, N. Y.

PLaza 5-7145

Vice-Pres.-Charge Sales. Everett F. Goodman
 Vice-Pres.-Charge TV. . . . Daniel R. Goodman
 Secretary H. D. Knuth
Services Offered: Producer of syndicated
 transcribed shows, live radio shows, syndi-
 cated TV availabilities and live TV shows.
 Also Custom Built AM and TV spots.

**GOODSON-TODMAN PRODUC-
 TIONS**

41 E. 57th St., New York 22, N. Y.
 Phone: PLaza 1-0600

Partner William S. Todman
 Partner Mark Goodson
 Business Manager. Howard F. Todman
 Exec. Dir. of Programs. Gil Fates
 Script Editor. Eugene Burr
 Sales Coordinator. David Wear
 Production Manager. Mitchell Leiser
Services Offered: Producing and packag-
 ing live and transcribed radio and live and
 finished TV programs.

GOTHAM RECORDING CORP.

2 W. 46th St., New York 36, N. Y.
 Phone: JUDson 6-5577

President. Herbert M. Moss
 Vice Pres. Stephen F. Temmer
 Gen. Manager. Harry F. Landon
 Comptroller. Robert M. Volkell
Services Offered: Recording (tape and
 disc), program production and packages.
 Transcriptions.

GREEN ASSOCIATES

520 N. Michigan Ave., Chicago 11, Ill.
 Phone: WHitehall 4-0818
 General Manager. Lewis G. Green
Services Offered: Production Spots, TV
 shows, film.

**JOHN GUEDEL RADIO
 PRODUCTIONS**

8321 Beverly Blvd., Los Angeles 48, Calif.
 Phone: YORk 6291
 Vice-Pres. & Exec. Producer. . . . John Guedel
Services Offered: Radio and television
 packaging and producing.

**LAURENCE HAMMOND
 PRODUCTIONS, INC.**

455 E. 51st St., New York 22, N. Y.
 Phone: PLaza 9-2210
 President Laurence Hammond
 Vice-Pres. Merikay Howard
Services Offered: Packaging radio and TV
 programs, live, transcribed and filmed. Also
 consultant work in directing, writing, pro-
 ducing and complete public relations facili-
 ties.

**SUE HASTINGS MARIONETTES,
 INC.**

3825 Bryan St., Dallas 4, Texas
 Phone: Tenison 8158
 President Linnea Roberts



Art Director.....W. Higgins
 Film & Program Director.....R. A. Green
Services Offered: Marionette productions for children and adults especially adapted for TV (live or film). Custom-built shows with original scripts and music. Special puppets made for commercials.

ARTHUR HENLEY PRODUCTIONS

Shelton Hotel, 190th St. & Lexington Ave.
 New York, N. Y.
 Phone: PLaza 5-7115

Producer.....Arthur Henley
 Production Asst.....Charline Mernon
Services Offered: Creative programming for radio and television. Complete package-and production, writing and consultation services.

Current Production: Make Up Your Mind.

WEST HOOKER, INC.

853 7th Ave., New York, N. Y.
 Phone: JUdson 2-3026

President.....West Hooker
Services Offered: Program production and programs, Talent, Artists' Representative.

HOWARD RADIO-TV PRODUCTIONS

123 W. Chestnut St., Chicago 10, Ill.
 Phone: MIchigan 2-0128

Owner.....Bernard Howard
Services Offered: All creative phases of Radio-TV-- ideas, writing, production—in-

cluding commercials; Consultant for agencies without their own Radio-TV departments; package producer; free-lance writing and production.

RICHARD W. HUBBELL & ASSOCIATES

1300 Knox Ave., Easton, Pa.
 Phone: 3-8493

Chairman.....R. W. Hubbell
Branch Office

120 Broadway, New York, N. Y.
 Phone: BArelay 7-7760

Exec.in-Charge.....Gilbert Parker
Services Offered: Program producer.

INTER-CALIFORNIA BROADCASTING SYSTEM

253 S. Broadway, Los Angeles 12, Calif.
 Phone: MUtual 2759

General Manager.....Gustavo Faist Moran
Services Offered: Specialists in Spanish language advertising. Production of Spanish language programs.

INTERNATIONAL 16mm CORP.

165 W. 46th St., New York 36, N. Y.
 Phone: PLaza 7-2265

President-Treasurer....Patrick E. Shanahan
 Secretary.....George Blake
 Board of Directors:....Patrick E. Shanahan, George Blake, Julia Cooke.

**e b arry
 e n right
 & f riendly
 inc**

"LIFE BEGINS AT 80"
 "JUVENILE JURY"
 "WINKY DINK AND YOU"
 "OH, BABY!"

667 MADISON AVE. NEW YORK 21, N. Y. TE 2-8600

Services Offered: Producers and distributors of motion pictures; prints in both 16mm. and 35mm. subjects. Classical music with Symphonic Orchestras.

THE JAFFE AGENCY, INC.

8553 Sunset Blvd., Hollywood 46, Calif.
Phone: CRestview 6-6121
N. Y. Phone: PL 7-0100

Dir. of Radio-TV.....Mary Baker
Services Offered: Artists' representatives; TX and Radio package producers.

JEWELL RADIO AND TELEVISION PRODUCTIONS

185 N. Wabash Ave., Chicago 1, Illinois
Phone: FInancial 6-4474

PresidentJames E. Jewell
Vice PresidentW. Ralph Jewell
ManagerCharles P. Flynn
Nat'l. Sales Rep.....Carl Wester
Treas.Lincoln Douglass
Musical Dir.....Richard Dix
Services Offered: A complete radio and television production service. Scripts, Copy, Music, Direction, Transcribed Package Shows, Spots.

KAGRAN CORPORATION

4 W. 58th St., New York 19, N. Y.
MUrray Hill 8-0585

Pres., Prod.Martin Stone
VP, Merch. Dir.....Allan Stone

Merch. Acct. Execs.....Milton P. Kayle,
Daniel G. Forbes
Asst. to Prod.....Joseph Clair,
Jerome Coopersmith
Pub. & Prom. Dir.....Murray Benson
Services Offered: Merchandising and TV and Radio package producers.
Current Productions: Howdy Doody, Johnny Jupiter, Gabby Hayes, Author Meets Critics, Jackie Robinson.

MAXINE KEITH

234 W. 44th St., New York, N. Y.
ManagerMaxine Keith

SONNY KENDIS, INC.

509 Fifth Ave., New York 17, N. Y.
Phone: VAnDerbilt 6-0890

Pres., Exec. Prod.....James Sonny Kendis
Services Offered: Live & filmed radio-TV programs. Complete program packaging service—ideas, scripts, production, talent, sales. Personal management of top talent.

JACK KURTZE AGENCY

214 North Canon Drive, Beverly Hills, Calif.
Phone: CRestview 45403

PresidentJack M. Kurtze
Vice-PresidentLulu Mae Kurtze
Vice President.....John Graves
Executive Producer.....Guy Cooper
Services Offered: Specialized services to advertisers and advertising agencies, produc-

KAGRAN CORPORATION

Martin Stone, President

RADIO and TV PRODUCTIONS

HOWDY DOODY

GABBY HAYES

JOHNNY JUPITER

THE AUTHOR MEETS THE CRITICS

4 West 58th St., New York 19, N. Y.

MU. 8-0585

tion, direction and casting facilities for TV, Radio and motion pictures.

LANG-WORTH DISTRIBUTING CORP.

Steinway Hall, 113 W. 57 St., New York 19, N. Y.

Phone: JUdson 6-5700

President.....C. O. Langlois
 Secretary.....John D. Langlois
 Treasurer.....C. O. Langlois, Jr.
 Vice-President.....W. O'Keefe

Services Offered: Open end and commercial transcriptions, dramatic and musical for radio broadcasting.

LANG-WORTH FEATURE PROGRAMS, INC.

Steinway Hall, 113 W. 57th St., New York 19, N. Y.

JUdson 6-5700

President.....C. O. Langlois
 Secretary.....John D. Langlois
 Treasurer.....C. O. Langlois, Jr.
 Vice President.....W. O'Keefe
 Stations Relations.....Addison C. Amor
 West Coast Mgmt.....Hugh S. Allen

Services Offered: Transcribed music library service for radio stations, advertising agencies and advertisers. Custom built radio programs, both live and transcribed.

HERBERT S. LAUFMAN & COMPANY

616 No. Michigan Ave., Chicago 11, Ill.
 Phone: WHitehall 4-2370

Partner, Sales.....Herbert S. Laufman

Services Offered: Packagers and producer of TV programs, supervision of production for TV film commercials.

LAWRENCE & LEE, INC.

Equitable Bldg., Hollywood 28, Calif

Phone: HOllollywood 4-0101

N. Y. Phone: PL 9-4122

President.....Jerome Lawrence
 Vice-President.....Robert E. Lee

Services Offered: Production consultants. Delivery of literary rights for television, radio and motion pictures.

LES LEAR PRODUCTIONS CORP.

Hotel Sherman, Chicago 1, Ill.

Phone: FRanklin 2-2100

President.....Les Lear

Services Offered: Radio, TV and film production. Personal management.

LESTER LEWIS ASSOCIATES

11 East 48th St., New York 17, N. Y.

Phone: PLaza 3-5083

Partner.....Lester Lewis

Services Offered: TV package shows, personal management.

On Television:

LES PAUL & MARY FORD SHOW (Series)
 (Writer-Director thru Fordel Films Inc.)
 GREATEST STORY EVER TOLD (Series)
 FIGHTS FOR FREEDOM (Series)

Theatrical Releases Through:

RKO-RADIO PICTURES, Inc.
 TWENTIETH-CENTURY FOX

(In Preporation) "MISSING PERSONS" & "The COWBOY-DETECTIVE"
 "ADVENTURE WITH LEE DICKENS"

The Charles E. Skinner Productions

Producers • Adapters • Consultants

TELEVISION - MOTION PICTURES - RADIO

1600 Broadway Suite 312)
 Circle 6-6915-6

STUDIO FACILITIES
 New York--Miami Beach--Hollywood
 & Detroit

Contract Producing for Package Producers
 Producers of Sponsored Sales Influence, Commercial Films
 NATIONWIDE & FOREIGN Television & Non-Theatrical Distribution

Creator of the
 FILM — LIVE INTEGRATION
 Method for TV

Formerly TV and film
 Adapter — DIRECTOR
 (Poll Mall Cigarettes)
 THE BIG STORY

PHILLIPS H. LORD, INC.

501 Madison Ave., New York 22, N. Y.
Phone: PLaza 5-2211

President.....Phillips H. Lord
Manager.....Dorothy E. Levy
Program Supervisor.....Leonard L. Bass
Services Offered: Radio and TV package shows.

THE FREEMAN LUSK COMPANY

1618 No. Argyle Ave., Hollywood 28, Calif.
President.....Freeman Lusk
Sec.-Treas.....Elsie V. Horner
Services Offered: Moderator and producer of discussion programs in the public interest; news reporting and commentary; actor.

C. P. MacGREGOR

729 S. Western Ave., Hollywood 5, Calif.
Phone: DUmkirk 4-4191

President.....C. P. MacGregor
Manager.....George R. Jones
Services Offered: Transcription library productions: music library service, dramatic and musical programs; recording studios. Complete packaging including recording electroplating of masters and production on vinylite pressings.

MARK VII, LTD.

(For full listing see TV Film
Producer-Distributors)

ARNOLD MARQUIS PRODUCTIONS, INC.

717 N. La Cienega, Hollywood 46, Cal.
Phone: CRestview 6-8796
President.....Arnold Marquis
Services Offered: Write, direct, produce and package radio and television programs and spots.

MARSHALL—HESTER PRODUCTIONS, INC.

521 Fifth Ave., New York 17, N. Y.
Phone: MUrray Hill 7-2722-3-4
President.....A. W. Marshall
Vice-President.....Harriet Hester
Legal Representative.....Gerald Dickler
Services Offered: Producing and Packaging Live and Transcribed Radio and TV Programs. Directorial and Supervising Service. Complete Radio and TV Public Relation services for Social, Professional and Trade Organizations.

MASTERTSON, REDDY & NELSON

10 E. 49th St., New York 17, N. Y.
Phone: PLaza 9-1120
Partner.....John Mastertson
Partner.....John Reddy
Partner.....John Nelson
Director.....Ed Leftwich
Producer.....Jerry Bowne
Production Supvr.....Ruth Kyle

*"If you have a problem that has to do
with a radio or television show . . .
maybe we have the answer."*

ROUNTREE—PRESBREY, INC.

Tel.: PLaza 5-7770

Business Mgt. Helen Guy
Services Offered: Packaging and production of radio and TV programs.

ALEXANDER McQUEEN & ASSOCIATES

5222 N. Lakewood Ave., Chicago 40, Ill.
 Phone: RAvenswood 8-9010
 Owner Alexander McQueen
Services Offered: "Nothing But The Truth" feature (Reg. U. S. Pat. Office), in person, transcribed, or TV. Research for human-interest stories on sponsor's product.

CHARLES MICHELSON, INC.

15 W. 47th St., New York 19, N. Y.
 Phone PLaza 7-0695
 President Charles Michelson
 Secretary A. Michelson
 Divisional Sales Manager Ray Linton
 Traffic Manager R. Mantell
 Export Manager Martin Diamond
Services Offered: Producers and distributors of open end quarter hour and half hour radio and television programs. Radio Transcription feature of mystery shows for local station use and TV film series on 16 mm motion picture film.

MILVERNE PRODUCTIONS, INC.

Hotel Bryant, 230 W. 54th St., N. Y. 19, N. Y.
 Phone: Circle 5-6224; Circle 6-2100, Ext. 219
 Executive Producer Milton E. Stanson
 Executive Producer Vernon P. Becker

Services Offered: Origination and production of creative TV programs for every budget. Creation and production of TV Film and Radio commercials; Programming and film consultants to agency and client

MOLE & LEE, INC.

105 W. 55th St., New York 19, N. Y.
 Phone: Circle 6-0006
 President John Mole
Services Offered: Production of packaged shows for Radio and TV.

WILLIAM MORRIS AGENCY, INC.

1740 Broadway, New York 19, N. Y.
 Phone. JUdson 6-5100
 Exec-in-Chg. of Radio. . Wallace S. Jordan
Services Offered: Production of packaged shows for radio and TV, also talent reps.

CARLTON E. MORSE ENTERPRISES, INC.

1500 Vine St., Hollywood 28, Calif.
 Phone Hollywood 9-6161
 Owner Carlton E. Morse
Services Offered: Recording, program production, scripts, package programs.

MORTON RADIO PRODUCTIONS, INC.

64 East Lake St., Chicago 1, Ill.
 Phone CEntral 6-4144
 President Morton Jacobson



"FREEDOM FORUM"
"V.I.P."

FREEMAN LUSK

1618 No. Argyle

Hollywood 28, Calif.

HO 5-2121

◆◆ PROGRAM PRODUCERS ◆◆

Services Offered: Syndicated Radio & TV shows.

HERBERT M. MOSS PRODUCTIONS

2 W. 46th St., New York 36, N. Y.
Producer.....Herbert M. Moss
Services Offered: Live and transcribed shows for Radio and TV.

MUSIC CORPORATION OF AMERICA

MCA Artists, Ltd.

598 Madison Ave., New York 22, N. Y.
Phone: PLaza 9-7500
139 Piccadilly, W1, London, England
430 N. Michigan Ave., Chicago, Ill.
9370 Santa Monica Blvd., Beverly Hills, Cal.
105 Montgomery St., San Francisco, Cal.
2102 N. Akard St., Dallas, Texas
837 Book Tower, Detroit, Mich.
45 Newbury Street, Boston, Mass.
1048 Northwestern Bank Bldg., Minneapolis, Minn.
Services Offered: Production and sales service for live, recorded and filmed TV and radio programs.

MUZAK CORPORATION

(For detailed listing see Associated Program Service, Div. of Muzak Corp. under Transcription Companies.)

THE NATIONAL RESEARCH BUREAU, INC.

415 N. Dearborn St., Chicago 10, Ill.
Phone: SUperior 7-5080
Ed. Dir.-Merch.....Milton Paule
Services Offered: Copy and programming services for radio stations, three monthly sections for the Station Manager, Program Director and Continuity Director.

NATIONAL PRODUCTIONS, INC.

1001 Connecticut Ave., N. W.
Washington 6, D. C.
Phone: STerling 3-2222
President.....Robert J. Enders
Vice-President.....Howard A. Enders
Executive Producer.....Robert L. Friend
Coordinator.....Mary Griffin, Jr.
Services Offered: Radio and television complete production, Transcriptions and films; program consultants; producers of motion pictures for television and industry. Commercials, animation, packagers of programs for local sponsorship.

NELSON PRODUCTIONS, INC.

341 Madison Ave., New York 17, N. Y.
Phone: MUrray Hill 6-5862
President.....Raymond E. Nelson
Secy.-Treas.....Betty Nelson
Services Offered: Production-direction on retainer or free-lance basis, package production, consultation to agencies and clients.

LES LEAR



**RADIO, TELEVISION,
FILMS, PUBLIC RELATIONS,
SPECIAL EVENTS,
PRODUCT REPRESENTATION**

Procter & Gamble's
**WELCOME
TRAVELERS**

starring
TOMMY BARTLETT
NBC } Radio — 7th Year
NET } TV — 2nd Year

LES LEAR PRODUCTIONS
Hotel Sherman
Chicago 1, Ill.
Phone: FRanklin 2-2100

time buying, filmed commercials, research.
Current Productions: Little Lady Story-time, Rod & Gun Club of the Air (TV) Rod & Gun Club of the Air (AU).

OLIVER W. NICOLL PRODUCTIONS

37 W. 16th St., New York 36, N. Y.
 Phone: JUl-on 2-9150
 Cable Address: ARREFFAY New York
 Producer-Dir.

Executive-Dir.....Oliver W. Nicoll
 Associate Director.....Sandra Munsell
Services Offered: Radio—Program production and consultation, package live shows, syndicated transcriptions, scripts, talent, phonograph records and albums; Television - Program production and consultation, package live and film shows, scripts, talent. Members of NSTP—National Society of Television Producers.

OLIO VIDEO TELEVISION PRODUCTIONS, INC.

(See Television Film Producers)

PALLADIUM RADIO PRODUCTIONS, INC.

415 Park Ave., New York 22, N. Y.
 Phone: PLaza 9-8611
 Pres.....Maurice W. Greenthal
Services Offered: Package producers.

PAN AMERICAN BROADCASTING CO.

17 E. 12nd St., New York 17, N. Y.
 Phone: MUrray Hill 2-0810
 Program Director.....Leo Shore
Services Offered: Scripting, producing and recording programs in over 50 foreign languages for use in United States and in foreign countries.

PETERSON RADIO PRODUCTIONS

1157 Broadway, New York 36, N. Y.
 Phone: WI-scon-in 7-0069
 OwnerDonald Peterson
Services Offered: Recording, program production (religious, economic).

GEORGE LOGAN PRICE, INC.

20828 Pacific Coast Hwy., Malibu, Calif.
 Phone: Globe 6-2135
 President.....George Logan Price
 Sales Manager.....S. M. Lauch
 Copy and Production...George L. Price, Jr.
Services Offered: Production of packed radio serials geared to sell to and for ethical accounts of every type. Complete accompanying on commercials, publicity, promotion and public relations.

PROCKTER TELEVISION ENTERPRISES, INC.

221 West 57th St., New York, N. Y.

WM. F. BROIDY PRODUCTIONS INC.

**4TH CONSECUTIVE YEAR
 OF TV FILM PRODUCTION
 FOR KELLOGG* . . .**

*Thru
 LEO BURNETT COMPANY

**America's Top TV Series
 of Western Adventure!**

"WILD BILL HICKOK!"

Co-Starring

GUY MADISON • ANDY DEVINE

5545 Sunset Blvd. • Hollywood 28, Calif. • HOLLYWOOD 3-6844

Phone: JUdson 6-6800
 President Bernard J. Prockter

**RCA VICTOR CUSTOM RECORD
 SALES DIVISION**
 (See Transcription Companies.)

RADIO CITY PRODUCTIONS, INC.
 525 Lexington Ave., New York 17, N. Y.
 Phone: MU 8-6745

Pres. & Sales Mgr..... Morton D. Catok
 V.P. & Prog. Dir.... Raymond R. Chambers
 General Manager..... Frank Scott
Services Offered: Program production,
 both transcribed and live; specialize in pack-
 aging transcribed sports shows and filming
 of TV sports serials. Scripts created. Radio,
 TV celebrity endorsements packaged.

Productions: Radio: "Phil Rizzuto's
 Sports Caravan"; "Junior Jamboree";
 "Sports Forum of the Air." TV: "Tommy
 Henrich Show."

REEMACK ENTERPRISES, INC.
 527 Fifth Ave., New York 17, N. Y.
 Phone: MUrray Hill 7-7979

President Lou Goldberg
 Vice-President Ted Mack
 Secretary Lloyd Marx
Services Offered: Producers of "The Ori-
 ginal Amateur Hour," starring Ted Mack.

STU REYNOLDS PRODUCTIONS
 1416 LaBrea Blvd., Los Angeles 28, Calif.
 President Stuart Reynolds
Services Offered: Specializing in the pro-
 duction and sale of filmed TV programs;
 also in the filming of television programs for
 others and TV commercials; also produc-
 tion and sale of radio programs.

R. S. ROBBINS
 163 Bleecker St., New York 12, N. Y.
 Phone: SP 7-2568

President R. S. Robbins
 Mgr. of Prize Promotion. Edward E. Finch
Services Offered: Radio and Television
 package producers and merchandise prizes.

BOB L. ROBERTS PRODUCTIONS
 152 W. 54th St., New York 19, N. Y.
 Phone: PLaza 7-4314-5

President..... Bob L. Roberts
Services Offered: A—Radio and TV live
 and film productions. B—Specialized pub-
 licity and promotion.

**RICHARD H. ROFFMAN
 ASSOCIATES**

675 West End Ave., New York, N. Y.
 Phone: RIverside 9-3647
 President Richard H. Roffman
Services Offered: Package programs and
 production, Talent, Public Relations. Guest



CREATED BY

Mike Moser

Sponsored by
RALSTON PURINA CO.
 and **NESTLE CO.**

Over
**ABC RADIO AND TELEVISION
 NETWORKS**

KEEP YOUR EYES ON THE FUTURE
 THERE'S MORE COMING FROM

TOWER PRODUCTIONS

11541 Landale, North Hollywood, Calif.

and Prize procurement, Publicity and Promotion, Scripts, Legal Counsel.

ROBINSON RECORDING LABS.

35 S. 9th St., Philadelphia 7, Pa.
Phone: WA 2-6800

President W. P. Robinson
Recording Engineers..... W. W. Jost,
Chas. Metz

Services Offered: Manufacture professional recording equipment. Produce transcribed spots and electrical transcriptions for broadcast and TV.

ROCKHILL PRODUCTIONS, INC.

18 E. 50th St., New York 22, N. Y.
Phone: PLaza 9-7979

President.....Stanley J. Wolf
Services Offered: Complete packages, radio, TV and film.

JACK ROURKE PRODUCTIONS

6331 Hollywood Blvd., Hollywood 28, Calif.
Phone: HE 7178

PresidentJack Rourke
Treasurer.....Joan Lane Rourke
Production Manager.....Dick Wendelken
Office Mgr.....Marjorie Lawson
Musical Dir.....Robert Garretson

Services Offered: Live and transcribed radio and TV programs; spot announcement campaigns and jingles.

Productions: "Ladies Matinee," "Jack Rourke Varieties," "Beauty Parade."

LESLIE ROUSH PRODUCTIONS, INC.

333 W. 52nd St., New York 19, N. Y.
Phone: COlumbus 5-6430

President.....Leslie M. Roush
Vice-Pres.....Jules Sindle
Gen. Mgr.....John Fox

Services Offered: Producers of commercial motion pictures, sound slide films, slide motion films, TV programs and TV commercials.

Productions: TV Commercials: Canada Dry Ginger Ale; Shredded Wheat; Fig Newtons; Vanilla Wafers; White Rose Tea & Coffee; Benrus Watch Co. Comm'l Mot. Pix: "Why Nuts & Bolts" (Bethlehem Steel); "Ichabod-The Headless Man" (Assoc. Amer. Railroads); various films for U. S. Navy.

BARNARD L. SACKETT TELEVISION-RADIO PRODUCTIONS

Empire Bldg., Philadelphia 7, Pa.
Phone: KIngsley 5-6063

Production Manager....Barnard L. Sackett

Services Offered: Complete television service for video stations and advertisers, live

Douglas Sterling Paddock

Consultant

Rear-Screen Projection . . . the
Techniques and Equipment.

Photography, R. P. Slides, Stock
Photos and Special Photographic
Effects for Television.

77 Locust Road Pleasantville, N. Y.

(Associated with Trans Lux Corp., N. Y. C.)



**MARSHALL—HESTER
PRODUCTIONS, Inc.**

521 FIFTH AVENUE
NEW YORK 17, N. Y.



MURRAY HILL 7-2722-3-4

and film productions, commercials, minute spots, custom-built shows, television consultants, personal radio-television representation, concert management.

JAMES L. SAPHIER AGENCY, INC.

9538 Brighton Way, Beverly Hills, Calif.
 Phone: CRestview 1-7231
 6 East 45th St., New York, N. Y.
 Phone: MUrray Hill 7-8370

President.....James L. Saphier
 Mgr. of New York Office.....James Schulke
Services Offered: Radio and TV productions, sale of package programs and talent.

KERMIT SCHAFER RADIO & TELEVISION PRODUCTIONS

443 W. 50th St., New York 19, N. Y.
 Phone: JU 6-1496-7

President.....Kermit Schafar
Services Offered: Live and film television productions, transcribed radio series and kinescope television series, specialists in cooperative advertising also offers celebrity securing and prize procuring services.

BERNARD L. SCHUBERT, INC.

509 Madison Ave., New York 22, N. Y.
 Phone: MUrray Hill 8-0944

President.....Bernard L. Schubert
Services Offered: Talent, production radio and TV package management.

SCREEN GEMS, INC.

(For complete listing see TV Film Producers).

WALTER SCHWIMMER PRODUCTIONS, INC.

75 E. Wacker Drive, Chicago 1, Ill.
 New York Phone: LExington 2-1791
 President.....Walter Schwimmer
 Vice President.....George Guyan
 Sales Manager.....Bernie Crost
 Program Director.....Arthur Pickens
Services Offered: TV and Radio package programs.

SESAC, INC.

475 Fifth Ave., New York 17, N. Y.
 Phone: MUrray Hill 5-5365

President.....Paul Heinecke
 Secretary-Treasurer.....R. C. Heinecke
 Asst. to Pres.....E. S. Prager
Services Offered: Licensing the use of copyrighted music, transcribed library service, syndicated transcribed tailor-made programs for advertisers.

CHARLES E. SKINNER PRODUCTIONS

1600 Broadway, New York, N. Y.
 Phone: CI 6-6915

Executive Producer.....Charles E. Skinner
 Associate Producer.....Robert Sloan
 Production Manager.....Ray Rand

FROM HARRISCOPE

the finest
 in TV sports programming

- Wrestling
- Galopy Racing

Frank Leahy Presents:

- Football
- Baseball
- Tennis
- Golf

For complete information, write

Harriscope Inc.

355 North Beverly Dr.
 Beverly Hills, Calif.

Walt Framer Productions

specializing

HIGH RATING

**AUDIENCE-PARTICIPATION and
 DRAMATIC SHOWS at LOW COST**

CURRENT . . .

- "STRIKE IT RICH"
- "THE BIG PAYOFF"
- "DOUBLE OR NOTHING"
- on TV and Radio

IN PREPARATION . . .

- "CRISIS"
- "MAKE A MILLION"
- "BACKSTAGE REUNION"
- "CALLING ON AMERICA"
- "THE MAGIC LAMP"
- "FREE ENTERPRISE"
- "PASS THE BUCK"
- "JACK IN THE JUKEBOX"

WALT FRAMER PRODUCTIONS

1150 — 6th AVE. New York 36, N. Y.
 OXford 7-3322

Film Music Editor.....Alphonse Corelli
 Musical Director.....Skitch Henderson
 Set Designer.....Charles Carlotti
 Gen. Production Supervisor...William Toth
 Camera Directors.....Joseph Burn.
 George Webber, Drummond Drury
 General Business Mgr.....Melville Ruick
 Assoc. Prod., West Coast Rep...Albert Kelley
Services Offered: Creators and producers of television, theatrical and sales influence films plus live shows; producing contractors; adapters; consultants to package producers, advertising agencies, sponsors. Distribution facilities for television and theatres, U. S. and foreign. Production facilities New York, Florida, Hollywood.

FLETCHER SMITH STUDIOS, INC.
 321 E. 44th St., New York 19, N. Y.
 Phone: MUrray Hill 5-6626

PresidentFletcher Smith
 Vice-PresidentCharles Schettler
 Secretary-TreasurerPeter Caldera
Services Offered: Complete motion picture production; TV shows, spots, industrial films; large sound stage for live photography; animation staff.

SONG ADS, INC.

5927 Sunset Blvd., Hollywood 28, Calif.
 Phone: HOllwood 5-6181

PresidentRobert Saude
 Exec. V.P. Chg. of Sales.....Donald Estey

V.P.-Creative Dir.....Del Porter
 V.P.-Music Dir.....Larry Greene
 Vocal Director.....Ray Linn
Services Offered: Packagers of radio, television, and theatre custom and syndicated musical and dramatic commercials. Composers and producers of film background music. Transcribed and filmed short subjects for entertainment, industry, government and service organizations.

THE SOUVAINE COMPANY

119 W. 57th St., New York, N. Y.
 Phone: Circle 6-6100

General Partner.....Henry Souvaine
Services Offered: Producers of radio and TV programs.

STAR ENTERTAINMENT CORP.

211 W. 42nd St., New York 18, N. Y.
 Phone: LA 4-3450

PresidentMax Wolff
 TalentAJ Roth
Services Offered: Production and packaging of radio and TV shows and all product services for agencies and stations. Scripts, talent, directors and casting consultants.

RICHARD STARK & COMPANY

125 E. 72nd St., New York 21, N. Y.
 Phone: REgent 7-9608

Partners.....Richard Stark, Jane Troxell
 Fashion Photog. Consultant...J. T. Stark
 DesignGeorge Shealy

AFFILIATED ARTISTS

REPRESENTATIVES

IRENE ETKIN

ROBERT MAYBERRY

LEE WALLACE

20 East 53rd St., New York, N. Y.
 FLaza 3-1862

Since 1936

Combining Showmanship
 With Salesmanship

DEMBY PRODUCTIONS, Inc.

TV, Motion Pictures, Radio

Hotel Plaza

1 West 58 Street

Suite 1751

New York 19, N. Y.

PLaza 9-2495

Services Offered: Consultation and/or production of Radio-TV commercials; radio-TV programs prepared and produced by request only; fashion and costume design for TV.

WILBUR STARK-JERRY LAYTON, INC.

270 Park Avenue, New York 17, N. Y.
Phone: PL 3-1742

President.....Wilbur Stark
V.P.-Treas.Jerry Layton
Services Offered: Programs and personalities for television and radio.

RICHARD STROUT PRODUCTIONS

Box 614, Hollywood 38, Calif.
Phone: HOLLYWOOD 4-0277

PresidentRichard A. Strout
Services Offered: Complete production of custom made radio & TV programs and spots. Syndicated shows.

TV PROGRAMS, INC.

10 Washington Place, New York 3, N. Y.
Phone: GRamercy 7-0123

President.....Edward Roberts, Jr.
Director of Sales.....Leonard Beckinan
Services Offered: Package producers of live shows for TV. Also represent and furnish talent.

HAL TATE PRODUCTIONS

192 N. Clark St., Chicago 1, Ill.
Phone: FIancial 6-5450

PresidentHal Tate
S. W. Caldwell, Ltd.
Simcoe House, 150 Simcoe St., Toronto,
Canada
Phone: PL. 8727

THE TEE VEE CO.

(See TV Film Producers)

TELECREATIONS BY NOVAK

344 W. 72nd Street, New York 23, N. Y.
Phone: TRafalgar 4-1999

Owner-Musical Consult. .Frank J. Novak, Jr.
Manager, Charge of Radio/TV Formats

G. Kane Campbell
Radio/TV Producer.....John Gunn
Writers.....Paul Davis, Laura McGhee

Services Offered: Creators, producers of Radio/TV musical variety formats for local, regional or national sponsor. Musical consultants to advertising agencies.

TELEMOUNT PICTURES, INC.

(See TV Film Producers)

TELEVISION SCREEN PRODUCTIONS, INC.

(See TV Film Producers)

TELEVISION AND RADIO FEATURES OF AMERICA

37 W. 46th St., New York 36, N. Y.

Phone: JUdson 2-5130

Cable Address: ARREFFAY, Newyork

Executive Director.....Oliver W. Nicoll
Associate Director.....Sandra Munsell

Production Unit, Hotel New Weston,

Madison Ave. at 49th St., New York 22, N. Y.

Phone: PLaza 3-4800

Managing Dir.....J. H. Macdonnell
Program Coordinator.....Eileen Ellis

Services Offered: Radio—Program production and consultation, package live shows, syndicated transcriptions, scripts, talent, phonograph records, international radio service. Television—Program production and consultation, package live and film shows, script, talent. Members of NSTP (Natl. Society Television Producers).

TOWER PRODUCTIONS

11541 Landale, North Hollywood, Cal.

Phone: HO 4-5752

Services Offered: Production and sale of television package shows. Now featuring radio and television production of "Space Patrol."

**EACH
YEAR
MORE
AGENCIES
RELY
ON**

Endorsements, inc.

Est. 1945

The world's foremost research and service organization devoted EXCLUSIVELY to all phases of endorsements and testimonials.

EXECUTIVE OFFICES:

500 Fifth Avenue
New York 36, New York
CHickering 4-7257

Hollywood • Washington
Chicago • London • Paris

TRANSCRIBED RADIO SHOWS

2 W. 47th St., New York 36, N. Y.
Phone JUdson 2-3530

President.....M. E. Moore
Services Offered: Program productions, syndicated transcriptions, scripts, package programs.

TRANSCRIPTION SALES, INC.

117 W. High St., Springfield 35, O.
Phone: 2-4974

President.....J. P. Williams
Office Manager.....B. Deck
Services Offered: Open-end transcribed programs, 5 and 15 minute shows featuring top talent.

TRANSFILM, INC.

(For complete listing see TV Film Producers)

TRANSAMERICAN BROADCASTING & TELEVISION CORP.

1 E. 54th St., New York 22, N. Y.
Phone: PLaza 5-9800

President.....John L. Clark
Services Offered: Television and radio writing, direction, production and packaging.

TRENDLE-CAMPBELL-MEURER INC.

28 West Ave., Detroit 26, Mich.
Phone: Woodward 2-9184

President.....George Trendle
V. Pres. & Gen. Mgr.H. Allen Campbell
Secy. & Gen. Counsel....Raymond J. Meurer
Services Offered: Radio-TV production.

RICHARD H. ULLMAN, INC.

295 Delaware Avenue, Buffalo 2, N. Y.
Phone: CL 2066

President.....Richard H. Ullman
Vice-President.....Edward H. Kavinoky
Treasurer.....Minna Thorn
Production Manager.....Bill Jacob
Productions: Ad-ismation, syndicated animal film clips, Dollar Derby, participating auction program, Beatrice Kay Show, 78 quarter-hour variety transcriptions, Barber-shop Harmonies, 150 quarter-hour transcriptions, Tune-O-Musical, giveaway show.

ELY LANDAU INC.

509 Madison Ave., New York 22, N. Y.
Phone: MU 8-4800

Pres.Ely Landau
Sec.Harold Kovner
Services Offered: Producers of TV programs on film.

The TEEVEE Co.

Producers and Distributors

"LITTLE THEATRE"

**"INVITATION
PLAYHOUSE"**

"CAMERA'S EYE"

117 Quarter Hours in the Can
Produced expressly for Television

The TEEVEE Co.

211 So. Beverly Drive, Beverly Hills, Cal.

Beverly Hills • Hollywood • New York

"the house of quarter hour shows"

MILVERNE

PRODUCTIONS, INC.

"Creative TV programming for every budget"

**VERNON P. BECKER
MILTON E. STANSON**

Executive Producers

"THE JERRY LESTER SHOW"
ABC-TV Network

Tootsie Hippodrome
Western Show.....ABC-TV Network
Solo Drama.....ABC-TV Network
Kiddie Kollege...WABD-Dumont
Man About Music...WABD-Dumont
and many others

TV Film And Radio Commercials

Hotel Bryant
230 W. 54th St. Circle 5-6224-5
New York 19, N. Y. Circle 6-2100

**UNITED FILM & RECORDING
STUDIOS, INC.**

301 E. Erie St., Chicago 11, Ill.
Phone: SUperior 7-9144

PresidentWilliam L. Klein
Services Offered: Recording, Program and
Spot production, Package Programs, Syndi-
cated Transcriptions, Talent.

UNITED PRESS ASSOCIATIONS

220 E. 42nd St., New York 17, N. Y.
Phone: MURray Hill 2-0400

Pres.Hugh Baillie
Television Mgr.Wm. C. Payette
Radio Manager.....John Madigan
Gen. Sales Manager.....Leroy Keller
Services Offered: World-wide coverage of
news and sports for Radio and TV; special
programming for radio news, sports, women's
and farm shows; daily wire and film service
for TV.

UNITED ARTISTS TELEVISION

(See TV Film Producers)

THOMAS J. VALENTINO, INC.

150 W. 46th St., New York 19, N. Y.
Phone: CIRCLE 6-4675-6

President.....Thomas J. Valentino
Vice-President.....Michael T. Valentino
Vice-President.....Elsie F. Valentine
Gen. Mgr., Secy.....Peter J. Riolo
Services Offered: Sound effects records,
transcriptions, chime and organ recordings,
pressings, recording service.

VIDEO EVENTS, INC.

535 Fifth Ave., New York 17, N. Y.
Phone: MURray Hill 7-1668

President.....Julienne (Judy) Dupuy
Services Offered: Live TV programs, radio
programs, TV commercials, consultants; spe-
cializing in children's shows.

V. I. P.

35 W. 53rd St., New York 19, N. Y.
Phone: PLaza 7-0130

PresidentBill Murphy
Vice-PresidentCharlotte Morgan
Services Offered: Procuring prizes for quiz
shows, producing quiz shows, endorsements
by Very Important People, furnish guests for
Radio-TV shows, servicing out-of-towners
with reservations in hotels, theatre tickets
and travel accommodations.

VIDEO PICTURES, INC.

(For complete listing see TV Film Producers)

CHICK VINCENT CO.

509 Madison Ave., New York 22, N. Y.
Phone: EL 5-0734

Director Producer.....Chick Vincent

Assoc. Pro.Norman Schwartz
Services Offered: Package producers, pro-
gram production, TV programs, live and
film.

W. L. S. ARTIST BUREAU

1230 Washington Blvd., Chicago, Ill.
Phone: MO 6-9700

Co-Partners..George Ferguson, Earl Kurtze
Services Offered: Representing the artists
on Radio Station WLS plus others.

WOLF ASSOCIATES, INC.

420 Madison Ave., New York 17, N. Y.
Phone: PLaza 5-2050

President, Gen. Mgr.....Edward Wolf
Vice-PresidentHerbert Wolf
Exec. Producer-Dir.....Jack Rubin
Sales ManagerPaul Ross
Services Offered: Radio-TV package pro-
duction.

**FRANK WRIGHT NATIONAL
CORPORATION**

995 Market St., Rm. 332, San Francisco, Calif.
Phone: DOuglas 2-5470

Manager.....Frank Parke Wright
TreasurerSylvia C. Wright
V.P.-SalesPerry Hatlen
Vice Pres.....Aphie Tavernas
Services Offered: Merchandised advertis-
ing in the food products field.

WYNN WRIGHT ASSOCIATES

17 West 57th Street, New York 19, N. Y.
Phone: PLaza 3-4417-8

ProducerWynn Wright
Producer-Manager.....Charles Granzow
Casting Director.....Helen Wright
Services Offered: Creation and production
of radio dramas.
Current Productions: Squad Room, Of-
ficial Detective, Crime Fighters, Under Ar-
rest, Farm Quiz.

FREDERIC W. ZIV CO.

1529 Madison Rd., Cincinnati 6, O.
Phone: PLaza 1323

PresidentFrederic W. Ziv
Services Offered: Network and transcribed
programs.

ZIV TELEVISION PROGRAMS, INC.

488 Madison Ave., New York 22, N. Y.
Phone: MURray Hill 8-4700

Chairman of the Board....Frederic W. Ziv
President.....John L. Sinn
Vice-President.....M. J. Rifkin
Treasurer & Comptroller...Joseph L. Moore
Services Offered: Film programs.
Productions: "Favorite Story," "The Un-
expected," "Boston Blackie," "The Cisco
Kid," "Your TV Theatre," "Story Theatre,"
"The Living Book," "Yesterday's News-
reel," "Sports Album."



TRANSCRIPTIONS

- **PRESSINGS**

All sizes, all speeds from three inch to sixteen inch, from 16 rpm to 78 rpm.

- **WORLD'S FINEST ENGINEERS**

- **PROMOTIONAL IDEA SERVICE**

- **COMPLETE PACKAGING FACILITIES**

Art Work
Jockets
Individual Packing
Mailing Service

- **SCRIPT, MUSIC, PRODUCTION
AND CASTING SERVICE**

- **COAST-TO-COAST FACILITIES**

Studios
Engineering
Pressing Plants

COLUMBIA TRANSCRIPTIONS

A DIVISION OF COLUMBIA RECORDS INC.

New York

799 Seventh Ave.
CI-5-7300
Gil McKean, Director
Al Shulman,
National Sales Manager

Chicago

410 N. Michigan Ave.
Whitehall-4-6000
Jerry Ellis, Manager

Hollywood

8723 Alden Dr.
Crestview 6-1034
Al Wheeler, Manager

T*ranscription Companies*

- **PERSONNEL**

- **ADDRESSES**

- **SERVICES OFFERED**

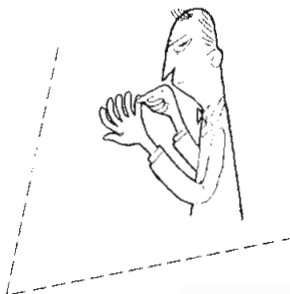
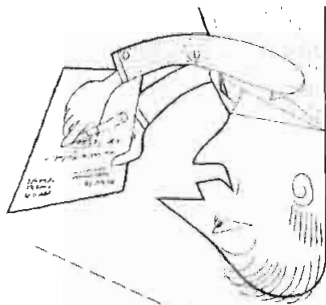

Any
way
you
figure...

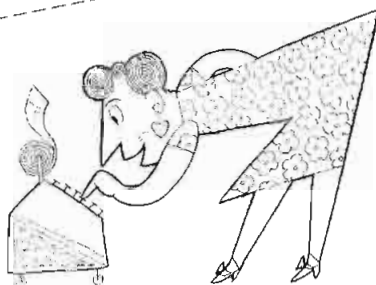
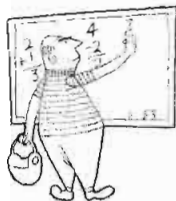

RCA VICTOR Transcriptions serve buyers best!

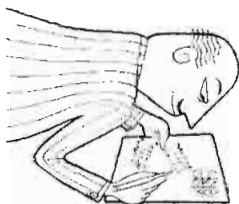

Transcriptions of every description—Whether you buy for an advertising agency, a recording studio, public service institution or your own business, RCA Victor Custom Record Sales is set up to fill your every need. Just name it: audition discs, spot announcements, full length programs—10" and 12" microgroove; 12" and 16" standard groove...

Complete facilities, strategically located—Recording and re-recording, processing, pressing, shipping and handling are all part of RCA Victor service. Script-writing and complete radio production also available. And you get the benefit of the country's best-equipped studios and plants, the world's top engineers.

Fast service: large order or small—You can count on a delivery cycle timed to your orders. Regardless of size, every transcription order gets full attention and prompt handling every step of the way.

It adds up! Finest quality at a low, competitive price—The best of materials and most advanced methods team up with RCA Victor skill, to bring you a product that leads the industry in sound, uniformity, high-fidelity and appearance. All this is yours at a competitive price! Check with an RCA Victor Custom Record Sales office for electrical transcription service at its best!

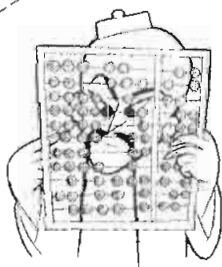

Custom Record Sales



RADIO CORPORATION OF AMERICA RCA VICTOR DIVISION

630 Fifth Ave.
Dept. D-10
New York 20, N. Y.
JUdson 2-5911

445 N. Lake Shore Dr.
Dept. D-10
Chicago 11, Ill.
WHitehall 4-3215

1016 N. Sycamore Ave.
Dept. D-10
Hollywood 88, Calif.
WHitehall 4-5171

TMAS ©

TRANSCRIPTION COMPANIES

AFFILIATED PROGRAM SERVICE, INC.

535 Fifth Ave., New York 17, N. Y.
Phone: MURray Hill 7-1881

President.....Paul F. Adler
Services Offered: Production and sales of transcribed series. Specialize in syndicated disc jockeys. Radio script library.

ALL-CANADA RADIO FACILITIES, LTD.

80 Richmond St. W., Toronto 1, Ont., Can.
Phone: EMpire 6-7691

President.....H. R. Carson
General Manager.....G. F. Herbert
Asst. Gen. Mgr.....Stuart MacKay
Manager.....Robert Tait
Services Offered: Canadian representatives and distributors for transcription companies.

ALLIED RECORD MFG. CO.

1041 N. Las Palmas, Hollywood 38, Calif.
Phone: HOLlywood 9-5107
619 W. 54th St., New York 19, N. Y.
Phone: JUDson 2-3791

President.....D. K. Broadhead
Vice Pres. of Mgr.....Sam Salzman
Comptroller.....J. S. Van Leer
Sales Manager.....John F. Wegner
New York Div. Mgr.....K. R. Smith
New York Div. Asst. Mgr.....Hal G. Neely
Wash., D. C. Mgr. & Contr. Dir..W. S. Adams
Services Offered: Processing and pressing electrical transcriptions and phonograph records. All types, sizes, and speeds. Complete recording facilities available.

AMERICAN INSTITUTE OF FOOD PRODUCTS, INC.

608 5th Ave., New York 21, N. Y.
Phone: JUDson 6-7600

General Manager.....Robert A. Bories
Services Offered: Production of programs for food merchandising for TV and radio.

ARTISTS RECORDING STUDIOS

15 West 10th St., Kansas City 6, Mo.
Phone: HA 6109

Owner.....Bill L. Godden
Engineer-Operator.....Bill L. Godden
Services Offered: Original or direct copy masters, TV sound production, phonograph record production, "custom built programs," spot announcements, air-checks, copies of disc, tape or wire, portable tape recordings, complete sound effects libraries, sync. cutting tables, script writers, talent files.

ASSOCIATED PROGRAM SERVICE (Div. of Muzak Corp.)

221 Fourth Ave., New York 19, N. Y.
Phone: ORchard 4-7400

Vice-Pres. & Gen. Mgr.
Edward Hochhauser, Jr.

Services Offered: A transcription library comprised exclusively of radio music not available on phonograph records; including jingles for advertisers, time, weather, dollar-day spots and shopping-days-til-Christmas jingles. Also TV production music library and special transcription library for industrial slide film producers.

AUDIO-MASTER CORP.

17 East 54th St., New York 17, N. Y.
Phone: OXFord 7-0725

President.....Herbert Rosen
Service Offered: Transcriptions; mood and bridge music library; three speed record and transcription players.

AUDIO-VIDEO RECORDING CO., INC.

730 5th Ave., New York 19, N. Y.
Phone: PL 7-3091

President.....Charles E. Rynd
Vice-Pres.....T. J. Merson
Vice-Pres., Treas.....Richard Rynd
Sales Manager.....Ray Rand
Services Offered: Facilities for recording for radio and TV, disc mastering and dubbing, mfr. facilities transcription and phonograph records, mass tape duplication for radio, educational, religious and industrial programs; complete program production service.

A-V TAPE LIBRARIES, INC.

730 Fifth Avenue, New York 19, N. Y.
Phone: PLaza 7-3091

President.....Joseph F. Hards
Services Offered: Full library of recordings on tape, recording, program production.

AUDIVOX RECORDS, INC.

140 West 57th St., New York 19, N. Y.
Phone: COLumbus 5-2517

Owners....Raymond Scott, Dorothy Collins, Leonard Wolf
Officers...Raymond Scott, Dorothy Collins, Leonard Wolf, Bob Briody
General Manager.....Leonard Wolf
Services Offered: Manufacturers of phonograph records for commercial use in all speeds, 78, 45 and 33 1/3 r.p.m.

LOCAL RADIO IS HE

MORE THAN

**1000
STATIONS
NOW SUBSCRIBE TO
WORLD**

Never before, have so many stations turned to one source for the answer to hundreds of local sales problems!

M-M-M-M-M MORE AND MORE FOR '54!

The pot's boiling now with World's biggest, brightest sales-booming ideas.



ALTHIER THAN EVER!

Stronger... sturdier... this vital advertising medium is now enjoying the most aggressive selling year in its history.

Yes, radio at the local level, where it hits hardest and produces the best is booming... setting new business records in market after market!

RADIO DAILY REPORTS:

WORLD BROADCASTING SYSTEM HITS RECORD IN SUBSCRIBERS

"As another indication of the continually broadening scope of local radio, World Broadcasting System has hit a history-making record in the radio transcription industry with over a thousand station subscribers to its services."

BROADCASTING REPORTS:

"World's emphasis on more merchandising designed for local spot business and local sales for radio has been confirmed by this tremendous upsurge of subscriptions."

WORLD-AFFILIATES REPORT:

- Record-breaking sales with "YOU WIN"—½ hour telephone quiz series... stars, excitement, prizes. "FOOTBALL TIME"—¼ hour shows with scores, predictions, songs, thrills.
- Sales-making jingles series gives advertisers the effectiveness of commercials on network shows.
- Booming sales with World's annual package of Christmas programming including ½-hour, open-end drama starring Charles Coburn.



WORLD SALES AND PROGRAM SERVICE

WORLD BROADCASTING SYSTEM, INC.
488 Madison Avenue, New York 22, New York

CINCINNATI HOLLYWOOD
CANADIAN REPRESENTATIVES ALL-CANADA RADIO,
FACILITIES LIMITED, VICTORY BUILDING, TORONTO

Clip and
Mail NOW!

★ WORLD BROADCASTING SYSTEM, INC.

488 Madison Avenue
New York 22, N. Y.

Please rush all the facts on your money-making program and sales service. No obligation.

STATION MANAGER _____

RADIO STATION _____

STREET ADDRESS _____

CITY _____ ZONE _____ STATE _____



20 YEARS
OF
RECORD
SERVICE

PROCESSING

Better in dozens of ways,
because of scientific
testing at every step.

PRESSING

Proved better by hundreds
of satisfied clients all
over the world.

TAPE DUPLICATION

Guaranteed broadcast
quality—now used in
broadcasts everywhere.

SHIPPING

Allied's cross checking
controls assure on-time
delivery under any
circumstance.



ALLIED RECORD
MANUFACTURING COMPANY

619 W. 54th STREET
NEW YORK, NEW YORK

1041 N. LAS PALMAS
HOLLYWOOD, CALIFORNIA

BELL SOUND STUDIOS, INC.

112 W. 89 St., New York 24, N. Y.
Phone: TR 3-4328-9

PresidentAllen Weintraub
Secy.-Treas.Daniel Cronin
Services Offered: Complete services for tape, disc and film recording with studio production facilities. Masters (standard and microgroove), N.A.B. Standard transcriptions for broadcast or audition. Remote and location recording for broadcast and film.

S. W. CALDWELL, LTD.

447 Jarvis St., Toronto 5, Ontario, Canada
Phone: Kingsdale 2103

President.....Spence W. Caldwell
Services Offered: Syndicated transcriptions, package programs.

CAPITOL RECORDS DISTRIBUTING CORP.

Studio and Rec. Sales Services Div.

5515 Melrose Ave., Hollywood 38, Calif.
Phone: HOLlywood 3-7114
151 West 46th St., New York 36, N. Y.
N. Y. Phone: COLUMbus 5-4758

Vice-President.....Walter S. Heebner
Western Sales Rep.....Gene J. Becker
Eastern Sales Mgr.....Herbert I. Sachs
Production Mgr.....John Seely
Services Offered: Custom recording for records and television; mastering, processing and pressing; full library of production music.

CENTURY RECORD MFG. CO.

160 West Olive Ave., Burbank, Calif.
Phone: ROKkwell 9-1593

Sr. Partner.....James B. Keysor
Plant Manager.....James B. Keysor, Jr.
Sales Manager.....Richard B. Keysor
Services Offered: Complete services for recording, processing and pressing electrical transcriptions and phonograph records. Licensed by Western Electric for lateral or vertical recording.

COASTAL RECORDING CO.

136 W. 52 St., New York 19, N. Y.
Phone: CIRCLE 6-3900

Managing Director.....Arthur Shaer
Services Offered: Complete recording and transcription service—sound effects library, Hammond organs, celeste, Steinway grands. A complete staff for foreign transcriptions. Ampex tape recording.

COLUMBIA RECORDS, INC.

799 Seventh Ave., New York 19, N. Y.
Phone: CIRCLE 5-7300

President.....James B. Conkling
Executive Vice-Pres.....Goddard Lieberston
Vice-Pres. Chg. Research
& Development.....James H. Hunter

Vice-Pres. Chg. of

West Coast Op.....A. J. Schrade
Vice-Pres. Chg. of Sales.....Paul J. Wexler
Secretary.....Kenneth E. Raine
Treasurer.....W. C. Wilkin
General Auditor.....Arthur S. Padgett
Services Offered: Records, phonographs and attachments and transcriptions.

COLUMBIA TRANSCRIPTIONS

(A Division of Columbia Records, Inc.)

799 Seventh Ave., New York 19, N. Y.
Phone: CIRCLE 5-7300

Director.....Gilbert S. McKean
N. Y. Acct. Exec.....Carl Reinschild
Natl. Sales Manager.....Albert Shulman
Manager, Chicago Office.....Girard D. Ellis
410 N. Michigan Ave., Chicago, Ill.
8723 Alden Dr., Los Angeles 47, Calif.
Mgr. L.A. Office.....William A. Wheeler
Services Offered: Studio facilities and manufacturing plants New York, Chicago, Hollywood, all speeds, all size records and transcriptions. Complete package from idea to finished jacketed recording.

COMMODORE PRODUCTIONS AND ARTISTS, INC.

971 N. La Cienega, Hollywood 46, Calif.
Phone: CRESTview 4-2023

Pres. and Exec. Prod.....Walter White, Jr.
Associate Prod.....Bill Heath
Production Mgr.....Vernon Keays
Coordinator.....Eleanor Payne
Casting Director.....Miriam Powers
Film Editor.....Robert Warwick, Jr. (a.c.e.)
Art Director.....James Sullivan
Services Offered: Hopalong Cassidy, 104 episodes transcribed open-end for radio ½ hr.; "The Clyde Beatty Show," radio; transcribed open-end shows ½ hr.; TV 13 ½ hr. films in color; "Strolling Tom" 156 — 15 min. episodes; "Down Our Way" 25 — 30 min. episodes.

GORDON M. DAY PRODUCTIONS

108 E. 30th St., New York 16, N. Y.
Phone: OREGon 9-3595

Writer-Composer.....Gordon M. Day
Producer-Director.....Carol Bulkeley
Production Manager.....Edith Adelson
Treasurer.....Leo L. Reich
Services Offered: Specialists in writing, producing and recording singing commercials and spots of all types, and serving as radio-TV department for advertising agencies.

DECCA RECORDS, INC.

50 W. 57 St., New York 19, N. Y.
Phone: COLUMbus 5-2300

Mgr., Special Service.....Edward Strauss
Services Offered: Studio rental; records pressed.

IN 1954...

RCA's *Thesaurus* will

to more sales!

because Thesaurus gives you planned programming — and sales aids such as —

Big-name talent in complete shows . . . Exclusive singing Jingle Library . . . Special feature program signatures . . . Tailored sound effects for sponsor identification . . . Sales-clinching audition discs . . . Sponsor-selling brochures . . . Exclusive Monthly Marketing Bulletin . . . Sponsor success stories!

to more profits!

because Thesaurus cuts operating costs!

Only with Thesaurus do you get so many exclusive services that save valuable staff time and reduce your sales expense. Big weekly continuity service . . . Specially prepared marketing research . . . Time and money-saving sales packages that produce peak sales with minimum time and minimum effort on your part!

to more listeners!

because Thesaurus gives you top shows, popular big names and plenty of promotion aids!

You can build audiences faster . . . and keep them . . . with these popular, big name Thesaurus shows. Plenty of the kind of promotion you need to sell — mats, photos, press releases, tune-in announcements — to keep folks in your area talking about . . . and tuning in . . . your station!

Only with Thesaurus do you get so many exclusive door openers!

1 BASIC LIBRARY OF BIG-NAME SHOWS:

Look at that Thesaurus talent roster! Not just big names . . . but big name shows complete with full continuity, open end for local announcements. The basic library has a minimum of 52 new musical selections added each month!

2 EXCLUSIVE MARKETING BULLETIN:

Here's a really thrifty way to save staff research time. Marketing Bulletin gives you the latest information on what are the "hot items" for the coming month — what to promote, who is your likeliest prospect. And, it's exclusive with Thesaurus!

3 EXCLUSIVE JINGL-LIBRARY:

The world's largest collection of singing jingles! More than 1800 jingles, for every kind of product, for every situation . . . something to hit the mark with every prospect. Open end for local tune-in

4 CONTINUITY SERVICE:

Every week you get expertly written continuity for 31 different shows. In addition the library includes production aids such as voice tracks, theme music, tie-ins, cross-plugs, sound effects . . . plus signatures for sports, news and feature programs.

5 SALES TOOLS:

Thesaurus provides you with sales aids — sponsor-selling brochures, sales-clinching audition discs, testimonials, case histories, success stories, publicity and promotion kits, advertising assistance . . . the works!

No other Library offers all these features

And no other service opens doors to more profits, more sponsors and more listeners the way Thesaurus does. Get in touch with a Thesaurus representative today for all the profitable details.



recorded
program
services

Radio Corporation of America RCA Victor Division

610 Fifth Avenue, New York 20, N.Y.
Judson 2-5011
445 N. Lake Shore Drive, Chicago 11, Ill.
Whitehall 4-3530
1016 N. Sycamore Ave., Hollywood 38, Calif.
Hollywood 4-5171
522 Forsyth Bldg., Atlanta 3, Ga.
Lamar 7-703
1907 McKinney Ave., Dallas 1, Tex.
Riverside 1-371

TM 56A

The Hour of Charm



Phil Spitalny's All-Girl
Orchestra and Choir—
Featuring Evelyn and her
Magic Violin . . .
half-hour show—
once a week.

THIS IS YOUR TALENT LIST WITH THESAURUS . . .

The Sammy Kaye Show
The Hour of Charm
The Wayne King Serenade
Music by Roth
Music Hall Varieties
Concert Hall of the Air
Men Behind the Melody

"DATE IN HOLLYWOOD"

Starring Eddie Fisher
and Gloria de Haven
with Hugo Winterhalter and
his Orchestra . . .
quarter-hour show—
three times weekly.



SONS OF THE PIONEERS

An all-star, quarter-
hour musical
round-up of
Western and
Cowboy music
at its best
. . . five times
weekly.



Norman Cloutier
The Freddy Martin Show
Date in Hollywood
Sons of the Pioneers
The Tex Beneke Show
Hank Snow
Music of Manhattan
Church in the Wildwood
Fran Warren Sings
A Festival of Waltzes
The Singing Americans
Vincent Lopez
Music in March Time

The Sammy Kaye Show

Starring Sammy Kaye and his
Orchestra with Peggy Powers,
Jeffrey Clay, the Kaydels and
the Kaye Choir . . . quarter-
hour show three
times a week.



"the FREDDY MARTIN Show"

Freddy Martin and his Orchestra
with Merv Griffin, Murray
Arnold and the Martin Men
. . . quarter-hour show
—three times weekly.



**I Hear the Southland
Singing**
Music to Dream By
Slim Bryant
and his Wildcats
Here's June Christy
Organairs
Old New Orleans
Claude Thornhill
Artie Shaw
Ray McKinley
Jumpin' Jacks

The WAYNE KING Serenade

The "Waltz King" and his
Orchestra with Harry Hall,
Gloria Yan, Jacqueline
James and the Wayne
King Chorus . . . half-
hour show—once
a week.



EMPIRE RECORDING

TAPE - DISC
—
STUDIOS
—
AIR/LINE CHECKS
—
AM-FM-TV
—
PORTABLE JOBS
—
FILM
SYNCHRONIZATION



EMPIRE BROADCASTING CORP
480 LEXINGTON AVE.
NEW YORK 17, N. Y.
PLaza 9-4500-01-
02-03-04-05-06

Services Offered: Syndicated transcriptions, package programs.

EMPIRE BROADCASTING CORPORATION

180 Lexington Ave., New York, N. Y.
Phone: PLaza 9-4500

President & Treasurer.....Helen D. Kellher
Vice-President.....Arthur Lubo
Vice-President.....Fred de Jaager
Secretary.....John Hughes Dwyer
Services Offered: Recording, program production and packages, talent.

FINE SOUND, INC.

711 Fifth Ave., New York 22, N. Y.
Phone: PLaza 3-5400

President.....C. R. Fine
Operations V.P.....Seymour Moses
Rec. Super.....G. Piro
Services Offered: Equipped for all media. Complete engineering for disc, tape and film including mobile equipment for location work. Western Electric Film Recorders, Ampex and Fairchild tape machines, Fairchild and Scully lathes, 35mm and 16mm facilities.

FULTON RECORDING CO.

80 W. 40 St., New York 18, N. Y.
Phone: LAckawanna 4-7187

General Manager.....Thomas E. Farrell
Chief Engineer.....Robert Doherty
Services Offered: Sound recording, tapes, discs, Ampex tape recorders; Separate facilities for cutting of masters and tape editing. Western Electric magnetic and optical film recorders.

MITCHELL GERTZ AGENCY, INC.

240 S. Beverly Dr., Beverly Hills, Calif.
Phone: CR 4-5491

Owner.....Mitchell Gertz
Associate.....Harold Gelsky
Services Offered: Packagers of Radio and TV shows - live and transcribed. Representing authors, actors, composers, directors, playwrights and other artists.

HARRY S. GOODMAN PRODUCTIONS

19 E. 53 St., New York 22, N. Y.
Phone: PLaza 5-6131

President-Gen. Mgr.....Harry S. Goodman
Vice-Pres.-Charge Sales.....Everett F. Goodman
Vice-Pres.-Charge TV.....Daniel R. Goodman
Secretary.....H. D. Knuth
Services Offered: Producer of syndicated transcribed radio shows, live radio shows,

— RECORDINGS ◆ ◆ ◆

syndicated TV availabilities and live TV shows. Also Custom Built AM and TV spots.

GOTHAM RECORDING CORP.

2 West 46th St., New York 36, N. Y.
Phone: JU 6-5577

President.....Herbert M. Moss
Vice-President.....Stephen F. Temmer
Comptroller-Treas.....Robert M. Volkell
General Manager.....Harry F. Landon
Services Offered: Six medium and large studios available—12 Ampex tape machines—Heated stylus masters, TV, AM spots, high quality transcriptions. Writing and production staff available.

GEORGE HEID PRODUCTIONS

William Penn Hotel, Pittsburgh 30, Pa.
Phone: GRant 1-3696

PresidentGeorge Heid
V.P., Treas.....Margaret Heid
Chief Engineer.....Joseph P. Gearing
Musical Director.....Everett Neill
Services Offered: Recordings, transcriptions, package programs for radio and TV, film productions, air check for radio and TV, scripts, talent.

MARY HOWARD RECORDINGS

37 E. 49 St., New York 17, N. Y.
Phone: PLaza 8-2910

OwnerMary Howard
Chief Engineer.....L. MacDonald
Office Manager.....Gretchen C. Howard
Services Offered: Ampex Tape, Scully Lathe, Pic-Sync Generator for synchronizing tape to film—Studio, live, off-the-air recordings; Microgroove recordings, pressings.

FLORRIE JAYE

48 West 48th St., New York 36, N. Y.
Phone: JUdson 6-9734

Services Offered: Custom-built Radio & TV jingles, recordings.

ESTELLA H. KARN

49 West 45th St., New York 19, N. Y.
Phone: JUdson 2-2170

Owner.....Estella H. Karn
Services Offered: Recording, program production and packages.

KEYSTONE BROADCASTING SYSTEM, INC.

111 W. Washington St., Chicago, Ill.
Phone: State 2-6303

President (Dir.).....Sidney J. Wolf
Vice-President (Dir.).....Joseph Bayer
Vice-President.....Noel A. Rhys
Vice-President.....Edwin R. Peterson
Vice-PresidentWilliam Bayer
Secretary-Treasurer (Dir.).....Arthur Wolf
580 Fifth Ave., New York, N. Y.
Phone: PLaza 7-1460

V.P., East. Sales Dir.....Noel A. Rhys
Acct. Executive....Charles A. Hammarstrom
Office Manager.....Eve Banner
Director of Research.....John Scanlan

Mood Music

for

TV FILMS

INDUSTRIAL

DOCUMENTARY FILMS

and **FEATURE**

Motion Pictures

Five complete recordings of
the following libraries:

PAXTON — BOSWORTH

— BRULL — ODEON —

AND

FRANCIS DAY & HUNTER

Also the largest selection of
sound effects records in exist-
ence. Anything from a "cat's
meow to a lion's roar" all on

MAJOR RECORDS

SEND FOR FREE CATALOGUE

THOMAS J. VALENTINO, INC.

Established 1932

150 West 46th Street

Dept. RD

New York 36, N. Y.

*Music Clearance on Above Catalogues
Arranged by Our Firm*

111 W. Washington St., Chicago, Ill.
Phone: State 2-6303

President.....Sidney J. Wolf
Vice-President.....Edwin R. Peterson
Secretary-Treasurer.....Arthur Wolf
Dir. of Station Relations.....Blanche Stein
Traffic Manager.....Kay Krause
Program Director.....Jane McFadgen
1330 Wilshire Blvd., Los Angeles, Calif.

Phone: DU nkirk 3-2910

Vice-President.....William Bayer
Account Executive.....Henry G. Eschen
75 Post St., San Francisco

Phone: SU iter 4-7140

Account Executive.....Don Kerwin
Services Offered: The Keystone Broadcast-
ing System is a transcription network which
services local radio stations in their pro-
gramming with transcriptions, with KBS

making their time available to national ad-
vertisers and their agencies at an attractive
network package rate.

At the present, there are more than 700
Keystone affiliates, located in towns with
10,000 to 100,000 population where they reach
both the small town and rural markets. For
the most part, these Keystone stations serve
those areas which are beyond clear reception
areas of the large metropolitan radio stations
or other high power stations. The number of
radio homes in these Keystone markets,
based on Nielsen Coverage Service areas 4-
17,131,010. There are an additional 1,332,319
homes in the primary of 59 KBS stations for
which the Nielsen reports were not available,
therefore, the total radio homes within the
primary area of Keystone represents a total
of 13,653,850.

memo from *Ed Hochhauser Jr.*

THERE'S ONLY ONE REAL
TV PRODUCTION MUSIC TRANSCRIPTION LIBRARY
AND
ONLY APS HAS IT !

CONTENTS:.....321 different specially arranged selec-
tions laterally recorded on 16 inch
cherry red virgin vinylite.

ARTISTS:.....The very finest.

PRICE:.....\$19.50 per month, minimum one year
contract.

Auditions, catalog:.....Yours on request.

APS
Associated Program Service
(A division of Muzak Corp.)

221 Fourth Ave., New York 3, N. Y. • ORchard 4-7100

Keystone is a flexible media easily purchased, whole or in part. Entire areas or spot coverage may be selected . . . whichever meets the needs of the advertising program. Regardless of the schedule, Keystone makes its time available at a considerable savings.

In operation, Keystone offers the same advantages as the wired networks. Instead of a large number of individual transactions, KBS reduces your problem to one order, one time clearance, one series of Affidavits of Performance, and one invoice.

Many of the nation's largest advertisers are using the facilities of Keystone. Types of programming vary from 25 word spots to one hour shows.

LANG-WORTH FEATURE PROGRAMS, INC.

113 W. 57 St., New York 19, N. Y.
Phone: JUDson 6-5700

President.....C. O. Langlois
Secretary.....John D. Langlois
Treasurer.....C. O. Langlois, Jr.
Vice-PresidentW. O'Keefe
Mgr. of West Coast Oper.....Hugh S. Allen
Station Relations.....Addison C. Amor

Services Offered: Music scoring for television, documentary or industrial pictures—live or from film sound track or magnetic tape libraries. Original music for commercial spots. Transcribed library recorded especially for television stations.

C. P. MacGREGOR

729 S. Western Ave., Hollywood 5, Calif.
N. Y. Phone: Dunkirk 4-4191

President.....C. P. MacGregor
Manager.....George R. Jones
Services Offered: Transcription library productions: music library service, dramatic and musical programs; recording studios. Complete packaging including recording electro-plating of masters and production on vinylite pressings.

MASTERPIECE RECORDING CO.

1 E. 54th St., New York 22, N. Y.
Phone: PL 5-9760

Owner-Mgr.Nat Levy
Services Offered: Disc, tape and film recording. Studio and remote facilities. Micro-groove and standard masters and pressings.

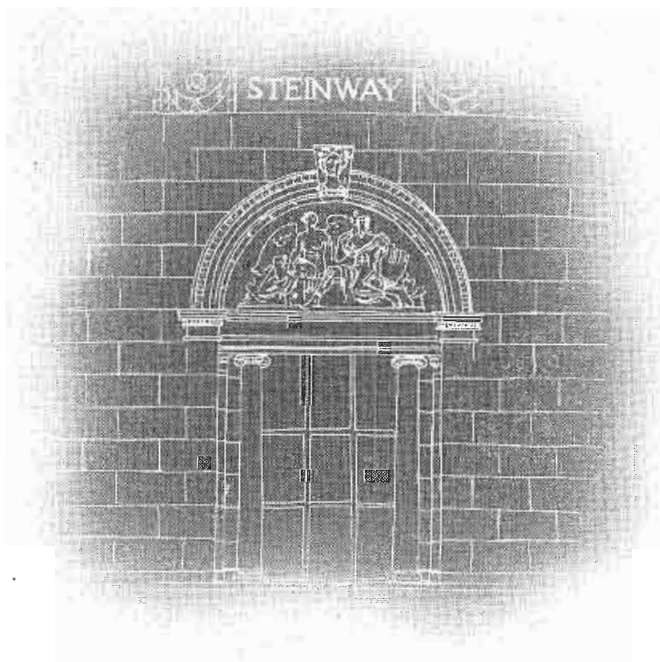

FULL RANGE RECORDING

*The
Penthouse
Studios*

of V. J. Nola

STEINWAY HALL

JUDson 6-0040

113 WEST 57th STREET

New York 19, N. Y.

••••• **FILM** ••••• **TAPE** ••••• **DISC** •••••

Nola Studios, Inc., WMCA Building
1657 Broadway, New York 19, N. Y. • Plaza 7-4870

Auditions, AM, FM and TV air checks, expert tape editing.

FRED C. MERTENS & ASSOCIATES
20826 Pacific Coast Highway, Malibu, Calif.
Phone: Globe 6-2135

Sales Manager.....George L. Price
Services Offered: 156 five-minute transcribed spots, Miracles of Faith, open in middle and at each end, 78 miracles of religious origin; 78 pertaining to political, social, and economic advancement of mankind.

M G M RECORDS

701 Seventh Avenue, New York, N. Y.
Phone: Circle 5 4820

General Manager.....Frank B. Walker
Advertising & Promotion...Sol Haulwerger
Artist & Repertory.....Harry Meyerson
Services Offered: Popular and classical records, original movie cast albums 78, 45, 33 1/3 r.p.m.'s.

CHARLES MICHELSON, INC.

15 West 47 St., New York 19, N. Y.
Phone: PLaza 7-0695

PresidentCharles Michelson
Divisional Sales Mgr.....Ray Liuton
Services Offered: Open end dramatic and musical transcribed feature programs. Gennet and Speedy-Q Sound Effect Libraries.

MODERN RECORDING STUDIO

55 W. Wacker Drive, Chicago 1, Ill.
Phone: FI 6-4183

Owner.....Edwin M. Webb
Services Offered: Transcription, commercial records, slide film, television sound track, microgroove and aircheck recording on tape or disc. Tape and disc copying. Tape remotes. Tape editing. Master processing and pressing.

MORTON RADIO PRODUCTIONS, INC.

61 E. Lake St., Chicago 1, Ill.
Phone: Central 6-1114

PresidentMorton Jacobson
Services Offered: Syndicated transcriptions, package programs.

MUSICOMMERCIALS

344 W. 72 St., New York 23, N. Y.
Phone: TRafalgar 4-1999

PresidentFrank Novak
Radio-TV Producer.....John Gunn
Mgt. Writer.....Lewis Reid
Associate Producer.....Betty Marshall
Promotion Manager.....Richard Davis
Services Offered: Creators of live or transcribed radio and television spots and jingles. Overall production including talent, musicians and all mechanicals for the conveni-



EXCLUSIVE RIGHTS GRANTED

FREE SAMPLE DISKS ON REQUEST

EST. 1929
C. P. MacGregor

729 S. WESTERN

HOLLYWOOD

DUNKIRK 4-4191

ence of out-of-town agencies. Musical variety formats with mass appeal for both radio and TV.

MUZAK CORPORATION

221 Fourth Ave., New York 3, N. Y.
Phone: ORchard 4-7400

President.....Harry E. Houghton
Exec. Vice-Pres.....Charles C. Cowley
Vice-Pres. & Treas.....John R. Andrus
Vice-Pres. Nat'l Sales.....Nils W. Hillstrom
Vice-Pres.-Spec. Svcs...Alexander B. Motenko

Wired Music Div.

229 Fourth Ave., New York 3, N. Y.
Phone: ORchard 4-7400

Vice-Pres. N. Y. Oper.....Ethel W. Maclean
Vice-Pres. Chg. of Sales...Curt H. Pfenniger
Promotion Mgr.....Roger L. Thaxter

Associated Program Service Div.

221 Fourth Ave., New York 3, N. Y.
Phone: ORchard 4-7400

V.P. & Gen. Mgr....Edward Hochhauser, Jr.

Technical Research and Engineering Div.

229 Fourth Ave., New York 3, N. Y.
Vice-Pres.....Emil F. Hembrooke

NOLA RECORDING STUDIOS

1657 Broadway, New York, N. Y.
Phone: PL 7-4870

Steinway Hall, 113 W. 57 St., New York, N. Y.
Phone: JU 6-0040

President.....Vincent J. Nola
Vice-PresidentV. Thomas Nola
Chief Engineer.....Stanley Bumbly
Mgr. Film Prod. Facilities.....Peter Wilde

Services Offered: Film-Tape-Disc transcriptions for TV, Radio, Industry and Education—Studio and Location. Shooting facilities—Masters—Processing and pressings—Tape Duplication. Air and Line checks.

PALMETTO BROADCASTING SYSTEM

1 Martin St., Anderson, S. C.
Phone: LD14

President.....Wilton E. Hall
General Manager.....Glenn P. Warnock
DirectorJimmy Scribner

Services Offered: Network and Transcription Productions for Radio and Television. Sound Film Recordings, Uncle Remus, the Johnson Family and Doggon Dawn.

PRESS ASSOCIATION, INC.

50 Rockefeller Plaza, New York 20, N. Y.
Phone: PLaza 7-1111

President.....Frank J. Starzel
Vice-Pres., Mgr.....Oliver Gramling

Services Offered: Sports Star Special—a 15-minute interview and dramatization of personalities who are the "who's who" of the

To Our Many Friends . . .

Thanks for all your help in making our first year such a successful one.

As we enter our second year, we further dedicate ourselves, to produce the finest in recorded entertainment.

Cordially,
Leonard Wolf
GENERAL MANAGER

Hear Your Favorite
DOROTHY COLLINS and
RAYMOND SCOTT Recordings

78 RPM 45 RPM 33 1/3 RPM



- AUDIVOX RECORDS
- 140 West 57th St.
- New York, N. Y.

-ports world; **Special Assignment**—a 15-minute dramatization of the exciting or unusual experiences of reporters in covering news; **Personality Time**—a 5-minute interview and dramatization presenting prominent personalities in the news, and from stage, screen, radio, art, science and literature.

GEORGE LOGAN PRICE, INC.

20828 Pacific Coast Highway, Malibu, Calif.
Phone: Globe 6-2435

President.....George Logan Price
Sales Manager.....S. M. Lauch

Services Offered: Radio transcriptions of morale-building, constructive, open-ended 15- and 30-minute programs. Scripts, ideas, commercial tie-ins, production, and advice on talent availabilities. (Not a talent agency.)

RCA VICTOR CUSTOM RECORD SALES DIV.

630 Fifth Ave., New York 20, N. Y.
Phone: JUDson 2-5011

Vice-Pres., Gen. Mgr.....Emanuel Sacks
Manager.....James P. Davis
Artist & Repertoire Mgr.....Ben Selvin
Advtg. & Prom. Mgr.....Frank J. O'Donnell
Custom Record Sales Sections

Manager.....D. J. Finn
Chicago Manager.....A. E. Hindle
Hollywood Manager.....R. C. Bucholz
N. Y. Mgr. Orders & Service

Richard E. Bylandt

N. Y. Sales Rep. (Phonograph Records).....Ralph C. Williams
N. Y. Slide Film Rep.....Marjorie Tahaney
N. Y. Sales Rep.....James R. Gunnison
Chicago Sales Rep.....Geoffrey B. Bennett
Services Offered: Recording, processing, pressing of all types of phonograph records, transcriptions, slide film and promotion records; shipping and handling.

RCA Recorded Program Services
Sales Manager.....A. B. Sambrook
Central Northeast

Sales Manager.....William F. Reilly
Western Sales Manager.....William C. Gartland
Northeastern Sales Rep.....George Field
Southeastern Sales Rep.....Wallace Cochran
Central Northwest

Sales Rep.....Hugh Gravel
Southwestern Sales Rep.....Robert Fender
Mgr. Sales Service.....Chas. Broderick
Mgr. Comm'l Research.....Donald D. Axt

Services Offered: THESAURUS (musical program service); RCA SYNDICATED PROGRAMS (recorded dramatic, variety, musical shows), TV film distributor.

Studios and Regional Offices

630 Fifth Ave., New York 20, N. Y.

Phone: JUDson 2-5011

145 North Lake Shore Drive, Chicago 11, Ill.

Phone: WHITEhall 1-3530

1016 No. Sycamore Ave., Hollywood 38, Calif.

Phone: HOLLYwood 4-5171

522 Forsyth Bldg., Atlanta 3, Ga.

Phone: LAMar 7-703

1907-11 McKinney Ave., Dallas, Texas

Phone: RIVERSide 1371

RADIO FEATURES OF AMERICA

37 W. 46 St., New York 36, N. Y.

Cable Address: ARREFFAY, New York

Phone: JUDson 2-5130

Executive Director.....Oliver W. Nicoll
Assoc. Dir. of Svcs.....Sandra Munsell
Mng. Dir. of Prod.....J. H. Macdonell
Program Coordinator.....Eileen Ellis

Services Offered: Program production and consultation, syndicated transcribed programs, scripts, talent, package, live shows, phonograph records, international radio service.

RADIO RECORDERS

7000 Santa Monica Blvd., Hollywood 38, Cal.

Phone: HOLLYwood 3-3382

Chair, of Bd., Secy. & Treas.....H. DeVoe Rea
President.....G. Howard Hutchins
Vice-President.....J. Joseph Sameth
Vice-President.....H. L. Bryant
Vice-President.....E. F. Dummel

Service Offered: Complete recording facilities.

RADIOZARK ENTERPRISES, INC.

606 St. Louis St., Springfield, Mo.

Phone: 2-4122

Vice-President, Mgr.....E. E. Siman, Jr.
Vice-President, Mgr.....John B. Mahaffey

**PROVEN *
QUALITY**

**COASTAL
RECORDING
COMPANY, Inc.**

136 West 52nd Street
Circle 6-3900 New York 19, N. Y.

Fine quality — dependable, rapid service — experienced personnel — have resulted in a representative clientele.

* Proven by the repeated patronage of New York's finest advertising agencies.

ARTHUR SHAER, Managing Director

Services Offered: Open-end and packaged programs; custom made spots and jingles, script and idea to vinylite pressings. Current programs: Smiley Burnette Show, Geo. Morgan Show, Bill Ring Show, Tennessee Ernie Show.

REEVES SOUND STUDIOS, INC.

304 East 44th St., New York 17, N. Y.
Phone: ORegon 9-3550

President.....Hazard E. Reeves
Vice-President.....Chester L. Stewart
Mgr.—Film Div.....Richard Vorisek
Mgr.—Disc Div.....John Vorisek
Chief Engineer.....Lyman J. Wiggan
Services Offered: Sound recording for motion pictures and television, transcriptions.

ROCKHILL RADIO RECORDING

18 E. 50 St., New York 22, N. Y.
Phone: PL 9-7979

President.....Stanley J. Wolf
Sales Manager.....Emanuel H. Wolf
Recording Manager.....Leo L. Launer
Services Offered: Studio recordings; Off-the-air and off-the-line recordings; Masters; Shellac and vinylite pressings; Electrical transcriptions; Television recordings; Tape recordings.

SESAC INC.

475 Fifth Ave., New York 17, N. Y.
Phone: MUrray Hill 5-5365

President.....Paul Heinecke
Secretary-Treasurer.....R. C. Heinecke
Asst. to President.....E. S. Prager
Services Offered: Transcribed library including many categories: jazz, American folk, barbershop, hill billy, concert, Spanish, novelties, band, religious. Script service including special continuities for holidays. Bridges, moods and themes. Saleable shows built from the library, production and sales aids.

THE CHARLES E. SKINNER PRODUCTIONS

1600 Broadway, New York 18, N. Y.
Phone: Circle 6-6915

Exec. Producer-Director..Charles E. Skinner
Associate Producer.....Robert Sloan
Musical Director.....Skitch Henderson
Associate Producer, West Coast Rep.
Albert Kelley
Gen. Business Mgr.....Ray Rand
Designer.....Charles Carlotti

Services Offered: Creators, Producing Contractors, Adapters and consultants to package show producers, advertising agencies or sponsors. Production facilities in New York, Florida and Hollywood. National Television, theatrical, non-theatrical distribution in United States, Canada, Mexico, and South America.

HARRY SMITH RECORDING STUDIOS, INC.

48 W. 48th St., New York 36, N. Y.
Phone: JUDson 6-2893

Services Offered: Commercial phonograph records, transcriptions and audition records, and all type aid checks.

K. R. SMITH

(Division of)

ALLIED RECORD MFG. CO., INC.

619 W. 54 St., New York 19, N. Y.
Phone: JUDson 2-3791

Gen. Mgr.....K. R. Smith
Nat. Sales Mgr.....Hal G. Neely
Services Offered: Processing, pressing, shipping and handling all sizes and types of transcriptions and phonograph records. Recording studio available.

L. S. TOOGOOD RECORDING CO.

221 N. LaSalle St., Chicago 1, Ill.
Phone: CEntral 6-5275

Owner.....L. S. Toogood
Services Offered: Transcription service and magnetic tape duplicating.

TOWERS OF LONDON, LTD.

67 Younge St., Toronto, Ontario, Canada
Phone: Empire 4-9296

General Manager.....John Adaskin
Services Offered: Syndicated transcriptions.



The Greatest Name
In Entertainment

78 RPM

Extended Play Albums

45 RPM

33 1/3 Long Playing Records

Leader In The Field Of

Movie Sound Track Albums

TRANSCRIBED RADIO SHOWS

2 W. 17th St., New York 36, N. Y.
Phone: Hudson 2-3530

President.....M. E. Moore
General Manager.....Norm Bart
Services Offered: A series of Christmas-Spot Jingles for 15-, 20-, 30-second spot announcements, spots made to order.

TRANSCRIPTION SALES, INC.

117 W. High St., Springfield 35, O.
Phone: 2-1971

President.....J. P. Williams
Executive Vice-Pres.....John S. Zarka
Office Manager.....Bess Deck
Services Offered: Open end transcriptions quarter hour and five minute programs featuring "Singin' Sam," Mullen Sisters, Charlie Magnante, Emile Cote, Curley Bradley, The Golden Gate Quartet.

RICHARD H. ULLMAN, INC.

295 Delaware Ave., Buffalo 2, N. Y.
Phone: Cleveland 2066

President.....Richard H. Ullman
Vice-President.....Edward H. Kavinsky
Treasurer.....Mina Thorn
Production Manager.....Bill Jacobs
Services Offered: Spot-Lite Spots, ten second copy aids packaged for radio stations; Tune-O, musical give-away show; \$1000 Derby's, a participation auction program;

Beatrice Kay Show; Barber-ship Harmonies; Joe McCarthy Speaks. 100 five minute programs featuring one of baseball's greats.

UNITED FILM & RECORDING STUDIOS

301 East Erie St., Chicago 11, Ill.
Phone: Superior 7-9114

Gen. Mgr. & Exec. Producer...Wm. L. Klein
Exec. Vice-President...Wm. C. Hutchings
Management.....Egmont Sonderling
Office & Studio Mgr.....John Brunn
Services Offered: Everything is disc and tape recordings. Also film recordings.

UNITED RECORDING LABS.

1650 Broadway, New York 19, N. Y.
Phone: CI 7-3718, 2089

Partners.....George Adams, Anita Smith
Services Offered: Commercial spots, electrical transcriptions, complete sound recording service, on records and tape, air checks. Studios for radio and TV.

UNIVERSAL BROADCASTING SERVICE, INC.

205 Union Savings Bank, Boston 16, Mass.
Phone: Liberty 2-9293

President.....Richard L. Colten
Exec. Vice-Pres.....
Network Operations...P. C. Huellmantel
Vice-Pres., Chief Engr...Michael Pesantelli
Vice-Pres., West Coast...Wm. L. Gleason

UNITED RECORDING LABS.

TAPE — DISC — STUDIOS
Editing

1650 Broadway
New York 19, N. Y.
CI 7-3718-2089



Vice-Pres.—Genl. Sales.....Wm. Scott, Sr.
 TV Oper. Mgr.....Wm. E. Serripps
 Univ. Bestg. of Canada..John Batson, Mgr.
 University Broadcasting of France

Madame Golda G. Antignac
 Univ. Bestg. Service, Inc.—Sales of
 Electronic and TV units

President.....J. Lonis Mayer
Services Offered: A newly established radio network, interlocking stations in many parts of the U. S. and Canada via tape recording. Programs cover all phases of radio. The network sales departments sells the associated stations time to clients on their behalf. The programs run from five to sixty minutes; no spots sold.

UNIVERSAL RECORDERS, INC.

6757 Hollywood Blvd., Hollywood 28, Calif.
 Phone: HOLlywood 9-8282

General Manager.....Roger LeFont
Services Offered: All types of recording on acetate, magnetic tape and magnetic film for transcription, phonograph records and film use. Complete 16 mm. dummy setup with interlock and facilities for recording 16 mm. and 17½ mm. magnetic. Substantial vinylite pressing business done also.

UNIVERSAL RECORDING CORP.

111 E. Ontario St., Chicago 11, Ill.
 Phone: MI 2-6465

President.....Milton T. Putnam
 Vice-President.....A. B. Clapper
 Secretary-Treasurer.....Robert A. Weber
 Office Manager.....Belinda Richmond
 ControllorTony Parri
Services Offered: Recording, transcriptions, package programs, masters and pressings.

THOMAS J. VALENTINO, INC.

150 W. 46th St., New York 36, N. Y.
 Phone: Circle 6-4675

President.....Thomas J. Valentino
 Vice-Presidents.....Michael T. Valentino,
 Elsie F. Valentino
 Gen. Mgr. & Sec.....Peter J. Riolo
Services Offered: Mood music for TV,

sound effects of all types, miscellaneous recordings.

WESTERN RECORDERS

6000 Sunset Blvd., Hollywood 28, Calif.
 Phone: HO 3-6811

Owner.....H. Dixon McCoy
Services Offered: Tape and Disc. Recording-Assembly and Editing. Radio Broadcasting from our Studios.

WORLD BROADCASTING SYSTEM

488 Madison Ave., New York 22, N. Y.
 Phone: MURray Hill 8-4700

5255 Clinton St., Los Angeles, Calif.
 President.....John L. Sinn
 Chairman of Board.....Frederic W. Ziv
 Vice-President.....Robert W. Friedheim
 General Manager.....Pierre Weis
 West Coast Mgr.....James L. Weathers
Services Offered: Sales and program transcription service for radio and TV.

ZAHLER MUSIC LIBRARY

418 So. Robertson Blvd., Los Angeles 48, Cal.
 Phone: CRestview 5-4373

President & Owner.....Gordon Zahler
Services Offered: Complete music service for TV and non-theatrical films; original scores composed, arranged, orchestrated, copied and conducted for theatrical films. Sound effects, scoring, editing, supervision, complete dubbing facilities Wild Bill Hickok, Private Secretary Series, Cavalcade of America and others.

FREDERIC W. ZIV CO.

1529 Madison Rd., Cincinnati 6, O.
 Phone: PLaza 1323

488 Madison Ave., New York 22, N. Y.
 Phone: MURray Hill 8-4700
 President.....Frederic W. Ziv
 Vice-President (Executive)...John L. Sinn
 Vice-Presidents.....Alvin E. Unger,
 Herb Gordon
 Treas. & Comptroller.....Joseph L. Moore
Services Offered: Network and transcription productions; package shows.

WHY IS **AP** THE BEST?

BECAUSE—**AP** has more news correspondents, more news bureaus, more miles of news wire than any other news service.



Gains of AWRT Emphasized As Membership Grows

By BETTY ROSS

*National AWRT and President of
Illinois Chapter*

SIGNIFICANT strides in both size and stature were made in 1953 by the industry's professional women's organization, American Women in Radio and Television, Inc., with membership now nearing 900, more than double the initial number at our organizing convention just two short years ago. The majority are active members, those who are full-time employed in the radio and television industry or its related fields; and about one-sixth are Associate members, those whose work partially involves radio and TV activities. The entire membership is selected on the basis of professional standing, either in creative program and production work or in administrative and executive functions at the various stations, networks, agencies, service organization, trade associations, and business concerns.

Through the fine stewardship of our national president, Doris Corwith, the counsel of our immediate past president, Edythe Meserand, and the able assistance of our executive secretary, Betty Chapin, our Association has made significant strides during its organizing years.

On the credit side of the ledger for 1953 certainly would be the work and accomplishments of AWRT's Chapters. These are city, state, or regional groups which formed because of their enthusiasm and strong belief in the purposes of AWRT and the important value of women serving in the industry. To give recognition to these Chapters the national office was proud this year to prepare and issue "Certificates of Organization" to eleven AWRT Chapters—New York City, Philadelphia, Atlanta, San Diego, Illinois, Michigan, District of Columbia, Western New York, New England, "Heart of America" including Iowa, Kansas, Missouri, Nebraska, North Dakota, and South Dakota, and "Deep in the Heart of—Texas! These Chapters hold regular meetings, transact business, devise projects, and translate into action

at the local area level the objectives and interests of the national organization.

And, AWRT is not without its "Projects." Two such projects have been adopted nationally for consideration by women broadcasters and telecasters across the country. The first was on "Civil Defense" in an attempt to arouse our nation's citizenry to the danger of aggression and attack and inform them of defensive measures which could be taken to protect the home and family. Rather than the usual approach based on fear and destruction, this project stressed the positive side of woman's natural, far-reaching influence in the home. A second project of AWRT was "Woman and her Money." This was undertaken to help women understand their role in our national economy and the importance of their actions in buying, investing, will-making, and handling a major portion of the nation's wealth.

So with these statistics and for this year's work—in substantial increase in membership, in the high personal standards and attractive qualities of its women members, in its projects of national influence, in its monthly publication of "AWRT News and Views," in its good public and community relations, in its advice and counsel to young people contemplating careers in the industry, in its constant attunement to listener and viewer preferences, in its spirited interest in its own endeavors, and mostly in its firm belief and support of the American system of broadcasting and telecasting—we, the *American Women in Radio and Television*, submit our "Statement of the Year" and let our record stand, knowing full well that any true balance of accounts comes through the new challenge of every year and the results of each day's work; for it is through the concerted effort of all members in the industry that significant progress can be made.

ORGANIZATIONS

PERSONNEL — ADDRESSES — UNIONS
GUILDS — ASSOCIATIONS — RADIO-TV GROUPS

ACADEMY OF TELEVISION ARTS AND SCIENCES

Hollywood Athletic Club, 6525 Sunset Blvd.,
Hollywood 28, Calif.
HO 3-8942

OFFICERS

President	Charlie Ruggles
1st Vice-President	Guy V. Thayer, Jr.
2nd Vice-President	Hal Hudson
Secretary	Robert Cummings
Treasurer	Ernest Felix
Recording Secretary	Isabelle Pantone
Secretary to Treasurer	Mildred Beach
Corresponding Secretary	Robert Pelgram
Director-at-large	Don Norman
Director-at-large	Harry Koplan
Director-at-large	Sidney Solow
Director-at-large	Maurice Levy
Director-at-large	Don DeFore

FUNCTIONS

A non-profit organization dedicated to the advancement of television. Its most important function is the Annual Awards Banquet when the coveted "Emmy" is awarded for outstanding achievements in the industry.

ACTORS EQUITY ASSOCIATION

45 W. 47 St., New York 36, N. Y.
PLaza 7-7660

OFFICERS

President	Ralph Bellamy
1st Vice-President	Maurice Evans
2nd Vice-President	Bill Ross
3rd Vice-President	Frederick O'Neal
4th Vice-President	Margalo Gillmore
Treasurer	Paul Dultzell
Recording Secretary	John Effrat
Exec. Sec.	Angus Duncan
Ass't. Exec. Sec.	Willard Swire
Admin. Asst. Sec.	Alfred Eiting
Auditor	Charles Mesurac

COUNCIL

Edward Andrews, Joseph Anthony, Osceola Archer, Philip Bourneuf, George Britton, Thomas Chalmers, Dorf Clark, Edwin Clay, Donald Cook, Robin Craven, Doris Dalton, John Drew Devereaux, Alfred Drake, Mildred Dunnock, Paul Ford, John Forsythe, Florida Friebus, Larry Gotes, Marjorie Gatenon, Wynne Gibson, Dorothy Gish, Richard Gordon, Del Hughes, Kim Hunter, Paul Kelly, Dennis King, Edith King, Ben Kranz, Rusty Lane, Carmen Mathews, Ruth Marteson, Frank Maxwell, Scott McKay, Katherine Meskill, Thomas Mitchell, Claudia Morgan, Arnold Moss, Elliott Nugent, William Redfield, Polly Rowles, Edmon Ryan, Jane Seymour, Kent Smith, Chester Stratton, William Talman, Frederic Tozere, Lee Tracy, David Wayne, Eleanor Wilson, Lais Wilson.

THE ADVERTISING COUNCIL, INC.

25 West 45th Street, New York 36, N. Y.
JUdson 2-1520

OFFICERS

Chairman	Stuart Peabody
Vice-Chairman	Louis N. Brockway
Vice-Chairman	Leo Burnett
Vice-Chairman	John C. Sterling
President	Theodore S. Repllier
Vice-President	Allan M. Wilson
Vice-President	George P. Ludlam
Secretary	Frederick R. Gamble
Treasurer	Paul B. West
Radio-TV Director	Gordon C. Kinney
Pub. Rel. Director	Maxwell Fox

BRANCH OFFICES

1200 18th Street, NW, Washington 6, D. C. STerling 3-9153. T. S. Repllier, President.

203 N. Wabash Ave., Chicago 1, Ill. RAndolph 6-1753. L. S. Schwartz, midwest representative.

1680 N. Vine Street, Hollywood 28, Cal. HO 7-7166. R. C. Coleson, West Coast Representative.

425 Bush Street, San Francisco 8, Cal. GA 1-6868. Charles W. Collier, (A.A.W.).

FUNCTIONS

A non-profit organization representing all phases of advertising and dedicated to the uses of advertising in the public service.

ADVERTISING FEDERATION OF AMERICA

330 W. 42nd St., New York 36, N. Y.
BRyant 9-0430

OFFICERS

President	Elon G. Borton
Chairman of Board	Robert M. Gray
Secretary	Rita G. Eastman
Treasurer	Ben R. Donaldson

FUNCTIONS

An organization of advertising clubs, national advertising groups and companies interested in advertising to:

To help make advertising increasingly more effective.
To raise continually higher standards of advertising practice.

To promote better public understanding of advertising.

To promote cooperative effort in advertising.
To encourage improvement in advertising education.

ADVERTISING RESEARCH FOUNDATION

11 W. 42 St., New York 36, N. Y.
LONgacre 3-5100

OFFICERS

Chairman	Henry Schachte
Vice-Chairman	Marion Harper, Jr.
President	Edgar Kablak
Treasurer	Frederic R. Gamble
Secretary	Paul B. West
Managing Dir.	A. W. Lehman
Technical Dir.	D. B. Lucas

FUNCTIONS

To further scientific practices and promote greater effectiveness in advertising and marketing through objective and impartial research.

AMERICAN ASSOCIATION OF ADVERTISING AGENCIES

420 Lexington Ave., New York 17, N. Y.
LExington 2-7980

OFFICERS

Chairman of the Board	Earle Ludgin
Vice-Chairman	William R. Baker, Jr.
President	Frederic R. Gamble
Secretary-Treasurer	Winthrop Hoyt
Vice-President	Richard L. Scheidker
Vice-President	Richard Turnbull
Secretary to Committee on Broadcast Media	Kenneth Godfrey

FUNCTIONS

The national organization of the advertising agency business. Aims: To protect, strengthen and improve the advertising agency business; to advance the cause of advertising as a whole; to give service to members.

AMERICAN COMMUNICATIONS ASSOCIATION

5 Beekman St., New York 38, N. Y.
COrtlandt 7-1374

OFFICERS

President, Joseph P. Sclly
 Secty.-Treas., Joseph F. Kehoe
 Publicity Director, Charles Silberman

BRANCH OFFICES

Eastern Branch, 1737 Chestnut Street, Phila. 3, Pa
 Phone: LO 4-1251. Mort Barrow, Chairman.
 Atlantic Branch, 5 Backman St., N. Y. C. 38, N. Y.
 Phone: CO 7-1734. W. Bender, Chairman.

FUNCTIONS

Independent Union, Broadcast Department devoted to organization of all employees in the Radio Broadcasting Industry, excepting Musicians and Actors

AMERICAN FEDERATION OF MUSICIANS

570 Lexington Ave., New York 22, N. Y.
 Plaza 8 0600

OFFICERS

Pres., James C. Petrillo
 Vice-Pres., C. L. Bagley
 Secretary, Leo Cluesmann
 Treasurer, Harry J. Steeper

EXECUTIVE COMMITTEE

Wm. J. Harris, Stanley Ballard, Herman D. Kenin,
 George V. Clancy, Walter M. Murdach.

BRANCH OFFICES

570 Lexington Ave., New York 22, N. Y. Phone:
 Plaza 8-0600 James C. Petrillo, Pres.
 220 Mt. Pleasant Ave., Newark 4, N. Y. Phone
 Humboldt 2-8010 Leo Cluesmann, Sec.
 220 Mt. Pleasant Ave., Newark 4, N. J. Phone
 Humboldt 2-8010 Harry J. Steeper, Treas.

AMERICAN FEDERATION OF TELEVISION & RADIO ARTISTS (AFTRA)

15 W. 44th St., New York 36, N. Y.
 V. A. 6-1810

NATIONAL OFFICERS

President, Alan Bunce
 1st Vice-President, Frank Nelson
 2nd Vice-President, Donald B. Hirsch
 3rd Vice-President, John Gannon
 4th Vice-President, Vinton J. Hayworth
 5th Vice-President, Janet Baumhoyer
 6th Vice-President, Eric Winstanley
 7th Vice-President, Bob Bruce
 Recording Secretary, Bruce Grant
 Treasurer, Conrad Nagel
 National Executive Secretary, George Heller

BRANCH OFFICES

6331 Hollywood Blvd., Hollywood 28, Cal. Hollywood
 4-5125. Claude L. McCue, Western Regional Director
 102 E. Hubbard St., Chicago 11, Ill. Whitehall 3
 1344 Raymond A. Jones, Central Regional Director

FUNCTIONS

Union affiliated with A. F. of L., representing radio and TV performers (actors, singers, announcers), for collective bargaining purposes

AMERICAN GUILD OF MUSICAL ARTISTS, INC.

276 W. 43 St., New York 18, N. Y.
 LOngacre 5-7508

OFFICERS

Honorary President, Lawrence Tibbett
 President, John Brownlee
 1st Vice-President, Jascha Heifetz
 2nd Vice-President, Leopold Sachse
 3rd Vice-President, Betty Stone
 4th Vice-President, Astrid Varnay
 5th Vice-President, James Pease
 Treasurer, Abba Bogin
 Recording Secretary, Elisabeth Hoepfel
 National Executive Secretary, Hyman R. Faine

BRANCH OFFICES

6636 Hollywood Boulevard, Hollywood 28, Calif
 Phone: HO. 2-2334. Lee Harris, Representative
 216 Pine Street, San Francisco, Cal. Phone: Sutter
 1-0855. Theodore Hale, Rep.
 188 West Randolph Street, Chicago, Ill. Phone: State
 2 0585. Irving Meyers, Rep

215 S. Broad St., Philadelphia, Pa. Phone: Kingsley
 5-4310. Edward Davis, Rep.

FUNCTIONS

A labor organization having jurisdiction in the fields of opera, concert, ballet and dance; a branch of the Associated Actors and Artists of America. Its scope is nationwide, covering the United States and Canada, and its activities consist of protecting the interests and working conditions of its members in the above fields as well as the furthering and expansion of opera, concert and ballet institutions and performances throughout the United States and Canada

AMERICAN MARKETING ASSOCIATION

1525 East 53rd St., Chicago 15, Illinois
 MU. 4-5267

OFFICERS

President, Neil H. Barden
 Vice-President, Lawrence C. Lockley
 Vice-President, Allen K. Goetjens
 Vice-President, Donald E. McGofalin
 Secretary, Ira D. Anderson
 Treasurer, Chas. W. Smith
 Executive Director, Wm. C. Gordon, Jr.

BRANCH OFFICES

33 Chapters in 33 American Cities.

FUNCTIONS

A non-profit organization dedicated to the advancement of science in marketing. Membership open to all persons actively engaged in the field of marketing

AMERICAN NEWSPAPER PUBLISHERS ASSOCIATION

370 Lexington Ave., New York 17, N. Y.
 MUrray Hill 5-2000

OFFICERS

President, George C. Biggers
 Vice-President, Richard W. Slacum
 Secretary, Wm. Dwight
 Treasurer, W. L. Fanning
 General Manager, Cranston Williams

BRANCH OFFICE

360 N. Michigan Ave., Chicago 1, Ill. Phone:
 Franklin 2-3746, George N. Dale, Manager.
 ANPA Research Laboratory, Box 598, Easton, Pa.,
 Phone: 8159 C. M. Flint, Dir. of Research

FUNCTIONS

To foster and protect the business and business interests of daily newspapers.

AMERICAN SOCIETY OF COMPOSERS, AUTHORS AND PUBLISHERS (ASCAP)

575 Madison Ave., New York 22, N. Y.
 MUrray Hill 8-8800

President, Stanley Adams
 Vice-President, Louis Bernstein
 Secretary, John Tasker Howard
 Asst. Secretary, Geo. W. Meyer
 Treasurer, Saul H. Bourne
 Asst. Treasurer, Frank H. Connor

BOARD OF DIRECTORS

Stanley Adams, Louis Bernstein, Saul H. Bourne,
 Gene Buck, Irving Caesar, Frank H. Connor, Paul Cunningham,
 Mox Dreyfus, Bernard Goodwin, Donald Gray,
 Oscar Hammerstein II, Otto A. Harbach, John Tasker Howard,
 A. Waller Kramer, Edgar Leslie, George W. Meyer, Jack Mills,
 Abe Olman, J. J. Robbins, Gustave Schirmer, Hermon Storr, Deems Taylor, Jack Yellun

BRANCH OFFICES

In all principal cities throughout the United States.

FUNCTIONS

ASCAP is a performing right society through which commercial users of music obtain clearance of the right to perform publicly for profit the copyrighted works of its members.

AMERICAN WOMEN IN RADIO AND TELEVISION, INC.

70 East 45th St., New York 17, N. Y.
 MUrray Hill 9 8520

ORGANIZATIONS

OFFICERS

President...Doris Corwith, NBC, New York
 President...Doris Corwith
 NBC, New York (Term expires May, 1954)
 Vice-President—Eastern Area...Dorothy Fuller
 WBET, Brockton, Mass.
 Vice-President—Southern Area...Alice Friberg
 WCYB, Bristol, Va.
 Vice-President—Central Area...Elizabeth Marshall
 WBEZ, Chicago, Ill.
 Vice-President—Western Area...Molly Morse
 KFMB, San Diego, Calif.
 Secretary-Treasurer...Jane Dalton
 WSPA, Spartanburg, S. C.
 Executive Secretary...Betty Chapin

DIRECTORS

Jane Barton, New York State Radio-Motion Picture Bureau, Albany; Betty Barnett, KSD-TV, St. Louis
 Nena Badenoch, National Society for Crippled Children & Adults, New York; Betty Ross, NBC, Chicago; and Gertrude Trobe, WBVP, Beaver Falls, Pa.

CHAPTERS

New York City, Western New York, Philadelphia, Atlanta, San Diego, Illinois, Michigan, District of Columbia, New England, Texas and "Heart of America" (including Iowa, Kansas, Missouri, Nebraska, North and South Dakota).

FUNCTIONS

American Women in Radio and Television, Inc., is a self-supporting, non-profit organization open to all women professionally engaged in creative and administrative work in the radio and television industry or in industries directly related to radio and television broadcasting. Its purpose is to make each member a greater asset to her station and network, her clients, her community and her country.

ARTISTS' REPRESENTATIVES ASSOCIATION, INC.

1270 Ave. of the Americas, New York 20, N. Y.
 Circle 6-1379

OFFICERS

President...William Kent
 Vice-Presidents...Harry A. Romm, Eddie Elkort,
 James Lanagan, Jack Russell, Wm. J. O'Halloran,
 H. C. Moore
 Secretary...Milton Berger
 Treasurer...Howard L. Hausman
 Assistant Secretary...Ruth L. Simonson
 Counsel...Jack J. Katz

BOARD OF GOVERNORS

Hattie Althoff, Milton Berger, John F. Dugan, Joseph Glaser, Howard L. Hausman, William Kent, Ben Kuchuk, James Lanagan, Nat Lefkowitz, Harold C. Moore, Leon Newman, Wm. J. O'Halloran, Harry A. Romm, Jack Russell, Billy Shaw, Art Weems.

FUNCTIONS

Trade Association of Theatrical Agents.

ASSOCIATED MUSIC PUBLISHERS, INC. (AMP)

25 W. 45th Street, New York 36, N. Y.
 JUdan 2-1790

Cable Address: MUSICPUB—NEW YORK

OFFICERS

Chairman of the Board...Sydney M. Kaye
 President...Charles A. Wall
 Vice-President...Karl Bauer
 Vice-President...Richard F. French
 Vice-President...Earl B. Hall
 Secretary...Robert J. Burton
 Comptroller...Alexander D. Nicol

BOARD OF DIRECTORS

Carl Haverlin, President, BMI; William Hedges, National Broadcasting Co.; Paul Morency, Radio Station WTIC; J. Harold Ryan, Storer Broadcasting Co.; Charles A. Wall, BMT.

FUNCTIONS

Associated Music Publishers, Inc. is a publisher and distributor of serious music in the United States and represents many of the principal serious music catalogs of Europe.

ASSOC. OF CANADIAN ADVERTISERS, INC.

701 Federal Building, 85 Richmond St., West,
 Toronto 1, Ontario
 Empire 3-8046

OFFICERS AND DIRECTORS

President—J. O. Pitt, Can. Fairbanks-Morse Co., Ltd., Montreal, Que.
 Exec. Vice-President—Robert E. Day, Bulova Watch Co.

FUNCTIONS

This association was incorporated in March 1917. For 38 years the Association of Canadian Advertisers has functioned as an organization of Canadian companies devoted to the interests and promotion of good advertising.

ASSN. OF NATIONAL ADVERTISERS, INC.

285 Madison Ave., New York 17, N. Y.
 ORegon 9-4940

OFFICERS

President...Paul B. West
 Vice-President...Lowell McElroy
 Vice-President...Cy Norton
 Secretary...Peter W. Allport
 Chairman of the Board...B. R. Donaldson
 Ford Motor Company

Vice-Chairman...Guy Berghoff
 Pittsburgh Plate Glass Co.

FUNCTIONS

Promotes the most effective and profitable use of advertising as a tool of selling, promotes a better understanding and more effective use of advertising as a tool of management and protects the interests of national advertisers and serves their collective needs.

ASSN. OF RADIO NEWS ANALYSTS

24 East 39th St., New York 16, N. Y.
 MUrray Hill 5-7400

President...H. V. Kaltenborn
 Vice-President...William Costello
 Vice-President...Raymond Swing
 Executive Committee...George Fielding Eliot,
 Merrill Mueller, Leon Pearson
 Secretary...John MacVane
 Treasurer...Cesar Saerchinger
 Asst. Secy.-Treas...John W. Vandercook

FUNCTIONS

To maintain the independence and prestige of the profession and to improve the standards of analytical broadcasting and to protect the best interests of the public and the industry.

THE AUTHORS GUILD OF THE AUTHORS LEAGUE OF AMERICA, INC.

6 E. 39 St., New York 16, N. Y.
 MUrray Hill 9-4950

President...Merle Miller
 Vice-Pres...William Schirer
 Secretary...Phyllis McGinley
 Membership Secretary...Edith Mackin

COUNCIL

Martha Albrand, Cleveland Amory, Betsey Barton, Evelyn Barkins, Howard Breslin, John Brick, Wolcott Gibbs, Samuel Grafton, John Hersey, Helen Hull, Lenard Kaufman, Mrs. Arnold W. Koehler, Christopher LaFarge, Robert J. Landry, John Lardner, Frances Lockridge, Richard Lockridge, Phyllis McGinley, Ralph Moody, Ann Petry, Henry F. Pringle, Marjorie Hillis Roulston, Budd Schulberg, Max Shulman, Rex Stout, John T. Winterich, Theodore H. White, Herman Wouk.

FUNCTIONS

National business organization of authors in the publication field.

THE AUTHORS LEAGUE OF AMERICA, INC.

6 E. 39 St., New York 16, N. Y.
 MUrray Hill 9-4950

President...Rex Stout
 Vice-Pres...John Hersey
 Secretary...Erik Barnauw
 Exec. Sec...Luise M. Sillcox
 Treasurer...Richard Levine

FUNCTIONS

The national business organization of authors and dramatists.

BRAND NAMES FOUNDATION, INC.

17 West 57th St., New York 19, N. Y.
Plaza 9-8425

OFFICERS

Chairman of the Board Barry T. Luththead
 (President, Cluett, Peabody & Co., Inc.)
 Vice-Chairman Don Francisco
 (Vice-President, J. Walter Thompson Co.)
 Vice-Chairman Charles T. Lawson
 (Vice-President, Nash-Kelvinator Corp.)
 Chairman of the Executive Committee James Hill, Jr.
 (President, Sterling Drug, Inc.)
 Treasurer Louis Hausman
 (Vice-President, CBS Columbia, Inc.)
 President Henry E. Abt
 Vice-President Nathan Keats

FUNCTIONS

Conducts a national program of educational activity, to get across to the public the tremendous importance of brand responsibility and free choice of brands

THE BRITISH BROADCASTING CORPORATION

630 Fifth Ave., New York 16, N. Y.
Circle 7-0656

OFFICERS

North American Rep Basil Thornton
 Program Director Alec Sutherland
 Program Assistant Lillian Lang
 Transcription Assistant Marian Moss
 Chief Engineer Arthur S. Toby

BRANCH OFFICES

United Nations Office Room C 309, United Nations,
 N. Y. Plaza 4-1234, Ext. 3121 Bernard Moore, U. N.
 Correspondent

Natl. Press Bldg., Washington, D. C. Phone: Execu-
 tive 3-1465 Christopher Serpel, Washington corres-
 pondent

FUNCTIONS

Activities of the North American offices of the British Broadcasting Corporation cover two inter-related but separate operations. The first, Eastbound operations, are concerned with the interpretation of the American scene to British audiences. The other, Westbound operations, are concerned with making available to independent radio stations and networks regular and specially requested programs broadcast from England in BBC's North American Service.

BROADCAST ADVERTISING BUREAU, INC.

270 Park Ave., New York 17, N. Y.
MUrray Hill 8 4020

President Kevin B. Sweeney
 Dir. of Nat'l. Prom. Norman Nelson

BRANCH OFFICE

333 N. Michigan Ave., Chicago 1, Ill. Phone:
 Central 6-5066 Gale Blocki, Jr., Dir. of Midwestern
 Sales.

BOARD OF DIRECTORS

Charles C. Coley, Chairman, WMBD, Peoria, Ill.
 Charles T. Ayres, ABC, New York
 Joseph E. Baudino, Westinghouse Radio Stations,
 Washington, D. C.
 John P. Blair, Blair & Co., New York
 Kenyon Brown, KWFT, Wichita Falls, N. Y.
 Martin B. Campbell, WFAA, Dallas, Tex.
 John C. Cohen, KSBW, Salinas, Cal.
 Robert Dunville, WLW, Cincinnati, Ohio
 Wm. H. Finchesriber, Jr., NBC, New York
 Simon Goldman, WJTN, Jamestown, N. Y.
 John F. Hayes, WTOP, Washington, D. C.
 George J. Higgins, KNBC, Kansas City, Mo.
 J. Herbert Hollister, KCOL, Ft. Collins, Colo.
 Ward D. Ingram, KHJ, Los Angeles, Cal.
 Edgar Kobak, WTWA, Thomson, Ga.
 Howard Lane, KOIN, Portland, Ore.
 William McGrath, WHDH, Boston, Mass.
 Arch L. Madsen, KOVO, Provo, Utah
 John Meagher, KYSM, Manoka, Va.
 James H. Moore, WLSL, Roanoke, Va.
 Adrian Murphy, CBS, New York
 Good Will stations, WGAR, Cleveland and WJR, De-
 troit, Mich.
 H. Preston Peters, Free & Peters, N. Y.
 William B. Quartan, WMT, Cedar Rapids, Iowa
 Robert A. Schmid, Mutual, New York

George B. Storer, Storer Broadcasting Co., Miami
 Beach, Fla.

Kevin B. Sweeney, WDSU, New Orleans, La.
 Donald Thornburgh, WCAU, Philadelphia, Pa.
 Allen M. Woodall, WDAK, Columbus, Ga.

FUNCTION

The Broadcast Advertising Bureau, Inc., is a service organization supported by the entire Radio Industry and devoted solely to the promotion of Radio as an advertising medium.

BROADCASTING AND FILM COMMISSION, NAT'L COUNCIL OF CHURCHES

220 Fifth Ave., New York 1, N. Y.
 ORegon 9-2968

OFFICERS

Exec. Director Ronald Bridges
 Asst. Exec. Dir. W. B. Goodman
 Director of Television Albert Crews
 Business Manager Arthur W. Rhinow
 Director of Films S. Franklin Mack
 Director of Radio Prod. John Gunn
 Supervisor Special Events Arthur Austin

BRANCH OFFICE

5746 Sunset Blvd., Hollywood 28, Calif.
 Phone: Hillside 7464 George Heimlich, Director of
 Radio & TV

FUNCTIONS

The Broadcasting and Film Commission produces network radio and television programs, radio transcrip-
 tions, and television films representative of Protestant
 and Orthodox Churches

BROADCAST MUSIC, INC. (BMI)

580 Fifth Ave., New York 19, N. Y.
 PLaza 7-1800

OFFICERS

President Carl Haverlin
 Vice-President—General Counsel Sydney M. Kaye
 Vice-Pres. in charge of Finance & Treasurer Charles A. Wall
 Vice Pres. in charge of Publisher Robert J. Burton
 and Writer Relations, Sect. in charge of Non Radio License Harry P. Somerville
 Vice Pres. in charge Station Relations Glenn Dalberg
 Vice-Pres. in charge Foreign Relations Jean Geiringer
 Vice Pres. in charge Station Service Roy Harlow
 Comptroller Alexander D. Nico
 Assistant Treasurer Charles E. Lawrence

BOARD OF DIRECTORS

Chairman, Justin Miller, NARTB, Washington, D. C.
 Vice-Chairman, Sydney M. Kaye, Broadcast Music,
 Inc., N. Y.; Herbert V. Akerberg, Columbia Broad-
 more, Roy Diaz, ABC, N. Y.; Joseph Baudino, Westing-
 house Radio Stations Inc., Wash., D. C.; Carl Haverlin,
 BMI, N. Y.; William S. Hedges, National Broadcasting
 Co., N. Y.; Herbert Hollister, KCOL, Ft. Collins, Colo.
 Leonard Kaper, WCAE, Pittsburgh; Paul W. Maroney,
 WTIC, Hartford, Conn.; J. Leonard Reinsh, WSB, At-
 lanta; J. Harold Ryan, Fort Industry Co., Toledo,
 Ohio; James E. Wallan, Mutual Broadcasting System,
 N. Y.

BMI CANADA, LTD.

229 Yonge St., Toronto 1, Ont., Elgin 0040, Wm
 Harold Moon, Asst. Gen. Mgr.

STATION RELATIONS

Glenn Dalberg, Director, Ralph Wentworth, James
 L. Cox, Al Martin, Linn Patton, Ken Sparnon, Burt
 Squire, Dorsey Owings

NON-RADIO LICENSING DEPT

Vice-President, Harry P. Somerville
 Chicago Office, 360 N. Michigan Ave.; Andover
 3-5394, Stan Myers, Mid-West Representative,
 Los Angeles, 1549 N. Vine St., Hillside 7-7447,
 Lawrence Conti, Far Western Representative.

PROFESSIONAL DEPT.

Julian Stearns, General Professional Mgr.; Profes-
 sional Staff, Harold Wald, George Furness.
 Chicago Office, 360 N. Michigan Ave. Andover
 3-5349 Jimmie Carris, Professional Representative
 Hollywood, Calif. Office, Wm. Walters, 1549 N.
 Vine St., Hillside 7-7447. Gen. Mgr., Eddie Janis.

FUNCTIONS

The functions of BMI are (1) To coordinate and
 license the performing rights to music of a group of

affiliated publishers and performing rights societies;
(2) to provide equal opportunity of recognition for all
writers, composers and publishers.

**THE BUREAU OF BROADCAST
MEASUREMENT**

85 Richmond Street West,
Toronto 1, Ontario, Canada
EMpire 3-8046
President: Charles R. Vint, Colgate-Palmolive-Peet
Co. Ltd., Toronto.
Vice-President: Horace N. Stovin, Horace N. Stovin
& Company, Toronto.
Treasurer: Athol McQuarrie, Assoc. of Canadian
Advertisers, Toronto.
Executive-Secretary: Charles J. Follett, Assoc. of
Canadian Advertisers, Toronto.

DIRECTORS

W. T. Cranston, Radio Station CKOC, Hamilton,
Ont.; Walter E. Powell, Canadian Broadcasting Corp.,
Toronto, Ont.; W. E. Trimble, Baker Advertising
Agency Limited, Toronto, Ont.; G. C. Hammond,
Cockfield, Brown & Co. Ltd., Montreal, P. Q.; A. M.
Sanderson, Whitehall Pharmacy Ltd., Toronto; Lee
Talley, Coca-Cola, Ltd., Toronto, Ont.; G. F. Mills,
Spitzer & Mills Ltd., Toronto.

FUNCTIONS

To conduct surveys and to assemble statistical and
other data relating to radio broadcasting and par-
ticularly relating to the number, distribution and
listening habits of persons who are or may be listen-
ing to the various broadcasting stations at different
times and from time to time.

To adopt standard methods of appraising broad-
casting station coverage, and/or the listening habits
of the public.

To prepare reports, charts and other forms of pub-
licity based on surveys and statistical and other data
assembled as aforesaid.

To print, publish and distribute to members the
reports, charts and other forms of publicity prepared
as aforesaid.

**CANADIAN ASSOCIATION OF
BROADCASTERS**

108 Sparks St., Ottawa 4, Ont.
3-4036
President of the Board..... F. H. Elphicke
Vice-President of the Board..... E. F. McDonald
Exec. Vice-President..... T. J. Allard
Secretary-Treasurer..... Flora Love
Copyright Counsel..... Samuel Rogers
French Language Counsel..... Guy Roberge
F. H. Elphicke, Vancouver, B. C.; E. F. McDonald,
Halifax, N. S.; William Rea, New Westminster, B. C.;
Gerry Gaetz, Edmonton, Alta.; H. A. Crittenden,
Regina, Sask.; John Craig, Brandon, Man.; J. E. Cam-
peau, Windsor, Ont.; F. B. Ricard, Sudbury, Ont.;
Wallace Saltter, Guelph, Ont.; J. M. Davidson, Toron-
to, Ont.; J. P. Lemire, Hull, P. Q.; J. A. Dupont, Mon-
treal, P. Q.; Henri Lepoge, Quebec City, P. A.;
D. Malcolm Neill, Fredericton, N. B.

BRANCH OFFICE

373 Church St., Toronto, Ont. Phone: EM. 4-8244.
Director of Adv. & Research..... Patrick Freeman

FUNCTIONS

The Canadian Association of Broadcasters is a
voluntary trade organization of 120 privately owned
(independent) broadcasting stations in Canada.

**CATHOLIC ACTORS GUILD OF
AMERICA, INC.**

Hotel Astor, New York 19, N. Y.
Circle 6-5566

OFFICERS

President..... Gene Buck
1st Vice-Pres..... Pat O'Brien
2nd Vice-Pres..... Jay Jestyn
Recording Secretary..... Ed Begley
Historian..... Jane Taylor
Executive Secretary..... George Buck
Chairman of Executive Board..... Frank McNellis
Chaplain..... Rev. Vincent J. Brosnan
Treasurer..... Rev. Francis M. Costello

FUNCTIONS

Social and benevolent organization which strives

to care for the spiritual and physical needs of mem-
bers of the profession, regardless of creed. In par-
ticular, every effort is made to assure members of
the organization of care and attention in the case
of illness, hospitalization, burial whenever the need
arises.

**CATHOLIC WRITERS GUILD OF
AMERICA, INC.**

128 W. 71 St., New York 23, N. Y.
ENdicott 2-0412

OFFICERS

Spiritual Director..... Rev. John B. Kelly
President..... William Fay
Vice-Pres..... Richard Reid
Vice-Pres..... Joseph A. Duffy
Executive Secretary..... Eleanor M. Tucker

FUNCTIONS AND ACTIVITIES

A national organization of writers and persons inter-
ested in literary work. To promote the interest of
writers, and to take cognizance of and make appro-
priate record of notable achievements in the literary
world. To give to the press, screen, stage and radio
the Catholic mind on Church issues.

**COMPOSERS, AUTHORS AND
PUBLISHERS ASSN. OF CAN. LTD.**

182 St. George St., Toronto 5, Ont., Canada
Phone: M. 8457

OFFICERS

President..... Sir Ernest MacMillan, B.A.,
General Manager..... William S. Low

FUNCTIONS

Composers, Authors and Publishers Association of
Canada Limited licenses in Canada public perfor-
mances of the copyright music of its own Canadian
members, and of the members of affiliated perform-
ing right societies in twenty-seven (27) countries.

**THE DRAMATISTS GUILD OF THE
AUTHORS LEAGUE OF AMERICA,
INC.**

6 E. 39 St., New York 16, N. Y.
Murray Hill 9-4950

President..... Moss Hart
Vice-Pres..... George S. Kaufman
Secretary..... Dorothy Fields
Exec. Sec..... Mills Ten Eyck, Jr.

FUNCTIONS

The national business organization of dramatists.

**EPISCOPAL ACTORS GUILD OF
AMERICA, INC.**

1 East 29th St., New York, N. Y.
Murray Hill 5-2927

OFFICERS

Hon. Presidents..... Rt. Rev. Henry Knox Sherrill,
Rt. Rev. Horace W. B. Donegan
President..... Vinton Freedley
Vice-Presidents..... Rev. Randolph Ray,
Charles Coburn, Bobby Clark, Peggy Wood
Rec. Secy..... Rev. Chas. Breck Ackley
Treasurer..... John Knight
Exec. Secy..... Helen Morrison

COUNCIL

Very Rev. James A. Pike, Rev. John Ellis Largo,
Rev. G. P. T. Sargent, Walter Abel, Dorothy Black-
burn, Sidney Blackmer, Mrs. Milo Boulton, Leo G. Car-
roll, Margaret Dale, Mrs. Owen Davis, J. Colville
Dunn, Carl M. Eckstrom, Boris Karloff, Tessa Costa,
Thais Lawton, Harry McNaughton, Reginald Mason,
Raymond Massey, Carmen Mathews, Margery Maude,
John Morley, Kate Oglebay, Helen Ormsbee, Basil
Rathbone, Mrs. Chas. M. Richter, Cornelia Otis Skin-
ner, George Somnes, Frances Starr.

FUNCTION

The Guild ministers to actors of all religious faiths.

**FEDERAL COMMUNICATIONS BAR
ASSOCIATION**

400 DeSales Bldg., Washington, D. C.

President..... Fred W. Albertson
1st Vice-Pres..... Vincent B. Welch

2nd Vice-Pres ... Percy H. Russell, Jr.
 Secretary ... Everett D. Johnston
 Treasurer ... Robert M. Booth, Jr.
 Delegate to American Bar Assn ... Arthur W. Scharfild

EXECUTIVE COMMITTEE

Corwin Lockwood, Jr., William J. Dempsey, Vernon L. Wilkinson, George O. Sutton, Leonard H. Marks, Stephen H. Fletcher.

FUNCTIONS

To promote the proper administration of the Communications Act of 1934 and related acts, to uphold the honor of practice before the Federal Communications Commission, and to encourage cordial intercourse among the practitioners. It issues a quarterly publication, the Federal Communications Bar Journal, which is devoted to matters of interest pertaining to communications law.

FEDERAL TRADE COMMISSION

Pennsylvania Ave., at 6th St., N.W., Washington 25, D. C.
 Executive 6800

PERSONNEL

Chairman ... Edward F. Howrey
 Commissioner ... Lowell B. Mason
 Commissioner ... James M. Mead
 Commissioner ... Albert A. Carrctta
 Commissioner ... John W. Gwynne
 Sec to the Commission ... Alex. Akerman, Jr.
 Executive Director ... Robert M. Parrish
 Legal Advisor and Asst. to the Chairman ... David C. Murchison
 Executive Assistant for Public Affairs ... Fitzhugh Green
 General Counsel ... Earl W. Kintner
 Dir., Bur of Antimonopoly ... Joseph E. Sheehy
 Dir., Bur of Antideceptive Practices ... Daniel J. Murphy
 Dir., Bur of Industry Cooperation ... James A. Harton
 Dir. of Hearing Examiners ... Everett F. Hoycraft
 Dir., Bur of Industrial Economics ... Corwin D. Edwards (on leave)
 Acting Dir., Bur of Industrial Economics ... Dr Jesse W. Morkham
 Dir., Bur of Administration ... Alex. Akerman, Jr.

BRANCH OFFICES

U. S. Court House, Foley Square, New York 7, N. Y.
 Rolf H. Kielland, Attorney in Charge. ORtland 7 7100
 Room 1500, 173 W. Madison St., Chicago 2, Ill.
 Donald P. MacDonald, Attorney in Charge. Financial 6-0790
 Room 133, Federal Office Bldg., San Francisco 2, Calif.
 Clarence T. Sadler, Attorney in Charge. KLon dke 2-2350
 Room 811, U. S. Court House, Seattle 4, Wash.
 Walter W. Harris, Attorney in Charge. MUtual 3300
 Room 413, Masonic Temple Bldg., 333 St. Charles St., New Orleans, La.
 William B. Lott, Attorney in Charge. CAnal 3481

FUNCTIONS

Under several laws designed to promote free and fair competition in interstate trade, the Commission takes action against monopolistic and deceptive practices and publishes economic studies of factors of affecting the competitive economy.

THE FRENCH BROADCASTING SYSTEM (RADIODIFFUSION FRANCAISE) IN NORTH AMERICA

972 Fifth Ave., New York 21, N. Y.
 Regent 4-1501

Director ... Pierre Crenesse
 Ass't. Dir. ... Alice Lewitn
 Manager ... Suzanne Weltman
 Prog. Dir. & Pub. Relations ... Jacqueline Landry

FUNCTIONS

The activities of the French Broadcasting System in North America are twofold: on the one hand, for the purpose of strengthening the good will and understanding between France and the U. S., it distributes to independent stations all over the country English-language programs prepared in Paris for North American listeners, covering all aspects of life in France today; on the other hand, it keeps French listeners informed of all events taking place in America today.

INSTITUTE FOR EDUCATION BY RADIO-TELEVISION

Ohio State Univ., Columbus 10, O.
 UN 3148 Ext. 280

FUNCTIONS

Specifically, the Institute acts as sponsor for an Annual Exhibition of Educational Radio and Television Programs, welcoming entries from stations and organizations. A yearbook containing the proceedings of the Conference is published annually under the title, EDUCATION ON THE AIR

THE INSTITUTE OF RADIO ENGINEERS, INC.

1 East 79th St., New York 21, N. Y.
 LEligh 5-5100

OFFICERS

President ... W. R. Hewlett
 Vice-President ... M. J. H. Ponte
 Treasurer ... W. R. G. Baker
 Secretary ... Haraden Pratt
 Editor ... J. R. Pierce
 Executive Secretary ... G. W. Bailey

DIRECTORS

S. L. Bailey, A. N. Goldsmith, J. T. Henderson, A. G. Jensen, A. V. Loughren, C. J. Marshall, J. W. McRae, L. E. Packard, J. M. Pettit, C. A. Priest, J. R. Ragazzini, George Rappaport, J. D. Ryder, B. E. Shockcliff, D. B. Sinclair, A. W. Stratton, J. A. Stratton, Ernst Weber, H. W. Wells.

FUNCTIONS

An incorporated non-profit organization having as its object the advancement of the theory and practice of radio and electronics, including allied branches of engineering and all related arts and sciences.

INTERCOLLEGIATE BROADCASTING SYSTEM

2808 Erie St., S.E., Washington 20, D. C.
 Victor 7210
 706 Sanders Ave., Schenectady 2, N. Y.
 Schenectady 3-6028

OFFICERS

President ... George Abraham
 Vice-Pres & Operations Mgr ... David W. Borst
 Treasurer ... James R. Wylie
 Secy & Prog. Mgr. ... Howard C. Hansen
 Engineering Dir. & Bulletin Editor ... Richard H. Cromptan
 Sales Promotion & Pub. Relations Mgr ... Thomas M. Blaisdell
 General Counsel ... Vail Pischke

DIRECTORS

Garrett L. Stormer, Herbert B. Barlow, Francis J. Hayden, Takashi Koko, John B. Roberts

BRANCH OFFICES

1 B S Storrs, Connecticut; University of Oklahoma, Tulsa, Okla., 113 Locust Drive, Baltimore 28, Md., 1562 Van Vranken Ave., Schenectady 8, N. Y.

FUNCTIONS

The Intercollegiate Broadcasting System is a non-profit association of college and university campus stations established to pool the resources of these stations and further the development of this form of educational radio in this country.

JEWISH THEATRICAL GUILD

1564 Broadway, New York 36, N. Y.
 Plaza 7-5237

Chairman, Bd of Trustees ... Wm. Dejen Weinberger
 President ... Eddie Cantor
 Exec. Vice-Pres ... Harry E. Gould
 1st Vice-Pres ... George Jessel
 Vice-Presidents ... Jack Benny, Jack Bregman, Emil Friedlander, Marcus Heiman, A. A. Jaller, Ted Lewis, Wm. Morris, Jr., Jock Pearl, James Sauter, Milton Weintraub
 Treasurer ... Abe Lastfogel
 Asst. Treasurer ... Nat Lefkowitz
 Chairman of Relief ... Dr. Leo Michel
 Legal Committee ... Henry M. Katz
 Chaplain ... Rabbi Abraham Burstein
 Executive Secretary ... Dave Ferguson

FUNCTION

Non-sectarian theatrical assistance agency

JOINT COMMITTEE ON EDUCATIONAL TELEVISION

1785 Massachusetts Ave., N. W., Washington 6, D. C.
Hudson 3-6620
Executive Director.....Ralph Steelt
Chairman.....Dr. Edgar Fuller, Nat'l Council of Chief State School Officers
Vice-Chairman.....Dr. David D. Henry, American Council on Education

JCET MEMBERS
Dr. Franklin Dunham, Association for Education by Radio-Television; James H. Denison, Association of Land-Grant Colleges and Universities; Graydon Ausmus, National Association of Educational Broadcasters; Dr. Albert N. Jorgensen, National Association of State Universities; Dr. Belmont Farley, National Education Association.

THE LAMBS

130 W. 44th St., New York 36, N. Y.
LUXemburg 2-1515

OFFICERS
Shepherd.....William Gaxton
Boy.....Fred Waring
Corresponding Secretary.....Bobby Clark
Recording Secretary.....Herman Phillips
Treasurer.....James E. Meighan
Librarian.....Harold G. Hoffman

DIRECTORS
Earl Benham, Joseph S. Buhler, Harry Hershfield, Conrad Nagel, Lep Solomon, Ralph Bellamy, Happy Felton, Emil Friedlander, Horace MacMahon, Arthur Vinton, Joseph Downing, Len Doyle, Robert Griffith, H. Pierson Mapes, Saul E. Rogers.

LIFE DIRECTORS EX-SHEPHERDS: Bert Lytell, Fred Waring, John Golden.

FUNCTIONS
The object of this club shall be the promotion of social intercourse among persons, engaged professionally in the drama, music, authorship, and the fine arts, as well as friends of those professions, and the collection and preservation of objects of interest thereto, and the creation and maintenance of funds for the benefit of persons engaged professionally in the drama, music, authorship, and the fine arts who shall be in need of financial aid or assistance, to be disbursed in the discretion of the Council of the Club.

LOWELL INSTITUTE COOPERATIVE BROADCASTING & STATION WGBH

Symphony Hall, Boston 15, Mass.
KENmore 6-6522
President.....Ralph Lowell
Gen. Mgr., Station WGBH.....Parker Wheatley
Asst. Mgr. for Operations.....Hartford N. Gunn, Jr.
Dir., Community Relations.....Ann Doyle

FUNCTIONS
The Lowell Institute and Boston College, The Boston Symphony Orchestra, Boston Museum of Fine Arts, Boston University, Harvard University, Mass. Institute of Technology, New England Conservatory of Music, Northeastern University, and Tufts College, cooperate in the operation of non-commercial educational station WGBH and in the presentation of educational broadcasts over Boston's commercial stations.

MUSIC PUBLISHERS' CONTACT EMPLOYEES UNION OF GREATER NEW YORK, LOCAL 22102, A.F.L.

1270 Sixth Avenue, New York 20, N. Y.
CO. 5-7362
President.....Robert Miller
Vice-President.....Joe Santly
Treasurer.....Chas. Lang
Executive Secretary.....Bob Miller

MEMBERS OF EXECUTIVE COUNCIL
Bob Baumgart, Edgar Burton, Leo Diston, Mickey Garlock, Mac Kooper, Jack Perry, Bernie Pollack, Harry Santly, Sammy Smith, Jack Spatz.

BRANCH OFFICES
54 W. Randolph St., Chicago, Ill., Morton Schaefer, Regional Dir.; 1491 N. Vine St., Hollywood, Cal.,

Lucky Wilber, Regional Dir.; 225 - 26th St., Santa Monica, Cal., Al Comparte, Reg. Secy.; 36 E. 5th St., Cincinnati, Ohio, Danny Engel, Reg. Director.
FUNCTIONS
Labor Union.

MUSIC PUBLISHERS' PROTECTIVE ASSOCIATION, INC.

45 Rockefeller Plaza, New York 20, N. Y.
Circle 6-3084

OFFICERS
Chairman of the Board.....Walter G. Douglas
President.....Louis Bernstein
Vice-President.....Jack Mills
Secretary.....J. J. Bregman
Treasurer.....Abe Olman
Agent and Trustee.....Harry Fox

NATIONAL ASSN. FOR BETTER RADIO AND TELEVISION

882 Victoria Ave., Los Angeles, Cal.
Whitney 4245

OFFICERS
President.....Mrs. Clara S. Logan
1st Vice Pres.....Dr. Richard Atkinson
2nd Vice Pres.....Dr. Lee DeForest
Recording Secretary.....Mrs. Victor Roberts
Correspondence Secretary.....Mrs. A. Stanley Adams
Treasurer.....Mrs. Gertrude Blackstock

FUNCTIONS
To co-ordinate the interest of civic, religious, educational, business and labor organizations and individuals for the purpose of encouraging the presentation of radio and television programs of high standards.

NATIONAL ASSOCIATION OF RADIO & TELEVISION BROADCASTERS

(For Complete Listing See NARTB Section)

NATIONAL ASSOCIATION OF BROADCAST UNIONS AND GUILDS (NABUG)

37 W. 46th St., New York 36, N. Y.
JUdson 2-5130

OFFICERS
National Chairman.....Oliver W. Nicoll

COUNCILS
37 W. 46th St., New York 36, N. Y. Phone: LUXemburg 2-5130. Oliver W. Nicoll, Chairman, New York Council; 341 Menomonee St., Chicago 11, Ill. Phone: DElaware 7-7017, J. Walter Thompson, Chairman, Chicago Council; 6331 Hollywood Blvd., Hollywood 28, Calif. Phone: HILLSide 5125. Claude McCue, Chairman, Hollywood Council.

CORRESPONDING OFFICES
Washington, D. C.; Albuquerque, N. M.; Atlanta, Ga.; Boston, Mass.; Charlotte, N. C.; Cincinnati, Ohio; Cleveland, O.; Dallas, Texas; Denver, Colo.; Detroit, Mich.; Durham, N. C.; Erie, Pa.; Fort Wayne, Ind.; Fort Worth, Tex.; Independence, Mo.; Indianapolis, Ind.; Kansas City, Mo.; Kenosha, Wis.; La Crosse, Wis.; Louisville, Ky.; Madison, Wis.; Miami, Fla.; Milwaukee, Wis.; Minneapolis-St. Paul, Minn.; New Orleans, La.; Norfolk, Va.; Omaha, Neb.; Peoria, Ill.; Philadelphia, Pa.; Pittsburgh, Pa.; Portland, Ore.; Pueblo, Colo.; Racine, Wis.; Raleigh, N. C.; Rochester, N. Y.; Salt Lake City, Utah; San Francisco, Cal.; Schenectady, N. Y.; Seattle, Wash.; Sioux City, Iowa; St. Louis, Mo.; Syracuse, N. Y.; Utica, N. Y.

FUNCTIONS
"NABUG" is the National Association of Broadcast Unions and Guilds in the radio and television industry, organized on behalf of their respective memberships for the solution of parallel problems and the working together of the unions and guilds in those directions—cultural, legislative, economic—where their mutual interests coincide.

NATIONAL ASSOCIATION OF EDUCATIONAL BROADCASTERS

14 Gregory Hall, Univ. of Ill., Urbana, Ill.

ORGANIZATIONS

Urbana 7-6611, Ext. 2779 and 3174

OFFICERS

President	Graydon Ausmus
Vice-President	John Dunn
Treasurer	Frank Schooley
Secretary	Armand Hunter
Executive Director	Harry J. Skornia

DIRECTORS

Region I: James MacAndrews, WNYE, Board of Education, 29 Ft. Greene Place, Brooklyn, N. Y.; Region II: Earl Wynn, WUNC, University of North Carolina, Chapel Hill, N. C.; Region III: Paul B. Rickard, Director of Radio and TV, Wayne University, Detroit, Mich.; Region IV: Richard B. Hall, Director of TV and Radio, Iowa State College, Ames, Iowa; Region V: Margaret Fleming, KSLH, Board of Education, 1517 S. Theresa Ave., St. Louis, Mo.; Region VI: Allen Miller, KWSC, State College of Washington, Pullman, Wash.

BRANCH OFFICE

2500 Municipal Bldg., New York 7, N. Y.
WH 3-3600, Seymour N. Siegel, Past President

FUNCTIONS

Representing non-commercial educational AM, FM and TV stations, workshops and production centers owned and operated by colleges, universities, school systems, State systems, community organizations, and public-service agencies.

NATIONAL ASSN. OF PERFORMING ARTISTS

630 Fifth Ave., New York 20, N. Y.
Circle 7 8194

OFFICERS

President	Fred Waring
Treasurer	Don Voorhees
General Counsel	Alfred Rice

FUNCTIONS

To obtain moral and pecuniary rights of performing artists in the commercial uses of such performances.

NATIONAL ASSN. OF TELEVISION & RADIO FARM DIRECTORS

Address care of President

President	Jack Jackson, KCMO, 125 E. 31st St., Kansas City, Mo., Jefferson 6789
Vice-President	Frank Atwood, WTIC 26 Grove St., Hartford, Conn. 5-0801
Sec.-Treas.	Merrill Langhill, KMA, Lowell & Elm Streets, Shenandoah, Iowa, 192
Historian	Herb Plambeck, WHO 914 Walnut St., Des Moines, Iowa 3-7147
CHATS Editor	Harvey Dinkins, WSJS, 419-21 N. Spruce St., Winston-Salem, N. C. 5-2311

FUNCTION

NATFRD is an organization dedicated to the service of agriculture, station management and the advertiser.

NATIONAL BETTER BUSINESS BUREAU, INC.

Chrysler Bldg., New York 17, N. Y.
Murray Hill 6-3535

OFFICERS

Chairman of Board	Charles H. Watts
President	Kenneth B. Willson
1st Vice-Chairman	Warren Agry
2nd Vice-Chairman	Lorimer B. Slocum
Secretary	Lowell Shumway
Treasurer	Frank F. Soule

FUNCTIONS

This organization assists the public, advertisers and publishers to avoid false and deceptive advertising. It cooperates with law enforcement agencies in this work.

NATIONAL SOCIETY OF TELEVISION PRODUCERS, INC.

17 East 45th St., New York 17, N. Y.
Murray Hill 2-8877
Room 504

WEST COAST OFFICE

7063 Sunset Blvd., Hollywood 28, Calif.
Griffith 6930

FUNCTIONS

The National Society of Television Producers (NSTP) is an industry association comprised of manufacturers or producers of live, filmed, or iconoscope recorded tele. programs. Membership in NSTP is open to all such independent producers or production firms provided they are not a part of, or associated with, an advertising, agency, tele. network, or local tele. station.

NAT. TELEVISION FILM COUNCIL

1501 Broadway, New York 36, N. Y.
LO 4-8234

OFFICERS

President	Archie Mayers
V.P., Press Rep.	(Unity TV, N. Y. C.) Solly Perle
Secretary	(Mesal Organizations, N. Y. C. OR 9-3747) William Van Proag
Treasurer	(Van Praag Prods., N. Y. C.) Waldo Mayo
	(Mayo Productions, N. Y. C.)

BOARD OF DIRECTORS

Melvin L. Gold, Chairman, National Screen Service, N. Y. C.; Bill Holland, Hyperion Films, N. Y. C.; Henry Brown, Atlas Television Corp., N. Y. C.; Sidney A. Mayers, Attorney, N. Y. C.; David Savage, WCBS, N. Y. C.; Lou Feldman, Tri-Art Color Corp., N. Y. C.; Frank Bibas, McConn Erickson, N. Y. C.; Dr. Alfred N. Goldsmith, RCA Chief Consultant, N. Y. C.; Andrew Jaeger, PSI Productions, N. Y. C.; William Reddick, W. J. German Co., N. Y. C.; David Bailor, TV Film World, N. Y. C.

NATIONAL VARIETY ARTISTS, INC.

218 W. 47th St., New York 36, N. Y.
Columbus 5-0956

OFFICERS

President	Louis Handin
First Vice-Pres.	B. N. Walker
Second Vice-Pres.	Dorothy A. Masters
Treasurer	Lester Rose
Secretary	Bette North

DIRECTORS

Jack Boyk, Leonard Conner, Jeanette D'Amico, Bob Jones, Henry Lewinsohn, Ruth Lyons, Lillian McNeill, Edna Osborne, Evelyn Silver, Evelyn Saunders Sollich, Joe Verdi, Joe Woods Chaplain, Harry Jackson

FUNCTIONS

The function of National Variety Artists, Inc., is to promote Americanism, fraternal and welfare activities among the members of the theatrical profession.

NEGRO ACTORS GUILD OF AMERICA, INC.

1674 Broadway, New York 19, N. Y.
Circle 5 4343

OFFICERS

President	Noble Sissle
Vice-President	Leigh Whipper
Executive Secretary	Lillian Brown
Treasurer	W. C. Handy
Assistant Treasurer	A. Edward Walters
Recording Secretary	Evelyn Davis
Assistant Secretary	Lillian Roberts
Chaplain	Dr. John H. Johnson
Counsel	Harry G. Brogg

FUNCTION

To help indigent performers

PHILADELPHIA RADIO AND TELEVISION BROADCASTERS ASSOCIATION

2043 Locust St., Philadelphia 3, Pa.
LO 4-0886

President.....Patrick J. Stanton
Vice-President.....William B. Caskey
Treasurer.....John D. Scheuer, Jr.
Secretary.....Max M. Leon
Executive Secretary.....Josephine Oris

FUNCTIONS

To initiate and promote studies of all phases of radio and television broadcasting for the purpose of improving service to the public and advertisers.

PROFESSIONAL MUSIC MEN, INC.

1270 Sixth Ave., New York 20, N. Y.
Columbia 5-7362

OFFICERS

Honorary President.....Rocco Vacco
President.....Robert Miller
Vice-President.....Joseph Santly
Treasurer.....Charles Lang
Executive Director.....Bob Miller
Board of Governors.....Bob Boumgort,
Edgar Burton, Leo Diston, Mickey Garlock, Mac
Kooper, Jack Perry, Bernie Pollack, Harry Santly,
Sommy Smith; Jack Spatz.

BRANCH OFFICES

54 W. Randolph St., Chicago, Ill.
Regional Director.....Morton Schaefer
1491 N. Vine St., Los Angeles, Calif.
Regional Director.....Lucky Wilber
36 E. 5th St., Cincinnati, O.
Regional Director.....Danny Engel
225 - 26th St., Santa Monica, Calif.
Regional Secretary.....Al Comparte

FUNCTIONS

Charitable and Benevolent Organization.

RADIO FREE EUROPE

110 West 57th St., New York 19, N. Y.
PLaza 7-7600

Central Broadcasting Headquarters,
1 Englischer Garten, Munich, Germany

OFFICERS

Director.....Robert E. Lang
Deputy Director.....George Caesar
Asst. Director.....Thomas H. Brown, Jr.
Program Director.....Melvin P. Wamboldt
Public Relations Director.....Alton Kastner
Policy Advisor.....Lewis Galantiere
Chief Engineer.....Cloud Harris
European Dir. (Munich Office).....Richard Condon

FUNCTIONS

Radio Free Europe, a private organization supported by contributions to Crusade for Freedom, transmits to Czechoslovakia, Hungary, Poland, Rumania and Bulgaria. In its programs, written and broadcast by freedom loving exiles, R. F. E. brings the captive peoples behind the iron curtain news of the free world and their own countries, knowledge that they are not forgotten, and hope for their liberation.

RADIO-NEWSREEL-TELEVISION WORKING PRESS ASSOCIATION OF NEW YORK, INC.

270 Park Ave., New York 22, N. Y.
PLaza 1-2720

OFFICERS

President.....Arnold Lerner
Vice-President.....Thomas Priestley
Sgt. at Arms.....Herbert Mulligan
Secretary.....Ruth N. Knopf
Asst. Secretary.....Monroe Benton
Treasurer.....David B. Tullen
Board of Governors.....A. A. Brown,
David Klein, Larry Racies, Nick Archer, Robt. Donahue, Jr.; George Jordan; Carl Larsen, Sr.

FUNCTIONS

A membership corporation whose object is to pro-

te and protect the interest and welfare of radio, newsreel, and television newsmen and cameramen. Membership is limited to radio, newsreel, television, and newsmen who are engaged in outside assignments for the coverage of spot news. Those eligible include working reporters, cameramen, contact men, soundmen, tape recording men, etc.

THE RADIO PIONEERS CLUB

580 Fifth Ave., New York 19, N. Y.
PLaza 7-1800

OFFICERS

President.....Paul W. Morency
1st Vice-President.....Arthur B. Church
Vice-President.....Raymond F. Guy
Vice-President.....Victor Diehm
Secretary.....John Patt
Treasurer.....Charles A. Wall

FUNCTIONS

"To establish a membership organization of persons who by their long years of service in the field of Radio desire to become associated for the purposes of friendship and education. The Club shall be a central clearing house for the exchange of information and historical data about the Radio industry and shall record in form to be determined facts and data about the history of the Radio industry and its traditions for use by this and future generations. It is felt that this organization with the resultant exchange of information would make a valuable contribution to the public interest."

The purposes as outlined in the constitution are sufficiently broad to enable the Radio Pioneers to undertake almost any task which the Club may desire for the furtherance of the Radio Industry.

Accordingly, 1950 will mark the establishment of a Radio Hall of Fame in which the memories of men and women whose contribution have placed them among the immortals will be perpetuated.

RADIO AND TELEVISION DIRECTORS GUILD (A.F. OF L.)

114 East 52nd St., New York 22, N. Y.
PLaza 3-4300, Ext. 214

OFFICERS

International President.....Franklin Schaffner
1st Vice-President.....Ted Bliss
2nd Vice-President.....Charles Dargan
3rd Vice-President.....Ian Harrower
Secretary.....Alan Fishburn
Treasurer.....Andrew McCullough

NATIONAL BOARD

Grover Allen, Chicago; Ted Bliss, Hollywood; Richard Borden, Washington; Frank Danzig, Hollywood; Charles Dargan, Cleveland; Hal Davis, New York; Alan M. Fishburn, Chicago; Ian Harrower, Detroit; Max Hutto, Hollywood; Dick Mack, Hollywood; Andrew McCullough, New York; Paul Nickell, New York; Oliver W. Nicoll, New York; Ernest D. Ricca, New York; Robert Robb, Hollywood; Franklin J. Schaffner, New York; Richard N. Schneider, New York; Alex Segal, New York.

National Executive Director.....Newman H. Burnett
Gen. Counsel.....Charles Ballou
(Phillips, Nizer, Benjamin & Krim)

BRANCH OFFICES

New York Local—114 East 52nd St., N. Y. 22, PLaza 9-0875. Newman H. Burnett, Exec. Secy.; Richard Schneider, Pres.

Hollywood Local—1655 No. Cherokee, Hollywood 28, Hollywood 7-5866. Elizabeth Gould, Exec. Secy.; Robert L. Robb, Pres.

Chicago Local—1413 N. Dearborn, Chicago, Ill., DELaware 7-4867, Alan Fishburn, President.

Detroit Local—1257 Penobscot Bldg., Detroit 26, WOodward 5-0061. Boaz Siegel, Exec. Secy.; Ian Harrower, Pres.

Washington Local—Sheraton Park Hotel, Washington, D. C., ADams 4-5400. Richard Borden, Pres.

Cleveland Local—13300 Second Ave., East Cleveland 12, O. Charles Dargan, Pres.

FUNCTIONS

A national organization to advance, foster, promote

ORGANIZATIONS

and benefit the interests of directors, associate directors and floor managers of television, live and film, and radio programs and to protect and secure their rights in their professional activities.

RADIO AND TELEVISION EXECUTIVES SOCIETY, INC.

420 Lexington Ave., New York 17, N. Y.
LExington 2-3988

OFFICERS

President	James M. Gaines
1st Vice-President	George Shupert
2nd Vice-President	Robert Burton
Secretary	Claude Barrere
Treasurer	Joseph A. McDonald
Executive Secretary	Elizabeth Clarkson

BOARD OF GOVERNORS

Lester Gottlieb, G. W. Johnstone, Eugene Katz, Marvin Kirsch, Donald McClure, Bruce Robertson, Elliot M. Sanger, Robert W. Sarnoff, Reggie Schuebel, Chris Wilting.

FUNCTIONS

1. To create a lasting fraternity of persons professionally engaged or interested in radio and television broadcasting and its allied fields and to provide a common meeting place for all members. 2. To provide a forum for the exchange of ideas and discussions of problems affecting or concerning radio and television broadcasting or relating to its improvement or usefulness and to promote higher standards for the radio and television industry as a scientific, literary, informational, entertainment, and cultural medium. 3. To provide and sponsor the dissemination of information pertaining to radio and television broadcasting which may be of mutual interest and value to members, the public and the industry. 4. To do all and everything necessary, suitable and proper for the complete accomplishment of these purposes and the attainment of the objects herein set forth within such limitations as are provided by law.

RADIO-ELECTRONICS-TELEVISION MANUFACTURERS ASSOCIATION

See Equipment Section

RADIO-TV MANUFACTURERS ASSOCIATION OF CANADA

Room 301, 159 Bay St., Toronto 1, Ontario, Canada
EM 3-1531

OFFICERS

President	A. B. Hunt
Executive Secretary	S. D. Brownlee
Chairman, Paris Division	N. H. Futher
Chairman, Receiver Division	C. A. Pollock
Chairman, Tech. Products Division	H. S. Dowson

FUNCTIONS

This Association is a non-profit and co-operative organization to promote the interests of the radio-TV manufacturing industry in Canada

THE RADIO-TELEVISION NEWS DIRECTORS ASSOCIATION

Executive Secretary, Rob Downey, c/o WKAR, East Lansing, Mich.

OFFICERS

President	James Byron
Vice-President	Russ Van Dyke
Treasurer	Sheldon Peterson
Editor of Bulletin	Prof. Art Bornes

WBAP-TV, Fort Worth, Texas
KRNT, Des Moines, Iowa
KLZ, Denver, Colo
University of Iowa, Iowa City, Iowa

FUNCTIONS

Publishes monthly bulletin and booklets on radio-TV news. Basic purpose to advance standards of radio and television as news media

RADIO-TELEVISION PROGRAM MATERIALS

U. S. Office of Education, Washington 25, D. C.
EXecutive 6300, Ext. 2897

Chief Franklin Dunham
Radio-TV Education Specialist. Gertrude C. Broderick

FUNCTIONS

The exchange is designed to promote more effective local broadcasting by educational and civic organizations and radio and television stations by serving as a clearing house for selected television educational scripts, kinescopes and production aids, and as a source of all kinds of information pertaining to the field of educational radio and television

THE RADIO WRITERS' GUILD OF THE AUTHORS' LEAGUE OF AMERICA, INC.

2 East 23rd St., New York 10, N. Y.
GRamercy 7-9190

OFFICERS

National President	Jerome Lawrence
Eastern Region Vice-Pres.	Nelson E. Sykes
Western Region Vice-Pres.	Gomer Cool
Midwestern Region Vice-Pres.	Russ Bensley
Eastern Region Exec.-Sec.	May Bolhower

BRANCH OFFICES

188 W Randolph St., Chicago 1, Ill.
Financial 6-5575
1 Meyers, Attny.
1655 N. Cherokee, Hollywood 28, Calif.
GLadstone 7128
Gomer Cool, Vice-Pres.

FUNCTIONS

For the improvement of general conditions affecting men and women engaged in writing for broadcasting

SCREEN ACTORS GUILD, INC.

7046 Hollywood Blvd., Hollywood 28, Calif.
HOLlywood 9-7311

President	Walter Pidgeon
1st Vice-President	Leon Ames
2nd Vice-President	John Lund
3rd Vice-President	William Holden
Recording Secretary	Paul Harvey
Treasurer	George Chondler

BRANCH OFFICES

67 W. 44th St., New York 36, N. Y.
MUrray Hill 7-4623, Mrs. Florence B. Marston, East. Rep.
102 E. Hubbard St., Chicago 11, Ill.
WHitehall 3-1344, Raymond Jones, Chicago Exec. Secy.
1257 Penobscot Bldg., Detroit 26, Mich
WOODward 1-8214, Boaz Siegel, Det. Exec. Secy
421 Phelan Bldg., San Francisco 2, Cal
EXbrook 2-6990, Charlotte Coholan, S. F. Exec. Secy.
513 Bulkley Bldg., Cleveland 15, Ohio
SUperior 1-1930, Ted Smoot, Cleve. Exec. Secy
1505 Fountain Square Bldg., Cincinnati 2, Ohio
DUrban 2121, Ben Gettler, Cin. Exec. Secy.
11 Beacon St., Boston 8, Mass.
Richmond 2-0208, Robt. Segal, Boston Exec. Secy
FRick Bldg., 5th Ave. & Grant St., Pittsburgh 19, Pa
ATLantic 1-2428, Donald Hirsch, Pitt. Exec. Secy.

SESAC INC.

475 Fifth Ave., New York 17, N. Y.
MUrray Hill 5-5365

OFFICERS

President	Paul Heinecke
Treasurer	R. C. Heinecke
Asst to President	E. S. Proger

FUNCTIONS

Licensing the use of copyrighted music transcribed library service, syndicated transcribed programs, including extensive catalog of bridges, moods and themes, and scripts.

SOCIETY OF MOTION PICTURE AND TELEVISION ENGINEERS

40 West 40th St., New York 18, N. Y.
LONgacre 5-0172

OFFICERS

President	Herbert Burnett
-----------	-----------------

Past President.....Peter Mole
 Executive Vice-Pres.....John G. Frayne
 Engineering Vice-Pres.....Axel G. Jensen
 Editorial Vice-Pres.....N. L. Simmons
 Financial Vice-Pres.....Barton Kreuzer
 Convention Vice-Pres.....John W. Servies
 Treasurer.....George Colburn
 Secretary.....Edward S. Seeley
 Executive Secretary.....Boyce Nemeck

FUNCTIONS

The advancement of motion picture engineering and the allied arts and sciences; the standardization of the mechanisms and practices employed in the motion picture industry, and the dissemination of scientific knowledge by publication.

SONG WRITERS' PROTECTIVE ASSOCIATION (SPA)

158 W. 55th St., New York 19, N. Y.
 Circle 6-2536

OFFICERS

President.....Charles Tobias
 Vice-President.....Louis Alter
 2nd Vice-President.....Sam H. Stept
 Secretary.....Joseph Meyer
 Treasurer.....Abel Baer
 Counsel.....John Schulman
 Assoc. Counsel.....William Klein II
 Executive Director.....Miriam Stern
 Chmn., West Coast Comm.....L. Wolfe Gilbert

MEMBERS OF THE COUNCIL

Milton Drake, Chairman; Stanley Adams, Milton Ager, Louis Alter, Abel Baer, Paul Cunningham, Dorothy Fields, Ira Gershwin, Oscar Hammerstein 2nd, Otto Harbach, Edgar Leslie, John Jacob Loeb, George W. Meyer, Joseph Meyer, Geoffrey O'Hara, Richard Rodgers, Arthur Schwartz, Sam H. Stept, Charles Tobias, Jack Yellin.

FUNCTIONS

The objects of this Association are and shall be: To cultivate and establish harmony and unity of action and understanding among the members of the Association, and between them and corporations, firms or individuals with whom they have or may have business dealings, and to promote the equitable adjustment of all matters relating to the professional work of the members.

SOUTHERN CALIFORNIA BROADCASTERS' ASSN.

6047 Hollywood Blvd., Hollywood 28, Calif.
 Hollywood 9-7254

OFFICERS

Managing Director.....J. Norman Nelson
 Assistant.....Marjorie Walker
 Assistant.....Louise Sanders

BOARD OF DIRECTORS

President...Frank Burke, Jr., Mgr. KFVD, Los Angeles
 V.-P...Norman Ostby, V.-P, Don Lee-Mutual, Hollywood
 Secy.-Treas...Thelma Kirchner, Mgr. KGfJ, Hollywood

BOARD

Calvin Smith, Mgr. KFAC, Los Angeles; Bill Beaton, Mgr. KWKW, Pasadena; A. E. Joscelyn, Dir. Oper. CBS, Hollywood; Bob McAndrews, Comm'l Mgr. KBIG, Avalon; Bob Reynolds, Mgr. KMPC, Hollywood; Gene De Young, Mgr. KERO, Bakersfield.

FUNCTIONS

Represents 59 member stations and networks, located in Southern California from San Luis Obispo to San Diego in all matters concerning broadcast industry as a whole in that area. Acts as central source of research, information, public service, promotion of use of media, etc. Regular meetings, second Thursday of every month, (noon), Hollywood-Roosevelt Hotel.

SPORTS BROADCASTERS ASSOCIATION

c/o Toots Shor, 51 West 51st St., New York 20, N. Y.

OFFICERS

President.....Joe Hasel
 1st Vice-President.....Sam Taub
 2nd Vice-President.....Guy Lebow

Treasurer.....Lenny Dillon
 Secretary.....Bob Allison

STATION REPRESENTATIVES ASSOCIATION, INC.

101 Park Avenue, New York 17, N. Y.
 MUrray Hill 5-4141

OFFICERS

President.....John Blair
 Vice-President.....John E. Pearson
 Secretary.....Adam J. Young, Jr.
 Treasurer.....Thomas F. Clark

DIRECTORS

Joseph J. Weed, Joseph Timlin, Russel Woodward, George Brett.
 Managing Director.....T. F. Flanagan
 Dir. of Advertiser Relations.....Reginald Rollinson

FUNCTIONS

To develop the use and increase the sale of National Spot Radio and Television Advertising.

ULTRA HIGH FREQUENCY TV ASSOCIATION

400 DeSales Building, Washington 6, D. C.
 NAtional 8-0032

OFFICERS

President.....Lou Poller, WCAN-TV, Milwaukee, Wis.
 Vice-Pres.....A. Donovan Faust, WENS, Pittsburgh, Pa.
 Treasurer.....Harry Tenenbaum, WTVI, Belleville, Ill.
 Acting Exec. Secy.....Melvin A. Goldberg
 General Counsel.....William A. Roberts

DIRECTORS

A. Donovan Faust, WENS, Pittsburgh, Pa.; Jack Garrison, KACY, Festus, Mo.; Ben K. McKinnon, WGVL, Greenville, S. C.; Marshall H. Pengra, KSTM-TV, St. Louis, Mo.; Lou Poller, WCAN-TV, Milwaukee, Wis.; Byrne Ross, KLPB-TV, Oklahoma City, Okla.; Harry Tenenbaum, WTVI, Belleville, Ill.

UNITED NATIONS—RADIO DEPARTMENT OF PUBLIC INFORMATION DIVISION

United Nations, New York, N. Y.
 PLaza 4-1234

OFFICERS

Asst. Sec'y. Gen.....Benjamin Cohen
 Dir, Radio Div.....Peter Aylen
 Chief of Production.....W. Gibson Parker
 U. S. Station Rel.....Dorothy Lewis
 Sr. Broadcast Engineer.....Arthur E. Barrett
 Film Div. TV Officer.....Maxwell Dunn

BRANCH OFFICES

Moscow, Prague, London, Paris, Geneva, Copenhagen, Belgrade, Cairo, Terheran, Karachi, New Delhi, Shanghai, Sydney, Monrovia, Washington, Rio de Janeiro, Buenos Aires, Mexico City, Bangkok, Djakarta, Los Angeles, Manila and Santiago.

FUNCTIONS

Provides radio, TV programs and program material; assists networks and stations in planning and preparation of UN coverage.

U. S. INFORMATION AGENCY BROADCASTING SERVICE

Voice of America
 251 West 57th Street,
 New York 19, N. Y.
 JUdson 6-2000
 Washington Headquarters:
 1778 Pennsylvania Avenue, Room 920
 Washington 9, D. C.
 REpublic 7-8340, Extension 3634

OFFICERS

Director.....Theodore C. Streibert
 Asst. Dir. for Broadcasting.....Leonard F. Erikson

FUNCTIONS

To submit evidence to the people of other nations of the objectives and policies of the United States. More than 75 separate programs, ranging up to one hour and amounting to about 28 program hours, are broadcast daily in 34 language services.



OPERATION SUCCESS!

with du mont telecasting equipment

The rich heritage of over 12 years' experience in the design, manufacture and use of telecasting equipment is reflected in every piece of Du Mont equipment today. This experience results in equipment without peer for performance, dependability and operating economies.

Du Mont-equipped stations were among the first to "break into the black" a few years ago. Today a roster of the most successful stations in the television world shows an impressive percentage of partial or

100% Du Mont-equipped operations.

It was Du Mont who first advocated the "Grow As You Earn" basis of station equipment. This has paid dividends to the many stations who recently increased their transmitting power through the Acorn-to-Oak Series Transmitters. Such power increases were achieved with no loss of "time on the air" or loss of former equipment.

Truly, a Du Mont-equipped TV station exemplifies OPERATION SUCCESS!

DU MONT

Television Transmitter Division,

Allen B. Du Mont Laboratories, Inc., Clifton, N. J.

Television--1954

THE moving story of the modern miracle—television—unfolds in the pages that follow as Radio-Television Daily presents the 1954 edition of Television Year Book.

THIS is an authoritative report on the day-to-day progress of the sight and sound medium based on the facts, figures and feature data compiled from many sources which have contributed to the matchless progress of the expanding new industry.

THE progress of black and white television, the future of color and the expansion of program production are just a few of the many categories covered in this year's volume. In addition there are sections devoted to networks, stations, FCC statistics, TV film producers and many other services which have played important roles in the unprecedented advancement of the new art.

TO the many sources of information who have contributed to this volume we express our gratitude. Their contributions have made this year's edition of the Television Year Book the most comprehensive reference volume yet produced in the interest of the video art.

JACK ALICOATE
Editor-in-Chief



AS a new year rolls around, Philco sends a heartfelt "thanks" to all the fine actors, writers and technicians who year after year have made PHILCO TELEVISION PLAYHOUSE America's leading dramatic program.

PHILCO TELEVISION PLAYHOUSE

Alternate Sundays • 9-10 P.M. E.S.T. • NBC-TV

T *ele* **vision** *Code*



of the
NARTB

Now Zenith completes your "home entertainment center"



WITH THE NEW
ZENITH CHAIRSIDE
RADIO-
PHONOGRAPH

The Gibson, Model E2271R, 21" TV console with the fabulous Giebman Pierre Table.

Zenith's brilliant new chairside Radio-Phonograph puts all types of music at your fingertips . . . right beside the chair where you watch TV! Even more than a radio-phonograph, it's a strikingly handsome piece of furniture that will lend no end of style to your living room. Serves beautifully as an end table, in any sectional or conversational grouping. Put flowers on it . . . books, ashtrays, anything.

The tone is no less than superb, whether you're listening to Super Sensitive FM . . . Long Distance AM . . . or hearing (very possibly for the first time) the beauty of the original music that went into your favorite recordings. All your Zenith dealer asks is that you *hear* it . . . and *see* it!

Zenith gives you History-Making Pitch and Tempo Control!

Hear your records at exact recorded speed . . . at perfect pitch and tempo. On Zenith's Cobra Matic Record Player with built-in Stroboscope, a dot of light *shows* you when your records are playing at exact recorded speed, whether 78, 33 $\frac{1}{3}$ or 45 RPM. (The Cobra-Matic lets you play records at *any* speed from 10 to 35 RPM, including the new 16 $\frac{1}{2}$ RPM talking book speed.)

The result is music . . . more than fidelity of tone . . . it's music with a new *reality*.



"Lazy Bones" Remote control let's you "click" on the station you want, without getting out of your chair. Optional.



Backed by 35 Years of Leadership in Radio's Endorsement
ALSO MARKETS OF FINE HEARING AIDS
Zenith Radio Corporation • Chicago 39, Illinois

Now Even Better!
Invest More in Savings Bonds!

©1958, 1959

THE TELEVISION CODE OF THE NARTB

PREAMBLE

TELEVISION is seen and heard in every type of American home. These homes include children and adults of all ages, embrace all races and all varieties of religious faith, and reach those of every educational background. It is the responsibility of television to bear constantly in mind that the audience is primarily a home audience, and consequently that television's relationship to the viewers is that between guest and host.

THE REVENUES from advertising support the free, competitive American system of telecasting, and make available to the eyes and ears of the American people the finest programs of information, education, culture and entertainment. By law the television broadcaster is responsible for the programming of his station. He, however, is obligated to bring his positive responsibility for excellence and good taste in programming to bear upon all who have a hand in the production of programs, including networks, sponsors, producers of film and of live programs, advertising agencies, and talent agencies.

THE AMERICAN businesses which utilize television for conveying their advertising messages to the home by pictures with sound, seen free-of-charge on the home screen, are reminded that their responsibilities are not limited to the sale of goods and the creation of a favorable attitude toward the sponsor by the presentation of entertainment. They include, as well, responsibility for utilizing television to bring the best programs, regardless of kind, into American homes.

TELEVISION, and all who participate in it are jointly accountable to the American public for respect for the special needs of children, for community responsibility, for advancement of education and culture, for the acceptability of the program materials chosen, for decency and decorum in production, and for propriety in advertising. This responsibility cannot be discharged by any given group of programs, but can be discharged only through the highest standards of respect for the American home, applied to every moment of every program presented by television.

IN ORDER that television programming may best serve the public interest, viewers should be encouraged to make their criticisms and positive suggestions known to the television broadcasters. Parents in particular should be urged to see to it that out of the richness of television fare, the best programs are brought to the attention of their children.

(Continued on Page 776)

Fresh! Vigorous!

**2nd GREAT YEAR
NOW IN PRODUCTION!**

A grand new total of 78 magnificent half-hours!

**ADOLPHIE
MIENJOU**

YOUR STAR AND HOST IN

**"FAVORITE
STORY"**

EACH MAGNIFICENT HALF-HOUR DRAMA A VIVID AND REWARDING EXPERIENCE
IN TELEVISION ENTERTAINMENT!

Planned for 3 Full-Length
Commercials Plus Opening
and Closing Sponsor
Identification

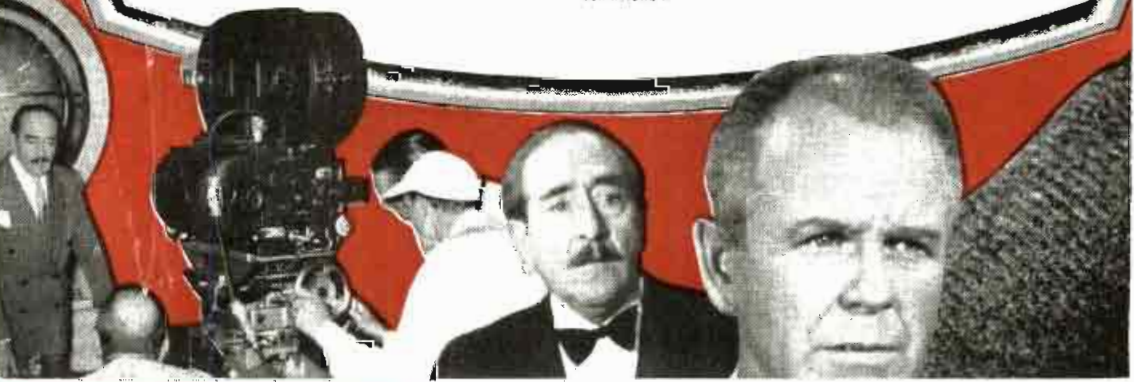

Exciting!

PRODUCED WITH A

Masters' Flair!

NOT ANYWHERE, NOT BY ANYONE HAS
TELEVISION BEEN SO HANDSOMELY
AND LAVISHLY STAGED!

BEYOND BELIEF:

Brilliant Stories!

ALL THRILLINGLY NEW
TO TELEVISION!

NEVER BEFORE HAVE SO MANY
TALENTS BEEN COMBINED, FOR
THE SOLE PURPOSE OF BUILDING

Sales and Profits!
FOR YOU!

Thrill to
television's
greatest
dramatic
achievement!



ZIV-TV

ZIV TELEVISION PROGRAMS, INC.
1399 MADISON ROAD, CINCINNATI, OHIO
NEW YORK HOLLYWOOD

ADVANCEMENT OF EDUCATION AND CULTURE

1. Commercial television provides a valuable means of augmenting the educational and cultural influences of schools, institutions of higher learning, the home, the church, museums, foundations, and other institutions devoted to education and culture.

2. It is the responsibility of a television broadcaster to call upon such institutions for counsel and co-operation and to work with them on the best methods of presenting educational and cultural materials by television. It is further the responsibility of stations, networks, advertising agencies and sponsors consciously to seek opportunities for introducing into telecasts factual materials which will aid in the enlightenment of the American public.

3. Education via television may be taken to mean that process by which the individual is brought toward informed adjustment to his society. Television is also responsible for the presentation of overtly instructional and cultural programs, scheduled so as to reach the viewers who are naturally drawn to such programs, and produced so as to attract the largest possible audience.

4. In furthering this realization, the television broadcaster:

a) Should be thoroughly conversant with the educational and cultural needs and desires of the community served.

b) Should affirmatively seek out responsible and accountable educational and cultural institutions of the community with a view toward providing opportunities for the instruction and enlightenment of the viewers.

c) Should provide for reasonable experimentation in the development of programs specifically directed to the advancement of the community's culture and education.

ACCEPTABILITY OF PROGRAM MATERIAL

Program material should enlarge the horizons of the viewer, provide him with wholesome entertainment, afford helpful stimulation, and remind him of the responsibilities which the citizen has toward his society. Furthermore:

a) (i) Profanity, obscenity, smut and vulgarity are forbidden, even when likely to be understood only by part of the audience. From time to time, words which have been acceptable, acquire undesirable meanings, and telecasters should be alert to eliminate such words.

(ii) Words (especially slang) derisive of any race, color, creed, nationality or national derivation, except wherein such usage would be for the specific purpose of effective dramatization such as combatting prejudice, are forbidden, even when likely to be understood only by part of the audience. From time to time, words which have been acceptable, acquire undesirable meanings, and telecasters should be alert to eliminate such words.

(iii) The Television Code Review board shall maintain and issue to subscribers, from time to time, a continuing list of specific words and phrases, which should not be used in keeping with this subsection. This list, however, shall not be considered as all-inclusive.

b) (i) Attacks on religion and religious faiths are not allowed.

(ii) Reverence is to mark any mention of the name of God, His attributes and powers.

(iii) When religious rites are included in other than religious programs, the rites are accurately presented, and the ministers, priests and rabbis portrayed in their callings are vested with the dignity of their office and under no circumstances are to be held up to ridicule.

c) (i) Contests may not constitute a lottery.

(ii) Any telecasting designed to "buy" the television audience by requiring it to listen and/or view in hope of reward, rather than for the quality of the program, should be avoided.

d) Respect is maintained for the sanctity of marriage and the value of the home. Divorce is not treated casually nor justified as a solution for marital problems.

e) Illicit sex relations are not treated as commendable.

f) Sex crimes and abnormalities are generally unacceptable as program material.

g) Drunkenness and narcotic addiction are never presented as desirable or prevalent.

h) The administration of illegal drugs will not be displayed.

i) The use of liquor in program content shall be de-emphasized. The consumption of liquor in American life, when not required by the plot or for proper characterization, shall not be shown.

j) The use of gambling devices or scenes necessary to the development of plot or as appropriate background is acceptable only when presented with discretion and in moderation, and in a manner which would not excite interest in, or foster, betting nor be instructional in nature. Telecasts of actual sport programs at which on-the-scene betting is permitted by law should be presented in a manner in keeping with Federal, state and local laws, and should concentrate on the subject as a public sporting event.

k) In reference to physical or mental afflictions and deformities, special precautions must be taken to avoid ridiculing sufferers from similar ailments and offending them or members of their families.

l) Exhibitions of fortune-telling, astrology, phrenology, palm-reading, and numerology are acceptable only when required by a plot or the theme of a program, and then the presentation should be developed in a manner designed not to foster superstition or excite interest or belief in these subjects.

m) Television drama shall not simulate news or special events in such a way as to mislead or alarm. Reference is made to the section of the Code on News.

n) Legal, medical and other professional advice, diagnosis and treatment will be permitted only in conformity with law and recognized ethical and professional standards.

o) The presentation of cruelty, greed and selfishness as worthy motivations is to be avoided.

p) Excessive or unfair exploitation of others or of their physical or mental afflictions shall not be presented as praiseworthy.

q) Criminality shall be presented as undesirable and unsympathetic. The condoning of crime and the treatment of the commission of crime in a frivolous, cynical or callous manner is unacceptable.

r) The presentation of techniques of crime in such detail as to invite imitation shall be avoided.

(Continued on Page 781)



BMI

**OFFERS
THESE
PROGRAM
AIDS
TO THE
BROADCASTER**



CONTINUITY

Music programs that sell . . . ready for immediate use . . . smooth, well-written scripts for a variety of program purposes:

ACCORDING TO THE RECORD (five minutes, daily)

THE BOOK PARADE (quarter hour, weekly)

MUSIC AND SPORTS (quarter hour, 3 times weekly)

MILESTONES (half hour, periodically)

CONCERT MUSIC

Monthly Pin Up Sheet, listing new recordings of outstanding contemporary and standard compositions.

YOUR CONCERT HALL — a series of half-hour radio scripts, three times weekly.

TODAY IN MUSIC — dates and facts about the important music events of the month.

PIN UP SHEETS

Convenient and timely reference to the current song leaders . . . pop hits, folk favorites, standards, rhythm and blues successes . . . issued monthly.

COPYRIGHT RESEARCH

Thorough, up-to-the-minute information on music clearance . . . a complete basic catalog and regular weekly supplements of newly published music with consolidated indexes provided semi-annually.

NEWSLETTER

Personal monthly message to the broadcasters. An exchange of radio and music ideas.

MUSIC MEMO

Monthly informational bulletin . . . the radio man's guide to BMI music . . . contains helpful feature articles, the Platter Spinners Parade and Tips on Tunes.

MEET THE ARTIST

Valuable reference of vital statistics on 144 of the nation's popular recording artists.

CHECK LIST

Digest of trade press ratings of the newest record releases.

HOLIDAY MUSIC

Timely suggestions of appropriate music for seasonal and holiday occasions.

MUSIC DISTRIBUTION

Music of every type, published by BMI and affiliated publishers, mailed to stations frequently.

PERFORMINDEX

Handy, time-saving catalog of most-performed BMI-licensed titles.

CATEGORICAL INDEX

Provides immediate reference to a wide variety of song titles, arranged for selecting appropriate music in countless script situations.

BMI services are all designed to aid the broadcaster and are available to every BMI-licensed station. Check with your program director or music librarian for this material.

BROADCAST MUSIC, INC.

580 FIFTH AVENUE • NEW YORK 36, N.Y.

NEW YORK • CHICAGO • HOLLYWOOD • TORONTO • MONTREAL



BMI

PRODUCT and SERVICE REACH A NEW HIGH!

With each succeeding year BMI's products and services attain new highs in volume and value.

The large and growing catalog of BMI-licensed music in all classes—popular, folk, standard, symphonic, operatic, educational—gives continuing evidence of the quality and ability of the composers and publishers affiliated with BMI.

BMI Service, too, is reaching new highs. BMI not only serves its broadcast licensees—AM, FM and TV—with a steady flow of practical program aids, but provides its repertoire and facilities to every user of music . . . ballrooms, night clubs, motion pictures, hotels, restaurants, skating rinks, amusement parks, wired music, industrial plants, symphony orchestras, chamber music groups, choirs and choruses, motion picture exhibitors using intermission music and many others.

BMI-licensed pop song hits are maintaining leading positions in all of the music trade popularity charts—the Hit Parade, the Variety scoreboard, Billboard charts, Downbeat polls, the everyday best-seller lists—and, for the past four consecutive years, were voted Number One in all categories by the nation's juke box operators in the Annual Cash Box Popularity Poll.

In the field of Concert Music, BMI continues to foster composition and encourage public interest through its annual Student Composers Radio Awards, its support of the American Composers Alliance, and the extensive publication of Concert Music through its wholly owned subsidiary, Associated Music Publishers, Inc.

Similar BMI services and efforts in the entire field of music are being conducted throughout the Provinces of Canada by BMI Canada Limited.

BROADCAST MUSIC, INC.

580 FIFTH AVENUE • NEW YORK 36, N.Y.

NEW YORK • CHICAGO • HOLLYWOOD • TORONTO • MONTREAL

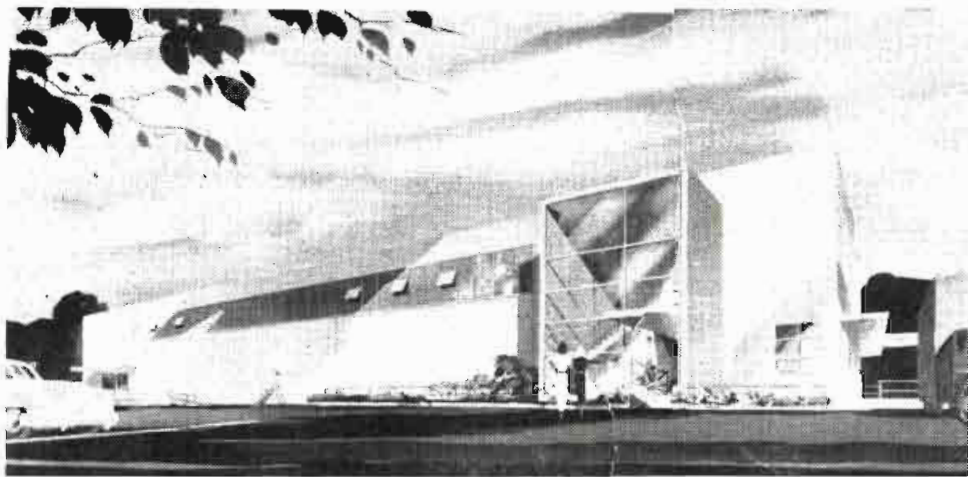

CONSOLIDATED FILM INDUSTRIES

NEW 16mm LAB

In addition to its complete facilities for 35 mm black & white and color, Consolidated is proud to make available to the Television Industry its new 16mm laboratory.

This is the first large, fully equipped, professional laboratory ever built for the processing of 16mm film exclusively. It incorporates every advanced facility for attaining the finest possible quality in 16mm black & white and color.

*In Every Field, One Name Stands Out.
In Film Laboratories, It's... CFI*

CONSOLIDATED FILM INDUSTRIES

959 Seward St., Hollywood 38, Calif. • HO 9-1441

1740 Broadway, N.Y.C. 19, N.Y. • JU 6-1700

A DIVISION OF REPUBLIC PICTURES CORP.



s) The use of horror for its own sake will be eliminated; the use of visual or aural effects which would shock or alarm the viewer, and the detailed presentation of brutality or physical agony by sight or by sound are not permissible.

t) Law enforcement shall be upheld, and the officers of the law are to be portrayed with respect and dignity.

u) The presentation of murder or revenge as a motive for murder shall not be presented as justifiable.

v) Suicide as an acceptable solution for human problems is prohibited.

w) The exposition of sex crimes will be avoided.

x) The appearance or dramatization of persons featured in actual crime news will be permitted only in such light as to aid law enforcement or to report the news event.

y) The use of animals, both in the production of television programs and as a part of television program content, shall, at all times, be in conformity with accepted standards of humane treatment.

RESPONSIBILITY TOWARD CHILDREN

1. The education of children involves giving them a sense of the world at large. Crime, violence and sex are a part of the world they will be called upon to meet, and a certain amount of proper presentation of such is helpful in orienting the child to his social surroundings. However, violence and illicit sex shall not be presented in an attractive manner, nor to an extent such as will lead a child to believe that they play a greater part in life than they do. They should not be presented without indications of the resultant retribution and punishment.

2. It is not enough that only those programs which are intended for viewing by children shall be suitable to the young and immature. (Attention is called to the general items listed under "Acceptability of Program Materials.") Television is responsible for insuring that programs of all sorts which occur during the times of day when children may normally be expected to have the opportunity of viewing television shall exercise care in the following regards:

a) In affording opportunities for cultural growth as well as for wholesome entertainment.

b) In developing programs to foster and promote the commonly accepted moral, social and ethical ideals characteristic of American life.

c) In reflecting respect for parents, for honorable behavior, and for the constituted authorities of the American community.

d) In eliminating reference to kidnapping of children or threats of kidnapping.

e) In avoiding material which is excessively violent or would create morbid suspense, or other undesirable reactions in children.

f) In exercising particular restraint and care in crime or mystery episodes involving children or minors.

DECENCY AND DECORUM IN PRODUCTION

1. The costuming of all performers shall be within the bounds of

GOOD PROGRAMS SELL GOOD PRODUCTS

★★★★ THE NEW KEN MURRAY SHOW
"WHERE WERE YOU?"

★★★★ CROWN THEATRE WITH
GLORIA SWANSON

★★★★ ROYAL PLAYHOUSE

★★★★ COUNTERPOINT

★★★★ THE CHIMPS

★★★★ GENERAL ELECTRIC THEATRE*

Bing Crosby Enterprises, Inc.

TELEVISION  TELEVISION



9028 Sunset Blvd., Los Angeles 46, California

* Production on shows by Enterprises started January 18th, 1951

propriety, and shall avoid such exposure or such emphasis on anatomical detail as would embarrass or offend home viewers.

2. The movements of dancers, actors, or other performers shall be kept within the bounds of decency, and lewdness and impropriety shall not be suggested in the positions assumed by performers.

3. Camera angles shall avoid such views of performers as to emphasize anatomical details indecently.

4. Racial or nationality types shall not be shown in television in such a manner as to ridicule the race or nationality.

5. The use of locations closely associated with sexual life or with sexual sin must be governed by good taste and delicacy.

COMMUNITY RESPONSIBILITY

A television broadcaster and his staff occupy a position of responsibility in the community and should conscientiously endeavor to be acquainted fully with its needs and characteristics in order better to serve the welfare of its citizens.

TREATMENT OF NEWS AND PUBLIC EVENTS

News

1. A television station's news schedule should be adequate and well-balanced.

2. News reporting should be factual, fair and without bias.

3. Commentary and analysis should be clearly identified as such

4. Good taste should prevail in the selection handling of news:

Morbid, sensational or alarming details not essential to the factual report, especially in connection with stories of crime or sex, should be avoided. News should be telecast in such a manner as to avoid panic and unnecessary alarm.

5. At all times, pictorial and verbal material for both news and comment should conform to other sections of these standards, wherever such sections are reasonably applicable.

6. Pictorial material should be chosen with care and not presented in a misleading manner.

7. A television broadcaster should exercise due care in his supervision of content format, and presentation of newscasts originated by his station; and in his selection of newscasters, commentators, and analysts.

8. A television broadcaster should exercise particular discrimination in the acceptance, placement and presentation of advertising in news programs so that such advertising should be clearly distinguishable from the news content.

9. A television broadcaster should not present fictional events or other non-news material as authentic news telecasts or announcements nor should he permit dramatizations in any program which would give the false impression that the dramatized material constitutes news. Expletives, (presented aurally or pictorially) such as "flash" or "bulletin" and statements such as "we interrupt this program to bring you . . ." should be reserved specifically for news room use. However, a television broadcaster may properly exercise discretion in the use in non-news programs of words

The standard of quality
wherever films are used

EASTMAN PROFESSIONAL MOTION PICTURE FILMS

THE EASTMAN 16mm PROJECTOR, MODEL 250

THE EASTMAN TELEVISION RECORDING CAMERA

Whether you use film to bridge
the coast-to-coast gap of time
and space . . . to overcome the
confinements of studio walls . . .
or to pre-test your investment
in time and talent, Eastman is
always the first choice both
for production and projection.

Motion Picture Film Department

EASTMAN KODAK COMPANY

Rochester 4, N. Y.

or phrases which do not necessarily imply that the material following is a news release.

Public Events

1. A television broadcaster has an affirmative responsibility at all times to be informed of public events, and to provide coverage consonant with the ends of an informed and enlightened citizenry.

2. Because of the nature of events open to public, the treatment of such events by a television broadcaster should be effected in a manner to provide for adequate and informed coverage as well as good taste in presentation.

Controversial Public Issues

1. Television provides a valuable forum for the expression of responsible views on public issues of a controversial nature. In keeping therewith the television broadcaster should seek out and develop with accountable individuals, groups and organizations, programs relating to controversial public issues of import to its fellow citizens; and to give fair representation to opposing sides of issues which materially affect the life or welfare of a substantial segment of the public.

2. The provision of time for this purpose should be guided by the following principles:

a) Requests by individuals, groups or organizations for time to discuss their views on controversial public issues, should be considered on the basis of their individual merits, and in the light of the contribution which the use requested would make to the public interest, and to a well-balanced program structure.

b) Programs, devoted to the discussion of controversial public issues should be identified as such, and should not be presented in a manner which would mislead listeners or viewers to believe that the program is of entertainment, news or any other character.

Political Telecasts

Political telecasts should be clearly identified as such, and should not be presented by a television broadcaster in a manner which would mislead listeners or views to believe that the program is of any other character.

Religious Programs

1. It is the responsibility of a television broadcaster to make available to the community as part of a well-balanced program schedule adequate opportunity for religious presentations.

2. The following principles should be followed in the treatment of such programs:

a) Telecasting which reaches men of all creeds simultaneously should avoid attacks upon religion.

b) Religious programs should be presented respectfully and accurately and without prejudice or ridicule.

c) Religious programs should be presented by responsible individuals, groups, and organizations.

d) Religious programs should place emphasis on broad religious

truths, excluding the presentation of controversial or partisan views not directly or necessarily related to religion or morality.

3. In the allocation of time for telecasts of religious programs it is recommended that the television station use its best efforts to apportion such time fairly among the representative faith groups of its community.

PRESENTATION OF ADVERTISING

1. Ever mindful of the role of television as a guest in the home, a television broadcaster should exercise unceasing care to supervise the form in which advertising material is presented over his facilities. Since television is a developing medium, involving methods and techniques distinct from those of radio, it may be desirable, from time to time, to review and revise the presently suggested practices.

(a) Advertising messages should be presented with courtesy and good taste; disturbing or annoying material should be avoided; every effort should be made to keep the advertising message in harmony with the content and general tone of the program in which it appears.

b) A sponsor's advertising messages should be confined within the framework of the sponsor's program structure. A television broadcaster should avoid the use of commercial announcements which are divorced from the program either by preceding the introduction of the program (as in the case of so-called "cow-catcher" announcements) or by following the apparent sign-off of the program (as in the case of so-called "trailer" announcements). To this end, the program itself should be announced and clearly identified BOTH AUDIO AND VIDEO before the sponsor's advertising material is first used, and should be signed off BOTH AUDIO AND VIDEO after the sponsor's advertising material is last used.

c) Advertising copy should contain no claims intended to disparage competitors, competing products, or other industries, professions or institutions.

d) Since advertising by television is a dynamic technique, a television broadcaster should keep under surveillance new advertising devices so that the spirit and purpose of these standards are fulfilled.

e) Television broadcasters should exercise the utmost care and discrimination with regard to advertising material, including content, placement and presentation, near or adjacent to programs designed for children. No considerations of expediency should be permitted to impinge upon the vital responsibility towards children and adolescents, which is inherent in television, and which must be recognized and accepted by all advertisers employing television.

f) Television advertisers should be encouraged to devote portions of their allotted advertising messages and program time to the support of worthy causes in the public interest in keeping with the highest ideals of the free competitive system.

g) A charge for television time to churches and religious bodies is not recommended.

ACCEPTABILITY OF ADVERTISERS AND PRODUCTS

General

1. A commercial television broadcaster makes his facilities available

for the advertising of products and services and accepts commercial presentations for such advertising. However, a television broadcaster should, in recognition of his responsibility to the public, refuse the facilities of his station to an advertiser where he has good reason to doubt the integrity of the advertiser, the truth of the advertising representations, or the compliance of the advertiser with the spirit and purpose of all applicable legal requirements. Moreover, in consideration of the laws and customs of the communities served, each television broadcaster should refuse his facilities to the advertisement of products and services, or the use of advertising scripts, which the station has good reason to believe would be objectionable to a substantial and responsible segment of the community. The foregoing principles should be applied with judgment and flexibility, taking into consideration the characteristics of the medium and the form and content of the particular presentation. In general, because television broadcast is designed for the home and the family, including children, the following principles should govern the business classifications listed below:

a) The advertising of hard liquor should not be accepted.

b) The advertising of beer and wines is acceptable only when presented in the best of good taste and discretion, and is acceptable subject to federal and local laws.

c) Advertising by institutions or enterprises which in their offers of instruction imply promises of employment or make exaggerated claims for the opportunities awaiting those who enroll for courses is generally unacceptable.

d) The advertising of firearms and fireworks is acceptable only subject to federal and local laws.

e) The advertising of fortune-telling, occultism, spiritualism, astrology, phrenology, palm-reading, numerology, mind-reading or character-reading is not acceptable.

f) Because all products of a personal nature create special problems, such products, when accepted, should be treated with especial emphasis on ethics and the canons of good taste; however, the advertising of intimately personal products which are generally regarded as unsuitable conversational topics in mixed social groups is not acceptable.

g) The advertising of tip sheets, race track publications, or organizations seeking to advertise for the purpose of giving odds or promoting betting or lotteries is not acceptable.

2. Diligence should be exercised to the end that advertising copy accepted for telecasting complies with pertinent federal, state and local laws.

3. An advertiser who markets more than one product should not be permitted to use advertising copy devoted to an acceptable product for purposes of publicizing the brand name or other identification of a product which is not acceptable.

ADVERTISING OF MEDICAL PRODUCTS

1. The advertising of medical products presents considerations of intimate and far-reaching importance to the consumer, and the following principles and procedures should apply in the advertising thereof.

a) A television broadcaster should not accept advertising material which in his opinion offensively describes or dramatizes distress or morbid situations involving ailments, by spoken word, sound or visual effects.

b) Because of the personal nature of the advertising of medical products, claims that a product will effect a cure and the indiscriminate use of such words as "safe", "without risk", "harmless", or terms of similar meaning should not be accepted in the advertising of medical products on television stations.

Contests

1. Contests should offer the opportunity to all contestants to win on the basis of ability and skill, rather than chance.

2. All contest details, including rules, eligibility requirements, opening and termination dates should be clearly and completely announced and/or shown or easily accessible to the viewing public, and the winners' names should be released and prizes awarded as soon as possible after the close of the contest.

3. When advertising is accepted which requests contestants to submit items of product identification or other evidence of purchase of product, reasonable facsimiles thereof should be made acceptable.

4. All copy pertaining to any contest (except that which is required by law) associated with the exploitation or sale of the sponsor's product or service, and all references to prizes or gifts offered in such connection should be considered a part of and included in the total time allowances as herein provided. (see Time Standards for Advertising Copy.)

Premiums and Offers

1. Full details of proposed offers should be required by the television broadcaster for investigation and approval before the first announcement of the offer is made to the public.

2. A final date for the termination of an offer should be announced as far in advance as possible.

3. Before accepting for telecast offers involving a monetary consideration, a television broadcaster should satisfy himself as to the integrity of the advertiser and the advertiser's willingness to honor complaints indicating dissatisfaction with the premium by returning the monetary consideration.

4. There should be no misleading descriptions or visual representations of any premiums or gifts which would distort or enlarge their value in the minds of the listeners.

5. Assurances should be obtained from the advertiser that premiums offered are not harmful to person or property.

6. Premiums should not be approved which appeal to superstition on the basis of "luck-bearing" powers or otherwise.

Time Standards for Advertising Copy

1. In accordance with good telecast advertising practices, the time standards for advertising copy are as follows:

Length of Program (minutes)	Length of Advertising Message (minutes and seconds)		
	News Programs	All Other Programs	
	Day and Night	Class "A" Time	All Other Hrs.
5	1:00	1:00	1:15
10	1:45	2:00	2:10
15	2:15	2:30	3:00
25		2:50	4:00
30		3:00	4:15
45		4:30	5:45
60		6:00	7:00

2. Reasonable and limited identification of prize and statement of the donor's name within formats wherein the presentation of contest awards or prizes is a necessary and integral part of program content shall not be included as commercial time within the meaning of paragraph 1. above; however, any oral or visual presentation concerning the product or its donor, over and beyond such identification and statement, shall be included as commercial time within the meaning of paragraph 1. above.

3. The time standards set forth above do not affect the established practice of reserving for station use the last 30 seconds of each program for station break and spot announcements.

4. Announcement programs are designed to accommodate a designated number of individual live or recorded announcements, generally one minute in length, which are carried within the body of the program and are available for sale to individual advertisers. Normally not more than 3 one-minute announcements (which should not exceed approximately 125 words if presented live) should be scheduled within a 15-minute period and not more than six such announcements should be scheduled within a 30-minute period in local announcement programs; however, fewer announcements of greater individual length may be scheduled, provided that the aggregate length of the announcements approximates three minutes in a 15-minute program or six minutes in a 30-minute program. In announcement programs other than 15 minutes or 30 minutes in length, the proportion of one minute of announcement within every five minutes of programming is normally applied. The announcements must be presented within the framework of the program period designated for their use and kept in harmony with the content of the program in which they are placed.

5. Programs presenting women's services, features, shopping guides, market information, and similar material, provide a special service to the listening and viewing public in which advertising material is an informative and integral part of the program content. Because of these special characteristics the time standards set forth above may be waived to a reasonable extent.

6. Even though the commercial time limitations of the Code do not specifically prohibit back-to-back announcements such a practice is not recommended for more than two announcements, either at station break or within the framework of a single program.

7. Any casual reference BY TALENT in a program to another's product or service under any trade name or language sufficiently descriptive to identify it should, except for normal guest identifications, be condemned and discouraged.

8. Stationary backdrops or properties in television presentations showing the sponsor's name or product, the name of his product, his trade mark or slogan may be used only incidentally. They should not obtrude on program interest or entertainment. "On Camera" shots of such materials should be fleeting, not too frequent, and mindful of the need of maintaining a proper program balance.

Dramatized Appeals and Advertising

Appeals to help fictitious characters in television programs by purchasing the advertiser's product or service or sending for a premium should not be permitted, and such fictitious characters should not be introduced into the advertising message for such purposes. When dramatized advertising material involves statements by doctors, dentists, nurses or other professional people, the material should be presented by members of such profession reciting actual experience or it should be made apparent from the presentation itself that the portrayal is dramatized.

Sponsor Identification

Identification of sponsorship must be made in all sponsored programs in accordance with the requirements of the Communications Act of 1934, as amended, and the Rules and Regulations of the Federal Communications Commission.

★

REGULATIONS AND PROCEDURES

The following REGULATIONS AND PROCEDURES shall obtain as an integral part of the Television Code of the National Association of Radio and Television Broadcasters:

I

Name

The Name of this Code shall be the Television Code of the National Association of Radio and Television Broadcasters.*

II

Purpose of the Code

The purpose of this Code is cooperatively to maintain a level of television programming which gives full consideration to the educational, informational, cultural, economic, moral and entertainment needs of the American public to the end that more and more people will be better served.

III

Subscribers

Section 1. Eligibility

Any individual, firm or corporation which is engaged in the operation of a television broadcast station or network, or which holds a construction permit for a television broadcast station within the United States or its

* "Television Board. The Television Board is hereby authorized:—(4) to enact, amend and promulgate standards of practice or codes for its Television members, and to establish such methods to secure observance thereof as it may deem advisable; —". *By-Laws of The National Association of Radio and Television Broadcasters, Article VII Section 2, B. (4).*

dependencies, shall, subject to the approval of the Television Board of Directors as hereinafter provided, be eligible to subscribe to the Television Code of the NARTB to the extent of one subscription for each such station and/or network which it operates or for which it holds a construction permit; provided, that a non television-member of NARTB shall not become eligible via code subscription to receive any of the member services or to exercise any of the voting privileges of a member.

Section 2. Certification of Subscription

Upon subscribing to the Code, subject to the approval of the Television Board of Directors, there shall be granted forthwith to each such subscribing station authority to use the "NARTB Television Seal of Good Practice", a copyrighted and registered seal to be provided in the form of a certificate, a slide and/or film, signifying that the recipient thereof is a subscriber in good standing to the Television Code of NARTB. The seal and its significance shall be appropriately publicized by the NARTB.

Section 3. Duration of Subscription

Subscription shall continue in full force and effect until thirty days after the first of the month following receipt of notice of written resignation. Subscription to the Code shall be effective from the date of application subject to the approval of the Television Board of Directors; provided, that the subscription of a television station going on the air for the first time shall, for the first six months of such subscription, be probationary, during which time its subscription can be summarily revoked by an affirmative two-thirds vote of the Television Board of Directors without the usual processes specified below.

Section 4. Suspension of Subscription

Any subscription, and/or the authority to utilize and show the above-noted seal, may be voided, revoked or temporarily suspended for television programming, including commercial copy, which by theme, treatment or incident, in the judgment of the Television Board constitutes a continuing, willful or gross violation of any of the provisions of the Television Code, by an affirmative two-thirds vote of the Television Board of Directors at a regular or special meeting; provided, however, that the following conditions precedent shall apply: (1) The subscriber shall be advised in writing by Registered Mail of the charges preferred; (2) Such subscriber shall have a right to a hearing and may exercise same by filing an answer within 10 days of the date of such notification; (3) Failure to request a hearing shall be deemed a waiver of the subscriber's right thereto; (4) If hearing is requested by the subscriber, it shall be designated as promptly as possible and at such time and place as the Television Board may specify. Oral and written evidence may be introduced by the subscriber and by the Television Code Review Board (hereinafter provided for). Oral argument may be had at the hearing and written memoranda or briefs may be submitted by the subscriber and by the Television Code Review Board. The Television Board of Directors may admit such evidence as it deems relevant, material, and competent and may determine the nature and length of the oral argument and the written argument or briefs to be submitted. The Television Board of Directors shall decide the case as expeditiously as possible and shall notify the subscriber and the Television Code Review Board in writing of the decision.

Section 5. Additional Procedures

The Television Board of Directors shall, from time to time, establish such additional rules of procedure as, in its opinion, may be necessary for the proper administration of the Code; provided, that special considerations shall be given to the procedures for receipt and processing of complaints and to necessary rules to be adopted from time to time, taking into account the source and nature of such complaints; such rules to include precautionary measures such as the posting of bonds to cover costs and expenses of processing same; and further provided, that the Board of Directors shall take the steps necessary to insure the confidential status of any proceedings before it.

Section 6. Amendment and Review

Because of the new and dynamic aspects inherent in television broadcast, the Television Code, as a living, flexible and continuing document, may be amended from time to time by the Television Board of Directors; provided that said Board is specifically charged with review and reconsideration of the entire Code, its appendices and procedures, at least once each year.

Section 7. Termination of Contracts

All subscribers on the air at the time of subscription to the Code shall be permitted that period prior to and including the earliest legal cancellation date to terminate any contracts, then outstanding, calling for program presentations which would not be in conformity with the Television Code, provided, however, that in no event shall such period be longer than fifty-two weeks.

IV

Rules

Each subscriber shall pay 'administrative' rates in accordance with such schedule at such time, and under such conditions as may be determined from time to time by the Television Board (see Article VII Section 2.B (3) and (4), *By-Laws of the NARTB*); provided, that appropriate credit shall be afforded to a television member of the NARTB against the regular dues which he or it pays to NARTB-TV.

V

The Television Code Review Board

* Section 1. Composition

The Television Board of Directors shall establish a continuing committee entitled the Television Code Review Board, upon the promulgation of the television code. The Review Board shall be composed of five members, all of whom shall be from the Television membership of NARTB. Members of the Television Board of Directors shall not be eligible to serve on the above specified Review Board. Members of the Review Board shall be appointed by the President of the NARTB, subject to confirmation by the Television Board of Directors. Due consideration shall be given, in making such appointments, to factors of diversification of geographical location, company representation and network affiliation. Those members appointed, following promulgation of the Code, shall serve until immediately following

¹ Amended February 4, 1953.

the annual NARTB Convention of 1953. Immediately following the end of the meeting in 1953 there shall be appointed three members who shall serve for two years and two members who shall serve for one year starting at the time of appointment.

Starting in 1954 and every even numbered year thereafter, two members shall be appointed for two-year terms; and then in every odd numbered year thereafter, three two-year members shall be appointed.

Limitation of Service

A person shall not serve consecutively as a member of the Review Board for more than two two-year terms or for more than four years consecutively, after April 30, 1953.

Section 2. Quorum

A majority of the membership of the Television Code Review Board shall constitute a quorum for all purposes unless herein otherwise provided.

Section 3. Authority and Responsibilities

The Television Code Review Board is authorized and directed:

(1) To maintain a continuing review of all television programming, especially that of subscribers to the television code of the NARTB; (2) to receive, screen and clear complaints concerning television programming; (3) to define and interpret words and phrases in the Television Code; (4) to develop and maintain appropriate liaison with government agencies and with responsible and accountable organizations and institutions; (5) to inform, expeditiously and properly, a subscriber to the Television Code of complaints or commendations, as well as to advise all subscribers concerning the attitude and desires program-wise of accountable organizations and institutions, and of the American public in general; (6) to review and monitor, if necessary, any certain series of programs, daily programming, or any other program presentations of a subscriber, as well as to request recordings, aural or kinescope, or script and copy, with regard to any certain program presented by a subscriber; (7) to reach conclusions, and to make recommendations or prefer charges to the Television Board of Directors concerning violations and breaches of the Television Code by a subscriber; (8) to recommend to the Television Board of Directors, amendments to the Television Code.

A. Delegation of Powers and Responsibilities

The Television Code Review Board may delegate, from time to time, such of its above-specified responsibilities, as it may deem necessary and desirable, to a Staff Group of the NARTB-TV.

B. Meetings

The Television Code Review Board shall meet regularly once each quarter of the calendar year on a date to be determined by the Chairman. The chairman of the Review Board may at any time on at least five days' written notice call a special meeting of the Board.



Film's Place in Color TV As Viewed by Producer

By JOHN L. SINN
President
Ziv Television Programs, Inc.

THE position of film in black and white television is now self-evident. The trend toward filmed television that began four years ago has proceeded at an accelerated pace. The exact proportion of filmed shows to live shows is unimportant—all agree that film is a tremendously vital and important part of black and white television programming.

But color is just ahead, and coming faster perhaps than most people realize. What will be film's position in color television? Before we speculate, let's study the facts as we know them.

The Ziv Company has been a pioneer in the field of color films for television. Since as long ago as early 1949, we have been shooting color film on a regular production basis. During those four years we have used every existing color film stock. We have exposed these various emulsions under every conceivable lighting condition. We have tried all of the time proven techniques, developed by the motion picture industry, and pioneered new lighting and photographic techniques especially suitable to the television medium. We have run literally hundreds of tests in conjunction with the laboratories to determine the proper method to obtain prints from our negatives in order to achieve maximum results in telecasting.

We have had an opportunity now to run many of these tests over the television color system. We have been able to see for ourselves exactly which tests looked best on the color tube. In short, based on the actual production of 228 films in color, plus 286 separate and additional color tests, we have developed a technique of lighting, photography and printing which we call Zivcolor, which produces an excellent color picture.

Zivcolor produces as well a fine compatible black and white picture. Our engineers and cameramen believe that it is superior to the black and white picture from black and white prints.

As a result, we now have the proof positive that color film made under the

proper conditions is perfectly adaptable to the color television system. This is the resounding affirmative answer to the question you have heard so many times during the past two years — "Will color film work in color television?"

To all of us who have been literally head over heels in color during the past 18 months, another point has become clear, too. There has always been a wide gap between the production values possible in the best television film as opposed to the best television live shows. In color television, this gap becomes even wider and more pronounced. Painted backings and scenery look false. Process shots look faked and unreal. The wonderful color that exists naturally in the finest exterior locations just cannot be created artificially. Therefore, the mobility that has always been one of the great qualities of film, the ability to take cameras into distant exteriors, into practical and exciting interiors far removed from the studio, these will enable us to bring to the tube, through the medium of color film, an area of color excitement and interest beyond the reaches of the live camera.

And just one final word of caution. Let the entire industry not forget that color is a wonderful adjunct, a great and wonderful new addition to this modern theater that is television. But it is not an end in itself. A bad play in black and white will not suddenly become a good play simply because it is in color. Although the audience will find eye catching interest in the fact that the leading lady is wearing a beautiful red dress, they will quickly become much more interested in what that leading lady says.

A good play on the other hand, becomes more thrilling and impressive by the addition of color presentation. We have seen with our own eyes one of our "Favorite Story" productions, which won much critical acclaim everywhere in black and white, become even more dramatic and satisfying in color.

*T*elevision *N*etworks

•
**EXECUTIVE
PERSONNEL**

•
MAPS

•
ARTICLES



Major Steps Taken For Audience-Sponsor Approval

By ALEXANDER STRONACH, JR.

*Vice-President in Charge
ABC-TV Network*

THE wonderful "magic" of television is no longer a parlor trick for the average American viewer. Electronically, it may still be "magic" to the average viewer—but selection-wise, it certainly is not. Viewers have become highly selective in their choice of programming. They now want a variety of good, substantial video fare—and what's more—they get it. And they get it because sponsors, stations and networks are well aware of this fact—that in order to gain the greatest number of viewers—a program must offer top quality entertainment—of a sort that will hold the viewer and bring him back week after week.

ABC-TV knows this too—and with this in mind, has set out to gain the hearty approval and endorsement of the public and sponsors alike. The network took major steps in this direction in 1953.

Nineteen hundred and fifty-three was a year of signal significance highlighted by the FCC-approved merger of the American Broadcasting Company with the United Paramount Theatres, Inc. (in February), which resulted in the formation of American Broadcasting-Paramount Theatres, Inc. The merger brought with it additional assets—personnel-wise and financial—to give ABC new vigor and still greater goals.

Immediately, the network embarked on a broad program of acquiring, creating and expanding its television facilities and programs. In rapid succession, ABC signed exclusive contracts for the services of such top-flight entertainers as Ray Bolger, Danny Thomas, George Jessel, Sammy Davis, Jr. and the Will Mastin Trio, Joel Grey, Paul Hartman, Bill Stern and Martin Block.

To help guide its course unflinchingly toward an ever expanding horizon, ABC acquired the services of such brilliant executives as George T. Shupert to head up ABC's newly formed Film Syndication Division as Vice President; and

John Daly, Vice President in charge of Television News, Special Events and Public Affairs.

The full effects of the merger unfolded with the fall program schedule, ABC's first major season since the merger.

Within a short period of time, ABC-TV established undisputed leadership in the field of drama. Four major drama series were added to the new program schedule. These are the United States Steel Hour, Kraft TV Theatre, The Motorola TV Hour and the new Sunday series, The Mask.

Advertisers, anxious to establish a franchise on the new ABC-TV, brought many new programs and stars to our audience. The fall program schedule attracted twenty-three new national advertisers who placed a record total of \$20,000,000 in gross annual television billings—the greatest single volume ever placed with the ABC-TV Network. This peak figure does not include renewal orders. Gross time sales for the last quarter of the year were up 50 per cent over the previous year.

ABC Film Syndication, the company's newest division, within a week wrapped up a quarter million dollars of sales on two of its top rated properties, "Racket Squad" and "The Playhouse."

And so the network moves on to 1954, riding the crest of this contagious tide of success in every phase of its operations. What new developments will 1954 bring to ABC-TV?

First, the network will move into early morning programming on February 22 with a simulcast of Don McNeill and the ABC Breakfast Club, a 20-year favorite on radio.

Additional "star power" will be added to the network's talent roster with even greater frequency than that of 1953 in program vehicles designed to make the ABC-TV Network an even greater part of the every day American scene.

A. B. C. TELEVISION NETWORK

ROBERT M. WEITMAN *Vice President in Charge of Programming and Talent*

One of the most valuable executives that the broadcasting-telecasting industry could acquire is ROBERT M. WEITMAN who joined ABC last year as a vice president in charge of programming and talent as a direct result of the merger of the American Broadcasting Company, Inc., and the United Paramount Theatres, Inc. Bob Weitman is well known to the people in show business. His acumen as a showman and developer of outstanding talent had far



WEITMAN

reaching effects in the success of the original Paramount Pictures, Inc., and as a vice president of UPT, Inc., sparked that company's immediate success as an independent operation. He now brings all of his outstanding abilities to the newly strengthened American Broadcasting Company and its new era of "star power" in his executive capacity as vice president in charge of programming and talent.

GEORGE T. SHUPERT *Vice President in Charge of ABC Film Syndication*

Rich with experience in both the motion picture and television industries, GEORGE T. SHUPERT joined ABC in August as vice president in charge of ABC's newly created Film Syndication division. His dynamic leadership and organizational ability have gained for him recognition in both industries as an outstanding executive in the visual media field. He has held executive positions with Paramount Pictures where he organized its Industrial Film Division;



SHUPERT

Paramount Television Productions where he organized the company's nation-wide TV film supplying network; Peerless Television Productions, Inc., which he helped organize and United Artists Television Corporation.

As vice president in charge of ABC Film Syndication, Shupert is responsible for the overall supervision of the division's purchasing, selling and servicing of television films to the entire television industry.

CHARLES R. ABRY *National Sales Director For the ABC-TV Network*

Heading the ABC-TV sales department is CHARLES R. (CHICK) ABRY who last year was promoted to the position of national sales director for the ABC-TV Network a rather phenomenal rise considering that he first joined ABC in June 1951 as an account executive in the network's television sales department. And it was only a short while after he became associated with ABC that he proved himself one of the most capable account executives in the net-



ABRY

work field. His salesmanship meriting greater executive latitude, brought him the appointment of Eastern Sales Manager for the ABC-TV Network in November 1952. His present duties as National Sales Director for the ABC-TV Network entail the close supervision of a large selling force of account executives as well as close surveillance of a number of top level national accounts currently using the facilities of the ABC-TV Network.

AMERICAN BROADCAST

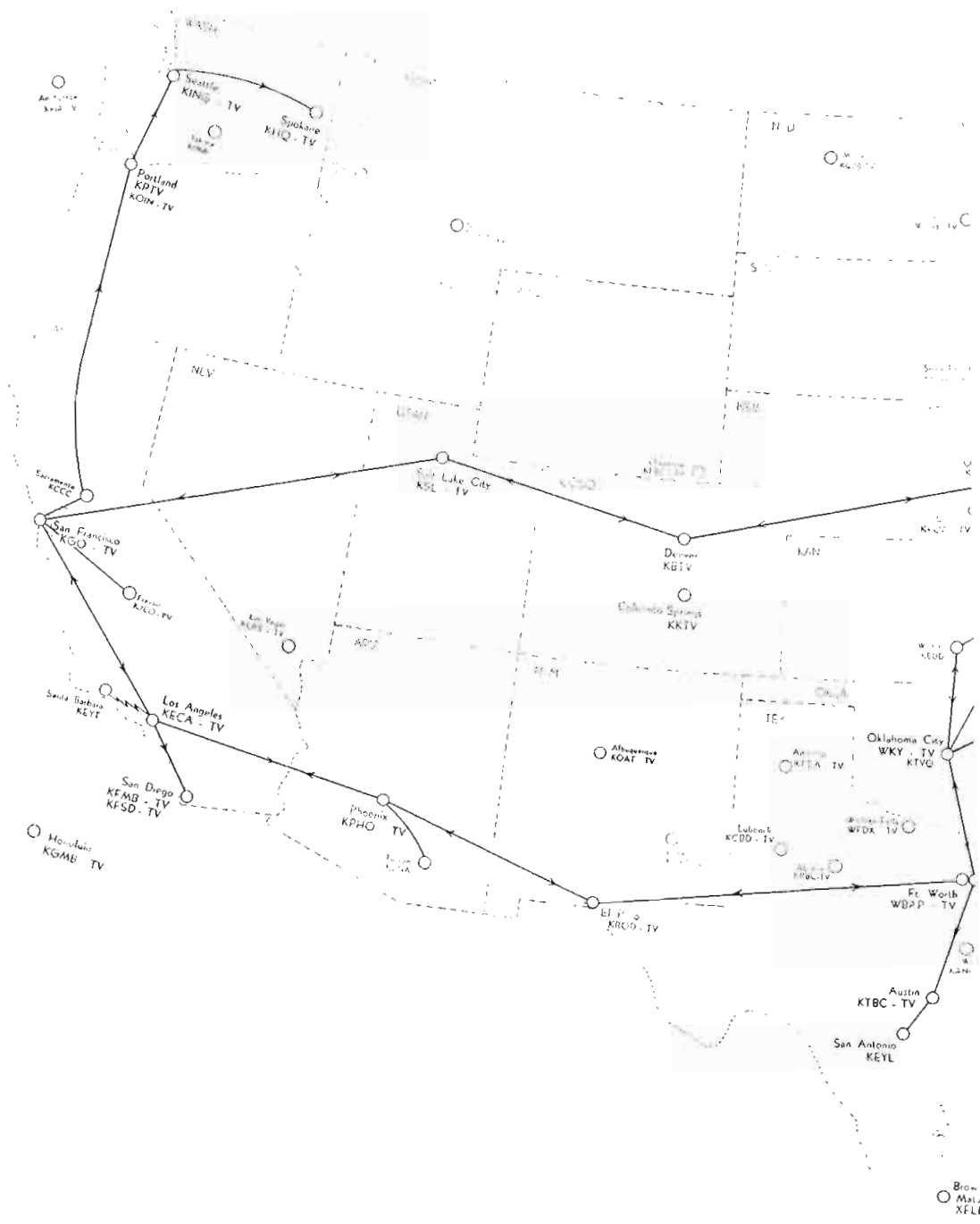

CASTING COMPANY

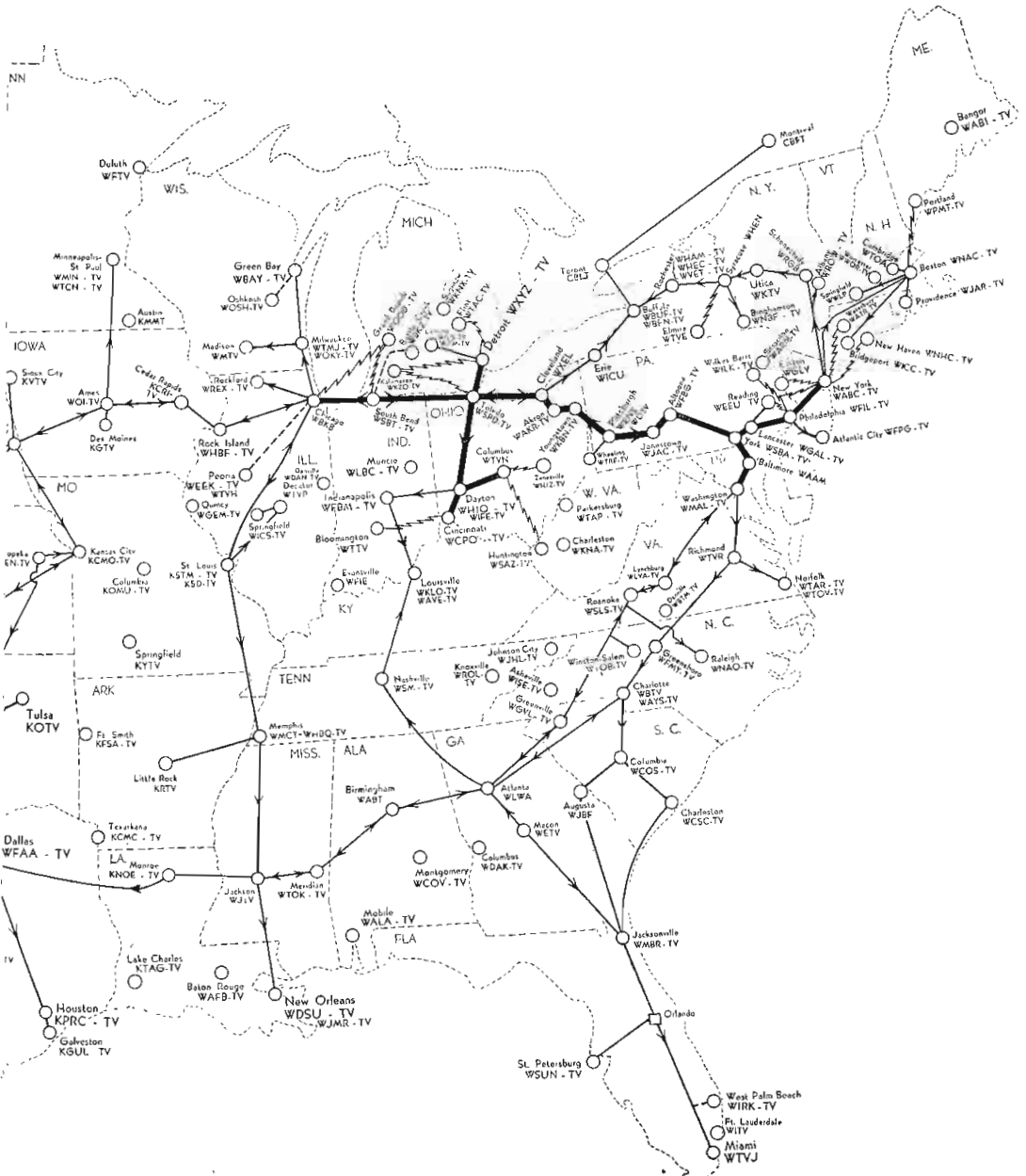

A M E R I C A N BROADCASTING COMPANY, INC.

(A Division of American Broadcasting-Paramount Theaters, Inc.)

R.C.A. Bldg., 7 West 66th Street, New York 23, N. Y.

(Telephone Number: SUsquehanna 7-5000)

OFFICERS

Edward J. Noble..... Chairman of Finance
Committee, AB-PT
Robert E. Kintner..... President
Robert H. O'Brien..... Exec. Vice-President
Earl E. Anderson..... Vice-President
Charles T. Ayres..... Vice-President
Slocum Chapin..... Vice-President
James Connolly..... Vice-President
Robert H. Hinckley..... Vice-President
Charles Underhill..... Vice-President
Earl Hudson..... Vice-President
Frank Marx..... Vice-President
Ernest Lee Jahncke, Jr..... Vice-President
John Mitchell..... Vice-President
Harold L. Morgan, Jr..... Vice-President
& Comptroller
John Daly..... Vice-President
Theodore I. Oberfelder..... Vice-President
George Shupert..... Vice-President
Alexander Stronach, Jr..... Vice-President
Thomas Velotta..... Vice-President
Robert M. Weitman..... Vice-President
Paul Whiteman..... Vice-President
Geraldine B. Zorbaugh..... Gen. Attorney
and Secretary
Omar Elder..... Assistant Secretary &
Asst. Gen. Counsel

TELEVISION

Alexander Stronach, Jr..... Vice President in
Charge of Television Network
John Mitchell..... Gen. Mgr. WABC

Engineering & General Services

Frank Marx..... Vice President in Charge
Thomas F. Foy..... Purchasing Agent
Richard Hamilton..... Supervisor of Communications
Clure Owen..... Administrative Assistant
John Preston..... Director of Engineering
Facilities & General Services
Lawrence Ruddell..... Recording Director
Joseph J. Spagnola..... Office & Studio Services
Director
William Trevarthen..... Director of Engineering
Operations

Reginald Willcocks..... Traffic Manager
Merle Worster..... Eastern Operations Manager

FINANCE, PERSONNEL

Thomas J. Martinez..... Treasurer of WABC
Jason Rabinovitz..... Assistant Comptroller
Walter C. Tepper..... Chief Accountant
Marie McWilliams..... Director of Personnel

Legal

Geraldine B. Zorbaugh..... Secretary &
General Counsel
Omar Elder..... Assistant Secretary &
Assistant General Counsel

Labor Relations

Mortimer Weinbach..... Director of Labor Relations

Program

Robert M. Weitman..... Vice-President in charge
of Programming and Talent

Services

Robert L. Stone..... Dir. of Television Services Dept.
Gordon Kunz..... Production Manager of WABC
Robert Holland..... Manager of Film Services
John Dullaghan..... Mgr. of Technical & Film Oper.
Ruth K. Blainey..... Operations Manager
John L. Kelly..... Plant Superintendent
George Smith..... Mgr. of Station Clearance
James McNaughton..... Art Director
Harold Sobolov..... Studio Supervisor
Andrew Ross..... Director of Graphic Arts

Programming

Charles Underhill..... Vice-Pres. in Chg. of
Program Department
Ardien B. Rodner..... Program Manager WABC
Freelon Fowler..... Film Program Manager
George Shupert..... Vice-Pres. in Chg. of ABC
Film Syndication
Charles Holden..... Asst. National Director of the
Program Department
Robert F. Lewine..... Eastern Program Director

Francis N. Littlejohn..... Director of News &
Special Events
Leslie Arries..... Director of TV Sports
James Stabile..... Administrative Manager
Paul Whiteman..... Vice-Pres. in Chg. of Music
Frank Vagnoni..... Manager of Music Division

**Public Relations, Advertising &
Promotion and Continuity
Acceptance**

John Pacey..... Director of Public Rel. &
Special Features
Ruth Crawford..... Librarian
Mitchell DeGroot..... Manager of Advertising &
Promotion
Ernest E. Stern..... Manager of Publicity
Ellen Heagerty..... Sup. of Audience Information
Grace Johnsen..... Dir. of Continuity Acceptance
Ruth Trexler..... Exec. Prod. of Religious &
Educational Programs

Sales

Charles Abry..... National Director of Sales
Don Kearney..... Sales Manager for
Film Syndication
Jerome Harrison..... Eastern Sales Manager
Don Durgin..... Director of Network
TV Sales Development
Malcolm B. Laing..... Business Manager for
Network Sales
Henry T. Hede..... Administrative Manager
Network Sales

**Station Relations, Sales & Station
Traffic Operations, Research &
Sales Development**

Ernest Lee Jahncke, Jr.... Vice Pres. & Assistant
to the President
Frank Atkinson..... Manager of Co-operative
Program Department
William Materne..... Coordinator of
Owned Radio & TV Stations
Alfred Beckman..... National Director of Station
Relations Department
Donald Buck..... Director of Operations for
Sales & Station Traffic
Alice Stamatis..... Manager of Order Processing
Donald Coyle..... Director of Research
William A. Wylie..... Manager of Station
Relations Department

CHICAGO

**20 North Wacker Drive
Chicago 6, Ill.**

James L. Stirton..... Dir. of Network Television
Sterling C. Quinlan..... Gen. Mgr. of WBKB-WENR
Matthew Vieracker..... Treasurer
Daniel Schuffman..... Program Manager WBKB
James W. Beach..... Sales Manager WBKB
Elliott W. Henry, Jr.... Dir. of Pub. & Promotion
George Rice..... Director of Film, WBKB
William P. Kusack..... Director of Engineering,
WBKB-WENR

DETROIT

**1700 Stroh Building
Detroit 26, Mich.**

James G. Riddell..... President
John Pival..... Mgr. WXYZ-TV
John Lee..... Television Studio Manager
Joseph C. Cassel..... Controller
Robert Baldrice..... Advertising, Promotion,
Publicity Director
Elizabeth Ashton..... Traffic Manager
Ralph Dawson..... Asst. TV Sales Mgr.
Charles Kocher..... Chief Engineer

HOLLYWOOD

**1539 North Vine Street
Hollywood 28, Calif.**

Earl Hudson..... Vice-Pres., Western Division
Donn B. Tatum..... Dir. of TV, Western Division
John C. Wagner..... Controller
Frank King..... Manager, KECA-TV
Stanton Kramer..... Dir. of TV Network
Promotion Publicity
Elton Rule..... Sales Mgr., KECA-TV
Sam Zelman..... News Dir., Western Division
Florence Shiro..... Personnel Director
Robert Forward..... Program Mgr., KECA-TV
Dorothy Brown..... Continuity Acceptance
Editor, Western Division
Philip Caldwell..... Mgr. of Engineering &
General Services, Western Division
Cameron Pierce..... TV Engineering
Operations Supervisor

SAN FRANCISCO

**420 Taylor Street
San Francisco 2, Calif.**

James H. Connolly..... Vice Pres. in Chg. of
San Francisco Office
Vincent Francis..... Manager, KGO-TV
William Hollenbeck..... Program Manager for TV
Henry Saroyan..... Auditor
David Sacks..... Sales Manager, KGO-TV
William E. Williams..... Mgr. of Publicity,
Advertising, Promotion
A. E. Evans..... Business Manager of
San Francisco Office
Lorraine Duchene..... Continuity Acceptance Editor
Edith Kirby..... Manager Traffic Dept.
Victor Reed..... Mgr. of News & Spec. Events
Harry Jacobs..... Chief Engineer
Andrew E. Akamian..... Merchandising Manager

WASHINGTON

**1735 DeSales Street N.W.
Washington, D. C.**

Robert H. Hinckley..... Vice Pres. in Chg. of
Washington Office

big news

big 3

One year ago, a "new" TV network was born, rich in showmanship, know-how, ambition and (last but not least) in money.

Since that time, no network has come so far so fast. Or provided TV and business editors with so many headlines . . . like these, which recall some of the exciting things that happened at the new ABC in its first 12 months:

- *Ray Bolger, Danny Thomas, George Jessel, Brandon DeWilde and Paul Hartman among many stars to sign with ABC.*
- *United States Steel, Motorola, Du Pont and Kraft place top dramatic shows on ABC.*
- *ABC-TV network expands with key affiliates . . . total is now 193.*
- *ABC-TV programs show steady rating growth.*
- *ABC's gain in new sponsors, new business, new billings lead all networks.*

Even as this issue goes to press, news is made at ABC-TV. January '54 billings set a new record, 71% over the same month last year. This is the fifth straight month the network has shown an increase in billings. More important, 8 new advertisers are included in January's business.

It certainly looks like this year, too, the big news in the big 3 will be ABC-TV.

ABC Television Network

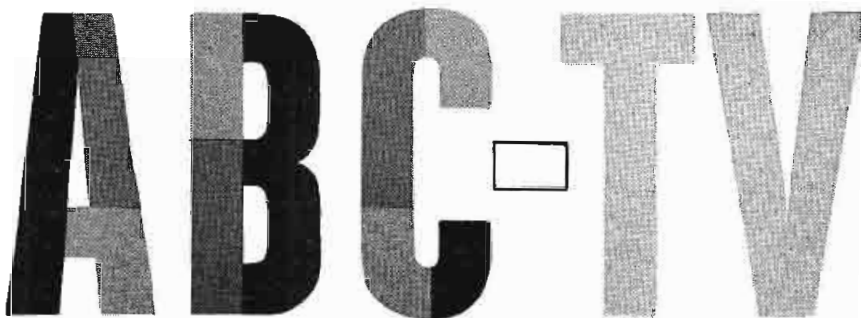



Network Efforts Aimed At Daytime TV Audience

By J. L. VAN VOLKENBURG

*President
CBS Television*

IN every way, 1953 has been an exciting year for CBS Television. Total advertising billings for the network enjoyed a 40 per cent increase over 1952, the greatest gain of any network. Station outlets for our programs were more than doubled, bringing to a total of 157 the stations which next year will carry CBS Television to the citizens of the United States, Mexico, Canada, Alaska, Honolulu and Cuba. Program quality was sustained throughout the year, with CBS Television dominating the top 10 shows on the air, month after month. But the most impressive development of the year has been the undisputed supremacy which CBS Television has gained in daytime programming.

From our year-end figures, we learned that, during 1953, CBS Television broadcast nearly twice as many sponsored hours of daytime television as the second network. On a basis of 10 a.m. to 5 p.m., Mondays through Fridays, CBS Television daytime billings averaged 50 per cent more than those of any other network. And since April, 1953, CBS Television has maintained a continuous rating leadership in the daytime, finishing the year with a 12-month average nearly 30 per cent higher than the second network.

This imposing record of growth could not exist without sales, which last year CBS Television delivered for sponsors on an unprecedented scale. Much of this merchandising success can be directly attributed to our great daytime team of personal salesmen — Arthur Godfrey, Garry Moore and Art Linkletter—all of whom set new individual records for moving their sponsors' products during 1953. Their strength with the consumer is well testified to by the fact that all of the commercial time on their programs is sold for months to come. This hard-hitting team is rounded out with a fourth member, personable Robert Q. Lewis, who has moved into the 4:30 p.m. spot

on the network with a new show of his own.

CBS Television has also built a strong feminine audience for its five daytime serials, "Valiant Lady," "Love of Life," "Search for Tomorrow," "The Guiding Light," and "The Brighter Day," designed to provide the housewife with pleasant hours of diversion from her housework. All of these shows are solidly sponsored and provide a sound base for our afternoon programming.

During the coming year, advertisers will spend a record \$8 billion to stimulate consumer buying. But for every dollar spent in network television, they will expect an unprecedented return in sales.

Many advertisers with modest budgets will find the answer to their advertising requirements in daytime television which, now that receivers are installed in more than 28,000,000 homes, is becoming an increasingly profitable buy. For in this low-cost medium, the advertiser can demonstrate his product simultaneously to millions of potential consumers at the place where his product finds its ultimate use—the American home. With the aid of television's top salesmen, he can build a direct pipeline to the greatest economic force in our society—the American housewife.

The advertiser who ventures into daytime television this year will be following an upward trend in the viewing habits of the nation. During 1953, average daytime viewing increased to 82 minutes daily, a rise of 34 per cent since the end of 1951. This increase is the direct result of better programs—strong entertaining network shows which hold the attention of audiences for a longer period each day, just as the highly creative efforts of our Program Department attract a constantly increasing number of viewers. To the job of producing more and more of this kind of daytime program, we will be ardently dedicated in 1954.

C. B. S. TELEVISION NETWORK

HUBBELL ROBINSON, JR. *Vice President in Charge of Network Programs*

HUBBELL ROBINSON, JR., joined CBS in July, 1947, as vice president in charge of network programs. In 1951, when CBS was reorganized into separate network operations for television and radio, he was named vice president and director of CBS Television network programs. Previous to his CBS affiliation, Robinson had been vice president and director of radio for Young & Rubicam. He was with the agency for sixteen years, from 1928 to 1944. He joined



ROBINSON JR.

the Blue Network, now ABC, in 1944, as vice president and director of programs. In 1945, he switched to Foote, Cone and Belding as vice president in charge of radio. Robinson was born in Schenectady, N. Y., on Oct. 16, 1905, and is a graduate of Brown University. He was a reporter on the Schenectady Union Star and the Knickerbocker Press in Albany after graduation. In 1928, he moved to New York and entered advertising.

HARRY S. ACKERMAN *Vice President in Charge of Network Programs — Hollywood*

HARRY S. ACKERMAN was named vice president of the Columbia Broadcasting System in charge of the network's Hollywood programs in June of 1951. His position includes general supervision of all CBS operations in the California entertainment capital.

Ackerman joined the Columbia network in 1948 in the capacity of executive producer. In June of the same year he transferred to Hollywood, where he served as director of network programs.



ACKERMAN

Ackerman attended Dartmouth College, from which he was graduated in 1935.

Following graduation from College, Ackerman became a writer and also filled roles as actor as well as director and producer of many radio shows. In 1936 he joined Young & Rubicam, Inc., as a program director. In 1946 he was made vice president of the advertising agency in charge of all program operations.

Ackerman was born in Albany, N. Y.

WILLIAM H. HYLAN *Vice President in Charge of Network Sales*

WILLIAM H. HYLAN, associated with CBS for sixteen years, was named vice president in charge of network sales for CBS Television in December, 1952. After four years as an account executive with CBS Radio Sales, from 1937 to 1941, Hylan entered military service with the army. In November, 1945, he returned to CBS Radio and was appointed assistant to the director of station administration. In 1948, Hylan switched to the network's new TV sales staff as an account execu-



HYLAN

tive. In July 1951, he was named assistant sales manager. In January, 1952, he was appointed eastern sales manager.

Hylan is a native of New York City, having been born in the town of Father Knickerbocker on October 16, 1905. He spent a goodly portion of his youth as a resident of the Island of Puerto Rico. Following his secondary school education he entered Yale University, of which he is a graduate.

CBS TELE

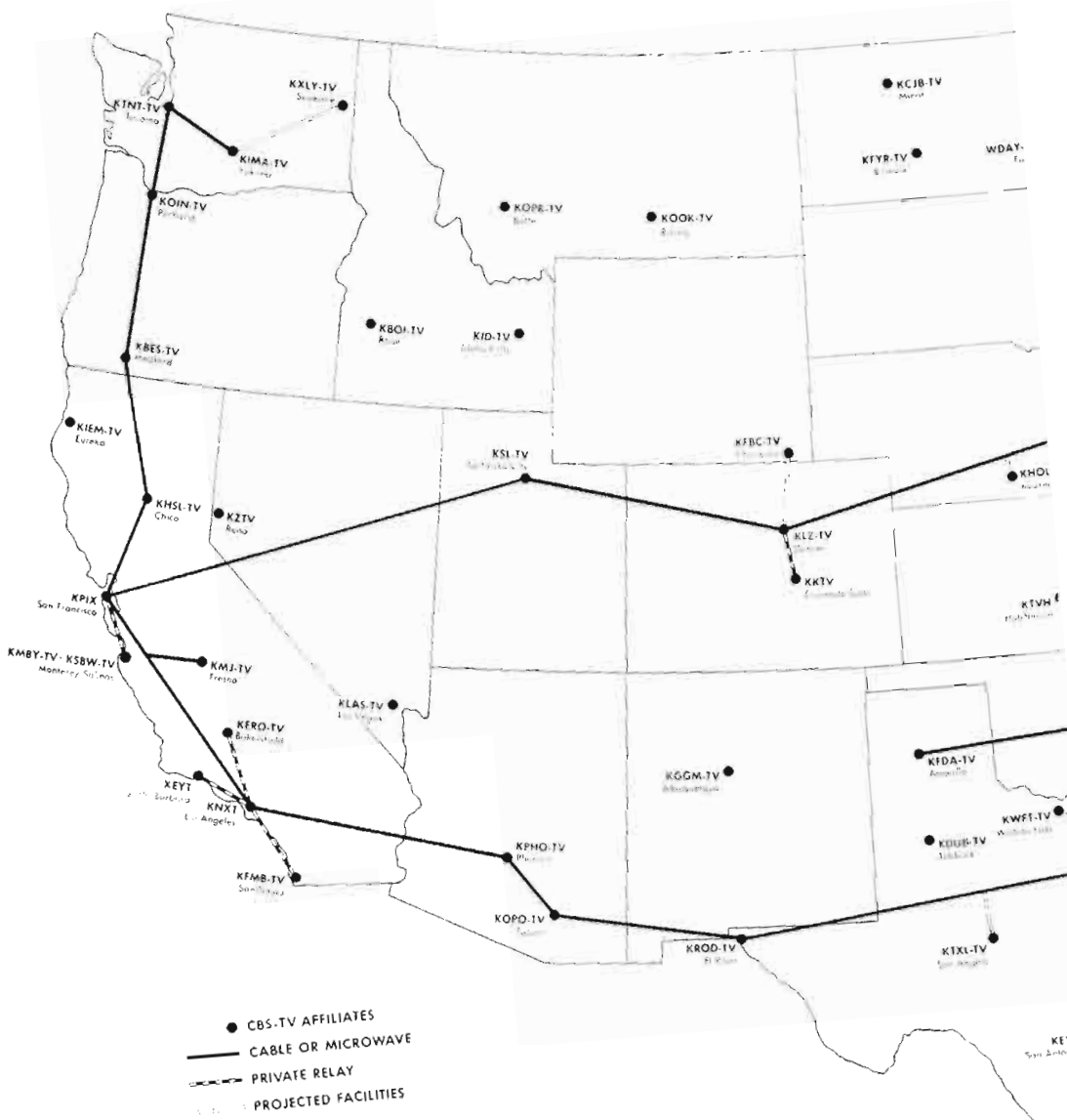

VISION

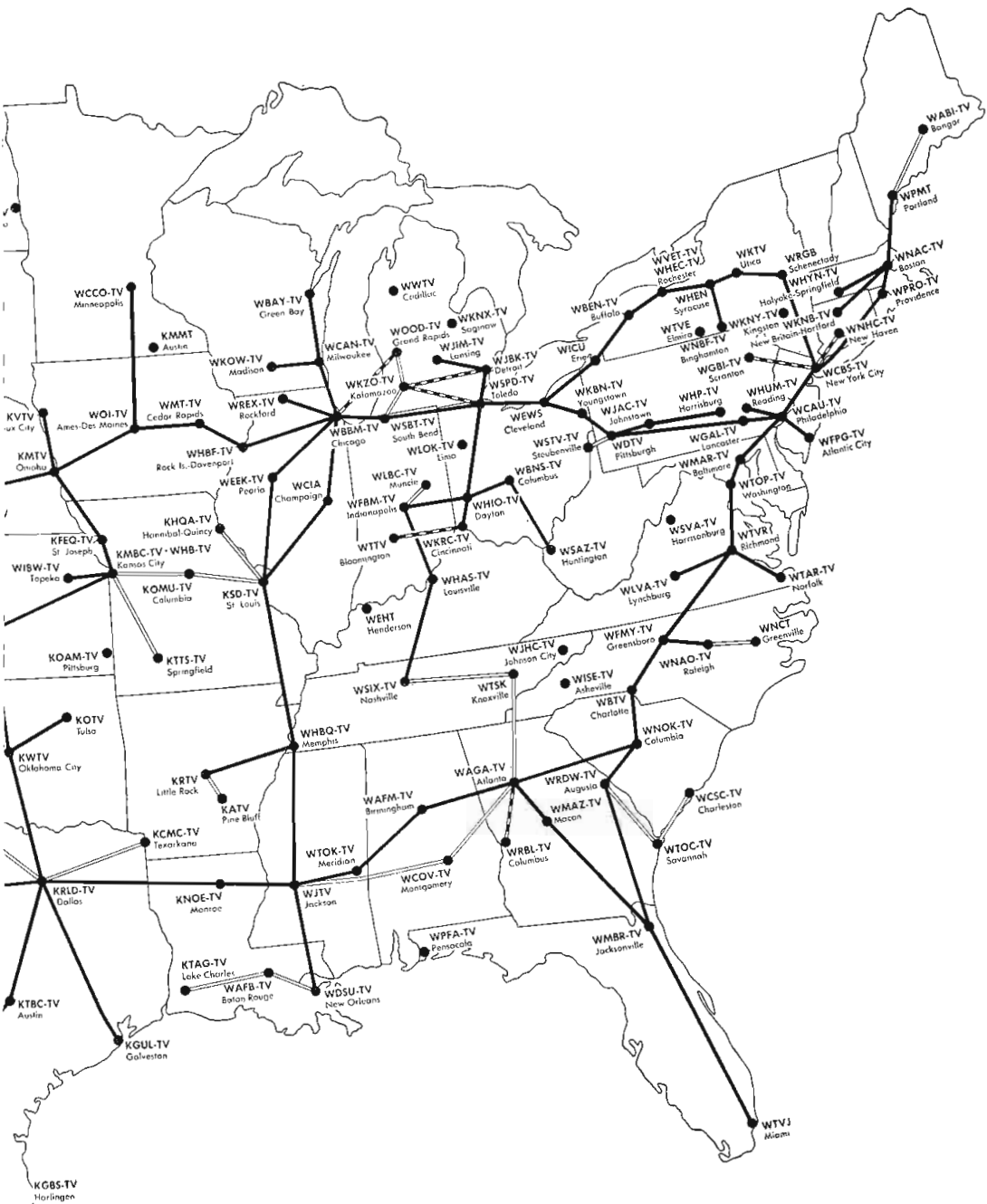

CBS TELEVISION

A DIVISION OF CBS, INC.

Executives and Staff

485 Madison Avenue, New York 22, N. Y.

Telephone: PLaza 1-2345

Registered Telegraphic Address—COLUMBIA NEW YORK

NOTE: A full listing of the CBS, Inc., Board of Directors and Officers, as well as Radio Div. executive personnel will be found on Page 268.

CBS TELEVISION DIVISION

OFFICERS

J. L. Van Volkenburg President
 William H. Hylan Vice President in Charge
 of Network Sales
 Hubbell Robinson, Jr. Vice President in Charge
 of Network Programs
 Harry S. Ackerman Vice President in Charge
 of Network Programs—Hollywood
 H. Leslie Atlass Vice President in Charge
 of Central Division, Chicago
 Frank B. Falknor Vice President in Charge
 of Operations
 Merle S. Jones Vice President in Charge of
 CBS-Owned Stations and General Services
 W. Spencer Harrison Vice President in Charge
 of Legal and Business Affairs
 Herbert V. Akerberg Vice President in Charge
 of Station Relations
 William B. Lodge Vice President in Charge
 of Engineering
 Edward Saxe V.P., Asst. to the President
 Charles L. Glett Vice President in Charge
 of Network Services—Hollywood
 William J. Flynn Comptroller

Network Sales

William H. Hylan Vice President in Charge
 of Network Sales
 Thomas H. Dawson Sales Manager
 George E. Klayer Chicago Sales Manager
 Charles K. Sterritt Detroit Sales Manager
 Frank Samuels Pacific Coast Sales Manager

William J. Fagan Business Manager
 T. D. Connolly Program Sales Manager
 Edward P. Shurick Manager of Sales
 Development
 Robert F. Jamieson Sales Service Manager
 George A. Kolpin Contract Manager
 James Shattuck Sales Manager, Color

Network Programs

Hubbell Robinson, Jr. Vice President in Charge
 of Network Programs
 Harry S. Ackerman Vice President in Charge
 of Network Programs, Hollywood
 William Dozier Executive Producer, Drama
 Marlo Lewis Executive Producer, Music and
 Variety
 Herbert Carlborg Director of Editing
 Harry G. Ommerle Program Director
 E. Carlton Winckler Production Manager
 Louis T. Stone Program Budget Manager
 R. Lewine Executive Producer, Color
 John Hundley Mgr., Program Service

Network News and Public Affairs

Sig Mickelson Dir. of Network News &
 Public Affairs
 Howard Kany Manager, CBS Television,
 News & News Film
 Paul Levitan Manager of Special Events
 Dallas Townsend Mgr. of News Broadcasts
 Judson Bailey Manager of Sports
 George Crowthers Dir., Religious Broadcasts

Operations

Frank B. Falknor Vice President in Charge
 of Operations
 Henry Grossman Director of Operations
 Walter Pierson Operations Production Manager

Gilbert DeStafano... Manager of Stage Lighting
 Anthony Boschetti... Manager of Procurement
 George Lehmann... Mgr. of Scenery Construction
 Herbert O. Phillips... Mgr. of Scenic Design
 Kingdon Tyler... Construction Manager
 William Vogel... Manager of Special Effects
 H. C. Meier... Manager of Network Operations
 H. Grant Theis... Manager of Film Service
 Operations
 Al Raymond... Mgr. of Stage Operations
 Paul Wittlig... Mgr. of Special Production Dev.
 R. G. Thompson... Director of Technical
 Operations
 Orville Sather... Manager of Technical Operations

Station Relations

Herbert V. Akerberg... Vice President in
 Charge of Station Relations
 Clark A. Snyder... Director of Station Relations
 Robert Wood... Asst. Dir. of Station Relations

Advertising and Sales Promotion

William Golden... Creative Director
 John P. Cowden... Operations Director
 Robert I. Elliott... Copy Chief
 Alex Kennedy... Director of Program Promotion
 Gordon Hellmann... Director of Presentations
 David Luhmann... Director of CBS-Owned
 Station Promotion Services
 Edward Side... Production Manager

Public Relations

David J. Jacobson... Director of Public Relations
 Michael J. Foster... Director of Press Information
 Arthur Perles... Administrative Director
 Hank Warner... Assistant Director
 Jack Goldstein... Director of Exploitation
 Dorothy Leffler... Director of Magazine Division

Research

Oscar Katz... Director
 Philip Eisenberg... Director of Coverage and
 General Surveys
 Rose Marie O'Reilly... Manager of Ratings
 Tore Hallonquist... Director of Program Analysis
 Leonard DeNooyer... General Surveys

Engineering

William B. Lodge... Vice President in Charge
 of Engineering
 A. B. Chamberlain... Chief Engineer
 H. A. Chinn... Chief Audio-Video Engineer
 J. W. Wright... Chief Radio Frequency Engineer

Legal and Business Affairs

W. Spencer Harrison... Vice President in Charge
 of Business and Legal Affairs
 Merritt H. Coleman... Director of Business Affairs
 Maurice Morton... Director of Business
 Affairs, Hollywood

Accounting

William J. Flynn... Comptroller
 Norman C. Hadley... Director of Accounting
 Operations

Network Services, Hollywood

Charles L. Glett... Vice President in Charge
 of Network Services, Hollywood
 Austin E. Joscelyn... Director of Operations,
 Hollywood

CBS Television Spot Sales

Sam Cook Digges... General Sales Manager of
 CBS Television Spot Sales
 Clark George... Eastern Sales Manager
 Edward A. Larkin... Midwestern Manager
 Warren Abrams... Detroit Manager
 Maclean Chandler... San Francisco Manager
 H. H. Holtshover... Atlanta Manager
 J. Richardson Loughrin... Los Angeles Manager

CBS Television Film Sales

Fred Mahlstedt... Director of Operations
 W. S. Edwards... General Sales Manager

CBS Owned Stations

WCBS-TV, 485 Madison Avenue, New York 22, New York

Craig Lawrence... General Manager
 George R. Dunham... General Sales Manager
 Hal Hough... Program Director
 Robert Patt... Promotion Manager

KNXT, 1313 North Vine Street, Los Angeles 28, California

James T. Aubrey, Jr... General Manager
 Edmund C. Bunker... Sales Manager
 Donald M. Hine... Program Manager
 Dean Linger... Promotion Manager

WBBM-TV, 410 North Michigan Ave., Chicago, Ill.

H. Leslie Atlass... Vice-President in Charge of
 Central Division, Gen. Mgr.
 E. H. Shomo... Asst. General Manager
 George J. Arkedis... Sales Manager
 Thomas A. Bland... Program Director
 C. W. Doebler... Promotion Manager

THEY'RE ALL

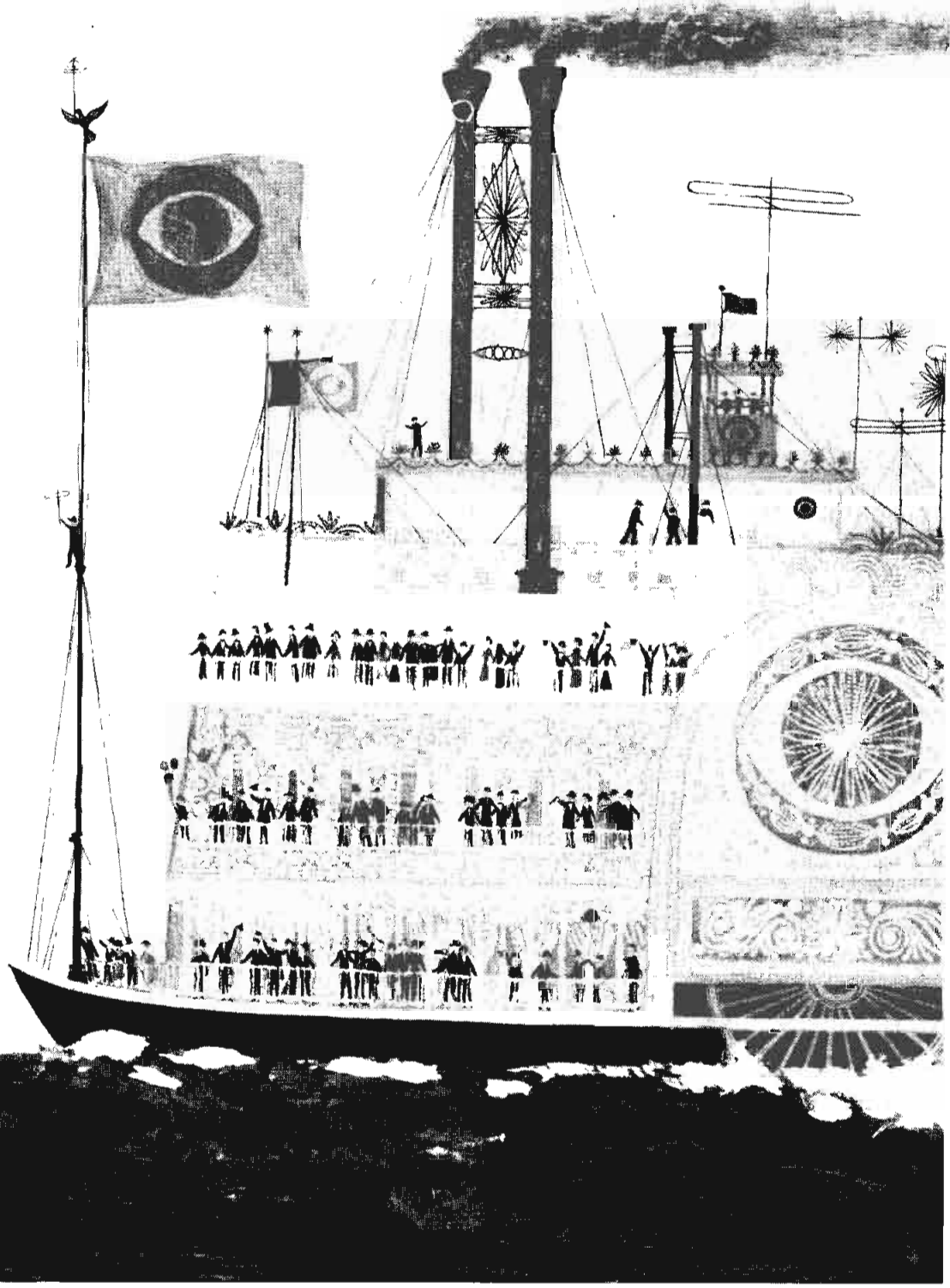

ABOARD

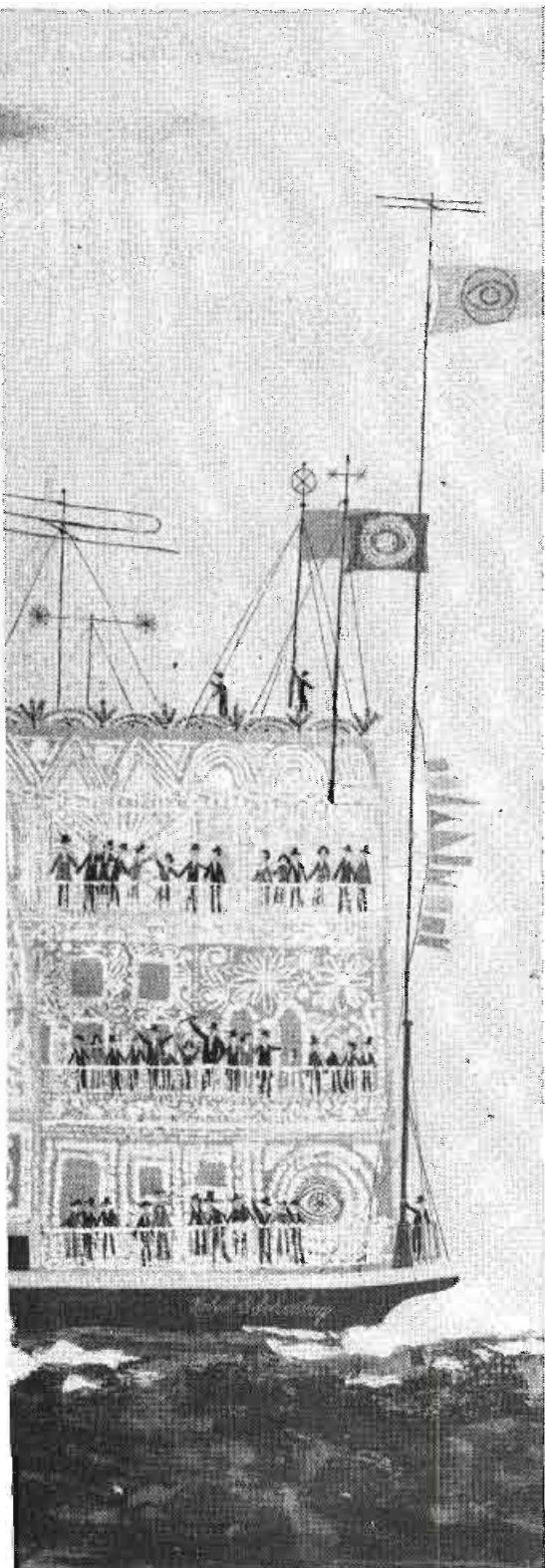

Television today is as much a part of American life as the great showboats were to the people of the big river towns.

It fills the same needs, brings the same excitement to more than 28 million families — who welcome it for almost five hours every day.

But whether a show reaches its audience by boat, by train, by theatrical van — or by electro-magnetic radiation — the most important thing to most people is the quality of the show itself.

And it's the show itself that matters most at CBS Television, where leadership in program popularity is the result of a continuous effort to secure and create programs that please people's tastes and sponsors' budgets.

In this 1953-1954 season alone it has presented 20 new programs to its audience ... and started the season with a 21% higher average rating than any other network at night—a 35% lead during the day.*

This popularity has specific meaning for advertisers. For it's a measure of network competition in the markets where you can best measure competition — in the major markets where networks compete ... and the audience has a choice of what to see.

Bringing this popularity into more and more markets, the CBS Television Network has grown from 74 stations last year to 156 today. And our sponsors are using an average nighttime network bigger by 68%.

This ever-widening popularity explains why advertising billings on CBS Television are bigger than on any other network — and bigger today than ever in television history.

CBS TELEVISION



1953 Groundwork Promises Profits Rise for '54

By **TED BERGMANN**
Managing Director
The DuMont Television Network

IN 1953 the Du Mont Television Network made excellent progress, most important of all in some phases which promise a substantial increase in billings for next year.

Heretofore, the Network needed two major items:

Production facilities which would enable it to handle the type of programs many of its sponsors wished to air.

Ability to clear sufficient stations to make such an investment a wise one. In 1953 both of these were attained.

Our new Tele-Centre, described by authorities as the finest production facility on the East Coast, went into use and has already proved its ability to mount the most elaborate productions on an efficient and economical basis. The Tele-Centre provides a smooth flow of production giving every possible advantage to cost-conscious advertisers.

Also in 1953, the Network developed the largest television station roster in the industry, with a total of 205 stations at the end of the year. These included 178 formal affiliates and 27 outlets on letter agreement. Through them the Network can now reach virtually every television set in the United States.

The Network's station clearances in 1953 were 50 to 100 per cent greater than the year before. This enabled Du Mont to put together some of the most extensive commercial networks in television.

In December, Du Mont purchased station KCTV in Kansas City—a move that enables all divisions of the corporation to pioneer in studying commercial and technical problems peculiar to UHF. Our organization thus became the first network to embrace the new medium.

Gross revenues of the Broadcasting Division in 1953 were 30 per cent greater than the year before, while Network billings rose 22 per cent—from \$10,140,000 in 1952 to approximately \$12,350,000 in 1953. Also, the Network was substantially ahead of 1952 in sponsors signed and in commercial hours telecast. Forty-three national advertisers were served.

Each of the three Du Mont owned and operated stations improved its position during the year. WABD, New York, applied a successful new sales formula for its participating programs, and had last-half net billings which were 24 per cent ahead of 1952, for the same months.

WABD became the city's third station in dollar billings. WTTG, Washington, moved into new and larger studios in the Raleigh Hotel, continued as leader in local programming with over 70 hours a week, and had billings in 1953 which were 32.9 per cent ahead of 1952. WDTV, Pittsburgh, prepared to move into ultra-modern studios in the new Gateway Centre early in 1954, and to increase its effective radiated power to 100 kilowatts. The station made the notable record of producing 127 local shows weekly in 1953.

Du Mont's substantial expansion of its station list in 1953 also sparked a considerable increase in activity in the cooperative program field, partly on telephone company facilities and partly through teletranscriptions. This field is a steadily growing enterprise which should continue to show gains in 1954.

The broadcasting division, which pioneered in the development of closed circuit television, expanded its activity by offering a complete service in connection with sales conferences, board meetings, demonstrations of the arts and sciences, entertainment programs and sporting events. The closed circuit department cooperated with the Atlantic Refining Company and the Esso Standard Oil Company in the use of this video service to launch new products before their national marketing organizations.

The film syndication department, in its second full year of operation, also saw considerable growth in the volume of its film sales to local stations and to advertisers.

All of the advances by the Du Mont organization in 1953 contributed greatly to the industry's magnificent service to the American people.

DuMONT TV NETWORK

TED BERGMANN *Managing Director*

TED BERGMANN became director of the broadcasting division of the Allen B. Du Mont Laboratories, Inc., and managing director of the Du Mont Television Network on January 1, 1954. Joining the Du Mont Television Network's sales staff in 1947 as an account executive, the first TV network sales group in the industry, he rapidly became the web's top salesman and has had an effective hand in signing most of the major time contracts bought by national advertisers since that time. He was made the network director of sales in July, 1951, and its general manager in July, 1953. He established an impressive list of TV "firsts." His presentations were responsible for first bringing into television sponsorship such important time

buyers as the P. Lorillard Company and Procter and Gamble. He helped develop the Drug Store Television project which laid the pattern for multiple-sponsorship of high-budgeted network programs which is now widely followed. More recently, he negotiated the contracts for the first nation-wide pro football TV game series for Westinghouse and a group of regional sponsors. As chairman of the Contract Standardization Committee of the NARTB, Mr. Bergmann was instrumental in helping to standardize TV time contracts for the industry. New York City-born, he started with NBC radio in 1941 and presently is, at the age of 33, the youngest man to head a major national TV organization.

JOHN H. BACHEM *General Manager*

JOHN H. BACHEM, with a long record of success in sales and advertising in television, radio and national magazines, moved up on January 1, 1954, from national sales manager to general manager of the Du Mont Television Network. He joined the organization in 1949 as an account executive, then became assistant sales head. His promotional and research-minded selling was responsible for many of Du Mont's initial sales at several of New York's major advertising agencies. Starting his career in New York as an advertis-



BACHEM

ing salesman for Cosmopolitan, House and Garden, American Home, Smart Set and the Butterick quarterlies, he became thoroughly grounded in the needs of national advertisers. He entered the young radio industry in 1932 as an account executive for NBC, was promoted to Eastern sales manager, and then to assistant to the vice president in charge of sales. Next followed 12 years on the radio sales staff of CBS, where he served as sales supervisor for Philadelphia and the Southern territories, until joining Du Mont.

DONALD H. McGANNON *Ass't. Dir., Allen B. DuMont Laboratories, Inc.—Gen. Mgr., O & O Stations:*

DONALD H. McGANNON, a member of the New York and Connecticut Bars and the Federal Bar, and an experienced industry representative in labor-management matters, is assistant director of the broadcasting division of the Allen B. Du Mont Laboratories, Inc., and also general manager of the four DuMont Laboratories, Inc., and also general manager of the four Du Mont owned and operated television stations in New York, Washington, Pittsburgh and Kansas City. He came to Du Mont



McGANNON

in February, 1952, as administrative assistant to the managing director of the network after several years of law practice. He was promoted to his present double-duty position in July, 1953. His responsibilities have been to a large measure centered about the development of the Du Mont station organization and the representation of Du Mont in various industrial negotiations, including ASCAP and labor organizations. He is a graduate of Fordham College and Fordham Law School.

DuMONT TELE

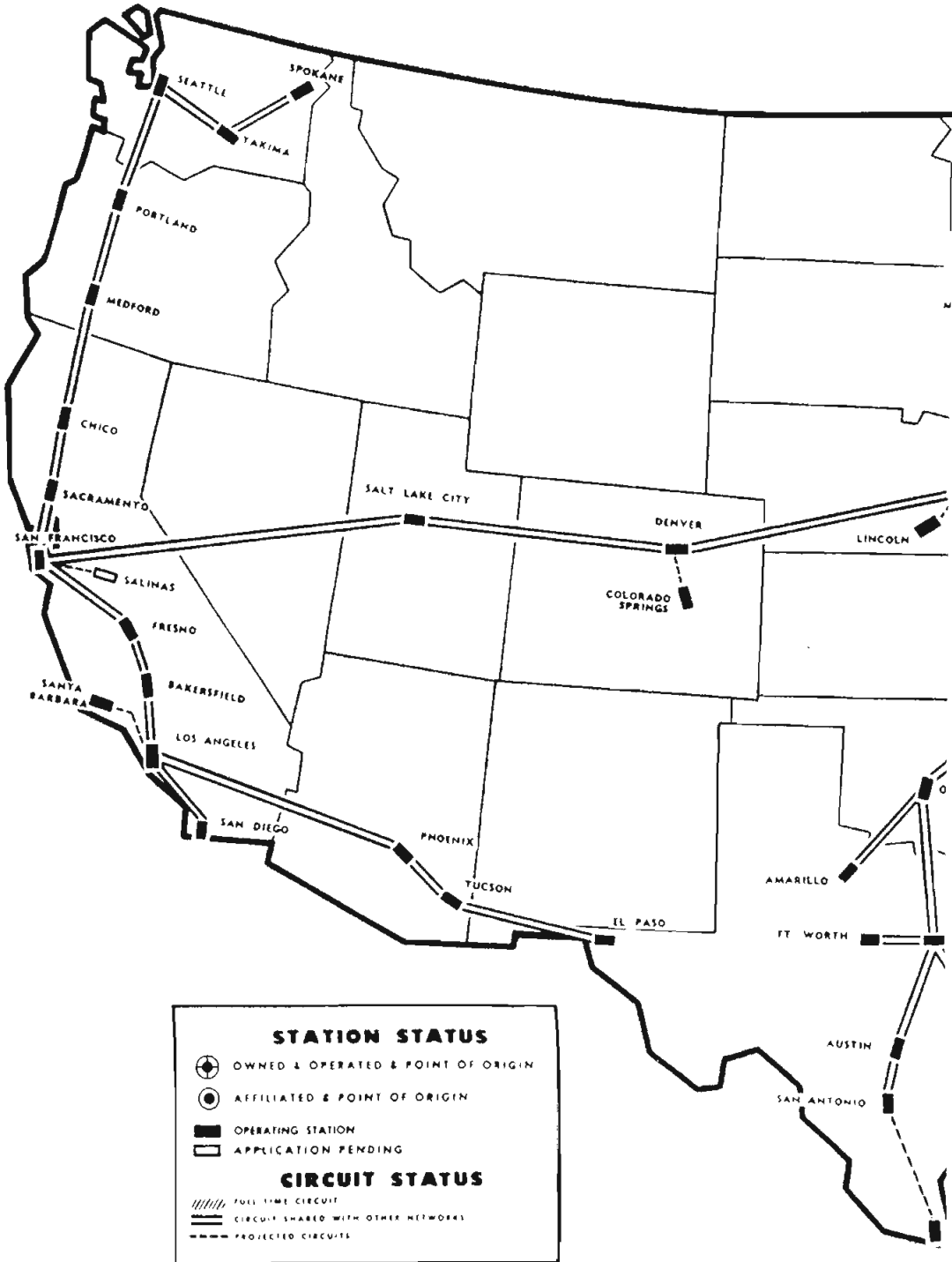

VISION NETWORK



(S)VILLE

D u M O N T

TELEVISION NETWORK

A Division of Allen B. Du Mont Laboratories, Inc.

515 Madison Avenue, New York 22, New York

Telephone: MU 8-2600

Network Executives

Ted Bergmann Director
 Donald H. McGannon Assistant Director
 John H. Bachem General Manager
 James L. Caddigan Dir. of Prog. and Production
 Elmore B. Lyford Director of Station Relations
 Robert L. Coe Mgr., Station Relations Dept.
 Rodney D. Chipp Director of Engineering
 Gerald Lyons Director of Public Relations
 and Publicity
 Thomas J. McMahon Director of Sports
 Morris A. Mayers Mgr. Closed Circuit Operations
 Gerry Martin Director of Sales
 Werner Michel Executive Producer
 Lynn Cleary Business Manager
 Joseph Hess Contoller, Broadcasting Division
 Donald H. McGannon Manager, Owned and
 Operated Stations
 Leslie G. Arries, Jr. Manager of WTTG,
 Washington, D. C.
 Harold C. Lund Manager of WDTV,
 Pittsburgh, Pennsylvania
 Norman Knight Manager of WABD,
 New York, N. Y.
 Donald Stewart Manager of KCTY,
 Kansas City, Mo.

Network Sales

Gerry Martin Director of Network Sales
 Robert Guthrie Mgr., Sales Service
 Lynn Cleary Business Mgr., Sales Dept.
 Edward R. Eadeh Manager of Research
 Gordon Mills Central Division Sales Mgr.
 435 North Michigan Avenue, Chicago 11,
 Illinois
 Robert Lethbridge & Robert H. Miller
 Account Executives, Central
 Division, 435 North Michigan Avenue,
 Chicago 11, Illinois

William Koblenzer Eastern Sales Manager
 James F. Owens Account Executive
 Duncan R. Buckham Account Executive
 H. Malcolm Stuart Account Executive
 Richard B. Stark Account Executive
 Harry Pertka Account Executive
 John A. Thayer, Jr. Account Executive
 Ted Douglas Account Manager
 Hank Opperman Account Manager

Programming and Production

James L. Caddigan Director of Programming
 and Production
 Werner Michael Executive Producer
 A. L. Hollander Mgr. Program Operations
 Richard Geismar Bus. Mgr. Program Dept.
 Jay Merkle Program Facilities Mgr.
 Joan Thompson Religious Programs
 Don Russell Chief Announcer
 Ed Lieberthal Chief Coordinator
 Elizabeth Mears Casting Director
 Dominick Celentano Supervisor of Music
 Acceptance
 David Heilweil Supervising Producer
 Ted Hammerstein Supervising Producer
 Frank Bunetta Supervising Producer
 Roger Gerry Supervising Producer
 Irwin Rosten Supervising Producer
 Frank Telford Producer-Director
 Frank Bunetta Senior Director
 Harry Coyle Director & Sports Producer
 Pat Fay Director
 H. Wesley Kenney Director
 Richard Eckler Director
 William Marceau Director
 Arnold Nocks Director
 Lee Polk Director
 David Lowe Dir. & Supervising Producer
 Barry Shear Director

Operations

Milton Morel.....Operations Manager
Saul Abraham.....Supervisor, Adelphia Theater
Samuel Spachner.....Supr., Ambassador Theater

Engineering

Rodney D. Chipp.....Director of Engineering
Robert F. Bigwood...Mgr. of General Engineering
H. C. Milholland...Mgr. of Technical Operations
S. Patremio.....Development Engineer
Robert Brown & Arthur Deneke
 Building Facilities Engineers
Ed Kavanaugh.....Bldg. Maintenance Engineer
Eric Herud.....Technical Operations Engineer
Malcolm Burselson.....Chief Engineer, WTTG,
 Washington, D. C.
Raymond Rodgers...Chief Engineer, WDTV, Pitt.

Station Relations

Elmore B. Lyford.....Dir. of Station Relations
Robert L. Coe.....Mgr., Station Relations Dept.
Roylance H. Sharp.....Mgr., Traffic Dept.
Edwin G. Koehler...Area Super., Station Relations
Joseph R. Cox.....Area Super., Station Relations
Jack Battey.....Area Super., Station Relations
James O'Grady...Area Super., Station Relations
Robert S. Woolf.....Teletranscription Dept.

Sports Department

Thomas J. McMahon.....Director of Sports

Accounting

Joseph Hess.....Controller, Broadcast Division
Willoughby Walsh.....Purchasing Agent

Public Relations and Publicity

Gerald Lyons...Director of Public Relations and
 Publicity

Research

Edward R. Eadeh.....Manager of Research

Personnel

Leil Tanenholz....Manager, Network Personnel
 Department
Paul O'Friel.....Asst. Dir., Labor Relations

Advertising and Promotion

Norman S. Ginsburg.....Manager, Advertising
 Program Promotion
Norman S. Brett.....Manager, Sales Promotion

DuMont Owned and Operated Stations

WABD, New York

Norman KnightManager
James L. Caddigan.....Program Director
Lawrence L. Wynn.....Sales Manager
Mike Wurster.....Sales Service Mgr.
Milton Morel.....Manager of N. Y. Operations
Saul Abraham.....Supervisor, Adelphi Theater
Sam Spachner...Supervisor, Ambassador Theater
S. W. Fairchild.....Production Facilities Super.
James Graham.....Prod. Facilities Super.
Edward Stevens.....Prod. Facilities Super.
Ralph Robbins.....Prod. Facilities Super.

SALES ACCOUNT EXECUTIVES

William Walters
Lawrence Buck
Perry Frank
Maxine Cooper
Robert Dwyer
Robert F. Adams

WDTV, Pittsburgh

Harold C. Lund.....Manager
Bill Burns.....Director of News
George Baren Bregge.....Sales Director
Raymond Rodgers.....Chief Engineer
William A. Krough.....Sales Service Manager
Paul P. Palangi.....Personnel Manager
Dick Fortune.....Publicity Manager
Byron Dowty.....Program Manager
Shirley Gray.....Traffic Manager
Dave Murray.....News and Special Events
Richard Dreyfuss.....Film Manager
Julian I. Drob.....Stage Manager
George F. Marlick.....Merchandising & Prom.

WTTG, Washington

Leslie Arries, Jr.....General Manager
Roger M. Coelos.....Program Manager
M. M. Burselson.....Chief Engineer
George Flax.....Publicity Director

KCTY, Kansas City

Donald StewartManager
Richard Ostrander.....Program Manager



Du Mont

1953...205 STATION AFFILIATES

SINCE THE END of the freeze the Du Mont Television Network has *tripled* in size! It now has 205 stations... *and still continues to grow!*

Leading this rise, in October 1953, Bishop Sheen's outstanding "Life Is Worth Living" program became the first network series to be scheduled over 165 stations. Du Mont's "Dollar A Second" program and *weekly* Professional Football broadcasts also topped 100 stations... setting another clear-

ance record. Even this record was broken by the Professional Football Championship Game of December 27th with 131 live stations... the largest *live* clearance in network television history.

In its 57% average annual rise in billings since 1950... in its network growth... and in the creation of top programs... the rising success of the Du Mont Television Network reflects new pleasure for its public, new profits for its advertisers.

VISION is the Du Mont Dimension

Zooms Up!

AVERAGE RATING ALL NETWORK QUARTER HOURS 17.7*

1950-53...57% AVERAGE ANNUAL INCREASE IN BILLINGS

*Source - Nielsen, Second Report for November, 1953.

DUMONT

TELEVISION NETWORK

515 Madison Avenue, New York 22, N. Y.
MUrray Hill 8-2600

435 N. Michigan Ave., Chicago 11, Ill.
MO 4-6262

A Division of The Allen B. Du Mont Laboratories, Inc.

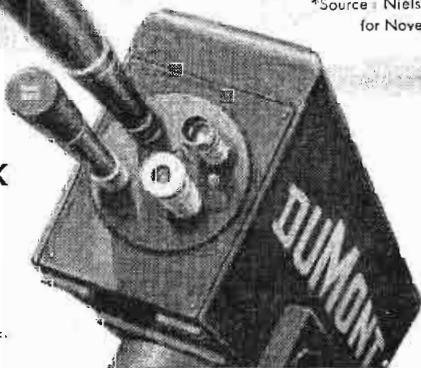



"Magazine" Sales Concept Unfolds In TV Industry

By GEORGE H. FREY

*National Broadcasting Company Vice President
In Charge of Television Network Sales*

AN exciting sales plan that differs radically from the buying and selling design inherited from radio is unfolding in the television industry.

I'm writing, of course, about the "magazine concept"—the flexible new sales pattern pioneered by NBC to help the large advertiser use TV more fully and effectively, offer the moderate budgeted manufacturer the opportunity to participate in the highest rated hits, and, above all, put network television on the media schedule of the small advertiser.

Make no mistake about it, the magazine concept has arrived.

Basically, the plan is designed to head the network advertiser away from single-program sponsorship to a broader use of the entire program schedule. Instead of putting all his TV budget into one limited audience show, the advertiser spreads it across the network's varied program fare to achieve greater audience penetration. His advertising might be positioned in a high circulation variety show, in a news program, perhaps a women's daytime show and in a special event of national interest. The total dollar value might equal what he would invest in a single show, but the effect is the same as if the advertiser branched out from the Saturday Evening Post and added the plus exposure of Good Housekeeping, Life, Better Homes & Gardens and Time. The advertiser's commercials can be rotated according to the market groups he is most interested in reaching, and in the ultimate pattern he can increase commercials when he needs that extra sales push and ease off at other times.

At NBC, "Today," the network's early morning news and special events television program, was deliberately designed and scheduled as a springboard for the magazine concept. "Today" works for advertisers of all shapes and sizes. Commercial time can be ordered as late as a day in advance of a "Today" show. The client may order one or more par-

ticipations for any day or week of his choosing. Local station cut-in announcements can be arranged at nominal cost to provide the audience with where-to-buy-it price information.

Has the magazine concept as practiced on "Today" been successful? Look at the figures: In 1953, time billings on the program topped the \$5,000,000 level. Ranging from little Appian Way Pizza Pie to giant General Motors, "Today" boasted of 90 different clients participating on the show during the year.

With "Today" a solid hit with audiences, clients and agencies, NBC-TV took a further step incorporating this new theory of selling television time with the introduction on March 1, 1954, of "Home"—the mid-morning, hour-long electronic magazine for women.

It is obvious that flexibility is a basic feature and attraction of the entire magazine concept operation. It is equally clear that the job of supplying the programs, or editorial content, in the magazine concept rests mostly with the network. Talent and production costs being what they are, and considering the rate at which television burns up material, it is necessary to centralize the source of programming to stay within reason. Only the network can divide up the operation into cost units that make sense and at the same time average out the hits and misses.

With such a system of centralized control, the network can afford to do far more program experimentation than in the past, trying out new ideas and testing new talent in the never ending search to enrich the service to the American audience. Certainly, few advertisers and no agencies can afford to run on-the-air laboratories, yet both are quick to agree that this experimentation is vital to a healthy future for television.

Under the system of program control that goes hand-in-hand with this stimulating new magazine concept, the networks will be able to assume the burden.

N. B. C. TELEVISION NETWORK

DAVID SARNOFF *Chairman of the Boards of RCA and NBC*

BRIG. GEN. DAVID SARNOFF, chairman of the Boards of RCA and NBC, entered the communications field as a messenger boy at the age of 15. As the importance of radio grew, he became successively Chief Inspector, Assistant Traffic Manager, and in 1917, Commercial Manager of the Marconi Wireless Telegraph Company of America. In 1919, when RCA was formed, it acquired the Marconi Company and appointed General Sarnoff commercial man-



SARNOFF

ager. During the following eleven years, he advanced from Commercial Manager to General Manager, then Vice President, Executive Vice President, and in 1930, at the age of 39, he was elected president of RCA. He was elected chairman of the board and chief executive officer of RCA in 1947. During World War II, he served as Special Consultant on Communications to General Dwight D. Eisenhower at SHAEF in Europe.

SYLVESTER L. WEAVER, JR. *President of NBC*

SYLVESTER L. WEAVER, JR., joined NBC in the summer of 1949 as head of television, after 23 years of outstanding accomplishment in the advertising and broadcasting fields, including service as advertising manager of American Tobacco Company and vice president in charge of radio and television for Young and Rubicam. After three years as Vice President in charge of TV for NBC, he was made Vice President in charge of both radio and television networks in the summer of 1952. In December, 1952, he was named Vice



WEAVER, JR.

Chairman of the Board and in December, 1953, he was elected NBC President. Weaver was born in Los Angeles and was graduated magna cum laude from Dartmouth, where he was elected to Phi Beta Kappa. He started in radio as a writer, then became program manager of the Don Lee network in San Francisco. In 1935, Weaver came to New York, where he joined Young and Rubicam. During World War II, he spent two years in the Navy in command of an escort vessel.

ROBERT W. SARNOFF *Executive Vice President of NBC*

Elected Executive Vice President of NBC in December, 1953, ROBERT WILLIAM SARNOFF joined the network on January 1, 1948, as an account executive in the sales department after three years of service in the Navy, followed by three years with the Cowles publications. After serving NBC in a variety of capacities, including television production manager and television program sales manager, he was appointed director of unit production for TV in 1951. It was in this capacity that he launched "Victory at Sea," the famous NBC-Navy documentary of



SARNOFF

the Navy's role in World War II, for which he received the Navy's Distinguished Public Service Award. In June, 1951, he was elected a Vice President of NBC and a year later was placed in charge of the newly created NBC Film Division. Sarnoff was named executive assistant to Sylvester L. Weaver, Jr. in September, 1953, and a month later was elected to the NBC Board of Directors. He was born in New York City, was graduated from Harvard and, after a year at Columbia Law School entered the Government service in August, 1941.

NATIONAL BROAD

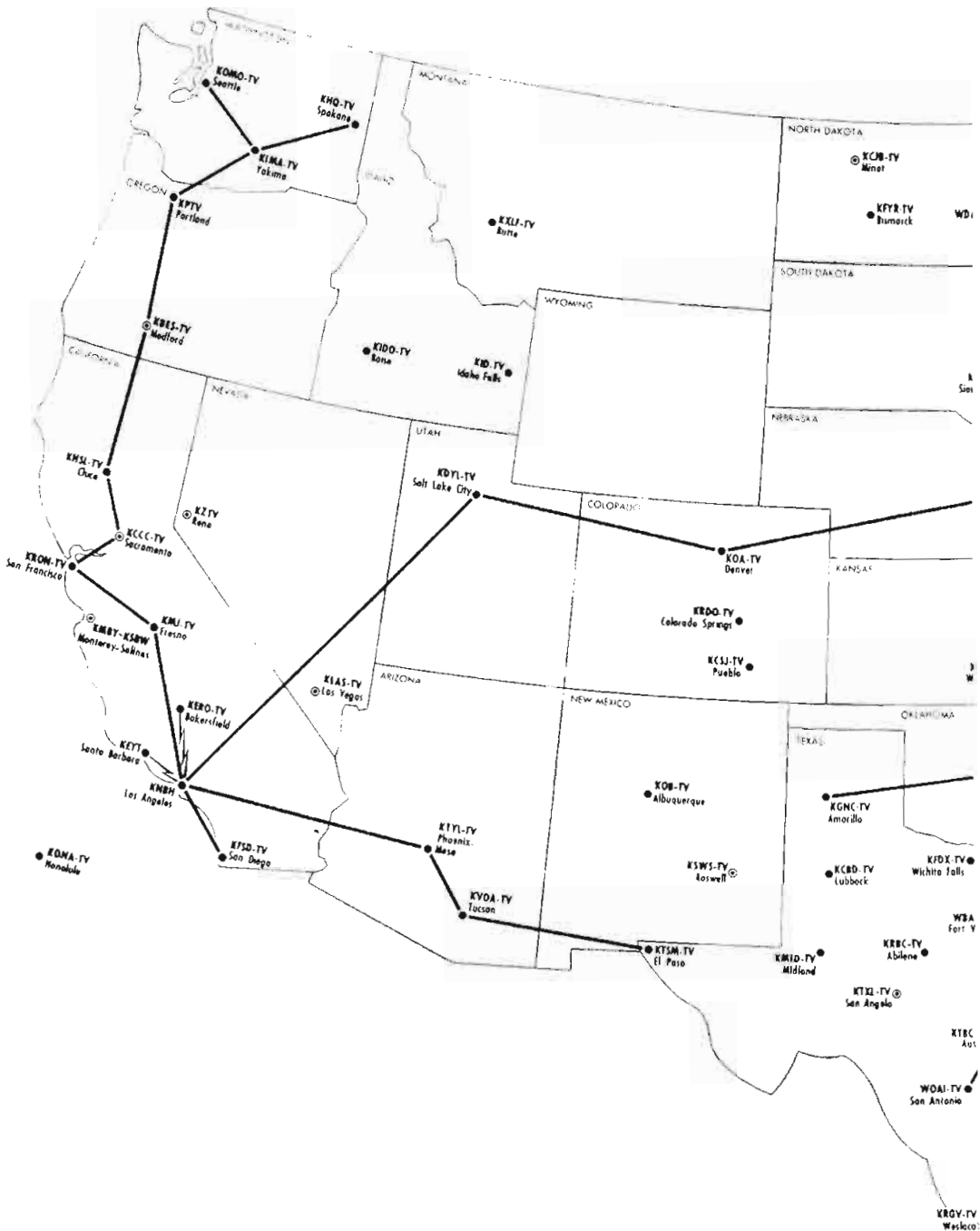

NATIONAL BROADCASTING COMPANY, INC.

30 Rockefeller Plaza, New York 20, N. Y.

Telephone: Circle 7-8300

Registered Telegraphic Address:

NATBROCAST

NEW YORK

NOTE: A full listing of the NBC corporate personnel, as well as the board of directors, will be found on Page 280.

ORGANIZATION UNDER THE PRESIDENT AND EXECUTIVE VICE PRESIDENT

Sylvester L. Weaver, Jr. President
Robert W. Sarnoff Exec. Vice President
Joseph V. Heffernan Vice Pres. in Chg. of
Finance & Services
David C. Adams Administrative Vice President
Samuel Chotzinoff General Music Director

Engineering

O. B. Hanson Vice Pres. & Chief Engineer
William A. Clark Administrative Assistant
Edward R. Cullen Liaison Engineer
Joseph D'Agostino Liaison Engineer
Raymond F. Guy Mgr. of Radio & Allocation
Engineering
George M. Nixon Mgr. of Engineering
Development
Chester A. Rackey Mgr. of Audio-Video
Engineering
Robert W. Shelby Dir. of Color TV Systems
Development
James Wood, Jr. Mgr. of Technical Services

Station Relations

Harry Bannister V.P. in Chg. of Station Rela.
Sheldon B. Hickox Dir. of Station Relations
Thomas Knode Mgr. of Station Relations
Harry A. Woodman Mgr. of Traffic Dept.

Treasurer

Joseph A. McDonald Treasurer
William A. Williams Assistant Treasurer
Harry F. McKeon Dir. of the Tax Dept.
William D. Bloxham Manager of Purchasing
Integrated Services

Integrated Services

William S. Hedges V.P. for Integrated Services

Edward M. Lowell Mgr. Bldg. & Gen
Services Dept
William B. Miller Night Executive Officer
Peter M. Tintle Mgr. of Guest Relations
Mildred Joy Chief Librarian

PRESS AND PUBLICITY

Sydney H. Eiges V.P. for Press & Publicity
Richard T. Connelly Dir. of Press Department
Don Bishop Mgr. of Program Publicity
Ellis Moore Mgr. of Radio-TV Business Pub.
Kathryn Cole Manager of Information
Cornelius Sullivan Public Rel. Representative

TELEVISION NETWORK SALES

George H. Frey Vice Pres. in Chg. of TV
Network Sales
Charles C. Barry Vice Pres. for Program Sales

Sales Department

John Lanigan Mgr. of Eastern Sales Division
Edward R. Hitz Mgr. of Central Sales Div.
John K. Williams Mgr. of Western Sales Div.

Sales Administration

Walter Scott Administrative Sales Manager
Stephen A. Flynn Manager of Sales Service
Robert McFadyen Dir. of Sales Development
Hamilton Robinson Mgr. of Office Services

Research and Planning Department

Hugh M. Beville Dir. of Research & Planning
Dr. Thomas E. Coffin Manager of Research
Allen R. Cooper Mgr. of Markets & Media
James H. Cornell Mgr. of Audience
Measurement
Barry T. Rumble Manager of Plans

Advertising and Promotion Department

Jacob A. Evans Dir. of Advertising & Promotion
John Porter Sales Promotion Manager
David Hedley Mgr. of Presentations
Pat Steel Advertising Manager
Clyde Clem Audience Promotion Manager
Fred Veit Mgr. of Art Production & Graphics

Merchandising Department

Fred Dodge Director of Merchandising

Murray Heilweil.....Manager of Merchandising
Loy Lee.....Asst. Mgr. of Merchandising
Gordon Lane.....Promotion Manager

TELEVISION NETWORK PROGRAMS DIVISION

Thomas McAvity.....Vice Pres. in Chg. of TV
Network Programs Division

National Television Program Department

Sam Fuller.....Natl. TV Program Mgr.
Michael Dann.....TV Network Program Mgr.
Leroy Passman.....TV Network Program
Administrative Manager

Production and Business Affairs Department

Earl Rettig.....In Chg. of Prod. & Business Affairs
Leonard Hole.....Director of Production
William V. Sargent.....Divisional Business Mgr.
Anthony M. Hennig.....Associate Dir. of Prod.
George McElrath.....Dir. of Technical Oper.
James A. Glenn.....Dir. of Plant Operations
Fred Shawn.....Dir. of Production Operations
Norman Grant.....Dir. of Design & Art Oper
J. Robert Myers.....Business Mgr. of Production
Edward J. Stegeman.....Mgr. of Program Budgets
Thomas Loeb.....Mgr. of the Business Unit
John J. Heywood.....Mgr. of Divisional Budgets

Public Affairs Department

Davidson Taylor.....Dir. of Public Affairs
William R. McAndrew.....Mgr. of News & Special
Events
Thomas S. Gallery.....Manager of Sports
Edward Stanley.....Mgr. of Public Service Programs
Eugene Juster.....Manager of Films
William Garden.....Sup. of Public Affairs Prod.

Talent Department

Gustav B. Margraf.....Vice Pres. for Talent
Hal Kemp.....Manager of Talent Office

FILM DIVISION

Carl M. Stanton.....Vice Pres. in Chg. of Film Div.
Edgar G. Sisson, Jr.....Asso. Dir. of Film Div.
Charles Henderson.....Director of Publicity
John B. Cron.....National Sales Manager
Stanton M. Osgood.....Production Manager
Robert A. Anderson.....Business Manager
David Savage.....Mgr. of Film Procurement
Frank LePore.....Film & Kinescope Operations &
Service Manager

NBC OWNED STATIONS AND NBC SPOT SALES DIVISION

Charles R. Denny.....Vice Pres. in Chg. of Owned
Stations and Spot Sales
Henry T. Sjogren.....Controller for Owned Stations
Charles H. Colledge.....Dir. of Technical Oper.
Charles C. Bevis.....General Executive
Robert F. Blake.....Director of Publicity

WNBT, New York

Hamilton Shea.....Gen. Mgr. of WNBT

Ernest de la Ossa.....Station Mgr. of WNBT
Richard M. Pack.....Dir. of Programs &
Operations, WNBT
Peter Affe.....Mgr. of Operations for WNBT
Max Buck.....Dir. of Advertising, Sales
Promotion & Merchandising
Jay Heitin.....Television Sales Manager

WNBQ, Chicago

Harry C. Kopf.....V.P. & Gen. Mgr. of WNBQ
Jules Herbubeaux.....Asst. General Manager
Charles Dress.....Director of Sales
George Heinemann.....Director of Programming
John F. Whalley.....Director of Operations
Howard C. Luttgens.....Engineer in Charge

WNBK, Cleveland

Lloyd E. Yoder.....General Manager for WNBK
Samuel E. Leonard.....Engineer in Charge
Brooks Taylor.....Program Director

WNBW, Washington

Carleton D. Smith.....V.P. & Gen. Mgr. of WNBW
Joseph Goodfellow.....Director of Sales
James Kovach.....Program Director
Lefferts A. McClelland.....Director of Operations
John G. Rogers.....Engineer in Charge

KNBH, Hollywood

Donald A. Norman.....General Manager
James Parks.....Sales Manager
John Wehrheim.....Station Business Manager
John Knight.....Station Engineer

National Spot Sales

Thomas B. McFadden.....Dir. of Natl. Spot Sales
Richard H. Close.....Mgr. for Represented Sta.
Harold Shepard.....Sales Development Advertising
& Promotion Manager
John Reber.....Natl. Mgr. for TV Spot Sales
Caroline Herbert.....Sales Service Mgr.

WASHINGTON AND PACIFIC DIVISION OFFICES

Washington

Frank M. Russell.....Vice President, Washington
George Wheeler.....Asst. to the Vice President

Pacific Division

John K. West.....Vice Pres. for the Pacific Div.
Frederic W. Wile, Jr.....Vice Pres. in Chg. of TV
Network Programs (Pacific Div.)
Frank Cleaver.....Program Mgr., TV Network
(Pacific Division)
Thomas W. Sarnoff.....Production Dir., TV
Network (Pacific Div.)
Frank Dellett.....Business Mgr. (Pacific Div.)
Lewis S. Frost.....Director of Public Relations
Leslie Raddatz.....Mgr. of Press & Publicity

*NOTE: A full listing of the personnel
of NBC's O & O stations, as well as
the organization of the Washington
and Hollywood offices, will be found
on Page 282.*

SHOW AND SALES

In these two words you'll find the crux of NBC Television's program philosophy. In application, it means that the subject of the program, whether it's news or a musical revue, should be created with pace and glamour, with all the showmanlike trappings that can be used. But also it should be designed to be an efficient selling vehicle which will make maximum use of television's special selling talents.

*To see how this policy is working,
let's look at the record: —————>*

MANSHIP

MANSHIP

Today
Home
Your Show of Shows
Philco-Goodyear
Television Playhouse
Colgate Comedy Hour
Life of Riley
Dragnet
Ding Dong School
Howdy Doody
The Pinky Lee Show
NBC Opera Theatre
The Dennis Day Show
I Married Joan
Robert Montgomery Presents
Zoo Parade
Kukla, Fran and Ollie
Mister Peepers
Hallmark Hall of Fame

*Last year 125 advertisers
found NBC Television's
showmanship and its
salesmanship eminently
suited to their needs.
It can work efficiently
for you too.*



TELEVISION

a service of Radio Corporation of America

28.5 Million TV Sets Manufactured Since 1946

Over 28.5 million television receivers were shipped to dealers in the United States, Hawaii and Alaska during the eight year period from 1946 to the end of 1953. The bulk of the sets, according to statistics released by the Radio-Electronics-Television Manufacturers Assn., went to dealers in the United States. TV dealers in Hawaii received 25,308 receivers in 1953, while a total of 2,330 sets went to Alaska.

The following table shows state-by-state shipments.

State	Total	State	Total
Alabama	252,860	Nebraska	203,133
Arizona	88,910	Nevada	12,061
Arkansas	87,670	New Hampshire	85,066
California	2,611,984	New Jersey	1,462,698
Colorado	172,027	New Mexico	12,281
Connecticut	510,026	New York	1,100,118
Delaware	92,885	North Carolina	378,770
District of Columbia	303,279	North Dakota	22,178
Florida	337,897	Ohio	2,236,969
Georgia	398,558	Oklahoma	310,388
Idaho	28,616	Oregon	133,563
Illinois	2,018,620	Pennsylvania	2,647,072
Indiana	812,578	Rhode Island	205,525
Iowa	107,832	South Carolina	125,677
Kansas	191,037	South Dakota	21,711
Kentucky	333,367	Tennessee	309,091
Louisiana	215,015	Texas	985,598
Maine	83,313	Utah	128,371
Maryland	516,100	Vermont	26,298
Massachusetts	1,257,588	Virginia	131,166
Michigan	1,386,512	Washington	366,311
Minnesota	128,080	West Virginia	216,998
Mississippi	87,712	Wisconsin	532,857
Missouri	711,062	Wyoming	7,123
Montana	12,808	Grand Total	28,468,818

Television Allocations Of The FCC

- **ALPHABETICALLY
BY STATE — CITY**

- **COMMERCIAL**

- **EDUCATIONAL**

OFFICIAL FCC TV ALLOCATIONS

ALABAMA

	Channel No.
Andalusta	20
Anniston	70
Auburn	*58
Bessemer	54
Birmingham	6, *10, 13, 42, 48
Brewton	23
Clanton	14
Cullman	60
Decatur	23
Demopolis	18
Dothan	9, 19
Enterprise	40
Eufaula	44
Florence	41
Fort Payne	19
Gadsden	16, 21
Greenville	49
Guntersville	40
Huntsville	31
Jasper	17
Mobile	5, 10, *42, 48
Montgomery	12, 20, *26, 32
Opelika	22
Selma	8, 58
Sheffield	47
Sylacauga	24
Talladega	64
Thomasville	27
Troy	38
Tuscaloosa	45, 51
Tuskegee	16
University	*7

ARIZONA

Ajo	14
Biabee	15
Casa Grande	18
Chifton	25
Coolidge	30
Douglas	3
Eloy	24
Flagstaff	9, 13
Globe	34
Holbrook	14
Kingman	6
Mesa	12
Miami	28
Morenci	31
Nogales	17
Phoenix	3, 5, *8, 10
Prescott	15
Safford	21
Tucson	4, *6, 9, 13
Williams	25
Winslow	16
Yuma	11, 13

ARKANSAS

Arkadelphia	34
Batesville	30
Benton	40
Blytheville	64, 74
Camden	50
Conway	49

Channel No.

El Dorado	10, 26
Fayetteville	*13, 41
Forrest City	22
Fort Smith	5, *16, 22, 39
Harrison	24
Helena	51
Hope	16
Hot Springs	9, 52
Jonesboro	8, 30
Little Rock	*2, 4, 11, 17, 23
Magnolia	28
Malvern	46
Morrilton	43
Newport	28
Paragould	58
Pine Bluff	7, 36
Russellville	19
Searcy	33
Springdale	35
Stuttgart	14

CALIFORNIA

Altura	9
Bakersfield	10, 29
Brawley	25
Chico	12
Corona	52
Delano	37
El Centro	16, 56
Eureka	3, 13
Fresno	12, *18, 24, 47, 53
Hanford	21
Los Angeles	2, 4, 5, 7, 9, 11, 13, 22, *28, 34
Madera	30
Merced	34, 66
Modesto	14, 58
Monterey (see Salinas)	
Napa	62
Oakland (see San Francisco)	
Oxnard	32
Palm Springs	14
Petaluma	56
Port Chicago	15
Porterville	55
Red Bluff	16
Redding	7
Riverside	40, 46
Sacramento	3, *6, 10, 40, 46
Salinas-Monterey	8, 28
San Bernardino	18, *24, 30
San Buenaventura	38
San Diego	8, 10, *15, 21, 27, 33, 39
San Francisco	
Oakland	2, 4, 5, 7, *9, 26, 26, 32, 38, 44
San Jose	11, 48, *54, 60
San Luis Obispo	6
Santa Barbara	3, 20, 26
Santa Cruz	16
Santa Maria	44
Santa Paula	16
Santa Rosa	50
Stockton	33, 36, *42, 64
Tulare	27
Ukiah	18
Visalia	43, 49
Watsonville	22
Yreka City	11
Yuba City	52

* Denotes Channel reservation for non-commercial educational use.

OFFICIAL FCC TV ALLOCATIONS

COLORADO

	Channel No.
Alamosa	19
Boulder	*12, 22
Canon City	36
Colorado Springs	11, 13, *17, 23
Craig	19
Delta	24
Denver	2, 4, *6, 7, 9, 20, 26
Durango	6, 15
Fort Collins	44
Fort Morgan	15
Grand Junction	5, 21
Greeley	50
La Junta	24
Lamar	18
Leadville	14
Longmont	32
Loveland	38
Montrose	10, 18
Pueblo	3, 5, *8, 28, 34
Salida	25
Sterling	25
Trinidad	21
Walsenburg	30

CONNECTICUT

Bridgeport	43, 49, *71
Hartford	3, 18, *24
Meriden	05
New Britain	30
New Haven	8, 59
New London	20, 81
Norwalk (see Stamford)	
Norwich	57, 63
Stamford-Norwalk	27
Waterbury	53

DELAWARE

Dover	40
Wilmington	12, 59, 83

DISTRICT OF COLUMBIA

Washington	4, 5, 7, 9, 20, *26, 50
------------	-------------------------

FLORIDA

Belle Glade	25
Bradenton	28
Clearwater	32, 50
Daytona Beach	2, 53
De Land	44
Fort Lauderdale	17, 23
Fort Myers	11
Fort Pierce	19
Gainesville	*5, 20
Jacksonville	4, *7, 12, 30, 36
Key West	14, 20
Lake City	33
Lakeland	16, 22
Lake Wales	14
Leesburg	26
Marianna	17
Miami	*2, 4, 7, 10, 27, 33
Ocala	15
Orlando	6, 9, 18, *24, 47
Palatka	17
Panama City	7, *30, 36
Pensacola	3, 15, *21, 46
Quincy	54
St. Augustine	25
St. Petersburg (see Tampa)	
Sanford	35
Sarasota	34

Channel No.

Tallahassee	*11, 24, 51
Tampa-St. Petersburg	*3, 8, 13, 38
West Palm Beach	5, 12, *16, 21

GEORGIA

Albany	10, 25
Americus	31
Athens	*8, 60
Atlanta	2, 5, 11, *30, 36
Augusta	6, 12
Bainbridge	35
Brunswick	28, 34
Cairo	45
Carrollton	33
Cartersville	63
Cedartown	53
Columbus	4, 28, *34
Cordele	43
Dalton	25
Douglas	32
Dublin	15
Elberton	24
Fitzgerald	23
Fort Valley	18
Gainesville	52
Griffin	39
La Grange	50
Macon	*41, 47
Marietta	57
Milledgeville	51
Moultrie	48
Newnan	61
Rome	9, 59
Savannah	3, *9, 11
Statesboro	22
Swainsboro	20
Thomasville	6, 27
Tifton	14
Toccoa	35
Valdosta	37
Vidalia	26
Warner Robins	13
Waycross	16

IDAHO

Blackfoot	33
Boise	*4, 7, 9
Burley	15
Caldwell	2
Coeur d'Alene	12
Emmett	26
Gooding	23
Idaho Falls	3, 8
Jerome	17
Kellogg	33
Lewiston	3
Moscow	*15
Nampa	6, 12
Payette	14
Pocatello	6, 10
Preston	41
Rexburg	27
Rupert	21
Sandpoint	9
Twin Falls	11, 13
Wallace	27
Weiser	20

ILLINOIS

Alton	48
Aurora	16
Belleville	54
Bloomington	15
Cairo	24

* Denotes Channel reservation for non-commercial educational use.

OFFICIAL FCC TV ALLOCATIONS

	Channel No.
Carbondale	34, *61
Centralia	32, 59
Champaign-Urbana	3, *12, 21, 27, 33
Chicago	2, 5, 7, 9, *11, 20, 26, 32, 38, 44
Danville	24
Decatur	17, 23
De Kalb	*67
Dixon	47
Elgin	28
Freeport	23
Galesburg	40
Harrisburg	22
Jacksonville	29
Joliet	48
Kankakee	14
Kewanee	60
La Salle	35
Lincoln	53
Macomb	61
Marion	40
Mattoon	46
Moline (see Davenport, Iowa)	
Mt Vernon	38
Olney	16
Pekin	69
Peoria	8, 19, *37, 43
Quincy	10, 21
Rockford	13, 39, *45
Rock Island (see Davenport, Iowa)	
Springfield	2, 20, *26
Streator	65
Urbana (see Champaign)	
Vandalia	28
Waukegan	22

INDIANA

Anderson	61
Angola	15
Bedford	08
Bloomington	4, *30, 36
Columbus	42
Connersville	38
Elkhart	52
Evansville	7, 50, *56, 62
Fort Wayne	*27, 33, 69
Gary	50, *66
Hammond	56
Indianapolis	6, 8, 12, *20, 26, 67
Jasper	19
Kokomo	31
Lafayette	*47, 59
Lebanon	18
Lazansport	51
Madison	25
Marion	29
Mishigan City	62
Muncie	49, 55, *71
Princeton	52
Richmond	32
Shelbyville	58
South Bend	31, *40, 46
Tell City	31
Terre Haute	10, *57, 63, 73
Vincennes	44
Washington	60

IOWA

Algona	37
Ames	5, 25
Atlantic	45
Boone	19
Burlington	32, 38
Carroll	39
Cedar Rapids	2, 9, 20, *26
Centerville	31
Charles City	18
Cherokee	14
Clinton	64

	Channel No.
Creston	43
Davenport-Rock Island & Moline	
Illinois	1, 6, *30, 36, 42
Decorah	43
Des Moines	8, *11, 15, 17, 23
Dubuque	50, 67
Estherville	24
Fairfield	54
Fort Dodge	21
Fort Madison	50
Grinnell	71
Iowa City	*12, 24
Keokuk	44
Knoxville	33
Marshalltown	49
Mason City	3, 35
Muscatine	58
Newton	65
Olwein	28
Oskaloosa	52
Ottumwa	15, 63
Red Oak	32
Shequodah	20
Sioux City	4, 9, *30, 30
Spencer	42
Storm Lake	34
Waterloo	7, 16, *22, 46
Webster City	27

KANSAS

Abletic	31
Arkansas City	49
Atchison	60
Chanute	50
Coffeyville	33
Colby	22
Concordia	47
Dodge City	8, 23
El Dorado	55
Emporia	39
Fort Scott	27
Garden City	9, 11
Goodland	31
Great Bend	2, 28
Hays	7, 20
Hutchinson	12, 18
Independence	20
Jola	44
Junction City	20
Larned	15
Lawrence	*11, 17
Leavenworth	64
Liberal	14
McPherson	26
Manhattan	*8, 23
Newton	14
Olathe	52
Ottawa	21
Parsons	46
Pittsburg	7, 38
Prairie	30
Sahna	34
Topeka	13, 42, *48
Wellington	24
Wichita	3, 10, 16, *22
Winfield	43

KENTUCKY

Ashland	59
Bowling Green	13, 17
Campbellsville	40
Corbin	16
Danville	35
Elizabethtown	23
Frankfort	43
Glasgow	28
Hartan	73
Hazard	19

* Denotes Channel reservation for non-commercial educational use.

OFFICIAL FCC TV ALLOCATIONS

	Channel No.
Hopkinsville	20
Lexington	18, 27, 64, 70
Louisville	3, 11, *15, 21, 41, 51
Madisonville	26
Mayfield	63
Maysville	24
Middlesborough	57, 63
Murray	33
Owensboro	14
Paducah	6, 43, 72
Pikeville	14
Princeton	45
Richmond	60
Somerset	29
Winchester	37

LOUISIANA

Abbeville	27
Alexandria	5, 62, 74
Bastrop	53
Baton Rouge	2, 28, *34, 40
Bogalusa	69, 78
Crowley	21
De Ridder	14
Eunice	64
Franklin	46
Hammond	57
Houma	30
Jackson	18
Jennings	48
Lafayette	10, 38, 67
Lake Charles	7, *19, 25, 60
Minden	36
Monroe	8, 43
Morgan City	36
Natchitoches	17
Now Iberia	15
New Orleans	4, 6, 8, 20, 26, 32, 61
Oakdale	54
Opelousas	58
Ruston	20
Shreveport	3, 12
Thibodaux	24
Winnfield	22

MAINE

Auburn	23
Augusta	10, 29
Bangor	2, 5, *16
Bar Harbor	22
Bath	65
Belfast	41
Biddeford	59
Calais	7, 20
Dover-Foxcroft	18
Fort Kent	17
Houlton	24
Lewiston	8, 17
Millinocket	14
Orono	*12
Portland	6, 13, *47, 53
Presque Isle	8, 19
Rockland	25
Rumford	55
Van Buren	15
Waterville	35

MARYLAND

Annapolis	14
Baltimore	2, 11, 13, 18, *24, 60
Cambridge	22
Cumberland	17, 30
Frederick	62
Hagerstown	52, 68
Salisbury	16

MASSACHUSETTS

	Channel No.
Amherst	82
Barnstable	52
Boston	*2, 4, 5, 7, 44, 50, 56
Brockton	62
Fall River	46, 68
Greenfield	58
Holyoke (see Springfield)	
Lawrence	72
Lowell	32
New Bedford	28, 34
North Adams	74, 80
Northampton	36
Pittsfield	64
Springfield-Holyoke	55, 61
Worcester	14, 20

MICHIGAN

Alma	41
Alpena	9, 30
Ann Arbor	20, *26
Bad Axe	46
Battle Creek	58, 64
Bay City	5, 63, *73
Benton Harbor	42
Big Rapids	39
Cadillac	13, 45
Calumet	13
Cheboygan	4, 36
Coldwater	24
Detroit	2, 4, 7, 50, *56, 62
East Lansing	60
East Tawas	25
Escanaba	3
Flint	12, 16, *22, 28
Gladstone	40
Grand Rapids	8, *17, 23
Hancock	10
Houghton	19
Iron Mountain	9, 27
Iron River	33
Ironwood	31
Jackson	48
Kalamazoo	3, 36
Lansing	6, 54
Ludington	18
Manistee	15
Manistique	14
Marquette	6, 17
Midland	19
Mount Pleasant	47
Muskegon	29, 35
Petoskey	31
Pontiac	44
Port Huron	34
Rogers City	24
Saginaw	51, 57
Sault Ste. Marie	8, 10, 28, *34
Traverse City	7, 20, *26
West Branch	21

MINNESOTA

Albert Lea	57
Alexandria	36
Austin	6, 51
Benidji	13, 24
Brainerd	12
Cloquet	44
Crookston	21
Detroit Lakes	18
Duluth-Superior, Wis.	3, 6, *8, 32, 38
Ely	16
Fairmount	40
Fairbault	20
Fergus Falls	16
Grand Rapids	20
Hastings	29

* Denotes Channel reservation for non-commercial educational use.

OFFICIAL FCC TV ALLOCATIONS

	Channel No.
Hibbing	10
International Falls	11
Little Falls	19
Mankato	15
Marshall	23
Minneapolis-St. Paul	*2, 4, 5, 9, 11, 17, 23
Montevideo	19
New Ulm	43
Northfield	26
Owatoma	45
Red Wing	63
Rochester	10, 55
St. Cloud	7, 33
St. Paul (See Minneapolis)	
Stillwater	39
Three River Falls	15
Virginia	26
Wadena	37
Wilmot	31
Winona	61
Worthington	32

MISSISSIPPI

Biloxi	13, *14, 50
Brookhaven	37
Canton	16
Clarksdale	6, 32
Columbia	35
Columbus	4, 28
Corinth	29
Greenville	21, 27
Greenwood	24
Grenada	15
Gulfport	56
Hattiesburg	9, 17
Jackson	3, 12, *19, 25, 47
Kosciusko	52
Laurel	33
Louisville	46
Meridian	11, 30, 36
Natchez	29
Pascagoula	22
Picayune	14
Starkville	34
State College	22
Tupelo	38
University	*20
Vicksburg	41
West Point	56
Yazoo City	49

MISSOURI

Cape Girardeau	12, 18, 69
Carthage	56
Caruthersville	27
Chillicothe	14
Clinton	49
Columbia	8, 16, 22
Farmington	52
Festus	14
Fullon	24
Hannibal	7, 27
Jefferson City	13, 33
Joplin	12, 30
Kansas City	4, 5, 9, *19, 25, 65
Kennett	21
Kirksville	3, 18
Lebanon	23
Marshall	40
Maryville	26
Mexico	45
Moberly	35
Monett	14
Nevada	18
Poplar Bluff	15
Rolla	46
St. Joseph	2, 30, *36
St. Louis	4, 5, *9, 11, 30, 36, 42
Sedalia	6, 28

	Channel No.
Sikeston	37
Springfield	3, 10, *26, 32
West Plains	20

MONTANA

Anaconda	2
Billings	2, 8, *11
Bozeman	*9, 22
Butte	4, 6, *7, 15
Cut Bank	20
Deer Lodge	25
Dillon	24
Glasgow	16
Glendive	18
Great Falls	3, 5, 23
Hamilton	17
Hardin	4
Hayre	9, 11
Helena	10, 12
Kalispell	8
Laurel	14
Lewistown	13
Livingston	16
Miles City	3, *6, 10
Missoula	*11, 13, 21
Polson	18
Red Lodge	18
Shelby	14
Sidney	14
Whitefish	16
Wolf Point	20

NEBRASKA

Alliance	13, 21
Bartlesville	40
Broken Bow	14
Columbus	49
Fairbury	35
Falls City	*38
Freemont	52
Grand Island	11, 21
Hastings	5, 27
Kearney	13, 19
Lexington	23
Lincoln	10, 12, *18, 24
McCook	8, 17
Nebraska City	50
Norfolk	33
North Platte	2, 4
Omaha	3, 6, 7, *16, 22, 28
Scottsbluff	10, 16
York	15

NEVADA

Banker City	4
Carlin	14
Carson City	37
Elko	10
Ely	3, 6
Fallon	29
Goldfield	5
Hawthorne	31
Henderson	2
Las Vegas	8, *10, 13
Lovelock	18
McCall	8
Reno	4, 8, *21, 27
Tonopah	9
Winnemucca	7
Yerington	33

NEW HAMPSHIRE

Berlin	28
--------	----

* Indicates Channel reservation for non-commercial educational use

OFFICIAL FCC TV ALLOCATIONS

	Channel No.
Claremont	37
Concord	27
Durham	*11
Hanover	*21
Keene	45
Laconia	43
Littleton	24
Manchester	9, 48
Nashua	54
Portsmouth	19
Rochester	51

NEW JERSEY

Andover	*69
Asbury Park	58
Atlantic City	46, 52
Bridgeton	64
Camden	*80
Freehold	*74
Hammonton	*70
Montclair	*77
Newark	13
New Brunswick	*19, 47
Paterson	37
Trenton	41
Wildwood	48

NEW MEXICO

Alamogordo	17
Albuquerque	4, *5, 7, 13
Artesia	21
Atrisco-Pive Points	18
Belen	24
Carlsbad	6, 23
Clayton	27
Clovis	12, 35
Deming	14
Farmingington	17
Gallup	3, *8, 10
Hobbs	46
Hot Springs	19
Las Cruces	22
Las Vegas	14
Lordsburg	23
Los Alamos	20
Lovington	27
Portales	27
Raton	46, *52
Roswell	*3, 8, 10
Santa Fe	2, *9, 11
Silver City	*10, 12
Socorro	15
Tucumcari	25

NEW YORK

Albany-Schenectady-Troy	6, *17, 23, 41
Amsterdam	52
Auburn	37
Batavia	33
Binghamton	12, 40, *46
Buffalo (also see Buffalo-Niagara Falls)	17, *23
Buffalo-Niagara Falls	2, 4, 7, 59
Carthage	7
Cortland	56
Dunkirk	46
Elmira	18, 24
Glens Falls	39
Gloversville	29
Hornell	50
Ithaca	*14, 20
Jamestown	58

	Channel No.
Kingston	66
Lake Placid	5
Malone	20, *66
Massena	14
Middletown	60
New York	2, 4, 6, 7, 9, 11, *25, 31
Niagara Falls (see Buffalo-Niagara Falls)	
Ogdensburg	24
Olean	54
Oneonta	62
Oswego	31
Patchogue	75
Plattsburg	28
Poughkeepsie	21, *83
Roehester	5, 10, 15, *21, 27
Rome (see Utica)	
Sarauae Lake	18
Schenectady (also see Albany)	35
Syracuse	3, 8, *43
Troy (see Albany)	
Utica-Rome	13, 19, *25
Watertown	48

NORTH CAROLINA

Ashokle	53
Albemarle	20
Asheville	13, *56, 62, 78
Burlington	63
Chapel Hill	*4
Charlotte	3, 9, 36, *42
Durham	11, *40, 46, 73
Elizabeth City	31
Fayetteville	18, 54
Gastonia	48
Goldsboro	34, 72
Greensboro	2, *51, 57
Greenville	9
Henderson	52
Hendersonville	27
Hickory	30
High Point	15
Jacksonville	16
Kannapolis	59
Kinston	45
Laurinburg	41
Lumberton	21
Mount Airy	55
New Bern	13
Raleigh	5, *22, 28
Roanoke Rapids	30
Rocky Mount	50
Salisbury	80
Sanford	38
Shelby	39
Southern Pines	49
Statesville	64
Washington	7
Wilmington	3, 6, 29, *35
Wilson	56
Winston-Salem	12, 26, *32

NORTH DAKOTA

Bismarck	5, 12, 18, *24
Bottineau	16
Carrington	26
Devils Lake	8, 14
Diekinson	2, 4, *17
Fargo	6, 11, *34, 40
Grafton	17
Grand Forks	*2, 10
Harvey	22
Jamestown	7, 42
Lisbon	23
Minot	*6, 10, 13
New Rockford	20
Rugby	38

* Denotes Channel reservation for non-commercial educational use.

OFFICIAL FCC TV ALLOCATIONS

	Channel No.
Valley City	4, 32
Wahpeton	45
Williston	8, 11, *34

	Channel No.
Seminole	59
Shawnee	53
Stillwater	29, *69
Tulsa	2, 6, *11, 17, 23
Vinita	28
Woodward	8

OHIO

Akron	49, *55, 61
Ashtabula	15
Athens	62
Bellefontaine	63
Bowling Green	70
Cambridge	26
Canton	20
Chillicothe	50
Cincinnati	5, 9, 12, *48, 54, 74
Cleveland	3, 5, 8, 19, *26, 65
Columbus	4, 6, 10, *34, 40
Coshocton	20
Dayton	9, 7, *16, 22
Defiance	43
Findlay	53
Fremont	59
Gallipolis	72
Hamilton-Middletown	65
Lancaster	28
Lima	35, 73
Lorain	31
Mansfield	36
Marion	17
Massillon	23
Middletown (see Hamilton)	
Mount Vernon	58
Newark	60
Oxford	*14
Piqua	44
Portsmouth	30
Sandusky	42
Springfield	52, 76
Steuensville (see Wheeling, W. Va.)	
Tiffin	47
Toledo	11, 13, *30
Warren	67
Youngstown	21, 27, 74
Zanesville	50

OKLAHOMA

Ada	10, 50
Altus	36
Alva	39
Anadarko	58
Armore	12, 55
Bartlesville	62
Blackwell	51
Chickasha	64
Claremore	15
Clinton	32
Duncan	39
Durant	27
Elk City	15, 26
El Reno	66
Enid	5, 21, *27
Frederick	44
Guthrie	48
Guymon	20
Hobart	23
Holdenville	14
Hugo	21
Lawton	7, *28, 34
McAlester	47
Miami	58
Muskogee	8, *15, 66
Norman	31, *37
Oklahoma City	4, 9, *13, 19, 25
Oklmulgee	26
Pauls Valley	61
Ponca City	40
Pryor Creek	54
Sapulpa	42

OREGON

Albany	55
Ashland	14
Astoria	30
Baker	37
Bend	15
Burns	16
Corvallis	*7, 49
Eugene	*9, 13, 20, 26
Grants Pass	30
Klamath Falls	2, 17
La Grande	13
Lebanon	43
McMinnville	46
Medford	5
North Bend	16
Pendleton	28
Portland	6, 8, *10, 12, 21, 27
Roseburg	4, 28
Salem	3, *18, 24, 66
Springfield	37
The Dalles	32

PENNSYLVANIA

Allentown	39, 67
Altoona	10, 19, 25
Bethlehem	51
Bradford	48
Bradford	70
Chambersburg	46
Du Bois	31
Easton	57
Emporium	42
Eric	12, 35, *41, 66
Harrisburg	27, 53, 71
Hazleton	63
Irwin	4
Johnstown	6, 56
Lancaster	8, 21
Lebanon	15
Lewistown	38
Lock Haven	32
Meadville	37
New Castle	45
Oil City	64
Philadelphia	2, 6, 10, 17, 23, 29, *35
Pittsburgh	2, 11, *13, 16, 47, 53
Reading	33, 61
Seranton	16, 22, 73
Sharon	30
State College	*44
Sunbury	65
Uniontown	14
Washington	63
Wilkes-Barre	28, 34
Williamsport	36
York	43, 49

RHODE ISLAND

Providence	10, 12, 16, *22
------------	-----------------

SOUTH CAROLINA

Aiken	54
Anderson	40, 58
Camden	14
Charleston	2, 5, *13, 17
Clemson	*68

* Denotes Channel reservation for non-commercial educational use.

OFFICIAL FCC TV ALLOCATIONS

	Channel No.
Columbia	10, *10, 25, 67
Conway	23
Florence	8, 60
Georgetown	27
Greenville	4, 23, *29
Greenwood	21
Lake City	55
Laurester	31
Laurens	45
Marion	43
Newberry	70
Orangeburg	44
Rock Hill	61
Spartanburg	7, 17, 74
Sumter	47
Union	65

SOUTH DAKOTA

Aberdeen	9, 17
Belle Fourche	23
Brookings	*8, 25
Hot Springs	17
Huron	12, 15
Lead	5, 26
Madison	46
Mitchell	5, 20
Mobridge	27
Pierre	6, 10, *22
Rapid City	7, 15
Sioux Falls	11, 13, 38, *44
Sturgis	20
Vermillion	*2, 41
Watertown	3, 35
Winner	18
Yankton	17

TENNESSEE

Athens	14
Bristol, Tenn.-Bristol, Va.	5, 46
Chattanooga	3, 12, 43, 49, *55
Clarksville	53
Cleveland	38
Columbia	39
Cookeville	24
Covington	19
Dyersburg	46
Elizabethton	22
Fayetteville	27
Gallatin	48
Harriman	67
Humboldt	25
Jackson	9, 16
Johnson City	11, 34
Kingsport	28
Knoxville	6, 10, *20, 26
Lawrenceburg	50
Lebanon	58
McMinnville	46
Maryville	51
Memphis	3, 5, *10, 13, 42, 48
Morristown	54
Murfreesboro	18
Nashville	*2, 4, 8, 30, 36
Oak Ridge	32
Old Hickory	5
Paris	51
Pulaski	44
Shelbyville	62
Springfield	42
Tullahoma	68
Union City	55

TEXAS

Abilene	9, 33
Alice	34
Alpine	12

	Channel No.
Amarillo	*2, 4, 7, 10
Athens	25
Austin	7, 18, 24, *30
Ballinger	25
Bay City	33
Beaumont-Port Arthur	4, 0, 31, *37
Beeville	38
Big Spring	4, 34
Bouham	43
Borger	33
Brady	15
Breckenridge	14
Brenham	61
Brownfield	15
Brownsville (also see Brownsville-Harlingen-Weslaco)	36
Brownsville-Harlingen-Weslaco (1)	4, 5

(1) These assignments may be utilized in any community lying within the area of the triangle formed by Brownsville, Harlingen and Weslaco.

Brownwood	19
Bryan	54
Childress	40
Cleburne	57
Coleman	21
college Station	*3, 48
Conroe	20
Corpus Christi	6, 10, *16, 22, 43
Corpuscana	47
Crockett	56
Crystal City	28
Cuero	25
Dalhart	16
Dallas	4, 8, *13, 23, 29, 73
Del Rio	16
Denison	52
Denton	*2, 17
Eagle Pass	26
Edinburg	20
El Campo	27
El Paso	4, *7, 9, 13, 20, 26
Falfurrias	52
Floydada	45
Fort Stockton	22
Fort Worth	5, 10, 20, *26
Gainesville	49
Galveston	11, 35, 41, *47
Gonzales	64
Greenville	69
Harlingen (also see Brownsville-Harlingen-Weslaco)	23
Hebronville	58
Henderson	42
Hereford	19
Hillsboro	63
Houston	2, *8, 13, 23, 29, 39
Huntsville	15
Jacksonville	36
Jasper	49
Kermit	14
Kilgore	59
Kingsville	40
Lamesa	28
Lampasas	40
Laredo	8, 13, *15
Levelland	38
Littlefield	32
Longview	32, 38
Lubbock	5, 11, 13, *20, 26
Lufkin	9, 46
McAllen	20
McKinney	65
Marfa	19
Marshall	16
Mercedes	32
Mexia	50
Midland	2, 18
Mineral Wells	38

* Denotes Channel reservation for non-commercial educational use.

OFFICIAL FCC TV ALLOCATIONS

	Channel No.
Mission	14
Monahans	9
Mount Pleasant	35
Nacogdoches	49
New Braunfels	62
Odessa	7, 24
Orange	43
Pampa	17
Paris	33
Pearsall	31
Pecos	16
Perryton	22
Plainview	29
Port Arthur (see Beaumont)	
Quanah	42
Raymondville	42
Rosenberg	17
San Angelo	1, 8, 17, 23
San Antonio	4, 5, *9, 12, 35, 41
San Benito	48
San Marcos	53
Searin	14
Seymour	24
Sherman	46
Snyder	30
Stephenville	32
Sulphur Springs	41
Sweetwater	12
Taylor	58
Temple	6, 16, 22
Terrell	53
Texarkana	6, *18, 24
Tyler	7, 19, 22
Hyalde	20
Vernon	18
Victoria	19
Waco	10, *28, 34
Waxahatchie	45
Weatherford	51
Westlake (see Brownsville-Harlingen-Westlake)	
Wichita Falls	3, 6, *16, 22

UTAH

Brigham	30
Cedar City	5
Logan	12, 30, *46
Ogden	9, *18, 24
Price	6
Provo	11, 22, *28
Richfield	13
St. George	18
Salt Lake City	2, 4, 5, *7, 20, 26
Tooele	44
Vernal	3

VERMONT

Bennington	33
Brattleboro	17
Burlington	*16, 22
Montpelier	3, 40
Newport	46
Rutland	49
St. Albans	34
St. Johnsbury	30

VIRGINIA

Blacksburg	*60
Bristol (see Bristol, Tenn.)	
Charlottesville	*45, 64
Covington	44
Danville	24
Emporia	25
Farmville	19
Fredericksburg	47
Front Royal	39

	Channel No.
Harrisonburg	3, 34
Lexington	54
Lynchburg	13, 16
Martinsville	50
Martinsville	35
Newport News (see Norfolk-Portsmouth-Newport News)	
Norfolk-Portsmouth (also see Norfolk-Portsmouth-Newport News)	27
Norfolk-Portsmouth-Newport News (also see Norfolk-Portsmouth-Newport News)	27
Norfolk-Portsmouth	3, 10, 15, *21, 33
Norton	52
Petersburg	8, 41
Portsmouth (see Norfolk-Portsmouth and also see Norfolk-Portsmouth-Newport News)	
Pulaski	37
Richmond	6, 12, *23, 29
Roanoke	7, 10, 27, *33
South Boston	14
Staunton	36
Waynesboro	42
Williamsburg	17
Winchester	28

WASHINGTON

Aberdeen	58
Anacortes	34
Bellingham	12, 18, 24
Bremerton	44, 50
Centralia	17
Ellensburg	49, *65
Ehlerata	43
Everett	22, 28
Grand Coulee	37
Hoquiam	52
Kelso	39
Kennewick (also see Kennewick-Richland-Pasco)	25
Kennewick-Richland-Pasco	*41
Longview	33
Olympia	60
Omak-Okanogan (also see Omak)	*35
Omak-Okanogan (also see Kennewick-Richland-Pasco)	19
Port Angeles	16
Pullman	*10, 24
Richland (also see Kennewick-Richland-Pasco)	31
Seattle	4, 5, 7, *9, 20, 20
Spokane	2, 4, 6, *7
Tacoma	11, 13, *56, 62
Walla Walla	5, 8, *22
Wenatchee	*45, 55, 67
Yakima	23, 29, *47

WEST VIRGINIA

Beckley	6, 21, 66
Bluefield	41
Charleston	8, *43, 49
Clarksburg	12, 22, 69
Elkins	40
Fairmont	35
Fayetteville	4
Hinton	31
Huntington	3, 13, *63
Logan	23
Martinsburg	58
Morgantown	*24
Parkersburg	15
Welch	25
Weston	5, 32
Wheeling (also see Wheeling-Steubenville, Ohio)	*57
Wheeling-Steubenville, Ohio	7, 9, 51
Williamson	17

* Denotes Channel reservation for non-commercial educational use.

OFFICIAL FCC TV ALLOCATIONS

WISCONSIN	
	Channel No.
Adams	*58
Appleton	42
Ashland	15
Beaver Dam	37
Beloit	57
Chilton	*24
Eau Claire	13, *19, 25
Fond du Lac	54
Green Bay	2, 5, 70
Janesville	63
Kenosha	61
La Crosse	8, *32, 38, 72
Madison	3, *21, 27, 33
Manitowoc	65
Marinette	11, 32, *38
Milwaukee	4, *10, 12, 19, 25, 31
Oshkosh	48
Park Falls	*18
Portage	17
Prairie du Chien	34
Racine	49, 55
Rhineland	22
Rice Lake	21
Richland Center	15, *66
Sheboygan	59
Shell Lake	*30
Sparta	50
Stevens Point	20, 28
Sturgeon Bay	44
Superior (see Duluth, Minn.)	
Wausau	7, 16, *46
Whitefish Bay	6
Wisconsin Rapids	14

WYOMING	
Buffalo	29
Casper	2, 6
Cheyenne	3, 5
Cody	24
Douglas	14
Evanston	14
Gillette	31
Green River	16
Greybull	40
Lander	17

	Channel No.
Laramie	*8, 18
Lovell	36
Lusk	19
Newcastle	28
Powell	30
Rawlins	11
Riverton	10
Rock Springs	13
Sheridan	9, 12
Thermopolis	15
Torrington	27
Wheatland	24
Worland	34

U. S. TERRITORIES AND POSSESSIONS

ALASKA

Anchorage	2, *7, 11, 13
Fairbanks	2, 4, 7, *9, 11, 13
Juneau	*3, 8, 10
Ketchikan	2, 4, *9
Seward	4, 9
Sitka	13

HAWAIIAN ISLANDS

Hilo, Hawaii	2, *4, 7, 9, 11, 13
Honolulu, Oahu	2, 4, *7, 9, 11, 13
Lihue, Kauai	3, *8, 10, 12
Wailuku, Maui	3, 8, *10, 12

PUERTO RICO

Arecibo	13
Caguas	11
Mayaguez	3, 5
Ponce	*7, 9
San Juan	2, 4, *6

VIRGIN ISLANDS

Charlotte Amalie	10, 12
Christiansted	8

* Denotes Channel reservation for non-commercial educational use.

WHY IS AP
THE BEST?

BECAUSE—AP has more news correspondents, more news bureaus, more miles of news wire than any other news service.



See how they run

(and re-run, too!)

All eleven of these television film shows give you the best possible run for your money — high ratings and high-quality production *at low cost*.

Two of them are in Telepulse's first seven syndicated shows, nation-wide.* *All* rate high, wherever they go. Second or third run, they're doing as good as or better than on the first. Sample: one show almost *doubled* its rating, third run over second, in San Francisco.

You're way out front with the showmanship and technical craftsmanship of such producers as Bing Crosby Enterprises and Flying A Pictures... not to mention our sales-building merchandising kits and on-the-spot counsel.

See how they run yourself. Ask your CBS Television Film Sales representative *today* for a private showing and the whole story. You've never seen such buys in your life.

CBS Television Film Sales

New York, Chicago, Los Angeles, San Francisco, Atlanta and Dallas

*Telepulse multi-market ratings for September 1953

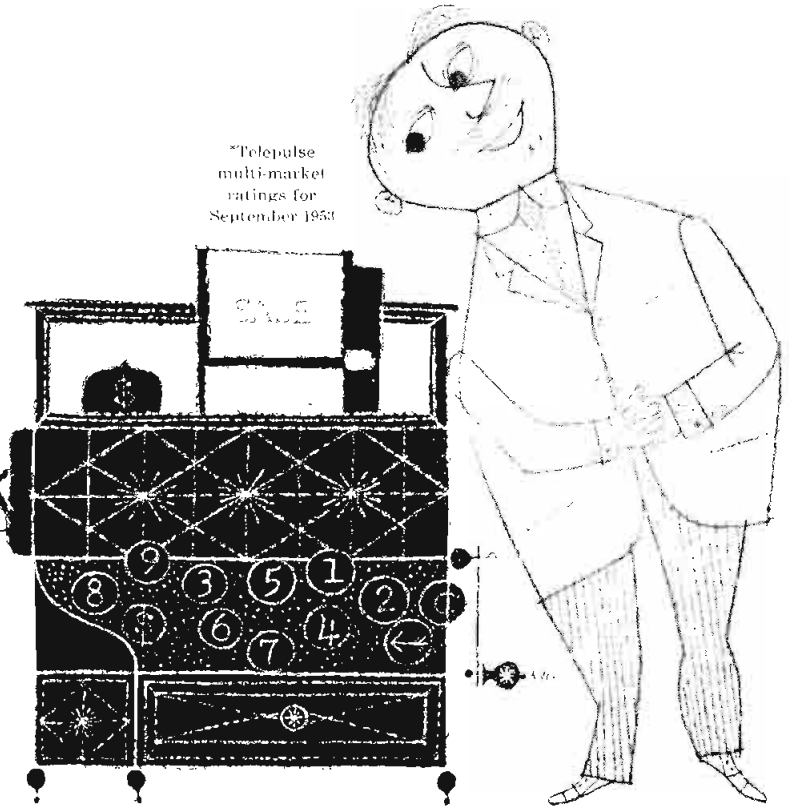

T *Television* *Stations*

•
**ALPHABETICALLY LISTED
BY CITIES — CALL LETTERS**

•
PERSONNEL

•
FACILITIES



UHF Advancement Seen As Prime Project For '54

By HERBERT E. TAYLOR, JR.
*Manager, Communication Products Division,
Allen B. Du Mont Laboratories, Inc.*

EMPHASIS on color research and equipment development will continue in 1954 and laboratory equipment will be installed and operated in a few major market stations capable of the financial luxury of color telecasts with few receivers. The basic pattern of expansion will be in the direction of added stations, higher power transmission in both UHF and VHF, higher quality film and recorded program transmission and additional accessory equipment designed to simplify operations.

The increasing availability of higher powered UHF transmitters and improved UHF television receivers may mark 1954 as the year when the terms UHF and VHF become just plain television to the viewing public and the UHF broadcaster becomes competitive with VHF for the advertising dollar on an equal basis.

Du Mont in 1953 proved that with higher power and careful installation UHF could be competitive with VHF. The fruits of the study made at WGLV in Easton, Pa., increased the assurance to the UHF broadcaster of financial success.

It takes little imagination to realize that a truly nationwide competitive television broadcast system is largely dependent upon UHF for success. The reason is simple. The Federal Communications Commission plans to license many more UHF stations than VHF. Of the approximately 2,000 stations now possible under the FCC allocation plans, more than two-thirds will be UHF. In order that television service may reach the nationwide scope planned, it is vital for UHF stations to provide strong area coverage.

Until recently, the rapid expansion of UHF had been retarded by the lack of high-power UHF transmitters and the resulting inability of UHF stations to provide strong local coverage. With high-power UHF now available, stations in the upper frequencies are now able to transmit signals which are as strong,

as reliable, and as free from interference as are VHF signals.

Advertisers therefore know that their dollars spent for commercials and time are resulting in sharp reproduction of their programs and messages. Manufacturers are finding a stronger demand for UHF receivers. Television networks can rest assured that UHF affiliates can be worthy and strong affiliates. And most important, the American public on an increasing scale is getting to know that UHF provides good reception. Educational television is also beginning to see its opportunities for service realized.

Therefore, major expansion for the equipment industry will have to be in this field. Transmitter power then becomes the hub for continued growth and 1954 may mark the first year of maturity for UHF transmission.

Color problems will not seriously disrupt the television broadcast equipment industry in this year of transition. The broadcasters' demand for color equipment should not be great considering the projected limited hours of programming and receivers that will be available. It would appear that the major problem lies in the receiver which must meet the public's requisites of large screen, simple operation and price, the combination of which represents a goal not obtainable in 1954.

The coming year will undoubtedly continue the growth trend of this industry extending the nationwide service through black and white. When color receivers meet the needs of the public and are capable of reproducing black and white reception equal to that of a standard monochrome receiver, the great rush will be on. This will not be in 1954. An excellent example of the public's attitude may be found in the action of a Wyoming man who wired associates in New York his answer to the FCC's approval of color. His wire read, "Color television? Hell, we just want television, period."

Index of The TELEVISION STATIONS of The United States



Station	City—State	Page	Station	City—State	Page
KABC-TV	— Los Angeles, Calif.	851	KIDO-TV	— Boise, Idaho	863
KACY	— St. Louis, Mo.	881	KIEM-TV	— Eureka, Calif.	849
KANG-TV	— Waco, Tex.	919	KIMA-TV	— Yakima, Wash.	923
KATV	— Pine Bluff, Ark.	848	KING-TV	— Seattle, Wash.	922
KBAK	— Bakersfield, Calif.	849	KIVA	— Yuma, Ariz.	848
KBAY-TV	— San Francisco, Calif.	854	KJEO-TV	— Fresno, Calif.	849
KBES-TV	— Medford, Ore.	903	KKTU	— Colorado Springs, Colo.	855
KBID-TV	— Fresno, Calif.	849	KLAS-TV	— Las Vegas, Nev.	887
KBOI	— Boise, Idaho	863	KLZ-TV	— Denver, Colo.	857
KBTV	— Denver, Colo.	855	KMBC-TV	— Kansas City, Mo.	881
KCBD-TV	— Lubbock, Tex.	918	KMBY-TV	— Monterey-Salinas, Calif.	853
KCCC-TV	— Sacramento, Calif.	853	KMID-TV	— Midland, Tex.	918
KCEB	— Tulsa, Okla.	903	KMJ-TV	— Fresno, Calif.	849
KCEN-TV	— Temple, Tex.	919	KMMT	— Austin, Minn.	878
KCJB-TV	— Minot, N. D.	897	KMO-TV	— Tacoma, Wash.	922
KCMC-TV	— Texarkana, Tex.	919	KMPT	— Oklahoma City, Okla.	902
KCMO-TV	— Kansas City, Mo.	881	KMTV	— Omaha, Neb.	885
KCOK-TV	— Tulare, Calif.	855	KNBH	— Hollywood, Calif.	851
KCOP-TV	— Hollywood, Calif.	851	KNOE-TV	— Monroe, La.	871
KCRI-TV	— Cedar Rapids, Ia.	867	KNUZ-TV	— Houston, Tex.	918
KCSJ-TV	— Pueblo, Colo.	857	KNXT	— Hollywood, Calif.	851
KDRO-TV	— Sedalia, Mo.	883	KOA-TV	— Denver, Colo.	857
KDUB-TV	— Lubbock, Tex.	918	KOAM-TV	— Pittsburg, Kan.	868
KDYL-TV	— Salt Lake City, Utah	920	KOAT-TV	— Albuquerque, N. M.	888
KDZA-TV	— Pueblo, Colo.	857	KOB-TV	— Albuquerque, N. M.	888
KEDD	— Wichita, Kan.	869	KOIN-TV	— Portland, Ore.	905
KELO-TV	— Sioux Falls, S. D.	913	KOLN-TV	— Lincoln, Neb.	885
KERO-TV	— Bakersfield, Calif.	849	KOMO-TV	— Seattle, Wash.	922
KETX	— Tyler, Tex.	919	KOMU-TV	— Columbia, Mo.	879
KEY-T	— Santa Barbara, Calif.	855	KONA	— Honolulu, T. H.	926
KFAZ	— Monroe, La.	871	KOOK-TV	— Billings, Mont.	883
KFBB-TV	— Great Falls, Mont.	885	KOOL-TV	— Phoenix, Ariz.	847
KFBC-TV	— Cheyenne, Wyo.	925	KOPO-TV	— Tucson, Ariz.	848
KFDA-TV	— Amarillo, Tex.	915	KOPR-TV	— Butte, Mont.	883
KFDX-TV	— Wichita Falls, Tex.	920	KOTV	— Tulsa, Okla.	903
KFEL-TV	— Denver, Colo.	855	KOY-TV	— Phoenix, Ariz.	848
KFEQ-TV	— St. Joseph, Mo.	881	KPHO	— Phoenix, Ariz.	848
KFIA	— Anchorage, Alaska	926	KPIC	— Salem, Ore.	905
KFMB-TV	— San Diego, Calif.	853	KPIX	— San Francisco, Calif.	854
KFOR-TV	— Lincoln, Neb.	885	KPRC-TV	— Houston, Tex.	918
KFSA-TV	— Fort Smith, Ark.	848	KPTV	— Portland, Ore.	905
KFSD-TV	— San Diego, Calif.	854	KQTV	— Fort Dodge, Ia.	867
KFYR-TV	— Bismarck, N. D.	896	KRBC-TV	— Abilene, Tex.	915
KGBS-TV	— San Antonio, Tex.	919	KRDO-TV	— Colorado Springs, Colo.	855
KGFT-TV	— Harlingen, Tex.	918	KRGV-TV	— Weslaco, Tex.	919
KGGM-TV	— Albuquerque, N. M.	888	KRLD-TV	— Dallas, Tex.	916
KGMB-TV	— Honolulu, T. H.	926	KROC-TV	— Rochester, Minn.	878
KGNC-TV	— Amarillo, Tex.	915	KROD-TV	— El Paso, Tex.	917
KGO-TV	— San Francisco, Calif.	854	KRON-TV	— San Francisco, Calif.	854
KGTV	— Des Moines, Ia.	867	KRTV	— Little Rock, Ark.	848
KGUL-TV	— Galveston-Houston, Tex.	917	KSD-TV	— St. Louis, Mo.	881
KHJ-TV	— Los Angeles, Calif.	851	KSL-TV	— Salt Lake City, Utah	920
KHOL-TV	— Kearney, Neb.	885	KSLA	— Shreveport, La.	871
KHQ-TV	— Spokane, Wash.	922	KSTM-TV	— St. Louis, Mo.	883
KHQA-TV	— Hannibal, Mo.	881	KSTP-TV	— St. Paul-Minneapolis, Minn.	879
KHSL-TV	— Chico, Calif.	849	KSWB-TV	— Salinas, Calif.	853
KID-TV	— Idaho Falls, Idaho	863	KSWO-TV	— Lawton, Okla.	902

TELEVISION STATION INDEX

Station	City—State	Page	Station	City—State	Page
KSW5-TV	— Roswell, N. M.	888	WCOG-TV	— Greensboro, N. C.	895
KTAG-TV	— Lake Charles, La.	871	WCOS-TV	— Columbia, S. C.	913
KTBC-TV	— Austin, Tex.	915	WCOV-TV	— Montgomery, Ala.	847
KTLA	— Los Angeles, Calif.	851	WCPO-TV	— Cincinnati, O.	899
KTNT-TV	— Tacoma, Wash.	922	WCSC-TV	— Charleston, S. C.	912
KTSM-TV	— El Paso, Tex.	917	WCSH-TV	— Portland, Me.	873
KTTS-TV	— Springfield, Mo.	883	WDAF-TV	— Kansas City, Mo.	881
KTTV	— Los Angeles, Calif.	851	WDAK-TV	— Columbus, Ga.	861
KTV4	— Anchorage, Alaska	926	WDAN-TV	— Danville, Ill.	864
KTVE	— Longview, Tex.	918	WDAY-TV	— Fargo, N. D.	896
KTVQ	— Oklahoma City, Okla.	903	WDEL-TV	— Wilmington, Del.	858
KTVU	— Stockton, Calif.	855	WDSU-TV	— New Orleans, La.	871
KTXL-TV	— San Angelo, Tex.	918	WDTV	— Pittsburgh, Pa.	939
KVAN-TV	— Vancouver, Wash.	922	WEAR-TV	— Pensacola, Fla.	860
KVEC-TV	— San Luis Obispo, Calif.	854	WEAU-TV	— Eau Claire, Wisc.	924
KVOA-TV	— Tucson, Ariz.	848	WECT	— Elmira, N. Y.	889
KVO5-TV	— Bellingham, Wash.	922	WEEK-TV	— Peoria, Ill.	864
KVTH	— Hutchinson, Kan.	868	WEEU-TV	— Reading, Pa.	909
KVTV	— Sioux City, Ia.	868	WEHT	— Henderson, Ky.	869
KWFT-TV	— Wichita Falls, Tex.	920	WENS	— Pittsburgh, Pa.	909
KWTV	— Oklahoma City, Okla.	903	WEWS	— Cleveland, O.	899
KWWL-TV	— Waterloo, Ia.	868	WFAA-TV	— Dallas, Tex.	916
KXLF-TV	— Butte, Mont.	883	WFAM-TV	— Lafayette, Ind.	866
KXLY-TV	— Spokane, Wash.	922	WFBC-TV	— Greenville, S. C.	913
KYTV	— Springfield, Mo.	883	WFBG-TV	— Altoona, Pa.	905
KZTV	— Reno, Nev.	887	WFBM-TV	— Indianapolis, Ind.	866
WAAM	— Baltimore, Md.	873	WFIE	— Evansville, Ind.	866
WABC-TV	— New York, N. Y.	889	WFIL-TV	— Philadelphia, Pa.	907
WABD	— New York, N. Y.	889	WFMJ-TV	— Youngstown, O.	902
WABI-TV	— Bangor, Me.	871	WFMY-TV	— Greensboro, N. C.	895
WABT	— Birmingham, Ala.	847	WFPG-TV	— Atlantic City, N. J.	887
WACH	— Newport News-Norfolk, Va.	921	WFTL-TV	— Ft. Lauderdale, Fla.	859
WAFB-TV	— Baton Rouge, La.	869	WFTV	— Duluth, Minn.	878
WAGA-TV	— Atlanta, Ga.	860	WGAL-TV	— Lancaster, Pa.	907
WAIM-TV	— Anderson, S. C.	912	WGAN-TV	— Portland, Me.	873
WAKR	— Akron, O.	897	WGBI-TV	— Scranton, Pa.	911
WALA-TV	— Mobile, Ala.	847	WGEM-TV	— Quincy, Ill.	865
WAPA-TV	— San Juan, P. R.	926	WGLV	— Easton, Pa.	905
WARD-TV	— Johnstown, Pa.	907	WGN-TV	— Chicago, Ill.	863
WARM-TV	— Scranton, Pa.	903	WGLV	— Greenville, S. C.	913
WATR-TV	— Waterbury, Conn.	858	WHAM-TV	— Rochester, N. Y.	891
WATV	— Newark, N. J.	887	WHAS-TV	— Louisville, Ky.	869
WAVE-TV	— Louisville, Ky.	869	WHB-TV	— Kansas City, Mo.	881
WAYS-TV	— Charlotte, N. C.	895	WHBF-TV	— Rock Island, Ill.	865
WBAL-TV	— Baltimore, Md.	873	WHBQ-TV	— Memphis, Tenn.	914
WBAP-TV	— Fort Worth, Tex.	917	WHEC-TV	— Rochester, N. Y.	891
WBAY-TV	— Green Bay, Wisc.	924	WHEN	— Syracuse, N. Y.	893
WBBM-TV	— Chicago, Ill.	863	WHIO-TV	— Dayton, O.	901
WBEN-TV	— Buffalo, N. Y.	889	WHIZ-TV	— Zanesville, O.	902
WBKB	— Chicago, Ill.	864	WHP-TV	— Harrisburg, Pa.	906
WBKZ-TV	— Battle Creek, Mich.	875	WHUM-TV	— Reading, Pa.	909
WBLN	— Bloomington, Ill.	863	WHYN-TV	— Springfield-Holyoke, Mass.	874
WBNS-TV	— Columbus, O.	901	WIBW-TV	— Topeka, Kan.	868
WBRC-TV	— Birmingham, Ala.	847	WICA-TV	— Ashtabula, O.	899
WBRE-TV	— Wilkes-Barre, Pa.	911	WICC-TV	— Bridgeport, Conn.	857
WBTM-TV	— Danville, Va.	920	WICS	— Springfield, Ill.	865
WBTV	— Charlotte, N. C.	895	WICU	— Erie, Pa.	905
WBUF-TV	— Buffalo, N. Y.	889	WIFE	— Dayton, O.	901
WBZ-TV	— Boston, Mass.	874	WILK-TV	— Wilkes-Barre, Pa.	911
WCAN-TV	— Milwaukee, Wisc.	925	WILS-TV	— Lansing, Mich.	877
WCAU-TV	— Philadelphia, Pa.	907	WINK-TV	— Fort Meyers, Fla.	859
WCBS-TV	— New York, N. Y.	891	WIRK-TV	— West Palm Beach, Fla.	860
WCCO-TV	— Minneapolis, Minn.	878	WIS-TV	— Columbia, S. C.	913
WCHA-TV	— Chambersburg, Pa.	905	WISE-TV	— Asheville, N. C.	893
WCIA	— Champaign, Ill.	863	WITV	— Ft. Lauderdale, Fla.	859
WCMB-TV	— Harrisburg, Pa.	906	WJAC-TV	— Johnstown, Pa.	907
WCOC-TV	— Meridian, Miss.	879	WJAR-TV	— Providence, R. I.	911

TELEVISION STATION INDEX

Station	City—State	Page	Station	City—State	Page
WJBF-TV	— Augusta, Ga.	861	WOR-TV	— New York, N. Y.	891
WJBK-TV	— Detroit, Mich.	875	WOSH-TV	— Oshkosh, Wisc.	925
WJDM	— Panama City, Fla.	859	WOW-TV	— Omaha, Neb.	885
WJHL-TV	— Johnson City, Tenn.	913	WPAG-TV	— Ann Arbor, Mich.	875
WJHP-TV	— Jacksonville, Fla.	859	WPFA	— Pensacola, Fla.	860
WJIM	— Lansing, Mich.	877	WPIX	— New York, N. Y.	891
WJMR-TV	— New Orleans, La.	871	WPMT	— Portland, Me.	873
WJPB-TV	— Fairmont, W. Va.	923	WPTZ	— Philadelphia, Pa.	909
WJTV	— Jackson, Miss.	879	WRAY-TV	— Princeton, Ind.	866
WKAB-TV	— Mobile, Ala.	847	WRBL-TV	— Columbus, Ga.	861
WKAQ-TV	— San Juan, P. R.	926	WREX-TV	— Rockford, Ill.	865
WKBN-TV	— Youngstown, O.	902	WRGB	— Schenectady, N. Y.	893
WKJF-TV	— Pittsburgh, Pa.	909	WROL-TV	— Knoxville, Tenn.	914
WKJG-TV	— Fort Wayne, Ind.	866	WROM-TV	— Rome, Ga.	861
WKLO-TV	— Louisville, Ky.	869	WROW-TV	— Albany, N. Y.	888
WKNA-TV	— Charleston, W. Va.	923	WRTV	— Asbury Park, N. J.	887
WKNB-TV	— New Britain, Conn.	587	WSAZ-TV	— Huntington, W. Va.	923
WKNX-TV	— Saginaw, Mich.	878	WSB-TV	— Atlanta, Ga.	860
WKNY-TV	— Kingston, N. Y.	889	WSBA-TV	— York, Pa.	911
WKOW-TV	— Madison, Wisc.	924	WSBT-TV	— South Bend, Ind.	866
WKRC-TV	— Cincinnati, O.	899	WSIL-TV	— Harrisburg, Ill.	864
WKST-TV	— New Castle, Pa.	907	WSIX-TV	— Nashville, Tenn.	915
WKTU	— Utica, N. Y.	893	WSJS-TV	— Winston-Salem, N. C.	895
WKY-TV	— Oklahoma City, Okla.	903	WSJV	— Elkhart, Ind.	865
WKZO-TV	— Kalamazoo, Mich.	877	WSLS-TV	— Roanoke, Va.	921
WLAM-TV	— Lewiston, Me.	873	WSM-TV	— Nashville, Tenn.	915
WLBC-TV	— Muncie, Ind.	866	WSPD-TV	— Toledo, O.	902
WLBB-TV	— Lebanon, Pa.	907	WSTV-TV	— Steubenville, O.	902
WLBT	— Jackson, Miss.	879	WSUN-TV	— St. Petersburg, Fla.	860
WLEV-TV	— Bethlehem, Pa.	905	WSVA-TV	— Harrisonburg, Va.	921
WLOK-TV	— Lima, O.	901	WSYR-TV	— Syracuse, N. Y.	893
WLVA-TV	— Lynchburg, Va.	921	WTAC-TV	— Flint, Mich.	877
WLW-A	— Atlanta, Ga.	860	WTAO-TV	— Boston, Mass.	874
WLW-C	— Columbus, O.	901	WTAP	— Parkersburg, W. Va.	924
WLW-D	— Dayton, O.	901	WTAR-TV	— Norfolk, Va.	921
WLW-T	— Cincinnati, O.	899	WTCN	— Minneapolis, Minn.	878
WMAL-TV	— Washington, D. C.	858	WTMJ-TV	— Milwaukee, Wisc.	925
WMAR-TV	— Baltimore, Md.	873	WTOB-TV	— Winston-Salem, N. C.	896
WMAZ-TV	— Macon, Ga.	861	WTOG-TV	— Savannah, Ga.	861
WMBR-TV	— Jacksonville, Fla.	859	WTOK-TV	— Meridian, Miss.	879
WMCT	— Memphis, Tenn.	915	WTOPTV	— Washington, D. C.	858
WMGT-TV	— Adams, Mass.	874	WTOV-TV	— Norfolk, Va.	921
WMIN-TV	— St. Paul, Minn.	879	WTPA	— Harrisburg, Pa.	906
WMT-TV	— Cedar Rapids, Ia.	867	WTRF-TV	— Wheeling, W. Va.	924
WMTV	— Madison, Wisc.	924	WTRI	— Schenectady, N. Y.	893
WMUR-TV	— Manchester, N. H.	887	WTSK-TV	— Knoxville, Tenn.	914
WNAC-TV	— Boston, Mass.	874	WTTG	— Washington, D. C.	858
WNAM-TV	— Neenah-Appleton-Menasha, Wisc.	925	WTTV	— Bloomington, Ind.	865
WNBF-TV	— Binghamton, N. Y.	888	WTVB-TV	— Elmira, N. Y.	889
WNBK	— Cleveland, O.	899	WTVH-TV	— Peoria, Ill.	864
WNBQ	— Chicago, Ill.	864	WTVI	— St. Louis, Mo.	883
WNBT	— New York, N. Y.	891	WTVJ	— Miami, Fla.	859
WNBW	— Washington, D. C.	858	WTVN	— Columbus, O.	901
WNCT	— Greenville, N. C.	895	WTVQ	— Rockford, Ill.	865
WNEM-TV	— Bay City-Saginaw, Mich.	875	WTVR	— Decatur, Ill.	864
WNET	— Providence, R. I.	912	WTVR	— Richmond, Va.	921
WNEX-TV	— Macon, Ga.	861	WTVU	— Scranton, Pa.	911
WNHC-TV	— New Haven, Conn.	857	WVEC-TV	— Hampton-Norfolk, Va.	920
WNOA-TV	— Raleigh, N. C.	895	WVET-TV	— Rochester, N. Y.	893
WNOK-TV	— Columbia, S. C.	913	WWJ-TV	— Detroit, Mich.	877
WNOW-TV	— York, Pa.	911	WWLP	— Springfield, Mass.	875
WOAI-TV	— San Antonio, Tex.	919	WWOR-TV	— Worcester, Mass.	875
WOC-TV	— Davenport, Ia.	867	WWTV	— Cadillac, Mich.	875
WOI-TV	— Ames, Ia.	867	WXEL	— Cleveland, O.	899
WOKY-TV	— Milwaukee, Wisc.	925	WXYZ-TV	— Detroit, Mich.	877
WOOD-TV	— Grand Rapids, Mich.	877	XELD-TV	— Brownsville, Tex.	916



SEE MORE
HEAR MORE
SELL MORE
ENJOY MORE

4

KNBH-HOLLYWOOD

TV STATIONS IN THE UNITED STATES

ALABAMA

TV HOMES 280,500

POPULATION 3,184,000

STATIONS IN STATE 5

WABT

BIRMINGHAM—1949—
ABC-CBS-DuM

Channel: 13...AP:190 Kw....VP: 316 Kw.
Owned-Oper. By.....Television Corp.
Business Address.....Protective Life Bldg.
Phone Number.....4-2506
Representative.....CBS Television Spot Sales
President.....Henry P. Johnston
V.P.-Sta. Mgr.....C. P. Persons
Sales Manager.....Charles F. Grisham
Technical Dir.....J. V. Sanderson

WBRC-TV

BIRMINGHAM—1949—NBC

Channel: 6...AP: 17 Kw....VP: 35 Kw.
Owned-Oper. By.....Birmingham Bcstg. Co.
Bus.-Studio Address.....P. O. 2311
Phone Number.....4-4701
Transmitter Location.....Red Mountain
Air Time.....17 hours daily
News Service.....AP, INS
Representative.....Paul H. Raymer Co.
President.....George S. Storer
Station Manager.....J. Robert Kerns
Program Director.....M. D. Smith, 3rd

WALA-TV

MOBILE—1953—ABC-CBS-NBC

Channel: 10 VHF...AP: 235 Kw...VP: 316 Kw.
Owned-Oper. By.....Pape Bcstg. Co., Inc.
Address.....210 Government St.
Representative.....Headley-Reed
President.....William Pape

WKAB-TV

MOBILE—1952—DuM-CBS

Channel: 48 UHF...AP: 12 Kw...VP: 22.5 Kw.
Owned-Oper. By.....Pursley Bcstg. Service

Address.....525 Donald St.
Representative.....Forjoe
General Manager.....Robert H. Moore
Program Director.....H. J. Grant

WCOV-TV

MONTGOMERY—1953—ABS-
CBS-NBC-DuM

Channel: 20...AP: 8.9 Kw....VP:17.9 Kw.
Owned-Oper. By.....Capitol Bcstg. Co.
Business Address.....Box 1029
Phone Number.....3-2318
Air Time.....8 hours daily
News Service.....UP
Representative.....O. L. Taylor
Membership.....NARTB
President.....O. P. Covington
General Manager.....Hugh Smith
Operations Mgr.....Carl Junker
Commercial Manager.....Morris South
Dir. of News.....Bob Underwood
Publicity Director.....Phil Taylor
Chief Engineer.....W. D. Weatherly

ARIZONA

TV HOMES 108,000

POPULATION 816,000

STATIONS IN STATE 6

KOOL-TV

PHOENIX—1953

Channel: 10...AP: 14.5 Kw....VP: 29 Kw.
Owned-Oper. By.....Maricopa Bcstrs. Inc.
Business Address.....511 West Adams St.
Phone Number.....Alpine 3-3121
Air Time.....8 hours daily
News Service.....UP
Representative.....Blair
President.....Gene Autry
General Manager.....Charles H. Garland
Commercial Manager.....William Connelly
Program Director.....Miles Reed
Publicity Director.....Dick Goebel
Chief Engineer.....Cliff Miller

KOY-TV

PHOENIX—1953

Owned-Oper. By.....KOY Bcstg. Co.
 Channel: 19...AP:16.7...VP: 33.5
 Business Address.....511 West Adams St.
 Phone Number.....Alpine 3-3121
 Air Time.....8 hours daily
 News Service.....UP
 Representative.....Blair
 Membership.....NARTB
 President.....John L. Hogg
 General Manager.....Albert D. Johnson
 Station Manager.....Richard E. Goebel
 Chief Engineer.....Cliff Miller

KPHO-TV

PHOENIX—1949—CBS-DuM-ABC

Channel: 5 VHF...AP: 8.7 Kw...VP: 17.5 Kw.
 Owned-Oper. By...Meredith Engineering Co.
 Business Address.....631 N. First Ave.
 Phone Number.....Alpine 8-4511
 Representative.....Katz
 Station Manager.....Richard B. Rawls
 TV Dir.....Payson Hall
 Film Director.....Julian M. Kaufman
 Commercial Director.....Robert T. Martin
 Chief Engineer.....G. L. McClanathan

KOPO-TV

TUCSON—1953—CBS-DuM

Channel: 13...AP: 16.5 Kw...VP: 33 Kw.
 Owned-Oper. By.....Old Pueblo Bcstg. Co.
 Business Address.....115 W. Drachman St
 Phone Number.....4-0431
 Representative.....Forjoe
 General Manager.....E. S. Mittendorf
 Program Director.....Bus Williams
 Chief Engineer.....Walter J. Stiles

KVOA-TV

TUCSON—1953—ABC-NBC

Channel: 4 VHF...AP: 5.5 Kw...VP: 11 Kw.
 Owned-Oper. By.....Arizona Bcstg. Co.
 Business Address.....209 West Elm St.
 Phone Number.....3-2555
 Air Time.....10 hours daily
 Representative.....Paul H. Raymer
 Pres.-Gen. Mgr.....R. B. Williams
 Business Manager.....Harper M. Phillips
 Sales Manager.....John C. Underwood
 Program Director.....Ben L. Slack, Jr.
 Chief Engineer.....Raymond H. Holsclaw
 Consulting Engineer.....George C. Davis

KIVA

YUMA—1953

Channel: 11 VHF...AP: 16 Kw...VP: 29 Kw.
 Owned-Oper. By.....Valley Telecasting Co.
 Business Address.....Box 1708
 Phone Number.....3-8311
 Representative.....Forjoe, Grant
 V.P. in Chg.....Park Dunford

General Manager.....Jack Fleet
 Sales Manager.....Bill Geddes
 Chief Engineer.....R. J. Schofield

ARKANSAS

TV HOMES 102,000

POPULATION 2,000,000

STATIONS IN STATE 3

KFSA-TV

FORT SMITH—1953—DuM-NBC-ABC-CBS

Channel: 22 UHF...AP: 12 Kw...VP: 22 Kw.
 Owned-Oper. By Southwestern Radio & TV Co.
 Business Address.....Box 569
 Phone Number.....2-9126
 Representative.....Pearson
 General Manager.....Weldon Stamps
 Sales Manager.....Roland Hundley
 Program Director.....Paschal Porta
 Chief Engineer.....Robert W. Platt, Jr.

KRTV

LITTLE ROCK—1953—CBS-DuM-NBC

Channel: 17 UHF...AP: 11 Kw...VP: 21 Kw.
 Owned-Oper. By...Little Rock Telecasters Inc.
 Business Address.....620 N. Beech St.
 Phone Number.....Mohawk 6-9401
 Representative.....Pearson
 Pres. Gen. Mgr.....Kenyon Brown
 Station Manager.....John H. Fugate
 Program Director.....George Hill
 Chief Engineer.....Jack Tudor

KATV

PINE BLUFF—1953—CBS-ABC-NBC

Channel: 7 VHF...AP: 10 Kw...VP: 20 Kw.
 Owned-Oper. By...Central South Sales Co.
 Business Address.....100 Williams Road
 Phone Number.....3880
 Representative.....Avery-Knodel Inc.
 President.....John T. Griffin
 V.P.....James C. Leake
 Sec.-Treas.....Bryan Mathes
 General Manager.....James P. Walker
 Com. Manager.....Bruce B. Compton
 Program Manager.....Roy Pickett
 Chief Engineer.....Louis Brown

CALIFORNIA

TV HOMES 2,846,500

POPULATION 12,479,000

STATIONS IN STATE 27

K B A K

BAKERSFIELD—1953—DuM

Channel: 29 UHF..AP: 10.5 Kw..VP: 20 Kw.
 Owned-Oper. By.....Bakersfield Bcstg. Co.
 Business Address.....2013 Chester Ave.
 Phone Number.....5-9401
 Air Time.....8½ hours daily
 News Service.....UP
 Representative.....Forjoe
 President.....Sheldon Anderson
 Station Manager.....Naum Healy
 Commercial Manager.....John Barrett
 Production Manager.....Jimmy Morrison
 Publicity Director.....Marlin E. Smythe
 Consulting Engineer.....Ron Oakley

K E R O - T V

**BAKERSFIELD—1953—
 ABC-CBS-NBC**

Channel: 10 VHF..AP: 15.2 Kw..VP: 30.4 Kw.
 Owned-Oper. By....Kern County Bcstrs. Inc.
 Business Address.....1420 Truxton Ave.
 Phone Number.....4-4548
 Air Time.....10 hours daily
 News Service.....UP
 Representative.....Avery-Knodel
 Membership.....NARTB, BAB
 Pres., Gen. Mgr.....Gene DeYoung
 Sales Manager.....Edward Urner
 Operations Director.....Kenneth Croes
 Production Manager.....Kenneth Michaels
 Publicity Director.....John Tomerlin
 Chief Engineer.....Edwin Address

K H S L - T V

CHICO—1953—CBS-NBC

Channel: 12 VHF.AP: 6.14 Kw.VP: 12.28 Kw.
 Owned-Oper. By.....Box 303
 Phone Number.....Fireside 2-5614
 Air Time.....7 hours daily
 News Service.....UP
 Representative.....W. S. Grant
 Membership.....NARTB
 President.....Mrs. Hugh McClung
 Sta. Com. Mgr.....M. F. Woodling
 News, Prog. Dir.....Martin Jacobsen
 Publicity Dir.....Frank Wood
 Chief Engineer.....E. P. Milburn
 Consulting Engr.....Kear & Kennedy

K I E M - T V

EUREKA—1953—CBS-NBC-DuM

Channel: 3 VHF..AP: 7.3 Kw..VP: 14.6 Kw.
 Owned-Oper. By.....Redwood Bcstg. Co.
 Business Address.....Foot of Bay St.
 Phone Number.....Hillside 2-5754
 Air Time.....7 hours daily
 News Service.....UP
 Representative.....Blair
 Membership.....NARTB
 President.....William B. Smullin
 Manager.....John G. Bauriedel
 Program Director.....Jerry Poulos
 Film Manager.....Harriet Nixon
 Consulting Engineers.....Lohnes & Culver

K B I D - T V

FRESNO—1954

Channel: 53 UHF..AP: 235 Kw..VP:470 Kw.
 Owned-Oper. By.....John Poole Bcstg. Co.
 Business Address.....1117 N St.
 Phone Number.....6-0791
 Representative.....Meeker
 President.....John H. Poole
 General Manager.....Robret H. Wesson
 Program Director.....Hal Davis
 Production Manager.....James Lilly
 Chief Engineer.....Ralph Smith

K J E O - T V

FRESNO—1953—ABC

Channel: 47 UHF..AP: 18.5 Kw..VP: 37 Kw.
 Owned-Oper. By.....O'Neill Bcstg. Co.
 Business Address.....Box 1708
 Phone Number.....7-8405
 Air Time.....9 hours daily
 News Service.....UP
 Representative.....Branham
 Membership.....NARTB
 President.....J. E. O'Neill, Sr.
 Vice Pres.....Joe Drilling, Charles Theodore
 Program Director, Prod. Mgr.....Jack Shepard
 Promotion Director.....Francis Quinn
 Publicity Director.....George Engstrom
 Film Manager.....Jay Mermoud

K M J - T V

FRESNO—1953—NBC

Channel: 24 UHF..AP: 16.5 Kw..VP: 33 Kw.
 Owned-Operated By...McClatchy Bcstg. Co.
 Address.....Van Ness & Calaveras Sts.
 Representative.....Raymer
 President.....Eleanor McClatchy
 Station Mgr.....Perry Nelson
 Consulting Engineer.....George C. Davis

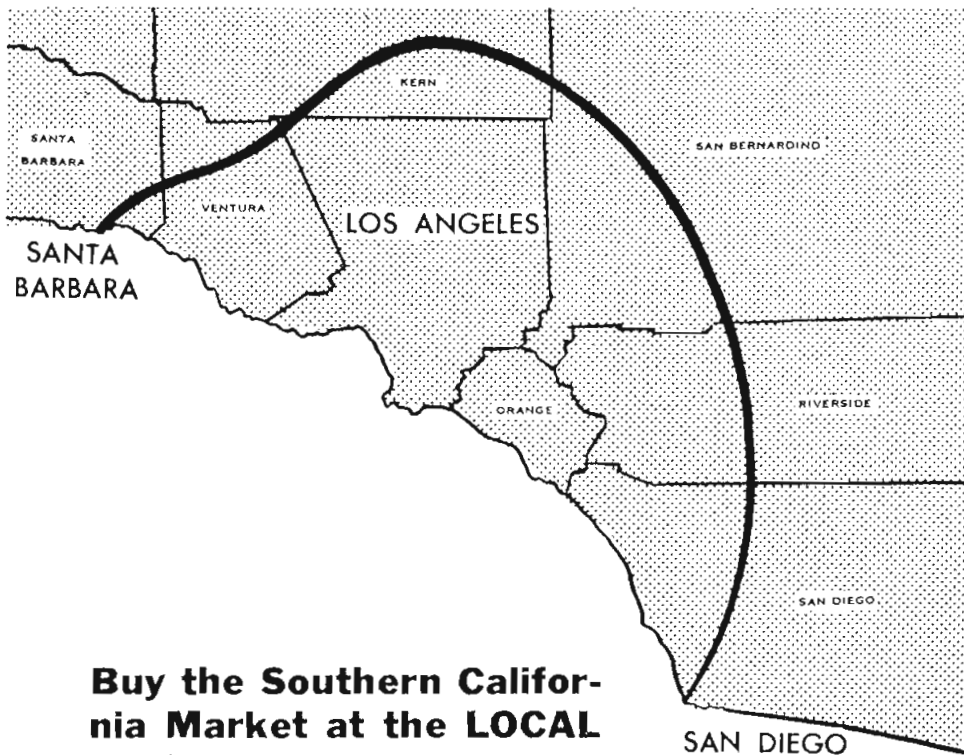

Buy the Southern California Market at the LOCAL level . . .

Buy the ONE television station that LOCALIZES your sales message in every one of the 225 communities within its coverage pattern . . .

KCOP

TELEVISION
LOS ANGELES



• represented nationally by the katz agency, inc.

K M B Y - T V

MONTEREY-SALINAS—1949—
CBS-ABC-DuM-NBC

Channel: 8 VHF...AP: 5 Kw...VP: 11.5 Kw.
Owned-Oper. By.....Monterey Radio-TV Co.
Business Address.....468 Calle Principal
Phone Number.....2-4541
Representative.....Hollingbery
Manager.....S. M. Aston
Program Director.....Bruce Ariss
Chief Engineer.....George Freeman

K C C C - T V

SACRAMENTO—1953—
CBS-NBC-ABC-DuM

Channel: 40 UHF...AP: 87 Kw...VP: 174 Kw.
Owned-Oper. By.....Capital City TV Corp.
Business Address.....Senator Hotel
Phone Number.....GI 3-4843
Air Time.....9 hours daily
News Service.....UP
Representative.....Weed
President.....Harry W. McCart
Vice President.....Frank Hurd
General Manager.....Ashley L. Robison
Commercial Manager.....John J. Kehoe
Program Director.....Kenneth Michael
Publicity Director.....Clarence P. Talbot

K S B W - T V

SALINAS—1953—
ABC-CBS-NBC-DuM

Channel: 8 VHF...AP: 5.9 Kw...VP: 11.5 Kw.
Owned-Oper. By.....Salinas Bcstg. Corp.
Phone Number.....2-6422
News Service.....AP
Representative.....Hollingbery Co.
Membership.....NARTB, BAB
President.....John Cohan
Comm. Manager.....W. M. Oates
Film Manager.....Peg Miner
Chief Engineer.....George Freeman
Consulting Engineer.....Robert Hammett

K F M B - T V

SAN DIEGO—1949—ABC-CBS
DUMONT

Channel: 8 VHF...AP: 13.7 Kw...VP: 27 Kw.
Owned-Oper. By
Wrather-Alvarez Broadcasting, Inc.
Business Address.....Fifth & Ash Sts.
Phone Number.....Main 2-2114
Air Time.....17½ hours daily
Representative.....Petry
News Service.....AP, UP
Membership.....NARTB, BAB
President.....Jack D. Wrather

*To completely cover
isolated SAN DIEGO,*

*(America's Fastest Growing-
Billion Dollar Market)*

**You Must Buy
KFMB-TV
-CBS-**

**SAN DIEGO'S MOST-WATCHED
AND FIRST TV STATION!**

General Manager.....George Whitney
 Gen. Sales Manager.....Robert Hoag
 Dir. of News & Spec. Events...Paul W. White
 Production Mgr.....Hal Coddon
 Prom., Pub. Rel.....William C. Miller
 Prog., Film Manager.....Bill Fox
 Chief Engineer.....Charles Abel

KFSD-TV

SAN DIEGO—1953—NBC

Channel: 10 VHF..AP: 35.4 Kw..VP: 63 Kw.
 Owned-Oper. By.....African Radio Corp.
 Business Address.....U. S. Grant Hotel
 Phone Number.....Woodcrest 8-7151
 Representative.....Katz
 President.....Thomas E. Sharp
 Manager.....John Merino
 Program Manager.....Jack Tolen
 Production Manager.....Charles Baldour
 Chief Engineer.....Leroy Bellwood

KBAY-TV

SAN FRANCISCO—1954

Channel: 20 UHF..AP: 9.6 Kw..VP: 17.8 Kw.
 Owned-Oper. By.....Lawrence A. Harvey
 Business Address.....321 S. Beverly Dr.
 Beverly Hills
 President.....Lawrence A. Harvey
 Chief Engineer.....Harold W. Jury

KGO-TV

SAN FRANCISCO—1949—ABC

Channel: 7 VHF..AP: 12.6Kw..VP: 25.4 Kw.
 Owned-Oper. By.....American Bcastg. Co.
 Business Address.....420 Taylor
 Phone Number.....Graystone 4-6565
 Air Time.....14 hours daily
 Representative.....Petry
 President (ABC).....Robert E. Kintner
 General Mgr.....James H. Connolly
 Station Mgr.....Vincent Francis
 Comm. Mgr.....David Sacks
 Promotion Director.....Gordon Grannis
 Dir. of News and Spe. Events.....Vic Reed
 Production Manager.....Bill Hollenbeck
 Publicity Director.....Gordon Grannis
 Film Manager.....George Green
 Chief Engineer.....A. E. Evans

KPIX

SAN FRANCISCO—1948—CBS
 DUMONT

Channel: 5 VHF..AP: 50 Kw..VP: 100 Kw.
 Owned-Oper. By.....KPIX, Inc.
 Address.....2655 Van Ness Ave.
 Phone Number.....Prospect 6-5100
 Air Time.....15½ hours daily
 News Service.....INS. AP
 Representative.....Katz
 Membership.....NARTB
 President.....Wesley J. Dumm
 Gen. Mgr.....Philip G. Lasky
 Commercial Manager.....Lou Simon
 Dir. of Prog., News, Spec. Events;
 Film Mgr.....R. W. Wassenberg
 Production Manager.....George Mathiesen
 Film Director.....William Ray
 Dir. of Engineering.....A. E. Towne
 Consulting Engineer Universal Research Labs

KRON-TV

SAN FRANCISCO—1949—NBC

Channel: 4 VHF..AP: 50 Kw..VP: 100 Kw.
 Owned-Oper. By.....The Chronicle Pub. Co.
 Business Studio Address.....901 Mission St.
 Phone Number.....Garfield 1-1100
 News Service.....AP
 Representative.....Free and Peters
 Membership.....NARTB
 President.....G. T. Cameron
 General Manager.....Charles Thieriot
 Station Manager.....Harold P. See
 Comm. Mgr.....Norman Louvau
 Program Dir.....Douglas Elleson
 Prom. Dir.....R. Irving
 Chief Engineer.....L. Berryhill
 Consulting Engineer.....Robert Hammett

KVEC-TV

SAN LUIS OBISPO—1953—DuM

Channel: 6 VHF..AP: 12.97 Kw..VP: 19.8 Kw.
 Owned-Oper. By.....The Valley Electric Co.

THE KEY

CBS • NBC
 • ABC •
 DU MONT

KEY-T



CALIFORNIA'S
 GREAT REGIONAL STATION
 SANTA BARBARA

TO COASTAL CALIFORNIA

- LOW CHANNEL POSITION
- HIGH ANTENNA AND POWER
- TOP SHOWS FROM CBS, NBC, ABC AND DU MONT
- HIGH CALIBER FILM AND LOCAL SHOWS
- LOW COST PER THOUSAND
- AUDIENCE WITH HIGH BUYING POWER

SEE YOUR HOLLINGBERY MAN

Business Address.....787 Higuera St.
 Phone Number.....San Luis Obispo 1100
 Air Time.....7 hours daily
 News Service.....AP
 Representative.....W. S. Grant Co.
 President.....Christina Jacobson
 Gen. Sta. Mgr.....Les Hacker
 Commercial Mgr.....Jack Wasson
 Program Director.....Robert S. Wilton
 Chief Engineer.....Edwin W. Franklin

KEY - T

SANTA BARBARA—1953—
 ABC-CBS-MBS

Channel: 3 VHF..AP:25.1 Kw..VP: 50.1 Kw.
 Owned-Oper. By..Santa Barbara Bcstg-TV Co.
 Business Address.....730 Miramonte Drive
 Phone Number.....5-8533
 Air Time.....12 hours daily
 News Service.....JP
 Representative.....Hollingbery
 Membership.....NARTB
 President, Gen. Mgr.....Colin M. Selph
 Operations Director.....Russell L. Furse
 Sales Manager.....R. Hill Carruth
 Program Director.....Mary Ann Casey
 Promotion Director.....Joe Costantino
 Chief Engineer.....Lloyd M. Jones

KTVU

STOCKTON—1953

Channel: 36 UHF..AP: 260 Kw..VP: 525 Kw.
 Owned-Oper. By....San Joaquin Telecasters
 Business Address.....2293 East Main
 Air Time.....6 hours daily
 News Service.....UP
 Representative.....George P. Hollingbery
 Membership.....NARTB
 President.....Warren Brown, Jr.
 General Manager.....Knox La Rue
 Operations Manager.....D. M. Greene
 Program Director.....Donald Russell
 Promotion Director.....Richard Block
 Chief Engineer.....C. W. McGee

KCOK - TV

TULARE—1953—DuM

Channel: 27 UHF..AP: 81.3 Kw..VP: 151 Kw.
 Owned-Oper. By.....Sheldon Anderson
 Business Address.....1385 East Tulare St.
 Phone Number.....Tulare 6-3481
 Air Time.....9 hours daily
 News Service.....UP
 Representative.....Forjoe
 Membership.....NARTB, BAB
 President.....Sheldon Anderson
 Manager.....Stanley S. Simpson
 Program Director.....Bob Merrifield
 Publicity Director.....Marcia Drake
 Chief Engineer.....Ron Oakley

COLORADO

TV HOMES 199,500

POPULATION 1,558,000

STATIONS IN STATE 8

KKTV

COLORADO SPRINGS—1952—
 ABC-CBS-DuM

Channel: 11 VHF..AP: 31 Kw..VP: 62 Kw.
 Owned-Operated By.....TV Colorado, Inc.
 Address.....512 South Tejon St.
 Representative.....Hollingbery
 Pres., Gen. Mgr.....James D. Russell
 Sales Manager.....Bob Ellis
 Chief Engineer.....Stan Sievers

KRDO - TV

COLORADO SPRINGS—1953—NBC

Channel: 13 VHF..AP: 5.65 Kw..VP: 11.31 Kw.
 Owned-Oper. By.....Pikes Peak Bcstg. Co.
 Business Address.....399 South Eighth St.
 Phone Number.....MElrose 2-1515
 Air Time.....7½ hours daily
 News Service.....AP, UP
 Representative.....McGillvra
 President.....Joseph H. Rohrer
 Station Manager.....Paul C. Crozier
 Commercial Manager.....Harry W. Hoth
 Program Director.....Jean Gitz
 Promotion Director.....Patricia Colt
 Chief Engineer.....Herbert W. Schubarth

KBTW

DENVER—1953—ABC-CBS

Channel: 9 VHF..AP: 141 Kw..VP: 282Kw.
 Owned-Operated By.....Colo. TV Corp.
 Address.....1089 Bannock St.
 Representative.....Free & Peters
 General Manager.....Joseph Herold
 Sales Manager.....Jerry Lee
 Program Manager.....Sam Worsham
 Film Manager.....W. L. Murray
 Chief Engineer.....James Butts

KFEL - TV

DENVER—1952—DuM

Channel: 2 VHF..AP: 50.1 Kw..VP: 100 Kw.
 Owned-Operated By..Eugene P. O'Fallon, Inc.
 Address.....550 Lincoln St.
 Representative.....Blair-TV
 Pres., General Manager.....Gene O'Fallon
 Sales Manager.....Bill Conklyn
 Consulting Engineer.....Comm. Radio Equip.

TV

THE STATION THAT BLANKETS THE RICHEST BUYING AREA IN THE UNITED STATES!*

If you want coverage, full coverage of the richest buying area in the United States — Stamford, Norwalk, New Haven, Bridgeport area — plus neighboring Long Island, WICC-TV is definitely the station to use. Check WICC-TV's Coverage Map shown here. See the rich cities, towns and counties WICC-TV covers. Call your nearest Adam J. Young, Jr. representative, Consult your Standard Rate & Data or contact WICC-TV direct.

* Based on a study by Sales Management Magazine

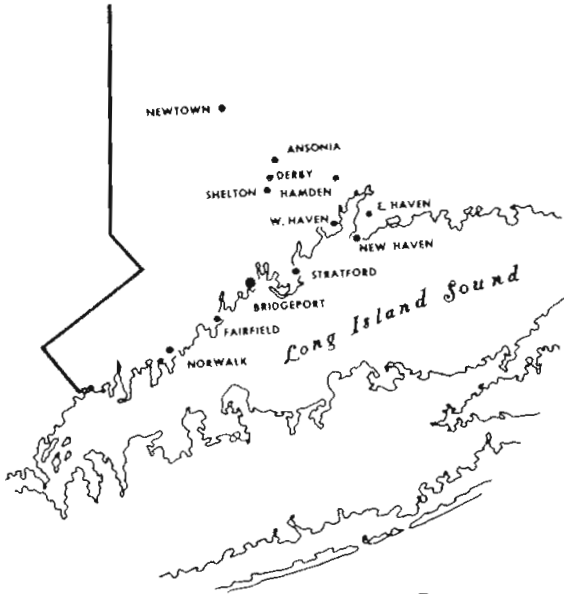

WICC-TV

CHANNEL **43**
AM 600

KLZ-TV

DENVER—1953—CBS

Channel: 7 VHF...AP: 6 Kw...VP: 10 Kw.
 Ownde-Oper. By...Alladin Radio & TV Inc.
 Business Address...131 Speer Blvd.
 Phone Number...Main 4271
 Air Time...12 hours daily
 News Service...AP, INS, UP
 Representative...Katz
 Membership...NARTB, BAB
 Pres., Gen. Mgr...Hugh B. Terry
 Commercial Manager...Jack Tipton
 Program Director...Clayton Brace
 Dir. of News...Sheldon Peterson
 Film Manager...William Witt
 Chief Engineer...Eugene Jenkins

KOA-TV

DENVER—1953—NBC

Channel: 4 VHF...AP: 15 Kw...VP: 25 Kw.
 Owned-Oper. By...KOA, Inc.
 Business Address...1625 California
 Phone Number...Main 6211
 Representative...Petry
 Exec. V.P., Gen. Mgr...Don Searle
 Program Manager...Jud Woods
 Com. Manager...Hank Henry
 Promotion Manager...Dick Harris
 Film Director...Harlan Mendenhall
 Chief Engineer...Bob Owen

KCSJ-TV

PUEBLO—1953—NBC

Channel: 5 VHF...AP: 10.6 Kw...VP: 17.5 Kw.
 Owned-Oper. By...Star Bcstg. Co.
 Business Address...211 W. 5th St.
 Phone Number...8522
 News Service...UP
 Representative...Avery-Knodel
 Membership...NARTB
 President...Douglas D. Kahle
 Commercial Mgr...Robert L. Clinton
 Program Director...Larry Go don
 Promotion Director...Tim O'Connell
 Production Manager...Bob Wilver
 Chief Engineer...Dale Redlingshafer

KDZA-TV

PUEBLO—1953

Channel: 3 VHF...AP: 16.7 Kw...VP: 8.3 Kw.
 Owned-Oper. By...Pueblo Radio Co. Inc.
 Business Address...3011 Elizabeth
 Phone Number...1255
 Air Time...4 hours daily
 Representative...McGillvra
 Membership...NARTB, BAB
 President...Dee B. Crouch
 Commercial Mgr...Bill Beck
 Program Director...Mary Smith
 Dir. of News...Paul Hinds
 Prod., Film Mgr...Bob Culver
 Chief Engineer...William Willie

CONNECTICUT

TV HOMES 485,000

POPULATION 2,097,000

STATIONS IN STATE 4

WICC-TV

BRIDGEPORT—1953—ABC

Channel: 43 UHF...AP: 91 Kw...VP: 182 Kw.
 Owned-Oper. By...Southern Conn. & Long
 Island Bcstg. Co.
 Business Address...Box 9140
 Air Time...9 hours daily
 News Service...AP
 Representative...Adam Young
 Membership...BAB
 Pres., Gen. Mgr...Philip Merryman
 Prog. Mgr., Dir. TV Oper...Wallie Dunlap
 Comm. Mgr...Manning Slater
 Pub. Dir...Joan Fisher
 Dir. of News & Spec. Events...Bill Whalen
 Film Ed...Irving Magilnick

WKNB-TV

NEW BRITAIN—1952

CBS Primary

Channel: 30 UHF...AP: 10 Kw...VP: 20 Kw.
 Owned-Oper. By...New Britain Bcstg. Co.
 Address...213 Main St.
 Phone Number...Baldwin 3-3603
 Air Time...9 hours daily
 Representative...Bolling
 President...Julian Gross
 Station Mgr...Peter B. Kenney
 Commercial Mgr...David Scott
 Publicity Dir...Dean Bafford
 Film Manager...Elliott Weisman
 Chief Engineer...John Shipley
 Consulting Engineer...George C. Davis

WNHC-TV

NEW HAVEN—1953—CBS,

NBC-DuM-ABC

Channel: 8 VHF...AP: 158 Kw...VP: 316 Kw.
 Owned-Oper. By...Elm City Bcstg. Co.
 Business Address...1110 Chapel St.
 Phone Number...SPruce 7-3611
 Air Time...17 hours daily
 News Service...AP, INS
 Representative...Katz
 Membership...NARTB
 President...Patrick J. Goode
 Gen. Mgr.-Sec.-Treas...Aldo DeDominicis
 Exec. V.P...Edward D. Taddei

Station Manager..... Edward C. Obrist
 Commercial Mgr..... J. Vincent Callaman
 Program Director..... James W. Evans

WATR-TV

WATERBURY—1953—ABC-DuM

Channel: 53...AP: 12.5 Kw...VP: 24.5 Kw.
 Owned-Oper. By.....WATR, Inc.
 Business Address.....440 Meadow St.
 Phone Number.....5-1121
 Air Time.....13 hours daily
 News Service.....UP
 Representative.....Rambeau, Bannan
 Membership.....NARTB
 President.....Harold Thomas
 Gen. Sta. Mgr.....Samuel Elman
 Prog., Prod. Mgr.....Edmund Waller
 Promotion Dir.....Wally King
 Dir. of News.....Phil Corvo
 Film Manager.....Astrid Curtis
 Chief Engineer.....Russel Jensen

DELAWARE

TV HOMES 76,000

POPULATION 324,000

STATIONS IN STATE 1

WDEL-TV

WILMINGTON—1949—NBC-DuM

Channel: 12 VHF...AP: 1.25 Kw...VP: 2.5 Kw.
 Owned-Oper. By.....WDEL, Inc.
 Business-Studio Address.....10th & King Sts.
 Phone Number.....6-2567
 Representative.....Meeker
 Station Executive.....Clair R. McCollough
 Station Manager.....Barton K. Feroc
 National Sales Manager.....J. Robert Gulick
 Chief Engr.....J. E. Mathiol

DIST. OF COLUMBIA

TV HOMES 201,500

POPULATION 834,000

STATIONS IN STATE 4

WMAL-TV

WASHINGTON, D. C.—1947—ABC

Channel: 7 VHF...AP: 12 Kw...VP: 22 Kw.
 Owned-Oper. By The Evening Star Bcstg. Co.
 Address.....4461 Connecticut Ave., N.W.
 Phone Number.....Kellogg 7-1100
 Air Time.....12 hours daily
 Newspaper Affiliation.....The Evening Star
 Membership.....NARTB
 News Service.....AP
 President.....S. H. Kauffmann
 V.P. & Gen. Mgr.....K. H. Berkeley
 Director of Sales.....Neal J. Edwards
 Dir. of News & Spec. Events.....Richard Rendell
 Production Mgr.....David Davis
 Chief Engineer.....Frank Harvey

WNBW

WASHINGTON—1947—NBC

Channel: 4...AP: 50 Kw...VP: 100 Kw.
 Owned-Oper. By.....National Bcstg. Co., Inc.
 Business-Studio Address.....Wardman Park Hotel
 Phone Number.....AD 4-5400
 Air Time.....115³/₄ Hours Weekly
 News Service.....AP, INS, UP
 Representative.....NBC Television Spot Sales
 Membership.....NARTB, BAB
 V.P., General Manager.....Carleton D. Smith
 Dir. of Sales.....Joseph Goodfellow
 Commercial Manager.....Charles de Lozier
 Program Director.....Ralph Burgin
 Press. Ad., Prom. Spvsr.....Robert Adams
 Dir. News & Spe. Events.....Cassius Keller
 Film Dir.....George Dorsey
 Chief Engineer.....John G. Rogers

WTOP-TV

WASHINGTON—1949—CBS

Channel: 9 VHF...AP: 14.4 Kw...VP: 27.3 Kw.
 Owned-Oper. By.....WTOP, Inc.
 Business Address.....Broadcast House
 Phone Number.....Emerson 2-9300
 Air Time.....18 hours daily
 Newspaper Affiliation.....Washington Post
 News Service.....AP, INS, UP
 Membership.....NARTB
 Pres., Gen. Mgr.....John Hayes
 V.P., Comm. Mgr.....George Hartford
 V.P., Prog. Dir.....Lloyd Dennis
 Dir. of News & Spec. Events.....William Wood
 Production Mgr.....H. Thomas Tausig
 Pub. & Prom. Director.....Cody Pfanstiehl
 Film Director.....H. Thomas Tausig
 V.P., Chief Eng.....Clyde Hunt

WTTG

WASHINGTON—1947—DuM

Channel: 5 VHF...AP: 10.5 Kw...VP: 17.5 Kw.
 Owned-Oper. By.....Allen B. DuMont Labs., Inc.
 Business-Studio Address.....Hotel Raleigh
 Phone Number.....STERling 3-5300
 Air Time.....14¹/₂ hours daily
 News Service.....UP

Representative Blair-TV
 Membership NARTB
 President Dr. Allen B. DuMont
 General Manager Leslie G. Arries, Jr.
 Comm. Mgr. Neal J. Edwards
 Dir. of Spec. Events Weston J. Harris
 Prom., Pub. Dir. George Flax
 Program Director Roger Coelos
 Film Director Vincent DeMaria
 Chief Engineer Malcolm M. Burleson

Representative Weed
 Gen., Com. Mgr. A. J. Bauer
 Technical Dir. Bob Bachman
 Program Dir. Frank Nodine
 Chief Engineer James E. Lacy

WJHP-TV

JACKSONVILLE—1953—NBC-DuM-ABC

Channel: 36 UHF..AP: 138 Kw..VP: 276 Kw.
 Owned-Oper. By Jacksonville Journal Co.
 Business Address 4038 Phillips Hwy.
 Phone Number 98-9898
 News Service UP
 Representative Perry
 Membership NARTB
 President John H. Perry, Jr.
 Gen., Sta. Mgr. T. S. Gilchrist, Jr.
 Commercial Mgr. W. Bill Fraker
 Program Director C. Speed Veal
 Promotion Director Martha Thomas
 Chief Engineer Beecher Hayford

FLORIDA

TV HOMES 397,500

POPULATION 3,192,000

STATIONS IN STATE 11

WFTL-TV

FT. LAUDERDALE—1953—ABC-NBC

Channel: 23 UHF..AP: 10 Kw..VP: 20 Kw.
 Owned-Oper. By Tri-County Bcstg. Co.
 Business Address 229 S. E. First Avenue
 Phone Number 3-6531
 Air Time 8 hours daily
 News Service AP
 Representative Weed
 Membership NARTB
 President J. W. Dickey
 Gen., Sta. Mgr. Noran E. Kersta
 Program Director John J. Crosby
 Dir. of News Robert LeFevre
 Publicity Director John E. Broderick
 Chief Engineer Richard Northey

WMBR-TV

JACKSONVILLE—1949
 ABC-CBS-NBC-DuM

Channel: 4 VHF..AP: 60 Kw..VP: 100 Kw.
 Owned-Oper. By Washington Post
 Business Address 605 S. Main
 Phone Number 9-4475
 News Service UP
 Representative Avery-Knodel
 President Philip L. Graham
 Vice Pres. John S. Hays
 Station Manager Glenn Marshall, Jr.
 Comm. Mgr. Charles Stone
 Program Dir. Harry Kalkines
 Dir. of News & Spec. Events Bill Grove
 Chief Engineer Ernest Vondermark

WITV

FT. LAUDERDALE—1953—ABC-DuM

Channel: 17 UHF..AP: 215 Kw..VP: 430 Kw.
 Owned-Oper. By Gerico Investment Co.
 Bus. Address 5500 Hallandale Beach Blvd.
 Phone Number 6650
 Air Time 14 hours daily
 News Service UP
 Representative O. L. Taylor
 Membership NARTB
 President Mortimer W. Loewi
 General Manager Robert W. Standart
 Operations Manager J. R. Troxel
 Commercial Manager Wallace E. Stone
 Asst. Prog. Dir. Jean Scurman
 Chief Engineer William M. Latham

WTVJ

MIAMI—1949—ABC-CBS-NBC-DuM

Channel: 4 VHF..AP: 89 Kw..VP: 100 Kw.
 Owned-Oper. By Southern Radio & TV
 Equipment Co.
 Address 316 N. Miami Ave.
 Phone Number Miami 2-6262
 Air Time 17½ hours daily
 News Service UP
 Representative Free & Peters
 President Mitchell Wolfson
 Vice-Pres., Gen. Mgr. Lee Ruwitch
 Vice-Pres., Operations Mgr. John A. Shay
 Program Director Lee Waller
 Pub. & Prom. Director Burt Toppaa
 Production Mgr. Ashe Dawes
 Sales Mgr. Stan Gordoni
 Dir. of News & Special Events Ralph Renick
 Chief Engineer Earl W. Lewis

WINK-TV

FORT MEYERS—1954—ABC

Channel: 11 VHF..AP: 6 Kw..VP: 12 Kw.
 Owned-Oper. By Fort Meyers Bcstg. Co.
 Business Address 54 Palm Beach Blvd.
 Phone Number 4-1341

WJDM

PANAMA CITY—1953—ABC-NBC

Channel: 7 VHF..AP: 5.36 Kw..VP: 10.7 Kw.

Owned-Oper. By.....J. D. Manly
 Business Address.....Box 428
 Phone Number.....ADams 4-2251
 Representative.....Hollingbery
 General Manager.....Mel Wheeler
 Station Manager.....George C. Blackwell
 Program Director.....Jerry Williams
 Chief Engineer.....Jim Smith

Business Address.....Box 2148
 Phone Number.....3-6836
 Representative.....Weed
 Pres., Gen. Mgr.....Joseph S. Field, Jr.
 Manager Oper.....Arthur L. Gray
 Chief Engineer.....William P. Heitzman

WEAR-TV

PENSACOLA—1953—ABC

Channel: 3.....AP: 33 Kw.....VP: 55 Kw.
 Owned-Oper. By.....Gulfport B'g. Corp.
 Business Address.....Box 1188
 Phone Number.....8-4449
 Representative.....Hollingbery
 General Manager.....Mel Wheeler
 Commercial Manager.....Tom Bloski
 Program Director.....Jerry Williams

WPFA-TV

PENSACOLA—1953—CBS-DuM

Channel: 15 UHF...AP: 11 Kw...VP: 20.4 Kw.
 Owned-Oper. By.....WPFA-TV, Inc.
 Business Address...North "O" & Loletta Sts.
 Phone Number.....3-1141
 News Service.....AP
 Representative.....Adam Young
 Membership.....NARTB
 President.....Charles W. LaMar, Jr.
 V.P. & Gen. Mgr.....F. E. Busby
 Prog. Prom. Dir.....Howard Gordon
 Dir. of News.....Max L. Anderson
 Publicity Director.....Elizabeth D. Hayter
 Film Manager.....M. C. Saviak
 Chief Engineer.....N. V. Pieler

WSUN-TV

ST. PETERSBURG—1953—
 ABC-CBS-NBC-DuM

Channel: 38 UHF...AP:11.02 Kw...VP: 20.42 Kw.
 Owned-Oper. By.....City of Petersburg
 Business Address.....Box 240
 Phone Number.....5-4121
 Representative.....Weed
 Manager.....George D. Robinson
 Commercial Mgr.....Vera New
 Program Director...Charles W. Vaughan, Jr.
 Film Editor.....Monte Gurwit
 News Dir.....Tom Eynon
 Chief Engineer.....Louis J. Link

WIRK-TV

WEST PALM BEACH—1953—ABC

Channel: 21 UHF...AP: 10 Kw...VP: 18.6 Kw.
 Owned-Oper. By.....WIRK-TV, Inc.

GEORGIA

TV HOMES 392,500

POPULATION 3,890,000

STATIONS IN STATE 10

WAGA-TV

ATLANTA—1949—CBS-DuM

Channel: 5.....AP: 50 Kw.....VP: 100 Kw.
 Owned-Oper. By.....Storer Bcstg. Co., Inc.
 Bus. Studio Address.1018 W. Peachtree, N.W.
 Phone Number.....Vernon 3553
 Air Time.....14 hours daily
 News Service.....AP
 Representative.....Katz
 President.....George B. Storer
 Managing Dir.....Glenn C. Jackson
 Commercial Manager.....John W. Collins, Jr.
 Program Dir.....Don Naylor
 News Director.....Dale Clark
 Promotion Mgr.....Charles E. Trainor
 Chief Engineer.....Hugo Bondy

WLW-A

ATLANTA—1951—ABC-DuM

Channel: 11 VHF...AP: 12.5 Kw...VP: 23.8 Kw.
 Owned-Oper. By Crosley Bcstg. of Atlanta Inc.
 Business Address...1611 West Peachtree St.
 Phone Number.....Cypress 6676
 Air Time.....17 hours daily
 News Service.....AP, UP
 Representative.....Crosley National Sales
 President.....W. P. Robinson
 Program Director.....John Sever
 Prom., Pub. Dir.....W. B. Colvin
 Dir. of News.....Bob Hendrickson
 Film Manager.....George Brimer
 Chief Engineer.....Harvey J. Aderhold

WSB-TV

ATLANTA—1948—NBC

Channel: 2 VHF...AP: 50 Kw...VP: 100 Kw.
 Owned-Oper. By.....The Atlanta Newspapers
 Address.....1601 Peachtree
 Phone Number.....Atwood 3827

Air Time 17 hours daily
 Newspaper Affiliations . . Atlanta News, Inc.
 News Service AP
 Representative Peiry
 Membership NARTB
 Managing Director J. Leonard Reinsch
 General Manager John M. Outler, Jr.
 Station Manager Marcus Bartlett
 Promotion Director Walter Paschall
 Dir. of News & Spec. Events Don Elliott
 Production Manager Mark Tolson
 Publicity Director Wayne Anderson
 Film Director Jean Hendrix
 Chief Engineer C. F. Daugherty

WJBF-TV

AUGUSTA—1953—NBC-ABC-DuM

Channel: 6 AP: 11.9 Kw. VP: 23.8 Kw.
 Owned-Oper. By . . Georgia-Carolina Bcstg. Co.
 Business Address Box 129
 Phone Number 7-7787
 Representative Hollingbery
 V.P.-Gen. Mgr. J. H. Manning
 V.P.-Sales Mgr. Donald M. Kelly, Jr.
 Program Director Thomas J. Hennessy
 Chief Engineer John Jopling

WDAK-TV

COLUMBUS—1953—
 ABC-CBS-NBC-DuM

Channel: 28 UHF AP: 10 Kw. VP: 16.8 Kw.
 Owned-Oper. By Television Columbus
 Business Address 1st Avenue
 Phone Number 2-8829
 Air Time 6 hours daily
 News Service AP
 Representative Headley Reed
 Membership NARTB
 President Allen Woodall
 Gen. Mgr. E. F. MacLeod
 Operations Dir. Jack Rathbun
 Commercial Mgr. Ed Hennessy
 Promotion Dir. John Hugenberg
 Dir. of News Bill Henry
 Production Mgr. George Land
 Chief Engineer Reeve Owen

WRBL-TV

COLUMBUS—1953—CBS

Channel: 14 VHF AP: 14.7 Kw. VP: 27.4 Kw.
 Owned-Oper. By Columbus Bcstg. Co.
 Business Address 1350 13th St.
 Phone Number 2-0601
 Air Time 9 hours daily
 News Service UP
 Representative Hollingbery
 Membership NARTB, BAB
 Pres., Gen. Mgr. J. W. Woodruff, Jr.
 Operations Dir. George A. Gingell
 Com. Mgr. B. Ed. Johnson
 Program Dir. Ridley Bell
 Publicity Dir. George Jenkins
 Consulting Engr. George C. Davis

WMAZ-TV

MACON—1953—CBS-DuM

Channel: 13 VHF AP: 30 Kw. VP: 60 Kw.
 Owned-Oper. By Southeastern Bcstg. Co.
 Business Address Bankers Insurance Bldg.
 Phone Number 2-7373
 Air Time 12 hours daily
 News Service UP
 Representative Kaiz
 President George Rankin, Jr.
 General Manager Wilton E. Cobb
 Station Manager Herman Hatton
 Promotion Dir. Ed Pendleton
 Dir. of News Ben Chatfield
 Production Mgr. Norman Gray
 Publicity Dir. Nelle Smith

WNEX-TV

MACON—1953—NBC

Channel: 47 UHF AP: 9 Kw. VP: 16.8 Kw.
 Owned-Oper. By Macon Television Co.
 Business Address Box 664
 Phone Number 3-9355
 Air Time 14 hours daily
 News Service AP
 Representative Headley-Reed
 President William A. Fickling
 Exec. Vice-Pres. Alfred Lowe
 Comm. Manager Carl Williams
 Asst. Mgr. John A. Hicks
 Promotion Dir. Dan Young
 Dir. of News Bob Sagasse
 Publicity Dir. David Reeves
 Chief Engineer Charlie Walker

WROM-TV

ROME—1953

Channel: 9 VHF AP: 15.5 Kw. VP: 30.9 Kw.
 Owned-Oper. By WROM-TV, Inc.
 Business Address 121 Broad St.
 Phone Number 2-0833
 Representative Weed
 President Dean Covington
 General Manager Ed McKay
 Commercial Manager Charles Doss
 Chief Engineer T. H. Robertson

WTOC-TV

SAVANNAH—1954—CBS-NBC-DuM

Channel: 11 VHF AP: 30 Kw. VP: 60 Kw.
 Owned-Oper. By Savannah Bcstg. Co.
 Business Address 516 Abercorn St.
 Phone Number 2-0127
 News Service UP
 Station Representative Kaiz
 Membership NARTB
 President William T. Knight, Jr.
 General Manager F. Schley Knight
 Commercial Mgr. Ben B. Williams
 Program Director Dwight J. Bruce
 Promotion Dir. Courtenay Knight
 Chief Engineer Kyle Goodman

Results That Count...

A LOCAL AGENCY told WGN-TV:

"The leads developed from a single announcement on your program were better than four times any other television show we have utilized."

A NATIONAL ADVERTISER said:

"Out of five markets used in this promotion, WGN-TV delivered 40% of the returns."



Whether you're large or small

... if you want RESULTS in Chicago

... make WGN-TV your Best Buy



The Chicago Tribune Television Station

IDAHO

TV HOMES 27,500

POPULATION 600,000

STATIONS IN STATE 3

ILLINOIS

TV HOMES 1,962,000

POPULATION 9,273,000

STATIONS IN STATE 16

KBOI

BOISE—1953—CBS

Channel: 2 VHF...AP: 7 Kw...VP: 14 Kw.
 Owned-Oper. By...Boise Valley Bcstrs. Inc.
 Business Address...311 North 10th
 Phone Number...2-2222
 Air Time...7½ hours daily
 News Service...UP
 Representative...Free & Peters
 Membership...BAB
 Gen. Mgr...Westerman Whillock
 Com. Mgr...Earl Glade, Jr.
 Station Mgr...James A. Johtz, Jr.
 Dir. of News...Dave Johnson
 Film Manager...Robert Howell

KIDO-TV

BOISE—1953—ABC-NBC-DuM

Channel: 7 VHF...AP: 26.5 Kw...VP: 53 Kw.
 Owned-Oper. By...KIDO, Inc.
 Business Address Chamber of Commerce Bldg.
 Phone Number...2-4611
 Air Time...8½ hours daily
 News Service...UP
 Representative...Blair
 Membership...NARTB, BAB
 President...George M. Davidson
 General Manager...Walter E. Wagstaff
 Commercial Mgr...Barry Tucker
 Prog. Prom. Dir...Jack Link
 Dir. of News...Vern Moore
 Chief Engineer...Harold Toedtemeier

KID-TV

IDAHO FALLS—1953—CBS-NBC
 DuM

Channel: 3 VHF...AP: 60.3 Kw...VP: 100 Kw.
 Owned-Oper. By...Idaho Radio Corp.
 Business Address...Box 701
 Phone Number...4
 Air Time...5 hours daily
 Representative...Gill-Perna
 Membership...NARTB
 President...A. W. Schweider
 Gen. Mgr...C. N. Layne
 Commercial Mgr...Claude Cain
 Prog. Prod. Mgr...Roy Southwick
 Chief Engineer...Carroll Secrist

WBLN

BLOOMINGTON—1953

Channel: 15 UHF...AP: 8.51 Kw...VP: 15.8 Kw.
 Owned-Oper. By...Cecil W. Roberts
 Business Address...Box 646
 Phone Number...4331
 Representative...McGillvra
 President...Cecil W. Roberts
 General Manager...Jerrill Henry
 Commercial Mgr...William T. Whitlock
 Program Manager...Fred Osborne
 Chief Engineer...Bob Coddington

WCIA

CHAMPAIGN—1953—CBS-NBC

Channel: 3 VHF...AP: 50 Kw...VP: 100 Kw.
 Owned-Oper. By...Midwest Television, Inc.
 Business Address...509 S. Neil St.
 Phone Number...6-8333
 Representative...Hollingbery
 President...August C. Meyer
 Gen. Sta. Mgr...Harry Y. Maynard
 Commercial Mgr...Guy Main
 Promotion Director...Leonard N. Davis
 Director of News...Fred Sorenson
 Chief Engineer...M. D. Hunnicutt, Jr.

WBBM-TV

CHICAGO—1953—CBS

Channel: 2 VHF...AP: 12.7 Kw...VP: 25.4 Kw.
 Owned-Oper. By...CBS, Inc.
 Bus. Studio Address...410 N. Michigan Ave.
 Phone Number...Whitehall 4-6000
 News Service...UP, INS, AP
 President...J. L. Van Volkenburg
 Vice-Pres., Gen. Mgr...H. Leslie Atlass
 Commercial Mgr...George Arkedis
 Program Director...Al Bland
 Production Director...William Ryan
 Publicity Director...Charley Wiley
 Film Manager...Vann Cominos
 Chief Engineer...Joseph Novy

WGN-TV

CHICAGO—1948—DuM

Channel: 9 VHF...AP: 60 Kw...VP: 120 Kw.
 Air Time...100-110 hours weekly

Owned-Operated By.....WGN, Inc.
 Business Address...441 N. Michigan Ave
 Phone Number.....SUperior 7-0100
 Air Time.....95-100 hours weekly
 Newspaper Affiliation.....Chicago Tribune
 News Service.....AP, UP, INS
 Representative.....George P. Hollingsbery
 President.....Col. Robert R. McCormick
 Station Manager.....Frank P. Schreiber
 Asst. Manager.....Robert Hibbard
 Program Director.....J. E. Faraghan
 Sales Manager.....Ted Weber
 Newsreel Director.....Spencer Allen
 Operations Director.....George E. Petterson
 Promotion Director.....Charles A. Wilson
 Publicity Director.....James Hanlon
 Film Director.....Elizabeth Bain
 Director of Remotes.....Donald Cook
 Chief Engineer.....Carl J. Meyers

W B K B

CHICAGO—1948—ABC

Channel: 7 VHF..AP: 57 Kw..VP: 114 Kw.
 Owned-Operated By....American Bcstg. Co.
 Business-Studio Address...20 N. Wacker Dr.
 Phone Number.....ANdover 3-0800
 Air Time.....17 hours daily
 News Service.....AP, INS
 Representative.....Blair-TV
 Membership.....NARTB, BAB
 General Manager.....S. C. Quinlan
 Sales Manager.....J. Beach
 Promotion Dir.....W. Smutzer
 Dir. of News & Spec. Events...Cornelius O'Dea
 Publicity Director.....Elliott Henry
 Film Director.....G. Rice
 Chief Engineer.....W. Kusack

W N B Q

CHICAGO—1949—NBC

Channel: 5 VHF..AP: 37.5 Kw..VP: 75 Kw.
 Owned-Operated By....National Bcstg. Co.
 Business-Studio Address...Merchandise Mart
 Phone Number.....SUperior 7.8300
 Air Time.....17:45 hours daily
 News Service.....AP, INS, UP
 Representative.....NBC Spot Sales
 Membership.....NARTB
 V.P. & Gen. Mgr.....Harry Kopf
 Commercial Manager.....John J. McPartlin
 Program Director.....George Heinemann
 Promotion Director.....1-hn Keys
 Dir. of News & Spec. Events...William B. Ray
 Publicity Director.....Chet Campbell
 Film Procurement.....Isabel Cooney
 Chief Engineer.....Howard C. Luttgens

W D A N - T V

DANVILLE—1953—ABC

Channel: 24 UHF..AP: 19.5 Kw..VP: 9.5 Kw.
 Owned-Oper. By...Northwestern Publishing Co.
 Business Address...1500 N. Washington Ave.
 Phone Number.....1700

Air Time.....5 hours daily
 Newspaper Affiliation..The Commercial News
 News Service.....AP
 Representative.....Everett-McKinney, Inc.
 Membership.....NARTB, BAB
 General Manager.....Robert J. Burow
 Commercial Manager.....John Eckert
 Program Director.....Honore Ronan
 Director of News.....Max Shaffer

W T V P

DECATUR—1953—ABC-CBS-DuM

Channel: 17 UHF..AP: 9.3 Kw..VP: 17.1 Kw.
 Owned-Oper. By.....Prairie Television Co.
 Business Address.....Box 108
 Phone Number.....8-4304
 Air Time.....9 hours daily
 News Service.....UP
 Representative.....Clark
 President.....W. L. Shellabarger
 General Manager.....Harold G. Cowgill
 Commercial Manager.....Downey Hewey
 Program Director.....Paul K. Taff
 Director of News.....James Crowell
 Chief Engineer.....James C. Wulliman

W S I L - T V

HARRISBURG—1953

Channel: 22 UHF..AP: 3.72 Kw..VP: 7.41 Kw.
 Owned-Oper. By.....Turner-Farrar Assn.
 Business Address.....21 W. Poplar St.
 Phone Number.....373
 Representative.....Walker
 President.....Oscar L. Turner
 Program Director.....Jim Bolen
 Chief Engineer.....Charles Gilliam

W E E K - T V

PEORIA—1953—NBC

Channel: 43 UHF..AP: 88 Kw..VP: 175 Kw.
 Owned-Operated By...West Central Bcstg. Co.
 Address.....1000 Comm. Nat'l Bank Bldg.
 Representative.....Headley-Reed
 President.....Robert S. Kerr
 General Manager.....Fred C. Mueller
 Sales Manager.....William J. Flynn
 Film Director.....Robert Kroepel
 Chief Engineer.....Wayne Lovely

W T V H - T V

PEORIA—1953—ABC

Channel: 19 UHF..AP: 10 Kw..VP: 20 Kw.
 Owned-Oper. By.....Hilltop Bcstg. Co.
 Business Address.....410 Fayette Bldg.
 Phone Number.....6-8771
 Representative.....Petty
 General Manager.....Hugh R. Norman
 Production Mgr.....Don Roper
 Commercial Mgr.....George Norman
 News Dir.....Jerry Dunphy
 Sports Director.....Morton Cantor
 Chief Eng.....W. Wurz

WGEM-TV

QUINCY—1953—ABC-NBC

Channel: 10 VHF...AP: 25 Kw...VP: 50.2 Kw.
 Owned-Oper. By.....Quincy Bcstg. Co.
 Business Address.....Hotel Quincy
 Phone Number.....6840
 Air Time.....7½ hours daily
 Newspaper Affiliation....Quincy Herald Whig
 Representative.....Walker
 Membership.....NARTB
 President.....T. C. Oakley
 General Manager.....J. S. Bonansinga
 Commercial Mgr.....James E. Muse
 Program Director.....Paul J. McClelland
 Promotion Director.....William C. Herbert
 Chief Engineer.....Frank E. Laughlin

WREX-TV

ROCKFORD—1953—ABC-CBS

Channel: 13...AP: 22.9 Kw...VP: 45.7 Kw.
 Owned-Oper. By....Greater Rockford TV, Inc.
 Business Address...Auburn & Winnebago Rds.
 Phone Number.....8-1813
 News Service.....UP
 Representative.....H-R Representatives
 Membership.....NARTB
 President.....L. E. Caster
 Gen., St. Mgr.....Soren Munkhof
 Program Director.....Elden Anspach
 Promotion Director.....Charles Olson
 Director of News.....Robert Clyde
 Chief Engineer.....Howard Elliott

WTVO

ROCKFORD—1953—DuM-NBC

Channel: 39 UHF...AP: 9.8 Kw...VP: 19.6 Kw.
 Owned-Oper. By...Winnebago Television Corp.
 Business Address.....Meridian Rd.
 Phone Number.....3-5413
 Representative.....Weed
 Manager.....Harold Froelich
 Production Mgr.....John W. Kelin
 Chief Engineer.....Herbert Eckstein
 Film Director.....Carl P. Stemler

WHBF-TV

ROCK ISLAND—1950—ABC-CBS

DuM

Channel: 4...AP: 50 Kw...VP: 100 Kw.
 Owned-Oper. By.....Rock Island Bcstg. Co.
 Bus.-Trans. Address...Telco Bldg., 231 18th St.
 Phone Number.....R. I. 6-5441
 Air Time.....14 Hours daily
 Newspaper Affil....."The Argus"
 News Service.....INS
 Representative.....Avery-Knodel, Inc.
 Membership.....NARTB, BAB
 President.....Ben H. Potter
 Gen., Sta. Mgr.....Leslie C. Johnson
 Commercial Manager.....Maurice Corken
 Program Director.....Forest W. Cooke
 Prom., Publ. Director.....(Miss) Fern Hawks

Prod., News, Spe. Ev. Dir.....William Ellison
 Chief Engineer.....Robert J. Sinnott
 Consulting Engineer.....E. C. Page

WICS

SPRINGFIELD—1953—ABC-NBC

DuM

Channel: 20 UHF...AP: 10 Kw...VP: 18 Kw.
 Owned-Oper. By.....Plains Television Corp.
 Business Address.....523 E. Capitol Ave.
 Phone Number.....8-0465
 Air Time.....4½ hours daily
 News Service.....AP
 Representative.....Adam Young
 President.....L. G. Pfefferle
 Sta., Com. Mgr.....Milton D. Friedland
 Program Director.....James Harelson
 Promotion Director.....John Begue
 Director of News.....Malden Jones
 Production Manager.....Robert Steffan
 Chief Engineer.....Bazil O'Hagan

INDIANA

TV HOMES 830,000

POPULATION 4,252,000

STATIONS IN STATE 9

WTTV

BLOOMINGTON—1949

ABC-CBS-NBC-DuM

Channel: 10 VHF...AP: 13.45 Kw...VP: 26.9 Kw.
 Owned-Oper. By.....Sarkes Tarzian, Inc.
 Address.....535 S. Walnut St.
 Phone Number.....2-1407
 Air Time.....12½ hours daily
 Representative.....Robert Meeker Assoc.
 President.....Sarkes Tarzian
 Gen., Sta. Mgr.....Robert Lemo
 Sales Manager.....Norman Cisso
 Program Manager.....Robert Petranof
 Traffic Director.....Susan Bartlett
 Dir. of News & Spec. Events...Edward Keath
 Production Mgr.....Steve Briggs
 Film Manager.....Warren Perney
 Chief Engineer.....Morton L. Welg

WSJV

ELKHART—1954—ABC

Channel: 52 UHF...AP: 105 Kw...VP: 195 Kw.
 Owned-Oper. By...Truth Publishing Co., Inc.
 Business Address.....416 S. 2nd St.
 Phone Number.....3-1960
 Pres., Gen. Mgr.....John F. Dille, Jr.

WFIE

EVANSVILLE—1953—NBC-ABC
DuM

Channel: 62 UHF AP: 11.75 Kw. VP: 23.5
Owned-Oper. By: Premier Television, Inc.
Business Address: 1115 Mount Auburn Rd.
Phone Number: 5-6201
Air Time: 12 hours daily
News Service: UP
Membership: NARTB, BAB
President: Jesse D. Fine
Gen. Sta. Mgr.: Ted M. Nelson
Commercial Mgr.: Jack D. Walker
Program Director: Frederick W. Smith
Promotion Director: Bud Johnson
Director of News: Fred Rollison
Chief Engineer: Harvey Shellito

WKJG-TV

FORT WAYNE—1953—ABC-CBS
NBC-DuM

Channel: 33 UHF AP: 145 Kw. VP: 277 Kw.
Owned-Oper. By: Northeastern Indiana Bcstg. Co.
Business Address: 220 E. Jefferson St.
Phone Number: Anthony 2295
News Service: AP, UP
Representative: Paul H. Raymer
Membership: NARTB
President: Clarence L. Schust
General Manager: Edward G. Thoms
Commercial Mgr.: Carleton B. Evans
Program Director: Calo Mahlock
Chief Engineer: Eugene A. Chase
Asst. Manager: Hilliard Gates
Consulting Engineer: George Gautney

WFBM-TV

INDIANAPOLIS—1949
ABC-CBS-NBC-DuM

Channel: 6 AP: 18.1 Kw. VP: 30.5 Kw.
Owned-Operated By: WFBM, Inc.
Bus. Studio Address: 1330 N. Meridian St.
Phone Number: Lincoln 8521
Air Time: 19 hours daily
News Service: AP, INS
Representative: Katz
Membership: NARTB, BAB
Pres., Gen. Sta. Mgr.: Harry M. Bitner, Jr.
Comm. Manager: William F. Kiley
Film Director: Hugh Kibbey
Promotion Director: Bernard Carney
Dir. of News: Gilbert Forbes
Production Mgr.: Carl Belles
Chief Engineer: Harold S. Holland

WFAM-TV

LAFAYETTE—1953—DuM

Channel: 59 UHF AP: 10.5 Kw. VP: 20 Kw.
Owned-Oper. By: WFAM, Inc.

Business Address: McCarty Lane
Phone Number: 2-4300
Air Time: 5½ hours daily
News Service: UP
Representative: Rambeau
Membership: BAB
President: O. E. Richardson
Gen. Sta. Mgr.: David F. Milligan
Program Director: Richard Long
Promotion Director: Pat Roberts
Chief Engineer: Richard Cochran

WLBC-TV

MUNCIE—1953—ABC-CBS-NBC
DuM

Channel: 49 UHF AP: 8.7 Kw. VP: 17.4 Kw.
Owned-Oper. By: Tri-City Radio Corp.
Business Address: Box 271
Phone Number: 4403
Air Time: 15 hours daily
News Service: AP, UP
Representative: Holman, Walker
President: Don Burton
Comm. Prom. Dir.: Bill Craig
Program Director: Lee Allerton
Director of News: Fred Hinshaw
Production Mgr.: George Marks
Chief Engineer: Maury Crain

WRAY-TV

PRINCETON—1953

Channel: 52 UHF AP: 250 Kw. VP: 500 Kw.
Owned-Oper. By: Southern Indiana Tele-Casting, Inc.
Business Address: Outer West Broadway
Phone Number: 52
Air Time: 8 hours daily
News Service: INS
Representative: Walker
Membership: BAB
President: M. R. Lankford
Gen. Sta. Mgr.: Robert L. Epstein
Prog., Prom. Dir.: Warren O. Wittkind
Director of News: Gene C. Peterson
Publicity Director: Ray J. Lankford
Film Manager: Harold S. Bass
Chief Engineer: Ray Shigley
Consulting Engineer: Everett Dillard

WSBT-TV

SOUTH BEND—1952—ABC-CBS
NBC-DuM

Channel: 34 UHF AP: 88 Kw. VP: 170 Kw.
Owned-Operated By: South Bend Tribune
Address: 225 W. Collfax Ave.
Representative: Raymer
President: F. A. Miller
General Manager: Neal B. Welch
Program Director: R. J. Drain
Prom., Pub. Dir.: R. H. Swintz
Consulting Engineer: Millard M. Garrison

IOWA

TV HOMES 422,000

POPULATION 2,647,000

STATIONS IN STATE 8

W O I - T V

AMES—1950—ABC-CBS-NBC-DuM

Channel: 5 VHF. AP: 50.1 Kw. VP: 100 Kw.
 Owned-Oper. By...Iowa State A & M
 Address...Service Bldg., Iowa State College
 Phone Number...2500 Extension 570
 Air Time...15 hours daily
 News Service...AP, UP
 Representative...Weed
 Membership...NARTB
 President...Dr. James Hilton
 General Manager...Richard B. Hull
 Oper. Manager...Robert Mulhall
 Program Director...Chris Donaldson
 Prog. Devel. Supervisor...Edward Wegener
 Prom., Pub. Dir....Marguerite Theobald
 Dir. of News & Spec. Events...George Halsey
 Film Manager...Donna DeCamp
 Chief Engineer...Keith Ketcham

K C R I - T V

CEDAR RAPIDS—1953—ABC-DuM

Channel: 9 VHF. AP: 16.5 Kw. VP: 33 Kw.
 Owned-Oper. By...Cedar Rapids Television Co.
 Business Address...Miller Bldg.
 Phone Number...4-4194
 Air Time...7½ hours daily
 Representative...H-R
 Membership...NARTB
 President...Southerland Dows
 General Manager...Wade S. Patterson
 Sales Director...Robert Z. Morrison, Jr.
 Program Director...Ralph D. Willey
 Promotion Director...Beth Rochefort
 Chief Engineer...Carl Rollert
 Consulting Engineers...Kear & Kennedy

W M T - T V

CEDAR RAPIDS—1953—CBS-DuM

Channel: 2 VHF. AP: 50.1 Kw. VP: 100 Kw.
 Owned-Oper. By...American Bcstg. Stations
 Business Address...807 Barr Building
 Phone Number...Cedar Rapids 6127
 Air Time...7½ hours daily
 News Service...AP, INS, UP
 Representative...Katz
 Membership...NARTB, BAB
 President...Wm. B. Dolph

Vice-Pres., Gen. Mgr...Wm. B. Quarton
 Program Director...Douglas B. Grant
 Sales Manager...Lew Van Nostrand
 Promotion Director...Leo Cole
 News Director...Dick Cheverton
 Production Mgr...Mark Barker
 Chief Engineer...George P. Hixenbaugh

W O C - T V

DAVENPORT—1949—NBC

Channel: 6...AP: 60.3 Kw. VP: 100 Kw.
 Owned-Oper. By...Central Bcstg. Co.
 Business Address...805 Brady St.
 Phone Number...3-3661
 Air Time...15 h s. daily
 News Service...UP
 Representative...Frec & Peters, Inc.
 Membership...NARTB
 President...Col. B. J. Palmer
 Vice-Pres. & Treas...D. D. Palmer
 Exec. Vice-Pres...Ralph Evans
 Secretary...William D. Wagner
 Vice-President...Paul Loyet
 Resident Manager...Ernest Sanders
 Resident Sales Mgr...Mark Wodlinge.
 Program Director...Raymond Guth
 Sales Prom. Mgr...Fred Reed
 Chief Engineer...Paul Arvidson

K G T V

DES MOINES—1953—ABC-CBS-NBC
 DuM

Channel: 17 UHF. AP: 10 Kw. VP: 18.5 Kw.
 Owned-Oper. By...Rib Mt. Radio Inc.
 Business Address...2d Ave. & Hobson Dr.
 Phone Number...8-6751
 Air Time...6 hours daily
 News Service...INS
 Representative...Hollingbery
 Membership...NARTB
 President...W. C. Bridges
 General Manager...S. H. McGovern
 Asst. Gen. Mgr...J. W. Bartikoski
 Commercial Mgr...J. C. Cosgrove
 Program Director...T. J. Kelly
 News Director...Jim McGovern
 Production Mgr...V. Fletcher
 Film Manager...Jim Moon
 Chief Engineer...W. M. Greely

K Q T V

FORT DODGE—1953

Channel: 21 UHF. AP: 11 Kw. VP: 18 Kw.
 Owned-Oper. By...Northwest Television Co.
 Business Address...Warden Bldg.
 Phone Number...Walnut 3761
 News Service...INS
 Representative...Pearson
 Membership...BAB
 President...Edward Breen
 Pgm., News Dir...Drexel Peterson
 Production Mgr...James Spear
 Film Manager...Leonard Greene
 Chief Engineer...David Sinclair

K V T V

SIOUX CITY—1953—CBS-NBC-DuM

Channel: 9 VHF... AP: 15.6 Kw... VP: 28.95 Kw.
 Owned-Oper. By... Cowles Bcstg. Co.
 Business Address... 614 Pierce Street
 Phone Number... 2-2711
 Air Time... 13 hours daily
 Newspaper Affiliation... Register & Tribune
 News Service... AP, UP
 Representative... Katz
 Membership... NARTB, BAB
 President... Gardner Cowles, Jr.
 General Manager... Robert R. Tincher
 Station Manager... Arthur J. Smith
 Commercial Mgr... Donald D. Sullivan
 Program Director... Norman L. Bacon
 Promotion Director... Joan Monfere
 Film Manager... E. Barton Jewell
 Chief Engineer... Jack Iverson

K W W L - T V

WATERLOO—1953—NBC-DuM

Channel: 7 VHF... AP: 25.1 Kw... VP: 50.1 Kw.
 Owned-Oper. By... Black Hawk Bcstg. Co.
 Business Address... Hotel Russell Lamson
 Phone Number... 4404
 News Service... UP
 Representative... Headley-Reed
 President... Ralph J. McElroy
 Commercial Mgr... Don E. Inman
 Prog., Prom. Dir... Charles R. Freburg
 Director of News... Ed Falk
 Production Mgr... Jack Turley
 Film Manager... Gene Bennett
 Chief Engineer... Ralph Mlaska
 Consulting Engineer... Frank McIntosh

KANSAS

TV HOMES 215,500

POPULATION 1,943,000

STATIONS IN STATE 4

K V T H

HUTCHINSON—1953—CBS

Channel: 12 VHF... AP: 10 Kw... VP: 20 Kw.
 Owned-Oper. By... Hutchinson TV, Inc.
 Business Address... 217 East First
 Phone Number... 5-5502-3
 Representative... H-R
 General Manager... Howard O. Peterson
 Program Director... Ray Huffer
 Promotion Manager... Wm. S. Ritchie
 Regional Sales... Doug Hough
 Traffic Manager... H. F. Means
 Chief Engineer... Robert B. Marye
 Production Mgr... Ben Butler

K O A M - T V

**PITTSBURG—1953—NBC-CBS
ABC-DuM**

Channel: 7 VHF... AP: 49 Kw... VP: 98 Kw.
 Owned-Oper. By... Mid-Continental Telecasting
 Business Address... Professional Bldg.
 Phone Number... 2165
 Representative... Katz
 President... E. V. Baxter
 Gen., Sta., Comm. Mgr... R. E. Wade
 Program Director... Louis R. Martin
 Chief Engineer... Leo Stafford
 Consulting Engineer... T. A. M. Craven

W I B W - T V

TOPEKA—1953—ABC-CBS-DuM

Channel: 13 VHF... AP: 5.35 Kw... VP: 10.7 Kw.
 Owned-Oper. By... Capper Publications, Inc.
 Business Address... 1035 Topeka Blvd.
 Phone Number... 3-2377
 News Service... AP, UP
 Representative... Capper
 President... Henry Blake
 General Manager... Ben Ludy
 Station Manager... Art Holbrook
 Commercial Mgr... Hilton Hodges
 Production Mgr... Claude Mann
 Publicity Director... Allan Young
 Chief Engineer... Gilbert Voiles

In LOUISVILLE
CHOOSE

W K L O - T V

CHANNEL 21

represented by

V E N A R D , I N C .

K E D D

WICHITA—1953—ABC-NBC

Channel: 16 UHF..AP: 11 Kw..VP: 20.4 Kw.
 Owned-Oper. By.....KEDD, Inc.
 Business Address.....Box 1740
 Phone Number.....TEmpLe 8-3321
 Air Time.....10 hours daily
 Newspaper Affiliation.....Wichita Beacon
 Representative.....Petry
 President.....Stanley H. Durwood
 V.P., Gen., Sta. Mgr.....Ben B. Baylor, Jr.
 Commercial Mgr.....John E. North
 Program Director.....Robert C. Currie
 Promotion Director.....Ben K. West
 Director of News.....Richard Hickox
 Production Mgr.....Don Markley
 Film Manager.....C. K. Bloomquist
 Chief Engineer.....George Smith

Commercial Manager.....Ralph Jackson
 Prog., Film Dir.....George Patterson
 Prom., Pub. Dir.....Charles Hill
 Director of News.....Rodney Ford
 Chief Engineer.....Wilbur Hudson
 Consulting Engineer.....R. C. Ring

W H A S - T V

LOUISVILLE—1950—CBS

Channel: 11....AP: 158 Kw....VP: 316 Kw.
 Owned-Oper. By.....WHAS, Inc.
 Address.....525 W. Broadway
 Phone.....Wabash 2211
 Representative...Harrington, Righter, Parsons
 News Service.....AP
 Membership.....NARTB
 President.....Barry Bingham
 Vice-Pres., Director.....Victor A. Sholls
 Station Manager.....Neil D. Cline
 Sales Director.....Albert J. Gillen
 Program Director.....Ralph Hansen
 Promotion Director.....William Loader
 Director of News.....Richard Oberlin
 Film Manager.....Charles McDaniel
 Chief Engineer.....Orrin W. Towne

W K L O - T V

LOUISVILLE—1953—ABC-DuM

Channel: 21 UHF..AP: 129 Kw..VP: 251 Kw.
 Owned-Oper. By...Mid-America Bcstg. Corp.
 Business Address.....Henry Clay Hotel
 Phone Number.....Clay 4441
 Representative.....Venard Inc.
 Pres., Gen. Mgr.....Joe Eaton
 Sales Manager.....John E. Scott
 Program Director.....Jack Everbach
 Chief Engineer.....D. C. Summerford

KENTUCKY

TV HOMES 359,500

POPULATION 3,004,000

STATIONS IN STATE 4

W E H T

HENDERSON—1953—CBS

Channel: 50 UHF..AP: 8.77 Kw..VP: 16:25 Kw.
 Owned-Oper. By...Ohio Valley Television Co.
 Business Manager.....Box 418
 Phone Number.....Henderson 9566
 Air Time.....12 hours daily
 News Service.....UP
 Representative.....Meeker
 Membership.....NARTB
 President.....Hecht S. Lackey
 Commercial Mgr.....William Vogel
 Progress Director.....Chester T. Behrman
 Promotion Director.....Marye Klaser
 Director of News.....Ralph Smith
 Chief Engineer.....Robert M. Cleveland

LOUISIANA

TV HOMES 281,500

POPULATION 2,738,000

STATIONS IN STATE 7

W A V E - T V

LOUISVILLE—1948—ABC-NBC-DuM

Channel: 3 VHF..AP: 50 Kw..VP: 100 Kw.
 Owned-Operated By.....WAVE, Inc.
 Address.....334 East Broadway
 Phone Number.....Wabash 2201
 Air Time.....17 hours daily
 News Service.....AP, UP
 Membership.....NARTB, BAB
 Representative.....NBC Spot Sales
 President.....George W. Norton, Jr.
 Gen., Sta. Manager.....Nathan Lord

W A F B - T V

BATON ROUGE—1953—ABC-CBS
 NBC-DuM

Channel: 28 UHF..AP: 11.5 Kw..VP: 22.5 Kw.
 Owned-Oper. By.....Modern Bcstg. Co. of
 Baton Rouge
 Business Address.....844 Government St.
 Phone Number.....4-8571
 Representative.....Adam Young
 President.....Jack S. Burk
 Vice-Pres., Gen. Mgr.....T. E. Gibbens

**“MARYLAND’S MOST HONORED
TELEVISION STATION”**

WAAM 13
Channel



THE GEORGE FOSTER PEABODY AWARD
TO
“THE JOHNS HOPKINS SCIENCE REVIEW”

Produced at WAAM in co-operation with
The Johns Hopkins University for the Du
Mont Television Network, twice honored by
the Peabody Committee for “excellence in
television.”



THE ALFRED I. DUPONT AWARD
TO
GERALD W. JOHNSON

WAAM’s fearless commentator, famous
newspaperman, essayist, biographer and
historian. Another example of WAAM’s use
of community materials to build for nation-
ally respected programs.

WAAM 13
Channel

TELEVISION HILL • BALTIMORE, MD.

Represented Nationally by HARRINGTON, RIGHTER & PARSONS, Inc.

Commercial Mgr. Ron Litteral
 Program Director..... John Ferguson
 Chief Engineer..... Donald K. Allan
 Program Manager..... Don Hallman
 Publicity Director..... G. Cranow

Program Mgr. Tom Hicks
 Prom., Pub. Dir..... Marion Annenberg
 Prog. Operations Mgr..... Stanley Holiday
 Chief Engineer..... Lindsey Riddle
 Consulting Engineer..... E. C. Page

KTAG-TV

LAKE CHARLES—1953—CBS-ABC
 DuM

Channel: 25 UHF.. AP: 11 Kw.. VP: 20.4 Kw.
 Owned-Oper. By..... KTAG-TV, Inc.
 Business Address..... Box 173
 Phone Number..... 9-9413
 Representative..... Adam Young
 General Manager..... James W. Lucas
 Sales Manager..... Quitman Henley
 Chief Engineer..... Maurice Wynne

WJMR-TV

NEW ORLEANS—1953—ABC-DuM

Channel: 61 UHF.. AP: 25 Kw.. VP: 50 Kw.
 Owned-Oper. By..... Supreme Bcstg. Co. Inc.
 Business Address..... 1500 Canal St.
 Phone Number..... Canal 0356
 Representative..... Bolling
 Vice-Pres., Gen. Mgr..... James E. Gordon
 Commercial Mgr..... Patrick J. Shannon
 Program Director..... Tom Abbott
 Film Buyer..... Ernest McKenna
 Exec. V.P., Chief Engr..... George A. Mayoral

KFAZ

MONROE—1953

Channel: 43 UHF.. AP: 10 Kw.. VP: 20 Kw.
 Owned-Oper. By..... Delta Television Inc.
 Business Address..... 2107 Forsythe Ave.
 Phone Number..... 2-4442
 Representative..... Pearson
 President..... J. O. Willet
 Vice-President..... Justin Wilson
 General Manager..... John Ferguson
 Sales Manager..... Robert Clegg

KSLA

SHREVEPORT—1953—NBC-CBS
 ABC-DuM

Channel: 12 VHF.. AP: 6.5 Kw.. VP: 13 Kw.
 Owned-Oper. By..... Interim Television Corp.
 Business Address..... Box 848
 Phone Number..... 2-0697
 Representative..... Paul H. Raymer
 Associate Managers..... Deane Flett,
 Owens Alexander, J. H. Pace
 Program Director..... Henry Davis
 Film Director..... Hugh Pickett
 Chief Engineer..... Morris C. Barton

KNOE-TV

MONROE—1953—CBS-NBC-ABC
 DuM

Channel: 8 VHF.. AP: 115 Kw.. VP: 230 Kw.
 Owned-Oper. By..... James A. Nos
 Business Address..... Box 1713
 Phone Number..... 8155
 Representative..... H-R
 Vice-Pres., Gen. Mgr..... Paul H. Goldman
 Comm., Prom. Mgr..... Jack Ansell Jr.
 Program Director..... Harry Arthur
 Operations Mgr..... Pete McCauland
 Chief Engineer..... Jack Ratliff

WDSU-TV

NEW ORLEANS—1948
 ABC—CBS—NBC—DuM

Channel: 6 VHF.. AP: 50 Kw.. VP: 100 Kw.
 Owned-Oper. By..... WDSU Bcstg. Corp.
 Business-Studio Address..... 520 Royal St.
 Phone Number..... Tulane 4371
 Air Time..... 119 hours weekly
 News Service..... AP, UP
 Representative..... Blair
 Membership..... NARTB, BAB
 President..... Edgar B. Stern, Jr.
 Exec. V.P., Gen. Mgr..... Robert D. Swezey
 V.P., Comm. Manager..... A. Louis Read
 Program Director..... Hubie Weiss

MAINE

TV HOMES 69,000
 POPULATION 922,000
 STATIONS IN STATE 5

WABI-TV

BANGOR—1953
 ABC-CBS-NBC-DuM

Channel: 5 VHF.. AP: 0.95 Kw.. VP: 1.9 Kw.
 Owned-Operated By
 Community Telecasting Serv.
 Address..... 57 State St.
 Phone Number..... 8255
 National Rep..... George P. Hollingbery
 New England Rep..... Kettell-Carter
 President..... Horace Hildreth
 Gen., Sta. Comm. Mgr..... Lee Gorman, Jr.
 Chief Engineer..... Walter L. Dickson

BALTIMORE'S NEIGHBORS

From the Blue Ridge to the blue Atlantic, Maryland's communities have been bound into a closer kinship to Baltimore through WMAR-TV's 100,000 watts of maximum "super power" . . . and each of the indicated neighbors has been "saluted" in a continuing series of half hour programs that combine film sequences with personal appearances by leading personalities of each locality.

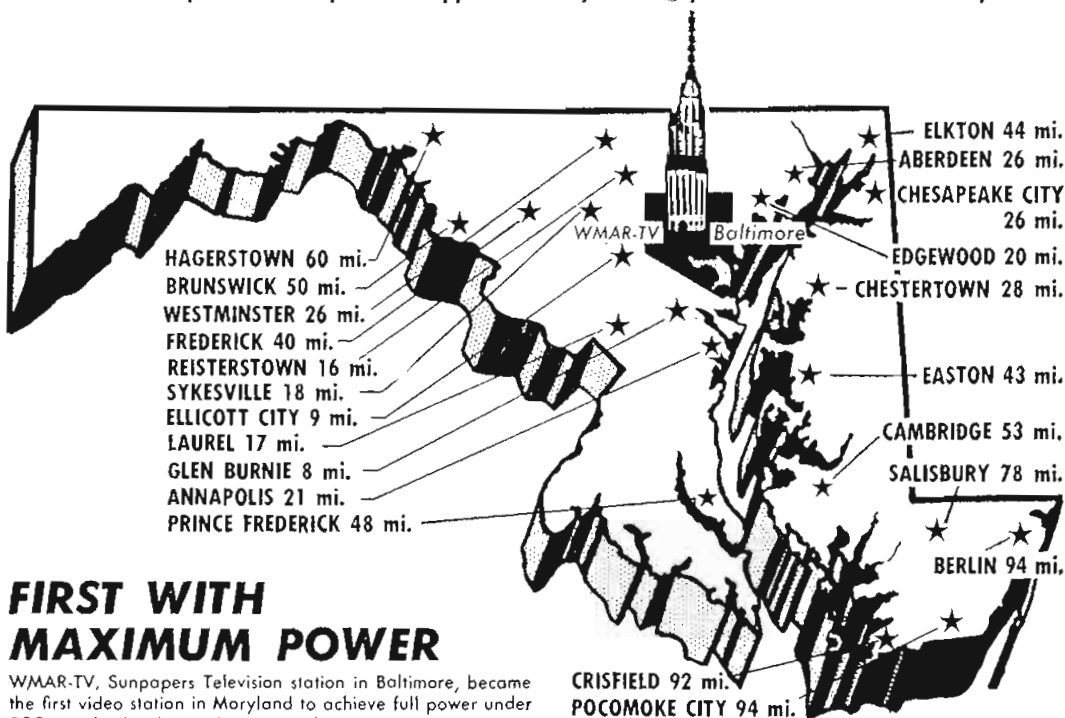

FIRST WITH MAXIMUM POWER

WMAR-TV, Sunpapers Television station in Baltimore, became the first video station in Maryland to achieve full power under FCC standards when it inaugurated service on a new super power 100,000-watt transmitter, July 22, 1953.

FIRST WITH LOCAL COLOR

The first broadcast of color slides using the new WMAR-TV color originating equipment took place in the early morning hours (after regular sign-off at 2 A.M.) on December 30th, and continued for several nights thereafter. The first announced telecast went on December 31st and on January 5th, 1954, WMAR-TV initiated regular daily color telecasts.

IN MARYLAND
MOST PEOPLE WATCH
WMAR-TV

CHANNEL 2 SUNPAPERS TELEVISION BALTIMORE MARYLAND
Telephone MULberry 5-5670 * TELEVISION AFFILIATE OF THE COLUMBIA BROADCASTING SYSTEM
Represented by THE KATZ AGENCY, Inc. New York, Detroit, Kansas City, San Francisco, Chicago, Atlanta, Dallas, Los Angeles

WLAM-TV

LEWISTON—1953—ABC-CBS-DuM

Channel: 17 UHF..AP: 8.54 Kw...VP: 15.7 Kw.
 Owned-Oper. By...Lewiston-Auburn Bcstg.
 Business Address.....129 Lisbon Street
 Phone Number.....4-5401
 Air Time.....7 hours daily
 News Service.....AP
 Representatives.....Everett-McKinney-
 Kettell-Carter
 President.....Elden H. Shute, Jr.
 General Manager.....Frank S. Hoy
 Comm., Prom. Dir.....Gerald T. Higgins
 Program Director.....Lester J. Richards
 Director of News.....F. Frank Hoy
 Chief Engineer.....Henry G. Root

WCSH-TV

PORTLAND—1953—NBC

Channel: 6 VHF..AP: 50 Kw...VP: 100 Kw.
 Owned-Oper. By...Congress Square Hotel Co.
 Business Office.....157 High Street
 Phone Number.....2-0181
 Air Time.....9½ hours daily
 News Service.....UP
 Representative.....Weed
 Membership.....NARTB, BAB
 President.....Adeline B. Rines
 General Manager.....William H. Rines
 Program Manager.....Daniel H. Smith
 Promotion Director.....Linwood T. Pitman
 Director of News.....Philip N. Johnson
 Production Manager.....Burnell Poole

WGAN-TV

PORTLAND—1954

Channel: 13 VHF..AP: 127.3 Kw...VP: 238.8 Kw.
 Owned-Oper. By...Guy Gannett Bcstg. Services
 Business Address.....390 Congress St.
 Phone Number.....2-7423
 Representative.....Avery-Knodel
 General Manager.....C. E. Gatchell

WPMT

PORTLAND—1953—ABC-NBC-CBS
 DuM

Channel: 53 UHF..AP: 11.5 Kw...VP: 22.2 Kw.
 Owned-Oper. By...Portland Telecasting Corp.
 Business Address.....Columbia Hotel
 Phone Number.....2-8327
 Air Time.....9 hours daily
 News Service.....AP
 Representatives.....Everett-McKinney-
 KettelCarter
 President.....Frank S. Hoy
 Station Manager.....George E. Curtis, Jr.
 Comm., Prom. Dir.....Gerald T. Higgins
 Prog., Prod. Mgr.....William Gildersleeve
 Director of News.....Parker Hoy
 Chief Engineer.....Fred Crandon
 Consulting Engineer.....George Adair

MARYLAND

TV HOMES 601,500

POPULATION 2,366,000

STATIONS IN STATE 4

WAAM-TV

BALTIMORE—1948—ABC-DuM

Channel: 13 VHF..AP: 25 Kw...VP: 50 Kw.
 Owned-Operated By...WAAM, Incorporated
 Business Address.....Television Hill
 Phone Number.....MOhawk 4-7600
 Air Time.....15 hours daily
 News Service.....AP
 Representative.....Harrington, Righter and
 Parsons, Inc.
 Membership.....NARTB
 General Manager.....Kenneth Carter
 Asst. Gen. Mgr.—Sales.....Armand Grant
 Program Mgr.....Herbert B. Cahan
 News Editor.....Ted Jaffe
 Publicity Director.....Joel Chaseman
 Chief Engineer.....Ben Wolfe
 (See Page 870)

WBAL-TV

BALTIMORE—1948—NBC

Channel: 11 VHF..AP: 120 Kw...VP: 240 Kw.
 Owned-Operated By...Hearst Corporation
 Business-Studio Address.....2610 N. Charles
 Phone Number.....Hopkins 7-3000
 News Service.....INS, UP, AP
 Representative.....Edward Petry
 Vice Pres. & Exec. Dir.....Charles B. McCabe
 Vice-Pres. & Gen. Mgr.....D. L. Provost
 Vice-Pres. (Engineering).....John T. Wilner
 Station Manager.....Leslie H. Peard, Jr.
 Dir. Public Affairs & Education...Arnold Wilkes
 Program Director.....Victor F. Campbell
 Business Mgr.....Freeman W. Cardall
 Sales Manager.....Willis K. Friert
 News & Publicity Mgr.....Thomas J. White, Jr.
 Dir. Women's Programs.....Mollie Martin
 Chief Engineer.....William C. Braham

WMAR-TV

BALTIMORE—1947—CBS

Channel: 2 VHF..AP: 50 Kw...VP: 100 Kw.
 Owned-Operated By...The A. S. Abell Co.
 Address.....Old Sun Bldg.
 Phone Number.....MULberry 5670
 Air Time.....15 hours daily
 News Service.....AP

RepresentativeKatz
MembershipNARTB
President William F. Schmick
V.D., Dir. of TVEwell K. Jett
Commercial Manager Ernest A. Lang
Program Director Robert B. Cochran
Dir. of News & Spec. Events and
Film Mgr.David V. R. Stickle
Production Mgr.Edwin B. Mick
Film DirectorDavid V. R. Stickle
Chief EngineerCarlton G. Nopper

MASSACHUSETTS

TV HOMES 1,190,500

POPULATION 4,738,000

STATIONS IN STATE 7

WMGT-TV

ADAMS—1953—DuM

Channel: 74 UHF...AP: 150 Kw...VP: 300 Kw.
 Owned-Oper. By.....Greylock Bcstg. Co.
 Business Address.....8 Bank Row
 Phone Number.....Pittsfield 2-1553
 Air Time.....8 hours daily
 Representative.....Walker
 Membership.....NARTB, BAB
 President.....Leon Podolsky
 General Manager.....John T. Parsons
 Commercial Mgr.....William Geary
 Program Director.....Edward Pearson
 Director of News.....Larry Vaber
 Film Manager.....Richard Bolander
 Chief Engineer.....Leonard Lavendol
 Consulting Engineer.....James C. McNary

WBZ-TV

BOSTON—1948—NBC

Channel: 4...AP: 50 Kw...VP: 100 Kw.
 Owned-Oper. By.....Westinghouse Radio Sta-
 tions, Inc.
 Address.....1170 Soldiers Field Rd.
 Phone Number.....ALgonquin 4-5670
 News Service.....INS, AP, UP
 Representative.....NBC Spot Sales
 President.....Chris J. Witting
 Gen., Sta. Mgr.....W. C. Swartley
 Sales Manager.....C. Herbert Masse
 Promotion Manager.....Richard E. Farnham
 Program Manager.....W. Gordon Swan
 News Dir.....F. Whitmarsh
 Film Manager.....R. Duffield
 Chief Engineer.....W. H. Hauser
 Production Mgr.....Iran Berlow

WNAC-TV

BOSTON—1948—CBS-(ABC-DuM)

Channel: 7 VHF...AP: 158 Kw...VP: 316 Kw.
 Owned-Oper. By.....General Teleradio, Inc.
 Business-Studio Address.....21 Brookline Ave.
 Phone Number.....Commonwealth 6-0800
 Air Time.....15 hours daily
 News Service.....INS, UP
 Representative.....H-R Reps, Inc.
 President.....Tom O'Neil
 Exec. V.P. & Gen. Mgr.....Linus Travers
 Comm. Mgr.....Tom Bateson
 Vice Pres., Dir. of Prog. and
 Remotes.....George Steffy
 Promotion Dir.....George Hallberg
 Dir. of News & Spec. Events.....Leland Bickford
 Production Mgr.....Tony Lang
 Publicity Dir.....Phyllis Doherty
 Film Director.....James Pike
 Technical Director.....Harry Whittemore

WTAO-TV

BOSTON—1953—ABC-DuM

Channel: 56 UHF...AP: 10 Kw...VP: 22 Kw.
 Owned-Oper. By.....Middlesex Bcstg. Corp.
 Business Office.....439 Concord Ave.
 Phone Number.....EL 4-0500
 News Service.....UP
 Representative.....Everett-McKinney
 President.....Frank J. Lyman, Jr.
 General Manager.....Frederic S. Bailey
 Commercial Mgr.....John H. Kimball, Jr.
 Program Director.....Theodore B. Pitman, Jr.
 Film Manager.....Fred Stein
 Chief Engineer.....Leonard Pray

WHYN-TV

SPRINGFIELD-HOLYOKE—1953

CBS-DuM

Channel: 55 UHF...AP: 91 Kw...VP: 182 Kw.
 Owned-Oper. By.....Hampden-Hampshire Corp.
 Business Address.....1300 Liberty St.
 Phone Number.....Springfield 4-1126
 Air Time.....11 hours
 News Service.....UP
 Representative.....Branham, Weed
 Membership.....NARTB, BAB
 General Manager.....Charles N. DeRose
 Commercial Mgr.....Patrick J. Montague
 Program Director.....Ken Smith
 Chief Engineer.....Harold Schumacher
 Consulting Engineers.....Kear & Kennedy

WWLP

SPRINGFIELD—1953—ABC-NBC

Channel: 61 UHF...AP: 75 Kw...VP: 150 Kw.
 Owned-Oper. By.....Springfield Television
 Bcstg. Corp.
 Business Office.....61 Chestnut St.
 Phone Number.....Springfield 2-4181
 Representative.....Hollingbery
 President.....Roger L. Putnam
 Treasurer.....William L. Putnam
 V.P., Comm. Mgr.....Alan C. Tindal
 Program Director.....Milton R. Slater
 Promotion Manager.....Howard S. Keefe
 Chief Engineer.....George R. Townsend

WWOR-TV

WORCESTER—1953—ABC-DuM

Channel: 14 UHF...AP: 16.2 Kw...VP: 8.71 Kw.
 Business Office.....P. O. Box 609
 Phone Number.....7-8374
 Air Time.....6 hours daily
 News Service.....UP
 Representative.....Paul H. Raymer, Bannan
 Membership.....NARTB
 President.....John Z. Buckley
 General Manager.....Ansel E. Gridley
 Commercial Mgr.....Leonard V. Corwin
 Program Director.....Thomas C. Sawyer
 Promotion Director.....Rupert Neily
 Director of News.....Frank Knight
 Production Mgr.....Richard Huntley
 Film Manager.....Norman "Cy" Locke
 Chief Engineer.....Donald P. Wise

MICHIGAN

TV HOMES 1,427,500

POPULATION 6,700,000

STATIONS IN STATE 13

WPAG-TV

ANN ARBOR—1953—DuM

Channel: 20 UHF...AP: 1 Kw...VP: 2 Kw.
 Owned-Oper. By.....Washtenaw Bcstg. Co.
 Business Address.....Hutzel Bldg.
 Phone Number.....2-5517
 Air Time.....5½ hours daily
 News Service.....AP
 Representative.....Weed
 Membership.....NARTB
 President.....Arthur E. Greene
 Vice-Pres., Gen. Mgr.....Edward F. Baughn
 Commercial Mgr.....Kenneth MacDonald

Program Director.....Roger Shepard
 Film Manager.....R. W. Kirkpatrick
 Chief Engineer.....Donald N. Bowdish

WBKZ-TV

BATTLE CREEK—1953—ABC

Channel: 64 UHF...AP: 15 Kw...VP: 25 Kw.
 Owned-Oper. By...Booth Radio-TV Stations Inc.
 Business Address.....Box 218
 Phone Number.....WWoodward 2-5506
 Air Time.....10 hours daily
 News Service.....AP
 Representative.....Weed
 Pres., Gen. Mgr.....John L. Booth
 Sta., Comm. Mgr.....Edwin J. Lasko
 Promotion Mgr.....Arthur Jackson
 Director of News.....Robert Wright
 Production Mgr.....Russell Webb
 Publicity Director.....Gilbert Ketcham
 Film Manager.....David Gahbart
 Chief Engineer.....Rex Cummings

WNEM-TV

BAY CITY-SAGINAW—1954—NBC
 DuM

Channel: 5 VHF...AP: 12 Kw...VP: 24 Kw.
 Owned-Oper. By.....North Eastern Michigan
 Corp.
 Business Address...814 Adams St., Bay City
 Phone Number.....3-5269
 Representative.....Headley-Reed
 President.....James Gerity, Jr.
 Exec. V.P.....O. William Myers
 Manager.....John Bone
 Commercial Manager...Harley M. West, Jr.
 Chief Engineer.....Lee Stevens

WWTW

CADILLAC—1953—CBS-DuM

Channel: 13 VHF...AP: 44 Kw...VP: 94.3 Kw.
 Owned-Oper. By.....Spartan Bcstg. Co.
 Business Address.....214 N. Mitchell St.
 Phone Number.....Prospect 5-3478
 Representative.....Weed
 President.....John J. Smith
 Vice-Pres., Gen. Mgr.....L. T. Matthews
 Sales Manager.....John Cundiff
 Program Director.....Keith Adams
 Film Editor.....Don Cunningham
 Chief Engineer.....Allen W. Daubendick

WJBK-TV

DETROIT—1948—CBS-DUMONT

Channel: 2 VHF...AP: 50 Kw...VP: 100 Kw.
 Owned-Oper. By.....Storer Bcstg. Co.
 Business-Studio Address.....500 Temple
 Phone Number.....Temple 3-7900
 Air Time.....16 hours daily
 News Service.....INS, UP
 Membership.....NARTB
 Representative.....Katz



Why Gamble
with your TV dollars?

Make Sure of More in '54

FACT
No. 1

POWER

Farthest reaching TV signal in the Michigan area . . . gigantic 1,057 foot tower with maximum 100,000 watt E.R.P. . . . plus favored Channel 2 dial position odd up to

MAXIMUM CIRCULATION

FACT
No. 2

PROGRAMMING

Daytime and nighttime, viewers customarily turn to Channel 2 for the best in entertainment, news and sports. And that means

MAXIMUM VIEWING

FACT
No. 3

RATINGS

Consistently leading with high-rated CBS, Dumont and local programs. For example, Pulse ratings for December, '53, show 9 out of the 15 top shows on WJBK-TV. And that gives you

MAXIMUM IMPACT

with

WJBK-TV

CHANNEL 2

Eliminate guesswork when you're buying TV time in the rich Great Lakes area. Make your money go farther, literally and figuratively, on WJBK-TV, Detroit's only full power station. Look at the facts! Prove to yourself that Channel 2 is the place for you. Get maximum return for your TV dollars on WJBK-TV.

WJBK-TV

Detroit

BASIC CBS NETWORK & DUMONT

STORER BROADCASTING COMPANY • National Sales Director, TOM HARKER, 118 E. 57th, New York 22, ELDORADO 5-7690



Represented
Nationally by
THE KATZ AGENCY

President.....George B. Storer
V.P., General Mgr......Gayle V. Grubb
Asst. Manag. Dir......Harry Lipson
Commercial Mgr......Maurice McMurray
Program Dir......Richard Fischer
Promotion Dir......Kenneth H. Boehmer
Publicity Director.....Elaine von Grimmenstein
Film Mgr......Arthur MacCall
Chief Engineer.....Paul Frincke
Consulting Engineer.....Earl Cullum
(See Opposite Page)

Production Mgr......Cecil Ruffin
Consulting Engineer.....James A. Gimbel

WOOD-TV
GRAND RAPIDS—1951
ABC-CBS-NBC-DuM

Channel: 8 VHF..AP: 158 Kw..VP: 316 Kw.
Owned-Oper. By.....Grandwood Bcstg. Co.
Address.....McKay Tower
Phone Number.....9-4125
Representative.....Katz
General Manager.....Willard Schroeder
Program Director.....Franklin Sisson
Sales Manager.....Art Swift
Sales Service Mgr......John Clay
Promotion Dir......John Dragomier
Asst. Prog. Dir......Clark Grant
Chief Engineer.....Louis Bergenroth

WWJ-TV
DETROIT—1947—NBC

Channel: 4 VHF..AP: 10.25 Kw..VP: 20.5 Kw.
Owned-Operated By...Evening News Assoc.
Business-Studio Address...615 W. Lafayette
Phone Number.....Woodward 2-2000
Newspaper Affiliation.....The Detroit News
News Service.....UP, AP
Representative.....Hollingbery
Membership.....NARTB
General Mgr......Edwin K. Wheeler
Asst. Gen. Mgr......Don DeGroot
Prog., Prod. Dir......James Schiavone
Pub. Affairs Dir......James Eberle
Publicity Director.....Harman R. Kates
Film Editor.....Frank Picard
Chief Engineer.....Edgar J. Love
Consulting Engineer.....Millard F. Garrison

WKZO-TV
KALAMAZOO—1950
ABC-CBS-NBC-DuM

Channel: 3 VHF..AP: 40 Kw..VP: 81 Kw.
Owned-Operated By.....Fetzer Bcstg. Co.
Address.....124 W. Michigan Ave.
Phone Number.....3-1223
Air Time.....15 hours daily
News Service.....AP
Representative.....Avery-Knodel, Inc.
Membership.....NARTB, BAB
Pres., Gen., Sta. Mgr......John E. Fetzer
Sales Director.....Donald W. DeSmit, Jr.
Program Director.....Charles Lynch
Managing Director.....Carl Lee
Chief Engineer.....Arthur E. Covell

WXYZ-TV
DETROIT—1948—ABC

Channel: 7 VHF..AP: 57 Kw..VP: 114 Kw.
Owned-Operated By.....WXYZ, Inc.
Business Address.....1700 Mutual Bldg.
Phone Number.....Woodward 3-8321
Air Time.....18 hours daily
News Service.....AP, INS
Representative.....Blair-TV
Membership.....NARTB, BAB
President.....James G. Riddell
Station Manager.....John Pival
Program Dir......John Lee
Production Mgr......Ford Vandervoort
Promotion Dir......Robert Baldrice
Dir. of Spec. Events & News.....Richard Fimmel
Film Director.....Ken Simms
Chief Engineer.....Charles Kocher

WILS-TV
LANSING—1953—ABC-DuM

Channel: 54 UHF..AP: 20 Kw..VP: 10 Kw.
Owned-Oper. By.....Lansing Bcstg. Co.
Business Address...407 N. Washington Ave.
Phone Number.....2-1655
Air Time.....8 hours daily
News Service.....UP
Representative.....O. L. Taylor
Membership.....NARTB
President.....W. A. Pomeroy
Commercial Manager.....Walter Dennis
Prog., Prod., Film Mgr......James Pollock
Promotion Dir......Walter Braeger
Director of News.....John Maters
Chief Engineer.....John Poberoy
Consulting Engineer.....Frank Macintosh

WTAC-TV
FLINT—1953—ABC

Channel: 16 UHF..AP: 8.4 Kw..VP: 17.4 Kw.
Owned-Oper. By.....TrendleCampbell Bcstg. Corp.
Business Address.....740 S. Saginaw St.
Phone Number.....2-1136
News Service.....UP
President.....George W. Trendle
General Manager.....H. Allen Campbell
Gen. Mgr. (AM-TV).....J. R. McKinley
Station Manager.....Rubin Weiss
Program Director.....James A. Washburn
Film Director.....Paul H. Toepp

WJIM-TV
LANSING—1950—ABC-CBS-DuM
NBC

Channel: 6 VHF..AP: 17 Kw..VP: 31 Kw.
Owned-Oper. By.....WJIM, Inc.
Address.....Bank of Lansing Bldg.
News Service.....UP
Phone.....2-1333
Representative.....H-R Representatives

President.....Harold F. Gross
 Station Manager.....Willard Waldbridge
 Prog., News Dir.....Howard Finch
 Film Director.....Phil Sherck
 Chief Engineer.....Charles Wallace

WKNX-TV

SAGINAW—1953

Channel: 57 UHF. AP: 10 Kw. VP: 19 Kw.
 Owned-Oper. By Lake Huron Bcstg. Co.
 Address.....221 S. Wash. Ave.
 Phone Number.....3-4471
 Representative.....Gill-Perna
 Membership.....NARTB, BAB
 General Manager.....William J. Edwards
 Station Manager.....Howard Wolfe
 Program Director.....Thomas A. Taylor
 Chief Engineer.....Max W. Thomas

President.....Herbert Scheffel
 General Manager.....C. G. Alexander
 S.a., Prom. Mgr.....James C. Cole
 Commercial Mgr.....Tony Marta
 Program Director.....Gerald Pearsen
 Director of News.....Herbert Widmark
 Production Mgr.....Victor Fletcher
 Film Manager.....Harvey Wick
 Chief Engineer.....Norman P. Gill

WCCO-TV

MINNEAPOLIS—1949

CBS-DuM

Channel: 4 AP: 50 Kw. VP: 100 Kw.
 Owned-Oper. By Mid-Continent Radio-TV Inc.
 Bus. Studio Address Radio City—50 S. 9th St.
 Phone Number.....Lincoln 0552
 News Service.....AP, UP, INS
 Representative.....Free & Pete's
 President.....Robert B. Ridder
 Exec. V.P. & Gen. Mgr. F. Van Konynenburg
 Station Manager.....Sherman Headley
 Production Director.....Charles D. Miller
 Film Director.....Harry C. Jones
 Prom., Publ. Director.....Florence Z. Cook
 Program Dir.....Gwen Harvey
 Chief Engineer.....John M. Sherman

MINNESOTA

TV HOMES 439,000

POPULATION 3,127,000

STATIONS IN STATE 7

KMMT

AUSTIN—1953—ABC-CBS-DuM

Channel 6 VHF. AP: 9.4 Kw. VP: 18.7 Kw.
 Business Office.....Minnesota-Iowa Television Co.
 Business Address.....405 1/2 North Main St.
 Phone Number.....8836
 Air Time.....6 hours daily
 News Service.....AP
 Representative.....Pearson
 President.....Harry Smith
 Gen. Sta. Mgr.....L. L. McCurnin
 Commercial Mgr.....Don Jones
 Program, Film Dir.....Tam Steensland
 Prom., Prcd. Mgr.....Ken Bryant
 Director of News.....Ken Cessna
 Chief Engineer.....Glen Klein
 Consulting Engineer.....Fred O. Grimwood, Inc.

WFTV

DULUTH—1953
 ABC-CBS-NBC-DuM

Channel: 38 UHF. AP: 10 Kw. VP: 20 Kw.
 Owned-Oper. By.....Great Plains Television
 Business Address.....232 East Superior St.
 Phone Number.....7-6881
 Air Time.....10 hours daily
 News Service.....AP
 Representative.....Adam Younq
 Membership.....NARTB

WTCN

MINNEAPOLIS—1953—ABC

Channel: 11 VHF. AP: 42 Kw. VP: 70 Kw.
 Owned-Oper. By Minnesota Television Public Service Corp.
 Business Address.....2925 Dean Blvd.
 Phone Number.....Mohawk 9-6771
 News Service.....AP, UP
 Representative.....Blair
 Membership.....NARTB
 President.....Robert Butler
 General Manager.....Edward G. Smith
 Commercial Mgr.....Ken Light
 Program Director.....George Hudak
 Director of News.....John Ford
 Production Mgr.....Robert Colburn
 Film Manager.....Eugene Wecker
 Chief Engineer.....Mike Fleming

KROC-TV

ROCHESTER—1953—NBC-DuM

Channel: 10 VHF. AP: 53 Kw. VP: 101 Kw.
 Owned Oper. By.....So. Minn. Bcstg. Co.
 Business Address.....100 1st Ave. Bldg.
 Phone Number.....3924
 Air Time.....9 hours daily
 News Service.....UP
 Representative.....Meeker
 Membership.....NARTB, BAB
 President.....Mrs. C. P. Gentling
 Gen. Comm. Mgr.....G. David Gentling
 Station Manager.....Willard Lampman
 Program Director.....Ray Skaran
 Director of News.....Ray Thompson
 Film Manager.....Jerry Kimery
 Chief Engineer.....Robert Cross

KSTP-TV

ST. PAUL-MINNEAPOLIS—1948
NBC

Channel: 5 VHF. AP: 17.3 Kw. VP: 24.7 Kw.
Owned-Operated By.....KSTP, Inc.
Bus., Trans. Co., 3415 University Ave., St. Paul
Phone Number.....Prior 2717
Air Time.....17½ hours daily
News Service.....AP, UP
Representative.....Edward Petry
Membership.....NARTB
Pres., Gen. Mgr.....Stanley E. Hubbard
Exec. V.P., Treas.....K. M. Hance
Nat. Sales Mgr.....Karl A. Plain
Local TV Sales Dir.....William R. Brazzil
Program Director.....Del Franklin
Promotion Director.....Joseph C. Cook
Chief Engineer.....Wm. S. Sadler
Consulting Engineer.....Andrew D. Ring

WMIN-TV

ST. PAUL—1953—ABC-DuM

Channel: 11 VHF. AP: 42 Kw. VP: 70 Kw.
Owned-Oper. By.....Minnesota Bcstg. Co.
Business Address.....538 Hamm Building
Phone Number.....Garfield 1361
Air Time.....5 hours daily
News Service.....AP
Representative.....H-R
Membership.....NARTB
President.....N. Lawrence Bentson
Commercial Mgr.....Frank M. Devaney
Prog. Dir., Prod. Mgr.....Fred H. Kaufman
Prom., Pub. Dir.....Thomas W. Letcher
Director of News.....Stuart A. Lindman
Film Manager.....Oscar Backlund
Chief Engineer.....Warren Fritze

MISSISSIPPI

TV HOMES 120,000

POPULATION 2,200,000

STATIONS IN STATE 4

WJTV

JACKSON—1953
ABC-CBS-DuM-NBC

Channel: 25 UHF. AP: 98 Kw. VP: 180 Kw.
Owned-Operated By
Mississippi Publishers Corp.
Address.....P. O. Box 427
Representative.....Katz
General Manager.....John Rossiter
Consulting Engineer.....Raymond M. Wilmotte

WLBT

JACKSON—1953—NBC

Channel: 3 VHF. AP: 50 Kw. VP: 100 Kw.
Owned-Oper. By.....Lamar Life Bcstg. Co.
Business Office.....Box 2171
Phone Number.....2-2691
Representative.....Hollingbery
General Manager.....Fred L. Beard
Sales Manager.....Frank Gentry
Program Director.....Maurice Thompson
Promotion Director.....Walter Henson
Film Director.....Al Fred Daniel
Chief Engineer.....Bob Smathers

WCOC-TV

MERIDAN—1953

Channel: 30 UHF. AP: 134 Kw. VP: 252 Kw.
Owned-Oper. By.....Mississippi Bcstg. Co.
Business Address.....Threefoot Bldg.
Phone Number.....7714
Pres., Gen. Mgr.....Withers Gavin

WTOK-TV

MERIDAN—1953
ABC-CBS-NBC-DuM

Channel: 11 VHF. AP: 15.5 Kw. VP: 31.2 Kw.
Owned-Oper. By.....Southern Television Corp.
Business Address.....Southern Bldg.
Phone Number.....3-1441
Air Time.....10 hours daily
News Service.....AP
Representative.....Headly-Reed
Membership.....NARTB
President.....Robert F. Wright
Commercial Manager.....W. B. Crooks
Program Director.....Cecil Germany
Promotion Dir.....Jerry Kerns
Dir. of News, Prod. Mgr.....George Shannon
Chief Engineer.....Joe Saxon
Consulting Engineer.....George E. Gaultney

MISSOURI

TV HOMES 681,500

POPULATION 4,034,000

STATIONS IN STATE 14

KOMU-TV

COLUMBIA—1953
ABC-CBS-NBC-DuM

Channel: 8 VHF. AP: 24.35 Kw. VP: 48.7 Kw.
Owned-Oper. By.....Curators of Univ. of Mo.
Business Address.....Highway 63 South

The **ONE** and **ONLY** television station
in the nation's 9th largest market which
operates with the **MAXIMUM POWER**
authorized by the Federal Communications Commission . .

KSD-TV

The St. Louis Post-Dispatch Television Station

...100,000 WATTS

on easy-to-tune

Very High Frequency Channel **5**

•
KSD-TV is America's **FIRST** completely postwar
equipped television station . . . established on
February 8, 1947 . . . and the **FIRST CHOICE** of
advertisers who have products and services to
sell to the St. Louis Market.

•
NBC TELEVISION NETWORK

National Advertising Representative: **NBC SPOT SALES**

Phone Number5251
 Air Time.....6 hours daily
 News Service.....UP
 Representative.....H-R
 General Manager.....George J. Kapel
 TV Director.....Dr. Edward C. Lambert
 Commercial Mgr.....Louis F. Allen
 Program Director.....William A. Vaughn
 Promotion Director.....Milton E. Gross
 Director of News.....Philip E. Berk
 Chief Engineer.....Duane M. Weise

KHQA-TV

HANNIBAL—1953—CBS-DuM

Channel: 7 VHF..AP: 18.3 Kw..VP: 36.8 Kw.
 Owned-Oper. By.....Lee Broadcasting, Inc.
 Business Address.....W. C. U. Bldg.
 Phone Number.....6200
 Air Time.....9 hours daily
 News Service.....AP, UP
 Representative.....Weed
 President.....Lee P. Loomis
 General Manager.....Walter Rothschild
 Program Director.....Merritt Milligan
 Promotion Director.....Gene Terry
 Director of News.....Don Nicholson
 Production Mgr.....Tom Roby
 Film Manager.....Charles Lotz
 Chief Engineer.....J. E. Gray

KCMO-TV

KANSAS CITY—1953—ABC—DuM

Channel: 5 VHF..AP: 42.6 Kw..VP: 71.1 Kw.
 Owned-Oper. By.....Meredith Engineering Co.
 Business Address.....125 East 31st St.
 Phone Number.....Jefferson 6789
 News Service.....AP
 Representative.....Katz
 President.....E. T. Meredith
 General Manager.....E. K. Hartenbower
 Program Director.....S. B. Tremble
 Promotion Director.....F. C. Strawn
 Director of News.....James Monroe
 Production Mgr.....Kenneth Heady
 Film Manager.....T. R. Thompson
 Chief Engineer.....Karl Troeglen

WHB-TV

KANSAS CITY—1953—CBS

Channel: 9 VHF..AP: 14.7 Kw..VP: 29.3 Kw.
 Owned-Oper. By.....WHB Bcstg. Co.
 Business Address.....Scarritt Bldg.
 Phone Number.....Baltimore 7109
 Representative.....Blair
 Pres., Comm. Mgr.....Donald D. Davis
 Vice-Pres., Gen. Mgr.....John T. Schilling
 Station Manager.....Morris Greiner
 Promotion Manager.....Ed Schultz, Jr.
 Chief Engineer.....Henry Goldenberg

KMBC-TV

KANSAS CITY—1953—CBS

Channel: 9 VHF..AP: 14.7 Kw..VP: 29.3 Kw.
 Owned-Oper. By.....Midland Bcstg. Co.

Business Address.....222 W. 11th St.
 Phone Number.....Harrison 2650
 News Service.....AP, UP
 Representative.....Free & Peters, Inc.
 President.....Arthur B. Church
 Managing Director.....George J. Higgins
 Program Director.....Roderick B. Cupp
 Promotion Director.....Harold W. Storm
 Production Mgr.....John Q. Quigley
 Chief Engineer.....Kenneth H. Cook

WDAF-TV

KANSAS CITY—1949

NBC

Channel: 4.....AP:50 Kw.....VP: 100 Kw.
 Owned-Oper. By.....Kansas City Star Co.
 Business Number.....1729 Grand Ave.
 Phone Number.....Harrison 1200
 News Service.....AP, UP
 Representative.....Harrington, Righter, & Parsons
 Managing Director.....H. Dean Fitzner
 Commercial Manager.....E. M. Russo
 Station Manager.....Bill Bates
 Chief Engineer.....Joseph Flaherty
 Program Dir.....Al Christy
 News Dir.....Randall Jessee
 Film Mgr.....John Krivas

KFEQ-TV

ST. JOSEPH—1953—CBS-DuM

Channel: 2 VHF..AP: 26 Kw..VP: 52 Kw.
 Owned-Oper. By.....KFEQ, Inc.
 Business Address.....KFEQ Bldg.
 Phone Number.....3-2528
 Air Time.....7 hours daily
 News Service.....AP
 Representative.....Headley-Reed
 Pres., Gen. Mgr.....Barton Pitts
 Commercial Mgr.....Glenn G. Griswold
 Program Director.....E. Carleton Schirmer
 Director of News.....Ralph Combes
 Production Mgr.....Wally Johnson
 Chief Engineer.....J. Wesley Koch

KACY

ST. LOUIS—1953

Channel: 14 UHF..AP: 280 Kw..VP: 490 Kw.
 Owned-Oper. By.....Ozark Television Corp.
 Business Address.....4010 Lindell Blvd.
 Phone Number.....Jefferson 1400
 Representative.....Raymer
 Pres., Gen. Mgr.....Jack G. Garrison
 Vice-Pres., Sta. Mgr.....Carl G. McIntire
 Treasure.....Philip L. Sincoff
 Commercial Mgr.....Richard Dawson
 Production Director.....John J. Weber
 Chief Engineer.....Leo Tevlin

KSD-TV

ST. LOUIS—1947

ABC-CBS-NBC

Channel: 5 VHF..AP: 60 Kw..VP: 100 Kw.
 Owned-Oper. By.....The Pulitzer Publishing Co.

"Big Mo" Captures St. Louis!

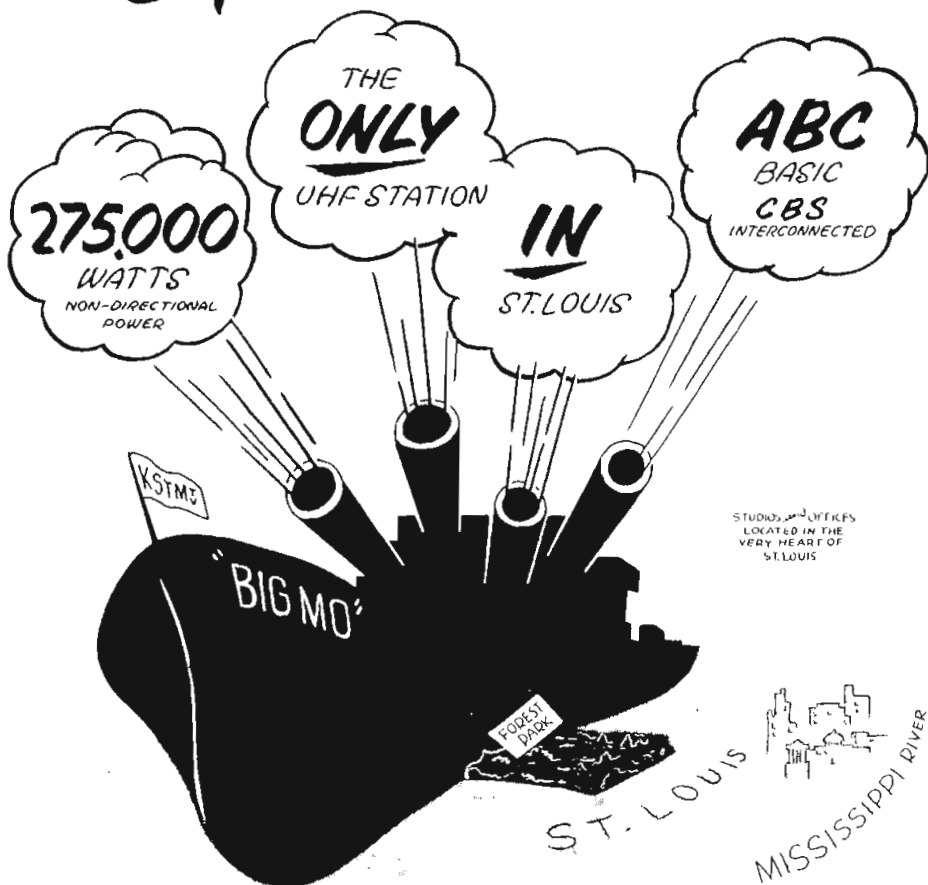

H-R TELEVISION INC. NEW YORK • CHICAGO • SAN FRANCISCO • LOS ANGELES

KSTMG
CHANNEL 36 SAINT LOUIS

Address.....1111 Olive St.
 Phone Number.....MAin 1111
 Air Time.....120 hours weekly
 Newspaper Affiliation..St. Louis Post-Dispatch
 News Service.....AP, INS
 Representative.....NBC Spot Sales
 Membership.....NARTB
 President.....Joseph Fultzter
 Gen., Sta. Mgr.....George M. Burbach
 Program Director.....Harold Grams
 Chief Engineer.....J. E. Risk
 Sales Manager.....Guy E. Yeddell
 Promotion Director.....David Pasternak

KSTM-TV

ST. LOUIS—1953—ABC

Channel: 36 UHF..AP: 125 Kw..VP: 250 Kw.
 Owned-Oper. By.....Broadcast House Inc.
 Business Address.....5915 Berthold Ave.
 Phone Number.....Sterling 3636
 Representative.....H-R
 Pres., Gen. Mgr.....Marshall H. Pengra
 Commercial Mgr.....Alvin M. King
 Program Manager.....Myron Bennett
 Promotion Director.....Frank E. Heaston
 Chief Engineer.....Ted Favors

WTVI

ST. LOUIS—1953—DuM

Channel: 54 UHG..AP: 124 Kw..VP: 248 Kw.
 Owned-Oper. By..Signal Hill Telecasting Corp.
 Business Address.....Boatmen's Bank Bldg.
 Phone Number.....Geneva 5454
 Representative.....Weed
 Pres., Gen. Mgr.....Bernard T. Wilson
 Vice-Pres., Comm. Mgr.....John I. Hyatt
 Program Manager.....Ted Wescott
 Production Mgr.....Robert Holt
 Chief Engineer.....Richard J. Trompeter
 (See Page 884)

KDRO-TV

SEDALIA—1954

Channel: 6 VHF..AP: 8.71 Kw..VP: 16.2 Kw.
 Owned-Oper. By.....Milton J. Hinlein
 Business Address.....2100 W. Broadway
 Phone Number.....4004
 Representative.....Forjoe
 General Manager.....Herb Brandes
 Commercial Mgr.....James Glenn
 Chief Engineer.....Bob Smith

KTTS-TV

SPRINGFIELD—1953—CBS-DuM

Channel: 10 VHF AP: 6.38 Kw..VP: 12.76 Kw.
 Owned-Oper. By.....Independent Bcstg. Co.
 Business Address.....Box 1716
 Phone Number.....2-7474
 Air Time.....10 hours daily
 News Service.....AP, UP
 Representative.....Weed
 Membership.....NARTB
 President.....J. H. G. Cooper
 Gen., Sta. Mgr.....G. Pearson Ward

Program Director.....Kevin McAndrews
 Director of News.....Bill Bowers
 Chief Engineer.....William F. Curry
 Consulting Engineer.....J. C. McNary

KYTV

SPRINGFIELD—1953—ABC-NBC

Channel: 3 VHF..AP: 31 Kw..VP: 61 Kw.
 Owned-Oper. By...Springfield Television Inc.
 Business Address.....999 W. Sunshine
 Phone Number.....6-2766
 Representative.....Hollingbery
 Gen., Comm. Mgr.....J. Gordon Wardell
 Film Director.....Carl Fox
 Chief Engineer.....E. Dennis White

MONTANA

TV HOMES 10,500

POPULATION 597,000

STATIONS IN STATE 4

KOOK-TV

BILLINGS—1953—CBS-DuM-ABC

Channel: 2 VHF..AP: 8.8 Kw..VP: 17.5 Kw.
 Owned-Oper. By.....Montana Network
 Business Address.....7002 S. Billings Blvd.
 Phone Number.....9-2382
 Representative.....Headley-Reed
 General Manager.....V. V. Clark
 Commercial Mgr.....John Connor
 Program Director.....Edmund Peiss
 Chief Engineer.....Grant French

KOPR-TV

BUTTE—1953—CBS-ABC

Channel: 4 VHF..AP: 7.3 Kw..VP: 14.5 Kw.
 Owned-Oper. By.....Copper Bcstg. Co.
 Business Address.....Hotel Finlen
 Phone Number.....6546
 Representative.....Hollingbery
 Vice-Pres., Gen. Mgr.....Ed Cooney
 Commercial D.....S. John Schile
 Chief Engineer.....John Gort

KXLF-TV

BUTTE—1953—NBC-DuM

Channel: 6 VHF...AP: 1 Kw...VP: 2 Kw.
 Owned-Oper. By.....Pacific Northwest
 Broadcasters
 Business Address.....Bcx 1956
 Phone Number.....2-2696
 Air Time.....5 hours daily
 Representative.....Walker
 President.....E. B. Craney

WTVI ... "the POWER!"

— SERVES and SELLS
ALL of the GREAT
SAINT LOUIS AREA
with the ...

MOST POWERFUL
TRANSMITTER
EVER BUILT

for UHF -TV... the "G-E 12"

For Availabilities, ask

WEED TELEVISION

DUMONT AND CBS SHOWS!



Station Manager.....Jim Manning
 Commercial Mgr.....J. Wythe Walker
 Chief Engineer.....Jack Provis
 Consulting Engineer.....George Adair

Prom., Pub. Dir.....Ruth Thone
 Director of News.....Ken Wayman
 Chief Engineer.....Charles Winkler

K F B B - T V

GREAT FALLS—1954—CBS—DuM

Channel: 5 VHF..AP: 12.6 Kw..VP: 21.5 Kw.
 Owned-Oper. By.....Buttrey Broadcast Inc.
 Business Address.....Box 1139
 Phone Number.....4-4377
 Representative.....Weed
 Pres., Gen. Mgr.....Joseph P. Wilkins
 TV Director.....LeRoy Stahl
 Program Director.....Robert Froemming
 Chief Engineer.....Wilbur Myhre

K O L N - T V

LINCOLN—1953—DuM

Channel: 12 VHF..AP: 13.5 Kw..VP: 27 Kw.
 Owned-Operated By

Cornhusker Radio & TV Corp.
 Address.....40th and W Sts.
 Representative.....Weed
 President.....John E. Fetzter
 General Manager.....H. E. Anderson
 Sales Manager.....Otis Segler
 Chief Engineer.....Ray Taylor

NEBRASKA

TV HOMES 181,500

POPULATION 1,353,000

STATIONS IN STATE 5

K H O L - T V

KEARNEY—1953—CBS—DuM

Channel: 13 VHF..AP: 30.2 Kw..VP: 56.2 Kw.
 Owned-Oper. By.....Bi-States Co.
 Business Address.....414 East Ave.
 Phone Number.....Axtell 42
 Air Time.....4½ hours daily
 News Service.....AP
 Representative.....Meeker
 Membership.....NARTB
 President.....Dr. Wayne Brewster
 General Manager.....Harold J. Hamilton
 Sta., Comm. Mgr.....Duane L. Watts
 Prog., Prom. Dir.....Jack Gilbert
 Chief Engineer.....Jack Lewis

K F O R - T V

LINCOLN—1953—ABC

Channel: 10 VHF..AP: 29.5 Kw..VP: 59 Kw.
 Owned-Oper. By.....Cornbelt Bcstg. Corp.
 Business Address.....626 Stuart Bldg.
 Phone Number.....2-6965
 Air Time.....5½ hours daily
 News Service.....AP
 Representative.....Paul H. Raymer
 Membership.....NART, BAB
 President.....James Stuart
 Gen., Sta. Mgr.....George Bastion
 Commercial Mgr.....Richard W. Chapin
 Program Director.....Av Bondarin

K M T V

OMAHA—1949—ABC—CBS—DuM

Channel: 3.....AP: 50 Kw.....VP: 100 Kw.
 Owned-Oper. By.....May Bcstg. Co.
 Bus. Trans. Address.....2615 Farnam St.
 Phone Number.....WEBster 9800
 Air Time.....15 hours daily
 News Service.....UP
 Representative.....Edward Petry & Co.
 Membership.....NARTB
 President.....Edward W. May
 V.P., Gen. Mgr.....Owen Saddler
 Commercial Manager.....Arden Swisher
 Program Director.....Glenn Harris
 Promotion Dir.....Joe Baker
 Dir of News and Spec. Events.....Floyd Kalber
 Production Director.....Lew Jeffrey
 Chief Engineer.....R. J. Schroeder
 Consulting Engineer.....Robert M. Silliman

W O W - T V

OMAHA—1949—NBC—DuM

Channels: 6 VHF..AP: 50 Kw..VP: 100 Kw.
 Owned-Oper. By.....Meredith WOW, Inc.
 Business Address.....Insurance Bldg.
 Phone Number.....WEBster 3400
 Air Time.....17½ hours daily
 News Service.....UP, INS
 Representative.....Blair TV
 Membership.....NARTB
 Chairman of Board.....Fred Bohlen
 President.....E. T. Meredith, Jr.
 General Manager.....Frank P. Fogarty
 Sales Mgr.....Fred Ebener
 Program Director.....Bill McBride
 Promotion Dir.....Bob Seitzer
 Film Manager.....Lyle DeMoss
 Dir. of News & Spec. Events.....Ray Clark
 Production Manager.....Vern Reynolds
 Dir. of Engineering.....Wm. J. Kotera
 Chief Engineer.....Glenn Flynn

serving **ALL**
of the Metropolitan
New York · New Jersey market

National Representatives
WEED TELEVISION CORP.

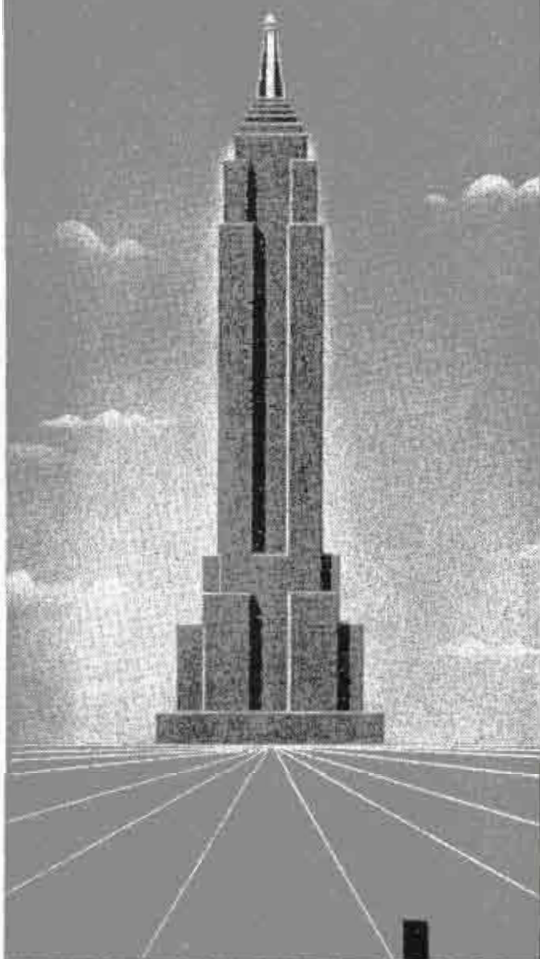

WQTV

10

NEVADA

TV HOMES 12,500
 POPULATION 176,000
 STATIONS IN STATE 2

KLAS-TV

LAS VEGAS—1953
 ABC-CBS-NBC-DuM

Channel: 8 VHF..AP: 14.5 Kw..VP: 29 Kw.
 Owned-Oper. By...Las Vegas Television Inc.
 Business Address.....Box 711
 Phone Number.....7138
 Air Time.....9 hours daily
 News Service.....UP
 Representative.....Weed
 Membership.....NARTB
 President.....R. G. Jolley
 General Manager.....Bob Gardner
 Promotion Dir.....Marian Y. Komar
 Program Director.....Ray Gallagher
 Director of News.....Jim Hart
 Publicity Director.....Lois Carpenter
 Film Manager.....Don Mumford
 Chief Engineer.....Les Nelson

KZTV

RENO—1952
 ABC-CBS-NBC-DuM

Channel: 8 VHF..AP: 1.4 Kw..VP: 2.7 Kw.
 Owned-Oper. By...Nevada Radio-Television
 Inc.
 Business Address.....770 East 5th St.
 Phone Number.....3-0721
 Air Time.....6½ hours daily
 News Service.....AP
 Representative.....Pearson
 President.....Donald W. Reynolds
 General Manager.....Harry Huey
 Commercial Mgr.....Richard Colon
 Program Director.....Lou Zegerman
 Director of News.....Leila Rowson
 Chief Engineer.....Curtis I. Kring
 Consulting Engineer.....Robert L. Hammett

NEW HAMPSHIRE

TV HOMES 86,500
 POPULATION 554,000
 STATIONS IN STATE 1

WMUR-TV

MANCHESTER—1954
 ABC-CBS-DuM-NBC

Channel: 9 VHF..AP: 67.6 Kw..VP: 112 Kw.
 Owned-Oper. By...Radio Voice of N. H. Inc.
 Business Address.....1819 Elm St.
 Phone Number.....5-5788
 Representative.....Weed
 President.....Francis P. Murphy
 General Manager.....Hervey Carter
 Commercial Mgr.....Gordon Moore
 Chief Engineer.....Vincent Chandler

NEW JERSEY

TV HOMES 1,375,000
 POPULATION 5,228,000
 STATIONS IN STATE 3

WRTV

ASBURY PARK—1953

Channel: 58 UHF..AP: 9.12 Kw..VP: 17.10 Kw.
 Owned-Oper. By...Atlantic Video Corp.
 Business Address.....710 Mattison Ave.
 Phone Number.....Asbury Park 2-7200
 President.....Walter Reade, Jr.
 Vice-Pres., Mgr.....Harold C. Burke
 Commercial Mgr.....Allen Preville
 Production Mgr.....Richard Behrman
 Film Director.....William Branham
 Chief Engineer.....Donald Volkman

WFPG-TV

ATLANTIC CITY—1952—ABC-NBC
 CBS-DuM

Channel: 46 UHF..AP: 9 Kw..VP: 18 Kw.
 Owned-Operated By...Neptune Bcstg. Corp.
 Address.....Steel Pier
 Representative.....Pearson
 Pres., Gen. Mgr.....Fred Weber
 Sales Manager.....Russell Truex
 Prog., Prom. Dir.....Ed Davis
 Milm Manager.....Elaine Bartholomei
 Chief Engineer.....Blair K. Thron
 Consulting Engineer...Craven, Lohnes & Culver

WATV

NEWARK—1948

Channel: 13 VHF..AP: 105 Kw..VP: 180 Kw.
 Owned-Oper. By...Bremer Bcstg. Corp.
 Business-Studio Address.....1020 Broad St.
 Phone Number.....Mitchell 2-6400
 Air Time.....13 hours daily
 Representative.....Weed

Pres., Gen. Mgr. Irving R. Rosenhaus
 Vice Pres. (Sales) Edmund S. Lennon
 Public Relations Dir. Robert MacDougall
 Program Director George Green
 Film Director Robert Paskow
 Vice-President Frank V. Bremer

K S W S - T V

ROSWELL—1953—ABC-DuM

Channel: 8 VHF... AP: 57.5 Kw... VP: 115 Kw.
 Owned-Oper. By John A. Barnett
 Business Address 1723 W. Second St.
 Phone Number 3737
 Air Time 7 hours daily
 News Service AP
 Representative Meeker
 Owner John A. Barnett
 General Manager J. C. Porter
 Commercial Mgr. Paul B. McEvoy
 Program Director Jack Shafer
 Chief Engineer Ray Summersgill
 Consulting Engineer George Gautney

NEW MEXICO

TV HOMES 51,000

POPULATION 760,000

STATIONS IN STATE 4

K G G M - T V

ALBUQUERQUE—1953—CBS

Channel: 13 VHF... AP: 45 Kw... VP: 89 Kw.
 Owned-Oper. By New Mexico Bcstg. Co.
 Business Address 1414 West Coal Ave.
 Phone Number 3-4543
 Air Time 8 hours daily
 News Service AP, UP
 Representative Weed
 President A. R. Hebenstreit
 Commercial Mgr. Jonny Grall
 Program Director Ed Sanchez
 Promotion Director Bob Van Driel
 Chief Engineer Leonard Dodds

K O A T - T V

ALBUQUERQUE—1953—ABC-DuM

Channel: 7 VHF... AP: 12.9 Kw... VP: 28.8 Kw.
 Owned-Oper. By Alvarado Television Co.
 Business Address 122 S.E. Tulane Dr.
 Phone Number 5-8716
 Representative Hollingbery
 Vice-Pres., Gen. Mgr. Phil Hoffman
 Program Director Ted Snider
 Chief Engineer Bill Carman

K O B - T V

ALBUQUERQUE—1948
 NBC-DuM

Channel: 4 VHF... AP: 5.6 Kw... VP: 11Kw.
 Owned-Oper. By Albuquerque Bcstg. Co.
 Bus. Studio Address 234 So. 5th
 Phone Number 3-4411
 Air Time 10 hours daily
 Representative Branham
 Membership NARTB
 President Wayne Coy
 Station Manager J. I. Myerson
 Program Director Dorothy B. Smith
 Film Mgr. Millard Williams
 Chief Engineer George S. Johnson

NEW YORK

TV HOMES 3,912,000

POPULATION 15,872,000

STATIONS IN STATE 21

W R O W - T V

ALBANY—1953—ABC-DuM-CBS

Channel: 41 UHF... AP: 138 Kw... VP: 269 Kw.
 Owned-Oper. By Hudson Valley Bcstg. Co.
 Business Address Box 4100
 Phone Number 3-2225
 Air Time 9 hours daily
 News Service UP
 Representative Bolling
 Membership NARTB, BAB
 President Dean P. Taylor
 General Manager Harry L. Goldman
 Station Manager Isabella Arden
 Commercial Mgr. Reed Gordon
 Program Director Charles Pogan
 Promotion Dir. Hilda Nauman
 Production Mgr. Al Strauss
 Chief Engineer Charles Heisler
 Consulting Engineer Frank McIntosh

W N B F - T V

BINGHAMTON—1943
 ABC-CBS-NBC-DuM

Channel: 12... AP: 125 Kw... VP: 250 Kw.
 Owned-Oper. By Clark Associates, Inc.
 Business Address P. O. Box No. 48
 Phone Number 3-7311
 Air Time 14 hours daily
 Representative Bolling
 Membership NARTB, BAB
 General Manager C. D. Mastin
 Sales Manager Stanley N. Heslop

Pgm. Dir. E. M. Scala
 Promotion Director John Turner
 Prod. Dir. Clark Pollock
 Chief Engineer L. H. Stantz
 Consulting Engineer Jansky & Bailey

WBEN-TV

BUFFALO—1948—NBC

Channel: 4 VHF..AP: 27 Kw..VP: 54 Kw.
 Owned-Oper. By WBEN, Inc.
 Phone Number MOhawk 0930
 Studio, Transmitter Location Hotel Statler
 Air Time 17 hours daily
 News Service AP, INS, UP
 Representative Harrington, Righter & Parsons, Inc.

President Edward H. Butler
 Vice-President Alfred H. Kitchhofer
 General Manager C. Robert Thompson
 Sales Manager Nicholas J. Malter
 Station Mgr. George R. Torge
 Promoton Director Joseph A. Haeffner
 Film Director Quintin P. Renner
 Program Dir. Frederick A. Keller
 Executive Producer John L. Hutch'nscn. Jr.
 Technical Director Ralph J. Kingsley

WBUF-TV

BUFFALO—1953—ABC-CBS-DuM

Channel: 17 UHF..AP: 8.5 Kw..VP: 19 Kw.
 Owned-Oper. By WBUF, Inc.
 Business Address 184 Barton St.
 Phone Number Summer 1717
 Air Time 12 hours daily
 News Service UP
 Representative H-R

Membership NARTB
 President Sherwin Grossman
 Exec. Vice-President Gary L. Cohen
 Commercial Mgr. Pat Swift
 Program Director Tom Molony
 Director of News Frank Fredericks
 Film Manager Michael Eisler
 Chief Engineer Ernest E. Rety
 Consulting Engineers Kear & Kennedy

WECT

ELMIRA—1953—NBC

Channel: 18 UHF..AP: 7.53 Kw..VP: 15.05 Kw.
 Owned-Oper. By El-Cor Television, Inc.
 Business Address 302 East Water St.
 Phone Number 7018
 News Service AP
 Representative Everett McKinney
 Membership NARTB
 President E. S. Underhill, Jr.
 General Manager Walter A. Valerius
 Commercial Mgr. John N. Prewitt, Jr.
 Program Director Kenneth Powell
 Prom'ion Director Matthew F. Carney, Jr.
 Film Manager John LaLiberte
 Chief Engineer Allen N. Bell

WTVE

ELMIRA—1953—ABC-CBS-DuM

Channel: 24 UHF..AP: 8.3 Kw..VP: 16.58 Kw.
 Owned-Oper. By Elmira Television
 Business Address 159 Madison Ave.
 Phone Number 3-6624
 Air Time 9 hours daily
 News Service UP
 Representative Forjoe
 Owners Thompson K. Cassel,
 John S. Booth

General Manager T. K. Cassel
 Commercial Mgr. Richard Rolfe
 Program Director Jim Pattison
 Promotion Director Jack Peet
 Director of News Dorothy Evans
 Production Mgr. Sally Martin
 Publicity Director Thomas Shafer
 Film Manager Lou Ganero
 Chief Engineer Robert Burkel
 Consulting Engineer Kear & Kennedy

WKNY-TV

KINGSTON—1954—CBS-NBC-DuM

Channel: 66 UHF..AP: 11.5 Kw..VP: 21.4 Kw.
 Owned-Oper. By WKNY-TV Corp.
 Business Address 601 Broadway
 Phone Number Kingston 4500
 Air Time 5½ hours daily
 Representative Meeker

Membership NARTB, BAB
 President Joseph K. Close
 General Manager Robert M. Peebles
 Station Manager Robert L. Sabin
 Prog., Prod. Dir. Robert Perry
 Chief Engineer Carl Egolf

WABC-TV

NEW YORK—1948—ABC

Channel: 7 VHF..AP: 40 Kw..VP: 80 Kw.
 Owned-Oper. By

American Bcstg.-Paramount Theaters, Inc.
 Business Address 7 W. 66th St.
 Phone Number SUsquehanna 7-5000
 Air Time 13 hours daily
 News Service INS
 Representative Petry
 Vice-Pres., Gen. Mgr. John H. Mitchell
 Sales Mgr. Trevor Adams
 Film Director Yale Roe
 Program Director Arden B. Rodner
 Treasurer Thomas Martinez
 Sales Secretary Mary A. Connell
 Production Mgr. Gordon Kunz

WABD

NEW YORK—1944—DuM

Channel: 5 VHF..AP: 8.4 Kw..VP: 16.7 Kw.
 Owned-Oper. By Allen B. Du Mont
 Laboratories, Inc.
 Business Address 515 Madison Ave.
 Phone Number MUrray Hill 8-2600



WPIX

*The Nation's Greatest
Sports Station!*

EXCLUSIVE TELECASTS:

- ... All home games, N. Y. Yankees
- ... All home games, N. Y. Giants
- ... Madison Square Garden
 - Knicks Basketball*
 - Rangers Hockey*
 - International Horse Show*
 - Westminster Kennel Club Dog Show*

TOPS IN SPORTSCASTERS:

- ... Jimmy Powers, Mel Allen, Jim Woods,
Russ Hodges, Bob Delaney, "Red" Barber,
Frankie Frisch, Bud Palmer

*For over five years, New Yorkers
have been turning to Channel Eleven
for the best in sports.*

The Station of Champions



Air Time.....13 hours daily
 News Service.....INS
 Membership.....NARTB
 Director.....Ted Bergmann
 Station Manager.....Norman Knight
 Pgm., Prod. Dir.....James L. Caddigan
 Chief Engineer.....Rodney D. Chipp
 Publicity Director.....Gerald Lyons
 Sales Prom. Mgr.....Norman S. Brett

WCBS-TV
 NEW YORK—1941—CBS

Channel: 2 VHF..AP: 22 Kw..VP: 43 Kw.
 Owned-Oper. By.....Columbia Bcstg. System
 Business Address.....485 Madison Ave.
 Phone Number.....PLaza 1-2345
 Air Time.....19 hours daily
 News Service.....AP, INS, UP
 Representative.....CBS TV Spot Sales
 Membership.....NARTB
 President (CBS Inc.).....Frank Stanton
 President (CBS TV).....J. L. Van Volkenburg
 General Manager.....Craig Lawrence
 Asst. to Gen. Mgr.....Clarence Worden
 Sales Manager.....George Dunham
 Program Director.....Hal Hough
 Promotion Manager.....Robert G. Patt
 Asst. Prog. Dir., Prod. Mgr.....Dan Gallagher
 Publicity Director.....Bob Fuller
 Film Manager.....Wm. C. Lacey
 Chief Engineer.....Robert G. Thompson

WNBT

NEW YORK—1941—NBC

Channel: 4...AP: 7.25 Kw...VP: 14.5 Kw.
 Owned-Oper. By.....National Bcstg. Co.
 Business Address.....30 Rockefeller Plaza
 Phone Number.....CIRCLE 7-8300
 Air Time.....17 hours daily
 News Service.....AP, INS, UP
 Representative.....NBC Spot Sales Dept.
 Membership.....NARTB, BAB
 President.....David Sarnoff
 General Manager.....Hamilton Shea
 Station Manager.....Ernest de la Ossa
 Commercial Manager.....Jay Heitlin
 Program Director.....Richard Pack
 Promotion Dir.....John Hurlbut
 Operations Mgr.....Peter Afte
 Publicity Dir.....Bob Blake
 Mgr., Publicity Dept.....Wm. Anderson
 Chief Engineer.....Alf Jackson

WOR-TV

NEW YORK—1949

Channel: 9.....AP: 44Kw.....VP: 88 Kw.
 Owned-Oper. By.....General Teleradio, Inc.
 Business Address.....1440 Broadway
 Phone Number.....LONGacre 4-8000
 Air Time.....7 hours daily
 News Service.....UP
 Station Representative.....H-R Reps.
 Membership.....NARTB
 President.....Thomas F. O'Neil
 V. P. In Charge.....Gordon Gray
 Commercial Director.....Robert C. Mayo

Promotion Director.....Robert Sullivan
 Dir. News & Spec. Events.....George Brown
 Production Manager.....Ivan Reiner
 Publicity Director.....Richard Jackson
 Film Manager.....Milford Fenster
 Chief Engineer.....Charles Singer

WPIX

NEW YORK—1948

Channel: 11 VHF..AP: 51 Kw..VP: 100 Kw.
 Owned-Oper. By.....N. Y. Daily News
 Address.....220 E. 42nd St.
 Phone Number.....MU 2-6500
 Air Time.....11 hours daily
 News Service.....AP, UP
 Newspaper Affiliation.....N. Y. Daily News
 Station Representative.....Free & Peters
 Membership.....NARTB
 President.....F. M. Flynn
 V.P., Gen., Sta. Mgr.....F. M. Thrower
 Operations Mgr.....L. Pope
 Program Director.....Louis B. Ames
 Director of News.....Walter Engels
 Publicity Director.....L. A. Hollingsworth
 Promotion Director.....M. Kraemer
 Chief Engineer.....O. Freeman
 Film Mgr.....Carol Levine
 Consulting Engineer.....A. D. Ring

WHAM-TV

ROCHESTER—1949

ABC-NBC-DuM

Channel: 6 VHF..AP: 11.7 Kw..VP: 23.4 Kw.
 Owned-Oper. By.....Stromberg Carlson Co.
 Business Address.....201 Humboldt St.
 Phone Number.....Culver 7240
 Air Time.....17 hours daily
 News Service.....UP
 Representative.....Hollingbery
 Membership.....NARTB
 Vice-Pres., Gen. Mgr.....William Fay
 Commercial Manager.....John W. Kennedy, Jr.
 Program Director.....Charles W. Siverson
 Promotion, Pub. Dir.....Terry David
 Director of News.....David E. Kessler
 Production Mgr.....James Trayhern
 Film Director.....David Manning
 Chief Engineer.....Kenneth Gardner

WHEC-TV

ROCHESTER—1953—ABC-CBS

Channel: 10 VHF..AP: 5 Kw..VP: 10 Kw.
 Owned-Oper. By.....WHEC, Inc.
 Business Address.....40 Franklin St.
 Phone Number.....Baker 6740
 Air Time.....14 hours daily
 News Service.....AP
 Representative.....Everett-McKinney, Bolling
 Membership.....NARTB, BAB
 President.....Frank Gannett
 General Mgr.....Glover DeLaney
 Asst. Gen. Mgr.....Lowell H. MacMillan
 Commercial Mgr.....LeMoine C. Wheeler
 Program Director.....William J. Adams
 Promotion Dir.....Ruth Bauer

In its 15th year— and **STILL GROWING!**

from
16 KW
832 feet above
average terrain
channel 4
Very
High
Frequency

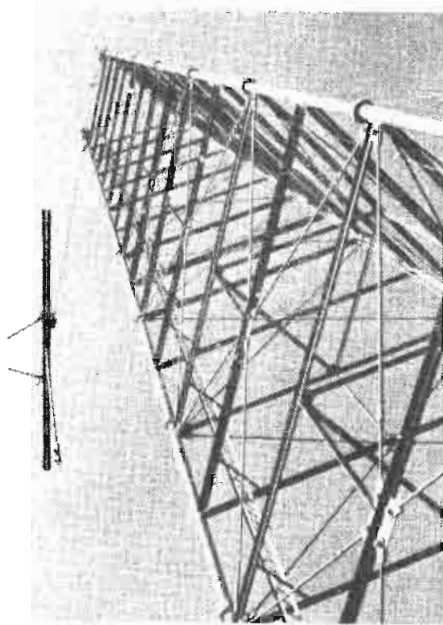

to
93 KW
1020 feet above
average terrain
channel 6
Very
High
Frequency

On January 4, 1954, WRGB increased its power from 16 KW to 93 KW; its antenna height from 832 feet to 1020 feet above average terrain, and, at the direction of the FCC, switched from channel 4 to channel 6. Now transmitting with the maximum signal permitted by the FCC, WRGB still sells the rich capital district, as it has for more than 14 years, plus Northeastern New York and Western New England. The more powerful signal adds some 10,000 square miles and more than 500,000 people to the old coverage area that previously delivered 301,750 sets.

WRGB
CHANNEL 6

The General Electric Station, Schenectady, N. Y.

Represented Nationally by NBC Spot Sales

Director of News.....Warren Doremus
 Production Mgr.....Douglas Tillet
 Film Manager.....James Reidenbach
 Chief Engineer.....Bernard C. O'Brien

Promotion Director.....Robert G. Peel
 Program Director.....Gordon J. Alderman
 Chief Engineer.....Frank Spain
 (See Page 894)

WVET-TV

ROCHESTER—1953—CBS-ABC

Channel: 10 VHF..AP: 20 Kw..VP: 40 Kw.
 Owned-Oper. By....Veterans Bcstg. Co., Inc.
 Business Office.....17 Clinton Ave. S.
 Phone Number.....Hamilton 4820
 Representative.....Bolling
 Pres., Gen. Mgr.....Ervin F. Lyke
 Vice-Pres., Prog. Dir.....Paul C. Louthar
 Commercial Mgr.....Arthur Murrellwright
 Operations Manager.....F. Chase Taylor
 Chief Engineer.....Ray Jobs

WRGB

SCHENECTADY—1939
 ABC-CBS-NBC-DuM

Channel: 6 VHF..AP: 47 Kw..VP: 93 Kw.
 Owned-Oper. By....General Electric Co.
 Business-Studio Address.....1 River Road
 Phone Number.....Schenectady 7-2261
 Air Time.....17½ hours daily
 News Service.....UP
 Representative.....NBC Spot Sales
 Membership.....NARTB, BAB
 Vice-President.....Chester H. Lang
 General Manager.....R. B. Hanna, Jr.
 Station Manager.....R. W. Welpott
 Commercial Mgr.....Robert F. Reid
 Program Director.....Albert G. Zink
 Station Manager.....R. W. Welpott
 Production Supervisor.....Merl Galusha
 Promotion Dir.....James Cobb
 Chief Engineer.....Willard J. Purcell

WTRI

SCHENECTADY—1954

Channel: 35 UHF..AP: 112 Kw..VP: 214 Kw.
 Owned-Oper. By....Van Curler Bcstg. Corp.
 Business Address.....432 State St.
 Phone Number.....4-8908
 Representative.....Headley-Reed
 General Manager.....Richard B. Wheeler
 Asst. Manager.....Paul L. Jacobson
 Chief Engineer.....Albert Chismark

WHEN

SYRACUSE—1948—ABC-CBS-DuM

Channel: 8 VHF..AP: 100 Kw. VP: 190 Kw.
 Owned-Oper. By..Meredith Syracuse TV Corp.
 Address.....101 Court St.
 Phone Number.....74-5711
 Air Time.....15½ hours daily
 News Service.....UP
 Representative.....Katz
 Membership.....NARTB
 President.....E. T. Meredith, Jr.
 V.P., Gen. Mgr.....Paul Adanti
 Commercial Mgr.....W. H. Bell

WSYR-TV

SYRACUSE—1950—NBC

Channel: 3 VHF..AP: 50 Kw..VP: 100 Kw.
 Owned-Oper. By....Central N. Y. Bcstg. Corp.
 Business Address.....224 Harrison St.
 Phone Number.....3-7111
 News. Affil...Post & Standard, Herald-Journal
 News Service.....UP
 Representative...Headley-Reed, Kettell-Carter
 Membership.....NARTB
 Pres., Gen. Mgr.....E. R. Vadeboncoeur
 Dir. of Sales.....W. R. Alford, Jr.
 Program Director.....William V. Rothrum
 Prom., Pub. Dir.....Thomas McCollum
 Dir. of News & Spec. Events.....Fred Hillegas
 Production Manager.....James McDonald
 Chief Engineer.....A. G. Belle Isle
 Consulting Engineer..Craven, Lohnes & Culver

WKTV

UTICA—1949—ABC-CBS-NBC-DuM

Channel: 13 VHF..AP: 100 Kw..VP: 186.9 Kw.
 Owned-Oper. By....Copper City Bcstg. Corp.
 Business Address.....P. O. Box 386
 Phone Number.....3-0404
 Air Time.....17 hours daily
 News Service.....UP
 Representative.....Donald Cooke, Inc.
 President.....Myron J. Kallet
 General Manager.....Michael C. Fusco
 Program Director.....Jack Fredericks
 Promotion Director.....Martin Kovacs
 Production Mgr.....Edwin Whittaker
 Film Director.....Joseph Casaletta
 Chief Engineer.....DeForest T. Layton, Jr.
 Consulting Engineer.....George P. Adair

NORTH CAROLINA

TV HOMES 398,000

POPULATION 4,224,000

STATIONS IN STATE 9

WISE-TV

ASHEVILLE—1953—NBC

Channel: 62.....AP: 13 Kw.....VP: 6 Kw.
 Owned-Operated By.....WISE, Inc.
 Address.....100 College St.
 Representative.....Bolling
 General Manager.....Harold H. Thoms



EVERYWHERE YOU GO THEY'RE WATCHING...

In Paris they're watching . . . in Texas, and Delhi, and in more than 250 similar communities in Central New York. Exotic place names notwithstanding, they're all good New York Staters, 2¼ million of them, but they've ridden the magic carpet of Channel 8, and they're all cosmopolitans, too.

(P. S. A little more worldly than their forebeors, perhaps, but it's still good old American dollars that they spend. WHEN shows 'em what to buy . . . and where . . . and how!)

SYRACUSE

NEW YORK

Commercial Mgr. Loyd B. Leonard
 Program Director. Art Waller
 Chief Engineer. John Randolph

WAYS-TV

CHARLOTTE—1953—ABC-NBC-DuM

Channel: 36 UHF. AP: 12 Kw. VP: 24 Kw.
 Owned-Oper. By. Inter-City Advt. Co.
 Business Address. 3229 South Blvd.
 Phone Number 3-7173
 Air Time 5 hours daily
 News Service UP
 Representative Bolling
 President. George W. Dowdy
 Gen., Sta. Mgr. James P. Poston
 Promotion Dir. Don Matney
 Chief Engineer. B. C. Stewart
 Consulting Engineer. Craven, Lohnes, Culver

WBTW

**CHARLOTTE—1949
 ABC-CBS-NBC-DuM**

Channel: 3 VHF. AP: 60.3 Kw. VP: 100 Kw.
 Owned-Oper. By. Jefferson Standard Bcstg. Co.
 Business-Studio Address. Wilder Bldg.
 Phone Number 3-8833
 Air Time 15 hours daily
 News Service. UP, AP
 Representative. TV Spot Sales
 Membership NARTB
 President. Joseph M. Bryan
 General Manager. Charles H. Crutchfield
 Program Director. Ken Tredwell
 Commercial Manager. Wallace J. Jorgenson
 Promotion Director. J. R. Covington
 Production Manager. Sam Zurich
 Publicity Director. Nelson Benton
 Film Manager. Lacy Sellars
 Chief Engineer. Thomas E. Howard
 Consulting Engineer. A. D. Ring

WCOG-TV

GREENSBORO—1954

Channel: 57 UHF. AP: 59 Kw. VP: 115 Kw.
 Owned-Oper. By. Inter-City Advt. Co.
 Business Address. 314 S. Greene St.
 Phone Number 3-6925
 Representative Bolling
 General Manager. Gilbert M. Hutchison
 Commercial Mgr. Jack Rimmer
 Chief Engineer. Joe Lamb

WFMY-TV

GREENSBORO—1948

Channel: 2 VHF. AP: 8.4 Kw. VP: 16.72 Kw
 Owned-Operated By. Greensboro News Co.
 Address. 212 N. Davie St.
 Phone Number 4-0114
 Air Time 14½ hours daily
 News Service. UP
 News. Affil. News, Record
 Representative. Harrington, Righter & Parsons
 Membership NARTB

Gen., Sta. Manager. Gaines Kelley
 Commercial Mgr. Wm. S. Baskerville
 Program Director. Gomer R. Lesch
 Film Manager. Charles Seward
 Chief Engineer. William E. Neill
 Consulting Engineer. Craven, Lohnes, & Culver

WNCT

**GREENVILLE—1953
 ABC-CBS-NBC-DuM**

Channel: 9 VHF. AP: 56 Kw. VP: 93 Kw.
 Owned-Oper. By. Carolina Bcstg. System Inc.
 Business Address. Box 898
 Phone Number 6181
 Air Time 6¼ hours daily
 News Service. INS, UP
 Representative Pearson
 Membership NARTB
 President. Earl W. Westbrook
 Gen., Sta. Mgr. A. Hartwell Campbell
 Commercial Mgr. John G. Clark
 Program Director. Larry Carr
 Director of News. Bob Dupree
 Production Mgr. Tom Chick
 Pub., Prom. Dir. Ec Wall
 Film Manager. Malcolm Nicholson
 Chief Engineer. Hank Tribley

WNOA-TV

**RALEIGH—1953
 ABC-CBS-NBC-DuM**

Channel: 28 UHF. AP: 8.8 Kw. VP: 17.5 Kw.
 Owned-Oper. Bq. Sir Walter Television Co.
 Business Address. 219 S. McDowell St.
 Phone Number 2-0321
 Air Time. 8 hours daily
 News Service AP
 Representative. Avery-Knodel, Inc.
 Membership NARTB, BAB
 President. John W. English
 Gen., Sta. Mgr. Charles G. Baskerville
 Commercial Mgr. Earl Welde
 Program Director. Byron Davidson
 Promotion Dir. Hal Stanley
 Film Manager. Georget Peterson
 Chief Engineer. Pete Miller

WSJS-TV

WINSTON-SALEM—1953—NBC

Channel: 12 VHF. AP: 21 Kw. VP: 40 Kw.
 Owned-Oper. By. Triangle Bcstg. Corp.
 Business Address. 419-21 N. Spruce St.
 Phone Number 5-2311
 Air Time 10 hours daily
 Newspaper Affiliate. Winston-Salem Journal
 . . . & Twin City Sentinel
 News Service UP
 Representative Headley-Reed
 Membership NARTB
 President. W. K. Hoyt
 Ev. Vice Pres., Gen. Mgr. Harold Essex
 Sales Manager. Harry B. Shaw
 Program Director. Robert C. Estes

North Carolina's
FIRST
Post-Freeze
VHF!



Winston-Salem

plus

Greensboro & High Point

*"The Tar Heel
 Golden Triangle"*



Interconnected Television Affiliate

National Representative: The Headley-Reed Co.

◆ U. S. TELEVISION STATIONS ◆

Operations Mgr. Phil Hedrick
 Film Manager. Carl Weigold
 Consulting Engineer. . Craven, Lohnes & Culver

W T O B - T V

WINSTON-SALEM—1953

ABC-DuM

Channel: 26 UHF. AP: 9 Kw. VP: 17.2 Kw.
 Owned-Oper. By. Winston-Salem Bcstg. Co.
 Business Address. 300 South Stratford Rd.
 Phone Number 3-4353
 Air Time. 8 hours daily
 News Service. AP, UP
 Representative. H-R Television
 Membership NARTB
 Pres., Ccmm. Mgr. James W. Coan
 Gen., Sta. Mgr. John G. Johnson
 Prog., Prod. Dir. Tracy Lounsbury
 Publicity Director. Avery Van Ethen
 Film Manager. Jack Wiggins
 Chief Engineer. Hassell Bailey
 Consulting Engineer. Frank Kear

NORTH DAKOTA

TV HOMES 13,500

POPULATION 626,000

STATIONS IN STATE 3

K F Y R - T V

BISMARCK—1953—NBC-CBS-DuM

Channel: 5 VHF. VP: 50 Kw. VP: 100 Kw.
 Owned-Oper. By. Meyer Bcstg. Co.
 Business Address. 202½ Fourth St.
 Phone Number 468
 Representative Blair
 Exec. V.-P., Gen. Mgr. Frank E. Fitzsimonds
 Program Director. Cal Culver
 Commercial Mgr. Alvin Anderson
 Chief Engineer. Ivar Nelson

W D A Y - T V

FARGO—1953—NBC-CBS-DuM

Channel: 6 VHF. AP: 33 Kw. VP: 66 Kw.
 Owned-Oper. By. WDAY, Inc.
 Business Address. 118 Broadway
 Phone Number 5357
 Representative. Free & Peters
 President. E. C. Reineke
 Manager Tom Barnes

Asst. Manager..... Jack Dunn
 Program Manager..... Ken Kennedy
 Promotion Mgr..... Roy Pedersen
 Production Dir..... Jack Gauritte
 Chief Engineer..... Julius Hetland

K C J B - T V

MINOT—1953—ABC-CBS-NBC-DuM

Channel: 13 VHF. AP: 15 Kw. VP: 29.5 Kw.
 Owned-Oper. By..... North Dakota Bcstg. Co.
 Business Address..... 15-A West Central Ave.
 Phone Number..... 51-161
 Air Time..... 9 hours daily
 News Service..... AP, UP
 Representative..... Weed
 Membership..... NARTB, BAB
 President..... John W. Boler
 Sta. Comm. Mgr..... W. L. Hurley
 Program Director..... Hal Kennedy
 Promotion Director..... C. Putnam
 Director of News..... W. H. Johnson
 Production Mgr..... Arvid Johnson
 Film Manager..... D. Lallathin
 Chief Engineer..... Joseph Main
 Consulting Engineer..... Lloyd R. Amoo

OHIO

TV HOMES 2,017,500

POPULATION 8,385,000

STATIONS IN STATE 20

W A K R - T V

AKRON—1953—ABC

Channel: 49 UHF. AP: 9.1 Kw. VP: 18.2 Kw.
 Owned-Oper. By..... Summit Radio Corp.
 Business Address..... First National Tower
 Phone Number..... Hemlock 4-6151
 Air Time..... 5 hours daily
 Newspaper Affiliation.. Akron Beacon Journal
 News Service..... AP
 Representative..... Weed
 Membership..... NARTB
 Pres., Gen. Mgr..... S. Bernard Berk
 Station Manager..... Roger G. Berk
 Commercial Mgr..... Lowell E. Jackson

"New TV Capitol of the Midwest"

(*No idle boast—read copy below
 for proof positive)

KFYR-TV TELECASTING
 ON CHANNEL 5
 BISMARCK, N. DAK.

Telecasting from atop the State Capitol building,
 KFYR-TV delivers unrivalled coverage in the
 wealthy, Midwest farm belt—and throughout
 the heart of the oil-rich Williston Basin.

KFYR-TV guarantees a ready-made,
 responsive buying audience, built up through
 years of top-flight radio programming.

NBC • DUMONT • CBS

KFYR-TV CHANNEL 5 BISMARCK, N. DAK.

REPRESENTED NATIONALLY BY JOHN ELLIS

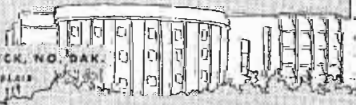
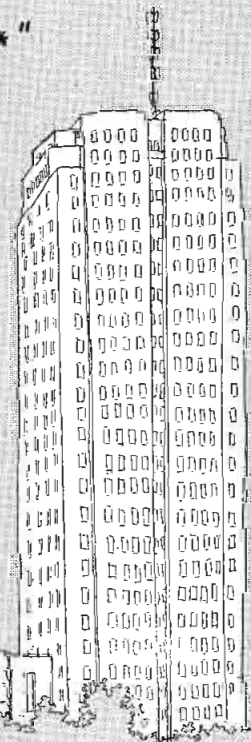



CLEVELAND'S FASTEST GROWING TELEVISION STATION

with

NEW HIGH TOWER

1,000 feet above average terrain... 684 feet above Terminal Tower

NEW HIGH POWER

Almost double effective radiated power

NEW HIGH ENTERTAINMENT

- TOP NETWORK SHOWS
- TOP LOCAL PERSONALITIES
- TOP SPORTS COVERAGE
- THE STATION FOR THE INDIANS-BROWNS

WXEL *Cleveland • Channel 8*

REPRESENTED NATIONALLY BY THE KATZ AGENCY, INC.

Owned and Operated by The Empire Coil Co.

Program Director.....Boyce M. Wright
 Promotion Director.....A. R. Cooper
 Film Manager.....William Mavrides
 Chief Engineer.....Irwin L. Knopp
 Consulting Engineer.....Kear & Kennedy

WICA-TV
ASHTABULA—1953

Channel: 15 UHF..AP: 10 Kw..VP: 19 Kw.
 Owned-Oper. By.....WICA, Inc.
 Business Address.....Jefferson Road
 Phone Number.....32-126
 Air Time.....3 hours daily
 News Service.....UP
 Representative.....Gill-Perna
 President.....D. C. Rowley
 General Manager.....John Colin
 Business Manager.....Donald Fassett
 Office Manager.....Jack Murray
 Program Director.....John Strassen
 Promotion Director.....Lawrence Geretty
 Publicity Director.....Arlene Klamer
 Film Manager.....Fred Baker
 Chief Engineer.....Frank Barnato

WCPO-TV

CINCINNATI—1949—ABC-DuM

Channel: 9 VHF..AP: 130 Kw..VP: 250 Kw.
 Owned-Oper. By.....Scripps-Howard Radio, Inc.
 Business Address.....2345 Symmes St.
 Phone Number.....Capital 0777
 Air Time.....17½ hours daily
 News Service.....UP
 Newspaper Affiliation.....Scripps-Howard
 Representative.....The Branham Co.
 Membership.....NARTB
 President.....Jack R. Howard
 V.P., Gen. Mgr.....M. C. Watters
 Station Manager.....Harry LeBrun
 Program Director.....Ed Weston
 Pub., Prom. Dir.....Richard Zavon
 Film Manager.....Sid Barger
 Chief Engineer.....Paul Adams

WKRC-TV

CINCINNATI—1949—CBS

Channel: 12 VHF..AP: 125 Kw..VP: 250 Kw.
 Owned-Oper. By.....Radio Cincinnati, Inc.
 Business Address.....Times-Star Bldg.
 Phone Number.....Garfield 1331
 Air Time.....17½ hours daily
 News Service.....AP
 Newspaper Affiliation.....Times-Star
 Representative.....The Katz Agency, Inc.
 Membership.....NARTB
 President.....Herbert Tait, Jr.
 General Manager.....U. A. Latham
 Asst. Gen. Mgr.....Don L. Chapin
 Pub. Dir.....Fred Thomas
 Program Director.....Paul Shumate
 Nat'l Sales Mgr.....Kenneth Church
 Promotion Director.....Lila Lambert
 Director of News.....George Palmer
 Production Manager.....Bob Huber
 Film Manager.....James S. Henkel

Comm., Prod. Mgr.....Barbara Hamrick
 Chief Engineer.....George A. Wilson

WLW-T

CINCINNATI—1948—NBC

Channel: 5 VHF..AP: 50 Kw..VP: 100 Kw.
 Owned-Operated By.....Crosley Bcstg. Corp.
 Address.....140 W. Ninth St.
 Phone Number.....Cherry 1822
 Air Time.....18 hours daily
 News Service.....UP, INS
 Representative.....WLW Sales
 President.....R. E. Dunville
 Dir. of TV Oper. & V.P.....John T. Murphy
 Sales Manager.....John H. Bone
 Promotion Dir.....Frederic Gregg
 Chief Engineer.....R. J. Rockwell
 Consulting Engineer.....Weldon & Carr

WEWS

CLEVELAND—1947—CBS

Channel: 5 VHF..AP: 47 Kw..VP: 93 Kw.
 Owned-Oper. By.....Scripps-Howard Radio, Inc.
 Business-Studio Address.....1816 E. 13th St.
 Phone Number.....Tower 1-5454
 Air Time.....16½ hours daily
 News Service.....UP
 Newspaper Affiliation.....Scripps-Howard
 Representative.....Branham
 President.....Jack R. Howard
 General Manager.....James C. Hanrahan
 Station Director.....J. Harrison Hartley
 Advertising Manager.....Floyd E. Weidman
 Dir. of News & Spec. Events.....Donald L. Perris
 Technical Director.....Joseph B. Epperson

WNBK

CLEVELAND—1948—NBC

Channel: 3.....AP: 50 Kw..VP: 100 Kw.
 Owned-Oper. By.....National Bcstg. Co.
 Business-Studio Address.....815 Superior Ave.
 Phone Number.....Cherry 1-0942
 Air Time.....18½ hours daily
 News Service.....AP, UP
 Representative.....NBC Spot Sales
 Membership.....NARTB, BAB
 General Manager.....Lloyd E. Yoder
 Dir. of Sales.....Charles Philips
 Program Manager.....Brooke Taylor
 Dir. of News & Spec. Events.....Edward R.
 Wallace
 Promotion Director.....Clement G. Scerback
 Film Director.....Albert L. Odeal
 Engineer-in-Charge.....S. E. Leonard
 Oper. Sup.....William A. Howard

WXEL

CLEVELAND—1949
ABC-DuM

Channel: 8 VHF..AP: 22.5 Kw..VP: 45 Kw.
 Owned-Oper. By.....Empire Coil Co., Inc.
 Address.....1630 Euclid Ave.

WFMJ-TV's

1,000 Ft. Tower



Is a measure not only of its strength and importance to northeastern Ohio and western Pennsylvania but also its usefulness to advertisers.



WFMJ-TV and AM

Youngstown, Ohio

Phone Number.....Tower 1-8989
 Air Time.....16 hours daily
 News Service.....UP, AP, INS
 Representative.....Katz
 Membership.....NARTB
 President.....Herbert Mayer
 Sta., Gen. Mgr.....Franklin C. Snyder
 Publicity Director.....Barbara Snyder
 Commercial Mgr.....R. C. Wright
 Prog. Dir., Film Mgr.....Ben Wickham
 Dir. of News.....Robert Rowley
 Chief Engineer.....H. A. Brinkman
 Consulting Engineer.....Benjamin Adler

WBNS-TV

COLUMBUS—1949—CBS

Channel: 10...AP: 123 Kw...VP: 219 Kw.
 Owned By.....Dispatch Printing Co.
 Business Address.....33 N. High St.
 Phone Number.....Fletcher 3538
 Air Time.....16 hours daily
 Newspaper Affiliation...Columbus Dispatch
 News Service.....AP
 Station Representative.....Blair
 Membership.....NARTB
 Dir. of Television.....Richard A. Borel
 Program Director.....Jerome R. Reeves
 Sales Director.....Robert D. Thomas
 Promotion Director.....Barbara Haddox
 Dir. News & Spe. Events.....Chester S. Long
 Production Dir.....John Haldi
 Public Serv. Dir.....Charles S. Cady
 Merchandising Dir.....Morton Sherman
 Chief Engineer.....Lester H. Nafzger
 Consulting Engineer.....Jansky & Bailey

WLW-C

COLUMBUS—1949—NBC

Channel: 4 VHF...AP: 13 Kw...VP: 26 Kw.
 Owned-Operated By.....Crosley Bcstg. Corp.
 Business Address...3165 Olentangy River Rd.
 Phone Number.....Jefferson 5441
 Air Time.....19 hours daily
 News Service.....UP, INS
 President.....Robert E. Dunville
 Gen. Sta. Mgr.....James Leonard
 Commercial Mgr.....James G. Burgess
 Program Director.....Walter S. Jacobs
 Promotion Director.....Donald H. Edgemon
 Dir. of News & Spec. Events...David Nichols
 Film Manager.....Nicholas Lupplno
 Chief Engineer.....Charles Sloan

WTVN

COLUMBUS—1949—ABC-DuM

Channel: 6 VHF...AP: 10.0 Kw...CP: 19.8 Kw.
 Owned-Oper. By.....Radio Cincinnati, Inc.
 Address.....753 Harmon Ave.
 Phone Number.....Fletcher 5801
 Air Time.....13 hours daily
 News Service.....AP
 Representative.....Katz
 Membership.....NARTB
 President.....Hulbert Taft, Jr.

Exec. Vice-President.....Kenneth Church
 General Manager.....J. W. McGough
 Sales Manager.....Edwin G. Richter, Jr.
 Program Director.....William T. Wagner
 Promotion Dir.....Beatrice Calderon
 Director of News.....William Palmer
 Film Manager.....Richard McKinney
 Chief Engineer.....Marvin Ingerson

WHIO-TV

DAYTON—1949—ABC-CBS

Channel: 7...AP: 158 Kw...VP: 316 Kw.
 Owned-Oper. By...Miami Valley Bcstg. Corp.
 Business Address.....45 S. Ludlow St.
 Phone Number.....Adams 2261
 Representative.....Hollingbery
 President.....James M. Cox, Jr.
 Managing Director.....J. Leonard Reinsch
 General Manager.....Robert H. Moody
 Asst. to Gen. Mgr.....Harvey R. Young, Jr.
 Program Director.....Don R. Lyons
 Chief Engineer.....Ernest L. Adams

WIFE

DAYTON—1953—ABC-DuM

Channel: 22 UHF...AP: 132 Kw...VP: 254 Kw.
 Owned-Oper. By.....Skyland Bcstg. Corp.
 Business Address.....380 West First St.
 Phone Number.....Michigan 6501
 Representative.....Headley-Reed
 Pres., Gen. Mgr.....Ronald B. Woodyard
 Nat. Sales Manager.....C. J. Thonquest
 Commercial Mgr.....Louis G. Froelich
 Program Director.....Paul Kane
 Chief Engineer.....Joseph P. Gill

WLW-D

DAYTON—1949—NBC

Channel: 2 VHF...AP: 50 Kw...VP: 100 Kw.
 Owned-Oper. By.....Crosley Bcstg. Corp.
 Business-Studio Address...4595 S. Dixie Hwy.
 Phone Number.....Walnut 2101
 Air Time.....17½ hours daily
 News Service.....UP, INS
 Representative...WLW Offices, New York,
 Chicago, Hollywood

Membership.....NARTB
 Station Manager.....H. Peter Lasker
 Commercial Manager...Wm. J. Williamson
 Program Manager.....Robert Head
 Prom. Pub. Dir.....Dorothy A. Sanders
 Dir. of News & Spec. Events...Omar Williams
 Film Manager.....Mary Lou Myers
 Production Manager.....Ray E. Brosseau
 Chief Engineer.....Lester Sturgill

WLOK-TV

LIMA—1953—NBC

Channel: 73 UHF...AP: 8.3 Kw...VP: 20 Kw.
 Owned-Oper. By.....WIOK, Inc.
 Business Address.....1424 Rice Ave.
 Phone Number.....6-3411
 News Service.....UP
 Representative.....H-R

Membership NARTB
 President L. A. Pixley
 Exec. Vice-Pres. Robert O. Runnerstrom
 Natl. Sales Manager Lawrence Webb
 Program Director William Hultman
 Promotion Dir. Peggy Miller
 Director of News Joe Rex
 Chief Engineer Darrel Hunter
 Consulting Engineer Craven, Lohnes & Culver

WSTV-TV

STEUBENVILLE—1953—CBS

Channel: 9 VHF.. AP: 70 Kw.. VP: 140 Kw.
 Owned Oper. By WSTV, Inc.
 Business Address Exchange Realty Bldg.
 Phone Number 2-6265
 Representative Avery-Knodel
 Vice-Pres., Gen. Mgr John J. Laux
 Commercial Mgr. Joseph M. Troesch
 Prod. Mgr. Robert E. Holt
 Prog. Dir. Harry Birrell
 Director of News Scott McMurray
 Chief Engineer Charles Shepherd

WSPD-TV

TOLEDO—1948—ABC-CBS-NBC-DuM

Channel: 13 VHF.. AP: 12.3 Kw.. VP: 24.5 Kw.
 Owned Oper. By Storer Bdcstg. Co.
 Business-Studio Address 136 Huron St.
 Phone Number Adams 3175
 Representative Katz
 Membership TBA, NARTB, BAB
 President George B. Storer
 Commercial Manager W. F. Shannon
 Gen., Sta. Mgr. Allen L. Haid
 Program Director Al Ruhfel
 Production Manager John Saunders
 Film Director Elaine Phillips
 Chief Engineer William Stringfellow

WFMJ-TV

YOUNGSTOWN—1953—NBC

Channel: 73 UHF.. AP: 89 Kw.. VP: 175 Kw.
 Owned-Operated By Vindicator Printing Co.
 Address 101 W. Boardman Street
 Phone Number 3-4121
 Newspaper Affil. The Youngstown Vindicator
 Representative Headley-Roed
 Pres., Gen. Mgr. William F. Maag, Jr.
 Comm. Mgr. Leonard E. Nasman
 Program Director Ronald Richards
 Film Manager Alan Suthmayd
 Chief Engineer Frank A. Dieringer
 (See Page 900)

WKBN-TV

YOUNGSTOWN—1953—ABC-CBS
 DuM

Channel: 27 UHF.. AP: 9.5 Kw.. VP: 15.8 Kw.
 Owned-Operated By WKBN Bcstg. Co.
 Address 3930 Sunset Blvd.
 Representative Raymer
 Station Manager J. L. Bowden
 Chief Engineer B. T. Wilkens

WHIZ-TV

ZANESVILLE—1953
 ABC-CBS-NBC-DuM

Channel: 50 UHF.. AP: 38 Kw.. VP: 70.8 Kw.
 Owned-Oper. By Southeastern Ohio TV
 System

Business Address Lind Arcade Bldg.
 Phone Number 2-5431
 Air Time 8½ hours daily
 News Service UP
 Representative Pearson
 Membership NARTB, BAB
 President Clay Littick
 Gen., Sta. Mgr. Vernon A. Nolte
 Comm. Mgr. Nate Miller
 Program Director Robert D. Maley
 Promotion Dir. Robert Cromwell
 Director of News Allan Land
 Production Dir. Edward Fisher
 Chief Engineer William A. Hunt
 Consulting Engineer Craven, Lohnes & Culver

OKLAHOMA

TV HOMES 320,000

POPULATION 2,280,000

STATIONS IN STATE 7

KSWO-TV

LAWTON—1953

Channel: 7 VHF.. AP: 4.8 Kw.. VP: 9.6 Kw.
 Owned-Operated By

Oklahoma Quality Bcstg. Co.
 Address P. O. Box 1385
 Representative Everett-McKinney
 Phone Number 7777
 Air Time 9 hours daily
 News Service UP
 Membership NARTB
 President R. H. Drewry
 Gen., Sta. Mgr. Paul N. Goode
 Commercial Mgr. L. W. Ozier, Jr.
 Program Director Henry Mattison
 Promotion Dir. Beverly Whitener
 Director of News William McReynolds
 Production Mgr. B. J. Wheatley
 Film Manager W. J. Evans
 Chief Engineer Willard Cochran
 Consulting Engineer William Buford

KMPT

OKLAHOMA CITY—1953—DuM

Channel: 19 UHF.. AP: 89 Kw.. VP: 178 Kw.

Owned-Oper. By.....KLPB Television Inc.
 Business Address.....128 W. Commerce
 Phone Number.....Central 2-1341
 Air Time.....8 hours daily
 News Service.....UP
 Representative.....Bolling
 Membership.....NARTB
 General Manager.....Fred Farha
 Program Director.....Douglas Carruth
 Director of News.....Grant Ladd
 Film Manager.....Phyllis Lewis
 Chief Engineer.....Jacob A. Davis

KTVQ

OKLAHOMA CITY—1953—ABC-CBS

Channel: 25 UHF..AP: 141 Kw..VP: 275 Kw.
 Owned-Oper. By.....Republic TV & Radio Co.
 Business Address.....Northwest Station
 Phone Number.....Jackson 8-4151
 Air Time.....8½ hours daily
 News Service.....AP
 Representative.....H.R.
 President.....John Esau
 Gen., Sta. Mgr.....J. Harry Abbott
 Commercial Mgr.....Raymond Ruff
 Prog., Prom. Dir.....Bill Sadler
 Director of News.....Jack Sherman
 Film Manager.....Wayne Taylor
 Chief Engineer.....Harold L. Coomes
 Consulting Engineer.....Vandivere, Cohen,
 Wearm

KWTW

OKLAHOMA CITY—1953—CBS

Channel: 9 VHF..AP: 158 Kw..VP: 316 Kw.
 Owned-Oper. By.....Oklahoma Television Corp.
 Business Address.....Box 8788
 Phone Number.....Victor 3-6641
 Representative.....Avery-Knodel
 General Manager.....Edgar T. Bell
 Commercial Mgr.....Fred L. Vance
 Promotion, Pub. Dir.....Montez Tjaden
 Film Manager.....David Hunt
 Director of News.....Bruce Palmer
 Program Director.....Russ Severin
 Chief Engineer.....Morris W. Thomas

WKY-TV

OKLAHOMA CITY—1949 ABC-NBC

Channel: 4 VHF..AP: 60 Kw..VP: 100 Kw.
 Owned-Oper. By.....WKY Radiophone Co.
 Studio Address.....500 E. Britton Rd.
 Phone Number.....Trinity 8-2161
 Air Time.....17½ hours daily
 News Service.....AP, UP
 News. Affil.....Oklahoman, Times
 Representative.....Katz
 Membership.....NARTB
 President.....E. K. Gaylord
 Manager.....P. A. Sugg
 Asst. Manager.....Hoyt Andres
 Program Director.....Robert Olson
 Promotion Director.....Dallas Wyatt
 Dir. of News & Spec. Events.....Grant Foster

Production Manager.....Robert Doty
 Adm. Assistant.....Eugene B. Dodson
 Natl. Sales Director.....Kieth Mathers
 Chief Engineer.....H. J. Lovell
 Consulting Engineer.....A. D. Ring Co.

KCEB

TULSA—1953—NBC

Channel: 23 UHF..AP: 95 Kw..VP: 180 Kw.
 Owned-Oper. By.....Elfred Beck
 Business Address.....1606 Natl. Bank of Tulsa
 Phone Number.....4-4044
 Representative.....Bolling
 Membership.....NARTB
 President.....Elfred Beck
 General Manager.....N. Ray Kelly
 Asst. to Manager.....Valeria O'Neal
 Commercial Mgr.....John Howley
 Program Director.....William G. McLaren
 Chief Engineer.....Richard W. Pickard
 Consulting Engineer.....George Davis

KOTV

TULSA—1949 CBS-NBC

Channel: 6....AP: 60.3 Kw....VP: 100 Kw.
 Owned-Oper. By.....Wrather-Alvarez, Inc.
 Business Address.....302 S. Frankfort St.
 Phone Number.....2-9233
 Station Representative.....Petry
 President.....Jack D. Wrather, Jr.
 Gen., Sta. Manager.....Maria Helen Alvarez
 Commercial Manager.....John B. Hill
 Program Director.....Don Thompson
 Asst. Gen. Mgr.....Robert Freeland
 Chief Engineer.....George Jacobs

OREGON

TV HOMES 187,000

POPULATION 1,854,000

STATIONS IN STATE 4

KBES-TV

MEDFORD—1953 CBS-ABC-NBC-DuM

Channel: 5 VHF..AP: 15.8 Kw..VP: 28.9 Kw.
 Owned-Oper. By.....Southern Oregon Bcstg. Co.
 Business Address.....Box 1189
 Phone Number.....Gold Hill 5-9333
 Representative.....Blair
 President.....Amos Voorhies
 Vice-Pres., Sta. Mgr.....Ed A. Malone
 Vice-Pres., Business Mgr.....Everett A. Faber
 General Manager.....William B. Smullin
 Advertising Manager.....John Burr

HOW! ONLY 1 TV STATION

Blankets the ENTIRE GREATER LEHIGH VALLEY AREA

PENNSYLVANIA'S 3RD RD MARKET

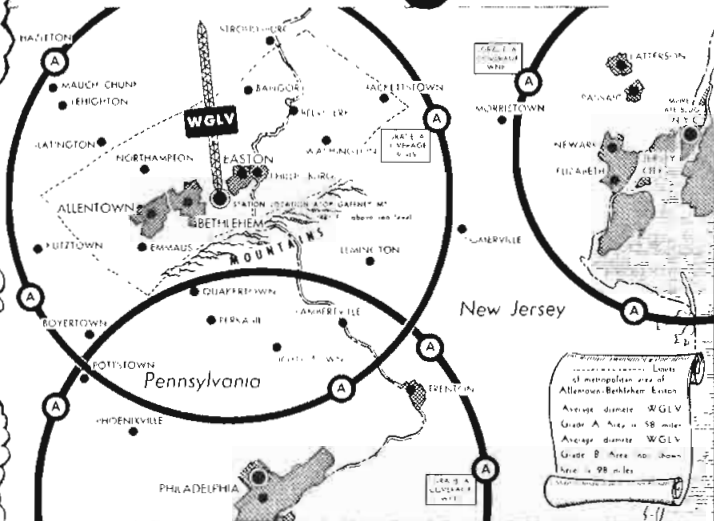

"This map shows Grade A, or reliable coverage areas as published by strongest stations in New York, Philadelphia, and Allentown-Bethlehem-Easton area (44th market in U.S.)"

CHANNEL 57
100,000 WATTS
AT 1481 FEET

ALLENTOWN-BETHEHEM-EASTON METROPOLITAN DISTRICT

POPULATION	RETAIL SALES	AVG. FAMILY INCOME
A —566,197	A —\$729,426,000	A—\$5,725
A & B—3,069,700	A & B—\$4,750,326,000	B—\$5,692

45% of the TV homes in the Allentown-Bethlehem-Easton area have converted to UHF in the past 10 months. This is proven by the monthly set count by Palmer & Company, certified public accountants, based upon receivers sold or converted by regular TV dealers.

*UHF SETS IN USE
 July 1, 1953 3,000 est.
 October 1, 1953 41,343
 November 15, 1953 51,944
 January 1, 1954 65,098
 February 1, 1954 79,340
 *Allentown-Bethlehem-Easton area representing only 40% of the WGLV primary coverage area.



WGLV (Television) and the EASTON EXPRESS (Newspaper) are owned and operated by the Easton Publishing Co., Easton, Pa.
 J. L. Stackhouse, President
 Richard W. Hubble, Assistant to the President in charge of Television and Radio.

Represented by *Headley-Reed TV*

NEW YORK • CHICAGO • SAN FRANCISCO • HOLLYWOOD • ATLANTA • PHILADELPHIA

KOIN-TV

PORTLAND—1953—CBS-ABC

Channel: 6 VHF...AP: 28 Kw...VP: 56 Kw.
 Owned-Oper. By...Mt. Hood Radio & TV Bcstg.
 Corp.
 Business Address.....140 S.W. Columbia St.
 Phone Number.....Atwater 6412
 Representative.....Avery-Knodel
 President.....Ted Gamble
 Vice-Pres., Manag. Dir.....C. Howard Lane
 Program Director.....Ted W. Cooke
 Film Director.....Ted M. Williams
 Production Mgr.....Roy Rector
 Film Director.....T. M. Williams
 Chief Engineer.....Louis Bookwalter

WLEV-TV

BETHLEHEM—1952—NBC

Channel: 51 UHF...AP: 2.24 Kw...VP: 2.24 Kw.
 Owned-Oper. By.....Associated Bcstrs. Inc.
 Business Address.....801 Hamilton St.
 Phone Number.....Hemlock 4-6278
 Air Time.....9 hours
 News Service.....UP
 Representative.....Meeker
 Membership.....NARTB
 General Manager.....Clair R. McCollough
 Station Manager.....Thomas R. Nunan, Jr.
 Natl. Sales Manager.....J. Robert Gulick
 Program Director.....Richard Getz
 Chief Engineer.....J. E. Mathiot

KPTV

PORTLAND—1952—CBS-DuM
 NBC

Channel: 27 UHF...AP: 44 Kw...VP: 88 Kw.
 Address.....735 S.W. 20th Pl.
 Owned-Operated By.....Empire Coil Co.
 Representative.....NBC Spot Sales
 President.....Herb Mayer
 Commercial Mgr.....Charles White
 Chief Engineer.....Wm. McAlister
 Program Manager.....Eugene Ragle

WCHA-TV

CHAMBERSBURG—1953—CBS-DuM

Channel: 46 UHF...AP: 10.5 Kw...VP: 21 Kw.
 Owned-Oper. By...Chambersburg Bcstg. Co.
 Business Address.....Craft Press Bldg.
 Phone Number.....1110
 Air Time.....7 hours daily
 News Service.....AP
 Representative.....Forjoe
 Membership.....NARTB
 Gen., Sta. Mgr.....John S. Booth
 Commercial Mgr.....Richard J. Koba
 Program Director.....Allan Saunders
 Film Manager.....Robert Glessner
 Chief Engineer.....James McCurdy

KPIC

SALEM—1954

Channel: 24 UHF...AP: 8.87 Kw...VP: 16.4 Kw.
 Owned-Oper. By.....Lawrence A. Harvey
 Business Address.....321 S. Beverly Dr.,
 Beverly Hills, Calif.
 President.....Lawrence A. Harvey
 Vice-President.....Joseph Brenner
 Chief Engineer.....Harold W. Jury

WGLV

EASTON—1953—ABC-DuM

Channel: 57 UHF...AP: 49.89 Kw...AP: 100 Kw.
 Owned-Oper. By.....Easton Publishing Co.
 Business Address.....30 N. 4th St.
 Phone Number.....3-8371
 Representative.....Headley-Reed
 President.....J. L. Stackhouse
 General Manager.....Richard W. Hubbell
 Business Manager.....Nelson Rounsley
 Sales Manager.....Nevin S. Paskow
 Program Manager.....Alice O'Hare
 Promotion Mgr.....William H. Youry
 Film Manager.....Percy E. DeWitt
 Chief Engineer.....Charles R. Thon

PENNSYLVANIA

TV HOMES 2,375,000

POPULATION 11,223,000

STATIONS IN STATE 28

WFBG-TV

ALTOONA—1953—NBC-ABC-DuM

Channel: 10 VHF...AP: 160 Kw...VP: 316 Kw.
 Owned-Operated By.....The Gable Co.
 Address.....Gable Arcade
 Representative.....H-R Reps
 President.....G. P. Gable
 General Manager.....Jack Snyder
 Film Manager.....B. Harley Shook
 Consulting Engineers
 Craven, Lohnes & Culver

WICU

ERIE—1949—ABC-CBS-NBC-DuM

Channel: 12...AP: 15 Kw...VP: 30 Kw.
 Owned-Oper. By.....Dispatch Incorporated
 Bus.-Trans. Address.....3515 State St.
 Phone Number.....4-5021
 Air Time.....18 hours daily
 Representative.....Petry
 President.....Edward Lamb
 General Manager.....Ben McLaughlin
 Program Director.....Dan Lick
 Film Director.....John W. Cook
 Commercial Mgr.....Karl Nelson
 Prom. Dir.....Jack Schumacher
 Chief Engineer.....Michael Csep

WCMB-TV

HARRISBURG—1954

Channel: 27 UHF..AP: 49.5 Kw..VP: 98.9
 Owned-Oper. By.....Rossmoyne Corp.
 Business Address.....230 Court St.
 Phone Number.....4-3005
 News Service.....INS
 Representative.....Cooke
 Membership.....NARTB
 President.....Edgar T. Shepard, Jr.
 General Manager.....Ed K. Smith
 Commercial Mgr.....Rudolph O. Marcoux
 Chief Engineer.....J. Howard Bair
 Consulting Engineer.....Frank McIntosh

WHP-TV

HARRISBURG—1953—CBS

Channel: 55 UHF..AP: 126 Kw..VP: 253 Kw.
 Owned-Oper. By.....WHP, Inc.
 Business Address.....216 Locust St.
 Phone Number.....4-3211
 Air Time.....9½ hours daily
 News Service.....UP
 Representative.....Bolling
 General Manager.....A. K. Redmond
 Program Director.....Dick Redmond
 Promotion Dir.....Beatrice Potteiger

Director of News.....Joseph Harper
 Production Mgr.....Edgar Gault
 Publicity Director.....Frank Noto
 Film Manager.....Charles Baddorf, Jr.
 Chief Engineer.....E. Daniel Leibensperger

WTPA

HARRISBURG—1953—NBC

Channel: 71 UHF..AP: 9.3 Kw..VP: 17.5 Kw.
 Owned-Oper. By.....Harrisburg Bcstrs. Inc.
 Business Address.....3235 Hoffman St.
 Phone Number.....Harrisburg 8-7171
 Air Time.....15½ hours daily
 Newspaper Affiliation.....Patriot-News
 News Service.....UP
 Membership.....NARTB
 President.....Donald Newhouse
 Gen. Sta. Mgr.....David J. Bennett
 Commercial Mgr.....Alan Solada
 Program Director.....Donald D. Wear
 Promotion Mgr.....Gladys Swift
 Director of News.....Roy Nassau
 Production Mgr....."Mac" McCauley
 Film Manager.....Edward J. McGinnis
 Chief Engineer.....Paul Gross
 Consulting Engineer.....Craven, Lohnes & Culver

BEST BUY

in Southwestern Pennsylvania

WJAC-TV JOHNSTOWN

3 Market Coverage for the Price of 1!

YOUR BUDGET GETS A BREAK, and your sales coverage a real bonus, when you choose WJAC-TV in Johnstown. Based on latest Hooper standings, WJAC-TV proves its audience appeal, not only in the Greater Johnstown Market, but in Pittsburgh and Altoona as well! One buy covers three . . . when you use WJAC-TV!

1st in Johnstown

2nd in Pittsburgh

1st in Altoona

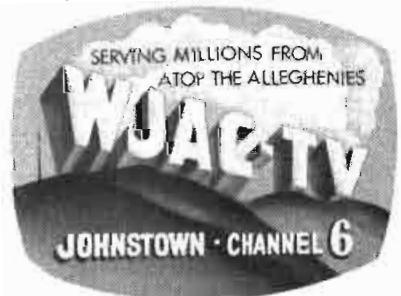

Get full details from your KATZ man!

WARD-TV

JOHNSTOWN—1953—CBS-DuM
ABC

Channel: 56 UHF...AP: 10 Kw...VP: 20 Kw.
Owned-Oper. By.....Rivoli Realty Co.
Business Address.....First Natl. Bank Bldg.
Phone Number.....81-216
Representative.....Weed
General Manager.....Robert R. Nelson
Chief Engineer.....Millard Coleman

WJAC-TV

JOHNSTOWN—1949
ABC-CBS-NBC-DuM

Channel: 6 VHF...AP: 35 Kw...VP: 70 Kw.
Owned-Operated By.....WJAC, Inc.
Business Address.....329 Main St.
Phone Number.....9-1965
Air Time.....14½ hours daily
Newspaper Affiliation...The Johnstown Tribune
News Service.....UP
Representative.....Katz
Membership.....NARTB
President.....Walter W. Krebs
Gen., Sta. Mgr.....Alvin D. Schrott
Sales Manager.....John H. Hepburn
Prog. Dir., Film Mgr.....Frank P. Cummins
Chief Engineer.....Theodore Campbell
Consulting Engineer.....McNary

WGAL-TV

LANCASTER—1949
ABC-CBS-NBC-DuM

Channel: 8 VHF...AP: 7.2 Kw...VP: 3.6 Kw.
Owned-Operated By.....WGAL, Inc.
Business-Transmitter Address...24 S. Queen St.
Phone Number.....5246
Studio Address.....24 S. Queen St.
Air Time.....116 hours weekly
News Service.....UP
Representative.....Meeker
Membership.....NARTB
President.....Clair R. McCollough
Station Manager.....Harold E. Miller
Gen. Sales Mgr.....J. Robert Gulick
Program Director.....Paul Rodenhauer
Technical Director.....J. E. Mathiot

WLBR-TV

LEBANON—1953

Channel: 15 UHF...AP: 69.2 Kw...VP: 129 Kw.
Owned-Oper. By.....Lebanon Television Corp.
Business Address.....8th & Cumberland Sts.
Phone Number.....2-4646
Air Time.....6 hours daily
Newspaper Affiliation...Lebanon Daily News
News Service.....UP
Representative.....Pearson
Membership.....NARTB
President.....Lester P. Etter
Station Manager.....Arthur H. Simmers
Program Director.....Arthur H. Simmers

Commercial Mgr.....Phillip J. Reilly
Promotion Dir.....Jack Schropp
Director of News.....Hy White
Film Manager.....Gene Dyssinger
Public Service.....Henry Homan
Chief Engineer.....Leonard Savage
Consulting Engineer.....A. D. Ring

WKST-TV

NEW CASTLE—1953—DuM

Channel: 45 UHF...AP: 10.5 Kw...VP: 20.8 Kw.
Owned-Oper. By.....WKST, Inc.
Business Address.....Cathedral Bldg.
Phone Number.....Oliver 4-5501
Air Time.....3 hours daily
News Service.....UP
Representative.....Everett-McKinney, Inc.
Pres., Gen. Mgr.....S. W. Townsend
Sta., Comm. Mgr.....Art Graham
Program Director.....Harry Reith
Promotion Dir.....Al Francis
Director of News.....Croy Pitzer
Chief Engineer.....Donald Dout

WCAU-TV

PHILADELPHIA—1947—CBS

Channel: 10 VHF...AP: 14 Kw...VP: 25 Kw.
Owned-Operated By.....WCAU, Inc.
Address.....City Ave. & Monument Ave.
Phone Number.....GR 7-8300
Air Time.....16 hours daily
Newspaper Affiliation...The Evening Bulletin
News Service.....AP, UP
Representative.....CBS TV Spot Sales
Pres., Gen. Mgr.....Dorald W. Thornburgh
V.P., Asst. Gen. Mgr.....Joseph L. Tinney
V.P. & TV Director.....Charles Vanda
Commercial Manager.....Robt. McGredy
Program Director.....John McClay
V.P. & Prom. & Pub. Dir.....Robert N. Pryor
Dir. News & Spec. Events.....Charles Shaw
Production Manager.....Richard Schlegle
V.P. & Technical Director.....John G. Leitch

WFIL-TV

PHILADELPHIA—1947—ABC-DuM

Channel: 6 VHF...AP: 50 Kw...VP: 100 Kw.
Owned-Oper. By.....Triangle Publications Inc.
Business Address.....46th & Market Sts.
Phone Number.....Evergreen 2-4700
Air Time.....16 hours daily
Newspaper Affiliation...Philadelphia Inquirer
News Service.....UP
Representative.....Katz
Membership.....NARTB
General Manager.....Roger W. Clipp
Commercial Mgr.....Kenneth W. Stowman
Program Director.....Jack Steck
Promotion Director.....Joe Zimmermann
Director of News.....Charles Harrison
Publicity Director.....John Hyland
Film Manager.....Ralph Goldstein
Chief Engineer.....Henry Rhea

2

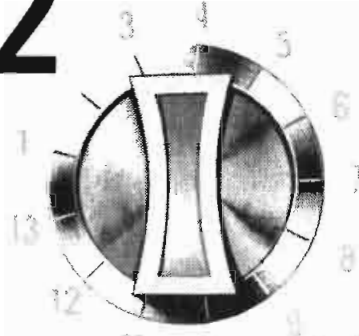

will get you **SIX** 
in
PITTSBURGH

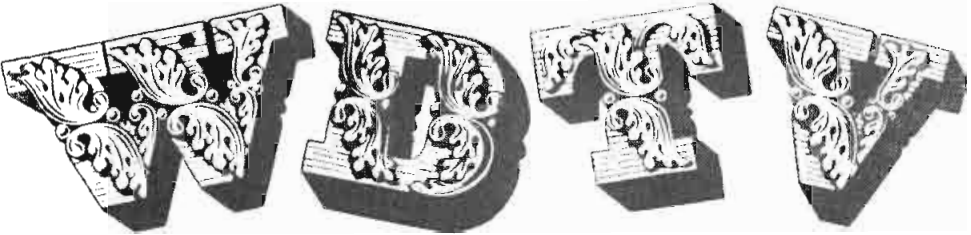

Want to capture the nation's sixth largest metropolitan market? Then tune your sales to WDTV—Channel 2—in Pittsburgh! Every day in over 800,000 homes in the Pittsburgh district, your customers are tuned

to Channel 2. They prefer WDTV with programs geared to Pittsburgh people, Pittsburgh habits and tastes. Use Du Mont's WDTV, Pittsburgh's first television station—and you'll sell Pittsburgh!

Pittsburgh's *First* Television Station

CHAMBER OF COMMERCE BLDG., PITTSBURGH 19, PA.

Owned and Operated by ALLEN B. DU MONT LABORATORIES, INC.

HAROLD C. LUND, General Manager

WPTZ

PHILADELPHIA—1941—NBC

Channel: 3... AP: 50 Kw... VP: 100 Kw.
 Owned-Oper. By... Westinghouse Radio Sta. Inc.
 Business Address... 1600 Architects Bldg.
 Phone Number... LOcust 4-5500
 Air Time... 19 hours daily
 News Service... UP, INS
 Station Representative... Free & Peters
 Membership... NARTB
 Gen. Mgr... Rolland V. Tooke
 Comm. Mgr... Alexander W. Dannenbaum, Jr.
 Program Manager... Stan Lee Broza
 Pub., Prom. Dir... John J. Kelly
 Chief Engineer... Raymond J. Bowley

Owned-Oper. By... Agnes J. Reeves Greer
 Business Address... 1715 Grandview Ave.
 Phone Number... Hubbard 1-2626
 Air Time... 14 hours daily
 Newspaper Affiliation... Dominion News & Morgantown Post
 News Service... UP
 Representative... Weed
 Membership... NARTB
 Owner... Agnes J. Reeves Greer
 Gen., Sta. Mgr... F. G. Raese
 Commercial Mgr... Joseph Jenkins
 Promotion Dir... Harold Stark
 Director of News... Harrison Eagles
 Production Mgr... John Ziegler
 Film Manager... Donald Redinger
 Chief Engineer... Peter E. Pappas

WDTV

PITTSBURGH—1949
 ABC-CBS-NBC-DuM

Channel: 2... AP: 8.3 Kw... VP: 16.6 Kw.
 Owned-Operated By... Allen B. Du Mont Laboratories, Inc.
 Business Address... Chamber of Commerce Bldg.
 Phone Number... Express 1-3000
 Air Time... 19 hours daily
 News Service... UP
 Representative... DuMont Network
 Membership... NARTB
 President... Dr. Allen B. Du Mont
 Gen. Mgr... Harold C. Lund
 Sales Dir... George Baren Bregge
 Publ. Dir... Dick Fortune
 Program Manager... Byron H. Dowdy
 Director of News... Bill Burns
 Film Manager... Richard Dreyfuss
 Chief Engineer... Raymond Rodgers

WEEU-TV

READING—1953—ABC-NBC

Channel: 33 UHF... AP: 87 Kw... VP: 167 Kw.
 Owned-Oper. By... Hawley Bcstg. Co.
 Business Address... 433 Penn St.
 Phone Number... 6-7335
 Air Time... 10½ hours daily
 Newspaper Affiliation... Eagle-Times
 News Service... UP
 Representative... Headley-Reed
 Membership... NARTB, BAB
 President... Hawley Quier
 Vice-Pres., Gen. Mgr... Thomas E. Martin
 Asst. Manager... K. Richard Creitz
 Program Director... George Carroll
 Promotion Dir... Jeanne Thompson
 TV Sales Director... Ewart M. Blain
 Production Mgr... Roy V. Swinamer
 Film Manager... Daniel W. Shields
 Chief Engineer... David J. Miller Jr.

WENS

PITTSBURGH—1953—ABC

Channel: 16 UHF... AP: 106 Kw... VP: 200 Kw.
 Owned-Oper. By... Telecasting, Inc.
 Business Address... 947 Aliver Bldg.
 Phone Number... Atlantic 1-4300
 Air Time... 9 hours daily
 News Service... INS, UP
 Representative... Petry
 Membership... NARTB
 President... Thomas P. Johnson
 Managing Director... A. Donovan Faust
 General Manager... Larry H. Israel
 Commercial Mgr... Donald Menard
 Program Director... David C. Murray
 Director of News... Dan Mallingner
 Production Mgr... Thomas Borden
 Publicity Director... Peter Thornton
 Film Manager... Jay Gould
 Chief Engineer... Fred M. Eames, Jr.

WHUM-TV

READING—1953

Channel: 61 UHF... AP: 135 Kw... VP: 260 Kw.
 Owned-Oper. By... Eastern Radio Corp.
 Address... Skyline Drive
 Phone Number... 4-4805
 Air Time... 14 hours daily
 News Service... INS, AP
 Representative... H R Television, Inc.
 Pres., Gen. Mgr... Humboldt J. Greig
 Program Director... Howard Davis
 Film Manager... Alan Lane
 Dir. of News & Spec. Events... John Deegan
 Production Mgr... Robert Bostian
 Sales Manager... Frank Elliott
 Chief Engineer... Louis E. Littlejohn
 (See Page 910)

WKJF-TV

PITTSBURGH—1953—NBC

Channel: 53 UHF... AP: 11.59 Kw... VP: 19.28 Kw.

WARM-TV

SCRANTON—1953—ABC

Channel: 16 UHF... AP: 152 Kw... VP: 256 Kw.
 Owned-Oper. By... Union Bcstg. Co.
 Business Address... 333 Madison Ave.
 Phone Number... Diamond 3-245
 Air Time... 8½ hours daily
 News Service... UP

We've Got Reading **WHUM**ming!

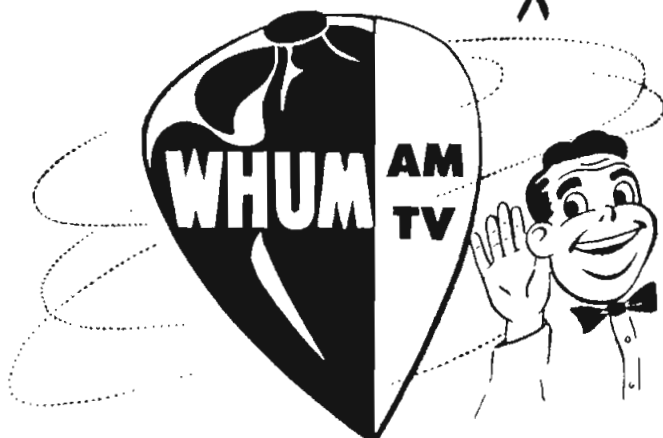

In One of the Nation's Top Markets

WHUM-AM

- Serving the Pennsylvania Dutch Country.
- WHUM is the most listened to station in the Reading Metropolitan Area.
- The WHUM audience exceeds the other two Reading stations combined . . . Pulse.
- WHUM is the only CBS station in Berks, Schuylkill, Lebanon, Lancaster, Chester and Montgomery Counties (4243 square miles).
- The WHUM Market is a Billion Dollar Market.

WHUM-TV CHANNEL 61

- Serving one of the nation's top 10 television markets with 2.7 million population in the Reading-Allentown - Harrisburg - York - Lancaster - Wilkes-Barre area.
- World's most powerful television station with 260,000 watts.
- Antenna height of 2680 feet above sea level (actual antenna height: 1050 feet), nearly twice the height of the antenna on the Empire State Building.
- Only General Electric Klystron transmitting equipment in the nation.
- On the air February 22, 1953.

READING, PA.

CBS Radio and Television Networks Affiliate • Represented Nationally by H-R Representatives

Representative Hollingbery
 Membership BAB
 President Martin F. Memolo
 Gen. Sta. Mgr. William M. Dawson
 Commercial Mgr. Sam M. Feigenbaum
 Program Director Joseph Salsburg
 Promotion Dir. Donald S. Preven
 Director of News John Von Bergen
 Chief Engineer Roswell J. Parker
 Consulting Engineer Jansky & Bailly

WGBI-TV
 SCRANTON—1953—CBS

Channel: 22 UHF.. AP: 114 Kw.. VP: 215 Kw.
 Owned-Oper. By Scranton Bcstrs. Inc.
 Business Address 1000 Wyoming Ave.
 Phone Number 2-0296
 Air Time 8½ hours daily
 News Service AP
 Representative Blair
 President M. E. Megargee
 General Manager George D. Coleman
 Station Manager R. E. McDowell
 Promotion Dir. Douglas Holcomb
 Chief Engineer K. R. Cooke
 Consulting Engineer George C. Davis

WTVU
 SCRANTON—1953

Owned-Oper. By Appalachian Co.
 Channel: 73 UHF.. AP: 8.42 Kw.. VP: 12.84 Kw.
 Business Address First Natl. Bank Bldg.
 Representative Everett-McKinney
 Phone Number 7-3334
 Exec. Vice-President Charles W. Stone
 General Manager Jan King
 Sales Manager John E. Karabin
 Chief Engineer Chas. F. Halle

WBRE-TV
 WILKES-BARRE—1953—NBC

Channel: 28 UHF.. AP: 500 Kw.. VP: 1000 Kw.
 Owned-Operated By Louis G. Baltimore
 Address 62 S. Franklin St.
 Representative Headley-Reed
 Owner L. G. Baltimore
 General Manager David Baltimore
 Program Director F. D. Coslett
 Chief Engineer Franklin D. Coslett

WILK-TV
 WILKES-BARRE—1953—ABC-DuM

Channel: 34 UHF.. AP: 87 Kw.. VP: 170 Kw.
 Owned-Oper. By Wyoming Valley Bcstg. Co.
 Business Address 88 North Franklin St.
 Phone Number 4-4666
 Representative Avery-Knodel Inc.
 Exec. Vice-President Roy E. Morgan
 General Manager Thomas P. Shelburne
 Sales Manager Malcolm Dale
 Program Director Hal Berg
 Director of News Thomas Bigler
 Film Manager Francis Lee
 Chief Engineer Theodore French

WNOW-TV
 YORK—1953—DuM

Channel: 49 UHF.. AP: 10 Kw.. VP: 20 Kw.
 Owned-Oper. By Broadcast Division, Helm
 Coal Co.
 Business Address 25 So. Duke St.
 Phone Number 27-821
 Air Time 10 hours daily
 News Service AP
 Representative Hollingbery
 Membership NARTB, BAB
 General Manager Lowell W. Williams
 Commercial Mgr. John O. Border
 Program Director William Whitaker
 Promotion Dir. Ed Schwalm
 Director of News Wilbur Groff
 Production Mgr. Richard Gillespie
 Film Manager John Clouser
 Chief Engineer Glen Winter
 Consulting Engineer John H. Mullaney

WSBA-TV
 YORK—1952—ABC

Channel: 43 UHF.. AP: 86 Kw.. VP: 170 Kw.
 Owned-Operated By Susquehanna Bcstg. Co.
 Address 53 N. Duke St.
 Representative Radio-TV Reps
 President Louis J. Appell, Jr.
 Program Director Fred Shaffer
 Sales Manager Philip Eberly
 Director of News O. B. Morse
 Film Manager Tom Miller
 Chief Engineer Llewellyn Jones
 Consulting Engineer George C. Davis

RHODE ISLAND

TV HOMES 230,000

POPULATION 816,000

STATIONS IN STATE 2

WJAR-TV
 PROVIDENCE—1949
 ABC-NBC-DuM

Channel: 10... AP: 113 Kw... VP: 225 Kw.
 Owned-Operated By The Outlet Co.
 Business-Studio Address 176 Weybosset St.
 Phone Number Gaspee 1-8255
 Air Time 120 hours weekly
 News Service AP, INS
 Representative Weed
 Membership NARTB, BAB
 Program Manager Seymour Horowitz
 Gen., Comm. Mgr. Norman Gittleson

Production Coordinator.....Manning Tesser
 Film Director.....William Cooper
 Chief Engineer.....Thomas C. J. Prior

WNET

PROVIDENCE—1953—ABC-DuM

Channel: 16 UHF..AP: 11 Kw..VP: 22 Kw.
 Owned-Oper. By..Channel 16 of Rhode Island,
 Inc.

Business Address.....Box 1533
 Phone Number.....Union 1-3100
 News Service.....UP
 Representative.....Raymer, Bannan
 President.....Harold C. Aycaro
 Vice-Pres., Gen. Mgr.....John R. Porterfield
 Promotion Dir.....Violette B. Marks
 Film Manager.....Robert Dykeman
 Chief Engineer.....Herbert F. Evans
 Consulting Engineer.....George C. Davis

SOUTH CAROLINA

TV HOMES 195,000

POPULATION 2,181,000

STATIONS IN STATE 7

WAIM-TV

ANDERSON—1953—CBS

Channel: 40 UHF..AP: 8.3 Kw..VP: 16.6 Kw.
 Owned-Oper. By.....Wilton E. Hall
 Business Address.....Box 806
 Phone Number.....3800
 Representative.....Burn-Smith, Dora-Clayton
 General Manager.....Glenn P. Warnock
 Sales Manager.....Adam C. Welborn
 Production Dir.....Jimmy Scribner
 Chief Engineer.....John Willis

WCSC-TV

CHARLESTON

ABC-CBS-NBC-DuM

Channel: 5 VHF..AP: 15.5 Kw..VP: 31 Kw.
 Owned-Oper. By.....WCSC, Inc.
 Business Address.....485 East Bay St.
 Phone Number.....3-8371
 Air Time.....9 hours daily
 News Service.....UP
 Representative.....Free & Peters
 President.....John M. Rivers
 Station Manager.....Roland Weeks
 Commercial Mgr.....Ralph Thornley
 Program Director.....Russell D. Long
 Promotion Dir.....Alma D. Davis
 Director of News.....Harry Gianaris
 Production Mgr.....Charlie Hall
 Film Manager.....Annie Laurie Quarterman
 Chief Engineer.....Wilbur R. Albee

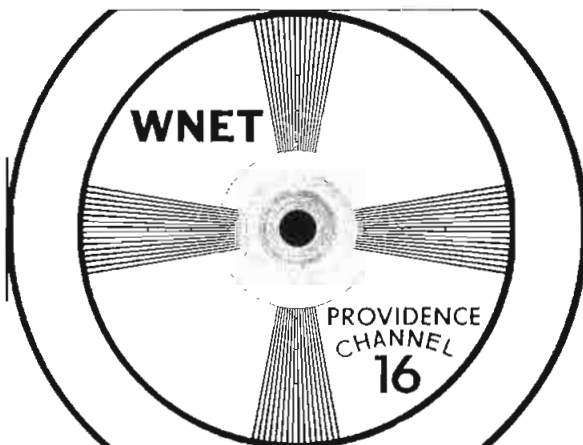

SERVING THE NATION'S 14th
 MARKET AREA

WCOS-TV

COLUMBIA—1952—ABC

Channel: 25 UHF..AP: 7.9 Kw..VP: 15.7 Kw.
 Owned-Oper. By.....Radio Columbia, Inc.
 Business Address.....Cornel Arms Bldg.
 Phone Number.....2-2177
 Air Time.....9 hours daily
 News Service.....AP
 Representative.....Headley-Reed
 President.....Charles W. Pittman
 Station Director.....Stewart Spencer
 Program Director.....Blair McKenzie
 Commercial Mgr.....Law Epps
 Chief Engineer.....Robert Lambert
 Consulting Engineer.....George C. Davis

WIS-TV

COLUMBIA—1953—NBC

Channel: 10 VHF..AP: 53 Kw..VP: 106 Kw.
 Owned-Oper. By.....WIS-TV Corp.
 Business Address.....1111 Bull St.
 Phone Number.....3-8356
 Air Time.....8½ hours daily
 News Service.....UP
 Representative.....Free & Peters
 Membership.....NARTB
 President.....G. Richard Shafto
 Managing Director.....Charles A. Batson
 Commercial Mgr.....Thomas F. Daisley
 Program Director.....Adrian Munzell
 Promotion Director.....Grenville Seibels
 Production Mgr.....Dixon Lovvorn
 Publicity Director.....James Jackson
 Film Manager.....Robert Donly
 Chief Engineer.....Herbert G. Eidson, Jr.

WNOK-TV

COLUMBIA—1953—CBS-DuM

Channel: 67 UHF..AP: 47 Kw..VP: 93.5 Kw.
 Owned-Oper. By.....Palmetto Radio Corp.
 Business Address.....Box 5307
 Phone Number.....3-9401
 Representative.....Raymer
 General Manager.....H. Moody McElveen, Jr.
 Natl. Sales Manager.....W. C. Bochman
 Program Manager.....David M. Campbell
 Chief Engineer.....Donald E. Willoughby

WFBC-TV

GREENVILLE—1953—NBC

Channel: 4 VHF..AP: 50 Kw..VP: 100 Kw.
 Owned-Oper. By.....WMRC, Inc.
 Business Address.....19 E. North St.
 Phone Number.....5-9653
 Representative.....Weed
 General Manager.....Beverly T. Whitmire
 Asst. Manager.....Norvin C. Duncan
 Program Director.....Frank Opra
 Production Dir.....Col. L. J. I. Barrett
 Sales Manager.....Robert Q. Glass, Jr.

WGVL

GREENVILLE—1953—ABC-DuM

Channel: 23 UHF..AP: 8.51 Kw..VP: 17 Kw.
 Owned-Oper. By.....Greenville Television Co.
 Business Address.....Box 2344
 Phone Number.....5-0471
 Air Time.....9 hours daily
 News Service.....AP
 Representative.....H.R. Ayers
 President.....Edgar M. Norris
 General Manager.....Ben K. McKinnon
 Prog., Prod. Mgr.....Ben Greer
 Prom., Pub. Dir.....L. Herbert Porter
 Film Manager.....Bill Banner
 Chief Engineer.....Emil A. Sellars

SOUTH DAKOTA

TV HOMES 18,500

POPULATION 666,000

STATIONS IN STATE 1

KELO-TV

SIoux FALLS—1953—ABC-CBS
 NBC

Channel: 11 VHF..AP: 33 Kw..VP: 55 Kw.
 Owned-Oper. By.....Midcontinent Bcstg. Co.
 Business Address.....8th St. & Phillips Ave.
 Phone Number.....4-5841
 Representative.....Raymer
 President.....Joe Floyd
 General Manager.....Evans A. Nord
 Production Mgr.....Dane Dedrick
 Chief Engineer.....Les Froke

TENNESSEE

TV HOMES 391,000

POPULATION 3,424,000

STATIONS IN STATE 7

WJHL-TV

JOHNSON CITY—1953
 ABC-CBS-NBC-DuM

Channel: 11 VHF..AP: 30 Kw..VP: 60 Kw.
 Owned-Oper. By.....WJHL, Inc.

Business Address.....145 W. Main St.
 Phone Number2780
 News ServiceUP
 RepresentativePearson
 President.....W. H. Lancaster, Sr.
 Gen., Sta. Mgr.....W. H. Lancaster, Jr.
 Program Director.....Walter Heeb
 Promotion Dir.....William Shell
 Director of News.....Michael Blancard
 Production Mgr.....Miss Pat Smithdeal
 Chief Engineer.....O. K. Garland

Owned-Oper. By.....Television Services of
 Knoxville
 Phone Number5-2113
 Business Address.....530 S. Gay St.
 RepresentativePearson
 Vice-Pres., Gen. Mgr.....Harold B. Rothbrock
 Production Mgr.....Jay Miller
 Program, Film Mgr.....Jerry Danziger
 Commercial Mgr.....Guy L. Smith III
 Publicity Director.....Marie Hogan
 Chief Engineer.....Joy Broyles

WROL-TV

KNOXVILLE—1953—ABC-NBC

Channel: 6 VHF..AP: 4.1 Kw..VP: 8.2 Kw.
 Owned-Oper. By..Mountcastle Bcstg. Co., Inc.
 Business Address.....612 S. Gay St.
 Phone Number2-7111
 News ServiceUP
 RepresentativeAvery-Knodel
 President.....Paul Mountcastle, Sr.
 Gen., Comm. Mgr.....W. H. Linebaugh
 Program Director.....John H. Reese
 Prom., Pub. Dir.....H. W. Hudson
 Production Mgr.....Bill Hubbard
 Chief Engineer.....Fred M. Andrews

WTSK-TV

KNOXVILLE—1953—CBS-DuM

DuM

Channel: 26 UHF..AP: 10.5 Kw..VP: 21 Kw.

WHBQ-TV

MEMPHIS—1953—CBS

Channel: 13 VHF..AP: 60 Kw..VP: 120 Kw.
 Owned-Oper. By.....Harding College
 Business Address.....Hotel Chisca
 Phone Number5-0825
 Air Time.....15 hours daily
 News ServiceUP
 RepresentativeBlair
 Membership.....NARTB. BAB
 President.....Dr. George S. Benson
 General Manager.....John H. Cleghorn
 Operations Manager.....W. H. Grumbles
 Sales Manager.....L. O. Dobson
 Program, Film Mgr.....Gordon A. Lawhead
 Prom., Pub. Dir.....Les Birchfield
 Director of News.....Gene Roper
 Production Mgr.....Wilson Northcross
 Chief Engineer.....Welton M. Roy
 Consultation Engineer.....Frank H. McIntosh

telecasting on **channel 8**

to
**Middle Tennessee,
 Southern Kentucky
 and portions of
 North Alabama . . .**

POWER: 90,000 video (CP for 316,000 watts).

ANTENNA: 1370 feet above sea level. (New antenna will be 1749 feet above sea level.)

TV HOMES: More than 136,000 in Nashville area as of January, 1954. (50-mile radius only.)

See your Hollingbery man or contact the station for availabilities . . . as well as for local participating features.

wsix-tv

NASHVILLE 3, TENNESSEE



CBS BASIC AFFILIATE
 SUPPLEMENTARY AFFILIATE
 ABC and DuMont

WMCT

MEMPHIS—1948—ABC-DuM

Channel: 5... AP: 60 Kw... VP: 100 Kw.
 Owned-Operated... Memphis Publishing Co.
 Business-Studio Address... Goodwyn Institute
 Bldg., P. O. Box 311
 Phone Number 8-7464
 Representative Branham
 President Enoch Brown
 Gen. Station Mgr. H. W. Slavick
 Commercial Manager..... Earl Moreland
 Program Director..... Wilson Mount
 Prom., Pub. Dir. Walter E. Frase
 Dir. of News & Spec. Events.... Edwin White
 Production Manager..... Tim Kiely
 Chief Engineer..... E. C. Frase, Jr.

WSIX-TV

NASHVILLE—1953
 ABC-CBS-DuM

Channel: 8 VHF.. AP: 45 Kw.. VP: 90 Kw.
 Owned-Oper. By..... WSIX-TV
 Business Address..... Nashville Trust Bldg.
 Phone Number 5-5431
 News Service AP
 Representative Hollingbery
 Air Time 14½ hours daily
 Membership NARTB
 Owner & Gen. Mgr..... Louis R. Daughon
 Operations Director..... Shelton Weaver
 Commercial Dir..... E. S. Tanner
 Production Mgr..... Jim Kent
 Publicity Director..... Martha Ferguson
 Chief Engineer..... Charles Duke

WSM-TV

NASHVILLE—1950
 ABC-CBS-DuM-NBC

Channel: 4.... AP: 11.9 Kw.... VP: 23.8 Kw.
 Owned-Oper. By..... WSM, Inc.
 Business Address.... 14th & Compton Aves.
 Phone Number 8-7181
 Representative Edward Petry
 Chairman..... E. W. Craig
 President..... John H. DeWitt, Jr.
 Commercial Manager..... Irving Waugh
 Public Relations..... William R. McDaniel
 Chief Engineer..... Aaron Shelton

TEXAS

TV HOMES 1,129,000

POPULATION 8,986,000

STATIONS IN STATE 28

KRBC-TV

ABILENE—1953—ABC-NBC

Channel: 9 VHF.. AP: 14.7 Kw.. VP: 29.5 Kw.
 Owned-Oper. By..... Reporter Bcstg. Co.
 Business Address..... Fulwiler Bldg.
 Phone Number 4-8557
 Air Time 5 hours daily
 News Service AP
 Representative Pearson
 President Dale Ackers
 Gen., Sta. Mgr..... Howard Barrett
 Commercial Mgr..... Robert Scott
 Prog., Prod. Mgr..... John Renshaw
 Prom., Pub. Dir..... Robert Nash
 Director of News..... Dub Bowlus
 Chief Engineer..... W. E. Kessel

KFDA-TV

AMARILLO—1953—ABC-CBS

Channel: 10 VHF.. AP: 30.4 Kw.. VP: 56.5 Kw.
 Owned-Oper. By..... Amarillo Bcstg. Co., Inc.
 Business Address..... Box 1400
 Phone Number 4-5343
 Air Time 8 hours daily
 News Service..... AP, UP
 Representative Branham
 President Wendell Mayes
 General Manager..... Stan Wilson
 Commercial Mgr..... Ed Moore
 Program Director..... Kindred Raley
 Production Mgr..... Buck Long
 Chief Engineer..... Bill Spiller

KGNC-TV

AMARILLO—1953

Channel: 4 VHF.. AP: 50 Kw.. VP: 100 Kw.
 Owned-Oper. By..... Plains Radio Bcstg. Co.
 Address Box 751
 Phone Number 4-4601
 Air Time..... 9½ hours daily
 News. Affil..... Globe-News Publ. Co.
 News Service..... AP, UP
 Membership NARTB ,BAB
 President..... B. E. Walker
 Gen., Sta. Mgr..... Tom Kritser
 Commercial Mgr..... Bud Thompson
 Prog. Dir., Dir. of Rem..... Kelly Maddox
 Promotion Director..... Marianne Johnson
 Dir. of News & Spec. Events.... Bob Izzard
 Film Manager..... Joan Jamison
 Chief Engineer..... W. H. Torrey
 Consulting Engineer..... A. Earl Cullum

KTBC-TV

AUSTIN—1952
 ABC-CBS-NBC-DuM

Channel: 7 VHF.. AP: 50 Kw.. VP: 00 Kw.
 Owned-Operated By..... Texas Bcstg. Corp.
 Address P. O. Box 717
 Representative Raymer
 President Claudia Johnson
 General Manager..... J. C. Kellam
 Consulting Engineer..... A. Earl Cullum, Jr.

XELD-TV

BROWNSVILLE—1951
NBC-DuM

Channel: 7 VHF...AP: 1.4 Kw...VP: 3 Kw.
Owned/Oper. By...Television de Metamoros
S.A.

Address...1014 E. Washington St.
Phone Number...Brownsville 6-6953
Representative...Adam Young
General Mgr...Monte Kleben
Comm. Mgr...L. W. Smith
Traffic Manager...Belva Younkman
Chief Engineer...Juan Suarez

KRLD-TV

DALLAS—1949—CBS

Channel: 4 VHF AP: 50 Kw...VP: 100 Kw.
Owned/Operated By...KRLD Radio Corp.
Business Address...Herald Square
Phone Number...RAndolph 6811
Newspaper Affiliation...Dallas Times Herald
Representative...Branham
Chairman...J. W. Runyan
President...Clyde W. Rembert
Comm. Mgr...William A. Roberts
Program Dir...Ves Box
Dir. of News & Spec. Events...Jay Hogan

Film Director...Nick Mueller
Chief Engineer...B. B. Honeycutt

WFAA-TV

DALLAS—1949—ABC-NBC-DuM

Channel: 8 VHF...AP: 13.5 Kw...VP: 27 Kw.
Owned/Operated By...A. H. Belo Corp.
Business Address...Young & Houston
Phone Number...Riverside 3315
Air Time...17 hours daily
Newspaper Affiliation...Morning News
News Service...UP
Reoresentative...Petty
Membership...NARTB
President...E. M. (Ted) Dealey
Sup. of Radio & TV...Martin B. Campbell
Station Manager...Ralph W. Nimmons
Prog., Remotes Dir...Jay Watson
Promotion Dir...Jack Saunders
Dir. of News & Spec. Events...Michael Hinn
Prod., Film Mgr...Howard Anderson
Publicity Director...Lois Jean Cooper
Chief Engineer...William C. Ellis
Technical Supervisor...George E. Krutitek
Consulting Engineer...A. Earl Cullum

Selling the SOUTHWEST'S LARGEST
METROPOLITAN AREA—over a MILLION

KRLD-TV
Channel 4

NORTH CENTRAL
TEXAS' ONLY STATION
with
MAXIMUM POWER

100,000 WATTS VIDEO
50,000 WATTS AUDIO

KRLD *Radio*

SATURATES MARKET
EQUAL TO 68 SECONDARY
STATIONS WITHIN
**KRLD'S 0.5 MILLIVOLT
LINE!**

50,000 WATTS

EXCLUSIVE OUTLET FOR CBS TELEVISION AND RADIO
NETWORK PROGRAMS IN DALLAS AND FORT WORTH
The Biggest Buy in the Biggest Market in the Biggest State

THE TIMES HERALD STATIONS . . . DALLAS, TEXAS

John W. Runyan, Chairman of the Board

Clyde W. Rembert, President

The BRANHAM CO., Exclusive Representative

K R O D - T V

EL PASO—1952—CBS-DuM-ABC

Channel: 4 VHF... AP: 28 Kw... VP: 56 Kw.
 Owned-Oper. By..... El Paso Times, Inc.
 Address..... 2201 Wyoming St.
 Representative..... Branham
 General Manager..... Val Lawrence
 Sales Manager..... Dick Waits
 Promotion Mgr..... Ken McClure
 Chief Engineer..... E. P. Talbot

K T S M - T V

EL PASO—1953—NBC

Channel: 9 VHF... AP: 33.1 Kw... VP: 55.1 Kw.
 Owned-Operated By..... Tri-State Bcstg. Co.
 Address..... 801 N. Oregon St.
 Representative..... Hollingbery
 General Manager..... Karl O. Wyler
 Commercial Mgr..... Roy T. Chapman
 Program Manager..... Jack B. Chapman
 Production Mgr..... Jack Rye
 Chief Engineer..... Kenneth Walton

W B A P - T V

FORT WORTH—1948—ABC-NBC

Channel: 5 VHF... AP: 8.2 Kw... VP: 16.4
 Owned-Oper. By..... Carter Publications, Inc.
 Business Address..... 3900 Barnett St.
 Phone Number..... Lockwood 1981
 Air Time..... 11 hours daily
 Newspaper Affiliation..... Fort Worth Star-
 Telegram
 News Service..... AP
 Representative..... Free & Peters
 Membership..... NARTB
 Chairman..... Amon Carter
 President..... Amon Carter, Jr.
 General Manager..... George Cranston
 TV Director..... Harold Hough
 Commercial Mgr..... Roy Bacus
 Prom., Publ. Dir..... Howard Fisher
 Program Director..... Robert Gould
 Film Manager..... Lynn Trammell
 Production Mgr..... Robert Grammer
 Director of News..... James A. Byron
 Chief Engineer..... R. C. Stinson

K G U L - T V

GALVESTON-HOUSTON—1953
 CBS

Channel: 11 VHF... AP: 125 Kw... VP: 235 Kw.
 Owned-Oper. By..... Gulf Television Co.
 Business Address..... 2002 45th St.
 Phone Number..... 3-1697
 Air Time..... 14 hours daily
 News Service..... AP
 Representative..... CBS Television Spot Sales
 President..... Paul E. Taft
 Station Manager..... Raymond E. Jones
 Program Director..... Thomas J. Thompson
 Promotion Dir..... William D. Evans, Jr.

IN EL PASO'S

Fabulous Southwest

YOU'LL
SELL

MORE
 ON
**CHANNEL
 4**



Because

MORE PEOPLE WILL SEE CHANNEL 4

WHY?

1. Most area coverage
2. Tower (transmitter) 1,585 feet above city and area
3. 56,300 Watts on Channel 4
4. Better picture in more homes
5. Unrivalled studio facilities
6. Maximum investment in finest equipment
7. Unequaled local programming
8. CBS and Dumont TV Networks
9. Thoroughly experienced TV staff
10. Program, Sales, and Promotion-minded staff
11. Newspaper affiliation

In El Paso, Texas it's . . .

KROD-TV

RODERICK BROADCASTING CORP.
 Dorrance D. Roderick, Chairman
 Val Lawrence, President
 Dick Waits, Sales Manager

NATIONALLY REPRESENTED BY THE O. L. TAYLOR COMPANY

Director of News.....Henry B. Williamson
 Film Manager.....Bud Johnson
 Chief Engineer.....William S. Sloat

KGBT-TV

HARLINGEN—1953—CBS-ABC

Channel: 4 VHF...AP: 6.9 Kw...VP: 13 Kw.
 Owned-Oper. By...Harbenito Bcstg. Co., Inc.
 Business Address.....Box 711
 Phone Number.....3500
 Representative.....Pearson
 General Manager.....Troy R. McDaniel
 Commercial Manager.....I. S. Roberts
 Program Director.....Fred Folk
 Chief Engineer.....Al Beck

KNUZ-TV

HOUSTON—1953—DuM

Channel: 39 UHF...AP: 12 Kw...VP: 20 Kw.
 Owned-Oper. By...KNUZ Telyevision Co.
 Business Address.....Box 2631
 Phone Number.....Keystone 6666
 Air Time.....8 hours daily
 News Service.....UP
 Representative.....Forjoe
 Membership.....NARTB
 President.....Max H. Jacobs
 Gen., Sta. Mgr.....David H. Morris
 Commercial Mgr.....Jack Healy
 Program Director.....Roger Van Duzer
 Promotion Director.....George Johnson
 Director of News.....Bill Crawford
 Production Mgr.....Chauncy Brown
 Publicity Director.....George Johnson
 Film Manager.....Glenn Armstrong
 Chief Engineer.....O. C. Crossland
 Consulting Engineer.....Weldon & Carr

KPRC-TV

HOUSTON—1950
 ABC-CBS-NBC-DuM

Channel: 2 VHF...AP: 50 Kw...VP: 100 Kw.
 Owned-Oper. By...Houston Post Co.
 Business Address.....2318 Polk Ave.
 Phone Number.....Madison 9271
 Representative.....Petry
 General Manager.....Jack Harris
 Commercial Mgr.....Jack McGrew
 Program Director.....Bert Mitchell
 Promotion Mgr.....Kirt Harris
 Film Manager.....Earl Corridon
 Publicity Director.....Edna Forester
 Traffic.....Pat Breech
 Chief Engineer.....Paul Huhndorf

KTVE

LONGVIEW—1953

Channel: 32 UHF...AP: 12 Kw...VP: 20 Kw.
 Owned-Oper. By.....A. James Henry
 Business Address.....Box 1232
 Phone Number.....6690
 Air Time.....7 hours daily
 News Service.....UP

Representative.....NARTB
 Pres., Gen. Mgr.....A. James Henry
 Commercial Mgr.....W. M. Morrow, Jr.
 Program Director.....Lawrence Birdsong, Jr.
 Director of News.....Herschel McClure
 Production Mgr.....Harold Miller
 Film Manager.....Barre Monigold
 Chief Engineer.....Wm. H. Dixon
 Consulting Engineer.....Irven Simpson

KCBD-TV

LUBBOCK—1953—ABC-NBC

Channel: 11 VHF...AP: 50 Kw...VP: 100 Kw.
 Owned-Oper. By...Bryant Radio & TV Corp.
 Business Address.....Box 1507
 Phone Number.....4-1414
 News Service.....AP, UP
 Representative.....Pearson
 Membership.....NARTB, BAB
 Pres., Gen. Mgr.....Joe H. Bryant
 Business Manager.....Robert L. Snyder
 Commercial Mgr.....George L. Tarter
 Program Director.....John Devine
 Promotion Dir.....Jack Tippit
 Director of News.....Choc Hutchison
 Film Manager.....Hulen Penney
 Chief Engineer.....Frank Lee
 Consulting Engineer.....Weldon & Carr

KDUB-TV

LUBBOCK—1952—CBS-DuM

Channel: 13 VHF...AP: 17.5 Kw...VP: 35 Kw.
 Owned-Oper. By...Texas Telectasting, Inc.
 Business Address.....7400 College
 Phone Number.....4-2345
 News Service.....INS
 Representative.....Avery-Knodel, Inc.
 Pres., Gen. Mgr.....W. D. (Dub) Rogers
 Sta., Comm. Mgr.....Mike Shapiro
 Program Director.....Ray Trent
 Prom., Pub. Dir.....Johnny Williams
 Director of News.....Jimmie Isaacs
 Production Mgr.....Vernon Poerner
 Film Manager.....Sidney Smith
 Chief Engineer.....Rudy Starnes
 Consulting Engineer.....Frank McIntosh

KMID-TV

MIDLAND—1953—NBC-ABC-DuM

Channel: 2 VHF...AP: 13.8 Kw...VP: 26.3 Kw.
 Owned-Oper. By...Midessa Television Co., Inc.
 Business Address.....Box 2758
 Phone Number.....2-7322
 Representative.....Venard Inc.
 General Manager.....Sid Grayson
 Commercial Mgr.....Bob Cain
 Program Director.....Bill Richie

KTXL-TV

SAN ANGELO—1953—CBS-NBC
 DuM

Channel: 8 VHF...AP: 15.5 Kw...VP: 27.5 Kw.
 Owned-Oper. By...WesTex Television Co.

Business Address.....1015 East 28th St.
 Phone Number7677
 Air Time.....9 hours daily
 RepresentativeTaylor
 MembershipNARTB
 President.....Armistead D. Rust
 Gen., Sta. Mgr.....John A. Kelly
 Commercial Mgr.....E. O. Thomesen
 Prog., Film Mgr.....Willa G. Black
 Prom., Pub. Dir.....Kenneth E. Markel
 Director of News.....Dean Chrysler
 Production Mgr.....Hal Black
 Chief Engineer.....Robert Benson
 Consulting Engineer..Craven, Lohnes & Culver

KGBS-TV
 SAN ANTONIO—1950
 ABC-CBS-DuM

Channel: 5 VHF..AP: 50 Kw..VP: 100 Kw.
 Owned-Oper. By...San Antonio TV Company
 Business Address.....Transit Tower
 Phone Number.....Garfield 8151
 Air Time.....15 hours daily
 News ServiceUP
 RepresentativeKatz
 MembershipNARTB
 President.....George B. Storer
 Commercial Manager.....W. E. Kelley
 Managing Director.....George B. Storer Jr.
 Program Director.....Ed Uhler
 Prom., Pub. Dir.....Ardyce Pfanstiel
 Dir. of News & Spec. Events...Robert Farrar
 Film Manager.....Betty Patton
 Chief Engineer.....William Jackson

WOAI-TV
 SAN ANTONIO—1949—NBC

Channel: 4 VHF..AP: 50 Kw..VP: 100 Kw.
 Owned-Oper. By...Southland Industries, Inc.
 Address.....1031 Navarro St.
 Phone Number.....Garfield 4221
 Air Time.....18 hours daily
 News Service.....AP, INS, UP
 RepresentativePetry
 President.....Hugh A. L. Halff
 General Manager.....James M. Gaines
 Comm. Mgr.....Edward V. Cheviot
 Promotion Mgr.....M. E. Grossman
 Program Manager.....W. Perry Dickey
 Film Manager.....Edward D. Hyman
 Publicity Director.....Imogene Stanley
 Director of Engineering.....C. L. Jeffers
 Consulting Engineer.....A. D. Ring

KCEN-TV
 TEMPLE—1953—NBC

Channel: 6 VHF..AP: 50 Kw..VP: 100 Kw.
 Owned-Oper. By.....The Bell Publishing Co.
 Business Address.....118 W. Avenue A
 Phone Number3-6868
 Air Time.....7¼ hours daily
 Newspaper Affiliation..Temple Daily Telegram
 News ServiceUP
 RepresentativeHollingbery

President.....Frank W. Mayborn
 General Manager.....Harry Stone
 Program Director.....Jim Bentley
 Film Manager.....Mrs. Gay Hoes
 Chief Engineer.....Wm. Crusinberry
 Consulting Engineer.....A. Earl Cullum, Jr.

KCMC-TV
 TEXARKANA—1953
 CBS-ABC-DuM

Channel: 6 VHF..AP: 15 Kw..VP: 28 Kw.
 Owned-Oper. By.....KCMC, Inc.
 Business Address.....317 Pine St.
 RepresentativeVenard Inc.
 President.....C. E. Palmer
 General Manager.....Frank O. Myers
 Sales Manager.....William F. Guy
 Director of News.....Tom Speer
 Chief Engineer.....Harvey Robertson

KETX

TYLER—1953—NBC-DuM-CBS

Channel: 90 UHF..AP: 141 Kw..VP: 270 Kw.
 Owned-Oper. By.....Jacob A. Newborn Jr.
 Business Address.....Box 686
 Phone Number2-0801
 RepresentativePearson
 Manager.....Jacob A. Newborn Jr.
 Station Manager.....E. R. Norris

KANG-TV
 WACO—1953—ABC-DuM

Channel: 34 UHF..AP: 10 Kw..VP: 18.6 Kw.
 Owned-Oper. By...Central Texas Television
 Inc.
 Business Address.....4811 Bosque Blvd.
 Phone Number31525
 Air Time.....7 hours daily
 News ServiceUP
 RepresentativePearson
 MembershipNARTB
 President.....Clyde Weatherby
 Station Manager.....Bob H. Walker
 Program Director.....Iris Wadley
 Prom., News Dir.....King Bridges
 Production Manager.....Frank Matthews
 Chief Engineer.....J. H. Smith
 Consulting Engineer.....Weldon & Carr

KRGV-TV
 WESLACO—1954—NBC

Channel: 5 VHF..AP: 14.5 Kw..VP: 28.8 Kw.
 Owned-Oper. By.....KRGV Television Inc.
 Business Address.....Box 626
 Phone Number375
 RepresentativeRaymer
 President.....O. L. Taylor
 General Manager.....Byron W. Ogle
 Commercial Mgr.....Allan Page
 Program Director.....Millman Rochester
 Production Dir.....Jim Cook
 Director of News.....Brad Smith
 Chief Engineer.....Lewis Hartwig

KFDX-TV

WICHITA FALLS—1953

Channel: 3 VHF...AP: 36 Kw...VP: 60 Kw.
 Owned-Operated By: Wichtex Radio & Tele. Co.
 Address: 801 Scott St.
 Phone Number: 2-8668
 President: Darrold A. Cannan
 General Manager: Howard H. Fry
 Station Manager: Henry Davis
 Commercial Mgr.: Mott Johnson
 Program Director: Warren Silver
 Prom., Pub. Dir.: W. P. Hood
 Director of News: Mike Henry
 Production Mgr.: William Angel
 Film Manager: Gene Jones
 Chief Engineer: John Adams
 Consulting Engineer: George C. Davis

KWFT-TV

WICHITA FALLS—1953—CBS

Channel: 6 VHF...AP: 11.7 Kw...VP: 23.4 Kw.
 Owned-Operated By: Wichita Falls Tele. Inc.
 Address: P. O. Box 420
 Phone Number: 3-4181
 Air Time: 10 hours daily
 News Service: UP
 Representative: Blair-TV
 President: Kenyon Brown
 Commercial Manager: Blaine Cornwell
 Prog., Prod. Mgr.: Cecil Sansbury
 Prom., Pub. Dir.: A. L. Pierce
 Director of News: Ed Hamlyn
 Film Manager: Tom Suars
 Chief Engineer: Herbert T. Wiley

UTAH

TV HOMES 121,000

POPULATION 724,000

STATIONS IN STATE 2

KDYL-TV

SALT LAKE CITY—1948—NBC

Channel: 4 VHF...AP: 15 Kw...VP: 30 Kw.
 Owned Oper. By: Intermountain Bcstg. & TV Corp.
 Business Address: 128 Social Hall Ave.
 Phone Number: 5-2931
 Air Time: 14 hours daily
 Station Representative: Blair-TV
 News Service: UP
 Membership: NARTB, BAB
 President: G. Bennett Larson
 Commercial Mgr.: Douglas R. Clawson
 Program Director: Dan Rainger

Director of News: Jack Goodman
 Publicity Director: Del Leeson
 Film Manager: James E. Chubb
 Chief Engineer: Allan Gunderson
 Consulting Engineer: George C. Davis

KSL-TV

SALT LAKE CITY—1948

ABC-CBS-DuM

Channel: 5 VHF...17.8 Kw...VP: 28.5 Kw.
 Owned-Oper. By: Radio Service Corp. of Utah
 Business Address: 145 Motor Ave.
 Phone Number: 5-4641
 Air Time: 14 hours daily
 News Service: UP
 Representative: CBS TV Spot Sales
 Membership: NARTB
 Exec. Vice Pres.: Ivor Sharp
 Comm. Mgr.: Edward B. Kimball
 Gen., Sta. Mgr.: D. Lennox Murdoch
 Program Director: Wayne Richards
 Promotion Director: A. Richard Robertson
 Director of News: Paul Alexander
 Production Manager: Scott R. Clawson
 Publicity Director: A. Richard Robertson
 Film Director: Richard V. Thriot
 Chief Engineer: Vincent Clayton
 Consulting Engineer: A. Ring

VIRGINIA

TV HOMES 512,000

POPULATION 3,452,000

STATIONS IN STATE 9

WBTM-TV

DANVILLE—1954—ABC

Channel: 24 UHF...AP: 12 Kw...VP: 22.5 Kw.
 Owned-Oper. By: Piedmont Bcstg. Corp.
 Business Address: 710 Grove St.
 Phone Number: 2350
 Representative: Hollingbery
 President: L. N. Dibrell
 General Manager: Edward G. Gardner Jr.
 Commercial Mgr.: John Holland III
 Program Director: Milton N. Adams
 Chief Engineer: Lyle C. Motley

WVEC-TV

HAMPTON-NORFOLK—1953—NBC

Channel: 15 UHF...AP: 6 Kw...VP: 12 Kw.
 Owned-Oper. By: Peninsula Bcstg. Corp.
 Business Address: 1490 Pembroke
 Phone Number: Hampton 6332
 Air Time: 17 hours daily
 News Service: AP

Representative Rambeau
 Membership NARTB, BAB
 President..... Thomas P. Chisman
 Sales Director..... Harol A. Brauer Jr.
 Program Director..... L. W. Duff Kliewer
 Prom., Pub. Dir..... Georgia McCarty
 Director of News..... Bob Drill
 Production Mgr..... Harry Middleton
 Film Manager..... Gordon Walsh
 Chief Engineer..... William C. King Jr.
 Consulting Engineer..... Lynn C. Smeby

WSVA-TV

HARRISONBURG—1953
 CBS-DuM-NBC-CBS

Channel: 3 VHF... AP: 4.17 Kw... VP: 8.32 Kw.
 Owned-Oper. By... Shenandoah Valley Bcstg.
 Business Address..... Rawley Pike
 Phone Number 4-4431
 Air Time 12 hours daily
 News Service UP
 Representative Devney
 Membership NARTB, BAB
 Pres., Gen. Mgr..... Frederick L. Allman
 Commercial Mgr..... Robert B. Harrington
 Program Director..... Richard H. Johnson
 Director of News..... Charles R. McGinley
 Production Mgr..... Robert E. Lee
 Chief Engineer..... Warren L. Braun
 Consulting Engineer..... Kear & Kennedy

WLVA-TV

LYNCHBURG—1953—CBS

Channel: 13 VHF... AP: 14 Kw... VP: 28 Kw.
 Owned-Operated By... Lynchburg Bcstg. Corp.
 Address..... 925 Church St.
 Representative Hollingbery
 President Edward Allen
 General Manager..... Phil Allen
 Sales Manager..... Joseph F. Wright
 Program Director..... Warren Uital
 Chief Engineer..... John T. Orth

WACH

NEWPORT NEWS-NORFOLK—1953

Channel: 33 UHF... AP: 10.5 Kw... VP: 20.9 Kw.
 Owned-Oper. By..... Eastern Bcstg. Corp.
 Business Address..... 114 24th St.
 Phone Number..... Avery-Knodel Inc.
 General Manager..... Frederic F. Clair
 Commercial Manager..... Etoyse Patterson
 Operating Mgr..... Thomas O. Bradshaw Jr.
 Chief Engineer..... Frederic F. Clair

WTAR-TV

NORFOLK—1949
 ABC-CBS-DuM

Channel: 3 VHF... AP: 50 Kw... AP: 100 Kw.
 Owned-Operated By..... WTAR Radio Corp.
 Business Address..... 720 Boush St.
 Phone Number 56711
 Air Time 17 hours daily

Newspaper Affiliation... Norfolk Newspapers, Inc.

News Service..... AP, INS
 Representative Petry
 Membership NARTB, BAB
 Pres., Gen. Mgr..... Campbell Arnoux
 Commercial Mgr..... Robert M. Lambe
 Prod., Pgm. Dir..... Harold Solding
 Promotion Dir..... Robert M. Davis
 Public Rel. Dir..... Joel F. Carson
 Director of News..... Gilbert McLeod
 Film Director..... Harry L. Nicholas
 Film Buyer..... P. C. Arnoux
 Chief Engineer..... Dick Lindell
 Consulting Engineer..... Jansky & Bailey

WTOV-TV

NORFOLK—1953—ABC-DuM

Channel: 27 UHF... AP: 10 Kw... VP: 20 Kw.
 Owned-Oper. By... Commonwealth Bcstg. Corp.
 Business Address..... 812 West 21st St.
 Phone Number 4-7786
 Air Time 10 hours daily
 News Service UP
 Representative Forjoe
 Exec. Vice-Pres., Gen. Mgr.... Robert Wasdon
 Production Mgr..... Dan Durniak
 Program Director..... Robert Drepperd
 Promotion Dir..... Tom Matthews
 Director of News..... Dick Harvey
 Film Manager..... Art Ross
 Chief Engineer..... Jim Robertson
 Consulting Engineer..... John Creutz

WTVR

RICHMOND—1947—NBC

Channel: 6 VHF... AP: 50 Kw... VP: 100 Kw.
 Owned-Oper. By..... Havens & Martin, Inc.
 Address..... 3301 W. Broad St., P. O. Box 5229
 Phone Number 5-8611
 Air Time..... 17 hours daily
 News Service UP
 Station Representative..... Blair TV
 Membership NARTB
 Pres., Gen., Sta. Mgr.... Wilbur M. Havens
 Program Director..... John V. Shand
 Film Manager..... G. Conrad Rianhard, Jr.
 Prom., Pub. Dir..... Walter A. Bowry, Jr.
 Dir. of News & Spec. Events..... Jack Tucker
 Chief Engineer..... James Kyle
 Consulting Engineer..... James C. McNary

WSLS-TV

ROANOKE—1952—NBC-ABC

Channel: 10 VHF... AP: 125 Kw... VP: 250 Kw.
 Owned Operated By
 Shenandoah Life Stations
 Address..... 301 1st St.
 Representative Avery-Knodel
 President..... P. C. Buford
 Exec. Vice-President..... J. H. Moore
 Promotion Dir..... Fred Corstaphney
 Commercial Manager..... H. Fitzpatrick
 Program Director..... George Chernault
 Chief Engineer..... J. P. Briggs

WASHINGTON

TV HOMES 411,500

POPULATION 2,814,000

STATIONS IN STATE 9

KVOS-TV

BELLINGHAM—1953—DuM

Channel: 12 VHF... AP: 17 Kw... VP: 34 Kw.
 Owned-Oper. By... KVOS Inc.
 Business Address... 1321 Commercial
 Phone Number... 790
 Air Time... 5½ hours daily
 News Service... UP
 Representative... Forjoe
 President... Rogan Jones
 General Manager... Jack Clarke
 Commercial Manager... Fred Elsethagen
 Prog., Prom. Dir... David Mintz
 Director of News... Bert Jackson
 Chief Engineer... Ernest Harper
 Consulting Engineer... William Foss

KING-TV

SEATTLE—1948—ABC

Channel: 5 VHF... AP: 50 Kw... VP: 100 Kw.
 Owned-Operated By... King Bcstg. Co.
 Business Address... 320 Aurora
 Phone Number... Mutual 3555
 Air Time... 14 hours daily
 News Service... UP
 Representative... Blair-TV
 Membership... NARTB, BAB
 President... Mrs. A. Scott Bullitt
 V.P., Gen. Mgr... Otto P. Brandt
 Commercial Manager... Al Hunter
 Dir. of News & Spec. Events... Charles Herring
 Production Mgr... Thomas Dargan
 Publicity Director... Melvin Anderson
 Program Director... Lee Schulman
 Dir. of Engineering... James L. Middlebrooks
 Consulting Engineer... Craven, Lohnes & Culver

KOMO-TV

SEATTLE—1953—NBC

Channel: 4 VHF... AP: 50 Kw... VP: 100 Kw.
 Owned-Oper. By... Fisher's Blend Station, Inc.
 Business Address... 100 4th Ave. N.
 Phone Number... Seneca 6000
 Representative... Hollingbery
 President... O. W. Fisher
 Vice-Pres., Gen. Mgr... W. W. Warren
 Commercial Mgr... Ray Baker
 Program Director... Dave Crockett
 Production Mgr... Tom Rogstad
 Chief Engineer... S. D. Bennett

KHQ-TV

SPOKANE—1952—NBC-ABC

Channel: 6 VHF... AP: 55 Kw... VP: 100 Kw.
 Owned-Operated By... KHQ, Inc.
 Address... 700 Radio Central Bldg.
 Representative... Katz
 General Manager... R. O. Dunning
 Program Director... William A. Neilson
 Commercial Mgr... John Pindell
 Prom., Pub. Dir... J. B. Blair
 Director of News... P. J. Cullen
 Consulting Engineer... George C. Davis

KXLY-TV

SPOKANE—1953—CBS-DuM

Channel: 4 VHF... AP: 28.5 Kw... VP: 48 Kw.
 Owned-Operated By... KXLY-TV
 Address... 315 W. Sprague
 Phone Number... Madison 1218
 Representative... Walker
 General Manager... Richard E. Jones
 Chief Engineer... Dave Green

KMO-TV

TACOMA—1953—NBC

Channel: 13 VHF... AP: 57 Kw... VP: 95.5 Kw.
 Owned-Oper. By... KMO Inc.
 Business Address... Box 1651
 Phone Number... Fulton 1581
 Air Time... 8 hours daily
 News Service... UP
 Representative... Branham
 President... Carl E. Raymond
 Gen., Sta. Mgr... Jerry Geehan
 Commercial Mgr... Earl Willhite
 Program Director... Dick Weeks
 Prog., Pub. Dir... Gene Dryden
 Director of News... Dan Seymour
 Production Mgr... Gordon Tuell
 Film Manager... Howard Perkin
 Chief Engineer... John Boor

KTNT-TV

TACOMA—1953—CBS-DuM

Channel: 11 VHF... AP: 63 Kw... VP: 125 Kw.
 Owned-Operated By... Tribune Publishing Co.
 Address... 711 St. Helens Ave.
 Representative... Weed
 President... Frank S. Baker
 Chief Engineer... Max Bice

KVAN-TV

VANCOUVER—1954

Channel: 21 UHF... AP: 62 Kw... VP: 107 Kw.
 Owned-Oper. By... KVAN, Inc.
 Business Address... Box 610
 Phone Number... Oxford 4-3325
 ReP-resentative... Bolling
 President... Sheldon F. Sackett
 General Manager... Fred F. Chitty
 Sales Manager... Russell Coughlin
 Chief Engineer... Leo Erickson

KIMA-TV

YAKIMA—1953

ABC-CBS-NBC-DuM

Channel: 29 UHF..AP: 7.5 Kw..VP: 15 Kw.
 Owned-Oper. By.....Cascade Bcstg. Co., Inc.
 Business Address...Radio & Television Center
 Phone Number6104
 RepresentativeWeed
 MembershipNARTB
 President.....A. W. Talbot
 Gen., Sta. Mgr.....Thomas C. Bostic
 Commercial Mgr.....H. R. Cary
 Program, Flm. Mgr.....James Nolan
 Promotion Director.....Joe Ryan
 Director of News.....John Knievel
 Production Mgr.....Tom Ewing
 Chief Engineer.....J. Barry Watkinson
 Consulting Engineer.....Frank McIntosh

WKNA-TV

CHARLESTON—1953—ABC-DuM

Channel: 49 UHF..AP: 12 Kw..VP: 22.5 Kw.
 Owned-Oper. By.....Joe L. Smith Jr. Inc.
 Business Address.....804 Kanawha Blvd.
 Phone Number25-153
 Pres., Gen. Mgr.....Joe L. Smith Jr.
 Sales Manager.....George J. Gray
 Program Director.....Don O. Hays
 Film Manager.....Ted McKay
 Chief Engineer.....A. J. Ginkel

WJPB-TV

FAIRMONT—1952—ABC-NBC-DuM

Channel: 35 UHF..AP: 10 Kw..VP: 20 Kw.
 Owned-Oper. By.....Fairmont Bcstg. Co. Inc.
 Business Address.....108 Gaston Ave.
 Phone Number.....Fairmont 5000
 RepresentativeHeadley-Reed
 President.....J. Patrick Beacom
 Gen., Sta. Mgr.....Robert Drummond
 Commercial Mgr.....J. F. Watkins
 Prog., Prod. Mgr.....Robert Frazier
 Prom., Pub. Dir.....Robert Ice
 Director of News.....Robert L. Mitchell
 Chief Engineer.....Richard McBride
 Consulting Engineer.....A. D. Ring

WEST VIRGINIA

TV HOMES 233,500

POPULATION 2,086,000

STATIONS IN STATE 5

WSAZ-TV

HUNTINGTON—1949—NBC

Channel: 3 VHF....AP: 42 Kw....VP: 84 Kw.

WHAT'S OUR BIGGEST PRODUCT?

• SERVICE

TO 3,892,300
 VIEWERS
 AND 987,300
 FAMILIES

WITH THE
 EFFECTIVE BUYING
 POWER \$4,064,724,000
 IN

114 COUNTIES OF
 W. VA., OHIO, KY., VA., TENN.

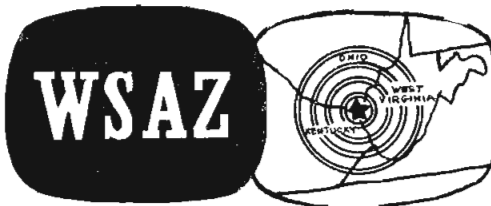

T E L E V I S I O N

Huntington - Charleston, West Virginia

CHANNEL 3 — 100,000 WATTS

NETWORKS: NBC — ABC — CBS — Dmt

Lawrence H Rogers, Vice President & General Manager, WSAZ, Inc.
 Represented nationally by The Katz Agency

Owned-Operated By. WSAZ, Incorporated
 Address 201 Ninth St.
 Phone Number 4-4126
 Air Time 15 hours daily
 Newspaper Affiliation Huntington Advertiser
 News Service AP
 Station Representative Katz
 Membership NARTB
 President Col. J. H. Long
 V.P., Gen. Mgr. Lawrence H. Rogers, II
 V.P., Tech. Dir. Leroy E. Kilpatrick
 Program Director J. H. Ferguson
 Promotion Dir. Charles W. Dinkins
 News Director Nicholas A. Basso
 Production Mgr. Bert Shimp
 Natl. Sales Manager R. E. White
 Film Mgr. Ned R. Brooke

WEAU-TV

EAU CLAIRE—1953—ABC-NBC-DuM
 Channel 13 VHF .AP: 29.53 Kw., VP: 59.05 Kw.
 Owned-Oper. By Central Bcstg. Co.
 Business Address 2415 So. Hastings Way
 Phone Number 6149
 Air Time 5½ hours daily
 News Service UP
 Membership NARTB
 Representative Hollingbery
 President W. C. Bridges
 General Manager H. S. Hyett
 Station Manager Richard Kepler
 Commercial Mgr. Robert Burnham
 Film Manager Zara Guenard
 Chief Engineer T. O. Jorgenson

WTAP

PARKERSBURG—1953—ABC-DuM
 Channel: 15 UHF .AP: 9.45 Kw., VP: 19.5 Kw.
 Owned-Oper. By West Virginia Enterprises
 Inc.
 Business Address 121 W. Seventh St.
 Phone Number 7-4589
 Representative Forjoe
 Membership NARTB
 Pres., Gen., Sta. Mgr. Theodore Eilan
 Commercial Mgr. James F. Cox
 Prog., Prom. Dir. Don Painter
 Director of News Jack See
 Film Manager Shirley L. Radiken
 Chief Engineer George W. DeBlieux

WBAY-TV

GREEN BAY—1953—ABC-CBS-DuM
 Channel: 2 VHF .AP: 50 Kw., VP: 100 Kw.
 Owned-Oper. By St. Norbert College
 Business Address 115 South Jefferson St.
 Phone Number Hemlock 2-3331
 Air Time 10 hours daily
 News Service AP, UP
 Representative Weed
 Membership NARTB
 General Manager Haydn R. Evans
 Station Manager Burkett Farquhar
 Commercial Mgr. Robert C. Nelson
 Promotion Dir. Robert Meister
 Director of News Clair Stone
 Production Mgr. Bill Manschot
 Film Manager Jm Krause
 Chief Engineer Wallace Stangel

WTRF-TV

WHEELING—1953—ABC-NBC
 Channel: 7 VHF .AP: 158 Kw., VP: 316 Kw.
 Owned-Oper. By Tri-City Bcstg. Co.
 Business Address 1329 Market St.
 Phone Number Wheeling 1177
 Air Time 10 hours daily
 News Service UP
 Representative Hollingbery
 President Thomas M. Bloch
 General Manager Robert W. Ferguson
 Commercial Mgr. H. Needham Smith
 Program Director Judy Lawton
 Promotion Dir. Gregg Van Camp
 Director of News George Diab
 Production Mgr. Gene Ryan
 Film Manager William Ney
 Chief Engineer Howard Daubenbeyer

WKOW-TV

MADISON—1953—CBS
 Channel: 27 UHF .AP: 8.49 Kw., VP: 16.98 Kw.
 Owned-Oper. By Monona Bcstg. Co.
 Business Address 215 West Washington Ave.
 Phone Number 7-2261
 Air Time 7 hours daily
 News Service UP
 Representative Headley-Reed
 President Stewart Watson
 Gen., Sta. Mgr. Michael Henry
 Commercial Mgr. Robert E. Loomer
 Program Director Audrey Bland
 Director of News Jerry Harper
 Production Mgr. Jack Hanson
 Film Manager Bill Harman
 Chief Engineer V. A. Vanderheiden

WISCONSIN

TV HOMES 568,500

POPULATION 3,607,000

STATIONS IN STATE 9

WMTV

MADISON—1953—ABC-DuM
 Channel: 33 UHF .AP: 9.6 Kw., VP: 17 Kw.
 Owned-Oper. By Bartell Television Corp.
 Business Address West Beltline Hwy.
 Phone Number 3-5381
 Air Time 10 hours daily
 News Service UP

Representative Meeker
 Pres., Gen. Mgr. Gerald A. Bartell
 Sta., Comm. Mgr. Morton J. Wagner
 Program Director Joyce Wickware
 Promotion Dir. Joyce Jaeger Bartell
 Director of News Michael Griffin
 Production Mgr. Roderick MacDonald
 Publicity Director Mary Hunter
 Film Manager Leon Jenkins
 Chief Engineer Earl W. Fessler
 Consulting Engineer Ralph Evans

WCAN-TV
 MILWAUKEE—1953—CBS

Channel: 25 UHF...AP: 11 Kw...VP: 22 Kw.
 Owned-Oper. By Midwest Bcstg. Co.
 Business Address 723 N. Third St.
 Phone Number Broadway 6-2154
 News Service UP
 Representative Rosenman
 President Lou Poller
 Program Director Dean McCarthy
 Promotion Dir. Mort Rosenman
 Director of News Kal Ross
 Production Mgr. Bud Marino
 Publicity Director Burl Levine
 Film Manager Ralph Andrews
 Chief Engineer Walter Wesley
 Consulting Engineer Russel P. May

WOKY-TV
 MILWAUKEE—1953—DuM

Channel: 19 UHF...AP: 12 Kw...VP: 18.5 Kw.
 Owned-Oper. By Bartell Bcstrs. Inc.
 Business Address 704 West Wisconsin
 Phone Number Broadway 1-8480
 Air Time 9 hours daily
 News Service UP
 Representative H-R
 President Gerald A. Bartell
 General Manager Lee B. Bartell
 Program Director Sheldon Kaplan
 Film Manager Art Whitaker, Jr.
 Chief Engineer William Armstrong

WTMJ-TV
 MILWAUKEE—1947—ABC
 NBC-DuM

Channel: 4 VHF...AP: 50 Kw...VP: 100 Kw.
 Owned-Oper. By The Journal Co.
 Business-Trans. Address 333 W. State St.
 Phone Number B'way 1-6000
 News Service AP
 Air Time 16 hours daily
 Representative Harrington, Righter &
 Parsons, Inc.
 Membership NARTB
 V.P. and Gen. Mgr. of Radio and TV,
 The Journal Co. Waller J. Damm
 Asst. Gen. Mgr. R. G. Winnie
 Station Mgr. George Comte
 Asst. Sta. Mgr. George Nicoud
 Res., Devel. Co-ordinator L. W. Herzog

Sales Mgr. Neale V. Baake
 Program Manager James Robertson
 Mgr. Radio & TV Engng. Phillip Laeser
 News Editor Jack Krueger

WNAM-TV
 NEENAH-APPLETON-MENASHA
 1953

Channel: 42 UHF...AP: 8.3 Kw...VP: 15.5 Kw.
 Owned-Oper. By Neenah-Menasha Bcstg. Co.
 Business Address Box 602
 Phone Number 2-6471
 News Service UP
 Representative George W. Clark
 Membership NARTB
 Pres., Gen. Mgr. Don C. Wirth
 Station Manager Stephen Pozgay
 Chief Engineer Harry W. Hill
 Consulting Engineer Walter Kean

WOSH-TV
 OSHKOSH—1953—ABC

Channel: 48 UHF...AP: 7.24 Kw...VP: 13.8 Kw.
 Owned-Oper. By Oshkosh Bcstg. Co.
 Business Address 1235 Bowen St.
 Phone Number Stanley 4580
 Representative Headley-Reed
 Pres., Gen. Mgr. William F. Johns Jr.
 Station Manager Clark Hogan
 Chief Engineer Donald Zuehke

WYOMING

TV HOMES 7,500

POPULATION 308,000

STATIONS IN STATE 1

KFBC-TV

CHEYENNE—1953—CBS-DuM

Channel: 5 VHF...AP: 50 Kw...VP: 100 Kw.
 Owned-Oper. By Frontier Bcstg. Co.
 Business Address 2923 East Lincolnway
 Phone Number 4-4461
 Newspaper Affiliation Wyoming Eagle &
 Wyoming Tribune
 News Service UP
 Representative Hollingbery
 President Robert S. McCracken
 Gen., Sta. Mgr. William C. Grove
 Commercial Mgr. C. P. Cahill
 Program Director Mae Sunada
 Promotion Dir. D. W. Young
 Director of News Kirk Knox
 Chief Engineer R. C. Pfannenschmid

TELEVISION STATIONS IN TERRITORIES AND POSSESSIONS



ALASKA

KFIA

ANCHORAGE—1953—CBS-ABC

Channel: 2 VHF.. AP: 8.32 Kw.. VP: 13.8 Kw.
Owned-Oper. By.....Kiggins & Rollins
Business Address.....Box 939
Phone Number.....5-3871
Representative.....Weed, Moore-Lund
Air Time.....5 hours daily
News Service.....AP
President.....Keith Kiggins
General Manager.....James G. Duncan
Treasurer.....Richard R. Rollins
Comm., Prom. Mgr.....Phil Howarth
Prog., Film Mgr.....Bard Melton
Prod., Pub. Dir.....Frank Freeman
Chief Engineer.....James G. Duncan

KTVA

ANCHORAGE—1953—NBC-DuM

Channel: 11 VHF.. AP: 1.61 Kw.. VP: 3.22 Kw.
Owned-Oper. By.....Northern Television, Inc.
Business Address.....Mt. McKinley Bldg.
Phone Number.....5-4321
News Service.....INS, UP
Representative.....Hugh Feltis
Air Time.....5 hours daily
Pres., Gen. Sta. Mgr.....A. G. Hiebert
Comm., Prom. Mgr.....C. M. Conner
Director of News.....Walt Welch
Production Mgr.....Janet Conner
Film Mgr.....Phil Schatz
Chief Engineer.....Jack M. Walden

HAWAII

KGMB-TV

HONOLULU—1952—ABC-CBS-NBC

Channel: 9 VHF.. AP: 62.4 Kw.. VP: 104 Kw.
Owned-Operated By.....
Hawaiian Bcstg. Syst., Ltd.
Address.....1534 Kapiolani
Phone Number.....9-2011
Air Time.....7½ hours daily
News Service.....UP
Representative.....Free & Peters
President.....J. Howard Worrall
General Manager.....C. Richard Evans

Station Manager.....Wayne Kearl
Program Director.....Robert Costa
Promotion Director.....Faye Johnson
Dir. News & Spec. Events.....Wayne Collins
Production Director.....Sheridan Reid
Merchandising Dir.....Donald Frink
Chief Engineer.....Dan Hunter

KONA

HONOLULU—1952—DuM-NBC

Channel: 11 VHF.. AP: 74 Kw.. VP: 12.5 Kw.
Owned-Operated By.....Radio Honolulu, Ltd.
Address.....1071 Bishop St.
Phone Number.....6-2366
Air Time.....9 hours daily
News Service.....INS, UP
Representative.....NBC Spot Sales
Membership.....NARTB
Pres., Gen. Mgr.....John D. Keating
Station Manager.....Jack Irvine
Chief Engineer.....Larry Trombly

PUERTO RICO

WKAQ-TV

SAN JUAN—1954—CBS

Channel: 2 VHF.. AP: 50 Kw.. VP: 100 Kw.
Owned-Oper. By.....El Mundo Bcstg. Corp.
Business Address.....Box 1072
Phone Number.....2-2000
Air Time.....6 hours daily
Representative.....Inter-American Publications
Inc.
Membership.....NARTB
President.....Angel Ramos
General Manager.....R. Delgado Marquez
Commercial Manager.....David H. Polinger
Program Director.....Fernando Cortes, Jr.

WAPA-TV

SAN JUAN—1954—NBC-DuM

Channel: 4 VHF.. AP: 33.9 Kw.. VP: 56.2 Kw.
Owned-Oper. By.....Ponce de Leon Bcstg. Corp.
Business Address.....357 Ponce de Leon
Phone Number.....3-3000
Representative.....Caribbean Networks Inc.
General Manager.....Charles E. Bell
Sales, Prom. Mgr.....Cal de Mier
Program Director.....Jose E. Franco
Production Dir.....Pepe Gonzalez Cordova
Chief Engineer.....Jose Arzuaga

TV Outside of United States

(TV stations in operation; or under construction (Cp) as of January 1, 1954. Prepared by Research Division, Allen B. Du Mont Laboratories, Inc.)



Location	Call Letters	Licensee or Grantee	Mc		Lines/Pix and Fields/Sec
			Carrier Visual	Freq. Aural	
— CANADA —					
Halifax, N. S.	CBHT	CP	61.25	65.75	525/60
Hamilton	CHCH-TV	CP	199.25	203.75	525/60
London	CFPL-TV	CP	193.25	197.75	525/60
Montreal	CBFT	CP	55.25	59.75	525/60
Montreal	CBMT	CP	83.25	87.75	525/60
Ottawa	CBOT	CP	67.25	71.75	525/60
Quebec	CFCM-TV	CP	67.25	71.75	525/60
Regina, Sask.	CKCK-TV	CP	67.25	71.75	525/60
Rimouski, Ont.	CJBR-TV	CP	61.25	67.75	525/60
St. John, N. B.	CHSJ-TV	CP	67.25	71.75	525/60
Sudbory, Ont.	CKSO-TV	CP	77.25	81.75	525/60
Sydney, N. S.	CJCB-TV	CP	67.25	71.75	525/60
Toronto	CBFT	CP	187.25	191.75	525/60
Vancouver, B. C.	CBUT	CP	187.25	191.75	525/60
Windsor, Ont.	CKLW-TV	CP	187.25	191.75	525/60
Winnipeg, Man.	CBWT	CP	67.25	71.75	525/60
— CUBA —					
Camaguey		CP	187.25	191.75	525/60
Camaguey		CP	55.25	59.75	525/60
Camaguey	CMJL-TV	CP	83.25	87.75	525/60
Ciego de Avila		CP	193.25	197.75	525/60
Havana	CMA-TV	CP	55.25	59.75	525/60
Havana	CMQ-TV	CP	83.25	87.75	525/60
Havana	CMBF-TV	CP	175.25	179.75	525/60
Havana	CMUR-TV	CP	67.25	71.75	525/60
Havana	CMTV	CP	199.25	203.75	525/60
Havana		CP	61.25	65.75	525/60
Havana		CP	211.25	215.75	525/60
Holguin		CP	193.25	197.75	525/60
Holguin	CMKJ-TV	CP	67.25	71.75	525/60
Holguin		CP	205.25	209.75	525/60
Matanzas	CMGC-TV	CP	187.25	191.75	525/60
Matanzas		CP	211.25	215.75	525/60
Santa Clara	CMNQ-TV	CP	61.25	65.75	525/60
Santa Clara	CMHQ-TV	CP	77.25	81.75	525/60
Santa Clara		CP	181.25	185.75	525/60
Santiago de Cuba	CMKN-TV	CP	55.25	59.75	525/60
Santiago de Cuba		CP	175.25	179.75	525/60
Santiago de Cuba		CP	199.25	203.75	525/60
Santiago de Cuba		CP	211.25	215.75	525/60
— MEXICO —					
Acapuleo		CP	83.25	87.75	525/60
Guadalajara		CP	193.25	197.75	525/60
Guadalajara		CP	61.25	65.75	525/60
Guanaajuato		CP	61.25	65.75	525/60
Guanaajuato		CP	205.25	209.75	525/60
Hermosillo		CP	83.25	87.75	525/60
Juarez	XECZ-TV	CP	55.25	59.75	525/60
Juarez	XECI-TV	CP	77.25	81.75	525/60
Juarez	XELD-TV	CP	199.25	203.75	525/60
Matamoros		CP	175.25	179.75	525/60
Merida		CP	61.25	65.75	525/60
Mexicali	XED-TV	CP	67.25	71.75	525/60
Mexicali	XEBC-TV	CP	61.25	65.75	525/60
Mexicali		CP	199.25	203.75	525/60
Mexico City	XEW-TV	CP	55.25	59.75	525/60
Mexico City	XHTV	CP	67.25	71.75	525/60
Mexico City	XHGC-TV	CP	77.25	81.75	525/60
Mexico City		CP	175.25	179.75	525/60
Mexico City	XEQ-TV	CP	187.25	191.75	525/60
Mexico City		CP	199.25	203.75	525/60
Monterrey		CP	55.25	59.75	525/60
Monterrey		CP	83.25	87.75	525/60
Nogales	XENS-TV	CP	55.25	59.75	525/60
Nuevo Laredo	XELN-TV	CP	61.25	65.75	525/60
Piedras Negras	XEPN-TV	CP	55.25	59.75	525/60
Reynosa	XERD-TV	CP	187.25	191.75	525/60

◆ ◆ ◆ TV OUTSIDE UNITED STATES ◆ ◆ ◆

Location	Call Letters	Licensee or Grantee	Carrier Visual	Freq. Aural	Lines/Pix and Fields/Sec
— MEXICO —					
Reynosa	NERA-TV	CP	205.25	209.75	525/60
Tampico		CP Emilio Azcarra	83.75	87.75	525/60
Tampico		CP Romulo O'Farrill, Sr.	61.25	65.75	525/60
Tijuana		CP	55.25	59.75	525/60
Tijuana	NTA		83.25	87.75	525/60
Tijuana	NETG-TV	CP	205.25	209.75	525/60
Turcon		CP Romulo O'Farrill, Sr.	61.25	65.75	525/60
Aguacruz		CP	83.25	87.75	525/60
Aguacruz		CP Emilio Azcarra	193.25	197.75	525/60
— ARGENTINA —					
Buenos Aires	LR3-TV				
		Radio Belgrano y Primera Cadena			
		ArgoCom de Broadasting	175.25	179.75	625/50
Buenos Aires	LR1-TV	CP	77.25	81.75	625/50
— BRAZIL —					
Bello Horizonte		CP	67.25	71.75	525/60
Rio de Janeiro	PR-5-TV		55.25	59.75	525/60
Rio de Janeiro	PRE-8-TV		83.25	87.75	525/60
Rio de Janeiro		CP	211.25	215.75	525/60
Sao Paulo	PR1-3-TV	E	61.25	65.75	525/60
Sao Paulo		CP	77.25	81.75	525/60
Sao Paulo		CP	175.25	179.75	525/60
— DENMARK —					
Copenhagen (Exp.)		Danish State Radio	62.5	67.5	625/50
— DOMINICAN REPUBLIC —					
Ciudad Trujillo	HIT-TV	La Voz Dominicana	67.25	71.75	525/60
— FRANCE —					
Lille		Adm. de la Radiodiffusion et de la Television	185.25	171.1	819/50
Lyon		CP Adm. de la Radiodiffusion et de la Television	63.5	59.0	819/50
Lyon		CP Adm. de la Radiodiffusion et de la Television	212.85	201.70	819/50
Marseille		CP Adm. de la Radiodiffusion et de la Television	186.55	175.1	819/50
Paris		Adm. de la Radiodiffusion et de la Television	16.0	12.0	111/50
Paris		Adm. de la Radiodiffusion et de la Television	185.25	171.1	819/50
Strasbourg		Adm. de la Radiodiffusion et de la Television	59.0	51.5	819/50
Strasbourg		CP Adm. de la Radiodiffusion et de la Television	161.0	175.15	819/50
— GERMANY, EAST —					
Berlin (East Sector)	Govt.		Approx 99 Mc		625/50
— GERMANY, WEST —					
Berlin (West Sector)		Northwest German Radio	182.26	187.76	625/50
Berlin (West Sector) (Exp.)		Allied High Command	196.25	201.75	625/50
Bremen		CP Northwest German Radio	67.25	71.75	625/50
Cologne		Northwest German Radio	196.25	201.71	625/50
Frankfurt (Feldberg)		Hessian Radio	196.25	201.75	625/50
Frankfurt (Exp.)		CP Allied High Command (171-216 Mc)			625/50
Hamburg		Northwest German Radio	175.25	180.75	625/50
Hamburg		Northwest German Radio	182.25	187.75	625/50
Hamburg		Northwest German Radio	210.25	215.75	625/50
Hannover		CP Northwest German Radio	189.25	191.75	625/50
Hannover		Northwest German Radio	193.21	201.71	625/50
Keln		CP Northwest German Radio	196.25	201.75	625/50
Laugenburg		Northwest German Radio	182.21	187.71	625/50
Laugenburg		CP Northwest German Radio	210.25	215.75	625/50
Weinblet (Mannheim-Heidelberg)		Southwest Radio	210.25	215.25	625/50
— GREAT BRITAIN —					
Aberdeen		CP British Broadcasting Corp.	61.75	58.25	105/50
Belfast		CP British Broadcasting Corp.	45.0	41.5	105/50
Birmingham (Sutton-Catfield)		British Broadcasting Corp.	61.75	58.25	105/50
Brighton		British Broadcasting Corp.	56.75	53.25	105/50
Cardiff (Wrenye)		British Broadcasting Corp.	66.75	63.25	105/50
Edinburgh (Kirk O'Shotts)		British Broadcasting Corp.	56.75	53.25	105/50
London (Alexandra Palace)		British Broadcasting Corp.	45.0	41.5	105/50
Manchester (Hulme-Moss)		British Broadcasting Corp.	51.75	48.25	105/50

TV OUTSIDE UNITED STATES

Location	Call Letters	Licensee or Grantee	Mc		Lines/Pix and Fields/Sec
			Carrier Visual	Freq. Aural	
— GREAT BRITAIN —					
Newcastle (Ponlop Pike)	CP	British Broadcasting Corp.	66.75	63.25	405/50
Plymouth	CP	British Broadcasting Corp.	51.75	48.25	405/50
Royvridge	CP	British Broadcasting Corp.	56.75	53.25	405/50
— ITALY —					
Alessandria (Piedmont) (Exp.)	CP	Radio Italiana, R.A.I.			625/50
Como (Lombardy) (Exp.)	CP	Radio Italiana, R.A.I.			625/50
Genoa	CP	Radio Italiana, R.A.I.			625/50
Milano	CP	Radio Italiana, R.A.I.	201.25	206.75	625/60
Monte Penice	CP	Radio Italiana, R.A.I.	62.25	67.75	625/50
Rome	CP	Radio Italiana, R.A.I.			625/50
Turin	CP	Radio Italiana, R.A.I.	82.25	87.75	625/50
Turin (Exp.)		Radio Italiana, R.A.I.			525/60
— JAPAN —					
Nagaya	CP	Broadcasting Corp. of Japan			525/60
Osaka (Exp.)		Japanese Broadcasting Corp.			525/60
Tokyo	JOAK-TV	Broadcasting Corp. of Japan	103.25	107.75	525/60
Tokyo	JOKR-TV	Radio Tokyo	183.25	187.75	525/60
Tokyo	JOAX-TV	Nippon TV Network Corp.	171.25	175.75	525/60
Tokyo (Ichigaga Heights)	CP	Radio Regulatory Commission			525/60
— MOROCCO, FRENCH —					
Casablanca	CP	Adm. de la Radiodiffusion et de la Television	174.1	185.25	819/50
— NETHERLANDS —					
Amsterdam (Utrecht-Lapik)		Netherlands Radio Union & Tv. Foundation of Hilversum	62.25	67.75	625/50
Eindhove (N. Brabant) (Exp.)	PAB-2	Philips Ltd.	48.25	53.75	625/50
Eindhoven	PAB-3	P.T. & T. Adm.	63.25	57.75	625/50
Kootwijk	PAB-4	P.T. & T. Adm.	41.25	46.75	625/60
— PHILIPPINE ISLANDS —					
Manila	DZBC-TV	Bolinau Electronic Corp.	61.25	65.75	525/60
— POLAND —					
Warsaw		Communications Inst.	89.57		625/50
Lodz	CP	Communications Inst.			625/50
— SAAR —					
Saarbruechen (Exp.)	Govt.				
— SPAIN —					
Barcelona	CP	Radiodifusion Nacional			625/50
Bilboa (Exp.)		Radiodifusion Nacional			625/50
Madrid (Exp.)		Radiodifusion Nacional	48.25	53.75	625/50
Madrid	CP	Radiodifusion Nacional			625/50
— SWEDEN —					
Stockholm (Exp.)		Swedish Board of Trade	62.25	67.75	625/50
Stockholm (Exp.)		Swedish Board of Trade	175.25	180.75	625/50
— SWITZERLAND —					
Basel	CP				625/50
Lusanne (Exp.)		Swiss Gen. Post Office	62.25	67.75	625/50
Zurich (Exp.)			55.25	60.75	625/50
— TURKEY —					
Istanbul (Exp.)		Tech. University of Istanbul	62.25	67.75	625/50
— U.S.S.R. —					
Kharkov (Exp.)		Govt.			300/?
Kiev		Govt.	77.25	83.75	625/50
Leningrad		Govt.	59.25	65.75	625/50
Moscow		Govt.	49.75	56.25	625/50
— VATICAN CITY —					
Vatican City	HJV	Radio Vatican	185.25	174.1	819/50
— VENEZUELA —					
Caracas	YVLV-TV	Television Venezolana	67.25	71.75	625/50
Caracas	YVKA-TV	Ministero de Comunicaciones	77.25	81.75	525/60
Caracas	YVKS-TV	Radio Caracas	175.25	179.75	525/60
— YUGOSLAVIA —					
Belgrad	YZO	Radiodifusion Belgrad	42.5	47.0	625/50

NEW TV STATIONS SET FOR OPENING IN 1954

On this page, and the pages following, we list geographically the television station organizations planning to begin operations in 1954, together with channel numbers and, where possible, date for start of broadcasting.

City	Call Letters	Licensee	Channel	Expected Date On The Air
ALABAMA				
Birmingham	WJLN-TV	Johnson Bestg. Co.	18	*
Birmingham	WSGN-TV	Jemison Bestg. Co., Inc.	42	*
Decatur	WMSL-TV	Tennessee Valley Bestg. Co.	23	*
ARKANSAS				
Little Rock	KARK-TV	Arkansas Radio & Eqp't. Co.	1	March *
Little Rock	KETV	Great Plains Television Prop.	23	*
CALIFORNIA				
Corona	KCOA	KOWL Bestg. Co.	52	*
Los Angeles	KBIC-TV	John Poole Bestg. Co.	22	*
Merced	KMER	Merced Tele. Corp.	31	*
Sacramento	KBIE-TV	John Poole Bestg. Co.	16	*
San Bernardino	KITO-TV	KITO, Inc.	18	*
San Diego		E. L. Cushman	21	*
San Francisco	KSAN-TV	S. H. Patterson	32	*
San Jose	KVIE	J. A. Victor, Jr.	18	*
Yuba City	KAGR-TV	John Steventon	52	*
COLORADO				
Grand Junction	KFXJ-TV	Western Slope Bestg. Co.	5	*
CONNECTICUT				
Bridgeport	WSJL	Harry L. Liffig	19	*
Hartford	WGTH-TV	General Times Television Corp.	18	*
New Haven	WELI-TV	Conn. Radio Foundation, Inc.	59	*
New London	WNLG-TV	Thames Bestg. Corp.	26	*
Stamford	WSTF	Stamford-Norwalk Television Corp.	27	*
DELAWARE				
Dover	WHRN	Rollins Bestg., Inc.	10	*
Wilmington	WILM-TV	Delaware Bestg. Co.	83	*
FLORIDA				
Clearwater		Pioneer Gulf Tele. Betr.	32	*
Jacksonville	WOBX-TV	Southern Radio & Eqp't. Co.	39	*
Miami	WMLB-TV	WMLB-TV, Inc.	27	*
Miami		Miami Biscayne Tele. Corp.	33	*
Orlando	WDRO-TV	Orlando Bestg. Co., Inc.	6	April *
West Palm Beach	WJNO-TV	Palm Beach Tele., Inc.	5	June *
GEORGIA				
Atlanta	WQXI-TV	R. W. Rounsaville	36	June *
Augusta	WRDW-TV	Radio Augusta, Inc.	12	*
Thomasville	WCTV	E. D. Rivers, Sr.	6	*
Valdosta	WGOV-TV	WGOV-TV, Inc.	37	*
IDAHO				
Boise	KTVI	Idaho Bestg. & Tele. Co.	9	*
Idaho Falls	KIFT	Idaho Falls Tele., Inc.	8	*
Nampa	KFXD-TV	Frank E. Hurst & Sons, Inc.	6	*
Pocatello	KISJ	Tribune-Journal Co., Inc.	6	*
Pocatello	KWIK-TV	Eastern Idaho Bestg. & Tele. Co.	10	*
Twin Falls	KLIX-TV	Southern Idaho Bestg. & Tele. Co.	11	May *
ILLINOIS				
Champaign	WCUI	Champaign-Urbana Tele., Inc.	21	*
Chicago	WHFC-TV	WHFC, Inc.	26	*
Chicago	WIND-TV	WIND, Inc.	20	*
Evanston	WTLE	Northwestern Tele. Bestg. Co.	32	June *
Joliet	WJOL-TV	Joliet Tele., Inc.	48	*
INDIANA				
Indianapolis	WJRE	Marion Bestg. Corp.	26	*
Marion	WMRI-TV	Chronicle Pub. Co., Inc.	29	*
Terra Haute	WTHI-TV	Wabash Valley Bestg. Corp.	10	*
Waterloo	WINT	Tri-State Tele., Inc.	15	March *
IOWA				
Cedar Rapids	KEYC	Hawkeye Tele. Corp.	20	*
Des Moines	WBO-TV	WBO-TV, Inc.	13	*

* Information not available

NEW TV STATIONS SCHEDULED

City	Call Letters	Licensee	Channel	Expected Data On The Air
Mason City	KGLO-TV	Lee Radio, Inc.	3	*
Sioux City	KCTV	Great Plains Tele. Prop.	36	*
KANSAS				
Topeka	KTKA	Alf M. Landon	42	*
KENTUCKY				
Ashland	WPTV	Polan Industries	59	*
Lexington	WLAP-TV	American Bestg. Corp.	27	March
Louisville	WLOU-TV	Robert Ronnsaville	41	*
Newport	WNOP-TV	Tri-City Bestg. Co.	74	*
Paducah	WTLK	Paducah Tele. Corp.	43	*
LOUISIANA				
Alexandria	KALB-TV	Alexandria Bestg. Co., Inc.	5	*
Alexandria	KSPJ	Barnet Brezner	62	*
Baton Rouge	KHTV	Capitol Tele. & Bratg. Co.	40	*
Lafayette	KLFY-TV	Comella Bestg. Co., Inc.	10	*
Lafayette	KVFL-TV	Evangeline Bestg. Co., Inc.	10	*
Lake Charles	KPLC-TV	Calcasieu Bestg. Co.	7	*
New Orleans	WCKG	CKG Television Co.	26	*
New Orleans	WCNO-TV	Community Tele. Corp.	32	June
New Orleans	WTLO	New Orleans Tele. Co.	20	*
MAINE				
Poland	WMTW	Mt. Washington TV, Inc.	8	September
MARYLAND				
Baltimore	WITH-TV	WITH-TV, Inc.	60	*
Baltimore	WSD-TV	United Bestg. Co. of E. Md., Inc.	18	*
Cumberland	WTBO-TV	Maryland Radio Corp.	17	*
Salisbury	WBOC-TV	Peninsula Bestg. Co.	16	March
MASSACHUSETTS				
Boston	WBOS-TV	E. Anthony & Sons, Inc.	50	*
Boston	WIDW	J. D. Wrafter, Jr.	44	*
Brockton	WPEF-TV	Trans-American Enterprises, Inc.	62	*
Lawrence	WGLM	General Bestg. Co.	72	*
New Bedford	WTEV	E. Anthony & Sons, Inc.	28	*
Pittsfield	WBEC-TV	Western Massachusetts Bestg. Co.	64	*
Worcester	WAAB-TV	Wilson Enterprises, Inc.	21	April
MICHIGAN				
Battle Creek	WBCK-TV	Michigan Bestg. Co.	58	*
Benton Harbor	WHFB-TV	Palladium Pub. Co.	42	*
Detroit	WCIO-TV	UAW-CIO Bestg. Corp.	62	*
Muskegon	WTVM	Versluis Radio & TV, Inc.	35	*
Saginaw	WSBM-TV	Booth Radio & TV Sta., Inc.	51	June
Traverse City	WPBN-TV	Midwestern Bestg. Co.	7	May
MINNESOTA				
Duluth	KDAL-TV	Rev River Bestg. Co., Inc.	3	March
Duluth-Superior	WDSM-TV	WDSM Television Co.	6	March
St. Paul	WCOW-TV	WCOW Telesharing Co.	17	*
MISSISSIPPI				
Columbus	WCBI-TV	Birney Innes, Jr.	28	*
Gulfport	WGCM-TV	WGCM Television Corp.	56	*
Jackson	WSLI-TV	Standard Life Bestg., Inc.	12	March
MISSOURI				
Cape Girardeau	KFVS-TV	Hirsch Bestg. Co.	12	*
Cape Girardeau	KGMO-TV	KGMO Radio Television, Inc.	18	*
Clayton	KFCO-TV	Lutheran Church-Missouri Synod	30	*
Joplin	KSWM-TV	Air Time, Inc.	12	July
Kirksville	KBIZ-TV	KBIZ, Inc.	3	May
St. Louis	WIL-TV	Missouri Bestg. Corp.	42	*
MONTANA				
Billings	KRHT	Rudman-Hayutin Tele. Co.	8	*
Great Falls	KFBB-TV	Buttrey Broadcast, Inc.	5	*
Great Falls	KMON-TV	Montana Farmer, Inc.	3	*
Missoula	KGVO-TV	Mosby's, Inc.	13	June
NEW HAMPSHIRE				
Keene	WKNE-TV	WKNE Corp.	45	*
NEW JERSEY				
Atlantic City	WOCN	Matta Enterprises	52	*
New Brunswick	WDHN	Home News Pub. Co.	47	*
Trenton	WTTM-TV	People's Bestg. Corp.	41	*
NEW MEXICO				
Clovis	KNEH	Teleopolitan Bestg. Co.	12	*
NEW YORK				
Albany	WPTR-TV	Patroon Bestg. Co., Inc.	23	*
Bloomington	WIRY-TV	Great Northern Tele., Inc.	5	*

* Information not available.

NEW TV STATIONS SCHEDULED

City	Call Letters	Licensee	Channel	Expected Date On The Air
Ithaca	WHCU-TV	Cornell University	20	*
Jamesstown	WJTN-TV	James Bestg. Co., Inc.	58	*
Poughkeepsie	WEOK-TV	Mid-Hudson Bestg., Inc.	21	*
Rochester	WCRF-TV	Star Bestg. Co., Inc.	45	*
Rochester	WENY-TV	Genesee Valley Tele. Corp.	27	*
Utica	WERR	Richard H. Balch	19	*
Watertown	WWSA-TV	Brockway Co.	48	*
NORTH CAROLINA				
Asheville	WLOS-TV	Skyway Bestg. Co.	13	*
Durham	WCTG-TV	T. E. Allen & Sons, Inc.	46	*
Goldshoro	WTVX	Goldshoro Tele. Corp.	31	*
Mt. Airy	WPAQ-TV	Ralph D. Epperson	55	*
Wilmington	WMFD-TV	WMFD-TV, Inc.	6	*
NORTH DAKOTA				
Valley City	KXJB-TV	North Dakota Bestg. Co.	1	July
OHIO				
Cleveland	WERE-TV	Cleveland Bestg., Inc.	65	*
Cleveland	WHK-TV	United Bestg. Co.	19	*
Lima	WIMA-TV	Northwestern Ohio Bestg. Corp.	35	*
Massillon	WMAC-TV	Midwe. TV Co.	23	April
Youngstown	WYTV	Polan Industries	21	*
OKLAHOMA				
Ada	KEOK	Eastern Okla. TV Co.	10	May
Enid		Streets Electronics, Inc.	5	June
Miami	KMYA	Miami Tele Co.	58	*
OREGON				
Eugene	KVMJ-TV	Eugene Television Inc.	13	*
Salem	KSLM-TV	Oregon Radio, Inc.	3	*
PENNSYLVANIA				
Allentown	WPMZ-TV	Penn Allen Bestg. Co.	67	*
Allentown	WQCV	Queen City Tele. Co., Inc.	39	*
Erie	WSEE	Great Lakes Tele. Co.	35	March
Erie	WLEU	Commodore Perry Bestg. Serv., Inc.	66	*
Harrisburg	WCMB-TV	Koss-mayne Corp.	27	March
Hazleton	WAZL-TV	Hazleton Tele. Corp.	63	*
Lancaster	WMLA	Harold C. Burke	21	*
Lewisstown	WURE-TV	Lewisstown Bestg. Co.	38	*
Philadelphia	WIBG-TV	Daily News Television Co.	23	*
Philadelphia	WIP-TV	Pennsylvania Bestg. Co.	29	*
Pittsburgh	WTVQ	Golden Triangle TV Corp.	17	*
Williamsport	WRVK-TV	WRVK, Inc.	36	*
RHODE ISLAND				
Providence	WPRO-TV	Cherry & Webb Bestg. Co.	12	*
SOUTH CAROLINA				
Aiken	WAKN-TV	Aiken Electronics Adv. Corp.	51	*
Camden	WACA-TV	Camden Bestg. Corp.	11	*
Florence	WPDA	Jefferson Standard Bestg. Co.	8	*
Greenwood	WCRS-TV	Greeno, Inc.	21	*
Spartanburg	WORD-TV	Spartan Broadcasting Co.	7	*
Spartanburg	WSCV	Sterling Telecasting Co.	17	*
TENNESSEE				
Chattanooga	WQUC	Chattanooga TV, Inc.	19	*
Chattanooga	WTVT	Tom Potter	13	*
Jackson	WDNI-TV	Dixie Bestg. Co.	9	*
Nashville	WLAC-TV	Life & Casualty Ins. Co.	5	*
TEXAS				
Amarillo	KLAN-TV	Plains Empire Bestg. Co.	7	*
Beaumont	KBMT	Television Bestg., Inc.	31	*
Corpus Christi		H. L. Hunt	13	*
Dallas	KDTX	UHF Television Co.	23	*
Dallas	KLIF-TV	Trinity Bestg. Corp.	29	August
Fort Worth	KTCO	Tarrant County Tele. Co.	20	*
Houston	KJVP	UHF Television Co.	23	*
Houston	KXAZ-TV	Shamrock Bestg. Co.	29	*
Lubbock	EVAO-TV	Globe News Pub. Co., Inc.	5	*
Lufkin	KURE-TV	Forest Capital Bestg. Co.	9	*
Marshall	KMSL	Marshall Tele. Corp.	16	*
Sau Antonio	KATV	Alamo Television Co.	35	*
Sherman	KSHM	Sherman Television Co.	16	*
Sweetwater	KPAR-TV	Texas Telecasting, Inc.	12	*
Victoria	KNAL-TV	KNAL Television Co.	19	*
UTAH				
Provo	KOYO-TV	KOYO Bestg. Co.	11	*
Salt Lake City	KUTV	Utah Bestg. & Tele. Corp.	2	*

* Introgation not available

NEW TV STATIONS SCHEDULED

City	Call Letters	Licensee	Channel	Expected Date On The Air
VIRGINIA				
Charlottesville Marion Richmond	WCHV-TV	Barham & Barham	64	*
	WMEV-TV	Mountain Empire Bestg. Corp.	50	*
	WOTV	Winston-Salem Bestg. Co., Inc.	29	*
WEST VIRGINIA				
Beckley Wheeling	WBEY	Appalachian Tele. Corp.	21	*
	WLTW	Polau Industries	51	
WISCONSIN				
LaCrosse LaCrosse Marinette	WKBT	WKBT Television, Inc.	8	
		LaCrosse Television Corp.	38	
	WMGB-TV	M&M Bestg. Co., Inc.	11	July
WYOMING				
Casper	KSPR-TV	Donald Lewis Hathaway	2	
ALASKA				
Fairbanks	KFIF	Kiggins & Rollins	2	*
HAWAII				
Honolulu	KULA-TV	Pacific Frontier Bestg. Co., Ltd.	4	March

* Information not available.

Radio-TV Receiver Production in 1953

Washington—A month-by-month breakdown of 1953 production of television and radio receivers, showing a total production for the year of more than 7.2 million TV's and 13.3 million radio receivers, as released by the Radio-Electronics-Television Manufacturers Assn., follows:

	Television	Home Sets	Portables	Auto	Clock	Total Radio
January ..	719,234	361,921	93,962	447,667	189,592	1,093,142
February .	730,597	402,742	87,711	491,062	210,924	1,192,439
March (5 weeks).	810,112	442,101	177,656	654,367	275,079	1,549,203
April	567,878	286,974	201,476	483,092	198,394	1,158,936
May	481,936	278,156	204,065	497,379	129,391	1,108,991
June (5 weeks)..	524,479	287,724	239,189	505,774	131,144	1,163,831
July	316,289	172,197	78,434	336,208	87,620	674,459
August ...	603,760	299,939	145,460	376,937	169,301	991,637
Sept. (5 weeks)..	770,085	529,427	147,355	357,326	182,417	1,216,525
Oct.	680,433	370,178	135,009	358,076	189,230	1,052,493
Nov.	560,197	457,151	127,316	309,962	171,356	1,065,785
Dec. (5 weeks).	449,787	514,428	103,931	365,084	117,672	1,101,115
TOTAL	7,214,787	4,402,938	1,741,564	5,182,934	2,041,120	13,368,556

PERFECT TV PRODUCTION REQUIRES

Precision Prints

**STEP PRINTING
ELIMINATES
CONTACT SHIFTS**

The sharpness of a print depends on close contact between original and print stock. In step printing at Precision, the two films are absolutely stationary during exposure. Timing and effects are produced without notching original. One-to-one optical sound printing assures broadcast quality.

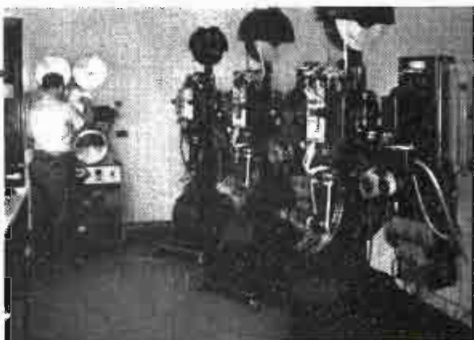

YOUR ASSURANCE OF BETTER 16_{mm} PRINTS

15 Years Research and Specialization in every phase of 16mm processing, visual and aural. So organized and equipped that all Precision jobs are of the highest quality.

Individual Attention is given each film, each reel, each scene, each frame — through every phase of the complex business of processing — assuring you of the very best results.

Our Advanced Methods and our constant checking and adoption of up-to-the-minute techniques, plus new engineering principles and special machinery

Precision Film Laboratories — a division of J. A. Maurer, Inc., has 14 years of specialization in the 16mm field, consistently meets the latest demands for higher quality and speed.

enable us to offer service unequalled anywhere!

Newest Facilities in the 16mm field are available to customers of Precision, including the most modern applications of electronics, chemistry, physics, optics, sensitometry and densitometry—including exclusive Maurer-designed equipment—your guarantee that only the best is yours at Precision!

PRECISION

FILM LABORATORIES, INC.

21 West 46th St.,

New York 19, N. Y.

JU 2-3970

TV FILM PRODUCERS AND DISTRIBUTORS



ABC Film Syndication

7 West 66th St., New York 23, N. Y.
V.P. in Chg.....George T. Shupert
Sales Mgr.....Donald L. Kearney

Academy Film Productions, Inc.

123 W. Chestnut St., Chicago 10, Ill.
Phone: Michigan 2-0128

Pres. & Dir. of Pro.....Bernard Howard
Services Offered—Producer of films for television—commercials and shows: Complete planning, writing, producing and directing of all kinds of motion pictures; industrial and educational films: animations; TV consultant to agencies.

Acme Film Laboratories

1161 North Highland Ave., Hollywood 38, Calif.
Phone: HOLLYWOOD 4-7471

Acus Pictures Corporation

165 West 46th St., New York 36, N. Y.
Phone: PLaza 7-2265
PresidentPatrick Shanahan
Services Offered — Films for television rental.

A. F. Films, Inc.

180 E. 60th St., New York 19, N. Y.
Phone: MU 8-1370

Pres.Rosalind Kossoff
Services Offered — Distribution of short films internationally produced. TV films for distribution in U. S. and Canada.

Aladdin Television Productions, Inc.

165 N. La Brea Ave., Los Angeles 36, Cal.
Phone: Webster 3-9437

President.....Harry M. Popkin
V.P., Assoc. Producer....Julius F. Tuchler
Secretary.....Kenneth N. Chantry
Treasurer.....Jack Y. Berman
Producer.....Harold Helvenston
Director.....Erle C. Kenton
Production Mgr.....William Persons
Services Offered — Producer of films in series form for TV.

Alexander Film Co.

Alexander Film Bldg., Colorado Springs, Colo.
Phone: MAin 3-1771
N. Y. Phone: PENnsylvania 6-3028

President.....J. Don Alexander
V.P. in Chg. Prod.....Don M. Alexander
V.P.....Don Alexander, Jr.
Sec'y-Treas.....E. B. Foster
V.P. in Chg. Sales.....M. J. McInaney
Production Mgr.....James Anderson
Dir. Advtg., Pub. Rel.....R. H. Geddy
Services Offered—Producer of TV commercials.

M & A Alexander Productions, Inc.

6040 Sunset Blvd., Hollywood 28, Calif.
Phone: HOLLYWOOD 4-3414

PresidentArthur Alexander
Vice-PresidentMax Alexander
Services Offered—Distributors of motion pictures for television: features, westerns, half-hour series, shorts.

All-Scope Pictures, Inc.

7525 Beverly Blvd., Hollywood 36, Calif.
Phone: WYoming 1128

President.....Gordon S. Mitchell
Vice-President.....C. D. Owens
Secretary-Treasurer.....L. B. Mitchell
Chairman of Bd.....Gordon S. Mitchell

Allegro Pictures, Inc.

4238 Mammoth Ave., Sherman Oaks, Cal.
Phone: STate 9-4952
Pres., Exec. Producer.....William Lava

Allen & Allen Productions

3947 W. 59 Place, Los Angeles 43, Calif.
Phone: AX 3-3314
Directing Mgr.....George E. Allen
Services Offered—TV package programs.

American Film Co.

1329 Vine St., Philadelphia 7, Pa.
Phone: WALnut 2-1800
Mgr.Ben Harris
Services Offered—Serving 35 and 16mm. film to TV stations, also cutting, editing, and photographing of events of all kinds. Also handle any form of advertising.

American Film Producers

1600 Broadway, New York 19, N. Y.
Phone: PLaza 7-5915
Executive Producers.....Robert Gross,
Lawrence A. Glesnes
Production Control....Sheldon Abromowitz
Editorial Chief.....Frank Madden
Services Offered—Sponsored motion pic-



Photographing the celebrated Columbus Boychoir and Founder-Director Huffman in action, with the Maurer "16"

From Maine to Texas



... MUSIC STRANGELY SWEET

A glorious twentieth century American cultural accomplishment is the founding, training and development of the Columbus Boychoir. Singing to packed houses in America's finest concert halls, and in hundreds of cities and towns throughout the land, "America's Singing Boys" are bringing the joy of music to millions.

"Movies, records and radio have brought our story to the public thousands and thousands of times," says Founder-Director Herbert Huffman, "Now we want a record of our own - so we bought the finest camera we could find, the Maurer '16'."

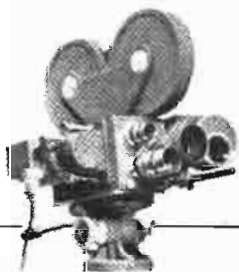

THE MAURER 16MM. designed specifically for professional use, equipped with precision high-power focusing and viewfinder. Standard equipment includes 235" dissolving shutter, automatic fade control, view finder, sunshade and filter holder, one 300-foot gear-driven film magazine, a 60-cycle 115-volt synchronous motor, one 8-frame handcrank, power cable and a lightweight carrying case.

J. A. MAURER, inc.

17-05 31st Street, Long Island City 1, New York
1107 South Robertson Blvd., Los Angeles 35, California

Cable Address: JAMAURER

**16mm
maurer**

maurer means *finer motion pictures!*

ture films and slide films for theatres, television, education, training, etc. Color or black and white; 16 or 35mm.; production and distribution.

American National Studios, Inc.

7324 Santa Monica Blvd., Hollywood, Calif.
Phone: HOLLYWOOD 2-6281

Services Offered—Complete production facilities for the making of motion pictures for television.

Animated Productions Inc.

1600 Broadway, New York, N. Y.
Phone: COLUMBUS 5-2942

PresidentAl Stahl
Vice-PresidentIrwin Stahl
V.P. in Chg. Production.....Jack Weisberg

Services Offered—Complete motion picture production service—live action—animation—film illusions. Producer of television film commercials, television shows, cartoons, training, industrial and public relations motion pictures, 35mm and 16mm, black and white, or color.

Animation Service Co.

1780 Broadway, New York 19, N. Y.
Phone: Circle 5-4832

Manager.....A. L. Simon
Chief Animator.....Abe Blashko
Art Director.....William Steinel
AdministrationMuriel Friedman

Services Offered — All film art services, maps, charts, cartoon animation, animation camera work in 16 mm and 35 mm.

Evan J. Anton Productions, Ltd.

60 W. 46th St., New York 36, N. Y.
Phone: Circle 6-0118

President.....Evan J. Anton
Vice-Pres.....Vera Kay

Services Offered—Producers of industrial and documentary films and slides, TV commercials and spots.

Arrow Productions, Inc.

7324 Santa Monica Blvd., Los Angeles 46, Cal.
Phone: HOLLYWOOD 4-3118
N. Y. Phone: PLaza 7-2765

PresidentMilton Gordon
Vice Pres.....Edward Small
Secy-Treas.Leon Fromkess

Services Offered: produce, distribute half-hour TV dramas—"Ramar of the Jungle" series.

Argyle Television Films, Inc.

60 W. 46th St., New York 36, N. Y.
Phone: Circle 6-4347
812½-14 N. La Brea, Hollywood 38, Cal.
Phone: HO 7-4882

President.....Lionis Goldstein
Vice President.....Bob Seidelman

Treasurer.....Jerome S. Hyams
Services Offered—Quality feature films, including "Night Train," "Young Mister Pitt," "Shipyard Sally," "A Girl Must Live," "The Girl In The News," "Kipps," "Inspector Hornleigh," and others.

Associated Program Service

(Division of Muzak Corp.)

237 West 54th St., New York 19, N. Y.
Phone: PLaza 7-7700

V.P.-Gen. Mgr.....Edward Hochhauser, Jr.
Services Offered—Exclusive TV distributor of Encyclopaedia Britannica Films. Lease of individual films and film packages.

Association Films, Inc.

347 Madison Ave., New York 17, N. Y.
Phone: MURray Hill 5-8573

President.....J. R. Bingham
Treasurer.....A. L. Fredrick
Director Adv. & Prom.....Robert Finehout

Services Offered—National distributors of industrial, educational, entertainment, religious and television films; library of 1,400 films, including 140 industrial (free-loan) films, 60 of which are cleared for TV use. Four regional libraries are maintained in Ridgefield, N. J., Chicago, San Francisco and Dallas.

Astor Pictures Corp.

130 W. 46th St., New York 36, N. Y.
Phone: LUXemburg 2-1287

Pres.-Treas.....Robert M. Savini
Exec. V.P.....Jacques Kopfstein
SecretaryFred Bellin
Adv. Mgr.....Cy Eichman
ComptrollerAnthony Tarrell

Services Offered—Producer and distributor of films for TV.

Atlantic Television Corp.

130 W. 46th St., New York 36, N. Y.
Phone: LUXemburg 2-1287

President.....R. M. Savini
Exec. V.P., Sls. Mgr..... Jacques Kopfstein

Services Offered—Producer and distributor of features and short subjects.

Atlas Film Corp.

1111 S. Blvd., Oak Park, Ill.
Phone: AUstin 7-8620

Vice-Pres. & Gen. Mgr.....L. P. Mominee
V.P. Chg. Sales.....Edward Schager
V.-P. Chg. Adv. & Prom..Frederick K. Barber
V.P. & Dir. of TV.....Norman C. Lindquist
V.P., Prod. Mgr.....Albert S. Bradish

Services Offered — Production of 16mm. and 35mm. motion pictures and slidefilms—in color or black and white, with RCA Sound. Experienced creative staff for TV commercials and programs. Laboratory and editing services.

RAMAR of the jungle

starring Jon Hall



It's the *only* show of its kind in all television! No chance of sponsor *mis-identification* with RAMAR, because there's no other show like it on the TV screens.

It's a show for children — with a host of adult fans. The jungle locale provides an exciting background for stirring episodes which appeal to the young and old of both sexes.

Sold in more than 85 markets. Act now for franchises on an individual market basis.



All of these TPA features are offered as complete selling packages, with effective, integrated merchandising and promotion plans to lift sponsors' sales.



for station operators...

THE EDWARD SMALL FEATURES

28 full-length feature films people like to watch . . . stations like to run . . . advertisers like to sponsor.

They're all produced by Edward Small, that outstanding Hollywood impresario whose sensitivity to public likes have given his productions a gross of more than \$100,000,000.

Features top name stars in every picture.

Now profitably shown by more than 100 station operators. If you're not one of them, you ought to be!



YOUR* STAR SHOWCASE

with your host, *Mr. Edward Arnold*



Here's a successful, *tested* program — that's *first-run* in over 150 markets!

It's a series of 52 star-studded network calibre half-hours which, as The General Electric Theatre, won ratings of 22.9 in Cleveland . . . 30.5 in San Antonio . . . 20.3 in Chicago . . . 32.6 in Kalamazoo, etc. (ARB, Feb., 1953).

YOUR* STAR SHOWCASE is a weekly parade of marquee names, sparkling scripts, tight direction and lavish production. It can be *the* showcase for your product.

*Advertiser or brand name

televisi**o**n **p**rograms of **a**merica, inc.

729 SEVENTH AVENUE, NEW YORK 19, N. Y. • 1041 N. FORMOSA AVENUE, HOLLYWOOD 46, CALIF.

coming soon...

THE ADVENTURES OF ELLERY QUEEN

starring *Hugh Marlowe*



A brand new half-hour series with a tradition of outstanding success — in every medium.

The Ellery Queen books have sold over 50 million copies. The radio series was a leading hit for years. Now, with Hugh Marlowe in the title role, a series of 52 never-before seen or heard adventures are being filmed in Hollywood for May release. Reserve your markets now. It's like putting money in the bank.

TWO PROVEN HITS

...top-rated
as network
shows...
now offered
locally!

RACKET SQUAD:

First run in over 110 markets — Second run in all others. A successful network show with a ready-and-waiting audience... combining fast-paced entertainment with public-service appeal... at just a fraction of its original cost!

THE PLAYHOUSE:

First run in over 150 markets — Second run in all others. This star-studded series has a big-time, network quality that you couldn't duplicate for many times the cost to you. And you can use the famous names to spark a sales campaign!

Want more information? Each of these shows has an outstanding history of success and it's yours for the asking... call our office nearest you (see list at bottom).

RACKET SQUAD

98 episodes
starring Reed Hadley
as "Captain Braddock"



The Playhouse

52 famous dramas, with famous
Broadway and Hollywood stars

ABC Film Syndication

In New York: Don L. Kearney, 7 West 66th Street, SU 7-5900

In Chicago: John Burns, 20 North Wacker Drive, Andover 3-0800

In Los Angeles: Bill Clark, ABC Television Center, Normandy 3-3311

Atlas Television Corp.

15 West 44th St., New York, N. Y.
Phone: MU 7-5535

President.....Henry Brown
Div. of East. Sales.....Jackson E. Dube
Div. of Mid-West Sales.....Pete Rodgers
Dir. of West. Sales.....Chas. Kennedy
Div. of Southwest Sales.....Wm. Dubensky
Booker.....Mitchell Sacks
Services Offered—American and British features; half- and full-hour Westerns; Comedy shorts; one hour comedy programs; an extensive library of comedy and musical vignettes, 3-5 minutes.

Audio Master Corp.

17 East 45th St., New York 17, N. Y.
Phone: OXford 7-0725

President.....Herbert Rosen
Services Offered—Library of mood and bridge music.

Audio Pictures, Ltd.

310 Lake Shore Rd., Toronto, Ont.
Phone: CLifford 1-5211

President.....Arthur Gottlieb
Vice Pres.....Gladys Glad Gottlieb
Asst. to Pres.....Murray Briskin
Sec'y-Treas.....Clem Williams
Services Offered—Producers of films for TV.

Audio Productions, Inc.

630 Ninth Ave., New York 36, N. Y.
Phone: COlumbus 5-6771

President.....Frank M. Speidell
Vice Pres.....Herman Roessle
Treas.....Lawrence W. Fox, Jr.
Sec'y.....Peter J. Mooney
Services Offered—Producer of TV commercials.

George Bagnall & Associates, Inc.

109 North La Cienega Blvd., Beverly Hills, Calif.
Phone: CR 15133

President.....George L. Bagnall
V.P.-Sales Mgr.....J. J. O'Loughlin
Secretary.....Fred C. Lindquist
Services Offered—Producer of films for TV.

Bailey Films, Inc.

6509 De Longpre Ave., Hollywood 28, Calif.
Phone: HILLside 7949

President.....Albert R. Bailey
Vice-President.....Delmar F. Hancock
Secretary-Treasurer.....Virginia B. Ryder
Services Offered—Three dimensional animation and live action shorts, educational motion pictures, advertising films, and special television subjects.

**THE FILM NETWORK
VOTED TOPS BY THE STATIONS***

Here's How The "Film Network" Can Work For You. You select 300 hours of programming from our more than 500 hours available. You pay a reasonable hourly rate based on the size of your market. Since top commercial shows are included in the package, selling them gives you the whole package practically free. For details and prices, contact

*BILLBOARD MAGAZINE'S Annual Poll Placed Sterling Tops with best library and/or "station starter" plan.

STERLING TELEVISION CO., INC.

205 East 43rd Street

New York

OXford 7-2520

Hollywood

There is an MPTV branch office
with a complete "on hand" film
selection in your area.
Consult your nearest
branch manager at any time
without obligation.



MPTV

*leader in the field,
offers you the largest
selection of feature
films in television*

MOTION PICTURES FOR TELEVISION, INC.
Feature Film Division

NEW YORK, 655 Madison Ave., TEmpleton 8-2000 E. H. Ezzes, Gen'l Mgr.
BOSTON, 216 Tremont St., Hancock 6-0897 Fred Yardley
CHICAGO, 155 E. Ohio St., Whitehall 3-2600 Dick Feiner
DALLAS, 3905 Travis St., Logan 2628 Irv Feld
DETROIT, 2211 Woodward Ave., Woodward 1-2560 Marv Lowe
LOS ANGELES, 9100 Sunset Blvd., Crestview 1-6101 John Cole
TORONTO, (MPTV Canada Ltd.) 277 Victoria St., Empire 8-8621 Alex Metcalfe

Tom Bailey Productions, Inc.

722 North Fourth Ave., Tucson, Arizona

Phone: 21907

Pres., Exec. Producer.....Tom Bailey
 Vice-President.....William Freytag
 Secretary.....Jay Fuller
 Treasurer.....Paul M. Arend, Jr.
 Associate Producer.....Walter Kimmell
 Dir. of Photography.....Albert Runkle

Barnett International Forwarders

723 Seventh Ave., New York 19, N. Y.

Phone: CIrele 5-6080

President.....William Barnett
 V.P., Sec'y.....Norman Barnett
 Treas.....Alan Barnett

Services Offered: International film forwarders, packers and custom brokers.

Busch Radio & Television Productions

(See Program Producers.)

Beacon Television Features Inc.

420 Boylston St., Boston 16, Mass.

President.....J. Leonard Sanderson
 Treasurer.....Barbara G. Keane

Services Offered—Syndicated package programs, outdoor type. Spot television commercials including complete creation, copy, etc.

Blinkey Productions Inc.

106 West End Ave., New York 23, N. Y.

Phone: SU 7-4429

Producer-DirectorMurray King
 Technical Director.....Lucille Emerick
 Production Supervisor.....Sydney Parker

Services Offered — Film producers, open-end films, TV series, video film commercials, package programs produced.

Fritz Blocki Productions

1152 No. Curson Ave., Hollywood 46, Calif.

ProducerFritz Blocki

Services Offered—Live TV show formats for local and/or network use.

ESPECIALLY MADE FOR TV!

GOODMAN'S ORIGINAL PRIZE WINNING WEATHER FORECAST JINGLES

51 thirty-second spots covering every possible weather condition. On sound film with full-action marionettes. These prize-winning spots copped National kudos two years in a row.

The Weatherman plays an important role in everyone's life. That's why audiences tune in just to get the weather report in the Tuneful, Bouncy Manner presented in these WEATHER FORECAST JINGLES-TV.

Exclusive Rights Granted.
 Write, wire or phone for full information.

Harry S. Goodman

19 EAST 53rd STREET at Madison Avenue... NEW YORK CITY



PEGGY LEE



LES BROWN



TERESA BREWER



RALPH FLANAGAN



FRAN WARREN



NAT "KING" COLE

bigger profits three ways!

Here is how you increase your profits with the new combined Studio Telescription Library*

1. BIGGER AUDIENCES are attracted to programs featuring Studio Telescriptions. With the Studio Telescription Library, over 1,100 three minute films produced especially for TV, you have the nation's top musical stars in lavish settings creating unprecedented popularity for your shows.

2. LOWER PRODUCTION COSTS are made possible because, with all talent on film, it takes only minutes to build any number of sparkling, production-type programs. The Library is complete with handy index files, sample scripts, program ideas and background material for your MC, and the monthly charge is unbelievably low!

3. MORE SPONSORS flock to Telescription shows with their high listener ratings. Now, even local advertisers can capitalize on the miracle selling power of top quality television and top name stars, wherever Telescriptions have eliminated high production costs

Find out today how the Studio Telescription Library, with its complete programming and merchandising service, can bring bigger-than-ever profits to you.

**consisting of Studio Must-Films and Snader Telescriptions*

put scores of top name artists on your regular staff

DON'T DELAY DON'T WRITE
CALL COLLECT: OXford 7-2590



STUDIO FILMS, INC.

380 MADISON AVENUE • NEW YORK 17, N. Y. • OXFORD 7-2590

Exclusive distributors of Studio Telescriptions

IN CANADA ALL-CANADA TELEVISION, 129 ADELAIDE ST. WEST, TORONTO, ONT., EMPIRE 3-2632

William Boyd Prod., Inc.

8901 Wilshire Blvd., Beverly Hills, Cal.

Phone: CRestview 4-5248

Pres., Exec. Producer.....William Boyd
 Vice Pres.....Robert Stabler
 Sec'y-Treas.Marguerite Cherry
 Production Mgr.....Glenn Cook
Services Offered—Producer of films for TV.

Bray Studios Inc.

729 Seventh Ave., New York 24, N. Y.

President.....J. R. Bray
 Vice-Pres. and Prod. Mgr.....Paul A. Bray
 Treasurer.....M. Bray
 General Mgr.....Max Fleisher
 Film Distribution Mgr.....B. D. Hess

Services Offered—Producers and distributors of all types of films for TV use including technical animation and cartoons. Owns extensive library of films available for TV. Films on health, hygiene, physiology and aeronautics.

Al Buffington Productions

6711 Sunset Blvd., Hollywood 28, Calif.

Phone: HOLlywood 9-8367

Sales & Program Mgr...Albert B. Buffington
 Staging Mgr.....Milford Capman
 Script Editor.....Donna Kellogg

Services Offered—Live package show, both national and local, AM and TV. Filming of

commercial film for TV. Making of radio transcriptions.

Brandon Films Inc.

200 West 57th St., New York 19, N. Y.

Phone: CI 6-4868

Film Librarian.....Edith Zornow
Services Offered—Distribute selected packages of feature films; specializing in "The Cavalcade of Great Motion Pictures of All Times."

William F. Broidy Productions, Inc.

5545 Sunset Blvd., Hollywood 28, Cal.

Phone: HEMpstead 6844

President.....William F. Broidy
 V.P. & Sec'y.....Edward J. Kay
 Prod. Mgr.....A. R. Milton
 Adv. Dir.....L. L. Kaufman

Services Offered—Full TV film production, including studio facilities, crew and executive personnel. Studios for rental. Package shows. *Productions*—"Wild Bill Hickok," "Case History."

**British Information Services
 —Film Division
 (Agency of the British
 Government)**

30 Rockefeller Plaza, New York 20, N. Y.

Phone: Circle 6-5100

Murray Hill 8-1162

CLIENTS

American Home Foods
 Armstrong Cork
 Benrus
 Borden
 Bulova
 Chesebrough
 Conti
 DuPont
 Ford
 General Electric
 General Foods
 General Mills
 CMAC
 Gulf
 Hinds
 Johns-Manville
 McKesson & Robbins
 Philco
 Remington-Rand
 Schlitz
 Simoniz
 Westinghouse
 and many others

VIDEO PICTURES, INC.
 41 East 50th Street New York 22, N. Y.

PARSONNET
TV FILM STUDIOS
I N C .

Producers of
“THE DOCTOR”

“HOLLYWOOD-OFF-BEAT”

Starring
MELVYN DOUGLAS

“AMERICAN WIT AND HUMOR”

Starring
THOMAS MITCHELL

Director Charles Dand
 Distribution Mgr..... Lester Schoenfeld
 Radio Officer..... Jack Aistroph
 Pub. & Adv. Mgr..... Joe Slevin
Services Offered—Official distributor in the United States of films produced by the British Government.

Calhoun Studios

266 East 78th St., New York 21, N. Y.
 Phone: RE 4-8017

Director of Photography.... Brian Calhoun
 Producer-Director..... William S. Kent
 Sound Engineer..... Howard Kaiser
 Talent and Scripts..... Robert K. Adams
 Art Director..... Larry Hotcaveg
 Film Editor..... Lottie Schaler
 Sales Manager..... William Hyer
 Public Relations Director..... Jack Petrill
Services Offered—Aid conditioned, sound-proofed and completely equipped for the production of 16mm and 35mm motion pictures for Television, Industry, Education and Entertainment.

Cavalcade Television Programs Inc.

7904 Santa Monica Blvd., Hollywood 46, Calif.
 Phone: HOLLYWOOD 4-3556
 N. Y. Phone: ACademy 4-2781
 President Harvey Pergament
 Vice Pres. Earl M. Robins
 Sec.-Treas. Esther Pergament

Services Offered — Producers representative, distribution of motion picture films, exporter of TV programs.

Campus Film Productions

14 E. 53rd St., New York 22, N. Y.
 Phone: PL 3-3280

Exec. Pro..... Nat Campus
Services Offered—Film production under contract for clients specific use.

Caravel Films, Inc.

730 Fifth Ave., New York 19, N. Y.
 Phone: Circle 7-6110

President..... David I. Pincus
 Exec. V.P..... Harold M. Manser
 V.P..... F. Burnham MacLeary
 Production Mgr..... Mauri H. Goldberg
Services Offered—Industrial and TV films to order.

Caston Productions

8611 Sunset Blvd., Hollywood 46, Cal.
 Co-owners and producers: Robert L. Casby and Milton L. Cashy.
 Sales Promotion..... William Beaudine, Jr.
 Supervising Editor..... Stuart O'Brien
Services Offered—Producers of films for TV.

Mr. Producer
**IF IT'S SOUND
 IN THE EAST
 ... IT'S REEVES**

That's the opinion of hundreds of producers using Reeves facilities.



REEVES SOUND STUDIOS, INC.

304 EAST 44th STREET • NEW YORK 17, N. Y. • OREGON 9-3550

The Largest Sound Service Organization in the World.

RCA Licensee

Western Electric Licensee



PARIS

LONDON

NEW YORK

CHICAGO

BEVERLY HILLS

SAN FRANCISCO

CLEVELAND

MINNEAPOLIS

DETROIT

DALLAS

BOSTON

ATLANTA



Cavalier Enterprises

1119 Sunset Blvd., Los Angeles 46, Calif.
Phone: CR 6-4174

PresidentRobert Young
Vice Pres.....Engene B. Rodney
Sec.-Treas.Ben Bisgeier
Services Offered—Owners and producers of
"Father Knows Best" starring Robert Young
on NBC for General Foods. Preparing same
on film for TV.

CBS-TV Film Sales

485 Madison Ave., New York 22, N. Y.
Phone: PLaza 1-2345

Vice-Pres. in Charge.....Merle S. Jones
Operations Director.....Fred J. Mahlstedt
Gen. Sales Mgr.....Wilbur S. Edwards
Prom. Mdsg. Mgr.....Walter A. Scanlon
Branch Offices

410 N. Michigan, Chicago, Ill.
Phone: WH 4-6000

Exec. in Charge.....Wm. Perkinson
1313 N. Vine St., Los Angeles 28, Cal.
Phone: HOLlywood 9-1212

Exec. in Charge.....Thomas Moore

Hu Chain Associates

40 East 40th St., New York 16, N. Y.
Phone: MUrray Hill 5-7220

Owner.....Hubert V. Chain
Services Offered—Custom built video film
programs and commercials.

Bruce Chapman Co.

55 W. 42nd St., New York 36, N. Y.
Phone: Wisc. 7-9244

PresidentBruce Chapman
Sec'y-Treas.Edna Chapman
30 Rue de Gramont, Paris, France
Phone: Richelieu 80-04

DirectorDan Morely
Services Offered—Producer of TV films
and commercials; industrial and educational
films; dubbing in U. S. and Europe.

Charter Oak Tele-Pictures

846 7th Ave., New York, N. Y.
Phone: CIrcle 6-2508

President.....Louis Cavrell
Services Offered: Production facilities for
TV and industrial 16 and 35mm color and
black-and-white films.

Cineffects, Inc.

115 W. 45 St., New York 36, N. Y.
Phone: CIrcle 6-0951

PresidentNathan Sobel
Secretary-TreasurerIrving Hecht
Services Offered—Special optical effects,
photography of titles, animation, trailers,
song reels, slide films, TV presentations in
16 and 35mm. black and white and 16mm.
Kodachrome.

CINEFFECTS, INC.

115 W. 45th STREET

NEW YORK 36, N. Y.

CI 6-0951

FOREMOST PRODUCERS AID IN THE EAST

Complete Art Service

- TECHNICAL and CARTOON ANIMATION
- ART TITLES
- MAPS — RETOUCHING

Optical Effects

- 35mm EASTMAN NEG. POS.
- 35mm ANSCO NEG. POS.
- 16mm BLACK AND WHITE
- 16mm EASTMAN & ANSCO REVERSAL

**ART LETTERING. ALL OPTICAL EFFECTS
FOR TELEVISION IN COLOR OR BLACK & WHITE**

UTP brought you in—

1951

REBOUND

ROYAL PLAYHOUSE

HOLLYWOOD OFF BEAT—

Melvyn Douglas

1952

THE CHIMPS

COUNTERPOINT

HEART OF THE CITY

OLD AMERICAN BARN DANCE

1953

LOOK PHOTOQUIZ

FULTON LEWIS JR.

THE GOSPEL SINGER

ROCKY JONES, SPACE RANGER

DOUBLE PLAY—Day & Durocher

—and even more—for '54

1954

LONE WOLF—Louis Hayward

WATERFRONT—Preston Foster

WHERE WERE YOU—Ken Murray

O'HENRY TV PLAYHOUSE

AUTHOR'S PLAYHOUSE

THE RUGGLES

MANHUNT

HOLLYWOOD

650 N. Bronson—HO. 9-8321
TWX-LA 1432

NEW YORK

444 Madison—Plaza 3-4620
TWX-NY1-1967

CHICAGO

360 N. Michigan—Central 6-0041
TWX-CG 2203

**CALL
UTP
FIRST***

*and be
a happy
buyer
too!*

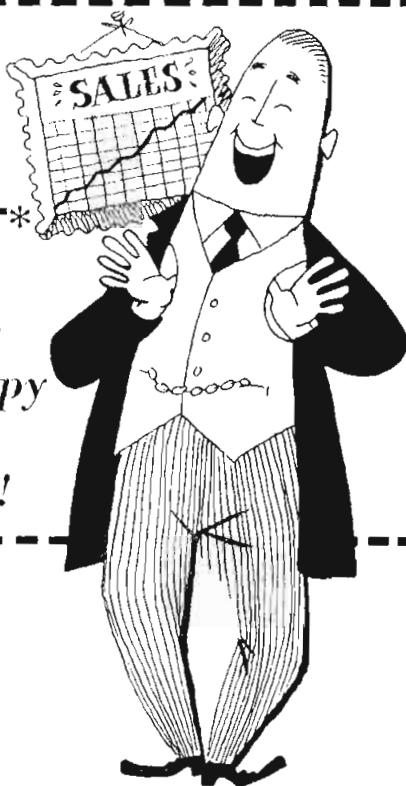

You called us **FIRST** in '51, '52 and '53. We've given you top shows and service.

Again in '54 you'll want to

CALL UTP FIRST

and here's why

...great, new first run

series, with outstanding per-

sonalities. Drama, adventure,

laughs, excitement, news,

and sports shows are what have

made UTP—**THE FIRST TO CALL.**

REMEMBER...CALL UTP FIRST...

**UNITED
TELEVISION
PROGRAMS INC.**

Exec. Sec'y.....Gloria Farrier
Services Offered—Personal management of talent and writers as well as the production of radio and television shows.

Cornell Film Co.

1501 Broadway, New York 36, N. Y.
 Phone: WISconsin 7-6650

President.....J. Milton Salzburg
 V.P., Sales Mgr.....David B. Dash
 Adv. Mgr., Asst. Sls. Mgr.....S. J. Krumholz
Services Offered—Producers and distributors of features and shorts.

Tom J. Corradine & Associates

5746 Sunset Blvd., Hollywood 28, Calif.
 Phone: HO 2-4448

President.....Tom Corradine
 Vice President.....Bob Nunes
Services Offered—Service Television stations and agencies with all types of film programming. Library includes: Features, westerns, half hour and fifteen minute shows produced especially for TV.

Courneya Productions

633 No. Almond Dr., Hollywood, Calif.
 Phone: CRestview 4-5621

Owner-Producer.....Jerry Courneya
 Vice Pres.....Henry E. Huntington
 Sec.-Treas.....Hugh Purcell

Services Offered—Short subjects, Features, and Commercials.

Clayton W. Cousens Prods.

333 W. 78th St., New York 24, N. Y.
 Phone: TRafalgar 3-5870

President.....Clayton W. Cousens
 Production Dir.....Ralph Porter
Services Offered—Producers of TV fashion shows and commercials.

Crest Television Productions

10361 McCormick St., No. Hollywood, Calif.
 Phone: SUNset 2-3138

President.....Lloyd Friedgen
 Sec.-Treas.....Elva Fraser
 Associate.....Meyer Willner
Services Offered—Distribution and production of features for television.

Bing Crosby Enterprises, Inc.

9028 Sunset Blvd., Los Angeles 46, Calif.
 Phone: Crestview 1-1171

N. Y. Phone: PLaza 7-2277
 President.....Everett N. Crosby
 Vice President.....John O'Melveny
 Vice President-Secretary..Todd W. Johnson
 Exec. V.P.....Basil F. Grillo
 V.P. Chg. Sales.....Charles B. Brown
 Treasurer-Controller.....Homer O. Duerr
Services Offered—Development of program

COLOR SERVICE

COMPANY, INCORPORATED

115 WEST 45th ST.

NEW YORK 36, N. Y.

Phone: JU 6-0853

Foremost Color Laboratory in the East

COMPLETE SERVICE IN COLOR PRINTING

- CONTACT • REDUCTION
- 16 mm EASTMAN REVERSAL
- 16 mm ANSCO REVERSAL
- 35 mm EASTMAN NEG. POS.
- 35 mm ANSCO NEG. POS.
- COLOR SLIDE FILM PRINTING

ideas for film and actual completion from idea to film production.

Crown Cinema Corporation

270 Park Avenue, New York 17, N. Y.
Phone: MU 8-6345

President James Hsu
Secretary Morley Cho
Assistant Secretary Samuel E. Grant

Crown Pictures International

961 N. La Bienega Blvd., Hollywood 46, Calif.
President Jack Covel
Exec. V.P. Samuel Singer
Sec. Treas. Sidney Michelson

Services Offered - Package TV programs, syndicate film.

Crystal Pictures, Inc.

1564 Broadway, New York 36, N. Y.
Phone: PLaza 7-5130

President Melvin M. Hirsh
Services Offered - Distributor of features, western, dramas and travelogues.

Current Production - Half-hour shows in Europe.

Shamus Culhane Productions

207 East 37th St., New York 17, N. Y.
Phone: MUrray Hill 2-8243

President Shamus Culhane

Vice-President Morris Coppersmith
Sec. & Treas. Maxine Marx

Services Offered—complete production of animated and live-action motion pictures and slide-films. Television commercials and industrial films also in black and white and color. Permanent staff includes producers, directors, animators, editors, creative writers, and production designers and cameramen.

Gordon M. Day Prods.

108 E. 30th St., New York 16, N. Y.
Phone: ORegon 9-3595

Writer-Composer Gordon M. Day
Director, Producer Carol Bulkley
Production Mgr. Edith Adelson
Treas. Leo Reich

Services Offered—Producers and jingles and spots.

D. P. M. Productions, Inc.

62 W. 45th St., New York 36, N. Y.
Phone: MU 2-0040

President Dorothy P. Mausby

De Frenes Co.

1909 Buttonwood St., Philadelphia 30, Pa.
Phone: RIttenhouse 6-1686

Pres., Gen. Mgr. Joseph De Frenes
Services Offered—Production of 16mm. & 35mm. films, black & white, color.

STARS GALORE

These are just a few of the stars featured in Your All-Star Theatre

Broderick Crawford
Paul Muni
Joanne Dru
Jane Greer
Maureen O'Sullivan
Edmond O'Brien
Sally Forrest
Ann Harding
Paul Henreid
Will Rogers, Jr.
Edward Arnold
Mark Stevens
Ellen Drew
Joan Caulfield
Lloyd Nolan
Charles Bickford
Wanda Hendrix
Louis Hayward
Laraine Day
Mercedes McCambridge
Terry Moore
and many, many others

Your
All-Star
Theatre

Originally telecast over 59 stations of the NBC network as THE FORD THEATRE

SCREEN GEMS, INCORPORATED
TELEVISION

SUBSIDIARY OF COLUMBIA PICTURES CORPORATION
233 West 49th St., New York City • Circle 5-5044

Demby Productions, Inc.

34 E. 51st St., New York 22, N. Y.
Phone: PLaza 9-2495

President Emanuel Demby
Vice Pres..... Mildred Demby
Acct. Supervisor..... Hunter W. Smith
Film Editor..... Myron L. Broun

Services Offered—Production of live and filmed TV shows and commercials.

Dephoure Studios

782 Commonwealth Ave., Boston 15, Mass.
Phone: BEacon 2-5722

Owner..... Joseph Dephoure

Services Offered—Motion picture production, studio facilities, processing laboratory, b&w and color printing, editing, slides and slidefilms, magnetic and sound on film recording.

Depicto Films, Inc.

254 W. 54th St., New York 19, N. Y.
Phone: COlumbus 5-7621

President John Haus
Exec. V.P..... Tom Dunford

Services Offered—Complete commercial and TV film, slidefilm and slide production, including art, writing, visualizing, animation, location and studio shooting.

Desilu Productions, Inc.

Business Office:

846 Cahuenga Blvd., Hollywood, Calif.
Phone: HOllywood 9-5981

President Desi Arnaz
Vice-President Lucille Ball
Exec. V.P..... Martin Leeds
Secretary-Treasurer..... Andrew G. Hickox
Representative..... Don W. Sharpe
Publicity Ken Morgan

Services Offered—Complete production facilities from script to final editing.

Sherman H. Dryer Productions

667 Madison Ave., New York 22, N. Y.
Phone: TEmpleton 8-7827

President..... Sherman H. Dryer
Services Offered—TV programs, talent, scripts.

Dudley TV Corp.

9908 Santa Monica, Beverly Hills, Calif.,
Phone: CR 1-7258

501 Madison Ave., New York, N. Y.
Phone: EL 5-1076

President Carl Dudley
Exec. Vice-Pres..... Don McNamara
Studio Mgr..... Gene Barnes

Services Offered—Producers of theatrical, commercial television and educational short subjects.



SCREEN GEMS TELEVISION

presents

26 "all-request" quarter hour sports programs on film starring

BILL STERN as host and narrator...

85 great stars ... 100 thrilling events!



SCREEN GEMS TELEVISION, 233 W. 49th St., New York

JOB WANTED!

Experienced PRODUCER wants JOB producing YOUR NEXT TV-FILM COMMERCIAL! Qualifications -- More than THIRTY YEARS experience producing MOTION PICTURE TRAILERS...that sell the MOVIES to an average of FIFTY-FIVE MILLION MOVIEGOERS Every Week! Experienced craftsmen in all departments! Complete facilities under one roof! References--the top agencies and advertisers, who are using TV FILM COMMERCIALS produced by NATIONAL SCREEN SERVICE! Write or phone 1600 Broadway, New York 19, N. Y. -- Circle 6-5700 - or - 7026 Santa Monica Boulevard, Hollywood -- Gladstone 3136.

Du Mont Television Network-Film

(Syndication Dept.)

515 Madison Ave., New York 22, N. Y.

Phone: LEhigh 5-1000

Supervisor.....Merriman H. Holtz, Jr.

Services Offered—Distributor and syndicator of features and TV series.

Dynamic Films, Inc.

112 West 89th St., New York 24, N. Y.

Phone: TRafalgar 3-6221

PresidentHenry Morley
 Ch. of Board.....Nathan Zucker
 Exec. Prod.....Lee Bobker
 Film Dist. Dir.....Margaret Pfeiffer
 Editorial Chief.....Luke Bennett
 Story Editor.....Lester Becker
 Production Mgr.....John Zane
 Sound Engr.....John DeBlau

Services Offered—Complete motion picture production in both 16 mm and 35 mm, sound recording studios, sound stages, film distribution, commercials, films for industry, documentaries, TV film packages, mobile sound and camera units for location production.

Educational Films Corp.

1501 Broadway, New York 36, N. Y.

Phone: PENnsylvania 6-1780

President.....Earl W. Hammons
 Vice President.....V. H. Hammons
 Vice-Pres.....Bernard J. Prockter
 Treasurer.....John Prockter
 Secretary.....L. Lowinthan
 Services Offered—Films for theatrical release, for educational purposes, television shows live or on film. Producing on the West Coast and in New York.

Douglair Corp.

666 N. Robertson Blvd., Los Angeles 46, Cal.

President.....H. Alexander MacDonald

V.P., Treas.....Fred Hoar

Vice Pres.....Irving Ruhine

Services Offered—Producer of TV series.

Peter Elgar Productions, Inc.

18 E. 53rd St., New York, N. Y.

Phone: MU 8-5626

President.....Peter Elgar

Corp. Sec'y.....Jeanne Osen Remusat

Services Offered — Producers of documentaries and films for television.

Endorsements, Inc. (TV)

500 Fifth Ave., New York 36, N. Y.

Phone: Chickering 4-7257

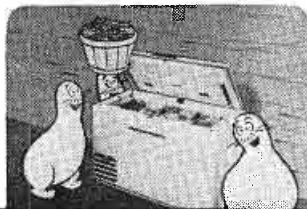

Mr. Animation
 CREATED THE RINSO BIRD — MARRIED LI'L ABNER TO DAISY MAE FOR KELVINATOR.
 LET MR. ANIMATION CREATE A DIFFERENT SPOT FOR YOU!
 CALL **AL STAHL** NOW
ANIMATED PRODUCTIONS INC.
 1600 BROADWAY CO 5-2942



NTA

has **more of everything you need...**

more new top-notch quality television programs on film...
to sell more productive time to sponsors... to sell
more sponsors' products to more consumers...
in more markets... at low, low costs!

NTA has a huge, new library of successfully sponsored properties already delivering mass audiences to advertisers in many markets!

these are the programs:

HALF-HOUR:

China Smith • The Beulah Show • Cowboy G-Men
Orient Express • Play of the Week • Pantomime Quiz
International Playhouse • Televideo Theater

QUARTER-HOUR:

The Passerby • The James Mason Show • The Bill
Corum Sports Show • The Eva Gabor Show • TV's
Baseball Hall of Fame • Bobo the Hobo • Find a
Hobby • Telecomics

PLUS:

Man's Heritage • Viz-Quiz • Superman (Cartoons)
Layman's Call to Prayer • Music of the Masters
Sands of Time

and over 100 feature films and westerns

Each NTA series is backed by a realistic, yet powerful, complete sales-merchandising and promotion package to support and tie-in entire campaigns.

CALL YOUR NTA MAN TODAY! • HE'S Only Minutes Away!
*Far name, address and phone number of the nearest NTA man:
phone — wire — or write

National Telefilm Associates, inc.



509 Madison Avenue, New York 22, N. Y. • MUrray Hill 8-4800

9172 Sunset Blvd., Hollywood 46, Calif.

Phone: Crestview 6-1272

President Jules Alberti
 Vice-Pres. Dr. Harold S. Wadro
 Sec.-Treas. Hazel F. McCabe
 Chg. Prod. F. Richard Mansfield
 Mgr., Wash. Edythe Galey
 Mgr., Hollywood. Stella March
Services Offered—Endorsements and testimonials live and film for TV.

**Espana Mexico Argentina,
 S.A. de C.V.**

Barcelona No. 15, Mexico D.F. 6, Mex.

Phone: 36-58-14

President General Juan F. Azvarate
 Gen. Mgr. Jesus Nieto M.
 Sales Mgr. Luis Gurza V.
Services Offered—Production of documentary films, film commercials, filmspots, musicals, etc.

Excelsior Pictures Corp.

1564 Broadway, New York 36, N. Y.

Phone: Circle 5-6157

President Walter Bibo
Services Offered—Rent various features and shorts.

Explorers Pictures Corp.

1501 Broadway, New York, N. Y.

Phone: LO 4-5592

Pres.-Gen. Sales Mgr. Jules B. Weill

Asst. Sales Mgr. Murray M. Kaplan

Services Offered—Motion picture films for TV, feature and half hour length.

Fair Deal Motion Picture Ser.

2040 Chatterton Ave., New York 72, N. Y.

Phone: TAlmadge 9-6728

Owner & President. Louis D. Colson

Services Offered—We offer package film shows for TV use.

Jerry Fairbanks Productions

6052 Sunset Blvd., Hollywood 28, Calif.

Phone: HOLLYWOOD 2-1101

Pres., Exec. Producer. Jerry Fairbanks
 Sales Mgr. Fenton McHugh
 Production Manager. John McKennon
 Director, Sound Dept. Lawrence Aicholtz
Services Offered—Producers of all types of films for television, including package programs, agency shows, spot announcements, and special featurettes. Also commercial and theatrical motion picture producers.

Don Fedderson Productions

120 El Camino, Beverly Hills, Calif.

Phone: BRadshaw 2-8031

President Don Fedderson

Producer Fred Henry

Services Offered—Current productions include "Liberace" and "Life With Elizabeth."

SHAMUS CULHANE PRODUCTIONS

*producers of T.V. commercials
 announce the opening of
 a west coast studio at...
 8802 Melrose Avenue
 Los Angeles, California
 under the direction of*

WILLIAM T. HURTZ

*For Outstanding
TV Motion Picture
Programming*

Use
COMMONWEALTH

MAJOR COMPANY FEATURES
DRAMAS
WESTERNS
CARTOONS
SERIALS
COMEDIES
MUSICAL SHORTS



COMMONWEALTH

Film and Television, Inc.

MORT SACKETT, Pres.

723 SEVENTH AVENUE

NEW YORK 19, N.Y.

Circle 5-6456

Federal Telefilms, Inc.

1041 N. Formosa Ave., Hollywood 46, Calif.

Phone: HOLlywood 7-5111

President.....William (Buster) Collier

Vice President.....Harry Joe Brown

Member Bd. of Dir.....Randolph Seott

Paul J. Fennell Co.

404 N. La Cienega Blvd., Los Angeles 48, Cal.

Phone: CRestview 6-0847

40 E. 40 Street, New York 16, N. Y.

N. Y. Phone: LExington 2-2384

President-Producer.....Paul J. Fennell

V.P.-Tech. Dir.....John E. Burks

Writer-Art Dir.....Donald B. Driscoll

Services Offered—Producers of Public Relations, training and commercial films; live action and animation; specializing in animated cartoons.

Filmack Corp.

1327 S. Wabash Ave., Chicago 5, Ill.

Phone: HArrison 7-3395

President.....Irving Mack

Vice-President.....Joe Mack

Secretary.....Bernard Mack

Treasurer TV Sales.....Don Mack

TV Production.....Pat Cascio

Services Offered — Film studio complete with art department, camera room, sound studio and laboratory. Fully equipped to produce the world's best TV commercials at a practical price.

Filmcraft Productions

8451 Melrose Ave., Los Angeles 46, Calif.

Phone: WEbster 3-9281

162 West 56th St., New York, N. Y.

Phone: CIrcle 5-8997

Pres., Exec. Prod.....Isidore Lindenbaum

Production Exec.....F. H. Fodor

Dir. of Programming.....Bob Marx

Technical Manager.....Paul Schmutz, Jr.

Film Distribution Mgr.....Hamilton Warren

Services Offered—TV films of all types.

Productions—“You Bet Your Life” and “Mark Twain Television Theater” series for national sales.

Filmeffects of Hollywood

1153 N. Highland Ave., Hollywood 38, Calif.

Phone: HOLlywood 9-5800

Manager.....Charles Leeds

Services Offered—Specialized 35mm and 16mm color and black and white laboratory services for motion pictures and television. Special effects, blow-ups, reductions, color release printing, slide film duplication experimental projects.

Films For Industry, Inc.

135 W. 52nd St., New York 19, N. Y.

Phone: PLaza 3-2800

Pres., Prod. Mgr.....Joseph McCaffery

Technician.....Ralph Friedman

CINEMA RESEARCH

Optical Printing

16 MM Animation • Titles 35 MM

COLOR—BLACK & WHITE

7000 ROMAINE

Hollywood 38, California

Phone — HOLlywood 2-7464

Now Servicing
11 Western States

from our NEW
Hollywood
office

THE 39 TOP
ARGYLE
FEATURES
including

RICHARD
GREENE · ANN
TODD
Showtime
with PETER
GRAVES

GRACIE
FIELDS · VICTOR
McLAGLEN
**WE'RE GOING
TO BE RICH**
with
BRIAN DONLEVY

**ROBERT
DONAT**
in
*"The YOUNG
MR. PITT"*

**THE GIRL IN
THE NEWS**

MARGARET
LOCKWOOD and REX
HARRISON
NIGHT TRAIN

directed by
CAROL REED

starring
MARGARET LOCKWOOD
BARRY K. BARNES
EMLYN WILLIAMS

directed by CAROL REED

directed by
CAROL REED

For further details and catalog, contact:

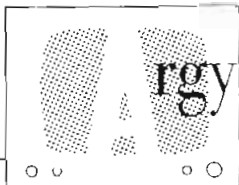

Argyle Television Films, inc.

HOLLYWOOD:
812½-14 North Le Brea
Hollywood 38, Calif.

NEW YORK:
60 West 46th Street
New York 36, New York

Films of the Nations, Inc.

62 W. 45th St., New York 36, N. Y.
Phone: Murray Hill 2-0040

Pres.....Henry M. Moolman
V.Pr.....Birger Nordholm
Treasurer.....Henry Pilliehody
Secretary.....William Rosenfeld
Exec. Dir.....Maurice T. Groen

Frieda Fishbein

11 W. 42nd St., New York 36, N. Y.
Phone: LO 5-1379

Owner.....Frieda Fishbein
Services Offered—Representing authors on material for radio and television.

Five Star Productions, Inc.

6530 Sunset Blvd., Hollywood 28, Calif.
Phone: HOLLYWOOD 3-4807

Exec. Producer.....Harry Wayne McMahan
Production Dir.....Chet Glassley
General Mgr.....Taylor Bvars
Casting.....Judy McMahan
Secretary-Treas.....Bernice C. McQuown
Services Offered—Motion picture and TV film spots.

Flying A Pictures, Inc.

and

Range Rider Productions

6920 Sunset Blvd., Hollywood 28, Calif.

Phone: HO. 9-1425

President.....Armand Schaefer
Executive Producer.....Louis Gray
Productions—in release or prod.—78 half hour television screenplays starring Gene Autry, 78 half hour television screenplays starring The Range Rider and Dick West (both series distributed by C.B.S. TV Film Sales). 20 Death Valley Days half hour television screenplays made for Pacific Coast Borax and handled by the McCann Erickson Advertising Agency.

Fortune Merchandising Corp.

(Productions Division)

104 S. Vermont Ave., Los Angeles 4, Calif.
Phone: DUNKIRK 8-0501

President.....Leonard Shane
Exec. V.P.....Maxim Konecky
Prod. Coordinator.....J. M. Lench
Office Manager.....Jeanne McFarland
Services Offered: Television film commercials, tailor-made and syndicated starring Pat Buttram, Range Rider & Dick West, Jon Hall, Rocky Jones, Vargas Girls, etc.

Foundation Films Corporation

Citizens Bank Building, Pasadena 1, Calif.
Phone: SYCAMORE 2-6476
Chairman of the Board.....John I. Bolen

**NOTHING SUCCEEDS
LIKE SUCCESS!**

One year ago General Film Lab entered the most fiercely competitive technical field in Hollywood. Today, through sheer performance, and the competency of its personnel, General Film Lab is the peer of any film processing laboratory in the nation! The imposing and ever-growing list of clients is the most eloquent testimony to the success of our policy of giving the industry superlative service—the finest, the fastest and the best controlled-quality laboratory work in filmdom!

FEATURE PRODUCTIONS

Allied Artists	Paramount Pictures
Wm. F. Broidy	Lindsley Parsons
Lippert Pictures	Edward Small
Hal Makellim	Three Dimensional Pic.
Panoramic	20th Century-Fox

TV PRODUCTIONS

Alpha TV	Edon-Murray
ABC-TV	Chester Erskine Pic.
Wm. F. Broidy	NBC-TV
Conne-Stephens	Hal Roach Studios
Desilu Productions	Superman, Inc.

(Ray Belter and Owen Corbett Shows)

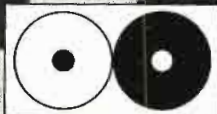

GENERAL FILM Laboratories Corp.

1546 ARGYLE AVE., HOLLYWOOD 28 HO. 9-6391



SNADER PRODUCTIONS, Inc.
and
TELESCRIPTIONS CORP.

NOW

AT

9130 Sunset Blvd.

CR. 4-6651

*Look for Another TV "Winner" . . .
We'll be telling you about it soon.*

President

Pres. & Gen.Mgr.....Richard Pearsall
 Sec.-Treas.Eldon Eby
Services Offered—Pioneer expert consultant, releasing and distributing service for religious and educational films to television and churches.

Fremantle Overseas Radio, Inc.

366 Madison Ave., New York 17, N. Y.
 Phone: MUrray Hill 7-4344

PresidentPaul Talbot
 Asst. to Pres.....Lee Volker
 Mgr. (Mexico).....Rene Anselmo
Services Offered—Package producers and procurers of feature films, shorts, cartoons and scripts for overseas radio & TV stations. Representatives in Mexico City, London, Rome, Berlin, Tokyo, Sydney, Manila and Johannesburg.

Hardie Frieberg Television Enterprises, Inc.

545 Fifth Ave., New York 17, N. Y.
 Phone: MUrray Hill 7-6865

PresidentHardie Frieberg
 TreasurerBernard Samuels
 SecretaryFluff Blome
Services Offered — Program productions, talent, live and film TV programs.

Leon Fromkess

Eagle Lion Studios, Hollywood 46, Calif.
 Phone: HOLlywood 4-3118

PresidentLeon Fromkess
Production—"Ramar of the Jungle."

Gainsborough Associates

(See Program Producers)

William J. Ganz Co.

40 E. 49th St., New York 17, N. Y.
 Phone: ELdorado 5-1443

PresidentWilliam J. Ganz
 Chg. of Production.....E. J. Spiro
 Chg. of Distribution.....Herbert Dietz
 Office ManagerJean Pomerance
Services Offered—Producers of motion pictures, slide films and films for TV, theatrical and non-theatrical audiences. Also, distributors of motion pictures through The Institute of Visual Training.

Paul Garrison Productions, Inc. (Workshop Productions, Inc.)

418 South Robertson Blvd., Los Angeles 48, Calif.

Phone: CRestview 5-4373

Presidents.....Paul Garrison and Ernest M. Baumeister
 TreasurerEdwin Gillette
 SecretaryLester M. Cook
Services Offered—Television film programs and commercials. Complete production, studio, dubbing, editing facilities.

Lalley and Love Inc.

**industrial pictures
 film spots and programs**

3 EAST 57th STREET
 NEW YORK 22, N. Y.
 ELDORADO 5-1382-3

TV FILM PROGRAMS:

**GROUCHO MARX
JACKIE GLEASON
LOUELLA PARSONS
RED SKELTON
EDDIE CANTOR
DENNIS DAY
J. CARROL NAISH**

**"You Bet Your Life" (4 Years)
"Life of Riley"
"My Week in Hollywood"
(Integrated Commercials)
"Colgate Comedy Hour"
"Mark Twain Theater"**

**For
Agencies**

FILMED For TV

(Partial List)

**For
Sponsors**

**BBD&O
Benton & Bowles
Biow
Russell Seeds
Sherman & Marquette
J. Walter Thompson
Warwick & Legler
Ted Bates
Wm. Estes**

**For
Networks**

**ABC
CBS
NBC**

**Bulova
Chevrolet
DeSoto-Plymouth
Elgin American
Meyenberg Milk Products
Pabst Blue Ribbon Beer
Procter & Gamble
Standard Oil Company
Colgate-Palmolive Co.**

**FILMCRAFT
PRODUCTIONS**

FACILITIES:

**Sound stages — Editing — Licensed Sound
FILMCRAFT'S patented multiple camera and sync control process**

FILMCRAFT PRODUCTIONS

8451 MELROSE AVE., LOS ANGELES

WEBSTER 39281

**ISIDORE LINDENBAUM, President
F. H. FODOR, Production Executive**

NEW YORK OFFICE:

**BILL DEMING
162 W. 56TH ST., N. Y.**

CIRCLE 5-8997

General Film Laboratories

1546 North Argyle Ave., Hollywood 28, Calif.
Phone: HOLLYWOOD 9-6391

Glenar Productions

6618½ Sunset Blvd., Hollywood 28, Calif.
Phone: HOLLYWOOD 4-0406

Owner Sid Glenar
Services Offered—Producer of theatrical, educational, commercial, TV motion pictures. Complete animated cartoon facilities.

Governor Television Attractions, Inc.

151 West 46th St., New York 36, N. Y.
Phone: JUdson 2-1877

President..... Arthur Kerman
Services Offered—Distributors of feature films and shorts to television stations.

Harry S. Goodman Productions

19 E. 53rd St., New York, N. Y.
Phone: PLaza 5-6131

President..... Harry S. Goodman
Television Director..... Dan Goodman
Secretary..... H. D. Knuth

Guild Films Co., Inc.

420 Madison Ave., New York, N. Y.
Phone: MUrray Hill 8-5365

President Reub Kaufman
V.P. Lou Shainmark
Gen. Sls. Mgr..... B. Goldman
Exec. Prod..... Wm. Berke
Secretary Jane Kay

Services Offered—TV package programs. Stock shot library. Feature films for television.

Productions—“Liberace,” “Invitation Playhouse,” “Lash of the West,” Sports Library.

Jack Goetz

1740 Broadway, New York, N. Y.
Phone: JUdson 6-1700

Owner Jack Goetz
Services Offered—Lab. service for all TV requirements; 16 & 35 mm. television features, serials and shorts.

Gross-Krasne, Inc.

650 No. Bronson, Los Angeles, Cal.
Phone: HO 9-8321

Producer..... Jack J. Gross
Producer Philip N. Krasne
Casting Dir..... Lynn Stalmaster
Publicity Dir..... Al Joyce

Services Offered—Studio facilities for TV and motion picture producers. Currently producing “Big Town” for Lever Bros. and “Lone Wolf” for syndication.

AMERICAN NATIONAL STUDIOS, Inc.

The First Major Studio Devoted Entirely to Television

7324 Santa Monica Blvd.
Hollywood 46, California

HOLLYWOOD 2-6281

THIS TRADE MARK
IS DEDICATED TO THE
PRODUCTION OF THE
HIGHEST QUALITY TELEVISION
MOTION PICTURE
ENTERTAINMENT.

WE ARE PROUD TO JOIN
WITH THOSE PIONEERS
OF TELEVISION WHO
HAVE MADE THE
VIGOROUS YOUNG GIANT
WHAT IT IS TODAY...



MORTON W. SCOTT, *President*
STUDIO CITY TV PRODUCTIONS, INC.

DISTRIBUTED BY HOLLYWOOD TELEVISION SERVICE, INC.

Hack Productions

535 N. Laurel Ave., Los Angeles 48, Calif.
Phone: Walnut 2068

OwnerHerman Hack
Services Offered—This series features The Frontier Parson, Herman Hack. They are youth program films, mostly for churches and schools. They are sold on lease fee and the rentals are handled by Film Rental Libraries. TV write for details.

Handel Film Corporation

6926 Melrose Avenue, Hollywood 38, Calif.
Phone: 5924

President.....Leo A. Handel
Vice President.....John Mansure
Secretary.....Monroe Manning
Services Offered—Production of films for television, production of film commercials.

The Jam Handy Organization

2821 E. Grand Blvd., Detroit 11, Mich.
Phone: TR 5-2450

N. Y. Phone: JUDson 2-4060

PresidentJanison Handy
Executive Vice-Pres.....Oliver Horn
V.P. Training Devices.....John Campbell
V.P. Sls. Devel.....Everett Schafer
V.P. Cust. Contact.....George B. Finch
V.P. Automotive Contacts...Wm. G. Luther
Secretary.....Avery W. Kinney
Treasurer.....Allan E. Gedelman
Services Offered — Producers of commer-

cial films and spots; industrial films, slide-films, sales training programs.

Harriscope, Inc.

355 North Beverly Drive, Beverly Hills, Calif.
Phone: CRestview 6-4632

President.....Burt I. Harris
Services Offered — Harriscope produces filmed commercials and programs for television. Package live shows and distribute film series for TV.

Mark Hawley Associates, Inc.

133 East 54th St., New York 22, N. Y.
Phone: PLaza 1-0450

President.....Mark H. Hawley
Services Offered—Station program representatives, program and station brokers, television consultants. Purchase TV film from all suppliers for stations.

Hawley-Lord, Inc.

205 E. 43rd St., New York 7, N. Y.
Phone: OXford 7-2520

PresidentAndre Lord
V.P. Treas.....Lewis D. Abbott
SecretaryGordon Shadwick
Services Offered—Production of 16 mm. color motion picture shorts on hunting and fishing.

Sam Hayes Productions

6000 Sunset Blvd., Hollywood 28, Calif.



W. K. HEDWIG

Your Assurance of
QUALITY

Because of the sound foundation on which the name of HEDWIG has been built, the trade may be assured of integrity and dependability.



G. W. HEDWIG

FILMS FOR TELEVISION

PROGRAMS EDITED TO FIT SPECIFIC TIME SEGMENTS

Telecast's selection includes dramas, sports, musicals, travel, cartoons, comedies, religious, short and feature subjects and educational studies.

INFORMATION AND PRICES ON REQUEST

TFI-TVTELECAST FILMS INC.**

112 W. 48th Street

New York 19, N. Y.

JUDson 6-5480

IT COSTS NO MORE
TO GET THE BEST!
WHY TAKE LESS THAN
A TOP MAJOR STUDIO
TO PRODUCE YOUR
TELEVISION COMMERCIALS?

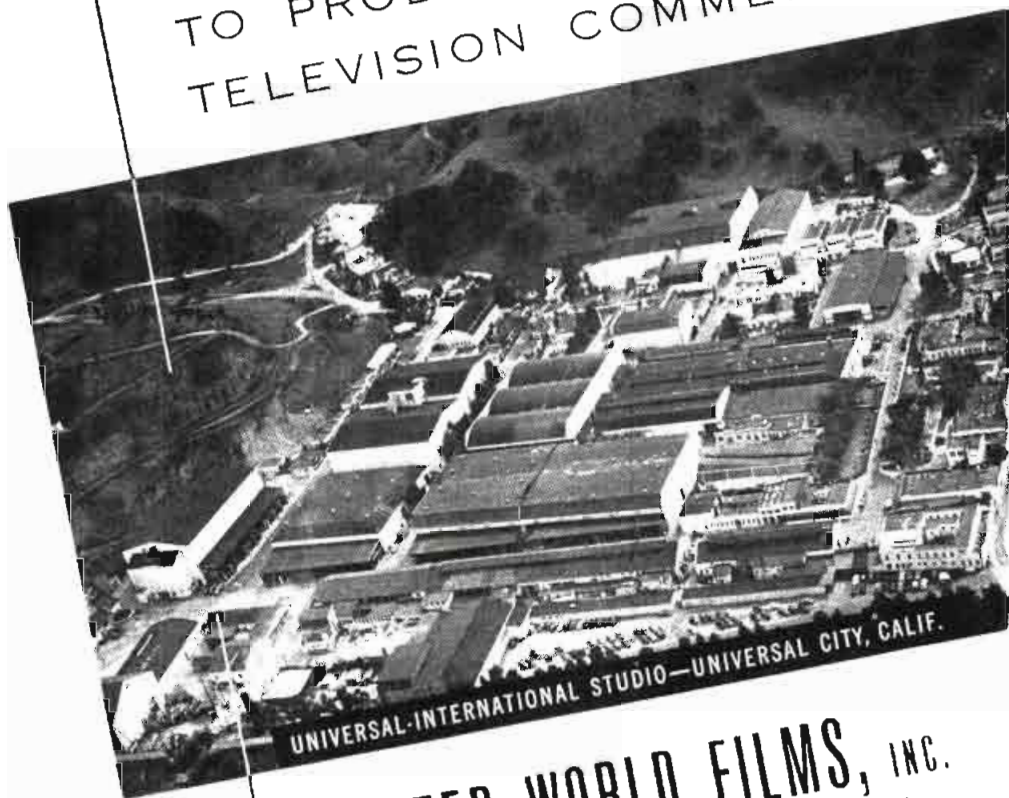

UNITED WORLD FILMS, INC.

A SUBSIDIARY OF UNIVERSAL PICTURES CO., INC.

An Incomparable Television Catalogue
ENTERTAINMENT • RELIGIOUS
EDUCATIONAL • PUBLIC SERVICE

TELEVISION DEPARTMENT
UNITED   **WORLD**
FILMS, INC.

445 PARK AVENUE • NEW YORK CITY • TR. 6-5200
PL. 9-8000



TV FILM PRODUCERS—
DISTRIBUTORS

Phone: HOLLYWOOD 3-1515

Pres. & Gen. Mgr.....Sam Hayes
Secretary.....Hazel Thornton
Services Offered—Radio news programs;
short subjects commentaries; motion picture
news and sports commentaries.

●
Leslie Helhena

932 N. La Brea Ave., Hollywood 38, Calif.
Phone: GRanite 3174

Owner-Producer.....Leslie Helhena
Services Offered—Complete production
facilities for filming spot announcements
open end commercial and entertainment
films.

●
Hile-Damroth, Inc.

270 Park Ave., New York 17, N. Y.
Phone: PLaza 5-2078

President.....Charles B. Alling, Jr.
Vice-President.....James L. Hile
General Manager.....John J. Collins
Services Offered—1 minute commercials.

●
Paul Hoefler Productions

7934 Santa Monica Blvd., Los Angeles 46,
Calif.

Phone: HOLLYWOOD 9-2001

Producer.....Paul L. Hoefler
Business Manager.....E. M. Bennett
Secretary.....Ruby Newstrand
Services Offered—Furnish one and two
reel films of adventure, travel and special
interest topics through our New York agent,
Zach Bayn Films.

●
Hoffberg Productions Inc.

362 W. 44th St., New York 18, N. Y.
Phone: CIrcle 6-9031

President.....Jack H. Hoffberg
Services Offered—Motion pictures for tele-
vision.

●
Hollywood Film Company

946 N. Seward St., Hollywood 38, Calif.
Phone: HOLLYWOOD 4-7191

Partners.....Ben & Harry Teitelbaum
Services Offered—Manufacture and sell
editing supplies and equipment, reels, cans
and shipping cases.

●
Hour Glass Productions

810 N. Highland Ave., Hollywood 38, Cal.
Phone: HOLLYWOOD 2-2301

President.....Wanda Tuchock
Vice-President.....George de Normand
Services Offered—Youth series, "Man of
Tomorrow."

●
Lucille Hudiburg Productions

131 E. 51st St., New York 22, N. Y.
Phone: EL 5-3508

Producer.....Lucille Hudiburg

●
Hurrell Productions Inc.

(Subsidiary of Walt Disney Productions)
333 No. Rodeo Dr., Beverly Hills, Calif.
Phone: CR 1-8593

President.....George E. Hurrell

THE TV WORKSHOP

**lowest rates in town
for**

Sound Stages, Recording, Dubbing,
Cutting and complete production
facilities . . .

We Make Package Deals!

WORKSHOP PRODUCTIONS

Producers of:

Quality TV programs and commer-
cials on film.

WORKSHOP TV DISTRIBUTION

Distributors of:

Household Hints · Science for Every-
one · I've Got a Hobby · Tall Tales
· The Casting Office · The Mink
Dynasty · History For Everyone ·
Chavez Performs Magic · A Thou-
sand Nights And A Night · Chain
Reaction · Do It Yourself!

CRestview 5-4373

**418 So. Robertson Blvd.
Los Angeles 48, Calif.**

For information contact Paul Garrison

LIFE WITH ELIZABETH

starring **BETTY WHITE**

featuring DEL MOORE

*Now seen in more than 70 markets.
Distributed by Guild Films Co., Inc.*

THE BETTY WHITE SHOW FROM HOLLYWOOD

Monday Through Friday — NBC

BANDY PRODUCTIONS
9344 Wilshire Blvd., Beverly Hills

Don Fedderson

Betty White

George Tibbles

in association with

LIFE WITH ELIZABETH

starring **BETTY WHITE**
featuring DEL MOORE

*Now seen in more than 70 markets
Distributed by Guild Films Co., Inc.*

in association with

LIBERACE

*in his own
filmed TV show*

*Now seen in more than 160 markets
Distributed by Guild Films Co., Inc.*

in association with

The Betty White Show From Hollywood

Monday Through Friday — NBC

in preparation

**DO YOU TRUST
YOUR WIFE?**

in preparation

THE UNKNOWN
*in association with
ARNOLD MARQUIS*

DON FEDDERSON PRODUCTIONS
120 El Camino, Beverly Hills

New York Office
 RKO Bldg., 1270 6th Ave., New York, N. Y.
 Phone: JUdson 6-3442
Services Offered—TV package programs
 (and commercials) and production.

HYGO Television Films, Inc.
 60 W. 46th St., New York 36, N. Y.
 Phone: Circle 6-4347
 812½-14 N. La Brea, Hollywood 38, Cal.
 Phone: HO 7-4882

President.....Jerome S. Hines
 V. P. & Treas.....Louis Goldstein
 Sales Mgr.....Bob Seidelman
Services Offered: Quality feature films for
 television.

Ideal Pictures, Inc.

58 E. So. Water St., Chicago 1, Ill.
 Phone: FI nancial 6-5245

President.....Paul R. Foght
 Asst. General Manager.....Carl Ross
Services Offered—16mm. sound films for
 television exhibitors.

Imppro Productions, Inc.

c/o Hal Roach Studios
 8822 W. Washington Blvd., Culver City, Cal.
 Phone: TE 0-2761
 President.....Herbert L. Strock
 Vice-President.....Richard G. Taylor

Services Offered: Produce filmed shows,
 commercials; rental sound effects library,
 cutting rooms & equipment.

**IMPS, Inc. International
 Movie Producers' Service**

515 Madison Ave., New York 22, N. Y.
 Phone: ELdorado 5-6620
 N. Y. Phone: PLaza 7-4823

President.....Ben Gradus
 Partner.....Victor M. Ratner
 Production Supervisor.....Walter Sachs
 Studio Manager.....Harry Wolf
 Dir. of Sales.....Ezra R. Baker, Jr.
Services Offered—IMPS produces docu-
 mentary, commercial TV spots, and indus-
 trial films. Feature films for theatrical re-
 lease; slide films.

Intercinema, Inc.

1025 Connecticut Ave. N.W., Washington,
 D. C.
 Phone: REpublic 7-3309

President.....Edmund M. Sciullo
 Managing Director.....John del Re
 Public Relations Dir....Thomas J. Hallahan

**Inter-Continental Television
 Corp.**

200 West 57th St., New York, N. Y.
 Phone: JUdson 6-1890

Now Available
 FIRST RUN

For Your Market . . .

"SOUTH OF PARADISE"

"FIGHTING GUERILLAS"

"THUNDER OVER CHINA"

CREST TELEVISION PRODUCTIONS

10361 McCormick Street

North Hollywood, Calif.

Phone: SUNset 2-3138

“LASSIE”

Starring LASSIE

with TOMMY RETTIG, JAN CLAYTON & GEORGE CLEVELAND

AT LAST the perennial favorite
of the motion picture screen comes
to television.

Now being produced in Hollywood by —

ROBERT MAXWELL & ASSOCIATES

GOLDWYN STUDIOS

1041 North Formosa Ave.

Hollywood 46, California

14 Rue Auguste Vacquerie, Paris, France
 Phone: Kleber 2878
 Chairman.....Edward Gruskin
 President.....Martin H. Poll
 Services Offered: Producers of TV films.

International Film Foundation, Inc.

345 East 46th St., New York 19, N. Y.
 Phone: OX 7-1888
 Executive Dir.....Julien H. Bryan
 Services Offered—(1) Production of documentary films. (2) Distribution of documentary films including TV use, chiefly twenty minute shorts on the peoples of various countries.

International Geographic Pictures

1776 Broadway, New York 19, N. Y.
 Phone: Circle 6-4486
 Executive Pres.J Allen Julier
 Services Offered—Producers of educational motion pictures.

International News Service

235 E. 45th St., New York, N. Y.
 Phone: MU 7-8800
 General Mgr.....Seymour Berkson
 Editor-in-ChiefBarry Faris
 Business Mgr.....Robert W. Brown

TV Sales Mgr.....Robert H. Reid
 Radio & TV News Dir.....John M. Cooper
 Services Offered—In association with Tele-news Productions: Daily, weekly, sports newsreels; Also film features; INP photos; INS leased wire; Projectall balopticon.

International Movie Producers' Service

515 Madison Ave., New York 22, N. Y.
 Phone: ELdorado 5-6620
 Studios: Ben Gradus Studios, Ltd.,
 321 W. 56th St., New York 19, N. Y.
 Phone: PLaza 7-4823
 PresidentBen Gradus
 Partner.....Victor M. Ratner
 Production Supervisor.....Walter Sachs
 Studio Manager.....Harry Wolf
 Director of Sales.....Ezra R. Baker
 Services Offered—Producer of TV commercial, industrial, PR, educational, sales, personnel training and filmed shows for TV.

International 16mm. Corp.
 (See Program Producers)

International Tele-Film Productions, Inc.

331 Madison Ave., New York 17, N. Y.
 Phone: MUrray Hill 7-9116
 PresidentPaul F. Moss



Film **Live**
 Producer
 Editor
 Commentator

TV & Radio

Industrial Exploitation
 Sales Promotion

Ed Thorgersen

245 West 55th St.
 New York 19, N. Y.
 Tel.: Circle 6-8935

"From Program Designs to Finished Package"

Be Sure At

ACME

35 MM — **FILM LABORATORIES** — 16 MM

**PIONEERS IN TV
FILM PROCESSING**

•

TOP RATINGS

FOR

SPEED AND EFFICIENCY

IN THE NATIONAL

BILLBOARD POLL

•

INSIST ON THE **FINEST**
SPECIFY —

ACME

Hollywood 4-7471

1161 North Highland Avenue • Hollywood 38, California

Vice President.....Thelma Schnee
Services Offered—TV live and film package shows, recordings, talent.

Interstate TV Corporation

4376 Sunset Drive, Hollywood 27, Calif.
 Phone: PLaza 7-3070

President.....G. Ralph Branton
 Vice-President.....Lloyd Lind
Services Offered—Production and distribution of motion pictures for television.
 30 minute package shows.

Lou Irwin, Inc.

9165 Sunset Blvd., Hollywood 46, Calif.
 Phone: CR 1-7131

President.....Lou Irwin
 Associate.....Ted Wilk
 Exec. Secretary.....Jay Schlein
Services Offered—Representing producers, directors, actors, actresses, dance directors and all personnel pertaining to the film, television and radio industry.

Jamieson Film Co.

3825 Bryan St., Dallas, Texas
 Phone: TE 8158

Manager.....Hugh V. Jamieson
Services Offered—Complete production service, industrials, TV spots, TV entertainment, sound service.

Jason Comic Art

480 Lexington Ave., New York 17, N. Y.
 Phone: PLaza 3-9370

Director.....Leon Jason
Services Offered—TV film, production, talent, puppet design.

Jewell Radio and Television Productions

185 No. Wabash Ave., Chicago 1, Ill.
 Phone: Financial 6-4474

President.....James E. Jewell
 Vice-President.....W. Ralph Jewell
 Manager.....Charles P. Flynn
 Natl. Sales Representative.....Carl Wester
 Treas.Lincoln Douglass
 Musical Dir.....Richard Dix
 Secretary.....M. P. Casey
 Editor.....James Lawrence
Services Offered—A complete radio and television production service. Scripts, Copy, Music, Direction. Transcribed package shows, spots. Current productions, "Silver Eagle," "The King's Jester Show."

Junior Programs, Inc.

100 King Rd., Madison, N. J.
 Phone: MA 6-3450

Pres. & Exec. Dir....Dorothy L. McFadden
Services Offered—Package shows for chil-

NOW AVAILABLE FOR TELEVISION

TV MOVIE CLUB INC.



26 HALF-HOUR SHOWS ON FILM
 ESPECIALLY PREPARED FOR THE
 PRE-TEEN AGE MARKET

ADVENTURE
 MYSTERY
 CARTOON
 EDUCATIONAL

1501 BROADWAY • NEW YORK 36, N. Y. • BRYANT 9-6734

TURNTABLES FOR EVERY PURPOSE ON TELEVISION



LARGE

• • • MODEL 1000 - 18 Used extensively in automobile displays on many network TV shows. 18 ft. diameter.

or



SMALL

• • • MODEL G 100, New all glass top, tilts, lifts, lowers and revolves. Can be lighted from underneath for displaying small 36 in. diameter

TURNTABLES and REVOLVING STAGES BUILT
TO YOUR OWN SPECIFICATIONS

CONSULT OUR ENGINEERING DEPARTMENT

Some Units Available for Rental

UNIQUE TURNTABLE AND DISPLAY CO.

1895 Park Avenue, New York, N. Y.

TRafalgar 6-2962

dren's audiences, also scripts, and consultant service for TV.

Bernard E. Karlen Productions

270 Park Ave., New York 17, N. Y.
Phone: PL 9-3107

Exec. Producer.....Bernard E. Karlen
Associate Producer.....Roland N. Karlen
Services Offered—Package program, both film and live. Production consultant, supply film clips for integrated shows, commercials and scripts.

Roger Kay Enterprises, Inc.

60 Sutton Place S., New York, N. Y.
Phone: PL 3-0549

Executive Producer.....Roger Kay
Services Offered — Creators, producers, packagers of TV and radio programs, live, transcribed, and film. Consultants on programming. TV show doctoring. Commercials.

Victor Kayfetz Productions

1780 Broadway, New York 19, N. Y.
Phone: CIrcle 5-4830

Pres., Exec. Prod.....Victor F. Kayfetz
Animation Dept. Dir.....Abe Blashko
Art Director.....Wm. L. Steinel
Services Offered—Victor Kayfetz Productions produces motion pictures: TV program series, TV program films (filler material), TV commercial spot films. We own complete

16mm. and 35mm. production equipment and are staffed by experienced film, stage, and radio personnel. Animated motion pictures.
Productions—The Water World TV Series.

Herbert Kerkow, Inc.

480 Lexington Ave., New York 17, N. Y.
Phone: PLaza 1-1833

President.....Herbert Kerkow
Services Offered—Sound stage and complete equipment for production of public relations and TV films.

Kling Studios, Inc.

601 N. Fairbanks Court, Chicago 11, Ill
Phone: Delaware 7-0400

N. Y. Phone: PLaza 9-4770

Hollywood Phone: HOLLYWOOD 5-8878

President.....Robert Eirinberg
Vice-President.....Lee Blevins
Dir. Motion Pic. & TV Dir.....Fred Niles
Services Offered—Complete production of TV commercials, film package shows TV. Services include full recording facilities, 35mm. & 16mm. production, black-and-white, or color, and animation.

Knickerbocker

Productions, Inc.

1600 Broadway, New York 19, N. Y.
Phone: CIrcle 6-9850

President.....Howard A. Lesser
Secy.-Treas.....Mary Morrissey

BARNETT INTERN'L FORWARDERS, Inc.

723 - 7 Ave.
N. Y.

Idlewild Airport,
N. Y.

Hollywood,
Calif.

AGENTS IN EVERY MAJOR WORLD CITY

EXPEDITORS IN INTERNATIONAL SHIPPING FOR OVER SIXTY YEARS

Specialists for the

TELEVISION AND MOTION PICTURE INDUSTRIES

CIRCLE 5-6080

Cable "BARINTFOR"



"BLINKEY"

is selling

AMAZO INSTANT DESSERT

in
24 Cities
for

American Maize Products Company

"THE ADVENTURES OF BLINKEY"

A series of 15 minute children's fantasy films

Created and Written by Lucille Emerick
Produced and Directed by Murray King

Some markets still available

BLINKEY PRODUCTIONS INC.

106 West End Ave., N. Y. 23, N. Y.
SUsqehana 7-4429

Vice-President.....Thomas S. Dignan
Services Offered—Producers of all types of Motion pictures for screen and TV.

Larry Kurtze

360 N. Michigan, Chicago 7, Ill.
 Phone: RAudolph 6-5216

Owner.....Larry Kurtze
Services Offered—Development of live or filmed TV shows. General copy and production services for broadcast media.

Lalley & Love Inc.

3 East 57th St., New York, N. Y.
 Phone: ELdorado 5-1382

President and Production.....James A. Love
 Editor.....Bill Henry
 Script Dir.....Ardis Smith
 Sales.....C. Austin Love
Services Offered—TV spots and programs, also industrial films.

Productions—"Professor Yes 'N' No," consecutive 15-min. TV series.
 (See Page 950)

Ely Landau, Inc.

101 W. 75th St., Suite 1-A, New York 19, N.Y.
 Phone: COlumbus 5-8616

President.....Ely A. Landau
Services Offered—Television programs on film for national, regional and local sponsorship.

Productions—"The Bill Corum Sports Life Program," "The Passerby," "Man's Heritage."

Albert Lang Productions

KTTV, Sunset Blvd., Hollywood 28, Cal.
 Phone: HU 2-7111

Pres., Gen. Mgr.....Albert Lang
 Vice-Pres., Sec'y.....Olga Hancy
Services Offered: Writing, producing, distributing TV commercial films.

Larchmont TV Studios

210 No. Larchmont Blvd., Los Angeles 4, Cal.
 Phone: HOllywood 9-2395

Manager.....Jack Miles
Services Offered—Large TV film sound stage. Every service available for 16mm & 35mm producer. Specialize in TV film commercials.

Lawrence & Lee, Inc.

Equitable Bldg., Hollywood & Vine,
 Hollywood 28, Calif.

Phone: HBBside 0101
 President.....Jerome Lawrence
 Vice-President.....Robert E. Lee
Services Offered—Production consultants.

Robert Lawrence Productions, Inc.

113 W. 51th St., New York 19, N. Y.
 Phone: JUdson 2-5212

President.....Robert L. Lawrence

LEONARD ANDERSON

MOTION PICTURES

PLANNING — PRODUCING — EDITING

"YOUR"

FILMED COMMERCIALS

TV PROGRAMS

INDUSTRIAL FILMS

FEATURES — SHORTS

COMPLETE PRODUCTION FACILITIES

FOR STUDIO & LOCATION SHOOTING

OWN EDITING ROOMS

115 WEST 45th ST.
 NEW YORK 36, N. Y.
 PLAZA 7-4162

Complete

STUDIOS • CREWS
 EQUIPMENT

producers of

TV commercials

Industrials

Medical films

Educational films

Theatricals

"a chain of undivided responsibility"

CHARTER OAK

tele-pictures

846 Seventh Ave., New York

Circle 6-2508

V.P. Studio Operations.....Louis Mucciolo
 V.P. Sales.....Mickey Dubin
 Casting Director.....Barbara Cooper
 Treasurer.....Philip Kornblum
 Chief Film Editor.....Henry Traiman
Services Offered—Film—to order—television commercial announcements and television package programs.

Leichter, Mitchell

6811 Hollywood Blvd., Hollywood 28, Calif.
 Pres., Head of Prod.....Mitchell Leichter
 General Mgr.....Dick Peterson
Services Offered—Producer, distributor of films for television.

Gene Lester Productions

1487 N. Vine St., Hollywood 28, Calif.
 Phone: Hillside 7287

Producer-Director.....Gene Lester
 Chief Technician.....Robert Ernst
 Comptroller.....Albert J. Silverman
 Production Manager.....Martin Sperber
 Sound.....Robert Ernst
Services Offered—TV film packages and commercials.

Productions—“Hollywood on the Line,” “Assignment Unknown” and others.

Lewis & Martin Films, Inc.

218 S. Wabash Ave., Chicago 4, Ill.
 Phone: WEbster 9-6434

President.....Martin Schmidhofer

Vice-President.....Dick Lewis
 Secretary-Treasurer.....Herschell Lewis
 Production.....Rudy Bratt
Services Offered—Motion picture production, script-writing, sound recording, still photography, slide-films, package shows, animation, commercial story films.

Libra Film Producers & Distributors

6525 Sunset Blvd., Hollywood 28, Calif.
 Phone: HO 5-7960

President.....Miss Loy Lester
 V.P., in Ch. of Prod.....Charles M. McCoy
 Sec.-Treas.....M. Briese
 Exec. Director.....C. Mandell
 Exec. Prod. & Ch. Eng.....Charles M. McCoy
 Producer.....John Leslie Hamilton
Services Offered—Motion picture facilities; technical, advertising, educational, public relations and documentary films. Live and package shows.

Library Films Inc.

25 West 45th St., New York 36, N. Y.
 Phone: PLaza 7-3450

President.....Paul N. Robins
 Manager.....Joan Raphael
Services Offered—Lease-sale TV rights mostly for foreign serials, features and shorts of all types; some domestic.

for television commercials

call

WILBUR STREECH PRODUCTIONS
 1697 BROADWAY
 NEW YORK 19

CARTOON ANIMATION
 TECHNICAL ANIMATION
 OFF CAMERA NARRATION
 DIRECT DIALOGUE
 SPECIAL EFFECTS

Judson 2-3816

NORWOOD STUDIOS
 a division of
 INTERNATIONAL MOTION PICTURE
 CONSULTANTS, INC.
 Producers of
FILMS FOR TELEVISION
 Complete Studio and Location Facilities
 35 mm. and 16 mm.
Warner Building
 13th and E Sts., N.W.
 Washington 4, D. C.
 Phone REpublic 7-2382



Lion Television Pictures Corp.

1501 Broadway, New York 36, N. Y.
Phone: PEennsylvania 6-1780

President.....E. W. Hammons
Vice-President.....Robert M. Savini
Secretary-Treasurer.....T. Newman Lawler
Services Offered—Financing TV shows and packages. Offering to TV stations packages of 13 Handy Andy episodes of 12½ minutes each.

Robert Longenecker Agency

8128 Melrose Place, Los Angeles 16, Calif.
President.....C. Robert Longenecker
Services Offered—Production of programs, both film and live for TV. Representation of talent for TV, acting and creative.

Loucks-Norling Studios, Inc.

245 W. 55th St., New York 19, N. Y.
Phone: CIrcle 7-2366

Partners.....J. A. Norling & Wil Marcus, Hans Tiesler
Services Offered—The production of industrial sales promotional, public relations, personnel training and educational motion pictures. Also 3D production specialists.

M A C Studios

Hollywood Roosevelt Hotel, Hollywood, Cal.
Phone: HOllywood 3-7111

Vice-President.....Howard Grafman
Services Offered—Production of films for television and industry.

Magnetic TV Sound Company

111 South Washington St., Green Bay, Wis.
Phone: Adams 2554

President.....James C. Gallagher
Services Offered—A magnetic TV sound system that permits TV stations to use magnetic sound with motion picture films in TV; allowing sound on the air an hour after development of film.

Major Television Productions, Inc.

9336 W. Washington Blvd., Culver City, Cal.
Phone: TEexas 0-2931

1270 Ave. of the Americas, New York 20
Phone: PLaza 7-6990
President.....Irving Lesser
Vice President.....Seymour Poe
Services Offered—Distributors of feature length pictures—half-hour Series and film shorts.

Marathon TV Newsreel Inc.

125 East 50th St., New York 22, N. Y.
Phone: MU 8-0985
President.....Konstantin Kaiser
Production.....Ken Baldwin
Services Offered—Public information films

**NATIONWIDE
COVERAGE**

OF THE GREATEST
EVENTS IN SPORTS

**TEL RA
PRODUCTIONS**

1518 Walnut Street
Philadelphia 2, Pa.

PRODUCERS OF

- Touchdown
- Sport Spotlight
- Telesport Digest
- Paddock Parade
- Baseball Briefs
- National Pro Highlights

BEFORE YOU MAKE A MOVIE
FOR SCREEN OR TV, SEE—

Charles Curran

Steve Fitzgibbon

or Don Langan

**Times Square
Productions, Inc.**

145 West 45th St. New York

Phone Circle 6-4443

produced and distributed to television stations; news and special event coverage; world-wide news service; station consultants on TV news setups.

●
Mark VII, Ltd.

2400 W. Alameda, Burbank, Calif.
Phone: RO 9-2461

Exec. Producer.....Stanley Meyer
Producer.....Michael Meshekoff
Director.....Jack Webb
Services Offered—Produce half-hour TV film & radio dramatic series—“Dragnet.”

●
Arnold Marquis Productions, Inc.

717 N. La Cienega Blvd., Hollywood 46, Cal.
Phone: CR 6-8796

President.....Arnold Marquis
Services Offered—Write, direct, produce and package radio and television programs; sales and service.

●
Robert Maxwell & Associates

1041 North Formosa Ave., Hollywood 46, Cal.
Phone: HOLLYWOOD 7-5111

Producer.....Robert Maxwell
Director.....Les Goodwins
Photographer.....Harold Stine
Services Offered—Series of 39 half hour filmed television shows of “Lassie.”

Medallion Productions

1570 North Gower St., Hollywood 28, Calif.
Phone: HOLLYWOOD 2-3313

Production.....John A. Ettinger
Creation.....Robert A. Forrest
Services Offered—Production of film programming and commercials for television. Packaging of live programming, local and network.

●
Mercury International Pictures, Inc.

6611 Santa Monica Blvd., Hollywood 38, Cal.
Phone: HOLLYWOOD 5-1101

President.....V. E. Ellsworth
Vice-President.....D. L. Monahan
Sec.-Treas.....G. C. Cable
General Mgr.....Olivia Eastus
Services Offered—Complete production of films for television from script to final print including mediums of animation, live action, sound in 16mm and 35mm.

●
MCA, TV, Ltd.

598 Madison Ave., New York 22, N. Y.
Phone: PLaza 9-7500

V.P. in Charge.....David Sutton
Eastern Regional Mgr.....Kirk Torney

Branch Offices

Union Commerce Bldg., Cleveland, O.
Phone: CHerry 1-6010

Exec. in charge.....De Arv Barton

LEON FROMKESS

Executive Producer

“Ramar of the Jungle”

●
**INTER-CONTINENTAL
TELEVISION FILMS**

●
PRODUCING

FLASH GORDON

●
200 West 57th St., New York 19, N. Y.

14 Rue Auguste Vacquerie
Paris, France

430 N. Michigan Ave., Chicago, Ill.

Phone: DElaware 7-1100

Mid-West Sales Mgr. Raoul Kent

2102 N. Akard St., Dallas, Tex.

Phone: PRespect 7536

Exec. in charge. Pat Dunavan

105 Montgomery St., San Francisco, Calif.

Phone: EXbrook 2-8922

Exec. in charge. Maury Baker

9370 Santa Monica Blvd., Beverly Hills, Cal.

Phone: CRestview 6-2001

Exec. in charge. Bob Greenberg

Services Offered—Producer, distributor TV series.

Charles Michelson, Inc.

15 West 47th St., New York 19, N. Y.

Phone: Plaza 7-0695

President Charles Michelson

Divisional Sales Mgr. Ray Linton

Services Offered—Open end TV film program series; special Christmas spots film series; minute film spots for jewelry store sponsorship; E. M. I. Gennett and Speedy-Q sound effect record library.

Carlton E. Morse Productions

1500 N. Vine St., Hollywood 28, Calif.

Phone: HOLlywood 9-6161

President Carlton E. Morse

Services Offered—TV film programs, production.

Morton Television Productions Inc.

64 E. Lake St., Chicago 1, Ill.

Phone: CEntral 6-1111

President Morton Jacobson

Services Offered—15 minute teleplays, vignette stories about history, science, art, literature, music, etc. O'Henry-type endings. Series called "This Is the Story."

Motion Picture Center Studios

846 N. Caluenga Blvd., Hollywood 38, Calif.

Phone: HO 9-5981

Pres., Gen. Mgr. Joseph Justman

Assistant-Secretary Joseph A. Schwalb

Studio Mgr. & Comptroller John K. Brent

Services Offered—Television rental studio 9 stages and complete facilities.

Motion Picture Productions Inc.

(See Program Producers)

Motion Pictures For Industry

2543 Kelton Ave., Los Angeles 64, Calif.

Phone: BRighton 0-1757

President Harry O. Hoyt

Sales Manager J. H. de la Chesnaye

Production E. G. Hayter

Services Offered—Produce all kinds of 16mm motion pictures, preferably in color under contract with sponsors with the ac-

cent on the organization and presentation of material both for industry and TV.

Movie Advertising Bureau

70 E. 45th St., New York 17, N. Y.

Phone: MURray Hill 6-3717

Dir. of National Sales Claude F. Lee

Services Offered—Spot commercials for TV and theatre.

Movietonews, Inc.

160 W. 51th St., New York 19, N. Y.

Phone: COLUMbus 5-7200

President W. C. Michel

Producer Edmund Reck

General Manager Jack Haney

Commercial Dept. Mgr. Frank Barry

Editors Harry Lawrenson, Louis Tetric

Associate Prods. Jack Gordon, Jack Kuhne

Director of Scripts Dan Doherty

Assignment Director Burt Reinhart

Asst. Assignment Dir. Art Sorenson

Services Offered—Produce, distribute news-reels, short subjects, commercials, documentaries, novelties.

Owen Murphy Productions, Inc.

723 Seventh Ave., New York 19, N. Y.

Phone: PLaza 7-8114

President Owen Murphy

General Manager Elwood Siegel

Production Mgr. Charles L. Turner

Chief Editor Edward F. Boughton

Services Offered—Complete motion picture production services; Commercial, advertising, institutional films, package shows on film especially made for TV; Scripts, photography art and animation facilities.

Nation Wide Television Corp.

1501 Broadway, New York 18, N. Y.

Phone: LONgacre 4-8234

President Irvin Shapiro

Services Offered—Feature films, streamliners.

National Productions, Inc.

1001 Connecticut Ave., N.W.,

Washington 6, D. C.

Phone: STerling 3-2222

President Robert J. Ender

Vice-President Howard A. Ender

Executive Producer Robert L. Friend

Coordinator Mary Griffin, Jr.

Services Offered—Producers of motion pictures for television and industry. Commercials; animation; consultants. Complete production from concept and story board. Packers of programs for local sponsorship.

National Screen Service Corp.

1600 Broadway, New York 19, N. Y.

Phone: CIRCle 6-5700

Adv. Publ. Director Melvin L. Gold

Services Offered—Television film commercials, TV trailers, weather spots, station breaks, openings, titles, etc.

Ted Nemeth Studios

729 7th Ave., New York 19, N. Y.
Phone: Circle 5-5147-3

Production Director.....Ted Nemeth
Art Dir.—Dir.....M. E. Bute
Services Offered—Producers, distributors of film made specifically for TV; TV film spots and commercial films.

Stanley Neal Productions, Inc.

45 Rockefeller Plaza, New York 20, N. Y.
Phone: COlumbus 5-8335

President.....D. J. Lane
Exec. V.P.....Charles W. Cromer
V.P. in Charge of Pub. Rel.....B. G. Kohn
Midwest Sales Dir.....Robert Cumming
V.P. in Charge of Prod.....Sobey Martin
In Charge of Scripts.....Edith Martin
Production Mgr.....Charles L. Smith
Services Offered—Producer of TV film; distributor.

Newsreel Service

5 Centre Market Place, New York 13, N. Y.
Phone: CANal 6-3284

Production Manager.....Howard Smythe
General Manager.....Charles Beckman
Chief Cameraman.....Larry Racies
Services Offered—Spot news coverage, 16 or 35 mm sound—24 hour service. Film inserts for live TV shows. Complete production facilities for TV shows on film.

Nola Studios Inc.

1657 Broadway, New York 19, N. Y.
Phone: PLaza 7-4870

President.....Vincent J. Nola
Vice-President.....V. Thomas
Chief Engineer.....Stanley J. Bumbly
Film Prod. Facilities Mgr.....PeterWilde
Services Offered — Complete production facilities to the independent producer. Film-Sync Tape, ¼", 16mm, 17½mm-Disc recording. Re-recording Tape to Film. Shooting and Scoring facilities.

Norwood Studios

Warner Bldg., Washington. D. C.

Executive Producer.....Philip Martin
Production Chief.....Doug Baker
Sales.....Stan Moss
Exec. Secretary.....Alicia B. Groff
Services Offered—Producers of theatrical, non-theatrical and TV films. Complete staff and equipment for production in 35mm and 16mm.

Nothing New Under the Sun Productions

240 S. Beverly Dr., Beverly Hills, Calif.
Phone: CRestview 4-5491

Producer.....Mitchell Gertz
Secretary.....Harold Bernson
Services Offered — Producer of 5-minute film features.

Productions — Nothing New Under the Sun.

Official Films, Inc.

(Official Television Inc.)

25 West 45th St., New York 36, N. Y.
Phone: PLaza 7-0100

President.....Harold L. Hackett
Chairman of the Board.....Michael Nidorf
Secretary.....Herbert J. Siegel
Sales Mgr. (Nat'l Sls.).....Bud Austin
Assistant to President.....Herman Rush
Treasurer.....Seymour Reed
Services Offered—Producer and distributor of 8mm and 16mm sound and silent films.

Olio Video Television Productions, Inc.

115 Christopher St., New York 14, N. Y.
Phone: WATkins 9-4508

President.....Harvey Cort
Treasurer.....Milton Subotsky
Services Offered—TV live and film production, film library of western and feature films. Fully-equipped sound studio.

Harry Owens Television Productions

6710 Melrose Ave., Hollywood 38, Calif.
Phone: WYoming 1491

President.....Harry Owens
Vice-President.....Homer O'Donnell
Services Offered—Motion picture productions.

Packaged Programs, Inc.

634 Penn Ave., Pittsburgh 22, Pa.
Phone: GRant 1-4756

General Manager.....M. E. Fierst
Tech. Supervisor.....G. J. Mikalauski
Services Offered—Program and news production; laboratory, studio and recording facilities.

Paramount Television Productions Inc.

1501 Broadway, New York 36, N. Y.
Phone: BRyant 9-8700

President.....Paul Raibourn
Vice-President.....Bernard Goodwin
Branch Office

5451 Marathon St., Hollywood 38, Calif.
Phone: HOLlywood 9-6363

Vice-President.....Klaus Landsberg
Services Offered—TV package programs, production, video transcription service, sales distribution.

Productions—"Wrestling from Hollywood," Erskine Johnson's "Hollywood Reel," "May-fair Mystery House."

Jack Parker Productions

(See Television Film of America for personnel listing.)

Paul Parry Productions

7557 Sunset Blvd., Hollywood 46, Calif.

Phone: HOLlywood 7-1771

Exec. Producer.....Paul Parry
Production Supervisor.....Betty Sinclair
Dir. of Photography.....Ray Foster
Services Offered—Production of Commercials, program films, sales promotion and training films.

Parsonnet TV Film Studios, Inc.

46-02 5th St., Long Island City, N. Y.

Phone: STillwell 4-6163-4-5

President.....Marion Parsonnet
Treasurer.....Walter Blake
Secretary.....Andrew Weinberger
Services Offered: Producer of films; production facilities for rent; films for syndication.

Lindsley Parsons Productions, Inc.

5536 Sunset Blvd., Hollywood 28, Calif.

Phone: HUDson 2-7111

President.....Lindsley Parsons
Treasurer.....Sam Wallis
Secretary.....Leonard W. Herman
Associate Producer.....Warren Douglas
Services Offered—All types of TV films including commercials.

Productions—"Files of Jeffrey Jones."

Pathescope Productions

(Pathescope Co. of America Inc.)

580 Fifth Ave., New York 36, N. Y.

Phone: PLaza 7-5200

President.....Edward J. Lamm
Production Manager.....James Pievel
Executive Producer.....William Nelson
Services Offered: Animation or live—specializing in use of rear screen projection.

Ray Patin Productions

4201 Sunset Blvd., Los Angeles 29, Calif.

Phone: HU 2-6650

Exec. Producer.....Ray Patin
Asst. Producer.....Gus Jekel
Sls. & Studio Mgr.....Lee R. Blevins
Services Offered: Complete production of animated television commercial films with live action sequences.

Peerless Film Processing Corp.

165 West 46th St., New York 36, N. Y.

Phone: PLaza 7-3630

President.....Kern Moyse
Vice-Pres., Treas.....R. S. Moyse
Asst. Secretary-Treasurer.....Barbara Holz

Eastern Sales Mgr.....Raoul J. Menendez
Mgr., Special Services.....Allan De Forest

West Coast Branch

959 Seward St., Hollywood 38, Calif.

Phone: HO 7-9223

Vice-Pres., West Op.....Victor C. Krupa
Sery., Branch Mgr.....Suzon Steinle Krupa
Plant Manager.....Thomas E. Ayers
Mgr., Special Services.....Paul Krupa
Services Offered—Complete distribution and servicing of TV films; distributor of reels, cans, shipping cases. Peerless film treatment to safeguard films against damage and deterioration; Peer-Renu treatment to stretch shrunken negatives; film cleaning and inspection.

Pictorial Films, Inc.

1501 Broadway, New York 36, N. Y.

Phone: PENnsylvania 6-3756

President.....J. Milton Salzburg
Chairman of the Board.....Frank Soule
V.P., Treasurer.....Hyman Rosner
Sales Manager.....David B. Dash
Advertising Manager.....S. J. Krumholz
Comptroller.....Paul Kern
Services Offered — Produce & distribute features & shorts.

Polaris Pictures, Inc.

5859 W. 3rd St., Los Angeles 36, Calif.

Phones: YORk 8058; WEBster 3-4608

President.....Juan C. Hutchison
Vice-President.....Perry King
Services Offered—Complete production facilities; live action and animation, 16 and 35 mm.

Post Pictures Corp.

115 West 45th St., New York 36, N. Y.

Phone: JU 2-4870

President.....Harry A. Post
Secretary.....Eli W. Post
TV Sales.....Alan I. Post
Services Offered—Packages of features and short subjects. Film distributor film rental.

Princess Pictures Inc.

11 West 42nd St., New York 36, N. Y.

Phone: LONgacre 5-1535

President.....Burt Balaban
Vice-President.....Bernard Donnenfeld
Services Offered—Motion picture production.

The Princeton Film Center, Inc.

270 Park Ave., New York 21, N. Y.

Phone: PLaza 5-0322

Carter Road, Princeton, N. J.

Phone: PRinceton 1-3550

Executive Director.....Gordon Knox
Treasurer.....Albert Califano
Prod. Mgr.....L. H. Holton
Vice-President.....Sherman Price
Services Offered—Production and distribution facilities for television films of all types.

Producers Representatives Inc.

1270 Ave. of the Americas, N. Y. 20, N. Y.
 Phones: PLaza 7-6990-1-2

President.....Irving M. Lesser
 Secy.-Treas.Seymour Poe
Services Offered—A complete motion picture distribution service to TV stations for features, westerns, serials and shorts.

Radiovision Corp.

1125 S. Elm Drive, Los Angeles 35, Calif.
 Phone: CRestview 5-1723

President.....Walter J. Nelson
Services Offered—Sport pictures and cartoons for rental to TV.

Reid Ray Television Productions, Inc.

2269 Ford Parkway, St. Paul 1, Minn.
 Phone: Emerson 1393

President.....Reid H. Ray
 Vice-President.....William H. Ringold
 Sales.....R. V. Jeffrey
 Vice-PresidentFrank Balkin
 Vice-PresidentJohn Lang
Services Offered—Production of television 26 and 13 minute films for local, regional and national sponsorship; TV commercials.

**RD-DR Corp.
 (Reader's Digest—
 deRochemont)**

35 W. 45th St., New York 36, N. Y.
 Phone: JU 2-1440

Chairman of Board....Louis de Rochemont
 PresidentBorden Mace
 Secretary.....Ambrose Doskow
 Treasurer.....Martin J. Maloney
Services Offered—Feature, commercial and educational film producers.

Reeves Sound Studios Inc.

304 East 44th St., New York 17, N. Y.
 Phone: OR 9-3550

President.....Hazard E. Reeves
 Vice-President.....Chester L. Stewart
Services Offered—Sound recording for motion pictures, TV, radio and transcriptions.

Regal Television Pictures Corp.

151 W. 46th St., New York 36, N. Y.
 Phone: JU 2-1877

PresidentMoe Kerman
 Vice-Pres.Joe Felder
Services Offered—Distribution of motion pictures including features, streamliners, and shorts, for TV showings.

Regency Productions, Inc.

112 W. 48th St., New York 19, N. Y.
 Phone: JUDson 2-0274

PresidentJoseph Schaeffer

Services Offered—Film assignments 35mm., 16mm., black and white or color. Film sequences for TV shows ("Martin Kane, Private Eye"). Filmed commercials for TV.

Republic Television Features

64 East Lake St., Chicago 1, Ill.
 Phone: STate 2-0460

PresidentCapico Kapps
Services Offered—Producers and distributors of live and filmed television programs.

Stuart Reynolds Productions

7324 Santa Monica Blvd., Los Angeles, Calif.
 Phone: CRestview 1-6155
 PresidentStuart Reynolds

RKO Pathe, Inc.

625 Madison Ave., New York 22, N. Y.
 Phone: PL 9-3600

Exec. Vice-President.....Jay Bonafield
 Treasurer.....James H. Herries
 SecretaryJoseph Laub
 ComptrollerGarrett VanWagner
 Production Mgr.....J. Douglas Travers
Services Offered—Producer of short subject releases for RKO Radio Pictures; producers of TV films on contract.

Hal Roach Studios, Inc.

3822 W. Washington Blvd., Culver City, Calif.
 Phone: VERmont 8-2185
 N. Y. Phone: CI 5-4135

President.....Hal E. Roach
 Vice-Pres. & Gen. Mgr.S. S. Van Keuren
Services Offered—Complete motion picture production facilities for the production of TV commercials and programs.

R. S. Robbins

163 Bleecker St., New York 12, N. Y.
 Phone: SPRing 7-2568

President.....R. S. Robbins
 Mgr. of Prize Promotion....Edward E. Finch
Services Offered—Radio and television prizes.

Bob L. Roberts Productions

152 W. 54th St., New York 19, N. Y.
 Phone: PLaza 7-43145

President.....Bob Levitt Roberts
Services Offered—Radio and TV live or film Package Productions.

Rocket Pictures, Inc.

6108 Santa Monica Blvd., Hollywood 38, Calif.
 Phone: HOLlywood 7-7131

President.....J. Richard Westen
 V.P. in Chge. Sales.....J. Harry Ebbert
 Exec. Vice-President.....Harlow Wilcox
 Production Manager.....Don Bartelli
Services Offered—Producers of industrial, institutional and sales training motion pictures and slide films, and TV programs.

Frederick E. Rockett Co.

6063 Sunset Blvd., Hollywood 28, Calif.

Phone: Hillside 3183

General Manager.....Fred K. Rockett
 Production Supervision.....Alfred Higgins
 Photographic Department.....Jay Adams
 Editorial Dept.....Paul Lord
 Stage Mgt.....James Conley
 Electrical Department.....Frank Contardo
Services Offered—Complete facilities including fully equipped modern sound proof stage and all electrical and illuminating equipment. Many standing sets. Every service from script to screen.

Roy Rogers Productions

Samuel Goldwyn Studio

1041 N. Formosa Ave., Hollywood 16, Calif.

Phone: CRanite 5111

Executive Producer.....Roy Rogers
 Producer.....Jack Lacey
 Director.....Donald McDougall
 Cameraman.....Joe Novak
Services Offered—Produces TV western films.

Rogell Productions Inc.

3949 Sunset Blvd., Los Angeles 46, Calif.

Phone: CR 4-5217

Owner.....Albert S. Rogell
Services Offered—Package, features and film productions.

Roland Reed Productions

3322 W. Washington Blvd., Culver City, Cal.

Phone: TExas 0-2761

President.....Roland D. Reed
 Vice-President.....Guy V. Thayer, Jr.
 Secy.-Treas.....Hazel Hall
 Production Manager.....Dick L'E-trengre
 Casting Dir.....William Tinsman
Services Offered—Producers of commercial, industrial and television films.

Rosamond Productions, Inc.

8913 Sunset Blvd., Hollywood 46, Calif.

Phone: CRestview 4-5101

President.....David Chudnow
 Vice-President.....Rosamond Chudnow
 Sec. & Treas.....Byron Chudnow
Services Offered—Producing motion pictures for TV.

Ross-Danzig Productions

6331 Hollywood Blvd., Hollywood 28, Calif.

Phone: HOLLYwood 5-1085

Partner.....Frank K. Danzig
 Partner.....Bart Ross
 Exec. Asst.....Betsy Boyd
 Assoc. Prod.....Al Burton
Services Offered—Package production of live television programs.

Leslie Roush Productions, Inc.

333 W. 52nd St., New York 19, N. Y.

Phone: COLUMbus 5-6430

Studios: 130 Herriicks Rd., Mineola, N. Y.

President.....Leslie M. Roush

Vice-President.....Jules K. Sindic

General Manager.....John Fox

Services Offered—Make TV films, commercials.

Danny Rouzer Studio

7022 Melrose Ave., Hollywood 38, Calif.

Phone: YORk 2494

President & Owner.....Dauny Rouzer

Services Offered—Complete 16mm. production service, including sound stage, cameras, lights, sound recording, projection, cutting & editing, special effects and tiling.

Ruby Film Company

729 Seventh Ave., New York 19, N. Y.

Phone: CIRCLE 5-5640

General Manager.....Edward Ruby

Production Mgr.....Sidney Nannes

Services Offered—Producers of commercial film for all purposes. Film editorial services equipment. Production facilities available. Current production: "Factual Presentation" (Mohawk Carpet).

Leo Russell & Alex Haberstroh

111 East 28th St., New York 16, N. Y.

Phone: MURray Hill 9-2568

Partners.....Leo Russell & Alex Haberstroh

Sack Television Enterprises

Film Exchange Bldg., Dallas 1, Tex.

Phone: STerling 3069

General Manager.....Alfred N. Sack

Sales Manager.....Julius M. Sack

New York Office

358 West 44th St., New York, N. Y.

Phone: JU 6-2258

Services Offered—Producers, distributors; representatives for independent producers.

Barnard L. Sackett Television Productions

(See Program Producers)

Sarra, Inc.

200 E. 56th St., New York 22, N. Y.

Phone: MURray Hill 8-0085

President.....Valentino Sarra

Sales Prod. Mgr.....Jack Henderson

Branch Office

16 East Ontario St., Chicago 11, Ill.

Phone: WHItchall 4-5151

Dir. of Film Planning.....Joseph G. Betzer

Production Manager.....Harry W. Lange

Services Offered—TV film production.

Scandia Films, Inc.

220 W. 42nd St., New York 36, N. Y.

Phone: WISconsin 7-7059

President Ernest Mattsson
Services Offered—Distributor and representative of foreign TV producers.

Sawyer-Wirth Associates, Inc.

430 North Rodeo Drive, Beverly Hills, Calif.
 Phone: BRadshaw 2-2244
 745 Fifth Ave., New York 22, N. Y.
 Phone: PLaza 8-1492

President Wayne Wirth
 Vice-President Stanley Sawyer
 Secretary Alan L. Klehan
 Treasurer Alfred Zucker

Screencraft Pictures, Inc.

341 West 44th St., New York 36, N. Y.
 Phone: CIrcle 6-8546

President J. S. Berkson
Branch Offices:

5746 Sunset Blvd., Hollywood, Calif.
 Phone: HOLlywood 2-4448

Sales Representative Ton Corradine
 1109 Currie Ave. No., Minneapolis, Minn.
 Phone: LINcoln 7013

Sales Representative Don Swartz
 1001 New Jersey Ave. N.W., Washington, D. C.
 Phone: REPUBLIC 0776

Sales Representative Myron Mills
Services Offered—Distributor and syndicator of feature and western films, half-hour film packages for television.

Screen Gems, Inc.

(A subsidiary of Columbia Pictures Corp.)
 233 W. 49th St., New York, N. Y.
 Phone: CIrcle 5-5044

V.P. & Gen. Mgr. Ralph M. Cohn
 V.P. in Chge. Sales John Mitchell
 Business Manager Burton Hanft
 Dir. Advtg., Pub. Rel. Harry K. McWilliams
 Eastern Prod. Mgr. M. Peter Keane
 Staff Prod. Dir. John Gilmour,
 Ben Berenberg

Casting Director Nancy Kassel
 Film Editorial Chief Dan Heiss
 West Coast: 1334 N. Beachwood St.,
 Hollywood 28, Calif.

V.P. Chge. Prod. Irving Briskin
 Producers Michel Kraike, Irving Starr
 Production Executive Fred Briskin
 Story Editor Harry Fried

Services Offered—produce, distribute TV films; produce animated or regular TV film commercials.

Al Simon Productions

General Service Studios

1040 N. Las Palmas, Hollywood 38, Calif.
 Phone: HO 7-3111

President Al Simon
Services Offered—Productions of filmed shows and commercials.

Productions: Burns & Allen Show, I Married Joan,

Sixteen Screen Service Company

6710 Melrose Ave., Hollywood 38, Calif.
 Phone: WYoming 1491

Partners Leonard Clairmont & Homer O'Donnell
Services Offered—Complete motion picture productions and production services.

Skibo Productions, Inc.

165 W. 46th St., New York 36, N. Y.
 Phone: PLaza 7-2265

President-Treas. Patrick E. Shanahan
 Secretary George Blake
Services Offered—16m. and 35mm. sound films for TV rental. Educational, comedies, novelties, musicals, features and short subjects.

The Charles E. Skinner Productions

1600 Broadway, New York, N. Y.
 Phone: CI 6-6915

Executive Producer Charles E. Skinner
 Associate Producer Robert Sloan
 Production Manager Ray Rand
 Film Music Editor Alphonse Corelli
 Musical Director Skitch Henderson
 Set Designer Charles Carlotti
 Gen. Production Supervisor ... William Toth
 Camera Directors Joseph Burn,
 George Webber, Drummond Drury
 General Business Mgr. Melville Ruick
 Assoc. Prod., West Coast Rep. Albert Kelley
Services Offered—Creators and producers of television, theatrical and sales influence films; producing contractors; adapters; consultants to package producers, advertising agencies, sponsors. Distribution facilities for television and theatres, U. S. and foreign. Production facilities New York, Florida, Hollywood.

Stephen Slesinger, Inc.

247 Park Ave., New York 17, N. Y.
 Phone: ELdorado 5-2544

President Stephen Slesinger
Services Offered—TV films, based on the following properties: "Red Ryder," "King of the Royal Mounted," "Ozark Ike," and "Winnie-the-Pooh."

Fletcher Smith Studios, Inc.

321 E. 44th St., New York 17, N. Y.
 Phone: MUrray Hill 5-6626

President Fletcher Smith
 Vice-President Charles Schetler
 Secretary-Treasurer Peter Caldera
Services Offered—Producers of programs and spots.

Snader Telescriptions Corp.

177 So. Beverly Dr., Beverly Hills, Calif.
 Phone: CR 5-4451

President Louis D. Snader
 Director Duke Goldstone

Casting Director.....Phil Bloom
Musical Director.....Bernard Brody
Production Manager.....Jesse Corallo
Services Offered—Producers of films for TV; own organization for syndication and distribution of features produced by others.
Productions—Liberace.

Soundac Productions Inc.

704 Elmwood Ave., Buffalo 22, N. Y.
Phone: Summer 6262

Pres., Sales Mgr.....Robert D. Buchanan
Production Dir.....Clarence Schleh, Jr.
Art Director.....Francis J. Noack, Jr.
Services Offered—Syndicated and tailored TV film commercial production; animation specialists; syndicated program production for TV.

Sound Masters, Inc.

165 W. 46th St., New York 36, N. Y.
Phone: PLaza 7-6600

Chairman of Brd.....W. F. Cithens
President.....Harold E. Wondsel
V.P., Sect.....F. C. Wood, Jr.
Treasurer.....Walter Kullberg
Services Offered—Producers of commercial spots and industrial films.

Sovereign Productions, Inc.

7324 Santa Monica Blvd., Hollywood, Cal.
President.....Stuart Reynolds
Producers.....David Hire, J. Sis'ron
Secretary-Treasurer.....Rudolph Moner
Services Offered—Production of 1/2-hour dramatic films.
Productions—“Cavalcade of America.”
“Gen. Electric Theatre,” “Jeweler’s Show-
cast.”

Specialty Television Films, Inc.

1501 Broadway, New York 36, N. Y.
Phone: LO 4-5592

Pres., Gen. Sales Mgr.....Jules B. Weill
Vice-President.....Murray M. Kaplan
Services Offered—Motion picture film, features and half-hour, for television broad-
casting.

Sportvision, Inc.

233 Sansome St., San Francisco 4, Calif.
Phone: EX 2-3837

President.....William Parry, Jr.
Vice-Pres., Bus. Mgr.....Keith Alderson
Production Mgr.....Don Schwab
Services Offered—Sports films for televi-
sion; weekly sports reel of western sports;
production and distribution.

Square Deal Pictures Corp.

Pines Bridge Road, Ossining, N. Y.
Phone: OSsining 2-2617
General Manager.....Donn Marvin
Production Mgr.....David Carpenter

Services Offered—Available for production of films of all types, produce and distribute own films for television.

Al Stahl Productions

1600 Broadway, New York 19, N. Y.
Phone: COlumbus 5-2942

President.....Al Stahl
Vice-President.....Irwin Stahl
V.P. chge. of Prod.....Jack Weisberg
Services Offered—Complete production fa-
cilities and service for filming live action,
animation, TV shows and commercials; also
produce training, industrial and public re-
lations films in black-white & color.

Station Films, Inc.

30 Rockefeller Plaza, New York 20, N. Y.
Phone: ClRele 7-1279

President.....Robert H. Salk
Asst. to President.....Gloria Wilson
Services Offered—Film buying service for
television stations.

Standard Television Corp.

1501 Broadway, New York 18, N. Y.
Phone: LOngacre 4-8234

President.....Irvin Shapiro
Services Offered—Major feature films and
shorts.

Star Entertainment Corp.

214 W. 42 St., New York 36, N. Y.
Phone: LA 4-3450

President.....Max Wolff
Vice-President.....Al Roth
Services Offered—Talent representatives,
casting, production, and packaging of films.

Station Distributors, Inc.

10 East 51st St., New York 19, N. Y.
Phone: CO 5-1352

President.....M. M. Gettinger
Sales Director.....Jay Williams
Services Offered—Film production for TV;
sales & distribution of package shows.

Stempel-Olenick Agency

717 No. La Cienega Blvd., Los Angeles 46,
Calif.
Phone: CRestview 1-7111
Owners....Frank Stempel & Julian Olenick

Sterling Television Co., Inc.

205 East 43rd St., New York 17, N. Y.
Phone: OXFord 7-2520

President.....Saul J. Turell
Secy-Treasurer.....Robert E. Rhoades
V.P. chge. of Station Sales...Bernice S. Coe
Mgr. of Agency Sales....Richard Carlton
Branch Office
6715 Hollywood Blvd., Hollywood 28, Calif.
Phone: HOllollywood 4-6111
Manager.....Lee OrgeI

Services Offered—Producer and distributor of TV features, shorts and film series. TV stock shots. Distributor for independent producers.

Mike Stokey Productions

6123 Selma Ave., Hollywood 28, Cal.
Phone: HOLlywood 2-1241

President.....Mike Stokey
Assoc. Producer.....Gene Colton
Assoc. Producer.....John Hueners
Service Offered: Producers of live and filmed television productions. General television packaging.

Wilbur Streech Productions

1697 Broadway, New York 19, N. Y.
Phone: JUdson 2-3816

Owner.....Wilbur J. Streech
Client Relations.....J. Arthur West
Services Offered—Production of all types of motion pictures including animation, live action, stop motion and special effects. Specialist in TV film commercials.

Studio City TV Productions, Inc.

4020 Carpenter, North Hollywood, Calif.
Phone: SU 3-8807

President.....Mort W. Scott
Secretary-Treasurer.....Lester J. Nelson
Directors...Hy Glick, Howard McDonnell
Services Offered—Complete production of films for television.

Studio Films, Inc.

380 Madison Ave., New York 17, N. Y.
Phone: OXford 7-2590

President.....S. A. Costello
Exec. Vice-President.....Ben Frye
Secretary.....Nina Lu Little
Services Offered—Producers and distributors of Studio Telescriptions, over 1100 musical films produced especially for TV.

Swift-Chaplin Productions, Inc.

4316 W. Jefferson Blvd., Los Angeles 16, Cal.
Phone: REpublic 2-4492

President.....Charles F. Chaplin
Vice-President.....Howard Swift
Secretary-Treasurer.....Harry Hinkle
Production Manager.....Miles E. Pike
Services Offered — The production of custom-built television commercials.

T-bar-V Productions, Inc.

5919 Hollywood Blvd., Hollywood 28, Calif.
Phone: HOLlywood 3-1088

Pres., Sls. Mgr.....Donna Fargo
V.P., Gen. Mgr.....Lois Landon
Sec'y., Treas.....H. B. Baumeister
Services Offered: Specialize in westerns, outdoor, animal packages.
Productions: "Trader Lee," "Window to the West" (Visual Quiz Kids), and others.

The TeeVee Company

211 S. Beverly Drive, Beverly Hills, Calif.
Phone: Crestview 5-1076

President.....Gifford Phillips
Asst. to Pres.....Ludlow Flower, Jr.
V.P., Gen. Mgr.....Marc Frederic
Services Offered—Producers, distributors.
Productions: "Little Theatre."

Telecast Films, Inc.

112 W. 48th St., New York 36, N. Y.
Phone: JUdson 6-5480

President.....W. K. Hedwig
Secty.-Treas.....G. W. Hedwig
Services Offered—Rentals 16mm. sound and silent films for TV programming; all types incl. features, westerns, short subjects, comedies, travel, etc.

Telemated Cartoons

70 E. 45th St., New York 17, N. Y.
Phone: MUrray Hill 6-8933

Prod.-Dir.Saul Faller
Services Offered—Production of TV film commercials; storyboards; jingles. Animated cartoons; live action; animated and optical effects in color or black and white; 35mm. or 16mm. facilities.

Telemount Pictures, Inc.

P. O. Box 4555, Los Angeles 24, Calif.
President.....Henry B. Donovan

Telenews Productions, Inc.

630 Ninth Ave., New York 36, N. Y.
Phone: JUdson 6-2450

President.....Herbert Scheftel
Exec. Vice President.....Alfred G. Burger
General Manager.....Charles N. Burris
Editor-in-chief.....Edward P. Genock
Production Manager....Marshall Davidson
Chief Film Editor.....William Sofio
Dir. Comm. Film Dept...Robert W. Schofield
Adv. & Prom. Mgr.....Robert Kirsten
Services Offered—Producers of television news film, film commercials, film programs; film stock shot library.
Productions: Telenews Daily, Telenews Weekly, This Week in Sports, Beat The Experts, Adventures in Sport.

Telepix Corporation

Times Tower Bldg., 1475 Broadway,
New York 18, N. Y.

Phone: PEEnsylvania 6-1821-2
President.....Albert G. McCarthy
Vice-President.....Richard Freitas
Secretary.....Rita Fables
Services Offered—TV films.

Telerama Productions

(See Television Films of America for personnel listing.)

Telescene Film Productions Co.

237 First Ave., New York City, N. Y.
Phone: AL 4-8470

President Robert Tobias
Office Manager Arthur Blackman
Services Offered—Fifteen minute television film series, "Pulse of the City."

Telescene Films

4238 Mammoth Ave., Sherman Oaks, Calif.
Phone: STate 9-1952

Exec. Producer William Lava
Production Assoc. Rex Lipton
Services Offered—The production of pure entertainment films for television.

Television Exploitation Inc.

101 West 55th St., New York 19, N. Y.

President Milton M. Gettinger
Exec. Vice-President Oliver O. Unger
Sales Representative Harold Goldman
Services Offered—In the television field, distributes, purchases, and produces full length features and short subjects.

Television International Co.

25 West 45th St., New York 36, N. Y.
Phone: PLaza 7-3450

General Manager Paul N. Robins
Services Offered—Lease and/or sale of TV rights foreign countries, small amount of domestic rights available. Material includes serials, shorts of all types.

Television Films of America

Box 1006, Beverly Hills, Calif.
Phone: NORmandy 2-2520

Exec. Producer Jack Parker
Exec. Director Ross Van Nibror
Production Mgr. Ray Bond
Services Offered—Package shows, complete films to order, open end films, TV film commercials, 2 to 3 minute fillers, amusement shorts, TV newsreels.

Television Programs of America, Inc.

729 Seventh Ave., New York 19, N. Y.
Phone: PLaza 7-2765

Chairman of Board Edward Small
President Milton Gordon
Exec. Vice-President Michael M. Sillerman
Asst. Vice-President Kurt Blumberg
Treasurer Seymour Malamed

Television Screen Productions, Inc.

17 East 45th St., New York 17, N. Y.
Phone: MURray Hill 2-8877

President Charles J. Basch, Jr.
Treasurer Clarence Schmidt
Secretary Frankie Basch
Services Offered—Film programs, film spots, industrial training and documentary

films, slide films. Will rent studio facilities with, or without, cameramen, scripts, direction and cast.

Tel Ra Productions

1518 Walnut St., Philadelphia 2, Pa.
Phone: KINGSley 6-4140

Producer W. Wallace Orr
Director of Programming & Sales George J. Kerrigan, Jr.
Director of Production Dan Wise
Film Editors Joe Arnold, Dan Endy, Marvin Fisher, William Friel
Services Offered—Complete facilities for producing TV film shows and commercials. Largest producers of film TV sports programs in the country.

Ed McLemore "Texas Rasslin"

Cadiz & Industrial Blvd., Dallas, Texas
Phone: Sterling 2173

V.P., Gen. Sales Mgr. Maurice Beck
Services Offered—50 to 54 minute wrestling film taken actually at live show every week at Dallas Sportatorium.

Ed Thorgersen

245 West 55th St.
Phone: Circle 6-8935

Exec. Producer Ed Thorgersen
Services Offered—Producer, Editor and Commentator. Package programs, (news & sports). Industrial motion pictures for institutional advertising and sales promotion.

Times Square Productions Inc.

145 West 45th St., New York 36, N. Y.
Phone: Circle 6-4443

President Chas. W. Curran
Vice-President Stephen E. Fitzgibbon
Production Assistant Diana Kembel
Associate Producer Fred Kelly
Services Offered—Specializing in the production of live-action, live-sound motion picture subjects for TV commercials and programs, for business, training and entertainment.
Productions: Fu Manchu.

Transfilm Inc.

35 West 51st St., New York 36, N. Y.
Phone: JUDson 2-1400

President William Miesegaes
Vice-Pres. William Burnham
Vice-Pres. Robert Klaeger
Exec. Vice-Pres. Walter Lowendahl
Secretary-Treasurer Peter A. Schlenker
Services Offered— Complete facilities for production of motion pictures, animation and slide films, for TV, black and white or color; 16mm. or 35mm. Permanent staff of producers, directors, writers, animators, artists, cameramen, editors.

TV Ads Inc.

3839 Wilshire Blvd., Los Angeles 5, Calif.
Phone: DUnkirk 8-1323

PresidentDoria Balli
Sales Manager.....Charlie Larrain
Services Offered—Specialists in producing 16mm., 35mm., black and white, or color television film commercials, using animated cartoons, live action, or stop motion.

TV Movie Club, Inc.

1501 Broadway, New York, N. Y.
Phone: BRyant 9-6734

President.....Dr. Arthur M. Epstein
Exec. Supervisor.....Richard F. O'Connell
Services Offered—Series of half-hour, open-end TV films for children.

TV-Programs, Inc.

10 Washington Place, New York 1, N. Y.
Phone: GR 7-0123

Executive Producer....Edward Roberts, Jr.
Director of Sales.....Leonard Beckman

TV-Unlimited Inc.

17 East 45th St., New York 17, N. Y.
Phone: OXford 7-0725

PresidentHerbert Rosen
Services Offered—Producers of complete films to order, package shows, full-length feature films, mood and bridge music library service for TV and 16 mm. productions, sound effect records.

United Artists Television Corp.

729 Seventh Ave., New York 19, N. Y.
Phone: CIRCLE 5-6000

Vice-Pres., Gen. Mgr.....F. A. Long
Asst. Gen. Mgr.....Robert Gaertner
Traffic Manager.....Sidney Dash
Mid-West Sales Rep.....Robert O'Brian
Division Sales Mgr.....Milton E. Olin
Services Offered — Distribution of television films.

United Press Associations

(See Program Producers)

United Productions of America

4440 Lakeside Dr., Burbank, Calif.
Phone: CHarleston 0-7171

New York Division—670 Fifth Ave.,
New York 19, N. Y.

Phone: PLaza 3-1672

Pres. & Exec. Produce....Stephen Bosnstow
Vice-PresidentRobert Cannon
N. Y. Office Mgr.....C. D. McCormick
V.P. in chge. Pub. Rel....Charles Daggett
Services Offered — Producers of TV film commercials — specializing in animation, also animation production services.

United Television Programs, Inc.

650 N. Bronson Ave., Hollywood 4, Calif.
Phone: HOLlywood 5-2195
N. Y. Phone: PLaza 3-4620

PresidentPhilip Krasne
Vice-PresidentJack Gross
Sales Manager.....Wynn Nathan
Services Offered—Sales distributors for TV film producers. Engaged in selling TV film programs to advertising agencies and TV stations.

Unity Television Corp.

1501 Broadway, New York 24, N. Y.
Phone: LOnacre 4-8234

President.....Arche A. Mayers
Sales Manager.....L. Firestone
Services Offered—Film producers, open end films, feature films, educational shorts, cartoons, sport reels, serials, series films, special spots featuring top name personalities, westerns.

Unity Television Corp. of Calif.

8051 Sunset Blvd., Hollywood 46, Calif.
Phone: CRestview 4-5693

N. Y. Phone: LOnacre 4-8234

ManagerConstance Lazar
BookerVincent Fiumano
Services Offered—Film producers, open-end films, feature films, educational shorts, cartoons, sport reels serials, etc.

**United World Films, Inc.
(Subsidiary of Universal Pictures)**

445 Park Ave., New York 29, N. Y.
Phone: PLaza 9-8000

P. O. Box 183, Universal City, Cal.

President.....J. M. Franey
V.P. in Chg. Sales.....N. E. Gluck
West Coast Production.....George Bole
N. Y. Prod. Dept.....Steve Alexander
Services Offered—Producer and distributor of programs and spot commercials.

Van Praag Productions

1600 Broadway, New York, N. Y.
Phone: PLaza 7-2857

Executive Producer....William Van Praag
Production Chief.....Gilbert M. Williams
Art Director.....Sidney Kupfershmid
Chief Cameraman—Unit A...Sidney Zucker
Chief Cameraman—Unit B....Sol Roizman
Casting Director.....Joan Topper
Services Offered—Producers and distributors of film made for TV. Producers of commercial and theatrical motion pictures. Producers of video film spots; package programs for networks, agencies and local sponsors.

Video Drama Productions

505 Fifth Ave., New York 17, N. Y.
Phone: MU 2-0326

PresidentHenri E. Marcuse
 PartnerGuy Calandreau
 Script Supervisor.....Charles Cinnamon
 As-oc. Supervisor.....Raymond Foucher
Services Offered—Live and film services for TV film series; script packages.

Video Pictures, Inc.

Executive & Sales Offices
 11 E. 50th St., New York 22, N. Y.
Phone: MUrray Hill 8-1162
 STUDIO: Video Pictures, Inc.
 510 W. 57th St., New York 19, N. Y.
Phone: Circle 7-2062

President.....William R. Deering
 Vice-President.....Martin Henry
 Vice-President.....George W. Goman
 Secretary.....Elsie M. Rice
 Supervisor of Sales.....Frank B. Woodruff
Services Offered—Complete facilities for production of motion pictures, television, commercials, programs, industrial and other.

Video Pictures, Inc.

1515 No. Western Ave., Hollywood 28, Calif.
Phone: HU 2-3030

President.....Hank McCune
 Asoc. Producer.....Charles Maxwell
 Production Manager.....Jack Caldwell
 Merchandising & Promotion...B. A. Babb
Services Offered—Producers of theatrical and commercial television subjects.

Video View, Inc.

7557 Sunset Blvd., Hollywood 16, Calif.
Phone: HOllYwood 3-4179

President.....Bradley Kemp
 Vice-President.....Marshall Taft
 Sales Director.....Kenneth Harp
Services Offered—New method of recording television programs, provide agencies and sponsors with low-cost, high-quality 16 mm sound-on-film records of television spots, exactly as they appear in the living room.

Vidicam Pictures Corp.

240 East 39th St., New York 17, N. Y.
Phone: MU 6-3310

President.....Alfred Justin
 Studio Chief.....William B. Shriner
 Staff Director.....James Rose

Visual Media, Inc.

21-29 15th Rd., Long Island City, N. Y.
Phone: STillwell 1-2941

President.....William M. Nelson
 Art Director.....Raymond Keane
 Advertising Consultant.....Weston Hill

Voeller Productions Inc.

1052 Carol Drive, Hollywood 16, Calif.
Phone: CRosview 4-6253

President.....Will H. Voeller
 Vice-President.....George Hughes
Services Offered—Production and distribution of live and transcribed radio and tele-

vision programs, industrial films, commercial spots, animated spots and cartoons.

Volcano Pictures Inc.

1040 N. Las Palmas, Hollywood 38, Calif.
Phone: HOllYwood 7-3111

President.....Robert Angus
 Vice-President.....James Banks
 Production Manager.....Edward Saeta
Services Offered—Producer of feature and commercial films for TV.

Vonna Productions, Inc.

General Service Studios, Hollywood, Calif.
Phone: HOllYwood 4-0811

President.....Edison von Ottenfeld
Services Offered—Producers of governmental and commercial radio transcriptions, custom recordings, jingles, motion picture trailers, TV spots.

Roger Wade Productions

15 West 46th St., New York 36, N. Y.
Phone: Circle 7-6797

Owner.....Roger W. Wade
Services Offered—TV commercials, animation, telops, balops, slides, commercial motion pictures.

Adrian Weiss Productions

655 No. Fairfax Ave., Los Angeles 36, Calif.
Phone: WEbster 8-5287

Producer.....Adrian Weiss
 Exec. in Chg. of Production....Louis Weiss
Services Offered—Production organization geared to produce all types of TV films from 20 second spots to one hour shows.

Louis Weiss & Co.

655 No. Fairfax Ave., Los Angeles 36, Calif.
Phone: WEbster 8-5287

Distribution Director.....Adrian Weiss
 Asst. Distr. Director.....Louis Weiss
Services Offered—Distribution organization, geared to distribute all types of television shows throughout the country.

Whitehead TV Pictures, Inc.

630 Ninth Avenue, New York, N. Y.
Phone: Circle 5-7210

President.....Charles G. Whitehead
Services Offered—Producers of TV film commercials, industrials, features and short subjects.

Wilding Picture Prods., Inc.

385 Madison Ave., New York, N. Y.
Phone: PL 9-0854

Vice Pres.....J. W. Inglefield

Frank Wisbar Productions Inc.

7321 Santa Monica, Los Angeles, Calif.
Phone: HUdson 2-2286

President.....Frank Wisbar
 Vice-President.....Benjamin H. Kline
 Asoc. Prod.....Sidney Smith

Dir. of Photo.....B. H. Kline
Services Offered — Film productions for TV.

Productions: "Fireside Theater."

Raphael G. Wolff Studios

5631 Hollywood Blvd., Hollywood 28, Calif
Phone: HOLlywood 7-6126
N. Y. Phone: PLaza 5-5386

Owner-Exec. Chairman...Raphael G. Wolff
 Exec. Dir., Creative Dept.

MacDonald MacPherson

Services Offered—Industrial, training and institutional motion pictures, sound and color; television programs and commercials.

World Video, Inc.

(See Program Producers)

Emerson Yorke Studio

245 W. 55th St., New York 19, N. Y.

Phone: LUXemburg 2-2216

Owner, Exec. Producer....Emerson Yorke

Services Offered—Producer of TV and other types of films.

Workshop TV Distribution, Inc.

418 South Robertson Blvd., Los Angeles 48, Calif.

Phone: CRestview 5-4373

PresidentPaul Garrison

Vice-President.....Ernest Baumeister

Secretary-Treasurer.....Edwin Gillette

Services Offered—Distribution of filmed TV programs, production facilities for rent,

production of filmed TV programs.

Zahler Productions, Inc.

118 South Robertson Blvd., Los Angeles 48, Calif.

Phone: CRestview 5-4373

President.....Gordon R. Zahler

Vice-PresidentMillard Jacobs

TreasurerRose Zahler

Services Offered—Production of television films.

Ziv Television Programs, Inc.

488 Madison Ave., New York, N. Y.

Phone: MURray Hill 8-4700

Chairman of the Board.....Frederic W. Ziv

President.....John L. Sinn

V.P. in Chge. Sales.....Maurice J. Rifkin

West Coast Office Mgr.....Maurice Unger

Eastern Div. Sales Mgr.....Albert Goustin

Central Div. Sales Mgr...Edward J. Broman

Western Div. Sales Mgr...Valter Kingsley

Services Offered—Production, sales and distribution of television films for syndication.

Productions: Boston Blackie, Cisco Kid, The Unexpected, Favorite Story, Yesterday's Newsreel, Sports Album, Story Theatre, Your TV Theatre, The Living Book.

Zorro Productions

2400 West Alameda Ave., Burbank, Calif.

Phone: CHARleston 8-5559

ProducerWilliam Cottrell

Business Manager.....Nat Winecoff

**FOR LISTINGS OF
 IMPORTANT**

ADVERTISING AGENCIES

AND

PERSONNEL

SEE PAGE 133



Films to Play Major Role in Television Broadcasting

By ARCHIE MAYERS

*President
Unity Television Corp.*

To forecast the responsibility and future use of films on television, one need not resort to the crystal ball. There is sufficient background, history and documentary evidence to furnish most of the answers regarding the part that film has played and will play in future telecasting. However, before looking into the future it may be well first to review the past.

In the so-called early days of television, assuming that 1946 would serve as a springboard, the motion picture as related to television was an orphan and stepchild; and quite often referred to as a dirty word spoken of only in hushed tones. And why not? Wasn't television supposed to be the electronic transmission of live figures and live shows? And was it not the intention and hope of the commercial producers to substitute live television for mechanical devices, meaning in one instance motion pictures? This certainly was the basic aim of television but quite often theory is superseded by reality. In the minds of many of the producers and telecasters, reality represented that form of visual projection, regardless of whether it was "live" or on film.

To project this viewpoint to a conclusion of the present-day, facts and statistics prove that motion pictures are as great a reality as live shows, the only difference being that one is projected electronically from a live stage, whereas the other is transmitted mechanically. Thus, it poses the question "What Is The Difference?" Actually, there is no discernible difference. It takes a practical expert and one highly attuned to these respective arts to look at a screen and differentiate between "live" and film. Given a good positive print with intelligent understanding of the electronic arts, with proper timing and projection, a play on motion picture film serves the same purposes as a live show without any of the failures that quite often occur in live production - particularly when one con-

siders that a motion picture film may be edited, the rough spots removed and generally primed to perfection before it is projected.

During the past seven years, the usage of motion picture films on television has grown beyond anyone's conception. From 1946 to 1948, film being considered a stepchild, was mostly employed for program fillers and standby usage. But in 1949 its practical and economical values were "discovered." Most of the 108 stations on the air at that time developed an awareness that motion pictures were more than a substitute; it being divined that motion pictures were the real McCoy. This discovery was no mere accident; it was based upon:

(1) Quick availability of many thousands of shows. (2) Public acceptance of predetermined values and star names. (3) Ease of handling and operations, and last but not least; (4) The economic aspect.

The latter had great significance to station operators, program directors, technicians and sponsors. They quickly saw and determined that motion pictures, having all of these qualifications, could be purchased at a fraction of the cost of live shows, could be obtained at a reasonable portion of the rate card and furthermore, could be auditioned beforehand to determine acceptability for the respective markets. Also, a tremendous economical factor not to be ignored is the advantage of residuals, which may be enjoyed only through film production - and certainly not through live shows. Thus, the general idea of using motion pictures on television began to snowball, and in the year 1950 grosses realized by distributors and station time sales catapulted into substantial figures. So the momentum continued through 1951, 1952 and 1953, until the gross volume done through motion pictures totalled in excess of thirty or forty million dollars for 1953.

*Television
Personalities
1953-1954*

•
A PICTORIAL PARADE OF SOME
OF THE LEADERS OF TELEVISION
—FROM THE STATION, AGENCY,
NETWORK AND PRODUCTION
FIELDS—DURING THE PAST YEAR

TV PERSONALITY INDEX

NAME	PAGE NO.	NAME	PAGE NO.
Adanti, Paul	1003	Evans, Haydn R.	1019
Alvarez, Maria Helen	1032	Fay, Bill	1006
Arnoux, Campbell	1003	Ferguson, Robert W.	1006
Arries, Leslie G., Jr.	1003	Fetzer, John E.	1033
Atlass, H. Leslie	1005	Floyd, Joe	1015
Aubrey, James T., Jr.	1003	Fogarty, Frank P.	1009
Bailey, Frederic S.	1005	Friedland, Milton D.	1017
Barnett, John A.	1011	Gaines, James M.	1002
Bartell, Gerald A.	1016	Gardner, Bob	1015
Bastian, George	1011	Garland, Charles H.	1018
Batson, Charles A.	1005	Geehan, Jerry	1018
Bitner, Harry M., Jr.	1003	Gentling, G. David	1018
Bononsinga, Joe	1016	Gittleson, Norman A.	1015
Borel, Richard A.	1005	Goggin, Richard J.	1009
Bostic, Thomas C.	1016	Goldman, Harry L.	1018
Brandt, Otto	1005	Goldman, Paul	1018
Breen, Ed	1016	Goode, Patrick J.	1009
Brown, Willet H.	1030	Goode, Paul N.	1018
Burbach, George M.	1003	Gray, Gordon	1010
Campbell, Martin B.	1004	Gridley, Ansel E.	1015
Carpenter, W. M.	1017	Gross, Harold Frederick	1009
Carter, Ken	1004	Grubb, Gayle V.	1031
Chisman, Thomas P.	1012	Hacker, Les	1015
Clark, Bud	1012	Haid, Allen L.	1014
Cleghorn, John H.	1017	Hanna, Robert B., Jr.	1009
Clipp, Roger W.	1002	Hanrahan, James Coleman	1008
Cobb, Wilton E.	1017	Harris, Jack	1032
Cole, James C.	1005	Hartenbower, E. K.	1008
Coleman, George D.	1004	Havens, Wilbur M.	1008
Colin, John A.	1012	Hayes, John S.	1008
Connolly, James Howard	1012	Hebenstreit, A. R.	1025
Cooney, Ed	1017	Herold, Joseph	1008
Coy, Albert Wayne	1034	Higgins, George J.	1014
Crutchfield, Charles H.	1004	Hoffman, Phil	1014
Damm, Walter J.	1006	Hoy, Frank S.	1014
Davis, Don	1019	Hubbard, Stanley E.	1008
Delaney, C. Glover	1017	Huey, Harry	1014
Dunning, Richard O.	1019	Jackson, Glenn C.	1004
Dunville, Robert E.	1004	Jett, E. K.	1002
Eaton, Joe	1006	Johnson, Claudia T.	1013
Edwards, William J.	1019	Johnson, Leslie C.	1002
Eiland, Theodore A.	1019	Johnston, Henry P.	1013
Ellis, Robert D.	1019	Kahle, Doug	1013
Essex, Harold	1006	Kapel, George J.	1016
Etter, Lester P.	1032	Kaufman, Julian M. "Julie"	1029
Evans, C. Richard	1006	Kelley, Gaines	1002

NAME	PAGE NO.	NAME	PAGE NO.
Kerns, J. Robert.....	1013	Provost, D. L. (Tony).....	1030
Kersia, Noran E.....	1007	Quarton, William B.....	1026
King, Frank G.....	1007	Quinlan, Sterling "Red".....	1021
Kirchhofer, Alfred H.....	1013	Reinsch, James Leonard.....	1034
Knight, Norman.....	1015	Rembert, Clyde W.....	1020
Koehler, Frank E.....	1002	Riddell, James G.....	1020
Konyenburg, F. Van.....	1007	Rogers, Lawrence H.....	1026
Kritser, Tom.....	1013	Rogers, W. D.....	1020
Lackey, Hecht S.....	1024	Rohrer, Joseph H.....	1026
Lancaster, W. Hanes, Jr.....	1016	Rosenhaus, Irving Robert.....	1020
Landsberg, Klaus.....	1007	Rossiter, John.....	1034
Lane, C. Howard.....	1010	Rust, Armistead.....	1025
Larson, G. Bennett.....	1010	Ruwitch, Lee.....	1020
Lasker, H. P.....	1011	Saddler, Owen.....	1028
Lasky, Philip G.....	1007	Schreiber, Frank P.....	1028
Latham, U. A. (Jake).....	1034	Schroeder, Willard.....	1029
Lawrence, Craig.....	1010	Schrott, Alvin D.....	1024
Lawrence, Val.....	1012	Shea, Hamilton.....	1028
Lemon, Robert.....	1023	Shelburne, Thomas P.....	1029
Leonard, James.....	1009	Sholis, Victor A.....	1024
Linebaugh, W. H.....	1010	Shute, Elden H. "Denny" Jr.....	1029
Loomis, Lee Pierson.....	1022	Slavick, Henry W.....	1032
Lord, Nathan.....	1011	Smith, Carleton D.....	1023
Lund, Harold C.....	1010	Smith, Edward G.....	1023
Ludy, Ben.....	1023	Snyder, Franklin.....	1024
Lyke, Ervin F.....	1023	Stackhouse, J. L.....	1032
Manning, J. Hampton.....	1027	Stahl, Leroy.....	1029
Martin, Thomas E.....	1012	Stamps, Weldon.....	1029
Mastin, Cecil D.....	1034	Stern, Edgar B., Jr.....	1033
Mayer, Herbert.....	1027	Sugg, P. A. "Buddy".....	1023
Maynard, Harry Y.....	1027	Swartley, Wilmer C.....	1024
McCollough, Clair R.....	1030	Swezey, Robert Dwight.....	1032
McDaniel, Troy.....	1027	Taft, Paul E.....	1031
McEleveen, H. Moody, Jr.....	1027	Terry, Hugh B.....	1022
McGough, Joseph Wallace.....	1021	Thieriot, Charles De Young.....	1024
McKinnon, Ben K.....	1011	Thomas, Harold H.....	1031
Merryman, Philip.....	1021	Thornburgh, Donald Wayne.....	1028
Milligan, David F.....	1022	Thrower, Fred M.....	1022
Moore, James H.....	1022	Tincher, Robert R.....	1022
Moore, Richard A.....	1011	Tindal, Alan C.....	1031
Morrison, Robert Z., Jr.....	1027	Tooke, Rolland V.....	1021
Myers, Frank O.....	1021	Travers, Linus.....	1031
Nelson, Ted.....	1026	Vadeboncoeur, E. R.....	1028
Nolte, Vernon A.....	1025	Wagstaff, Walter E.....	1033
Norman, Donald A.....	1021	Watters, M. C.....	1028
Norman, Hugh R.....	1025	Waugh, Irving.....	1031
O'Fallon, Gene.....	1025	Whitney, George.....	1033
Outler, John M., Jr.....	1020	Williamson, Warren P., Jr.....	1030
Pengra, Marshall H.....	1014	Wilson, Stan.....	1034
Peterson, Howard O.....	1026	Woodall, Allen M.....	1033
Pitman, Charles W.....	1026	Woodling, M. F.....	1030
Poller, Lou.....	1025	Woodruff, James W., Jr.....	1033
Porterfield, John Reed.....	1007	Yoder, Lloyd E.....	1030

TV PERSONALITIES

E. K. JETT, v.p. and chm. of WMAR-TV, Balti-



more, Md., joined the Federal Radio Commission in 1929 as a senior engineer. He was advanced two years later to asst. chief engineer, then chief engineer in 1938, and Commissioner in 1944. He resigned from the Commission to assume his present duties on Jan. 1, 1948. Jett was a member of the Censorship Operating Board during World War I

and the chairman of the Coordinating Committee of the Board of War Communications.

LESLIE C. JOHNSON, v.p. and gen. mgr. of



WHBF - AM - TV - FM, Rock Island, Ill., took his present post on Jan. 1, 1952. After a year as a reporter for the *Journal Review* and a year on the *Argus*, he became editor-manager for the *Democrat Publ. Co.* at Alton, Ill. Leslie returned to the *Argus* as adv. mgr. in 1939. He is an enthusiastic civic worker, having served on the Community Chest board, and

being a present member of the Chest Budget Committee. He is a 32nd degree Mason.

GAINES KELLEY, gen. mgr. of WPMY-TV,



Greensboro, N. C., has been with the station since it went on the air on Sept. 22, 1949. He was classified Adv. mgr. III in the *Greensboro Daily News* and the *Greensboro Record* for 15 years. When the News Co. expanded into radio operation, he was chosen manager of WPMY (FM) in 1948 and served in that capacity until FM operations ceased in April,

1953. Kelly was one of the organizers of the Frequency Modulation Assn. and active in it until its merger with NAB.

FRANK E. KOEHLER, gen. mgr. of Radio Rec-

ords, Inc., operator of WROV AM TV, began his career as an NBC radio boy. In 1950 he filed the first application in Roanoke for TV. In Sept., 1952 his CP was granted and the station went on the air Feb., 1953, becoming the 9th UHF station to begin operating. WROV-TV went off the air on July, 1955 when a VHF channel 7 application was filed for Roanoke, Va. Frank joined WROV in 1946, after an Army tour, which was just getting on the air.



JAMES M. GAINES, v.p. and gen. mgr. of

Southland Industries, Inc., owners and operators of WOAI-AM-TV, San Antonio, Texas, was formerly v.p. and a member of the Board of Directors of General Telephoto, Inc., head line WOR-WOR-TV, N. Y. Jim joined NBC in 1941 in the station relations dept. and held successive posts as asst. adv. and promotion dir., until 1946 when he was named gen. mgr. of WNBC, N. Y. In 1947, Jim was added to the post of dir. of all NBC owned stations and later v.p. of the network.



ROGER W. CLIPP, gen. mgr. of the Phila. In-

quirer stations WFIL-AM-FM-TV, was elected a member of the Board of Directors of the Chamber of Commerce of the U. S. in April, 1953. He is a veteran of the radio-TV broadcasting fields, and a 1925 graduate of the Wharton School of the University of Pennsylvania. He is past chairman of the ABC relations planning & advisory committee. Clipp recently completed his term of office as president of the Penna. Assn. of Broadcasters.



JAMES T. AUBREY, JR., general manager of KNXT, key station for CBS TV in Hollywood, took his present post in 1952. In 1941, Aubrey graduated cum laude, with a B.A. in English literature from Princeton University. Upon graduation he was commissioned as a Second Lieutenant in the U. S. Field Artillery and was called to active duty immediately. He was discharged in 1946 with the rank of Major.

In 1948 he joined CBS for KNX, moving to TV when CBS purchased channel 2 in Los Angeles in 1951.



LESLIE G. ARRIES, JR., gen. mgr. of WTTG, Washington, D. C., took his present post on June 29, 1953. He enjoys the distinction of being the only member of the Du-Mont organization to have worked in its 3 owned and operated stations. After serving as a junior engineer, he became a WTTG cameraman, production assistant and director of special events. In Feb. 1949, Arries was sent to WDTV in Pittsburgh, where as program operations manager, he helped establish the station.



CAMPBELL ARNOUX, pres. and gen mgr. of WTAR and WTAR-TV, Norfolk, Va., took his post in 1933. During the years at WTAR, he has installed WRID, Richmond, and obtained, built and staffed WPID, Petersburg, Va. In 1949 he was engaged in building and installing WTAR-TV which began operations on channel 4, April 2, 1950. Both WTAR and WTAR-TV switched after 19 years from NBC to become

basic stations of CBS's radio and TV network. Arnoux has been very active in civic affairs in Norfolk.



GEORGE M. BURBACH, gen. mgr. of the St. Louis Post-Dispatch stations KSD and KSD-TV, has been a TV enthusiast since 1936 when he viewed a BBC demonstration in London. Immediately on his return to the U. S., he inaugurated a series of discussions and events which resulted in the establishment of KSD-TV on February 8, 1947 as America's first completely post-war equipped TV station. He was appointed adv. mgr. of the Post-Dispatch in 1913 and has been a director of Pulitzer Publ. Co. since 1922.



HARRY M. BITNER, JR., pres. and gen. mgr. of WFBS, Inc., Indianapolis, worked in the circulation and editorial dept. of metropolitan newspapers in Pittsburgh during summer vacations from college. In 1942 he was named gen. mgr., and after being discharged from the U. S. Navy in 1946, he was named pres. Harry is also supervisor of WEOA, Evansville, Ind., dir. and V.P. of WFDF in Flint, Mich.

and V. P. of the Grandwood Broadcasting Co., (WOOD, WOOD-TV). He is a member of the city's Rotary Club.



PAUL ADANTI, gen. mgr. of WHEN, Syracuse, N. Y., has held that post since 1948. He started in TV with WRGB when he joined that G. E. pioneer station on its origination in 1939. After four years of work in all TV phases at WRGB, he was made head of TV operations, a post he held until joining WHEN. In 1950, he was elected to the board of directors and made vice president of the Meredith Syracuse Television Corporation, operators of WHEN.



◆ ◆ ◆ TV PERSONALITIES ◆ ◆ ◆

GLENN C. JACKSON, managing dir. of WAGA-



AM-TV, Atlanta, Ga., took his present post in March of 1952. His radio career began at WFLD Dayton, as an announcer, staying there three years. Glen then moved on to WSPD in Toledo, where he became prod. mgr. in 1943. From there he spent two years in the U. S. Navy, and was released in 1946. He returned to WSPD, and when WSPD-TV came into view, he was assigned additional responsibility. Jackson has become pres. of the Georgia A.P. Radio Assn.

GEORGE D. COLEMAN, gen. mgr. of WGBI-TV,



Scranton, Pa., became WGBI manager in 1932. Graduating from Technical H. S. in 1918, he joined the U. S. Army and served until after the Armistice ended World War I. He then went to the Hudson Coal Co. and later to the General Electric Co. in Schenectady. In 1929 Coleman joined Frank McGeorge as manager of the radio store, moving directly and exclusively into broadcasting in 1932. He has served as first v.p. of the Scranton Rotary Club.



ROBERT EDWIN DUNVILLE, pres. of the Cros-



ley Broadcasting Corp., is a native of St. Louis, Mo. In 1931 he joined the sales dept. at KMOX, St. Louis, and soon thereafter became assistant gen. mgr. On Nov. 17, 1949, Dunville was elected pres. of the Crosley Broadcasting Corp., having administrative responsibility for WLW and WLWT, Cincinnati; WLW-G, Dayton; WLW-C, Columbus; and WLW-A in Atlantic City, as well as the Voice of America, which Crosley operates for the U. S. State Dept. at Bethany, Ohio.



KEN CARTER, gen. mgr. of WAAM, Baltimore



spent his first year in radio, with WITH as a time salesman. From there he went to WEAL, becoming gen. sales mgr. of the coordinated radio-TV operation. He joined WAAM in 1942, as local sales mgr., and was made gen. mgr. in 1951. He is a member of the Baltimore Advertising Club and the Baltimore Press Club. He is serving his second elected term on the TV Board of Directors of the NABTB. Carter, a native of Baltimore is a Round Temple Shrine member.

MARTIN B. CAMPBELL, supervisor of



WFAA and WFAA-TV Dallas (Texas), has served as staff correspondent of the AP; in 1927 he was made assistant man. and program director of WJAS, Louisville, Ky. In 1932 he served a few months manager and program dir. of WDEF and WJLM in Wilmington, Del. From there he came to WFAA in May, 1932 as general mgr. In May 1950, he directed

the launching of WFAA's TV service. In 1952 he was made supervisor of radio and TV properties.

CHARLES H. CRUTCHFIELD, exec. v.p. of the



Jefferson Standard Broadcast Co. and gen. mgr. of WBT-WBTV, Charlotte, N. C., is a native of Spartanburg, S. C. In 1945, when the station was purchased from CBS by Jefferson, Crutchfield became gen. mgr. Then 33 years old, he was the youngest 50 kw. gen. mgr. in the nation. In 1951 he spent several months in Greece and the Near East as special State Dept. consultant in the broadcasting industry there. Charles' chief hobby is hunting in his native S. C.

◆ ◆ ◆ TV PERSONALITIES ◆ ◆ ◆

CHARLES A. BATSON, v.p. and director of WIS-TV, Columbia, S. C., acquired his present post in 1952. Previously he was dir. of TV for the NARTB, after serving as assistant dir. of the BAB. Batson served during WW II in the Army. He was assigned to the War Department's Radio Branch, following earlier service with Gen. Eisenhower's North African headquarters.



Born in Greenville, he was graduated from Furman University in 1938 and launched his radio career as an announcer with WFBC.

FREDERIC S. BAILEY, gen. mgr. of WTOA-TV, Cambridge, Mass., joined the Middlesex B'castg. Corp. operators of the station in Oct. 1951, as manager of WTOA-TV. Fred is a graduate of Dartmouth College, and has been associated with radio in and around Boston for more than 17 years. He was formerly commercial mgr. of WORL just prior to his appointment as gen. mgr. of WTOA-AM, Fred served as sales mgr. of WBMS. He continues his executive duties with the radio sta., in addition to TV.



H. LESLIE ATLASS, v.p. in charge of the Western Division of CBS and gen. mgr. of WBBM, Chicago, was born in Lincoln, Ill., where he spent his boyhood. In 1923 when radio listeners wore earphones, the brothers Ralph and H. Leslie founded their first station, a 200 watt at Lincoln. Leslie and WBBM first became affiliated with CBS in 1928. Later, when WBBM was purchased by the Columbia network in 1933, he was named to his present post. Atlass, his wife and three children live near Wheaton, Ill.



OTTO BRANDT, v.p. and gen. mgr. of King Broadcasting Co., Seattle, Wash., operators of KING and KING-TV, was named to his present post in 1951. He was born in N. Y. C., and attended Columbia University. Otto has been a resident of Seattle since 1951. He began his business career in 1933 as a NBC page boy in Radio City, N. Y. In 1942 he enlisted in the Air Force as a B-25 flying instructor, until 1945, emerging with the rank of first lieutenant. He is married and has two children.



RICHARD A. BOREL, dir. of TV for the Dispatch Printing Co., owners of WBNS-TV, Columbus, entered the radio field in 1933, first serving as business mgr. of WBNS. In the spring of 1949 he was named to his present post in addition to his duties at WBNS. During World War II, Borel served with the U. S. Army, emerging with the rank of lieutenant colonel. A graduate of Ohio State University,



Borel was prominent in such extra-curricular activities as Strollers and the Scarlet Mask, while in school.

JAMES C. COLE, manager of WFTV, Duluth, Minn., is a graduate of State Teachers College at Superior, Wis. Jim first ventured into the business world as an announcer for WEBC, 5000 watt outlet for NBC. Jim remained with WEBC for 10 years prior to his entrance in 1942 into the U. S. Air Force. On June 7, 1953, he gave the Iwin ports, Duluth and Superior, their first television station WFTV on channel 38, owned and operated by Great Plains TV Properties of Minnesota, Inc.



◆ ◆ ◆ TV PERSONALITIES ◆ ◆ ◆

BILL FAY, v.p. and gen. mgr. of WHAM-TV, FM, Rochester, N. Y., moved to Rochester in 1938 as program mgr. of WHAM and named gen. mgr. the following year. In 1942 he was elected v.p. of WHAM's parent company in 1942, and the following year he became a member of the Stromberg-Carlson board and in 1948 he was appointed v.p. and gen. mgr. of the company's broadcasting division.

Bill is v.p. of both the Rochester Chamber of Commerce and the Automobile Club and member of Rochester Adv. Council.



HAROLD ESSEX, exec. v.p. of Triangle B'castg. Corp., operators of WSJS-TV, Winston-Salem, N. C., joined the Piedmont Publishing Co. in 1939 as sales manager of its radio affiliate, WSJS. In 1942 he was named mgr. of WSJS and in 1946 was upgraded to v.p. in charge of broadcasting for Piedmont. In May 1953 the Piedmont Publ. Company merged its application for TV with that of former movie star Mary Pickford, and the Triangle Broadcasting Corporation was formed.



WALTER J. DAMM, v.p. and gen. mgr. of the Milwaukee Journal stations WTMJ and WTMJ-TV was a leader in the formation of Broadcast Music, Inc., and was on the board of directors of that organization for five years. During World War II, he was a member of the Broadcasters' Victory Council and of Committee IV of the Board of War Communications. Walter was chairman of the NABTB committee

that drafted the commercial section of the national TV code, and has been a member since its inception.



ROBERT W. FERGUSON, exec. v.p. and gen. mgr. of Tri-City B'castg. Co., operators of WTRF-AM-TV, Wheeling, W. Va., is a graduate of Ohio State University. During World War II, he was in the U. S. Navy and was released in 1946 with the rank of senior lieutenant. In April 1947, the Tri-City B'castg. Co. was making preparations to establish radio stations WTRF and WTRF-FM and Ferguson was appointed gen. mgr. In Nov. 1947, he was chosen as a member of the Tri-City board of dir. and elected v.p.



C. RICHARD EVANS, v.p. and gen. mgr. of KGMB-AM-TV, Honolulu, and KHBC, Hilo, T. H., started as a technician with KSL in Salt Lake City, and advanced to v.p. and gen. mgr. of KSL. In 1952 Evans was invited to Honolulu by the Bd. of Directors of the Hawaiian B'castg. System to survey the territory for TV. He did such a thorough job, they persuaded him to return immediately to get

KGMB-TV on the air just three months later, on Dec. 1, 1952. Evans is a member of the Rotary Club.



JOE EATON, pres. and gen. mgr. of the Mid-America B'castg. Corp., operators of WKLO and WKLO-TV, Louisville, Ky., is a past pres. of the Kentucky Broadcasters Assn. In 1948 he organized and constructed WKLO, and put Louisville's seventh station on the air Nov. 23, 1948. WKLO-TV started programming Oct. 18, 1953. Eaton has gained a nationwide reputation as being one of the pioneers of commercial radio. He went to Kentucky in 1929 and remained when offered a position by WHAS.



◆ ◆ ◆ TV PERSONALITIES ◆ ◆ ◆

JOHN REED PORTERFIELD, v.p. and gen. mgr. of WNET, Providence, R. I., was formerly mgr. of WSEE-TV, Fall River, Mass. John became active in the TV field in 1938 when he directed programs for the National TV Corp. in N. Y. and later in the production department of NBC. His book, "We Present Television," was chosen the June 1940 selection of the Scientific Book Club and was later reprinted

in Spanish as "He Aquí la Televisión." John has also been associated with the Radio Corp. of America.



KLAUS LANDSBERG, general manager, KTLA, Los Angeles, and vice-president, Paramount TV Productions, Inc., is well known in the broadcasting industry as a pioneer of KTLA. Born July 7, 1916, in Berlin, Germany, he amazed his boyhood friends by his keen and avid interest in the new form of communication — Television. Working 16 hours per day, he completely disproves the old theory that engineers should stick to engineering and showmen to show business. He has combined the two most successfully.



FRANK G. KING, station manager of KABC-TV, Los Angeles ABC affiliate, has a background of wide experience in the broadcasting industry. Born in England, he came to the United States while still an infant, and spent his early days in and around the City of New York. He was an infantry officer in World War II, and following his service was in charge of the N. Y. office of the Armed

Forces Radio Service. He has been sales mgr. of KNX, and while with CBS King secured the rights to the Rose Bowl game for that net.



PHILIP G. LASKY, vice-president and general manager, KPIX, San Francisco, is regarded as one of the industry's "heavyweights." Stations that profited by his guidance were KDYL, Salt Lake City, KROW, Oakland, and KSFO, San Francisco. It was while at KSFO that Phil and Guy Earl, owner of KNX, L. A., established the "western network," California's first successful regional chain. This two station network was absorbed by CBS in 1937. Now as KPIX begins its sixth year of operation, Lasky embellishes his role.



F. VAN KONYNENBURG, executive v.p. and gen. mgr. of WCCO-AM-TV, Minneapolis and St. Paul, Minn., is known to everyone as "Van." A graduate of the University of Wisconsin, Van has had heavy experience on newspapers in Milwaukee, Madison, and Minneapolis and after joining WTCN in the Twin Cities, was made general manager ten years later. When WTCN was merged

with WCCO, Van turned his managerial talents to maintaining top shows and ratings. Under his leadership, personnel has increased from 18 to 230 at WCCO.



NORAN E. KERSTIA, exec. v.p. and gen. mgr. of WFTL-AM-TV, Ft. Lauderdale, Fla., came to the Tri-County B'cstg. Co. as one of the leaders in the industry, having spent 17 years with NBC in the development of TV. He journeyed to Ft. Lauderdale in Feb. of 1953 to purchase part-interest in, and supervise the installation of WFTL-TV. Noran also represented NBC during Federal Communications Commission hearings for TV stations in L. A., Chicago, Cleveland and Washington, D. C.



◆ ◆ ◆ TV PERSONALITIES ◆ ◆ ◆

WILBUR M. HAVENS,



pres. and gen. mgr. of Havens & Morin, Inc., owners and operators of WMBG-WCOD-WTVR, Richmond, Va., organized his own automotive-electrical business in 1922. Havens became the Philco battery distributor and later took on the Philco power socket receivers. From there he secured a license from the Dept. of Commerce to place WMBG on the air with 15 watts power. The

station has not been on the air since. WCOD went on the air in 1946 and WTVR took to the air in 1948.

JOHN S. HAYES,



president of WTOP, Inc., operates WTOP TV, AM, Washington, D. C., on one air and one for radio and TV at the Washington Post Co., which owns 55 per cent of WTOP, Inc. (CBS owns 45 per cent). He began his radio career at WIP, Phila., later moving to WDR. He entered the U. S. Army in 1941 in title of the Quartermaster General. After the war he went

to WOR, The N. Y. Times station. In 1948 he went to Wash. as exec. v. p. of WINK, just moved to WTOP in 1949 when the Post bought control of CBS out-

JOSEPH HEROLD, station mgr. of KFTV, Denver, Colo., was technical director and manager of TV for WOW, Inc., Omaha, in 1945. Joe supervised construction and organization of WOW-TV in 1949-50. The following year he became TV consultant for CMUR-TV, Havana, Cuba, later came to Radio



Televisao Paulista, Sao Paulo, Brazil. He then became station planning consultant for RFA, and authored TV station cost and planning studies. Herold took his present post on Sept. 1, 1952.

JAMES COLEMAN HANRAHAN, gen. mgr. of

WEWS, Cleveland, O., has had that post since its founding in 1947. He enlisted in the U. S. Army in 1942, served 94th rank of major, later lieutenant colonel, until 1946. In 1935 he joined Scripps-Howard Radio, Inc., affiliated with the Scripps-Howard Newspapers, under Karl August Bickel. Since that time has acted as v. p. of the company and has been gen. mgr. from time to time for WNOX, Knoxville, WCPQ, Cincinnati. He is married and has two children.



STANLEY E. HUBBARD, pres., gen. mgr., and



manager of KSTP-AM-TV, Minneapolis-St. Paul, established Hubbard Field at Louisville, Ky., in 1919. A few months later he organized the first commercial outlet in the U. S. and laid out air ways still used by airlines today. In 1924 Hubbard started WAMB in Minneapolis, then in 1928 WAMB, was given a power increase to 10 thousand watts

and became KSTP, presently operating with 100,000 watts. KSTP-TV took to the air in April 1928.

E. K. HARTENBOWER, gen. mgr. of KCMO-AM-

FM-TV, Kansas City, Mo., took his present post in June, 1953. In 1929 he joined the H. K. McCann Co., now McCann-Erickson, Inc. In 1933, Hartenbower joined NBC, Chicago, as assistant to the production mgr. and in 1940 was selected to be NBC's contact to handle the network broadcasts of the Democratic and Republican National Committees. Hartenbower is a member of the board of directors of the NARTR. He belongs to the Kansas City Press Club.



FRANK P. FOGARTY, gen. mgr. of Meredith WOW, Inc., Omaha, Neb., was with the Omaha Chamber of Commerce for 15 years, serving as gen. mgr. He joined Meredith WOW, Inc., as general manager in Aug. 1950. In 1944 Fogarty became v.p. of Paxton & Gallagher Company, wholesalers of groceries, hardware, appliances, and liquor. He is currently vice president and chairman of the executive committee of the Omaha Chamber of Commerce. He is married and the father of four children.



ROBERT B. HANNA, JR., manager of General Electric Company's Broadcasting stations dept., is responsible for all activities in the company's AM, FM and TV operations. When Hanna was named station manager on Sept. 1, 1949, he had just completed his 20th year with G. E. During World War II, he served three and one half years with the Signal Corps, and was discharged with the rank of Captain in 1945. He is a past president of the Schenectady Chamber of Commerce, and past pres. of Lions Club.



RICHARD J. GOGGIN, gen. mgr. of KETC, St. Louis, was a member of CBS, N. Y.'s program dept., prior to World War II. He started in TV production during CBS's experimental period in 1939. After wartime service he became writer-prod.-director of both live and film programs for ABC-TV in N. Y., Phila., Schenectady and Chicago. In 1948 he was prod. dir. of WFIL-TV in Phila., later re-joined



PATRICK J. GOODE, pres. of WNHC-AM-FM-TV, New Haven, Conn., with his friends Aldo DeDominicis, initiated the first TV station in New England. He also inaugurated New Haven's first radio station in 1935. In 1936 President Roosevelt appointed him Postmaster of the New Haven P. O. He retired from this post in 1950 at the age of 70. In 1943 he sold his radio interest and joined Aldo DeDominicis, and thus the Elm City Broadcasting Corp. was born with Pat elected pres. WNHC-TV began operations in 1948.



ABC, and subsequently, in L. A., became senior dir. of KECA-TV. He has taught radio-TV at UCLA.

HAROLD FREDERICK GROSS, president and owner of WJIM and WJIM-TV, Lansing, Mich., is a graduate of the University of Michigan. He built WJIM 20 years ago, and has been continuously owned and operated by him ever since, and built WJIM-TV four years ago. Gross built WGFG (now WKMI) Kalamazoo, in 1947 owned and operated the station, until he sold it in August, 1952. He



JAMES LEONARD, vice-president and general manager of WLW-C, Columbus, Ohio, is a television pioneer in Ohio's capitol, having opened the first station in that city on April 1, 1949. Born in Bristol, Tenn., he is a graduate of the University of Florida. Leonard joined WLW, Cincinnati, in 1936 as executive announcer and master of ceremonies. In 1944, he was appointed program director of WSAI, and he remained at WSAI until he was appointed general manager of WLW-C, Crosley Broadcasting Corporation's Columbus television station. Leonard was made a v.p. of the Crosley Broadcasting Corporation in 1953.



has been a resident of Lansing and East Lansing, Michigan for 30 years. He is a native of Ann Arbor, Michigan.

GORDON GRAY. General Teleradio v.p. in charge of WOR and WOR-TV, N. Y., started as a reporter with the Kansas City Star. From there he managed the Kansas City offices of the Katz Agency, station reps. He took his present post on Jan. 1, 1954. Gordon has been associated with Central States Broadcasting Co., operating stations KFOR, Lincoln, Neb., KOHL, Omaha, WDGY, Minneapolis-St. Paul in



the capacity of gen. mgr. Early in 1951 he became v.p. of Goodwill Stations, Inc.

CRAIG LAWRENCE, general manager of WCBS-TV, key station of the CBS Television network, is no newcomer to New York City, although he was born in Wisconsin, educated in Michigan and Iowa, and spent a goodly portion of his broadcasting career outside this city. After serving as an account executive and commercial manager of WMT, Cowles station in Waterloo, Iowa, in August, 1944, Lawrence



returned to the N. Y. area to manage both WHOM in Jersey City and WCOP in Boston. When Cowles sold WHOM to Il Progresso, the Italian-language paper, Lawrence devoted his time to WCOP. Craig with family reside in Conn.

G. BENNETT LARSON, president and general manager, KDYL-AM-TV, Salt Lake City, Utah, is a native of Salt Lake City, and began his career in radio when he joined the staff of KDYL at the age of 16. A graduate of the University of Utah, he has had a distinguished career as manager of radio stations in Philadelphia, Washington, and New York. He was vice-president and general manager of tele-



vision station WFIX in N. Y. Before assuming his new post with KDYL and KDYL-TV in his native city.

HAROLD C. LUND, general manager, WDTV, Pittsburgh, although born in New Jersey, is practically a native Pittsburgher as his family moved to Pittsburgh while he was still an infant. A former general manager with Hess Federal Research Company, World War II altered his business plans and he entered the Navy as a lieutenant. Served four years and was raised in rank to Lt. Commander before the war ended. In July, 1951 he was named general manager of WDTV and since that time, WDTV enjoys top success.



C. HOWARD LANE, managing director, KOIN-TV, Portland, Oregon, has a background with a wealth of experience in the broadcasting industry. He has seen broadcasting grow in nearly every aspect of the industry. In 1942 he became central division manager of the stations relations department for CBS, and in 1943 until 1945 he was director of stations relations for CBS in New York. From 1940 until 1950 he was a member of the board of directors of the National Association of Broadcasters. Educated in Fresno, California public schools, he received his BA from Stanford University in 1930.



W. H. LINEBAUGH, vice-president and general manager of Mountcastle Broadcasting Co., Inc., is a native of Tennessee, born and reared in a small town, about 40 miles from Knoxville. Prior to coming to WROL in 1944 as business manager, he was with the Knoxville News-Sentinel in the advertising department for twenty three years. Linebaugh has developed a well rounded and hard-hitting sales force since he was made the vice-president and general manager in July, 1950. Linebaugh and his wife, Ethel, have two children, a daughter who is married and a son who attends the University of Tennessee.



◆ ◆ ◆ TV PERSONALITIES ◆ ◆ ◆

RICHARD A. MOORE, vice-president and general manager, KTTV, Hollywood, Calif., has in six short years established himself as one of the creative pioneers of television and probably the industry's leading exponent of local TV. He became head of KTTV in July, 1951, following a most successful career with the ABC television network, which saw him rise from the legal staff to the post of director of television for ABC's Western Division and manager of KECA-TV in Los Angeles. He was a captain, holding the Legion of Merit, when he was mustered out in 1946. Shortly later he joined the legal department of ABC in N. Y.



NATHAN LORD, vice-president and general manager for WAVE, Inc., Louisville, started his career as a reporter for the Louisville Post in 1921. In September, 1933, George W. Norton formed WAVE, Inc., an NBC outlet and the second radio station to commence operations in Louisville. Lord joined WAVE as vice-president and general manager at that time and has continued in this capacity ever since. In November, of 1948, WAVE, Inc., commenced operation of WAVE-TV, Kentucky's first TV station, and the nation's 44th. A native of Louisville, Kentucky, Nathan Lord is married and has three sons.



GEORGE BASTIAN, exec. v.p. of the Stuart Investment Co. and temporary mgr. for KFOR and KFOR-TV, Lincoln, Neb., first became associated with the Stuart Investment Co. in 1942. He was named to his present post in 1948. George was born in Nebraska, and except for a brief term of duty in the Navy, has given his complete time and efforts to Nebraska business and industry. His duties as temporary manager of KFOR and KFOR-TV, will be for a period of three to six months.



H. P. LASKER, vice-president and general manager WLW-D, Dayton, Ohio, was born and educated in Europe. In his eleventh year with the Crosley Broadcasting Corporation, Lasker was appointed sales manager for the company's TV outlet in Dayton, WLW-D. In 1951 he was named manager of WLW-D, a post he held until being promoted to vice-president in July, 1953. Lasker claims that the "harder you work the body, the harder you can work the mind" and ably proves the truth of his observation as a devotee of sports. It is not unusual to see him leading staff parties at skating, swimming, and tennis.



BEN K. MCKINNON, general manager, WGVL-TV, Greenville, S. C., assumed his duties April 1, 1953, organized the entire staff, and put the station on the air August 1, 1953. Formerly Carolina sales manager of WBT, Charlotte, N. C., McKinnon is also a former associate editor of Robeson Country's Hometown Newspapers in Lumberton, N. C. Ben is a native of Maxton, N. C., and a graduate of the University of North Carolina. He holds the rank of Lieutenant in the U. S. Naval Reserve, having served three years of active duty in World War II. He is also a member of the Board of Directors of the UHF Association.



JOHN A. BARNETT, owner of KSWs and KSWs-TV, New Mexico, is a graduate of Southern Methodist University, Dallas, in 1926. He is a geologist and petroleum engineer, and decided to go into business for himself seven years ago. In 1952, John decided to build the first regional TV station in the U. S. where the trade area includes no large cities. Later in 1952, he purchased KSWs. Barnett is a member of many geological and oil associations, being one of several oil men in the industry.



◆ ◆ ◆ TV PERSONALITIES ◆ ◆ ◆

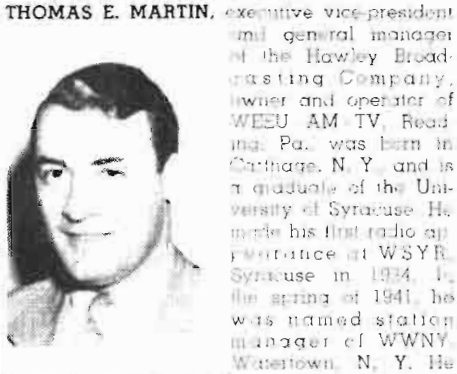

THOMAS E. MARTIN, executive vice-president and general manager of the Hawley Broadcasting Company, owner and operator of WEEU AM-TV, Reading, Pa., was born in Carthage, N. Y., and is a graduate of the University of Syracuse. He made his first radio appearance at WSYR, Syracuse in 1934. In the spring of 1941, he was named station manager of WWNY, Watertown, N. Y. He came to Reading in May of 1950 as a station executive of the Hawley Broadcasting Company and was named general manager in the summer of that year. In 1953, Martin was advanced to the position of executive vice-president and general manager.

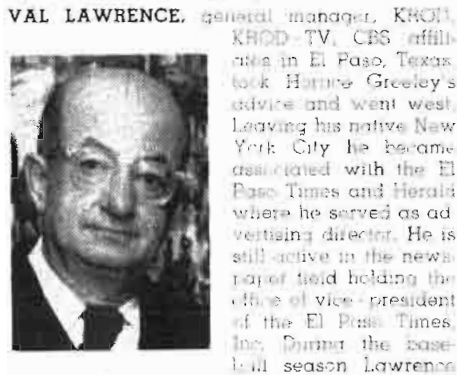

VAL LAWRENCE, general manager, KRCH, KRQD-TV, CBS affiliate in El Paso, Texas, took Harry Greeley's advice and went west. Leaving his native New York City he became associated with the El Paso Times and Herald where he served as advertising director. He is still active in the newspaper field holding the office of vice-president of the El Paso Times, Inc. During the baseball season Lawrence can usually find an excuse to be in N. Y., on business and his office is along the first base line in the Yankee Stadium. He is married to the former Gladys Pickett, and they have one married daughter.



JOHN A. COLIN, gen. mgr. of WICA-TV, Ash-tahula, O., is a native of that city. He also serves as assistant publisher of the four Rowley publications in N. E. Ohio, and also acts as gen. legal counsel for the newspapers and WICA. John was admitted to the Ohio Bar in 1941, having received his degree in 1939 from Cleveland Law School. During World War II, he served in the U. S. Army for five years. Colin is an active member of church and fraternal organizations.

BUD CLARK, gen. mgr. of The Montana Network, operators of KOOK and KOOK-TV, Billings, Mont., spent 3½ years in the U. S. Coast Guard during World War II. Upon discharge he took an announcing job at KVOS, Bellingham, Wash. Bud joined the Montana Network in 1950 when KOOK was in the blueprint stage. He took his present post in 1951, and began double duties when KOOK-TV began telecasting Nov. 9, 1953. Bud's hobby is hunting and fishing, which was a big contributing factor in moving to Montana.



THOMAS P. CHISMAN, pres. and gen. mgr. of WVEC-AM-TV, was born and educated in Hampton, Va. He served as a U. S. Naval officer from 1943-46. Thomas started with WVEC in 1948. He was recalled in 1950 with the National Guard and served in Wash. in the Air Defense. In his spare time he prepared his TV application for the FCC. He filed the application in July, 1952 and received approval in Feb., 1953. Thomas is a member of the Rotary Club, and on the Bd. of Directors for the Red Cross.



JAMES HOWARD CONNOLLY, ABC v.p. in charge of San Francisco office, KGO and KGO-TV, started with N. W. Ayer & Son in Phila. in 1926. He joined ABC in 1944 in the station relations department. Jim made the rounds out of N. Y. for two years prior to ABC assigning him to establish its station relations office in Chicago. This accomplished he returned to N. Y. and assumed an even stronger role in the network's station relations picture. In March 1952 Connolly was named to his present post.



◆ ◆ ◆ TV PERSONALITIES ◆ ◆ ◆

HENRY P. JOHNSTON, pres. of The Television Corp., operators of WAPI-AM-FM and WABT, Birmingham Ala., is also serving as exec. v.p. of the Birmingham News Co., and pres. of the Huntsville, Ala. Times. He was general manager of WSGN from 1937 until July, 1953, when the Birmingham News Co. sold that station to acquire WAPI. Since his graduation from Washington and Lee College in 1929, Henry has served as a Kelly-Smith newspaper rep., and local adv. mgr. of the Birmingham News.



J. ROBERT KERNs, v.p. and managing director of WBRC-TV, is a veteran of 14 years with the Storer Broadcasting Company, and began his broadcasting career as a salesman at WHIZ, Zanesville, Ohio, in 1939. In June, 1947, WHIZ was sold and KERNs was transferred to WLOK, Lima, Ohio, where the station under his dynamic leadership established new records in both sales and audience. He is married, has three children, and attended the Linsley Military Academy. He is also a member of the Elks.



CLAUDIA T. JOHNSON, pres. of the Texas Broadcasting Co., operators of KTBC-AM-TV, Austin, Texas, acquired KTBC-TV was one of the first stations to get into operation after the freeze was lifted, going on the air Thanksgiving Day, 1952. Claudia is a graduate of the University of Texas. She married Lyndon B. Johnson in 1934, and has two daughters. He is the present senior senator from Texas. She is a native of Alabama, and moved to Texas as a young child.



ALFRED H. KIRCHHOFER, v.p. of WBEN Inc., was a national figure and a leader in the newspaper world even before he became the managing editor of The Buffalo Evening News in 1927 and a WBEN official in 1930. Born in Buffalo May 25, 1892, he started cub reporting in 1910, and is now known across the country as managing editor and a director of The Buffalo Evening News as well as v.p., secretary, and director of WBEN Inc. Married and a member of the Buffalo Club, he's also a member of SDX.



DOUG KAHLE, pres. and gen. mgr. of KCSJ-AM-TV, Denver, Colo., purchased the station in June, 1952, in partnership with Bob Clinton. KCSJ-TV was established in June, 1953. In 1946 he established KCOL in Ft. Collins and was part owner and gen. mgr. until 1950. He established KOWB in Laramie, Wyo., in 1948 and held an interest in this station for about a year. He purchased KOKO in La Junta early in 1950 and sold this station in 1951. Kahle is a member of the Rotary Club and Elks Club.



TOM KRITSER, KGNC and KGNC-TV, Amarillo, Texas, began his radio career in KGNC's merchandising department in 1940 during summer vacations between college semesters. In 1948, he became gen. mgr. of KDDD, Dumas, Texas, and the following year he returned to KGNC where in Jan., 1950, he was named gen. mgr. Under his leadership KGNC boomed to its three most successful years. Kritser also assumed management of KGNC-TV, when in October, 1952 a CP was granted for the first "Panhandle" TV station.



FRANK S. HOY, gen. mgr. of WLAM-AM-TV, Lewiston, Me., is also gen. mgr. of WPMT, Portland, Me. He served as circulation mgr., advertising mgr. and business mgr. of Lewiston Sun-Journal from 1922 to 1945. Hoy resigned and sold his stock interest in Sun-Journal in 1945 to establish WLAM. He founded Portland Telecasting Corp. In Jan. 1953, WPMT (TV) went on the air Aug. 30, 1953.



WLAM-TV hit the airwave in Nov., 1953. He is former chairman and present member of Maine State Board of Education.

PHIL HOFFMAN, v.p. and mgr. of KOAT-TV, Albuquerque, N. M., managed KFJB from 1929-1932. In July, 1953 Phil purchased interest in KOAT-TV. Phil has been associated with WNAX, Yankton, S. D., KRNT, Des Moines, and was v.p. of Cowles Broadcasting Co., while still responsible for home office supervision of WNAX until pre-war WNAX manager returned from the armed services. He managed KECA-TV owned by ABC, from Nov., 1951 to July, 1953. Phil has also been associated with KOB, Albuquerque, N. M.



GEORGE J. HIGGINS, v.p. and managing dir. of KMBC-KFRM-KMBC-TV, Kansas City, entered radio in 1931 as sports director of WTUN, Minneapolis. In Feb., 1951, Higgins moved to KMBC-KFRM as v.p. in charge of sales and in Oct. of the same year, was made v.p. and managing dir. He has been associated KSO, Des Moines and WISH, Indianapolis. He was elected to the board of directors of the Midland Broadcasting Co. Jan. 4, 1954. Higgins is currently chairman of the NARTE Sports Committee.



ALLEN L. HAID, v.p. and managing dir. of the Storer Co.'s Toledo WSPD and WSPD-TV, joined the Storer organization in 1937 at its Wheeling operation, WWVA. In 1939 when Storer acquired its Zanesville, O. operation, he was transferred there as asst. mgr. and program dir. and was made managing dir. in 1942. In 1946 he was transferred to the company's operation in Fairmont, W. Va. In 1948 he was made v.p. and in 1949 elected to the board of directors. In the Fall of 1951, he took his present post.



HARRY HUEY, gen. mgr. of Nevada Radio-TV, Inc., (KZTV), Reno, Nev., entered Reno immediately after the date for KZTV was made. He made all initial business surveys as well as supervising all property acquisition and construction leading to the initial air date Sept. 27, 1953. He also assembled and employed all personnel, since responsible for its operation. Harry came to this assignment after 27 years with the same owner as advertising dir. of the Southwest Times Herald newspaper in Ft. Smith, Ark.



MARSHALL H. PENGRA, president and general manager, KSTM-TV, St. Louis' ABC affiliate, was formerly general manager of KGKB, Tyler, Texas. A native of Illinois and a graduate of the University of Illinois, the new KSTM-TV chief executive has long been active in the broadcast legislation field. He headed a group of Oregon radio men in 1941 in outlining a proposal to the FCC for relaxing operator requirements during the war period. The NAB has used his services on numerous occasions and he has also been on the NAB music advisory committee. He is married, and has two sons—Marshall, 18, and Michael, 15.



◆ ◆ ◆ TV PERSONALITIES ◆ ◆ ◆

LES HACKER, co-owner and mgr. of KVEC-AM-TV, San Luis Obispo, Calif., put KVEC on the air on May 8, 1937, and has seen the station grow both in size and power to its present radio and TV operation. The TV construction permit was applied for in May, 1948 and granted May, 1953. Les Hacker is single and lives in San Luis Obispo with his mother. His hobbies, ships and the sea, take second place



only to special events broadcasting on radio and television.



NORMAN KNIGHT, mgr., WABD, N. Y., had been, for four years, vice-president in charge of advertising and promotion for Sponsor Magazine, and before that, was Eastern manager of station relations for the Mutual Broadcasting System. After a varied background of announcing, writing, and promotion with several stations, his selling career started at WMMN, Fairmont, W. Va. Later, before



moving to N. Y., Norm became general manager of the West Virginia Radio Corporation. He has long been active as a speaker on broadcasting media before ad and sales groups, and is a member of the Friars Club and the Variety Club.



JOE FLOYD, pres. of Midcontinent B'castg. Co. and pres. of KELO-AM-TV, Sioux Falls, S. D., came to Sioux Falls in 1932 as the manager of the Granada Theater. Floyd is the originator of several network radio and TV productions, having actually produced both types of shows. He is nationally known as the originator of "Blind Date" as heard on NBC. Floyd is wing commander of the state



of South Dakota Civil Air Patrol, holding the rank of a Colonel. He has been active in community events since 1933.

NORMAN A. GITTLESON, gen. mgr. of WJAR-TV, Providence, R. I., started in TV in 1949 at WFMY-TV in Greensboro, N. C. Norman is a graduate of Morris-Harvey College in Charleston, West Virginia. He spent four years in the U. S. Navy, serving 26 mos. overseas. WJAR-TV's basic affiliation is NBC and secondary network is ABC. Norman is a member of the Providence Rotary Club, and Secretary-Treasurer of the Rhode Island Radio and TV B'casters. Association.



BOB GARDNER, gen. mgr. of KLAS-TV, Las Vegas, Nevada, is a graduate of the University of Minnesota. Following his studies he joined the staff of WMN in St. Paul as announcer. Except for a period with the special services div. of the Army Air Force, Bob remained with KYSM for 11 years, five of which were in the capacity of asst. mgr. In June, 1953, Gardner entered TV as commercial mgr. of KLAS-TV, and in Dec. of that year was made general manager of the operation.



ANSEL E. GRIDLEY, v.p. and gen. mgr. of the Salisbury B'castg. Corp., operators of WWOR-TV, Worcester, Mass., has been in radio and TV ever since he enrolled at Rollins College in Fla., and the University of North Carolina. During the war his experience was used by Uncle Sam in special overseas assignments. On one of these occasions he was cited for his achievements in the study of sporadic E behavior. He has been associated with WHOO, WARE, and in 1952 established WFGM, Mass.



GEORGE J. KAPEL, general manager of KOMU-TV, commercial station of the University of Missouri, was previously commercial manager of WAAB, Worcester, Mass., manager, WBYK Cumberland, Md., manager, WDNE, Elkins, W. Va., program director, WAJR, Morgantown, W. Va., and had been earlier, associated with KMJ, Fresno, Calif. He graduated from the University of Oregon in 1943.

Now married and the father of a son, Kapel is 31 and during the war served with Counter-Intelligence in both Manila and Tokyo.



THOMAS C. BOSTIC, v.p. and gen. mgr. of KIMA-AMTV, Yakima, Wash., is now in his ninth year with the company. Graduating from the University of Wash. College of Pharmacy in 1941, he entered radio at KBND in Bend, Ore., soon after graduation. He joined KIMA in 1945 as an announcer. Moving to all phases of operations at KIMA, was named to his present post in 1953. Tom is a member of the board of directors of the Yakima Rotary Club and is active in the Chamber of Commerce and the 4-H Clubs.



W. HANES LANCASTER, JR., vice-president and general manager, WHIL-TV, and WHL-AM is a graduate of Washington & Lee University, and spent three years with the Air Force in the Pacific area during World War II as a member of a B-29 bomber group. Originally joining the sales department of WHIL, Johnson City, Tenn., he assumed management in 1950. When WHIL-TV had its tower

collapse a week before air date, Oct. 17, 1953, he lost 15 pounds between the time the tower collapsed and went on the air Oct. 26, 1953.



JOE BONONSINGA, v.p. and gen. mgr. of WGEM, AM-FM-TV, Quincy, Ill., had his own dance orchestra, and is still a member of the AFM. Following a stint in the Army from 1943-45, he returned to Quincy and in Oct. 1947 went with WGEM as commercial mgr. Joe is a native of Quincy and is a graduate of Quincy College. He was associated in business with his father in a wholesale food company as sales rep. Joe is a member of the American Legion, Director of Sales Executives and Rotary International.



ED BREEN, pres. of KOTV, Fort Dodge, Ia., was formerly a county attorney and in the State Senate. KOTV is a TV outgrowth of the radio venture. Breen and others organized KVFH and took over during the early war years when it didn't look very promising. He was president of the Iowa Tull Corn Network, also of the Iowa Broadcasters Association. He served one term on the NAB board

and is presently chairman of the NABTB Copyright Committee. Breen has been active in radio associations.



GERALD A. BARTELL, pres. of WOKY and WOKY-TV, Milwaukee, Wis., pres. of WAPL, Appleton, Wis., and pres. of WMTV, Madison, Wis. is a graduate of the Univ. of Wisconsin. During World War II he served with the U. S. Naval Aviation. Returning to civilian life, he collaborated with his wife, Joyce (nee former associate dir. of the Wisconsin School of the Air, WHA, in a series of records for children on MGM label. He recently filmed a series of TV shows for children now running in New England.



◆ ◆ ◆ TV PERSONALITIES ◆ ◆ ◆

JOHN H. CLEGHORN, gen. mgr. of WHBQ and WHBQ-TV, Memphis, Tenn., has been in radio and TV continuously since 1929. He served two years as an officer in the Navy in World War II, and is a member of the Naval Reserve. Born in Atlanta, Ga., he was graduated from the University of the South at Sewanee, Tenn. Cleghorn went with WMC shortly thereafter as a combination staff man and reporter for "The Commercial Appeal" which owns the station. He is married and has two daughters.



WILTON E. COBB, gen. mgr. of WMAZ and WMAZ-TV, Macon, Ga., joined the station in 1927, when the station was operated by the Macon Chamber of Commerce. He became gen. mgr., and when the Southeastern B'cast. Co., of which he is secretary-treasurer, began program broadcasting from its TV transmitter in Sept. 1953, Cobb was made gen. mgr. of the combined radio-TV facilities. He is a member of the Macon Kiwanis Club. His hobbies are photography, boating and dogs.



ED COONEY, v.p. and gen. mgr. of KOPR and KOPR-TV, Butte, Mont., started with KGVO, Missoula, Mont., while he was attending Montana State University there. In 1948, Ed became gen. mgr. of KOPR which went on the air in June of that year. In April 1950, he was made v.p. of the Copper B'castg. Co. KOPR-TV started operations in Aug. 1953. He is a past president of Montana Radio Stations, Inc., a member of the Butte Rotary Club and the Butte Country Club. He is married and has two daughters.



C. GLOVER DELANEY, v.p. and general mgr. of WHEC and WHEC-TV in Rochester, N. Y., began his radio career as an announcer on WESG in Elmira, N. Y., after his graduation from Hobart College in Geneva, New York in 1933. He moved to Syracuse's WFBL, then to Hartford, Conn., where he became manager of WTHT in 1941. Delaney was appointed general manager of WHEC and managing director of the Gannett Radio Group in the spring of 1953.



W. M. CARPENTER, v.p. of WTOV-TV and WLOW, Norfolk, Va., entered radio as copywriter for WRAL, Raleigh, N. C. in 1939. He entered the U. S. Army in 1941 and was separated in 1946. He joined WLOW as a salesman in 1947, and named station mgr. of the station in June of 1947. In Oct. 1953, he was appointed v.p. of Commonwealth Broadcasting Corp., operators of WLW and WTOV-TV. He is married to former Hope Walker of Virginia Beach, Va., and has two children, boy 6, and girl 3.



MILTON D. FRIEDLAND, gen. mgr. of WICS, Springfield, Ill., entered the television field early 1948. He has had varied experience at WBKB, Chicago, serving in different capacities as assistant to John H. Mitchell. He also served at WBBM-TV in the capacity of sales service mgr. for both local and national business. Milton took his present post in July, 1953. He received his BA degree at Roosevelt College in Chicago, and did graduate work at the University of Chicago.



◆ ◆ ◆ TV PERSONALITIES ◆ ◆ ◆

CHARLES H. GARLAND, gen. mgr. of KOOL and the Radio Network of Arizona, secretary-treas. of Old Pueblo B'castg. Co., which operates KOPO-AM-TV, Nogales, is also sec-treas. and gen. mgr. of Maricopa B'casters Inc., which operates KOOL-AM-TV, and KOLD, Yuma. In 1945 he moved to Phoenix, Ariz. as gen. mgr. of KPHO, which was then owned by Gene Aulry and Rex Schapp, with



whom he has been associated for many years (Charles left in 1948 to take his present post)

G. DAVID GENTLING, gen. mgr. of KROC-TV, Rochester, Minn., is a graduate of the University of Minnesota. He joined KROC in 1937 as a salesman. Dave left in 1942 to become a member of the U. S. Naval Air Corps and returned to KROC in 1945. He took his present post in 1947. KROC-TV took to the air July 18, 1953. Dave is a past president of the Minnesota Broadcasters Association and has served three years on their board of directors. He is a native of Rochester, Minn.



PAUL GOLDMAN, v.p. and gen. mgr. of KNOE-TV, Monroe, La., came to Monroe in Feb. of 1951 from Alexandria. While in Alexandria he was gen. mgr. of KSYL and prior to that was news director and asst. mgr. of WSMB in New Orleans. During his college days at Oglethorpe University in Atlanta, Ga., he directed and produced plays over the college station. Goldman is also a



member of the executive board of the Twin City Concerts Association, and honorary member of the Kiwanis Club.

PAUL N. GOODE, gen. mgr. of KSWO-TV, Lawton, Okla., started with KSWO as a bookkeeper, elevating to office manager in 1948. The company now owns and controls KSWO, Lawton, KRHD, Duncan, KSWO-TV, and KMID-TV, Midland, Texas. Paul holds the post of comptroller of these four properties and general manager of KSWO-TV. He is a member of the Kiwanis Club and interested in various civic activities. He entered the broadcasting field in 1946 with the background of a public accountant.



HARRY L. GOLDMAN, gen. mgr. and v.p. of WROW - AM - TV, Albany, N. Y., started as a radio time salesman for WOKO in 1938, when that was the only radio station in Albany. He founded the advertising agency of Goldman, Walter and Kanna, which is still in existence under present management of brother Jack. In 1947 he opened his own radio station, WROW, which is now an ABC affiliate.



WROW-TV took to the air in 1953. Harry is gen. mgr. and v.p. of Albany's first UHF TV station.

JERRY GEEHAN, gen. mgr. of KMO-AM-TV, Tacoma, Wash., took his present post in 1953. He started with KMO in 1931, later leaving to join KVI as sports director. In 1939 he returned to KMO, working in the sports department and sales. In 1943 he was made sales manager and in 1949 appointed station manager. Geehan is a member of the Board of Directors of the Tacoma Chamber of Commerce, a member of the Kiwanis. He is a native of Tacoma and a graduate of the College of Puget Sound.



◆ ◆ ◆ TV PERSONALITIES ◆ ◆ ◆

DON DAVIS, pres. of WHB and WHB-TV, Kansas City, first became active in broadcasting in 1926 as a partner in the Kansas City advertising agcy. of Loomis, Baxter, Davis, and Whalen. In June 1953 the FCC granted the WHB B'castg. Co. a share-time license (with KMBC) for TV channel 9 in Kansas City. Don Davis became pres. of the newly organized WHB-TV at that time. Don has originated the station's "Weatherman-In-Person," and the "Musical Clock" and hundreds of other local shows.



HAYDN R. EVANS, general mgr. of WBAY and WBAY-TV, Green Bay, Wis., took his present post in 1940. He is a graduate of Cornell College. While at college, he wrote and produced musical shows, led the college glee club, and was business manager of various college publications. Haydn formed his own advertising agcy. After graduation, specializing in radio. He joined NBC sales 10 years later. In 1939 he created and sold "Pot O'Gold" program. WBAY-TV took to the air in 1952.



RICHARD O. DUNNING, pres. and gen. mgr. of KHQ-TV, Spokane, Wash., was born in Colorado Springs, Colo. He is a graduate of Washington State College at Pullman, Wash. He is a member of Beta Theta Pi and Sigma Delta Chi. Richard is a past president of the Washington State Association of Broadcasters. He is married and has two children, Richard H. 17, and George E. 10. Dick is a member of the SPAC-NBC Advisory Council for the Pacific Coast.



ROBERT D. ELLIS, v.p. and national sales dir. of KKTU, Colorado Springs, and gen. mgr. of KGHF in Pueblo, Colo. is a native of that state. Graduated from the University of Colorado with a Law Degree, he practiced law in Denver for several years before and after World War II. Robert joined KGHF in 1947 as manager. In 1952 TV Colorado, Inc. was formed under the joint ownership of KGHF in Pueblo and KVOR in Colorado Springs was appointed v.p. KTTV started TV broadcasting Dec. 7, 1952.



THEODORE A. EILAND, pres. and gen. mgr. of WTAP, Parkersburg, W. Va., and West Va. Enterprises, Inc., has been associated with the group which brought the first TV station in the Mountain State. After serving seven years in an executive capacity with WSAZ-AM-TV, Huntington, W. Va., he resigned in April of 1953 to associate with West Va. Enterprises, Inc., and begin construction of WTAP (TV), the only TV station allocated to the Parkersburg-Marietta, Ohio markets. He is married and has three sons.



WILLIAM J. EDWARDS, pres. and gen. mgr. of Lake Huron B'castg. Corp., operators of WKNX-AM-TV, Saginaw-Bay City, Mich., started as an announcer at WBRC, while attending Birmingham-Southern College in Birmingham, Ala. Before entering the Navy during the war, he was news commentator for KLAC in Hollywood. Upon his discharge from the Navy, he joined with Howard H. Wolfe in founding WKNX in 1946. He is vice pres. of the Michigan Association of Broadcasters. Edwards is a 20-year radio veteran.



◆ ◆ ◆ TV PERSONALITIES ◆ ◆ ◆

W. D. ROGERS, president of Texas Telecasting, Inc., owners of KDUH-TV Lubbock, Texas,



and the new station now under construction, KPAR-TV, Sweetwater, Texas, graduated from Texas University and started in radio during his college days. An Air Force veteran, "Dut" has been active in the National Association of Radio and Television Broadcasters, and served on the first board of directors of

the NARTB, and has been on many of its committees. He is now serving on the 1954 Convention Committee.

CLYDE W. REMBERT, president of KRLD-AM



FM, and TV, Dallas, was born in Columbia, S. C., and moved to Dallas with his parents at the age of 11. After his first job with an advertising agency as an apprentice, Clyde came to KRLD as an advertising man with broad experience in newspaper, agency and theatrical advertising. He has handled every job at the station, except engineering, and became president in 1952. A past president of NARTB, Clyde is also a past member of the Columbia Affiliates Advisory Board.

IRVING ROBERT ROSENHAUS, president and



gen. mgr., WATV Television and WAAT, its radio sister, Newark, New Jersey, first joined the staff of WAAT in 1941 as assistant manager. A former teacher, who holds degrees from both Rutgers and NYU, Irving has also received an honorary doctorate degree from Newark Hall University. An extremely civic-minded individual, he is a trustee for the New Jersey Society for Crippled Children, and also on the advisory committee for United Cerebral Palsy.

LEE RUWITCH, executive vice-president and



general manager, WTV, Miami, received his indoctrination in the communications field under the aegis of Admiral King during World War II. WTV began telecasting in March 1949, and in August of that year, Lee became its general manager. Lee was born in Escanaba, Michigan, and was graduated with a degree of Bachelor of Science in Business Administration from the University of Minnesota. Lee is a bachelor and lives the year around in Miami. His nonoccupational hobbies which progressively command less and less time are baseball and fishing.

JAMES G. RIDDELL, president, WXYZ, Inc.,



ABC's owned and operated station in Detroit, was born in Glasgow, Scotland, and after his family moved to America, started at WXYZ in 1931 as an office boy. Within a year he had a promotion, the first of many, and he began his climb to the top. Jim leads a well-rounded life of business and pleasure now, an accident ailer, he plays in the low 70's. He is also

an excellent bowler. A member of the Detroit Athletic Club, Jim is married and has two daughters.

JOHN M. OUTLER, JR., gen. mgr. of WSB-AM



FM TV, Atlanta, Ga., is a veteran of 40 years in the newspaper, radio and now TV business. He joined the Atlanta (Ga.) Journal staff and handled real estate advertising from 1916 until he enlisted in the Armed Forces in 1917, returning to the Journal in 1918. In 1931, Outler became business mgr. of WSB, and in 1944 was named gen. mgr. With the inauguration of TV service in 1949, he assumed double duties as general manager of both AM and TV.

DONALD A. NORMAN, general manager of KNBH, NBC's Hollywood TV station, joined NBC in 1943. He joined A. C. Nielsen Co. in 1937, and his travels really began. Completing a training course in Chicago, he was sent to Los Angeles, and with that base, traveled the Western United States, laying out the Nielsen samples. In 1944, he moved from San Francisco to Hollywood, and in Feb. the following



year went to N. Y. Don took his present post in April, 1952, succeeding Thomas B. McFadden.

PHILIP MERRYMAN, president and general manager for WICC-TV, Bridgeport, Conn., was born in Laredo, Mo., the son of Joseph and Ethel Breckenridge. He had been with NBC in various departmental functions from 1927 to 1947. Among others he was with the engineering, station relations, business planning and developing. Phil was also a broadcast consultant from 1947 to 1950, and has been



president of the Bridgeport Broadcasting Company since 1950. He is also a daily news commentator on WICC, and now makes his home in Edgewater Hillside, Westport, Connecticut.

JOSEPH WALLACE McGOUGH, general manager, WTVN, Columbus, Ohio, is better known to his colleagues and friends as Wally. Wally started in radio back during his high school years as a staff announcer with WJAC-AM, Johnstown, Pa., his home ground incidentally. During his three years in the Army, he was connected with the Armed Forces Network Stations in New Guinea and the Philippines.



Wally became sales manager of television station WJAC-TV in 1950, a position he held until he was offered the position of sales manager for WTVN in 1952. In December, 1953, Wally became general manager of WTVN.

STERLING "RED" QUINLAN, general manager of ABC's owned and operated WBKB and WENR, Chicago, started in the radio business at the amazing age of 14, a year after his father's death when he induced the then head of the old WJKS, Ralph Atlass, Gary, Ind., to give him a crack at handling an amateur talent show. When United Paramount Theatres, Inc., merged with ABC,



"Red" was appointed program director of WBKB, and on July 1, of that year he was named general manager, succeeding John Mitchell, who moved onto New York. "Red" was born in Maquoketa, Iowa, is married, and has one son, David, aged 7.

FRANK O. MYERS, general manager, KCMC-AM-FM-TV, Texarkana, is also vice-president of Camden Radio, Inc. operating KAMD, Camden, Ark., and KWFC, Hot Springs, National Park, Arkansas. He assumed management of KCMC in 1939 when Elliott Roosevelt was president of the Texas State Network where he was employed at Ft. Worth with KFJZ, key outlet. Meyers is a community leader in civic affairs, county chairman for U. S. Saving Bonds, radio advisor to the Red River Arsenal, director of Family Service, Red Cross, Community Chest, an ardent golf fan and member of Texarkana Country Club.



ROLLAND V. TOOKE, general manager of WPTZ, Philadelphia outlet of the Westinghouse Broadcasting Co., Inc., was born in Munnsville, N. Y., and graduated from the Wharton School, University of Pennsylvania. Mr. Tooke joined the Philco Corp. in 1941, then owners of WPTZ, from 1943 to 1945 was attached to the Navy Department as a member of the Philco Technicians Corp., returning to television broadcasting in 1945. He was named general manager of WPTZ in 1953.



◆ ◆ ◆ TV PERSONALITIES ◆ ◆ ◆

DAVID F. MILLIGAN, gen. mgr., WFAM-TV,



and WASK, Lafayette, Indiana, began his broadcasting career in 1931 while attending Butler University in Indianapolis, as a gag writer and producer. He then joined the staff of WFBM of that city as an announcer. Later Dave entered the advertising field as owner and general manager of his own agency in the Hoosier capital for three years. For the

past four years he has been in the sales promotion field as manager of sales promotion and public relations for WFBM-TV, Indianapolis. On July 4, 1953, Dave came to Lafayette as general manager of WFAM-TV.

HUGH B. TERRY, president of Aladdin Radio



& Television, Inc., operators of KLZ, KLZ-TV, Denver, Colo., CBS affiliate, was born in Alexandria, Neb., graduated from the University of Missouri, and joined the staff of WKY, Oklahoma City as a salesman in 1932. In 1936 Terry was named manager of KVOR, Colorado Springs, in 1941, manager of KLZ, Denver, which station was sold to Aladdin. He has won many awards, has served as district director of the NAB in NORTH.

JAMES H. MOORE, executive vice-president of



the Shenandoah Life Stations, WSLs-AM, FM, & TV, in Roanoke, Va., had his first experience with radio when he sang over the old WOL station in Washington. His musical education was instrumental in his creating an avid interest in radio and the business side of radio operation. Jim played a heavy part in the building of WSLs, and was its general manager

when the brand new station went on the air in October, 1940. He has been extremely active in civic organizations, and during the war gave his services as a consultant for OWI touring stations in Va., W. Va., and N. C.

ROBERT R. TINCHER, vice-president of the



Cowles Broadcasting Co. and general manager of KVTV, Sioux City, Iowa and WNAX, Yankton, S. D., was educated at the University of Pennsylvania and the Wharton School of Finance. Bob became vice president and treasurer of the Langwith Publishing Co., Minneapolis, and later, with the Iowa Emergency Relief Administration, was made assistant treasurer of the Iowa Broadcasting System. In 1938 he took over his duties at WNAX, and KVTV in 1953.

FRED M. THROWER, vice-president and general



manager, WPIX, New York, came to that station after almost 25 years experience with the National Broadcasting Company, ABC and CBS Television, Inc. He had been for nine years vice-president in charge of network sales for ABC prior to joining CBS TV in the same capacity. Fred served as a lieutenant in the U.S.M.R. during World War II, with service both in the European and the Far Eastern Theaters. He is married and has a home in Greenwich, Connecticut.

LEE PIERSON LOOMIS, president of Lee



Broadcasting Inc., Licensee of WTAD-AM-FM, Quincy, Illinois, and KHQA-TV, Hannibal, Mo., and Quincy, Illinois, was born in Hannibal, Mo., September 28, 1884. In the publishing field, Loomis has served as president of the Iowa Daily Press Association, a director of the Inland Daily Press Association, and was for seven years a director of the Bureau of Advertising, ANPA. He is a Mason and an Elk, and is an active member of the St. John's Episcopal Church, Mason City, Iowa. He is married, and has one adopted daughter, who lives in Mason City, Iowa.

TV PERSONALITIES

CARLETON D. SMITH, NBC vice-president and general manager of WNBW and WRC, NBC O & O stations in Washington, D. C., has been in broadcasting for 26 years. He joined NBC in Washington as a staff announcer in 1931, and became manager of WRC in 1941, and in 1947 put WNBW on the air as the nation's first postwar TV station. Carleton is married, and has a son twelve years old. He is a member



of the Columbia Country Club, the Burning Tree Club, the National Press Club, and Sigma Chi.

P. A. "BUDDY" SUGG, vice-president, WKY Radiophone Company, manager WKY-AM-TV, Oklahoma City, became interested in radio when it was still only a squealing and intriguing infant. A Navy reservist, "Buddy" was called to active duty in October, 1940, and had a major role in the development of radar during the war. He held the rank of captain when he was released in 1945. He also did



additional radar work at MIT. "Buddy" is married and makes his home in Oklahoma City. He has one daughter, Nancy.

ERVIN F. LYKE, president and general manager of Veterans Broadcasting Company, Inc., operating WVET and WVET-TV, began his radio career at WOLF, Syracuse in 1940. He worked at WENY, Elmira, and was chief engineer at WSLB, Ogdensburg, when in 1941, he went to CBS, N. Y., as an engineer and worked on the construction of the CBS-Office of War Information transmitters during



World War II. He came to Rochester and WVET in 1947 as chief engineer. He became general manager in 1950 and president of the company in 1951. Ervin is a member of the Rochester Advertising Council and the Institute of Radio Engineers.

ROBERT LEMON, station manager, WTTV, Bloomington, Indiana, is a young man straight from a local daily newspaper advertising staff. He spent a year as a sales manager for WTTTS, radio division of the Sarkes Tarzian Corporation, and then threw his energies into the sprouting television station as sales manager. In 1952, he was named station manager, and since then the sky's the limit for him with the direct supervision of Indiana's highest tower, a 1000 foot structure for WTTV's new channel 4 operations. With the WTTV expansion under way. Bob's leisure hours are spent at home with his wife and two daughters.



BEN LUDY, general manager, WIBW-AM, WIBW-TV, Topeka, Kansas, and KCKN, Kansas City, is a native of Cedar Rapids, Iowa, and attended the University of Iowa. He has spent all of his working years in the radio and sales game. In 1929 he went with KOIL, Omaha, Nebraska, where he remained until he came to Topeka and went with Senator Arthur Capper's station, WIBW in 1933. WIBW is one of the oldest stations in Kansas and today is one of the most prominent, building a wide following under Ludy's leadership. Married, and the father of a daughter, 8, Ludy is a Mason and member of the Shrine.



EDWARD G. SMITH, general manager, WTCN-AM, WTCN-TV, Minneapolis, is a 25-year veteran in the broadcasting business. He started out for WXYZ in Detroit, then managed a station in Grand Rapids, Michigan. After being with WGN in Chicago for six years as production director, he took on the responsibilities of looking after General Mills' radio and television programs. For two years he was director of the ABC Radio Network-Central Division. In 1951, he became general manager of WTCN-Radio, later WTCN-TV.



HECHT S. LACKEY, president and general manager of WEHT, was born in Paducah, Kentucky, August 9, 1901, one of seven sons, four of whom are in radio and television. Lackey entered radio in 1939 when WEHT was built. In addition to his duties as president and general manager of WEHT, he is owner and manager of WSON-AM and FM. Lackey also serves his town as mayor, chairman of the Methodist Hospital Board, director of the Red Cross Chapter, YMCA, Chamber of Commerce, Community Chest and director of the Kentucky Broadcasters Association. He is married and has three sons, ages six, eight and eleven.



WILMER C. SWARTLEY, station manager, WRZ-TV, Boston, was born in North Wales, Pa. in 1908. Wilmer has an engineering degree from Cornell University, and during World War II, he received a leave of absence from WBZ to serve with the Army as a major in the Ordnance Department. Wilmer is a director of the Boston Chamber of Commerce, a past director and member of the Radio Executives Club, and has served on numerous civic and charitable committees. He is a resident of Newton, Mass., married and a father.



CHARLES DE YOUNG THIÉRIOT, general manager of KRON-TV and KRON-FM, born February 1, 1915, graduated from Princeton University and served in the Navy from 1943 to 1945. Mr. Thiériot is vice-president of the Bakerfield Broadcasting Co., vice-president and director of the Chronicle Publishing Co., and director of the Bureau of Advertising, ANPA. Under him, KRON-TV has been commended by the City of San Francisco for notable achievements.



VICTOR A. SHOLIS, vice-president and director, WHAS-AM-TV, Louisville, Ky., was born in Glasgow, Scotland, and in 1929, after his family had moved to Chicago, became a citizen of the United States through the naturalization of his father. An honorary journalism graduate of the University of Illinois, and a member of Sigma Delta Chi, Victor has often aided Democratic nominees for the presidency. Married in 1943 to Jane McDonald, he is the father of three children, all boys, Victor, Robert and David.



FRANKLIN SNYDER, vice-president and general manager, WXEL, Cleveland, Ohio, has headed the station's operation since its opening in 1949. After leaving Carnegie Institute of Technology in 1931, he later joined the Empire Coal Company to supervise the final phases of construction of their station, WXEL in Cleveland. During the past four years he has directed the activities of WXEL's rapid and progressive growth, and finds his berth in TV broadcasting as one of the most interesting in his career.



ALVIN D. SCHROTT, manager, WJAC-TV, Johnstown, Pa., was appointed manager of the station six months before it went on the air. He is treasurer and secretary of the Johnstown Tribune Publishing Company, parent of WJACTV, and has been with that organization since June 1937. In January, 1934, he began national advertising for the newspaper and remained in the advertising department until he entered the U. S. Navy in March 1941. He was on submarine duty until his discharge in December, 1945.



◆ ◆ ◆ TV PERSONALITIES ◆ ◆ ◆

LOU POLLER, owner and operator, WCAN-AM, WCAM-TV, Milwaukee, Wisconsin, and president of the Ultra-High Frequency Television Association, is an old hand in radio, and a new, vigorous hand in television. He started in radio at the age of 16 as a sportscaster in Scranton. His first ownership venture in radio came in Scranton also, when in 1942, he built WARM. Shortly after this venture, he enlisted in the Marine Corps, serving until the end of World War II. Lou's primary purpose is to make WCAN-TV a model UHF station for the entire country, and his efforts have already focused national interest.



HUGH R. NORMAN, pres. of the Davenport Broadcasting Co., Inc., operators of KSTT, came to Davenport in 1946 and organized KSTT. He graduated from the University of Missouri in 1927 with a B. J. degree. He was associated with a few newspapers in the capacity of editor, business manager, and advertising department. From 1941-1946, Hugh was manager of WCOB, Cape Cod. He is a member of Kappa Tau Alpha, Kiwanis, Chamber of Commerce, Elks, and the Iowa Press and Radio Association.



listed in the Marine Corps, serving until the end of World War II. Lou's primary purpose is to make WCAN-TV a model UHF station for the entire country, and his efforts have already focused national interest.



GENE O'FALLON, gen. mgr. of KFEL-AM-FM-TV, Denver, Colo., came to Denver in 1906 to enter the plumbing and heating supply business. During World War I, he served in the 320th Aero Squadron. In 1925 he assumed ownership of KFEL, established KFEL-FM in 1948, and on July 18, 1952, KFEL-TV started operation on channel 2. From 1929 to 1938 Gene served three terms as a director of the NAB. From 1943-45 he was a member of H. V. Kaltenborn's 20 year radio club.



VERNON A. NOLTE, managing dir. of WHIZ and WHIZ-TV, Zanesville, O., attended the University of Missouri. Upon completion of his studies in 1937, Vern entered the broadcasting industry via WTMV, East St. Louis, Ill., as an advertising copywriter. From there he went to WMBD, Peoria, in 1939. His first job was a radio copywriter, from where he advanced through the ranks of continuity dir., program manager and finally sales promotion mgr. Vern is a member of the Rotary Club and Masons.



the NAB. From 1943-45 he was a member of H. V. Kaltenborn's 20 year radio club.



A. R. HEBENSTREIT, pres. and gen. mgr. of the New Mexico Broadcasting Co., operators of KGGM-AM-TV, Albuquerque, N. M., was graduated from Notre Dame University with a Civil Engineering degree in 1911. He became city manager of Albuquerque in 1921. In 1927, after the Pyle Bunion Derby's portable radio station settled in Albuquerque as KGGM, he bought the station. Hebenstreit purchased KVSF in Santa Fe, N. M. in 1938. KGGM-TV began program operation October 4, 1953.



ARMISTEAD RUST, president and gen. mgr. of KTXL-TV, San Angelo, Texas, has been one of the owners of KTXL-AM since its opening in 1947. During his university days at Princeton, he was a musician, actor, and producer of the famous Triangle Club musical comedies, working with among others, Jimmy Stewart, Josh Logan, and others. He was a major in World War II and is now mayor of San Angelo. This combination of "show business" talent, public service education and experience, plus proven ability as an able administrator and coordinator has made him a natural for television.





TV PERSONALITIES



JOSEPH H. ROHRER,



president and general manager of the Fikes Peak Broadcasting Co. put KREO radio on the air in 1947. He put its sister station KHDQ-TV, Colorado Springs, Colorado, on the air for the 1952 World Series. His first public job was with NBC in Denver in 1934. Two years earlier, he joined Fikes Peak and transmitted the event for NBC from coast to coast. He is coordinator of Civil defense, and in 1951, directed the local United Crusade. Married. He has one son, John.



CHARLES W. PITTMAN,



president and general manager, WCOS-AM, WCOS-TV, Columbia, South Carolina, began his radio career in Marion, Georgia, in 1941. He constructed WBML and served as its general manager until 1952. In 1952, he purchased the stock of WCOS and moved to Columbia, South Carolina, as president and general manager. WCOS-TV received approval for television

September, 1952, and WCOS-TV began operation in May 1, 1953. He is South Carolina's first television station.



HOWARD O. PETERSON,



general manager, KTVH Hutchinson, Kansas, broke into the radio field in 1935 in charge of promotion advertising for WDW, Omaha, Nebraska. In World War II, Peterson entered the Army as a soldier and specialized in radio during his tour of duty. In 1945 he became sales manager for KMA, Shenandoah, Iowa, and when KMA started KMTV in Omaha, Peterson became a pioneer in TV and major manager for both stations. Early in 1952, Peterson and himself starting KTVH from scratch, and the station had the honor of being the first Kansas TV station on the air. The Petersons have two children.

TED NELSON, gen. mgr. of WFI-TV, Evans-



ville, Ind., took his present post in July, 1953. In 1952 he bought a substantial interest in WHD, Hinton, O., and at the same time became gen. mgr. of the Palm Industries three TV stations. In Jan., 1954, Ted purchased an interest in WOHF, Bellefontaine, O. Ted attended Washburn College, University of Tulsa and Case University in Cleveland, O., holding two degrees, one of which is in communications engineering. He is a native of McPherson, Kansas.



LAWRENCE H. ROGERS, vice-president and



gen. mgr., WSAZ-AM-TV, Huntington, West Virginia, is a veteran of five years in the television industry, in spite of the youthful age of 32 years. He is an honor graduate of Princeton University, and served as a captain during World War II. A native of New Jersey, before settling in Huntington, West Virginia, he is credited with many of the firsts in his television station. An example is his first order for color equipment which has now arrived at WSAZ.



WILLIAM B. QUARTON, gen. mgr. WMT,



WMT-TV, Cedar Rapids, Iowa, was born in Algona, Iowa, on March 27, 1903, and attended both the University of Iowa and George Washington University. Since he first became interested in radio back in 1935, when he started with KWGB, in Cedar Rapids, Ill. has held many outstanding executive positions in the radio and television industry. He has been a director of the NABTB, vice-president of American Broadcasting Nations in Washington, D. C., and president of the Iowa Broadcasters Association. He is married and the father of one daughter, Diane.

J. HAMPTON MANNING, vice-president of WJBF-TV, in Augusta, Georgia, joined the staff of WJBF-TV in October, 1953, after having been associated with the aviation industry for more than fourteen years. Born in Dillon, South Carolina, on March 31, 1923, Hampton now makes his home in Augusta, having lived there since 1946, after completing five years as a pilot with the Air Force.



HERBERT MAYER, president of Empire Coil Company, Inc., is best known, for his outstanding achievement of bringing television to Portland, Oregon viewers, with Brig. Gen. Sarnoff, heading the list of notable speakers who paid tribute at the opening of KPTV. He was born in 1908 in New York City, son of a successful builder, and at Colgate he led both the track and debating teams. He got



his legal education at the University of Wisconsin and in 1936 married Wisconsin's Frances Leaper, a commercial artist. The Mayers have five children and make their home in Larchmont, New York.

ROBERT Z. MORRISON, JR., general manager, KCRI-TV, Cedar Rapids, Iowa, spent ten years with NBC in New York, San Francisco, and Washington, D. C. For many years, Bob worked and lived in New York City, selling AM & TV for NBC Spot Sales. He also managed the Syndicated Sales office for NBC in Washington, and San Francisco. He joined KCRI-TV as sales director when a CP was



granted in Aug., 1953. Bob became general manager in January, 1954, succeeding Frank D. Rubel, who since has moved to Des Moines to look after his theater interests. Bob is 39 and a graduate of the University of Pennsylvania.

TROY McDANIEL, general manager, KGBT-AM-TV, Harlingen, Texas, was in the advertising business in 1931. He worked as business manager for the Valley Morning Star in Harlingen, and was, for two years, the business manager for the Nevada State Journal in Reno, Nevada. Troy was also general manager for KGBS Radio, now KGBT, in Harlingen, Texas, for twelve years before being made the general manager for KGBT Radio and Television.



H. MOODY McELEVeen, JR., general manager, WNOK-AM, and WNOK-TV, Columbia, S. C., entered the radio business in 1939 as an announcer. In 1942 he was program director of another station in Columbia, S. C., until 1947, and the following year, in 1948, he was manager of WNOK. When WNOK entered the television field in 1953, he was made general manager of both the radio and television operations. For the past 15 years he has been very active in the broadcasting field and presently serves as a member of the board of directors of the South Carolina Radio and Television Broadcasters Association.



HARRY Y. MAYNARD, general manager, WCIA, Champaign, Ill., had served as sales manager for KTLA, Los Angeles, since 1948. Before joining KTLA he was with BBD&O, Hollywood. Before World War II, Harry operated an ad agency and public relations service in San Francisco, handling among others, Italian Swiss Colony Wines, and Tidewater Associated Oil Company. He served in the United States Marine Corps from 1941 through 1944 as a major in the recreation and athletic department at the base in San Diego, California. He is a native of California, born in San Jose, is married and has three daughters.



◆ ◆ ◆ TV PERSONALITIES ◆ ◆ ◆

DONALD WAYNE THORNBURGH, president



and general manager of the WCAU stations in Philadelphia, has played an outstanding part in building radio from its cradle in Italy into one of the greatest advertising mediums during the past 22 years. He had been vice president of CBS in charge of the western division when he resigned to assume on Aug. 1, 1942, his present position. He is

active in many of Philadelphia's civic and community organizations and is also a member of I.R.A.B.

FRANK P. SCHREIBER, manager and treasurer



of WGN, Inc., Chicago, has been with the Tribune Company and its radio and television operations for more than 30 years. In addition to his leadership of the Tribune stations, he has been extremely active in the operations of the Mutual network. He is a member of the board of directors of Mutual, WGN, Inc. and WPIX, New York. He is a member of the RTES in New York, Sigma Delta Chi and the Chicago Press Club. Married to Ann Walker, they reside in suburban Riverside.

HAMILTON SHEA, general manager, WNBC,



WNBC-FM, and WNBT returned to New York in Sept., 1935 after a period of two years as general manager of WTAM and WNBK, the NBC O&O stations in Cleveland. Prior to his association with NBC he had been treasurer, controller and a member of the board of directors of the Emerson Drug Company, Baltimore. A native of Brooklyn, he is a graduate of

Middlebury College, Middlebury, Vermont, and a member of the RTES in New York. He is married, has four daughters and lives in Chappaqua.

OWEN SADDLER, executive vice president and



general manager of the May Broadcasting Company, actively manages radio station KMA in Shenandoah, Va., which headquarters sixty-five miles away in his KMTV office in Omaha. To save time he usually flies to Shenandoah in the company plane. He received his BA and MA from Bucknell University and at one time was seriously considering the teaching profession. Owen is married and has three children. He and his family reside in western Omaha.

M. C. WATTERS, gen. mgr. of WCPO-AM-FM



TV, Cincinnati, O., is a graduate of Georgetown University. In 1930, Watters joined Scripps-Howard Radio, Inc. as gen. mgr. of WCPO and in 1940 he became a vice-president of Scripps-Howard Radio, Inc. and was made a director of the Corp. in 1941. Mort was honored in 1950 by being awarded the Variety Magazine Phil Suss Variety Key for

his leadership in that year of TV. He is a member of the Broadcasters' Advisory Council and the president of the U. S.

E. R. VADEBONCOEUR, president of the Central



N. Y. Broadcasting Corp., operators of W. Y. H. AM-FM-TV. Synd was came to the station in 1939 after 19 years in the newspaper field. In 1941, Vadeboncoeur became gen. mgr. of WSYR and a member of the board of directors of Central N. Y. Broadcast Corp. In a few years he became vp. In 1952 he became president of the corporation. He has been

Chairman of the Radio News Committee of the former NAB, and twice a member of NBC's SPAC.

TV PERSONALITIES

WILLARD SCHROEDER, gen. mgr., WOOD-TV,



and WOOD, Grand Rapids, Michigan, was born in St. Louis, Mo., and is a graduate of the University of Missouri. In 1950, he became general manager of WOOD-AM, owned by the Grandwood Broadcasting Company of Grand Rapids. Willard's wife is the former Barbara Will, a former teacher at Briarcliff Junior College in Briarcliff, New York.

They met at WINS in New York, where he at the time was general manager and she was a member of the station staff. They now live in Grand Rapids.

WELDON STAMPS, general manager, KFSA-



AM, TV, Ft. Smith, Arkansas, has been in the radio business ever since his graduation from high school in 1933. Between April, 1941, and December, 1945, he served as general manager of KADA, Ada, Okla., also serving at that time as a director on the Oklahoma network. Weldon is married, and has two children, Mike, 15, and Patricia, 13. Very active in civic work, he is president of the Kiwanis Club, a member of the Carnegie Library, and also the Knights of Columbus.

ELDEN H. "DENNY" SHUTE, JR., president of



the Lewiston-Auburn Broadcasting Corporation, Lewiston, Maine, station manager, WLAM-AM-TV, Lewiston-Auburn, Maine, is a graduate of Boston University. He entered radio in 1937 as an announcer with WCSH, Portland, later moving to WFEA, Manchester. A Marine Corps veteran, (First Marine Division) Denny is director of the Lewiston-Auburn Tuberculosis Association, Lewiston Salvation Army, a member of the Auburn Superintending School Committee, and president of the Kiwanis Club.

JULIAN M. "JULIE" KAUFMAN, manager,



KPHO-TV, Phoenix, Arizona, has been with the station since 1950 when he started there as account executive later to become executive sales manager. Prior to that "Julie" was with ABC-TV in San Francisco as an account executive where he established a national sales record in 1949. Born in Detroit, he was a former newspaper publisher before turning to broadcasting. "Julie" is married to ex-Conover model Kitty and has one daughter, Nikki, age 9.

LEROY STAHL, director of television, KFBB-TV,



Great Falls, Montana, was born in DeWitt, Iowa, and was a professional student at the Northwestern College of Speech Arts. Author of more than thirty plays and books related to the radio, dramatic, and entertainment fields, LeRoy's most recently published is "How to be a Successful Emcee," by T. S. Denison & Company, Minneapolis. With

KFBB, he has been successively, since 1941, copy editor, program director, and sales representative. He was appointed TV director in 1953.

THOMAS P. SHELBURNE, managing director



of WILK-TV, Wilkes-Barre, Pa., and treasurer of the Wyoming Valley Broadcasting Company, graduated from Hampden-Sydney College in Virginia, and received his MA degree from William and Mary. He has been very active in community affairs in Wilkes-Barre, having served as president of the Junior Chamber of Commerce, president of the Greater Wilkes-Barre Endorsement Board, on the Board of Directors of the Travelers Aid Society, and the Wilkes-Barre Rotary Club.

◆ ◆ ◆ TV PERSONALITIES ◆ ◆ ◆

LLOYD E. YODER, general manager, WTAM-



WNBK, Cleveland, has been a broadcasting career executive with NBC continuously since 1927, with the exception of those years spent serving as a Lt. Commander in the U. S. Navy during World War II. He is a graduate of Carnegie Institute of Technology, where he was Tech's first "All-American" playing on the great team of 1926 which

went on to defeat Rockne's undefeated Notre Dame squad of that season. He was appointed general manager of WTAM-WNBK in August, 1953.



CLAIR R. McCOLLOUGH, pres. and gen. mgr.



of Steinman Stations, which include WGAL-AM-TV-FM, Lancaster, Pa.; WDEL-AM-TV-FM, Wilmington, Del.; WKBO, Harrisburg; WRAW, Reading; WORK, York; and WEST-AM-FM, Easton, Pa., to mention nothing in his busy activity as a member of the NABE's TV board of directors. He was one of the original three-man TV Code Committee that laid the ground work for the new TV code, and was active on the TV Excess Profit Committee which secured relief for the industry.



M. F. WOODLING, mgr. of KHSL-TV, Chico,



Calif., started with KJES in San Francisco about 1930. In 1933 he was traffic mgr. for the new forgotten Northern Calif. Broadcasting System. In the early part of 1939 the McClung Stations purchased the Golden Empire Broadcasting Company, operating stations KHSL, Chico and KVCV, Redding. In the fall of that year Woody was asked to come to

Chico and take over as manager KHSL-TV is affiliated with CBS-TV and NBC-TV networks.



WARREN P. WILLIAMSON, JR., pres and gen.



mgr. of WKBN Broadcasting Corp., operators of WKBN-AM-FM-TV, Youngstown, O., obtained a government license authorizing construction and operation of WKBN in 1936. In 1947, WKBN-FM went on the air, and on Jan. 11, 1953, WKBN-TV began telecasting. His special hobby is candid photography. He is past president of the Ohio Association of Broadcasters, president of the Youngstown Board of Education, and a member of the Elks.



WILLET H. BROWN, pres. of the Mutual-Den



Lee Broadcasting System, is a native of Detroit, Mich. In 1932, he joined Den Lee Inc., the statewide distribution agency for Cadillac and LaSalle Automobiles in Calif., soon becoming assistant gen. mgr. Meantime, the organization had taken on a subsidiary, the Den Lee Broadcast System. Brown soon became asst. gen. mgr. With the expansion of

MBS, with which Den Lee is affiliated, Brown was named a member of the board of directors.

D. L. (TONY) PROVOST, vice-president and



member of the board of directors of Hearst Radio, Inc., as well as in charge of all Hearst operations, supervise WHAL and WHAL-TV, Baltimore, is a graduate of William and Mary College. He has been associated with Deereus & Co. and Miller Tape Recording Co. In 1942, Tony joined NBC and in short order became program director of the network's principal station. From there he moved to his present position with Hearst Radio, Inc.

◆ ◆ ◆ TV PERSONALITIES ◆ ◆ ◆

GAYLE V. GRUBE, vice-pres. and gen. mgr. of



WJBK-TV Detroit, is a graduate of Nebraska University. In 1924 he joined KFAB, Lincoln, where he was manager, program dir., entertainer and stenographer. He later went to WKY, Oklahoma City, as gen. mgr. In 1945 Gayle was appointed by ABC as gen. mgr. of the network-owned KGO in San Francisco. In May, 1949, when

ABC opened its TV station, KGO-TV, Gayle found himself once more in a pioneer role. Gayle is one of the nation's honest to goodness pioneers of b'castg.

HAROLD H. THOMAS, president of WEAM in



Arlington, Va., is one of the principal stockholders in the Inter-City Advertising Company, owners and operators of WAYS, and WAYS-TV, Charlotte, WCOG, Greensboro; and also has an interest in WTSK-TV, Knoxville, Tenn. He has two established television stations — WISE-TV, Asheville, and WAYS-TV in Charlotte. He is a graduate of Purdue and began his radio career in 1939 with WISE. His home is now in Asheville, where he resides with his wife and daughter.

IRVING WAUGH, commercial mgr. and executive assistant to the



pres. of WSM, Inc., in Nashville, Tenn., has been associated with WSM since 1941. Irving became comm. mgr. of WSM-AM TV in 1948, and in 1952 was appointed to the office of exec. assistant to the pres. During the war, he served as WSM's war correspondent in the Pacific and Japan. Waugh is a native of Norfolk, Va., and a

graduate of William and Mary College. He is married and the father of two sons, 17 and 4 years old.

ALAN C. TINDAL, vice-president of WWLP, in



Springfield, Mass., and the Springfield Television Broadcasting Corporation, and president of WSPR, Springfield, is a graduate of Harvard, and the Babson Institute of Business Administration. During the war he was a B-29 pilot and completed 28 combat missions over Japan. He is a member of the Springfield Rotary Club, the Advertising Club, the Springfield Sales Executive Club. He is married and lives with his wife and two sons in Longmeadow, Massachusetts.

LINUS TRAVERS, executive vice-pres. and gen.



mgr. of the Yankee Network, operators of WNAC and WNAC-TV, Boston, is a graduate of Brown University. He began his radio career while still a senior in college by joining WEAN, Providence. After a year he was transferred to WNAC, where he became production chief. Later, became v.-p. in charge of sales and production, and in 1943 he was

elected exec. v.-p. and member of the board of the Yankee Network. He makes his home in Wellesley, Mass.

PAUL E. TAFT, president of Gulf Television



Company, KGUL-TV, Galveston, Texas, was born in Wallingford, Vermont, attended the University of Vermont for two years, and then went to Annapolis, where he graduated in 1938. He served with the Navy during the war as a lieutenant. He moved to Texas in 1938, and after a position as assistant to the president for Duncan Coffee Co., he left in 1952 to take over the management of the Gulf Television Company. He is married, has three children and lives in Houston.

◆ ◆ ◆ TV PERSONALITIES ◆ ◆ ◆

ROBERT DWIGHT SWEZEY, gen. mgr. of

WLSU-AM-FM-TV, New Orleans, La. was gen. mgr. and v.p. of Mutual from 1944-48, and as gen. counsel and secretary of the Blue Network (ABC) from 1942-44. Originally, Swezey's profession was that of attorney at law, having practiced in Boston, N. Y. and Washington from 1932-38. He is a graduate of Harvard where he obtained his A.B. and

J.L.S. He is a past president of the Radio Executives Club of New York and v.p. of the New Orleans AB Club.



HENRY W. SLAVICK, gen. mgr. of WMC-AM-

TV, Memphis, Tenn., is a native of St. Louis. At 17, he became interested in radio, and in the Merchant Marine Service got his apprenticeship in installation of radio transmitting apparatus on Miss. transports. He joined WMC in 1925, and by 1929 was chief engineer, and has shown such ability that he was placed in complete charge of erecting WMC's transmitting plant, one of the first directional systems. In 1930 he was appointed gen. mgr.



MARIA HELEN ALVAREZ, gen. mgr. of

KOTV, Tulsa, Okla. started her radio career in 1943 as a continuity writer for a Tulsa radio station. In 1947 Maria was drawn to the TV industry which offered opportunities for creative expression and devoted herself to full time study of the new medium. Helen made the acquaintance of George F. Cameron Jr., head of the Cameron oil interests, who was

interested in TV as a business venture. Cameron TV, Inc. was formed and Helen headed up KOTV.



J. L. STACKHOUSE, president of the Eastern

Publishing Company, parent organization of WEEH FM and UHF television station WGLV, Elisha, Pa. entered the public communications field more than fifty years ago as a carrier for the Philadelphia Bulletin in his native Buck County, Pa. and in 1913 he has three sons and one daughter. He is a member of Sigma Delta Chi, and the Nation-Press Club of Washington, D. C. He has received a number of official honors for his efforts to elevate standards in the industry.



LESTER P. ETTER, pres. and gen. mgr. of

WLBB-TV, Lebanon, Pa. is a graduate of the University of North Carolina. Upon graduation he entered the U. S. Army, and at the end of WW II was required to inactive service with the rank of 1st Lieut. in the Field Artillery. Les then became one of the founders of Lebanon's radio station WLBB. He is vice-pres. of the station and until assuming his

duties as gen. mgr. of WLBB-TV, he served in the same capacity for the radio station.



JACK HARRIS, gen. mgr. of KPRC-AM-TV,

Houston, Texas, considers coverage of the Miss. flood in 1937 as one of the three most important big stories he took part in. At the time Jack was director of news and special events at WSM, Nashville. Together with Jack DeWitt, chief engineer, he staged short-wave broadcasts from half a dozen balloons underlined key spots in the flood area. During the war he covered initial Army maneuvers and took over Radio Tokyo facilities for Gen. MacArthur.



◆ ◆ ◆ TV PERSONALITIES ◆ ◆ ◆

GEORGE WHITNEY, gen. mgr. of KFMB-AM-TV, San Diego, Calif., is a graduate of the University of California. From 1937 to 1946 he was associated with KFI and KECA, L. A., as a salesman. From 1946 to 1948 he was a partner in the Harrington, Whitney and Hurst Adv. Agcy. of L.A. and San Francisco. From 1948 to 1949 he was gen. sales mgr. of radio and TV of the Don Lee Network. In 1951



he returned to Don Lee as v.p. in charge of television. He assumed his present duties on Nov. 6, 1953.

EDGAR B. STERN, JR., president of the WDSU Broadcasting Corporation in New Orleans, is responsible for the planning and building of WDSU-TV. A graduate of Harvard, he spent three years in the Army, and entered the broadcasting field when he became president of International City Broadcasting Service, which subsequently became WDSU Broadcasting Corporation. A pioneer in television, he is an active civic and cultural leader in New Orleans, heading the many local organizations there.



ALLEN M. WOODALL, president of Radio Columbus, Inc. licensee of WDAK, Columbus, Ga., is also president of the Middle Georgia Broadcasting Co., licensee of WBML, Macon, executive vice-president of Radio Augustus, Inc., licensee of WRDW, Augustus, president of Radio Brunswick, licensee of WMOG, in New Brunswick, and executive vice-president of WETV, the new NBC-ABC television station



in Macon. He's a member of Sigma Delta Chi, has two sons, age 19, and 15, and his hobbies are, you guessed it—radio and television.

JAMES W. WOODRUFF, JR., pres. and gen. mgr. of WRBL-AM-FM-TV, Columbus, Ga., is a native of Columbus. His early education was gained in the Columbus public schools. He attended the Episcopal H. S. in Alexandria, Va., where he graduated in 1934, and also attended the School of Commerce at the University of Georgia. James is a member of the Columbus Rotary Club, and a member of the Radio and TV Executives Society. He is also a director of the First National Bank of Columbus.



JOHN E. FETZER, owner of WKZO-TV, Kalamazoo, Mich., started as a radio engineer, helping to build a number of pioneer stations in the middle west. John is pres.-owner of the Fetzer Broadcasting Co., operating WJEF, CBS outlet in Grand Rapids and also heads up WKZO and WKZO-TV. He is a veteran of 10 years in the old NAB board and during the war served with Byron Price in the Office of Censorship as the Radio Censor, later joining the Eisenhower radio mission in ETO.



WALTER E. WAGSTAFF, gen. mgr. of KIDO-AM-TV, Boise, Idaho, went to Boise in 1944 when he went to assume the management of and minority ownership of KIDO. His career in TV began July 12, 1953 when KIDO-TV became the first TV station in Idaho to get on and stay on the air. He had served as vice president of the Advertising Association of the West, and presently, he is a member of the Planning Committee of Broadcasting Advertising Bureau. He is the father of two girls.



◆ ◆ ◆ TV PERSONALITIES ◆ ◆ ◆

CECIL D. MASTIN, gen. mgr. of WBNF and



WBNF-TV, Binghamton, N. Y., entered Syracuse University to study law but after two years left to pursue the study of voice in N. Y. He produced a vaudeville act, Mastin and Melvin, and gained theatrical experience from about five years with three different acts which he wrote and produced. Cecil became program director of WBNF in 1929. In 1932 he be-

came gen. mgr. and in 1942 WBNF-FM was added to his chores. WBNF-TV was launched on Dec. 1, 1949

U. A. (JAKE) LATHAM, gen. mgr. of WKRC-



TV, Cincinnati, O., switched to the field of television in 1949. Before entering radio he had been a factory representative and sales mgr. for Cincinnati automobile distributors. Jake sold the mgr. of WKRC some automobiles in such a quick fashion, he was immediately hired on the sales staff. In 1941 he was made local sales mgr. and three years later became gen. sales mgr. He was appointed gen. sales mgr. of WKRC TV in 1949 and was named manager in 1950.

JOHN ROSSITER, gen. mgr. of WJTV, Jackson,



Miss., began his broadcasting experience as sales manager of WKK Erie, Pa. When WICU was built in Erie, John went there as a salesman and rapidly rose to commercial manager. His tireless energy and ability made him logical choice for helmsman of the WTVN operation when it was built and took to the video-waves in 1949. John is

a World War II Air Corps veteran. He is interested in sport cars and has participated in many races throughout the country.

JAMES LEONARD REINSCH, managing dir. of



the Cox TV and radio properties in Atlanta, Miami and Dayton, O., became associated with Gov. James M. Cox of Ohio and in 1934 helped set up WHO. In 1942 he was made managing dir. of the three Cox stations. He developed WSB-TV, Atlanta, which went on the air in 1949 and WHO-TV which took to the airwaves the same year. In 1944 he was radio dir. of the Democratic National Committee and TV dir. at the Democratic National Convention in 1952.

ALBERT WAYNE COY, pres. of KOB-TV, Albuquerque, New Mexico,



was chairman of the FCC. Born in Indiana, he broke into the newspaper field in 1919, rising from reporter to city editor in 1926. Wayne got his introduction to radio in 1944 when he joined the Washington Post as assistant to Eugene Meyer. Before that he had been assistant director of the budget, from 1942-44, after having served

two years as one of President Roosevelt's special assistants and liaison men.

STAN WILSON, gen. mgr. of KFDA-AM-TV,



Amarillo, Texas, took his present post in Sept. 1953. He graduated from Texas Christian University in 1940, as class president. He started his radio career while still in college as merchandising representative for the Texas State Network. During World War II, he served as communications officer in the amphibious force and later was chief staff officer for an LCI Florida, in the South Pacific. He was manager of KRIO at McAllen, Texas.



Where Do We Go From Here? And Where Is Here?

By CHARLES B. BROWN

Vice President

Bing Crosby Enterprises, Inc.

EACH new year or at the end of given periods of stress or prosperity, as the case may be, we read so many articles entitled, "Where Do We Go From Here." It would seem fair to ask, Well, where in '11 are you now? Certainly everybody isn't in the same place even theoretically and by no means economically or sales-wise. Then too, it would seem sensible to inquire, "Where does one want to go from wherever one is?" In the business of television, whether as producer, buyer or user in any event, you are bound to be somewhere else by the time you finish the question because television, as one wag put it, is the one business about which you can't lie fast enough to keep up with the truth. This factor of speed is so dynamic an element that where any of us in TV may be going, including the sponsor, is not as important for the moment as is the point, are we moving in the *right* direction. The most fearful thing in business is motion without direction, it seduces the mind's eye with soothing panoramic vistas while denying it the opportunity of reading the names on the stations en-route and thus, pinpoint somewhere looks just as good as passport nowhere.

The purchasing of creative, productive television material so often is hindered by arid arguments as to which is best, live or film, origination East or West, half hour or quarter hour, etc., etc. No one ever heard a "live" or a "film," a half hour or a quarter hour. They heard people and saw them doing and saying something interesting or uninteresting, dynamic or static. All too often, entirely too much has already taken place before the thinking has been done and twilight has overtaken the stillborn spirit of a promise before the dawn of its acceptance by the public it was supposed to serve.

Selling, through any medium, is a process. There are no short cuts in human emotion; it never changes; it only reacts and the real problem of tomorrow is that

of retaining all of the human prerequisites in the moving of minds while using all of the mechanical means in the operational moving of merchandise. The mechanics of operation cannot be successfully used to effect confidence, imagination, intellect or the will itself. Sales problems will be aided but will never be solved by mechanical robotry.

The mind of man is a very strange world

'Tis filled with equations complexive
Never indeed will its processes heed
Machines which would make it
indexive.

The profitable production and sale of TV film will become increasingly more complex in '54 and the years ahead. Competitively, the business is bound to see an increase of new producers and distributors. More star names from the motion picture field will be seen in "starter" series and the economic promise of better days because of more markets will be offset by an ever-increasing flow of new product.

The action, will of necessity, be as dynamic in one area as the other. There can be no "bleacher bleating" by money at the expense of creative and production quality, nor any creative or production puerility because of lack of market information from the sales group, nor must sales make any errors in opportunistic advice based upon a quick dollar.

Properly integrated and activated teamwork of the character envisioned here will give agency and client, local or national, a service which will permit long-term association so that should a specific program have served the purpose, that condition will be recognized by *all*, accepted by *all* and the *same* group, along with agency and client, will be ready with the new show rather than with the axe which cuts both the relationship and the advantages which can only come from long term, efficient service and mutually profitable association.

BETTER PROJECTION

A Message of interest to:

Motion Picture Producers,
Distributors, Advertising Agencies,
Sponsors, Film Libraries,
TV Film Producers and Distributors . . .

THROUGH
PRINT
PROTECTION

Peerless
Services
include:

Peerless Protective and Preservative Film Treatments

Release Prints Trailers
Television Shows on Film
Kinescopes TV Commercials
Theatre Screen Advertising
Prints for Continuous Projection
Negatives Masters Originals
Filmstrips Transparency Slides
Microfilm

Film Rejuvenation

Shrinkage Reduction
Scratch Removal
Remineralization
Cleaning and Repairs

Film Library Servicing

Shipments, Inspection
Cleaning, Repairs, Inventory
and Booking Records, Storage

Servicing TV Shows on Film

Insertion of Commercials, Shipments
to Stations, Booking Records,
Follow-up, Inspection on Return
Cleaning, Repairs, Replacements,
Storage, Substitution of
Commercials, Reshipments

Film Distribution Servicing

Storage pending orders
Inventory Records
Shipments to Purchasers

Filmstrip Packaging

Breakdown of rolls into strips
Packaging in cans, Labeling,
Boxing of Sets, Storage
pending orders, Shipments

Without exception,
ALL film should be treated,
if you are to get maximum results
in terms of good projection and number
of showings. Without treatment, your film –
from initial release to the last booking – is much
more susceptible to damage. And damaged
film can result in an indifferent audience.
Peerless Treatment is the finishing touch and the
least expensive item in the whole process of picture-
making. Yet it safeguards millions of dollars
invested in finished prints.
Peerless Treatment assures: seasoned, toughened,
smoothly projecting prints. Peerless-treated prints
start off right and keep in good condition longer.
So when you order prints, don't forget to include
"PEERLESS TREATMENT" in every purchase order.

PEERLESS
FILM PROCESSING CORPORATION
165 WEST 46th STREET, NEW YORK 36, N. Y.
959 SEWARD STREET, HOLLYWOOD 38, CALIF.
20 YEARS EXPERIENCE IN SAFEGUARDING FILM

PEERLESS TREATMENT available also through Official Licensees in
ATLANTA • CHICAGO • CLEVELAND • DALLAS • DAYTON • DETROIT
HOLLYWOOD • KANSAS CITY • NEW YORK • PORTLAND • SAN FRANCISCO
ST. PAUL • WASHINGTON • Berne • Brussels • London • Mexico City • Sydney • Toronto

Services *to* *TV Producers*

•
LENSES
CARPETS
RAW STOCK
COSTUMES
PROJECTORS
LARGE SCREEN
LABORATORIES
SCREENING ROOMS
STORAGE VAULTS
PUPPET MAKERS
CARTOON PRODUCERS
COLOR PROCESSES
BACKGROUND PROCESSES
VENTILATION EQUIPMENT
STOCK SHOT LIBRARIES
SPOT AND FLOOD LAMPS
PRIZES, PREMIUMS, ETC.
RADIO-TV STATION BROKERS

TV SERVICE FIRMS

(Also see Equipment Manufacturers)

Large Screen

General Precision Laboratory, Inc., 63 Bedford Rd., Pleasantville, N. Y.
Radio Corporation of America, Camden, N. J.
S.O.S. Cinema Supply Corp., 602 West 52nd St., New York, N. Y.

Lenses

Bausch & Lomb Optical Co., 739 St. Paul St., Rochester, N. Y.
Camera Equipment Co., 1600 Broadway, New York, N. Y.
Century Projector Corp., 729 7th Avenue, New York, N. Y.
DeVry Corp., 1111 Armitage Ave., Chicago, Ill.
National Theatre Supply, 92 Gold St., New York, N. Y.
Projection Optics Co., Inc., 330 Lyell Avenue, Rochester, N. Y.
Raytone Screen Corp., 165 Clement Ave., Brooklyn 5, N. Y.

Projectors

Advance Projection Theaters, Inc., 729 Seventh Ave., New York 19, N. Y.
Ballantine Co., 1707 Davenport St., Omaha 2, Neb.
Century Projector Corp., 729 7th Ave., New York, N. Y.
Camera Equipment Co., 1600 Broadway, New York, N. Y.

Spot and Flood Lamps

Adams Lighting, Inc., 48 W. 27th St., New York, N. Y.
Amplex Corp., 111 Water St., Brooklyn 1, N. Y.
Ariel Davis Supply Co., 3687 S. State St., Salt Lake City, Utah.
Best Devices Co., Inc., 3459 W. 104th St., Cleveland 11, O.
Capitol Stage Lighting Co., 527 W. 45th St., New York, N. Y.
Compeco Corp., 2251 W. St. Paul Avenue, Chicago 47, Ill.
DeVry Corp., 1111 Armitage Ave., Chicago, Ill.
General Electric Co., Nela Park, Cleveland, O.
International Motion Picture Consultants, Inc., Warner Bldg., Washington 4, D. C.

Kliegl Bros., 321 W. 50th St., New York, N. Y.
Mitchell Camera Corp., 666 West Harvard St., Glendale 4, Calif.
Molliograph, Inc., 4431 W. Lake St., Chicago 24, Ill.
National Theater Supply, 92 Gold St., New York, N. Y.
Radiant Lamp Corp., 300 Jelliff Ave., Newark 8, N. J.
S.O.S. Cinema Supply Corp., 602 W. 52nd St., New York 19, N. Y.
Sylvania Electric Products Co., 1710 Broadway, New York, N. Y.
Wenzel Projector Co., 2509 S. State St., Chicago 16, Ill.
Westinghouse Electric Corp., Lamp Division, Bloomfield, N. J.
Radio Corp. of America, Camden, N. J.

Carpets

Bigelow-Sanford Carpet Co., 140 Madison Ave., New York, N. Y.
Goodall Fabrics, Inc., 525 Madison Ave., New York, N. Y.
Hardwick & Maceo Co., Lehigh Ave. & 7th St., Philadelphia 33, Pa.
A. & M. Karagheusian, Inc., 295 5th Ave., New York, N. Y.
James Lees & Sons Co., Bridgeport, Montgomery County, Pa.
C. H. Masland & Sons, Carlisle, Pa.
Alexander Smith & Sons Carpet Co., 295 5th Ave., New York 16, N. Y.

Background Processes

LOS ANGELES, CALIF.

Veme Film Laboratories, Inc.
1161 N. Highland Ave. (388) Hollywood 4-7171
Anderson, Howard A.
1611 Cosmo St. Hollywood 2-1247
Circular Corp.
2800 S. Olive St., Burbank Rockwell 9-1126
Cinema Research
7000 Romaine Hollywood (38)
Consolidated Films Industries, Inc.
959 Seward St. Hollywood 9-1443
Dunningcolor Corp.
932 N. La Brea Ave. Hollywood 7-3174
Mercer, Ray
4241 Normal Ave. Olympia 8436
Pacific Title & Art Studio
6350 Santa Monica Blvd. Hollywood 3-5611
Pathe Laboratories, Inc.
6823 Santa Monica Blvd. Hollywood 9-3961
Rabin, Jack
7321 Santa Monica Hollywood 5-4126
Technicolor Motion Picture Corp.
6311 Romaine St. Hollywood 7-1101

LABORATORIES



LOS ANGELES, CALIF.

Acme Film Laboratories, Inc.
1161 N. Highland Ave. (38)HOLlywood 4-7471

Anso Processing Lab.
1161 N. Highland Ave.HOLlywood 4-7471

Associated Film Laboratory
5631 Hollywood Blvd.HOLlywood 4-8195

Cinecolor Corp.
2800 W. Olive Ave, Burbank.ROckwell 9-1126

Cinema Research
7000 RomaineHOLlywood 2-7464

Color Reproduction Co.
7936 Santa Monica Blvd. (46)
HOLlywood 4-8225

Columbia Pictures Laboratory
1443 N. Beachwood Drive (28)
HOLlywood 5-5122

Consolidated Film Industries
959 Soward St. (38)HOLlywood 9-1441

Crescent Film Laboratories
7510 N. Ashland.AMBassador 2-5000

Dunningcolor Process Co. Inc.
932 La Brea Ave. (38)HOLlywood 7-3174

Eastman Kodak Research Laboratory
1017 N. Las Palmas Ave. (38)
HOLlywood 5-7151

Emmet-Vail Enterprises, Inc.
6926 Mehose Ave., HOLlywood (38)
WEBster 8-5171

Film Effects of Hollywood
1153 N. Highland (38)HOLlywood 9-5808

Filmservice Laboratories
6327 Santa Monica Blvd.HOLlywood 2-3237

Flora Color
1103 N. El CentroHOLlywood 7-9559

General Film Labs Corp.
1546 N. Argyle Ave.HOLlywood 9-6391

Hollywood Film Enterprises Inc.
6060 Sunset Blvd. (28)HOLlywood 4-2181

Hungerford Film Lab.
6327 Santa Monica Blvd.HOLlywood 2-3237

Morcer, Ray, & Co.
4241 Normal Ave. (29)OLympia 8436

Modern Movies, Inc.
6018 Fountain Ave.HOLlywood 4-7293

National Screen Service
7026 Santa Monica Blvd.HOLlywood 5-3136

Fathe Laboratories, Inc.
6823 Santa Monica Blvd.HOLlywood 9-3961

Peerless Process Labs.
959 Seward St.HOLlywood 7-9223

Picture Recorders
4992 Santa Monica Blvd.NORMandie 2-6985

Precision Film Lab.
1107 S. Robertson Blvd.BRadshaw 2-2340

Producers Photographie Lab. Inc.
6556 Santa Monica Blvd.HOLlywood 2-1334

Richters Film Lab.
1715 N. Mariposa Ave.OLympia 3215

Technicolor Motion Picture Corp.
6311 Romaine St.HOLlywood 7-1101

Telefilm, Inc.
6039 Hollywood Blvd.HOLlywood 9-7205

Williams Film Laboratories
1040 N. McCadden Pl.HOLlywood 4-8131

SAN FRANCISCO, CALIF.

Ball Film Laboratory
1256 Howard St.UNderhill 1-8638

Commercial Film Enterprises
125 Hyde St.ORdway 3-9162

Motion Picture Service Co.
125 Hyde St.ORdway 3-9162

Multichrome Laboratories
760 Gough St.HEmlock 1-6567

Palmer, W. A., Films, Inc.
611 Howard St.YUkon 6-5961

COLORADO SPRINGS, COLO.

Alexander Film Co.
Alexander Film Bldg.4206

DENVER, COLO.

Western Cine Service
114 East Eighth Ave.Tabor 2812

WASHINGTON, D. C.

Byron, Inc.
1226 Wisconsin Ave., N.W.DUpont 7-1800

Capital Film Laboratories, Inc.
1905 Fairview Ave., N.E.LAWrence 6-4634

ATLANTA, GA.

Paramount News Laboratory
154 Walton St., N.W.CYpress 1636

Strickland Film Co.
220 Pharr Rd., N.E.CHerokec 5317

CHICAGO, ILL.

Atlas Film Corp.
1111 S. Boulevard, Oak Pk.AUstin 7-8620

Bell and Howell Co.
7100 McCormick Lincolnwood
AMBassador 2-1600

Chicago Film Laboratories, Inc.
1322 W. Belmont Ave.BLitersweet 8-6780

Colburn, Geo. W., Laboratory
164 N. Wacker DriveSState 2-7316

Crescent Film Laboratories
7510 N. Ashland.AMBassador 2-5000

Film Laboratories Inc.
858 N. LaSalle.WWhitehall 4-5440

Filmack Laboratories
1327 S. Wabash Ave.HARRison 7-3395

Wilding Picture Productions Inc.
1345 W. Argyle St.LOngbeach 1-8410

DES MOINES, IA.

General Pictures Productions
Kemptor Rd.3-8275

Parrot Films Studio
1700 Keo Way.2-4211

NEW ORLEANS, LA.

Motion Picture Advertising Service Co. Inc.
1032 Carondelet St.MAGnolia 4545

BALTIMORE, MD.

Alpha Film Laboratories
6000 Pimlico Road.Lberty 6216

BOSTON, MASS.

Ambler Motion Picture Co.
42 Melrose Ave.HAncock 6-1158

Master Motion Picture Co.
50 Piedmont St.HAncock 6-3592

DETROIT, MICH.

General Film Laboratory, Inc.
68 SibleyWOOdward 1-7818

Jam Handy Organization
2821 E. Grand Blvd.TRinity 2-2450

Metropolitan Motion Picture Co.
121 Fisher Bldg.TRinity 5-4266

Wilding Picture Productions, Inc.
4925 Cadieux St.TUxedo 2-4600

ST. PAUL, MINN.

Reid H Ray Film Industries
2269 Ford Parkway.EMerson 1393

KANSAS CITY, MO.

The Calvin Co
1105 Truman Rd.HARRison 1230

Eso-S Pictures
1121 W. 47th St.VAlentine 8780

FORT LEE, N. J.

Consolidated Film Industries
Main StreetFort Lee 8-3400

NEW YORK, N. Y.

Aco Film Laboratories (Warner Bros.)
1277 E. 14th St., Brooklyn.ESplanade 7-8700

Cirelle Film Laboratories, Inc.
33 W. 60th St.Columbus 5-2180

Consolidated Film Industries

"IN THE EAST"

it's

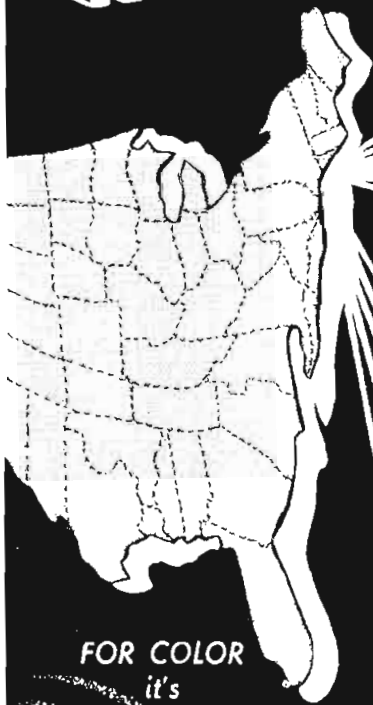

For COMPLETE FILM PROCESSING

ROUND THE CLOCK SERVICE

- Negative Developing
- First Print Department
- Ultra Violet & Flash Patch Track Printing
- 16mm & 35mm Release Printing
- Quality Control
- Title Department
- 22 Cutting Rooms

FOR COLOR
it's

Rainbowlab Inc.

AN ADDED FEATURE
"FOR THE PRODUCER"

Up-to-the-minute advances in motion picture techniques demand radical innovations in projection equipment... Movielab's new preview theatre brings TO THE EAST the ultimate in theatre projection.

- Three dimensional projection
- 16mm interlock projection

FEATURING

35mm THREE CHANNEL INTERLOCK
& TAPE INTERLOCK PROJECTION.



MOVIELAB FILM LABORATORIES, INC.

619 West 54th Street, New York 19, N. Y. Judson 6-0360

Div. of Republic Pictures Corp.
 1740 BroadwayJudson 6-1700
 Fort Lee, N. J.Fort Lee 8-3400
DeLuxe Laboratories, Inc. (20th Century-Fox)
 850 Tenth Ave.Circle 7-3220
Du-Art Film Laboratories, Inc.
 245 W 55th St.PLaza 7-4580
FilmLab, Inc.
 126 W. 46th St.Judson 2-2863
Forde Film Laboratories
 1187 University Ave.LUDlow 8-5100
Guffanti Film Laboratories, Inc.
 630 Ninth Ave.Columbus 5-5530
Major Film Laboratories Inc.
 653 Eleventh Ave.Circle 6-6950
Malcolm Laboratories Corp.
 244 W. 49th St.Circle 6-6150
Mecca Film Laboratories, Inc.
 630 Ninth Ave.Circle 6-5289
Mercury Film Laboratories Inc.
 732 Seventh Ave.Circle 5-4930
Movielab Film Laboratories
 619 W. 54th St.Judson 6-0360
National Screen Service Corp.
 1600 BroadwayCircle 6-5700
Paramount Laboratory
 Sixth & Pierce Sts., Astoria, Ravenswood 8-8000
Paramount News Laboratory
 Office: 544 W. 43rd St.LONgacre 3-4300
Pathe Laboratories, Inc.
 105 E. 106th St.TRfalgar 6-1120
Precision Film Laboratories
 21 W. 46th St.Judson 2-3970
Producers Laboratories, Inc.
 457 W. 46th St.Circle 6-5232
Rainbowlab, Inc.
 619 W. 54th St.Judson 6-0360
Star Safety Film
 630 Ninth Ave.Circle 6-0888
Tri Art Color Corp.
 245 W. 55th St.PLaza 7-4580
Video Film Laboratories
 131 W. 23rd St.WAlkIus 4-6156

CLEVELAND, O.

Escar Motion Picture Service, Inc.
 7315 Carnegie Ave.ENdicott 1-2707
Motion Picture Productions, Inc.
 Rockefeller Bldg.PRospect 1-4900

DAYTON, O.

Film Assoc., Inc.
 So. Dixey Hwy. & Winwood Ave.

PHILADELPHIA, PA.

Beswick, Harold W.
 1017 W. Allegheny Ave.BAlDwin 9-9355
News Reel Laboratory
 1733 Sanson St.RIttenhouse 6-3892
Welsh Studios
 1209 E. Chelton Ave.LIVingstone 8-4611

DALLAS, TEX.

Big D Film Lab
 4215 Gaston Ave.VICTor 1341
Jamieson Film Co.
 3825 BryantTENison 8158
Southwest Film Laboratory, Inc.
 2015 YoungRiverside 6782
Variety Pictures, Inc.
 3825 BryanTENison 8158

MILWAUKEE, WISC.

Film Arts Corp.
 1032 N. Sixth St.BRoadway 6-5670

CANADA

CALGARY

Barco's Calgary Film Production Co.

MONTREAL

Associated Screen News, Ltd.
 5271 Western Ave.DEXter 1180

Cinecraft Studios, Inc.
 1184 St. Catherine St., W.LANcasteR 8092

TORONTO

Associated Screen News, Ltd.
 100 Adelaide St., W.WAVerly 4671
Film Laboratories of Canada, Ltd.
 310 Lakeshore Rd.MURray 7226
Shelly Films, Ltd.
 156 King St., W., Toronto 14.LYndhurst 8431

OTTAWA

Crawley Films, Ltd.
 19 Fairmont Ave.8-0085
National Film Board of Canada
 John & Sussex Sts.DIDeau 9-5730

REGINA, SASK.

General Films, Ltd.
 1924 Rose St.

VANCOUVER

Motion Skreenadz, Ltd.
 Film Exchange Bldg.
Vancouver Motion Pictures, Ltd.
 Film Exchange Bldg.

Raw Stock

AnSCO

AnSCO Division of General Aniline & Film Corp.,
 Binghamton, N. Y.; 405 Lexington Ave.,
 MUrray Hill 6-0555, New York 19, N. Y.; 6424
 Santa Monica Blvd., Hollywood 4-6131, Holly-
 wood 38, California.

DuPont

I. E. du Pont de Nemours and Co. (Inc.).
 Photo Products Division, Wilmington, Del.:
 6656 Santa Monica Blvd., Hollywood 9-5147,
 Hollywood 38, Calif. Factories: Parlin, N. J.

Eastman

See W. J. German, Inc., Factories: Eastman
 Kodak Co., Rochester, N. Y.

German, W. J., Inc.

Distributor of Eastman motion picture film.
 John St., Fort Lee, N. J., Fort Lee 8-5100;
 6700 Santa Monica Blvd., Hollywood 7-6131,
 Hollywood 38, Calif.; 6040 N. Pulaski Rd.,
 Irving 8-4064, Chicago, Ill.

Gevaert Co. of America

423 W. 55th St.JUDson 6-2770



CIRCLE

Film Laboratories

24 HOUR SERVICE

A complete motion picture service

Serving the industry over a decade

CO. 5-2180

33 West 60th St. N.Y. 23, N.Y.

Storage Vaults

LOS ANGELES, CALIF.

Bekins Van & Storage Co.
1025 N. Highland Ave. Hollywood 9-8181
Hollywood Film Co.
946 Seward St. Hollywood 4-7191
Lyons Van & Storage Co.
6372 Santa Monica Blvd. Hollywood 9-1401

BOUNDBROOK, N. J.

United Storage Corp.
Band-Chestnut Sts. Boundbrook 9-3950

NEW YORK, N. Y.

Bonded Film Storage Corp.
630 Ninth Ave. Judson 6-1030
Consolidated Film Industries,
Div. of Republic Pictures Corp.
1740 Broadway Judson 6-1700
Lloyds Film Storage Corp.
729 Seventh Ave. Columbus 5-5400
Miles, Joseph R., Film Storage
729 Seventh Ave. Columbus 5-5400

Stock Shot Libraries

LOS ANGELES, CALIF.

Anguish, Toby
8470 Melrose Webster 3-8301
Camera Craft Audio Visual Sales & Rentals Co.
6764 Lexington Ave. Hollywood 3-9856
Dennis, Wm. M.
2560 1/2 W. Seventh St. Dinkirk 1-6722
Film Classic
1611 N. LaBrea Hollywood 7-4255
Ideal Pictures Corp.
2950 W. 7th St. Dinkirk 3-3195
Independent Film Library
c/o Hal Roach Studios, Culver City
TEXAS 9-2768

Mercer, Ray & Co.
4241 Normal Ave. (271) Olympia 8438
Smith, Howard K., Films
2408 W. Seventh St. Dinkirk 7-8228
Wild Life Film Co.
5151 Strohm, N. Hollywood Stanley 7-5845

NEW YORK, N. Y.

Lloyds Film Library
729 Seventh Ave. Columbus 5-5400
Miles Film Library
729 Seventh Ave. Columbus 5-5400
RKO Pathe, Inc.
105 E. 106th St. Sacramento 2-2800
Stock Shots Unlimited, Inc.
1600 Broadway Plaza 7-0878

Cartoon Producers

LOS ANGELES, CALIF.

Cinema Research Corp.
7070 Roman St., Hollywood (38)
HOLLYWOOD 2-7461
Disney, Walt
2400 W. Alameda, Burbank ROCKWELL 9-3461
Glenar (Sid) Productions
6618 1/2 Sunset Blvd. (38) Hollywood 4-0406
Lantz, Walter
861 N. Seward St. HOLLYWOOD 9-2907
Mercer, Ray
4111 Normal Ave. OLYMPIA 8438
Metro-Goldwyn-Mayer
Culver City TEXAS 0-3311
United Productions of America
4440 Lakeside Dr., Burbank, CHARLESTON 0-7171
Warner Bros. Cartoons, Inc.
1351 N. Van Ness Ave. HOLLYWOOD 5-4131

NEW ROCHELLE, N. Y.

Terry, Paul
271 North Ave. NEW ROCHELLE 2-3467

NEW YORK, N. Y.

Disney, Walt, Productions
1270 Ave. of Americas Judson 6-3442
Eshbaugh, Ted, Studios, Inc.
109 W. 64th St. TRAFALGAR 3-0720
Famous Studios
25 W. 15th St. Judson 2-4500
Smith, Fletcher, Studios, Inc.
321 E. 44th St. MURRAY HILL 5-6626

**Prizes,
Premiums, Etc.**

The Reuben H. Donnelley Corp.
305 East 45th St., N. Y. C. OREGON 9-4000
Richard S. Robbins
163 Bleeker St., N. Y. C. SPRING 7-2568
Spotlight Promotions
123 West 44th St., N. Y. C. PLAZA 7-0800
VIP Service, Inc.
35 West 53rd St., N. Y. C. PLAZA 7-0130

**Ventilation
Equipment**

Carrier Corp., 300 South Geddes St., Syracuse,
New York.
Frigidaire Division, General Motors Corp., 300
Taylor St., Dayton, Ohio.
General Electric Co., 5 Lawrence St., Bloomfield,
N. J.
General Elec. Co., 1 River Road, Schenectady,
N. Y.
Governair Corp., 513 N. Blackwelder, Oklahoma
City, Okla.
McQuay, Inc., 1800 Broadway, N. E. Minneapolis
13, Minn.
National Theatre Supply, 92 Gold St., New York,
N. Y.
S.O.S. Cinema Supply Corp., 602 W. 52nd St.,
New York 19, N. Y.
Typhoon Air Conditioner Co., Inc., 794 Union St.,
Brooklyn, N. Y.
United States Air Conditioning Corp., 2564 Como
Ave., Minneapolis 11, Minn.
Westinghouse Electric Corp., B. F. Sturtevant Div.,
420 Lexington Ave., New York, N. Y.
York Corp., York, Pa.

Color Processes

Anco Film Labs
1161 N. Highland, Hollywood 38, Calif.: HOLLY-
WOOD 4-7471.
Anso Color
Anso Division of General Aniline & Film Corp.
2029 Vaux Hall Rd., Union, N. J.: 405 Lexing-
ton Ave., N. Y.: Murray Hill 6-9555, 1157 N.
Highland Ave., Hollywood 28, Calif.: HOLLYWOOD
4-7471.
Associated Film Lab.
5631 Hollywood Blvd., Hollywood: HOLLYWOOD
4-8195.
Castagnaro, Mario
5748 Sunset Blvd., Hollywood: HOLLYWOOD
7-6818.
Cinecolor, Inc.
2800 W. Olive St., Burbank, Calif.: ROCKWELL
9-1126.

Cinema Research

7000 Romaine, Hollywood 38, Calif.: Hollywood 2-7464.

Color Research Corp.

105 E. 106th St., New York, N. Y.; Sacramento 2-7830.

Color Reproduction Co.

7936 Santa Monica Blvd., Hollywood 46, Calif.: Hollywood 4-8225.

Consolidated Film Ind.

959 Seward St., Hollywood: Hollywood 9-1441.

Donningcolor Corp.

Laboratory, 932 N. La Brea Ave., Hollywood 38, Calif.; Hollywood 7-3174.

Eastman Kodak Co.

Rochester, N. Y.

Eastman Kodak Co.

1017 N. Las Palmas Ave., Hollywood: Hollywood 5-7151.

Film Effect

1153 N. Highland Ave., Hollywood 38, Calif.: Hollywood 9-5808.

Flora Color

1103 El Centro Ave., Hollywood, Calif.: Hollywood 7-9559.

Kodachrome

Eastman Kodak Co., Rochester, N. Y. (16 and 8 mm. for motion pictures; 35 mm. cartridges for stills only.) 6060 Hollywood Blvd., Hollywood; HO 4-2181.

Mercer, Ray, & Co.

4241 Normal Ave., Hollywood 29; Olympia 8436.

Monopack

Technicolor's color negative system for use with regular black and white cameras.

Pathe Lab., Inc.

6823 Santa Monica Blvd., Hollywood: Hollywood 9-3961.

Polaroid Process

Polaroid Corp., Cambridge 39, Mass.

Rainbowlab, Inc. (Div. of Moviellab)

619 W. 54th St., New York, N. Y.; JUDson 6-0360.

Technicolor Motion Picture Corp.

6311 Romaine St., Hollywood 38, Calif.; Hollywood 7-1101; Laboratories: 1006 N. Cole Ave., Hollywood, Calif.; Office: 30 Rockefeller Plaza, New York, N. Y.; Circle 7-7934.

Trucolor

Republic Pictures Corp., 1740 Broadway, New York 19, N. Y.; JUDson 6-1700.

Screening Rooms

LOS ANGELES, CALIF.

Consolidated Film Industries, Inc.

959 Seward St. Hollywood 9-1441

Eastman Kodak Co.

1017 N. Las Palmas. Hollywood 5-7151

Hollywood Film Enterprises, Inc.

6060 Sunset Blvd. Hollywood 4-2181

Pathe Industries, Inc.

6823 Santa Monica Blvd. Hollywood 9-3961

RCA

1016 N. Sycamore Ave. Hillside 5171

NEW YORK, N. Y.

Advance Projection Theaters

729 Seventh Ave. JUDson 6-4954

Bonded's Film Center Theater

630 Ninth Ave. JUDson 6-1030

Johnny Victor Theater

40 W. 49th St. Circle 6-4030

Lloyds

729 Seventh Ave. Columbus 5-5400

Miles Public Projection Theaters

729 Seventh Ave. Circle 5-6873

Moviellab Theatre Service, Inc.

619 W. 54th St. JUDson 6-0360

Preview Theater

1600 Broadway Circle 6-0865



COSTUMES FOR TELEVISION

The largest collection of costumes and an experienced personnel with special training are available to give you immediate delivery of wardrobe at moderate rental charges. We ship out-of-town too.

BROOKS COSTUMES ARE ON EVERY TV CHANNEL EVERY DAY

Television's Official Costumer

BROOKS COSTUME CO.
3 WEST 61st STREET
NEW YORK CITY
 Telephone PLaza 7-5800

ALLEN KANDER
Negotiator

FOR THE PURCHASE AND SALE OF RADIO AND TELEVISION STATIONS

1701 K St., N.W.
 Washington 6, D. C.
 NA 8-3233

Lincoln Building
 New York 17, N. Y.
 MU 7-4242

401 Georgia Savings Bank Bldg.
 Atlanta 3, Georgia
 LAMar 2036

Puppet Makers

- Norbert's Puppets
107 Brooklyn Ave., Brooklyn, N. Y.
PResident 2-3805
- Scott Brinker
22 Livingston Court, Staten Island, N. Y.
GIBrattar 8 6991
- American Puppetry Workshop
439 E. 76th St., New York, N. Y.
REgent 1-6900

Costumes

NEW YORK, N. Y.

- Bally-Hoo Theatrical Costume Co.
160 W. 48th St. CIrcle 5-5634
- Berthe, Mme.
110 W. 47th St. PLaza 7-4170
- Brooks Costumes
3 W. 61st St. PLaza 7-5800
- Eavos Costume Co., Inc.
151 W. 46th St. PLaza 7-3730
- Lillian Costume Co.
1658 Broadway CIrcle 5-5199
- Stage Costumes, Inc.
3 W. 61st St. CIrcle 7-7948

**Radio-TV
Station Brokers**

- Blackburn-Hamilton Co.
Washington, D. C., Washington Bldg., STechnic

- 3-1341, James W. Blackburn, partner,
Chicago, Ill., Tribune Tower, DELaware 7-2755.
Ray V. Hamilton, partner,
San Francisco, Cal.; 235 Montgomery St.,
EXbrook 2-5672, Lester M. Smith.

- R. C. Crisler Co.
Cincinnati, O.; 1109 Union Trust Bldg., DUNbar
7775
Greenwich Conn., 20 Church St., 8-6692, Lanton
Wells, associate
New York: MURray Hill 8-3330

- Allen Kander
Washington, D. C.; 1701 R St. N.W. NATional
8-3233
New York 17, N. Y., Lincoln Bldg., MURray
Hill 7-1242,
Associates: Edwin Tornberg, George Cooper

- Howard E. Stark
New York 22, N. Y.; 50 East 58th St., EL
dorado 5-0105.

- Albert Zugsmith Corp.
W. Los Angeles 49, Cal.; 12015 San Vicente
Blvd., Arizona 9-8294.

Miscellaneous

- Tele Q
1227 Sixth Ave., New York 19, N. Y.
JUdson 6-5766
- Frank E. Yasah
7 West 44th St., New York, N. Y.
MURray Hill 7-4277
- Backdrops, Incorporated
2 West 46th St., New York, N. Y. CIrcle 6-6875

FOR LISTINGS OF
RADIO-TELEVISION
PROGRAM PRODUCERS

SEE PAGE

711



TV Film Distribution Looks To Record Year

By MICHAEL SILLERMAN

*Executive Vice President
Television Programs of America*

TV film distribution in 1954 should reach an all-time high. The phenomenal rise in the use of TV film by advertisers, both national and local, indicate the highly accelerated trend toward film. According to the latest figures of the NARTB, the average hours of film programming exceed the average live hours. This success of TV film may be attributed to a combination of many factors, namely: the advertiser has more flexibility with TV film; the film operation cost less and it permits the advertiser the opportunity of getting better time availabilities. In addition to these factors, the TV syndicators have developed outstanding merchandise programs to support their film series, thus, in effect, when the advertiser purchases a TV film series he also purchases a complete sales campaign including star endorsement, a title buildup and a long list of premiums which will bear the product's name. TPA as well as a few of the other leading film distributors recognized the great value of merchandising to the advertiser and have developed intense promotions and strong merchandising techniques which were more than welcomed by sponsors and the stations.

In terms of advertisers results, there are dozens of success stories. Perhaps the best evidence of their value is the length of time some advertisers have stuck with their programs. Even the blue-chip advertisers are going more into TV film. The huge operating cost of live network shows are forcing certain types of advertisers to TV film.

The market for the TV syndicators is becoming larger and larger. In addition to the fast trend toward film by the national and regional advertisers, there is also the fact that many new stations are opening or planning to open soon. There were approximately 350 stations in 1953 and by the end of 1954 there should be close to 600 stations actively broadcasting. The opening of these new markets and the increase of competing stations,

all of which are ready clients for syndicated properties, should result in an improvement in the quality of product. The residuals realized from this expanded market will be put back into production of new and better series.

The telefilm business emerged in 1953 as a sound and stable industry. TPA launched its first product "Ramar of the Jungle" with amazing success. In less than three months "Ramar" had been sold in over 115 markets proving that TPA in a short time had set up one of the most powerful sales organizations in the industry. TPA believes in concentrated selling policy, that is, to only sell one product at a time. We believe that this enables the salesman to become thoroughly acquainted with the product and give a presentation that the advertiser will be able to understand. By releasing only one film at a time our organization has been able to concentrate its efforts on making that one film "click" and by click we mean by doing the best possible sales and merchandising job for the advertiser. All our promotion efforts, all our services are aimed at this objective. 1954 will present a buyer's market in the entertainment as well as in the commercial sense. There is a new type of individual sitting before the TV set in ever increasing numbers. He is the selective viewer. We are gearing all our efforts towards this viewer for our new 52-week series "Your Star Showcase" hosted by Edward Arnold. We screened 345 plays before selecting 45 we considered worth showing. To these we are adding 7 new plays.

Looking ahead then, the year 1954 will be one of ever increasing demand for the syndicated product, for program quality, and for specific market by market sales and merchandising techniques. As one of the newest, largest and most imaginative organizations in the field, we at TPA are dedicated to supply some explicit and effective answers to these demands.



Ed Herlihy

*Behind the
Mike*

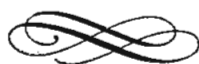

*Before the
Camera*



RADIO-TV ARTISTS

—their work during 1953



— A —

ABBOTT & COSTELLO
Colgate Comedy Hour
NBC-TV

ACREE, CHUCK
Man on the Farm
Mutual

ADAMS, MASON
Pepper Young's Family
NBC

ALDA, ROBERT
Bob Alda Show, ABC-TV, Pantomime Quiz, Dumont; Robt. Montgomery Show, NBC-TV; Lux-Video, CBS-TV; Milton Berle Show, NBC-TV.

ALLEN, GRACIE
B. 1906, San Francisco, Cal. The George Burns and Gracie Allen Show, CBS-TV.

ALLEN, STEVE
Steve Allen Show, NBC-TV; What's My Line, CBS-TV.

ALLISON, FRAN
Kukla, Fran & Ollie
NBC-TV

AMSTERDAM, MOREY
B. Dec. 14, 1912, Chicago, Ill. Breakfast with Music, WNBT, New York; Decca Records.

ANDERSON, EDDIE (ROCHESTER)
B. Sept. 18, 1905, Oakland, Cal. The Jack Benny Show, CBS-TV.

ANDREWS, ANN
Man on the Farm
Mutual

ARDEN, EVE
B. Mill Valley, Cal. Our Miss Brooks, CBS, CBS-TV.

ARLEN, MARGARET
Margaret Allen Show
CBS-TV

ARNAZ, DEST
I Love Lucy
CBS-TV

ARNOLD, EDWARD
B. Feb. 18th, 1890, New York City. Mr. President, ABC; Coronet Story Teller, ABC & Mutual; Your Star Showcase, Syndicated TV

ARTHUR, JACK
Jack Arthur's Toy Town Tunes
NBC-TV

AUTRY, GENE
Gene Autry Show
CBS-TV

AVERY, PHYLLIS
Meet Mr. McNulty
CBS

AYRES, MITCHELL
Perry Como Show
Mutual

— B —

BACHARACH, BERT
Men's Corner
Mutual

BAYLEY, JACK
Place the Face
CBS-TV

BALL, LUCILLE
I Love Lucy
CBS-TV

BANKHEAD, TALLULAH
All Star Revue, Buick Berle Show
NBC-TV

BARAGREY, JOHN
B. April 15, 1919, Haleyville, Ala. U. S. Steel Hour, ABC; You Are There, Suspense, Studio One, CBS-TV; Kraft Theatre, Philco Playhouse, NBC-TV

BARON, DON
Welcome Ranch
Mutual

BARRY, JACK
Juvenile Jury
CBS-TV

JIM and MARIAN
JORDAN

as

FIBBER McGEE
AND MOLLY

NBC

Monday thru Friday
10 P.M., EST



TENNESSEE ERNIE

VIDEO

"Hometown Jamboree"

KLAC-TV Saturday at 7:30 p.m.

RECORDS

Capitol Records

☆



☆

CLIFFIE STONE

RADIO

"Hometown Jamboree"

KXLA -- Monday thru Friday
and Saturday night

VIDEO

"Hometown Jamboree"

KLAC-TV -- Saturday at 7:30 p.m.

RECORDS

Capitol Records

☆



BARRYMORE, LIONEL
Hallmark Hall of Fame
CBS

BARTLETT, TOMMY
Welcome Travels
NBC, NBC-TV

BARTY, BILLY
B. Oct. 25, Pennsylvania. Red Skelton Show, NBC-TV; Alvino Rey, Spike Jones Varieties, KNBH, Los Angeles, Cal.

BECK, JACKSON
U.S. Steel Hour
ABC

BECKER, SANDY
Young Dr. Malone
CBS

BELL, DORESE
Dorese Bell Show
ABC

BELLAMY, RALPH
Man Against Crime
NBC-TV

BENDIX, WILLIAM
Life of Riley
NBC-TV

BENNY, JACK
B. Feb. 14, 1894, Chicago, Ill.
The Jack Benny Show, CBS; The Jack Benny Show, CBS-TV.

BENSON, BOBBY
B-Bar-B
Mutual

BENSON, RED
Take a Number
Mutual

BERG, GERTRUDE
The Goldbergs, NBC-TV
House, of Glass, NBC

BERLE, MILTON
Milton Berle Show, NBC-TV

BILLINGSLEY, SHERMAN
The Stork Club
NBC-TV

BLAINE, MARTIN
FBI in Peace and War
CBS

BLANC, MEL
Woody Woodpecker
Mutual

BLOCK, MARTIN
Make Believe Ballroom, WJW;
Make Believe Ballroom, WABC

BLUE, BEN
All Star Revue
NBC-TV

BOLGER, RAY
Where's Raymond
ABC-TV

BOULTON, MILO
Rod and Gun Club
Mutual

BREEN, ROBERT
Down You Go
DuMont

BRITTON, BARBARA
Mr. and Mrs. North
CBS

BROWN, JOE E.
Buck Circus Hour
NBC-TV

BROWN, VANESSA
I'll Buy That
CBS-TV

BRYSON, LYMAN
Lamp Unto My Feet
CBS-TV

BUNCE, ALAN
Ethel and Albert, NBC-TV

BURNS, GEORGE
B. Jan. 29, 1896, New York.
George Burns and Gracie Allen
Show, CBS-TV

BURT, HARDY
State of the Nation
Mutual

BUTTONS, RED
B. Feb. 15, 1919, New York.
Red Buttons Show, CBS-TV

— C —

CAGNEY, JEANNE
Queen for a Day
Mutual

CAIN, JEFF
Marge and Jeff
DuMont

CALDWELL, SAM
Garden Gate
CBS

CAMARGO, RALPH J.
Nick Carter, Mutual; Whispering Streets, ABC; Plainsclothesman, Dumont; Danger, Gongbusters, Crime Syndicated, CBS-TV; Kraft Theatre, NBC-TV

CAMP, SIS
Paul Dixon Show
DuMont

CAMPBELL, PATSY
Second Mr. Buton
CBS

CANNON, JIMMY
What's the Story
DuMont

CANOVA, JUDY
Judy Canova Show
NBC

CANTOR, EDDIE
Eddie Cantor Show, NBC
Colgate Comedy Hour, NBC-TV

CARHART, GEORGIANA
Life Begins at Eighty
DuMont



Mistress of Ceremonies
"TV Card Party"
WTOP-TV

Mistress of Ceremonies
"General Electric Theatre"
WMAL-TV

"Hi Neighbor"
Shopping Show
WHAM-TV

Hostess
"New Homes Preview"
WMAL-TV

Mistress of Ceremonies
WTTG-TV

"Dorese Bell Show"
WRNY

DORESE BELL

ABC Network
New York
"Dorese Bell Show"
Women's News Commentary

"RAIN OR SHINE"

with

Have a Happy

CAROL REED

WCBS-TV



**JACKSON
BECK**

ANNOUNCER
United States Steel Hour

ACTOR

NARRATOR

MU 8-6600

CARMICHAEL, HOAGY

Saturday Night Revue
NBC-TV

CARNEY, ART

Jackie Gleason Show, Studio One,
Toast of the Town, Danger; CBS-
TV; Robt. Montgomery Presents,
Campbell Sound Stage, NBC-TV;
Kraft Television Theatre, ABC-
TV

CARR, NANCY

Chicago Theatre of the Air
Mutual

CARROLL, JEAN

Take It From Me
ABC-TV

CARROLL, JIMMY

Wonderful City
Mutual

CARROLL, LEO G.

Topper
CBS-TV

CARROLL, MADELEINE

Starlight Theatre
CBS

CARSON, JACK

B. Oct. 11, 1911, Carmen, Mani-
toba, Canada. G.E. Theatre; CBS-
TV; Royal Show Case, NBC-TV

CARSON, KEN

Saddle Scouts
WABD, New York

CARSON, WHITEY

Tootsie Hippodrome
ABC-TV

CAULFIELD, JOAN

My Favorite Husband
CBS-TV

CEASAR, SID

Your Show of Shows, NBC-TV

CERF, BENNETT

What's My Line
CBS-TV

CESANA, RENZO

(The Continental)

Love Story
WABD, New York

CHANDLER, ROBIN

I'll Buy That
CBS-TV

CHAPMAN, JOHN

Best Plays
NBC

CHILDERS, ALVIN

Amos 'n' Andy
CBS-TV

CHURCHILL, SARAH

Hallmark Hall of Fame
NBC-TV

CLAIRE, MARION

Chicago Theatre of the Air
Mutual

CLARK, EVERETT

Chicago Theatre of the Air
Mutual

CLARK, LON

Nick Carter
Mutual

CLARKE, PHILIP

Mr. Keen, Tracer of Lost
Persons
CBS

COBB, BUFF

Masquerade Party, Mike and
Buff
CBS-TV

COCA, IMOGENE

Your Show of Shows, NBC-TV

COLEMAN, NANCY

Valiant Lady
CBS-TV

COLLINS, TED

Kate Smith Show
NBC-TV

COLLYER, BUD

Quick As a Flash, ABC-TV

COMO, PERRY

Perry Como Show
CBS-TV

CONRAD, WILLIAM

Gunsmoke
CBS

CONREID, HANS

"I'll Buy That"
CBS-TV

CONWAY, TOM

Mark Saber
ABC-TV

COOK, DONALD

My Son Jeep
NBC

COOKE, ALISTAIR

Omnibus
CBS-TV

COOKE, DWIGHT

Dwight Cooke's Guestbook
CBS

CORRELL, CHARLES

Amos 'n' Andy
CBS-TV

COTSWORTH, STAATS

Crime Photographer
CBS

COUGHLIN, FRANCIS

Down You Go
DuMont

COWAN, JEROME

Valiant Lady
CBS-TV

COY, JIM

Jim Coy Show
NBC

CRABBE, BUSTER

Luncheon with Buster Crabbe
NBC

CRONYN, HUME

The Marriage
NBC

George and Gracie

MARY
MARGARET
McBRIDE

ABC CO-OP
NETWORK COAST
TO COAST

— 0 —

Exclusive Management:
ESTELLA H. KARN
49 WEST 45TH STREET
NEW YORK CITY



ART CARNEY

Jackie Gleason Show
CBS-TV

Personal Management:
Wm. McCaffrey Agency
ELdorada 5-1076

CROSBY, BING
Bing Crosby Show
CBS

CROSBY, BOB
B. Aug. 23, 1913, Spokane,
Wash. The Bob Crosby Show,
Jack Benny Show, CBS-TV

CROSS, REGGIE
Man on the Farm
Mutual

CULLEN, BILL
I've Got a Secret, It Happens
Every Day, Fun for All, Walk a
Mile, Garry Moore Show, CBS-TV

— D —

DAHL, ARLENE
Playhouse
ABC-TV

DALEY, JAMES
Foreign Intrigue
NBC-TV

DALY, JOHN
What's My Line
CBS-TV

DAVIS, JOAN
I Married Joan, NBC-TV

DAVIS, WATSON
CBS

DAY, DENNIS
RCA Show Starring
Dennis Day
NBC-TV

DELMAR, KENNY
My Friend Irma
CBS-TV

DEMMING, ELIZABETH
Guiding Light
CBS

DENNING, RICHARD
Mr. and Mrs. North
CBS

DENNIS, JAMES
Turn to a Friend
ABC-TV

De SANTIS, JOE
Squad Room
Mutual

DEVINE, ANDY
Wild Bill Hickok
WABD, New York

DeWILDE, BRANDON
Jamie
ABC-TV

DIETRICH, MARLENE
Time for Love
CBS

DIXON, BOB
B. April 8, 1911, Stamford, Conn.
Perry Mason, Edward R. Murrow,
Red Buttons, Person to Person,
CBS-TV; Life Can Be Beautiful,
NBC

DONALD, PETER
Can You Top This
NBC

DONLEVY, BRIAN
Dangerous Assignment
NBC-TV

DOTY, ROY
The Roy Doty Show
WABD, New York

DRAKE, GALEN
Housewives Protective League,
Starlight Salute
CBS

DUBLIN, DR. LOUIS I.
Search That Never Ends
Mutual

DURANTE, JIMMY
B. Feb. 18, 1893, New York City.
Colgate Comedy Hour, NBC-TV

— E —

EDWARDS, ALLYN
Allyn Edwards Show
NBC

EDWARDS, JOAN
At Home With Joan
CBS

EDWARDS, RALPH
B. June 13, 1913, Merino, Colo.
This Is Your Life, NBC-TV;
Truth or Consequences, NBC

EDWARDS, WEB
Hawaii Calls
Mutual

ELLIOTT, WIN
Break the Bank, On Your
Account
NBC-TV

EMERSON, FAYE
Faye Emerson Show
NBC

**ERICKSON, CORYDON
ARVID**

B. Dec. 26, 1944, New York City.
Robt. Montgomery Presents,
Goodyear Theatre, Hit Parade,
NBC-TV; Take It From Me,
WABD, New York; Lux Video
Theatre, Freedom Rings, Danger,
CBS-TV

ERWIN, STU AND JEAN
Stu Erwin Show
ABC-TV

EVANS, DALE
Roy Rogers Show
NBC, NBC-TV



CHARLES IRVING

Producer - Director



HOLLIS IRVING

Radio - TV - Motion Pictures

— LE. 2-1100 —

Joan Davis

in

"I MARRIED JOAN"

NBC Television

Every Wednesday Night

Sponsored By General Electric

GERTRUDE BERG
and the **GOLDBERGS**

REPRESENTATION:

TED ASHLEY ASSOCIATES

◆ ◆ ◆ RADIO AND TELEVISION ARTISTS ◆ ◆ ◆

— F —

FADIMAN, CLIFTON
This Is Show Business
CBS-TV

FAIRBANKS, DOUGLAS
The Rheingold Theatre
NBC-TV

FAIRBANKS, TINY
Remember with Tiny
Fairbanks
Mutual

FALKENBERG, JINX
Jinx Falkenberg Diary
NBC-TV

FARRELL, CHARLES
My Little Margie
NBC-TV

FENNELLY, PARKER
Titus Moody
Mutual

FERRADAY, LISA
Dinner With Lisa, The Mask,
ABC-TV; Robert Montgomery,
Martin Kane, NBC-TV; Studio
One, CBS-TV

**FITZMAURICE,
MICHAEL**
Radio Registry

FLETCHER, TEX
B-Bar-B
Mutual

FOOTE, BRUCE
Chicago Theatre of the Air
Mutual

FORD, SENATOR ED
Can You Top This?
NBC

FOSTER, PRESTON
B. August 24, Ocean City, N. J.
Waterfront, Syndicated

FRANCES, ARLENE
What's My Line?
CBS-TV

FRANDSEN, TOM
B. July 20, Los Angeles, Cal.
Late Date at the Movies, KNBC,
Los Angeles, Cal.; The Unex-
pected, KECA-TV, Los Angeles,
Cal.; Colgate Comedy Hour,
NBC-TV

FREBERG, STAN
That's Rich
CBS

FREEMAN, FLORENCE
Wendy Warren and the News
CBS

FREEMAN, STAN
Stan Freeman Show
NBC

FROMAN, JANE
Douglas Edwards and the
News
CBS-TV

— G —

GILBERT, RUTHIE
Texaco Star Theatre,
Buick Berle Show
NBC-TV

GILMAN, TONI
Down You Go
DuMont

GLEASON, JACKIE
Jackie Gleason Show, CBS-TV

GNAGY, JON
Draw With Me
NBC-TV

GODFREY, ARTHUR
Arthur Godfrey Marning Show,
Arthur Godfrey and his Friends,
Arthur Godfrey's Talent Scouts,
Arthur Godfrey's Digest, CBS,
CBS-TV

GORDON, GALE
Our Miss Brooks
CBS-TV

GOSDEN, FREEMAN
Amos 'N' Andy
CBS-TV

GOTTSCHALK, NORMAN
Sky King, Chicago Theatre of
the Air
Mutual

GRAHAM, BILLY
Hour of Decision
ABC-TV

GRANIK, THEODORE
American Forum of the Air
NBC-TV

GRANT, HARVEY
Life With Father
CBS-TV

GRANT, KIRBY
Sky King
ABC-TV

GAMBLING, JOHN A.
John Gambling Show
Mutual

GARGAN, WILLIAM
Barrie Crane, Confidential
Investigator
NBC

GARROWAY, DAVE
Dial Dave Garroway, NBC
Today, Dave Garroway Show,
NBC-TV

GATESON, MARJORIE
One Man's Family
NBC

**GEARHART, VIRGINIA &
LIVINGSTON**
Fred Waring Show
CBS-TV



“MIKE
and
BUFF”

CBS-TV

JOHNNY MERCER



BOB
CROSBY

◆ ◆ ◆ RADIO AND TELEVISION ARTISTS ◆ ◆ ◆

GRAY, BARRY
Barry Gray Show
WABD, New York

GREAZA, WALTER
Treasury Men in Action
NBC-TV

GREENE, LORNE
Lorne Greene Show
Mutual

GREENE, MARGE
Marge and Jeff
DuMont

GROVE, BETTY ANN
The Big Payoff
CBS-TV

— H —

HAGEN, JEAN
Make Room for Daddy
ABC-TV

HAGY, RUTH GERI
Junior Preas Conference
ABC-TV

HALL, CLIFF
Search for Tomorrow
CBS-TV

HALL, HELEN
(Barbara Wells)
B. Kansas City, Mo. Bur-Mil
Cameo Lady, Helen Hall Show,
Mutual; Barbara Wells Show,
WOR, New York

HALOP, FLORENCE
Meet Millie
CBS-TV

HAMER, RUSTY
Make Room for Daddy
ABC-TV

HAMILTON, GENE
B. Feb. 22, 1910, Toledo, Ohio.
All Star Revue, NBC-TV; What's

the Score, Montovani Concerts,
Alemite News, Travelers Voices
& Events, NBC; Doctor Gino,
WNBC, New York

HAMILTON TRIO
Your Show of Shows
NBC-TV

HAMMOND, EARL
Rocky King, Dumont

HARDWICKE, SIR CEDRIC
Bulldog Drummond
Mutual

HARMON, LARRY

Commander Comet
Adventures of Patches

HARTLINE, MARY
Super Circus
ABC-TV

HARTMAN, PAUL
Pride of the Family
ABC-TV

HASTINGS, DON
Captain Video
DuMont

HAYES, GABBY
Gabby Hayes Show
NBC-TV

HAYES, HELEN
Omnibus
CBS-TV

HAYMES, BOB
Bob Haymes Show
CBS

HAYWORTH, VINTON
Keep Healthy
Mutual

HEATHERTON, RAY
The Merry Mailman, WOR TV &
Mutual

HEBERT, DON
Mr. Wizard
NBC-TV

HEILNER, VAN CAMPEN
Rod and Gun Club
Mutual

HENRICH, TOMMY
Tommy Henrich Show
ABC-TV

HENRY, BILL
Who Said That?
NBC-TV

HERSHFIELD, HARRY
Can You Top This?
NBC

HEWITT, VIRGINIA
Space Patrol
ABC-TV

HODGE, AL
Captain Video
DuMont

HOPE, BOB
B. London, England. The Bob
Hope Show, NBC, NBC-TV

HORWICH, DR. FRANCES
Ding Dong School
NBC-TV

HULL, WARREN
Strike It Rich
CBS-TV

HYATT, BOBBY
Pride of the Family
ABC-TV

— I —

IRVING, CHARLES
Search for Tomorrow, CBS-TV



BRYNA
RAEBURN

RADIO REGISTRY



"Here's Looking At You"

NBC-TV

RICHARD WILLIS

FOR THE FAMILY

**THE
JACK OWENS SHOW**

Starring

The West's MOST POPULAR
Family 5 Days a Week.

KECA-TV

and

Entire ABC RADIO NETWORK

*And don't forget —
"THINK" — the hit of
'54. Words and Music by
Jack Owens (Hear Jack
and Mary Ann Sing It
on Decca Records.)*



JACK and Daughter, MARY ANN

◆ RADIO-TV ARTISTS ◆

IRVING, HOLLIS

Somerset Maugham Theatre, Robert Montgomery Present, NBC; Ellery Queen, ABC-TV; Suspense, Love of Life, NBC-TV; Road of Life, NBC, CBS

IRWIN, CAROL

I Remember Mama
CBS-TV

— J —

JACKSON, EDDIE

All Star Revue,
Colgate Comedy Hour
NBC-TV

JACKSON, FELIX

Studio One
CBS-TV

JACKSON, SHERRY

Make Room for Daddy
ABC-TV

JAMESON, HOUSE

Aldrich Family
NBC-TV

JEFFREYS, ANNE

Topper
CBS-TV

JENKS, FRANK

Colonel Flack
DuMont

JESSEL, GEORGE

All Star Revue
NBC-TV

JOHNSON, BESS

Search for Tomorrow
CBS-TV

JOHNSON, GERALD W.

Where's Raymond
ABC-TV

JORDAN JAMES E.

B. Nov. 16, Peoria, Ill. Fibber
McGee & Molly, NBC

JORDAN, MARIAN

B. April 15, Peoria, Ill. Fibber
McGee & Molly, NBC

JOSLYN, ALLYN

Where's Raymond?
ABC-TV

— K —

KADELL, CARLTON

Sky King
Mutual

KAPLAN, MARVIN

Meet Millie
CBS-TV

KARNS, ROSCOE

Rocky King, Detective
DuMont

KAUFMAN, GEORGE S.

This Is Show Business
CBS-TV

KAUFMAN, MURRAY

The Murray Kaufman Show
WMCA

KAYE, VIRGINIA

Rosemary
CBS

KEENE, WILLIAM

Rocky King, Plainsclothesman,
DuMont; Ethel & Albert, Robert
Montgomery Presents, NBC-TV;
Nick Carter, The Falcon, Mr.
D.A., WOR, New York

KEMMER, ED

Space Patrol
ABC-TV



W
I
L
L
I
A
M
K
E
E
N
E



RADIO — TV
MOTION PICTURES

Slide Films

Columbia Recording Artist



LExington 2-1100



JACK STERLING

"The Jack Sterling Show"

WCBS

"The Big Top"

CBS-TV

"Make Up Your Mind"

CBS



the **HANK McCUNE** Show

**The Hank
McCune Show***
is available for
YOUR market.

* fifty-two, 30 minute
situation comedies.

Write, Wire or Phone

The HANK McCUNE SHOW

1515 N. Western Avenue

Hollywood 28, California

Phone: HOLLYWOOD 4-7558

◆ ◆ ◆ RADIO AND TELEVISION ARTISTS ◆ ◆ ◆

LEWIS, WANDA
Paul Dixon Show
DuMont

LIBERACE

B. May 16, 1920, Milwaukee,
Wis. The Liberace Show, Syndi-
cated TV

LIESTON, FREDDIE
Life With Father
CBS-TV

LINDLAHR, VICTOR T.
Diet Commentary
NBC

LINKLETTER, ART
House Party
CBS-TV

LINN, BAMBI
Your Show of Shows
NBC-TV

LITEL, JOHN
My Hero
NBC-TV

LOCKHART, JUNE
Who Said That
NBC-TV

LORRE, PETER
Nightmare
Mutual

LORRING, LYNN
Take It From Me
ABC-TV

LOWE, EDMUND
Front Page Detective
WABD, New York

LUDDY, BARBARA
First Nighter
NBC

LUND, JOHN
Yours Truly, Johnny Dollar
CBS

LYNCH, KEN
The Plainsclothes Man
DuMont

LYNCH, PEG
Ethel and Albert, NBC-TV

LYNN, BETTY
Where's Raymond
ABC-TV

LYNN, JEFFREY
My Son Jeep
NBC-TV

LYTELL, BERT
One Man's Family
NBC

— M —

MACK, DOTTY
The Dotty Mack Show
ABC-TV

MacLAUGHLIN, DONALD
Road of Life
CBS

MADISON, GUY
Wild Bill Hickok
WABD, New York

MAHONEY, CLAUDE
CBS

MANSON, CHARLOTTE
Nick Carter
Mutual

MARKLE, FLETCHER
Studio One
CBS-TV

MARSHALL, DR. ROY K.
The Nature of Things
NBC-TV

MARTIN, DON
Radio-TV School
Hollywood, Cal.

MARTIN, DEAN
B. June 7, 1917, Steubenville, O.
Colgate Comedy Hour, NBC-TV

MARTIN, JEAN
Chock Full O' Nuts Show, WNBT,
New York

MARX, GROUCHO
You Bet Your Life
NBC, NBC-TV

MASSEY, CURT
Curt Massey Time
CBS

**McBRIDE, MARY
MARGARET**
Mary Margaret McBride Co-Op
Show, ABC

McBURNEY, DR. JAMES H.
Northwestern University
Reviewing Stand
Mutual

McCARTHY, JOSEPHINE
Cooking Show
NBC-TV

McCAY, PEGGY
Love of Life
CBS-TV

McGRARY, TEX
Weekend, NBC
The President's Week, NBC-TV

LAWRENCE WELK

And His

Champagne Music

3rd Year At The

ARAGON BALLROOM

Lick Pier • Santa Monica, Calif.

KTLA — Channel 5

For The Dodge Dealers
of Southern California

Exclusively On

Coral Records

Management

GABBE, LUTZ and HELLER

Public Relations — Joe Sanson



STAN
SAWYER



JACK CARSON



"A Star is Born"

(Warner Bros.)

Management: MCA

Personal Management:

Frank Stempel

McCUNE, HANK

The Hank McCune Show

McDONNELL, CRAIG

Official Detective
Mutual

McELHONE, ELOISE

Leave It to the Girls
ABC-TV

McGUIRE, MAC

Mac McGuire Show
Mutual

McNELLIS, MAGGI

B. Chicago, Ill. Maggi's Magazine, WABC, New York; Maggi McNellis Show, WABC-TV, New York; Leave It to the Girls, ABC-TV

McVEY, PAT

B. Mor. 17th, Ft. Wayne, Ind. Big Town, CBS-TV; Heart of the City, Syndicated

MEADOWS, AUDREY

Jackie Gleason Show,
I'll Buy That
CBS-TV

MEADOWS, JAYNE

I've Got a Secret
CBS-TV

MEIKLE, PAT

Magic Cottage
WABD, New York

MENARD, GEORGE

Man on the Farm
Mutual

MENJOU, ADOLPH

Favorite Story
NBC-TV

MERCER, JOHNNY

B. Nov. 18th, 1909, Savannah, Ga. The Johnny Mercer Show, CBS

MERCER, RUBY

Ruby Mercer Show
Mutual

MEREDITH, BURGESS

Excursion
NBC-TV

MERRILL, GARY

The Mask
ABC-TV

MERRIMAN, RANDY

Big Payoff
NBC-TV

MILLAND, RAY

Meet Mr. McNulty
CBS-TV

MILLER, DAVE

Welcome Rauch
Mutual

MILLER, SIDNEY

B. Oct. 22, 1916, Shenandoah, Pa. Saturday Night Revue, Colgate Comedy Hour, NBC-TV

MINER, JAN

Hilltop House, Ma Perkins, CBS; Great Plays, Philco Theatre, NBC; Schlitz Playhouse, Robt. Montgomery Presents, Martin Kane, Tallulah Bankhead, All Star Revue, NBC-TV

MONTGOMERY, ROBERT

Robert Montgomery Presents, NBC-TV

MOORE, GARRY

Garry Moore Show
CBS-TV

MOORE, TIM

Amos 'n' Andy
CBS-TV

MOORE, TOM

Ladies Fair
Mutual

MOREHEAD, ALBERT

I'll Buy That
CBS-TV

MORELAND, DON

Man on the Farm
Mutual

MORGAN, EDWARD P.

Chronoscope
CBS-TV

MORGAN, HENRY

I've Got a Secret
CBS-TV

MORRIS, HOWARD

B. Sept. 4, 1919, New York City. Your Show of Shows, NBC-TV

MORRISON, BRET

The Shadow
Mutual

MOWBRAY, ALAN

Colonel Humphrey Flack
DuMont

MURRAY, JAN

Meet Your Match, NBC; Dollar A Second, Dumont

MURRAY, KATHRYN

Arthur Murray Party
NBC-TV



The Murray Kaufman Show

WMCA

MON.-SAT. — 11:05-12 P.M.

THURS. 8-9 P.M.

Personal Representative: WYNN LASSNER

PL. 7-0876



MAGGI McNELLIS



MICHAEL FITZMAURICE

Radio Registry



EDDIE "ROCHESTER" ANDERSON



JOE SILVER

Featured

RED BUTTONS SHOW — CBS-TV

SU 7-5400

MURROW, EDWARD R.
Person to Person, See It Now
CBS-TV

MYERSON, BESS
The Big Payoff
NBC-TV

MYNATT, HARRY
Queen for a Day
Mutual

— N —

NELSON, BARRY
My Favorite Husband
CBS-TV

NELSON, DOLF
Ladies Fair
Mutual

NELSON, JIMMY
Milton Berle Show, NBC-TV

NELSON, OZZIE & HARRIET
Adventures of Ozzie & Harriet
ABC-TV

NELSON, RAY
Rod and Gun Club
Mutual

NIGH, JANE
City Assignment
WABD, New York

NUSSBAUM, MORT
B. Aug. 10, 1914. Off the Record,
Take It Easy, You Can Be a
Star, WHAM, WHAM-TV,
Rochester, N. Y.

— O —

O'CONNOR, DONALD
B. August 28, 1925, Chicago,

Ill. Colgate Comedy Hour, NBC-TV

O'KEEFE, WALTER
Double or Nothing
NBC

OLIVIER, SIR LAURENCE
Theatre Royal
NBC

OLSEN, JOHNNY
Johnny Olsen Show
Mutual

OSBORN, LYN
Space Patrol
ABC-TV

OWEN, JAY
Dr. I. Q.
ABC-TV

OWENS, JACK
B. 1913. The Jack Owens Show,
ABC; The Jack Owens Show,
KECA-TV, Los Angeles, Cal.

— P —

PARKS, BERT
Double or Nothing
CBS-TV

PARSON, LOUELLA
Louella Parsons Show
CBS

PAUL, LES AND MARY FORD
Perry Como Show, Omnibus, CBS;
Red Skelton Show, Milton Berle
Show, Nothing But the Best,
NBC; Les Paul & Mary Ford at
Home, TV Film

PAUL, RALPH
B. Oct. 11, 1920, Denver, Colo.
Strike It Rich, CBS-TV; Sound
Stage, TV Playhouse, NBC-TV

PAYNE, VIRGINIA
Ma Perkins
CBS

PEARL, JACK
Baron and the Bee
NBC

PERKINS, R. MARLIN
Zoo Parade
NBC-TV

PETERSON, DON
Farm Quiz
Mutual

PETERSON, VIRGILIA
Author Meets the Critics
Mutual

PETRIE, GEORGE
Adventures of the Falcon
Mutual

PICKENS, JANE
Jane Pickens Show, ABC-TV;
Jane Pickens Show, NBC

POLERI, DAVID
Chicago Theatre of the Air
Mutual

POLESIE, HERB
Twenty Questions
Mutual

POPE, CARMELITA
Down You Go
DuMont

POTTER, PETER
Peter Potter Show
ABC-TV

PRINCE, WILLIAM
The Mask
ABC-TV



BOB RUSSELL
Director-Writer-M.C.-Composer
of
"Miss Universe Pageant" Long Beach, Cal.
"Miss America Pageant" Atlantic City, N. J.
"Big Top" "Joe DiMaggio Club"
CBS-TV NBC-TV
for Sealtest for Buitoni
Co-creator — "Live Like a Millionaire"



RAY HEATHERTON
"The Merry Mailman"
and
"The Ray Heatherton Show"
Coral Records — Personal Appearances
Personal Management
SANDY HOWARD PRODUCTIONS
CI 5-6971
853 - 7th Ave., N. Y. C.

**EDWARD
ARNOLD**

Now celebrating 47th
year in show business.



KAY WESTFALL

**GREETINGS
FROM
BOB
and
KAY**



BOB MURPHY

**NBC
CHICAGO**

Mon. - Fri.



JOHNNY OLSEN

CI. 7-7517



MOREY AMSTERDAM

WNBT — BREAKFAST WITH MUSIC
9-10 A.M. MON. thru FRI.

DECCA RECORDS

— R —

RAEBURN, BRYNA

B. March 14. Gangbusters, Helen Trent, CBS; Phrase That Pays, Big Story, Barrie Craig, Eternal Light; NBC; Official Detective, Counterspy, Nick Carter, Search That Never Ends; WOR, N. Y.

RANDOLPH, AMANDA

Beulah
CBS

RAYBURN, GENE

Bright Ideas
NBC-TV

RAYE, MARTHA

Martha Raye Show, NBC-TV

RAYMOND, GENE

Fireside Theatre
NBC-TV

REDDY, TOM

Journey Through Life
CBS-TV

REED, CAROL

Rain or Shine, CBS-TV

REINER, CARL

Your Show of Shows, NBC-TV

RINARD, FLORENCE

Twenty Questions
Mutual

RIO, ROSA

My True Story, When a Girl Marries, Ted Malone, ABC; Johnny Olsen, Opera Versus Jazz, ABC-TV; Front Page Farrell, NBC

RITZ BROTHERS

Colgate Comedy Hour
NBC-TV

ROBBINS, FRED

Fred Robbins Show,
Coke Time
Mutual

ROGERS, ROY

B. Nov. 5, 1912, Cincinnati, O.
Roy Rogers Show, NBC, NBC-TV

ROMERO, CESAR

Your Chevrolet Showroom
ABC-TV

ROSS, DAVID

Words in the Night,
Golden Treasury
NBC

ROUNTREE, MARTHA

Meet the Press
NBC, NBC-TV

ROWLES, POLLY

Jamie
ABC-TV

ROY, MICHAEL

B. July 18, 1913, Hanford,
N. D. Mike Roy's Kitchen, KLAC-
TV; Mike Roy's Key to the
Kitchen, KNBH, Los Angeles,
Cal.



JAN MINER

MU 8-6600

THE
RITZ
BROTHERS



S
T
E
V
E

A
L
L
E
N



CORYDON ERICKSON

Age 6-9 — 52 Inches High
LE 2-1100

TV. Philco Playhouse. Good Year, Lux Video.
Robert Montgomery Presents
FILMS: U-I. "Girls in the Night", Columbia.
"It Should Happen to You"
and many others



PAT McVEY
"Steve Wilson"
BIG TOWN
HEART OF THE CITY

DON MARTIN

SCHOOL OF
RADIO and TELEVISION
ARTS and SCIENCES

Now in our 17th Year

750 Stations in 44 States
Employ our Graduates

Operator of KSRT-FM
93.9 mc

HOLLYWOOD, CALIFORNIA

◆ RADIO-TV ARTISTS ◆

RUICK, MELVILLE
City Hospital
CBS

RUSSELL, BOB
Big Top, CBS-TV; Joe Di Maggio
Club, Live Like a Millionaire,
NBC-TV

RUSSELL, JACK
Your Show of Shows, NBC-TV

RUSSELL, TODD
Wheel of Fortune
CBS-TV

RUYKEYSER, MERRYLE
STANLEY
Ruykeyser Reports
Mutual

— S —

SAWYER, STAN
SCHILDKRAUT, JOSEPH
DuMont

SCOTT, JOHN
Footnotes to History
Mutual

SHEEN, BISHOP FULTON J.
Life Is Worth Living
DuMont

SHELDON, HERB
Herb Sheldon Show.
Egbert & Unily
NBC, NBC-TV

SHERWIN, WALLY
B. Aug. 26, 1918, Chicago, Ill.
Stairway to Stardom, KTTV, Los
Angeles; Here's the Pitch, KNBH;
Critical Court, KLAC-TV, Los
Angeles

SHIPP, MARY
My Friend Irma
CBS-TV

SHRINER, HERB
For for the Money
NBC-TV

SILVER, JOE
B. Sept. 28, 1922, Chicago, Ill.
Red Buttons Show, Studio One,
Danger, CBS-TV; Colgate Comed-
y Hour, Kraft TV Theatre, NBC-
TV

SINATRA, FRANK
Rocky Fortune, Songs with
Sinatra
NBC

SINCLAIR, DIANE
Dave Garroway Show.
Paul Winchell Show
NBC-TV

SKELTON, RED
B. July 18, Vincennes, Ind.
The Red Skelton Show, CBS-TV;
Syndicated

SLOANE, EVERETT
21st Precinct
CBS

SLOCUM, CHICK
Welcome Ranch,
New England Barn Dance
Mutual

SMITH, BILL
Brighter Day
CBS

SMITH, BOB
Howdy Doody
NBC-TV

SMITH, KATE
The Kate Smith Hour, NBC-TV

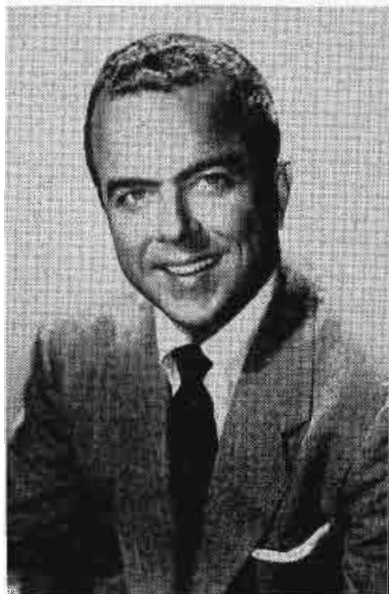

JAY STEWART

M.C.

"It Pays To Be Married" NBC
"Your Claim To Fame" ABC-TV
"Townhall Party" KTTV



GENE HAMILTON

"Dr. Gino"

NBC



EARL HAMMOND

TELEVISION

RADIO

LExington 2-1100



JERRY LAWRENCE

"Air Salesman"

TV-Radio — Coast-to-Coast

Whitney 8612

Hollywood, Calif.



**JACQUELINE
SUSANN**

3' 11"



BILLY BARTY

"A little bit of everything"

DIRECTION MCA

SMITH, SYDNEY

Market Melodies, Leave It to the Girls, WABC-TV; Quick on the Draw, NBC-TV; Your TV Shopper, Ask Miss Smith, WABD; To the Ladies, WPIX, New York

SMOLEN, VIVIAN

Our Gal Sunday
CBS

SOUBRIER, CLIFF

Sky King
Mutual

SOTHERN, ANN

Private Secretary
CBS-TV

SPIVAK, LAWRENCE E.

Meet the Press
NBC, NBC-TV

STANG, ARNOLD

House of Glass,
Buick Berle Show
NBC, NBC-TV

STEIN, FRED

Life Begins at Eighty
DuMont

STERLING, JACK

B. June 24, 1915, Baltimore, Md.
The Jack Sterling Show, WCBS,
New York; The Big Top, CBS-TV;
Make Up Your Mind, CBS

STERLING, PHIL

Counter-Spy
Mutual

STERLING, ROBERT

Topper
CBS-TV

STERN, BILL

The Name's the Same
ABC-TV

STEVENS, JULIE

Romance of Helen Trent
CBS

STEVENS, MARK

Martin Kane
NBC-TV

STEWART, JAY

It Pays To Be Married—NBC
Your Claim To Fame—ABC-TV
Townhall Party

STEWART, JIMMY

Six Shooter
NBC

STONE, CLIFFIE

B. Mar. 1, 1917, Stockton, Cal.
Hometown Jamboree, KLAC-TV;
KXLA, Los Angeles, Cal.

STORM, GALE

My Little Margie
Mutual

SULLIVAN, ED

Toast of the Town, Arthur
Godfrey & His Friends, Jackie
Gleason Show,
CBS-TV

SUSANN,

JACQUELINE

This Is Show Business, Studio
One, Your Surprise Store, CBS-
TV; Arthur Murray Party, Who
Said That, NBC-TV; Rocky King,
Dumont

SWENSON, KARL

Lorenzo Jones
NBC

— T —

TANDY, JESSICA

The Marriage
NBC

TAYLOR, DEEMS

Deems Taylor Concert
Mutual

TAYLOR, MARY LEE

Mary Lee Taylor Show
NBC



RALPH CAMARGO

RADIO — TV
ACTOR — ANNOUNCER
NARRATOR
REGISTRY — MU. 8-6600



LARRY HARMON

Stars as "Commander Comet" and
does voices on KNBH show.

Stars on "Adventures of Patches"



SYDNEY SMITH
NBC-TV

"Home" show

EVE ARDEN

"OUR MISS BROOKS"

CBS-TV

Your Blue-Eyed Boy, Rugged

MICHAEL ROY*



KNBH — 4
Los Angeles, Calif.

* Good TV Cooking Done Expensive



CARL KING

Personal Management
Madelyn Killeen

◆ RADIO-TV ARTISTS ◆

TENNESSEE, ERNIE

B. Feb. 13, 1919, Bristol, Tenn.
Tennessee Ernie Show, ABC;
Hometown Jamboree, KLAC-TV;
Hollywood, Cal.

THOMAS, DANNY

B. Jan. 6, 1914, Deerfield, Mich.
Make Room for Daddy, ABC-TV

THOMAS, FRANKIE

Tom Corbett.
Space Cadet
DuMont

THOMAS, SHIRLEY

B. July 16, 1920, California.
Shirley Thomas from Hollywood,
CBS; Shirley Thomas Reports,
NBC; Shirley Thomas Interviews,
KCOP-TV, Los Angeles; NBC's
Hollywood Correspondent

THOR, JEROME

Foreign Intrigue
NBC-TV

TIBBETT, LAWRENCE

Golden Voices
NBC

TILTON, MARTHA

Curt Massey Time
CBS

TOMPKINS, JOAN

This Is Nora Drake
CBS

TOMPKINS, TOMMY

Choose Up Sides
WCBS-TV, New York

TRACY, LEE

Martin Kane
NBC-TV

TRENDLER, ROBERT

Chicago Theatre of the Air
Mutual

TRIPP, PAUL

Lamp Unto My Feet
CBS-TV

TROHAN, WALTER

Report from Washington
Mutual

TRUEX, ERNEST

Jamie
ABC-TV

TRUMAN, MARGARET

Paul Winchell Show,
All Star Revue
NBC-TV

TUTTLE, LORENE

Life With Father
CBS-TV

TYLER, JANET

The Weather Girl
DuMont

TYLER, JUDY

Howdy Doody
NBC-TV

— V —

VALENTINE, JACK

Action in the Afternoon
CBS-TV

VANCE, VIVIAN

I Love Lucy
CBS-TV

VAN DEVENTER, FRED

Twenty Questions
Mutual

VAN HORNE, HARRIET

What's the Story
DuMont

VAUGHN, BERYL

Sky King
Mutual

VERDUGO, ELENA

Meet Millie
CBS-TV

— W —

WAKELY, JIMMY

B. Feb. 16, 1914, Mineola, Ark.
The Jimmy Wakely Show, CBS



TOM FRANSEN

Your Host

"Late Date at the Movies"

KNBH

WALLY SHERWIN

PRODUCES • WRITES • EMCEES



Currently Producing and emceeing

"STAIRWAY TO STARDOM"

KTTV — Los Angeles

Hollywood's Newest TV Star Talent Show

And can do the same for you.

SHERWIN and ASSOCIATES

15040 Dickens

Sherman Oaks, Calif.

SIDNEY MILLER

actor - writer

COLGATE COMEDY HOUR

NBC-TV

staged & directed

SATURDAY NIGHT REVUE

John Harry A CHRIST-KOPLAN PRODUCTION



The
Harry Koplan
Rosemary
LaPlanche
Show

TV Audience
Participation
Variety Show

ALSO—

"You're Never Too Old"

Talent hunt starring people over 60.

"Children Should Be Heard"

Children's show featuring adult appeal

"What's the Question"

Panel is given the answer—
tells you the question

ARGYLE ST., HOLLYWOOD 28

HO. 4-7332

WALKER, JOAN

Your Show of Shows, NBC-TV

WALLACE, MIKE

Mike and Buff
All Around the Town
CBS-TV

WARREN, CARL

Carl Warren Time
Mutual

WEAVER, NED

Under Arrest
Mutual

WEBB, JACK

Dragnet
NBC, NBC-TV

WEBER, HENRY

Chicago Theatre of the Air
Mutual

WEBSTER, CHUCK

Samal Room
Mutual

WELK, LAWRENCE

Coral Records
Aragon Ballroom
KTLA

WESTFALL, KAY

NBC

WESTMORE, ERN

Ern Westmore Show
ABC-TV

WHITE, BETTY

Life With Elizabeth
DuMont

WHITEMAN, PAUL

TV Teen Club
ABC-TV

WHITING, BARBARA

Junior Miss
CBS

WILLARD, DICK

Here's to My Lady
Mutual

WILLIAMS, SPENCER

Amos 'N' Andy
CBS-TV

WILLIS, RICHARD

Here's Looking at You, NBC

WILSON, LOIS

Aldrich Family
NBC-TV

WILSON, MARIE

My Friend Irma
CBS-TV

WINCHELL, PAUL

Paul Winchell Show
NBC-TV

WINCHELL, WALTER

ABC-TV

WINNER, HARRY

Wonderful City
Sports Ten
Mutual

WOOD, PEGGY

Mama
CBS-TV

WOODS, DONALD

Ouch! Award
ABC-TV

WOODS, NATALIE

Pride of the Family
ABC-TV

WRAY, FAY

Pride of the Family
ABC-TV

WRIGHTSON, EARL

Robert Q. Lewis Show
CBS

— Y —

YOUNG, AGNES

Aunt Jeany
CBS

YOUNG, LORETTA

Letter to Loretta
NBC-TV

YOUNG, ROBERT

Father Knows Best
NBC



Morning Radio Programming; A Pattern for AM Stations

By SAM SLATE
Program Manager
WCBS, New York

RADIO is anything but a static business and even though WCBS has been New York's top station for a long time we've made a number of program changes the past two years.

Our first problem was to find a "different" disc jockey for the 5:00 to 6:00 P.M. time slot. He had to be different as he'd be in direct competition with Martin Block and Art Ford, two long established performers.

I interviewed talent and listened to audition discs from all parts of the United States for several weeks. Finally John Henry Faulk came to see me and I decided he was the ideal person for this time period. Faulk had an interesting background. He'd been a professor at the University of Texas, had two degrees and specialized in Americana and folk music. He had a decided Texas drawl, an ability to tell both folk and "tall tales," and a rather unusual viewpoint on everyday events.

Johnny made his debut on December 17, 1951 and has become one of the station's best liked personalities.

The next problem was our morning schedule. It was obvious there was too much talk and not enough music. It was my belief that having music by a personality, combined with news, would be proper programming. I suggested to General Manager Carl Ward that we cut Bill Leonard's "This Is New York" from 45 minutes to a half-hour. He agreed, and we put in a live musical show, that meant WCBS programming would be a half hour of talk and a half hour of music. In April, 1952, a leading singing star, song writer and entertainer made her bow on WCBS in the person of Joan Edwards, today rated the top morning show among the local network stations in the Metropolitan area.

A short time later we were ready for another change. We still felt that there was still too much talk on the morning schedule. More music was wanted and so

we brought in Bob Haymes in August, 1952. Haymes was programmed for the 8:15-9:00 A.M. spot, preceding "This Is New York." At the same time WCBS acquired an additional 25 minutes in the afternoon and we promptly filled it with author-lecturer, Emily Kimbrough.

We next decided that the "Jack Sterling Show," on the air from 5:30-7:45 A.M. Monday thru Saturday, needed a "shot in the arm." In October, 1952, we added a 5 piece live musical unit, the Elliott Lawrence group, that gave the program live musical lead-ins for commercials and records, and which built the show materially.

As the WCBS morning programming shapes up today, we have one hour and fifteen minutes more music in addition to live units. Joan Edwards and Bob Haymes are stars in their own right. They write their own music and sing as well. In the afternoon we have 50 minutes more music than was on the air prior to the fall of 1951.

From a news standpoint, we have put in five minutes of news at 6:00, 6:30, 7:00, and 7:30 A.M., as well as at 5:00 P.M. In addition, our "Let's Find Out" program, a show that turns the spotlight of interest to New Yorkers every Sunday from 12:00 Noon to 12:30 P.M., has built tremendous public service.

Our "all-night show," which went on the air early this year, has increased listener interest. We were fortunate in finding a sponsor in American Airlines. Taking a look at the competition we decided to put in semi-classical music and add five minutes of news every hour on the hour, running from midnight to 5:00 A.M.

We are extremely careful about our selection of music. We are always trying to give our listeners the type of music we think they want. Our policy is to stay clear of novelty discs in the morning, play as many top ten and all time standards as possible and use the type of music that blends with Faulk's humor.



P e g g y L e e

VOCAL ARTISTS

RADIO AND TELEVISION

—their work during 1953



— A —

ALLEN, LLOYD
KCLS, Flagstaff, Ariz.

ALLEN, RAY
WTOP, Washington, D. C.

ANDERSON, PADDI
Just For You
KWHP, Cushing, Okla.

ANDERSON, PAUL
Breakfast With Bigclows
WJTN, Jamestown, N. Y.

ANDRESS, ANN
Man On the Farm
Mutual

ANDREWS, JOHNNY
Morning Bandwagon
WTAM, Cleveland, O.

APPLEGATE, BEN
Hymn Time With Mr. and Mrs.
Ben Applegate
KLCB, Libby, Mont.

APPLEWHITE, CHARLIE
Milton Berle Show, Arthur Mur-
ray Show; NBC-TV

APRIL, ODETTTE
CJFP, Riviere Du Loup, Que.

ARAKAKI, MICHIE
Together With Michiko
KPOA, Honolulu, Hawaii

ARCHER, GENE
A Visit With Archer
WNBW, Washington, D. C.

ARCHER, DON
KGST, Fresno, Cal.

ARDEN, JAN
Robert Q. Lewis Show
CBS

ARMEN, KAY
Meet Me at Kay's
NBC

ARMS, RUSSELL
Your Hit Parade
NBC-TV

ARNOLD, EDDY
Eddy Arnold Show
NBC

ASHBY, ALVAN
WGFB, Evansville, Ind.

ATCHER, BOB
Faultless Starch Time
NBC

ATTER, VIRGINIA
WMBR, Jacksonville, Fla.

AZALEA TRIO
Beantown Varieties
WEEI, Boston, Mass.

— B —

BAIN, BUDDY
Buddy Bain Show
WCMA, Corinth, Miss.

BAKER, MARIE
Starlite Serenade
KJEO, Fresno, Cal.

BALENTINO, BARRY
ABC

BARBER, LOUIS
Staffilers
WGAR, Cleveland, O.

BARRETT, RON
WEOL, Elyria, O.

BARTON, EILEEN
Broadway Open House, Milton
Berle Show, Lucky Strike Hit
Parade, NBC-TV; Jackie Gleason
Show, Songs for Sale, Perry Como
Show, CBS-TV

BECKER, JOHNNIE
KIUP, Durango, Colo.

BEERS, BOBBY
KFEL, Denver, Colo.

BIRCH, TOMMYE
KMO, St. Louis, Mo.

BOERSON, STAN
Open For Business
KING-TV, Seattle, Wash.

BOOTH, KEITH
ABC

BOUCK, LOUIS
Name the Song
WMTC, Vancleve, Ky.

BRADY, PAT
Pat Brady Sings
WABY, Albany, N. Y.

BRANDY, BOB
WRBL, Columbus, Ga.

BRANNEN SISTERS
WKKO, Cocoa, Fla.

BREES, BUD
WPEN, Philadelphia, Pa.

BRINKLEY, J. B.
Cedar Ridge Boys
WBAP, Ft. Worth, Tex.

BRIDGES, MERCER T.
ABC

BRITT, ELTON
Elton Britt Show
WCOP, Boston, Mass.

BRITTON, JAMES
WHEC, Rochester, N. Y.

BROOKS, MAGGIE
Date at Eight, Harmony Hall
WDSU, New Orleans, La.

BROWN, DOTTE
Don't the Town
KSL-TV, Salt Lake City, Utah

BRUNET, HARRY AND DOTTY
Welcome Ranch
Mutual

BUSSE, GLORIA
Gloria Sings
WDOK, Cleveland, O.

BYERLY, JAMES E.
ABC

— C —

CALDWELL, BOB
Music Shop
WDTV, Pittsburgh, Pa.

CARDWELL, JACK
WKAB, Mobile, La.

CARPENTER, BERT
Songs for You
KSUB, Cedar City, Utah

CARR, NANCY
Chicago Theatre of the Air
Mutual

CARROLL, JUDY
WJR, Detroit, Mich.

CARSON, KEN
Saddle Scouts
WABD

CAWOOD, JOHNNY
WMIK, Middlesboro, Ky.

CHAIR, BILL de
Camp Chaffee Mel Aires
KFSA, Ft. Smith, Ark.

CHARLES, RAY (Chorus)
Perry Como Show
Mutual

CHEROKEE, JACK
Lucky 13 Roundup
KMO-TV, Tacoma, Wash.

CHOATE, BILL
Dude Ranch Bill
KOB, Stockton, Cal.

CLARK, AL
KOTA, Rapid City, S. D.

CLAY, PATSY
Radio Rodeo
WOAI, San Antonio, Texas

CLOONEY, ROSEMARY
Rosemary Clooney Show
NBC

COLLINS, DOROTHY
Your Hit Parade
NBC-TV

COLTON, CLARENCE
CKTB, St. Catherines, Ont.

COMO, PERRY
Perry Como Show, CBS-TV; Perry
Como Show, Mutual

COMPTON, DEWEY
KTRH, Houston, Texas

CONNOR, ELLEN
KCBS, San Francisco, Cal.

COOK, JOE
Smile Away
KGGF, Coffeyville, Kan.

COOK, LOIS
Smile Awhile
KGGF, Coffeyville, Kan.

COREY, JILL
Dave Garraway Show
NBC-TV

COURY, ROSELLE
WCOU, Lewiston, Me.

COX, BETTY
Broadway to Hollywood
DuMont

COX, JIMMY
Time for Adventure
KCSJ, Pueblo, Colo.

CRANE, DICK
KNEA, Jonesboro, Ark.

CROMWELL, JEAN
WHEQ, Memphis, Tenn.

CULVER, RANDY
Morning Melodies
WEWS, Cleveland, O.



JIMMY WAKELY

CORAL RECORDS exclusively
CBS RADIO for Bristol-Myers
REPRESENTATION Radio & TV
PUBLIC RELATIONS

West Coast 7:30 P.M. Saturdays
M C A
The Ettinger Company

VOCAL ARTISTS — RADIO-TELEVISION

CUNNINGHAM, DAVIS
Chicago Theater of the Air
Mutual

CURTIS, KEN
Lucky U
KEJ, Los Angeles, Cal.

— D —

DACUS, MEL AND KATY
Carousel
WBAP-TV, Fort Worth, Tex.

DALE, DIANE
WIXIE Wonderland
WXYZ-TV, Detroit, Mich.

DARLENE, DONNA
WKBT, St. Marys, Pa

DATA, MARISHA
Polish Poppies
WSBC, Chicago, Ill

DAVIS, GEORGE
WRBL, Columbus, Ga.

DAVIS, JEANETTE
Arthur Godfrey Shows
CBS-TV

DAWN, MARION
Club 1300
WPBR, Baltimore, Md.

DAYE, MARLYN
Auction Antica
WLW-C, Columbus, O.

DEAN, EDDIE
Hoffman Hayride
KPIX, S. F., Cal.

DE CAMP, ARDEEN
KCBS, San Francisco, Cal.

DEER, JIMMY
Ole Chiz
WDAK, Columbus, Ga.

DELAND, JIM
WWJ, Detroit, Mich.

DELLENGER, LOU
KWBW, Hutchinson, Kan.

DEVLIN, COLETTE
CKCH, Hull, Que.

DONNADIO, TONY
WWIN, Baltimore, Md.

DOREY, RAY
WHDH, Boston, Mass.

DOUGLAS, MIKE
The Music Show
DuMont

DOWLING, JEANNE
WTOP, Washington, D. C.

DOWNING, CLYDE
Parade of Stars
WHBY, Appleton, Wis.

DRAKE, MILDRED
Gospel in Song
WMTC, Vancleve, Ky.

DURBIN, MARK
KOOK, Billings, Mont.

— E —

EAGER, CLAY
Burkhardt's Bunkhouse
WLOK-TV, Lima, O.

EARLES, BARBARA
WLOE, Leaksville, N. C.

EDEN, JOAN
Songs with Jean
WCCO, Minneapolis, Minn.

ELLIS, PEGGY ANN
ABO

ELLIS, SHIRLEY
Chapel Echoes
KFDA, Amarillo, Texas

EMERALD, GENE
KRNT, Des Moines, Iowa

EMERY, RUSS
New England Talent Club
WJAR-TV, Providence, R. I.

ERICKSON, HELENE W.
Opera—Concert—Radio-TV

ERLANDSON, BETTY
KGVO, Missoula, Mont.

ESTES, DON
Don Estes Show
KPRC, Houston, Tex.

EVANS, JOANNE
WAVU, Albertville, Ala.

— F —

FIELD, ELLIOT
Field House
WKAT, Miami Beach, Fla

FINCH, DICK
WPBC, Minneapolis, Minn.

FISHER, EDDIE
B. Aug. 10, 1928, Philadelphia, Pa.
Coke Time with Eddie Fisher,
NBC, NBC-TV

FLETCHER, TEX
B-Bar-B
Mutual

FOLEY, RED
Grand Ole Opry
NBC

FOOTE, BRUCE
Chicago Theater of the Air
Mutual



HELENE W. ERICKSON

Soprano
Opera — Concert
Radio — TV
TR 7-8308



JEAN MARTIN

NBT Singing Star
Sammy Kaye Show
Morey Amsterdam Show
and Jerry Lester's "Late Date"

FORD, MARY

Perry Como Show, Omnibus, CBS,
Red Skelton Show, Milton Berle
Show, Nothing But The Best,
NBC, Les Paul & Mary Ford At
Home, TV Film

FRANK, KEITH AND LELA

Sunlight Singers
KTOP Durango Colo

FRAE, GWEN

Gwen & Elizabeth
KTAT Frederick Okla

FURTADO, TOMMY

ABC

— G —

GAUDREAU, CARMELLE

CJEM Edmondston N B

GIPSON, JACK

Cedar Ridge Boys
Benley Barn Dance
WBAP WBAP TV
Ft Worth, Texas

GOODE, GLORIA

Mello-D-Roundup
WXYZ TV Detroit Mich

GORME, EVDIE

Steve Allen Show
NBC TV

GRAM, MARGO

Welcome Corner
WWSC Glenn Falls N Y

GRANT, HAL

WDBJ Roanoke, Va

GRAY, DOLORES

Bluek Circus Hour
NBC-TV

GROYE, BETTY ANN

The Big Payoff
NBC TV

— H —

HAGGART, BUD

The Blues Chasers
WDFB, Flint Mich

HALELOKE

Arthur Godfrey Shows
CBS-TV

HALETTOWN, CHIEF

Pony Express
WFIL-TV, Phoenix Ariz Tv

HALL, BUDDY

WSM Nashville Tenn

HALL, GEORGE

KZTV Reno Nev

HALL, WENDELL

Wendell Hall Reflections
WBRB, Chicago Ill

HAMILTON, DAVE

WLW, Cincinnati, O

HAMILTON, LOIS

Music & Meditation
CKNX, Wingham, Ont Can

HANNA, PHIL

Bride & Groom
NBC-TV

HANSON, BURT

Hanson Sings
WCCO, Minneapolis, Minn

HARMER, SHIRLEY

Dave Garraway Show
NBC-TV

HARMONY TRIO

WLEP, Tucson Ga

HARP, MARTHA LOU

ABC

HARPER, HECK

KEX Portland, Ore

HARRIS, JACK

WWJ Detroit Mich

HAYES, BILL

Your Show of Shows
NBC-TV

HETZER, DIANE

Twilight Time
WSAZ-TV Huntington W Va

HIT PARADERS

Your Hit Parade
NBC-TV

HOLDEN, JACK

Jack and Frances
WEAS, Decatur Ga

HUFFMAN, JULES

Coffee Time
WSAZ-TV Huntington W Va

HUGGLER, LYLE

WKBI St Marys Pa

RUTH, NITA

WTVN Columbus O

HUTCHINSON, LUCIA

WRBL Columbus Ga

— I —

IVANY, HAROLD

Echoes at Eventide
VOCM St John's Nfld

— J —

JACKSON, RUDOLPH

Valley Swing Session
KCSB San Bernardino, Cal

JESKE, FRED

The Jeske Programs
WNDR Syracuse N Y

**JANE
PICKENS**

DRAMATIC SINGING STAR

NBC NETWORK

RCA VICTOR RECORDS

Personal Management

M GALE

48 W. 48th St., N. Y



◆ ◆ ◆ VOCAL ARTISTS — RADIO-TELEVISION ◆ ◆ ◆

JOHNSON, JUDY
Your Show of Shows
NBC

JOHNSON, MARY JANE
Faultless Starch Time
NBC

JONES, PAUL
Song Souvenirs
WFLA, Tampa, Fla.

JORDAN, FRANK
WPKY, Frankfort, Ky.

JOY, JEANNE
Western Stampede
KOA, Denver, Colo.

— K —

KEAN, HAROLD
Operation Sunshine
WJR, Detroit, Mich.

KELLEY, JUDITH
Stars Over Fall River
WALE, Fall River, Mass.

KENDALL, FRED
Guest House
WJR, Detroit, Mich.

KEYS, CHARLIE
Ladies Matinee
KCBD-TV, Lubbock, Tex.

KING, BILL
King Sings
WTOG, Savannah, Ga.

KINNEY, WENDELL
Patterns in Black and White
KMO, Tacoma, Wash.

KIRSTEN, DOROTHY
Railroad Hour
NBC

KRUEGER, DICK
KXYZ, Houston, Texas

— L —

LA CHANCE, BOB
WHM, Providence, R. I.

LACHESNAYE, CHOEUR
Folklore
CJFP, Riviere Du Loup, Que.

LALONDE, JEAN
Cocktail Hour
CHLP, Montreal, Que., Cau.

LANE, FRANCEY
Morey Amsterdam Show
NBC-TV

LANE, LARRY
Larry Lane Show
KFGO, Fargo, N. D.

LANSON, SNOOKY
Your Hit Parade
NBC-TV

LAROSA, JULIUS
Toast of the Town,
Arthur Godfrey Shows
CBS-TV

LATULIPPE, DON
WJDA, Quincy, Mass.

LAWRENCE, STEVE
Steve Allen Show
NBC-TV

LECLERC, LOUIS
CKCV, Quebec

LEE, PEGGY
B. 1920, Jamestown, N. D.
Colgate Comedy Hour, NBC-TV

LEMKE, DAVE
Songs of the West
KTSM, El Paso, Texas

LESLIE, MARY ANN
Deline Gang
WSYR-TV, Syracuse, N. Y.

LEWIS, NANCY
WFIL, Philadelphia, Pa.

LINN, ROBERT
Cafe Continental
KTLA, Hollywood, Cal.

LONG, GENE
Auction Ancties
WLW-C, Columbus, O.

LOU, MARTY
KODY, North Platte, Neb.

LOVELL, MARILYNN
WWJ, Detroit, Mich.

LYNN, JACKIE
Morning Bandwagon,
Henry & Jackie
WTAM, WNBK, Cleveland, O.

— M —

MacKAY, RENEE
Guest House
WJR, Detroit, Mich.

MACKENZIE, GISELE
Your Hit Parade
NBC-TV

MacRAE, GORDON
Railroad Hour
NBC-TV

McCALL, BECKY
KNEA, Jonesboro, Ark.

McCOY, MARY
KMCO, Conroe, Tex.

McCRITCHIE, BARBARA
Melodies & Money
KGO, San Francisco, Cal.

McDONALD, HOWARD
CKCK, Regina, Sask.

McDOUGAL, EDDIE
Country Capers
WIRL, Peoria, Ill.



**ROBERT
MERRILL**

RADIO-TV
RCA VICTOR RECORDS
METROPOLITAN OPERA

Personal Management
M. GALE
48 W. 48th St., N. Y.

◆ ◆ ◆ VOCAL ARTISTS — RADIO-TELEVISION ◆ ◆ ◆

McGUIRE, MAC
Harmony Rumber
WIP, Philadelphia, Pa.

McGUIRE SISTERS
Arthur Godfrey Shows
CBS-TV

MAIN, EVERETT
Singer, Buckaroo
KLIX, Twin Falls, Idaho

MANN, JOE
Meet Your Neighbor
WDTV, Pittsburgh, Pa.

MARINERS, THE
Arthur Godfrey Shows
CBS-TV

MARLENE, MARLENE
TV WAAM Boree
WAAM, Baltimore, Md.

MARLOWE, MARION
Arthur Godfrey Shows
CBS-TV

MARTIN, HELEN
Breakfast With Ingeblows
WJTN, Jamestown, N. Y.

MARTIN, ILEAN
Albers for You
WLOK-TV, Lima, O.

MARTIN, JEAN
Jerry Lester's Late Date
NBC-TV

MARTIN, TONY
Tony Martin Time
NBC

MARYIN, BOB
Open House
WBNS, Columbus, O.

MASSEY, AERA
Our House
WDSU, New Orleans, La.

MATHEWS, ORVILLE
Slim Mathews Show
KMMO, Marshall, Mo.

MAURET, V.
French Folk Songs
WEVD, N. Y.

MAVO, MARY
ABC

MEIERS, MARY
KCOL, Ft. Collins, Colo.

MERCEDES
KING-TV, Seattle, Wash.

MERRIDEW, REG
WGAR, Cleveland, O.

MERRILL, ROBERT
Encore, NBC; RCA Victor Rec-
ords, Metropolitan Opera

MILLS, VICKI
Name That Tune
NBC-TV

MILNE, NANCY
WDRJ, Roanoke, Va.

MILTNER, JAY
WBBK, Cleveland, O.

MITCHELL, BOOTS
Boots and Bob
WGEM, Quincy, Ill.

MOLASKEY, EDDIE
Eddie Molaskey Show
KODI, Cody, Wyo.

MORATH, MAX
Shopping Notes
KKTU, Colorado Springs, Colo.

MORELAND, DON
Man on the Farm
Mutual

MORGAN, JAYE P.
Robert Q. Lewis Show
CBS

MORGAN, MARION
Bandstand Revue
KTLA, Hollywood, Cal.

— N —

NADEAU, YVON
CJEM, Edmuntson, N. B.

NELSON, GENE
Between Times
KFAM, St. Cloud, Minn.

NOEL, HENRI
The Music Show
DuMont

NOONAN, STANLEY
KCBS, San Francisco, Cal.

NORWOOD, JACK
WTAR-TV, Norfolk, Va.

— O —

O'BRIEN, MARY LOU
Career Girl
KENT, Shreveport, La.

O'DAY, PAT
WHDH, Boston, Mass.

O'HARA, PATTI
WLW, Cincinnati, O.

OLIVER, JEAN
WFAA, Dallas, Tex.

— P —

PAGE, KIKI
Take 10
WBNS, Columbus, Ohio.

PAGE, PATTI
Scott Music Hall
NBC-TV



WENDY WAYE
Coral Recording Artist

PALMER, JANIE

WWJ, Detroit, Mich

PARADISO, CARL

Starliners
WGAR, Cleveland, O.

PARKER, FRANK

Arthur Godfrey Shows
CBS-TV

PARKER, MARGE

Marge's Song Shop
KMA, Shenandoah, Iowa

PATTERSON, C. P.

WGTH, Hartford, Conn.

PERKINS, RAY

KFEL, Denver, Colo.

PIATT, JOHN

Buick Circens Hour
NBC-TV

PIAZZA, MARGUERITE

Encore, Your Show of Shows
NBC, NBC-TV

PICKENS, JANE

Jane Pickens Show
NBC

PINZA, EZIO

All Star Revue, Bonito
NBC-TV

POLERI, DAVID

Chicago Theater of the Air
Mutual

PORTER, TONY

WHIL, Medford, Mass.

POWERS, DON

WJAT, Swainsboro, Ga.

PRICHARD, PATTI

KPIX, San Francisco, Cal.

PUDNEY, EARLE

WRGB, Schenectady, N. Y.

— R —

RAYE, RUTH

WTAR-TV, Norfolk, Va.

RAYMOND, NORMA

ABC

RAZOR, JERRY

WTVN, Columbus, O.

REED, CAROL

Rain or Shine
WBES, New York, N. Y.

REYNOLDS, BRAD

KGW, Portland, Ore.

RICHARDS, ERNIE

Songs at Twilight
WMMT, McMinnville, Tenn.

RICHMOND, BOB

Marking Show
WREN, Topeka, Kan.

RIDDLE, GEORGIE

Georgie Riddle Show
WBAT, Marion, Ind.

RHIL, MARY K.

Once Upon a Time
WITV, Ft. Lauderdale, Fla.

ROBINS, GEORGE

WEBR, Buffalo, N. Y.

RODDA, WALT

Ranch House
WKAT, Miami Beach, Fla.

ROECKER, EDDIE

WFIL, Philadelphia, Pa.

ROESNER, GEORGE

Farm Front
KTRH, Houston, Texas

ROGERS, DOLORES

WPTA, Pensacola, Fla.

RUSSELL, JACK

Your Show of Shows
NBC-TV

RUTH, VIOLA

Viola Ruth Sings
KAYS, Hays, Kans.

RHYTHM PALS

CKWX, Vancouver, B. C.

— S —

SCHMITZ SISTERS

WPBC, Minneapolis, Minn.

SELF, JIMMY DEAN

KICA, Clovis, N. M.

SHELTON, LORRAINE

Every Little Moment
WITV, Ft. Lauderdale, Fla.

SHORE, DINAH

The Dinah Shore Show
NBC, NBC-TV

SIMMS, LU ANN

Arthur Godfrey Shows
CBS-TV

SKOK, ELEANOR

Serenade in the Night
KGA, Spokane, Wash.

SNOW, SPENCER

KERG, Eugene, Ore.

SONGSTERS QUARTET

KRHD, Duncan, Okla.

SOUTHERN GOSPEL QUARTET

WLET, Toccoa, Ga.

SPELMAN, MARIAN

WLW, Cincinnati, O.

STALKER, KAY

Breakfast Frolic
KFH, Wichita, Kan.

STARR, ROCKY

Western Stampede
KOA, Denver, Colo.

STEWART, CLAIRE

Money Man Program
WFAA, Dallas, Texas

STEWART, JAN

KNUZ-TV, Houston, Texas

STEWART, SANDY

Kovacs Unlimited
WBES, New York, N. Y.

STEVENS, GARRY

TV Showcase
WRGB, Schenectady, N. Y.

STOVER, JAMES A.

ABC

STRACKE, WIN

Animal Playtime
WNDQ, Chicago, Ill.

SUTTS, GORDON

Suits Song Shop
KGNC, Amarillo, Texas

SWANN, JIMMY

Jimmy's Jamboree
WESY, Hattiesburg, Miss.

SWANSON, BYRON

Serenade in the Night
KGA, Spokane, Wash.

SWERER, BOB

KCOL, Ft. Collins, Colo.

— T —

TALLEY, JOHN

Melody Trio
WYVE, Wytheville, Va.

TALLY, RUTH

Lonesome Sweetheart
WRHC, Jacksonville, Fla.

TAYLOR, BETTY

KHJ, Los Angeles, Cal.

TAYLOR, DARRELL

Music for Inspiration
KFDX-TV, Wichita Falls, Tex.

TAYLOR, MORRIS

Western Roundup
KMOR, Oroville, Cal.

TAYLOR, WAYNE

KTVQ, Oklahoma City, Okla.

TEAGUE, NANCY

KCBD-TV, Lubbock, Tex.

TENNY SISTERS

Welcome Ranch
Mutual

TEXAS BUCKAROOS

WJCH, Norwich, Conn.

THERIOT, AL

Roundup
KVOL, Lafayette, La.

THOMASON, JIMMY

KAFY, Bakersfield, Cal.

TRAIL HERDERS

The Trail Herders
WKNB, New Britain, Conn.

TANNER, PAT

The Record Shop
KMPT, Oklahoma City, Okla.

TUREK, BEVERLY

Beverly Sings
WFAU, Augusta, Me.

— V —

VALLI, JUNE

Your Hit Parade
NBC-TV

VAN, JACKIE

The Music Show
DuMont

VAN ARSDALE, EILEEN

Beantown Varieties
WEET, Boston, Mass.

VANDERBILT, EILEEN

Song By Eileen
WPLA, Plant City, Fla.

VAUGHAN, DENNY

CFRB, Toronto, Ont.

VERDI, LOU

Like Magic
WGAY, Silver Spring, Md.

— W —

WAGNER, ANN

WFBM, Indianapolis, Ind.

WAGONER, PORTER

KWVO, Springfield, O.

WAKELY, JIMMY

West Coast—CBS Radio
Coral Records

WALLS, VIVAN

Songs From the Heart
KRDA, Amarillo, Texas

WARD, RUTH

WSIC, Charlotte, S. C.

WARENSKJOLD, DOROTHY

Railroad Hour
NBC

WARNER, ELEANORE

The Music Show
DuMont

WARREN, DOC

KWFT-TV, Wichita Falls, Tex.

WATSON, DOLORES

WSM, Nashville, Tenn.

WAYE, WENDY

Coral Records

WAYNE, RICK

Matinee
WTVE, Elmira, N. Y.

WEBB, CARL

WLOE, Leaksville, N. C.

WEBER, HARRY

KMOX, St. Louis, Mo.

WEISS, DICK

The Minute Man
WFDF, Flint, Mich.

WESSELS, MAX H.

Continental Favorites
WWRL, New York, N. Y.

WILLIAMS, BILLY

B. Dec. 28, 1915, Waco, Texas

Your Show of Shows, NBC-TV

WILLIAMS, BILLY QUARTET

Your Show of Shows
NBC-TV

WILLIAMS, EDDIE

KDAL, Duluth, Minn.

WOODS, DOROTHY

WHGB, Harrisburg, Pa.

WORKMAN, DICK

Deline Gang
WSYR-TV, Syracuse, N. Y.

WRIGHT, NYLA

Club 1300
WFBR, Baltimore, Md.

— Y —

YATES, GLORIA

KTVQ, Oklahoma City, Okla.



TELEVISION LIFE
MAGAZINE

JANUARY 1954

After 19 years at NBC, Bill Stern made headlines by suddenly switching to ABC. The top sports commentator moved trophies, portable recorder, and Inga (secretary)—despite the year left on his NBC contract. What's more, Bill had just been wooed & won by a new sponsor. The question making the rounds was: *Why did he hand over this lucrative setup to ABC instead of NBC?* The inside story is that Bill was not happy at NBC—hadn't been for several years. He felt that he was being wasted. Furthermore, he was obliged to slant his sports news. The same Stern who'd reached the top by way of fresh, hot news—plus a resonant voice and diction that left no doubt as to *who* was on first. The talents and pressures from within inevitably resulted in stale news items. There was also the rule of eternal praise for the Yankees, right or wrong. Stern's not anti anything. He simply feels that there are several worthy ball clubs. As an impartial reporter who likes to do his work in his own way, Bill did the only thing possible—he opened the nearest door, and walked out. . . .

THANKS
TELEVISION LIFE
MAGAZINE
and
RADIO-TELEVISION
EDITORS



*Bill
Stern*

SPORTS COMMENTATORS

RADIO AND TELEVISION

—their work during 1953



— A —

ABLEMAN, BERWYN
WPDR, Portage, Wisc.

ACHOR, DAVE
Sportsman
WBEX, Chillicothe, O.

ACKERMAN, AL
Sports Notebook
WHTC, Holland, Mich.

ADAMS, TONY
Sports Tonite
WCAX, Burlington, Vt.

ADELSON, JIM
Today in Sports
KCJB, Minot, N. D.

AGRESTA, PHIL
WBT, Charlotte, N. C.

ALAN, MARC
WMFS, Chattanooga, Tenn.

ALBERTS, MAL
KPUG, Bellingham, Wash.

ALDRIDGE, MAHLON R.
Sports Page
KFRU, Columbia, Miss.

ALLAN, STAN
WPAC, Patchogue, N. Y.

ALLEN, MEL
E. Feb. 14, 1913, Birmingham, Ala. N. Y. Yankees Baseball, WPIX, WINS; World Series, NBC-TV; Rose Bowl, NBC-TV; Major League All Star Game, NBC-TV; NCAA College Football, NBC-TV; White Owl Sports Spot, CBS-TV; Sports Daily, NBC

ALLEN, STEVE
Sports Parade
KICD, Spencer, Iowa

AMBROSE, JOHNNY
Speaking of Sports
WTAG, Worcester, Mass.

ANDERSON, ALLEN
WASA, Havre de Grace, Md.

ANDERSON, ANDY
Sports Highlights
WESH, Hattiesburg, Miss.

ANDERSON, DICK
WEOA, Evansville, Ind.

ANDERSON, KIRK
WFGM, Fitchburg, Mass.

ANDERSON, TOM
Sports Roundup
WGEZ, Beloit, Wisc.

ANTHONY, GEORGE
Sports Parade
WOND, Pleasantville, N. J.

ARKISON, JIM
Sports Beat
WALE, Fall River, Mass.

ARO, SAM
WPIX, N. Y. C., N. Y.

ARROYO, VICTOR
WKVM, San Juan, P. R.

ARTHUR, DON
Sports Edition
WDUZ, Green Bay, Wisc.

ARTHUR, FRANK
KSAN-TV, San Francisco, Cal.

ARTHUR, HARRY
Sports Whirl
KNOE, Monroe, La.

ASHLEY, ERNIE
WOWO, Ft. Wayne, Ind.

ATWOOD, TED
The Sportspage
WCNT, Centralia, Ill.

— B —

BABB, HUGH WEBSTER, JR.
WPOR, Portland, Maine

BAGLI, GUY
WALT, Tampa, Fla.

BAILEY, CHARLIE
WEBB, Buffalo, N. Y.

BAIR, PAUL
WEOA, Evansville, Ind.

BAKER, BILL
WMIK, Middlesboro, Ky.

BAKER, DICK
Sports Time
WSAI, Cincinnati, O.

BAKER, NELSON
Melody Scoreboard
WFBR, Baltimore, Md.

BAKER, PAUL
Good Morning Sports
WLAD, Danbury, Conn.

BALDING, CHUCK
WOAY, Oak Hill, W. Va.

BALDWIN, BILL
KRNR, Roseburg, Ore.

BALDWIN, KEN
WCOS, Columbia, S. C.

BALLARD, CHARLES
WEAW, Winston, W. Va.

BALTER, SAM
KLAC, Los Angeles, Cal.

BARBER, RED
Football Roundup
Senior Bowl Game
CBS

BARRON, RUSS
Down the Line
WKLV, Blackstone, Me.

BARRUS, GABBY
Sports Report
KODI, Cody, Wyo.

BARRY, DONALD J.
WIKE, Newport, Vt.

BARRY, KEITH
Fanfare
CHNS, Halifax, N. S.

BARRY, NORMAN
Let's Look at Sports
WNBQ, Chicago, Ill.

BARTON, DALE
Sports Parade
KCIM, Carroll, Iowa

BATES, JACK
KFOR, Lincoln, Nebr.

BATES, MARVIN
WGBF, Evansville, Ind.

BATES, ROY
WWST, Wooster, O.

BEARD, CHARLIE
KDNT, Deaton, Texas

BEATTY, ROSS
WLOL, Minneapolis, Minn.

BEAUMONT, JOE
WBHB, Fitzgerald, Ga.

BECKER, HARRY
KCLS, Flagstaff, Ariz.

BECKNER, ART
WKBV, Richmond, Ind.

BEHAN, DENNIS
World of Sports
KLMB, Lamar, Colo.

BELCHER, ROD
KOL, Seattle, Wash.

BELL, GABBY
WILD, Birmingham, Ala.

BELL, MONTE
KADA, Ada, Okla.

BELOTE, WILLARD
WGAJ, Valdosta, Ga.

BENDER, BOB
Bob Bender's Sport Show
WGY, Schenectady, N. Y.

ENDER, TOM
WTMA, Charleston, S. C.

BENINGTON, L. H.
KMPT, Oklahoma City, Okla.

BENNETT, DON G.
KREW, Sunnyside, Texas

BENNETT, ELDEAN
KSL, Salt Lake City, Utah

BERONIO, DAVE
What Do You Know About Sports
KVON, Napa, Cal.

BERRILL, LARRY
KBIG, Avalon, Cal.

BERRYMAN, EDWARD
Sports Roundup
WBBC, Flint, Mich.

BIRD, BUD
Bird's Eye on Sports
KISD, Sioux Falls, S. D.

BIRLEFFI, LARRY
KFBC-TV, Cheyenne, Wyo.

BISHOP, HAROLD
Sports Roundup
WCCM, Lawrence, Mass.

BITTERMAN, JACK
WAB, Mobile, Ala.

BIVENS, CHARLES
WMOZ, Mobile, Ala.

BLACK, JIM
Quarterback Club
KCBD-TV, Lubbock, Tex.

BLACK, MARTIN
KRANM, Las Vegas, Nev.

BLACKBURN, BOB
KEX, Portland, O.

BLAINE, GENE
Today's Games
WGST, Atlanta, Ga.

BLATTNER, BUDDY
Baseball
ABC-TV

BLESSEY, EARL B.
WVMI, Biloxi, Miss.

BLUE, IRA
KNBC, S. R., Cal.

BLUM, BOB
KEEN, San Jose, Cal.

BODA, LOU
WMBH, Joplin, Mo.

BODIE, ARMOND
WSOC, Charlotte, S. C.

BODNEY, AL
KDSH, Boise, Idaho

BOGGESS, JOHN
Sports Revue
WLAG, Lagrange, Ga.

BOLAND, JOE
WSBT, South Bend, Ind.

BOND, LYLE
KIL, Los Angeles, Cal.

BONNELL, GEORGE
WIHL, Hammond, La.

ROUTON, ED
WKTU, Utica, N. Y.

BOWMAN, DON
WIOD, Miami, Fla.

BOYD, DON
WCLO, Janesville, Wisc.

BOYER, JOHNNY
KDKA, Pittsburgh, Pa.



BUD PALMER

*"Palmer has developed into
one of our very finest sports announcers . . ."*

CUE

*"Pre-game coverage was
excellently handled by Bud Palmer"* VARIETY

Press Box Preview (Oldsmobile)—NBC-TV—Sat. Afternoons

"It Happened in Sports"—NBC-TV, 10:45-11 P. M. Tuesdays

National Tennis Championships—NBC-TV

Today—NBC-TV

Sports Final—WNBT

Madison Square Garden—WPIX:

Hockey, Basketball, Westminster Dog Show,

National Horse Show

1953

Personal Management: LESTER LEWIS ASSOCIATES

11 East 48th Street, New York 17

PLaza 3-5083

— C —

BRADLEY, JACK
Sports Almanac
WSAZ-TV, Huntington,
W. Va.

BRADWAY, HARRY
WASK, Lafayette, Ind.

BRADY, BILL
WPRC, Lincoln, Ill.

BRANSON, TODD
Sportshow
WWCA, Gary, Ind.

BRAX, DICK
WCKY, Cinn., O.

BREEN, GORDON
Big Dine In Sports
CKTS, Sherbrooke, Que.

BRENGEL, BILL
WWL, New Orleans, La.

BRENT, LARRY
Sports Parade
WAJF, Decatur, Ala.

BRETAG, JERRY
WLPO, La Salle, Ill.

BRICKHOUSE, JACK
All-Star Game, NBC-TV

BRISCOE, WALLY
KCLA, Pine Bluff, Ark.

BRITT, JIM
B. April 11, 1910, San Francisco,
Cal. Sports Final, NBC-TV; Dumont
Pro Football, Dumont; Jim
Britt's Sports Reports, ABC

BRITTON, JACK
KTRN, Wichita Falls, Texas

BROCK, ART
WVEC-TV, Hampton, Va.

BROCKHAM, CHARLES
Kingam's Klubhouse
WIRE, Indianapolis, Ind.

BRODY, STEVE
KJNO, Juneau, Alaska

BROOKS, BOB
KCRI, Cedar Rapids, Iowa

BROWN, BILL
WBTA, Batavia, N. Y.

BROWN, BOB
WAYS, Charlotte, N. C.

BROWN, CHARLES N.
WKOZ, Kosciusko, Miss.

BROWN, DON
KWFT-TV, Wichita Falls, Tex.

BROWN, GLENN
KVET, Austin, Texas

BROWN, HANK
KGNC, Amarillo, Texas

BROWN, MORGAN M.
WIKE, Newport, Vermont

BROWN, R. FRED
WLOS, Asheville, N. C.

BROWN, ROBERT
WSBT, South Bend, Ind.

BROWNE, LANCE
CHVC, Niagara Falls and
Welland, Ontario

BRYSON, GEORGE
KYNO, Fresno, Cal.

BUCKLE, BOB
Sports Fare
WRDW, Augusta, Ga.

BUDGE, DON
National Tennis Championships
NBC-TV

BULLETT, BUCKY
WMNB, North Adams, Mass.

BURGESS, SMOKEY
Sports Report
WGDA, Columbus, Georgia

BURICK, SI
Sports With Burick
WHIO, Dayton, O.

BURNES, BOB
KMOX, St. Louis, Mo.

BYER, HAL
Sports Slants
KWIL, Albany, Ore.

BYERS, WAYNE
Panorama Of Sports
WATG, Ashland, Ohio

CAIN, DOYLE
Sports Roundup
KFPD, Nappa, Idaho

CALLIGAN, BOB
WSDR, Sterling, Ill.

CAMMAROTA, ED
WEEU, Reading, Pa.

CAMPBELL, BUD
WIND, Chicago, Ill.

CAMPBELL, JACK
KFBI, Wichita, Kansas

CAMPBELL, JOHN T.
Coaches Corner
KXLL, Missoula, Mont.

CAMPBELL, NEENIE
WMCK, McKeesport, Pa.

CAMPFREDA, NICK
WAAM, Baltimore, Md.

CANE, LENNY
WENT, Gloversville, N. Y.

CAPOSELLA, FRED
Gillette Racing Series
NBC-TV

CARIKER, KEN
KDUB, Lubbock, Texas

CARNEAL, HERB
KYW, Phila., Pa.

CARNEGIE, TOM
WPBM, Indianapolis, Ind.

CARPENTER, JOHN
KOIN, Portland, Ore.

CARR, GEORGE
WEEB, Sylacauga, Ala.

CARR, LARRY
WNET, Greenville, N. C.

CARTER, CAL
KAMD, Camden, Ark.

CASH, AL
WCPM, Cumberland, Ky.

CASPER, TEE
KCUL, Ft. Worth, Tex.

CASTENEDA, LES
KNGS, Hanford, Cal.

CASTLE, CLYDE
WFIE, Evansville, Ind.

CAULEY, AL
Sports Final
CJAD, Montreal, Canada

CHALMERS, JIM
Speaking For Sports
WELM, Fitchburg, Mass.

CHAMBERS, NICK
Sports Reel
KMOR, Oroville, Cal.

CHARLES, AL
WAYB, Waynesboro, Va.

CHARLES, BERT
WVKO, Columbus, O.

CHARLES, DICK
WMJV, Omaha, Neb.

CHARVAT, JACK
KTUL, Tulsa, Okla.

CHASE, HOWARD
WWOR, Worcester, Mass.

CHRISTIAN, CHARLIE
KTOP, Topeka, Kan.

CHRISTIAN, GUY
KSBW, Salinas, Cal.

CIRALDO, AL
Sports Column
WGLS, Decatur, Ga.

CLAHAN, JOHN
Marin Sports
KTIM, San Rafael, Cal.

CLAPPER, KEN
WRTA, Altoona, Pa.

CLARK, BILL
Sports Page
KBTA, Batesville, Ark.

CLARK, CHRIS
In the Spotlight
WBSM, New Bedford, Mass.

CLAYTON, TOM
WLLH, Lowell-Lawrence,
Mass.

CLEMENTS, JOE
KLIX, Twin Falls, Idaho

CLIFRO, CHARLIE
KRED, Los Angeles, Cal.

CLOSE, BILL
KOY, Phoenix, Arizona

COBURN, HUGH
WRBL, Columbus, Ga.

COLBY, LEN
WKZO-TV, Kalamazoo, Mich.

COLE, DON
KCCX, Sidney, Montana

COLEMAN, KEN
"Cleveland Browns"
WTAM, Cleveland, Ohio

COLES, ED
Sports Roundup
WTK, Durham, N. C.

COLEY, HAL
Sports Roundup
KMCO, Conroe, Tex.

COLKITT, JERRY
KALE, Richland, Wash.

COLLARD, RENE
CECV, Quebec

COLLINS, JOE
KGN, Amarillo, Texas

COLLINS, SID
Fox's Den
WIBC, Indianapolis, Ind.

COLON, JACK
KCOY, Santa Maria, Cal.

COLTHORPE, LLOYD
CHAT, Medicine Hat, Alta.

COLTON, LARRY
In This Corner
WGUY, Bangor, Maine

CONRAD, STEVE
WAPO, Chattanooga, Tenn.

COOK, BOE
KICA, Clovis, N. M.

COOK, DICK
WMPB, Memphis, Tenn.

CORBIN, LOU
WPBR, Baltimore, Md.

CORLEY, BILL
WBNS, Columbus, O.

CORNISH, W. C.
WGAN, Portland, Maine

COSSITER, DON
WFBG, Altoona, Pa.

COUPEE, AL
KRNT, Des Moines, Iowa

COWELL, ED
WCYB, Bristol, Va.

CREAGER, MACK
KRMG, Tulsa, Okla.

CREWS, BILL
WTAD, Quincy, Ill.

CROWLEY, PAUL C.
WJPD, Ispemting, Mich.

CRUM, JIM
WLW-C, Columbus, O.

CUMMINS, JACK
WTVJ, Miami, Fla.

CUMMINS, TAIT
WMT-TV, Cedar Rapids, Ia.

CURLEE, DICK
WSIC, Charlotte, S. C.

CURRY, ERNEST "BUTCH"
Big Town Sports
WMRY, New Orleans, La.

CURTIS, BOB
KCLX, Fairfax, Wash.

CUSICK, FRED
WEEL, Boston, Mass.

1954



Guy Le Bow

SPORTS ANNOUNCER — MC — NARRATOR

TV — RADIO — PICTURES

HA. 6-0763

— D —

D'ACCARDO, GENE
KNOD, Modesto, Cal.

DODAY, JOHNNY
WGPA, Bethlehem, Pa.

DAHL, DON
On the Sidelines
KDAL, Duluth, Minn.

DAIL, ROLLIE
Spotlight On Sports
KAUS, Austin, Minn.

DALE, JACK
KFYO, Lubbock, Tex.

DANES, SPENCER
WKBV, Richmond, Ind.

DARLAND, BILL
Sports Review
KELD, El Dorado, Ark.

DAVENPORT, EDDIE
Sports Review
WWPB, Miami, Fla.

DAVIDSON, AL
CFPA, Port Arthur, Ont.

DAVIES, BOB
KMYR, Denver, Colo.

DAVIS, DICK
WKNX, Saginaw City, Mich.

DAVIS, HANK
Sports Parade
KFDX-TV, Wichita Falls, Tex.

DAVIS, JEFF
WDAK, Columbus, Ga.

DAVIS, JERRY
KGBX, Springfield, Mo.

DAVIS, LEN
Sports Eye
WGL, Ft. Wayne, Ind.

DAVIS, LES
KVTV, Sioux City, Iowa

DAWSON, BUD
WQUA, Moline, Ill.

DEAN, DIZZY
Baseball
ABC-TV

DECKER, TOM
Sports Journal
WNEB, Worcester, Mass.

deFOREST, ED
KOY-TV, Phoenix, Ariz.

DELANEY, BOB
Inside Story on Sports
WHDN, Boston, Mass.

DELESAGE, JOHNNY
WJAT, Swainsboro, Ga.

DENSON, JIM
WBMD, Baltimore, Md.

DENTON, BILL
KPQ, Wenaycher, Wash.

DERE, JOHN
John Derr's Scoreboard
CBS

De VICTOR, MARTY
WBNS, Columbus, O.

DEWITT, DEWEY
Geigy Sportscaast
WABM, Houlton, Maine

DIAB, GEORGE
Ohio Valley Sports Reel
WTRF, Bellaire, Ohio

DIAZ, JOSE R.
Deportivas
WIAC, San Juan, P. R.

DIEHL, BILL
WTOV, Norfolk, Va.

DIGESU, FRED
Sports Mike
WBBS, Huntsville, Ala.

DIHLMANN, HANK
KROS, Clinton, Iowa

DILLON, EUGENE
WCMW, Canton, O.

DILLON, FRED
Sports Review

WCMA, Corinth, Miss.

DILLON, GENE
WCMW, Canton, Ohio

DILLON, LENNY
WFAS, White Plains, N. Y.

DINATALE, JOE
KODY, North Platte, Neb.

DITERT, ED
KRIC, Beaumont, Texas

DOHL, PAUL
Speaking Of Sports
WCHN, Norwich, N. Y.

DOLAN, FRANK
All Outdoors
WKOP, Binghamton, N. Y.

DOMMER, WM.
Time In For Sports
SONW, Defiance, O.

DONLEY, "RED"
Let's Talk Sports
WSTV, Steubenville, O.

DOOLEY, TED
KVCV, Redding, Cal.

DOUGLAS, GEORGE
WDSR, Lake City, Fla.

DOUGLAS, WAYNE
KOCA, Kilgore, Texas

DRAPER, LARRY
Sports Quarter
WSIP, Paintsville, Ky.

DREES, JACK
Drees On Sports
WJID, Chicago, Ill.

DRILLING, JOE
KJEO, Fresno, Cal.

DROELLE, GEORGE P.
WCLI, Corning, N. Y.

DRURY, DICK
Sports Spotlight
WMAN, Mansfield, O.

DUFFY, GEORGE P.
WICE, Prov., R. I.

DUGAS, PAUL
WABJ, Bangor, Maine

DUITSMAN, DOUG
Sports Scoreboard
KGMB-TV, Honolulu, T. H.

DUNBAR, WALT
WBET, Brockton, Mass.

DUNPHY, DON
Football

DYER, BRAVEN
Rose Bowl
NBC

DYER, JOHN
Sports Final
KSTV, Stephenville, Tex.

— E —

EATON, TOM
WREB, Holyoke, Mass.

EDGAR, GEORGE A.
KLAN, Renton, Wash.

EDWARDS, NORMAN
KSTL, St. Louis, Mo.

EGAN, LEO
All About Sports
WBZ, Boston, Mass.

EISENHAUER, GEORGE
Sports Final
WDTV, Pittsburgh, Pa.

ELLIOT, WIN
Gillette Racing Series
NBC-TV

ELLIOTT, BILL
KROY, Sacramento, Cal.

ELLS, STEVE
WFPL, Ft. Lauderdale, Fla.

ELSTON, BOB
Bob Elston Sports
KIOA, Des Moines, Iowa

ENGELBRETSSEN, HAL
Sports Roundup
KGYW, Vallejo, Cal.

ENNIS, JIM
KRKO, Everett, Wash.

ENROTH, DICK
WLOL, Minneapolis, Minn.

ERDMANN, JAKE
Sports Special
WRAC, Racine, Wisc.

ERDSOY, WILLIAM
WHP-TV, Harrisburg, Pa.

ERLICH, GEORGE
WHAY, New Britain, Conn.

ERVIN, BILL
Sports Special
KARE, Atchison, Kan.

ERVIN, PUSS
KCNL, Fort Worth, Tex.

ETCHISON, HUB
WKBV, Richmond, Ind.

EUBANKS, BLAIR
WTAR, Norfolk, Va.

EVANS, STAN
KYOS, Merced, Cal.

EYRE, ALFRED
WTOR, Torrington, Conn.

— F —

FALKENSTEIN, MAX
Speaking Of Sports
WREN, Topeka, Kan.

FALLERT, RALPH
WCAE, Pitts., Pa.

FALLON, FRANK
WMEX, Boston, Mass.

FALLON, FRANK
KWTX, Waco, Texas

FANTASIA, JACK
WJPB, Fairmont, W. Va.

FARKAS, CHARLES W.
KBEI, Alice, Texas

FARRINGTON, FRANK
Farrington Sports
KFAM, St. Cloud, Minn.

FARRIOR, BILL
WTAM, Williamston, N. C.

FARRIS, JOE
WGKV, Charleston, W. Va.

FAUCHER, RALPH
WTAQ, Lagrange, Ill.

FAULCONER, J. B.
WLAP, Lexington, Ky.

FAY, BILL
Football
ABC

FAY, HAINES
Sports of Day
KVOS, Bellingham, Wash.

FEILD, BILL
Sport Spotlight
KERV, Kerrville, Tex.

FELDMAN, IRWIN
WBIP, Booneville, Miss.

FENNER, LOWELL, JR.
Sports Review
WBLJ, Dalton, Ga.

FERRIS, JACK
WSDR, Sterling, Ill.

FINCH, HOWARD K.
Sports Column
WJIM, Lansing, Mich.

FINEGAN, JAMES R.
WHAS, Louisville, Ky.

FINLAYSON, JACK
KRDO, Colorado Spgs., Colo.

FINNEGAN, BOB
Fights, Football
ABC

FISER, JACK
Sports Final
KWKH, Shreveport, La.

FISHER, CARL
CKSF, Cornwall, Ontario

FISHER, HANK
WEEK, Peoria, Ill.

FISHER, JACK
WPRS, Paris, Ill.

◆ ◆ ◆ SPORTS COMMENTATORS—RADIO-TELEVISION ◆ ◆ ◆

FITZGERALD, LARRY
KRBC, Arlington, Texas

FLAHERTY, RAY
KNEW, Spokane, Wash.

FLEMING, BILL
WWJ, Detroit, Mich.

FLETCHER, BEBBE
WBZ, Boston, Mass.

FLETCHER, RAY
WEHT, Henderson, Ky.

FLORA, EARL
WBNS, Columbus, Ohio

FLOWER, EM.
Sports Review
WBAT, Marion, Ind.

FLYNN, JERRY
WBFB, Rochester, N. Y.

FOLEY, TOM
Sports At Six
CFRA, Ottawa, Ont.

FORSYTHE, GRANT
CFOR, Oshawa, Ont.

FOSTER, LLOYD
Hi-Lites in Sports
WENC, Fayetteville, N. C.

FOOTS, BOB
KGO, S. F., Cal.

FOX, BILL
Fox's Den
WHDN, Indianapolis, Ind.

FRANKLIN, WARREN
WTVB, Coldwater, Michigan

FREEMAN, HARRY
KFSA, Ft. Smith, Ark.

FRENCH, BOB
WSSC, Somerset, Pa.

FRENCH, JACK
KNOX, Grand Forks, N. D.

FREZZA, AL
Sports Digest
WHLE, Medford, Mass.

FRICKE, ROGER
Sports Parade
WBWV, Bedford, Ind.

FRINK, BILL
WJMA, Lima, O.

FROH, DALE
Sports Reporter
WHS, Lansing, Mich.

FULTON, BOB
WNOK, Columbia, S. C.

— G —

GAINES, JERRY
WHAT, Phil., Pa.

GANN, HAROLD
KRDI, Dunbar, Cal.

GANNON, BILL
WHK, Cleveland, Ohio

GARDNER, BILL
WVOA, Williamsport, Pa.

GARDNER, DON
WKBN-TV, Youngstown, O.

GARDNER, JACK
KSL-TV, Salt Lake City, Utah

GARNES, CLARENCE
Spotlight On Sports
WSAV, Savannah, Ga.

GARRIOCK, TOMMY
Sports Roundup
KTFB, St. Catharines, Ont.

GARRITY, VINCE
Sports Review
WAAP, Chicago, Ill.

GAUCHET, GORDON
Sports
WNLK, Norwalk, Conn.

GEAGAN, BILL
The Great Outdoors
WLIZ, Bangor, Maine

GEORGE, STEVE
KCMS, Sacramento, Cal.

GEORGE, TONY
ROME, Tulsa, Okla.

GIBBONS, JIM
WMAL-TV, Washington, D. C.

GIBBS, FRANK
KEXO, Grand Junction, Colo.

GIGUERE, REAL
CHLP, Montreal, Que.

GILBERT, GLEN
KSID, Sidney, Neb.

GILCHRIST, BASIL
WGAD, Gadsden, Ala.

GILLESPIE, EARL
WEMP, Milwaukee, Wis.

GILMORE, ROBERT
WCPO, Cincinnati, O.

GLEASON, JIM
WNBH, New Bedford, Mass.

GLEESON, ART
Game Of The Week
Mutual

GLICKMAN, MARTA
Quarterback Incof
WARD, New York

WGMG, N. Y.

GOODING, RALPH
WJFW, Eau Claire, Wis.

GOOBICH, BILL
WORD, Sparta, N. J.

GORDON, JAMES
Twin View Of Sports
WDRR, Syracuse, N. Y.

GOTDILL, GLENN
WMSA, Massena, N. Y.

GOVE, DICK
WLAM, Lewiston, Maine

GOVIX, CURT
Football, Football Roundup
NBC

GOVETTE, GILLES
CHEF, Granby, Que.

GRAHAM, BILL
Sports Hitites
WAZL, Hazleton, Pa.

GRANGER, JIM
WJW, Cleveland, O.

GRANGE, RED
Football
ABC-TV

GRAS, HAROLD W., JR.
KVOA, Tucson, Arizona

GRIFFIN, JOHNNY
KPHO, Phoenix, Arizona

GREENWOOD, KEN
KFOR, Lincoln, Nebraska

GREGSON, JACK

DANA
B. July 14, 1915, Spokane, Wash.
Jack's Place, ABC; Saturday
Night Fights, ABC-TV

GREHAN, JIM
WLNA, Peckskill, N. Y.

GRIFFIN, WAYNE
Wrestling
ABC

GRIFFITHS, BILL
WELM, Elmira, N. Y.

GRIFFITHS, DAVE
Sportsreel Of The Air
WARM, Scranton, Pa.

GRIMBERG, WARREN
KAST, Astoria, Oregon

GRIMES, WM.
Today In Sports
WKJF-TV, Pittsburgh, Pa.

GRISWOLD, ROGER
Highlights in Sports
WCAO, Baltimore, Md.

GROSS, DON
KFSB, Joplin, Mo.

GROVE, BOB
WMDG, Richmond, Va.

GUERRA, EUGENIO
WKVM, San Juan, P. R.

GUINAN, JACK
Athlete of Week
WQAN, Scranton, Pa.

GUNDAKER, EDWARD
Let's Talk Sports
WHP-TV, Harrisburg, Pa.

GUOKAS, MATT
WFEN, Phil., Pa.

GUYMAN, BILL
KPIX, S. F., Cal.

— H —

HALE, S. B.
KWEL, Weiser, Idaho

HALL, DONALD W.
WSSV, Petersburg, Va.

HALL, ED
Speaking of Sports
KHOB, Watsonville, Cal.

HALL, HALSEY
Time Out for Sports
WCCO, Minneapolis, Minn.

HAMILTON, ED
KRUS, Ruston, La.

HAMILTON, MILO
WTVI, Belleville, Ill.

HAMLIN, TOM
Sport's Eye
WLOK-TV, Lima, O.

HANCOCK, ROSS
WNBH, Daytona Beach, Fla.

HANEY, BOB
WSSC, Somerset, Ky.

HANLEY, DON
Sports Finals
KPEQ, St. Joseph, Mo.

HANNA, BUD
KHSL, Chico, Cal.

HANSEN, BILL
KCOL, Fort Collins, Colo.

HANSEN, CARROLL
KCBS, San Francisco, Cal.

HANSON, HARLEY
KOTA, Rapid City, S. D.

HANSSSEN, THOMAS R.
Sports Today
WMBR, Banbridge, Ga.

HANSSON, PETER
Sports Final
WJOC, Jamestown, N. Y.

HARRISON, SHELBY T.
WTFX, Springfield, Ill.

HARDAWAY, JOHN
KSEL, Poeretto, Idaho

HARDING, JIM
Hi School Hitites
WDAK, Columbus, Ga.

HARGETT, REX
WSTR, Sturgis, Mich.

HARLING, HUGH
Sports Review
San Luis Obispo, Cal.

HARMON, PAT
WCPO-TV, Cincinnati, O.

HARMON, TOM
Rose Bowl
NBC-TV

HARDER, BILL
CKNB, Campbellton, N. B. I.

HARPER, BOB
KGNO, Dodge City, Kan.

HARRIS, HAL
WLAU, Laurel, Miss.

HARRISON, CHARLES H.
Sports Review
KBOA, Kennett, Mo.

HARRISON, JACK
Sportlites
WLAV, Grand Rapids, Mich.

HART, HAL
Heart of Sports
WOC, Davenport, Iowa

HARTMAN, ROME
Sportscope
WIRK, W. Palm Beach, Fla.

HASEL, JOE
Football, Football Round-Up,
All-American Sports Show
NBC

HASSE, WARREN
KPDN, Pampa, Texas

HATHAWAY, GENE
Sports Spotlite
WKBB, Muskegon, Mich.

Haughee, JOHN
Sports Review
WPIC, Lake Wales, Fla.

HAWKINS, VERN
Sports Spotlight
KWTO, Springfield, Mo.

HAYDEN, JIM
Sports Spotlight
KSRV, Ontario, Ore.

HAYES, GAYLE
K TSA, San Antonio, Texas

HAYNES, JERRY
WFAA, Dallas, Texas

HEALY, CHUCK
WBEN, Buffalo, N. Y.

HEALY, DAN
WMGT, Adams, Mass.

HEALY, DAN
WBRK, Pittsfield, Mass.

HEARN, F. D.
WEEK, Peoria, Ill.

HEILNER, VAN CAMPEN
Rod and Gun Club
Mutual

HEISS, BOB
WTMJ, Milwaukee, Wisc.

HELPER, AL
Al Helfer Sports Show
Mutual

HENDRYX, GENE
KVLV, Alpine, Texas

HENRICH, TOMMY
WCBS, N. Y., N. Y.

HENRIKSON, LES
World of Sports
WAGA, Atlanta, Ga.

HENRY, RON
CKRD, Red Deer, Alta.

HERMANN, CLEVE
Trophy Room
KNBH

HEWEY, IRA I.
Spotlighting the Spotlight
WHAI, Greenfield, Mass.

HICKERSON, EARL
KRES, St. Joseph, Mo.

HICKS, FRANK
WBFB, Rock Island, Ill.

HILL, DON
WKLO, Louisville, Ky.

HILL, DON
Red Bird Baseball
WHKC, Columbus, O.

HILL, EDDIE
WRR, Dallas, Texas

HILL, HUGH
WJOB, Hammond, Ind.

HILL, JOE
WTVN, Columbus, O.

HINKLE, CHARLIE
Sports Diary
WHIO, Dayton, O.

HODGES, RUSS
Scoreboard, Sports Daily
NBC-TV, NBC

HOFF, PAUL
KTIL, Tillamook, Ore.

HOGAN, BILL
WEWO, Lauringburg, N. C.

HOPKINS, GEORGE
Rod & Gun Club
KVAN, Vancouver, Wash.

HORSTMAN, BOB
You and Conservation
KFEQ, St. Joseph, Mo.

HOUGH, BOB
Sports-Eye-View
KVNI, Coeur d'Alena, Idaho

HOUSTON, BOB
Spotlite On Sports
KNEA, Jonesboro, Ark.

HOWARD, BOB
Sports by Howard
WVVO, Columbus, O.

HOWER, BOB
KFMB, San Diego, Cal.

HOYT, WAITE
WCPO-TV, Cincinnati, O.

HUBBELL, NED S.
Sports In Review
WHLS, Port Huron, Mich.

HUBBELL, RALPH
WBEN, Buffalo, N. Y.

HULL, CHUCK
KLAS, Las Vegas, Nev.

HULL, DICK
Lel's Talk Sports
WFRP, Savannah, Ga.

HULL, FRED VANT
KEYD, Minneapolis, Minn.

HUME, ART
WORLD Sport Page
WORLD, Boston, Mass.

HUNDLEY, ED
Sportstime
KLWN, Lawrence, Kan.

HUNTER, DAN
Sports Extra
WDFB, Flint, Mich.

HUNTER, HERBERT
Baseball Bench
KMON, Great Falls, Mo.

HUNTLEY, MACK
WJRI, Lenoir, N. C.

— I —

INGHAM, BOB
Sportsviews
KSD, St. Louis, Mo.

IZZARD, BOB
KGNC, Amarillo, Texas

INGALLS, WALLIE
KGRH, Fayetteville, Ark.

JIM BRITT

Radio-TV

NBC-TV
SPORTS FINAL

Mon.-Fridays
11.15 pm

DUMONT
Pro Football
Sundays

ABC

Jim Britt's Sports Report

Fridays
9:55 pm



— J —

JACKSON, BILL
KVIC, Victoria, Texas

JACKSON, JIM
WIS, Columbia, S. C.

JACKSON, RICHARD E.
WSAL, Logansport, Ind.

JAFFEE, SYD
Sportscope
WHNC, New Haven, Conn.

JAMES, ANDY
KWKW, Pasadena, Cal.

JAMES, CHARLES
WHMP, Northampton, Mass.

JAMES, KEN
WOW-TV, Omaha, Neb.

JANSSEN, WIFE
KIDO, Boise, Idaho

JARVIS, BILL
KVBG, Great Bend, Kan.

JAY, BILL
WNOX, Knoxville, Tenn.

JENKINS, BOB
Sports Corner
KAYS, Hays, Kan.

JENSEN, ERY
KCOW, Alliance, Neb.

JOHNSON, ARTHUR
WATR, Waterbury, Conn.

JOHNSON, ARTHUR
WCHB, Waltham, Mass.

JOHNSON, BOB
WKBY, Muskegon, Mich.

JOHNSON, BOLLIE
WCO, Minn., Minn.

JOHNSON, TED
KMAC, San Antonio, Texas

JOHNSON, WARREN
WFFB, Middletown, Ohio

JOHNSTON, KEN
KAGH, Crossott, Ark.

JONES, DEL
KHQ, Spokane, Wash.

JONES, DICK
KULP, El Camp, Texas

JONES, EARL D.
WFTM, Maysville, Ky.

JONES, GORDON
WCMB, Harrisburg, Pa.

JORDAN, NICK
KCSB Sportsdesk
KCSB, San Bernardino, Cal.

JOVNER, JACK
WBIR, Knoxville, Tenn.

JUDKINS, HARLAN
KPPW, Ft. Smith, Ark.

— K —

KAHN, AL
WPKB, Pikesville, Ky.

KALLEY, ED
WAVE, Louisville, Ky.

KANS, MEL
WMIE, Miami, Fla.

KAUFMAN, SAM
WOL, Washington, D. C.

KAY, MARVIN
KYLJ, Alpine, Texas

KAYE, DENNY
WSBA, York, Pa.

KAZMAIER, DICK
Scoreboard

KEATING, BILL
WHVN, Springfield, Mass.

KEENE, BILL
Sports Scene By Keene
KFEL, Denver, Colo.

KEHL, BILL
Let's Talk Sports
WING, Dayton, O.

KEITER, LES
KYA, San Francisco, Cal.

KELLEY, BOB
KMPC, L. A., Cal.

KELLEY, STEVE
WHIP, Kenosha, Wis.

KENNESSET, TED
KAFF, Pataluma, Cal.

KENNEDY, ED
WRRG, Cinn., O.

KENNEDY, JAMES
WGCD, Chester, S. C.

KENWORTHY, KEN
WGET, Gettysburg, Pa.

KERCE, JOHN CECIL
WRGA, Rome, Ga.

KEYES, MICHAEL
WJNO, W. Palm Beach, Fla.

KIBBY, GORDON
WFOR, Grand Rapids, Mich.

KIELTY, TERRY
Sportsreel
CFRA, Ottawa, Ont.

KIMBALL, BILL
KCOM, Sioux City, Iowa

KIMBLE, WESLEY
WENY, Elmira, N. Y.

KING, DICK
KJPO, San Bernardino, Cal.

KING, DUKE
WINN, Louisville, Ky.

KINSER, JOE
KAFF, Bakersfield, Cal.

KINSLEY, C. H.
KYOS, Merced, Cal.

KIRBY, BOB
WOOD, Grand Rapids, Mich.

KIRTON, DONN
Night Final
CJRL, Kenora, Ont.

KLAUSS, CARL N.
WJMC, Rice Lake, Wisconsin

KLEIN, DON
KPIX, S. F., Cal.

KLISE, BOB
KGA, Spokane, Wash.

KNAPP, DEL
Rod & Gun
WNJK, Norwalk, Conn.

KNOX, KEN
KRBC, Abilene, Texas

KOESTER, TONY
Sports Final
KFBR, Sacramento, Cal.

KOSCHMAN, MARTY
KXLY, Spokane, Wash.

KRAIS, BILL
KFIR, North End, Oregon

KREMER, DON
WKNX, Sarnow City, Mich.

KRIEGEL, GIL
WITH, Baltimore, Md.

— L —

LAFLIN, JACK
WE-R, Bradford, Pa.

LAING, ART
CKLW, Detroit, Mich.

LAMAS, TURIN
WKAQ, Santurce, P. R.

LAMB, DON
Sports Roundup
WHIS, Bluefield, W. Va.

LAMKIN, NORM
WVLN, Oiney, Ill.

LAND, JOHNNY
KDON, Salinas, Cal.

LANDMAN, LOU
WMTV, Madison, Wis.

LANE, DICK
KTLA, Hollywood, Cal.

LANE, HAROLD
WQNY, Newburgh, N. Y.

LASSEM, LEO
KOL, Seattle, Wash.

LASSONDE, JEAN PAUL
CHLT, Sherbrooke, Que.

LAEN, FRANCE
Sports Gallery
KKOK, St. Louis, Mo.

LAWRENCE, JAMES
KOVO, Provo, Utah

LAWS, BILL
KLX, Oakland, Cal.

LAWSON, JERRY
Sports Reporter
WJOP, Jamestown, N. Y.

LAYER, BRUCE
KPRC, Houston, Tex.

LEAMING, JIM
Sports Parade
Mutual

LEAMING, JIM
WIP, Phila., Pa.

LEAVITT, BUD
WABT, Bangor, Maine

LEAVITT, MEL
WDSU, New Orleans, La.

LEBOW, GUY
WPIX, N. Y. C., N. Y.

LECIUS, ED
WOTW, Nashua, N. H.

LEE, BARNEY
WJLB, Detroit, Mich.

LEE, BERT
B. Mar. 28, 1907, New York City.
Warm-Up Time & Sports Extra,
Today's Baseball, Take a Tip
From Me, Hockey, WMGM, New
York; World Series, Sports Extra,
Mutual; Wilson, Glickman & Lee,
Dumont

LEE, BOB
KCOK, Fresno, Cal.

LEE, FRANK
WMMN, Fairmount, W. Va.

LEE, GEORGE
WEVA, Emporia, Va.

LEE, JACK
KBNZ, LaJunta, Colorado

LEE, JACK
KNUZ-TV, Houston, Texas

LEE, ROBERT
Sports Special
KICK, Springfield, Mo.

LEE, TOM
KORK, Las Vegas, Nev.

LEE, ZEB
WSKY, Asheville, N. C.

LEEDS, LYLE
KOJM, Haver, Mont.

LEGER, ROGER
CKCH, Hull, Que.

LELAND, CY, JR.
KEPO, El Paso, Tex.

LENIHAN, ROBERT
Sports Desk
WAGA, Monticello, Ga.

LENOX, JOHN
KGKB, Tyler, Texas

LEONARD, ED
Spotlight On Sports
WICH, Norwich, Conn.

LEWIS, BARNEY
WJDS, Jacksonville, Ill.

LEHRMAN, NED
KMYC, Maysville, Cal.

LISSNER, GIL
Sports Slants
KJUN, Redmond, Oregon

LINN, CASEY
KGUL, Galveston, Texas

LINNEN, HERB
Sports Review
WDDL, Carbondale, Pa.

LITCHFIELD, EDDIE
WPEP, Taunton, Mass.

OVINGTON, RAY

Rod And Gun Club
Mutual

OWENS, MOREY

Sports Review
WROK, Rockford, Ill.

OYE, PAUL

Inside Of Sports
KXGI, Fort Madison, Iowa

— P —

PACKARD, CHARLEY

KSTM-TV, St. Louis, Mo.

PAGE, ELIOT

WSKI, Montpeher, Vt

PAGE, JOHN

Paging Sports
WCSS, Amsterdam, N. Y.

PAIGE, CARL

KYMA, Yuma, Ariz.

PALMER, BUD

B. Sept. 14, 1921, Hollywood,
Cal. Jackie Gleason Show, CBS-
TV; Natl. Tennis Championships,
Kate Smith Show, NBC-TV;
Basketball, Hockey, Dog and
Horse Shows, WPIX, New York

PALMER, ROBERT

KTSW, Emporia, Kansas

PARKER, JOHN

KERO, Bakersfield, Cal.

PARKER, JOHNNY

WCOG, Greensboro, N. C.

PARKER, TONY

WTVP, Decatur, Ill.

PARKER, VIRGIL

KORE, Eugene, Ore.

PARKS, DARYL

WKRC, Cinn., O.

PARMET, GUS

WHIM, Prov., R. I.

PARRY, TINY

WLBR, Lebanon, Cal.

PARSONS, MARSHALL

WQAM, Miami, Fla.

PATTON, BILL

Sports Unlimited
KLFY, Lafayette, La.

PAUL, SYD

WHOL, Allentown, Pa.

PAULIN, ED

WBRN, Marion, O.

PAYNE, JACK

WOW-TV, Omaha, Neb.

PAYNE, MAURY

Speaking of Sports
KSUB, Cedar City, Utah

PEISS, EDMUND

Mustang Baseball
KOOK, Billings, Mont

PELLOW, DAVE

WGBF, Evansville, Ind

PENFIELD, ADD

WBIG, Greensboro, N. C.

PENNEWELL, RALPH

WWIN, Baltimore, Md.

PEREZ, RUDY

WCOL, Columbus, Ohio

PERLIN, BERNIE

KOPO, Tucson, Ariz.

PERRIE, DON

Jax World of Sports
WJBO, Baton Rouge, La

PERRO, LOU

WHUC, Hudson, N. Y.

PETERS, BOB

WAFB, Baton Rouge, La

PETERSON, EDWIN L.

Great Moments in Sports
KSUB, Cedar City, Utah

PETERSON, GENE

WRAY, Princeton, Ind.

PHELAN, JOHN

KTSM, El Paso, Texas

PHILLIPS, BYRON

WGBI-TV, Scranton, Pa.

PHILLIPS, DALE

Sports Wire
KXOB, Stockton, Cal.

PIEPER, WILLIAM P.

WTOU, Kokomo, Ind.

PLATT, BILL

Sports Extra
WBBZ, Ponca City, Okla.

PLEUNIK, ROBERT

WLOA, Braddock, Pa.

PLOC, RUDY

WKOW, Madison, Wisc.

POLITZ, J. C.

WIBR, Baton Rouge, La.

POLLACK, TED

WLAN, Lancaster, Pa.

POPE, BILL

Sportscope
WABY, Albany, N. Y.

POPHAM, GUY H., JR.

Time in for Sports
KTLW, Texas City, Tex.

PORTER, HERB

WGV, Greenville, S. C.

PORTON, BOB

KRSN, Los Alamos, N. M.

POUCHER, WAYNE

WCOS, Columbia, S. C.

POWELL, DON

Poach The Coach
KLCB, Libby, Mont.

POWERS, JIMMY

Cavalade of Sports
NBC-TV

POWERS, PERCY

Sports Roundup
WRBC, Jackson, Miss.



MARK SCOTT

"Tops in Sports in the West"

POWERS, RALPH
Sports Page
KCNO, Astoria, Cal.

PRIBBLE, BILL
KULP, El Campo, Texas

PRIEST, DON
Sarasota Sports Reporter
WSPB, Sarasota, Fla.

PRINCE, BOB
WENS, Pittsburgh, Pa.

PROCTOR, BOB
WLBJ, Bowling Green Ky.

PROVENCE, BOB
WLWT, Cincinnati O.

PRUETT, HENRY
KLMX, Clayton, N. Mex.

PRYOR, BILL
Spotlight On Sports
WNBF-TV, Binghamton, N. Y.

— Q —

QUIGLEY, DON D.
KWEL, Weiser, Idaho

— R —

RABER, ALAN D.
WKAP, Allentown, Pa.

RAMPTON, CLARE
KYWL, Waterloo, Iowa

RANDALL, DAVE
Scores
WTOG, Savannah, Ga.

RANDALL, SCOTT
CKGB, Timmins, Ont.

RASK, PAUL
KGW, Portland, Ore.

KATNER, SOL
Sports Review
WDAR, Savannah, Ga.

RAYMOND, JOE
WASL, Annapolis, Md.

RAYMOND, STAN
WQXI, Atlanta, Ga.

REDDY, JOHN
WOKY, Milwaukee, Wis.

REED, BILL
KFEL, Denver, Col.

REEVE, RAY
WRAL, Raleigh, N. C.

REID, DICK
WSFA, Montgomery, Ala.

REINHART, TED
WPHG, Altoona, Pa.

REITH, HARRY
Sports Roundup
WKST, Newcastle, Pa.

RENAUD, CHAS.
In the World of Sports
CKFF, Ft. Frances, Ont.

RENICK, SAM
Racing Series
NBC-TV

REPKO, JOE
WBKZ, Battle Creek, Mich.

KEYNOLDS, BOB
Sports Scripts
WJR, Detroit, Mich.

RHODY, RONNIE
WPKY, Frankfort, Ky.

RICHARDSON, EARL
WASK, Lafayette, Ind.

RICHARDSON, MEL
KBUE, Brigham City, Utah.

RICHMOND, DICK
Home Edition Sports
KRGH, McAllen, Texas.

RICKERT, LOU
WFTV, Duluth, Minn.

RIDDLE, BILL
WDBQ, Augusta, Ga.

RIDEMOUR, DAVE
Sports Showcase
WTVF, Elmira, N. Y.

RIDER, WILLIAM K., JR.
KVOA, Tucson, Ariz.

RIDLER, DON
CKLW, Detroit, Mich.

RILEY, CHAD
Sports Spotlite
WDVK, Cumberland, Md.

RIND, JULES
WPEN, Philadelphia, Pa.

RINGGIST, LEN
WJDA, Quincy, Mass.

RITZERT, BOB
WNAB, Bridgeport, Conn.

RIVAS, CARLOS
Sportsfeed
KPOA, Honolulu, Hawaii.

RIVAS, LOUIS
Put It to Pat
Mutual

ROBERTS, DON
WKNE, Keene, N. H.

ROBERTS, JACK
Off the Sports Wire
WBNS, Bristol, Conn.

ROBERTSON, BOB
Sports Revue
KMO-TV, Tacoma, Wash.

ROBINSON, MAX
Reports on Sports
WJTN, Jamestown, N. Y.

ROBINSON, SOL
Sports Roundup
WLAD, Danbury, Conn.

RODRICK, BOB
KFVD, Ft. Dodge, Iowa.

ROSTROM, LLOYD
KRRQ, Everett, Wash.

ROEWE, PHIL
WMOK, Metropolis, Ill.

ROMAN, JUAN R.
WPAB, Ponce, Puerto Rico.

ROPER, DON
Time Out for Sports
KBOL, Boulder, Colo.

ROPER, JAMES
KRTN, Raton, N. M.

ROPER, KEITH
Sports Slants
SABF, Adrian, Mich.

ROSE, EARL
CKCW, Moncton, N. B., Can.

ROSE, JOE
RGI, Honolulu, Hawaii.

ROSEHILL, DAVID
WGSN, Huntington L. I.

ROSELLE, JIM
Sports Roundup
WJTN, Jamestown, N. Y.

ROSS, ALLEN
WHOP, Philadelphia, Pa.

ROSS, JIM
KTRH, Houston, Texas.

ROSS, KAL
WVAN, Milwaukee, Wis.

ROWLANDSON, HUGH
WTVL, Waterville, Me.

RUSHTON, RAY
WINA, Charlottesville, Va.

RUSSELL, EARLE
KSHO, San Jose, Cal.

RUST, BILL
KGYL, Greenville, Tex.

RUTLEDGE, BUDDY
Sports Roundup
WSPC, Amstetion, Mt.

RYAN, ALBERT C.
KBRV, Edinburg, Texas.

RYAN, JOE
WALB, Middletown, N. Y.

— S —

SADD, JOE
WKNA, Charleston, W. Va.

SALTER, ELMER G.
WACD, Auburn, Ala.

SAUNDERS, ERNIE
WCBS, Charleston, W. Va.

SAUNDERS, LLOYD
CKCK, Regina, Sask.

SAVAGE, BOB
WMAZ, Macon, Ga.

SAVARD, RAOUL
CFEP, Riviere Du Loup, Que.

SAVARD, UBALD
CFEP, Riviere Du Loup, Que.

SAVITT, DUKE
Great Moments in Sports
WCAP, Lowell, Mass.

SAYLES, FRED
WATV, Newark, N. J.

SCHAPPER, HERB
Sports News
KNLJ, New Lim, Minn.

SCHENKEL, CHRIS
Monday Night Boxing
DuMont.

SCHOENDIENST, TOM
Points On Sports
WSOY, Deontar, Ill.

SCOTT, BILL
KSCR, Liberal, Kan.

SCOTT, DAVE
Sports Revue
WKNB, New Britain, Conn.

SCOTT, JEFF
WPWA, Chester, Pa.

SCOTT, MARK
All-Pro Football, Boston Blackie.
NBC-TV; Hollywood Legion Box-
ing, ABC-TV; Hollywood Stars
Baseball, Speaking of Sports,
KFWB, Jr. College Football,
KHJ-TV, Los Angeles.

SCOTT, RAY
Sports Editor
WPTV, Pittsburgh, Pa.

SCULLY, VIN
World Series
NBC-TV

SEARLES, NEIL
Sports Page
WFOK, Milwaukee, Wis.

SELLEY, WM. A., JR.
WMBM, Miami Beach, Fla.

SEMPRINI, EDGAR, JR.
Up & Islands Sportsweek
WQOB, W. Yarmouth, Mass.

SETZER, ARNOLD
WIKY, Hickory, N. C.

SHACKLETON, BOB
WKAR, East Lansing, Mich.

SHAND, JOHN V.
Spotlight
WTVR, Richmond, Va.

SHANER, BUD
KOLN, Lincoln, Nebr.

SHANLEY, GIB
WILZ, Zanesville, O.

SHANNON, YINC
WJEL, Springfield, O.

SHAYER, DANNY
The Sportsman
WJBB, Warren, O.

SHELLEY, BOB
Sports Reporter
WFBC, Greenville, S. C.

SHELTON, JIM
KEYL-TV, San Antonio, Tex.

SHEPARD, STEVE
KOIL, Omaha, Neb.

SHEPARD, LARRY
Sports Talk
KBZ, Atamwa, Iowa.

SHERMAN, BARRY
On the Sports Scene
WIDR-TV, Wilkes-Barre, Pa.

SHERMAN, BUD
Sports With Sherman
WBAP-TV, Fort Worth, Tex.

SHERMAN, DICK
WITZ, Jasper, Ind.

SHERMAN, GENE
KCOM, Sioux City, Iowa.

SHERMAN, JACK
KTVQ, Oklahoma City, Okla.

SHIVELY, DICK
WSM, Nashville, Tenn.

SHNOPER, HARVEY
Sports Roundup
WWSR, St. Albans, Vt.

SHORT, SELDON
The Sportlight
WMTC, Vancleve, Ky.

SHUDT, ROY
WTRY, Troy, N. Y.

SHUMATE, GENE
Sports Page
KSO, Des Moines, Iowa

SIEGEL, MORRIE
WTOP, Washington, D. C.

SILVERSTEIN, LOU
KTUC, Tucson, Ariz.

SIMPSON, JACK
WSIX, Nashville, Tenn.

SIMPSON, JIM
WTTG, Washington, D. C.

SIMPSON, JIMMY
WNAO, Raleigh, N. C.

SIMS, FRANK
WKMH, Detroit, Mich.

SINGER, MEL
Sports Summary
WVCG, Coral Gables, Fla.

ART, SIPHERD
KCMJ, Palm Springs, Cal.

SISMONDI, JAMES
WMBS, Uniontown, Pa.

SIZOO, ROGER
KTRE, Lufkin, Tex.

SJOLANDER, HERB
Sarasota Angler
WSPB, Sarasota, Fla.

SKIRVIN, MAX
WTTS, Bloomington, Ind.

SLATER, MANNING
WICC-TV, Bridgeport, Conn.

SLATER, WOODY
Four Pages in Sports
KUGN, Eugene, Ore.

SMITH, ART
WPRO, Fremont, O.

SMITH, BILL
WMFR, High Point, N. C.

SMITH, BOB
KKTU, Colorado Springs, Col.

SMITH, BOB
Sports Desk
WABD, New York

SMITH, DALE
WMRP, Lewistown, Pa.

SMITH, DOUG
CFCF, Montreal, Can.

SMITH, FRANK
KHUM, Eureka, Cal.

SMITH, JIM
WEVD, N. Y.

SMITH, MAURICE
CKBC, Winnipeg, Manitoba

SMITH, WILLARD
KTOE, Mankato, Minn.

SNOWDEN, CHARLES T.
Parade of Sports
WLSI, Pikeville, Ky.

SNYDER, BILL
WONN, Lakeland, Fla.

SNYDER, DON
KUBC, Montrose, Colo.

SNYDER, DWIGHT
WJAY, Mullins, S. C.

SOLJE, GORDON
WPLA, Plant City, Fla.

SORENSEN, PHIL
KVNU, Logan, Utah

SPAHR, BILL
Sports Roundup
WRAD, Radford, Va.

SPANN, OWEN
Sports With Spann
WTOB-TV, Winston-Salem, N. C.

SPENCER, DONN
Sports Report
KVOE, Santa Ana, Cal.

SPENCER, MILTON
Sports Section
WFLA, Tampa, Fla.

SPENCER, PAT
Sports As We See It
From Here
KHOZ, Harrison, Ark.

SPENCER, PHIL
1st in Sports
WCSS, Amsterdam, N. Y.

SPIEGEL, SID
WRY, Plattsburg, N. Y.

SPIRO, WALTER
WLOV, Montgomery, Ala.

SPOKES, A. E.
WJOY, Burlington, Vt.

SPRACKLIN, JIM
KWYO, Sheridan, Wyo.

SPRY, DON E.
WJOL, Florence, Ala.

SQUIER, KEN
WDEV, Waterbury, Vt.

STANFIELD, RAY
WIS, Columbia, S. C.

STANGELS, WOODROW
WTRW, Two Rivers, Wis.

STANTON, BOB
WPTZ, Philadelphia, Pa.

STATHAM, TOM
CFJR, Brockville, Ont.

STEELE, JIMMIE
Sportsall
WNOE, New Orleans, La.

STERN, BILL
B. July 1, 1907, Rochester, N. Y.
Sports Today, Sports Final, The
Name's the Same, Away You Go,
Football, ABC, ABC-TV

STERRETT, BOB
WTON, Staunton, Va.

STEVENS, JESS
WEOL, Elyria, O.

STEVENS, MILT
WWBZ, Vineland, N. J.

STEVENSON, BILL
CKWX, Vancouver, B. C.

STIMERS, REX
Spice of the Sports News
CKTB, St. Catharines, Ont.

STOGNER, EARL
WDVA, Danville, Va.

STONE, CLAIR
WBAY, Green Bay, Wis.

STONE, PHIL
CHAM, Toronto, Can.

STONE, VIRGIL
KDMS, El Dorado, Ark.

STOREY, ROY
KGST, Fresno, Cal.

STOUT, ALLEN
WLW, Cincinnati, O.

STOUT, WILLIAM
Sports Review
KPTV, Portland, Ore.

STRATTON, DICK
WMBR, Jacksonville, Fla.

STREET, MALCOLM
Sports Parade
Anniston, Ala.

STRICKLAND, BILL
WIRA, Ft. Pierce, Fla.

STUCKEY, BILL
WVOT, Wilson, N. C.

STUMPO, LOU
Sports Roundup
WAKR, Akron, O.

SULLINS, BILL
KVLH, Pauls Valley, Okla.

SULLIVAN, CHARLIE
WMCT-TV, Memphis, Tenn.

SULLIVAN, CLAUDE
WVLK, Lexington, Ky.

SULLIVAN, PAT
Put It to Pat
Mutual

SUMMER, CHUCK
Sports Digest
WOSA, Wausau, Wis.

SUTER, BUD
KGLD, Mason City, Iowa

SUTTERFIELD, PHIL
WHAS, Louisville, Ky.

SWANSON, CARL
Sports Spotlight
WIDE, Biddeford, Me.

SWANWICK, BILL
WALL, Middletown, N. Y.

SWARTZ, LARRY
WLYC, Williamsport, Pa.

SWENEY, BUDD
Sports by Sweeney
WHKC, Columbus, O.

SWINDLE, O. G., JR.
WIMO, Winder, Ga.

— T —

TANGUY, VIC
WSAL, Logansport, Ind.

TAYLOR, JOHN
WIKY, Evansville, Ind.

TEGTMAYER, DOUG
KTRF, Thief River Falls,
Minn.

TERRELL, JIM
KCBG, Lubbock, Texas

THACKER, JIM
WPLH, Huntington, W. Va.

THOMAS, DAVE
WNRC, New Rochelle, N. Y.

THOMAS, DAVID N.
WJMX, Florence, S. C.

THOMAS, GLENN
Sports Parade
WJEJ, Hagerstown, Md.

THOMAS, JAMES C.
WNOP, Newport, Ky.

THOMAS, VAL
WGAY, Silver Springs, Md.

THOMPSON, GEO.
Sports Extra
WMPA, Aberdeen, Miss.

THORNLEY, HENRY
KROY, Sacramento, Cal.

TIBBETTS, DONN
WKXL, Concord, N. H.

TIERNEY, JACK
WWCO, Waterbury, Conn.

TOAL, FRANK
WCRO, Johnston, Pa.

TOBIN, ROY
WFUR, Grand Rapids, Mich.

TOLBERT, JERRY
WSON, Henderson, Ky.

TOOTHMAN, ROBERT
WEAR, Clarksburg, W. Va.

TORGERSON, STAN
Sports Highlights
WBIZ, Eau Claire, Wis.

TRABER, JIMMY
KNAL, Victoria, Texas

TRAEGER, JOHN
KWED, Seguin, Texas

TRAYNOR, PIE
KQV, Pittsburgh, Pa.

TURNER, BOB
WHAM, Rochester, N. Y.

TURNER, JIM
WSTP, Salisbury, N. C.

TURNER, RAY
Spotlight on Sports
WTAR-TV, Norfolk, Va.

TWERRELL, BRUCE
KWIK, Pocatello, Idaho

TYLER, WAYNE
World of Sports
WLVA, Lynchburg, Va.

— U —

UFER, ROBERT
WPAG, Ann Arbor, Mich.

UNDERWOOD, RALPH
WCNB, Connersville, Ind.

— V —

VACHE, BOB
KYVL, Mesa, Ariz.

VAGNER, JACK C.
KRAL, Rawlins, Wyo.

VALENTI, FRANK
Sports Camera
KGBM-TV, Honolulu, T. H.

VALICENTI, JOSEPH
WBWW, Youngstown, O.

VAN, FRITZ
WEBR, Duluth, Minn.

VAN ROBY, C.
Sports Parade-Final
WCTM, Cumberland, Md.

VAN SANT, JOHNS V.
Sports Chat
WSAN, Allentown, Pa.

VAN TOL, TOM
Sport Notes
WGRD, Grand Rapids, Mich.

VARNELL, LARRY
KLZ, Denver, Colo.

VAUGHN, MARTIN
KTAN, Sherman, Texas.

VASQUEZ, PEDRO
WAPA, San Juan, P. R.

VEACH, BOB
WFRX, W. Frankford, Ill.

VEIDT, BILL
Sports Call
WHSY, Hattiesburg, Miss.

VESTRO, AL
WATH, Waterbury Conn.

VESTRO, AL
Sports of the Day
WATR, Waterbury Conn.

VICK, RICHARD
KGEZ, Kato-poli, Mont.

VODNOVIC, SAM
WMCK, McKeosport, Pa.

VOGEL, GEORGE
KCOW, Alliance, Neb.

— W —

WAGNER, BOB
WHIZ, Zanesville, O.

WATPE, DAVID L.
Speaking of Sports
WFOR, Hattiesburg, Miss.

WAITES, JIM
Speaking of Sports
KWHP, Oshong, Okla.

WALDEN, WARREN
TV Sports Page
WJAR-TV, Providence, R. I.

WALDEN, WARREN
WJAR, Providence, R. I.

WALESKI, EDDIE
WSBA, York, Pa.

WALLACE, BOB
WROW, Albany, N. Y.

WALLACE, FORREST
KFAL, Fulton, Mo.

WALLIS, DAVE
KCLA, Pine Bluff, Ark.

WALSH, FRANK J.
WBOM, Bay City, Mich.

WALSH, GEORGE
WELL, Philadelphia, Pa.

WATTRICK, DON
WXYZ-TV, Detroit, Mich.

WELSHAK, DAVID
Cavalcade of Sports
KCFI, Gonzales, Tex.

WALTON, LUKE
WASH, Indianapolis, Ind.

WALTZ, HANK
Local Sport News
KTHP, Porterville, Cal.

WANZER, H. L.
KCOG, Centerville, Iowa.

WARDLE, JEMMA
CFAR, Elm Flon, Man.

WARREN, KEN
This Week in Sports
KERG, Eugene, Ore.

WARREN, MERT
WLOE, Leaksville, N. C.

WATERMAN, BERNIE
WUCS, Springfield, Ill.

WATERMAN, BERNIE
WMAV, Springfield, Ill.

WATSON, DRANE
WDFN, Gainesville, Fla.

WATTRICK, DON
WXYZ, Detroit, Mich.

WEATHERLY, BOB
Sports Headlines
WPAN, Clearwater, Fla.

WEAVER, RICK
WQEM, Quincy, Ill.

WEAVER, RICK
WQEM, Quincy, Ill.

WEBB, JACK
KWRC, Pendleton, Ore.

WEBER, FRED
WIZE, Springfield, Ohio.

WELLS, JACK
Spotlight on Sport
CKY, Wimping, Mo.

WELLS, LINN
WFOU, Lewisport, Mo.

WENDLING, JIM
Sports Parade
WUER, Dover, O.

WENSTROM, SAM
KRAM, St. Cloud, Minn.

WESLEY, JOSEPH
WBVY, Belleville, Ill.

WESPE, JACK
WISC, Haysville, Mo.

WESTERVELT, DICK
WJBS, Deland, Fla.

WESTHALL, JAMES
WLNH, Leesona, N. H.

WESTMORELAND, HORACE
WPAQ, Mt. Airy, N. C.

WESTON, DON
Sports Shorts
KGVO, Missouri, Mont.

WHALEN, JOE
WYPO, Strongsville, Pa.

WHEELER, JACK
Sports Roundup
WPDQ, Jacksonville, Fla.

WHEELER, RON
KTAT, Proterook, Okla.

WHITAKER, ROBERT L.
KAFT, Decatur, Ala.

WHITEHEAD, BOB
WRAK, Wilkes-Barre, Pa.

WHITMORE, TOM
WVVA, Gary, Ind.

WHITTIER, CHUCK
WLLR, Wilkes-Barre, Pa.

WHITTINGTON, JIMMIE
WIRG, Atlanta, Ga.

WHITWORTH, RAY
KCSJ, Pueblo, Colo.

WIBLE, DARL
Sports Desk
WBOW, Topeka, Kan.

WIGGINS, JOE
KABC, San Antonio, Texas.

WILBER, DEL
KSTN-TV, St. Louis, Mo.

WILBURN, GENE
It's Time for Sports
KRMI, Cheag, Colo.

WILKINSON, JIM
WOME, Owensboro, Ky.

WILLIAMS, BEN B.
The Old Salt
WTOG, Savannah, Ga.

WILLIAMS, BILL E.
KROP, Brewster, Cal.

WILLIAMS, BILL
Sports Review
WYVB, Jacksonville Beach, Fla.

WILSON, BERT
WIND, Chicago, Ill.

WILSON, BOB
WADC, Akron, O.

WILSON, DAVE
KANS, Wichita, Kan.

WILSON, JOE
Sports Corner
WNBB, Chicago, Ill.

WILSON, JOE
WMAQ, Chicago, Ill.

WILSON, JOHN
WFLO, Farmville, Va.

WILSON, KEN
Sports Special
WGST, Atlanta, Ga.

WILSON, WARD
WGMN, New York, N. Y.

WRIGHT, JEFF
WKCP, Bowling Green, Ky.

WISMER, HARRY
WOR, New York, N. Y.

WISMER, HARRY
Wonderful City, WOR-Mutual
WISMER, HARRY
Sports-Ten
Mutual

WITTER, STAN
KAPA, Raymond, Wash.

WOLCHIN, STEVE
Hopewell, Va.

WOLF, FRED
WXYZ, Detroit, Mich.

WOLFE, CLARE
Take 5 for Sports
WPAM, Pottsville, Pa.

WOLFE, BOB
WVDC, Washington, D. C.

WOLFE, BOB
Professional Football
DuMont

WOLFE, BOB
Football
Mutual

WOOD, JAMES L.
WJZ, Decatur, Ill.

WOOD, JIM
WAVY, Norfolk, Va.

WOODSIDE, SAM
Ringside On Sports
WHCF, Durham, N. Y.

WOODWARD, LEROY
WVJS, Owensboro, Ky.

WORNER, MURRAY
KFDA, Amarillo, Tex.

WRATHER, LOU
Sports Spotlight
WENR, Union City, Tenn.

WRIGHT, JOE
The Sport Page
WKML, Kalamazoo, Mich.

WYLLIE, BOB
WAKR, Akron, Ohio.

WYLLIE, BOB
Sports at a Glance
WAKR, Akron, O.

WYMAN, BILL
WOMI, Florence, Ala.

— Y —

YEINGST, JIM
KYVC, Ventura, Cal.

YELLERT, STARR
Denver Calling
KOA, Denver, Colo.

YORK, TOM
WJOL, Florence, Ala.

YOUNG, BILL
Carnival of Sports
KAKA, Wichita, Kan.

— Z —

ZACK, SAM
Sports Journal
WHDQ, Orlando, Fla.

ZEDMAN, IRVING
WSMB, New Orleans, La.

ZELIZH, MARK
World of Sports
WATW, Ashland, Wis.



Many Projects Included In Public Service Program

By T. S. REPPLIER

President

The Advertising Council, Inc.

THE people who read Radio and Television Daily throughout the year do not need to be told about the work of The Advertising Council. Radio and Television Daily reports to them regularly and frequently the generous time, effort and energy that broadcasters, advertisers, performers and persons in all phases of advertising contribute to The Advertising Council's campaigns in the public interest.

However, it might be encouraging to all those who participate in public service campaigns at one time or another during the year to see before them, in this Annual, the impressive roster of national public service projects and events that broadcasters and advertisers assist so effectively in a 12-month period.

I think broadcasters and advertisers should feel proud of the many areas in which they work so hard and so faithfully to help solve national problems by voluntary public action. Let me list these national efforts that are helped so forcefully:

American Economic System, American Education Week, American Heart Month, American Heritage Foundation, American-Korean Foundation Drive, American Red Cross, Armed Forces Day, Arthritis & Rheumatism Drive, Better Schools, Big Brother Week, Boy Scout Week, Boys Club Week, Brotherhood Week, Canada Day, Cancer Control Month, CARE, Cerebral Palsy Drive, Child Health Day, Child Safety, Civil Defense, Community Chest.

Also Crusade For Freedom, Diabetes Week, Easter Seals Appeal, Employ The Physically Handicapped Week, Engineers Wanted, 4-H Achievement Day, Farm Safety Week, File Income Tax Returns Early, Fire Prevention, Flag Week & Flag Day, Freedom Foundation Awards Program, Girl Scouts Birthday; Girl Scout Week, Girls Club Week, Ground Observer Corps, Home Demonstration Week, Home Gardening and

Food Preservation, Hospital Day, Jr. Red Cross Annual Enrollment, Letters From America Week, Mail Call, Mail Early For Xmas, March of Dimes.

Also Mental Health Week, National Blood Program, National Defense Week, National Guard Recruiting, National Hearing Week, National YMCA Week, Needlework Guild, Prevent Forest Fires, Religion In American Life, Salvation Army Xmas Appeal, Sight Saving Month, Social Security For The Self-employed, Stop Accidents, Student Nurse Recruiting, TB Xmas Seal Sale, United Defense Fund, United Nations Day, United Negro College Fund, U. S. Savings Bonds, and YWCA Week.

Also, I believe that broadcasters and advertisers should feel a sense of pride in scanning such quick statistics as the following figures that the Council pulled together at the end of 1953:

In 1953, advertisers and broadcasters, through the Council's Radio and Television Allocation Plans alone, contributed major national coverage to 17 different top-priority campaigns and gave additional support to 39 other causes.

The circulation contributed to these campaigns — by commercial network programs alone—was more than 5½ billion radio and television home impressions. This figure is based on Nielsen ratings. The additional circulation given by networks and stations on sustaining programs would undoubtedly double, perhaps triple this figure.

And 1954 will be bigger! Yes, the combination of broadcasters and their advertisers (who devote vast amounts of valuable time and talent to public service campaigns on the programs that they sponsor) is a powerful one, serving the nation and the community forcefully every day of the year.



JOHN CAMERON SWAYZE

BRISBANE, DR. ROBT.

Dr. Brisbane
 WERD, Atlanta, Ga.
BRISCOE, ROY
 WSTV, Steubenville, O.
BROADLEY, KARL
 WHTN, Huntington, W. Va.
BRONSON, R. B.
 WABI, Bangor, Maine
BROOKS, CLIFF
 WGBF, Evansville, Indiana
BROOKS, GILL
 WKNA, Charleston, W. Va.
BROOKS, NED
 Three Star Extra
 NBC

BROPHY, FRED

WHIO, Dayton, O.
BROUGHMAN, GLEN
 WRBL, Columbus, Ga.
BROWN, A. B.
 WGWR, Asheville, N. C.
BROWN, CECIL
 Mutual

BROWN, DON

KOWL, Santa Monica, Cal.

BROWN, FRANK R.

KTIP, Porterville, Cal.

BROWN, HANK

KGNC, Amarillo, Texas

BROWN, ROBERT

WMAY, Springfield, Ill.

BROWNING, ROBERT

WKNY, WKNY-TV, Kingston,
 N. Y.

BRUCE, DONALD

News at Noon
 WIRE, Indianapolis, Ind.

BRUNEAU, ROGER

La Semaine Qui Finit
 CKCB, Quebec

BRUNER, MARSHALL

WOMI, Owensboro, Ky.

BRUNET, FRADERA

KIWW, San Antonio, Texas

BRYAN, BILL

KTOW, Oklahoma City, Okla.

BRYSON, CONREY

KSTM, El Paso, Texas

BULLER, RICHARD

WKMH, Detroit, Mich.

BURDETT, WINSTON

CBS Radio News
 CBS

BUURGMEIER, FRANK

WAGE, Syracuse, N. Y.

BURK, SAM A.

KIRX, Kirksville, Mo.

BURKE, GORDON

KULA, Honolulu, Hawaii

BURKE, J. FRANK

KFVD, Los Angeles, Cal.

BURKE, MERLE

WLPO, La Salle, Ill.

BURNS, ALLAN

WBHQ, Memphis, Tenn.

BURNS, BILL

WDTV, Pittsburgh, Pa.

BURNS, JOSEPH

WNHC, New Haven, Conn.

BUSLEE, HENRY

WISC, Madison, Wis.

BUTLER, HOMER

WEBQ, Harrisburg, Ill.

BUTZ, BOB

KLZ, Denver, Colo.

BYRON, JAMES A.

James A. Byron and the News
 WBAP, WBAP-TV, Ft. Worth,
 Texas

— C —

CADDELL, RAYMOND

WHSC, Hartsville, S. C.

CALDWELL, HOWARD

WTHI, Terre Haute, Ind.

CALDWELL, MERLE

Week in History
 KOLS, Pryor, Okla.

CALLIGAN, VAN

WOKY, Milwaukee, Wisc.

CALLISON, GEORGE T.

KVOA, Tucson, Arizona

CALMER, NED

CBS Radio's World News
 Roundup

CBS**CALVIN, HAROLD**

WFFB, Middletown, Ohio

CAMP, DAVE C.

KNGS, Hanford, Cal.

CAMPBELL, CHARLES

WLID, N. Y.

CANHAM, ERWIN

The Monitor Views the News
 ABC

CAPUTO, ED

WNHC, New Haven, Conn.

CARDEN, VINCE

WVMI, Biloxi, Miss.

CAREY, BILL

Carey's Corner
 WSPB, Sarasota, Fla.

CARLSON, TED

KRUL, Cowallis, Oregon

CARMICHAEL, LES

KWK, St. Louis, Mo.

CARROLL, JIM

KWYO, Sheridan, Wyo.

CARTER, DIAMOND

WMPR, High Point, N. C.

CARTRIGHT, LOWELL

WKTU, Utica, N. Y.

CARVEL, TONY

WRGB, Schenectady, N. Y.

CASSIDY, HENRY

NBC

CASTRO, GABRIEL

WTIL, Mayaguez, Puerto Rico

CATTERTON, A. V.

WMMB, Melbourne, Fla.

CAYWOOD, D. T.

WFKY, Frankford, Ky.

CENTER, WAYNE

KPHO, Phoenix, Arizona

CHERULA, PAUL

WAZL, Hazleton, Pa.

CHAMBERS, J. F.

WHOL, Allentown, Pa.

CHAPLIN, W. W.

NBC

CHARLES, VIRGIL

WMIX, Mt. Vernon, Ill.

CHASE, BRANDON

WDSU, New Orleans, La.

CHIASTAIN, TONY

WBSR, Pensacola, Fla.

CHATFIELD, CHARLES

Letter to the Editor
 WHCU, Ithaca, N. Y.

CHAYCE, FABIAM

KTRC, Sante Fe, N. M.

CHENEY, TEENUS

WSTP, Salisbury, N. C.

CHEVERTON, DIC

WMT-TV, Cedar Rapids, Iowa

CHRISTI, GEORGE

WFEA, Manchester, Vt.

CIOFFI, LOU

CBS Radio's World News
 Roundup

CBS**CLANCY, HAL**

Hal Clancy—City Editor
 WHDH, Boston, Mass.

CLARK, HAL

KWIE, Kennewick, Wash.

CLARK, JIM

WWJ, WWJ-TV, Detroit, Mich.

CLARK, LES

WEOL, Elyria, Ohio

CLARK, RAY

WOW-TV, Omaha, Neb.

CLARK, TOM

WKXL, Concord, N. H.

CLAUSSEN, GENE

KXIC, Iowa City, Iowa

CLAYTON, EDGAR

WERH, Hamilton, Ala.

CLEARY, J. M.

WESB, Bradford, Pa.

CLINE, KEN

WJBK-TV, Detroit, Mich.

CLOS, JEAN

Clos Looks at the News
 WKLO, Louisville, Ky.

CLYDE, ROBERT

WREX-TV, Rockford, Ill.

COBB, WILTON

WMAZ, Macon, Ga.

COCHRAN, HARRY

WEIR, Weirton, W. Va.

COCHAN, RON

Man of the Week, Capitol
 Cloakroom
 CBS

COLLINGSWOOD, CHARLES

CBS Radio News
 CBS

COLLINS, CARL, JR.

WKRO, Cocoa, Fla.

COLLINS, REID

KWKH, Shreveport, La.

COMBS, GEORGE HAMILTON

George Hamilton Combs News,
 Spotlight New York
 ABC

Through the Curtain
 ABC-TV

CONAWAY, RAY

KTHT, Houston, Texas

CONDON, GLENN

Condon News
 KRMG, Tulsa, Okla.

CONNER, GEORGE W.

Man Next Door
 KVAN, Vancouver, Wash.

CONNER, RALPH

KVOR, Colorado Springs,
 Colo.

CONNORS, DAVE

WNLC, New London, Conn.

CONSIDINE, BOB

On the Line With Bob Con-
 sidine
 NBC, NBC-TV

CORNEAL, GEORGE

KPRO, Riverside, Cal.

CORNELL, CAMERON

WABD, New York

COSLETT, FRANKLIN D.

News of the World
 WBRE, WBRE-TV, Wilkes-
 Barre, Pa.

COSTELLO, BILL

News Analysis with Bill
 Costello
 CBS

COSTELLO, ED

KOSA, Odessa, Texas

COURCIER, JOHN

KOY-TV, Phoenix, Ariz.

COURTNEY, ALAN

Alan Courtney Show
 WGBS, Miami, Fla.

COVAIA, AL

KFBS, San Francisco, Cal.

COVINGTON, TED

WONN, Lakeland, Fla.

COX, REG

WCAP, Lowell, Mass.

CRABILL, VON

WWSO, Springfield, O.

CRAIG, WARREN

WREB, Holyoke, Mass.

CRAWFORD, BILL

KNUZ, KNUZ-TV, Houston,
 Texas

CRISWELL, BILL

WCUM, Cumberland, Md

CROCKETT, WALTER

WGYB, Bristol, Va.

CULP, JESSE

Country Visitor
 WCRI, Scottsboro, Ala.

CUMMISKEY, JOE

WAGE, Syracuse, N. Y.

CUNNINGHAM, BILL

Mutual
CURRIE, CARLTON
 KSUE, Susanyille, Cal
CURTIS, FRANK
 Dayline Ohio Valley
 WTRF, Belleaire, Ohio
CUTLER, JACK
 WEEK, Poughkeepsie, N. Y.
CUTTER, JOE
 WNAO, Balcarh, N. C.

— D —

D'ACCARDO, GENE

KMOD, Modesto, Cal
DAHLBY, JACK
 WNAB, Bridgeport, Conn.
DALE, JAMES
 WIND, Chicago, Ill.
DALTON, KENNETH G.
 WBET, Brockton, Mass.
DALA, JOHN
 This Week Around the World
 ABC, ABC-TV
DAVIDSON, W. R.
 WAKN, Aiken, S. C.
DAVIS, BRUCE
 WPWA, Chester, Pa.
DAVIS, ELMER
 Elmer Davis Commentary
 ABC
DAVIS, JACK
 WKOW, Madison, Wisc.
DAVIS, REX
 KMOX, St. Louis, Mo.
DAVIS, SIDNEY
 WKBN-TV, Youngstown, Ohio
DAY, JOHN
 World News Roundup
 WHDH, Boston, Mass.
DENTIER, WARREN
 KNAL, Victoria, Texas
DEUTSCH, HERMAN
 WWL, New Orleans, La.
DIAB, GEORGE
 Headlines Now
 WTRF, Belleaire, Ohio
DICKENS, PETER
 CHLO, London, Ont.
DIETRICH, ROY
 KEY, Santa Barbara, Cal.
DILABER, MAYNARD E.
 WMVA, Martinsville, Va.
DILLINGHAM, ALEX
 WOOD, Grand Rapids, Mich.
DILLON, GARRY
 Talk of Town
 WCSS, Amsterdam, N. Y.
DILLON, GENE
 WCMW, Canton, Ohio
DI MEO, JOHN
 KPIG, Bellingham, Wash.
DIXON, FRANK
 WWNH, Rochester, N. H.
DIXON, FRED
 WSOU, Charlotte, S. C.
DIXON, MASON
 This & That
 KUCB, Spencer, Iowa
DODD, TOM
 WDEV, Waterbury, Vermont
DONNELLY, BOB
 KOOL, Phoenix, Ariz.
DOW, MIKE
 The Noon News
 KCNO, Actunas, Cal.
DOWNEY, BOB
 WKAR, East Lansing, Mich.
DOWNES, BILL
 CBS Radio's World News
 Roundup
 CBS
DREIER, ALEX
 WNBQ, WMAQ, NBC, Chicago,
 Ill.
DREW, A. L.
 WEVA, Emporia, Va.
DRILL, BOB
 WVEC-TV, Hampton, Va.

DRISCOLL, CASSIDY

Todays Commentary
 WICH, Norwich, Conn.
DRYFOOS, LEON
 WLEU, Erie, Pa.
DUDDLESON, IRVIN
 KBLI, Blackfoot, Idaho
DUNBAR, DR. WILLIS F.
 WKZO, WKZO-TV, Kalamazoo,
 Mich.
DUSEN, HAROLD, VAN
 WGLI, Corning, N. Y.
DUTRISAC, JEAN
 Entre Les Lignes
 CHEF, Granby, Que.
DUTTON, E.
 CKRC, Winnipeg, Manitoba
DUVAL, LIONEL
 CKCH, Hull, Que.

— E —

EAGLES, HARRISON

Harrison Eagles and the News
 WKJP-TV, Pittsburgh, Pa.
EARLE, GLENN
 KPAC, Port Arthur, Texas
EARNHART, MILT
 KFSA, Ft. Smith, Ark.
EASH, HAROLD
 WTAQ, LaGrange, Ill.
EDMONDS, GENERAL
 WLOS, Asheville, N. C.
EDMONDSON, AUSTIN
 WAOV, Vincennes, Ind.
EDWARDS, BILL
 WJDA, Quincy, Mass.
EDWARDS, DOUGLAS
 Douglas Edwards and the News
 CBS, CBS-TV
EDWARDS, FRANK
 MUTUAL
EDWARDS, MARK
 WROW, Albany, N. Y.
EDWARDS, JOHN
 This Week Around the World
 ABC
EDWARDS, ROSS
 WCHS, Charleston, W. Va.
EID, LEIF
 NBC
ELDERS, FRANK
 WGGH, Marion, Ill.
ELDRIDGE, JAMES
 Behind World News
 WBEX, Philadelphia, Ohio
ELLIOTT, I. A.
 KRJE, Miles City, Montana
ELIOTT, LOU
 On the Local Scene
 WCAN, Camden, N. J.
ELLIOTT, BILL
 WNOE, New Orleans, La.
ENGLE, CLIFF
 KFRD, San Francisco, Cal.
ENGLE, HOLLAND
 Mutual
ENGLER, BOB
 KAYO, Seattle, Wash.
ERNI, ART
 WRDB, Reedsburg, Wisc.
ESCHEN, FRANK
 KSD, KSD-TV, St. Louis, Mo.
EVANS, DICK
 KLRA, Little Rock, Ark.
EVANS, ROBERT
 CHLO, London, Ont.
EVERSOLE, JACK
 WKCT, Bowling Green, Ky.
EVERSULL, DR. FRANK
 Date Line
 WTVB, Belleville, Ill.
EWING, DONALD M.
 KWKH, Shreveport, La.

— F —

FAHEY, JOHN

RGA, Spokane, Wash.
FAIRBANKS, CARROLL
 KWHP, Cushing, Okla.
FAIRBURN, TED
 WLDS, Jacksonville, Ill.
FAIRLAMB, GEORGE
 Beyond the Horizon
 KBOL, Boulder, Colo.
FALGE, O. J.
 WLDY, Ladysmith, Wisc.
FALK, EDWIN L.
 KWVL, Waterloo, Iowa
FANNING, WALLACE
 Mutual
FARMER, HELEN
 WNAB, Macon, Ga.
FAREN, WM.
 WPEN, Philadelphia, Pa.
FELL, BOB
 KCOW, Alliance, Neb.
FIELD, TOM
 11th Hour News
 WTAM, WNBZ, Cleveland
 Ohio
FILLINGTON, BILL
 KANS, Wichita, Kan.
FINNEV, FRED
 KTUC, Tucson, Arizona
FIRMIN, JIM
 WMOK, Metropolis, Ill.
FISCHER, HAL
 WALK, Patchogue, N. Y.
FITZGERALD, WILLIAM
 NBC
FITZPATRICK, JACK
 KFEL, Denver, Colo.
FIX, K. W.
 WJAM, Marion, Ala.
FLACK, MILTON
 KRES, St. Joseph, Mo.
FLAGLER, PHIL
 CJBQ, Belleville, Ont.
FLAHERTY, PAT
 KPRC, Houston, Texas
FLAXINGTON, WARD B.
 WWHG, Hornell, N. Y.
FLEETWOOD, HARRY
 WPIX, N. Y., N. Y.
 WNDC, N. Y.
FLYNN, JOHN
 KBUH, Brigham, Utah
FLYNN, JOHN T.
 America Speaks
 KVON, Napa, Cal.
FLYNN, JOHN T.
 Mutual
FLYNN, JOHN T.
 Commentary
 WABY, Albany, N. Y.
FLYNN, JOHN T.
 WBHP, Booneville, Miss.
FLYNN, PAT
 KLYN, Amarillo, Texas
FLYNN, ROBERT
 WEHT, Henderson, Ky.
FOGARTY, JACK
 WCPO, Cincinnati, O.
FORBES, GILBERT
 WFBM, Indianapolis, Ind.
FORD, DOUG
 WOAY, Oak Hill, W. Va.
FORD, JOHN
 WTCN, TV, Minneapolis
 Minn.
FORESTIER, THARCIS
 CBFA, Edmonton, Alberta,
 Canada
FOSTER, CEDRIC
 Mutual
FOOTS, BOB
 KGO, San Francisco, Cal.
FOWLKES, WM.
 Courier News
 WERD, Atlanta, Ga.
FRANK, BOB
 WOC, Davenport, Iowa

FRANK, PAUL
WHCK, Columbus, O.

FRANKLIN, JOHN
KYW, Philadelphia, Pa.

FRASER, GORDON
News of Tomorrow
ABC

FRAZIER, ROBERT
WJPB, Fairmont, W. Va.

FRAZIER, BOB
WVVV, Fairmont, W. Va.

FREDERICK, PAULINE
NBC

FREDERICKS, FRANK
WBUF, Buffalo, N. Y.

FRENCH, PETE
WHAS, Louisville, Ky.

FRICTE, ROGER
WBW, Bedford, Ind.

FRIESEN, JOHN
CKPR, Ft. William, Ont.

FROST, REX
CFRB, Toronto, Ont.

FULDHEIM, DOROTHY
Highlights of the News
WEWS, Cleveland, O.

FULTON, DAVE
Greater Pensacola
WEAR, Pensacola, Fla.

FOURNISS, WALTER
WCOL, Columbus, O.

— G —

GAFFANEY, L. L.
World to Now
KOLS, Pryor, Okla.

GAILLARD, MARSHALL
WAIM, Anderson, N. C.

GALBRAITH, JOHN
KNXT, Los Angeles, Cal.

GARDINER, DON
Monday Morning Headlines

ABC

GARDNER, HY
Three City Byline
ABC

GARDNER, JACK
KNXT, Los Angeles, Cal.

GARRETSON, JOSEPH
WSAI, Cincinnati, Ohio

GATES, HALLEY
KORK, Las Vegas, N. M.

GAUDET, BILL
WWL, New Orleans, La.

GAVITT, DICK
KFH, Wichita, Kan.

GAYMAN, VAUGHN
Roshek News
WDEQ, Dubuque, Iowa

GEARHART, NICK
KCIS, Shreveport, La.

GEBERS, KEITH
KFIR, North End, Oregon

GEERDES, ROBERT W.
WSTR, Sturgis, Mich.

GENTRY, BILL
WCHV, Charlottesville, Va.

GEORGE, ABNER H.
KOTA, Rapid City, S. D.

GEORGE, NICK
KWWL, Waterloo, Iowa

GERAGHTY, LARRY
City Report
WCSH, Portland, Maine

GILSON, BRACE
WNHC, New Haven, Conn.

GILREATH, HOWARD
WVOP, Vadaia, Ga.

GIVNEY, JOHN J.
Speaking of News
WTRY, Troy, N. Y.

GLADDING, ALBERT
WNOW, York, Pa.

GLADSTONE, HENRY
WOR, N. Y., N. Y.

GLEASON, JACK
WATV, Newark, N. J.

GLENN, JAMES
WCSI, Columbus, Indiana

GLOVER, JAY
CFCH, North Bay, Ontario,
Canada

GODDARD, BILL
WITZ, Jasper, Ind.

GODDARD, HERB
WTAP, TV, Parkterburg,
W. Va.

GODWIN, EARL
Earl Godwin's Washington
NBC

GORCH, CARL
WTFP, Raleigh, N. C.

GOLDEN, SID
WBNS, Columbus, O.

GOLDER, HARRY
KMPC, Los Angeles, Cal.

GOLDSBOROUGH, MURRAY L.
KGET, Gettysburg, Pa.

GONZALES, CHELA
KAFY, Bakersfield, Cal.

GORDON, L.P.
WESB, Bradford, Pa.

GORN, LES
KTIP, Porterville, Cal.

GOSCH, GENE
WJRI, Lenoir, N. C.

GOUNDER, JACK
WEEU, Reading, Pa.

GOW, GEORGE
KANS, Wichita, Kan.

GRAHAM, BOB
KAYL, Storn Lake, Iowa

GRAHAM, SHELAH
Three City Byline
ABC

GRANT, AUSTIN
CKLW, Detroit, Mich.



DOUGLAS EDWARDS

CBS News Reporter



KENNETH BANGHART

N. B. C.

NEWSCASTER

RADIO

TELEVISION

CI 7-8300

GRANT, PETER
WTW, Cincinnati, O.
GRANT, TAYLOR
Headline Edition
ABC

GRAUER, BEN

B. June 2, 1908, New York City.
March of Medicine, Show of Shows, NBC-TV; Between the Lines, WNBC, N. Y.; NBC Symphony, NBC; Citizens Union Searchlight, Ben Grauer News, WNBC, N. Y.

GRAY, ALLEN
WPEN, Philadelphia, Pa.

GRAY, JOHN
WOOD, Chattanooga, Tenn.

GREEN, H. E.

News & Interviews
KFKA, Greeley, Colo.

GREEN, MORT
WFGN, Albany, N. Y.

GREENHOE, BOB
Breakfast Table News

WLAV, Grand Rapids, Mich.

GREENSWORD, LEN
KGA, Spokane, Wash.

GREENWOOD, BOB
Bob's Eye View

WFGM, Fitchburg, Mass.

GREEP, J. WALTER
J. Walter Greep's Analysis of the News

WVJX, Owensboro, Ky.

GREER, BEN
WGVL, Greenville, S. C.

GREGG, MARY
KAFY, Bakersfield, Cal.

GRESS, ED
WTHI, Terre Haute, Ind.

GRIFFIN, PAUL
KOY, Phoenix, Arizona

GRIFFIN, MICHAEL
WMTV, Madison, Wis.

GRIFFITH, LES
ABC

GROSS, LOUIS
WJMJ, Philadelphia, Pa.

GROSSMAN, DICK
WHEN, Syracuse, N. Y.

GUERRA, ELISEO COMBAS
WKAQ, San Antonio, Texas

GUERRA, HENRY
WOAJ, San Antonio, Texas

GUTHRIE, WARREN
WXEL, Cleveland, O.

GUYMAN, BILL
KNBC, San Francisco, Cal.

H

HAAZTON, VAN
KOA, Denver, Colo.

HACKES, PETER
Peter Hackes and the News

CBS

HAILINE, RICHARD
Hailine Commentary

KICK, Springfield, Mo.

HAIRGROVE, JIM
KPRD, Rosenberg, Texas

HALL, FRANK
WFL, Philadelphia, Pa.

HALTERMAN, KENNA
WUPE, Akron, O.

HAMILTON, E. K.
WNER, Live Oak, Fla.

HAMM, JIM
KSTU, Houston, Texas

HANCOCK, HAL
WENE, Binghamton, N. Y.

HANSEN, PAUL
CKMR, Newcastle, N. B.

HAPGOOD, ART
Behind the Headlines

KVEC, San Luis Obispo, Cal.

HARDIN, JAMES O., JR.
WCOH, Newnan, Ga.

HARKNESS, RICHARD
NBC

HARRIER, BOYD
News Parade

WTAR-TV, Norfolk, Va.

HARPER, JERRA
WKOW, Madison, Wis.

HARPER, JOSEPH
News in Review

WHP-TV, Harrisburg, Pa.

HARRIS, CHAS.
Blue Ribbon Reporter

WJHP, Jacksonville, Fla.

HARRIS, HAL
WJOB, Hammond, Ind.

HARRIS, HERB
WQXI, Atlanta, Ga.

HARRISON, BOB
WHNC, Henderson, N. C.

HARRISON, CHARLES
WFLD, Philadelphia, Pa.

HARRY, RAY
WRAY, Princeton, Indiana

HAKSCH, JOSEPH C.
NBC

HART, BOB
KTRH, Houston, Texas

HART, RUSSELL
WRBW, Bedford, Ind.

HARTLEY, HOWARD
Hitting the Headlines

WTAN, Clearwater, Fla.

HARTLEY, JIM
The Local Angle

WDCN, Gainesville, Ga.

HARTLEY, M. B.
Hartley Views the News

KNO, Astoria, Ore.

HARTZELL, JACK
WUSJ, Lockport, N. Y.

HARVEY, BOYD
KWNX, Searow, City, Mich.

HARWOOD, GEOFFREY
Background to the News

WBZ, Boston, Mass.

HATCH, DUANE A.
WSAY, Savannah, Ga.

HAWKEY, ROBERT
WJNO, W. Palm Beach, Fla.

HAYES, SAM
Mutual

HAYWARD, BRUCE
WTVI, Belleville, Ill.

HEAD, IVAN
KVSE, Santa Fe, New Mex.

HEASTON, FRANK
KSTW-TV, St. Louis, Mo.

HEATTER, GABRIEL
Mutual

HENDRICKSON, BOB
Assignment Atlanta

WLW-A, Atlanta, Ga.

HENLE, RAY
Three Star Extra

NBC

HENNESSEY, HARRA
WOR, N. Y., N. Y.

HENRY, BILL
WDAK, Columbus, Ga.

HENRY, BILL
Mutual

HENRY, H. D.
WHKY, Hickory, N. C.

HENRY, JACK
KQV, Pittsburgh, Pa.

HENRY, MIKE
Southwest Tonight

KFDX-TV, Wichita Falls, Texas

HERMAN, GEORGE
News Analysis with George

Herman

CBS

HERRING, CHARLES
World Today

KING-TV, Seattle, Wash.

HEARNE, ROBT. L.
Tri-State News

KSUB, Cedar City, Utah

HEYWOOD, E. L.
CFAC, Calgary, Alberta

Canada

HICKS, CAP
WRGA, Rome, Ga.

HICKS, GEORGE
George Hicks and the News

ABC

HIGBEE, ARTHUR L.
Eight O'Clock Edition

KSUB, Cedar City, Utah

HIGBIE, LES
Mutual

HIGGINBOTHAM, CHRIS
CKCK, Regina, Sask.

HILBURN, JIM
KTRH, Houston, Texas

HILL, EDWIN C.
Philco News-

ABC

IHLE, JOE
Talk of the Town

WMGR, Bambridge, Ga.

HINDMAN, BILL
WLWC, Columbus, O.

HINES, HARLAN
Lines by Hines

KOOR, Billings, Mont.

HINES, JACK
KLVN, Lawrence, Kansas

HINES, LINDLEY
KMOX, St. Louis, Mo.

HOBBS, DICK
WJLB, Detroit, Mich.

HODGE, ALAN
CJOY, Guelph, Ontario

HODGINS, ERIC
A Minority of One

CBS

HOFFMAN, GILBERT A.
WKBL, St. Mary's, Pa.

HOGAN, GENE
KXLI, Helena, Montana

HOGAN, J.
KRLD, Dallas, Tex.

HOLCOMB, GRANT
KNXT, Los Angeles, Cal.

HOLIDAY, MASON
KGMB, Honolulu, T. H.

HOLLENBECK, DON
CBS Radio News, CBS;

Sunday News Special, GBS TV

HOLLIS, EVERETT
Mutual

BOLM, A. S.
KGPB, Flagstaff, Arizona

HOLMES, JOHN
Personalities in the News

VOOM, St. Johns, Nfld.

HOLT, BROOKS
KDNT, Denton, Texas

HOLT, CHARLES
Charles Holt and the News-

WHSY, Batesburg, Miss.

HOOD, BILL
KFDX, Wichita Falls, Texas

HOOD, W. P.
Wichita Falls Scene

KFDX-TV, Wichita Falls, Tex.

HOOLEY, JACK
WRAM, Rochester, N. Y.

HOOPER, JACK
WHGB, Harrisburg, Pa.

HOSTETTER, W. D.
WHIS, Bluefield, W. Va.

HOUSER, ROBERT
WSBT, South Bend, Ind.

HOWARD, BOB
WKLO, Louisville, Ky.

HOWELL, REX
KFXJ, Grand Junction, Colo.

HOY, FRANK S.
WLAM, Lewiston, Maine

HOYMAN, DON
WJEF, Grand Rapids, Mich.

HOYT, ROBERT
WSBT, South Bend, Ind.

HUBSON, IRLAND
WKLF, Chantoo, Ala.

HUGHES, EVAN H.
KVOL, Lafayette, La.

HUGHES, JOHN J.
KMMO, Marshall, Mo.

HURLEIGH, ROBERT
Mutual

HUME, ART
Newsreel of the Air
WORL, Boston, Mass.

HUNTER, BOB
Costal Plain News
WWGS, Tifton, Ga.

HURD, JOHN
WMBS, Uniontown, Pa.

HUTCHESON, KEN
KNEW, Spokane, Wash.

— I —

IDE, CARL
WDTV, Pittsburgh, Pa.

IONNE, JOE
Front Page News
WMRN, Marion, O.

ISAACS, JIMMIE
KDUB, Lubbock, Texas

ISSARD, BOB
KGNC, Amarillo, Texas

IZZARD, WES
KGNC, Amarillo, Texas

— J —

JACKSON, ALLAN
Allan Jackson and the News
CBS

JACKSON, CAROL
KVOU, Uvalde, Texas

JACKSON, HARRY A.
KNGS, Hanford, Cal.

JANES, DOLPH
KORE, Eugene, Ore.

JARRELL, MRS. W. W.
News Priorities
WKTZ, Thomasville, Ga.

JEFFRIES, ALLEN
Five Star Final
WIRE, Indianapolis, Ind.

JENNEWAIN, PAUL
WMFD, Wilmington, N. C.

JENNINGS, REX
KBWD, Brownwood, Texas

JOHNS, BILL
KFDA, Amarillo, Tex.

JOHNSON, BOS.
WSAZ, WSAZ-TV, Hunting-
ton, W. Va.

JOHNSON, ARV
KCJB, TV, Minot, N. D.

JOHNSON, DAVE
KSDH, Boise, Idaho

JOHNSON, GERALD W.
WAAM, Baltimore, Md.

JOHNSON, RON
Local News Page
WHOK, Lancaster, O.

JOHNSON, TOM
WPTC, Kinston, N. C.

JOHNSON, WM.
KCJB, Minot, N. D.

JONES, BILL
KFDA, Amarillo, Texas

JONES, FRANK
Tops in News
WKEN, Topeka, Kan.

JONES, LOIS
WPAR, Parkersburg, W. Va.

JONES, MALDEN
WICS, Springfield, Ill.

— K —

KALBER, FLOYD
KMTV, Omaha, Neb.

KALLEN, DICK
Mutual

KALTENBORN, H. V.
NBC, NBC-TV

KEATING, KENNETH B.
WHEC, Rochester, N. Y.

KELLY, JACK
WRFW, Eau Claire, Wis.

KELLY, TOM
WEBC, Duluth, Minn.

KENDALL, GEORGE
WJLB, Detroit, Mich.

KENDRICK, ALEXANDER
CBS Radio's World News
Roundup
CBS

KENNARD, ART
CKRM, Regina, Saskatchewan,
Canada

KENNEDY, HAL
KCJB, Minot, N. D.

KENNEDY, KELVIN
WPIX, N. Y., N. Y.

KENNY, H. B.
WCOM, Parkersburg, W. Va.

KENT, FRANK
WPEN, Philadelphia, Pa.

KENT, JIM
WSIX, Nashville, Tenn.

KERLIN, J. C.
KGBF, Evansville, Indiana

KESSLER, DAVID E.
WHAM, Rochester, N. Y.

KEW, KEN
KGLO, Mason City, Iowa

KIDNEY, DICK
WVEC, TV, Hampton, Va.

KILLMER, WAYNE
KALE, Richland, Wash.



BEN GRAUER

NBC

Radio

TV

KING, CHARLES
WKAI, Rome, N. Y.

KING, DAVE
WBIZ, Lock Haven, Pa.

KIRLINGER, AUSTIN
ABC-WKBB, Chicago, Ill.

KIRBY, BILL
WATV, Newark, N. J.

KIRK, DON
WCOL, Columbus, Ohio.

KIRKHAM, ARTHUR W.
KOIN, Portland, Ore.

KIRKWOOD, JOHN
KFEL, Denver, Colo.

KNEEL, JACK
WBT, Charlotte, N. C.

KNOX, RALPH
KHOZ, Harrison, Ark.

KNUTSON, KEN
KLPB, Minn., N. D.

KNUTSON, MILO G.
WLCX, La Crosse, Wis.

KOBRIN, JERRY
WEEU, Reading, Pa.

KOELSCH, JOSEPH
WRCO, Richland Center, Wis.

KREGGLOH, HUBERT
WSPR, Springfield, Mass.

KULT, IRV
WDLB, Marshfield, Wis.

KUPCINET, IRV
Three-City Byline
ABC

KUURASHI, TOMOMICHI
Kuranishi Reports
KGMB-TV, Honolulu, T. H.

— L —

LADD, GRANT
KMP, Oklahoma City, Okla.

LAND, ALLAN
WHIZ, Zanesville, O.

LANDELL, GRANVILLE
WWGK, Worcester, Mass.

LANDIS, DEWITT
Clovis Speaks
KICA, Clovis, N. M.

LANDON, PAT
WPTZ, Philadelphia, Pa.

LANKER, BUD
Detroit Deadline
WXYZ-TV, Detroit, Mich.

LARSEN, GENE
KFMA, Davenport, Iowa.

LARSEN, WHITEY
WNAX, Vankton, S. D.

LARSON, BEN
WOW-TV, Omaha, Neb.

LATIMER, SAM
Special Edition
WFLA, Tampa, Fla.

LAVALLE, GENE
Editor's Desk
WLOK-TV, Lima, O.

LAWSON, JOEL
WVOP, Wilson, N. C.

LAWS, RAY
WHAM, Rochester, N. Y.

LAYTON, HARRISON
WEVL, N. Y., N. Y.

LEDFORD, R. E.
WVOP, Vidalia, Ga.

LEFFAIRE, BILL
WFPR, Baltimore, Md.

LEGOFF, JACK
WJBR-TV, Detroit, Mich.

LEONARD, BILL
WCBS, N. Y., N. Y.

LEONARD, DAN
WDR, Syracuse, N. Y.

LEOPOLD, DAVE
WEBR, Buffalo, N. Y.

LESCEUR, LARRY
U. S. Report
CBS

LEVINE, IRVING R.
NBC

LEVINSON, LES
Feature Story
WEIM, Fitchburg, Mass.

LEWIS, FULTON, JR.
Mutual

LINDMAN, STUART
WMIN, St. Paul, Minn.

LINK, JERRY
KSLM, Salem, Oregon.

LIPSON, MAC
CKOY, Ottawa, Ont., Canada.

LITTLE, JAMES G.
Jim Little Views the News
WTAG, Worcester, Mass.

LOGAN, GLENN
WJOL, Juliet, Ill.

LOHMAN, PHILIP
WJOY, Burlington, Vermont.

LOKEY, FRANK
WQWV, Augusta, Ga.

LONG, CHET
WBNS, Columbus, O.

LOUTER, JOHN
WRTV, Union, N. Y.

LOWRY, BYRON
KWTX, Waco, Texas.

LAONS, JIMMY
KWCB, Searcy, Ark.

— M —

MacDONALD, BRUCE
WJW, Cleveland, Ohio.

MacLANE, JOHN
News of Tomorrow
ABC

McBRIDE, BILL
WOW-TV, Omaha, Neb.

McCAFREY, JOHN
11th Hour News
WNBT, N. Y., N. Y.

McOFFREY, JOE
Mutual

McCALL, T. LAWSON
KGW, Portland, Oregon.

McCARTHY, CLAS
ABC; WABI, N. Y., N. Y.

McCOLLUM, BURT
CKLB, Oshawa, Ontario.

McCOMBER, JERRY
KHQ, Spokane, Wash.

McCLURE, BERSHEL
KIVE, Longview, Texas.

McKEN, CHARLES
WCCO, Minneapolis, Minn.

McDONALD, CAMPBELL
Campbell McDonald Reports
CFRA, Ottawa, Ont.

McDONALD, IRVING T.
More Light on the News
WEET, Boston, Mass.

McINTYRE, FRANK C.
KLIX, Twin Falls, Idaho.

McHALE, BOB
WSCR, Scranton, Pa.

McKEEL, JOHN
WAYS, Charlotte, N. C.

McKENZIE, JOHN
KMG, Stockton, Cal.

McLAREN, J. G.
Tomorrow's Headlines Today
KFEL, Ft. Frances, Ont.

McLEAN, CLYDE
WBT, Charlotte, N. C.

McMULLEN, JOHN
WPCF, Panama City, Fla.

McMURTRIE, BURT
Burt McMurtrie Presents
KMO, KMO-TV, Tacoma, Wash.

McNAMARA, JIM
KLAC, Los Angeles, Cal.

McQUARRIE, DEATH
Weekend Review
CKX, Bradford, Man.

MERANOLDS, BILL
KSWO, Lawton, Okla.

McSHERRY, HARRY
Capitol Comments
WDOV, Dover, Del.

MAUK, VERN
KAFY, Bakersfield, Cal.

MAUCK, VERN
KCOK, Tulare, Cal.

MAHONEY, CLAUDE
CBS Radio Farm News
CBS, WTOP, Washington, D. C.

MALDONADO, JUAN
WIAC, San Juan, P. R.

MAIKIE, DEL
KENI, Anchorage, Alaska.

MALLORY, DON
KURV, Edinburg, Texas.

MAJONE, TED
News
ABC

MANNIEX, MARTIN D.
WIRY, Plattsburg, N. Y.

MARSHALL, GENE
WGAI, Elizabeth City, N. C.

MARTYN, GIL
KTLA, Hollywood, Cal.

MASON, BILL
WQUA, Moline, Ill.

MATERS, JOHN
In the Backlot
WJLS, Lansing, Mich.

MATLOCK, STAN
WKRC, Cincinnati, O.

MATT, M. LEONARD
WDAS, Philadelphia, Pa.

MATTHEWS, FRANK
WOAL, San Antonio, Texas.

MAYER, JOHN
KMYC, Marysville, Cal.

MAYER, KEN
WBZ, Boston, Mass.

MAYNERS, JOSE A.
WAPA, San Juan, P. R.

MAZHAM, GLENN
WFBG, Duluth, Minn.

MEEKS, MAX
WMEF, High Point, N. C.

MELTON, ORRIN
KSOO, Sioux Falls, S. D.

MENEFFEE, BOB
WIP, Philadelphia, Pa.

MERCHANT, BILL
KSTT, Davenport, Iowa.

MERRAMAN, PHILIP
WICC; WIC-TV, Bridgeport Conn.

MEYER, ED
WDYK, Cumberland, Md.

MEYER, RICHARD
Arcostook Daily
WAGM, Presque Isle, Maine.

MIDDIE, SUTIN
Looking at Lawrence County
WYMC, Mt. Carmel, Ill.

MILLER, CEDRIC
WKBY, Richmond, Ind.

MILLER, MARYE
WKPV, Richmond, Ind.

MILNER, CAL
WBAT, Philadelphia, Pa.

MITCHELL, BOB
WVWV, Fairmont, W. Va.

MITCHELL, FORD
KABC, San Antonio, Texas.

MITCHELL, JACK
Between the Lines
KSYC, Vreka, Cal.

MITCHELL, ROBERT F.
WFB, Farmont, W. Va.

MITCHELL, VIRGIL
Voice of the News
KSDW, Salinas, Cal.

MOEGLE, FRED
KWK, St. Louis, Mo.

MONROE, STU
CFCR, Kitchener, Ont.

MONTANO, JUAN LOPEZ
CMN, Arcebo, Puerto Rico.

MOONEY, DOW
KMPT, Oklahoma City, Okla.

MOORE, JIM
WTRF, Wheeling, W. Va.

MORAN, WARREN
WHIZ, Zanesville, O.

MORGAN, EDWARD P.
The World Today
CBS

MORGAN, HANK
WCIN, Cincinnati, O.

MORGAN, JOE
CKFH, Toronto, Ont.

MORRIS, JACK
KTUL, Tulsa, Okla.

MORRIS, STEVE
WAYS, Charlotte, N. C.

MORRISON, GEORGE
KOB, Albuquerque, N. Mex.

MORRISON, HERBERT
WJAS, Pittsburgh, Pa.

MORRIS, WALTER
KJIM, Beaumont, Texas

MORSE, OTIS B.
WSBA, York, Pa.

MORSE, TONY
KGO, San Francisco, Cal.

MUELLER, MERRILL
NBC

MUELLER, VERN
KPOJ, Portland, Oregon

MUMEY, JACK
Behind the Headlines
KMYR, Denver, Colo.

MUNGER, JOHN
WJPS, Evansville, Ind.

MUNN, E. H., JR.
WTVB, Coldwater, Mich.

MUNYAN, HARRY
WIOD, Miami, Fla.

MURO, JOSE PEREZ
WKAQ, Santurce, P. R.

MURPHY, C. JIM
WRLD, West Point, Ga.

MURPHY, PAT
KWSH, Wewoka, Okla.

MURPHY, TED
KPHO, Phoenix, Arizona

MURRAY, DAVID
WENS, Pittsburgh, Pa.

MURROW, EDWARD R.
Edward R. Murrow with the
News, This I Believe
CBS

HINN, MICHAEL
WFAA, Dallas, Texas

— N —

NADIG, HENRY DAVIS
Cheshire Cat
WNLK, Norwalk, Conn.

NANCE, BOB
KNAL, Victoria, Texas

NATION, HERSCEL
WDXB, Chattanooga, Tenn.

NEAL, BILL
WBIG, Greensboro, N. C.

NEEDHAM, JOHN
News with Needham
KGM-B-TV, Honolulu, T. H.

NEEL, BILL
KTHS, Little Rock, Ark.

NEIL, JACK
KTRM, Beaumont, Texas

NELLANY, JAMES
WNAR, Norristown, Pa.

NEWELL, JOHN
KVLK, Alpine, Texas

NICHOLS, DAVID
WLWC, Columbus, O.

NICHOLSON, DON
KHQA, Hannibal, Mo.

NICHOLSON, DON
WTAD, Quincy, Ill.

NIMS, ROBERT
WAAB, Worcester, Mass.

NIVEN, PAUL
CBS Radio's World News
Roundup
CBS

NOEL, DICK
WABD, N. Y., N. Y.

NORWOOD, CHARLES
WNHC, New Haven, Conn.

— O —

OBERLIN, DICK
WHAS, Louisville, Ky.

O'BREIN, LEO
WRGB, Schenectady, N. Y.

O'BRIEN, PAT
Commentary
KIUP, Durango, Colo.

O'CONNOR, DON
WEMP, Milwaukee, Wis.

O'CONNOR, THOMAS
WEMD, Baltimore, Md.

O'DELL, STEWART
WLSI, Pikesville, Ky.

O'DELL, TERRY
CKLW, Detroit, Mich.

OLIVER, WILLIAM M.
WREV, Reidsville, N. C.

O'MEAKA, DAN
WIOU, Kokomo, Ind.

O'NEAL, GLENN
KWHN, Ft. Smith, Ark.

OSGOOD, DICK
WXYZ, Detroit, Mich.

OTTO, ROBERT
WCPO, Cincinnati, O.

OWEN, AL
WMID, Atlantic City, N. J.

OWENS, J. PAT
KLCB, Libby, Mont.

— P —

PAGE, NORMAN
WMIN, St. Paul, Minn.

PALMER, GEORGE
WKRC, Cincinnati, O.

PAPE, GILLES
CJFP, Riviere Du Loup, Que.

PARIS, MORRIS
WEVD, N. Y., N. Y.

PARKER, PHIL
KXLE, Ellensburg, Wash.

PASHLEY, RALPH
CJVI, Victoria, B. C., Canada

PASSAGE, GEORGE
WRVA, Richmond, Va.

PATTEE, FLOYD
WKNB, New Britain, Conn.

PAUL, VERNE
WJPS, Evansville, Ind.

PAYNE, LARRY
WAPJ, Adrian, Mich.

PEACOCK, CLETIS
WBIG, Greensboro, N. C.

PEARSON, LEON
News and Weekend, Critic at
Large
NBC

PEGDADE, JIMMY
Around the Town
WICH, Norwich, Conn.

PEPPER, BILL
WBNS, Columbus, Ohio

PERKINS, DR. DEXTER
WHEC, Rochester, N. Y.

PERRY, C. STUART
What's New in St. Albans
WWSR, St. Albans, Vt.

PETERSON, GENE C.
WRAY, Princeton, Ind.

PETTIT, ED
Mutual

PHILLIPS, GEORGE T.
WAVZ, New Haven, Conn.

PIERPONT, ROBERT C.
CBS Radio's World News
Roundup
CBS

PIGGOTT, JOE
WLRP, New Albany, Ind.

PISTON, ED
KYNO, Fresno, Cal.

PITMAN, LINWOOD T.
Editor's Comment
WCSH, Portland, Maine

PLATT, BILL
KFH, Wichita, Kan.

PORTA, PAT
KFSA, Ft. Smith, Ark.

POULIN, HENRI
CKVL, Verdun-Montreal,
P. Q., Canada

POWELL, RUSS
KFRE, Fresno, Cal.

POWELL, TOM
WGBI, WGBI-TV, Scranton,
Pa.

PRESTON, JIM
WKAN, Kaukaee, Ill.

PRICE, JOHN
WKAT, Miami Beach, Fla.

PUCKETT, JOHN R.
KOFB, Pullman, Wash.

PUTNAM, GEORGE
B. July 14, 1914, Breckenridge,
Minn.
George Putnam and the News,
George Putnam First Edition,
KTTV, Los Angeles, Cal.
George Putnam and the News,
KFI, Los Angeles, Cal.

— Q —

QUESTA, GEORGE
WHDL, Olean, N. Y.

— R —

RADFORD, JACK R.
CFJR, Brockville, Ont.

RALEIGH, JOHN
KYW, Philadelphia, Pa.

RAMEY, WANDA
KGO, San Francisco, Cal.

RAND, TED
KDRS, Prargould, Ark.

RANDALL, JIM
KFSE, Joplin, Mo.

RANDALL, JOHN
WXLW, Indianapolis, Ind.

RASH, BRYSON
White House Report,
ABC, ABC-TV: WMAL, Wash-
ington, D. C.

RAY, BOB
WIRK, West Palm Beach, Fla.

REEH, DOUGLAS
WRAG, Carrollton, Ala.

REGAN, ROBERT
KCBQ, San Diego, Cal.

REITER, FRED
WFLA, Tampa, Fla.

RENNIE, BILL
WALT, Tampa, Fla.

RENDELL, RICHARD
WMAL, WMAL-TV, Washing-
ton, D. C.

RENICK, RALPH A.
WTVJ, Miami, Fla.

REPAID, BILLY
WMAL, Washington, D. C.

REX, JOE
News Parade
WLOK, WLOK-TV, Lima, O.

REYNOLDS, LENORE M.
Our Town
WCMA, Corinth, Mass.

RICHMOND, FRANCIS
WMGW, Meadville, Pa.

RIDENOUR, REX
WJER, Dover, O.

RIDEL, JACK
WELS, Kingston, N. C.

ROBERTS, DON
WFGV, Fuquay Springs, N. C.

- ROBERTS, JOHN B.**
WFIL, Philadelphia, Pa.
- ROBERTS, PETER**
WNBC, N. Y., N. Y.
- ROBINSON, DON**
KIXL, Dallas, Texas
- ROBINSON, PRESCOTT**
WOR, N. Y., N. Y.
- ROGERS, BOB**
The World Today
WDAR, Savannah, Ga.
- ROLLISON, FRED**
WFIE, Evansville, Ind.
- ROPER, ELMO**
Political Analyst
NBC
- ROPER, GENE**
WHBQ, Memphis, Tenn.
- ROPP, JOHN**
WCOS, Columbia, S. C.
- ROSAMOND, ROBERT**
WTBO, Cumberland, Maryland
- ROSS, CHARLES**
Background to News
WMOU, Berlin, N. H.
- ROSS, JACK**
WHAM, Rochester, N. Y.
- ROSS, SAM**
Sam Ross Reports
CKWX, Vancouver, B. C.
- ROTH, JOE, JR.**
KWPC, Muscatine, Iowa
- ROULEAU, GREG**
Front Page of the Air
KXGI, Fort Madison, Iowa
- RUHMINGER, ELMER**
WMUJ, Greenville, S. C.
- RUNYON, BOB**
WOOD, Grand Rapids, Mich.
- RUSSELL, DAVE**
KFDM, Beaumont, Texas
- RUSSELL, DON**
WABD, New York, N. Y.
- RUSSELL, FLOYD**
Labor News
WWCA, Gary, Ind.
- S —
- SAGUE, S. K.**
WSRS, Cleveland, Ohio
- ST. LAWRENCE, ROBERT**
Today's Headlines
WTOB-TV, Winston-Salem, N. C.
- SALMON, DR. E. T.**
CKOC, Hamilton, Ont., Canada
- SANDERS, ALBERT**
WMAS, Macon, Ga.
- SANDERS, BOB**
The World Today
KCB-TV, Lubbock, Texas
- SAUNDERS, C. J.**
KCLS, Flagstaff, Arizona
- SAVAGE, BOB**
KGBC, Galveston, Texas
- SAXE, JOHN**
WISN, Milwaukee, Wis.
- SCHERER, RAY**
NBC
- SCHERMERHORN, JACK**
WKOW, Madison, Wis.
- SCHERING, KARL**
WLAN, Lancaster, Pa.
- SCHOENBRUN, DAVID**
CBS Radio's World News Roundup
CBS
- SCHORR, DANIEL**
Daniel Schorr and the News
Capitol Clockroom
CBS
- SCHOTTELKOTTE, AL**
WSAL, Cincinnati, O.
- SCHREIBER, ART**
WHIZ, Zanesville, O.
- SCHWEIK, ROLAND**
KRIO, McAllen, Texas
- SCOTT, JOHN W.**
KTSA, San Antonio, Texas
- SCOTT, RICHARD**
CKEY, Toronto, Ont., Canada
- SEIBELS, GREN**
WIS, Columbia, S. C.
- SEIFFERT, FRANK**
WMIN, St. Paul, Minn.
- SELINER, KEG**
CKCR, Kitchener, Ont.
- SEMPRINI, EDGAR, JR.**
Cape Comment
WOOC, W. Yarmouth, Mass.
- SETTERS, JIM**
KWDB, Wichita, Kan.
- SEVAREID, ERIC**
News Analysis with Eric Sevareid
- SHACKLETTE, JAMES**
WTCO, Campbellsville, Ky.
- SHADE, ROBERT**
WTVP, Decatur, Ill.
- SHADEL, BILL**
CBS Radio's News of America
CBS
- SHAND, JOHN V.**
WMBG, WTVR, Richmond, Va.
- SHAW, GORDON**
Herald Reporter
WQAM, Miami, Fla.
- SHEPHERD, JAY**
KREL, Baytown, Texas
- SHERMAN, JACK**
KTVO, Oklahoma City, Okla.
- SHERWOOD, RALPH**
WKBI, St. Marys, Pa.
- SHINN, JUNEAU**
Report to the Valley
KLIJ, Twin Falls, Idaho
- SHIPLEY, ROBERT**
KENT, Sheeppoint, La.
- SHUREY, AL**
KVLK, Little Rock, Ark.
- SHROYER, LARRY**
WPRC, Lincoln, Ill.
- SHUMATE, TOM**
Evening Journal
KICD, Spencer, Iowa
- SHUMWAY, HI**
WASK, Lafayette, Ind.
- SICPE, EV**
Wordsey View of the News
KLMR, Lamar, Colo.
- SHUKIAN, H. S., JR.**
WARE, Ware, Mass.
- SIEGRIST, BOB**
WGST, Atlanta, Ga.
- SINGISER, FRANK**
Mutual
- SINGLETON, JIM**
KTAN, Sherman, Texas
- SKINNER, GEORGE**
WPTZ, Philadelphia, Pa.
- SKINNER, RALPH**
WLAM, Lewiston, Maine
- SLATTON, JOHN L.**
WJBB, Haleyville, Mo.
- SMART, DWIGHT**
KGEW, Boise, Idaho
- SMILEY, TEX**
KTSW, Emporia, Kansas
- SMITH, ART**
WERO, Fremont, O.
- SMITH, BECKLEY**
KQV, Pittsburgh, Pa.
- SMITH, DAVE**
KVET, Austin, Texas
- SMITH, DAVENPORT**
WBRG, Birmingham, Ala.
- SMITH, F. COURTNEY**
WEOA, Evansville, Ind.
- SMITH, HOWARD K.**
World Affairs Report, CBS
Radio's World News Roundup
CBS
- SMITH, JIM**
WPMC, Ocala, Fla.
- SMITH, RALPH**
WEHT, Henderson, Ky.
- SMITH, STARR**
WJRD, Tuscaloosa, Ala.
- SMITS, LEE**
WXYZ, Detroit, Mich.
- SMOOT, DAN**
KFAL, Fulton, Mo.
- SNYDER, ARNOLD**
WTM, Trenton, N. J.
- SOKOLSKY, GEORGE**
ABC
- SORENSEN, FRED**
WCA, TV, Champaign, Ill.
- SPRAGG, GRAYDON H.**
News Around the Country
WHAJ, Greenfield, Mass.
- SPRAGUE, WILLIAM**
NBC
- STAULDING, FRANCIS**
WMIJ, Greenville, S. C.
- SPRY, DON E.**
WJOI, Florence, Ala.
- SQUIRES, ENOCH**
WGV, Traveler
WGY, Schenectady, N. Y.
- STADLER, GLEN**
KERG, Eugene, Ore.
- STANFIELD, RAY**
WIS, Columbia, S. C.
- STANLEY, HAL**
WNAO, Raleigh, N. C.
- STANLEY, REX**
KOY-TV, Phoenix, Ariz.
- STANTON, ED**
KPAM, Portland, Oregon
- SPARK, GENE**
WBBN, TV, Youngstown, O.
- STARR, HAL**
KPDQ, Portland, Oregon
- STEELE, JOHN W.**
WFBZ, Baltimore, Md.
- STEIN, ELLIOTT**
Views of the News
WBIS, Bristol, Conn.
- STEWART, BILL**
WPBC, Minneapolis, Minn.
- STEWART, DEANE**
KCBS, San Francisco, Cal.
- STEWART, JACK**
WRJM, Newport, R. I.
- STEWART, WM. G.**
Congressional Highlights
KFKA, Greeley, Colo.
- STILLE, BERT**
WIKC, Columbus, O.
- STONER, PETE**
WHAY, New Britain, Conn.
- STOUT, NED C.**
WOLT, Newark, Ohio
- STRIPLING, LUKE**
KSEY, Seamore, Texas
- STRONG, JOHN A.**
CKNX, Wingham, Ont.
- KSEY, Wingham, Ont.**
- SULLIVAN, JOHN A.**
Vermont News & Comment
WCAX, Burlington, Vt.
- SULLIVAN, PAUL**
WIP, Philadelphia, Pa.
- STUMPE, RUSS**
WBRV, Waterbury, Conn.
- SUNKEL, CARL**
WPRS, Paris, Ill.
- SWAYZE, JOHN CAMERON**
B. April 4, 1906, Wichita, Kans.
Camel News Caravan, Sightseeing
with the Swayzes: NBC-TV; John
Cameron Swayze Reports, NBC
- SWING, WILLIAM**
KPTV, Portland, Ore.
- T —
- TAFF, PAUL K.**
WTVP, Decatur, Ill.
- TAKLES, LOWELL E.**
WAUD, Auburn, Ala.
- TALBOT, BILL**
KMTY, Omaha, Neb.
- TAYLOR, HENRY J.**
Your Land and Mine
ABC

TAYLOR, GEO. E.

Taylor Reports
KING-TV, Seattle, Wash.

TAYLOR, PAUL
KYW, Philadelphia, Pa.

TAYLOR, S. BRYDEN
WVPO, Strousburg, Pa.

TAYLOR, VESTAL
News Commentary
WFNC, Fayetteville, N. C.

TEMBY, BRITT
WKNX, Saginaw City, Mich.

TEMPLE, AL
WKCT, Bowling Green, Ky.

TEMPLE, FRED
Granger News
WDSR, Lake City, Fla.

TERRY, JOHN
Ohio Go Round
WKO, Columbus, Ohio

TERWEY, TYE
WMPS, Memphis, Tenn.

THAYER, WOODY
Venete Reporter
WSPD, Sarasota, Fla.

THOMAS, LOWELL
Lowell Thomas and the News
CBS

THOMAS, LYNN C.
KWRO, Coquille, Oregon

THOMAS, WAYNE
KTIM, San Rafael, Cal.

THOMPSON, BOB
WRAL, Raleigh, N. C.

THOMPSON, JIMMY
WJLL, Niagara Falls, N. Y.

THORNE, TED
Covering Calumet
WWCA, Gary, Ind.

THORNLEY, HENRY
KROY, Sacramento, Cal.

TIGHE, JAMES
WFHR, Wisconsin Rapids,
Wisc.

TILLMAN, JOHN
WPIX, New York, N. Y.

TODD, JACKIE
KJEF, Jennings, La.

TOMPKINS, BILL
Sojio Reporter
WTAM, Cleveland, Ohio

TORINUS, JOHN B.
WJPG, Green Bay, Wisc.

TOWNSEND, DALLAS
CBS Radio's World News
Roundup
CBS

TRAVIS, FULTON F.
KREW, Sunnyside, Wash.

TREETER, RAYS
WKOW, Madison, Wisc.

TRELAND, MILLARD
KOMO, Seattle, Wash.

TRIBOLET, PROF. L.
Trend of the Times
WLAD, Danbury, Conn.

TROTTER, JOHN
Stories Behind the News
KRMG, Tulsa, Okla.

TROUT, ROBT.
Robert Trout and the News
CBS

TRUE, HAROLD
WWJ, WWJ-TV, Detroit, Mich.

TRUERS, BOB
WTAM, Charleston, S. C.

TUCKER, ED.
KOPO, Tucson, Arizona

TUCKER, JACK
WMBG, WTVR, Richmond, Va.

TURNER, ULMER
WBKB, Chicago, Ill.

— U —

UTLEY, CLIFTON
NBC, WMAQ, WNBQ,
Chicago, Ill.

— V —

VABER, LARRY
WBRK, Pittsfield, Mass.

VALE, FRANKLIN S.
KLMX, Clayton, N. M.

VAN, LYLE
WOR, N. Y., N. Y.

VANDERCOOK, JOHN W.
CIO News
ABC

VAN HORN, ARTHUR
ABC

VAN TOL, TOM
Van Tol Edits the News
WGRD, Grand Rapids, Mich.

VARGAS, REYES
WITA, San Juan, P. R.

VELAZQUEZ, DIAZ
WKVM, San Juan, P. R.

VIFRA, GABRIEL
WHLI, Hempstead, N. Y.

VINGL, RAYMOND
WKWK, Wheeling, W. Va.

VINSON, AL W.
WGEZ, Beloit, Wisc.

VOGEL, PHIL
WKNA, Charleston, W. Va.

VOGELMAN, ROY
WHA, Madison, Wisc.

VON BERGEN, JOHN
WARM, WARM-TV,
Scranton, Pa.

VON FOBEL, PHILIP
Van Fobel & News
WATR, Waterbury, Conn.

— W —

WADE, TOM
WIMA, Lima, Ohio

WALKER, FRANKIE C.
WFOY, St. Augustine, Fla.

WALLACE, ED
WNBK, Cleveland, O.

WALSH, FRANK J.
WBCM, Bay City, Mich.

WALTERS, DICK
WBFB, Rochester, N. Y.

WARD, JIM
CKOY, Ottawa, Ont., Canada

WARDLE, DENNIS
5 Star Final
KCSB, San Bernardino, Cal.

WARNER, CARL
WJJD, Chicago, Ill.

WARNER, FORD
KXOB, Stockton, Cal.

WARNER, PHILLIS
WRMN, Elgin, Ill.

WASHINGTON, CHESTER
Covering the Town
KOWL, Santa Monica, Cal.

WATTS, BILL
WTSF, St. Petersburg, Fla.

WAYMAN, KEN
KFOR, Lincoln, Neb.

WELCH, ED
KWBE, Hutchinson, Kan.

WELCH, JOE
WSAR, Fall River, Mass.

WEICHER, WALT
KTVA, Anchorage, Alaska

WELDON, JACK
Between the Lines
WAIR, Winston-Salem, N. C.

WELLS, H. W.
WFMW, Madisonville, Ky.

WENTZEL, DICK
WPAZ, Pottstown, Pa.

WEST, BILL
KPBM, Carlsbad, N. Mex.

WEST, KELLY
KLYN, Amarillo, Texas

WESTBROOK, TED
WKBV, Richmond, Ind.

WESTON, DON
KGVO, Missoula, Mont.

WHELAN, MARTIN
WKBZ, Mnskegon, Mich.

WHITE, HY
WLBK, Lebanon, Pa.

WHITE, PAUL W.
Speaking of San Diego
KFMB, San Diego, Cal.

WHITE, THOMAS
KTQE, Mankato, Minn.

WHITFORD, R. A.
Whitford Commentary
WHLB, Port Huron, Mich.

WICKENBERG, CHARLES, JR.
WMSC, Columbia, S. C.

WIDMARK, HERBERT
WFTV, Duluth, Minn.

WIGGINTON, BILL
KELO, Sioux Falls, S. D.

WILFY, VIC
Tri-County Comments
WWSC, Glens Falls, N. Y.

WILKINS, PATRICK
Report to the Valley
KSRV, Ontario, Oregon

WILLIAMS, DOC
WADC, Akron, Ohio

WILLIAMS, GLENN
WNDR, Syracuse, N. Y.

WILLIAMS, PAUL
WWJ, Detroit, Mich.

WILLIAMSON, BRUCE
WHIM, Providence, R. I.

WILLIAMSON, HENRY B.
KGUL, Galveston, Texas

WILLIS, ED
WWJ, Detroit, Mich.

WILSON, BOB
KWYO, Sheridan, Wyo.

WILSON, BOB
NBC TV

WILSON, JOSEPH J.
WPLA, Plant City, Fla.

WILSON, PHIL
Voice of the News
WEEK, Peoria, Ill.

WILSON, RAY
KFMB, San Diego, Cal.

WINCHELL, WALTER
ABC, ABC-TV

WINGATE, JOHN
WNBT, WNBC, New York

WINTER, WILLIAM
KPIX, San Francisco, Cal.

WOLF, JOHN ALLEN
WSFA, Montgomery, Ala.

WOOD, LEE
KHJ, Los Angeles, Cal.

WORKHOVEN, MERRILL
WOW, Omaha, Neb.

WORKMAN, W. D. JR.
WIS, Columbia, S. C.

WRIGHT, HOLLY
Today in Washington
WNBW, Washington, D. C.

WRIGHT, RICHARD
Herald Reporter
WQAM, Miami, Fla.

WYMAN, NAL
KALL, Salt Lake City, Utah

— Y —

YAEGER, DON
WSMI, Litchfield, Ill.

YOUNG, JIM
KROW, Oakland, Cal.

— Z —

ZEGERMAN, LOU
KZTV, Reno, Nev.

ZEIDMAN, IRVING
WSMB, New Orleans, La.

ZEIGIN, JACK
WING, Dayton, O.

ZIEBARTH, DR. E.
WCCO, Minneapolis, Minn.

ZIMMERMAN, PAUL E.
WMVA, Martinsville, Va.



Bright Future Seen For Transcription Services

By A. B. SAMBROOK

Manager

Recorded Program Services, Thesaurus and Syndicated Sales

I'M sure it's no news to anyone in the broadcasting industry that we're now going through a period of transition. Bound up as it is with the industry, RCA Thesaurus, together with every other transcription library, will be affected by the changes that come about through this transition.

What do I think this will mean to transcription libraries? I think that it can mean nothing but good. Let me explain.

Now that the freeze is off, television stations are sprouting up all over the country. It's only a question of time, then, until TV evolves from a high-priced advertising medium to a lower-priced one.

Let's take a look at the localities where this has already begun to happen. How has the competition been met? Some radio stations have invested a large part of their time in the "music and news" formula. Either they have scheduled long hours of "mood music" with participating sponsors, or they've extended their disc jockey time. Is this the answer?

On first examination, it might appear to be, but let's take a closer look; let's ask a few questions. Is the "music and news" audience unlimited? Obviously, no. It would seem likely, then, that the stations doing the best programming job for both his listeners and his advertisers will win out.

Next question: How many top disc jockeys can one town produce? As anyone in the broadcasting business knows—not many, not nearly enough.

A few more questions: With either of these two applications of the "music and news" formula, is the best interest of the advertiser served?

Is it possible for the local advertiser to identify his product or services with really big name talent, with a show that produces proven results? Is it possible for the advertiser to merchandise his radio time? Can he tie in newspaper ads and point-of-sale displays with a spot announcement? Again, obviously, no on

both counts.

Actually, then, there is really only one way for the broadcaster to give the advertiser more than ever before at very low cost and thereby beat competition. A library service — as exemplified by RCA Thesaurus—is the answer.

For an unbelievably small investment, broadcasters can acquire the personalized services of name shows like the famous Phil Spitalny, and his All Girl Orchestra and Evelyn in the role of emcee, The Sammy Kaye Show, "The Freddie Martin Show." And this is only the beginning of what RCA Thesaurus offers its subscribers.

Promotion kits, supplied by RCA Thesaurus, give the advertiser every opportunity to fully merchandise his radio purchases; ad mats, tie-in announcements, and publicity stories for local release, give the advertiser a planned and packaged campaign.

All of this is just a part of the RCA Thesaurus' regular service. And we are continually working with the future in mind. To demonstrate: Only a few months ago RCA Thesaurus presented its new subscribers with what was practically a gift—and a very valuable gift at that—1,600 singing jingles to fill the needs of every conceivable type of local advertiser. Recently, we announced the signing of June Valli as a new RCA Thesaurus artist. By the time this is published we will have announced the acquisition of the Melachrino Strings. Melachrino is being presented by us in a show entitled "The Melachrino Musicale." This program is of a calibre that would have been available only on a high-priced network show a few years ago. And in the months to come, RCA Thesaurus will announce even more exciting news about new shows, new big name artists, new sales tools, new promotions that will give the local advertiser even more than ever before for his advertising dollar.

DISC JOCKEYS

RADIO AND TELEVISION

—their work during 1953



— A —

ACEVEDO, TOMMY
WKVM, San Juan, P.R.

ACREE, JIMMY
WAGF, Dotham, Ala.

ACCUFF, JACK
KFOX, Long Beach, Cal.

ADAMS, BOB
Top Twenty Tunes
KFH, Wichita, Kan.

ADAMS, CHAS.
Sunrise Salute
WTAN, Clearwater, Fla.

ADAMS, CLIFF
KTOE, Mankato, Minn.

ADAMS, JIM
Nite Club Of The Air
WSTV, Steubenville, O.

ADAMS, JOE
Mayor Of Melody Show
KOWL, Santa Monica, Cal.

ADAMS, WESS
WKRT, Cortland, N. Y.

ALBERGHINI, HAL
Krackpot Kollege
WCOU, Lewiston, Me.

ALEXANDER, DAN
Matinee Showcase
KORA, Bryan, Texas

ALEXANDER, KURT
Roll Jordan
WEAS, Decatur, Ga.

ALLEN, BILL
WLAC, Memphis, Tenn.

ALLEN, DAVE
Rise & Shine
WJEJ, Hagerstown, Md.

ALLEN, GARY
Disc Derby
KFRU, Columbia, Miss.

ALLEN, LEN
KLO, Ogden, Utah

ALLEN, LLOYD
KCLS, Flagstaff, Arizona

ALLEN, PAUL
KCLS, Flagstaff, Arizona

ALLEN, ROGER
WOTW, Nashua, N. H.

ALLEN, TIONY
Music For You
WPIK, Alexandria, Va.

ALTMAN, LEN
Music in the Night
WSAR, Fall River, Mass.

AMOLE, GENE
Amole's Corner
KMYR, Denver, Colo.

AMOS, JOHNNY
Johnny's Band Box
KBAK, Bakersfield, Cal.

ANDERSON, BILL
WKDM, Des Moines, Iowa.

ANDERSON, ERNIE
Record Review
WHIM, Providence, R. I.

ANDERSON, JOHN
Musical Clock
WBAT, Marion, Ind.

ANDERSON, MARVIN
Requestfully Yours
KCIEM, Carroll, Iowa

ANDREWS, JOHNNY
Johnny Andrews Musical
WTAM, Cleveland, Ohio

ANNONI, JERRY
KGYW, Vallejo, Cal.

APPLE, BILL
Bill Apple Show
KAYO, Seattle, Wash.

ARJM, TOM
Day-Dreamer
WSTV, Steubenville, O.

ARNOLD, CHARLES
WAFB, Baton Rouge, La.

ARREDONDO, FRANK
WKQA, Santurce, P. R.

ART, BOBBY
RFD 1050 Party
WRFW, Eau Claire, Wis.

ARTHUR, SID
KSO, Des Moines, Iowa

AUGELLO, JOE
WJLB, Detroit, Mich.

AUSTIN, DICK
Evening Melodies
KNOX, Grand Forks, N. D.

AVERY, BEN
Call Of The Rockies
KOA, Denver, Colo.

AYRES, ART
Tops In Pops
KODI, Cody, Wyo.

— B —

BACKMAN, HARVEY
Record Party
KOOK, Billings, Mont.

BAILEY, BILL
Welcome Inn
KRIZ, Phoenix, Ariz.

BAILEY, CARL
Jack The Earlybird
KBIG, Avalon, Cal.

BAILEY, JIM
1240 Juke Box
KRDU, Danuba, Cal.

BAILEY, WILLIAM
Bill Bailey Show
WBV, Belleville, Ill.

BAINTER, JACK
Music For Monday
KHQ, Spokanc, Wash.

BAKER, BABE
Harlem Express
WSAI, Cincinnati, O.

BAKER, BILL
Western Caravan
WMIK, Middlesboro, Ky.

BAKER, BOB
KORK, Las Vegas, Nev.

BAKER, PAUL
Rise & Shine
WLAD, Danbury, Conn.

BALDWIN, BUD
Best of Baldwin
WING, Dayton, O.

BALDWIN, CLYDE
KDMS, El Dorado, Ark.

BALDRIDGE, GENE
Gene's Record Shop
WSP, Paintsville, Ky.

BALL, BOB
WMUU, Greenville, S. C.

BANKSTON, BOB
Sunrise Serenade
WSPC, Anniston, Ala.

BANNINGER, DOREEN
WIEL, Elizabethtown, Ky.

BARBER, BILL
Music Hall Matinee
WJR, Detroit, Mich.

BARBER, PAUL
Spanish Hour
KVOE, Santa Ana, Cal.

BARCLAY, AL
Danceland
WAMS, Wilmington, Del.

BARLOW, JACK
WQUA, Moline, Ill.

BARLOW, JAY
Mantrip
WHLN, Harlan, Ky.

BARNARD, DALLAS
KOL Karnival
KOL, Seattle, Wash.

BARNES, CHRIS
Late Date
WALE, Fall River, Mass.

BARON, HENRY
Mood Indigo
WSSV, Petersburg, Va.

BARR, FRED
Spiritual Time
WWRL, N. Y., N. Y.

BARRETT, BILL
WCJU, Columbia, Miss.

BARRY, DONALD, J.
Journey Into Melody
WIKL, Newport, Vermont

BARRY, GENE
Swing With Wing
WING, Dayton, O.

BARTER, BOB
Musical Variety
KNEX, McPherson, Kan.

BEAGIE, DALE
Show That Dale Built
CKRD, Red Deer, Alta.

BEAULIEU, BOB
CJEM, Edmundston, N. B.

BEAULIEU, REMI
CJFP, Riviere Du Loup, Que.

BEAVER, WIN
Ole BM
WMOX, Meridian, Miss.

BECK, TOM
Tom's Turnstable
KTLW, Texas City, Tex.

BEECHER, DON
Nite Flite
WEOA, Evansville, Ind.

BEECHER, FRANK
Showcase
WKLO, Louisville, Ky.

BEGHOLD, KENNETH
WGBI, Scranton, Pa.

BEKAS, TONY
WKAP, Allentown, Pa.

BELL, DON
KRNT, Des Moines, Iowa

BELL, GENE
Heller's Honor
KYOS, Merced, Cal.

BELLE, JOHNNIE
The Bellboy Show
WDOG, Marine City, Mich.

BENEDICT, GORDON
WMMW, Meriden, Conn.

BENHAM, DICK
WBET, Brockton, Mass.

BENNETT, FRED
WPEN, Phila., Pa.

BENNETT, JACK
WPTR, Albany, N. Y.

BENNETT, AL
Musical Menn
WHLI, Medford, Mass.

BENNETT, MARGARET
WESC, Greenville, S. C.

BENTON, DOUG
WMBY, Montgomery, Ala.

BENTON, LOU
WAPX, Montgomery, Ala.

BERG, ALAN
Tops n' Pops
KRKB, Los Angeles, Cal.

BERGNER, CARL
Early Roots
WLYA, Grand Rapids, Mich.

BERRY, JACK
To The Ladies
WIOH, Miami, Fla.

BERRY, JAMES F.
Berry's Bandstand
WIBO, Orlando, Fla.

BERRY, JOHN
WGBF, Evansville, Ind. (radio)

BETHUEA, FRED
Musical Check
WTEM, Ocala, Fla.

BIDDLEY, ALAN
Dream Street
KTUL, Tulsa, Okla.

BINETTE, BOB
Dream Street
KTUL, Tulsa, Okla.

BINGE, KALPH
Gentle & Binge
WBBK, Detroit, Mich.

BIRRELL, HARRY
Day-Breaker
WSPY, Steubenville, O.

BLACKWELL, DILLARD
WLOE, Leaksville, N. C.

BLAIR, BILL
Moonlit Moods
ROME, Tulsa, Okla.

BLAIR, CHUCK
WFRX, W. Frankfort, Ind.

BLAIR, HARRY
Late Date
WGL, Ft. Wayne, Ind.

BLAKE, ALIX
Star Dreams
WABY, Albany, N. Y.

BLOCK, MARTIN

Make Believe Ballroom, WNEW, New York
Make Believe Ballroom, WABC, ABC

BLUM, GEORGE
KORN, Mitchell, S. D.

BASSETT, BOB
Rosebud Revue
WPEP, Taunton, Mass.

BASSETT, JOHN
PM 1230 Club
WNEB, Worcester, Mass.

BATCHELDER, BOB
WEAN, Providence, R. I.

BATEV, HUGH
WPDQ, Jacksonville, Fla.

BOBROW, NORM
Bandstand
KXA, Seattle, Wash.

BOHREK, ROBERT
Morning Matinee
WGYA, Geneva, N. Y.

BOIGT, WALLA
Of The Record
WAIR, Winston-Salem, N. C.

BOLIN, ART
Dream Team
WARM, Scranton, Pa.

BONNER, ED.
St. Louis Ballroom
KXOK, St. Louis, Mo.

BOOTH, JIMMY
Music At Your Request
WNGR, Bandbridge, Ga.

BOONE, JOE
Moonlight Melodies
WMBG, Milledgeville, Ga.

BORRELLI, RALPH
WIMJ, Philadelphia, Pa.

BORT, KEN
Smokin' Hot Sounds
KFXD, Nampa, Idaho

BOWDEN, JAMES
Juvie'n Junction
KTPJ, Porterville, Cal.

BOWEN, HAL
Alarm Clock Club
KOFI, Ocala, Fla.

BOWERS, BUD
WSEA, York, Pa.

BOWERS, JACK
Platter Party
WMBK, McKeesport, Pa.

BOWERS, TOM
Morning Special
WLAG, Lakeland, Fla.

BOWLES, FRANK
Hi Neighbor
WOPW, Owosso, Mich.

BOWMAN, GENE
Of The Record
KRL, Beeville, Tex.

BOYD, ALBERT
Of The Record
WBPJ, Boonville, Miss.

BRANCH, GEORGE
WELC, Welch, W. Va.

BRANDNER, CHUCK
No Name
WRMN, Elmira, Ind.

BRANDT, JACK
Varnay Time
WFPZ, Jasper, Ind.

BRANT, BILL
WJAS, Pittsburgh, Pa.

BRAY, AL
Jukebox Matinee
WKNB, New Britain, Conn.

BRAY, ED.
Surprise Show
WKTG, Thomasville, Ga.

BRETAG, JERRY
WLP, La Salle, Ill.

BRENNER, PAUL
Reminiscence Young
WYVI, Newark, N. J.

BRINGIER, ERNEST
Lynn "The World"
WMBY, New Orleans, La.

BROCK, RAY
In 2 Three
WHDY, Appleton, Wis.

BRODE, BUDDY
WNAZ, Northtown, Pa.

BROOKS, AL
Platter Party
WBC, Indianapolis, Ind.

BROOKS, JACK
WCC, Hartford, Conn.

BROOKS, JIM
KMOD, Modesto, Cal.

BROOKS, KIRBY
Kirby Brooks Show
WQAM, Miami, Fla.

BROOKS, MARK
WNRG, New Rochelle, N. Y.

BROOKS, PHIL
WKPA, New Kensington, Pa.

BROOKS, VANCE
WGD, Chester, S. C.

BROWN, ART
Art Brown Show
WDBT, Washington, D. C.

BROWN, BILL
AM 1230 Club
WNEB, Worcester, Mass.

BROWN, DON
Tune Out With Music
KREI, Ft. Frances, Ind.

BROWN, FLOYD
Me D. J.
WEAR, Pensacola, Fla.

BROWN, KEITH
KFLA, Amarillo, Tex.

BROWN, PAT
Quartet Time
KAPK, Minden, La.

BROWN, RHODA
Ted And Rhoda Brown Show
WMBM, New York, N. Y.

BROWN, SAM
WARI, Arlington, Va.

BROWN, TED
Ted Brown Show
WMBM, New York, N. Y.

BROWNELL, LARRY
Larry Brownell Show
WBHD, Warren, Ohio

BRVANT, JAY
KOA, Kitzon, Texas

BRVANT, WILLIE
All-Over Hours Swing Session
WBOM, N. Y., N. Y.

BUCK, GEORGE, JR.
WJNO, W. Palm Beach, Fla.

BULL, FRANK
America Dances
KFWB, L. A., Cal.

BULLOCK, SHEL
Juke Box Serenade
WASC, Glens Falls, N. Y.

BURFORD, BILL
Morning on the Mahoning
WBHD, Warren, Ohio

BURTON, BOB
Breakfast With Burton
WEEK, Peoria, Ill.

BURNETTE, DAVE
WMBR, Richmond, Va.

BURGESS, FRANK
Chuck Watson Roundup
WHMA, Ansonia, Ala.

BURGE, HARRY
Jukebox Serenade
WQAM, Miami, Fla.

BURKHART, KEN
KLBZ, Houston, Tex.

BURGESS, RALPH
Open House
WGBA, Columbus, Ga.

BURKS, SPIDER
House of Joy Show
KXLA, St. Louis, Mo.

BUSTARD, HAROLD
KGEZ, Kalspell, Mont.

BUTLER, JIM
KMOX, St. Louis, Mo.

BUTLER, SHERM
Record Shop
WMAI, Washington, D. C.

BUZZARD, DICK
WELM, Elmore, N. Y.

— C —

CADDELL, GRAHAM
WJMX, Florence, S. C.

CAFFREY, BOB
Wood Grand Rapids, Mich.

CALDWELL, LARRY
WPC, Sharon, Pa.

CALLAHAN, CHARLES W.
Lucky Seven
WESB, Bradford, Pa.

CALVERT, BOB
WTPJ, Charlestown, W. Va.

CAMPBELL, JIM
WATM, Amore, Ala.

CAMPBELL, DICK
WDVA, Danville, Va.

CAMPBELL, GEORGE
WHD, Niagara Falls, N. Y.

CAMPBELL, BILL
WHOL, Allentown, Pa.

CAMPO, TONY
Midnight Flyers
WEDC, Chicago, Ill.

CAPPS, JIMMY
Our Best To You
WPTF, Raleigh, N. C.

CAREY, STAN
Hi Neighbor
WGAC, Augusta, Ga.

CARLETON, LAD
1580 Club
WFGM, Fitchburg, Mass.

CARLSON, TED
WTAQ, Lagrange, Ill.

CARMACK, ALLEN
KVCV, Redding, Cal.

CARPENTER, BOB
Masquerade Bandstand
WDBQ, Dubuque, Iowa

CARR, ROY
Record Shop
WLOL, Minneapolis, Minn.

CARRINGTON, JIM
WLEU, Erie, Pa.

CARROLL, RAY
After Hours Swing Session
WHOM, N. Y., N. Y.

CARTER, DIAMOND
WMFR, High Point, N. C.

CARTER, LEROY
Carter's Clambake
KCTX, Childress, Tex.

CARVER, JOHN
KODY, North Platte, Neb.

CASE, HARRY
Music in the Air
WHIM, Prov., R. I.

CASERSON, CARL
Friendly Time
KDAL, Duluth, Minn.

GAUDILL, CARL B.
WFTC, Kinston, N. C.

CHAMBERS, BOB
Musical Capers
WEBK, Tampa, Fla.

CHAMBERS, JOELYN
Jo's House
KANE, New Iberia, La.

CHAMBERS, PAT
Gulf Coast Serenade
WFLA, Tampa, Fla.

CHANDLER, JOEL
WJOY, Burlington, Vermont

CHAPMAN, FRED
WBAX, Wilkes Barre, Pa.

CHAPMAN, GLEN
Supper Club
KOLS, Pryor, Okla.

CHAPMAN, JERRY
The Lowdown
WIRE, Indianapolis, Ind.

CHAPMAN, RALPH
Plattler Playhouse
WHAV, Haverhill, Mass.

CHARLES, PRESTON
Top Five
WAGA, Atlanta, Ga.

CHASE, EDDIE
Eddie Chase Show
CKLW, Detroit, Mich.

CHASMAN, POLA
The Pola Chasman Show
WQXR, New York

CHASUK, DAVE
Danceable Ditties
KTIM, San Rafael, Cal.

CHRISTIAN, JERRY
KGYW, Vallejo, Cal.

CHRISTIANSON, CHRIS
KLFY, Lafayette, La.

CHRISTIE, MIKE
CKCR, Kitchener, Ont.

CHURCHILL, DON
KWBR, Oakland, Cal.

CLARK, CHRIS
1230 Club
WBSM, New Bedford, Mass.

CLARK, DANNY
The Danny Clark Show
WEAR, Savannah, Ga.

CLARK, DOCK
Caravan of Music
WFIL, Phila., Pa.

CLARK, JOHN
Date With Rhythm
WPRC, Lincoln, Ill.

CLARK, JOHN
WKAI, Macomb, Ill.

CLARKE, DEL
WJMR, New Orleans, La.

CLARKE, ROBERT
Night Owl
WRTA, Altoona, Pa.

CLAY, TOM
Sunrise Serenade
WKOP, Binghamton, N. Y.

CLAYTON, JOHN
Happy Days
WRFW, Eau Claire, Wis.

CLEMENT, JOHNNIE
Record Shop
WKLV, Blackstone, Va.

CLEMENTS, CLEM
Clem's Chicken Coop
KLEA, Lovington, N. M.

CLIFFORD, BILL
Bill Clifford Show
KWRN, Reno, Nev.

CODY, WAYNE
KALL, Salt Lake City, Utah

COLONE, ANN
WGL, Ft. Wayne, Ind.

COLVIN, LOU
KOL, Seattle, Wash.

COLLETTE, JACK
WHJC, Matewan, W. Va.

COLLIER, ART
WPKE, Pikeville, Ky.

COLLINS, PAUL
Super Serenade
KFRD, Rosenberg, Texas

COMER, FRANK
Top Twenty
WLAD, Danbury, Conn.

CONNORS, BOB
Club Jet
WJET, Erie, Pa.

LARRY FINLEY

KFWB

Los Angeles

Broadcasting from

The LARRY FINLEY RESTAURANT

on the Sunset Strip



POLA CHASMAN
DRAMA DISC JOCKEY

ON

WQXR

Thursday — 9:05 to 9:30 p.m.

CONRAD, BOB
Platter Time
WJFJ, Montgomery, Ala

COOK, BILL
Musical Caravan
WAAT, Newark, N. J.

COOK, DICK
Musical Caravan
WAAT, Newark, N. J.

COOK, DICK
WMPB, Memphis, Tenn

COOK, YERN
980 Melody Lane
WTRY, Troy, N. Y.

COOPER, ALEX
KLAC, Los Angeles, Cal

COOPER, JACK L.
WSBC, Chicago, Ill.

COPE, FRANK
KJBS, San Francisco, Cal.

COPE, FRANK
Ole Lazy Man
WFRG, Greenville, S. C.

COREY, RICHARD
KCSL, Provo, Utah

COUGHLIN, LOU
WCLL, Corning, N. Y.

COURTNEY, DEL
KTLX, Oakland, Cal

COWELL, ED
WCYB, Bristol Va

CRAGIE, BOB
Melody Matinee
WWCO, Waterbury, Conn

CRANE, DICK
Coffee Club
KNFA, Jonesboro, Ark

CRAWFORD, DALE
Night Train
WOAY, Oak Hill, W. Va

CROFT, DON
Housewives Matinee
KFPW, Ft. Smith, Ark

CROUCH, AL
Pak-a-Sak Time
WBDO, Baton Rouge, La

CROUTER, WALLY
CFRB, Toronto, Ont.

CROWLEY, RICHARD
Crowley Calling
WJIM, Lansing, Mich

CUMMINGS, AL
King's Kloak
KING, Seattle, Wash.

CUMMINS, ED
WQBC, Vicksburg, Miss.

CURL, RONNIE
KURV, Edinburg, Texas

CURRY, RAY
KVON, Bandstand
KVON, Napa, Cal.

CURTIN, BOB
KTNN, Tucumcari, N. Mex

CURTIS, BILL
KALL, Salt Lake City, Utah

CURTIS, RAY
WCLD, Cleveland, Miss

— D —

DAIGRE, ROLAND
Top Twenty
WAFB, Baton Rouge, La

DALSTRÖM, EARL
KRJF, Miles City, Montana

DALE, REX
Make Believe Ballrooms
WCKY, Conn., O.

DALE, WILLIAM
WTAO, Cambridge, Mass

DAMIREZ, DAN
KWED, Seguin, Texas

DANIELS, DAN
Dan Daniels Show
WKMI, Kalamazoo, Mich

DARBY, JOE
WEVA, Emporia, Va

DARIEN, FRANK
Frank's Juke Box
KSJO, San Jose, Calif.

DARNELL, TRUMAN
1270 Jamboree
WGBA, Columbus, Ga

DARY, ALAN
Dary-Go-Round
WORL, Boston, Mass

DAVIDS, BUD
Your Boy Bud
CKLW, Detroit, Mich

DAVIS, BILL
KPIJT, Paris, Texas

DAVIS, CHUCK
Nightrider
KFPW, Ft. Smith, Ark

DAVIS, DAN
Dan's Downbeat
KCTX, Chidress, Tex

DAVIS, DAVE
Mid Day Magic
KOME, Tulsa, Okla

DAVIS, DON
Rdk Tik
KFRG, S. F., Cal

DAVIS, GENE
Request Review & Matinee
WAKR, Akron, O.

DAVIS, GEOF
WROW, Albany, N. Y.

DAVIS, HAL
Breakfast Nook
KVOE, Santa Ana, Cal

DAVIN, JACK
WKOZ, Kosciusko, Miss

DAVIS, NORM
The Record Shop
WRAJ, Craig, Colo

DAVIS, TONY
Harlem Hit Parade
KTOW, Okla. City, Okla.

DAVIS, WENDELL
WBAC, Cleveland, Tenn

DAVISON, ROGER
Night Mare Inn
WDBK, Baton Rouge, La

DAWES, WILLIAM
WCPO, Cincinnati, O.

DAWSON, JACK
CKTE, St. Catharines, Ont

DAY, GEORGE
KERO, Bakersfield, Cal.

DEAL, ARCHIE
WIRC, Hickory, N. C.

DEAL, JACK
Jack Deal Show
WHCU, Ithaca, N. Y.

DEAN, DON
1500 Club
WABJ, Adrian, Mich

DEAN, JOHN W.
WBNC, Durham, N. C.

DEANE, JOE
KQV, Pittsburg, Pa.

DECK, STAN
Stan's Deck Party
KMON, Great Falls, Mont

DEHAVEN, BOB
Card's Corral
WCCO, Minneapolis, Minn.

DEMARSE, BILL
WJOY, Burlington, Vermont

DEMICHELE, JIM
Musically Yours
WBSB, Bristol, Conn

DEMING, CHARLIE
Gloom Chaser
WKPT, Kingsport, Tenn

DENNIS, LOU
Song & Dance Club
WCOL, Lewiston, Maine

DENSON, BOB
Midday Revue
KYW, Philadelphia, Pa.

DENT, AL
KLRA, Little Rock, Ark

DENT, LARRY
Nightcap
WMAN, Mansfield, O.

DERBACK, ED
All Time Hit Parade
CKY, Winnipeg, Man.

DERRICK, JIM
Swing Out Sweet Music
WPLA, Plant City, Fla.

DESMOND, ED
Top O' The Morning
WINA, Charlottesville, Va

DESUZE, CARL
WBZ, Boston, Mass.

DEVON, PRU
WQXR, N. Y., N. Y.

DEXTER, RON
KFRD, Roseburg, Texas

DICKSON, BILL
Hillbilly Hits
WTWA, Thomson, Ga.

DEHL, BILL
Diehl 'n' Muse
WMIN, St. Paul, Minn

DILL, GLEN
The Sundial
WTSP, St. Petersburg, Fla

DILLARD, SAM
Fat Sam
WPNX, Phenix City, Ala

DILLNER, BILL
The Bandwagon
WCNT, Centenna, Ill

DISALVO, HUGO
Ingo's Handout
WIOU, Kokomo, Ind

DIXON, DAVE
Rhythm & Blues
KSTL, St. Louis, Mo.

DIXON, JOHN
WALA, Mobile, Ala.

DIXON, PAUL
The Paul Dixon Show
TUMONT

DIXON, RANDY
WBAS, Phila., Pa.

DOBBINS, JOE
WCOT, Columbus, Ohio

DOBBS, JACK
WZOB, Ft. Wayne, Ala.

PODD, LARRY
WKEV, Covington, Va.

DONAHUE, PAT
Moby Dick Club
WALE, Fall River, Mass

DONALDSON, FRANK
Lampighter
WPIX, New Orleans, La

DONALDSON, SAM
Sam's Show
KEPO, El Paso, Tex.

DONNELLY, BOB
Music Till Midnight
CFOR, Onitla, Ont.

DONOVAN, JERRY
Jamboree
WOPI, Bristol, Tenn

DOREMUS, JOE
Early Bird Show
KRMG, Tulsa, Okla.

DORSEY, JOE
Wire Request
WEMP, Milwaukee, Wis

DOREY, RAY
Ray Dorey Show
WHDH, Boston, Mass

DOTY, BILL
WENY, Elmira, N. Y.

DOUGHERTY, JIM
The Morning Show
WHOL, Allentown, Pa.

DOUGLAS, MERLE
Merle Douglas Show
KMA, Shreveport, La

DOUTHITT, BILL
KGPB, Phoenix, Arizona

DOW, W. C.
Turntable Terrace
WCAX, Burlington, Vt

DOWDY, JIM
Country Junction
WMOX, Meridian, Miss.

DOWLING, AL
WZOB, Fort Payne, Ala.

DOWNEY, GEORGE
WEAN, Providence, R. I.

DOWNEY, JACK
WGTH, Hartford, Conn.

DOWNING, DYER
KGY, Olympia, Wash.

DOYLE, EDWARD
WDNE, Elkins, W. Va.

DOYLE, JIM
KCKY, Coolidge, Arizona

DOYLE, JOHN
KILQ, Grand Forks, N. D.

DRAKE, MYRON
Star Matinee
KTAR, Phoenix, Arizona

DRUM, DEWEY
Early Riser's Club
WSOC, Charlotte, S. C.

DUGDAIE, CHARLIE
KFOR, Lincoln, Nebraska

DULANE, CHUCK
Chuck Dulane Show
WKAY, Silver Spring, Md.

DUMAS, ROLAND
Tops in Pops
WMAS, Springfield, Mass.

DUNBAR, ED
Cousin Ed Show
WBBQ, Augusta, Ga.

DUNBAR, JERRY
Wax Works
KEMO, Hannibal, Mo.

DUNCAN, JAMES
Motel Matinee
WGGH, Marion, Ill.

DUNN, TOM
WPEO, Peoria, Ill

DURAND, THOMAS
WTFM, Trenton, N. J

DURHAM, HAL
620 Club
WROL, Knoxville, Tenn.

DUTCH, HAL
WLAM, Lewiston, Maine

DUTRISAC, JEAN
Club 1450
CHEF, Granby, Que.

DUVAL, JACQUES
Paris Chante
CKCV, Quebec

DWELLEY, DALE
KVCV, Redding, Cal

DYKE, VAN HENDRICK
WFUR, Grand Rapids, Mich.

DYER, WILLIAM
WKOK, Sunbury, Pa.

— E —

EAGER, BILL
KVLF, Alpine, Texas

EARLY, BOB
WALK, Patchogue, N. Y

EASTMAN, JIM
Country Junction
WGAP, Maryville, Tenn.

EATON, BOB
WLEU, Erie, Pa.

EDMUND, JOHN
Music Matinee
KISD, Sioux Falls, S. D.

EDMUNDSON, NEAL
Starlite Souvenirs
KSBW, Salinas, Cal.

EDWARDS, ACE
KWCB, Searcy, Ark.

EDWARDS, ALLYN
Wake Up Easy
WNBC, N. Y., N. Y.

EDWARDS, CHARLIE
Crackerjack Show
WPDQ, Jacksonville Fla.

EDWARDS, GENE
Candlelight & Gold
KLPF, Dallas, Tex

EDWARDS, JOAN
WCBS, N. Y., N. Y.

EDWARDS, MERLE
Caravan
WMIN, St. Paul, Minn

EDWARDS, RICK
WRAC, Racine, Wis.

EGGLESTON, BILL
Barn Dance
WSWN, Belle Glade, Fla

EICHORN, ROBERT
Swingtime Serenade
WCLT, Newark, Ohio

EIGEN, JACK
Chez Show
WMAQ, Chicago, Ill.

EINARSON, DON
Club 1300
KOL, Seattle, Wash

ELIOTT, CHUCK
WMGY, Montgomery, Ala.

ELLIOTT, BILL
Bill's Bandstand
WNOE, New Orleans, La.

ELLIOTT, GLENN
Spins & Needles
WANE, Ft. Wayne, Ind

ELLISON, ED
Western Spotlight
KBTA, Batesville, Ark

ELLISON, PAUL
WHAR, Clarksburg, W. Va

EMBODY, DICK
Western Jamboree
KGGF, Coffeyville, Kan

EMM, LOU
Breakfast In Bedlam
WHIO, Dayton, O

ENO, JACK
Musical Food Basket
WEBR, Buffalo, N. Y.

ERRARD, JIM
KAWT, Douglas, Arizona



ART FORD

PL 3-3300

MORT
NUSBAUM

on
ROCHESTER, N. Y.'s
Number 1
Radio and TV Station
WHAM; WHAM-TV

ERWIN, JIM
Smith Time
WMLX, Mt. Vernon, Ill.

EVANS, DONALD M.
Record Shop
WLE, Cambridge, O.

EVANS, GREGORY
Personality Time
WFAI, Augusta, Maine

EVANS, JOHN
WIS, Columbia, S. C.

EVANS, MARK
WTOP, Washington, D. C.

EVANS, SAM
Jani With Sam
WVCY, Gary, Ind.

EYERS, CHARLES
1190 Club
WHOT, Philadelphia, Miss.

EWING, JIM
WISN, Milwaukee, Wis.

— F —

FABELO, RUBEN
Festa, En Tampa
WALT, Tampa, Fla.

FAGLE, DICK
WHAU, New Britain, Conn.

FANNING, WILLIAM
Fp & M Em
KPTN, Tacoma, Wash.

FARLEY, KEN
KGEZ, Kilspeil, Mont.

FARMER, JON
Early Worm
WAGA, Atlanta, Ga.

FARR, JIM
Platter Parade
KSTV, Stephenville, Tex.

FARREL, REED
Spms and Needles
KGBR, Galveston, Texas.

FARRELL, LOYAL
Jam For Supper
KHD, Spencer, Iowa.

FARRINGTON, ROBERT
WFNC, Thomasville, N. C.

FALK, JOHN HENRY
WBS, N. Y. N. Y.

FAWCETT, DON
Hour of Stars
KWX, Vancouver, B. C.

FAYE, MARY
Mary Faye Show
WAAF, Chicago, Ill.

FELD, BILL
Puz, Music
KFRV, Koryville, Tex.

FELDMAN, IRWIN
Saturday Special
WBTP, Booneville, Miss.

FENDER, HARRY
The Stereobase
KXOK, St. Louis, Mo.

FERLAND, EDWARD
Soft & Sweet
WBFE, Rochester, N. Y.

FERRIBA, E. O.
Ernie Ferriba Show
WHLS, Port Huron, Mich.

FIELDS, BENNY
Seely and Fields
WJGM, New York, N. Y.

FIELDS, ERIC
Good Music Series
WNIK, Syracuse, N. Y.

FIELDS, JERRY
KBNZ, La Junta, Colorado.

FILIPAL, S. J.
Matinee at Sun-Up
WHRY, Ann Arbor, Mich.

FISCH, HOWARD
Mt. Music Maker
WJIM, Jackson, Mich.

FINLEY, LARRY
B. May 4, 1913, Syracuse, N. Y.
The Larry Finley Show, KFWB,
Hollywood, Cal.; Hollywood Movie
Premieres, WMGM, N. Y.; KLAC-
TV, KECA-TV, KNXT-TV, Holly-
wood, Cal.

FISCHER, STEVE
WHLL, Hempstead, N. Y.

FISHER, EARL
Reggie-Cluddy Young
WVJS, Owensboro, Ky.

FITZGERALD
KOLD, Yuma, Ariz.

FLANAGAN, PAUL
Record Man
WTRY, Troy, N. Y.

FLANDERS, GUY
WJAT, Swansboro, Ga.

FLINDERS, DON
Flinders Frolic
KLIK, Twin Falls, Idaho.

FLYNN, JIM
KFRF, Fresno, Cal.

FOLAND, MALES
WCOL, Columbus, Ohio.

FONDELL, RALPH
WHUC, Mahewan, W. Va.

FORBES, BILL
1350 Club
WNLK, New dk, Conn.

FORBES, JERRY
Melody Express
WMAK, Springfield, Mass.

FORD, ART
Milkman's Matinee
WNEW, New York.

FORD, FRANK
WFEN, Phila., Pa.

FORD, LLOYD
Music Out Of The West
KAYS, Hays, Kan.

FORD, MILTON Q.
Puz, Party
WWDG, Washington, D. C.

FORSTER, BOB
WSRS, Cleveland, O.

FORSYTHE, GRANT
Forsyth It's Forsythe
CFOR, Griffin, Ont.

FOWLER, BILL
WGPR, Albany, Ga.

FOWLER, JIM
WGPR, Albany, Ga.

FRAME, CARL
Saturday Night
KUCN, Blytheville, Ark.

FRANCIS, BILL
Saturey Nite Jambores
WNHC, New Haven, Conn.

FRANKLIN, JOE
B March 9, 1926, Bronx, N. Y.
Joe Franklin's Memory Lane,
WABC
Joe Franklin's Memory Lane,
WABC-TV, New York.

FRANKMAN, DICK
WJEL, Springfield, Ohio.

FRAY, JACQUES
WQXR, N. Y. N. Y.

FRAZIER, BOB
1230 Club
KRIZ, Phoenix, Ariz.

FRAZIER, HAL
WSTP, Salisbury, N. C.

FREED, ALAN
Mooding Show
WJW, Cleveland, O.

FRENCH, NED
Breakfast with Ned
WOND, Pleasantville, N. J.

FRICTKE, ROGER
WBLW, Bedford, Ind.

FROST, DON
WLPO, La Salle, Ill.

FULLEN, GENE
Club 33
WBNS, Columbus, O.

FULLER, CHUCK
WLEE, Richmond, Va.

— G —

GABEHART, KEITH
Club 380
WJLK, Campbellville, Ky.

GAIL, MIKE
Sportsman
WBHH, Warren, Ohio.

GAINES, CHUCK
Chuck Gaines Show
WLET, Toledo, Ga.

GAINES, FOSTER
WLYC, Williamsport, Pa.

GALE, EDDIE
Wake Up Burlington
KBUR, Burlington, Iowa.

GALE, JACK
WSRS, Cleveland, O.

GALGON, PAUL
WKAP, Allentown, Pa.

GALLAHER, EDDIE
Soundful
WTOP, Washington, D. C.

GAMBLING, JOHN
MUTUAL

GANNAWAY, TOM
Spencerly Yours
WRAE, Radford, Va.

GARDNER, BILL
KROS, Clinton, Iowa.

GARDNER, BILL
WWPA, Williamsport, Pa.

GARDNER, BUD
Coffee Crayon
KFAE, Taylor, Texas.

GARDNER, BUDDY
Jive Time
WHIT, New Bern, N. C.

GARDNER, JACK
Ranch Party
WBTP, Booneville, Miss.

GARDNER, JIM
Jim Gardner Show
WJTN, Jamestown, N. Y.

GARDNER, JOHN
WSDR, Sterling, Ill.

GARGANO, BILL
Sunny-side of the Street
WHPC, Holland, Mich.

GARLAND, HOWARD
Her's Garland
KFMB, San Diego, Cal.

GARNETT, PAUL
Music in the Blue of Evening
WHUM, Prox., R. I.

GARR, BILL
Bill Garr Show
KWKW, Pasadena, Cal.

GARRETT, RAND
Listeners Choice
KONO, Acturas, Cal.

GASS, GEOFFERY
Club 10
KSRV, Ontario, Ore.

GASTON, MARCUS
KSIW, Woodward, Okla.

GATLIN, JOHN
Yawn Patrol
WFMV, Madisonville, Ky.

GAY, CONNIE
WARK, Arlington, Va.

GEORGE, REAL
Real George Show
KXOB, Stockton, Al.

GENTILE, JOE
Gentile & Binge
WJBK, Detroit, Mich.

GENTILE, LARRY
WJBK, Detroit, Mich.

GERARD, JOE
KVEE, Albany, Texas.

GERARD, RICK
KROS, Clinton, Iowa.

GETCHEL, LARRY
Spinner Sanctum
KFGT, Fremont, Neb.

GIBBON, BILL
The Room
WANT, Richmond, Va.

GIBNEY, JOE
Ol' Joe's Klix Klub
KLIX, Twin Falls, Idaho

GILBERT, DICK
KYTL, Mesa, Arizona

GILL, GIRT
WGBQ, Greensboro, N. C.

GILSON, BRACE
1340 Club
WNHC, New Haven, Conn.

GLEASON, STEVE
The Juke Box
KASM, Albany, Minn.

GLICK, LARRY
Merely Music
WRHC, Jacksonville, Fla.

GLYNN, JOHN
Platter Chatter
WWSO, Glens Falls, N. Y.

GOLDEN, RAY
Ray Golden Show
KSTN, Stockton, Cal.

GOODMAN, LEE
MUTUAL

GOODWIN, JIM
WEBQ, Harrisburg, Ill.

GORE, ELLIOTT
WSYR, Syracuse, N. Y.

GORDON, LEE
Pleasure Parade
WABY, Albany, N. Y.

GORDON, LLOYD
Pic'd Piper
WESB, Bradford, Pa.

GRAHAM, DICK
Merry Go Round
WMAS, Wilmington, Del.

GRAHAM, FRANK
WVEC, Hampton, Va.

GRANT, BRUCE
Record Shop
WGRD, Grand Rapids, Mich.

GRANT, JOHNNY
KMPC, L. A., Cal.

GRANT, MILT
WOL, Washington, D. C.

GRAWETT, JOE
Call The Spin
WJVB, Jacksonville Beach, Fla.

GRAYSON, NICK
WISC, Madison, Wis.

GREEN, ART
Ballroom
WKAT, Miami Beach, Fla.

GREENE, RON
KAIC, Tulsa, Okla.

GREER, BOB
KMon Along & Listen
KMON, Great Falls, Mont.

GREGORY, GEO.
Music Til Midnight
WGTM, Wilson, N. C.

GRENNAN, ED
WQUA, Moline, Ill.

GREWE, GRED
WHLL, Wheeling, W. Va.

GRIEVE, OLIVER
Dance Time
KAWT, Douglas, Arizona

GRISWOLD, JACK
Yawn Patrol
WQAN, Scranton, Pa.

GROTH, BETTY
Jazz Time
KMOR, Oroville, Cal.

GRUBB, JACK
WTNC, Thomasville, N. C.

GRUNDBERG, GUNNAR
WAAB, Worcester, Mass.

GUNNING, JACK
WAKU, Latrobe, Pa.

GUNTER, GEORGE
KTBB, Tyler, Texas

GURNETT, RICHARD
KSCO, Santa Cruz, Cal.

GWENN, EASY
Easy Does It
WIBC, Indianapolis, Ind.

— H —

HADLEY, EDWARD
Musical Nitecap
WCLO, Janesville, Wis.

HAGGERTY, FRED
Marine Ballroom
WFPG, Atlantic City, N. J.

HALE, PHIL
Phil Hale Show
WKNB, New Britain, Conn.

HALEY, AMBROSE
KEAL, Fulton, Mo.

HALL, ED
Early Express
KELD, El Dorado, Ark.

HALL, JOHN
1490 Club
WESB, Bradford, Pa.

HALL, RUSS
Ayem Mayhem
KENT, Shreveport, La.

HAMILTON, GENE
WNBC, N. Y., N. Y.

HAMILTON, STANLEY
Good Music Cafe
WGMS, Washington, D. C.

HANCOCK, HUNTER
KFVD & KGFJ, L. A., Cal.

HANEY, BOB
WSFC, Somerset, Ky.



"JOE FRANKLIN'S
MEMORY LANE"

on
WABC and WABC-TV
PL 8-2664

who's
he
smiling
at?



his 37 happy Sponsors!



in Chicago

he's the Busiest and the Best

BILL O'CONNOR

WCFL — WJJD — WMAQ — WIND
WGN — WAAF — WAIT
AND ALL 4 TV STATIONS

DISC JOCKEYS—RADIO-TELEVISION

HANGER, ROBERT
WDNE, Elkins, W. Va.

HANLEY, DON
Best on Wax
KFQQ, St. Joseph, Mo.

HANNA, BOB
Bob Hanna Show
WWPB, Miami, Fla.

HANNA, ERLIE
WJAM, Marion, Ala.

HANSON, KEN
WPRC, Minneapolis, Minn.

HARGIE, JIM
Sunshine Club
WJPC, Lake Wales, Fla.

HARLING, HUGH
Bye Bye Blues
KVBC, San Luis Obispo, Cal.

HAROLD, RON
Coffee Club
WPEM, Martinsburg, W. Va.

HARRELSON, JIM
Supperclub
WSYD, Mt. Airy, N. C.

HARRIS, CHAZ
Swing Shift
WJHP, Jacksonville, Fla.

HARRIS, DEAN
WAGE, Syracuse, N. Y.

HARRIS, JOHN
Honest John's Houseparty
WHYI, Newport News, Va.

HART, BOB
KEAL, Fulton, Mo.

HART, RUSS
Coffee with Russ
WAOV, Vincennes, Ind.

HART, RUSSELL
WBIW, Bedford, Ind.

HARVEY, JOHN
Good Morning Show
KGO, San Francisco, Cal.

HARVEY, PAT
Pat Harvey Show
KBMO, Hannibal, Mo.

HASTON, LESTER
Platter Party
WCRI, Scottsboro, Ala.

HAYMES, BOB
WCBS, N. Y., N. Y.

HAYNES, DICK
KLAC, Los Angeles, Cal.

HAYNES, JOHNNY
WMLS, Sylvauga, Ala.

HAZLETT, BOB
Hulbilly Houseparty
KTVY, Crockett, Tex.

HEATHLIN, BOB
Sachlinin Serenade
WGGG, Gainesville, Ga.

HEDMAN, DON
KJR, Seattle, Wash.

HELGESON, BOB
KSOO, Sioux Falls, S. D.

HEMINGWAY, JACK
Rise and Shine Club
RAYO, Seattle, Wash.

HENDERSON, GERRA
WHFR, Manchester, N. H.

HENDON, R.D.
Western Jamboree
KMOO, Conroe, Tex.

HENLEY, HAROLD
Platter Parade
WOPI, Bristol, Tenn.

HENRY, GIL
King's Open House
KING, Seattle, Wash.

HENRY, JULES
WBNS, Fontstown, Pa.

HERARD, GILBERT
CKOU, Hull, Que.

HERMAN, D. A.
Discapades
WHRY, Ann Arbor, Mich.

HERRING, BILL
KWTX, Waco, Texas.

HESTER, JAMES
Record Ray
WCRZ, Oil City, Pa.

HESTERMAN, BILL
KLO, Ogden, Utah.

HOCKOK, BILL
WPTT, Albany, N. Y.

HUCKS, CAP
WRGA, Rome, Ga.

HULL, ED
WMOK, Metropolis, Ill.

HULL, EDDIE
WSM, Nashville, Tenn.

HULL, DICK
Record Party
WBIZ, Eau Claire, Wis.

HULL, ROBERT
Platter Club
WAYNE, Ft. Wayne, Ind.

HULL, WALTER
WHUL, Hammond, La.

HIRSCH, STEVE
Time Time
WCHN, Norwich, N. Y.

HIRSCH, WOODY
KBIZ, Ottumwa, Iowa.

HOBBS, FRED
1490 Club
KBOL, Boulder, Colo.

HOPFER, DAVE JR.
Hymn Request Time
KRDU, Durham, Cal.

HOGE, ALAIN
Chansonettes
CHP, Montreal, Que.

HOLIDAY, JOHN
KOV, Phoenix, Arizona.

HOLIDAY, JOHN
KTHS, Little Rock, Ark.

HOLDEN, WILLIAM
WOHL, East Liverpool, O.

HOLMES, JACK
Jack Holmes Show
WLOW, Norfolk, Va.

HOLT, DAN
Happy Dan, The Record Man
WBEX, Chillicothe, Ohio.

HOOD, TAL
Tal Hood Show
WFGM, Fitchburg, Mass.

HORMAN, GABBY
WGL, Ft. Wayne, Ind.

HOSEA, FRANK
Frank Calling
WSMB, New Orleans, La.

HOSKINS, JACK
Opry House of Stars
WJLN, Harlan, Ky.

HOUFBURG, HOLLA
Holly's Hollies
KLIK, Twin Falls, Idaho.

HOWARD, BILL
WDVA, Danville, Va.

HOWARD, BOB
Top 20 at 1280
WLSC, New Orleans, La.

HOWARD, PAUL
Top of Morning
WTRF, Bohma, Ohio.

HOWARD, JOHN
WML, Waycross, Ga.

HOWE, CHARLES
Top Rail
KMAN, Manhattan, Kan.

HUBER, LARRY
WLYC, Williamsport, Pa.

HUDSON, FLOYD
KJMS, El Dorado, Ark.

HUDSON, HARVEY
WLEE, Richmond, Va.

HUDAK, JOHN
For You By Request
WGPA, Bethlehem, Pa.

HUGG, ARLÖE
Breakfast with Arlöe
WSAV, Savannah, Ga.

HUGHES, CLAUDE
Sunny Side Of The Street
KNEX, McPherson, Kan.

HUGHES, HUGH
WWWF, Fayette, Ala.

HUGHEY, BRETT
KBOR, Brownsville, Texas.

HULL, NIKI
KCID, Caldwell, Idaho.

HUMBLE, BILL
WJAM, Williamsport, N. C.

HUNT, JOHNNY
Top Spot
WVEC, Hampton, Va.

HUSAK, JOHN
Rendezvous Room
WDBQ, Dubuque, Iowa.

HUSING, TED
Ted Husong's Bandstand
WJGM, New York, N. Y.

HUSTAD, DICK
WBUR, Clarksburg, W. Va.

HUTCHINS, BAILEY
Music Out of the Night
WRBC, Jackson, Miss.

HVDEN, JOE
Rhythm At Random
WRJM, Newport, R. I.

— I —

IULENFELD, WARREN
WISK, Butler, Pa.

INGERSOLL, JOHN
Mobile Matinee
WKRQ, Mobile, Ala.

INNS, BEN
From Studio C
KSEI, Pocatello, Idaho.

IRVING, BOB
WMAV, Springfield, Ill.

IRWIN, KEN
KLOG, Kelso, Wash.

— J —

JACK, HARRY
The Music Shop
WBIZ, Maizee, Mich.

JACKSON, TED
WHAM, Rochester, N. Y.

JAMES, CARROLL
On the Horizon
WJEL, Hagerstown, Md.

JAMES, RUSS
What Time Is It?
San Luis Obispo, Cal.

JAMISON, BICK
Pam Richards' Almanac
WBYK, Cumberland, Md.

JARVIS, AL
Make Believe Bedroom
KFWB, L. A., Cal.

JASIN, JAY
Jay's Penthouse
WIKY, Columbus, Ohio.

JEFFRIES, DICK
By Request
WOAP, Owosso, Mich.

JENKINS, BON
KGV, Olympia, Wash.

JEWELL, WAYNE
Record Matinee
WBBC, Flint, Mich.

JOHNSON, ALAN
KHO, Grand Forks, N. D.

JOHNSON, ART
Ballad Box
WATR, Waterbury, Conn.

JOHNSON, BILL
KGIJL, Flagstaff, Arizona.

JOHNSON, BILL
WLAC, Memphis, Tenn.

JOHNSON, BUCKY
Blue Dreamer
WIRK, W. Palm Beach, Fla.

JOHNSON, IRWIN
Early Worm
WBNS, Columbus, O.

JOHNSON, JOE
WPAQ, Mt. Airy, N. C.

JOHNSON, KEN
Melody Time
WGAP, Maryville, Tenn.

JOHNSON, KIMBERLEY
Top o' the Morning
WCSH, Portland, Maine

JOHNSON, PETE
WBET, Brockton, Mass.

JOHNSON, ROOSEVELT
Roosevelt's Record Club
WERD, Atlanta, Ga.

JOHNSTON, JACKIE
Mad House
KOLS, Pryor, Okla.

JOHNSTON, J. J.
Harlem Express
WWPB, Miami, Fla.

JOHNSTON, KEN
WNRC, New Rochelle, N. Y.

JONES, ART
Buldy's Ballroom
KOTA, Rapid City, S. D.

JONES, BOB
Greensboro, N. C.

JONES, DICK
199 Club
KUBC, Montrose, Colo.

JONES, DON
KBYM, Billings, Montana

JONES, DON
WLEA, Hornell, N. Y.

JONES, PAUL
In A Sentimental Mood
WSAI, Cincinnati, O.

JONES, VERNE
WREB, Holyoke, Mass.

JOSEPH, EDWARD
Morning Show With Eddy Jo
WHLD, Niagara Falls, N. Y.

— K —

KALLAS, BESS
Lady Professor
WKBI, St. Mary's, Pa.

KARNOW, DICK
WGSM, Huntington, L. I.

KARNS, BRUCE
Record Room
KMAN, Manhattan, Kan.

KARRENBAIR, BILL
Bill's Inn
WHBC, Canton, O.

KASSEL, S. I.
Your Musical Caravan
WCCM, Lawrence, Mass.

KAY, ANDY
Swinging With Andy
KGST, Fresno, Cal.

KAY, ARTY
WVLC, Lexington, Ky.

KAYE, BARRY
WJAS, Pittsburgh, Pa.

KAYE, LARRY
KCMJ, Palm Springs, Cal.

KEHOE, JERRY
WVSC, Somerset, Pa.

KELLER, ROGER
Turntable Matinee
WEPM, Martinsburg, W. Va.

KELLY, BOB
WJLM, Wilmington, Del.

KELLY, DAN
1400 Club
WRDO, Augusta, Maine

KELLY, TOM
Tom Kelly Show
WLAV, Grand Rapids, Mich.

KELSO, BILL
Platter Chatter
KHUM, Eureka, Cal.

KENNEDY, ALFRED
1490 Club
WIKI, Newport, Vt.

KENNEDY, MICHAEL
Club 800
KTOW, Okla. City, Okla.

KENYON, WAYNE
KGNC, Amarillo, Texas

KERN, DON
KRJF, Miles City, Montana

KERSHAW, ART
WJAR, Providence, R. I.

KEYES, FRANK
ALPO, La Salle, Ill.

KEYES, WILLIAM
WJNO, W. Palm Beach, Fla.

KEYS, DICK
WOHI, East Liverpool, O.

KILLMAN, EARL
WEBQ, Harrisburg, Ill.

KINDELL, EARL
Platter Pantry
WSWN, Belle Glade, Fla.

KING, ART
1230 Calling
WBSM, New Bedford, Mass.

KING, DUKE
WINN, Louisville, Ky.

KING, FULTON
The Coffee Pot
WTON, Staunton, Va.

KING, JOHNNY
WJAR, Providence, R. I.

KING, NELSON
Daily Hit Parade
WCKY, Cinn., O.

KING, PAUL
Paul King Show
WONW, Defiance, O.

KING, VERN
Platter Parade
KSD, St. Louis, Mo.

KING, WALLY
KSFO, San Francisco, Cal.

KIRBY, GENE
Hillbilly Jamboree
WWSR, St. Albans, Vt.



BILL SILBERT

DISC JOCKEYS—RADIO-TELEVISION

KIRBY, BAL
WWVR, Tusculloville, Ala.

KIRBY, JIM
WBIC, Birmingham, Ala.

KIRK, JOHN
WWST, Wooster, O.

KIRKWOOD, JIM
Mutual

KIRWAN, JAMES
Korwan's Karousel
WDLA, Walton, N. Y.

KISSER, CHESTER
Music Hall
WWIN, Baltimore, Md.

KIZER, WALTER
WACL, Waycross, Ga.

KNEISLER, CHUCK
WINN, Louisville, Ky.

KNIGHT, FRED
1230 Club
WMMT, Mt. Murray, Tenn.

KNIGHT, GEORGE
CKRC, Winnipeg, Manitoba

KNIGHT, JOE
Tulsa Ballroom
KRMG, Tulsa, Okla.

KNIGHT, KEN
Knight Train
WRIC, Jacksonville, Fla.

KNIGHT, LLOYD
LAZY L
KMYR, Denver, Colo.

KNIGHT, SID
Knight Of The Round Table
WGCA, Gary, Ind.

KOLBY, CAL
Record Shop
WDRG, Hartford, Conn.

KOLZ, BOB
WNDB, Daytona Beach, Fla.

KORTE, ODELL
WMOK, Metropolis, Ill.

KRAHLING, BOB
Town & Country
WHBC, Canton, O.

KRETTNER, RICHARD
WCDL, Carbondale, Pa.

KRELL, FRED
Krell Show
WSGW, Saginaw, Mich.

KRISTOF, JOHN
WCHS, Crileston, W. Va.

KYLE, JACK
Make Believe Ballroom
CKWX, Vancouver, B. C.

— L —

LABOE, ART
Art Labor Show
KGEI, Hollywood, Cal.

LACOM, AL
Afternoon with Al
KGA, Spokane, Wash.

LALLY, JOE
WHLI, Wheeling, W. Va.

LA MAR, JACK
Housewive's Serenade
WGAM, Camden, N. J.

LAMB, BILL
Jam For Breakfast
WBBC, Flint, Mich.

LAN, TED
WSDR, Sterling, Ill.

LANE, BRYANT
Record Room
WGAF, Valdosta, Ga.

LANE, ED
Monroe County Hoedown
WMPA, Aberdeen, Miss.

LANE, JEFF
Street of Dreams
WKMI, Kalamazoo, Mich.

LANG, BOB
Bob Lang Show
KPOA, Honolulu, Hawaii

LANDOE, LEE
WPFH, Middletown, Ohio

LANGE, JIM
WPPB, Minneapolis, Minn.

LANGILL, EDDIE
1230 Club
KLVT, Levelland, Texas

LARSEN, BOB
Coffee Club
WEMP, Milwaukee, Wis.

LARRE, RAY
Country Concert
WOAL, San Antonio, Texas

LAUF, DICK
WJCD, Seymour, Ind.

LAUVENDER, WENDOL
Rise And Shine
WGLS, Decatur, Ga.

LAWRENCE, DICK
Melody Matinee
WHIC, Alexandria, Va.

LAWYER, JOHN
KORA, Bryan, Texas

LAWRENCE, KEN
House of Music
WHLS, Lansing, Mich.

LAWRENCE, LARRY
Music For You
WOPJ, Boston, Mass.

LAY, SLIM
Slim Lay Show
WRBS, Birmingham, Ala.

LEAYTT, ROBERT
Afternoon Of Music
WWSR, St. Albans, Vt.

LEE, ARCHIE
WHOP, Hopkinsville, Ky.

LEE, DICK
Surprise In The Rockies
KVOE, Colorado Springs, Colo.

LEE, TOMMY
Variety With Melody
KSLB, Cedar City, Utah

LEE, VINCE
Morning Salute
KYW, Phila., Pa.

LEFFLER, GENE
Parade of Pops
KAYL, Storm Lake, Iowa

LEONARD, BUD
Wake Up Mississippi
WKBC, Jackson, Miss.

LEONARD, HOWIE
Matinee Frolic
WFOR, Portland, Maine

LEVI, SY
Top Band Show
WACE, Springfield, Mass.

LEWIS, DEAN
KLRM, La Grande, Oregon

LEWIS, GERRY
Music You Want
WCSH, Portland, Maine

LEWIS, J. D.
WRAL, Raleigh, N. C.

LEWIS, WILBUR
WANT, Robinson, Va.

LEADEN, BILL
KFWB, L. A. Cal.

LILLY, R. G.
WLQU, Louisville, Ky.

LIND, ELLIS
Ellis Lind Show
KSTN, Stockton, Cal.

LINDEMANN, BUD
The Big Bud Show
WGRD, Grand Rapids, Mich.

LINDHOLM, BILL
Record Rendezvous
KSTT, Davenport, Iowa

LING, CLAUDE
Something For The Ladies
WGAM, Camden, N. J.

LINN, BANDEL
At Home With Bandel Linn
WSPB, Sarasota, Fla.

LISLE, KEN
Top Of The Mornin'
KCOM, Sioux City, Iowa

LLOYD, BOB E.
Bob E. Lloyd Show
WAVZ, New Haven, Conn.

LOGAN, GEORGE
KXLW, St. Louis, Mo.

LOHMAN, DIXIE
Open House
KAYL, Storm Lake, Iowa

LOKEY, FRANK
WRDW, Augusta, Ga.

LOMAX, KEN
Phonics And Encores
KERG, Eugene, Ore.

LOMBARD, JIM
1400 Club
KCNZ, LaJunda, Colorado

LONG, JAMES
Chatter Parade
WLCK, Campbellville, Ky.

LONG, JOE
Music At Random
KLCN, Blytheville, Ark.

LoPRESTO, STANLEY
WRBS, Oyster Bay, N. Y.

LORD, JOHN
KGLD, Mason City, Iowa

LOTRIDGE, EROLD
Music In The Night
KRTA, Batesville, Ark.

LOUDEM, ROD
Music In Music
KPOJ, Portland, Oregon

LOWE, JAMES
WRR, Dallas, Texas

LOWE, WALTER V.
Eise Jockey Jamboon
KSLB, Cedar City, Utah

LOWERY, BILL
Bill Lowery Show
WGST, Atlanta, Ga.

LOWRY, LEW
Housewive's Hour
KTRH, Houston, Texas

LUCAS, BEN
WRGA, Rome, Ga.

LUCAS, BILL
Two To Get Ready
KOLN, Lincoln, Nebraska

LUCIER, ROD
KIROX, Crookston, Minn.

LUCK, "LUCKY"
Wake Up Hawaii
KPOA, Honolulu, Hawaii

LANN, JAMES
WPWA, Chester, Pa.

LYONS, JIMMY
KDOX, Salinas, Cal.

— M —

MacADIE, JACK
Sittin' In The Sun
WICH, Norwich, Conn.

MacDONALD, DON
KLCB, Lobby, Mont.

MacDONALD, RON
MVC On A Moonbeam
KLCB, Lobby, Mont.

MACK, DANNY
WAKN, Aiken, S. C.

MACK, JOHNNY
Melody Time
WVOK, Birmingham, Ala.

MacKECHNIE, BILL
Time Teller
WLAT, Tampa, Fla.

MacKELVIE, ART
Saturday Matinee
KHK, Spokane, Wash.

MACTAVISH, DON
Warm Sounds
CJRI, Kenora, Ont.

MADDON, ED
Swing Session
WARM, Scranton, Pa.

MADDOX, SKIP
WANE, Ft. Wayne, Ind.

MAHONEY, JOHN
Platter Parade
WJTN, Jamestown, N. Y.

MAIZE, JIM
KONA, Tucson, Arizona

DISC JOCKEYS—RADIO-TELEVISION

- MALONE, CHARLES**
Charlie's House
KANE, New Iberia, La.
- MALLOY, LES**
KYA, San Francisco, Cal.
- MAPLES, TOM**
WLEL, Elizabethtown, Ky.
- MARCH, JIM**
Open House
KODL, Cody, Wyo.
- MARKLE, TINY**
Tiny Markle Jamboree
WAVZ, New Haven, Conn.
- MARLOWE, OWEN**
Record Revue
WALK, Patchogue, N. Y.
- MARSHALL, JOHN**
Rise 'N' Shine
WCEN, Norwich, N. Y.
- MARTIN, CLIFF**
WMRP, Flint, Mich.
- MARTIN, JOE**
590 Club
WOW, Omaha, Neb.
- MARTIN, JOE**
KPMC, Bakersfield, Cal.
- MARTIN, JOHNNY**
WWPA, Williamsport, Pa.
- MARTIN, MARY ELLEN**
Merry-Go-Round
KCSB, San Bernardino, Cal.
- MARTIN, MIKE**
WVLC, Lexington, Ky.
- MARTINEZ, AL**
WKIP, Poughkeepsie, N. Y.
- MARTINI, MARTY**
Music Mart
WIOU, Kokomo, Ind.
- MARVIN ELLIS**
Nite Owl
KSTT, Davenport, Iowa
- MASON, CHARLES**
WJMX, Florence, S. C.
- MASON, JOHN**
Coffee Call
WRMN, Elgin, Ill.
- MASON, WILLIAM**
WKYR, Koyser, W. Va.
- MASSEY, BOB**
Melody Hour
WIOD, Miami, Fla.
- MATHEL, CHET**
After Hours
WOOD, Grand Rapids, Mich.
- MATTHEWS, DOUG**
WFRX, W. Frankfort, Ill.
- MATTHEWS, SAM**
Rural Rhythym
KGKB, Tyler, Texas
- MAUGANS, BILL**
Western Jamboree
Poncea City, Okla.
- MAXWELL, BOB**
WWJ, Detroit, Mich.
- MAXWELL, RAYMOND**
Songs To Remember
WTVL, Waterville, Maine
- MEYER, BILL**
Mayor of Morning
WGAR, Cleveland, O.
- MAYER, JOE**
WLOK, Cleveland, O.
- MAYHEW, TOMMY**
Penthouse Serenade
WGAP, Maryville, Tenn.
- MAYHUGH, BILL**
Bill Mayhugh Show
WMAL, Washington, D. C.
- MAYNARD, DAVE**
Mr. D. M. in the AM & PM
WHIL, Medford, Mass.
- MAYO, HIRAM**
KPOC, Pochahontas, Ark.
- MAYS, JOHN**
All Request Jamboree
KBOA, Kennett, Mo.
- McATEE, JOHN**
KTYL, Mesa, Arizona
- McARTHUR, RED**
Red McArthur Show
WHGB, Harrisburg, Pa.
- McARTHUR, TOM**
WKRC, Cincinnati, O.
- McCAULEY, JOE**
Dawn Patrol
WIP, Phila., Pa.
- McCOY, RONNIE**
Morning with McCoy
KFEL, Denver, Colo.
- McCUULLOUGH, SCOT**
Dance Party
KAKE, Wichita, Kans.
- McDOWELL, CHESTER**
Daddy-O-Hot Rod
KCIS, Shreveport, La.
- McELRONE, GREG**
WHYB, Appleton, Wis.
- McFARLAND, WAYNE**
Night Watch
KNEB, Scottsbluff, Nebraska
- McGHEE, TOM**
WKKO, Cocoa, Fla.
- McGRATH, NED**
Mac's Musical Clock
WJOC, Jamestown, N. Y.
- McGRAW, DON**
WCYB, Bristol, Va.
- McGUIRE, MAC**
Start The Day Right
WIP, Phila., Pa.
- McKASSON, CHUCK**
Money For Music
KRIO, McAllen, Tex.
- McKEE, BOB**
WQXI, Atlanta, Ga.
- McKINLEY, LARRY**
Larry McKinley Show
WMBY, New Orleans, La.
- McKINNEY, JIM**
Just For You
WMIX, Mt. Vernon, Ill.
- McLACHLAN, ARDELL**
WSON, Henderson, Ky.
- McLEAN, BILL**
Music Mart
KAKE, Wichita, Kan.
- McLEAN, DONALD**
Morning Serenade
WHDL, Olean, N. Y.
- McLEOD, DON**
WJBK, Detroit, Mich.
- McMILLAN, WILLIAM S.**
KRKL, Kirkland, Wash.
- McNEELEY, MARTY**
Music Hall
WJR, Detroit, Mich.
- MCRAE, JUNE**
WMBM, Miami Beach, Fla.
- McROBERTS, EARL**
WBHY, Appleton, Wis.
- McEHAN, BOB**
Just Name It
WEAN, Providence, R. I.
- MELIA, KAY**
Club 400
KAYS, Hays, Kan.
- MEENDES, JIM**
WICE, Prov., R. I.
- MENEHAN, JIM**
Club 1230
KLCB, Libby, Mont.
- MERRITT, EDWARD**
Journey Into Melody
WBRK, Pittsfield, Mass.
- MERTZ, BILL**
Music Maestro
WVKO, Columbus, O.
- MEYERS, DUTCH**
KFOR, Lincoln, Nebraska
- MEYERS, JACK**
Gloomnsters
KOLN, Lincoln, Nebraska
- MOFFITT, JIM**
KLOG, Kelso, Wash.
- MOLNAR, EMERY**
Record Hits
WMCK, McKeesport, Pa.
- MONK, MARION**
Listening Post
WMGA, Moultrie, Ga.
- MONKMAN, BOB**
WRJN, Racine, Wis.
- MONROE, JOE**
Joe Monroe Show
KCIS, Shreveport, La.
- MONTGOMERY, ROBERT**
WGBC, Greensboro, N. C.
- MOORE, DON**
WWWF, Fayette, Ala.
- MOORE, JACK**
Melody Shop
KAKC, Tulsa, Okla.
- MOORE, LEE**
WWVA, Wheeling, W. Va.
- MOORE, VIRGIL**
WJAM, Marion, Ala.
- MORALES, LUIS A**
Club 550
WPAB, Ponce, Puerto Rico
- MOBATH, MAX**
Time Out With Max
KVOR, Colorado Springs, Colo.
- MORELLI, HAL**
KLAS, Las Vegas, Nev.
- MORGAN, HAL**
Morgan's Matinee
WGAR, Cleveland, Ohio
- MORGAN, JOE**
Music With Morgan
KERV, Kerrville, Tex.
- MORRIS, JIMMY**
Late Date
WKRK, Mobile, Ala.
- MORRIS, JOHNNY**
Johnny on the Spot
WLWL, Minneapolis, Minn.
- MORRIS, LEROY**
R.F.D.
WEAR, Pensacola, Fla.
- MORROW, FRANK**
Frank Morrow Show
KTUL, Tulsa, Okla.
- MORSE, CLINTON**
Country Music Time
WHYL, Carlisle, Pa.
- MOSENA, DICK**
Burlington Buggy Ride
KBUR, Burlington, Iowa
- MOSER, VERYL**
Coffee Time
KISD, Sioux Falls, S. D.
- MICHAEL, JAY**
WCAE, Pitts., Pa.
- MICKEY, ERNEST L.**
KBKI, Alice, Texas
- MILES, JERRY**
KLMM, Lamar, Colo.
- MILLER, DICK**
The Ole Hep Cat
WRBC, Jackson, Miss.
- MILLER, DOTIE**
A Miss With The Hits
WBBQ, Augusta, Ga.
- MILLER, FRED**
Afternoon Serenade
KMMO, Marshall, Mo.
- MILLER, HOWARD**
WMAQ, Chicago, Ill.
- MILLER, HOWARD**
WIND, Chicago, Ill.
- MILLER, MEL**
Breakfast Club
WARE, Ware, Mass.
- MILLER, PAUL**
WCKY, Cinn., O.
- MILLERAND, GABE**
On The Sunnyside
KYW, Phila., Pa.
- MILNER, GEORGE**
Turntable Caravan
KGVL, Greenville, Tex.
- MILLS, DICK**
Dick Mills Show
KIOA, Des Moines, Iowa
- MILLS, LEE**
WRAD, Radford, Va.

MILTON, BOB
Bob Milton Show
WDOG, Marine City, Mich.

MINIARD, TOM
WATM, Amore, Ala.

MINTZ, HERBIE
Herbie Mintz Show
WAAF, Chicago, Ill.

MITCHELL, BOB
WELM, Elmira, N. Y.

MITCHELL, FROSTY
KWDN, Des Moines, Iowa

MITCHELL, HARRY
KCDQ, San Diego, Cal.

MULLEN, JAY
Music with Mullen
WJMA, Charleston, S. C.

MULLIGAN, RAY
Mulligan's Show
WPAM, Pottsville, Pa.

MULHILL, JOE
1100 Club
WTAM, Cleveland, Ohio

MURDOCK, JIM
ROCKY, Coolidge, Arizona

MURPHY, BOB
Bob Murphy Show
WIRK, W. Palm Beach, Fla.

MURPHY, DENNIS
Discs with Dennis
WREN, Topeka, Kan.

MURPHY, MARTIN
Outwest Special
KOVE, Lander, Wyo.

MURPHY, PAUL
The PM Show
WONW, Defiance, O.

MURPHY, TOM
WKNA, Charleston, W. Va.

MURPHY, JACK
Strictly Informal
WOMI, Owensboro, Ky.

MYERS, BILL
KILQ, Hilo, Hawaii

— N —

NAUGHTON, RUSS
Music Off The Record
WDRR, Hartford Conn.

NEAL, BOB
WMPB, Memphis, Tenn.

NEDEL, CHUCK
Chuck Nadel Show
WXTD, Daytona Beach, Fla.

NEIDER, OSCAR
Let's Dance
WAGM, Presque Isle, Maine

NELLS, MARY
WSAU, Wausau, Wis.

NELSKOG, WALLY
KJR, Seattle, Wash.
KGA, Spokane, Wash.

NELSON, BOB
Top Times
KSLB, Jamestown, N. D.

NELSON, BOB
Morning Call
WDSU, New Orleans, La.

NELSON, GENE
KGMN, Sacramento, Cal.

NELSON, STANLEY
KUTE, San Antonio, Texas

NEUBERGER, STAN
WEKZ, Monroe, Wis.

NEWSOME, GIL
First Five
KWK, St. Louis, Mo.

NEWTON, JIM
Western Caravan
KYYC, Little Rock, Ark.

NEXTER, ROY
Town's Top Times
WDFB, Flint, Mich.

NICHOLSON, JIM
Musical Clock
WJGW, Meadville, Pa.

NICKSON, NICK
950 Club
WBBF, Rochester, N. Y.

NIERSBACH, BILL
WKBY, Richmond, Ind.

NILES, DAVID
WEVD, N. Y.

NOBLE, BOB
WTOF, Savannah, Ga.

NOBLES, GENE
WLAC, Nashville, Tenn.

NORDEN, LEE
Disc King
WSAM, Saginaw, Mich.

NORGARD, ROBERT
WFRQ, Fremont, O.

NORMAN, GEORGE
Night Call
KTOP, Oklahoma City, Okla.

NORMAN, ROBERT
Melody Matinee
WHDL, Olean, N. Y.

NORRIS, RANDY
Random Runch

NORTON, RICHARD
Coffee Time Musicals
WFEAT, Augusta, Maine

NORVAL, BUD
Breakfast Serenade
WFOR, Baton Rouge, La.

NOVER, BRUNO
Merry-Go-Round
WBOW, Torrington, Conn.

NUSBAUM, MORT
WHAM, Rochester, N. Y.

— O —

O'BRIEN, ALBERT
Al O'Brien Show
WOPA, Oak Ridge, Ill.

O'BRIEN, BILL
Commuter's Special
WSAR, Fall River, Mass.

O'CONNOR, BILL
Shows For WCFL, WJJD, WMAG,
WIND, WGN, WAAF, WAIT,
Chicago, Ill.

O'DONNELL, BOB
WHEC, Rochester, N. Y.

O'LEARY, JIM
KIDQ, San Diego, Cal.

OLESEN, PAUL
WDLR, Carbondale, Pa.

OLENEA, DEL
Lunchtime
KWJL, Portland, O. con.

O'NEILL, MARTIN
WKXV, Sarasota, Fla.

ORANCH, JACK
WKRT, Cortland, N. Y.

ORAVEC, ED
A.M. Mayhem
WHDK, Lancaster, O.

ORCHARD, RAY
CJQC, Quebec City, Que.

ORISEK, RUDY
WTAQ, Lagrange, Ill.

OSBORNE, WAYNE
1490 Club
WOPA, Oak Park, Ill.

OVERTON, RAY
Timekeeper
KOA, Denver, Colo.

OWENS, DON
WGAI, Elizabeth City, N. C.

— P —

PAILETTE, DON
KWLN, Portland, Oregon

PAINTER, DICK
After Hours Staff
KUGB, Great Bend, Kan.

PAINTER, FRANK
The Coon Hunter
WBLL, Dalton, Ga.

PANSULLO, JIM
Timekeeper
WNEB, Worcester, Mass.

PARKER, AL
Anything Goes
WJJD, Chicago, Ill.

PARKER, DICK
WKUP, Poughkeepsie, N. Y.

PARKER, EDDIE
WGN, Knoxville, Tenn.

PARKER, ERIC
Eric Parker Show
WREZ, Muskegon, Mich.

PARKS, DEL
WPEN, Phila., Pa.

PARKS, DON
Silver City Serenade
WPEP, Taunton, Mass.

PARRISH, JOHN
WJBY, New Orleans, La.

PARSONS, CLAUDE
WBW, Bedford, Ind.

PARSONS, LES
KBAR, Burley, Idaho

PATRICK, LARRY
Tops In Pops
WAIR, Winston-Salem, N. C.

PATTERSON, JIMMY
By Jimmy
WBT, Charlotte, N. C.

PAUL, DON
WTAX, Springfield, Ill.

PAVNE, BILL
Bill's Record Shop
KWHP, Cushing, Okla.

PAVNE, LLOYD
Almanac & Dinnerbell
WDXB, Chattanooga, Tenn.

PEARCE, MARSHALL
Musical Clock
WSME, New Orleans, La.

PEARS, TOM
KVOL, Lafayette, La.

PEARV, HAL
Hal Peary Show
WMGM, New York, N. Y.

PEBBLES, ED
Country Store
WBML, Macon, Ga.

PEER, LEE
Lee Peer Show
KOOK, Billings, Mont.

PELLOW, DAVE
Record Rack
WGBF, Evansville, Indiana

PENNEY, EDWARD
WTAL, Cambridge, Mass.

PERAZZO, DON
Sunrise Serenade
KRON, Omaha, Neb.

PERKINS, RAY
Ray Perkins Show
KFLC, Denver, Colo.

PERKIN, T. E.
Coffee, Kip, Kapers
KATH, Fayetteville, Ark.

PERRY, BOB
Bob Perry Show
WCMP, Lowell, Mass.

PERRA, LOE
WBWW, Youngstown, O.

PETERS, BOBBY
Bobby Peters Show
WBAP, Ft. Worth, Tex.

PETERSON, ARNOLD
WATW, Ashland, Wis.

PETERSON, BILL
Phoenix U.S.A.
KTAR, Phoenix, Arizona

PETERSON, BRENT
WMUS, Muskegon, Mich.

PETERSON, DON
1500 Club
KROD, Brawley, Cal.

PETERSON, RALPH
KSL, Salt Lake City, Utah

PETTIT, BILL
Wide, Biddeford, Maine

PETTACK, KEITH
WPDR, Portage, Wis.

PETTI, RALPH
WESP, Greenville, S. C.

- PHELAN, TOM**
Ladies Matinee
KXLF, Butte, Mont.
- PHILLIPS, BILL**
WBAX, Wilkes Barre, Pa.
- PHILLIPS, DEWEY**
WHQ, Memphis, Tenn.
- PHILLIPS, JERRY**
KDNZ, LaJunta, Colorado
- PHILLIPS, RALPH**
Melody Ballroom
WPBR, Baltimore, Md.
- PHILLIPS, WALTER**
WLW, Cinn., O.
- PICKENS, DICK**
KEBE, Jacksonville, Texas
- PIQUETT, BOB**
Rise And Shine Club
KAYO, Seattle, Wash.
- PLUNKETT, PATRICK**
Buckeye Bugle Call
WGLT, Newark, O.
- POOLE, BOB**
WBIG, Greensboro, N. C.
- POTTER, PHIL**
WHYL, Carlisle, Pa.
- POWELL, HARRELL**
Music Til Midnight
WSAT, Salisbury, N. C.
- POWELL, JACK**
WOWO, Ft. Wayne, Indiana
- POWERS, JOE**
WBMD, Baltimore, Md.
- POWERS, NED**
Two & Eight Date
WHDH, Boston, Mass.
- POWERS, TOM**
Melody Time
WLOA, Braddock, Pa.
- PRADER, GEORGE**
Hurlem Express
KGBC, Galveston, Texas
- PRESCOTT, NORM**
Norm Prescott Show
WORL, Boston, Mass.
- PRESTON, ART**
Art Preston Show
WSPR, Springfield, Mass.
- PRUETT, GEORGE**
KVOL, Lafayette, La.
- PROUGH, CARL**
Rhythm Range
KHUM, Eureka, Cal.
- PUDNEY, EARLE**
Earle Pudney Show
WGY, Schenectady, N. Y.
- PUTNAM, DON**
Cosmo Wax
WBEZ, Ponca City, Okla.
- PUTNAM, MAX**
Mailbag Show
WMMT, McMinneville, Tenn.
- PYLE, JACK**
Musical Clock
KYW, Phila., Pa.
- Q —
- QUATTLEBAUM, HOWARD**
WAGF, Dothan, Ala.
- QUINN, BILL**
Good Music Series
WNDR, Syracuse, N. Y.
- R —
- RADKA, AL**
Gayride
KFRE, Fresno, Cal.
- RADZINSKI, STANLEY**
WJMJ, Philadelphia, Pa.
- RAIFORD, BOB**
Weekend Dancing Party
WBT, Charlotte, N. C.
- RAINS, CAL**
Swing Shift
WIRL, Peoria, Ill.
- RAMAY, JOE**
KLYN, Amarillo, Texas
- RAMSAY, BILL**
WVOT, Wilson, N. C.
- RAMSEY, RAYMOND L.**
WHIR, Danville, Kentucky
- RANDLE, DEAN**
Randle's Island
KCOM, Sioux City, Iowa
- RANDOLPH, JAMES**
WLOU, Louisville, Ky.
- RAY, FRANKIE**
Club 1230
KWNR, Reno, Nev.
- REED, KERMIT**
The Record Roundup
WDUN, Gamesville, Ga.
- REEVES, GEORGE**
WKYW, Louisville, Ky.
- REEVES, MAX**
KJSK, Columbus, Neb.
- REID, BILL**
TNT
WDOK, Cleveland, O.
- REID, CLARK**
Clark Reid Show
WJR, Detroit, Mich.
- REMINGTON, JACK**
WKRC, Cincinnati, O.
- RENO, WALT**
Wake Up With Music
WOC, Davenport, Iowa
- REUTZ, ED**
WRAC, Racine, Wis.
- REYNOLDS, BOB**
Bobbin Along
KRQP, Brawley, Cal.
- REYNOLDS, RUSS**
Sundial
WUCM, Cumberland, Md.
- REYNOLDS, STEVE**
Off The Record
WSAL, Logansport, Ind.
- RHOARDNER, SCOTTY**
Top Ten Of The Week
WTK, Durham, N. C.
- RHODES, MARY**
Bar 1590
KSJO, San Jose, Cal.
- RHYNER, RUSS**
WSAU, Wausau, Wis.
- RICH, GLENN**
Hillbilly Supper Club
KXOL, Ft. Worth, Texas
- RICHARDS, GRAHAM**
WPAW, Pawtucket, R. I.
- RICHARDS, RON**
Spotlight On Broadway
KGVO, Missoula, Mont.
- RICHARDS, STAN**
Stan's Coffee Stand
- RICHBOURG, JOHN**
WLAC, Nashville, Tenn.
- RICHMOND, DICK**
Richmond's Record Room
KRIO, McAllen, Tex.
- RIPLEY, RONALD**
Coffee Caravan
KBWD, Brownwood, Texas
- RITTER, KEN**
KFDN, Beaumont, Texas
- ROBBINS, FRED**
Mutual
- ROBERTS, ART**
Art Roberts Show
KXLR, St. Louis, Mo.
- ROBERTS, BILL**
WPRS, Paris, Ill.
- ROBERTS, HAROLD**
Yours For The Asking
CKX, Brandon, Man.
- ROBERTS, HI**
Hi and Homer
KWKH, Shreveport, La.
- ROBERTS, KEN**
KLMR, Lamar, Colo.
- ROBERTS, JAY**
Three R. Show
KVLC, Little Rock, Ark.
- ROBERTS, MARTY**
Night Riders
WKY, Cinn., O.
- ROBERTS, WALT**
Dance Parade
WMAN, Mansfield, O.
- ROBIN, TOM**
Robin's Round Table
KAYO, Seattle, Wash.
- ROBINSON, GENE**
Off The Record
WTAN, Clearwater, Fla.
- ROBINSON, RUTH**
KBYE, Oklahoma City, Okla.
- ROCHE, DICK**
Rise And Shine
WTWA, Thomson, Ga.
- ROCKWELL, AL**
KRNZ, Des Moines, Iowa
- RODONETS, R.**
Club 940
GIGX, Yorkton, Sask.
- RODRIGUEZ, EDDIE**
Buenos Dias
KFVD, L. A., Cal.
- RODRIGUEZ, JOHNNY**
Cabellero Hour
KTIP, Porterville, Cal.
- ROGERS, BILL**
KAGH, Crossett, Ark.
- ROGERS, BOB**
After Hours
KXOX, Sweetwater, Texas
- ROGERS, TOMMY**
Sunday Music Time
KEPO, El Paso, Tex.
- ROLLINS, BILL**
Afternoon Serenade
WAYS, Charlotte, N. C.
- ROMANS, ROY**
The Timekeeper
WMBG, Richmond, Va.
- ROMNEY, LANCE**
KMDD, Modesto, Cal.
- ROPER, KEITH**
Platter Parlor
WABJ, Adrian, Mich.
- ROPER, TEX**
KPAL, Fulton, Mo.
- ROSS, ART**
Yawn Patrol
WLOW, Norfolk, Va.
- ROSS, BILL**
The Bill Ross Show
WIOD, Miami, Fla.
- ROSS, BOB**
CKOV, Kelowna, B. C., Canada
- ROSS, WALT**
Dealers Choice
KSRV, Ontario, Ore.
- ROSCOE, BEN**
Cousin Ben Show
KALE, Richland, Wash.
- ROSSI, JAMES**
Best On Wax
KIBL, Beville, Tex.
- ROTH, BOB**
Breakfast Time
WPIK, Alexandria, Va.
- ROTH, DON**
WEOA, Evansville, Indiana
- ROWE, RED**
KFWB, L. A., Cal.
- ROWLANDSON, HUGH**
Record Rack
WTVL, Waterville, Maine
- RUBIO, ZATARAIN**
KIWW, San Antonio, Texas
- RUSE, GEORGE**
Koffee Club
KYA, San Francisco, Cal.
- RUSSELL, JOHNNY**
Juke Box Johnny
WJR, Detroit, Mich.
- RUSSELL, LEW**
WPIC, Sharon, Pa.
- RUSSELL, VERNE**
Pleasure Parade
KUJ, Walla Walla, Wash.

RUTHERFORD, KEITH
Turntable Terrace
CKX, Brandon, Mon.
RUTLEDGE, NED
WHVR, Hanover, Pa.
RYAN, DAN
WBWV, Youngstown, O.
RYAN, KEITH
WLEU, Erie, Pa.
KYMAN, PAUL
Rhyme 'N Rhythm
KRRQ, Eugene, Ore.

— S —

ST. GEORGE, BRUCE
CKTB, St. Catharines, Ont.
SALAMON, MIKE
Accent On Music
WBSR, Butler, Pa.
SALTER, BOB
KJR, Seattle, Wash.
SAMM, JOHN
Parade of Hits
WPAM, Pottsville, Pa.
SAMPSON, BILL
Bill Sampson Show
KWKW, Pasadena, Cal.
SAMS, B. J.
WBEL, Elizabethton, Tenn.
SAMSON, GUY
Paris Chante
CKCV, Quebec
SAN ANTONIO, UGO
Request Time
WCAP, Lowell, Mass.
SANDERS, GEORGE
KRRD, Los Angeles, Cal.
SAUNDERS, EDDIE
Jump n' Jive
WVIO, Columbus, O.
SAVAGE, LAMAR
Club 35
WGGA, Gainesville, Ga.
SAWYER, TOM
Tom Sawyer Time
WHDG, Orlando, Fla.
SAWYER, WAYNE
WGCD, Chester, S. C.
SAXON, BERT
WBKV, West End, Wis.
SCAMMELL
WELC, Welch, W. Va.
SCIENCK, HENRY
Bud's Music Room
WTRF, Bellaire, Ohio
SCHINDLER, PETE
Top Pops
KASII, Eugene, Ore.
SCHMEER, BILL
Afternoon Ballroom
WAZL, Hazelton, Pa.
SCHMIDTKE, IRVING V.
KRWC, Forest Grove, Oregon
SCHNEELY, LARRY
KVOA, Tucson, Arizona
SCHROCKWET, BILL
Bill's Ballam
WIRK, W. Palm Beach, Fla.
SCLIMMER, JOHN
WNMP, Evanston, Ill.
SCOTT, D'ARCY
CKRD, Maunee
Red Deer, Alta.
SCOTT, KEN
WPEO, Peoria, Ill.
SCRUGGS, WILLIS
The Sound
WERD, Atlanta, Ga.
SEANEY, E. JAMES
Jump Seaney Show
WDBZ, Decatur, Ill.
SEARLES, TOM
WOW, Omaha, Neb.
SEARS, ZENAS
Diggin' The Discs
WGST, Atlanta, Ga.

SEAN, ALAN
1400 Club
KDWT, Stamford, Texas
SEELEY, BLOSSOM
Seeley and Fields
WMGM, New York, N. Y.
SEIVERS, FRANK
Western Jamboree
KOTI, Gonzales, Tex.
SELF, JIM
Western Caravan
KICA, Clovis, N. M.
SELF, MITCHELL
1490 Club
WADF, Decatur, Ala.
SENEDEK, TONY
Coffee Pot Parade
WVVG, Milledgeville, Ga.
SERGI, SYL
Night Shift
WRST, New Castle, Pa.
SERYEL, CARL
560 Club
WMLK, Middlesboro, Ky.
SESMA, LIONEL
Chicago
KOWL, Santa Monica, Cal.
SESSIONS, CLIFF
Off The Record
WFOR, Hattiesburg, Miss.
SHARP, IRVING
Musical Clock
WDEJ, Roanoke, Va.
SHARPE, BILL
KRES Jamboree
KRES, St. Joseph, Mo.
SHARPE, JERRY
WKY, Frankfort, Ky.
SHARPE, LEONARD
WSTL, Sturgis, Mich.
SHAW, EARL
WKAL, Raleigh, N. C.
SHAW, TOM
KFDA, Amarillo, Tex.
SHELA, BILL
KJR, Seattle, Wash.
SHELLER, LEROY
Rhythm Express
KXAN, Glendive, Mont.
SHEPPARD, CHARLES
KAPA, Raymond, Wash.
SHEPPARD, GIL
WCPO, Cincinnati, O.
SHEPHERD, JEAN
WLW, Cincinnati, O.
SHEPPARD, VERN
Request Express
KOTA, Rapid City, S. D.
SHERBAIN, DICK
Platter Parade
WLAN, Lancaster, Pa.
SHERER, ED
Ed Sherer Show
WATG, Ashland, Ohio
SHERIDAN, BILL
Uncle Sam Show
WRJM, Newport, R. I.
SHERIDAN, PHIL
Rise and Shine
WELF, Phila., Pa.
SHERMAN, DONALD A.
WBCM, Bay City, Mich.
SHERMAN, GENE
Spin The Platter
WPTS, Bloomington, Ind.
SHERMAN, JOHN
KJL, Walla Walla, Wash.
SHERKILL, BOB
WAKN, Alben, S. C.
SHERWOOD, BOBBY
WABC, New York
SHERWOOD, DON
KSPQ, San Francisco, Cal.
SHINE, BILL
1230 Club
KLAN, Renton, Wash.
SHORE, HAL
Shore Show
WSGW, Saginaw, Mich.

SHUMWAY, HARLEY
Computer's Special
KVON, Napa, Cal.
SHURIAN, BUD
Bud's Place
WARE, Ware, Mass.
SICKLESTEEL, TOM
Tom Sicklesteel Show
WHLS, Port Huron, Mich.
SIEVERS, BOB
WOWO, Ft. Wayne, Indiana
SILBERT, BILL
Bill Silbert Show
WMGM, New York, N. Y.
SIMMONS, JACK
Music a la Why!
WHYL, Carlisle, Pa.
SIRY, ED
Hillbilly Fever
WBIS, Bristol, Conn.
SLACK, D. J.
Moonblad
WCAJ, Burlington, Vt.
SMITH, BILL
Pop Parade
WGOR, Lebanon, Tenn.
SMITH, BILL
WSFA, Montgomery, Ala.
SMITH, BOB
WTOG, Savannah, Ga.
SMITH, DON
Horsewife's Restless
WGSJ, Tifton, Ga.
SMITH, EDWIN
Wake Up & Live
KGRB, Tyler, Texas
SMITH, FLETCHER
WGBG, Greensboro, N. C.
SMITH, GENE
WCRS, Greenwood, S. C.
SMITH, HAL
WELP, Hensley, S. C.
SMITH, HERB
WCRD, Johnston, Pa.
SMITH, JACK
KTKR, Taft, Cal.
SMITH, MARK
The Sun Dial
WSBA, York, Pa.
SMITH, ROBERT
Off The Record
KVEC, San Luis Obispo, Cal.
SMITH, ROBERT
House of Music
WGET, Gettysburg, Pa.
SMITH, SMOKY
WELP, Hensley, S. C.
SOLLIE, GORDON
This 'N' That
WFLA, Plant City, Fla.
SOMMERS, BILL
Melody Unlimited
WKST, New Castle, Pa.
SOMOHANO, HECTOR M.
WCMN, Arcebo, Puerto Rico
SORENSEN, KEN
Best on Wax
WDBZ, Green Bay, Wis.
SORG, RICHARD
Platter Party
WPRO, Fremont, O.
SPANGLER, BOB
Off The Record
KWIL, Albany, Ore.
SPENCER, NEAL
Best On Wax
WAQV, Vincennes, Ind.
SPIEGLE, STAN
Doodlebug
KXRO, Aberdeen, Wash.
SPRINGER, THURSTON
WJAT, Swansboro, Ga.
STAMBUCK, WALLY
CLOC, Lehighville, Alta.
STANLEY, BILL
Happiness Exchange
WNOE, New Orleans, La.
STARBUCK, MARK
PNX Jamboree
WPNX, Phenix City, Ala.

STARR, RAYMOND
KWWL, Waterloo, Iowa
STARWYCK, STEVE
Platter Party
KGRH, Fayetteville, Ark.
STEELE, DONALD
WKBI, St. Marys, Pa.
STEIN, LES
Top "40"

WTLX, New Orleans, La.
STELL, BILL
WSVS, Crews, Va.

STEPHENS, ERNIE
KMPC, Marysville, Cal.

STERLING, JACK
Top of the Morning
WCBS, New York, N. Y.

STEVEN, LERM
WTRW, Two Rivers, Wis.

STEVENS, AL
Al Stevens Show
WWIN, Baltimore, Md.

STEVENS, DICK
R S V P
KMYR, Denver, Colo.

STEWART, BILL
Bill Stewart Show
KLIF, Dallas, Tex.

STEWART, CHARLES
KITE, San Antonio, Texas

STEWART, FAYE
KSFO, San Francisco, Cal.

STILL, JAY
Platter Parade
WDUN, Gainesville, Ga.

STOKLEY, CHARLIE
Red River Roundup
KWKH, Shreveport, La.

STONE, HAROLD
WOPI, Bristol, Tenn.

STORR, BILL
Curley's Corner
WLET, Toccoa, Ga.

STRADER, KARL
WMUU, Greenville, S. C.

STRADER, TED
Club 1320
WJHP, Jacksonville, Fla.

STREETER, HOWARD
Starlight Revue
WFBR, Baltimore, Md.

STRENGTH, BILL
Lunchtime Parade
WEAS, Decatur, Ga.

STULL, BILL
KLYN, Amarillo, Texas

STUTHMAN, FRED
Relaxin' Time
KGO, San Francisco, Cal.

SUGAR, DICK
WEVD, N. Y.

SULLIVAN, PERRY
WRDW, Augusta, Ga.

SUMNER, BUTLER A.
Butler's Bull Barn
KLEA, Lovington, N. M.

SUTTON, LEE
Jamboree Party
WWVA, Wheeling, W. Va.

SWAIN, HACK
The Hack Swain Show
WSPB, Sarasota, Fla.

SWANEY, HAL
Matinee Melodies
WIDE, Biddeford, Maine

SYRDAL, JIM
KTRF, Thief River Falls,
Minn.

— T —

TANGUY, VIC
The Nightwatch
WSAL, Logansport, Ind.

TAPLIN, TAP
TNT

WEBR, Buffalo, N. Y.

TATAR, TED
Easy Pickin's
WHYU, Newport News, Va.

TAYLER, BYRON
Record Review
KFXD, Nampa, Idaho

TAYLOR, BEN
WNDB, Daytona Beach, Fla.

TAYLOR, PAT
Musical Hayloft
WAIR, Winston-Salem, N. C.

TEIG, DAVE
Club Time
WILK, Wilkes-Barre, Pa.

TEMPLE, JOE
Serenade
KONO, San Antonio, Texas

TERRY, CHEM
Saturday Morning Roundup
WBAP, Ft. Worth, Tex.

THEISS, DIXIE
WBBD, Ft. Lauderdale, Fla.

THOMAS, DICK
Honor Roll of Hits
KMMO, Marshall, Mo.

THOMAS, JOHNNY
WMFD, Wilmington, N. C.

THOMAS, LLOYD
Morning Melodies
KHAS, Hastings, Neb.

THOMAS, VAL
Melody Circus
WGAY, Silver Spring, Md

THOMPSON, BERNICE
WDAS, Phila., Pa.

THOMPSON, GENE
Off the Record
KRCC, Rochester, Minn.

THOMPSON, GOLDIE
WBBO, Tampa, Fla.

THOMPSON, GRAHAM
Rhythm On The Range
CKPR, Ft. William, Ont.

THOMSEN, JACK
Night Watch
WOC, Davenport, Iowa

THORNTON, WALLY
Saturday Nile Record Party
KWIL, Albany, Ore.

THORSON, ROY
Western Jamboree
KISD, Sioux Falls, S. D.

TIGHE, RON
KSID, Sidney, Neb.

TOMASON, JIMMY
Jimmy Tomason Show
KBAK, Bakersfields, Cal.

TOTTEN, JOHN
WGBF, Evansville, Indiana

TOTTEN, VERN
Music Of The West
KXLF, Butte, Mont.

TOWNE, GORDON
T.N.T. Talk 'N Towne
WBSR, Pensacola, Fla.

TOWNSEND, DUDLEY
Musical Clock
WDBJ, Roanoke, Va.

TRACEWELL, JIM
Platter Party
KCSB, San Bernardino, Cal.

TRAP, W. L.
Bill Trap Show
WKBZ, Muskegon, Mich.

TRUDEAU, WALTER
Tea Time
CKTS, Sherbrooke, Que.

TRUMPETER, JAY
WIND, Chicago, Ill.

TUCK, BUD
Top o' the Mornin'
WGUY, Bangor, Maine

TURK, AL
Good . . . Good Morning Show
WSAM, Saginaw, Mich.

TURNER, RAY
WEAV, Plattsburg, N. Y.

TURNER, SHIRLEY
Date With Shirley
KRRC, Lewiston, Idaho

TWOMEY, MORRIE
Melody Theatre
KNOE, Monroe, La.
TYLER, WAYNE
WLVA, Lynchburg, Va.

TYSON, DAVEY
Wake Up With Davey
WGAE, Pitts., Pa.

— U —

UGLUM, JIM
Let's Go Places
KGVO, Missoula, Mont.

ULRICH, BOB
KBIF, Sanger, Cal.

UNDERHILL, LEO
Breakfast Time
WCKY, Cinn., O.

USHER, DON
KJR, Seattle, Wash.

— V —

VAINRIB, STAN
WBRC, Birmingham, Ala.

VALENTINO, GENE
Coffee Corner
WWCO, Waterbury, Conn.

VALENZUELA, EFREN
Serenata Nocturnal
KRIZ, Phoenix, Ariz.

VALLES, CHINA
WPAW, Pawtucket, R. I.

VAUGHN, JOE
Request Review
WJER, Dover, O.

VANCE, SID
Bernies Bandwagon
KYOS, Merced, Cal.

VANDERHOOF, BRUCE
B. V.
KDYL, Salt Lake City, Utah

VAN OSS, JUKE
Clockwatcher
WHCC, Holland, Mich.

VAN STEENBURGH, BILL
Southern Melodies
WIPC, Lake Wales, Fla.

VEITH, DON
Free For All
KVAN, Vancouver, Wis.

VELEZ, GERMAN
WPTL, Mayaguez, Puerto Rico

VONDELL, JOHN
Breakfast Hour
WREB, Holyoke, Mass.

VOSBURGH, HERMAN
Tunetown
KTAT, Frederick, Okla.

— W —

WADE, OZZIE
Sunrise Serenade
WKNE, Keene, N. H.

WAGNER, DAN
Breakfast Club
WLOA, Braddock, Pa.

WALDROP, JIM
Music For Romance
WGAC, Augusta, Ga.

WALKER, BILL
CKRC, Winnipeg, Manitoba

WALKER, FLETCHER
Rise and Shine
WEMA, Anniston, Ala.

WALKER, WILFRED
Variety Time
WFBD, Greenville, S. C.

WALL, ART
WKRT, Cortland, N. Y.

WALLACE, GIL
Wake Up With Wallace
WVMC, Mt. Carmel, Ill.

WALLGREN, REX
KLO, Ogden, Utah

WALPERF, JERRY
WKBS, Oyster Bay, N. Y.

WALSHAK, DAVID
J450 Club
KCTL, Gonzales, Tex.

WALTERS, BILL
Easy Listening
WDFZ, Green Bay, Wis.

WALTERS, BUCKEY
Tune Time
WEEK, Peoria, Ill.

WALTHER, HAL
Platter Party
KFRI, Columbia, Miss.

WATTS, JIM
Old General Store
KWRP, Cushing, Okla.

WAMBACH, PETE
WCMB, Harrisburg, Pa.

WANKE, HUGH
600 Serenade
WCAO, Baltimore, Md.

WARD, BILL
WIS, Columbia, S. C.

WARD, FRANK
WEBW, Buffalo, N. Y.

WARD, JIM
Morning Mayor
WLIK, Wilkes-Barre, Pa.

WARD, PAT
Club 800
WCCM, Lawrence, Mass.

WARD, REGGIE
Reggie Ward Show
KAPK, Minden, La.

WARREN, CYRL
Mutual

WARREN, JIM
KXA, Seattle, Wash.

WATKINS, FRED
WMLT, Dublin, Ga.

WATSON, BOB
WQXI, Atlanta, Ga.

WATSON, CHARLIE
KBOA, Kennett, Mo.

WATSON, ED
The Early Worm
KPAM, Portland, Oregon.

WATSON, JIM
WGTM, Wilson, N. C.

WAX, JERRY
WALL, Middletown, N. Y.

WAYMAN, TOM
Rhythm In The Rockies
KDYI, Salt Lake City, Utah.

WEAVER, JOHN
Weaver's Waxworks
KSYC, Yreka, Cal.

WEBB, CHARLES, T.
KVOA, Tucson, Arizona.

WEBBER, HAROLD
KXJK, Forest City, Ark.

WEBSTER, JIM
Melody Bedroom
WCTM, Cumberland, Md.

WEDEL, JACK
Jam For Supper
KICD, Spencer, Iowa.

WEGMAN, BILL
WGFH, Quincy, Ill.

WEISS, DICK
The Minute Man
WFLF, Flint, Mich.

WEITZELL, JOHN
Dance Date
WGET, Gettysburg, Pa.

WELCH, LARRY
Voice of the Turtle
WCOP, Boston, Mass.

WELLS, BILL
WMPB, Memphis, Tenn.

WELLS, CHRIS
WLEF, Clanton, Ala.

WELLS, JIMMY
On Stage
WENK, Union City, Tenn.

WESLEY, JIM
Matinee Melodies
WGLS, Decatur, Ga.

WESTER, BOSTICK
KLAS, Las Vegas, Nev.

WESTERFIELD, DENVER
Denver's Den
WVMC, Mt. Carmel, Ill.

WEST, HUGH
WJAT, Swainsboro, Ga.

WHEELER, DOC
Morning Spirituals
WWRL, N. Y., N. Y.

WHELAN, DOUG
Wake With Whelan
DJRL, Kenora, Ont.

WHINGHILL, DICK
KMPC, L. A., Cal.

WHITE, FRANK
Cook Watcher
KMYR, Denver, Colo.

WHITE, FRED
Records Staff
KROY, Sacramento, Cal.

WHITNEY, ROBERT
Blue Ribbon Club
WSYR, Syracuse, N. Y.

WHITTED, NORFLEY
WHNC, Durham, N. C.

WHITTEN, WILL
Klockwatcher
WRBO, Augusta, Maine.

WHITTINGTON, DICK
Dick Whittington Show
KXOB, Stockton, Cal.

WHYTE, BOB
KNOX, Grand Forks, N. D.

WILLARD, DICK
Mutual

WILCOX, JOHN
Woods & Wax
KBOL, Boulder, Colo.

WILDER, JIM
Sundial
WJML, Macon, Ga.

WILLET, SLIM
KRBC, Abilene, Texas.

WILLIAMS, CHUCK
Tunycville Trolley
KAME, Camden, Ark.

WILLIAMS, DICK
Strictly Off The Record
KAKE, Wichita, Kan.

WILLIAMS, ELBERT
Melody Round Up
WSYD, Mt. Airy, N. C.

WILLIAMS, FREDDIE
Freddie Williams Show
WAAF, Chicago, Ill.

WILLIAMS, JIM
Musical Clock
KTRH, Houston, Texas.

WILLIAMS, JOHN
Musical Nightmen
CKPR, Ft. William, Ont.

WILLIAMS, KAE
Wake Up Philadelphia
WHAT, Phil., Pa.

WILLIAMS, LLOYD
WLIB, N. Y.

WILLIAMS, RICHARD
Nite Watch
WKIV, Richmond, Ind.

WILLIAMS, WOODY
WATS, Sayre, Pa.

WILLIFORD, EARL
Spring Party
WOLF, Dothan, Ala.

WILLSE, BILL
WICE, Prov., R. I.

WILLSON, PARKER
Cinetown Jamboogie
KNDL, Ft. Worth, Texas.

WILNER, RON
Turntable
WASA, Havre de Grace, Md.

WILSON, ED
KWK, St. Louis, Mo.

WILSON, FLOOD
DIX, Dickinson, N. D.

WILSON, LARRY
WRIX, New Orleans, La.

WILSON, STU
Are Ya Listening?
KBIG, Acadon, Cal.

WINN, BILL
Hardy Gurdy Club
WJOC, Jamestown, N. Y.

WINTER, PAUL
Winter Wonderland
WXYZ, Detroit, Mich.

WISE, WES
KRIC, Beaumont, Texas.

WOLF, FRED
Wacky Wigloo
WXYZ, Detroit, Mich.

WOOD, BILL
KODY, North Platte, Neb.

WOOD, CALLIE
WVOT, Wilson, N. C.

WOOD, FRED
WWBZ, Vineland, N. J.

WOOD, ROBERT
WRL, Lenoir, N. C.

WOOD, ROY
Avenue Boogie Hour
WLDL, Birmingham, Ala.

WOODROW, BOB
WDEL, Springfield, Ohio.

WOODRUFF, BOB
KCCA, Kilgore, Texas.

WOODS, GEORGE
House of Jive
WHAJ, Phil., Pa.

WOODS, JOHN
WPAQ, Warenesset, Mass.

WORTMAN, DAVE
Clock's Corn Club
KXON, Napa, Cal.

WRAV, JOHN
These Are Records
KFGN, Eugene, Ore.

WRIGHT, RAY
KGCX, Sidney, Montana.

WRIGHT, WILL
KNAK, Salt Lake City, Utah.

WRISLEY, JOHN
Ramblin' with Wrisley
WSAY, Savannah, Ga.

WYGANT, TED
Polka Party
WJET, Erie, Pa.

WYLLIE, GEORGE
Money for Music
KTOK, Oklahoma City, Okla.

WYSE, BILL
KRWB, Hutchinson, Kan.

— Y —

YATES, JOHN
Platter Parade
KFEQ, St. Joseph, Mo.

YOUNG, JOE
KURB, Chanute, Kansas.

YOUNGBLOOD, HARLEY O.
KMM, McMinnville, Ore.

YOUNGBLOOD, JIM
Home Hour
WPAD, Palestine, Ky.

— Z —

ZIGLER, DICK
Rise n' Shine
WEIM, Fitchburg, Mass.

ZIMMERMAN, BILL
Rumpus Room
WHOK, Lancaster, O.

ZOOK, LOUIS
WBW, Bedford, Ind.



An Independent View Of TV Film Syndication

By EDWARD D. MADDEN

*V. P. and General Manager, Film Syndication
Motion Pictures for Television*

USUALLY, the spokesman for film syndication in a piece like this is the head of a film syndication operation allied with a television network. In such cases the gentleman in question is always conscious of his network affiliation and cannot speak with real freedom about film syndication. Speaking for a leading independent in the film syndication field I have no such inhibitions.

Let's start with the fact that the quality of film syndication shows is being upgraded to the point where in story, cast and production value, they are in many cases the equal of, and in some cases superior to, the network film shows. If this starts anyone on a rebuttal line, let him first carefully examine the rating records of film syndication shows vs. film and live network shows market by market. He will be in for some distinct surprises. In many areas, including the biggest television population markets, film syndication shows, in what might be termed "fringe" time are achieving ratings equal to, and in some cases superior to, network film and live shows. Some of these ratings are so good that you will find cases in individual markets where the station has opened up really prime evening time for film syndication shows.

In addition to the overall quality of the syndicated film show noted above there is an important plus in terms of the attitude of the regional and national spot sponsor and his approach to the local-level merchandising, publicity and sales promotion support of his show. Despite the quantity of able manpower in the publicity operation of any network, they cannot hope to equal the performance of a team composed of a regional advertiser, his agency, and the film syndicator.

Today there is an increasing trend on the part of network advertisers to turn to national spot placement of their television dollars through the avenue of film syndication. This is not only due to the "must buy" market policy of the net-

works and its impact on total advertising appropriations, but is also brought about by the much greater flexibility given to the advertiser in putting his television advertising pressure where he needs it most and where it can be most productive for him.

The swing over to color film has been progressing steadily in the film syndication field. The tremendous importance of the impact color will make on the consumer has alerted the advertisers and agencies to prepare for the beginning of a new cycle. There are many practical applications to merchandising and selling at retail to be considered for the color TV audiences of the near-future. Color advertising will make any and every commercial attractive. The great increase in self-service retail stores in almost every product classification makes brand identification outstandingly important.

The networks have done a fine job in promoting the importance of color, even though there has been some criticism in certain quarters that they have not been as attentive as they might be to the proper means of projecting color film. I think this is an unfair criticism because, to my knowledge, they are all experimenting with proper projection techniques for color film and I believe, are just as anxious to lick this problem as anyone in the film syndication field. The real engineering pros in the business will tell you that any color film that projects well on direct viewing will come through satisfactorily on the television system and that it's only a matter of time until they have the projection problem thoroughly in hand. For our part, we are so convinced of this that we are in production in color with "Duffy's Tavern" and "Junior Science." We will shift to color on "Janet Dean, Registered Nurse" this year and produce "Paris Precinct" in color, starting May first. So when color TV homes are available in quantity during the fall of 1955, our clients will be there first.

ARCHIE BLEYER



AL GOODMAN

MUSICAL DIRECTORS

RADIO AND TELEVISION

— their work during 1953



— A —

ACKLEY, WAYNE
KRNT, Des Moines, Iowa

AIDERS, EDNA
WLSI, Pikeville, Kent.

AGNEW, JOHN K.
WHKC, Columbus, O.

ALLEN, JAMES
WTJS, Jackson, Tenn.

ALIEN, JOHN
KSDN, Aberdeen, S. D.

ALLWOOD, JIM
KGBX, Springfield, Mo.

ANDERSON, PADDI
KWHP, Cushing, Okla.

ANDREWS, BETTY
WJEJ, Hagerstown, Md.

ANTHONY, RAY
All Star Parade of Bands,
NBC

ANTOINE, SALLY
KLFY, Lafayette, La.

ANTONINI, ALFREDO
Twentieth Century Concert
Hall, CBS

ARMBRUSTER, ROBERT
NBC Western Div.
RCA Victor Records

ASTON, BUZZ
Buzz & Bill Show, WDTV,
Pittsburgh, Pa.

AYRES, MITCHELL
Perry Como Show, Mutual

AYRES, NORMAN
WOSH, Portland, Me.

— B —

BAKER, FRANK
WWCA, Cary, Ind.

BALZER, FRITZ
WNBW, Washington, D. C.

BANCROFT, PUERSON
KTAR, Phoenix, Ariz.

BANFIELD, BOB
Breakfast Party
WHIZ, Zanesville, O.

BARBER, RED
Fred Waring Show
CBS-TV

BARDO, LYLE
KFRC, S. F., Cal.

BARDUEN, ART
KING-TV, Seattle, Wash.

BARGY, ROY
Colgate Comedy Hour
NBC-TV

BARLOW, HOWARD
Voice of Firestone
NBC, NBC-TV

BARNETT, RUBY
KXOB, Stockton, Cal.

BARRETT, EVANELL
KEPO, El Paso, Tex.

ARRETTE, ROGER
WMUR, Manchester, N. H.

BASS, FRED
CKWX, Vancouver, B. C.

BAUGH, GENE
WBAP, Ft. Worth, Tex.

BAXTER, LEO
WBOW, Terre Haute, Ind.

BEALS, RAY H.
KVGB, Great Bend, Ind.

BEHAN, CLAIRE
KLMR, Lamar, Colo.

BELL, ALLEN E.
KREW, Sunnyside, Wash.

BELL, FRANK
WEEL, Boston, Mass.

BELL, GENE
KYOS, Merced, Cal.

BENNETT, BILL
WNHC, New Haven, Conn.

BENSON, BROWNIE
Twilight Time
WSAZ-TV, Huntington, W. Va.

BERCOVITZ, ABE
KGW, Portland, Ore.

BERLIN, CHARLES VERNON
KSCO, Santa Cruz, Cal.

BERQUIST, WHITEY
National Farm & Home Hour
NBC

BERRY, ROBERT E.
WOTW, Nashua, N. H.

BESTOR, DON
WICC-TV, Bridgeport, Conn.

BETHEL, FRED
WRNY, Rochester, N. Y.

BIGGS, E. POWER
CBS

BISHOP, JILL
WHBQ, Memphis, Tenn.

BLACK, HAL
KTXL, San Angelo, Texas

BLAKE, AFTON
KFPW, Ft. Smith, Ark.

BLEYER, ARCHIE
B. June 12, 1909, New York.
Arthur Godfrey Time, Arthur
Godfrey's Talent Scouts, Arthur
Godfrey and his Friends, CBS

BLOCH, RAY
Toast of the Town, Jackie
Gleason Show, Philip Morris
Playhouse, CBS-TV

BODYCOMBE, ANEURIN
KDKA, Pittsburgh, Pa.

BOETEL, CLAUDE
Delinc Gang
WSYR-TV, Syracuse, N. Y.

BOSWORTH, CHESTER O.
WIRY, Plattsburgh, N. Y.

BOVERO, PHIL
KGO, San Francisco, Cal.

BOYUM, JERRY
KRCC, Rochester, Minn.

BRADLEY, J. HAROLD
WHLB, Niagara Falls, N. Y.

BRADLEY, OWEN
WSM, Nashville, Tenn.

BRADY, WILLIAM P.
WEDC, Chicago, Ill.

BREKMAN, MISCHA
WCCO, Minneapolis, Minn.

BRESTOFF, PHIL
WXYZ, Detroit, Mich.

BRIGHT, WELDON
KGNC, Amarillo, Texas

BRINKMAN, HELEN
WDLB, Marshfield, Wis.

BRITAIN, HERB
CKRC, Winnipeg, Manitoba

BROOKS, LORETTA
WKLO, Louisville, Ky.

BROOKS, LOU
WGTH, Hartford, Conn.

BROWN, LES
Bob Hope Show Colgate
Comedy Hour
NBC, NBC-TV

BROWN, MAURICE
Let's Pretend
CBS

BROWN, ROBERT
WSOY, Decatur, Ill.

BRUCE, DWIGHT
WTOG, Savannah, Ga.

BRUCE, PEG
KQV, Pittsburgh, Pa.

BRYAN, BILL
KTOW, Oklahoma City, Okla.

BUCK, GEORGE H., JR.
WJNO, W. Palm Beach, Fla.

BUCKLEY, EMERSON
WOR, New York, N. Y.

BUCKLEY, EMERSON
Wonderful City
Mutual

BUNN, NEAL
KRLW, Walnut Rose, Ark.

BURG, RICHARD
WNOW, York, Pa.

BURKE, JOE
WSCR, Scranton, Pa.

BURT, GARLAND
WLAK, Lakeland, Fla.

BUSSE, GLORIA
WDOK, Cleveland, O.

BUTTERFIELD, BILLY
ABC

BYRD, VIRGINIA
WISH, Indianapolis, Ind.

BYRNE, BOBBY
Steve Allen Show
NBC-TV

— C —

CALICCHIO, JOSEPH
WMAQ, Chicago, Ill.

CAMPBELL, DEWITT
WING, Dayton, O.

CAMPBELL, DICK
WDVA, Danville, Va.

CAMPBELL, WISHART
CFRB, Toronto, Ont.

CANTELL, GUIDO
NBC Symphony
NBC

CARLOS, SAM
WJBW, New Orleans, La.

CARN, DERWOOD
WJTM, Lansing, Mich.

CARPENTER, ETHEL
WDBQ, Dubuque, Iowa

CARPENTER, JAMES
KFBI, Wichita, Kans.

CARTER, RAY
Arthur Murry Party
NBC-TV

CARTER, ROGER
WADC, Akron, O.

CARTER, TONY
WAUD, Auburn, Ala.

CASEY, JEWELL
WSAV, Savannah, Ga.

CATTERTON, AUSTIN Y.
WMMB, Melbourne, Fla.

CEASER, CHARLES
WLW-C, Columbus, O.

CHANDLER, JOEL
WJOY, Burlington, Va.

CHATTAWAY, DON
WMAS, Wilmington, Del.

CLARK, ALLAN
WKY, Oklahoma City, Okla.

CLARK, DANNY
WDAR Savannah, Ga

CLARK, JAMES L.
WBLJ, Dalton, Ga

CLARK, JOHN
WPRC, Lincoln, Ill.

CLUM, SHIRLEY
KVSP, Santa Fe, N. Mex.

COALE, JACK
KGMP, Honolulu, T. H.

COFFRON, IRMA
KEYD, Minneapolis, Minn.

COLLINS, JERRY
WNOX, Knoxville, Tenn.

COLLINS, PAT
KYNO, Fresno, Cal.

COLLINS, PAUL
KFRD, Rosenberg, Texas

COMBSKEY, LILLIE MAE
KWFT-TV, Wichita Falls, Tex.

CONE, JOY
WSPB, Sarasota, Fla.

CONTE, JOSEF
WRIB, Providence, R. I.

CORBOY, JOANNE
WLEE, Richmond, Va.

CORNWALL, J. SPENCER
Salt Lake Tabernacle Choir
CBS

COSTA, JOHNNY
WDTV, Pittsburgh, Pa.

CRAWFORD, EGEN
WGFB, Evansville, Ind.

CRANE, RUTH
WMAL-TV, Washington, D. C.

CROMWELL, VIRGINIA
KFDA, Amarillo, Tex.

CROOK, GEORGE
Organ Recital
NBC

CROSS, GEORGE F.
WHIS, Port Huron, Mich.

CRUMBAKER, MARGE
KGUL, Galveston, Texas

CUMMINGS, FRANK
KUN, Pecos, Tex.

CUSIC, PAUL
WBAX, Wilkes-Barre, Pa.

— D —

DAILY, DON
WCSM, Huntington, L. I.

DANTZLER, RAY
WRF, Gainesville, Fla.

DAUGHERTY, STAN
KMOX, St. Louis, Mo.

DAVID, RUSS
KSD, St. Louis, Mo.

DAVID, RUSS
KSD-TV, St. Louis, Mo.

DAVIS, LARRY
KVEE, Austin, Texas

DAVIS, NORM
KRVI, Craig, Colo.

DEAN, JIMMIE
WABL, Arlington, Va.

DeJULIO, ED
KUBC, Montrose, Colo.

DeKOSTER, CLARE
KUCD, Spencer, Iowa.

DE LUGG, MILTON
Murray Amsterdam Show
NBC-TV

DENNY, FRANCES
WATR, Winston-Salem, N. C.

DeREMER, LIONEL H.
WRCM, Bay City, Mich.

DERISE, FLORENCE
WEAR, Pensacola, Fla.

DeVOL, FRANK
Betty White Show—NBC-TV
Dinah Shore Show—NBC-Radio

DIMAIO, DOROTHY
WEAN, Providence, R. I.

DONALDSON, EARL
KALL, Salt Lake City, Utah

DORNBROCK, NOREEN
WKBW-TV, Youngstown, O.

DOUGLAS, JIM
KJNO, Juneau, Alaska

DRAGON, CARMEN
Ratroul Hour

DRILL, BOB
WVEC, Hampton, Va.

DULANE, CHUCK
WGAY, Silver Spring, Md.

DUNKELBERGER, TOMMY
WHIO, Dayton, O.

DUNLAP, DAVE
WHOL, Allentown, Pa.

DUNN, VIOLA
KHO, Spokane, Wash.

DUNNING, ARTHUR
ROIN, Portland, Ore.

DURAN, KEN
KXYZ, Houston, Texas

DYER, ARLENE
WRCO, Richland Center, Wis.

— E —

ECKFORD, RAYMOND
CKGB, Timmins, Ont.

EDDINGTON, JON
BLAS, Las Vegas, Nev.

EDGES, CLARENCE
WBAY, Green Bay, Wis.

EICHER, JIM
KEXO, Grand Junction, Colo.

ELLIOTT, ANN
WMON, Montgomery, W. Va.

EMMEL, JOHN
KEX, Portland, Ore.

FRANK DeVOL

MUSICAL CONDUCTOR

COMEDIAN

"The Betty White Show
From Hollywood"
NBC TV Network

"The Dinah Shore Show"
NBC Radio Network

Derby Records



ROSA RIO
Organist-Composer

SU. 7-5400

EMERSON, BYRON
 WWHG, Hornell, N. Y.
ENGLISH, R. S.
 WTRY, Troy, N. Y.
ERLICH, MIKE
 WWNH, Rochester, N. H.
ETTERS, CLARENCE
 WBT, Charlotte, N. C.
EXUM, LORETTA
 WDAK, Columbus, Ga.
EVLES, ELIZABETH
 WGBA, Columbus, Ga.

— F —

FAULKNER, JACK
 WTSP, St. Petersburg Fla.
FENNEY, NEWTON
 KRAL, Rawlins, Wyo.
FERRISS, TOMMY
 WARE, Ware, Mass.
FUELDING, JERRY
 You Bet Your Life,
 Saturday Night Revue
 NBC-TV
FIGORE, TONY
 Starlito Serenade
 KJEO, Fresno, Cal.
FISHER, JAMES W.
 KPRO, Riverside, Cal.
FISHER, JOHN
 WJDA, Quincy, Mass.
FLAGENS, RAY
 WFAA, Dallas, Texas
FOWLER, BETTY
 KRTV, Little Rock, Ark.
FOX, ROGER P.
 KFAL, Fulton, Mo.
FRANCK, KARIN
 WKBZ, Muskegon, Mich.

FRICK, SHIRLEY
 WITZ, Jasper, Ind.
FRIEND, G. W.
 WPLA, Plant City, Fla.
FRY, RICHARD L.
 CHNS, Halifax, N. S.
FUHRMAN, CLARENCE
 KYW, Philadelphia, Pa.
FULTON, ROBERT
 KERG, Eugene, Ore.

— G —

GALLICCHIO, JOSEPH
 Big City Serenade. Intermezzo
 NBC
GARRET, MERLE
 WRRI, Columbus, Ga.
GARRETT, ROGER
 WBNS, Columbus, O.
GARST, FRED
 WAYB, Waynesboro, Va.
GASTON, LYLE
 KSWO, Lawton, Okla.
GEER, C. W.
 WALT, Tampa, Fla.
GEISLER, BETTY
 WCPO, Cincinnati, O.
GEYER, BILLY
 WFDF, Flint, Mich.
GIERSDORF, H. W.
 KRLD, Dallas, Tex.
GILES, GLENN
 KDWT, Stamford, Texas
GLENN, TONY
 KSTL, St. Louis, Mo.
GOLDBERG, LOUIS
 WCOB, Boston, Mass.
GOODIN, DEL
 KXOB, Stockton, Cal.

GOODMAN, AL
 B. Baltimore, Md. Colgate
 Comedy, NBC-TV
GOW, ART
 KLZ, Denver, Colo.
GRAHAM, TED
 KFRE, Fresno, Cal.
GREEN, BERNARD
 U. S. Steel, Ford Ann. Pro-
 gram, Take It From Me. ABC
 Album
 ABC-TV
GRIZZELL, LLOYD
 WMMT, McMinnville, Tenn.
GROULX, AUKELE
 CKCH, Hull, Que.
GUDENBERG, MARTIN
 KIXL, Dallas, Texas
GUILLAUME, CATHERINE
 WLCX, La Crosse, Wisc.

— H —

HACKETT, BOBBY
 Opera vs. Jazz
 ABC-TV
HACKETT, RAY
 KCBS, San Francisco, Cal.
HAIGH, NANCY
 KABC, San Antonio, Texas
HALEY, PAT
 WMOK, McKeesport, Pa.
HALL, DAVE
 WATW, Ashland, Wis.
HALL, WM. J.
 WCHN, Norwich, N. Y.
HAMBRIGHT, JO
 WFGN, Gaffney, S. C.
HAMILTON, EARLINE
 WKKO, Cocoa, Fla.

DAVID ROSE



HANK SYLVERN

Music Director

MU. 8-6600

HAMILTON, MARY
CJQ Quebec City, Que

HANING, BEVERLY
KFOR, Lincoln, Neb

HARKER, JAMES
KBON, Omaha, Neb

HARRISON, GUY FRASER
Oklahoma City Symphony Orch
Mutual

HARRISON, HERBERT H.
KFBK, Sacramento, Cal

HARTLEY, JAMES A.
WJUN, Gainesville, Fla

HARTMAN, LOLA
KFEQ, St. Joseph, Mo

HARVEY, LLOYD
WHRL, Peoria, Ill

HATHAWAY, LEN
WENE, Burlington, N. Y.

HAYEMAN, TOM
KBER, Mount Vernon, Wash

HAWLEY, SHERWOOD
WCHA, Chambersburg, Pa

HAYES, DENNY
KNTD, New Canaan, Conn

HAXTER, ELIZABETH D.
WPEA, Pensacola, Fla

HEINES, SHIRLEY
WJPS, Evansville, Ind

HENDERSON, SKITCH
Dave Garroway Show
Faye & Sketch Show
NBC-TV

HENKE, CARL
WCMB, Harrisburg, Pa

HENLEY, HAROLD
WOPI, Bristol, Tenn

HENSEBERRA, JAMES
WCNT, Centralia, Ill

HERMANN, RALPH
ABC

HERRON, JOEL
WMGM, New York, N. Y.

HICKS, MARY ELIZABETH
Garden Gate
CBS

HILDEBRAND, MARIE
KXGN, Glendive, Mont

HILL, J.
KLIX, Twin Falls, Idaho

HILL, MAURICE
KBOS, Modesto, Cal

HOFMAN, JANE
KEAR, San Francisco, Cal

HOGAN, HARLAN
WSBT, South Bend, Ind

HOLLINGSWORTH, ELIZ. M.
WKBS, Oyster Bay, N. Y.

HOLM, CLAYTON
KHPD, Durango, Colo

HOOD, TAL
WFGM, Fitchburg, Mass

HOPKINS, RAYMOND L.
WIBC, Indianapolis, Ind

HOPKINS, WES
WPTM, Trenton, N. J.

HOSS, BOB
WFIL, Philadelphia, Pa

HOUSTON, E. H.
CKEY, Toronto, Ont., Can

HOWELL, BERNIE
KCBQ-TV, Lubbock, Tex.

HUBBARD, HENRY M.
KVOA, Tucson, Ariz

HUNT, GEORGE
KAKE, Wichita, Kan

HUSOME, JANE
WRFW, Eau Claire, Wis

HUTTON, INA RAY
KTLA, Hollywood, Cal

— I —

IGLEHART, RAY
WFFH, Middletown, O.

IRRKE, ELMAR
WEMP, Milwaukee, Wis

IMBROGI LIO, JOSEPH
WFBR, Baltimore, Md

INCARDON, A. SAMMY
KANG, Waco, Texas

— J —

JACKSON, MAURICE
WVRO, Columbus, O.

JAMES, RUSS
KVEI, San Luis Obispo, Cal

JENSEN, BARON
KQVO, Provo, Utah

DEROME, JERRA
WPIX, New York, N. Y.

JESTER, SHIRLEE
WKRC, Cincinnati, O.

JOHNSON, EDDIE
WTRE, Wheeling, W. Va.

JOHNSTON, J. EDDIE
WTRE, Bellare, Ohio

JONES, COLSON E.
WRTA, Altoona, Pa

JONES, CARL
WILM, Wilmington, Del

JORDON, NICK
KCSB, San Bernardino, Cal.

— K —

KALER, RANDALL
WFAS, White Plains, N. Y.

KANE, DAVE
WLAT, Laurel, Miss.

KATIMS, MILTON
NBC Symphony
NBC

KAYE, RICHARD L.
WCRB, Waltham, Mass.



MURRAY ROSS

Musical Director-Organist

THE COMEBACK STORY
TURN TO A FRIEND
MODERN ROMANCES
THE ERN WESTMORE SHOW

**EARL
SHELDON**

KAYE, SAMMY

Sammy Kaye's Sunday Serenade,
NBC

KEATHLEY, HAMP

KTRB, Lufkin, Tex

KEATON, CHARLES

WTTG, Washington, D. C.

KEITH, CARROLL

WSPC, Anniston, Ala.

KELLOGG, JACK

WMBG, Richmond, Va.

KELLY, DANNY

WRDO, Augusta, Maine

KEMBLE, ELEANOR

WLAD, Danbury, Conn

KENTON, STAN

Stan Kenton Concert

NBC**KIEL IRWIN**

KHUB, Watsonville, Cal

KILEY, JOHN

WMEX, Boston, Mass

KING, PEE WEE

Pee Wee King & Orchestra

NBC**KINNEY, WENDELL**

KMO, Tacoma, Wash.

KINNEY, WENDELL

KMO-TV, Tacoma, Wash

KINSER, JOE

KAFY, Bakersfield, Cal.

KIPEN, MAURICE

WTMJ, Milwaukee, Wisc

KIRSTEN, GEORGE

WJRT, Lenoir, N. C.

KLINGER, EDYTH

KFVD, Los Angeles, Cal

KNICK, WALTER

WBNS, Columbus, O

KOSAK, JOE

WVFN, Olney, Ill.

KOTTLER, MISCHA

WWJ-TV, Detroit, Mich.

KRISS, MARIE

KMAN, Manhattan, Kan.

KUHN, ARNOLD Y.

WKBI, St. Marys, Pa.

— L —

LACASSE, MAURICE

CJEM, Edmundston, N. B.

LACHANCE, ROGER

CKCV, Quebec

LACONI, JOE

ETCU, Erie, Pa.

LAMBERT, NORMAN

WLBZ, Bangor, Me

LAMM, AL

WOW, Omaha, Nebr.

LANDEMANN, PETE

WDSU, New Orleans, La

LANE, HAZEL

KROW, Oakland, Cal.

LARGE, DON

Make Way for Youth

CBS**LARSEN, GENE**

KFMA, Davenport, Iowa

LASH, CLIFF

WLW-T, Cincinnati, O

LANSITER, CHAD

KNEA, Jonesboro, Ark

LAVALLE, PAUL

Cities Service Band of America

NBC**LAWRENCE, ELLIOT**

Stars on Parade

LEA, ROD

WLVA, Lynchburg, Va.

LEAF, ANN

On Your Way

DuMont**LEE, PETE**

WJW, Cleveland, O

LEHNHOFF, HENRY

KWED, Seguin, Texas

LEIBERT, RICHARD**NBC****LEON, MAX M.**

WDAS, Philadelphia, Pa.

LEVERETT, LULA, MAE

WVOP, Vidalia, Ga.

LEVY, HAROLD

Theatre Guild of the Air

NBC**LEVINE, HENRY**

WTAM, Cleveland, O.

LIBRARIAN, KAY

WSON, Henderson, Ky

LISON, SUE

WDUZ, Green Bay, Wisc.

LIVINGSTON, BOB

WIS, Columbia, S. C.

LIVINGSTON, JIMMY

Carrousel

WBAP-TV, Fort Worth, Texas

LOCKHART, HARRY

WAVE, Louisville, Ky.

LOEB, HOWARD

KRIZ, Phoenix, Ariz.

LOFTSNESS, RAY

KSOO, Sioux Falls, S. D.

LOGAN, WAYNE

KNAK, Salt Lake City, Utah

LOMBARDO, GUY

B. June 2, 1901, London, Ont.

Canada, Lombardland, USA,

Mutual; Guy Lombardo Show,

Transcribed, Syndicated

VICTOR
YOUNG



HENRY
HOT-LIPS
LEVINE
WTAM-WNBK
NBC, CLEVELAND
MUSICAL DIRECTOR

LOOS, JACK
 WOWO Ft. Wayne, Ind.
LOPEZ, VINCENT
 Mutual
LORD, EDWIN J.
 WDBO, Orlando, Fla.
LOWELL, EUGENE
 The Choralists
 CBS
LYON, JOHN
 WBBQ, Augusta, Ga.
LYONS, JOSEPH
 WJOL, Joliet, Ill.

— **Mc** —

McCULLLEY, JOE
 WSNJ, Bridgeton, N. J.
McCRAE, MARILYN
 WBRD, Ft. Lauderdale, Fla.
McDEVITT, LEO
 WALE, Fall River, Mass.
McDONALD, HELEN
 KRRX, San Jose, Cal.
McELRATH, NANCY
 WIS, Columbia, S. C.
McGRATH, NED
 WJOC, Jamestown, N. Y.
McGRATH, PEG
 KOWH, Omaha, Neb.
McKEOWN, GEORGE
 WERZ, Monroe, Wis.
McNELL, IDA A.
 KGFN, Pierre, S. D.

— **M** —

MANNERS, SIDNEY
 WJPB, Farmington, W. Va.
MANNING, CHARLES
 WFKY, Frankfort, Ky.

MANTOVANI
 Music By Mantovani
 NBC
MARSH, MARIAN
 WRR, Dallas, Texas
MARKLE, ERWIN J.
 WAVZ, New Haven, Conn.
MARSEN, GAV
 KWBK, Wichita, Kan.
MARSHALL, ANN
 KPLT, Paris, Texas
MASON, ELEANOR TERRY
 KGMH-TV, Honolulu, Hawaii
MASON, JOHN
 WRMX, Elgin, Ill.
MAVTOLO, TONY
 Love Story, WARD, N. Y.
 McDoy Street
 DuMont
MAUGANS, BILL
 WBBZ, Ponca City, Okla.
MAUPIN, REX
 WBBK, Chicago, Ill.
MERCHANT, BILL
 KSTP, Davenport, Iowa
MEREDITH, EARL
 KFMS, San Diego, Cal.
MERRIMAN, BERNARD V.
 KVEN, Coeur d'Alene, Idaho
MERRITT, EDWARD
 WTRK, Pittsfield, Mass.
MESERVY, NORMAN
 WOLF, Syracuse, N. Y.
MESSINA, FRANKIE
 KJL, Los Angeles, Cal.
METCALFE, ROBERT E.
 WOHl, East Liverpool, O.
METCHNEK, WM.
 WCCO, Minneapolis, Minn.
MICHAEL, JOSE H.
 WJEF, Grand Rapids, Mich.

MILL, WILLIAM
 KWNB, New Britain, Conn.
MILLS, LEE
 WRAD, Radford, Va.
MILLER, ARNOLD B.
 WBSC, Chicago, Ill.
MILLER, HARRISON A.
 KIT, Yakima, Wash.
MILLER, HELEN
 KULP, El Campo, Texas
MITROPOULOS, DIMITRI
 New York Philharmonic
 Symphony
 CBS
MOLNARO, LARRY
 WNAR, Norristown, Pa.
MONTEUX, PIERRE
 NBC Symphony
 NBC
MONTGOMERY, PAUL
 WNAO, Raleigh, N. C.
MORRIS, JIM
 CKNW, New Westminster, B. C.
MOSENA, RICHARD
 KBBR, Burlington, Iowa
MOSS, PHIL
 WMPB, Memphis, Tenn.
MUFF, FRED
 WLAC, Nashville, Tenn.
MURPHY, TOM
 WRNA, Charleston, W. Va.

— **N** —

NAPIER, BYRON
 KCRG, Enid, Okla.
NASH, BARNES H.
 WHTS, Bluefield, W. Va.

WALTER SCHARF

Musical Director and Composer

"Living It Up" — Paramount

"The French Line" — RKO

NEAL, FURMAN
WGVL, Greenville, S. C.
NEAL, PAUL
WENS, Columbus, O.
NELSON, GENE
KFAM, St. Cloud, Minn.
NICHOLS, TOM
WCOG, Greensboro, N. C.
NIDES, HARRY
WROL, Knoxville, Tenn.
NININGER, EVE
WDBJ, Roanoke, Va.
NOBLE, LEIGHTON
KTLA, Hollywood, Cal.
NORMAN, RALPH
Motorola, ABC Album
ABC-TV
NOVELL, WALT
KBIF, Sanger, Cal.

— O —

O'BRIEN, ALBERT
WOPA, Oak Park, Ill.
ORMANDY, EUGENE
Philadelphia Orchestra
CBS
OSBORNE, SHIRLEY
WINN, Louisville, Ky.
OSSER, GLENN
Vandeville, ABC Album
ABC-TV

— P —

PAFUMI, VINCE
Trio Time
WTAR-TV, Norfolk, Va.
PARKER, ED
KHSI, Chico, Cal.
PARKER, RUEL
Music Shop
WLW-A, Atlanta, Ga.

PARRY, DAVE
WLPY, Lexington, Ky.
PAUL, CHARLES F.
B. New York City, Martin Kane,
WNBT, New York; The Shadow,
AMA, Transcriptions, WOR,
N. Y.; Mr. & Mrs. North, Young
Dr. Malone, Nora Drake, CBS

PAUL, LES
Perry Como Show, Omnibus,
CBS; Red Skelton Show, Milton
Berle Show, Nothing But The
Best, NBC; Les Paul & Mary
Ford At Home TV Film

PAVEY, RICHARD
WJLB, Detroit, Mich.
PEHLMAN, CARL
KKTU, Colorado Springs, Colo.
PELLOT, HECTOR
WTIL, Mayaguez, Puerto Rico

PELTRE, PAUL
WMAS, Springfield, Mass.
PENDLETON, CHARLES F.
KJBS, San Francisco, Cal.

PERKINS, ELEANOR
WREB, Holyoke, Mass.
PETERSON, CAROLYN SUE
WHBY, Appleton, Wis.

PETRILLO, CEASAR
WBBM-TV, Chicago, Ill.
PFLUEGER, GEORGE
WJTN, Jamestown, N. Y.

PHELAN, TOM
KXLF, Butte, Mont.
PIASTRO, MICHEL
Lingine Symphonette
CBS

PICKENS, CHARLES
WHBC, Canton, O.
PIGGOT, GLENN
KNUZ-TV, Houston, Texas

PILDNER, HENRY
WGAR, Cleveland, O.

POLLOCK, JAMES
WLS, Lansing, Mich.
PORTER, KING
WBCO, Birmingham, Ala.
POWELL, RICHARD
WTOP, Washington, D. C.
PRENTICE, CHARLES D., JR.
WHAT, Greenfield, Mass.

PRESTON, ED
CHML, Ontario, Can.
PREZZEL, GEZZA
KROP, Brawley, Cal.
PRINCE, HARVEY
KPAC, Port Arthur, Texas
PRINGLE, DAVE
KEPL, El Paso, Tex.
PRYOR, LARRY
Bruce Vanderhoof's Open
House
KDYL-TV, Salt Lake City,
Utah

— R —

RAINBOW TRIO
New England Talent Club
WJAR-TV, Providence, R. I.

RAMIREZ, JOSE RAUL
WIAC, San Juan, P. R.
RAMP, SALLY
WBAT, Marion, Ind.

RANDALL, GORDIE
TV Showcase
WRGB, Schenectady, N. Y.

RANDOM, MICHAEL DONN
KLX, Oakland, Cal.
RAUER, MAX
KWDM, Des Moines, Iowa

REDUS, JACK
KPKA, Greeley, Colo.
REED, BEN
WRHC, Jacksonville, Fla.



CHARLES PAUL

Conductor-Composer

ROBERT ARMBRUSTER

Musical Director

NBC Western Division

RCA-VICTOR
RED SEAL RECORDS

Management
ART RUSH, Inc.

REISNER, FRITZ
Chicago Symphony
DuMont
REPINE, BURT T.
WRVA, Richmond, Va.
RICARDO, DON (Dick Ridgely)
ABC
RICARDS, RON
RGVO, Missoula, Mont.
RICHARDSON, EDNA
WTMA, Charleston, S. C.
RICKARD, PAUL
WOWL, Florence, Ala.

RIO, ROSA
My True Story, When A Girl
Morries, Ted Malone, ABC;
Johnny Olsen, Opera Versus
Jazz, ABC-TV; Front Page Far-
rell, NBC

RIPLEY, RONALD
KBWB, Brownwood, Texas
ROBERTS, BILL
WPRS, Paris, Ill.
ROBIDOUX, P. M.
CHLT, Sherbrooke, Que.
ROGERS, SMOKEY
KFMB, San Diego, Cal.
ROMINGER, BART
KOLP, Ft. Worth, Tex.
ROOS, REG.
KUGN, Eugene, Ore.
ROSCH, MICHAEL
WHOM, New York, N. Y.

ROSE, DAVID
B. London. Red Skelton Show,
CBS-TV

ROSS, ANTHONY N.
WBBW, Youngstown, O.

ROSS, MURRAY
The Comeback Story, Turn To
A Friend, Modern Romances,
The Ern Westmore Show, ABC,
ABC-TV

ROTH, ALAN
Bank Barle Show
NBC-TV

ROUSSEAU, GENE
WWON, Woonsocket, R. I.

ROWAN, ELOISE
KPIX, San Francisco, Cal.

RUBIN, ART
WVOM, Boston, Mass.

RUHLING, JEAN
WMAJ, Washington, D. C.

RUMMINGER, BARBARA
WMTT, Greenville, S. C.

RUSS, RICHARD
WTFB, Minneapolis, Minn.

RYAN, JOSEPH J.
KIM, Yakima, Wash.

— S —

ST. JOHN, CHARLIE
KJIM, Beaumont, Texas.

SAETER, HARRY
Name That Tune
NBC, NBC-TV

SAMPSON, GARY
WIRE, Indianapolis, Ind.

SANDEFUR, BILL
WBPM, Danville, Va.

SANFORD, CHARLES
Your Show of Shows, NBC-TV

SARGENT, MICHAEL
WRHW, Bedford, Ind.

SASLAVSKY, NICHOLAS L.
WEVD, N. Y.
SAYITZ, LOUIS
WBRE, Wilkes-Barre, Pa.

SCHARF, WALTER
B. Aug. 3, New York. The Phil
Harris-Alice Faye Show, NBC

SCHMITT, PAUL
KPRC, Houston, Tex.
SCHRAGER, RUBY
Lux Radio Theatre
CBS

SCHULTZ, MYRON
WAAF, Chicago, Ill.

SCOTT, KINGHAM
WTFE, Raleigh, N. C.

SCOTT, RAYMOND
Your Hit Parade
NBC-TV

SEMONY, CARRIE
WWSC, Glen Falls, N. Y.

SERRA, LOUIS
WEIR, Winston, W. Va.
SHADDUCK, JAMES
KARE, Johnson, Kan.

SHELDON, EARL
B. Jan. 1, 1915, New York. Club
Embassy, NBC-TV. Musical Di-
rector For Muzak Transcriptions

SHERMAN, ROBERT
WTNJ, Trenton, N. J.

SHERWOOD, BOBBY
Texas on Star Theatre
NBC-TV

SHERIN, ALLEN
WHY, Belleville, Ill.

SHOOP, DAVID
WHF-TV, Harrisburg, Pa.

SHORES, ALICE
WKOW, Madison, Wis.

SILVER, JULIAN
WHIE, Miami, Fla.

SIMON, T. AUDIE
KBOJ, Boulder, Colo.

SIMPSON, JOHN
KOTV, Rapid City, S. D.

SIVERTON, CHARLES
WIAM, Rochester, N. Y.

SLACK, PETER
RGER, Long Beach, Cal.

SLATTERY, JOE
KWTO, Springfield, Mo.

SMITH, BEASLEY
WSM, Nashville, Tenn.

SMITH, BLANCHE
WGST, Atlanta, Ga.

SMITH, BOB
WNBC, New York, N. Y.

SMITH, DONNA
WFGB, Bunkirk, N. Y.

SMITH, E.
CFOS (Owen Sound), Ont.

SMITH, ROBERT
KVEU, San Luis Obispo, Cal.

SNOWDEN, ALAN P.
KTHP, Porterville, Cal.

Snyder, GEORGE A.
WSAN, Allentown, Pa.

SONTAG, GEORGE
WOC, Dayton, Iowa.

SOUCY, ARMAND
CFPX, Antigonish, Nova
Scotia, Canada

SPRY, DON E.
WJOF, Florence, Ala.

STABILE, DICK
Colgate Comedy Hour
NBC-TV

STADER, EVELAN
WKWK, Wheeling, W. Va.

STAMLER, ART
WBIL, Medford, Mass.

STANFORD, SAMMY
KOSA, Odessa, Texas.

STANLEY, JAY
WATV, Newark, N. J.

STANZIOLA, JOHN
WAZL, Hazelton, Pa.

STARR, RAYMOND
KWWL, Waterloo, Iowa.

STEIN, REX
WJDS, Jacksonville, Ill.

STELL, SARAH V.
WSSS, Cowa, Va.

STEVENS, ROBERT S.
WVFG, Coral Gables, Fla.

STOGER, DAVE
Western Rhythmares
KJED, Fresno, Cal.
STOKER, ED
KPTA, Salt Lake City, Utah

STONE, DALE
WRGA, Rome, Ga.

STONER, PETE
WHAY, New Britain, Conn.

STORDAHL, ALEX
Coke Time
Mutual

STORR, BILL
WLET, Topeka, Ga.

STRUCKELL, JOHN G.
WONO, Pleasantville, N. J.

STUART, EARL
WWJ, Detroit, Mich.

STAJA, FRANK
KING-TV, Seattle, Wash.

SYLVERN, HENRY
"HANK"
This Is Show Business, Jone
Froman Show, CBS-TV

— T —

TAYLOR, DOUGLAS
KFEL, Denver, Colo.

TEAFUE, NANCY
KQBD, Lubbock, Texas.

TEMPLEMAN, MARGON
KWPC, Muscatine, Iowa.

TERRY, VIRGIL
KKBK, Abilene, Texas.

THOMAS, JOHN
WKKO, Cocoa, Fla.

THOMPSON, GLENN
Music Country Style
WTOB-TV, Winston-Salem,
N. C.

TILDEN, LOLA
WGMN, Washington, D. C.

TOBIAS, RICHARD
WCLI, Corning, N. Y.

TOSCANNI, ARTURO
NBC Symphony
NBC

TRAVIS, VICTOR
WMD, Atlanta, Ga., N. J.

TRENDLER, ROBERT
Chicago Theatre of the Air,
Eighteenth Hour
Mutual

TURK, AL
WBAW, Saginaw, Mich.

TURNER, HARRY
KGBL, Billings, Mont.

— V —

VALLER, GEORGE
WREN, Topeka, Kan.

VAN DAMME, ART
WNBQ, Chicago, Ill.

VAN GHAN, LES
KLPF, Dallas, Tex.

VELEZ, JULIE
WPTA, San Juan, P. R.

VIDACOVICH, IRVING
WWL, New Orleans, La.

VOGEL, DONALD
WHA, Madison, Wis.

VOGT, GERALD
WHEC-TV, Rochester, N. Y.

VOORHEES, DONALD
The Telephone Hour
NBC

— W —

WACKER, PHILLIP
KXRO, Aberdeen, Wash.

WAGNER, ANN
WFPM, Indianapolis, Ind.

WAGY, NORMAN
WBBW, Youngstown, O.

WALK, LAWRENCE
B. March 11, 1903, Strasburg,
N. Dakota. The Lawrence Walk
Show, KTLA, Los Angeles, Cal.

WALLENSTEIN, DR. ALFRED
Symphonies for Youth
Mutual

WAMSER, FRED
KXLW, St. Louis, Mo.

WARING, FRED
B. June 9, 1900, Tyrone, Pa.
Fred Waring Show, CBS-TV

WASHBURNE, COUNTRY
Curt Massey Time
CBS

WATERS, RUSS E.
CFOR, Orillia, Ont.

WATKINS, JOHNNY
KWTK, Waco, Texas

WATSON, GARA
KICA, Clovis, N. M.

WAYNE, BERNIE
Jerry Lester's Late Date
NBC-TV

WEAKLEY, HERSCHEL
KXIC, Iowa City, Iowa

WEBB, FRED
WMFS, Chattanooga, Tenn.

WEBER, HENRY
Chicago Theatre of the Air
Mutual

WEBSTER, F.
CJON, St. Johns, Canada

WEED, BUDDY
George Jessel Show
ABC-TV

WEED, HAROLD
ABC

WEELANS, LES
KFEL, Denver, Colo.

WEHL, ERNEST
KWKW, Pasadena, Cal.

WEILER, EVA
CHAT, Medicine Hat, Alta.

WELK, LAWRENCE
KTLA, Hollywood, Cal.

WEST, PAUL
KENI, Anchorage, Alaska

WHEELER, RON
KTAT, Frederick, Okla.

WHITE, BEVERLY
WTSC, Madison, Wis.

WHITSELL, JACK
KCHA, Charles City, Iowa

WILD, ERIC
GBK, Winnipeg, Man.

WILDER, LEE
WMIK, Middlesboro, Ky.

WIELADT, ALLE
WFBG, Altoona, Pa.

WILLIAMS, GENE
KMOD, Modesto, Cal.

WILLIAMS, TED
WAJR, Morgantown, W. Va.

WILSON, DON
WDYK, Cumberland, Md.

WILSON, GRANT
WXEL, Cleveland, O.

WILSON, MEREDITH
Meredith Wilson's Music
Room, NBC
All Star Revue, NBC-TV

WILSON, RINI
Ev-ry Day
NBC

WINCH, SY
KSYC, Yreka, Cal.

WINTERS, MEL
WOAI, San Antonio, Texas

WIRGES, BILL
Roy Doty Show
WABD, New York

WOLFF, KARL
CKFI, Ft. Frances, Ont.

WOOD, TOMMY
WMBR, Jacksonville, Fla.

WOODALL, BOOTS
WAGA, Atlanta, Ga.

WROTEN, WYNEZ
WBIP, Booneville, Miss.

WYSE, BILL
KWBW, Hutchinson, Kans.

— Y —

YANDON, DEL
KXLY, Spokane, Wash.

YATES, GLORIA
KTVQ, Oklahoma City, Okla.

YEAGER, RAY
KROW, Oakland, Cal.

YOKOM, MOSE
CJKL, Kirkland Lake, Ont.

YOUNG, VICTOR
B. Aug. 8, 1900, Warsaw, Po-
land.

YOUNGBLOOD, JIM
WPAD, Paducah, Ky.

YOURK, LOUISE
KOVE, Lander, Wyo.

— Z —

ZIMMERMAN, HARRY
KHJ, Los Angeles, Cal.

ZIMMERMAN, PAUL E.
WMVA, Martinsville, Va.

For
"BEHIND THE MIKE
AND
BEFORE THE CAMERA"
LISTINGS FOR ALL TALENT

SEE PAGE 1047



BILL CULLEN

Exclusive Management

Martin Goodman

ANNOUNCERS—MC'S

RADIO AND TELEVISION

—their work during 1953



— A —

ADAMS, BILL
Let's Pretend
CBS

ADAMS, BOB
Kiddie Roundup
WBSM, New Bedford, Mass.

ADAMS, DEAN
Good Morning
WBNF, Binghamton, N. Y.

ADERHOLD, BOBBIE
WJBB, Haleyville, Ala.

AFMAN, DAVE
WMUU, Greenville, S. C.

AGEE, ALETHA
WTTG, Washington, D. C.

ALCALA, ED
Dance Party
KWNR, Reno, Nev.

ALEXANDER, DICK
WICC, Bridgeport, Conn.

ALEXANDER, GRAHAM
KCMJ, Palm Springs, Cal.

ALEXANDER, JACK
Hour of Stars
WFSU, New Orleans, La.

ALLEN, BOB
WSDR, Sterling, Ill.

ALLEN, DAVE
KWK, St. Louis, Mo.

ALLEN, ED JR.
WDOR, Sturgeon Bay, Wis.

ALLEN, FRANK
Musical Clock
KFEQ, St. Joseph, Mo.

ALLEN, RONALD K.
WNOF, Newport, Ky.

ALLEN, TOMMY
KTVQ, Oklahoma City, Okla.

ALSTON, JOE
KEYL-TV, San Antonio, Tex.

ALTON, GENE
CJLS, Yarmouth, N. S.

AMADON, ART
WBZ, Boston, Mass.

AMECHE, DON
Coke Time
Starring Eddie Fisher
NBC, NBC-TV

AMECHE, JIM
Jim Ameche Show
WJJD, Chicago, Ill.

AMOS, JOHN
KAFY, Bakersfield, Cal.

ANDERSON, DON
Chow Time
KFH, Wichita, Kan.

ANDERSON, DON
KASH, Eugene, Ore.

ANDERSON, HANS
WNLC, New London, Conn.

ANDERSON, JACK
WPIC, Sharon, Pa.

ANDERSON, KIRK
A. M. Alley
WFGM, Fitchburg, Mass.

ANDERSON, MILTON
WJAS, Pitts., Pa.

ANDERSON, ROY
WMNB, North Adams, Mass.

ANDERSON, SAM
WNAR, Norristown, Pa.

ANDERSON, WARREN
KFDA, Amarillo, Texas

ANDREWS, DAVE
KOLN, Lincoln, Neb.

ANDREWS, JOHNNY
Lights, Camera, Questions
WNEK, Cleveland, O.

ANDRICK, WILLIAM
WBLC, Clarksburg, W. Va.

ANTOINE, TEX
Weather By Wethbee
NEC-TV

ARCHER, GRAHAM
KGW, Portland, Oregon

ARMSTRONG, STUART
WEEK, Peoria, Ill.

ARMSTRONG, TOM
Starjitters
WGAB, Cleveland, O.

ARNOLD, BOB
Bob & Eddie
WLBZ, Bangor, Maine

ASH, KEN
WHA-V, Haverhill, Mass.

ASHBY, DICK
WMAZ, Macon, Ga.

ASHBY, MARGARET
KCOG, Centerville, Iowa

ASHER, JAMES D.
WJDA, Quincy, Mass.

ATKINSON, CHAS.
WILD, Birmingham, Ala.

ATKINSON, JIM
KSEL, Lubbock, Texas

ATWATER, F. KENT
WJRI, Lenoir, N. C.

AUSTIN, DICK
CKCR, Kitchener, Ont.

AUSTIN, FLETCHER
WBT, Charlotte, N. C.

AVERA, GROVER
WGAF, Valdosta, Ga.

AVERY, MARC
WIZE, Springfield, Ohio

AVRUCH, FRANK
WNEB, Worcester, Mass.

AYERS, S. CARLTON
WRTA, Altoona, Pa.

— B —

BAKER, ART

B. Jan. 7, 1898, New York
You Asked For It, ABC-TV;
Dino Shore Show, NBC-TV; Life
of Riley, Badge 714, KTTV

BALLARD, DAVID
KFWB, L. A., Cal.

BARBER, DON
Today's Top Five
WGDS, Miami, Fla.

BARCLAY, PAUL
WHUM, Reading, Pa.

BARLOW, JOHN
KSL, Salt Lake City, Utah

BARNET, JAMES
KRUS, Ruston, La.

BARRY, JACK
Life Begins At Eighty
Dumont

BARTLETT, RAY
KWKH, Shreveport, La.

BARTON, HAL
WTAD, Quincy, Ill.

BASILEON, GEORGE
WEEK, Peoria, Ill.

BATES, KARL
Bates Box Office
WTAM, Cleveland, Ohio

BATTERSEA, WES
KNXT, Los Angeles, Cal.

BEALE, CLYDE
WRUF, Gainesville, Fla.

BECK, JACKSON

B. July 23, 1912, New York City.
Theatre Guild, ABC-TV; Search
That Never Ends, MBC; F.B.I. In
Peace and War, CBS; Space
Cadet, Dumont; Doctor's Wife,
NBC; Paramount Newsreel

BECKER, JACKSON
KCLS, Flagstaff, Arizona

BELL, BOB
WLW, Cinn., O.

BELL, DORESE E.

B. June 21, 1925, Decatur, Ala.
TV Card Party, WTOP-TV; Gen-
eral Electric Theatre, New Homes
Preview, WMAL-TV; Hi Neighbor,
WHAM-TV; Sports Celebrities,
WTTG-TV; Dorese Bell Show,
WRNY

BELL, KENNETH
WSMB, New Orleans, La.

BELL, WAYNE
WCKY, Cinn., O.

BENSON, RED

Phrase That Pays, NBC; Name
That Tune, NBC, NBC-TV; Take
a Number, Mutual; Great Day,
Mutual; Movie Motinee, Mutual;
Red Benson Show, Dumont

BOISVERT, LOUIS, A.
 WBRV Waterbury Conn
BOLLINGER, JIM
 WKYW Louisville Ky
BOLTON, LESLIE, R.
 KARK Little Rock Ark
BOLAN, JAY
 WHAV Haverhill Mass
BORDERN, JACK
 WGHJ Hartford Conn
BOURNE, PORTER
 WXYZ Detroit Mich
BOWICK, BILL
 WALB Albany Ga
BOWLES, JOHN
 KNBC S F, Cal
BOWTON, DON
 WROK Rockford Ill
BOVETT, BILL
 KLEN Tomball Texas
BOYLE, JIM
 WWJ Detroit Mich
BRACKEN, DENNIS
 WOLF Syracuse N Y
BRADLEY, CURTIS
 WFHT Henderson Ky
BRADY, ED
 KNBR San Francisco Cal
BRANDL, MITT
 WISN Milwaukee Wis
BRANDT, MEI
 News
 NBC
BRANSON, BRUCE
 KFBK Sacramento Cal
BRANSON, TERRY
 KTRH Houston Texas
BRENDLER, GENE
 Wedding Belles
 RPTV Portland Ore
BRENNAN, DAN
 WVOK Birmingham Ala
BRENNER, PAUL
 WAAT Newark N J

BRENNER, SVD
 WNHC New Haven Conn
BRINK, ART
 KROC Rochester Minn
BRINK, CHARLES
 WHAM Rochester N Y
BROCK, RAY
 The Fox Club
WHBY Appleton Wis
BROOK, PHILIP
 WDBO Orlando Fla
BROOKS, FOSTER
 WAVE Louisville Ky
BROOKS, NORMAN
 WPTZ Phila Pa
BROWN, AL
 WIBC Bridgeport Conn
BROWN, ART
 WENS Pitts Pa
BROWN, BERNARD
 WAPO Chattanooga Tenn
BROWN, ED
 KSTW-TV, St Louis Mo
BROWN, LARRY
 WPEW Phila Pa
BROWN, NELSON
 WNLC New London Conn
BROWN, PAUL
 WERD Atlanta Ga
BROWN, TED
 Phrase Thea Pays
 NBC
BRUCE, JACK
 WNAX York Pa S Jr
BRUTON, ERIC
 WGGG Gainesville Fla
BUCK, HERBERT
 WBBO Tampa Fla
BUCKMAN, GENE
 WMAY, Springfield Ill
BUICE, ROBERT L.
 KARK Little Rock Ark
BUKER, NORM
 WLAM Lewiston Maine

BUTLER, CLIFF
 WLOU Louisville Ky
BURNS, BILL
 WGTN Wilson N C
BURGESS, TOM
 WMSO Columbia S C
BURKETT, LOU
 WFRQ Fremont O
BURLEY, DON
 WBBZ Boise City OIda
BURNETT, JAMES
 Rimpus Room
 WHBC Canton O
BURNS, AL
 WPTV Albany N Y
BUTHERUS, ED
 KGW Portland, Oregon
BUTLER, DON
 Bu's Party
 WGES Miami Fla
BYD, JO
 Listen Ladies
 WMPA, Aberdeen Miss

— C —

CALDWELL, CHUCK
 Rendezvous
 WPAD Paducah Ky
CALLAHAN, GREG
 WEOA Evansville Indiana
CAMERON, DAVE
 WRGB Schenectady N Y
CAMPBELL, DEWITT
 Cadillac Music Hall
 WING Dayton O
CAMPBELL, REX
 KSL Salt Lake City Utah
CANADA, BILL
 WSRS Cleveland O
CANE, LARRY
 KNIZ Houston Texas

BILL LAZAR

RADIO
 TELEVISION
 FILMS

MURRAY Hill 8-6600



CANNON, JOHN
Guiding Light
CBS

CARLSON, CARL
KAFY, Bakersfield, Cal.

CARLSON, HARRY
WOR, New York

CARPENTER, KEN
Lux Radio Theatre
CBS

CARSON, TOM
WJW, Cleveland, O.

CARTER, FRANK
WPEN, Phila., Pa.

CARTER, JERRY
WKIP, Poughkeepsie, N. Y.

CARVELL, TONY
T N' T
SGY, Schenectady, N. Y.

CARY, TOM
KMTV, Omaha, Neb.

CASE, LEE
WITH, Baltimore, Md.

CASE, NELSON
B. Feb. 3, 1910, Long Beach, Cal.
NBC Symphony; Omnibus, CBS-TV; Road of Life, CBS-NBC; Lowell Thomas, CBS; Rob't. Montgomery Presents, NBC-TV; Amahl and the Night Visitors, NBC-TV

CASSINI, IGOR
Igor Cassini Show
Dumont

CASTBERG, RALPH
KNGS, Hanford, Cal.

CHAMBERLIN, MIKE
KEAR, San Francisco, Cal.

CHANDLER, JACK
Club 11
KONA, Honolulu, T. H.

CHAPEAU, TED
WMBR, Jacksonville, Fla.

CHASE, EDDIE
WOOD, Grand Rapids, Mich.

CHARLES, LELAND
WSFA, Montgomery, Ala.

CLAPP, CHARLES
WEBB, Southern Pines, N. C.

CLAYTON, BOB
Boston Ballroom
WHDH, Boston, Mass.

CLEFTON, ROD
Clefton's Corner
KHQ, Spokane, Wash.

CLUTE, JOHN
WEAV, Plattsburg, N. Y.

COBB, JACK
WTVJ, Miami, Fla.

COGGIN, RUSS
KROW, Oakland, Cal.

COLEM, FRED B.
Carnival of Music
WHDH, Boston, Mass.

COLEMAN, HERMAN
Man On The Street
WMGR, Bainbridge, Ga.

COLLIER, RALPH
WHAM, Rochester, N. Y.

COLLINS, FRED
WNBC, N. Y., N. Y.

COLLINS, GEORGE
WWJ, Detroit, Mich.

COLLYER, BUD
Break The Bank
NBC, NBC-TV

COLLYER, BUD
Break The Bank, NBC; Beat The Clock, CBS-TV; Quick As A Flash, ABC-TV; On Your Way, Dumont

COMO, HUNTER
KDAL, Karnival
KDAL, Duluth, Minn.

COMPTON, PAUL
KOWL, Santa Monica, Cal.

CONCHAN, CLIFF
WISC, Madison, Wis.

CONDREN, STEWART
KCBD, Lubbock, Texas

CONFER, BILL
Matinee Melodies
WJAC-TV, Johnstown, Pa.

CONNEL, MEL
WNRC, New Rochelle, N. Y.

CONOVER, WILLIS
1260 Club
WWDC, Washington, D. C.

CONRAD, JOHN
WNBQ, Chicago, Ill.

COOK, BILL
WAAT, Newark, N. J.

COOK, ED
WMBM, Miami Beach, Fla.

COOK, JACK
WNOK, Columbia, S. C.

COONS, JOHNNY
WNBQ, Chicago, Ill.

COONTZ, EDDIE
KHJ, Los Angeles, Cal.

COOPER, AL
WEEU, Reading, Pa.

CORCORAN, BILL
King's Kamera
KING-TV, Seattle, Wash.

CORLEY, BOB
WQXI, Atlanta, Ga.

CORNELIUS, MERLE
KTOW, Okla. City, Okla.

CORNWELL, BLAINE
KWFT-TV, Wichita Falls, Tex.

CORNINGTON, J.
WLOK, Lima, O.

CORVO, PHIL
Musical Memories
WATR, Waterbury, Conn.

KEVIN KENNEDY

NEWS AT — 7:00-7:10 P.M.
YOUR MOBILGAS DEALER
EVERY NIGHT

TV

WPIX

TV

ANNOUNCER

SALESMAN

What's My Line
Pentagon, U.S.A.
Madison Square Garden
Events
Diamond Dust

FILM

Narration
Curtis Wright, Noma
Liqui-Moly



Piel's Beer
Robert Burns Cigars
Colgate-Palmolive
Remington-Rand
Gallo Wine
Birdseye
Merkin Paints
Adam Hats

Murray Hill 2-6500

COUGHLIN, FRANCIS
Chicago Symphony
Dumont

COUGHLIN, PAUL
WNRC New Rochelle N Y

COURTNEY, DEL
KPIX S.F., Cal

COWAN, JIM
KIDO Boise Idaho

COV, JIM
WNB New York N Y

CRAIG, VERN
WKAP Allentown Pa

CRANE, BOB
WIC Bridgeport Conn

CROSSBY, BEN
KYOC Casper Wyo

CROSSBY, LOU
KHJ Los Angeles Cal

CROW, TIM
WAMS Wilmington Del

CULLEN, BILL
Walk A Mile
NBC

CULP, JESSE
WVVC Albertville Ala

CUNNINGHAM, HOWARD
KEYL TV San Antonio Tex

CURTIS, RON
WFBL Syracuse N Y

— D —

DALEA, BUDD
CoRec Time
WSAZ TV Huntington
W Va

DAILEY, TOM
KWK St Louis Mo

DALE, BOB
Lunch Patter
WEWS Cleveland O

DALE, STAN
BreakFast Frisb
WJJD Chicago Ill

DANA, ROBERT
Dining Out With Dana
WABD New York

DANE, JEFF
Variety Show
WTAR TV Norfolk Va

DANICO, BOB
WGC Davenport Iowa

DARGO, BOB
WCSH Portland Maine

DAVID, TOBY
Toby David Show
CKLW Detroit Mich

DAVIS, DON
WLV Cinn., O

DAVIS, GENE
WARR Akron O

DAWSON, BOB
KGTV Des Moines Iowa

DAWSON, JACK
CFRR Toronto Ont

DAY, BOB
KGO S.F. Cal

DEAN, BOB
WBT Charlotte N C

DEANE, JOE
KQV Pittsburgh Pa

DON DELAGO
KTRC Santa Fe N M

DE LA VEGA, JOSE
WWRL New York N Y

DELFINO, FRANK
WIC Bridgeport Conn

DELINE, JIM
Delmo Gang
WSYR TV Syracuse N Y

DELMONT, JIMMY
WLOL Minneapolis Minn

DENSTON, DAVID S.
WRFA Attoing Pa

DENSON, CHUCK
KGRB Tyler Texas

DENVER, DEE
GSO Party Line
KFEQ St Joseph Mo

DEPEW, ART
KGST Fresno Cal

DESMOND WARREN
KNEW Spokane Wash

DE YOUNG, JOHN
Dinner Wine
WGI, Ft Wayne Ind

DIAZ, R COLON
WTIL
MAYAGUEZ Puerto Rico

DICKERMAN, CARL
WEEI Boston Mass

DINSMORE, ED
WBEN Buffalo N Y

DIXON, BOB
B April 8, 1911, Stamford, Conn
Perry Mason, Edward R Murrow.
Red Buttons, Person To Person.
CBS, CBS-TV, Life Can Be
Beautiful, NBC

DIXON, BOB
Easy Listen
KFMA Davenport Iowa

DOCHEE, JACK
WBBS On-to Bay N Y

DONALD, TONY
WPTH Baltimore Md

DONALDSON, DAN
Make Up Your Mind
GLS

DONEY, JIM
WXEL Cleveland Ohio

DONNELLY, BOB
KOOL Phoenix Ariz

DOYLE, LARRY
KGO San Francisco Cal



TODD RUSSELL

"Wheel of Fortune"—CBS-TV
"Rootie Kazootie"—ABC-TV

Personal Management
William Morris Agency



BUD COLLYER

ANNOUNCERS—M-C'S

DRAKE, RONALD
TV Teen Time
WHP-TV, Harrisburg, Pa.

DREW, JOHN
WOL, Washington, D. C.

DREWS, BOB
Detour With Drews
WAAF, Chicago, Ill.

DRISKILL, JIM
WINN, Louisville, Ky.

DUNBAR, RUSS
WOR, New York

DUNLAP, WALLY
WICC, Bridgeport, Conn.

DURHAM, TEX
KPAC, Port Arthur, Texas

DYER, BOB
WKNX, Saginaw, Mich.

— E —

EAST, HENRY
Breakfast Club
WLAG, Lagrange, Ga.

EATON, GORDON
Music Made in USA
WCCO, Minneapolis, Minn.

ECKOFF, GENE
KSWO, Lawton, Oklahoma

EDELL, BOB
WROK, Rockford, Ill.

EDGAR, BILL
KTRN, Wichita Falls, Texas

EDGAR, NEAL
WUSJ, Lockport, N. Y.

EDGREN, BOB
WNLC, New London, Conn.

EDWARDS, EARL
WNAH, Nashville, Tenn.

EDWARDS, MERLE
WMIN, St. Paul, Minn.

EDWARDSON, BILL
Harmony House
KJEO, Fresno, Cal.

EGGERT, GEORGE
WFBG, Altoona, Pa.

ELDER, EMERSON
KPQ, Weathee, Wash.

ELLIOTT, BRUCE
Movie QUICK QUIZ
WABD, New York

ELLIOTT, SAM
Tea Dance
WPAD, Paducah, Ky.

ELLIS, BOB
KGW, Portland, Oregon

ELLSWORTH, JACK
WALK
Patchogue, N. Y.

EMERSON, BYRON
WVHG, Hornell, N. Y.

EMERSON, LOU
WCMJ, Ashland, Ky.

ENGEL, BOB
WSRS, Cleveland, O.

ENGLES, ED
KTHS, Little Rock, Ark.

ESCRIBANO, RAFAEL
WCMN, Arecibo, Puerto Rico

ETON, JERRY
WFIG, Sumter, S. C.

EVANS, AL, JR.
1400 Club
KCLA, Pine Bluff, Ark.

EVANS, DR. BERGEN
Down You Go
Dumont

EVANS, MARK
WTOP, Washington, D. C.

EVANS, MEL
WAVU, Albertville, Ala.

EVANS, STAN
Shower of Silver
KYOS, Merced, Cal.

EVENS, EMERY
Neighborhood News
WKTC, Thomasville, Ga.

EWING, CLIFF
Kook's Tour
KOOK, Billings, Mont.

EWING, THOMAS E.
KIMA, Yakima, Wash.

— F —

FAIR, BRILL
KDNT, Denton, Texas

FANT, JULIAN
WFOY, St. Augustine, Fla.

FARMER, JON
WAGA, Atlanta, Ga.

FARRELL, JIM
Musical Clock
CKPR, Ft. William, Ont.

FARRINGTON, FIELDEN
Romance of Helen Trent
CBS

FARRINGTON, GLEN
WTAX, Springfield, Ill.

FASSETT, JAMES
Music Commentator, N. Y.
Philharmonic Symphony
Broadcasts
CBS

FELDMAN, GEORGE
WJPS, Evansville, Ind.

FENNEMAN, GEORGE
You Bet Your Life, Dragnet
NBC-NBC-TV

FIELD, RED
KRIZ, Phoenix, Ariz.

FILES, BURT
WHUC, Hudson, N. Y.

FILKINS, LARRY
KGNC, Amarillo, Texas

FINDLAY, BOB
WSKB, McComb, Miss.



PHIL TONKEN

ACTOR - ANNOUNCER - M.C.

HIGH TENSION — TV
GREATEST FIGHTS OF CENTURY — TV
THE GREATEST DRAMA — TV
RADIO PLAYHOUSE
—NEMO —WEATHER REPORTER
MAN FROM TIMES SQUARE

RADIO REGISTRY MU 8-6600 TV



RED BENSON

"NAME THAT TUNE"

NBC-TV

monday nite at 8

"TAKE A NUMBER"

MUTUAL

friday nite at 8

ANNOUNCERS — M-C'S

FINLEY, LARRY

B May 4, 1913, Syracuse, N. Y.
The Larry Finley Show, KFWB,
Hollywood, Cal., Hollywood Movie
Premiers, WMGM, N. Y., KLAC-
TV, KECA-TV, KNXT-TV, Holly-
wood, Cal.

FISHER, NORM

KBZ, Kalspell, Mont.

FISHER, ROBERT

WJPR, Fremont, W. Va.

**FITZMAURICE,
MICHAEL**

B April 28, 1908, Chicago, Ill.
Lowell Thomas, Fun For All, CBS,
Right to Happiness, John Camer-
on Swoyze, NBC; Whispering
Streets, ABC

FITZPATRICK, LEO

KTIQ, Spokane, Wash.

FLAHERTY, BOB

WKY, Cincinnati

FLEMING, ED

Our G. J. Sunday
CBS

FLESEY, JERRY

Valley Goodwill
KSRV, Ontario, Ore.

FLETCHER, FRED

WRAL, Raleigh, N. C.

FLINN, JIM

WPTV, Pring, Ohio

FLINT, WALTER

WGP, Albany, Ga.

FLOWERS, SALLY

WLV, Columbus, O.

FLYNN, CHARLES

WFRG, Altoona, Pa.

FLANN, JACK

WBY, Madison, N. Y.

FLYNN, PETER

KLBS, Houston, Tex.

FORBES, BOB

WJMN, Florence, S. C.

FORMAN, WIN

Music For The Muses

WARM, Stanton, Pa.

FORREST, JOHN

ROL, Seattle, Wash.

FORREST, RON

KYMA, Miami, Ark.

FOSTER, FRED J.

KFSD, San Diego, Cal.

FOX, BILL

KRBB, Abilene, Texas

FOX, DAVE

KLIX, Twin Falls, Idaho

FOX, JOHN

WKKO, Cocoa, Fla.

FRANCIS, AL

Fun With Francis

FRANKLIN, DELMAS

Morning Jamboree

FRANKLIN, WALTER

WLAQ, Rome, Ga.

FREDERICKS, JACK

WKTV, Udon, N. Y.

FREEMAN, FRANK

WBBF, Rock Island, Ill.

FREEMAN, WALTER

KTMC, McAlester, Oklahoma

FREEMUTH, BOB

KVIC, Victoria, Texas

FRENCH, DICK

Strictly From Richard

FRIDBERG, ALICE

WCYB, Bristol, V.

FROST, DON

WLPG, La Salle, Ill.

FURMANN, DON

KSEI, Pocatello, Idaho

FULGHAM, BILLY

WVOP, Auldrin, Ga.

FULKERSON, FRED

WAMC, Mt. Carmel, Ill.

FULTON, ROBERT

Lady's Balcony

FURKELL, WIL

KERG, Eugene, Ore.

FURKELL, WIL

KCCC-TV, Sacramento, Cal.

— G —

GABHART, DAVID

WBKZ, Battle Creek, Mich.

GAINES, JERRY

WHAT, Phil, Pa.

GALLAGHER

WLAS

Wilmington, Del.

GALLAGHER, PAUL

WHDL, Okla. N. Y.

GARCIA, GENE

Link Gem

WALT, Tampa, Fla.

GARDNER, JACK

Music Varieties

WBFD, Booneville, Miss.

GARWOOD, JOHN

WNBZ, Saratoga Lake, N. Y.

GASQUE, KENNETH

WJAY, Millbus, S. C.

GAYNOR, BOB

WVOW, Logan, W. Va.

GEDON, GEORGE

WBPD, Lock Haven, Pa.

GEER, SANDY

WALT, Tampa, Fla.

GENTRY, WAYNE

Keep It Happy

KCOM, Sioux City, Iowa

GEORGE, CAL

Casino

KRW, Vancouver, B. C.



WALTER HERLIHY



MORT LAWRENCE

Host "Big Payoff" — CBS-TV and NBC-TV
Announcer, "We Love Dogs" — ABC-TV

LExington 2-1100

GEORGE, RUSS
The Russ G. Show
WNLK, Norwalk, Conn.

GERMAN, LOU
After Hours Show
WORL, Boston, Mass.

GERO, NORM
WCOG, Greensboro, N. C.

GERON, H. NORMAN
WWSO, Springfield, O.

GETZ, ART
WSAN, Allentown, Pa.

GIBBONS, BILL
WFGN, Gaffney, S. C.

GIBBONS, JIM
WMAL, Washington, D. C.

GIBBS, JIM
KIVY, Crockett, Tex.

GIBSON, ALEC
WTVJ, Miami, Fla.

GIBSON, JIM
KTRF, Thief River Falls, Minn.

GILBERT, JAY
WEAR, Pensacola, Fla.

GILBERT, JOHN
WRR, Dallas, Texas

GILL, EARLE
WPTZ, Phila., Pa.

GILLIGAN, ROY
WKRC, Cinn., O.

GILMAN, HAL
WSLB, Ogdensburg, N. Y.

GILREATH, H. C.
WVOP, Vidalia, Ga.

GIRONA, ENRIQUE
WKVM, San Juan, P. R.

GISH, ED
KLIX, Twin Falls, Idaho

GLASS, CHARLES
After Hours
KROP, Brawley, Cal.

GLEBA, TOM
WBNS, Columbus, Ohio

GOLDEN, JERRY
WLIP, Kenosha, Wis.

GOODWIN, ART
WAGE, Syracuse, N. Y.

GORDON, DOROTHY
New York Times Youth Forum
Dunont

GORDON, JOHN
CKLW, Detroit, Mich.

GORDON, WILLIAM
WEAT, Lake Worth, Fla.

GRADY, JACK
KRYO, Fresno, Cal.

GRAHAM, VIRGINIA
The Virginia Graham Radio Show,
WABC, N.Y.; Here's To Your
Health, WABC-TV, New York;
Where Was I?, Food For Thought;
Dumont, WABD-TV, New York

GRAHAM, WILLIAM
WIKE, Newport, Vermont

GRANGER, ALLEN
WOR, N. Y., N. Y.

GRANGER, JERRY
KWBE, Beatrice, Neb.

GRAUE, KEN
KTLA, Hollywood, Cal.

GRAUER, BEN
B. June 2, 1908, New York City.
March of Medicine, Show of
Shows, NBC-TV; Between The
Lines, WNBT, N. Y.; NBC Sym-
phony, NBC; Citizens Union
Searchlight, Ben Grauer News,
WNBC, N. Y.

GRAY, JOHN
WHBO, Tampa, Fla.

GREEN, EARL
WTVN, Columbus, O.

GREEN, GEORGE
KGHL, Billings, Mont.

GREEN, JOHNNY
KPHO, Phoenix, Arizona

GREENE, ERVIN
KMUR, Murray, Utah

GREENWOOD, DEL
WGBF, Evansville, Indiana

GREGORY, GREG
Harbor Lights
WTMA, Charleston, S. C.

GREGSON, JACK
DANA
B. July 14, 1915, Spokane, Wash.
Jack's Place, ABC; Saturday
Night Flights, ABC-TV

GREY, JERRY
Open House
KXGI, Fort Madison, Iowa

GRIMSBY, ROGER
WEBC, Duluth, Minn.

GRONDIS, FREDDIE
Musique En Tete
CKCV, Quebec

GROVER, JOHN
KNBC, S. F., Cal.

GUEST, BOB
Guest House
WJR, Detroit, Mich.

GUNN, BEN
WAGA, Atlanta, Ga.

GUNN, BOB
WJRD, Tuscaloosa, Ala.

GUNN, DICK
Dance Band Parade
KSUB, Cedar Rapids, Utah

— H —

HAEPNER, GEORGE
WHAM, Rochester, N. Y.



JAY JACKSON
M. C.—"Twenty Questions"



CY HARRICE
Lexington 2-1100

HAGERMAN, JOHN
 WKXX, Saginaw City, Mich.
HAGGART, BUD
 The Blues Chasers
 WFDF, Flint, Mich.
HAGLI, DAVE
 KWKH, Shreveport, La.
HALE, GEORGE
 WAB, Bangor, Maine
HALEY, PAT
 WMCK, McKeesport, Pa.
HALEY, TOM
 Haley's Lady
 WNBK, Cleveland, O.
HALL, HOWARD
 WOW, Omaha, Neb.
HALL, JIMMA
 KMAC, San Antonio, Texas
HALTER, BARON
 WLDS, Jacksonville, Ill.
HAMPTON, JACK
 KPAM, Portland, Oregon
HANDLON, GEORGE
 KGU, Honolulu, Hawaii
HANN, JERRY
 KNOL, Ft. Worth, Texas
HANNAH, RALPH
 KVOI, Ukiah, Texas
HANSON, JACK
 WNAX, Yankton, S. D.

HARRICE, CY
 B. March 1, 1915, Chicago, Ill.
 The Big Story, Cavalcade of
 America, NBC; Broadway to Hol-
 lywood, Dumont; Philco Tele-
 vision Playhouse, Philco Radio
 Playhouse, CBS

HARRILL, NELSON
 WGWR, Ashboro, N. C.

HARRIS, BOB
 KERE, Fresno, Cal.

HARRIS, LLOYD
 WMAZ, Macon, Ga.

HARTLEY, JIM
 Alarm Clock Club
 WDCN, Gainesville, Ga.
HART, BILL
 KWBW, Hutchinson, Kan.
HART, BOB
 KEAL, Fulton, Mo.
HARVEY, ROY
 Esco Bandwagon
 WGL, Ft. Wayne, Ind.
HASTINGS, JACK
 WPBC, Minneapolis, Minn.
HATFIELD, LANSING
 WWNC, Asheville, N. C.
HAYIG, DEAN
 KMO-TV, Tacoma, Wash.
HAWKINS, LEM
 KPGO, Fargo, N. D.
HENKE, BILL
 KOLN, Lincoln, Neb.
HENDRIX, CLIFF
 KESJ, Pueblo, Colo.
HENNESSY, FRANK
 Morning Timekeeper
 WNDR, Syracuse, N. Y.
HENRY, CARL
 WRIB, Providence, R. I.
HENRY, PAT
 KROW, Oakland, Cal.
HENSON, DOUG
 WJMJ, Philadelphia, Pa.

HERLIHY, EDWARD
 Horn & Hardart Children's Hour,
 Your Show of Shows, Kraft The-
 atre, NBC-TV; Weekend, NBC

HERLIHY, WALTER F.
 Kraft Television Theatre, Music
 From Meadowbrook, ABC-TV;
 Dionne Lucas Show, Glorio De-
 Haven Show, Lisa Ferraday Show,
 Ann Rutherford Show, WABC-TV,
 New York

HERMAN, BERNIE
 Music 'Til Midnight
 WIRE, Indianapolis, Ind.
HETHERINGTON, KEITH
 My Mike's Kitchen
 KMO-TV, Tacoma, Wash.
HETRICK, WAYNE
 WLAN, Lancaster, Pa.
HEYDE, BUDD
 KNBC, San Fran., Cal.
HICKMAN, HENRY
 Club 1300
 WFBR, Baltimore, Md.
HICKS, GEORGE
 Theatre Guild On The Air
 NBR
HILL, BOB
 KMTV, Omaha, Neb.
HILL, DUANE
 Surprise Package
 KSL-TV, Salt Lake City, Utah
HINDS, BILL
 Buzz & Bill
 WDTV, Pittsburgh, Pa.
HINES, PETE
 WFSR, Lake City, Fla.
HINKLEY, HARRY
 Pat Parade
 WHP-TV, Harrisburg, Pa.
HITE, BOB
 Crime Photographer
 CBS
HOAG, DAVE
 WWNH, Rochester, N. Y.
HOBBY, WES
 WNAB, Bridgeport, Conn.
RODGSON, JAY
 Mother's Delight
 KTRC-TV, Austin, Tex.
HOFFMAN, HOWARD
 WNEL, Cleveland, Ohio



JOHN SAVAGE

MU 8-6600



JACK GREGSON

LE 5-1371

HOFFMAN, WALT
WHAM, Rochester, N. Y.

HOGAN, HARLAN
WSDT, South Bend, Ind.

HOLDEN, DONALD
WDZ, Decatur, Ill.

HOLMES, BOB
WFBL, Syracuse, N. Y.

HOLT, FRED
WCKY, Cinn., O.

HONEYMAN, KEN
WHIO, Dayton, O.

HONEYMAN, RUSS
City Court
WWCA, Gary, Ind.

HOPKINS, BILL
KLBS, Houston, Tex.

HOSTETTLER, CHUCK
KHOZ, Harrison, Ark.

HOULIHAN, BILL
Weather Show
WEEK, Peoria, Ill.

HOYLE, SUNNY
WHKY, Hickory, N. C.

HUBBARD, HARRY
KFIR, North End, Oregon

HUBBARD, ROY
WMAZ, Macon, Ga.

HUGH, IVOR
WCCC, Hartford, Conn.

HUNT, RALPH
Rise & Shine
WABI, Bangor, Maine

HURLBUT, JIM
Zoo Parade
NBC-TV

— I —

INGSTAD, BOB
KOVC, Valley City, N. D.

IRVING, CHARLES
Search For Tomorrow
CBS-TV

— J —

JACKSON, BOB
KRBD, Duncan, Okla.

JACKSON, CARROLL
WLAU, Laurel, Miss.

JACKSON, JAY

B. Nov. 4, 1918, Waverly, Ohio.
My Little Margie, Philco Television Playhouse, NBC-TV; Omnibus, CBS-TV; Twenty Questions (TV) Dumont; Twenty Questions (Radio) Mutual

JACKSON, KENT
Stump The Experts
WTOB-TV, Winston-Salem, N. C.

JACKSON, MAURICE
Jackson's Beat
WVKO, Columbus, O.

JAFFEE, TED
WAAM, Baltimore, Md.

JAMES, BOB
WWHG, Hornell, N. Y.

JAMES, DENNIS
Two For The Money,
Amateur Hour
NBC-TV

JAMES, HERB
KWWL, Waterloo, Iowa

JAMES, HUGH
Wendy Warren And The News
CBS

JAMES, KEN
WOW-TV, Omaha, Neb.

JAMES, JERRY
KEAR, San Francisco, Cal.

JASS, MEL
WCCO, Minn., Minn.

JEFFREYS, ALLAN
WTOP, Washington, D. C.

JENKINS, BOB
WPFB, Middletown, Ohio

JENKINS, BOB
KONO, San Antonio, Texas

JENKINS, WAYNE
Breakfast With Blondie
WBOW, Terre Haute, Ind.

JENSEN, LEIF
WDRG, Hartford, Conn.

JOHNSON, BOB
KRIZ, Phoenix, Ariz.

JOHNSON, BUDDY
KRIC, Beaumont, Texas

JOHNSON, JOHNNY
Birthday Club
KMCO, Conroe, Tex.

JOHNSON, WALLY
KFEQ, St. Joseph, Mo.

JONES, AL
WRR, Dallas, Texas

JONES, BILL
KLZ, Denver, Colo.

JONES, DICK
WREB, Holyoke, Mass.

JONES, JIMMY
Rhythms At Random
KGVU, Greenville, Tex.

JONES, ROYCE A.
WIMO, Winder, Ga.

JORGENSEN, FRED
KGO, S. F., Cal.

— K —

KABAY, MIKE
KGBC, Galveston, Texas

KANE, PHIL
Breakfast Set
WOC, Davenport, Iowa

KARLE, DON
WXYZ, Detroit, Mich.

KASSERA, LOREN
WLCX, LaCrosse, Wisc.



ART BAKER



NELSON CASE

KAVANAGH, AL
WSAV Savannah, Ga.

KAY, BOB
WMBE Miami Fla.

KAY, BOB
WAVE Louisville, Ky.

KAYE, BOB
Varieties of the American
Theatre
KEYD Minneapolis, Minn

KEARNEY, GERRY
WFEA Mon-hotel N H

KEEFE, AL
Ladies Choice
KSCB Liberal, Kan.

KEEP, BARNEY
Keeps Corner
KEN Portland, Ore.

KELLY, GENE
WEBR Buffalo, N Y

KELLY, PAUL F.
KSLW Woodward, Okla.

KELLY, WARREN
Warren Kelly Show
WXYZ TV Detroit, Mich.

KENNEDY, BOB
Sense & Nonsense
NBC-TV

KENNEDY, KEN
WFRX W. Frankfort, Ill.

KENNEDY, KEVIN
WPIX New York, N Y

KENNEDY LEE
WRVY Princeton, Indiana

KENNEDY, C. WARREN
All Star Jukebox
WTTX New Orleans, La.

KENT, CARI
KPAR Phoenix, Arizona

KENT, GEORGE
Here and There
CBK Winnipeg, Man.

KESSENIOL, JACK
Music Music Chest
WDHZ Green Bay, Wis.

KESSELER, DON
WAKN Staken, S. C.

KEYS, CHARLIE
Ladies Matinee
KCBF TV Lubbock, Tex.

KIERNAN, WALTER
Who Said That?
NBC-TV

KILLAM, JIM
WVAM Baltimore, Md.

KINDER, KOD
WNAR, Norristown, Pa.

KING, BILL
WIRL Peoria, Ill.

KING, BOB
KVTV-TV St. Louis, Mo.

KING, CARL
8 July 30, St. Louis, Mo.
King's Crossroad, Syndicated,
Rocket Rangers, Journey Through
Life, CBS-TV

KING, CARL
Woodehoppers Ball
KTRE Lubbock, Tex.

KING, DON
WCIL Carbondale, Ill.

KING, STUBBY
WKBI St. Marys, Pa.

KING, WILLIAM O.
Anchor: Club
WTOG Savannah, Ga.

KIRBY, BURWARD
Hilltop House
CBS

KIRCHNER, DICK
KTVQ Oklahoma City, Okla.

KIRKPATRICK, DAVE
WVNB North Adams, Mass.

KITTELL, CLYDE
News
NBC

KNIGHT, CY
CHAB Moose Jaw,
Saskatchewan, Canada

KNIGHT, JACK
WCOS Columbia, S. C.

KORDECKI, DON
WFOM Marietta, Ga.

KOVACS, ERNIE
WCBS N Y

KOZIOL, RONALD
WRDB, Reedsburg, Wis.

KROLL, JAY
WELS, Kingston, N. C.

KRUPP, LARRY
WJW, Cleveland, O.

KUNDER, CLAY
KHSL, Chico, Cal.

KYLE, FORREST
KPMC Bakersfield, Cal.

— L —

LACY, JOHN
Happiness Exchange
RNOE Monroe, La.

LAMB, ART
WTTG Washington, D. C.

LAMB, BOB
KEOX Long Beach, Cal.

LAMBERT, KENNETH
WLDJ Jacksonville, Ill.

LAMPMAN, HUGH
KCLN Fort Worth, Tex.

LANE, LARRY
WEBK Tampa, Fla.

LANGSTON, JOE
WNPT Tuscaloosa, Ala.

LARKIN, DON
WAAT Newark, N J.

LARSEN, GENE
Breakfast With Gene
KFMA Davenport, Iowa.



DEL SHARBUTT

"The Betty White Show"

NBC-TV

LARSON, BEN
WOW, Omaha, Neb.
LAUGHLIN, JIM
Coffee Club
KLCB, Libby, Mont.
LAWRENCE, JACK
WPWA, Chester, Pa.
LAWRENCE, JERRY
KFAL, Fulton, Mo.
LAWRENCE, JOHNNY
WOKO, Albany, N. Y.

LAWRENCE, MORT

B. Dec. 4, 1914, Philadelphia, Pa.
The Big Payoff, CBS-TV and
NBC-TV; We Love Dogs, ABC-
TV

LAWSON, JOHN
Record Shop
CFOR, Orillia, Ont.
LAWSON, RALPH
WZIP, Covington, Ky.
LAYMAN, EARLE
Radio Council
WPRC, Lincoln, Ill.

LAZAR, BILL

B. July 8, 1921, Appleton, Wis.
Pepper Young's Family, NBC;
Oscar Awards Telecast, Paul
Winchell Show, Kuika, Fran &
Ollie, NBC-TV; Search for To-
morrow, Red Buttons Show, CBS-
TV

LAZAROW, ART
WWJ, Detroit, Mich.
LEAHY, TOM
KWBB, Wichita, Kan.
LEE, BOB
KCOK, Tulare, Cal.
LEISURE, CLARENCE
KNBC, S. F., Cal.
LEMEN, WALTER H.
KCOG, Centerville, Iowa
LEMON, DOC
Doc's Digest
WVKO, Columbus, O.
LEONARD, BOB
WMMN, Fairmont, W. Va.
LEONARD, LEE
WTOV, Norfolk, Va.
LePAGE, JEAN
WMSA, Massena, N. Y.
LESTER, BILL
KOY, Phoenix, Arizona
LESTER, DON
WLW, Cinn., O.
LEVERING, PETE
KGFH, Flagstaff, Arizona
LEVITT, AL
KROW, Oakland, Cal.
LEWIS, RALPH
WTAD, Quincy, Ill.
LEYDEN, BILL
KTTV, Los Angeles, Cal.
LEZOTTE, GEORGE E.
Tune Inn
WAVZ, New Haven, Conn.
LIDDLE, BOB
KGA, Spokane, Wash.
LIEBMAN, JERRY
WPIC, Sharon, Pa.
LIENEMANN, GENE
KSID, Sidney, Neb.
LILES, MARDI
Farm Hour
WFLA, Tampa, Fla.
LILLIGREN, CHUCK
WDLB, Marshfield, Wis.
LINDBERG, WALLY
KCNA, Tucson, Arizona
LINDMAN, STUART
Show Tunes
WMIN, St. Paul, Minn.
LINGLE, DICK
WFEB, Indianapolis, Ind.
LIVELY, BILL
KWIN, Ashland, Oregon

LOCKHART, GLENN
WPCF, Panama City, Fla.
LOCKWOOD, GLENN
Fun For Breakfast
KOOK, Billings, Mont.
LONGER, HELDON
WVVV, Fairmount, W. Va.
LONG, DAN
Musical Clock
WJVB, Jacksonville Beach,
Fla.
LONG, DEANE S.
Meet Your Neighbor
KVOE, Santa Ana, Cal.
LONGFELLOW, TOMMY
KARK, Little Rock, Ark.
LONGMAN, BILL
Of The Record
KFMA, Davenport, Iowa
LOTT, JOHNNIE
WERH, Hamilton, Ala.
LOWE, JACKSON
WOL, Washington, D. C.
LUBECK, ROBERT
KROY, Sacramento, Cal.
LUCAS, BEN
WRGA, Rome, Ga.

LUCK, BOB
Lucky Luck Show
KONA, Honolulu, T. H.
LUDDEN, ALLEN
College Quiz Bowl, Mind Your
Manners
NBC, NBC-TV
LUKE, HARRY
WICC, TV
Bridgeport, Conn.
LUND, JACK
KXRX, San Jose, Cal.
LUND, ROGER
WECT, Elmira, N. Y.
LUNDBERG, VIC
You Win
KTUL, Tulsa, Okla.
LUSK, BERNIE
KROC, Rochester, Minn.
LYNN, KEN
WFBM, Indianapolis, Ind.

— Mc —

McADOO, DICK
KFDM, Beaumont, Texas
McBRIDE, GORDON
Wake Up Everyone
CFKI, Ft. Frances, Ont.
McCAFFERY, JOHN K. M.
What's The Story
DuMont
McCARTNEY, DICK
KCUL, Ft. Worth, Tex.
McAULIFFE, TOM
WERI, Westerly, R. I.
McCOY, BOB
KGVO, Missoula, Mont.
McCOY, JACK
Glamour Girl
NBC-TV
McCOY, RONNIE
KFEL, Denver, Colo.
McCULLOUGH, DAN
Movie Quick Quiz
WABD, New York
McDANIEL, GRANT
KIDO, Boise, Idaho
McDANIELS, EARL
KFVD, L. A., Cal.
McDEVITT, LEO
Shopper's Matinee
WALE, Fall River, Mass.
McDONALD, H.O., JR.
WELP, Easley, S. C.
McDONALD, RODERICK
WMTV, Madison, Wis.
McELRATH, JACK
Time Out
KEPO, El Paso, Texas
McGUIRE, JOE
WEOH, Clinton, Ill.
McIVER, RAY
WEED, Atlanta, Ga.

McKAY, JAMES
WLBB, Carrollton, Ga.
McKEEHAN, BOB
KCNA, Tucson, Arizona
McLAIN, BOB
WFKY, Frankfort, Ky.
McMULLAN, JACK
WMBS, Uniontown, Pa.
McNUTT, JACK
WJBB, Haleyville, Ala.

— M —

MacDONALD, ARCH
WBZ, Boston, Mass.
MacDONALD, DON
KCMJ, Palm Springs, Cal.
MACK, BILL
Music Time
WEDC, Chicago, Ill.
MACK, TED
Ted Mack's Original Amateur
Hour
NBC-TV
MacRAE, JOHNNY
Matinee With MacRae
WABI, Bangor, Maine
MADDON, ED
WARM-TV, Scranton, Pa.
MAHAFFET, CHUCK
KXA, Seattle, Wash.
MAHAN, JOHN
WDAS, Phila., Pa.
MAHER, WILLIAM
WOR, New York
MALE, COLIN
WCPO-TV, Cincinnati, O.
MALONE, BILL
WMAL-TV, Washington, D. C.
MANLOWE, DUDLEY
KNBC, S. F., Cal.
MANNIS, BILL
WIP, Phila., Pa.
MARGARITE, LEON
Dawn Patrol
WBBF, Rochester, N. Y.
MARION, ED
Flash Gordon
KGMB-TV, Honolulu, T. H.
MARSHALL, ROBERT
Record Jury
WGBS, Miami, Fla.
MARTELL, TONY
WQAN, Scranton, Pa.
MARTIN, BOB
Record Round Up
WALT, Tampa, Fla.
MARTIN, GLENN
KLZ, Denver, Colo.
MARTIN, JACK
WCUE, Akron, Ohio
MARTIN, JIM
Jim Martin Show
WEOO, Orlando, Fla.
MARTIN, JOHNNY
WLOU, Louisville, Ky.
MARTINEZ, MANUEL
WKVM, San Juan, P. R.
MASINGILL, LUTHER
WDEF, Chattanooga, Tenn.
MATTOLA, TONY
Melody Street
DuMont
MAXWELL, DAVE
KBIG, Avalon, Cal.
MAXWELL, RUDOLPH
WDIX, Orangeburg, S. C.
MAYER, BRUCE
Ladie's Man
WABD, New York
MAYER, JACK
WALB, Albany, Ga.
MEATH, ED
Musical Clock
WHEC, Rochester, N. Y.
MEHRMAN, BOB
WTAO, Boston, Mass.
MELA, GRAHAM
WONN, Lakeland, Fla.

WELTON, CHARLES
 WIS, Columbia, S. C.
MERCEN, TOM
 WTMJ, Milwaukee, Wis.
MERCER, RAY
 Alarm Clock Club
 WPKR, Portland, Maine
MERKER, GARY
 WAKE, Akron, Ohio
MERRITT, HERBERT A.
 WHAL, Greenfield, Mass.
MEYERS, DUTCH
 KFOR, Lincoln, Neb.
MICHELMAN, ED
 KGMB, Honolulu, T. H.
MIDDLETON, BOB
 1450 Club
 WWSO, Glens Falls, N. Y.
MILLER, GEORGE, JR.
 KAL-A, Ada, Okla.
MILLER, HARVEY
 WBRF-TV, Wilkes-Barre, Pa.
MILLER, LEE
 WRTA, Altoona, Pa.
MILLER, LINDY
 WBZ, Boston, Mass.
MILLER, OTTO
 KFSD, San Diego, Cal.
MILLER, PAT
 Jamboree
 WTAQ-TV, Norfolk, Va.
MILLER, WES
 KAFY, Bakersfield, Cal.
MILLS, FRANK
 It Seems Like Yesterday
 WBAF-TV, Fourth Ward, Tex.
MILNER, ART
 WRDN, Camden, N. J.
MENTER, ERNIE
 WOW, Ft. Wayne, Indiana
MICHELL, BOB
 WDAS, Phila., Pa.
MICHELL, CHUCK
 WSOB, Nashville, Tenn.
MICHELL, CLIFF
 Morning Marathon
 KASB, Albany, Minn.
MICHELL, EVERETT
 National Farm & Home Hour
 NBW
MOFFAT, CHARLES
 WJOB, Hammond, Ind.
MOLNAR, EMERY
 WMCK, McKeesport, Pa.
MOODY, BLAIR
 Meet Your Congress
 DuMont
MOORE, CARL
 Beantown Varieties
 WEEI, Boston, Mass.
MOORE, ED
 WDMA, Charleston, S. C.
MOORE, FREDERICK
 KFOX, Long Beach, Cal.
MORALES, JOE
 KVAL, Pasadena, Texas
MOREAU, AL
 Invitation To Music
 WSPB, Sarasota, Fla.
MORETTI, SKIP
 KCLO, Leavenworth, Kansas
MORGAN, DICK
 WDBL, Roanoke, Va.
MORGAN, WAYNE
 WMFR, High Point, N. C.
MORRIS, BEN
 WKY, Oklahoma City, Okla.
MORRIS, ELMER
 KWHN, Ft. Smith, Ark.
MORRIS, GILBERT
 WDAS, Phila., Pa.
MORROW, JACK
 Country Carnival
 WIBC, Indianapolis, Ind.
MORSE, JIM
 WENY, Elmira, N. Y.
MOSTELLER, JERRY
 WAKE, Greenville, S. C.
MUNZELL, SPECS
 WIS, Columbia, S. C.

MURPHY, BOB
 Bob Murphy Calling
 WJBR-TV, Detroit, Mich.
MURPHY, ED
 WCAN, Milwaukee, Wis.
MURPHY, HARVEY
 WHEIT, Henderson, Ky.
MURPHY, JACK
 WUSJ, Lockport, N. Y.
MURRAY, DEAN
 Studio A
 KCOM, Sioux City, Iowa

— N —

NABORS, TED
 KPHH, Houston, Texas
NAGEL, CONRAD
 Broadway To Hollywood
 DuMont
NAGLESTAD, FRED
 WOW-TV, Omaha, Neb.
NAVA, MILT
 Latin American Rhythms
 KWKW, Pasadena, Cal.
NEAL, BOB
 WMPB, Memphis, Tenn.
NEFF, ERNEST
 Pets On Parade
 WKBF-TV, Pittsburgh, Pa.
NEBRING, WALLY
 Dawn Patrol
 WIKR, Indianapolis, Ind.
NEULAN, RAY
 WKNB, New Britain, Conn.
NELSON, ART
 KLFJ, Dallas, Tex.
NELSON, CHARLES
 WFBG, Altoona, Pa.
NELSON, DAVE
 Mart of Music
 KSTT, Davenport, Iowa
NELSON, DEV
 KFOR, Lincoln, Nebraska
NELSON, GEORGE
 Hour of Music
 KSTN, Stockton, Cal.
NELSON, GEORGE
 WHIT, New Bern, N. C.
NELSON, JOHN
 Bride And Groom
 NBC-TV
NELSON, JEE
 WFNC, Fayetteville, N. C.
NELSON, LLOYD
 The Clock Spinner
 WDAE, Savannah, Ga.
NELSON, PAUL
 Trading Post
 KSO, Des Moines, Ia.
NELSON, TED
 WJRD, Tusculoussa, Ala.
NEWHOUSE, SHELBY
 WWJ, Detroit, Mich.
NEWMAN, ROBERT
 WEEU, Reading, Pa.
NICOL, DON
 WTIK, New Orleans, La.
NICOL, DON
 WTIK, New Orleans, La.
NIELSON, WARREN
 KMA House Party
 KMA, Sheandoah, La.
NIEL, TED
 WRBN-TV, Youngstown, O.

NIMMO, BILL

B. June 18, 1917, Cincinnati, O.
 Jackie Gleason Show, CBS-TV;
 Wednesday Boxing, Crime Syndi-
 cated, Heaven For Betsy, CBS;
 Plainsclothes Man, DuMont

NIXON, MILT
 WRAP, Norfolk, Va.
NOEL, DICK
 Sense And Nonsense
 WABD

NOEL, JACK
 Jukebox
 WTTs, Bloomington, Ind.
NOLAN, GEORGE
 KFDA, Amarillo, Tex.
NOLAN, JAMES
 KMA, Yakima, Wash.
NOLTON, JOHNNY
 KGSC, Amarillo, Texas
NORDINE, KEN
 WMAQ, Chicago, Ill.
NORGARD, ROBERT
 WFRO, Fremont, O.
NORK, DON
 WHTB, Talladega, Ala.
NORMAN, DON
 WBRF, Birmingham, Ala.
NORMAN, HAL
 WLCH, Torrington, Conn.
NORMAN, HERB
 WWRL, N. Y., N. Y.
NORTON, IVERS
 WHDL, Olean, N. Y.
NORMAN, STAN
 KOY-TV, Phoenix, Ariz.
NORWOOD, BOB
 WAJM, Albion, Mich.
NUZUM, BILL
 WBNS, Columbus, O.
NUZUM, CHUCK
 WTVN, Columbus, O.
NUZUM, CHUCK
 WTVN, Columbus, O.

— O —

O'BRIEN, JOE
 Rosemary
 CBS
O'CONNOR, BILL
 Shows For WCFL, WJJD, WMAG,
 WIND, WGN, WAAF, WAIT,
 Chicago, Ill.
O'CONNOR, JOHN
 Rendezvous with Music
 WCCM, Lawrence, Mass.
O'DELL, STEWART
 Record Shop Time
 WSLI, Pikeville, Ken.
O'DONNELL, BOB
 WHEE-TV, Rochester, N. Y.
O'DONNELL, CHARLES
 WHAT, Phil., Pa.
O'DONNELL, ROBERT
 Midnight Mayor
 WHEC, Rochester, N. Y.
OGILVIE, JACK
 WBN, Buffalo, N. Y.
O'GRADA, JOE
 WJSH, Lansford, Pa.
O'HALLORAN, HAL
 WBAY, Green Bay, Wis.
O'HARA, PEGGY
 Sense And Nonsense
 WABE, New York
OLINGER, DICK
 WCRO, Johnston, Pa.
OLIPHANT, PAUL
 Garden Gate
 CBS
OLIVE, GRAY
 WMSC, Columbia, S. C.
OLIVER, DOUG
 KCBQ, San Diego, Cal.

OLSEN, JOHNNY

Second, Chance, NBC; Johnny
 Olsen Show, Mutual

OLSEN, JOHNNY
 Second Chance
 NBC

OLSON, HARVEY
 Shoppers Special
 WDIR, Hartford, Conn.
O'NEAN, PAT
 WJNN, Louisville, Ky.

O'NEILL, CHUCK
WFEA, Manchester, N. H.

ORLAND, GENE
WESB, Bradford, Pa.

O'REILLY, JACK
WOR, New York

O'TOOLE, BILL
Life Is Worth Living
Dumont

OTTE, JOHNNY W.
WJCD, Seymour, Ind.

OWENS, AL
WFNC, Fayetteville, N. C.

OZIMEK, STAN
FNH Varieties
WKNB, New Britain, Conn.

— P —

PAEVEY, DON
WCKY, Cinn., O.

PAGE, SAM
Meet Your Neighbor
WNBF-TV, Binghamton, N. Y.

PALMER, BUD

B. Sept. 14, 1921, Hollywood, Cal.
Jackie Gleason Show, CBS-TV;
Natl. Tennis Championships, Kate Smith Show, NBC-TV; Hockey, Basketball, Dog and Horse Shows, WPX, N. Y.

PALMER, INGHAM

CKCL
Truro, Nova Scotia, Canada

PARKER, BILL
Ranch Club
WNBF-TV, Binghamton, N. Y.

PARKER, KEN
WPTK, Albany, N. Y.

PARRISH, HELEN
WKLF, Clanton, Ala.

PARRISH, WEBBER
WNAH, Nashville, Tenn.

PARSONS, BOYD
WGAD, Gadsden, Ala.

PARSONS, GERRARD
CHNS, Halifax, N. S.

PARTRIDGE, DICK
WELM, Fitchburg, Mass.

PASSE, LOEL
KTHH, Houston, Texas

PATE, JOE
KNED, McAlester, Okla.

PATRICK, PAT
Time Show
WERD, Atlanta, Ga.

PATTERSON, JOHN
KDLR, Devils Lake, N. D.

PATTISON, JIM
Kids Klub
WTVE, Elmira, N. Y.

PAUL, NORMAN
KSJO, San Jose, Cal.

PAUL, RALPH

B. Oct. 11, 1920, Denver, Colo.
Strike It Rich, CBS-TV; Sound Stage, TV Playhouse, NBC-TV

PAXTON, TOM
WKY, Oklahoma City, Okla.

PAYMAR, GORDON
WFTV, Duluth, Minn.

PAYNE, HOWARD
Coffee Club
WSWN, Belle Glade, Fla.

PEARL, SUMNER
WICE, Providence, R. I.

PEHLMANN, CARL
Spotlight
KKTV, Colorado Springs, Colo.

PERKINS, RONNIE
KTYL, Mesa, Ariz.

PERRIN, CAROLYN
WHBB, Selma, Ala.

PERRY, SID
WVLN, Olney, Ill.

PERRY, WES
WCIL, Carbondale, Ill.

PETERS, BOB
WFAS, White Plains, N. Y.

PETERS, BOBBY
Bobby Peters Show
WBAP-TV, Fort Worth, Tex.

PETERSON, ART
WHEN, Syracuse, N. Y.

PEELZER, EGEN
WALA, Mobile, Ala.

PHILLIPS, JOE
WDMX, Orangeburg, S. C.

PHILLIPS, LEA
KWRC, Pendleton, Ore.

PHILLIPS, N.
Photo Night
CJGX, Yorkton, Sask.

PHIPPS, JOHN
WHLN, Harlan, Ky.

PICCOLO, DOM
WKBI, St. Marys, Pa.

PICKWORTH, AL
KTHS, Little Rock, Ark.

PIERCE, BILL
WQAN, Scranton, Pa.

PIERCE, JOHN
Musical
CJRL, Kenora, Ont.

PITCOCK, BOB
KFSA, Ft. Smith, Ark.

PITTMAN, CHUCK
WJAY, Mullins, S. C.

PITZER, CRODY
WKST, New Castle, Pa.

PLATTER, PAUL
Paul Platter Show
WSAI, Cincinnati, O.

POOLE, BOB
Poole's Party Line
WFBC, Greenville, S. C.

POOLE, BOB
WFBC, Greenville, S. C.

POPKINS, GEORGE
WXGI, Richmond, Va.

POTTER, BILL
WMOU, Berlin, N. H.

POWELL, BOB
WPTZ, Phila., Pa.

POWELL, KEN
WECT, Elmira, N. Y.

PRESCOTT, ALLEN
WFIL, Phila., Pa.

PRESSON, GENE
WCMA, Corinth, Miss.

PRICE, CLYDE
WNPT, Tuscaloosa, Ala.

PUCKETT, TRUMAN
Southern Jubilee
WJLD, Birmingham, Ala.

PURCELL, CHAS. W.
WCAO, Baltimore, Md.

— Q —

QUAVE, MACKIE
WIS, Columbia, S. C.

— R —

RAINES, JAMES H.
WCBC, Anderson, Indiana

RANDALL, DALE
KWWL, Waterloo, Iowa

RANDALL, WILLIAM E.
WHAI, Greenfield, Mass.

RAPCHAK, MIKE
On Mike
WAAF, Chicago, Ill.

RASHLEIGH, WARREN
KAKE, Wichita, Kan.

RASKIN, DICK
WGNV, Newburgh, N. Y.

RAST, MIKE
WCOS, Columbia, S. C.

RAVEN, GEO.
KYJC, Medford, Oregon

RAWSON, RON
Young Dr. Malone
CBS

RAY, CURT
KMOX, St. Louis, Mo.

RAYCEE, DEL
WICY, Malone, N. Y.

RAYMOND, JACK
WISN, Milwaukee, Wis.

RAYMOND, OLLIE
KMOX, St. Louis, Mo.

REAGON, MAT
WBUF, Buffalo, N. Y.

REARDON, RUSS
WCOG, Greensboro, N. C.

REAU, DAVE
Keyd to Good Listening
KEYD, Minneapolis, Minn.

REDDY, JOHN
WCBS, N. Y., N. Y.

REDFERN, JACK
Requestfully Yours
WWIN, Baltimore, Md.

REEVES, JACK
The Rendezvous
KSTV, Stephenville, Tex.

REIHL, ALLEN
WOKZ, Alton, Ill.

REINHARDT, FRED
KITO, San Bernardino, Cal.

REMY, MEL
KNAK, Salt Lake City, Utah

REYNOLDS, GENE
Juke Box Favorites
WBAP, Ft. Worth, Tex.

REYNOLDS, PAUL
WTSP, St. Petersburg, Fla.

REZNOR, JOHNNY
WPFH, Middletown, Ohio

RICE, BILL
WMAV, Springfield, Ill.

RICE, C. B.
KLVL, Pasadena, Texas

RICHARDS, BILL
WESA, Charleroi, Pa.

RICHARDSON, BRUCE
WROK, Rockford, Ill.

RICHARDSON, TOMMY
KRHD, Doncan, Okla.

RILEY, BILL
Teen Time
KRNT, Des Moines, Ia.

RILEY, JAY
WMOK, Metropolis, Ill.

RININGER, RON
WJAC-TV, Johnstown, Pa.

RIPPY, RONNIE
WLOE, Leaksville, N. C.

RISSLING, BOB
WBZ, Boston, Mass.

RITTER, DON
WGGH, Marion, Ill.

ROBERTS, BURT
WFOM, Marietta, Ga.

ROBERTS, CHARLES
Ten O'Clock Tunes
WGAR, Cleveland, O.

ROBERTS, CLIFF
Music Room
WDSU, New Orleans, La.

ROBERTS, JAMES
Music In The Air
WIBC, Canton, O.

ROBERTS, KEN
This Is Nora Drake
CBS

ROBERTS, KENNY
KLMR, Lamar, Colo.

ROBERTS, PAUL
Robin's Nest
WSPB, Sarasota, Fla.

ROBERTS, PETER
WNBT, N. Y., N. Y.

ROBERTS, PETER
News, NBC

ROBERTS, WILLIAM
KGYW, Vallejo, Cal.

ROBINSON, JIM
KWBE, Beatrice, Neb.

ROCHON, CLAUDE
CJSO, Sorel, Quebec, Canada

RODDY, JIM
WEAV, Plattsburg, N. Y.

ROGERS, DON
WRIB, Providence, R. I.

ROGERS, DON
WMIX Mt. Vernon, Ill.

ROHN, JIM
Stumpus Boys
KSJB, Jamestown, N. D.

ROMAN, RALPH
WTAQ, Lagrange, Ill.

ROMAN, ROY
WMBG, Richmond, Va.

ROMANO, THOMAS
WNHC, New Haven, Conn.

ROQUIE, JACK
Night Beat
WWDC, Washington, D. C.

ROSS, GEORGE
WKXL, Concord, N. H.

ROSS, RICHARD
Early Edition
KING-TV, Wash.

ROTHMAN, LEE
WKOW, Madison, Wis.

ROWEL, PECK
WJHO, Opelika, Ala.

RUGGLES, DON
KRFS, St. Joseph, Mo.

RUNDEL, ANN
Community Reporter
WLAD, Danbury, Conn.

RUSSELL, FRAN
WCYB, Bristol, Va.

RUSSELL, TODD

Roothie Kazootie, ABC-TV; The
Wheel of Fortune, CBS-TV

— S —

SACCO, BOB
The Spinning Wheel
WAZL, Hazelton, Pa.

SANDS, ILEE
WOL, Washington, D. C.

SANTON, CHESTER
WQXR, N. Y., N. Y.

SARGENT, KENNY
KLIF, Dallas, Tex.

SATER, HARTLEY
KGO, San Francisco, Cal.

SAVAGE, JOHN
Safeway Theatre—WPIX; Boston
Blackie, The Unexpected, WABC-TV

SCHNEELY, LAWRENCE
KVOA, Tucson, Arizona

SCHOOLAN, IVAN
Dinner Bell
KOA, Denver, Colo.

SCHROT, BOB
KHSL, Chico, Cal.

SCOFIELD, LEEDS
WEEU, Reading, Pa.

SCOTFIELD, CARTER
WDBO, Orlando, Fla.

SCOTT, ANDY
WSGN, Birmingham, Ala.

SCOTT, FRED
Captain Video
DuMont

SCOTT, JOE
Club 28
WBRE-TV, Wilkes Barre, Pa.

SELDES, GILBERT
NBC Lecture Hall
NBC

SEYMOUR, DAN
Aunt Jenny
CBS

SHANLEY, JIM
Bill & Jim
WICH, Norwich, Conn.

SHARBUTT, DEL
B. Feb. 16, 1913, Cleburne, Tex.
Betty White Show, All Star Re-
vue, Kukla, Fran and Ollie, NBC-
TV; Hollywood Music Hall,
KTL5, Los Angeles

SHAW, CHARLES
WOLF, Syracuse, N. Y.

SHAW, HAL
WABI, Bangor, Maine

SHEPPER, GLENN
WCMB, Harrisburg, Pa.

SHELEY, BOB
WEEC, Greenville, S. C.

SHELTON, JIM
Pick-A-Pocket
WIBC, Indianapolis, Ind.

SHELTON, JOHN
Every Little Moment
WTV, Ft. Lauderdale, Fla.

SHEPHERD, CHARLES R.
WWNC, Asheville, N. C.

SHEPARD, ALAN
KROY, Sacramento, Cal.

SHERMAN, ART
Matinee Melodies
WJAC-TV, Johnstown, Pa.

SHERMAN, DEAN
WDG, Minneapolis, Minn.

SHERWOOD, BOBBY
Stars On Parade
Dumont

SHEPHERD, LARRY
KFMB, San Diego, Cal.

SHREVE, LEN
KGW, Portland, Oregon

SHRIVER, BOB
KFEL, Denver, Col.

SILBERT, BILL
B. Jan. 1, 1921, Detroit, Mich.
Bill Silbert Show, WAGM, New
York; Bill Silbert Show, Let's Go
Bowling, WABD, New York

SIMMS, AL
WSNJ, Bridgeton, N. J.

SIMMS, HANK
KIKI, Honolulu, Hawaii

SIMMS, HANK
Spotlite Review
KONA, Honolulu, T. H.

SIAMSON, RALPH
Greenville, S. C.

SKINNER, BOB
WTMJ, Milwaukee, Wis.

SLOANE, ROBERT
The Big Story
NBC, NBC-TV

SMITH, BILL
WPEN, Phila., Pa.

SMITH, BILL
WSPA, Montgomery, Ala.

SMITH, CLAYTON
Breakfast Time
WAGM, Presque Isle, Maine

SMITHERMAN, ROSS
WALA, Mobile, Ala.

SNOW, BOB
WEEK, Peoria, Ill.

SNYDER, JAY
KGO, S. F., Cal.

SOBOL, JOHNNY
WILK, Wilkes-Barre, Pa.

SOUTHWICK, TOREA
Top O' The Morning
WAKR, Akron, O.

SPILLMA, SANDY
KPIX, S. F., Cal.

SPOO, EDDIE
WWHG, Hornell, N. Y.

STAMPER, WILLIAM
WKDN, Camden, N. J.

STANLEY, ART
KBON, Omaha, Neb.

STANLEY, BILL
Bill & Jim
WICH, Norwich, Conn.

STANLEY, DAVE
WCPO-TV, Cincinnati, O.

STANLEY, MITCH
WWON, Woonsocket, R. I.

STANLEY, RAY
KWBB, Wichita, Kan.

STARKEY, DALE
KHQ, Spokane, Wash.

STEADMAN, W. R.
WNOB, Daytona Beach, Fla.

STEELE, DALE
WSOC, Charlotte, S. C.

STEELE, TED
WPIX, N. Y., N. Y.

STEVENS, LARRY
Movielime
KGMD-TV, Honolulu, T. H.

STEWART, BOB
WBRY, Waterbury, Conn.

STEWART, CAL
WOWO, Ft. Wayne, Indiana

STEWART, JAY

B. 1920, Summitville, Ind.
It Pays To Be Married, NBC;
Your Claim To Fame, ABC-TV;
Townhall Party, KTTV, Los An-
geles

STEWART, JOHN
WKOP, Binghamton, N. Y.

STEWART, RAY
It Pays To Be Married
NBC

STILLE, BERT
Sweet & Swing
WHKC, Columbus, O.

STIR, JACK
WFLA, Tampa, Fla.

ST. LEGER, JOHN
WOR, N. Y., N. Y.

STOHL, HANK
Home Edition
WDTV, Pittsburgh, Pa.

STOKES, MIKE
Pantomime Quiz
Dumont

STONE, GEORGE
WMAQ, Chicago, Ill.

STRIBLING, BILL
WBCU, Union, S. C.

STUART, STREETER
WBZ, Boston, Mass.

STULL, EILEEN
Dick & Eileen Show
WKDW, Augusta, Ga.

STURGES, JIM
WKOP, Binghamton, N. Y.

STURM, DEAN
Saturday Night Jamboree
WSAZ-TV, Huntington, W. Va.

SUDDETH, GENE
WEAR, Pensacola, Fla.

SULLIVAN, BILL
WHGB, Harrisburg, Pa.

SUTTER, J. RICHARD
WRMN, Elgin, Ill.

SUTTON, BILL
KPHE, Fresno, Cal.

SWART, JACK
WFTL, Ft. Lauderdale, Fla.

SWARTZ, BOB
Money Man
KHQ, Spokane, Wash.

SWARTZ, FRANK
WFRO, Fremont, O.

SWEENEY, BUDD
Sweet & Swing
WHKC, Columbus, O.

SWIHART, WALT
WTO, Dayton, O.

— T —

TAPLEY, CHARLIE
WKRQ, Mobile, Ala.

TAYLOR, BILL
Weather
KCBD-TV, Lubbock, Tex.

TAYLOR, SAM
WCHA, Chambersburg, Pa.

TAYLOR, STEVE
KCOK, Fresno, Cal.

TAYLOR, TOM
WKNX, Saginaw City, Mich.

TEAS, FRANK
WABI, Bangor, Maine

TEAS, WALT
Morning in Maryland
WFBR, Baltimore, Md.

TESCH, BUDD
WHCC-TV, Rochester, N. Y.

TESCH, BUDD
WHCC, Rochester, N. Y.

THEISS, BOB
WKOW, Madison, Wis.
THOMAS, EARL
Early Bird
WWSO, Glens Falls, N. Y.
THOMAS, GORDON
WTMJ, Milwaukee, Wis.
THOMAS, NEWTON
WXGI, Richmond, Va.
THOMAS, STEVE
WFIG, Sumter, S. C.
THOMAS, WARREN
WKRC, Cinn., O.
THOMASON, BILL
Billboard Tops
WLAQ, Rome, Ga.
THOMASON, JIMMY
KAFY, Bakersfield, Cal.
THOMPSON, JOSEPH
KSCC, Santa Cruz, Cal.
THOMPSON, RAY
KROC, Rochester, N. Y.
TIBBETTS, DONN
WFEA, Manchester, N. H.
TICE, OLIN
FBI In Peace And War
CBS
TIDMORE, EVELYN
WNPT, Tuscaloosa, Ala.
TOBIN, PAT
WBEZ, Ponca City, Okla.
TOMASON, JIMMY
KBAK, Bakersfield, Cal.
TOMPKINS, JACK N.
WVNC, Asheville, N. C.
TONEY, LYNN
WVFA, Pensacola, Fla.

TONKEN, PHIL

B. April 13, 1919, Hartford, Conn. High Tension, WOR-TV; Greatest Fights of the Century, ABC-TV; Squad Room, Mutual News, Man From Times Square, Mutual; NEMO Weather Reporter, WOR, New York

TOWNES, MILO
WSRS, Cleveland, O.
TRACY, BILL
WSKB, McComb, Miss.
TRAVIS, LEWIS
KRIC, Beaumont, Texas
TRUDAU, NED
Sunrise Symphony
WABY, Albany, N. Y.
TUFTS, PETE
KTUC, Tucson, Arizona
TUCKER, DICK
WBZ, Boston, Mass.
TUCKER, DICK
WBZ, Boston, Mass.
TUCKER, TOMMY
WRAL, Raleigh, N. C.
TUCKER, TOMMY
WMBR, Jacksonville, Fla.
TUPPER, HOWARD
T 'N' T
WGY, Schenectady, N. Y.
TURNER, HARRY
KGHL, Billings, Mont.
TUTTON, RON
WMBR, Jacksonville, Fla.

— U —

UHLIS, FRAN
KGBX, Springfield, Mo.
UMBACH, BOB
WILD, Birmingham, Ala.
UNDERWOOD, CHARLES
WMBS, Uniontown, Pa.

— V —

VABER, ALAN
WBRK, Pittsfield, Mass.
VALLE, DAN
WVFA, White Plains, N. Y.

VAN ARSDALE, RUSS
New England Talent Club
WJAR-TV, Providence, R. I.
VANDERHOOF, BRUCE
B. V.'s Open House
KDYL-TV, Salt Lake City, Utah
VAN DYKE, DICK
Music Shop
WLW-A, Atlanta, Ga.
VAN PATTEN, GRANT
WRGE, Schenectady, N. Y.
VANWART, KENNETH
WTAO, Boston, Mass.
VENTRELLA, TONY
Music Time
WEDC, Chicago, Ill.
VARNEY, BILL
WKXL, Concord, N. H.
VEAL, SPEED
The Speed Veal Show
WJHP, Jacksonville, Florida
VENTER, MEL
KFRS, S. F., Cal.
VERNON, MAC
Mail Order Melodies
KSCB Liberal, Kan.
VERNON, ROY
WREN, Topeka, Kan.
VIHMAN, ED
Mr. Nobody
WCCO, Minneapolis, Minn.

— W —

WAGNER, GENE
KMO, Tacoma, Wash.
WAGNER, GENE
KMO, Tacoma, Wash.
WAHL, JIM
KSTM, El Paso, Texas
WALLINGTON, JIMMY
Ask Hollywood
NBC
WALTON, ART
WILD, Birmingham, Ala.
WARNER, RICHARD
Dick Warner Show
WRDW, Augusta, Ga.
WARREN, BOB
On Your Account
NBC-TV
WARREN, DOUG
WKDN, Camden, N. J.
WARREN, JERRY
KYW, Phila., Pa.
WASHINGTON, TOM
KOB, Albuquerque, N. Mex.
WATSON, BOB
KGNC, Amarillo, Texas
WEAVER, BILL
KCBS, San Francisco, Cal.

WEBB, BILL
KAKC, Tulsa, Okla.
WEBBER, BILL
WBEU, Reading, Pa.
WEBSTER, DAVIES
WJNO, W. Palm Beach, Fla.
WEEKS, DICK
KMO, Tacoma, Wash.
WEGMET, NORM
KGHL, Billings, Mont.
WEINER, MILTON
WLW, Cinn., O.
WENDELL, BILL
Letter To Lee Graham
WABD, New York
WERTENBAKER, TOM
WNBZ, Saranac Lake, N. Y.
WERTZ, IRA
WFBG, Altoona, Pa.
WHEAT, HENRY
KMBC, Kansas City, Mo.
WHEELOCK, HOWARD E.
Reveille
WKNE, Keene, N. H.
WHITE, ALBERT
KNEC, S. F., Cal.
WHITE, HENRY
Clock Watcher
WDOV, Dover, Del.

WHITE, MAURY
KGHL, Billings, Mont.
WHITE, RALPH, JR.
WBGI, Scranton, Pa.
WILCOX, DICK
WSAR, Fall River, Mass.
WILCOX, JOHNNY
WIP, Phila., Pa.
WILLIAMS, DICK
WCKY, Cinn., O.
WILLIAMS, JACK
WBRC, Birmingham, Ala.
WILLIAMS, TED
WEAN, Providence, R. I.
WILLIS, FORREST
Interview Time
WPRY, Troy, N. Y.
WILLIS, JACK
KTAR, Phoenix, Arizona
WILSON, DEAN
KCOL, Ft. Collins, Colo.
WILSON, GLENN
WLW, Cinn., O.
WILSON, JACK
Sunny Side Of The Street
WARM, Scranton, Pa.
WILSON, JIM
KAYS, Hays, Kan.
WILSON, JOHN J.
WFTC, Kingston, N. C.
WILSON, READ
WVNC, Asheville, N. C.
WILSON, STU
KNXT, Los Angeles, Cal.
WILSON, WARD
Can You Top This
NBC
WINTERS, GEO.
WCKY, Cinn., O.
WOLF, ROD
Matinee Melodies
WJAC-TV, Johnstown, Pa.
WOLFF, LESTER "L"
Between The Lines
WABD, New York
WOODARD, HAL
KYW, Phila., Pa.
WOODWORTH, S. J.
Truth or Consequences
KCHS, N. M.
WORKHOVEN, BOYD
Sentimental Journey
WKLO, Louisville, Ky.
WORTLEY, ROBERT
KTUL, Tulsa, Okla.
WYNN, BERT
Car Tunes
KYA, San Francisco, Cal.

— Y —

YOUNG, AL
WCMA, Corinth, Miss.
YOUNG, DUKE
Duke's Dilemma
KUGN, Eugene, Ore.
YOUNG, JAMES
Breakfast Party
WITZ, Jasper, Ind.
YOUNG, JIM
WERL, Westerly, R. I.
YOUNGBLOOD, WES
KSEL, Lubbock, Texas
YOUNT, CHARLES
WKBY, Richmond, Ind.

— Z —

ZACHARY, HUGH
KADA, Ada, Okla.
ZAPITUL, BILL
KLIX, Twin Falls, Idaho
ZIEDMAN, AL
WKWK, Wheeling, W. Va.
ZIMMERMAN, DAVE
WWJ, Detroit, Mich.
ZIMMERMAN, HARRY
WLWL, Minneapolis, Minn.



IRVING MANSFIELD

Frank Wisbar

Producer-Director

"FIRESIDE THEATER"

"GENERAL ELECTRIC THEATER"

RADIO-TV PRODUCERS

Network and Independent
—and their work during 1953



— A —

ACREE, CHUCK
Man On The Farm
Mutual

ADAMS, WM. J.
WHEC-TV, Rochester, N. Y.

ADLER, DR. PETER H.
NBC Opera. Recital Hall
NBC-TV

ANDREWS, CLARK
Top Guy, Modern Romances
ABC

ANDREWS, DAVE
Capsule of Knowledge
KOLN, Lincoln, Neb.

ANNON, JACK
Movie Quick Quiz
KGMB-TV, Honolulu, T. H.

APPY, GERALD
Variety Plus
WLWA, Atlanta, Ga.

ARNELL, PETER

I'll Buy That, The Name's the Same, Wheel of Fortune, CBS-TV

ATEX, SUSAN
KSAN-TV, San Francisco, Cal.

AVERY, IRA
Theatre of Today
CBS

AWSUMB, ROGER
Inside City Hall
WMIN, St. Paul, Minn.

— B —

BACKLUND, RALPH
Feature Project, Public Affairs Programs
CBS

BAILY, MEL
Wonderful City
Mutual

BAKER, RUSS
KGO, S. F., Cal.

BARNHILL, DICK
Commissioner's Report
WMAL-TV, Washington, D. C.

BARNUM, MERRITT
Excursion
NBC-TV

BARNUM, PETE

B. April 20th, 1904, Ossining, N. Y. Colgate Comedy Hour, Excursion, NBC-TV

BATTLE, CHARLOTTE
WKLO, Louisville, Ky.

BECKERMAN, LARRY
WTOP, Washington, D. C.

BEHRE, ARNOLD
Maggi McNellis Show, Home Gardener
ABC

BELKCOM, LLOYD
Talk Of The Town
WMIN, St. Paul, Minn.

BELL, JACK
WICC, WICC-TV, Bridgeport, Conn.

BIRDSONG, LAWRENCE
Startime
KTVE, Longview, Texas

BLACK, HARRY
WXEL, Cleveland, Ohio

BLACKWELL, BURT
WAVE, Louisville, Ky.

BLOOM, SEYMOUR L.
Buzz & Bill Show
WDTV, Pittsburgh, Pa.

BOLIN, ART
WARM-TV, Scranton, Pa.

BORGE, PAUL
KMTV, Omaha, Neb.

BOSMAN, JOHN
Mutual Newsreel
Mutual

BOUNDY, GLENN, JR.
WJBK-TV, Detroit, Mich.

BOWER, ROGER
Baron And The Bee, Can You Top This, G.I. Joe
NBC

BRANNAN, JIM
WAGA, Atlanta, Ga.

BRANT, BILL
Bill Brant Show
WSTV, Pittsburgh, Pa.

BRENNER, PAUL
WATV, Newark, N. J.

BROWN, HIMAN
Bulldog Drummond
Mutual

BUNETTA, FRANK
Life Is Worth Living
Dumont

BURGOON, GEORGE R.
WEBG, Altoona, Pa.

BURKLEY, OWEN
WOW-TV, Omaha, Neb.

BURKE, CAROLINE

Masterpiece Playhouse, Red Feather Revue, Heralds of Good Will, Around the Town, Vacation Wonderlands, Watch the World, Elder Wiseman-Wanda Landowska at Home, NBC-TV

BURT, HARDY
State Of The Nation
Mutual

BURNETT, MURRAY

Time For Love
CBS

BURNETT, MURRAY
True Detective Mysteries
Mutual

— C —

CAMPBELL, RAY
Mary Margaret McBride, All League Clubhouse, Beth Holland Show
ABC

CAREY, BERNIE
TV Tryouts
KING-TV, Seattle, Wash.

CARLSON, HARRY
Vincent Lopez
Mutual

CARRUTH, DOUGLAS
KMPT, Oklahoma City, Okla.

CARTOON, ALAN
Longines Symphonette
CBS

CHRISTIAN LYNN
Window Shopping
KNUZ-TV, Houston, Texas

CLAIRE, MARION
Chicago Theater Of The Air
Mutual

CLARK, DON
Stars Over Hollywood
CBS

CLEMENT, ROBERT
WBRE-TV, Wilkes-Barre, Pa.

CLEMMER, RICHARD
Here's To Your Health, The Goldbergs, Three Steps To Heaven, Follow Your Heart, Academy Award Show
NBC-TV

CODDON, HAL
KFMB, San Diego, Cal.

COE, FRED
Bonino, TV Playhouse, Mr. Peepers, First Person Singular
NBC-TV

COLBURN, ROBERT
WTCN-TV, Minneapolis, Minn.

COMPTON, GAIL
Animal Fair
WITV, Ft. Lauderdale, Fla.

COOPER, HAL
Magic Cottage
WABC, New York

COWAN, ABE
Dotty Mack Show
WCPO-TV, Cincinnati, O.

CRAMER, MARCIA
KPIX, S. F., Cal.

CRIAR, ROBERT G.

WINS, New York

CROTHERS, GEORGE
Invitation To Learning, Church of The Air
CBS

CUMMINGS, IRVING
Lux Radio Theatre
CBS

— D —

DANIEL, OLIVER
20th Century Concert Hall
CBS

DAVIS, WENDY
WBZ, Boston, Mass.

DAVIS, WILLARD
Success Story
KGO, S. F., Cal.

del VALLE, JAIME
B. Jan. 19, 1919, Los Angeles, Cal. Johnny Dollar, The Line Up, G. E. Theatre, CBS; Richard Diamond, NBC

AXEL GRUENBERG

Co-Producer and Director

for

RALPH EDWARDS'

"THIS IS YOUR LIFE"

GUY V. THAYER, JR.

Executive Producer

ROLAND REED PRODUCTIONS

DEMAREST, BILL

George Jessel Show, Valentino.
American Music Hall
ABC

DEMPSEY, MARY ANN

WTLV-TV, New Brunswick,
N. J.

DICK, HENRY

Bobby Sherwood Afternoon
Show, Betty Crocker Show
ABC

DIEKER, HAL

KOY-TV, Phoenix, Ariz.

DIERKES, SHIELDS

WWJ, Detroit, Mich.

DIETZ, JOHN

Crime Photographer
CBS

DORN, LARRY

Bandstand, U.S.A.
Mutual

DRYER, SHERMAN

Search That Never Ends
Mutual

DUDEK, LEE

WBAY, Green Bay, Wisc.

DUERR, EDW.

Ma Perkins
CBS

DUFF, GORDON

TV Playhouse, Bonino, First
Person Singular
NBC-TV

DYE, ROBERT

WKZO-TV, Kalamazoo, Mich.

— E —

EARLE, JOHN

WKNX, Saginaw City, Mich.

EDWARDS, SUSAN

WSAZ-TV, Huntington, W. Va.

EDWARDS, WEB

Hawaii Calls
Mutual

ELLIOTT, ART

KMO-TV, Tacoma, Wash.

ELLIS, MINERVA

Road Of Life
CBS

ENGELBACH, DEE

Tallulah Bankhead, Man Of
The Year, Red Feather Show
NBC-TV

— F —

FALENZA, TONY

KCJB, TV, Minot, N. D.

FASSETT, JAMES

N. Y. Philharmonic Symphony
CBS

FAUSETT, HUDSON

Armstrong Circle Theatre, My
Son Jeep, Wonderful John
Acton
NBC-TV

FEEMAN, FRANK

Hi Jinks
KFIA-TV, Anchorage, Alaska

FERGUSON, FRENCH

WOAI, San Antonio, Texas

FERRIN, FRANK

B. Nov. 13, Minneapolis, Minn.
Smilin' Ed's Gang, ABC-TV;
Spot Radio

FISHER, EDWARD

WHIZ, Zanesville, O.

FOERSTER, FRED

WBRE-TV, Wilkes-Barre, Pa.

FORMAN, WIN

WARM-TV, Scranton, Pa.

FOX, BILL L.

KFMB, San Diego, Cal.

FRAMER, WALTER H.

B. April 7, 1908, Strike It Rich,
The Big Payoff, CBS; Double or
Nothing, CBS-TV, ABC; The
Silver Horseshoe, Dumont

FRAZEE, HARRY

Woman In Love, Public
Affairs Show
NBC

FULLER, SAM

B. July 3, 1909, Pittsburgh, Pa.
Colgate Comedy Hour, NBC-TV

FURNELL, WILLIAM

KCCC, TV
Sacramento, Cal.

— G —

GARRIGUS, FRED

Public Service Programs
CBS

PETE BARNUM

Executive-Producer

"COLGATE COMEDY HOUR"

NBC TV

Jaime
del Valle

PRODUCER-DIRECTOR
RADIO AND TELEVISION

The TV Film Series with
the Longest Run and the
Top Audience Rating for
Kids is
“SMILIN’ ED’S GANG”

Produced by
FRANK FERRIN

*11th Year for
Buster Brown Shoes
ABC TV*

*11th Year
on Radio for
Buster Brown Shoes*

GAULT, ED
TV Showcase
WHP-TV, Harrisburg, Pa.

GEORGE, EVERETT
Here's Howell
KCBD-TV, Lubbock, Tex.

GERRY, ROGER
Melody Street, Rocky King,
Stars On Parade
Dumont

GIBBS, PARKER
The Big Preview, Roadshow
NBC

GRAHAM, JOE
Whispering Streets, Call Me
Freedom, Horatio Hornblower
ABC

GRAMMER, ROBERT
WBAP-TV, Fort Worth, Tex.

GRANZO, CHUCK
Farm Quiz
Mutual

GRAY, NORMAN
WMAZ, Macon, Ga.

GRAY, ORLON
WVEC-TV, Hampton, Va.

GREANE, ED
WMCT-TV, Memphis, Tenn.

GREEN, GEORGE
WATV, Newark, N. J.

GREENE, DAVID
WWJ, Detroit, Mich.

GREINER, BOB
Turn To A Friend, Eddie
Dunn Show
ABC

GOORIAN, LEN
Paul Dixon Show
WCPO-TV, Cincinnati, O.

GORDON, HOWARD A.
WFFA, Pensacola, Fla.

GROTHERS, GEORGE
Church Of The Air
CBS

GRUENBERG, AXEL
This Is Your Life, NBC-TV; Re-
vue Productions

GUIDICE, FRANCIS V.
WTTG, Washington, D. C.

GUTTER, LARRY
WBBM-TV, Chicago, Ill.

— H —

HALE, PHIL
WKNB, New Britain, Conn.

HAMMERSTEIN, TED
Broadway To Hollywood
Dumont

HANSON, JACK
WKOW, Madison, Wis.

HARDISON, DON
WKLO, Louisville, Ky.

HARELSON, JAMES
Art's Workshop
WICS, Springfield, Ill.

HARRIS, DAVID K.
This Is Your World
WNHC, New Haven, Conn.

HARRIS, HARRY
WSBA, York, Pa.

HARRIS, MARY
Second Mrs. Burton, Brighter
Day
CBS

HARRIS, WESTON J.
WTFG, Washington, D. C.

HARROWER, IAN
WWJ, Detroit, Mich.

HARTZELL, RICHARD
KETC, St. Louis, Mo.

HARVEY, DICK
WTOV, Norfolk, Va.

HAUPT, JAMES
Cities Service Band of America
NBC

HAYS, LARRY
KHJ, Los Angeles, Cal.

HEEB, WALTER
WJHL, Johnson City, Tenn.

HEILWELL, DAVID
Plainclothes Man; Dumont
Love Story, WABD, New York

HELLEDY, DICK
Pitch And Hit Club
KSTM-TV, St. Louis, Mo.

HENLEY, DICK
Make Up Your Mind, CBS

HEPNER, ARTHUR
Dwight Cooke Guest Book
CBS

HIGHT, JEAN
Let's Pretend
CBS

HILL, DUANE
Playtime Party
KSL-TV, Salt Lake City Utah

HILL, PHIL
KIDO, Boise, Idaho



Devised and Directed

by

Albert Mac Cleary



JACK HURDLE
 PRODUCER
 of the
"JACKIE GLEASON SHOW"
 CBS-TV



CAROLINE BURKE
 NBC-TV Producer Director
 Masterpiece Playhouse
 Red Feather Revue
 Heralds of Good Will
 Around the Town
 Vacation Wonderlands
 Watch the World
 3 der Wisemen. Wanda Landowska At Home



ROBERT G. CRIAR
 Program Director
 -- Producer
 Illinois 8-3186



CHARLES POLACHECK
 NBC-TV PRODUCER
"VOICE OF FIRESTONE"
"RECITAL HALL"
 ASSOCIATE PRODUCER
"NBC OPERA THEATER"

HOLLES, EVERETT

Reporter's Roundup
Mutual

HOLLOWCHAK, EUGENE

WWJ, Detroit, Mich.

HOPKINS, RICHARD

AEC

HOSTETLER, VINCE

KKTU, Colorado Springs, Colo.

HOTIS, GEORGE

KTXK, San Angelo, Texas

HUDELSON, BEN

WBZ, Boston, Mass.

HUGHES, GORDON T.

B. July 30, 1909, Worcester, Mass. My Little Margie, Meet the Missus, CBS

HUMMERT, FRANK AND ANNE

Romance of Helen Trent, Our Gal Sunday
CBS

HURDLE, JACK

B. June 13, 1909, Washington, D. C. Jackie Gleason Show, CBS-TV

HURWITZ, VICTOR

WWJ, Detroit, Mich.

HUTCHINS, GEORGE

KVTV, Sioux City, Iowa

— I —

IRVING, CHARLES

Search For Tomorrow, CBS-TV

IRWIN, CAROL

Mama, Stage Door, CBS-TV;
Claudia, NBC-TV; Mr. Moto,
NBC; Baby and Me, ABC-TV

IVES, JOHN

21st Precinct, Gangbusters
CBS

— J —

JACOBS, RAY

Shootin' Sheriff
KJEO, Fresno, Cal.

JACOBSON, ART

KMTV, Omaha, Neb.

JANIS, HAL

B. July, 1906, San Francisco, Cal. Your Show of Shows, All Star Revue, NBC-TV

JENSEN, PAUL

Make Mine Music
KON, Lincoln, Neb.

JETERS, JIMMY

KGUL, Galveston, Texas

JOHNSON, BILLY

WTOP, Washington, D. C.

JOHNSON, CHARLES

KCCC-TV, Sacramento, Cal.

JOHNSON, VANCE

WIS, Columbia, S. C.

JOHNSON, WALLY

KFEQ, St. Joseph, Mo.

JOHNSTONE, ROY

WRBL, Columbia, Ga.

JONAS, PAUL

Sports Parade
Mutual

JONES, BOB

KMBC, Kansas City, Mo.

— K —

KATZ, PETE

WLW-TV, Cincinnati, Ohio

KEELER, DAN

Margaret Masters' Kitchen
KSL-TV, Salt Lake City, Utah

KELLY, JOHN A.

KTXL, San Angelo, Texas

KING, CHRISTOPHER

Sounding Board
Mutual

KING, ED

Lorenzo Jones, NBC Star Playhouse. The Marriage, Eternal Light
NBC

KIRK, DANNY

Paul's Place
KNUZ-TV, Houston, Texas

KOATS, WALTER

WWJ, Detroit, Mich.

KONTELON, JIM

WTRF, Wheeling, W. Va.

KOURIS, P. C.

Mr. and Mrs.
KVTV, Sioux City, Iowa

KUNDERT, RUSS

KLAS-TV, Las Vegas, Nevada

KURTZ, JOHN

Penny Wise Show
KSTM-TV, St. Louis, Mo.

— L —

LAFORGE, JOHN

WKNX, Saginaw City, Mich.

LASHER, SID

WBRC, Birmingham, Ala.

LAUNER, JACKSON

Pantomime Hit Parade
WCPO-TV, Cincinnati, O.

LAUSHNER, FRED

Beat The Bench
WTPA, Harrisburg, Pa.

RALPH LEVY

CBS-TV

Producer-Director

"JACK BENNY" TV SHOW



VICTOR McLEOD

TV

Writer - Producer - Director

LAWYER, FATHER JOSEPH

Family Theater
Mutual
LEONARD, WILLIAM R.
WTVP, Localur ID
LESAN, DAVID
Gingins Light
LESURE, LARRY
T. N. Report
CBS

LEVY, RALPH

B. Dec. 18, 1919, Philadelphia, Pa. The Jack Benny Show, The Burns & Allen Show, CBS-TV

LEWIS, ELLIOTT
On Stage, Suspense, Crime
Classics
CBS

LEWIS, J. C.
Lucky 7
KBL Los Angeles, Cal

LEWIS, RICHARD
Mickey Spillane
Mutual

LIEBMAN, MAX

Your Show of Shows, NBC-TV

LINAIL, JIM
Western Party
WSIX Nashville, Tenn

LINCOLN, ED
WSRA York, Pa

LODGE, DON
KFOR Lincoln, Neb
LOGAN, C. H.
WTVP, Des Moines, Ill

LOVETON, JOHN W.
Mr. and Mrs. North
CBS

LOYVORN, BIXON
WIS Columbia S. C

LOWE, DAVID
Joseph Schildkraut, What's
The Story
Dumont

LUGT, JOHN

The Stars Show Six Gun
Theatre
KGMB-TV, Honolulu T. H

LUND, BILL
KFEQ St. Joseph, Mo

LUNGRIN, LYNN
Beth Holland Show, Tom
Cornell Show
ABC

— **Mc** —

MACCULLUM, BILL
Live Like A Millionaire
Mystery Theatre
CBS

MAC McCAULEY
Skyline Towers
WTPA-TV, Harrisburg, Pa

MacDONNELL, NORMAN
Gunsmoke
CBS

MacGIEGOR, JOCK
Nick Carter
Mutual

MacGREGOR, KEN
House of Glass, Ebert and
Umily, Theatre Royal, College
Quiz Bowl
NBC

McCLEERY, ALBERT
B. Lawrence, Kansas, The Hall-
mark Hall of Fame, NBC-TV

McDERMOTT, TOM
Wendy Warren And The News
CBS

McGARRETT, GEORGE
Show of Shows, All Star
Review
NBC-TV

McGREW, RALPH
Plano & Porter
KPTV, Portland, Ore.
McHENDRIX, ROBT.
WKRC Cincinnati, O.

McLEOD, VICTOR IAN

B. August 2, 1906, Nampa, Id-
aho, The Spike Jones Show,
NBC-TV; Lose The Blues,
KNBB, Los Angeles, Cal.

McMENEMY, JIM
B-Bar-B
Mutual

McMULLEN, JAY
Feature Project, Public Affairs
Programs
CBS

— **M** —

MACK, HELEN
This Is Your America
KAFY, Bakersfield, Cal

MANDEVILLE, BETTY
FBI In Peace And War
CBS

MANNO, CHUCK
Football Games, Doug Brown
ing Show
ABC

MANSFIELD, IRVING

This Is Show Business, CBS-TV
MANZA, RALPH
KPIX, San Francisco, Cal.

MARLOW, LEA KNOX

B. Sept. 21, Kentucky, Peter
Angel, Syndicated

MARSHALL, BILL
Whispering Streets, Metropoh
lan Auditions, Community
Chest Show
ABC

Star Time

... over 3 years *CONSISTENTLY*
Top-Rated in Time Spot!

★
NEVER without a Sponsor!

★
WNBT - Sat. - 7 to 7:30 PM

★
PRODUCER:
George Scheck

PRODUCTION ASSOCIATE:
Mike Gargiulo

AGENCY:
The Arnold Cohan Corporation

SPONSOR:
GERALD O. KAYE
AND
ASSOCIATES CORP.

WALTER STRENGE

A.S.C.

Director of Photography

"WATERFRONT"

"TROUBLE WITH FATHER"

"MY LITTLE MARGIE"

"MYSTERY THEATER"

"BEULAH"

"SPACE RANGER"

MARTIN, CHARLES

Philip Morris Playhouse, CBS-TV

MAZZIE, JACK

WREX-TV, Rockford, Ill.

MEAD, WARREN

KWWL, Waterloo, Iowa

MELAMED, LOU

Julius LaRosa Show
CBS

MELTON, BARD

Personality Parade
KFIA-TV, Anchorage, Alaska

MEURER, RAY

Sgt. Preston of The Yukon
Mutual

MIDDLETON, HARRY

WVEC-TV, Hampton, Va.

MILLER, HARVEY

WBRE-TV, Wilkes-Barre, Pa.

MILLER, LOUIS

KMPT, Oklahoma City, Okla.

MITCHELL, ROBERT

WJPB, Falmount, W. Va.

MONIGOLD, BARRE

Unusual Occupations
KTVE, Longview, Texas

MONROE, BOB

Nightmare, Starlight Theater
Mutual

MONTGOMERY, ROBERT

Robert Montgomery Presents
NBC-TV

MORGAN, AL

Feature Project, Public Affairs
Programs
CBS

MORGAN, JIM

Queen For A Day
Mutual

MORRIS, JOHN

WKRC, Cincinnati, O.

MORSE, CARLTON E.

B. June 4, Jennings, La. One
Man's Family, Woman In My
House, NBC; Family Skeleton,
CBS; I Love A Mystery, Spot

MUCKENHAUPT, FRANK

College Choirs
Mutual

MUIR, ROGER

Howdy Doody, Gabby Hayes
NBC-TV

MURDOCK, DON

WTRF, Wheeling, W. Va.

MURRAY, JEANNE

WTLV-TV, New Brunswick,
N. J.

MYERS, THOMAS

Northwest Digest
KPTV, Portland, Ore

— N —

NEALE, TOM

Big Red Review
WTAP, Parkersburg, W. Va.

NEFF, DON

WTCN, Minneapolis, Minn.

NELSON, DOLF

Ladies Fair
Mutual

NELSON, RAY

Rod and Gun Club
Mutual

NOBLE, FRED

Katie's Kitchen
KTBC-TV, Austin, Tex.

NOTHCROSS, WILSON

WHBQ, Memphis, Tenn.
CBS

NOVAK, ROBERT

Bobby Benson
Mutual

NYE, DOROTHY

Mary Carter's Cookbook
KGO, San Francisco, Cal.

— O —

OLIPHANT, PAUL

Garden Gate
CBS

OLIVER, ROBERT

WKNX, Saginaw City, Mich.

OLSON, CHARLES

WREX-TV, Rockford, Ill.

OLSON, DOLORES

Keen Acc Kapers
KAFY, Bakersfield, Cal.

OPENSHAW, BYRON Q.

Doin' The Town
KSL-TV, Salt Lake City, Utah

— P —

PAINTER, DON

Bev and Ivory
WTAP, Parkersburg, W. Va.

PAINTON, LEE

Mrs. U.S.A., Prologue To The
Future
NBC-TV

PAUL, NICK

WOAI, San Antonio, Texas

PEHLMAN, CARL

KKTV, Colorado Springs, Colo.

PEMBERTON, MURDOCK

Bill Stern Show, All League
Club House
ABC

PIANO, TONY

Dancing Party, Music In The
Afternoon
ABC

PIERCE, ED

Tallulah Bankhead, Man Of
The Year, Red Feather Show,
Seasons Greetings
NBC-TV

SIDNEY SMITH

"FIRESIDE THEATER"

SAM FULLER

EXECUTIVE PRODUCER

"Colgate Comedy Hour"

NBC-TV

FIGG, AL

WTVP, Decatur, Ill.
 POGAN, CHARLES
 WROW, Albany, N. Y.

POLACHECK, CHARLES

B Jan 19, 1914, Milwaukee, Wis. NBC Opera Theatre Production, Voice of Firestone, Recital Hall Series, Opera Vignettes on Kate Smith Show, NBC-TV, Experimental Color Series, Operatic Vignettes, NBC-TV

POOLE, LYNX

Johns Hopkins Science Review
 WABD, New York

POTER, JIM

WPAM-TV Lafayette Ind

PRESCOTT, BILL

WTPA-TV Harrisburg, Pa

PRINGLE, BOB

Glass Hat Show, Birdland
 AFR

— Q —

QUIRK, PHIL

WBRE-TV Wilkes-Barre, Pa

— R —

REED, MARY

Faith In Our Time
 Mutual

REED, MILES

KOOL, Phoenix, Ariz

RENN, JACK

WHBQ, Memphis, Tenn

RICHARDS, ART, JR.

Perry Mason
 CBS

RINEHART, HUGH

WHIZ, Zanesville, O

RIPPEN, ROBERT

Howdy Doody, Lobby Hayes
 NBC-TV

RITTER, DICK

America's Town Meeting
 Metropolitan Opera
 ABC

RITTER, ROBERT

WWJ, Detroit, Mich

ROGERS, JOHN

WWJ, Detroit, Mich

ROTIL, MICKEY

WSAZ-TV, Huntington, W. Va.

RUSSON, FRANK

WAGA, Atlanta, Ga

RUSSELL, WARREN

Delina Gang

WNYR-TV, Syracuse, N. Y.

RUST, RALPH R.

WJBK-TV, Detroit, Mich

— S —

SADLER, BILL

KTVQ, Oklahoma City, Okla

SAGASSE, BOB

WETV, Macon, Ga

SAMISH, ADRIAN

Three Steps To Heaven, Follow Your Heart, Backbone of America, Glamour Girl, Atom Squid
 NBC-TV

SAMMON, PAT

WBBM-TV, Chicago, Ill

SAVALAS, TELLY

Glass Hat, Birdland
 ABC

SCALA, ED

WNYE-TV, Bushington, N. Y.

SCANLAN, WALTER

Headline Edition, Fights
 Walter Winchell
 AFR

SCHECK, GEORGE

Star Time, WNBT, New York

SCHENKER, JOHN

KCJB-TV, Minot, N. D.

SCHERER, ED

Hand To Heaven
 WMAL-TV, Washington, D. C.

SCHNEIDER, GIL

WKY, Oklahoma City, Okla

SCHIFF, SAM

Kate Smith Show
 NBC-TV

SCHUBERT, BERNARD

Adventures Of The Falcon
 Mutual

SCHULMAN, LEE

March On

KING-TV, Seattle, Wash

SCHWARTZ, LEW

WKRB, New Britain, Conn

SHARP, JAMES J.

The Swinebills
 WLWA, Atlanta, Ga

SHAW, BETTY

Rosemary
 CBS

SHEA, ROGER M.

WTTG, Washington, D. C.

SHEA, TOM

Bobby Shea Double or
 Nothing
 ABC

SHEPARD, JACK

Western Jamboree
 KJEO, Fresno, Cal

SHOLLENBERGER, LEWIS

Capital Cloakroom,
 Washington, USA
 CBS

SINAWER, MITCH

WICC, Bridgeport, Conn

SIOUSSAT, HELEN J.

Man's Right To Knowledge
 CBS



GORDON T. HUGHES

Producer-Director

"My Little Margie"

CBS — Mutual

FURTH ULLMAN

Production Designer

Colgate Comedy Hour

SIMON, MAYO
KETC, St. Louis, Mo.

SKEDGELL, ROBERT
The World Today, World
Assignment, Correspondents'
Scratchpad
CBS

SMITH, SIDNEY
B. Nov. 19, 1914, Chicago, Ill.
Fireside Theatre, Royal Play-
house, Strange Adventure, NBC-
TV

SMITHDEAL, PAT
WJHL, Johnson City, Tenn.

SNELL, GEORGE
TV Chapel
WEEU, Reading, Pa.

SNYDER, DONALD
WFBG, Altoona, Pa.

SOMERVILLE, WARREN
Sammy Kaye Cameo Serenade.
When A Girl Marries
ABC

SPURGEON, JAY
WOW-TV, Omaha, Neb.

STAMBAUGH, ELLIS
Ask Your Doctor
KCBD-TV, Lubbock, Tex.

STAUDERMAN, BRUCE
WXEL, Cleveland, Ohio

STERNFIELD, TOMMY
Teen Age Barn
WRGB, Schenectady, N. Y.

STEDMAN, BILL
John Conte Show, Sammy
Kaye Show
ABC

STEVENS, GARY
Twenty Questions
Mutual

STONE, MARTIN
Author Meets the Critics
Mutual

STRAND, PETER
WXYZ-TV, Detroit, Mich.

STRENGE, WALTER
Waterfront; Trouble With Father;
My Little Margie; Mystery The-
atre; Beulah; Space Ranger

SUTTER, DAN
Jane Pickens Daily Show,
Second Chance
NBC

SUTTON, THOMAS
WWJ, Detroit, Mich.

SWINAMER, ROY
You And Your Health
WEEU, Reading, Pa.

SWING, RAYMOND
This I Believe
CBS

— T —

TANAKA, GEORGE
Cherry Blossom Time
KONA, Honolulu, T. H.

TELFORD, FRANK
Captain Video, Secret Files of
Captain Video
Dumont

THAYER, GUY V., JR.
B. Los Angeles, Cal. My Little
Margie, CBS-TV; Waterfront,
Rocky Jones Space Ranger, Syn-
dicated

THOMPSON, ARTHUR R.
KOY-TV, Phoenix, Ariz.

TILLETT, D.
WHEC-TV, Rochester, N. Y.

TOMLINSON, WILLIAM H.
WKAR, East Lansing, Mich.

TORMEY, BOB
Greatest Story Ever Told,
Horse Races
ABC

TRAYHERN, JAMES
WHAM, Rochester, N. Y.

TUELL, GORDON
KMO-TV, Tacoma, Wash.

TURLEY, JACK
KWWL, Waterloo, Iowa

— U —

ULLMAN, FURTH
Colgate Comedy Hour

— V —

VAN ABEL, BOB
WBAY, Green Bay, Wis.

VINCENT, CHICK
The Shadow
Mutual

VINSANT, SAM
KOB, Albuquerque, N. Mex.

VOUTSAS, GEORGE
Golden Voices, Music By Man-
tovani, Jane Pickens Night
Show
NBC

— W —

WADE, WARREN
WOR, New York, N. Y.

WALL, ED
WNCT, Greenville, N. C.

WEBB, RUSSELL
WBKZ, Battle Creek, Mich.

WEBER, HENRY
Enchanted Hour
Mutual

WEIHE, FRED
My Secret Story, NBC Star
Playhouse
NBC

WEIST, GEORGE
My Truc Story, American
Music Hall, Hollywood Star-
way
ABC

WILLIAMS, NORMAN
KMTV, Omaha, Neb.

WILLIAMS, RICK
KLAS-TV, Las Vegas, Nevada

WILLIS, FRED
WMCT-TV, Memphis, Tenn.

WISBAR, FRANK
B. Dec. 12, Lithuania. Fireside
Theatre, G. E. Theatre, Syndica-
ted

WITEKIND, WARREN
WRAY, Princeton, Ind.

WOLD, ED
Hilltop House
CBS

WOOD, BARRY
NBC Color Shows, Kate Smith
Show
NBC-TV

WRIGHT, BURTON
WWJ, Detroit, Mich.

WRIGHT, WYNN
Squad Room, Official Detective
Mutual

WYGANT, PHIL
WBAP-TV, Fort Worth, Tex.

— Z —

ZINN, STEVE
WFTL, Ft. Lauderdale, Fla.

ZIRATO, BRUNO, JR.
A Minority Of One, Robert
Q. Lewis Show
CBS

Join

CIVIL DEFENSE

NOW



BARRY SHEAR

DUMONT-TV

DIRECTOR OF

"Joseph Schildkraut Series"

"Guide Right"

"Melody Street"

WILLIAM ASHER

AL LEWIS

DIRECTING and CO-WRITING

"OUR MISS BROOKS"

CBS-TV



ALAN NEUMAN

DIRECTOR

INNER SANCTUM

FILM SERIES

RADIO-TV DIRECTORS

—and their work during 1953



— A —

ALLEN, CRAIG

Juvenile Jury, Mr. Peepers, Scoreboard, Break The Bank, Candid Camera
NBC-TV

ASHER, WILLIAM

B. August 8, 1921, New York City. I Love Lucy, Our Miss Brooks, CBS-TV; Make Room for Daddy, Where's Raymond?, ABC-TV; The Dennis Day Show, NBC-TV

— B —

BASS, LEONARD L.

Gangbusters
CBS

BOWER, ROGER

Baron And The Bee, Can You Top This, G. I. Joe
NBC

BROWN, HIMAN

Bulldog Drummond
Mutual

BROWN, JIM

Emily Kimbrough Program
WCBS, New York

BROWNING, KIRK

NBC Opera, TV Recital Hall
NBC-TV

BUNETTA, FRANK

Life Is Worth Living
Dumont

BURKE, CAROLINE

Masterpiece Playhouse, Red Feather Revue, Heralds Of Good Will, Around the Town, Vacation Wonderlands, Watch the World, Elder Wiseman-Wanda Landowska at Home, NBC-TV

BURNETT, MURRAY

True Detective Mysteries
Mutual

— C —

CHATEAUVERT, WALLY

Second Mrs. Burton
CBS

CHEETHAM, WALTER

At Home With Joan
WCBS, New York

CORDAY, TED

Guiding Light
CBS

CORRIGAN, WILLIAM

Hollywood Opening Night, TV Playhouse
NBC-TV

COYLE, HARRY

Twenty Questions, Pantomime Quiz
Dumont

— D —

DANIELS, MARC

B. Pittsburgh, Pa. I Love Lucy, CBS-TV; I Married Joan, Backbone of America, NBC-TV

DAVIS, HOWARD

Howdy Doody, Gabby Hayes
NBC-TV

del VALLE, JAIME

B. Jan. 19, 1919, Los Angeles, Cal. Johnny Dollar, The Line Up, G. E. Theatre, CBS; Richard Diamond, NBC

DIETZ, JOHN

Crime Photographer
CBS

DONEHUE, VINCENT

TV Playhouse
NBC-TV

DRAKE, GALEN

Housewives Protective League, Starlight Salute
WCBS, New York

— E —

EBI, EARL

Lux Radio Theatre
CBS

ECKLER, RICHARD

Stars On Parade
Dumont



HERBERT SUSSAN

Directs and Stages

“COKE TIME”

starring

EDDIE FISHER

for

The Coca-Cola Company
(NBC-TV)

Freedom Award Winner Guedel Award Winner Peabody Award Nominee

FRANK SATENSTEIN

CBS-TV

DIRECTOR

of

The Jackie Gleason Show



JOE GRAHAM

WRITER — DIRECTOR

Currently directing:

"WHISPERING STREETS"

for General Mills and the Toni Company

"IT'S YOUR BUSINESS"

for the National Association of Manufacturers
and

"HOLLYWOOD AIRPORT"

Also created and directed in color:

"THE MAN FROM HARTFORD"
(film)



Cort Steen

DIRECTOR

OF

**"ARMSTRONG
CIRCLE THEATRE"**

NBC-TV

RICHARD IRVING

Director

Revue Productions

— F —

FAY, PAT
Broadway To Hollywood
Dumont

FELTON, NORMAN
Robert Montgomery Presents
NBC-TV

FERRIN, FRANK
B. Nov. 13, Minneapolis, Minn.
Smilin' Ed's Gang, ABC-TV;
Spot Radio

FRAZEE, HARRY
Woman In Love, Public
Affairs Shows
NBC

— G —

GIBBS, PARKER
The Big Previews, Roadshow
NBC

GOETZ, JOHN
Christmas With The Stars,
Voice Of Firestone, Prologue
To The Future, Mrs. U.S.A.
NBC-TV

GORMAN, WALTER
Road of Life
CBS

GRAHAM, JOE
B. Sept. 15, 1916, Portsmouth,
Ohio. Whispering Streets, It's
Your Business, Call Me Freedom,
ABC; The Mon From Hartford;
Film

— H —

HANNA, ARTHUR
This Is Nora Drake, Our Gal
Sunday
CBS

HARRIS, MARY
Brighter Day
CBS

HAUPT, JAMES
Band of America
NBC

HIGHT, JEAN
Let's Pretend
CBS

HOBIN, CHARLES
Your Show of Shows, Nothing
But The Best
NBC-TV

HULTGREN, ROBERT
Howdy Doody, Gabby Hayes
NBC-TV

— I —

ICKES, DON
Jack Sterling Program, Let's
Find Out
WCBS, New York

IRVING, CHARLES
Search For Tomorrow, CBS-TV

IRVING, RICHARD
Revue Productions

— K —

KENNY, H. WESLEY
Rocky King Detective
Dumont

— L —

LaFRANDRE, JACK
Chicago Theater Of The Air
Mutual

LANDERS, LEW
B. Jan. 2, 1901, New York City.
Topper

LARGE, DON
Make Way For Youth
CBS

LEVINE, JACK
Wonderful City
Mutual

LEWIS, AL
B. Oct. 25th, 1912, Brooklyn,
N. Y. Our Miss Brooks, CBS-TV

LOWE, DAVID
What's The Story, Life Begins
At Eighty
Dumont

— M —

MacGREGOR, JOCK
Nick Carler
Mutual

MANDEVILLE, BETTY
FBI In Peace And War
CBS

MARCEAU, WILLIAM
Plainclothes Man
Dumont

MARSHALL, SANDY
Nightmare, Starlight Theater,
High Adventure
Mutual

**MARTINSON, LESLIE
H.**
Chevron Theatre; Pepsi-Cola The-
atre; Revlon Mirror Theatre; Roy
Rogers Show

MOELLER, DICK
Jack Sterling Program, This
Is New York
WCBS, New York

MONKOE, ELEANOR
Take A Number, Titus Moody
Mutual

LARRY SCHWAB

Producer - Director

**LEW
LANDERS**

SID SMITH

DIRECTOR

"COLGATE COMEDY
HOUR"

NBC-TV
Hollywood

JIMMY DURANTE
EDDIE CANTOR

MARC DANIELS

DIRECTOR

Wm. Morris Agency
Phil Weltman

DICK SCHNEIDER

DIRECTOR

OF

"THE BIG STORY"

and

"STORK CLUB"

NBC-TV

LESLIE H. MARTINSON

Director

"CHEVRON THEATRE"

"PEPSI-COLA THEATRE"

"REVLON MIRROR THEATRE"

for

REVUE PRODUCTIONS



"ROY ROGERS SHOW"

— N —

NELSON, RAY
Rod And Gun Club
Mutual

NEUMAN, ALAN
Kate Smith Hour, NBC-TV;
Lights Out, Blind Date, Here's
To Your Health, NBC

NISS, STANLEY
21st Precinct
CBS

NOCKS, ARNEE
Capt. Video. On Your Way
Dumont

— P —

PHELPS, STOWE
Music 'Til Dawn
WCBS, New York

POLK, LEE
Opera Cameos, Magic Cottage
WABD, New York

— R —

REGAN, KEN
Bob Haynes Program
WCBS, New York

REVNER, KATHIE
Housewives Protective League.
Starlight Salute
WCBS, New York

RICCA, ERNIE
Romance of Helen Trent
CBS

RICHARDS, ART, JR.
Perry Mason
CBS

RUBIN, JACK
Hilltop House
CBS

— S —

SATENSTEIN, FRANK P.
B. Oct. 7, 1924, New York.

Jackie Gleason Show, I've Got
a Secret, Robert Q. Lewis Show,
CBS-TV

SCHNEIDER, DICK
Big Story, Down To Danger,
Stork Club, NBC-TV

SCHWAB, LARRY
Kate Smith Show, NBC-TV

SCHWARZ, BILL
John Henry Faulk Program
WCBS, New York

SHEAR, BARRY
Melody Street
DuMont

SMITH, SID
B. 1920, Minneapolis, Minn.
Colgate Comedy Hour, All Star
Revue, NBC-TV

STEEL, BOB
Aunt Jenny
CBS

STEEN, CORT
Armstrong Circle Theatre, NBC-
TV; City Hospital, CBS-TV;
Door Way To Danger, Two
Girls Named Smith, Hollywood
Screen Test, ABC-TV

STEVENS, GARY
Twenty Questions
Mutual

SUSSAN, HERBERT
Coke Time, Kate Smith Show,
Christmas with the Stars, NBC-
TV; Fred Waring Show, Ken
Murray Show, Actors Studio,
CBS-TV

— T —

TELFORD, FRANK
Joseph Shildkraut
Dumont

TYLER, JACK
Theatre of Today
CBS

— V —

VINCENT, CHICK
The Shadow
Mutual

VOUTSAS, GEORGE
Golden Voices, Music By
Mantovani, Jane Pickens
Night Show
NBC

— W —

WALLACE, DON
Wendy Warren And The News
CBS

WEIHC, FRED
My Secret Story, NBC Star
Playhouse
NBC

WESTIN, AV
The World Today, World
Assignment
CBS

WOLD, RODGER
Housewives Protective League,
Starlight Salute, Music 'Til
Dawn
WCBS, New York

WOLFE, ED
Ma Perkins
CBS

— Z —

ZEAMER, MICHAEL
Bride and Groom, Today
NBC-TV

ZIRATO, BRUNO, JR.
Robert Q. Lewis Little Show
CBS

THE BARNES PRINTING CO.

INCORPORATED

Has printed the

RADIO ANNUAL—TELEVISION YEAR BOOK

for 17 years

"There must be a reason"

229 West 28th Street

New York, N. Y.

RADIO-TV WRITERS

Advertising Agency — Network — Free Lance
and their work in 1953

— A —

ACE, GOODMAN
Buck-Berle Show
NBC-TV

ADAMS, BEA
Mary Lee Taylor Show
NBC

ALEXANDER, BEN
Dramatist
NBC, NBC-TV

ANDREWS, CHARLIE
Dave Garraway Show 1951
Dave Garraway
NBC, NBC-TV

ARNOLD, DANNY
Colgate Comedy Hour
NBC-TV

AUCHINCLOSS, GORDON
Coke Time Starring Eddie
Fisher
NBC, NBC-TV

AUTHUR, ROBERT ALAN
Bonino Television Playhouse
NBC-TV

— B —

BARRETT, BILL
The Bennetts Hawkins Falls
NBC-TV

BECKER, DON
Life Can Be Beautiful
NBC

BERG, GERTRUDE
House of Glass, NBC
The Goldbergs, NBC-TV

BIXBY, CARL
B. May 4, 1895. Life Can Be
Beautiful, NBC

BLAKE, HOWARD
Bob Hope Daytime show
NBC

BRITT, JIM
B. April 11, 1919, San Francisco, Cal Sports Final, NBC-TV; Dumont Pro Football, Dumont; Jim Britt's Sports Report, ABC

BROOKS, MEL
Your Show of Shows, NBC-TV

BROWN, GEORGE CARLETON
My Little Margie
NBC-TV

BULLOCK, WALTER
Life of Riley
NBC-TV

BURLINGHAM, LLOYD
This Farming Business
NBC

BURT, FRANK
Six Shooter
NBC

BURTON, BUD
Paul Winchell Show
NBC-TV

BURTON, JAY
Buck-Berle Show
NBC-TV

BUTTS, VIRGINIA
Dave Garraway Show
NBC-TV

— C —

CARRINGTON, ELAINE
Pepper Young's Family
NBC

CENDELLA, ROBERT
Best Plays, Old Vic Theatre,
NBC Star Playhouse, Woman
In Love, My Secret Story
NBC

CHARIG, PHIL
Buck-Berle Show
NBC-TV

CHAYEFESKY, PADDY
TV Playhouse
NBC-TV

CLARK, HARRY
Life of Riley
NBC-TV

COOPER, HAL
Magic Cottage
WARD, New York

CRANE, HARRY
Colgate Comedy Hour
NBC-TV

— D —

DALZELL, BILL
Melody Street
Dumont

DAVID, MARVIN
Eddy Arnold Show
NBC

DIAMOND, WELMA
Buck-Berle Show
NBC-TV

DOUGALL, BERNARD
American Must-Hall, Modern
Romances, Mr. President, Call
Me Freedom
ABC

DOUGLAS, JACK
Woman In My House
NBC

DUDLEY, PAUL
Martha Kane
NBC-TV

— E —

EDWARDS, PAUL
Truth or Consequences
NBC

ELINSON, JACK
Colgate Comedy Hour
NBC-TV

ELLIOTT, SUMNER LOCKE
TV Playhouse
NBC-TV

ELLIOTTE, JOHN
Great Gildersleeve
NBC

ETTINGER, EDWARD
Sammy Kaye Cameo Serenade,
Dancing Party, Don Cornell
Show, Paul Whiteman Teen
Club
ABC

— F —

FERRIN, FRANK
B. Nov. 13, Minneapolis, Minn.
Smilin' Ed's Gang, ABC-TV;
Spot Radio

FISCHER, MARVIN
Woman In My House
NBC

FOOTE, HORTON
TV Playhouse
NBC-TV

FOWLER, KEITH
Fisher McGee and Molly
NBC

FOX, FRED
Bob Hope Show, My Little
Margie
NBC-TV

FRANK, REUBEN
Camel News Caravan
NBC-TV

FRANKLIN, FRANKIE
Dial Dave Garraway
NBC

FRIEDBERG, BILLY
All Star Revue
NBC-TV

FRITZELL, JIM
Mr. Peepers
NBC-TV

— G —

GRAHAM, LEE E.
B. January 23, 1918, New
York City Letter to Lee
Graham, WARD, New York

GREENBAUM, EVERETT
Mr. Peepers
NBC-TV

GUSSMAN, CHARLES
Road of Life
NBC

— H —

HAMNER, EARL
Best Plays, NBC Star Play-
house, My Secret Story, Holly-
wood Love Story, Woman In
Love
NBC

HANDLEY, ALAN
Dinah Shore Show
NBC, NBC-TV

HAZAM, LOU
March of Medicine
NBC-TV

HENNING, PAUL
TV Violator Show
NBC-TV

◆ RADIO-TV WRITERS ◆

HERBERT, DON

Mr. Wizard
NBC-TV

HIKEN, NAT

All Star Revue
NBC-TV

HOLCH, ARTHUR

Camel News Caravan
NBC-TV

HUMMERT, FRANK and ANNE

Front Page Farrell, Just Plain
Bill, Lorenzo Jones, Backstage
Wife, Stella Dallas, Young
Widder Brown
NBC

— I —

ISAACS, CHARLES

Colgate Comedy Hour
NBC-TV

— J —

JACOBSON, BILL

Kate Smith Show
NBC-TV

JURIST, ED

Colonel Flack
Dumont

— K —

KALISH, ROCKY

Colgate Comedy Hour
NBC-TV

**CARL
BIXBY**

Life Can Be Beautiful

•

Television

•

Sturges Highway

Southport, Conn.

Fairfield 9-3275

**CARLTON E.
MORSE**

Writer-Producer

presents:

“ONE
MAN’S
FAMILY”

(RADIO)

“FAMILY
SKELETON”

(RADIO)

“THE
WOMAN
IN
MY
HOUSE”

(RADIO)

“I
LOVE
A
MYSTERY”

(RADIO)

“ONE
MAN’S
FAMILY”

(TV)

KALLEN, LUCILLE

Your Show of Shows, NBC-TV
KEAN, ED

Howdy Doody
 NBC-TV

KINoy, ERNEST

Best Plays, NBC Star Playhouse, My Secret Love, Hollywood Love Story, Woman In Love, The Marriage
 NBC

KULLER, SID

Colgate Comedy Hour
 NBC-TV

— L —

LACHMAN, MORT

Bob Hope Show
 NBC-TV

LAWRENCE & LEE

Railroad Hour
 NBC

LEAR, NORMAN

Colgate Comedy Hour
 NBC

LEFFERTS, GEORGE

Rocky Fortune, Jane Prevens Nighttime Show, Best Plays
 NBC Star Playhouse, Hollywood Love Story
 NBC

LESLIE, PHIL

Fibber McGee And Molly
 NBC

LEWIS, MORT

Stroke of Fate
 NBC-TV

LYNCH, PEG

Ethel and Albert, NBC-TV

LYONS, JO

On Your Way
 Dumont

— Mc —

McGINNESS, A. J.

Voice Of Firestone
 NBC-TV

McGRAW, PEG

Phrase That Pays
 NBC

— M —

MARCK, LARRY

Bob Hope Show
 NBC-TV

MARION, IRA

Mr. President, Jan Peerve Show
 ABC

MILLER, SID

Colgate Comedy Hour
 NBC-TV

MILLS, ROBERT

Thy Neighbor's Voice
 NBC

MONASH, PAUL

Atom Squad
 NBC-TV

MORGENTHAU, HENRY, III

For Better Living
 NBC

MORSE, CARLTON E.

B. June 4, Jennings, La. One Man's Family, Woman in My House, NBC; Family Skeleton, CBS; I Love A Mystery, (Spot)

MOSEL, TED

TV Playhouse
 NBC-TV

— O —

OSTROFF, MANNING

Colgate Comedy Hour
 NBC-TV

— P —

PEDICINI, RICHARD GEORGE

Last Man Out

PHILLIPS, FELLA

Joseph Schillkraut
 Dumont

— R —

RAPP, JOHNNY

Colgate Comedy Hour
 NBC-TV

RIPLEY, BETTE

Beth Holland Show, Call Me Freedom
 ABC-TV

ROBINSON, JOHN

Diagnet
 NBC, NBC-TV

ROSS, CLARIS

My Secret Story, Best Plays
 NBC Symphony
 NBC

ROSS, DAVID

Golden Treasury
 NBC

RUBEN, AARON

Buick-Berle Show
 NBC-TV

RYAN, BILL

Weekend
 NBC

— S —

SEELAN, JERRY

Buick-Berle Show
 NBC-TV

SHAPIRO, STANLEY

RCA Victor Show
 NBC-TV

SHAW, DAVID

Television Playhouse
 NBC-TV

SHELDON, HERB

Exbert & Ummly
 NBC

SHERWOOD, ROBERT E.

Backbone of America
 NBC-TV

SIMMONS, GENE

Colgate Comedy Hour
 NBC

SIMON, DANNY AND DOC

Your Show of Shows, NBC-TV

SMALL, ARTHUR

NBC Symphony
 NBC

SMITH, BARBARA

Cities Service Band of America
 NBC

SMITH, BERNIE

You Bet Your Life
 NBC-TV

SOUVAINE, MRS. HENRY

Golden Voices
 NBC

STANDER, ARTH

I Married Joan
 NBC-TV

STARR, SHELDON

Hollywood Starway Modern
 Roomers
 ABC

STARR, BEN

I Married Joan
 NBC

STARR, MANYA

Doctor's Wife
 NBC

STEIN, JOE

Your Show of Shows, NBC-TV

STEWART, CHARLES

Bob Hope Nighttime Show
 NBC

SULLIVAN, NORMAN

Bob Hope Nighttime Show
 NBC

— T —

TALMAN, ROBERT

My Secret Story, Hollywood Love Story, Best Play
 NBC

TARLOFF, FRANK

I Married Joan
 NBC

TODD, ELIZABETH

Mary Lee Taylor Show
 NBC

TOKIN, MEL

Your Show of Shows, NBC-TV

TRAVERS, VIRGINIA

Turn To A Friend
 ABC

— V —

VAN HARTSVELDT, FRED

Roy Rogers Show
 NBC

— W —

WEBB, JACK

Diagnet
 NBC, NBC-TV

WEBSTER, TONY

Your Show of Shows, NBC-TV

WHITE, ANDY

Great Gildersleeve
 NBC

WHITE, LES

Colgate Comedy Hour
 NBC-TV

WILLSON, MEREDITH

Every Day
 NBC

WILSON, JACK

My Secret Story
 NBC

WITTY, DON

Call Me Freedom, The Adventurer
 ABC

WOOD, ARLENE

The Evening Comes, Valentine
 ABC

— Y —

YOUNG, JOHN M.

Right To Happiness
 NBC

WOMEN KIUN COMMENTATORS

HOME ECONOMISTS

of U. S. TV and Radio Stations



— A —

Abanatt, Dorothy..... WILS. Lansing, Mich.
 Abdou, Gloria..... WCAE, Pitts, Pa.
 Abeyla, Vergie..... KGGM, Albuquerque, N. Mex.
 Adams, Betty..... WJAR-TV, Providence, R. I.
 Adams, Carol..... WHBC, Canton, O.
 Adams, Jane..... KYUM, Yuma, Arizona
 Adams, Norma..... KIUN, Pecos, Tex.
 Adams, Susan..... WABD, New York
 Adamson, Norma..... KWIK, Pocatello, Idaho
 Aders, Edna..... WLSI, Pikeville, Ky.
 Aitken, Kate..... CFRB, Toronto, Ont.
 Alden, Ann..... WBAP-TV, Fort Worth, Tex.
 Aldrich, Darrach..... WCCO, Minneapolis, Minn.
 Alexander, Barbara..... WKRK, Mobile, Ala.
 Alexander, Mildred..... WTAR-TV, Norfolk, Va.
 Allau, Carolyn..... WKRT, Cortland, N. Y.
 Allen, Ardith..... WDLB, Marshfield, Wis.
 Allen, Barbara..... WCOS, Columbia, S. C.
 Allen, Beth..... KLAS-TV, Las Vegas, Nev.
 Allen, Betty..... WCMI, Ashland, Ky.
 Allen, Dolores..... WDOR, Sturgeon Bay, Wis.
 Allison, Mayme..... KBON, Omaha, Neb.
 Altman, Lou..... KWBB, Wichita, Kan.
 Allyn, Kay..... WSAN, Allentown, Pa.
 Allyn, Roz..... WHEC-TV, Rochester, N. Y.
 Anderson, Blanch..... WLOA, Braddock, Pa.
 Andrews, Miriam..... WRUF, Gainesville, Fla.
 Anno, Mary Jean..... WATW, Ashland, Wis.
 Anten, Norma..... WCPQ-TV, Cincinnati, O.
 Anthony, Nina..... CKWV, Vancouver, B. C.
 Arch, Shirley..... WHLD, Niagara Falls, N. Y.
 Arledge, Mabel..... KIVY, Crockett, Tex.
 Arlen, Margaret..... WCBS, New York
 Armand, Dorothy..... WLOV, Montgomery, Ala.
 Arnett, Robin..... KBOL, Boulder, Colo.
 Arnold, Lynn..... KSL-TV, Salt Lake City, Utah
 Ashwell, Mary..... CFPL, London, Ont.
 Ater, Alycen..... KCTZ, Childress, Tex.
 Ater, Virginia..... WMBR, Jacksonville, Fla.
 Ayer, Esther..... WMUR, Manchester, N. H.

— B —

Bacher, Jeanne..... KST, Fresno, Cal.
 Badham, Mary..... WBRC, Birmingham, Ala.
 Bahman, Alice..... WIZE, Springfield, O.
 Bailey, Marie..... KSRV, Ontario, Ore.
 Bailey, Mitzi..... KMUR, Murray, Utah
 Bailin, Joan..... KCOM, Sioux City, Iowa
 Baker, Betty..... WGET, Gettysburg, Pa.
 Baker, Evangelina..... KGO, San Francisco, Cal.
 Baker, Mary..... WSEB, Chicago, Ill.
 Baldwin, Bettie..... KMMO, Marshall, Mo.
 Baldwin, Helen..... WBNF-TV, Binghamton, N. Y.
 Ball, Jane Ellen..... WJAS, Pittsburgh, Pa.
 Bancroft, Barbara..... WMME, Melbourne, Fla.
 Barberito, Celeste..... WIHL, Hammond, La.
 Barer, Betty Jenkins..... WJBY, Gadsden, Ala.
 Barnes, Dorothy..... WIOU, Kokomo, Ind.
 Barnett, Ruby..... KXOB, Stockton, Cal.
 Barrett, Maxine..... WITV, Ft. Lauderdale, Fla.
 Barthell, Lois..... WHLN, Harlan, Ky.
 Barlett, Edna..... WENY, Elmira, N. Y.
 Barton, Betty..... WNBH, New Bedford, Mass.
 Bates, Mercedes..... KNXT, Los Angeles, Cal.
 Battle, Lisa..... WIS, Columbia, S. C.
 Baum, Dale..... WJTV, Jackson, Miss.
 Baustian, Evelyn..... KROX, Crookston, Minn.
 Baxter, Joan..... CFRA, Ottawa, Ont.
 Bayne, Alice..... WIBC, Indianapolis, Ind.
 Bayne, Barbara..... WLOL, Minneapolis, Minn.
 Beagle, Maude..... WBBE, Flint, Mich.
 Beal, Joyce..... WJER, Dover, O.
 Bean, Ruth..... WATV, Newark, N. J.
 Beeley, Helen..... WORD, Spartanburg, S. C.
 Behan, Claire..... KLMR, Lamar, Colo.
 Bell, Patricia..... WLOU, Louisville, Ky.
 Bell, Peggy..... KFYO, Lubbock, Tex.
 Bender, Leona..... K TSA, San Antonio, Tex.
 Benell, Julie..... WFAA, Dallas, Tex.

Benson, Beverly..... WJOC, Jamestown, N. Y.
 Best, Laverne..... WTAX, Springfield, Ill.
 Bestor, Beulah..... WICC-TV, Bridgeport, Conn.
 Bickel, Helen..... WMMN, Fairmont, W. Va.
 Bidle, Mary..... WIP, Philadelphia, Pa.
 Birch, Tommye..... KMOX, St. Louis, Mo.
 Bishop, Barbara..... KPOA, Honolulu, Hawaii
 Blair, Anne..... WGMS, Washington, D. C.
 Blake, Julie..... WFEA, Manchester, N. H.
 Blalock, Muriel E..... WASL, Annapolis, Md.
 Blattner, Barbara..... KASM, Albany, Minn.
 Blazer, Eleanor..... WHOK, Lancaster, O.
 Bledsoe, Jo..... WNEB, Daytona Beach, Fla.
 Bouda, Mayme..... WMBM, Miami Beach, Fla.
 Booth, Bette..... KLWN, Lawrence, Kan.
 Bos, June..... WFUR, Grand Rapids, Mich.
 Bosone, Reva Beck..... KDYL-TV, Salt Lake City, Ut.
 Bowen, Jerri..... KHSL, Chico, Cal.
 Bowman, Helen..... WKEE, Newport, Vt.
 Box, Mary J..... WFRX, W. Frankfort, Ill.
 Boyd, Jo..... WMPA, Aberdeen, Miss.
 Boyd, Mary Ellen..... KALE, Richland, Wash.
 Boyles, Leticia B..... WGVN, Greenville, Miss.
 Bracken, Virginia..... WDOV, Dover, Del.
 Bradford, Ann..... WLLH, Lowell-Lawrence, Mass.
 Bradford, Betty..... WESB, Bradford, Pa.
 Bradley, Debbie..... WGVN, Greenville, S. C.
 Brady, Toni..... WABY, Albany, N. Y.
 Bramblett, Gladys..... WSAR, Fall River, Mass.
 Brees, Beth..... KNOE, Monroe, La.
 Brendt, Nancy..... WNLK, Norwalk, Conn.
 Brennan, Libby..... WILK, Wilkes-Barre, Pa.
 Bride, Billie..... WMAN, Mansfield, O.
 Briers, Evelyn..... WCOL, Columbus, O.
 Briggs, Ruth..... KENI, Anchorage, Alaska
 Brink, Norma..... WGRD, Grand Rapids, Mich.
 Britt, Catherine..... WLNA, Peekskill, N. Y.
 Brock, Grace..... WABB, Mobile, Ala.
 Broeg, Heloise Parker..... WEEI, Boston, Mass.
 Brooks, Ann Cole..... KFAL, Fulton, Mo.
 Brooks, Barbara..... WOCM, St. John's, Nfld.
 Brooks, Dorothy..... WTAN, Clearwater, Fla.
 Brooks, Helen..... WFBR, Baltimore, Md.
 Brooks, Martha..... WGY, Schenectady, N. Y.
 Brophy, Margaret..... CKNX, Wingham, Ont.
 Braughton, Betty..... WSAV, Savannah, Ga.
 Brown, Beverly..... KIMA, Yakima, Wash.
 Brown, Liz..... KDAL, Duluth, Minn.
 Brown, Lynn..... KREW, Snnyside, Wash.
 Brown, Mac..... WMAS, Springfield, Mass.
 Brown, Minnie..... KGA, Spokane, Wash.
 Brown, Molly..... WLET, Toccoa, Ga.
 Brown, Nancy..... WAUD, Auburn, Ala.
 Bence, Fran..... KVCV, Redding, Cal.
 Brunsey, Geraldine..... WTVR, Richmond, Va.
 Bryant, Ruby..... WVOP, Vidalia, Ga.
 Bryant, Ruth..... KNAK, Salt Lake City, Utah
 Byrdia, Barbara..... KATY, San Luis Obispo, Cal.
 Burbank, Sara..... WBNF, Binghamton, N. Y.
 Burbank, Vaumana..... KODY, North Platte, Neb.
 Burr, Gwenn W..... KSUE, Susanville, Cal.
 Burrish, Vina..... KNAL, Victoria, Tex.
 Bushnell, Georgiana..... WJBS, Deland, Fla.
 Butler, Jane..... WGBS, Miami, Fla.
 Byrne, M. M..... WCAK, Columbus, Ga.
 Byrne, Maggi..... WNBK, Cleveland, O.
 Byron, Eva..... WALT, Tampa, Fla.

— C —

Caldwell, Jo..... WLDS, Jacksonville, Ill.
 Calfee, Lu..... WAAM, Baltimore, Md.
 Callahan, Ellen..... WWNC, Asheville, N. C.
 Callaway, Carol..... KVCV, Ventura, Cal.
 Cameron, Barbara..... WKRC, Cincinnati, O.
 Campbell, Dorothy..... WOKU, Milwaukee, Wis.
 Campbell, Pauline..... WARE, Ware, Mass.
 Carey, Willa..... KMAN, Manhattan, Kan.
 Carlson, Mildred..... WBZ, Boston, Mass.
 Carr, Paula..... WIRE, Indianapolis, Ind.
 Carroll, Lee..... KONA, Honolulu, T. H.

WOMEN COMMENTATORS—RADIO-TV

Carroll, Lynn.....WCAO, Baltimore, Md.
 Carroll, Sue.....KJEO, Fresno, Cal.
 Carson, Joan.....WBKL, Clarksville, W. Va.
 Carter, Betty.....KTOW, Oklahoma City, Okla.
 Carter, Frances.....WAZL, Hazleton, Pa.
 Cartwright, Christian.....WCOM, Lawrence, Mass.
 Case, Marilu.....WSAI, Cincinnati, O.
 Casey, Wynne.....WJOY, Burlington, Vt.
 Cason, Marian.....WAH, Winston-Salem, N. C.
 Castel, Eilamac.....WKBN-TV, Youngstown, O.
 Cato, Evelyn.....WMFS, Chattanooga, Tenn.
 Chaffee, Berben.....KEPO, El Paso, Tex.
 Chamber, Joclyn.....KANE, N. W. Berna, La.
 Chase, Barbara.....CFOR, Orilla, Ont.
 Chase, Julie.....WTAG, Worcester, Mass.
 Chase, Mildred.....WKEB, Holyoke, Mass.
 Chase, Penny.....WAAM, Baltimore, Md.
 Chessler, Faye.....KWED, Seznam, Tex.
 Chilton, Ruth.....WJMJ, Philadelphia, Pa.
 Chism, Beverly.....WITZ, Jasper, Ind.
 Chornuk, Pauline.....CKPI, Ft. William, Ont.
 Christian, Lorina.....WKKO, Cocoa, Fla.
 Clark, Gail.....KTNT, Tacoma, Wash.
 Clark, Helen.....KXXX, Colby, Kan.
 Clark, Hilda.....KTUC, Tucson, Ariz.
 Clark, Lucille.....WTAR-TV, Norfolk, Va.
 Clayton, Roba.....WQXI, Atlanta, Ga.
 Clifton, Ann.....WALE, Fall River, Mass.
 Cole, Mrs. W. H.....WHOC, Philadelphia, Miss.
 Coleman, Dorothy.....WNHC, New Haven, Conn.
 Coleman, Roz.....WTRF, Wheeling, Va.
 Collins, Edna, G.....KCIW, Carroll, Iowa
 Collins, Kay.....WIS, Columbia, S. C.
 Connelly, Jean.....WKTU, Pittsburgh, Pa.
 Connelly, Jeanne.....WNEB, Worcester, Mass.
 Connelly, Pat.....KABQ, Albuquerque, N. M.
 Connors, Dorsey.....WNBQ, Chicago, Ill.
 Conrad, Fran.....KWRN, Reno, Nev.
 Conville, Mary.....CJOC, Lettbridge, Alta.
 Conyers, Maureen.....KIDO, Boise, Idaho
 Cook, Connie.....WOW-TV, Omaha, Neb.
 Cook, Irene.....KGER, Long Beach, Cal.
 Cook, Patti.....KPOJ, Portland, Ore.
 Cook, Tish.....KXGI, Fort Madison, Iowa
 Cooney, Josephine.....WFBQ, Altoona, Pa.
 Coons, Tom.....KLFY, Lafayette, La.
 Cooper, Midge.....WMRN, Marion, O.
 Cooper, Pauline.....WTPA-TV, Harrisburg, Pa.
 Cooper, Ruby.....KTLT, Lomview, Tex.
 Conry, Connie.....WCOU, Lewiston, Me.
 Crane, Ruth.....WMAL, Washington, D. C.
 Craven, H. Marie.....WGGG, Greensboro, N. C.
 Croft, Lorraine.....KHMO, Hannibal, Mo.

— D —

Dale, Dorothy.....WBET, Brockton, Mass.
 Daley, Wanda.....KRAL, Rawlins, Wyo.
 Daniel, Jacqueline.....KFRK, Sacramento, Cal.
 Daniels, Catherine.....WISH, Indianapolis, Ind.
 Dazubart, Catherine.....WKBI, St. Marys, Pa.
 Davenport, Gwen, KKTU, Colorado Springs, Colo.
 Davenport, Michael.....KPFY, Portland, Ore.
 Davis, Glenda.....KRAL, Craig, Colo.
 Day, Helen.....WBAV, Green Bay, Wis.
 Daye, Sunny.....WLOS, Asheville, N. C.
 Deane, Martha.....WQOL, New York, N. Y.
 DeMas, Jara.....WKRC, Cincinnati, O.
 DeMers, Norma.....KSYC, Yreka, Cal.
 Deunay, Eve.....WCHN, Norwoceta, N. Y.
 Derrick, Eda.....KNOG, Nogales, Ariz.
 Dietzner, Alma.....WQXR, New York, N. Y.
 DeVaney, Maxine.....WMBH, Joplin, Mo.
 Dexter, Mrs. A. H.....CHNS, Halifax, N. S.
 Dickens, Betty.....WIOD, Miami, Fla.
 Dickens, Dean.....WGST, Atlanta, Ga.
 Di Fant, Mary.....WKNB, New Britain, Conn.
 Dickman, Elizabeth.....KTUL, Tulsa, Okla.
 Dillon, Alberta.....WFOV, St. Augustine, Fla.
 Dionne, Glette.....CJPP, Riviere Du Loup, Que.
 Dixon, Nancy.....WJAR-TV, Providence, R. I.
 Doherty, Frances.....WBPP, Bonnewille, Miss.
 Donahoe, Cathy.....WATG, Ashland, O.
 Doffer, Lynn.....WPTZ, Philadelphia, Pa.
 Donham, Betty Jo.....KNEX, McPherson, Kan.
 Donohoe, Benlah.....WTMJ, Milwaukee, Wis.
 Donovan, Bea.....KING-TV, Seattle, Wash.
 Donovan, Joyce.....WTRY, Troy, N. Y.
 Dosley, Dorothy.....KFDX-TV, Wichita Falls, Tex.
 Dorsey, Polly.....WBMD, Baltimore, Md.
 Dow, Bess.....KCSO, Actunras, Cal.
 Doyle, L.....CFOS, Owen Sound, Ont.

Drew, Sally.....WJER, Dover, O.
 Drewson, Dorothy.....WHMP, Northampton, Mass.
 Drivas, Chris.....WIDE, Biddeford, Maine
 Brooz, Elaine.....WROW, Albany, N. Y.
 Duke, Ann.....WBLL, Springfield, Conn.
 Dunham, Earline.....WPNX, Phenix City, Ala.
 Dunlop, Ruth.....KPBO, Phoenix, Ariz.
 Dunn, Jo Ann.....WTRP, Bellaire, O.
 Dunn, Marjorie.....WFBL, Syracuse, N. Y.
 Durham, Jo.....WHAW, Weston, W. Va.

— E —

Earr, Barbara.....KVNJ, Coeur d'Alene, Idaho
 Easton, Louise.....WTOR, Torrington, Conn.
 Eaton, Marguerite.....WJMK, Florence, S. C.
 Edwards, Lynn.....WFOM, Marietta, Ga.
 Elderman, Carmen G.....WZIP, Covington, Ky.
 Elder, Julie.....KSTM-TV, St. Louis, Mo.
 Elliott, Jean.....WCUE, Abrop, O.
 Elliott, Frances.....KGNQ, Dodge City, Kan.
 Elliott, Jeanette.....WTVI, Bethelville, Ill.
 Elliott, Pat.....WAGF, Bethham, Ala.
 Ellis, Carolyn.....WCPO-TV, Cincinnati, O.
 Elperi, Margaret.....KZTV, Reno, Nev.
 Emerson, Faye.....WNBC, New York, N. Y.
 Emery, Jane.....WASA, Havre de Grace, Md.
 Emmons, Grysone.....WMTB, Mansfield, Minn.
 Engle, Lura.....WLPQ, La Salle, Ill.
 Ensey, Anita.....KRHD, Duncan, Okla.
 Erdawson, Betty.....KGYO, Missouri, Mont.
 Erwin, Rosamund.....KMON, Great Falls, Mont.
 Escate, Leche.....WBRAD, Radford, Va.
 Eubanks, Velma.....WMTU, Greenville, S. C.
 Evans, Anne.....KSWO, Lawton, Okla.
 Evans, Christine.....WHDH, Boston, Mass.
 Evans, Dunnie.....WMOX, Meridian, Miss.
 Evans, Dorothy.....WTVF, Elmira, N. Y.
 Evans, Sonja.....KMO-TV, Tacoma, Wash.
 Evans, Stacey.....WVGA, Gary, Ind.
 Ezell, Connie.....KHQZ, Harrison, Ark.

— F —

Falkenburg, Jinx.....WNBT, New York, N. Y.
 Farenco, Peg.....WCMB, Harrisburg, Pa.
 Farmer, Helen.....WMAZ, Macon, Ga.
 Feldman, Lenore.....WWIN, Baltimore, Md.
 Fillingham, Joanne.....KANS, Wichita, Kan.
 Flora, Katherine.....WCOM, Cumberland, Md.
 Fiscus, Virginia.....WTTT, Bloomington, Ind.
 Fisher, Alice.....KBIZ, Ottumwa, Iowa
 Fitzwater, Jean.....KGEZ, Kalispell, Mont.
 Flanders, Lyda.....WTAG, Worcester, Mass.
 Fletcher, Louise.....WSOK, Nashville, Tenn.
 Fletcher, Marian.....WLOK-TV, Lima, O.
 Flintoff, Elda.....CKTB, St. Catharines, Ont.
 Floyd, Marco.....WGUU, Bakers, Maine
 Foshish, Joan.....WWSO, Glens Falls, N. Y.
 Folley, Bernice.....WCPO-TV, Cincinnati, O.
 Fontaine, Mary.....WKZO-TV, Kalamazoo, Mich.
 Forque, Sonia.....WLAM, Lewiston, Maine
 Forman, Lynn.....WARM-TV, Scranton, Pa.
 Fortescue, Priscilla.....WEEI, Boston, Mass.
 Fouts, Nell V.....WUNC, Thomasville, N. C.
 Fowler, Fern.....WMTV, Madison, Wis.
 Fowler, Nancy.....WHAP, Hopewell, Va.
 Fowles, Olive.....KGYW, Vallejo, Cal.
 Foxall, Lois.....WSIX, Nashville, Tenn.
 Freed, Mary.....WKXZ, Oil City, Pa.
 Freeland, Mildred.....WMID, Atlanta City, N. J.
 Freeman, Lois.....WGBF, Evansville, Ind.
 Friberg, Alice F.....WCYB, Bristol, Va.
 Fritchell, Colleen.....WAKU, Latrobe, Pa.
 Funchell, Mildred.....WTAM, Cleveland, O.

— G —

Gaffney, Pauline.....WHIEC, Rochester, N. Y.
 Gagne, Mme. R.....CJFP, Riviere Du Loup, Que.
 Gaines, Myrtle.....WOKZ, Alton, Ill.
 Galan, Gilda.....WKAP, Santurce, P. R.
 Gallant, Catherine Rice.....WFAU, Augusta, Maine
 Galvin, Grace H.....WBRY, Waterbury, Conn.
 Gardner, Dorothy.....KTLA, Hollywood, Cal.
 Gardiner, Evelyn.....KDKA, Pittsburgh, Pa.
 Gaskin, Frances.....WGAJ, Elizabeth City, N. C.
 Gay, Pat.....KLZ, Denver, Colo.
 Gay, Virginia.....WEVA, Emporia, Va.
 Gayst, Marion.....WAKR, Alton, O.
 Gibbs, Agnes.....WCSH, Portland, Maine
 Gibbs, Jane.....WKJP-TV, Pittsburgh, Pa.
 Gilchrist, Norma.....KTTV, Los Angeles, Cal.
 Gitsdrop, Karne.....KTAE, Taylor, Tex.

◆ ◆ ◆ WOMEN COMMENTATORS—RADIO-TV ◆ ◆ ◆

Given, Marge.....WIRI, Peoria, Ill.
 Glasner, Anne.....WMMT, McMinnville, Tenn.
 Gluck, Imogene.....WCMC, Wildwood, N. J.
 Godofsky, Miriam.....WHLL, Hempstead, N. Y.
 Good, Ann.....WGLO, Mason City, Iowa
 Goodman, Ruth.....WTOC, Savannah, Ga.
 Gordon, Mimi.....WPRC, Lincoln, Ill.
 Gordon, Windy.....CKTS, Sherbrooke, Que.
 Gorman, Marge.....KVOA, Tucson, Ariz.
 Gottlieb, Ruth.....WMSC, Columbia, S. C.
 Graham, Dorothy.....KFEQ, St. Joseph, Mo.
 Graham, Lee.....WABD, New York, N. Y.
 Graham, Marie.....KFXD, Nampa, Idaho
 Graham, Peg.....KDXB, Dickinson, N. D.
 Graham, Virginia.....WABD, New York, N. Y.
 Gray, Elaine.....KHQ, Spokane, Wash.
 Gray, Ethel.....WSBA, York, Pa.
 Grayson, Garnet.....WCPO-TV, Cincinnati, O.
 Graziani, Rory.....WWON, Woonsocket, R. I.
 Green, Carol.....WOSA, Wausau, Wis.
 Greene, June K.....WHAI, Greenfield, Mass.
 Gregg, Mary.....KAFY, Bakersfield, Cal.
 Grenier, Madeleine.....CFRG, Gravelbourg, Sas.
 Griffith, Marge.....WRTA, Altoona, Pa.
 Grim, Lec.....KOME, Tulsa, Okla.
 Grindlay, Hilary.....WTTT, Bloomington, Ind.
 Grover, Gertrude.....WHCU, Ithaca, N. Y.
 Grunskay, Roberta.....WLGR, Torrington, Conn.
 Gunning, Elizabeth.....WJAR, Providence, R. I.

— H —

Haden, Evelyn.....WKWK, Wheeling, W. Va.
 Hadley, Cis.....KSJB, Jamestown, N. D.
 Haerberle, Arlc.....WCCO, Minneapolis, Minn.
 Hagen, Vi.....WCOU, Montgomery, Ala.
 Haig, Barbara.....WHRV, Ann Arbor, Mich.
 Hale, Betty.....WPMT, Portland, Me.
 Hale, Violet.....WFIL, Philadelphia, Pa.
 Hall, Harriet.....WBSM, New Bedford, Mass.
 Hall, Jane.....WMGR, Bainbridge, Ga.
 Hall, Ruth Ellen.....WSBA, York, Pa.
 Ham, Lois.....KSID, Sidney, Neb.
 Hammersly, Evadua.....KOA, Denver, Colo.
 Hanscomb, Olga.....WFLA, Tampa, Fla.
 Hansen, Flo.....KFRE, Fresno, Cal.
 Hanson, Eleanor.....WHK, Cleveland, O.
 Hanzel, Betty.....WBBW, Youngstown, O.
 Hapgood, Louise.....KCOY, Santa Maria, Cal.
 Hardy, Doris.....WEIM, Fitchburg, Mass.
 Harper, Ann.....KRBC, Abilene, Tex.
 Harpole, Mary.....KVOU, Uvalde, Tex.
 Harris, Betty.....WHOW, Clinton, Ill.
 Harris, Fran.....WWJ-TV, Detroit, Mich.
 Harris, Frances Kay.....KGBC, Galveston, Tex.
 Harris, Joann.....KSTA, Coleman, Tex.
 Harvey, Mary.....WGEM, Quincy, Ill.
 Hausler, Barbara.....KCTI, Gonzales, Tex.
 Hawkins, Louise.....KIUN, Pecos, Tex.
 Hay, Galla.....KVSF, Santa Fe, N. Mex.
 Hayes, Fern.....KVAN, Vancouver, Wis.
 Hayward, Joyce.....WGAC, Augusta, Ga.
 Hazard, Aline.....WHA, Madison, Wis.
 Heath, Martha Ann.....WPFC, Panama City, Fla.
 Heckman, Nan.....WEEU, Reading, Pa.
 Heider, Joan.....WSGW, Saginaw, Mich.
 Heitger, Abbie.....WBIW, Bedford, Ind.
 Henderson, Freddie.....WERD, Atlanta, Ga.
 Heppburn, Helen.....WKBE, Muskegon, Mich.
 Hersch, Gladys, E.....WKAP, Alclntown, Pa.
 Hickey, Jean.....WSDR, Sterling, Ill.
 Hileman, Marie.....KVOC, Casper, Wyo.
 Hill, Jean.....WHTC, Holland, Mich.
 Hillegas, Kay.....KSBW, Sulinas, Cal.
 Hines, Maryalice.....KIMA, Yakima, Wash.
 Holden, Ann.....KGO, San Francisco, Cal.
 Holgate, Helen.....KSDN, Aberdeen, S. D.
 Holland, Jean.....KGNC, Amarillo, Tex.
 Holliday, Mary.....WACO, Waco, Tex.
 Holmgren, Lois R.....WJPD, Ishpeming, Mich.
 Hoover, Marjorie.....KRLC, Lewiston, Idaho
 Hope, Helen.....WHYN, Springfield, Mass.
 Hopper, Marie.....KUBC, Montrose, Colo.
 Horn, Elaine.....KVOS, Bellingham, Wash.
 Horne, Lucille.....KOWL, Santa Monica, Cal.
 Horsfall, Dorothy.....WPDQ, Jacksonville, Fla.
 Horstman, Betty Ann.....WING, Dayton, O.
 Hoskins, Phyliss.....WMMB, Melbourne, Fla.
 Houglum, Mimi.....KUGN, Eugene, Ore.
 Howard, Nancy Richards.....KMUS, Muskogee, Okla.
 Hubbard, Margie L.....KPIT, Paris, Tex.
 Hubert, Anne.....WAVE, Louisville, Ky.

Hughes, Claire.....KWKW, Pasadena, Cal.
 Hughes, Mae.....KQP, Wenatchee, Wash.
 Huie, Mildred.....WALB, Albany, Ga.
 Hulin, Bernice.....WGTV, Des Moines, Iowa
 Hull, Martha.....KCID, Caldwell, Idaho
 Hume, Marge.....KFME, San Diego, Cal.
 Hummel, Janice.....WDOK, Cleveland, O.
 Huse, Polly.....WBZ, Boston, Mass.
 Hutch, Nita.....WTVN, Columbus, O.
 Hutchinson, Lueia.....WRBL, Columbus, Ga.

— I —

Imholz, Dorothy.....KRBZ, Abilene, Tex.
 Ingalls, Mary.....KGRH, Fayetteville, Ark.
 Isaac, Rose.....WJMS, Ironwood, Mich.
 Israel, Dorothy.....WKNY, Kingston, N. Y.

— J —

Jabenis, Elaine.....WOW, Omaha, Neb.
 Jackson, Alice.....WJAR-TV, Providence, R. I.
 Jackson, Fay.....WGAF, Valdosta, Ga.
 Jackson, Gretchen.....WVOM, Boston, Mass.
 Jackson, Louise.....KYOS, Merced, Cal.
 Jackson, Rosemary.....WSKB, McComb, Miss.
 James, Vee.....WCKY, Cincinnati, O.
 Jarman, Frances.....WDNC, Durham, N. C.
 Jensen, Marie.....KTBC-TV, Austin, Tex.
 Jenkins, Polly.....WDEV, Waterbury, Vt.
 Johannesma, Shirley.....KTAR, Phoenix, Ariz.
 John, Alma.....WWRL, New York, N. Y.
 Johnson, Eca.....KMBC, Kansas City, Mo.
 Johnson, Bunny.....WAKN, Aiken, S. C.
 Johnson, Fern.....KSUB, Cedar City, Utah
 Johnson, Gwenn.....KROS, Clinton, Iowa
 Johnson, Sibyl.....WKY, Oklahoma City, Okla.
 Jollivette, Jo.....KISD, Sioux Falls, S. D.
 Jones, Gwen.....KWBS, Oyster Bay, N. Y.
 Jones, Lavernc.....KTRE, Lufkin, Tex.
 Joy, La Velle.....KMOR, Oroville, Cal.
 Julien, Chrystal.....KOEL, Oelwein, Iowa

— K —

Kaess, Virginia.....KVRH, Salida, Colo.
 Kay, Bonnie.....WJBW, New Orleans, La.
 Kaye, Susan.....WRGB, Seheencctady, N. Y.
 Keane, Leontine.....WJLB, Detroit, Mich.
 Keeble, Daisy.....WCRI, Scottsboro, Ala.
 Keefe, Ann.....WHAM, Rochester, N. Y.
 Keefer, Lolly.....WGVV, Charleston, W. Va.
 Keesling, Jane.....WCST, Columbus, Ind.
 Kelley, La Delle.....KVLF, Alpine, Tex.
 Kelley, Miriam.....WAVE, Louisville, Ky.
 Kelly, Ely.....WRFW, Eau Claire, Wis.
 Kelly, Norinc.....CFJR, Brockville, Ont.
 Kelso, Marcia.....KMPT, Oklahoma City, Okla.
 Kercheval, Mary.....WSAZ-TV, Huntington, W. Va.
 Kerry, Katherine.....KCCC-TV, Sacramento, Cal.
 Kieckhafer, Anne.....WBKV, West Bend, Wisc.
 Killmade, Liz.....KSTM-TV, St. Louis, Mo.
 Kimball, Betty.....WHAY, New Britain, Conn.
 Kimbrough, Emily.....WCBS, New York, N. Y.
 Kincannon, Sue.....KFSA, Ft. Smith, Ark.
 King, Carol.....WCAX, Burlington, Vt.
 King, Ethel Jane.....KFH, Wichita, Kan.
 King, Fran.....WGAP, Maryville, Tenn.
 King, Marjorie.....KNBC, San Francisco, Cal.
 Kingbay, Meg.....WMIN, St. Paul, Minn.
 Kirby, Bea.....WTTM, Trenton, N. J.
 Knapp, Winnie.....WSDR, Sterling, Ill.
 Kneeland, Eileen.....WHAV, Haverhill, Mass.
 Knos, Virginia.....KSCB, Liberal, Kan.
 Knott, Martha.....KBYE, Oklahoma City, Okla.
 Koelling, Maxine.....WRE, Dallas, Tex.
 Kole, Ronnie.....WPFA, Pensacola, Fla.
 Kretschman, Lorraine.....KUBC, Montrose, Colo.
 Krueger, Carol.....WIGN, Medford, Wisc.
 Kundert, Dorothy.....WEKZ, Monroe, Wisc.

— L —

Labbitt, Myrtle.....CKLW, Detroit, Mich.
 Lafferty, Betty.....KOPO, Tucson, Ariz.
 Lanctot, Simone.....CKCH, Hull, Que.
 Lane, Barbara.....WISC, Madison, Wisc.
 Lane, Laura.....WMBY, New Orleans, La.
 Lane, Martha.....KXOK, St. Louis, Mo.
 Lane, Sharon.....WANE, Ft. Wayne, Ind.

WOMEN COMMENTATORS—RADIO-TV

Lang, Polly WNOP, Newport, Ky
 Lankford, Virginia WZOB, Ft. Payne, Ala
 Larkin, Jean S. WHEN, Wats, Sayre, Pa
 Larson, Kay WGAN, Portauise, N. Y
 Laiten, Jane WGAN, Portland, Maine
 Lavigne, Claire WATH, Waterbury, Conn.
 Lavitan, Gladys WAYS, Charlotte, N. C.
 Leclerc, Louise CKCY, Quebec
 Lee, Bobbi WHIL, Medford, Mass
 Lee, Elmer WTOP, Washington, D. C.
 Lee, Gretchen WOOD, Grand Rapids, Mich
 Lee, Judy WPTZ, Philadelphia, Pa.
 Lee, June KFXT, Grand Junction, Colo
 Lee, Linda KWET, Austin, Tex
 Lee, Lois KWVO, Cheyenne, Wyo
 Lee, Marjorie WRRR, Jackson, Miss
 Lee, Nora Lou KFPW, Ft. Smith, Ark
 Leeds, Margaret WCHL, Chambersburg, Pa
 Lemma, Joyce KBWD, Brownwood, Tex
 Leonard, Beth KING-TV, Seattle, Wash
 Leslie, Ann WISN, Milwaukee, Wis
 Lewallen, Dorothy WGWR, Ashboro, N. C.
 Lewis, Doris WJAT, Swainsboro, Ga
 Lewis, Emogene KWSH, Wewoka, Okla
 Lexa, Alice KXGN, Glendive, Mont
 Lieser, Mearline KJLN, Redmond, Or
 Lindbert, Allen WABJ, Adrian, Mich
 Lindgren, Irene WFHM, Indianapolis, Ind
 Livermore, Mercer WKKO, Cocoa, Fla
 Lobsinger, Joan CKCR, Litchener, Ont
 Long, Jane WFAM-TV, Lafayette, Ind
 Long, Mary WFMD, Frederick, Md
 Lovett, Annie Warren WJJJ, Monticello, Ala
 Lowe, Kay WKLO, Louisville, Ky
 Linsen, Peggy WND, Pleasantville, N. J.
 Lull, Laura WTBS, Huntsville, Ala
 Lynn, Kathryn KFAL, Fulton, Mo
 Lyons, Dandra WSCS, Charleston, S. C.
 Lyons, Ruth WTWT, Cincinnati, O

McKinnie, Peggy WTJS, Jackson, Tenn
 McMillan, Sue WILD, Birmingham, Ala
 Mead, Dotie WSPR, Sarasota, Fla
 Meath, Jennie KXOB, Stockton, Cal
 Meier, Evelyn WVMC, Mt. Carmel, Ill
 Mellon, Edna WPAZ, Pottstown, Pa
 Melrose, Thelma WXYZ-TV, Detroit, Mich
 Merman, Rayleen KERO, Bakersfield, Cal
 Merryfield, Mary WMAQ, Chicago, Ill
 Messer, Alice KJEO, Fresno, Cal
 Miles, Roy WBRF, Wilkes Barre, Pa
 Miller, Betty B. KDFB, Lubbock, Tex
 Miller, Mary KROC, Rochester, Mont
 Miller, Mildred WBEX, Buffalo, N. Y
 Milligan, Marian WTAD, Quincy, Ill
 Mills, Nancy KVIC, San Luis Obispo, Cal
 Mitchell, Julia WATM, Atmore, Ala
 Mitchell, Stella G. WPAR, Savannah, Ga
 Mitchell, Eleanor WRTT, Bowling Green, Ky
 Alce, Jean KAVL, Storm Lake, Iowa
 Morum, Lorraine WAOV, Vincennes, Ind
 Moore, Pat WPEX, Philadelphia, Pa
 Moon, Virginia KTRM, Beaumont, Tex
 Moore, Bettye KVGK, Great Bend, Kan
 Moore, Betty WDLA, Walden, N. Y.
 Moore, Eleanor WSET, South Bend, Ind
 Moore, Mary WLVA, Atlanta, Ga
 Moore, Mary WJAG, Norfolk, Neb
 Morrison, Mary CRAY, Detroit, Mich
 Morris, Louise WDAK, Columbus, Ga
 Morse, Molly KFMB, San Diego, Cal
 Morrison, Luella WKOV, Madison, Wis
 Mosser, Sue KPEA, Greeley, Colo
 Mossman, Sally WMCK, McReesport, Pa
 Mounts, Wyletta KCOV, Alliance, Neb
 Munoz, Margarita KTXN, Austin, Tex
 Murphy, Marian WTPA-TV, Harrisburg, Pa
 Murray, Jean WRDO, Augusta, Maine

— M —

MacDonald, Elaine CHOK, Sarnia, Ont
 MacDonald, Marie KFBI, Wichita, Kan
 MacGregor, Marguerite WPEP, Taunton, Mass
 Mack, Ellyn KBR, Burlington, Iowa
 MacMorris, Margaret KBWB, Hutchinson, Kan
 Madden, Gertrude WWPA, Williamsport, Pa
 Maddox, Mary Lou WHPS, Evansville, Ind
 Madory, Mary KPFL, Denver, Colo
 Mahoney, Esther WSPA, Monticomey, Ala
 Malicord, Boo WHOQ, Orlando, Fla
 Mallory, Martha WWNH, Rochester, N. H.
 Mann, Claire WABD, New York, N. Y.
 Manning, Mary WLAG, Nashville, Tenn
 Markel, Hazel WWTG, Washington, D. C.
 Marlowe, Lorelle WBRW, Welch, W. Va.
 Marshall, Mary Louise WOC, Davenport, Iowa
 Marshall, Shirley WAVE, Louisville, Ky
 Martin, Ann WKRC, N. Wilsboro, N. C.
 Martin, Jean KPEX, San Jose, Cal
 Martin, Josephine KFRQ, San Francisco, Cal
 Martin, Mary Ellen KSWB, San Bernardino, Cal
 Martin, Sally WTVE, Elmira, N. Y.
 Martin, W. L. WWGS, Tifton, Ga
 Mason, Eleanor KGMB-TV, Honolulu, T. H.
 Mason, Mary WJVB, Jacksonville Beach, Fla
 Mason, Shirley KFRF, Columbia, Miss
 Massey, Vera WFSB, New Orleans, La
 Masters, Margaret KSTV, Salt Lake City, Utah
 Mathre, Dianne WCTA-TV, Champaign, Ill
 Matson, Shirley WTAC, Worcester, Mass
 Maxwell, Betty WLAP, Lexington, Ky
 Maxwell, Virginia WCAV, Silver Springs, Md
 May, Catherine KTT, Yakima, Wash
 May, Joyce WXP, Evanston, Ill
 McBride, Jean WWJ, Detroit, Mich
 McBride, Maureen WHTD, Pough City, Olla
 McCall, Betty WTAO, Baltimore, Md
 McCartney, Manda H. KQJM, Havre, Mont
 McCormack, Dorothy WSON, Henderson, Ky
 McCune, Paula KLO, Orem, Utah
 McDonald, Helen KRRX, San Jose, Cal
 McDonald, Margaret WBAP-TV, Fort Worth, Tex
 McDonald, Mary WGL, Ft. Wayne, Ind
 McDonald, Mary Virginia WGAJ, Valdosta, Ga
 McDougal, Elizabeth CHAT, Medicine Hat, Alta
 McDowell, Winifred WRGB, Schenectady, N. Y.
 McElroy, Elvise WPIX, New York, N. Y.
 McFarland, Dorothy KCHA, Charles City, Iowa
 McGivren, Marje KWBE, Beatrice, Neb
 McKee, Linda WLAG, Lagrange, Ga

— N —

Neilson, Shirley WJWB, Rutland, Vt
 Neumann, Kay WPTV, Pittsburgh, Pa
 Newell, Vera KFGO, Fargo, N. D.
 Newman, Ida WJDA, Quincy, Mass
 Newsome, Daphne WNHX, Fitzgerald, Ga
 Niles, Helen WAPN, Montgomery, Ala
 Norman, Beth KVA, San Francisco, Cal
 Norman, Kay KNEA, Jonesboro, Ark
 Norton, Sally KRON, Napa, Cal
 Norton, Serena WEDC, Chicago, Ill
 Novak, Lois WBRE-TV, Wilkes Barre, Pa
 Nyberg, Gertrude KGH, Billings, Mont

— O —

Oblinger, Jackie WRIS, Bluefield, W. Va
 O'Brien, Lee KRPD, Durango, Colo
 O'Brien, Margaret KFBC-TV, Cheyenne, Wyo
 O'Brien, Mary Lou KENT, Shreveport, La
 O'Day, Billie WIOD, Miami, Fla
 O'Neil, Kay LJK, Winnipeg, Man
 Oppenheimer, Kitty KTEM, San Rafael, Cal
 Oser, Eddie WOAD, Owosso, Mich
 Owen, Gordon KALL, Salt Lake City, Utah

— P —

Page, Mrs. WJR, Detroit, Mich
 Paige, Dotie WREN, Topeka, Kan
 Paige, Evelyn WTVL, Waterville, Me
 Parnell, Sue WFKF, Fayetteville, N. C.
 Parker, Paige WEWS, Cleveland, O
 Parker, Paige WNST, Wagonaw, Va
 Parker, Zelmadeen KADA, Ada, Okla
 Part, Jean WKOW, Madison, Wis
 Parris, Helen WAGA, Atlanta, Ga
 Patton, Rae KRAM, Las Vegas, Nev
 Payne, Lorraine KWHP, Cushing, Okla
 Pedlow, Marian WPPA, Chester, Pa
 Peed, Emily May WJPR, Farmington, W. Va
 Peuband, Nell Estes WACL, Waycross, Ga
 Person, Violet WNTC, Waynesville, Ky
 Phelps, Carmen WOM, San Antonio, Tex
 Phillips, Lee WBEM-TV, Chicago, Ill
 Philippi, Mary Jane KGFH, Flagstaff, Ariz
 Pison, Rama WSPR, Suptis, Mich
 Plank, Laura RASH, Eugene, Ore

◆ ◆ ◆ WOMEN COMMENTATORS—RADIO-TV ◆ ◆ ◆

Pons, Norma.....KORK, Las Vegas, Nev.
 Pope, Lucy.....WAPX, Montgomery, Ala.
 Pope, Sara T.....Winder, Ga.
 Popham, Virginia F.....KTLW, Texas City, Tex.
 Porter, Carrie.....WSPR, Springfield, Mass.
 Porter, Elaine.....WCOA, Pensacola, Fla.
 Porter, Jeanne.....WKNB, New Britain, Conn.
 Potter, Cliffordean.....WOMI, Owensboro, Ky.
 Potter, Grace.....WMOU, Berlin, N. H.
 Prentice, Janet.....KHSL, Chico, Cal.
 Pressly, Harriet.....WPTF, Raleigh, N. C.
 Priess, Shirley.....KOLQ, Reno, Nevada
 Proffitt, Sally.....WBOW, Terre Haute, Ind.
 Protsman, Faith.....WNER, Live Oak, Fla.
 Pulliam, Billie.....KPDN, KPDN, Pampa, Tex.
 Purcell, Joan M.....WCLI, Corning, N. Y.

— Q —

Quick, Nettie.....WAJF, Decatur, Ala.
 Quinn, Carolyn.....KWEN, Ft. Smith, Ark.
 Quinn, Frances.....KYNO, Fresno, Cal.

— R —

Ramey, Wanda.....KROW, Oakland, Cal.
 Randall, Joanne.....WLAV, Grand Rapids, Mich.
 Ransom, Jane.....WASK, Lafayette, Ind.
 Ray, Ruth.....WKST, New Castle, Pa.
 Ray, Snetia.....KBOA, Kennett, Mo.
 Ready, Mary Jane.....WOHI, East Liverpool, O.
 Redington, Ruth.....WKNE, Keene, N. H.
 Reich, Betty.....WJMC, Rice Lake, Wis.
 Reich, Marion.....WKBN-TV, Yonngstown, O.
 Rexach, Sylvia.....WKVW, San Juan, P. R.
 Reynolds, Lenore M.....WCMA, Corinth, Miss.
 Riano, Renie.....WBNS, Columbus, O.
 Richards, Joan.....WIPC, Lake Wales, Fla.
 Richter, Barbara.....WVEC, Hampton, Va.
 Risk, Hcster.....WMBS, Uniontown, Pa.
 Rissley, Fern.....WRMN, Elgin, Ill.
 Ritchie, Ruth.....WBEJ, Elizabethton, Tenn.
 Roasles, Doris.....KWSO, Wasco, Cal.
 Roberts, Fran.....WCSS, Amsterdam, N. Y.
 Roberts, Marion.....WBEN, Buffalo, N. Y.
 Robinson, Blanche.....WOCB, W. Yarmouth, Mass.
 Robinson, Carol Ann.....KALG, Alamodorado, N. M.
 Robinson, Dottie, B.....WENE, Binghamton, N. Y.
 Robinson, Penny.....KPOJ, Portland, Ore.
 Rogers, Ann.....WHAM, Rochester, N. Y.
 Roland, Rusty.....WKOP, Binghamton, N. Y.
 Rooney, Midge.....WCRB, Waltham, Mass.
 Rose, Pat.....KYMA, Yuma, Ariz.
 Rosenbaum, M. Virginia.....WTBO, Cumberland, Md.
 Ross, Janet.....KDKA, Pittsburgh, Pa.
 Roth, Janie.....KAYS, Hays, Kan.
 Rowe, Flo Beach.....WSLB, Ogdensburg, N. Y.
 Ruetz, Julie.....WRAC, Racine, Wis.
 Rule, Jacqueline.....WSIP, Paintsville, Ky.
 Rundle, Ann.....WLAD, Danbury, Conn.
 Rundvold, Inga.....WNBW, Washington, D. C.
 Russell, Kay.....WSYR-TV, Syracuse, N. Y.
 Russell, Marvel.....KWTX, Waco, Tex.
 Rutherford, Wilma.....KNUZ-TV, Houston, Tex.
 Ryan, Helen.....WKNX, Saginaw City, Mich.
 Ryte, Rita.....WEWO, Lauringburg, N. C.

— S —

Salas, Irma.....KBKI, Alice, Tex.
 Salzar, Florence.....KODI, Cody, Wyo.
 Sampson, Judy.....KPRO, Riverside, Cal.
 Samuelson, Connie.....WJTN, Jamestown, N. Y.
 Sanderson, Elsie Neely.....KOLN, Lincoln, Neb.
 Sant Amour, Joyce.....WUDZ, Green Bay, Wis.
 Santiago, Andrea Rosa.....WCMN, Arecibo, P. R.
 Sawyer, Ila Mae.....WGCD, Chester, S. C.
 Sawyer, Junc.....WSOC, Charlotte, S. C.
 Schneider, Eunice J.....WEPM, Martinsburg, W. Va.
 Schram, Violet.....KFVD, Los Angeles, Cal.
 Scott, Dottie.....KOVE, Lander, Wyo.
 Scott, Romaine.....WPAM, Rottsville, Pa.
 Seidner, Mary Lee.....KLIX, Twin Falls, Idaho
 Shaffer, Pat.....WLBC, Muncie, Ind.
 Shank, Dorothy.....WEBR, Buffalo, N. Y.

Sharp, Fern.....WBNS, Columbus, O.
 Sharp, Patricia.....WICA, Ashtabla, O.
 Shaw, Monette.....KABC, San Antonio, Tex.
 Shea, Jeanne.....WBNS, Columbus, O.
 Shean, Darcy.....WFPL, Ft. Lauderdale, Fla.
 Shelby, Beta.....KXOA, Sacramento, Cal.
 Shelly, Edna.....KARE, Atchison, Kan.
 Shipham, Winnifred.....KHUM, Eureka, Cal.
 Schroer, Fran.....WALM, Albion, Mich.
 Shumate, May-Floyd.....KSO, Des Moines, Iowa
 Shuriz, Margaret.....WUHL, Johnson City, Tenn.
 Silver, Marjorie.....WIRA, Ft. Pierce, Fla.
 Simpson, Diane.....CFAR, Flin Flon, Man.
 Simpson, Sloan.....WOR, New York, N. Y.
 Smith, Betty.....WBTM, Danville, Va.
 Smith, Doris.....WDUN, Gainesville, Ga.
 Smith, Jeanne.....KPUG, Bellingham, Wash.
 Smith, Libby.....WFTV, Dnlth, Minn.
 Smith, Libby.....KWRO, Coquille, Ore.
 Smith, Margaret.....WIRC, Hickory, N. C.
 Smith, Margaret.....KHQ, Spokane, Wash.
 Smith, Nona.....WOKO, Albany, N. Y.
 Smith, Patti.....KNUJ, New Ulm, Minn.
 Smith, Sue Marshall.....WDEC, Americans, Ga.
 Smith, Wileen.....KXLF, Butte, Mont.
 Snively, Mary Lois.....KSTP, Davenport, Iowa
 Snyder, Gerry.....KBMN, Bozeman, Mont.
 Somerville, Joy.....WICH, Norwich, Conn.
 Spann, June.....KWAK, Stuttgart, Ark.
 Speece, Wynn Hubler.....WNAX, Yankton, S. D.
 Speltz, Bernardine.WFHR, Wisconsin Rapids, Wis.
 Shugars, Florence L.....WROK, Rockford, Ill.
 Spicer, Rita.....CKCK, Regina, Sask.
 Spiegel, Shirley J.....WMIE, Miami, Fla.
 Stackpole, Connie.....WKBR, Manchester, N. H.
 Standish, Martha.....WPOP, Portland, Me.
 Stark, Beverly.....WMTV, Madison, Wis.
 Stark, Jean Marie.....WEAR, Pensacola, Fla.
 Starker, Irene.....WHAR, Clarksburg, W. Va.
 Stebbins, Hazel.....KFOR, Lincoln, Neb.
 Stephenson, Peggy.WSAZ-TV, Huntington, W. Va.
 Sterling, Ann.....KJR, Seattle, Wash.
 Stevens, Dorothy.....WLAN, Lancaster, Pa.
 Stevens, Jane.....WJW, Cleveland, O.
 Stevens, Jean.....WNOW, York, Pa.
 Stewart, Becky Ann.....WPBC, Minneapolis, Minn.
 Stoddard, Betty.....KATO, Reno, Nev.
 Stone, Bobby.....KLEA, Lovington, N. M.
 Stone, Sue.....KVIC, Victoria, Tex.
 Storms, Edna.....KGA, Spokane, Wash.
 Strickland, Dolly.....CKGB, Timmins, Ont.
 Stringer, Tippy.....WNBW, Washington, D. C.
 Stroope, Mary.....KARK, Little Rock, Ark.
 Stulb, Eileen.....WRDW, Augusta, Ga.
 Sullivan, Jean.....KMTV, Omaha, Neb.
 Summers, Connie.....KTRC, Sante Fe, N. M.
 Syx, Betty.....WTVN, Columbus, O.

— T —

Tabor, Maida.....WSMB, New Orleans, La.
 Tackett, Norma Loy.KKTU, Colorado Springs, Col.
 Taylor, Lynn.....KCOG, Fresno, Cal.
 Taylor, Marline.....KOLD, Yuma, Ariz.
 Taylor, Nancy J.....WOTW, Nashua, N. H.
 Taylor, Olive.....KEXO, Grand Junction, Colo.
 Taylor, Rosemary.....KLAN, Renton, Wash.
 Taylor, Teena.....WFMA, Anniston, Ala.
 Taylor, Willi.....KFEL, Denver, Colo.
 Temple, Alma.....WDSR, Lake City, Fla.
 Terry, Ann.....CJCB, Nova Scotia, Can.
 Theaux, Mrs.....KVOL, Lafayette, La.
 Thomas, Jane.....WCMW, Canton, O.
 Thomas, Prissy.....WKY, Oklahoma City, Okla.
 Thompson, Bernice.....WDAS, Philadelphia, Pa.
 Thompson, Nancy.....WCLT, Newark, O.
 Thompson, Ruth.....KJBS, San Francisco, Cal.
 Tidmore, Evelyn.....WNPT, Tuscaloosa, Ala.
 Tinder, Olive.....WJAR-TV, Providence, R. I.
 Todd, Jane.....KCBS, San Francisco, Cal.
 Tolson, Bettie.....KMTV, Omaha, Neb.
 Torregrosa, Angela L.....WITA, San Juan, P. R.
 Tovey, Vera.....WKXL, Concord, N. H.
 Towne, Peggy.....WFIL, Philadelphia, Pa.
 Tracy, Iona.....WAGE, Syracuse, N. Y.
 Traphagen, Mary Lois.....WICU, Erie, Pa.
 Tremblay, Jeanne.....CHLT, Sherbrooke, Quec.
 Trimm, Bettyce.....WBAC, Cleveland, Tenn.
 Truax, Anne.....KLX, Oakland, Cal.
 Tuschhoff, Carol.....WSOY, Decatur, Ill.

— U —

Edstrand, LoisKTRE, Thief River Falls, Minn.
Underwood, BettyWNOE, New Orleans, La.

— V —

Van Cleve, RachelWEWS, Cleveland, O.
Van Etten, Mrs. AveryWTOB-TV, Winston-Salem, N. C.
Veuilleux, PierretteCHIEF, Granby, Que.
Vioni, PatriciaWKBY, Richmond, Ind.

— W —

Waekerman, Olga S.WSKY, Montpelier, Vt.
Waldo, DorothyWBSM, Superior, Wis.
Walker, MaryWROL, Knoxville, Tenn.
Walpole, SherliRGBX, Springfield, Mo.
Walsh, MargaretWVEC-TV, Hampton, Va.
Walters, LiddieWPEC, Greenville, S. C.
Ward, DianneWLS, Lansing, Mich.
Ward, DottieWISL, Shamokin, Pa.
Ward, VirginiaKERV, Kerville, Tex.
Warren, JoanWJEL, Springfield, O.
Warren, WendyCKY, Winnipeg, Man.
Wayne, RosemaryWJDD, Chicago, Ill.
Webber, Edith L.KWDM, Des Moines, Iowa
Webster, BernadineWIRK, W. Palm Beach, Fla.
Weedman, PollyKOTA, Rapid City, S. D.
Weedon, RadineKCEN, Temple, Tex.
Weeks, NormaKJNO, Juneau, Alaska
Weiler, LouiseWINN, Louisville, Ky.
Welch, Barbara W.WSAT, Salisbury, N. C.
Welles, RuthKYW, Philadelphia, Pa.
Wells, BarbaraWOR, New York, N. Y.
Wells, BettyKIOA, Des Moines, Iowa
Wertman, LouiseWKYB, Keyser, W. Va.
West, BelleKOLL, Omaha, Neb.
West, KayKEX, Portland, Ore.
West, JaneKTMS, Santa Barbara, Cal.

Weston, AliceWXEL, Cleveland, O.
Weston, JaneWOWO, Ft. Wayne, Ind.
Wharton, AnnWJNO, W. Palm Beach, Fla.
Wheeler, MaryKTAT, Frederick, Okla.
Wheeler, Mary AnnKVEC, San Luis Obispo, Cal.
Whiteman, PhyllisWBAT, Marion, Ind.
Wibush, JudyKANG, Waco, Texas
Wilbur, BobetteKHAS, Hastings, Neb.
Willard, TessWJET, Erie, Pa.
Willeford, MillieWDVA, Danville, Va.
Willeke, SallyWBRK, Pittsfield, Mass.
Williams, AnneWRCP, Berkeley, Cal.
Williams, CarolKRCP, Albany, N. Y.
Williams, JosieWMGY, Montgomery, Ala.
Williams, Terry L.KAWT, Douglas, Ariz.
Willis, KathrynWJHL, Johnson City, Tenn.
Winner, JerryKPSA, Ft. Smith, Ark.
Wilson, LouiseWHAM, Rochester, N. Y.
Wilson, MaryWPTZ, Philadelphia, Pa.
Winther, VannirKBLL, Blackfoot, Idaho
Wise, MadelineWHIO, Dayton, O.
Wise, PennyWHUM, Reading, Pa.
Wisler, DoloresWNAR, Norristown, Pa.
Withee, AliceWJHP, Jacksonville, Fla.
Wolfe, MadelineWEIM, Fitchburg, Mass.
Wood, DonnaKTVQ, Oklahoma City, Okla.
Wood, Dorothy S.WPTM, Mayeville, Ky.
Wood, JeanneCHSJ, St. John, N. B.
Woodruff, KateWCHS, Norwich, N. Y.
Wright, GerryKWPT-TV, Wichita Falls, Tex.
Wright, NinaKSOO, Sioux Falls, S. D.
Wuiff, MaggieWXEL, Cleveland, O.
Wynne, Jennie V.KCRD, Lubbock, Tex.

— Y —

Young, Mary EmmaWRUC, Rolland, Mich.
Young, NormaKHL, Los Angeles, Cal.

— Z —

Zahel, MegWGAR, Cleveland, O.
Zwart, Elizabeth ClarksonKRNT, Des Moines, Ia.

barnes
printing
company
inc.



229 West 28th Street, New York 1, N. Y.
printers of this annual



Musical Commercials Gain Stature As Sales Technique

By PHIL DAVIS

President

Phil Davis Musical Enterprises, Inc.

THE penetration of the musical commercial — on the buying habits of the American public — is one of the phenomena of advertising. Once the hybrid of broadcasting and the butt of critics' jibes, it's emerged not only as an important medium of the advertising world, but also as big business.

Gone are the days when every mother's son from Brooklyn to Boise fancied himself a copy man and a musician, forcing sales lyrics to music and music to sales lyrics. Gone, too, is the monotonous ransacking of public domain tunes — on all levels: local, regional, and national — that dissipated all sponsor identification in the deluge of product confusion and triteness of music.

It would be a blatant over-statement to contend that the era of such irritating musical commercials is over. But the outlook for 1954 is most promising, and more promising as one views the widening horizon of the television picture. For television — more than any other mass medium — is establishing a national standard of quality that invites comparison. It is the only selling medium that impinges both on the eyes and the ears of the public, making a two-fold impact.

It's an impact that is also intimate, going into the hearts of homes in their most relaxed moments when faculties — free of outside influence — are most critical. This intimacy of impact psychologically establishes every viewer as supreme arbiter of the good, the bad, and the mediocre entertainment, commercial or otherwise. If a viewer sees and hears an excellent musical commercial for a national beer, let us say, that is entertaining, in good taste, and featuring talent, musically and vocally, equal to the best popular recordings, he — consciously or unconsciously — associates the quality of the television commercial with the quality of the product.

On the other hand, if — later in the evening — he sees a television commercial for a local or regional beer that is inferior to the television commercial of the national beer, he again — by the same psychological process — associates the inferior quality of the television commercial with the product, though it may not be necessarily true.

This is one of the factors that accounts, in part, for the national growth of the musical commercial as a standard advertising technique.

Today, advertising agencies, servicing local and regional clients, demand and buy — on the whole — the same high quality radio and television musical commercials for local and regional advertisers as those usually purchased for the national advertiser.

But probably the main factor responsible for the expansion and growing prestige of the musical commercial field is the men who have made it a business that commands the respect of sponsors and advertising agencies, many of whom have established musical commercial departments, though these agencies, too, frequently call in outside firms, as ours, for example, on particular assignments.

Recognizing the highly specialized talents that go into the creation of effective musical commercials, agencies and sponsors also know that it is neither accident nor chance that dictates the effectiveness of a musical commercial; but the blood, sweat, tears, and often sleepless nights of men trained in advertising, public psychology, meter, and music.

It's this training that's behind the new direction sales technique of the musical commercial's foremost practitioners. It's a technique that utilizes and embraces, in originating musical commercials, not only sales impact of performance and sales impression created; but also the highly important bonus impression that accrues to a sponsor every time someone whistles, hums, or sings the melody of the musical commercial thereafter.



A REPERTORY
OF DISTINCTION

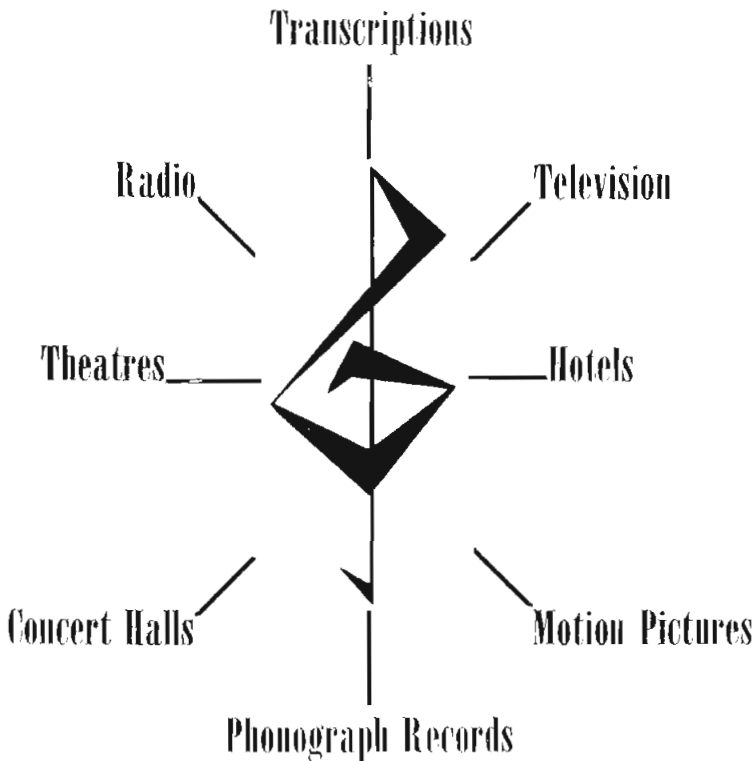

AND AN OUTSTANDING
TRANSCRIBED LIBRARY

SESAC Inc.

475 FIFTH AVENUE N. Y. 17, N. Y.

Serving The Entertainment Industry Since 1931

M*usic*

•

**MUSICAL COMMERCIAL
PRODUCERS**

•

**PERFORMING RIGHTS
SOCIETIES AND MEMBERS**

•

**ASCAP, AMP,
BMI, SESAC**

● **DISTINCTIVE MUSICAL TRADEMARKS . . .**

● *that "SING" sales for —*

All	Hudson Paper Napkins
Brach's Mint Bar	Johnson's Wax
Broughton's Farm Dairy, Inc.	Kellogg's Sugar Frosted Corn Flakes
Camay Soap	Koehler's Beer
Carling's Black Label Beer	Niagara Instant Laundry Starch
Cereal Institute	Nucoo
Chevrolet Dealers	Old Dutch Beer
Crisco	Old Georgetown Beer
Eskimo Anti-Freeze	Olympia Beer
Gosinator	Pick-N-Pay Super Markets
Genesee Beer	Rainier Beer
Goebel Beer	Schoenling Beer
Green Mint Mouth Wash	Tivoli Beer
Hudepohl Beer	WNBT, New York
Hudson Motors	Zest

● *through distinguished agencies coast-to-coast —*

New York

Benton & Bowles, Inc.
 Biow Company, Inc.
 Cecil & Presbrey, Inc.
 Compton Advertising, Inc.
 Gardner Advertising Co.
 C. L. Miller Co., Inc.
 Williom H. Weintraub, Inc.

Chicago

Leo Burnett Co., Inc.
 Arthur Meyerhoff & Co.
 Needham, Louis & Brorby, Inc.

Detroit

Brooke, Smith, French, Dorrance

Seattle

Batsford, Constantine & Gardner
 Miller and Company

Washington, D. C.

Kal, Ehrlich & Merrick, Inc.

Erie, Pennsylvania

Yount and Company

Rochester

Rogers & Parter

Cincinnati

Rollman and Peck
 Leonard M. Sive & Associates
 Stockton, West, Burkhardt, Inc.

Cleveland

Long, Fisher & Stashower, Inc.
 Marcus Advertising Agency, Inc.

Denver

Boll & Davidson, Inc.

Phoenix

Advertising Counselors of Arizona

● **PHIL DAVIS MUSICAL ENTERPRISES, INC.**

"DISTINCTIVE MUSICAL COMMERCIALS"

and subsidiary - -

PAVIS RECORDS

1650 BROADWAY • NEW YORK 19, NEW YORK • COLUMBUS 5-8148

GOLDSWAN PRODUCTIONS



**CREATORS AND PRODUCERS
OF THE
FINEST MUSICAL COMMERCIALS
FOR
RADIO AND TELEVISION**

INCLUDES

- **CREATION OF ORIGINAL MUSIC**
- **COPY WRITING**
- **COMPLETE STUDIO PRODUCTION**

JUST A FEW OF OUR RECENT SUCCESSES

PRODUCED FOR AGENCY

AJAX
PEPSODENT
MANISCHEWITZ
V-8 VEGETABLE JUICE
NESCAFE
NATIONAL SHOES
PEPSI COLA
HALO
VASELINE HAIR TONIC
SWANSDOWN CAKE MIXES

WRITTEN AND PRODUCED FOR AGENCY

PIEL'S
RONSON
SUNBEAM
JELLO
CHEVROLET
KELLOGG'S
GENERAL TIRES
WESSON OIL
DREFT

IF YOUR JINGLE IS ALREADY WRITTEN WE WILL PRODUCE IT FOR YOU.

EXPEDITIOUS — EFFICIENT — ECONOMICAL SERVICE

CHUCK GOLDSTEIN
730 FIFTH AVENUE, N. Y., N. Y.

BOB SWANSON
PLaza 7-3091

MUSICAL COMMERCIAL PRODUCERS

Jingle Writers



ASSOCIATED BROADCAST ADV. CO.

8409½ Melrose Place
Los Angeles 46, Calif.
DUnkirk 8-2972

GUS HAENSHEN'S MUSICAL FEATURES

444 Madison Avenue
New York, N. Y.
PLaza 3-2114

BASCH RADIO & TV PRODUCTIONS

17 East 45th Street
New York, N. Y.
MUrray Hill 2-8877

THE LANDT TRIO

Bedford Road
Armonk, N. Y.
HA 9-5971

GORDON M. DAY *Jingle & Spot Productions*

—Complete writing-pro-
duction facilities for
handling radio and TV
jingle and spot pack-
ages.

—94 sponsors serviced
through 39 advertising
agencies in 7 years.

GORDON M. DAY PRODUCTIONS

108 E. 30th St., N. Y. C. ORegon 9-3595

Complete MUSIC SERVICE

For Your Every Need in
TELEVISION

Radio

Motion Pictures

Stage Presentations

MUSICAL DIRECTORS

The Danny Thomas Show
The Ray Bolger Show

RCA Label "X" Records



MUSIC SERVICE INC.

CRestview 4-1914

8848 Sunset Blvd., Hollywood 46, Calif.

LEO CORDEY PRODUCTIONS
1619 Broadway
New York, N. Y.
Circle 6-7782

ANDY LOVE PRODUCTIONS
65 Park Avenue
New York, N. Y.
Murray Hill 6-1017

PHIL DAVIS MUSICAL
ENTERPRISES
1650 Broadway
New York, N. Y.
CO 5-8148

GEORGE R. NELSON
208 State Street
Schenectady, N. Y.
Schenectady 4-4135

GORDON M. DAY
108 East 30th Street
New York, N. Y.
ORegon 9-3595

JACK ROURKE PRODUCTIONS
6331 Hollywood Blvd.
Hollywood 28, Calif.
HE 7178

GOLDSWAN PRODUCTIONS
730 Fifth Avenue
New York, N. Y.
PLaza 7-3091

SONG ADS
5927 Sunset Boulevard
Hollywood, Calif.
Hollywood 5-6181

LANNY & GINGER GRAY:
JINGLES
70 East 96th Street
New York, N. Y.
EN 9-7777

TELEWAYS RADIO
PRODUCTIONS, INC.
8949 Sunset Boulevard
Hollywood 46, Calif.
BR 2-1447, CR 6-7238

Attention

ARTIST • PRODUCER • MUSIC DIRECTOR

MUSIC IS OUR BUSINESS

We have THE Song You seek.

Write for OUR list of NEW SONGS available to you, at NO cost.



"If we do not have the song
you seek, I will write it for you."

NICHOLAS J. GILIO



39 PARK AVENUE, RUTHERFORD, N. J.

1914

1954

The American Society of Composers, Authors and Publishers will be forty years old in 1954. During these forty years many important changes have taken place in the entertainment world.

America's listening audience has increased by the millions with the growth of new media—such as sound pictures, radio, television and juke boxes. And the one ingredient in the field of entertainment which has survived all technological changes—not only survived, but has increased and expanded—is Music! It has remained a basic requirement for all phases of show business. For a good song always is good entertainment!

ASCAP—entering its forty-first year—is justly proud of the repertory of its more than 3,000 song-writers and composers. ASCAP also is proud of its many years of service to its licensees, and pledges itself to a continuation of making available to the entertainment world the best in music.

AMERICAN SOCIETY OF COMPOSERS, AUTHORS AND PUBLISHERS

575 MADISON AVENUE, NEW YORK 22, N. Y.

A. S. C. A. P.

By **STANLEY ADAMS**
President



USERS of copyrighted musical works in public performance for profit are required under the United States Copyright Law to first clear performing rights of such works with the copyright owner. Because of the vast use of these musical works in radio and television, copyright clearance is one of the major responsibilities of the operators of franchises in these fields.

Performing rights societies exist throughout the world for the purpose of expediting these copyright clearances. Notable among such groups is the American Society of Composers, Authors and Publishers—familiarily known, wherever radio and television are known, as ASCAP. In the great reservoir of the ASCAP repertory are musical works of every conceivable sort in great number, covering two generations of composers and authors and their publishers. With the simple machinery of a blanket agreement between ASCAP and the user, hundreds of thousands of performing rights become instantly available, at a cost to the user that reflects the Society's high operational efficiency. It spends some three million dollars yearly to make its repertory readily available, absorbing in great part the music clearance costs that otherwise would be borne by the users.

ASCAP now enters its 41st year of service to its members and its licensees, with membership approaching the 3,500 mark, and a repertory to meet every possible need of its patrons. ASCAP is proud of its contributions to the incredible growths of both radio and television. As its president, I am happy to speak for all our members in pledging continued and greater effort to make available to radio and television, as well as to the entire entertainment world, a repertory of ever-increasing usefulness.

ASCAP maintains headquarters at 575 Madison Ave., New York City, with 25 branches throughout the country. Officers as of Jan. 1, 1954, are:

<i>Stanley Adams</i>	<i>President</i>
<i>Louis Bernstein</i>	<i>Vice President</i>
<i>John Tasker Howard</i>	<i>Secretary</i>
<i>George W. Meyer</i>	<i>Asst. Secretary</i>
<i>Saul H. Bourne</i>	<i>Treasurer</i>
<i>Frank H. Connor</i>	<i>Asst. Treasurer</i>

The Board of Directors comprises 12 writer- and 12 publisher-members, elected biennially, the writers by writer-members, the publishers by publisher-members, for two-year terms.

- A B C Music Corporation
 A-M Music Corp.
 Abbey Music Co., Inc.
 Adams, George, Mus. Pub. Co.
 Adrienne Music Co.
 Advanced Music Corp
 Affiliated Musicians Inc
 Alamo Music, Inc.
 Alba Music, Inc.
 Albert Music Corp.
 Alfred Music Co., Inc
 Allied Music Corp.
 Allison's Music, Inc
 Ania Music Co.
 Ambassador Music, Inc.
 Anico Music Co.
 American Academy of Music
 American Music Pub. Co.
 Antobal Music Company
 Anton Publications
 Antony, Frank
 Apollo Music Co.
 Arbee Music Pub. Co
 Arch Music Co., Inc.
 Arcot Music Pub. Co
 Ardmore Music Corp.
 Argosy Music Corp.
 Arndt, Nola, Inc
 Arnel Music Co.
 Arrow Music Co.
 Arthur, Irving, Music Corp.
 Artists Music, Inc.
 Ascher, Emil, Inc.
 Atlas Music Corp.
 Axelrod Publications, Inc
 Badoian Music Publishers
 Ballard, Pat, Publisher
 Bantam Music Pub. Co., The
 Barbour-Lee Music Corp
 Baron, M., Co.
 Barton Music Corp.
 Bel-Air Music Corp.
 Bell Song Publishing Co.
 Bellamy Music
 Belwin, Inc.
 Berlin, Irving, Music Corp
 Bernie, Dave, Music Co.
 Beverly Music Corp.
 Biba Music, Inc.
 Biltmore Music Corp.
 Birchard, C. C., & Co
 Bishop Music Co.
 Blasco Music, Inc.
 Bloch Publishing Co
 Block, Martin
 Bloom, Ben, Music Corp
 Blossom Music Corp.
 Blue Circle Music Pub
 Blue Ribbon Music Co.
 Bogat Music Corp.
 Boland, Clay, Inc.
 Bond, Carrie Jacobs, & Son
 Boston Music Company
 Bourne, Inc
 Box & Cox (Pub.)
 Brandom Music Co.
 Bregman, Vocco & Conn, Inc.
 Briegel, Geo., F., Inc.
 Bristol Music Corporation
 Broadway Music Corporation
 Bromaur Music Corp.
 Brooks Music Corp.
 Broude Bros.
 Brull Music, Inc
 Bulls-Eye Music, Inc.
 Burke & Van Heusen Inc.
 Burlington Music Corp.
 Burnett, Ltd.
 Burvan Music Corp
 Buxton Hill Music Corp
 Caesar, Irving
 Cahn, Sammy
 Cal Music Co.
 Campbell-Connelly Inc
 Cara Music Pub. Co
 Carvan Music Corp
 Carlton Music Corp.
 Carlyle Music Corp
 Carmen Music, Inc
 Carmichael Music
 Carroll Publications
 Champagne Music Corp
 Chappell & Co., Inc.
 Charling Music Corp
 Chatsworth Music, Inc
 Choice Music, Inc.
 Christopher Music Co
 Church, John, Co., The
 Claire Music Co
 Clare Music Corp.
 Clarick Music Co., Inc.
 Clarion Music Co.
 Coachella Music Inc.
 Cohan, Geo. M., Music Pub.
 Coleman-Ross Co., Inc.
 Colony Music, Inc
 Commercial Music Co.
 Congress Music Publications
 Cornell Music, Inc.
 Coronado Pub. Co., Inc.
 Coslow Music
 Cosmic Music, Inc
 Cosmopolitan Music Pub
 Crane Music Pub.
 Crescendo Music Corp.
 Crescent Music Co Inc.
 Crest Music Company
 Crestview Music Corp.
 Criterion Music Corp
 Cromwell Music, Inc.
 Crystal Music Publishers, Inc.
 Crystalette Music Co.
 Cunningham, Paul, Inc.
 Cusenza, Frank J., Music Pub.
 Daniels, Charles N., Inc.
 Dartmouth Music, Inc.
 Dash, Connelly, Inc
 Davis, Joe, Music Co., Inc
 Dawn Music
 Dawson Music Co., Inc.
 Dayton Music Corp.
 De Sylva, Brown & Henderson
 Dewinter Music Co
 Dee Jay Music Co.
 Delkas Music Pub. Co.
 Delmore Music Co.
 Denton & Haskins Corp.
 Disney, Walt, Music Co.
 Ditson, Oliver, Co., Inc.
 Donaldson Pub. Co.
 Dorian Music Publishing, Inc.
 Dorsey Brothers' Music, Inc.
 Double-A-Music Corp.
 Dubonnet Music Publishing
 Duct Music, Inc.
 Durante, Jimmy, Music Pub.
 E D. M. Music Pub.
 East-West Music Co.
 Edition Musicus—New York
 Edmonds, Shepard N., Music
 Edwards Music Co., Inc.
 Elar Music Corp.
 Elkan-Vogel Co., Inc.
 Elliott Music Co., Inc.
 Elliott Music Co.
 Emory Music, Inc.
 Ensemble Music Press
 Enterprise Music Corp.
 Erwin-Howard Music Co
 Essex Music, Inc.
 Evans Music Company
 Evans, Redd, Music Co.
 Famous Music Corporation
 Fanfare Music Co.
 Farrow Music, Inc.
 Favorite Publishers, Inc
 Feist, Leo, Inc.
 Fenner Publications
 Fideree Music Corp.
 Fields, Arthur, Publications
 Fillmore Music House
 Finburgh, Lee, Inc.
 Fischer, Carl, Inc.
 Fischer, J., & Bro.
 Fisher, Fred, Music Co., Inc.
 Flammer, Harold, Inc.
 Foley, Charles
 Foreign & Domestic Music
 Foremost Music Co., Inc.
 Forster Music Publisher, Inc
 Fortune Music, Inc.
 42 Publishing Co., Inc.
 Four Jays Music Co.
 Fox, Sam, Publishing Co.
 Frank Music Corp.
 Franklin, John, Co., Inc.
 Fredbee Music Corp.
 Friend Music Pub. Co. Inc.
 G & C Music Corporation
 Galaxy Music Corporation
 Gallico, Al, Music Co., Inc.
 Gamble Hinged Music Co
 Gannon & Kent Music Co
 Gary Music, Inc.
 Gate Music Co.
 Gateway Music, Inc.
 Gaumont Music Publishers, Ltd
 Gem Music Corporation
 General Music Publishing
 Georgeoff, Evan, Mus. Pub. Co
 Gershwin Pub. Corp.
 GI Music Corp.
 Glenmore Music, Inc.
 Global Music, Inc.

- Gold, Jack, Music Co.
 Gold, Joe, Music Co.
 Goldmine Music, Inc.
 Goldsen, Michael, Inc.
 Goldwyn, Samuel Music Pub.
 Goodman Music Co., Inc.
 Gordon, Kaufman & Real, Inc.
 Gramercy Music Corp.
 Grand Music Corp.
 Granite Music Corp.
 Gray, H. W., Company, Inc.
 Greenwich Music Co., Inc.
 Grimes Music Publishers
 Guild Music Publishers, Inc.
 Guild Publications of California
 Haggard Music Co.
 Hall-Mack Company
 Hallmark Music Co.
 Halsey Music, Inc.
 Hamilton Music Corp.
 Hampshire House Pub. Corp.
 Handy Bros., Music Co., Inc.
 Hanover Music Corporation
 Hansen, Charles H., Music Co.
 Harding Music Co.
 Hargail Music Press
 Harman Music, Inc.
 Harmony Music Corp.
 Harms, Inc.
 Harms, T. B., Company
 Harris, Charles K., Music Pub.
 Harris, Harry, Music Pub. Co.
 Harris & Vavrin, Inc.
 Hartley Music Co.
 Harwin Music Corp.
 Hawthorne Music Corp.
 Heartbeat Music Pub.
 Helayne Music Pub. Co., Inc.
 Hennings, Frank, Music Pub'g
 Herbert Music Co., Inc.
 Herman Music, Inc.
 Hillcrest Music Corp.
 Hilltop Music, Inc.
 Hobby Music, Inc.
 Hollybrook Music Co.
 Homeyer, Chas. W., & Co., Inc.
 Hope Publishing Company
 Horton, Vaughn, Inc.
 Howard, Joe, Music Pub.
 Hub Music Co.
 Hubert Music Corp.
 Hudson Music Corp.
 Huntzinger, R. L., Inc.
 Idriss-Brown-Tibbles, Inc.
 Imperial Music Publications
 International Music, Inc.
 Ivy Music Corp.
 J. P. Music Co.
 Jacobs, Walter, Inc.
 James, Billy, Music Corp.
 James Music, Inc.
 Jaybar Music Co.
 Jayvee Music Pub. Co.
 Jefferson Music Co.
 Jem Publications
 Jenkins, Gordon, Inc.
 Jenkins Music Company
 Jericho Music Co.
 Jerome Music Co.
 Jewel Music Pub. Co., Inc.
 Jones, Isham, Music Corp.
 Joy Music, Inc.
 Jungnickel, Ross, Inc.
 Kahn, Gus, Music Co.
 Kanes Music Publishers
 Karen Music Corp.
 Kassel Airs Music Co.
 Kassner, E., Music Co.
 Keane, Michael, Inc.
 Kearney Music Co.
 Keene Music
 Kellem, Milton, Music Co.
 Kelton, Inc.
 Kendis Music Corporation
 Kenmor Music Co.
 Kerwin Music Co., Inc.
 Keystone Music Co.
 Keystone Music Company of
 California
 King, Charles E.
 Knickerbocker Music, Inc.
 Kramer-Whitney, Inc.
 Lake Forest Music Co.
 Lake Shore Pub. Co., Inc.
 La Salle Music Publishers, Inc.
 Laurel Music Corp.
 Lear Music, Inc.
 Lee, George, Music Co.
 Leeds Music Corp.
 Leslie, Edgar, Inc.
 Leslie Music Corp.
 Lewis Music Pub. Co., Inc.
 Lion Music Corp.
 Lincoln Music Corp.
 Lindley Music Pub. Co.
 Lombardo Music, Inc.
 Longridge Music Inc.
 Longview Music Co. Inc.
 Lopez, V., Music
 Lorenz Publishing Co.
 Lubin Music Co.
 Ludwig Music Pub. Co.
 Luther Publications
 Lyric Music Publishers, Inc.
 M & C Music Pub. Co.
 M. S. K. Music Co.
 Macap Music Publishers, Inc.
 Magidson Music Co.
 Manchester Music, Inc.
 Manhattan Music Publishers
 Manners Music
 Manor Music Company
 Marchant Music Publishers
 Marian Music Corp.
 Mark-Jules Music Co.
 Marks, Gerald, Music, Inc.
 Marlen Music Co.
 Marpet Music Corp.
 Marlo Music Corp.
 Mars Records, Inc.
 Martin Music
 Martone Music, Inc.
 Marvin Music Co.
 Massey Music Co., Inc.
 Maurice, Peter, Music Co., Ltd.
 Maxwell-Wirges Publications
 Mayfair Music Corp.
 Maypole Music, Inc.
 McHugh & Adamson Music, Inc.
 Meadowbrook Music
 Mecca Music Corp.
 Melo-Art Music Publishers
 Melomusic Publications, Inc.
 Melrose, Walter, Music Co.
 Melrose Music Corp.
 Memory Music Publishers
 Midway Music Co.
 Milene Music
 Miller, Bob, Inc.
 Miller Music Corp.
 Mills Music, Inc.
 Milton Music, Inc.
 Modern Music Pub.
 Mogull Music Corp.
 Monaco, James V., Inc.
 Monmar Music, Inc.
 Mood Music Co., Inc.
 Morris, Edwin H., & Co., Inc.
 Movietone Music Corp.
 Musette Publishers, Inc.
 Music Hall Songs, Inc.
 Music Makers Publishing Co.
 Music Productions, Inc.
 Music Workshop
 Musical Works
 Mutual Music Society, Inc.
 Myers Music
 Nacio Publications, Inc.
 National Music Pub. Corp.
 Nationwide Songs, Inc.
 New World Music Corp.
 Newman, Charles Pub.
 Noble Music Co., Inc.
 Northern Music Corp.
 Novelty Music Company
 Oahu Publishing Co.
 Odette Music Corp.
 O'Flynn, Charles, Publications
 O'Kay Music Company
 Old Homestead Pub. Co.
 Oriole Music Corp.
 Orlob Music Co.
 Orten Music Company
 Ostrow Music Pub. Corp.
 Owens-Kemp Music Co.
 Oxford Music Corp.
 Oxford University Press, Inc.
 P.D.S. Music Publishers, Inc.
 Paley Music Co.
 Paley-Epstein Music Enterprises
 Parakeet Music Corp.
 Paramount Music Corp.
 Paramount-Roy Rogers Co. Inc.
 Parker Publications
 Paxton Music, Inc.
 Penn Music Co.
 Pepper, J. W., & Son, Inc.
 Photo Play Music Co., Inc.
 Piantadosi Music Publications
 Pic Music Corp.
 Pickwick Music Corp.
 Piedmont Music Co., Inc.

ASCAP PUBLISHER MEMBERS

- Pincus, George, Music Corp.
Pineridge Music, Inc.
Pinkard Publications, Inc.
Piper Music Co.
Players Music Corp., The
Pleasant Music Pub. Corp.
Plymouth Music Co., Inc.
Pollsam Music Co.
"Pops" Music Publishing Co.
Popular Music Co.
Portilla Music Corp.
Presser, Theodore, Company
Promenade Music, Inc.
Putnam Music, Inc.
Pyramid Music Co.
- Randy Smith Music Corp.
Randolph Music
R. F. D. Music Pub. Co., Inc.
Record Music Corporation
Record Songs, Inc.
Reinbert & Co., Inc.
Remick Music Corp.
Remsen, Alice
Renault Music Co., Inc.
Rene, Loen, Publications
Reynolds Music Co.
Rhyme & Rhythm, Inc.
Rialto Music Pub. Corp.
Ricordi, C., & Co. (of N. Y.)
Ringle, Dave
Rinn Music Co., Inc.
Ritchie Music Co., Inc.
Ritter, Tex, Music Publications
Riverside Music Publications
Robar Music Co.
Robbins Company, The
Robbins Music Corporation
Robert Music Corporation
Robert Music Co.
Robinson, J. Russel
Rodeheaver Co., The
Roger Music, Inc.
Roncom Music Co.
Ronell, Ann, Music, Inc.
Ross, Charles, Music Co., Inc.
Rossiter, Will
Row, R. D., Music Co.
Roxbury Music Co.
Roy Music Co., Inc.
Royal Music Publisher
Rubank, Inc.
Ruby, Harry, Music Co.
Ruval Music Co.
Rytvoc, Inc.
- St. Nicholas Music Publishing
Sanders, George H., Music
Sanson Music Co.
Saunders Publications
Savoy Music Co., Inc.
Schirmer, G., Inc.
Schroeder, D. L.
Schroeder & Gunther, Inc.
Schumann Bourne Music, Inc.
Schwartz Music Co.
Schwarz, Merrell, Music Co
Serenade Music Co.
Shamrock Music Publishers
- Shapiro, Bernstein & Co., Inc.
Shattinger, Inc.
Shawnee Press, Inc.
Shelley Music, Inc.
Sheriton Music Pub. Co.
Sherman, Al, Music Co.
Sherwin Music, Inc.
Shilkret, Nathaniel, Music Co., Inc.
Show Tunes, Inc.
Shubert Music Pub. Corp.
Sigma Music, Inc.
Simon, George, Inc.
Sinatra Songs, Inc.
Skidmore Music Co., Inc.
Skinner Music Co., Inc.
Skokie Music Co.
Skylark Songs Music Publisher
Smith, Ethel, Music Corp.
Smith-Foley Music Publications
Smith, Ulysses, Music Pub. Co.
Smith, Wm. J., Music Co., Inc.
Snyder Music Corp.
Society for the Publication of American Music, Inc.
Songs, Inc.
Songsmiths, Inc.
Southern Music Company
Southern Music Pub. Co., Inc.
Southwest Music Co.
Souvenir Songs
Spier, Larry, Inc.
Spina-Green Music Corp.
Spinlan Music Corp.
Spitzer, Henry, Mus. Pub. Co., Inc.
Stage Craft Music Corp.
Standard Music Publishers. Ltd.
Standard Songs
Standish Music Corp.
Staney and Livingston, Inc.
Stanwood Music Corp.
Star Songs
Starlight Music
Starlight Songs
Stasny Music Corp.
State Music Pub. Co., Inc.
Stephens, Bob, Inc.
Stone Music Corp.
Studio Music Corp.
Summy, Clayton F., Co.
Sunflower Music Corp.
Sunset Music Publishers, Inc.
Supreme Music Corporation
Symphony House Music Pub.
- TV Music Corp.
Talent, Leo, Inc.
Taubman, Paul, Music Corp.
Taylor, Larry, Music Co.
Teepee Music Co.
Templeton, Alec, Inc.
Tempo Music, Inc.
Tempo Pub. Co., The
Tennessee Music Publishers, Inc.
Terl Music Company
Thomas, John, Music Corp.
- Thornhill Music Co.
Tin Pan Alley
Tobey Music Corporation
Tobias & Lewis, Music Pubs.
Tone Music Co.
Top Tunes Co.
Towne Music Corp.
Trans American Music Co.
Transcontinental Music Corp.
Triangle Music Corp.
Tropical Music Publishers
Tropicana Music Publishers
True Blue Music Pub.
- United Music Corp.
University Music Corp.
Urban Music Publications
Valando Music Corp.
Valmount Music Corp.
Variety Music
Venus Music Corp.
Veronique Pub. Co., Inc.
Victor Publishing Co.
Victoria Music Corp.
Victoria Publishing Co.
Viking Music Corp.
Villa-Lobos Music Corp.
Villa-Moret, Inc.
Vinrob Music Co.
Vogel, Jerry, Music Co., Inc.
Volkwein Bros., Inc.
Von Tilzer, Harry, Music Pub. Co.
Voss Music Company
- Walden Music Corp.
Waldo Music Corp.
Waner, Art, Music Co.
Warnow, Mark, Music
Warock Music, Inc.
Warren, Harry, Music, Inc.
Waverly, Jack
Weingarten, David, Music Publications
Weintraub Music Company
Weiss, Sam, Music, Inc.
West'n Music Pub. Co.
Whale Music Corp.
Whalen Music
White Way Music Co.
Williamson Music, Inc.
Willis Music Co.
Windsor Music Corp.
Witmark, M., & Sons
Wizell, Murray Pub. Co.
Wizell & Day Music Corp.
Wood, B. F., Music Co.
Woodward Music, Inc.
Words & Music, Inc.
World Music, Inc.
Worth, Bobby, Music Publishers, Inc.
Wynn, Charles, Publications
- Young, Victor, Publishing Co
Yellen and Fain
Zephyr Music Pub. Co.

ASSOCIATED MUSIC PUBLISHERS, INC.

By CHARLES A. WALL
President and Treasurer



Associated Music Publishers, Inc. is one of the foremost publishers of serious music in the United States. It has an extensive catalog of orchestra, instrumental, chamber, and choral music. In addition, it represents exclusively in the United States many of the principal serious music catalogs of Europe, such as Breitkopf & Haertel, N. Simrock, B. Schott's Soehne, of Germany; Universal Edition and Ludwig Doblinger of Austria; Schott & Co., Ltd. of England; Editions Max Eschig and Enoch & Cie of France; Songs of Spain, Spain; Suvini Zerboni and Casa Musicale Sonzogno of Italy.



AMP also is sole selling agent for BMI and BMI Canada, Ltd. publications. The AMP Board of Directors is as follows:

Sydney M. Kaye, Chairman of the AMP Board and Vice President, BMI; Carl Haverlin, President of BMI; William S. Hedges, Vice President of National Broadcasting Company; Paul W. Morency, WTIC Hartford; J. Harold Ryan, Storer Broadcasting Co.; Charles A. Wall, President AMP and Vice President in Charge of Finance and Treasurer, BMI.

AMP Officers: Charles A. Wall, President and Treasurer; Karl Bauer, Vice President; Richard F. French, Vice President; Robert J. Burton, Secretary.



Publishers

Associated Music Publishers, Inc., New York
Edition Bote & G. Bock, Berlin
Breitkopf & Haertel, Leipzig & Wiesbaden
Breitkopf Publications, Inc., New York
Broadcast Music, Inc., New York
BMI Canada, Ltd., Toronto
Ludwig Doblinger, Vienna
Editions Max Eschig, Paris
C. F. Kahnt, Leipzig
F. E. C. Leuckart, Munich

Editions Adolph Nagel, Hanover
Oesterreichischer Bundeslag, Vienna
Schott & Company, Ltd., London
B. Schott's Soehne, Mainz
N. Simrock, Leipzig
Casa Musicale Sonzogno, Milan
Universal Edition, Vienna
Edizioni Suvini-Zerboni, Milan
Songs of Spain, Inc. (Union Musical Espanol),
Madrid

BROADCAST MUSIC, INC.

By CARL HAVERLIN

President

IN 1953, as in each of the previous 14 years of its active corporate existence, Broadcast Music, Inc., continued to increase its repertoire of performing rights and to develop further its many services to all licensees.

During the past year, authors, composers and publishers affiliated with BMI made significant contributions to all fields of American music. BMI licensed material has continued to appear among the most performed music on radio and TV. Extensive juke box use of BMI music is indicated by the fact that for the fourth consecutive year BMI songs not only took top awards in all categories of the *Cash Box* magazine pole but scored 50 out of 76 positions. Last year 15 BMI licensed or published songs appeared on "Your Hit Parade," holding 131 out of a possible 364 positions.

BMI also made gains in its non-radio licensing activities, concluding agreements with members of the National Ballroom Operators Association and issuing contracts to cover motion picture intermission music.

Another valuable aspect of BMI service has been the BMI Program Clinics, held throughout the United States and Canada. These clinics were initiated in 1951, and the 137 clinics presented in three years have drawn a total attendance of nearly 12,000. (Current year, 1954, not included.)

During 1953 we devoted further effort to develop an awareness of contemporary foreign composers and their music as well as that of American composers. The first major concert of all-Canadian music ever to be held in the United States was sponsored by BMI, conducted by Leopold Stokowski at Carnegie Hall. BMI's subsidiary, Associated Music Publishers, Inc., while maintaining its position as an outstanding representative of major European music catalogues, increased its output of leading American contemporary music. Through our agreements with European performing rights societies, other outstanding works by foreign composers and publishers have been popularized in the United States by many BMI affiliated publishers.

During 1954 we at BMI will continue our efforts, through energetic competition, promotion and service, on behalf of music of all types—popular and concert. For in only that way can anyone aid in the growth of all musical creativity in the United States.

OFFICERS OF BMI: Carl Haverlin, President; Sydney M. Kaye, Vice-president and General Counsel; Robert J. Burton, Vice-president in charge of Publisher and Writers Relations, Secretary; Charles A. Wall, Vice-president in charge of Finance; Roy Harlow, Vice-president in charge of Station Service; Glenn Dolberg, Vice-president in charge of Station Relations; Jean Geiringer, Vice-president, Foreign Relations; Harry P. Somerville, Vice-president, Non-Radio Licensing; Robert Sour, Assistant Vice-president, Publisher Relations.

DIRECTORS: (elected annually): Sydney M. Kaye, Chairman; Herbert V. Akerberg, CBS; John Elmer, WCBM; Jos. E. Baudino, Westinghouse Radio Stations, Inc.; Carl Haverlin, BMI; William S. Hedges, NBC; Herbert Hollister, KBOL; Leonard Kapner, WCAE; Paul W. Morency, WTIC; Ernest Lee Jahncke, Jr., ABC-PT; J. Leonard Reinsch, WSB; J. Harold Ryan, Storer Broadcasting Co., and James E. Wallen, MBS.

Aaron Music Company
 Abbott Music Pub.
 Acuff-Rose Publications
 Adams-Vee & Abbott, Inc.
 Adanac Music Company
 Adler, Larry, Music Co.
 Adorian Music Co.
 Agatha Music Corp.
 Airlane Music, Inc.
 Aladdin Music Publications
 Algonquin Music, Inc.
 Allen Rick Publications
 Alvin Music Corporation
 American Composer's Alliance
 American Music, Inc.
 American Performing Rights
 Amijo Music
 Amusement Publ.
 Angel Music Inc.
 Appleton-Century, D. Co., Inc.
 A.Q.V. Corp.
 Aragon Music Company
 Arlene Music Co.
 Ariston Music Inc.
 Arrow Music Press, Inc.
 Associated Composers, Inc.
 Associated Music Publishers, Inc.
 Atlantic Music Corp.
 Autry, Gene Music Publishing
 Avas Music Pub. Co.
 Avery Music Company
 Avon Music, Inc.
 Barton, Earl, Music Co.
 Ball Music Publishing Company
 Ballet Russe de Monte Carlo
 Banbury Music, Inc.
 Bar Music Publishing Company
 Barclay Music Company
 Barron Music Company
 Bartlett & Hartman Music
 Beacon Music Company
 Becker-Williams Publications
 Beechwood Music Corp.
 Begonia Music
 Belfry Music
 Bellemeade Music
 Bell Music Co.
 Bell-Tone Music Publishing Co.
 Bentley Music Co.
 Bergallam Music
 Berger Publishing Company
 Berkshire Music Inc.
 Berwick Music Corp.
 Beverly Music Inc.
 Big "D" Pub. Co.
 Billace Music Co.
 Biltmore Music, Inc.
 Blackwood Music
 Blane Music Company
 Blazer Music Co.
 Blazon Music Company
 Block, Martin Music Inc.
 Bluebird Music Company
 Blue Grass Music
 Blue Jay Songs
 Blue Note Records
 Blue River Music Inc.
 BMI Canada Ltd.
 Babb Music

Bob-Dan Music Co.
 Bomart Music Corp.
 Bond, Johnny, Music Co.
 Boulevard Music Inc.
 Boxer Music Co.
 Boyt, Earl Pub. Co.
 Bradshaw Music Co.
 Brazos Valley Music
 Brenner Music, Inc.
 Brewster Music Pub. Inc.
 Brightlights Music Publishing
 Broadcast Music, Inc.
 Brookdale Music Co.
 Brownwood Music Co.
 Burley Music
 Byron Music Co.
 Calvert Pub. Co.
 Cameron Music Co.
 Camille's Music Company, Ltd.
 Campbell Music, Inc.
 Cammarota Record & Pub. Co.
 Candice Music Inc.
 Candy's Playhouse Inc.
 Capri Music
 Cardinal Music Publications
 Carnegie Music Co.
 Carnival Music Company, Inc.
 Carol Music Company
 Carson-Carrier Publications
 Casa Musicale Sonzogno
 Cascales, Joe, Music Publisher
 Castle Music Pub. Co.
 Cavalier Music Pub. Co.
 Cedarwood Pub. Co., Inc.
 Celestial Music Pub. Co., Inc.
 Century Songs, Inc.
 Cerabino, L. G.
 Challenge Music
 Chambers Music Co.
 Charill Music Pub. Co.
 Checker Music Publishing Co.
 Chelsea Music Corporation
 Cherio Music Publishers, Inc.
 Children's Record Guild
 Children's Songs, Inc.
 Chips Music
 Chords Music Publishers
 Christian Music Publishing Co.
 Cille and Dail Publications
 Claremont Music Company
 Clow, O. B. (Estate of)
 Coast to Coast Music Corp.
 Cole Corporation, M. M.
 Collins Music Co.
 Collwill Corporation
 Colonial Music Publishing Co.
 Colortunes Publishers
 Columbia Music Publishing Co.
 Commercial Music, Inc.
 Commodore Music Corporation
 Continental Record Co.
 Copyright Music
 Cosmo Music
 Country Music
 Crestline Music Pub.
 Crestwood Publications
 Cross Music Company
 Crossroads Music Co.
 Crowe, Edward and Pyle, Pete

Cundy-Betty Co.
 D. R. & P. Co.
 Dallas Music Co., Inc.
 Dana Records
 Dance Music Corp.
 Davis & Ostergard
 Davis Music Company
 D. Dreyer Co., Inc.
 Delaware Music Co.
 DeMorat Music Co.
 DeSoto Songs
 Debut Publications
 Dennis Music Co.
 Destiny Music Pub.
 Devere, Robert Music Co.
 Dexter, Al and Paris, James
 Dexter, Al, Music Publishing
 Dickinson, Harold H.
 Dinehart Music Company, The
 Diav Records, Inc.
 Dixie Music Publishing Co.
 Dolan, Ann
 Domino Music Corporation
 Doraine Music Publishing Co.
 Doraine, Peter, Inc.
 Doray, T., Music Publishing Co.
 Dorchester Music Co.
 Dornix Music, Inc.
 Dioro Music Pub.
 Douglas Publishing Company
 Duchess Music Corporation
 Dumac Music Corporation
 Dunbar Music Co.
 Dunhill Music Corp.
 Dunray Music Company
 Eagle Music Publishing Corp.
 East Coast Music Publications
 Eastern Music Publishers
 Eastwick Music Co.
 Eccma Music Company
 Edgar Music Co.
 Editions Musicales Victoria Mu-
 sical Editions
 Editora Dominicana De Musica
 Edizioni Kramer (Milano)
 Edizioni Mascheroni (Milano)
 Edizioni Musicali Di Lazzaro
 Edizioni Musicali Italiane
 Edizioni Suvini Zerboni
 Edlee Music Corp.
 Edwards, Norman, Music Pub.
 Elkane Music Company
 Elmore, C. M. Publisher
 Elsmo Patrillo
 Embassy Music Corp.
 Emco Music Company
 Emerald Music Company
 Emerson Music Publications, Inc.
 Emperor Music Inc.
 Encore Music Publications, Inc.
 Englewood Pub.
 Ericsson & Peppers Music Co.
 Esquire Music Co.
 Essay Music Company
 Excelsior Music Publishing Co.
 Executive Music Corporation
 Fairfax Music Company
 Fairway Music Corp.
 Fargo Music Inc.

Ferrer, Jose, Music Inc.
 Fi-DeJ Music Publishing Co.
 Fine Songs
 Flair Pub. Co.
 Florida Music Company
 Folk Songs
 Folkways Music Publishers Inc.
 Ford Music, Inc.
 Four-Star Music Company
 Fowler, Wallace Publications
 Franco Music Company
 Francis & Wilmore Music Pub.
 Franco-American Publications
 Franklin Pub. Co.
 Frannan Music Co., Inc.
 Freed & Hall Music Publishers
 Frederick Music Publ. Co.
 Freeman, Albert Edward
 Freeman Music Co.
 Freeman, Porky, Pub. Co.
 Fremart Music Company
 Frey, Fran and Company
 G-Note Record Corp.
 G. M. S. Music Publishing Co.
 Gabriel Records
 Gainsborough Music, Inc.
 Gala Music Publishing Corp.
 Gale & Gale, Inc.
 Garlock, Scherer
 Gallico, Al
 Gallatin Music Corp.
 Gaviota Music Inc.
 Gay, Evelyn Pub. Co.
 Gaylord Music Co.
 Gilbert Music Publishers
 Glenwood Music Corp.
 Globe Music Corp.
 Gloria Music Co.
 Goday Music Inc.
 Gold Coast Pub. Co.
 Golden Gate Quartet Music Co.
 Golden Songs
 Golden State Songs
 Golden Tune Publishers
 Golden West Melodies, Inc.
 Golden West Music Publications
 Goode Music, Inc.
 Gordon Music Company
 Granson, Jose, Music Co.
 Granite Music Co.
 Great Oaks Music
 Green Music Publications
 Guinand, Clinton
 H. M. Banner Publications
 Halama, Frank J., Publications
 Halliburton Music
 Halmac Company
 Hamblen, Stuart, Music Co.
 Hamilmeyer Music Publishing
 Hanna & Co.
 Har-Bock Music Co.
 Harcourt, Brace & Co., Inc.
 Harmony House
 Harmony Music Publishers
 Harris & Vavrin
 Hartmann, Edward & Lynette
 Hartmann & Van Horn
 Harvard

Harvey Music
 Harwall Music Publishers
 Hawaii Conservatory Pub. Co.
 Heartline Music Co.
 Helpport Music
 Heim, Marty Music Co.
 Hemispheric Publications
 Highland Music Co
 Hill and Range Songs, Inc.
 Hill Music Publishing Company
 Hillbilly Music Publishing Co.
 Hillside Music Publishers
 Hilltown Music Inc.
 Hinds, Hayden & Eldredge, Inc.
 Hit Parade Publications
 Hockenhull's Music Publications
 Hoffman Songs
 Holden, Alfred H.
 Hollendon Music Co.
 Hollis Music, Inc.
 Hollywood House Music Publishing Co.
 Holmes Publications
 Hoosier Music Publications
 Hopkins, Earle C.
 House of Carols
 House of Erin
 House of Fortune
 House of Irish Songs
 Howard, Jack, Publications, Inc.
 Imco Music Publishing Co.
 Imperial Music Publishing Co.
 Inco Music Company
 Independent Music Publishers
 Indigo Music, Inc.
 Inman, Autry, Music Pub. Co.
 Inspired Music Company
 Inspirational Music Corp.
 Instrumental Music Inc.
 Inter-American Music Pub. Co.
 Intermountain Specialty Sales
 International Popular Music Co.
 Iris Music Pub.
 Iris-Trojan Music Corp.
 J.A.Y. Music Company
 Jaglea
 Jackson Music Corporation
 Jamboree Music
 Jarman Publications, Ltd.
 Jayco Music
 Jay-Dee Music Corporation
 Jean Music Company
 Jill Music Co.
 Jo-Ann Music Company
 Johnstone-Monteil, Inc.
 Johnstone Music, Inc.
 Jones, J. Grayson, Music Co.
 Joni Music Inc.
 Joshua Corp.
 Judson Music Co.
 Kahl Music Co.
 Kampas, William T.
 Kaolene Corp.
 Karen Publications
 Karr, Jerome J.
 Kaymusic Publishers
 Keith Music Pub.
 Keenote Music
 Kelly Music Publications

Kelly-Stool
 Kelton-Romm Music Company
 Kendis, Sonny, Music Pub.
 Kenneth Publishing Company
 Kerr, Bob, Prod.
 Kerr, Edward
 Keyes, Baron, Pub.
 Keystone Music Co.
 Kingsbury Music, Inc.
 Kinkade's Songs
 Kit Music Company
 Knight Publishing Co.
 Knobloch, M. H.
 Knotty Pine Music Pub.
 Kolbert, Marguerite (Productions)
 Kord Music Company
 L. A. Songs
 La Chapelle Music Publications
 Lake Erie Music
 Lance Music Pub.
 Lana Music
 Langley Music Co.
 Lang-Worth Publications, Inc.
 Latin American Publishing Corp.
 Laura-Lea Music
 Laurel Music Publishers, Inc.
 Lawn Music
 Lawrence, Johnny, Music
 Leal, Felipe Valdes
 Lee, Robert, Music Publishers, Inc.
 Lee Music
 Lennerts Music Publications
 Leora Music
 Liberty Music Publishers
 Lind Music Company
 Little Jazz Music Pub., Inc.
 Lois Music Publishing Co.
 Lomax, Carl, Music Publishing Company
 London Music Corp.
 Lone Star Music Co.
 Long, J. Baxter
 Los Feliz Music Co.
 Love Music
 Lowden, C. Harold
 Lowell Music Corp.
 Lowery Music Co.
 Lubin, Jimmy, Music Publishers
 Lucky Music Publishers
 Ludlow Music, Inc.
 Lutz Brothers Music Co., Inc.
 Lydian Music Publishers
 Lynbrook Music Inc.
 Lynch, Edward J.
 Lynn Music Corp.
 M. and F. Music Publisher, The
 M-E Melodies
 Mac Angelo
 Mack Music Company
 Mack-Nell Publications
 Mackley Music Publishing Co.
 Maestro Music Company
 Magnet Music, Inc.
 Magnolia Music Corp.
 Main Music Publishing Company, The
 Main Street Songs, Inc.

- Majestic Music Company
 Major Melodies
 Major Minor Music
 Malamar Music, Inc.
 Manhattan Melodies Music Pub.
 Marmor Music Inc.
 Marvin Music Corp.
 Mann Music Co.
 Manning Music Company
 Marchant, J. C., Publications
 Marcy, Victor
 Mardi Gras Music Company
 Maresh Music Co.
 Marino Music Company
 Mark-Lee Music Company
 Marks, E. B. Music Corp.
 Marsales, Frank
 Martens, W. F., Music Co.
 Maxted Music Co.
 Master Music Publishers
 Masters Music
 Maywood Music Co.
 McCall and Malin Publishing
 McClellan Music Company
 McClure, Ruth D.
 McCune Music Company
 McDonald Music Company, The
 McGinty Music Publishing Co.
 McClean, Gene, Music Co.
 McMahan, Frank
 Meadowbrook Music Publishing
 Mellin Music, Inc.
 Mellow Music Publishing Co.
 Mellostone Music Co.
 Melody Lane, Inc. (Peer)
 Melody Moderne Incorporated
 Melody Trails
 Memphis Music Publishers, The
 Mercer Music
 Merian Music Inc.
 Meridian Music Corp.
 Merit Music, Inc.
 Merit Music Publishing Co.
 Merrick Music Co.
 Merrymount Music Inc.
 Merrywood Publishers
 Metro Music
 Metropolitan Music Company
 Metropolitan Music Publishers
 Michele Pub. Co.
 Micor Publishing Company
 Midland Music Company
 Midwestern Publishers
 Millbrook Music
 Miller-Steinberg-Katz Music
 Milliegene Music Publishing
 Miracle Music Company
 Mission Hills Publications
 Missud, Jean M. (B.M.I.)
 Modern Melo Melody Publ.
 Modern Melodies Publishing Co.
 Modern Music Publishing Co.
 Mohawk Music Publishing Co.
 Monahan Music Publications
 Monarch Music Company
 Monmouth Publishing Company
 Mono-Music
 Monroe Music Company
 Monroe, Bill, Music Inc.
- Montauk Music
 Montclare Music Corp.
 Moon Ray Music Publishers
 Moonlight Music
 Morris Music Publications
 Morrison Music Company
 Morrissey Music Company
 Morro Music Corp.
 Morse, Dave, Studio Pub. Co.
 Morton Music Corp.
 Motton Music Co.
 Motley Music Publishing Co.
 Motor City Music Publishers
 Mr. Music Co.
 Murob Music Publishers
 Music Art Publications
 Music Box Melodies
 Music City Copyrights
 Music Enterprises
 Music for Frets
 Music For Young America Co.
 Music Incorporated
 Music Manuscript Reporter
 Music Products, Inc.
 Music Row Publications
 Musin, Ovid (E. B. Marks)
 Muzik Masters Company
 National Association For Blind
 Composers, Inc.
 National Broadcasting Co., Inc.
 National Music Corp.
 Navajo Music, Inc.
 Nelson, Overson Publications
 New England Song Publishing
 New Era Music Corporation
 Newton, Al
 Niksch, Donald E.
 Nimisilla Music Company
 Nolton, Frances Stuart
 Normandy Music, Inc.
 Northeastern Music Company
 Northern Bell Music Pub. Co.
 Noteworthy Music, Inc.
 Nu-Tune Music Corporation
 Nutter, Carl, Music Pub. Co.
 Oakhurst Music Pub. Co.
 Ohio Music Co.
 Old Charter Pub. Co., Inc.
 Old Town Records Corp.
 Omnibus Music Co.
 Oliver-Jacobs Music
 Onyx Publishers
 Opal Music Inc.
 Optimist Songs Co.
 Oree Music
 Original Music Publishing Co.
 Orpheum Music Corp.
 Otis, Johnny, Music Co.
 Out West Music Publisher, The
 Pace Music Co.
 Pacific Music Publications
 Palladium Music Publishing Co.
 Palomar Music Corp.
 Pan-American Publications
 Panhandle Music
 Parade Music Company
 Paradise Music Company
 Paris, James B.
 Parliament Music, Inc.
- Pastor Music Co.
 Paterson, James A.
 Patmar Music Company, Inc.
 Patricia Music
 Paul Music
 Paxson, Margaret O.
 Peer International Corporation
 Pemora Music Company, Inc.
 Peskin Music Publishing Co.
 Phoenix Music Corp.
 Phono-Tunes Music Company
 Piccadilly Music Corp.
 Pitchpipe Music Co.
 Pitts, P. S., Publications
 Plamor Music Company
 Pleasant Valley Music
 Plumb, Neely Publishing Co.
 Pollard Music
 Pond, Frank, Music Company
 Porgie Music Corporation
 Powell, Wayne
 Prelude Music Co. (E. B. Marks)
 Premier Music Publishing
 Pre-View Publications
 Pritchett Publications
 Professional Music, Inc.
 Progressive Music Publishing
 Pro Musica Publishing Co.
 Prosser Music Publishing Co.
 Proven Publications
 Pulse Music
 Pulse Publishing Corp.
 Putman Publications
 Quaker Music Company
 Quality Music Company, Inc.
 Quincy Music Publishers
 R. S. Rose Publishing Co.
 Radio & Video Music Publishing
 Radio Music Publishers
 Radon Music Co.
 Rainbow Melodies Music Co.
 Rainbow Music Publishers
 Rainier Music Publishers
 Raleigh Music Publishing Co.
 Rancho Music
 Rand Music Co.
 Randolph, Al, Publications
 Rayven Music Co., Inc.
 Real Music Company
 Reardon, Harry, Music Pub.
 Record Music Publishing Co.
 Recordo Music Publishers
 Red River Songs
 Redskin Publishing Co.
 Redwood Music Co., Inc.
 Reeny Rhythms
 Regent Music Corp.
 Reiner, Paul, Music Pub. Co.
 Reis, Herb, Music Corp.
 Remarque Music Publishing Co.
 Republic Music Corporation
 Rex Music Publishers
 Rhodes, David W.
 Rhythm Enterprises
 Rhythms Of The West
 Ricordi, G. & Co.
 Ridgeway Music
 Rinehart, Marion W., Music
 Rinker, Charles, Music Pub.

- Riverdale Music Co.
 Rivervale Music, Inc.
 Rockland Music Corp.
 Rocky Hill Music Corp.
 Rod Jon Music Company
 Romance Music Publications
 Romaunt Music Publications
 Rondo Music
 Rork, Ernest A., & Son
 Rosarch Pub. Co.
 Rosyln Music Company
 Ross Music Co.
 Roth, Howard H., & Co., Inc.
 Roxy Music Corp.
 Royal Crown Music Company
 Royal Gorge Music Publishing
 Royal Music Corporation
 Royalty Music Company
 Ruby Music Co.
 Rudy Vallee Music Publications
 Rujanart Music Publications
 Rumbalero Music, Inc.
 Rush Music Corp.
 Russell Music Co.
 S. B. G. Music Publishers
 Sagebrush Music Pub. Co.
 Salamanca Music Publishers
 Salvatori Music Company
 San Juan Music Publishing Corp.
 Sapphire Music Publisher
 Savoy Music Company
 Sawaya Publications, Inc., The
 Schaeffer's, Peter, Music Corp.
 Schirmer, E. C., Music Co.
 Scholl Publishing Company
 Scripser's
 Seattle Music Publishing Co.
 Seidel, Emil, Music Pib'g Co.
 Selroy Music Pub. Co.
 Sensational Music Pub. Co.
 Sentinel Music Publications
 Seven-Eleven Music Pub.
 Shaw, Charlie, Publications
 Shealy Music Pub. Co., Inc.
 Shelby Music Publishing Co.
 Sheldon-Mitchell Pub. Corp.
 Sheldon Music, Inc.
 Sheridan Music Corp
 Sheraton Music Corp.
 Shermack Company
 Sherman Music Co.
 Sherwood Music
 Shopa Music Publications
 Show-Biz Music Co.
 Shutt, Albert Music Publisher
 Signet Music Co.
 Simon House, Inc.
 Singer, Murray, Music Pub.
 Skrivanek Music
 Skyway Records & Music Pub
 Slate Enterprises, Inc.
 Smith, Jerry, Publications
 Smith Publications
 Snyder, Fenton Publications
 Society of Jewish Composers,
 Publishers and Songwriters
 Song Ads Inc.
 Song-Ranch Publications
 Song Writers' Cooperative, Inc.
- Sonorous Music Co., Inc.
 Sophisticate Music, Inc.
 Sound Music Pub. Co.
 Spanish Music Center
 Speed Pub. Co.
 Spin Music
 Spitzer Songs, Inc.
 Spotlight Music Company
 Spry Music Publishing Co.
 Staff Music
 Staff Music Corporation
 Stampede Pub. Co.
 Stan-Host Melodies
 Stark Music Printing Company
 Starr Songs
 Starrite Pub. Co.
 Stavin Milt, Music Company
 Steele, Ted, Publishing Co.
 Stella Music Co., Inc.
 Stern, Jos. W., & Co.
 Stern Music Publishing Co.
 Steven, Arthur Publications
 Stevens Music Company
 Stevens Music Corporation
 Stone Jack & Associates
 Strand Press Music Publishers
 Stratton, A. D., Music Co.
 Stuart Music, Inc.
 Studio Music Co.
 Sudlik & Siegel
 Sultan Associates
 Sunbeam Music Corp.
 Sundial Songs
 Sunrise Music Company
 Susquehanna Prod., Inc.
 Sutton Music Company
 Swansongs Publications
 Sweet Music Publications
 Sweet, William R.
 Swing & Tempo Music Co.
 Symbolic Music Publishing Co.
 Syncopation Songs
 Syndicate Music Publishers, Inc.
 Tamasa Music Co.
 Tannen Music, Inc.
 Taps Agency
 Tarry-Town Music Co.
 Temerity Music Inc.
 Tennessee Music Corp.
 Terrific Tunes
 Terry Tune Studios
 Thomas Cole Publishing Co.
 Thornwood Music Pub. Co.
 Tic-Toc Publishing Company
 Tiffany Music Company
 Timberland Publishing Co.
 Time Music Company
 Times Square Music Publishing
 Tingor Music, Inc.
 Tobby Music Publishers
 Tono Record Co.
 Topik Tunes
 Trans Music Corp.
 Trans-American Music Pub.
 Trend Music
 Triad Music Company
 Trianon Publications
 Trinity Music Co., Inc.
 Trio Music Company
- Tropical Song Counter
 Tubb, Ernest, Music Inc.
 Tune-Time Music
 Tune Towne Tunes
 Turnpike Music, Inc.
 U. S. Music, Inc.
 Ultra Music Company
 Una Publishing Co.
 Unger Music Publisher
 Unique Music Publishers
 Universal Music Sales
 Uranus Music Company
 Val Music Corporation
 Valentine Music Publications
 Valiant Music Company, Inc.
 Valley-Hill Music Co.
 Valley Publishers, Inc.
 Valor Publications
 Van Brunt Publishing Company
 Van Russ Music
 Vance Music Company
 Vander Music Company
 Vanguard Songs
 Van's Music Company
 Variety Music Company
 Velleca Publishing Company
 Versailles Music Co., Inc.
 Vesta Music Corp.
 Vetter, Jack, Music Corp.
 Vicca's Music Co.
 Village Music Co.
 Villanovia Music Co.
 Vincent Music Co., Inc.
 Vogue Music Corporation
 Volunteer Music Sales Co.
 Von Hallberg Music Company
 W. F. A. Enterprises
 Wade Franklin, Publications
 Wallace Publishing Company
 Ward & Sears Music, Inc.
 Ward, Allan W., Music Pub.
 Warner Studio
 Warren Publications
 Washington Music Bazaar
 Webster Music Company
 Weddington Music, Inc.
 Weiss & Barry, Inc.
 Wemar Music Corporation
 Westbrook Publications
 Whimsy, Ltd.
 White, Elmore, Music
 White Mountain Music
 Wilcox Music Publishing Co.
 Willard Herring, Ltd.
 Willet, Slim, Songs
 Wilson Publishing Co.
 Winchester Music Inc.
 Winneton Music Corp.
 Winthrop, G. & Company
 Wise Music Publications
 Wonder Music Pub. Co.
 Wonderland Music Co., Inc.
 Wood Song and Record Co.
 Woodard, Harry, Music Pub.
 Woodland Music Company
 Woods Music Co.
 Wortham Music Co.
 Wrightman, Neale Publishers
 Wyner Music Publishers

SESAC, INC.

By PAUL HEINECKE

President



IN this, SESAC's 23rd year as the second oldest performance rights organization in the United States, I would like to tell you about its prowess and growth, not only as a firm offering a vast repertory of copyrighted musical and dramatic-musical works which are found on thousands of phonograph records, electrical transcriptions, transcribed programs and live shows, and as the producer of the top-flight SESAC Transcribed Library now in its 10th year, but also as an organization dedicated to serving the entire entertainment industry particularly fulfilling the program needs of radio and television broadcasters everywhere.

During the year, SESAC representatives, as in the past, attended and participated in State Broadcasters Meetings, NARTB District Meetings and the national convention of both the NARTB, the AWRT, and the CARTB. Further, the successfully inaugurated SESAC Speakers Bureau offered the services and talents of SESAC representatives. They have also participated as guest speakers at schools, colleges and State Broadcasters Meetings, and are continuing to do so.

A number of our new publisher affiliates have come to SESAC from other performance right licensing organizations. The repertory keeps growing; thousands of new copyrights add up to millions of additional performances for SESAC. That's why more AM, FM and TV stations call for SESAC music—the answer to the demand for the best music in America.

Supplementing and co-ordinating the efforts of the SESAC family of publishers, representatives, producers, salesmen and musicologists, is the monthly bulletin, SESAC MUSIC. During the thirteen years of our bulletin's existence, SESAC's Promotion and Editorial staffs have brought to the broadcasting industry, as well as to the producers of phonograph records, motion pictures, transcribed programs, and television shows, "program helps" and information concerning SESAC's 263 publishers' catalogs and their new works.

News of radio and television stations, and articles of interest and value written expressly for SESAC MUSIC by members of your own radio and television stations, are all included in the bulletin. I am delighted that SESAC MUSIC has an extensive and growing circulation, for just as SESAC music is heard wherever music of lasting value is played, so SESAC MUSIC is read wherever people are doing a top-notch job throughout the entertainment industry, public service organizations, educational and government institutions.

For me it is an honor and a privilege to work hand in hand with you, the leaders, in developing a vital segment of our national culture.

- Accordion Music Publishing Co.
 Adamus, A.
 Adamus, Zenobuisz
 Albright Music Company
 Alford, Harry L.
 Alkire, Eddie, Publications
 Amsco Music Publishing Co.
 Andrea Music Co., Inc.
 Arct, M.
 Arct Wydawnictwo Muzyczne
 Ashmall, Wm. E., Company
 Augsburg Publishing House
 Avalon Music Publishing Co.
 Aztec Music Company
- Babwin Publications
 Barnes, A. S., & Company, Inc.
 Barnhouse, C. L., Company
 Bartlett, E. M.
 Barwicki, K. T.
 Bass Co., The, Music Publishers
 Bava's, John, Music
 Beazley, Samuel W., & Son
 Beirly, Alfred, Co.
 Bendix Publishing Corp.
 Benson, John T., Publishing Co.
 Berge Music Co.
 Blake, Whitney, Music Publishers
 Braun, Hubert J.
 Braun Music Co.
 Braun Organization, The
 Breuer, Harry
 Broadcast Music Publishers
 Broadman Press, The
 Brumley, Albert E., and Sons
 Bryant Music Company
- Capitol Music Co.
 Cardilli, M. V.
 Catholic Music Co.
 Central Music Co.
 Century Music Publishing Co.
 Cerruti, John M.
 Chart Music Publishing House,
 Inc.
 Choral Press
 Church Music Co., The
 Clayton, Norman J.
 Clef Music Corp.
 Coanacher, B.
 Coleman, Robert H.
 Coleman, Robert H., Publishing
 Co.
 Composers Press, Inc., The
- Concord Music Publishing Co.,
 Inc.
 Concordia Pub. House
 Crawford, Percy B.
 Cooper, W. Oliver
 Craig, Ivy E.
 Cummings, M. Homer
 Czytelnik
- Daniel, John, Quartet Song Pub.
 Darom
 Davis, Marion, Company, The
 Dawson, William L.
 Dean, Emmet S.
 Dean & Edmiaston
 Dean & Etridge
 Dean & Franklin
 Dean & Hensley
 Dean & Morgan
 Dean & Sebren
 Deiro, Pietro
 Denison, T. S., & Company
 Denson Trio Music Co.
 Denson-Parris Music Co.
 Di Bella, O., Music Co.
- Edel, Yizchak
 Edition Darom
 Edition Gil-Ron
 Edition Hazemer
 Edition Jastrzab
 Edition Olympia
 Edition Pizmon
 Edition Pro Arte
 Eulenburg, Ernst, Ltd.
 Europa Music Co.
 Evangel Music Co., Inc.
- Fairbank, H. W., Company
 Ferrill, J. W.
 Firm Foundation Publishing House
 Fitzsimons, H. T., Co., Inc.
 Forberg, Rob.
 Fouts, S. C.
 Fouts-Payne Music Co.
 Future Music Co.
- Gebethner & Wolff
 Georgi & Vitak Music Co.
 Gilbert Music Company
 Gil-Ron
 Goddard Publishing Corp.
 Gornston, David
 Gospel Music Publications
 Gospel Songs, Inc.
- Grabczewski, F.
 Grammer, Frank
 Gregorian Institute of America
- Hall Music Co., The
 Hall & McCreary Co.
 Hanson, Eddy
 Harmonia Publishing Co.
 Harper & Brothers
 Hartford Music Co., The
 Hart's Music Company
 Hathaway, Franklin Earl, Mus.
 Pub.
 Hazemer
 Heinrichshofen's Verlag
 Henson, J. M., Music Co.
 Heritage Music Publications, Inc.
 Hoffman, Raymond A., Co.
 Holbrooke, Josef
 Huffer, Fred K.
 Hymntime Publishers
- Idzikowski, Leon
 Idzikowski, M.
 "IPA," Israel Publishers Agency
 "Iscam," Israel Society of Com-
 posers, Authors & Music Pub-
 lishers
- Jastrzab
 Jeffress Music Company
 Jewell, Fred, Music Co.
- Kanner Music Publishing Co.
 Keene, Hank, Inc.
 Kelman Music Corp.
 Keyboard Publishing Co.
 King, K. L., Music House, Inc.
 King Music Publishing Corp.
 Kjos, Neil A., Music Co.
 Krachtus, John, Inc.
 Krone, Max and Beatrice
 Kuthan, E.
- Lillenas Publishing Co.
 Littig, Frank, Music Publishing
 Co.
 Liturgical Music Company
 Liturgical Music Press, Inc.
- Maciejowski, ZB.
 Markiewicz, Adam
 Master Music Press, Inc.
 McLaughlin & Reilly Co.
 Mercury Music Corp.

- Modern Music Library
 Moniuszko Publishing Co.
 Morris-Henson Music Co.
 Music Press
 Music Press, Inc.
 Music Products Corp.
 Musical Melody Publishers
- National Music Company
 National Music Company, Inc.
 Natrass-Schenck, Inc.
 Nazarene Publishing House
 Network Music Publishers
 Northwestern Press, The
 Nowa Scena
 Nowacki, Henryk X.
- Olympia
- Pace, Adger M.
 Pagani, O., & Bro., Inc.
 Pallma, Frank, Music Publisher
 Pallma Music Products Corp.
 Panella, Frank A.
 Panella Music Co.
 Paragon Music Publishers
 Parks, J. A., Company, The
 Parris Music Co.
 Parris, O. A.
 Perry, F. Clark, Co.
 Perry's Sons, A. W.
 Pioneer Music Press
 Pizmon
 Podgorski, I.
 Polonia Publishing Co.
 Polskie Towarzystwo Muzyki
 Wspolczesnej
 Polskie Wydawnictwo Muzyki
 Wspolczesnej
 Poltawski, Aleksander
 Pomaranski, Zygmunt
 Popular Music Publications
 Princes Publications
 Pro Art Publications
 Pro Arte
 "PWM," Polskie Wydawnictwo
 Muzyczne
 "PWM," Polskie Wydawnictwo
 Wydawnictwo Polskich (Asso-
 ciation of Polish Publishers)
 Puritan Publishing Co.
 Quartet Music Company
- Quincke, Walter A.
- Radio City Guitar Studio
 Ramola Music
 Ramsey, Will M.
 Ramsey & Parker
 Revival Music Company, The
 Ricart & Cia, Luis, S. L.
 Roat, Chas. E., Music Co.
 Rolseth Pub. Co.
 Rozan Publishing Co.
 Rudnicki, Walery
 Rynczak, J.
 Rzepecki, J.
- Sacred Music Foundation, The
 Sajewski, W. H., Music
 Publishing Co.
 Schmidt, Arthur P., Co., Inc., The
 Schmitt, Paul A., Music Company
 Schubert, Edward, & Co., Inc.
 Sebren, George W., Music Co.
 Select Music Company
 Selmer, H. & A., Inc.
 Seyfarth, G.
 Showalter, A. J., Company, The
 Showalter, G. H. P.
 Simon, Frank
 Sing Time Publishing Company
 Singenberger, John
 Singenberger, Otto
 Singspiration Associates
 Sisk Music Company, The
 Slaski, H.
 Slater, Will W.
 Smith, Alfred B.
 Smith, Wm. J., Music Co.
 Southern Music Plate Co.
 Stamps-Baxter Music & Printing
 Co.
 Stamps Quartet Music Company,
 Inc.
 Stamps, V. O., Music Company
 Standard Music Company
 Standard Songs
 Stanphill, Ira
 Stirling Music Publishing Co.
- Sunday School Board of the
 South Baptist Convention, The
- Target Music Co.
 Tav-Rina
 Teddlie, Tillit S.
 Tennessee Music & Printing Co.
 Thomas, Alvis O.
 Thomas, J. E.
 Thompson Music Company
 Top Music Publishers, Inc.
 Tovey, Herbert G.
 Towarzystwo Wydawnicze
 Muzyki Polskiej
 Treasure Chest Publications, Inc.
 Triangle Music Co.
 Trio Music Co.
 Tuskegee Institute
- Universum
- Vaughan, James D., Music
 Publishers
 Vitak-Elsnic Co.
 Volpe Music Co.
- Walls, W. M.
 Warde, Harry
 Warner, F. Eugene
 Weaner-Levant Publications
 Weaner, Maxwell
 Wells, Kenneth H.
 Western Accordion Music
 Company
 Wheelwright, Lorin F.
 Whitney Blake Music Publishers
 Wiehler, Z.
 Wilensky, Moshe
 Windsor Music Company
 Winsett, R. E.
 Witczyk, Stanislaw
 "WJR"
 Wohl, Jehuda
 Wydawnictwo Muzyczne Arcta
- "Zaiks," Zwiasek Autorow,
 Kompozytorow i Wydawcow
 Zak, Czeslaw
 Zalewski, B. J.
 Zaremba, Alojzy



Dual Operator Evaluates Impact of Television

By EDWARD LAMB

President

Edward Lamb Enterprises, Inc.

WE no longer talk about the future of television as "tremendous" or even "fantastic." We realize clearly enough that the video industry has now become almost national in scope and in the foreseeable future it may become globe encircling.

Although we accept the sound-sight medium as a part of our daily living pattern, we must not lose sight of certain elementary truths. Its use in politics, in education and in entertainment will increase and become much more effective.

For half a dozen years video has proven that it is the world's ideal way to demonstrate merchandise under almost perfect conditions before a mass audience. At the outset we learned to our surprise that regardless of the hour of the day or night we have a certain number of viewers in attendance. Now, through the test of trial and error, we have found certain times during the broadcast day much more suitable than others for the sale of certain products.

But as the number of stations and the broadcast hours increase, our viewing friends have become much more selective. I don't say that the largest number of viewers will turn to the best programs. Folks may not turn from a variety show to an opera, and they don't dial a worthwhile educational program in preference to watching the antics of an alleged comedian.

None of us are soothsayers and none there are who can outline the course of future commercial trends. As broadcasters we must, of course, perfect our own product. We can adopt efficiency, economy and good business practices.

There are many signs abroad of slackening retail activities. And yet, as many businesses become more competitive, there are reasons to believe that adver-

tising media, at least those elements which are built solidly, may survive and even prosper.

We'd kid ourselves not to admit that there are going to be a lot of casualties among the TV broadcasters. Even now we see more frequently the "For Sale" signs appearing in the broker's portfolios. And the marginal operators will be counted among the dead ducks irrespective of the part of the broadcast spectrum they occupy.

We're trying in our operations to improve programming to the extent that each operation is much more closely wed to every phase of community life. We believe that additional competitors will be a good thing for us—if we have sense enough to broaden our base and make our media a more essential part of local affairs.

Again, we're trying to get and stay in sound financial condition. We're pouring every available dollar into improvement of property and personnel. Being too deeply in hock to the banks, or equipment suppliers, just as being over-staffed with needless labor, pointed the road to disaster when the last depression started.

Of course, the ownership of the second, the third or even the tenth radio or TV operation diversifies and strengthens each. Every businessman is conscious of the savings derived from multiple operation. There are some activities we can handle from a central office, like relationships with the networks and placement of advertising. Other experiments, like billing from the central office, just haven't turned out successfully.

As long as we keep a station keyed to local needs, and under aggressive leadership, we can see that each is a training ground providing expanded opportunity for each employee.

*F*requency
*M*odulation
*S*tations—FM

•

IN OPERATION

AS OF

JANUARY 1, 1954

•

ALPHABETICALLY

LISTED BY STATE—CITY

FM STATIONS IN OPERATION

As of Jan. 1, 1954

Call Letters City Licensee

ALABAMA

WAVU-FM, Albertville; Sand Mountain Bcstg. Service
 WRFS-FM, Alexander City; Piedmont Service Corp.
 WCTA-FM, near Andalusia; Andalusia Bcstg. Co., Inc.
 WHMA-FM, Anniston; Anniston Bcstg. Co.
 WAFM, Birmingham; The TV Corp.
 WJLN, Birmingham; Johnston Bcstg. Co.
 WSGN-FM, Birmingham; The Jemison Bcstg. Co.
 WKLF-FM, Clanton; Southeastern Bcstg. Co.
 WFMH-FM, Cullman; The Voice of Cullman
 WHOS-FM, Decatur; North Alabama Bcstg. Co.
 WJOI-FM, Florence; Florence Bcstg. Co., Inc.
 WJBY-FM, Gadsden; Gadsden Bcstg. Co., Inc.
 WHBS-FM, Huntsville; The Huntsville Times Co., Inc.
 WWWB-FM, Jasper; Bankhead Bcstg. Co., Inc.
 WRLD-FM, Lanett; Valley Bcstg. Co., Inc.
 WABB-FM, Mobile; The Mobile Press Register, Inc.
 WKRG-FM, Mobile; Giddens & Rester
 WCOV-FM, Montgomery; Capital Bcstg. Co.
 RHTB-FM, Talladega; Voice of Talladega, Inc.
 WTBC-FM, Tuscaloosa; Tuscaloosa Bcstg. Co.
 WUOA, Tuscaloosa; Board of Trustees, U of Ala

ARIZONA

KTYL-FM, near Mesa; Horkins Bcstg., Inc.

ARKANSAS

KLCN-FM, Blytheville; Harold L Sudbury
 KFPW-FM, Ft. Smith; Tulsa Bcstg. Co.
 KFSA-FM, Ft. Smith; Southwestern Publishing Co.
 KBTM-FM, Jonesboro; Regional Bcstg. Co.
 KPOC-FM, Pochahontas; Pochahontas Radio, Inc.
 KUOA-FM, Siloam Springs; KUOA, Incorporated

CALIFORNIA

KERN-FM, Bakersfield; McClatchy Bcstg. Company
 KMAR, Bakersfield; Marmat Radio Co.
 KPFA, Berkeley; Pacifica Foundation
 KRE-FM, Berkeley; Central California Bcstrs., Inc.
 KRED, Eureka; Redwood Bcstg. Co., Inc.
 KARM-FM, Fresno; KARM, The George Harm Station
 KMJ-FM, Fresno; McClatchy Bcstg. Company
 KRFM, Fresno; California Inland Bcstg. Co.
 KUTE, Glendale; Robert P Adams
 KFWB-FM, Hollywood; Union Bcstg. Corp.
 KHJ-FM, Hollywood; General Teleradio, Inc.
 KFOX-FM, Long Beach; Nichols & Worininer, Inc.
 KNOB, Long Beach; The Cerritos Bcstg. Co.
 KCBH, Los Angeles; A. A. Crawford
 KFAC-FM, Los Angeles; Los Angeles Bcstg. Co.
 KNX-FM, Los Angeles; Columbia Bcstg. System
 KRKD-FM, Los Angeles; Radio Broadcasters, Inc.
 KSRT, Los Angeles; School of Radio Arts
 KUSC, Los Angeles; U. of Southern California

Call Letters City Licensee

KMYC-FM, Marysville; Marysville-Yuba City Bcstrs.
 KVME, Merced; Merced Bcstg. Co.
 KBEE, Modesto; McClatchy Broadcasting Co.
 KTRB-FM, nr. Modesto; KTRB Bcstg. Co., Inc.
 KXOA-FM, nr. Sacramento; Sacramento Bcstrs., Inc.
 KLX-FM, Oakland; Tribune Building Company
 KEDO, Ontario; The Daily Report Co.
 KWKW-FM, Pasadena; Southern California Bcstg. Corp.
 KVRE, nr. Redding; Golden Empire Bcstg. Co.
 KPOR, Riverside; Broadcasting Corp. of Americo
 KCRA-FM, Sacramento; KCRA, Inc
 KFBK-FM, Sacramento; McClatchy Bcstg. Co.
 KXOA-FM, Sacramento; Sacramento Bcstrs., Inc.
 KSBK, San Bruno; Radio Diablo, Inc.
 KFSD-FM, San Diego; Airfan Radio Corp., Ltd.
 KCBS-FM, San Francisco; Columbia Bcstg. System, Inc.
 KGO-FM, San Francisco; American Bcstg. Co., Inc.
 KNBC-FM, San Francisco; National Bcstg. Co., Inc.
 KRON-FM, San Francisco; The Chronicle Publishing Co.
 KXXK, San Francisco; Electronic Service Corp.
 KSJO-FM, San Jose; Santa Clara Bcstg. Company
 KVOE-FM, Santa Ana; The Voice of the Orange Empire
 KCRW, Santa Monica; Santa Monica School Board
 KDFC, Sausalito; Sundial Bcstg. Corp.
 KGDM-FM, Stockton; E. F. Peffer

COLORADO

KFEL-FM, Denver; Eugene P. O'Fallon, Inc.
 KLZ-FM, Denver; Aladdin Radio & Television, Inc.
 KOA-FM, Denver; Metropolitan TV Co.
 KCMS, Manitou Springs; Garden of Gads Bcstg. Co.

CONNECTICUT

WDRG-FM, Hartford; The Connecticut Bcstg. Co.
 WTIC-FM, Hartford; Travelers Bcstg. Serv. Corp.
 WMMW-FM, Meriden; Silver City Crystal Co.
 WBIB, New Haven; Connecticut Radio Foundation, Inc.
 WNHC-FM, New Haven; The Elm City Bcstg. Corp.
 WSTC-FM, Stamford; The Western Cann. Bcstg. Co

DELAWARE

WDEL-FM, Wilmington; WDEL, Inc.

DISTRICT OF COLUMBIA

WASH, Washington; Commercial Radio Equipment Co.
 WCFM, Washington; Cooperative Bcstg. Assoc.
 WFAN, Washington; United Bcstg. Co., Inc.
 WGMS-FM, Washington; Good Music Station, Inc
 WMAL-FM, Washington; Evening Star Bcstg. Co.
 WOL-FM, Washington; Washington Bcstg. Co.
 WRC-FM, Washington; National Bcstg. Co., Inc.
 WTOP-FM, Washington; WTOP, Inc.
 WWDC-FM, Washington, Capital Bcstg. Co.

◆ ◆ ◆ **FM STATIONS IN OPERATION** ◆ ◆ ◆

Call Letters City Licensee

FLORIDA

WNDB-FM, Daytona Beach; News-Journal Corp.
 WRUF-FM, Gainesville; University of Florida
 WIVY-FM, Jacksonville; Edward J. Oberle
 WJAX-FM, Jacksonville; City of Jacksonville
 WJHP-FM, Jacksonville; Jacksonville Journal Co.
 WMBR-FM, Jacksonville; Washington Post Co.
 WGBS-FM, Miami; Storer Bcstg. Co.
 WIOD-FM, Miami; Isle of Dreams Bcstg. Corp.
 WQAM-FM, Miami; Miami Bcstg. Co.
 WTHS, Miami; Lindsey Hopkins Vocational School
 WWPB-FM, Miami; Paul Brake
 WKAT-FM, Miami Beach; WKAT, Inc.
 WLRD, Miami Beach; Mercantile Bcstg. Co.
 WDBO-FM, Orlando; Orlando Bcstg. Co., Inc.
 WHOO-FM, Orlando; WHOO, Inc.
 WORZ-FM, Orlando; Central Florida Bcstg. Co.
 WWPB-FM, Palm Beach; Palm Beach Bcstg. Corp.
 WDLF-FM, Panama City; Panama City Bcstg. Co., Inc.
 WTSP-FM, St. Petersburg; Pinellas Bcstg. Co.
 WTAL-FM, Tallahassee; John H. Phipps
 WDAE-FM, Tampa; Tampa Times Co.
 WFLA-FM, Tampa; The Tribune Company

GEORGIA

WGAU-FM, Athens; J. K. Patrick & Co.
 WAGA-FM, Atlanta; Storer Bcstg. Co.
 WATL-FM, Atlanta; Atlanta Bcstg. Co.
 WBGE-FM, Atlanta; General Bcstg. Co.
 WGST-FM, Atlanta; Georgia Institute of Tech.
 WSB-FM, Atlanta; Atlanta Newspapers, Inc.
 WAUG-FM, Augusta; Garden City Bcstg. Co.
 WRBL-FM, Columbus; Columbus Bcstg. Co.
 WDWD-FM, Dawson; Dawson Bcstg. Co.
 WDUN-FM, Gainesville; Northeast Georgia Bcstg. Co.
 WKEU-FM, Griffin; Radio Station WKEU
 WLAG-FM, LaGrange; LaGrange Bcstg. Co.
 WMAZ-FM, Macon; Southeastern Bcstg. Co.
 WNEX-FM, Macon; Macon Broadcasting Co.
 WCOH-FM, Newnan; Newman Bcstg. Co.
 WRGA-FM, Rome; Rome Broadcasting Corp.
 WSAV-FM, Savannah; WSAV, Incorporated
 WTOG-FM, Savannah; Savannah Bcstg. Co.
 WJAT-FM, Swainsboro; Jack A. & Nancy M. Thompson
 WLET-FM, Toccoa; R. G. LeTourneau
 WGOV-FM, Valdosta; WGOV, Inc.

HAWAII

KAIM, Honolulu; Christian Bcstg. Assn.
 KHTL, Honolulu; Henry T. Lee

IDAHO

KSEI-FM, Pocatello; Radio Service Corp.
 KRXX-FM, Rexburg; Snake River Radio & TV Co.
 KTFI-FM, Twin Falls; Radio Broadcasting Corp.

ILLINOIS

WJBC-FM, Bloomington; Bloomington Bcstg. Corp.
 WBYS-FM, Canton; Fulton County Bcstg. Co.
 WROY-FM, Carmi; Carmi Bcstg. Co.
 WCNT-FM, nr. Centralia; Southern Illinois Bcstg. Corp.
 WDWS-FM, Champaign; The Champaign News-Gazette
 WAAF-FM, Chicago; Corn Belt Publishers, Inc.
 WBBM-FM, Chicago; Columbia Bcstg. System, Inc.

Call Letters City Licensee

WBEZ, Chicago; Bd. of Ed., City of Chicago
 WBIK, Chicago; Balaban & Katz Corporation
 WEFM, Chicago; Zenith Radio Corporation
 WEHS, Chicago; WHFC, Inc.
 WENR-FM, Chicago; American Bcstg. Co., Inc.
 WFJL, Chicago; Lewis College of Science & Tech.
 WFMF, Chicago; WFMF, Incorporated
 WFMT-FM, Chicago; Gale Bcstg. Co., Inc.
 WSEL, Chicago; Chicago Skyway Bcstg. Co.
 WMAQ-FM, Chicago; National Bcstg. Co., Inc.
 WCHI, Chicago Heights; Chicago Heights Bcstg. Co.
 WSOY-FM, Decatur; Illinois Broadcasting Co.
 WLEY, Elmwood Park; Elmwood Park Bcstg. Corp.
 WEAW, Evanston; North Shore Bcstg. Co., Inc.
 WFJS, Freeport; Stephenson Corp.
 WEBQ-FM, Harrisburg; Harrisburg Bcstg. Co.
 WLDS-FM, Jacksonville; Jacksonville Radio & TV Bcstg. Corp.
 WLBH-FM, Mattoon; Mattoon Bcstg. Co.
 WMIX-FM, Mt. Vernon; Mt. Vernon Radio & TV Co.
 WOPA-FM, Oak Park; Village Bcstg. Co.
 WPRS-FM, Paris; Paris Bcstg. Corp.
 WMBD-FM, Peoria; WMBD, Inc.
 WGEM-FM, Quincy; Quincy Bcstg. Co.
 WTAD-FM, Quincy; Lee Broadcasting, Inc.
 WROK-FM, Rockford; Rockford Broadcasters, Inc.
 WHBF-FM, Rock Island; Rock Island Bcstg. Co.
 WCVS-FM, Springfield; WCBS, Inc.
 WTAX-FM, Springfield; WTAX, Inc.
 WIUC-FM, Urbana; University of Illinois
 WKID-FM, Urbana; Sterling Bcstg. Co.

INDIANA

WCSI-FM, Columbus; Syndicate Theatres, Inc.
 WCNB-FM, Connersville; News-Examiner Company
 WTRC-FM, Elkhart; Truth Publishing Co., Inc.
 WIKY-FM, Evansville; South Central Bcstg. Corp.
 WMLL, Evansville; On the Air, Inc.
 WKJG-FM, Ft. Wayne; Northeastern Ind. Bcstg. Co.
 WJIZ, Hammond; South Shore Bcstg. Corp.
 WFAM, near Lafayette; WFAM, Inc.
 WINL, Lebanon; Lebanon Bcstg. Co.
 WORX, Madison; Knight-Cutler System
 WMRI, near Marion; Chronicle Publishing Co., Inc.
 WIMS-FM, Michigan City; Northern Ind. Bcstrs., Inc.
 WMUN, near Muncie; Tri-City Radio Corp.
 WCTW, New Castle; The Courier-Times, Inc.
 WSRK, Shelbyville; Shelbyville Radio, Inc.
 WBOW-FM, Terre Haute; Banks of the Wabash, Inc.
 WTHI-FM, Terre Haute; Wabash Valley Bcstg. Corp.
 WRSW-FM, Warsaw; Reub Williams & Sons, Inc.
 WFML, Washington; Washington Radio, Inc.

IOWA

WOI-FM, Ames; Iowa State College
 KFGQ-FM, Boone; Boone Biblical College
 KCRK, Cedar Rapids; The Gazette Company
 KROS-FM, Clinton; Clinton Bcstg. Corp.
 WOC-FM, Davenport; Tri-City Bcstg. Company
 KRNT-FM, Des Moines; Cowles Bcstg. Co.
 KSO-FM, Des Moines; Murphy Bcstg. Company
 WHO-FM, Des Moines; Central Bcstg. Co.
 WDBQ-FM, Dubuque; Dubuque Bcstg. Co.
 KFMY, Fort Dodge; Northwest Bcstg. Co.

◆ ◆ ◆ FM STATIONS IN OPERATION ◆ ◆ ◆

Call Letters	City	Licensee
KOKX-FM,	Keokuk;	Keokuk Bcstg. Co.
KGLO-FM,	Mason City;	Lec-Radio, Incorporated
KWPC-FM,	Muscatine;	Muscatine Bcstg. Co., Ltd
KSCJ-FM,	Sioux City,	Perkins Brothers Co.
KAYL-FM,	Storm Lake;	Cornbelt Bcstg. Company
KXEL-FM;	Waterloo;	Josh Higgins Bcstg. Co

KANSAS

KIND-FM, Independence; Central Bcstg. Inc
 KFH-FM, Wichita; Radio Station KFH Company

KENTUCKY

WCMI-FM, Ashland; Ashland Bcstg. Company
 WLBJ-FM, Bowling Green; Bowling Green Bcstg. Co.
 WFUL-FM, Fulton; Ken-Tenn Bcstg. Corp.
 WSON-FM, near Henderson; Henderson Bcstg. Co., Inc.
 WHOP-FM, Hopkinsville; Hopkinsville Bcstg. Co., Inc
 WBKY, Lexington; University of Kentucky
 WLAP-FM, Lexington; American Bcstg. Co.
 WFMW-FM, Madisonville; Messenger Bcstg. Co., Inc.
 WOMI-FM, Owensboro; Owensboro Bcstg. Company
 WVJS-FM, Owensboro; Owensboro on the Air, Inc.
 WKYC, Paducah; WKYB, Inc
 WPAD-FM, Paducah; Paducah Bcstg. Co., Inc.

LOUISIANA

KALB-FM, Alexandria; Alexandria Bcstg. Co., Inc.
 WAFB-FM, Baton Rouge; Modern Bcstg. Co.
 WBRL, Baton Rouge; Baton Rouge Bcstg. Co., Inc.
 WLCS-FM, Baton Rouge; Air Waves, Inc
 KVOL-FM, Lafayette; Evangeline Bcstg. Co., Inc.
 KMLB-FM, Monroe; Limer's Bcstg. Station, Inc
 WDSU-FM, New Orleans; WDSU Bcstg. Corp.
 WRCM, New Orleans; Supreme Bcstg. Co., Inc
 KTBS-FM, Shreveport; KTBS, Inc.
 KRMD-FM, Shreveport; Radio Station KRMD
 KWKH-FM, Shreveport; International Bcstg. Corp.

MAINE

WGUY-FM, Bangor; Murray Carpenter
 WCOU-FM, Lewiston; Twin City Bcstg. Co., Inc.

MARYLAND

WNAV-FM, Annapolis; The Capital Bcstg. Co.
 WCAO-FM, Baltimore; The Monumental Radio Co.
 WITH-FM, Baltimore; Maryland Bcstg. Company
 WUST-FM, Bethesda; Bcst. Management, Inc.
 WBUZ, Bradbury Heights; Chesapeake Bcstg. Co., Inc
 WCUM-FM, Cumberland; The Tower Realty Co.
 WFMD-FM, Frederick; The Monocacy Bcstg. Co.
 WJEJ-FM, Hagerstown; Hagerstown Bcstg. Co.
 WESN, Salisbury; The Peninsula Bcstg. Co.

MASSACHUSETTS

WBZ-FM, Boston; Westinghouse Radio Stations, Inc.
 WCOP-FM, Boston; WCOP Bcstg. Co.
 WEEI-FM, Boston; Columbia Bcstg. System, Inc.
 WHDH-FM, Boston; Matheson Radio Company, Inc
 WNAC-FM, Boston; General Teleradio, Inc
 WLAW-FM, Boston-Lawrence; Hildreth & Roacers Co
 WBET-FM, Brockton; Enterprise Publishing Co.
 WXHR, Cambridge; Middlesex Bcstg. Corp.

Call Letters	City	Licensee
WHA1-FM,	Greenfield;	John W. Haigis
WHYN-FM,	Holyoke;	Hampden-Hampshire Corp.
WLLH-FM,	Lowell;	Merrimac Bcstg Co., Inc.
WLYN-FM,	Lynn;	Puritan Bcstg. Service, Inc.
WBSM-FM,	New Bedford;	Bay State Bcstg. Co.
WFMR,	New Bedford;	E. Anthony & Sons, Inc.
WBEC-FM,	Pittsfield;	Western Mass. Bcstg Co
WBZA-FM,	Springfield;	Westinghouse Radio Sta , Inc
WMAS-FM,	Springfield;	WMAS, Inc.
WSPR-FM,	Springf'eld;	WSPR, Inc.
WJKO-FM,	Springfield;	Springfield Bcstg. Co.
WOCB-FM,	West Yarmouth;	E. Anthony & Sons, Inc.
WTAG-FM,	Worcester;	WTAG, Inc.

MICHIGAN

WUOM, Ann Arbor; Regents of University of Mich.
 WBCM-FM, Bay City, Bay Broadcasting Co., Inc.
 WHFB-FM, Benton Harbor; Palladium Publishing Co
 WTVB-FM, Coldwater; Twin Valley Bcstrs., Inc.
 WKMH-FM, Dearborn; WKMH, Inc.
 CKLW-FM, Detroit; Essex Bcstrs Inc
 WBRI, Detroit; Booth Radio & TV Stations, Inc.
 WDET-FM, Detroit; Wayne University
 WDTR, Detroit; Bd. of Ed., City of Detroit
 WJBK-FM, Detroit; Storer Bcstg. Co
 WJR-FM, Detroit; WJR, The Goodwill Station, Inc.
 WWJ FM, Detroit; The Evening News Association
 WXYZ-FM, Detroit; WXYZ, Inc.
 WKAR-FM, East Lansing; Michigan State Collge
 WJEF-FM, Grand Rapids; Fetzer Bcstg Co.
 WLAV-FM, Grand Rapids; Versluis Radio & TV, Inc
 WMLN, Mt. Clemens; Macomb Publishing Co.
 WKBZ-FM, Muskegon; Ashbocker Radio Corp
 WLDM, Oak Park; Lincoln Bcstg Company
 WCAR-FM, Pontiac; WCAR, Inc.
 WOMC, Royal Oak, Sparks Bcstg. Co.
 WSAM-FM, Saginaw; Saginaw Bcstg. Co.
 WSTR FM, Sturgis; WSTR, Inc.

MINNESOTA

WEBC-FM, Duluth; Head of the Lakes Bcsta Co.
 KYSM-FM, Mankato; Southern Minn. Supply Co.
 KTJS-FM, Minneapolis; Nw'n.-Theo. Sem & Bible
 Trng. Sch.
 WTCN-FM, Minneapolis; Minn Television Pub. Serv.
 Corp.
 KFAM-FM, St. Cloud; The Times Publishing Co.
 WMIN-FM, St. Paul; WMIN Bcstg. Co.
 KWNO-FM, Winona; Winona Radio Service

MISSISSIPPI

WGCM-FM, Gulfport; WGCM Bcstg. Company
 WRFM, Hattiesburg; Forrest Bcstg. Co., Inc.
 WJDX-FM, Jackson; Lomar Life Insurance Co.
 WAPF-FM, McComb; Southwestern Bcstg. Co

MISSOURI

KCHR, Charleston; South Missouri Bcstg. Co.
 KFUO-FM, Clayton; Lutheran Church-Missouri Synad
 KWOS-FM, Jefferson City; Capital Bcstg. Company
 WMBH-FM, Joplin; Joplin Bcstg. Company
 KCMO-FM, Kansas City; Meredith Engrg Co.
 KBOA-FM, near Kennett; Kennett Bcstg. Corp.

◆ ◆ ◆ **FM STATIONS IN OPERATION** ◆ ◆ ◆

Call Letters	City	Licensee
KWOC-FM,	Poplar Bluff;	Poplar Bluff Bcstg. Co.
KTTS-FM,	Springfield;	Independent Bcstg. Co.
KWPM-FM,	West Plains;	Robert F. Neathery

NEVADA

KENO-FM,	Las Vegas;	Nevada Bcstg. Company
KNEV,	Reno;	Everett B. Cobb

NEW HAMPSHIRE

WMOU-FM,	Berlin;	White Mts. Bcstg. Co., Inc.
WTSV-FM,	Claremont;	Grandview, Inc.
WKBR-FM,	Manchester;	Granite State Bcstg. Co., Inc.
WOTW-FM,	Nashua;	Nashua Bcstg. Corp.

NEW JERSEY

WFMN,	Alpine;	Edwin H. Armstrong
WJLK-FM,	Asbury Park;	Asbury Park Press, Inc.
WSNJ-FM,	near Bridgeton;	Eastern States Bcsta. Corp.
WAAT-FM,	Newark;	Bremer Bcstg. Corp.
WNJR-FM,	Newark;	North Jersey Radio, Inc.
WCTC-FM,	New Brunswick;	Chanticleer Bcstg. Co.
WSOU,	South Orange;	Seton Hall College
WTOA,	Trenton;	Mercer Broadcasting Co.
WAWZ-FM,	Zare Phath;	Pillar of Fire Inc.

NEW YORK

WROW-FM,	Albany;	Hudson Valley Bcstg. Co., Inc.
WMBO-FM,	Auburn;	WMBO, Inc.
WRBS,	Bay Shore;	Great South Bay Bcstg. Co.
WKOP-FM,	Binghamton;	Binghamton Bcstrs., Inc.
WNYE,	Brooklyn;	Bd. of Ed., City of New York
WRRE,	Bristol Center;	Northeast Radio Corp.
WBEN-FM,	Buffalo;	WBEN, Inc.
WBNY-FM,	Buffalo;	Roy L. Albertson
WWOL-FM,	Buffalo;	Greater Erie Bcstg. Co.
WXRC,	Buffalo;	Western New York Bcstg. Co.
WVCV,	Cherry Val. Twp.;	Rural Radio Network, Inc.
WRRR,	Cherry Valley;	Northeast Radio Corp.
WCLI-FM,	Corning;	Radio Corning Inc.
WKRT-FM,	Cortland;	Radio Cortland, Inc.
WVCN,	DeRuyter Twp.;	Rural Radio Network, Inc.
WRRD,	DeRuyter;	Northeast Radio Corp.
WSHS,	Floral Park;	Bd. of Ed., Sewanhaka High School
WHLI-FM,	Hempstead;	FM Broadcasting Corp.
WWHG-FM,	Hornell;	The W. H. Greenhow Co.
WHCU-FM,	Ithaca;	Cornell University
WRRR,	Ithaca;	Northeast Radio Corp.
WJTN-FM,	Jamestown;	James Bcstg. Co., Inc.
WMSA-FM,	Massena;	The Brockway Company
WGNR-FM,	New Rochelle;	New Rochelle Bcstg. Serv., Inc.
WNRC-FM,	New Rochelle;	Radio New Rochelle Inc.
WBCA,	New Scotland;	Capitol Bcstg. Co., Inc.
WABC-FM,	New York;	American Bcsta. Co., Inc.
WABF,	New York;	Metropolitan Bcstg. & TV., Inc.
WCBS-FM,	New York;	Columbia Bcstg. System, Inc.
WEVD-FM,	New York;	Debs Memorial Fund, Inc.
WFUV,	New York;	Fordham University
WGHF,	New York;	WGHF, Inc.
WHOM-FM,	New York;	Atlantic Bcstg. Co., Inc.
WMGM-FM,	New York;	Marcus Loew Booking Agency
WNBC-FM,	New York;	National Bcstg. Co., Inc.
WNYC-FM,	New York;	City of N. Y. Municipal Bcstg. System

Call Letters	City	Licensee
WOR-FM,	New York;	General Teleradio, Inc.
WQXR-FM,	New York;	Interstate Bcstg. Co., Inc.
WWRL-FM,	New York;	Long Island Bcstg. Corp.
WHLD-FM,	Niagara Falls;	Niagara Falls Gazette Pub. Co.
WSLB-FM,	Ogdensburg;	St. Lawrence Bcstg. Corp.
WHDL-FM,	Olean;	WHDL Inc.
WALK-FM,	Patchogue;	Suffolk Bcstg. Corp.
WHVA,	Poughkeepsie;	Poughkeepsie Newspapers, Inc.
WRRH,	Poughkeepsie;	Northeast Radio Corp.
WHFM,	Rochester;	Stromberg-Carlson Company
WRNY-FM,	Rochester;	Rochester Bcstg. Co., Inc.
WBCA,	Schenectady;	Capitol Broadcasting Co., Inc.
WGFM,	Schenectady;	General Electric Company
WVBT,	S. Bristol Twp.;	Rural Radio Network, Inc.
WSYR-FM,	Syracuse;	Central New York Bcstg. Corp.
WEVR,	Troy;	Veterans Vocational School
WFLY,	Troy;	The Troy Record Company
WIBX-FM,	Utica;	WIBX, Inc.
WRUN-FM,	Utica;	Rome Sentinel Company
WWNY-FM,	Watertown;	The Brockway Company
WFNF,	Wethersfield Twp.;	Rural Radio Network, Inc.
WRRL,	Wethersfield;	Northeast Radio Corp.
WFAS-FM,	White Plains;	Westchester Bcstg. Corp.

NORTH CAROLINA

WGWR-FM,	Asheboro;	Asheboro Broadcasting Co.
WLOS-FM,	Asheville;	Skyway Bcstg. Co.
WBBB-FM,	Burlington;	Alamance Bcstg. Co., Inc.
WFNS-FM,	Burlington;	Burlington-Graham Bcstg. Co.
WAYS-FM,	Charlotte;	Inter-City Advertising Co.
WSOC-FM,	Charlotte;	Radio Station WSOC, Inc.
WMIT,	Clingman's Park;	Mount Mitchell Bcstrs. Inc.
WDNC-FM,	Durham;	Durham Radio Corp.
WIFM-FM,	Elkin;	James B. Childress
WFNC-FM,	Fayetteville;	Cape Fear Bcstg. Co.
WBBO-FM,	nr. Forest City;	Rutherford County Radio Co., Inc.
WGNC-FM,	Gastonia;	Catherine T. McSwain
WEQR,	Goldboro;	Eastern Carolina Bcstg. Co., Inc.
WHNC-FM,	Henderson;	Henderson Radio Corp.
WNOS,	High Point;	The North State Bcstg. Co.
WHPE-FM,	High Point;	High Point Enterprise, Inc.
WMFR-FM,	High Point;	Radio Station WMFR, Inc.
WNOS-FM,	High Point;	North State Bcstg. Co.
WEWO-FM,	Laurinburg;	Scotland Bcstg. Co.
WLOE-FM,	Leaksville;	WLOE, Inc.
WBUY-FM,	nr. Lexington;	Davidson County Bcsta. Co.
WFMB,	nr. Mayodan;	Mayo Bcstg. Corp.
WNAO-FM,	Raleigh;	Sir Walter Television Co.
WPTF-FM,	Raleigh;	WPTF Radio Company
WRAL-FM,	Raleigh;	Capitol Bcstg. Co., Inc.
WREV-FM,	Reidsville;	The Reidsville Bcstg. Co., Inc.
WKFM,	Roanoke Rapids;	WCBT, Inc.
WFMA,	Rocky Mount;	Eastern Carolina Electronics, Inc.
WEED-FM,	Rocky Mount;	William Avera Wynne
WSTP-FM,	Salisbury;	Piedmont Bcstg. Co.
WSNS,	Sanford;	Sanford Broadcasting Co.
WWGP-FM,	Sanford;	Sandhills Bcstg. Corp.
WOHS-FM,	Shelby;	Western Carolina Radio Corp.
WSIC-FM,	Statesville;	Statesville Bcstg. Co., Inc.
WCPS-FM,	Tarboro;	Coastal Plains Bcstg. Co., Inc.
WTNC-FM,	nr. Thomasville;	Thomasville Bcstg. Co.
WADE-FM,	Wadesboro;	R. P. Lyon & Son

◆ ◆ ◆ FM STATIONS IN OPERATION ◆ ◆ ◆

Call Letters *City* *Licensee*

WMFD-FM, Wilmington, Richard Austin Dunlea
 WAIR-FM, Winston-Salem, WAIR Broadcasting Co
 WSJS-FM, Winston-Salem; Piedmont Publishing Co.
 WMIT, Yancey County; Mt Mitchell Bcstrs, Inc

Call Letters *City* *Licensee*

PENNSYLVANIA

WFMZ, Allentown, Penn-Allan Bcstg. Co.
 WSAN-FM, Allentown; Lehigh Valley Bcstg Co
 WYAM-FM, Altoona; The General Bcstg. Corp.
 WGPA-FM, Bethlehem, Bethlehem's Globe Pub. Co.
 WBUT-FM, Butler, J Patrick Beacom
 WCHA-FM, Chambersburg; Chambersburg Bcstg. Co., Inc.
 WCED-FM, Dubois; Tri-County Bcstg. Co., Inc.
 WEEZ, near Easton; Easton Publishing Company
 WEST-FM, Easton; Associated Bcstrs., Inc.
 WERC-FM, Erie; Presque Isle Bcstg Co.
 WLEU-FM, Erie; Commodore Perry Bcstg. Service Inc
 WHP-FM, Harrisburg; WHP, Inc.
 WAZL-FM, Hazleton; Hazleton Bcstg. Co., Inc.
 WARD-FM, Johnstown; Central Bcstg. Co., Inc.
 WJAC-FM, Johnstown; WJAC, Incorporated
 WGAL-FM, Lancaster; WGAL, Inc.
 WLAN-FM, Lancaster; The Peoples Bcstg. Co
 WLBK-FM, Lebanon, Lebanon Bcstg. Co
 WLTV, Lewisport; Lewisport Bcstg. Co.
 WMGW-FM, Meadville; Meadville Bcstg. Service, Inc
 WMCK-FM, McKeesport; Mon-Yough Bcstg. Co.
 WCAU-FM, Philadelphia; WCAU, Inc
 WFIL-FM, Philadelphia; Triangle Publications, Inc.
 WFLN, Philadelphia; Franklin Bcstg. Corp.
 WHAT-FM, Philadelphia; Independence Bcstg Co
 WIBG-FM, Philadelphia; Seaboard Bcstg. Corp.
 WIP-FM, Philadelphia; Pennsylvania Bcstg. Co
 WPEN-FM, Philadelphia; Wm Penn Bcstg. Co.
 KDKA-FM, Pittsburgh; Westinghouse Bcstg. Co., Inc
 WJAS-FM, Pittsburgh, Pittsburgh Radio Supply House
 WKJF, Pittsburgh; Mrs. A. J. R. Greer
 WWSW-FM, Pittsburgh; WWSW, Inc.
 WPAM-FM, Pottsville; Miners Bcstg. Service Inc.
 WPPA-FM, Pottsville; Pottsville Bcstg.
 WGBI-FM, Scranton; Scranton Broadcasters, Inc.
 WEJL, Scranton; E. J. & Elizabeth Lynett
 WPIC-FM, Sharon; Sharon Herald Bcstg. Co.
 WKOK-FM, Sunbury; Sunbury Bcstg. Corp.
 WRRN, Warren; Northern Allegheny Bcstg. Co.
 WJPA-FM, Washington; Washington Bcstg. Co.
 WBRE-FM, Wilkes-Barre; Louis G Baltimore
 WLYC-FM, Williamsport; Lycoming Bcstg Co.
 WRAC-FM, Williamsport; WRAC, Inc.
 WNOW-FM, York; The Helm Coal Co. (Bcst. Div.)
 WRZE, York; White Rose Broadcasting Co.

OHIO

WAKR-FM, Akron; Summit Radio Corporation
 WFAH-FM, Alliance; Review Publishing Company
 WATG-FM, Ashland, Ashland Bcstg Co.
 WICA-FM, Ashtabula; WICA, Inc.
 WOUI, Athens; Ohio University
 WTRF-FM, Bellaire; Tri-City Broadcasting Co.
 WHBC-FM, Canton; The Ohio Bcstg. Co.
 WCPO-FM, Cincinnati; Scripps-Howard Radio, Inc.
 WKRC-FM, Cincinnati; Radio Cincinnati, Inc
 WLWA, Cincinnati; Crosley Bcstg. Corp
 WERE-FM, Cleveland; Cleveland Bcstg. Co.
 WGAR-FM, Cleveland, Peoples Bcstg. Corp.
 WHK-FM, Cleveland; United Cstg. Co.
 WJW-FM, Cleveland; WJW, Inc.
 WTAM-FM, Cleveland; National Bcstg Co., Inc.
 WSRS-FM, Cleveland Hts.; WSRS, Inc
 WCOL-FM, Columbus; Air Trails, Inc
 WELD, Columbus; RadiOhio, Inc.
 WHKC-FM, Columbus; United Broadcasting Co.
 WLWF, Columbus; Crosley Broadcasting Co.
 WYKO-FM, Columbus; Sky Way Bcstg. Corp
 WHIO-FM, Dayton; Miami Valley Bcstg. Corp
 WEOL-FM, Elyria; Elyria-Lorain Bcstg. Co.
 WFIN-FM, Findlay; The Findlay Publishing Co.
 WFOB-FM, Fostoria; Seneca Radio Corp.
 WFRO-FM, Fremont; Wolfe Bcstg Corp.
 WMOH-FM, Hamilton; The Fort Hamilton Bcstg. Co.
 WIMA-FM, Lima; Northwestern Ohio Bcstg Corp
 WMRN-FM, Marion; Marion Bcstg. Co.
 WMVO, Mt. Vernon; The Mt Vernon Bcstg. Co.
 WCLT-FM, Newark; The Advocate Printing Co.
 WPAY-FM, Portsmouth, The Scioto Bcstg. Co
 WSTV-FM, Steubenville; WSTV, Inc.
 WSPD-FM, Toledo; Storer Bcstg. Co.
 WTOL-FM, Toledo; Community Bcstg Co
 WTRT, Toledo; Unity Corp, Inc.
 WWST-FM, Wooster; Wooster Republican Ptg Co
 WFMJ-FM, Youngstown; The WFMJ Bcstg. Co.
 WKBN-FM, Youngstown; WKBN Bcstg. Corp.

OKLAHOMA

KMUS-FM, Muskogee; Eastern Okla. Bcstg Co.
 KSPI-FM, Stillwater; Stillwater Publishing Co.
 KTUL-FM, Tulsa; Tulsa Bcstg Co.

OREGON

KWIL-FM, Albany; Central Willamette Bcstg Co.
 KUGN-FM, Eugene; KU 9N, Inc.
 KGPO, Grants Pass; Southern Oregon Bcstg. Co.
 KEX-FM, Portland; Westinghouse Bcstg. Co.
 KGW-FM, Portland; Pioneer Bcstrs., Inc.
 KOIN-FM, Portland, Mount Hood Radio & TV Bcstg Corp.
 KPFM, Portland; Oregon Bcstrs., Ltd
 KPOJ-FM, Portland; KPOJ, Inc.

RHODE ISLAND

WPJB-FM, Providence; Providence Journal Co.
 WPRO-FM, Providence; Cherry & Webb Bcstg. Co.
 WWON-FM, Woonsocket; Woonsocket Bcstg. Co.

SOUTH CAROLINA

WCAC, Anderson; Wilton E. Hall
 WCSC-FM, Charleston; WCSC, Inc
 WTMA-FM, Charleston; Atlantic Coast Bcstg Co.
 WCOS-FM, Columbia; Radio Columbia
 WIS-FM, Columbia; The Bcstg. Co. of the South
 WDSC-FM, Dillon; Border Bcstg. Co.
 WAKE-FM, Greenville; Piedmont Bcstg Co.
 WESC-FM, Greenville; Greenville Broadcasting Co.
 WFBC-FM, Greenville; WMRC, Inc.

Call Letters	City	Licensee
WCRS-FM	Greenwood	Grengo, Inc.
WORG	Orangeburg	WTND, Inc.
WRHI-FM	Rock Hill	York County Bcstg. Co.
WSNW-FM	Seneca	Blue Ridge Bcstg. Co., Inc.
WDXY	Spartanburg	The Spartan Radiocasting Co.
WSPA-FM	Spartanburg	The Bcstg. Co. of the South
WALD-FM	Walterboro	Walterboro Bcstg. Co.

SOUTH DAKOTA

KOZY, Rapid City; Black Hills Bcstg. Co. of Rapid City

TENNESSEE

WOPI-FM, Bristol; Radiophone Bcstg. Sta. WOPI, Inc.
 WAPO-FM, Chattanooga; WAPO Bcstg. Serv. Inc.
 WDOF-FM, Chattanooga; WDOF Bcstg. Co.
 WAEW-FM, Crossville; WAEW Inc.
 WHBT-FM, Harriman; Harriman Bcstg. Co.
 WTJS-FM, Jackson; The Sun Publishing Co., Inc.
 WJHL-FM, Johnson City; WJHL, Inc.
 WKPT-FM, Kingsport; Kingsport Bcstg. Co., Inc.
 WBIR-FM, Knoxville; Radio Station WBIR, Inc.
 WLIL-FM, Lenoir City; WLIL, Inc.
 WMCF, Memphis; Memphis Publishing Company
 WSOK-FM, Nashville; Nashville Bcstg. Co.

TEXAS

KREL-FM, Baytown; Tri-Cities Bcstg. Co.
 KRIC-FM, Beaumont; The Enterprise Co.
 KCLE-FM, Cleburne; Marti, Inc.
 KIXL-FM, Dallas; Variety Bcstg. Co., Inc.
 KRLD-FM, Dallas; KRLD Radio Corporation
 WRR-FM, Dallas; City of Dallas
 KDNT-FM, Denton; Harwell V. Shepard
 WBAP-FM, Fort Worth; Carter Publications, Inc.
 KLUF-FM, Galveston; The KLUF Bcstg. Co., Inc.
 KPRC-FM, Houston; The Houston Post Company
 KTRH-FM, Houston; KTRH Bcstg. Co.
 KXYZ-FM, Houston; Shamrock Bcstg. Co.
 KLTI-FM, near Longview; Le Tourneau Radio Corp.
 KRBA-FM, Lufkin; Darrell E. Yates
 KISS, San Antonio; The Walmac Co.
 KITE-FM, San Antonio; Radio KITE, Inc.
 KONO-FM, San Antonio; Mission Bcstg. Co.
 K TSA-FM, San Antonio; Sunshine Bcstg. Co.
 KTEM-FM, Temple; Bell Broadcasting Co., Inc.
 KCMC-FM, Texarkana; KCMC, Incorporated
 KWFT-FM, Wichita Falls; Rowley-Brown Bcstg. Co.

UTAH

KDYL-FM, Salt Lake City; Intermountain Bcstg. & TV Corp.
 KSL-FM, Salt Lake City; Radio Serv. Corp. of Utah
 KUTF, Salt Lake City; Utah Bcstg. & TV Co.

VIRGINIA

WARL-FM, Arlington; Northern Virginia Bcstrs., Inc.
 WSVS-FM, Crewe; Southern Virginia Bcstg. Corp.
 WBTM-FM, Danville; Piedmont Bcstg. Corp.
 WEVA-FM, Emporia; Stone Bcstg. Corp.

Call Letters	City	Licensee
WSVA-FM	Harrisonburg	Shenandoah Valley Bcstg. Corp.
WLVA-FM	Lynchburg	Lynchburg Bcstg. Corp.
WWOD-FM	Lynchburg	Old Dominion Bcstg. Corp.
WMVA-FM	nr. Martinsville	Martinsville Bcstg. Co.
WGH-FM	Newport News	Hompton Roads Bcstg. Corp.
WRVC	Norfolk	Larus & Brother Co., Inc.
WTAR-FM	Norfolk	WTAR Radio Corporation
WCOD	Richmond	Havens & Martin, Inc.
WLEE-FM	Richmond	Lee Bcstg. Corp.
WRNL-FM	Richmond	Richmond Newspapers, Inc.
WRVB	Richmond	Larus & Brother Co., Inc.
WDBJ-FM	Roanoke	Times-World Corporation
WROV-FM	Roanoke	Radio Roanoke, Inc.
WLSL-FM	Roanoke	Shenandoah Life Stations, Inc.
WRFL	Winchester	Richard Field Lewis, Jr.

WASHINGTON

KALE-FM, Richland; KALE, Inc.
 KING-FM, Seattle; KING Bcstg. Company
 KIRO-FM, Seattle; Queen City Bcstg. Co., Inc.
 KISW, Seattle; Ellwood W. Lippincott
 KOMO-FM, Seattle; Fisher's Blend Station, Inc.
 KREM-FM, Spokane; Louis Wasmer
 KTNT-FM, Tacoma; Tribune Publishing Co.

WEST VIRGINIA

WJLS-FM, Beckley; Joe L. Smith, Jr., Inc.
 WGV-FM, Charleston; Kanawha Valley Bcstg. Co.
 WKNA-FM, Charleston; Joe L. Smith, Jr., Inc.
 WPDX-FM, Clarksburg; Clarksburg Bcstg. Corp.
 WJPB, Fairmont; Fairmont Bcstg. Co.
 WHTN-FM, Huntington; Greater Huntington Radio Corp.
 WLOG-FM, Logan; Clarence H. Frey & Robert O. Greever
 WEPM-FM, Martinsburg; Martinsburg Bcstg. Co.
 WAJR-FM, Morgantown; West Virginia Radio Corp.
 WOAY-FM, Oak Hill; Robert R. Thomas, Jr.
 WPAR-FM, Parkersburg; Ohio Valley Bcstg. Corp.
 WKWK-FM, Wheeling; Community Bcstg., Inc.
 WWVA-FM, Wheeling; Storer Bcstg. Co.

WISCONSIN

WEAU-FM, Eau Claire; Central Bcstg. Company
 WCLO-FM, Janesville; Southern Wisc. Radio Inc.
 WHA-FM, Madison; State of Wisc., State Radio Council
 WIBA-FM, Madison; Badger Bcstg. Co.
 WISC-FM, nr. Madison; Radio Wisconsin, Inc.
 WMFM, Madison; Earl W. Fessler
 WDLB-FM, Marshfield; Dairyland's Bcstg. Serv., Inc.
 WLN, Merrill; Alvin E. O'Konski
 WEMP-FM, Milwaukee; Milwaukee Bcstg. Co.
 WISN-FM, Milwaukee; The Hearst Corp.
 WWCF, Poyette; Wm. C. Forrest
 WRJN-FM, Racine; Racine Bcstg. Corp.
 WJMC-FM, Rice Lake; WJMC, Inc.
 WLBL-FM, Sheboygan; WLBL, Inc.
 WFHR-FM, Wisconsin Rapids; William F. Huffman Radio, Inc.

Have you seen and
tried the newest

PRESTO EQUIPMENT?

Here is a sampling of the complete Presto line of precision disc and tape recording and reproducing equipment specifically designed for ease of operation and professional results.

**PRESTO RELIABLE
LONG-PLAYING
TAPE REPRODUCER
PB-17**



Automatically reversible for continuous playback of background music. Frequency response uniform from 50-8,000 cps (± 2 db.) Tape speed $3\frac{3}{4}$ " per sec. Reels up to 14" dia. (4,800' of tape) with dual track. Mechanism will re-cycle or stop after 8-hours of play.

**PRESTO 92-B
RECORDING
AMPLIFIER
FOR VERTICAL
RACK MOUNTING**



Has low internal output impedance and high degree of feed-back and its response is virtually unaffected by changes in load. Holds distortion to minimum. 60-watt output ample for transient peaks. Push-button selector for recording character issues.

**PRESTO PORTABLE,
HIGHLY ACCURATE
PROFESSIONAL-TYPE
RECORDER 6-N**

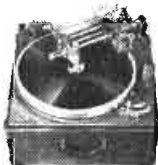

A fine, high-quality recorder for portable or stationary operation. Especially designed for professional use. Presto 1-D cutting head supplied. Precision overhead mechanism including spinning feed-screw. May be equipped for microgroove recording at extra cost.

**PRESTO
PRECISION-ENGINEERED
"UNITIZED"
TAPE RECORDER
RC-11**



Presto's revolutionary RC-11 has self-contained capstan drive with dual-speed motor plus two torque motors. Tape speed of $7\frac{1}{2}$ " and 15" per sec. with complete push-button operation. Takes reels up to $10\frac{1}{2}$ ".

**PRESTO
PRECISION FIELD
TAPE AMPLIFIER
900 A-3**

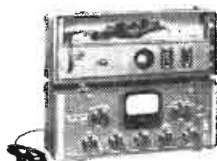

High quality amplifier to match Presto's RC-7 and RC-11 tape recorders. Separate power supply eliminates noise. Three microphone input, low distortion. 900-A-1 amplifier identical except for single input transformer.



**PRESTO 16" TRANSCRIPTION
TURNTABLE 10-B FOR RADIO STATIONS
AND RECORDING STUDIOS**

An improvement on the long popular model 10-A. Operates at $33\frac{1}{3}$, 78 rpm and 45 rpm. With its 3-speed mechanism, the Presto 10-B is an extremely accurate rim-driven table. Available as chassis only or in console cabinet.

PRESTO

**RECORDING CORPORATION
PARAMUS, NEW JERSEY**

Export Division: 25 Warren St., New York 7, N. Y.

Canadian Division: Walter P. Downs,
Dominion Square Bldg., Montreal

WORLD'S LARGEST MANUFACTURER OF PRECISION RECORDING EQUIPMENT AND DISCS

Equipment

- **RADIO-TELEVISION
EQUIPMENT
MANUFACTURERS**

- **RETMA PERSONNEL
AND COMMITTEES**

- **CONSULTING
ENGINEERS**

A LIST OF IMPORTANT RADIO, TELEVISION AND FM
EQUIPMENT FIRMS

Admiral Corporation

3800 W. Cortland St., Chicago 47, Ill.
 Phone: Spaulding 2-0100
 N. Y. Phone: PLaza 7-7500

Pres., Chairman.....Ross D. Siragusa
 Exec. Vice-Pres.....John B. Huarisa
 Vice-Pres., Appliance Div.....Lee H. D. Baker
 Vice-Pres., Sales.....Wallace C. Johnson
 Vice-Pres., Purchasing.....Frank J. Kazda
 Vice-Pres., Prod.....Cy S. Rossate
 Treasurer.....Lynn C. Park
 Secretary.....George E. Driscoll
 Vice-Pres., Gen. Counsel.....F. H. Ulrich
 Vice-Pres., Adv. Dir.....Seymour Mintz
 Public Relations Dir.....Martin Sheridan
 PRODUCTS: Television receivers, television consoles and combinations, table radios, clock radios, portable radios, radio-phonographs.

Allen-Bradley Company

136 W. Greenfield Ave., Milwaukee 4, Wis.
 Phone: ORchard 1-2000

Radio Sales Mgr.....D. S. W. Kelly
 PRODUCTS: Fixed composition resistors, variable composition resistors, ceramic capacitors, ferrite parts.

Allied Radio Corp.

100 N. Western Ave., Chicago 80, Ill.
 Phone: HAYmarket 1-6800

Industrial and Sales Mgr.....Leo Brook
 PRODUCTS: Distributors of radio, TV, and industrial electronics parts and equipment including broadcast station tubes, parts, and supplies.

Altec Lansing Corp.

9356 Santa Monica Blvd., Beverly Hills, Calif.
 Phone: CRestview 5-5101

161 Sixth Ave., New York 13, N. Y.
 Phone: ALgonquin 5-3636

Vice-President.....A. A. Ward
 Prod. Sales Mgr.....S. H. Morris
 PRODUCTS: Speech input consoles and amplifiers, microphones, limiter amplifiers, monitoring loudspeakers, public address and sound reinforcement systems for studios, AM and FM.

Amperex Electronic Corp.

230 Duffy Ave., Hicksville, N. Y.
 Phone: HICKsville 3-6200

Pres. & Sales Manager.....Sam Norris
 Dir. of Engineering.....Simcon Weston
 Advertising Mgr.....M. D. Smoller
 PRODUCTS: Tubes; Transmitting, Power, Vacuum Condensers, Rectifiers.

Ampex Electric Corp.

934 Charter St., Redwood City, Calif.
 Phone: MURray Hill 4-4137

Chmn. of Board.....T. Kevin Mallen
 President.....A. M. Poniatoff
 V.P.-Gen. Mgr.....George I. Long
 Secretary.....C. E. McSharry
 Gen. Sales Mgr.....Harrison Johnston
 Comptroller.....Thomas L. Taggart
 PRODUCTS: Magnetic Tape Recorders, Tape Film Synchronizing Equipment, Mixers, Stereophonic Sound Equipment.

American Television & Radio Co.

300 East Fourth St., St. Paul 1, Minn.
 Phone: Cedar 3791

Pres. & Sales Mgr.....Albert A. Goffstein
 PRODUCTS: Auto Radio Vibrators, Heavy Duty Inverter Vibrators, DC-AC Inverters, Vibrator Packs, Battery Eliminators, and Rectifier Power Supplies.

Amy, Aceves & King, Inc.

11 W. 42nd St., New York 36, N. Y.
 Phone: LONgacre 5-6622

President.....Ernest V. Amy
 V.P.-Treas., Pur. Agt.....Frank King
 Sales Manager.....F. A. Klingenschmitt
 PRODUCTS: Master antenna systems, TV and FM antennas. Electronic developments.

Andrea Radio Corp.

27-01 Bridge Plaza North, L.I.C.I., N.Y.
 Phone: STillwell 4-5411

President.....Frank A. D. Andrea
 Sales Manager.....Lynn Eaton
 Gen. Sec. & Chief Engineer.....H. J. Heindel
 Service Mgr.....Joseph Haug
 Credit Manager.....Victor J. Back
 Purchasing Agent.....Bruce B. Donald
 Industrial Relations Mgr.....John Andrea
 Export Manager.....Ramon Masvidal
 PRODUCTS: Radio and TV-FM receivers and TV-AM-FM phone combinations.

Andrew Corporation

363 East 75th St., Chicago 19, Ill.
 Phone: TRIangle 4-4400

N. Y. Phone: RIDgewood 6-9181
 Sales Manager.....Robert P. Lamons
 PRODUCTS: Coaxial transmission line for TV-FM-AM, FM antennas, (special) TV antennas, antenna phasing and tuning equipment, monitoring equipment (AM), microwave link antennas and cable, VHF equipment.

Audak Company

500 Fifth Ave., New York 18, N. Y.

Phone: LA 4-3723-3724

PresidentMaximilian Weil
 Vice-President.....Geo. V. Sullivan
 AdvertisingHart Lehman
 Purchasing Agent.....J. C. Parvey
 PRODUCTS: Electronic reproducing and recording equipment.

Audio Devices, Inc.

444 Madison Ave., New York 22, N. Y.

Phone: PLaza 3-0973

President.....Wm. C. Speed
 Vice-President-Sec.Bryce Haynes
 PRODUCTS: Recording discs (Audio-discs), recording and playback points (Audio-points), Magnetic Recording Tape (Audiotape), Magnetic Recording Film (Audio-film).

Audio Masters Corp.

17 East 45th St., New York 17, N. Y.

Phone: OXford 7-0725

PresidentHerbert Rosen
 PRODUCTS: Transcription and electric playback machines, recording tape, tape playback machine.

Audio & Video Products Corp.

730 Fifth Ave., New York, N. Y.

Phone: PLaza 7-3091

President.....Charles E. Rynd
 Vice-Pres. Sales.....Robert D. Winston
 Vice-Pres. Engineering.....T. J. Merson
 Vice-Pres., Treasurer.....R. S. Rynd
 SecretaryJoseph Connolly
 PRODUCTS: Sales and engineering representatives for magnetic tape and disc recording equipment as well as associated accessory items manufactured by: Altec Lansing, Ampex, Cinema Engineering Co., Electro-Voice, Fairchild, MacIntosh, Presto, Pickering, Rek-O-Kut, Tapak, Scotch.

John F. Beasley Construction Co.

P. O. Box 1624, Muskogee, Okla.

Phone: MUrray 7-6381

President.....John F. Beasley
 Vice-President.....Marvin W. Kyger
 Vice-President.....Lothar E. Berg
 Secretary-Treasurer.....Andrew B. Lytle
 PRODUCTS: Steel crotors (radio-television towers and antennas).

Bell and Howell Company

7100 McCormick Road, Chicago 45, Ill.

Phone: AM 2-1600

Sales Manager.....George L. Oakley
 PRODUCTS: Film printers, film splicers, sound projectors, cameras, lenses.

Bendix Television & Broadcast Receiver Division (Bendix Aviation Corp.)

East Joppa Road, Towson 4, Md.

Phone: VA 3-2200

General Manager.....E. K. Foster
 Asst. Gen. Mgr.....A. E. Welch
 Merchandise Mgr.....C. J. Hassard
 Adv. & Sales Prom. Mgr.....H. S. Sacks
 Credit Manager.....H. F. B. Kerr
 Chief Engineer.....J. M. Miller, Jr.
 Service Manager.....W. P. Muller
 PRODUCTS: 17", 21", 24" and 27" TV receivers, both table models and console AM and FM Console radios.

Blaw-Knox Equipment Div.

Blaw-Knox, Pa.

Phone: STerling 1-2700

405 Lexington Ave., New York 17, N. Y.

Phone: VAnderbilt 6-0661

Sales Mgr., Tower Dept.....A. H. Jackson
 Manager, N. Y. Office.....W. F. Simmons
 PRODUCTS: Self-support and guide towers.

The William Brand & Co., Inc.

North and Valley Sts., Willimantic, Conn.

Phone: Willimantic 3-1661

Manager.....R. H. Robinson

Chicago Office, 1313 W. Randolph St.

Phone: SEeley 8-0345

PRODUCTS: Insulating materials.

William W. L. Burnett Radio Lab.

4814 Idaho St., San Diego 16, Calif.

Phone: Talbot 4943

Owner-Chief Eng....William W. L. Burnett
 PRODUCTS: Pico-electric crystals, crystal holders, constant temperature controlled ovens, frequency measuring equipment, laboratory equipment, conducting regular radio laboratory measurements, offering a completed frequency measuring service, from 10 Kc. to 500 mcs. covering both AM and FM measurements. All stations must be within receiving distance of the laboratory. Special laboratory equipment developed and tested.

Califone Corp.

1041 N. Sycamore Ave., Hollywood 38, Calif.

Phone: HOLlywood 2-2353

President.....Robert G. Metzner

PRODUCTS: Portable transcription players, high fidelity magnetic tape recorders.

Cambridge Thermionic Corp.

445 Concord Ave., Cambridge 38, Mass.

Phone: TRowbridge 6-2800

Crystal Engineer.....Clarence Cheyney

PRODUCTS: Frequency check service.

Canadian Marconi Co.

2442 Trenton Ave., Montreal 6, Que., Can.

Phone: ATLantic 9441

Sales Supervisor.....J. H. Martin

PRODUCTS: Transmitter studio equipment, turntables, remote control equipment, transmitting and receiving tubes for AM, FM and facsimile.

Carrier Corporation

300 S. Geddes St., Syracuse 1, N. Y.

Phone: Syracuse 76-9911

385 Madison Ave., New York 17, N. Y.

Phone: PLaza 9-5000

Manager, Syracuse.....C. V. Fern
 Manager, New York.....A. Peacock

PRODUCTS: Air conditioning and refrigeration equipment for studios, including room air conditioners, packaged equipment from 2 to 20 h.p. and equipment for built-up systems to maximum studio.

CBS-Columbia

3400 17th Ave., Long Island City, N. Y.

Phone: EXeter 2-3000

President.....Seymour Mintz

Vice-Pres.....Louis Hausman

V.P. Chg. of Engr.....Anthony Wright

V.P. Chg. of Purchases.....Mario A. Gardner

V.P. Chg. of Sales.....Harry Schechter

PRODUCTS: TV and radio receivers.

CBS Laboratories Division

485 Madison Ave., New York 22, N. Y.

Phone: PLaza 1-2345

President.....Dr. Peter C. Goldmark

Vice-Pres.....John W. Christensen

SERVICES: Engineering research and development.

Chicago Telephone Supply Corp.

1112 W. Beardsley Ave., Elkhart, Ind.

Phone: 3-0310

President.....J. C. Best

Exec. Vice-President.....B. S. Turner

V. P. & Gen. Sales Mgr.....W. A. Nicely

Secy.-Treas.....J. Mayo Lenz

Chief Engineer.....W. H. Budd

General Superintendent.....G. M. Cooper

PRODUCTS: Composition variable resistors, wirewound variable resistors, associated switches.

Century Lighting, Inc.

521-525 West 13rd St., New York 36, N. Y.

Phone: CH 4-7050

President.....Edward Kook

Exec. Vice-Pres.....Saul Levy

Secy.-Treas.....Donald Levy

Asst. to Pres.....James Fridigan

Production Engr.....F. M. Wolff

PRODUCTS: Spotlights, scoops, slimline, striplights, projection machines and slides, connector batten borders, barn doors, funnels, diffusers, elliptical spotlights, gobos, light lifts, remote control spotlights and C-lectors, electronic switchboards, manual mike booms.

Collins Radio Co.

855 35th St., N. E., Cedar Rapids, Ia.

Phone: 3-0281

N. Y. Phone: LOngacre 4-3930-1-2-3

President.....Arthur A. Collins

Exec. V. P. (New York).....W. J. Barkley

Vice-Pres., Gen. Mgr.....R. S. Gates

V.P. Chg. Engr. & Mfg.....L. M. Craft

Secretary-Treasurer.....S. J. Storm

PRODUCTS: Broadcast transmitters, FM antennas, ten and seven position studio consoles, accessory equipment for studios.

Continental Electronics Mfg. Co.

1212 Buckner Blvd., Dallas 7, Texas

Phone: EVergreen 1137

General Manager.....W. M. Witty

PRODUCTS: AM transmitters and associated apparatus.

Corning Glass Works

Corning, New York

President.....W. C. Decker

V.P. & Controller.....George D. Macbeth

V.P. & Secretary.....William H. Curtiss

V.P. & Treasurer.....Chas. D. LaFollette

Vice-President.....Harry M. Hosier

Vice-President.....Jesse T. Littleton

Vice-President.....William C. Taylor

Asst. Secretary.....Wm. W. Sinclair

Asst. Secretary.....Frederick H. Knight

Asst. Treasurer.....C. H. Kruidenier

Mgr. Elec. Products Div.....J. L. Hanigan

Mfg. Mgr. Elec. Products Div.....N. J. Vang

Sales Mgr. Electronic Sales Dept.

J. S. Muller

Purchasing Agent.....F. S. Conable

Dir. Public Relations.....Harlan Logan

PRODUCTS: Glass envelopes for tubes used for radio receiving, broadcasting, cathode ray, television and all other electronic purposes, tubing and special sealing glasses, pyrex brand radio, insulators.

Cornish Wire Co., Inc.

50 Church St., New York, N. Y.

Phone: BArelay 7-5110

President.....John Cook

Treasurer.....J. C. Stagg

PRODUCTS: Radio and TV wire products including electronic and intercommunicating wires and cables, electric wire products including lamp cords, fixture wire, rubber jacketed cords and cord sets, wiring harnesses.

Crosley Radio & Television,

Avco Mfg. Co.

1329 Arlington St., Cincinnati 25, Ohio

Phone: Kirby 6600

New York Phone: MUrray Hill 3-0202

Vice-Pres., Radio & TV.....L. F. Craner

Gen. Works Mgr.....W. H. Graham

Gen. Controller.....W. A. Smith

Purchasing Agent.....A. J. Berax

Dir. Ind. Relations.....H. C. Tipping

Dir. Pub. Relations.....C. L. Lewis

Dir. Engineering, Radio & TV.....H. A. Bass

Dir. Research.....R. H. Maner

Western Sales Mgr., Radio & TV

D. F. Miersch

Eastern Sls. Mgr., Radio & TV.....J. M. Farrell

Adv. Mgr. Radio & TV.....Fred Gregg

PRODUCTS: Television, radio and phonocombinations, AM-FM models.

Avco of Canada, Ltd.

Crosley Radio & Television Division
121 McCormack Street
Toronto 9, Ontario, Canada
Phone: Lindhust 1186

Vice-Pres. & Gen. Mgr.....Ivor M. Leslie
Gen. Sales Mgr.....Alex Peters
Asst. Secy. & Treas.....J. M. Reynolds
Work Manager.....A. J. Roper
Purchasing Agent.....F. B. Martin
Chief Engineer.....R. W. Walker
Service Manager.....W. Whittall
Products Manager.....H. G. Fisher

PRODUCTS: Television, models including table, consoles and console phono-combinations. Radio, AM table models in wide color range, clock radios, AM-FM models, portable models, phono-combinations, and versatile radio-TV combination.

Crouse-Hinds Co.

Syracuse 1, N. Y.
Phone: 74-1011

11 Park Pl., New York 7, N. Y.
Phone: Cortland 7-0750

Vice-President.....A. H. Clarke
Manager, New York.....C. H. Gurney

PRODUCTS: Aircraft obstruction lighting equipment for towers; flashing beacons, obstruction marker lights, flashing switches, photoelectric controls.

Allen B. Du Mont Laboratories, Inc.

750 Bloomfield Ave., Clifton, N. J.
Phone: MULberry 4-7400
for all divisions

President.....Allen B. Du Mont
Vice-President.....Stanley F. Patten
Gen. Asst. to Pres.....Keeton Arnett
Vice-Pres. Marketing.....W. H. Kelley
Dir. of Oper., TV

Receiv. & Cathode-ray Tube Div.....Irving G. Rosenberg
Dir. of Oper., Trans.

& Instru. Div.....C. E. Williams
Dir. and Gen. Mgr.,

Du Mont Televis. Netwk..Chris J. Witting
Controller.....B. L. Graham
Indus. Relat. Dir.....Harry Houston
Gen. Supt.....Bruce Du Mont
Pub. Rel. Mgr.....J. H. Ruiter

Teleset Division

35 Market St., E. Paterson, N. J.

Dir. of Operations...Irving G. Rosenberg
General Sales Mgr.....Dan D. Halpin
Receiv. Mfg. Div. Mgr.....Paul Eshelman
Produc. Control Mgr.....H. A. Whitehead
Chief Engineer.....R. T. Cavanaugh
Purchasing Agent.....William Paton

PRODUCTS: TV receivers, yokes, transformers, timers, coils, and government electronic equipment.

Cathode-ray Tube Division

750 Bloomfield Ave., Clifton, N. J.
Chief Engineer.....K. Hoagland
Gen. Sales Mgr.....William C. Scales
Purchasing Agent.....A. R. Dutcher

Mfg. Mgr.....Wm. Carlin
TV Receivers, Industrial and Special Purpose Cathode-ray Tubes

Transmitter Division

1500 Main Ave., Clifton, N. J.

Division Manager.....H. E. Taylor, Jr.
Asst. Division Mgr.....R. E. Kessler
Engineering Manager.....G. S. Gregory
Sales Manager.....J. B. Tharpe
Advertising Mgr.....Frank Newman
Sub Division Mgr.....C. E. Greenwood

Purchasing Agent.....L. A. Fuller
Television transmitters, Cameras, Studio Equipment, Field and Remote Equipment, Government Electronic Equipment

Instrument Division

760 Bloomfield Ave., Clifton, N. J.

Division Manager.....Rudolf Feldt
Asst. Division Mgr.....Dr. P. S. Christaldi
Engineering Manager.....G. R. Mezger
Sales Manager.....E. G. Nichols
Purchasing Agent.....C. Paul Martin
Manufacturing Mgr.....Robert Svozil

Design and manufacture of Cathode-ray Oscillographic and Associated equipment; Oscillographic recording and government electronic equipment

Research Division

2 Main Ave., Passaic, N. J.

Dir. of Research.....T. T. Goldsmith, Jr.
Dir. of Circuit Res.....R. T. Cavanagh
Mgr., Patent Department.....R. G. Pelton

Government Contracts, Negotiations and Bid Division

750 Bloomfield Ave., Clifton, N. J.

Director.....C. E. Williams
Manager.....H. B. Graham
Sales Manager.....Zeus Soucek

International Division

Empire State Bldg., 350 Fifth Ave.
New York, N. Y.

Phone: MUrray Hill 8-2600

Director.....Ernest A. Marx

PRODUCTS: Du Mont Television Receivers, Du Mont Imputuners and Sensituners, Television Component Parts, Cathode-ray Tubes for Television Receivers and Industrial Use, Complete Television Transmitting Equipment including Control and metering accessories, camera chains, film pick-up chains, mixing desks, sync generators, and studio control consoles. Cathode-ray Oscillographs for Television and Radio Testing, and general industrial use.

Ectro, Inc.

425 S. Sandusky St., Delaware, Ohio
Phone: 3-1201

President.....R. Stahl
Secy.-Treas.....George H. Beall
Comptroller.....A. F. Deres

PRODUCTS: Portable tape recorder, battery operated.

Hugh H. Eby, Inc.

4700 Stenton Ave., Philadelphia, Pa.
Phone: DAvenport 4-7000

President.....James L. Hawley

President Bernard Offerman
 Secretary-Treasurer Jules Sussman
 Vice-President Joseph M. Vananzi
 Chief Engineer E. E. Ritter
 Purchasing Agent A. H. Hankinson

PRODUCTS: Adaptors, jacks, knobs, plugs, male and female connectors, binding posts, oval sockets, miniature sockets (seven and nine pin), terminal strips, terminal boards, special assemblies (both mechanical and electrical) true shields, metal stampings, rack and panel connectors, battery plugs and connectors.

Electrical Tower Service, Inc.

206 S. Washington St., Peoria 2, Ill.
 Phone: 3-9846

President Stanley Bernstein
 PRODUCTS: Erect towers, microwave systems.

Electronic Specialty Co.

3456 Glendale Blvd., Los Angeles 39, Calif.
 Phone: NO. 2-2168

Chicago Phone: Superior 7-7572

President William H. Burgess
 Sales Mgr. (Shavex Div.) Wm. F. Edwards
 Div. Mgr., TV L. G. Burgess
 Div. Mgr., Contracts D. A. Marcus

PRODUCTS: Electronic Equipment-Contract Division: Sensitometer and intervalometers. Electric shaver accessories. Shavex Div.: Shavex for changing AC to DC for a faster, smoother shave with any electric shaver (a rectifier device). TV Service Division: Do not manufacture any equipment—service only.

Electronic Tube Corp.

1200 E. Mermaid Lane, Phila. 18, Pa.
 Phone: Chestnut Hill 7-6800

Pres., Chief Eng. Henry S. Bamford
 Vice-President Theo. T. Toole
 Purchasing Agent John J. Wajcik
 Sales Manager Robert F. Brunner
 Treasurer M. H. McCloskey
 Secretary J. D. Pannell
 Chief Acct. D. H. Brownell

PRODUCTS: Cathode Ray Receiving, Multi-gun and Special Purpose Cathode Ray Tubes; Multi-Channel Oscilloscopes; High gain DC Amplifiers, Special design AC and DC Amplifiers; Special design Signal Generators; Electronic Engineering and Development.

Emerson Radio & Phonograph Corp.

111 Eighth Ave., New York 11, N. Y.
 Phone: ORegon 5-7000

President B. Abrams
 Secretary-Treasurer M. Abrams
 Exec. Vice-Pres. Dorman D. Israel
 V.P. Govt. Contracts Morton P. Ronie
 V.P. Purchasing Harve Tullo
 V.P. Works Manager E. J. Kelly
 V.P. Chg. of Sales S. W. Gross
 Controller A. Vogel

V.P. Dir. of Engineering R. T. Capodanno
 Distribution Manager Joseph Kattan
 Sales Promotion Mgr. Albert Leon
 Export Manager Joseph Kattan
 Personnel Manager P. R. Certo
 Parts Sales-Service Mgr. Floyd Makstein

PRODUCTS: Emerson Television Receivers: 17 in., 21 in., 27 in. picture size, table and console models, console model television phonoradio. Emerson Radio Receivers: AC/DC compact and table models for AM and FM-AM. Portable Radio: Self-powered models (operate on batteries): "3-way" models (operate on batteries, AC, DC). Phonoradio: Table and console models. Electronic Equipment: For Government defense program.

Espey Manufacturing Co., Inc.

528 East 72nd St., New York 21, N. Y.
 Phone: TRafalgar 9-7000

Pres. & Treas. Nathan Pinsley
 Vice-Pres. & Secy. Sol Pinsley
 Vice-Pres. Eng. Sam Sack
 Sales Manager Bert Kohl

PRODUCTS: AM-FM Radio receivers, trophy models 100 and 200; AM-FM tuners, trophy models 101, 300 and 400; audio amplifiers, trophy model 500.

Fairchild Recording Equipment Corp.

154th St. & 7th Ave., Whitestone, N. Y.
 Phone: INdependence 3-2100

President Sherman M. Fairchild
 Exec. Vice-Pres. Ray F. Crews
 Mgr. Sales & Adv. J. H. Quinn

PRODUCTS: Sound recorders: synchronous disk recorders, synchronous magnetic tape recorders; transcription tables; magnetic cutterheads; dynamic pickups; miniature cartridges; recording equalizers; pickup equalizers; unitized amplifier systems and audio systems. Special development projects.

Federal Telephone and Radio Corp.

100 Kingsland Road, Clifton, New Jersey
 Phone: NUdeley 2-3600

President Raymond S. Perry
 Vice-Presidents W. P. Maginnis,
 T. M. Douglas, S. J. Powers, G. T. Scharf-
 fenberger

Comptroller R. D. Osborne
 Secretary W. B. Levat
 Treasurer W. E. Ogilvie
 Dir. of Vacuum Tube &

Selenium-Intelin Dept. S. J. Powers
 Gen. Sales Mgr. J. A. Frabutt
 Advertising Mgr. Grump Smith

PRODUCTS: Radio and Television equipment, transmitting and rectifying tubes, TV receiving tubes, microwave radio relay links and carrier systems. HF cable, field intensity meters, radar, miniature and standard selenium rectifier stacks, battery chargers and power supplies, measuring equipment.

The Gabriel Co. Workshop Assoc. Div.

Endicott St., Norwood, Mass.
Phone: Norwood 7-3300

General Manager.....T. F. O'Donnell
General Sales Mgr.....W. P. Short
Comm. Sales Mgr.....C. R. Lane
Govt. Sales Manager.....W. L. Page
Plant Manager.....J. Van Epps
PRODUCTS: UHF-TV Transmitting Antenna and Related Components.

Gates Radio Co.

123 Hampshire St., Quincy, Ill.
Phone: 8202

N. Y. Phone: MURray Hill 7-7971

President.....P. S. Gates
Vice-President.....L. I. McEwen
Secretary.....A. S. Petzoldt
Sales Manager.....L. J. Cervone
Dir. of Engr.....J. Colvin
Chief Engineer.....F. W. Wentura
Works Manager.....Howard Young
Purchasing Agent.....John Bowers
PRODUCTS: Radio broadcast transmitters AM; radio broadcast transmitters FM; TV broadcast transmitters UHF and VHF; speech input equipment for radio and video; transcription turn tables; recording equipment; communications transmitters (high frequency); communications transmitters (very high frequency); airway communications equipment; homing beacon equipment; directional phasing equipment; antenna coupling equipment; transmission line equipment; portable remote amplifiers; rack cabinets (relay); cabinets (transmitter); master control systems.

General Electric Co.

Electronics Park, Syracuse 1, N. Y.
Phone: 76-4411

General Manager P. L. Chamberlain
Merchandise Mart, Chicago 54, Ill.
Phone: Whitehall 4-3915
Manager.....G. E. Webster
3460 Wilshire Blvd., Los Angeles, Calif.
Phone: DUnkirk 5-2391
Manager.....F. R. Walker
570 Lexington Ave., New York 22, N. Y.
Phone: PLaza 1-1311
Manager.....C. J. Simon
4227 Lindell Blvd., St. Louis 8, Mo.
Phone: Lucas 8873
Manager.....W. R. Chapin
235 Montgomery St., San Francisco 6, Calif.
Phone: DOuglas 2-3740
Manager.....C. T. Haist, Jr.
777 14th St., N.W., Washington 5, D. C.
Phone: EXecutive 3-3600

Manager.....J. H. Painter
PRODUCTS: Audio consoles, amplifiers—limiting, portable and complete line for program monitoring and transcription use, both plug-in and rack mounted. Audio accessories—turntable tone arms, equalizers and pickup heads, patch cords and jacks. Rack cabinets,

power and audio boards, cable, microphone and audio; speakers.

The General Industries Co.

Olive and Taylor Sts., Elyria, Ohio
Phone: 2235

President.....Allan W. Writzsche
V.P.-Sales Mgr., Motor Div.....H. E. Moon
Sales Mgr., Plastic Div.....James M. Callihan
Purchasing Agent.....Clete Heidrich
Treasurer.....C. F. Russert
Chief Eng. Motor Div.....Howard Shumaker
Chief Eng. Plastic Div.....Russell Smith
PRODUCTS: Electric Phonograph motors, Smooth power motors, Disc Recording assemblies, Tape Recording assemblies.

General Instrument Corp.

829 Newark Ave., Elizabeth 3, N. J.
Phone: Elizabeth 3-4400

Chairman of the Board....A. Blumenkrantz
President.....M. Cohen
Treasurer.....A. Konecny, Jr.
Sales Manager.....E. A. Freed
Asst. Chief Engineer.....R. R. Stubbe
Credit Manager.....W. A. Anderson
Export Agents.....Ad. Auriema, Inc.
PRODUCTS: TV tuners, UHF and VHF, UHF converters, variable condensers, auto radio tuners.

General Laminated Products, Inc.

2857 South Halsted St., Chicago 8, Ill.
Phone: Victory 2-0707

President.....Morris Perlman
Chief Engineer.....Dr. Einar Hedin
Purchasing Agent.....Arthur Kossnar
Eastern Sales Mgr.....R. M. Perlman
PRODUCTS: Sockets, Terminal Board Assemblies, Laminated Phenolic Parts, Battery Connectors, Coil Forms, Resistor Board Assemblies, multiple and single Male and Female Pin Plug Assemblies.

General Precision Laboratory, Inc.

63 Bedford Road, Pleasantville, N. Y.
Phone: Pleasantville 2-2000

President.....H. G. Place
V.P., Gen. Mgr.....J. W. Murray
V.P., Managing Dir.....R. L. Garman
Vice-President.....Blair Foulds
Chief Engineer.....F. N. Gillette
Gov't Contract Rep.....W. Cooper
PRODUCTS: Television Studio and Transmitting Equipment including Camera Chains, Projectors, Switchers, Syn Generators, Video Recorders and Transmitters; also Theater Television equipment.

General Radio Co.

275 Massachusetts Ave., Cambridge 39, Mass.
Phone: TRowbridge 6-4400

N. Y. Phone: WOrth 2-5837
Chairman of Board.....H. B. Richmond
President.....E. H. Locke

Vice-Pres. for Sales.....A. E. Thiessen
 Vice-Pres. for Mfg.....C. C. Carey
 Secretary-Treasurer.....F. L. Tucker
 Sales Manager.....M. T. Smith
 Export Manager.....S. W. DeBlois
 Chief Engineer.....D. B. Sinclair
 Publicity Manager.....C. E. Worthen
 Service Manager.....H. H. Dawes

PRODUCTS: AM, FM and TV frequency and modulation monitors, distortion and noise meters, audio test oscillators, transmitter test equipment.

Graybar Electric Company, Inc.

120 Lexington Ave., New York 17, N. Y.
 Phone: LE 2-4000

President.....W. E. Henges
 Vice-President.....G. E. Hessler
 General Communications

Sales Mgr.....J. W. La Marque
 Mgr., Electronic Sales.....G. I. Jones

PRODUCTS: Amplifiers, antenna equipment, attenuators, cabinets, consoles, loud-speakers and accessories, monitors, recorders and accessories, speech input equipment, test equipment, towers, tower lighting equipment, transmission line and accessories, transmitters, broadcast, tubes, turntables, reproducers and accessories, wiring supplies and devices. All TV broadcasting equipment.

The Hallicrafters Co.

4401 W. Fifth Ave., Chicago 24, Ill.
 Phone: Van Buren 6-6300

President.....Wm. J. Halligan
 PRODUCTS: TV receivers, short-wave "Ham" transmitters, and receivers, portable radios, FM/AM radios, two-way radio-telephone equipment.

The Hammarlund Mfg. Co., Inc.

460 West 34th St., New York 1, N. Y.
 Phone: LOngacre 5-1300

President.....Lloyd A. Hammarlund
 Treasurer.....Joseph Lush
 Sec. & Comptroller.....Edward A. Wittner
 Production Mgr.....Hugh A. McCloskey
 Sales Manager.....Robert B. Moon
 Chief Engineer.....S. H. Van Wambeek
 Advertising Manager.....Dale Samuelson
 Personnel Director.....George Guellich
 Purchasing Manager.....William Griffin
 PRODUCTS: Communication receivers, variable capacitors, remote supervisory controls, diversity receivers.

Haydu Brothers

P. O. Box 1226, Plainfield, N. J.
 Phone: PLainfield 6-0878

President.....George K. Haydu
 Vice-Pres. and Secy.....Zoltan Haydu
 Chief Engineer.....Ben Artan
 Sales Engineer.....Arthur Shesser
 Purchasing Agent.....Vincent Perrucci
 PRODUCTS: Television picture tubes, miniature receiving tubes, power tubes for

transmitting and industrial use, electron guns for television picture tubes, components for all types of vacuum tubes, including receiving and transmitting, TV radio, x-ray, incandescent and special purpose tubes, equipment for the manufacture of such tubes, equipment for the manufacture of neon signs, cold cathode lamps, and various special purpose lamp machinery, Precision machine parts and wire and forming parts.

Hazeltine Electronics Corp.

58-25 Little Neck Pkway., Little Neck, L. I., N. Y.

Phone: FLushing 7-8700

President.....F. Robinson
 Exec. Vice-President.....J. B. Dow
 V.P. in Chg. of Engrng.....O. M. Dunning
 V.P. in Chg. of Mfr.....J. Willenbecher
 Director of Procurement.....M. E. Bahr
 Manager Sales.....F. Mansur

PRODUCTS: Military types of radio and radar equipment. Air and marine electronic navigational equipment. Radio, radar and TV test equipment for laboratory and production testing.

Hughey & Phillips, Inc.

3300 N. San Fernando Blvd., Burbank, Calif.
 Phone: ROckwell 9-1104

60 East 42nd St., New York 17, N. Y.

Phone: MUrray Hill 7-4550

President.....M. S. Phillips
 Manager, New York.....H. J. Geist

PRODUCTS: Tower lighting equipment, beacons, obstruction lights, flashers, photoelectric controls, junction boxes, lamp failure indicators and complete tower lighting kits.

Hytron Radio & Electronics Corp.

(Division of CBS, Inc.)

100 Endicott St., Danvers, Mass.
 Phone: Danvers 2360

N. Y. Phone: MAket 3-5832

Manager.....John Q. Adams
 PRODUCTS: Receiving and electronic tubes; special purpose tubes, germanium diodes, TV picture tubes.

The Indiana Steel Products Co.

Valparaiso, Indiana
 Phone: 2-5601

President.....R. F. Smith
 V.P. Manufacturing.....J. H. Bouwmeester
 V.P. Engineering.....C. A. Maynard
 Treasurer.....A. J. Astrologes
 Sales Manager.....I. A. Dickey
 PRODUCTS: Permanent magnets for the radio-television-electronics industries.

Insuline Corp. of America

3602 35th Ave., Long Island City 1, N. Y.
 Phone: AStoria 8-3738

President.....S. J. Spector
 Secretary-Treasurer.....A. S. Spector

V.-P., Gen. Sales Mgr. B. L. Cahn
 Advertising Manager A. S. Chambers
 Superintendent F. Henneke
 Industrial Sales Mgr. I. Romm
 Chief Engineer J. Donato
 Purchasing Agent H. Weston
 Production Chief J. Brush

PRODUCTS: Adapters, phone pick-up; aligning tools; amplifier chassis; angles and brackets antenna, auto radio, antenna connectors; antenna kits; antennas, home mast; antennas, FM & television; auto radio noise suppressors; bases, steel; beads, cable; binding posts; binding post heads; bushings, insulated; cabinets, metal; cabinets, speaker; cable clamps; chassis base; chassis, bottom plate; chokes; chrome trim; clips, alligator; clip, brass spring; code set, triplex; coils, coil forms; condensers; cords, double phone; cords, resistor; couplers, flexible; cushions, ear; cutters, replacement; cutting tools; dial markers; dial plates; displays; drill, replacement; eyelets; equalizing condensers; FM Antennas; fuse mountings; fuse retainers; grid caps; grid cap shield; grommets, rubber; hardware, radio; headphones; insulators; jacks; jacks, microphone; jacks, shielded; jacks, tip; jacks, transmitting; jars, glass; knobs; lugs, soldering; lugs, spade; lugs, terminal; meter cabinets; Morse code records; mountings, fuse; name plates; Neutralizing tools; noise eliminators; nuts; oscillators; panels, aluminum, bakelite, Masonite, metal, meter, racks; panel bearings; phone cords; phones, ear; phone plugs; phone tips; plates, bottom; plugs; punches; recks, brackets, chassis; radio panels; record player switch; reducers; resistor cords; riveting punch set; rivets, rods; screw drivers, insulated; screws; shearing punch; shields; shields, grid cap; sockets; soldering irons; soldering iron elements; spaghetti, flexible; spacers, bushings; spade lugs; speaker cabinets; steel cabinets; strips, terminal; suppressors, auto radio; switches; television, accessories; antennas, tools; terminal lugs; terminal strips; test leads; test lead wire; test prods; test tools; tools; tools, neutralizing; trans. coil mountings; transmitting tube caps; tube shields; tubing; washers; window pole antenna; wire, test lead; wrenches, wrench sets.

Jackson Electrical Instrument Co.

18 S. Patterson Blvd., Dayton 2, O.
 Phone: M1cbigan 0367

President Paul F. Jackson
 Vice-President Myron Fulkerson
 Secretary J. E. Beery
 Purchasing Agent R. C. Groves
 Credit Manager J. E. Beery
 Production Superintendent Carl Wack

PRODUCTS: Oscillograph, receiving tube testers, CR tube testers, sweep generators, audio oscillators and condenser testers, vacuum tube volt meters, TV signal generators.

Jefferson Electric Co.

25th Ave. & Madison St., Bellwood, Ill.
 Phone: MANSfield 6-7161

N. Y. Phone: BARclay 7-8972
 Pres., Chair. of Board J. M. Bennan
 Exec. Vice-President E. J. Bennan
 Vice-Pres., Engineering L. Mauere:
 Treasurer W. S. Minter
 Secretary V. E. Lee
 Sales Manager J. D. O'Brien
 Export Manager M. J. Schmitt
 Dir. of Purchases E. J. Banigan

PRODUCTS: Power transformers, chokes and audio input and output transformers, horizontal and vertical scanning transformers, centering and focusing coils.

Jensen Manufacturing Co.

6601 S. Laramie Ave., Chicago 38, Ill.
 Phone: POrtsmouth 7-7600

Sales Manager Charles A. Hausen
PRODUCTS: Loudspeakers and accessories, cabinets for radio and TV equipment.

JFD Manufacturing Co., Inc.

6101-6123 16th Ave., Brooklyn 4, N. Y.
 Phone: BENsonhurst 6-9200

President Julius Finkel
 Vice-President Albert Finkel
 Secretary-Treasurer Edward Finkel

PRODUCTS: VHF, FM and UHF antennas, piston type variable trimmer capacitors, lightning arresters, stand-off line insulators, antenna masts, guy wires; open-wire, polyethylene flat twin-lead transmission line; ballasts, voltage regulators, dial belts, phono switches, test leads, resistor line cords, video cross-over networks, wire measuring machines, tuning cable remote replacer machines for auto radio service, control knobs, radio lubricants, stroboscopes, wave traps, co-axial connectors, insulators for antennas, TV set-couplers.

Johns-Manville

22 East 40th St., New York 16, N. Y.
 Phone: LEXington 2-7600

Commodity Manager J. P. Washburn
 (Acoustical Materials)

PRODUCTS: Sound control materials for broadcasting and recording studios.

King Laboratories, Inc.

127 Solar St., Syracuse 4, N. Y.
 Phone: 74-3359

President Aden J. King
 Vice-President F. M. Michaelian
 Treas. & Gen. Mgr. W. R. MacLeod
 Secretary Barbara H. Sisson

PRODUCTS: Special alloys, chemicals and metals, radio tube parts, barex getters.

Kliegl Bros. Universal Electric Stage Lighting Co., Inc.

321 West 50th St., New York 19, N. Y.
 Phone: COlumbns 5-0130

President J. H. Kliegl

Vice-President.....Herbert A. Kliegl
 Secretary.....Frank H. Bliss
 Treasurer.....Anna Kliegl
 Plant Superintendent.....Joseph Kliegl
 Purchasing Agent.....Henry Fisher
 PRODUCTS: Lighting equipment, wiring devices and switchboards for TV studios, theatres and M.P. studios.

Langevin Manufacturing Corp.
 37 W. 65 St., New York 23, N. Y.
 Phone: ENdicott 2-7200

Chairman of Board.....H. A. Leander
 President.....Donald S. Morgan
 Vice-President.....W. H. Beal
 Secretary-Treasurer.....H. A. Kondolf
 Sales Manager.....E. K. Hankinson
 Engineering Director.....Robert Edwards
 Mgr. of Operations.....P. C. Marrone
 PRODUCTS: Audio Amplifiers — both standard and miniaturized plug-in. Power Supplies, Video Amplifiers, Consoles, Automatic Limiting Amplifiers, Audio, Power and Pulse Transformers. Complete custom design audio facilities for broadcast and television.

Lehigh Structural Steel Co.

17 Battery Place, New York 4, N. Y.
 Phone: WHitehall 4-1424

Sales Mgr., Radio Div.....J. F. Neary
 PRODUCTS: Towers for TV-AM-FM Vertical Radiators Relay Towers.

John E. Lingo & Son, Inc.

2814 Buren Ave., Camden 5, N. J.
 Phone: WOODlawn 4-0487

President.....John E. Lingo
 PRODUCTS: Tubular steel vertical radiators; VHF antennas and supporting towers; FM antennas and supporting towers; facsimile supporting poles.

Machlett Laboratories, Inc.

1063 Hope St., Springdale, Conn.
 Phone: STAmford 4-5781

Vice-Pres. Power Tube Sales...H. J. Hoffman
 PRODUCTS: Broadcast tubes.

Magnecord, Inc.

225 W. Ohio St., Chicago 10, Ill.
 Phone: WHitehall 4-1889

Sales Director.....John W. Hines
 PRODUCTS: Professional magnetic tape recorders—reproducers.

**Majestic Radio & Television,
 Div. of Wilcox-Gay Corp.**

79 Washington St., Brooklyn 1, N. Y.
 Phone: ULter 2-6000

President.....Leonard Ashbach
 Vice-President.....Barnett S. Trott
 Vice-President.....Maurice Raphael
 Secretary.....Arthur Homans

Advertising Mgr.....Joseph G. DeVico
 Chief Engineer.....Frank Dioli
 PRODUCTS: TVreceivers; TV-radio receivers; TV-radio-phonograph combinations; AM-FM phono combinations; table AM-radio phonographs; Hi-Fi radio phonographs.

J. A. Maurer, Inc.

37-01 31st Street, Long Island City 1, N. Y.
 Phone: STillwell 4-4600

President.....John A. Maurer
 Treasurer.....Daniel R. Ehrlich
 General Manager.....Donald G. McKay
 Chief Elec. Engr.....Lauge Fanoe
 PRODUCTS: 16mm. professional motion picture cameras; 16mm. sound recorders; 16mm. film phonographs. 16 & 35 mm. Galvanometers.

Miles Reproducer Co., Inc.

812 Broadway, New York 3, N. Y.
 Phone: SPring 7-7670-1

President.....George Ruskin
 Sec-Gen. Mgr.....J. M. Kuhlik, Sc.D.
 Chief Eng.....I. W. Kuhlik
 Purchasing Agent.....J. V. Conniff
 Treasurer.....H. B. Kuhlik
 Advertising Mgr.....B. Burns
 PRODUCTS: "Walkie-Recordall" sound-on-film recorders and reproducers, continuous recorders and reproducers, tape recorders and reproducers, automatic recorders and reproducers, permanent recorders and reproducers, reference recorders, conference recorders, telephone recorders, interview recorders, telemike, induction units for listening to or recording two-way telephone conversations, battery operated recorders, portfolio type recorders.

James Millen Mfg. Co., Inc.

150 Exchange St., Malden 48, Mass.
 Phone: Malden 4-4108

President.....James Millen
 Sales Mgr.....E. E. Williams
 Credit Manager.....Frances Bearse
 Purchasing Agent.....George E. Pike
 Chief Engineer.....Wade Caywood
 PRODUCTS: Electronic components for receivers, transmitters, including inductances, condensers, coil forms and specialized hardware, test equipment including oscilloscopes, grid dip meters, synchrosopes and power supplies.

Minnesota Mining and Mfg. Co.

900 Fauquier Ave., St. Paul 6, Minn.
 Phone Cedar 3071

Sales Mgr., Magnetic Prod....P. W. Jansen
 1500 S. Western Ave., Chicago 8, Ill.
 Phone: MOnroe 6-6126

Manager.....A. J. Forss
 446 N. LaBrea Ave., Hollywood 36, Calif.
 Phone: WEBster 1-1289

Manager.....M. D. Benson
 401 N. Broad St., Philadelphia 8, Pa.

Manager.....C. M. Jacobson
PRODUCTS: Magnetic tape, film and associated accessories.

Mirror Record Corp.

4025 206 St., Bayside, L. I., N. Y.
 Phone: BAYside 9-5656

Pres. & Treas.....P. K. Trautwein
PRODUCTS: Recording accessories (discs, cutting needles, playback needles).

The Muter Co.

1255 S. Michigan Ave., Chicago 5, Ill.
 Phone: WABash 2-8800

President.....Lealie F. Muter
 Vice-Pres. & Sales Mgr.....K. E. Rollefson
 Vice-Pres. & Credit Mgr.....A. A. Dailey
 Purchasing Agent.....D. R. Capparelli
PRODUCTS: Resistors, switches, ceramic capacitors, Spirashields, coils, precision potentiometers, I.F. and R.F. transformers.

National Carbon Co.—Div. of Union Carbide & Carbon Corp.

30 East 42nd St., New York 17, N. Y.
 Phone: MURray Hill 7-8000

Chairman of Board.....J. M. Spangler
 President.....A. S. Johnson
 Exec. Vice-Pres.....C. O. Kleinsmith
 Exec. Vice-Pres.....P. M. Buhrer
 Vice-President.....A. C. Bryan
 Mgr. Battery Eng. Dept...G. H. Didinger, Jr.
 V.-P., Adv. Sales Mgr.....H. M. Warren
PRODUCTS "Eveready" "Mini-Max" "B" batteries for portable and farm type receivers, "Eveready" dry cells, "Eveready" flashlight batteries for miniature receivers, "Eveready" "Air Cell" batteries for 2-volt and 1.4 volt receivers.

National Union Radio Corp.

Jacksonville Rd., Hathoro, Pa.
 Phone: 1791

President.....K. C. Meinken
 V.P. in Chg. of Research.....A. M. Skellett
 Equipment Sales Mgr....K. C. Meinken, Jr.
 Renewal Sales Mgr.....V. K. Ulrich
 Credit Manager.....H. A. Pope
PRODUCTS: Electron tubes, receiving, TV, transmitting, cathode ray, special purpose, tube research & development, panel lamps, transistors and germanium diodes.

Oxford Electric Corp.

3911 S. Michigan Ave., Chicago 15, Ill.
 Phone: ATlantic 5-6161

V.P., Gen. Sales Mgr.....Hugo Sundberg
PRODUCTS: Loud speakers, dial lamps, transformers, focus coils, miscellaneous coils.

Packard-Bell Company

12333 W. Olympic Blvd., Los Angeles 64, Cal.
 Phone: Arizona 7-6721

President.....Herbert A. Bell
 Exec. Vice-President.....Robert S. Bell

Vice-President.....Joe M. Spain
 Sec.-Treas.....Lowell R. Day
 Chief Engineer.....Charles Nichols
 Plant Manager.....Jean Gleis
 General Sales Mgr.....Kenneth R. Johnson
 Dir. of Adv. & Sales

Prom.....Robert H. Thompson
 Service Manager.....Carl Duffy
 Personnel Director.....Charles Askin
 Purchasing Agent.....William P. Kennedy
PRODUCTS: Radios, Radio-Phonograph-Recorder Combinations, Television, Radio-Phonograph Combinations, Television-Radio-Phonograph Combinations, special electronic equipment for the Armed Services.

The Pentron Corp.

664 N. Michigan, Chicago 11, Ill.
 Phone: WHitehall 3-2120

President.....Irving Rossman
 Treasurer.....Bernard Sahlins
 Secretary.....Theodore Rossman
 Chief Engineer.....Rudolph A. Bierwirth
 Comptroller.....Marshall Peiros
 Production Chief.....Bernard Sahlins
 Purchasing Agent.....Theodore Rossman
PRODUCTS: Tape recorders, tape playback units, electronic mike mixer, basic tape mechanism, pre-amplifiers, AM Tuner, foot pedal, speaker and baffle, continuous tape magazine, laarge reel adapter, telephone pick-up, and other accessories.

PEMBREX TV (Div.

PEMBREX Theater Supply, Inc.)

1969 So. Vermont Ave., Los Angeles 7, Calif.
 Phone: REpublic 1-3111

President.....Louis M. Wutke
 Vice-President.....Edwin C. Wutke
 V.P. in Chg. of TV.....Lois E. Landon
PRODUCTS: PEMARC Rear-screen Projection (still-slide) Hi-Intensity Arc Projectors, 20,000 to 25,000 Lumen, Pemink Rear-screen Projection (still-slide) incandescent 5,000 watts dimmer control single or double units with special effects attachments. Pemsync motors and 16 and 35 mm Rear-Screen motion picture units. Translucent screens, (blue/black) portable aluminum frames and TV's most complete still and moving plate (slide and footage) library available. TV Model Visualcast for prompting, special effects and layovers.

Philco Corp. (Govt. and Indus. Div.)

4700 Wissahickon Ave., Philadelphia 44, Pa.
 Phone: TEnnessee 9-4000

Industrial Sales Mgr.....George A. Hagerty
 666 Lake Shore Drive, Chicago 11, Ill.
 Phone: WHitehall 4-5750

Manager.....Robert A. MacDonald
 Southland Life Bldg., Dallas, Texas
 Phone: Prospect 8657

Manager.....Richard A. Fay
 Russ Bldg., San Francisco 4, Calif.
 Phone: SUTter 1-6262

Manager.....Lewis J. Boss

PRODUCTS: Microwave for broadcast STL use; program channel multiplex equipment.

Philmore Manufacturing Co., Inc.

113 University Place, New York, N. Y.
Phone: ALgonquin 4-3363

President.....M. L. Granat
Vice-President.....Gary Granat
Chief Engineer.....Reginald Burke
Treasurer.....Murray Granat

PRODUCTS: TV chassis, completely wired and aligned, TV kits with video and sound wired and fully aligned, with full instructions to complete the wiring, TV kits completely unassembled with full instructions for wiring. One, two and three tube kits, aerial kits, microphones (carbon type), crystal sets, crystal set kits, crystal detectors, coils, transmitter kits, amplifier kits, radio control kits.

Pilot Radio Corp.

37-06 36th St., Long Island City 1, N. Y.
Phone: STillwell 4-5151

President.....Isidor Goldberg
Vice-President.....J. N. Benjamin
Secretary-Treasurer.....I. W. Wyckoff
Sales Manager.....J. I. Benjamin
Purchasing Agent.....Paul Lefko
Chief Engineer.....Richard Shottenfeld

PRODUCTS: AM-FM table models and phono combinations, portable radio receivers, and remote control TV receivers, AM-FM timers, amplifiers, pre-amplifiers, HI-FI tuners and assemblies.

Presto Recording Corp.

P. O. Box 500, Paramus, N. J.
Phone: Diamond 3-5700

Sales Manager.....Thomas B. Aldrich
220 Kedzie St., Evanston, Ill.
Phone: Davis 8-4800

Manager.....Warren Cozzens
505 N. Ervar St., Dallas, Tex.
Phone: C 2966

Manager.....J. Earl Smith
2331 W. Washington Blvd., Los Angeles, Cal.
Phone: Republic 0203

Manager.....Lee Owens
7 East 48th St., New York, N. Y.
Phone: ELdorado 5-6021

Manager.....Thomas Aye
PRODUCTS: Disc recording, tape recording, transcription equipment, amplifiers, equalizers, blank recording discs.

Polarad Electronics Corp.

100 Metropolitan Ave., Brooklyn 11, N. Y.
Phone: STagay 2-3464

President.....Dr. D. L. Jaffe
Chief Engineer.....P. H. Odessey
Comptroller.....C. J. Eisen
Dir. of Contract Rel.....R. K. Hartman
Eng., Contract Relations.....P. J. Reuter

PRODUCTS: Color TV; color video monitor, flying spot scanner system, color bar

generator, color sync generator, portable sync generator NTSC color monochrome; TV: sync generator, monoscope signal source, studio picture monitor, portable waveform monitor, portable picture monitor, picture and waveform monitor; General: video distribution amplifier, wide band video amplifier, single and dual regulated power supplies, radio cue system (intra-studio wireless communication).

Radio Condenser Co.

Davis & Copewood Sts., Camden 3, N. J.
Phone: EMerson 5-5500

President.....R. E. Cramer
Exec. Vice-President.....W. W. Paul
Vice-President.....R. E. Cramer, Jr.
Sales Manager.....E. J. Penberthy
Chief Engineer.....J. S. Robb

PRODUCTS: VHF and UHF Tuning devices, variable air condensers, variable air capacitors and tuners for Government and special communications equipment, Automotive push-buttons permeability tuning units.

RCA Victor Division, Radio Corp. of America

Front & Cooper Sts., Camden, N. J.
Phone: WOODlawn 3-8000

Vice-Pres., Gen. Mgr., Rec.....Emanuel Sacks
V.P. and Gen. Mgr.....W. A. Buck
Oper. Vice-Pres.....C. M. Odorizzi
V.P. Chg. of Consumer Prod.....J. B. Elliott
V.P. Chg. of Tech. Prods.....W. W. Watts
V.P., Chairman Bd., RCA Estate

Appl. Corp.....R. A. Seidel
Dir. Org. Develop.....A. K. Weber
General Attorney.....S. E. Ewing
V.P., Chg. Home Department.....H. G. Baker
V.P., Dir. Reg. Operations.....P. A. Barkmeyer
V.P. Chg. Tube Dept.....R. T. Orth
V.P. Chg. Eng. Prod. Dept.....T. A. Smith
V.P. Chg. Fin.....J. S. Carter
V.P. Chg. Materials.....V. deP. Goubeau
V.P. Chg. Eng.....D. F. Schmit
A. & R. Manager.....Ben Selvin
Dir. Plant Eng.....Frank Sletter
Dir. Accounting.....D. L. Trouant
Dir. Personnel.....V. F. Watters
Dir. Consumer Prod. Distr.....J. M. Toney
Dir. of Tech. Prods.....H. V. Somerville
Dir. of Pub. Rel.....Julius Haber
Dir. of Cons. Prod. Advstg.....R. H. Coffin
V.P., Dir. Planning.....E. D. Foster
V.P., Western Mgr.....H. R. Magg
Pres., RCA Service Co., Inc.....E. C. Cahill
Pres., RCA Victor Distributing

Corp.....W. M. Norton
Pres., RCA Estate Appliance
Corp.....Cecil M. Dunn
Gen. Sales Mgr., Home Instrument
Department.....R. W. Saxon
Advstg. and Sales Prom. Mgr., Home
Instrument Dept.....J. M. Williams
Gen. Sales and Mds. Mgr.,
Record Department.....L. W. Kunaga

Advstg. and Sales Prom. Mgr.,
 Record Department.....W. I. Alexander
 Advstg. and Sales Prom. Mgr., Engr.
 Products Department.....John P. Taylor
 Publicity Director.....H. D. Desfor
 Gen. Sales Mgr., Tube Dept.....L. S. Thees
 Adv. and Sls. Prom. Mgr.,
 Tube Department.....H. S. Stamm

PRODUCTS: Aircraft and airport communication systems, AM, FM, and television receivers, AM, FM and television transmitting equipment, Amateur radio equipment, Antenaplex, Antenna Systems, Aviation Radio Equipment, Beverage and ampule inspection machines, Broadcast station studio equipment, Communications equipment, Custom recordings, Direction finders, Electronic business machines, Electronic components and service parts, Electronic fire control apparatus, Electron microscopes, Electron tubes—receiving, power, cathode-ray and special types, Engineering services, Film, disc and magnetic recording equipment, Gas and electric home kitchen ranges, Heatrola space heaters, Home Air Conditioners, Industrial electronic products, Industrial television equipment, Inter-communication equipment, Microphones, Microwave equipment, Mobile radio communication equipment, Phonograph records (45, 33 1/3 and 78-rpm), Public address and industrial sound equipment, Radio batteries, Record players, Service and maintenance on electronic equipment, 16-mm and 35-mm motion picture projectors and theater equipment, Sonar apparatus, Sound-powered telephones, Test and measuring equipment, Theater television equipment, Tube parts and tube-making machinery, Vicrola Radio-Phonographs.

Radio Engineering Laboratories, Inc.

36-40 37th St., Long Island City 1, N. Y.
 Phone: STillwell 6-2100

President.....C. R. Runyon, Jr.
 V. P. & Mgr. of Sales...Frank A. Gunther
 Secy. & Dir. of Purchases....Joseph Behr
 Chief Engineer.....Joseph Tennis
 Director of Research.....James R. Day
 Comptroller.....James A. Cronin

PRODUCTS: Broadeast transmitter, FM, 250 watts to 50 kw; Antennas-FM, speech input equipment, FM monitors, FM receivers, FM studio to transmitter link equipment, custom built high quality audio equipment. Quadrilene Amplifiers, Serrasoid modulators, Ten watt FM educational transmitters, Broadcast mobile transmitter link equipment, point-to-point multiplex communications equipment, FM radio relay links, special FM communications systems, FM store receivers, FM bus receivers and radio music receivers.

Rangertone, Inc.

73 Winthop St., Newark 4, N. J.
 Phone: HUmboldt 5-2550

President.....R. H. Ranger

V.P. Charge Eng.....P. M. Brubaker
 SecretaryH. Gallina
 Purchasing Agent.....A. C. Willms
 Accounting.....E. D. Longstreet

PRODUCTS: Magnetic Tape Recorders: for normal Broadcast; for TV Synchronized Sound to Motion Picture Film. Thyatron Inverters: for Controlled frequency Power, and Magnetic Heads, Tape-to-Film editing and transfer to sound film.

Raytheon Manufacturing Co.

Waltham 54, Mass.
 Phone: 5-5860

N. Y. Phone: Whitehall 3-4980
 PresidentCharles Adams
 V.-P. in chg. Equip. Sales.....L. A. Rooney
 V.-P., Int'l Div.....R. Ellis
 V.-P. & Treas.....D. T. Schultz

PRODUCTS: Tubes, TV microwave relay equipment, communications, microwave equipment.

Reeves Soundcraft Corp.

10 East 52nd St., New York 22, N. Y.
 Phone: PLaza 9-2644

President.....Hazard E. Reeves
 Vice-President-Sales.....Frank B. Rogers
 Vice-Pres.-ProductionHomer Clapper
 V.P. Springdale Pl.....Edward Schmidt
 V.P. Allentown Pl.....Harry F. Scheirer
 Advertising Manager...Thomas J. Dempsey

PRODUCTS: Blank recording discs, magnetic recording tape, full width magnetic recording film, striped magnetic film, styli.

Rek-O-Kut Company

38-01 Queens Blvd., Long Island City 1, N. Y.
 Phone: STillwell 4-7062-3-4

President, Sales Manager....George Silber
 Export Dept.....Morhan Exporting Corp.

PRODUCTS: Instantaneous Recording Equipment, Transcription Turntables.

Rust Industrial Co., Inc.

608 Willow St., Manchester, N. H.
 Phone: Manchester 3-3596

President.....W. F. Rust, Jr.

PRODUCTS: Packaged remote control equipment; remote control components; rotary and linear actuator assemblies, RF monitor preamplifiers, etc.; failure alarms.

Self Winding Clock Co., Inc.

207 Willoughby Ave., Brooklyn 5, N. Y.
 Phone: MAin 2-6300

Asst. Sales Mgr.....Harvey S. Wellman

PRODUCTS: Sweep seconds, dry cell battery operated self winding clocks containing connections for receiving automatic synchro-

nizing pulses from Western Union lines or manual synchronized pulses from control kit.

Sentinel Radio Corp.

2100 Dempster St., Evanston, Ill.
Phone: UNiversity 4-2400

President E. Alschular
Vice-President..... M. D. Bloek
Secretary..... R. S. Lawton
Production Manager..... I. J. Jacobsen
Chief Engineer..... W. J. Schnell
Director of Sales..... E. G. May
Sales Manager..... R. B. Parks
Advertising Mgr..... H. J. Lance
Export Manager..... H. A. Sillcox

PRODUCTS: Sentinel radio receiving sets and table, console models, portable radios, table and console models, FM-AM table console and radio phonograph combinations, television receivers of all types.

Sherron Electronics Co.

(Div. of Sherron Metallic Corp.)

1201 Flushing Ave., Brooklyn 37, N. Y.
Phone: BYaacinth 7-2820

President..... P. H. Sherron
Vice-President..... J. W. Hunter
Senior Vice-President..... R. M. Stock
Vice-President..... J. A. Geddes
Purchasing Agent..... I. C. Tierney

PRODUCTS: Amplitude modulated transmitters, frequency modulated transmitters, TV transmitters, modulators at all power levels for above transmitters, control consoles for radio stations, pulse generators, oscilloscopes, regulated power supplies, custom built equipment designed and manufactured to customers requirements.

Special Effects & Equipment, Inc.

418 W. 59th St., New York 19, N. Y.
Phone: CIrele 7-828

President Roy Benjamin
Exec. Vice-President..... Robert Lawrence
Operations Vice-Pres..... Bob Paulson
Treasurer Phillip Kornblum

PRODUCTS: Complete sales, engineering, and consultation service on line of TV and film production equipment, Beseler Arc. Incandescent and T-Vu-Graph Projectors, Moving background projectors, RP screens and frames, M. B. Paul Translucent Photographic Backgrounds, Slide and Film Library, Script Prompting Service, Optical Effects Kit, Special Effects Gimmicks.

Stainless, Inc.

Third & Montgomery Sts., North Wales, Pa.
Phone: North Wales 871
50 Church St., New York 7, N. Y.
Phone: DIgby 9-4379
Mgr. Pa. Office..... John F. Guzewicz

Mgr. N. Y. Office..... Henry J. Guzewicz
PRODUCTS: Self-supporting Rhomic array, guyed and micro wave towers; antenna masts; FM self-supporting and guyed towers.

Stancil-Hoffman Corporation

921 N. Highland Ave., Hollywood 38, Calif.
Phone: HOLlywood 4-7461

President..... William V. Stancil
Secretary Mary Diehl

PRODUCTS: Magnetic recorder/reproducer for Tape Model R4, magnetic recorder/reproducer for film Model S5 16 mm. & 17.5 mm., magnetic recorder for tape-battery operated portable—Model M5A (miniature), magnetic recorder/reproducer—multi-channel for tape Model CRM-15, pre-amplifier/mixer 4 channel Model AM3, tuning fork controlled power supply—425 watts output Model VIA.

Standard Electronics Corp.

(Subsidiary of Claude Neon, Inc.)

285 Emmet St., Newark 5, N. J.
Phone: BIGelow 3-5540

Vice-President..... W. H. Zillger
6728 S. Halstead, Chicago, Ill.

Phone: Wentworth 6-5128

Manager..... R. R. Howard
PRODUCTS: Transmitters; associated equipment.

Stromberg-Carlson Co.

100 Carlson Rd., Rochester 3, N. Y.
Phone: CULver 0260

President..... Robert C. Tait
Vice-Pres..... Gordon G. Hoyt
V.P. & Gen. Mgr.

Broadcasting Div..... William Fay
V.P. Gov't Contracts..... Sidney R. Curtis
Corporate Secretary..... Arthur F. Gibson
General Manager, Tel. Div..... John H. Voss
Treasurer Charles Pritchard
Controller..... D. G. Schuman
Mgr. Industrial Relations.... George E. Eyer
Mgr., Sound Equip. Div..... A. G. Schifino
Gen. Mgr.-Radio-TV..... Clifford J. Hunt
Mgr. Adv. & Public Rel.. Stanley H. Manson

PRODUCTS: TV Table Models, TV Consoles, TV Combinations with AM, FM, and 3-speed record changer, Hi-Fi Amplifiers, Tuners, Cabinets; Electronic Carillon Equipment, Intercommunicating Systems, Telephones, and Switchboard Equipment.

Sylvania Electric Products, Inc.

1740 Broadway, New York 19, N. Y.
Phone: JUDson 6-2424

Chairman of Board..... Don C. Mitchell
President..... H. Ward Zimmer
Vice-President..... E. Finley Carter
Vice-President..... Arthur Chapman

Vice-President.....Curtis Haines
 V.P. Charge of Sales.....B. K. Wickstrum
 Gen. Sales Mgr., Radio Div.....H. P. Gilpin
 Dir. of Advertising.....T. P. Cunningham

PRODUCTS: Television Picture Tubes, Radio and Television Receiving Tubes, Germanium Diodes, Radio and Television Testing Equipment, Radio and Television Receivers, Tube Parts, Tungsten and Chemical Products.

Sylvania Electric Products, Inc.

43-20 34th St., Long Island City 1, N. Y.
 Phone: STillwell 4-1160

Mfg. Supt.....C. F. Genentz
 Mechanical Circuit.....A. Lederman
 Purchasing Agent.....Jack Blau
 Service Manager.....Ray Smith
 Office Personnel.....G. J. Gaffney

PRODUCTS: Laminated Bakelite Tube Sockets, Laminated Terminal Boards, Air-loop Assemblies, Wired Assemblies, Tube Contacts, Component Parts for Molded Assemblies.

**Sylvania Electric Products, Inc.
 Radio & Television Division**

254 Rano St., Buffalo 7, N. Y.
 Phone: Victoria 2450

General Manager.....J. K. McDonough
 General Mfg. Manager.....H. H. Martin
 Gen. Sales Mgr.....B. O. Holsinger
 Chief Engineer.....N. L. Harvey
 Div. Controller.....E. J. Vigneron
 Div. Personnel Manager.....H. S. Hagen

PRODUCTS: Television, AM and FM receivers.

Tele Q

1227 Sixth Ave., New York 19, N. Y.
 Phone: JUdson 6-5766

PRODUCTS: Cuing equipment for TV networks and stations.

Television Associates, Inc.

E. Michigan St., Michigan City, Ind.
 Phone: 7-7207

Pres. & Gen. Mgr.....W. C. Eddy
 Plant Supt.....K. P. Humbert
 Secretary.....Margaret Durnal

PRODUCTS: Studio lighting equipment: Ceiling mounted incandescents, and fluorescents; dolly mounted fluorescents; control fixtures for mounting spotlights; light panel control equipment and switch panels. Micro-wave relay equipment: Reflectors and mounting supports; parapet clamps; metal tripods. Studio equipment: Camera Dollies, tripods, hi-hats and lo-hats for camera mounting, cable clamps. Projection Room accessories: Continuous reel magazines, rewind mandrels, and storage racks for continuous reel film

loops; kaleidoscope projectors; specialized film loops for continuous reel use.

Television Specialty Co., Inc.

350 West 31st St., New York 1, N. Y.
 Phone: LOnacre 4-5326

President.....Alfred Jenkins
 Sales Manager.....Leonard Gumley
 Secretary-Treasurer.....Lee Jenkins
 Production Mgr.....Anthony C. Warren
 Traffic Manager.....Carman Laurino

PRODUCTS: Wide angle rear screen projector and rear projection screens, studio lights and lighting equipment, switchboards and patch panels, camera dollies and tripods, microphone booms, theatre TV equipment, film room and dark room equipment, news-reel cameras and equipment. Free lighting consultant.

Tower Construction Co.

1923 Geneva St., Sioux City, Iowa
 Phone: 5-7653
 2002 P St. N.W., Washington, D. C.
 Phone: ADans 4-6447

Owner.....M. M. Lascnsky
 PRODUCTS: Towers, microwave passive reflectors and tower erections.

**Transmitter Equipment Mfg.
 Co., Inc.**

35 Ryerson St., Brooklyn 5, N. Y.
 Phone: UL 5-6800

Pres., Treas.....Morton B. Kahn
 Secretary.....F. C. Botscheller

PRODUCTS: Broadcast Station Equipment, AM and FM, Studio Amplifying Consoles, Radio Communication Transmitters, both AM and FM, Air, Ground Communication Equipment, AM and FM, Electronic Computers, Radar Equipment, Guided Missile Controls, etc.

Truscon Steel Division

Republic Steel Corp.
 Albert St., Youngstown 1, Ohio
 Phone: RIVerside 6-7211

General Mgr. of Sales.....C. B. McGehee
 Asst. Gen. Mgr. of Sales.....D. M. Schmid

PRODUCTS: Radio towers for AM & FM, TV and micro wave, copper mesh ground screen.

Unique Turntable & Display Co.

1895 Park Ave., New York 35, N. Y.
 Phone: TRafalgar 6-2962

President.....Albert W. Nuccel
 PRODUCTS: Manufacture and rent turntables and revolving stages; manufacturer of animation stands and consultants for animation for TV work.

U. S. Recording Company

1121 Vermont Ave., N.W. Washington 5, D. C.
Phone: Lincoln 3-2705

General Manager.....Joseph Tait
Chief Engineer.....Henry P. Meisinger
Sales Manager.....Eugene Rosen

PRODUCTS: Manufacturers and distributors of audio, sound and hi-fidelity equipment. Manufacturer Panacoustic transcription equipment, audio consoles and custom equipment. Distribute, Magnecord, McIntosh, Presto equipment, microphones and loud-speakers. Specializing in engineering manufacturing and assembling custom equipment for radio Broadcast stations. Complete Studio and Technical plant for Sound Recording—both tape and disc. Also complete facilities to produce TV films.

Westinghouse Electric Corp.

2519 Wilkens Ave., Baltimore 3, Md.

Phone: Edmondson 2300

President.....G. A. Price
V.P. (Cons. Prods.).....J. M. McKibbin
Television-Radio Division

1354 Susquehanna Ave., Sunbury, Pa.

Phone: 2520

Manager.....F. M. Sloan
Asst. Mgr.....A. G. Rogers
Asst. to Mgr.....L. J. Fitzpatrick
Chief Engineer.....G. C. Larson
Purchasing Agent.....J. R. Todd
Sales Manager.....J. F. Walsh
Adv. & Sales Prom. Mgr.....Earl L. Hadley
Service Manager.....A. H. Kuttruff

PRODUCTS — *Receivers: Battery* — Console, Table, Personal, Portable; *Radio* — AM Midget AM Table, AM Console, AM Portable AC-DC, AM Portable Wet Cell, AM Console with Phonograph, AM Console with Phonograph and Recorder, FM Table, FM Console, FM Console with Phonograph, FM Console with Phonograph and Recorder, AM-FM Table, AM-FM Console, AM-FM Console with Phonograph, AM-FM Console with Phonograph and Recorder; *Television* — Table, Console, AM Table, AM-FM Console with Phonograph, AM-FM Console with Phonograph and Recorder. Record Players. *Tubes:* Industrial, Transmitting and Special Purpose. X-Ray, Receiving, Cathode Ray. *Communications Equipment:* Aviation, Industrial, Marine, Public Utility, Railroad, Trucks and Busses. *Transmitters:* AM, FM, Shortwave, VHF, UHF, Microwave, Relay, Facsimile. *RADAR:* Marine, Land.

Weston Electrical Instrument Corp.

614 Frelinghuysen Avenue, Newark 5, N. J.
Phone: Bigelow 3-4700; Worth 4-3510 in N.Y.
President.....Earl R. Mellen
Exec. Vice-Pres.....Ross Nichols
V.P. & Plant Mgr.....A. H. Lamb
Chief Engineer.....F. X. Lamb

Controller & Sec.....F. Gerald Hawthorne
Director of Sales.....Philip Barnes
Advertising Manager.....Chas. B. Denton
Purchasing Agent.....A. L. Morrison

PRODUCTS: Electrical Indicating Instruments, Sensitive Relays and Associated Devices, Service and Tube Testing Equipment, Electrical Speed and Temperature Indicating Equipment, Photoelectric Devices and Photographic Exposure Meters, Weston Industrial and Laboratory Thermometers, Weston Aircraft Instruments.

Wheeler Laboratories, Inc.

122 Cutter Mill Rd., Great Neck, N. Y.

Phone: Great Neck 2-7806

President.....Harold A. Wheeler

PRODUCTS: Consulting services and laboratory facilities for special problems in the field of radio and electronics,—microwave waveguide components on special order.

Wilcox-Gay Corporation

79 Washington St., Brooklyn 1, N. Y.

Phone: Ulster 2-6000

President.....Leonard Ashbach
Vice-President.....L. M. Sandwick
Vice-President.....Maurice Raphael
Secretary.....Arthur Homan
Advertising Mgr.....Joseph G. DeVico
Chief Engineer.....Ed Jahns

PRODUCTS: Portable tape recorders, portable tape and disc recorders, console tape recorders, high fidelity phonographs, recording tape and discs, needles, extension speakers and cables.

Zenith Radio Corp.

6001 W. Dickens Ave., Chicago 39, Ill.

Phone: Berkshire 7-7500

N. Y. Phone: Longacre 1-6600

Pres. and Gen. Mgr.....E. F. McDonald, Jr.
Exec. V.P.....Hugh Robertson
V.P. and Dir. of Sales.....H. C. Bonfig
V.P. in Chg. of Eng.....G. E. Gustafson
V.P. in Chg. of Prod.....Donald MacGregor
V.P. and Treas.....S. Kaplan
V.P. in Chg. of Purchases.....J. E. Anderson
V.P. in Chg. of Res.....Dr. Alexander Ellett
V.P. in Chg. of Household Receiver

Sales.....Leonard C. Truesdell
Secty. and Asst. V.P.....Karl E. Hassel
Asst. V.P.....J. E. Brown
Asst. Treas and Asst. Secty.....J. Kuhajek
Asst. Secty.....H. M. Chesser
Advertising Dir.....Erik Isgrig
Public Relations Director.....Ted Leitzell

PRODUCTS: Table model radios, table radio-phonographs, portable radios, clock radios, console radio-phonographs, table television receivers, console television receivers, console television-radio-phonograph combinations.

RADIO-ELECTRONICS TELEVISION MFRS. ASSOCIATION

Officers and Executive Personnel—1953-1954

777 14th Street, N.W., Washington 5, D. C.



Chairman, Board of Directors

Robert C. Sprague, Sprague Electric Co.,
North Adams, Mass.

President and General Counsel

Glen McDaniel, 777 - 14th St. N.W.,
Washington 5, D. C.

Exec. V.P. and Secretary

James D. Secrest, 777 14th Street, N.W.,
Washington 5, D. C.

Treasurer

Leslie F. Muter, The Muter Company,
Chicago 5, Illinois.

Vice-Presidents

(Set Division)

Robert S. Alexander, Wells-Gardner &
Co., Chicago 39, Ill.

(Tube Division)

R. E. Carlson, Tung-Sol Electric Inc.,
Newark 4, New Jersey.

(Parts Division)

R. G. Zender, Lenz Electric Mfg. Co.,
Chicago 47, Ill.

(Technical Products Division)

H. J. Hoffman, Machlett Labs., Inc.,
Springdale, Conn.

(Amplifier & Sound Equipment Division)

Sidney Harman, Harman-Kardon, Inc.,
New York 12, N. Y.

RETMA Headquarters Staff

Asst. to Exec. V.P.

Peter H. Cousins

Editorial Director

Tyler Nourse

Service Co-Ordinator

Albert Coumont

Director of Statistics

William F. E. Long

Attorney

William L. Reynolds

Government Relations Officer

Charles Maechling, Jr.

Manager, International Dept.

Louis E. De La Fleur

RETMA BOARD OF Directors

Term Expiring 1954

Benjamin Abrams, Emerson Radio &
Phonograph Corp., New York 11, New
York.

W. J. Baker, Collins Radio Company,
New York 18, New York.

Max F. Balcom, Sylvania Electric Pro-
ducts Inc., Emporium, Pennsylvania.

H. C. Bonfig, Zenith Radio Corporation,
Chicago 39, Illinois.

Herbert W. Clough, Belden Manufac-
turing Company, Chicago 44, Illinois.

Leonard F. Cramer, Avco Manufacturing
Co.

Russell E. Cramer, Jr., Radio Condenser
Co.

E. G. Fossum, Stewart-Warner Electric
Division, Chicago 51, Illinois.

E. K. Foster, Bendix Radio Div., Balti-
more 4, Md.

Harlan B. Foulke, Arvin Industries, Inc.,
Columbus, Indiana.

G. Richard Fryling, Erie Resistor Corpo-
ration, Erie, Pennsylvania.

Sidney Harman, Harman-Kardon, Inc.

F. R. Lack, Western Electric Company,
Inc., New York 5, New York.

W. A. MacDonald, Hazeltine Electronics
Corporation, Little Neck, Long Island,
New York.

Leslie F. Muter, The Muter Company.

W. Myron Owen, Aerovax Corporation.
 A. D. Plamondon, Jr., Plamondon Magnetics Co.
 L. S. Racine, Chicago, Standard Transformer Co.
 Fred D. Wilson, Capelhart-Farnsworth Co.

Term Expiring 1955

Floyd W. Bell, Bell Sound Systems, Inc.
 Lloyd H. Coffin, CBS-Hytron.
 Allen B. DuMont, Allen B. DuMont Laboratories, Inc., Clifton, New Jersey.
 Harry A. Ehle, International Resistance Company, Philadelphia 8, Pennsylvania.
 J. B. Elliott, RCA Victor Division of RCA, Camden, New Jersey.
 Frank Freimann, The Magnavox Company, Fort Wayne, Indiana.
 Paul V. Galvin, Motorola Inc., Chicago 51, Illinois.
 Frank W. Godsey, Jr., Westinghouse Electric Corporation, Baltimore 3, Maryland.
 W. J. Halligan, The Hallcrafters Co., Chicago 24, Illinois.
 Larry F. Hardy, Philco Corporation, Philadelphia 34, Pennsylvania.
 D. S. W. Kelly, Allen-Bradley Company, Milwaukee 4, Wisconsin.
 Matt Little, Quam-Nichols Company, Chicago 16, Illinois.
 Sam Norris, Amperex Electronic Corporation, Brooklyn 1, New York.
 W. S. Parsons, Centralab, Div. Globe-Union Inc., Milwaukee 1, Wisconsin.

Term Expiring 1956

Robert S. Alexander, Wells-Gardner & Co.
 E. Alschuler, Sentinel Radio Corp.
 Robert S. Bell, Packard-Bell Co.
 R. E. Carlson, Tung-Sol Electric Inc.
 B. W. Cooper, Delco Radio Division.
 Harold L. George.
 H. J. Hoffman, Machlett Laboratories, Inc.
 H. Leslie Hoffman, Hoffman Radio Corporation.
 H. C. Mattes, Raytheon Manufacturing Company.
 Ray F. Sparrow, P. R. Mallory & Co., Inc.
 Robert E. Sprague, Sprague Electric Company.
 Robert C. Tait, Stromberg-Carlson Company.

Raymond G. Zender, Lenz Electric Manufacturing Co.

RETMA DIVISION ORGANIZATION

Set Division

Robert S. Alexander, Chairman.

Tube Division

John Q. Adams, Chairman.

Parts Division

Matt Little, Chairman.

Technical Products Division

Carlyle W. Miller, Chairman.

Amplifier & Sound Equipment Division

Floyd W. Bell, Chairman.

Annual Awards Committee

Chairman: Leslie F. Muter, The Muter Co.

Credit Committee

Chairman: H. A. Pope, National Union Radio Corp.

Export Committee

W. M. Adams, Sprague Electric Co.

Finance Committee

Chairman: Leslie F. Muter, The Muter Company.

Industrial Relations Committee

Chairman: Leslie E. Woods, Raytheon Manufacturing Company.

Industry Statistics Committee

Chairman: Frank W. Mansfield, Sylvania Electric Products, Inc.

Jobber Relations Committee

(Parts Division)

Chairman: J. A. Milling, Howard W. Sams & Co., Inc.

Legal Committee

Chairman: Glen McDaniel, RETMA General Counsel.

Membership Promotion Committee

Co-Chairmen: J. J. Kahn, H. J. Hoffman, Machlett Laboratories, Inc.

Public Relations and Advertising Committee

(Set Division)

Chairman: John F. Gilligan, Philco Corp.

Sales Managers Committee

(Set Division)

Chairman: Dan D. Halpin, Allen B. DuMont Laboratories, Inc.

School Equipment Committee

Chairman: Fred D. Wilson, DuKane, Corporation.

Service Committee

Chairman: H. J. Schulman, Allen B. Du Mont Laboratories, Inc.

Subscription TV Committee

Chairman: Paul V. Galvin, Motorola, Inc.

**Sports Broadcasting Committee
(Set Division)**

Chairman: J. B. Elliott, RCA Victor Division.

Tax Committee

Chairman: A. M. Freedman, RCA Victor Division.

Television Committee

Chairman: W. R. G. Baker, General Electric Company.

**Trade Practice Conference Committee
(Special)**

Chairman: Benjamin Abrams, Emerson Radio & Phonograph Corp.

Traffic Committee

Chairman: John B. Swan, Jr., Philco Corporation.

**JOINT TECHNICAL
ADVISORY COMMITTEE
of RETMA and IRE
(JTAC)**

Chairman: A. V. Loughren, Hazeltine Electronics Corp., 58-25 Little Neck Parkway, Little Neck, Long Island, N. Y.

Dr. Ralph Brown, Bell Telephone Labs., Murray Hill, N. J.

Donald G. Fink, Philco Corporation, Philadelphia 34, Pa.

John V. L. Hogan, Hogan Laboratories, Inc., 155 Perry Street, New York 14, New York.

Philip F. Siling, RCA Frequency Bureau, 1625 K Street, N.W., Washington 6, D. C.

Lloyd V. Berkner, President, Associated Universities, Inc., New York, N. Y.

Dorman D. Israel, Emerson Radio & Phonograph Corp., New York, N. Y.

Ira J. Kaar, General Electric Co., Syracuse, N. Y.

L. G. Cumming, Secretary (Non-Member), Institute of Radio Engineers, 1 East 79th Street, New York 21, N. Y.

**RETMA ENGINEERING
DEPARTMENT**

Dr. W. R. G. Baker, Director, General Electric Company, Electronics Park, Syracuse, New York. (Syracuse 76-4411), (Schenectady 4-2211).

David B. Smith, Vice-Director, Philco Corporation, Philadelphia 34, Pennsylvania. (NEbraska 4-5100).

Virgil M. Graham, Associate Director, Sylvania Electric Products, Inc., Sylvania Center, Bayside, L. I., N. Y., (BAyside 4-4400), (JUdson 6-2424).

Ralph R. Batcher, Chief Engineer, Jean Caffiaux, Engineer, 500 - 5th Ave., New York 36, N. Y. (LONgacre 5-3450).

**General Standards
Committee**

Dorman D. Israel, Chairman, Emerson Radio & Phonograph Corp., New York 11, New York.

Observer: R. A. Hackbusch, RTMA of Canada

**JOINT ELECTRON TUBE
ENGINEERING COUNCIL
of
RETMA and NEMA (JETEC)
Directors**

W. R. G. Baker, General Electric Company, Syracuse 1, New York.

H. J. Hoffman, Machlett Laboratories, Inc., Springdale, Connecticut.

Council

Virgil M. Graham, Chairman, Sylvania Electric Products, Inc., Flushing, New York.

V. L. Ronci, Bell Telephone Laboratories, Allentown, Pennsylvania.

K. C. DeWalt, General Electric Co., Schenectady, N. Y.

J. A. McCullough, Eitel-McCullough, Inc., San Bruno, Cal.

A. C. Rockwood, Raytheon Manufacturing Co., Newton 58, Mass.

G. R. Shaw, RCA Victor Division of RCA, Harrison, New Jersey.

A. K. Wright, Tung-Sol Electric Inc., Bloomfield, New Jersey.

CONSULTING ENGINEERS

specializing in AM, FM & TV

GEORGE P. ADAIR

1610 Eye St., N.W., Washington 6, D. C.
Phone: Executive 3-1230

BEN ADLER

Adler Communications Labs.
1 Lefevre Lane, New Rochelle, N. Y.
Phone: New Rochelle 6-1620

LLOYD R. AMOO

1433 First St., S.E. Minot, N. D.
Phone: 6-3162

ANDREW CORP.

363 E. 75th St., Chicago 19, Ill.
Phone: Triangle 4-4400

GEORGE B. BAIREY

210 W. Cameron Rd., Falls Church, Va.
Phone: Jefferson 2-7703

WILLIAM E. BENNS, JR.

3738 Kanawha St., N.W., Washington, D. C.
Phone: EMerson 2-8071
Box 1447, Montgomery, Ala.
Phone: 2-3851

BERNARD ASSOCIATES

5010 Sunset Blvd., Hollywood 27, Calif.
Phone: NOrmandy 2-6715
Field Office: 86 Webster Ave., Harrison, N. Y.
Phone: Harrison 8-3023J

A. R. BITTER

2233 Parkwood Ave., Toledo 10, Ohio
Phone: Kingswood 5159

RUDY BRETZ

Croton-On-Hudson, N. Y.
Phone: CRoton 1-3478

WILLIAM W. L. BURNETT

4814 Idaho St., San Diego 16, Calif.
Phone: Atwater 2-2710

CRAVEN, LOHNES & CULVER

Munsey Building, Washington 4, D. C.
Phone: District 7-8215

JOHN CREUTZ

710 Fourteenth St., N.W.
Washington 5, D. C.
Phone: Executive 3-5670

MURRAY G. CROSBY

Robbins Lane, Hicksville, N. Y.
Hicksville 3-3191

A. EARL CULLUM, JR.

Highland Park Village, Dallas 5, Tex.
Phone: Justin 6108

GEORGE C. DAVIS

Munsey Bldg., Washington 4, D. C.
Phone: Sterling 3-0111

DOOLITTLE RADIO, INC.

7421 S. Loomis Blvd., Chicago 36, Ill.
Phone: Radcliffe 3-4100

A. JAMES EBEL

212 S. Jefferson St., Peoria, Ill.
Phone: 6-0711

WILLIAM L. FOSS, INC.

927 15th St., N.W., Washington 5, D. C.
Phone: Republic 7-3883

MILLARD M. GARRISON

710 Fourteenth St., N.W.
Washington 5, D. C.
Phone: Executive 3-5670

GEORGE E. GAUTNEY

Warner Bldg., Washington 4, D. C.
Phone: National 8-7757

GLENN D. GILLETT

National Press Bldg., Washington 4, D. C.
Phone: National 8-3372

PAUL F. GODLEY

Paul Godley Co., P. O. Box "J",
Upper Montclair, N. J.
Laboratories: Great Notch, N. J.
Phone: Montclair 3-3000

DR. ALFRED N. GOLDSMITH

597 Fifth Ave., New York 17, N. Y.
Phone: Plaza 3-4150

J. B. HATFIELD

936 35th Ave., Seattle 22, Wash.
Phone: Franklin 7860

RICHARD R. HAYES

210 Olmos Dr., W., San Antonio 12, Texa-
Phone: Travis 9751

JOHN B. HEFFELFINGER

815 E. 83rd St., Kansas City 10, Mo.
Phone: Hiland 7010

JOHN V. L. HOGAN

155 Perry St., New York 14, N. Y.
Phone: Chelsea 2-7855

W. J. HOLEY

1146 Briarcliff Pl., N.E., Atlanta, Ga.
Phone: Atwood 3328

GUY C. HUTCHESON

1100 W. Abram St., Arlington, Texas
Phone: AR 4-8721

JANSKY & BAILEY, INC.

1735 De Sales St., N.W.,
Washington 6, D. C.
Phone: Metropolitan 8-5411
Laboratories
1339 Wisconsin Ave., N.W., Wash. 7, D. C.
Phone: Adams 4-2414

WALTER F. KEAN

1 Riverside Road, Riverside, Ill.
Phone: Riverside 7-2153

KEAR & KENNEDY

1302 18th St., N.W., Washington 6, D. C.
Phone: Hudson 3-9000

JOHN J. KEEL

1121 E. Capitol St., Washington 3, D. C.
Phone: Lincoln 4-5131

RUSSELL P. MAY

711 Fourteenth St., N.W.,
Washington 4, D. C.
Phone: Republic 7-3984

WINFIELD SCOTT McCACHREN

2404 Columbia Pike, Arlington, Va.
Phone: Jackson 8-9096

FRANK H. McINTOSH

Wyatt Bldg., Washington, D. C.
Phone: Metropolitan 8-4477

JAMES C. McNARY

National Press Bldg., Washington 4, D. C.
Phone: District 7-1205

**PAGE, CREUTZ, GARRISON
and WALDSCHMITT**

710 Fourteenth St., N.W.,
Washington 5, D. C.
Phone: Executive 3-5670

RADIO ENGINEERING CO.

1355 Market St., San Francisco 3, Calif.
Phone: Market 1-8171

GARO W. RAY

Hilltop Dr., Stratford, Conn.
Phone: Bridgeport 7-2465

WILLIAM E. RICHARDSON

1935 S. W. Moss St., Portland 1, Ore.
Phone: Cherry 4070

A. D. RING & CO.

Munsey Bldg., Washington 4, D. C.
Phone: Republic 7-2347

HAROLD B. ROTHROCK

530 So. Gay St., Knoxville, Tenn.
Phone: 5-0630

MERL SAXTON

P. O. Box 575, Lufkin, Texas
Phones: 3-4242 and 3-9558

ROBERT M. SILLIMAN

1405 G St., N.W.,
Washington 5, D. C.
Phone: Republic 7-6646

HAROLD C. SINGLETON

4488 S.W. Council Crest Dr., Portland 1, Ore.
Phone: Beacon 1201

LYNNE C. SMEBY

1311 G St., N.W., Washington 5, D. C.
Phone: Executive 3-8073

**T & T RADIO
MEASUREMENTS CO.**

2559 Atlantic Ave., Long Beach 6, Cal.
Phone: Long Beach 4-2015

ARCHER S. TAYLOR

P. O. Box 1479 Missoula, Mont.
Phone: 9-1589

WELDON & CARR

1001 Connecticut Ave., N.W.,
Washington, D. C.
Phone: Sterling 3-2550
Laboratory Div.
Cannon Chappel Road, Leesburg, Va.
Phone: Republic 7-2571

BRANCHES

4212 S. Buckner Blvd., Dallas 10, Tex.
Phone: Evergreen 1137

MARTIN R. WILLIAMS

7401 East 14th St., Indianapolis 19, Ind.
Phone: Market 3326

NATHAN WILLIAMS

20 Algoma Blvd., Oshkosh, Wis.
Phone: Blackhawk 22

RAYMOND M. WILMOTTE

1469 Church St., N.W., Washington 5, D. C.
Phone: Decatur 2-1231

HERBERT L. WILSON

1025 Connecticut Ave., N. W., Wash. 6, D. C.
Phone: National 8-2266

THOSE WHO KNOW FAMOUS BRANDS

Says WLEU'S General Manager Philip B. Hirsch at Erie, Pa.: "Since banks make their mark on dependability and prestige, what's more natural for them than a program of **Associated Press** news?"

. . . . KNOW THE MOST FAMOUS
BRAND IN NEWS IS **AP**

Programs

AM-TV

1953

•
TITLES

•
SPONSORS

•
PRODUCTS

•
NETWORKS

•
ADVERTISING AGENCIES

COMMERCIAL AM PROGRAMS OF 1953

(NETWORK)

The following pages contain a complete alphabetical listing of program titles of the four national networks' commercial programs heard during the 12-month period ending Dec. 31, 1953. Listing includes program title, sponsor and product, network and the advertising agency handling the account. Compilation has been made through the cooperation of ABC, CBS, MBS, and NBC. Programs are all of 13-week duration or longer.

A

PROGRAM	ADVERTISER AND PRODUCT	NETWORK	ADVERTISING AGENCY
Adams, Cedric	Sonotone Corp. (Hearing Aid)	CBS	Kudner Agency, Inc.
	The Murine Co. (Murine)		B.B.D. & O.
Admiral Presents World News, With Robert Trout	Admiral Corp. (Radios, refrigerators, household appliances)	CBS	Erwin Wasey & Co., Inc.
Adventures of Ozzie and Harriet	Hotpoint, Inc. (Electric household prod.)	ABC	Maxon, Inc.
	The Lambert Co. (Listening products)		Lambert & Feasley, Inc.
Adventures of the Falcon	Co-operative Sponsors	MBS	
Allsweet Music Box	Swift & Co. (Allsweet Margarine)	MBS	J. Walter Thompson Co.
America Calling	Riggio Tobacco Corp. (King Size Cigarettes)	CBS	Hilton & Riggio, Inc.
America's Top Tunes	Poundex Products (Poundex)	NBC	Ruthrauff & Ryan, Inc.
American Way, Starring Horace Heidt	American Tobacco Co. (Lucky Strike Cigarettes)	CBS	B.B.D. & O.
Amos 'n' Andy	Rexall Drug Co. (all drug products)	CBS	B.B.D. & O.
Answer Man, The	Doubleday & Co. (Dollar Book Club)	CBS	Thwing & Altman, Inc.
Arlington Classic	Schick, Inc. (Electric Razors)	CBS	Kudner Agency, Inc.
Armstrong Theatre of Today	Armstrong Cork Co. (Quaker Rugs, Luxolium floor coverings)	CBS	B.B.D. & O.
Army-Navy Game	General Motors Corp. (Cadillacs and GMC trucks)	NBC	Kudner Agency, Inc.
Arnold, Eddie Show	Ralston-Purina Co. (Feed and cereals)	NBC	Brown Radio Productions, Inc. Gardner Advertising Co.
Aunt Jemima Home Folks	Quaker Oats Co. (Aunt Jemima Cake Mix, Pancake Mix)	CBS	Price, Robinson & Frank, Inc.



COMMERCIAL AM PROGRAMS



PROGRAM	ADVERTISER AND PRODUCT	NETWORK	ADVERTISING AGENCY
Aunt Jenny	Lever Brothers Co. (Rinso, Surf)	CBS	Foote, Cone & Belding
Autry, Gene Show	Wm. Wrigley, Jr. Co. (Doublemint Chewing Gum)	CBS	Ruthrauff & Ryan, Inc.

B

Babbitt, Harry Show	American Home Products Corp. (Anacin) S. & W. Fine Foods, Inc. (Food and Coffee)	CBS	John F. Murray Advertising Agency Foote, Cone & Belding
Back to God Backstage Wife	Christian Reformed Church (Cheer)	MBS	Glenn-Jordan-Stoetzel, Inc.
Backstage Wife	Procter & Gamble (Cheer)	NBC	Young & Rubicam, Inc.
Baker, Art and the News	Edwards Food Co. (Nob Hill Coffee)	NBC	M. E. Harlan Advertising
Baker, Morgan Program	Holland Furnace Co.	CBS	Lindeman Adv. Service
Bakers Theatre of Stars	American Bakers Association (Bakery Products)	CBS	Foote, Cone & Belding
Bekins Music Hall	Bekins Van & Storage Co. (Storage & Moving)	CBS	Brooks Advertising Agency
Belmont Race	Schick, Inc. (Electric Razors)	CBS	Kudner Agency, Inc.
Benny, Jack Program	American Tobacco Co. (Lucky Strike Cigarettes)	CBS	McCann-Erickson, Inc.
Benson, Bobby	Kraft Foods Co. (Kraft Caramels)	MBS	J. Walter Thompson
Berch, Jack	Prudential Insurance Co of America	ABC	Calkins, Holden, Carlock, McClinton and Smith, Inc.
Bergen, Edger & Charlie McCarthy Show	Hudnut Sales Co. (Shampoo, Home Permanents, Creme Rinse) Consolidated Cosmetics (Lanolin Plus, Liquid, cream, lotions)	CBS	Kenyon & Eckhardt, Inc. B.B.D. & O., Inc. Erwin, Wasey of Canada, Ltd.
Beulah	General Foods Corp. (Krinkles, Post Toasties) The Murine Co. (Murine)	CBS	Foote, Cone & Belding B.B.D. & O.
Big Story, The	American Cigarette & Cigar Co., Inc. (Pall Mall Cigarettes)	NBC	Sullivan, Stauffer, Colwell & Bayles, Inc.
Blue Rose Show	Garden Guild of America	CBS	Hirsch & Rutledge, Inc.
Bob and Ray	Colgate-Palmolive Co. (Ajax, Toothpaste, Vel)	NBC	William Esty Co., Inc.

◆ ◆ ◆ **COMMERCIAL AM PROGRAMS** ◆ ◆ ◆

PROGRAM	ADVERTISER AND PRODUCT	NETWORK	ADVERTISING AGENCY
Break the Bank	Miles Laboratories, Inc. (Aika-Seltzer, Nervine, Tabcin, Bactine, One-a-Day Vitamins)	NBC	Geoffrey Wade Advertising
Break the Bank	Co-operative Sponsors	ABC	
Breakfast Club	Co-operative Sponsors	ABC	
Brighter Day	Procter & Gamble Co. (Cheer, Blue Cheer)	CBS	Young & Rubicam, Inc.
Brown, Cecil, Commentary	State Farm Mutual Auto Ins. Co. (Auto Insurance)	MBS	Needham, Louis & Brorby, Inc.

C

Cadillac Choral Symphony	General Motors Corp. (Cadillac Division)	CBS	MacManus, John & Adams, Inc.
Camel Caravan starring Vaughn Monroe and the Sauter-Finegan Orchestra	R. J. Reynolds Tobacco Co. (Camel cigarettes)	CBS	Wm. Esty Co., Inc.
Camel Lineup and Scoreboard	R. J. Reynolds Tobacco Co. (Camel cigarettes)	MBS	Wm. Esty Co., Inc.
Cameo Lady Talk	Burlington Mills Corp. (Bur-Mil Cameo Stockings)	MBS	Donahue & Coe, Inc.
Cameo Serenade Room	Burlington Mills Corp. (Cameo hosiery and other products)	ABC	Donahue & Coe, Inc.
Canova, Judy	Co-operative Sponsors	NBC	
Cantor, Eddie	Coleman Co., Inc. (Gas heating and household appliances)	NBC	N. W. Ayer & Son, Inc.
Capitol Commentary	S. C. Johnson & Son, Inc. (Johnson's Glo-Coat and other products)	MBS	Needham, Louis & Brorby, Inc.
Carson, Mindy Show	General Motors Corp. (Buick Div.)	CBS	Kudner Agency, Inc.
Carter, Nick	Co-operative Sponsors	MBS	
Carter, Paul Show	General Products Corp. (Looz Reducing Tablets)	CBS	Dean & Simmon's
Cavalcade of America	E. I. Du Pont de Nemours & Co., Inc. (Institutional)	NBC	B.B.D. & O.
CBS Newsroom	Co-operative Sponsors	CBS	
Chevrolet Soap Box Derby	Chevrolet Motor Div. of General Motors Corp. (Cars, trucks, parts, services)	NBC	Campbell Ewald Co.
Chevrolet Spotlights the News	Chevrolet Motor Division (Cars)	ABC	Campbell-Ewald Co., Ltd.

◆ ◆ ◆ COMMERCIAL AM PROGRAMS ◆ ◆ ◆

PROGRAM	ADVERTISER AND PRODUCT	NETWORK	ADVERTISING AGENCY
Christian Science Monitor Views the News	Christian Science Monitor (Newspaper)	ABC	Walton Butterfield
Christmas Show	Bank of America National Trust & Savings Anns. (Banking Services)	CBS	Chas. R. Stuart Advertising
Cities Service Band of America	Cities Service Petroleum Inc. (Petroleum products)	NBC	Campbell Ewald Co.
Club 15 with Bob Crosby	Campbell Soup Co. (Soups)	CBS	Ward Wheelock Co.
Club Time	Club Aluminum Products Co. (Household utensils)	ABC	The Buchen Co.
Coke Time	Coca-Cola Co. (Coca-Cola)	NBC MBS	D'Arcy Advertising Co., Inc.
Cole, Grady Show	General Foods Corp. (Calumet, Satina)	CBS	Foote, Cone & Belding
Collingwood, Charles, News	Co-operative Sponsors	CBS	
Como, Perry Show	Liggett & Myers Tobacco Co. (Chesterfield cigarettes)	MBS	Cunningham & Walsh, Inc.
Cornell, Don, Sings	The Whitehouse Co. (Recordings)	NBC	National Mail Order Network
Coronation, The	General Motors Corp. (Institutional)	NBC	Kudner Agency
Cotton Bowl	Philco Corp. (TV Sets)	NBC	Hutchins Advertising Co.
Counterspy	Gulf Oil Corp. (All products)	NBC	Young & Rubicam, Inc.
Craig, Barrie	Co-operative Sponsors	NBC	
Craig, Stuart Show	General Products Corp. (Looz Reducing Tablets)	CBS	Dean Simmon's
Crime Classics	Chrysler Corp. (Plymouth Cars)	CBS	N. W. Ayer & Son, Inc.
Crime Files of Flamond	Co-operative Sponsors	MBS	
Crosby, Bing Show	General Electric Co.	CBS	Young & Rubicam, Inc. MacLaren Adv. Co. Ltd. (Canada) B.B.D. & O.

D

Dallas, Stella	Sterling Drug, Inc. (All products)	NBC	Dancer-Fitzgerald-Sample, Inc.
Day, Doris Show	CBS-Columbia, Inc. (TV sets, radios)	CBS	Ted Bates & Co.
Deadline	Co-operative Sponsors	MBS	
Diamond, Richard Private Detective	Rexall Drug Co. (All drug products)	CBS	B.B.D. & O.
Dial Dave Garroway	Armour & Co. (Dial Soap)	NBC	Foote, Cone & Belding, Inc.

◆ ◆ ◆ **COMMERCIAL AM PROGRAMS** ◆ ◆ ◆

PROGRAM	ADVERTISER AND PRODUCT	NETWORK	ADVERTISING AGENCY
Doctor's Wife	Ex-Lax, Inc. (Ex-Lax)	NBC	Warwick & Legler, Inc.
Drake, Galen	Co-operative Sponsors	CBS	
Drier, Alex	Skelly Oil Co. (Petroleum products)	NBC	Henri, Hurst & McDonald, Inc.
Double or Nothing	Campbell Soup Co. Soups, Franco-American Spaghetti and macaroni	NBC ABC	Ward Wheelock Co.
Dr. Christian, with Jean Hersholt	Chesebrough Mfg. Co. (Vaseline Hair Tonic, Petroleum Jelly, Lip Ice)	CBS	McCann-Erickson, Inc.
Dr. Paul	Co-operative Sponsors	NBC	
Dr. Scholl's News with Ed Pettitt	Scholl Mfg. Co. (Foot comfort appliances)	MBS	Donahue & Coe, Inc.
Dragnet	Liggett & Myers Tobacco Co. (Chesterfield Cigarettes)	NBC	Cunningham & Walsh, Inc.
Duke of Paducah	Locke Stove Co. (Stoves)	CBS	R. J. Potts, Catkins & Holden, Inc.

E

Easy Money	Roman Meal Co. (Meal, Cereal and muffin mix)	NBC	Guild Bascom & Bonfigli, Inc.
Edwards, Frank	American Federation of Labor (Institutional)	MBS	Furman, Feiner & Co., Inc.
Escape	Chrysler Corp. (Plymouth Cars)	CBS	N. W. Ayer & Son, Inc.
Ev'ry Day	Florida Citrus Industry (Fresh, canned and frozen oranges and grapefruit)	NBC	J. Walter Thompson Co.

F

Family Skeleton	The Toni Co. (Prom Home Permanent)	CBS	Leo Burnett Co.
	Manhattan Soap Co. (Sweetheart soap, Blue-White flakes)		Scheideler, Beck & Werner, Inc.
Father Knows Best	General Foods Corp. (Cereals)	NBC	Benton & Bowles, Inc.
Faultless Starch Time	Faultless Starch Co. (Starch)	NBC	Bruce B. Brewer & Co.
F. B. I. in Peace and War	Co-operative Sponsors	CBS	
Fibber McGee & Molly	Co-operative Sponsors	NBC	
First Nighter	Miller Brewing Co. (Beer)	NBC	Mathisson & Associates, Inc.
Fisher Body Award	Fisher Body Div., General Motors Corp. (Fisher bodies)	NBC	Kudner Agency, Inc.

◆ ◆ ◆ **COMMERCIAL AM PROGRAMS** ◆ ◆ ◆

PROGRAM	ADVERTISER AND PRODUCT	NETWORK	ADVERTISING AGENCY
Fisher, George Show	Colonial Dames, Inc. (Cosmetics)	CBS	Geoffrey Wade Advertising
Fisher's George Let's Go Hollywood	North American Van Lines, Inc. (Transportation and storage)	CBS	Castor & Associates
Frank & Ernest	Dawn Bible Students Ass'n. (Religious Books)	MBS	Wm. Gleeson & Co.
Front Page Farrell	Whitehall Pharmacal Co. (Aerowax, Wizard Wick, Melcalose, Chef Boy-ar-dee)	NBC	John F. Murray Advertising Agency, Inc.
Fun For All	Toni Co. (Prom Home Permanent, White Rain Shampoo)	CBS ABC	Leo Burnett Co., Inc.

G

Game of the Day	Falstaff Brewing Corp. (Beer)	MBS	Dancer-Fitzgerald-Sample, Inc.
Gangbusters	General Foods Corp. (Grape Nuts)	CBS	Young & Rubicam, Inc.
Garden Gate	Ferry-Morse Seed Co. (Seeds)	CBS	MacManus, John & Adams, Inc.
Gardiner, Don, News	Pharmaco, Inc. (Feenamint, Chooz gum)	ABC	Doherty, Clifford, Steers & Shenfield, Inc.
	Durkee Famous Foods (Margarine)		Leo Burnett Co.
G. E. Comedy Theatre (Ray Milland in Meet Mr. McNutley)	General Electric (Electronics Division)	CBS	Maxon, Inc. MacLaren Adv. Co. Ltd. (Canada)
General Electric Playhouse	General Electric Co. (Major Appliance Division)	CBS	Young & Rubicam, Inc.
Gillette Fights	Gillette Safety Razor Co. (Blue Blades, razors, shave products)	ABC	Maxon, Inc.
Give and Take	Cannon Mills, Inc. (Hosiery, sheets, towels)	CBS	Young & Rubicam, Inc.
Godfrey, Arthur Digest	Owens-Corning Fiberglas Corp. (Furniture cushion- ing, textiles, filters, insulation)	CBS	Fuller & Smith & Ross, Inc.
Godfrey's Arthur Talent Scouts	Lever Brothers Co. (Lipton's tea and soup mixes)	CBS	Young & Rubicam, Inc.
Godfrey, Arthur Sunday Hour	VCA Laboratories (Division of Rexall Drug Co., Inc.,— Rybutal, Juvenal)	CBS	Kastor, Farrell, Chesley & Clifford, Inc. Ronalds Adv. Ltd. (Canada)
Godfrey, Arthur Time	Co-operative Sponsors	CBS	
Golden Horseshoes Sweepstakes	Gillette Safety Razor Co. (Blue Blades, razors)	ABC	Maxon, Inc.

COMMERCIAL AM PROGRAMS

PROGRAM	ADVERTISER AND PRODUCT	NETWORK	ADVERTISING AGENCY
Goss, Frank, News Grand Central Station	Co-operative Sponsors Cream of Wheat Corp. (Cereals)	CBS	B.B.D. & O., Inc.
Grand Ole Opry	R. J. Reynolds Tobacco Co. (Kings, Albert Tobacco)	NBC	William Esty Co., Inc.
Grand Slam, with Irene Beasley	Continental Baking Co., Inc. (Wonder Bread, Hostess Cake)	CBS	Ted Bates & Co.
Grant, Taylor, News	P. Lorillard Co. (Old Gold Cigarettes)	ABC	Lennen and Newell, Inc.
Great Gildersleeve, The	Kraft Foods Co. (Tallay, cheeses and mustards)	NBC	Needham, Louis & Brorby, Inc.
Greatest Story Ever Told	Goodyear Tire and Rubber Co. (Institutional)	ABC	Kudner Agency, Inc.
Griffiths, Los and the News	Liggett and Myers (Crownfield Cigarettes)	ABC	Cunningham and Walsh, Inc.
Guiding Light	Procter & Gamble Co. (Tory Flakes, Duz)	CBS	Compton Advertising, Inc.
Gunsmoke	General Foods Corp. (Krinkles, Post Toasts)	CBS	Foote, Cone & Belding

H

Hallmark Playhouse and Radio Hall of Fame	Hall Bros. Inc. (Coring Cords)	CBS	Foote, Cone & Belding Spitzer & Mills, Ltd. (Canada)
Hambletonian Race	Reynolds Metals Co. (Institutional)	CBS	Buchanan & Co., Inc.
Hanlon's, Tom Press Box (Sports Review)	Regal Amber Brewing Co. (Beer)	CBS	Guild, Bascom & Bonfigli
Harmon's, Tom Pigskin Predictions	Household Finance Corp. (Personal Loan)	CBS	Needham, Louis & Brorby, Inc.
Harvey, Paul Comments	Beltone Hearing Aid Co.	ABC	Olian and Bronner, Inc.
Harvey, Paul, News	Burton-Dixie Corp. (Mattresses, sleep products)	ABC	Turner Advertising Agency
Hawk, Bob Show	R. J. Reynolds Tobacco Co. (Cameis)	CBS	Wm. Esty Co., Inc.
Hayes, Sam, News	General Mills, Inc. (Flour, cereal, formula, food)	ABC	Dancer-Fitzgerald-Sample, Inc.
Headline News	S. C. Johnson & Son, Inc. (Glidden's Glor-Glour and other products)	MBS	Needham, Louis & Brorby, Inc.
Heatter, Gabriel	Co-operative Sponsors	MBS	
Henry, Bill and the News	Johns-Manville Corp. (Industrial Products)	MBS	J. Walter Thompson Co.

◆ ◆ ◆ **COMMERCIAL AM PROGRAMS** ◆ ◆ ◆

PROGRAM	ADVERTISER AND PRODUCT	NETWORK	ADVERTISING AGENCY
Herald of Truth	Highland Church of Christ (Institutional)	ABC	Martin Co.
Hill, Edwin C.	Philco Corp. (Radios)	ABC	Hutchins Advertising Agency
Hilltop House	Miles Laboratories, Inc. (Alka-Seltzer)	CBS	Geoffrey Wade Advertising Cockfield Brown & Co., Ltd. (Canada)
Holles, Everett	S. C. Johnson & Son, Inc. (Johnson's Glo-Coat and other products)	MBS	Needham, Louis & Brorby, Inc.
Hollywood Barn Dance	Bristol-Myers Co. (Sal Hepatica, Ipana)	CBS	Young & Rubicam, Inc.
Hollywood Park Gold Cup Races	Apple Valley Inn Hotel	CBS	Swafford & Co.
Hollywood Playhouse of Romance	Andrew Jergens Co. (Lotion, face cream)	CBS	Robert W. Orr & Associates, Inc.
Hollywood Star Playhouse	American Bakers Association (Bakery Products)	NBC	Foote, Cone & Belding, Inc.
Hollywood Story	Lewis Food Co.	CBS	Rockett-Lauritzen
Hope, Bob	General Foods Corp. (Jell-o puddings, pie fillings) American Dairy Association (Dairy Products)	NBC	Young & Rubicam, Inc. Campbell-Mithun, Inc.
Hour of Decision	Billy Graham Evangelistic Assn. (Institutional)	ABC	Walter E. Bennett and Co.
Houseparty	Co-operative Sponsors	CBS	
Howdy Doody	International Shoe Co. (Poli Parrot shoes)	NBC	Henri, Hurst & McDonald, Inc.
Hunt, Jack Show	Pillsbury Mills, Inc. (Ballard Oven-Ready Biscuits)	CBS	Campbell-Mithun, Inc.

I

Inauguration Ceremonies	General Motors Corp. (Automobiles)	NBC	Kudner Agency, Inc.
Inside News from Hollywood	Hazel Bishop, Inc. (Lipstick)	NBC	Raymond Spector Co., Inc.
It Happens Every Day	The Toni Co. (Toni Creme Rinse, White Rain Shampoo)	CBS	Leo Burnett Co.
It Pays to be Married	Lewis-Howe Co. (Tums)	NBC	Ruthrauff & Ryan, Inc.
It's the Barry's	Serutan Co. (Serutan)	NBC	Edward Kletter Association

J

Jackson, Allan and the News	Metropolitan Life Insurance Co.	CBS	Young & Rubicam, Inc.
-----------------------------	--	-----	-----------------------

◆ ◆ ◆ COMMERCIAL AM PROGRAMS ◆ ◆ ◆

PROGRAM	ADVERTISER AND PRODUCT	NETWORK	ADVERTISING AGENCY
Jordan, Rocky	Ranier Brewing Co. (Beer)	CBS	Brisacher, Wheeler & Staff
	General Foods Corp. (Calumet, Post Toasties)		Foote, Cone & Belding
Junior Miss	Chrysler Corp. (Plymouth Cars)	CBS	N. W. Ayer & Son, Inc.
	The Murine Co. (Murrel)		B.B.D. & O.
Just Plain Bill	Whitehall Pharmacal Co. (Anacin, Kolyndis)	NBC	John F. Murray Advertising Agency, Inc.
	Carter Products (Little Liver Pills, Anid, Nair)		Ted Bates & Co.

K

Kentucky Derby	Gillette Co. (Shaving Cream, Razors, Blades)	CBS	Maxon, Inc.
----------------	---	-----	-------------

L

Ladies Fair	Sterling Drug Co. (Bayer Aspirin, Philips Milk of Magnesia, Dr. Lyon's tooth powder, Double Dandine, Ironic Yeast)	MBS	Dancer-Fitzgerald-Sample, Inc.
Lee, Peggy Show	General Motors Corp. (Punk Div.)	CBS	Kudner Agency, Inc.
LeSueur, Larry and the News	The Murine Co. (Murrel)	CBS	B.B.D. & O.
Lewis, Robert Q. Little Show	General Foods Corp. (Calumet, Post Toasties)	CBS	Foote, Cone & Belding
Lewis, Robert Q. Show	Milner Products Co. (Fruit Sol, Gala Bling's)	CBS	Gordon Best Co., Inc.
Life Begins at 80	Beltone Hearing Aid Co. (A.B.T.)	ABC	Olian and Bronner, Inc.
Life Can Be Beautiful	Procter & Gamble Co. (Tide)	NBC	Benton & Bowles, Inc.
Life Is Worth Living	Admiral Corp. (TV and radio receivers and amplifiers)	MBS	Erwin, Wasey & Co., Inc.
Life With Luigi	Wm. Wrigley Jr. Co. (Spearment, Chewing Gum)	CBS	Arthur Meyerhoff & Co. J. Walter Thompson Co. Ltd. (Canada)
Light and Life Hour	Free Methodist Church of North America	ABC	Walter F. Bennett and Co.
Lindlahr, Victor	Serutan Co. (Serutan)	NBC	Franklin Bruch Advertising Corp. Edward Kletter Association, Inc.
Little Brown Jug Race	Reynolds Metals Co. (Institutional)	CBS	Buchanan & Co., Inc.

COMMERCIAL AM PROGRAMS

PROGRAM	ADVERTISER AND PRODUCT	NETWORK	ADVERTISING AGENCY
Log Cabin News	General Foods Corp. (Syrup)	NBC	Benton & Bowles, Inc.
Lombardo Orchestra	American Tobacco Co. (Lucky Strike Cigarettes)	CBS	B.B.D. & O.
Lone Ranger	American Bakeries (Merita bread, cakes)	ABC	Tucker Wayne and Co.
	General Mills, Inc. (Cheerios and other products)		Dancer-Fitzgerald-Sample, Inc.
Longines Symphonette	Longines-Wittnauer Watch Co. (watches)	CBS	Victor A. Bennett Co., Inc. Desbarats Adv. Agency, Ltd. (Canada)
Lorenzo Jones	Colgate-Palmolive Co. (Fab, dental cream)	NBC	William Esty Co., Inc.
Lutheran Hour	Lutheran Laymen's League	MBS	Gotham Advertising Co., Inc.
Lux Radio Theatre	Lever Brothers, Co. (Lux Soap, flakes)	CBS	J. Walter Thompson Co. Natl. Expert Adv. Services, Inc. (Hawaii)

M

Make Up Your Mind, with Jack Sterling	Continental Baking Co., Inc. (Wonder Bread, Hostess Cake)	CBS	Ted Bates & Co.
Man on the Farm	Quaker Oats Co. (Ful-O-Pep Feed)	MBS	Sherman & Marquette, Inc.
Man on the Go	International Harvester Co. (Trucks, refrigerators, industrial farm and power equipment)	NBC	Young & Rubicam, Inc.
Manning, Knox, News Ma Perkins	Co-operative Sponsors Procter & Gamble Co. (Oxydol Detergent)	NBC CBS	Dancer-Fitzgerald-Sample, Inc.
Martin & Lewis	Liggett & Myers Tobacco Co. (Chesterfield Cigarettes)	NBC	Cunningham & Walsh, Inc.
Mason, Perry	Procter & Gamble Co. (Tide)	CBS	Benton & Bowles, Inc.
Massey, Curt Time	Miles Laboratories, Inc. (Alka-Seltzer, One-A-Day-Tablets)	CBS MBS	Geoffrey Wade Advertising Cockfield, Brown & Co., Ltd. (Canada)
Meet Corliss Archer	Electric Company's Advertising Program (Institutional)	ABC	N. W. Ayer and Son, Inc.
Meet Millie	Co-operative Sponsors	CBS	
Meet the Missus	Leslie Salt Co. (Salt)	CBS	Long Advertising Service
Meet the Music	The Whitehouse Co. (18 Top Hit Records)	CBS	Victor & Richards, Inc.
Mercer, Johnny Show	The Murine Co. (Murine)	CBS	B.B.D. & O.

COMMERCIAL AM PROGRAMS

PROGRAM	ADVERTISER AND PRODUCT	NETWORK	ADVERTISING AGENCY
Metropolitan Opera	Texas Co. (Gasoline and motor oils)	ABC	Kudner Agency, Inc.
Mexican Pan-American	Continental Mfg. Co. (Lifetimé Batteries)	CBS	W. H. Hunt Associates
Modern Romances	Ex-Lax, Inc. (Ex-Lax, jests)	ABC	Warwick & Legler, Inc.
Monday Morning Headlines	P. Lorillard and Co. (Embassy Cigarettes)	ABC	Young and Rubicam
Movie Quiz	General Mills, Inc. (Kix cereal)	MBS	Tatham-Laird, Inc.
Mr. & Mrs. North	Colgate-Palmolive-Peet Co. (Colgate Toothpaste, Halo Shampoo, Palmolive Shampoo, Veto)	CBS	Sherman & Marquette, Inc. Spitzer & Mills, Ltd. (Canada)
Mr. Information	National Biscuit Co. (Dog Biscuits)	CBS	McCann-Erickson, Inc.
Mr. Keen, Tracer of Lost Persons	Co-operative Sponsors	CBS	
Murrow, Edward R. News	Co-operative Sponsors	CBS	
Music with Hormel Girls	Geo. A. Hormel & Co. (Meats & Meat Products)	CBS	B.B.D. & O., Inc.
My Friend Irma	Co-operative Sponsors	CBS	
My Little Margie	Philip Morris Co., Ltd. (Cigarettes)	MBS	The Biow Co., Inc.
My True Story	Sterling Drug Co. Inc. (Haley's M. O., ZBT, other products)	ABC	Dancer-Fitzgerald-Sample, Inc.
Mystery Theater	Sterling Drug, Inc. (Bayer aspirin, Phillips Milk of Magnesia, Mollie Shaving Cream, other products)	ABC	Dancer-Fitzgerald-Sample, Inc.

N

National Farm & Home Hour	Allis-Chalmers Mfg. Co. (Farm Equipment)	NBC	Bert S. Gittins Advertising
National Golf Tournament	Time, Inc. (Time Magazine)	CBS	Young & Rubicam, Inc.
NBC Symphony	Socony-Vacuum Oil Co. (Instructional)	NBC	Compton Advertising, Inc.
New York Philharmonic Symphony	Willys Overland, Inc. (Willys Cars & Trucks)	CBS	Ewell & Thurber Associates Spitzer & Mills, Ltd. (Canada)
News of the World	Miles Laboratories, Inc. (Alka-Seltzer)	NBC	Geoffrey Wade Advertising
News of Tomorrow	Wine Corp. of America (Mogen David Wine)	ABC	Weiss and Geller, Inc.
Norman, Phil	Leslie of California (Toys)	CBS	M. B. Scott & Associates

◆ ◆ ◆ **COMMERCIAL AM PROGRAMS** ◆ ◆ ◆

PROGRAM	ADVERTISER AND PRODUCT	NETWORK	ADVERTISING AGENCY
Norwell Gillespie Ortho Garden Guide	California Spray Chemical Co. (Ortho Garden Sprays)	NBC	McCann-Erickson, Inc.

O

Official Detective	Co-operative Sponsors	MBS	
Old Fashioned Revival Hour	Gospel Broadcasting Assn. (Institutional)	ABC	R. H. Alber Co.
On Stage, with Cathy & Elliott Lewis	Chrysler Corp. (Plymouth Cars)	CBS	N. W. Ayer & Son, Inc.
On the Line with Bob Considine	Mutual Benefit Health & Accident Assoc. of Omaha (Insurance)	NBC	Bozell & Jacobs
One Man's Family	Miles Laboratories, Inc. (Cactine, Alka-Seltzer, Tabcin, Nervine, One-a-Day Vitamins)	NBC	Geoffrey Wade Advertising
Orange Bowl Football Game	Gillette Co. (Shaving Cream, Razors, Blades)	CBS	Maxon, Inc.
Our Gal Sunday	American Home Products Corp. (Anacin, Chef Boy-Ar-Dee Foods, Heet, Kolynos, Melaclose, Sperti Biodyne)	CBS	Young & Rubicam, Inc.
Our Miss Brooks	Colgate-Palmolive Co. (Chlorophyll Tooth Paste, Palmolive Soap, Shave Cream)	CBS	Ted Bates & Co. Spitzer & Mills, Ltd. (Canada)

P

Packard Spotlights the News	Packard Motor Co. (Cars)	ABC	Maxon, Inc.
Parson's, Louella Show	Colgate-Palmolive Co. (Lustre Creme Shampoo)	CBS	Lennen & Newell, Inc. Harry E. Foster Adv. Ltd. (Canada)
Paul, Les & Mary Ford at Home	Lambert Co. (Listerine Antizyme and Antiseptic)	CBS	Lambert & Feasley, Inc.
Pearson, Drew	Carter Products, Inc. (Arrid, Nair, Carter's Little Liver Pills)	ABC	Ted Bates and Co.
People Are Funny	Mars, Inc. (Candy Bars)	CBS	Leo Burnett Co., Inc.
	Amara Refrigeration, Inc. (Food Freezers)		Maury, Lee & Marshall
Peterson, Elmer	Co-operative Sponsors	NBC	
Philco Radio Playhouse	Philco Corp. (Radios, refrigerators, home freezer units, air conditioning units)	ABC	Hutchins Advertising Co., Inc.

COMMERCIAL AM PROGRAMS

PROGRAM	ADVERTISER AND PRODUCT	NETWORK	ADVERTISING AGENCY
Philip Morris Playhouse	Philip Morris & Co., Ltd. (Cigarettes)	CBS	The Biow Co., Inc.
Preakness Race	Schick, Inc.	CBS	Kudner Agency, Inc.
Presidential Inauguration Day Program	Packard Motor Car Co.	CBS	Maxon, Inc.
Prizefights (Carl Olson vs. Randy Turpin)	Pabst Sales Co. (Beer)	CBS	Warwick & Legler, Inc.
Progress	Chrysler Corp. (Cars)	CBS	McCann-Erickson, Inc.
Pure Oil News Time	The Pure Oil Co. (Petroleum products)	NBC	Leo Burnett Co., Inc.

Q

Queen for a Day	Co-operative Sponsors	MBS	
-----------------	-----------------------	-----	--

R

Radio Bible Class	Radio Bible Class	ABC, MBS	John M. Camp and Co.
The Railroad Hour	Association of American Railroads (Institutional)	NBC	Benton & Bowles, Inc.
Renfro Valley GATHERIN'	General Foods Corp.	CBS	Foote, Cone & Belding
Revival Time	Assemblies of God (Institutional)	ABC	Walter F. Bennett and Co.
Richfield Reporter	Richfield Oil Corp. (Gasoline, motor oil)	NBC	Hixson-Jorgensch, Inc.
Right to Happiness	Procter & Gamble Co. (Dreft, Oxydol, Pearl)	NBC	Dancer-Fitzgerald-Sample, Inc.
Ring, Bill Show	General Mills, Inc. (Tostitos, Red Star, Para-Soup, other products)	ABC	Knox Reeves Advertising
Road of Life	Procter & Gamble Co. (Crisco, Ivory Soap)	NBC CBS	Compton Advertising Inc.
Robert Q.'s Waxworks	Webster Chicago Corp. (Record Players)	CBS	Fuller & Smith & Ross, Inc.
Roberts, Dr. Oral	Healing Waters, Inc. (Institutional)	ABC	White Advertising Agency
Rogers of the Gazette	Chrysler Corp. (Plymouth Cars)	CBS	N. W. Ayer & Son, Inc.
Rogers, Roy	General Foods Corp. (Post Cereals)	NBC	Benton & Bowles, Inc.
Romance of Helen Trent	American Home Products Corp. (Auro Wax, Beautol, Black Flag, Crest, Dix-Ar-Dige Foods, Hair, Sport, Brylcreem, Wizard, Wick)	CBS	Geyer Agency
Rose Bowl (football game)	Gillette Safety Razor Co.	NBC	Maxon, Inc.
Rosemary	Procter & Gamble Co. (Ivory Soap)	CBS	Benton & Bowles, Inc.

COMMERCIAL AM PROGRAMS

PROGRAM	ADVERTISER AND PRODUCT	NETWORK	ADVERTISING AGENCY
Ross, Lanny Show	J. R. Wood & Sons, Inc. (Jewelry)	MBS	B.B.D. & O.
S			
Salute to a Star	General Products Corp. (Looz Reducing Tablets)	CBS	Dean Simmon's
Sanka Salutes with Win Elliott	General Foods Corp.	CBS	Young & Rubicam, Inc.
Santa Anita Race	Republic Van & Storage Co., Inc. (Transportation and services)	CBS	Dan Lawrence Agency
Second Chance	Lewis-Howe Co. (Tums)	NBC	Ruthrauff & Ryan, Inc.
Second Mrs. Burton	General Foods Corp. (Corn-Fetti, Instant Maxwell House Coffee, Swansdown Cake Flour)	CBS	Young & Rubicam, Inc.
Sgt. Preston of the Yukon	Quaker Oats Co. (Quaker puffed grains)	MBS	Sherman & Marquette, Inc.
Shadel, Bill and the News	Campana Sales Co. (Italian Balm, Solitair Make-up and Lipstick)	CBS	Wallace-Ferry-Hanly Co.
Shadow, The	Wildroot Co., Inc. (Wildroot toilet preparations and Frostilla lotion)	MBS	B.B.D. & O.
	Sylvania Elec. Prod. Inc. (TV and radio sets)		Roy S. Durstine, Inc.
Shore, Dinah	Chevrolet Motor Div. of General Motors Corp. (Cars, trucks, parts and services)	NBC	Campbell Ewald Co.
Silver Eagle	General Mills, Inc. (Wheaties, Cheerios, Kix, and other products)	ABC	Knox Reeves Advertising, Inc.
Six Shooter	Coleman Co., Inc. (Gas heating and household appliances)	NBC	N. W. Ayer & Son, Inc.
Skelton, Red	Co-operative Sponsors	NBC	
Sky King	Derby Foods, Inc. (Peter Pan peanut butter, salted peanuts, Derby line of canned meats and specialties)	MBS	Needham, Louis & Brorby, Inc
Smilin' Ed McConnell	Brown Shoe Co., Inc.	ABC	Leo Burnett Co., Inc.
Space Patrol	Ralston Purina Co. (Rich Chex, Ry- Krisp and other products)	ABC	Gardner Advertising Co.
Spillane, Mickey	Co-operative Sponsors	MBS	

◆ ◆ ◆ COMMERCIAL AM PROGRAMS ◆ ◆ ◆

PROGRAM	ADVERTISER AND PRODUCT	NETWORK	ADVERTISING AGENCY
Sports Today with Bill Stern	Anheuser-Busch, Inc. (Beer)	ABC	D'Arcy Advertising Co.
Sports "Ten" with Harry Wismer	Philip Morris Co. (Cigarettes and tobacco products)	MBS	The Biow Co.
Standard Hour, The	Standard Oil Co. of California (Petroleum products)	NBC	B.B.D. & O.
Stars Over Hollywood	Carnation Co. (Evaporated Milk)	CBS	Erwin, Wasey & Co., Inc.
Star Story Time	Mayflower Warehousemen's Association (Transportation and moving)	CBS	Virgil A. Warren Advertising
Stone, Paula Show	Naumkeag Steam Cotton Co. (Pocket shirts and pillow cases)	MBS	Jackson & Co.
Stroy's, Ralph Backyard	Pan American Coffee Bureau (Instantaneous) Best Foods Co. (Nuts, Mayonnaise)	CBS	Cunningham & Walsh, Inc. Benton & Bowles, Inc.
Squad Room	Co-operative Sponsors	MBS	
Strike It Rich	Colgate-Palmolive Co. (Toile, dental cream, Palmolive Soap, Fab)	NBC	William Esty Co., Inc.
Sunoco Three Star Extra	Sun Oil Co. (Oil, fuel oil, Sunoco Gas)	NBC	Hewitt, Ogilvy, Benson & Mather, Inc.
Sunshine Sue	Corn Products Sales Co. (Niagara Starch, Karo Syrup)	CBS	C. L. Miller Co., Inc.
Super Noodle Show	I. J. Grass Noodle Co., Inc. (Noodles & Soup Mix)	CBS	Phil Gordon Agency, Inc.
Suspense	Electric Auto-Lite Co. (Spark Plugs, Batteries)	CBS	Cecil & Presbrey, Inc. Ruthrauff & Ryan, Inc. (Canada) National Export Adv. Service Inc. (Hawaii)
Swayze, John Cameron	Co-operative Sponsors	NBC	

T

Take a Number	Co-operative Sponsors	MBS	
Tarzan	General Foods Corp. (Krinkles, Post Toastles)	CBS	Foote, Cone & Belding
Taylor, Mary Lee	Pet Milk Co. (Pet Milk, Sago Milk)	NBC	Gardner Advertising Co. Gillham Advertising Agency, Inc.
Telegram for You	Western Union	ABC	Albert-Frank-Gunther Law, Inc.
Tennessee Ernie	Toni Co. (Toys, Home Potpourri, Wisc Rain, Tonette)	ABC	Weiss and Geller, Inc.

◆ ◆ ◆ COMMERCIAL AM PROGRAMS ◆ ◆ ◆

PROGRAM	ADVERTISER AND PRODUCT	NETWORK	ADVERTISING AGENCY
The Evening Comes	Thomas Nelson and Sons (Revised Standard Version of the Bible)	ABC	B.B.D. & O.
The Telephone Hour	Bell Telephone System (Institutional)	NBC	N. W. Ayer & Son, Inc.
The Whistler	Signal Oil Co. (Gas, Oil)	CBS	Barton A. Stebbins Agency
The World Today	Co-operative Sponsors	CBS	
Theatre Guild on the Air	U. S. Steel Corp. (Institutional)	NBC	B.B.D. & O.
Theatre of Today	Cream of Wheat Corp. (Cereal)	CBS	B.B.D. & O.
This Farming Business	Skelly Oil Co. (Petroleum products)	NBC	Henri, Hurst & McDonald
This is Nora Drake	Co-operative Sponsors	CBS	
Thomas, Lowell, News	Co-operative Sponsors	CBS	
Thomas, Shirley from Hollywood	Lewis Food Co. (Dog and cat foods)	CBS	Rockett-Lauritzen
Thompson, Hank & His Brazos Valley Boys	Flagstaff Brewing Corp. (Beer)	MBS	Dancer-Fitzgerald-Sample, Inc.
Time for Betty Crocker	General Mills, Inc. (Flour, cake mixes)	ABC	Dancer-Fitzgerald-Sample, Inc.
Time for Love, with Marlene Dietrich	Andrew Jergens Co. (Lotion, face cream)	CBS	Robert W. Orr & Associates, Inc.
Tinney, Cal	General Mills, Inc. (Flour, cake mix, cheerios)	ABC	Dancer-Fitzgerald-Sample, Inc.
Titus, Moody	Emerson Drug Co. (Bromo-Seltzer) Wildroot Co., Inc. (Wildroot toilet preparations and Frostilla lotion)	MBS	Lennen & Newell, Inc. B.B.D. & O.
Top of the Morning	Bank of America National Trust & Savings Assn. (Banking Services)	CBS	Chas. R. Stuart Advertising
Trout, Robert	Ford Motor Co. (Cars)	CBS	J. Walter Thompson Co.
True Detective Mysteries	Motorola, Inc. (Radios and TV sets) Williamson Candy, Inc. (Oh Henry candy bars)	MBS	Aubrey, Finlay, Marley & Hodgson, Inc.
Turn to a Friend	Toni Co. (Prom Home Permanent, White Rain)	ABC	Leo Burnett Co.
Truth or Consequences	Pet Milk Co. (Evaporated Milk, Sego Milk)	NBC	Gardner Advertising Gillham Advertising Agency, Inc.
Twenty Questions	Co-operative Sponsors	MBS	
Twenty-fifth Annual Academy Awards Presentation	RCA Victor Div. (All products and services)	NBC	J. Walter Thompson Co.
21st Precinct	Chrysler Corp. (Plymouth Cars)	CBS	N. W. Ayer & Son, Inc.

COMMERCIAL AM PROGRAMS

PROGRAM	ADVERTISER AND PRODUCT	NETWORK	ADVERTISING AGENCY
Two for the Money	P. Lorillard Co. (Old Cole Cigarettes)	CBS MBS	Lennen & Newell, Inc.
U			
Utley, Clifton and the News	Onondaga Pottery Co. (China and Pottery)	NBC	Barlow Advertising Agency, Inc.
V			
Vaile, Dave, News	Metropolitan Life Insurance Co.	CBS	Young & Rubicam, Inc.
Vandercook, John W., News	Congress of Industrial Organizations (Institutional)	ABC	Henry J. Kaufman and Assoc.
Vicks News with Ed Pettitt	Vick Chemical Co. (Vicks-vough drops, syrup and VapoRub)	MBS	Morse International, Inc.
Visitin' Time	Morton Salt Co.	CBS	Klau-Van Pieterseon-Dunlap Associated, Inc.
Vitalis Warm-up	Bristol-Myers Co. (Vitalis)	MBS	Doherty, Clifford, Steers & Shenfield, Inc.
Voice of Firestone	Firestone Tire & Rubber Co. (Tires and tubes)	NBC	Sweeney & James Co.
Voice of Prophecy	Voice of Prophecy, Inc. (Religious talks)	MBS ABC	Western Advertising, Inc.
W			
Wakely, Jimmy Show	Co-operative Sponsors	CBS	
Walk a Mile	R. J. Reynolds Tobacco Co. (Camel Cigarettes)	CBS NBC	Wm. Esty Co., Inc.
Weekend	B. R. Goodrich Co. (Tires and tubes)	NBC	B.B.D. & O.
Welcome Travelers	Procter & Gamble Co. (Lava, Spic & Span, Joy, Prol, Oiler, Clorox)	NBC	The Biow Co., Inc.
Wendy Warren and the News	General Foods Corp. (Maxwell House Coffee, Post Bran Flakes)	CBS	Benton & Bowles
What's My Line?	Jules Montenier, Inc. (Dietrich)	CBS	Earle Ludgin & Co. Ronlads Adv. Agency, Ltd.
Wheaties Scoreboard	General Mills, Inc. (Wheaties)	MBS	Knox-Reeves Advertising
When a Girl Marries	Co-operative Sponsors	ABC	
Whispering Streets	General Mills, Inc. (Flour, cake mixes) Toni Co. (Prim Home Permanent)	ABC	Dancer-Fitzgerald-Sample, Inc. Leo Burnett Co., Inc.
Wild Bill Hickok	Kellogg Co. (All products)	MBS	Leo Burnett Co., Inc.
Wills, Johnnie Lee	General Mills Co., Inc. (Sperry Dry — Larro Formulated Frieds)	NBC	Zimmer-Keller & Calvert, Inc.



COMMERCIAL AM PROGRAMS



PROGRAM	ADVERTISER AND PRODUCT	NETWORK	ADVERTISING AGENCY
Winchell, Walter	Carters Products (Nair, Arrid, Rise cream) Gruen Co. (Watches)	ABC	McCann-Erickson, Inc.
Wings of Healing	Wings of Healing (Religion)	MBS	Century Advertising Agency
Wittnauer Choraliers	Longines-Wittnauer Watch Co. (Watches)	CBS	Victor A. Bennett Co., Inc. Desbarats Adv. Agency Ltd. (Canada)
Wizard of Odds	The Toni Co. (Prom Home Permanents) Manhattan Soap Co. (Sweetheart Soap, Blue-White Flakes)	CBS	Leo Burnett Co. Scheideler, Beck & Werner, Inc.
Woman in My House	Manhattan Soap Co., Inc. (Sweetheart Soap, Blu-White Flakes)	NBC	Scheideler, Beck & Werner, Inc.
Women's News Desk	Hills Brothers Coffee, Inc. (Coffee)	CBS	N. W. Ayer & Sons, Inc.
Wonderful City	Holland Furnace Co. (Furnace and furnace cleaning)	MBS	Lindeman Advertising
World Music Festivals	Willys-Overland Motors, Inc. (Willys Cars and trucks)	CBS	Ewell & Thurber Associates Spitzer & Mills, Ltd. (Canada)
World Tomorrow	Radio Church of God	ABC	Huntington, Parmelee Advertising

Y

Years of Crisis; Frank Goss, News	American Safety Razor Corp. (Silver Star Blades, Razors)	CBS	McCann-Erickson, Inc.
You Bet Your Life	DeSoto Motor Corp., Div. of Chrysler Corp. (Cars and services)	NBC	B.B.D. & O.
Young Dr. Malone	Procter & Gamble Co. (Crisco, Joy)	CBS	Compton Advertising Inc.
Young Widder Brown	Sterling Drug, Inc. (All Products)	NBC	Dancer-Fitzgerald-Sample, Inc.
Young's, Pepper Family	Procter & Gamble Co. (Ajax, Vel, toothpaste)	NBC	William Esty Co., Inc.
Your Hit Parade	American Tobacco Co. (Lucky Strike Cigarettes)	NBC	B.B.D. & O.
Your Land and Mine	General Motors Corp. (Cars and automotive services)	ABC	Kudner Agency, Inc.
Your Top Tunes	Poundex Products (Poundex)	NBC	Ruthrauff & Ryan, Inc.
Yours Truly, Johnny Dollar	Wm. Wrigley, Jr. Co. (Spearmint Chewing Gum)	CBS	Arthur Meyerhoff & Co. J. Walter Thompson Co., Ltd. (Canada)

COMMERCIAL TV PROGRAMS — 1953

(Network)

The following pages contain an alphabetical listing by program title of the four national television networks' commercial programs during 1953. The programs listed are for the 12-month period ending Dec. 31, 1953. Listing includes program title, sponsor and product, network and the advertising agency handling the account. Programs are all of 13-week duration or longer. Compilation has been made through the cooperation of ABC, CBS, DuMont and NBC.

A

TITLE	SPONSOR-PRODUCT	STATION	ADVERTISING AGENCY
Adventures of Ozzie and Harriet	Hotpoint Co. (Refrigerators, household appliances)	ABC-TV	Maxon, Inc.
	Lambert Co. (Toothpaste, antiseptic)		Lambert & Feasley, Inc.
Aldrich Family	Campbell Soup Co. (Soups)	NBC-TV	Ward Wheelock Co.
All Star Baseball Game	Gillette Safety Razor Co. (Safety Razors)	NBC-TV	Maxon, Inc.
All Star Revue	Co-operative Sponsors (Surgical Dressings, Evaporated Milk, Studebaker)	NBC-TV	
Armstrong's Circle Theatre	Armstrong Cork Co. (Linslem, building materials)	NBC-TV	Batten, Barton, Durstine & Osborn, Inc.
Autry, Gene	Wm. Wrigley, Jr. Co. (Doublemint Gum)	CBS-TV	Ruthrauff & Ryan, Inc.

B

Barber, Red	Commercial Solvents Corp. (Peak & Norway Anti-Freeze)	CBS-TV	Fuller & Smith & Ross, Inc.
Beat the Clock	Sylvania Electric Products, Inc.	CBS-TV	Cecil & Presbrey, Inc.
Benny, Jack Show	American Tobacco Co. (Newly Strike Cigarettes)	CBS-TV	B.B.D. & O.
Best of Groucho	DeSoto Div., Chrysler Corp. (Automobiles)	NBC-TV	B.B.D. & O.
Beulah	Procter & Gamble Co. (Dettol, Geydol)	ABC-TV	Dancer-Fitzgerald-Sample, Inc.
Big Town	Lever Bros. Co. (Rinso, Chlorodont, Shadow Wave)	CBS-TV	McCann-Erickson, Inc.

◆ ◆ ◆ COMMERCIAL TV PROGRAMS ◆ ◆ ◆

TITLE	SPONSOR-PRODUCT	STATION	ADVERTISING AGENCY
Blind Date	Hazel Bishop, Inc. (Cosmetics)	DuMont	Raymond Spector Co., Inc.
	The Toni Co. (Hair preparations)		Weiss & Geller, Inc.
Blue Ribbon Bouts	Pabst Sales Co. (Beer)	CBS-TV	Warwick & Legler, Inc.
Bonino	Lady Esther, Ltd. (Cosmetics)	NBC-TV	The Biow Co., Inc.
	Philip Morris & Co. Ltd. Inc. (Dunhill Cigarettes)		
Both Sides	A. F. of L. (Institutional)	ABC-TV	Furman, Feiner & Co.
Boxing from Eastern Parkway	Co-operative Sponsors	DuMont	
Break the Bank	Co-operative Sponsors (Deodorant Pads, Associated Products, Baby Foods)	NBC-TV	
Broadway to Hollywood	Tide Water Associated Oil Co. (Tydol)	DuMont	Lennen & Newell, Inc.
Buick-Berle Show	General Motors Corp. (Buick)	NBC-TV	Kudner Agency, Inc.
Buick Circus Hour	Buick Motor Div., General Motors Corp. (Automobiles)	NBC-TV	Kudner Agency, Inc.
Burns & Allen	Carnation Co. (Evaporated Milk)	CBS-TV	Erwin, Wasey & Co.
	B. F. Goodrich Co. (Tires)		B.B.D. & O.
Buttons, Red Show	General Foods Corp. (Instant Maxwell House Coffee, Gaines Dog Food)	CBS-TV	Benton & Bowles, Inc.

C

Camel News Caravan	R. J. Reynolds Tobacco Co. (Camel Cigarettes)	NBC-TV	William Esty Co., Inc.
Campbell Soundstage	Campbell Soup Co. (Soups, Pork & Beans)	NBC-TV	Ward Wheelock Co.
Candid Camera	Hazel Bishop (Cosmetics)	NBC-TV	Raymond Spector Co., Inc.
Captain Video	General Foods Corp. (Past Cereals)	DuMont	Benton & Bowles, Inc.
Cavalcade of America	E. I. DuPont de Nemours, Inc. (Institutional)	NBC-TV ABC-TV	B.B.D. & O.
Cavalcade of Sports	Gillette Safety Razor Co. (Razors, Blades)	NBC-TV	Maxon, Inc.
Chance of a Lifetime	P. Lorillard Co. (Old Gold Cigarettes, Muriel Cigars)	DuMont, ABC-TV	Lennen & Newell, Inc.
Chrysler Medallion Theatre	Chrysler Corp. (Automobiles)	CBS-TV	B.B.D. & O.
Club Embassy	P. Lorillard Co. (Tobacco Products)	NBC-TV	Lennen & Newell, Inc.

◆ ◆ ◆ COMMERCIAL TV PROGRAMS ◆ ◆ ◆

TITLE	SPONSOR-PRODUCT	STATION	ADVERTISING AGENCY
Coke Time	Coca-Cola Co.	NBC-TV	D'Arcy Agency
Colgate Comedy Hour	Colgate-Palmolive-Peet Co. (Soap, Dental Cream)	NBC-TV	Sherman & Marquette, Inc.
Colonel Humphrey Flack	American Chicle Co. (Churet, Gum) Allen B. DuMont Laboratories, Inc. (Toiletries)	DuMont	Dancer-Fitzgerald-Sample, Inc.
Comeback Story	EKCO Products Co. (Kitchen Utensils)	ABC-TV	Dancer-Fitzgerald-Sample, Inc.
Como, Perry Show	Liggett & Myers Tobacco Co. (Crestfield Cigarettes)	CBS-TV	Cunningham & Walsh, Inc.
Crosby, Bob Show	American Dairy Assn. (Milk products) Tappan Stove Co. (Stoves)	CBS-TV	Campbell-Mithun, Inc. Ketchum, McLeod & Grove, Inc.

D

Daly, John and the News	American Home Products Corp. (Anacin, Bisodol, Kalydos, Mills Cold Tablets) Realemon Puritan Co. (Flavoring juice products)	ABC-TV	The Biow Co. Schwimmer & Scott, Inc.
Danger	Block Drug Co. (Amm-D-Dent toothpaste)	CBS-TV	Cecil & Presbrey, Inc.
Ding Dong School	Co-operative Sponsors (Paper, Scotch Tape)	NBC-TV	
Dixon, Paul Show	Vitamin Corp. of America (Rybutol) River Brand Rice Mills, Inc. Scholl Manufacturing Co. (Foot Aids)	DuMont	Kastor, Farrell, Chesley & Clifford, Inc. Donahue & Coe, Inc.
Dollar A Second	Mogen David Wine Corp.	DuMont	Weiss & Geller, Inc.
Doorway to Danger	American Cigarette & Cigar Co., Inc. (Pal-Mali Cigarettes)	ABC-TV NBC-TV	Sullivan, Stauffer, Colwell & Bayles, Inc.
Double or Nothing	Campbell Soup Co. (Soups)	CBS-TV	Ward Wheelock Co.
Down You Go	Helene Curtis Industries, Inc. (Spraynet) Carter Products, Inc. (Aard, Rice, Nave)	DuMont	Ruthrauff & Ryan, Inc. Ted Bates and Co., Inc.
Douglas Edwards with the News	American Cigarette & Cigar Co. (Pal-Mali Cigarettes) General Motors (Chevrolet Cars)	CBS-TV	Sullivan, Stauffer, Colwell & Bayles, Inc. D. P. Brothier & Co.

◆ ◆ ◆ COMMERCIAL TV PROGRAMS ◆ ◆ ◆

TITLE	SPONSOR-PRODUCT	STATION	ADVERTISING AGENCY
Dragnet	Liggett & Myers Tobacco Co. (Fatima & Chesterfield Cigarettes)	NBC-TV	Cunningham & Walsh, Inc.

E

Erwin, Stu	General Mills, Inc. (Wheaties, Gold Medal flour)	ABC-TV	Dancer-Fitzgerald-Sample, Inc.
Ethel and Albert	Sunbeam Corp. (Electrical appliances)	NBC-TV	Perrin-Paus Co.

F

Faith for Today	Faith for Today, Inc. (Institutional)	ABC-TV	Rockhill Co.
Fifty Years Forward	Ford Motor Co. (Ford Division)	NBC-TV	Kenyon & Eckhardt, Inc.
Fireside Theatre	Procter & Gamble Co. (Ivory Soap, Crisco)	NBC-TV	Compton Advertising, Inc.
First Person (1st Person)	Gulf Oil Corp. (Gasoline, Oil)	NBC-TV	Young & Rubicam, Inc.
Fisher Body Craftsman's Guild Annual	Scholarship Awards Dinner (Fisher Body, Division of General Motors Corp.)	NBC-TV	Kudner Agency, Inc.
Ford Theatre	Ford Motor Co. (Automobiles, trucks)	NBC-TV	J. Walter Thompson Agency
Four Star Playhouse	Singer Sewing Machine Co.	CBS-TV	Young & Rubicam, Inc.
Froman, Jane, The Show	General Electric Lamp Division (GE Lamps)	CBS-TV	B.B.D. & O.

G

Game of the Week	Falstaff Brewing Corp. (Beer)	ABC-TV	Dancer-Fitzgerald-Sample, Inc.
Garroway, The Show	Pontiac Motor Division, General Motors (Cars, parts, service)	NBC-TV	MacManus, John & Adams, Inc.
General Electric Theater	General Electric Co. (Institutional)	CBS-TV	B.B.D. & O.
Gleason, Jackie Show	Schick, Inc. (Electric shavers) Nestle Co., Inc. (Nescafe) W. A. Sheaffer Pen Co. (Fountain Pens)	CBS-TV	Kudner Agency, Inc. Sherman & Marquette Russel M. Seeds Co.
Godfrey, Arthur and his Friends	The Toni Co. (Toni Home Permanent) Pillsbury Mills, Inc. (Cake and bread mixes)	CBS-TV	Weiss & Geller, Inc. Leo Burnett Co., Inc.

◆ ◆ ◆ COMMERCIAL TV PROGRAMS ◆ ◆ ◆

TITLE	SPONSOR-PRODUCT	STATION	ADVERTISING AGENCY
	Liggett & Myers Tobacco Co. (Chesterfield Cigarettes)		Cunningham & Walsh, Inc.
Godfrey's, Arthur Talent Scouts	Thomas J. Lipton, Inc. (Tea, soup mixes)	CBS-TV	Young & Rubicam, Inc.
Godfrey, Arthur Time	Esquire Boot Polish, Omaha Mutual Insurance, Snow Crop Frozen Food Products, Kleenex, Pepsodent Dentifrices, Toni Home Permanent, Frigidaire Home Appliances, Kellogg Cereals	CBS-TV	
Goodyear Television Playhouse	Goodyear Tire & Rubber Co. (Tires)	NBC-TV	Young & Rubicam, Inc.
Greatest Fights of the Century	Chesbrough Mfg. Co. (Vaseline Hair Tonic)	NBC-TV	Cayton, Inc.
Guiding Light	Procter & Gamble Co. (Ivory Soap, Dur Crystal)	CBS-TV	Compton Advertising, Inc.

H

Hail the Champ	Fred W. Amend Co. (Chuckles, Spice drops)	ABC-TV	Henri, Hurst & McDonald
Hallmark Theatre	Hall Bros. Inc. (Greeting Cards)	NBC-TV	Foote, Cone & Belding
Happy's Party	Florida Citrus Commission (Fruits)	DuMont	J. Walter Thompson Co.
Harvey, Paul, News	Burton-Dixie Corp. (Sleep products)	ABC-TV	Turner Advertising
Hawkins Falls	Lever Bros. Co. (Surf)	NBC-TV	N. W. Ayer & Son, Inc.
Hayes, Gabby Show	Minute Maid Corp. (Orange juice) Quaker Oats Co. (Cereal)	NBC-TV	Ted Bates & Co. Sherman & Marquette, Inc.
Hickman, Herman Show	General Cigar Co. (Robert Burns Cigars)	NBC-TV	Donahue & Coe
Hollywood Opening Night	Pearson Pharmacal Co. (Chlorophyll Tablets & Eyedrops)	NBC-TV	Harry B. Cohen Advertising Co., Inc.
Hollywood Screen Test	Ironite, Inc. (Home Appliances)	ABC-TV	Brooke, Smith, French & Dorrance, Inc.
Hope, Bob, Show	General Foods, Corp. (Minute Tapioca, Jell-O)	NBC-TV	Young & Rubicam, Inc.
Hour of Decision	Billy Graham Evangelistic Assn. (Institutional)	ABC-TV	Walter F. Bennett
Howdy-Doody	Co-operative Sponsors (Dental Cream, Bread, International shoes, Grape juice, Puddings, Cereals, Candy Bars)	NBC-TV	

◆ ◆ ◆ COMMERCIAL TV PROGRAMS ◆ ◆ ◆

I

TITLE	SPONSOR-PRODUCT	STATION	ADVERTISING AGENCY
I'll Buy That	Seeman Bros. Inc. (Airwick, Nylast)	CBS-TV	Wm. H. Weintraub & Co., Inc.
I Love Lucy, Starring Lucille Ball	Philip Morris Co. (Cigarettes)	CBS-TV	The Biow Co.
I Married Joan	General Electric (Appliances)	NBC-TV	Young & Rubicam, Inc.
Inspector Mark Sabre	Sterling Drug Co. (Bayer Aspirin, Phillips Milk of Magnesia)	ABC-TV	Dancer-Fitzgerald-Sample, Inc.
I've Got a Secret	R. J. Reynolds Tobacco Co. (Cavalier Cigarettes)	CBS-TV	Wm. Esty Co., Inc.

J

Jamie	Duffy-Mott Co., Inc. (Mott apple products)	ABC-TV	Young & Rubicam
	EKCO Products Co. (Kitchen Utensils)		Dancer-Fitzgerald-Sample, Inc.
Jessel, George Show	Co-operative Sponsors	ABC-TV	
Judge for Yourself	P. Lorillard Co.	NBC-TV	Lennon & Newell, Inc.
Juvenile Jury	Pharmaceuticals, Inc. (Geritol)	CBS-TV NBC-TV	Edward Kletter Associates, Inc.
	Serutan Co. (R.D.X.)		

K

Keep Posted	Curtis Publishing Co. (Saturday Evening Post)	DuMont	B.B.D. & O.
Kraft Television Theatre	Kraft Foods Co. (Kraft cheeses and other products)	NBC-TV ABC-TV	J. Walter Thompson Co.
Kukla, Fran and Ollie	Radio Corp of America (R.C.A. Products and/or Service)	NBC-TV	J. Walter Thompson Agency

L

Lash of the West	Reymer & Bros. Inc. (Soft drinks)	ABC-TV	Ketchum, McCleod & Grove
Leave It to the Girls	Ex-Lax, Inc. (Ex-Lax, Jests)	ABC-TV	Warwick & Legler, Inc.
Letter to Loretta	Procter & Gamble (Tide)	NBC-TV	Benton & Bowles, Inc.
Life Begins at Eighty	The Serutan Co. (Serutan, Geritol)	DuMont	Edward Kletter Associates, Inc.
Life is Worth Living	Admiral Corp. (Household appliances)	DuMont	Erwin, Wasey & Co., Inc.
Life with Father and Mother	S. C. Johnson & Son, Inc. (Cleaners)	CBS-TV	Needham, Louis & Brorby, Inc.

◆ ◆ ◆ COMMERCIAL TV PROGRAMS ◆ ◆ ◆

TITLE	SPONSOR PRODUCT	STATION	ADVERTISING AGENCY
Life With Riley	Gulf Oil Corp	NBC-TV	Young & Rubicam, Inc.
Linkletter's Art House Party	Green Giant Co Lever Bros Pillsbury Mills, Inc Kellogg Co	CBS-TV	Leo Burnett Co., Inc B B D & O Leo Burnett Co., Inc.
Live Like a Millionaire	Charles Antell, Inc	ABC-TV	Television Advertising Associates
Lone Ranger	General Mills, Inc	CBS-TV ABC-TV	Dancer-Fitzgerald-Sample, Inc. Knox Reeves Advertising, Inc
Longines Chronoscope	Longines-Wittnauer Watch Co.	CBS-TV	Victor A. Bennett Co.
Longines-Wittnauer Christmas Day Festival	Longines-Wittnauer Watch Co.	CBS-TV	Victor A. Bennett Co.
Longines-Wittnauer Thanksgiving Day Festival	Longines-Wittnauer Watch Co.	CBS-TV	Victor A. Bennett Co.
Lov of Life	American Home Products Corp.	CBS-TV	The Brow Co., Inc
Lux Video Theatre	Lever Bros. Co	CBS-TV	J. Walter Thompson Co

M

Mack's, Ted Original Amateur Hour	Pet Milk Co.	NBC-TV	Gardner Advertising Co
Make Room for Daddy	American Tobacco Co Speidel Corp	ABC-TV	B B D & O Sullivan, Stauffer, Colwell & Bayles, Inc
Mama	General Foods Corp.	CBS-TV	Benton & Bowles, Inc
Man Against Crime	R. J. Reynolds Tobacco Co.	NBC-TV, DuMont	William Esty Co., Inc
Man Behind the Badge	Bristol Myers Co.	CBS-TV	Doherty, Clifford, Steers & Shenfield, Inc
March of Medicine	Smith, Kline & French Laboratories	NBC-TV	Doremus-Eshleman Co
Martin Kane	United States Tobacco Co.	NBC-TV	Kudner Agency, Inc.
Meet Mr. McNutley	General Electric Co	CBS-TV	Maxon, Inc

◆ ◆ ◆ COMMERCIAL TV PROGRAMS ◆ ◆ ◆

TITLE	SPONSOR-PRODUCT	STATION	ADVERTISING AGENCY
Meet the Press	Revere Copper & Brass Inc. (Copper, Brass, Steel Products)	NBC-TV	St. Georges & Keyes, Inc.
Meet Your Congress	Benrus Watch Co.	Dumont	Cecil & Presbrey, Inc.
Montgomery, Robert Presents	S. C. Johnson & Sons, Inc. (Polishes)	NBC-TV	Needham, Louis & Brorby, Inc.
Montgomery, Robert Presents Your Lucky Strike Theatre	American Tobacco Co. (Lucky Strike Cigarettes)	NBC-TV	B.B.D. & O.
Moore, Garry Show	Ballard Biscuits, Rit, Shinola, Gro-Pup, Hoover Vacuum Cleaners, Masland Rugs, Cat's Paw Heels, Uncle Ben's Converted Rice, Swift'ning, Norge Products, Purex Dry Bleach	CBS-TV	
Motorola TV Theatre	Motorola, Inc. (Radios and TV receivers)	ABC-TV	Ruthrauff & Ryan, Inc.
Mr. Peepers	Reynolds Metals Co. (Aluminum & Aluminum Products)	NBC-TV	Russell M. Seeds Co.
Murray, Arthur Dance Party	Consolidated Royal Chemical Corp. Arthur Murray School of Dancing	NBC-TV DuMont	Dancer-Fitzgerald-Sample, Inc. Ruthrauff & Ryan, Inc.
My Favorite Husband	International Silver Co. (Silverware) Simmons Co. (Beauty-Rest, Hide-A-Bed)	CBS-TV	Young & Rubicam, Inc.
My Friend Irma	Brown & Williamson Tobacco Corp. (Kool Cigarettes)	CBS-TV	Ted Bates & Co.
My Hero	Philip Morris & Co., Ltd. (Cigarettes)	NBC-TV	Biow Co., The
My Little Margie	Scott Paper Co.	NBC-TV	j. Walter Thompson Agency

N

Name's the Same	American Chicle Co. (Chiclets)	ABC-TV	Dancer-Fitzgerald-Sample, Inc.
	S. C. Johnson & Son, Inc. (Waxes)		Needham, Louis & Brorby, Inc.
	C. A. Swanson & Sons (Canned and frozen meat products)		Tatham & Laird
N.C.A.A. Football Game	General Motors Corp.	NBC-TV	Kudner Agency, Inc.

O

Oldsmobile Press Box Review	General Motors Corp. (Oldsmobile Division)	NBC-TV	
-----------------------------	---	--------	--

◆ ◆ ◆ COMMERCIAL TV PROGRAMS ◆ ◆ ◆

TITLE	SPONSOR-PRODUCT	STATION	ADVERTISING AGENCY
Omnibus	American Machine & Foundry Co. (Machinery) Greyhound Corp. (Transportation) Scott Paper Co. (Cut-Kee and Scotties)	CBS-TV	Fletcher D. Richards, Inc. Beaumont & Hohman, Inc. J. Walter Thompson Co.
On The Line With Considine	Mutual Benefit Health & Accident Assoc. of Omaha	NBC-TV	Ted Bates & Co.
On Your Account On Your Way	Procter & Gamble Welch Wine Div., Quality Importers, Inc. (Welch's Wine)	NBC-TV DuMont	Benton & Bowles Monroe Greenthal, Inc.
Orchid Award	Brown & Williamson Tobacco Corp. (Viceroy Cigarettes)	ABC-TV	Ted Bates
Our Miss Brooks	General Foods Corp. (Swandown Flour, Sanka, Instant Sanka Coffee)	CBS-TV	Young & Rubicam, Inc.

P

Palm Beach Golf Tournament	Palm Beach Co. (Men's Suits)	DuMont	Ruthrauff & Ryan, Inc.
Pantomime Quiz	Benson & Hedges, Inc. (Parliament Cigarettes)	DuMont	Benton & Bowles, Inc.
Pepsi-Cola Playhouse	Pepsi-Cola Co.	ABC-TV	The Biow Co.
Person to Person	American Oil Co. (Amoco Gasoline)	CBS-TV	The Joseph Katz Co.
	Hamm Brewing Co. (Beer - midwest)		Campbell-Mithun, Inc.
Philco Television Playhouse	Philco Corp. (Radios, TV Sets, Refrigerators)	NBC-TV	Hutchins Advertising Co., Inc.
Philip Morris Playhouse	Philip Morris & Co. (Cigarettes)	CBS-TV	The Biow Co., Inc.
Place the Face	The Toni Co. (Prom, White-Kain Shampoo)	CBS-TV	Leo Burnett Co., Inc.
	Carter Products, Inc. (Arnold, Rise, Nair)	NBC-TV	Sullivan, Stauffer, Colwell & Bayles, Inc.
Plainclothes Man	Larus and Brother, Co., Inc. (Holiday Cigarettes, Edgeworth Tobacco)	DuMont	Warwick & Legler, Inc.
	Carter Products (Arnold, Rise, Nair)		Ted Bates & Co., Inc.
Plymouth Playhouse	Plymouth Div. of Chrysler Corp. (Cars)	ABC-TV	N. W. Ayer & Son, Inc.
Peter Potter Show	Hazel Bishop (Cosmetics)	ABC-TV	Raymond Spector Co., Inc.
Pride of the Family	Armour & Co. (Dial soap and shampoo) Bristol-Myers Co. (Ipana, Vitalis)	ABC-TV	Foote, Cone & Belding Young & Rubicam

◆ ◆ ◆ **COMMERCIAL TV PROGRAMS** ◆ ◆ ◆

TITLE	SPONSOR-PRODUCT	STATION	ADVERTISING AGENCY
Private Secretary	American Tobacco Co. (Lucky Strike Cigarettes)	CBS-TV NBC-TV	B.B.D. & O.
Professional Football Games	Standard Oil Co. of Indiana (Gas and oil)	ABC-TV	McCann-Erickson
Professional Football Games	Westinghouse Electric Corp. (Household appliances)	DuMont	Ketchum, MacLeod & Grove, Inc.
	Miller Brewing Co. (Beer)		Mathisson & Associates, Inc.
	Brewing Corp. of America (Red Cap Ale)		Lang, Fisher & Stashower, Inc.
Professional Football Games	Wm. B. Scull Co. (Boscull Coffee)	DuMont	Lamb & Keen, Inc.
	Pittsburgh Zone Chevrolet Dealers (Cars)		Ketchum, MacLeod & Grove, Inc.
	Chester Ford Dealers (Cars)		J. Walter Thompson Co.

Q

Quick as a Flash	EKCO Products Co. (Kitchen Utensils) Thor Corp. (Washing Machines)	ABC-TV	Dancer-Fitzgerald-Sample, Inc. Henri, Hurst & McDonald
------------------	---	--------	---

R

R. C. A. Victor Show Starring Dennis Day	Radio Corp. of America (Radios, TV sets, record players)	NBC-TV	J. Walter Thompson Agency
Rebound	Packard Motor Cor Co. (Cars)	DuMont	Maxon, Inc.
Revlon Mirror Theatre	Revlon Products Corp.	CBS-TV, NBC-TV	W. H. Weintraub Co., Inc.
Riviers Show	Roto-Broil Corp. (Broiler)	DuMont	Product Services, Inc.
Rocky King, Detective	American Chicle Co. (Clorets Gum)	DuMont	Dancer-Fitzgerald-Sample, Inc.
	Kreisler Manufacturing Co. (Watch Bands)		Foote, Cone & Belding, Inc.
	Pharmaceuticals, Inc. (Drug Products)		Edward Kletter Associates, Inc.
	Procter & Gamble, Inc. (Ivory Flakes)		Compton Advertising Co.
Rod Brown Rocket Ranger	General Foods Corp.	CBS-TV	Young & Rubicam, Inc.
Rootie Kazootie	Gordon Baking Co. (Silvercup bread)	ABC-TV	N. W. Ayer & Sons
	Walter H. Johnson Candy Co. (Power House candy bars)		Franklin Bruck Adv.
Rose Bowl Game	Gillette Safety Razor Co.	NBC-TV	Maxon, Inc.

◆ ◆ ◆ COMMERCIAL TV PROGRAMS ◆ ◆ ◆

TITLE	SPONSOR-PRODUCT	STATION	ADVERTISING AGENCY
Roy Rogers Show	General Foods Corp. (Crape Nuts, Pop Toasties, Sugar crisp)	NBC-TV	Benton & Bowles, Inc.
S			
Saturday Nite Fights	Bayuk Cigars, Inc. (Phillies, Webster cigars)	ABC-TV	Ellington Adv Agency
	S. C. Johnson & Son, Inc. (Wax products)		Needham, Louis & Brorby
Saturday Night Revue	Benrus Watch Co. Griffin Manufacturing Co. (Shoe polish)	NBC-TV	Cecil & Presbrey, Inc. Birmingham, Castleman & Pierce, Inc.
	Bendix Home Appliances		Earl Ludgin & Co.
Saturday Night Wrestling	Co-operative Sponsors	DuMont	
Search for Tomorrow	Procter & Gamble Co. (Joy, Spic & Span)	CBS-TV	The Biow Co., Inc.
See It Now	Aluminum Co. of America (Alcoa Aluminum products)	CBS-TV	Fuller & Smith & Ross, Inc.
Schlitz Playhouse of Stars	Schlitz Brewing Co. (Beer and Ale)	CBS-TV	Lennen & Newell, Inc.
Scott Music Hall	Scott Paper Co.	NBC-TV	J. Walter Thompson Agency
Shore, Dinah Show	Chevrolet Motor Div., General Motors (Cars, trucks, parts, service)	NBC-TV	Campbell-Ewald Co
Short, Short Drama	Pepsi-Cola Co.	NBC-TV	The Biow Co., Inc.
Skelton, Red Show	Pharmaceuticals, Inc. (Genital)	CBS-TV	Edward Kletter Associates, Inc.
	Procter & Gamble (Tide)	NBC-TV	Benton & Bowles, Inc.
Sky King	Derby Foods, Inc. (Peter Pan peanut butter)	ABC-TV	Needham, Louis & Brorby
Smilin' Ed McConnell	Brown Shoe Co., Inc. (Buster Brown shoes)	ABC-TV	Leo Burnett Co., Inc
Smith, Kate Show	Co-operative Sponsors (Drugs, Foods, Household Products)	NBC-TV	
Space Patrol	Ralston-Purina Co. (Rice-Chex, Wheat- Chex, Ry Kisp)	ABC-TV	Gardner Adv. Agency
Speidel Show	Speidel Corp. (Watch bands)	NBC-TV	Sullivan, Stauffer, Colwell & Bayles, Inc.
Sports Reel	Gillette Safety Razor Co.	NBC-TV	Maxon, Inc.
Sports Showcase	Boyle-Midway, Inc. (Waxes and Polishes)	DuMont	Geyer Advertising, Inc.
Sports Spot	General Cigar Co. (White Owl Cigars)	CBS-TV	Young & Rubicam, Inc
Strike It Rich	Colgate-Palmolive- Peet Co. (Soaps, cosmetics)	CBS-TV	Wm. Esty Co., Inc

◆ ◆ ◆ COMMERCIAL TV PROGRAMS ◆ ◆ ◆

TITLE	SPONSOR-PRODUCT	STATION	ADVERTISING AGENCY
Studio One	Westinghouse Electric Corp. (Kitchen appliances, radio, TV sets, Turbojet plane motors)	CBS-TV	McCann-Erickson, Inc.
Summer Theatre	Lambert Co. (Listerine products)	ABC-TV	Lambert & Feasley
Sunday News Special	Norwich Pharmacal Co. (Pepto Bismol, Unguentine, Teedk)	CBS-TV	Benton & Bowles, Inc.
Super Circus	California Fruit Growers Exch. (Sunkist fruit)	ABC-TV	Foote, Cone & Belding
	Kellogg Co. (Cereals)		Leo Burnett Co., Inc.
	Mars, Inc. (Candy)		
Suspense	Electric Auto-Lite Co. (Spark plugs, auto accessories)	CBS-TV	Cecil & Presbrey, Inc.

T

Talent Patrol	U. S. Army (Institutional)	ABC-TV	
Tales of Tomorrow	Jacques Kreisler Mfg. Corp. (Watchbands)	ABC-TV	Hirshon-Garfield, Inc.
Texaco Star Theatre	The Texas Co.	NBC-TV	Kudner Agency, Inc.
The Big Payoff	Colgate-Palmolive- Peet Co. (Toilet articles, soap)	CBS-TV NBC-TV	Wm. Esty Co., Inc. Ted Bates Co., Inc.
The Big Story	American Cigarette & Cigar Co. (Pall Mall Cigarettes)	NBC-TV	Sullivan, Stauffer, Colwell & Bayles, Inc.
The Big Top	National Dairy Products Co. (Sealtest dairy products)	CBS-TV	N. W. Ayer & Son, Inc.
The Doctor	Procter & Gamble Co. (Camay)	NBC-TV	Benton & Bowles, Inc.
The Goldbergs	Radio Corp. of America (RCA Products)	NBC-TV	J. Walter Thompson Co.
The Web	P. Lorillard Co. (Kent Cigarettes)	CBS-TV	Young & Rubicam, Inc.
This is My Melody	A. C. Weber & Co. (Pfaff sewing machines)	ABC-TV	Bozell & Jacobs, Inc.
This Is Show Business	Carter Products Co. (Little Liver Pills, Arrid, Nair, Rise)	CBS-TV	Sullivan, Stauffer, Colwell & Bayles, Inc.
	Schick, Inc. (Electric shavers)		Kudner Agency, Inc.
This Is Your Life	Hazel Bishop, Inc. (Cosmetics)	NBC-TV	Raymond Spector Co., Inc.

◆ ◆ ◆ COMMERCIAL TV PROGRAMS ◆ ◆ ◆

TITLE	SPONSOR-PRODUCT	STATION	ADVERTISING AGENCY
Those Two	Procter & Gamble Co. (Tide, Drene, Camay)	NBC-TV	Benton & Bowles, Inc.
Toast of the Town	Lincoln-Mercury Dealers (Cars)	CBS-TV	Kenyon & Eckhardt, Inc.
Today	Co-operative Sponsors	NBC-TV	
Tom Corbett, Space Cadet	International Shoe Co. (Red Goose Shoes)	DuMont	D'Arcy Advertising Co.
Tootsie Hippodrome	Sweets Co. of America, Inc. (Tootsie Rolls)	ABC-TV	Moselle & Eisen
Top Stake Horse Races	Gillette Safety Razor Co.	NBC-TV	Maxon, Inc.
Topper	R. J. Reynolds Tobacco Co. (Camel Cigarettes)	CBS-TV	Wm. Esty Co., Inc.
Touchdown Thrills of All Time	Parker Pen Co. (Pens)	DuMont	J. Walter Thompson Co.
Treasury Men in Action	The Borden Company (Instant Coffee)	NBC-TV	Doherty, Clifford, Steers & Shenfield, Inc.
TV Teen Club	Sweets Co. of America, Inc. (Tootsie Rolls)	ABC-TV	Moselle & Eisen
Twenty Questions	Bauer & Black (Card Plastic Luggage)	DuMont	Leo Burnett Co., Inc.
Two for the Money	P. Lorillard Co. (Old Gold Cigarettes)	CBS-TV NBC-TV	Lennen & Newell, Inc.

U

U. S. Steel Hour	U. S. Steel Corp. (Institutional)		B.B.D. & O.
------------------	--------------------------------------	--	-------------

V

Valiant Lady	General Mills, Inc. (Coke and biscuit mixes)	CBS-TV	Knox Reeves Advertising Co.
	The Toni Co. (Prom, White Rain Shampoo)		Leo Burnett Co., Inc.
Vacation Land America	Pram Corp.	NBC-TV	Van Sant Dugdale, Inc.
Voice of Firestone	Firestone Tire & Rubber Co. (Tires, valves, batteries)	NBC-TV	Sweeney & James Co.

W

Waring, Fred Show	General Electric Co. (Institutional)	CBS-TV	B.B.D. & O.
Welcome Travelers	Procter & Gamble Co. (Pam, Ivory Soap)	NBC-TV	Dancer-Fitzgerald-Sample, Inc.
	EKCO Products Co. (Cutlery)		
What's My Line?	Jules Montenier, Inc. (Stoppette, Pool, Finisar)	CBS-TV	Earle Ludgin & Co.
	Remington Rand, Inc. (Electric Shavers)		Young & Rubicam, Inc.

◆ ◆ ◆ COMMERCIAL TV PROGRAMS ◆ ◆ ◆

TITLE	SPONSOR-PRODUCT	STATION	ADVERTISING AGENCY
What's My Name?	Crosley Div. Avco Mfg. Corp. (Electrical appliances)	NBC-TV	Benton & Bowles, Inc.
What's the Story?	Allen B. Dumont Laboratories, Inc. (DuMont Telesets)	DuMont	
What's Your Bid?	Charles Antell, Inc. (Hair Preparations)	DuMont ABC-TV	Television Advertising Associates
Where's Raymond?	American Cigarette & Cigar Co., Inc. (Pall Mall Cigarettes)	ABC-TV	Sullivan, Stauffer, Colwell & Bayles, Inc.
	Sherwin-Williams Co. (KemTone)		Fuller, Smith & Ross, Inc.
Winchell, Paul Show	Procter & Gamble (Cheer)	NBC-TV	Young & Rubicam, Inc.
Walter Winchell	Carter Products, Inc. (Arrid, Nair, Rise)	ABC-TV	Sullivan, Stauffer, Colwell & Bayles, Inc.
	Gruen Watch Co. (Watches)		McCann-Erickson, Inc.
Window on Washington	Sunbeam Corp.	NBC-TV	Perrin-Paus Co.
World Series	Gillette Safety Razor Co.	NBC-TV	Maxon, Inc.

Y

You Are There	Electric Companies Advertising Program Prudential Insurance Co.	CBS-TV	N. W. Ayer & Son Calkins & Holden, Carlock McClinton & Smith
You Asked for It	Rosefield Packing Co., Ltd. (Skippy Peanut Butter)	ABC-TV	Guild, Bascom & Bonfigli, Inc.
You Bet Your Life	DeSoto Division, Chrysler Corp. (Automobiles)	NBC-TV	B.B.D. & O.
Your Hit Parade	American Tobacco Co.	NBC-TV	B.B.D. & O.
Your Pontiac Scoreboard	Pontiac Motor Div., General Motors Corp. (Automobiles)	NBC-TV	MacManus, John & Adams, Inc.
Your Show of Shows	Benrus Watches, Griffin Shoe Polish, Lysol, Hind's Cream, Prudential Insurance, Camel Cigarettes, S. O. S. Cleanser, Adolph's Meat Tenderizer, Bristol-Myers Products, Cats Paw Rubber Heels, Samsonite Luggage and Furniture, Tums, Johnson & Johnson Surgical Dressings	NBC-TV	
Youth on the March	Young People's Church of the Air	DuMont	J. M. Camp, Inc.

Z

Zoo Parade	Quaker Oats Co.	NBC-TV	Needham, Louis & Brorby, Inc.
------------	-----------------	--------	-------------------------------

RADIO-TV EDITORS

*The nation's radio and TV broadcasters in response to
questionnaires sent out by Radio-Television Daily
contributed the accompanying list of editors.*

— A —

MITCHESON, MARION
Herald
Miami, Fla.

ALLEN, BILL
Reporter
Bethle N. H.

AMES, WALTER
Times
Los Angeles, Cal.

ANDERSON, PAUL
Daily Journal
International Falls, Minn.

ANDERSON, STANLEY
Press
Cleveland, O.

APPEL, DAVID
Inquirer
Phila., Pa.

ARMSTRONG, JAMES
Illinois State Register
Springfield, Ill.

MICHER, BILLY
Jacksonville News And Views
Jacksonville, N. C.

— B —

BARBOUR, GEORGE
Star
Portsmouth, Va.

BARRA, JOHN
WDNO, Durham, N. C.

BARTON, BILL
Daily News
Dayton, O.

BEAMISH, JAMES F.
Review
Carbondale, Pa.

BEAUMONT, JAMES N.
Herald And Review
Beaufort, Ill.

BECKER, FRED
Evening Independent
Masonville, O.

BENNY, J. EDWARD
Altoona Mirror
Altoona, Pa.

BERRIGAN, THOMAS J.
Niagara Falls Gazette
WILD, Niagara Falls, N. Y.

BETTA, LEO BELLA
Tucson Daily Star
Tucson, Arizona

BODIE, WINSTON
Press
Houston, Texas

BOLL, JENNE
Daily Times
Davenport, Iowa

BOWEN, T. C.
Herald
Huntsville, Ga.

BOYD, DON
Janesville Gazette
Janesville, Wisc.

BOYD, PATRICIA
Post-Journal
Jamestown, N. Y.

BRADY, NANCY
Charleston Gazette
Charleston, W. Va.

BRANDSOKFER, AL
Evening Sentinel
Holland, Mich.

BRASWELL, SAM
Times
Kerrville, Tex.

BRIGHT, RED
Democrat Chronicle
Rochester, N. Y.

BROOKHAUSER, FRANK
Bulletin
Phila., Pa.

BROOKS, ED
Times-Picayune
New Orleans, La.

BROOKS, ELSTON
El Worth Star Tribune
El Worth, Texas

BROWN, BOB
Ledger
Columbus, Ga.

BURDICK, RENE
Morning Dispatch
Moline, Ill.

BURDINE, BILL
Union City Messenger
Union City, Tenn.

BURGESS, BOB
Journal
Ottawa, Ont.

BYRNE, ED
Sun
Jamestown, N. Y.

— C —

CAHILL, CARL
Ledger Dispatch
Norfolk, Va.

CALDWELL, LILA MAX
News
WBRC, Birmingham, Ala.

CALLAN, OWEN
Herald-Express
Los Angeles, Cal.

CANNON, AIVAN
Mobile Press-Register
Mobile, Ala.

CAREA, WILLIAM
Scranton Tribune
Carbondale, Pa.

CARNE, EDWARD F.
Free Press
Burlington, Vt.

CARROLL, TIM
Morning News
Dallas, Tex.

CARTER, LUCIA
WMAQ, Chicago, Ill.

CERRA, FRANK
Scranton Times
Carbondale, Pa.

CHITTENDEN, ED
Keeney Daily Hub
Keamey, Neb.

CHRISTIANO, AL
Sun
WBEC, Rochester, N. Y.

COHEN, HAROLD
Post-Gazette
Pittsburgh, Pa.

COHEN, JERRY
Louisville Times
Louisville, Ky.

COLLINS, RIP
Evening Sentinel
WBTC, Holland, Mich.

COLTIN, WENDELL
Gazette
Haverhill, Mass.

CONDON, GEORGE
Plan Dealer
Cleveland, Ohio

COSGROVE, IRENE
Advocate, Newark, Ohio

COTTON, PAUL
Register & Tribune
Des Moines, Iowa

CULL, KEMER
The Evening Bulletin
Phila., Pa.

CELLISON, ART
Beacon Journal
Albion, O.

CURTIS, ANN
Canton Repository
Canton, O.

CAENGRON, KATHLEEN
Times
Indianapolis, Ind.

— D —

DARR, BERT
Call Bulletin
San Francisco, Cal.

DAVID, HAL
Barlow Herald
Cartersville, Ga.

DAVIDSON, E. O.
El Payne Journal
El Payne, Ala.

DAVIS, BOB
Times
Scranton, Pa.

DAVIS, CHARLES
Times Union
Albany, N. Y.

DERA, CLAUDE
CHIEF, Granby, Que.

DEANE, JAMES
The Cincinnati Enquirer
Cincinnati, O.

DIESPECKER, DICK
Province
Vancouver, B. C.

DINAN, PATSY
Amarillo Globe News
Amarillo, Texas

DOBENS, FRED H.
 Telegraph
 WOTW. Nashua, N. H.

DORN BROOK, DON
 Milwaukee Journal
 Milwaukee, Wisc.

DOUDNA, BILL
 Wisconsin State Journal
 Madison, Wisc.

DOWNER, J. A.
 Times News Era
 Ft. Payne, Ala.

DRISCOLL, VINCENT
 Gazette
 Haverhill, Mass.

DUNCIL, CHARLES
 The Fairmont Times
 Fairmont, W. Va.

DYER, WM.
 News-Dispatch
 Shamokin, Pa.

— E —

EISENHOWER, JOE
 News
 Frederick, Maryland

ELYOT, GENE
 KLAS
 Las Vegas, Nev.

EMHAUSER, BOB
 Chronicle
 Spokane, Wash.

ENKING, MINNIE
 Beloit Daily News
 Beloit, Wisc.

— F —

FAHR, JOHN
 Tucson Daily Citizen
 Tucson, Arizona

FAIRWEATHER, JAMES
 Reedley Exponent
 Reedley, Cal.

FANNING, WIN
 Post Gazette
 Pittsburgh, Pa.

FERGUSTON, E. C.
 Mail Tribune
 Medford, Oregon

FINDEISEN, PAUL
 Star-Bulletin
 Honolulu, Hawaii

FISHBACK, JOHN W.
 Denver Time
 Denver, Colo.

FITZGERALD, TOMMY
 Courier Journal
 Louisville, Ky.

FLANNELLY, S.
 Las Vegas Sun
 Las Vegas, Nev.

FLORES, J.
 Daily News
 Agana, Guam

FOOTE, GRACE
 Port Arthur News
 Port Arthur, Texas

FREEMAN, DON
 San Diego Union
 San Diego, Cal.

— G —

GAGHAN, JERRY
 Daily News
 Philadelphia, Pa.

GAIGE, JERRY
 Herald-Journal
 Syracuse, N. Y.

GEARHART, ART
 Call-Chronicle
 Allentown, Pa.

GEORGE, JAMES
 Philadelphia Inquirer
 Philadelphia, Pa.

GERRITY, EDWARD J.
 The Scranton Times
 Scranton, Pa.

GIANAKOS, GEORGIA
 News
 Indianapolis, Ind.

GILMARTIN, THOMAS
 Daily News
 Carbondale, Pa.

GOODHEART, JOAN
 Sun
 Jamestown, N. Y.

GORDON, JACK
 Press
 Ft. Worth, Tex.

GOULD, TOM
 WHAM, Rochester, N. H.

GRAHAM, GORDON
 Journal Courier
 Lafayette, Ind.

GRAY, GEORGE
 Uniontown Standard
 Uniontown, Pa.

GRAY, HARVEY
 Springfield Papers
 Springfield, Mass.

— H —

HADLEY, JACK
 Times Union
 Rochester, N. Y.

HAGER, LARRY
 Messenger
 Owensboro, Ky.

HALL, BOB
 Call Bulletin
 San Francisco, Cal.

HALL, JACK
 Post-Journal
 Jamestown, N. Y.

HALL, W. EARL
 Globe Gazette
 Mason City, Iowa

HAMBY, CECIL
 Advance
 Vidalia, Ga.

HAMMERSON, CLAUDE
 Citizen
 Ottawa, Ont.

HARBAUGH, WILLIAM
 Gettysburg Times
 Gettysburg, Pa.

HARRIS, BOB
 Illinois State Journal
 Springfield, Ill.

HARRIS, HARRY
 Evening Bulletin
 Philadelphia, Pa.

HARRIS, MARY ANN
 Post
 Houston, Tex.

HARRISON, BERNIE
 Times Herald
 Washington, D. C.

HART, HERSCHELL
 News
 Detroit, Mich.

HAYNES, ANN
 Chronicle
 Houston, Tex.

HERZOG, BUCK
 Journal
 Milwaukee, Wisc.

HILL, JERRY
 Daily Times Herald
 Dallas, Texas

HITCH, BILL
 Star-Telegram
 Ft. Worth, Tex.

HOGLE, W.
 Daily News
 Medicine Hat, Alta.

HARRIGAN, AL
 KFGO, Fargo, N. D.

HOSTETTER, WM.
 Daily Telegraph
 Bluefield, W. Va.

HOVEMEYER, HENRY L.
 Delaware Republican
 Delhi, N. Y.

HOYLAND, BOB
 Kansas City Star
 Kansas City, Mo.

HULL, BOB
 Herald Express
 Los Angeles, Cal.

HUMPHREY, HAL
 Mirror
 Los Angeles, Cal.

HUNT, MARSHALL
 Daily Olympian
 Olympia, Wash.

— J —

JACKSON, EMMETT
 News Examiner
 Connersville, Ind.

JACKSON, J. ROY
 Drive in News
 Fulton, Mo.

JAHN, BILL
 Post Intelligencer
 Seattle, Wash.

JAMES, BURT
 Daily Tribune
 Hastings, Neb.

JARLSON, ALAN
 Las Vegas Sun
 Las Vegas, Nev.

JEWELL, WILLET C.
 Putnam County Courier
 Carmel, N. Y.

JOHNS, BOB
 Daily News Tribune
 La Salle, Ill.

JOHNSON, BOBBY
 Gazette
 Phoenix, Ariz.

JOHNSON, ELMER
 Brookfield Enterprise
 Brookfield, Ill.

JOHNSON, JOHNNIE
 The Register
 Danville, Va.

JOHNSON, RICHARD
 Rice Lake Chronotype
 Rice Lake, Wisc.

JONES, EDDIE
 Nashville Banner
 Nashville, Tenn.

JONES, ROSS
 Marine City Independent
 Marine City, Mich.

JONES, W. EMERSON
 Lagrange Shopper
 Lagrange, Ill.

JONES, WILL
 Morning Tribune
 Minneapolis, Minn.

— K —

KEMBLE, PENN
 Item
 Mt. Carmel, Pa.

KEOUGH, BILL
 Providence Journal
 Providence, R. I.

KERN, JANET
 American
 Chicago, Ill.

KNAPP, ARNOLD
The Daily Mail
Charleston, W. Va.

KONUCK, JEANNE
The Philadelphia Inquirer
Philadelphia, Pa.

KRI G. KARL
Sun Telegraph
Pittsburgh, Pa.

— **L** —

LADD, BILL
Courier Journal
Louisville, Ky.

LADOUCEUR, GUY
Le Messenger
Lewiston, Maine

LAIT, JACK, JR.
Examiner
Los Angeles, Cal.

LAURENT, LARRA
Washington Post
Washington, D. C.

LEDFORD, BILLA
Virgilia Advance
Vienna, Ga.

LEE, BILL
Chico Enterprise Record
Chico, Cal.

LESTER, JOHN
Newark Star Ledger
Newark, N. J.

LEYDON, LOUISE
Daily News
Miami, Fla.

LINDBIOM, ROLAND
Evening News
Newark, N. J.

LIZZA, TED
The Item
New Orleans, La.

LOCKE, BILL
Dunbar Sentimental
Dunbar, Cal.

LOCKMIR, WRISTON
Observer
Charlotte, N. C.

LOWES, GLENNA
Daily Times
Seattle, Wash.

— **Mc** —

McARTHUR, HARRY
Evening Star
Washington, D. C.

McCAULEY, HARRY
Chronicle Telegraph
Quebec, P. Q.

McCOY, KEN
Lebanon Express
Lebanon, Ore.

McGLYNN, PATRICK
Tribune
Scranton, Pa.

McPHERSON, FRED R.
Sentinel News
Santa Cruz, Cal.

McPHERSON, MARGIE
Herald
Bellevue, Wash.

— **M** —

MACK, BOB
Knickerbocker News
Albany, N. Y.

MAHAFFEY, J. Q.
Texarkana Gazette
Texarkana, Texas

MAIRHOFER, LOI
Altoona Tribune
Altoona, Pa.

MALEY, S. ROY
Tribune
Winnipeg, Man.

MAULIN, GENE
Democrat Herald
Albany, Or.

MEYER, CAL
News
Newburgh, N. Y.

MEYERS, DEAN
Wool, Columbus, Ohio

MILES, WATT
Commercial Appeal
Danville, Va.

MOORE, BOB
The Light
San Antonio, Texas

MOYSE, JIM
Star Gazette
Flint, N. Y.

MORRIS, FRANK
Free Press
Winnipeg, Man.

MOYSE, WM.
Oregon Journal
Portland, Oregon

MURPHY, FRANCIS
Opinion
Portland, Oregon

MURRAY, CHARLES
New Yorker
Poughkeepsie, N. Y.

— **N** —

NELSON, DON
KJLN, Redmond, Oregon

NEWTON, DWIGH
Examiner
San Francisco, Cal.

NOLAN, MARSHA
Daily Press
St. Marys, Pa.

NORDMARKEN, AD
Dickinson Press
Dickinson, N. D.

— **O** —

O'BRIEN, ROSE
Lewiston Sun Journal
Lewiston, Maine

O'DAY, RAY D.
Gazette
Pt. Wayne, Ind.

O'LAHERTY, TERRANCE
Chronicle
San Francisco, Cal.

OLIVER, DELBERT
Daily Advertiser
Lafayette, La.

OLIVER, KAYE P.
The Review
Radville, N. Carolina

OWENS, PAT J.
The Crow's Nest
KLCB, Lobby, Mont.

— **P** —

PAGE, MARK
News
Dalton, Ga.

PALMER, HAYDEN
State Journal
Lansing, Mich.

PALMER, ZUMA
Citizen News
Hollywood, Cal.

PAPPAS, LEONA
Express & News
San Antonio, Texas

PARRISH, RICHARD
The West Virginian
Fairmont, W. Va.

PATRICK, CORBIN
Star
Indianapolis, Ind.

PAULSON, MORTON
News Journal
Daytona Beach, Fla.

PEPIN, BEA
Milwaukee Journal
Milwaukee, Wis.

PEEP, DOMINIC
Daily Times
Watertown, N. Y.

PETERSON, DON
News-Tribune
Caldwell, Idaho

PETRICAN, JIM
Sun Telegraph
Pittsburgh, Pa.

PLATT, BRAINARD
Journal Herald
Layton, O.

POULTON, RON
Evening Telegram
Toronto, Ont.

POUND, JOHN
Tribune, Cocoa, Fla.

POUNTS, JOE
Enterprise
Pecos, Tex.

PRICE, PAUL
Daily News
Los Angeles, Cal.

— **R** —

RAHN, PETE
Globe Dispatch
St. Louis, Mo.

RAINEVILLE, PIERRE
Le Droit Ottawa, Ont.

RICCI, ART
Record
Ramy River, Ont.

RICHARDS, BART
News
New Castle, Pa.

RILEY, WYMAN
Times Herald
Vallejo, Cal.

ROBERTS, LA VERNE
Sumbury Daily Item
Sumbury, Pa.

ROBERTSON, JAMES L.
CJCH, Halifax, Nova Scotia,
Canada

ROGERS, HELEN
Tacoma News Tribune
Tacoma, Wash.

ROSENFELD, JOHN, JR.
Morning News
Dallas, Tex.

ROTH, HENRY
Gettysburg Times
Gettysburg, Pa.

ROWE, NORMAN
Richmond Times Dispatch
Richmond, Va.

RUBY, EARL
Courier Journal
WINN, Louisville, Ky.

RYAN, JACK
News
Chicago, Ill.

— S —

SALTER, FORREST
Mountain Sun
Kerrville, Tex.

SANDERS, C. H.
Rock Island Argus
Rock Island, Ill.

SANDLER, NORMA JEAN
Courier Express
WEBER, Buffalo, N. Y.

SCHUBRING, CARL
Times
Fort Frances, Ont.

SCHWARTZ, MITCHELL
Philadelphia Daily News
Philadelphia, Pa.

SCOTT, GEORGE
The Progress
Clearfield, Pa.

SELBY, EARL
Bulletin
Philadelphia, Pa.

SHEPHERDSON, R. M.
Peoria Journal
Peoria, Ill.

SHRIVING, BILL
Knickerbocker News
Albany, N. Y.

SHROYER, LARRY
Herald
Decatur, Ill.

SHULER, EVELYN
KRTN, Raton, N. M.

SIGL, AL
Times Union
Rochester, N. Y.

SIMPSON, PEG
Post-Standard
Syracuse, N. Y.

SINCLAIR, GORDON
Daily Star
Toronto, Canada

SLIFKA, ADRIAN
Vindicator
Youngstown, Ohio

SMITH, TAYLOR
Star
Anniston, Ala.

SPANGLER, ROBERT
South Bend Tribune
South Bend, Ind.

SPEEGLE, PAUL
News
San Francisco, Cal.
Patchogue, N. Y.

SPENCER, JAMES
St. Louis, Post Dispatch
St. Louis, Mo.

STANLEY, ED
Aberdeen Daily World
Aberdeen, Wash.

STEINHAUSER, SI
Press
Pittsburgh, Pa.

STELLING, JACK
Press Gazette
Green Bay, Wis.

STEVENS, DALE
Daily News
Dayton, O.

STONE, ED PERRY
Transcript
Fall River, Mass.

STRICKLAND, ZACK
Sentinel
Orlando, Fla.

SUBLETTE, BOB
N. O. States
New Orleans, La.

SWANSON, NORRIS
Telegram
Superior, Wis.

SWARTZ, MITCHELL
Daily News
Philadelphia, Pa.

— T —

TAYLOR, PAT
Daily News
Hays, Kansas

THRO, BETTY
Rockford Morning Star
Rockford, Ill.

TOLAND, BILL
Sunbury Daily Item
Sunbury, Pa.

TUCKER, CLIFF
Enquirer
Columbus, Ga.

TWYFORD, WARNER
Virginian Pilot
Norfolk, Va.

— U —

UNDERWOOD, FRANCES
WGAD, Gadsden, Ala.

— V —

VAN METRE, MAURICE
News
Cleveland, O.

VARGAS, P. A. REYES
El Imparcial
San Juan, P. R.

VOCHES, JOHN
Seattle Post Intelligencer
Seattle, Wash.

— W —

WALLACE, CHARLTON
The Cincinnati Times Star
Cincinnati, O.

WALLACE, JOHN
Consolidated Press
Bay Shore

WALLER, MARGE
Evansville Press
Evansville, Ind.

WASSERMAN, JACK
Sun
Vancouver, B. C.

WASSON, DON
Ledger-Enquirer
WPNX, Phenix City, Ala.

WATSON, WEIR
Las Vegas Sun
Las Vegas, Nev.

WEBER, CARL
Daily News Digest
Allentown, Pa.

WENNERGREN, EARL
Rocky Mtn. News
Denver, Colo.

WHEELER, WILLIAM
Idaho Statesman
Boise, Idaho

WHIPKEY, BOB
Herald
Big Spring, Tex.

WHITE, GEORGE
Walton Reporter
Walton, N. Y.

WHITE, KEN
Post
Denver, Colo.

WHITESIDE, WILL
Richmond News Leader
Richmond, Va.

WILLIAMS, DICK
Review
Spokane, Wash.

WILSON, IRENE
Houston Press
Houston, Texas

WILSON, MAGGIE
Arizona Republic
Phoenix, Arizona

WISTER, EMERY
The Charlotte News
Charlotte, N. C.

WOLFE, BARBARA
Star
Indianapolis, Ind.

WOLFE, WARREN
Middletown Journal
Middletown, Ohio

WOLTERS, LARRY
Tribune
Chicago, Ill.

WOOD, JIM
News
LaGrange, Ga.

WOODRESS, FRED
Post-Herald
WBRC, Birmingham, Ala.

WOODS, MARY
The Cincinnati Post
Cincinnati, O.

WRIGHT, PRESTON
Olympia News
Olympia, Wash.

— Y —

YOUNG, DICK, JR.
Charlotte News
Charlotte, S. C.

YOUNG, S. A.
Macomb County Journal
Van Dyke, Mich.

YOCKEY, HARRY
Reporter
Dover, O.

BUILDING!

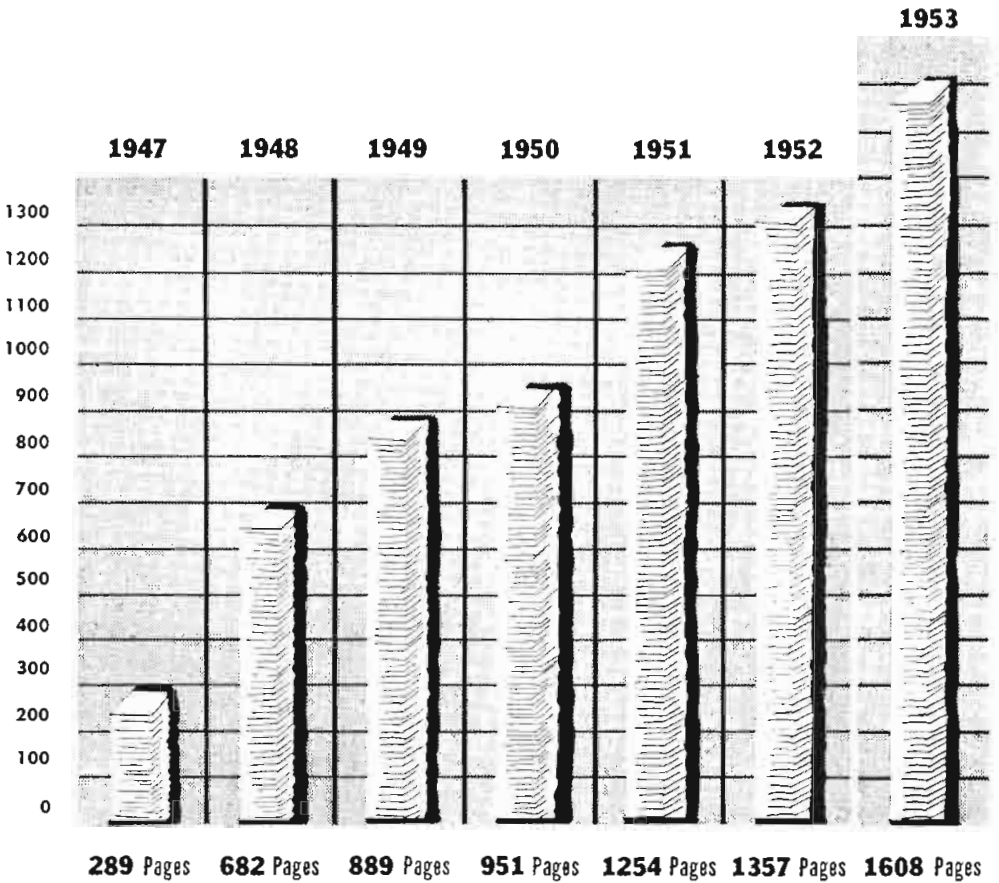

SPONSOR *The magazine radio and tv advertisers use*



SPONSOR builds on a solid basis. Our policy: turn out useful issues and the advertising will follow. This common-sense approach to tv and radio trade paper publishing has appealed to station advertisers increasingly since our first issue in November 1946. Our promise for 1954: new, improved use departments, more use articles for buyers of radio and television.

*P*ublications

•

TRADE

•

FAN

•

TECHNICAL

•

GENERAL



Radio and Television leaders who advertise in The ADVERTISER Magazine . . . and, MARKETS of AMERICA:

Varied Sample

- NBC-TV Network
- WMAQ, Chicago
- Steinman Stations
- KMBC-KMBC-TV, Kansas City
- CKLW, Detroit
- WWJ, Detroit
- WJR, Detroit
- WDSU, New Orleans
- XL Stations
- KTUL, Tulsa
- Frederic W. Ziv
- RCA
- KDYL, KDYL-TV, Salt Lake
- KFAB, Omaha
- WLS, Chicago
- KSD, St. Louis
- WISH, Indianapolis
- KQV, Pittsburgh
- KWNA, Charleston
- WTRY, Troy
- WCAR, Cleveland
- WJBK, Detroit
- KMPC, Los Angeles
- WBT, WBT-TV, Charlotte
- WCAN-TV, Milwaukee
- WKBW, Buffalo
- CMQ-TV, Havana
- XEW-TV, Mexico City
- Weed and Co., New York
- WFIL, WFIL-TV, Philadelphia
- Broadcast Music Inc., N. Y.

6 Major Reasons

Why Advertising in
The ADVERTISER Magazine . . .
and, MARKETS of AMERICA
BRINGS TOP RADIO and TV TIME SALES

UNPARALLELED MARKET ATTENTION . . .

● Profit by exclusive, practical experience articles . . . creating unequalled readership. Written by the nation's top advertising executives . . . they serve the people YOU want to SELL!

BASIC EDITORIAL FORMULA . . .

● Our unique treatment of *basic* advertising techniques, on an *industry-by-industry* basis, guarantees *buying power attention* to your advertisement.

WE BLANKET ALL BUYERS OF TIME . . .

● Both The ADVERTISER Magazine . . . and, MARKETS of AMERICA offer a select audience comprised in the main of Radio and TV Time Buyers, Account Executives, plus National and Regional Advertisers! Our more than 15,000 circulation offers you ALL of YOUR *buying* prospects.

CONTINUITY PAYS OFF . . .

● Radio and Television stations with us for 3 to 24 years have found both our monthly, The ADVERTISER Magazine . . . and our annual, MARKETS of AMERICA outpulling *all* other publications . . . at lower cost.

LOW SPACE RATES . . .

● Priced right to win and hold your schedule year in and year out . . . gaining incomparable results for your ad dollar at lowest "per prospect" cost. Page rate \$390 . . . scaled down to \$320 on a 13-time contract.

MORE READER IMPACT . . .

● The ADVERTISER Magazine . . . and, MARKETS of AMERICA have the added reader impact you *need* for your time sales promotion story. Join the scores of Radio and Television Stations who continually *profit* by selling in The ADVERTISER Magazine and in MARKETS of AMERICA.

The ADVERTISER Magazine

Publishers of MARKETS of AMERICA

11 West 42nd Street

LONGacre 5-2125

New York 36, N. Y.

PUBLICATIONS

Covering The Field Of Radio—Television—FM
TRADE — FAN — TECHNICAL — GENERAL



THE ADVERTISER

11 W. 42 St., New York 36, N. Y.

Phone: LOnacre 5-2125

Publisher & Editor.....Manuel Rosenberg
Business Manager.....L. B. Rosenberg
Camera Editor.....Lydie Bloch
Advertising Manager.....Robert M. Jason
Media Service Dir.....Ellis Porter
Production Mgr.....Arnold Hallock
Circulation Dir.....Sam J. Davis
Associate Editors.....Diana Ghia,
Tom Patterson, Arthur Coles

ADVERTISING AGE

200 E. Illinois St., Chicago 11, Ill.

Phone: DE 7-1336

Publisher.....G. D. Crain, Jr.
Editor.....S. R. Bernstein
Exec. Editor (N. Y.).....John Crichton
Managing Editor.....Jarlath J. Graham

ADVERTISING AGENCY & ADVERTISING & SELLING

48 West 38th St., New York 18, N. Y.

Phone: LOnacre 5-3320

Editor.....Roger Barton
Publisher.....Moore Pub. Co.
President.....J. H. Moore, Jr.
Advertising Dir.....Lucian Neff
Circulation Dir.....Harland J. Wright
Promotion Dir.....Coleman McCampbell

THE BILLBOARD

1564 Broadway, New York, N. Y.

Phone: PLaza 7-2800

Co-Publisher.....W. D. Littleford
Co-Publisher.....R. S. Littleford, Jr.
Branch Offices

188 W. Randolph St., Chicago, Ill.

Phone: CEntral 6-8761

Manager.....Maynard L. Reuter
6000 Sunset Blvd., Hollywood 28, Calif.
Phone: HOLlywood 9-5831

Manager.....Sam Abbott
2160 Patterson St., Cincinnati, O.
Phone: DUnbar 6450

Pres. & Treas.....E. W. Evans
Arcade Bldg., 8th & Olive Sts., St. Louis, Mo.
Phone: Chestnut 0443

Manager.....Frank Joerling

BROADCASTING-TELECASTING

1735 De Sales at Connecticut Ave.

Washington 6, D. C.

Phone: MEtropolitan 1022

Editor & Publisher.....Sol Taishoff
Senior Editor.....Edwin H. James
Managing Editor.....Art King
Assoc. Editor.....J. Frank Beatty

Assoc. Editor.....Earl B. Abrams
Asst. Managing Editor.....Fred Fitzgerald
Vice Pres. & Business Mgr.....Maury Long
Cir. Mgr. & Readers Serv....John P. Cosgrove

Branch Offices

444 Madison Ave., New York 22, N. Y.

Phone: PLaza 5-8355

New York Editor.....Rufus Crater
Senior Assoc. Editor.....Bruce Robertson
Sales Mgr.....Winfield R. Levi
360 N. Michigan Ave., Chicago 1, Ill.

Phone: CEntral 6-5115

Midwest Adv. Rep.....Warren Middleton
Taft Bldg., Hollywood & Vine, Hollywood 28,
Calif.

Phone: HEMpstead 8181

West Coast Mgr.....David Glickman
417 Harbour Commerce Bldg., Toronto, Can.
Phone: Empire 4-0775

Executive-in-Charge.....James Montagnes

DAILY VARIETY

6311 Yucca St., Hollywood 28, Calif.

Phone: HOLlywood 9-1141

Editor & Publisher.....Joe Schoenfeld
Managing Editor.....Albert Scharper
Advertising Manager....Charles Gerlach, Jr.
Business Manager.....Barbara Oneal

Main Office

(See listing under VARIETY)

DOWN BEAT

2001 Calumet Ave., Chicago 16, Ill.

Phone: VICTory 2-0310

Publisher.....Norman S. Weiser
Editor.....Jack Tracy

EDITOR AND PUBLISHER

1700 Times Tower, New York 36, N. Y.

Phone: BRyant 9-3052

Publisher.....Charles T. Stuart
Chm. of Board.....James Wright Brown
Pres. & Editor.....Robert U. Brown
Exec. Editor.....Jerome H. Walker
Advertising Mgr.....Leach Laney
Classified Mgr.....Evelyn Kolojay
Dir. of Circulation.....George McBride

ELECTRONICS

330 W. 42 St., New York 36, N. Y.

Phone: LOnacre 4-3000

Executive Editor.....W. W. MacDonald
Managing Editor.....Vin Zeluff

FILM DAILY

DAILY. 1501 Broadway, New
York, 18, N. Y. Phone, BRyant
9-7117. J. W. Alicoate, President;

Feature Pictures and Serials

A list of over —

26,000

Features and Serials, with Titles, Distributor and THE FILM DAILY Review Dates, is just one of the many features in the

1954 YEAR BOOK OF MOTION PICTURES

Published by

THE FILM DAILY

The Industry's Oldest Daily Trade Paper

Subscription, \$15.00 (Foreign, \$20.00)

1501 Broadway

New York 36, N. Y.

Chas. A. Alicoate, Exec. Vice-President and Treasurer; Patti Alicoate, Vice-President; Chester B. Bahn, Vice President & Editor; Merlin Lewis, Vice-Pres.; Winfield Andrus, Managing Editor; West Coast Offices: West Coast Division Manager, Paul Devoe; Office Manager, Ethel Rosen; 6425 Hollywood Blvd., Phone Hollywood 7-6607; Washington Bureau, James J. Butler, 1140-42 Nat'l Press Bldg., Phone ME 8-0823; Chicago Bureau, Joseph Esler Chief; C. L. Esler, 6241 N. Oakley Ave., Phone BRIar-gate 4-7441. Far East Bureau, Glenn F. Ireton, Mgr., 756 Seta-Machi, Setagaya Ku, Tokyo.

THE HOLLYWOOD REPORTER

6715 Sunset Blvd., Hollywood 28, Calif.
Phone: Hollywood 4-7411

Publisher.....W. R. Wilkerson
Editor.....Don Carle Gillette
Advertising Mgr.....Geo. H. Kennedy

MARKETS OF AMERICA

11 W. 42nd St., New York 36, N. Y.
Phone: LOn-gacre 5-2125

Publisher & Editor.....Manuel Rosenberg
Managing Editor.....Col. Don R. Jason
Business Mgr.....L. B. Rosenberg
Camera Editor.....Lydie Bloch
Advertising Mgr.....Robert M. Jason
Production Mgr.....Arnold Hallock
Circulation Mgr.....Sam J. Davis

METRONOME CORP.

114 E. 32nd St., New York 16, N. Y.
Phone: LExington 2-6550

Editors.....George T. Simon, Barry Ulanov
Ass't Editor.....Bill Coss
Avertising Mgr.....Gus O. Greiff
Production Mgr.....Earl Umpenhour
Publishers.....Ned Bitner, John W. Bitner

MIKE & SCREEN PRESS ANNUAL

270 Park Ave., New York 17, N. Y.
Phone: PLaza 1-2720

Editor.....Charles Burger

MUSIC DEALER

114 E. 32nd St., New York 16, N. Y.
Phone: LExington 2-6550

Executive Editor.....Barry Ulanov
Editor.....Doron K. Antrim
Advertising Mgr.....Gus O. Greiff

MUSICAL AMERICA

113 W. 57 St., New York 19, N. Y.
Phone: CIRCLE 7-0520

Publisher.....John F. Majeski
Treas.....John F. Majeski, Jr.
Editor.....Ronald F. Eyer
Advertising Mgr.....Maurice B. Swaab
Production Mgr.....Edward I. Davis

MUSICAL COURIER

119 W. 57 St., New York 19, N. Y.

Phone: CIRCLE 7-4500

Publisher.....Gainsburg Shark, Inc.
President.....Roy E. Gainsburg
Editor.....Dr. Gid Waldrop
Editor.....Dr. Henry Levinger

PRINTERS' INK

205 E. 42 St., New York 17, N. Y.

Phone: MUrray Hill 3-6500

President & Publisher.....C. B. Larrabee
Asst. Publisher.....Henry W. Marks
Advertising Dir.....Robert E. Kenyon, Jr.
Editor.....Eldridge Peterson
Managing Editor.....Joel Lewis
News Editor.....W. Richard Bruner
Radio.....W. Richard Bruner
Circulation Mgr.....R. R. Rountree

Branch Offices

208 S. LaSalle St., Chicago 4, Ill.
Mid-West Editor.....Harold E. Green
Statler Bldg., Boston 16, Mass.
Manager.....E. P. Meade
5127 Whittier Blvd., Los Angeles 22, Calif.
Western Editor.....Louis F. Thomann
Rhodes-Haverty Bldg., Atlanta 3, Ga.
Executive-in-Charge.....H. F. Cogill
1175 Woodbury Rd., Pasadena 6, Calif.
Executive-in-Charge.....J. W. Conrow
520 Bond Bldg., Washington 5, D. C.
Washington Editor.....Richard Y. Giles

RADIO ANNUAL & TELEVISION YEAR BOOK

YEARLY. 1501 Broadway, New York 36, N. Y. Phone. Wisconsin 7-6336. Jack Alicoate, Publisher; Marvin Kirsch, Associate Publisher and Vice-President; Charles A. Alicoate, Exec. Vice-President; Frank Burke, Vice President & Editor; Robert R. Gallagher, Associate Editor. Published annually as the accepted reference volume of the radio and television industry.

RADIO-TELEVISION DAILY

DAILY. 1501 Broadway, New York 36, N. Y. Phone, Wisconsin 7-6336. John W. Alicoate, President and Publisher; Marvin Kirsch, Vice President & Associate Publisher; Charles A. Alicoate, Executive Vice President & Secretary-Treasurer; Chester B. Bahn, Vice-President; Frank Burke, Vice-President & Editor; West Coast Offices, 6425 Hollywood Blvd., Phone Hollywood 5-8436, Paul K. Devoe, Western Division Manager; Jerry Tidwell, Ethel Rosen,

Manager; Washington Bureau.
 Ted Kellogg, 983 National Press
 Bldg. Phone Jefferson 2-5957; Chi-
 cago Bureau. Herb Kraus, Suite
 505, 140 No. Dearborn St. Phone
 Franklin 2-8961.

RADIO-ELECTRONICS

25 W. Broadway, New York 7, N. Y.
 Phone: WEctor 2-8630

Editor-in-Chief.....Hugo Gernsback
 Editorial Director... M. Harvey Gernsback
 Managing Editor.....Fred Slunaban
 Technical Editor.....Robert F. Scott
 Production Mgr.....Angie Pascale
 Technical Illustration Dir.

Wm. Lyon McLaughlin

Advertising Mgr.....John J. Lamson
 General Mgr.....Lee Robinson
 Circulation Mgr.....G. Aliquo
 Promotion Mgr.....Robert A. Fallath

RADIO & TELEVISION NEWS

366 Madison Ave., New York 17, N. Y.
 Phone: MUrray Hill 7-8080

Ch. of Bd. & Publisher.....William B. Ziff
 President.....B. G. Davis
 Editor.....Oliver Read
 Managing Editor.....William Stocklin
 Technical Editor.....Harold S. Renne

SALES MANAGEMENT

386 Fourth Ave., New York 16, N. Y.
 Phone: LExington 2-1760

Publisher.....Raymond Bill
 Editor.....Philip Salisbury
 Managing Editor.....A. R. Hahn
 Advtg. Service Mgr.....R. E. Smallwood

SERVICE

(Radio-Television Electronic)

52 Vanderbilt Ave., New York 17, N. Y.
 Phone: MUrray Hill 4-0170

Pres. & Bus. Mgr.....Bryan S. Davis
 Vice-Pres.....Paul S. Weil
 Editorial Dir.....Lewis Winner

SPONSOR

40 East 19th St., New York 21, N. Y.
 Phone: MUrray Hill 8-2772

Pres. and Editor.....Norman R. Glenn
 Managing Editor.....Miles David
 V. P. & Business Mgr.....Bernard Platt
 Advtg. Prod. Mgr.....John Koychok
 Serty. Treas.....Elaine C. Glenn

RADIO ADVERTISING RATES

& DATA

Published by

STANDARD RATE & DATA

SERVICE, INC.

1710 Ridge Ave., Evanston, Ill.
 Phone: HOLlycourt 5-2400

Publisher & Chmn. of Bd...Water E. Botthof
 President & Treasurer... C. Laury Botthof
 Executive Vice-Pres... Albert W. Moss
 Asst. Publisher... R. A. Trenkmann
 Secretary... Elsa Laury Botthof
 V.P. and Asst. Treas... Frank J. Ceithaml

Branch Offices

420 Lexington Ave., New York 17, N. Y.

Phone: MUrray Hill 9-6620

Exec. Vice-President.....Albert W. Moss
 1709 W. 8 St., Los Angeles 14, Calif.

Phone: DUmkirk 2-8576

Executive-in-Charge.....Don Harway

TELE-TECH

480 Lexington Ave., New York 17, N. Y.

Phone: PLaza 9-7880

Editorial Dir.....O. H. Caldwell
 Publisher.....M. Clements
 Business Mgr.....M. H. Newton

TELEVISION DIGEST

Wyatt Bldg., Washington 5, D. C.

Phone: STerling 3-1755

Editor & Publisher.....Martin Codel
 Assoc. Editor.....Albert Weinstein
 Assoc. Editor.....David Lackenbruch
 Business Mgr.....Robert Cadel

TELEVISION

600 Madison Ave., New York 22, N. Y.

Phone: PLaza 3-7671

Editor & Publisher.....Frederick A. Kugel
 Senior Editor.....Abby Rand
 News Editor.....Geri Cohen
 Vice President.....Edwin Fisher
 Business Manager.....Jack L. Blas
 Art Director.....Richard Rose

TIDE

232 Madison Ave., New York 16, N. Y.

Phone: MUrray Hill 3-7700

Editor.....Reginald Clough
 Vice-President.....Jacob F. Weintz
 Advertising Dir.....Bruce Addison
 Managing Editor.....Morgan Browne

TV GUIDE

Local Editions Office

251 W. 42nd St., New York 36, N. Y.

Phone: BRyant 9-0050

National Edition Office

100 N. Broad St., Philadelphia, Pa.

Phone: RIttenhouse 6-1600

Publisher, Editor.....Walter H. Annenberg
 Business Mgr.....Roger Clipp
 Asst. to Publ.....Lee Wagner
 Nat'l Edition Mg. Ed.....Merrill Panitt
 Mg. Editor Local Editions...H. B. Clemenko
 Nat'l Prog. Ed.....Herbert Rikles
 Circulation Dir.....C. J. Bodkin, Jr.

VARIETY

151 West 46th St., New York 36, N. Y.

Phone: LExemburg 2-2700

President.....Harold Erichs
 Editor.....Abel Green

Branch Offices

612 N. Michigan Ave., Chicago 11, Ill.

Manager.....Don Wilson
 6341 Yucca St., Hollywood 28, Calif.

Editor (Daily Variety).... Joe Schoenfeld
 8 St. Martins Pl., London, W.C.2,
 London, Eng.

Bureau Head.....Harold Myers
 1292 National Press Bldg.,
 Washington 1, D. C.

Bureau Head.....Herman Lowe

Play and Story

BROKERS



Los Angeles, Calif.

Bentel, George
6606 Sunset Blvd.....GRanite 8608

Bergerman Agency
141 El Camino Dr., B. H.CRestview 6-4124

Bloom, Phil, Agency
416 N. Bedford Dr.....CRestview 6-1339

Elwood, Maren, Agency
4949 Hollywood Blvd.....OLympic 4786

Famous Artists Corp.
9441 Wilshire Blvd.....CRestview 1-5222

French, Samuel, Inc.
7623 Sunset Blvd.....HEmpstead 3146

Goldstone, Nat C.
9121 Sunset Blvd.....CRestview 6-1071

Jaffe, Sam, Inc.
8553 Sunset Blvd.....CRestview 6-6121

Herzbrun, Walter, Agency
8820 SunsetCRestview 6-4157

Irwin, Lou
9165 Sunset Blvd.....CRestview 1-7131

Kohner, Paul, Inc.
9169 Sunset Blvd. (46)....CRestview 1-5165

Mack & Levene Agency
9128 Sunset Blvd.....CRestview 1-2141

Morris, William, Agency
202 N. Canon Dr., Bev. Hills.CRestview 1-6161

Music Corp. of America
9370 Santa Monica Blvd., B. H.CRestview 6-2001

Orsatti & Co.
300 S. Beverly Dr.....CRestview 6-6241

Preminger, The Ingo, Agency
204 S. Beverly Dr., B. H.....CRestview 6-6213

Ring, S. E.
1654 CherokeeHollywood 7-6412

Shurr, Louis, Agency
327 N. Rodeo Rd., B. H.....CRestview 1-1116

Small, Paul
448 S. Canon Dr., B. H.....CRestview 1-5246

Swanson, H. N., Inc.
8523 Sunset Blvd.....CRestview 1-5115

Winckler, D. M.
9606 Santa Monica Blvd., B. H.CRestview 1-7244

New York, N. Y.

American Play Co.
523 Fifth Ave.....MUrray Hill 2-0156

Bartsch, Hans
523 Fifth Ave.....MUrray Hill 2-0156

Brandt & Brandt
101 Park Ave.....MUrray Hill 3-5890

Brown, Curtis, Ltd.
347 Madison Ave.....MUrray Hill 6-6170

Century Play Co., Inc.
522 Fifth Ave.....MUrray Hill 2-0156

Cowl, Carl
516 Fifth Ave.....MUrray Hill 7-6782

Fishbein, Frieda
11 W. 42nd St.....LONgacre 5-1379

French, Samuel
25 W. 45th St.....LUXemburg 2-4700

Hayward, Leland, Ltd.
655 Madison Ave.....TEmpleton 8-5100

International Literary Bureau, Inc.
11 W. 42nd St.....LONgacre 4-5576

King, Eleanor
19 W. 44th St.....MUrray Hill 2-6390

Matson, Harold
30 Rockefeller Plaza.....CIRcle 6-2750

Morris, William, Agency, Inc.
1740 BroadwayJUdson 6-5100

Pauker, Dr. Edmond
1639 Broadway.....COLumbus 5-1726

Reynolds, Paul R. & Son
599 Fifth Ave.....MUrray Hill 8-4767

Salisbury, Leah
234 W. 44th St.....LACKawanna 4-8628

Taylor, Ethel C.
55 W. 55th St.....CIRcle 5-8620

Writers Workshop, Inc.
280 Madison Ave.....LEXington 2-9878

Radio-Television Daily's Almanac

of

Holidays and Special Events

1954

January

- 1: New Year's Day (In all States, Territories, District of Columbia and Possessions). Paul Revere born (1735). Emancipation Proclamation (1863). Blue Network organized (1927).
- 2: Georgia admitted (1778).
- 3: Battle of Princeton (1777). William S. Paley is elected president of CBS (1929).
- 4: Utah admitted (1896).
- 5: Stephen Decatur born (1779). George Washington Carver Died (1943). Week of Prayer, first week in January.
- 6: Carl Sandburg born (1878). New Mexico admitted (1912).
- 7: Millard Fillmore, 13th President born (1800). Electronic system for television, including a dissector tube to scan the image for transmission patented by Philo Taylor Farnsworth (1927).
- 8: Anniversary of the Battle of New Orleans (Louisiana).
- 9: Connecticut ratified the U. S. Constitution (1778). Connecticut admitted (1788).
- 10: Ethan Allen born (1737).
- 11: Alexander Hamilton born (1757).
- 12: John Singer Sargent born (1856).
- 13: Salmon Portland Chase born (1808).
- 14: First Written Constitution adopted at Hartford, Conn. (1639).
- 15: Mathew B. Brady died (1896).
- 17: Benjamin Franklin born (1706). Feast of St. Anthony.
- 18: Daniel Webster born (1782).
- 19: Robert E. Lee's birthday (1807) (Alabama, Arkansas, Florida, Georgia, Kentucky, Mississippi, North Carolina, South Carolina, Tennessee, Virginia). Edgar Allen Poe born (1809).
- 20: Inauguration Day. Begun in 1937. To be observed every fourth year from that date by the 20th Amendment to the Constitution.
- 21: Foundation Day. In the Canal Zone. Thomas Jonathan (Stonewall) Jackson born (1824).
- 23: S. S. Republic collides with S. S. Florida off N. Y. harbor and flashes CQD signal, summoning rescuers proving value of Marconi apparatus in time of disaster at sea (1909).
- 24: Gold discovered in Calif. (1848).
- 25: Weather Signs. It is an old belief that the

- weather of the whole year depends upon this day. "Sun on St. Paul's Day means a good year, rain or snow foretells indifferent weather, a mist means want, while thunder predicts 12 months of wind and death." (Shepherd's Almanack, 1676). Scottish Poet Robert Burns born (1759).
- 26: Michigan admitted (1837). General Douglas MacArthur born (1880). A.E.F. landed in Ireland (1942). FM Broadcasters, Inc., holds first annual meeting in N. Y. with attendance of 750 (1944).
 - 27: Wolfgang Amadeus Mozart born (1756). Lewis Carroll, pen name of Charles Lutwidge Dodgson, born (1832).
 - 28: Thomas Edison granted patent on his incandescent light (1880).
 - 29: William McKinley born (1843). Kansas admitted (1861).
 - 30: Franklin D. Roosevelt born (1882).
 - 31: Franz Schubert born (1797). Child Labor Day. Last Sunday in January, also the Saturday preceding and the Monday following.

February

- 1: Victor Herbert born (1859). Supreme Court of the U. S., Chief Justice John Jay presiding, held its first meeting (1790). CQD is adopted as wireless distress call by Marconi Co. (1904).
- 2: Fritz Kreisler born (1875). Ground Hog Day. Candlemas. Treaty of Guadalupe Hidalgo signed by U. S. and Mexico (1848).
- 3: Horace Greeley born (1811).
- 6: Massachusetts admitted (1788). Aaron Burr born (1756). American Forces recapture Manila from Japan (1945). George Herman ("Babe") Ruth born (1895).
- 7: Charles Dickens born (1812).
- 8: Boy Scout Day.
- 9: William Henry Harrison, 9th President, born (1773). Nebraska Admitted (1867).
- 10: Peace Treaty Signed with Spain Ending Spanish-American War (1899).
- 11: Thomas A. Edison born (1847). Daniel Boone born (1734).

- 12: Lincoln's Birthday (Alaska, California, Connecticut, Delaware, Illinois, Indiana, Iowa, Kansas, Kentucky, Michigan, Minnesota, Missouri, Montana, Nevada, New Jersey, New York, North Dakota, Ohio, Oregon, Pennsylvania, South Dakota, Tennessee, Utah, Virgin Islands, Washington, West Virginia, Wyoming).
Georgia Day.
- 14: Valentine's Day.
Arizona admitted (1912).
Oregon admitted (1859).
- 15: Destruction of the Maine (1898).
Constitution Day. In the Canal Zone.
Susan B. Anthony Day. Observed in honor of the birthday of the pioneer crusader for equal rights for women. Governors of 33 States and 3 Territories have honored the day by special proclamations.
- 16: Katharine Cornell born (1898).
- 18: Inauguration of Jefferson Davis as President of the Provisional Government of the Confederacy (1861).
Ash Wednesday.
- 19: Ohio admitted (1803).
Shrove Tuesday (1947). Tuesday preceding Ash Wednesday. Observed as Mardi Gras in Florida (in cities and towns where carnival is celebrated), Louisiana (Parishes of Jefferson, Orleans, St. Bernard, St. Charles, St. John the Baptist, East Baton Rouge), Canal Zone.
Phonograph patented by Edison (1878).
- 20: U. S. purchased the Danish West Indies (1917).
- 21: Beginning of the Battle of Verdun (1916) which ended Dec. 15.
Brotherhood Week. Always includes Washington's Birthday; the Sunday nearest Feb. 22 is Brotherhood Day.
- 22: Florida ceded to the U. S. by purchase and treaty with Spain (1819).
Washington's Birthday (All the States, Territories, District of Columbia and Colonial Possessions).
Edgar Wilson ("Bill") Nye died (1896).
James Russell Lowell born (1819).
- 23: Johannes Gutenberg died (1468).
President Calvin Coolidge signs Dill-White Radio Bill, creating Federal Radio Commission and ending chaos caused by industry's wild growth (1926).
- 25: Enrico Caruso born (1873).
John Adams appointed first Minister of U. S. to England (1785).
- 26: William F. Cody (Buffalo Bill) born (1846).
- 27: Henry Wadsworth Longfellow born (1820).
- 29: Leap Year. The name given to every year of 366 days.
- 3: Florida admitted (1845).
First Postage Stamp used in U. S. (1847).
Alexander Graham Bell born (1842).
- 4: Pennsylvania Day.
Vermont admitted (1791).
- 5: Boston Massacre (1770).
- 6: Fall of the Aïamo (1836).
- 7: Luther Burbank born (1849).
Maurice Ravel born (1875).
Patent granted to Alexander Graham Bell for first telephone (1876).
- 8: Oliver Wendell Holmes, Jr. born (1841).
- 9: Battle of the "Monitor" and "Merrimac" off Hampton Roads, Va. (1862).
Edwin Forrest born (1806).
- 10: Lillian D. Wald born (1867).
- 11: Johnny Appleseed, properly John Chapman, died (1847).
The great blizzard in New York City and New England States (1888).
- 12: U. S. Post Office established by act of Congress (1789).
Girl Scout's Birthday.
- 13: Standard Time established in U. S. (1884).
- 14: Albert Einstein born (1879).
First Trans-Atlantic radio broadcast (1925).
- 15: Maine admitted (1820).
Andrew Jackson born (1767).
- 16: James Madison born (1751).
U. S. Military Academy established at West Point by act of Congress (1802).
- 17: Saint Patrick's Day.
Evacuation Day. In Boston, Chelsea, Revere, Winthrop and Suffolk County.
- 18: Feast of Esther.
Grover Cleveland born (1837).
- 19: William Jennings Bryan born (1860).
- 21: First Day of Spring.
- 22: Emancipation Day (Puerto Rico).
- 23: Patrick Henry delivered his famous speech (1775).
- 25: The Annunciation Day.
Arturo Toscanini born (1867).
Greek Independence Day. Greece celebrates its freedom won from Turkey (1827).
Maryland Day.
- 27: President Washington signed the act creating the U. S. Navy (1794).
Marconi flashes first wireless signals across English Channel (1889).
- 29: John Tyler born (1790).
- 30: Seward Day. Alaska (Not observed by Federal Employees).
- 31: Transfer Day. In the Virgin Islands.

April

- 1: All Fools' Day.
- 2: Sergei Rachmaninoff born (1873).
U. S. Mint established (1792).
- 3: First Pony Express riders left Sacramento to ride East and St. Joseph, Mo. to ride West.
Washington Irving Born (1783).
Good Friday.

March

- 1: Nebraska admitted (1867).
- 2: Texas Independence Day.

- 4: Adoption of the present American Flag's design (1818).
- 5: Elihu Yale Born (1648).
Easter Sunday.
- 7: Peary Discovered North Pole (1909).
Louisiana admitted (1812).
Bell Telephone Laboratories demonstrates wire television between Washington and New York, and radiovision between Whippany, N. J., and New York (1927).
Henry Ford died (1947).
- 8: Ponce de Leon (1460-1521) Spanish soldier, landed in Fla. near the present site of St. Augustine, Easter Sunday (1513), claiming the land for Spain. The anniversary of the event is observed by the city.
- 9: Surrender of General Lee (1865).
Bell Telephone Laboratories demonstrate two-way television in which speakers at the ends of a 3-mile circuit see each other as they converse (1930).
- 10: Salvation Army Founder's Day.
William Booth born (1829).
Joseph Pulitzer born (1847).
U. S. Patent System established by Congress (1790).
National Be Kind to Animals Week falls about this date.
- 11: Charles Evans Hughes born (1862).
- 12: Franklin Delano Roosevelt died (1945).
Halifax Independence Resolution (N. C.)
- 13: Thomas Jefferson born (1743).
National Sunday School Week.
- 14: Pan-American Day.
S. S. Titanic disaster at sea proves value of wireless (1912).
- 15: Abraham Lincoln assassinated (1865).
- 16: Charles Spencer Chaplin born (1889).
- 17: Charter granted American Academy of Arts and Letters (1916).
- 18: San Francisco Fire (1906).
- 19: Patriots' Day. (Maine, Massachusetts)
- 20: Adolf Hitler born (1889).
- 21: Anniversary of Battle of San Jacinto (Texas)
- 23: James Buchanan born (1791).
William Shakespeare born (1564).
St. George Day (English).
Marconi transatlantic American-Europe service opened (1910).
- 24: First Newspaper Issued in America (1704).
U. S.-Mexican War (1846).
U.N. Charter Conference opens in San Francisco (1945).
- 25: War declared with Spain (1898).
St. Mark's Day.
Guglielmo Marconi born (1874).
- 26: Confederate Memorial Day (Florida, Georgia, Mississippi).
Slavery abolished in U. S. (1865).
First Shot of War with Germany (1917)
John James Audubon born (1785).
- 27: General U. S. Grant born (1822).
CBS takes leadership in urging plans for post-war television in the higher frequencies (1944).
- 28: James Monroe born (1758).
Maryland admitted (1788).
- 29: Sir Thomas Beecham born (1879).
- 30: Boys and Girls Week always includes May 1.
Louisiana purchased (1803).
Washington became First President (1789)
Rhode Island settled (1636).
Benito Mussolini; executed (1945).

May

- 1: May Day.
Child Health Day
Labor Day (Canal Zone).
Dewey's Victory in Manila Bay (1898)
- 2: Stonewall Jackson fatally wounded (1863)
National Music Week.
FCC authorized full commercial television (1941).
- 3: Shenandoah Valley Apple Blossom Festival
- 4: Rhode Island Independence Day.
- 5: Napoleon's death (1821).
Cinco de Mayo celebrations (Mexico).
Arbor Day.
- 6: Corregidor Surrender (1942).
Admiral Robert E. Peary born (1856).
- 7: Germany surrendered to United States, England and Russia (1945).
Lusitania torpedoed (1915).
Johannes Brahms born (1833)
Robert Browning born (1812).
Plans to spend \$1,000,000 for field television tests are announced by R.C.A. president David Sarnoff; tests to start from Empire State Building, N. Y. early in 1936 (1935).
- 8: V.E. Day (1945).
- 9: John Brown born (1833).
- 10: Confederate Memorial Day (Kentucky, North Carolina, South Carolina).
Mothers Day, second Sunday in May.
Completion of First Transcontinental Railroad (1869).
- 11: Minnesota admitted (1858).
- 12: Florence Nightingale Born (1820).
- 13: WDRC-FM goes on air under call letters of WIXPW, utilizing Armstrong FM system (1939).
- 14: Rockefeller Foundation Granted Charter (1913).
Free State of Israel proclaimed (1948)
- 15: First regular Air Mail service in the world inaugurated by the U. S. Government.
- 17: "I am An American Day," often referred to as Citizenship Recognition Day
Norwegian Independence Day (1814).
- 18: World Good-Will Day, formerly Peace Day.

- 19: First American Confederation of United Colonies of New England (1643).
- 20: Anniversary of the Signing of the Mecklenburg Declaration of Independence (North Carolina) (1775).
FCC gives FM green light authorizing full commercial operation as of Jan. 1, 1941 (1940).
Armed Forces Day.
- 21: Lindbergh's Flight to Paris (1927).
- 22: National Maritime Day.
- 23: South Carolina admitted (1788).
- 24: First Telegraph Message sent (1844).
- 25: Ralph Waldo Emerson born (1803).
- 27: Golden Gate Bridge, San Francisco opened (1937).
- 29: Wisconsin admitted (1848).
Rhode Island admitted (1790).
Patrick Henry born (1736).
- 30: Memorial Day (In all the States, Territories, District of Columbia and Colonial Possessions, except Alabama, Arkansas, Florida, Georgia, Louisiana, Mississippi, New Mexico, North Carolina, South Carolina, Virginia and Tennessee).
- 31: Walt Whitman born (1819).
The Johnstown (Pa.) flood (1889).
Battle of Jutland (1916).
- 12: John Augustus Roebling born (1806).
Baseball Centennial Celebration of the invention of the game at Cooperstown, N. Y. (1939).
- 14: Hawaii organized as U. S. territory (1900).
Harriet Beecher Stowe born (1811).
Flag Day.
- 15: Pioneer Day (Idaho).
Franklin demonstrated the identity of electricity and lightning by use of a kite (1752).
Arkansas, 25th state admitted to the Union (1836).
Oregon boundary treaty signed at Washington by Great Britain and the U. S.
- 16: Commencement, the climax of the academic year when degrees are conferred with impressive ceremony.
- 17: Bunker Hill Day. (In Massachusetts, Suffolk County).
- 18: Battle of Waterloo (1815).
- 19: Beginning of War of 1812.
King John of England signed Magna Carta (1215).
- 20: West Virginia Day.
- 21: Longest Day in Year.
Father's Day; 3rd Sunday in June.
New Hampshire joined the Union (1788).
Constitution Ratified (1788).
- 22: Bolivarian Day (Canal Zone).
- 24: San Juan Day (Puerto Rico).
U. S. approves act requiring certain passenger ships to carry wireless equipment and operators (1910).
- 25: Virginia Admitted (1788).
North Korean Communists attack So. Korea (1950).
Battle of Little Big Horn, Montana (1876)
"Custer's last stand," his defeat by the Sioux Indians.
- 26: Virginia ratified the U. S. Constitution (1788).
President Truman orders U. S. troops into Korea battle (1950).
First American Troops land in France (1917).
- 27: Helen Keller born (1880).
- 28: Archduke Franz Ferdinand Assassinated in Sarajevo (1914).
U. S. purchased rights and franchises of France in the Panama Canal (1902).
Treaty of Versailles ending World War I signed (1919).
- 29: George Washington Goethals born (1858).
St. Peter's Day.
- 30: St. Paul's Day.
Congress granted Yosemite Valley and Mariposa Big Tree Grove to Calif. for a public park (1864). The valley was discovered in 1851.
Fourth Atomic Bomb dropped (experimental over water) Bikini (1946).

June

- 1: Kentucky admitted (1792).
Tennessee admitted (1796).
- 3: Confederate Memorial Day (Louisiana, Tennessee).
King's Birthday (Canada).
Birthday of Jefferson Davis (1808) (Florida, Mississippi, South Carolina, Texas, Virginia).
- 6: American Marines victorious at Belleau Wood, June 6-10 (1918).
Nathan Hale born (1756).
D-Day (1944).
- 7: Daniel Boone Day (Kentucky)
- 8: Battle of New Orleans (1815).
Children's Day, second Sunday in June.
Regular TV schedule, three times weekly, inaugurated by WGY, Schenectady (1928).
- 9: Feast of St. Columba.
Confederate Memorial Day (Petersburg, Virginia).
- 11: Feast of St. Barnabas.
The Continental Congress appointed John Adams, Thomas Jefferson, Benjamin Franklin, Roger Sherman and Robert R. Livingston to draft a declaration of independence (1776).
Kamehameha, first King of Hawaii, observed in Hawaii.
Transatlantic radiophoto of Pope Pius XI by Korn appearing in the New York World declared "a miracle of modern science." (1922).

July

- 1: Battle of San Juan Hill (1898).
Dominion Day (Canada).
Battle of Gettysburg (1863).
Federal fiscal year designated by the law of Aug. 26 (1842), as beginning July 1.
Dept. of Commerce organizes a radio division to enforce wireless act of June 24, 1910 (1911).
- 2: Richard Henry Lee's resolution declaring the U. S. independent passed by the Continental Congress (1776).
Garfield assassinated (1881).
- 3: Idaho admitted (1890).
John Singleton Copley born (1737).
- 4: Independence Day.
U. S. Military Academy at West Point Opened (1802).
Calvin Coolidge born (1872).
Slavery abolished in New York (1825).
Providence, R. I. founded by Roger Williams (1636).
Work on Erie Canal commenced (1817).
Thomas Jefferson died (1826).
James Monroe died (1831).
John Adams died (1826).
Cornerstone of Washington Monument laid (1848).
Surrender of Vicksburg (1863).
Bartholdi's Statue of Liberty presented to U. S. in Paris (1833).
American pilots first participated in air raids over Germany (1942).
- 5: Admiral David G. Farragut born (1801).
- 6: Republican Party founded (1854).
John Paul Jones born (1747).
Columbia University opened (1754)
- 7: U. S. annexed Hawaii (1898).
- 8: John D. Rockefeller born (1839).
Liberty Bell Cracked Tolling Death of John Marshall (1835).
- 9: Elias Howe born (1819).
- 10: Wyoming admitted (1890).
James McNeill Whistler born (1834).
- 11: John Quincy Adams born (1767).
Federal Communications Commission is organized to succeed Federal Radio Comm. and also to regulate wire telephony and telegraphy (1934).
- 12: Orangeman's Day.
- 13: Forrest's Day (Tennessee).
- 14: Stars and Stripes adopted (1777).
Bastille Day—First Celebrated in U. S. (1914).
Admiral Perry Opened First Negotiations for Trade With Japan (1853).
- 15: St. Swithin's Day.
- 16: Mary Baker Eddy Born (1881).
First Atomic Bomb exploded (experimental) New Mexico (1945).
- 17: Munoz Rivera's birthday (Puerto Rico).
- 18: William Makepeace Thackeray born (1811)
- 19: Franco-Prussian War began (1870).
- 20: Guglielmo Marconi died (1937).
- 21: Spanish Armada defeated by England (1588).
Society of Jesuits abolished by Pope Clement XIV (1773).
First Battle of Bull Run (1861).
CBS begins TV broadcasting from station W2XAB (1931).
- 24: Simon Bolivar born (1783).
Pioneer Day (Utah).
Mormon Pioneer Day (Idaho).
- 25: Occupation Day (Puerto Rico).
Fifth Atomic Bomb exploded (experimental under water) Bikini (1946).
- 26: George Bernard Shaw born (1856).
Serge Koussevitzky born (1874).
New York ratified the U. S. Constitution (1788).
- 27: First successful Atlantic Cable (1866).
Barbosa's birthday, in the Canal Zone.
- 28: Austria declared war on Serbia (1914).
Volunteers of America Founder's Day.
National Vegetable Week begins.
- 29: Booth Tarkington born (1869).
Benito Mussolini born (1883).
- 30: Henry Ford born (1863).
First Representative Assembly in America convened (1607).
First patent for wireless telegraphy granted in U. S. (1872).
Experimental television transmitter W2XBS opened by NBC in N. Y. (1930).
- 31: Feast of St. Ignatius Loyola.

August

- 1: Colorado Day.
Beginning of World War I (1914).
- 2: Government of India transferred to British Crown (1858).
U. S. War Dept. purchased its first military plane from the Wright Brothers (1909) thus founding the Army Air Corps.
- 3: Civic Holiday (Canada).
Germany declared war on England and France (1914).
Columbus sailed from Spain (1492).
- 4: Feast of St. Dominic.
- 5: Battle of Mobile Bay (1864) with Admiral Farragut in command.
Second Atomic Bomb dropped (1945) Hiroshima.
- 6: Feast of the Transfiguration.
Westinghouse discloses Stratovision plan (1945).
- 7: International Peace Bridge, dedicated (1927), commemorating more than 100 years of peace between the U. S. and Canada.
Creation of War Department (1789).

- Society of Jesuits restored by Pope Pius VII (1814).
- 8: Charles A. Dana born (1819).
Third Atomic Bomb dropped (1945) Nagasaki.
- 9: First Train Drawn in U. S. by Steam Locomotive (1831).
Izaak Walton born (1593).
- 10: Herbert Clark Hoover born (1874).
Russia declared War Against Japan (1945).
- 11: The "Clermont" Fulton's steamboat made a successful run up the Hudson River (1807).
- 14: V-J Day (1945).
Atlantic Charter Agreement between President F. D. Roosevelt and Prime Minister Winston Churchill (1941).
- 15: Panama Canal opened (1914).
- 16: Bennington Battle Day (Vermont).
First transatlantic cable opened (1858).
George Herman ("Babe") Ruth died (1948).
- 18: Virginia Dare born (1587).
- 19: National Aviation Day.
Orville Wright born (1871).
- 20: Benjamin Harrison born (1833).
- 21: Lincoln-Douglas debate began (1858).
- 22: Claude Debussy born (1862).
- 23: Oliver Hazard Perry born (1785).
- 24: British Burn White House (1814).
St. Bartholomew's Day Massacres, France (1572).
Festival of St. Bartholomew.
- 25: Edgar Wilson ("Bill") Nye born (1850).
- 26: Suffrage for Women—19th Amendment (1920).
- 27: Drilling of first oil well completed in Western Pennsylvania by Col. Edwin Lourentine Drake (1859).
- 28: Spanish landed at the site of St. Augustine, Fla. (1565).
Johann Wolfgang von Goethe born (1749).
- 29: Oliver Wendell Holmes born (1809).
- 30: Germany declared war on Poland (1939).
Beginning of World War II.
French fleet arrived in Chesapeake Bay to further the interest of American independence (1781).

September

- 1: Germany invaded Poland (1939).
Official V-J Day (1945). (Surrender Terms Signed Aboard U.S.S. Missouri.)
Labor Day.
Eugene Field born (1850).
- 3: First American Peace Treaty with England (1783).
Allies invaded Italy (1943).
- 4: Henry Hudson discovered Manhattan Island (1609).
- 5: First Continental Congress (1774).
- 6: Lafayette Day.
First Battle of the Marne (1914):
- 7: James Fenimore Cooper born (1789).
Japanese Peace Treaty (WW II) signed (1951).
- 8: Dutch Surrendered New Amsterdam (New York) to British (1664).
Italy surrendered (1943).
Crimean War ended (1855).
- 9: Admission Day (California—1850).
- 10: Arthur Holly Compton born (1892).
Rosh Hashonah.
Battle of Lake Erie (1813).
- 11: Harvest Festival.
O. Henry (pen name William Sydney Porter) born (1862).
- 12: Henry Hudson entered the river (1609).
Defender's Day (Maryland).
- 13: Walter Reed born (1851).
John Joseph Pershing born (1860).
Battle of Quebec (1759).
Battle of St. Mihiel (1918) First battle planned and carried out by American forces in World War I.
- 14: Great Britain and its colonies in America adopted the Georgian calendar (1752).
"The Star Spangled Banner" written by Francis Scott Key (1814).
- 15: Independence Day of the Central American Republics (1821).
William Howard Taft born (1857).
- 16: Russians burned Moscow (1812).
- 17: Constitution Day.
- 18: Cornerstone of U. S. Capitol laid in Washington, D. C. (1793).
N. Y. Times established (1851) when its first issue appeared.
Columbia Broadcasting System goes on air with basic network of 16 stations. Major J. Andrew White is president (1927).
- 19: Washington issued his farewell address to people of U. S. (1796).
Yom Kippur.
- 21: Great hurricane swept Atlantic Coast of N. Y. and New England thence going inland and causing great loss of life and property (1938).
- 22: Lincoln issued the preliminary proclamation freeing the slaves (1862).
Nathan Hale Executed (1776).
First day of Autumn.
- 23: Naval battle between "Bonhomme Richard" commanded by John Paul Jones and British frigate "Serapis" in North Sea (1779).

- 24: John Marshall born (1775).
- 25: Balboa discovered the Pacific (1513).
Bill of Rights (1789).
- 26: George Gershwin born (1898).
Battle of the Meuse-Argonne (Sept. 26-
Nov. 11, 1918).
- 27: American Indian Day (4th Friday).
- 28: Georges Eugene Benjamin Clemenceau born
(1841).
- 29: Michaelmas Day.
- 30: Mutual Broadcasting System starts as co-
operative four-station hookup (WOR, WGN,
WLW, and WXYZ), carrying first commer-
cial program (1934).

October

- 7: Francisco Franco proclaimed head of Spanish
Nationalist Government (1935).
Germany Crossed Border Into Czechoslo-
vakia (1938).
- 2: Ferdinand Foch born (1851).
Mohandas Gandhi born (1869).
- 3: Religious Education Week. First full week in
October.
- 4: Rutherford B. Hayes born (1822).
Wright Brothers took first long distance
flight in an Airplane (1905).
Chester A. Arthur born (1830).
- 5: Missouri Day.
National Business Women's Week, generally
the second week of Oct.
- 7: Stamp Act Congress held and Declaration
of Rights issued by Colonies (1765).
James Whitcomb Riley born (1853).
- 8: Edward Vernon Rickenbacker born (1890).
- 9: Fire Prevention Week.
Fraternal Day (Alabama).
Chicago Fire (1871).
- 10: U. S. Naval Academy in Annapolis opened.
(1845).
- 11: Eleanor Roosevelt born (1884).
Farmer's Day (2nd Friday) (Florida).
YMCA Founder's Day—Sir George Williams
born (1821).
FCC approves CBS color TV tests (1950).
National Bible Week.
- 12: Columbus Day.
- 14: William Penn born (1644).
- 15: First public demonstration of ether as an
anesthetic, Massachusetts General Hospital
(1846).
- 16: Noah Webster born (1758).
- 17: Surrender of General Burgoyne at Saratoga
(1777).
- 18: General Tojo appointed Premier of Japan
(1941).
Alaska Day.
FCC sets aside bands in ultra-high fre-
quencies for television aural or apex broad-

- casting and relay broadcasting, above 30,000
kc. (1937).
- 19: Surrender of Cornwallis (1781).
Volstead Act (Prohibition) passed (1919).
John Adams born (1735).
- 22: The Metropolitan Opera House opened with
presentation of Gounod's Faust (1883).
- 23: Sarah Bernhardt born (1845).
Al Jolson died (1950).
- 24: Transcontinental telegraph line completed
(1861).
Pennsylvania Day.
United Nations Day
William Penn born (1644).
- 26: Erie Canal opened to traffic (1825).
Better Parenthood Week, observed last week
in Oct.
- 27: Theodore Roosevelt born (1858).
- 28: Dedication of Statue of Liberty (1866).
- 31: Hallowe'en.
Admission Day, Nevada (1864).

November

- 1: All Saints' Day (Louisiana).
Liberty Day (St. Croix, Virgin Islands
Only).
National Broadcasting Co. is organized with
WEAF and WJZ in N. Y. as key stations,
and Merlin Hall Aylesworth as president
(1926).
- 2: General Election Day.
North Dakota admitted (1889).
South Dakota admitted (1889).
James K. Polk born (1795).
Warren G. Harding born (1865).
George Bernard Shaw died (1950).
- 3: Panama declared its independence of Colom-
bia (1903).
- 4: John Philip Sousa born (1854).
- 5: Guy Fawkes Day (English).
U. S. General Election Day.
- 6: Static-less radio system based on FM in-
stead of AM, is demonstrated on 2½ meter
wave by Maj. E. H. Armstrong at the insti-
tute of Radio Engineers, N. Y. (1935).
American Art Week.
- 7: Marie Sklodowska Curie born (1867).
- 8: N. Y. Symphony Orchestra gave its first con-
cert under Leopold Damrosch (1858).
Montana admitted (1889).
- 9: Great Fire in Boston (1872).
American Education Week
- 10: Martin Luther born (1483).
U. S. Marine Corps was created by the Con-
tinental Congress (1775).
- 11: Armistice Day, World War I.
Washington admitted (1889).
- 13: Robert Louis Stevenson born (1850).
Edwin Booth born (1833).

- 14: Robert Fulton born (1765).
Book Week.
- 15: Pike's Peak discovered (1806).
- 16: Oklahoma admitted (1907).
- 17: Sixth Congress Met for First Time in Washington (1801).
Suez Canal opened (1869).
- 18: Standard Time went into effect in the U. S. (1883).
Dr. V. K. Zworykin demonstrates his kinescope or cathode ray television receiver before a meeting of the IRE at Rochester, N. Y. (1929).
- 19: Lincoln's address at dedication of National Cemetery on the battlefield at Gettysburg (1863).
James A. Garfield born (1831).
- 21: North Carolina admitted (1789).
Edison Announced Invention of Phonograph (1877).
- 23: Franklin Pierce born (1804).
- 24: Zachary Taylor born (1784).
- 28: Thanksgiving Day (4th Thursday).
- 29: Admiral Byrd Discovered South Pole (1929).
- 30: Samuel L. Clemens (Mark Twain) born (1835).
Russia Invaded Finland (1939).
Winston Churchill born (1874).
- 13: Council of Trent (1545).
- 14: Alabama admitted (1819).
George Washington died at Mt. Vernon (1799).
- 15: Bill of Rights Day.
Dr. E. F. W. Alexanderson demonstrates his multiple lightbrush television system and projector at St. Louis (1926).
- 16: Boston Tea Party.
Ludwig von Beethoven born (1770).
- 17: John Greenleaf Whittier born (1807).
Aviation Day.
First Mechanical Airplane Flight by Wright Brothers (1903).
- 18: New Jersey admitted (1787).
First Sunday paper published (1796).
- 19: Tyrus (Ty) Cobb born (1886).
Washington went into winter quarters at Valley Forge (1776).
- 20: First Electric Lights on Broadway (1880).
- 21: Pilgrims Landed at Plymouth Rock (1620).
First day of winter.
- 23: George Washington Resigned Army Commission (1783).
NBC establishes a permanent coast-to-coast network (1928).
- 24: "Aida" first performed in Cairo, Egypt (1871) composed for celebration of opening of Suez Canal.

December

- 2: Promulgation of the Monroe Doctrine (1823).
- 3: Illinois admitted (1818).
Gilbert Stuart born (1755).
- 5: Martin Van Buren born (1782).
Walt Disney born (1901).
- 7: Pearl Harbor attacked (1941).
Roosevelt, Churchill, Stalin confer at Teheran (1943).
Delaware Day.
Daily facsimile broadcasting inaugurated by KSD, St. Louis (1938).
- 8: Eli Whitney born (1765).
U. S. Declared War on Japan (1941).
- 9: Germany-Italy Declare War on U. S. (1941).
- 10: U. S. Declared War on Germany-Italy (1941).
Peace Treaty Signed With Spain (1899).
Mississippi admitted (1817).
Human Rights Day.
- 11: Alfred Nobel born (1833).
Indiana admitted (1816).
- 12: First Marconi Wireless Across Atlantic (1901).
Pennsylvania admitted (1787).
Washington, D. C. became the permanent home of the U. S. Govt. (1800).
- Reginald Fessenden transmits human voice by wireless (1906).
- 25: Washington crossed the Delaware to attack Trenton (1776).
Christmas Day.
- 26: Battle of Trenton (1776).
Record snow fall in New York, exceeding in depth the blizzard of 1888 (1947).
- 27: Louis Pasteur born (1822).
- 28: Iowa admitted (1848).
Woodrow Wilson born (1856).
Irish Free State became State of Eire (Ireland).
- 29: Texas admitted (1845).
Andrew Johnson born (1808).
First American YMCA established in Boston (1851).
MBS, after operation as limited network for two years, expands transcontinentally by adding Don Lee Broadcasting System of California and other stations (1936).
- 30: Rudyard Kipling born (1865).
The Gadsden purchase and new boundary treaty ratified by Mexico and the U. S (1853).
- 31: New Year's Eve.

BIBLIOGRAPHY

OF

TELEVISION REFERENCE BOOKS

Beginning Television Production

by Melvin R. White
Burgess Publ. Co.
1953 - 107 pp.

Best Television Plays of 1952-53

Ed. by William Kaufman
Merlin Press
1954

The 1954 Radio Annual; Television Yearbook

Pub. by Jack Alicoate
Radio Daily Corp.
1954 - 1296 pp.

Broadcasting Projects: Radio & TV

by Henry L. Webank &
Sherman P. Lawton
Harper
1953 - 152 pp.

Campaigning on TV

Pub. by NARTB
1952 - 18 pp.

The Candidate and Television

by Suzanne F. Roberts
TV Digest
1952

Designing for TV

by Robert J. Wade
Pellegrini & Cudahy
1952

Eavesdropper at Large

by Allen Funt
Vanguard
1952 - 207 pp.

Handbook of TV and Film Techniques

by Charles W. Curran
Pellegrini & Cudahy
1953 - 120 pp.

Here is Television

by Thomas H. Hutchinson
Hastings House
1950 - 368 pp.

How to Announce for Television

Ed. by William Kaufman
Merlin Press
1954 - 100 pp.

Movies for Television

by John H. Battison
Macmillan
1950 - 376 pp.

Operation Backstage

by Robert J. Wade
Nat'l Bestg. Co.
1951 - 79 pp.

Radio and Television Acting

by Edwin Duerr
Rinehart
1950 - 417 pp.

Producing and Directing for Television

by Charles Adams
Henry Holt
1953 - 282 pp.

Radio and Television News

by Donald E. Brown &
John P. Jones
Rinehart
1951 - 480 pp.

Radio and Television Sound Effects

by Robert B. Turnbull
Rinehart
1951 - 334 pp.

Report On Rear Screen Slide Projection

by Fredric Stange
Dept. of U. S. Navy
1952 - 40 pp.

Science Via Television

by Lynn Poole
Johns Hopkins Press
1950 - 198 pp.

TV

by Layton Mabrey
Baylor University Press
1950 - 302 pp.

TV Writers Guide

by Margaret R. Weiss
Pellegrini & Cudahy
1952 - 224 pp.

The Technique of Film Editing

Compiled by Karel Reisz
Farrar, Straus & Young
1953 - 285 pp.

Techniques of Television Production

by Rudy Bretz
McGraw-Hill
1953 — 488 pp.

Television Do's and Don'ts

Compiled by Charles Schmitz
Nat'l. Council of Churches of Christ
1952

The Television Manual

by William Hodapp
Farrar, Straus & Young
1953 — 296 pp.

Television News Handbook

Ed. by Baskett Mosse &
Fred Whiting
Medill School of Journalism
1953 —

The Television Program

by Edward Stasheff & Rudy Bretz
A. A. Wyn
1951 — 355 pp.

Television Report

Pub. by Dept. of Agr., Radio-TV Service
1950-1953

Television Scripts for Staging and Study

by Rudy Bretz &
Edward Stasheff
A. A. Wyn
1953 — 322 pp.

The Television Workshop

by Howard Tooley
Northwestern Press
1953 — 108 pp.

Twenty-Two Television Talks

Pub. by Broadcast Music, Inc.
1953 — 260 pp.

U. S. Government Films for Television

by Seerley Reid &
Anita Carpenter
U. S. Office of Education
1952 — 54 pp.

Writing for Television

by Gilbert Seldes
Doubleday
1952 — 254 pp.

Membership List: Trade Directory, 1953-54

Pub. by RETMA
1953 — 132 pp.

1954 Television Directory

Pub. by Ross Reports on TV
Television Index, Inc.
1954

1953 Annual Data Book

Pub. by Frederick Kugel Co.
1953 — 100 pp.

A Radio and Television Bibliography

Compiled by Burton Paulu
Nat'l. Assn. of Ed. Bcstrs.
1952 — 129 pp.

Radio-TV Personalities Directory 1953-54

Pub. by Radio Reports, Inc.
1953 — 119 pp.

TV Film Program Directory (Nov. 1953)

by Judy Dupuy
Best. Information Bureau
1953 — 455 pp.

Telecasting Yearbook — Marketbook, 1953-54

Pub. by Bestg. Publications
1953 — 456 pp.

Television Factbook

Pub. by Television Digest
1954

All About Television

by John Derby
Popular Mechanics Press
1952 — 171 pp.

The Crowded Air

by Roger Manvell
Channell Press
1953 — 99 pp.

Dunlap's Radio & Television Almanac

by Orrin E. Dunlap, Jr.
Harper
1951 — 211 pp.

Film in Television

Pub. by Sullivan, Stauffer,
Colwell & Bayles, Inc.

Foreign Television Developments

by Guida B. Hall
U. S. Bureau of Foreign & Dom.
Commerce
1953 — 12 pp.

Foundations in Broadcasting

by Edgar E. Willis
Oxford
1951 — 439 pp.

Fundamentals of Television

by Murray Bolen
Hollywood Radio Pub.
1950 — 270 pp.

Out of the Blue

by John Crosby
Simon & Schuster
1952 — 301 pp.

Radio Broadcast Primer

Pub. by FCC
1952 — 22 pp.

Radio, Television and Society

by Charles A. Stepmann
Oxford
1950 110 pp.

TV Dictionary Handbook for Sponsors

by Herbert True
Sponsor Magazine
1951 70 pp.

The TV Jeebies

by Paul Ritts
Winston
1951 150 pp.

Television and Radio in American Life

Ed. by Herbert L. Marx, Jr.
H. W. Wilson Co.
1953 198 pp.

Television: Terminology — Bibliography

Compiled by Benjamin Draper
Academy of Sciences
1953 57 pp.

Television, The Magic Window

by Frank Denman
Macmillan
1952 60 pp.

What's The Right Word? Common and Uncommon Terms in Radio-TV-Electronics

Pub. by RCA
1952 50 pp.

World Communications

Pub. by UNESCO
Columbia University Press
1951 223 pp.

Your Slip is Showing!

Compiled by Kermit Schafer
Grayson Pub. Corp.
1953 120 pp.

Advance Promotion for the New TV Stations

Pub. by NARTB
1953 i pp.

Application Data and Filing Information for Television Stations

RCA Engr. Products Dept.
1952 73 pp.

Considerations in the Early Planning of Television Stations

by Joseph Herold
Broadcast News, May-June
1952

Guide to Greater Profits for TV, Radio, Record and Electrical Appliance Retailers

by Editors of Radio & TV Retailing
Caldwell-Clement
1951 183 pp.

Opportunities in Television

by Jo Ranson & Richard Pack
Grosset & Dunlap
1950 128 pp.

The P's and Q's of V's and U's

Pub. by American Best. Co.
1953 59 pp.

Pattern for TV Profit

by Roy F. Allison
F&M-TV Magazine
1952

The Planning and Construction of Television Broadcasting Stations

Pub. by NARTB
1952 33 pp.

Station Management Takes a Look at Television Jobs

Pub. by NARTB
1952 17 pp.

TV and Electronics as a Career

by Ira Kamen &
Richard H. Dorf
Rider
1951 326 pp.

TV Station Operating Costs

by Joseph Herold
Television Digest April 19
1952 6 pp.

Television Station Planning

Compiled by NARTB Library
1953 3 pp.

UHF-VHF: Circulation Promotion for Television Stations

Pub. by NBC
1953 45 pp.

Your Career in Television

by William E. Kaufman &
Robert S. Colodzin
Merlin Press
1950 206 pp.

Your Television Set: How to Buy and Service It

by James C. Hamlett
William Frederick
1953 22 pp.

Audience Reaction to Evening Television Programs

Erwin, Wasey & Co.
1951 — 31 pp.

Chicago Summer Television

by Horton, Mauksch, Lang
Opinion Research Center & Univ. Chi.
1952 — 71 pp.

Cooperative Advertising: The Way to Make it Pay

by Mosher S. Hutchins
Ronald Press
1953 — 255 pp.

Five Big Reasons for Getting Into Daytime Television Now

CBS Television Network
July 1951

How to Increase the Effectiveness of Television Commercials

Natl. Bcstg. Co.
1952 — 48 pp.

Just What Has Television Done to Recreation — Communications?

Pub. by Radio-TV Mfrs. Assn.
1952 — 16 pp.

Modern Radio Advertising (2nd Ed.)

by Charles H. Wolfe
Funk & Wagnall
1953 — 738 pp.

A Plan for the Evaluation of Audience Measurement Methods

Natl. Assn. of Bctrs.
March 1951 — 32 pp.

Profitable Advertising in Today's Media and Markets

by Ben Duffy
Prentice-Hall
1951 — 416 pp.

A Report on the Impact of Television in a Major Metropolitan Market

by Harold W. Zorbaugh & C. Wright Mills
Puck, the Comic Weekly
1952 — 35 pp.

Sixth Annual Television Poll

by Gordon Levoy
1953 — 32 pp.

Starch Evaluation of Television Commercials

by Daniel Starch & Staff
1952 — 15 pp.

Successful Radio and Television Advertising

by E. F. Seehafer & J. W. Laemmar
McGraw-Hill
1951 — 574 pp.

TV Film Commercials

Pub. by American TV Society
1952

TV Results (1953 Ed.)

Pub. by Sponsor Services
1953 — 56 pp.

"TV Today": Report II

by Thomas E. Coffin
Natl. Bcstg. Co.
1952 — 131 pp.

Tele-Census

Pub. by Woodbury College
1949

Television Advertising and Production Handbook

Ed. by Irving Settel & Norman Glenn
Thomas Y. Crowell
1953 — 480 pp.

Three Years of New York Television 1951-53

by Dallas W. Smythe
Natl. Assn. of Ed. Bcstrs.
1953 — 161 pp.

What TV is Doing to Us

by Jack Gould
New York Times
1951 — 13 pp.

What's Happening to Leisure Time in Television Homes?

Pub. by B, B, D & O Adv. Agy.
1951

Why Sales Come in Curves

Pub. by NBC
1953 — 67 pp.

Education on the Air: Twenty-Second Yearbook of the Institute for Education By Radio & TV

Ed. by O. Joe Olson
Ohio State University
1953 — 396 pp.

Educational Television Moves Forward: A Report of the Montclair Project

by Lawrence H. Conrad
State Teachers College
1952 — 39 pp.

Educational Television Plans

RCA Engr. Prod. Dept.
1953 — 12 pp.

**Grade School Families Meet
Television**

by Frank L. Sweetzer
Boston University
1953 - 28 pp.

Of Children and Television

Pub. by Xavier University
1951

**A Study of Television as a
Teaching Tool**

by Russell E. Helmick
University of Cincinnati
April 23, 1951 - 35 pp.

**Tales of Seven Cities — And
of Video That Teaches**

Pub. by Natl. Citizens Committee
for Educational Television
1953 - 37 pp.

**Television and Education in
The United States**

by Charles A. Sieppmann
Columbia Univ. Press
1952 - 131 pp.

Television in Our Schools

by Franklin Dunham &
Ronald R. Lowdermilk
Dept. of Health, Ed. & Welfare
1953 - 34 pp.

Television and Our Children

by Robert L. Shayon
Longmans, Green
1951 - 94 pp.

**Television in School, College,
And Community**

by Jennie Waugh Callahan
McGraw-Hill
1953 - 339 pp.

**A Television Policy for
Education**

Edited by Carroll V. Newsom
American Council on Education
1952 - 266 pp.

Training by Television

by Robert T. Rock Jr., James S.
Duva and John E. Murray
Navy Special Devices Center
1951 - 2 vols. (24 pp. each)

Vision in Television

by Hazel Cooley
Channel Press
1952 - 80 pp.

**Youth Discussion on
Television**

Pub. by Jr. Town Meeting League
1952 - 80 pp.

**Broadcasting and Telerising
Baseball Games**

Govt. Print Off.
1953 - 206 pp.

**First Report to the People of
The United States**

Pub. by Television Code Review Bd.
Nov. 1953 - 34 pp.

The Judges and the Judged

by Merle Miller
Doubleday
1952 - 220 pp.

Radio and Television Law

by Harry P. Warner
Matthew Bender
1948 - 1095 pp.

**Risks and Rights in
Publishing, Television,
Motion Pictures, Advertising
and the Theater**

by Samuel Spring
Norton
1952 - 385 pp.

**Rules Governing Television
Broadcast Stations**

Pub. by FCC
Federal Register
July 4, 1953 - 31 pp.

**Questions and Answers in
Television Engineering**

by Carter V. Rabinoff &
Magdalena E. Wolbrecht
McGraw-Hill
1950 - 300 pp.

The Science of Color

Pub. by Optical Society of America
Thomas Crowell
1953 - 385 pp.

Standards on Television

Pub. by Institute of Radio Engineers
Part I, 1953

Television-Broadcasting

by Howard A. Chinn
McGraw-Hill
1953 - 700 pp.

Television Principles

by Robert B. Dome
McGraw-Hill
1951 - 291 pp.

**Television Simplified
(4th Ed.)**

by Milton S. Kiver
Van Nostrand
1951 - 608 pp.

Video Handbook

by Morton G. Scherage &
Joseph J. Roche
Howard W. Sams
1951 - 892 pp.

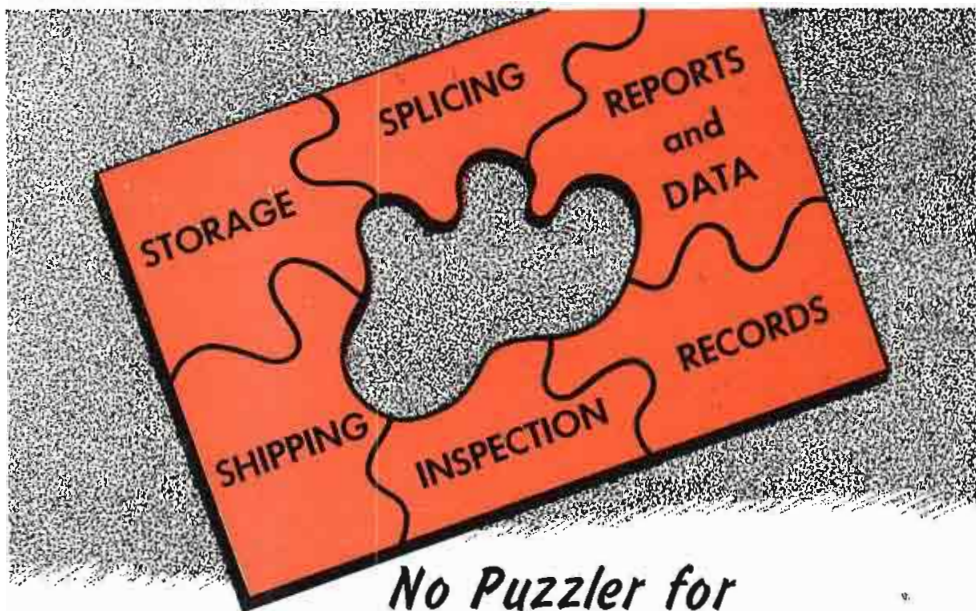

No Puzzler for TV FILM USERS and DISTRIBUTORS

Whether you're an advertising agency, film producer or distributor, station or network, handling 16mm or 35mm film, don't be puzzled when these and similar questions arise:

Will the film be shipped on time? Are the commercials spliced in properly?

Where can we store surplus film? Where can we consign returned film? Who will examine and repair damages? Who will remove out-dated commercials?

Call Bonded, the world's largest film service organization servicing and shipping over 5,000,000 reels of film yearly for the film and television industries.

Bonded's Television Film Service Division is organized to handle as many film service operations as you require—storage, inspection, shipping, splicing, keeping records and preparing reports and data on all your film—at a nominal fee.

You'll find that Bonded offers the largest film service facilities available anywhere—from storage through screening:

FILM STORAGE—six huge, centrally located warehouses equipped with the latest and best means of protecting film.

PHYSICAL DISTRIBUTION & HANDLING—thoroughly experienced personnel to insure maximum efficiency for both 16mm and 35mm film.

SCREENING—Bonded's *Film Center Theatre* available for day and night 16mm and 35mm screenings.

For additional information, call Judson 6-1030.



BONDED FILM STORAGE
CO., INC.

630 NINTH AVENUE, NEW YORK CITY

Judson 6-1030

MEMBER OF NATIONAL FILM SERVICE, INC.

BONDED'S FACILITIES ARE NOW AVAILABLE IN LOS ANGELES AND NEW YORK

1001 TITLES

from **UNITY!**

★ **300 FEATURES**

starring - CAREY GRANT • GENE TIERNEY • VICTOR MATURE
LINDA DARNELL • JAMES MASON • MERLE OBERON • ROCHESTER
CONSTANCE BENNETT • ROLAND YOUNG • JOAN BLONDELL
EMLYN WILLIAMS • FRANCES LANGFORD • WALTER HUSTON, et cetera

★ **52 LAUREL & HARDY comedies**

★ **39 HALF HOUR Programs**

★ **125 CARTOONS**

★ **44 WESTERNS**

★ **22 SERIALS**

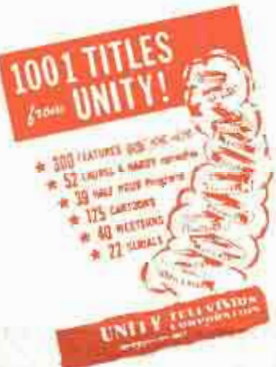

Write
for the
new

Unity 1954 catalogue

UNITY TELEVISION CORPORATION

1501 BROADWAY, NEW YORK 36, N. Y. • LOnacre 4-8234

West Coast Representative • UNITY TELEVISION CORP. of California • 8951 Sunset Boulevard • Hollywood 46, Cal

RADIO
ANNUAL
TELEVISION
YEAR BOOK

ZIV'S "HOUR OF STARS"



**TONY
MARTIN**

**GINGER
ROGERS**

UP TO 75 SPOTS PER WEEK SOLD IN "HOUR OF STARS"

**LOOK
AT THESE
STATION
SELL-OUTS!**

WSAI CINCINNATI, OHIO
"HOUR OF STARS" . . .
SOLD OUT!
75 SPOTS WEEKLY ON FIRST AUDITIONS
TO THESE ALERT ADVERTISERS . . .

- ALBERS SUPER MARKET
- JUMBO PEANUT BUTTER
- PEPSI-COLA
- HOTPOINT APPLIANCES (dealer)
- BAVARIAN BREWING CO.
- MR. MUSTARD
- WORTHMORE SOUP
- DORSEL'S FLOUR

All 8 Sponsors New to WSAI

KLMR LAMAR, COLORADO
"HOUR OF STARS" . . .
SOLD OUT!
75 SPOTS WEEKLY TO THIS
GREAT GROUP OF SPONSORS . . .

- FLORA REXALL STORE
- MILNE INSURANCE CO.
- LAMAR LIGHT & POWER CO.
- PEERY ELECTRIC
- POWER'S FIRESTONE STORE
- CUT RATE GROCERY & MARKET
- DON WESTFALL CREDIT BUREAU
- MAIN CAFE
- MORANS HARDWARE STORE

Hour of Stars Creates New Business!

WDOY
"HOUR OF STARS"
SOLD OUT!
75 SPOTS WEEKLY TO THIS
GREAT GROUP OF SPONSORS . . .

- EMANUEL'S
- DOVER HADY
- PHILCO DEALER
- VOGUE SHIRT S
- DANNEMANS
- NAP & SPINCE
- SANDERS JEW
- WESTERN ELECT
- GENERAL ELECT
- HUBER BREAD

The FAMOUS

"plus 80" PACKAGE

LYNN BARR

CARY GRANT

JEFF CHANDLER

RANDOLPH SCOTT

VIVIEN LEIGH

JOHN WAYNE

PAULETTE GODDARD

RAY MILLAND

ANN SHERIDAN

GARY COOPER

BLAN LAIN

MARILYN MONROE

20



Charlie Chan Mysteries

20



All Star Adventure Classics

20



International Masterpieces

20



Hollywood Major Package



Ask for your "plus 80"
...The Major Series... NEW
Feature Films for TV... from
the great production studios of
Hollywood... Alexander Korda
Hal Roach... with brilliant stars
and exciting personalities... now
being telecast by the Major Stations
of the Nation.

UNITY TELEVISION CORPORATION

1501 BROADWAY, NEW YORK 36, N. Y. • LOngacre 4-8234

West Coast Representative • UNITY TELEVISION CORP. of California • 4951 Sunset Boulevard • Hollywood 46, Cal



"Dedicated to pioneering and steadfast in our purpose to give America pre-eminence in communications, we shall continue our efforts to advance and to merit the faith and confidence the American people have in 'RCA' as an emblem of quality, dependability and progress."

Chairman of the Board

RADIO CORPORATION OF AMERICA