

# RADIO AGE

RESEARCH · MANUFACTURING · COMMUNICATIONS · BROADCASTING

*1-3-40*



OCTOBER

1943

IN TRIBUTE TO AMERICA'S RADIO INDUSTRY...WORKING TOGETHER FOR VICTORY

EAST SIDE

WEST SIDE

ALL AROUND THE WORLD



## .... Radio Brings Them the Sidewalks of Home

Sure enough, that's a New York announcer giving the football scores! And there's no mistaking that hot music—it's a famous Chicago "name" band. And that comedian from Hollywood—why, he's the same zany who kept them in stitches every week back home.

American radio manufacturers have supplied sturdy little short-wave sets that bring America to any part of the globe. And that's been a big factor in the sky-high morale of our fighting men overseas.

Every day, U. S. radio manufacturers are making huge deliveries of military radio equipment to speed the day of victory. Their war experience, added to their manufacturing skill, is effecting technical advances that will be important to peacetime production.

*Your purchase of War Bonds will help supply American fighting men with the world's finest equipment.*



SCIENCE SMASHES AT THE AXIS in RCA Laboratories, working unceasingly in radio-electronic research. Proud of the privilege of serving America's great radio industry in its united war against the Axis, RCA will continue to make the fruits of its basic research available to American makers of radio equipment. This will help American manufacturers to provide finer radio-electronic products and services to a world at peace.

# RCA Laboratories



A SERVICE OF RADIO CORPORATION OF AMERICA

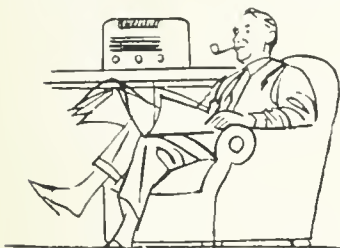
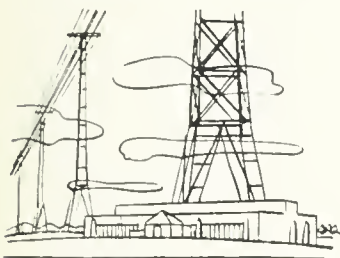
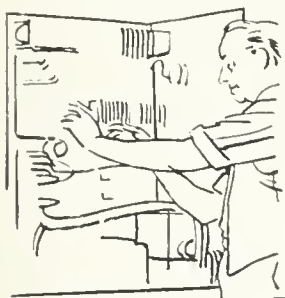
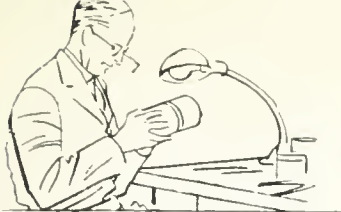

# RADIO AGE

RESEARCH · MANUFACTURING · COMMUNICATIONS · BROADCASTING

VOLUME 3 NUMBER 1

OCTOBER 1943

## CONTENTS

|   | PAGE |
|---|------|
| RADIO RELAYS FOR TELEVISION<br><i>An Interview with Ralph R. Beal, RCA Director of Research</i> . . . | 3    |
| PHOSPHORS BRIGHTEN RADIO PICTURE<br><i>by H. W. Lereenz</i> . . . . .                                 | 7    |
| RADIO REPORTS THE WAR<br><i>by William F. Brooks</i> . . . . .  | 11   |
| RADIO CRYSTAL BOTTLENECK BROKEN<br><i>by Harry E. Leroy</i> . . . . .                                 | 15   |
| ENGINEERS PREDICT RADIO WEATHER<br><i>by Henry E. Hallborg</i> . . . . .                              | 18   |
| PERSONNEL AIMS OUTLINED<br><i>by Forrest H. Kirkpatrick</i> . . . . .                                 | 21   |
| OCCUPIED NATIONS HEAR NBC<br><i>Escaped French Aviator Brings Report</i> . . . . .                    | 22   |
| NBC BUILDS ITS AUDIENCE<br><i>by Jean E. Harston</i> . . . . .  | 23   |
| CHEMISTRY AIDS WAR WORK<br><i>by Clifford Eddison</i> . . . . .                                       | 25   |
| PRODUCTION WINS 3 AWARDS<br><i>RCA Victor, Radiomarine Workers Honored</i> . . . . .                  | 27   |
| "WHAT'S NEW?" IS RADIO HIT<br><i>Critics Praise RCA's New Broadcast Program</i> . . . . .             | 28   |
| OWI USES RECORDING UNITS<br><i>Studios Equipped with RCA Lathes</i> . . . . .                         | 30   |
| BLUE NETWORK SALE ANNOUNCED BY RCA<br><i>Agreement with Edward J. Noble Revealed</i> . . . . .        | 31   |
| RCA WORKERS LAUNCH SHIP<br><i>Production Suggestions Win Honor</i> . . . . .                          | 32   |
| RCA SETS AID SICILY FIGHT<br><i>Facilitated Invasion, Rear Admiral Cochrane Says</i> . . . . .        | 33   |
| LISTENING-IN FROM "MIDDLE OF NOWHERE"<br><i>Sarnoff's Son Writes from South Pacific</i> . . . . .     | 33   |
| LUCY MONROE STARTS NEW RALLY SERIES . . . . .   | 34   |
| PLAN POST-WAR TELEVISION . . . . .  | 34   |
| SARNOFF MEETS RCA CADETTES IN INDIANA . . . . .   | 34   |

THE COVER—This color photograph of various phosphor applications was taken in a dark room with "black light," i.e. ultraviolet, to excite the phosphors. The large letters are cardboard coated with phosphors; the glass bottles and two series of glass vials contain phosphor crystals; the oscillograph panels are phosphor-coated by the silk screen process; the small RCA emblems are phosphors enamelled on iron plates, and the discs and knobs are transparent plastics containing embedded phosphor crystals. All of the phosphors shown are derivatives of zinc sulphide. (See story on page 7)

Radio Age, published quarterly by the Department of Information of the Radio Corporation of America, RCA Building, New York, N. Y., for the RCA services: RCA Laboratories, RCA Victor Division, R.C.A. Communications, Inc., Radiomarine Corporation of America, National Broadcasting Company, Inc., R.C.A. Institutes, Inc., RCA Service Company, Inc.





*O say, can you see,  
by the dawn's early light,  
What so proudly we hailed  
at the twilight's last gleaming?  
Whose broad stripes and bright stars,  
through the perilous fight,  
O'er the ramparts we watched  
were so gallantly streaming?*

---

THIS UNUSUAL SCENE, PHOTOGRAPHED AT DAWN SEPTEMBER 14, SHOWS LUCY MONROE (LEFT), RCA'S DIRECTOR OF PATRIOTIC MUSIC, SINGING THE STAR SPANGLED BANNER ON THE RAMPARTS OF OLD FORT MC HENRY, BALTIMORE, MD. HERE, ON THE SAME DATE 129 YEARS AGO, FRANCIS SCOTT KEY CONCEIVED OUR NATIONAL ANTHEM.

—NBC Photo by Sydney Destor



# Radio Relays for Television

FARFLUNG NETWORKS, LINKED BY AUTOMATIC STATIONS, ARE ENVISAGED BY RALPH R. BEAL

TELEVISION networks—international as well as domestic, made possible by automatic, unattended radio relay stations and other new developments—are envisaged by Ralph R. Beal, Research Director of RCA Laboratories. Turning in the swivel chair at his desk high up in Radio City, Mr. Beal looked reflectively into the west. He was framing an answer to the oft-asked question “What will be new in post-war radio?”

All America stretched out before him as he looked across the Hudson and over the New Jersey countryside. It was as if the emptiness of space above, and the country and its people beneath held the answer. After the war there would be tiny wavelengths for television made more powerful by wartime research; after the war, in millions of homes from coast to coast there would be countless people anxious to see as well as to hear by radio. For almost twenty years they have had network broadcasting; now they are ready for network television.

“Will there really be a nationwide television system similar to that of broadcasting?” Mr. Beal was asked. As if he definitely had found the answer, he quickly sketched the American landscape from the Atlantic to the Pacific, in fact all the world, dotted with a radically new form of “lighthouse”—the radio relay station.

Below his lofty window, directly down 49th Street, at the edge of the Hudson River, a great engineering feat was progressing. Inch by inch, the Normandie was rising out of the mud. And out of the silt of war, Mr. Beal could see another engineering triumph emerging, the definite promise of a radically new method of

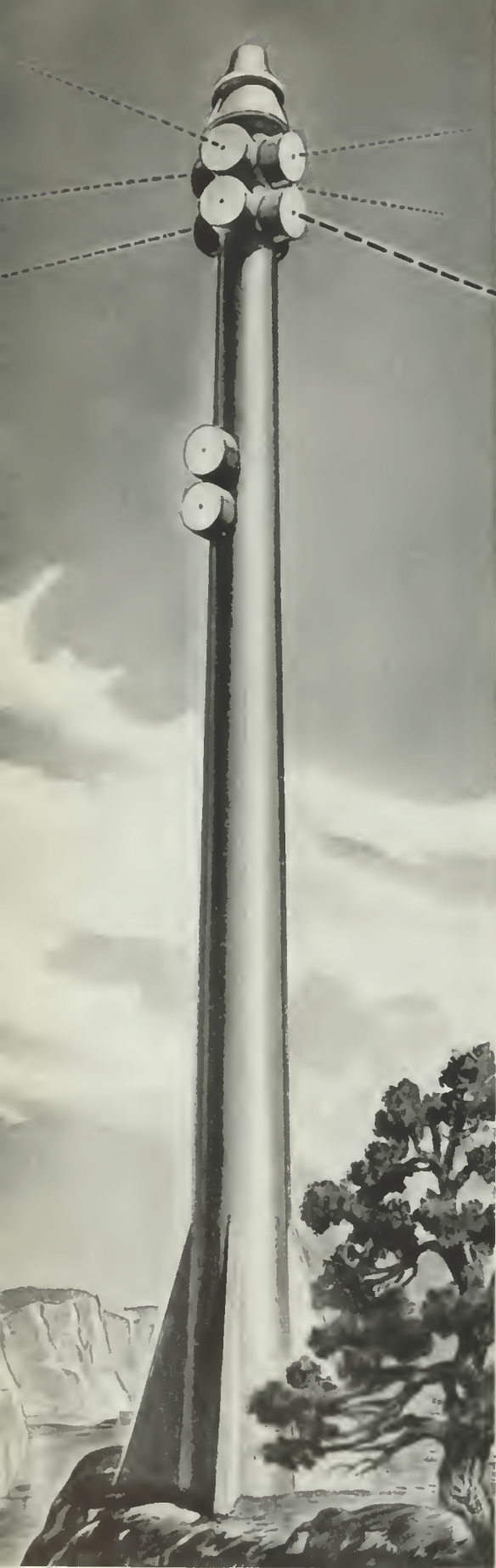

communication—the automatic relay of television pictures and messages from city to city, from country to country. Just as surely as the Normandie was rising, so was the dawn breaking on a new era in radio.

“Are radio relays sufficiently developed so that television can depend upon them for distribution of its pictures from city to city?” Mr. Beal was asked.

“Yes, indeed,” he said. “Radio can serve itself. Doing so would introduce a new form, or a new branch of radio communication. It will have to be less expensive, of course, than other methods, but there are encouraging indications that this will be possible and practical. Had radio relaying descended upon us at the advent of wireless, we would have looked upon it as a miracle rather than a new artery of communication. Automatic, unattended radio relay stations, located 20 to 50 miles apart, will link television stations into national chains. But the scope of this new development goes much further afield in communication than merely to hook up television transmitters, some of 50-kilowatt power.

“Think what these unattended radio relay stations promise to such vast areas as China, Russia and Africa; think what they will mean for countries which haven’t enjoyed the splendid trunk line communication services as found in the United States and the British Isles. It is my belief that in the post-war era other regions will also have extensive trunk line systems of communication made possible by radio relays of telegraph messages, telephone calls, sound broadcasting and television. The routes of these radio relays will extend to any part of the world. They can go through the jungles, from island to island, across mountains and the polar wastes. Neither tropical heat, nor arctic snow, neither fog nor hurricane will ‘cut’ these global lines. They can be built to be practical, efficient, and foolproof.”

Opening a drawer in his desk, Mr. Beal brought out a picture of a radio relay station as the engi-

neers have envisaged it and made it part of their plans. It looks like a streamlined lighthouse with little bulging eye-like windows at the top facing to the four winds. Behind each of these windows is a highly directive centimeter wave antenna.

The radio relay system is to be no one-way ethereal street, as Mr. Beal charts it. Multiple channels make it all the more promising in efficiency, flexibility and service. The relay towers will handle numerous circuits, for example, down and back from New York to Washington. Furthermore, the circuits can be multiplied to any reasonable extent, not only to carry one television program but several simultaneously, as well as “FM” sound broadcasts, telegraphic traffic and facsimile. In fact, relay circuits should be among the busiest in the air.

The main relay system, envisaged by Mr. Beal, will be like a great inter-city spine, becoming interstate and eventually transcontinental. The ribs will spread to television stations. To illustrate its possibilities, he describes it as it is likely to function between New York and Washington: While the NBC television program is being broadcast from the aerial on top of the Empire State Building, a different program will be originating in Washington. Both programs will be fed simultaneously into the relay system leading from Manhattan Island through Philadelphia to the Nation’s capital. One Philadelphia station can elect to broadcast the program from New York, while another taps the relay channel carrying the program staged in Washington.

Also, if a New York station, aside from the NBC transmitter, desires to broadcast the Washington program, it can do so by tapping the relay channel. In this way, the relay system becomes a trunk line that can be tapped at will by the television stations, thereby affording greater freedom of program selection and operation. The relay enhances variety in programming, because there may be four or five relay channels simultaneously car-

rying different programs, which can be selected by the main television stations.

In addition to this main system, there are supplementary methods of operation. In the simplest form the relay stations might serve as links in a chain of stations. For example, if one of these "radio lighthouses" were located atop the Orange Mountains in New Jersey, its eastern "eye" might intercept pictures from the NBC station on the Empire State Building in New York, and "bounce" them along to the stations in other directions within a 50-mile radius.

Standard television stations within that area would intercept the pictures and re-broadcast them to homes. Simultaneously, these standard stations, as well as the relay stations within the 50-mile circle, would toss the pictures beyond the horizon to be picked up by other stations and relayers. Already telecasts from New York have been intercepted 129 miles away, at the Helderberg Mountains, near Schenectady, without intervening relays in the Catskill Mountains. Philadelphia also has re-broadcast the New York programs without intervening relays. Nevertheless, it has been found that by use of relays, the picture quality is near perfect, while without relays, a degrading effect is inherent, and it is more noticeable as the distance between stations increases.

Radio relaying will be comparatively simple, Mr. Beal explained. The relay transmitters will operate on microwaves with the energy concentrated almost in a beeline. Practically all the power is made to serve a useful purpose; it is not scattered as in broadcasting. Therefore, relatively small amounts of power will operate the relay transmitters. The apparatus is neither cumbersome nor complicated. It is simple and compact. It could not be otherwise and still perform in the domain of tiny wavelengths which bring radio men so close to the frontiers of light, he said.

"We know, of course," continued Mr. Beal, "that ultra-short waves and centimeter waves travel in a straight line and leave the earth on

a tangent at the horizon. The area of the earth's surface touched by such waves, is much like that touched by a stick held against a basketball. Obviously, if we use high towers or antennas on lofty buildings or mountain peaks, we capture and re-transmit the waves at higher levels, and therefore their effective range is lengthened. With the use of radio relay stations, the average range is about 30 miles, depending upon the terrain and various other factors. It is interesting to recall that an airplane over Washington, D. C., carrying a television receiver intercepted the pictures from the NBC aerial on the dome of the Empire State Building 200 miles away. But for such long distance reception of the ultra-short waves, the plane had to go up 20,000 feet."

"It is to be expected," continued Mr. Beal, "that television stations will first go on the air in such broadcasting centers as New York, Chicago and Los Angeles. But there

is every indication that alert broadcasters will keep pace with them in such localities as Boston, Philadelphia, Washington, Pittsburgh, Cleveland, Detroit, St. Louis, Kansas City, Omaha, Denver, and San Francisco. It seems logical to assume that the first television network linked by radio relay stations, will be formed along the Atlantic Seaboard.

"But television will not be limited to the larger cities. The radio map will be dotted with stations in cities like Schenectady, Utica, Syracuse, Minneapolis, Erie, Buffalo, Louisville and many others. By the use of radio relays, these too will become outlets for the television network which before many years pass after the war, will weave from the east across the Mississippi and the mid-west plains to meet a Pacific Coast link striking eastward across the Rockies. A relay station atop Pike's Peak might well be the key station to complete a transcontinental television chain.



"It seems clear that the tree of radio development is about to spread new branches extending in many directions," said Mr. Beal. "The roots of post-war radio television are in the soil of wartime research. They are being cultivated by radically new electron tubes. Radio is being prepared for vision. All America will go radio sightseeing, for science is equipping the United States with a new optic nerve."

Responding to Mr. Beal's enthusiasm and confidence in nation-wide television, the interviewer asked whether international television would some day be possible. If the ultra-short waves leap into space at the curvature of the earth, how could they ever be made to encircle the globe.

"I firmly believe that we shall find the key to world-wide television," said Mr. Beal. "Radio history will repeat itself. Broadcasting started locally in big cities and rapidly extended to smaller towns encompassing a vast audience. Gradually, east and west coast networks were formed, and in 1927 their wire tentacles met in the Rockies and we had the first transcontinental hook-up.

"Then, before many years, short-wave stations linked the continents and international broadcasting was achieved. The pattern for television will be much the same. The post-war world will be ready for it; television promises to be one of the great contributions of science to the new world. It symbolizes the spirit of the United Nations by bringing new vision to all people regardless of race, color, or creed.

"Just think what television trunk lines will mean to China," continued Mr. Beal. "I have been there and

I feel that I know how welcome the new art of radio relaying will be to the millions of Chinese, for it will bring them communications, entertainment, and education on a scale they have never known. What a gigantic task it would be to wire all China and its great open spaces for sound. But how much easier it will be to do the job by 'wireless,' to dot the countryside with relatively inexpensive radio relay transmitters that will give to China a trunk line system of communication for television, radio, telephone and telegraph. Even the Himalayas will be no barrier to such radio relaying. Their high mountain peaks will speed the process, for relay stations at such altitudes can reach far beyond the horizons of the valley. China will then have a new Burma Road—a road of television.

"Of course, you will understand," said Mr. Beal in concluding the interview, "that I have spoken of these technical developments from the standpoint of the engineer. I realize, as do others, that it will take money to establish such a radio relay system as I have described. Indeed, it will take more than money. It will require a sympathetic and helpful attitude on the part of Governmental agencies concerned with licensing and regulation and the daring spirit of the American industrial pioneers who have led the way in so many new developments."

Radio engineers know that scientifically, and technically, radio relay transmitters are practical and efficient. These stations are no overnight development. Great headway had been made long before the war. As early as 1932, field tests of 240-line electronic television were con-

ducted by RCA at Camden, N. J., with pictures from New York relayed through an automatic station at Arney's Mount, near Trenton, N. J.

Further revealing the utility of this system, in June, 1936, RCA demonstrated a facsimile ultra-short wave radio circuit connecting New York and Philadelphia with radio relay stations at New Brunswick and at Arney's Mount.

Demonstrating continued progress, in 1941, RCA relayed television pictures by radio from Camp Upton, Long Island to New York. As a feature of the test, pictures from the NBC transmitter on the Empire State Building were picked up at Upton by a mobile television unit, which relayed them across 17 miles to Hauppauge from which point they were "bounced" to Bellmore for direct 28-mile relay to Radio City for reproduction on a 20-foot theatre screen as well as on home-receivers.





# Phosphors Brighten Radio Future

HIGHLY EFFICIENT LUMINESCENT MATERIALS. DEVELOPED BY RCA RESEARCH. OPEN NEW FIELDS OF APPLICATION— BENEFITS MAY EXTEND TO HOME, HEALTH, SCIENCE, AND INDUSTRY



By H. W. Leverenz

RCA Laboratories,  
Princeton, N. J.

ONE dark night in mediaeval Italy, a weird blue glow started a sequence of experiments which led to electronic television, fluorescent lighting and a score of other useful services catering to the human eye. The glow was observed by Vicenzio Casciarolo, a Bolognese alchemist, who, in 1603, observed light emanating from some white barite rocks which had been accidentally heated with charcoal in his forge. Casciarolo's material had the amazing facility of absorbing daylight and then emitting a feeble blue light during the night. Similar materials, though vastly improved, are now called phosphors, or luminescent materials, and are produced in hyper-clean laboratories or special factories for use in war and peace.

Development and use of phosphors languished for more than three centuries until electronic television research, pioneered principally by RCA, devised highly efficient luminescent materials capable of glowing in practically any conceivable color. Prior to the advent of television, phosphors had had only minor application in radio-active watch dials, x-ray fluoroscope screens, and theatrical "black magic", each of which required negligible amounts of material.

Television research on phosphors yielded at least one product which may be likened to the tail which wagged the dog. The new luminescent material became the keystone of the tremendous luminescent lighting industry which dwarfed television within a year after its inception. The particular phosphor is a beryllium-containing silicate which exceeds the tungsten filament in efficiency of light production and may be made to emit almost any color in the major portion of the rainbow spectrum. It found immediate application as the screen which converts electron energy into a visible image in television, but its main use is as the principal constituent in the light-producing coatings of white fluorescent lamps.

Phosphors are synthesized as clear, tiny crystals measuring about one ten-thousandth of an inch in size. These crystals gleam like miniature diamonds when viewed under a microscope. Phosphors are unique in being able to do the following:

1. Instantaneously transform invisible radiations, such as cathode rays (swiftly-moving electrons) or ultraviolet, into visible light.
2. Store light, or "remember" information, for controllable time intervals lasting from less than a hundred-thousandth of a second to more than a day.
3. Convert electric power into white or colored light more efficiently than any other known practical means.

Some of the properties of phosphors have ranges which are astronomical in magnitude. For example a phosphor may be made to glow for several minutes after a fleeting excitation lasting less than one millionth of a second. The same phosphor will produce visible light under impingement of electrons accelerated by as little as six volts or as much as six million volts. Furthermore, some phosphors are so

sensitive that electron beam currents smaller than one one-hundred-millionth of an ampere suffice to excite discernible luminescence, whereas the same materials, in coatings as thin as tissue paper, can withstand high voltage electron bombardment of intensity adequate to crack an underlying Pyrex glass disc.

The aforementioned extraordinary qualities are not possessed by ordinary materials. Sugar, salt, window glass, quartz, diamond and other commonly known substances luminesce only faintly under cathode rays or ultraviolet. Such substances lack the delicate, though sturdily incorporated, arrangement of certain cooperative and electronically-active atoms present in phosphors. Then, too, ordinary materials are far too impure and too imperfectly crystallized to be respon-

NO VISITORS ARE ALLOWED IN THE DUSTLESS RCA CHEMICO-PHYSICS LABORATORIES AT PRINCETON, N. J. MOISTENED RUGS TRAP ANY SHOE-BORNE DIRT.

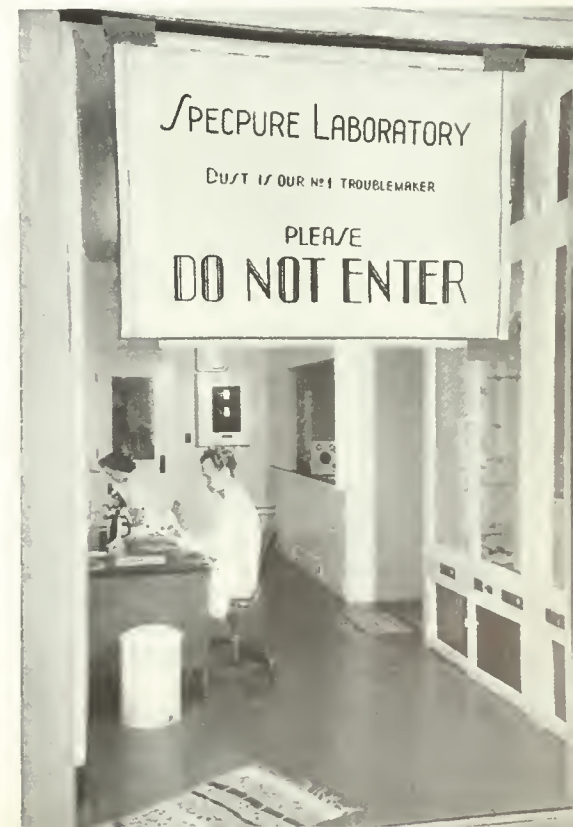



E. J. WOOD, RESEARCH CHEMIST, MANIPULATES A BUBBLING GAS TO PURIFY A SOLUTION WHICH IS BEING ELECTRICALLY HEATED AND SHAKEN IN THE PYREX FLASK.

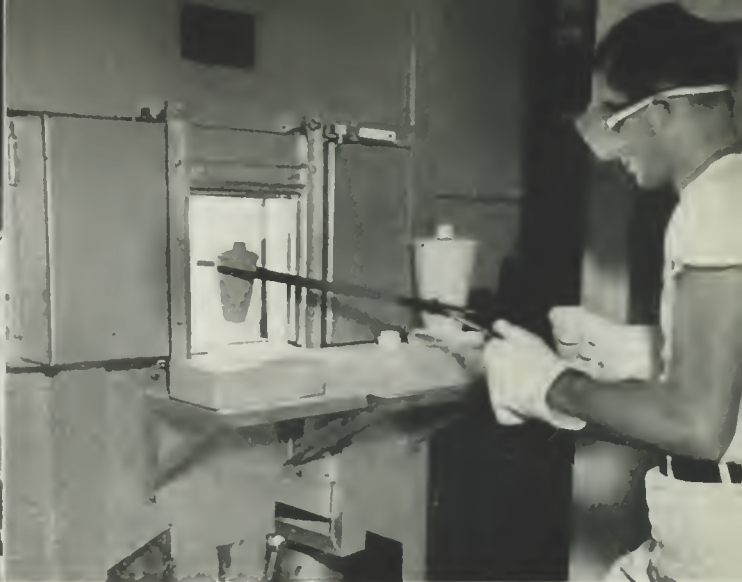

H. W. LEVERENZ HEATS PHOSPHOR INGREDIENTS TO THEIR REACTION POINT AT 2500°F. THEY ARE THEN COOLED AND CRYSTALLIZED AS ULTIMATE PHOSPHOR CRYSTALS.

sive to the low energy excitations which are sufficient for good phosphors.

Oddly enough, the ingredients comprising phosphors must be painstakingly purged of all impurities in order that one or two useful "impurities" may be deliberately added. The chemicals used for the preparation of phosphors are purchased in the purest obtainable form and are then subjected to lengthy purifications carried to a state far beyond "chemically pure" or even "spectroscopically pure." In fact, a new term has been introduced into the scientific vocabulary, "luminescence-pure," meaning free of undesirable constituents to a degree which, numerically speaking, exceeds 99.9999 per cent. Apropos of the detrimental effect which impurities may have on luminescent materials, it may be mentioned that a television phosphor of the zinc sulphide type loses 25 per cent of its pristine efficiency if as little as 0.0001 per cent of nickel is left in the material. On the favorable side of the ledger, however, the efficiency of the same phosphor may be in-

creased 100 per cent by the addition of only 0.0001 per cent of silver.

It is obvious that successful phosphor research must be performed in spotless laboratories. In the chemico-physics rooms of RCA Laboratories at Princeton, N. J., the laboratory air is made dust-free by thick filters and large electrical precipitators which remove even sub-microscopic particles. Laboratory personnel are required to change to clean white clothing before entering the inner rooms. Water, the essence of chemical operations, is redistilled four times in electronically-controlled Pyrex and quartz stills. Acids are redistilled in quartz and platinum stills. The laboratory construction and most of the equipment are of commensurably special design, since standard apparatus or methods are inadequate for the task of divorcing chemical elements

from their inherent impurities.

Purification rubs nature the wrong way. There is a ceaseless natural tendency for all things to mingle and become chaotic. This inexorable mixing process is called entropy in scientific parlance. The relentless increase of entropy reputedly shares with the unvarying speed of light in a vacuum the distinction of being one of the two absolute properties in the relativistic scheme of things known to man. Victory gardeners who have striven to eliminate every weed from their plots can appreciate the exasperating persistence of nature in trying to attain homogeneity of matter. The segregation of myriads of invisible atoms from their similarly constituted impurities, until less than one in ten million of the latter remain, is a task to strain one's perseverance and skill.

R. H. PLUMLEE, PHYSICAL CHEMIST, AND MRS. W. F. KASER, LABORATORY ASSISTANT, ANALYZE AND MIX PURIFIED PHOSPHOR CONSTITUENTS. COMPARTMENTS PREVENT CROSS-CONTAMINATION.

[8 RADIO AGE]



Crystallization, the final step in the synthesis of a phosphor, is relatively brief but spectacular. A quartz or platinum crucible, filled with the precisely compounded mixture of pure ingredients, is placed in an electric furnace operating at 2000-3000° F. At the elevated furnace temperature, the haphazard agglomeration of the various chemicals becomes mobile and, naturally, the different varieties of atoms commingle to a homogeneous mass on a molecular scale. After some minutes, the white hot crucible contents are withdrawn from the furnace and allowed to cool. As the cooling proceeds, the slithering atoms move more and more sluggishly until, at the crystallization temperature, the entire assemblage locks into perfect three-dimensional rows which are characteristic of a true crystal. The crystallization process is analogous to the manner in which trained soldiers snap out of the sprawling confusion of "at rest" into neat marching array.

An accurately organized crystalline condition is essential to good phosphors. The luminescent mechanism usually involves electron transfer through extensive regions within the crystal. Manifestly, electron transfer would be seriously impeded if the mass were a disordered jumble such as exists in glass, amorphous solids, and other non-crystalline materials.

Incongruously, it is necessary to have carefully devised imperfections scattered sparsely throughout the otherwise faultless phosphor crystal. Such scientifically produced faults are essential for persistent luminescence. The desired imperfections provide temporary halting places or traps for the electrons engaged in the luminescent processes.

Minute concentrations, viz., one part in a million, of certain "foreign" elements such as copper are suitable for this purpose.

A very diminutive Alice in Wonderland who could act as an observer when a swift cathode ray or quantum of ultraviolet struck a phosphor crystal, might report the following happenings. One of the "bombed" atoms in the crystal would be stripped of its least tenacious electron, which electron would wander through the crystal until it was trapped in one of the few imperfections. Some time later, latent heat energy would again liberate the electron so that it could once more wander about until it chanced near its own "home" or another vacant site. On close approach, the electron would dive into the parent haven, which would acknowledge receipt by emitting a momentary scintillation of light. Multiply that simplified act by "skintillions" and you have an inkling of the process whereby electric energy is converted into a television image or into a flood of light from a fluorescent lamp. The electron guns of television Kinescopes or the invisible radiations from agitated mercury atoms in fluorescent lamps furnish the cathode ray or ultraviolet quanta "bombs" which excite light from phosphors.

Testing of the completed phosphors is an art unto itself. It is necessary to provide and measure both visible and invisible radiations with accurate determinations of intensities ranging from those of starlight to that of sunlight. Ingenious high-voltage electronic equipment is used to measure atomic spacings in crystals, wavelengths and energies of luminescent light, surface potentials of phosphors,



TWO QUARTZ AND FIVE PYREX ELECTRONICALLY-CONTROLLED STILLS FURNISH QUADRUPLY DISTILLED WATER AND ACIDS —THE "LIFEBLOOD" OF LABORATORY OPERATIONS.

and many other pertinent data. One rather impressive apparatus, the electronic phosphoroscope, makes measurements of light intensity within time intervals as short as millionths of a second or as long as days after excitation of the phosphor has ceased.

Our present knowledge of phosphors is far from being exact or complete. Despite the great forward steps of the past decade, research on luminescent materials still relies considerably on scientific intuition for its direction. This state of affairs reflects the defiance of the subatomic domain with respect to science's attempts at detailed investigation.

Although it is not possible to guarantee the predicted properties of untried phosphors, many luminescent materials have been custom-made to fulfill special require-

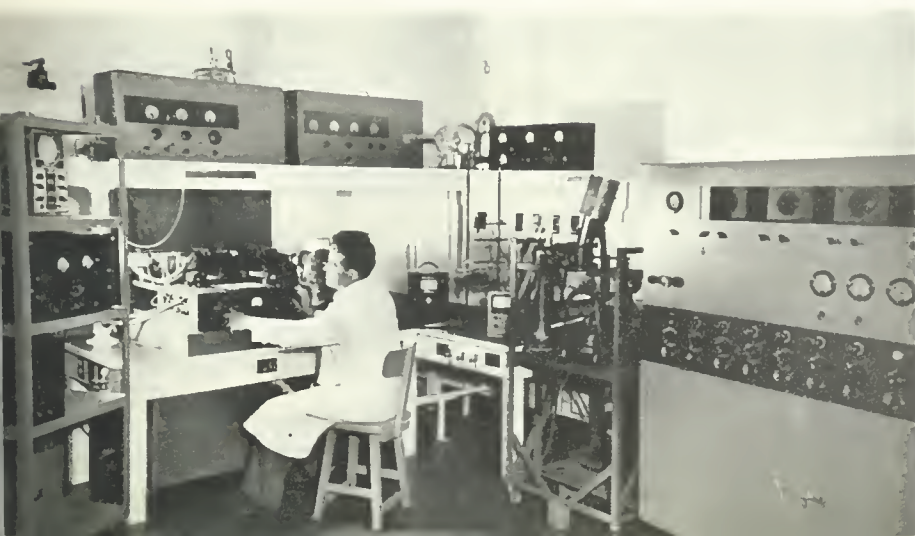

DR. R. E. SHIRADER, RESEARCH PHYSICIST, TESTS COMPLETED BUT UNTRIED SYNTHETIC PHOSPHORS WITH A RECORDING SPECTRORADIOMETER.

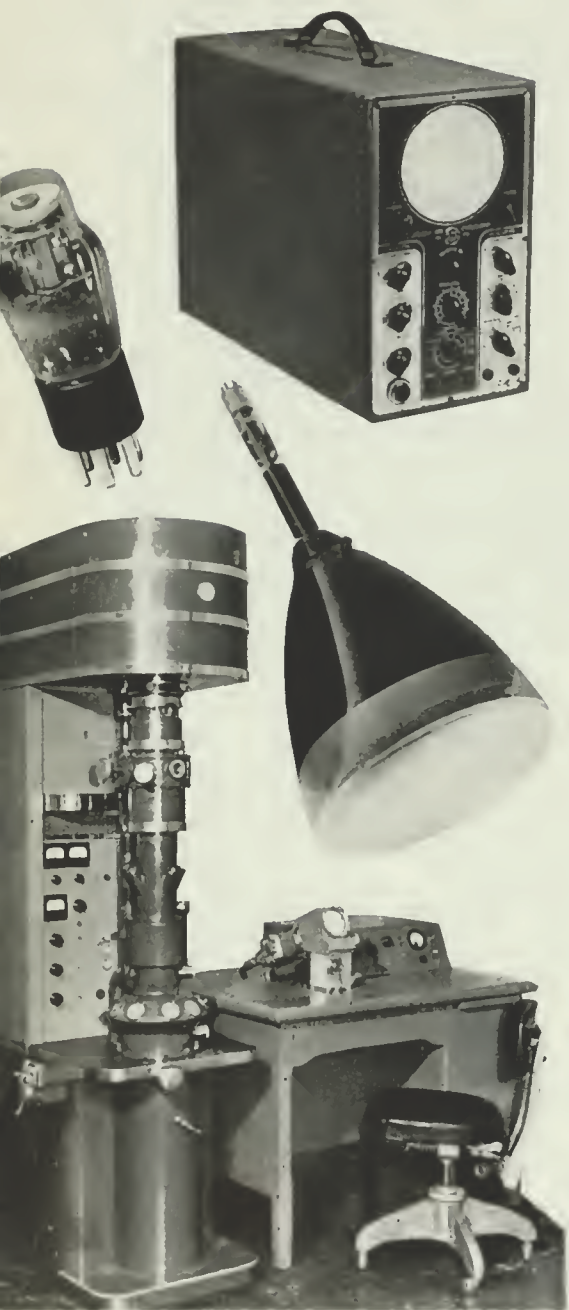

ments. This type of "aimed," or vector, research has been especially valuable in problems arising from our wartime needs.

The abnormal conditions incidental to the present world conflict, re-emphasized the folly of labelling any scientific development as useless. For example, some of the thousands of phosphors synthesized prior to the war had unusual properties, but low efficiencies. They were promptly ignored during the search for greater brilliancies required by television and lighting. When blackout conditions were imposed, however, the despised phosphors received careful reconsideration because the dark-adapted eye is some 200,000 times as sensitive as it is in daylight vision.

When this war ends and our fighting men return, they will have an opportunity to help achieve a resplendent new electronic era. In that era, phosphor crystals in fluorescent lamps will inexpensively illuminate workplaces and homes or gaily brighten the streets of our cities with varicolored sign tubing. Other phosphor crystals will display news and entertainment on the screens of our television sets which may be tuned by the light from phosphors in Magic Eye tuning indicators. Kindred phosphors in the

screens of electron microscopes will aid in fathoming the mysteries of bacteria and molecules in order to ensure a healthier and happier life.

There are a number of other possible uses for phosphors, including intense light sources for sound recording and theater projection; indirect illumination wherein the very walls, ceilings, and murals luminesce to illuminate as well as decorate the room; luminescent plastics in thousands of forms to make night-time safer and more colorful; and phosphors emitting specific radiations for controlled treatments of living tissues and organisms.

Casciarolo's eyes undoubtedly widened with amazement when he first spied that weak blue glow one night in the year 1603. His eyes would probably pop were he to witness phosphors in action today. It would be fun to show him our host of factories illuminated to daylight brilliancy with miles of cool fluorescent lamps requiring tons of phosphors. The *pièce de résistance*, though, would be to demonstrate to Casciarolo how a thin phosphor coating, only seven inches in diameter and four ten-thousandths of an inch thick, in a television projection tube, can amply illuminate a theater screen measuring 15 by 20 feet.

TOP: RCA OSCILLOGRAPH, THE PHOSPHOR SCREEN OF WHICH INDICATES ELECTRICAL FLUCTUATIONS.

MOTION OF A FLUORESCENT PATTERN IN THE RCA "MAGIC-EYE" TUNING INDICATOR INDICATES PRECISE TUNING OF RADIO AND TELEVISION SETS. THE KINESCOPE IS A FUNNEL-SHAPED TUBE, THE FLAT FACE OF WHICH IS A FLUORESCENT SCREEN ON WHICH THE TELEVISION PICTURES APPEAR.

THE RCA ELECTRON MICROSCOPE MAGNIFIES MORE THAN 100,000 DIAMETERS WITH THE PICTURES APPEARING ON PHOSPHORIC SCREENS.

IN TELEVISION RECEIVERS, KINESCOPIES OF THE TYPE SHOWN ABOVE REPRODUCE IMAGES AS BROADCAST.

LOWER RIGHT: FLUORESCENT MATERIALS IN LAMPS MAKE POSSIBLE BRIGHT AND EFFICIENT ILLUMINATION.



# Radio Reports the War

NBC NEWS DIRECTOR SEES BROADCASTING'S ROLE IN COVERING THE PEACE EQUAL IN IMPORTANCE TO WARTIME NEWSCASTS



By William F. Brooks

*Director of News and Special Events,  
National Broadcasting Company*

RADIO has taken its place in the news picture—with a bang—in the past five years. News always has been a part of radio programming, and radio has served the public from its inception with a certain quota of news broadcasts. In the past five years, however, news has come to the forefront in a way which few people expected prior to that time.

For twenty-five years, I have been in the news business and have watched the developments in radio news very closely. For fourteen years of that time, I was with the Associated Press. In 1937, I went to Europe and when I came back I went into radio. I took up the job of Director of News and Special Events of the National Broadcasting Company with a great deal of trepidation. I had been told it was a strange new world and that none of my news experience could be adapted to it easily. Fortunately, I have found this is not so. Hundreds of problems newspaper and press association men have to settle every day also have to be settled in radio, and because radio is so new compared to press I find that radio news men have borrowed heavily from the practices and procedures which have been standard in newspapers for scores of years.

In the News Department at NBC, we are charged with the writing and preparation of straight news broadcasts, the scheduling and contact with commentators, the arranging and covering of foreign pickups and the handling of special events. Up to the time the material actually goes on the air, the collection, preparation and organizational work required parallels to a large extent that of a press association or a newspaper. We have our news writing and special events staffs in New York, Washington, Cleveland, Chicago, Denver, San Francisco and Hollywood. Most of these men have spent a large part of their lives in newspaper work. I have found that virtually all of them have carried into radio the high principles and awareness of their responsibility to the public which was their daily fare in newspaper work.

Because of the difference in the method of dissemination, radio does have its special problems and certainly as many things can go wrong as quickly as on a newspaper. As a matter of fact, I think, more quickly! All of my newspaper life the minute hand on a clock regulated activity. As an executive editor of a press association, I have been on the receiving end of messages from some managing editors on occasions when the fact that an opposition service was two minutes ahead with a flash was conveyed in language none of us could permit on Page One, or on the air. In radio, it is the second hand that counts.

In England, I remember being quite amused when the BBC would end a program and leave you hanging on dead air for two or three or even several more minutes until it was time for the next program to begin. I really didn't appreciate what it requires to synchronize a broadcasting schedule as we do in American radio so that one pro-

gram will slip smoothly into the next, and that switches from one point to another take place with clocklike precision.

Many things can botch a program—politics in Africa, for instance. John MacVane, who covered the African campaign for us, told me that he and Charles Collingwood of CBS both suffered a sort of sabotage. It seems that when they were broadcasting from Allied Headquarters in the early days of the African campaign, there were four French engineers attached to the station. Two were pro-Ally and two were pro-Vichy. When the pro-Ally men were on duty in the control room the signal was usually fine and clear; when the pro-Vichyites were operating, the broadcasters sounded like they were talking into a barrel, the engineers fiddling with the control knobs and generally making it difficult for the radio news men.

When I heard that story I couldn't help but remember a similar incident from my own newspaper work. I was a reporter on a middle-west newspaper and the printer in the back shop had a pet peeve against the chief of police of the town. Maybe the chief had given him a parking ticket, or

DON HOLLENBECK, NBC CORRESPONDENT ATTACHED TO ALLIED HEADQUARTERS IN THE TURBULENT AFRICAN CITY OF ALGIERS, COVERS THE FIGHTING FRONT IN ITALY BY AIRPLANE.



[RADIO AGE 11]



JOHN MAC VANE, NBC WAR REPORTER IN ALGIERS, BROADCASTING TO THE UNITED STATES FROM ALLIED NORTH AFRICAN HEADQUARTERS.

something. But in several months of painstaking effort I will swear I never was able to get any story into the paper about the chief without something going wrong. The slug with his name would be accidentally turned, the spacing would be off, or the name would be misspelled, even after the most careful proof-reading on my part.

Regular news broadcasts from abroad had been the business of radio for several years prior to the Munich crisis of 1938, but that event made them almost a daily necessity from then on. With the devil's brew of Europe thickening day by day, the National Broadcasting Company at once multiplied its foreign staff of reporters many times over. Instead of offices only in London, Paris, Geneva and Shanghai, a foreign staff was swiftly recruited in every important capital in the world, especially those of the likely belligerent nations.

#### *Reporters Standing By*

There were three requisites for membership on this staff—first, knowledge of news; second, a good speaking voice; and third, American citizenship. Long before the actual outbreak of war, there were NBC reporters in every European capital and most of those in South

America, as well as in Tokyo, Manila, Batavia, Singapore, Sydney, Alaska, and scattered throughout Africa from Cairo to Johannesburg. Today—four years later—only two of those forty-five reporters are still at their same posts. They are John MacVane in London and Grant Parr in Cairo. The others have been shifted to other points, or have been recalled home, or are in Japanese internment camps. Their successors are carrying on.

Today, several important news areas have been eliminated from American loudspeakers, principally Berlin, Tokyo and Rome. In addition to Axis territory, listeners hear only occasionally from the neutral countries in Europe, although NBC is well staffed in every neutral capital there. These reporters are continually standing by for word from New York that they are wanted in front of their microphones, either for a special program or for the daily NBC roundups of international news at 8:00 a.m. and 7:15 p.m., EWT. Each Thursday, radiograms go out from New York telling each reporter abroad, to the exact minute and second, just what broadcasting time has been assigned him for each day of the following week. These radiograms may read like this:

“ROMAG  
MOSCOW  
WANT 1208 1210 TUESDAY  
THURSDAY SATURDAY  
ALSO 2319 2321 MONDAY  
ETTHURSDAY RETURNING  
NEWYORKWARD CONFIRM”

This sounds like nonsense, but the numerals are Greenwich Mean Time. Instead of radioing Henry Cassidy in Moscow that he should be prepared to broadcast from 8:10-8:12 a.m. EWT, on the following Tuesday, Thursday and Saturday, a time is given to him in Greenwich Mean Time. Greenwich Mean Time means ten minutes after noon in Greenwich, England, where the parallels of longitude begin. All he has to do is consult a chart which tells him what time it is in Moscow when it is 12:10 p.m. in Greenwich, England. That is the time that he goes to the Studio in Radiocenter Moscow, and begins his broadcast.

Cassidy has no contact with NBC in New York or anywhere else just before or during his broadcast. He arranges with Radiocenter to broadcast his talk by short wave from Moscow on certain regular frequencies—for instance, 15,750 kilocycles for the 8:00 a.m. show in New York and 11,948 kilocycles for the 7:15 p.m. program.

#### *RCA Relays Signal*

Meanwhile, NBC in New York has given an order to Radio Corporation of America to pick up a signal of the Moscow Radio on those assigned frequencies at that exact time. RCA picks up the signal at Riverhead, New York, far out on Long Island, and feeds it over telephone lines to the master control desk in NBC. From there, it is fed to the studio where the news program is being conducted. Then, just ten seconds before Cassidy is due to start broadcasting in Moscow, the “m.c.” of the news show—who may be either John W. Vandercook, W. W. Chaplin, or some other well known news commentator—will say something like this: “Our next report comes from Henry Cassidy in Moscow. We take you now with the speed of light to the capital of the Russian Soviet. Come in Moscow.”

Moscow is a “blind” pickup. That is, Cassidy starts on a time basis because Moscow Radio cannot contact RCA by short wave, due principally to the Russian censorship. Even at points where censorship is lenient—such as Chungking and Algiers—we sometimes have difficulty contacting them due to sun spots or other atmospheric disturbances, depending even on the time of day or night the broadcast is attempted. But if censors and atmospherics permit, RCA in New York can converse with the foreign broadcast point and arrange final details for the pickup, to the point of telling the pickup point “Go ahead” at exactly the time that the cue is given on the network by the NBC announcer.

This calls for perfect conditions and split-second cooperation by half a dozen operating points, including the commentator in the studio, the announcer who is pushing the buttons on the announcer's panel for his microphone, his production man

in the studio who holds a watch on the program, the engineer in the control room who must select Moscow or Algiers or Chungking from among several foreign signals and feed it into the network at exactly the right time, the men on duty at the office of RCA, the engineer in the Moscow radio station and his announcer and production man and perhaps half a dozen other people somewhere along the line.

One of these points is the NBC Special Events department, where a man sits in the control room beside the engineer and listens in turn to all the foreign signals ordered up for the program. He must decide which ones are worth feeding to the network and, if possible, bring them in at exactly the time wanted. Of course, on the Moscow signal all he can do is approve it as understandable to the listener and listen to the time checks which Moscow puts on the air for several minutes in advance of the program.

He hears the Russian announcer in Moscow saying over and over in English: "Hello, New York. Hello, the National Broadcasting Company. This is Radio Center Moscow calling the National Broadcasting Company for Henry Cassidy, who will be on the air at 3:00 p.m. and ten minutes by Moscow time. By Moscow time it is now 3:00 p.m. and eight minutes exactly. Hello, NBC. Hello, New York. This is Radiocenter Moscow calling the National Broadcasting Company for Henry Cassidy, who will be on the air in exactly two minutes from now."

#### *Timing Is Problem*

The NBC Special Events man listens to the time checks, with his eye on the NBC clock. If Moscow is ten seconds faster than NBC, he must arrange for the switching cue to Moscow to be given ten seconds earlier than planned. If Moscow's clock is ten seconds slower than NBC's, he must arrange for the New York announcer to drag his cue—or eat up an extra ten seconds before calling in Moscow in order that there be no silence on the network. This sometimes involves cutting short the previous pickup point, which may be Australia, or London, or Algiers, and thus require the New York commentator

to "ad lib" a quick cue to Moscow in order to make the switch on time.

This is only one of the problems involved. The Moscow signal may start strong and then grow weak or be interfered with by cross talk from another station on almost the same frequency, or by static, or sun spots, or the Aurora Borealis, or half a dozen other things. In that case it may be necessary to cut Moscow off the air and for the New York commentator to make a brief explanation and apology to the listener for the poor signal from Moscow.

There are a few foreign pickup points which the Special Events man in New York can contact direct just before their broadcast is wanted and thus check cues and timings with them, identify the broadcaster and afterwards give him the report on how his spot was received. This is true of London, Cairo, Panama, Bern, and Madrid. In addition to ordering the line from London to New York, NBC orders the New York-to-London half of the circuit also and thus can talk two-way with London before the broadcast. This is not true of many other points, which are received on one-way radio circuits.

This routine is followed on every news broadcast from abroad; rather, on every radio broadcast of any sort from abroad. It is duplicated many times a day, and the technique has been perfected to the point where nearly all broadcasts

are delivered to the loudspeaker of the listener on schedule.

In handling such a 15-minute program of news from abroad, the NBC Special Events man sits at an object which resembles nothing so much as an old-fashioned school desk. On a panel in front of him, he has a dial with eleven channels on which he can, by turning a switch, monitor three signals fed up to him by RCA, also two signals fed by AT&T, as well as Station WEAJ in New York, the rest of the NBC network, the announcer's office upstairs, and the principal New York stations of the other networks. In fact, he has two dials exactly alike, one of which controls a loudspeaker in his desk panel and the other which is fed through a pair of earphones. He uses the earphones to listen to one signal, and the loudspeaker to listen to another at the same time.

#### *Other Things to Do*

In case this appears to call for ambidexterity, it may be said that he has several other things that he must also do at the same time. He has a telephone to the production man in the studio adjoining the control room; he has an inter-office telephone through which he can get any other 'phone in the building as well as outside points such as Washington, Chicago, etc. He has an emergency 'phone on which he can reach all of the six or eight operating points of NBC which must

EDWARD WALLACE, STANDING THIRD FROM RIGHT, IS CHIEF NBC WAR CORRESPONDENT IN THE SOUTH PACIFIC. THIS PICTURE WAS MADE DURING A TRIP THROUGH THE SOLOMONS AND NEW GUINEA.





RALPH HOWARD, ATTACHED TO THE AIR FORCE COMMAND IN ALGIERS, TYPES A NEWS STORY FOR TRANSMISSION TO NBC IN NEW YORK.

function in case of any change of program plans. Then he has a "super-duper" emergency 'phone on which he can reach only the three essential operating points, which are the master control desk, the traffic department, and the announcer's office. He also has a switch which he can throw to talk direct to the adjoining studio when it is not on the air. He also has an electric teletype machine which NBC contracts for by the year and which reaches all the stations across the country that are managed and operated by NBC, such as KPO in San Francisco, WMAQ in Chicago, and other principal network operating points such as Denver and Hollywood.

With these half dozen methods of communication at his command, a Special Events director can make almost any necessary last-minute change required in the program. He can tell San Francisco to tell Australia to hold up their broadcast for a minute or two minutes if necessary. On his telephone line to London, he can tell the London announcer to cut his spot ten seconds short or to take an extra fifteen seconds or whatever may be necessary in order to make the next switch on time. He can reach Wash-

ington on a direct line to tell the commentator there to switch to New York instead of Chicago, if that is required. He can reach RCA by direct line to inquire what's wrong with the signal from Stockholm and whether or not it may be expected to improve, if it is bad. He can tell Chicago to watch for a cue to reverse the network earlier or later than expected. By this we mean that if New York is feeding the network to the West Coast and back, and a switch to San Francisco is desired, then six seconds must be allowed for operating points such as Chicago and Hollywood to cut the network feed from New York and to open the channel from San Francisco so that when San Francisco takes the air six seconds later, the network program will then be fed eastward to New York and thence back to San Francisco.

Many a time we have torn up a regular news show and thrown out Australia or Moscow in order to get in a special broadcast from Cairo or Algiers, as the case may be. It involves ordering facilities from one of the communications companies, notifying the Engineering, Traffic, Announcing and Production departments, and frequently the various switching points between New York and San Francisco. If we cannot make room for the broadcast on the network, we always record the broadcast by transcription here in New York and also monitor it while it is on in order to check on the nature of the broadcast. Then, if it is important enough, we can always play the record on our local station at a later time. If the news is of greatest importance or the special feature has some historical value, we can sometimes play it to the network, too.

#### *Best Possible Service*

At NBC, we have worked out a schedule of news broadcasts throughout the day which is intended to give the best possible service to the public. This program structure has been evolved from practical experience. We know there are certain people who turn their dials every few minutes to get a new news program, or a new commentator. But we also know that the majority of people like other

types of information and entertainment mixed with their news broadcasts. To meet the increased demand for information, in the past few years NBC has stepped up its news coverage. In 1938, news reports, analyses, and special events took up 3.8 per cent of the total program time of NBC. In 1941 this had jumped to 10.5 and in 1942 it rose to 15.4 per cent.

#### *No End of News*

As far as I personally am concerned, I think we have about the proper proportion now, and that it would be bad programming to step this up in any considerable amount. We feel that we are servicing the bulk of our listeners throughout the day and night hours very adequately.

Trade reporters have asked whether we expect to maintain this proportion when the war ends. That is a very difficult question to answer, but I think that news of the peace is not going to be any less important than news of the war. As a matter of fact, I think it will be even more dramatic in some respects, and will affect more people directly than news of the actual fighting.

I am sure this view is not a new one, but some people seem to have the idea that the minute an armistice is signed, there will not be any more interesting news. I believe there will be an increased interest, and that both press and radio will have one of their biggest jobs in keeping the people informed of the readjustments and compromises which will have to be made before the world can completely disarm and embark on any safe program for the future.

The war is developing new equipment, and we are on the verge of new service and a new industry through the wider use of ultra high frequencies in fields of television, frequency modulation and facsimile. These new services are certain to assert a revolutionary influence upon our social and economic life in the years to come—and it is just as certain that both the press and radio will adapt these new discoveries in their respective fields for greater service to the listening and reading public.





DIAMOND SAW OPERATOR AT CAMDEN PLANT OF RCA VICTOR DIVISION, CUTTING A NATURAL CRYSTAL WHICH, AFTER PROCESSING, WILL CONTROL RADIO AND ELECTRONIC APPARATUS.

# Radio Crystal Bottleneck Broken

MIRACLE OF PRODUCTION AT RCA VICTOR DIVISION PLANT AT CAMDEN, N. J., SPEEDS OUTPUT OF COMPONENTS VITAL TO RADIO-ELECTRONIC COMMUNICATIONS DEVICES FOR ARMED FORCES



By Harry E. Leroy

*Plant Manager,  
RCA Victor Division,  
Camden, N. J.*

**A**MONG the many miracles of American production to be credited with helping to turn the tide of the war against the Axis is

the breaking of a critical bottleneck in crystals, a vital component of radio, sound and electronic communication equipment. The statement revealing the breaking of the bottleneck was made recently by the War Production Board, and it serves to focus attention on the contributions to the war effort made by the men and women of the RCA Crystal Manufacturing Department in Camden.

Paced by a rapid rise in demand for radio, electronic, and communication equipment for the armed forces following this country's entry into the war, crystal production expanded almost overnight from a small section of the Special Apparatus Department, occupying about two-thirds of a floor in the Camden plant, into a separate department, now occupying two complete floors

and part of a third.

To meet the Government's imperative wartime need for crystals, RCA Victor within a few months recruited and trained enough new operators and technicians to swell the department's personnel to more than 800 per cent of its peacetime peak, and increased the production of crystals by 1,500 per cent.

The percentage of increase in production over that in personnel was in part accomplished by labor and material saving production refinements, credited to three sources: First, suggestions made by employees; second, advances made by the department's research engineers; and third, shortcuts developed by members of the laboratory's supervisory staff in the course of breaking down and simplifying procedures for new employees.

Encouraged and rewarded by the company through suggestion contests sponsored by the plant's labor-management War Production Drive Committee, workers in the Crystal Manufacturing Department have submitted since Pearl Harbor a total of 700 ideas to conserve time and materials and improve production. Of this total, 155, or 22 per cent, have been found practicable and adopted. Fifteen workers are members of the RCA Century Club, highest distinction awarded by the company for excellence of employees' suggestions. Robert W. Young, a crystal finisher, was top winner for all RCA Victor plants in the recent suggestion contest climaxed by participation of the winners in a Victory ship launching at Mobile, Alabama.

The special value of quartz crystals in radio and electronic equipment is their piezo-electric property—that is, their ability to convert electrical energy into mechanical energy, or mechanical energy into electrical energy. Since the frequency of the crystal is determined by its thickness, crystals of varying thicknesses can be used to control the frequency of an oscillating circuit.

Although such a circuit can be and has been made and operated

without crystals, the precision control which crystals afford is essential in modern transmitters, in single-frequency receivers such as those used in police radio, in two-frequency receivers of the type used by the armed services in "walkie-talkie" sets and tank unit communication equipment, and in other equipment.

#### *Function Is Outlined*

The function of the crystal in such equipment is analogous to the function of the balance wheel in a watch, or the pendulum in a clock, serving to regulate the entire unit and keep it "on time," or, in the case of radio, "on the beam."

Staffed with a few seasoned experts headed by Walter Groeber, manager, the Crystal Manufacturing Department was established in the Camden plant in 1932 as a "short order" or "model" shop for maintenance engineering, to undertake the production of crystals on a small scale, largely for internal use in test equipment. Within the next two years, it developed into a research unit and a modest commercial manufacturing unit. Working relationships between the manufacturing and engineering staffs were close from the start. Normal growth through the next eight

years brought the personnel of the laboratory up to 80 by the winter of 1941-42.

Meantime, in the fall of 1941, there had become apparent the need for mass production of crystals for military and naval requirements of America's defense program, and plans had been laid for the design and production of the necessary manufacturing equipment.

Expansion in space and personnel began shortly after Pearl Harbor, and by October of 1942, the department was manned by a peak staff of about 700 workers. The late Summer of 1942 brought the beginning of a rapid climb in production, which rose a total of 1,500 per cent in the next six months.

In the initial personnel recruitment which raised the staff from 80 to 700, both men and women were employed, but the male element remained in the majority. As more and more men were lost to the armed forces in later months, however, it became necessary to adapt the work to the capacities of women workers and establish a comprehensive training program, since few women were available who had acquired either training or experience in this field. Special machinery was designed and various techniques were altered to permit the mechan-

THESE GIRLS SOLDER AND ASSEMBLE CRYSTAL HOLDERS FOR USE IN RADIO AND ELECTRONIC EQUIPMENT FOR THE ARMED FORCES.



ANNA MAY GALLAGHER, RCA VICTOR WAR WORKER, GAUGES THE THICKNESS OF CRYSTAL BLANKS.

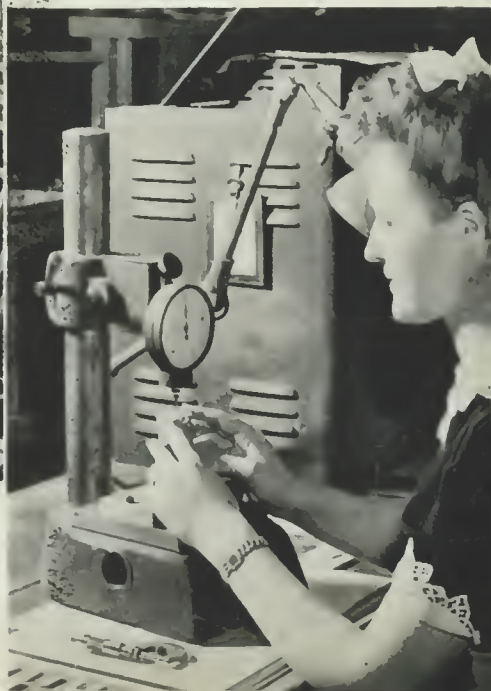

ization of operations which the new workers could not perform by hand.

Success in this effort is evidenced by the fact that women constitute approximately 65 per cent of the present staff. Aided by training under skilled employees, both on the job and in the company's own classrooms, and by the preparatory breaking down and simplification of procedures, women and girls are proving highly proficient.

The necessity for cutting the raw quartz along carefully predetermined lines to prevent damage and obtain the required angles, plus the need for grinding the finished crystals to precise dimensions (often too fine to be measured mechanically), makes the cutting and finishing process an exacting one.

The ideal natural crystal, or "mother" quartz, is a six-sided prismatic body, capped at each end by an apex. However, since larger crystals are generally found protruding from clusters of smaller crystals, bound by other rock formations, the usual method of mining involves breaking the larger crystal off near its base in the cluster. When it comes into the market from Brazil, where the bulk of this mineral is mined, it usually consists of only part of the body and one apex. A "mother" crystal suitable

for crystal manufacturing use may weigh from a few ounces to about 30 pounds, but the average now coming into the market weighs about one pound.

When the natural crystals arrive at the laboratory, trained crystal layout specialists determine the three primary angles on the basis of which they should be cut. These angles are clearly indicated by the shape of a regular six-sided crystal, and methods involving the use of light have been devised to find these angles in irregular-faced crystals.

#### *Examined By X-ray*

Once determined, the angles are marked on the crystals to guide the operators of the diamond saws used to cut the thin sections, known as blanks, from which finished crystals or plates are to be processed. The first saw sample is examined by X-ray to insure the proper angle before more blanks are cut.

The blanks are next immersed in a chemical solution to reveal possible defects, which, when found, must be cut out of the blank. After further processing, the edges of the blanks are squared up and the blanks are individually inspected and sorted according to their thickness.

Automatic equipment then grinds them to prefinished dimensions and they are tested for oscillation, sorted to various frequencies, and each is tested against a master crystal to permit adjustment to final frequency. The finished crystal is then ready for installation in the holder in which it will function, but before the cover is sealed on the unit it must again be inspected and tested at various temperatures.

The final test involves placing the sealed units in an automatic test equipment with adjustable temperature controls, to check performance under conditions ranging from extreme cold to extreme heat. If any one of the units fails to function properly in these temperatures, either as to frequency or activity, it is set aside for reworking.

Maintaining its high level of production, the crystal department is now producing each month considerably more than the total of a year's production before the war. Scheduling has at times been a challenging problem, due to sudden changes in requirements based on battle experience of the armed forces, but that challenge has been met.

---

### Buy War Bonds

---

HERBERT RATNER WORKING WITH QUADRUPLEX AUTOMATIC TEST EQUIPMENT USED IN FINAL TEST FOR MISCELLANEOUS TYPES OF CRYSTAL.

KATHERINE DANLEY LOADS AN AUTOMATIC DRUM TO GIVE THE FINAL TEST TO CRYSTAL BLANKS. THE DRUM REJECTS BAD CRYSTALS AUTOMATICALLY.

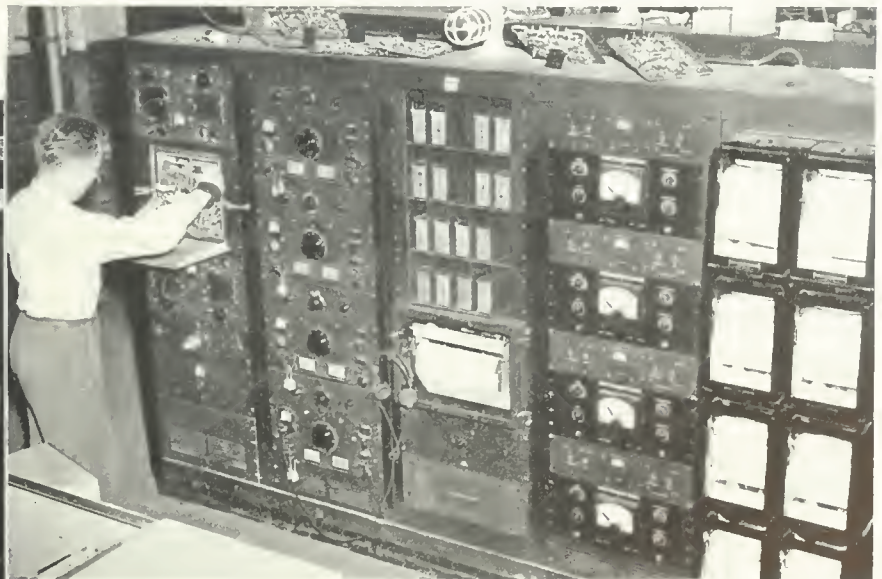

# Engineers Predict Radio Weather

RCA RESEARCH GROUP THROUGH LONG OBSERVATION OF SUN SPOT ACTIVITY AND OTHER SOLAR PHENOMENA CAN FORECAST COMMUNICATION CONDITIONS ON WORLD-WIDE CIRCUITS



By Henry E. Hallborg  
*Communications Research,  
RCA Laboratories, New York*

A TELEPHONE rings in the Communications Research office of RCA Laboratories at 66 Broad Street, New York City. The engineer answering gets the query:

"What are radio conditions going to be between now and the end of the month?" He refers to a chart on his desk, and replies:

"The 17th will be moderately disturbed, the 26th and 27th severely disturbed, but otherwise quiet."

Simple? Yes, but the development of means that enables such forecasts, which have become practical aids to the international communications services of RCA, and of other organizations, is another story.

Radio weather must not be confused with rain, fog, pressure and temperature at the earth's surface. It pertains to the condition of electrified layers far above the earth.

These solar-created layers enshroud the earth like onion skins. Those which affect radio weather exist at altitudes ranging normally from seventy-five to 250 miles, in the form of free ions in a vacuum as perfect as the finest radio tube. Atmospheric air and storms, on the other hand, occur in the "troposphere" extending not more than ten miles above sea level. It is the outermost of the earth's layers, the "ionosphere," that determines radio weather. Solar radiation activity is the generator of conditions prevailing in this "radio roof."

The sun sends us light and heat. It also sends us radiations of many wavelengths, ranging from deadly actinic rays, which are fortunately dissipated in the "ozonosphere" at about thirty miles up, to the slower rays which are manifested by terrestrial magnetic disturbances. Actinic and light rays take  $8\frac{1}{3}$  minutes to travel from sun to earth. The rays creating magnetic disturbances may require from one to three days to bridge the 93 million-mile gap. These slower rays originate in spot group areas on the sun.

Sun spots have been observed and charted for centuries. Their existence took on practical significance when their characteristics and cycles were found to have a close relationship to radio transmission. The occurrence of a sun spot group was found to coincide with a series of radio circuit interruptions. This

series of disturbances may be repeated, with more or less fidelity, after a solar rotational period of twenty-seven days. In addition to the twenty-seven-day cycle, sun spot groups have an abundance cycle from maximum, through minimum to maximum of about eleven years. The last maximum coincided with the outbreak of World War II in 1939. The sensational aurora of March 1, 1941, was followed by abnormally high terrestrial magnetic activity at forecast twenty-seven-day intervals, for the four immediately succeeding rotations of the sun.

Astronomers have observed, and radio circuit observations confirm, that the birth of a sun spot group may be preceded by a sudden eruption of the lighter solar gases, such as hydrogen. The radio term for such a solar eruption is "flare." Flares produce sudden brief interruptions on short wave circuits. After formation of the sun spot group, a longer and more persistent set of disturbances may occur. The flare is effective, whatever its relative position on the solar disc, in producing a disturbance on the light side of the earth. On the other hand, sun spot disturbance occurs only when the spot group is near the center of the sun's disc, which, of course, is the point closest to the earth.

Flare type disturbances, in view of the above, are found to have no regularity of occurrence. Sun spot

AN ARC OF PROMINENCES ON THE SUN IS PHOTOGRAPHED AT YERKES OBSERVATORY. THE WHITE DOT IN THE UPPER RIGHT HAND CORNER REPRESENTS THE COMPARATIVE SIZE OF THE EARTH.



groups, having a short-lived, but fixed, solar location, are synchronized with the rotation of the sun. These two distinct and separate types of short wave interruptions are well known to radio traffic men as "drop-outs," and "magnetic blankets."

When short wave radio signals transmitted from the earth's surface encounter the under side of the ionosphere, the peculiarities of penetration, reflection and absorption are again in evidence. The wave suffers repulsion and bending when it enters the ionosphere. The bending reaches a maximum for the low frequency long waves. It becomes progressively less to the point of penetration as the wave length shortens. Microwaves (extremely short) consequently are useless for direct long distance communication, since they are not turned back by the "radio ceiling."

In crossing the Atlantic, a short wave signal is bounced between the radio ceiling and the sea. The number of hops required varies with the distance between terminals, with wave length and with radio ceiling height. The signal strength varies with the turbulence of the ceiling and its absorbing properties. Solar radiations account for nearly all these variations, which simultaneously are reflected in terrestrial magnetic activity.

A flow of ions, whether in a wire, or in the thin upper atmosphere, is an electric current. The upper atmospheric currents produce measurable effects in the earth's magnetism. These effects are concentrated at the magnetic poles. Magnetic reactions between the agitated magnetic poles and the upper atmospheric currents cause the radio ceiling to be more turbulent, hence less useful as a reflecting medium over the poles than in lower latitudes. During a magnetic storm, a signal path over the magnetic pole may be opaque for radio communication. The blanketing effect increases as the circuit path approaches the magnetic pole. It has consequently been considered sound practice not to lay out a circuit path closer than 30° to the magnetic pole.

The magnetic storm is accompanied by an after-effect, which likewise is more pronounced and of

longer duration near the poles. The lower latitudes, on the other hand, are affected only by the most severe of storms, and for relatively short periods. The after-effect within 30° of the magnetic pole may last four or five days. It may be more difficult to get a signal through, at a high latitude, three days after a storm has passed than at low latitude during the height of the storm.

Considerable study and research has been applied to the causes of "drop-outs" by many organizations. Noteworthy contributions have been made by Dr. J. H. Dellinger of the National Bureau of Standards, by the Carnegie Institution of Washington, which has sponsored annual conferences for ionospheric study, and by Communications Research, RCA Laboratories. The generally accepted theory is that the solar flare sets up radiations that pierce the normal layers of the earth's ceiling. These penetrations establish temporary absorption regions in the normal path of the radio wave. The temporary absorption may produce a complete, or partial, drop-out depending upon the violence of the solar eruption. When the flare subsides, the absorbing screen dissipates, and normal conditions return. The entire drop-out may last from two to thirty minutes, seldom longer.

Agreement is not so general upon the "magnetic blanket" type of disturbance. It is probable that a similar process is involved, over a longer time, in which the source is the slower radiation from a sun spot group passing the center of the sun's disc. The longer interval would permit the above noted reactions from the earth's magnetic poles.

Fading was one of the first observed characteristics of short wave signals. The range varied from a slow drift to the extremely rapid type called "flutter fading." As far back as 1925, a relationship was noted between fading and terrestrial magnetism. Poor circuit conditions soon became synonymous with "magnetics." At this early date, the radio ceiling was just beginning to be explored and studied. There soon followed the development of radio echo technique, permitting heights of distinct ionized

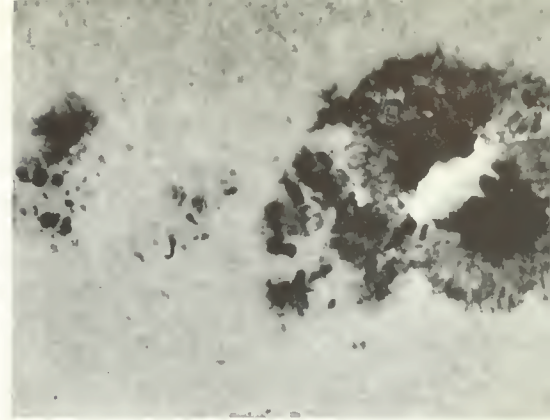

A PHOTOGRAPH OF THE GREAT SUN SPOT OF JULY, 1905, TAKEN FROM THE YERKES OBSERVATORY AT WILLIAM BAY, WISCONSIN.

layers to be measured. The occurrence of a sun spot maximum in 1928 further interrelated fading, circuit interruptions and terrestrial magnetism. The tools were evidently available for a considerable degree of success in "radio weather" forecasting. Magnetics could not be fully understood, however, until an extended correlation could be undertaken on typical radio circuits all over the earth.

Through the agency of the Research Department of RCA Communications Inc., this study was undertaken on its world wide commercial radiotelegraph circuits. It involved the development of a measuring unit for magnetic variability, as well as long period signal recordings on many great circle paths. A circuit disturbance rating number system supplemented signal recordings to make the project more general.

The investigation indicated that, on a given circuit, a decrease in the signal was proportional to an increase in magnetic variability. It also became evident that general radio circuit conditions could be monitored by a magnetic observatory located near the mid-point of the circuit. The mid-points of trans-Atlantic circuits lie in mid-ocean. The practical compromise was therefore selection of an observatory nearest the terminals of the most disturbed high latitude circuits. The U. S. Coast & Geodetic Survey Magnetic Observatory at Cheltenham, Maryland was the selection. Daily "magnetograms" from Cheltenham are analyzed, and

charted in sequence of solar rotations of twenty-seven days.

Cheltenham Magnetic Activity charts show peaks solidly filled in above the magnetic range level corresponding to a circuit disturbance. A glance at the chart reveals whether peaks are increasing or decreasing, and the manner of their grouping and recurrence. Consequently, it is possible to estimate what the

probable "radio weather" will be for twenty-seven days following the conclusion of the plotting of the last analyzed magnetic sequence.

A North Atlantic Circuit Disturbance Rating chart, obtained from R.C.A. Communications, Inc., traffic operating reports, supplements the Cheltenham Magnetic Activity chart. There is thus provided a comparison of magnetic

activity with circuit disturbance. The similarity of the charts is quite apparent when consideration is given to the after-effect on the North Atlantic circuits.

Eventually, it was desirable to have an immediately available reference source for radio weather. This was provided at the RCA Communications Research Department Receiving Section, at Riverhead, L. I., N. Y. It consists of a six-mile-long long wave receiving antenna, abandoned when short waves supplanted long waves for South American communications. This loop is grounded at both ends. The currents circulated by magnetic disturbances are continuously registered on an earth current recorder. These "earthograms" provide a direct source of information on radio conditions.

These methods, briefly described, are the ones adopted by Communications Research, RCA Laboratories to follow and to forecast radio weather. They provide a clue to the logic which the engineer could apply when he answered the query: "What are radio conditions going to be between now and the end of the month?"

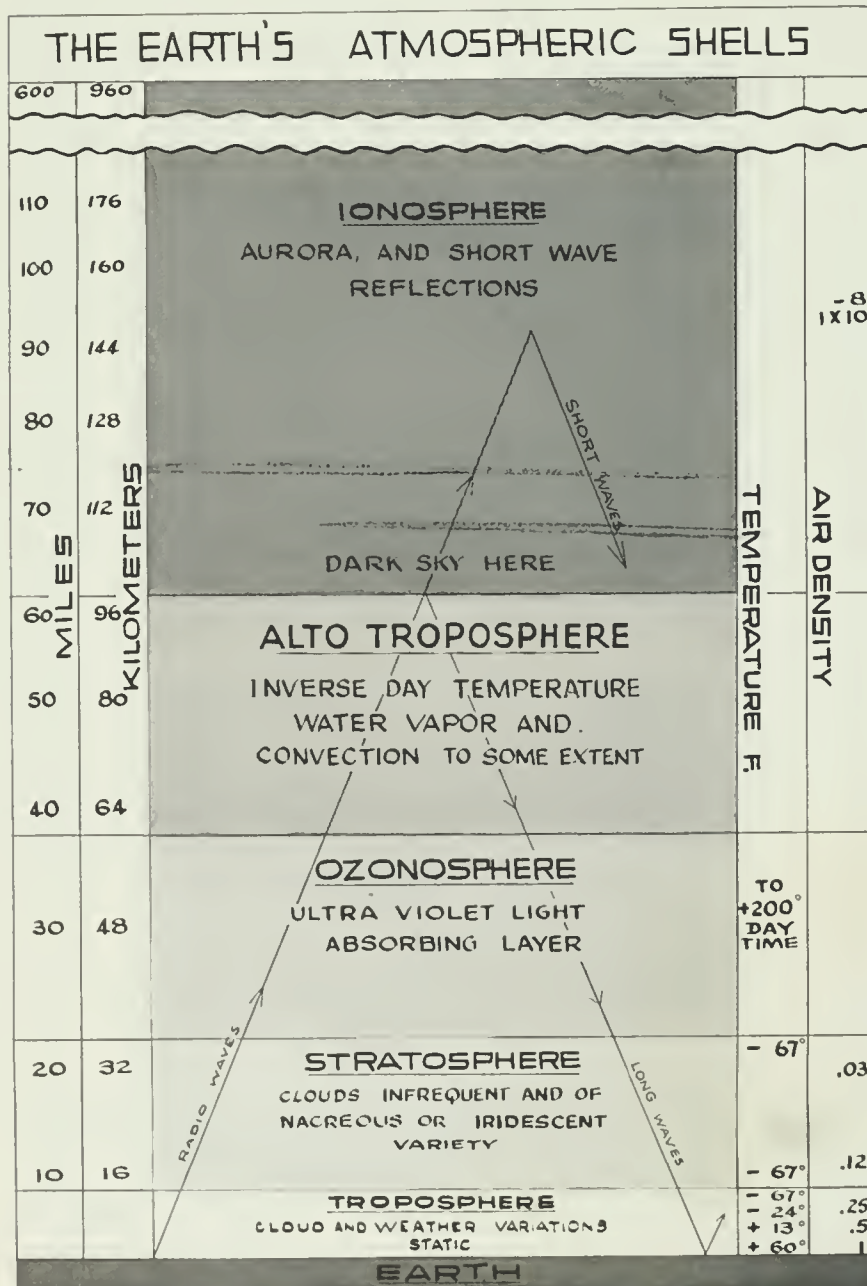

### New Public Service Goal

Attainment during the coming year of public service programs of still greater quality was the goal set for the NBC Public Service Department by Niles Trammell, president, on September 15 at the conclusion of a two-day department meeting. Dr. James Rowland Angell, public service counsellor, presided.

Trammell expressed satisfaction with developments in the public service picture since the establishment of a separate public service department nine months ago, but added that he expected further progress in the future.

Frank E. Mullen, vice-president and general manager, declared that the department, in the short period of its existence, had succeeded in integrating itself with the complicated network setup and that public service programming had profited as a result.

# PERSONNEL AIMS OUTLINED

*Sarnoff Appoints Committee, Representative of All RCA Divisions, to Work Out Expanded Program of Employee Relations—Kirkpatrick is Chairman.*

---

By Forrest H. Kirkpatrick  
*Chairman,  
RCA Committee on Personnel*

---

The recent appointment by David Sarnoff, president, of an inter-company committee on personnel gives added evidence of the interest of Radio Corporation of America in the development and best utilization of men and women who make up the whole RCA Family. The membership of the committee includes personnel representatives from every unit of the Corporation. It is certain that the scope and influence of the Committee's work will be watched with great interest.

In the metamorphosis of business development, personnel management is emerging as a major business responsibility rather than as a necessary evil. In many companies, the beginnings of personnel management were none too fortunate. Sometimes, nondescript crews of uplifters and trouble shooters were put into personnel posts. Occupying about the same status as chief clerks, they kept employment records, interviewed job applicants, distributed Christmas baskets, operated cafeterias and athletic associations. That no personnel man had the authority to represent management except at the annual company picnic was well known to every employee.

There are signs on every hand, however, to indicate that business and industrial management has a broader, more intelligent, and more helpful understanding of personnel management than ever before. The appointment of the RCA Committee on Personnel has considerable significance in our own company. It is recognized by Mr. Sarnoff that we may be moving into a new social era, the structure and function of which are only faintly perceivable. It would seem to be a period when "human resources" are counted at a much higher value in the business

and industrial life of this country. This period may mark the end of the "welfare and paternalism" concept of personnel work; it may lift the worker to a new sphere of importance; it may call for new techniques and channels for collaboration between management and labor; and it may ultimately find the means to free men from dissatisfaction in work and the fears that come with lack of work.

## *Problems Outlined*

Customarily we think of certain human problems as being representative of personnel functions with which this committee should be concerned, viz.:

- (1) There are problems of employment and induction: how to select the right people and how to place them in the right jobs.
- (2) There are problems of training: how to instruct new workers in the techniques of their jobs and in their responsibilities.
- (3) There are problems relating to working conditions, safety and health: reasonable hours, and congenial conditions at work.
- (4) There are problems relating to promotions: how to advance in accordance with their abilities and accomplishments.
- (5) There are problems relating to payment: how to pay workers appropriately for the work they do.
- (6) There are problems relating to the total welfare of employees: how to help them in times of need, as well as to provide recreational and social activities during their period of employment.
- (7) There are problems of collective planning and bargaining: that is how to give employees the opportunity of saying and doing something with regard to the conditions of their employment.

The Committee on Personnel rec-

ognizes that personnel management, at its best, is not a technique or a department, but rather it is a leaven of confidence, fair play, and honest dealings which permeates all phases of business operation with the chief responsibility resting upon persons in supervisory or management positions. A personnel department can only be a "service bureau" to a program of personnel management and to the enterprise as a whole. Genuine personnel relationships must remain decentralized if maximum satisfactions are to be realized. The personnel department, therefore, should be a centralized agency dedicated to the aid and direction of all other departments in personnel matters.

As the work of the committee is undertaken, all members of the RCA Family should be aware of certain bases which undergird their thinking and planning, viz.:

- (1) Serious study of practices, policies, and trends in the field of personnel management will make clear that there are many forces at work and many problems to solve. These are of varying value and import. None can be disassociated from the total scene or from the climate of opinion in which the industrial enterprise lives and moves and has its being. This climate of opinion is created by the attitude of management, workers, organized labor unions, and of the general public. It is shifted and changed by government controls and by the necessities of a war economy.
- (2) RCA is definitely interested in healthy, intelligent, and honest personnel management. This means that the tasks to which this committee is committed are recognized as important and significant. It also means that the company is interested in every step that can be taken to develop better men and better women, to improve personal relations between the company and each employee, and to increase job satisfaction in all departments and at all levels.
- (3) Healthy, intelligent, and honest personnel management does not come from wishful think-

ing or pious preachments. It will develop only as we have men and women in personnel management who are professionally alert, sensitive to human values, and constructive builders of a healthy RCA spirit.

- (4) Healthy, intelligent, and honest personnel management cannot be delegated to a department or accumulated around techniques and devices. It becomes the responsibility of all management and all supervisors. It is important to remember that the man who supervises the most inconspicuous worker represents the Radio Corporation of America to that man, hence he represents good personnel management or bad personnel management on behalf of the company.
- (5) In personnel management as in the conduct of our total business, decisions are seldom difficult if the basic facts can be developed. Where decisions are made which vitally affect individuals, our concern should be to see that such decisions are based on facts rather than on guesses, on a consistent, well-thought out policy, on fairness and reasonableness rather than prejudice and arbitrary action.
- (6) The extraordinary personnel problems that come as a result of war economy represent a special challenge for our abilities and experience. They represent not only a challenge but an opportunity. The opportunity is to render a service to our country and to the things we believe in most—at a time when such service is badly needed and when such a contribution can be a great help.

Members of the new RCA Committee on Personnel as appointed by Mr. Sarnoff on July 30, are:

RCA Executive Offices, C. J. Finch, O. E. Dunlap, Jr.; RCA Victor Division, F. H. Kirkpatrick; RCA Laboratories, G. D. Nelson; R. C. A. Communications, Inc., J. F. Rigby; National Broadcasting Co., E. de la Ossa; Radiomarine and RCA Institutes, W. F. Aufenanger.

Mr. Kirkpatrick is chairman, and Mr. Dunlap is secretary.

## OCCUPIED NATIONS HEAR NBC

*Young French Aviator, Who Escaped Recently From Homeland, Tells of People Listening to Newscasts — Letters Praise Service.*

THE young French aviator found NBC's International Division in Radio City and told Herman Rogers, head of the French Section:

"I wanted to meet the voices I know so well."

"I was strolling along Sixth Avenue," the flyer explained, "and I happened to see the NBC marquee. I listened to NBC's French-language shortwave broadcasts every evening before my escape to England, and so does everyone else in my home neighborhood. I liked them so much that I got to know these 'voices,' and felt they were my friends.

"And you might be interested to know," he went on, "that among the 18 of us who escaped to England in a 25-foot fishing boat was an American flyer who parachuted from a Flying Fortress. We found him, sheltered him and hid him when the authorities came around. When we were ready for our escape, we took him along."

The aviator said he had escaped from France three months before, and was on his way to Florida—on this August day in 1943—to take an advanced naval aviation course which would enable him to instruct other French pilots.

The testimonial by this young Frenchman only served to add to the long body of proof that NBC's shortwave news broadcasts are picked up regularly by the peoples of the occupied countries.

A recent letter from Morocco says:

"So many thanks I owe you since June, 1940, for all the courage you have given us. . . . During that tragic month of June, every day, for hours at a time, I tried to listen to news . . . all the news available on the radio. It was my good fortune to discover some American stations, and, since then, I have been a faithful listener."

The writer explains she would have written her appreciation long before but it was only since the Al-

lied liberation of North Africa that mail has been permitted to leave the country.

"You may not be aware how much your words mean to us, to all those who have known defeat, to all those who fell under the German heel! . . . I have always shared your point of view, whether it refers to a purely French situation, or to a world situation. . . . You may be sure that all your messages . . . are deeply felt by all 'true Frenchmen'. . . . So many others would cry out to you their hope, if they only could."

The letter is signed: "Madame H. Belnoue."

NBC shortwaves news, under Government auspices, not only in French, but in eight other languages as well. Daily broadcasts in German, Italian, Turkish, Danish, Swedish, and English are beamed to Europe and Africa, while a regular series of programs is beamed in Spanish and Portuguese to our neighbors in Latin America.

News broadcasts comprise only a part of the schedule. Many of NBC's regular network programs are shortwaved. The English section alone has a five-and-a-quarter hour schedule daily, directed primarily to the men of the armed forces of the United Nations.

The other language sections also have received word that their programs are being heard.

Niels Bonnesen, whose Danish broadcasts are heard in Denmark every day at 6:15 and 9:15 p.m., has been informed that that country's underground newspaper, which is said to have 120,000 readers, gives the time of NBC's broadcasts, and adds: "We recommend listening to NBC."

Bonnesen also has been told that King Christian of Denmark receives a mimeographed copy of all broadcasts each day.

Einar Thulin, of NBC's Swedish Section, received several postcards recently, commenting on his programs. The broadcasts are heard clearly in most parts of Sweden.





A STRIKING LOBBY DISPLAY SET UP BY STATION KWBW, HUTCHINSON, KANSAS, TO ANNOUNCE THE 1943-1944 NBC PARADE OF STARS.

## NBC BUILDS ITS AUDIENCE

*Network's Parade of Stars Is Designed to Create Greater Listener Interest In the New Season's Schedule of Radio Programs from Coast to Coast.*



By Jean E. Harstone

*Assistant to the Manager of Network Promotion, National Broadcasting Company*

"STARFACE," NBC's ambassador of goodwill and top service to its stations and clients, has led the 1943-44 NBC Parade of Stars off to a rousing start. For the past month all the NBC stations have concentrated their efforts on this elaborate promotion campaign.

Behind the story of the compilation of this promotion and its purpose, is the foundation and structure of the principles upon which the National Broadcasting Company was founded—principles

which still guide its operations today—service through teamwork.

In 1926, when the National Broadcasting Company was incorporated, definite policies were set up. First of all, NBC visualized radio as an instrument of service—

A service to the owner of the local affiliated station from the National Broadcasting Company by providing programs, both commercial and sustaining, of a quality which the National Broadcasting Company was in a position to offer because of its vast facilities and more accessible talent.

A service to advertisers by furnishing them a large circulation over a vast territory—an audience to whom they could talk directly.

A service to the public by bringing to them in their homes a world of new ideas and enjoyment, a wealth of music and information through the medium of programs—the best of their kind, sufficiently diversified to appeal to all possible listeners.

Nor was this new instrument of communication to be a monopoly of the air. On the contrary, all-comers, competitive or otherwise, were welcomed; for the founders of the National Broadcasting Company envisaged radio as an instrument of freedom in the service of the people of all sects and nationalities. And in the organization itself, the services and work were to be unified by cooperation. This policy established then is maintained today. It is exemplified by the inter-organization motto—"You are the NBC and the NBC is you."

It is due to the basic idea—service through teamwork—that the NBC Parade of Stars is the great promotion it is—a radio-star-client-station-program-promotion with each participating group working in complete cooperation for one purpose and to one end.

The purpose of the Parade of Stars is simple and direct—to tell the public about the NBC network shows they will hear over their local stations during the coming season, thus creating interest in network programs. This teamwork benefits the listeners who look forward eagerly for their season's enjoyment through their NBC local station network shows. It benefits the sponsors and the stations, too, by building audiences and strengthening the position of the affiliated stations in the communities they serve.

The promotional material of the campaign included recordings, which the clients, their stars and agencies cut for their shows, and the publicity material prepared by the National Broadcasting Company to publicize the recordings and the shows. The publicity material consisted of speeches, scripts, announcement, newspaper and program mats and ads, posters and bus cards, photographs and mats of stars and a catalogue of promotion ideas.

All this material was coordinated into a unified promotion presented in deluxe portfolios and record albums, and sent to each station where it is being synchronized into their own promotion plans and presented to the listeners of NBC network programs in every State in the Union.



"STARFACE," NBC'S AMBASSADOR OF GOOD WILL AND SERVICE, WHO IS MARCHING THROUGH THE COUNTRY AS DRUM MAJOR OF THE PARADE OF STARS.

The first Parade of Stars, sent to the stations in September, 1942, was such a resounding success, with the stations exploiting every feature of the promotion, that the preparation of a 1943-44 Parade was a foregone conclusion.

After the results of the 1942 promotion were tabulated, these amazing figures were revealed:

7,566 actual broadcasts of the Parade of Stars recordings were made.

315 hours of programs, equivalent to 20 full days of radio shows.

5,603 newspaper ads and press announcements were placed by the stations.

1,377 lobby displays were used as well as 1,783 car, window and bus cards.

Many stations linked their promotions with local celebrations such as Fall Fairs, and took every opportunity to make the public aware of the great NBC shows that would bring them their favorite stars and programs throughout the season.

This year, with the experience of the first promotion behind it, and

with many valuable suggestions from the stations themselves, the National Broadcasting Company expanded the scope of the Parade of Stars. Instead of functioning as a Fall promotion, publicizing the return of the network shows to the air after the Summer, the 1943-44 Parade of Stars was designed to promote NBC network shows throughout the year.

The scope was broadened in many directions. Instead of twenty shows — as in the 1942 Parade — this year's Parade presented forty-five sponsored shows and five NBC Public Service programs, fifty in all, with twenty-seven clients and twenty-eight agencies giving splendid cooperation. The format of the promotion was more streamlined. All the promotional material was included in compact and attractive portfolios beautifully printed in red and purple on a pastelle gray background. The record albums which carried the recordings, were designed to provide the stations with a permanent case for their Parade of Stars transcriptions. Incorporated in the back of each album are pads of "Recording Use Sheets" for a record of the stations' use of their Parade of Stars transcriptions. The entire promotion was distinguished by a special recognizable symbol "Starface," the smiling major domo, who is carrying it so successfully throughout the country.

In addition, the National Broadcasting Company has prepared an extensive newspaper promotion for its owned and operated stations in

New York, Chicago, Cleveland, Washington, Denver and San Francisco. This newspaper campaign, backing the Parade of Stars promotion, consists of full page opening ads, followed by a series of 600 line ads featuring the daily program schedules.

At the time of writing "Starface" has been in circulation two weeks with the Parade of Stars. It is therefore too early to give a complete picture of the results of the promotion. But from the scores of station letters that have come to NBC telling of station promotion plans and from the re-orders of promotional material during the past two weeks, the National Broadcasting Company has every reason to believe that "Starface" and the NBC Parade of Stars are making a hit all over the country.

The creation and the organization of the NBC Parade of Stars was a prodigious task. The work could not have been accomplished in its present comprehensive form without the wholehearted cooperation of all who participated in its production — performers, advertisers, agencies, associated stations and the National Broadcasting Company. All gave their best efforts to the project as a united team. It is NBC promotions such as the Parade of Stars, designed to service its clients, their agencies and NBC network stations, that have helped maintain for the National Broadcasting Company since its inception, its leadership as the No. 1 network.

PROMOTIONAL HELPS ARE INSERTED IN THE NBC 1943-1944 PARADE OF STARS PORTFOLIOS.



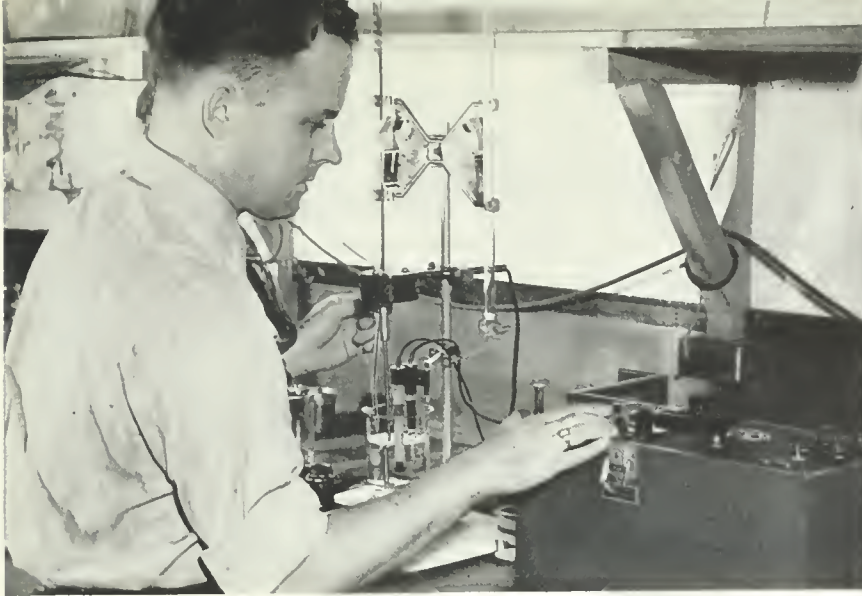

DR. O. D. BLACK OF RCA VICTOR USES AN ELECTRONIC DEVICE TO TEST THE ACIDITY OF A MATERIAL DEVELOPED TO MODIFY PETROLEUM ASPHALT FOR USE IN POTTING TRANSFORMERS.

## CHEMISTRY AIDS WAR WORK

*Chemical Engineers at RCA Victor Apply Science In Producing Best In Radio-Electronic Equipment for Armed Forces.—War Brings New Problems.*



**By Clifford Eddison**

*Manager,  
Chemical Engineering Section,  
RCA Victor Division*

**M**INERAL oil from the drug-store shelf, common starch from the household laundry, a pigment developed for the paint industry, and many other substances have been commandeered by RCA Victor Division chemical engineers to produce the best and most dependable radio and electronic equipment for our armed forces.

The war brought to our organization, as to other industries throughout the country, new and more rigid specifications for completed products, more critical inspection standards, and, almost simultaneously,

materials shortages necessitating the use of new and often relatively unknown materials. Resulting materials and process problems have been numerous, but in applied science we have found the answers.

As a result, RCA radio coils for military and naval use are now protected against moisture with a substance that merrily thumbs its nose at the torrid temperatures of North African deserts and South Pacific island jungles, and just as merrily defies the frigid cold of Iceland and the snow-blanketed Aleutians.

By the same token, bomber and fighter crews carrying RCA aircraft radio equipment are relieved of excess weight without sacrifice of strength and serviceability, and men whose lives and whose victories for us depend on the accurate performance of devices kept "on the beam" by quartz crystals are assured of mass production of these crystals without loss of their essential accuracy.

DR. C. W. MELL EXAMINING AN ALUMINUM PANEL PLATED BY A METHOD DEVELOPED BY THE CHEMICAL ENGINEERS TO PROVIDE A SOLDERABLE SURFACE.

Similarly, a new compound for the potting of RCA transformers for the armed forces has been developed in order to meet the more severe conditions of operation, and various items in which efficiency depends on the soldering of steel parts are made available through the discovery and use of a new fluxing agent which is sufficiently active for such soldering but free of corrosive tendencies.

Mineral oil was pressed into service by the Chemical Engineering Section when it was found that the wax ordinarily used to impregnate radio coils would flow when too hot and crack or crystallize when too cold, all within the extremes of temperature at which these coils would be required to function. Either failure would expose the wires to moisture, adversely affecting the electrical properties of the coils.

The problem was solved with the development of a new impregnating agent, made from mineral oil and cumar resin, which will withstand both extremes of temperature without loss of its protective characteristics.

But a tougher problem was posed by our need for a means of soldering aluminum to permit the use of this light-weight metal in products where weight is an important factor, such as chassis for aircraft radio equipment.

Since aluminum cannot be directly soldered in a commercially



[RADIO AGE 25]

convenient manner by any known method, a means was sought for plating the aluminum with another metal, to provide an easily solderable surface and, at the same time, a better means of assuring good electrical contact. But neither can aluminum be directly plated, so an indirect approach was necessary.

After some study, our laboratory found a conducting material which could be applied to aluminum as film by means other than plating, and developed a process for applying it and for subsequent plating of the aluminum thus treated.

Common starch came to the rescue as a fluxing agent for various soldering operations when we found that neither rosin nor zinc chloride, which are the agents most extensively used, would do the job in certain applications.

Fluxing agents are used to cleanse the surfaces to be soldered, and make the solder alloy with the base metal. Zinc chloride is a powerful flux, but tends to cause corrosion unless the soldered parts are washed to remove the excess flux after soldering. Rosin, though free of this fault, is not a very active flux, particularly when used with such metals as steel.

In certain types of equipment it was found necessary to solder steel parts together, but impossible to wash the parts after the operation. Our laboratory solved the problem with the discovery that levulinic acid, derived from common starch, was a much more active flux than common rosin. It was found that

this acid, when blended with rosin, could be used in soldering steel parts without the necessity for subsequent washing.

Process as well as materials problems have yielded to applied science in our laboratory. The problem of how best to deposit silver on quartz crystals to form electrodes, for example, was one of the serious potential bottlenecks faced by our organization when the war made it necessary for us to convert to a mass production industry, almost overnight, what had been only a limited activity in the manufacture of crystals.

Although the Rochelle salts method appeared to be the most adaptable to mass production, the first results with this method were disappointing. The method had been applied largely in the past to satisfying optical requirements, and the technique of operation had been directed to that end. It was found that uniformity of film thickness, directly affecting electrical results, could not be guaranteed, while the adhesion between silver and quartz was poor.

A process overcoming these difficulties and satisfying all requirements was developed, but not until after we had completed a study of the effect of solution concentrations, temperatures, times of immersion, rate of flow of solutions over the crystal face, and the role played by the compound, silver tartrate.

As has already been indicated, not all of our materials problems have resulted from shortages. New requirements, rendering materials formerly used unsatisfactory, have played their part. This was true in the case of petroleum asphalt as a substance for impregnating and potting transformers.

Although petroleum asphalt remained plentiful, it did not inherently possess the properties required to meet more exacting test specifications as it became necessary for transformers to operate under more severe conditions. In this instance our laboratory found means of modifying the substance by blending it with other materials.

Our borrowings from the paint industry involve the use of a black oxide of iron, specifically developed

as a pigment, as the essential material in the manufacture of cores used in controlling the effective permeability of magnetic circuits.

Such satisfactory solutions of materials and process problems as those enumerated have been possible at RCA Victor because of the fact that our organization, with its background of experience in the various kinds and applications of engineering and science, was from the beginning in a relatively fortunate position to meet the challenge of wartime requirements.

Some manufacturers were not so well prepared. Actually, wartime manufacturing conditions have, in some instances, only emphasized fundamental weaknesses that were present in pre-war days, increasing costs and constituting a self-imposed break on maximum progress.

However, as more and more rigid specifications have been introduced and the number of new or substitute materials increased, even manufacturers lacking previous experience in the scientific solution of such problems have begun to seek out the special training and experience most applicable to help them meet their emergencies.

To make the wisest use of the chemical sciences, it is essential to know the scope and purpose of the various specialized branches. Gone are the days when the individual chemist might be expected to give an authoritative opinion on such widely different subjects as metals and alloys, dyes, plastics, and textiles. Partly because of the ever-expanding horizon of the chemical sciences, and partly because of the number and complexity of raw materials and process requirements entering modern manufacturing industries, it has been almost imperative for the individual chemist to undertake some specialty.

While it may rarely be either advisable or necessary to utilize all the branches of the chemical sciences in a specified industry, the bringing together of the needed specializations to form a strong, well-organized unit dedicated to the scientific solution of materials and process problems can do much to reduce costs and to keep products ahead of the field.

DR. LEOPOLD PESSSEL SPRAYING A WASH ON QUARTZ CRYSTALS TO REMOVE EXCESS SILVER SOLUTION. SILVER IS DEPOSITED ON THE CRYSTALS TO FORM ELECTRODES.

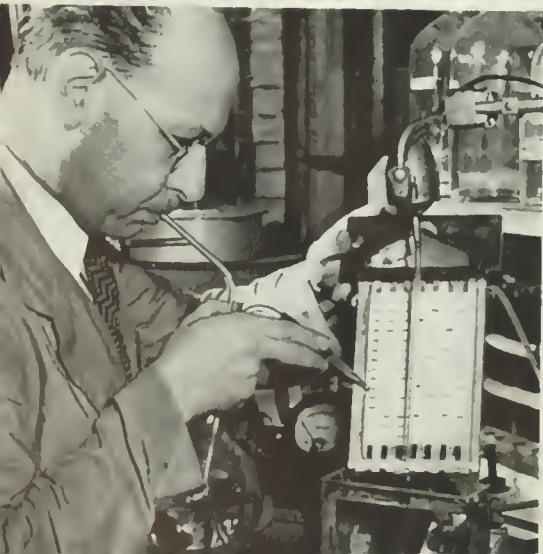



EMPLOYEES OF THE RCA VICTOR PLANT IN CAMDEN, N. J., RAISE THEIR NEWLY AWARDED ARMY-NAVY "E" FLAG WITH THREE STARS FOR CONTINUED EXCELLENCE OF WAR PRODUCTION.

## PRODUCTION WINS 3 AWARDS

*RCA Victor Plants In Camden and Indianapolis and Radiomarine All Get Government Honors for Outstanding War Production.*

**T**HE efficiency of RCA workers on the war production front has again received official recognition. On August 17, the Camden plant of the RCA Victor Division won a third star for its Army-Navy "E" Flag and on September 7, Radiomarine Corporation of America added a star to its Maritime "M" Pennant. Moreover, the Indianapolis plant of RCA Victor has been notified that it will be awarded the Army-Navy "E" Flag in the near future.

Including the Indianapolis award, RCA organizations have now won five Army-Navy "E" Flags with a total of five stars, a Maritime "M" Pennant with one star, and a Victory Fleet Flag.

The Camden plant of RCA-Victor began the flag-winning parade in January, 1942, when it became the first RCA unit privileged to fly the Army-Navy "E" Flag. Since that time it has won three stars for its flag, each star representing six months of continued production efficiency. In awarding the third star on August 17, Admiral C. C. Bloch of the Navy Board for Procurement

Awards said in part:

The men and women of RCA Victor have achieved a signal honor by continuing their splendid production in such volume as to justify this renewal of their award. In the first instance, it was difficult to win the Army-Navy "E", and by meriting a renewal the management and employees have indicated their solid determination and ability to support our fighting forces by supplying the equipment which is necessary for ultimate victory.

Workers at the Harrison plant of RCA Victor won the Army-Navy "E" Flag in September, 1942. A star was added to the Harrison flag in April, 1943, when Under-Secretary of War Robert P. Patterson declared that it was "the symbol of appreciation from our armed forces for your continued and determined effort and patriotism."

Radiomarine Corporation of America was awarded the Army-Navy "E" Flag in December, 1942, and a star for continued production was added in March, 1943. Radio-

marine also holds the Victory Fleet Flag and the coveted United States Maritime Commission "M" Pennant to which a star was affixed on September 7. Both these flags were awarded in March, 1943. In presenting the flags, Admiral H. L. Vickery, Vice Chairman of the United States Maritime Commission praised Radiomarine employees for on-time delivery of vast amounts of radio equipment for the Merchant Marine despite innumerable difficulties in procurement of materials.

The fourth Army-Navy "E" Flag won by the RCA organization was awarded to RCA Laboratories in June, 1943. Rear Admiral Harold G. Bowen, who spoke to the research workers for the Navy, said:

You who have been in the middle of things like I have, appreciate the enormous amount of technological development successfully completed before actual combat took place. You who participated in this effort made great contributions to win the war long before the war started. To you we are indebted for our present technological excellence. But not content with what you accomplished before the war, you are still contributing to the war with conspicuous success.

The announcement that the RCA Victor Division plant in Indianapolis was soon to be the fifth RCA winner of the Army-Navy "E" Flag was greeted with a spontaneous display of employee enthusiasm throughout the factory when the letter from Undersecretary of the Navy James N. Forrestal was read over the plant-wide broadcasting system by C. N. Reifsteck, plant manager.

---

Buy War Bonds

---



DON AMECHE AND JEANNETTE MAC DONALD GIVE THEIR AUTOGRAPHS TO MEMBERS OF THE STUDIO AUDIENCE AFTER A "WHAT'S NEW?" BROADCAST.

## "WHAT'S NEW?" IS RADIO HIT

Critics Praise RCA's New One-Hour Saturday Night Program—  
Sarnoff Keynotes Series During Opening Broadcast On Blue Network.

RCA's big show is on! "What's New?" is on the air. The big tent is, in effect, the entire nation, and every one of the 159 stations of the Blue Network offers a free pass. The show lasts one hour and can be heard every Saturday at 7 p.m., EWT. The theme of the performance is what's new in the world at large—in entertainment, music, news, personalities, sports, science, and politics.

Ringmaster of "What's New?" is Don Ameche, versatile star of screen and radio, who qualifies for his key role as Master of Ceremonies by a natural flair for showmanship coupled with marked ability as an entertainer. He is ably seconded by the RCA Victor Orchestra and Chorus and a host of guest stars drawn from the entire world of entertainment.

At the Hollywood premier of "What's New?" on September 4, a big variety program offered entertainment to please every taste.

Music, of course, played a prominent role in the program. The main musical surprise of the evening was furnished by the great concert pianist, Jose Iturbi. That Iturbi should play De Falla's "Fire Dance" superbly was no surprise. But that he should also play "The

Joint Is Really Jumpin' " in boogie-woogie startled lovers of classical music as much as it delighted "hepcats." Fresh and sparkling tunes were sung by Cass Daley, bright new comedienne, and Dinah Shore, one of the "great ladies" of popular song.

Anne Baxter, screen star of "Five Graves to Cairo," teamed with Don Ameche in a humorous one-act play of modern marriage entitled, "You Can't Stay Mad." Cass Daley also joined Don Ameche in a comical skit and Ed Gardner, whose spectacular rise in 1943 makes him the newest of major radio comedians, played his famous role of "Archie" of Duffy's Tavern.

A patriotic note was struck when a switchback from Hollywood to New York brought Jim Ameche, Don's brother, to the microphone to introduce Lucy Monroe, director of patriotic music for RCA. Miss Monroe described how she teaches

workers and management in war plants to sing together for relaxation and inspiration.

David Sarnoff, president of the Radio Corporation of America, keynoted the opening program when he spoke for the men and women of RCA.

"Our search for things new," said Mr. Sarnoff, "is primarily in the field of radio and electronics. This work has produced the present day marvels of communications, of broadcasting, and television through the air. It has revolutionized methods of warfare, and created new industries of peace. But the promise for the future, is even greater than the past.

"While an electron is the smallest thing in the world, we can control its behavior, and put it to work. When we do so, we call it electronics. And the heart of electronics is the radio tube. The tubes in a sending set enable you to speak by radio, and the tubes in a receiving set, enable you to hear. We constantly find new uses for electronic tubes. They can see, smell, and feel. On land, at sea and in the air, they guide friendly vehicles to their destination, and locate unfriendly objects more accurately than the enemy likes.

"Out of our search for the new, has come the electron microscope—developed by RCA Laboratories. This instrument magnifies by 100,000 diameters. As an illustration of what this order of magnification means, I might tell you that if the average football field were enlarged by 100,000 diameters, it would be five times as large as all of the United States. Only with a microscope of this power, can we

DAVID SARNOFF, JOHN U. REBER AND DON AMECHE AT A REHEARSAL FOR THE FIRST "WHAT'S NEW?" PROGRAM.





PERFORMERS AT THE "WHAT'S NEW?" PREMIERE INCLUDED (LEFT), LOU BRING, ANNE BAXTER, CASS DALEY, JOSE ITURBI, ED GARDNER, DINAH SHORE, AND DON AMECHE. THE RCA VICTOR CHORUS (ABOVE) CONTRIBUTES SKILLFULLY TO THE MUSICAL PORTION OF EVERY "WHAT'S NEW?" BROADCAST.

see many important things, otherwise entirely invisible. For example, the influenza virus, at last can be seen. This should help to find a way to conquer it, and thus to benefit mankind.

"This microscope is only one of a thousand electronic wonders that can open a new world for all of us. Within the limits necessarily imposed by the requirements of military secrecy, we plan to tell you about them from week to week, on this program."

Typical of press and public reaction to the first performance of "What's New?" was the comment of *The New York Times*.

"'What's New?' is a good show. . . . There are music, drama, comedy and some serious talk, and, all in all, it is an omnibus on which every passenger should find something to please him. . . ."

Variety, trade paper of screen, radio, music, and stage, said:

". . . The Blue Network becomes the beneficiary of an hour of upper-crust popular entertainment. . . . That opening program seemed to have the answers to what constitutes mass appeal entertainment. The ingredients were consistently know-how, the runoff was oily-smooth, and the commercials were astutely tied in. . . ."

The second performance of "What's New?", like the first, brought an impressive guest list of new or well-known voices to the mi-

crophone. Headlined were Captain Clark Gable who spoke via short-wave from "somewhere in England"; Lena Horne who sang the title song from her latest film-musical, "Stormy Weather"; the popular comedy team of Wally Brown and Alan Carney; Monty Woolley whose newest movie venture is "Holy Matrimony"; and Katrina Paxinou, the Greek actress who made her American screen debut as Pilar in "For Whom the Bell Tolls."

Major Alexander de Seversky, one of the greatest aeronautical engineers of all time and author of "Victory Through Air Power" prophesied a new era of international peace for the post-war world.

"There is a lot of discussion these days about the post-war relations between the countries of this planet," he said. "The plain fact is that science and technological progress will force the whole world to become, in effect, one neighborhood. People in any part of the world will be able to see each other through television, to hear each other through radio, regardless of distances. And space, when measured in the time of flight through the air, will be so contracted that any spot on the face of the globe can be reached in a few hours. The science of destruction is making war more and more horrible. Ultimately, we may be sure, war will become unthinkable because it

would be tantamount to suicide."

Major de Seversky also foretold a tremendous post-war expansion of aviation made possible by the use of electronics. The airplane's universal use by average people he no longer considers an engineering question but rather a problem of effective communications.

"Electronics will ultimately make it possible for anyone to get into his private aircraft, turn a knob and *tune in* on his point of destination anywhere, and get there automatically and safely. . . . aircraft will travel on invisible rails and highways of radio. . . . or they will be able, at will, to abandon the chartered highways to soar through all space. The automobile turned *nations* into neighborhoods. Aviation and electronics will turn the *world* into a neighborhood. Life will be lifted into new dimensions, and will acquire new horizons."

The first two performances of "What's New?" set the pace for the new show and revealed that the program makers had aimed well in pointing to new horizons and glimpses of the future. For anything can happen on "What's New?". Next week's program may bring a dramatic eyewitness account of a battle between American and enemy forces, the announcement of an important new discovery in science, or a new love song destined to wing its way around the world.

# OWI USES RECORDING UNITS

*Studios of Overseas Operation Branches Equipped With RCA Recording Lathes for Preparing Radio News and Entertainment Programs.*

A TOUR of the headquarters of the Office of War Information in New York City reveals how America employs a weapon which the enemy dare not use—truth on the wings of radio. Day and night, twenty-four hours out of twenty-four, OWI bombards the enemy with the facts about the war.

The ammunition for this barrage is prepared in the engineering studios of the OWI Overseas Operation Branches in New York and San Francisco. In each of these studios are long lines of RCA recording lathes, the machines which ceaselessly cut into disk records the news and entertainment programs that are the backbone of OWI's overseas propaganda service. These OWI broadcasts are recorded as they are made. At the same time, OWI produces a large number of special programs specifically for record reproduction and transcribes many of America's most entertaining domestic programs.

This technique of multiple program reproduction by RCA recording lathes increases by many times the effectiveness of OWI broadcasts. The ability to rebroadcast a program repeatedly has become vitally important. For it is the aim of OWI to send America's message of freedom to the farthest corners of the earth, to reach their peoples in their own languages, and at an hour

when these messages are most likely to be heard. All this, despite the fact that to the ordinary technical difficulties of world-wide broadcasting are added the artificial obstacles devised by a resourceful enemy.

In Axis-occupied territories, liberty to listen has long since disappeared. If Heinrich, Yamato, Halvor, and Jean are found listening to foreign broadcasts, the penalty may be imprisonment or death. Moreover, whenever possible, the enemy "jams" the "Voice of America" broadcasts to remove all such temptation.

It is explained by OWI representatives that even though time was not invented by the enemy, the time factor is another major obstacle that could cost the "Voice of America" many listeners. For instance, if President Roosevelt begins a "fireside chat" on a Monday night at 10 o'clock, a convenient hour for American listeners, it will be at the same moment 4 a.m. Tuesday in Berlin and Vienna, and 11 a.m. Tuesday in Manila and Shanghai, a most inconvenient time for listeners in those cities. Moreover, many important listeners are unable to plan their radio listening. An American soldier in New Guinea may have far more pressing business than to listen to a specific radio program at a specific hour.

OWI's answer to these problems is to rebroadcast important programs many times and to beam all programs at a time and in a direction where its prospective listeners have access to the radio. Records produced on the recording lathe make possible this procedure.

Italy's unconditional surrender on September 8, one of radio's biggest news assignments of all time, afforded a dramatic illustration of the value of this aerial task force of records to the OWI. When the first news of the great event was flashed from Algiers, OWI immediately began broadcasting bulletins. And when General Dwight D. Eisenhower spoke at 12:30 p.m., EWT, his words were instantly transcribed by the OWI recording lathes. In a matter of minutes, the General's announcement was translated into eighteen languages, recorded, and broadcast to all the world over twenty short-wave transmitters. In the first 24 hours after General Eisenhower spoke, his announcement was broadcast approximately 150 times. Europe, in particular, was bombarded with the good news, which was repeated continuously in Italian, French, German, and English.

Marshal Pietro Badoglio's proclamation of the surrender of the Italian armies which followed the announcement of General Eisenhower, was also rebroadcast many times. Specially prepared records were beamed to the people of Italy urging them to aid the Allied armies and to deny help to German soldiers.

If Heinrich, Yamato, Halvor, and Jean turned on their radios at any

A SECTION OF THE RCA-BUILT RECORDING LATHE BANK AT OWI HEADQUARTERS IN NEW YORK CITY.



A RECORDING MASTER CONTROL DESK REGULATES THE OPERATION OF THE RCA RECORDING LATHES.

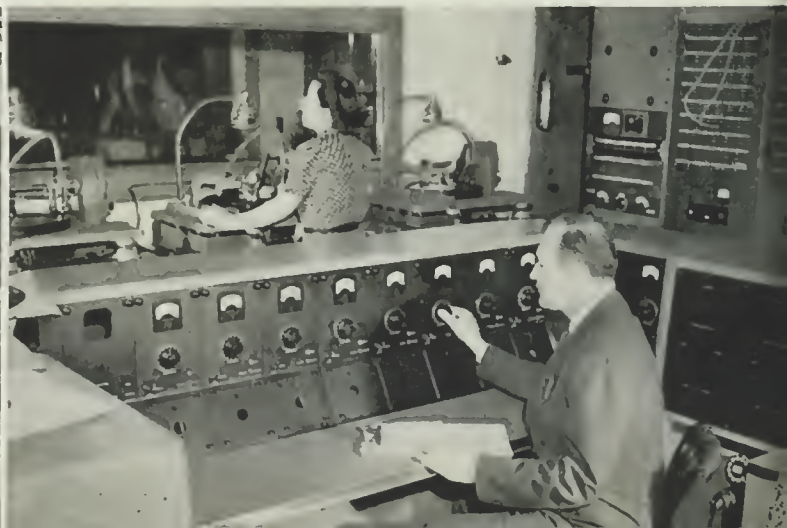



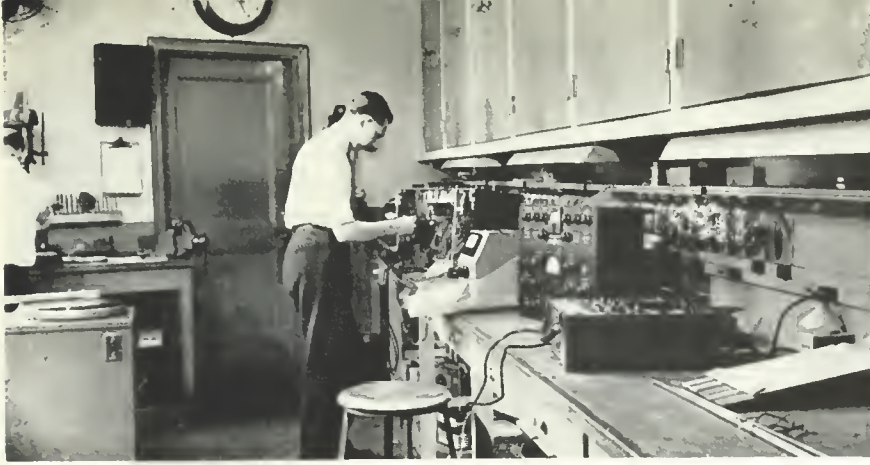

AN ENGINEER IN THE OWI REPAIR SHOP (ABOVE) MAKES A ROUTINE EQUIPMENT CHECK-UP. FROM THE RECORD ON THE RCA TURNTABLE (RIGHT) A MESSAGE IS BEING SENT BY SHORT WAVE TO EUROPE.



hour of the day or night during this critical period, they heard the important news as if they lived in the United States. American service men and women abroad also heard their commander's voice. Neutral countries received the news quickly, accurately, and with fortunate political results.

The RCA-built recording lathes in the OWI studios are by no means exclusively devoted to the preparation of news broadcasts. Every day and night, they record the best domestic radio programs for retransmission to our fighting men abroad. A Marine sergeant in the Solomons or a seaman on a destroyer in the Mediterranean can listen to the NBC Symphony Orchestra or to one of his favorite comedians at almost any hour he can get to a radio—even though many hours may have elapsed since the original programs were presented in New York or Hollywood.

In superficial appearance, the RCA recording lathe is not unlike the chassis of a Victrola manufactured for home use. But there the resemblance ends. For the recorder is designed not to play records, but to cut them, a much more complex task.

The heart of the machine is the cutter-head, which actually carves the grooves that record the sound. The cutter-head is designed so that groove adjustments can be easily made while the machine is in operation. Most important of all—the head must not be susceptible to shocks, rumbles, or vibrations,

which distort the sound. The cutter-head which RCA Victor scientists designed for the OWI is so delicate that each of the fourteen in use in New York and the twelve in San Francisco had to be made by hand.

The carriage assembly, the main unit of the machine, is a standard RCA product. It is as remarkable in its own way as the cutting head. Complicated but precise mechanism, operating with two motors, makes it possible to record at either 33½ or 78 revolutions per minute. Records can be cut from the outside-in or the inside-out, at 96, 112, 120, 136, or 154 lines to the inch. Speed and groove adjustments can be simply and quickly made by turning a knob. There are no bothersome gears or belts to change or to get out of order.

Adjusting the depth of a record groove to produce the best sound results is a highly skilled art, requiring many months of practice. Each recorder is equipped with a high-powered microscope to make possible a minute study of the grooves. The microscope is mounted on an adjustable arm, which permits it to be moved to any part of the record. A small shielded lamp, mounted on the same arm, can be independently adjusted to illuminate the particular grooves under observation.

Since the slightest vibration would make perfect record reproduction impossible, the motor is shock-mounted in rubber. In addition, each of the OWI recorders is supported by 700 pounds of con-

crete, resting on rubber mats.

It is difficult for the casual visitor to the OWI recording studios to realize that the long rows of quiet machines are preparing verbal bombardments for overseas, or that the engineers operating the machines are actors in an international drama. Yet the results of this activity are as effective politically in America's prosecution of the war as are airplanes, battleships, or tanks on the military front.

## BLUE NETWORK SALE ANNOUNCED BY RCA

*Agreement to Sell Nation-wide System to Edward J. Noble for \$8,000,000 Revealed by Sarnoff*

David Sarnoff, President of Radio Corporation of America, on July 30 announced that an agreement had been reached to sell the Blue Network for the sum of \$8,000,000 in cash to Edward J. Noble, former Under-Secretary of Commerce.

This move came a year and a half after the Blue was organized as a separate coast-to-coast network, and in conformity with the new regulations of the F.C.C. relating to ownership of more than one network by any single organization. The Radio Corporation of America remains the owner of the National Broadcasting Company which will continue to operate the "Red" Network.



"THE BIG SPLASH" AS MRS. LENA RETTBERG (ABOVE), INSTRUCTRESS AT THE RCA VICTOR PLANT AT HARRISON, CHRISTENS THE S.S. ROSEBUD AT MOBILE, ALABAMA. MRS. RETTBERG STANDS WITH ROBERT YOUNG (RIGHT), CRYSTAL PROCESSOR IN THE CAMDEN PLANT, WHO CO-SPONSORED WITH HER THE NEW 21,600-TON TANKER.

## RCA WORKERS LAUNCH SHIP

*Suggestions for Speeding War Production, Conserving Man-power and Critical Materials Bring Special Honors to Contest Winners.*

PRESENTING a new way of stimulating and rewarding employees' suggestions for speeding war production, the RCA Victor Division completed early in September a five-day series of special events in honor of six RCA war workers.

The program was one of the most comprehensive yet developed in recognition of the contribution of workers to the war program, through suggestions for speeding production and conserving man-power and critical materials.

Packed into the five days were a variety of entertainment in three cities, official receptions by municipal authorities, presentation of the contest winners to top officials of their company, participation in several radio broadcasts including an international hookup, tours of home plant and headquarters offices of both the division and the corporation, and, capping the climax, participation in the launching of a big Victory ship at Mobile, Alabama.

Those honored were top place plant winners in suggestion contests sponsored by labor-manage-

ment production drive committees in RCA plants at Camden and Harrison, N. J.; Lancaster, Pa.; and Indianapolis and Bloomington, Ind. Conducted through a two-weeks period under the slogan "Don't Miss the Boat," the contest resulted in 3,500 employee suggestions, a substantial percentage of which were found practicable, and adopted.

All workers whose suggestions were adopted received awards of war bonds and war savings stamps in varying amounts up to \$350. The top winner for each plant received, in addition to these awards, a trip to Mobile to share honors in the launching. Visits to Camden, N. J., headquarters of the RCA Victor Division, and New York City, home of the Radio Corporation of America, were made enroute to Mobile.

Converging at Camden from their several plants, the honor group, including five men and one woman, were presented to Robert Shannon, general manager of the RCA Victor Division, feted at a luncheon, and conducted on a tour of the plant.

Continuing to New York that afternoon, they were quartered at

the Governor Clinton Hotel, and received at City Hall by Newbold Morris, President of the City Council, who presented the top winners with a silk American flag. They made guest appearances on several radio programs and were entertained at a Manhattan night club. The following morning, they were presented to Lieut. Gen. James G. Harbord, chairman of the board of Radio Corporation of America; and then taken on a tour of Radio City.

Arriving at Mobile, the party of war workers were accorded an old-fashioned brass band station greeting. On hand were the Mayor of Mobile, officials of the Alabama Dry Dock & Shipbuilding Company, from whose ways the launching was scheduled, a band, and a turn-out of Mobile citizens. The local radio station, WMOB, broadcast a 15-minute on-the-spot program.

At night, the workers were guests at a traditional Mobile "shrimp dinner." The following morning, they were escorted on tours of the shipyards and various points of interest in the city.

The crowning event came Friday night at the shipyards, when Robert Young, of Philadelphia, crystal processor in the Camden plant and top winner for all plants, cut the rope that released the *S.S. Rosebud*, 21,600-ton tanker, and Mrs. Lena Rettberg, of Newark, instructress in the Harrison plant and only woman among the winners, smashed a bottle of champagne against the ship's prow as it slid down the ways into Mobile Bay.

Adding color and significance to the occasion, the launching was broadcast over the nation-wide Blue Network. On this radio program, RCA Victor workers joined with workers in Moscow, London, and Chungking in a salute to war workers of the United Nations.

Edwin C. Hill, world-famed news commentator, directed the radio program from New York, while Ben Grauer, noted announcer, described the launching and introduced the RCA Victor workers, from Mobile. Rear Admiral H. L. Vickery, vice chairman of the U. S. Maritime Commission, was cut in from Cleveland to pay tribute to the workers.

Robert Young, who is 26, won his honors, including a \$350 war bond

prize, for his suggestion of a method of cutting quartz crystals which has increased the yield of usable crystals in his department by 50 per cent.

Mrs. Rettberg, an employee of the Harrison plant for thirteen years, received in addition to the Mobile trip the first \$300 war bond prize to be won by a woman worker in the company's plants. Her suggestion was for simplification of an engineering problem in the making of radio tubes. The award was her fourth.

The other winners in the party were:

Ray C. Aument, of the Lancaster plant, whose suggestion of a new way of setting up a "basing" operation in the assembly of radio tubes has virtually doubled the output.

William A. Wilson, junior time study engineer in the Bloomington plant, whose idea of a "sliding anvil" saves 37 man hours per thousand units in the processing of parts of sound system terminal boards.

Delmar Taylor, matrix setter in the Indianapolis plant, who devised a time and material-saving operation in the making of matrices.

Charles Yanzer, spray man and co-winner with Taylor at the Indianapolis plant, who suggested a rack for use in spraying paint on the chest plates of field telephone apparatus, enabling the operator to spray eight units at once, instead of one at a time.

## RCA SETS AID SICILY FIGHT

*Equipment Enabled U. S. Destroyers to Lay Down Bombardment That Facilitated Invasion Landing. Employees Told by Rear Admiral Cochrane.*

**R**ADIO messages flashed over RCA-built communications equipment enabled two American destroyers spearheading the Allied invasion of Sicily to lay down a shore bombardment that facilitated the landing of our troops with a minimum of casualties, Rear Admiral B. L. Cochrane, USN, Chief of the Bureau of Ships, revealed early in September in a message to the men and women of the RCA

Victor Division, Radio Corporation of America.

Quoting from a combat report received in Washington from the two destroyers, which carried the RCA apparatus, Rear Admiral Cochrane described the part played by the units as "vital," and concluded his message by saying: "We need more of this fine equipment for invasions to come."

The full message follows:

"THE VITAL PART PLAYED BY RCA COMMUNICATIONS EQUIPMENT IN THE INVASION OF SICILY IS RELATED IN A COMBAT REPORT JUST RECEIVED FROM TWO DESTROYERS WHICH SPEARHEADED THAT OPERATION. SHORE BOMBARDMENT BY THESE SHIPS FACILITATED THE LANDING OF OUR TROOPS WITH A MINIMUM OF CASUALTIES. ON ONE OCCASION, INFORMATION RECEIVED FROM A SHORE CONTROL UNIT OVER YOUR \_\_\_\_\_ RECEIVER NO. \_\_\_\_\_ AND CONFIRMED WITH YOUR \_\_\_\_\_ TRANSMITTER GAVE THE LOCATION OF A GERMAN 88 MM. BATTERY HOLDING UP OUR PARATROOPERS. ONE MINUTE OF RAPID FIRE WIPED OUT THE BATTERY. INFORMATION RECEIVED OVER YOUR \_\_\_\_\_ RECEIVER NO. \_\_\_\_\_ AND CONFIRMED WITH YOUR \_\_\_\_\_ NO. \_\_\_\_\_ TRANSMITTER ENABLED THE DESTROYERS TO BREAK UP AN ENEMY COUNTERATTACK WITH TANKS. OTHER EQUIPMENT MADE BY YOU WHICH FUNCTIONED EFFICIENTLY IN THIS ACTION INCLUDED YOUR \_\_\_\_\_ RECEIVER NO. \_\_\_\_\_; \_\_\_\_\_ AND \_\_\_\_\_ RECEIVERS NO. \_\_\_\_\_, AND THE HANDSETS AND HEADSETS OF THE DESTROYERS' INTERCOMMUNICATION SYSTEMS. WE NEED MORE OF THIS FINE EQUIPMENT FOR INVASIONS TO COME."

## Listening-in from "Middle of Nowhere"

**L**ISTENING to broadcasts while "sitting in the-middle of nowhere," six to nine thousand miles from the source, has given Lieut. Robert W. Sarnoff, USN, a new perspective of radio, he reveals in a recent letter to his father, David Sarnoff, President of the Radio Corporation of America. Lieutenant Sarnoff is stationed at a base "somewhere in the South Pacific."

An excerpt from his letter to Mr. Sarnoff follows:

"First of all let me thank you for the magnificent radio which arrived in A-1 condition a few days ago. It was beautifully packed and started to work at full blast as soon as I

was able to round up some wire, end plugs, etc. My hut has now become the great gathering place, as we all sit around and listen to San Francisco, London, Berlin, Tokyo, and Australia. They all (the stations) come in with strong, clear signals. There is considerable local interference at times (trucks, generators, etc.) but I am having a special antenna rigged up which will eliminate the noise.

"Having accepted radio as a natural, unquestionable fact all my life, I get a new perspective of it out here. It really is an amazing affair, when you consider sitting in the middle of nowhere and hearing



LIEUT. ROBERT W. SARNOFF

clearly six to nine thousand miles away. It certainly helps to make an otherwise cutoff existence more bearable. Many thanks again."

## LUCY MONROE STARTS NEW RALLY SERIES

*Industrial "Sings" to Promote  
Win-the-War Spirit Sponsored  
Jointly by RCA and WPB.*

A SIX-MONTHS tour of the New England States, New York, New Jersey, Pennsylvania, Ohio, and Michigan to conduct industrial "sings" and patriotic rallies for employees of war plants throughout those areas is being made by Lucy Monroe, Director of Patriotic Music of the Radio Corporation of America, under the joint sponsorship of RCA and the War Production Board.

The object of the tour is to promote morale and "win-the-war" spirit among the soldiers of production who will hear and sing with the "Star Spangled Banner Girl," as Miss Monroe is national known. The officially recommended rally program, timed for 20 minutes, includes brief talks by company and labor representatives and may be featured by a singing contest for employees. The rallies are being presented by the joint labor-management production drive committees of the plants participating.

RCA's "Sing for Victory" coach and sound truck, equipped with microphones, inbuilt public address system, and a small speakers' platform atop the cab of the truck, accompanies Miss Monroe on the tour, for use at plants which may not have an adequate plant broadcasting or public address system.

All leading war plants in the areas to be covered by the tour have been invited by WPB to apply for a place in Miss Monroe's itinerary, with the understanding that her appearance at their rallies will be scheduled wherever possible. Applications are made direct to Daniel D. Halpin, Radio Corporation of America, RCA Victor Division, Camden, N. J.

Miss Monroe's services, the traveling sound coach and individual songsheets for distribution to workers, are being made available through Production Drive Headquarters of WPB by RCA without cost to the plants staging the rallies.

## PLAN POST-WAR TELEVISION

*Trammel Appoints Royal Chairman of NBC Committee to Formulate  
Plans for Expansion of Art After War—Foresees Rapid Development.*

TELEVISION, in the opinion of Niles Trammel, president of the National Broadcasting Company, needs only the release of vital materials and the services of electronic engineers, both now confined to war needs, to provide the nation with a new and significant service of sound and sight.

"As a supplement to present National Broadcasting Company service, television," said Mr. Trammell, "promises much as a new dimension in entertainment, education and advertising."

### *To Initiate Studies*

Envisaging the rapid development of television immediately following the end of the war, Mr. Trammell in August announced the creation of a post-war television planning committee to formulate plans for the company's post-war expansion of the art. Essential technological studies and the surveys of the problems involved are to be initiated now and the conclusions held in readiness for the first days of peace.

The committee consists of John Royal, vice president in charge of International, Shortwave and Television, as chairman; William S. Hedges, vice president in charge of Stations; O. B. Hanson, vice president and chief engineer, and C. L. Menser, vice president and manager of the Program Department. John T. Williams, assistant to Noran Kersta, now in the Marine Corps, was named secretary.

Currently, NBC is operating its Empire State television transmitter four hours weekly: Mondays, 4:00 to 5:00 p.m., and 7:30 to 10:30 p.m. Hereafter, programming will be under the direction of NBC's Program Department, with Williams and his staff reporting to Menser.

The NBC television committee is coordinating its activities with the research work of the RCA Laboratories at Princeton, N. J., and with the television development plans of the RCA Victor Division at Camden, N. J.

---

Buy War Bonds

---

## Sarnoff Meets RCA Cadettes in Indiana

DAVID SARNOFF (RIGHT), PRESIDENT OF THE RADIO CORPORATION OF AMERICA, GREETES RCA ENGINEERING CADETTEES AT PURDUE UNIVERSITY DURING HIS VISIT TO INDIANA IN LATE JULY. ACCOMPANYING HIM IS JOHN M. SMITH, GENERAL MANAGER OF MANUFACTURING, RCA VICTOR DIVISION.



# DIRECT

## Radio-Facsimile Service

between the United States and

# SWITZERLAND

is now available . . . for the transmission of diagrams, drawings, financial statements, legal papers and other important documents.

Direct RADIOPHOTO CIRCUITS  
"Via RCA" already in operation  
with Argentina, Australia, Egypt  
Great Britain, Honolulu, Sweden  
and U. S. S. R.

| RESOURCES                         |                   |
|-----------------------------------|-------------------|
| FROM BANKS                        |                   |
| ENT OBLIGATIONS, DIRECT AND FULLY | \$ 943,768,352.68 |
| ICIPAL SECURITIES                 | 2,548,663,686.79  |
| RESERVE BANK                      | 77,379,783.82     |
| ND BANKERS' ACCEPTANCES.          | 6,016,200.00      |
|                                   | 122,814,076.28    |
|                                   | 717,908,709.96    |
|                                   | 36,215,027.42     |
|                                   | 5,432,358.29      |
|                                   | 7,327,882.90      |
|                                   | 4,101,112.50      |
|                                   | 12,979,244.50     |

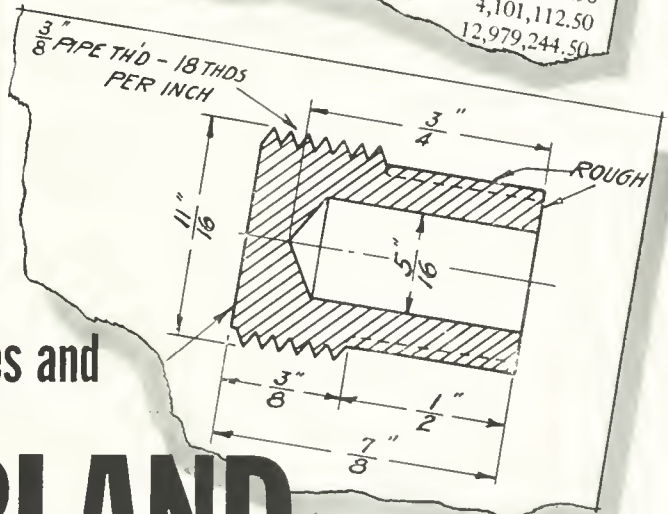

Above are specimen of typical material acceptable for transmission.

**R.C.A. COMMUNICATIONS, Inc.**  
A SERVICE OF RADIO CORPORATION OF AMERICA  
64 Broad Street, New York 4, N. Y. HANOVER 2-1811

## A Six-Hour Concert Every Night . . . That Nobody Hears

**T**HIS is the story of a man who plays the piano—in an empty broadcasting studio.

Triumphant chords, nimble arpeggios, brilliant melodies flow from the instrument in startling succession—but nobody ever listens to him.

His job is to tune the pianos at NBC—all thirty-three of them. Every night, he tours the empty studios on a carefully planned schedule. Under his expert fingers, each piano is made to respond until it is at precise concert pitch—ready for a symphony performance or for a boogie-woogie virtuoso.

Every piano at NBC is tuned by him once a week. Every piano you hear played from Radio City is always pitch perfect.

It's part of NBC's routine attention to detail . . . to the very smallest of details that make for better broad-



casting. Not of world-shaking importance, perhaps. Yet—if it weren't done?

It is precisely this meticulousness, this almost automatic insistence on having *every* detail and feature of *every* program on NBC as perfect as possible, that enables advertisers

and listeners both to depend on NBC for the *best* in broadcasting.

Perfectionism, insistence on quality, care—even for details that no client or listener is directly aware of—*these are some of the things that make NBC "The Network Most People Listen to Most."*



—The **N**ational **B**roadcasting **C**ompany

America's No. 1 Network—A SERVICE OF THE RADIO CORPORATION OF AMERICA

In War or Peace the  
Finest Ships Rely on  
**RADIOMARINE**

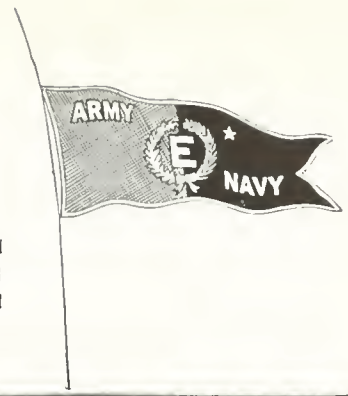

**T**HE United States Merchant Marine is now engaged in the most important job in its history . . . supporting our fighting forces throughout the world.

The passenger fleet of the Merchant Marine is making an impressive record delivering troops to our fighting fronts. And Radiomarine equipment is helping to get our troops through safely and on schedule.

The entire facilities of Radiomarine Corporation of America, including its service stations at 21 ports, are devoted to equipping merchant ships and the ships of our armed forces needed to win the war.

When victory comes, the improved radio-electronic equipment developed for war will be made available to all vessels from pleasure craft to luxury liners.



**RADIOMARINE CORPORATION OF AMERICA**

*A Service of Radio Corporation of America*

75 Varick Street, New York, N. Y.





ELECTRONICS IN ACTION

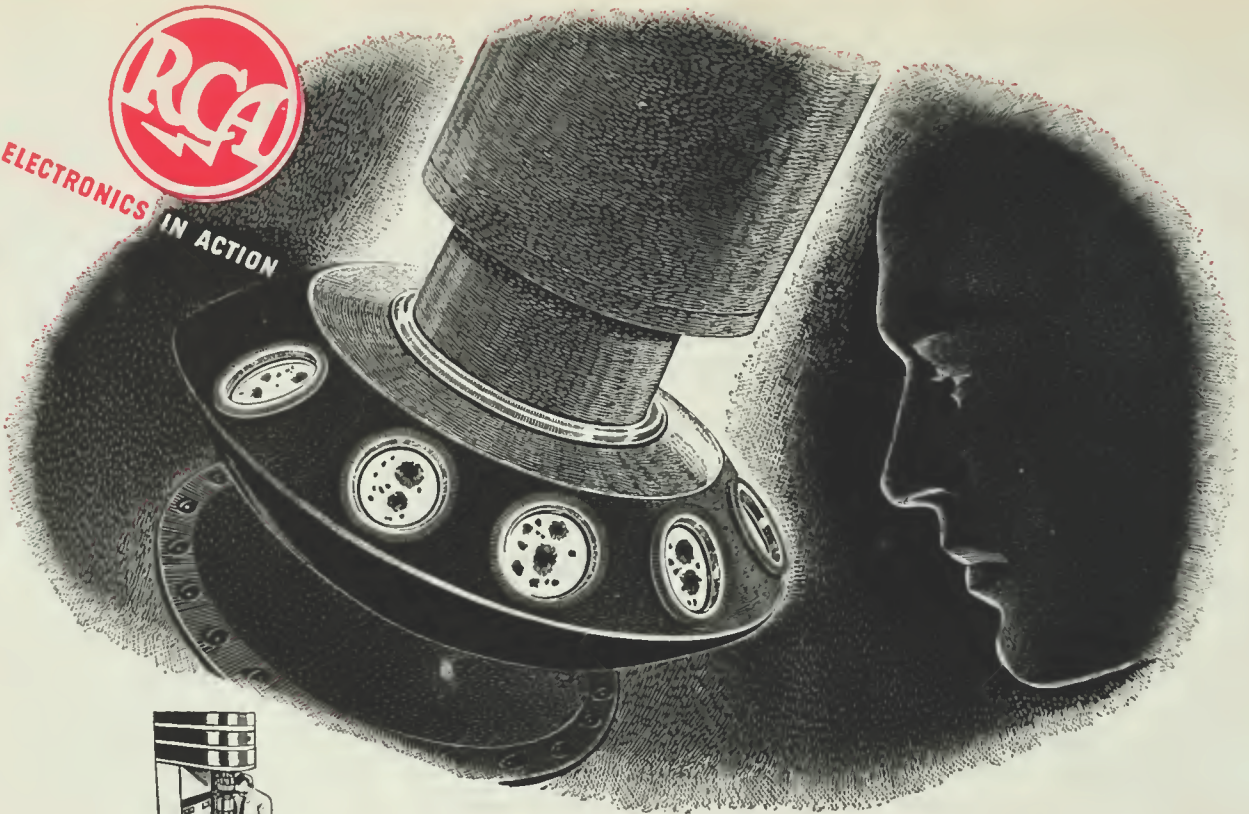

## Exploring a New Universe

**T**HROUGH those small round windows—observation ports of an RCA Electron Microscope—this bacteriologist is studying influenza virus—magnified 25,000 times!

For years medical research men have had to fight the devastation of influenza "blindfolded" — for the simple reason that flu germs are invisible even under the most powerful light microscope. *But why invisible?* Why couldn't this virus be seen? The answer is—even the shortest waves of visible light are *far too long* to permit seeing anything so small. Nothing so infinitesimal ever was seen—or could be seen—prior to invention of the Electron Microscope.

But man *needs* to see these smaller things—among which are long-hidden causes of many diseases destructive to

human beings, animals and plants. Man *needs* to be able to peer down, down, down into molecular structures—in order to learn what makes rubber behave like rubber, leather like leather, wool like wool, lubricating oil like lubricating oil, or metal like metal. For under the whirl-lash of war it is imperative to learn now, not tomorrow, *why* one kind of rubber, leather, fiber, oil or metal is more elastic, tougher, stronger, more useful than another.

*Every branch of science and industry can benefit through proper use of this extraordinary microscope—which utilizes electrons instead of light for illumination.* The RCA Electron Microscope is only one of many RCA applications of *electronics*—the art of harnessing electrons to the service of man. *Every elec-*

*tronic device of every kind depends basically on electron tubes.* And RCA is the fountain-head of modern electron tube development.

In addition to our armed forces, the list of industrial firms and scientific institutions now using RCA Electron Microscopes reads like a Blue Book of American Industry and Science. Inquiries regarding this instrument will be welcomed from research men connected with similar organizations, and will be promptly answered. Address Department 131-765, RCA Victor Division, Radio Corporation of America, Camden, N. J.

TUNE IN "WHAT'S NEW?"

RCA's great new show, Saturday nights, 7 to 8, E. W. T., Blue Network.



*A new booklet—"RCA ELECTRONICS IN INDUSTRY"—may suggest electronic applications important to your business. Free on request. Please use business letterhead when writing. Address—Dept. 68-2J, RCA Victor Division, Radio Corporation of America, Camden, New Jersey.*



**RADIO CORPORATION OF AMERICA**

