

Blueprint Section Every Month

# RADIO AGE

*The Magazine of the Hour*



(See Story page 15)

**October**  
**1926**

Radio Age 9 Tube Super  
❑ Converting 9BHX to  
Crystal Control ❑ Survey  
of Power Supply Devices

**25¢**

**Complete Broadcast List and Log**  
*In Each Issue*



**\$132.50** Plus installation and transportation; Ozarka Senior 5 Tube Model complete with Loud Speaker and all accessories.



**\$100** Plus installation and transportation; Ozarka Junior 5 Tube Model complete with built-in speaker and all accessories.



**\$215** Plus installation and transportation; Ozarka Console 5 Tube Model, solid walnut cabinet, complete with all accessories.

## Some People Will never Learn — The Truth About Radio

**M**ANY a new radio will perform perfectly. Whether it continues to do so or not will depend entirely on one thing—the very truth that is seldom discussed.

Do you drive a car?

Don't little troubles happen occasionally?

Do you depend on a handy man for service or do you prefer a mechanic who has been factory trained on *your* make of car?

Experience has, no doubt, proven to you that men who know *all* about *all* makes of cars generally don't make the best mechanics to work on *your* car.

You wouldn't think of buying any car, no matter how low its price, unless you knew you could receive service by men who know how.

Treat the purchase of a radio instrument in exactly the same manner if you wish lasting satisfaction.

Service is just as necessary, just as important on a radio instrument as it is on an automobile.

Occasionally little things will go

wrong. They will be serious to you and almost as serious to the handy man who can fix all radios but—

Such troubles will mean just a few seconds' time to a factory trained service man who knows that make of radio as he should.

While radio is rather a new industry, even now there are 4364 factory trained Ozarka service men—let us give you the name and address of the one nearest you.

Allow him to set up an Ozarka in your home.

He will let you do all the tuning so that you can satisfy yourself as to exactly what it will do for distance, volume, tone and ease of tuning.

His factory training enables him to keep every Ozarka which he sells, working just as it did when new.

*Any radio, no matter what its price may be, will only be as satisfactory as the trained service behind it.*

# OZARKA

INCORPORATED

120 W. Austin Avenue B

CHICAGO, ILL.

### We have a few Openings for the Right Men

**W**HILE there are today 4364 Ozarka representatives, some territory is still open—men who are tired of working for some one else men who would like to add to their present income by devoting their evenings to Ozarka.

At the start you can keep your present job. Later on, after you have proven what you can then you will give us all your time because it pay far more than your present position.

The man we want may not have much money but he is not broke. He has lived in his community for some time—he has a reputation that his word is good. He may not have made any startling success but he has never "put over something" to make money. He may know nothing about radio salesmanship but he will be successful if he is willing to study what we are willing to teach him, without cost.

The field in radio is wide open for the trained man. The success of the 4364 Ozarka representatives proves what men can do. If you are interested, ask for a copy of the Ozarka Plan, a 108 page book which tells a true story of how big money and a permanent business can be built in radio. It is a story of life; of why some men fail while others succeed. This book has shown many men how to start making extra money immediately and within a very short time establish a business of their own.





**\$50. to \$250 a week**  
**IN WORK THAT IS**  
**ALMOST ROMANCE**

**Be a Radio Expert**



Get into the great new Big-Pay Industry—Radio. If you're earning a penny less than \$50 a week, **clip coupon now.** Send for **AMAZING FREE BOOK.** Be a Radio Expert and draw down big money for the easiest and most fascinating work in the world. Positions everywhere. Thoroughly-trained men are in big demand. Need for Radio Experts in every community. Short hours. **BIG PAY.** **Free book gives all the facts.**

Astonishing opportunities—thousands of them! Every day N. R. I. trained men are taking good place in the Radio field. Free book tells all about their success. Send for it now!

**LEARN QUICKLY AND EASILY**  
**AT HOME**

Master Radio Engineers will show you how to qualify quickly and easily at home for Radio's fine jobs. We **Guarantee** to train you successfully. Lack of experience no drawback—common schooling all you need. Our tested clear methods make it easy for you. Send coupon now for free proof.

**Instruments Given with Course**

All instruments shown here and many others given to students for practice work while learning. Receiving sets from simplest kind to thousand mile receiver, an **UNEQUALLED OFFER.** Many other big features for limited time only.

**Famous Training That "Pays for Itself"**

Spare-time earnings are easy in Radio. Increase your income almost from the start through practical knowledge we give you. This is the famous practical training that *pays its own way.*



**Operates WMAQ**

"Accepted a position with Chicago Daily News—Station WMAQ. My income practically doubled, thanks to your fine course."

KATIE KIMBALL, Chicago.



**Gets Big Job**

"Just been made Sales Manager of this Radio concern—a big raise in pay. Regret I did not take course sooner."

R. E. JONES, Bay City.

Get this Amazing Book

Most amazing book on Radio ever written—full of interesting facts about this great field and how we

prepare you and help you start. You can do what others have done. **GET THIS BOOK.**

**Send Coupon**

Send coupon today for special limited offer, including all instruments—you'll get full particulars by return mail.

**National Radio Institute**  
 DEPT. MU-3 WASHINGTON, D. C.

You get all of these



**MAIL THIS NOW**

**NATIONAL RADIO INSTITUTE,**  
 Dept. MU-3  
 Washington, D. C.

Without obligating me in any way, send me your free book, "Rich Rewards in Radio," and all information about your practical, home-study Radio course.

Name \_\_\_\_\_

Address \_\_\_\_\_

Town \_\_\_\_\_ State \_\_\_\_\_

**Radio Needs Trained Men**

**LARGEST RADIO SCHOOL IN THE WORLD**

**ORIGINATORS OF RADIO HOME-STUDY TRAINING**



# RADIO AGE

The Magazine of the Hour  
Established March, 1922

Volume 5

October, 1926

Number 10

## CONTENTS FOR OCTOBER ISSUE

Cover insert by Gordon K. Martin

Survey of Power Supply Devices.....	5
By F. A. Hill	
See and Hear Wavelength with Crystal Tube.....	8
By S. R. Winters	
Nine Tube Super Brings Back Fan's Faith.....	9
Broadcasting and the U. S. Navy.....	11
By Lieut. Comdr. A. P. H. Tawresay	
Allen-Bradley Supplies Two Fields.....	13
By F. A. Hill	
Radio Patrol of Railroad Trackage.....	15
What Type Loud Speaker Should I Use?.....	17
By H. Melchior Bishop	
Tube Socket as Plug for Receiver Testing.....	20
By Charles E. Felstead	
"The Ladies—God Bless 'Em".....	21
By Dorothy Brister Stafford	
Converting 9BHX Into Crystal Control.....	25
By F. A. Hill	
Raytheon Design for ABC Power Unit.....	33
By Miles Pennybacker	
Uncle Sam Chats with His Dairymen.....	37
By Milton S. Eisenhower	
Pickups and Hookups by Our Readers.....	41
With the Manufacturers.....	44
Correct List of Broadcasting Stations. 54-56-58-60-62	
Ductile Thorium and Its Uses.....	64
By F. C. Kelley	
Classified Advertisements.....	68

Radio Age is published monthly by RADIO AGE, Inc.

Member: Audit Bureau of Circulations.

Publication Office, Mount Morris, Ill.

404 North Wesley Ave.,

Address all communications to RADIO AGE, Inc.

Executive, Editorial and Advertising Offices

500 N. Dearborn Street, Chicago, Ill.

FREDERICK A. SMITH, *Editor*  
F. A. HILL, *Associate Editor*  
M. B. SMITH, *Business Manager*

*Advertising Manager*  
HARRY A. ACKERBURG  
500 N. Dearborn St., Chicago, Ill.

*Eastern Representative*  
HEVEY & DURKEE, 15 West 44th St., New York, N. Y.

*Pacific Coast Representative*  
V. M. DEPUTY & ASSOCIATES, 515 F. W. Braun Bldg.,  
Los Angeles, Cal.

Final Advertising forms close on the 20th of the 2nd month  
preceding date of issue

Vol. 5, No. 10. Issued monthly. Subscription price \$2.50 a year.  
September, 1926. Entered as second-class matter at post office at  
Mount Morris, Illinois, under the Act of March 3, 1879.

Copyright, 1926, by RADIO AGE, Inc.

## Chats With the Editor

EVERY now and then the truth of the old slogan "Quality material is the cheapest in the long run" is forcefully brought to our attention. This time by the performance of one of our readers who admits that for years he has been a liberal patron of the dime counters in the well known 5 and 10 emporiums where he bought all the constituent parts of a great radio-to-be.

For years this gentleman has been writing to this magazine to extricate him from some of his dilemmas with the radio sets he has built. In every case we have tried to straighten him out and put him on the right track, in many instances with good success.

Our greatest surprise recently, however, was a chance visit to his neighborhood when we decided to drop in on this reader and see just how much radio material he had collected during his four years apprenticeship in radio.

Mr. Reader was quite glad to see us and immediately took great pains to display the latest result of his handiwork, a tuned radio frequency set, in a beautiful cabinet; with an excellent power supply device on the floor below the receiver table and an accompanying high grade A battery.

But our greatest marvel was the interior of the set. Instead of the material from the red front bazaars on which he had previously placed so great reliance, we now beheld an aggregation of the highest quality merchandise on the market. Every single item was absolutely first class and some of it was quite expensive. In reply to our query he said at last he had become wise to the ways of the world and if a magazine consistently used only quality material in its hookups there must be some good reason for it. He found he could save money by using the recommended parts of high quality which gave uniformly good results.

Consequently there is one less eager fan leaning over the bargain counters and our reading public again is let in on the interesting metamorphosis of a radio fan.

*Frederick Smith*

Editor of RADIO AGE.





*"They last twice as long as  
the smaller Batteries  
of equal voltage"*

"THAT's a pretty broad statement, Tom. Won't you have to make it conditional on the number of tubes in the set or the use of the new power tubes?"

"No, sir! Under the same operating conditions—whether you use four, five tubes or more, whether you use a power tube that uses up to 135 volts, the Eveready Heavy-Duty No. 770 or the even longer-lived Eveready Layerbilt No. 486 will last twice as long as the smaller sized 45-volt batteries."

"Well, they ought to, they cost more."

"Yes, about a third more—but lasting twice as long, they cost much less."

"Your arithmetic is good, Tom, but if that's so, when I bought my set why did the dealer equip it with the smaller Eveready 772's? Why didn't he put in the Eveready Heavy-Duty Batteries?"

"He probably thought he was doing

you a favor—making your first investment cost you a little less. That little difference looks like a lot to a good many folks who are buying their first set, equipped with tubes, loud speaker, 'A' and 'B' batteries and everything."

Heavy-Duty batteries last twice as long as the smaller batteries of equal voltage. Eveready Heavy-Duty Batteries are the great contribution that the world's foremost electro-chemical

laboratories has made in "B" battery economy, dependability and satisfaction.

Dry "B" batteries give a noiseless current, pure D. C. (direct current), the kind that is essential if you prize pure tone.

Send for booklet, "Choosing and Using the Right Radio Batteries," which we will be glad to send you upon request. This booklet also tells about the proper battery equipment for use with the new power tubes. There's an Eveready dealer nearby.

Manufactured and guaranteed by  
**NATIONAL CARBON CO., Inc.**  
New York San Francisco

Canadian National Carbon Co., Limited  
Toronto, Ontario

Tuesday night means Eveready Hour —  
9 P. M., Eastern Standard Time, through  
stations:

WEAF—New York	WSAI—Cincinnati
WJAR—Providence	WTAM—Cleveland
WEEB—Boston	WJZ—Detroit
WTAG—Worcester	WON—Chicago
WFI—Philadelphia	WOC—Davenport
WOR—Buffalo	WOL—Minneapolis
WCAL—Pittsburgh	WCCO—St. Paul
WRC—Washington	KSD—St. Louis



**EVEREADY**  
**Radio Batteries**  
*—they last longer*

NOTE: A "C" battery gives a quality of reception unobtainable without it and greatly increases the life of your "B" batteries.

# ELECTRAD

When You Put  
**ELECTRAD**  
CERTIFIED JACKS  
on Your Set, You  
Can Forget Them

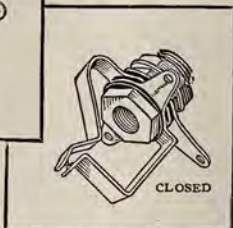
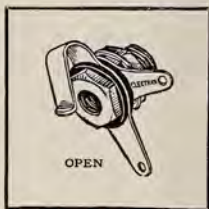

IT'S a lot of fun experimenting with different circuits and hookups, but you don't want to waste any time experimenting with jacks. You want jacks that can be depended upon to do their work without your giving them any thought.

The new Electrad Certified Single Circuit Jacks, open and closed, are that kind. Solid brass construction. Positive acting spring of phosphor bronze. Sterling silver contact points. Insulation of hard rubber. Tinned soldering lugs, so placed that good connections can easily be made. Require little space behind panel.

Any good radio store has these jacks or can easily get them for you. Guaranteed electrically and mechanically. Prices—open, 25c; closed, 35c; in Canada, open, 35c; closed, 50c.



## ELECTRAD CERTIFIED SWITCHES

*On When They're On — Off When They're Off!*

You don't want any halfway business about a switch. It must be either 100% on or 100% off. When you hear your Electrad Certified Switch click you *know*. Solid brass construction. Tinned soldering lugs placed to make easy connections. Neatly designed, genuine Bakelite knob. Requires less than one inch behind panel. Adds to the appearance of your set. Price 40c, in Canada 60c.



For Perfect control of tone and volume use the Electrad 500,000-ohm Compensator. For free hookup write 428 Broadway, New York City



# ELECTRAD

Inc.



# RADIO AGE

## The Magazine of the Hour

M. B. Smith  
Business Manager

A Monthly Publication  
Devoted to Practical  
Radio

Frederick A. Smith  
Editor

## Power Supply Devices are Taking Strong Hold on Public

By F. A. HILL  
(Associate Editor)

UNLESS one has been following the plate supply device subject from its inception it is rather hard to appreciate the obstacles which have been overcome in the production of a substitute for batteries in the operation of a receiver.

Theoretically plate supply devices have been possible for a long time but there have been numerous factors which had to be considered, and which when disregarded, made eliminators impractical. Rectifying devices in the earlier days were none too efficient and had limitations in only being able to handle a relatively low voltage. Chokes, as first constructed, were rather

bulky objects and costs excessive. Condensers of high capacity were not so easy to manufacture and keep costs within reason.

Early in the game there were only perhaps one or two interests devoting any of their research to the production of a good eliminator. As the commercial broadcast sets progressed from the two tube variety into the four, six, eight and ten tube class, the drain on B batteries (even with a biasing current on the grid) was rather heavy, and on unbiased receivers the drain was excessive. This meant that *someone* had to develop an eliminator that would take care of heavier current with greater voltages, and which would have an exceedingly long life; in fact the life of the eliminator would be an almost indefinite one, being limited only by the life of the rectifying device, which of course is replaceable.

While manufacturers were turning their attention to the question of chokes, condensers, transformers, the tube makers were doing research on the rectifying devices of which there are now only two on the market. The first is that made by the Raytheon interests and described elsewhere in this issue. The second was the Rectron made by the Radio Corporation. In the former no filament is required while in the latter a filament is

provided. This gives us two types of rectifiers from which a startling number of combinations can be made, and which has proved a boon to the makers of power supply devices.

A recent survey made by the writer in Chicago somewhat surprised us as to the magnitude of the local manufacture of power supply devices.

### Where Majestic Is Made

ONE of the plants visited was that of Grigsby, Grunow and Hinds Co., who manufacture the well known Majestic current supply units, and whose president, B. J. Grigsby, gave the writer an idea of the scope of this particular plant.

Manufacturing eliminators from assembled parts would be



Above is seen the Majestic Master-B with a capacity of 60 milliamperes at 150 volts, suitable for use with Radiolas 25, 28 and 30



For sets up to 12 tubes the Majestic Super-B with a rating of 45 milliamperes at 150 volts is used



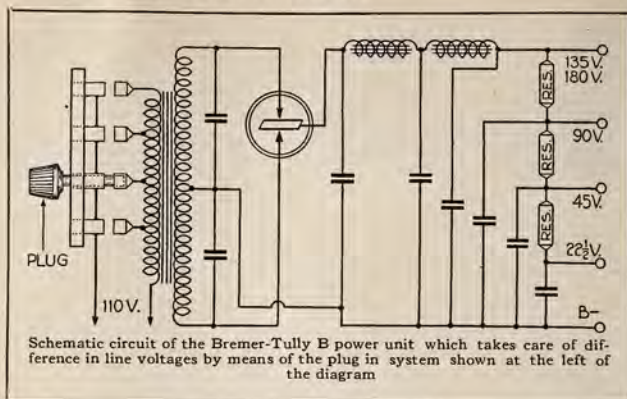

satisfactory if all the parts could be selected with that object in view, but such a condition seldom obtains. Grigsby, Grunow and Hinds, formerly in the manufacture of automotive accessories, immediately saw the necessity of making every component article themselves and accordingly set about it. They made up their own transformers, which are completely shielded in a single unit. Then they made their condenser block, which is likewise shielded. The chokes they also made and placed in another shielded container. The resistances and the tubes are the only articles which they do not make.

By construction of the transformer, choke and condenser bank in individual units, the assembly of the finished product is expedited. It also provides for complete shielding of all parts. Likewise it means that if a defect develops in any one of the units, the offending unit alone has to be removed, leaving the balance of the assembly unaffected.

Quantity production methods similar to those used in all large manufacturing establishments are in use in the production of current supply units. In the construction of the condensers the paper and foil are fed, rolled, and completed by mechanical process so high speed work is possible. These condensers are, when ready for insulation, placed in pressure vats where the Halowax used as an

insulating medium, thoroughly impregnates the condenser. A baking process is used first to dry out any possible moisture, after which the Halowax is allowed to



Here is the American electric plate supply set which also uses the Raytheon tube now grown so popular both with manufacturers and broadcast listeners

fill in air spaces in the condenser. When finished and dried the unit is rigid and hard as a brick. It

is then placed in its metal container and sealed, to become one of the integral parts of the eliminator, and one on which a great deal depends.

### Condensers Need Tests

CONDENSERS which are to remain in an eliminator for a long time and which must operate under varying service conditions, must be thoroughly tested beforehand to make sure they will stand up under the voltages impressed. Accordingly they are tested two or three times during course of manufacture, and when finally assembled are given a final test to see if they will break down. Since the supply units must contend with high voltages, it is imperative that the condenser bank have an ample safety factor over and above the normal voltage rating of the unit to take care of stray potentials of a higher order than usually encountered.

During the season there are twelve hundred workers assembling these products. Twenty-five hundred supply units per day is the capacity of the plant and when we are informed that the Grigsby, Grunow and Hinds interests absorb more than half of the Raytheon tube factory output, it is not difficult to see that this industry is of more than passing importance.

Here, as in other large establishments, rigid inspection is necessary to insure elimination of returns. Even the Raytheon tube is again tested up to its manufacturer's rating of 60 mills

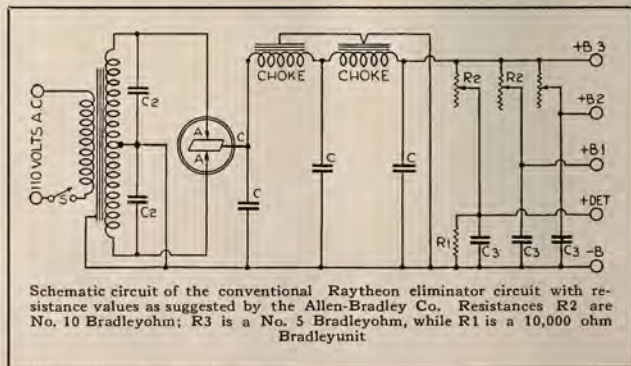



and is repacked in another container and sealed by the makers of the Majestic so when it reaches the public it will be o. k. in every respect. Variable resistances for the voltage control are made by Allen-Bradley Co., and this feature enables one not only to take care of the different voltages required on a receiver, but to compensate for differences in line voltages.

### Bremer-Tully Unit

ANOTHER form of voltage compensation is the method used by Bremer-Tully Mfg. Co., and shown schematically in the diagram on page 6. In this case the resistors at the output end of the supply device are fixed, and variation is made by plugging in the plug on a tapped primary which is in the 110 volt line. This scheme was adopted by Bremer-Tully when they decided to manufacture an eliminator for use with their own receiver which they could recommend without reservation. This was due, probably, to the fact the lay public has an idea that any eliminator will do for any receiver, whereas there is no subject on which a fan can get into more trouble than trying to make certain types of rectifiers that will handle a two or three tube set, work efficiently on an eight or ten tube receiver. Hence to obviate this difficulty on the part of the public the B-T organization made their own plate supply device and know exactly what it will do with their own receivers.

Aside from the fixed resistances which are included in the Bremer-Tully B power unit, there is also included a separate set of resistances to give different values of voltage than those shown in the unit on this page, namely; positive 22½, positive 45, positive 90 and positive 135 volts. Thus the plug-in arrangement gives some control over the line voltage while the extra set of resistances gives still further flexibility to the unit. These resistances are merely slipped into clips which are shown on a diagram attached to the supply unit.

Schematically on page 6 is also shown the conventional Raytheon

hookup with resistance values which Allen Bradley consider best for general operating conditions. The fixed resistance, R1, is a Bradleyunit, 10,000 ohms. The two variable resistances, R2, the first handling the detector, and the second the positive 45 volt tap, are known as the Bradleyohm No. 10, while the variable resistance shown to the right of the R2, is known as the Bradleyohm No. 5 and controls the 90 to 120 volt tap. The high position of course has no resistance and represents the full output voltage of the unit.

Included in this article is a view of the American Electric plate supply unit, shown on page 6 and which also uses the Raytheon tube. In our September



Bremer Tully's B power unit made for use particularly with their own receivers, but can also be used with other standard sets

blueprint section we showed the Thordarson-Rectron combination for plate supply and power tube operation, while in another portion of the magazine the Silver plug-in B supply unit was described. Reference back to these two articles will help in gaining an idea of the power supply question.

### "A" Elimination Next

AS to the future. Elimination of the A battery is next on the list, but it will not be accomplished until a great deal of engineering work and research will

have been expended on the problem. A elimination is quite possible if several contingencies are met; the first the filtering, or smoothing out of the supply at a heavy current draw, and the second the rectifying device which must handle considerable current. What form of A eliminator will ensue is difficult to forecast, although it is well known in the industry that many an organization is working feverishly to be the first to come on the market with a perfect A eliminator.

One type of A eliminator has been built on the thermo-couple principle, but so far as we know this type has not been developed to a conclusion.

Another method tried is making use either of the half wave Tungar charger, or an arrangement for double wave Tungar rectification, the output being smoothed down by chokes and condensers. It is this method which seems to lend promise, viewed from the fan's standpoint, since a great number of enthusiasts already have the bulb type of A battery charger, and would have only to secure the filter and the chokes to complete the layout. However in this case the filter and the chokes are the devices on which further research work must be done in order to get them down to a practical and inexpensive basis. When this objective is attained the radio public will then be in a position to fully realize the benefits of simplified radio.

All of the foregoing applies only to the metropolitan areas where city lighting current is available. In the remoter districts where power is not available the batteries remain and will remain supreme for a number of years. All battery manufacturers are seeing the necessity of developing the rural markets to a greater extent than before. And since the rural market is probably many times larger than the city market, it would seem that battery makers of both the dry and wet cells, will have a good volume of business for years to come.



# See and Hear Wavelength With Quartz Crystal Tube

*Visual Indication  
of Resonance is  
Now Developed*

By S. R. WINTERS

**Q**UARTZ crystal not only possesses the magical property of acting as a governor in precisely controlling the frequency or wavelength of a radio transmitting station but, by virtue of a newly discovered quality, it demonstrates the almost uncanny power of lighting a lamp. Thus, the magic mineral becomes the magic Aladdin lamp, too!

The phenomenon of a piece of quartz crystal producing a visible light in a lamp containing a gas mixture of helium and neon was discovered by two German scientists—Professor E. Giebe and Dr. A. Schiebe of Berlin. "Light-resonators as frequency standards for the measurement of wavelengths," descriptive terms designating new devices designed as a result of discovering this phenomenon, were recently demonstrated at the Radio Laboratory of the Bureau of Standards by David L. Loewe of Berlin.

If these light-resonators are universally adopted by the approximately 19,000 radio stations in the United States, it will mean that the operators are enabled to both see and hear whether or not their transmitters are functioning precisely on the assigned wavelengths. Of this new German invention, we are told that the resonance effect is not only made visible but may be rendered audible by use of a loud speaker. This implies remote-controlled transmitters in the scientific as well as the popular sense of the word. "For instance," suggests Professor Giebe, "the luminous effect for adjusting the wavelength may be employed in the transmitting room itself, while acoustical de-

vices may be provided at one or more controlling points, which may be at any desired distance from the transmitter. The auxiliary apparatus for this purpose



consists only of an amplifier and as many loud speakers as there are controlling points."

## Frequency Standard

**T**HE light-resonator as a frequency standard is a directly indicating-measuring instrument. As originally discovered by Prof. W. G. Cady of Wesleyan University, a quartz rod when properly placed between two condenser plates of an electrically oscillating circuit vi-

brates mechanically at a rate of very high frequency. The two German scientists found, upon further investigation, that the stationary electrical oscillations of quartz crystal, which action takes place in case of resonance, may be visible. This luminous effect is accomplished by hooking up the condenser plates and the quartz rod with a glass vessel, which must be evacuated to a pressure of 10 to 15 millimeters of mercury. Lead-in wires, sealed airtight into this vacuum lamp, serve the purpose of connecting the condenser plates to the oscillating circuit.

"The alternating electrical field of such an oscillating circuit," indicate these German inventors in explaining the phenomenon, "will cause by reason of the electrical polarization of the quartz-rod alternating deformations of the latter, which in the case of resonance will have the effect of generating stationary elastical oscillations. The deformations due to these oscillations will give rise to secondary alternating voltages upon the quartz-rod, which bring the rarified gas contained in the glass-vessel to luminescence. The resonance is extremely sharp and, therefore, the luminous effect is adjustable down to one-half per mille of the wavelength. By properly choosing the condenser plate and the degree of vacuum the result may be attained that the discharge will take place throughout the discharge space."

The light resonator, according to claims, is absolutely accurate, so long as the quartz rod



# Building 9 Tube Super Brings Back Faith in this Receiver

*Absence of Oscillation and Simplicity of Construction are Features*

SO MUCH has been written on superheterodynes at times it seems the subject has been worn threadbare, yet when we are just at the point of exhaustion something generally turns up that is interesting. These remarks apply aptly to the nine tube super which is herein described, and whose performance is such that it is felt readers of this magazine will find the flame of their interest renewed on the question of superheterodynes.

Simplicity of control and ease of assembly are the two features which should appeal to the set builder, while the selectivity of the receiver itself will appeal to both the set builder and the experimenter in search of good results.

Pictorially the nine tube super is shown on this page. A

glance will readily show the simplicity of assembly, everything being on a line. The baseboard layout was used instead of the subpanel on account of this type of arrangement being more pleasing to the set builder. If the set looks nice in this dress, it will look even better if done up in sub-panel fashion, although a bit more work is involved in following that form of construction.

Taking advantage of the fact that transformers designed for long wave work will serve nicely for the intermediate stages of a super, we secured a set of long wave transformers designed by the High Frequency Laboratories of Chicago and which are peaked for 37.5 kilocycles, this value being desirable to dodge between the ten kilocycle separation allowed by

the government to broadcasting stations.

The set consists of the first detector, four intermediate stages using long wave transformers, the second detector, the oscillator, and two audio frequency stages. No potentiometer is used since flexibility of the intermediate stages is provided through filament rheostat controlling all of the intermediate tubes. Amperites are used in the remainder of the circuit which does away with further filament control. A grid modulator serves to alter the volume in the loud speaker. Thus there are two major and one minor controls. The condenser on the left is that for the loop; the condenser on the right is the oscillator. The rheostat for the intermediate stage filaments is shown as volume and is located at the left of

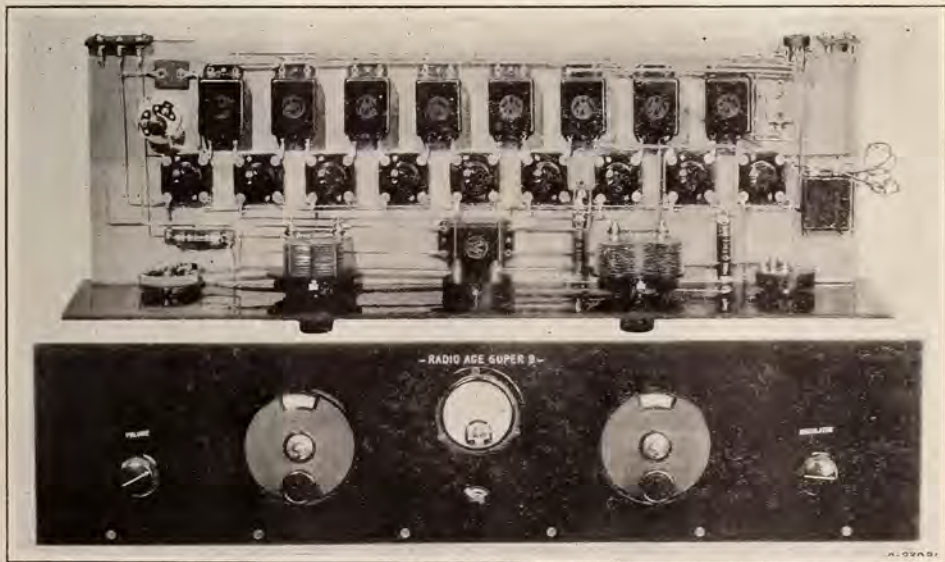

In the upper picture is shown the baseboard layout of the Radio Age Super 9. Beginning at the left of the baseboard the transformers used are as follows: H210, H210, H215, H210, H215, F320, L425, F320. The transformer shown between the two Remler condensers is an L430 RF transformer. The grid of the sixth and seventh transformer is not bridged directly to the tube socket. See the schematic for the actual electrical connections



the panel. The loop terminals come in at the rear of the baseboard at the right, while the Jones base mounting is located at the right rear corner of the baseboard, where also are found connections for the loud speaker and the C battery.

Schematically the circuit is shown on page 10. This arrangement is for nine 201-A tubes. It can readily be converted for use with 199's by simply altering the Amperite resistances. Examination of the schematic will show that two intermediate stages are followed by a filter, then another intermediate followed by another filter.

#### No Body Capacity

ON ACCOUNT of using the Remler condensers there is complete absence of body capacity both on the oscillator and loop circuits. These condensers are of the twin rotor type and the shaft extending through the panel (to which are affixed the Marco dials) does not become a part of the circuit since the shaft carries a bakelite gear which engages the rotor plate gears. In previous types of supers this form of condenser has been found highly satisfactory where the oscillator capacity span is from grid to plate. If the oscillator circuit is changed to the grid-filament capacity span body capacity can be eliminated, although the loop might still have a trace.

Grid condensers and leaks are not used but instead detection is accomplished by C bias of the detector grid. The bias value for all 201-A tubes was found to be 6 volts, thus simplifying the C battery voltage problem. Using the voltages specified in this article and with the proper C battery value, the total milliamperage current used runs from 10 to 16 mills, which is exceedingly low considering the number of tubes and the results secured.

A center tap loop, such as the

Duro-Metal, is used with the receiver, provision being made at the left rear of the baseboard for the three loop connections. A total of 135 volts of B battery, (three 45 volt blocks in series) will suffice for operation. A good B eliminator may also be used if desired. The Jones 7 wire cable should be connected as follows: Red—A; Green—A; Black—B; Brown 22½; Pink 67½; Yellow 112½ and Blue 135 volts. It will be noted the

#### LIST OF PARTS

- 1—7x30 panel, 3-16
- 3—HFL H210 transformers
- 2—HFL H215 transformers
- 1—HFL L425 choke unit
- 2—HFL F320 audio transformers
- 1—HFL L430 R. F. transformer
- 2—Remler .0005 mfd variable condensers
- 2—Marco dials for above condensers
- 1—Chelton midget condenser
- 5—Yaxley Imp jacks
- 1—Jones base mounting and 7 wire cable plug
- 1—Yaxley 6 ohm rheostat
- 1—Yaxley filament switch
- 3—Amperite resistances 1—1-A; 2—112 and mountings
- 9—Benjamin cushion sockets
- 1—Electrad 1 mfd bypass condenser
- 2—Muter condensers .0005 mfd
- 1—Duro Metal Qualitone collapsible loop
- 1—Duro Metal Qualitone loud speaker
- 1—Centralab 0-200,000 ohm Rahiohm

oscillator is supplied with only 22½ volts which is very desirable in order to cut down the possibility of the oscillator producing a variety of harmonics. These harmonics are naturally produced at any voltage, but they are weakest at 22½ volts, whereas with double and triple that voltage these harmonics would be more than bothersome. The range of the oscillator coil with the Remler condenser referred to will be from approximately 190 to 595 meters, which should serve to take in all of the present broadcast channels. To go further down in the wavelength scale another oscillator could be used which would throw the set into the short waves—but that is another subject on which we may have more to say later.

#### Operation Simple

OPERATION of the nine-tube was quite simple. Assuming that all connections have been made in accordance with the schematic, turn battery switch on; set the midget condenser half way in; turn the

(Please turn to page 45)

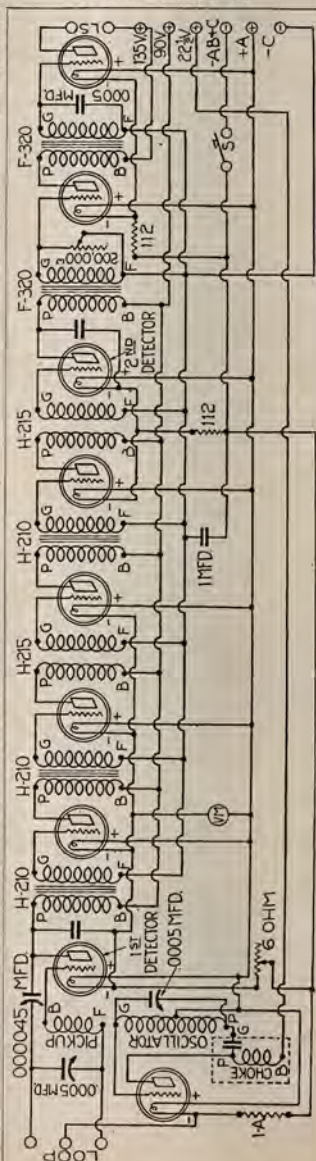



# Broad- casting and the U.S. Navy

By Lieut. Comdr.  
Alfred P. H. Tawrescy

**T**O many people the advent of broadcasting about five years ago marks the beginning of radio history. They know vaguely that radio telegraphy was used prior to that time for sending distress messages from ships, but relatively few know the large part played by radio in the conduct of the world's business, even prior to the World War.

The United States Government as a whole became interested in radio in 1904. At that time none but government departments could risk the outlay necessary to develop and maintain what was then an untried and uncertain means of communication. The first administrative policy in regard to radio was drawn up in 1904, and was approved by President Roosevelt.

Advances in the art and changed conditions, including broadcasting, aircraft communication, radio beacon, and the radio direction finder, made it imperative to revise the administrative policy with regard to the use of radio by the government. In 1925 a committee of representatives of all the government departments and several independent government agencies drew up a tentative statement of government domestic radio policy. One important feature of this statement, carried forward in principle from the earlier draft of 1904, is as follows:

*"The government's interest in radio communication is paramount for national defense. The*



U. S. Navy battleship showing various radio antennas, each for a separate transmitter

*government is charged with the regulation of radio communication as a means for rendering a public service. The government uses radio communication in the administration of its business."*

## National Defense

**N**ATIONAL defense is similar in some respects to a conflagration and the forces of national defense to a fire department. In training for the purpose for which they exist both fire departments and national defense forces require constant exercise with their special equipment, for which they must enjoy special privileges on the common highways. When quelling a fire or subduing an enemy they must enjoy undisputed sway over such portion of the common way as they need.

The ordinary citizen demands of radio merely that he be able to send a message from "A" to "B" and receive a reply in a reasonable time, or the ability to listen simultaneously with countless others to broadcast program. Naval communication requires in addition to these ordinary demands, rapid, reliable, accurate and often secret communication between large numbers of correspondents in restricted areas, simultaneously with that at extreme distances and against deliberate enemy interference.

Some do not appreciate that

broadcasting, the newest form of public service to enter the radio field, entered a field already congested. It has been provided for by readjusting the frequency channels, and even the types of equipment, used by the older services. These readjustments have been difficult and costly and in many cases have entailed serious derangement of established service.

The band of frequencies relinquished to the exclusive use of broadcasting is the one band which can be covered efficiently by a simply constructed receiver. Frequencies below it (wavelengths above it) require more expensive apparatus of greater weight and occupying more space. Frequencies above it are difficult to handle and are uncertain and erratic.

Ships, aircraft, and extremely isolated points on shore should have preference in the use of radio facilities over communities already well supplied with cables, wires, telephones, newspapers and other means of communication. Such radio communication as forms the sole dependence for the safety of human life, or the sole means of conducting the world's essential business should have rights superior to that which exists solely for entertainment, individual profit, or other private purpose which could be achieved by other means.



The Fourth National Radio Conference marked an attempt to reach a needed degree of stabilization in radio matters, particularly in the general assignment of frequency bands to various services. Radical changes in frequency assignments by previous conferences, not only prevented rapid compliance with the recommendations of the conferences, but also tended to engender a lack of confidence in the ability of the radio industry to regulate itself by mutual agreement.

Each general branch of the radio industry should be able to know reasonably in advance what general frequency bands it may expect to use for the conduct of its business, within which it may be expected to reap the benefits of advances in the art and to settle its own problems. This implies neither rigidity nor stagnation. New services, or improved services can be provided for by suppression in whole or in part of older and less effective ones.

The navy owns and operates one of the largest radio systems under single control in the world. Many things have been undertaken for the express purpose of aiding broadcasting. Owing to the extent of the navy's radio system, which was full grown before the advent of broadcasting, and to the necessity for long and costly development of non-interfering equipment, modernization of the navy's apparatus has not been rapid. Much unjustified criticism has been leveled at the navy on this account, regardless of the facts that research and development consume time; that the forces of national defense cannot adopt new and untried equipment without exhaustive tests as to its efficacy and reliability; and that the provision of public funds for simultaneous rehabilitation of all the navy's equipment is not economically justifiable.

#### World-Wide System

WHEN broadcasting started the navy was operating about 150 radiotelegraph stations on shore, in a world-wide system, and radiotelegraph stations in about 500 vessels at sea. Many of the vessels used two or more

transmitters for simultaneous communication on different circuits, and practically all the shore stations used two or more transmitters to effect simultaneous communication with two or more ships or other stations.

Practically all this apparatus was designed to operate only in



The Navy's only broadcast transmitter, NAA, located at Arlington, Va.

the band of frequencies (wavelengths) later reserved for the exclusive use of broadcasting. The principal dependence was the cheap, simple, rugged and reliable spark apparatus. Unfortunately this type of apparatus causes disturbance over a wide band of frequencies on either side of the one to which it is adjusted.

There were a few arc transmitters ashore and afloat. The arc transmitter is rugged and reliable and can be adjusted so as to occupy a much narrower band of frequencies than the spark. Unfortunately, however, the arc emits energy in a series of harmonic frequencies. Objectionable and interfering energy has been measured in arc harmonics as high as the thirtieth. Also, arcs create in their immediate vicinity

a form of disturbance known as "mush" which is apparently without frequency adjustments, and which effectively blankets reception on all frequencies.

The properties of the vacuum tube were known to the navy, but the tube had not yet proved its reliability for naval use. Tubes were not available in quantity, nor was their average life in service sufficient to warrant their adoption. Suitable vacuum tubes were not then made by American manufacturers, and while foreign procurement would have been possible it would have been unpatriotic and militarily unsound.

Since the beginning of broadcasting, the navy has replaced spark transmitters for regular service in 27 shore radio stations. Twenty-four shore radio stations, formerly using spark transmitters have been closed permanently, and the final closing of two more is projected for the near future. Plans for the current year include the replacement of 14 more spark transmitters with vacuum tube transmitters for regular service.

#### Exit the Spark Set

COMPLETION of this program will leave but 43 spark transmitters in regular service in the entire shore system of the navy. Of these, 4 are in Alaska, and 12 are outside the continental United States, leaving but 27 in regular service on shore in the United States. Of these 27, 21 are low-powered transmitters restricted solely to use on the radio direction finder frequency which is well removed from the broadcasting band.

Four arc transmitters on shore have been replaced with vacuum tube transmitters, and 4 other arcs have been fitted with special devices to reduce their disturbing emissions. Experimental high powered tubes are being developed to replace the high powered arcs. The first of these experimental tubes is already in service and the other is expected to begin operation in a few days.

In places where it has been impossible to replace interfering

(Please turn to page 50)



# Allen-Bradley Co. Supplies Electrical and Radio Field

By F. A. HILL

(Associate Editor)

**R**ESISTANCES whether fixed or variable have long been, and will for many years be a vital and essential part of radio transmission and reception. Resistances had their first inning with the birth of the electrical industry; their second inning came with the appearance of broadcasting. Other fields will later be developed just as nearly everything today is adaptable to more than one use.

In the manufacture of resistances some of the larger organizations which had been making resistances for the electrical field saw a new outlet for their product and entered the new field with a product on which they already had years of experience. Thus they not only served their original industry, the electrical, but also took in new territory in the broadcast game.

Allen-Bradley Company, at Milwaukee, were admirably suited



Here is shown the Bradleystat assembly line with a capacity of 5000 per 8 hour day. Five testing stations are provided to insure electrical perfection

to enter the radio business when it first blossomed. That company has been making resistance and other controller equipment for years and had built up an enviable reputation in the electrical

world. When the public demand for radio sets assumed such proportions the Allen-Bradley organization, having noted the trend, launched into the new business with a line of variable resistors, later adding fixed resistors, condensers and other small parts. Today it occupies one of the upper places in the realm of radio with a name that is as well known and favorably received by the public as any of the large manufacturers.

## More Current Capacity

**B**ATTERY elimination, it is believed spurred the Allen-Bradley Co., on to even greater effort in the making of fixed and variable resistances, for in the beginning much of the poor success of the eliminators was traceable to the fact that resistances then supplied did not stand up under service conditions. Hence there was a crying need for a good variable resistor that would carry enough current to supply



Allen-Bradley's chemical laboratory where much of their research work is done

receivers using up to the capacity of the rectifying devices, generally either the Raytheon or the Rectron.

While the regular line of Bradleyohms were doing well on work for which they were designed, it became necessary to design a new resistor for greater current carrying capacity. In order to do this the resistor housing was made larger, the graphite discs doubled in number although reduced in thickness, and greater safeguards added in the way of insulating factors, such as from the frame to the active elements. On account of an eliminator being a power device it was necessary that better insulation be provided and that new standards of inspection be set up. This was done after a little research work on the problem, and today we have in radio the Bradleyohm type E which was made especially for eliminator work.

An inspection of the Allen-Bradley factory at Milwaukee recently made by the writer de-

veloped a number of interesting features in connection with the manufacture of graphite resistances. This substance was found years ago to be an excellent resistance material and the Allen-Bradley interests adopted it as their standard for resistance material. It was and is used in the makeup of their industrial controller equipment, such as motor starters, overload relays and other current controlling devices known more intimately in the electrical field.

#### Carbon to Graphite

**D**ISCS making up these resistance units are originally in carbon form. They are heated in an electrical furnace to 5500 degrees, Fahrenheit, and after 72 hours ensue as graphite. The electrical furnace which the writer observed had a capacity of 60,000 of their largest controller discs to 2,500,000 of the size used in the Bradleystats.

A battery of disc making machines take the powdered carbon, form it into discs, then stack it

and tie automatically in packages ready for the electric furnace. The capacity of each machine is 45,000 discs per 8 hour day and there are a large number of them necessary to make up the rated output of the factory.

Rigid inspection tests are applied to all apparatus to insure its meeting requirements both as to accuracy of resistance and insulation factor. This results in diminishing to almost a negligible quantity the return of material due to poor assembly.

Some views of the various departments are shown in the pictures illustrating this story, the one of the chemical laboratory being interesting because not many readers know that chemistry is playing a greater part in radio than it was ever thought capable of doing. In fact the impression received after visiting the Allen-Bradley organization is that highly trained, specialized men are more in demand than ever and this company makes good use of all the data that science and research affords.

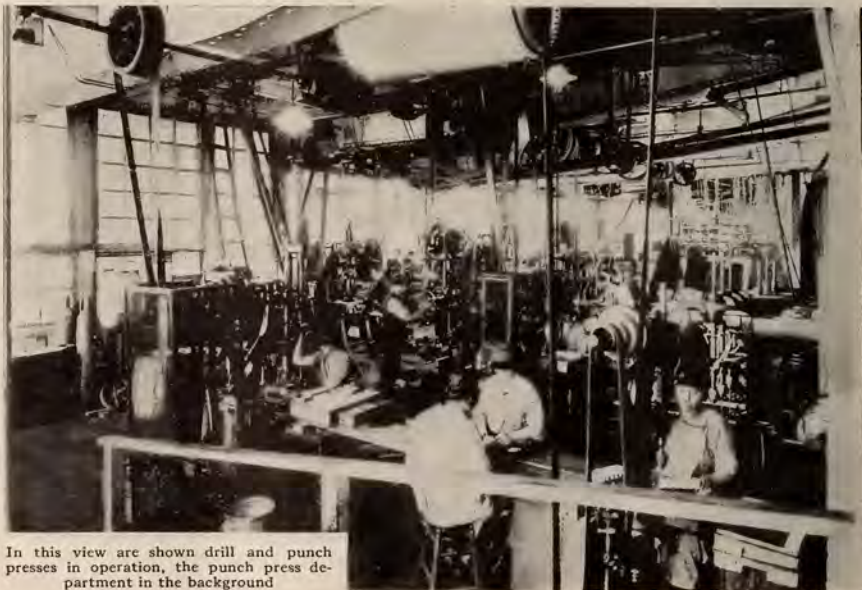

In this view are shown drill and punch presses in operation, the punch press department in the background



# Radio to Patrol 11,000 Miles of Railroad Trackage

*Chicago, Milwaukee and St. Paul to Install Short Wave Transmitters*

**R**ECENT announcement by the Chicago, Milwaukee & St. Paul Railway that it was about to install radio communication over its 11,000 miles of trackage has aroused nationwide interest in the project.

The press of the country, commenting upon the idea, in many instances goes so far as to prophesy that it may mark a new era in the nation's transportation history.

This important new adjunct to the ordinary telegraph systems used by railroads will mean an uninterrupted communication at all times. Only operating officials of a railroad can fully realize what this will mean. Tornadoes, floods, landslides, washouts and other disasters which prostrate land communication will not affect the radio.

During the past two or three years, newspapers throughout the country have recorded a number of instances where storms have isolated a whole community or section. Then somewhere in that vicinity cut off from all communication an amateur radio operator would get busy with his little transmitting set. Soon the mysterious ether waves were carrying a series of staccato dots and dashes that always began the message with the most electrifying word in the language—Help!

Startled by this sudden dramatic appeal shooting out of the air, other amateurs, perhaps hundreds of miles away, would nervously start recording the message.

Last year, when the greatest tornado ever recorded wiped out nearly a thousand lives and left a path of unparalleled destruction across Missouri, Illinois and Indiana, it was an amateur radio

operator who got out the first appeal for help. It was another amateur who received the message and startled the world with his report.



Lieut. F. H. Schnell, who has pioneered in short wave work, as he appeared on his recent naval cruise to the Antipodes in the interest of naval-amateur long distance work

On another occasion a great mine explosion occurred in an area that for hours had been cut off from communication with the outside by a blizzard. Again, it was one of these legionnaires of the air who got out the message calling for doctors and nurses to be rushed to the scene of the disaster.

The general public little realizes that perhaps tonight the silent starlit ether may be carrying a message from some lone amateur that tomorrow will startle millions.

The Chicago, Milwaukee & St. Paul Railway is the first to take advantage of the science largely developed by this army of 20,000

American radio amateurs and apply it to a great transportation system.

## At Strategic Points

**A**T strategic points on its 2,200 mile main line from Chicago to Seattle it will establish stations for transmitting and receiving code on short wave lengths of 20, 40 and 80 meters. Thus will be put into operation for the first time in history a complete radio communications service on a railroad. It will be linked at all times with the great net of amateur stations, so that its operations will be doubly checked, and, as far as human ingenuity can make it, practically infallible.

Like many other discoveries that have proved revolutionary in their effects, the new mode of railway communication is comparatively simple when reduced to its essentials. It is now possible for the first time to describe in detail the transmitting and receiving sets to be installed by the Chicago, Milwaukee & St. Paul Railway. They were planned and designed by F. H. Schnell, former traffic manager of the American Radio Relay League and who last year, while with the Pacific Fleet, conducted remarkable demonstrations on the practicability of short wave radio off Samoa and Hawaii. The success of these experiments led officials of the Chicago, Milwaukee and St. Paul Railway to take up with Schnell the feasibility of applying short wave radio to railroad communications. At their request he devoted lengthy study to the problem, and finally evolved the sets described below as the best adapted for the railroad's radio communication service.

Schnell believes that higher frequencies are more reliable than the lower frequencies for communication over the distances required by the railroad. In this connection it may be mentioned that amateur radio station 9EK at Madison, Wis., and 4 DM at Bokeelia, Fla., maintained scheduled operation on 20 meters (15,000 kilocycles) and communicated with each other twice every day from December, 1925, to May, 1926.

### Use Fifty Watts

It is believed that frequencies of 7500 kilocycles (40M) and 3750 kilocycles (80M) with power of about 50 watts to be satisfactory to provide communication between pivotal stations of the St. Paul's radio communications service. It is based on experiences of stations 9EK and 4DM and many amateurs. The transmitter is an amateur type. The accompanying drawing shows the schematic circuit diagram of the transmitter, using two 50-watt tubes, one on each half of the cycle supplied with 60 cycle current.

In making up the spiral inductances, oak or some other hardwood strips about one-half inch square will be used in supporting a brass or copper ribbon.

The radio frequency chokes 1 and 2 are designed for  $\frac{1}{4}$  wavelength operation for 40 meters, but will serve also for 80 meter operation. The radio frequency chokes 3 and 4 are for use in the grid leads of the tubes and while not absolutely necessary, they may help stabilize the input to the tubes.

In designing sets to be used by the railroad Schnell suggested an antenna consisting of six wires built up in the form of a cage of about 4 to 6 inches in diameter, using No. 12 enameled copper wire with the supporting pieces of substantial hardwood.

A piece of solid rod or tubing substantially guyed will be used to prevent swaying or swinging in the wind. Complete specifications for transmitting and receiving sets to be installed by the Chicago, Milwaukee & St. Paul Railway are as follows:

### Specifications

Ant. Antenna 33' long for 40 meter band. Antenna 66' long for 80 meter band.

CPse. Counterpoise 31' long for 40 meter band. Counterpoise 62' long for 80 meter band.

L-1. Spiral inductance (antenna coupling) 6 turns  $\frac{1}{4}$ " brass or copper ribbon about  $1\frac{1}{32}$ " thick, spaced  $\frac{1}{4}$ ", inside diameter 3".

L-2. Same as antenna inductance except 10 turns for 40 meter band. Same as antenna inductance except 18 turns for 80 meter band.

L-1 and L-2 mounted in oak strips  $\frac{1}{2}$ " x  $\frac{1}{2}$ ", slotted to take the ribbon.

A. Jewell Pattern 64 flush mounting 0-5 (R. F.) ammeter.

C-1. National type 450 variable transmitting condenser (.000450 mfd.).

C-2. National type 150 variable transmitting condenser (.000150 mfd.).

C-3 C-4. Faradon model UC-  
(Please turn to page 36)

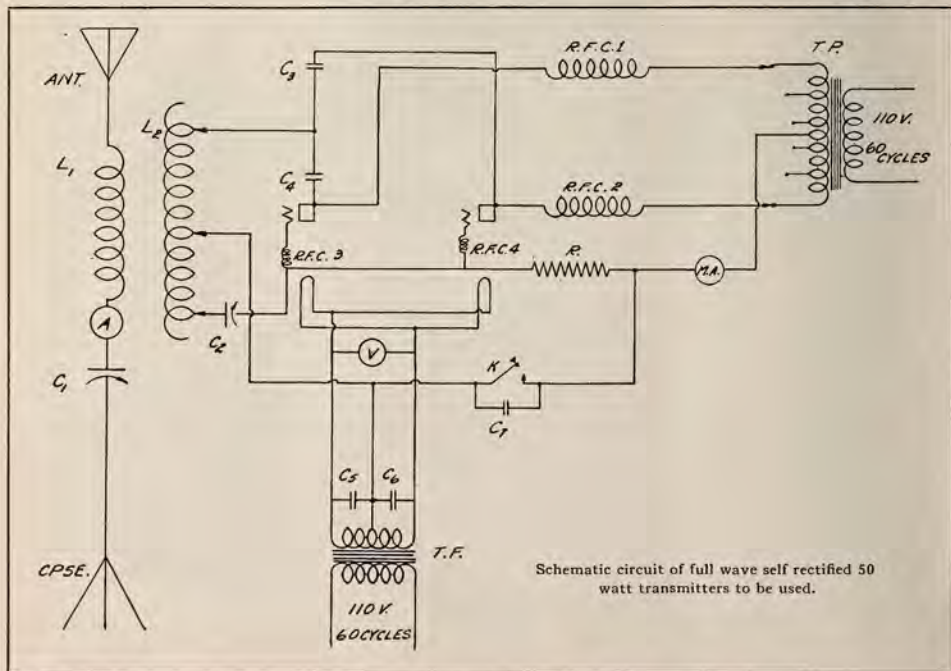

Schematic circuit of full wave self rectified 50 watt transmitters to be used.



# What Type of Loud Speaker Should I Use?

By H. Melchior Bishop

THE question above is one which puzzles many broadcast fans and, in addition, is one to which it is hard to secure a safe, sane and impartial answer. This is due chiefly to the undeniable fact that each and every salesman, unless he is a real radio expert, has his own favorite type, and even *make*, of speaker, which he recommends indiscriminately for use with any set, regardless of make, model, age, or inherent tone quality.

A little common sense and thought will show to anyone (regardless of his or her technical knowledge, or lack of it, with regard to radio and acoustics) that this indiscriminate and slipshod method of recommending loud speakers is absolutely and thoroughly wrong, and is bound to result in many misfits due to the fact that both receiving sets and speakers differ widely in their general characteristics. This leads to the condemnation, very often, of both receivers and reproducers which are not in any sense at fault within themselves, but whose characteristics are undeniably entirely unsuited for use in conjunction with each other. The same speaker used with another type or make of set, or the same receiver connected to another more suitable loud speaker would probably be capable of emitting a quality and volume of sound superbly true in tone and speech value, and surpassingly sweet in musical quality.

"How, then, is one with no technical knowledge of receivers and reproducers to tell what speaker is most suitable for use with his or her set?" you ask.

There are two ways of settling this question with perfect satisfaction, and it is manifestly desirable for the best results to employ a little of both.

The first of these methods is to gain, by the judicious reading of advertising claims made for various speakers and receiving sets, and of magazine articles

dealing with them, at least a superficial knowledge of which type of speaker is most suitable for the set which you are going to buy, or which you have already bought and are using with more or less indifferent results.

The second, and by far the more important step, is to verify, *preferably in your own home*, the wisdom of your choice or choices by actually hearing the resulting speech and musical quality produced by its or their actual operation. I say choices, for the course of greatest wisdom is to make not one, but rather several selections, and then *let your own ears tell you* which is best.

The latter course is necessary due to the proven fact that a quality of tone which is perfectly euphonious to one person may grate harshly upon the hearing of another, and vice versa; not due to a lack of musical perception in either case, but merely to a fundamental difference in the peculiar sensibilities of the person hearing that particular tone. The individual, or the group of

individuals who are to use the receiving set and reproducer in question *must* be served!

## Different Types

IN order to try to ascertain what particular combination of receiver and loud speaker is most apt to please you, let us consider for a few moments the variation in the characteristics of the different types of loud speakers on the market.

There are two general types of speakers on the market, that is, the horn type and the cone type. These types may be subdivided into a number of more specialized forms. This is done in the accompanying table, Figure No. 1, which gives a method of quick reference to the different forms of reproducer as they are mentioned in the following discussion, in which they will be referred to, for the sake of clearness and brevity, by the numbers appearing in the table.

The difference between conical and exponential horns is shown in Figure No. 2, which represents the approximate cross section of these two types. The conical horn often has an enlarged bell, which does not, how-

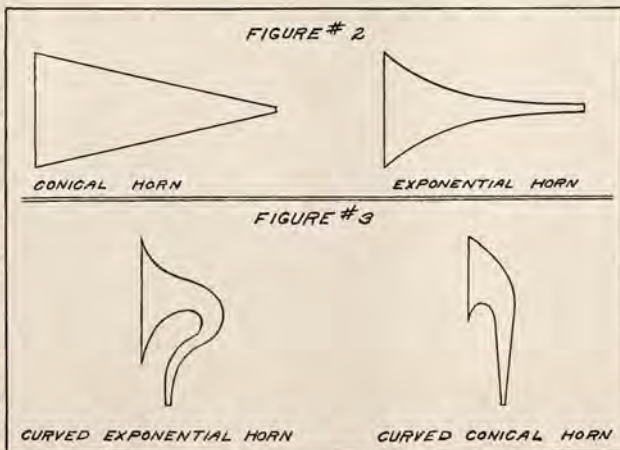



ever, alter its characteristics in any way other than to slightly improve the tone due to decreased sound reflection at this point. These types of horns may be curved into any conceivable shape without altering their general behavior provided that the turns are not too sharp. Figure No. 3 shows the two most common types of curved horns.

Speaker No. 1H is the type generally encountered in the cheap horns, and is fairly satisfactory. Due to the distinct limitations of this form, however, which are partly caused by the deadening effect of the soft horn material and partly by the usual small size of horn in this type, it is apt to be harsh and unpleasant, or thin and whiney, as the case may be, in the upper musical registers. The lower tones are invariably slighted and often almost missing in this type of speaker due to the same defects which are discussed above. If your pocket book permits it is wise to shun this type of speaker as it is considerably inferior to the more advanced types, and will seriously handicap the tone qualities of any receiver.

Type No. 2H is without doubt the poorest speaker on the list, and No. 3H (while it is slightly better due to its exponential type of horn in which there is less sound reflection and interference, and consequently less

metallic vibration) is almost as bad. Due to the manifestly poor tone of this type of loud talker (regardless of the set it is used with) it has been practically driven off the market and probably will never be encountered.

#### Similar Tonal Quality

**I**N spite of the widely differing materials used in the horn construction of types No. 4H, all five of these have almost identical tone characteristics, and have consequently been included under the one number, as it is our purpose to classify horn types by tone and volume attributes. These No. 4H type horns have proven to be one of the most highly successful forms yet evolved, due principally to their mellow, even tones, even in the very high notes and overtones. The lower register, while it does not strongly reproduce, is definitely present.

Type No. 5H is somewhat similar to No. 4H, but the tone, while pleasingly mellow, is somewhat more brilliant, and reproduction is considerably even over the entire musical range; high, middle, and low notes and overtones being reproduced with marked fidelity and strength. Low tones are brought out in this type far better than in type No. 4H, but unless very carefully designed it may show a slight shrillness on soprano solos and the like.

Coming now to cone type speakers, Figure No. 4 shows the different general types; also, as in the case of Figure No. 3, in cross section. The *face view* of a pleated parchment disc is also shown, as this type is probably less familiar than the other cone types.

The variation of tone quality is less pronounced among cone type speakers than among horn type reproducers, but this variation is, nevertheless, existent to such an extent that best results can be obtained only by paying attention to it.

Once more referring to the table, cone reproducer No. 1C gives its best response in the middle and lower registers, sometimes rattling a little on the very high tones, as the production of sound in this type of loud talker depends principally upon the flexing of the material of which the cone is composed. This same flexure of the material composing the cone also tends to produce a pronounced "paper crackle" when heavy static discharges are encountered. Due to both of these reasons, the cone proper is usually constructed of a comparatively soft grade of paper. This in turn leads to a certain flatness or dullness of tone, and occasionally causes a slight muffling of the spoken word.

Types No. 2C, the free edge cones, are constructed in three

Figure No. 1  
**CLASSIFICATION of LOUD SPEAKER TYPES**

HORN SPEAKERS				CONE SPEAKERS		
No.	Shape of Horn	Horn Made of	Diaphragm Made of	No.	Type of Cone	Cone Made of
1H	Conical or Exponential	Papier maché or Fibre	Metal or Mica	1C	Rigid Edge, Single or Double Cone	Heavy-Cold Pressed-Medium Hard-Long Fibre Paper.
2H	Conical	Thin Metal	Metal or Mica	2C	Free Edge, Single or Double Cone	Heavy-Cold Pressed-Hard Long Fibre Paper or Parchmentized Paper.
3H	Exponential	Thin Metal	Metal or Mica	3C	Rigid Edge, Single or Double Pleated Disc. (Lumiéré Type)	Parchmentized Paper or Varnished Fabric or Genuine Parchment.
4H	Exponential	Heavy Metal or Heavy Metal and Wood or Hard Rubber or Special Horn Fibre or Bakelite	Metal or Mica			
5H	Conical Throat, Exponential Body and Bell.	Wood with Drawn Brass Throat	Metal or Mica			



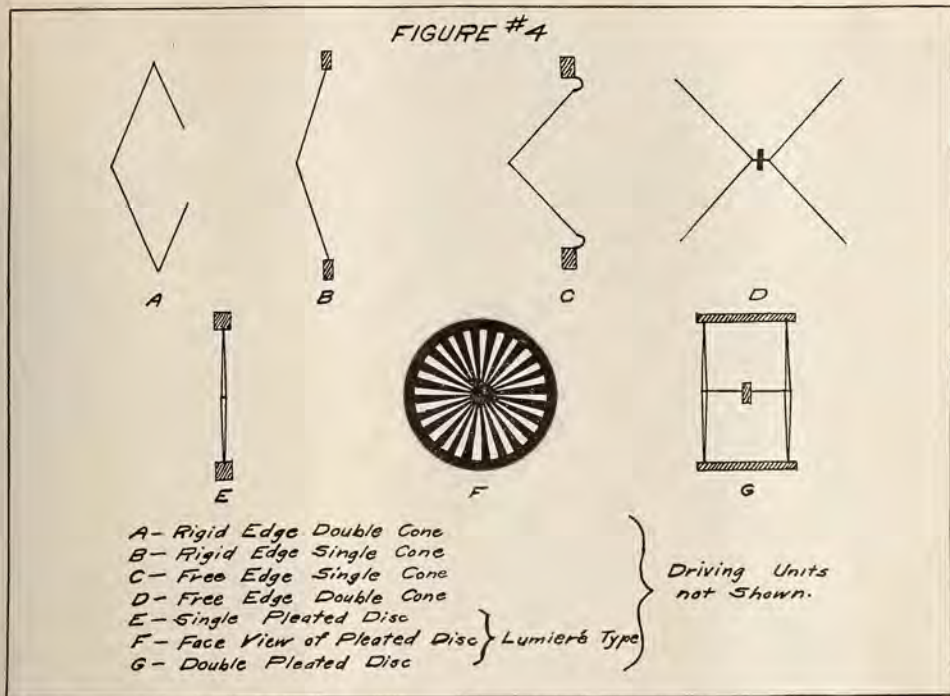

general ways. Sometimes the edge of the cone is flexibly supported by circumferential rubber or kid leather strips; sometimes it is loosely held by soft felt packing around the periphery; and in one or two makes, it is absolutely free, all support of the cone being accomplished by the driving pin, which is made proportionately stronger to bear the additional strain imposed upon it.

The results obtained are practically identical in all three types. The sound is produced in this type of cone speaker by the movement of the cone rather than by its flexure, consequently its response is very even over the entire musical range; in fact, any variation from pure straight line reproduction is caused not by the inertia of the cone so much as by the limitations of the driving unit. Due to the lack of flexure in the cone, its tendency to cause paper crackle with static discharges is negligible. The cone in this type of talker is generally

made of hard, stiff, parchmentized paper to obtain the proper rigidity; consequently its tone is full, brilliant, clear, and free from any tendency to produce "barrelly," muffled tones.

The Lumière type of reproducer, designated as No. 3C, is quite similar in tonal characteristics to the free edge cones (Type No. 2C) except that it is possibly even more brilliant and sparkling in musical quality, due to the fact that its rigid, pleated, parchmentized paper disc or discs are held firmly clamped at their edges. It does, however, produce considerable paper crackle, which is, nevertheless, of a soft, swishing nature, causing little interference or unpleasantness. Response is pleasingly even over the entire musical range. Due to its very rigid clamping, blasting and considerable distortion may occur if it is pushed to too great a volume production. For ordinary home use, however, this last consideration may be entirely disregarded.

**Consider An Example**

BY referring to the above discussion of the tonal qualities of the different types of loud speakers in common use, and to their classification in the table, Figure No. 1, accompanying this paper, an approximate selection of the proper speaker may be made. To illustrate the method followed, let us consider one or two typical examples.

Suppose, for the sake of argument, that the type of set in which you are interested is tentatively connected to a speaker of No. 4H type. The set is tuned to a broadcasting station over which a pipe organ is playing, and while a fair tone is obtained, a considerable amount of the overtones and low notes are missing.

(Note—For the purpose of comparing the tone qualities of sets and reproducers, piano or pipe organ music is best, as the widest possible bands of fundamental tones and overtones are

(Please turn to page 48)

# Use Tube Socket as Plug for Testing Receivers

By CHARLES E. FELSTEAD

(Radio 6CU)

THE tube socket plug shown in A in the drawing can be put to a large variety of uses. Only two uses will be given here. If the experimenter has several of them on hand, it will save him a tremendous amount of muss and work in trying out new

sets and finding trouble in his old sets. The plug can be made by breaking the base off a burned out tube, soldering long leads to the wires attached to the pegs in the base, and filling the base with

melted sealing wax. Before putting the sealing wax in the base, small glass beads, or short lengths of spaghetti tubing, can be put over the wires to make certain they are insulated from each other. Three or four foot lengths of flexible insulated lamp cord can be used for the leads. If the experimenter has one set hooked up and wishes to try out another set, he can connect the two A battery leads and the plate lead of the tube socket plug to the battery binding posts on the new set, and put the socket plug into the detector socket of the set that is already hooked up. Then all he needs do to test out the new set is to short circuit the phone binding posts on it, and connect the aerial to it, as shown in B of the drawing. In this manner, new sets can be tested out without disconnecting the regular receiving set. By connecting a voltmeter to the two filament leads, as shown in C, the socket plug makes it easy to find out exactly how much voltage is being applied to the filament of each tube in the set.

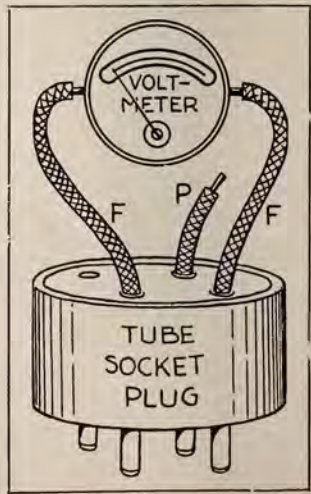
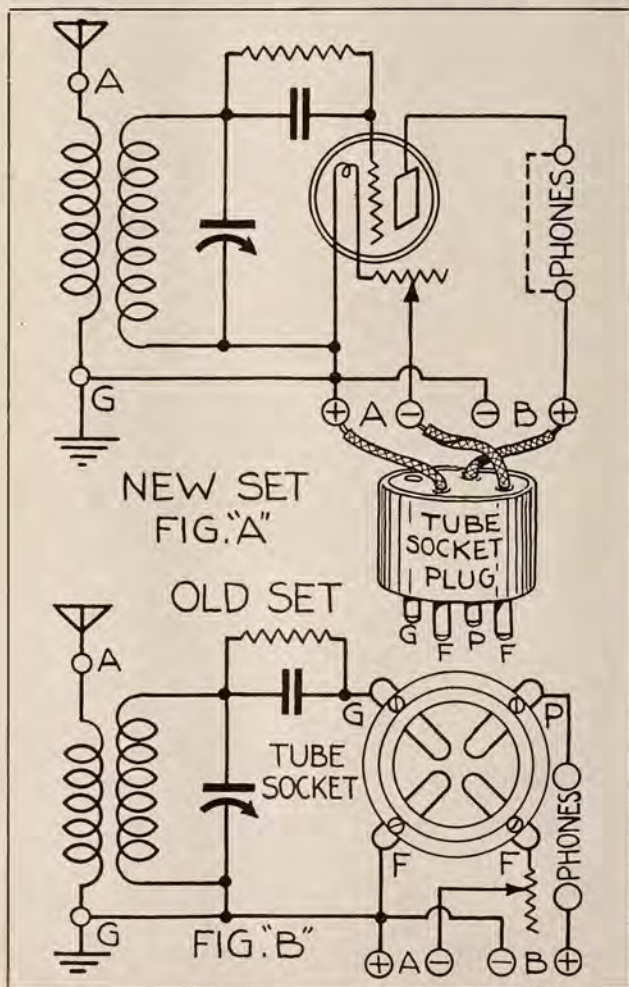



# “The Ladies— God Bless ’em!”

By

DOROTHY BRISTER  
STAFFORD

MRS. McINNIS is president of the League of Women Voters, an ardent radio devotee—that is, she listens to all the special women’s programs that hurry busily hither and yon through the air in the mornings, likewise the philharmonic concerts and university extension lectures—and has even enjoyed the thrill of the microphone herself, when she has given to the waiting world some of the salient features of her well-known lecture, “Are the Cinema and the Radio a Menace to the Rising Generation?” and she was taking us severely to task for our seeming inclination to ignore the great place women were playing in radio broadcasting.

We never come in contact with Mrs. McInnis and the various feminine pies in which she has a finger, that one little, semi-atrophied brain-cell doesn’t try to function and bring to life a quotation that seems so admirably adapted to this lady and her out-



Johanna Grosse shown in the pensive mood above is the concert organist at station WLW, Cincinnati

look on life. We can never quite get it right, and small wonder, for it must have been when we were somewhere around the plastic age of sixteen that we suffered from a violent attack of Ella Wheeler Wilcox—(why is it, we wonder, that at that age one’s mind ran to “The Ballad of Reading Gaol,” “The Moving Finger Writes” and like bitter doses, and today leans to such classics as “The Hermit of Shark Tooth Shoal” and “Said E. P. Roe to

Opie Read”?) but what we started to say is that there remains, heaven knows why, as a hang-over from those dim, discouraged solemn days of youth this choice fragment:

*“There’s not a thing in heaven or earth,  
There’s not a life, a death, a birth,  
There’s not a feather’s-weight of worth  
Without a woman in it.”*

And if such a sweeping statement of feminine omnipotence could come out of the Mid-Victorian era, how much more true it should be in this, Mrs. McInnis' day, when enthusiasts of her like are rampant throughout the land, seeing that no opportunity goes ungrasped that may further their crusade of glorifying the feminine cause. And since she had put it into our head we began seriously to wonder why the fair sex is not playing an even more prominent part than they are in radio circles. For when it comes to real achievement, in numbers at least, the feminine entertainers seem to be lagging behind their brothers in the matter of established popularity and assured success in the radio world. One wonders, perhaps, if it

isn't because, in many cases, broadcasting, with its unstabilized and rather vague remuneration, is regarded merely by most women artists as but a stepping stone to the legitimate stage or concert platform, an opportunity for publicity that leads to a more secure and established position. Thus, in many instances, we have just become nicely acquainted with a charming voice as some station's regular feature, when it vanishes from the air, gone we know not whither. If the singer has achieved big-time vaudeville, she is lost to us forever, by reason of the ban against broadcasting.

#### May Be Side Issue

AGAIN broadcasting may be a side-issue with a young woman preparing for some other

profession, as in the interesting case of Rosaline Greene, who for two years was leading woman with the WGY Players. It probably never occurred to the average listener, who followed Miss Greene's very creditable work with this popular organization that the young woman was other than an actress by profession—when in fact she was a student at New York State Teachers' College, preparing herself for a teaching career. With her graduation last June, she said farewell to the microphone, and this will undoubtedly be the course taken by many able women workers until the puzzling problem of who is going to pay for our radio entertainment has a solution.

We timidly hazarded our opinion that the dear girls weren't making as big a splash as they might, and put forth the foregoing reason, but Mrs. McInnis fairly snorted her indignation.

"Why there are dozens of capable women performers appearing on the air nightly," she protested, "and still you seem to be able to find no one to talk about but the men."

"All right," we told her, "Go ahead and name a few dozen of the women who have national reputations as radio entertainers equal to those of the men we have been writing about. We aren't discussing their ability—it's the fame they have acquired in this new profession."

Our critic started bravely off with a few well-known names from the large stations, a local celebrity or two, who are unknown two hundred miles from home, and wound lamely up with a number of grand opera stars she had heard the past winter.

"But you can't call Schumann-Heink and Homer radio performers, can you?" we asked her, and when she realized how relatively few women had achieved what might be called a lasting place in broadcasting, she had to admit that her argument was extremely wobbly.

"But why is it?" she persisted,



Lottice Howell, coloratura soprano, late of the Capitol theatre and recently heard through WSMB at New Orleans



"aside from the fact that you say they aren't paid enough to make them stick to it?"

We had what seemed to be an illuminating idea.

"Attend," we told her. "Radio seems to be essentially a masculine pursuit, doesn't it? And have you ever yet met a man who didn't have the sneaking, low-down trick of turning off a soprano before she had a chance to convince him that she was worth hearing? The girls simply don't get an opportunity. It seems that vision is necessary to carry charm to the average male and it takes a peculiar sort of personality to put a woman over when she is invisible to the eye."

Mrs. McInnis sighed, and agreed that, alas, it seemed to be true.

#### Stage vs. Radio

THEN the two of us cited a number of vaudeville and light opera stars whose greatest asset is personality and decided that all of them might be miserable flops as radio entertainers despite the fact that they are headliners upon the stage. We recall a young woman impersonator, persistently exploited by one of the great stations recently, who probably in a visual appearance had a wide appeal through her charm, but though we listened to her many times in an effort to discover just why she should be featured by a station with extremely high standards as to the quality of its broadcasting—to us she registered absolute zero as a radio attraction. We had nothing to judge her by but her voice, and that was very bad. When one realizes how much attention is given to a stage artist's wardrobe, scenery and lighting effects, the importance of the picture in bringing the entertainer success is so evident, that it is small wonder, that stripped of all these accouterments, it is only the occasional lucky one who registers with the radio listener. And there is no question that the *feminine entertainer relies more*



"Bernice" (and she's nice, too) popular pianist at station WCX, Detroit

on these aids than her huskier brother. A good, honest, hearty baritone voice needs neither camouflage nor personality to make it register. But much is forgiven a beautiful woman, and oftentimes a thin soprano or off-key contralto goes over big on the stage by the sheer force of its owner's personality.

We had a pleasing experience one night early in the summer that demonstrated how much importance we listeners attach to a familiar voice upon the air. We like to hear the people we have come to know, just, as casting our eyes over a vaudeville bill, we are most likely to be interested if the name of a familiar turn appears thereon. It must have been something over a year ago that we became quite enthusiastic over an exquisite soprano voice that turned up one night on

the Capitol program. The selection was, of all things, the Blue Danube Waltz—an opus we have always contended that needs oodles of dreamy violins and 'cellos to bring out its exquisite rhythm—and it was being sung from the theatre stage with full orchestral accompaniment by a coloratura of fine tone beauty and an exceptional range. We were so impressed that we immediately got busy, and found that the voice belonged to Lottice Howell, a name heretofore unknown to our musical experience. From the breadth of tone and apparent years of culture, we mentally placed Miss Howell as a grand opera singer of at least forty, of regal embonpoint and unmistakably a blond. When the obliging press agent came across with a photograph we almost fell off our chair to find that the voice be-



longed to what seemed a mere child of twenty or so, possessed of unusual personal beauty, and showing not a sign of the years of strenuous labor that must have gone into perfecting a voice of such unusual purity of tone and flexibility of handling.

#### Lottie at WSMB

**P**RESENTLY came that night last summer when WSMB, New Orleans, was having one of its periodical fits of coming up like thunder from the gulf. The program was from the Strand theatre, and the room was filled with tones of liquid beauty that we would have recognized had Hong-Kong been broadcasting them. It was Lottie Howell filling a special engagement at that theatre, and we were as delighted at happening upon her again as though she were a friend of many years' standing. We were disappointed to learn, however, that we were to have her back but temporarily, as she is this winter to sing the prima donna role in "Deep River," an Arthur Hopkins production. Incidentally those loyal southerners down at WSMB claim to have discovered Miss Howell long before Roxy did.

An attractive young woman known simply to listeners as "Bernice," in the two years during which she has been a regular member of the studio staff of WCX, Detroit, has gathered to herself a great following of those listeners who enjoy jazz piano playing when executed by one born with the gift for the trick orchestrations of modern music. "Bernice" may be regarded as a veteran broadcaster, for she started as accompanist at the Free-Press station when a mere child, and as her popularity grew, extended her work to recitals and request hours, and became the star of WCX's weekly revel, "The Red Apple Club." In addition to her radio work "Bernice" makes player piano records and demonstrates the same. She has always been presented in an inti-

mate manner, and the announcers have succeeded in working up almost as much mystery about her as surrounds the w. k. gentleman in the Silver Mask. To our notion she can do just as much with a piano as any of her masculine contemporaries, and if one can put any faith in what her enthusiastic announcer tells us, she is just as popular.

At WLW, Cincinnati, there is a young radio entertainer not only of unusual ability, but of remarkable personality, and since she is so fortunate as to be featured by a station of great power, her audience of appreciative listeners equals that of any of the great eastern stations. She is Johanna Grosse, concert organist, and while few girls would select an organ as the instrument to bring unusual fame—our great organists being almost without exception of the masculine persuasion—the surprising technique and mastery of the multitudinous keys displayed by this young woman, placed her almost from the time she began broadcasting in the front rank of radio entertainers.

#### Request Numbers

**W**E first became interested in her when we happened in on a program where she was complying with requests that seemed to come from all over the radio world, and it was at first mere surprise that such a multitude of listeners should be interested in organ music that prompted us to stay by the Crossley station long enough to realize that Johanna Grosse was far from being the average studio organist. She seems to have an unlimited repertoire at her gifted finger tips, and a singular genius for extracting all the melody possible with a technique peculiarly her own, from the great organ. And the story of her life carries out one's first impression—that of an artist born with a genius for one instrument. Born in Hungary in a small village between Vienna and Budapest, Johanna's musical ed-

ucation began at the mature age of six. Coming to this country when eleven, she studied piano at the Cincinnati College of Music, but has never had an organ lesson in her life. A year later she embarked upon her career as a theatre organist, surely one of the youngest professionals of her time. Her prestige as a master of this intricate instrument grew with the years, until now she is in demand whenever a great organ is to be dedicated in a church, temple or theatre.

It is not our contention to present these aforesaid young women as the only successful feminine radio entertainers. They are merely a few who by widely different means—though all are hard and zealous workers—may be said to have really arrived in this new and rather difficult profession. If we were so fortunate as to possess a radio set such as seems to be owned by almost every newspaper reviewer, where, judging from the reviews, one may hear a dinner concert in San Francisco, run up to Seattle for a bedtime story, listen to a French lesson in Boston, the Municipal Band in Havana, and get back home in time to follow the New York hookup, we might get acquainted with more entertainers. But since our listening is restricted to what comes over the best commercial set we can buy, which, even when doing its noblest seems to be limited to only twenty-five hundred miles, and as we have a queer prejudice against hazarding an opinion of an artist to whom we haven't personally listened, it is not possible at this time to pass judgment upon the feminine stars of the entire country.

Mrs. McInnis has been looking over the photographs. "I begin to understand," she said, "why my Harold is so set on becoming an announcer. And it would be rather a pity if these young women had to spend their lives shut up in broadcast studios where no one sees them but the announcers."

And wouldn't it?



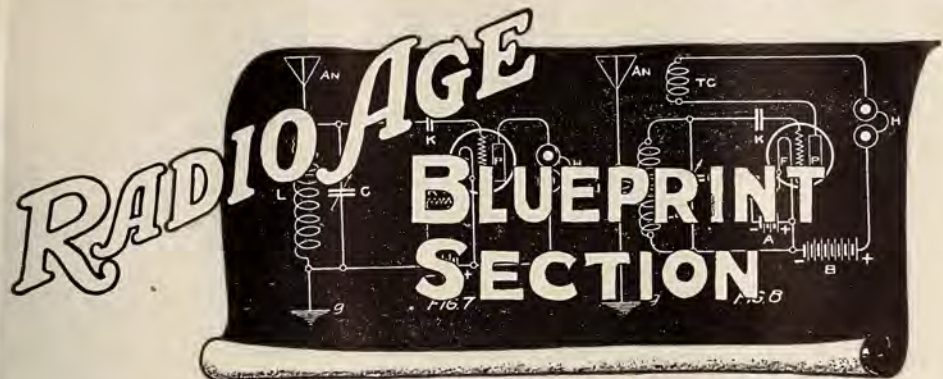

## Converting Station 9BHX To Crystal Control Set

*Better Note and Constant Frequency Obtained Through Change*

By F. A. HILL  
*(Associate Editor)*

SINCE the description of the short wave, low power, transmitter by the writer in the August issue of RADIO AGE, we have made a change in the 9BHX set, going from the single seven and a half watt as an oscillator, to the crystal control, crystal oscillator, power amplifier combination.

Results have been more than gratifying. Where with the old arrangement the signal was fair enough considering the low power, yet there was much to be desired in the way of stability. Swinging of antenna, or the presence of body capacity made sufficient change in the signals to render them unstable. With the use of crystal control this trouble has been eliminated and reports now show 9BHX from R5 to R6 at distances from a thousand to two thousand miles. So far nothing has been accomplished on trans-oceanic transmission but with a little more time to spend it is believed greater DX can be secured.

In the August issue the plate voltage was given as 180 volts,

In this article we have doubled the voltage, using World storage B batteries, 4 additional banks of 45 volts, bringing our total up to 360 volts. Such an increase of voltage would have helped the

old transmitter somewhat but we would still have been far from our ideal of having a constant signal with the pretty crystal tone like 4BY, 4XE, 2MU, 9MO, 8PL, 9AOT and a few others whom it is a pleasure to work on account of the permanency and clean cut signal.

Quite a number of combinations were tried out before the final arrangement was decided upon. For the benefit of those who are just entering the crystal stage we will recount some of the details in the conversion of a set from the simple oscillator to the crystal oscillator, power amplifier combination.

### Position of Crystal

BY referring to Figure 1 in the blueprint section you will observe the elementary layout on which we first experimented. The crystal, with a fundamental of 3700 kc. was secured from our friend 4BY who couldn't rest in peace until 9BHX was converted to crystal control. It oscillated easily and freely at that frequency and was easily put into

### Parts for Transmitter

- 1 Thordarson 8½ volt filament transformer
- 3 Benjamin cushion sockets (new type for UX bases)
- 3 Allen-Bradley fixed resistors: Figure 3, R1, 50,000 ohms; R2, 25,000 ohms; R3, 10,000 ohms
- 1 Crescent lavite resistance R4, 10,000 or 5,000 ohms
- 8 Jewell meters: RFA 0-1; RFA 0-2; RFA 0-3; RFA 0-3 (antenna); MA 0-100; MA 0-250; MA 0-500; AC voltmeter 0-15
- 5 Sangamo bypass condensers 2.002 and 3.006 mfd.
- 2 Electrad bypass condensers C5 and C6, 1 mfd each
- 3 Cardwell condensers C1, C2 and C3, .00025 mfd. each
- 8 World wet B batteries, 45 volts each

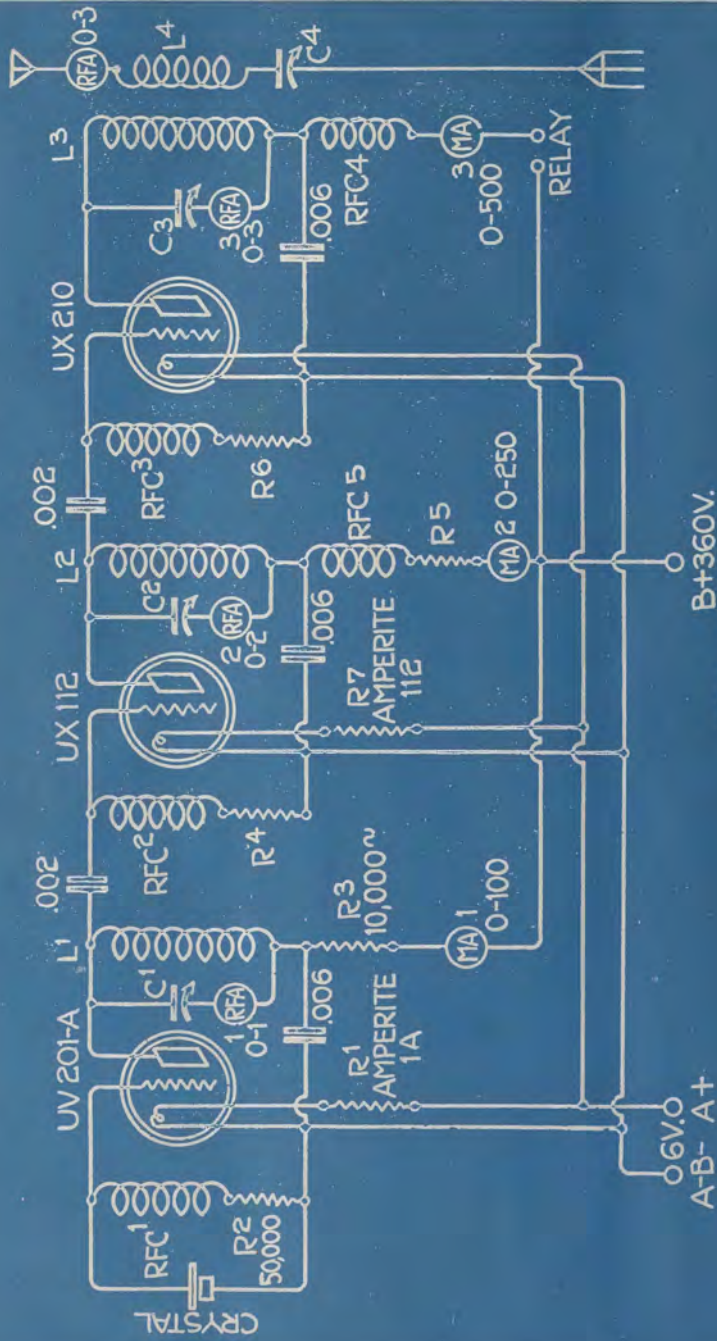

**FIG. 1**  
**RADIO AGE**  
**CRYSTAL CONTROL SHORT WAVE TRANSMITTER**  
 42.21 AND 40.52 METERS



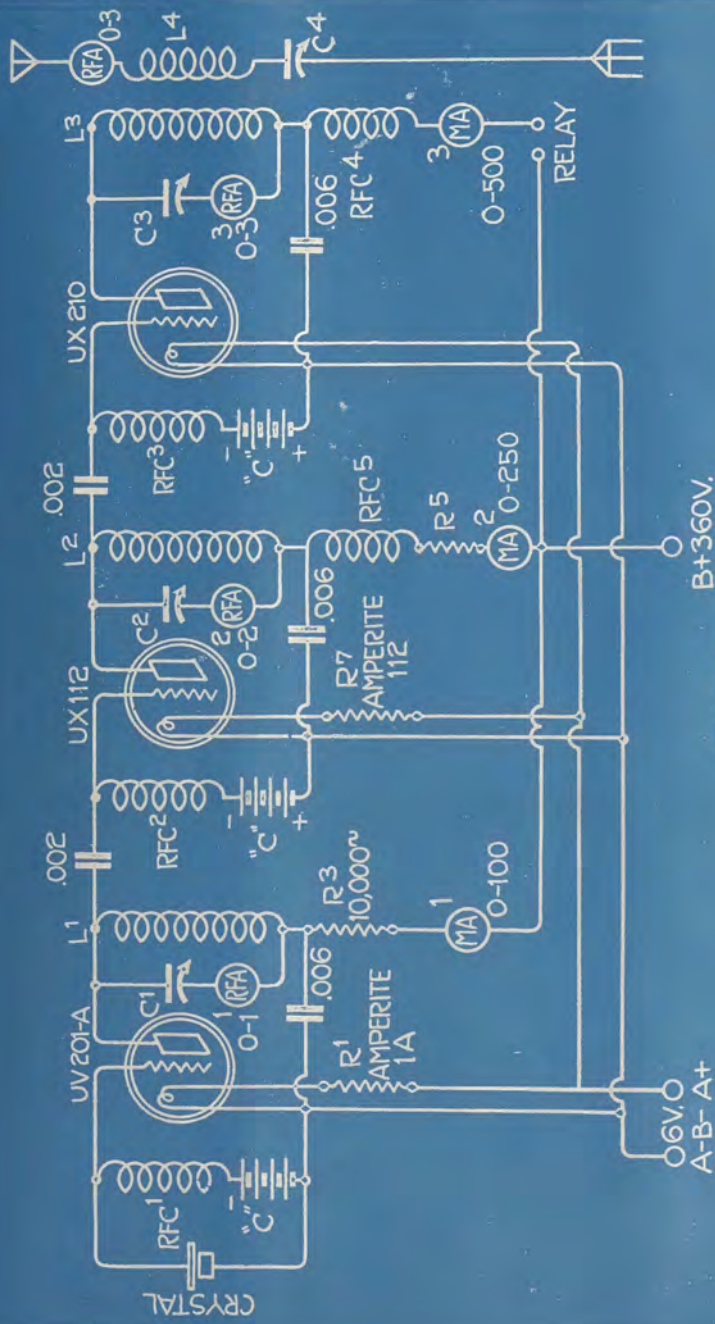

**FIG. 2**  
**RADIO AGE**  
**CRYSTAL CONTROL SHORT WAVE TRANSMITTER**  
 42.21 AND 40.52 METERS

operation as a simple crystal oscillator.

Grid to filament position of the crystal was decided upon after numerous tests with the grid to plate scheme, the latter not giving nearly as much power as the former, although perhaps a trifle steadier in operation. The RF choke shown in the first tube circuit in Figure 1 was made up of 150 turns of No. 30 wire on an inch form, (cardboard tube). The resistance in series with it was an Allen-Bradley 50,000 ohm fixed resistor. The resistance value between grid and filament in turn limits the plate mills of that particular tube down to a reasonable value. The same object may be obtained with C batteries as shown in the schematic circuit Figure 2, which is the same as Figure 1 with the exception of the C batteries used for biasing the different grids.

In order to tell when the crystal is oscillating we used a zero to one hundred DC milliammeter (Jewell) in series with the 360 volt battery. Between the meter and the plate circuit is a 10,000 ohm Crescent Lavite fixed resistor. This value can be changed

to 5,000 if it is desired to give more power to the 201-A which acts as a crystal oscillator. When the power is put on the crystal circuit alone the plate mills will read about 35 to 50 mills with the crystal not oscillating. By varying C1 over its range and watching the milliammeter closely there will be found a position where the plate mills drop sharply to about 15 to 20 mills. Capacity changes above and below that position will read 35 to 50 mills. This is graphically comparable to a V figure in which the non-oscillating conditions (35-50 mills) are at the top of the figure, and the oscillating condition (15-20 mills) at the bottom of the V, or the point of lowest dip. Crystals which oscillate freely and do not have any obvious parasitic fundamentals, will show only one dip, while crystals which have parasitic fundamentals close to the main fundamental will have an irregular dip. Crystals which need a regenerative coil in series with them to cause oscillation, will show two dips, one for the coil's period, and one for the fundamental of the crystal. But the dip of the coil will be a gradual

one, while the crystal fundamental dip is abrupt and very decided.

By using a zero to one RF ammeter in series with one side of the tuning condenser, as shown in Figure 1, will give maximum RF reading when the mills in the plate circuit are at a minimum. While the use of the two meters is nice, if the pocketbook does not permit, the DC milliammeter may be retained and used as a guide to indicate the oscillation point of the crystal.

#### Getting Crystal Going

**H**AVING tuned the inductance L1, (made up of about 12 turns of No. 6 gauge aluminum or copper wire, wound on a 3 inch form tightly, then allowed to slip; then spaced as shown in Figure 4-C) to the fundamental of the crystal, which in this particular case was 3700 kc, we find maximum RF current in the tank circuit with minimum mills in the plate circuit. Under these conditions the crystal is oscillating nicely and we are ready to transfer this constant frequency energy to the next tube, or the frequency doubler as it is called.

A Sangamo .002 works very



In this photo is shown the short wave receiver now used at 9BHX



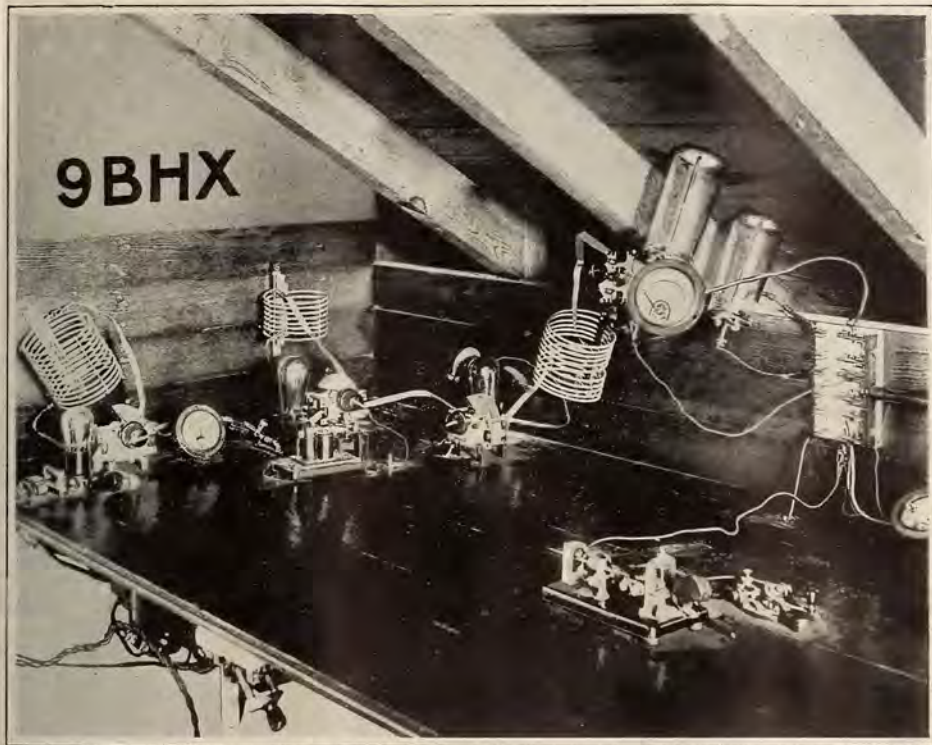

Inspection of this photograph will show the manner of placing the apparatus used in conversion of 9BHX to crystal control

nically for the coupling condenser and it stands up exceedingly well under heavy RF currents. The inductance L2 is wound in the same manner as L1, only it has but approximately four to six turns. The RF choke in the grid circuit of the UX112 is wound the same as RFC1, but the resistance R2 is a value from 10,000 to 50,000 ohms. The plate circuit of the frequency doubler is the same as that of the preceding tube only for a shorter wave. An RF ammeter in the tank circuit and a DC milliammeter in the plate lead will give you an idea of the working of this circuit. Condenser C2 is run over its range until current rises in RFA 2. This current will be at the second harmonic of the tube, the grid circuit being at the fundamental (or first harmonic) 3700 kc, while the plate circuit will be at 7400 kc. This is called

#### Parts for Receiver

- 1 Silver Marshall plug in coil and socket
- 1 Cardwell .000075 mfd. taper plate condenser
- 1 Silver-Marshall short wave condenser
- 1 Silver-Marshall midget condenser for antenna coupling
- 1 Allen Bradley 25,000 ohm resistance, fixed
- 2 Amperite R1 for UV 199 from 6 volts; R2 201-A from 6 volts
- 1 Sangamo .00025 mfd. grid condenser and slips for leak
- 1 Durham 7 megohm grid leak
- 1 General Radio audio transformer
- 1 Jones multiplug and base mounting
- 2 Two XL pushposts
- 2 Silver-Marshall sockets
- 2 National vernier dials, dual range
- 1 Yaxley filament switch

frequency doubling. This circuit should be used with maximum RF current and minimum plate mills—there is a definite point at which best results are secured.

With the plate circuit of the second tube, or the frequency doubler, amplifying at 7400 kc we now wish to transfer this energy to the antenna circuit, but since probably the energy is not very strong at this point, we will put it through a power amplifier which in this case was a UX210 operated from a 6 volt storage battery. Where the crystal tube had an Amperite 1A in its filament, and the UX112 has an Amperite 112 in its filament lead, there is none in the 210 filament so it receives full 6 volts. This is about a volt and a half below the normal operating point of this tube's filament, but it will serve unless you happen to have an eight volt storage battery, or









desire to go to AC filament operation as is shown in later figures in the blueprint section.

The output of the 112 is at 7400 kc, the input of the 210 is at the same frequency, and the emitted wave in the antenna circuit will be the same. There is also a definite point in the tank circuit of the 210 where you will get maximum RF reading with a minimum of plate mills. This energy is inductively passed into the antenna circuit L4, equipped with an RF ammeter and a variable condenser. Where inductances L2 in the 112 circuit and L3 in the 210 circuit are from 4 to 6 turns of wire, L4 may be from 6 to 8 turns, depending upon the amount of coupling required to properly transfer a maximum of the energy to the antenna circuit. Slight changes in the tuning of L4 will react back on the tuning of L3 and thence to L2, but after carefully working at this you will be able to get the transmitter properly tuned and then it will remain in resonance through the whole set without having to make changes all the time. Antenna coupling may be from a half inch to inch depending on the power.

In the assembly of L1, L2 and L3 we found it very advantageous to keep the distance between these inductances at least 18 inches. This eliminated any trouble with inductive RF feedback and obviated the necessity of neutralizing between the frequency doubler and the power amplifier circuit. If you desire to economize on space, you will probably have to neutralize.

#### Condenser and Resistances

**B**YPASS condensers of a .006 value (Sangamo) are provided as shown in the schematic. Resistance R5 may be 5,000 or 2,500 ohm Crescent Lavite, the same as R3. Radio frequency chokes 5 and 4 are the same as RFC 1 and 2. Keying is accomplished in the plate lead of the last power amplifier. Resistance R6 is anywhere from 5,000 to 25,000 ohms. Keep changing resistance values in the grid circuits until you get maximum output without the tubes getting

white hot. A slight red glow will not be harmful but do not let the plates get white hot.

Figures 1 and 2 will give you all the data necessary on the small tube arrangements, the latter blueprint showing C batteries instead of resistances in the grid circuit. A total of about 90 volts (perhaps 120) will be required for this purpose. From 22 to 45 will be used on the crystal grid; from 45 to 60 on the frequency doubler grid, and from 60 to 90, or possibly 120, on the grid of the last power amplifier.

Unless all circuits are tuned exactly to resonance with the crystal circuit there is a possibility of oscillation in the amplifier tubes, and this is destructive to a good signal, so be sure that all tubes are functioning as amplifiers instead of oscillators (except the crystal tube which of course is supposed to oscillate).

Going over to the use of UX210 tubes throughout, Figure 3 will give the schematic, showing the use also of AC on the filaments through a Thordarson 8½ volt filament transformer. The operation of the set is the same as before with the exception of larger tubes, and keying in the plate supply of both the frequency doubler and the last power amplifier, instead of the last P. A. alone as was the case in Figure 1 and 2.

Radio frequency chokes in Figure 3 are the same value as heretofore. R1 in the grid circuit of the crystal may be from 50,000 to 100,000 ohms. Resistance R4 in the crystal tube plate circuit is 5,000 (Crescent). There are no plate resistances in the other tubes since we wished to get as much from the 210's as was possible without injury. Bypass condensers described previously are the same in this arrangement. The coupling condensers are the same. Resistance R2 will run from 25,000 to 50,000 ohms, while the resistance R3 will run from 5,000 to 10,000 ohms. Two Elettad or Dubilier one mfd bypass condensers are shown from ends of the filament secondary to center tap, which is common with all grid returns, negative B, and ground, the latter if desired. With us it did not make the

slightest difference between grounding the filaments and not grounding them, but for simplicity we left them grounded.

#### Antenna is Vertical

**A**NTENNAs used was a single wire, vertical, 32 feet long. Counterpoise 32 feet, horizontal. Eight turns of L4 as coupling, this coil being the same diameter (4 inches) as the other inductances in the set. Capacity C4 was .00035 mfd although it may be .00025 if more turns are added to L4. Capacities C1, C2 and C3 were all .00025 mfd—any good make of condenser will do. The photograph of the transmitter on page 29 will give an idea of the manner in which the transmitter was laid out. Since photographing the set, some of the wires have been put in permanently, made up of No. 6 gauge aluminum wire—it is big enough so it is stiff and solid. Since it is not easy to solder aluminum we hammered the ends which we desired to connect to other points, and after hammering them out flat drilled a hole through the flat section for screw assembly. This gave us tight assembly and very good contact.

Figures 4-D and 4-E give two forms of crystal holders, the one in sketch 4-E being designed by J. E. Hodge of 4BY. It is not required that very much pressure be placed on the crystal which fits between two smooth brass or copper plates. Apparently just the weight of the upper plate will generally suffice, although just a trifle tension on top will prevent the plate shifting due to jarring of the table or other radio room commotion.

Schematic circuits 4-A and 4-B show the receiver circuit, the first the throttle control Armstrong and the second the Weagant. We have several times arranged these receiving circuit so that a single pole double throw switch would switch from one to the other. So far we have failed to find enough difference between the two to cause us to show a technical preference, although we have a personal leaning towards the Weagant. The phones are totally isolated from

(Please turn to page 35)



# Raytheon Design for A B C Power Unit

*Type BH Tube Gives Increase in Voltage and Current*

By Miles Pennybacker\*

**D**EVELOPMENTS of the new type BH Raytheon rectifier now makes it possible for the first time to satisfactorily obtain A, B and C voltages from the alternating current light socket. The radio experimenter and set builder have long awaited the opportunity to obtain a rectifier which would have sufficient current and voltage capacity to light the filaments of 199 type radio tubes in series, and at the same time supply sufficient plate voltage to operate a power amplifier.

The new Type BH fulfills these requirements in a particularly satisfactory manner, and there remains a reserve of power from which the radio set may draw at momentary overloads, without fear of burning out the tube or impairing the quality of reproduction.

In order to clearly see the picture made possible by this new development, let us look at Figure 1 which is a schematic drawing of a Raytheon A. B. C. power unit with the Type BH tube. The power transformer is built to supply 350 volts on each side of the high voltage secondary winding at no load. The current carrying capacity of this winding should be at least equal to 85 milliamperes, and in order to insure good regulation in keeping with that already determined by the Type BH Raytheon, the regulation of the power transformer should not be more than 10%. The power transformer also has a filament supply winding which delivers five volts at .5 amperes for the filament of a UX 112 or a UX 171 power amplifier tube.

The usual buffer condensers of .1 microfarad capacity are placed



This is the new BH Raytheon tube which has a materially higher current and voltage output

across each half of the transformer secondary as shown in Figure 1, by C<sub>1</sub> and C<sub>2</sub>. The fil-

ter circuit consists of two choke coils capable of carrying at least 85 milliamperes D C and having an inductance of at least 25 henries per choke at this value of D C. Thordarson, General Radio, Amertran, and several other manufacturers are now supplying these choke coils. The filter condensers are arranged as shown in Figure 1. This first section condenser C<sub>1</sub> has a capacity of 4 microfarads, C<sub>2</sub> is 4 and C<sub>3</sub> is 6 microfarads.

## Resistances for Control

**R**ESISTANCE control unit which is used to determine the various B voltages for the receiver and to drop the B plus maximum voltage to that value required by the filaments in series, presented quite a problem in development. This situation existed because practically no manufacturers of resistance units had conceived the demand for the types required particularly in the case of variable resistors. The great difficulty was to find resistors of sufficient current carrying capacity and wide enough range of resistances to be of value. (Allen Bradley now makes them. —Editor).

The ideal unit for this service would be a variable resistor of at least 60 milliamperes current carrying capacity and a resist-

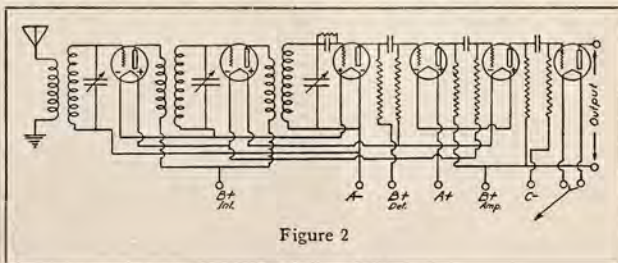

Figure 2

\*Chief Engineer Raytheon Mfg. Co.



ance range of from 2500 to 5000 ohms. One arrangement which was used to achieve the degree of control required was a combination of a Ward-Leonard fixed 3000 ohm resistance  $R_1$  in series with another fixed resistance  $R_2$  of 5000 ohms, around which was shunted a third resistance,  $R_3$ .  $R_3$  has a variable resistance of 2000 ohms, maximum value.

Several potentiometers on the market, will fill this position although there are none which have yet been specifically designed for the circuit. The value of the remaining resistances in Figure 1 are shown in drawing, and are the customary B-power supply specifications such as have been approved by the Raytheon laboratories from time to time.

The filament of the power amplifier tube, being supplied with raw A C has a 400 ohm potentiometer connected across its terminals. The center tap of this potentiometer is returned to B minus, and is set at such a position as to give minimum A C hum. The "C" voltage for the power amplifier is obtained from a variable resistor,  $R_4$ , connected as shown in Figure 1. In order to obtain 45 volts "C" battery from this source, it will be necessary that  $R_4$  have a maximum resistance of at least 600 ohms.

The performance of the A. C. power unit is to a very great degree dependent upon the characteristics of the new Raytheon Type BH rectifier. These char-

acteristics are of an extremely technical nature, and can best be appreciated from a comparison of the new Type BH tube with other rectifiers designed for B-power service.

#### More Powerful Tube

FOR example—if a B-power supply which has hitherto been equipped with a Type B is now equipped with one of the new Type BH tubes, there will be an average increase in voltage output from the power supply unit of 30 volts for any given radio set. When adjustment of the radio frequency and detector voltages is made, reducing them to their previous values, there will be a further increase in the voltage output of the power supply unit, of from five to fifteen volts. This high voltage is of course available and extremely desirable for use in connection with the power amplifier, and for this reason and others, it is not advisable to use any rectifier but the Type BH.

Another feature of the new rectifier which is of great importance in connection with the A. B. C. power supply unit, is the improved regulation of the tube itself. Actual measurements in the Raytheon laboratories have shown that the new tube has a constant voltage drop from a very low current up to 85 milliamperes. If the output from the rectifier is never less than 10 milliamperes, as will be the case if

recommended Raytheon circuits are adopted, the only regulation of the power supply circuit will be that of the transformer and filter circuit. There will be no loss of voltage due to changing characteristics of the Type BH. This feature in itself is really remarkable and one which has never before been incorporated in power supply rectifiers.

In order to take advantage of this good characteristic, the constructor of the unit may well pay attention to the proper design of its power transformer and filter circuit, with regard to loss of voltage caused by poor regulation.

An opportunity to improve the regulation of the filter circuit may be found in condenser C of Figure 1. By increasing this capacity from 2 to 4 microfarads at 85 milliamperes, an increase in D C voltage output of approximately 15 volts may be secured.

#### Reserve Power

STILL another feature of the Type BH which is of considerable importance in obtaining high quality reproduction, is the reserve power available for momentary overloads without damage to the rectifier. Extreme bursts of volume from the speaker demand proportional amounts of energy from the power supply unit. If this energy is not available at a constant voltage, there is certain to be distortion and a considerable loss of quality. If the power supply unit is properly designed with regard to regulation, and if the rectifier is capable of delivering these peaks of energy without loss of voltage, good reproduction is insured at all times.

The various constants shown at the end of this article enable the builder to construct a power supply unit of good regulation, and by using the Raytheon Type BH he will have achieved all that is to be desired.

For those who are not thoroughly familiar with the method of connecting the filaments of radio tubes in series, Figures 2 and 3 will be of interest.

Two methods of making these connections are possible. First using the voltage drop along the

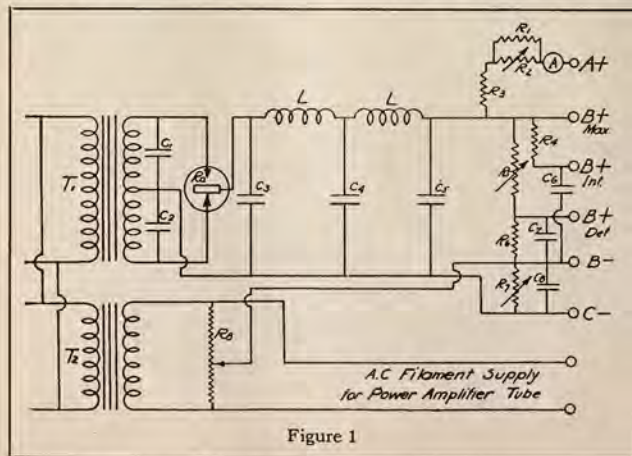

Figure 1



various filaments as a source of grid bias, and using no grid bias on the various tubes. The first method is better from the standpoint of the amount of amplification secured and is possible when the degree of filtering of the power supply unit is very good.

The filter circuit shown in Figure 1 gives excellent filtering, and the user of this unit is therefore enabled to make use of the grid biasing method shown in Figure 2. Where the degree of filtering is not sufficient, it is better to connect the grid return leads of the various radio tubes to the negative side of the respective filaments. In general, this scheme is much less difficult to handle, altho it gives a lowered overall amplification on account of the necessity of reducing the plate voltages on these tubes without negative grid bias.

**Four Year Research**

The type BH is the culmination of four years of concentrated research on one problem.

Current rating—85 milliamperes output, an increase of 40% over the well known Type B.

Voltage rating—200 volts, an increase of 33% over the well known Type B.

Voltage drop due to rectifier—practically constant from 10 to 85 m. a. (This is in sharp contrast to the filament type of rectifier, which often requires a voltage regular tube.)

This tube marks a real advance in a. c. operation since it is a practical solution of lighting Type 199 filaments from a. c.

This announcement promises to be of equal significance to the radio public as was the original announcement of the Raytheon rectifier, one year ago.

The constants covering Figure 1 are:

- R.—Ward Leonard 5000 ohms.
- R.—Federal No. 25 Potentiometer.
- R.—Ward Leonard 3000 ohms.
- R.—Clarostat.
- R.—Bradleyohm No. 10.
- R.—10,000 ohm fixed resistor.
- R. & R.—General Radio No. 141 Potentiometers.
- C. & C.—0.1 mfd. condensers.
- C.—4 mfd. condenser.
- C.—4 mfd. condenser.

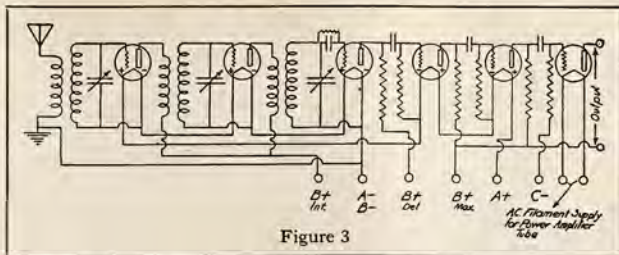

Figure 3

- C.—6 mfd. condenser.
- C<sub>1</sub>, C<sub>2</sub> & C<sub>3</sub>—1 mfd. condensers.
- A—0 to 75 m. a. milliammeter.
- L—25 henries at 85 m. a., d. c.
- T—Thordarson Transformer supplying 350 volts per anode.
- T—Thordarson Transformer supplying 5 volts at 1/2 ampere.

**Converting Station 9BHX to Crystal Control Set**

(Continued from page 32)

the plate circuit by means of a discarded audio transformer, any ratio seems to do.

**Receiver Coils**

IN winding coils for the receiver, these are wound on a blank, threaded, Silver-Marshall coil form of the plug in variety. We wound the secondary double spaced, and the tickler winding single, as is evident from a look at the picture on page 28. For the secondary we used a Cardwell 191-E taper plate with a minimum capacity of 5 picofarads and a maximum capacity of .000075 microfarads. For the regenerative condenser we used one of the new Silver-Marshall type made especially for short wave work. Antenna coupling is capacitive instead of inductive, because with our constant changing of antennas we found the capacity coupling easier. The secondary of the coil for the American band is wound with 13 turns of No. 28DCC double spaced. The tickler winding is 10 turns, single spaced. With this coil and the Cardwell condenser shown, with a UV199 tube, our range was from about 6900 to 7900 kc. Station 4BY on 6960 kc was found at 20 degrees on a National vernier dial (dual range) while WIZ on 6970 kc was found at 87, giving practically 67 degrees for tuning over the American 40 meter band, which made

it admirable for handling traffic. For short wave broadcast work such narrow limits are not required.

Parts used in the transmitter shown in Figure 3, and the receiver shown in Figure 4-B are shown elsewhere in this article. The resistance R3, in Figure 4B and 4C was 25,000 ohms and was used instead of a RF choke coil since it was found to be free from a period of its own, which is generally not the case with the RF choke coil.

We would be glad to hear from other amateurs who have had experience with either the foregoing arrangement or a similar one. The station is now using two crystals, one on 42.21 meters and the other on 40.52. The latter is generally used for traffic.

The wavemeter described by F. H. Schnell in the September issue of RADIO AGE is exceedingly handy for use in connection with a transmitter, while the grid meter driver written up by W. H. Hoffman in the same issue will also repay its builder for the trouble because of the number of stunts that may be performed with it. The wavemeter, resonance type such as was described by the writer in the August blueprint section was used to pick up the fundamental as well as the second harmonic of the crystal.

Minimum number of meters required: one good wavemeter; one DC milliammeter 0 to 500 mills. With these two you can get started, but with more meters you will have to do less guessing. If using only the 0-500 mills meter then use it in series with the negative B so it will register for all circuits. With the frequency doubler and the power amplifier off you can find the crystal dip.



## TRY SELECTONE TRANSFORMERS AT OUR RISK!



DESIGNED BY E. H. SCOTT  
whose famous receiver—The World's Record Super 9—established new world records for consistent reception of stations located 5,000 or more miles distant.

### SELECTONE FEATURES

**Patented Transformer**—Rigid—has especially designed closed iron core, which limits inductive coupling and is impregnated in a vacuum so that all characteristics of coil remain constant. The coil design gives an extremely high amplification.

**Tuned Stage Transformer**—Rigid—has air core. Each transformer is matched to within one turn before being in use. The matching of these filters is so perfect that where extreme selectivity is desired, two can be used and are guaranteed to match perfectly. This is an exclusive SELECTONE feature.

Either 199 or 201A Tubes Can Be Used

No potentiometers are needed to stabilize these transformers. They can be used in any circuit requiring a long wave transformer. Selectones are so extremely efficient that they are guaranteed to give improved results. If your present receiver is not getting results, or has poor tone quality, replace the long wave unit with Selectone. You will be amazed at the improvement.

### GUARANTEED

We guarantee that SELECTONES will improve the performance of any receiver using Long Wave Transformers. Try them in your set. If they do not prove far superior to any transformer you have ever used, return them, and your money will be refunded in full. Price each \$6.00.

Responsible Distributors—Desirable territories still available. Write or wire today.

Johbers and Dealers—See your Distributor or write direct. 2012 N. W. 25th St., P. O. Box 127, P. O. Distributors: Chicago Territory—Electrical Sales Co., 8, S. Clinton St., Chicago; New England States—Electrical Sales Co., 263 Franklin St., Boston, Mass.

### SCOTT TRANSFORMER CO.

9 S. CLINTON ST. CHICAGO, ILL.

## Bradleystat

PERFECT FILAMENT CONTROL



Provides complete noiseless filament control for all radio tubes without change of connections. Metal parts are nickel plated. One hole mounting. Self contained switch opens battery circuit when desired.

Allen-Bradley Co.

Electric Controlling Apparatus

289 Springfield Avenue Milwaukee, Wis.

## Radio to Control 11,000 Miles of Railroad Trackage

(Continued from page 16)

1805 fixed condensers (.002 mfd. 5000 volts).

C-5 C-6 Faradon model T fixed condensers (.00250 mfd.).

C-7. Fixed condenser (.25 to .5 mfd.) 1000 volts.

R. Grid leak Ward-Leonard 5000 ohms (100 watts).

K. Key-Western Union or Mesco.

M. A. Jewell Pattern 54 flush mounting 0-1000 (D. C.) (milliammeter).

V. Jewell Pattern 74 flush mounting 0-15 (A. C.) volt meter 60 cycles.

R. F. C. 1 R. F. C. 2 Radio frequency chokes, 90 turns of No. 22 D. C. C. wire wound on a form  $1\frac{1}{2}$ " diameter—winding space 3".

R. F. C. 3 R. F. C. 4 Radio frequency chokes (grid). 12 turns No. 22 D. C. C. wire wound on a form  $1\frac{1}{2}$ " diameter.

T. F. Thordarson 150 watt filament transformer. Primary 110 volts, 60 cycles; secondary, 12 volts, center tap at 6 volts.

T. P. Thordarson 1000 watt plate transformer. Primary 110 volts, 60 cycles; secondary two windings, each of 3000 volts, tapped at 1000, 1500, 2000 and 2500 volts. Built to specifications if not available from stock.

## KYW on Crystal Control For Last Thirty Days

DEVELOPMENTAL work on the conversion of KYW, Westinghouse station at Chicago, to direct crystal control, as exclusively reported in Radio Age for September, has now been completed and the station is running at full output rating under crystal control.

This gives Chicago the only directly crystal controlled transmitter West of the Alleghenies, and is a step in the same direction which all stations must eventually take in order to guarantee their frequency stability. Many Chicago stations, however, are using crystal control oscillators as a means of checking their emitted frequency and holding it to a standard.



## PRODUCTS AS DESCRIBED IN THIS ISSUE.



N.C.T.  
ADJUST-  
MENT!



Patented

## 8,000 MILE RECORD

The Quali-Tone Loop pictured above holds two World's Records for distant reception, having brought in stations 8,000 miles away. Write for verification of these records. Exclusive Thumbcrew Adjustment keeps wires taut always. Guaranteed to improve the reception of any receiver.

Price \$10

## Quali-Tone No. 4



Quali-Tone Speakers are unequalled for purity of tone and volume. Made in four artistic models priced from \$7.50 to \$25. Illustrated literature sent upon request. Quali-Tone Radio Units \$6.00 and \$7.50.

DEALERS Write for discounts. JOBBERS Send for circulars.

DURO METAL PRODUCTS CO.  
2653 North Kildare Avenue, Chicago

## NEW STATIC ELIMINATOR

Smith underground aerial reduces static and interference. Enjoy radio all the year. Recommended by authorities as the best. Very easy to install. No tools or soldering required. To be used with any set. Does away with outside aerial. Price \$6.75 delivered. Write Smith's Lab., 676 Euclid Ave., Beaumont, Tex.

## WORLD'S RECORD SUPER 9

All parts in stock. Write for our wholesale prices.

THOR RADIO MFG. CO.  
319 CRILLY BLDG. CHICAGO, ILL.



# Uncle Sam Chats with His Dairymen

## *Radio Is a Potential Force in Farm Education*

By MILTON S. EISENHOWER

EVERY American school kid knows and loves the story of the canvas-covered prairie schooners of the '50's. He has seen "The Covered Wagon" and he has read "North of 36." The attacks of Indians, of renegade bands, the fury of forest and prairie fires have been re-enacted in thousands of corn fields, back yards, and haymows. The American youngster finds in this history his greatest romance—a mental picture of the days of brawn's triumph over nature, wild men, and wild animals. But there is one phase of that romance which the boy or the girl does not picture; it is the fact that the first characteristic of the American farmer was developed while he fought to hold his staked claim—the characteristic of individual action. When Indians attacked, there were no telegraphs nor telephones to use to call neighbors or national guardsmen. When fire swept across his land, he had to fight it as best he could, for no help was at hand.

Similarly, as obstacle after obstacle was overcome, the farmer had no one to aid him in choosing the crops that were to be planted on a particular piece of land. There was no scientist to analyze the soil and designate whether alfalfa or sweet clover would bring greater returns. Pure-bred cattle were practically unknown. Therefore the characteristic of individual judgment and action became paramount with the men who struggled to maintain themselves on the land.

During those pioneer days, the brawny men of the soil could have been saved months of labor—valuable energy—if they had had the modern equipment of today. Moreover, if the knowledge which every American farmer possesses now had been available, thousands of struggling men and women might have been saved a needless migration from land

which could have been made productive.

Today, the layman believes that the great agricultural colleges, the numerous agricultural experiment stations, and the

"Radio, the newest of inventions, is proving of great and increasing usefulness to agriculture, the oldest of the occupations of civilized man. Not only is it supplying accurate information in time for the farmer to use it, but it is giving the rest of the population an understanding of the problems and needs of farming. Everywhere farming and the farmer need clear-headed sympathetic understanding on the part of the population as a whole. Nowhere in the world can we have a permanently prosperous civilization, if agriculture is unsuccessful and rural life unsatisfactory.

"In our complex modern life, all groups in the population must in the last analysis stand or fall together. Cooperation, not conflict, is essential to steady progress. I am confident that all elements in the population will cooperate for the permanent betterment of agriculture, once they understand what is necessary.

"To this end the radio will contribute much. This may be made a potent means of stimulating understanding, good-will and cooperation."—W. M. JARDINE, Secretary of Agriculture.

many valuable farm publications have solved all the problems which thousands of pioneers did not know how to meet. It is certainly true that many bad farming practices have been changed under scientific instruction; but many major problems still remain to be solved. These problems, such as better cooperative marketing, improved crop rotations, more judicious use of fertilizers, replacement of scrub stock with pure-breds, better farm management, etc., are chiefly a question of getting pertinent, timely facts to the men who are operating America's basic industry. They are being

slowly solved by a steady tap, tap, tap of sound facts from various sources.

There is no group in America today more eager for up-to-date scientific information than the farmers themselves. Overflowing agricultural colleges in every section of the United States are ample proof of that. But the dissemination of valuable scientific information to a great mass of people is no easy task; even with the young men and women securing instruction in the agricultural colleges, with the telephone and telegraph, the newspapers and farm magazines, there remains a gap to be filled. This gap requires the instantaneous and simultaneous dissemination of up-to-the-minute farm information to every corner of this vast country.

### Largest Class Room

RADIO has proved to be the "missing link" in the chain of media that are used to send timely information to farmers. Today the largest classroom in the world is the United States. Within its forty-eight states are scattered comfortable seats and desks at which the pupils sit. Some are in overalls, aprons; others, in business suits, are smoking their evening cigars. There are only two things in common among the individuals who represent the largest single class of students ever assembled for self improvement—their curiosity for knowledge and their proximity to a radio set.

A few developments during the past week have proved beyond all doubt that the radio is taking its place along with other agencies as a potential power in education. The State of Connecticut has decided that all of its rural schools should be equipped with radios; the instruments will be installed this fall, loud speakers will be installed in every room, and the in-





W. V. Morris, near McCollum, Georgia, new at the farming business, says that he depends largely upon radio talks for guidance. He owns a 1-tube set

struments will be used as a regular feature in the educational development of the rural students of that state. Agricultural programs, prepared by the United States Department of Agriculture, will be one of the main features stressed.

Every school in the city of Atlanta, Georgia, will be equipped this fall with radio sets and loud speakers will be placed in all the rooms. Special programs will be given by the best talent of the southeast, and included in those programs will be the dramatization of interesting, important agricultural material.

In the State of Arkansas is seen a development which will undoubtedly serve as a model to other agricultural sections in disseminating information to our rural population. E. D. Mathews, Director of Vocational Education, Little Rock, Arkansas, is working in connection with G. C. Arnoux, announcer for station KTHS at Hot Springs, on the dramatization of agricultural programs sent out by the Department of Agriculture. These two enthusiasts have worked out a system of rural adult schools and to date there are 112 of these schools organized in the state. Each teacher of vocational education under Mr. Mathews' direction has been supplied with up-to-date radio equipment; these teachers will call together the

farmers in their respective territories and all will gather together to hear agricultural programs when the National Radio Farm School begins in October. Mr. Mathews and Mr. Arnoux have experimented with the dramatization of agricultural programs and they have found that such a feature is one of the most popular ever sent out from station KTHS.

As a matter of fact, all of the agricultural radio programs sent out from Washington, D. C., have passed the stage of the conventional lecture—the material now

lends itself to dramatization and broadcasting stations are prepared to use special talent in putting before the microphones educational, popularized material.

I have pointed out that in the past farming, as a life, has been somewhat handicapped because of the fact that instantaneous communication with various sections of the country was impossible; I believe the foregoing facts make it obvious that radio is indeed the "missing link." I would like to show you just how the radio is benefiting one group of American agriculturists—the dairymen.

#### Radio Saves Money

**B**ACK in 1923 the radio fans at Kansas State Agricultural College decided that the dairy farmer would be keenly interested in information which would help him in his business. So they commenced giving it to him. Scores of letters poured in to Sam Pickard, now Chief of Radio for the U. S. Department of Agriculture and then director of the Kansas Station. A typical letter was received from K. C. Kough, Scott City, Kansas, who said, "Your advice saved me the loss of five milk cows. Two cows died before I heard your lecture, but I saved the other five as a result of your information." Imagine that—the one saving would pay for a dozen radio sets!



Mrs. Sam Goodwin, just east of West Point, Alabama, says she wouldn't take a gold guinea for her set, and attributes her success with poultry to the many fine pointers heard over the air





Twenty-five years ago this western Kansas farm of the Kuhrt family was a barren plain. 1901 marked the purchase of cream separator and the turning from wheat to general farming. It was then that prosperity smiled on the Kuhrt ranch. Today the most modern equipment of dairymen in Kansas and other states is the radio. This article tells what the Department of Agriculture is trying to do for American dairymen

When the Department of Agriculture began its radio service, it took the tip from Kansas and instituted a national classroom for dairymen. Immediately thousands of letters commenced pouring in from these agriculturists in every section of the country, and those questions touched on every possible phase of the dairy industry. A dairyman in Nebraska asked, "I have bran corn and cob meal, and whole oats in my grain mixture to go with alfalfa and corn silage. Should I grind the oats also?" The Department did not confine its answer to that one farmer, nor to a small group of farmers, as would have to be done by any other agency than radio; the Department told the entire nation: "By all means grind the oats. You are losing a large part of the feeding value by feeding it whole. This is true of all whole grain feed for dairy cows. Oats may be either ground or crushed. Your grinder can, no doubt, be set to grind the oats as well as the corn."

A Missouri dairyman wrote, saying, "I have some complaint about silage flavor in milk. How can it be prevented?" and the Department replied, via radio, "Feed silage immediately after, instead of previous to or during

milking. While milk will absorb some silage taint from the air, by far the greatest amount comes through the body of the cow; and



A typical hill country farm house in the Ozarks of Arkansas. Forty miles from a railroad, the George Page family find radio a great source of joy

it passes into the milk in an incredibly short time. By feeding silage after milking, the substance causing the silage flavor and odor is thrown off from the cow's body before the next milking. Never feed moldy or decayed silage."

From Illinois came the question, "How much roughage should cows be fed?" The Department replied "Feed all the roughage a cow will eat, including liberal quantities of some succulent feed like silage or root crops."

The vital interest shown by American dairymen in radio and its benefits drove home to officials of the Department that an enlarged program was being demanded by the farmers themselves. Consequently Mr. Pickard and his associates drew up a tentative program and submitted it to broadcasting stations. Over 100 station directors requested this service, so beginning in October the following dairy program may be heard in every section of the United States: Beginning October 8, and continuing for eight weeks: Dairy Herd Selection and Improvement; Production of Good Milk; beginning December 3: Feeding of Dairy Cattle; and Marketing Dairy Products on the Farm; beginning January 28: Dairy Buildings and Equipment; Problems in Dairy Cattle Breeding; beginning March 25: Common Diseases of Dairy Cattle; Dairy Herd Management.

It is obvious that such an inclusive program will touch on





Horns  
\$22.50-\$25.00

Units  
\$10.00-\$12.00

**DOUBLE ENJOYMENT**  
From your set with

**Burns**

**LOUD SPEAKER**  
Volume with Perfect Tone

Why sacrifice the excellent work of the set by using an inferior speaker? A BURNS will reproduce with pleasing exactness every tone and sound that the set can pick up.

At your dealers or direct.

American Electric Company

STATE AND 64TH STREETS  
CHICAGO, U. S. A.  
Ask about Burns "B" Eliminator

## The Biggest Dollar's Worth in RADIO



514 PAGES

Compiled by  
HARRY F. DART,  
E.E.Formerly with the  
Western Electric Co.,  
and U. S. Army In-  
structor of Radio.  
Technically edited by  
F. H. Dossie

NO MORE need you turn from book to book, hoping to find what you want. It is all here, in 514 pages crammed full of every possible radio detail. Written in plain language, by engineers for laymen. More than 100,000 sold.

IT EXPLAINS: Electrical terms and circuits, antennas, batteries, generators and motors, electron (vacuum) tubes, many receiving hook-ups, radio and audio frequency amplification, broadcast and commercial transmitters and receivers, super-regeneration, codes, etc.

Send \$1 today and get this 514-page I. C. S. Radio Handbook—the biggest value in radio today.

International Correspondence Schools

Box 2784-E, Scranton, Penna.

I enclose One Dollar. Please send me—post-paid—the 514-page I. C. S. Radio Handbook. It is understood that if I am not entirely satisfied I may return this book within five days and you will refund my money.

Name \_\_\_\_\_

Address \_\_\_\_\_  
Check here  and enclose \$1.50 if you wish the  
de luxe edition, bound in Leatheroid.

every question that is vital to the dairyman. All topics will not be of value to all farmers who are interested in the dairy industry; but there is a potential helping hand for every American dairyman contained in a million farmer-owned radio sets.

### Farmers Like It

RECENTLY the Department sent out a million enrollment cards, on which the courses in dairy, poultry, and livestock were outlined. Almost without exception these cards are being returned with a number of the dairy courses checked. This is ample proof that farmers are awake to the value of radio in their daily schedule.

I could cite many specific cases which vividly tell of the benefits secured by farmers from the radio farm programs. I believe that one more, however, will adequately picture the type of work the Department is undertaking. A farmer in Alabama wrote to the Department, boasting that he was making a good profit from a group of scrub dairy cows. The county agent was instructed to investigate the situation in order that the complete records would be on file, and the county agent found that the farmer was actually losing money on those scrub cows but was making fairly good returns by dragging county roads in his neighborhood. The farmer was induced to commence replacing his scrub cows with pure-bred stock in order that his business could be put on a money-making basis; at the same time he was advised to take the radio course in Dairy Herd Management in order that he could tell accurately how his business stood at all times.

The radio service works in close connection with the county agents who are stationed in all of the forty-eight states. Certain information that is given by radio must be followed up by intensive demonstration on the part of the agents, and in many cases the county agents send in pertinent questions which farmers in their respective territories desire to have answered. The work of the county agent is, of course, extremely important and cannot

be replaced; radio must work in cooperation with those men who have close contacts with the farmers. But radio has one outstanding element which no other agency can hold before the farmers. It has made greater strides towards a position of a farm necessity than has any other piece of machinery, educational force, or idea during the past century. Unquestionably, the radio will stay with the farmer.



**SM** **630**

**Shielded Six**

THE Shielded Six is one of the highest types of broadcast receivers. It embodies complete shielding of all radio frequency and detector circuits. The quality of reproduction is real—true to the ear.

Behind the Shielded Six is competent engineering. Day in and day out it will get distance—on the speaker. Local stations in the most crowded area separate completely—yet there are but two dials to tune. These features—its all metal chassis and panel, its ease of assembly and many others, put it in the small class of ultra-fine factory-built sets, priced at several times the Six's cost.

The S-M 630 Shielded Six Kit—including all specified matched and measured parts—price \$95.00.

The 633 Shielded Six Essential Kit contains four condensers, four radio frequency transformers, four coil sockets, four stage shields and the link motion—all factory matched—price \$45.00.

Clear and complete instructions, prepared by S-M engineers, go with each kit—or will be mailed separately for 50c.

**635 SHORT WAVE KIT**

Contains the carefully designed and matched essentials for a real short wave set. Its range is 18 to 150 meters. The kit contains 4 plug-in coils, 1 coil socket, 1 coupling condenser and two 140 mmf. condensers—all carefully designed for operation together. With the four coils, the amateur bands fall well to the center of the tuning scale—and "dead spots" are totally eliminated. The antenna condenser allows coupling adjustment to suit individual conditions. Price \$23.00.

**SILVER-MARSHALL, INC.**  
850 W. Jackson Blvd.  
Chicago, U. S. A.





# Pick-ups and Hook-ups by our Readers



Conducted by F. A. Hill

THE material appearing under the title "Pickups and Hookups by Our Readers" in RADIO AGE, is contributed by our readers. It is a department wherein our readers exchange views on various circuits and the construction and operation thereof. Many times our readers disagree on technical points, and it should be understood that RADIO AGE is not responsible for the views presented herein by contributors, but publishes the letters and drawings merely as a means of permitting the fans to know what the other fellow is doing and thinking.

**S**HORT wave receivers have been used for many purposes other than reception, but it remained for H. F. Bloom, 18 Chestnut St., Stoneham, Mass., to catalog another useful occupation for the short wave set. He built one from the April issue of RADIO AGE, logged all the U. S. districts and a Frenchman. Then he found he could hear the neighbor's telephone conversations by listening on his own set. He has not told us any of the DX he got from the neighbor's phone but we will award him the DT button anyway.

**O**N this page is shown the transmitter, receiver and inside of the radio shack of Station 7AIB, owned by Herman F. Helgesen, at Port Angeles, Washington, one of the many stations with whom 9BHX has maintained communication. The transmitter uses a DeForest H tube; with Hartley circuit; plate supply 1100 volts rectified by 24 jar chemical rectifier with the old reliable borax solution. Antenna current of a half ampere is secured, using the third harmonic of the antenna system. The transmitter panel at the right has all parts mounted behind, with the electrolytic rectifier beneath the table. The receiver, left, is a Reinartz with a single stage of amplification. The antenna is 93 feet long, one wire, 33 feet high at one end and 53 feet at the other. The counterpoise is 90 feet long, single wire, and is 9 feet above the ground. Helgesen uses a breakin system by means of a 90 foot single wire at right angles to the transmitting antenna, and reports good results thereby in handling traffic.

**O**NE of our old readers who has been twisting dials for some time all over the world, W. H. Shorter, writes telling us he is returning to England to locate at 39 Walton Road, East Molesey, Surrey, England. After having been on this side of the globe for some time we believe our DT's will be curious to know what luck he has in picking up the American stations from abroad throughout the year.

**B**BROADCAST listeners who desire to get good code practice should tune in WIZ on 43.02 meters who seems to work 24 hours a day, except Sunday night. This station, belonging to the Radio Corporation and handling trans-Atlantic traffic, generally uses a tape transmitter. The matter is therefore very clean cut and easily readable. The speed is anything from 18 to 40 or more words per minute, depending

upon the amount of traffic to be handled and the weather conditions on the Atlantic lanes.

**U**SING his L-2 Ultradyne, George S. Everhart, P. O. Box 105, Macatawa, Mich., sends in a list of 101 stations logged since June 21 of this year. He has such good reception conditions there he brings in WJZ, KDKA and WCCO without antenna, loop or ground, and gets them on the loudspeaker, too! Sure, you rate a DT button!

**B**BROADCASTING station call letters with something significant or distinctive attached thereto, have become more of an obsession than we ever expected. Witness the latest change in the call letters of the Atlantic Automobile Co.'s station KFLZ, at Anita, Iowa, now broadcasting under the call KICK. Tie that!



# The "Passing of By-Pass" Condensers



Dubilier Condenser Type 907  
Capacities 0.1 to 2.0 mids.  
Price \$0.60 to \$1.75 |

"By-Pass" was the name originally given to small paper condensers by Dubilier. This name described their functions—such as shunting radio frequency currents around high resistances, and their use in amplifier circuits.

But now the clumsy old "By-Pass" condenser is out of date. The high voltages used in radio today along with sub-panel construction, demand a condenser of higher electrical efficiency and more compact size.

In the new Type 907, Dubilier has made a compact all-purpose condenser with a *working voltage*\* of 160 volts D. C. With improved soldering lug terminals and mounting feet, Type 907 will give more efficient service in smaller space for every purpose for which the old "By-Pass" type of condenser has been used.

For long life at high voltages insist on Dubilier Paper Condensers.

## Dubilier

CONDENSER AND RADIO CORPORATION

\*Working voltage means more than "test voltage." It is the voltage at which a condenser may be safely used in continuous operation.

ONE of our recent visitors at the RADIO AGE laboratory was C. J. Bolger, 822 West 6th St., Topeka, Kans., who is very much interested in the conversion of a low power transmitter to crystal control. While there, Mr. Bolger had a chance to examine the transmitter described in this issue's blueprint section and feels he will shortly have one of his own in Topeka.

TWO pictures of Station 6BXC, belonging to Harold H. Day, 1661 Grover St., Los Angeles, Calif., are shown on page 42. In the lower one Mr. Day himself is shown at the key, while the upper picture shows the transmitter on the right. This is another of the American amateur stations that is filling the air with a good signal, having worked Zedders and Frenchies as cards on the wall show.

THOSE who can seldom see any difference in the amount of static on the different wave bands used in radio should fix up their receiver *a la* plug in and make a rapid comparison between the 40, 80, 120, 250 and 550 meter bands. One night particularly we noted static terrific on 80 meters and yet on 40 you could hardly notice it. The same night static on the 250-550 meter bands was very slight. While this pattern does not always hold true nevertheless it is interesting during the evening to go up and down the band to see which channel carries the heaviest load of static.

## 9BHX TRANSMISSION

During the month of August 9BHX (42.21 and 40.52 crystal control) reports communication with the following stations:

WVZ	6BXC
8HR	2ASQ
3EE	2AQW
9MO	4BY
4AV	5PH





# 7 Tube Set Single Dial Radio

**30  
DAYS  
FREE  
TRIAL**

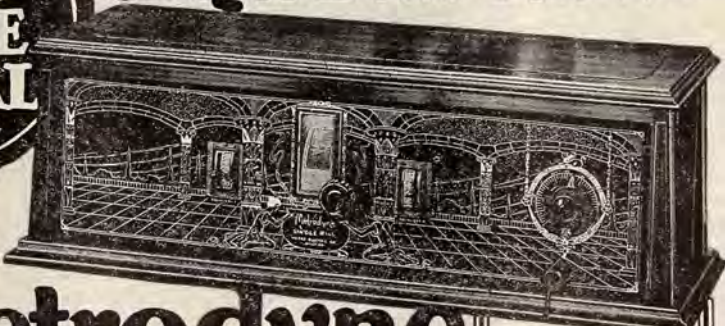

## The Metrodyne

**ONLY ONE DIAL TO TUNE**

**Retail Price**  
**\$75**  
**Completely Assembled**  
**Big Discounts to Agents and Dealers**

Wonderful offer direct from the factory! The world's greatest radio. A perfect working, single dial control, 7 tube receiver. And just to prove our claims, we will ship it to your home for **30 days' free trial**. Test it under all conditions. Test it for distance, volume and tonal quality — and if you are not convinced that it is the best single dial set you ever heard, return it to the factory. We don't want your money unless you are completely satisfied.

**BIG PROFITS TO AGENTS AND DEALERS**

Our Agents and Dealers make big money selling Metrodyne Sets. You can work all or part time. Demonstrate the superiority of Metrodynes right in your home. Metrodyne Radios have no competition. Lowest wholesale prices. Demonstrating set on 30 days' free trial. Greatest money-making opportunity. Send coupon below—or a letter—for our agent's proposition.

### Metrodyne Super-Seven Radio

A single dial control, 7 tube, tuned radio frequency set. Approved by America's leading radio engineers. Designed and built by radio experts. Only the highest quality low loss parts are used. Magnificent, two-tone walnut cabinet. Artistically gilded genuine Bakelite panel, nickelled piano hinge and cover support. All exposed metal parts are beautifully finished in 24-k gold.

Easiest set to operate. Only one small knob tunes in all stations. The dial is electrically lighted so that you can log stations in the dark. The volume control regulates the reception from a faint whisper to thunderous volume, 1,000 to 3,000 miles on loud speaker! The Metrodyne Super-Seven is a beautiful and efficient receiver, and we are so sure that you will be delighted with it, that we make this liberal **30 days' free trial offer**. You will be the judge.

**Mail COUPON Below!**

**Let us send you proof of Metrodyne quality**

F. L. Warnock, Greentown, Ind., writes: "I received the Metrodyne in good shape and am more than pleased with it. Got stations 2,000 miles away."

C. J. Walker, Mariposa, Calif., writes: "Received my Metrodyne Single Dial set O. K. I believe that these one-dial sets are going to be excellent sellers. I had no trouble in tuning in stations enough to satisfy anyone, so you will please send me another set."

Roy Bloch, San Francisco, Calif., writes: "Very often we travel from New York to the Hawaiian Islands quickly—from station to station—by means of the little turner-knob which operates the electrically-lighted dial. The Metrodyne Single Dial Set is much easier to operate than any radio set I've ever seen."

We will send you hundreds of similar letters from owners who acclaim the Metrodyne as the greatest radio set in the world. A postal, letter or the coupon brings complete information, testimonials, wholesale prices, and our liberal **30 days' free trial offer**.

-----

**METRO ELECTRIC COMPANY**  
2161-71 N. California Ave., Dept. 117  
Chicago, Illinois

Gentlemen:

Send me full particulars about Metrodyne 6 tube and 7 tube sets and your **30 days' free trial offer**

Name \_\_\_\_\_

Address \_\_\_\_\_

\_\_\_\_\_

If you are interested in AGENT'S proposition, place an "X" in the square



**30 Days' FREE Trial**

**6 Tube Set**  
**\$48.50**  
**RETAIL PRICE**  
**Completely Assembled**

### Metrodyne Super-Six

Another triumph in radio. Here's the new 1927 model Metrodyne 6 tube long distance tuned radio frequency receiving set. Approved by leading radio engineers of America. Highest grade low loss parts, completely assembled in a beautiful walnut cabinet. Easy to operate. Dials easily logged. Tune in your favorite station instantly on same dial readings every time. No guessing.

Mr. Howard, of Chicago, said: "While five Chicago broadcasting stations were on the air, I tuned in seventeen out-of-town stations, including New York and San Francisco, on my loud speaker horn, very loud and clear, as though they were all in Chicago."

We are one of the pioneers of radio. The success of Metrodyne sets is due to our liberal **30 days' free trial offer**, which gives you the opportunity of trying before buying.

**MAIL THIS COUPON**   
or send a postal or letter. Get our proposition before buying a radio. Deal direct with manufacturer—**Save Money.**

**METRO ELECTRIC COMPANY**  
2161-71 N. California Ave. • Dept. 117 • Chicago, Illinois



# WITH THE MANUFACTURERS



## Upright Resistor Mounting Issued



**I**NTERNATIONAL Resistance Company's new type upright resistor mounting base illustrated above will perhaps be of interest to readers of RADIO AGE.

This unit is made of very high test insulation moulding and is designed to accommodate the standard size fixed and grid resistor as well as to accommodate a standard type of grid condenser.

It is thought that an upright mounting of this type would be of advantage to manufacturers and set builders in the conservation of space in assembly.

## Radio Industry Does Not Care for Czar

**R**ADIO manufacturers through their association gave a definite "No" to the proposal that a czar be appointed for the radio industry at a meeting recently held.

A. T. Haugh, president of the association characterized recent published reports of chaos in broadcasting as the work of publicity seekers and expressed the opinion that the situation is well in hand.

The board voted disapproval of international Radio Week. The association, it was explained, will no longer sponsor or support the overseas radio tests, because of poor results.

## New West Coast Sales Company

**A** NEW manufacturers' agency, the Western States Sales Company, Inc., has recently been formed for the purpose of actively and completely representing manufacturers on the Pacific Coast whose sales in this territory have heretofore not been fully realized.

The members of the new organization are: B. R. Hassler, president; George J. Lane, vice-president; and E. W. Kennard, secretary and treasurer. Mr. Hassler was for the past three years general sales manager of the Colin B. Kennedy Corporation, St. Louis, and for two years prior to that time was in charge of the Kennedy Corporation's Pacific Coast sales.

Headquarters of the Western Sales Company, Inc., are at 1632 South Los Angeles Street, Los Angeles, California, with district sales offices in San Francisco and Seattle.

## High Current Resistor



Resistors shown above, made by the Tobé Deutschmann Co., are especially designed for operation with changeless characteristics, capable of carrying a larger current for B eliminators where resistances are required through which the plates of several tubes will be supplied.

In the Tobé veritas Hi-Current Resistor, designed and protected by patent applications of S. B. Allen, the resisting material is directly on the inside of the outer glass tube, and permanently united with it.

## Burns Speaker Units



**T**O produce a speaker unit which is capable of reaching the full range of the musical scale with the utmost clarity and trueness has been the aim of all speaker manufacturers. It has been the good fortune of the American Electric Company of Chicago to develop such an instrument in their Burns Hi-Lo models shown above.

## Radio Shows

Following are some of the radio shows being held during the Fall of 1926 season:

Los Angeles, Calif., Fourth annual Radio Exposition, Ambassador Auditorium, September 3 to 11, inclusive.

New York, N. Y., Third annual Radio Show, Madison Square Garden, September 13 to 18, inclusive.

Cleveland, Ohio, Second annual Radio Exposition, Municipal Auditorium, September 20 to 26, inclusive.

Chicago, Ill., Allied Radio Congress, Hotel Sherman, September 27 to October 2, inclusive.

Columbus, Ohio, Third annual Radio Show, Memorial Hall, September 28 to October 2, inclusive.

Youngstown, Ohio, First annual Radio Show, September 30 to October 2, inclusive.

Chicago, Ill., Fifth Annual



Radio Show, Coliseum, October 11 to 17, inclusive.

Indianapolis, Ind., Second annual Radio Exposition, State Fair grounds, October 25 to 30, inclusive.

Detroit, Mich., Annual Radio Show, October 25 to 31, inclusive.

### How Many Laughs Per Meter to Be Decided

HOW many laughs to the wave-length is a poser to be determined in a microphone experiment conducted by Stanley Hall over KOA, Denver.

Can the voice, unaided by acrobatic antics, in itself produce streams of chuckles and side-aching laughs?

How much of the tickling of the resiliencies of an audience is due to facial expression in telling a funny story? Is it possible that facial unsmiling can be brought into the voice so that the laugh will come 100 per cent? Broadcast listeners are asked to decide.

Formerly of the Keith and Orpheum circuits, and known from coast to coast as "the man of a million stories," Mr. Hall is chalked up for a thirty minute novelty program, "Wit and Humor of the Age," every Tuesday evening at 8:30.

His program is a cross section of wise-cracks, thrusting merrily at everything from evolution to flappers and from Irishmen to the Einstein theory, it is said.



Above is shown the Model 5 receiver made by the Apex Electric Co., Chicago, Ill. It is a five-tube set, transformer coupling, single control with illuminated dial. It is but one of the many Apex models which will be seen at the Chicago Radio Show.

### Building 9-Tube Super Brings Back Faith in This Receiver

(Continued from page 10)

volume knob up to the point where the panel voltmeter reads between 3½ and 4 volts, then rotate the oscillator dial (right) over its scale. As you increase capacity on the oscillator condenser you will begin picking up stations; hold a given setting on the oscillator, and turn the loop dial to position where signal strength is at a maximum. If further volume is required turn up volume control and turn out resistance in the modulator knob.

In tests at the laboratory using the loop and loudspeaker made by the Duro Metal Products Co., on other than a Monday night, the results were exceptionally good. Local stations were sidetracked at will and distance considered excellent for August secured. As a matter of fact the operation of this set has brought back some of the good opinion of supers which we had lost through the deluge of tuned radio frequency sets.

We will be glad to receive comments from our readers on this super and if the interest shown warrants, further super material will be printed.

Be sure to get the November number—Full of Excellent Hookup Articles.



From Atlantic to Pacific  
From Canada to South America



Registered

U. S. Pat. Off.

## TRANSFORMERS

### Have Made Finer Radio Reception Possible

THEY are no interference from powerful local broadcasting stations possible with these units. They can be used under the towers of a super power station and they still will assure selection of broadcast concerts at choice.

THEY combine tremendous power with a faithful tonal quality not obtainable with other transformers.

THEY amplify the weakest signals to the utmost loudspeaker volume.

THEY are independent of confusion in broadcast conditions.

THEY will operate with all types of standard tubes.

THEY are all that the most critical set-builder could desire, unsurpassed for quality, clarity and volume.

- No. H.210 Transformers .....\$8.00
- No. H.215 Transformer ..... 8.00
- No. F.320 Transformer ..... 8.00
- No. L.425 R.F. Choke ..... 5.50
- No. L.430 R.F. Transformer 5.50

Remember  
The Name H. F. L.  
Insist  
On H. F. L. Units

## HIGH FREQUENCY LABORATORIES

133 N. Wells Street  
Chicago Illinois





## Precision!

Scientific precision of a high order enters into the manufacture of the Durham Metallized Resistor. Noiseless and guaranteed to maintain the resistance marked on its label.

10 meg. to 500 ohms, from 50c to \$1.00

# DURHAM METALLIZED RESISTORS

INTERNATIONAL RESISTANCE CO.  
Dept. C, Perry Bldg. Philadelphia, Pa.

## PRICES CUT

**World STORAGE BATTERIES at Cost!**

**World**

### LIMITED TIME OFFER!

For a limited time only, genuine World Storage Batteries can be gotten at actual cost. Every cent of profit has been cut out in order to keep our full factory organization busy during the slack season. Prices below are lowest in history.

World Batteries are nationally known for dependable, long wearing performance. Solid Rubber Case prevents acid and leakage.

### Send No Money!

Just state battery wanted and we will ship same day order is received, by Express C. O. D. subject to examination on arrival. 5% discount for cash in full with order. Send your order now and get your World Batteries at actual manufacturing cost.

**WORLD BATTERY COMPANY**  
1215 So. Wabash Avenue Chicago, Ill.  
Dept. 36

Solid Rubber Case  
Best Batteries  
6-Volt, 100-Ampere \$1.25  
6-Volt, 120-Ampere \$1.40  
6-Volt, 140-Ampere \$1.55

Get your Radio Dial for the new 1000 to World. It's a Radio Battery Station W. R. C. Chicago. Interference free—proves every night.

### 2-Year Guarantee Bond in Writing

Approved and Listed as Standard by Leading Authorities

Including Radio News Laboratories, Popular Science Institute of Standards, Popular Radio Laboratories, Radio Broadcast Laboratories, Radio in the Home, and Leaflet, Inc.

Solid Rubber Case  
Auto Batteries  
8-Volt, 11-Plate \$10.50  
6-Volt, 11-Plate \$12.50  
12-Volt, 7-Plate \$16.50

## See and Hear Wavelength With Quartz Crystal Tube

(Please turn to page 8)

and glass vessel are unimpaired, frequency and wavelength of the transmitter to which it is adjusted. "Although the frequency may be easily calculated from the given wavelength," points out Professor Giebe, "there will be some uncertainty in this calculation on account of the uncertainty in respect of the exact velocity of light. For this reason, the exact frequency is stated, which is independent from the velocity of light. These quartz resonators, therefore, may be better designed as 'frequency standards'. By means of indirect methods capacities and self-inductions may be measured quite exactly by means of these quartz-resonators."

### Plurality of Devices

IF A TRANSMITTING station desires to operate over a slightly variable range of wavelengths, a number of resonators are used. In this plurality of devices, the resonance of each is only slightly at variance. For example, there may be an arrangement of five resonators, adjacent to each other. The middle resonator is tuned exactly to the desired wavelength, while the two resonators on the left and the two on the right of the middle resonator are tuned just a fraction higher and lower, respectively, of the latter. The sensitive gas-filled lamp is placed above these resonators, it serving a threefold purpose—indicates how to tune the transmitter; protects the resonators against excessive current; and the luminous effect tells when the transmitter is operating precisely on the desired wave length.

"Since it is practically impossible to ascertain any influence due to variations of temperature," state the inventors in explaining the behavior of the modern Aladdin lamp, "these 'frequency standards' may be regarded as being entirely independent from the temperature. The quartz-resonators in

their form as described, will respond, if excited by a voltage as low as 30 volts, but only in case the exciting voltage is within the limits of 0.1 per mille identical with the resonance frequency of the quartz.

"On account of the low tension required, the strain imposed upon the quartz-body is reduced to a minimum and the life-time of these resonators is, therefore, unlimited. In case of higher voltages the cell will also become luminescent; this luminescence, however, is solely due to a glimmering discharge between the electrodes. By means of an interposed oscillatory circuit, which is approximately tuned for the proper wave, it is easy to tune a transmitting station exactly to the prescribed wavelength. First, the coupling is made somewhat more close and any preliminary tuning is made by means of the glimmering effect. If now the coupling is made looser, the luminescence proper of the quartz will be obtained, which takes place only in case the tuning is accurate within a frequency limit less than 1 per mille."

## Bradleyleak

THE PERFECT GRID LEAK



Provides a noiseless range of grid leak resistance from 1/4 to 10 megohms. Assures most effective grid leak resistance value for all tubes. Small grid condenser (0.00025) is separate. Metal parts nickel plated. One hole mounting.

**Allen-Bradley Co.**

Electric Controlling Apparatus  
289 Greenfield Avenue Milwaukee, Wis.

## EVERYTHING IN RADIO AT BARGAIN PRICES

Just bet all the pros—1927 Radio Catalog & Guide brimful of latest ideas, newest hoodlum—all free. Shows savings as high as 50% on standard guaranteed radio parts, sets, kits. Be sure to get this directory book before you buy. It puts money in your pocket. Unusual! You'll say in when you get it. Also shows names of radio friend. Write today.

**THE BARAWIK COMPANY**  
544 Monroe St. Chicago, U. S. A.

KDKA WSBG WEAF KYW

Subscribe to Radio Age  
\$2.50 a year

Please mention Radio Age when writing to advertisers



# AERO COIL

## SUPER-SENSITIVE INDUCTANCE UNITS

*The most important factors in perfect set performance!*

### AERO TUNED RADIO FREQUENCY KIT—PRICE \$12.00



Replace your present inductance with this Aero Coil Tuned Radio Frequency Kit. It will positively improve the performance of your receiver. Special patented Aero Coil construction eliminates radio frequency losses. You will notice instantly, a tremendous improvement in volume, tone and selectivity. This kit consists of three matched units. The antenna coupler has a variable primary. Uses .00035 condenser. Coils are uniformly air spaced. No dope is used. Consequently they tune into resonance on a "knife's edge."

### FREE with Each Kit

Eight page colored blue print, actual size layout book, and complete instructions for building the super-sensitive 5-tube AERO-DYNE RECEIVER. (Extra copies, 75c each.)



This is the super-sensitive set that has caused such a sensation because of its remarkable performance and extreme selectivity under the most adverse conditions. Tunes extremely sharp. Brings in far distant stations through heaviest local broadcasting. Remarkable in tone. All in all, probably the most efficient 5-tube set thus far perfected. You should build it. It's easy with the instructions we furnish.

#### Aero Short Wave Kit



Stock No. LWT-125  
Completely Interchangeable

Adopted by experts and amateurs. Range 15 to 110 meters. Completely interchangeable. Includes 3 coils and base mounting, covering 17 S. bands 20, 40 and 80 meters. Uses .00014 condenser on secondary, and .00025 on feedback control.

Price.....\$12.50

#### Aero R. F. Regenerative Kit



Stock No.  
RFR-110

One Radio Frequency Coil and one tapped 3-circuit tuner. Makes the world's most efficient 4-tube set; uses .00035 condenser.

Price.....\$10.00

#### Aero Interchangeable Coils No. 4 and 5



Stock No.  
INT-4



Stock No.  
INT-5

Increase range of your short wave tuner by securing coil No. 4 and coil No. 5, combined range 125 to 550 meters. Both interchangeable coils fit the same Aero base supplied with the short wave kit, and uses the same condensers.

Coil No. 4—range 125 to 250 meters.....\$4.00

Coil No. 5—range 235 to 550 meters.....4.00

#### Aero Oscillator

Greatly improves the performance of the oscillator circuit of super-heterodynes, uses .0005 condenser.

Price.....\$5.50



Stock No. OS-55



#### Aero 3 Circuit Tuner

The true low-loss tuner. Variable primary, uses .00035 condenser.

Price \$6.50



Stock No. AX-45

A genuine low-loss Aero Coil antenna coupler, with variable primary. Uses .00035 condenser.

Price.....\$4.50

#### Aero Crystal Coil or Wave Trap Unit



Stock No. WT-10

Very effective because of its ideal Aero Coil characteristics. Also for crystal sets. Uses .00035 condenser.

Price.....\$4.00

Order these coils from your dealer today

## AERO PRODUCTS, INC.

Dept. 106, 1772 Wilson Ave.

Chicago, Illinois

Pacific Coast Representatives: Henger-Seltzer, 1111 Wall St., Los Angeles; 377 Brannan St., San Francisco





## THORDARSON

Power Amplification  
and  
B—Supply  
From the A. C. Line

Force a car up a steep hill and the engine knocks. Force a radio set and the quality becomes ragged and the reproduction distorted.

Faithful reproduction of the deeper bass tones requires a considerable expenditure of electrical energy,—more, in fact, than the vacuum tube of the average receiver can handle.

A power amplifier built with Thordarson transformers and chokes uses larger capacity tubes and reproduces the heavier, more vibrant tones with undistorted quality and volume.

*Operates from the light circuit B—supply for entire receiver. No controls. Requires no adjustment. Uses larger capacity tubes.*

TRANSFORMER R-198 supplies 25 V. plate and 7 1-2 V. filament for UX 210 tube.

Price \$12.00

30 HENRY CHOKE R-196, 70 M. A. capacity for filter circuits.

Price \$5.00

**Thordarson Electric  
Mfg. Co.**

500 W. Huron St., Chicago, Ill.

**Transformer Specialists Since 1895  
WORLD'S OLDEST AND LARGEST  
EXCLUSIVE TRANSFORMER MAKERS**

## What Type of Loud Speaker Should I Use?

(Continued from page 19)

covered by these instruments. If there seems to be any tendency to blasting or rattle, it is well to hear a saxophone or cornet solo, or a soprano singer. If muffling of tone is present, the speaking voice offers the best chance of comparison.)

Since the lower tones are present to a certain degree while we are using the No. 4H reproducer, we may assume that the reproduction of music by this set is fairly even over the entire musical scale, therefore we take for the next choice speaker No. 2C, whose tonal reproduction curve, as we have seen, is approximately a straight line. Upon connecting it to the set, however, we find the resulting tone to be somewhat unpleasant—what might be called "rough" or "fuzzy"—although the low tones are now brought out in their true values.

What we need, then, is a reproducer giving practically straight line response in connection with a mellow tone. Checking over our characteristics, we find that loud speaker No. 5H should "fill the bill," and, sure enough, a trial proves it to be all that could be desired.

As a final word, it should again be stated that all mental judgments of loud talker and receiver compatibility must be backed up with audible proof if the very best results are to be obtained. The value of being able to form a mental judgment is that one is enabled to come more directly to the selection of the proper speaker, and is consequently less liable to be satisfied with a combination of set and speaker that is not wholly satisfactory in the belief that—"radio can't be expected to give perfect results, anyway." That so many people are satisfied with such a weak excuse is deplorable, and is many times responsible for the condition we often find of musically sensitive people becoming disgusted with radio. These same people would all become enthusiastic fans if they only had the opportunity to hear really euphonius reproducer and receiver combinations.

## Heavy-Duty RADIOHM



for  
**Simple Control  
of B-Battery  
Eliminator**

Get full efficiency from your "B" Battery Eliminator by installing a Centralab Heavy-Duty Radiohm. Full resistance variation with a single turn of knob, allowing panel marking for proper setting to provide various voltages. *Tested and approved by the Raytheon Laboratories.*

Resistance remains permanent as adjusted (no carbon particles or discs), and remains same for any knob setting regardless of how often adjusted. Bushing and shaft insulated to withstand 1500 volts. Its smooth and noiseless operation will greatly improve your set.

\$2 at your dealer's or  
mailed direct on receipt  
of price.

Central Radio Laboratories  
24 Keefe Ave., Milwaukee, Wis.

Makers of a full line of variable resistances for 59 manufacturers of leading standard sets.

## Centralab



**6-Volt  
Storage  
Radio "A"  
Battery**

Most amazing battery value ever offered! A genuine World 6-Volt Radio "A" Battery with 25 ampere capacity for only \$5.00! Just the thing for Truck Changer, Famous World Quality assured. Equipped with

**\$5.00**  
C. O. D.  
Send No  
Money

**Solid Rubber Case**

an assurance against acid and leakage. Order Now. We ship same day—by express C. O. D. subject to your examination on arrival. Extra Offer: 5% discount for cash in full with order. ACT TODAY!

**World BATTERY CO.**  
Dept. 136  
WORLD BATTERIES 12195. Wabash Ave., Chicago

INDY • WPE • WGR • WJS • HU • KGO • KAT • WJ • KOP



# FREE

## This 84 Page Wonder Book of RADIO Bargains



Send  
for  
it  
TO-DAY

Save  
1/3 to 1/2

Send for this guide to Radio prices and Radio quality. All of our vast resources and radio experience have been utilized to assemble for you in one gigantic institution, the best and newest things in radio. The Randolph catalog is indeed the radio market place of the world—a masterpiece of merchandising that befits our house—the largest exclusive radio mail order house in the world.

### What Our Catalog Contains

Over 2,000 items—from the most beautiful, fully equipped console model radio set, down to the smallest part or tool for the set builder—kits, parts, and supplies of every conceivable type and style. All beautifully illustrated and interestingly described. And to give this book added value, we have included radio data that makes it an invaluable text book for every lover of today's most fascinating and most wonderful achievement—RADIO.

#### Radio Sets

In this great radio market place you will find table model sets and console types with built-in loud speakers; the newest amphiphonic console sets; new Spanish period consoles; five, six, seven, and eight tube sets, with three dial, two dial, and the newest and most popular single simplified control. All sets are assembled in beautiful, genuine mahogany and walnut cabinets in a choice of latest types and designs.

**5 Tube sets as low as \$24.90**  
**Latest 1927 Models**

All Randolph sets are sold at amazingly low prices. No matter what kind of set you want—no matter how little you want to pay—you can select YOUR SET AT YOUR PRICE from the Randolph catalog.

#### Radio Kits

Includes the following well known circuits, designed and approved by the world's foremost radio engineers: Madison Moore Super; Vietoren Super; Silver Marshall Six; Sargent's Infradyne; Remler Super; Short Wave Kits; 9-in-line Super; New Acme Reflex; Cockaday; Neutrodine; Browning-Drake; all classes of radio frequency, Super Heterodyne and every other approved popular circuit.

### YOU MUST HAVE THIS BOOK

Space limitations here prevent our telling you more about the Randolph Catalog. Simply fill out and mail the coupon—or you may send a postal or letter—and this truly remarkable Radio book will come to you **ABSOLUTELY FREE. MAIL THE COUPON NOW.**

**Randolph Radio Corporation**  
180 North Union Avenue • Dept. 16 • Chicago, Ill.

#### Radio Parts and Supplies

The Randolph catalog also contains a most complete line of "B" Battery Eliminators, including the famous Raytheon Eliminators; the latest type of Loud Speakers, Cone Speakers, a complete line of quality "A" power units—in fact, you will find listed in this wonder book every part that goes into the construction of a radio set, or any accessories you desire, at prices that mean a substantial saving to you.

#### Free Radio Service

Everyone has need for radio service. The average man has no time to keep up with the rapid developments of radio. We employ Radio Engineers who have made radio their life work. Their expert advice and helpful suggestions solve every radio problem of our customers.

#### Our Guarantee

Every article in our catalog is based on careful laboratory analyses and tests. We guarantee to back up every item in our catalog with our own as well as manufacturer's assurance of quality.

### Why We Save You Money

Because we handle radio exclusively and sell a tremendous volume of everything in Radio, we can concentrate our buying power for the benefit of our customers.

Volume purchases regulate prices. We command rock bottom prices from manufacturers, and in many cases we contract for entire factory output of exclusive products. You will benefit by our great volume of purchases and sales, by securing anything you may want in radio at a substantial saving.

### This Coupon Brings the Great RADIO Book FREE

RANDOLPH RADIO CORPORATION  
180 N. Union Ave., Dept. 16  
Chicago, Illinois

Send me—free—your 84-page, 1927 Radio Book.

Name

Street and No.

R. F. D.  Box

City  State



## Broadcasting and the Navy

(Continued from page 12)

apparatus, and where the public interest served by the navy's communication system permitted it, the hours of work have been so arranged that the stations remain silent, except for emergencies, between the hours of 7 and 11 p. m., local time. In special cases it has been possible to arrange further silent periods.

There are now about 300 ships of the navy using radio for constant exercise and for the conduct of the navy's and the nation's business. Most of these are in a single organization, the U. S. Fleet, the Commander in Chief of which has recently reported that the use of spark transmitters has been reduced to emergencies only and that the ships are using only the frequencies permitted them by the recommendations of the Fourth National Radio Conference.

THE navy has vigorously pushed technical research and development for the improvement of the radio situation and its efforts have been crowned with an appreciable degree of success. It was the first service to follow the amateurs in the development of high frequency (short wave) communication on a practical traffic-handling basis, reducing necessity for use of higher frequencies which cause disturbance to broadcast reception. It has devised and applied new methods of stabilizing frequency adjustment, of eliminating extraneous emissions and of suppressing harmonics. It has reduced interference to other services by reducing the time on the air to clear messages, through development of improved methods of operation and the development of competition among operators.

The Navy Department has consistently loaned a sympathetic ear to the pleas of the broadcast listener and has championed his cause where possible. All complaints received from broadcast listeners have been sympathetically received, appropriate action has been taken thereon, and in countless cases naval personnel has given direct assistance to

broadcast listeners in overcoming their individual difficulties.

In most foreign countries radio is a government monopoly, and broadcasting has been retarded not alone by what we regard as restrictive legislation and decrees, but by the actual radio activities of the governments themselves. Broadcasting in foreign countries is not given the exclusive use of the favorable band of frequencies it enjoys here, but is scattered over a wide band of frequencies impossible to cover efficiently with a single, simply constructed receiver. In many cases taxes are imposed on reception, and in some cases reception is limited to specified frequencies. Some foreign governments have opened new and powerful spark stations for marine communication, and even for point to point communication where wires or cables are available. Little or nothing has been done in most foreign countries to reduce harmonics and other interfering emissions from radiotelegraphic stations which were already in service when radio-broadcasting began.

In the United States, on the other hand, not only has the government avoided restriction on broadcasting as far as possible, but it has cleared a wide band of frequencies for exclusive use of the new service and has actively aided it by removing its own stations from this band and by requiring the removal of other radiotelegraphic stations from this band. The navy has commissioned no new spark stations since the advent of broadcasting nor has it purchased or manufactured any spark or arc apparatus since that time.

The navy is today maintaining a world wide radio service of constantly increasing efficiency, operating about 150 transmitters in about 100 stations on shore and some 900 transmitters in more than 300 vessels at sea. It is constantly effecting improvements as regards disturbances created to broadcast reception, and stands ready at any time to do all within its power to aid the radiobroadcast listener, and to further the development of what it believes to be the world's finest

broadcasting system. In return it asks nothing beyond careful consideration of all the facts and fair play on the part of the broadcast listener and the broadcast industry.

## "B" BATTERY ELIMINATOR

Only \$7.95

**MONEY-BACK GUARANTEE**  
Stop being a slave to the "B" Battery eliminator! Throw the old-fashioned cells in the ash can! Hook up a new Roll-O-Radio "B" Battery Eliminator in 20 seconds, and forget battery troubles forever. This wonderful device means better reception, clear cut sound, and more enjoyable listening. More real pleasure from your set.

**COMPLETELY EQUIPPED—NO "EXTRAS" TO BUY**  
Operates perfectly on direct or alternating current. Simple directions enclosed—anyone can plug it in to any kind of set up to six tubes. Constant voltage gives set more power without danger of burning out tubes.

**Send \$1.00**  
Order now! Don't blame your set because it won't work right. Don't blame your "B" Batteries when they don't work right. Order your Eliminator NOW. Former price \$12.95. Now cut to \$7.95. Write name and address on a piece of paper, plus a dollar bill to it, and mail it TODAY. Pay postman balance \$6.95 plus a few cents postage when he delivers your Eliminator. Use ten days. If not more than satisfied, return it and get your money back.

THE ROLL-O-RADIO CO.

Dept. 8.

Third and Sycamore Sts., Cincinnati, Ohio

**WORLD'S FINEST LOUD SPEAKER**

A three-foot cone speaker—unit developed by the inventor of the Tropadyne. Easily assembled, saving 80% of the cost. Complete Kit with blue prints sold on rigid money-back guarantee—shipped prepaid or C. O. D.—\$10.00

**ENGINEERS' SERVICE COMPANY**  
25 Church St. New York, N. Y.

**RADIO** We want to hear from hard-hitting radio dealers operating live-wire stores who want to make the best jobber connection in America.

**DEALERS**

Our eight big warehouses furnish you with the finest products in radio. And we ship fast.

**WANTED**

Write today on your letterhead for big catalog of nationally advertised lines. Ask for R 1006

**WAKEM & McLAUGHLIN, INC.**  
225 E. ILLINOIS STREET, CHICAGO, ILL.

**MAKE MONEY EVENINGS**

Let me show you how 4364 men, without experience add \$25 to \$75 weekly to their income without giving up their present position.

B. Z. FISCHER, 122 W. Austin Ave., Chicago, Ill.



RADIO FOG SIGNALS



**R**ADIO to the front again. This time in conjunction with the very familiar farm lighting plant, to perform an invaluable maritime service by providing fog signals, to be sent out from the various lighthouses in the United States.

This recent innovation in the field of the small power plant is one that is extremely important and yet is novel and unique. At most of the dangerous points in the various navigable waters of the United States, the government has installed a safe and accurate plan for determining the location of the ships by radio fog signals, operated by electrical energy, supplied by Westinghouse light and power plants.

In order to insure against failure of these fog signals the type chosen was a three hp., four cycle, single cylinder, valve in-head, air cooled engine; with a rating of 1½ kw. and for use on 110 volts. It operates at 1200 rpm. on kerosene or natural gas.

These light and power plants are now being installed at such points as the Galveston Jetty, at Galveston, Texas, San Francisco Harbor, Detroit River Lighthouse in Michigan, Cape Spencer Lighthouse, Alaska, Buffalo, N. Y., and others making up a total of forty-six in all.

**Bradleyohm-E**  
PERFECT VARIABLE RESISTOR  
for B-Eliminators



Bradleyohm-E is a new and enlarged Bradleyohm designed especially for B-Eliminator Voltage Control. The extra long columns of scientifically-treated graphite discs insure perfect voltage control over a wide range. It is made in several ranges for various B-Eliminator circuits.

**Bradleyunit-A**  
PERFECT FIXED RESISTOR

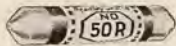

Bradleyunit-A is a solid molded resistor for radio circuits. It is molded and heat-treated under high pressure, making it impervious to moisture. The silver-capped ends can be soldered without affecting the calibration of the Bradleyunit.



Are You Building a B-Eliminator?

**I**F so, follow the example of leading radio engineers and use the Bradleyohm-E and Bradleyunit-A for your voltage control

Most of the well-known factory built B-Eliminators are equipped with Bradleyohms as standard equipment. Surely, no better recommendation of the reliability and stability of the Bradleyohm can be asked.

Build permanent performance and high efficiency into your B-Eliminator by asking your dealer for Bradleyohm-E and Bradleyunit-A for your circuit.

**Allen-Bradley Co.**

289 Greenfield Ave., MILWAUKEE, WIS.

**Free Mailing Lists**  
Will help you increase sales  
Send for FREE, catalog driving orders  
and prices on thousands of classified  
merchandise, very best prospective respon-  
ders—National, State and Local, Individ-  
uals, Professions, Business Associa-  
tions  
**99% Guaranteed 5¢ each**  
by refund of 5¢ each  
**ROSS-Gould Co.** 209 N. St. Louis

Use  
**Allen-Bradley**  
Perfect Radio Devices



# FIFTH ANNUAL CHICAGO RADIO SHOW

COLISEUM---CHICAGO  
October 11 to 17 inclusive, 1926

PRESENTED BY  
RADIO MANUFACTURERS' SHOW ASSOCIATION

U. J. HERRMANN  
[Managing Director

127 N. Dearborn St., Chicago  
1800 Times Bldg., New York City

G. CLAYTON IRWIN, JR.  
General Manager

"The World's Foremost Radio

Expositions"

"Greatest, Newest Developments Shown in Radio"



RADIO SHOW



**Silent "B" Power with World Radio Storage "B" Battery**  
Lasts Indefinitely—Pays for Itself  
Dependable. Quiet "B" power, clear without "hum."  
Economy you have never before thought possible.  
Convenience. Outstanding performance. Recharged  
for almost nothing. Solid rubber case insures against  
leakage or acid. Extra heavy glass jars. Heavy rug-  
ged plates. Approved and listed as standard by Pop.  
Laboratory, Pop. Sci. Inst., Standard, Radio News Labo-  
ratory, etc., and other Radio authorities.

Extra Office & Batteries in service (96 Voids) \$10.50.  
Send NO MONEY! Just state number of batteries  
you want and we will ship same  
day order is received. Pay expression after examining battery, 5  
per cent discount for cash with order. Send your order today—NOW!

**WORLD BATTERY COMPANY**  
1219 S. Wabash Ave. Dept. 81 Chicago, Ill.  
Makers of the Famous World Radio "A" Storage Battery.  
Prices: 6-volt, 120 Amp. \$15.00; 12-volt, 120 Amp. \$25.00; 12-volt, 240 Amp. \$45.00.  
All equipped with Solid Rubber Case.

**World STORAGE BATTERIES**  
RKO—WEAF—WGN—WJS—KJL—KGO—WJAF—WYF—KOB



Dealers Jump at this live line of radios and accessories,  
including Bremer Tully, Balkite, All American, G. E.  
Tuner, Thorol, Majestic, Utah, R. C. A. Tubes, nationally  
advertised parts, batteries, chargers, etc. Send for catalog  
and attractive dealer's proposition. Exclusive territories to  
responsible dealers. Wholesale only. Quick sales and splendid  
profits assured. Don't pass this up. Write today.

**NEW ENGLAND MILLS COMPANY**  
Distributors of Nationally Advertised Radio Glass  
Dept. 91 J 855 Washington Blvd. Chicago, Ill.

New Surface Finish  
**A** NOUNCEMENT has just  
been made of a new finish  
known as "crackle surface"  
which may now be had on hard  
rubber panels, made by the  
American Hard Rubber Co. This  
surface somewhat resembles a  
coarse grain, high grade leather.  
The surface can be engraved as  
is the case with a smooth finish  
panel yet it does not show ordi-  
nary scratches or finger marks.  
The back of the panel is pol-  
ished as usual so a choice of  
either side is available. It is  
made in the standard sizes.

Small Joins Verges  
**P** AUL SMALL, one of Amer-  
ica's most popular radio fa-  
vorites, formerly of Little &  
Small, the Radio Troubadours,  
and writer of several song hits  
of the day, has joined Joe  
Verges in a new harmony team,  
making their first radio appear-  
ance at WQJ recently.

**Free** 60-page Reference Book

**POLK'S REFERENCE BOOK FOR DIRECT MAIL ADVERTISERS**

Shows how to increase your business by the use of Direct Mail Advertising. 60 pages full of vital business facts and figures. Who, where and how many prospect you have. Over 8,000 lines of business covered.

Write for your FREE copy.

**R. L. POLK & CO., Detroit, Mich.**  
599 POLK DIRECTORY BUILDING  
Branches in principal cities of U. S.

Mailing List Catalog No. 55

**MARVELOUS NEW AUDIO TRANSFORMER** adds a musical quality to any set far beyond anything you ever heard before. **KARAS HARMONIK** Amplifier low, middle and high tones—all to the same big volume, thus eliminating distortion. Brings out the vital harmonics and overtones of music. Price \$7.00. Write Karas Electric Co., Dept. 1077, 6912 N. Rockwell St., Chicago

Please mention Radio Age when writing to advertisers



**WGN Moves Into New Studios**

**I**N PREPARATION for the unusual program of entertainment and public service it is planning for the winter, WGN, Chicago, moved recently into its recently completed studios and control room on the twelfth floor of the Drake hotel.

Products of one of the finest engineering organizations possessed by any radio station, the new studios and control room have been specially designed and constructed to meet the various needs of the swiftly moving day and night schedule of WGN. The present studio facilities have been taxed to the utmost, and when the enormous program developed for the fall and winter months came under consideration, the station officials realized they were inadequate and plans were at once drawn for new studios and a control room that would be the last word in radio engineering.

The new control room is a marvel of its kind. Four huge panels, designed under the direction of Chief Engineer Carl Meyers, and constructed by Assistant Engineer George Leverett and his staff, have numerous unique features in addition to being modern in every respect. Chief among these is the "mixer panel," permitting simultaneous broadcasting from twelve microphones. This panel will be used for productions and features where unusual blending of music is necessary.

# The CHELSEA Truphonic Six

Easily one of the real sensations of the year, the Chelsea Truphonic Six must be seen and heard to be appreciated. Built by one of the oldest radio manufacturers, noted the world over for its reliable products, this Chelsea receiver incorporates the new truphonic circuit, called the greatest radio contribution of the season. The circuit is fully shielded. Since a power tube may be used in the last stage, tremendous amplification and a tone stability wholly new is now obtained.

*Ask Your Dealer To Demonstrate This Remarkable Value  
Or Write Us Direct*

**CHELSEA RADIO CO., CHELSEA, MASS.**

Other Chelsea Sets \$26.00 and \$30.00—each a leader in its class.  
Send for details.

**\$60**



### Temperature Affects Signal Strength

**T**HAT temperature influences the strength of radio signals is the conclusion reached by L. W. Austin and Miss Wymore of the Bureau of Standards, Department of Commerce. This work is a part of the program of the International Union of Scientific Radio Telegraphy, adopted at Brussels in 1922 and carried on in the various countries belonging to the Union.

Two years ago Dr. Austin described a decided increase in the signals received at Washington from the Radio Corporation trans-Atlantic stations at Tuckerton and New Brunswick, N. J., during the passage of severe cold waves over the eastern states. Further study now indicates that whenever the temperature rises along the signal path there is a tendency for the signal to drop; and conversely, a falling temperature produces a stronger signal.

**No Noises!**

Tones clearer, voices more distinct, and volume greater with—AMPERITE. No moving parts. It brings the utmost out of each individual tube. Specified in all popular construction sets. Price \$1.10.

**Radiall Company**

Dept. R.A.-10, 50 Franklin Street, New York City

Write for  
**FREE**  
Hook-ups

**AMPERITE**  
50-4-3-PAT. OFF.

The "SELF-ADJUSTING" Rheostat



## Correct List of Broadcast Stations

KDKA	Westinghouse Electric & Mfg. Co.	EastPittsburgh, Pa.	309	KFQP	G. S. Carson, Jr.	Iowa City, Ia.	224
KDLR	Radio Electric Co.	Deviis Lake, N. D.	231	KFOU	W. Riker	Holy City, Calif.	231
KDYL	Newhouse Hotel	Salt Lake City, Utah	246	KFOW	C. F. Knierim	North Bend, Wash.	216
KFAB	Nebraska Buick Auto Co.	Lincoln, Neb.	341	KFQZ	Taft Products Co.	Hollywood, Calif.	225
KFAD	McArthur Bros. Mercantile Co.	Phoenix, Ariz.	273	KFRB	Hall Bros.	Beeville, Texas	248
KFAF	A. E. Fowler	San Jose, Calif.	217	KFRG	City of Paris Dry Goods Co.	San Francisco, Calif.	268
KFAU	Independent School Dist	Boise, Idaho	280	KFRU	Stephens College	Columbia, Mo.	500
KFBB	F. A. Buttrely & Co.	Havre, Mont.	275	KFRW	Western Broadcasting Corp.	Olyn pia, Wash.	219
KFCB	W. K. Azbill	San Diego, Calif.	216	KFSD	African Radio Corp.	San Diego, Calif.	246
KFCB	Kimball-Upson Co.	Sacramento, Calif.	248	KFSG	Echo Park Evan. Assn.	Los Angeles, Calif.	275
KFLB	Leese Bros.	Everett, Wash.	224	KFUL	Thomas Groggan & Bros. Music Co.	Galveston, Texas	258
KFBS	School District No. One	Trinidad, Colo.	238	KFUM	W. D. Corley	Colorado Springs, Colo.	239
KFBU	St. Matthews Cathedral	Laramie, Wyo.	375	KFUG	Concordia Seminary	St. Louis, Mo.	545
KFCB	Nielson Radio Supply Co.	Phoenix, Ariz.	238	KFUP	Fitzsimmons General Hospital	Denver, Colo.	234
KFDD	St. Michaels Cathedral	Boise, Idaho	275	KFUR	Peery Bldg. Co.	Ogden, Utah	224
KFDM	Magnolia Petroleum Co.	Beaumont, Texas	316	KFUS	Louis L. Sherman	Oakland, Calif.	256
KFDX	First Baptist Church	Shreveport, La.	250	KFUT	University of Utah	Salt Lake City, Utah	261
KFDY	South Dakota State College	Brookings, S. D.	306	KFUV	Colburn Radio Labs.	Oakland, Calif.	220
KFDZ	Harry O. Iverson	Minneapolis, Minn.	231	KFVW	McWhinnie Electric Co.	San Pedro, Calif.	205
KFEC	Meier & Frank Co.	Portland, Ore.	248	KFVE	Benson Broadcasting Corp.	St. Louis, Mo.	240
KFEL	Eugene P. O'Fallon, Inc.	Denver, Colo.	254	KFVG	First M. E. Church	Independence, Kans.	236
KFEQ	J. L. Scroggin	Oak, Neb.	268	KFVI	Headquarters Troop, 56th Cavalry	Houston, Texas	240
KFEY	Bunker Hill & Sullivan Min. & Con. Co.	Kellogg, Idaho	233	KFVN	Carl E. Bagley	Fairmont, Minn.	227
KFFP	First Baptist Church	Moberly, Mo.	242	KFVS	Hirsch Battery and Radio Co.	Cape Girardeau, Mo.	224
KFGO	Crary Hardware Co.	Boone, Iowa	226	KFVY	Radio Supply Co.	Albuquerque, N. M.	250
KFH	Hotel Lassen	Wichita, Kans.	268	KFWB	Warner Bros.	Hollywood, Calif.	252
KFHA	Western State College of Colo.	Gunnison, Colo.	252	KFWC	L. E. Wall	San Bernardino, Calif.	211
KFHL	Penn. College	Oskaloosa, Iowa	240	KFWF	St. Louis Truth Center	St. Louis, Mo.	214
KFI	E. C. Anthony, Inc.	Los Angeles, Calif.	468	KFWH	F. Wellington Moise, Jr.	Eureka, Calif.	254
KFIF	Benson Polytechnic Institute	Portland, Ore.	248	KFWI	Radio Entertainments, Inc.	South San Francisco, Calif.	226
KFIO	North Central High School	Spokane, Wash.	265	KFWM	Oakland Educational Society	Oakland, Calif.	207
KFIQ	First Methodist Church	Yakima, Wash.	250	KFWO	Lawrence Mott	Avalon, Calif.	211
KFIU	Alaska Electric Light & Power Co.	Juneau, Alaska	226	KFWU	Louisiana College	Pineville, La.	238
KFIZ	Daily Commonwealth	Fond du Lac, Wis.	273	KFWV	Wilbur Jerman	Portland, Ore.	213
KFJB	Marshall Electrical Co.	Marshalltown, Iowa	248	KFXB	Bertram O. Heller	Big Bear Lake, Calif.	203
KFJC	R. B. Fegan (Episcopal Church)	Junction City, Kans.	219	KFXD	Service Radio Co.	Logan, Utah	205
KFJD	National Radio Manf. Co.	Oklahoma City, Okla.	261	KFXE	Pike's Peak Broadcasting Co.	Colorado Springs, Colo.	250
KFJI	E. E. Marsh	Astoria, Ore.	246	KFXH	Bledsoe Radio Company	El Paso, Texas	242
KFJM	University of North Dakota	Grand Forks, N. D.	278	KFXJ	Mt. States Radio Dist. Inc.	Denver, Colo.	216
KFJR	Ashley C. Dixon & Son	Portland, Ore.	263	KFXR	Classen Film Finishing Co.	Oklahoma City, Okla.	214
KFJY	Tunwall Radio Co.	Fort Dodge, Iowa	246	KFXY	Mary M. Costigan	Flagstaff, Ariz.	205
KFJZ	W. E. Branch	Ft. Worth, Tex.	254	KFYF	Carl's Radio Den	Oxnard, Calif.	205
KFKA	Colo. State Teachers College	Greeley, Colo.	273	KFYJ	Chronicle Publishing Co.	Houston, Texas	238
KFKU	The University of Kansas	Lawrence, Kans.	275	KFYU	Buchanan-Vaughan Co.	Texasarkana, Tex.	210
KFKX	Westinghouse Elec. & Mfg. Co.	Hastings, Neb.	288	KFYR	Hoskens-Meyers, Inc.	Bismarck, N. Dak.	248
KFKZ	Chamber of Commerce	Kirkville, Mo.	226	KGAR	Tucson Citizen	Tucson, Ariz.	244
KFLR	University of New Mexico	Albuquerque, N. M.	254	KGBS	A. C. Dailey	Seattle, Wash.	210
KFLU	San Benito Radio Club	San Benito, Texas	236	KGBU	R. R. Thornton	Ketchikan, Alaska	229
KFLV	Swedish Evangelical Church	Rockford, Ill.	229	KGBW	Martin Brothers	Joplin, Mo.	283
KFLX	George Roy Clough	Galveston, Texas	240	KGBX	J. A. Abercrombie	St. Joseph, Mo.	348
KICK	Atlantic Automobile Co.	Anita, Ia.	273	KGBY	Albert C. Dunning	Shelby, Neb.	203
KFMR	Morningside College	Sioux City, Iowa	261	KGBZ	Federal Livestock Remedy Co.	York, Neb.	331
KFMX	Carleton College	Northfield, Minn.	337	KGCA	C. W. Greenley	Decorah, Iowa	280
KFNF	Henry Field Seed Co.	Shenandoah, Iowa	461	KGCB	Wallace Radio Institute	Oklahoma, Okla.	331
KFOA	Rhodes Department Store	Seattle, Wash.	454	KGGG	Moore Motor Co.	Newark, Ark.	234
KFOB	Chamber of Commerce	Burlingame, Calif.	226	KGGI	International Radio Co.	San Antonio, Texas	240
KFON	Echophone Radio Shop	Long Beach, Calif.	233	KGCH	Wayne Hospital	Wayne, Neb.	450
KFOO	Latter Day Saints' University	Salt Lake City, Utah	236	KGO	General Electric Co.	Oakland, Calif.	361
KFOR	David City Tire & Electric Co.	David City, Neb.	226	KGTT	Glad Tidings Tabernacle	San Francisco, Calif.	207
KFOT	College Hill Radio Club	Wichita, Kans.	231	KGU	Marion A. Mulroy	Honolulu, Hawaii	270
KFOG	Board of Education, Tech. High School	Omaha, Neb.	248	KGW	Portland Morning Oregonian	Portland, Ore.	491
KFOY	Beacon Radio Service	St. Paul, Minn.	252	KGY	St. Martins College	Lacy, Wash.	278
KFPL	C. C. Baxter	Dublin, Texas	252	KIJJ	Times-Mirror Co.	Los Angeles, Calif.	405
KFPM	The New Furniture Co.	Greenville, Texas	242	KHO	Louis Wasmer	Seattle, Wash.	394
KFPR	Los Angeles County Forestry Dept.	Los Angeles, Calif.	231	KJBS	J. Brunton & Sons	San Francisco, Calif.	220
KFPW	St. Johns M. E. Church	Cartersville, Mo.	258	KJR	Northwest Radio Service Co.	Seattle, Wash.	384
KFPY	Symons Investment Co.	Spokane, Wash.	273	KLDS	Reorganized Church	Independence, Mo.	441
KFOA	The Principia	St. Louis, Mo.	261	KLS	Warner Brothers Radio Supplies Co.	Oakland, Calif.	250
KFOB	The Searchlight Publishing Co.	Fort Worth, Texas	263	KLX	Tribune Publishing Co.	Oakland, Calif.	508
KFQD	Chovin Supply Co.	Anchorage, Alaska	227	KLZ	Reynolds Radio Co.	Denver, Colo.	266



**Effect of Northern Lights on Radio Described**

TO what extent Northern lights affect radio reception in the Arctic circle is outlined in a detailed report delivered today to Denver's General Electric broadcasting station, KOA.

The communication was written by Sgt. Frank A. Barnes of the Royal Northwest Mounted police, Coronation gulf, Northwest territories, and was seven months on the way.

"As the green and gold lights sweep across the blackened sky there is a corresponding rise and fall in radio reception," writes Sergeant Barnes. "An unusually brilliant flash of flaming red and yellow lights puts the instrument out of commission."

Sergeant Barnes also noted that howling blizzards and icy, stormy weather and the sunless months of November, December and January afford the best reception.

"No stations are received in daylight, but particularly good results are obtained during the second and third quarters of the moon," Sergeant Barnes explains.

"Some nights we receive all over the United States; other nights, all eastern stations or all western," the letter continues. "Stationed on the frozen outposts of the earth, radio is our only contact with a white man's world."

"Your programs come over to us most clearly and frequently. In four months, we have listened to your programs exactly ninety times."

**A&B Battery Charger ONLY \$2**

**SATISFACTION GUARANTEED**



Charges any type of storage A or B battery, using a few cents worth of ordinary house current, either alternating or direct. Cannot injure battery. Complete directions enclosed. Anyone can operate. No expensive "extras" to buy. Why pay

\$10.00 to \$15.00 for a charger when you can get this splendid GUARANTEED R. B. Charger by mailing us two dollars (bills, money order, check or stamps) plus ten cents in stamps or coin to pay mailing costs. Charger will be sent postpaid. If you are not satisfied, return within five days and we will refund your money. Order at once—TODAY.

**R. B. SPECIALTY COMPANY**  
Dept. X1, 308 East Third St., Cincinnati, Ohio



135-A Tip-Jack Voltmeter  
(7½ and 150 Volts)

Send for  
Circular  
No. 1015  
Describing  
The  
New Jewell  
Tip-Jack  
Voltmeter

Owners of the newer sets in which manufacturers have installed two tip-jacks on the panel, should write to us for circular No. 1015. The new Jewell tip-jack voltmeter not only has two adjustable prods, to fit varying horizontal spacing of these jacks, but the back plate can be rotated to fit sets having pin-jacks placed vertical, one above the other. It has a high resistance movement and is of the highest quality.

All tubes have a rated voltage. Don't burn them too high or too low.

**Jewell Electrical Instrument Co.**

1650 Walnut St., Chicago

"26 Years Making Good Instruments"

**"It Does the Trick!"**

-- say those who use the Cushion Base Tube.

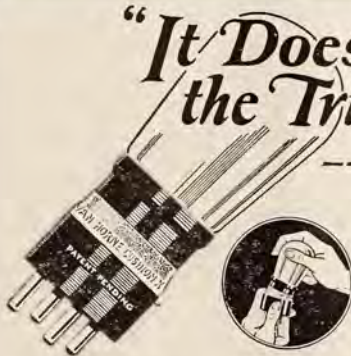

The rubber cushion absorbs vibration and eliminates microphonic noises

The Cushion Base tube is a Van Horne development manufactured only by the Van Horne Company under patents pending to J. S. Van Horne. A variety of tube types in both the Van Horne Selected and Certified brands are manufactured, all of which are unconditionally guaranteed.

THEIR use in your set will eliminate microphonic trouble—will smooth out reception—and give that fullness and clearness of tone that you have always desired.

Put a set of Cushion Base tubes in your set and note what an improvement the soft sponge rubber cushion makes.

Order a set from your dealer today.

**THE VAN HORNE COMPANY, Inc.**  
92 Center Street, FRANKLIN, OHIO



KMA	May Seed & Nursery Co.	Shenandoah, Iowa	461
KMJ	Fresno Bee	Fresno, Calif.	234
KMMJ	M. M. Johnson Co.	Clay Center, Nebr.	229
KMO	Love Electric Co.	Tacoma, Wash.	250
KMOX	Voice of St. Louis	St. Louis, Mo.	280
KMTR	Turner Radio Corp.	Los Angeles, Calif.	238
KNRC	C. B. Juneau	Los Angeles, Calif.	208
KNX	Los Angeles Evening Express	Los Angeles, Calif.	337
KOA	General Electric Co.	Denver, Colo.	322
KOAC	Oregon Agricultural College	Corvallis, Oreg.	280
KOB	N. Mex. College Ag. & Me. Arts.	State College, N. Mex.	349
KOCH	Central High School	Omaha, Neb.	258
KOCW	Oklahoma College for Women	Chickasha, Okla.	252
KOIL	Monarch Manufacturing Co.	Council Bluffs, Iowa	278
KOIN	Inc.	Sylvan, Ore.	319
KOMO	Bert F. Fisher	Seattle, Wash.	306
KOWW	Blue Mt. Radio Assn.	Walla Walla, Wash.	285
KPO	Hale Bros.	San Francisco, Calif.	428
KPPG	Pasadena Presbyterian Church	Pasadena, Calif.	229
KPRC	Houston Post Dispatch	Houston, Texas	297
KPSN	Star-News Publishing Co.	Pasadena, Calif.	316
KQV	Doubleday-Hill Electric Co.	Pittsburgh, Pa.	275
KQW	Charles D. Herold	San Jose, Calif.	333
KRE	Berkeley Daily Gazette	Berkeley, Calif.	256
KSAG	Kansas State Agricultural College	Manhattan, Kans.	341
KSD	Pulitzer Printing Co.	St. Louis, Mo.	545
KSL	Radio Service Corp. of Utah	Salt Lake City, Utah	300
KSMR	Santa Maria Valley Railroad Co.	Santa Maria, Calif.	210
KSO	A. A. Berry Seed Co.	Clarinda, Iowa	242
KTAB	Associated Broadcasters	Oakland, Calif.	303
KTBI	Bible Institute	Los Angeles, Calif.	294
KTBR	M. E. Brown	Portland, Ore.	263
KTHS	New Arlington Hotel Co.	Hot Springs, Ark.	375
KTNT	N. Baker	Muscataine, Iowa	333
KTUE	Uhalt Electric Co.	Houston, Texas	265
KTW	First Presbyterian Church	Seattle, Wash.	454
KUOA	University of Arkansas	Fayetteville, Ark.	300
KUOM	State University of Montana	Missoula, Mont.	244
KUSD	University of South Dakota	Vermillion, S. D.	278
KUT	University of Texas	Austin, Texas	231
KVOD	The Voice of Oklahoma	Bristow, Okla.	375
KWCR	H. F. Paar	Cedar Rapids, Iowa	278
KWG	Portable Wireless Telephone Co.	Stockton, Calif.	248
KWKX	Wilson Duncan Studios	Kansas City, Mo.	236
KWKH	Henderson Iron Works	Shreveport, La.	312
KWSC	State College	Pullman, Wash.	349
KWUC	Western Union College	Le Mars, Iowa	252
KWWG	City of Brownsville	Brownsville, Texas	278
KYW	Westinghouse Electric & Mfg. Co.	Chicago, Ill.	535
KZIB	I. Beck	Manila, P. I.	250
KZKZ	Electrical Supply Co.	Manila, P. I.	270
KZM	Preston D. Allen	Oakland, Calif.	240
KZRO	Far Eastern Radio	Manila, P. I.	222
KZUY	F. J. Elser	Manila, P. I.	360
NAA	U. S. Navy Dept.	Arlington, Va.	434
WAAD	Ohio Mechanics Institute	Cincinnati, Ohio	258
WAAF	Chicago Daily Drivers Journal	Chicago, Ill.	278
WAAW	Omaha Grain Exchange	Omaha, Nebr.	278
WABB	Harrisburg Radio Co.	Harrisburg, Pa.	204
WABC	Asheville Battery Co., Inc.	Asheville, N. C.	254
WABI	1st Universalist Church	Bangor, Me.	240
WABO	Lake Avenue Baptist Church	Rochester, N. Y.	278
WABQ	Haverford College, Radio Club	Haverford, Pa.	261
WABR	Scott High School	Toledo, Ohio	263
WABW	College of Wooster	Wooster, Ohio	207
WABX	Henry B. Joy	Mt. Clemens, Mich.	246
WABY	John Magaldi, Jr.	Philadelphia, Pa.	242
WABZ	Coliseum Place Baptist Church	New Orleans, La.	275
WADC	Allen T. Simmons (Allen Theatre)	Akron, Ohio	258
WAFD	Albert B. Parfet Co.	Port Huron, Mich.	275
WAGM	R. L. Miller	Royal Oak, Mich.	225
WAHG	A. H. Grebe & Co.	Richmond Hill, N. Y.	316
WAIT	A. H. Waite Co.	Tuanton, Mass.	229
WAIU	American Insurance Union	Columbus, Ohio	294
WAMD	Radison Radio Corp.	Minneapolis, Minn.	244
WAPI	Alabama Polytechnic Institute	Auburn, Ala.	248
WARG	American Radio & Research Corp.	Medford, Mass.	261
WATT	Edison Electric	Boston, Mass.	244
WBAA	Purdue University	W. Lafayette, Ind.	273
WBAC	Pennsylvania State Police	Harrisburg, Pa.	275
WBAL	Consolidated Gas & Elec. Co.	Glen Morris, Md.	246
WBAO	James Mileikan University	Decatur, Ill.	270
WBAP	Wortham-Carter Pub. (Star Telegram)	Ft. Worth, Texas	476
WBAW	Braid Elec., & Waldrum Drug Co.	Nashville, Tenn.	236
WBAX	John H. Stenger, Jr.	Wilkes-Barre, Pa.	256
WBBC	P. J. Testan	Brooklyn, N. Y.	250
WBBL	Grace Covenant Presbyterian Church	Richmond, Va.	229
WBBM	Atlas Investment Co.	Chicago, Ill.	226
WBPP	Petoskey High School	Petoskey, Mich.	238
WBBR	People's Pulpit Assoc.	Rossville, N. Y.	416
WBBS	First Baptist Church	New Orleans, La.	252
WBBW	Ruffner Junior High School	Norfolk, Va.	222
WBBY	Washington Light Inf. Co. "B" 118th inf.	Charleston, S. C.	268
WBBZ	C. L. Carrel	Chicago, Ill.	216
WBCN	Forster & McDonnell	Chicago, Ill.	266
WBDG	Baxter Laundry Co.	Grand Rapids, Mich.	256
WBES	Bliss Educational School	Takoma Park, Md.	222
WBNY	B. A. Ruchome Corp.	New York, N. Y.	322
WBOQ	A. H. Grebe & Co., Inc.	Richmond Hill, N. Y.	236
WBPI	I. R. Nelson	Newark, N. J.	263
WBRC	Bell Radio Corporation	Birmingham, Ala.	248
WBRE	Baltimore Radio Exchange	Wilkes-Barre, Pa.	231
WBRS	Universal Radio Mfg. Co.	Brooklyn, N. Y.	394
WBT	Charlotte Chamber of Commerce	Charlotte, N. C.	375
WBZ	Westinghouse Elect. & Mfg. Co.	Springfield, Mass.	231
WBZA	Westinghouse Elect. & Mfg. Co.	Boston, Mass.	242
WCAG	Connecticut Agricultural College	Mansfield, Conn.	275
WCAD	St. Lawrence University	Canton, N. Y.	263
WCAE	Kaufman & Baer Co. & The Pitts. Pr.	Pittsburgh, Pa.	461
WCAG	Nebraska Wesleyan University	University Place, Nebr.	254
WCAL	St. Olaf College	Northfield, Minn.	337
WCAM	City of Camden	Camden, N. J.	236
WCAO	A. A. and A. S. Brager	Baltimore, Md.	275
WCAP	Chesapeake & Potomac Tel. Co.	Washington, D. C.	468
WCAR	Southern Radio Corp. of Texas	San Antonio, Texas	263
WCAT	State College of Mines	Rapid City, S. Dak.	240
WCAU	Universal Broadcasting Co.	Philadelphia, Pa.	278
WCAX	University of Vermont	Burlington, Vt.	250
WGBA	Charles W. Heimback	Allentown, Pa.	254
WGBD	Wilbur C. Voliva	Zion, Ill.	345
WGBE	Uhalt Radio Co.	New Orleans, La.	263
WGBH	University of Mississippi	Oxford, Miss.	242
WGBM	Charles Swarz	Baltimore, Md.	229
WGBR	C. H. Mester	Providence, R. I.	210
WGBS	H. L. Dewing, Portable	Providence, R. I.	242
WCGO	Washburn-Crosby Co.	Anoka, Minn.	416
WCPT	Knights of Pythias	Tullahoma, Tenn.	252
WCLO	C. E. Whitmore	Camp Lake Wis.	231
WCLS	H. M. Couch	Joliet, Ill.	214
WCMA	Culver Military Academy	Culver, Ind.	258
WCOA	City of Pensacola	Pensacola, Fla.	222
WCRW	Clinton R. White	Chicago, Ill.	416
WCSH	Henry P. Rines	Portland, Maine	256
WCSO	Wittenberg College	Springfield, Ohio	248
WCWS	Chas. W. Selene (Portable)	Providence, R. I.	210
WCX	Free Press and Jewett R. & P. Co.	Detroit, Mich.	517
WDAD	Dad's Auto Accessories, Inc.	Nashville, Tenn.	226
WDAE	Tampa Daily Times	Tampa, Fla.	273
WDAF	Kansas City Star	Kansas City, Mo.	366
WDAG	J. Laurence Martin	Amarillo, Texas	263
WDAH	Trinity Methodist Church	El Paso, Texas	268
WDAY	Radio Equipment Corp.	Fargo, N. Dak.	261
WDBE	Gilham-Schoen Elec. Co.	Atlanta, Ga.	270
WDBJ	Richardson Wayland Elec. Corp.	Roanoke, Va.	229



# SANGAMO

Mica Condensers



in the

## Stromberg-Carlson RECEIVER

RADIO enthusiasts sat up and listened when the opportunity came to hear the Stromberg-Carlson receiver. That firm's name means *quality*. Their set won a leading place immediately in a market that seemed over-crowded with good makes. No claims are made of revolutionary ideas in new circuits, but every part is made with scientific precision.

Sangamo Mica Condensers are used in the Strongberg-Carlson because they are permanently accurate. Sangamo condensers are solidly molded in bakelite. All edges are sealed tight; no moisture can creep in to change the capacity. Their accuracy is guaranteed to be within 10 per cent and to remain unchanged. Distinctive in appearance, too; completely enclosed in velvet-smooth brown bakelite; all corners rounded to prevent chipping; reinforcing ribs for mechanical strength.

Experiment with "world-beater" circuits if you will—but remember that accurate Sangamo Mica Condensers will improve the tone and range of any set. You can fit your set exactly—there are 35 capacities to choose from.

Tried SANGAMO  
BY-PASS CONDENSERS?

They stand the surges  
without breaking down.



Sangamo Electric Company

6332-8 Springfield, Illinois

RADIO DIVISION, 50 Church Street, New York

SALES OFFICES—PRINCIPAL CITIES

For Canada—Sangamo Electric Co. of Canada, Ltd., Toronto

For Europe—British Sangamo Co., Ponders End, Middlesex, Eng.

For Far East—Ashida Engineering Co., Osaka, Japan

## Radio Religious Programs Fill the Churches

RADIO religious programs are filling the churches rather than emptying them. This is the trend indicated by a survey of sacred broadcasting just made by Sears-R o e b u c k Agricultural Foundation.

Returns show that the church which broadcasts is on its mettle when it knows the church is listening in and puts an added zest into the music and service that brings people into the church instead of encouraging them to take their religion in comfortable doses at home.

One church in New Jersey states that since its services have begun to be sent out on the air, the gallery pews have been opened up and dusted off for the first time in twenty years.

The church that does not broadcast, on the other hand, feels the competition and makes every effort to bring its services and sermon up to the standard of the radio churches.

One hundred and seventy-eight radio stations from every part of the United States and in Canada from the Saskatchewan to Montreal, participated in this survey. One hundred and three of these stations, or sixty per cent, are giving some sort of religious service or sacred music as a part of their regular programs. Four per cent are considering adding this feature and six per cent have religious observance only on such occasions as Christmas, Easter and Holy Week.

Fourteen of these 103 stations are owned or operated by some church or religious body. The rest simply include these features along with secular programs, because they feel their audiences want and appreciate them.

### Most On Sundays

SUNDAY is the day that 86 of these stations send out their sacred programs while 22 are on week-days. The week-day programs consist of sacred music or instructional address. A num-

# WHY GUESS

The B Voltage Delivered?



There are no knobs to turn on the Bremer-Tully B-Power unit.

Cartridge type fixed resistances are furnished. A chart shows the ones to use for your set. Insert the resistances and there is nothing further to be done.

When purchasing a B-Power Unit, more stress should be laid on the ability and integrity of the manufacturer than on any other radio product.

### INVESTIGATE B-T!

Read "Better Tuning"—It tells about the new B-Power Unit and new sets.

Price 10c

Circulars free.



DEALERS SELLING  
COUNTERPHASE SETS  
display this sign

BREMER-TULLY MFG. CO.  
520 So. Canal St.  
Chicago, Ill.

### COUPON

Please send 10th Edition "Better Tuning,"  
10c enclosed  Free circulars

NAME

ADDRESS



WDBK M. F. Broz.....	Cleveland, Ohio	227
WDBO Rollins College, Inc.....	Winter Park, Fla.	240
WDBZ Kingston Radio Club.....	Kingston, N. Y.	233
WDEL Wilmington Elec. Specialty Co.....	Wilmington, Del.	266
WDGY Dr. George W. Young.....	Minneapolis, Minn.	263
WDOD Chattanooga Radio Co., Inc.....	Chattanooga, Tenn.	256
WDRS Doolittle Radio Corp.....	New Haven, Conn.	268
WDWF Dutee Wilcox Flint, Inc.....	Cranston, R. I.	441
WDZ J. L. Bush.....	Tuscola, Ill.	278
WEAF Broadcasting Co. of America.....	New York, N. Y.	491
WEAI Cornell University.....	Ithaca, N. Y.	254
WEAM Bor. of N. Plainfield.....	North Plainfield, N. J.	261
WEAN Shepard Co.....	Providence, R. I.	367
WEAO Ohio State University.....	Columbus, Ohio	294
WEAR Willard Battery Co.....	Cleveland, Ohio	389
WEAU Davidson Bros. Co.....	Sioux City, Iowa	275
WEGC Walter Cecil Bridges.....	Superior, Wis.	242
WEBB Edgewater B. H. & Herald Examiner.....	Chicago, Ill.	370
WEBJ Third Avenue Railway Co.....	New York, N. Y.	273
WEBL Radio Corp. of America (Portable).....	New York, N. Y.	226
WEBQ Tate Radio Corp.....	Harrisburg, Ill.	226
WEBR H. H. Howell.....	Buffalo, N. Y.	244
WEBV Beloit College.....	Beloit, Wis.	268
WEBZ Savannah Radic Corp.....	Savannah, Ga.	263
WFCE Frank Crook, Inc.....	Pawtucket, R. I.	229
WEET The Edison Elec. Illuminating Co.....	Boston, Mass.	349
WEHS Robert E. Hughes.....	Evanston, Ill.	203
WEMC Emanuel Missionary College.....	Berrien Springs, Mich.	285
WENR All-American Radio Corp.....	Chicago, Ill.	266
WEW St. Louis University.....	St. Louis, Mo.	360
WEAA Dallas News & Dallas Journal.....	Dallas, Tex.	476
WFAM Times Publishing Co.....	St. Cloud, Minn.	273
WFAY University of Nebraska.....	Lincoln, Neb.	275
WFBC First Baptist Church.....	Knoxville, Tenn.	250
WFBE John Van De Walle.....	Seymour, Ind.	226
WFBG The Wm. F. Gable Co.....	Altoona, Pa.	278
WFBH Peoples Broadcasting Corp.....	New York, N. Y.	273
WFBJ St. John's University.....	Collegeville, Minn.	236
WFBM Onondaga Hotel Co.....	Syracuse, N. Y.	252
WFBM Merchants Heat & Light Co.....	Indianapolis, Ind.	268
WFBF Fifth Inf. Md. Nat'l Guard.....	Baltimore, Md.	254
WFBZ Knox College.....	Galesburg, Ill.	254
WFCE Frank Crook, Inc.....	Pawtucket, R. I.	229
WFCL Chicago Federation of Labor.....	Chicago, Ill.	491
WFDF F. D. Fallain.....	Flint, Mich.	234
WFI Strawbridge and Clothier.....	Philadelphia, Pa.	394
WFKB F. K. Bridgman (Inc.).....	Chicago, Ill.	217
WFLR Robert Morrison Lacey.....	Brooklyn, N. Y.	205
WGAL Lancaster Elec. Supply & Const. Co.....	Lancaster, Pa.	248
WGBB Harry H. Carman.....	Freeport, N. Y.	244
WGBE First Baptist Church.....	Memphis, Tenn.	278
WGBF Fink Furniture Co.....	Evansville, Ind.	236
WGBI Scranton Broadcasters, Inc.....	Scranton, Pa.	240
WGBR George S. Ives.....	Marshfield, Wis.	229
WGBS Gimbel Brothers.....	New York, N. Y.	316
WGBU Florida Cities Finance Co.....	Fulford By-The-Sea, Fla.	278
WGBX University of Maine.....	Orono, Me.	234
WGCP May Broadcast Corp.....	Newark, N. J.	252
WGES Coyne Electrical School.....	Chicago, Ill.	250
WGHB Fort Harrison Hotel.....	Clearwater, Fla.	266
WGHP G. H. Phelps.....	Detroit, Mich.	270
WGM Verne and Elton Spencer.....	Jeanette, Pa.	372
WGMUA H. Grebe & Co. Inc. (Portable).....	Richmond Hill, N. Y.	236
WGN The Tribune.....	Chicago, Ill.	303
WGR Federal T. and T. Co.....	Buffalo, N. Y.	319
WGST Georgia School Technology.....	Atlanta, Ga.	270
WGY General Elec. Co.....	Schenectady, N. Y.	379
WHA University of Wisconsin.....	Madison, Wis.	535
WHAD Marquett Univ. & Mhw. Journal.....	Milwaukee, Wis.	275
WHAM Univ. of Rochester (Eastman S. of M.).....	Rochester, N. Y.	278
WHAP W. H. Taylor Finance Corp.....	Brooklyn, N. Y.	431
WHAR Seaside House.....	Atlantic City, N. J.	275

WHAS Courier-Journal & Louisville Times.....	Louisville, Ky.	400
WHAZ Rensselaer Polytechnic Institute.....	Troy, N. Y.	379
WHBZ Sweeney School Co.....	Kansas City, Mo.	366
WHBA C. C. Shafer.....	Oil City, Pa.	250
WHBC Rev. E. P. Graham.....	Canton, Ohio	254
WHBD Chamber of Commerce.....	Bellefontaine, Ohio	222
WHBF Beardsley Specialty Company.....	Rock Island, Ill.	222
WHBG John S. Skane.....	Harrisburg, Pa.	231
WHBJ Lauer Auto Co.....	Ft. Wayne, Ind.	234
WHBL C. L. Carrell.....	Chicago, Ill.	216
WHBM C. L. Carrell, (Portable Station).....	Chicago, Ill.	216
WHBN First Ave. Methodist Church.....	St. Petersburg, Fla.	238
WHBP Johnstown Automobile Co.....	Johnstown, Pa.	256
WHBQ St. John's M. E. Church South.....	Memphis, Tenn.	233
WHBU Riviera Theatre & Bing's Clothing.....	Anderson, Ind.	219
WHBWD R. Kienzle.....	Philadelphia, Pa.	216
WHBY St. Norbert's College.....	West de Pere, Wis.	250
WHDI W. H. Dunwoody Ind. Institute.....	Minneapolis, Minn.	278
WHEC Hickson Electric Co., Inc.....	Rochester, N. Y.	258
WHFC Hotel Flanders.....	Chicago, Ill.	258
WHK The Radio Air Service Corp.....	Cleveland, Ohio	273
WHN George Schubert.....	New York, N. Y.	361
WHO Banker's Life Co.....	Des Moines, Ia.	526
WHT Radiophone Broadcastinging Corp.....	Deerfield, Ill.	238
WHT Radiophone Broadcastinging Corp.....	Deerfield, Ill.	400
WIAD Howard R. Miller.....	Philadelphia, Pa.	250
WIAS Home Electric Co.....	Burlington, Iowa	254
WIBA The Capital-Times Studio.....	Madison, Wis.	236
WIBG St. Paul's Protestant E. Church.....	Elkins Park, Pa.	222
WIBH Elite-Radio Stores.....	New Bedford, Mass.	210
WIBI Frederick B. Zitteli, Jr.....	Flushing, N. Y.	219
WIBJ C. L. Carrell (Portable).....	Chicago, Ill.	216
WIBM Billy Maine (Portable).....	Chicago, Ill.	216
WIBO Nelson Brothers.....	Chicago, Ill.	226
WIBR Thurman A. Owings.....	Werton, W. Va.	246
WIBS T. F. Hunter (portable).....	Elizabeth, N. J.	203
WIBU The Electric Farm.....	Poynette, Wis.	222
WIBW Dr. L. L. Dill.....	Logansport, Ind.	220
WIBX WIBX, Inc.....	Utica, N. Y.	234
WIBZ A. D. Trum.....	Montgomery, Ala.	231
WIL Benson Radio & The Star.....	St. Louis, Mo.	273
WIOD Wonderful Isle of Dreams.....	Miami, Fla.	248
WIP Gimbel Bros.....	Philadelphia, Pa.	508
WJAF Fenberg Radio Co.....	Ferndale, Mich.	400
WJAD Jackson's Radio Eng. Laboratories.....	Waco, Texas	353
WJAG Norfolk Daily News.....	Norfolk, Nebr.	270
WJAK Clifford L. White.....	Kokomo, Ind.	254
WJAM D. M. Perham.....	Cedar Rapids, Iowa	263
WJAR The Outlet Co. (J. Samuels & Bro.).....	Providence, R. I.	306
WJAS Pittsburg Radio Supply House.....	Pittsburgh, Pa.	275
WJAX City of Jacksonville.....	Jacksonville, Fla.	337
WJAZ Zenith Radio Co.....	Mt. Prospect, Ill.	322
WJBA D. H. Lentz, Jr.....	Joliet, Ill.	207
WJBB Financial Journal.....	St. Petersburg, Fla.	254
WJBC Hummer Furniture Co.....	LaSalle, Ill.	234
WJBI Robert S. Johnson.....	Red Bank, N. J.	219
WJBK E. F. Goodwin.....	Ypsilanti, Mich.	233
WJBL Wm. Gushard Dry Goods Co.....	Decatur, Ill.	270
WJBO Valdemar Jensen.....	New Orleans, La.	268
WJBR Geusch and Stearns.....	Omro, Wis.	227
WJBT John S. Boyd.....	Chicago, Ill.	238
WJBU Bucknell University.....	Lewisburg, Pa.	211
WJBV Union Course Laboratories.....	Woodhaven, N. Y.	470
WJBW C. Carlson, Jr.....	New Orleans, La.	341
WJBX Henderson & Ross.....	Osterville, Mass.	280
WJBY Electric Construction Co.....	Cadسدn, Ala.	270
WJJD Supreme Lodge, L. O. of Moose.....	Mooseheart, Ill.	370
WJRW Jewett Radio & Phon. Co. & D. F. P.....	Pontiac, Mich.	517
WJY Radio Corp. of America.....	New York, N. Y.	405
WJZ Radio Corp. of America.....	Bound Brook, N. J.	454
WKAF WKAF Broadcasting Co.....	Milwaukee, Wis.	261
WKAQ Radio Corp. of Porto Rico.....	San Juan, P. R.	341







WKAR Michigan State College.....	East Lansing, Mich.	285	WOAW Woodman of the World.....	Omaha, Nebr.	526
WKVA Laconia Radio Club.....	Laconia, N. H.	224	WOAX Franklyn J. Wolff.....	Trenton, N. J.	240
WKBA Arrow Battery Co.....	Chicago, Ill.	210	WOC Palmer School of Chiropractic.....	Davenport, Iowa	484
WKBB Sanders Bros.....	Joliet, Ill.	283	WOGL A. E. Newton.....	Jamestown, N. Y.	275
WKBC H. L. Ansley.....	Birmingham, Ala.	225	WODA James K. O'Dea.....	Paterson, N. J.	391
WKBD F. V. Bremer.....	Jersey City, N. J.	235	WOI Iowa State College.....	Ames, Iowa	270
WKBE K. & B. Electric Co.....	Webster, Mass.	270	WOK Neutrowound Radio Mfg. Co.....	Homewood, Ill.	217
WKBF N. B. Watson.....	Indianapolis, Ind.	244	WOKO Harold E. Smith.....	Peekskill, N. Y.	233
WKBG C. L. Carrell (Portable).....	Chicago, Ill.	216	WOO John Wanamaker.....	Philadelphia, Pa.	508
WKBH Callaway Music Co.....	LaCrosse, Wis.	250	WOOD Grand Rapids Radio Co.....	Grand Rapids, Mich.	242
WKBI F. L. Schoenwolf.....	Chicago, Ill.	220	WOQ Unity School of Christianity.....	Kansas City, Mo.	278
WKBJ Gospel Tabernacle Inc.....	St. Petersburg, Fla.	280	WOR L. Bamberger and Co.....	Newark, N. J.	405
WKDR Edward A. Dato.....	Kenosha, Wis.	428	WORD People's Pulpit Assn.....	Batavia, Ill.	275
WKRC Kodak Radio Corp.....	Cincinnati, Ohio	326	WOS State Market Bureau.....	Jefferson City, Mo.	441
WKRC Kodak Radio Corp.....	Cincinnati, Ohio	422	WOVO Main Auto Supply Co.....	Fort Wayne, Ind.	227
WKY WKY Radio Shop.....	Oklahoma City, Okla.	275	WPAK N. D. Ag. College.....	Agricultural College, N. D.	275
WLAL First Christian Church.....	Tulsa, Okla.	250	WPGC North Shore Cong. Church.....	Chicago, Ill.	258
WLAP Wm. V. Jordan.....	Louisville, Ky.	275	WPDO H. L. Turner.....	Buffalo, N. Y.	205
WLAQ Arthur E. Shilling.....	Kalamazoo, Mich.	283	WPG The Municipality of Atlantic City.....	Atlantic City, N. J.	300
WLB University of Minnesota.....	Minneapolis, Minn.	278	WPRC Wilson Printing & Radio Co.....	Harrisburg, Pa.	216
WLBL Bureau of Marketing.....	Stevens Point, Wis.	378	WPSG Pennsylvania State College.....	State College, Pa.	261
WLIB Liberty Magazine.....	Elgin, Ill.	203	WQAA Horace A. Beale, Jr.....	Parkersburg, Pa.	220
WLIT Lit Bros.....	Philadelphia, Pa.	394	WQAG Gish Radio Service.....	Amarillo, Tex.	234
WLS Sears Roebuck & Co.....	Crete, Ill.	345	WQAE Moore Radio News Station.....	Springfield, Vt.	246
WLSI Lincoln Studios.....	Cranston, R. I.	441	WOAM Electrical Equipment Co.....	Miami, Fla.	285
WLTS Lane Technical High School.....	Chicago, Ill.	258	WOAN Scranton Times.....	Scranton, Pa.	250
WLW Crosley Mfg. Co.....	Cincinnati, Ohio	422	WQAO Calvary Baptist Church.....	Cliffside, N. J.	360
WLWL Miss. Society of St. Paul the Apostle.....	New York, N. Y.	288	WQJ Calumet Rainbo Broadcasting Co.....	Chicago, Ill.	447
WMAC C. B. Meredith.....	Casenville, N. Y.	275	WRAF The Radio Club (Inc.).....	LaPorte, Ind.	224
WMAF Round Hills Radio Corp.....	Dartmouth, Mass.	441	WRAH S. N. Read.....	Providence, R. I.	235
WMAK Norton Laboratories.....	Lockport, N. Y.	266	WRAK Economy Light Co.....	Escanaba, Mich.	256
WMAL M. A. Lesse Optical Co.....	Washington, D. C.	213	WRAM Lombard College.....	Galesburg, Ill.	244
WMAN First Baptist Church.....	Columbus, Ohio	278	WRAW Antioch College.....	Yellow Springs, Ohio	263
WMAQ Chicago Daily News.....	Chicago, Ill.	447	WRAW Horace D. Good.....	Reading, Pa.	238
WMAJ Kingshighway Presbyterian Church.....	St. Louis, Mo.	248	WRAX Berachah Church.....	Philadelphia, Pa.	268
WMAZ Mercer University.....	Macon, Ga.	261	WRBC Immanuel Lutheran Church.....	Valparaiso, Ind.	278
WMBB American Bond & Mortgage Co.....	Chicago, Ill.	250	WRC Radio Corp. of America.....	Washington, D. C.	468
WMBG Michigan Broadcasting Co.....	Detroit, Mich.	256	WRGO Wynne Radio Co.....	Raleigh, N. C.	252
WMBF Miami Beach Hotel.....	Miami Beach, Fla.	384	WREC Wooten's Radio & Electric Co.....	Coldwater, Miss.	254
WMBI Moody Bible Institute.....	Chicago, Ill.	288	WREO Reo Motor Car Co.....	Lansing, Mich.	285
WMC Commercial Appeal.....	Memphis, Tenn.	500	WRHF Radio Hospital Fund.....	Washington, D. C.	256
WMRJ Peter J. Prinz.....	Jamaica, N. Y.	227	WRHM Rosedale Hospital, Inc.....	Minneapolis, Minn.	252
WMGA Hotel McAlpin (Greenley Sq. Hotel Co.).....	New York, N. Y.	341	WRH Doron Bros.....	Hamilton, Ohio	270
WNAB Shepard Stores.....	Boston, Mass.	280	WRM University of Illinois.....	Urbana, Ill.	273
WNAG Shepard Stores.....	Boston, Mass.	430	WRMU A. H. Grebe & Co., Inc., M. Y. "MU-1".....	New York, N. Y.	236
WNAD University of Oklahoma.....	Norman, Okla.	254	WRNY Experimenter Publishing Co.....	New York, N. Y.	375
WNAL Omaha Central High School.....	Omaha, Nebr.	258	WRR Municipal Station.....	Dallas, Tex.	246
WNAT Lenning Bros. Co. (Frederick Lenning).....	Philadelphia, Pa.	250	WRST Radiotel Mfg. Co., Inc.....	Bay Shore, N. Y.	216
WNAX Dakota Radio Apparatus Co.....	Yankton, S. Dak.	244	WRVA Larus & Brother Co., Inc.....	Richmond, Va.	256
WNBH New Bedford Hotel.....	New Bedford, Mass.	248	WSAI United States Playing Card Co.....	Cincinnati, Ohio	326
WNJ Radio Shop.....	Newark, N. J.	252	WSAJ Grove City College.....	Grove City, Pa.	229
WNOX Peoples Tel. & Tel. Co.....	Knoxville, Tenn.	262	WSAN Allentown Call Publisher Co.....	Allentown, Pa.	229
WNRC W. B. Nelson.....	Greensboro, N. C.	224	WSAR Daughy & Welch Electrical Co.....	Fall River, Mass.	251
WNYG Dept. of Plant & Structures.....	New York, N. Y.	526	WSAU Camp Marlen.....	Chesham, N. H.	229
WOAI Southern Equipment Co.....	San Antonio, Texas	394	WSAX Zenith Radio Corp. (Portable).....	Chicago, Ill.	268
WOAN Vaughn Con. of Music.....	Lawrenceburg, Tenn.	283	WSAZ Chase Electric Shop.....	Pomeroy, Ohio	244

## RADIO AGE SUBSCRIPTION BLANK

Radio Age, Inc.  
500 North Dearborn Street  
Chicago

\$2.50 A YEAR

Gentlemen: Please enter my subscription for RADIO AGE, the Magazine of the Hour, for one year, beginning with the \_\_\_\_\_ issue, for which I enclose \$2.50.

Name.....

Street Address.....

City.....

State.....

Send cash, money order or draft.

(10-26)

Use the  
Log-a-Wave  
Chart  
on Page 56







WSB Atlanta Journal.....	Atlanta, Ga.	428	WTAB Fall River Daily Herald Publishing Co.	Fall River, Mass.	266
WSBC World Battery Co.....	Chicago, Ill.	288	WTAD Robt. E. Compton.....	Carthage, Ill.	236
WSBF Stix-Baer-Fuller D. G. Co.....	St. Louis, Mo.	273	WTAG Telegram Pub. Co.....	Worcester, Mass.	545
WSBT South Bend Tribune.....	South Bend, Ind.	275	WTAL Toledo Radio & Electric Co.....	Toledo, Ohio	252
WSDA Seventh Day Adventist Church.....	New York, N. Y.	263	WTAM Willard Storage Battery Co.....	Cleveland, Ohio	389
WSKC World's Star Knitting Co.....	Bay City, Mich.	261	WTAQ C. S. Van Gordon.....	Eau Claire, Wis.	254
WSM Nashville Life & Accident Ins. Co.....	Nashville, Tenn.	283	WTAR Reliance Electric Co.....	Norfolk, Va.	261
WSMB Saenger Amuse. Co. & Maison B. Co.....	New Orleans, La.	319	WTAW Agricultural & Mech. Col. of Texas. College Sta., Texas		270
WSMG Madison Sq. Garden Bdcast Corp.....	New York, N. Y.	303	WTAX Williams Hardware Co.....	Streator, Ill.	231
WSMH Shattuck Music House.....	Owosso, Mich.	240	WTAZ Thomas J. McGuire.....	Lambertville, N. J.	261
WSMK S. M. K. Radio Corp.....	Dayton, Ohio	275	WTIC Travelers Insurance Co.....	Hartford, Conn.	476
WSOE School of Engineering.....	Milwaukee, Wis.	246	WWAE Electric Park.....	Plainfield, Ill.	242
WSRO Radio Company.....	Hamilton, Ohio	252	WWGL Radio Engineering Corp.....	Richmond Hill, N. Y.	213
WSSH Tremont Temple Bap. Church.....	Boston, Mass.	261	WWRL Woodside Radio Labs.....	Woodside, N. Y.	258
WSUI State University of Iowa.....	Iowa City, Iowa	484	WWJ Detroit News.....	Detroit Mich.	353
WSVS Seneca Vocational School.....	Buffalo, N. Y.	219	WWL Loyola University.....	New Orleans La.	275
WSWS Illinois Broadcasting Corp.....	Wooddale, Ill.	275			

### Dominion of Canada

CFAC Calgary Herald.....	Calgary, Alta.	434	CJCL A. Couture.....	Montreal, Que.	279
CFCF Toronto Star Pub. & Prtg. Co.....	Toronto, Ont.	356	CJGC London Free Press.....	London, Ont.	329
CFCF Marconi Wireless Teleg. Co. (Lt.L) Can.	Montreal, Que.	411	CKAC La Presse.....	Montreal, Que.	411
CFCH Abitibi Power & Paper Co. (Ltd.)	Iroquois Falls, Ont.	500	CKGD Vancouver Daily Province.....	Vancouver, B. C.	397
CFCK Radio Supply Co.....	Edmonton, Alta.	517	CKCK Leader Pub. Co.....	Regina, Sask.	476
CFCN W. W. Grant (Ltd.).....	Calgary, Alta.	434	CKCL Dominion Battery Co.....	Toronto	357
CFCR Laurentide Air Service.....	Sudbury, Ont.	410	CKCO Ottawa Radio Association.....	Ottawa, Ont.	434
CFCT Victoria City Temple.....	Victoria, B. C.	329	CKCX P. Burns & Co. (Ltd.).....	Calgary, Alta.	434
CFCU The Jack Elliott (Ltd.).....	Hamilton, Ont.	341	CKFC First Congregational Church.....	Vancouver, B. C.	411
CFCH Henry Birks & Sons.....	Calgary, Alta.	434	CKLC Wilkison Electric Co. (Ltd.).....	Calgary, Alta.	434
CFKC Thorold Radio Supply.....	Thorold, Ont.	248	CKNC Canadian National Carbon Co.....	Toronto, Ont.	357
CFQC The Electric Shop (I. Ltd.).....	Saskatoon, Sask.	329	CKOC Wentworth Radio Supply Co.....	Hamilton, Ont.	341
CFRC Queens University.....	Kingston, Ont.	450	CKY Manitoba Tel. System.....	Winnipeg, Man.	384
CFXC Westminster Trust Co.....	Westminster, B. C.	291	CNRA Canadian National Railways.....	Moncton, N. B.	312
CFYC Commercial Radio (Ltd.).....	Vancouver, B. C.	411	CNRC Canadian National Railways.....	Calgary, Alta.	436
CHBC The Calgary Albertan.....	Calgary, Alta.	434	CNRE Canadian National Railways.....	Edmonton, Alta.	517
CHCM Riley & McCormack (Ltd.).....	Calgary, Alta.	434	CNRM Canadian National Railways.....	Montreal, Que.	411
CHCS The Hamilton Spectator.....	Hamilton, Ont.	341	CNRO Canadian National Railways.....	Ottawa, Ont.	435
CHIC Northern Electric Co.....	Toronto, Ont.	357	CNRR Canadian National Railways.....	Regina, Sask.	476
CHNC Toronto Radio Research Society.....	Toronto, Ont.	357	CNRS Canadian National Railways.....	Saskatoon, Sask.	329
CHUC International Bible Ass'n.....	Saskatoon, Sask.	329	CNRT Canadian National Railways.....	Toronto, Ont.	357
CHXC R. Booth, Jr.....	Ottawa, Ont.	434	CNRV Canadian National Railways.....	Vancouver, B. C.	291
CHYC Northern Electric Co.....	Montreal, Que.	411	CNRW Canadian National Railways.....	Winnipeg, Man.	384
CJCA Edmonton Journal.....	Edmonton, Alta.	511			

### Republic of Mexico

CYB Mexico City.....	380	CYL Mexico City.....	400	CZE Mexico City.....	350
----------------------	-----	----------------------	-----	----------------------	-----

### Republic of Cuba

PWX Cuban Telephone Co.....	Havana	400	5DW R. S. Calderon.....	Matanzas	200	6KW F. H. Jones.....	Tuinucu	272
2BY F. W. Barton.....	Havana	260	6VY Jose Ganduxe.....	Cienfuegos	260	7SR S. Rionda.....	Central Elia	350
20K M. G. Velez.....	Havana	360	6JK F. H. Jones.....	Tuinucu	340	8BY A. Ravelo.....	Santiago de Cuba	250
20L Oscar Collado.....	Havana	257						

### Great Britain

2LO London.....	365	5XX Daventry.....	1600	2ZY Manchester.....	378
5IT Birmingham.....	479	2RN Dublin.....	390	5NO Newcastle.....	404
5WA Cardiff.....	353	6BM Bournemouth.....	386	5SC Glasgow.....	422
2BE Belfast.....	440			2BD Aberdeen.....	495

### France

YN Lyons.....	550	FL Paris (Eiffel Tower).....	2,650	8AJ Paris.....	1,780	ESP Paris.....	458
---------------	-----	------------------------------	-------	----------------	-------	----------------	-----

### Short Wave Phone Broadcasting

		KC	Meters
2XK	Schenectady, N. Y.*	4600	65.16
KDKA	Pittsburgh, Pa.*	4760	63.00
KDKA	Pittsburgh, Pa.*	5100	58.79
2XAF	Schenectady, N. Y.*	9143	32.79

\*Crystal Control





"You'll make no mistake, madam, in taking this set. It's a wonder."  
 "Yes, but see here, how often do you have to wind it?"

**Successful Tests of Radio Weather Maps**

DAILY weather maps similar to those you sometimes see in your local post office or library, are now being transmitted each day by radio from the Arlington station, NAA on 8000 meters. This is the latest application of the radio picture and manuscript transmitting and receiving apparatus invented by C. Francis Jenkins of Washington about three years ago.

Through the cooperation of the Navy Department, the U. S. Weather Bureau at Washington is offering its daily weather map to anyone afloat or ashore who has facilities for picking it up. This map is made up each day by experts of the Washington Weather Bureau from data received by telegraph and radio from regional observation bureaus. The regular map shows the weather situation for the whole United States, but now only the eastern half is being sent out by radio. It is intended specifically for mariners. To find out how it worked at a distance, after the first successful local tests, the Navy fitted out the U. S. S. Kittery and Trenton with Jenkins receivers. To date reception on board the Kittery at Norfolk, Va., has been perfect. Soon one of the Shipping Board vessels will be equipped for reception, and it is expected the Weather Bureau will have a receiver installed at its Chicago office.



**Cardwell Condensers**

DYNASTIES have come and gone. New peoples, new races, new civilizations have flourished and fallen. Through it all for over 2,000 years this great wall has nobly withstood assaults of man and the elements. So stands the Cardwell Condenser—ideals of strength, efficiency, craftsmanship.

The Taper Plate Type "E"



Type "C" for more long wave separation



**PRICES:**

192E	.0005	\$5.00	173-C
169E	.00035	\$4.75	171-C
168E	.00025	\$4.25	170-C
167E	.00015	\$4.00	168-C

**The Allen D. Cardwell Manufacturing Corp.**  
 81 Prospect Street - Brooklyn, N. Y.  
 Pacific Coast Agent, Baldwin Pacific Co., Pacific Bldg., San Francisco

**"THE STANDARD OF COMPARISON"**

W. GORHAM

**Have You Read "HOWDY JUDGE"?**

By GEORGE D. HAY  
 "The Solemn Old Judge"

A book of character stories all filled with good humor, written on the Memphis levee and in Police Court. The Judge's book is out at last.

Mail Orders are being received by The McQuiddy Press, 110 Seventh Avenue North, Nashville, Tennessee. Price \$1.25 per copy.



Remember . . .

on your present set, or the one you're building, you can't sacrifice the added convenience, neatness and mechanical superiority of the

**Jones MULTI-PLUG**  
 THE STANDARD OF CONNECTOR

Ask Your Dealer  
**HOWARD B. JONES**  
 618 S. Canal St. Chicago, Ill.



# Ductile Tungsten and Some of Its Uses

*No Other Metal Has Such Industrial Importance*

By F. C. KELLEY\*

IT is not my purpose to give you the historical facts connected with the discovery of tungsten, and the various chemical methods of separating it from its ores, for space does not permit. I simply wish to convey some idea of the method used to produce it in its ductile form, and its application to the radio industry.

Although little use had been made of this metal up until the time it was obtained in its ductile form, it was by no means rare. Deposits of its ores occur in many parts of the world, and especially in the United States, Portugal, British India and South America. The chief ones are wolframite, and iron and manganese tungstate, sheelite, a calcium tungstate, and stolzite, a lead tungstate.

The pure oxide of tungsten is obtained from the ore by chemical separation. It is canary yellow in color and in its finely divided state resembles flour. This yellow powder is loaded into porcelain tubes, electric resistance furnaces, through which hydrogen is passed. The temperature and flow of hydrogen gas are carefully regulated for upon these conditions depend the character of the reduced metal. The furnace is heated gradually to a bright yellow heat, causing hydrogen to combine with the oxygen of tungstic oxide forming water which vaporizes leaving the pure uncrystalline metal behind.

The hydrogen-reduced metal powder is next pressed in a mold under hydraulic pressure in the form of bars. If a bar is handled at this stage, it will break under its own weight, so it is carefully

transferred to a slab of molybdenum, tungsten, or some highly refractory material, and re-fired in hydrogen at nearly a white heat for half an hour. This high temperature sinters the metal so the bar can be handled without breakage. It is next clamped between two water-cooled clamps in a metal treating bottle, and a heavy current is passed through it. This heats the bar to a dazzling white heat, and causes it to sinter still more. It is now strong, but not ductile, and a sharp blow with a hammer will break it. The bar may now be rolled into sheets or hammered into rods or wire by means of swaging machines. The process depends upon the use to which the metal is to be put. The treatment is as follows. The bar is heated in a hydrogen electric resistance furnace to nearly a white heat. It is then pulled out of the furnace by means of tongs and inserted quickly into the swaging machine. It is immediately withdrawn and reheated. This time the opposite end is inserted into the swager. A smaller set of dies are now put into the machine for the next operation. This heating, hammering, and gradual reduction in the size of the dies continues until the bar is worked down into wire. The bar is not allowed to become cold during the swaging operation, because it would break up. The temperature of working, however, is gradually decreased with its size. When the bar has been worked down into a long wire, it is fed automatically through the machine by rolls, being heated by a gas flame just before it goes into the swager. It is reduced in this way until the diameter becomes about one half that of

the lead in a pencil. At this stage it is tough and ductile at room temperature, and can be bent cold without breaking. The process of reduction to still smaller diameters is accomplished by drawing through diamond dies. The wire is drawn at a dull red heat at first by heating in a gas furnace as before, but as it becomes smaller the heat is gradually reduced, so that it will not burn the fine wire. The amount of reduction for each pass through the die also becomes less as the size decreases. By this method, wire five ten thousandths of an inch in diameter, or smaller, can be drawn.

If the desired form of the metal should not be wire, the highly sintered bars are rolled hot, just as they were when swaged. Metal sheets rolled in this manner furnish the material from which a variety of products are made.

The method of making ductile tungsten is very different from the processes used to produce other metal. It is never melted in any part of the process like iron, copper, nickel, etc., but is made by pressing finely divided powder and heating to a temperature several hundred degrees below the melting point. During sintering at such a high temperature the individual particles grow together forming grains. The bar then actually develops a crystalline structure which may be seen with the naked eye if it is broken. The size of the grains depends upon the temperature, time, etc., of heating. The grains of a sintered bar when worked hot into wire are elongated, giving it a fibrous structure. If the wire is then reheated to a high temperature the fibers undergo a

\*Research Laboratory, General Electric Co.



# RAYTHEON

## ANNOUNCES

### Light Socket Power for Filament and Plate for Type 199 Tubes Now Practical

FOUR years ago the scientists in the Raytheon Laboratory tackled the problem of using alternating current as a supply for radio power. After three years of research the well-known Raytheon, Type B, was developed. In the one short year since this tube was introduced the B-power market has been revolutionized, and the Raytheon equipped B-power units today are unquestionably the leaders in quality.

Raytheon, Type B, the 60 milliamper tube, remains the standard for regular B-power service.

Now these same engineers have perfected the next logical step toward a. c. operation—a new and exceptional rectifier for a new and exceptional service. Raytheon, Type BH, has a rated capacity of 85 milliamperes, more than enough to supply the 60 milliamper current for the filaments of Type 199 receiving tubes connected in series. Here is a wonderful opportunity for the home constructor to obtain complete a. c. operation. Think of it, both A and B power from a single rectifier! Leading radio magazines will carry detailed information on how this may be accomplished.

The new tube has been rated 200 volts output. This is just what has been needed for the new power amplifiers using the UX-171, the latest development in quality reproduction for the home. This unit will also be described in articles by radio authorities, and complete factory-built B-power units of this type are now available at radio dealers for those who require the extra power.

One last word on Reliability to those who are not already familiar with Raytheon and the Raytheon policy. Complete power units, equipped with Raytheon tubes, are manufactured by Companies selected for their excellent engineering and production facilities. No others are authorized to sell Raytheon rectifiers or to use the trademark word RAYTHEON. Hence, by making certain that you are purchasing a genuine Raytheon unit you are not only assured of the utmost in reliable rectification, but also that the unit has been carefully designed for the service for which it is intended. You will find a variety of prices and styles to meet every requirement.

Raytheon is the Heart of Reliable Radio Power.

RAYTHEON MANUFACTURING COMPANY : : : CAMBRIDGE, MASSACHUSETTS

change and form new equiaxed grains.

Ductile tungsten is too hard and tough to be machined with tools, so other methods are used to obtain it in the desired form. Discs are punched from hot sheets, and various other forms are made by forging the hot sintered bars. Heavy sheets may also be sheared while hot to get the required shape.

The high melting point, tensile strength, low vapor pressure, under the best vacuum conditions, and some other qualities, make it a very desirable metal for

lamp filaments and cathodes for radio and x-ray tubes. These have proved to be its most important uses. It is also extensively used in the electrical industry as a contact material where electrical circuits have to be made and broken frequently, as in magnetos, distributors of automobiles, and voltage regulators. A very valuable use has been made of it as a target in x-ray tubes. Phonograph needles are also produced with a tungsten point. Its use as a heating unit in the tube form, and as a heater-winding, has been of very great value in electric furnaces, where the metal is protected from oxidation at high temperatures by a vacuum or an atmosphere of hydrogen. A temperature of 2500°C can be obtained in a few minutes in the tungsten tube furnace, while in the resistance type, the temperature is limited only by the melting point of the refractory material upon which it is wound.

Tungsten has also taken a prominent place in the field of

(Please turn to page 66)

Please mention Radio Age when writing to advertisers

## TRANSMITTING APPARATUS

In addition to our regular broadcast apparatus we carry a very good stock of transformers, chokes, grid leaks, high test condensers, etc., for transmitting purposes.

We will shortly issue our new catalog and we quote discounts to dealers or set builders who can give satisfactory buying references. Please address us on your regular letterhead.

CHICAGO RADIO  
APPARATUS COMPANY  
415 South Dearborn St.,  
Chicago  
CHI-RAD

BUILD THE NEW SHIELDED

Hammarlund

HiQ

RECEIVER

Send 25c for construction book  
Hammarlund-Roberts 112-D Broadway, New York

"Outsell, Because They Excel"

Empire  
All Types

All Types

Including NEW  
Detector (EX-200A)  
High MU and  
Power Amplifier

Ask for Folder "L"  
Distributors and Jobbers  
Write for Prices



EMPIRE ELECTRICAL  
PRODUCTS COMPANY  
Sales Office, 132-134 Greene St., New York  
Also Mfrs. of Empire Case and  
Horn Speakers  
Laboratories & Factory—Kenilworth, N. J.



You Get It All



With an Austin Aerial

A few advantages of the AUSTIN AERIAL. Increases selectivity. Non-directional. Minimizes interference. Eliminates wires. Easily installed. Guaranteed.

THE TRIANGLE ELECTRIC CO.,  
329 Rex Ave. NE.  
Canton, Ohio

- Payment enclosed.  
 C. O. D.     Send circular.

Name .....

Address .....

City .....

## Can You

Pick out the program you want, without getting any interference from other nearby stations? Or can you cut out your local stations and get the distant ones? If you want to get the best results from your radio use an

### Austin Aerial

Regardless of the kind of reception you are getting, we GUARANTEE the Austin Aerial will improve it. PRICE, \$14.00.

At your dealers, or direct from us. MONEY BACK GUARANTEE.

Manufactured by

THE TRIANGLE  
ELECTRIC CO.

329 Rex Ave. CANTON, OHIO

### See That Screw

A screw-driver adjusts an X-L in crowded places



X-L  
VARIO DENSER

RESULTS in easier tuning, more distance, volume and clarity—greater stability. Isolated by leading radio authorities.

Model "N". A slight turn obtains correct tube oscillation on all tuned radio frequency circuits. Neurodyne, Roberts two tubes, Brownie-Drake, McMurdo Silver's Knockout, etc., capacity range 1.5 to 20 micro-micro farads. Price \$1.00

Model "C". With grid slips obtains the proper grid capacity on Cockaday circuits, filter and intermediate frequency tuning in heterodyne and positive grid bias in all. Capacity range: Model C-1 .00002 to .0001 MFD. Model C-2 .0001 to .0005 MFD. Model C-10 .0003 to .001 MFD. Price \$1.50

X-L Push Post. Push it down with your thumb, insert wire, remove pressure and wire is firmly held. Releases instantly. Price 15c. Also furnished seven to a strip. Nicely marked in white with seven standard markings. Price \$1.50.

Information on Request  
X-L RADIO LABORATORIES  
2424 N. Lincoln Ave. Chicago, Ill.



## POSITIVELY ELIMINATE ALL BATTERIES

Run ANY set, ANY number of ANY type tubes from 110 volt A. C. Positively no hum. Easily done with NEW TYPE ELIMINATOR, quickly made for few dollars from STANDARD parts. No liquids. No salts. NO TRICK CHARGES! No battery of any kind. Give perfect "A" and "B" current in any quantity. Nothing like it. Dealer bill brings detailed blue prints and instructions that assure perfect results.

J. M. MULLEN, Consulting Engineer, 549 N. Washburn Ave., Chicago

Now is the time to  
Subscribe to Radio Age.

\$2.50 per year.

metallurgy. Alloyed with iron and cobalt it is used as a permanent magnet material. Alloys of tungsten with iron, and iron-chromium-manganese, etc., are used in the production of "high speed" steels. Tools made from these alloys are capable of taking heavy cuts from steel at high rates of speed, thus saving much time and money for industries using them. Much heat is generated in such an operation, but still the tool maintains its cutting edge. Carbon tool steels would lose their cutting properties under such conditions in a very short time.

Compounds of tungsten are used as fire-proofing materials, for weighing silks and in the arts for producing bronze colors on glass and porcelain.

### YOU CAN GET

Greater reflex or crystal set reception if you use the

BROWNLIE  
VERNIER DETECTOR

\$2.00 at Your Dealer or Direct.  
ROLAND BROWNLIE & CO.  
21 Sanders St., Medford, Mass.



## Weather and Time are Subject of Investigation

WEATHER conditions and the time of day definitely affect radio signals in short-wave transmission over relatively short distances, engineers of Massachusetts Institute of Technology have found in experiments being carried on at a new station for radio research on the estate of Colonel E. H. R. Green at Round Hill near South Dartmouth, Mass.

These experiments, which are being carried on under the direction of Dr. Vannevar Bush, Professor Edward L. Bowles and James K. Clapp of the Institute's Department of Electrical Engineering, are made possible through the generosity of Colonel Green, whose interest in radio is widely known. His own private broadcasting station, WMAF, stands close to Technology's field station, for which Colonel Green recently provided additional buildings and antennæ equipment.

Amateur operators as far distant as lonely islands in the South Seas and in Europe as well as America and South America have already "talked" with 1XV, the call letters of Technology's field station.

Through the cooperation of Colonel Green further studies over a period of several years are to be made with the object of definitely establishing the relations between weather conditions,

## PATENTS

### To the Man with an Idea

I offer a comprehensive, experienced efficient service for his prompt, legal protection and the development of his proposition.

Send sketch of model and description, for advice as to cost, search through prior United States patents, etc. Preliminary advice gladly furnished without charge.

My experience and familiarity with various arts frequently enable me to accurately advise clients as to probable patentability before they go to any expense.

Booklet of valuable information and form for properly disclosing your idea free on request. Write today.

RICHARD B. OWEN, Patent Lawyer  
81 Owen Bldg., Washington, D. C.  
41-M Park Row, N. Y. City



the time of day, and radio transmission. Much is being accomplished with the cooperation of the amateur operators in all parts of the world. Operating schedules of Station 1XV and cards upon which data may be forwarded to the station have been sent to all interested amateurs.

Experiments have revealed that signals are more or less regular when the sky is clear, but weaken or entirely disappear when certain conditions of cloudiness are encountered. A widespread area of rain which includes both transmitter and receiver has generally been found to give better signals than those obtained in clear weather.

It has been found that for short wave transmission to a fixed receiving station there is a minimum wave-length beyond which signals disappear entirely at the receiving station. The wave-length at which the signals disappear is called the "cut-off" wave-length. In transmission over a distance of 75 miles, for example, the "cut-off" wave-length varies between 32 and 50 meters for various times of the day. Commencing soon after noon the "cut-off" wave-length is smallest throughout the afternoon, which is considered the best time of day for short-wave sig-

nals over short distances, but rises rather rapidly after sunset until the maximum value of about 50 meters is reached soon after midnight. From that hour until noon it decreases slowly and fairly regularly except for slight variations at sun-rise. It again reaches its lowest value of about 32 meters shortly after noon.

Tests are also being made with many types of antennae for short-wave transmission. These vary from a small antenna mounted entirely within the station to a large exterior structure more than 100 feet in the air. One of the most remarkable features of the short wave research is that signals may be sent great distances without a large antenna structure. Communication between Station 1XV and various stations in Europe, Australia and South America has been carried on regularly on an antenna system consisting of only two wires slightly more than 20 feet long and six feet apart.

A special form of transmitter has been constructed and is now being tested.

We Carry a Complete Line of Parts  
for the Following Circuits:

## RADIO AGE SUPER 9

St. James	Madison Moore
Qualitone	Samson 7C
Short Wave	Victoreen
Browning-Drake	Universal
Hammerlund Roberts	Aerodyne

Orders shipped same day received

WHOLESALE      RETAIL

## NEWARK ELECTRIC CO.

*Nothing But Radio*

226 WEST MADISON STREET

TELEPHONE  
MAIN 4627

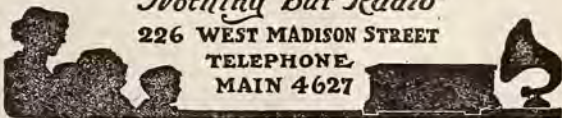

WHEN YOU BUY



TRADE-MARK

CONDENSERS

for your Radio set or your B-Eliminator, your condenser problem is a problem no longer.

Tobe Deutschmann Co.

Engineers and Manufacturers of  
Technical Products  
Cambridge, Mass.

WANTED: RADIO EXPERTS  
\$60 to \$100 A WEEK TO START!

Everywhere men who know radio are wanted. Manufacturers, distributors, dealers, broadcasting stations, want competent men. Big salaries paid. Bright future in this fast-growing business.

**OUR ENGINEERS WILL TRAIN YOU**  
Now is the time to make the big money in radio. We will train you for those big-pay jobs. A thorough, practical course in radio prepared by radio's great engineers. Get this training now at no cost to you.

**WE GIVE TRAINED MEN POSITIONS**  
We give all Ambu-trained radio men a chance to make good at big pay. Our plan enables you to start right in making money, either working for us or in your own business.

**Radio Set FREE!** Every Ambu student in radio set FREE! given an Ambu five-tube radio set from 40 to 550 meters.

Write at once for special offer.  
**AMBU ENGINEERING INSTITUTE**  
2632-J Prairie Avenue Chicago, Illinois



**FREE book**

Shows how to get — greater distance, more volume, amazing selectivity, finer tone

Science has discovered a new principle in radio amplification . . . a striking new development that is bringing unheard of results. This principle is founded upon a new kind of coil—the Erla Balloon Circleoid. It brings 4 distinct improvements. These are explained in a fascinating book just published and being mailed free.

**Edition limited—Write today**

Get this book and read about this newest scientific radio principle. See the many different circuits in which it may be used. Find out how you can turn your present set into the latest example of radio engineering—and at a remarkably small cost. There are only a limited number of these books, so you must write immediately.

Address: **Electrical Research Laboratories**  
2500 Cottage Grove Ave., Dept. 69-D, Chicago, Ill.

Please mention Radio Age when writing to advertisers







# You be the judge of its value"

Dealers who sell the Majestic "B" Current Supply are confident that it improves reception. So confident, they make you this unusual offer: Buy a Majestic today. Attach it to your set and use it for one week right in your own home. If, at the end of this time, you are not fully convinced that it gives you better radio performance—*more dependable power at less cost*—your money will be refunded!

## Economical to Operate

You couldn't want a better proposition than this. The Majestic "B" Current supply, because of its unvarying constant voltage, gives you improved tone, greater volume—all at the low cost of about one-tenth cent an hour. So you can appreciate that here is a *practical* radio investment.

Your original purchase price will be returned through operating economy alone.

## Majestic "B" Current Supply

delivers pure direct current—From your light socket

Give that set of yours the power it needs—power for any variation in tone. Then you'll have a new appreciation of radio. You will have one delightful program after another—summer evenings—winter evenings—*ALL the time!*

That's when your set is equipped with Majestic "B" Current Supply. Your set seems *Alive* with marvelous energy. You sense a new joy in radio.

You at last forget its mechanics, for a simple switch releases all the power you need for any program. Power—*clean—constant—abundant!* Power that instantly responds to high soprano, and as easily brings you the full resonance of an orchestration! Easily attached to your light socket saving you constant bother and attention.



SEE YOUR DEALER  
FOR DEMONSTRATION



## Grigsby-Grunow-Hinds Co.

4586 Armitage Avenue

Chicago, Illinois

**No Filament to Burn Out**  
All the Majestic "B" Current Supply units are manufactured complete in our factory and are equipped with the famous Raytheon Tube. (Endorsed by numerous radio engineers and editors) which is a non-filament tube with full wave rectification, no acids or back surge. Tests of the Majestic "B" on the oscillograph demonstrate that all A-C hum is eliminated.

**Majestic Standard-B**  
Especially adapted for sets having not more than seven 201-A tubes, or six 201-A plus one 135-150 volt power tube. Popularly priced for the average set. Improves tone—better reception.

Price . . . . . \$32.50  
West of Rocky Mts. . . \$35.00

**Majestic Super-B**  
Capacity 1 to 12 tubes, including the use of 135-150 volt power tubes. Complete with switch to control current from light socket.

Price . . . . . \$35.00  
West of Rocky Mts. . . \$37.50

**Majestic Master-B**  
Rating 60 mils at 150 volts. Particularly adapted for Radiola 25, 28 and 30 and Super heterodynes. Will operate all power tubes, also the new super power tube UX-171 (180 volts). Unequalled for sets having a very heavy current draw.

Price . . . . . \$42.50  
West of Rocky Mts. . . \$45.00





# QUALITY

with  
**100% Reserve Power**



**\$99.50**

## GENUINE RCA RADIOTRONS

are shipped with Freshman Masterpiece Receivers — matched and tested for each individual set. Price with this equipment (one UX 112 Power Tube; one UX 200A Detector Tube; three UX 201A Amplifying Tubes) **\$117**

## New and Improved **FRESHMAN MASTERPIECE**

### "THE ARISTOKRAT"

A one-piece Console  
of finely selected

## Genuine Mahogany

One of the finest pieces of furniture in which a radio-receiving set has ever been installed. It is truly an aristocrat with its distinctive, finely proportioned lines and rich lustrous finish.

## Equipped with the finest of CONE SPEAKERS

especially designed to bring forth the full merit of the new construction of the Freshman Masterpiece circuit. Designed for the employment of the new UX-112 Radiotron Power Tube and the necessary "C" battery connection—all metal SHIELDED front and sub-panel.

**Sold on easy terms by Authorized  
Freshman Dealers, who also  
install and service them**

CHAS. FRESHMAN CO., INC.,  
FRESHMAN BUILDING, NEW YORK  
2626 W. Washington Blvd., Chicago

Write for our beautiful new booklet illustrating  
and describing our 1927 Receivers and Accessories

# Worlds Greatest Radio!



# Scanned from the collections of The Library of Congress



Packard Campus  
for Audio Visual Conservation  
[www.loc.gov/avconservation](http://www.loc.gov/avconservation)

Motion Picture and Television Reading Room  
[www.loc.gov/rr/mopic](http://www.loc.gov/rr/mopic)

Recorded Sound Reference Center  
[www.loc.gov/rr/record](http://www.loc.gov/rr/record)



**This file including all text and images are from scans of a private personal collection and have been scanned for archival and research purposes. This file may be freely distributed, but not sold on ebay or on any commercial sites, catalogs, booths or kiosks, either as reprints or by electronic methods. This file may be downloaded without charge from the Radio Researchers Group website at <http://www.otrr.org/>**

**Please help in the preservation of old time radio by supporting legitimate organizations who strive to preserve and restore the programs and related information.**