

Blueprint Section Every Month

# RADIO AGE

*The Magazine of the Hour*



December  
1925

25¢

**Radio Age Model Receiver**  
*In this Issue*

A.P.  
MEHLUM  
25



# SM

## SILVER SIX



S-M .00035 SLF  
CONDENSERS

have been chosen for  
the new Radio Age  
Receiver. Get them  
from your Dealer.

### FACTS THE "WHY OF THE SIX"

as described in *Radio Broadcast* of November  
and December

**SELECTIVITY** is such that out of town stations may be brought to Chicago through twelve powerful local stations. Selectivity can be regulated at will, from a degree satisfactory for ordinary reception, up to the surprising limit where side-bands are cut.

**SENSITIVITY** is so great that nothing will surpass the "Six" except special laboratory-built super-heterodynes. Either coast may be brought in to Chicago during the summer months on a small antenna—in many cases on a loop.

**FLEXIBILITY** permits the use of antenna or loop with either detector, one or both stages of radio frequency amplification. Interchangeable R. F. Transformers, with adjustable antenna coupler, permit operation on all waves from 50 to 550— or higher if desired.

**VOLUME** is so great as to paralyze any but the best loud-speakers. Yet it may be adjusted to any degree by a single knob.

**QUALITY** cannot be excelled due to resistance coupled amplification. It is the only receiver that will bring real appreciation of "cone" speakers.

**CIRCUIT** consists of two stages of R. F. amplification with special oscillation control uniformly effective at all wavelengths, grid-biased detector and three stage resistance coupled audio amplifier.

**EASE OF CONTROL** allows use of one, two or three dials at will.

**TUBES** may be either dry cell or storage battery, with UV201-A's recommended. "B" Battery Consumption at 135 volts is below 10 milliamperes— less than one-third that of other six-tube receivers.

**ASSEMBLY** requires but a few hours, using only parts supplied in kit.

### claims vs. PRAISE

The new "Six" by McMurdo Silver lays claim to a marvelous selectivity—an uncanny ease of control—a tone quality beyond belief—sensitivity that makes DX work fascinating—volume more than sufficient. Here you have the reports of two builders who were among the first to buy Silver Six Kits. The claims are justified.

#### from a Haberdasher

*Mr. L. H. STREETER, Chicago, Ill.*

"Two weeks ago I purchased your 'Silver Six' Kit . . . constructed it easily and quickly . . . logged seventeen out of town stations Tuesday evening through Chicago locals . . . only one mile from WQJ . . . KOA comes in at 40, WSAI at 40 1-2 and WLS at 41 1-2 . . . able to separate each. Recommend Six for ease of tuning and volume . . . wrecked a small cone speaker with volume from local station. . . . Sure is a wonder!"

#### from an Auditor

*Mr. V. H. PLENGE, Chicago, Ill.*

"Your 'Six' gets wonderful results . . . nothing to outperform it. . . . Second station I got was KOA . . . on Monday logged 21 stations with clarity and volume equal to locals . . . found set extremely simple to wire . . . completed job in 3 hours . . . Six has a fine tone and an unusual degree of selectivity."

#### Mail this Coupon

Silver-Marshall, Inc., Chicago, Ill.  
Gentlemen: Please send me:

A—Complete building data on the Silver "Six,"  
for which I am enclosing 50c.

B—Descriptive circulars on S-M Products.

Name \_\_\_\_\_

Type 600 Kit including all parts necessary to build the complete "Six" **\$53.00**

Type 610 Kit, essentials only, including 3 condensers, 3 inductances and 3 inductance sockets. **\$27.75**

See These and Other S-M Products at Your Dealers

## Silver-Marshall, Inc.

114 South Wabash Avenue

CHICAGO



# Earn \$50 to \$200 a Week in RADIO

You can! Hundreds of ambitious men are already earning thousands of dollars in this wonderful new industry—you, too, can get your share. Mail coupon below for Free Book which describes fully the amazing money-making opportunities in Radio and tells you how YOU can earn from \$5,000 to \$10,000 a year.

THE astounding growth of Radio has created thousands of big money opportunities. Millions of dollars were spent during the past year on Radio, and thousands of young men are needed right now to meet the ever-increasing demand of work.

Men are needed to build, sell and install Radio sets—to design, test, repair—as Radio engineers and executives—as operators at land stations and on ships traveling the world over—as operators at the hundreds of broadcasting stations. And these are just a few of the wonderful opportunities.

## Easy to Learn Radio at Home in Spare Time

No matter if you know nothing about Radio now, you can quickly become a Radio Expert, by our marvelous new method of practical instruction—*i n s t r u c t i o n* which includes all the material for building the latest up-to-date Receiving Sets.

Scores of young men who have taken our course are already earning

from \$75 to \$200 a week. Merle Wetzel of Chicago Heights, Ill., advanced from lineman to Radio Engineer, increasing his salary 100% *even while taking our course!* Emmet Welch, right after finishing his training, started earning \$300 a month and expenses. Another graduate is now an operator of a broadcasting station—PWX of Havana, Cuba—and earns \$250 a month. Still another graduate, only 16 years old, is averaging \$70 a week in a Radio store.

## Wonderful Opportunities

Hardly a day goes by without our receiving urgent calls for our graduates. "We need the services of a competent Radio Engineer." "We want men with executive ability in addition to Radio knowledge to become our local managers." "We require the services of several resident demonstrators"—these are just a few small indications of the great variety of opportunities open to our graduates.

Take advantage of our practical training and the unusual conditions in Radio to step into a big paying position in this wonderful new field. Radio offers you more money than you probably ever dreamed possible—fascinating, easy work—a chance to travel and see the world if you care to, or to take any one of the many Radio positions all around you at home. And Radio offers you a glorious future!

The National Radio Institute is America's Pioneer Radio Home-Study School—established in 1914. Our course is an absolutely complete one which qualifies for a government first-class commercial license. It trains you for *bigger* paying jobs in Radio.



## Send for FREE RADIO BOOK

Learn more about this tremendous new field and its remarkable opportunities. Learn how you can quickly become a Radio Expert and make big money in Radio.

We have just prepared a new 48-page book which gives a thorough outline of the field of Radio—and describes our amazing, practical training in detail. This Free Book, "Rich Rewards in Radio," will be sent to you without the slightest obligation. Mail coupon for it *now!*

For a short time we are offering a reduced rate to those who enroll at once. Act promptly and save money.

## National Radio Institute

Dept. 53-OB  
Washington,  
D. C.



## NATIONAL RADIO INSTITUTE. Dept. 53-OB, Washington, D. C.

Please send me without the slightest obligation your Free Book, "Rich Rewards in Radio," and full details of your Special Free Employment Service. Please write plainly.

Name: \_\_\_\_\_  
Address: \_\_\_\_\_  
City: \_\_\_\_\_ State: \_\_\_\_\_

**PAY INCREASES OVER \$100 A MONTH**



I am averaging anywhere from \$75 to \$150 a month more than I was making before enrolling with you. I would not consider \$10,000 too much for the course.  
(Signed) A. N. LONG,  
Greensburg, Pa.

**DOUBLES SALARY**



I can very easily make double the amount of money now than before I enrolled with you. Your course has benefited me approximately \$3,000 over and above what I would have earned had I not taken it.  
T. WINDER,  
Grand Junction, Colo.

**FROM \$15 TO \$80 A WEEK**



Before I enrolled with you I was making \$15 a week on a farm. Now I earn from \$2,080 to \$4,420 a year, and the work is a hundred times easier than before. Since graduating a little over a year ago, I have earned almost \$4,000, and I believe the course will be worth at least \$100,000 to me.  
(Signed) C. E. O. ADAMS,  
Tamaqua, Pa.



# RADIO AGE

The Magazine of the Hour

Established March, 1922

Volume 4

December, 1925

Number 12

## CONTENTS

Cover Design by Anker P. Mehlum

Radio Age Model Receiver.....	7
By the Technical Staff	
A Receiver that Employs Inductive Gang Control.....	15
By H. Frank Hopkins	
Making Radio for Quality.....	17
By S. R. Winters	
Tuned R. F. and Regeneration.....	19
By Brainard Foote	
Tuning with Chart Curves.....	21
By Bertram C. Rogers	
More Pictures of Models at the Radio Show.....	22-23
What Constitutes a Good Variable Condenser.....	24
Back from the Arctic.....	25
What the Broadcasters Are Doing. Feature Section.....	28-38
RADIO AGE Blueprint Section—A 3 Tube Inductive Coupled Feedback Receiver.....	39-46
By John B. Rathbun	
Pickups and Hookups by Our Reader.....	47
Corrected List of Broadcasting Stations.....	66, 68, 70

Radio Age is published monthly by RADIO AGE, Inc.  
Member: Audit Bureau of Circulations.

Publication Office, Mount Morris, Ill.  
404 North Wesley Ave.

Address all communications to RADIO AGE, Inc.  
Executive, Editorial and Advertising Offices  
500 N. Dearborn Street, Chicago, Ill.

FREDERICK A. SMITH, *Editor*  
F. A. HILL, *Associate Editor*  
FRANK D. PEARNE, *Technical Editor*  
M. B. SMITH, *Business Manager*

*Advertising Director*  
HARRY A. ACKERBURG  
500 N. Dearborn St., Chicago, Ill.

*Eastern Representative*  
DAVIDSON & HEVEY, 17 West 42nd St., New York City

*Pacific Coast Representative*  
V. M. DEPUTY & ASSOCIATES, 515 F. W. Braun Bldg.,  
Los Angeles, Cal.

Final Advertising forms close on the 20th of the 2nd month preceding date of issue

Vol. 4, No. 12. Issued monthly. Subscription price \$2.50 a year. December, 1925.  
Entered as second-class matter at post office at Mount Morris, Illinois, under the Act of March 3, 1879.

Copyright, 1925, by RADIO AGE, Inc.

## A Chat With the Editor

IT IS noteworthy that, in presenting our Radio Age Model Receiver, Type H, in this issue, we are not claiming that it will set the technical world afire. It is not revolutionary, not radically different. But we do claim that it is a good circuit and that it is well worth the while of the set-builder to build one like it. We also believe we have presented the instructions and blueprints, drawings and photographs in such a manner that the experimenter can build the receiver with a minimum of time and trouble. Our technical staff has constructed, tested and proved the circuit and you may assemble it with assurance that it will give you distance, volume and a pleasurable degree of selectivity.

We foresee, however, that some readers will hail one or two elements of this receiver with enthusiasm. For example the owner of a neutrodyne, by studying this hook-up will find a way of changing coils in his set that will enable him to get better results without feedback, insuring maximum amplification over practically the entire American wave band. The circuit also makes use of twin resistances restricting the plate voltages to prevent undesired oscillation.

Another type of the Radio Age Model Receiver will be described in complete detail in the January issue of this magazine. Progress already made with this model, which we are calling "Type HX" indicates that it will thoroughly satisfy the ambitions of the set-builder who wants performance and quality in his home-built set. There will be other types in later issues.

We suggest particularly that you do not miss the January issue. It is our honest belief that it will be a liberal education in set-construction to any fan who follows these types of the Model Receiver as they are developed from month to month.

*Frederick Smith*

Editor of RADIO AGE



**EVEREADY HOUR**  
EVERY TUESDAY AT 9 P. M.  
*Eastern Standard Time*

For real radio enjoyment, tune in the "Eveready Group," broadcast through stations—

- |                  |                  |
|------------------|------------------|
| WEAF New York    | WCAE Pittsburgh  |
| WJAR Providence  | WSAI Cincinnati  |
| WEEL Boston      | WWJ Detroit      |
| WTAG Worcester   | WCCO Minneapolis |
| WFI Philadelphia | WOC St. Paul     |
| WGR Buffalo      | WOC Davenport    |
| KSO St. Louis    |                  |

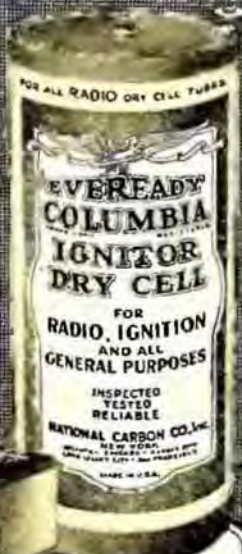

No. 764  
Portable  
22½-volt  
Vertical  
Price \$1.75



Eveready Columbia Ignitor "A" Battery, the proven dry cell for all radio dry cell tubes 1½ volts



No. 779  
22½-volt  
Large  
Vertical  
Price \$2.00

No. 771  
4½-volt  
"C"  
Battery  
Price 60 cents



# For radio economy

EVEREADY Radio Batteries are noted for their long service and economical operation. They are made in different sizes and types so that every radio user can enjoy the economy and convenience to be had by fitting exactly the right Eveready to his receiver. The five dry cell types of Eveready Radio Batteries are here illustrated and described to make it easy for you to decide just which will give the longest and most economical service on your set. A dealer near you sells Evereadys.

*Eveready Heavy-duty "B" Battery for four or more tubes*

No. 486. *Extra-large Layerbilt*. 45 volts. Vertical. Eveready's latest contribution to radio. The new Layerbilt construction which gives much greater service. Same size as No. 770. Price \$5.50.

*Eveready "B" Battery for one to three tube sets*

No. 779. *Large*. 22½ volts. Vertical. Especially adapted for Radiola 25, DeForest D-17 and Operadio receivers. Same capacity as No. 766, and suitable wherever variable taps are not required. Price \$2.00.

*Eveready "B" Battery for portable sets*

No. 764. *Portable*. 22½ volts. Vertical. For portable sets where medium weight and size are permissible. Price \$1.75.

*Eveready "A" Battery*

Eveready Columbia Ignitor Dry Cell Radio "A" Battery for all dry-cell tubes. 1½ volts. The dry battery used by vacuum-tube engineers in developing the dry-cell tube.

*Eveready "C" Battery*

No. 771. 4½ volts. Saves "B" Batteries, improves tone. Price 60 cents.

*Manufactured and guaranteed by*

**NATIONAL CARBON COMPANY, Inc.**  
New York San Francisco  
Canadian National Carbon Co., Limited, Toronto, Ontario

# \* EVEREADY Radio Batteries

- they last longer



No. 486  
45-volt  
Layerbilt  
Extra-large  
Vertical  
Price \$5.50



# RADIO EDITORIALS

**M**R. W. WITT BURNHAM, head of the Burndept Company, London, England, manufacturers of loud speakers, is seeking a market for his goods in the United States. For this reason it is puzzling to encounter a letter written by Mr. Burnham and published in "The Wireless Trader," a London periodical, in which Mr. Burnham accuses American manufacturers of "dumping" inferior radio apparatus on the English market. The letter recites what purports to be a review of the efforts of American manufacturers to sell their last season's merchandise in the United States and continues:

"These operations proving unsuccessful, the American manufacturer is now trying to unload his last season's stock on the world; to make room for his 1926 models which, I am given to understand, will be of entirely different patterns."

The point that puzzles us is the fact that Mr. Burnham launches such a general attack on American manufacturers simultaneously with his effort to make friends in this market. Observe his candor in the closing paragraph of his letter:

"Finally, I would urge your readers to keep the British Wireless Trade in British hands. Do not send unnecessary dollars to America. The British manufacturers know exactly what is wanted to please the British public, and they can produce enough—and some to spare."

Mr. Burnham's views are to be accepted as representative for he is chairman of the National Association of Radio Manufacturers and Traders.

The editor of "The Wireless Trader" readily acquiesces in Mr. Burnham's request that his letter be published. Going a step further, he writes an editorial indorsing Mr. Burnham's views and giving them even stronger expression. The London editor says:

"It is admitted that there are many unique points of design and practice in American apparatus; but these are peculiarly suited to reception conditions such as those which obtain in the United States, and are of extremely little use in Great Britain. Moreover, so far as tone quality in reception is concerned, although there is still room for improvement, British apparatus is much better than any produced in America."

The editor concludes with the following paragraph:

"In short, it is an irrefutable fact that British manufactured apparatus is best for the British market. Therefore do not be deluded by the big talk and flashy productions."

The English editor reminds his readers of the national slogan "Buy British Goods." We have no quarrel with the editor regarding the slogan. We believe sometimes that Americans would do well to adopt a similar slogan. But we believe even British readers of our magazine will agree with us that the criticisms in the letter of Mr. Burnham and in the editorial of the London periodical lose much of their force because of the fact that they are so sweeping in their character. We are compelled to admit many American receiving sets would not work well on the higher wave lengths used by broadcasting stations in the British Isles. But neither critic makes any distinction between the

American sets offered for sale in England. Neither do they exclude American parts and accessories from their attack.

The writer of this editorial has spent considerable time in England and in Continental Europe making observations of broadcasting conditions and radio apparatus and we want to go on record as saying that much of our American apparatus compares very favorably with that manufactured abroad. It occurred to us that American receiving sets are much more simple in operation and fully as effective in results as those we saw in London. The gentlemen appear to have erred in over-stating their case and in making their assertions too general.

As editor of an American radio magazine of pronounced technical tendencies, it has been our privilege to personally inspect a great deal of radio equipment produced by manufacturers in all parts of the United States. We have taken pride in the universal effort of those manufacturers to make *good* merchandise. We have marvelled at the refinements which have been added to these products. We have not been surprised at reading the official figures on the increase of our export business. It has not escaped our attention that American radio goods are finding an encouraging reception in Canada and Australia. There may be unscrupulous manufacturers who are trying to "dump" inferior stuff on English markets but we know of many important American manufacturers who are building parts and accessories on sheer merit and who are trying to merchandise them abroad without apology or the necessity of apologizing. We know of an English loud speaker that is really good and which is being sold in America. We believe that several American loud speakers surpass this English instrument in quality of performance. But it would scarcely occur to us to make that fact the basis for an appeal to our readers to boycott English goods.

**T**HIS number of RADIO AGE finds us at the close of our fourth year in the radio publication field. It is pleasing to us to be able to announce that this last issue of 1925 has by far the biggest press run in our history.

**T**HERE are still many individuals who believe that newspapers have difficulty in finding a sufficient number of news items to "fill up." Editors, on the contrary, will tell you they throw away vastly more news than they print. They could publish many more pages of news and still have a reserve supply. But the quality of the newspaper would suffer from its lack of editorial selection and condensation. Could not many broadcast stations take a leaf from the editor's book? Would it not be better to broadcast only what was excellent than to establish an arbitrary period of time and set about filling that period at the expense of selection and condensation? The question as to whether there are too many broadcasting stations is open to argument. That many broadcasting stations do entirely too much broadcasting is not open to argument.



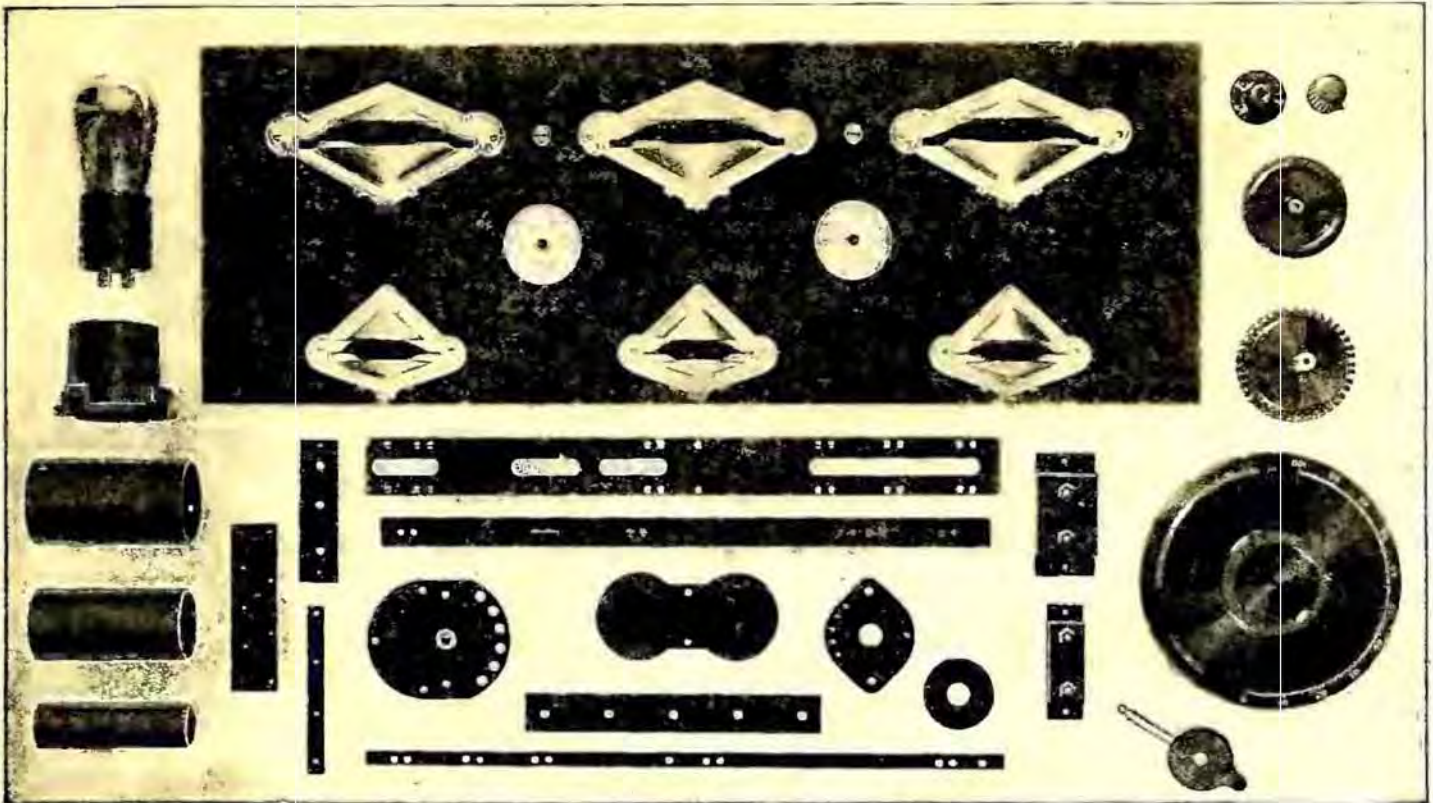

## Imagine a Radio Set stripped of these parts

What a useless collection of wood, wire and metal it would be. Realizing that the parts, and accessories shown here are wholly or partly of Bakelite, gives you a vivid picture of its importance to Radio.

Today Bakelite is used in a greater variety of radio parts than ever before—and the number grows constantly. This dominance of Bakelite in radio

reflects the experience and the opinions of radio manufacturers, great and small.

Radio set and parts manufacturers have every facility for testing all insulation materials and over 95% have standardized on Bakelite. This indicates how really important it is for you to make sure that the set or parts that you buy are Bakelite insulated.

Write for Booklet 31

### BAKELITE CORPORATION

247 Park Avenue, New York, N. Y.  
Chicago Office: 636 West 22d St.



Bakelite is an exclusive trade mark and can be used only on products made from materials manufactured by the Bakelite Corporation. It is the only material which may bear this famous mark of excellence.

# BAKELITE



**BAKELITE**  
is the registered trade mark for the phenol resin product manufactured under patents owned by the Bakelite Corporation.

THE MATERIAL OF A THOUSAND USES

Tested and Approved by RADIO AGE



**Ozarka Senior Console—\$197.50** East of Rockies  
Complete with Tubes, Batteries and Speaker



The Sweetest Story  
Ever Told



# If Your Radio is Bought Right It Will be a Life-Long Pal

**A** LITTLE more time, a little more care in making the selection in the first place generally tends to more lasting satisfaction.

Out of every 100 Ozarka's sold in 1922 only eight are not today in the hands of the original owners—this does not include 17 out of each 100 who have purchased later Ozarka models in newer type cabinets. If there is a single Ozarka that is not in active service today, we have never heard of it.

Without the Ozarka Service in charge of direct factory trained representatives, such a record would not be possible. Ozarka service can be had today in almost every country. Purchasers in South Africa, Alaska, Sweden, Newfoundland, New Zealand, and Japan all receive the same practical service as those in Canada, United States, Mexico and Cuba. Whenever you find the sign of the Ozarka long distance goose, you'll find a man who knows Ozarka instruments perfectly.

If such service added more to your cost price it might be a matter to consider, but it doesn't. Quality for quality you'll find Ozarka prices lower—four tube Ozarka's with built-in loud

speakers retail for \$58.00—five tube with built-in speaker \$64.00, up to solid walnut console design, \$160.50.

Our nearest representative will gladly set up an Ozarka in your home, without any obligation whatever. He won't tell you what it will do—he will let you do all the tuning. With the Ozarka you must satisfy yourself, as to distance, tone, volume, ease of tuning and selectivity.

More than this you will be very agreeably surprised at Ozarka prices—selling as we do, thru our own direct factory representatives, our selling expense is very low—we give Ozarka purchasers the benefit of it.

Where is there a value to compare with the one shown above—solid walnut cabinet (no walnut finish or veneer), imported English loud speaker of a marvelous tone, five tube instrument with 75 ampere Exide storage battery, 90 volts of Eveready "B" battery, 5 tubes, aerial equipment all erected and the price is only \$197.50.

## A Few More Men are Needed to Sell Ozarka

In a great many counties we have the man we want. He is rapidly building up a permanent and profitable business of his own because he has an instrument that will more than meet all competition. More than this, he is trained to back up his sales with the kind of service that counts.

Many well established Ozarka representatives started by giving us only their spare time—their evenings. If your county is open you can do the same.

The investment in cash is very small. The investment in time necessary for study is considerable. It requires patience, but the results have enabled many men to get out of the salary and time clock class.

Any previous sales experience is helpful but not necessary. We can and will teach you how to sell.

### Send for 84 Page Book— "The Ozarka Plan"



This book is entirely too expensive to be sent out on postal card requests. It will be sent FREE to any man who mails the coupon below and who is really anxious to improve his condition. Tell us about yourself—ask for Ozarka Plan No. 100 and don't fail to give the name of your county.

# OZARKA

122 Austin Avenue A  
Chicago, Illinois



Ask the Man Who  
Wears this Button

# INCORPORATED

122 Austin Avenue A  
Chicago, Illinois

Gentlemen: Without obligation send book "Ozarka Instruments No. 200" and name of Ozarka representative.

Name.....  
Address..... City.....  
County..... State.....

Gentlemen: I am greatly interested in the FREE book "The Ozarka Plan No. 100," whereby I can sell your radio instruments.

Name.....  
Address..... City.....  
County..... State.....

\* Tested and Approved by RADIO AGE \*



# RADIO AGE

## The Magazine of the Hour

M. B. Smith  
Business Manager

A Monthly Publication  
Devoted to Practical  
Radio

Frederick A. Smith  
Editor

## An R. F. Receiver You Can Rely On— The Radio Age MODEL Receiver

**I**N presenting to its readers the present Radio Age Model Receiver this magazine believes it is making a distinct contribution to the sum total of the average readers experience in set building, in that the article to follow is written coincident with the construction of the set; it follows the newspaper form of reporting an event in the greatest detail consistent with making such narrative personal and readable.

The Model H was selected after receiving quite a bit of data from fans and others who seem to center their preference on a five tube set. Straight radio frequency amplification, with a variable means of controlling regeneration was adopted in order to prevent as much grief as possible in the construction and operation of the set. Despite the vast amount of knowledge on the subject of radio we feel there is still room for independent thinking on the part of serious minded experimenters and manufacturers. Consequently in the presentation of this article we would like to have the comments, adverse or favorable, of our readers, regardless of whether they are fans, technicians or manufacturers. The series has been contemplated to reach well into the next year and in that period there will be many opportunities for putting into practice in an actual receiver some of the best suggestions brought forth by a discussion of this set.

As has been previously announced the Model H will be exhibited by the Radio Age in its booth at the Chicago Radio Show and after the exposition it will be given away, details of circumstances governing the award being made known to every visitor at the Radio Age booth.

The idea of an intimate and informal recital of the various steps taken in the assembly of this model we believe will be welcomed alike by the novice or the advanced student of radio. If there are short cuts in such construction, or if handy kinks occur to you as you follow us on this personally conducted tour, do not hesitate to let us have the advantage of your suggestions or criticisms. We hope to make Radio Age the clearing house or forum for all the worth while

By Radio Age Technical Staff  
(Copyright: 1925)

### Latest Refinements Added to Furnish Distance and Tone

technical and practical data on radio as it is applied to ordinary uses. We can neither be too technical nor inane; simple in our work; rather we must adopt a middle ground in which good American common sense plays a leading part.

#### Here We Go

Since we are not making a manufactured set for the market we have a little more latitude in the construction of the Model H. The progressive system of construction, in this particular instance, seems best adapted to properly and clearly conveying the ideas to the mind of the reader. In all this work there should be continuity or sequence, at least electrically. Thus we can build the set from left to right in the order in which the various units and parts perform their respective functions.

#### The Baseboard

Perhaps a prettier model might be made if sub-base work were resorted to, but we believe there is still ample justification for the pine baseboard, with the panel firmly affixed to the front edge by a number of long screws. Further bracing, with small angle braces, can be used effectively if the set is to undergo much handling. The baseboard size has been determined upon as seven-eighths of an inch thick; nine and a half inches wide, and twenty-five inches long. The length of the baseboard is a half an inch shorter at each end than the bakelite panel, which is a 7 by 26 by 3/16, in order to allow the placing of the completed panel in any kind of a cabinet without the baseboard touching cabinet walls. For home use we would not treat the base-

board but since it is to be exhibited, we will use a coat of asphaltum paint, the kind used on storage batteries, there being no paraffin handy.

#### The Panel

We now take our bakelite panel, get a T square or some other square and lay it out. First run a line from end to end of the panel 3 1-2 inches down from the top. This divides the panel equally since it is a 7 inch panel and gives us a straight line all the way across. By previous temporary layout of the material on hand we decide to put the first variable condenser with its center two and a half inches from the left edge of the panel. The second variable is 5 inches from the first one, center to center, and the third one is 5 inches from the second. Five inches from the third condenser is the center for the meter hole. Two inches down from this center and square with the center hole above, is the hole for the rheostat for the detector stage. Back up again to the center line and taking 4 inches from center of the meter hole we put another punchmark for the combination switch and pilot light; then three inches from that we have the hole for the phone jack. This almost completes our work on the center line. Using the templates that come with the condensers we set and punch for the three condensers. Not having a template use one of the three point centering punches, several makes of which can be found on the market. The lineup on the panel along the center line, reading from left to right, is as follows: first variable, second variable, third variable, voltmeter (with rheostat below it) filament switch and finally the hole for the jack.

Now draw a line 7/16 of an inch from the bottom of the panel, running the line all the way across the panel. This will give you the line for the holding screws for the panel. Put a mark at 13 inches (half the length of the bakelite). Then halve the distance between the center and the left edge; then halve the distance between the center and right edge. This will give you three holes for mounting the panel against the baseboard. Put another hole an inch and a



half from the right end of the panel, and one the same distance from the left edge. This will give five holes in all and will be enough to hold any panel under most any circumstances.

Ten inches from the left edge of the panel and one and a quarter inches down make another punchmark for the twin-resistor. This concludes the punchmarks on the panel. Make them very lightly at first if you are not sure of yourself. Re-check your measurements and if o. k., then go ahead with a heavier punch-mark so the drill will not slip out and cut wrong position.

#### Cutting Big Holes

For cutting the meter hole, take a pair of compasses and scribe a circle two and one-sixteenth of an inch in diameter. If you have a fly-cutter the job will be easy. If not make a number of punch marks around the scribed circle and drill small holes around the circle, later cutting from hole to hole with a sharp instrument until the circle is complete. Clean with a rat-tail file. Fortunately for us we resurrected, from the dust of a generation, the old foot power scroll saw and managed to make a very nice job out of what might otherwise have been a tedious process.

#### Oh! for Single Mountings

Anyone who has assembled more than one radio set will join with us in wishing for the universality of the single hole mounting applied to everything that is attachable to a panel. Everything on the panel is single mounting except the three condensers; four holes apiece must be drilled for them. The centers and three holding screw holes for the condensers should be made in accordance with the directions accompanying the condensers. We always ream the center hole out large enough to obviate the possibility of binding on the shaft. The holes for the holding screws should be countersunk in order to allow the screw heads to go up snug and smooth with the surface of the panel.

From the time we started out with the baseboard until the present moment when we have finished drilling the panel two hours have elapsed. See how much time you can cut off that. If you have successfully withstood the fumes of the carbolic acid, iodine, permanganate of potash and other hospital odors that greet you when drilling panels, you are now ready to take the next step, which is the assembling of the material on the

baseboard and putting in the lower wiring before parts are placed on the panel.

#### Socket Line

Mark off a line three inches from the panel on the baseboard for the socket line. Four inches from the left end of the baseboard make a punch mark for the screw on the left side of the Benjamin sockets which are being used. Five inches to the right of this mark will be the left hole for the second socket. Six and a half inches is the distance from the second to the third socket screw hole. From the

socket which is the cushion type, allowing the tube to float on spring contacts. This gives you an opportunity of making a solid wire assembly direct to the sockets instead of using flexible wire assembly, contributing somewhat to the finished appearance of the set. Place the sockets so the filament connections are towards the panel, this putting the grid on the left and the plate on the right, away from the panel. If you happen to strike an unusually tough baseboard and have difficulty in running up the screws, take a bar of laundry soap and soap up the screws; you'd be surprised how easy they go in after such treatment. After you have screwed down the sockets take a square edge and lay along the line to see that all sockets are straight; this will help later in running your wire. Slight discrepancies in alignment can be equaled through unscrewing the sockets; the play in the screw holes will generally be sufficient to throw them all in line unless you have been too careless in marking off the socket line.

#### Low Potential Lines

To facilitate laying of the negative and positive A wires, grid returns and other points of low potential, it is suggested you do not have anything mounted on the panel. Let the panel be attached to the baseboard (if necessary you can drill it in this position, probably better than laying on the bench). Then go ahead with your negative A line. Refer to Fig. 1, which is the schematic of Radio Age Model H. All wiring should be done from the schematic, never the isometric plan or any other view of a set, since it

is generally assumed the schematic is always correct electrically, whereas errors can creep into perspective drawings.

For hooking up the sockets and other units we will make use of a time saving device known as a soldering lug. The kind which we used, made by the Kellogg people, has a generous soldering surface and saves considerable time that would otherwise be spent in making loops and curleycues. In addition we can make a much more symmetrical job. The left hand lower binding post on all the sockets is negative A. This line can be run straight from the first socket on the left over to the extreme right and then around to the binding post panel at the right rear of the baseboard.

#### Binding Post Strip

At this point it would be a good idea to put on the binding post strip attached  
(Turn to page 10)

## LIST OF PARTS

- 3 Silver-Marshall .0005 S. L. F. Variable condensers.
- 3 Henninger type "D" r.f. transformers.
- 2 Erla Concert Grand audio transformers.
- 1 Bremer-Tully twin resistor, variable.
- 3 X L variodensers, 2 type N, 1 type G.
- 5 Benjamin Cleratone sockets for 201-A tubes.
- 4 Amperites for 201-A tubes.
- 1 Bradleystat.
- 1 Jewell 0-8 d.c. voltmeter.
- 1 Yaxley combination switch and pilot light.
- 8 X L metal spring binding posts.
- 3 Bremer-Tully vernier dials.
- 1 Daven 1 meg grid leak.
- 1 Muter 1 mfd bypass condenser.
- 1 Muter .001 mfd bypass condenser.
- 1 Apex choke coil.
- 1 Pacent single circuit jack.
- 1 Pacent phone plug.
- 1 Bakelite panel 7 x 26 x 3-16.
- 1 Kodol microphone type loud speaker.
- 1 American Electric loud speaker unit.
- 1 Seaman-Jones enclosed loud speaker.
- 1 General Electric 2 ampere Tungar.
- 3 DeForest tubes, 2 r.f. and 1 detector.
- 2 Daven tubes, 1 MU20, 1 MU6.
- 1 4.5 volt Ever-Ready C battery.
- 2 Ever-Ready 45 volt block B batteries.
- 1 Six volt World A battery.
- 1 Cabinet, Newark Electric Co.
- 1 Jefferson tube rejuvenator.
- 100 Kellogg connection lugs.
- 100 Feet Belden enamel antenna wire.
- 20 Lengths square Dudlo bus bar wire.

(While the above parts were used in the December Model H, any parts of equal merit may be consistently used in the construction of such a receiver.)

third to the fourth the distance is  $3\frac{3}{4}$  inches, while from the fourth to the fifth socket screw hole is four inches. This lines up your sockets so they center between the three variables and are fairly well spaced at the audio end of the baseboard. Before screwing down the Benjamin sockets be sure all the hexagonal nuts on the four binding posts are up tight. Do not exert too much force in tightening the hex nuts or you might either strip the thread or throw the spring out of alignment. For hurriedly running up the binding posts on these sockets a set of Stevens "spin-tite" wrenches will prove quite handy. Since you have a socket line marked off the left hand screws (round head wood screws) can be put in to hold the sockets in place. True them up against the line by sighting through the right socket hole, then put the screw in the upper right corner. Only two screws are necessary to hold down this kind of



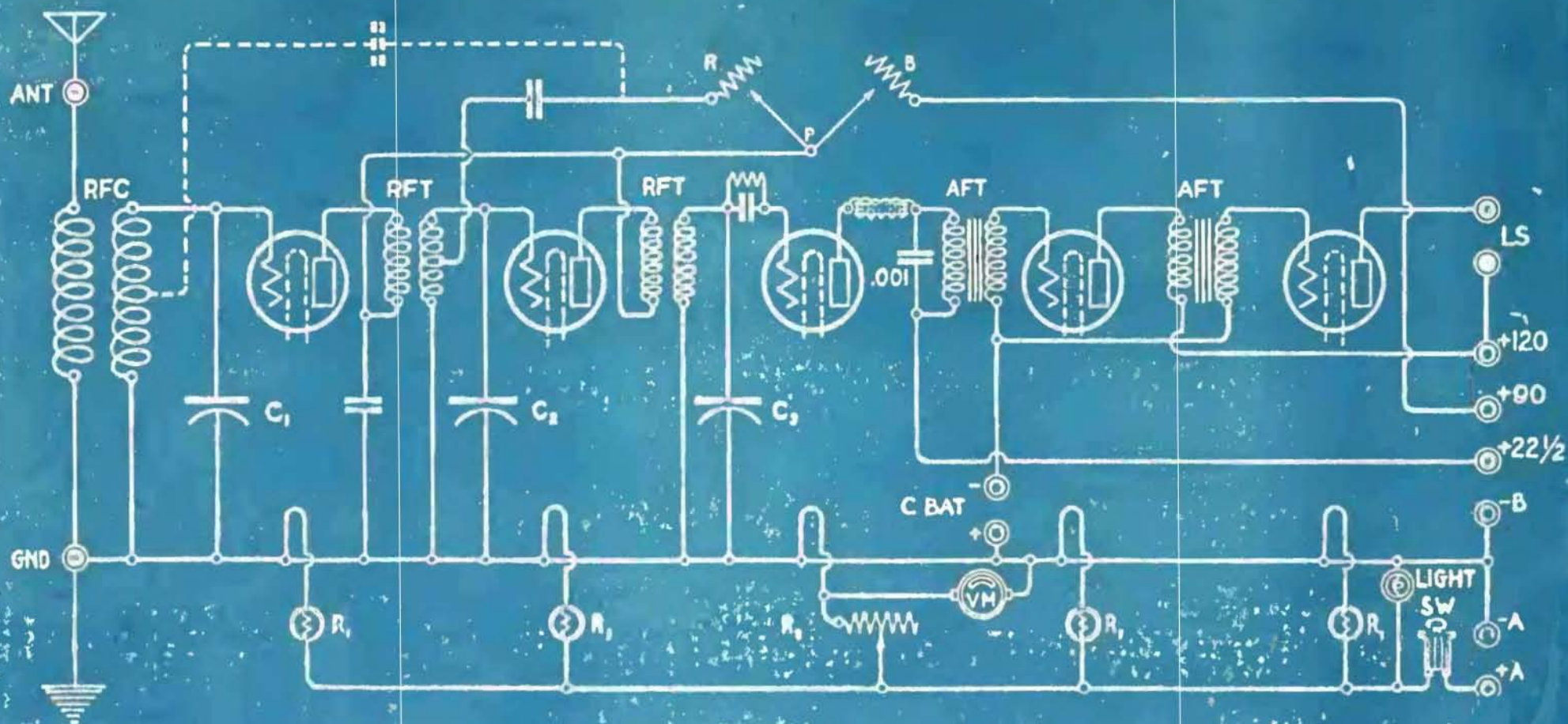

Fig. 1  
**RADIO AGE MODEL "H"**  
 TUNED R.F. RECEIVER  
 DECEMBER  
 1925



to the rear of the baseboard. In this set 8 binding posts are used made by the XL Radio Laboratories, who also make the XL variometer which we are using in this model. Reading from right to left the binding posts which are located about 7/8 of an inch apart are as follows: plus A, minus A, minus B, plus C, minus C, plus 22 B, plus 45 B and plus 90 B. Each one of the binding posts is fitted with a soldering lug so connection can be easily made from the rear of the strip, which is about 8 inches long and one and a quarter inches wide. It can be made of bakelite or hard rubber and should be affixed to the edge of the base. These details may be seen from Fig. 2 which is an isometric sketch showing all parts in their proper relation. Also see Fig. 3 which is a photograph of the set looking down upon it and showing all units in place but not wired. Figure 4 is the same photograph with the exception that all wiring is shown as in the completed job. Figure 5 gives a front view of the Radio Age Model H. It might not be a bad idea to scan all the diagrams and photos carefully before going ahead so as to get a strong mental image of the layout as you go.

With the sockets in position, the binding post strip secured to the extreme right edge of the baseboard in the rear, the r. f. coupler and transformers in place and the audio transformers located, we are ready to go ahead with the soldering.

#### Soldering the Set

Many of our readers have asked us regarding the best manner of soldering. Our preference is for rosin core solder with a cleaning solution made up of a saturated solution of rosin in alcohol. This acts as an excellent flux and you need not worry about corrosion. Do not use acid core solder or any acid flux. Acid flux has cost many a manufacturer a good sum in returned sets (this applies principally to the early days of the broadcast craze). If you

have an electric iron some time may be saved in the soldering, otherwise you will probably have to chase back and forth between the set and the kitchen range, unless you have a Bunsen burner in the work shop. A five cent lump of sal-ammoniac on the bench onto which you occasionally rub the iron will serve to keep it from burning off and keep it well tinned.

We have a personal preference for straight lengths of square busbar wire although the round may be used; in fact any kind of wire may be used but for speeding and prettifying up the job either the square or round busbar is best. Wire used in the Model was furnished for this occasion by the Dudlo Manufacturing Co.

Having put a soldering lug on each of the left hand filament posts and made it tight, take a pair of long nose pliers and turn the hole end of the lug so the hole points along the line of the sockets. This means to turn the hole on the lug at right angles to the position it normally occupies. In this position you can feed busbar wire straight through from the first to the fifth socket all in one piece. Put a tiny drop of alcohol-rosin flux on the wire and the lug and solder with a good hot iron. Solder each one of the lugs. At the extreme right of the set allow the wire to project a little beyond the socket line as you will make a turn here to lead the wire to the negative A binding post on the strip in the rear. The wire and the lugs are now elevated a little above the floor of the baseboard. Push each lug down carefully, one lug with each thumb, so the wire lays flat along the board. This is now your low potential line and may be left uninsulated if desired. All grid returns, etc., are made fast to this line as you will observe in the schematic diagram, Fig. 1.

#### Ground Wire.

The low potential line is also your ground line so the ground tap on the

first Henninger D coil may be run straight toward the panel to meet the negative wire. It is this wire to which all rotors of the condensers are attached.

As stated before a single piece of wire may be used as the base line onto which may be soldered all the negative filament connections, grid returns from the three variable condensers, the rotors of the three condensers, the plus of the C battery (unless you wish to include this battery on the wiring shown on the binding post strip) the ground connection, and grounded side of the 1 mfd bypass condenser whose other connection is to the common tap at the bottom of the two primaries of the r.f. transformers.

For simplicity's sake consider the left hand filament terminal on the socket the negative and follow Fig. 1, the schematic, in wiring up everything. After getting in all the wiring that is common with the negative terminal, you can run a wire over to the negative A binding post on the strip, this being common with the negative B and positive C battery leads.

#### Positive Line

Next comes the positive A line which takes in the Amerpites in the positive line to the first, second, fourth and fifth tubes. In the third tube you will note a Bradleystat to provide variable filament voltage for the soft detector, if one is used. The Jewell 0-8 d.c. voltmeter is connected from the negative of the A to the right hand filament terminal on the third socket so as to give you actual voltage applied to the detector. The Amerpites will take care of proper voltage to the balance of the tubes. The combination switch and pilot light, made by Yaxley, should be connected between the positive A and the last Amerpiterite as shown in Fig. 1. The light acts as a warning the set is still on; probably intended for some of our radio fans who have a tendency to nap while listening and who might forget the set was on if a

(Turn to page 12)

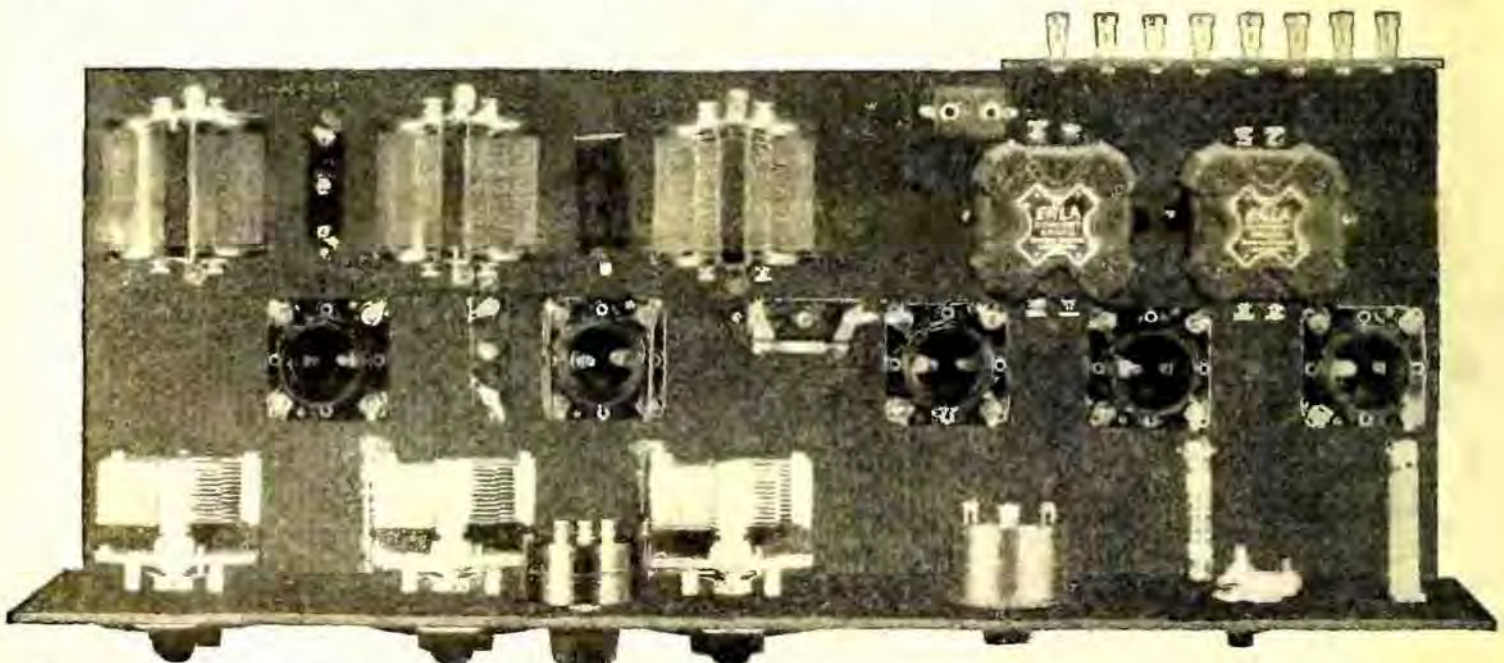

Fig. 3. Photograph of Radio Age Model taken from above, showing all parts in position but not wired. This picture and the isometric, Fig. 2, should help the fan to get a clear idea of the unwired set.







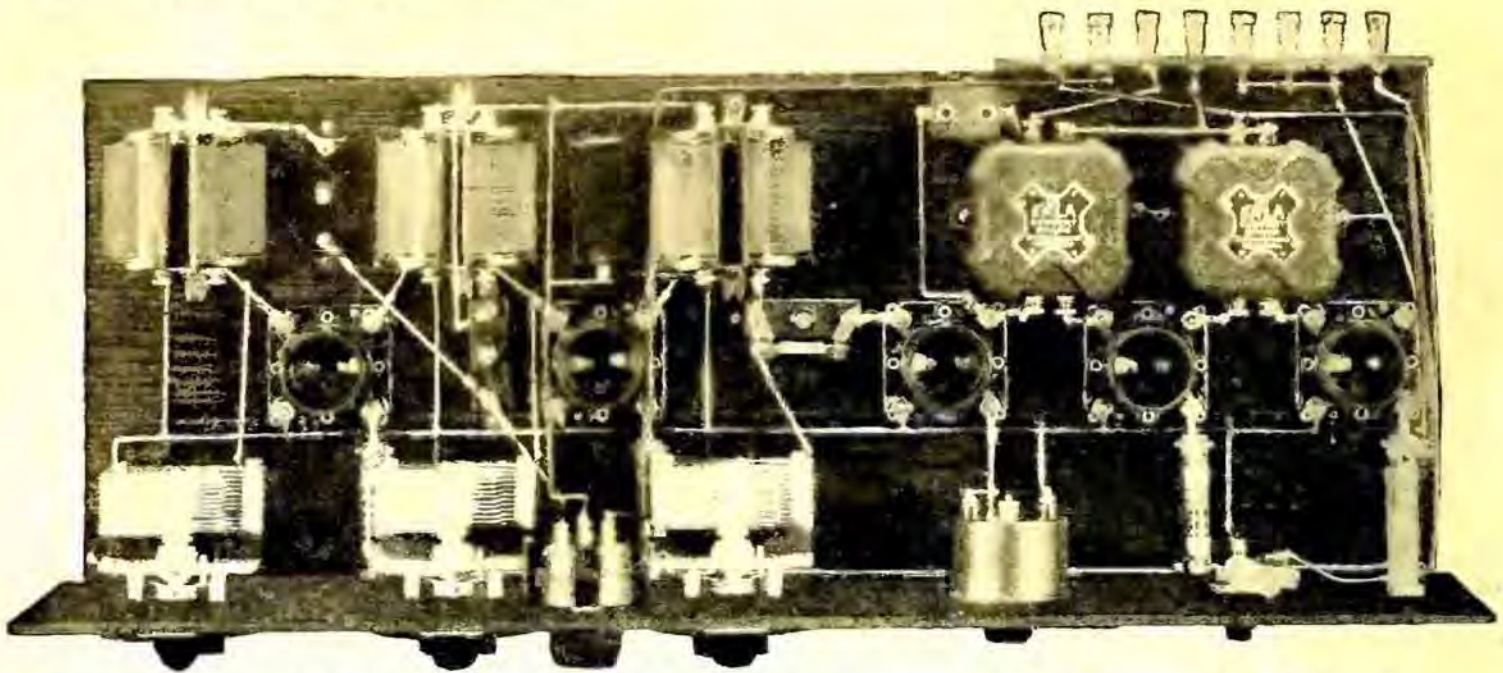

Fig. 4. This picture, looking down on baseboard, shows all units located and wired. This is the complete job. Follow schematic Fig. 1 for accuracy in wiring.

station quit transmission. This will conclude the low potential wiring. By use of the Kellogg soldering lugs, sockets lined up properly and Dudlo square wire we are enabled to run practically all of the low potential stuff without resorting to the favorite Italian insulating dish. If you are in doubt, however, use spaghetti.

#### R. F. Coils

The Heninger type D coils are located with their centers about on a line with the condenser centers and as far back from the condensers as the baseboard will permit. Not much use of slamming your r.f. units (regardless of by whom made) up against the field of a variable condenser and running up the r.f. resistance of the unit. These coils are marked P and B for the primary, meaning plate and B battery (except in the case of the first unit which is the antenna coupler; there the P and B can mean antenna and ground. The secondaries are all marked G and F, the former grid and the latter filament. No chance to go wrong there. Remember the rotors of the variables ALWAYS go to filament and the stators to grid; forget it and you issue an engraved invitation to body capacity to attend the ceremonies.

The XL variodenser which is being used as a grid condenser is mounted right up to the grid terminal of the detector tube; see Fig. 2 on page 10. This unit has clips for the Daven 1 meg grid leak being used.

The use of the Apex choke coil is more or less experimental with the user and the type of material in the set. In the original rough layout it was used while in the finished product it was found better results were secured without it. Better arrange to leave it in and then short out by means of clips; try for yourself and see which you prefer. Such a choke is a handy thing to have around the house for future hookups.

#### Audio Stages

The Erla Concert Grand audio transformers have P and G terminals arranged so the transformers may be mounted close to the sockets in the interest of space economy. The plate and grid terminals are on the front towards the line of sockets and the B and F are at the back away from the sockets; this permits short wiring on both sides since the transformers are close to the sockets and also to the binding post strip at the right rear of the baseboard. The primary of the first audio is shunted by a .001 fixed condenser, Muter. The value of this does not seem to be critical, apparently anything above .001 will suffice, although too great a capacity will probably reduce the signals inordinately. The two F. terminals on the transformers are commoned and led to the minus C terminal on the binding post strip.

#### Oscillation Control

As a means of control of any tendency on the part of the tubes to oscillate we adopted the expedient used by the Bremer-Tully people in their "Counter-phase" set, which method is made the subject of recent patents by Harry A. Bremer, of the above mentioned firm. Essentially it consists of a twin variable resistance; one leg of which is in series with the positive B potential applied to the r.f. tubes and the other in series with a neutralizing capacity from plate inductance of one tube to the grid of the same tube. The resistor acts in a dual capacity; it limits the plate potential on the tubes by the voltage loss method and at the same time changes the capacity of the neutralizing capacity through introducing resistance in series with it. While the maximum efficiency of such a system of balance is not fully realized unless the inductances and associated balancing windings are built one for the other, nevertheless the system, we believe, has more in its favor than the

simple capacity method of neutralization where the balance is set once for all for a given set of tubes and which process does not take into account the necessity for a change more or less in step with the wavelength changes. We all know the limitations of the neutrons which give us good efficiency on one band, fair on another and punk results on still another. Mr. Hazeltine should have gone further with his system so the Dial Twisters could squeeze every bit of energy out of all waves. The aforementioned twin resistor is mounted on the panel where it becomes a semi-control; generally speaking in the model it came into play principally when on the extremely short waves to prevent oscillation, while on the higher bands little change was required.

#### Size of Condensers

The Silver-Marshall s.l.f. variables, three in number, were changed from the original .00035 mfd in the hastily put-together affair to the .0005 mfd type in the final receiver in order to take advantage of KYW and KSD which were not in reach with the .00035. This is probably on account of the inductances which might have been designed for the .0005 size instead of a smaller capacity. If you care to sacrifice the two high wave stations (we wouldn't suggest it for a moment) you can use the .00035; otherwise the .0005 is proper. The s.l.f. type was chosen, together with the three Bremer-Tully vernier dials, in order to afford a little greater facility in tuning the secondaries than with the straight line capacity. The selectivity of one condenser as compared with another (s.l.f. versus s.l.c.) is identical provided the inductances are good ones. Neither s.l.f. nor s.l.c. will make a selective set if the inductances are broad; the only thing we get from the s.l.f. on account of its cut-away construction is a more equal spacing of frequencies with less nervous prostra-



tion in sliding over a station due to a minute change in capacity of the condenser. The frequencies covered and the graduations on the dial do not agree, nor could they be expected to. For such to be the case both the inductances and the capacities would have to be finely balanced, and such a process is out of the question in ordinary radio. Accordingly graduation of the dial scale is an arbitrary method of dividing a full circle; most manufacturers use the half circle divided into 100 degrees while some adopt the 360 degree rotation with its attendant larger scale.

#### Few More Details

A few more notes and the staff will have made a round-up of all the details necessary in the actual construction of the receiver.

In the twin resistor the terminal B is put in series with the plate potential; the terminal R goes through the single or double neutralizing capacities, as you desire, while the terminal P is common with both the B terminals on the primaries of the second and third r.f. transformers. The use of the first balancing capacity is shown in dotted lines in the schematic diagram, Fig. 1. In the actual set the two XL type N variocapacitors are used because we found better results as contrasted with the use of a single capacity. The resistance R is then in series with the two capacities and has a tendency to allow dual control of balancing capacity.

In mounting the audio transformers just to be consistent we grounded the cases to the negative A line. The two transformers were placed close enough so only a little loop of busbar wire was necessary to bond the two together between transformers while about an inch and a half piece of bus wire served to run from the right side of the last audio to the negative A line passing nearby.

#### Tell Us About It

Perhaps during the reading of this account our readers have thought of short cuts in assembly, or other means of

making the description simple and lucid to the average reader. Radio Age is always (and has ever been) glad to hear from any of its readers regardless of whether the suggestion is favorable to the magazine or not. If we merely saved all of the honeyed missives ours would be indeed a cloyed existence. So if something occurs to you about this set or its manner of presentation, hasten to the mill or grab the well known pencil and dash off your comments while you are in the mood.

After all of the wiring had been done the whole thing was checked and rechecked. No one but a department handling thousands of letters can appreciate the value of checking over your work once it is finished, especially if the work is done at odd moments. In many cases of trouble it can definitely be placed at the door of failure to check the wiring. Even after you have checked back your wiring against the schematic shown on Fig. 1 insert your tubes in the socket, one at a time, so if there is a conflagration it will not burn up all of the five tubes.

In putting the receiver into operation makes the necessary connections on the binding post strip, which reads from right to left: plus A, minus A, minus B, plus C, minus  $4\frac{1}{2}$  C, plus 22 (or 45 if using other than soft detector) plus 45 (higher if you care) and finally the plus 90 or 120 volts.

#### Dial Readings

The first and second variable condensers will probably read within a degree

of each other, while the third condenser, possibly on account of its grid condenser and leak, will read about from ten to fifteen degrees higher. Thus if you pick up a station at zero on the first and second condensers, the third one controlling the secondary of the detector circuit, will probably read 15 degrees. In working on locals it is a simple matter to get your bearings, but those living away from a broadcasting station will perhaps have to exert more patience in getting the first signal. Turn the knob of the twin resistor to the extreme right in working on the short waves. The capacities of the two balancing condensers should be as near minimum as possible, although personal experimentation on this score may help some. Minimum capacity with these variocapacitors means running the set screw out as far as it will go so the plates of the condenser will be farthest apart.

#### More In January

In the December model we have made use of the three condensers and dials because there are quite a number of fans who have the three dial sets and who perhaps might desire to make a change so as to give greater flexibility than they now possess. Frankly and editorially we are not sold on the three dial control and will have something further to say on this subject in the January number which will describe the further work of the staff in presenting advances along these lines. However for those who already have the three dials the foregoing will allow a chance to secure greater flexibility as regards the control of undesirable oscillations due to only partial balance of tube capacities at all waves. It will also allow the experimenter to begin work on the restricted field inductance. No form of winding so far is completely fieldless, nevertheless the more recent trend of inductance design is certainly cutting down the area of the field and permitting the assembly of r.f. units without the heretofore critical angle, upon which subject there is scarcely a unanimity of opinion. At least we honestly believe there is a worthwhile advantage in the use

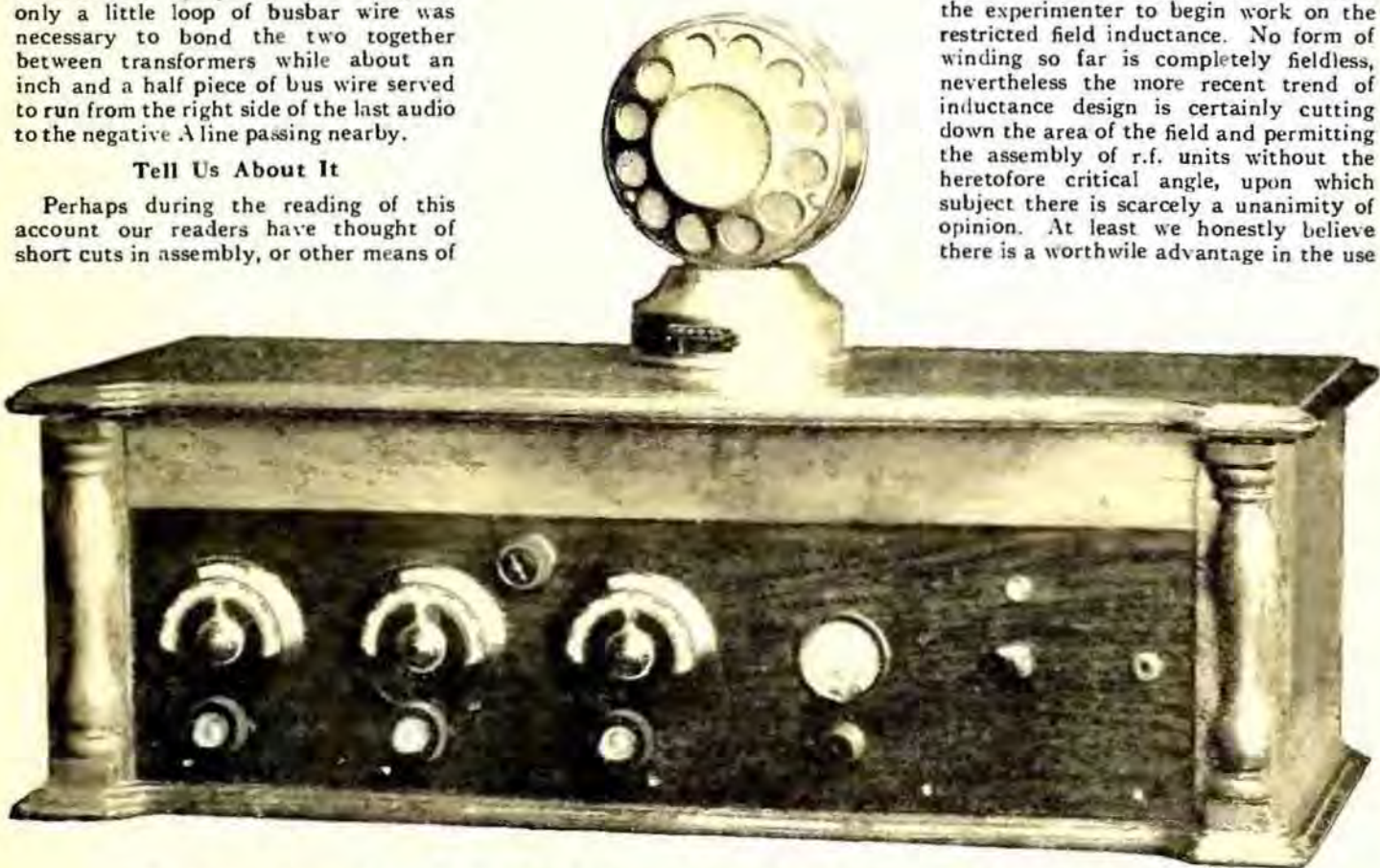

Fig. 5. Here is your finished set shown in its cabinet with the Kodak Microphone loudspeaker placed on top.



of the restricted windings as compared to the straight solenoid. For further data on the restricted field inductance we would refer you to the January number in which the matter will be gone into in detail as the construction of the Model HX is outlined for the benefit of our readers.

Ere we forget, be sure to use the little templates furnished with the vernier dials in order to get the holding hole for the dial in proper position. The instructions accompanying the dial will show clearly the method. There is no one thing on a radio set that will cause more cussing in actual operation than a dial binding on the panel, or a condenser shaft for which due space allowance has not been made and which consequently binds against the panel.

### Tuning the Set

After once getting your first station on the lower band, close to zero on the first two condensers and about fifteen on the right hand one, you should encounter no difficulty in jumping from one to the other right up the wavelength scale. In increasing capacity (locally) you can do it in bounds of five degrees at a time. However for those at a distance from a transmitter it would be better to make the jumps in two degree steps.

In the diagram the ground and the filament connections are shown as common. Under certain circumstances this will give a strong signal, and it might be too strong for use under congested radio conditions. Separating the primary inductance connection so the ground tap goes to ground and cutting apart the tie between the ground and the negative filament will serve to sharpen up the set to some extent although at a sacrifice of volume. In cases of strong local signals a certain amount of the excess energy in the antenna circuit finds its way to the grid of the first and succeeding tubes via the common filament connection. Theoretically the only cure for this condition would be individual A and B batteries and all units shielded so as to take full advantage of the repeater action of each tube, but such a thing is not possible in the average American radio household so we will dismiss that thought from our minds.

### Serves A Purpose

We feel the Model H receiver will be a good one for the use of our friends who are afflicted with critical angle inductances and tubes that make violent protest against being operated on the lower wave band without adequate means of balancing tube capacities. We do not wish you to gain the impression that this will be the ultimate in receivers for there is always room for honest experimentation in the assembly of associated apparatus to get maximum efficiency. In the next of this series to appear in the Radio Age for January another type of receiver will be described which we believe will be an improvement over the present model. From time to time as we work on these sets changes and refinements occur to us which offer an opportunity of incorporation in succeeding models and we would be derelict in our duty to our readers if

we did not give them the benefit of these advances, each one slight by itself perhaps, but in the aggregate constituting an advancement in set building.

Maybe some of our readers have gone over the same ground covered in the present article. Perhaps they met with success or the reverse. We would like to have the benefit of their advice. If you see something in the Model H which you believe may be improved to give greater efficiency, do not hesitate to inform us of that fact and let us broadcast it to the fraternity at large. The greatest factor, in the building up of the vast radio industry, aside from the purely financial and patent angles, has been the almost amazing number of devotees of the art.

### MORE DATA

Incomplete details on building the super-het without intermediate stages, prepared by Roscoe Bundy in the November number, prompts Radio Age to give further details from the author which might help many of the constructors.

The diameter of tubing for the oscillator and the antenna tuning inductance is  $3\frac{1}{2}$  inches. Separation between windings may be from a quarter to a half inch, depending upon the degree of coupling desired. The secondary of 46 turns has a tap at the 10th turn from the filament end.

In making the RFT 1 which is a special coupler, either of several methods may be followed. It may be wound on a  $3\frac{1}{2}$  inch tube, but will be bulky. A honeycomb coil of approximately the same number of turns may be used and tap taken off at the 90th turn; or the RFT may be wound on spools with the winding scattered. The number of turns and the size of wire is as given in the November number but the form of the inductances was omitted. A little experimentation on the part of the reader will probably solve the difficulty.

Show us a single calling or science which can number its adherents to anything near the hosts of radio enthusiasts. These enthusiasts are not merely listeners; great numbers of them are actual tinkers, and it is the tinkerer with a genuine intellectual curiosity to see what makes the darn thing tick who can be considered the one responsible for many of the changes in the game. This is not in disparagement of the vast sums spent on scientific research by trained technicians employed by the industry for undoubtedly they too, are responsible in a great measure for the wonderful strides taken during the few years which have intervened since the close of the World War. But mass experimentation represents thousands of seekers after knowledge whereas the technicians barely number hundreds.

Get to work on the Model H and see what your results will be. Then cuss or praise us for starting this series; but

above all, keep your eyes peeled for the January number.

### Console Model

In the beginning we contemplated making up the model in the console form and with this in view we secured the phone unit and tone chamber, the former from the American Electric Co., and the latter from Seaman Jones Co. On account of the press of time it was impossible to make up the console model and as a consequence we are showing it in the cabinet type. The builder of the set may use his own discretion and if the set is to be used for show purposes in the home it might not be a bad idea to convert it into a console model by slipping the panel into one of the regular consoles and making arrangements for the built in loud speaker to be used instead of the separate speaker.

### New Base Tubes

Another point which may be of interest to owners of the neutrodyne type of receivers is the fact that with the newer issues of bases on tubes the capacity between elements seems to have been reduced compared to the value obtained when a metallic shell was used for the tube's lower housing. This has made a change in the operation of some of the neutrodynes on account of the neutrodynes being larger in capacity than the value of the inter-element capacities, and as a consequence it has been hard to get good neutralization.

In the Model set the tubes used were of the insulating base type and the variable balance feature introduced by the use of the twin-resistor made the compensation a simple matter. This difficulty may have attracted the attention of neutrodyne owners or it may have passed unnoticed, but anyway there is a difference between the two types of bases if you care to make the tests on them.

### Pep Up Tubes

We have always found that the proper way to find a poor tube is to put a bunch of tubes into a set and try to tune it. If you are using new tubes you will not encounter this difficulty, but if using a number of tubes which have seen service ten chances to one that one of the lot will be a drone and should be pepped up. For that reason we made use of the Jefferson tube rejuvenator and found one tube which had been bad merely needed a little treatment at the hands of the rejuvenator to be in good condition for another siege of long hours. Also swap your tubes around in the receiver. Theoretically this should not be necessary if all tube constants are the same but nevertheless there is generally enough variation in tubes so this practice is warranted. The detector tube in the outfit, if of the soft variety, is the only one which will pull more amperage than the rest; the others are the quarter ampere type. If your A battery happens to be low put it on charge for a while, the General Electric Tungar being a sturdy and efficient rectifier of the bulb type, probably the first on the market years ago for battery stations before the great wave of radio popularity engulfed this world of ours.



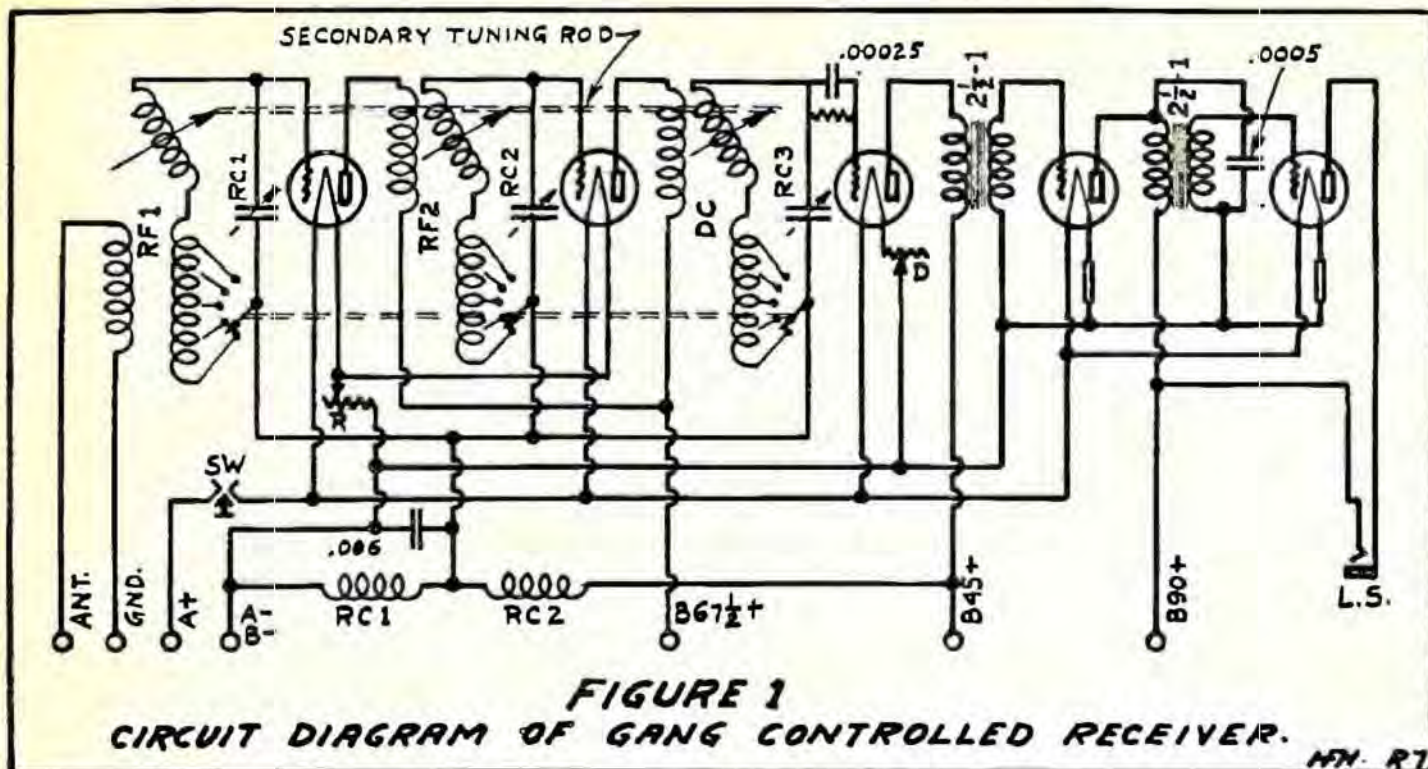

*A Receiver that Employs*

## Inductive Gang Control

*"How Simple is Tuning?" Answered Satisfactorily With This Unique System*

By H. FRANK HOPKINS

THE method of tuning a receiving set is by far the most important feature to the broadcast listener of today. With the maze of broadcasting stations on the air, it has developed into a science to be able to select what one wants, when he wants it; in fact, it is impossible for some to successfully operate the usual type of set employing several controls, which are necessary in the ordinary run of receiving sets.

In the selection of a manufactured receiving set, or in deciding upon a set to build, the prospective broadcast listener first asks, "How simple is the tuning?" and as a secondary matter, he inquires as to how far it will reach out and reproduce the distant signals. Distant reception seems no longer to be the prime factor in an evening's entertainment for the vast majority of fans. It is only the more recent addicts, or the dyed-in-the-wool fan, who want to sit up all night listening to static, with a few occasional strains of sound caused by music a few thousand miles away, to hear someone announce that "This is station 2 S-S-S-T-k broadcasting from their studio in SCRATCH, bzzz, bla," and then complete silence, a frantic twisting of the dials with more static, failing to get them back again, then to hear a faint signal and sit and listen to

an ear-straining, long, tiresome lecture on the effect of the snow-shoe crop in Hawaii, to find that it is only a harmonic on one of the local stations.

### The Latest Trend

THE general trend of the public toward one or two-dial-controlled receivers where the tuning is as simple as possible; a set that may be logged so that every member of the family can tune in a program as easily as putting a record on the phonograph in the old days, with somewhere near the same degree of selection.

To meet this demand, a circuit has been developed which utilizes gang control effectively. This receiver, to a certain extent, resembles the old variometer, or tuned inductance type of selection; that is, the receiver is tuned by varying the inductance, rather than the capacity of the radio frequency stages as is customary with the majority of receivers. It embodies tuned radio frequency amplification and has five tubes, which seems to be the most popular size of receiver at the present time.

In tuning by varying the inductance, it is possible to adjust each unit to resonance by using semi-variable condensers shunted across the secondary

coils of the radio frequency and detector couplers.

These condensers are placed in the assembly of the completed receiver so they may be adjusted as required, but when once set, they need not be changed, except when a different length antenna is used. This will bring the filter qualities of each unit into resonance with the others and by changing the inductance of the secondaries of the couplers, each will be accurately set to pass signals of a given frequency, by moving them all to the same degree, making it possible to use gang control without the usual vernier adjustments on each unit.

The couplers used in this circuit resemble the usual form of coupler used in the detector circuit of the three circuit regenerative type receiver except the windings are different. The primaries are wound upon a tube or shell four inches in diameter and about three inches in length. A part of the secondary coil is also wound upon this same tube, or shell. This part of the secondary has nine taps brought out, which are connected to a tapped inductance switch. A three inch tube, or shell, one and one half inches in length, is then used for the balance of the secondary coil and this is placed inside of the four inch tube, or shell, so that it will revolve freely in



an arc of about 160 degrees. Three of such couplers are used in this receiver and are shown designated RF1, RF2 and DC, in the circuit diagram, Figure one.

The taps from the secondary coil of each coupler are then connected to a nine point inductance switch and the three switches are so mounted, that a rod, or lever will move each switch from one point to another simultaneously by the operation of a dial or knob on the front panel of the receiver.

#### Mounting the Couplers

THE three couplers are mounted into the completed set so a rod, or lever, may be fastened to the three inch diameter tubes or rotors, as they are named, of each unit. This rod, or lever is gear-connected to a dial or knob on the front panel of the receiver and by changing the position of the dial setting each rotor is moved to the same degree or angle from the outer shells or stator of the units.

The usual form of detector circuit is used in this receiver; it is non-regenerative, as regeneration or feed-back of the detector tube would make it impossible to bring the coupler DC into resonance with the others. Two stages of transformer coupled audio amplification provide volume enough to operate the loud speaker on all signals. The tubes of this receiver are controlled by two rheostats and two automatic filament control devices. The radio frequency amplifier tubes are both controlled by the six ohm rheostat R, the detector tube is controlled by the twenty-five ohm rheostat D and each audio amplifying tube has a separate automatic filament control which does not require the operator's attention.

Two radio frequency choke coils are placed into this circuit for the purpose of keeping the radio frequency currents from by-passing to the detector tube through the batteries of the receiver. These coils are shown in the circuit diagram, Figure one, as RC1 and RC2.

The panel layout for this type of receiver is shown in Figure 2, and will more readily show the simple tuning operation required. At the extreme left of the panel is shown a dial pointer. This dial and pointer controls the rod or lever which moves the inductance switches from one contact to another. When the pointer is on the 200 mark, the inductance switches will all be on the first contact. This should roughly tune the secondaries of the three couplers to pass signals in the wavelength band of from 200 to 250 meters and is what we will call primary tuning. The steps on this adjustment will vary the tuning of the receiver in bands of fifty meters, ranging from 200 meters to 600 meters.

At the extreme right of the panel will be found a 100-point dial, which is the fine tuning, or secondary tuning adjustment of the receiver. This dial controls the rotors of the three couplers, thus varying the inductance of the coils so the units will be tuned throughout the wavelength bands, or steps of fifty meters. A 100 point scale is used so it will be direct reading, each division representing one half of a meter above the reading of the primary, or rough tuning dial. This feature makes it very easy to log the set or locate a station whose wavelength is known.

#### Locating Stations

TO FIND a station whose wavelength is known, and all station wavelengths are published along with their daily schedule of broadcasting, in most of the daily papers and radio publications, it is only necessary to move the two dials to correspond with the number of meters, as follows; To tune in a station, say KYW at Chicago, whose wavelength happens to 536 meters, the left hand pointer, or primary tuning control would be put on the 500 marking and the right hand dial or secondary tuning control would be revolved to the setting of seventy-two. This should tune the set to the wavelength of 536 meters.

To tune in a station whose wavelength is in the lower band of frequencies, say WLS at Chicago, which happens to be 344 meters the rough, or primary tuning dial would be set at 300 and the fine, or secondary tuning dial would be set at eighty-eight, thus making a total of 344 meters, as each division on the secondary tuning control scale is equal to one half meter.

Tuning such as this eliminates the necessity of wavemeters, tuning charts, etc. and provides a scale reading so that one can readily pick out the different stations without guess-work. The scale readings on the model set were accurate to one half meter.

The semi-variable condensers of the set are three in number, one for each coupling unit. They are shown in the circuit diagram, Figure 1, as C1, C2 and C3. These condensers are adjusted so the coupler associated with it is in resonance with the other couplers when the set is being worked on an antenna of the same length as was used to adjust the set. The condensers may easily be adjusted by tuning the set to a given wavelength, such as KYW, at a dial setting of 572. The condensers will then be moved to a position where the signal is at its maximum volume. This may be checked by retuning the set to a lower wavelength station, say WIBO at Chicago, whose wavelength is 216.5 meters; the dial settings would be 233. If the result is slightly off color, re-adjust the three condensers until the signal is brought in at its maximum volume and then turn the dials back to the original setting for the higher wave station. If the signal is satisfactory at this setting, the set will be balanced and each tuning unit will be in resonance with the others. The condensers need not be again adjusted until the length of the antenna is changed. If the adjustment is a little off color yet, tune to a station of about 300 and set the condensers, readjusting them again at the high and low wavelengths until a good average is obtained.

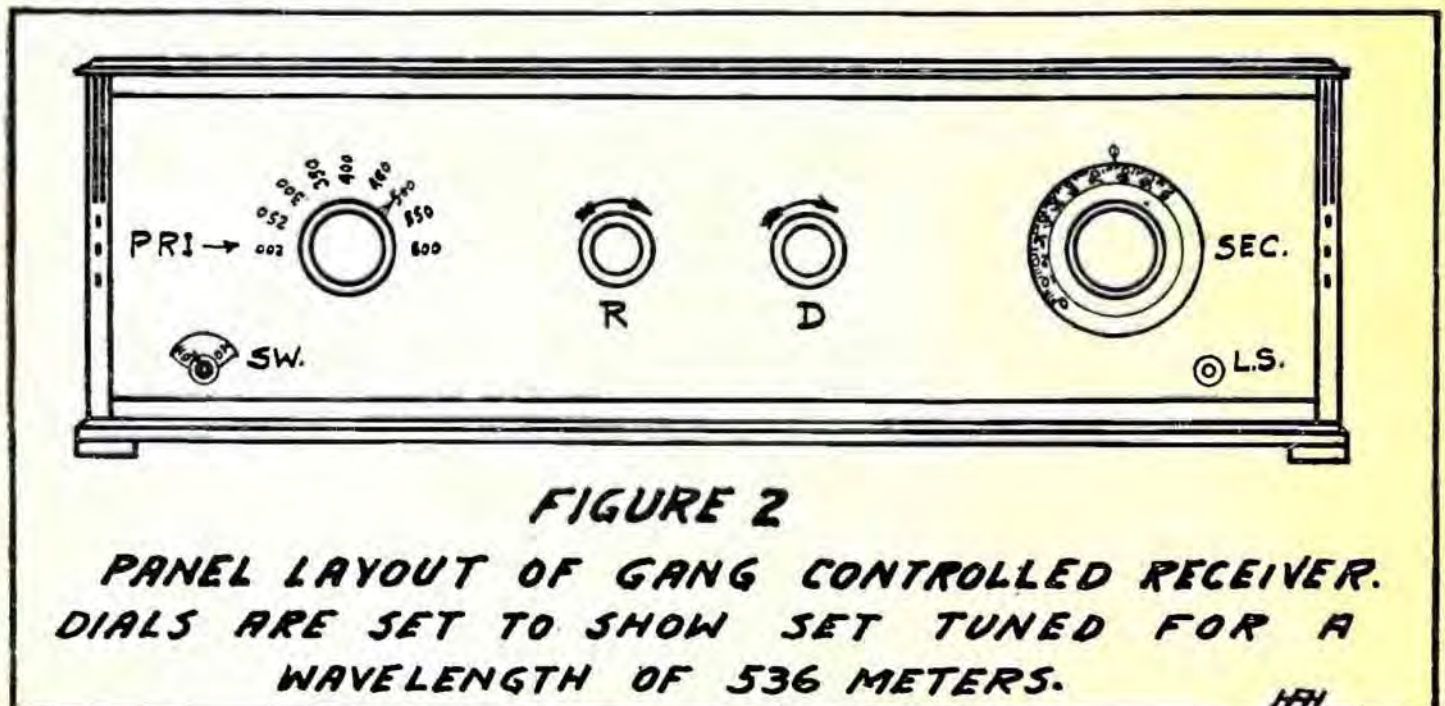



# Making Radio for QUALITY

The living room of Francis W. Dunmore in Washington, D. C., in which it is only necessary to press a button and radio entertainment issues forth from the cone loud speaker shown in the photo. Buttons installed in each room make instant reception an easy matter.



## Unique Receiver for Providing Radio "Outlets" in Any Part of Your Home

BY S. R. WINTERS

**R**ADIO for the Home," is no mere platitude or catch phrase with Francis W. Dunmore of the Radio Laboratory of the Bureau of Standards. He has not only designed and built a radio receiving set distinguished for its tonal quality, but has provided outlets for reception of music and speech at seven points throughout his residence—cellar, sun porch, living room, bedroom, sewing room, radio laboratory, and kitchen.

When at least one radio broadcasting station is entitled to the classification of "super-power" and a dozen or more stations are increasing their use of power appreciably, the radio receiving outfit of Mr. Dunmore invites special attention by reason of the designer placing emphasis on quality of reproduction of music and speech. For instance, with WGY of Schenectady using 50 kilowatts in the transmitter and with nearly 600 broadcasting stations in operation, this radio receiver can be built and used with pleasure by thousands of fans who are forsaking "DX" feats for quality music and speech. The approaching winter, with a great many nearby stations "on the air," will find the "DX" tribe decreasing in numbers and the recruits to quality reproduction multiplying.

This radio receiver, distinguished for its tonal quality, does not involve any radically different electrical principle or

trick circuit. It is different from the conventional type of equipment to the extent of being a reactance instead of a transformer-coupled amplifying unit, but this is not new to radio engineers. Mr. Dunmore, however, has made one departure and to this may be attributed, in part, his success in developing an ideal receiver for use in receiving programs of local or nearby broadcasting stations. Condensers are shunted across the secondaries of the audio-frequency transformers. These transformers are, however, not used as transformers, but the secondaries are employed as chokes. This arrangement seems to fit in admirably with the use of a cone-type loud speaker, which, of course, helps materially in quality reproduction. The circuit diagram reproduced with this article illustrates the manner of connection.

A crystal detector and three vacuum tubes as amplifiers are employed in this outfit, two of the latter being UV-201A and the third 216A. The primary tuning device consists of a home-made variometer, actually constructed from paper boxes formerly containing oatmeal and hominy. The rotating element of this homespun variometer consists of a hominy box, on which is wound 40 turns of fine copper wire. The stator or stationary unit of

this unique tuning device consists of an oatmeal box, and to add to the completeness of its odd makeup, an ordinary 5-cent pencil is used as the shaft for adjusting the rotating element of the variometer for tuning purposes. When more selectivity is needed a coupled crystal circuit may be used. As there is but one local station on the air at a time in Washington, a selective crystal circuit is not needed. Of course, if the broadcast listener, contemplating the building of this radio receiver, is lacking in such cleverness of design, he will find that a commercial type of variometer will answer the same purpose. By the use of a crystal set the distortionless crystal quality is put into the amplifier, which in turn is faithfully reproduced.

### .005 Condensers Used

**A**S PREVIOUSLY stated, condensers of .005 microfarad capacity are shunted across the secondary windings of the two audio-frequency transformers. Three grid leaks are used of varying resistances— .1, .25, and .5 megohm, respectively. The power consumption of the third or output vacuum tube, type 216A, is greater than that of the UV-201A tubes, the former consuming one ampere. This tube seems to be ideally adapted to this particular type of loud-speaker, although it is not absolutely necessary.

(Turn the page)



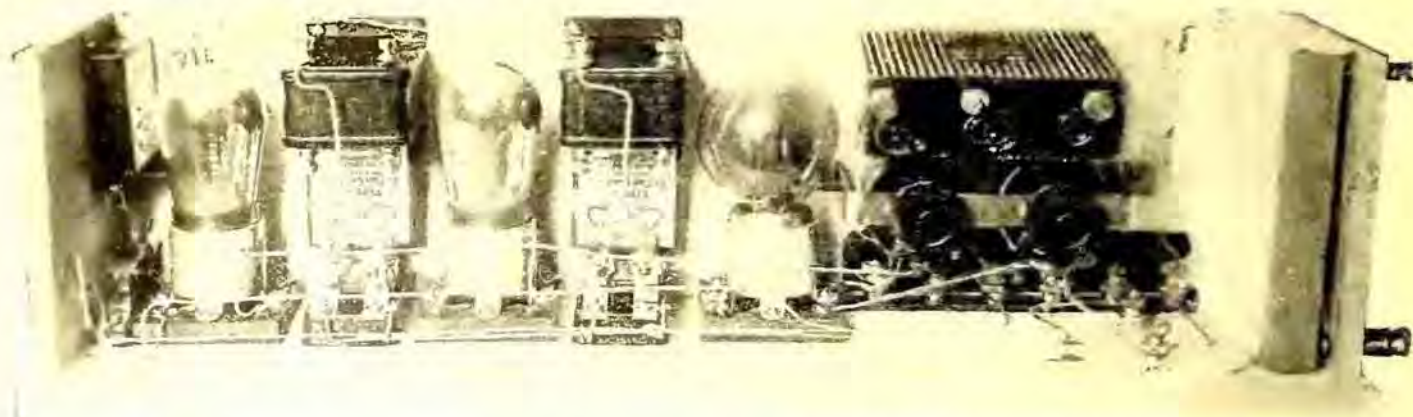

A close-up view of the ideal type of radio receiver for receiving music or speech from local broadcasting stations. A crystal detector (not shown in the picture), is used, and two types of vacuum tubes—UV201A and 216A. Condensers are shunted across the secondary of the audio-frequency transformers. The circuit is of the impedance coupled type, using a cone type loud speaker

An 80-ampere-hour storage battery is used for lighting the filaments, and the use of an electrolytic type of battery charger renders it possible to charge the battery while the radio receiver is operating without experiencing any disturbing effects. The reader is cautioned not to charge while using unless he is familiar with his charger circuit.

By means of two fine wires, run parallel, Mr. Dunmore has conveniently placed outlets for the music or speech intercepted by this receiver at seven places throughout his residence. That is to say, if he happens to be in the cellar, sun porch, living room, bedroom, sewing room, radio laboratory, or kitchen, he can connect the loud-speaking cone to an outlet and music or speech will issue forth, provided a local broadcast station is operating. For instance, upon entering his front door a button can be pressed and speech or music heard within less than half a minute. In less time than that, he can increase or decrease the value of the sound by means of a shunt resistance which he places across the parallel wires extending from the radio receiver located in his radio laboratory on the second floor. Developing this extension system a bit further, his neighbor can hear a concert by simply attaching a loud-speaking device to the extension wires running from the residence of Mr. Dunmore.

If you, as a broadcast listener, are obsessed with the itch for distance, the radio receiver outlined in this article cannot be expected to meet your requirements. If, however, you are one of the increasing multitude who appraise radio apparatus but as an instrumentality to enjoyable, uninterrupted entertainment or worthwhile instruction dispersed from nearby broadcasting stations this homemade outfit will furnish unalloyed pleasure. The cost need not be excessive—the kit, excluding vacuum tubes, batteries and loud speaker, costing less than \$25.00. The cone type of loud speaker, of very modern design, represents the most costly single item.

This writer has heard many types of receiving equipment, expensive and otherwise, and I can state without qualifications that the music emanating from this homemade set, using a cone type loud speaker, comes nearer approaching the

ideal than any I have heard. Of course, it places a potential value on programs broadcast from nearby stations and ignores the "DX" radio fan who prefers a squeal coming from a distance of 2,000 miles to the soft, inspiring strains of music having their source only a few miles distant. This receiver and similar designs in the interest of delivering tonal quality may be indicative of a not remote future when radio will assume its destined important role of universal entertainer and educator instead of being made a victim of squeals, howls, and figurative cat calls.

#### Home Talent First

THE humorist who cartooned a radio fan listening to a gnat sneeze in Hawaiian Islands in preference to hearing Grand Opera in Chicago was expressing in ludicrous terms the viewpoint of the DX broadcast listener. And, not so long ago this desire for distance at any cost found expression in any army of radio fans. To "get the coast" was the ultimate achievement of "DX hounds" of the East and those of the West probably were seeking to "get New York City."

The distance craze, however, is subsiding somewhat, an evidence of which is the absence on radio pages of newspapers and in radio magazines of the long list of "calls heard" and stations logged. If resistance-coupled amplifiers and cone types of loud speakers are to be accepted as a criterion, the broadcast listener of the future will challenge his neighbor radio fan in this manner: "I heard every note of the orchestra last night, faithful in reproduction. It was like listening to music in your own home. Can you beat it?"

Francis W. Dunmore of the Radio Laboratory of the Bureau of Standards, both in theory and practice, is a distinguished exponent of quality in radio programs in preference to distance, merely for the sake of annihilating space. You would probably surmise that this brilliant radio engineer would possess an 8 or even 16 tube radio receiving set. Instead, however, he has designed and built a receiver purely adapted to local reception and where increased power is used at the transmitting station, he could probably pick up signals from KDKA or WGY.

This radio receiving set was designed and built by Mr. Dunmore during his spare hours, when off duty as a member of the staff of the Radio Laboratory of the Bureau of Standards. Some of the parts are homemade—for instance, the tuning device—and every instrument is put together with the single objective of possessing a radio receiver distinguished for the reproduction of tonal quality in music and the clear, unmuffled words of a speaker. This objective he has accomplished in no small measure.

#### Room For All

There will always be room for two types of receivers, just as there is room for more than one kind of automobile, shaving brushes and clothes. There is a definite class of listeners who care nothing for the music emanating from a source further than their local horizon, individuals of a temperament which will not permit their constant fiddling and tinkering to obtain long distance reception. This type of listener wants his music loud and clear, the emphasis on the clear. He probably feels, and rightly so, the local broadcast will serve him with everything he desires in the line of entertainment, the quality of which may be fully as good as the type of entertainment being broadcast from a thousand mile station.

On the other hand there is the insatiable fan who must have distance at all costs and who by nature is never content with a simple set which may be turned on by merely pressing a button. Late hours and a loss of sleep mean nothing to him; his prime object in life is the accumulation of a list of distant stations which he may exhibit with pride to his neighbors and friends. While he may tolerate the local broadcasting, nevertheless he feels he would like to reach beyond the rim of the teacup and find out what is going on out in the wide world. Both types of listeners are necessary to the advance of the game. The first type, demanding stability, ease of operation, tone quality; the latter asking distance-getting and selectivity. The manufacturers have two fields before them in the construction of sets, all lending variety and making for changes in equipment to satisfy the demands of the two camps of listeners.



## A Favorite for DX—

# Tuned RF and REGENERATION

By BRAINARD FOOTE

## Stations Missed in RF Sets Picked Up by the Whistle; Distance Improved

**I**N THE wake of the five tube tuned R. F. set comes another aspirant for long distance honors—one which has been slowly coming into popularity in the past six months and is now widely favored. It is a simple union of tuned radio frequency and regeneration and has the following distinguishing points:

1. Two tuning controls.
2. Regeneration—permitting tuning in by the "whistle."
3. Neutralized R. F.—preventing radiation and R. F. oscillation.
4. Uniform sensitivity over the entire wave range.

The use of regeneration has two marked advantages besides the close control over the sensitivity. In the first place, the faintest station can be located on the dial by permitting the detector to oscillate, by the carrier or "whistle." Again, the tuning in the detector circuit is greatly sharpened by regeneration, thereby making the circuit just as sharp as that of a three control set like the neutrodyne or other tuned R. F. having two stages of radio frequency. And the tuning is confined to two controls—an important simplification. Of course, the whistle system of tuning would be a nuisance were it carried on with a regular regenerative set, but with a neutralized R. F. tube ahead of it, no radiation can occur. Moreover the R. F. augments the incoming signals a lot and sharpens the tuning besides.

Uniformity in amplification is obtained by the regenerative control, wherein greater coupling is required as the wavelength increases. Here is the biggest fault with the three control tuned R. F. outfit. Of course, the latter can have a regeneration or sensitivity control, but this is somewhat troublesome where there are three tuning dials already.

### Many Kinds of This Type

**T**HERE are numerous forms of this popular circuit. The information presented here should be of interest to those already having such an outfit, as well as to others interested in it. In the small sketch we present a sample arrangement of the panel, which should measure about 7 by 24 inches. It can be assembled on a smaller panel, with a little care, too. The controls shown cover the needs of the ideal receiver—

1. Ability to tune to the desired station.
2. Sensitivity.
3. Selectivity.

The tuning controls shown tune the radio frequency and detector. The tickler controls the sensitivity and incidentally the volume. Although with a nominal degree of coupling the selectivity will be good, on account of the two tuning controls and the regenerative detector, a variable coupling is highly useful. The coupling control at the left permits a

variation in the selectivity—a feature most valuable for high and low waves. On wavelengths under 250 meters, a reduction in coupling by using fewer turns in the antenna primary coil lowers the natural period of the aerial and sharpens up the tuning. On long waves, it is of great help to use a larger antenna primary coil. A coupling variation with three adjustments is most helpful all around. It upsets the dial readings of the R. F. dial slightly, but since those of the detector dial are unaffected, these dial readings are used for "logging."

To permit the use of headphones for DX listening, a jack is provided for this purpose. This is a filament control jack, which automatically turns off the second audio amplifier tube. The loud speaker cords are permanently connected to binding posts. Rheostats or filament resistors are placed inside the set, since they may be adjusted once and left alone. A snap switch in the "A" battery circuit turns the set on and off.

### Parts in Use

**T**HE panel lay-out suggested is that used by the writer and preferred because of its convenience and handiness. As to the parts employed in the receiver, considerable latitude of choice is permitted. There is no especial type of coil or condenser necessary, although these tuning instruments, being the very essence of the set, should be of the highest quality. Standard couplers may be used, many companies providing two types—one with a tickler and one without, otherwise the same. The coils ought to be on a skeletonized frame and if they are space-

wound, that is with an air space between turns, so much the better. A low-loss condenser, of the straight line wavelength, or still better, of the straight line frequency type should be employed for tuning. To make the dials agree fairly well, coils should be of the same design, as well as the condensers. In selecting a straight line frequency condenser, care must be taken to note the action and balance, as such instruments, while theoretically best for easy and uniform tuning, are apt to be unsound mechanically. Adjustable bearings are essential, to compensate for friction. Good vernier dials are pretty important as it is hard to set a non-vernier dial just right for so selective a receiver, except perhaps for locals.

The remainder of the apparatus is of lesser importance. Sockets should be chosen to fit the types of tube desired. Best results are obtained with quarter ampere, 6 volt tubes in the detector and audio sockets and either the 199 type or the quarter ampere 6 volt type in the R. F. Some claim better results for the 199 as the radio frequency tube, but there is some doubt about this. At any rate, it is preferable to use the socket meant for the chosen tube and avoid adapters. The circuit given considers quarter ampere 6 volt tube throughout.

The neutralizing condenser may be one of the "vernier" variables, or a regular neutrodon. A good neutralizing condenser of the XL type is adjusted by a screw. Grid condenser and leak are combined in one and have capacity of about .00025 mfd. and resistance of about 2 megohms, respectively. A .001 or .002 mfd. by-pass condenser is needed also. The jack is the double circuit filament control type. The audio amplifier may be coupled by transformers, resistances or chokes, according to preference. Transformers are indicated here. One rheostat, R-1, controls three tubes and has a resistance of 6 to 10 ohms, carrying capacity of about 1 ampere. R-2 has a resistance of 15 to 30 ohms, carrying capacity at least  $\frac{1}{2}$  ampere.

### Connections

**O**N THE panel we have the two variable condensers, the two couplers, if they are of the panel mounted type, the jack, battery switch, tickler knob and coupling or selectivity switch. The antenna coupler is the one without the tickler. It has two windings—primary and secondary. The primary should have about ten turns. This amount represents the average condition of coupling and is connected to the center of the three switch points, as shown. Minimum coupling is had with about 5 turns, to which the right hand switch point is tapped. To make the tap, pry up the turn with a knife-point, slip a bit of mica or

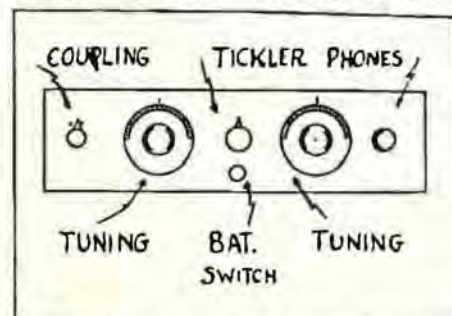

A sample panel lay-out, arranged for neatness, balance and convenience. The coupling adjustment permits a variation in selectivity.







Here  
Is a  
Simple  
Method  
That  
Will  
Improve  
Your  
Tuning

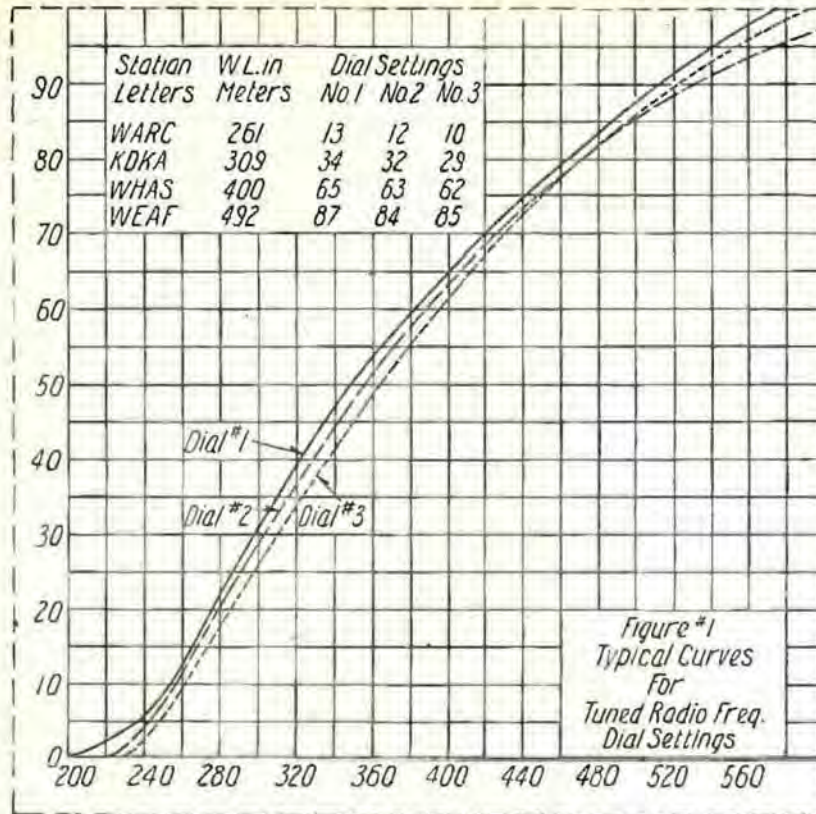

By Bertram  
C. Rogers,  
Engineer  
for  
the  
Westinghouse  
Electric  
at  
KDKA

No Need to "Comb the Air"—

## TUNING with CHART CURVES

THE radio set owner does not need to comb the air aimlessly to bring in any desired station, if he will take the trouble to make a simple chart showing curves of his dial settings at various wavelengths.

To obtain the best results from a radio receiver, it is necessary that the operator know how to tune it accurately and quickly. There are so many different types of radio receivers now on the market that it will be necessary to describe the manipulation of several of them, but no attempt will be made to include all of them, nor any of the ones having trick circuits.

The first set of which we shall speak is the "Tuned Radio Frequency." This ordinarily has five controls, three for selection of stations and two for filament current to the vacuum tubes. The detector is usually controlled by a separate rheostat as an additional aid to tuning. The second rheostat controls all four amplifier tubes.

### Making Adjustments

IF your set has a filament voltmeter, adjust the filament current until the meter

reads the proper value. Otherwise adjust the rheostat or battery setting controls to the proper position. They should be adjusted until the filament of the tubes glow at the proper color, and then should be left alone unless the battery is so nearly discharged that it

will not maintain a constant glow of the tube filaments. If more than one re-setting of the filament rheostat is necessary, it is advisable to replace the battery. It is then necessary to tune all three "Station Selectors" so that they will respond to the same waves.

The setting of all three dials is usually the same, except that one control may differ slightly from the other two. If you do not know the proper settings, adjust the second and third so that the dials read the same and then adjust the first dial so that some sort of sounds are heard. In general the setting of the first dial will be approximately the same as the setting of the other two dials, but may be slightly above or below the other two. When the dials are at the proper setting, atmospheric noises which are commonly known as static will be heard and possibly also signals from a broadcasting station. In case you do not succeed at the first trial, go through the same process again starting at a slightly different setting. Record the settings of all three dials for three or more stations of different wave-

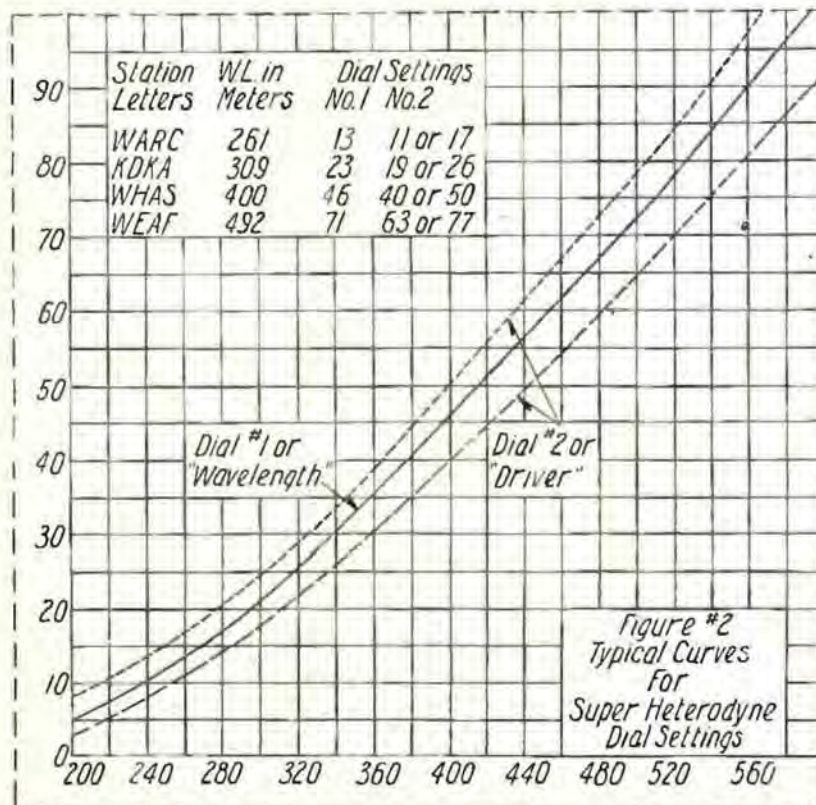

(Turn to page 62)



# Graceful Beauty and Tonal Clarity



**T**HE DeForest Radio booth at the shows held in Chicago and New York represented a Spanish bungalow, in which was placed the new DeForest W-6 Renaissance Radiophone, a typical example of "harmonizing" receivers. The set was placed against a chrome stucco wall, with ornate iron grill work.



**O**NE of the most attractive sets recently produced by radio manufacturers is the Erla console, shown above. It is the product of the Electrical Research Laboratories of Chicago, and is of the tuned radio frequency type, five tubes, with exceedingly simple and attractive controls.

**T**HE receivers depicted on this and the opposite page represent the latest trend in radio design; namely, for enhanced grace of beautiful design, and for the greatest possible clarity of tone and simple operation. Mechanical development seems to have stood still while the artistic side of radio goes forward by astounding leaps and bounds. No expense has been spared by some manufacturers to attain the greatest beauty, to harmonize with the most elaborate surroundings; others have achieved beauty, combined with simplicity, and yet keep their products in the low-priced group. These receivers were among those on display at the Fourth Annual Chicago Radio Show, held at the Coliseum from November 18 to 23.



**F**RESHMAN Masterpiece Receiver, with a separate battery case console, one of the latest developments of Chas. Freshman, Inc. The loud speaker is built-in, and the panel especially grained and engraved. The receiver may be had with or without the cabinet for batteries, although the latter innovation greatly adds to the set's appearance.



# Predominate in Sets at Chicago Show

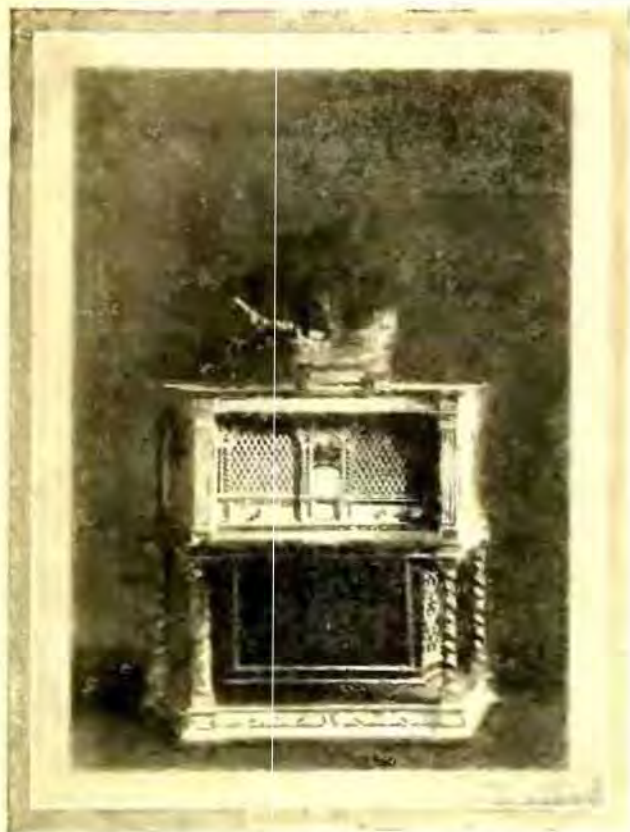

**G**ETTING into the higher priced class of receivers, we discover such elaborate models as this Spanish Model made especially by the Zenith Radio Corporation and embodying the Zenith circuit. The price of this set, which, by the way, is enclosed in this exquisite piece of furniture, is \$2,000.

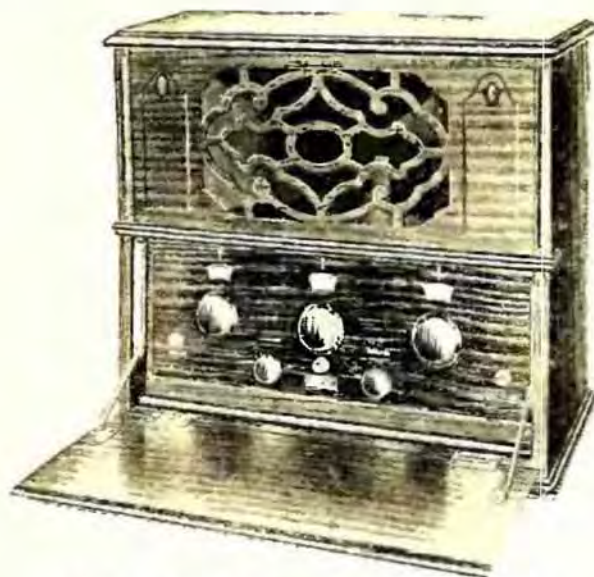

**T**HE regular upright model Freshman Masterpiece Receiver, with extra large built-in loud speaker. Otherwise this model is identical to the Freshman receiver pictured on the opposite page. The circuit is of the popular tuned radio frequency type, and the finish gives the appearance of finished mahogany furniture.



**T**HE improved model Laboratory Type Silver-Super-heterodyne, a development of McMurdo Silver. The set claims great selectivity, and uses the new Silver-Marshall S-L-F condensers and interchangeable coils. This super is on display at the Fourth Chicago Show, with other Silver-Marshall parts.

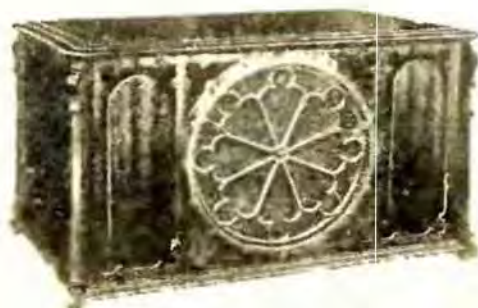

**T**HE new model Ultradyne receiver, a development of Robert E. Lacault of the Phenix Radio Corporation. The feature of this receiver, a six tube T. R. F. type, is its "No Dial" arrangement. Tuning is accomplished by small lever adjustments which follow a tuning scale marked on the outside of the built-in loudspeaker. There is only one other adjustment—the "on-off" switch. Simple, isn't it? And the appearance blends with home surroundings anywhere.



# Just What Constitutes a GOOD VARIABLE CONDENSER?



Variety of Claims  
Apt to Confuse  
the Listener

E. L. Hall,  
Government  
Radio Expert,  
Gives His Opinion  
of Ideal Condenser

**W**HEN we speak of the condenser in a radio receiving set, some people will think immediately of the variable air condenser which is used for tuning in the desired station or some other one that happens to come in," said E. L. Hall of the U. S. Bureau of Standards at Washington. "Other people will think also of the fixed condensers which serve important functions in a radio receiving set. Fixed condensers are used in some radio receiving sets in the tuning circuit to extend the frequency range of the set."

In general, fixed condensers are found chiefly in the grid lead of the detector tube, and as a bypass for radio frequency currents across a path of high impedance such as the primary winding of an audio-frequency transformer or the windings of a telephone receiver.

There are a very large number of manufacturers of variable air condensers at the present time and when desiring to construct a radio receiving set, one wonders which condenser to buy. A perusal of the advertising of the different manufacturers leaves the layman as undecided as ever, being overwhelmed by such terms as low loss, low minimum, grounded rotor, straight-line, square law, non-dielectric, etc. The result is that he buys a condenser recommended by the salesman, which may or may not be satisfactory.

Now what constitutes a variable air condenser which will give satisfactory operation in a radio receiving set? A few years ago the list of manufacturers of good condensers would have included

a very few names because there were very few manufacturers of such apparatus at that time. Today such a list would be very long indeed so that instead of mentioning the names of the makers of the best condensers, the essential points to look for in the best condensers will be given.

### Construction of Condenser

**B**EFORE giving these points let us consider the construction of a variable air condenser. It consists essentially of two sets of parallel metal plates, one set being rigidly fastened to a mounting while the other set is fastened to a shaft enabling these plates to rotate between the fixed plates. The two sets of plates are electrically insulated from each other.

For this purpose different manufacturers use different materials and methods for obtaining this result. Materials used for insulation include bakelite, glass, hard rubber, isolantite, porcelain and quartz. The electrical requirements for the best condenser if met are such as to produce a very poor condenser mechanically, so that a compromise is necessary.

However, a satisfactory condenser will have no lateral or longitudinal motion of the shaft; will turn freely and positively; will have the plates made of material of sufficient thickness to maintain its calibration; will not have stops to prevent the complete rotation of the movable plates and the possible jarring of plates out of line or displacement of the dial; will employ a minimum amount

of insulating material consistent with strong mechanical design and have it placed well away from the plates of the condenser; will have sufficient spacing between plates to guard against shorting the two sets of plates; will have a neat and pleasing appearance.

It will be noticed that these requirements are chiefly of a mechanical nature. None of the advertising terms have been mentioned because the advantages claimed for some types of condensers are questionable.

One illustration will suffice. Manufacturers have vied with one another to produce a variable condenser having the lowest minimum capacity. Condensers used near the low part of the capacity scale have relatively large changes in total capacity of the circuit for a slight movement of the dial, which means that it is extremely difficult to tune in a station on this part of the dial.

### Operator's Hand May Affect It

**I**N SOME sets it may be found that the presence of the operator's hand or body will tune or detune the receiving set. In such sets this will be extremely marked for low settings of the dial of the condenser. The resistance of the condenser is also quite high for low settings of the dial, which is a disadvantage.

The whole question as to the condenser may be summed up by saying that dependable results may be expected in a receiving set employing a variable air condenser made by a reputable firm, where due regard for mechanical design has been taken.



# BACK FROM *the* ARCTIC



Radio group on maiden voyage of the Peary. Left to right, Paul B. Klugh, Eastern Manager Zenith Radio Corp., Commander E. F. McDonald, Jr., President Zenith Radio Corp., Commander Donald B. MacMillan, famous Arctic explorer, Douglas Rigney, Manager A. H. Grebe & Co. and C. H. Thordarson, President Thordarson Electric and Mfg. Co.

## National Geographic Society and U. S. Navy, Sponsors of the Adventurous Summer Voyage are Given Accurate Records of the Eventful Trip

**P**RESIDENT E. F. McDonald, Jr., of the Zenith Radio Corporation, returned to Chicago on October 23 after an adventurous summer in the arctic, where he was second in command of the MacMillan Arctic Expedition. Mr. McDonald was in command of the "Peary," the larger of the two vessels that carried the explorers to their base, less than 12 degrees from the north pole.

### Perils of Journey

Several volumes could be written about the perils of the journeys to the polar region and back again. Commander McDonald's brief reports on a few incidents of the expedition are suggestive of tales of Sinbad the Sailor, with the difference that Commander McDonald's experiences really happened and those of the gentleman mentioned were pure fiction.

Happily the facts about the MacMillan expedition are in the accurate records of the National Geographic Society and the United States Navy Department, both of which organizations sponsored the expedition and gave it their active cooperation.

### Radio Research

From a radio point of view, the main interest in Commander McDonald's experiences naturally centers about his

radio researches and demonstrations while up there in the land of the midnight sun, amid electrical disturbances and phenomena which are not encountered in the temperate zones.

One great achievement of Commander McDonald and his staff was the solving of the problem of daylight transmission by radio. As head of the Zenith Corporation Commander McDonald naturally was deeply interested in the wireless knowledge to be obtained from experiments in a region where for months at a stretch there is continuous sunlight.

### Heavy Message Traffic

Low wave transmission was the special object of Commander McDonald's interest and he gave this phase of wireless communication a most exhaustive and successful test. Through the intelligent and industrious efforts of Chief Operator Paul J. McGee, also a Chicagoan, the "Peary" was able to dispatch more than one and one half millions of words while the ship was in the north country.

Not in the volume of correspondence alone but in the vast distances regularly reached by the "Peary's" forty-meter transmitter did the achievements of the expedition attract the attention and gain the applause of the radio world. Regular communication was maintained in daylight with New Zealand and Aus-

tralian stations. Intermediate points almost without number, were almost continuously talking back and forth with the explorers.

The Arctic expedition demonstrated the fact that the low wave could penetrate great distances and established the ease with which regular daylight communication could be maintained.

### Ultra-short waves

As greater research is made on the subject of the ultra-short waves covering the zone between 5 and 50 meters, it seems their performance becomes more freakish than the uniform and fairly regular antics of the higher waves between 100 and 200 meters. Much of the success and ease of the transmission between the Polar regions and the antipodes can probably be traced to the fact extremely short waves are great for long distance transmission whereas they are not quite so successful for what might be termed local work. It is not unreasonable to expect in the near future the distance to be covered will determine largely the wavelength to be used. For essentially local work the 200 meter band might be o. k., whereas if it is desired to plunk a signal into the ears of a listener thousands of miles away the short band from 5 to 20 and perhaps up to 50 meters will be utilized.



# Another Model

---

Having presented our readers with the December Radio Age Model H receiver in this issue of our magazine, we are now going ahead with the Model HX which is scheduled for the January number.

Many refinements and improvements will be added to the January Model. Other inductances, capacities and allied units will make up the January feature so the reader inclined towards the building of sets will have an excellent opportunity of observing the manner in which full advantage is taken of all types of radio apparatus in the series of articles now well under way.

## *A Workable Set*

All of the bugs and grief which the ordinary experimenter encounters in the construction of a set has been taken out by the Technical Staff of Radio Age and as a consequence you can go ahead with the building without having to scratch your head and puzzle over some of the little details. We believe this practice of sidetracking your troubles before they reach you will prove one of the most popular features ever presented in the pages of Radio Age.

## Several Surprises

We are withholding the intimate details of the receiver because we have a few surprises in store for you—something which we believe will still further convince you of the fact Radio Age leads in the radio magazine field. Keep your eyes on the news-stands; the January number will be out about December 15.

# RADIO AGE, Inc.

510 N. Dearborn Street

--

--

Chicago, Illinois



## A Case of "Microphone Fright"



**S**TAGE fright may have its terrors, but for that real, helpless feeling, a first appearance before a stern microphone is recommended. Above is Patsy Ruth Miller, Warner Brothers movie star, at the Microphone of Station KWBR, endeavoring to broadcast for the first time. Louise Fazenda, an old-timer at the gentle art of broadcasting, is offering moral support, with doubtful success.





# What the Broadcasters are Doing



## South to Get a New Station

November 1st saw the advent of one of the largest radio broadcasting stations in the south, erected at Boca Raton, by the Mizner Development Corporation. The announcement of the huge station that was installed by the Western Electric Company from designs of the Bell Telephone laboratories, comes with great interest for the radio fans all over the country.

The station is being built under the supervision of George Sheffield, of New York. The call letters of the new station will be WFLA.

The two great towers that rear themselves to the height of two hundred feet will become familiar landmarks to travelers through Boca Raton. The studio of the station that snuggles near the towers was designed by Addison Mizner, following the architectural precedent set in Boca Raton of the languorous Spanish style, also the barracks that house the members of the Yerkes Flotilla Orchestra, one of the principal performers engaged for the winter season.

Technically, the station is one of the finest that has ever been installed. The rated power output of the station is 1000 watts, but ample tube capacity is provided for the peak value reached during modulation. This is ordinarily about 2500 watts. The equipment consists of the radio transmitter with the necessary speech input apparatus. The transmitter is complete in one unit.

To the radio engineer the station at Boca Raton presents a dream of perfection. The entire station is the last word in effective radio design, and the maximum utility from the station is guaranteed at all times. The power apparatus, the motor generators and starting equipment is located in a separate room from the transmitter but is controlled from the front panel of the transmitter. Two motor generators provide the supply. One set consists of a 24 volt generator to provide the filament current; a 250 volt story generator for the grid voltage supply and the excitation of the high voltage machine; and a four horsepower mounted in the same base with the two generators. The other set consists of two 2000 volt generators and an eight horsepower driving motor.

The two machines are controlled by automatic starters.

The entire station will be active all winter long. Programs featuring the foremost luminaries of the opera stage and concert stage as well as jazz concerts and dance music will be broadcast. Through a special microphone that may be carried around from place to place, outstanding events and concerts from Palm Beach and the other nearby towns may be broadcast.



Logan ("Steve") Trumbull, formerly Chief announcer of KYW, who is unable to resist the lure of the open road, and is going West, so we understand. After he has finished visiting the South. Steve is an old newspaperman; writes plays and they are really produced; and does many other things, but he hasn't been able to vanguard the wanderlust. Good luck, Steve—they'll miss you on the air.

## Air Channel Proves Valuable

Within a short time there may be a new commodity on the market—broadcast wave lengths. The possession of a good broadcasting channel, of say 400 meters, is worth far more today than 400 shares of any radio stock. It is probably worth four times that amount due to the scarcity of broadcast channels suitable for Class B stations. A good broadcasting station or a "seat on the air" may be worth just as much as a seat on the stock exchange.

At any rate, it is reported that Charles E. Erbstein of Elgin, Illinois, has sold his two stations to the Liberty Magazine for \$250,000. The value of these stations was perhaps \$50,000 each; they could certainly be duplicated for half the amount paid for their possession. But their ownership without a broadcasting wave channel would be valueless, and wave lengths are exhausted.

This leads to the estimated value of some wave lengths at about \$75.00 each, dependent upon certain factors, location for example. Evidently the Liberty Magazine wanted to go on the air and as their were no available channels for broadcasting, this company bought two stations, wave lengths included. This transaction is altogether proper as far as can be determined. The Department of Commerce is understood to be disposed to O. K. the transfer of ownership, provided the station is not moved. The Government will probably renew the broadcasting license when it is expired in the name of the new owner. But the station with its wave channel could not be removed to another city due to allocations.

## Another New Zealander Tunes In on WBBM

New Zealand, approximately one-third of the way around the world, is now tuning in on Chicago regularly, according to a letter received by Ralph Atlass, co-director of Station WBBM at Chicago.

The letter, from Spencer Speedy, Pipi banks, Herbertville, Hawks Bay New Zealand, states the writer had been receiving WBBM regularly "the last few weeks" prior to Sept. 21.

## Wireless Matters May Be Delayed Until Next Fall

Echoes from the Paris Telegraph Conference, drawing to a close, indicate that the American Radio Telegraph Conference scheduled to be held in Washington next spring, will probably be postponed until late next fall.

Although invitations have been sent to over forty foreign nations asking them to participate in the world-wide wireless sessions, and the appropriations made by Congress provide that the monies must be used prior to June 30, 1926, it is believed by "those in the know," that a postponement will be found necessary or at least advantageous.

One of the chief reasons for believing that a delay would be desirable is because the Paris Telegraph delegates are reported as unanimous in the belief that a combination of the telegraph and the radio telegraph conventions is desirable. Another is because certain committees have been created and directed to work out some of the world's communication problems, reporting by October 31, 1926, to the first international conference. It would appear advantageous to have these matters discussed at Washington rather than to have them lie unadopted possibly for several years awaiting the next general conference.

Nothing was done in Paris to interfere with the scope of the forthcoming radio parley at Washington; that is, nothing pertaining to radio of a technical nature was injected into the wire conference. So questions relating to wireless communication including broadcasts and amateur work will remain open for discussion when the Washington conference is held.

Upon the recommendations of the delegates of Great Britain, France, Germany, Italy, China and some other countries, the Paris conference went on record as favoring a combination of the two world communication conventions into one to cover electrical communications sent by wire, cable or via radio, which will probably be effected at the next conference.

Recent reports from Paris state that a sub-committee on rates and codes passed a resolution creating a special committee composed of delegates from Great Britain, Germany, Greece, France, Belgium, Turkey, Russia, the Dutch East Indies and Italy, to study the code systems with regard to the adoption of a new universal five-character code. This committee, if appointed, and it is believed the Conference will agree to do so, would also fix new tariffs in accord with those of the present codes approved by the Conference. It would naturally report to the first international conference held, probably the Washington Radio Conference, as there is not likely to be another Telegraph Conference for several years.



## E. Warren K. Howe New Musical Director WJAZ

The Zenith Radio Corporation announces it has obtained the services of Mr. E. Warren K. Howe as Musical Director of station "WJAZ."

That Mr. Howe's influence cannot help but be a tremendous factor in giving to the public only the highest type of musical program is indicated by his training from childhood in the musical field. Through the influence of a genuine artistic environment in his youth, Mr. Howe enjoyed unusual advantages for a healthy development of his decided musical gifts. In his early days, he was a student of violin and piano and boy soloist in the Church of the Ascension, Chicago.

After three years of orchestral experience as violinist, he took up the study of voice, undergoing a thorough course of training with one of America's noted teachers; then entered upon a stage career under the management of Abbey, Schoeffel and Grau. After this, he was a member of the Schiller Opera Company in repertoire light opera, thus gaining valuable stage experience.

After five years' experience as singer and teacher of voice, Mr. Howe went to Paris, further perfecting himself under the guidance of Jacques Bouhy, the eminent master of the voice. Through the influence of Bouhy, he established himself in Paris as a teacher of singing and as bass soloist of Trinity Church, Avenue de l'Alma. He was also Paris correspondent for the Musical Leader.

Returning to America, Mr. Howe entered actively into musical work as pedagogue, in concert and oratorio singing, and subsequently as conductor of light opera and oratorio. He has had at various times under his baton in conjunction with musical festivals the country's best artists and the New York Symphony Orchestra, the Chicago Symphony Orchestra, the St. Louis Symphony Orchestra and the Minneapolis Symphony Orchestra seven times. He has also been at the head of the vocal department of one of America's foremost conservatories for several years.

## Goodrich and KFNF to Liberate Balloons

Three hundred sounding balloons ranging in sizes from two to three feet in diameter and inflated with hydrogen gas are soon to be liberated from Shenandoah, Iowa. This will be the beginning of an experiment being arranged by The B. F. Goodrich Rubber Company in cooperation with the Henry Field Seed Company's radio station KFNF.

The purpose of the experiment is twofold. First to study the directional features of different atmospheric levels for aeronautical information and second to study those currents with respect to their possible influence upon radio broadcast reception.

The Goodrich Company's interest applies to both fields. They were the first rubber company to accept radio as a medium for presenting good-will entertainment to millions of radio listeners and they manufacture many hard rubber radio accessories. On the other hand they are extensively interested in aeronautics, being manufacturers of many accessories for both lighter-than-air and heavier-than-air crafts.

The balloons to be used in this experiment are of the type government meteo-

logical experts use in taking altitude tests of atmospheric conditions. They will be inflated at varying pressures predetermined to gauge the altitude at which the balloon will travel.

Tags attached to the balloons have specific instructions. These instructions together with the announcements that will daily be broadcast from KFNF are expected to get full cooperation of those who find the balloons in reporting location and time.



Miss Irma Carpenter, soprano, who appears in role of soloist on the Teaberry Time programs, broadcast from Station KDKA at Pittsburgh.

## Hurrah! We'll All Angle for DX Now

Broadcasters of the United States will gladly stay off the air one hour each evening during International Radio Week, January 24-30, 1926, according to advance information received by the executive committee handling this event.

Formal action by the broadcasters of the United States will come at a meeting of the National Association of Broadcasters this body being expected to handle the broadcasting features of the week from the American side.

"While we have no official word from the broadcasters society," L. A. Nixon, secretary of the radio week committee said, "we have had advance assurance from some of the more prominent broadcasters of the country that there will be no question of a hitch in observing the silent hour so that American listeners may hear the overseas stations.

"The official silent hour will be from eleven to twelve eastern standard time, according to our present information.

"The change of date from late in November to January 24-30 which was authorized at the recent meeting of the radio week committee, was made so as to bring the event and the accompanying international radio broadcasting tests into the best possible season of the year, January being conceded a better radio month than November, for overseas broadcasting.

## National Exchange of Radio Recipes

Radio has brought about a national exchange of cooking recipes. When Mrs. New York is a little bit in doubt about the meringue for her pie, she is just as likely to ask Mrs. California or Mrs. Minnesota for advice as she is her next-door neighbor. If young Mrs. Wisconsin can't get her baked beans quite as brown as "mother used to bake them," she can call upon the famed authority on the subject, Mrs. Boston. If a contemplated Southern dinner is on the mind of Mrs. Michigan, she can get suggestions for it from her friend, Mrs. Missouri.

It has all happened since Betty Crocker began broadcasting her Home Service Talk on September 21st from twelve of the largest broadcasting stations from Boston to Los Angeles. From Coast to Coast, according to letters received by the stations participating, housewives tune in on their favorite broadcaster at approximately 10:45 Mondays, Wednesdays, and Fridays to hear what Betty Crocker has to say and to get the newest recipes she offers. Their next step, as a rule, is to sit down and write Miss Crocker, telling her how the recipe came out and to send her a few of their own favorites. Then they write to their friends, relatives, and daughters in other cities to tell them about this new cooking school over the air and urge them to listen in on the nearest station which is broadcasting the service.

For instance, a farmer's wife in northern Minnesota wrote that she had been so busy cultivating corn, poisoning potato bugs, helping with the harvest, and putting up approximately a thousand quarts of preserves, that she hadn't had time to listen to the radio all summer, but now that Betty Crocker was on the air, she had had the radio set fixed up.

"I get the talks," she wrote, "from WCCO, but I have a daughter married and living in an apartment in New York City. She always liked to cook, but don't imagine she has much opportunity now. I am sure, however, that she will like these radio cooking school lessons, so I have written her to tune in on WEAJ."

Many of the Eastern housewives who wish to listen to the Betty Crocker Talks have the choice of getting them from WEAJ, New York, WEEI, Boston, WGR, Buffalo, or WFI, Philadelphia. In the Middle West Betty Crocker's audience tunes in on WCAE, Pittsburgh, WWJ, Detroit, or WHT, Chicago. In the South and Southwest, these various culinary suggestions go out from KSD, St. Louis, and WDAF, Kansas City, Mo. Up in the Northwest, where Betty Crocker made her debut last year, they tune in on the Gold Medal Station, Saint Paul—Minneapolis, WCCO. Although the range of this Station extends to the Pacific Coast and up into Canada, the ladies in the far West depend upon KFI.

## Has Dulcetone

One of the most unique instruments to be heard on the air, the dulcetone, has been added to the musical equipment of the Wrigley building studios of WHT and selections are played nightly on it by Al Carney and Miss Helen Rauh, staff accompanists.

The dulcetone in effect is a miniature piano and has but 44 keys. It is 34 inches long and can be held on the knees of the artist playing it. The dulcetone was obtained by WHT in Glasgow, Scotland.



# Bring Christmas Cheer twelve times a year!

*RADIO AGE, a gift that will bring joy to your radio fan friends every month for the whole year*

## Our Offer

You can multiply your holiday gift by twelve in a very simple and inexpensive manner.

You probably know of one or more friends to whom you wish to make a present. We want to make it easy for you to select the gift, and we want to take care of all the work connected with delivering it safely twelve times.

Of course, your friend, relation or whoever is to be remembered, is a radio lover. No other gift could bring as much interest to them as the RADIO AGE. It is a quality publication for the entire family; for experimenters and those who "listen in."

The blueprint section in each issue is a delight to the home constructor of radio sets and the illustrated features on what the broadcasters are doing have a large following. RADIO AGE is an ideal gift, particularly for men and boys. At a special thirty day rate of \$2.00 (regular rate is \$2.50) we will have the mail carrier deliver a copy of RADIO AGE each month for twelve months. Fill in the coupon on this page with the name and address to which you wish the magazine mailed; we will do the rest.

With the first issue we will send a beautifully engraved gift card informing your friend that RADIO AGE is sent to him by you with Christmas greetings and Best Wishes for the New Year.

If you wish to order subscriptions for more than one person you may do so by writing the additional names and addresses on a slip of paper attached to the coupon. Start with any issue you desire, but send the coupon now!

## A thousand gifts in one

RADIO AGE, a magazine brim full of hook-ups and good construction articles.

An eight page section in each issue containing actual blueprints showing how to make the best and latest circuits at home.

Many pages of pictures and interesting stories about the world's favorite broadcast entertainers and about the stations and studios.

A complete, up to date list of U. S. and foreign broadcasting stations.

A department for readers who want to tell other radio fans about the sets they have made, how they're made and what results they have had with them.

All the best news of the radio world and its magic progress.

A magazine your friends will treasure as a gift from you.

Twelve times for Two Dollars!

**Radio Age**  
Inc.

500 N. Dearborn St.

Chicago, Ill.

## Gift Subscription Coupon

RADIO AGE, Inc., 500 N. Dearborn St., Chicago, Ill.

Please send RADIO AGE, the Magazine of the Hour, to the following for one year, at your special holiday rate, beginning with the ..... issue.

Name .....

Address .....

City .....

I enclose \$2.00 (in currency, check or money order). With the first magazine delivered send one of your notices informing the recipient that RADIO AGE is sent to him by the undersigned with Christmas greetings and Best Wishes for the New Year.

Sender's Name .....

Street .....

12-25 City .....



**B**ATTLING in the ring amid the cries of thousands and attempting to deliver a short address over the radio in the quiet surroundings of a broadcasting studio, are altogether different, according to Mike McTigue, world's light heavy-weight champion boxer who recently visited WGY, the General Electric broadcasting station at Schenectady, N. Y.

Kolin Hager, chief announcer at the station, recalls it as one of the outstanding humorous events of the three years that the station has been in existence.

"He was scheduled to deliver a few words on boxing," explained Mr. Hager. "Naturally, he was the last man in the world that we expected would suffer a case of 'microphone fright,' but he did. He stepped up to the pick-up device, but he could not talk. 'I would rather face Dempsey than talk into that thing,' he said. The result was that his trainer, who accompanied him to the studio, was compelled to read the written address."

WGY is about to celebrate the fourth year of its existence. Mr. Hager has been in charge of the announcements since the institution of the station.

#### Wasted Energy!

**I** MADE my first announcement on the night of February 21, 1922, and with many misgivings," said Hager. "I had rehearsed just what I was going to say twenty-five or thirty times, and then, when the time for the announcement arrived, I said something altogether different from that which I had intended."

The WGY studio is a comfortably furnished suite of rooms on the first floor of a new office building. The room from which come the songs and selections, speeches, readings, comedies and dramas, is furnished with nothing in the way of scenery such as is found in theatres. Yet it was only a short time ago that the studio officials received a call from a traveling scenic artist who had been told that he might land a job at WGY painting scenery for the radio. He was advised that he would get the job if he could arrange a suitable tableau for the radio.

#### Wants Hubby's Death Broadcast

"One day the phone rang rather vigorously," said Hager, "and I answered it to receive this message: 'My husband is dead, thank God, and I wish you would broadcast the fact.'" Hager said that

*It's All In Fun!*

## An Impromptu Chat with Station WGY

By MILTON LIEBERMAN



*The WGY orchestra has been heard all over the United States, England, France and other European countries, particularly during the last few weeks, when WGY has been experimenting with 50,000 watts. This orchestra has been with WGY ever since it first came on the air, and is still going strong.*

it wasn't news—husbands never last long, anyway.

WGY was the first of three stations to be constructed by the General Electric Company. The second, KGO, located at Oakland, California, opened early in 1924, and the third was put in operation at Denver in the winter of the same year. All three stations are operated under the management of Martin P. Rice. The equipment of the stations at Oakland and Denver resulted from the experience gained at WGY, and the experimenting of G-E engineers at Schenectady. WGY has been a laboratory for transmission development.

While the radio engineers have always sought first for quality, they take pride in the fact that WGY on a single evening—it was December 24, 1923—was heard and reported from every state in the Union as well as from Hawaii, South America, Canada and England. The station's record is Johannesburg, South Africa, a distance of 7890 miles. This reception was reported by N. Grant Dalton, an amateur, on May 22, 1924.

In connection with the development of broadcasting equipment and the improvement of transmission quality at WGY, General Electric engineers have developed a magnetic piano microphone. By its use music is received through loud speakers with improved quality. Extensive experiments have been made

with short waves from 107 meters to 15 meters. To facilitate broadcasting of programs originating outside of the studio, such as concerts in public halls, productions in theatres, church services, etc., WGY has developed a portable transmitting apparatus by means of which the customary land wire link between the scene of the concert and the transmitting apparatus is supplanted by a radio link. The portable station, of comparatively low power, picks up the signal and relays on 100 meters wavelength to WGY, where it is put on the air with greater power and on 380 meters.

#### Cop Wants to Arrest Speaker

**K**OLIN HAGER, after the first year of broadcasting, concluded that the radio audience would soon tire of a repetition of programs made up of solo numbers, even tho given by artists of international reputation. To provide novelty and entertainment he has included in WGY program several features which invariably bring a flood of

complimentary letters. For example, WGY periodically puts on a farmer's night program. On one occasion it was Josh Quinby's golden wedding anniversary; on another Josh had a husking bee. The minstrel show has also been a popular feature of the station, and recently a burlesque on the national conventions was produced so successfully that a "return engagement" was booked. WGY has a light opera company which has produced three of four of the Gilbert and Sullivan rollicking operas.

In August, 1922, Edward H. Smith and a small group of players, all of professional experience, were engaged to produce Eugene Walter's play, "The Wolf." It was the first experiment with the radio drama. The play made an instantaneous hit. Letters were received from all parts of the country and from people in all walks of life, urging a continuance of radio dramas. A Pittsfield, Mass., policeman, hearing cries for help coming from a modest bungalow, demanded admission and the cause for the shouts. He was shown the loud-speaker from which were issuing the cries of a heroine in the grip of the villain.

Not so long ago the WGY players delivered the comedy, "Get Rich Quick Wallingford" in a most excellent manner. The story of the play has to do with the

*(Continued on page 62)*



# Radio Finally Links Motion

## 30,000 Radio and Movie Fans Crowd Theaters to See World's First Radio-Cinema

OVER 30,000 radio and motion picture fans crowded Loew's State Theatre, and fourteen other West Coast Theatres last month, to see and hear the world's first Radio-Cinema.

A full page of history was written that night, for it was the first linking of the "silent drama" with the human "voice over the air." Talking pictures had at last become a practical reality.

The vast crowds which jammed the theatres sat almost bewildered—so uncanny seemed to be the perfect synchronization of the lip movements and the voice of Norma Shearer and Lew Cody, the principals in this remarkable experiment. Then came the awakening as out of a dream and the theatre applause became almost deafening.

It was an undisputable success, which put in the hall of fame those who so earnestly collaborated in making the Radio-Cinema practical—including Metro-Goldwyn-Mayer, West Coast Theatres, Inc., local radio experimenters, Los Angeles Examiner and Station KFI.

### "A New Epoch"

THE attempt to synchronize the voice with the action of the players on the screen via radio marks a new epoch in the amusement world," said Louis B. Mayer, vice-president of the Metro-Goldwyn-Mayer Corporation following recent experiment.

"Metro-Goldwyn-Mayer has been glad to lend every cooperation to the experiment as have Miss Shearer and Lew Cody, who have given it much of their time. Most of the work came under the care of Douglas Shearer, brother of Norma, a well known electrical engineer. The Los Angeles Examiner is to be com-

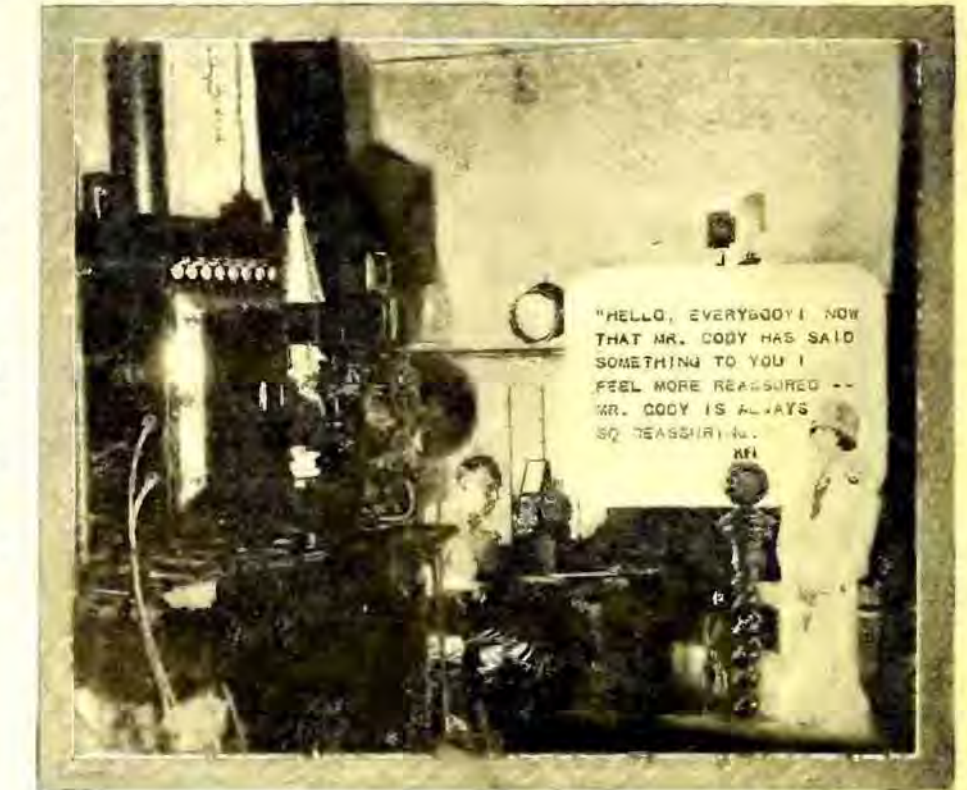

Revealing the secret of radio-cinema! Above Norma Shearer, beautiful movie star, is seen broadcasting through the KFI microphone, while her "speech" is photographed in rolling title form on a motion picture film. The KFI announcer is shown at the control board giving out the "cues." The machine in the foreground is a combination camera and projector.

plimented for the way it fostered the experiment as is also KFI."

After weeks of experiment the studio and the radio mechanical experts declared that 100 per cent synchronization of the human voice with motion pictures was possible.

Sharply at 9 p. m., August 24, the Metro-Goldwyn-Mayer Radio-Cinema was put on the air over KFI.

On the stages of every theatre involved in the experiment, a powerful receiving set had been set up. The operators in each of the theatre projection rooms wore head-phones, which gave them the metronome time setting cues for starting the film as well as the interval cues during the run of the picture.

Literally, the operator's duty was to beat time with the projection crank after starting his machine with the signal of the Radio studio broadcasting chimes. No effort was made to present an elaborate play. As the announcer stated, the only effort was to show that it was possible to synchronize voice with the movement of the player's lips. The promoters of the project proved their point. With the exception of one or two instances where operators became nervous the results were remarkably successful.

### A Personal Appearance

NORMA SHEARER and Lew Cody, actually talking from KFI, were heard in the various theatres throughout

Southern California, while the audiences watched the motion pictures of them talking with the same true effect as though it were a personal appearance. The demonstration opened the door to conjecture. The Radio-Cinema has undoubtedly arrived.

Now that inventors are announcing the control of radio waves, it may be possible soon for a group of theatres to present any length film story to their individual audiences over special tuned sets without making the same show available to others who have not paid for the service.

At the same time the doors also opened to the inventive genius who can make it possible for every home to have its own talking motion pictures.

At the first public demonstration the entire "secret" of the Radio-Cinema was laid bare to the audience in Loew's State Theatre through a special act which was presented on the stage.

The "act" revealed a stage set which was an exact replica of the KFI studio revealing Norma Shearer and Lew Cody with the official announcer at the microphone. The KFI projection machine was there throwing a picture on a miniature screen while above them was the regular Loew's State screen.

The audience was rather startled to see two pictures exactly alike unfolding them-



# Pictures and the Human Voice



*Linking the silent drama with the voice of the air was successfully accomplished in Los Angeles recently. Norma Shearer and Lew Cody are "doing their stuff" on the screen for the fans in the theater, while the loud speakers on the stage bring in the "voices" from KFI, in perfect synchronization with the screen action. The film was shown in fifteen different theaters simultaneously.*

selves on two different screens. The Loew's State orchestra played the thematic score they had prepared.

Then came that part of the experiment where Miss Shearer and Cody arrived at the KFI studio and actually talked "over the air"—and another surprise for the audience. Just as Mr. Cody stepped before the microphone on the stage, the picture on the miniature screen disappeared and a rolling title appeared in its stead. Lew was actually reading his lines from one screen, while the screen above showed the movement of his lips in perfect synchronization.

## Telling 'Em the How

**GLENN RICE**, program manager at KFI explained in terms that both radio fans and the public could easily understand how the Radio-Cinema had been made an actuality.

More than 200 seats had been reserved for Metro-Goldwyn-Mayer officials and various film celebrities.

Among the distinguished guests in the audience, were: Sol Lesser, A. Gore, M. Gore, Fanchon and Marco, Hobart Henley, director of "Slaves of Fashion," A. M. Bowles, general manager of West

Coast Theatres; Louis B. Mayer, Harry Rapf, E. J. Mannix, Irving Thalberg, John McCormick, general manager of First National production units; Colleen Moore, Dorothy MacMail, Constance Talmadge, Anita Stewart, Bert Lytell, Milton Sills, Claire Windsor, Lon Chaney, J. H. Goldberg, M. R. Rosenberg, Fred Niblo, Victor Seastrom, Tod Browning, Robert Leonard, Aileen Pringle and many others.

Old timers in the experimental world will remember the efforts of Edison, DeForest and a host of others who have tried to competely synchronize the voice and the picture; the amount of brain work expended in the years past on this topic would seem sufficient to operate goodness knows how many windmills and other mechanical devices if such energy were translated into terms of mechanical or electrical energy.

Unquestionably the end is near; the contributions of Edison, DeForest, Jenkins and many others, are piling up. Each independent investigator unearths something of value which is bound to be of benefit to the project as a whole. A resumé of the radio-cinema in its entirety would involve too much space at this

time, but needless to say there are indefatigable workers probing the problem and they believe success can be assured very shortly.

What the public's reaction will be, is a question subject to the most violent debate. We can all remember the early movies and their effect on the public. They were laughed at, condemned, finally reluctantly accepted as one of the evils of modern days. Today they occupy a prominent niche in our social life.

Perhaps the period of newness and strangeness of the radio cinema will not be as long as that attendant upon the ushering in of the first movies. Today we are accustomed to thinking in terms of electricity and radio; everything is done to speed up our work and our pleasures to crowd more into each hour. Under these conditions, with a public already partly prepared through the wonders of radio, the radio-cinema may not encounter such obstacles as its foster-parents did.

We have come to accept our film favorites in their appearance on the silver screen, but will we care for them so much when their voice issues from a loud speaker? This is a point which time alone will settle.



# NEW VOICE Appears at WDAF



H. Dean Fitzter  
 New Leader  
 of Famous  
 "Night-Hawk"  
 Club in  
 Kansas City  
 Studio

*Doesn't this genial countenance look able to take the place of the "Merry Old Chief" of WDAF's nighthawks? Mr. Fitzter knows broadcasting and he has a voice that travels well on WDAF's new power. He promises to make the famous Night-hawks "nuttier" than ever.*

**K**ANSAS CITY, MO.—There is a new voice being heard these days and nights from the studio of WDAF, the broadcasting station of The Kansas City Star, home of the famous Nighthawks. The station's new director and announcer is H. Dean Fitzter, succeeding Leo Fitzpatrick, who has gone to WJR, Detroit.

Mr. Fitzter is a baritone and formerly was a member of The Star's reportorial staff. In the latter capacity he has for three years directed the Midwestern Zone in the National Oratorical contest on the Constitution, his management of that popular and educational project extending from Canada to the Gulf of Mexico and from the Mississippi river to the Rockies. Throughout the war Mr. Fitzter served as a musician aboard the U. S. S. Dixie, stationed in foreign waters.

Along with the change in personnel at the WDAF studio, big plans are in a stage of development for the station's future. A new transmitter, now being installed, will give WDAF 1,000 watts power, twice the power of the present station. This will be a boon to operators of crystal sets and should cause the

By  
**GEORGE GRAHAM**

station to be heard from greater distances. London has heard WDAF many times with its present transmitter.

**New Studio Planned**

**A** LARGE studio has been built for WDAF, as well as spacious rooms for the operating equipment. With the

**THE NIGHTHAWKS CHANGE HANDS**

The famous Kansas City "Nighthawks" are known all over the world for their eccentric programs. Under the direction of "Merry Old Chief" Leo Fitzpatrick, the Nighthawk club has grown to a membership of over 50,000 radio fans.

And now the torch is changed. Leo Fitzpatrick has gone to WJR, and Dean Fitzter, whose story is given on this page, bids for your favor.

exception of the large aerials that tower above the Star building, the entire station is new. Special programs ushered in the new WDAF, its new director and announcer and its new equipment.

Type programs will be the goal under the station's new direction. Experience has taught that radio audiences do not agree on the kinds of programs they prefer would come to them through the ether. And, too, jazz to classical, all within a single program, is an inexcusable conglomeration. In view of this, Mr. Fitzter is planning type programs for certain definite periods.

Programs for the housewives will be offered mornings and afternoons; a matinee string trio; the "School of the Air" and the Tell-Me-A-Story Lady in the early evenings; refined ensemble music for the dinner hour; Monday nights, semi-popular programs in "Around the Town with WDAF;" Wednesday and Friday nights, programs of standard classical music.

Somebody asked where does the jazz come in? "Stay up for the Nighthawk frolics and you'll be filled full," comes the answer from WDAF.



## Studio Visitor Given

IMPRESSION  
OF SPEEDTrend of Radio Design in Keeping with  
Advances in Art are Seen in Sears-  
Roebuck New Studio in Hotel Sherman

SCIENCE and art at the peak of their present-day development have been fused together to produce the new WLS, the Sears-Roebuck Agricultural Foundation Station, Chicago. The broadcasting studio just completed in the new Hotel Sherman Annex, Chicago, is an example of an entirely original and modern type of art, while no phase of science which radio wizards have been able to discover has been left untouched in building the superpower transmitting station for WLS near Crete, Illinois. The inaugural program on the new Station was given Oct. 31.

## Water Cooled System

This station will give the last word in transmitting efficiency. The transmitter is 5,000-watt capacity and the tubes will be 10,000 watt units. A specially designed frequency amplifier system will assure the holding of the same wave length under all conditions and the use of the capacity coupling will reduce possibility of interference with other stations, according to Curtis D. Peck, chief operator.

The station is located on a two and a half acre plot on the Dixie highway, just south of Crete. The site is landscaped and beautified with hedges and creeping bent grass lawns. Drives and parking space for visitors also are provided. Fifteen miles of ground wire were plowed in rows under the lawn, very much as a farmer plants potatoes.

## Merge Beauty and Utility

Utility and beauty have been combined in the building which is now completed. The building contains an extra large operating room, an office, an attractive reception room for visitors, the generator and battery rooms, switch closets and an entrance hall. The most up-to-date construction has been employed throughout with extreme emphasis placed on furnishing perfect transmission. The metal lath, for example, is joined together to make a perfect circuit which will insure against absorption in case it should ever become necessary to get down to lower wavelengths. An elaborate hot water heating system has been installed to prevent freezing of the water in cooling tubes. The towers are 200 feet high and forty feet at the base. They can easily be seen as far distant as the Indiana state line.

A series of exhaustive tests were made by the Western Electric Company before the station's inaugural program.

## Same Wave Length

The wave length will remain the same, 344.6 meters or 870 kilocycles. The Army experimental call letters will be A Z 3.

The new studio is located on the 6th floor of the Hotel Sherman Annex. Alphonse Ianelli, well known interior decorator developed for the occasion what might well be called, radio art. That is, he has gone to the radio itself for his inspiration in designing this most unique of all radio studios. Every piece of equipment and furniture, the walls, ceiling and lighting fixtures bear out the radio motif and emanate the speed, intensity and universality of the mysterious forces of the air. Even the piano and microphones were especially designed to carry out the radio theme.

Twin studios have been provided. One, 55 feet long and 20 feet wide, is for orchestras, bands and dramatic productions, and a smaller one is to accommodate soloists. Separated from the larger studio by a plate glass window is the little theatre which will be open to the general public. It is about twenty feet square and will seat fifty people. A loud speaker will enable the audience to hear the program, as well as watch the artists broadcast.

## Expressive of Speed

Black, red and silver is the color scheme for these unusual rooms. Ethereal energy and motion, captured by the painter's brush, greet the eye. Representation of sound waves on the walls and ceilings give the visitor the impression that he has stepped inside of Einstein's brain. The lightning finger of radio speeding through the dark of night is expressed in the black woodwork touched with lines of silver and white. Black and red chenille carpetings cover the floor, while from above, indirect lighting provides startling effects.

A reception room is also provided. This has a distinctly agricultural background, portraying the "voice of the farm" which the educational work of the Sears-Roebuck Agricultural Foundation is carrying from coast to coast. A large mural painting representing the four corners of the earth, furnishes the key note of the room.

In addition there are the general offices, the operating and battery rooms and the room for the pipes of the famous Barton organ, all of which are equipped in the most modern and efficient style.



"By his toots shall ye know him" might be an apt paraphrase covering George Hay, well known in the old days at WMC, famous later at WLS, and now forsaking the beautiful new WLS studio in the Hotel Sherman to become announcer-extraordinary of the new radio station WSM at Nashville, Tenn.

It may have been the snow up here, or the plantation melodies down there, whatever it is George Hay is leaving the Sears Roebuck station to return to his former stamping grounds in Tennessee, where he started out in the newspaper game, later to become a leading figure among announcers.

When informed of the fact that George Hay, "the solemn old Judge" of WLS was to return to his southern heath we immediately came to the conclusion there must be a conspiracy on between the famous southern triumvirate, the Hired Hand down at WBAP, the Little Colonel, Lambdin Kay at WSB and the redoubtable Hay himself; the plot of which we perhaps will never know; the main point is—try to get these three gentlemen away from their favorite haunts.

We do not know whether it is the whistle on the upper part of this page which George is so industriously tooting or what it is, but nevertheless there seems to be a plethora of whistles on the air these evenings—vide WSMB at New Orleans, WSM at Nashville (whence George goes with his own whistle) and perhaps by the time these lines reach the public gaze there may be several more. You can imitate the whistle but you can't duplicate the Judge.



# The Dean of Radio Adventurers

Inborn  
Craving for  
Adventure  
Led this  
Fan to  
Fame in  
Radio



A great part of Mr. Henninger's early career was spent in an airplane. In the air service of the government he made several experiments in inter-airplane communication.

A Peep  
into the  
Early Life  
of a  
Typical  
"Radio  
Pioneer"

WHEN you meet up with a fellow like A. F. Henninger, Jr., you immediately sense that behind his quiet and modest ways there is a tempestuous career. As you are talking things over with him he will reluctantly allude to some minor characteristic of the natives of the South Sea Isles or he might give you a brief description in about ten or fifteen words of what an aviator thinks about when shells are bursting all about him.

Radio has been the very life of this prominent engineer for the past fifteen years. Radio has taken him around the world; has caused him to be hungry and cold while riding a disabled plane in the rough sea; it has made him a general or something equally grand, in the army of a small Central American Republic during the time that it was indulging in its semi-annual revolution. Radio has caused him to be lost in the wildest of jungles for two weeks with one foot made totally helpless by a revolutionist's bullet. Those are adventures that few men alive today can equal, but frankly, generous reader, it took 18 working hours of cordial questioning and gentlemanly prying and prodding to illicit this information from the lips of A. F. Henninger, Jr.

With a wireless outfit consisting of a telephone receiver resurrected from the junk box, a small piece of coal, then very inexpensive, that was used for a crystal detector in place of galena, some wire from the magnets of an old Morse telegraph sounder and some iron wire for the antenna, Henninger set to the unusual task of constructing some sort of an apparatus that would make it possible for him to hear the time signals from Arlington, Virginia. Frankly, folks, success was not to be so easily achieved. A few more months of experimentation revealed

## By WILLIS ARNOLD

the need of a loose coupler, consisting of two large cardboard tubes wound with wire and telescoping one into the other. Henninger was particularly careful to see that it was made small and compact, for when these tubes were extended they only covered an area of about four square feet!

AS NO doubt you already realize, Henninger is not the type of inventor to pace up and down his labora-

tory pulling his wavy locks with unrivaled enthusiasm and glee. But he could have well afforded a few minutes devoted to such a demonstration. He had actually heard the time signals from Arlington!

Of course it can be said that the same crystal set that Henninger constructed 15 years ago can now be purchased complete, ready to use, for less than a dollar—and the whole set can be held in the palm of the hand.

During the early part of the war, Henninger, devoted his thorough knowledge of radio to helping his government. He was stationed at the Naval Air Station at Pensacola, Florida, as instructor in radio aviation. When not out riding disabled airplanes on the rough waters of the Caribbean Sea, he could be found in the valuable and costly laboratories that the government had equipped, doing research and pioneer work in the many new phases of radio aviation.

He was later transferred to a land radio station and later to take charge of the model radio equipment on a new destroyer. It might be interesting to note that this destroyer was equipped with three transmitters, including a radio telephone, and a multiplicity of receivers. Although it was not a particularly valuable instruction, Henninger learned the art of bailing salt water out of a radio receiver.

Then, as prominent novelists frequently say, his mental make-up demanded a change. He found himself the proud possessor of an adventure complex. He wanted to free himself. Arming himself with a commercial operator's license, he left for New York.

He had heard dreamy tales of Central and South American life. Others had told him of gentle

(Turn to page 60)



A. F. Henninger at work in his private laboratory, where he spends hours at a time "fussing" with new radio ideas.





Harold Geiser, director of the Vincent Lopez Hotel Statler dance orchestra, and reproducing record organization from WGR, Buffalo. Here he is shown all dolled up before the microphone and ready to slide a wicked trombone for his legion of listeners.

## Step up and Meet The PLAY BOY of the DAKOTAS

Here's a Radio Artist who  
Sees More in His Art  
than the Tom-Tom of  
Jazz Bands and the  
Sway of Dancers

By LLOYD S. GRAHAM

**D**O YOU know WGR? Do you know Harold Gieser? If you know either one you know the other.

Also, if you know Harold Gieser, you also know good jazz music.

A friend of this well known director of the Vincent Lopez Hotel Statler Dance orchestra, Buffalo, who used to know him as a boy on a ranch near Aberdeen, South Dakota, and who is one of the thousands of long-distance admirers of his music received the air-way, has affectionately dubbed him "the play-boy of the Dakotas."

The pseudonym sticks, chiefly because it is fitting. Harold Gieser is a play-boy; that is, if we understand the term to mean one who has a joyous and philosophical viewpoint on life and who takes a great deal of pleasure in making it possible for others to play.

Harold Gieser is outstandingly a leader among the youthful directors of popular orchestras today. He is well under thirty and looks it. His musical interpretations have the joyousness of youth overflowing in them.

### A Bunch of Mail

**T**HAT is partly the reason why WGR receives more radio mail on Harold Gieser and the Vincent Lopez orchestra than on any other two or three regular station features combined.

Harold Gieser's gang of syncopators are on the air three nights each week for

two hours each time. They go on at 11 o'clock, Mondays, Wednesdays and Fridays, and continue to play until 1 o'clock in the morning. Supper-dance music, they program it.

But there is another reason why this orchestra always has been the leading feature of WGR and why the fan mail referring to it steadily increases.

Harold Gieser takes the radio audience with tremendous seriousness. Ostensibly the orchestra which he directs is only one of the thirty or more in the famous Lopez combination. Ostensibly it is engaged by E. M. Statler to play for the guests in his pet hotel—the hostelry built by him in his own home town. Ostensibly broadcasting privileges go with that contract. This is the arrangement in hundreds of hotels and theaters and cabarets throughout the United States today.

In a great many of them, too many of them, the orchestra director plays what he pleases regardless of the radio audience. Microphones are placed to pick up what he offers the patrons of the place which engages him. That which the microphone picks up is merely a by-product, and many directors are acutely conscious that it is a by-product. A great many directors are so engrossed in their own comparatively little job of entertaining a few hundred people during an evening that they cannot take the uncoun- ted thousands out in the air with much seriousness. It reminds one of the

aviator who had his little son up in the air. They were flying over a city. The boy said something about the big men of the city but the wise father replied that there were no big men there, some were merely smaller than others.

### A "Man of Vision"

**V**IEWED from this angle, Harold Gieser's conception of his job is all the more important and interesting. A learned admirer of Gieser's in Buffalo put it another way when he said that the director was a man of vision. He sees more in the situation than the mere, ordinary, work-a-day routine of it.

When he manipulates the slide trombone and directs his men he sees more than the richly garbed men and women out at the tables. He catches more than the sight of clinging figures weaving their way in and out of the polished tiled floor of the Statler to the strains of "All Alone." He sees more than the rich decorations, the snowy linen, the glittering silver and crystal, the obsequious waiters.

There may be something in the fact that he was born and raised in the Dakotas, where he of necessity learned to know intimately the elemental and fundamental things of life, that enables his inner vision to see, besides those in the dining room, that enormous other audience and realize what good music means to it.

(Turn to page 62)



# A British View of Broadcasting

## Capt. L. F. Plugge of Britain's Radio Society Speaks His Mind

**I**N AMERICA broadcasting started some two years before it did in this country, and consequently we in England had the advantage of looking back to what had been done over there before facing our problems. This advance trial as it were, was certainly very useful to us in many spheres. One of the principal decisions which we arrived at (and the American experiences were much quoted in this respect), was the principle of placing broadcasting in the hands of one central organization in order to assure co-ordination and to avoid the chaos which has often been said to exist in America owing to the great number of stations controlled by a like number of independent bodies.

There was one problem, however, with which America was not faced, and this problem in Europe we are the first to grapple. It is the difficulty arising from the close neighbourhood of so many different countries in which different languages are spoken and in which different laws prevail. Except for Havana stations, United States radio amateurs have practically only one language and one law to contend with. The South American stations separated by land from the States have only been received in very exceptional circumstances, and the Canadian stations, except for La Presse, which is a bi-lingual station, use English.

In Europe things are quite different. Here we have a large number of countries very close to one another—a twenty-four hours journey can hardly be made in a straight line without visiting three of them. They all have different languages and different laws, and it is beginning to dawn on us that our centralisation of broadcasting as compared with America, is a myth, and what it is supposed to avoid, is growing greater every day. Wireless knows no frontiers. It appears useless for a geographically small country like England to hope that a scheme of centralization confined to its own border is going to overcome this chaos said to be detrimental to good reception.



*Capt. L. F. Plugge, member of the General Committee of the Radio Society of Great Britain, and European authority on broadcasting. In this article he urges an international radio conference for solution of outstanding problems.*

### The Problem of Laws

**T**HERE then is the question of law. Some of these countries have laws quite different from our own. Nothing can stop them from building high powered stations within very short range of foreign countries, powerful enough to interfere with the home stations and useful enough to pour their propaganda into other states. There is a common danger here, on which many views might be taken.

Either centralisation of broadcasting authorities is no good, and then we might discard it straight away, or else the centralisation which the B. B. C. have achieved in England should in the largest measure possible, be extended to the whole of Europe. Co-ordination should exist among the various broadcasting organizations. They should come to some understanding with reference to the numerous points which are at present looked at from so many different angles. How can this be done?

The first thing which should be tackled, and efficiently, is an International Broadcasting Conference, and this Conference should be called by an Independ-

## Problem of Conflicting Languages Greatest that Europe has to Face

ent body. That the B. B. C. are in touch with Foreign stations there is no doubt, several of the Continental programmes have been relayed by 2LO, and other facts have shown this. The B. B. C. carried great weight with it throughout the length and breadth of Europe, but it would be a wrong policy for the B. B. C. to call such a Conference. There is already a feeling in many of the small broadcasting organizations of Europe that the B. B. C. is trying to enforce its will and to extend its British monopoly to other countries. These other countries, jealous of their independence, could not tolerate such an attitude. Everything should be done so as to make it clear that it is not the B. B. C. that is stage managing the Conference. Paris would be an excellent seat but Geneva would probably be better.

It would be good, however, that the calling of the Conference should come from our country. We are

admittedly the country in Europe where broadcasting has made the most rapid strides, and it is natural, therefore, that the calling of this Conference should originate from a recognised body in this country. There should be no delay in the calling of this Conference. If we do not take steps now, France, who is also much alive to these international problems, is in an excellent position to call such a Conference, and we will lose the credit of the initiative.

There are a considerable number of subjects which will be suitable for discussion at this conference, and although on many of these points an agreement is not likely to be reached, a great step will be made forward towards harmony and co-operation which unfortunately exist in so small a degree at present.

### The Question of KW

**T**HERE would be the question of power to be allowed. We are only at present using something like 15 kilowatts on our most powerful broadcasting station, and the average number of stations rarely use more than a couple of kilowatts. At present it would be

(Turn to page 64)



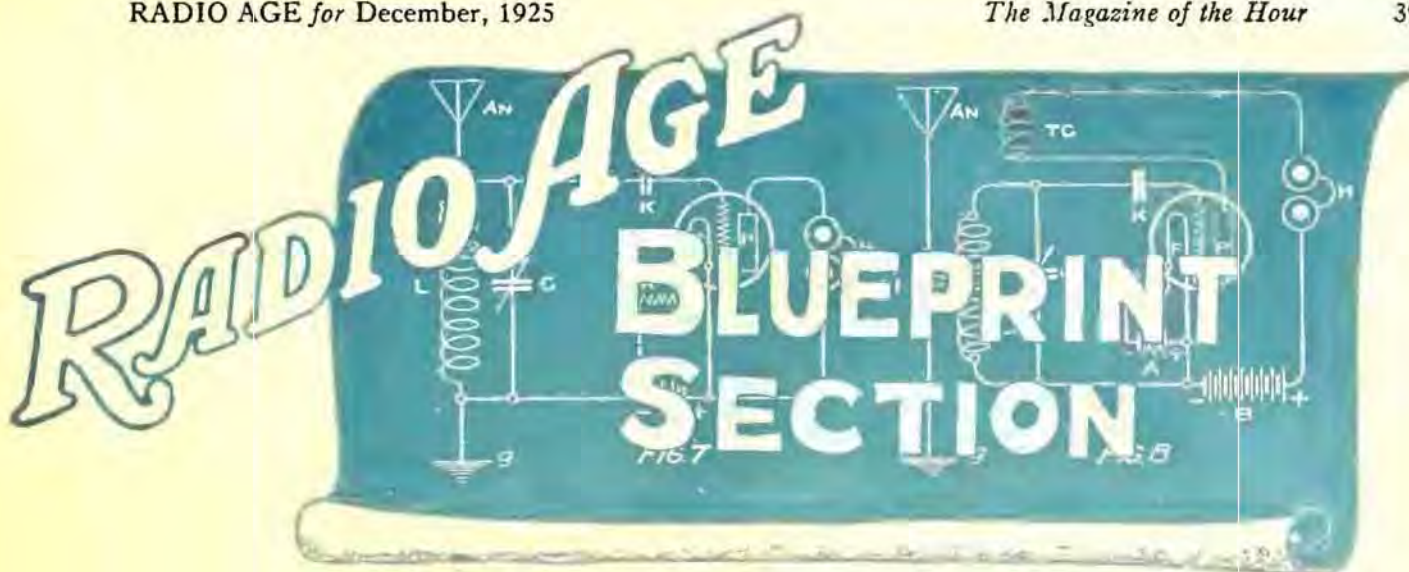

Something for the Beginner—

## A 3-Tube Inductive Coupled Feed-back Receiver

By JOHN B. RATHBUN

Copyright: 1925

### A Regenerator that Affords Clear 'DX' On the Loudspeaker

**R**EGENERATION still stands high in the regard of the seasoned radioite in spite of the frequency "dynes" that have been promoted from time to time, particularly when the matter of DX is of paramount importance. Tube for tube and dollar for dollar of investment, it yields the greatest returns of any circuit. Another point in favor of the simple regenerative circuit lies in the fact that it is easily built by the beginner.

Our subject for the present blueprint section is a three tube inductive coupled feed-back regenerative detector of the low loss type to which are added two stages of audio-frequency amplification, transformer coupled. With this combination of tubes, loud speaker operation is possible on quite long distances and with the extremely loose coupling used between the primary and secondary of the antenna coupler, the circuit will be found very selective and comparatively free of any tendency toward radiation. The main objection to the use of a regenerative circuit in crowded centers of population has been the radiation by a single circuit or tightly coupled regenerative.

Two tuning controls, only one of which is a wavelength control, makes it easy to tune in and log. The second control is the dial on the shaft of the tickler coil by which the plate coupling and regeneration are controlled. The single rheostat used for regulating the filament current of the detector tube is not particularly critical and therefore does not need sufficient handling to put it under the classi-

fication of tuning controls. The use of an untuned or aperiodic primary coil in the tuning unit does away with the antenna variable condenser commonly used with this type of regenerative circuit, and by providing a means of coupling adjustment between the primary and secondary coils for determining the required degree of selectivity, the antenna condenser is no longer necessary.

#### The Circuit Diagram

**FIG. 1** on the first blue print shows the complete schematic circuit of the detector and audio stages. Starting at the left, the tube (T1) is the detector tube, (T1) is the first audio frequency amplifier and (T2) is the second audio amplifier. The rheostat (R1) controls the filament current of the detector while the two audio stage filaments are maintained at a constant potential by the two Amperites (R2) and (R3). A rheostat can be used for the audio tubes if desired in place of the fixed resistance, but as it increases the complication without adding any desirable features to the performance it was omitted in the circuit shown.

At (CPLR) is the three circuit tuner

with the antenna primary coil (L1), the secondary coil (L2) and the regenerative tickler (Adjustable) marked (L3). There are a number of three circuit tuners on the market that are suitable for this purpose, the Bremer-Tully, Aero-Coil, Bruno coil, Uncle Sam, Sickles, Etc., all of which are of the "low-loss" type with a minimum of insulating material in the electrostatic field of the windings. Air-spacing between turns, bank-winding or wave-weaving should be adopted in any case in order to reduce the distributed capacity to a minimum. Homemade coils in which the turns are packed closely side by side and wound on a massive cylinder of insulating material have a high degree of distributed capacity and this is not desirable.

To control the feed-back and regeneration, the tickler coil (L3) is arranged so that it can be turned back and forth on a shaft near the (F) or filament end of the secondary coil (L2). This coil should never be installed at the grid end (G) of the secondary for every movement of the tickler will then upset the capacity relations and the tuning. Placed at the low potential end (F) of the secondary, which is grounded, the rotation of the tickler has little if any effect on the wavelength control. While this may seem of little consequence to the beginner, it is really very important, particularly when working on faint signals.

In the same way, the primary coil (L1) should be mounted near the (F) end of the secondary or away from the grid end (G)

(Turn to page 42)

Original Blueprints of the 3-Tube Regenerator on pages 40, 41, 44 and 45







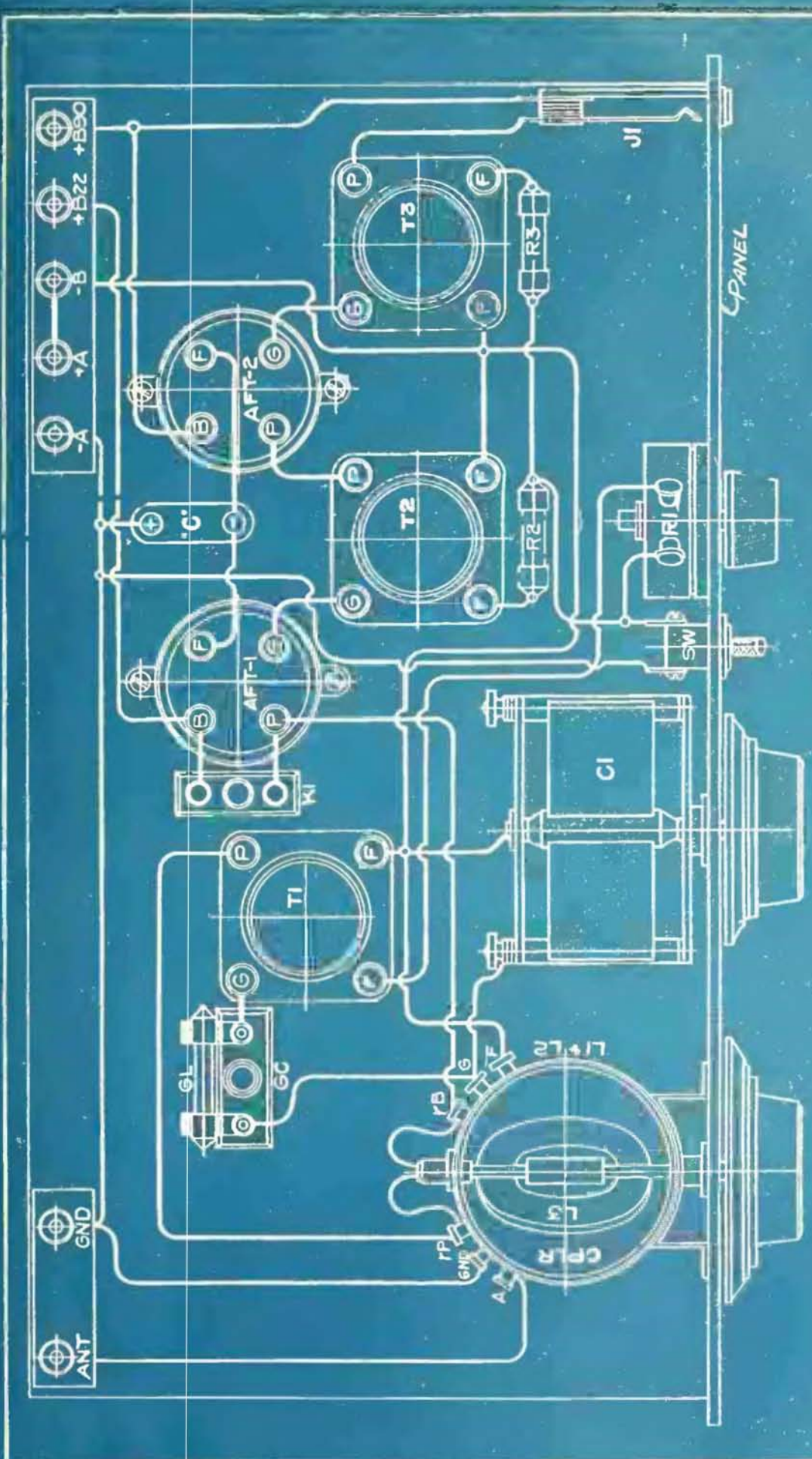

**FIG. 2**  
**THREE TUBE REGENERATIVE**  
 PICTURE TYPE DIAGRAM SHOWING WIRING AND PLAN  
 VIEW OF APPARATUS ARRANGEMENT IN WHICH THE  
 LETTERS AND FIGURES CORRESPOND TO FIG. 1.



(Continued from page 39)

of the secondary. If your coil is not marked with connections choose the open end of the secondary for making the grid connection to the detector tube, or that end that is farthest away from the primary and tickler coils. Where possible, the primary coil should be adjustable in regard to the secondary, and when this adjustment is not provided, the primary should be separated from the secondary by at least  $\frac{1}{4}$  inch to insure selectivity. The farther (P1) and (S1) are separated, the sharper will be the tuning and the more selective the receiver will be. If the primary is more than  $\frac{1}{2}$  inch from the secondary, it is likely that the set will be too selective for country service unless extreme care is used in moving and adjusting the wavelength dial. It may be made so selective, in fact, that the faint stations will be jumped over without any indication that they are on the air.

At (GC) is the grid condenser in the grid circuit of the detector, and connected across the ends of the grid condenser is the grid leak (GL). The grid condenser or leak can either be of the fixed or adjustable type, but the adjustable leak and condenser is probably preferable as it can be adjusted to meet the exact requirements of the tube used. Every individual tube, even when of the same make, has its own particular characteristics that demand certain values of capacity and leak resistance. When the fixed type of condenser and leak are used, the condenser should have a capacity of 0.00025 m.f., and the leak resistance approximately 1.0 megohm.

One of the factors in the construction of a regenerative set is that a positive bias must be maintained on the detector tube (T1) so that it is properly sensitive to weak incoming signals. In other words, the "A" battery must be connected to the grid return circuit (F) in such a way that its positive pole (+A) goes toward the grid leak (GL), thus permitting a very small flow of positive current through (GL) to the grid of the tube. This has been accomplished in Fig. 1 where it will be seen that the (+A) connection goes to the grid return (F) and hence to the grid post (G) through the grid-leak (GL). Putting a negative bias on the detector tube increases the volume of local stations or other strong signals but reduces the sensitivity to weak distant stations. Don't be misled by the greater volume on local stations obtained by a negative grid bias.

#### Tuning to Wavelength

TUNING to wavelength is accomplished by the variable condenser (C1) having a maximum capacity of from 0.00035 m.f. to 0.0005 m.f. depending upon the type of coil used. This should preferably be equipped with some form of vernier dial so that close accurate ad-

justments can be made, and when possible, should be of the "straight-line-wavelength" or "straight-line-frequency" type, the latter to avoid crowding of the 200 meter band of stations on the lower end of the dial. As a rule, a 0.00035 m.f. condenser will completely cover the band of broadcasting wavelengths ranging from 200 to 600 meters when commercial coils are employed, but to be on the safe side one should note the capacity required by the makers of the given coil. If the condenser is too small, the receiver will not reach the higher wavelengths. If it is too large, it is likely that the minimum

### Don't Fail to Read the Detailed Description

of the

### "RADIO AGE" MODEL RECEIVER

In This Issue of  
RADIO AGE.

Watch future issues for Improvements of this unique set.

capacity will be so great that the set will not go down to 200 meters and thus will lose the greater number of the low wave stations.

In connecting the variable condenser (C1) into circuit it is of importance to connect the stator or stationary plates to the grid (G) side of the secondary coil with the rotary plates connected to the (F) end. If this should be reversed, there will be trouble from "body capacity" as the grid potential would then be brought out along the shaft close to the hand when adjusting the dial. This is about the thirtieth time that this constructional feature has been mentioned in the pages of Radio Age, but as the writer ran down a case of trouble due to reversed rotor last week it is thought advisable to again call the attention of the builder to it. In the diagram, the rotor plate in condenser (C1) is indicated by the curved line while the straight line represents the stator.

As an additional safe guard against body capacity, the (F) end of the secondary coupler coil and the (-A) battery line are

grounded. In this way, the batteries and rotor end of the condenser shaft are brought to zero potential and thus high grid potentials will not be affected by moving bodies which are also at or near zero potential. Body capacity effect, or squealing when the hand is placed near the dial, is the most annoying trouble experienced with a poorly designed receiver. It absolutely prevents you from getting distance as it upsets the tuning every time that you place your hands on the dials, and further, causes nerve racking shrieks and whistles on nearby stations.

Ordinarily, a "B" battery voltage of 22.5 volts works best on the detector tube for all around service, but with 201A type tubes as high as 45 volts can be used. Increasing the plate voltage of the detector tube above normal makes the circuit unduly critical and difficult to tune and in addition makes it very noisy. Greater signal strength on local stations will be had by applying from 67.5 to 90 volts on the plate of the detector but on distant stations this amplifying quality seems to be lost and the increased tendency toward "flopping over" makes it difficult to get real distance with more than 45 volts. In the figure, the detector tap to the "B" battery is shown at 22.5 volts.

#### Audio Frequency Stages

THE PLATE output of the detector tube passes through the primary coil (PR1) of the first audio frequency transformer (AFT-1), entering the transformer at the plate post (P) and leaving at the (B) post. This transformer can be any good make of audio frequency transformer having a turn-ratio not greater than 6.0, and preferably not greater than 3.5. Ratios greater than 3.5 tend to cause distortion and noise, and above a turn ratio of 6.0 the noise increase is greater than the apparent increase of amplification. The secondary coil (SEC) is connected to the grid post (G) of the first audio tube (T2) at post (G) while the (F) post of the transformer goes to the (-C) of the biasing battery "C."

Here, the matter of grid bias is exactly reversed for we require a strong negative bias on the grid of an audio amplifying tube instead of the positive bias used on the detector. The "C" battery provides this negative bias and with 90 volts of "B" battery on the plates of the amplifiers, about 4.5 volts of negative bias will be required from the "C" battery. This negative bias reduces the tendency toward self-oscillation or regeneration in the audio frequency stages and thus not only reduces noise and distortion in this circuit but also increases the amplification without the expenditure of more "B" battery current. In fact, the "C" battery will cut down the "B" battery by about half, and at the "C" is practically on an open circuit the demand on this cell is practically nil.



At (K1) is a bypass condenser, either of the fixed or adjustable type, which affords a free passage for the radio frequency current on its return to the filament circuit. Its capacity of approximately 0.001 m.f. is sufficient to carry radio frequency current but is not great enough to transmit an appreciable amount of audio frequency current, hence the audio phase of the detector output passes through the transformer while the R. F. current is bypassed around the primary coil. This at least reduces the amount of radio frequency current in the audio stages, and as radio frequency current in the audio tubes causes self-oscillation and noise it is desirable to reduce the R. F. phase to the lowest possible amount when audio amplification takes place.

Condenser (K1) may be fixed or adjustable, the latter type being, preferable for the reason that the capacity can be adjusted so that a minimum of audio current is short circuited through the bypass condenser. This is not a variable condenser (represented on the panel front by a dial) but is a special type of "Adjustable" condenser designed for this purpose. When once adjusted to the circuit, no further attention is required.

A fixed condenser (K2) having a capacity ranging from 0.002 m.f. to 0.006 m.f. is connected across the (+B) and (-A) lines to reduce the radio frequency resistance in the "B" batteries when the batteries get old and partly dried up. The value of the condenser is not critical, and probably no advantage will be noted when the "B" is new and fresh, but when the batteries get old, condenser (K2) will show a marked improvement in performance. It is then easier for the radio frequency current to pass through the capacity of (K2) than through the high resistance of the old "B" batteries. A capacity of 0.006 m.f. will insure proper bypassing under all conditions without diminishing the strength of the R. F. phase.

After amplification in the first audio stage, giving greatly increased sound volume, the output of the first audio tube (T1) is passed through the primary coil of the second audio transformer (AFT-2). The posts of this transformer are marked in proper relation to the balance of the circuit, the post (P) going to the plate (P) of tube (T1) and post (B) going to the (+90) post of the "B" battery. For proper amplification, 90 volts will be required on the plates of both audio frequency tubes (T1-T2) and when the voltage drops much below 80 volts due to an exhausted battery there is a pronounced falling off in the volume.

The (F) post of the secondary, transformer (AFT-2), is connected to the (-C) of the "C" battery so that this stage is also given a negative bias by the same battery. The (G) connection of the secondary goes to the grid of the second audio tube (T3) as usual, and this com-

pletes the connections in the audio stages. No intermediate jacks are used, only the output jack (J1) connected to the second audio frequency stage.

#### Picture Diagram Layout

FIG. 2 is the same circuit drawn out in picture for as it really appears. All of the parts shown in Fig. 2 are given the same letters and figures as corresponding parts in Fig. 1 so that the relation between the two drawings can be easily followed. We are looking down on the set with the panel edge next to us, and the panel can be easily identified by

## A Treasure of Blueprints!

—may be found in back issues of "Radio Age, the magazine with blueprints," see page 50 for list of subjects in back number blueprint sections. 30 cents a copy.

the dials and rheostat knob drawn on the outer face of the panel. Starting from the left we have in order, the tuning coil unit, the variable condenser (C1), the detector rheostat (R1) and then the audio frequency stages at the extreme right. The output jack (J1) is at the right end of the panel with the battery switch (SW) near the center. The battery switch is also shown at (SW) in Fig. 1, so placed that it opens the "A" battery circuit. This is necessary as the audio stages are not provided with rheostats and some means must be provided to cut them out of circuit simultaneously with the detector tube.

This receiver is "back-connected" with all outside wires connected to connection strips fastened to the rear edge of the baseboard. At the left is the connection strip carrying the antenna post (ANT) while at the right is the battery connection strip with the posts (+A), (-B), (+22) and (+90). This arrangement makes installation very simple and convenient and avoids a clutter of wires around the front of the instrument which

is always in evidence with a front connected set. Holes must be drilled in the back of the cabinet to accommodate these wires, but in no case attempt to run the ground wire and antenna lead-in wire through the same hole. For the best results, a separate hole should be drilled for each wire, the hole being placed directly opposite to the binding posts so that it will lead directly into the post.

Owing to the form of the coil, and to the fact that it is standing with its axis in a vertical line, it has been rather difficult to show the actual connections at this point as they actually appear. The connections, however, have been lettered as they actually are marked on the manufactured coils, and this marking should be followed. One rotor connection goes to the plate of the detector tube (T1) and the other goes to the (P) posts of the first audio frequency transformer (AFT-1). These are marked respectively (rP) and (rB) in the drawing.

Connection from the antenna goes to the primary of the tuner at (A), and the ground to (GND). The grid to the grid condenser is indicated by post (G) while the remaining post (F) goes to the (-A) line. All of these connections can be traced through in Fig. 1 if the reader is familiar with radio symbols.

By careful arrangement, a 7"x14"x $\frac{3}{8}$ " panel can be used, but a 7"x18"x $\frac{3}{8}$ " panel gives more room and is easier for the beginner to wire. The baseboard should be deep enough to fit closely in a cabinet having a depth of eight inches. Most of the standard cabinets have an inside depth of eight inches but this should be checked up with the cabinet that you intend to use and the baseboard cut accordingly.

It is a good plan to install the variable condenser (C1) with the stator or stationary plates uppermost and with the rotary plates turning out from underneath. This will afford protection to the unsupported rotor plates and at the same time will prevent so much dirt from falling into the condenser. Turned the other way about, the rotor plates are likely to be struck accidentally and injured.

When the plates are completely disengaged, the capacity should be at a minimum and in this position (or close to it) the lowest wave lengths are received. The dial should now be moved around on the shaft until a reference scratch on the panel points to the (O) division on the dial. Further experiment will indicate whether the true zero point lies at either side of the apparent zero and then corrections can be easily made by slightly shifting the dial. At maximum capacity and highest wavelength, the plates are fully meshed with the indicator pointing to the (100) division on the dial. As explained before, a vernier dial is highly desirable on this sort of set so that the

(Turn to page 46)







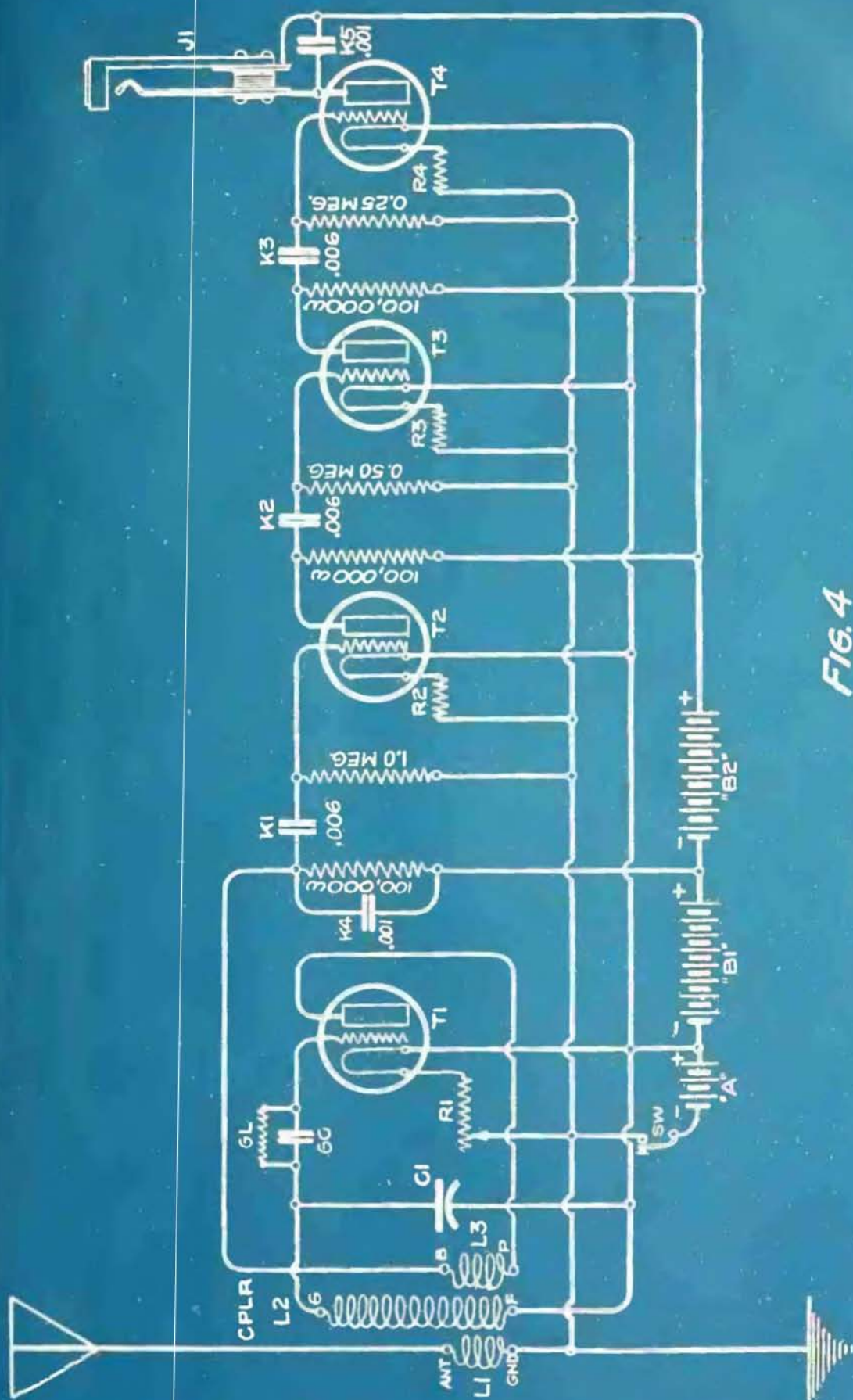

**FIG. 4**  
**FOUR TUBE REGENERATIVE**  
 DETECTOR TUBE WITH THREE STAGES OF AUDIO FRE-  
 QUENCY AMPLIFICATION. APPROXIMATELY THE EQUIVA-  
 LENT OF TWO TRANSFORMER COUPLED STAGES. (FIG. 1).



(Continued from page 43)

utmost selectivity can be attained by small accurate dial movements.

### Wiring Instructions

FOR a long time, radio set builders have employed bare tinned copper bus-bar for wiring the sets, the bus-bar being square cross-section instead of round. This was sufficiently rigid to support its own weight for a considerable distance and when securely soldered to the connection lugs gave a very rigid wiring structure. However, this system had its faults when used by the amateur. It was difficult for the novice to arrange the wiring in a simple manner in accord with the arrangement of the apparatus, and unless great care was taken it was difficult to avoid short circuits and grounds. Further, the soldering was not always of the best and the total result was that many circuit troubles developed which were due to poor construction, poor layout and still poorer manipulation of the soldering copper.

The introduction of the rubber covered flexible strand wire did much to reduce wiring troubles for the rubber insulated wire could be easily run in any direction regardless of the arrangement of the apparatus. The condensers, sockets, transformers and tuning coils could be put into the most advantageous positions without it being necessary to make compromises on account of the rigid bus wiring. Short circuits became almost a thing of the past, and by properly running the wires they were made almost invisible instead of being the most prominent features of the receiver. For this reason I recommend that rubber covered flexible strand be used for wiring, and this wire can no be found at nearly any radio store.

For ease in making connections, the rubber covering should be of the type used in telephone switchboard wiring, a wire having an insulation that is easily stripped off at the ends for making connections. The solid wire with the adhering type of rubber insulation used for electric light wiring is not suitable. For ease in making connections, copper eyelets or connection lugs should be clamped to the ends of the flexible strands so that a good solid electrical contact will be had at the connection posts. With the lugs firmly clamped to the wire it is a simple matter to solder them firmly into place.

Fig. 3 shows the center-to-center dimensions for the panel mounted apparatus. The outlines of the parts hidden behind the panel are shown dotted so that the purpose of the various controls can be easily seen. As the screw holes of the different makes of radio parts employed vary somewhat, these holes are not dimensioned, but with the apparatus centers located it should be a simple matter to layout these special screw centers about the center lines shown on the drawing.

The panel itself should not be less than  $\frac{3}{8}$ " as thinner panels make it difficult to fasten standard parts in place, the screw and bushing of the majority of parts being designed for  $\frac{3}{8}$ " to  $\frac{1}{4}$ " panel thicknesses. Any standard panel material can be used such as Bakelite, Radion, Dilecto, etc., but wood should be avoided even for temporary constructions, unless it has previously been boiled in paraffine. The appearance of the panel is greatly enhanced by having the names of the controls, the arrows and indicator marks engraved directly on the face of the panel. This can be done at a small expense by many of the radio houses when they are supplied with a sketch showing the names and their location.

### Resistance Amplification

FIG. 4 is a schematic diagram of the same detector circuit supplied with resistance coupled audio frequency amplification in place of the audio transformers. This requires a third tube in the audio stages so that we now have four tubes instead of the three previously used. In many cases the results obtained with the resistance coupling amply justify the additional tube particularly when tone quality is a matter of importance.

Inter-stage audio coupling in the audio circuit is had by the 0.006 m.f. fixed condensers (M1-M2-M3) that extend between the output of one tube and the grid of the following tube. Resistors (r1-r2-r3) connect between the plate and the (+B) line, and the drop of potential over these resistors is responsible for the amplification. The resistors have a high resistance as indicated on the drawings but their resistance is much less than that of the grid leaks (rL) connected on the grid side of the coupling condensers. The grid leaks give a negative bias to the grids of the three audio tubes and their value is marked on the drawing.

When the 201A type of tube is used with resistance amplification, a plate voltage of 135 volts is necessary on the plates for maximum results, but with the new tubes developed especially for resistance coupled amplification the usual 90 volts can be used with perfect satisfaction. A potential of 90 volts with 201A tubes gives less volume but the tone is still good although the volume is somewhat reduced.

While the resistance of the resistors will give good results under nearly all ordinary conditions, yet there is always some optimum value that will give the best performance with the given tubes and units used in the circuit. To insure the best all around results it will be best to try a number of different resistors until the best value is determined. While the grid leak values are not critical yet there is a noticeable difference when different leaks are used, and it will usually be found that a different leak will be required

in each of the resistance coupled stages.

While the dry battery tubes such as the WD-12 or the "199" type can be used, yet the storage battery tubes such as the 201A will always give the greatest volume and the best all around results. The distance obtained on the phones will be about the same with both classes of tubes but the volume of the dry battery tubes is greatly inferior to that of the 0.25 ampere type. The volume produced by the "199" tubes can be greatly augmented by the addition of the new UX-120 dry cell tube in the last stage of the transformer coupled receiver. Similarly the use of the UX-112 or the Daven Mu-6 in the last stage of a storage battery operated set will increase the volume over that obtained by a 201A in the last stage. The latter tubes take 0.5 ampere at 6 volts or just twice the current taken by the 201A.

The "UV200" tube, gas filled, is probably more sensitive than the 201A in detecting distance but it is also more critical and difficult to control. It takes more current than the 201A and requires very careful filament current adjustment, but it will often bring in stations with a regenerative circuit that will never be found with the 201A. The "200" tube, however, is not an amplifier and can only be used as a detector at (T1).

### The Antenna and Ground

An aerial from 60 feet to 75 feet long, hung more than 35 feet above the ground will be found most suitable for this set. It is long enough to catch distant stations successfully and yet is not so long that the selectivity is impaired. An aerial of excessive length is as bad as an aerial that is below normal length for the long aerial will seriously interfere with the selective properties of the receiver and in these days of congestion this is as bad as not receiving the station at all. The aerial should be hung well out in the open or else at least seven feet above the top of a flat top roof in case that the wire cannot be hung in the yard and away from the building.

The ground is nearly of as much importance as the antenna. The best ground is had by clamping the wire to a water or steam pipe, the pipe being cleaned free from paint, rust and grease before the clamp is applied. In case the building is not piped for water, the ground can be made by driving a steel pipe or rod into the ground until it strikes permanently moist earth. A copper plate dropped into a well, hung so low that it is well below the water level at all times is also a method of making a ground. Never use a gas pipe for a ground for the reason that the house gas pipes are generally insulated from the meter and the chandelier is insulated from the house pipes. Of course, this would interrupt the primary current and cause trouble with the operation of the set.





# Pick-ups and Hook-ups by our Readers



THE material appearing under the title "Pickups and Hookups by Our Readers" in RADIO AGE, is contributed by our readers. It is a department wherein our readers exchange views on various circuits and the construction and operation thereof. Many times our readers disagree on technical points and it should be understood that RADIO AGE is not responsible for the views presented herein by contributors, but publishes the letters and drawings merely as a means of permitting the fans to know what the other fellow is doing and thinking.

Conducted by Fred Hill

THE radio bacillus apparently does not confine its manifestations to the male gender, as the following letter from Mrs. Howard P. Crosby, 78 Main St., Fairfield, Maine, will show: "Yes, I think there are at least a few women who take much interest in not only radio and its progress, but also in the RADIO AGE. I, as well as my husband, take great pride and interest in our set. We had a R— in the first place and as all the parts were metal they seemed to be of a mongrel type so we took it all apart and then I started to rebuild one to suit ourselves. My husband and I made a set and it was far superior to the old one. Later we thought we could improve it so we made a three tube regenerative set consisting of one regenerative detector and two stages of transformer coupled audio amplification. We have a 100 foot aerial and with a counterpoise. I am wondering if my list of stations which I am enclosing will entitle me to a Dial Twister's button."

Goshamighty! The list the lady sends in is four pages long, typewritten, and covers everything from hearing the chimes in Westminster Abbey from 2LO to everything on the North American continent. Such energy can not long go unrewarded and as a starter we are forwarding two DT buttons to Mrs. Crosby, one for herself and the other for Hubby. If our better half scampered ethereally around after DX in such a manner there is one column conductor who would have to depend upon the one-arm lunch stands for subsistence, but perhaps Mr. and Mrs. Crosby have some sort of a watch-and-watch system as at sea; the Mrs. watching the kitchen and the radio and the Mr. watching the clock. We would like to have more letters like the foregoing since we believe there are hosts of married radio fans who both take a keen interest in the game. Some comparison to the old days when the wife used to threaten divorce proceedings simply because we spilled a quart of hot paraffine on the gas range while we were doping up some long wave coils!

Now from the nation's Capitol, a letter from William C. Peace, 126 Seaton Place, Washington, D. C., who constructed a two tube ultra-audion from the March issue of Radio Age, added one stage of audio and hopped after the DX signals. He says he could not detune the locals

CONTRIBUTORS		
M. J. Sahanel 3917 Grand Blvd. Chicago, Ill.	George H. Hawley 69 Walnut Ave. Roxbury, Boston, Mass.	Carl Streiferd Braintree, Mass.
DIAL TWISTERS		
George Balta.....	4226 Todd Ave.....	East Chicago, Ind.
George Morrow.....	Radio 8DTN.....	Salem, Ohio
Leon C. O'Connor.....	47 Brownell Ave.....	Hartford, Conn.
Frank Wiles.....	110 North 9th St. ....	Lamar, Colo.
Harold Bassett.....	216 North Tower.....	Centralia, Wash.
John D. Zahn.....	.....	Canal Winchester, O.
Robert Sieglinger .....	120 East 90th St. ....	Chicago, Ill.
J. P. Morrison, Jr.....	1711 South Peoria.....	Tulsa, Okla.
Mr. and Mrs. H. P. Crosby.....	78 Main St.....	Fairfield, Me.
Ralph E. Riley.....	1711 5th St.....	Oakland, Calif.
William C. Peace.....	126 Seaton Place.....	Washington, D. C.
G. V. Skal.....	Ober-Schreiberhau.....	Alter Baudenweg, Ger.
Lloyd Wilson.....	663 Fairview St.....	Oakland, Calif.
F. J. Ferguson.....	2635 East 69th St. ....	Cleveland, Ohio
Ralph Litch.....	.....	Hudson, S. D.
G. A. Winkle.....	223 Old 50th St.....	Birmingham, Ala.

but between the hours of 11 p. m. and 3 a. m. he dragged down quite a bunch of stations, to say nothing of a flock of amateur signals. Pretty tough on a chap who has to stay up until milk time for stations, so to assuage somewhat his feelings over such hard lines we are enrolling Mr. Peace in the fraternity of Dial Twisters. Peace be to his radio!

There seems to be a Destiny that shapes our ends, after all. We thought at first the makers of panels would soon have to go out of business. But now we have found out how their annual output is always taken. The condenser manufacturers are the best friends of the panel makers. These remarks are as a result of a three hour session in the lab. last night changing from one set of condensers to another on our test set. In all the condensers in our possession not a one would fit in holes meant for another type. Consequently, not having any putty, it was necessary to junk every panel when putting in a new type. If some genius would only invent a patent holding device which would accommodate every conceivable combination of condenser holes we would breathe easier. We still have a great respect for the man

who designed the single hole mounting for condensers and we believe the fraternity is with us on this subject. And while on this, some day we hope to see the dial manufacturers all agree upon a clockwise rotation for dials; wouldn't it be a great world if the alarm clocks read clockwise, the station clock counter-clockwise; the office clock with 24 hours instead of 12, and our wrist watches with markings of one degree for each of the 43,200 seconds in the twelve hours. How in the name of microfarad would we ever get around?

George Balta, 4226 Todd Ave., East Chicago, Ill., browsed around the news stands until he found RADIO AGE, which magazine now becomes his radio Bible according to a letter received recently. He says: "RADIO AGE with the blueprint section, editorials which every radio user present or future should read, and the worth while articles couched in terms anyone with average intelligence can understand, gets my subscription enclosed herewith." That's music to our ears. The list of stations submitted also shows a great deal of patience spent over the set and the button will be forthcoming as a result. (Turn the page)



George Morrow, Salem, Ohio, known to the amateur gang as 8DTN (wonder if it means Dial Twisting Nut?) tells us he built the short wave set following our diagram in the September number which worked so well he had to let us know of his success. With the set he copied a flock of 6th District amateurs in daylight; outside of the U. S. he logged South Americans, Mexicans, Porto Ricans, Bermudans, Cubans, Englishers, French, New Zealanders, WAP and WNP while at Etah, Greenland, and a host of others. This on a two tube set with a 50 foot vertical antenna. The stations above were in addition to about 200 other Canadians and Americans. All of which we would say speaks eloquently both for the perseverance of 8DTN and the sure-fire dope in our columns.

From the West Coast comes a letter from Ralph E. Riley, 1711 5th St., Oakland, Calif., who hearkened to our advice to build the set described on page 23 of the February, 1925, RADIO AGE. He says the results obtained are nothing short of remarkable and thanks RADIO AGE for the competent advice rendered. He says: "you surely know your stuff—you'll find me a constant booster." Mr. Riley made a few changes in the r. f. t. unit, using a basket wound, the secondary turns ranging from 65 to 70, and with eight to twelve turns on the primary.

Another West Coaster, Harold Bassett, 216 North Tower, Centralia, Washington, writes as follows: "Please excuse my apparent boastfulness but I am proud of the operation of my set. I have several sets, the most prominent of them a one tuber. With this set I regularly tune in Eastern stations among which are Cleveland, Chicago, Kansas City, Oklahoma City and Pittsburgh. I have received Pittsburgh with no aerial, on the loud speaker. All the before-mentioned cities were received on the speaker. Recently this set pulled down three different stations in Chicago in one evening. With an Armstrong regenerative and two stages of amplification many more Eastern stations were added to the list, including Washington, D. C., Buffalo, Atlanta, Schenectady and PWX, Havana. Local fans with 5 and 6 tube sets equal but do not pass this for distance." Attaboy! Looks like the simple life is just as good after all, at least in the selection of the reliable circuits for maximum distance and constancy.

John D. Zahn, Canal Winchester, Ohio, also sends in a good looking list of stations with which he qualifies for the emblem of the fraternity.

Robert Sieglinger, 120 East 90th St., Chicago, Ill., also is enrolled in the organization after submitting a list of broadcasters yanked in during the course of an evening. Chicago listeners must have good sets in order to batter down the local barrage on every night except Mondays.

J. P. Morrison, Jr., amateur radio 5BT, at 1711 South Peoria St., Tulsa,

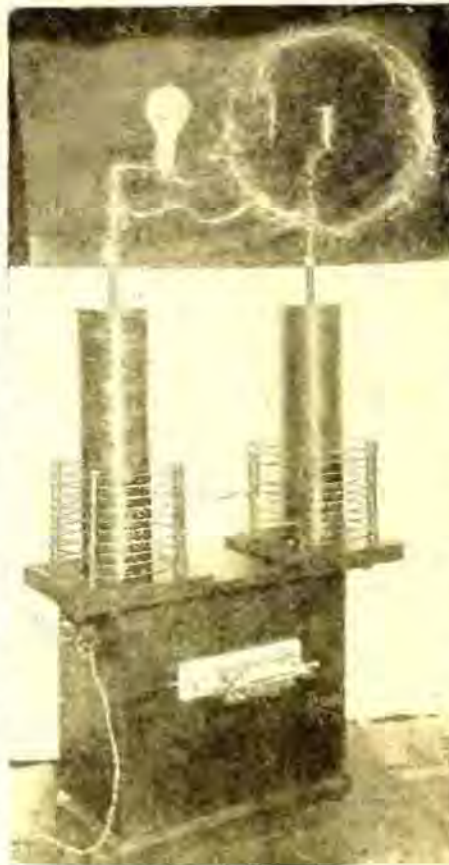

*Ladies and gentlemen of the DT's! Here at last we present an exclusive picture of the greatest malefactor of radio than whom there is no peer. It is the cause for more cussing, inquiring into a set with pliers, changing of grid leaks and the purchase of new B batteries than any of the other agencies of science with which the distance hunter is accursed. It has potentialities for great harm and yet some good. It throws a twenty inch spark with a magnificent brush discharge, the voltage being approximately ten million. The wax immersed condenser has a capacity of 24 quart Leyden jars.*

*Seriously, however, the photograph shows a Tesla-Oudin coil with condenser, designed by the Joseph G. Branch Institute of Engineering, Chicago, Ill. The picture is furnished by M. J. Sahanel, secretary of the Institute who sardonically remarks that this apparatus in operation destroys all radio reception in the neighborhood and opens great possibilities for use in this work. With it most beautiful spectacular experiments can be performed and in scientific investigation especially in radio work is of much value.*

*We have not quite figured out how we are going to use this coil in our laboratory work but we might use it in connection with the extermination of the incessant blooper or canary hound who eternally pierces the night with his dismal shriek, the mating song of the grid calling to its plate.*

Oklahoma, reports a broadcasting station in Buenos Aires in addition to the conventional dx work in the U. S. A., Canada and Mexico. Another member added to the DT family.

Perhaps some members of the radio family are busily engaged in trying to

tandem their condensers so as to get single control of two tuned r. f. stages. There are many methods of balancing the capacities in the twin units and the most direct and simple expedient is to buy a good tandem variable condenser already provided with equalizing or balancing verniers consisting of a midget condenser alongside the main capacities. However there are many who have a whole shelf full of old condensers and it is to this gentry the remarks of George H. Hawley, 69 Walnut Ave., Roxbury, Boston, Mass. are dedicated. Mr. Hawley writes as follows:

"The radio magazines are bringing to the experimenter the idea of less dials by means of gang condensers. The idea is good but most fans have at present a very nice box full of condensers which they would like to press into service. Suggestions have appeared showing how to join the singles into a tandem condenser. But I do not agree with the method of balancing with a smaller condenser shunted across the big one as the capacity is not constant through the entire dial range, but drops from the maximum amount when the plates are all in to zero when the plates are all out. Thus a balancing condenser with its capacity set would not be in balance over the entire range. It would only balance for the wavelength for which it was balanced and would be out for any higher wave, thus throwing out of tune one of the coils and perhaps losing the weak signals by being off tune. The better way to balance is to balance the condensers themselves, which is not so hard as it seems and does not require laboratory instruments to make a very good job. After the gang is made up, being certain of perfect alignment of rotors so they enter at same time, mount on a temporary panel and put on dial. Now tune your favorite set to a distant station of high wavelength and shunt your condenser to be tested across the one in your set. Turn the dial on your set to about 10 and retune the set using one of the gang to be tested. Without moving the instruments shift the connection on the gang to the other stator. If this throws the set out of tune go to your dial on set and move slowly backwards and forwards from the mark 10 and you will find the condenser which has the greatest capacity. The remedy is very simple and will balance through the entire range. Remove the end plate from the offending member and take off one stator plate. With a pair of dividers scribe a circle about the shaft clearance portion (as shown by dotted lines in Fig. 3) so as to remove about an eighth or a quarter of an inch of the plate, then replace for test. It will probably take several trips to balance but you make a real job of the matter, and not a makeshift with an extra control. A fine jeweler's saw will remove the part you have marked very nicely."

We often wonder how long it will take the radio world to realize that sharpness of the signal (though weak) in the secondaries of tuned r. f. stages



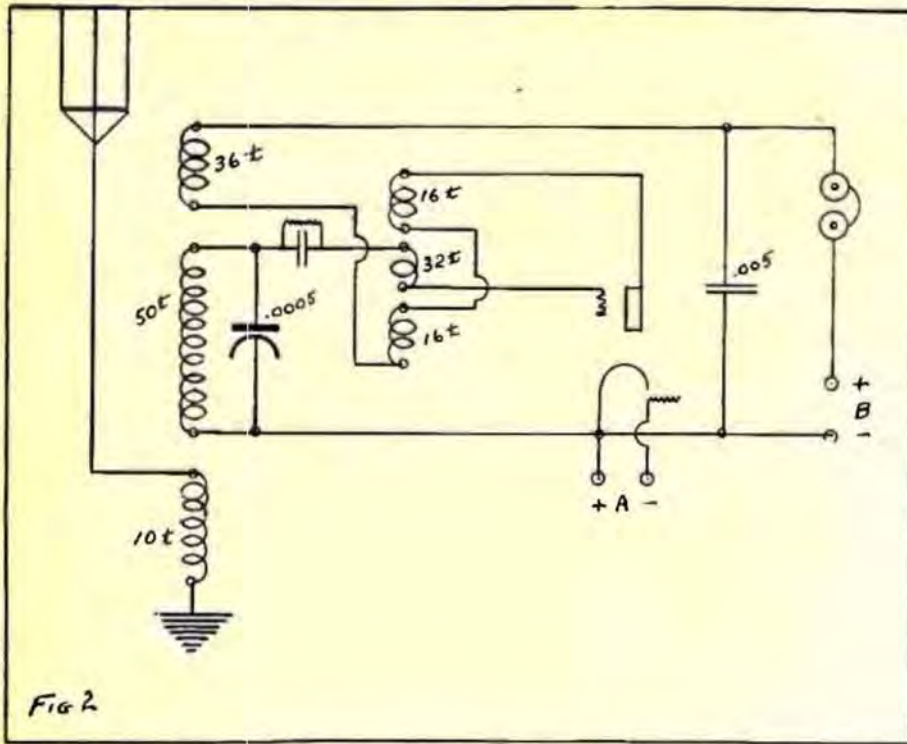
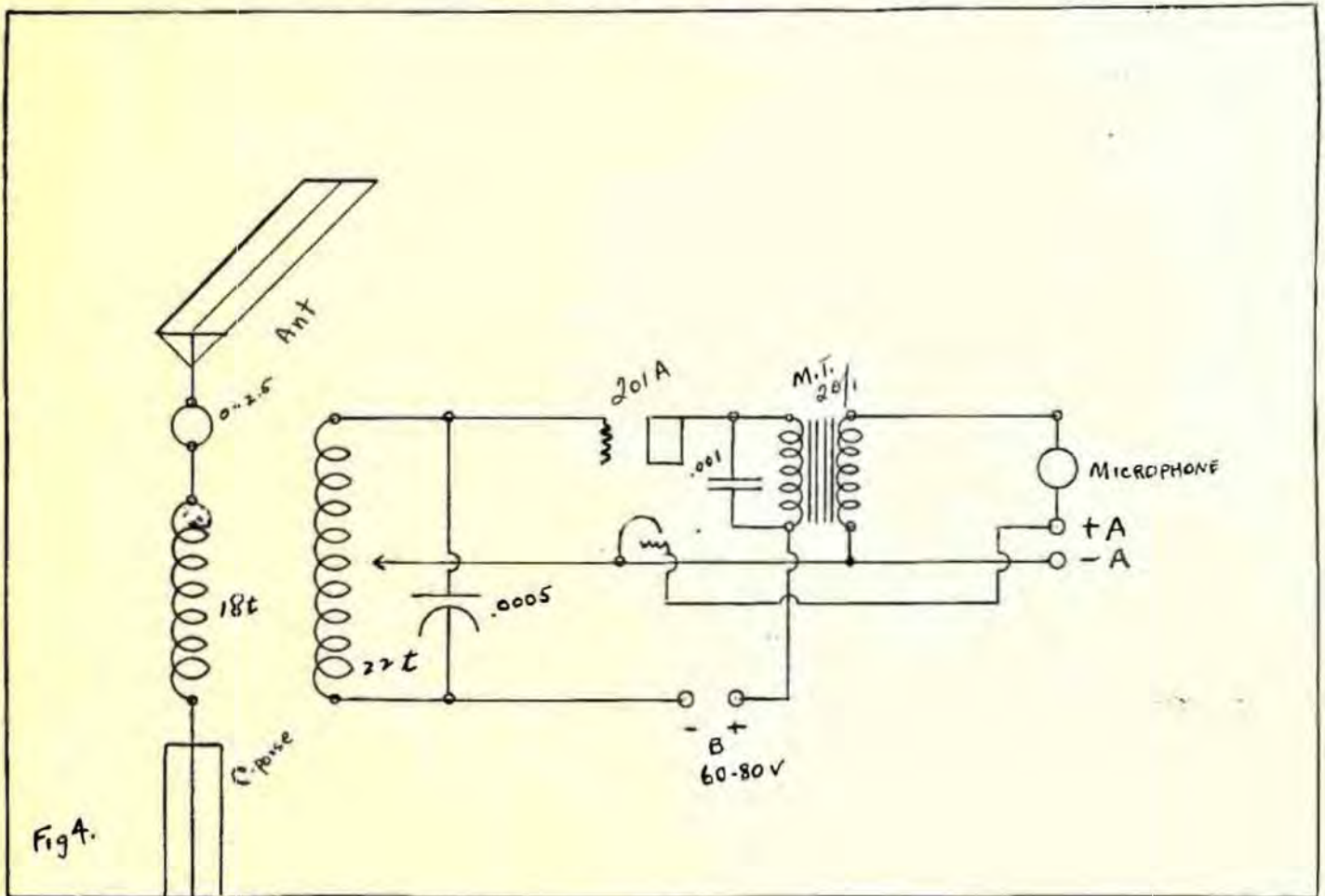

Fig. 2. This is the form of regenerative set used by Carl Streiferd, South Braintree, Mass. It seems to have plenty of inductances, whose functions are explained in the text. The circuit is conventional although the arrangement of inductances departs from the well known methods. The 32 turn and 36 turn windings are rotors, the latter governing regeneration. Selectivity may be altered by tapping the primary winding.

(which can later be amplified at will) is preferable to a strong, broad signal. The reason for the above remark is a recent test of two types of r. f. tuning units in actual operation. With one there was a great deal of volume but the signal nushed over a section of the dial corresponding to about seven to ten degrees either way from a given point. With the other units in place, no other changes having been made, the same signal was sharp as a briar, and could be tuned out within two divisions on the scale either side of a given point. The sharp signal was then properly amplified and we attained the desired volume with excellent selectivity. The other unit whose signals were broad was hooked up to the amplifier and wonderful volume resulted, but ye gods selectivity had departed via the back door and Charlie Erbstein's voice at the new Liberty station WLIB (formerly WTAS) smeared itself all over the entrancing notes of the Little Symphony at KDKA. The separation in wave length at this band is about six meters. The good unit makes the grade; the poor one falls down. The moral of this tale is that all tuned r. f. units should be good. If necessary a definite standard of excellence should be established, perhaps by the Bureau of Standards, and then all manufacturers should try to beat the mark if possible instead of merely



The circuit above is a low power telephone transmitter, for which it will be necessary to have a government license. It is contributed by Paul M. Hayes of Pasadena, Calif. The constants are shown in the diagram and in the text in this department. B battery plate potential will be ok for short range work. A flashlight may be used instead of the ammeter in series with the antenna. The modulation transformer is 20 to 1 ratio. The A battery lights the tube and also furnishes current for the microphone.



dumping on the market just one more tuned r. f. unit. But we are inclined to optimism and are at least thankful there are some manufacturers turning out good parts.

Frank Wiles, 110 North 9th St., Lamar, Colo., uses a one tube Reinartz in logging his stations and reports a list that easily entitles him to the coveted button. The list takes in all directions including Canada and Mexico.

Carl Streiferd, Braintree, Mass., uses the circuit shown in Fig. 2, using 199 tubes, 45 volts B battery, and no C battery. He says his results are ahead of other sets using a different hookup. The circuit is conventional but the number of inductances is probably in excess of the number required to get good signals. But if the fans did not have different ideas on the game we would all be using the single circuit or a crystal. In the circuit shown in Fig. 2 regeneration is controlled by the 36 turn rotor. Rotor No. 1, which is the 32 turn rotor, is not varied much after once finding the correct setting. The two 16 turn windings are fixed, the 32 turn winding being on a rotor as is the 56 turn winding. The 50 turn secondary is fixed as is the 10 turn primary. The selectivity may be altered by tapping the primary winding. The coils are wound, a la Lorenz, using No. 22 DCC wire. The antenna 10 turns, secondary 50 turns and tickler 36 turns are on one line, the latter being a rotor at the end of the 50 turn secondary. The two 16 turn and one 32 turn windings are on another tube, the 32 turn winding also being on a rotor. The variable across the secondary is a .0005 mfd condenser. In your spare moments you might rig it up and try it.

Leon C. O'Connor, 47 Brownell Ave., Hartford, Conn., using a super, dry cell tubes and loop, sends in a list of stations the nearest one mile and the farthest 2050 miles, which we would say is pretty good work even for a super. Welcome into the family.

Readers who may be interested in a cheap, low-power telephone transmitter (for which of course you will have to get a government license) will find this detailed in Fig. 4, the contribution of Paul M. Hayes, Pasadena, Calif. The primary of the oscillation transformer consists of 18 turns of wire, using antenna and counterpoise, a zero to two and a half ampere meter in series with the antenna. The secondary is 22 turns, with grid at one end, filament about the center and B supply line at the other end, with a .0005 variable spanning the extremities of the coil. A modulation

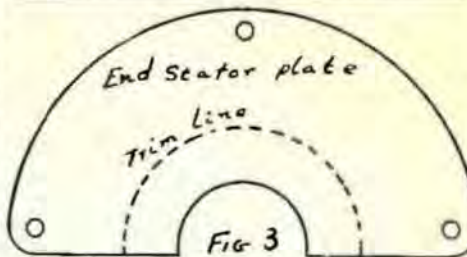

Scheme outlined by Mr. Hawley is shown in Fig. 3 above. The end stator plate is removed from the gang that is high in capacity, and trimmed down in accordance with the dotted line. Probably an eighth of an inch should be taken off at a time until the capacity on a given signal is equal to that of its mate in the tandem arrangement. A jeweler's saw will do the work nicely. However it is more or less of a cut and try method.

transformer, ratio 20 to 1 is used, energized by the microphone and A battery, the latter also serving to light the transmitter tube. Sixty to eighty volts B battery will run the set, using a 201-A or the like. The ammeter in the antenna circuit may be replaced by a small flashlight bulb which will glow when resonance is established. Be sure to get a government license before trying the set out on the air. The schematic is shown in Fig. 4.

It was originally intended to publish the circuit shown in Fig. 4 in the November number but lack of space at the last moment prevented. However the contribution of Mr. Hayes is included in the department this month.

Perhaps many radio fans would like to get into the transmitting game but are prevented through their inability to master the Continental code. Knowledge of the code at a speed of about ten words per minute and ability to recognize the SOS signal sent at that rate of speed, together with a transmitter that will pass the government inspector's eagle eye is about all that is required in the way of securing a license. But the transmitting game certainly takes a lot of your time and money; be prepared to weep copiously every time you burn out a five watt bottle or when you short an 8 volt scale voltmeter across 220 volts. But there is a kick in it after all and perhaps it is the kick you have been seeking.

George A. Winkle, 223 Old 50th St., Birmingham, Ala., tells us of the success he has with the conventional regenerative circuit, adapted to three tubes for the chap who is not able to stand the expense of a six or ten tube set.

## End Your Radio Troubles for 30c in Stamps

We have laid aside a limited number of back issues of RADIO AGE for your use. Below are listed hookups to be found in these volumes. Select the ones you want and enclose 30c in stamps for each desired. The supply is limited, so enrich your store of radio knowledge by laying in an ample stock of copies NOW!

### January, 1924

- Tuning Out Interference—Wave Traps—Eliminators
- Filters
- A Junior Super-Heterodyne.
- Push-Pull Amplifier.
- Rosenbloom Circuit.

### March, 1924

- An Eight-Tube Super-Heterodyne.
- A simple, low loss tuner.
- A Tuned Radio Frequency Amplifier.
- Simple Reflex Set.

### April, 1924

- An Efficient Super-Heterodyne (fully illustrated).
- A Ten Dollar Receiver.
- Anti-Body Capacity Hookups.
- Reflexing the Three-Circuit Tuner.

### Index and first two installments of Radio Age Data Sheets.

### May, 1924

- Construction of a Simple Portable Set.
- Radio Panels.
- Third Installment of Radio Age Data Sheets.

### June, 1924

- Important Factors in Constructing a Super-Heterodyne.
- A Universal Amplifier.
- A Sure Fire Reflex Set.
- Adding Radio and Audio to Baby Heterodyne.
- Radio Age Data Sheets.

### July, 1924

- A Portable Tuned Impedance Reflex.
- Operating Detector Tube by Grid Bias.
- A Three-Tube Wizard Circuit.
- Data Sheets.

### August, 1924

- Breaking Into Radio Without a Diagram.
- The English 4-Element Tube.
- Filtered Heterodyne Audio Stages.
- An Audio Amplifier Without an "A" Battery.
- Data Sheets.

### September, 1924

- How Careful Mounting Will Improve Reception.
- One Tuning Control for Hair's Breadth Selectivity.
- Four Pages of Real Blueprints of a New Baby Heterodyne and an Aperiodic Variometer Set.
- Data Sheets.

### October, 1924

- An Easily Made Super-Het.
- Two Radio and Two Audio for Clear Tone.
- A Simple Regenerative Set.
- The Ultradyne for Real DX.
- Real Blueprints of a 3-Tube Neutrodyne and a Midset Reflex Set.

### November, 1924

- Blueprints of a Single Tube Loop Set and a Capacity Feedback Receiver.
- A 3-Tube Low Loss Regenerator.
- Mastering the 3-Circuit Tuner.

### December, 1924

- Blueprints of a New 8-Tube Super-Heterodyne.
- How to Make a Receiver that Minimizes Static.
- A Trans-Atlantic D.N. Receiver.
- How to Make a Home Made Battery Charger and a Loud Speaker at a Small Cost.

### January, 1925

- A Reflected Neutrodyne.
- A Six Tube Super-Het.
- An Efficient Portable Set.
- A Tuned Plate Regenerator.
- Making a Station-Finder.

### February, 1925

- A Sure Shot Super-Het.
- A Three Circuit Regenerator.
- A Real, Low Loss Set.
- Blueprints of a 3-tube Reflex.

### March, 1925

- A Permanent Sup-Het.
- A 5-Tube R. F. Receiver.
- How to Wind Low Loss Coils.
- A Short Wave Receiver.
- Blueprints of a Two-Tube Ultra Audion and a Regenerative Reflex.

### April, 1925

- A 3-Tube Portable Set.
- "B" Voltage from the A. C. Socket.
- An Amplifier for the 3-Circuit Tuner.
- Blueprints of a Five-Tube Radio Frequency Receiver.

### May, 1925

- A "Quiet" Regenerator.
- A Power Supply Receiver.
- How to Make a Tube-Tester.
- A Unique Super-Het and an Improved Reinartz.
- A Six Tube Portable Receiver Illustrated with Blueprints.

### June, 1925

- Reducing Static Disturbances.
- A Seven-Tube Super-Heterodyne.
- The Double Grid Tube in Ordinary Sets.
- Browning-Drake Receiver.
- Overcoming Oscillations in the Roberts Receiver.
- An Ideal Set in Practical Form.
- Soldering Secrets.

### July, 1925

- Learning Tube Characteristics.
- How Much Coupling?
- The Six-Tube Super-Autodyne.
- A Simplified Portable Super-Set.
- Blueprints of Conventional Radio.
- Symbols and Crystal Detector Circuit.

### August, 1925—50c per copy

- How to Attain Smooth Tuning.
- Alternating Current Tubes.
- Deciding on a Portable Super—
- And a big 60-page blueprint section, in which is contained blueprints of all the basic circuits from which all radio hookups have been developed since the birth of Radio.

### September, 1925

- Thirty-one ways to prevent self-oscillations.
- Tuning efficiency with two controls.
- Ideal Audio Amplifier Circuits.
- Blueprint section.

### October, 1925

- Auto-Transformer Coupling.
- Some Facts about Quality.
- An Improved Slide-Wire Bridge.
- Blueprints of Circuits Using Single and Dual Controls.

### November, 1925

- A Super-Het without I. F. Stages.
- How to Make a Windless, Pipeless Organ
- A New Low Loss "Special, Four."
- How to make a Low Wave Transmitter
- Blueprints of Making R. F. Stages.

Radio Age, Inc., 500 N. Dearborn St., Chicago



# The World's Greatest Radio Story



## Ward's New Radio Catalogue is Now Ready

Are you interested in seeing what is new in Radio—what is best and what has been approved?

And do you wish to know the lowest prices on tested sets, prices made without the usual "Radio profits?"

### This Catalogue is a Complete Guide to Radio

Ward's is headquarters for Radio, with probably the largest retail radio department in the whole world.

This new 52 page Radio Catalogue shows everything in parts, batteries, cabinets, contains a list of stations, a radio log for recording stations. It shows the best of the new sets. One tube sets that give amazing results.

Five tube sets with a single dial to turn. Think of tuning in one station after another by turning a single dial!

Every price quoted means a big saving to you. Everything offered is tested by our own Radio Experts. In fact, the best experts compiled this Catalogue for you.

Write for this 52 Page Book. It is yours free.

### Our 53 year old Policy

For 53 years we have sold only quality merchandise under a Golden Rule Policy. You can rely absolutely upon the quality of everything shown in this Radio Catalogue.

ESTABLISHED 1872  
**Montgomery Ward & Co.**

The Oldest Mail Order House is Today the Most Progressive  
Baltimore Chicago Kansas City St. Paul Portland, Ore. Oakland, Calif. Ft. Worth

To Montgomery Ward & Co., Dept. 18-R

Baltimore Chicago Kansas City St. Paul  
Portland, Ore. Oakland, Calif. Fort Worth

(Mail this coupon to our house nearest you.)

Please mail my free copy of Montgomery Ward's  
New Radio Catalogue.

Name.....

Local address.....

Post office.....

State.....



# WITH THE MANUFACTURERS



## Dealers Attend De Forest "Pep" Meeting

Over three hundred metropolitan dealers attended the "pep" dinner, given by the De Forest Radio Company and its five metropolitan distributors at the Waldorf-Astoria Hotel on October 2nd.

The dinner was opened by an address of welcome by H. L. Lanphear, General Manager of the De Forest Company, who stressed the value of a set sold one hundred percent, and pointed out that Radio was witnessing the same growth as other young industries, namely the public placed their faith in a dealer who not merely "sold" them, but who gave service.

Samuel H. Darby, general counsel for the De Forest Company, urged the dealers to encourage the ideas of amateurs in radio. Very often a man comes into a shop and falls into conversation with a salesman over the counter. He may have an idea toward improving a set that is really fundamental, and in which the manufacturer would be interested, but these two seldom get together. The dealer is in a personal relationship to both. The De Forest Company has been very gracious to inventors all during its history, and very often a man with a good idea has been helped to find a market. So long as dealers can keep alive a healthy curiosity about radio their sales will be big. They must do their part in keeping the interest of the man who likes to tinker and experiment.

Robert E. Rinehart, Vice President of the William H. Rankin Company, in charge of advertising and publicity, spoke on the good luck of the dealer in radio, for this is one industry which needs no excuse for its being. Mr. Rinehart laid emphasis on the fact that crowds visited the dealer just as a matter of information. Because of the fact that radio is in its infancy, the dealer is looked on as a sort of bureau of public information, as a reference handbook. The public wants to know what the manufacturer is doing, and he comes to the place where he knows this news can be obtained.

## Eby Has Cushion Socket For UX Tubes

With the advent of the new UX tubes comes the development of sockets that are in keeping with their efficiency.

The H. H. Eby Mfg. Company of Philadelphia has just announced a new type of cushion socket that insures a positive contact at all times.

This socket grips each of the four tube prongs their entire length with three-jawed Phosphor Bronze spring clips. Each spring clip is securely riveted to the Bakelite base assuring a good electrical joint and permitting the tube to "float" when in service. This shock-absorbing feature eliminates microphonic noises and is a guarantee against tube damage.

## Fixed Resistors That Do Not Deteriorate

The Allen-Bradley Company of Milwaukee, have perfected a fixed resistor of the molded composition type, which is impervious to moisture and atmospheric changes, and does not deteriorate with age or service. Silver plated contacts on each end of the Bradleyunit, as this resistor is called, are molded in place. The Bradleyunit does not rely upon hermetic sealing to avoid deterioration. The silver plated contacts are provided with holes for soldering, or they may be used in the standard mounting clip.



Bradley-unit Amplifier Resistors are six Bradleyunits of the correct rating for resistance-coupled amplifiers. Since Bradleyunit resistors do not deteriorate, and are guaranteed to be within 5 per cent of the rated resistance, they can be used with the most satisfactory results possible, either in building resistance-coupled amplifiers, or replacing resistors not of the molded type, in amplifiers in service.

## Bosch Builds Wood Cone Reproducer

An entirely new trend in radio reproduction is advanced by the American Bosch Magneto Corporation in its Ambotone Reproducer with a wooden conoid. The entire cone diaphragm is wood instead of the conventional paper.

Unusual mellowness is claimed for this feature as wood in musical instruments has always been looked to for pleasing tone qualities. This wood diaphragm is 18 inches across which contributes to the full reproduction of the bass tones so often lost in radio reproduction.

The wood conoid is finished in mahogany with a parquetry inlay touch. The base and metal parts are finished in art bronze.

## Shortage Over

The temporary shortage which existed recently on MU 6 tubes, power type, made by the Daven Radio Corporation at Newark, N. J., has been relieved, according to advices from their factory. Both the MU20 which is the amplifier type for resistance coupled sets and the MU6 which is a power tube for the last stage, are in full production.

## Furnell Taper Coil Condensers

The Furnell Taper Coil Condenser introduces the first "new idea" principle offered in condenser design. Up to its advent, practically all variable condensers were of the same general type.

Heretofore, condensers have been made up of two series of projecting plates, that intermeshed by the movement of a rotating shaft, or rotor. The limitations, as well as the deficiencies of this old type condenser, have long been recognized by the professional.

The Furnell Taper Coil principle is such an advance forward in condenser efficiency, as to distinguish it as the new standard of condenser design.

Due to their improved principle—their simplicity—their ruggedness—their permanent alignment under all conditions—Furnell Taper Coil Condensers afford a smoothness of action, an accuracy, and a sharpness of tuning.

## Westinghouse Intl. Announces New Appointments

C. V. Allen, formerly Manager of the Westinghouse Electric International Company in Mexico, has been elected Assistant Treasurer of the Company, with headquarters in New York City as general assistant to H. A. Carmichael, Treasurer. The appointment was effective October 15, according to an announcement from the executive offices of the Company in New York. Clayton T. Rogers, Sales Manager for the Mexican Branch, is Acting Manager succeeding Mr. Allen.

Mr. Allen has been with the Westinghouse organization for thirty years. Before being made Manager of the Mexican Branch of the International Company, he had acted as Westinghouse Special Agent in Mexico. He assumed the Managership of the branch division at the time of its organization in 1921.

Mr. Allen is a graduate of the Massachusetts Institute of Technology, and began his career with the Westinghouse Company as a graduate student, working in both the East Pittsburgh and New York Offices before entering the foreign field.

## Adds Floor Space

To keep pace with its expansion program the R. E. Thompson Manufacturing Company, radio manufacturers, has acquired by lease an additional two floors in a separate building in Jersey City, where its main plant is located.

Including the two floors just leased, at 314 Claremont Avenue, and four entire floors recently leased in the 103 Greene Street, Jersey City Building, the company has now added approximately 25,000 square feet of leased floor space to the plant facilities it owns at 66 York Street, Jersey City.



## Equal Impedance Secret of New Radio Sets

Simultaneously with the introduction of two revolutionary types of talking machines embodying newly discovered principles of sound reproduction, the Victor Talking Machine Company, of Camden, N. J., announces that models of both lines of instruments will be produced in combination with radio receiving sets ranging from five to eight tubes. The new Orthophonic Victrola, and the electrical amplifying talking machine to be known as the Electrola, are to be put on the market with built-in radio sets of the very latest types (Radiolas 25 and 28) announced by the Radio Corporation of America.

At the same time, the Victor Company is announcing a clock type loud speaker, based on distinctly new principles of sound reproduction, which employs the double balanced diaphragm principle, and a pleated parchment sound radiating surface. The electro-magnetic unit energizes the entire surface of the diaphragm, giving loud, undistorted reproduction when used in connection with any good audio-frequency amplifier.

It is the mechanical application of the principle of matched impedance which has made possible the Orthophonic talking machine used in all the new line of combination instruments. Acoustical engineers state the Orthophonic talking machine, by reason of the matching of all impedances, has made possible the mechanical reproduction of sound from a talking machine record which is infinitely more efficient than any previous accomplishment in this industry.

## Tube Vitalizer Put Out By Hemco

The Hemco Radio Tube Vitalizer has been placed on the market recently by George Richards & Co., of Chicago.

This device brings any tube, new or old, to maximum operating efficiency by application of the rethorating principle. The 201A and UV199 tubes, which comprise practically all the tubes in radio receivers today, owe their success largely to the tungsten-thorium alloy of which their filaments are made. They are excellent detectors, and unexcelled as amplifiers, and use less battery current than any other type of tube.

The Hemco Tube Vitalizer is built to operate on either A. C. or D. C. 110 volt circuit, so it can be attached directly to the electric light circuit.

## Test Handles Fill Need In Radio Experimenting

A set of test handles for use in cadmium, voltage, polarity, leaking cells, meter leads and many other tests which will suggest themselves to the radio experimenter, is announced by the Universal Test Equipment Co.

Among the radio uses of the handles, one of which is fitted with a cadmium point, are the following: Testing opens, shorts, grounds, condenser tests, polarity tests and resistance tests. The points are made of a special alloy to prevent breaking, bending or corrosion.

## Leads are Separated in New De Forest "H" Tube

A new transmitting tube, in design the most radical departure from any tube ever placed on the market, is the latest achievement of the De Forest Engineering laboratories.

This makes possible the use of extremely high voltages with no chance of flash over. Under this plan the tube's efficiency is not only increased, but the danger of breakdown or burn-out is reduced.

In construction the "H" tube differs from the ordinary transmitting tube by having its leads placed like the four points of a cross, one out from either side,—and one top and bottom.



In construction, the new "H" follows the general design of the Singer tube. The filament operates on Tungsten emission, drawing approximately 2.3 amperes at 10 volts. The grid and plates are of the best quality material that the Engineering Department of the De Forest Radio Company, pioneers in tube manufacture—have been able to find.

The tube has a normal output of 20 watts at a plate voltage of approximately 700 volts, but due to the unique features in its design, 3000 volts may be applied to the plate without causing any breakdown or in any way shortening the life of the tube. The application of high plate voltages naturally increases the output of the tube and it has been found that with 2000 volts on the plate, the output varies between 150 and 200 watts, depending entirely on the circuit and to a large extent upon the necessary "C" bias which is used. The maximum safe plate dissipation is approximately 170 watts. With 1200 volts in the plate no "C" battery is necessary.

## National Carbon Has New Battery

The National Carbon Company announces a new Eveready "B" battery to be known as No. 779. This is designed particularly to fit the battery compartments of certain types of Operadio and DeForest receivers. The voltage is 22½ and dimensions 4¼x3¾x7¾.

This battery is added to the Eveready line in accordance with its established policy of meeting every existing radio battery need. The new battery permits the use of the largest size cells possible in the battery compartments of the sets referred to, resulting in the greatest economy permitted by the space available for power supply.

## "Bull Dog" Socket Made By Camfield

Another quality product recently brought out by the Camfield Radio Manufacturing Company is the Type 11 Bull Dog Grip Socket. This socket is designed to accommodate three different types of tube bases. Tubes having the Navy standard base, the new X Dry Storage Battery base, or the new X Dry battery base, are all interchangeable in this socket without the use of an adaptor.

The heavy phosphor bronze contact springs grip the prongs on all sides insuring absolutely perfect contact, eliminating one of the greatest troubles encountered in set operations in the past.

## Variances in "B" Batteries

Since the first set was rigged up in the cellar, amateurs and engineers have spent years in developing that most important source of local energy, the plate battery. Government investigation has revealed the fact that there is a very wide variance in the standard B battery. Also, that the results obtained from any make receiver depends first, of course, on the make of battery; and second, on the length of time which elapses between its assembly at the factory and its installation in the home.

F. M. Ronsfeld, who is the president of the Diamond Electric Specialties Company, in a recent interview, declared that his firm's policy was to get batteries to the purchaser with a minimum loss of time and to make this possible, shipments are sent directly to the dealer. The company keeps in very close touch with their dealers and batteries are not allowed to lose energy on jobber's shelves. This procedure, they feel, is the only one that is fair to the customer who is anxious to get the best out of his receiver.

## The "Accuratune Junior"

An Accuratune Junior has just been announced for the radio fans and the trade by the Mydar Radio Co., Newark, N. J. It is moulded entirely of bakelite with clearly defined graduations. It is beautifully made and substantial. The same important features are incorporated in it as used in the regular Accuratune. Coarse or fine tuning is furnished through a double worm drive. The dial is graduated either zero to one hundred or the reverse. Its diameter is four inches. It is also furnished in mahoganite finish. This is a new addition to a line of verniers and dials which have long been familiar to readers of the advertising pages of Radio Age and should be of interest to those desiring a medium priced vernier.



## Build the Set That Holds 4 World's Records



The receiver that brought in stations 6,000 to 8,000 miles distant with loud speaker volume night after night.

### Holds World's Records For

- (1) Longest distance ever received on a loop aerial—8,375 miles
- (2) Most consistent reception of stations 6,000 to 8,000 miles distant—117 programs in three months.
- (3) Brought in 6 different stations in 2½ hours—all over 6,000 miles

Full sized blue prints with complete instructions showing how to make exact duplicate of this marvelous receiver.

### PRICE \$5

Story of development and proofs of records sent on receipt of stamped and addressed envelope.

**Scott Radio Laboratories**  
35 S. Dearborn St., Chicago  
Dealers and Jobbers Write

## Myers Tubes Now to be Made at Cleveland

The radio public in general and radio fans in particular will unquestionably welcome the Myers Radio Corporation, which will manufacture the Myers tubes in the United States, their plant being located in Cleveland.

The heartbreaking experiences of the radio inventors, the privations they were compelled to suffer, the patent legal battles, and their undying tenacity, made the present radio reception possible. Fortunately, the Myers Radio Corporation was able to overcome these difficulties, its Board of Directors made up of prominent and representative Cleveland business men.

Prior to December 1922, Myers Tubes were manufactured in Jersey City. Their type of construction was entirely different from the ordinary style of tube made, in that the Myers tube elements were small, reducing tube capacity and having the leads separated, that is, the leads of plate and positive filament were brought out of one end of the tube and the leads of the grid and negative filament out of the opposite end.

The Myers tubes were a success and the demand was beyond any possible supply. Of course at that time there were but few radio sets in use and the users were anxious to have their families and their neighbors enjoy the broadcasting of the one or two broadcasting stations then in operation.

Just at a time when production was being speeded up to cope in a small measure with the pressing demand, a legal patent battle unprecedented in the annals of radio ensued, with the result Myers tubes were compelled to move to Canada, where the complications with respect to the three element patent did not exist. It is understood the Company now owns the patents and patent applications on the styles of tubes they are going to manufacture and the machinery used in the process of manufacturing.

The Myers Radio Corporation is equipping a factory where they will not alone make the famous double end type of tubes, but also all types commonly used in all receiving sets now on the market. They claim certain improvements that will give clarified reception with greater amplification. The factory is being equipped for a large production capacity.

## O'Neil Loud Speaker For Canadian Marconi

The O'Neil Manufacturing Company, whose plant is at 4738 Hudson Boulevard, West New York, N. J., are the builders of the Audiphone loud speaker, which incorporates the three-way-control balanced armature, laminated electro magnet, large permanent magnet, and India Mica diaphragm.

The factory is located on the boulevard and is an attractive little place with plenty of light and good air. Raymond R. O'Neil, who is at the head of the organization, is assisted by Mrs. O'Neil, a score of engineers, and assemblers.

Among the firms for which the O'Neil Company supplies loud speakers is the Marconi Wireless Company of Canada.

\* Tested and Approved by RADIO AGE \*

## Ireland's Latest "Wonder" Coil

DISTANCE VOLUME  
SELECTIVITY



Price \$6.50

Manufactured by the Inventor  
**A. E. IRELAN,**  
Sharon Hill, Pa.

Distributed by  
**RADIO SERVICE CO.**  
3704 N. 6th St., Phila., Pa.

Dealers Write for Our Proposition



The Indoor Aerial that is more selective and more efficient than any outside antenna. This device has established an enviable D-X record in the congested district of Chicago for the past two years.

Send prepaid on receipt of money order  
**AERION AERIAL CO.**  
7255 CORNELL AVE  
CHICAGO, ILL.

**\$1**

## FREE HOOK-UPS

AND  
**BIG RADIO GUIDE**

Free, big Radio Catalog and Guide brimful of newest ideas, over 100 special hook-ups and illustrations. You save as much as 50% on sets and parts. Be sure to get this thrifty book before you buy. It puts money in your pocket. Shows standard radio parts, sets, kits, all reliable, guaranteed goods. Please include name of radio fan to whom we may send copy also. Write letter or postal now.

**THE BARWIK CO.**  
104-128 E. Canal St., Chicago, U.S.A.

## \$1.50 for Your Old Radio Tubes

regardless make or condition, toward purchase of each new standard \$2.50 tube. Positively guaranteed. We do not sell re-built or bootleg tubes. Agents wanted.

**SUPER-SERVICE LABORATORIES,**  
Dept. B, Room 58,  
39 West Adams, Chicago, Ill.

## The Five Tube Set which startled the World!

## FRESHMAN MASTERPIECE

## The Greatest Value Ever Offered in A Radio Receiving Set

At Authorized Dealers

## "B" Battery Eliminator

\$8.90

For the price of "B" Batteries it is now possible to get a "B" Battery Eliminator that is guaranteed for eighteen months. For direct current only.



**POWER SUPPLY CO.**  
320 E. 176 St. N. Y. City



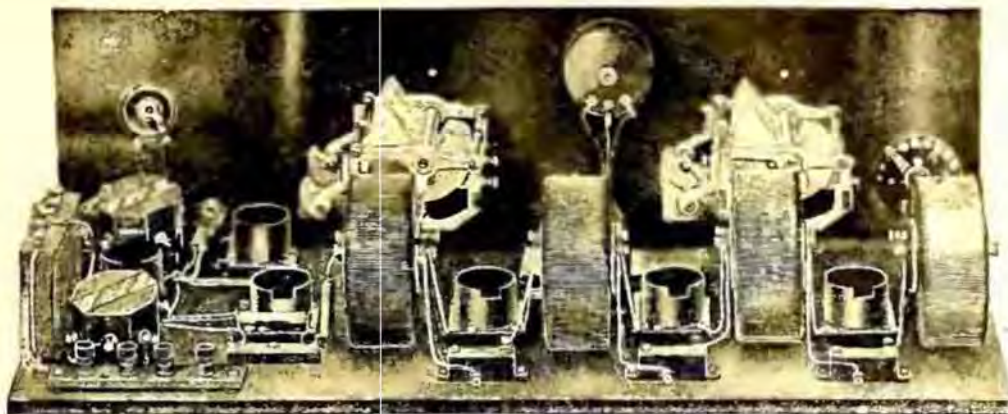

# Build a B-T "Counterphase Six"

## New Construction Plans Eliminate Chances of Error

A six tube receiver with three stages of radio frequency,—a set that gives distant reception with only a short indoor aerial and is the last word in selectivity, yet uses only two tuning dials.

Such a receiver is the new B-T "Counterphase"-Six, which a leading radio editor terms, "The only new circuit of the season."

You can build this master-set yourself. The B-T system of instructions makes it easy for the most inexperienced to construct a "Counterphase." B-T Kits contain the essential parts together with all radio frequency leads cut and ready to place in position. A series of progressive charts in nine-color combinations show exactly where each wire goes. Printed instructions take you through the whole job step by step. You can't go wrong,—never before has there been such an easy way to build a receiver. A set of these instructions is included in each kit.

You can also build a "Counterphase" with two or one stage of radio frequency for use with an outdoor antenna.

See your dealer about a "Counterphase." Ask him to show you the new B-T method of construction.

### "The Best we Ever Tested—"

says a leading laboratory of the "Euphonic" Audio Transformer. Tone quality is the outstanding feature of this transformer. We have named it the "Euphonic" because it is "Pleasing to the Ear."

In addition to being a transformer of merit the "Euphonic" possesses an added mechanical feature that eliminates howling and distortion due to crossed or too close leads. Case and brackets are so designed that the "Euphonic" may be mounted in any desired position with the terminals always in place for correct wiring.

*This feature is found only on B-T "Euphonic."*

### Condensers Built as only B-T Can Build

Never has there been a condenser that made the success with radio engineers, technical writers, experienced set builders,—the men who know that did the B-T "Lifetime" Condenser. Its mechanical and electrical superiority appealed to them from the first.

You can now secure this same quality in Straight Line Frequency. You can pay more for condensers but you can't buy as much. That's why we print on every carton, "If you don't find it better, send it back."

### 80 Pages of Radio

in the new 80-page 8th Edition of "Better Tuning." Tells all about the "Counterphase," new apparatus, current discussions of radio, etc. Postpaid, 10 cents.

Circulars on B-T products sent free on request.



Ratio: 2.2 to 1 ..... Price \$5.00  
4.7 to 1 ..... Price 5.75



SLF-13, Capacity .00025. Price \$5.50  
SLF-17, " .00035. Price 5.75  
SLF-23, " .0005. Price 5.75

# BREMER-TULLY MFG. Co.

532 S. Canal St.



Chicago, Ill.



# REX for your 'B' battery eliminator



REX answers the eliminator problem. The B Battery eliminator equipped with Magnatron Rex tubes works day in and day out — silently and economically.

Magnatron Rex is the product of long research by the oldest exclusive manufacturers of thermionic valves in the country. It has been designed primarily and only for eliminator work.

Magnatron and Excellence have come to mean one and the same thing. Impartial laboratories and radio engineers throughout the country have certified this. Their reports explain why Magnatrons in your set will make it function better.

Your dealer has the Rex as well as the other Magnatrons. Ask him today! They list for only \$2.50.

Write for your FREE copy of "Pot Pourri — a snappy review of mirth and music", to Dept. A, CONNEWY ELECTRIC LABORATORIES, Magnatron Building, Hoboken, New Jersey.

West Coast supplied from complete stocks carried by PACIFIC RADIO LABORATORIES, 256 So. Los Angeles St., Los Angeles, Calif.



# MAGNATRONS

## Tuning Your Radio By Chart Curves

(Continued from page 21)

lengths as follows:

Take a sheet of paper eleven inches square. Rule off a one-inch margin on the lower and left-hand edges, and in the larger space draw faint intersecting lines a half inch apart, as in Figs. 1 and 2. Number the bottom horizontal line 0, the one-inch line above it 10, the two-inch line 20, and so on up to and including 100 to correspond with the numbers on the tuning dials. Now number the left-hand vertical line 200, the one-inch line to the right 240, and two inch line 280, and so on up to 600, to cover the meter wavelength range of the broadcast receiver.

Suppose the first station recorded has a wavelength of 326, and the dial settings which brought it in are 32, 30 and 28 for dials No. 1, 2 and 3 respectively. Take a rule and place it parallel to the vertical lines so as to pass through a point on the lower line between the 320 and 360 points, which will coincide with the 326 meter position. Place dots at the edge of the rule at the dial positions 32, 30 and 28. These dial positions are found by consulting the dial position figures in the left hand margin of the paper; after finding the line marked 30, the location of dial positions 32 and 28 can be estimated.

### The Dial Settings

In a similar way, make dots representing the dial settings of three or four other stations whose wavelengths range up to 550. Some way of distinguishing the dots should be employed such as marking the dial No. 1 dots red, the dial No. 2 dots blue, and the dial No. 3 dots black. Now draw a smooth curve line passing through all of the dial No. 1 dots. Draw a similar line passing through the dial No. 2 dots, and a third passing through the dial No. 3 dots.

With these three curves drawn, it is a simple matter to bring in any station whose wavelength is known. For instance, if the desired station has a wavelength of 400 meters, lay the ruler down on the curve chart on the vertical 400 meter line. The points on the horizontal lines at which the ruler intersects the three curves will indicate the positions to which the dials must be turned in order to bring in the desired station by means of this home-made curve chart. Thus the radio fan who desires to tune in various stations, whose wavelengths are known, can do so conveniently by preparing a curve chart for his particular set.

The next set which we will discuss is the super-heterodyne, which is one of the most complicated sets in its mechanical construction but is one of the easiest to operate. There are usually three controls, one of which is for adjustment of the battery current to the vacuum tubes. This adjustment should be made as usual. In this case use a low setting to start with. The other two controls serve to select the stations, one of them tuning the loop circuit while the other tunes what is called a "driver" or "oscillator." These sets are usually designed so that when signals are to be received the positions of the two selectors will be very nearly but not quite the same.

The principle on which this set operates is that the frequency of the "driver"

(Turn to page 58)

## Radio Dealers HEADQUARTERS

Dealers—if you want the best products, the fastest shipments and the most liberal discounts, write on your letterhead for our catalog L1003.

WAKEM & McLAUGHLIN, 225 E. ILLINOIS ST. — CHICAGO

## FREE RADIO STAMPS

618 beautiful copper etched American, Canadian, and European stamps, each with the call letters of a station. FREE with Ideal 48-page Radio Stamp Album and Log. Also contains complete list of stations both alphabetically and by call letters. As you hear new stations, just put the proper stamps in your album. Album and stamps become a permanent and interesting record of the stations you receive. You and your children will enjoy it. Complete album, 8" x 11", heavy board covers. \$1 plus postage.

### Send No Money

Just pay postman after album and stamps arrive. We prepay postage if you prefer to pay with order. MONEY REFUNDED if not DELIGHTED. Send order today—NOW. Postal will do. IDEAL CO., Dept. 2029, 366 Wrigley Bldg. Chicago



\* Tested and Approved by RADIO AGE \*





Resistor Manual

The Handbook of Resistance Coupled Amplification at best radio dealers 25c. Direct by mail, postpaid 30c.

CLIP THIS COUPON

DAVEN RADIO CORPORATION  
158-160 Summit Street (H-12-25)  
Newark, New Jersey

Please send me the following on Resistance Coupled Amplification:

Check one.

- Resistor Manual. 30c is enclosed.
- Complete catalogue (free)

Name .....

Address .....

For dealers: Send your letter-head or card, or this coupon and we will have our nearest distributor communicate with you.

## Resistance Coupled Amplification For All

**T**HE Daven Super-Amplifier is for set owners who want more volume and better quality or for set builders or manufacturers who want resistance coupled amplification without the labor of assembly.

All the plate resistors, grid leaks and fixed condensers of the proper value, as well as all necessary binding posts, are supplied. There is nothing to do but connect with the tuner and the batteries.

Thousands have changed over their amplifiers to the resistance coupled system and testify to the wonderful improvement in richness and sweetness of tone and hearty, generous volume. The Daven Super-Amplifier makes even the best set a little better.

### A ONE-PURPOSE TUBE

The new Daven Tube MU-20, 6 volt,  $\frac{1}{4}$  ampere, increases the amplification of The Daven Super Amplifier fifty percent, without distortion. The tone remains sweet and true. Daven Power Tube Type MU-6 is recommended for the last or output stage in any set.

Any Daven dealer will show you how to hook up the Daven Super-Amplifier.

DAVEN PRODUCTS ARE SOLD ONLY BY GOOD DEALERS



*"The Sine of Merit"*

DAVEN RADIO CORPORATION

Resistor Specialists

Newark

Reg. U. S. Pat. Off.

New Jersey

THE BIG LITTLE THINGS OF RADIO

\* Tested and Approved by RADIO AGE \*





Superior Results Guaranteed

**\$9.75**

# Now-Plate Voltage for any Set — and You can afford it!

First Cost Economy now makes it possible for EVERYONE to obtain efficient "B" current supply right from their electric light socket. Now one of the biggest improvements in modern-day radio reception is placed within the reach of all. Think of it! A perfect, always efficient source of plate voltage for any set for \$9.75! It marks a revolutionary step forward and will be welcomed by millions of radio enthusiasts.

## Ferbend "B" Eliminator

The price of this remarkable new unit is spectacular in more than one way. Besides saving you from \$15 to \$50 it is amazingly low considering the quality and superiority. You may ask "how could it be possible to build such a unit for the ridiculously low price of \$9.75?" True mechanical genius and resourcefulness alone are responsible. But the logical way to answer this question is to equip your set at once with this marvelous unit and be convinced.

ASK YOUR DEALER—OR SEND DIRECT

**FARBEND Wave Trap**

This company also manufactures the famous Ferbend WAVE TRAP—the instrument which has been widely imitated but never equalled. It is the only original and genuine. See advertisement on page 69.

Until nation-wide distribution is completed it is possible that your dealer hasn't stocked the MAXMIN "B" Battery Eliminator as yet. So you will not have to wait, we will make prepaid shipment direct to you upon receipt of \$9.75, or C. O. D., plus postage. Remember, superior results are guaranteed or your money back. Be one of the first to own and use the Ferbend MAXMIN "B" Battery Eliminator.

Use the COUPON NOW!

Complete, nothing else to buy.

Operates at maximum efficiency at all times on either direct or alternating current, any frequency.

Delivers unlimited current to any receiving set regardless of number of tubes.

Delivers 100 volts to ANY set.

Cost of operation less than 50c a year.

It lasts indefinitely.

All parts are specially designed and manufactured by us for this purpose only.

**Unconditionally Guaranteed**

to be equal or superior to any eliminator on the market, regardless of price.

## Tuning Your Radio By Chart Curves

(Continued from page 56)

shall be different from the frequency of the incoming waves by a certain amount. Thus there are two positions of the loop tuner, one position corresponding to the condition when the driver is operating at a higher frequency than the incoming waves and the other when the driver is at a lower frequency than the incoming waves. Therefore, the proper method is to set the loop tuner and then turn the driver slowly in either direction from a position corresponding to the setting of the loop tuner until the sounds indicate that the "air is open." As in the case of the tuned radio frequency set it will be found convenient to draw the curve chart already described that different stations may be easily selected. See Fig. 2.

It will be noticed on the super-heterodyne that for every position of the loop tuner or "selector No. 1," which corresponds to the wavelength of a given station, that there are two distinct settings of the "oscillator dial" or "selector No. 2," at which the signals or broadcasting from that particular station will come through. A curve should be drawn for each of these two positions. A great advantage of making both these curves is that in case of interference from a powerful local station at one setting of the oscillator dial or "selector No. 2," it may be immediately changed to the other setting by reference to the curves.

The next type of receiver to be described, the single circuit regenerative receiver, has several tuning dials, and no accurate curve can be made for tuning this set, because several variables such as size of antenna, temperature of filaments, etc., will affect the setting. However, under any given condition a curve for the tuning dial only made in the manner already described will serve as a rough guide in finding new stations whose wavelengths are known.

## An Informal Chat with WGY

(Continued from page 31)

exploiting of an invention for "carpet covered carpet tacks" and it is really amusing, as all Wallingford stories are. Not long after the play was broadcast the studio received a visit from a woman who appeared very much excited.

"You have exposed my secret," she said. "I have been working for a considerable length of time on this proposition and just as I get it perfected I hear you broadcasting it to the world, telling every one about it."

The microphones do not come into view at the first survey of the studio. The first thought of the uninitiated person, upon stepping into the studio, is that a considerable number of floor lamps are used. Several of them with small ornate silk shades are located in various sections of the room. Closer inspection, however, discloses the fact that instead of electric lights, the fringe of the shade conceals the microphone.

Ferbend Electric Company  
431 West Superior Street  
Chicago, Ill.

## Ferbend Maxmin "B" Eliminator

**FARBEND ELECTRIC CO.**  
431 West Superior St., Chicago

Send Postpaid. I am enclosing \$9.75.  
 Send C. O. D., Plus few cents postage.  
 Send Literature.

Name.....  
Address.....  
City.....  
State.....

**FLINT** Distortionless Audio Transformer \$3.50  
—Highest Quality—  
From your dealer or direct  
We stand back of each one  
**\*FLINT RADIO CO.**  
1882 Wilson Ave. CHICAGO

**YOU CAN GET**  
Greater reflex or crystal set reception if you use the  
**BROWNLIE VERNIER DETECTOR**  
\$2.00 At your dealer or Direct.  
**ROLAND BROWNLIE & CO.**  
21 Sanders St. Medford Mass

**BIG DISCOUNTS TO RADIO DEALERS**

Dealers get our big catalog before you buy huge stocks of standard radio parts, sets, kits at rock-bottom wholesale prices. Special order on sets, tubes, batteries.

**FREE CATALOG SETS PARTS KITS**

W. C. Brown Co. 36-50 S. Clinton St., Chicago, Ill.

**ULTRA-VERNIER TUNING CONTROL**

A VERNIER DIAL ON WHICH YOU CAN PENCIL RECORD THE STATIONS GEARED TO TO 1 SILVER FINISH \$2.50 - GOLD FINISH \$3.50

**PHENIX RADIO CORP., 116-F East 25 St., N.Y.C.**



# Send for this RADIO BOOK FREE



# 1926 Catalog of RADIO BARGAINS Save 1/3 to 1/2

**The World's  
Largest Exclusive  
Radio Mail Order House  
Will Send You This Wonderful Book FREE**

## AMERICAN RADYNOLA 5 TUBE SET

64 illustrated pages containing thousands of bargains in radio sets, semi-finished sets and radio kits of all styles, sizes and approved circuits. **5 tube complete sets as low as \$29.50.** Beautiful models of the very latest designs and types. Elaborate console models with **loud speakers built right into cabinets** of genuine mahogany and walnut. **ALL SETS GUARANTEED.** Coast to coast receiving range. Catalogue also contains everything in radio supplies, including batteries, chargers, loud speakers, transformers, condensers, rheostats and any other parts you may want for improving your set or building a new one. **Guaranteed saving to you of 1/3 to 1/2.**

### The Biggest 5-Tube Value on the Market

Positively the world's greatest 5 tube radio bargain. **REGULAR \$75.00 VALUE.** Our large quantity production enables us to sell this set for **ONLY \$29.50**, fully built and wired in beautiful mahogany cabinet of latest design with sloping Bakelite panel of Satin finish, handsomely etched and engraved as illustrated. Constructed of the finest low-loss condensers, coils and sockets, bakelite baseboard, panel and dials. **PRICE FOR SET ONLY.** Transportation charges extra, shipping weight 25 pounds.



### This Set with All Accessories, Including The Famous American Bell Loud Speaker

with adjustable unit, 2-45 volt "B" batteries, one guaranteed 100 Ampere Hour storage "A" battery, cable for battery connection, 5-201A tubes, Aerial and ground equipment, and everything complete ready to set up and operate. Nothing else to buy. **PRICE \$59.75** Transportation charges extra. Shipping weight 100 pounds. Complete instructions with set.

**Order Direct From This Page!** Save 1/3 to 1/2. Our guarantee protects you. Money cheerfully refunded if you are not satisfied. Write your order and prices plainly. Send post office money order or bank draft for full amount to insure safety. Refer to any bank or commercial agency regarding our reliability.

### Semi-Finished 5-Tube RADIO FREQUENCY RECEIVING SET

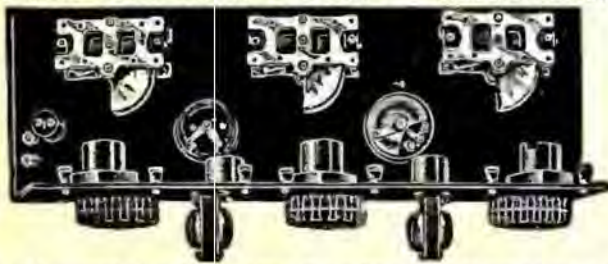

This special offer is astounding the radio world. Coast to coast reception on loud speaker. Low loss condensers and sockets. Highest quality transformers. Bakelite rheostats. All wiring concealed under baseboard. 7x18 panel fits into any standard 7x18 cabinet. Complete instructions for operating. **GUARANTEED SAVING TO YOU OF \$50.00.** Price of set all mounted. Not wired. Cabinet of same model as American Radynola pictured above \$5.65 extra. **\$18.75**

You must have our catalog no matter what set or kit you want. Our line is complete and includes all popular sets, such as Superheterodyne, Neutrodyne, Ultra-dyne, Reimartz, Regenerative, Radio Frequency, Browning-Drake, Reflex and all other latest circuits. Kits, sets and parts manufactured by all well known manufacturers such as Frost, Howard, Baldwin, Brandes, Western Electric, Columbia and others.

Our semi-finished sets come with all parts mounted on panel and baseboard ready for wiring. Do not fail to send for our catalog. Remember—we are the largest exclusive radio mail order dealers in the world and carry the best of everything in radio. We save you 1-3 to 1-2 on the following kits. Detailed description appear in our catalog.

### Semi-Finished 8-Tube Super-Heterodyne



#### World's famous 8-tube Super-Heterodyne

Complete Parts for Best's 45 Kilocycle Super-Heterodyne Genuine Remler Parts **\$49.50**

Fully mounted on panel and baseboard. These pictures show interior set and how it looks when enclosed in cabinet. Comes completely assembled ready to wire and operate. We have testimonials from thousands of builders of this set. **Some Have Received Foreign Stations on Loop Aerial.** Unsurpassed in volume and tone quality. Low-loss straight line frequency condensers, vernier dials, finest quality rheostats. Matched Columbia long wave transformers. Requires only three screws for attaching panel and baseboard and set is ready to operate. 7x30 panel. Price of set only.

Requires following accessories to complete this set. 7x30 cabinet, 8-201A tubes for storage battery operation or 199 tubes for dry cell operation. 100 Ampere hour storage battery, 2-45 volt "B" batteries, loud speaker, center tapped loop aerial, All these items are listed in our catalog at a tremendous saving. **\$43.75**

<b>NEUTRODYNE</b> Genuine Licensed Neutrodyne kit of parts come fully assembled on the panel and baseboard with complete instructions ready to wire <b>\$29.75</b>	<b>COCKADAY</b> 3-tube Cockaday kit of parts, fully assembled on panel and baseboard, ready to wire <b>\$15.85</b>	<b>BROWNING DRAKE</b> 4-tube complete low-loss parts <b>\$32.40</b>	<b>ULTRA-AUDION</b> One-tube Ultra-Audion. Wizard of radio. Fully assembled and ready to wire, with instructions <b>\$6.35</b>	<b>AMBASSADOR</b> 3-tube Litz wire receiver—complete parts <b>\$19.95</b>	<b>OUR CATALOG</b> includes complete list of broadcasting stations and general information and facts about our free service division. Our radio engineers will help you solve all your radio problems. Send your name and address on a card or in a letter. We will send catalog FREE.
--	--	---	--	---	---

**OUR GUARANTEE**  
Every article exactly as represented. Every article is tested before shipping. Complete satisfaction or money cheerfully refunded.

**RANDOLPH RADIO CORPORATION**  
159 N. Union Ave. Dept. 185 Chicago, Illinois





## What to give the radio fan

Give him a two-ampere Tungar if he has a storage battery of any kind. It will charge all his radio batteries and his auto battery, too.

Or, for bigger jobs, give him a five-ampere Tungar—built to do the same work but to do it more than twice as fast.

Every man who has a storage battery wants a charger. And every man who wants a charger wants the original General Electric bulb charger—the Tungar.



The Tungar is a G-E product, developed in the Research Laboratories of General Electric.

The new Tungar charges any make and size of storage battery: radio "A" and auto batteries, and "B" batteries as high as 96 volts in series.

#### Prices

Two ampere size \$18.00  
Five ampere size \$28.00  
60 cycles . . . 110 volts

# Tungar

REG. U.S. PAT. OFF.

## BATTERY CHARGER

Tungar—a registered trademark—is found only on the genuine. Look for it on the name plate.

Merchandise Division

General Electric Company, Bridgeport, Conn.

# GENERAL ELECTRIC

**5 TUBE GUARANTEED RADIO**

Get Special Offers

**BIG POWERFUL MIRACO ultra 5**

Users everywhere report it gets programs coast to coast. Canada to Gulf, loud and clear on speaker; outperforms \$100 to \$200 sets. Many \$59.50 value. Hear Europe. Mar. 21. Hear Value. Let users' testimonies convince you. Retail

**FACTORY PRICES—SAVE 1/3 TO 1/2.** Smaller Sets \$13.75 up, retail. FREE Literature on latest 10 5 tube models. (Agents new low prices and Dealers SPECIAL OFFER! Write!) **MIRACO RADIO GETS 'EM COAST & COAST**

**MIDWEST RADIO CORPORATION**  
Pioneer Builders of Sets  
522-B-E 8th St., Cincinnati, Ohio

## Premier 5 TUBE Ensemble

TRADE MARK

Before you decide on a radio of any kind at any price, see the new Premier 5 Tube Ensemble. A complete Ensemble of genuine Premier parts (not a kit) already attached to panels of genuine black walnut grained Bakelite. Selectivity! Distance! Superb reception! Does anything any set at three or four times its price can do. It is today's unmatched radio value. See your dealer at once. Find out why a hundred thousand Ensembles will be sold in the next few months. See your dealer. Ask him. There is a genuine surprise waiting you.

Premier Electric Co., Dept. P-21, 3813 Ravenswood Ave. CHICAGO ILLINOIS



The January Radio Age Model will Be Easier to Build

## Dean of Radio Adventurers

(Continued from page 36)

tropical breezes and warm, soothing sunbeams that meet the dashing seaman! "That's the life," he told himself—and his mind was made up.

Now we find A. F. Henninger, Jr., the proud radio operator on a South American banana boat. In fact, Henninger says that during those many months that every man, woman and child in North America was loudly singing, "Yes, We Have No Bananas," he can personally vouch that his banana boat brought millions of bananas to the shores of the American Country. It would be a simple matter to picture Henninger excitedly broadcasting through his banana boat transmitter some such chaotic announcement. "Americans! Will arrive in two days with full cargo of bananas. Famine averted!"

Safely in the port of New Orleans with his valuable bananas, Henninger was approached by a dark skinned almond eyed native of a prominent South American Republic. They joined in a secret mysterious conference. Henninger's companion proved to be a revolutionist. The proposition was simply this, Henninger was to go to Central America and take charge of the revolutionist radio equipment. He was to be their Official Radio General for a matter of \$350 a week. Henninger had been searching for adventure—and here it was spread out on a platter ready to be taken at an instant's notice.

### A Real Revolutionist

HENNINGER became a high-salaried revolutionist. Careful as the revolutionists had been in their plans they must have overlooked some important link in their scheme for it was not many weeks later that the revolution was lost, the treasury was lost and the radio apparatus was lost—and Henninger found himself in the dense jungles, with a foot made useless and painful by nationalist's bullet. For two weeks he wandered about the forest, trying to get himself out—but so weak and hungry that what strength he had left could only be used to help him find berries and herbs for his meals.

This last experience caused him to spend several months in a New York hospital. Later he became a chief engineer for radio manufacturers. And now we find him a quiet, unassuming radio manufacturer whose taste for adventure seems to have departed entirely. Possibly his adventures are over, but one can never tell! He lives in Chicago.

### Set Builders Save Space With DUPLEX CONDENSERS

Specially designed shaped-out stators make these straight-line frequency condensers as small as ordinary condensers.

Write for literature  
**DUPLEX CONDENSER & RADIO CORP.**  
42 Flatbush Ave. Extension, Brooklyn, N. Y.



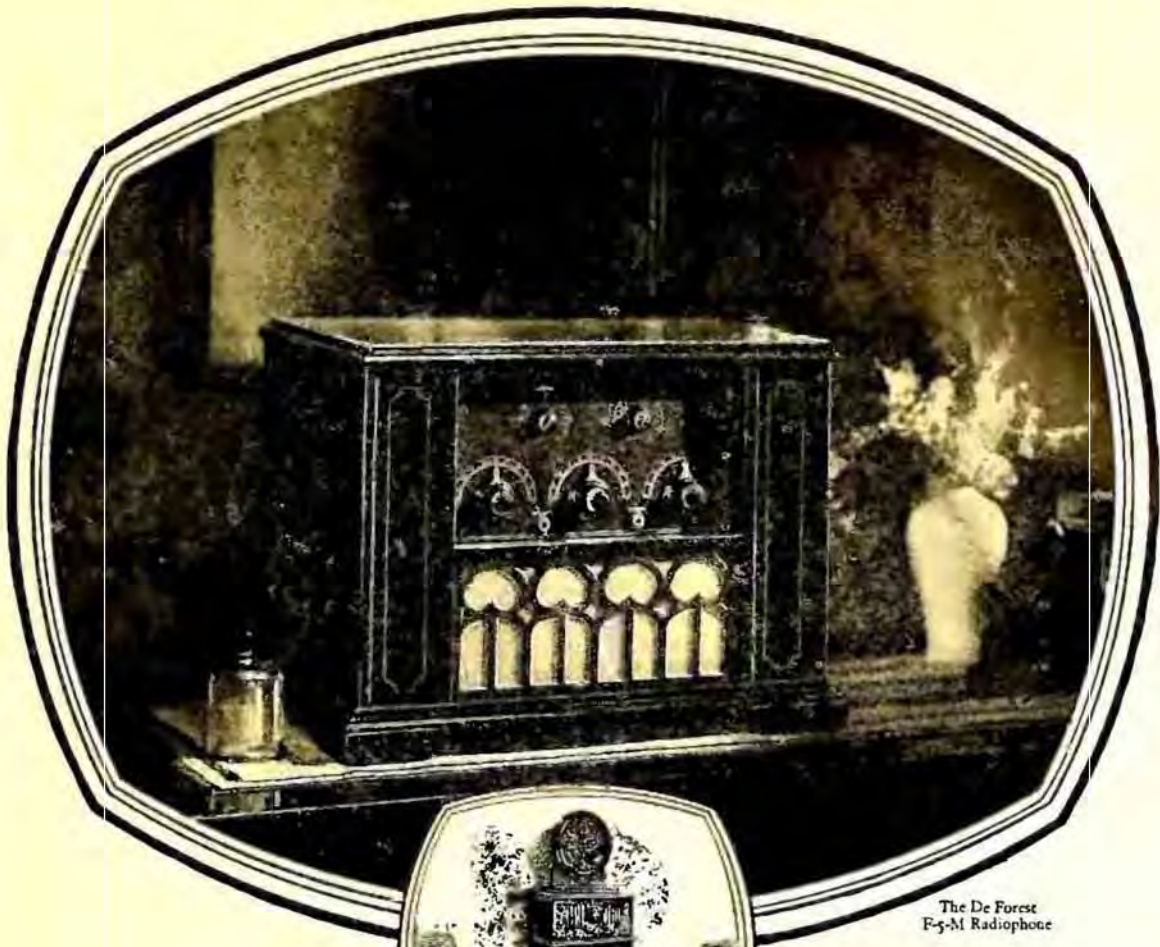

The De Forest  
F-5-M Radiophone



The De Forest W-5 which sets a  
new epoch in cabinet artistry and  
tone reception.

# DE FOREST

*The Greatest Name in Radio*

## A Peerless Value from the Master Scientist of Radio

**S**ELDOM are the finer things of life introduced at popular prices. The cost of originating the new usually prohibits low price.

But here is a notable exception—the De Forest F-5-M Radiophone, a masterpiece in performance, quality and dignified beauty, from the master mind of radio science.

Everything about this marvelous set is exceptional. The circuit is new—and ingenious. Known as the De Forest Balanced Circuit, it gives to radio tone the rich realism of life. Low and soft tones that usually die away in a misty blur are reproduced distinctly and musically. Very high tones that seem to climb into the infinite and flutter away like white butterflies against a blue summer sky are borne to your ear with a clearness and sweetness new to radio devotees. Individual parts in quartette and choral harmony are intensified—something new in reception.

This self-same circuit also contributes economy to

operation. It reduces the drain on batteries, thereby lengthening "B" battery life and the interval of recharging or replacing "A" batteries.

Refreshing, also, is the manner in which this new circuit tunes in stations . . . without scraping and whistling.

New power qualities, distance mastery, station separation and volume are added by other newly devised mechanisms. And art intervenes to add the final touch . . . grace and symmetry in cabinet design, the tone reproducer in-built and out of sight, "B" batteries housed in a compartment within the cabinet.

Yet the price is only \$110! (*Western prices slightly higher.*) See and hear the F-5-M at your nearest Authorized De Forest Dealer's.

*Price range of De Forest Radiophones—\$85 to \$450.*

**DE FOREST RADIO COMPANY**  
Jersey City, N. J.



For better reception and longer tube life always buy De Forest Audions. There's a special one for each socket. De Forest invented the radio tube—there can be none finer. \$3.00

\* Tested and Approved by RADIO AGE \*



## Meet the Play Boy of the Dakotas

(Continued from page 37)

He sees, from the moment the microphone is cut in up in the WGR operating room, the lonely places out on the prairies—the home where the radio is chief means of entertainment. He sees the old couple, left alone by their children who have gone out into the world, whose loneliness is lightened by the melodies which he is able to bring forth. He sees the group of youths and maidens dancing to the tunes of his artists obtained by medium of the loud-speaker set on the stage of the little village "opera house."

And for that reason Harold Gieser pays special attention to the radio audience. For that reason Harold Gieser plays as much—perhaps more—to the radio audience when the microphone is open as to the Statler audience.

Many fans complain that some directors repeat indiscriminately and interminably. Harold Gieser sees to it that a selection is rarely if ever repeated to the radio audience during any one week. That is why WGR fans always listen to the Vincent Lopez bunch at Buffalo when they are on the air—always the variety with the uniform quality. Harold Gieser takes great pride in the fact that he has built up what he calls his "radio repertoire" of more than seventy-five different selections.

### What Does He Do?

ANYONE want to know what a jazz orchestra director's day is like? Well, Harold Gieser is up at ten in the morning—breakfast—and then probably off to a rehearsal from eleven until about two in the afternoon. Meet friend wife for luncheon. Nothing to do then until about five-thirty except shop, or write letters, or work on an orchestration, or mess around with the orchestra's library, or take a little ride in the car, or meet someone who wants a try-out, and so on and so on.

About five-thirty—something to eat—a fresh shave—fly into the dear old Tuxedo and so to the hotel all set to begin the dinner music program at six-thirty. Off for a bit in the middle of the evening but on the job with a vengeance from eleven until two or thereabouts in the morning—thence home, but not to bed, but to listen in on some of the far distant stations to see what kind of jazz is produced in various parts of this country and Canada and to pick up new ideas for arrangements, and then to bed at three or four or five o'clock.

### New Crystals Tested

Specimens of the Alkemite crystals manufactured by the Mineral Novelty Co., Joplin, Mo., have been received at the Radio Age office and tested, having been found uniformly good. Instead of the usual Wood's metal mounting the Alkemite crystals are set into a three prong base, which grips the crystal tightly.

## Quam Transformers for Better Amplification



3 to 1 Ratio

Are made with the same painstaking attention to detail as Quam condensers. Only the best materials used in their construction. All steel casing, forming perfect magnetic shield. Each transformer subjected to audibility and breakdown test, protecting you against "Dubs." Unqualifiedly guaranteed. For perfect reproduction and lasting satisfaction, insist on Quam Audio Frequency Transformers. Each .....\$5.00

QUAM Condensers, with the Pyrex endplate. Lowest Loss, Highest Quality. Straight Line Frequency or Straight Line Wavelength, \$6 and up.



If your dealer cannot supply you remit to us direct and send us name of dealer.

## QUAM RADIO CORPORATION

1925 S. Western Ave.  
CHICAGO, U. S. A.

### CRESCENT Lavite Resistances

Insure distortionless amplifications and a clarity of tone not obtained through any other resistances. All capacities 12,000 ohms and up. List price \$1.50. Special sizes to order. Write for full information.

CRESCENT RADIO SUPPLY COMPANY  
\* Liberty Street JAMAICA, N. Y.

### Increase Distance, Volume, Clarity

"Colytt" adjustable grid leak improves receiving. Gives proper value of leak in grid circuit, and holds it. Simple, compact, easy to install, only one hole in panel. Tunes any tube perfectly. Try the "Colytt" on Money-back guarantee. \$1.00 complete, with full directions. 3301

\$1.00  
Complete



R. A. COLYTT LABORATORIES  
\* 565 Washington Blvd., Chicago



### Big Money in Radio

Demand for high pay radio men is so great that a big Kansas City wholesale concern is now fitting men free to get into the radio business for themselves and make \$60 to \$200 a week without any capital invested. Select territory open. Send today for free catalog and amazing offer. Write direct to Mr. H. J. Saizow, Standard Radio Co., 1424 Walnut St., Kansas City, Mo.



A regular \$25 loud speaker for \$16. Loud, clear, mellow tone. Bell 13 1/4 in. diameter, horn 22 in. high, equipped with Lakeside Adjustable Unit. Agents wanted, write for particulars.

Lakeside Supply Co.  
73 W. Van Buren St., Chicago



# POWER-PLUS Coils Chosen!

*Used in RADIO AGE Model Receiver*

The latest, most improved Coil on the market has been signally honored. Radio Age Institute is staking its reputation with thousands of radio enthusiasts all over the country by specifying and recommending the use of POWER-PLUS Coils in its Model Receiver. Radio Age Engineers have given every possible test to these superior fieldless coils. Their endorsement is conclusive proof to the fan. POWER-PLUS Coils have established themselves. They have proved their superiority!

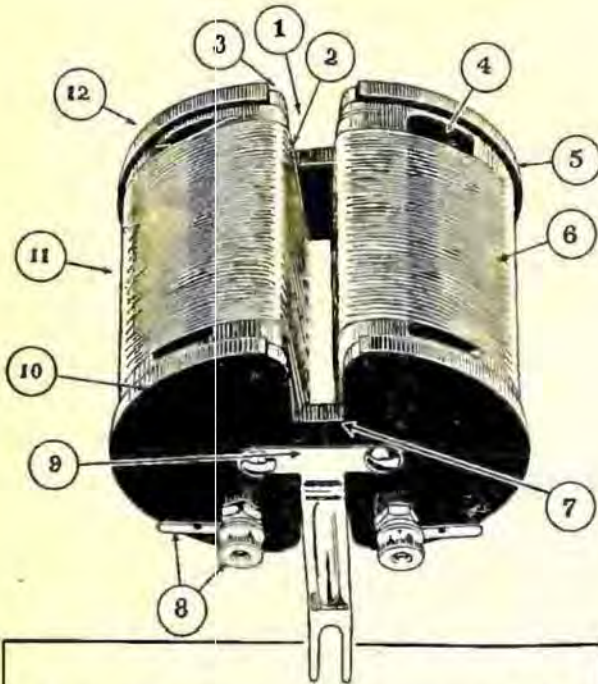

1. System of winding localizes magnetic field.
2. Flat-Sided units give high mutual inductance, lowering resistance.
3. New design prevents coil from picking up interference.
4. Ribbed frame of hard rubber lowers losses.
5. End ribs protect coil.
6. Windings with wide air spacing lower distributed capacity.
7. Low primary to secondary capacitive coupling, increases power.
8. Both binding posts and lugs provided.
9. Mounting bracket also supports frame. Less metal parts.
10. Design of primary gives extremely high amplification.
11. Coil extremely compact. 3" high with bracket.
12. No coupling between coils.

## One Dozen Improvements You Need

Study these one dozen electrical and mechanical improvements that have established POWER-PLUS Coils as the leaders in the field. They can be mounted in any position—at any angle—no neutralizers are necessary. Tuning with them is simple, speedy and sure. You get just the station you want sharp and clear—unrivalled selectivity. The POWER-PLUS Kit-Set—3 fieldless Coils and 3 Straight Line Frequency Condensers—all accurately matched—will give you the best in radio. The superiority of POWER-PLUS Coils and Condensers is sweeping the country. You, too, should know POWER-PLUS performance. Send the coupon below for the FREE booklet as illustrated and seven copyrighted Hook-Up Blueprints. Just fill in the Coupon—and mail it today.



7 Hook-Up Blueprints  
**FREE**



# POWER-PLUS

**A. F. HENNINGER CORP.**

4507 Ravenswood Ave.

Chicago, Ill.

A. F. HENNINGER CORP.,  
4507 Ravenswood Ave., Chicago, Ill.

12

Gentlemen:

Kindly send me your booklet and 7 Copyrighted hook-up blueprints. I understand they are absolutely FREE—and I am not obligated in any way.

Name.....

Address.....

Town..... State.....



# ORIOLE!

The Most Amazing Performer  
You've Ever "Tuned In"



Oriole—Model 7—5 Tubes

Oriole radio receivers step right out and make astounding records on distant stations—they give exceptional volume—unequaled for clarity and sweetness of tone—the most selective, sharpest tuning set you ever played with—you'll be "sold" on the ORIOLE the minute you turn its dials.

Model 7—5 Tubes. Model 8—4 Tubes.  
Write for illustrated folder.  
Dealers: There is some exclusive territory open—ask for details.

## W-K Electric Co.

KENOSHA, WISCONSIN

# While They Last!

We have a limited number of the 1925 RADIO AGE ANNUALS, the big \$1.00 book, and will send one free of charge to each of the lucky fans who use this coupon and send in their subscription for RADIO AGE. Everyone knows about the ANNUAL, it is radio's biggest dollar's worth. Here is a chance to get this free! Clip the coupon now, attach your check or a money order for the regular subscription price, \$2.50, and you will be "another booster for RADIO AGE"—and will have the ANNUAL, too.

Radio Age, Inc.,  
500 No. Dearborn St.,  
Chicago, Illinois.

Send me a copy of the 1925 RADIO AGE ANNUAL free, and enter my subscription for the RADIO AGE beginning with the \_\_\_\_\_ issue at the regular price of \$2.50. Enclosed is my check (or money order.)

Name.....

Address.....

City..... State.....

## A British View of Broadcasting

(Continued from page 38)

possible for Russia, for instance, to erect a very powerful station from which they might force upon the listeners of neighbouring countries and even of distant countries, the harm or good of their propaganda. This fact must be borne in mind to-gether with the question of interference. The whole point turns round the question: should a country be allotted a large number of weak stations distributed over its whole area, or should it have one powerful one in the centre? This latter policy is not always possible because the geographical centre is not always the political centre, we have countries like France, where the capital is four hours from one frontier and twelve hours from the other. This means that their powerful station, if designed with a view to supplying the whole of the inhabitants, will also cover with equal strength other countries too. Here there is great room for co-ordination, and no doubt from the numerous discussions which are bound to arise of so complex a subject, many solutions will be put forward, among which a good one which may be adhered to.

From an international point of view, there is also the question of hours of transmission. No doubt stations are mainly concerned with their near listeners, but they sometimes forget that these same listeners are very likely to become wireless enthusiasts and to pay their license so as to be able to listen to distant stations. In other words, the position is very much like that of foreign postage. A man in England pays the B. B. C. for his license, but listens to a German station to which he does not pay. As against this, a man living in Germany pays the German broadcasting stations and occasionally listens to the British concerts, and everybody is, as it were, quits. But this is not really the case; Great Britain is situated on the western edge of Europe, consequently its time—Greenwich Mean Time—is ahead of the other times in the centre and eastern parts of Europe which use Central European Time (one hour behind our own) and Eastern European Time (two hours behind our own). For a man living in Budapest, the Savoy bands go on, on Saturdays, until 2 o'clock in the morning, whereas his own stations which close down at 10 o'clock in his country, cannot be heard later than 8 o'clock in England. There is obviously an unfairness here, since at that time the British stations are working on full power and the British listener consequently has not so good an opportunity to tune in the Hungarian stations. How can this be remedied? One good way would be for all broadcasting stations to agree to give special transmissions say once a month, at special hours which would render it easier for the distant listeners to tune in. It does not appear to me much, to ask every station to give a special programme say of two hours

(Continued on page 67)



## Langmuir Finally Gets Patent

A basic patent for the highly evacuated tube, used extensively in radio, X-ray work and in repeaters used in long distance telephony, has recently been granted the General Electric Company by the U. S. Patent Office. This tube was invented by Dr. Irving Langmuir, assistant director of the General Electric research laboratory, in 1912, but because of contests the patent was not granted until recently.

The tube is characterized by its hard, constant vacuum, by its freedom from visible discharge and other gaseous effects and by its steadiness and reliability in operation. It can be made in large sizes operating with 50,000 volts and upward, as well as in the smaller sizes such as are used in the ordinary home radio receiving sets.

### Tubes Were Soft

Prior to Dr. Langmuir's invention radio and X-ray tubes were of what is now known as the soft variety, that is they glowed and acted erratically and unreliably except when used on exceedingly low voltages. Dr. Langmuir's invention, by removing this severe voltage restriction, has made possible practical radio as we know it today.

The patent application has had an eventful career. Following his invention of the tube in 1912, Dr. Langmuir spent months in thoroughly testing the invention. He filed his application in the patent office in Washington in 1913 and made the invention known to the world by papers read before scientific societies and by descriptions of the tube in scientific and popular publications. The tubes were used for radio work by the French army early in the war and were soon in regular use in radio and X-ray work in this country.

The patent application, however, did not enjoy such immediate success. The Patent Office Examiner passed the application for issue in 1916, but this action was revoked before the patent was issued in order to permit another person who had in the meantime applied for a patent on this invention to contest Dr. Langmuir's right to a patent in what is called an interference proceeding.

On the declaration of the interference Dr. Langmuir's opponent attempted to show that the invention was not patentable. On account of the unusual importance of the invention the Patent Office departed from its usual practice and permitted elaborate testimony to be taken on the question of patentability, including even testimony, taken in England, on behalf of Langmuir's opponent, a world famous British scientist.

### Held Up By War

After the United States went into the war the Secretary of the Navy requested the Commissioner of Patents to suspend proceedings because the full time of both parties was required upon war work of great importance to the Government. After the war testimony was resumed,

(Continued on page 69)



## Hear ALL the Music with the Bradley-Amplifier

THE delicate variations and shadings of instrumental music and the exquisite strains of the vocalist, are amplified with faithfulness and clarity by the Bradley-Amplifier. It matters not whether you own a factory-built set or a home-built receiver, either will be improved by using the Bradley-Amplifier.

Bradleyunit resistors, that are impervious to moisture and unaffected by atmospheric changes, take the place of the audio-frequency transformers of ordinary amplifiers. There is no distortion and no loss of low or high frequencies. All tones are reproduced with equal facility. As a result, the low notes of the piano are greatly improved and the high notes are not choked or distorted into a metallic sound. With a good loud speaker, the Bradley-Amplifier produces a marked improvement in tone quality.

Ask your dealer for the Bradley-Amplifier today, and substitute it for your present audio-frequency amplifying transformers. Resistance coupled amplifiers are acknowledged by radio experts to be the most perfect type of amplifier. You can make your set perfect with a Bradley-Amplifier.

### Retail Prices:

In U. S. A., \$15.00 • In Canada, \$21.00

**Allen-Bradley Co.**

Electric Controlling Apparatus

Milwaukee



Wisconsin



Mfrs. of  
Electrical Devices  
for Over  
Twenty Years



Can be installed within radio cabinet. UX tubes as well as old tubes can be used.



All resistors, condensers and wiring, are concealed within the compact Bakelite base.



Bradleyunit resistor is made of solid molded material which does not change with age. All units soldered.

Allen-Bradley Co., Milwaukee, Wis.  
229 Greenfield Ave., Milwaukee, Wis.  
Please send me your latest literature on the Bradley-Amplifier, explaining how it will improve my receiver.

Name .....

Address .....

Mail the Coupon



# Corrected List of Broadcasting Stations

KDKA	Westinghouse Electric & Mfg. Co.	East Pittsburgh, Pa.	309	KFWH	F. Wellington Morse, Jr.	Chico, Calif.	254
KDLR	Radio Electric Co.	Devils Lake, N. D.	231	KFWI	Radio Entertainments, Inc.	South San Francisco, Calif.	220
KDPM	Westinghouse Electric & Mfg. Co.	Cleveland, Ohio	270	KFWO	Oakland Educational Society	Oakland, Calif.	224
KDYL	Newhouse Hotel	Salt Lake City, Utah	250	KFWM	Lawrence Mott	Avallon, Calif.	211
KDZB	Frank E. Siefert	Bakersfield, Calif.	240	KFWP	Rio Grande Radio Supply House	Brownsville, Texas	214
KDZI	Electric Supply Co.	Wenatchee, Wash.	360	KFWU	Louisiana College	Pineville, La.	236
KFAB	Nebraska Buick Auto Co., 13th & Que Sts.	Lincoln, Nebr.	341	KFXB	Bertram O. Heller	Big Bear Lake, Calif.	203
KFAD	McArthur Bros. Mercantile Co.	Phoenix, Ariz.	343	KFXC	Santa Maria Valley Railroad Co.	Santa Maria, Calif.	210
KFAE	State College of Washington	Palman, Wash.	348	KFXD	H. Stroop	Loan, Utah	205
KFAJ	University of Colorado	Boulder, Colo.	360	KFXE	Electrical Research & Mfg. Co.	Waterloo, Iowa	236
KFAU	Boise High School	Boise, Idaho	271	KFXF	Pia's Peak Broadcasting Co.	Colorado Springs, Colo.	250
KFAW	The Radio Den (W. B. Ashford)	Santa Ana, Calif.	280	KFXH	Biedace Radio Company	El Paso, Texas	242
KFBB	F. A. Buttrey & Co.	Havre, Mont.	360	KFXJ	Mountain States Radio Distributors, Inc. (Portable station)	Denver, Colorado	216
KFCB	W. K. Asbill	San Diego, Calif.	278	KFXM	Neches Electric Co.	Beaumont, Texas	227
KFCG	First Presbyterian Church	Tacoma, Wash.	250	KFXN	Mary M. Costigan	Fleetstaff, Ariz.	205
KFCB	Kimball-Uspon Co.	Sacramento, Calif.	283	KFYF	Carl's Radio Den	Oxnard, Calif.	205
KFBK	Leese Bros.	Everett, Wash.	274	KFYJ	Houston Chronicle Publishing Co.	Houston, Texas	238
KFB	School District No. One	Trinidad, Colo.	238	KGB	Temple Day Leader	Tacoma, Wash.	252
KFCU	Bishop N. S. Thomas	Laramie, Wyo.	270	KGO	General Electric Co.	Oakland, Calif.	361
KFCB	Nielson Radio Supply Co.	Phoenix, Ariz.	238	KGU	Marion A. Mulrony	Honolulu, Hawaii	370
KFCF	Frank A. Moore	Walla Walla, Wash.	256	KGW	Portland Morning Oregonian	Portland, Oreg.	491
KFCZ	Omaha Central High School	Omaha, Nebr.	258	KGY	St. Martin College (Reb. Sebastian Ruth)	Lacy, Wash.	253
KFDD	St. Michaels Cathedral	Boise, Idaho	252	KHJ	Times-Mirror Co.	Los Angeles, Calif.	405
KFDD	University of Arizona	Tucson, Ariz.	368	KHQ	Louis Washner	Seattle, Wash.	273
KFDJ	Oregon Agricultural College	Corvallis, Ore.	250	KJR	Northwest Radio Service Co.	Seattle, Wash.	384
KFDM	Magnolia Petroleum Co.	Beaumont, Texas	315	KJB	Bible Institute of Los Angeles, Inc.	Los Angeles, Calif.	383
KFDX	First Baptist Church	Shreveport, La.	260	KJDS	Reorganize Church of Jesus Christ of Latter Day Saints, Independence, Mo.	Independence, Mo.	441
KFDY	South Dakota State College	Brookings, S. Dak.	360	KLS	Warner Brothers Radio Supplies Co.	Oakland, Calif.	242
KFDZ	Harry O. Iverson	Minneapolis, Minn.	231	KLX	Tribune Publishing Co.	Oakland, Calif.	508
KFEK	Meier & Frank Co.	Portland, Oreg.	248	KLZ	Reynolds Radio Co.	Denver, Colo.	283
KFEK	Augustine Seminary	Minneapolis, Minn.	261	KMJ	San Joaquin Light & Power Corp.	Fresno, Calif.	243
KFEL	Winner Radio Corp.	Denver, Colo.	254	KMO	Love Electric Co.	Tacoma, Wash.	250
KFEQ	J. L. Scroggin	Oak, Nebr.	268	KNX	Los Angeles Evening Express	Los Angeles, Calif.	337
KFEY	Bunker Hill & Sullivan Mining and Concentrating Co.	Kellogg, Idaho	233	KOA	General Electric Co.	Denver, Colo.	323
KFFP	First Baptist Church	Moberly, Mo.	260	KOB	New Mexico College of Agriculture & Mechanic Arts, State College, N. Mex.	State College, N. Mex.	378
KFGD	Heidbreder Radio Supply Co.	Lamoni, Iowa	280	KOIL	Monarch Manufacturing Co.	Council Bluffs, Iowa	277
KFGC	Louisiana State University	Utica, Neb.	224	KOP	Detroit Police Department	Detroit, Mich.	286
KFGD	Chickasha Radio & Electric Co.	Baton Rouge, La.	254	KPO	Hale Bros.	San Francisco, Calif.	425
KFGH	Leland Stanford University	Chickasha, Okla.	248	KPPC	Pasadena Presbyterian Church	Pasadena, Calif.	229
KFGS	Crary Hardware Co.	Stanford University, Calif.	273	KPRC	Houston Post-Dispatch	Houston, Texas	270
KFHA	Western State College of Colorado	Boone, Iowa	226	KQP	H. B. Read	Portland, Ore.	212
KFHH	Ambrose A. McCue	Cunison, Colo.	252	KQV	Doubleday-Hill Electric Co.	Pittsburgh, Pa.	270
KFHL	Fenn College	Neah Bay, Wash.	261	KQW	Charles D. Herrold	San Jose, Calif.	228
KFHM	E. C. Anthony	Oskaloosa, Iowa	240	KSAK	Kansas State Agricultural College	Berkeley, Calif.	275
KFIF	Benson Polytechnic Institute	Los Angeles, Calif.	458	KSD	Post Dispatch (Pulitzer Pub. Co.)	Manhattan, Kans.	347
KFIO	North Central High School	Portland, Oreg.	248	KSL	Radio Service Corp. of Utah	Salt Lake City, Utah	299
KFIQ	First Methodist Church	Spokane, Wash.	252	KSO	A. A. Berry Seed Co.	Clarinda, Iowa	242
KFIU	Alaska Electric Light & Power Co.	Juneau, Alaska	242	KTAB	Teuth Ave. Baptist Church	Oakland, Calif.	216
KFIZ	Daily Commonwealth	Fond du Lac, Wis.	273	KTBR	Brown's Radio Shop	Portland, Oreg.	263
KFJB	Marshall Electrical Co.	Marshalltown, Iowa	248	KTCL	American Radio Telephone Co., Inc.	Seattle, Wash.	306
KFJC	R. B. Fegan (Episcopal Church)	Junction City, Kansas	219	KTHS	New Arlington Hotel Co.	Hot Springs, Ark.	375
KFJF	National Radio Manufacturing Co.	Oklahoma City, Okla.	252	KTW	First Presbyterian Church	Seattle, Wash.	455
KFJG	Liberty Bazaar (E. E. Marsh)	Astoria, Iowa	252	KUO	Examiner Printing Co.	San Francisco, Calif.	246
KFJL	Hardage Manufacturing Co.	Ottumwa, Iowa	242	KUOM	State University of Montana	Missoula, Montana	244
KFJM	University of North Dakota	Grand Forks, N. Dak.	280	KUT	University of Texas	Austin, Texas	231
KFJR	Ashley C. Dixon & Son	Portland, Oreg.	258	KWG	Portable Wireless Telephone Co.	Stockton, Calif.	248
KFJX	Iowa State Teacher's College	Cedar Falls, Iowa	280	KWK	Wilson Duncan Studios	Kansas City, Mo.	236
KFJY	Tunwall Radio Co.	Fort Dodge, Iowa	246	KWVG	City of Brownsville	Brownsville, Texas	276
KFJZ	Southwest Bap. Theo. Seminary	Fort Worth, Texas	254	KYO	Electric Shop	Honolulu, Hawaii	277
KFKA	Colorado State Teachers College	Greeley, Colo.	273	KYW	Westinghouse Electric & Mfg. Co.	Chicago, Ill.	242
KFKQ	Conroy Radio Laboratories (Ben H. Woodruff)	Conway, Ark.	250	KZM	Prason D. Allen	Oakland, Calif.	242
KFKR	The University of Kansas	Lawrence, Kans.	275	WAAB	Valdemar Jensen	New Orleans, La.	263
KFKX	Westinghouse Electric & Manufacturing Co.	Healing, Nebr.	288	WAAC	Tulane University	New Orleans, La.	275
KFLD	Paul E. Creelaw	Franklinton, La.	234	WAAD	Ohio Mechanics Institute	Cincinnati, Ohio	248
KFLR	University of New Mexico	Albuquerque, New Mexico	254	WAAF	Chicago Daily Drivers Journal	Chicago, Ill.	286
KFLU	Rio Grande Radio Supply House	San Benito, Texas	236	WAAM	I. R. Nelson Co.	Newark, N. J.	263
KFLV	Rev. A. T. Frykman	Rockford, Ill.	229	WAAW	Omaha Grain Exchange	Omaha, Nebr.	285
KFLX	George Roy Clough	Calveston, Texas	240	WABC	Asheville Battery Co., Inc.	Asheville, N. C.	254
KFLZ	Atlantic Automobile Co.	Atlantic, Ia.	273	WAB	1st Universalist Church	Banor, Me.	240
KFMB	Christian Churches	Little Rock, Ark.	254	WAB	Connecticut Agricultural College	Berra, Conn.	283
KFMG	University of Kansas	Fayetteville, Ark.	299	WABQ	Lake Avenue Baptist Church	Rockester, N. Y.	283
KFMR	Morningside College	Sioux City, Iowa	261	WABR	Haverford College, Radio Club	Haverford, Pa.	261
KFMW	M. C. Sateran	Houghton, Mich.	266	WABW	Scott High School, N. W. B. Foley	Toledo, Ohio	270
KFMX	Carleton College	Northfield, Minn.	336	WABX	College of Wooster	Wooster, Ohio	234
KFNF	Henry Field Seed Co.	Shenandoah, Iowa	266	WABY	Henry B. Joy	Mt. Clemens, Mich.	270
KFNG	Wooten's Radio Shop	Coldwater, Miss.	254	WABZ	John Masaldi, Jr.	Philadelphia, Pa.	242
KFNV	L. A. Drake Battery and Radio Supply Shop	Santa Rosa, Calif.	234	WADC	Coliseum Place Baptist Church	New Orleans, La.	263
KFOA	Rhodes Department Store	Seattle, Wash.	454	WAD	Allen T. Simmons (Allen Theatre)	Akron, Ohio	275
KFOB	Moberly High School	Moberly, Mo.	242	WAE	Albert B. Parlet Co.	Port Huron, Mich.	263
KFON	Echophone Radio Shop	Long Beach, Calif.	284	WAEG	H. C. Creche Co.	Richmond Hill, N. Y.	315
KFOO	Latter Day Saints' University	Salt Lake City, Utah	261	WAMD	Hubbard & Co.	Minnetonka, Minn.	244
KFOP	Robber Elec. Co.	Marshfield, Ore.	240	WAPI	Alabama Polytechnic Institute	Auburn, Ala.	248
KFOR	David City Tire & Electric Co.	David City, Nebraska	226	WBAA	Purdue University	W. Lafayette, Ind.	283
KFOT	College Hill Radio Club	Wichita, Kansas	231	WBAC	Clemson Agric. College	Clemson College, S. C.	331
KFOX	Board of Education, Technical High School	Omaha, Nebraska	248	WBAD	The Dayton Co.	Minneapolis, Minn.	417
KFOY	Beacon Radio Service	St. Paul, Minn.	226	WBAK	Peonysylvania State Police	Harriburg, Pa.	276
KFC	Carretton and Dennis	Los Angeles, Calif.	238	WBAQ	James Millikan University	Decatur, Ill.	369
KFCP	C. C. Baxter	Dublin, Texas	242	WBAP	Wybram-Carter Publishing (Star Telegram)	Fort Worth, Texas	475
KFCM	The New Furniture Co.	Crescentville, Texas	242	WBAY	Ernst & Hopkins Co.	Columbus, Ohio	292
KFCR	Los Angeles County Forestry Dept.	Los Angeles, Calif.	231	WBAX	John H. Steeger, Jr.	Wilkes-Barre, Pa.	254
KFCU	Cape & Johnson	Salt Lake City, Utah	286	WBAY	Western Electric Co.	New York, N. Y.	492
KFCV	St. Johns M. E. Church	Corterville, Mo.	268	WBBC	Irvine Vermilya	Mattapoisett, Mass.	248
KFCW	Symons Investment Co.	Spokane, Wash.	283	WBBL	Crace Covenant Presbyterian Church	Richmond, Va.	253
KFOA	The Principia	St. Louis, Mo.	264	WBBM	Atlas Investment Co.	Chicago, Ill.	228
KFOB	The Searchlight Publishing Co.	Fort Worth, Texas	221	WBBN	Blake, A. B.	Wilkinson, N. C.	275
KFOC	Kidd Brothers Radio Shop	Tait, Calif.	259	WBBS	Petowky High School	Petowky, Mich.	246
KFOD	Kidd Radio Service Co.	Burlingame, Calif.	231	WBBS	People's Pulpit Assoc.	Rossville, N. Y.	273
KFOP	C. S. Carson, Jr.	Iowa City, Ia.	254	WBBS	First Baptist Church	New Orleans, La.	252
KFOU	Texas National Guard	Holy City, Calif.	253	WBBS	Jenks Motor Sales Co.	Monmouth, Ill.	224
KFOV	W. Riker	North Bend, Wash.	248	WBBS	Ruffner Junior High School	Norfolk, Va.	222
KFOZ	C. F. Knierim	Hollywood, Calif.	240	WBBS	Washington Light Infantry Co. "B" 118th Inf.	Charleston, S. C.	266
KFRM	Taft Products Co.	San Francisco, Calif.	248	WBBS	C. L. Carrel (portable)	Chicago, Ill.	210
KFRN	City of Paris Dry Goods Co.	Ft. Hill, Okla.	242	WBBS	Poster & McDonnell	Chicago, Ill.	506
KFRU	James P. Boland, 1st Lt., U. S. Army	Columbia, Mo.	500	WBBS	Baxter Laundry Co.	Grand Rapids, Mich.	256
KFRV	Stephens College	Olympia, Wash.	220	WBBS	Bliss Electrical School	Takoma Park, Md.	232
KFRW	United Churches of Olympia	Wilmington, Del.	217	WBBS	Williams Mfg. Co.	Baltimore, Md.	254
KFRX	J. Cordou Klemsard	Fullman, Wash.	270	WBBS	H. Grebe & Co., Inc.	Richmond Hill, N. Y.	236
KFRZ	The Electric Shop	Hartington, Neb.	222	WBBS	W. H. Grebe & Co., Inc.	Butler, Pa.	286
KFSG	Anselus Temple	Los Angeles, Calif.	272	WBBS	Bell Radio Corporation	Birmingham, Ala.	248
KFUI	Hopper Plumbing and Heating Co.	Breckenridge, Minn.	242	WBBS	Baltimore Radio Exchange	Wilkes-Barre, Pa.	231
KFUL	Thomas Coggan & Bros. Music Co.	Calveston, Texas	258	WBBS	D. W. May, Inc.	Newark, N. J.	252
KFUM	W. D. Pyie	Colorado Springs, Colo.	242	WBBS	Charlotte Chamber of Commerce	Charlotte, N. C.	250
KFUP	Concordia Seminary	St. Louis, Mo.	549	WBBS	Westinghouse Electric & Mfg. Co.	Springfield, Mass.	333
KFUR	Fitzsimmons Casper Hospital	Denver, Colo.	234	WBBS	Westinghouse Electric & Mfg. Co.	Hotel Brunswick, Boston, Mass.	242
KFUS	Julius Brunton and Sons Co.	San Francisco, Calif.	234	WBBS	St. Lawrence University	Canton, N. Y.	280
KFUV	H. W. Peery and C. Redfield	Oakden, Utah	224	WBBS	Kaufmann & Baer Co. and The Pittsburgh Press	Pittsburgh, Pa.	461
KFUW	Louis L. Sherman	Oakland, Calif.	233	WBBS	Entrekia Electric Co.	Columbus, Ohio	286
KFUU	Colburn Radio Labs	Sacramento, Calif.	231	WBBS	Nebraska Wesleyan University	University Place, Nebr.	283
KFV	McWhinnie Electric Co.	San Pedro, Calif.	202	WBBS	St. Olaf College	Northfield, Minn.	336
KFV	Film Corporation of America	St. Louis, Mo.	245	WBBS	Sanders & Stayman Co.	Baltimore, Md.	275
KFV	Clarence B. Junenu	Hollywood, Calif.	208	WBBS	Chesapeake & Potomac Telephone Co.	Washington, D. C.	666
KFV	First M. E. Church	Independence, Kansas	236	WBBS	Alamo Radio Electric Co.	San Antonio, Texas	246
KFVH	Whan Radio Shop (Herbert Whan)	Minneapolis, Minn.	218	WBBS	W. H. Dunwoody Industrial Institute	Minneapolis, Minn.	280
KFVI	Headquarters Troop, 56th Cavalry	Houston, Texas	248	WBBS	State College of Mines	Rapid City, S. Dak.	240
KFVN	Carl E. Basler	WELCOME, Minn.	248	WBBS	Durham & Co.	Philadelphia, Pa.	276
KFVO	F. M. Henry	Kirkville, Mo.	226	WBBS	University of Vermont	Burlington, Vt.	250
KFVR	Moonlight Ranch	Route 6, Denver, Colo.	246	WBBS	Carthage College	Carthage, Ill.	246
KFVS	Cape Girardeau Battery Station	Cape Girardeau, Mo.	224	WBBS	Charles W. Heinebach	Allentown, Pa.	280
KFV	Radio Supply Co.	Albuquerque, N. M.	250	WBBS	Wilbur C. Voliva	Zion, Ill.	244
KFV	Glad Tidings Tabernacle	San Francisco, Calif.	234	WBBS	Thalt Radio Co.	New Orleans, La.	263
KFVZ	Brownie Bros. Co.	Oakden, Utah	214	WBBS	Paul J. Miller	Pittsburgh, Pa.	336
KFWA	Warner Bros.	Hollywood, Calif.	252	WBBS	Howard S. Williams (Portable)	Pascaoula, Miss.	242
KFWB	L. E. Wall	Upland, Calif.	211	WBBS	University of Mississippi	Oxford, Miss.	268
KFWC	Wilbur Jerman	385 58th St. S., Portland, Ore.	212	WBBS	Charles Swars	Baltimore, Md.	229
KFWV	St. Louis Truth Center	St. Louis, Mo.	214	WBBS			



## Here's British View of Broadcasting

(Continued from page 64)

at a very late hour once a month. In exchange, its nearby listeners would be having the opportunity of tuning in other distant stations during the remainder of the month during their special hours.

The B. B. C. have often said that they wish to study the crystal user, and they are naturally justified in looking at broadcasting from this angle. A crystal user pays 10 shillings for his license just as does the multivalve user. But what the B. B. C. seem to forget is that the multivalve user does much more for the wireless trade in general than his crystal user brother, and most of the B. B. C. shareholders are directly or indirectly interested in the development of wireless trade. We are all interested in the relief of unemployment in this country to which this trade contributes its share. There is then, no reason why the multivalve users should not be especially studied, and the introduction of these silent nights and special transmissions would be a great boon to them. I do not want to accuse the B. B. C. of doing nothing to help them, I am pleased to say that I recently heard that once a week at the closing down of every station, the announcer will specially give out the name of the B. B. C. station which continues transmitting for a half hour on that day. Things are being done and we know that the B. B. C. is alive to all these problems, but a lot more should be done and can be done, and we, the leading nation in Europe in these matters, should take the initiative. We have powerful wireless bodies in this country, and the Conference can be called. Let it then be called without delay.

## Class B Interference Not Bad, Says Canadian Fan

THE OTHER day, Secretary of Commerce Hoover had a shock—not from his radio set, but due to a commendatory letter from a radio fan. Instead of being a complaint about interference, the letter stated that there was little difficulty in separating the Class B stations, except two stations on one wave length and three on another.

The writer, John Young, of Little Current, Ontario, believes the present arrangement of stations is very satisfactory and that much of the reported interference comes from owners of poor or badly operated receivers.

His letter to Secretary Hoover, for publication, follows in part:

"There has been a lot of discussion in the radio columns of the press lately about interference of Class B stations on account of your recent separation of these broadcasters by ten kilocycles. For your information and in view of the approaching conference, I should like to give you my experience as an operator of all types of receiving sets for several years.

"In my opinion the present arrangement of stations is very satisfactory, and much of this interference talk arises from owners of poor receivers, badly tuned and

from a misconception of what causes heterodyning and cross-talk."

While experimenting one night recently, Mr. Young decided to log a number of the higher powered U. S. stations, noting any interference. This he did, listing 36 stations with good, loud speaker volume in five hours. His only complaint is that something ought to be done to get WGR, Buffalo, and WSMB, New Orleans, to split time on the 319 meter wave, and to persuade

stations WNYC, New York; WHO, Des Moines; and WOAW, Omaha, to divide time three ways on their wave length of 526 meters.

"Outside of that," he reports, "Class B stations are O.K."

"As for Class A stations," he continues, "nothing can be done. There are so many on the same wave length that serious heterodyning is bound to occur," he concludes, thanking the Secretary for his interest in radio.

# ERLA's New Audio Gives Marvelous Tone Curve

Exact laboratory tests show that no other audio gives such perfect reproduction. Note how uniformly and evenly all notes are amplified at frequencies from 32 to 10,000 cycles.

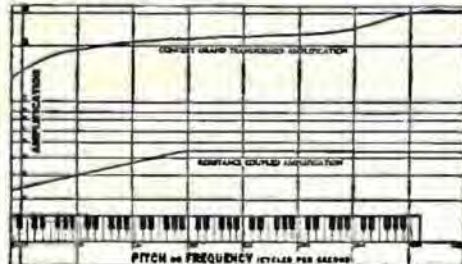

Note the smooth, even progression of the Concert Grand curve, revealing supreme uniformity of amplification, from lowest notes to highest in the musical scale.

AN amazing improvement has been made in audio amplification. A new transformer—the Erla Concert Grand—gives results far superior to any other system of amplification.

### Amazing Improvement

Ordinary designs permit too much leakage to amplify properly at low frequencies. So we use the "quadriform type," heretofore unknown in radio work. In this design magnetic leakage is practically eliminated by providing twice as many paths for the magnetic field and by a better distribution of the core metal around the copper wire coils. Each of the four core units are complete magnetic circuits within themselves without breaks or joints to the main central core, and it will also be noticed that the central core section has a far greater area than conventional core types. The large area thus obtained reduces the effect of the direct "B" battery current on the pulsating voice currents and eliminates a cause of distortion common to transformers using smaller core sections.

The Concert Grand saves you money, too. Resistance coupling depends solely



One-piece drawn steel shell provides perfect magnetic shielding. Finished in black crystalline lacquer and attractive in appearance.

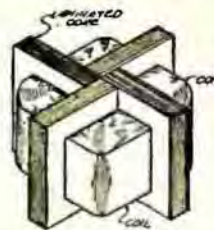

Note the quadruple core surrounding the coil, forming an almost perfect path for the flux within the coil. The core is a special grade of laminated silicon steel that provides highest permeability and lowest hysteresis loss, with consequent maximum conductivity in the magnetic circuit of the transformer. Price \$10. West of Rocky Mountains, \$10.50.

upon the tubes for amplification. Consequently they must be operated at maximum for efficiency, requiring more "A" battery current and higher plate voltage—135 to 150 volts. Filaments wear out more rapidly as a result and battery life is more than cut in half. The higher initial cost of Concert Grand amplification is therefore saved many times over, not only in improved performance but also in lowered upkeep cost.

### Booklet Sent FREE

Get the Audio Grand at your dealer's today. See what a tremendous difference it will make in your set. If you wish to return the coupon, we will send you a new booklet giving the latest information on audio frequency amplification

Electrical Research Laboratories  
Chicago, U. S. A.

Electrical Research Laboratories,  
2500 Cottage Grove Ave., Dept. 6-C, Chicago  
Send me information about the Erla Concert Grand  
Audio. Also latest developments on audio frequency  
amplification.

Name .....

Address .....

City..... County..... State.....



\* Tested and Approved by RADIO AGE \*



WCBN	James P. Boland	Ft. Beni, Harrison, Ind.	266	WIBI	Frederick B. Zittel, Jr.	Flushing, N. Y.	219
WCBQ	First Baptist Church	Nashville, Tenn.	236	WIBJ	C. L. Carrell (Portable)	Chicago, Ill.	216
WCBR	C. H. Meester	Providence, R. I.	246	WIBO	Nelson Brothers	Chicago, Ill.	226
WCBT	Clark University, Collegiate Dept.	Worcester, Mass.	238	WIBQ	F. M. Schmidt	Farina, Ill.	205
WCBX	Radio Shop of Newark (Herman Lubinsky)	Newark, N. J.	233	WIBR	Thurman A. Owens	Werton, W. Va.	246
WCCO	Washburn-Crosby Co.	Two Cities, Minn.	218	WIBS	New Jersey Nat'l Guard Hdq. Co.	Elizabeth, N. J.	203
WCLO	C. E. Wap	Camden, La.	231	WIBU	The Electric Farm	Poyntest, Va.	222
WCLS	H. M. Couch	Joliet, Ill.	214	WIBW	Dr. L. L. Dill	Loanpook, Ind.	220
WCSH	Henry P. Rines	Portland, Maine	256	WIBX	Grid-Leak Inc.	Utica, N. Y.	205
WCX	Free Press and Jewett Radio & Phonograph Co.	Detroit, Mich.	517	WIBZ	Powell Electric Company	Montgomery, Ala.	231
WDAE	Dad's Auto Accessories, Inc.	Nashville, Tenn.	226	WIL	Continental Electric Supply Co.	Washington, D. C.	360
WDAF	Tampa Daily Times	Tampa, Fla.	365	WIP	Gimbel Bros.	Philadelphia, Pa.	509
WDAJ	Kansas City Star	Kansas City, Mo.	365	WJAB	American Electric Co.	Lincoln, Nebr.	259
WDAK	J. Lawrence Martin	Amarillo, Texas	261	WJAD	Jackson's Radio Engineering Laboratories	Waco, Texas	352
WDAR	Lit Brothers	Philadelphia, Pa.	193	WJAG	Norfolk Daily News	Norfolk, Nebr.	283
WDAY	Radio Equipment Corp.	Fargo, N. Dak.	244	WJAK	Clifford L. White	Georgetown, Iowa	254
WDBA	Frederic Ray	Columbus, Ga.	236	WJAM	D. M. Perham	Cedar Rapids, Iowa	258
WDBB	A. H. Waite & Co., Inc.	Taunton, Mass.	229	WJAR	The Outlet Co. (J. Samuels & Bro.)	Providence, R. I.	106
WDBC	Kirk Johnson & Co.	Lancaster, Pa.	258	WJAS	Pittsburgh Radio Supply House	Pittsburgh, Pa.	284
WDBD	Herman Edwin Burns	Marionburg, W. Va.	269	WJAZ	Zenith Radio Co.	Mt. Prospect, Ill.	322
WDBE	Gilham-Schoen Elec. Co.	Atlanta, Ga.	278	WJBA	D. H. Lents, Jr.	Joliet, Ill.	207
WDBJ	Richardson Wayland Electric Corp.	Rosolake, Va.	225	WJBB	L. W. McClure	St. Petersburg, Fla.	207
WDBK	M. F. Bros.	Cleveland, Ohio	227	WJBC	Hummel Furniture Co.	LaSalle, Ill.	234
WDBL	Wisconsin Dept. of Markets	Stevens Point, Wis.	278	WJBG	Interstate Radio, Inc.	Charlotte, N. C.	224
WDBN	Electric & Power Co.	Bangor, Me.	252	WJBI	Robert B. Johnson	Red Bank, N. Jersey	219
WDBO	Rollins College, Inc.	Winter Park, Fla.	240	WJBK	E. F. Goodwin	Ypsilanti, Mich.	333
WDBQ	Morton Radio Supply Co.	Salem, N. J.	234	WJBL	Wm. Guahard Dry Goods Co.	Decatur, Ill.	270
WDBR	Tremont Temple Baptist Church	Boston, Mass.	256	WJBN	St. Johns Ev. Luth. Church	Sycamore, Ill.	256
WDBV	The Strand Theatre	Fort Wayne, Ind.	258	WJJD	Denison University	Granville, Ohio	229
WDBY	North Shore Congregational Church	Chicago, Ill.	258	WJJE	Supreme Lodge, Loyal Order of Moose	Mooseheart, Ill.	303
WDBZ	Boy Scouts, City Hall	Kingstown, N. J.	233	WJRF	Jewett Radio & Phonograph Co. and Detroit Free Press	Pontiac, Mich.	517
WDCH	Dartmouth College	Hanover, N. H.	256	WJRY	Radio Corp. of America	New York, N. Y.	405
WDOD	Chattanooga Radio Co., Inc.	Chattanooga, Tenn.	258	WKAA	H. F. Paar	New York, N. Y.	455
WDOW	Duquesne Radio, Inc.	Cranston, R. I.	441	WKAD	Chas. Looff (Crescent Park)	Cedar Rapids, Iowa	400
WDZ	J. L. Bush	Tuacola, Ill.	278	WKAF	WKAF Broadcasting Co.	East Providence, R. I.	400
WEAA	F. D. Fallain	Flint, Mich.	250	WKAQ	Radio Corp. of Porto Rico	Milwaukee, Wis.	261
WEAF	American Telephone & Telegraph Co.	New York, N. Y.	485	WKAR	Michigan Agriculture College	San Juan, P. R.	340
WEAH	Hotel Lauen	Wichita, Kans.	280	WKAV	Laconia Radio Club	East Lansing, Mich.	285
WEAL	Cornell University	Ithaca, N. Y.	286	WKBB	Sanders Bros.	Laconia, N. H.	254
WEAM	University of South Dakota	Vermillion, S. Dak.	283	WKBC	K. A. B. Electric Co.	Joliet, Ill.	214
WEAN	Borough of North Plainfield (W. Gibson Buttfield)	North Plainfield, N. J.	273	WKBF	Dutree Wilcox Flint	Webster, Massachusetts	231
WEAO	Ohio State University	Providence, R. I.	281	WKBG	C. L. Carrel, Portable	Cranston, Rhode Island	286
WEAR	Goodyear Tire and Rubber Co.	Cleveland, Ohio	389	WKBK	Miss Shirley Kats	Chicago, Ill.	278
WEAU	Davidson Bros. Co.	Sioux City, Iowa	275	WKY	Wky Radio Shop	New York, N. Y.	210
WEB	Benwood Co.	St. Louis, Mo.	273	WLAC	Cutting & Washington Radio Corp.	Oklahoma City, Okla.	475
WEBA	Electric Shop	Highland Park, N. J.	233	WLAL	First Christian Church	Minneapolis, Minn.	217
WEBC	Walter Cecil Bridges	Superior, Wis.	242	WLAP	Wm. V. Jordan	Tulsa, Okla.	250
WEBD	Electrical Equipment and Service Co.	Anderson, Ind.	246	WLAQ	Arthur E. Shilling	Louisville, Ky.	286
WEBE	Roy W. Walker	Cambridge, Ohio	248	WLB	Pulsam Electric Co.	Kalamazoo, Mich.	231
WEBF	Edgewater Beach Hotel, Chicago Evening Post Station	Chicago, Ill.	370	WLB	University of Minnesota	Greencastle, Ind.	237
WEBJ	Third Avenue Railway Co.	New York, N. Y.	273	WLB	Wisconsin State Dept. of Markets	Minneapolis, Minn.	278
WEBK	Grand Rapids Radio Co.	Grand Rapids, Mich.	242	WLB	Liberty Magazine	Stevens Point, Wis.	303
WEBM	Radio Corporation of America	Portable	280	WLS	Bears, Roebuck & Co.	Chicago, Ill.	344
WEBP	E. B. Pedicord	New Orleans, La.	280	WLTS	Lane Technical High School	Chicago, Ill.	258
WEBT	The Dayton Coop. Industrial High School	Dayton, Ohio	270	WLW	Crosley Mfg. Co.	Cincinnati, Ohio	422
WEBW	Beloit College	Beloit, Wis.	283	WLWL	Missionary Society of St. Paul the Apostle	New York, N. Y.	288
WEEL	The Edison Electric Illuminating Co.	Boston, Mass.	475	WMAK	J. Edw. Page (Oliver B. Meredith)	Casnovia, N. Y.	261
WEHS	Robert E. Hughes	Evansville, Ind.	286	WMAK	Radio Laboratories	Dartmouth, Mass.	440
WEHR	All-American Radio Corporation	Chicago, Illinois	268	WMAK	Norton Laboratories	Lockport, N. Y.	273
WEW	St. Louis University	St. Louis, Mo.	280	WMAK	M. A. Lease Optical Co.	Washington, D. C.	286
WEAA	Dallas News & Dallas Journal	Dallas, Tex.	472	WMAN	First Baptist Church	Columbus, Ohio	286
WEAF	Times Publishing Co.	St. Cloud, Minn.	273	WMAQ	Chicago Daily News	Chicago, Ill.	447
WEAV	University of Nebraska, Department of Electrical Engineering	Lincoln, Nebr.	275	WMAZ	Kimberlyway Presbyterian Church	St. Louis, Mo.	280
WFBC	First Baptist Church	Knoxville, Tenn.	250	WMB	Mercer University	Macon, Ga.	261
WFBD	Gethsemane Baptist Church	Philadelphia, Pa.	234	WMB	Trinon Ball Room	Chicago, Ill.	250
WFBE	Van De Walle Music and Radio Co.	Seymour, Ind.	226	WMB	Michigan Broadcasting Co.	Detroit, Mich.	256
WFBG	The Wm. F. Cable Co.	Altoona, Pa.	251	WMB	Niagara Beach Hotel	Miami Beach, Fla.	384
WFBI	Conners Radio Corporation	New York, N. Y.	271	WMC	Commercial Appeal	Memphis, Tenn.	503
WFBJ	Johns Hopkins University	Collegeville, Minn.	236	WMC	Hotel McAlpin (Greenway Square Hotel Co.)	New York City	278
WFBJ	Wynne Radio Co.	Raleigh, N. C.	255	WMI	Ainsworth-Gates Radio Co.	Cincinnati, O.	321
WFB	Fifth Inf. Md. Nat'l Guard, 5th Reg. Armory	Baltimore, Md.	452	WNAC	Shepard Stores	Boston, Mass.	284
WFBW	Ainsworth-Gates Radio Co.	Cincinnati, Ohio	309	WNAD	University of Oklahoma	Norman, Okla.	258
WFBZ	Knox College	Galena, Ill.	254	WNAL	Omaha Central High School	Omaha, Nebr.	255
WFI	Strawbridge and Clothier	Philadelphia, Pa.	394	WNAP	Wittenberg College	Springfield, Ohio	271
WFKB	Francis K. Bridgman	Chicago, Ill.	217	WNAR	First Christian Church	Butler, Mo.	230
WFL	Robert Morrison Lacey	Brooklyn, New York	287	WNAR	Lennie Brothers Co. (Frederick Lennie)	Philadelphia, Pa.	254
WFLV	Ward	Springfield, Mo.	252	WNAT	Dakota Radio Apparatus Co.	Yankton, S. Dak.	248
WFLW	Earl William Lewis	Moberly, Mo.	233	WNB	Peoples & Tel. Co.	Knoxville, Tenn.	286
WGAU	Lancaster Electric Supply & Construction Co.	Lancaster, Pa.	248	WNYC	Dept. of Plant and Structures	New York, N. Y.	526
WGAZ	Yourses Hotel	Shreveport, La.	260	WQAC	Page Organ Co.	Lima, Ohio	260
WGBC	South Bend Tribune	South Bend, Ind.	352	WQAE	Midland College	Fremont, Nebr.	280
WGCB	Harry H. Carman, 217 Bedell St.	Freeport, N. Y.	244	WQAG	Apollo Theatre (Belvidere Amusement Co.)	Belvidere, Ill.	272
WGCF	First Baptist Church	Memphis, Tenn.	266	WQAI	Southern Equipment Co.	San Antonio, Texas	394
WGFB	Fink Furniture Co.	Evansville, Ind.	217	WQAN	Vaughn Conservatory of Music (James D. Vaughn)	Lawrenceburg, Tenn.	269
WGFI	Frank S. Marange	Scranton, Pa.	248	WQAO	Wradon Mfg. Co.	Mishawaka, Ind.	380
WGFK	Lawrence Campbell	Johnstown, Pa.	248	WQAR	Lowell Harty F.	Kenosha, Wis.	225
WGFM	Theodore N. Saaty	Providence, R. I.	234	WQAS	Boyd M. Hamp	Wilmington, Del.	169
WGGB	Stout Institute	Menominee, Wis.	234	WQAV	Pennsylvania National Guard, 2d Battalion, 112th Infantry	Eric, Pa.	242
WGHR	Marshfield Broadcasting Assn.	Marshfield, Wis.	229	WQAW	Woodman of the World	Omaha, Nebraska	526
WGHS	Gimbel Brothers	New York, N. Y.	315	WQAX	Franklyn J. Wolf	Trenton, N. J.	240
WGBU	Florida Cities Finance Co.	Fullord By-The-Sea, Florida	278	WQCC	Palmer School of Chiropractic	Davenport, Iowa	484
WGBX	University of Maine	Orono, Mo.	252	WQCG	Triple Alliance Radio Station	Sycamore, Illinois	205
WGHP	G. H. Howles, Inc.	Detroit, Mich.	270	WQCL	Hotel Jamestown, Inc.	Jamestown, N. Y.	273
WGHS	Conner Electric School	Oak Park, Ill.	250	WQDA	James K. O'Donnell	Pateron, New Jersey	205
WGHB	G. H. Howles Developments	Cleveland, Fla.	266	WQEA	Wes. St. Coll.	Ames, Iowa	270
WGI	American R. & Co.	Medford Hillside, Mass.	261	WQEK	Neutrowound Radio Mfg. Co.	Homewood, Ill.	317
WGMU	A. H. Crebe & Co., Inc., Portable	Richmond Hill, N. Y.	236	WQEO	Otto Baur	New York, N. Y.	233
WGN	The Tribune	Chicago, Ill.	370	WQEP	John Wanamaker	Philadelphia, Pa.	509
WGR	Federal T. and T. Co.	Buffalo, N. Y.	319	WQEQ	Unity School of Christianity	Kansas City, Mo.	278
WGY	General Elec. Co.	Schenectady, N. Y.	379	WQER	L. Bamberger and Co.	Newark, N. J.	405
WHAD	University of Wisconsin	Madison, Wis.	535	WQES	People's Pulpit Assn.	Batavia, Ill.	275
WHAG	Marquette University and Milwaukee Journal	Milwaukee, Wis.	280	WQET	State Marketing Bureau	Jefferson City, Mo.	440
WHAH	University of Cincinnati	Cincinnati, Ohio	283	WQEU	Low Battery Company	New Orleans, La.	270
WHAM	Hafer Supply Co.	Joplin, Mo.	283	WQEV	Maio Auto Supply Co.	East Wayne, Ind.	225
WHAP	University of Rochester (Eastman School of Music)	Rochester, N. Y.	278	WQFA	Pennsylvania State College	State College, Pa.	183
WHAR	H. Alvin Simmons, 290 Flatbush Ave	Brooklyn, N. Y.	240	WQFB	Donaldson Radio Co.	Oklmulgee, Okla.	360
WHAS	Seaside House	Atlantic City, N. J.	275	WQFC	Doolittle Radio Corp.	New Haven, Conn.	266
WHAT	Courier-Journal & Louisville Times	Louisville, Ky.	399	WQFD	North Dakota Agricultural College	Agricultural College, N. D.	283
WHAY	Dr. George W. Young	Minneapolis, Minn.	231	WQFE	Superior Radio & Telephone Equipment Co.	Columbus, Ohio	286
WHAZ	Wilmington Electrical Specialty Co.	Wilmington, Del.	360	WQFG	H. L. Turner	Buffalo, N. Y.	205
WHB	Remondier Polytechnic Institute	Troy, N. Y.	379	WQFH	The Municipality of Atlantic City	Atlantic City, N. J.	300
WHBA	Emergency School Co.	Kansas City, Mo.	250	WQFI	Wilson Printing Radio Co.	Harrisburg, Pa.	216
WHBC	C. C. Shaffer	Oil City, Pa.	250	WQAJ	Howe A. Bask, Jr.	Arkersburg, Pa.	270
WHBD	Rev. E. P. Graham	Canton, Ohio	245	WQAK	E. B. Gish	Amarillo, Texas	234
WHBF	Chas. W. Howard	Bellfontaine, Ohio	222	WQAL	Moore Radio News Station (Edmund B. Moore)	Springfield, Vt.	275
WHBG	Beverly Specialty Company	Rock Island, Illinois	222	WQAM	Electrical Equipment Co.	Miami, Fla.	283
WHBI	John S. Skene	Harrisburg, Pa.	231	WQAN	Scranton Times	Scranton, Pa.	280
WHBK	Culver Military Academy	Culver, Ind.	222	WQAO	Calvary Baptist Church	New York, N. Y.	260
WHBL	Lower Auto Co.	Ft. Wayne, Ind.	234	WQAP	Calumet Rainbo Broadcasting Co.	Chicago, Ill.	447
WHBM	Franklin St. Garage, Inc.	Ellsworth, Me.	231	WQAR	The Radio Club (Inc.)	LaPorte, Ind.	224
WHBN	James H. Shuster	Logansport, Ind.	220	WQAS	Lombard Radio	Chicago, Ill.	244
WHBP	C. L. Carrall, Portable Station	Chicago, Ill.	231	WQAT	Lowell Radio Service Co.	St. Louis, Mo.	263
WHBQ	First Ave. Methodist Church	St. Petersburg, Florida	258	WQAU	Antioch College	Yellow Springs, Ohio	242
WHBR	Johnston Automobile Co.	Johnston, Pennsylvania	256	WQAV	Avenue Radio Shop (Horace D. Good)	Reading, Pa.	238
WHBS	St. John's M. E. Church South	Memphis, Tenn.	233	WQAW	Flaxon's Garage	Gloucester City, N. J.	268
WHBU	Scientific Electric & Mfg. Co., 1004 Vine St.	Cincinnati, Ohio	216	WQAX	Immanuel Lutheran Church	Valparaiso, Ind.	278
WHBV	Hoyer, Theatre and Bin's Clothing	Anderson, Ind.	218	WQAY	Radio Corp. of America	Washington, D. C.	468
WHBW	D. R. Kiehn	Philadelphia, Pa.	215	WQAZ	Reo Motor Car Co.	Lansing, Mich.	288
WHBY	St. Norbert's College	West De Fore, Wis.	250	WQBA	Washington Radio Hospital Fund	Washington, D. C.	256
WHBC	Hickson Electric Co., Inc.	Cleveland, Ohio	273	WQBB	Rosedale Hospital, Inc.	Minneapolis, Minn.	325
WHH	The Radio Air Service Corp.	New York, N. Y.	360	WQBC	Doron Bros.	Hamilton, Ohio	260
WHI	George Schubert	New York, N. Y.	326	WQBD	Union College	Schenectady, N. Y.	270
WHIA	Bauers' Life Co.	Des Moines, Ia.	560	WQBE	University of Illinois	Urbana, Ill.	273
WHIB	Wright Building, Chicago	Deerfield, Ill.	238	WQBF	A. H. Grebe & Co., Inc., Motor Yacht "MU-1"	New York, N. Y.	238
WHIC	Howard R. Miller	Philadelphia, Pa.	254	WQBG	Experimenter Publishing Co.	New York, N. Y.	258
WHID	Chandler Publishing Co.	Marion, Ind.	228	WQBH	Radiotell Mfg. Co., Inc.	Bay Shore, New York	218
WHIE	Home Electric Co.	Buena Vista, Iowa	283	WQBI	Tarrytown Radio Res. Labs.	Tarrytown, N. Y.	273
WHIF	The Capital-Times Studio	Madison, Wis.	226	WQBJ	United States Playing Card Co.	Washington, D. C.	258
WHIG	L. M. Tate Post, No. 29, Veterans of Foreign Wars	St. Petersburg, Florida	222	WQBK	Grove City College	Grove City, Pa.	258
WHIH	St. Paul's Protestant Episcopal Church	Elkins Park, Pa.	222	WQBL	Allentown Call Publishing Co.	Allentown, Pa.	229
WHII	Elite-Radio Stores	New Bedford, Mass.	209	WQBM	Seventh Day Adventist Church	New York, N. Y.	263



## Langmuir Finally Gets Patent

(Continued from page 65)

and the merit of the invention was eventually sustained by the Patent Office, after an attack for which there are few precedents in vigor or in skill. Thereupon the contest became one to determine whether Dr. Langmuir or the later applicant was the first inventor, and more testimony had to be taken by both parties to establish their dates of invention. The Examiner of Interferences adjudged Dr. Langmuir the first inventor. On appeal to the Examiners-in-Chief the decision was again in favor of Dr. Langmuir. On further appeal, the Assistant Commissioner held in favor of the later applicant. But on still further appeal to the Court of Appeals of the District of Columbia, the Assistant Commissioner was reversed and the Court, agreeing with the Examiner of Interferences and the Examiners-in-Chief, found that Dr. Langmuir was the prior inventor. The appeals, though diligently prosecuted, were not terminated until June of the present year.

Dr. Langmuir is a world known scientist and inventor. Among a large number of other scientific and practical inventions made and patented by him, the best known is probably the Type C, or gas-filled Mazda.

The application of Dr. Langmuir's vacuum tube invention to X-ray tubes was the invention of Dr. William D. Coolidge, another world known scientist-

inventor working in the research laboratory of the General Electric Company at Schenectady. The Coolidge X-ray tube, embodying the inventions of Dr. Langmuir and Dr. Coolidge, is now in operation in all hospitals and X-ray laboratories.

## A Universal Socket with Isolantite Insulation

Granted that there is nothing novel in the universal socket idea, since many sockets of this type have now appeared on the market to take care of the new X type tubes as well as the old standard UV and C types, the fact remains that the Patent Universal Socket has several features which stamp it as decidedly different.

The Patent Universal Socket is entirely made of isolantite—the super-insulating material—with the exception of its metal parts. Therefore, the capacity effect between plate and grid is practically negligible, which is a distinct advantage in many of the highly critical circuits now in use. The contact members are of the one-piece phosphor-bronze type, with Patent self-cleaning, side-wiping contact for each tube prong. Connections can be made by means of the slotted hexagon nut binding posts, or by soldering to the soldering lugs. The Patent Universal Socket is supplied in the popular mounting type and also for mounting on sub-panels.



## The Traffic Cop of the Air

Add a Ferbend Wave Trap to your Radio Set and "Police" your reception. Regulate traffic! Guaranteed to tune out any interfering station. Widely imitated but never equalled. Not a "toy"—quality, material, workmanship equal to that of the finest receiving sets. The original and only successful WAVE TRAP. Now in its fourth year. Sent postpaid upon receipt of \$8.50 or C. O. D. plus postage. Send for Free Booklet.

**Ferbend Electric Co.**  
431 W. Superior St., Chicago  
See the new Ferbend "B"  
Eliminator announcement  
on page 58

U. S. Post Office,  
Billings, Mont.

\*Ferbend Electric Co. Gentlemen:  
With my Fada New, 120/125 and Ferbend Wave Trap I received the address of Pres. Coolidge from W.O.A.W. Omaha, on a special wave length. Many fans tried to get it but failed. Also the baseball World Series from W.D.A.W. and K.M.A. St. Paul, Minn. I got W.E.A.F. New York, loud enough to carry across the street. Will put my Set and Wave Trap up against any in the city regardless of price.  
(Signed)  
J. A. Thompson,  
Supt. of Mails.



## DEALERS BIG DISCOUNTS

Radio's biggest season is here. Get our new catalog showing huge stocks of radio parts, sets, kits at lowest rock-bottom prices. Quick service. Wonderful special offer on best sets, tubes, batteries. Write for free copy.



W.C. Braun Co., 36-50 S. Clinton St., Chicago, U.S.A.

## Make Your Set Do the Impossible!

# BARRETT & PADEN

## Micrometer Condenser

(for Any Type of Set)

THERE is real enjoyment in having a set which will do things that other sets can't even attempt to do.

When you install Barrett & Paden condensers in any set you immediately increase its capabilities manyfold. These condensers bring in stations which, because of the characteristics of your other condensers, could not be found. Separating stations which are closely upon one another is easy and positive because of the wider range of minute capacity variations which this and only this condenser has.

The Barrett & Paden Condenser works like a mechanic's micrometer. Just as this latter mentioned device makes possible the laying-off and determination of minute distances, so the Barrett & Paden Micrometer Condenser makes it possible to obtain the minute capacity variations so necessary for precision tuning.

Build your next set with Barrett & Paden Micrometer Type Condensers. The tremendous difference in performance will amaze you. You will have a set which will do things almost beyond the belief of anyone who has not seen the set in actual operation. At your dealers or direct.

.00025—straight line wave length \$ 6.00  
.00035—flat wave length curve  
.0005 —straight line capacity  
including dial

## BARRETT & PADEN

1314 Sedgwick St., Chicago, Ill.

Prepared by Kirtland-Rogel Adv. Co., Chicago

The Only True  
Micrometer  
Type  
Condenser

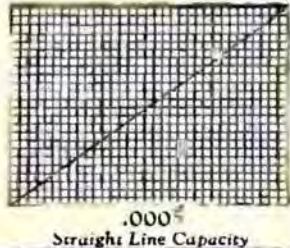
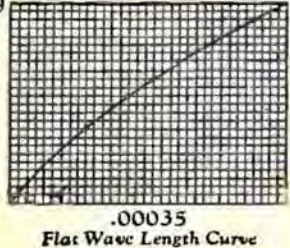
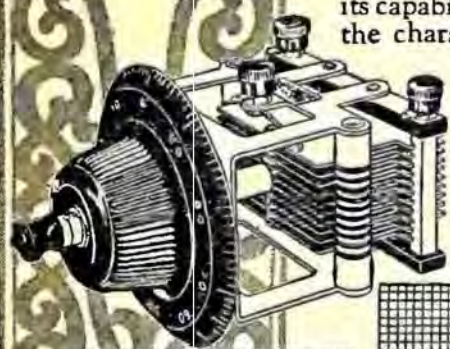



WSAR	Daughtry & Welch Electrical Co.	Fall River, Mass.	254	WTAL	Toledo Radio & Electric Co.	Toledo, Ohio	352
WSAZ	Chas. Electric Shop	Pomeroy, Ohio	258	WTAM	Willard Storage Battery Co.	Cleveland, Ohio	390
WSB	Atlanta Journal	Atlanta, Ga.	428	WTAP	Cambridge Radio & Electric Co.	Cambridge, Ill.	342
WSBC	World Battery Co.	1219 S. Wabash Ave., Chicago, Ill.	210	WTAQ	S. H. Van Gordon & Son	Ouseo, Wis.	220
WSBF	Ritz-Barr-Fuller D. G. Co.	St. Louis, Mo.	275	WTAR	Reliance Electric Co.	Norfolk, Va.	283
WSCK	World's Star Knitting Co.	Bay City, Mich.	261	WTAT	Edison Electric Illuminating Co. (portable)	Boston, Mass.	240
WSM	Nashville Life and Accident Ins. Co.	Nashville, Tenn.	283	WTAW	Agricultural & Mechanical College of Texas	College Station, Texas	280
WSMB	Saenger Amusement Co., and Maison Blanche Co.	New Orleans, La.	319	WTAX	Williams Hardware Co.	Streator, Ill.	231
WSMH	Shattuck Music House	Oxosso, Mich.	240	WTBZ	Thomas J. McGuire	Lambertville, N. J.	283
WSMK	S. M. H. Radio Corp.	Dayton, Ohio	275	WTG	Kansas State Agricultural College	Manhattan, Kans.	273
WSOE	School of Engineering	Milwaukee, Wis.	246	WTIC	Travelers Insurance Co.	Hartford, Conn.	323
WSU	Camp Marionfield	Chesham, N. H.	229	WTX	H. G. Saal Co.	Chicago, Ill.	358
WSUJ	State University of Iowa	Iowa City, Iowa	498	WWAD	Wright & Wright (Inc.)	Philadelphia, Pa.	360
WTAB	Fall River Daily Herald Publishing Co.	Fall River, Mass.	248	WWAE	The Alamo Ball Room	Joliet, Ill.	243
WTAC	Peon Traffic Co.	Johnstown, Pa.	360	WWI	Ford Motor Co.	Dearborn, Mich.	273
WTAD	Robt. E. Compton	Carthage, Ill.	236	WWJ	Detroit News (Evening News Assn.)	Detroit, Mich.	352
WTAG	Telegram Pub. Co.	Worcester, Mass.	268	WWL	Loyola University	New Orleans, La.	260

FOREIGN BROADCASTING STATIONS

Canadian

CFAC	Calgary Herald	Calgary, Alta.	434	CJCA	Edmonton Journal	Edmonton, Alta.	511
CFCA	Toronto Star Pub. & Print. Co.	Toronto, Ont.	357	CJCL	A. Couture	Montreal, Que.	279
CFCF	Marconi Wireless Telegr. Co. (Ltd.) Canada	Montreal, Que.	411	CJCC	London Free Press	London, Ont.	321
CFCH	Abitibi Power & Paper Co. (Ltd.)	Iroquoia Falls, Ont.	500	CKAC	Vancouver Daily Province	Vancouver, B. C.	411
CFCK	Radio Supply Co.	Edmonton, Alta.	517	CKCD	Leader Pub. Co.	Regina, Sask.	478
CFCN	W. W. Grant (Ltd.)	Calgary, Alta.	434	CKCK	Ottawa Radio Association	Ottawa, Ont.	434
CFCR	Laurentide Air Service	Sudbury, Ont.	410	CKCO	P. Burns & Co. (Ltd.)	Calgary, Alta.	434
CFCT	Victoria City Temple	Victoria, B. C.	329	CKCX	First Congregational Church	Vancouver, B. C.	411
CFCU	The Jack Elliott (Ltd.)	Hamilton, Ont.	341	CKFC	Wilkinson Electric Co. (Ltd.)	Calgary, Alta.	434
CFHC	Henry Birks & Sons	Calgary, Alta.	434	CKIC	Canadian National Carbon Co.	Toronto, Ont.	357
CFKQ	Thorold Radio Supply	Thorold, Ont.	248	CKKC	Wentworth Radio Supply Co.	Hamilton, Ont.	347
CFQC	The Electric Shop (Ltd.)	Saskatoon, Sask.	329	CKOC	Granitche Tel. System	Winnipeg, Man.	384
CFRC	Queen's University	Kingston, Ont.	450	CKY	Canadian National Railways	Montreal, P. Q.	312
CFSC	Westminster Trust Co.	Westminster, B. C.	291	CNRA	Canadian National Railways	Calgary, Canada	434
CFYC	Commercial Radio (Ltd.)	Vancouver, B. C.	411	CNRC	Canadian National Railways	Edmonton, Alta.	517
CHBC	The Calgary Albertan	Calgary, Alta.	434	CNRE	Canadian National Railways	Montreal, P. Q.	411
CHCM	Riley & McCormack (Ltd.)	Calgary, Alta.	434	CNRM	Canadian National Railways	Ottawa, Ont.	434
CHCS	The Hamilton Spectator	Hamilton, Ont.	341	CNRO	Canadian National Railways	Regina, Sask.	478
CHIC	Northern Electric Co.	Toronto, Ont.	357	CNRR	Canadian National Railways	Saskatoon, Sask.	329
CHNC	Toronto Radio Research Society	Toronto, Ont.	357	CNRS	Canadian National Railways	Toronto, Ont.	357
CHUC	International Bible Ass'n	Saskatoon, Sask.	329	CNRV	Canadian National Railways	Vancouver, B. C.	411
CHXC	R. Booth, Jr.	Ottawa, Ont.	434	CNRW	Canadian National Railways	Winnipeg, Man.	384
CHYC	Northern Electric Co.	Montreal, Que.	411				

Cuban

PWX	Cuban Telephone Co.	Habana	400	2TW	Roberto E. Ramirez	Habana	230
2BY	Frederick W. Borton	Habana	260	2WW	Amadeo Saens	Habana	210
2CX	Frederick W. Borton	Habana	320	SEV	Leopoldo E. Figueroa	Colon	360
2DW	Pedro Zayas	Habana	300	6BY	Jose Ganduie	Cienfuegos	300
2EV	Westinghouse Elec. Co.	Habana	220	6CX	Antonio T. Figueroa	Cienfuegos	170
2HC	Hauldo de Cuba	Habana	275	6DW	Eduardo Terry	Cienfuegos	225
2HD	Raul Perez Falcon	Habana	180	6KJ	Frank H. Jones	Tuinau	375
2J	Alvira Daza	Habana	105	6KW	Alfredo Ravelo	Stgo. de Cuba	150
2KD	E. Sanchez de Fuentes	Habana	200	8BY	Pedro C. Anduz	Stgo. de Cuba	275
2LC	Luis Casas	Habana	250	8FU	Andres Vinnet	Stgo. de Cuba	225
2MG	Manuel G. Salas	Habana	280	12AB	Alberto S. de Bustamante	Habana	240
2ML	Fausto Simon	Habana	270	16AZ	Valentin Ullivarri	Cienfuegos	300
30L	Oscar Cullado	Habana	290	20K	Mario Garcia Velaz	Habana	260

British

21.O	London	365	5NO	Newcastle	400
51T	Birmingham	475	5SC	Glasgow	420
5WA	Cardiff	350	2BD	Aberdeen	492
6BM	Bournemouth	385	6SL	Sheffield (relay station)	303
1ZY	Manchester	375			

French

YN	Lyon	740	8AJ	Paris	1,870
FL	Paris (Eiffle Tower)	2,600	ESP	Paris	450

**Get the New MATCHED AERO COILS**

T. R. F. Kit Matched Coils \$12.00



**For SELECTIVITY and DISTANCE**

Regardless of how good your set seems to be, you can make it many times more selective and much more powerful by replacing your T. R. F. transformers with Aero Coils. Get Aero Coils now — and tune through strong locals and bring in DX with tremendous loud speaker volume!

**95% AIR DIELECTRIC**

The secret of Aero Coils' markedly superior performance in its patented construction which makes possible the correct use of 95% air dielectric and dopeless, air-spaced windings with the consequent advantages of lower high frequency resistance and distributed capacity.

**AT YOUR DEALERS OR DIRECT**

T. R. F. Regenerative Kit...\$11.00  
 3 Circuit Tuner..... 8.00  
 Wave Trap Coll..... 4.00  
 Oscillator..... 5.50

Write for the Aero Booklet

**AERO PRODUCTS, Inc.**  
 217 N. Desplaines Street, CHICAGO

**Amateur Radio Gets Recognition**

Amateur radio has received definite recognition as an international undertaking of value to the entire world, with the official acceptance of the International Amateur Radio Union by the League of Nations headquarters in Geneva. This organized group of amateur radio telegraphers has branches in most of the civilized countries of the globe and sections are in process of forming in those countries not yet represented.

In the United States and Canada, the Union has thriving sections, with the 20,000 members of the American Radio Relay League as a nucleus.

Officers of the Union are International President Hiram Percy Maxim of Hartford, Conn.; International Vice President, Gerald Marcuse of Caterham, Surrey, England; International Secretary-Treasurer, K. B. Warner of Hartford, Conn.; International Counsellors-at-large, Jean G. Mezger, Neuilly-sur-Seine, France, and Frank D. Bell, Palmerston, South, New Zealand.

The organization aims to promote cooperative regulation for international amateur radio communication, to provide international amateur tests and to develop a system of handling international private messages based upon the message plan now in use with the American Radio Relay League.

**BIG MONEY!**

**\$3,000 to \$10,000 a year**

Want to make big, easy money? Learn how to install, operate, repair, construct and sell Radios. Write now for facts about the amazing opportunities for Radio experts, and our special offer of a FREE 1000-mile receiving set, and how you can quickly train at home by mail.

**Be a Radio Expert**

No previous experience necessary. Anyone with ordinary education can now learn Radio quickly under our simplified home-study plan. We need men right now to represent our Association. Be the Radio expert in your neighborhood. Get your share of the big profits. Hundreds about you want Radios and advice how to operate. You can earn enough money right from the start to pay for course. Nothing difficult about it. Low cost and easy terms.

**FREE 1,000-MILE Receiving Set**

Don't miss this big special offer to supply FREE all parts necessary to construct a high-grade 1000-mile receiving set. You can sell this set alone for practically the entire cost of the course. Send for the facts now. Find out all about this big-pay field. Address

**Radio Association of America**  
 6513 Ravenswood Ave., Dept. 212 Chicago, Ill.



### A Guide to Readers who Want Radio Books

**I**N THE belief that our readers will be interested in knowing where to obtain booklets on various radio subjects, from manufacturers, engineers, and other sources, RADIO AGE is continuing the publication of its directory for such literature.

The title of the booklet, the person or company from whom it can be obtained and the latter's address, are given for your convenience. This service will be continued from month to month in RADIO AGE, and readers desiring to know where to get literature not listed herewith may obtain this information by addressing our Technical Department.

The directory for this month follows:

Free mailing lists of prospective customers. Ross Gould Co., 589 North 10th St., St. Louis, Mo.

Circular covering cabinets and consoles. Raulf Radio Console Mfg. Co., 562 Vedder St., Chicago, Ill.

Sales proposition and discount terms, also booklet R-A. Diana Radio Co., 1429 South Michigan Ave., Chicago, Ill.

Reference book for direct mail advertisers. R. L. Polk & Co., 599 Polk Director Bldg., Detroit, Mich.

Catalog L1003 for radio parts with list of discounts. Wakem & McLaughlin, 225 East Illinois St., Chicago, Ill.

Booklet 31, covering use of bakelite in radio. Bakelite Corporation, 247 Park Ave., New York, N. Y.

Tube characteristics. Cleartron Tube Co., 28 West 44th St., New York, N. Y.

Radio products. Acorn Radio Products Co., 712 West Madison St., Chicago, Ill.

Seven hook-ups in blueprint form. A. F. Henninger Corp., 4507 Ravenswood Ave., Chicago, Ill.

Illustrated folder of sets made by W-K Electric Co., Kenosha, Wis.

Pamphlet 15-B descriptive of electrical instruments for radio purposes, Jewell Electrical Instrument Co., 1650 Walnut St., Chicago, Ill.

General catalog including radio hook-ups, Barawik Co., 104-126 South Canal St., Chicago, Ill.

General catalog of radio parts and kits, W. C. Braun Co., 36-50 South Clinton St., Chicago, Ill.

Illustrated 1926 radio catalog, and free log Economy Radio Sales Co., 288 6th Ave., Dept. C, New York City, N. Y.

Literature on tandem condensers, Duplex Condenser and Radio Corp., 42 Flatbush Ave., Extension, Brooklyn, N. Y.

Descriptive folder covering radio parts, Telephone Maintenance Co., Dept. C, South Wells St., Chicago, Ill.

Complete catalog of parts, (also Resistance Coupled Manual 30 cents) Daven Radio Corporation, 158-160 Summit Ave., Newark, N. J.

Data on resistance coupled amplifiers, Allen-Bradley Co., 289 Greenfield Ave., Milwaukee, Wis.

Fifty-two page catalog covering all types of radio sets and parts. Montgomery Ward and Co., Dept. 18-R, Chicago, Ill.

Latest data on audio frequency amplification. Electrical Research Labora-

tories, 2500 Cottage Grove Ave., Dept 6-C, Chicago, Ill.

Literature on radio parts, Steinite Laboratories, 302 Radio Bldg., Atchison, Kansas.

Literature on 1 to 5 tube sets, Midwest Radio Corp., 523 B East 8th St., Cincinnati, Ohio.

Literature on inductances and allied products, Aero Products, Inc., 217 North Desplaines St., Chicago, Ill.

Literature on Lavite resistances, Crescent Radio Supply Co., Liberty St., Jamaica, N. Y.

Literature on Ozarka instruments No. 200, Ozarka Inc., 122 Austin Ave., A, Chicago, Ill.

General catalog including list of stations and general radio information, Randolph Radio Corp., 159 North Union Ave., Dept. 185, Chicago, Ill.

### Perfect Alignment in Perryman Tube

Making somewhat of a departure in tube construction the Perryman Electric Co., have placed on the market the Perryman tube in which the plate, grid and filament elements are held in perfect alignment by a non-conducting bridge located at the top and bottom of the tube, thus insuring rigid tension on all the elements.

A set of these tubes used in Radio Age's laboratory operated with uniform good results in a three tube set, a five tube tuned r.f. and an 8 tube super-het. The grid to filament capacity seems to be less in this type of tubes and they served as excellent r.f. amplifiers. The filament current is the conventional quarter of an ampere, operated off a six volt battery. The Perryman Electric Co., also makes 199 type with the same bridge suspension.

**The Season's Sensation**

**\$15<sup>00</sup>**

**THE KODEL MICROPHONE LOUD SPEAKER** is an exact replica of the transmitting microphone used in broadcasting.

The efficient Kodol reproducing unit, with an ingenious new snail-shell horn, mounted inside the microphone case, produces a remarkably clear, full-toned volume. Non-vibrating tone chamber eliminates distortion.

The \$15 model incorporates the new Kodol, Jr. unit; with the large Kodol unit. \$20

Radio dealers everywhere have them

**THE KODEL RADIO CORP**  
506 E. Pearl St., Cincinnati, O.

**The KODEL MICROPHONE**

**LOUD SPEAKER**

Design Patented



# Radio Parts **FREE!**

If your friends are not receiving RADIO AGE each month, ask them to subscribe through you, then pick out your prize from the list of guaranteed radio parts given below. Each part has been tested and approved by the RADIO AGE INSTITUTE, which assures you of the best parts made. More complete description will be sent upon request.

The subscription price is \$2.50 a year. Send in your new subscriptions with the checks or money orders and the premium you want will be sent immediately.

Get in on this now!

For **ONE** new subscription the following parts are offered as your premiums:

1. AMSCO Bakelite Dials, 100 graduations, 2,3 or 4 inches.
2. AMSCO Tube Sockets, panel or table mounting.
3. EVER READY C Battery.
4. BURGESS C Battery.
5. RED SEAL Dry Cell Battery.
6. BREMER TULLY type U L Socket. Eliminates use of adapters.
7. RADIAL "AMPERITE," a "self adjusting" rheostat. Does away with hand rheostats and filament meters.

For **TWO** new subscriptions the following parts are offered as your premiums:

1. AMSCO Rheostats, Arrow Knob or Bakelite Dial. 2, 6, 8, 10, 12, 15, 20, 30, or 50 Ohm.
2. AMSCO Potentiometers, Arrow Knob or Bakelite Dial. 250 or 400 Ohm.
3. AMSCO Grid-Leak and Condenser. Fixed condenser, .00025 mfd. capacity and Grid-Leak, 2 Megohms.
4. Genuine non-inductive CRESCENT LAVITE Resistances. 12,000, 48,000, 50,000, or 100,000 ohms.
5. DAVEN LEAKANDENSER. Combination grid leak and grid condenser. 2, 3, 4, 5, or 7 megohms.
6. DAVEN RESISTO Couplers. Two pair of clips, one for holding the plate resistor and one for holding the grid leak.
7. STEINITE Interference Eliminator. Enables you to tune out locals and get distant stations.
8. Small BURGESS "B" Battery.
9. Small EVER READY "B" Battery.

For **THREE** new subscriptions the following parts to choose from:

1. CRESCENT Bakelite Panels.  $\frac{3}{8}$ " thick. Size 7"x10" or 7"x12".
2. BREMER-TULLY Variable High Resistances. Maximum resistances of 2,000, 50,000, 100,000 or 200,000 ohms.
3. BREMER-TULLY Volume Control or Modulator. Used in audio circuits for noiseless adjustment of volume and improvement of tone qualities.
4. BREMER-TULLY Non-Inductive Potentiometer. A variable high resistance with three terminals. Slider connects to center terminal and varies at either outer terminal to maximum resistance. 400 or 2,000 Ohm maximum resistance.

For **FOUR** new subscriptions the following premiums to choose from:

1. KLADAG EUPHONIC, Bakelite base, no tip, thoriated filament tube. 201A or 199 type.
2. CRESCENT Bakelite Panels.  $\frac{3}{8}$ " thick. 7"x14" or 7"x16" or 7"x18".
3. VAN HORNE 3VA "Double Service" or Compromise Tube. Operates at 3 volts from either dry cells or batteries.
4. BREMER-TULLY Tuning Control. 12 to 1 ratio. Provides positive control with a smooth easy action. With disc for marking station call letters.

For **FIVE** new subscriptions you can pick your premiums from the following:

1. ENSIGN Variable Condenser. Either .00025 or .0005 capacity.
2. MUSSELMAN Selective Antenna. 75 foot length coil.
3. Model 5VA, 3VA or 3VB MUSSELMAN Certified

Electron Tubes. 5VA and 3VA fit 201-A sockets 3VB fits 199 sockets.

4. AMSCO Allocating Condenser. Straight Line Frequency. 13 plates or 17 plates, .0003 or .00035 mfd. Single unit.
5. CRESCENT Bakelite Panel.  $\frac{3}{8}$ " thick. 7"x21".

For **SIX** new subscriptions you have the following to choose from:

1. The AERO COIL Wave Trap Unit. Makes a very efficient wave trap or crystal set.
2. CRESCENT Bakelite Panels.  $\frac{3}{8}$ " thick. 7"x24" or 7"x26".
3. SILVER-MARSHALL S.L.W. type, .00025, 11 plate, or .00035, 17 plate, condensers. Silver plated. Three inches square.
4. BREMER-TULLY Three Circuit Tuner. A tuner of unquestioned merit for use in one to four tube sets. Two types, for 200 to 566 meters reception and for 50 to 150 meters reception.
5. BREMER-TULLY "Torostyle" Transformers. Three types: Antenna Coupler, for Intermediate R. F. Stages, and for four tube sets.
6. WERNER Radio Frequency Transformer, Type W-1, W-2, or W-3

For **EIGHT** new subscriptions we offer the following premiums:

1. AERO COIL Oscillator for Super Heterodynes, as advertised in RADIO AGE.
2. CREST Convertible Condenser. 23 plate. Convertible to all capacities. S.L.F.
3. Model 5VC MUSSELMAN Certified Electron Tube. Fits 201-A sockets.
4. SILVER-MARSHALL type 105 Low Loss Coupler. For three circuit, tuned R.F., or other circuits requiring a highly efficient inductance unit. Wave length range, with stator shunted by .0005 mfd. condenser, 200 to 550 meters.
5. SILVER-MARSHALL S.L.F. type, .0005 mfd., 35 plate, or .00035, 25 plate, or .00025, 17 plate condensers. Silver plated. Three inches square.
6. Seven by eighteen inch cabinet with hinged cover. (SILVER-MARSHALL).
7. BREMER-TULLY "Euphonic" Audio Transformers. Type 210, ratio 2.2 to 1 and Type 410, 4.7 to 1.
8. BREMER-TULLY S.L.F. condensers. 13 or 17 plate, .00025 or .00035 mfd.

For **TEN** new subscriptions you can pick your prize from this list:

1. The AERO COIL Three Circuit Tuner. Advertised in RADIO AGE.
2. AMSCO ALLOCATING Condensers. S.L.F. 17 or 23 plates, .00035 or .0005 mfd. Double Unit.
3. KLADAG Knock Down, Mahogany Loop Antenna. Bank Wound, Centre Tapped.
4. STEINITE long distance crystal set. In beautiful hand-rubbed, walnut finish case.
5. STEINITE one tube regenerative set. 1500 mile range. Mahogany cabinet.
6. SILVER-MARSHALL "Two Ten" Transformer. A long wave inter-stage transformer, peaking at 60 kilocycles. Combination iron core type and air core type. Turn ratio, 1 to 2.3.
7. SILVER-MARSHALL "Two Eleven" Transformer. Peaks at 60 kilocycles in conjunction with the tuning condenser supplied. Air core type. May be used at input or output end of the amplifier, turn ratio 1 to 10. Complete with 60RC tuning condenser.

**RADIO AGE, Inc.,** 500 N. Dearborn Street, Chicago



**CROSLLEY Radios with these New Prices should be Radio's best values!**

**Crosley 2-Tube 51 Regular**



This efficient little set uses any make of tubes. Nearby stations on loud speaker, long range on headphones.

**NOW \$14.75** WAS \$18.50

**Crosley 3-Tube 52 Regular**



For a less expensive 3-tube set the Crosley 52 Regular cannot be surpassed at the new low price.

**NOW \$25.00** WAS \$30.00

**Crosley Super-Trirdyn Regular**



In the Super-Trirdyn, 3 tubes do the work of 5. Matchless performance. Beautifully finished solid mahogany cabinet.

**NOW \$45.00** WAS \$50.00

**The Famous Musicone**

This marvelous loud speaker—well on its way to REPLACE HALF A MILLION HORNTYPE SPEAKERS by January 1st—is substantially reduced because of assembly improvements developed by Crosley engineers. Reproduces all tones—without distortion. Crosley patented unit, not cone, secret of its amazing perfection.

**NOW \$14.75** WAS \$17.50

*These prices do not include accessories. Add ten per cent to all prices West of the Rockies.*

**CROSLLEY RADIO**

BETTER COSTS LESS

**THE CROSLLEY RADIO CORPORATION**  
Dept. 63 Cincinnati, Ohio



**DON'T WAIT! PEP UP THAT SET NOW WITH X-L VARIO DENSERS**

ENDORSED BY ALL LEADING RADIO AUTHORITIES FOR USE IN THE LATEST AND BEST CIRCUITS.

MODEL N—Capacity range 1.8 to 20 micro-microfarads, for balance in Roberts two tube, Brownings-Drake, McMurdo Silver's Knockout, Neutrodyne and tuned radio frequency circuits. Price, \$1.00

MODEL G—Two capacity ranges, .00018 to .00055 and .0003 to .001 Microfarads, for the Cockaday circuit, filter and intermediate frequency tuning in superheterodyne and positive grid bias in all sets. Price \$1.50

X-L RADIO LABORATORIES,  
2424 Lincoln Ave. N. CHICAGO

**Fourth Chicago Radio Show  
Nov. 17-22**

THE doors of the Coliseum will open on the greatest radio exposition in the history of the industry, when the fourth annual Chicago Radio Show begins Tuesday, November 17 and continues until the 22nd.

The number of exhibitors and the variety of features will eclipse all other shows, and it is expected the attendance will be greater than any other radio show this year, or in past years. Over a quarter of a million dollars has been spent by the management of the show and the exhibitors, in preparing this enormous spectacle for displaying the latest in radio to the public

**New Equipment**

Entire new equipment and booth construction will be used this year, it will be decorated differently from last year, and will be much more attractive generally. Manufacturers have also learned the necessity of putting in real exhibits and showing something distinctive, in order that they may attract the public, and the displays will reflect this during the week.

A number of features, including a monster set building contest, in which prizes amounting to \$1,000 are offered for the best handiwork of radio fans, have been planned. This contest is divided into nine sections, with a prize for the best set in each division. This gives everyone a fair chance to win one of the prizes, and does not place the girls in competition against the boys, who are apt to be more experienced, or the boys against the men. The sets are to be on exhibition at the show in a special section reserved for this purpose.

**Miss Radio On the Job**

Miss Radio, the girl radio fan from Illinois, Indiana, or Wisconsin with the best long distance reception record, will be the guest of the management and will be crowned as queen of the show.

Special features of the show will be an exhibition of radio currents frying an egg on top of a cake of ice, lighting electric light globes without wires, and other marvelous tricks that seem beyond human belief. The unseen ether waves will be harnessed to do man's bidding, and perform a number of unnatural stunts.

A complete list of foreign exhibits will be displayed, and it is expected that a good many foreign representatives will be present in person to view the latest in advancement of American radio apparatus.

**Smallest Radio Sets**

In another section of the show will be an exhibition of the smallest radio sets and parts in the world, featuring a tiny loud speaker that just covers a half-dollar, complete receivers smaller than a hazelnut, and tiny headphones that would hardly be large enough for a small doll.

*(Continued on page 80)*

\* Tested and Approved by RADIO AGE \*

**M & M Low Loss INSULATORS**

**Storm, Weather and Water Proof**

PERFECT your entire insulation by insulating your antenna and ground system. Your set is not responsible for energy lost through a poorly insulated aerial. M & M Low Loss Lead-in and Wall Insulators will give your set insulation



4" Lead-in Insulators .....50c.  
10" Lead-in Insulators .....80c.



20" Lead-in Insulators for heavy walls,  
\$1.50

**WALL INSULATORS**



The 5 in. Wall Insulator illustrated here is made to hold all sizes of wire from 4 to 14. Meets Underwriters' requirements and makes your antenna insulation perfect.

Price, 60c.

Dealers: If your jobber cannot supply you, write us direct giving your jobber's name.

Send for our catalog

**The M & M Co.**  
CLEVELAND, OHIO.

**for—  
Real Enjoyment**

No. 205



**Burns  
LOUD SPEAKER**

Assures utmost in volume and clarity of tone—reaches full range of musical scale, giving a faithfulness of reproduction that equals hearing the original.

Flare in several handsome finishes.  
Prices \$22.50 - \$25.00 - \$30.00

Manufacturers

**American Electric**  
COMPANY  
State and 64th Streets  
CHICAGO, U. S. A.



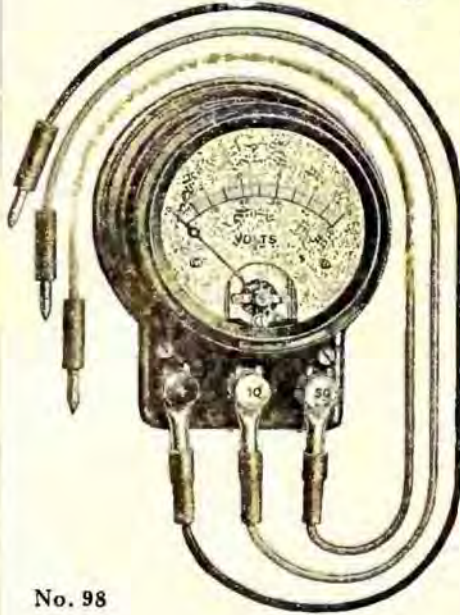

No. 98

## An Instrument for Every Radio Test

### The Jewell No. 84

2-inch "B" Battery Voltmeter for set owners' sells for \$2.75; Our No. 95 complete radio test set sells for \$75.00. The No. 98 double reading voltmeter (10 and 50 volts) shown opposite is used by Dealers and Jobbers to check batteries—Price \$12.50.

Send for Jewell 15-B Complete Radio Instrument Catalog

Order from Dealer

## Jewell Electric Instrument Co.

1650 Walnut St., - Chicago

"26 YEARS MAKING GOOD INSTRUMENTS"

## Radio Plays Bigger Part in College Life

That radio plays an important part in college and university life is indicated by the institutions which are linked together for the organ recitals presented by the Skinner Organ Company through broadcasting station WAHG, Richmond Hill, N. Y., for thirty-six consecutive Friday nights, which program began November 6 at eight o'clock.

George Rogers Pratt, Organist of the University of Virginia, represents the East; while Warren D. Allen, organist of the Leland Stanford University, California, is one of the contributing artists from the Golden West. Others include Walter Hartley of Pomona College, California; Allan Bacon, College of the Pacific at Stockton, California. The tall corn country is represented by Marshall Bidwell of Coe College, Cedar Rapids, Iowa; the midwest by Palmer Christian, organist of the University of Michigan at Ann Arbor; Western New York brings Hugh Porter, organist of the Chautauqua Institution Summer School; while central New York presents Harold Glesson of the Eastman School at Rochester. Western Pennsylvania will be represented by Charles Heinroth, organist of the Carnegie Institute, Pittsburgh.

## Well Known Amateur Goes Into Business

F. J. Marco, formerly associated with the Bremer-Tully Manufacturing Co., of Chicago, has gone into business for himself as a consulting radio engineer, located at 5723 Winthrop Ave., Chicago, Ill.

Many amateurs will remember Mr. Marco as one of the old time operators at 9ZN and actively engaged in the "ham" game in the old days.

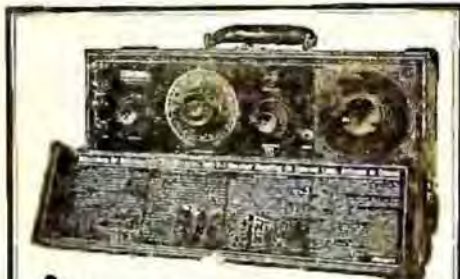

### \* The Famous Truly Portable TELMACO P-1 Receiver

Four Tubes Do the Work of Seven

The peer of portables in size, weight, ease of tuning, selectivity, distance, volume, workmanship and price. Aerial, loud speaker and batteries self contained. Compleats with tubes and batteries. \$125.00

#### P-1 Kit Saves You Money!

Our offer of the Telmaco P-1 Receiver in kit form has met with enthusiastic reception. This contains all parts, as built by us, including case, drilled and engraved panel, and illustrated instructions. \$80.00

Compleats kit  
Ask your dealer or write us. Descriptive folder free.  
Radio Division:  
**Telephone Maintenance Co.**  
20 So. Wells St. Dept. C Chicago, Ill.



Quality Radio Exclusively Established 1918



### NO MORE LOOSE CONNECTIONS X-L PUSH POSTS

A binding post that really does excel, looks, action, service, and convenience. Push it down—insert wire—cannot jar loose from vibration. No screwing or danger of shearing off wires. Furnished attractively plated with soldering lug and necessary markings. Price Each 15 Cents  
X-L RADIO LABORATORIES.  
2424 Lincoln Avenue N. Chicago

**You Save 50%**

**Approved!**  
Listed as Standard by Leading Authorities including Radio News Laboratories, Popular Science Institute of Radio Laboratories, Radio Broadcast Laboratories, Radio in the Home and Lex, Inc.

World Radio "A" and Auto Batteries are famous for their guaranteed quality and service. Backed by years of successful manufacture and thousands of satisfied users. Equipped with Solid Rubber Cases, an insurance against acid leakage. You save 50 per cent.

<p><b>Radio Station W S B C</b> Set your Radio Dial at 210 meters for the new 1000 watt World Storage Battery Sca., W S B C, Chicago, Ill. Watch for announcements.</p>	<p><b>2-Year Guarantee Bond in Writing</b> WORLD Battery owners "tell their friends." That's our best proof of performance. Send your order in today. Solid Rubber Case Radio Batteries 6-volt, 100 Amperes . . . \$11.25 6-volt, 120 Amperes . . . 13.25 6-volt, 140 Amperes . . . 14.00 Solid Rubber Case Auto Batteries 6-volt, 11-Plate . . . \$11.25 6-volt, 15-Plate . . . 13.25 12-volt, 7-Plate . . . 16.00</p>
---	---

**SEND NO MONEY**

Just state battery wanted and we will ship day order is received, by Express, C. O. D., subject to your examination on arrival. Extra Offer: 5 per cent discount for cash in full with order.  
Buy new and get a guaranteed battery at 50 per cent easy to you.

**WORLD BATTERY COMPANY**  
Dept. 36  
1219 So. Wabash Ave., Chicago, Ill.

# World

# YAXLEY

*The New*  
**YAXLEY**  
Panel Light

**50¢**

Bulb Extra

At your dealer's. If he cannot supply you send his name with your order to

**YAXLEY MFG. CO.,**  
Dept. E, 217 No. Desplains St., Chicago



**Radio Foundation, Inc.,  
Has Double-Toroid Coil**

A set of Double-toroids, manufactured by the Radio Foundation, Inc., has been received by Radio Age and put through tests in the laboratory.

In the coils referred to above the primary and secondary are both true toroids and can be effectively used in any of the tuned r. f. combinations now so popular. On account of the form of winding, the toroid, it is possible to shield receivers using these coils, without sacrificing too much efficiency.

The Foundation also has marketed a no-noise variable grid leak using a liquid medium and a semi-coiled contact wire.

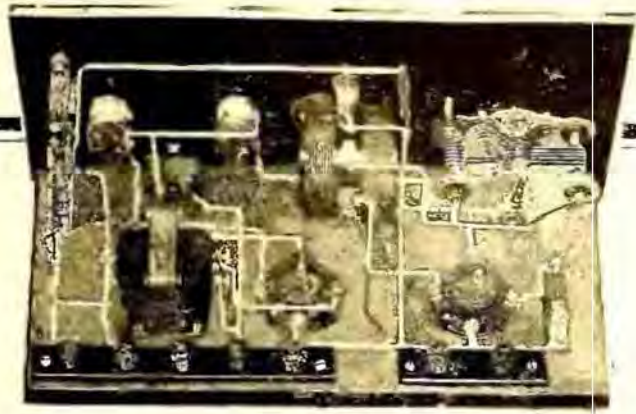

**You Can Build This Efficient  
Receiver for \$27.27**

Built Around the  
**HEALTH VARIABLE CONDENSER**  
By the Citizens Radio Call Book

**T**HE remarkable performance of the Heath .0025 Variable Condenser caused The Citizens Radio Call Book Laboratory to design this remarkable high-power, low-cost radio set. Go to your nearest dealer and get your set of plans—they are with each purchase of a Heath Condenser. Start right now to get the parts to build this super-efficient receiver. You'll have a radio that all your friends will envy. If your dealer doesn't carry Heath Condensers, write us direct.

**Heath Radio and Electric Mfg. Co.**

206-210 First St.

Newark, N. J.

Manufacturers of

HEATH CONDENSERS

HEATH SOCKETS

HEATH DIALS

HEATH RESISTANCE COUPLED AMPLIFIERS

**ROPE-CORE  
AERIAL**

A marvelous, new aerial that is guaranteed to give greater distance, easier tuning, more perfect selectivity. Consists of pure copper ribbon, heavily enameled, wound around sturdy, weather-proof rope. Try this new aerial for better reception.

50 ft. \$3.00  
75 ft. 3.85

100 ft. \$5.00  
150 ft. 7.00



**Acorn Window  
Lead In**

Fits into sash as pictured. Made of pure copper ribbon 1/2-inch wide, heavily enameled by special process. Triply insulated with waterproofed fabric. Thousands of users recommend them for satisfactory service. Each 35c. (Unenameled—25c.)

**Acorn Master Switch**

Instantly connects your battery to charger or battery to receiver. Single socket type \$5.00. Double socket type (for use with B-eliminator) \$6.25.

Send for circulars on Acorn Products.

**JOBBERS—Write for discounts—DEALERS**



\* Acorn Radio Prod. Co.  
712 W. Madison St., Chicago

**New Perpetual LOG**

Loose Leaf for Revisions—Radio Map FREE



New 64 page log. Corrected sheets may be secured as changes in calls, wave lengths, owners, addresses, etc., occur. Holds 604 stations. Shows dial settings, remarks, etc. Tuning suggestions. Station list by wave lengths in meters and kilocycles—by states, etc. Repair notes. Trouble aids. Other valuable information. So convenient. Worth many times small cost. A joy to use. Only \$1. Postpaid if pay with order. Money refunded if not delighted. Order today—now.

Radio Printers, Dept. 2029, Marengo, Ill.

Order Your January  
Radio Age Now—  
A New Model Set  
Coming



**SAVE** on all the latest Standard Radio Merchandise. Our 1926 Beautifully illustrated Catalog—**JUST OFF THE PRESS**—rush your name and address and get also **LOG BOOK FREE**

ECONOMY RADIO SALES COMPANY  
288 6th Ave., Dept. C. New York, N. Y.



**Free Mailing Lists**

Will help you increase sales. Send for FREE catalog giving counts and prices on thousands of classified names of your best prospective customers—National, State and Local—Individuals, Professions, Business Concerns.

**99% Guaranteed 5¢ each**  
by refund of 5¢ each

**ROSS-Gould Co.** 589 N. 10th St. St. Louis

\*  
**RAULF RADIO CONSOLE**  
MFG. CO. 562 VEDDER ST.  
CHICAGO. WRITE FOR CIRCULAR

**RADIO AGENTS  
WANTED**  
5 Tube Demonstrator FREE!

Earn \$25 to \$100 a week, part or full time. Everyone a prospect. Complete line standard sets and accessories, \$5 to \$90. Write today for illustrated catalog and exclusive selling plan for live dealers and community agents. 20TH CENTURY RADIO CO., 1021 Coca Cola Bldg., Kansas City, Mo.



**RADIO AGE ANNUAL FOR 1924—AT SPECIAL PRICE!**

Clip the coupon and send it with 50 cents, and the RADIO AGE ANNUAL FOR 1924 will be sent you by return mail.

RADIO AGE,  
500 N. Dearborn St., Chicago.

Enclosed is 50 cents, for which send me the RADIO AGE ANNUAL for 1924.

Name.....

Address.....

City.....

**Christmas on the Air!**

—are Your Tubes In Shape?

At Christmas Tide! Listen to sweeter "Christmas Carols"—clearer chimes and more celestial music broadcast by the great cathedral choirs throughout the land.

**A Rhamstine ★  
TUBE BOOSTER**

will renew your old tubes with all the pep and freshness of new ones. Just put them in the socket and turn on the current—do it once a month—it will treble the life of your tubes and give you better distance, volume, and a tone as clear as a bell at all times. It will pay for itself in a few days.

Works on any alternating current 110-120 volts, 50-133 cycles—201-A or 199 Type Tubes.  
Send no money—check the coupon below—pay on delivery.



Rhamstine ★  
Tube  
Booster  
Only  
\$6

**Rhamstine ★ "B" Rectifier**  
(Eliminates "B" Batteries)



Price Only  
\$25  
(Tube not included)

Eliminates all your "B" Battery troubles such as recharging, dead cells,

and chemical action. A Rhamstine ★ "B" Rectifier will more than take the place of a "B" Battery—it will give continuous and uniform current year in and year out with absolutely no trouble at all. Small, compact, good looking, endorsed by the leading radio manufacturers, and reasonably priced. You should have one.

Send no money—just check the coupon.

Tube Boosters are Trade Boosters. DEALERS—write for our attractive proposition.

J. THOS. RHAMSTINE ★ (12)  
504 E. Woodbridge,  
Detroit, Mich.

Please send me

— Rhamstine Tube Booster at \$6.

— Rhamstine "B" Rectifier at \$25.

by express C. O. D., subject to inspection. If not entirely satisfied with the "B" Rectifier I will return it to you in five days and receive a refund of full purchase price.

Name.....

Address.....

**J. THOS. RHAMSTINE ★**  
Radio and Electrical Products  
504 E. Woodbridge Detroit, Mich.

**Grid Leak and Condenser  
Now Combined**

One of the improvements in radio devices brought out this season is the new Daven "Leakandenser," an unique device which combines in a most attractive form, a grid leak and a grid condenser. The Leakandenser attracted considerable attention at the recent New York Radio Show. It is similar in size and shape to the conventional cartridge type of grid leak, with metal end caps, and may be mounted conveniently in the set by means of two spring clips supplied with the unit.

In construction it consists of a hollow bakelite spool, within which a Daven grid leak is suspended. Each end is threaded and fits into a nickel plated terminal cap. Around the outside of the spool, and connected to the end caps, is the grid condenser, which is formed by two separate and insulated wires, wound parallel in a single layer. One wire connects with one terminal and the other with the other terminal; each wire of course having its other end open. There being no physical contact between the two wires, they form a condenser, the capacity of which has been designed to be just right to function properly as a grid condenser.

Grid condensers in the past have been criticised for their lack of uniformity in capacity, their susceptibility to injury during soldering operations and the tendency to alter in capacity under various conditions after installation. These troubles have been remedied in the new Daven unit by the unique method adopted to obtain the condenser effect. Leakandensers are made with five different values of grid leak—2, 3, 4, 5, or 7 megohms, so that a selection may be made suitable for any detector tube. The Leakandenser takes up less space, is infinitely easier and more convenient to install, and makes the set look better.

**New "A" Power Unit  
—Made by Gould**

The Gould Storage Battery Company, 250 Park Avenue, New York, are now placing on the market a highly perfected "A" power unit which they term Unipower.

It is not a battery eliminator but is an "A" power unit that automatically converts house lighting current into radio power of constant, full voltage. It is a single compact unit, enclosed in a beautifully finished gas-tight case that fits comfortably and safely inside most radio cabinets. There are no tubes, bulbs, lamps or working parts that require frequent replacement.

A single master control switch operates both the radio set and Unipower. When the radio set is on, the house current is off—when the set is off, the house current is on.

It is impossible to damage Unipower through the failure to add water when necessary. When this happens, the charger automatically cuts off and prevents harm to the battery unit. Unipower is supplied in the models for 60-cycle, 110-125 volt A. C. Each model is equipped with a Bakelite charger of special design. Models are also made of the 25-50 cycle lines.

January Model Receiver  
Will Be a Revelation  
Order Your Copy Now  
from Your Newsstand



CONDENSERS  
VERNIERS  
RHEOSTATS

AMSCO PRODUCTS, Inc. New York City

**EFFICIENCY**

That Meet8 the Require-  
ments of Eminent  
Radio Engineers

Apex Vernier Dials are more than mere "knobs." In reality they are instruments endowed with an ultra degree of efficiency. Their rich elegance of finish lends a touch of striking attractiveness to any set. Precision of production and of operation makes a good set a better set—providing greater range of selectivity—positiveness of control—and utmost simplicity of tuning in most difficult stations. Ratio 12 to 1. Clockwise and counter clockwise. No back lash. Royal Brass finish 4-inch \$1.50—3 1/4-inch \$1.25. Satin Silver Finish 4-inch \$1.75—3 1/4-inch \$1.50. DeLuxe Gold (24K) Finish 4-inch \$2.50—3 1/4-inch \$1.85. Your dealer has them. If not, order direct.

**APEX Rheostat Dials**

are essential to successful operation and pleasing appearance as are Apex Vernier Dials. Royal Brass Finish—60c. Satin Silver Finish—70c. DeLuxe Gold (24K)—80c.

APEX ELECTRIC MFG. CO.

Dept. 1211

1410 W. 59th Street

CHICAGO







A Six Tube  
IN CONSOLE  
**\$125 LIST**  
(With Loud Speaker) \*

## DIANA "SIX"

A perfect set in a beautiful cabinet. A real six tube set. Two models. Cabinet Grand \$100 list. Console as shown above with loud speaker, \$125 list. A long distance set. Easy to tune.

### Exclusive Territory Open

Write for Liberal Discount and splendid Sales Proposition. Booklet R-A upon request.

**DIANA RADIO COMPANY**  
1429 So. Michigan Ave., Chicago

## Broadcast Waves to Stay "Put"—Hoover

WASHINGTON, D. C.—Secretary Hoover is not contemplating another general reallocation of broadcast wavelengths or frequencies. Unless a large majority of radiodom decrees otherwise or another conference recommends a change, he is disposed to leave the situation as it is today with a ten kilocycle separation between the radio-telephone channels.

Judge S. B. Davis, Acting Secretary of the Department of Commerce, who aids the Secretary in the administration of radio, explained that the Department would not change the broadcasting channels again, despite recent reports and rumors to the contrary.

If the slate were clean, so to speak, or there were no broadcasters on the air today, and the Department was about to inaugurate broadcasting, it would undoubtedly assign all class B stations wavelengths separated by fifteen kilocycles, limiting the number of stations which might broadcast and insuring better reception for all, but unfortunately this is not the case; there are 563 stations on the air and more clamoring to open. During its recent experiments, the Department experts tried to create additional wavelengths by decreasing the separations to seven kilocycles, only to find that the spaces were too narrow between the wave channels to insure good reception and minimum interference. So the plan was given up.

The Departmental Officials realize that transmission and reception would be better if the wave channels were fifteen kilocycles apart instead of only ten, but if greater separation between the stations was made, congestion and consequently interference would soon be worse. That is the one thing these radio experts wish to avoid. If the 83 Class B stations were assigned new wavelengths with a separation of fifteen meters, there would be fewer broadcasting routes; some stations would have to get off the air or divide time further with each other. There are only 47 channels available for the 83 B broadcasters, which requires that they double up. Actually 68 are now splitting time, and there are still applications for Class B privileges on file. Fans would soon raise a cry of protest if some of the nationally known efficient stations which put out high-class programs were made to share their wavelengths or time with inferior or new broadcasters.

The broadcast wave band from 545 to 205 meters cannot well be extended upward, else it would interfere with the "SOS" marine distress call on 600 meters; if pushed further downward, it would encroach upon the band assigned to the amateurs, who have already been ousted from their original channels.

But there is another reason why the broadcast band cannot be widened; it is on account of the limits of average radio receiving sets, many of which, although rated as capable of receiving on any wave between 600 and 200 meters, are not efficient at both extremes.

**To-day  
-in every  
good set!**

**Every Tube  
\* Full of Life!**

What a wonderful difference AMPERITE makes! Every tube is so brimful of snap, so eager to deliver 100% value. Individual tube regulation to meet each tube's individual needs is the answer. And only AMPERITE can fill that requirement. Permits the use of any type or combination of tubes. Specified in all popular construction sets. Price \$1.10. There is an AMPERITE for every tube

Write for free hook-ups

**Radiall Company**  
Dept. R. A.-12, 50 Franklin St., N. Y. City

**AMPERITE**  
REG. U.S. PAT. OFF.

The "SELF-ADJUSTING" Rheostat

# Amperite No. 1 A

## Used in the Radio Age Model Receiver "H"

Featured in this issue

See Page 7



## 'RADIO Storage "B" Battery

**32 Cells** Lasts Indefinitely—Pays for Itself  
24 Volts Economy and performance unheard of before. Recharged at a negligible cost. Approved and listed as Standard by leading Radio Authorities, including Pop. Radio Laboratories, Pop. Sci. Inst. Standards, Radio News Lab., Lenox, Inc., and other important institutions. Equipped with Solid Rubber Case, an insurance against acid and leakage. Extra heavy glass jars. Heavy, rugged plates. Order yours today!

**SEND NO MONEY** Just state number of batteries wanted and we will ship day order is received. Extra Offer: 4 batteries in series (96 volts), \$12.75. Pay expressman after examining batteries. 6 per cent discount for cash with order. Mail your order now!

**WORLD BATTERY COMPANY**  
1219 So. Wabash Ave., Dept. 81, Chicago, Ill.  
Makers of the Famous World Radio "A" Storage Battery  
Price: 6-cell, 100 Amp. \$12.25; 120 Amp. \$14.25; 140 Amp. \$16.00.  
All equipped with Solid Rubber Case.

**World** FOR RADIO  
STORAGE BATTERIES

**ARROW BATTERY**

**WRITTEN 2-YEAR GUARANTEE**

**Battery Prices SMASHED!**

To Consumers Only  
Here is a real battery quality, guaranteed to you at prices that will astound the entire battery-buying public. Order Direct From Factory. Put the Dealer's Profit in your own pocket. You actually save much more than half, and so that you can be convinced of true quality and performance, we give a **Written 2-Year Guarantee**. Here is your protection! No need to take a chance. Our battery is right—and the price is lowest ever made. Convince yourself. Read the prices!

<b>Auto Batteries</b>	<b>Radio Batteries</b>
6 Volt, 11 Plate, \$9.50	6 Volt, 100 Amp, \$9.50
6 Volt, 15 Plate, 11.50	6 Volt, 120 Amp, 11.50
12 Volt, 7 Plate, 13.00	6 Volt, 140 Amp, 13.00

**Buy Direct—Send No Money**  
We ask no deposit. Simply send name and address and style wanted. Battery will be shipped same day we receive your order Express C.O.D. subject to your examination on arrival. Our guarantee accompanies each battery. We allow 5% discount for cash in full with order. You cannot lose! Send your order today—NOW!

**ARROW BATTERY CO.**  
Dept. 12, 1215 So. Wabash Ave., Chicago

**ARROW BATTERY**





Patented Nov. 18, 1924

Windsor Loudspeaker Console

## For EVERY Radio Set

A stunning piece of furniture that restores order in the room where you have your Radio! No more cluttered table-tops, nor litter of equipment under-foot.

No unsightly horn in evidence, either! This console has its own loudspeaker, in-built. It's out of sight, but with very apparent tonal superiorities. For it has the highest-developed type of unit. With horn built of special non-vibrating, extra-hard, ceramic material. Produces clear non-vibrant tone.

There's ample room for everything; space for largest A and B wet batteries—or battery eliminator—required for any home set; and for a big charging outfit, too.

Finished in mahogany, or walnut color. Dainty design of parquetierie on two front panels. Top, 38 in. x 18 in. Substantially built; the product of a 40-year-old furniture maker.

The price, forty dollars, is for the complete console and includes the loudspeaker horn and unit. Thousands of dealers are showing this artistic addition to home radio equipment.

Rear View—Set Hooked Up



Price, \$40  
West of Rocky Mts., \$42.50

Windsor Furniture Co.  
1428 Carroll Ave.  
Chicago, Ill.

## The New Word in Radio

In radio, "kilocycle" is gradually taking the place of "wavelength" says the Bureau of Standards, Department of Commerce. All listeners and users of sets will want to know and understand the new rating which increasingly governs their tuning in. The making or logging of dials is found to have certain advantages when in the newer terms. Already one of the oldest stations is announcing its broadcasts on the "kilocycle" or frequency rating. It is really quite simple, for frequency (waves per second) replaces wavelength (in meters).

Just as a musician can vary the number of oscillations of his vocal chords but cannot control the length of the sound waves, which vary with the medium, so a radio station can vary the number of oscillations per second, and let the wavelengths be what they will. A high tenor "C" gives sound waves 2 feet in length but the standard rating is frequency, or pitch, in this case 512 vibrations per second. Frequency is the number of waves produced per second, the number of waves on the air after one second of transmission. "Kilocycle" means a thousand cycles, hence a broadcast on a 500-kilocycle frequency emits 500,000 radio waves per second.

To aid radio amateurs and experts the Bureau of Standards is about to issue a table so that all can, at a glance, translate from the old rating by "wavelength" (in meters) into the new rating by frequency (in kilocycles), and vice versa. Radio waves travel with the speed of light, about 300,000 kilometers per second. This is the sum of all the waves emitted in one second. Dividing this by the wavelength gives the frequency; dividing by the frequency gives the wavelength.

The bureau gives the simple rule to obtain the frequency when the wavelength (in meters) is known: Divide 300,000 by the wavelength in meters. The answer is in kilocycles. Likewise the other way around; divide 300,000 by the number of kilocycles to get meters. It is interesting that the ratio is the same both ways; 100 meters equals 3,000 kilocycles; 100 kilocycles is 3,000 meters.

## Inexpensive Tube Test Set Made by Jewell

An interesting booklet, known as 15-A has just been issued by the Jewell Electrical Instrument Co., of Chicago, for the information of the radio trade and experimenters.

The Jewell Company has placed on the market a simple tube tester, known as Pattern 110, which should meet the demand for an inexpensive tube test set desired by many of the experimenters in the game, as well as the dealers. It is fully described in the 15-A booklet.

- New Coils
- New Condensers
- Easier Control
- Watch for the January Radio Age Model Set



All Standard Types \*  
\$2.50

CLEARTRON

GUARANTEED RADIO TUBES

Cleartron is the only radio tube sold under an Iron-Clad Guarantee of perfect service or instant replacement.

At All Reliable Dealers.  
Write for Free size page tube folder.  
Hi-Constrol Model C-T 101A—\$3.00. The original Hi-Mu Tube for Resistance-Coupled Amplifiers.

CLEARTRON VACUUM TUBE COMPANY  
Executive Offices, 28 West 44th Street, New York City.  
Factories: West New York, N. J., U. S. A. Birmingham, Eng.

## FOR BETTER RECEPTION

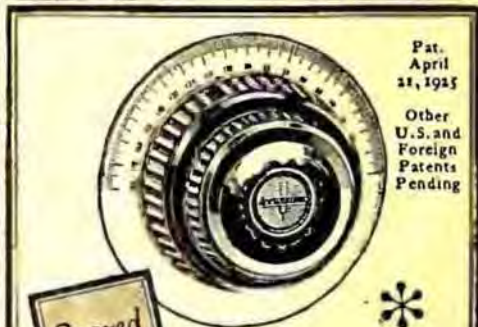

Pat. April 11, 1925

Other U.S. and Foreign Patents Pending

Geared 80 to 1  
Ideal

**THE ACCURATUNE**  
Is ideal for coarse or extremely fine tuning, segregating even those stations now so closely grouped on the lower wave lengths; it brings them in with absolute precision. Volume and clarity are matters of course to the Accuratune. Quickly substituted without alteration of your set.

MYDAR RADIO CO.  
17 CAMPBELL ST., NEWARK, N. J.

**ACCURATUNE**  
REGISTERED TRADE MARK U.S. PAT. OFF.



# CLASSIFIED ADVERTISEMENTS

If you have anything to buy or sell, don't overlook the value of RADIO AGE'S classified advertisements. Many such messages have paved the way to independent incomes.

The classified advertising rates are but ten cents per word for a single insertion. Liberal discounts are allowed on three, six and twelve-time insertions, of five, fifteen and thirty per cent respectively. Unless placed through an accredited advertising agency, cash should accompany all orders. Name and address must be included at foregoing rates and no advertisement of less than ten words will be accepted.

All classified ads for the January issue must be sent in by December 1.

## ADVERTISING SERVICE

QUEX Sales Letters Get More Business. Write him today. Quex, 4418 Michigan Ave., Chicago.

## AGENTS WANTED

FORDS. 60 miles on one gallon of Gas. It has been proven such mileage can be made. AIRLOCK guarantees to increase gas mileage; also prevents radiator boiling in summer or freezing in winter. Cools, Fuels, Decarbonizes the Ford motor. Splendid territory open. AIRLOCK PRODUCTS, Box 703G, Willow Street, Long Beach, Calif.

RADIO—Join our sales organization and make big money. We want a man in every county to sell well advertised sets and parts made by the leading manufacturers. Widenar of Kansas City makes \$150.00 weekly. You can do as well or better. Write today for catalog and discounts. Name your county. Waveland Radio Company, Div. 52, 1027 No. State St., Chicago, Ill.

MANUFACTURER'S AGENT calling on Radio-Electrical Jobbers, Chicago and vicinity, has opening for 3 additional lines carrying volume business, as we cater to large jobbers. Edelstein, 1804 McCormick Bld., Chicago.

Man wanted for this territory to sell wonderful value men's, women's, Children's shoes direct, saving consumer over 40%. Experience unnecessary. Samples supplied. Big weekly permanent income. Write today Tanners Mfg. Co., 1334C St., Boston, Mass.

RADIO SALESMEN and SET BUILDERS in every county write Grenzer Radio, 1479 Hodiament, St. Louis, Mo.

AGENTS—90c AN HOUR TO ADVERTISE AND DISTRIBUTE samples to consumer. Write quick for territory and particulars. American Products Co., 4202 American Bldg., Cincinnati, Ohio.

## "B" BATTERIES

100 VOLT EDISON TYPE "B" BATTERY, knocked down. Parts and plane—complete, \$12.50. Lane Mfg. 2937 W. Lake, Chicago.

BATTERIES FOR SALE—Four 24-volt "Main" Storage "B" Batteries, never used, shipped and ready to wire for \$38.00. First order gets the batteries. Address Box B, Radio Age, 500 N. Dearborn St., Chicago, Ill.

## BUSINESS OPPORTUNITIES

\$100 weekly up. We want experienced Radio men to operate branch assembling plants. Part or whole time. Barfield Radio Co., 13 Tillery Street, Dept. A R, Brooklyn, New York.

WE WILL START YOU IN THE RADIO BUSINESS IN your community at a cost within the reach of anyone. Quick, steady profits assured from the start. Here is a real chance to make big money in radio this season. Write for details, at no obligation. KELLY RADIO SUPPLY CO., 3312 Warren Ave., Chicago, Ill., Box 11B.

Classified ad. copy for the January RADIO AGE must be sent in by December 1, 1925.

## CRYSTALS

Supersensitive Galena Crystals: Pound \$1.00, prepaid. ALKEMITE. Allsensitive Crystals 50c. Buskett, Geologist, Joplin, Missouri.

## HELP WANTED

RADIO SALESMEN and SET BUILDERS—We need you and you need us. If you are reliable and well known in your community, we will appoint you our representative and furnish you with standard well advertised sets and parts at prices that will enable you to sell at a handsome profit. Write at once for catalog and sales plan. Waveland Radio Co., Div. 53, 1027 N. State St., Chicago, Ill.

MEN wanting forest ranger, railway clerk and other government positions, write for free particulars of exams. Mokane, Dept. B-33, Denver, Colo.

MEN WISHING TO ENTER DINING, SLEEPING CAR SERVICE AS CONDUCTORS, PORTERS, WAITERS, WRITE 123 RAILWAY EXCHANGE, KANSAS CITY.

## INVENTIONS

NEW IDEAS WANTED—Well known Radio Manufacturer whose products are nationally advertised and sold everywhere wants new Radio device to sell. Will pay outright or royalty for idea or invention which is really new and saleable. Address: Mr. R. F. Davine, Room 1101, 116 West 32nd St., New York, N. Y.

## PATENTS

FOR SALE: U. S. and Canadian Patent on an Attachment for Phonographs: is the most beautiful invention of the age. Address Chas. F. Smith, Huff, N. Dak.

## PRINTING

WE print Stationery, Booklets, Catalogs, Circulars, Samples. Commercial Press, Batavia, Ohio.

## RADIO

A PRACTICAL TUBE RECEIVING SET FOR \$10. Postpaid, less phones and tube. Complete with phones, tube and battery. \$18.00. J. B. RATHBUN, 1067 Winona St., Chicago, Ill.

Standard solderless radio Jacks. Binding post attachments. Double circuit. One dollar bill. Postpaid. Clinton Seward, Jr., New Paltz, New York, N. Y.

Three Cosmopolitan Phasiformers, each \$5.50, book of instructions included. F. A. Mall, Triopi, Iowa.

15 to 25 per cent discount on nationally advertised sets and parts. Every item guaranteed. Tell us your needs. IMPERIAL RADIO COMPANY, Delaware, Ohio.

RADIO SETS. Our prices save you money. Lists free. The Radio Shoppe, Box 645, East Liverpool, Ohio.

AT LAST! The Radio Static Eliminator. Eliminates 50 to 90% Static. Many satisfied users. Write for particulars. Radio Specialties Company, Sioux Falls, South Dakota.

\$1.00 For Your Old Tubes regardless of make or condition towards the purchase of each new Standard \$2.50 tube. Positively guaranteed. We do not sell rebuilt or bootleg tubes. Order today. Luxem & Davis Mfg. Co., 6229 Broadway, Chicago, Ill.

## RADIO CIRCUITS

### SPECIAL FOR NOVEMBER

The Rainerts Radio Booklet, by Frank D. Peerna, fully illustrated, and RADIO AGE, for \$2.50. Price of Booklet alone is 50c. Send check, currency or money order to RADIO AGE, 500 N. Dearborn Street, Chicago.

## RADIO DEALERS

DEALERS—Write for our illustrated catalog of reliable Radio Merchandise. Rossiter-Manning Corporation, Dept. D, 1830 Wilson Ave., Chicago, Ill.

## RADIO SUPPLIES

HAVE YOU SEEN THE NEW DIALITE, THE UNIQUE lamp that lights up your panel and adds a decorative touch to any radio set? Retail at \$2.75, complete. Send for folder and dealer's proposition on this fast moving article. Also, we are distributors for the famous Knurled Walnut Cabinets, the most beautiful cabinets made. American-Universal Radio Co., 6255 Broadway, Chicago, Ill., Box 11.

## SALESMEN WANTED

Make \$100 WEEKLY in spare time. Sell what the public wants—long distance radio receiving sets. Two sales weekly pays \$100 profit. No big investment, no canvassing. Sharpe of Colorado made \$955 in one month. Representatives wanted at once. This plan is sweeping the country—write today before your county is gone. UZARKA, INC., 126 F. Austin Ave., Chicago.

STAMPS, 50 varieties: Africa, Brazil, Peru, Cuba, Mexico, etc., 10c. 50 different U. S., 25c; 1,000 mixed, 40c; 1,000 hints, 10c. List free. C. Stegman, 5950 Cote Brillante, St. Louis, Missouri.

MANUFACTURERS OF NEW AND IMPROVED STATION finder and vernier tuning-dial want live salesmen to call on radio trade. Excellent side-line; good commissions; exclusive territories. Weterland Corporation, Dobbs Ferry, New York.

## WANTED

WANTED—To complete my set RADIO AGE need August, September, October, November, 1923, issues, bound or unbound. Advise price. Lloyd C. Henning, Hollbrook, Arizona.

## WIRELESS

WANT TO MEMORIZE THE WIRELESS CODE? The Coryden Snyder Code Method, Patented, is quickest. Send 50c coin, stamps or M. O. to C. G. Snyder, 1423 Elmwood Ave., Chicago, Ill.

TELEGRAPHY—Morse and Wireless—taught at home in half usual time and at trifling cost. Omnigraph Automatic Transmitter will send, on Sounder or buzzer, unlimited messages, any speed, just as expert operator would. Adopted by U. S. Govt. and used by leading Universities, Colleges, Technical and Telegraph Schools throughout U. S. Catalog free. Omnigraph Mfg. Co., 13 F Hudson St., New York.

## PERSONAL

LONELY HEARTS: Exchange letters; make interesting new friends in our jolly club. Eva Moore, Box 908, Jacksonville, Florida. Enclose stamp.

Look! You Radio Bug! Join Radio Correspondence Club. Entirely new. Broaden your acquaintance, exchange ideas. Membership open to LADY BUGS also. Dime stamp brings pamphlet and Radio Novelty Cards. Radio Rose, Box 662, Cleveland, Ohio.

## WRITERS

Make big money writing Movie Plays. Circulars free. W. C. Krus, Ashton, Illinois.

*Radio Age Classified Ads Bring Results*



# Steinite LOW LOSS Interference Eliminator

No Radio Set Complete Without It

Now you can select stations at will, cut out interference and undesired stations—tune in loud and clear. Wonderful results with any tube or crystal set using any kind of aerial except loop antenna. Partially absorbs static.



**\$1** Amazing Results, Better Reception Guaranteed or We Refund Your Post-Dollar. Send paid. Order Today

## Select Stations At Will

Try this Interference Eliminator on your set—no tools—nothing to add—attached in 2 minutes to aerial. Doesn't disturb present log. Directions easy to follow. Two big banks testify to our reliability. Order today—dollar bill will do—we take the risk—money back if you say so.

### STEINITE LABORATORIES

302 Radio Building, ATCHISON, KANSAS  
Write for complete Steinite Radio literature—it's FREE. Most beautiful and least expensive radio sets in America.

## Fourth Chicago Radio Show, Nov. 17-22

(Continued from page 73)

The fourth annual Chicago Radio Show is the official show of the Radio Manufacturers' Association, and it is expected dealers and jobbers from as far west as the Pacific coast will be on hand to make the acquaintance of the big men of the industry who will be present at this, the biggest radio show and gathering of manufacturers, dealers and jobbers ever held in the middle west.

### New York's 1926 Radio Show In Bigger Quarters

The radio industry next year will have its annual New York show in the finest exposition palace in America, according to Maj. Herbert H. Frost, president of the Radio Manufacturers' Association. A lease has just been signed on the new Madison Square Garden and Exposition Hall, now nearing completion as the successor to the famous old Madison Square Garden.

The radio show will occupy the entire two floors of the new structure. The larger exhibits will be displayed in the Grand Arena, 285 feet long and 110 feet wide. This floor is larger than the old Garden. The Exposition Hall, 376 feet long and 200 feet wide, built expressly for the housing of the largest trade shows, will also be used. This will make in all a total of about 102,000 square feet of exhibition space. The rental is the highest ever paid by a trade show.

This tremendous space will be necessary because all the leading manufacturers are centering on this show, the industry being opposed to the holding or more than one show in each city each year. Heretofore there have been two shows annually in New York.

### Amateurs Help

Minneapolis, Minn.—The Twin Cities Radio Club, a joint organization of transmitting radio amateurs of this city and St. Paul, served in a helpful capacity during the recent Twin Cities Radio Show, when, during the course of the show they handled over 700 messages from patrons of the show. These messages were started on their way to all parts of the United States via the medium of American Radio Relay League member stations. The Twin Cities club is allied with the League.

# Yours-free!



**WRS 96-PAGE RADIO GUIDE BOOK**  
Profusely illustrated, "cocktail" of data for the radio fan.

Trouble Shooting Chart. Complete New List of Broadcasting Stations. Log Chart—and details of newest apparatus and hundreds of

**Exceptional Radio Values on our**

### MONEY BACK GUARANTEE

From bus bar to the finest multi-tube set, we carry one quality—THE FINEST! EVERY article represents 100 cents worth of value for every dollar you invest! EVERYTHING purchased from WRS is guaranteed. Your Money is still YOUR Money until you are thoroughly satisfied in every way.

WRS IS HEADQUARTERS FOR KITS AND SETS

Cockade Super  
Cockade D. X.  
Utrodyne  
Roberta's Knock-Out

EVERY STANDARD RECEIVER

Neutrodyne  
Superdync  
Dressley Super  
Rials

**FREE** A postal brings you our latest radio guide book. Costs you nothing. Write for it TODAY.

**WHOLESALE RADIO SERVICE CO.**  
6 Church St. Cat. R. A. 10, New York City

# PATENTS

## To the Man with an Idea

I offer a comprehensive, experienced efficient service for his prompt, legal protection and the development of his proposition.

Send sketch of model and description, for advice as to cost, search through prior United States patents, etc. Preliminary advice gladly furnished without charge.

My experience and familiarity with various arts frequently enable me to accurately advise clients as to probable patentability before they go to any expense.

*Booklet of valuable information and form for properly disclosing your idea free on request. Write today.*

**RICHARD B. OWEN, Patent Lawyer**  
81 Owen Bldg., Washington, D. C.  
2278-M Woolworth Bldg., N. Y. City

### MARVELOUS NEW AUDIO TRANSFORMER

adds musical quality to any set far beyond anything you ever heard before.

**KARAS HARMONIK**  
Amplifies low, middle and high tones—all to the same big volume, thus eliminating distortion. Brings out the vital harmonics and overtones of music. Price \$7.00. Write Karas Electric Co., Dept. 58-93 4042 N. Rockwell St., Chicago

### MASTERTONE RADIO TUBES \$2.00

ALL TYPES GUARANTEED  
Dealers' Proposition  
Dextron Radio Lab.  
74 Sterling, Dept. R. A.  
East Orange, N. J.

—Radio Nut's Headquarters—Parts only, no sets. \$20,000 stock. Most comprehensive. If you can't find it, ask us. Weekly latest "dope"—10 wks. 50c. "Change your Neut" Kit—\$5 prepaid. Particulars—10c. 48 page parts catalog—10c. Knock Down Loop Kit—\$7.50. 150 v., 55 milamp B Eliminator, off 110 v. a. c., knock down kit including 2000 hr. Z 50 tube—\$36.55. Assembled, ready to use—\$40. Data—10c. Kladag Radio Laboratories, Kent, Ohio.

*nothing like this radio set has ever been known before*

*You can build it yourself!*

"A new 5-Tube Set with all the power and none of the grief of the Supers!" —wrote Henry M. Neely, Editor of Radio in the home, Philadelphia

# Get This Book

Write today for this big fascinating 32-page booklet which tells how you can build the truly amazing new **QUADRAFORMER** receiver. Based on a new radio principle, five tubes give remarkable results.

Enclose 10c and you'll have it by return mail

**Gearhart-Schlueter Radio Corp'n**  
713 Voorman Avenue, Fresno, California

# Free 60-page Reference Book

## POLK'S REFERENCE BOOK FOR DIRECT MAIL ADVERTISERS

Mailing List Catalog No. 55

**POLK'S REFERENCE BOOK FOR DIRECT MAIL ADVERTISERS**  
Shows how to increase your business by the use of Direct Mail Advertisers. 60 pages full of vital business facts and figures. Who, where and how many prospects you have. Over 8,000 lines of business covered.

Write for your FREE copy.

**R. L. POLK & CO., Detroit, Mich.**  
599 POLK DIRECTORY BUILDING  
Branches in principal cities of U. S.

## The January Radio Age Model will Be Easier to Build



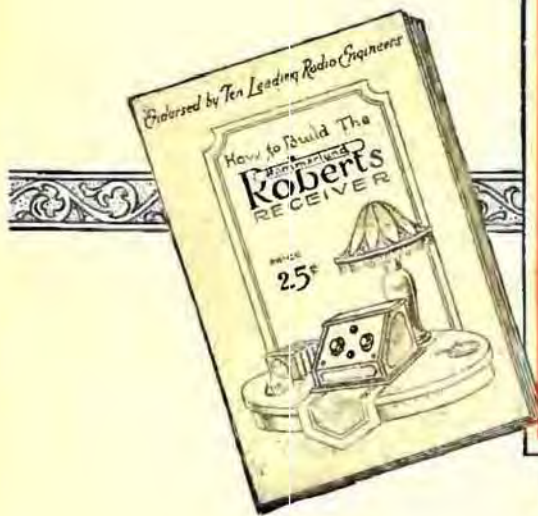

**Write for This  
"How To Build"  
Book**

You will find it surprisingly easy to build the Hammarlund-Roberts Receiver from this instruction book. Fully illustrated throughout; gives complete information on assembling, wiring and operation. . . . **25c**

**Associate  
Manufacturers**

- All-American Radio Corp.
- Alden Manufacturing Co.
- Radiall Co.  
(Amperites)
- Carter Radio Co.
- Union Radio Corp.
- International Resistance Co. Inc.  
(Durham Resistors)
- Westinghouse Micarta
- Hammarlund Mfg. Company, Inc.

# Every Part Designed by a Specialist

**N**O ordinary standards of five-tube reception or ease of operation can be applied to the Hammarlund-Roberts Receiver. It compels so complete a revolution in all previous ideas of performance and value that you can understand its sensational results only through a personal experience.

Every single unit that goes to make up this remarkable receiver was chosen by a specialist after months of research. The transformers were selected by an engineer familiar with every reliable make; the condensers by a man who had made a special study of condenser constructions and functions. So it was even with the smallest, usually neglected units. From the work of these engineer-designers, backed by the endorsements of ten famous radio parts manufacturers, comes the Hammarlund-Roberts, a receiver that is truly the ultimate in five-tube possibilities. The equal of any standard eight tube set, in selectivity and volume—so simple in design and operation that anyone might construct it. Priced amazingly low, the Hammarlund-Roberts offers the greatest value possible in the radio field today.



This instrument and other parts shown are some of the famous units used in the Hammarlund-Roberts.

# Hammarlund Roberts

HAMMARLUND-ROBERTS, 1182-D Broadway, New York

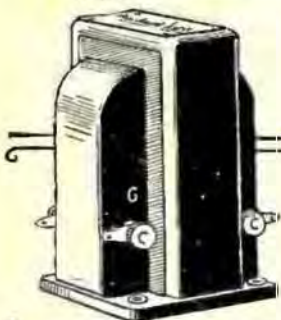

**NA-ALO**

Dials and  
Sockets



**Carter**

Switches  
and Rheo-  
stats



**UNION**

The most efficient  
Phone Tip Jack.



**DURHAM  
RESISTOR**



# For some—a “radio”

# For others—Zenith!



### Super-Zenith IX

Built-in Zenith loud-speaker;  
ample compartments for dry  
and storage batteries.

Super-Zeniths priced from \$240 to \$355.  
DeLuxe Art Model Cabinets from \$500 to \$2,000  
Other Zenith Sets \$100 and \$175



### New Zenith De Luxe Chinese Model

Equipped with two built-in loud speakers, Bates  
Rotary Log, illuminated dial, single control  
specially constructed Zenith Radio Circuit.

Some prefer the blare of a circus band—or the friendly jangle of a hurdy-gurdy. To them it is the only music.

Those who delight in blare and jangle do not need a Zenith—but they will find that even such music rings truer to their ears brought in by Zenith radio.

Others go breathless at the golden notes of a lyric soprano—or the rapturous harmonies of a great symphony.

Such people—born with a love for music—should never content themselves with any radio instrument less fine than Zenith.

Zenith's appeal to the eye is instant—and enduring. Its clear, sweet tone is a revelation.

To see and hear one of the new Super-Zeniths for the first time is a memorable experience. Yet that experience is yours for the asking—in your own home if you so desire.

Simply telephone your nearest Zenith dealer.

Again Commander Donald B. MacMillan chose Zenith for his Arctic Expedition. When human lives may depend upon the reliability of radio performance, only one reason can explain his choice: Zenith has proved to be the best obtainable at any price.

ZENITH RADIO CORPORATION  
Straus Building, Chicago

**ZENITH**  
—LONG DISTANCE—**RADIO**

It Costs More  
But It Does More!







**This file including all text and images are from scans of a private personal collection and have been scanned for archival and research purposes. This file may be freely distributed, but not sold on ebay or on any commercial sites, catalogs, booths or kiosks, either as reprints or by electronic methods. This file may be downloaded without charge from the Radio Researchers Group website at <http://www.otrr.org/>**

**Please help in the preservation of old time radio by supporting legitimate organizations who strive to preserve and restore the programs and related information.**