

Blueprint Section Every Month

RADIO AGE

The Magazine of the Hour



JULY
1925
25¢

In This Issue—

Ten Commandments
for the Listener

A New Super-Heterodyne
Solving Tube Troubles

News of Radio Age's
Popularity Contest

ANKER
PAUL
MEHLUM
1925

MEET YOUR BROADCAST FAVORITES

SUPER-SM AUTODYNE

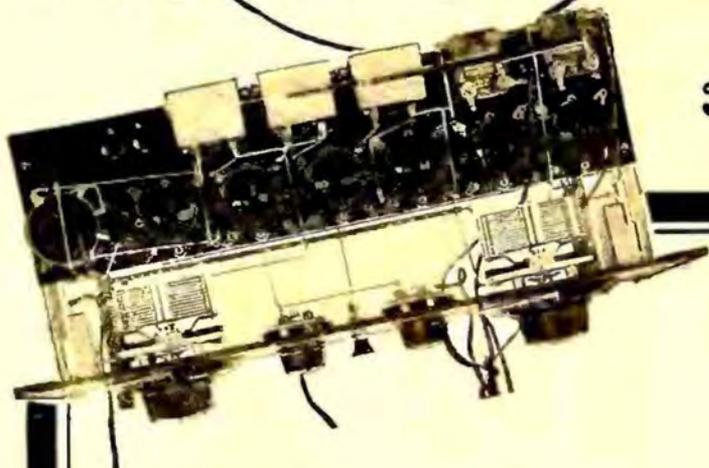

New!

A Perfected Super-Heterodyne

Again Silver-Marshall Engineering leads the field, just as it has since the first Silver Design was offered less than a year ago.

Not content with a seven-tube super-heterodyne, which has become the acknowledged standard of comparison with radio engineers and editors, McMurdo Silver, Assoc., I. R. E., has developed "The Super-Autodyne," a six-tube receiver that will outperform average seven and eight-tube sets.

Read the description of this remarkable radio achievement in this issue of "Radio Age." Plans and instructions describing this set in detail may be had for 50c.

Complete Parts

	Each		Each
2 S-M 305A S-L-W Condensers	\$ 5.00	2 Thordarson 3 1-2-1 Transformers	\$ 4.00
2 4" Moulded Dials	1.00	2 .002 Condensers	.40
1 U. S. L. 6 Ohm Rheostat	1.00	1 .0075 Condensers	.75
1 U. S. L. 240 Ohm Potentiometer	1.50	2 .000025 Balancing Condensers	1.50
3 Insulated Top Binding Posts	.05	1 S-M 25 Meg. Leak	.50
1 Carter 101 Jack	.70	1 S-M 2 meg. Leak	.50
1 Carter 102A Jack	.80	1 Carter No. 3 Jack Switch	1.15
1 S-M 211 Filter with Matched Tuning Capacity	8.00	1 Benjamin 8630 Switch	.30
2 S-M Charted Intermediate Transformers	8.00	1 Belden Color cable	.85
1 S-M 101B Coupling Unit	2.50	1 Pair Benjamin 8629 Shelf Brackets	.70
1 S-M 6-Gang Socket shelf (536-201A, 537-UV199)	10.80	1 Bakelite panel, 7"x18"x3-16", drilled, grained and engraved	6.00
		Spaghetti, bus bar, lugs, screws, butts, etc.	1.00

Send for "The WHY of the Super-Autodyne"—It's Free;
Dealers—Ask for Our New S-M Catalog

*Trade
Mark

Silver-Marshall, 114 S. Wabash Avenue,
Chicago, Illinois

Stations Don't "Bunch" On the Dials

Showing stations "Bunched" as they are found on a 100 degree dial using any ordinary condenser.

The location of the same stations on the same dial using Ultra-LowLoss Condensers—"spread," simplifying tuning.

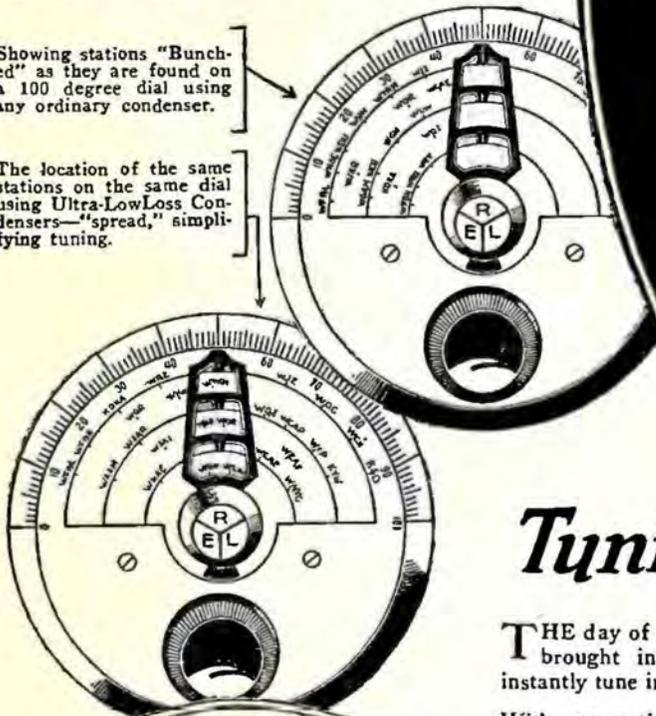

ULTRA-VERNIER TUNING CONTROL

Simplifies radio tuning. Pencil record a station on the dial—thereafter, simply turn the finder to your pencil mark and you get that station instantly. Easy—quick to mount. Eliminates fumbling, guessing. A single vernier control, gear ratio 20 to 1. Furnished clockwise or anti-clockwise in gold or silver finish.

Silver \$2.50

Gold \$3.50



This seal on a radio product is your assurance of satisfaction and a guarantee of Lacault design.

ULTRA-LOWLOSS CONDENSERS



\$5⁰⁰

PATENT PENDING

Tuning Simplified Now!

THE day of tedious fumbling about for your stations is past—science has been brought into play. Now, with the Ultra-LowLoss Condenser you can instantly tune in on any station as easy as turning the hands of a clock to the hour.

With one station of known wave length located on the dial, all others can be found instantly. Each degree on a 100 degree dial represents approximately 3½ meters difference in wave length. This applies to both high and low wave lengths. Other than 100 degree dials vary accordingly.

This simplification of tuning is made possible by the new Cutless Stator Plates to be found only in the Ultra-LowLoss Condensers. Every feature of the Ultra-LowLoss Condenser was developed with one predominating purpose—to overcome losses common in other condensers. Designed by R. E. Lacault, originator of the famous Ultradyne Receivers and Ultra-Vernier Tuning Controls.

At your dealer's, otherwise send purchase price and you will be supplied postpaid.

Design of lowloss coils furnished with each condenser for amateur and broadcast wave lengths showing which will function most efficiently with the condenser.

To Manufacturers Who Wish To Improve Their Sets

Mr. Lacault will gladly consult with any manufacturer regarding the application of this condenser to his circuit for obtaining best possible efficiency.

ULTRA-LOWLOSS CONDENSER

PHENIX RADIO CORPORATION, 116-B East 25th St.
New York City

RADIO AGE

The Magazine of the Hour

Established March, 1922

WITH WHICH IS COMBINED RADIO TOPICS

Volume 4 ✓

July, 1925

Number 7 ✓

CONTENTS

Cover Design by A. P. Ehlum

	Page
Radio Editorials.....	4
Four, Five or Six Tubes?.....	7
By Roscoe Bundy	
Learning Tube Characteristics.....	11
By H. Frank Hopkins	
How Much Coupling?.....	13
By Brainard Foote	
The Six-Tube Super-Autodyne.....	15
By McMurdo Silver	
Vacuum Tubes as Distortion Devices.....	18
By Dr. Peter I. Wold	
A Word on the Care of Batteries.....	19
A Simplified Portable Super-Het.....	21
By A. J. Haynes	
Tricks of Summer Static.....	24
"Gloria Confesses": A Photograph.....	25
RADIO AGE "What the Broadcasters Are Doing" Studio-Land Feature Section.....	26
RADIO AGE Institute Monthly Tests.....	34
RADIO AGE Blueprint Section.....	35
By John B. Rathbun	
Pickups and Hookups by Our Readers.....	43
With the Radio Manufacturers.....	69

Radio Age is published monthly by RADIO AGE, Inc.
Member: Audit Bureau of Circulations.

Address all communications to RADIO AGE, INC.
Executive, Editorial and Advertising Offices
500 N. Dearborn Street, Chicago, Ill.
Publication Office, Mount Morris, Ill.

FREDERICK A. SMITH, *Editor*
FRANK D. PEARNE, *Technical Editor*
M. B. SMITH, *Business Manager*

Advertising Director
HARRY A. ACKERBURG
500 N. Dearborn St., Chicago, Ill.

Eastern Representative
DAVIDSON & HEVEY, 17 West 42nd St., New York City

Final Advertising forms close on the 20th of the 2nd month
preceding date of issue

Vol. 4, No. 7. Issued monthly. Subscription price \$2.50 a year. July, 1925.
Entered as second-class matter at post office at Mount Morris, Illinois, under the
Act of March 3, 1879.

Copyright, 1925, by RADIO AGE, Inc.

A Chat With the Editor

YOU can count on the fingers of your two hands the basic radio receiver circuits from which all the many scores of hook-ups now existing may be developed. All those basic circuits are to appear in blueprint form in the August issue of this magazine. Our technical staff has selected the typical circuits which represent the various basic arrangements, most of which have appeared during 1924 and 1925 in RADIO AGE.

John B. Rathbun, the able draughtsman whose blueprints in this magazine have become standard in schools and in many thousands of radio homes, will have in this *de luxe* edition of RADIO AGE an exhibit of tested basic circuits which will make our August issue one of the most important radio contributions since broadcasting began. The blueprint section of the August number will itself be of almost the bulk of the regular magazine. With the addition of other standard RADIO AGE features the book will take on proportions that should delight the fan who wants his radio course from crystal to super, all under one cover.

Notwithstanding the unusual value offered in this big issue of our magazine the news-stand price will be the same as other issues; 25 cents. It is a matter of wide comment that RADIO AGE costs no more from month to month than other standard radio publications, although its blueprint section in each issue sets it apart from all other magazines. Now we are to offer you a complete collection of blue prints with complete constructional instruction in a single issue and for the regular price.

We would advise readers who wish to make sure of getting this remarkable August number that they tell their newsdealer to reserve their magazine for August NOW. If your dealer does not handle RADIO AGE write to us at 500 North Dearborn street, Chicago, enclosing 25 cents in stamps and we will mail you one on July 15, the day it goes on sale.

Frederick Smith

Editor of RADIO AGE

EVEREADY HOUR
EVERY TUESDAY AT 9 P. M.
(Eastern Standard Time)

For real radio enjoyment tune in the "Eveready Group." Broadcast through stations—

WEAF New York	WEAR Cleveland
WJAR Providence	WSAI Cincinnati
WEI Boston	WWJ Detroit
WFI Philadelphia	WCCO Minneapolis
WGR Buffalo	WOC St. Paul
WCAE Pittsburgh	WOC Davenport

Get a good set— and Evereadys

To ENJOY radio for the rest of your life, get the best set you can afford. There are receivers at all prices, made by reputable manufacturers; it isn't necessary for anyone to get 'round-the-corner, unproved, unreliable merchandise at any price. That applies to batteries too. Eveready Radio Batteries are made in so many sizes and prices that there is a correct, long-lasting Eveready for every receiver and for every radio home, ship or commercial station. Specify Evereadys for your new radio set. It is false economy to buy nondescript batteries at any time. In the long run you'll find it most economical to buy either the large or extra large Evereadys. Always buy Evereadys and enjoy the knowledge that no one can get any more in batteries for the money than you. There is an Eveready dealer nearby.

Manufactured and guaranteed by
NATIONAL CARBON CO., Inc.
 New York San Francisco
 Canadian National Carbon Co., Limited, Toronto, Ontario

EVEREADY Radio Batteries

—they last longer

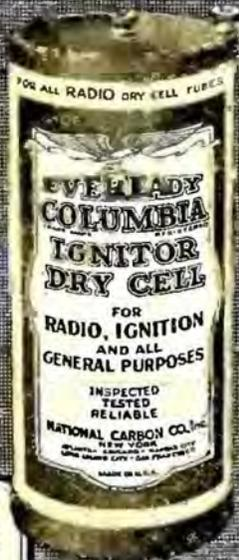

Eveready Columbia Ignitor the proven Dry Cell for all Radio Dry Cell Tubes 1½ volts

No. 766 22½-volt Large Horizontal Price \$2.00



No. 772 45-volt Large Vertical Price \$3.75



No. 771 4½-volt "C" Battery improves quality, saves "B" Batteries Price 60c

RADIO EDITORIALS

RADIO CORPORATION of America has completed its "proof" that in adopting the name RADIO AGE this magazine stepped on the eleven hoof of the corporation. The RCA contends that RADIO AGE, as a name, infringes on the name "Wireless Age," a publication owned by the Radio Corporation. Radio Corporation last fall brought formal action in the United States Patent Office at Washington opposing the application to have RADIO AGE registered as a trade mark.

The \$33,000,000 group apparently held the fond notion that RADIO AGE would immediately yield its rights, rather than go into a legal battle with one of the Four Horsemen of Radio. On the contrary, RADIO AGE engaged the services of several of the best lawyers obtainable and we have seen the thing through. On May 5, in the Corporation offices in New York, the Corporation completed the taking of testimony of its own witnesses. The Corporation labored and brought forth a peanut tube.

It was an imposing array of witnesses and we regretted that Mr. Sarnoff, vice president and general manager of the RCA horse, was unable to be present. Mr. Sarnoff was busy preparing for a banquet. He is a banqueteer of parts. No hungry Cassius he.

At the last Hoover conference, Charles E. Erbstein faced the representatives there present in the interest of the Radio Corporation. Westinghouse, General Electric and American Telephone and Telegraph, and told them they were the Four Horsemen of Radio.

The name stuck. A few weeks later Mr. Sarnoff and Mr. Erbstein were present at a radio dinner in New York. Mr. Sarnoff approached Mr. Erbstein and asked in a gently sardonic tone:

"Tell me; which one of the Four Horsemen am I?"

"Pestilence!" responded Mr. Erbstein in a flash.

"Not famine?" inquired Mr. Sarnoff, somewhat taken back.

"You, Famine? Never!" murmured Mr. Erbstein.

So, on the occasion of the taking of depositions calculated to prove that RADIO AGE is guilty of unfair competition and is injuring the business of "Wireless Age," Mr. Sarnoff was preparing for another banquet.

It was necessary that the RCA witnesses swear to facts that would support the contention that the words "wireless" and "radio" mean the same thing. If this were proved, Radio Corporation might hope to get somewhere with its argument that in adopting the name, RADIO AGE, this magazine was appropriating, in effect, the name "Wireless Age," which does not belong to this magazine, but belongs to the New York monthly wireless publication, every share of stock in which is owned by Radio Corporation.

The witnesses then swore "wireless" and "radio" meant the same thing. No distinction whatever so far as the man on the street was concerned. But it developed, on cross examination, that all the witnesses were on the payroll of the Corporation and therefore could not well be criticised if their expert views on the significance of words partook of the same general tendency as the views of the kind and loving old Radio Corporation.

It also was necessary to prove that the use of the name RADIO AGE was causing injury to the business

of Radio Corporation's magazine, which, they assure us, is called "Wireless Age." Therefore, a witness testified that newsdealers get the two magazines all mixed up and that although one is published in New York and the other in Chicago, dealers often send unsold copies of RADIO AGE to "Wireless Age." The circulation manager of "Wireless Age" produced one letter in support of this contention. He said he had looked hard for other documentary evidence of the universal confusion between RADIO AGE and "Wireless Age" but the one letter was the best he could do.

Another Corporation employe swore that at the Pageant of Progress in 1922 he heard subscription solicitors in the RADIO AGE booth telling the gullible public that RADIO AGE was published by the Radio Corporation of America. This witness testified he immediately complained to the manager of the Pageant that the RADIO AGE solicitors were telling naughty little lies. So, he testified, the manager threw the solicitors out of the Pageant, and the RADIO AGE booth remained empty and free of guile from then on until the show closed. This witness admitted he never brought these matters to the attention of the officers of RADIO AGE, Inc., and that he didn't report the incident to "Wireless Age" until May, 1924—almost two years later. A long time to carry such a pineapple around in one's craw.

Mr. Pierre Boucheron, general manager of the advertising and publicity departments of Radio Corporation and vice president and General manager of Wireless Press, Inc., which publishes "Wireless Age" for Radio Corporation, was easily the star witness for Radio Corporation. He, too, thought "wireless" and "radio" were identical in meaning. But on cross examination he admitted that since the action against RADIO AGE was begun, the name of the magazine which is claiming it is suffering great injury from competition by RADIO AGE *changed its own name* from "The Wireless Age" to "Wireless Age, The Radio Magazine." The change was officially announced in the corporation's magazine last November. It was explained in this announcement that the old title was being retained in part so that the magazine might be more easily identified by those who were more specially interested in *wireless*. Yet "wireless" and "radio" mean the same thing!

A man might be obviously right from start to finish in a controversy such as this and in the end might prove himself to be right. But he would have been compelled to finance his defense and, though he be right as a trivet, he could not obtain recourse against predatory interests who put him to all the trouble and expense. That's why a \$33,000,000 band of patriots has a big advantage in opposing an individual of much more modest resources. Doesn't seem to be quite all square with our fundamental ideals of equal opportunity and equal rights under the law, does it? We were warned three years ago that if RADIO AGE criticised certain radio interests those interests would step on us. Yet we criticised radio monopoly and we are going to keep it up. If we still thrive where others faint, it may be because our readers and newsdealers are not so confused as some folks hope they are.

"Radio Age" Contest Is

Popularity Now Closed!

Race is Still Neck and Neck As Aldine Starts the Official Count of Last-Minute Ballots; Name of Winner to Be Revealed Next Month



At the left is the attractive shield which will be awarded the winner in the RADIO AGE Popularity Contest, which closed on June 15. Its size overall is six by eight inches, and a detailed description is contained in the article on this page by Mr. Aldine, the persevering Contest Editor for this magazine.

BY THE time this issue of RADIO AGE appears on the news-stands, the RADIO AGE Popularity Contest will have ended, as only those votes received before midnight of June 15 will be credited to the total count of candidates.

As this review is being written (May 16,) there still remain a full thirty days, during which period the winner will be definitely named, and judging from the heavy voting which has taken place during the past thirty days, no candidate is yet assured of the coveted position at the head of the list. At no time in the history of the contest have the three leading candidates been so closely bunched.

To further complicate matters, "Uncle John" Daggett, 'way out on the Pacific Coast, has jumped from ninth to fourth place, where he stands menacingly, offering dangerous competition to the three popular leaders. By referring further to the "Standing to May 15" it will be found that Art Linick has also bettered his position by stepping one more round toward the top of the ladder, from eighth to seventh place.

On this page will be found an illus-

By HARRY ALDINE

tration of the shield which will be awarded the winner of the RADIO AGE Popularity Contest. From a background of artistic black will stand out in raised gold letters The Winner's Name, and the inscription, "First Annual RADIO AGE Broadcast Entertainers' Popularity Contest—1924-25."

Surrounding this will be a plain gold border conforming to the shape of the shield. The gold plate will in turn be mounted on a dead black bevel-edged wooden plaque, to which is attached a chain for hanging. The size, overall, is six by eight inches.

While several ideas were offered for the design of the shield, the one accepted seemed to conform most to the principles of dignified simplicity, and was therefore the most forceful manner of declaring to the world the winner of the contest.

Following is the standing of the candidates as they are lined up at present:

WINNERS OF PRECEDING MONTHS

July.....	Duncan Sisters, KYW
August.....	Bill Hay, KFKX
September.....	Karl Bonawitz, WIP

October.....	H. W. Arlin, KDKA
November.....	Bert Davis, WJQ
December.....	Jack Nelson, WIJD
January.....	Art Linick, KYW
February.....	Coon-Sanders Orchestra, KYW
March.....	John S. Daggett, KHJ

STANDING TO MAY 15

Name and Classification	Where Heard
Karl Bonawitz, Organist.....	WIP, Philadelphia
Bert Davis, Entertainer.....	WJQ, Chicago
Bill Hay, Announcer.....	KFKX, Hastings
John S. Daggett, Announcer.....	KHJ, Los Angeles
H. W. Arlin, Announcer.....	KDKA, Pittsburgh
Coon-Sanders' Nighthawks, Orchestra, KYW, Chi.	
Jack Nelson, Announcer.....	WJJD, Mooseheart
Art Linick, Entertainer.....	KYW, Chicago
Harry M. Snodgrass, Entertainer	
Ford & Glenn, Entertainers.....	WOS, Jefferson City
Duncan Sisters, Entertainers.....	WLS, Chicago
Lee Sims, Pianist.....	KWY, Chicago
Lambdin Kay, Announcer.....	WSB, Atlanta
J. Remington Welsh, Organist.....	KWY, Chicago
Fred Smith, Announcer.....	WLW, Cincinnati
E. L. Tyson, Announcer.....	WWJ, Detroit
Hired Hand, Announcer.....	WBAP, Fort Worth
"Sen" Kaney, Announcer.....	KWY, Chicago
Nick B. Harris, Entertainer.....	KFI, Los Angeles
Jerry Sullivan, Announcer-Entertainer, WJQ, Chi.	
Edward H. Smith, Director-Player	
Charles E. Erbstein, Announcer.....	WGY, Schenectady
Wendell Hall, Entertainer.....	WTAS, Elgin
Howard Milholland, Announcer.....	WDAF, Kansas City
Scottich Rite, Orchestra.....	KGO, Oakland
Banks Kennedy, Entertainer.....	KGO, Oakland
S. Hastings, Announcer.....	WEBH, Chicago
Robert Boniel, Announcer.....	KFI, Los Angeles
Arion Trio, Instrumental.....	WEBH, Chicago
Gold Dust Twins, Entertainers, WDAF, New York	

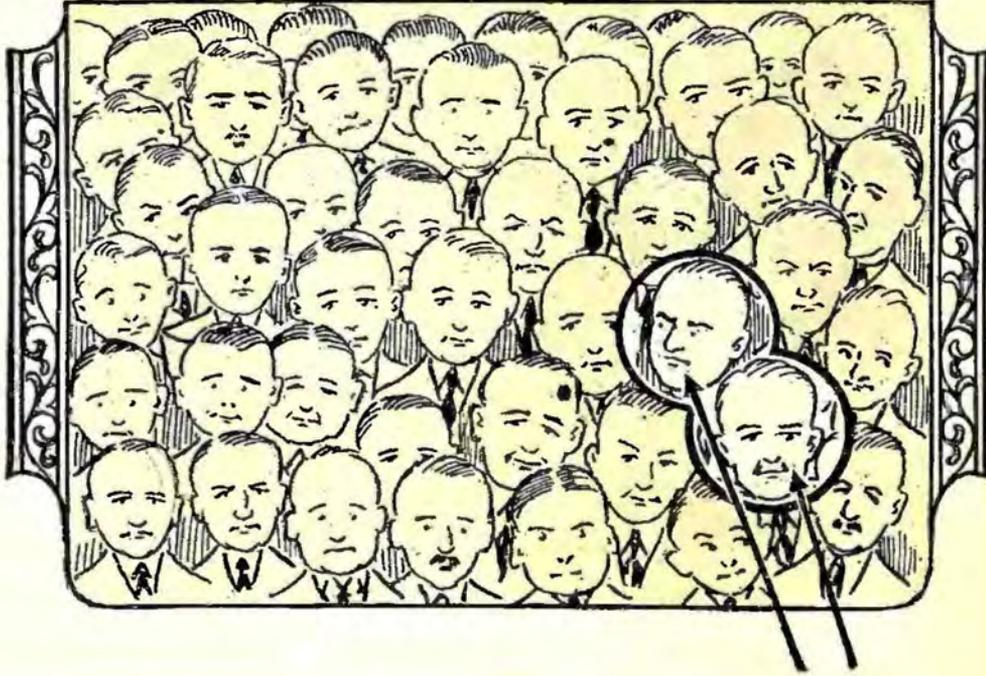

Mr. Manufacturer

**Would you write 100
letters to 100 people
to reach just two men?**

Then, before you invest your advertising dollars—THINK!

*This Association
is comprised of
the leading Ra-
dio Magazines.*

An analysis shows that publications of general circulation, newspapers and magazines, devote less than 2% of their reading columns to Radio—proving that in the opinion of their own Editors less than 2% of their readers are interested in Radio. In fact, many general publications carry no Radio editorial matter. Therefore—98% of your investment is lost!

On the contrary, the Radio magazine offers 100% Radio editorial—attracts 100% potential buyers.

Spend your advertising appropriation in Radio Magazines. Be sure of the greatest possible return on your advertising dollar.

Radio Magazine Publishers' Association, Inc.

RADIO AGE is a member of the Radio Magazine Publishers Association, Inc.

RADIO AGE

The Magazine of the Hour

M. B. Smith
Business Manager

A Monthly Publication
Devoted to Practical
Radio

Frederick A. Smith
Editor

What will Tomorrow Bring— Four, Five or Six TUBES?

Our readers' vote is requested upon the number of tubes that will prove most popular during the coming radio season. Will economy rule with the use of the four tube set, will we adhere to the present popular five tube set, or will we attain quality with the six tube set regardless of the increased price? This is a question that the radio dealers and RADIO AGE would like to have answered by our readers.

It was not so very long ago that the three tube regenerative receiver marked the height of affluence in the radio world and that the owner of such a super-set was enviously regarded by his fellow B. C. L.'s who were still getting their music via the single tube and the crystal set. In those days we could consistently get coast-to-coast reception or its equivalent on three tubes, and with the tubes retailing at \$6.50 each and the receiver itself hovering around the \$200 mark, the old three lugger was held in the same regard as the most elaborate five tube set of the present day. It tuned as broad as a barn, howled like a fiend and munched up the signals, but in her day the old three did her stuff, as the many DX records of 1921-1922 will testify.

Repeated refinements in the regenerative circuit, brought the three tube regenerative up to a high degree of efficiency in bringing in distance, but in the craze for distance we sacrificed selectivity and tonal quality. They were superlatively sensitive to weak signals, but as most of the old timers were of the single circuit type or were provided with the old inefficient vario-coupler, they were very broad-tuning and could not possibly cope with the present day congestion of radio traffic, even though they did have from five to ten tuning controls. There were more dials and less selectivity in 1922 than at any other time in radio history.

Just as a review on the subject of tuning controls let me list the dials and knobs that commonly appeared on the panels of the old time three tube three circuit regenerative:

1. Primary Variable Condenser Dial.
2. Rotor of Vario-Coupler Dial.
3. "Tens" Tap Switch Knob.
4. "Units" Tap Switch Knob.
5. Series-Parallel Switch (Sometimes).
6. Secondary Variable Condenser Dial.

By ROSCOE BUNDY

Trend Seems To Be Toward Clear Music

7. Secondary Tap Switch Knob.
8. Grid variometer Dial.
9. Plate variometer Dial.
10. Variable Grid Leak Dial.
11. Detector Rheostat Knob.
12. First Stage Audio Rheostat Knob.
13. Second Stage Audio Rheostat Knob.
14. Battery Switch Knob.

The Man Pays This Time!

SOME price to pay for an attempt at selectivity! A maze of confusing controls that were not half as effective as the three tuning dials and two rheostats that appear on the panel of the present time tuned radio frequency receiver, and which required considerable practice before they could all be brought into adjustment.

The constant urge for more distance resulted in the first appearance of radio frequency steps which at that time were simply auxiliaries to the original regenerative receiver and increased the complication considerably without much return

in the way of improved performance. The radio frequency steps were coupled with primitive untuned radio frequency transformers that were little better than coupling condensers, and which peaked badly on some particular wavelength, generally on the wavelength of one of the local stations that you were trying to tune out.

At this stage of development the addition of tubes was a serious proposition, for the tubes then drew anywhere from 0.75 to 1.0 ampere each, so that a four tube outfit would draw up to four amperes total, or four times as much "A" battery juice as the largest tubes of the present day.

You could easily run down a freshly charged battery in the course of one evening and then wait over for a day while you recharged your battery with some ineffective trickle charger, generally of the buzzer type. Those were the days when the buzz of the charger was continuous in the land and when the battery spent as much time on the charger as on the receiver. You would feed it five amperes all day only to have the receiver drain out all of the profits by 12 o'clock p. m.

There is no doubt but what the 0.25 ampere tube of the 201A type made the multi-tube set a practical possibility, and that further increases in the number of tubes will also depend upon the development of tubes of the 199 type which will make dry cell operation practicable with five tubes or more.

The Reflex Enters

OWING to the necessity for battery conservation with the old tubes, the coming of the reflex circuit was heralded with joy and much of 1923 was devoted to the development of the reflex circuit by experimentally inclined amateurs. Partly for the reason that the radio frequency transformers of 1923 did not measure up to the standards demanded by the reflex, and partly for the reason that reflex principles were not well understood, the reflex did not attain the popularity that was expected by its sponsors, and there was a decided tendency toward falling back on the old reliable regenerative circuit, with which almost any beginner could expect to get some sort of results. There were many reflexes that gave phenomenal performance, but in the main, the radio public soon discovered that the reflex of that time was not an ideal circuit for the

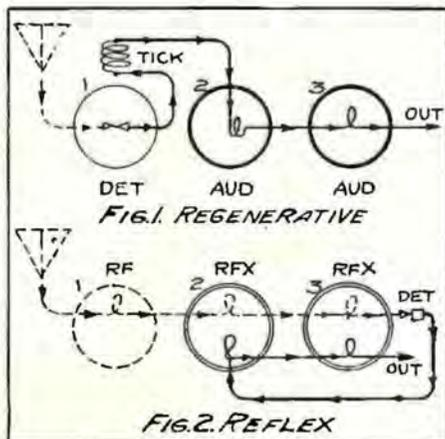

Figs. 1-2. Three Tube Circuits Commonly Used. Dotted Line Represents Radio Frequency and Solid Line is Audio Frequency.

novice and that special precautions were necessary that rather took it out of the home-builder's province.

Things hovered around this condition for some time until a change in radio took place with the appearance of the five tube neutrodyne, the father of all the numerous five tube "dynes" now on the market and the salvation of the reflex principle. The neutrodyne was not the first tuned radio frequency outfit by any means, for we had plate tuned circuits long before this, but it was the first stable five tube radio frequency set that could be built with any degree of success by the average home-builder.

With all due respect to the neutralizing principle as applied to the suppression of self-oscillation in the radio frequency stages, the real advantage of the neutrodyne, according to my idea, lay in the constructional details such as the tuned radio frequency transformer and the aperiodic or semi-aperiodic coupler. By these units we could approach a degree of selectivity hitherto unknown, by means of very simple units; and further, we could peak our radio frequency amplification on the desired wavelength instead of adopting the compromise amplification of the older fixed transformer. Again, this was the first fairly high power set within reach of the average amateur and the first practicable set with more than three tubes which had appeared. Tonal quality was improved as well as distance and selectivity, and in general it took the radio world by storm in spite of the cost of the five tubes, which averaged about \$5.00 each at that time.

The rapid increase in the popularity of the neutrodyne brought a perfect flood of five-tube tuned frequency sets on the market with all sorts of weird methods of suppressing free oscillations. The question of battery current consumption could no longer be leveled against these circuits, for the 201A tube gave a total consumption of only 1.25 amperes against the 3.0 amperes formerly necessary with the old tubes in the three tube regenerative receivers; hence we could run longer per charge with the new five tube combination than with the old detector-and-two-stage outfit.

Under the new system, coast-to-coast reception on the loud speaker was so common as to cause no comment and we could bring in real distance through the most powerful, local broadcasting stations with ease. For the first time we could bring in a station without the

accompaniment of the shrieks and wild wailings that were prevalent in the regenerative era and hear music and voice without a background of hissing and frying sounds that formerly detracted so much from the enjoyment of a program. In clarity of tone, the five tuber was nearly equal to the reflex at its best, and the problem of perfect reception was therefore put up squarely to the manufacturers of loud speakers. It was now a question of developing a horn that was a fit running mate for the receiver.

New Twists Developed

In the meantime, we must not forget that all this improvement also stimulated experimental work on the regenera-

fixed primary coil. In fact, a modern three-tube circuit with this sort of tuner is fully the equal of an old four tube using the vario-coupler, and is not half as bothersome. Further, it can be "logged" so that each station comes in on a definite dial position, which was not formerly the case, making tuning certain and prompt when provided with a table of station wavelengths and a well prepared "log" of the corresponding dial positions. Logging is an essential with a modern receiver of any type.

Out of this perfection in regeneratives sprang a hybrid four-tube circuit type which is very popular today. This consists of a stage of tuned radio placed in front of the three tube regenerative which both increases the distance and

selectivity and also counteracts the tendency of the regenerative unit toward causing annoying aerial radiations. The Browning-Drake circuit is a prominent example of this type, which consists of one stage of tuned radio frequency amplification, regenerative detector, and two stages of audio frequency amplification. Both the coupler-tuner and the radio frequency transformer are special adaptations of the tuned coils originally used in the neutrodyne, although much more efficient and selective because of the absence of electrostatic coupling between the primary and secondary coils. Such circuits are rapidly increasing in favor, for they have great distance getting qualities for the number of tubes employed and are simple and cheap to build.

Revised Reflex Circuits

OUR reflex circuits now took on new life with the advent of the aperi-

odic type coupler and tuned air core radio frequency transformers, with the result that the modern reflex much more nearly approaches its theoretical advantages. The radio frequency component is now tuned by the same air core transformer units employed in the tuned radio frequency sets with greatly increased range and stability. By the same means, ohmic resistance is reduced, selectivity increased, and wonderful results are being obtained with only a few tubes. Two tube reflex sets with coast-to-coast reception and loud speaker volume on 500 mile stations are not uncommon where the improvements have been added. Where fixed R. F. transformers are used we now have true magnetic coupling instead of the capacity coupling had in the older types, and with modern untuned transformers we have excellent performance.

A regenerative circuit of the new era consisted of a dial for tuning to wavelength, and perhaps another dial for the tickler. This was all there was to the proposition and we not only simplified things, but also obtained better selectivity, tone and distance with the

RADIO AGE BALLOT

(How Many Tubes Do You Prefer?)

BALLOT EDITOR,
Radio Age, Inc.,
500 N. Dearborn St.,
Chicago, Ill.

On the following list I have checked off the radio receiver that best fills my requirements, and have written my reasons in the blank space following the specifications.

CLASS 1. THREE AND FOUR TUBES. (a) Three Tube regenerative with transformer coupled audio stages, (b) Four Tube Regenerative with resistance coupling, (c) Three Tube Reflex, (d) Four tube reflex with loop, (e) Four tube regenerative with one stage of radio frequency.

CLASS 2. FIVE AND SIX TUBES. (a) Five Tubes, two stages of radio, detector, and two stages of resistance coupled audio, (b) Five tubes, One stage of radio, regenerative, detector and three resistance coupled stages, (c) Five Tube Reflex with loop, (d) Five Tubes, Two stages radio, regenerative detector and two stages of transformer coupled audio, (e) Six Tubes, Two stages of radio, regenerative detector, and three stages of resistance coupled audio, (f) Six Tubes, two radio, detector, three stages transformer coupled audio.

CLASS 3. SUPER-HETERODYNES. (a) Six Tube, (b) Seven tube (c) Eight tube.

REASON FOR MY CHOICE.....

.....

Name.....

Street or R. F. D.

City..... State.....

NOTE: If you do not wish to tear this blank out of your book, send a brief note covering the above points. It will do just as well.

Three tube reflex circuits, using tuned radio frequency transformers throughout, give fully the results of a five tube straight radio frequency set when properly built, and have the advantage that they can be operated with dry cell "A" batteries with success. There are a number of "kit-sets" or complete sets of parts now on the market for building reflexes of this type, so that the construction of a reflex no longer is a problem for the advanced student of the radio, but is entirely practicable for the rawest novice. This is in contrast to the conditions experienced in the old days when the builder of a reflex frequently had to buy enough material for two sets before he could find parts that would match up and function properly when hooked up in a reflex circuit.

In writing the above paragraph it brings to mind the great advantages enjoyed by the present day radio set builder compared with the trials and tribulations of the old-timer who had little to work with in the way of materials and still less data. In the old times, a smudgy illustration cut out of a newspaper with an exceeding inaccurate description was considered a "find," and with a few yards of barb wire and other miscellaneous junk, a valiant attempt was made toward the construction of a workable receiver. Nowadays, the builder can obtain accurate apparatus put up in complete kits so that an hour's work with a screw driver and pliers is all that is necessary. Each wire is cut to length and a detailed series of picture diagrams gives all the data that anyone could possibly ask for. In one way, however, all this spoon-feeding is a bad proposition, for it is getting to such a point that the experimenter is now too dependent upon others and is rapidly losing his spirit of self-reliance. Here at RADIO AGE, we find that the slightest omission in a description or in a drawing is sufficient to throw him all out of joint, and instead of trying a few simple experiments that could be performed in five minutes, he will write in and calmly wait for some one to work out his simplest problems for him.

The Super-Heterodyne

During the past year much work has been done on the development of the super-heterodyne principle and great progress has also been made along these lines. Properly designed, and with the proper materials, the super-het is the king of all receivers, but once again we warn the novice that he should obtain his apparatus in kit-set form to insure all of the parts being properly matched so that they will work together. To assemble a super-heterodyne out of a miscellaneous mass of unmatched parts of different makes requires a considerable amount of skill and experience.

Continued experiment has resulted in

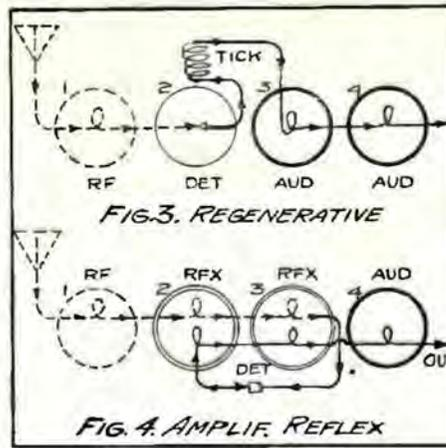

Figs. 3-4. Four Tube circuits, Regenerative, With One Radio Stage (3) and Reflex Four Tube (4)

the development of six and seven tube super-hets which give fully as good performance as the standard eight-tube type, and have the further advantage that they are more compact, cost less, and take less battery current. Satisfactory results are being had with six and seven 199 tubes, which brings the set well down toward the limits of dry cell operation, and with such sets we obtain wonderful selectivity and loud speaker operation over great distances. Their tone value is of the best, and with a little experience they are easy to tune and handle. In fact, two condenser dials and a potentiometer are the only controls necessary.

Super-heterodynes are essentially a type designed for operation on a loop aerial, and for this reason they make a great appeal to those who have no chance to erect an effective outdoor aerial. Certain radio frequency and reflex receivers will also give good results on a loop, but the super-het is particularly adapted for this kind of service, and to a great extent, its selectivity is due to the directional properties of the loop aerial with which it is used. Its only drawback is its cost, which is considerably greater

than that of a corresponding grade of radio frequency or reflex receiver, and this item, of course, is sufficient to rule it out among many classes of radio fans.

When the DX fever was at its height, with every effort bent toward getting distance at any cost, very little attention was paid toward eliminating disagreeable noises or for improving the tone of the receiver. In fact, the noise in the early broadcast receivers, coupled with the crude loud speakers of that period, was very effective in holding back prospective customers who possessed the most elementary sense of tone. The field was entirely in the hands of the distance fanatics, and they continued to hold it until the coming of the tuned radio frequency sets, with their improved reception, made an appeal to another class of listeners. The latter formed the bulk of those who purchased radio during the past year; people who objected to listening to the mangled remains of a sonata, just so that they could boast of hearing some peanut station 1,500 miles away. Better have good, clear, local reception on a crystal set for these prospects than a mushed up mess coming in from a distant station.

In addition to the inherent noises of the regenerative receiver, which were really not always so bad on the headphones, the early audio transformers were far from being perfect and added their din to the collection of noises annexed in the detector stage. High ratio audio transformers with their distortion, poor design and other factors made life miserable for the musician who was forced to hear the blasting and blare of the old horns or noise chutes. Improved transformer design, together with the use of low turn ratios, has greatly improved these conditions so that there is little distortion or noise within the receiver itself. Further, the introduction of resistance coupling in the audio stages made another step toward perfect tone, so that the tendency of today is rather in the direction of clear, undistorted reception than toward mere distance.

I am thoroughly convinced that future improvements in radio apparatus will be

along the lines of tonal improvement and that the buying public is more interested in tone quality than in the attainment of distance. A good, clear natural tone with moderate distance getting qualities; low current consumption so that dry batteries can be employed; stable performance without nerve racking shrieks and howls, and perfect selectivity are the characteristics of the salable radio receiver of the future. The experimenter and the DX hound have already been served, so that our next appeal is to that class of music lovers who have not yet seen fit to buy radio equipment.

The reproduction must be fully equal to that of the best modern phono-

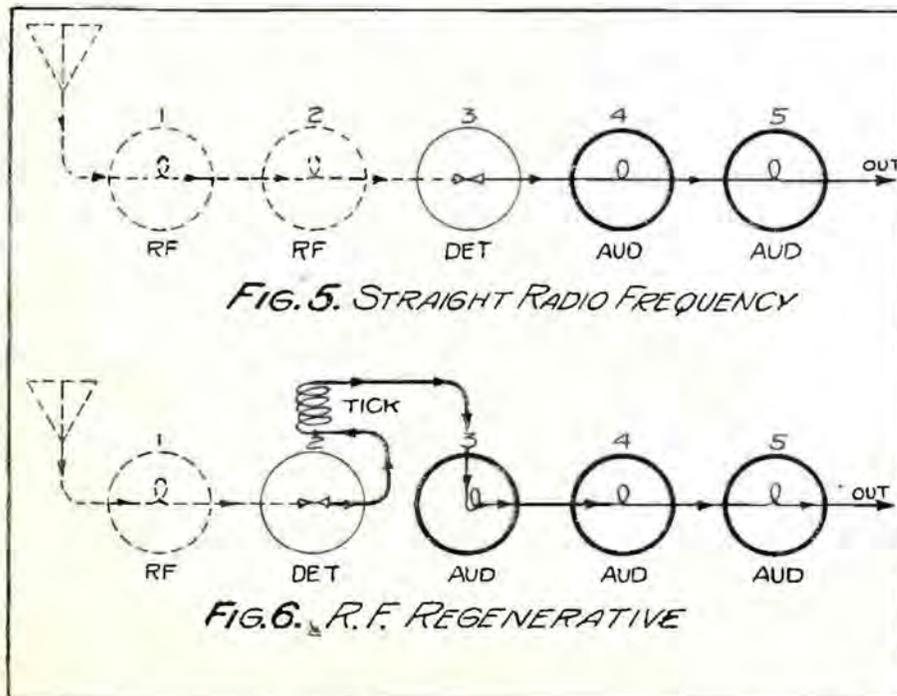

Figs. 5-6. Five Tube Circuits. Two Stages of Radio Frequency and Audio (5), and Resistance Coupled Five Tube With One Radio Stage (6).

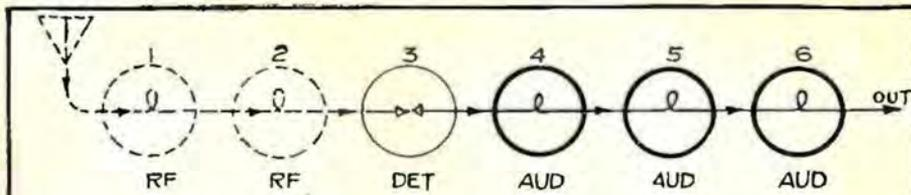

FIG. 7. TWO STAGE RADIO AMPLIFIER

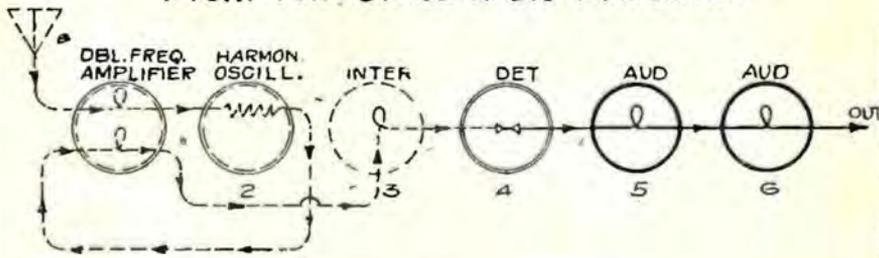

FIG. 8. SUPER-HETERODYNE

THE ABOVE SIX TUBE SUPER-HETERODYNE IS OF THE SECOND HARMONIC TYPE IN WHICH THE FIRST TUBE IS REFLEXED AT BOTH LONG AND SHORT R.F. WAVELENGTHS.

Figs. 7-8. Six Tube Circuits. Two Stages of Radio With Resistance Coupling (7), Super-heterodyne (8).

graph, and this should not be so difficult to attain, as there are certain mechanically connected linkages in the phonograph which do not exist in the radio; hence sound without distortion should be more perfectly accomplished where the transmission is performed electrically than where loose jointed mechanisms are employed.

Resistance Coupling

PERFECT as the modern audio frequency transformer may be, there is even less distortion with resistance coupling, for the amplification is always in exact "straight-line" proportion to the drop of potential over the resistor coupler. As with other items in radio, however, the resistance coupling method is a compromise that is not without drawbacks of its own. In the first place, we must use three amplifying tubes with the resistor to get the degree of amplification obtained by two tubes with transformer coupling; and in the second place, we must use at least 135 volts of "B" battery instead of the conventional 90 volts used with the transformers. It is the same here as everywhere else. If we wish to gain the benefits of perfect reproduction, we must pay the price of admission, and according to my ideas, the better quality obtained by the resistors fully compensates for one extra tube and one extra block of "B" battery. The application of the resistors is simple and reasonable in cost.

In what is to follow, add one tube to the set for resistance coupling where transformer coupling is specified. Some increase in amplification with little or no effect on the quality can be had by combining resistance and transformer coupling with one transformer stage and two resistance coupled stages.

How Many Tubes?

At last we are getting back to our original question, the subject of this article, after wandering around among the various types of radio receivers. What is your preference, or rather, what sort of a radio outfit would you buy if you were to purchase one tomorrow? With a limited amount of cash available, would you prefer a three tube regenera-

tive with good distance getting qualities but only fair tone value, to a four tube set with slightly better distance and tone providing that the latter only cost a few dollars more? Would you prefer these sets to a three or four tube reflex with wonderful tone value, great volume, and moderate distance? I am omitting reference to the one and two tube sets which are really for the head-set and can only be used on the speaker with powerful local stations.

If you had more money to spend, would you spend it on the conventional five tube tuned radio frequency set with transformer audio stages, or would you like to add another tube for resistance coupling so that you would have the superlative in tone value for the R. F. class of receiver? How would a five tube reflex operating on a loop strike you?

Now for the third class, which costs quite a little more than any of the others. We speak of the super-heterodyne with its loop aerial, from six to eight tubes, and with its excellent tone and volume? Do you believe that these increased virtues compensate for the additional cost over those offered by the five and six tube sets of class two? That's what the manufacturer wishes to know, that is what we wish to know, and that is what will affect the market in which you are to buy your radio. There is only one way in which public demand can be determined and that is by asking the buying public to vote on their opinion or desires just as we are doing here. We have guessed until we are blue in the face, but as yet have come to no conclusion, and there are a whole lot more in the same boat with us.

In making your choice, please consider the many factors that enter into the proposition. The question of tube economy, compactness and portability, dry cells versus the storage battery, first cost, distance, tone, volume, selectivity, loop aerial or outdoor aerial, and the cost of maintenance. There is some one combination of these factors that will suit your conditions best and we wish to know what it is. We have divided the receivers into three classes according to price, for we believe that price is the determining factor in the majority of cases.

If this were not so, then everyone would place their check mark opposite one of the more powerful and costly sets and we would be as much in the dark as ever.

Mark your ballot candidly; we want to know just what is on the minds of our readers. Place your check mark opposite the type that you most desire and then make a note of why you prefer this particular circuit. This is as much to your advantage as to ours and is not an advertising scheme—we want to know.

The Universal Need

LOUD-SPEAKER operation is almost a universal requirement with the receiving set of today; hence, we must always be assured of the equivalent of at least two transformer coupled audio frequency stages. So far as marketable sets go, the days of the headset are probably gone, even, on distances that were considered of the DX order several years ago. Even with portable sets, we see provision for the loud speaker and in most cases the loud speaker unit is built into the set proper.

Shorter and shorter aeriels, or aeriels of the indoor type, increase with the increasing numbers of broadcasting stations, for a short aerial is almost a necessary adjunct to selectivity in these days. Loop aeriels are very popular for much the same reason, and also because they avoid the trouble of erecting an outdoor structure.

There is probably not any increased risk due to thunderstorms; in fact, the risk may possibly be less, but they are not desirable.

Talks on Cuisine Station KYW

A SERIES of eight talks closely related to the cuisine in your home is being given over Westinghouse station KYW, each Thursday at 9:15 p. m. until June 25, which will be the date of the last talk.

KYW has secured the co-operation of John C. Cutting, to give these talks. Mr. Cutting has been telling the New York women, over WJZ, how to manage their homes and husbands. This was a weekly feature in New York for over sixteen months, and his thoughtful and valuable home hints, so delightfully put forth, proved to be of such value that the same propoganda is going to be exploited in Chicago, over Westinghouse station KYW.

Mr. Cutting, who is secretary of the Meat Council of Chicago, began his series of weekly talks from KYW on May 7, at 9:15 p. m. having chosen for his first subject "Filling Four Stomachs With a Dollar Bill." Mr. Cutting, who enjoyed the prestige of being the only man on WJZ's program who discussed subjects dear to a woman's heart, has a faculty of putting these talks over with the enthusiasm and pep required to promote his idea. He will tell young wives how to spank up a roast or hem-stitch hamburger in a way that will bring them the eternal love of their respective husbands.

Tune in and let him do his stuff. KYW, Thursdays at 9:15 p. m.

Formulae and Tables for Testing and Plotting Charts for Vacuum Tubes Used in Radio Reception

Learning Vacuum Tube Characteristics

By H. FRANK HOPKINS



The milliammeter shown above shows the plate current characteristic in milliamperes.

THERE are numerous characteristics of vacuum tubes used in radio reception and transmission that may be determined, but which have no value to the average radio fan. However, there are a few of vital importance to all users of vacuum tubes and it is the writer's intention to make clear such of these characteristics which are of importance to the fan so that he will be able to plot curves or charts and match his tubes as easily as he tunes his receiving set.

The equipment required for this work is a good vacuum tube test set, such as described in the May issue of RADIO AGE. An instrument such as this may be built at a nominal cost or one similar may be purchased ready made at a good range of prices, from the simple one-meter affair to those having a complete set of meters.

The One-Meter Tester

THE one meter tube testers are limited in their use, however, and outside of a plate current curve at a fixed grid bias, no other features may be determined. This type of test set

will only give a fair idea of how a tube will act. They will sometimes show a good plate current curve, but fail to perform efficiently when in operation. Therefore, it is worth the difference in price to have a set that will show the filament current or voltage and the grid bias voltage in addition to the plate current.

For this article, the RADIO AGE test set was used. It consists of three meters; a filament voltmeter, a grid volt meter and a plate milliammeter with the necessary resistances to vary the filament and plate voltage and grid bias voltage as desired.

It was prepared for operation by connecting an "A" or filament battery of suitable voltage for the tube under test—to terminals (A BAT+) and (A BAT -).

A "B" or plate battery of ninety volts was connected across the binding posts (B-) and (B90) with taps at 22½ volts, connected to binding post (B22), 45 volts to binding post (B45), and 67½ volts to binding post (B67). Two 7½ volt "C" or grid batteries were connected to the "C"

battery terminals. The negative terminal of one connected to binding post (C-) the positive terminal of this and the negative terminal of the second "C" battery connected to binding post (C+-) and the positive terminal of the second "C" battery to binding post (C+).

The filament rheostat (R) is moved to its off position, a tube placed in the socket (T) and the set is ready for operation. By moving the switch (BS) to point (-) and closing switch (GS) a negative grid bias voltage will be shown on the two-scale voltmeter (GM), this grid bias voltage may be varied at will from 0 volts to 7½ volts by moving the potentiometer (GP) until the meter shows the desired voltage. By moving the switch (BS) to the (+) point, a positive grid bias will be shown on the meter (GM) and will be varied as above.

The switch (PS) and the rheostat (BR) regulate the "B" or plate battery voltage. By moving the switch (PS) to terminal (1) and moving the rheostat (BR) a plate voltage range from

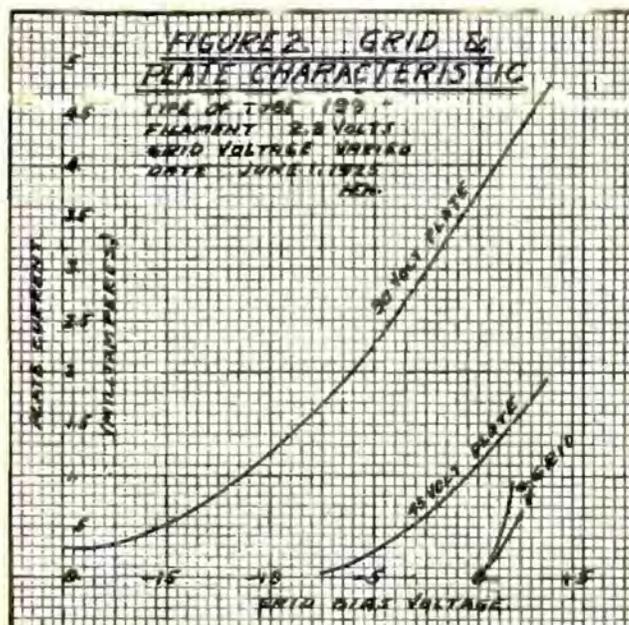
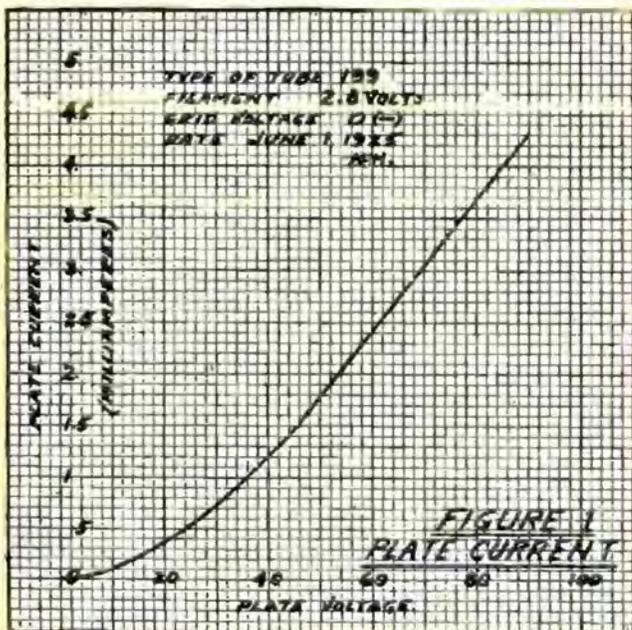

Figs. 1 and 2. Fig. 1 shows the typical curve of plate current voltage, while Fig. 2 shows the typical curves of grid and plate characteristics, the result of tests described in the accompanying article.



The two-scale voltmeter, showing the grid bias voltage.

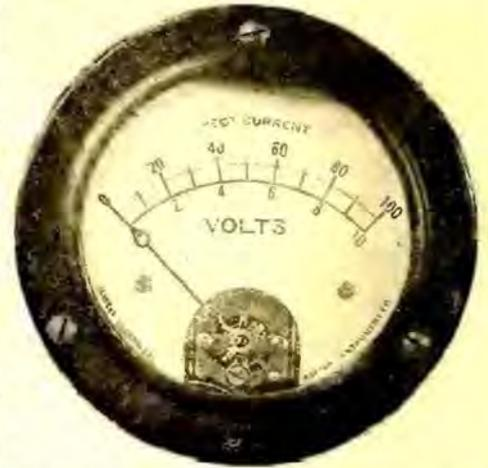

The 0-10, 0-100 scale voltmeter, which shows the filament voltage and plate voltage, respectively.

0 to 22½ volts is obtained, to point (2) from 22½ to 45 volts, to point (3) from 45 to 67½ volts and to point (4) from 67½ to 90 volts. This voltage is read on the meter (PF) by moving the transfer switch to position (4). The filament voltage will be read on the same meter (PF) by moving the transfer switch to position (3). The filament voltage is varied by the rheostat (R).

Plate Current Curve

FOR the first test, we will use a 3-4 volt 199 type of tube—placed in the socket (T) by use of an adapter. This is a high vacuum receiving tube with the filament normally operating at 3 volts and a filament current drain of .06 amperes or 60 milliamperes. This type of tube is most used in super-heterodyne receiving sets and is by far the most critical of everyday tubes.

A piece of cross section paper will be prepared by marking the plate voltage scale on the lower edge and the plate current scale on the left edge as in figure one. The filament voltage will be adjusted to a point just below 3 volts, say 2.8 volts, the grid will have a 0 volt

negative reading on the meter (6m) and the plate voltage will be adjusted to 0 volts.

By moving the rheostat (BR) the plate voltage is increased. A reading will be taken from the milliammeter and a point corresponding to this reading and the reading of the plate voltmeter (PF) will be marked on the cross section paper, as in the chart (figure one). This reading—with 5 volts on the plate, showed a plate current of about .1 milliampere. At 10 volts it read practically the same, and so on, gradually until 20 volts was applied and read at .3 milliampere. At 25 volts the plate current was about .5 at 30 .7 and at 40 it was 1.2 milliamperes. It increased rapidly until 90 volts showed a plate current of about 4.3 milliamperes—which is average for a tube of this type.

When all of these points are marked they will be joined by a line running through each, and a completed plate current curve as in figure one will be made. Simple, isn't it? This performance may be repeated—on the same chart, at different grid bias voltage—say a 1-2 volt negative and a 1-2 volt positive bias, thus giving a complete plate current story of the tube at various operating conditions.

Grid Characteristic Curves

TO make a grid characteristic curve—figure 2, the plate voltage will be set at 40 volts—the grid bias voltage will be adjusted until the meter (GM) shows 0 with the switch on point (+). The reading of the milliammeter (MA) will be located on the chart as before—and readings for each fraction of a volt will be spotted—as in figure two. The 40 volt curve showed a plate current of 1.2 milliamperes and at 1 volt (+) it read 1.5 milliamperes and so on to 2 volts (+) it read 1.8 milliamperes. Going back to 0 volts and shifting the switch (BS) to a negative bias, the readings were taken the same as above, except they were inversely proportional to the grid voltage,

showing 1.2 milliamperes at 0 volts negative and so on down until .1 milliamperes was obtained at slightly over 4 volts negative bias.

This curve will show the best "C" battery voltage or grid bias for a tube at various plate voltages, and it may not be amiss to say that as we add to the plate voltage, the higher the grid bias voltage may be, several curves may be made on one chart for this characteristic at various plate voltages, as shown in Figure four, on page 12 of RADIO AGE for May, 1925.

A filament voltage curve may be made and a filament current curve also if an ammeter is included in the test set. This will be plotted from periodic readings as in the other curves, and will make it possible to show an emission curve (Figure 3). This is one of the factors so important to users of vacuum tubes, as the life of a tube depends upon the proper emission of the electrons from the filament, and is usually ended by a decrease in emission, necessitating excessive filament voltage to keep it in

(Turn to page 53)

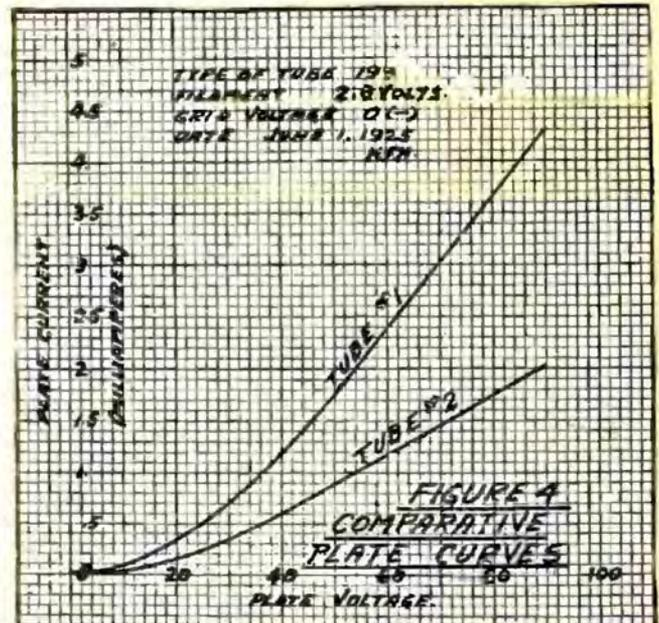
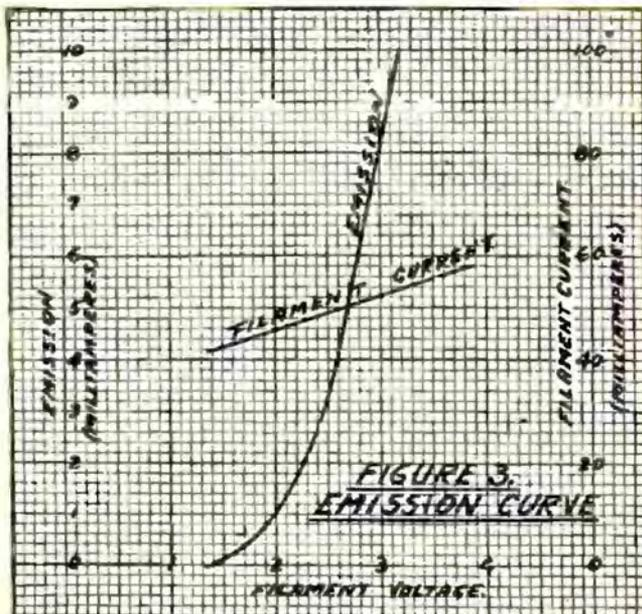

Figs. 3 and 4. Fig. 3 is an example of an emission curve, as described in Mr. Hopkins' article. Fig. 4 reveals the difference between a good tube under normal operation and a poor tube under the same conditions.

How Much Coupling is Necessary?

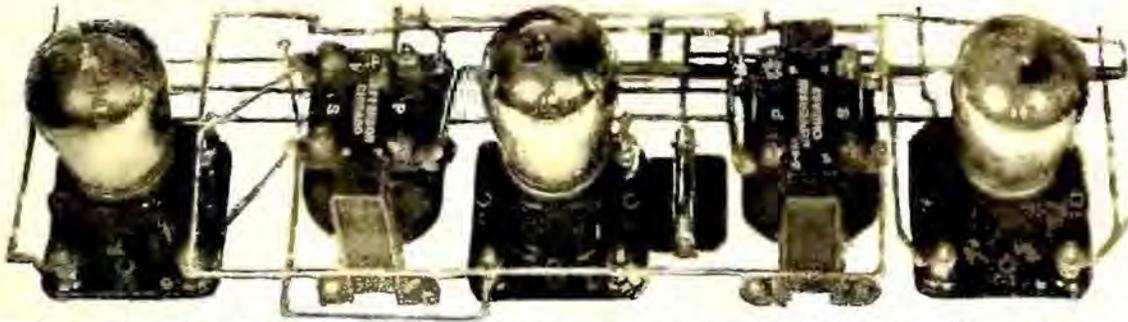

Coupling can be construed as the method by which energy is transferred from one circuit to another. It can be energy from the antenna to the detector tube, energy between tubes of a radio frequency amplifier, or again audio energy passing between audio stages. Coupling passes the energy across in each case.

Big Advantage in Having a Variable Coupling Scheme to Enable Adapting the Receiver to Different Aerials; Suiting Coupling to Varied Wavelengths a Real Problem

COUPLING" is a broad term in its interpretation. It signifies the method by which energy is transferred from one radio circuit to another. Whether it be the energy from the antenna travelling to the detector tube, or energy being transferred between tubes of a radio frequency amplifier, or still again the audio energy passing between the audio stages—it is through coupling that the energy is passed across.

To have coupling, there must be two associated circuits carrying alternating current. One circuit may consist largely of inductance (coil) and the other largely of capacity (condenser) or the coupling may even exist because of a resistance which is common to both of the circuits. The sort of coupling with which we must deal almost exclusively is that due to associated inductances or coils. And inasmuch as the coupled coils wound on iron cores which form the commercial audio transformer are not to be adjusted, our discussion will be confined to radio frequency transformers.

R. F. Coupling

LET us first talk about the coupling between the aerial system and the radio receiving set. In Fig. 1 two methods whereby this coupling is accomplished are illustrated. The type of "A" is perhaps more common and it possesses several distinct advantages. In the first place, the separation between the primary P and the secondary S may be made fairly great, and the capacity effect of the aerial upon the secondary thereby minimized. In other words, a receiver so coupled to the aerial will tune almost the same on any aerial, large or small.

In "B" another popular scheme is shown. Here there is really a transformer as in "A" with two distinct windings, but a portion of the secondary acts as the primary also. Here the coupling is very much closer than in "A" for the same number of turns included. Its disadvantage lies in the great effect of the aerial's capacity upon the broadness of the secondary tuning condenser. A

By BRAINARD FOOTE

large aerial will increase broadness and a small aerial will reduce it. Slightly greater volume may be had with connection "B," however, so that many listeners prefer it even though it does upset the dial readings. In the case of a set like the neutrodyne, the three dials do not read the same, but the first one is lower than the other two.

It is of great advantage to have a variable coupling scheme to adapt the set to different aerials. With a long aerial, only 5 to 10 turns are needed in coil P, but with a very small aerial, as many as 15 or 20 may be used. The dotted line in "A" shows where the filament circuit is grounded, a measure ordinarily desirable because of its good effect upon inductive noises and upon hand capacity.

A coupler as in "A" may be wound on one piece of tubing, with a primary coil of as many turns as are necessary for the individual case. To get the maximum of volume on different wavelengths, a small switch might be provided to change the number of turns, as follows:—short waves 5, medium waves 10 and long waves 15 turns. KSD and stations of similar wavelength may then be almost doubled in volume, with the average set. But for the shorter waves, the number of turns must be reduced because of the absorption effect of so large a primary coil.

Antenna Wavelength

THE aerial system has a "natural" wavelength of its own, which must be reckoned with. Users of tuned R. F. or even regenerative receivers with aerials having very long lead-ins have found certain "dead spots" on the dial. These are caused by absorption where attempt is made to tune the set to the natural of the antenna. This natural ought to be less than the shortest broadcast wavelength received, in order that it may not interfere seriously with short wave reception. To smooth out such a dead spot caused by a lengthy aerial system, either reduce the aerial's capacity or use a series condenser of .00025 or .0005 mfd. capacity. The simplest method of reducing the capacity of the antenna, if it is too long, is to shorten it. Simply shortening it, however, does only half the job. The greatest improvement comes by increasing its altitude. An antenna of 60 or 70 feet, raised 20 feet above a roof, is far superior for sensitivity to a 150 foot aerial only five feet above the roof. Not only does the passing radio wave induce more voltage in the wires because of their greater height, but the antenna's natural wavelength is reduced at the same time.

So much for antenna coupling. We now come to a more "ticklish" coupler—that which transfers energy from one R. F. amplifier tube to another one, or to the detector. (Turn the page)

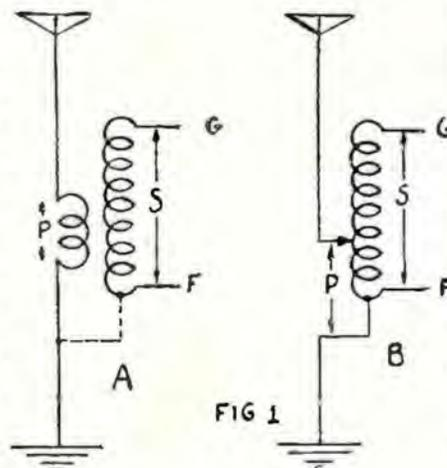

Fig. 1—The aerial is coupled to the set by a "coupling coil." This may be a separate winding as at "A" or a portion of the secondary as at "B." The former method is better in most cases. The aerial's natural wavelength must be kept low if you wish good short-wave as well as long-wave reception.

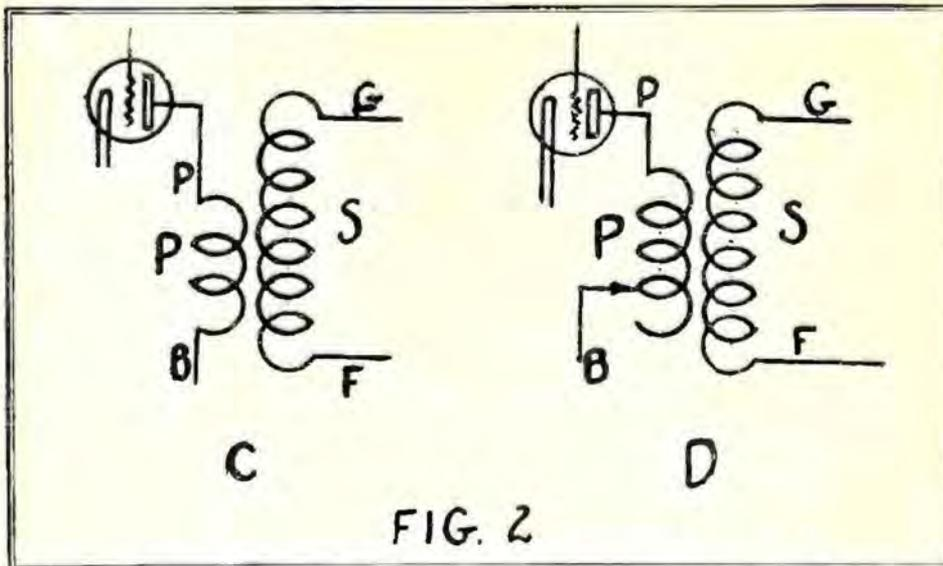

Fig. 2—How radio frequency tubes are coupled to each other. At "C" is the universally popular "fixed primary" type. This, however, is efficient only over a moderate wave band. Varying the coupling from about 5 to 12 turns, as at "B," gives better results on all wavelengths.

In Fig. 2, "C," is shown such a coupler in circuit form. The secondary, of course, is of the proper size to cover the broadcast band in conjunction with the variable condenser that tunes it. The primary is as large as possible, but not so large that it passes sufficient energy back to the grid to cause oscillation of the tube. In practise, such an ideal transformer is out of the question, for it is perfectly efficient for only one wavelength or a very narrow band of wavelengths.

The average tuned R. F. transformer is of this type and is so constructed that its primary does not feed back enough energy to cause oscillation on the shorter wavelengths. For this reason, it is not quite as efficient as it might be on longer waves. This peculiarity accounts for the difficulty many tuned R. F. receivers experience in getting volume from long wave stations like KYW, KSD and the like, whereas stations of much less power on the shorter waves can be received with enormous volume, by comparison.

Variable Coupling

OF COURSE, the obvious method for getting around this inequality of wavelength is to change the coupling, making it greater on longer wavelengths.

Shall this changing be accomplished by a moving coil whose angular relationship can be altered—like a tickler coil? Or shall we have a permanently set winding, with its number of turns controllable by a tap switch? The first method is better from the standpoint of uniformity and gradual movement, but it has a big disadvantage. The capacity coupling is changed too much and causes upsets in the secondary dial settings. Besides, there are too many turns on the coil for short wavelengths and the plate circuit is tuned so high that oscillation commences.

Hence the better plan is to provide a tap switch for cutting in or out the primary turns. It is astonishing what an immense difference in signal volume may be had with such a device, with variable coupling for the last stage of the radio frequency amplifier, or between the R. F.

amplifier and detector in the case of a single step amplifier. By this method, the R. F. coupling is as great as possible without causing oscillations and the volume as well as the selectivity are very much greater.

In "D," Fig. 2, is shown the variable primary coupler. Here a tap switch is connected to change the coupling for long and short waves. Such a plan is of most value in sets having only one stage of tuned radio frequency and a detector, either crystal or tube. With the average coupling coil, a fixed primary of about 6 to 8 turns is adopted. Many tuned R. F. reflex sets are made up in this manner. If they are good for long waves, oscillations prevent good reception on short waves, and if excellent on short waves, the long wave stations come in poorly, although with no trace of oscillation.

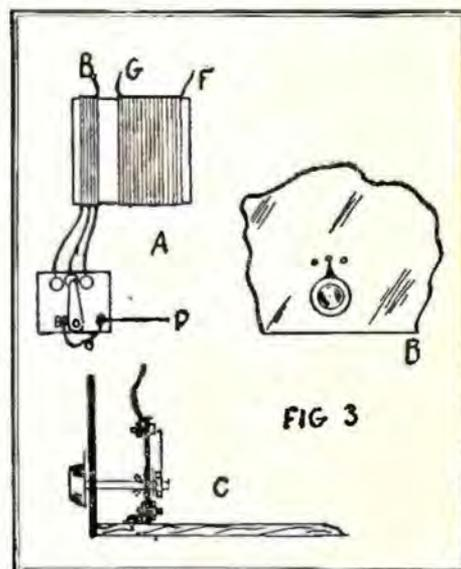

Fig. 3—Details of a variable coupler. Primary and secondary are fairly well separated, to avoid capacitive coupling. A sub-panel tap switch permits the use of any desired number of turns in the primary. White dots on the panel show where the lever is to be set.

Perhaps the easiest method of adopting the variable primary is to install a number of switch points and a switch knob and lever on the panel, where it is readily accessible from the R. F. transformer in the set. This, however, requires long connecting leads and is unsightly in view of modern receiver construction. A superior method is indicated in Fig. 3. At "A" the coupler itself is pictured, "G" and "F" being the secondary terminals. The smaller winding is the primary and it consists of approximately 15 turns. With a crystal detector, it may be advisable to go as high as 20 turns, although no more than this are needed if the R. F. amplifier tubes are good ones.

For the average set used chiefly for local reception, the switch may have three taps and the entire primary have only twelve turns in all. A tap is taken at the 7th turn, at the 9th and at the 12th. In sets using two stages of radio, the primary may be smaller, even for DX work, some primary coils working well with a total of ten turns, tapped at the 5th and 8th and 10th. The number of turns in the primary must really be worked out by the individual set operator to fit his own conditions.

Back-Panel

THE switch points are laid out on a small piece of panel material, about 2 inches square. The switch lever may be of the regular style or be cut from spring brass or phosphor bronze. It is soldered to a $\frac{1}{4}$ -inch set collar. Good contact to the lever may be made by using a long set screw and attaching a nut to it for holding the end of a short piece of flexible wire. This forms the plate connection "P" of the transformer. The taps are laid out and so connected that a left-to-right movement of the panel knob brings an increase in coupling. The set collar is attached to a length of bakelite or brass rod, $\frac{1}{4}$ -inch diameter, which passes through a $\frac{1}{4}$ -inch hole in the sub-panel and also in the main panel. The assembly is given at "C" and at "B" the front panel is shown. Three small white dots indicate the position of the switch arm. These are made by filling with white wax crayon small depressions made with the twist drill.

In case there is special interest in DX reception, more taps are taken, thus giving a more gradual change in coupling. The best way to determine how the primary should be wound is to make up an experimental primary coil of about 20 turns, with a tap at every second turn. The taps are merely bared places in the wire, twisted into loops. A spring clip is then used to connect to the taps in lieu of the switch arm and points.

In most cases, the final result will be a coil of about twelve turns, with taps at the 5th, 7th, 8th, 9th, 10th and 12th turns, or about six taps in all. The adjustments should be tested with good "B" batteries of at least 90 and preferably a little higher voltage, with good R. F. amplifier tubes and the coupling coils properly in place with about 1-4 inch separation between the primary and secondary.

(Turn to page 50)

THE receiving system to be described in this paper is the result of a very considerable amount of research and experiment put forth in an endeavor to produce a super-heterodyne that would give equal or better results than could be obtained with any existing type, yet which would employ a maximum of six tubes, for this number must certainly be considered the maximum allowable limit henceforth, if the word "efficiency" be used in connection with this system of reception.

In the past, there has been no question in the mind of even the most uninformed fan but that the super-heterodyne was the ideal radio receiver, and the ultimate desire of every enthusiast has been to be the proud owner of a set containing many more brightly lit tubes than any other set in his community. Yet this has been the real drawback of the

super; the necessity of using from seven to ten tubes in order to obtain truly super-heterodyne results. Therefore, the aim of receiver designers has not been to improve results, for a super that really justifies the name will go down to the lowest noise-level—the limit of practical sensitivity; but rather, to reduce the number of tubes used and at the same time retain the sensitivity, selectivity and quality of reproduction obtainable with the best of sets.

Two Ways To Do It

TO the mind of the engineer, there are but two practical methods of attacking this problem; either make the tubes used do more work, or raise the efficiency of each circuit of the receiver right up to the maximum limit, or do both simultaneously. The first method of attack may be considered an expedient, and boils down to reflexing, causing one or more tubes to perform various functions, such as radio and audio amplification simultaneously. This is not entirely practical, in view of the frequencies to be handled, except in one section—the frequency changer. Here, there is no reason why one tube may not be used for the first detector and oscillator, providing the separate tuning circuits may be satisfactorily isolated. Up to the present, this has been impossible, except by the second harmonic method, which will be considered later.

A Big Step Toward Efficiency in Super-Heterodyne Design

A SIX TUBE "SUPER-AUTODYNE" RECEIVER

The Super-Het Reduced to Six Tubes, Yet Giving Results More Efficient Than Seven and Eight

By McMURDO SILVER



Fig. 1. The completed super-autodyne illustrating clearly what can be done with standard circuits in producing a symmetrical design that is pleasing to the eye.

The next method, and the more straight-forward one, is to improve the efficiency of each section of the system so that fewer tubes will be required to give the same amplification that has hitherto been obtained. An example of such a receiver was described by the author in the March issue of RADIO AGE. This set incorporated a regenerative first detector, thus giving the greatest possible gain obtainable for

both detector and oscillator has been that of isolating the loop or pickup circuit from the local oscillator circuit. It has been impossible to couple a tuned pickup circuit to a tuned oscillator when the two are to operate but fifty or sixty kilocycles apart throughout the broadcast wavelength range, and not have the tuning of one section react on that of the other.

Armstrong and Houck developed the expedient of the second harmonic system, whereby the oscillator, working at double the desired wave, did not react greatly upon the loop circuit. Then, a harmonic of the oscillator was used for heterodyning. This meant two waves were being produced by the oscillator of sufficient power to cause radiation, which necessitated the use of a muffler tube ahead of the detector-oscillator to prevent radiation. Thus, two tubes were still used, though the gain in signal strength was equal to or slightly better than that obtained with a good regenerative detector and oscillator. At best, the system is not entirely satisfactory for home assembly.

Then came the development by J. H. Pressley, a Signal Corps engineer, of the balanced autodyne circuit, which not only performs the required function with one tube, but does it much better than either the second harmonic autodyne, with its amplifying muffler, or what has hitherto been considered about the limit

the input circuit. But two stages of intermediate frequency amplification were used, for due to the careful design of the transformers employed, it was found possible to realize as much amplification with two stages as had previously been realized with three stages. In each circuit, efficiency had been increased as much as possible, and the fact that with but seven tubes receivers of this type give a fairly consistent range of two to three thousand loud-speaker miles, even under present weather conditions, is probably the best indication that this latter method of attacking the problem is the most logical one.

A Practical Combination

THE next step was obviously to combine the detector and oscillator functions in one tube. The difficulty which has heretofore prevented the use of one tube for

A REMARKABLE ROUND-UP OF HOOKUPS

The August RADIO AGE will be the most unusual issue of a radio magazine ever printed. It will consist of more than 100 pages of basic radio hookups from crystal to super-het, illustrated with actual color RADIO AGE blueprints. Don't miss this wonder issue.

Order your August issue from your news-dealer now or send \$2.50 for a year's subscription.

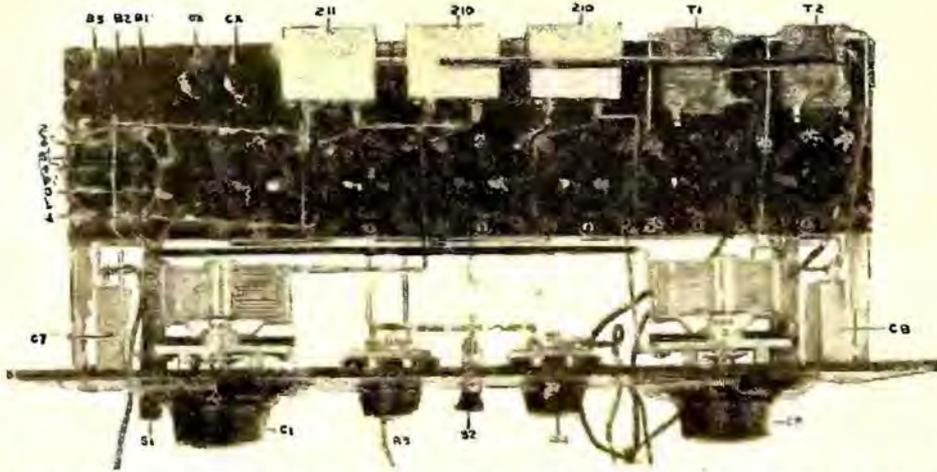

Fig. 2. Interior view of the super-autodyne. The instrument designations will be found in the text. The sockets, from left to right, are: V1, autodyne; V2, 1st R. F.; V3, 2nd R. F.; V4, 2nd Det.; V5, 1st A. F.; V6, 2nd A. F.; Socket shelves may also be procured for UV199 or C299 tubes.

for sensitivity—the regenerative detector and separate oscillator. This autodyne circuit, in actual tests, appears to give a much greater gain than any of the frequency-changing circuits previously utilized, and, at the same time, is far simpler to build and operate than any of its predecessors.

The Circuit

THE actual first tube circuit is shown in Figure 4. The coils L2, L3 are theoretically equal, as are the condensers CX, CX. Actually, they cannot be made fixed and equal, so CX, CX are made adjustable, to obtain substantially a condition of equality. These units make up a bridge circuit, shown by the heavy lines. Since L2 equals L3, the potential across them is equal, so that it is also equal between points 3 and 4, and 5 and 6. Likewise, the potential across CX and CX is equal. Since the potential across 3 and 6 is the same for both inductance and capacity, then points 4, 5 and the joint between CX, CX are at equal potential, and are also theoretically at zero potential, since these points are neutral with respect to 3 and 6. Then, circuit B1, C2, B2, may be connected at these neutral points, with substantially no reaction on the frequency of the bridge circuit. Further, as these points are neutral with respect to 3 and 6, no energy in the bridge circuit can get into B1, C2, B2, since there is no potential difference across these points of the bridge. Therefore, the frequency adjustment of the bridge circuit cannot react upon that of the B1, C2, B2, circuit, and vice versa.

Since the signal is fed from the loop and its tuning condenser to the oscillator, it will divide equally across the bridge arms. If a tube detector is connected across one capacity CX, the drop in potential may be used to cause rectification. It would appear that some of the signal voltage is lost by this method, but actually it is not. It is, as a matter of fact, considerably reinforced when the new component is finally fed to the amplifier, probably due to regenerative amplification. The coil L1, coupled to L2, L3, causes the bridge circuit to oscillate at a frequency determined by

these coils, CX, CX and C1, which is made variable for the purpose of tuning the oscillator circuit. As previously explained, this energy cannot get into the loop circuit, so radiation is confined to what may be experienced from the oscillator coil system itself—a negligible amount. By means of this circuit, which is surprisingly efficient when it is considered that one tube delivers a stronger signal than two tubes in the conventional circuit, and is consequently much more sensitive, it is possible to eliminate one tube from the receiver, and still obtain better results than with two.

The intermediate amplifier is the only other unusual feature of the receiver. It employs but two stages and is on the order of those described by the writer in RADIO AGE for March, 1925. It differs, however, in that it employs special laboratory charted transformers which are a compromise between the extreme selectivity of properly designed air-core coils, and the great stability and amplification of good iron core transformers. But two core laminations are used in each transformer, of 7 mill silicon steel, one in the shape of an "F" and one an "L." The air gap formed, together with other recently developed features of the design, permits the realization of almost an ideal curve—extra-

ordinarily high amplification over a 10,000 cycle band, with a sharp cutoff either side. The amplifier, employing two of these transformers, together with a sharply tuned filter which is provided with a laboratory adjusted tuning capacity, C5, gives tremendous amplification, for it also employs controlled regeneration, adjustable by means of R3.

More Stages Unnecessary

WHILE more than two stages might be employed, two will go down to the best noise level, so that more are unnecessary. Further, there is a decided drop in amplification in adding more stages, which will react upon the preceding two, so that three stages give only slightly better results than two. This should really be written "slightly more noise," for two stages give more than enough gain.

Before going into a description of a receiver designed along the lines outlined, it might be well to justify the use of the name "super-autodyne." "Heterodyne" is generally considered to refer to a source of external power—a separate detector and oscillator tube. "Autodyne" refers commonly to a tube performing the functions of rectification and oscillation simultaneously, so it was considered logical to call the six tube receiver a "super-autodyne"—and it certainly deserves the appellation, "super," for the results obtainable are surprising.

Below is a log, representing one hour's work by an operator unfamiliar with the system. The set was located 600 feet from WGN, one-half mile from KYW, and WMAQ, and many other Chicago locals were also operating. All stations were heard on the loud-speaker.

WCEE	19	48.5	S	KSUO	67.5	78	L
WTAS	23	61	S	WCBD	29	23	L
KDKA	23.5	65	S	WHAZ	33	30	L
WGR	31	71	S	WLW	42	41	L
WDAF	31.5	21	L	WTAC	50.5	54	L
WTAM	36	31	L	KFI	49.5	53	L
KSID	36.5	33.5	L	KSUI	43	32	L
WCCO	40.5	39	L	WQJ	50	45	L
WOS	44.5	45	L	WTAY	16	37	S
WCAP	50	53	L	WBCN	18	43	S
WSU1	53	58	L	WJJD	22.5	61	S
WEAF	55.5	58	L	WLS	28	85	S
WCX	60.5	67	L	WBAP	52	56	L
WOAW	63	70	L	WEBH	32	95	S
WGN	32	28	L				

The station separation was very pleasing on some of the unlisted lower wave stations, due to the use of the straight-line-wavelength condensers. A comparison with a standard five-tube neutro-

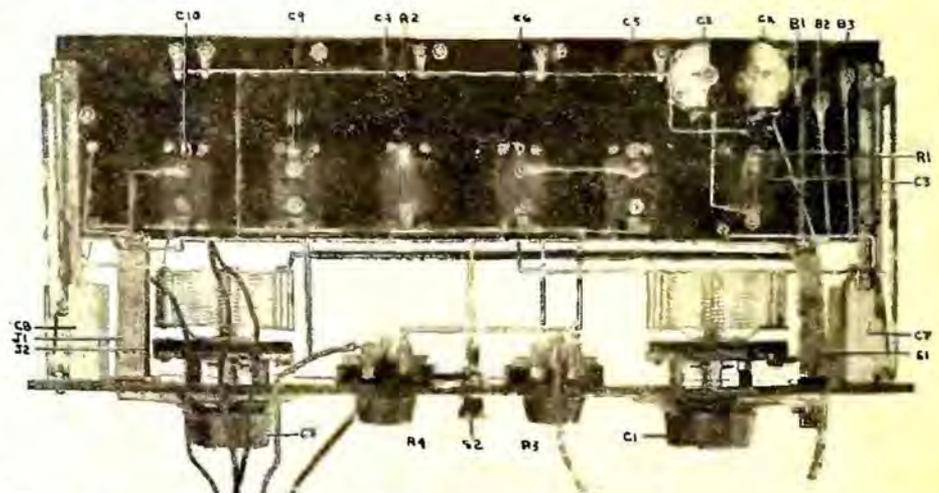

Fig. 3. Bottom view of the socket shelf assembly. Notice how all parts are rigidly fastened in place—an important feature for portable receivers.

dyne on a 100 foot antenna was unfavorable to the neutrodyne both on the count of selectivity as well as sensitivity and volume. A standard super (see March RADIO AGE) failed to produce any better results, as did another eight-tube set employing air-core transformers.

While the outfit will deliver about the same energy with either dry cell or storage battery tubes, the dry cell tubes will generally be sadly over-loaded, and it is, therefore, suggested that UV-201-A tubes be used throughout, although even so, it is possible to overload the sixth tube. This will be appreciated when it is realized that in Chicago it is possible to get volume sufficient for dancing from the West Coast stations on five tubes using only a small loop, under favorable conditions.

The portability of the set may be realized even with storage battery tubes by means of special leads if a car is handy. These leads permit connection to the car battery through the dashboard light socket for the "A" supply. If this is not possible, it is suggested that the necessary dry batteries be carried in an old hand satchel, or even a lunch box or tool kit. Then connections can be made quickly with the color cable used for the battery leads, and the receiver set up in a few seconds' time. This battery can also easily contain the folded loop and a small speaker, when they are not in use. Blanket straps will provide an easy means of carrying the receiver, so that the whole set can readily be managed by one man.

Portable or Permanent

THE advantage of this arrangement is that the same set serves for camping or traveling that is used to provide entertainment at home at other times. It is possible, if the builder prefers, to have a luggage shop make a carrying case so arranged that the receiver is at the top, the batteries below, and the loud speaker in the lower compartment with them, either at the side or in the

middle. A small speaker is to be recommended for its small size and general portability, and it certainly talks up very much "bigger" than it looks.

The material required to build this receiver is listed below, with the designation letters used in the diagrams and cuts following the quantity of each item required. While it is entirely permissible to substitute any other standard parts for those listed, it is strongly recommended that the parts specified be used for several reasons. The actual space available is such that parts of larger or different dimensions could not be substituted in some instances, and in the case of the RF Transformers, and SLW condenser, it would be inadvisable to substitute, since the results of the receiver depend in a large measure upon the use of the types recommended.

- 2 C1, C2—S. I. W. Condensers.
- 2 1" Moulded dials, vernier type preferably
- 1 R4 5 ohm rheostat
- 1 R3 240 ohm potentiometer
- 3 BL, B2, B3 insulated top binding posts
- 1 J2 101 jack (1-spring)
- 1 J1 102-A jack (3-spring)
- 1 C-5, 211 filter with matched tuning capacity
- 2 210, 210 charted intermediate transformers
- 1 L1, L2, L3, coupling unit
- 1 6 gang socket shelf (530-201-A, No. 537-199)
- 2 T1, T2, 3 1/2" or 2.1 transformers
- 2 C7, C8 .5 condensers
- 2 C3-C4 .00025 condensers with clips
- 2 C9, C10 .002 Condensers
- 1 C6 .0075 condensers
- 2 CX, CX .000025 condensers
- 1 R1 .5 Meg leak
- 1 R2 meg leak
- 1 S1 No. 3 jack switch (S. P. D. T)
- 1 S2 8630 switch (S. P. S. T.)
- 1 No. 701 color cable (5 lead)
- 1 pair No. 8629 shelf brackets
- 1 Bakelite Panel, 7"x18"x1/8"
- Small parts: 29 6/32 R. H. C. P. Machine screws 3/8"
- 2 6/32 R. H. N. P. Machine screws 1 1/4"
- 31 6/32 nuts, 1 spaghetti, 10-bus-bar, 25-lugs

- Tools required:
- 1 hand-drill with drills and counter-sink
 - 1 soldering iron with rosin-core solder and non-corrosive paste
 - 1 side-cutting pliers
 - 1 screw driver

Inspecting the Set

AS SOON as the material has been procured, each item should be carefully examined to see that all screws and nuts are tight, and lugs placed as shown in the photographs, so that those on the various instruments will point in the best directions for short leads. Socket springs should be bent up to make good contact with tube pins. Condenser bearings should be adjusted to give the desired tension.

The actual assembly of the receiver is extremely simple, providing a standard socket gang and a drilled panel are used. If this is not done, it will be necessary to drill up a sub-base and panel to take the instruments. The panel may be grained if desired by rubbing with fine sandpaper and oil until all traces of the original finish has been removed. Indicating marks for the condensers can be scratched with a scribe and filled with white.

If Figures 2 and 3 are carefully studied, no difficulty should be encountered in mounting all the parts, following the designations shown, which are also given in the parts list. As the parts are mounted, the wiring may be started and put in progressively on the base and panel, then the two joined together and the final connections made. It is necessary to use a well-tinned soldering iron, with rosin core solder and some non-corrosive paste. The battery leads are brought out through a color cable, coded in accordance with the A. M. E. S. code, thus obviating binding posts and providing permanently attached connecting leads at one operation.

After the receiver has been wired, the necessary batteries should be connected to it, the rheostat just turned on, and the autodyne tube inserted in its socket. The phones must be connected to the set, the switch S1 set at "L," C1 at 40, and C2 varied rapidly throughout its scale.

A "plunk" will be heard, indicating an unbalanced bridge circuit. With one condenser CX set all in, turn the other CX slowly out, rotating C2, meanwhile. If the plunk does not disappear, reverse the operation, leaving the other balancing condenser all in to start with. Once the plunk has been balanced out for all settings of C1 and C2, condensers CX, CX should never be touched. If squealing or clicking is experienced at low settings of C1, it will be necessary to use a smaller grid leak at R1. This leak will generally vary between .25 and .5 megohms.

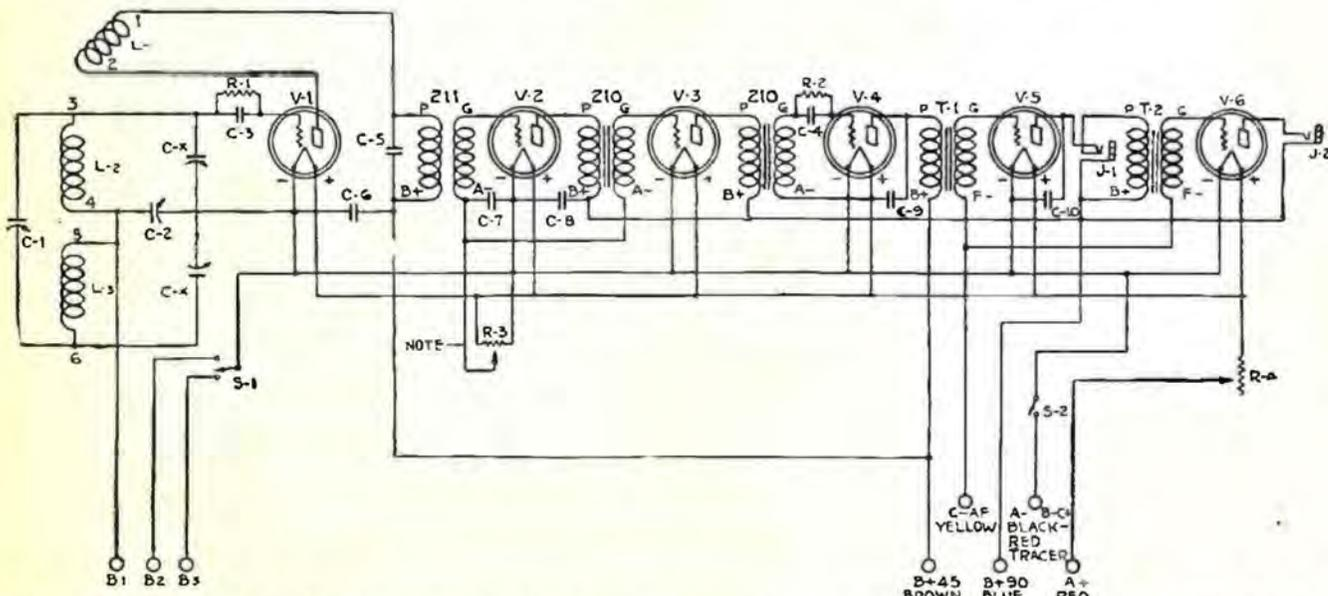
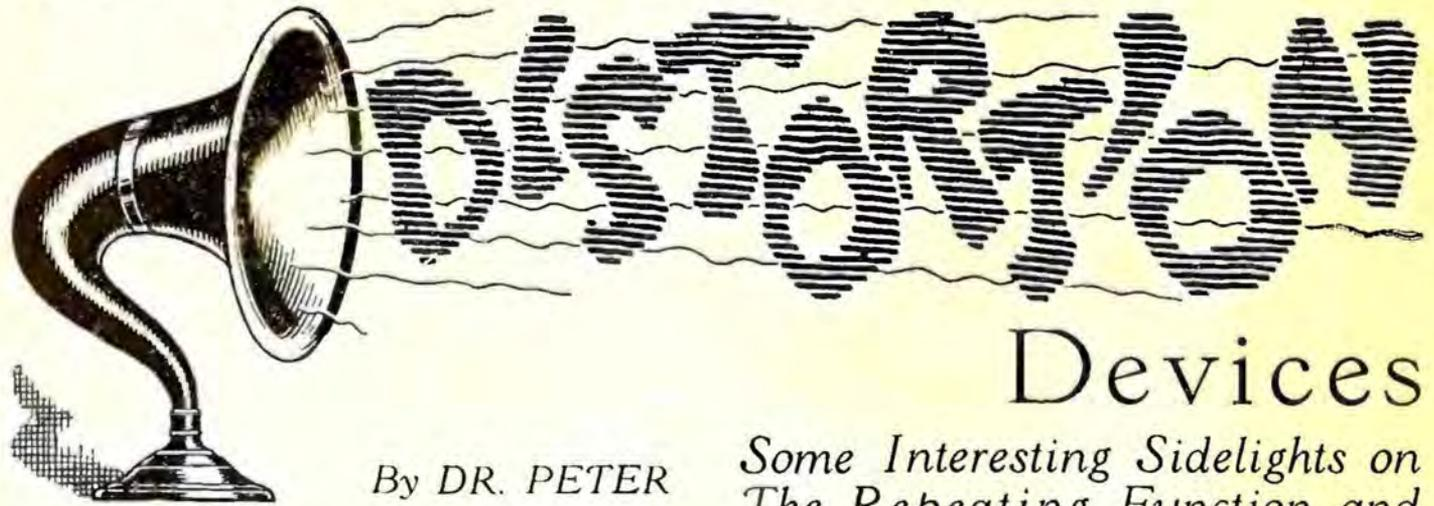

Fig. 4. The wiring diagram of the new super-autodyne receiver. Heretofore to obtain neutrodyne results on a loop aerial, seven and eight tubes were necessary. But in this receiver only six tubes are needed to achieve the same end.

Vacuum Tubes as



Devices

By DR. PETER
I. WOLD

Some Interesting Sidelights on The Repeating Function and "Distorting" Function of Tubes

IN THESE days all of us have become so well acquainted with vacuum tubes, through actual use or through the countless articles on radio sets making use of them, that anything further might almost seem superfluous. On the other hand, there may be some who have only recently acquired an interest in radio, or it may be that the exceedingly versatile device very commonly but very poorly called a vacuum tube offers some point of view which may be new to many.

If you have followed the radio art for some time, you have heard of these tubes being used in a number of different ways, as for audio frequency amplification, radio frequency amplification, detection, regeneration, reflex regeneration, any or all of these occurring in your receiving sets; and if your interest carries over to the broadcasting station, you have heard of oscillation generators and modulation.

All of these terms may suggest a confusing variety of uses for the vacuum tube, but it may simplify matters if it is pointed out that this tube has two functions only, which are separate and distinct, and the various uses mentioned come under the one or the other. These two functions may be spoken of as the *repeating* function and as the *distorting* function. The two are present in every tube in an amount depending on the design of the tube; i. e., the relative sizes and spacing of the elements in the tube. By the way in which the tube is operated, and by the circuit with which it is associated, one of these functions may be emphasized.

What It All Means

BY the first of these functions, I mean that of re-

peating electrical variations impressed on the grid generally with amplification and, at least theoretically, faithfully, or without any distortion. By the second, I refer to that property of the tube by which electrical variations on the grid result in variations, generally amplified, which are substantially different. As an example of the first, we may take the relaying of telephone messages across a transcontinental line in which the greatest precautions are taken to make the repeating action as faithful as possible; i. e., to reduce distortion to a minimum. As an example of the second, we may take the detection of a radio message in which electrical oscillations or variations of perhaps a million cycles—and therefore quite inaudible—are so distorted or converted as to

give oscillations of an audible frequency.

The repeating action of the tube and its circuit, with amplification, would probably be held to be the more important property, for it includes such applications as long distance telephony and all the actions in radio work mentioned above, except those of detection and modulation. On the other hand, its property as a distortion device is the more interesting, though not so generally understood.

Let me remind you for a moment of the essential elements of the standard vacuum tube. There is a filament which may be raised to a high temperature, whereupon it may give off electrons—those smallest particles of matter or electricity which we have come to recognize as playing so important a part in all our affairs. Then there is a plate kept at a positive potential by the B battery, and which therefore attracts the electrons from the filament, thus giving rise to an electric current to the plate. Finally, there is the grid placed between the two. When the grid is made more positive, a larger current flows to the plate and through its circuit, and when it becomes more negative a smaller current flows. It is possible thus to control a current by changing the potential of the grid; and the important point is that the energy for exercising this control may be very much less than the energy of the controlled current. It is for this reason that the device acts as an amplifier.

Getting Minimum Distortion

IF, starting with a small current to the plate, you draw a line showing how this current changes as the potential of the (Turn to page 60)

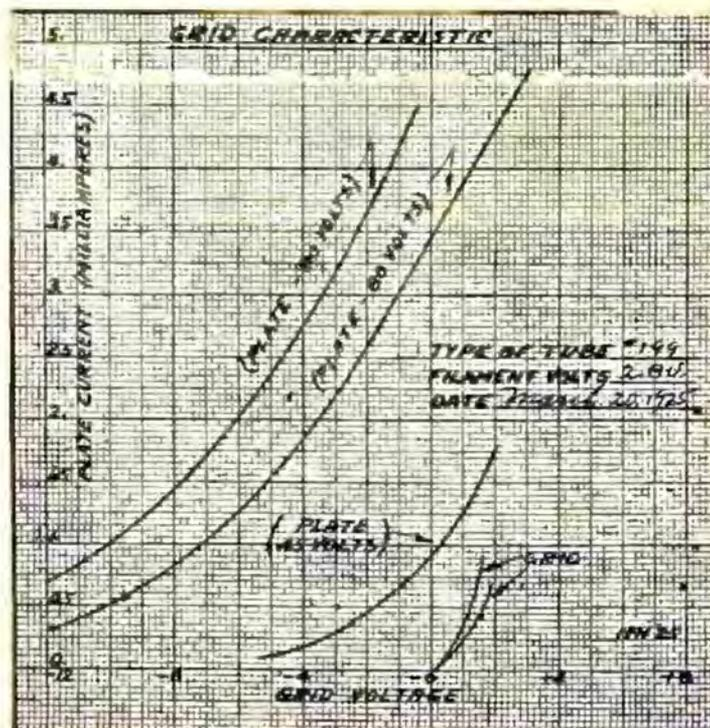
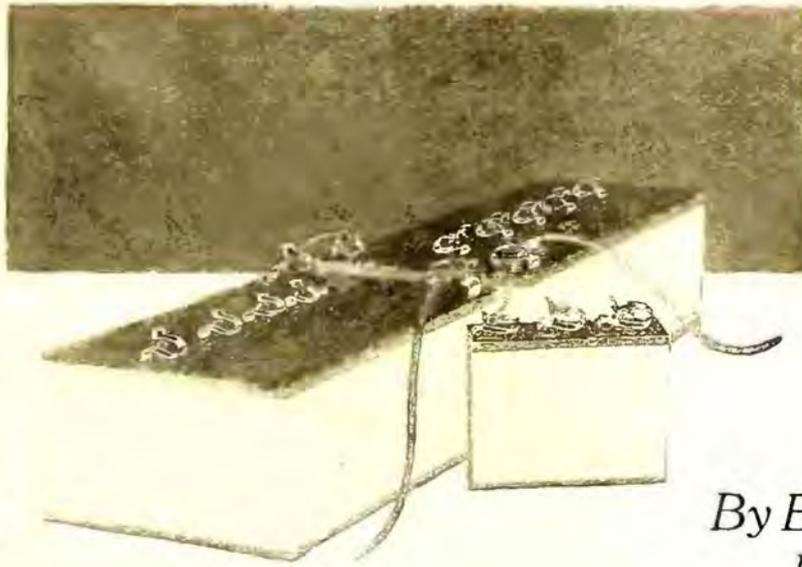

Fig. 1. A typical grid characteristic chart for 199 type (3 volt) tubes with plate voltages of 45-80 and 90 volts.

The Correct "B" Battery for your Portable

Success
or
Failure
of the
Vacation
Radio
Depends
on the
Condition
of Your
"B" Battery
Outfit



Liberal
Supply
at Start
Will
Insure
Success

By Edgar H.
Felix

THE B battery is the power plant of your radio set and its failure means that the portable is temporarily useless. At home, batteries are not difficult to replace from the liberally stocked shelves of a nearby radio store, but in the wild and woolly haunts where many of us seek rest from the rigors of city life, B batteries are as rare as the proverbial dinosaur.

Hence, give this important element of your Summer radio set all of the consideration which it deserves. Take the same precautions that you would before starting on a motor trip across a hundred mile desert—make sure that your fuel supply will be sufficient to carry you to the next service station, with an ample margin to spare.

There are two kinds of service for which portable sets are designed and your B batteries should be selected with these in mind. First, there is the pack set, which can be carried on a hike, like other portable camp equipment; and second, there is the self-contained semi-portable, for temporary installation during vacation time, in camp or bungalow.

The Pack Set

IN THE pack set, everything must be sacrificed to secure light weight.

Economical upkeep and long service without renewal of batteries must give way to the utmost portability. For this reason, the smallest and lightest B battery obtainable must be used, because the larger sizes are altogether too bulky and heavy to be carried for any great distance.

To meet these requirements, B battery manufacturers have placed tiny radio power plants on the market. These consist of an assemblage of very small cells, sealed in a small container. They represent the greatest possible amount of electrical energy which can be crowded into so small a space. But the output of

any B battery, in milli-ampere hours, is proportional to the quantity of active chemicals within each cell. Only a certain amount of each essential chemical can be placed in a given space. Consequently, the size of the battery places definite limitations upon the output which may be expected from it. The smaller the battery, the shorter its life and its current output. B battery costs, per hour of operation, increase rapidly as the size of the battery becomes smaller.

Before starting on your trip with a portable set, be certain that you have a B battery power supply which will last

over the period of your trip. Do not expect long life from tiny batteries called upon to deliver heavy currents for multi-tube sets. The smallest B battery, shown at the left of the illustration on this page, has all the capacity which can be incorporated in a battery of that size. It has a volume of 17.5 cubic inches.

The next larger size, at the center, has a cubic content of 28.6 cubic inches, or 63% larger. The tall, slim battery at the right is 50.3 cubic inches or 186% larger than the smallest battery. Obviously, there is considerable advantage both in milli-ampere hour capacity and economy in

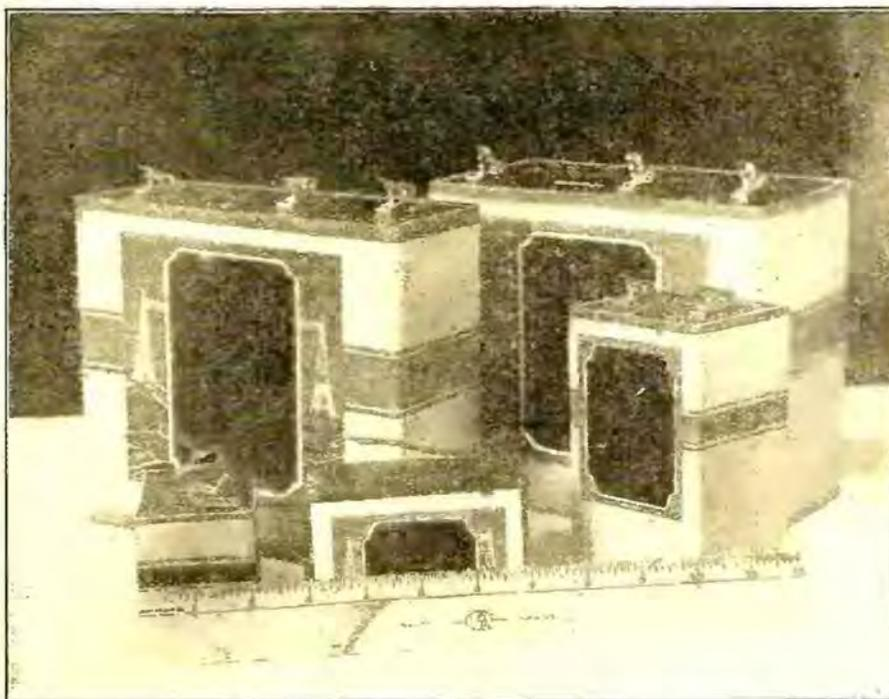

This layout shows the various sizes of "B" batteries. It is advisable to spend liberally in equipping a portable set with "B" batteries, for a stingy investment at the start usually results in woe later on.

Voltage of Tubes	No. of Tubes in Set	Type of Tubes (see foot-note)	Total Rated Ampere Drain	Storage "A" Battery Size Recommended		
				Amp. Hours at 1 Amp. Drain	Days between Chargings	
5-Volt Tubes C-300 and UV-200 are interchangeable C-301A, DV-2 and UV-201A are interchangeable	1	UV-200	1	65 or 47	22 16	
	2	UV-201A	$\frac{3}{4}$	47	33	
	2	1 UV-200 1 UV-201A	$1\frac{1}{4}$	80 or 65	22 17	
	3	UV-201A	$\frac{3}{4}$	65 or 47	29 22	
	3	1 UV-200 2 UV-201A	$1\frac{1}{2}$	95 or 65	21 14	
	4	UV-201A	1	65 or 47	22 16	
	4	1 UV-200 3 UV-201A	$1\frac{3}{4}$	115 or 80	22 15	
	5	UV-201A	$1\frac{1}{2}$	80 or 65	22 17	
	5	1 UV-200 4 UV-201A	2	115 or 80	19 13	
	6	UV-201A	$1\frac{1}{2}$	95 or 65	21 14	
	8	UV-201A	2	125 or 95	21 15	
	For sets using current at a rate higher than 2 amperes.			$2\frac{3}{4}$	140 or 95	22 13
				$2\frac{1}{2}$	140 or 125	19 16

For combinations of tubes not listed: Use the same battery combinations recommended for tubes having voltage and current requirements similar to the tubes you have.
NOTE: If you use a loud speaker operated from your "A" Battery, add $\frac{1}{2}$ ampere to the total rated current drain of your tubes and then select a battery giving this total current consumption.

This chart, recently prepared by storage battery experts, should come in handy for fans whose knowledge of "A" battery characteristics is limited. Cut it out and tack it up near your radio set.

buying the largest possible battery which you can carry with you.

A pack set, intended for several weeks' use during vacation time, will give more satisfactory service if large batteries are used outside the set, while it is used at its semi-permanent location. When designing your portable, therefore, equip it with flexible B battery leads so that, whenever possible, you can use larger batteries and so that you may limit the service on the small batteries to those occasions when convenience in portability compels their use. For instance, if you plan to take your set with you on an all-day picnic, use the small portable batteries; but when you get back to the permanent camp at the shore of the lake, substitute the larger batteries for the smaller ones. Your two sets of batteries may then last you all through the summer season.

The Semi-Portable Set

THE semi-portable set can give all of the satisfaction of the permanent installation, so far as battery upkeep is concerned. Thousands of motor campers take good radio sets with them because they provide the finest kind of entertainment after the day's drive. Even if the battery compartments in the set do not

provide sufficient space for larger batteries, leave the diminutive batteries home, and make space in your car for large or even extra large B batteries. If you have room for a radio set, you have room for the right kind of batteries to go with it. Nothing takes quite so much space as a radio set which is useless because its tiny inadequate B batteries have given out.

The realization that an adequately powered set is the only kind which gives satisfaction is gradually becoming general. Nevertheless, many sets on the market, including some intended for permanent installation, are equipped with compartments for small B batteries, encouraging inadequate sources of power supply.

On any loud speaker set, the audio-frequency amplifier can be made very economical in its current requirements through the use of a C battery. A $4\frac{1}{2}$ volt negative bias on the grids of the audio-frequency amplifier tubes frequently reduces their current drain by one-half or two-thirds. Consequently, the little C battery is well worth its weight, even in a pack set. The current drain to which the C battery is subjected is so small that its serviceability is limited only by its shelf life.

The illustration shows five sizes of B batteries in such a manner that you will be able to identify them when you purchase B batteries for your portable sets.

The smaller sizes, shown at the front of the illustration, should be used only when portability requires their selection. Their output in milli-ampere hours increases more than in proportion to their increase in size. Considering that the largest of these portable units—the tall battery at the right—has less than 25% of the electrical capacity of the large battery shown at the left in the back, the greater lasting qualities of the larger batteries become obvious.

The large size, back of the small batteries at the left, has considerably greater lasting quality than the next preceding size. It is the middle ground between the utmost economy, as embodied in the extra large size, and the uneconomical smaller sizes. There are several makes of semi-portable sets equipped with battery compartments which will house these large batteries.

On the other hand, if it is possible to employ the heavy duty battery for a three or five tube set, as illustrated at the right, you attain the greatest economy possible in radio receiving power supply. These batteries will last much longer than the smaller sizes and they represent the best buy in radio power.

Selecting Strong Batteries

WHEN selecting a storage battery, every owner of a receiving set desires one of sufficient capacity to make frequent recharging unnecessary, yet small enough to reduce the first cost to a minimum. Has ideas as to just what to specify, in order to obtain this highly desirable combination, may be somewhat hazy, but he is never in doubt as to the result he seeks.

Various types of storage battery selection charts have been developed in the past, which were intended to assist the owner of a receiving set in making a proper selection. Lately a chart has been developed which takes into consideration number, type and combinations of tubes in a way that makes selection of a satisfactory battery a simple matter.

Voltage of tubes, number of tubes, type of tubes, rated ampere drain and recharging interval are treated in the chart in such a way that the receiving set owner has a choice of two recharging periods. For instance, for a set using one UV-200 and three UV-201A tubes, with a rated ampere drain of $1\frac{3}{4}$, and "A" battery of 115 amperes (at one ampere drain) will give 22 days of service without recharging when used for an average of three hours daily; while with the same tube combination, a battery of 80 amperes will have a recharging interval of 15 days. Similarly, for a set having three UV-201A tubes at $\frac{3}{4}$ ampere drain, a battery of 65 amperes insures 29 days' service while the smaller 47 ampere battery gives 22 days' service between rechargings.

By calling attention to the types of tubes that are interchangeable, it will be noted that the accompanying chart gives practically every combination of 5-volt tubes in general use.

A Simplified Portable Super

By A. J. HAYNES

Here is
An Outfit
Whose Cost
Can Be
Kept Well
Below
\$130 by
the Careful
Home-
Builder

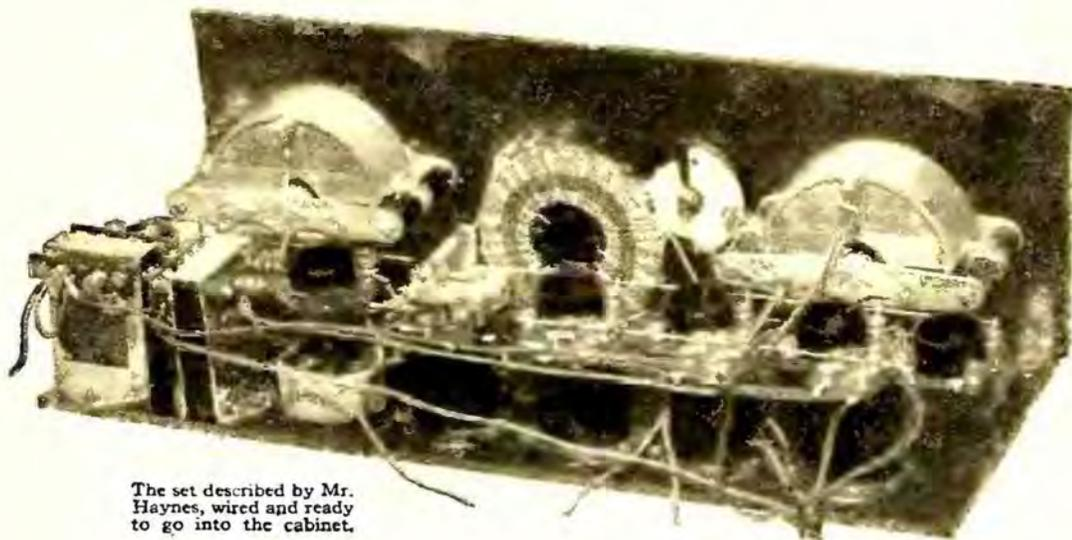

The set described by Mr. Haynes, wired and ready to go into the cabinet.

A Popular Receiver That Will Give Dependable Loud Speaker Results in Summer Up to 1,000 Miles

FOR the past three years, portable radio sets have been built in great profusion—in Winter conversations. When the good old Summer time rolls around, however, rarely does a radio set accompany Dad in his jaunt to the Maine woods or the family on their annual flivver trip.

This lack of enthusiasm in the past can be attributed to a number of real reasons. There were only two or three broadcasting stations with sufficient power to make reception pleasant through static disturbances a year ago, many portable sets were "portable" only because the case was leather, and sometimes the batteries were enclosed, and finally, the cost of a good portable receiver was almost prohibitive for the average family.

This year these faults have been remedied to a great extent. Stations have increased their power until the "static level" has been pushed some hundreds of miles into the sticks. There are now a number of factory built portables which can be classed as real sets, and what is more important to most of us, the cost of both parts and accessories has moved downward in a very satisfactory manner during the last year.

The design of the set shown in this

article has been thought out with complete portability, low cost and good performance as the primary considerations. The set is completely self-contained. Although the loop is built in the case cover, it will be found as efficient as the ordinary loop of approximately the same dimensions. The cost of the outfit can be kept below \$130.00 for the complete units and this price includes all the necessary tubes and batteries. Even this comparatively low price can be cut considerably by judicious shopping.

Same Constants

IF YOU substitute parts other than those shown in the material list, be sure that the new parts have constants exactly similar with those specified.

The circuit employed is a conventional "regenerative loop" affair. The only change which you might notice is the fact that the pickup coil is placed in the filament lead instead of in the grid lead of the first detector tube. This was done to reduce body capacity effects, which are often severe in supers using a grid pickup with regeneration.

The battery supply indicated is wholly adequate for the drain put on it. Our test set ran almost continually for two weeks while we were making tests and

the batteries still have lots of pep. The "What will it do?" club is probably becoming quite anxious by now, and it is fair that they be answered. First, claims of the "coast-to-coast-on-the-loud-speaker-in-daylight" type are ruled out. The set will give dependable loud speaker results in the Summer time on stations up to a distance of 1000 miles. This means results which you can enjoy and, if you are listening to music, dance to it without having to imagine half of the tune. On nights that are favorable to reception, you can make a very comfortable and thorough tour of the country via the loud speaker.

Most of the tests run on this set were made in Chicago, which is notorious for the difficult receiving conditions caused by the numerous and powerful stations there, and the results were highly satisfactory. The set was tried in the North, West and South sections of the city—each with its own particular set of problems, and in no test was the set unable to pull in fewer than fifteen out-of-town-stations. These tests were all made while the local stations were broadcasting.

You can have the carrying case constructed by a local firm or a suitable



The socket strip for the simplified portable super-heterodyne, showing one filament lead and method of binding lugs for other filament lead.

case may be purchased from one of a number of firms advertising them. Owing to the chance for confusion, it is best to cut the leads only as needed and to mark the drawing as they are used. In this way a double check is kept on the work as you go along.

Assembling and Wiring the Set

If the instructions given are followed carefully, particularly the order in which the leads are connected, the average fan should be able to complete the wiring of the set in three hours or less. The time required to complete the balance of the work depends on the cabinet. If you have purchased one ready-made, the set should be operating about four hours after you start work on it.

The only two leads which must be soldered in the set itself run to the jacks and, owing to their position, are easily attached.

Material List

- 1 5"x16 1/2"x3/16" Bakelite Panel
- 1 1 1/4"x16 1/2"x3/16" Bakelite Strip
- 1 7"x16 1/2"x3/16" Veneer Baseboard
- 2 .0005 mfd. Variable Condensers
- 1 Set I. F. Transformers
- 1 Oscillator Coupler
- 1 3 Plate Condenser & Knob
- 8 UV199 Sockets
- 2 Audio Transformers
- 1 400 Ohm Potentiometer
- 1 Filament Switch
- 2 Jacks
- 1 Turnit Condenser
- 2 .006 mfd. Condensers
- 1 .005 mfd. Condenser
- 1 .002 mfd. Condenser
- 2 .00025G mfd. Condensers
- 1 3 Megohm Grid Leak
- 1 5 Megohm Grid Leak
- 1 10 Ohm Type 301
- Rheostat,
- 50 ft. Hookup Wire
- 3 ft. 5-conductor Battery Cable
- 29 6-32x5/16" F. H. Brass Machine Screws
- 12 6-32x3/8" F. H. Brass Machine Screws
- 7 6-32x1 1/4" F. H. Brass Machine Screws
- 40 6-32 Brass Nuts, 1/4" Across Flats
- 12 6-32 Brass Nuts, 3/8" Across Flats
- 2 Brackets No. 1509
- 2 Brackets No. 1506
- 8 Brackets No. 1505
- 3 Brackets No. 1470
- 9 Doz. Small Lugs
- 4 Lengths Rosin Core Solder
- 18 Brass Washers for 6-32 Machine Screws
- 12 3/8" Brass Wood Screws
- 5 Rubber Binding Posts
- 4 Bakelite Loop Support Straps
- 100 ft. Stranded Loop Wire
- 1 Portable Cabinet
- 1 Loud Speaker



Here is the completed set ready for action, with a new type of loud-speaker. This is truly a portable outfit, and tests in the crowded Chicago area showed it cuts thru locals up to 1,000 miles on the speaker. That's good for summer, isn't it? Note the loop wound in the cover.

place a lug under each nut which locks both a socket and condenser in place. This is done at points A10, A11, and A12.

Before attaching the .00025G condenser in place, put a 6-32x3/8" machine screw through the condenser at H5. Lead No. 35 is now cut to length and attached under the nut at L and the other end secured at L1, the Grid of the first detector tube.

Lead No. 1 is attached at the end of the 5" section to the first grid condenser at H5.

Leads are now partially completed to each of the by-pass condensers on the socket strip. Lead No. 25 is soldered to the .006 condenser at G4. Solder one end of lead No. 22 to the other .006 condenser at D6. One end of lead No. 26 is soldered to the .005 condenser at C4. At L2 of the .002 condenser solder lead No. 23 and attach the other end to the plate of the second detector tube, L.

The lugs which were left at points A10, A11 and A12 are now turned until they pass under the nuts at A6, A8 and A13. The negative filament lead is later attached to these points and the lugs form a very convenient method of making short leads.

Leads 8 and 9 are now cut from two pieces of round bus bar and form the two filament bus lines on the socket strip. Place a lug under each of the filament terminals on the sockets projecting at right angles to the socket strip, bend the tips to right angles, insert and solder the bus bar and finally bend the completed leads as close to the sockets as possible. No identifying letters have been placed on the diagram to show the position of these leads but as the sockets are marked, you should have no difficulty in doing the job correctly. These last operations complete for a moment the work on the socket strip and we shall turn to the wiring of the oscillator coupler.

When the panels have been drilled and countersunk, mount the proper parts on the panel and baseboard. Do not mount the oscillator coupler on the baseboard at this time, as there is some preliminary wiring on it which can be done more easily if it is not mounted. 6-32x3/8" machine screws are used to secure the instruments to the board.

The Socket Strip

THE assembly and partial wiring of the socket strip should now be undertaken. Where a bolt is used to attach only the socket to the strip, use 6-32x3/8" machine screws. Where a bolt attaches both a socket and a condenser to the strip, use 6-32x1 1/4" machine screws and cut off the extra length. Be sure to

SCHEMATIC DIAGRAM

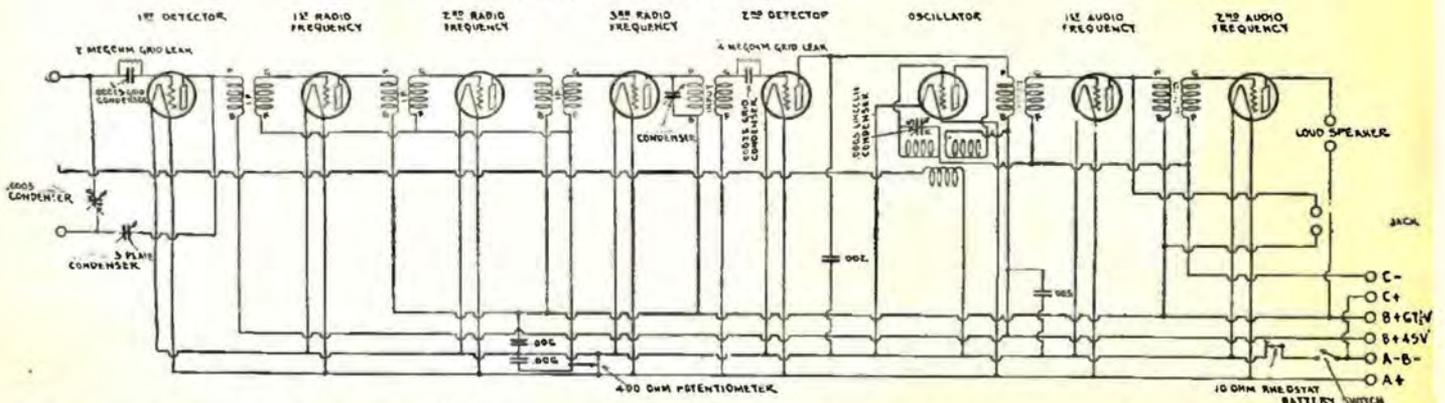

The schematic wiring diagram of Mr. Haynes' receiver. By following this layout the beginner should have no trouble in building the portable super.

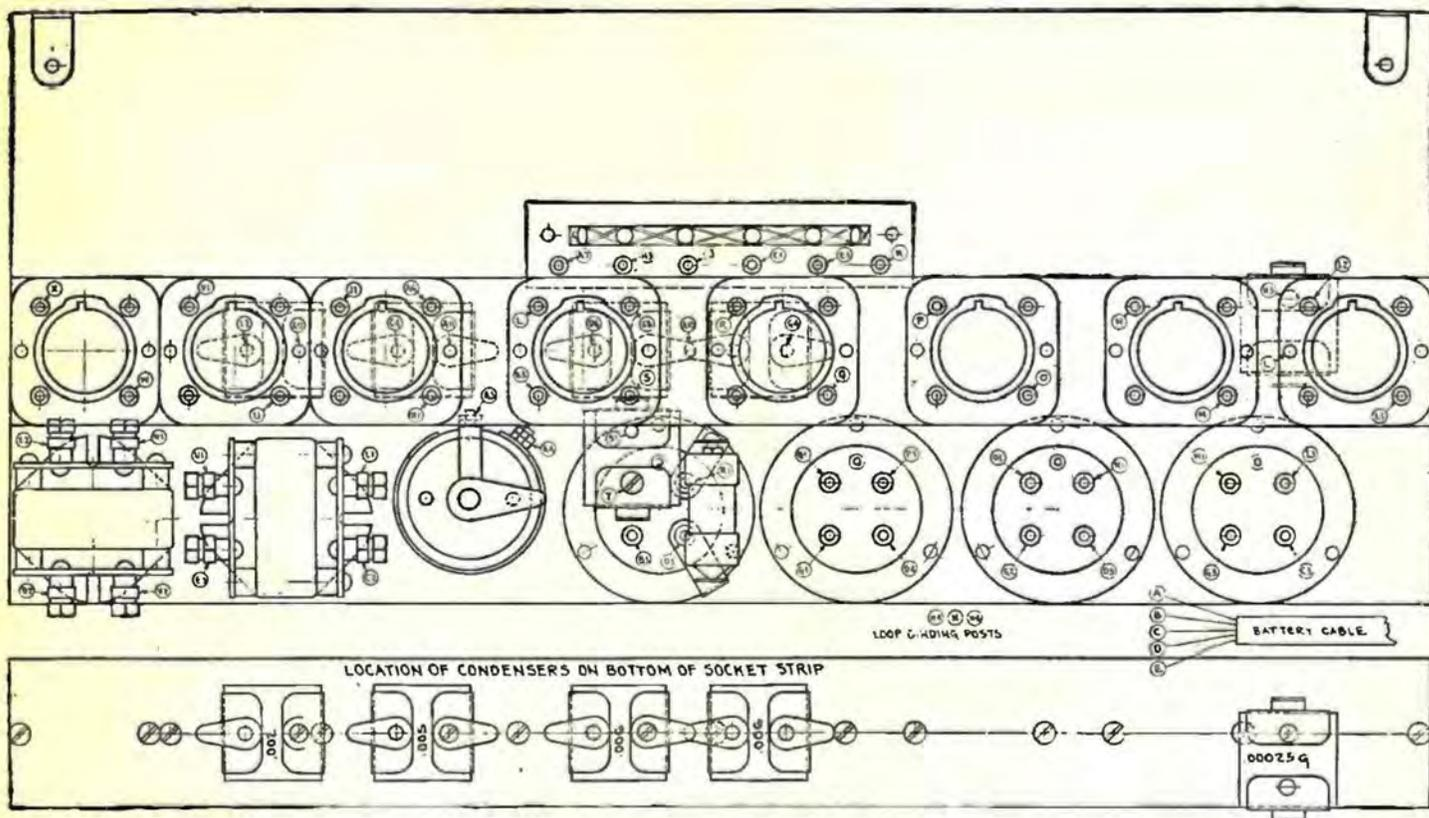

The oscillator coupler consists of three separate windings: the pickup coil, the grid coil and the plate coil. In referring to the "inside" or "outside" connections to a section of the coil, the tap nearest the center or furthest from the center

is meant respectively. Attach one end of lead No. 32 to the inside terminal of the pickup section at A7. Lead No. 3 is attached to the outside terminal at H3. Lead No. 19 is attached at J to the inside terminal of the plate section.

Attach the lug at the end of the 10" section of lead No. 5 to the outside terminal of the plate section at C1. Fasten lead 11 with the tap at the end of the 10 1/2" section to the inside terminal of the grid coil at E1. The lug at the end

LENGTHS OF LEADS IN SET

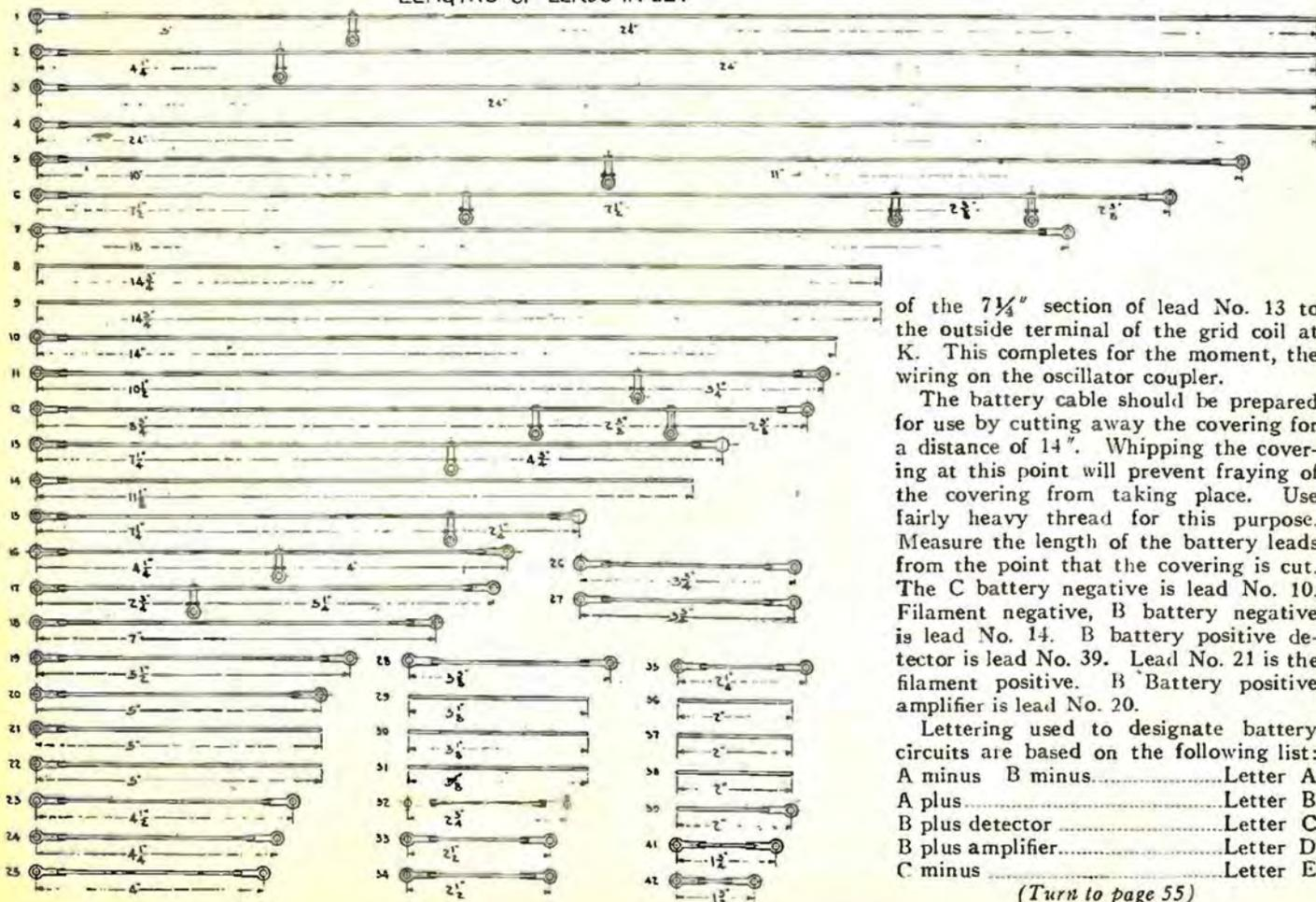

of the 7 1/4" section of lead No. 13 to the outside terminal of the grid coil at K. This completes for the moment, the wiring on the oscillator coupler.

The battery cable should be prepared for use by cutting away the covering for a distance of 14". Whipping the covering at this point will prevent fraying of the covering from taking place. Use fairly heavy thread for this purpose. Measure the length of the battery leads from the point that the covering is cut. The C battery negative is lead No. 10. Filament negative, B battery negative is lead No. 14. B battery positive detector is lead No. 39. Lead No. 21 is the filament positive. B Battery positive amplifier is lead No. 20.

Lettering used to designate battery circuits are based on the following list:
 A minus B minus.....Letter A
 A plus.....Letter B
 B plus detector.....Letter C
 B plus amplifier.....Letter D
 C minus.....Letter E

(Turn to page 55)

Tricks of Summer Radio

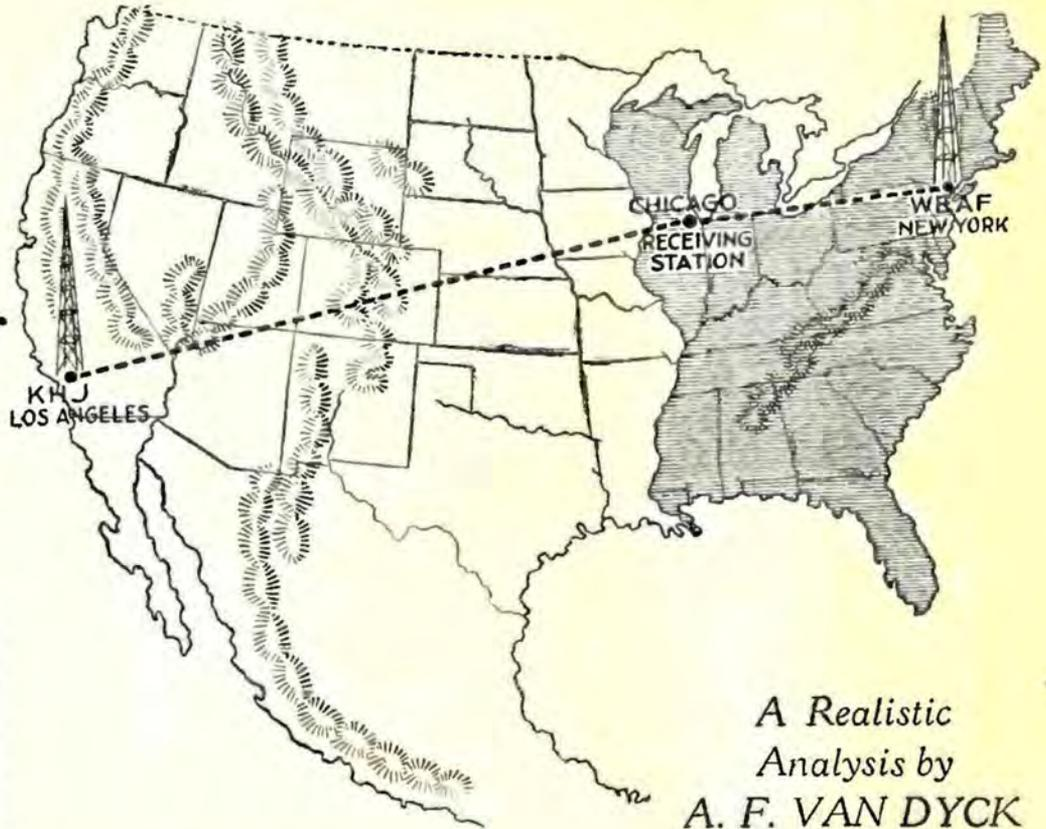

Suppose a receiving station in Chicago is receiving both from New York and Los Angeles. A patch of radio fog might appear between New York and Chicago and weaken the New York signals, while the signals from Los Angeles remain unchanged. The map shows how we sometimes receive signals from the West better than those from the less distant East.

A Realistic
Analysis by
A. F. VAN DYCK

EVERYONE who has a radio receiving set has met the atmospheric nuisance called "static." It comes in, especially during the warm months, and interferes with clear reception. A particularly pleasing musical number may be on, but that makes no difference to Old Man Static.

So many inquiries have been received at the General Electric station, WGY, at Schenectady, that A. F. Van Dyck, a radio engineer, has prepared the following paper, explaining some things that are known about static and what is being done to get rid of it. Mr. Van Dyck's explanation follows:

IN THE letters which WGY has received from listeners, certain questions have been asked by many different inquirers. Some of these questions involve radio phenomena which are not completely understood by scientists today, and the answers and explanations which we shall give should be understood to be the ones which are believed to be nearest the truth, although they are not subject to rigid proof.

First, let us consider what radio transmission is. We know that a radio sending station sends out from its antenna in all directions, a disturbance of electric forces. We cannot see or hear or otherwise observe with our senses just how this disturbance behaves, as we can with light waves and sound waves. We consider it quite natural that a stone wall stops the light beam from a searchlight, or that a bugle call can be heard much farther over water than through a forest, or that under certain air conditions on a desert, the mirage phenomenon is observed; and to know what to expect in radio, we need only to remember

that some things in space will stop, or reflect, or perhaps absorb the travelling radio waves, just as some other things in space stop or absorb or reflect light waves, or sound waves. We must not expect radio waves to travel out from a transmitting station, over some enormous distance to a receiving station, without encountering some obstacles somewhere in its path.

How Radio Pierces Walls

SUBSTANCES which are obstructions to light or sound waves are not necessarily such to radio waves. For example, we know that radio waves pass through the walls of a house with only slight loss. But there is some substance in the space around the earth which does have effect upon radio waves. This substance is not uniformly distributed through space, but is present here and there, and is continually changing location and magnitude, and consequently has very erratic effects on the passage of radio waves.

The condition is quite similar to the use of a searchlight in a fog, which might be varying rapidly in density or location, or both. This radio fog is commonly supposed to be made of ionized air; that is, air which by some influence has become a partial conductor of electricity. Of course, this radio fog never stands still and is changing from moment to moment under the influence of the complicated conditions of our atmosphere, and so the radio wave passing through space surely has an adventurous journey because it meets electrically charged clouds, patches of ionized air, and perhaps other obstacles of which we know nothing.

It is a fact often observed that it is

possible to work radio communication over much greater distances at night than in the daytime. This may be explained by the effect of the sun upon the air, which causes ionization of it, and is most active in the daytime and practically absent at night. The sun seems to be responsible without question, in view of the fact that very erratic results in long distance reception are always noticed at sunrise and sunset.

Wave Power Varies

WITH the preceding statements in mind, it should be clear that when one is receiving over long distances—several hundreds of miles—it is natural for the waves to come through strong at one moment, and to fade away considerably the next moment, as some obstacle to radio waves comes between the transmitter and receiver. This explains, too, why one transmitting station, of two or more which are being heard, may get weaker, while the others do not. For example, suppose a receiving station in Chicago is receiving from New York and also from Los Angeles. A patch of radio fog might appear between Chicago and New York and weaken the New York signals, while the signals from Los Angeles remained unchanged. Whenever in reception over a considerable distance, one observes a variation in the intensity of the signals, it is most likely due to so-called "fading," caused by some obstruction to the traveling waves somewhere between the two stations, and not to any fault of the transmitting station itself. These effects are much more frequent in the Summer than in the Winter, presumably because of the greater influence of the sun on the earth and

(Turn to page 60)

Gloria Confesses



Gloria Swanson, who since her marriage to a dashing Frenchman is Marchioness Something-or-Other, made her first broadcasting appearance under her new name from WGN, located on the Drake Hotel, Chicago. Seated before the "Mike," she answered several exceedingly personal questions put to her by Announcer Quin A. Ryan of WGN. The questions, by the way, had been sent in by inquisitive listeners who had been notified of the famous "Radio Interview" with Gloria as the interviewee, who seemed willing to tell all her deep secrets for her radio and movie admirers.

(Photo Copyright by Drake Studio, Chicago)



What the Broadcasters are Doing



Portable "Pick-up" Station for KDKA

TO TAKE care of the ever-increasing "pick-up" situation that has confronted Westinghouse station KDKA, at E. Pittsburgh, the Westinghouse engineering department detailed Engineer Carrol J. Burnside to construct a portable short wave sending station, to permit the immediate and practical broadcasting of various interesting and important events, as they take place in their vicinity, despite the fact that location may not permit telephone wire connection with KDKA.

A one-ton truck chassis was purchased and suitable house-body built, wherein the pick-up apparatus was constructed. The requirements of this transmitter were that it be absolutely dependable at all times, in any location, and make use of a low wavelength, which is free from interference. The equipment must be compact and its personnel small and upkeep low, to justify its use. The body of the truck is 5 ft. wide by 9 ft. long and is 6 ft. high inside, solidly built to withstand the jar of movement of the truck in motion. All equipment is cushioned to minimize the jarring of apparatus.

The transmitter is a quarter-KW set, using 110V from lighting circuit where program is being broadcast, and a power transformer in the truck is used to step up to the high voltage required to operate the set. Power at this high voltage is passed through a vacuum tube rectifier using two quarter KW air-cooled rectifier tubes, which gives single phase full wave rectification. The output of the tubes is passed through a brute force filter of choke coils and condensers, which delivers 2000 volts DC power to the transmitter, which makes use of the standard Hartley oscillator circuit with Heising modulation.

The equipment used in this portable set is capable of wavelengths varying from 20 to 100 meters, although the set will ordinarily be operated on about 53 meters—KDKA to pick up its broadcast and rebroadcast on their standard wavelength of 309 meters.

Because of a likelihood of broadcasting from some downtown section of the city, where it would not be practical to operate a regular antenna, a vertical oscillator type is used. A copper pole of three sections, of the telescoping type was constructed, which is folded and stored in the truck when not in use.



Iris Virginia Gruber has the distinction of broadcasting more than any artist in Philadelphia and is the winner of the Radio Cup presented for singing the greatest number of times during the concert season from January 1st to May 1st.

"Ford and Glenn" to Tour U. S.

FORD RUSH and Glenn Rowell, the "Lullaby Boys," whose songs and bed-time stories during "Lullaby Hour" and "Ford and Glenn Time" over WLS, the Sears-Roebuck station, Chicago, have endeared them to the hearts of kiddies and their parents throughout the nation, will start on a transcontinental tour of the United States June 2. The WLS favorites will broadcast their most popular features over nineteen of the principal radio stations clear to the Pacific Coast.

The journey from station to station will be made in their new sedans, in which they will carry complete camping outfits. In many of the places they will live out in the open with their families, who will accompany them.



Above is "Si" Berg, nationally known ukelele artist and songster, who has appeared all over the country before prominent microphones. He is now appearing consistently from WHT and KYW, Chicago, having contributed recently to the success of many RADIO AGE programs from the latter station.

McNamee of WEA F Chosen Best Announcer

GRAHAM McNAMEE of WEA F was selected as the best all-round local announcer by the Radio Voice Technique Committee of New York University at a meeting held recently, according to announcement made by the committee. McNamee nosed out Brockenshire of WJZ by the small margin of four-tenths of a point, the scores being 87.3 for McNamee and 86.9 for Brockenshire.

This committee meeting terminated the series of three which were held during the past four months under the direction of R. C. Borden and A. C. Busse, voice experts of New York University, to determine the ideal qualities to be looked for in radio announcers. The aim of the committee, which is composed of radio editors, dramatic critics and members of the faculty of New York University, is not to standardize the voice and art of broadcasting, but to point out faults to be avoided and to determine what the public prefers to hear.

Special phonograph records were made by Mr. Borden and Mr. Busse of representative announcers from the following nine New York stations:—WJZ, WEA F, WGBS, WHN, WEBJ, WOR, WAHG, WMCA, and WBBR. Each announcer passed upon his own record and all those entered in the contest had been accepted by the makers as fairly representative of their work.

Ten men out of the number considered were chosen as the best local announcers. In addition to McNamee and Broken-shire they are Barnett of WOR, Reed of WJZ, Carlin of WEA F, Squires of WMCA, Granland of WHN, Haupt of WEA F, Cross of WJZ and Morgan of WGBS.

The committee rated the records upon the points which were decided upon at earlier meetings as those most desirous for radio announcing. They are as follows: (1) Average rate of speaking—175 words a minute. (2) Pitch of voice—low middle range. (3) Announcements should be made with variation of rate, pitch and stress. (4) Manner of announcer—formal but friendly. (5) Distinctness and enunciation.

A summary of the comments made by the committee during the course of the meeting has been arranged by Mr. Borden and Mr. Busse for public distribution.

THE alluring Miss adorning the perfume bottle is none other than Mlle. Rosario Duprez, prominent New York fashion queen, who is telling the flappers and gay matrons in the East how to achieve personality by means of perfume. Needless to say, she has a large feminine (and masculine) following, both for her radio as well as her pulchritudinous attainments.



Radio's "Interview Lady" Scoops the World!

By MILTON

LIEBERMAN

THE Great and the Near Great Appear Before the WGBS "Mike" in New York To Be Interviewed and Reveal How to Achieve Success.

A WOMAN has brought the newspaper to the radio world. She has woven the two together and has brought shortcomings of one to be valuable features of the combination.

She is Terese Nagel, the "Interview" lady of WGBS, the Gimbel Brothers store, New York City. A newspaper woman of ten years experience, Miss Nagel, just a short time ago, brought that most famous of newspaper features, the interview, within reach and audibility of every radio fan.

The scheme is clever. Nearly everyone wants to become as nearly acquainted as possible with famous people, but it seemed a difficult matter to bring the celebrities to the public through radio. Those who could sing or play an instrument, of course, were immediately brought on the air, but it remained for Miss Nagel to bring those who conquered art in its more inaudible forms before the microphone in a satisfactory manner.

She Gets the Celebrities

ALMOST every person of importance in New York and visiting the city has spoken before the WGBS microphone through the efforts of Miss Nagel. She takes them there, and then, with her newspaper instinct and ability, draws forth their thoughts, their hopes and ambitions for all the world to hear. Fay King has called Miss Nagel the "newspaper woman of the air."

She got a "scoop" the day that I visited her for an interview on her work. When I approached the beautiful studio on the seventh floor of Gimbel Brothers, having passed a group of people who were standing outside of the glass-windowed studio, I found that Miss Nagel was on the radio.

She finished her interview and dashed for the telephone. "A scoop," she said,

and I waited until she had finished her call.

"I just did a good piece of newspaper work," she told me. "I was just interviewing Mrs. Anna Norton, who was chairman of the democratic party during their national convention, and found that she is going after a big political job here in New York. I rather think that she let it slip unintentionally, but I found out that she will run for the nomination for registrar of the city. It pays \$12,000 a year. I just finished speaking to the city editor of the New York American, and he has congratulated me.

"That just goes to show," she continued, "that the radio has unlimited possibilities. Just at present knowledge of who will run for registrar is very important, and the fact that a woman will do it makes the scoop valuable."

How She Does It

SHE then told me about her job of interviewing celebrities, and how, by her clever questions, she draws information from them which they probably would never divulge in another way.

"I have interviewed hundreds of famous people. I can tell you some of

them. There was Rube Goldberg, Miss Oliver Herriman, Jane Cowl, Tony Sarg, Victor Depew, the cartoonist, Willem Van Hoogstratten, conductor of the New York philharmonic orchestra, Fay King, several actresses, including Miss Blanche Yurka and Miss Mary Mellish. The Hamilton brothers, Cosmo Hamilton and Hamilton Gibbs, were very interesting. There was also Countess Caroli, whose husband was first president of the Hungarian Republic.

"It is very interesting, and I think I shall bring more newspaper features to the air. I plan to start a radio column and become the first radio columnist. The public will be asked for a name for the column and contributions like those used in newspapers will be accepted."

Rosario Duprez is another favorite from WGBS. She is the "Perfume and Personality" lady who believes that perfume, properly used, will enhance the personality of any woman. Miss Duprez, unfortunately, cannot be seen on the radio. Unfortunate it is, for she is the essence of charm and personality. WGBS, however, has many other ambitions, besides linking newspaper work and perfume with radio.



MARY MELISH, famous Broadway stage star, was one of the first celebrities to be interviewed by Miss Nagel from WGBS. The radio audience enjoyed her demure confessions of stage life, but they would have enjoyed them much more if they could have seen the lady in question. (M. Kessler Photo.)

A Station Broadcast

Where They "Personality"

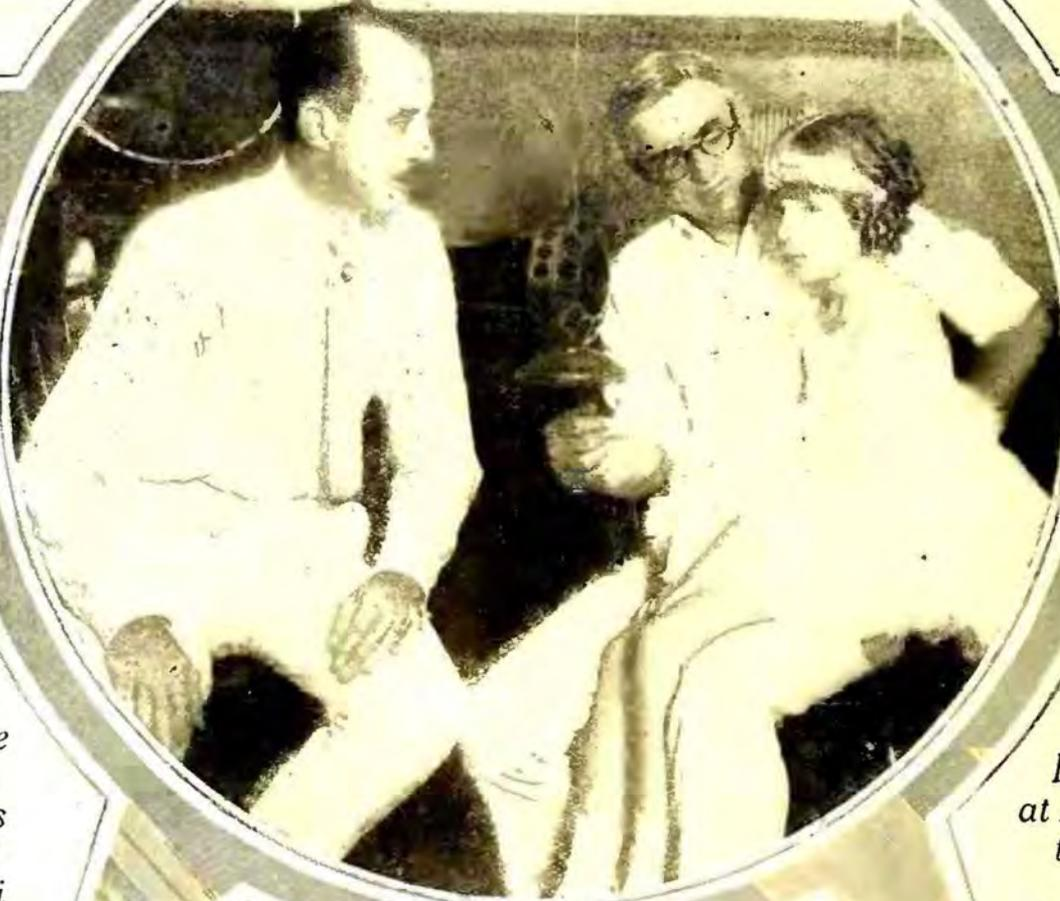

By C. Clyde Cook, who Knows His Hollywood as Marconi Knows His Radio

Real Joy Dispensers at KHJ Keep the Home Fires Burning in California

Three of KHJ's scintillating stars are shown above, in their proper atmospheric setting. From left to right they are "The Sandman," who lulls the children to sleepy land, "Uncle John" Daggett, the Good Samaritan of KHJ, and on his knee, the little Queen Titania, who is a fairy optimist for thousands of hard-working Californians.

WHEN Signor Marconi invented the Wireless Telegraph, little did he think that in the near future this same great invention would advance with such strides that Personality should some day be broadcast to the inhabitants of this universe.

Although it may sound like another Hollywood Press Agent's stunt, this phenomenon has certainly been accomplished at station KHJ, The Los Angeles Times, Los Angeles, California, where none other than John S. Daggett, affectionately known to Radio fans as Uncle John, works this miracle with a resonant voice which, according to motion picture standards, registers "personality plus." Personality, some great philosopher

has epitomized, is that intangible and indescribable force which, of necessity, must come from within. Which, reduced to understanding English, only means that, to possess Personality in a marked degree, one must radiate that magnetic force or power from a most dynamic source—the heart! And that is the sole reason why Uncle John, directorial wizard of KHJ, has such a wonderful personality—he has a magnanimous heart, and his Radioland converts are becoming legion.

KHJ'S "Father"

THIS famous broadcasting station owes its existence, perhaps, to Uncle John's genius, for it was he who dedi-

cated KHJ to the horde of inhabitants of Radioland on April 13th, 1922. Like Aladdin's magic lamp, Uncle John has wrought miracles with this magnificent broadcasting station. KHJ has brightened more homes of sorrow, brought more harmony and joy into homes of discord, than any other three stations combined. And this is because his attitude towards his duties as an announcer has been that of a minister of humanity, and his cheery voice has come to mean as much in the home as the teachings of the scripture.

Bringing to this position of announcer a splendid college education and the invaluable experiences of a successful newspaper man, there is little wonder that Uncle John's name has virtually

become a household term in the Southwestern United States, and wherever the powerful KHJ broadcasting station can be heard. For Uncle John has seen fit to arrange programs which appeal to every member of the family, with a view to entertaining and enlightening his great following of Radio fans, for he has a penchant for broadcasting the best talent obtainable anywhere.

Thanks to KHJ and its progenitor, Uncle John, concerts of the highest type can be heard in one's home. KHJ is probably the only station which has on its staff an accomplished and famous musician.

In the person of Claire Forbes Crane, Radio Editor of the *Times*, KHJ boasts a pianist who has been soloist with such large musical aggregations as the Boston Symphony Orchestra, the Los Angeles Philharmonic Orchestra, and others. With the technique acquired as associate artist of Madame Melba, Arthur Hackett and other renowned artists, she brings to Radioland a veritable "Open Sesame" to shut-ins with musical longings. Under her artistic guidance the musical programs of KHJ have thrilled music lovers throughout the nation.

His Universal Appeal

BUT Uncle John's magical Radio wand is not confined to classical music. His musical programs are so arranged as to carry the universal appeal, running the gamut of musical emotions in the human race. Just to prove how broad a scope and range these musical entertainments cover, permit me to quote verbatim the mutterings of an alkili-coated miner from the great open spaces:

"Out on the Mojave Desert we gets mighty lonesome; times we don't keer if we live or die, and along comes Uncle John with one of his side-bustin', gun-totin' musical fests which makes us plumb ashamed of ourselves for even thinkin' of kicking off!"

And through all this good samaritan work of broadcasting cheer and entertainment runs that indescribable force—Personality. Why, the entertainers selected by Uncle John's inborn genius fairly exude it. So thoroughly saturated with it are these skilled entertainers and educators that they proceed to broadcast it to the many radio fans with astonishing results. You can feel the personality of various musicians, vocalists as well as pianists, in your very home. Most miraculous and yet a pleasant possibility in this day and time, with such a genuinely human announcer at the



G. Allison Phelps is known as the Radio Philosopher of KHJ, Los Angeles. Usually philosophy is either dry or preaching. But not the way "Al" tells it. He makes you cry for more.

helm of the good ship Broadcast! And not all of Uncle John's programs are solely entertainment. Professor Sylvester Hertzog lectures to the youngsters, in the

language with which they are familiar, upon subjects which stimulate thought action, compelling them subconsciously to master precepts and quotations which they thought impossible before. This is conducted during the "Children's Hour," from 6:30 to 7:30 p. m., a time which all children in homes equipped with radio sets hold most sacred. They are also treated to special readings from the Bible by

Uncle John, in that inimitable voice which children recognize as readily as they do their parents.

Another feature of KHJ, which has aided people in solving their daily problems, is the weekly lectures by Fred C. McNabb on the "Care of Gardens." In over fifty-two weeks of constant broadcasting, Mr. McNabb has done such creditable work that his bulky daily mail from grateful housewives attests the results obtained. Then Harold Swartz, one of America's most promising sculptors, delivers a weekly lecture on "Art." "Care of the Body" talks are broadcast by Dr. Philip M. Lowell, a recognized authority on this subject, while Captain Salisbury and other well-known globe-trotters tell of their thrilling experiences in foreign countries.

Talks Easily Understood

DR. MARS. BAUMGARDT, noted astronomer, delivered a lecture every Wednesday evening for over a year upon astronomical subjects, couched in such simple language that the layman could acquire a fair working knowledge of the rather mysterious science of astronomy. The "Radio Philosopher," G. Allison Phelps, has written and broadcast over thirty-six essays on momentous subjects, which are troubling people in the ordinary walks of life. Taking the smudgy commonplaces of life, this wise phil-

osopher animates them with his magic flow of metaphors and similes, so that grim bugbears and obstacles are soon converted into scintillating rays of sunshine.

Queen Titania

AND last but not least of the legion of KHJ broadcasters is the famous Queen Titania, who broadcasts the innermost workings of Fairyland every Tuesday night. In conjunction with her father, The Sandman, who also writes and directs these unique sketches, Queen Titania and Uncle John broadcast the most instructive of juvenile programs, accompanied with the most melodious of music.

Hundreds of children, ranging from five years to fifty, throng the auditorium on these nights and are taken for a pleasant journey through the mystic realms of Fairyland, under the personal guidance of the diminutive Queen Titania.

During its brief existence KHJ has been responsible for more innovations, perhaps, than any other station on the Pacific Coast. In addition to the aforementioned features, Uncle John has inaugurated Saturday morning broadcasting classes. All persons are eligible, providing they register in advance. This novel Radio instruction is deemed one of the greatest constructive influences toward a better understanding of radio.

While performers appear before the microphone, Uncle John stations himself down in the operating room the better to judge of the pupil's aptitude at broadcasting, and at its conclusion he lectures to the class upon their broadcasting from a radio point of view. This constructive criticism is also broadcast, making it possible for all members of radioland to learn the profound secrets of broadcasting.

When we radio converts shuffle off this mortal coil, we no doubt will consult the Recording Angel to ascertain our respective positions on the great list of those who served their Master well in radioland. If so, we no doubt will find that Uncle John's name, like Abou Ben Adhem, heads the list.



E. K. Barnes is assistant manager of KHJ and the boy who helps keep the wheels moving day and night at this ever-popular haven of "Kindness, Happiness and Joy."

(The foregoing account is the second of an interesting series of articles on California radio stations, which are known from coast to coast for their excellence. The first of this series appeared in the June RADIO AGE, and other equally interesting stories will be published in an early issue.)

Favorites of MOVIEDOM Give Snappy Show at WIP

Fans Get Real Insight Into Adventures of Famous Stars

PHILADELPHIA:—One of the most unusual gatherings of famous stage and screen folk was held last month. Moving picture stars of the Metro-Goldwyn picture corporation, together with such famous men as Marcus Loew and noted stage stars, gathered around the microphones in the Studio of Station WIP, the radio broadcaster of the Gimbel store, to entertain the radio public and to answer all personal questions sent in to the station.

It was a real party—the stars sang, dined, danced to two orchestras; and the microphones did full duty all the while.

Lillian Gish, Jackie Coogan, Barbara LaMarr, Johnny Hines, Mae Busch, Dorothy Mackaill, Marion Davies, Anita Stewart, Harry Morey, Dagmar Godowsky, Louise Glaum, Fritzi Brunette, Ben Finney, Flora LaBreton and many more screen players.

Raymond Hitchcock, Eddie Cantor of "Kid Boots" fame, with Mary Eaton and her sisters, Doris and Pearl, Cecil Lean and Cleo Mayfield who made "No, No, Nanette" famous and the leading men and women of the two "Music Box Revue" shows represented the stage and Broadway. Nils T. Granlund,



Above, Jackie Coogan in a speculative mood before appearing before the WIP "mike" and telling his innermost secrets to a host of radio admirers. Mae Busch, popular leading lady, is the demure miss at the lower left. She was one of the principal speakers on this all-star movie program from the Philadelphia station.



famous "N. T. G." of Station WHN in New York City; Marcus Loew, president of the Metro-Goldwyn Picture Corporation and head of the Loew chain of theatres, and the great "Sir Joseph" Ginzburg, Broadway's biggest "nut."

Plenty of Humor

ELI M. OROWITZ, the famous "Emo" whose weekly movie broadcasts from Station WIP have created a sensation all over the country, arranged the party and was the announcer for the evening. "Emo's" witty remarks, aided by those of Johnny Hines, to say nothing of the other comedians present, made the radio sets bulge with laughter.

The party was strictly informal. Most of the stars spoke on the impulse of the moment. The movie fans who have seen their favorite screen star as many times as they possibly can, had the opportunity to hear their voices.

And if you wondered why Dorothy Mackaill bobbed her hair, or just what Barbara LaMarr thinks of vamps, or any of a thousand questions that run through movie fan's heads, you found out if you heard this unique program.

This idea of having movie stars speak from big broadcasting stations is meeting with more and more favor every day. For instance, at WGN, Chicago, recently, according to dispatches received at WIP, Gloria Swanson, the prominent Hollywood resident and fashionably cinema actress, consented to be "interviewed" by the Announcer, the questions in the interview having been sent in by interested listeners. This is but one example of how movie stars are gaining wonderful publicity for themselves as well as providing more or less amusement.

Look Out for "THE RADIO SPIES"

By **FREDERICK A. SMITH**
Editor, Radio Age

IT IS somewhat noticeable that in spite of the sensational nature of charges made against the Radio Corporation of America in the New Jersey Courts, comparatively few radio publications and newspapers gave publicity to the astonishing accusations made by the De Forest Radio Company. RADIO AGE is publishing these facts for the reason that both parties to the prosecution are big factors in the radio industry. We believe that it is due our readers to tell them the truth about this industrial scandal, not permitting the fact that the Radio Corporation of America is the biggest radio advertiser in the field to deter us from adhering to the straight line of editorial responsibility.

Among publications which have given space to this situation are The New York Times, New York Herald-Tribune, Chicago Herald and Examiner, Radio Retailer and Jobber, and Radio Guide. There are a few others, but the publications named have come to our hands and we know that many publications did not make room in their columns for a line of this publicity. While it may be extremely unpleasant to the Radio Corporation of America to have these court proceedings reported to the public, we will assume that the Corporation will welcome a full investigation of the charges and will be willing, as a Corporation admitting it was organized for patriotic purposes, to accept the judgment of the American public as to whether it has done wrong.

Briefly, the De Forest Radio Company, on May 1, 1925, obtained an injunction in Trenton, N. J., restraining the Radio Corporation of America from attempting to steal business and scientific secrets from the De Forest Radio Company. The injunction was granted after Vice Chancellor Backes had read affidavits and other documents tending to support the charge that the Radio Corporation of America had introduced spies into the plant and offices of the De Forest Radio Company and that the Radio Corporation's secret agents had, with bribes of money, seduced employes of the De Forest Radio Company into acts of treachery.

We publish the following from the New York Times of May 5, 1925:

The Radio Corporation of America maintained secret offices at 25 Beaver Street, where its special investigators, known only by code numbers, reported the results of their espionage on the De Forest Radio Company and other concerns, according to affidavits filed yesterday in the Chancery Court of New Jersey. The papers were filed to support the injunction suit of the De Forest Radio Company against the Radio Corporation of America, brought last week at Trenton.

The affidavits alleged that agents of the Radio Corporation of America in the De Forest Radio Company's plant furnished John S. Harley, chief special agent of the Radio Corporation, with valuable information concerning secret methods of manufacturing radio apparatus, as well as the names and addresses of employes, the number of radio tubes produced, addresses of persons and concerns dealing with the De Forest Company, notices posted in the various departments, changes in the personnel, efforts made to speed up production, and especially what took place in the power tube department.

The information alleged to have been passed on to

the Radio Corporation of America also included drawings of machines and samples of products made by the De Forest Company.

Details of how Harley is alleged to have placed his agents in the De Forest establishment and of his employment of De Forest employes to furnish him with stolen information are also contained in the affidavits.

General Electric Accused

President Theodore Luce of the De Forest Radio Company, in an affidavit, alleges that the General Electric Company, with which, he asserted, the Radio Corporation was in combination, had succeeded in buying up the Electron Relay Company of Toledo, and cut off from the De Forest Company its source of filament wire.

"If the defendant and its associates, the General Electric Company and the Westinghouse Electric and Manufacturing Company, can control the filament wire output, they can, of course, prevent competition in vacuum tubes," he adds.

No statement was forthcoming yesterday from the Radio Corporation of America in connection with the filing of the affidavits. General J. G. Harbord, President of the corporation, declined to comment. Vice President David Sarnoff was out of town.

The charges of commercial espionage and theft of valuable business information are contained in great detail in the affidavit of Charles F. Bowlby, cost accountant of the De Forest Company, employed by them between 1921 and 1923, who worked for the Radio Corporation from the early months of 1923 until April or May, 1924. Since Feb. 23, 1925, he has again been employed by the De Forest Company.

Bowlby's employment by the Radio Corporation came about in this way, he says:

Prior to leaving the De Forest concern he was told by his fiancée, Mildred Michael, a co-employee, that a man who gave the name of "Jameson," and who claimed to have met her at a radio dinner, had telephoned her for an appointment. Bowlby met "Jameson" at his fiancée's home. Her sister Madeline was present.

"Jameson" said he knew nothing about the details of the radio business but was devoting himself to the merger of various radio companies. He said he had been informed that there was some relation between the De Forest Company and the Radiocrafts Company, and asked Bowlby and his fiancée many questions about the De Forest Company, how it kept its books, cost records, production records, stock records, payroll and other records, saying that such information would be useful to him in connection with the enterprise on which he was engaged.

Hears More of "Jameson"

Two weeks after the meeting with "Jameson," Bowlby was told by William W. Buckbee, an employe in the De Forest laboratory, that he had been asked by an employe of the Radio Corporation of America, calling himself "Hurley," for information regarding instruments made by the De Forest Company; that he had been asked to furnish drawings of such instruments; that he, Buckbee, several times met a man who called himself "Hurley." The latter was accompanied by a young woman called "Miss Johnson." Buckbee said he knew her to be a De Forest employe. Buckbee's description of "Hurley" tallied with Bowlby's recollection of "Jameson," and Bowlby was satisfied they were the same person.

At that time, Bowlby called on Miss Johnson in the De Forest plant and questioned her concerning her relationship with the Radio Corporation of America. She denied she was in any way interested in the Radio Corporation, but Bowlby did not believe her and obtained her discharge.

In February, 1923, Bowlby married Miss Michael and the following April he left the employ of the De Forest Company. Subsequently his wife was discharged. Then he sought employment with the Radio Corporation. While calling on a friend at the 233 Broadway offices of the Radio Corporation, "Jameson" stepped into the room and recognized him, says Bowlby. He handed Bowlby a card on which was printed "John S. Harley, Chief Special Agent, Radio Corporation of America, 64 Broad Street." He called on Harley and found Miss

Johnson in the office. Bowlby's affidavit reads as follows:

"She then admitted in the presence of Mr. Harley that at the time I had questioned her she was in the employ of the Radio Corporation of America, and that she had secured her position with the De Forest Radio Company under instructions from Harley. Harley confirmed her statement, and they joked about my catching Miss Johnson at the De Forest plant, and that I had procured her discharge, and now I was seeking employment with the Radio Corporation of America."

At Harley's request Bowlby took his wife to the Broad Street office of Harley, who said he had other operatives in the De Forest plants besides Miss Johnson. He offered Mrs. Bowlby a position, which she refused.

Offices Kept Secret

Bowlby was employed as special investigator under Harley from May, 1924, until January, 1925, and he reported regularly in writing to Harley in Rooms 301, 302 and 303, at 25 Beaver Street.

"These were secret offices," he says, "and, as I was informed, were known only to certain officers of the Radio Corporation of America. There was nothing on the doors of the offices or on the bulletin board of the building to indicate that Harley or the Radio Corporation of America had any offices in that building; in fact there was nothing upon the doors of those offices except the room numbers."

"While in the employ of the Radio Corporation, Harley asked him, Bowlby alleges, to purchase radio tubes and roll filament wire from the De Forest Company, and to obtain the names of persons or firms from which the De Forest Company was purchasing its filament wire. He had been unable to do so, and Harley said he was particularly interested in obtaining the names of the makers of the apparatus in the tube department, and of the high frequency bombardiers used in the De Forest plant. He wished to have a diagram of the layout of the tube department, giving the names and locations of all the machines."

"He asked me to get a position with the De Forest Radio Company as a means of getting this information for him, at the same time continuing in the employ of the Radio Corporation of America," asserts Bowlby.

Continuing, Bowlby says he told Harley he could not obtain employment with the De Forest Company, but said that Henry Thies, a former De Forest employe might be able to get the information. Harley directed him to employ Thies for that purpose. He took Thies to Harley who told him what he desired. Two weeks later he met Thies in Room 217 of the secret Beaver Street offices, "the room where the investigators were accustomed to go when they came in from their work and where some of them wrote up their reports."

Bowlby says he suggested that Thies obtain re-employment with the De Forest Company. Harley thought it a good idea and directed Thies to make prompt application.

"During the whole time that I was working for the Radio Corporation of America I was under the supervision and direction of Harley, but I was always paid by the check of Radio Corporation of America," Bowlby's affidavit continues.

Known as "C-1"

"While I was employed by the Radio Corporation I was designated as 'C-1' and made all reports under that designation. I never signed my own name to any reports. When I telephoned to Harley, as I frequently did, I always identified myself under that designation, never by any name. I know, of my own knowledge, that all employes working under Harley went by initial letters and numbers, as I would meet them in the room where their reports were being made out and they would tell me their designations and I would see these designations on the reports which they were preparing."

"While employed by the Radio Corporation of America, I frequently met Cecelia Lambert at Harley's office and I knew her as 'C-3.' She was doing investigating work and reporting to Harley under that designation. Since my recent employment by the De Forest Company I have on several

(Continued on page 51)



Dorothy and Marjorie Moline are determined to get across Jack Nelson's juvenile idea even if they have to dress in the part, as shown in the photo. Naturally, they have succeeded.

How the Alert Jack Nelson is

Making Us CHILDREN Again

RADIO SHOULDN'T BE TOO SOLEMN, IS HIS DOCTRINE

JACK NELSON is a great favorite among the kiddies. His best claim to fame in that line lies in the fact that he has lived among thousands of orphan boys and girls at Moosheart, Ill., the city founded by the Loyal Order of Moose to care for children of deceased members. In his capacity of director of the Moosheart radio station, WJJD, Jack came in contact daily with these children, who formed a large part of the station's daily programs—and still do. Consequently he knows whereof he speaks in the juvenile line.

After several years of broadcasting experience, Mr. Nelson is prepared to announce that radio listeners, whether young or old, like to be reminded they were children once. They prefer this reminder more than they do solemn

speeches, sad music and uninteresting programs, according to Jack. He is an ardent believer in the policy that anything light-hearted and juvenile will "go over" with a radio audience much better than any other form of entertainment.

By this Jack does not advocate a continual round of bedtime stories, for he has never featured that sort of broadcasting. He does, however, believe in keeping people young—anywhere from 12 to 20, he says, and in the attainment of that ideal he has mapped out some wonderful programs that have won an instantaneous response among fans all over the country who have learned to listen regularly for the programs from WJJD every night after 10:30 o'clock, on a wavelength of 302 meters.

For example, the Moline sisters,

popular vaudeville artists, come attired as little girls when they enter Jack's studio in the Palmer House, Chicago. Not that the listeners can see them, but Jack describes them picturesquely and then lets them "do their stuff." They cut up for all they're worth, and the radio waves virtually ripple with laughter. The girls don't exactly act foolishly kiddish, but they are funny and light-hearted, and that's the kind of spirit Jack wants to send out from WJJD on his popular programs.

At other times the children themselves broadcast from Moosheart, and sometimes little kiddies of 7 years of age make the announcements. All this makes a tremendous "hit" with the listeners, and no doubt in the near future WJJD will probably mean "Watch Jack's Joy Diggers."

Radio Age Institute

Manufacturers' Testing Service

MEMBERS of the staff of RADIO AGE will be pleased to test devices and materials for radio manufacturers with the object of determining their efficiency and worth. All apparatus which meets with the approval of various tests imposed by members of the technical staff of RADIO AGE will be awarded our endorsement, and the seal shown to the right will be furnished free of charge. Materials for testing should be sent to

RADIO AGE INSTITUTE
504 N. Dearborn Street, Chicago, Ill.



DEVICES

displaying this seal have been tested and approved by the RADIO AGE INSTITUTE.

Apparatus illustrated and described below has successfully passed our tests for July, 1925.



Test No. 70, WET "B" BATTERIES, submitted by the Kelman Electric Co., Rochester, N. Y. Consists of twelve cells in glass jars, set in a wooden frame. Tops are provided with vents for filling with distilled water. There is a sufficient plate area to allow a generous milliampere capacity for use in receiving sets where a wet B battery is desired. A card giving detailed instructions for filling the battery originally, and for watering and charging it, accompanies the battery, which arrived in good condition as a result of good packing. Tested and approved by RADIO AGE Institute.



Test No. 73, KELLOGG SHIELDED TRANSFORMERS. Codes 503 and 504 were tested, having been submitted by the makers, the Kellogg Switchboard and Supply Company, 1066 W. Adams St., Chicago, Ill. These unshielded types of audio transformers are of 4:1-2 to 1 and 3 to 1 ratio respectively, and over a period of strenuous tests were found to produce a really distortionless amplification, consistently. The design is exceedingly simple, very high grade wire being used. The tops are of sheet bakelite. Satisfactorily passed the tests and requirements of the RADIO AGE Institute.

Test No. 76, STRAIGHT-LINE, WAVELENGTH CONDENSER. Submitted by the manufacturers, Silver-Marshall, Inc., of 110 S. Wabash Ave., Chicago, Ill. This condenser is a new low loss condenser designed for perfect S-L-W tuning. It is of the single-bearing type, equipped with a long cone brass bearing, adjustable, and tension adjustment mounted on, but independent of, the bearing. All plates are of heavily hardened and flattened brass, entirely silver-plated, as are all current-carrying surfaces. This feature, in conjunction with the use of a minimum of high-grade insulation well out of the electro-static field, results in this condenser having even lower losses than many laboratory standards. The single end-plate, as well as the shape of the plates, is responsible for the very low minimum capacity and the exceptionally high capacity ratio.

Instead of separating by wavelengths, with this new S-L-W condenser it is possible to separate stations by kilocycles, thus insuring greater selectivity and more separation of stations. Comprises latest design in low loss construction. Tested and approved by RADIO AGE Institute.

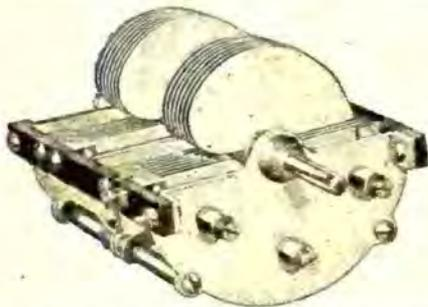

Test No. 71, CONTINENTAL 2-GANG CONDENSER. Submitted by Gardner and Hepburn, Inc., 2100 Washington Ave., Philadelphia, Pa. Consists of a two gang variable condenser, well made and suitable where tuning of two inductances simultaneously is desired. Or it can be used with the two halves in series to decrease the capacity of the condenser. Tested and approved by RADIO AGE Institute.



DX chase that his filaments are still lit, and should be extinguished in the interest of battery economy. Tested and approved by RADIO AGE Institute.

Test No. 74, FILAMENT WARNING SWITCH. Sample submitted by The Yaxley Mfg. Co., 1103 W. Monroe St., Chicago, Ill. Consists of a single hole mounting filament switch and socket for a miniature light, the light in parallel across the A battery through the switch so that while current is on the light is illuminated, giving warning current is being used. This light sits back of the panel and a bezel of colored glass permits the set-owner to see it. It serves as a warning to the radio fan who gets ready to turn in after a strenuous

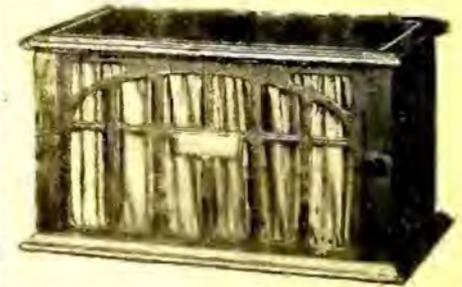

Test No. 77, JEWETT SUPERSPEAKER CONSOLE. A quality loud speaker, submitted by the Jewett Radio and Phonograph Company of Pontiac, Mich. The horn in the Superspeaker console is made of the same materials as the super-speaker horn, with the exception that the final finish coats being enclosed, are not necessary. The horn floats within the cabinet, and is thoroughly padded on three sides with piano felt, there being a resonance chamber below the horn, which adds greatly to the excellent tonal qualities produced by this speaker. The unit is of the Jewett Vemco Design. Tested and approved by RADIO AGE Institute.

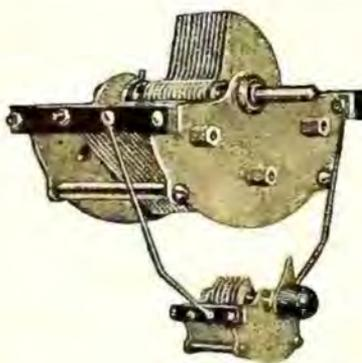

Test No. 72, CONTINENTAL LOW LOSS AND JUNIOR CONDENSER. Submitted by Gardner and Hepburn, Philadelphia, Pa. It is known as the Continental lo-loss condenser, with the vernier arrangement consisting of the Junior condenser shown at the bottom of the above illustration. It can be used separately or in parallel with the lo-loss as a means of fine tuning. Tested and approved by RADIO AGE Institute.

Test No. 75, REMOTE CONTROL LIGHT. Also submitted by the Yaxley Mfg. Co., of Chicago, Ill. This device consists of a single hole mounting brace and socket for miniature light, for use at a point other than right on the battery switch. It is known as a remote control light. It also serves as a warning that filaments are lighted. Tested and approved by the RADIO AGE Institute.



A ROUNDUP OF HOOKUPS—

Something you've never seen before
in the August
RADIO AGE



Test No. 78, REMO RADIO TUBE REVIVER. Submitted by the manufacturers, the Remo Corporation, of Meriden, Conn. This device was put on the market in response to the popular demand for a tube reviver. The Remo reviver has two sockets, for large and small tubes, and tests showed that tubes waning in efficiency, if placed in the Remo reviver, would practically regain their old life. Certain periods of time, according to the degree of age in the tube being tested, were necessary. The reviver connects to the electric light socket. Tested and approved by RADIO AGE Institute.

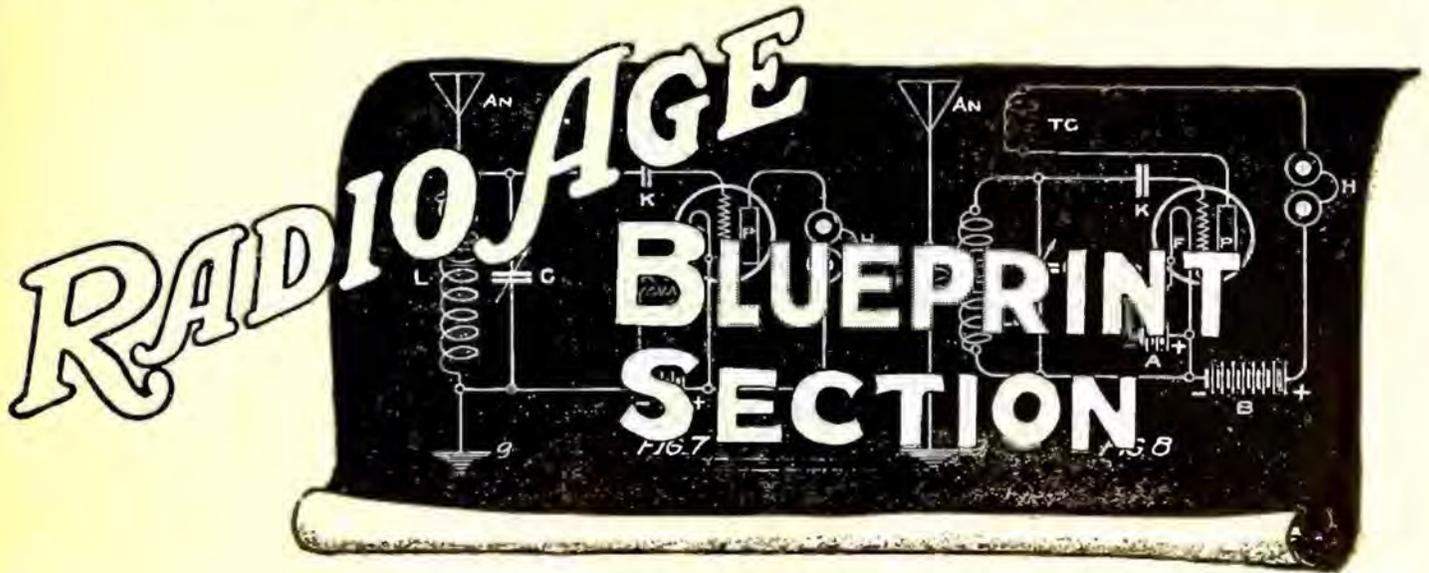

A Timely Discourse on

Conventional Radio Symbols and Crystal Detector Sets

By JOHN B. RATHBUN

Copyright: 1925

How to Understand All Radio Symbols; Giving the Crystal Its Merited Attention

CONVENTIONAL radio circuit diagrams, the short-hand of radio, have always proved a sticker to the tyro in this science, and it is certain that many a prospective builder has contracted a bad case of cold feet and quit the game when he was brought face to face with the curley-cues and zig-zag lines of the technical diagram. Not being very familiar with the apparatus itself, it is no wonder that the prospect of learning still more of the technique filled him with dismay.

However, when these symbols are once understood, they are more easily read and understood than the picture diagrams for they show the functioning and general principles of the circuits far more clearly to the experienced eye than pictures of the apparatus. You can see the course taken by the current in the different branches of the circuit at a glance, and can immediately classify the circuit with little chance of error; something that I have never yet been able to do with the picture type. However, the picture diagram has its place in the scheme of things where the reader is not interested in theory, but simply in building something that will bring in the voice and music with the least delay and study.

For the benefit of those who have not yet become familiar with the standard conventional symbols used in radio circuit diagrams, I have prepared the accompanying two pages of blueprints in which the more common symbols and abbreviations have been defined. In addition to the listing of the symbols, I have taken up a short description of the various parts used in the receiving circuits so that the subject will be more easily followed.

Circuit Symbols (Sheet No. 1)

1. **INDUCTANCE (Air Core Type).** The hollow coil of wire or other inductance coil with an air core is shown by a continuous scroll or helix as in Item No. 1. Its purpose is to choke back or impede the flow of radio frequency current or for tuning radio circuits to the wavelength of the

transmitting station. The abbreviation is the letter (L) and its magnitude is generally expressed in millihenries, or by the number of turns of wire.

2. **IRON CORE CHOKE.** This consists of a great many turns of wire wound around a core of soft steel wire or thin steel sheets called "laminations." It is used when a greater retardation must be had than is convenient with an air core choke, and can choke back audio as well as radio frequency currents. Values in henries or millihenries.

3. **TRANSFORMER-COUPLER (Air Core Type).** This transformer for radio frequency currents consists of two coils of wire called respectively the **PRIMARY (PRI.)**, and the **SECONDARY (SEC.)** coils. Radio frequency currents passing through the primary induce similar currents in the secondary coil, thus affording a means of "coupling" two circuits together magnetically. In our diagrams the primary coil (PRI) is shown with fewer turns than the secondary and is shown on the end opposite to the grid connection (G). The other connections are the filament (F), the plate connection (P), the positive "B" battery connection (B) and the neutral tap (N) used for certain neutralized circuits. The abbreviation is (RFT), and it may be tuned or untuned, the former by a variable condenser.

4. **VARIOMETER.** This is a form of variable inductance used in place of the air core choke, and consists of a movable member (The Rotor) which turns inside of a stationary coil called the "Stator." The abbreviation is (VAR). By this means the inductive or choke effect can be varied through a wide range without condensers and the device is frequently used for tuning a circuit inductively. It may be tapped at the mid-point as shown at (Q).

5. **ANTENNA-GROUND-ARRESTOR.** At the right is shown the symbol for the antenna or aerial, abbreviation (ANT). In the center is the symbol for a ground connection (GND), and at the right is the convention for a lightning arrestor (LA).

6. **OUTPUT - PHONES - SPEAKER.** The symbol for the beadset or phones is shown at the

left, which may indicate the output of any radio receiving circuit. Abbreviation (PH). The polarity may be marked by (+) or minus as shown, or this may be omitted at will. The positive connection of the phone cords is colored red and this red strand should be connected to the (+) connection of the circuit. At the right is the symbol for the horn or loud speaker which can also be marked with the polarity.

7. **CONDENSERS.** A "fixed" condenser consists of alternate sheets of tinfoil and paper or mica compressed into a compact pile, and adds "capacity" to the circuit, an effect opposite to that of an inductance coil. The symbol for a fixed condenser is at the left where the abbreviation is shown as (K) and where the capacity in microfarads is also added where advisable. A **VARIABLE CONDENSER** used for tuning inductances is shown at the right, where the rotor plates are indicated by the curved line and the stationary or stator plates are shown by the short straight line. The Stator (Straight line) should go to the grid of a tube, while the rotor is connected to the ground side or (-A) side of the circuit. This condenser is also rated in microfarads (m. f.).

8. **RESISTANCES—RHEOSTATS.** A fixed or unvarying resistance is shown by the zig-zag line which distinguishes it from an inductance. For low resistances used for controlling the filaments of the tubes, its magnitude is given in terms of ohms. For very high resistances, as used for grid leaks, the resistance is given in terms of MEGOHMS, abbreviated (MEG).

A **RHEOSTAT** or variable resistance is shown at the right and is usually employed for controlling the filament current of tubes. The letter (R) is used for a rheostat, or resistance.

9. **BATTERIES.** An "A" or filament battery or a "C" battery is shown by the symbol at the left which consists of alternate short heavy lines and longer light lines. The short heavy lines indicate the negative (-) plates while the long lines are the positive plates (+). Each pair of these lines represents one cell, and it is the best practice to mark the voltage below it as at (6v.) and the letter (A), (B) or (C) above it to designate the type of battery. A "B" battery is at the right where the dotted line indicates a number of omitted cells, there being too many cells in a "B" battery to draw them complete. When the battery is tapped at some low voltage, as at (+22), the voltage of the tap is marked in this way.

10. **POTENTIOMETER.** This is a device which looks much like a rheostat used for the accurate control of voltages, generally the biasing voltages applied to the grid of a vacuum tube. It consists of a fixed resistance of from 200 to 400 ohms connected across the battery and a sliding contact which taps off the drop of potential at any point of the resistance. The polarity of the slider also

(Turn to page 38)

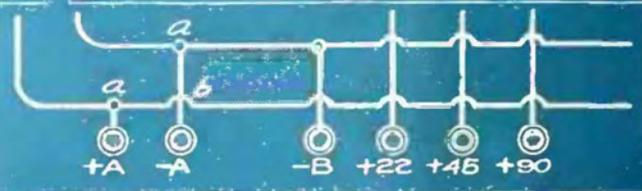
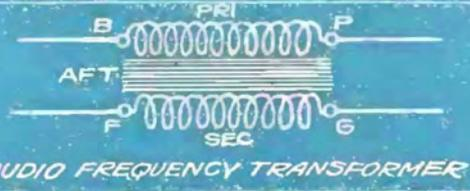
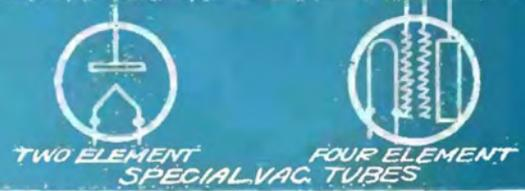
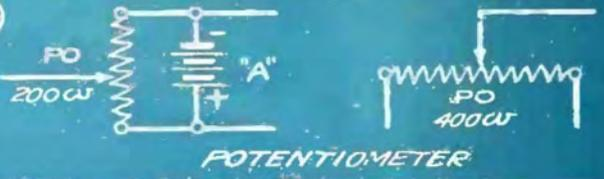
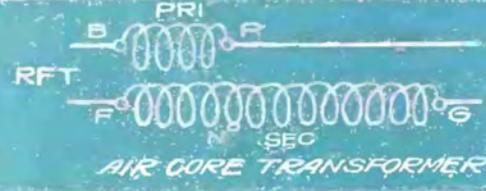

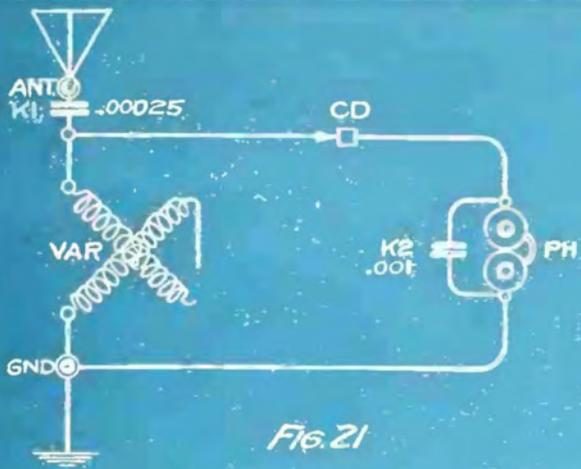

FIG. 21

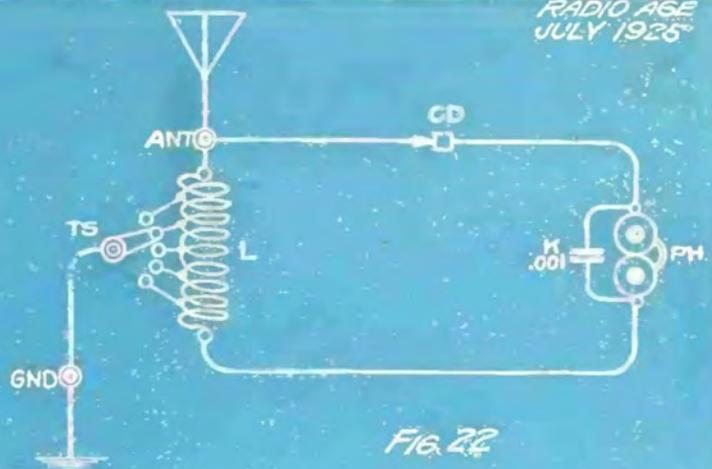

FIG. 22

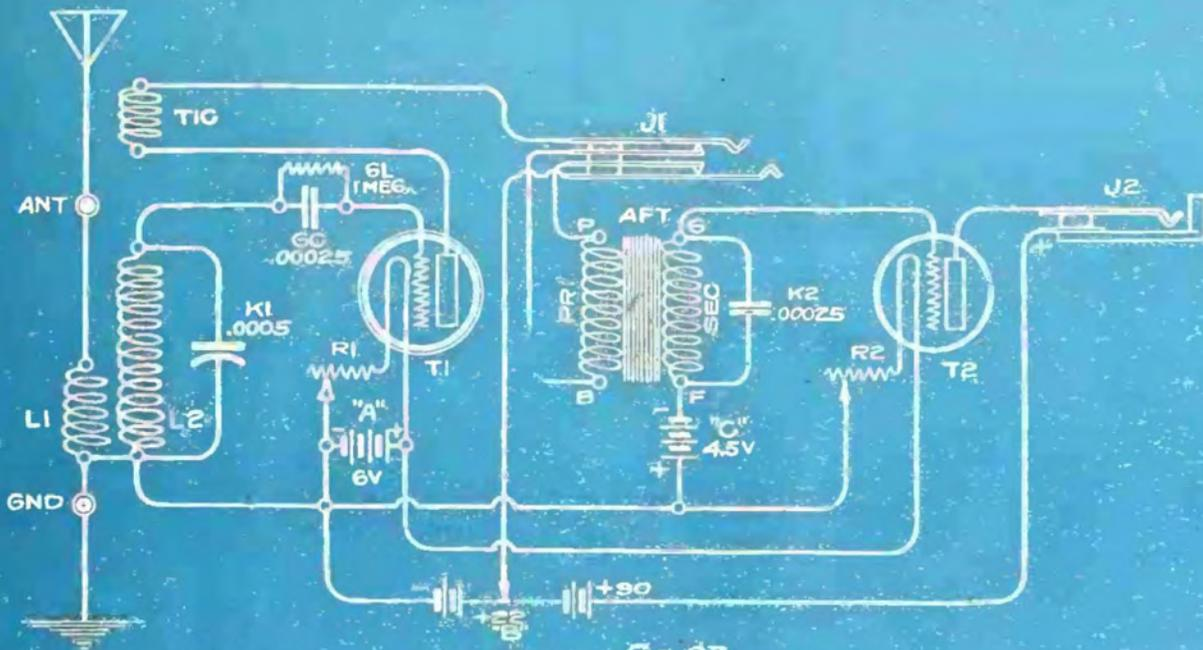

FIG. 23

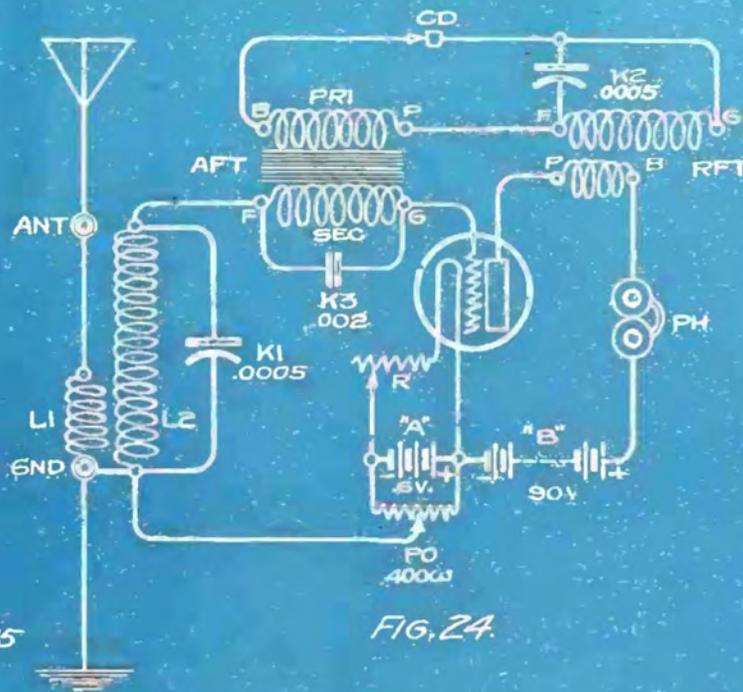

FIG. 24

(Continued from page 35)

varies with its position, becoming negative at one end and positive at the other.

11. **THREE ELEMENT VACUUM TUBES.** The three elements of a vacuum tube are the filament (F), the grid (G) and the plate (P), although these parts need not be marked as shown. A "hard" amplifying tube is indicated by a single heavy circle drawn around the elements and as a hard tube is much used at present for a detector as well as for an amplifier. When a soft detector tube must be used, two circles are used, as at the right. The word amplifier is abbreviated (AMPL) and detector by (DET).

12. **TWO AND FOUR ELEMENT TUBES.** A two element tube or Fleming valve is indicated at the right and has the filament and plate but no grid. This is most generally used as a rectifier for charging storage batteries from alternating current, but is also used as a detector. The four element tube at the right has two grids.

13. **GRID CONDENSER AND LEAK.** This symbol used with detector tubes is simply a combination of the symbol of a condenser and that of a resistance (The leak). The leak abbreviation is (GL) and the grid condenser is (GC). If either of these items is variable, then this fact is indicated by drawing a slanting arrow across it as at the right.

14. **CRYSTAL DETECTOR.** A crystal detector is indicated by an arrow head for the cat-whisker and a small block for the crystal. Abbreviation is (CD).

15. **AUDIO (IRON CORE) TRANSFORMER.** An iron core transformer, commonly known as an audio frequency transformer, is used for increasing the voltages of currents approximating voice frequencies or audible frequencies. It consists of a primary winding (PRI) and a secondary winding (SEC) with a few parallel lines drawn between the coils to indicate the iron core. The four connections are marked as follows: (G) for grid, (P) for plate, (F) for filament and (B) for "B" battery connections. These apply to vacuum tube connections with which the transformer is most commonly used. Iron core transformers of a special type are also sometimes used on radio frequencies, but when this is the case the fact will be particularly noted on the drawing. Ahhr. is (AFT).

16. **WIRING AND CONNECTIONS.** In general, wiring is indicated by very heavy lines, and curved by an arc where a turn is made. Where two wires connect, a small OPEN circle is used to mark the connection as at (a). Where one wire crosses over another, the cross-over is shown as at (b). Connection posts or terminals for batteries, etc., are shown by a circle with a heavy black dot inside, as shown in a horizontal row. The letters indicating the "A", "B", and "C" batteries are marked at the terminals, together with their polarities. In the case of the "B" battery connections the various taps are marked by the voltages as at (+22), (+45) and (+90), but the letter "B" is not used.

17. **TAP SWITCHES.** Tap switches used for cutting out active turns in a coil should be connected so that the contact points go to the grid or aerial side of the circuit with the hinge connected to ground or on the far side from the grid connection to prevent body-capacity effect.

18. **INSTRUMENTS.** Measuring instruments such as the voltmeter (VM), the ammeter (AM) or the hot wire ammeter (HWA) are shown in circles. The polarity should be marked, and also the range of volts or amperes at at (0-10) and (0-5).

19. **JACKS.** Jacks are specially arranged contacts used for making temporary connections by means of plugs and may be of many types. At the left is shown the single circuit jack (J2) generally used for the last stage connection and at the left is a two circuit jack (J1) used for plugging in between stages. These are by far the most common types.

20. **SWITCHES.** Different types of battery switches are shown, the left symbol being for symbolic diagrams while the second from the left is used frequently on picture diagrams. The switch at the right is a double pole knife switch used for heavy currents.

Sample Symbolic Drawings

ON SHEET No. 2 we show four representative circuit drawings which include most of the symbols tabulated. Each symbol is lettered with the standard abbreviation so that it will not be difficult to trace out the relation between the parts in the table and the corresponding parts in the diagram.

A simple crystal detector set, tuned by the variometer (VAR) is shown in Fig. 21. Here we have the symbols for the variometer, crystal, aerial, ground, phones and two fixed condensers. Note that when two condensers are shown that they are numbered as at (K1) and (K2). In Fig 22 we have another single circuit crystal set tuned by a simple tapped inductance (L), the tap switch

(SW) being used to vary the number of turns in circuit.

In Fig. 23 is a regenerative circuit with one stage of audio frequency amplification, a type of circuit, very commonly met with. The detector tube (T1) is a soft tube, while the amplifier tube (T2) is a hard tube, as will be seen from the circles. A coupler is used for tuning, having the primary coil (L1) and the secondary coil (L2), this being used sometimes instead of the abbreviations "PRI" and "SEC." The secondary is tuned by the variable condenser (K1). For regeneration we have the tickler coil (TIC) placed directly above the secondary coil (L2) and connected with it by means of an arrow. The arrow in this case indicates that the two coils are inductively coupled by a variable relation; that is, that the position of (TIC) can be varied in respect to (L2). The grid condenser (GC) and the grid leak (GL) are shown connected to the grid of the tube.

Current for lighting the tube filaments is supplied by the six volt "A" battery which is connected so that the negative pole goes to the detector rheostat (R1). The negative pole of the "A" battery connects with the negative pole of the "B" battery, and the latter is tapped at the (+22) volt point for the detector current. The total voltage of the "B" battery at (+90) goes to the last stage jack (J2). A two circuit jack (J1) permits us to plug in on the detector tube alone without amplification, or without lighting the amplifier tube (T2). Plugged in on (J2) we get the amplified or intensified current for the operation of a loud speaker.

An iron core audio frequency transformer (AFT) transfers the plate energy of the detector tube (T1) to the amplifier tube (T2), and it will be noted that the terminals of the transformer are marked in accordance with the points that they connect. Thus (G) goes to the grid of (T2), connection (P) goes to the plate of tube (T1), connection (B) goes to the (+22) volt tap of the "B" battery, and connection (F) goes to the (-A) through the "C" battery. A fixed condenser (K) is shunted across the secondary. A 4.5 volt "C" battery is used for biasing the grid of the tube (T2) and the negative pole (-) is connected to (F) of the transformer so that the current gets to the grid of the tube through the windings. Tube (T2) is controlled by rheostat (R2).

Fig. 24 is a typical reflex circuit with the radio frequency transformer (RFT) and the audio frequency transformer (AFT), the former being tuned by the variable condenser (K2). A coupler is provided with the primary (L1) and secondary (L2) by which the set is tuned to wavelength. The grid bias on the tube is varied by the potentiometer (PO). The rest of the parts have been explained before.

Crystal Detector Sets

TO ME, the crystal set has always seemed the most wonderful of all radio receivers, for with this device we employ the feeble energy of the radio waves alone to vibrate the diaphragms of the phones without aid or reinforcement from local sources of energy. After traveling fifty miles or so, there is still sufficient energy left in the waves to move a relatively stiff piece of metal and to produce the audible air vibrations known as sound. Further, it is an exhibition of the remarkable sensitivity of the modern headset which produces

understandable signals on so small an amount of current that it can be estimated in millionths of an ampere; and yet, with all of this delicacy, the apparatus is perfectly simple and so rugged that it can withstand a considerable amount of abuse at the hands of the listener.

To most of our readers who have had experience only with the cheap and simple single-slide, single-circuit crystal detector sets sold on the open market, the crystal detector is considered only in the light of a toy having only a very limited use in reception. This, however, is not the case, for with proper attention to the details of construction and with as much care taken with the tuning units as we pay to the construction of a tube set, the performance can be greatly improved in regard to distance range and signal strength. If we constructed our tube sets with the same lack of care and with the same primitive tuning systems that are used on commercial crystal sets, we would not get very much better performance. Single-slider, single-circuit tuners are not conducive of good results with either the crystal or tube detector, for they cannot be tuned accurately in resonance with the incoming waves, and there is always a considerable loss taking place that limits the distance and volume.

The Crystal Detector Circuit

OUR primitive crystal detector circuit consists of three principal units: (1) The tuning unit, by which it is brought into resonance with the incoming waves, (2) The crystal detector employed for rectifying the radio frequency impulses for the development of the audio waves, and (3) The audio output mechanism which converts the audio frequency electrical waves into mechanical sound vibrations (Phones). All three elements must be as perfect as possible if we are to extract the maximum output in the form of sound, for the incoming energy is exceedingly feeble and must be carefully utilized with the least possible loss. This means sharp tuning, a crystal having excellent rectifying qualities and an exceedingly sensitive pair of phones, none of which are in evidence in the usual \$2.00 crystal detector set. In reviewing the requirements, we must also remember to include an efficient antenna into the assembly, which should have greater length and capacity than the antenna commonly used with tube sets. The latter item is generally neglected in the installation of a crystal set, with the result that very little volume or distance is had. Conservation of energy is a prime requisite.

It is here that the low-loss coil and the low-loss condenser hold forth with particular advantage; spiderweb, honeycomb or barrel-wound coils being of great advantage in the construction of such a set. The phones should preferably be of the mica diaphragm class or with very thin flexible metal diaphragms so that the slightest current in the coils will give a maximum vibration. When we look at the cheap phones ordinarily supplied with crystal sets, with their thick cast-iron diaphragms and their weak magnets, it is no wonder that reception is limited to 10 or 15 miles. This would be almost the case with a tube set if it were supplied with the same sort of phones. The feeble impulses received demand the most sensitive and efficient equipment that we can supply if the crystal set is to be more than a mere toy for children's use.

Please don't infer that I am recom-

mending the crystal set as a substitute for the tube set, for I am not. I am simply bringing to your attention the fact that the crystal set performance can be wonderfully improved by a little care in the construction and that it is a most desirable proposition for local reception where we do not wish to go to the trouble of installing batteries and similar complications. The crystal set has a field all its own and is almost indispensable for certain purposes, and for this reason I believe that more attention should be paid to the development of its performance rather than to cutting down on the expense of construction, as has been done heretofore. You cannot get long distance consistently, nor can you get full loud speaker volume of the crystal alone, but you can get locals with good volume, clear and sweet, without the fuss attending the operation of a tube receiver.

When loud speaker volume is required on local, with particular attention to quality, we can add one or more stages of audio frequency amplification to the detector. Of course, we are now getting back to vacuum tube complications and batteries, but with very simple layouts we can obtain wonderful tone values on the loud speaker and a somewhat increased distance. Just as an experiment, it is very interesting to add resistance coupled stages to a crystal detector to discover what real tone purity is like. The natural tone and life-like quality will be a revelation to you, and if you live within 25 miles or so of a broadcasting station, I am sure that you will keep this circuit hooked up permanently.

Future of the Crystal Set

CONSIDERING the many 5,000 watt broadcasting stations now under construction, and the increasing practice of re-broadcasting, it is certain that the crystal detector receiver will find a more extended use than has been the case in the past. Increased power at the stations and the relaying of these stations at close intervals over the country will mean that the crystal will take on a new life. At least ten telephone companies have adopted local re-broadcasting systems as an additional service to their subscribers, and I do not believe that the telephone companies will be the only people to engage in this work. If the network of re-broadcasting stations is fully developed the use of the crystal set will be practical in almost any part of the United States.

One re-broadcast station equipped with a good receiving set and a transmitter of moderate power will easily cover a radius of 25 miles and will efficiently serve crystal detectors in this 50-mile circle. The expense of maintaining such a station is comparatively small and can be borne by the local Granges or community associations with a great saving to their members. The station receives the voice and music from distant stations and then broadcasts these signals through simple apparatus to local listeners, thus avoiding the expense and trouble of arranging programs. So far, this arrangement has increased the total number of listeners tremendously without appreciably affecting the sale of tube sets. On the contrary, one re-broadcasting station states that the interest aroused in radio via crystal sets has greatly increased the sale of tube sets in its territory, and that a great proportion of the listeners now have both crystal and tube sets in their homes. Tiring of the local re-broadcasts, and desiring different programs, they turn to their tube sets and tune in the distant stations for themselves.

While the complete theory of contact rectification is not yet well understood, I will explain the functioning and purpose of the crystal in a general way so that the beginner can at least get a working knowledge of its properties when installed in the receiving set. Mechanically it is very simple, consisting of a small piece of mineral called the crystal, and a thin wire making light contact with the crystal at a sensitive spot. In some cases, contact is had between two crystals instead of between the wire and crystal, but in any event the radio frequency current must pass through a high resistance contact of some sort before passing through the phones, so that the audio or "hearable" portion of the incoming waves can be developed.

Owing to the rapidity with which the radio wave oscillates back and forth, the diagrams of the phones cannot follow the radio frequency currents in the receiver

Galena, silicon, carborundum, cerusite, pyrites, perikon, radiocite, and hecite are among the most commonly used simple minerals, and in addition to these are the numerous synthetic crystals that bear a multitude of trade names. A good galena crystal is probably one of the most sensitive crystals, but it is not stable and must be readjusted frequently. Silicon and carborundum do not require so frequent adjustment and are quite sensitive if carefully selected and mounted. The synthetic crystals are in most cases stable and sensitive, and have the advantage of having a greater effective area or more "hot spots" than the natural crystals, so that it is not so difficult to adjust them.

For the catwhisker wire, we require a metal that will not corrode under ordinary atmospheric conditions and one that will maintain a bright metallic contact area at the point where it rests on the crystal. A copper wire will work well with most crystals, but a silver or gold wire is better, as it does not corrode or get dull as rapidly. With the exception of the carborundum crystal, the catwhisker wire should make very light contact with the crystal, working best when only just barely touching the surface. With the carborundum detector a very heavy pressure is required, which in itself is one reason for the stability of the carborundum, as the heavy pressure prevents the displacement of the contact when subjected to vibration.

There has been a great deal of argument for and against the fixed crystal detector with the immovable catwhisker, but I believe that the fixed detector will prove best in the long run for the beginner, at least, as it avoids the necessity of constant readjustment and the detuning effect when these adjustments are made. It will perhaps be of interest to know that the crystal has a great deal of effect in the tuning of the circuit and very often we can tune a station in and out by means of the crystal adjustment alone. For the experienced crystal set operator, the adjustable crystal is therefore often an advantage, as it is an aid to selectivity and tuning, particularly where there are many strong local stations and other interferences.

It is a good plan to get a number of crystals and then select the best crystal by actual test. There is a great deal of variation among crystals even of the same make, and the only way that you can be assured of the maximum results is to select the best crystal from a number of samples.

The Hook-Up or Circuit

THERE are about a thousand different crystal detector hook-ups from which to make a choice, and all of them have their adherents, who believe that they have the only circuit worth using. Some employ variometers for tuning inductances, others use spiderweb coils, vario-couplers, honeycomb coils and straight solenoid coils in all sort of combinations, but as a matter of fact, a close examination will show that most of these circuits can be boiled down to six distinct classes. The type of inductance does not change the characteristics of a circuit as a circuit; it simply adds or detracts from its efficiency by the sharpness of its tuning properties and the losses occurring within the coil. A variometer may show better results than a simple tuning coil, simply for the reason that it can be more closely adjusted to wavelength than the coil—not because it is a variometer. An inductance is an inductance no matter what form it may be used.

(Turn to page 42)

A ROUND-UP OF HOOK-UPS

in the Deluxe AUGUST ISSUE OF RADIO AGE.

Never before have you seen such a galaxy of hookups, from the simplest though efficient crystal to the most recent simplified super-heterodyne receivers. Radio from its humble beginning to its present peaks of achievement in the Special Summer Number of RADIO AGE.

All basic Hookups.

THIRTY PAGES OF DELUXE BLUEPRINTS.

Order your Copy in Advance. \$2.50 a year.

25c at your Newsdealer

directly and nothing will be heard in the phones if some sort of rectifier or "detector" is not inserted into the circuit. These waves are "alternating," that is, they flow first in one direction and then in the other, and before we hear the signals these waves must be made "unidirectional" so that they will flow in one direction through the phones but with an intensity that varies according to the sounds sent out by the broadcasting station. The crystal detector with its contacting "catwhisker" wire acts as such a rectifier and permits the passage of only one set of waves that are flowing in the same direction.

With the radio frequency current rectified, the "audio frequency" waves are developed so that the diaphragms of the phones follow the slower voice frequency pulsations, thus producing sound. Our station waves therefore consist of two components, the high radio frequency carrier waves oscillating at the rate of about 1,000,000 vibrations per second, and the audio frequency waves impressed on them that will range from a few hundred to an upper limit of about 15,000 vibrations per second. These latter waves are produced by varying the intensity of the radio waves by "modulation," and are not actually an independent series.

There are a great number of minerals that will act as detectors to some extent, but only a few that are effective enough to be used in the practical crystal set.

FIG. 1. BELOW

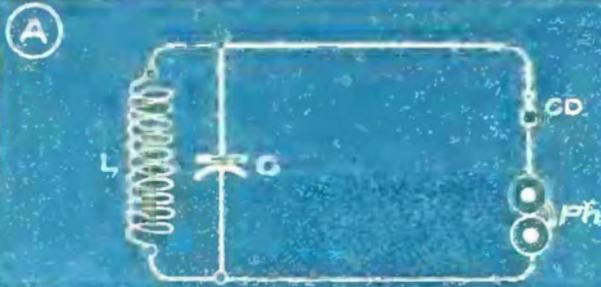

RELATIVE AUDIBILITY = 55

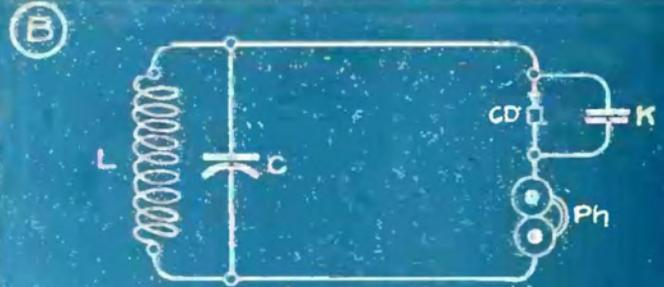

RELATIVE AUDIBILITY = 85

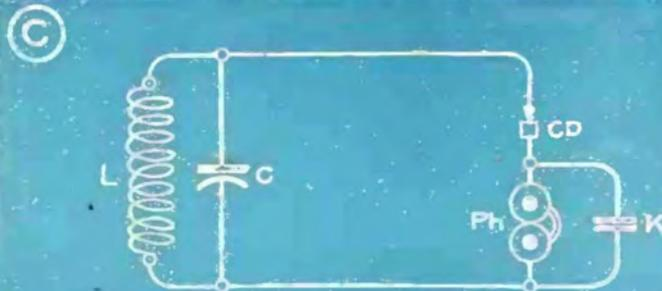

RELATIVE AUDIBILITY = 45

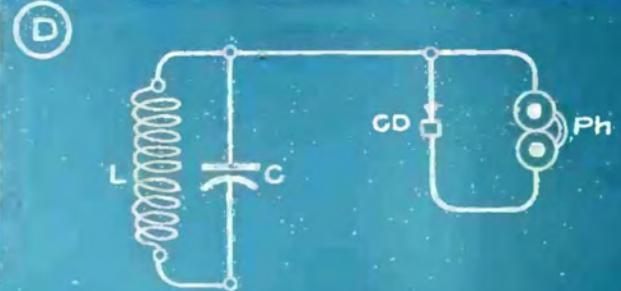

RELATIVE AUDIBILITY = 10

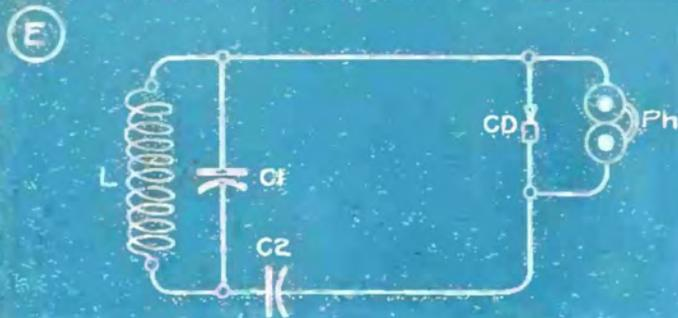

RELATIVE AUDIBILITY = 40

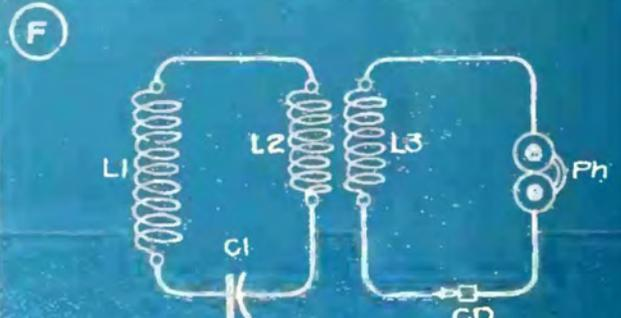

RELATIVE AUDIBILITY = 15

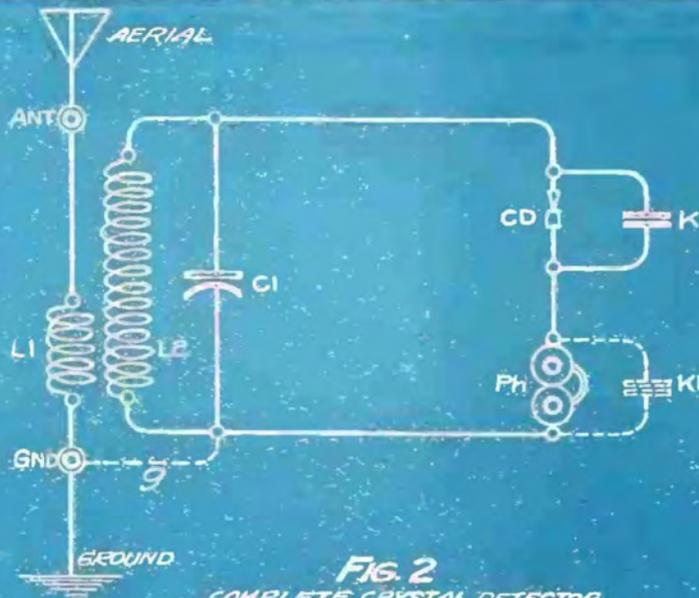

FIG. 2

COMPLETE CRYSTAL DETECTOR
CIRCUIT WITH ANT. COUPLER.

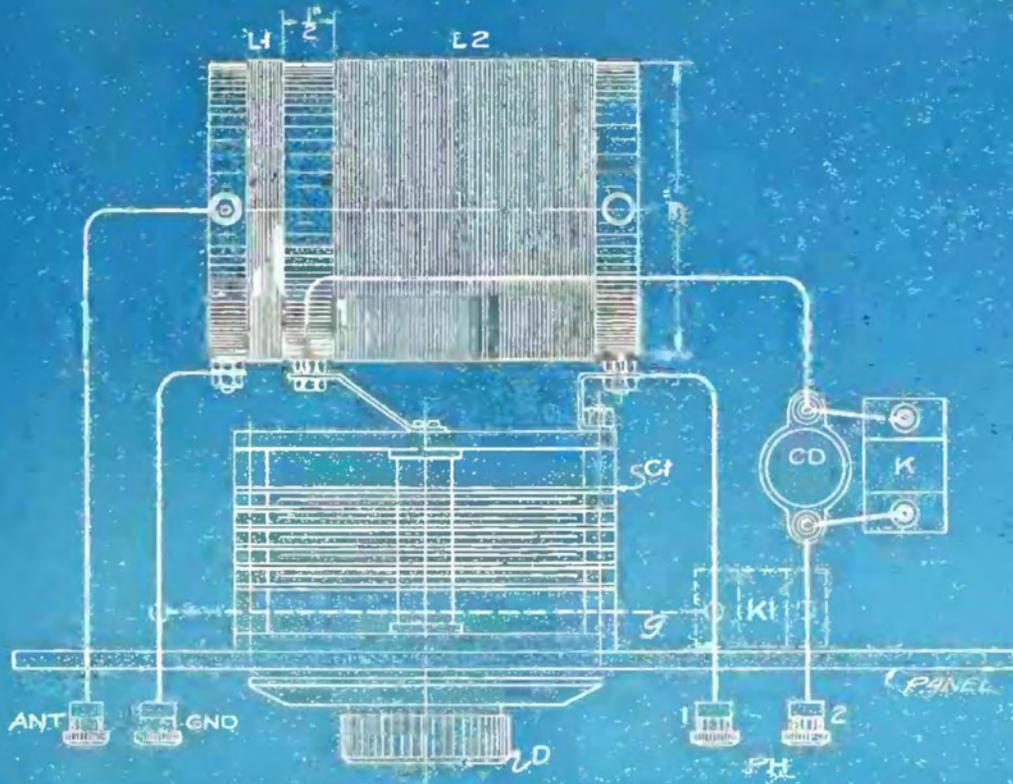

FIG 3
PLAN VIEW OF CRYSTAL SET

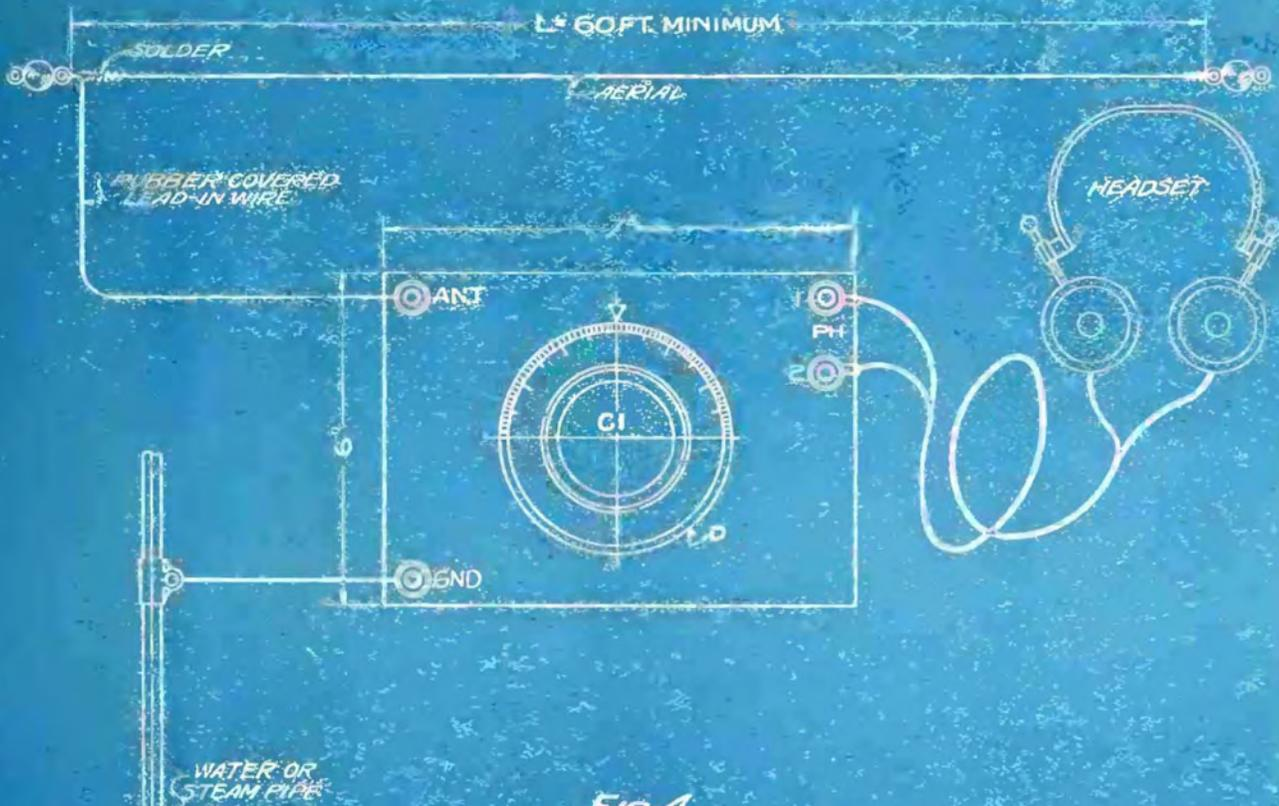

FIG 4
INSTALLATION DRAWING

(Continued from page 39)

Fig. 1 shows the six basic circuits with their relative audibility value, as determined by the U. S. Bureau of Standards. The relative signal strengths are given in terms of percentages, and it will be seen that the hook-up has a great deal to do with the reception, varying as it does from 10 per cent to 85 per cent. These diagrams refer only to the detector circuit itself and do not consider the various methods of coupling or connecting the circuit to the aerial and ground. A variable condenser is used for tuning a fixed inductance in all cases.

Diagram (A) shows a simple form of circuit often used, which contains the inductance (L), the variable condenser (C), the crystal detector (CD) and the phones (Ph) all connected in series. For ordinary broadcasting wavelengths there will be about 55 turns of wire in (L) when wound on a three inch tube, and the capacity of the variable condenser (C) will be from 0.00035 m.f. to 0.0005 m.f. The audibility is 55 per cent.

In Diagram (B) we have the same circuit with the addition of the small fixed condenser (K) connected across the crystal detector. This fixed condenser acts as a storage capacity for the waves and adds considerably to the volume, as it supplies an additional current to the crystal. This addition has increased the audibility from 55 per cent to 85 per cent, the maximum value determined by the Bureau.

The capacity of (K) depends upon the nature of the crystal detector, but in any event the capacity must be small to prevent by-passing much of the current across the detector. With some detectors 0.00025 m. f. is about right, while with other types this may be as low as 0.0001 m.f. or even less. A small three-plate variable condenser will often prove of value in getting the adjustment correctly.

In Diagram (C) we have the same circuit as in Diagram (A), but a fixed condenser (K) is used to bypass radio frequency current around the phones. The average audibility under all conditions is reduced to 45 per cent; hence, this is not always an advisable addition. In many makes of phones there is a considerable amount of distributed capacity in the windings of the magnets and this frequently is sufficient to properly by-pass the radio frequency current around the inductance without the addition of external capacity. However, in case the phones have a high inductive value with little distributed capacity, a by-pass (K) may be necessary.

Diagram (D) is a type of crystal detector circuit often used on wave-meters and similar instruments where very sharp tuning is necessary. The audibility is so low (10 per cent) that it is impracticable for a receiver and therefore need not be discussed further. Its only virtue is its extreme selectivity.

Diagram (E) a second variable condenser (C2) is employed in addition to the original variable condenser (C1). This sharpens the tuning considerably and has a much greater audibility than the circuit in Diagram (D). The audibility is four times as great as with (D) and is almost equal to that of the first diagram.

Our last diagram (F) is the ultimate in selectivity but has a very low audibility factor. The circuit is split by means of the coupler coils (L2) and (L3) so that almost any degree of selectivity can be attained but at the expense of a great loss in signal strength. We can obtain

a good degree of selectivity by other means and without so much loss in signal strength; hence, this type or circuit can be neglected for the time being.

Circuit With Coupler

FOR the sake of selectivity we will connect our aerial and ground to the detector circuit by means of an aperiodic or semi-aperiodic coupler of the type so commonly use in tube sets. For the detector circuit we will adopt the circuit shown in Diagram (B) to obtain the greatest signal strength and will depend entirely upon the coupler construction for our selectivity and tuning. This combination will probably give us the best all-round combination for signal strength and selectivity and at the same time is simple to build and tune.

In Fig. 2 we have the schematic diagram of the complete circuit. The coupler consists of the primary coil (L1) connected at one end to the aerial and to the ground at the other end. The radio impulses from (L1) are communicated to the secondary coil (L2) which is identical with the coil (L) in Diagram (B). A variable condenser (C1) is connected across the secondary coil so that it can be tuned to wavelength. The fixed condenser (K) connected across the crystal detector (CD) serves the purpose already described. The phones (Ph) are in series with the crystal detector.

By means of the inductively coupled coils (L1) and (L2) we can obtain much better selectivity than with the aerial and ground connected directly to the detector circuit. The selectivity depends largely upon the distance between these two coils. The greater the distance the greater will be the tuning qualities where there are many strong local stations. Properly adjusted, it is possible to tune in and out on a difference of five meters wavelength, but with comparatively little loss in signal strength. With the aerial and ground connected directly to the detector circuit, it is probable that a nearby station will come in all around the dial, no matter how it may be turned.

In regard to a crystal detector, it may be said that it is much more difficult to get selectivity with a crystal than with a tube receiver and that greater care will be required in the adjustment. The crystal has the peculiar property of hanging on to a station even against powerful controls, and while it has not much distance or ability on weak signals, it will hold on like grim death to fairly strong signals.

Under some conditions it may be advisable to connect the lower part of the circuit to the ground connection (GND) by means of the short dotted wire (g). The rotary plates should also go to this side of the circuit (ground) as indicated by the curved line at (C1) and the stationary plates are connected directly to the crystal detector (CD).

With some phones, which have very little distributed capacity, it may help matters to connect the fixed condenser (K1) across the phones (Ph) as indicated by the dotted lines. This is best determined by actual test, after the set has been built and connected up to the aerial. This may be a 0.001 m.f. fixed condenser.

Picture Diagram of Set

A complete drawing of the circuit with all of the parts in place is shown by Fig. 3, the letters in this drawing corresponding with similar letters in the schematic diagram of Fig. 2. A detail view of the coupler coil is shown which is connected to the variable tuning condenser (C1), the latter being connected directly across the secondary coil (L2) of the tuning in-

ductance. The crystal detector (CD) is best placed as shown and should not be mounted on the front panel where it is likely to be thrown out of adjustment by the jar of the hand every time we move the tuning dial.

The tuning inductance (L1-L2) is wound on a cardboard tube three inches in diameter and about 4 1-2 inches long. The primary winding consists of 12 turns of No. 24 D.C.C. wire, and a space of about 1-2 inch is left between this coil and the secondary coil (L2). Starting coil (L2), we wind on 55 turns of the same size wire, and fasten the ends of the coil securely by passing them through holes punched in the cardboard tube. For strong local stations, it may be necessary to increase the distance between coils to 5-8 inch or 3-4 inch to obtain the required selectivity, but this space should be no greater than actually required for the complete tuning out of the strongest station. If the gap is much greater than this, the signal strength will be reduced. The tentative wire (g) and the experimental fixed condenser (K1) are shown in dotted lines as they may not be needed with the combination of parts used in your set.

The condenser (C1) can be either a 17 plate or 23 plate variable condenser having a capacity of 0.00035 m.m. to 0.0005 m.m., but the latter is preferable. If you do not wish to wind the coil yourself, you can use a neodyne transformer which can be purchased complete and mounted on the back of the variable condenser. Such combinations cover a wavelength band of from 200 to 600 meters, the range of the average broadcasting stations.

It is most convenient to mount the apparatus on a 6 in. x 7 in. x 3-16 in. panel as shown by Fig. 4 with the tuning dial (D) appearing on the front of the panel as shown. The aerial binding post is at ANT, the ground connecting post at GND, and the phone posts at PH. The method of connecting to the aerial and ground is also shown in this view, the ground being a connection to a water or steam pipe.

The aerial should not be less than 60 feet in length, and more than this is desirable where the necessary room can be obtained. With a crystal detector set, the more aerial wire that we hang up, the better will be our reception, and any length (L) can be used up to 150 feet.

With two wires placed side by side, 150 feet long and with the set located in the open country, quite long distances can be covered. However, with a 60 foot aerial in a good locality, we can get good reception with fair distance, providing that the aerial is not screened by steel structures such as steel factory and office buildings, bridges, etc.

Higher Power Licensed To Beat Static

THE Department of Commerce has announced that favorable consideration will be given to applications from owners of Class B broadcasting stations for permission to use higher power without requiring the increases to be made in steps of 500 watts as has been the practice heretofore, provided the stations are situated outside of congested receiving centers.

In taking this action the Department is endeavoring to satisfy the demand of broadcast listeners that the use of increased power be permitted in order to overcome the existing static conditions which are making reception difficult.



Pick-ups and Hook-ups by our Readers



THE material appearing under the title "Pickups and Hookups by Our Readers" in RADIO AGE, is contributed by our readers. It is a department wherein our readers exchange views on various circuits and the construction and operation thereof. Many times our readers disagree on technical points, and it should be understood that RADIO AGE is not responsible for the views presented herein by contributors, but publishes the letters and drawings merely as a means of permitting the fans to know what the other fellow is doing and thinking.

IF THE filaments of your vacuum tubes begin acting as you feel during the Summer, it is not necessarily an indication that their span of life has been bridged, for rejuvenation of tubes seems to be as welcome to inanimate thoriated filaments as it is to those who have sought the fountain of eternal youth.

Tube manufacturers have cautioned their customers, via the literature accompanying the tubes in the cartons, that a paralyzed tube may be restored to its pristine activity by leaving it lighted in the set for ten minutes with the "B" battery shut off, this process apparently bringing the thorium from the filament center and giving the tube new life.

One of our prominent manufacturers has come forward with a tube-rejuvenator on which radio fandom's interest seems to have centered.

It consists primarily of a small step-down transformer, similar to the toy transformers used for running toy railroad trains, etc., being made in two types, one for 110-20 volt primary with ten, four, sixteen and eight volt secondary sections, and the other for the 220-230 volt circuits with the same secondary outputs. This, together with a socket for each size of tube, comprises the layout, to which the owner adds his timepiece.

For the UV 199 tubes the tube is placed in the socket after the transformer has been plugged into the lighting mains. It is given ten volts on the filament for 30 seconds, then the voltage is cut to four volts and the tube is allowed to remain for ten minutes. The first voltage is known as the shocking charge and serves to drive the thorium from the filament center. The ten minute lighting of the filament at four volts is known as the baking charge and serves to solidify the thorium on the filament so its electronic emission is again at a maximum.

For the UV201-A type the shocking voltage is sixteen volts for a period of 30 seconds, and a baking charge at eight volts which lasts for ten minutes. The same action takes place as with the 199.

One Need Remains

As a result the owner of emaciated tubes need no longer worry about a means of bringing back their life. However, neither the tube manufacturers' method of restoring life by allowing the tubes to remain lighted without the B battery on, nor the transformer method

CONTRIBUTORS

Name	Address	City
R. S. Parks.....	1419 Cleveland Blvd.....	Caldwell, Idaho
Clement Hampton.....	427 Jeanne Mance St.....	Montreal, Canada
Walter E. Fee.....	115 Beecher St.....	Atlanta, Ga.
Carl Wininger.....	20 William St.....	St. Catharines, Can.
Joseph A. Smith.....	723 Wallace Ave.....	Wilkinsburg, Pa.
Francis Davis.....		Cushing, Okla.

DIAL TWISTERS

Albert C. McKee.....	2306 Seminary Ave.....	Chicago, Ill.
P. French.....	1209 Franklin St.....	Beaumont, Texas]
A. Robert.....	327a Richmond St.....	Montreal, Canada
William Laning.....	325 North Bambyr St.....	Philadelphia, Pa.
Alfred T. Chandler.....	280 Randol Ave.....	San Jose, Calif.
Charles H. Leach.....	1000 Van Buren St.....	Chicago, Ill.
James P. Williamson.....	327 Dorion St.....	Montreal, Canada
Warren King.....	100 South Crest Road.....	Chattanooga, Tenn.
Homer W. Good.....	R. F. D. 1.....	Wescosville, Pa.
H. Bowden.....	Box 44, R. F. D. 1, Mt. View.....	Plainville, Conn.
Mrs. Eva A. Taylor.....	69 Murdock St.....	Youngstown, Ohio
Fergus Mackay.....	Grange St.....	Pictou, N. S., Can.
Kermit Fisher.....	4335 Jacob St.....	Wheeling, W. Va.
Ackley T. Bush.....	941 No. University Ave.....	Shawnee, Okla.
A. C. Taylor.....		Steele, N. Dakota
Floid Omond.....	16 Alsace Ave.....	Buffalo, N. Y.
D. C. Atkinson.....	788 Hohman St.....	Hammond, Ind.
C. C. Peugh.....	54 Linden St.....	Schenectady, N. Y.
Kendall McNeil.....		Ottawa, Canada
Jack Cordy.....	Box 251.....	Globe, Arizona
C. A. Hendrick.....	Horizon Apts.....	Venice, Calif.
George A. Moutsatson.....	265 Ohio St.....	Benton Harbor, Mich.
E. N. Girard.....	715 South 58th St.....	Philadelphia, Pa.
Roy R. Winder.....		Pedro Miguel, Canal Zone
Charles Markarian.....	110 Summer St.....	Worcester, Mass.
Lyle F. White.....	523 So. Washington St.....	Kankakee, Ill.
A. L. Snow.....	619 Hendrie Blvd.....	Royal Oak, Mich.
E. C. Kelley.....		Underhill, Vt.
Earl Hamden, Jr.....		Globe, Ariz.
John Hogle.....	321 Selma Ave.....	Kenosha, Wis.
Henry W. Werner, Jr.....	Box 419.....	Valhalla, N. Y.
W. Manning, Jr.....	619 Princess St.....	Woodstock, Can.
Robert B. Otto.....	85 Lowell St.....	Mathuen, Mass.
Frank Barclay.....	R. M. D. 1.....	Victoria, B. C., Can.
Edward Nolan.....	657 Tenth Ave.....	New York, N. Y.
Allan S. Wilson.....	244 Kenwood Ave.....	Dayton, Ohio
Harold W. Fairley.....	121 Gilmour Ave.....	Toronto, Canada
Robert W. Barnhill.....	116 East 9th Ave.....	Bristow, Okla.
Harold A. Reynolds.....	229 North Montello St.....	Brockton, Mass.
Wallace Buxton.....	4166 Emerald Ave.....	Oakland, Calif.
George A. Winkle.....	902 South 15th St.....	Birmingham, Ala.
J. A. Myers, Jr.....	944 West Capitol St.....	Jackson, Miss.
M. E. Walter.....	117 Lafayette St.....	Niles, Ohio
Fred Brunton.....		Anaconda, Mont.
Cecil Carrigg.....	215 21st Ave.....	San Francisco, Calif.
William Heinochowitz.....	135 Johnson Ave.....	Newark, N. J.
George D. Hillstrom.....	10135 Lafayette Ave.....	Chicago, Ill.
D. Gabelhouse.....		Vegreville, Alta., Canada

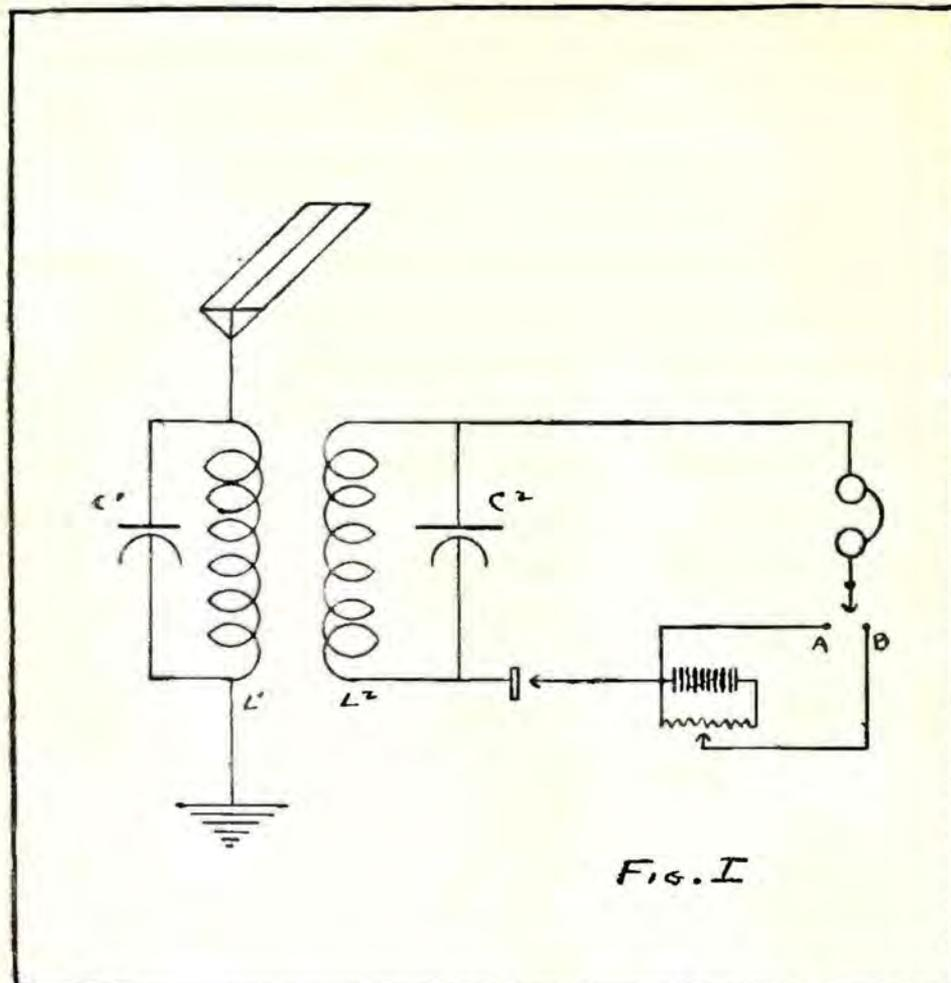

FIG. 1

An old reliable crystal circuit, one of the early types used in the U. S. and still popular with those who do not care for the expense of a tube set for short distance reception on headphones

mentioned before, will restore a filament from which the spark of life has departed due to a breakage. When someone invents a filament restorer for burned out filaments he will be kissed on the brow by all the broadcast listeners, the amateurs and the owners of broadcasting stations, although doubtless the tube manufacturers would chase him into the wilds of Patagonia with a sawed off shotgun.

At the last moment in our June issue we were able to get together interesting data on the binocular and toroid coils which are designed to eliminate the necessity for neutralization in radio frequency amplifiers. The Pickups Editor will be glad to hear from readers of RADIO AGE as to the success encountered with these new types of fieldless inductances.

Here's a fan who is even willing that shoes should be shied at him, but he has the courage of his convictions and writes us as follows:

"An interested observer may be intimidated many times before making his debut into a certain field; but there comes a time when he can restrain himself no longer, and makes a headlong dash by giving his views on a subject. His suggestions may be of little benefit and then again they might open up a way for something better. It is with the latter in view I write this.

"Possibly you have meant the Pickups

and Hookups Department to be what it is —no more, but personally I believe that you gave this section of your magazine to the experimenter for a means of radio development. If so, then it is up to the contributor to use it and use it widely.

Dx Lists?

"DX lists do not occupy a seat of honor in my household simply because I do not invite them, or to put it in the words of an amateur, 'I didn't get the Pacific Coast because I was not fishing.' To me the logging of numerous stations merely for a long list is a waste of time. The logging of twenty-nine stations in so many minutes as given by one of the contributors is laughable. May I ask how many of us today would know anything of radio and its possibilities if the early experimenters spent all their time at such foolish toying? Wouldn't it be of more interest and of more educational value if the contributors to this department gave discussions of different circuits, as many are doing, effect of weather conditions, code interference and most of all, receiver interference?

"You will also notice that this section contains hookups, nine-tenths of which are of the regenerative, one-tube type.

"Fine, I say, in the hands of one who knows how to use them without spoiling half a dozen neighbors' good natures. But how few of us there are who are ideal.

Down with regeneration? No! Emphatically no! Let's keep it, but not abuse it.

"This is merely a suggestion and many an old shoe will be shied at me, I'll venture, yet I hope it may stimulate others to give their views."

The writer of the above, R. S. Parks, 1419 Cleveland Boulevard, Caldwell, Idaho, seems to put the case up not so much to this department but to fandom, since it has been the policy of RADIO AGE to give its readers what they desire. If there has been a desire for DX lists, it is simply because the burden of the Editor's mail has been of that type. If the single tube regenerative has been unduly touted in these columns, it is merely because so far the majority of the contributors seem to have been most impressed with it. We realize there is a growing demand for the experimenter's section in this department, but so far the genius experimenter has not made his voice heard.

Perhaps the publication of the above letter and the comment made will serve to stir up interest. Perhaps it will lead to the creation of a band of experimenters who have passed the one tube stage and wish eagerly for more experiences, although RADIO AGE cannot very well afford to forget the beginners who have many more problems than those who have already taken the dive into the pool of radio and have learned to swim.

Henceforth, we will watch the mail very carefully, and the tenor of the department will be merely a reflection of the contributions received. It is up to readers like Mr. Parks to sound the call to arms to his fellows; then let the station list enthusiasts marshal their forces. May the better man win; we feel our readers will always wish us to abide by the desires of the majority.

Old timers will readily recognize the circuit in Figure 1 as the inductively or loose-coupled crystal set, with an arrangement for switching from the use of carborundum and a potentiometer to galena and other types of crystal on which no battery current is used. In the old days the carborundum was considered good because it was fairly stable and rugged and would stand the lurch of the ship and the pound of the engines at sea.

It is sent in by Clement Hampton, 427 Jeanne Mance St., Montreal, Que., Canada, who says his old friend, W. J. Featherstone of 213 Ella St., Hull, East York, England, passed it on to him.

The antenna variable is a .001 and the secondary a .0005 mfd. The inductances can be either honeycombs, a loose coupler, two spiderwebs, or almost any form of good inductance. A fixed condenser across the phones would do no particular harm and might help a little.

This circuit is popular in England where no one is allowed to use a regenerative set capable of feeding energy into the antenna, and where the distances are not great, as is the case in the British Isles and continental Europe.

Known under seventeen or eighteen different names, the circuit shown in

Figure 2, and sent in by Walter E. Fee, of 115 Beecher St., Atlanta, Ga., is the single circuit Armstrong, noted for its ability to squeal, and one of the oldest regenerative sets known to experimenters. L 2 is inductively placed against L 1 for feedback.

In Atlanta this circuit works out quite nicely (though we hardly dare think what the neighbors have to say on this subject when the tube is oscillating). It tunes in the long distance stuff while WSB is batting out flies, and for a change Mr. Fee hooks it on a loop and goes fishing for distance, with results as follows: WSMB, WOC, WEA, WCCO, KDKA, KSD, WOAW and WQJ. Of course, this is used on head phones only. It is one of the tried and true types of receivers, although not recommended for congested areas where your neighbor might have one too.

Here's another one familiar to the fellows who have been following the game for longer than a couple of years. The circuit sent in by Carl Winger, 20 William St., St. Catherine's, Ont., Canada, was originally published by Weagant shortly after Armstrong gave the world his regenerative circuit. Later Weagant's circuit was taken up and popularized by Reinartz. It has masqueraded under a thousand different names, but, the circuit fundamentally is the same which is the point in which most experimenters are interested.

Instead of using a variable regenerative coil for control of oscillation, the Weagant circuit, alias Reinartz, alias et al, uses a variable capacity in series with an inductance, the two paralleling the plate and filament. The control of oscillations seems easier with this type of receiver than with the straight variable plate coil.

The receiver shown in Fig. 3 happens to be the single circuit Weagant, which can be made up with honeycombs, spiderwebs, straight winding on a tube, or any other form of inductance. While it is good for excellent work on distant stations, for the sake of other listeners it would be best to loose couple it, by having an untuned primary in inductive relation to L 1. The condensers in the circuit shown are .0005 mfd. Reinartz found that oscillations could be better controlled by inserting a small choke in series with the phone lead at the point marked X in the diagram.

In the inductively coupled receiver the condenser C1 spans L1, while the antenna comes down through a fifteen turn coil to ground. The secondary is then removed from direct contact with the aerial and if the receiver does feed back into the aerial it will be with lessened energy.

L1 can be approximately fifty to seventy-five turns, while L2 can be somewhere between thirty-five and fifty turns, the condenser C2 making it unnecessary for the exact number of turns to be found for the inductance L2.

Another form of the Armstrong regenerative is sent in by Joseph A. Smith, 723 Wallace Ave., Wilksburg, Pa., who tells of the good work it has done for him. He says it is good away from con-

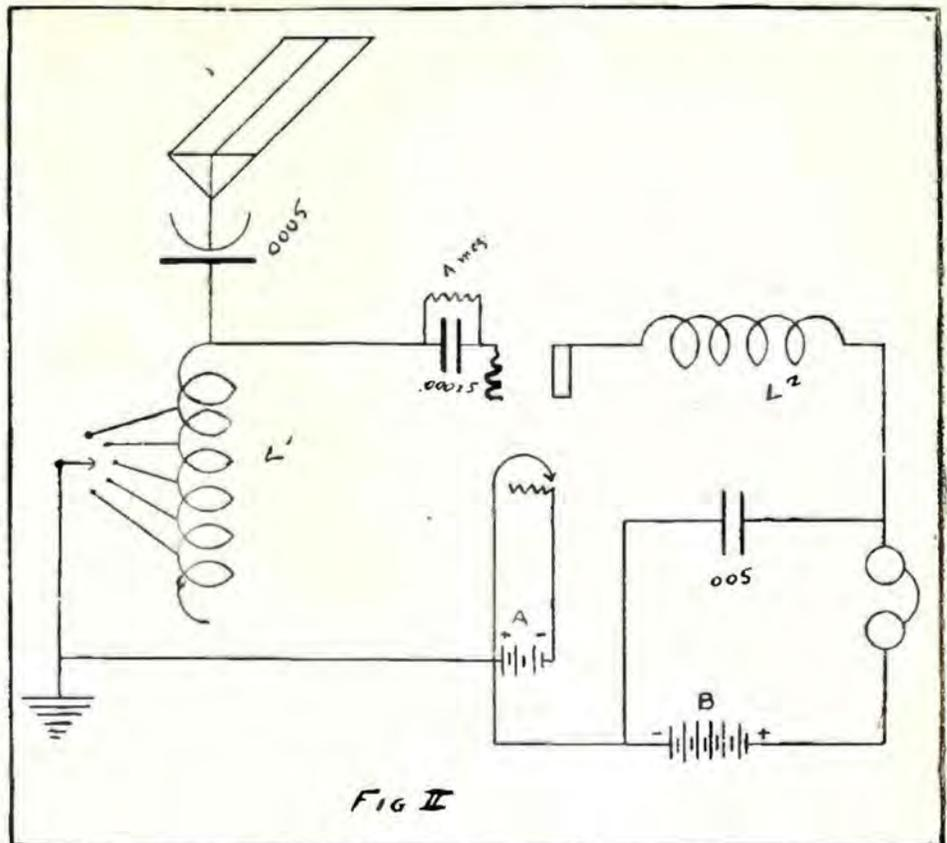

FIG II

This is the single circuit Armstrong. L 2 is inductively coupled to L 1 for feedback purposes, and its relationship is variable. The inductance change in L 1 is by means of taps and the condenser in the antenna circuit. Good for results but hard on your neighbor if you let your tube oscillate

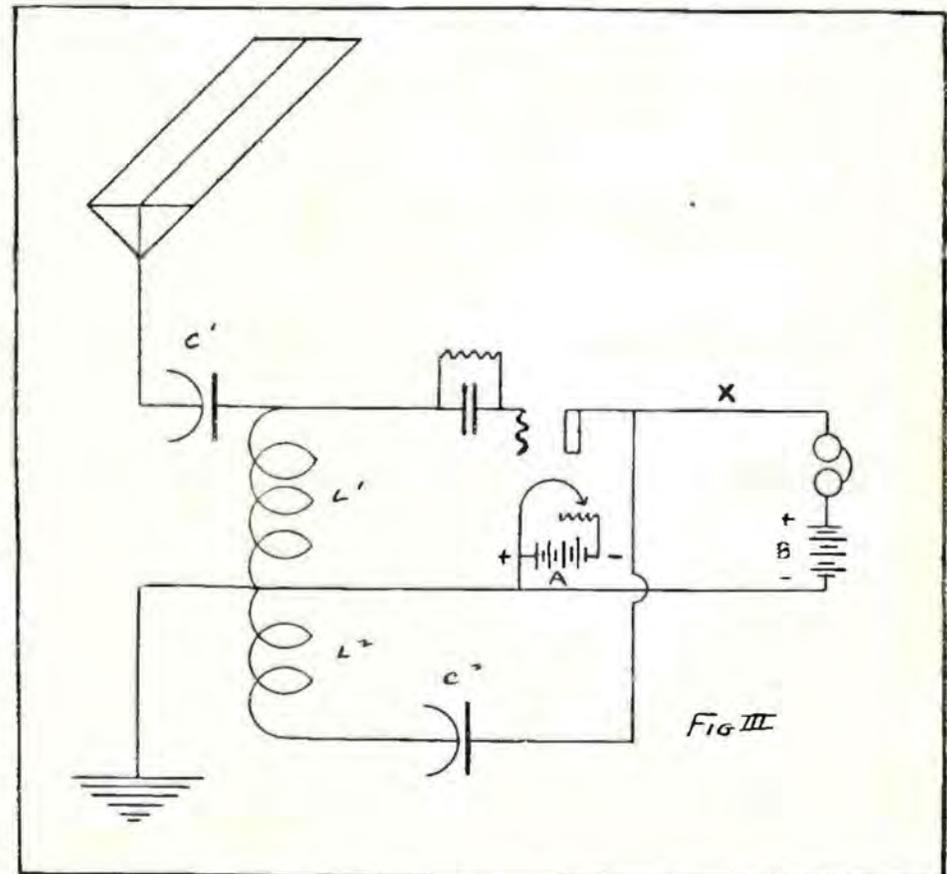

FIG III

Another popular type of receiver in which regenerative control is by a variable capacity in series with an inductance paralleling the plate and filament. Known years ago as the Weagant circuit, later popularized by Reinartz and others. Better build it loose coupled for the sake of the neighbors, unless you happen to live out in the exact geographical center of the Gobi desert

gested districts. His coils are wound as follows: L2 52 turns 18 or 20 DSC on a three or three and a half inch form. Around center of winding one layer three quarters inch cambric. Stick 8 pieces of hard rubber 3-4 by 3-16 by 1-4 placed equidistant around the piece of cambric, fastened with collodion. Coil L1 is wound on these blocks and consists of 3 to 10 turns of the same wire. An ordinary plate variometer is used for L3. C1 is .0005 and C2 .001 mfd. This circuit is inductive and even if oscillating would not cause the same amount of annoyance which a single circuit would. He submits a list of DX stuff that certainly entitles him to the DT button.

Another circuit which has proved very popular with those who wished to economize on tubes and material, is the reflex circuit, originally attributed to Latour, the Frenchman, who gave it to the Allied communication authorities during the early part of the war and which was immediately pounced upon by everyone on this side of the water as an excellent circuit from an economical standpoint. It has been rearranged countless times and additions and deletions made to the original.

This circuit, Fig. V, is sent in by Francis Davis of Cushing, Okla., who tells us L1 is wound on a 3 inch tube with 15 turns of No. 22; L2 same size tube with 50 turns; L3 is the same as L1 and L4 is the same as L3. The variables C1 and C2 are .0005 mfd. C3 is .00025 and C4 is .001 mfd.

Davis' list of DX stations also gets him the DT button.

Looks like the ladies are not to be prevented from having equal rights in radio as well as economics, for in this week's mail come two letters from

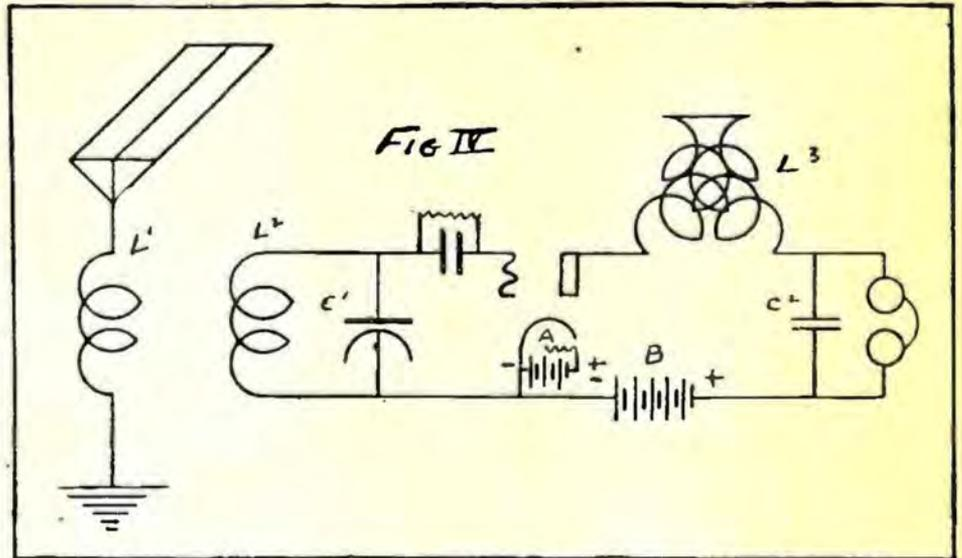

An inductively coupled Armstrong regenerative. Coils L1 and L2 are wound by the contributor, while L3 is an ordinary plate variometer. He gets good results on it, as he should with a loose coupled regenerative set.

feminine fans, the first from Floid Omond, 16 Alsace Ave., Buffalo, N. Y., who finds RADIO AGE interesting in every way, and specially the Pickups and Hookups. She has built a one tube and a three tube set and has received fine DX stuff with these. So we will send her a button, but regret we haven't a little wisp of ribbon to send along with it; we used up the last piece in winding a coil.

The other feminine ether chaser is Mrs. Eva A. Taylor, 69 Murdock St., Youngstown, Ohio, who reads RADIO AGE with a great deal of interest, especially since she ran across one of the Youngstownian names in the magazine. She has qualified for the button by sending in a list of stations she has

received on a manufactured four tube set with built in loud-speaker. She wonders if there is anybody in Chicago who does not own a broadcasting station, as her experience on the air seems to show that nearly everybody in Chicago is broadcasting.

We got quite a laugh out of a letter from Albert C. McKee, 2306 Seminary Ave., Chicago, Ill., who says his set is in a second edition of "Hell's Kitchen" where he has to contend with regenerative squeals and howls. In his letter he tells of making a crystal detector out of an old mouse trap but fails to tell whether he was bothered with squeaks on account of this fact. He
(Turn to page 48)

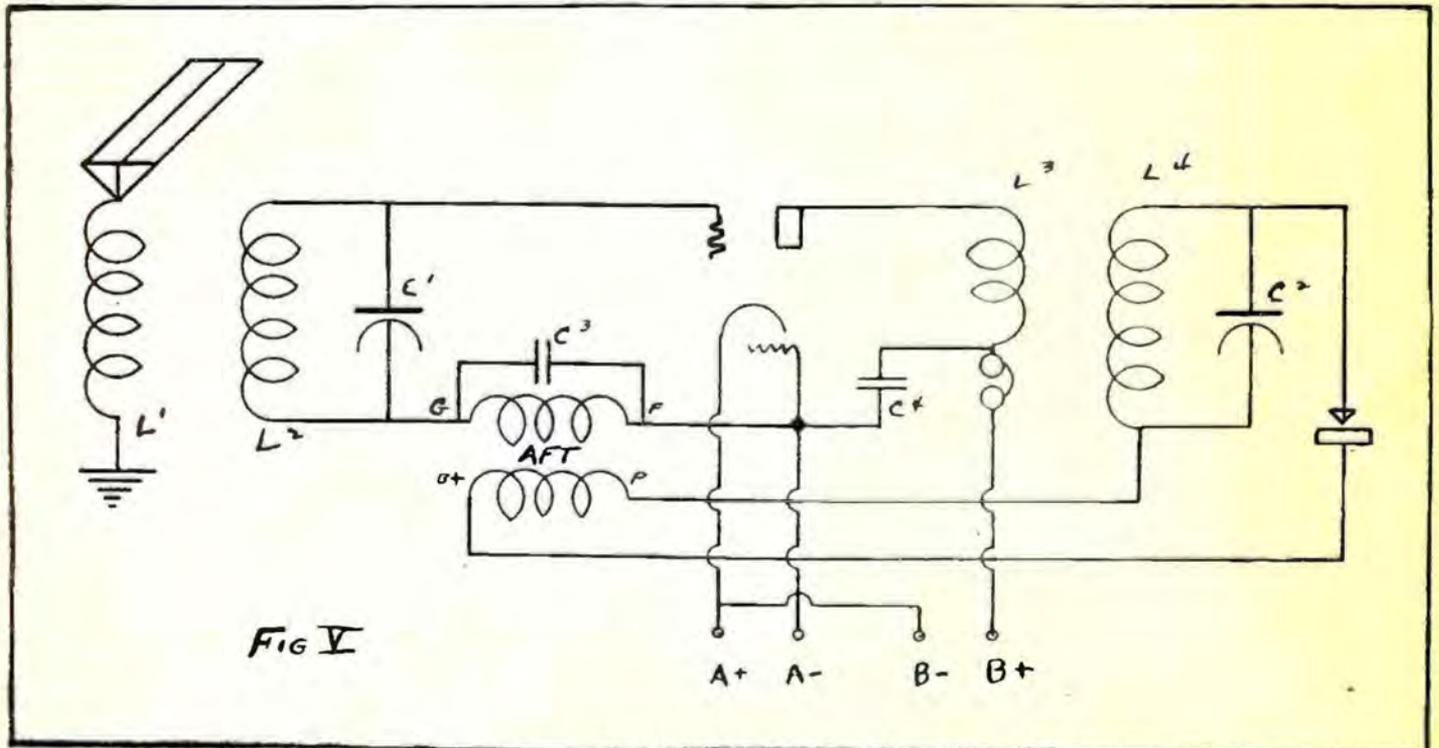

Another popular circuit, the reflex which sprang from Latour, the Frenchman, during the war. It is simple, effective and economical. What more can the fan ask? This one was sent in by Francis Davis, of Cushing, Okla.

RADIO AGE

The Magazine of the Hour

*Offers to Its Readers the
First Feature of Its Kind Ever Published in
a Radio Magazine*

A Round-up of Hook-ups

ALL Basic Circuits from which ALL Radio Hook-ups
are Developed Described and Illustrated with

62-Page Blueprint Section

FOR the first time in any radio magazine, RADIO AGE is publishing in its August, 1925, issue, an array of radio hookups that will impress and delight every lover of technical radio information and accuracy.

In this big number, which is to be our "Deluxe August issue," RADIO AGE will prove its superiority in the technical field by giving its readers, at no additional cost for the magazine, many pages of hookups, from the early diagrams to the very latest developments in multi-tube design.

Because of the inevitable popularity of this number, and the demand its publication will cause, readers are asked to order copies in advance.

In the
"De Luxe"
August Issue
of RADIO AGE,
Out July 15

THIS unusual number will sell for the usual price of 25c a copy. Of the pages in this number, fully 56 will contain actual constructional articles, of which THIRTY OR MORE pages will be typical RADIO AGE blueprints, which have made the "Magazine of the Hour" distinctively famous the world over.

From the simplest crystal set, the articles in this number will enable the reader to travel by an orderly process to the super-heterodyne, taking in every popular type of receiver introduced since the advent of the radio science.

Where improvements have been made, the latest technical explanations will be given. Everything will be strictly up-to-the-minute, and written so clearly and simply that either the rawest novice or the most seasoned technical expert will understand the articles almost at a glance.

Order Your Copy of This Wonder Issue In Advance!

25 CENTS A COPY,
\$2.50 A YEAR

RADIO AGE, Inc.,

500 N. DEARBORN ST.,
CHICAGO



(From page 46)

thinks J. B. Rathbun, who makes up the blueprints for the various hookups appearing in RADIO AGE, is to be complimented on their uniform accuracy and efficiency. He is using a five tube reflexed radio frequency set recently described by Rathbun and gets wonderful results with it. His list of stations entitles him to the button all right.

A. C. Taylor, Steele, North Dakota, says he finds there is no other publication that deals with radio that has such a vast amount of good reading matter as RADIO AGE has. He says he was surprised to see the circuit used by E. H. Jones in the April number, and feels that too much cannot be said for such a circuit.

P. E. Chapman, 805 North Preston St., West Philadelphia, Pa., thinks RADIO AGE is the best on the market and reads it with great interest. He thinks our invitation to readers and experimenters to forward their results with new circuits is certainly a boost to the amateur and a great help to all who are interested in radio. He is still using the four-tube circuit published by RADIO AGE in September, 1924, and with it has logged 167 stations; three Europeans, two Cubans, five Canadians, six Pacific coast and one Alaskan

P. French, 1209 Franklin St., Beaumont, Texas, took us at our word as to Spring cleaning referred to in the May RADIO AGE. He reports that Spring cleaning from aerial to ground clamps

did help his set to such an extent that he logged quite a batch of DX stuff, for which he is hereby awarded the D. T. emblem.

George D. Hillstrom, 10135 Lafayette Ave., Chicago, Ill., is a 14 year old youngster who is following RADIO AGE circuits with great success. His letter containing a DX list entitles him to one of the coveted buttons.

George A. Winkler, 902 South 15th St., Birmingham, Alabama, wants RADIO AGE to keep on pouring it into a certain radio octopus with which we are all acquainted. He sends in a diagram of an eight tube super which he is using with good results.

Charles Markarian, 110 Summer St., Worcester, Mass., gets fine results with the reflexed neutrodyne described by Mr. Hopkins in the January issue of RADIO AGE.

T. L. Kent, 721 North Ave., Waukegan, Ill., formerly 6US, is now out of the "ham" and into the BCL game, which he likes very much.

John Hogle, of 321 Selma Ave., Kenosha, Wis., says he is bothered by only one station, that being Zion. He asks for a wave trap that will obliterate that station. He has made up his set from RADIO AGE blueprints. He gets excellent results from his three circuit regenerative. A wave trap might be used on Zion with good results. Make it on a cardboard form about three inches in diameter, winding it with

about fifty turns of No. 18 bell wire (also known as annunciator wire), spanning it with one of the Remler condensers he uses. Insert in series with the aerial lead of your normal primary and tune to Zion's wave, leaving it there while you chase off in quest of other signals.

Roy R. Winder, Pedro Miguel, Canal Zone, sends word of his luck with radio in the land of static down around "Pete-Mike" on the Panama Canal. The first station he has a chance to pick up is PWX, Havana, about 900 miles to the northward. He is a regular reader of RADIO AGE, considering it one of the most valuable assets of radio.

Another fourteen-year-old radio fan is E. N. Girard, 715 South 58th St., Philadelphia, Pa., who uses RADIO AGE hookups as his guide. He gets out of town stuff without trouble from the locals and sends in a dandy DX list.

Kendall McNeil, of Ottawa, who neglects to send his address, writes interestingly of his excellent results with the improved three tube Reinartz described in the May RADIO AGE by Mr. Piety. He gets all the stations in the U. S. and also nabbed two or three of the Continentals, namely London, Newcastle and Aberdeen, all of which he has confirmed.

D. C. Atkinson, 788 Hohman St., Hammond, Ind., one day used his downspout on the eave-troughs of the house instead of an antenna, getting stronger signals. He used this on a crystal set, but says he has not tried it on a tube set yet. Let's hope his experience will not start an epidemic of down-spouting or else all the landlords in the country will be faced with the necessity of installing tinned copper downspouts with binding post connections for each experimenter. Many tin roofs have worked better than a poor antenna, but always remember there is NO substitute for a GOOD antenna.

How are
Your DX Lists
Coming This
Summer?
Let the
"Pickups and
Hookups"
Readers
Know About
Them!

DAVEN SUPER AMPLIFIER

It is a recognized fact, that only a Resistance Coupled Amplifier delivers perfect amplification. With the SUPER AMPLIFIER you are assured of ample volume, lower "B" Battery consumption, minimum of assembly labor, unimpeachable quality—an amplifier which makes any good set better.

The Sine of Merit

DAVEN RADIO CORPORATION

"Resistor Specialists"
NEWARK N. J.

Obtain from your Dealer the Resistor Manual a complete handbook on Resistance Coupled Amplification. Price 25 cents or postpaid 35 cents.

TRADE MARK REG. U. S. PAT. OFF.

Amplifier Kits in 3 or 4 stages for those who would rather build than buy the completely assembled Super Amplifier.

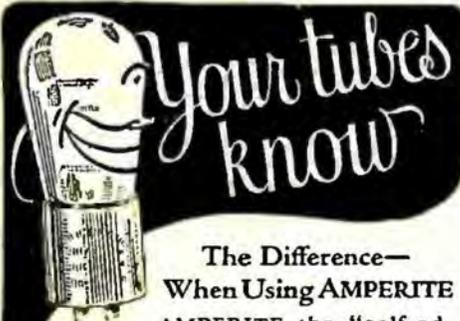
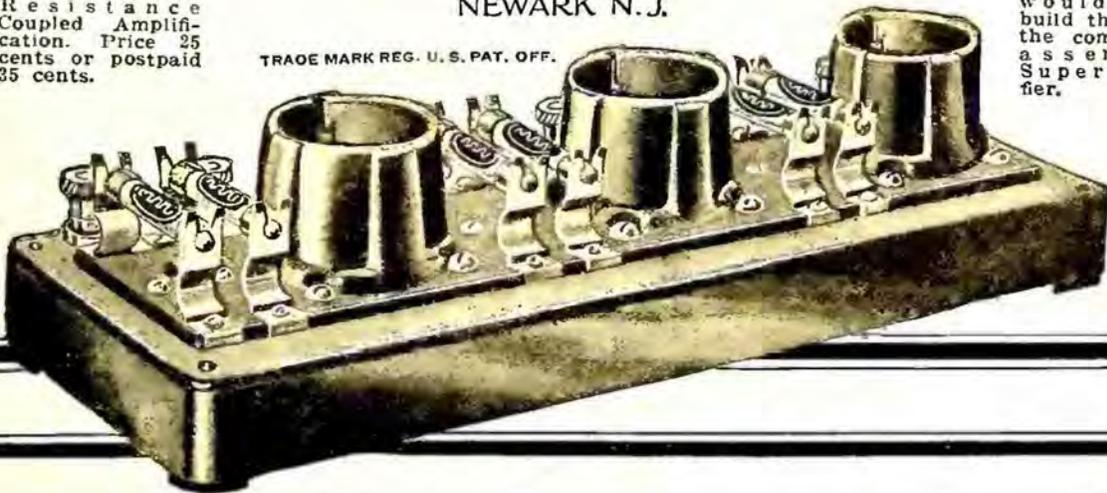

The Difference—
When Using AMPERITE

AMPERITE the "self-adjusting rheostat", automatically controls the flow of current, and makes hand controlled rheostats obsolete.

Permits the use of any type of tubes or any combination of tubes. Specified in every popular construction set.

For perfect results you must use AMPERITE for filament control. Price \$1.10 everywhere.

RADIALL COMPANY

Dept. R.A.-7, 50 Franklin Street, New York City

Write for
FREE
Hook-ups



AMPERITE
REG. U.S. PAT. OFF.
"means right amperes"

Sales Distributor Wanted

to start now in the fastest growing business the world ever knew—Three Million radio sets were sold last year—22 Million will be sold in the U. S. A.

THE MUSIC BOX RADIO RECEIVER

is the peerless seller of them all. Think! Only two orders weekly means \$600 per month. Four orders \$1200 per month. The Set with the Marvelous Tone and Volume Supreme, the Distance getter of them all. Write now, today, for our liberal 15-day trial offer and protected territory.

THIELEN, Manufacturer
1207 North Shore Ave., Chicago,

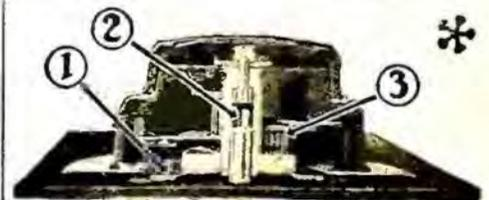

Geared
80
to
1

Another important development in ACCURATUNE construction—the use of a full brass gear train, built exceptionally rugged and designed for Accurate Tuning. "Absolutely essential for sensitive sets."
1. Friction Clutch. 2. Long Center Bushing. 3. New Gear Mesh.

At your dealers, otherwise send price (\$3.50) and you will be supplied postpaid

MYDAR RADIO CO., 9-K Campbell St., Newark, N. J.

ACCURATUNE
REGISTERED GEARED BOWEN U.S. PAT. OFF.
MICROMETER CONTROLS

"The Roundup of Hookups"—112 pages of every conceivable kind of radio hookups—will be the big feature of the "Deluxe" Edition of the August RADIO AGE. On the stands July 15, but order your copy in advance if you want to get this wonder issue. More than thirty pages of blueprints and scores of hookups! 25 cents a copy.

* Tested and Approved by RADIO AGE *

The Broadcast of Plays Written for Radio

By E. E. Mattson
Westinghouse K Y W

SINCE the advent of radio, its progress has brought many improvements, some of them expected and some not looked for. However, improvements from a technical point of view have not been the only goal sought in radio. From the beginning radio was popular because of its newness, its mysteries and seeming intangibility. A person bit by the radio bug soon became almost diabolical in his lust to grope into the distance, and spared no effort to purchase or build a set that brought him clear and distinct reception. Those were fascinations that led him on.

With the advance of radio activity, and the many angles taught its leaders by experience and study, it became apparent that the mere broadcasting of vocal or instrumental numbers accompanied by conventional announcing would not suffice. The rendition was heard well but it appeared automatic, it lacked the personality that would make it pleasing and beautiful. The artist was taught to impress the invisible listener-in by sound, what the stage artist did by pantomime. The announcer was given the idea of making his remarks fit the occasion and blending them into the program as part of it, thereby assisting the proper balancing of the act. These, and many other things were essential.

After about four years of radio activity, numerous ideas have presented themselves to radio directors, visualizing the need of a change of venue. Wilson Wetherbee, director of Westinghouse Station K Y W, has long felt this need and for some time past has been active in coaching the personnel of K Y W toward this goal. Radio broadcasting demands new things, and it will get it. The movie industry started with one-reel features, and during its evolution it grew until today the cinema features full plays brought out with a studied skill, wherein the personality of the actresses and actors, aided by elaborate stage settings, convey to the audience the same impressions that the spoken drama would. The success of the movie is evident by its popularity among all classes, the highly educated and those less favored.

A Radio Technique

Mr. Wetherbee's ideas have brought out that radio thirsts for something more than "one reelers." His experience has taught him a technique of radio more than the mere announcing of a selection and then putting it over clear and distinct. The announcer, the artists, the stage setting—all are unseen by the listener. The general atmosphere has to be impressed upon the listener by sound, and by the personality injected into the microphone in the studio. So far this policy has succeeded admirably. Now Mr. Wetherbee's plans bring forth radio's demand of short acts, in which several persons take part, and in which the scenes are laid with the same care and forethought as on the stage or in a photo-studio. With radio, however, technique finds employment in drawing

for the listener-in a vision of the layout concerning which he hears the spoken version. In the movie, the audience sees but does not hear. In the radio, it hears and will see by virtue of the impression that will be given the listener by the personnel of the act.

It is the purpose of Station K Y W to give life to this plan. Mr. Wetherbee will supervise the writing of plays to be used over K Y W. He has completed the first one act play, "The Fates Decide" which will soon be put on the ether. In this play he employs three people, Norman Landon, a wealthy newspaper owner, Marion Landon, his wife, and Franklin Ames, his life long friend. The entire plot is laid out with the same care and thought as given a play for the stage. It will be acted by three artists of the station, who have been coached in rehearsal until the effect intended has been brought out to a high degree.

Summer Radio Conditions To Be Surveyed

H. FRANK Hopkins and Harvey T. Kelley, Assoc., I. R. E., and well known radio engineers, plan to leave Chicago some time during August on an extended trip throughout the Western and Southwestern portion of the United States, to carry on an intensive survey of broadcasting conditions in so-called "dead spots."

Because radio reception is so difficult in the Summer-time, under most conditions, the two experts will endeavor to trace the causes and record them for public use. Their findings will be sent for publication in RADIO AGE as the trip progresses.

A 100-watt broadcasting station will be part of the equipment carried on this trip, and arrangements have been made to carry on tests in Colorado, Utah, Arizona, New Mexico, Southern California, and where static conditions at this time of the year are unusual. Under these extremely adverse conditions, an attempt will be made to determine just what kind of radio circuit performs the best. Several circuits will be taken on the trip and tested under varying atmospheric and geographic conditions.

Communication with Eastern and Pacific broadcasting stations will be maintained throughout the long trek, which will be made by automobile. Several stations have expressed a desire to broadcast the findings of the experts, to guide them in reaching districts and listeners in isolated parts of the world who at present encounter difficulties in maintaining consistent touch with radio stations throughout the year, and especially in the Summer-time.

Mr. Hopkins and Mr. Kelley intend to devise several new types of radio apparatus to meet the difficulties they expect will confront them. These varied types of apparatus, which will be designed after thorough tests, will be described to readers of RADIO AGE this Fall, thereby being of great value to those fans who live far from strong stations and who are bothered by static, fading and other unaccountable disturbances.

Both Mr. Hopkins and Mr. Kelley have long been identified in radio circles, having done much research and development work. Both are past masters in the transmitting and receiving art.

How Much Coupling is Necessary?

(Continued from page 14)

In making the final primary coil, it is best to allow taps at two or three turns more than necessary on long waves and at least two less than necessary to produce oscillations on short waves. This makes sufficient allowance for depreciating tubes and batteries.

The variable coupler makes up for lots of little differences in sets, such as aerials of different capacities, tubes of more or less oscillatory tendencies, batteries differing in voltage, detectors of more or less absorbing powers and the like. It avoids the necessity for variable feed-back coils like reversed ticklers, for inducing regeneration on some wavelengths and counter-acting it on others. And it permits long wave stations to come in as well as others; in fact, it makes reception uniform all over the dial's scale.

Phonograph Stores Are Handling Radio

NEW YORK—Radio parts are now being handled by phonograph stores throughout the country and on a growing scale, declared Ben Aplin, eastern sales manager for the Shaw Insulator Co., of Irvington-Newark, N. J. Mr. Aplin, who is one of the best known salesmen for molded radio materials in this country, has been deeply impressed by the increasing volume of sales being recorded by phonograph and music stores for small parts which hold such an important part in the radio industry.

"Hundreds of dealers throughout the eastern section of the country who previously handled musical instruments and records, and eventually added radio sets have been finding that small parts have been invaluable sources of profit to their sales total.

"This fact is more apparent as one, in travelling throughout the greater cities, finds that dealers everywhere are adding small parts as the direct results of demands made upon them by their trade. There are always some parts of their set which they desire to replace to add greatly to the efficiency of their sets.

"With that idea in mind they go to the music store which sold them the set and insist upon buying some particular part. If the dealer does not carry that part or for that matter any part in stock the customer goes elsewhere. The natural result is that the dealer, rather than see business going to another store, gradually stocks up new and small parts which he finds hold ready sales appeal to his customer.

"Many dealers were first of the belief that the carrying of small parts would be the means of cluttering up their stock. Instead they are gradually finding that by simplifying the arrangement of their merchandise they are able to fill the customers, demands at once.

"It is no longer necessary to spread these small parts in every section of the store. They are now systematizing their stocks of these small radio parts with the result that a show case or two in a particular section of the store carries the stock required.

The Radio Spies

(Continued from page 32)

occasions seen this same Cecelia Lambert at the De Forest plant in Jersey City. I was likewise told by another employe who was working under Harley, whose name I do not recall, that there was at that time another investigator stationed at the De Forest plant who was known as "E-10."

After saying that he arranged for Thies to procure certain information concerning the complainant, Bowlby declares he passed on Thies's written report to Harley, adding, "this report contained, among other things, a description of all the machinery used in the tube department of the De Forest Radio Company while he was working there, as far as he could remember the same, together with the method of operating these machines; also the information regarding filament wire used by that company in making its tubes and where they obtained the same."

Bernice M. Jennings, employed as typist by the Radio Corporation of America from November, 1924, to April, 1925, said an employment agency sent her to Room 301, 25 Beaver Street, where she asked for Mr. Harley. She was engaged by a Mr. Silvertan. There were six girls under Mr. Harley in Rooms 301 and 302, she says. Harley's private office was Room 303. She alleges that Room 217 in the same building was also occupied by a girl under Harley's direction and was also used by Radio Corporation's investigators.

Instructed on Secrecy

Soon after she began work, alleges Miss Jennings, she was told by several other employes in the office not to give out any information regarding the people in the three rooms, or their business, and also not to let anybody know that there was any connection between the employes there and the Radio Corporation of America. Two weeks later she was transferred to Room 217. Once a man dropped in and asked for Mr. Harley. She directed him to Room 301. When Harley heard of the incident he is alleged to have said to Miss Jennings, "In the future, if any one comes here and asks for me, you don't know me nor anything about me, and no one here has anything to do with any radio business whatever."

Harley, the affidavit continues, received written reports from many investigators. They were usually stamped with Harley's initials and then went to Silvertan, who stamped them with his designation, "C-2."

When she first began copying the reports, says Miss Jennings in her affidavit, they were headed by the name of the person or concern under investigation. For three months prior to April 10, 1925, she received almost daily reports from "C-3," Cecelia Lambert, reports headed "In re De Forest," but subsequently the heading was changed to "381" and that number was given to the file which contained matters relating to the De Forest Company.

The reports covered many things, the affidavit alleges, including the time employes began and quit work, "whether there were few or many employes at work, whether they worked overtime or less than full time, whether business was brisk or slow, what employes were discharged and what new ones were taken on, the names and addresses of employes, so far as she was able to give them; instructions issued to foremen and persons in charge, notices posted in the departments governing the personnel of superintendents and foremen, why a foreman had been laid off, efforts made to speed up production, and especially what took place in the power tube department: on two or three occasions her reports contained attempted drawings of machines used in the department in which she was working."

Several times Miss Lambert, it was alleged, sent in with her report some pieces of filament wire, and she also sent in what she designated as "gold seals," used in connection with the manufacture of power tubes.

Corroborates Bowlby

William Buckbee, a tester in the De Forest Laboratory, swears in an affidavit that in company with a young lady he met Harley, at the latter's suggestion. With Harley was Miss Johnson, whom Buckbee says he knew to be a De Forest employe. Harley, Buckbee asserts, told him that Miss Johnson was an investigator for the Radio Corporation and that she was one of five or six employed in the De Forest plant who were also employed by the defendant.

"At that interview," the affidavit continues, "Harley offered the young lady accompanying me a position as confidential investigator for the Radio Corporation of America and stated to her that as such confidential investigator he could get her a position with the De Forest Radio Company, as stenographer, and that he wanted her, after having

(Turn to page 60)

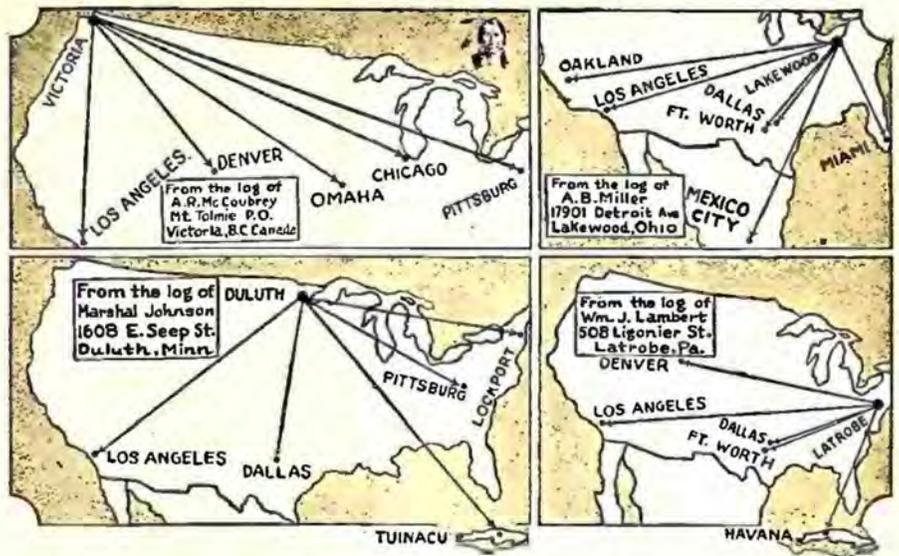

Through the Locals - ALL-AMAX Reaches Out

Every ALL-AMAX Set, wherever it may be, brings to its owner his choice of all the beauties in the air. Every day come more and more letters to our office, telling of the long distance reception, almost unbelievable on a three-tube set, which has rewarded the owners of ALL-AMAX.

Remember, too, that ALL-AMAX is completely mounted on panel and baseboard. You can wire it in one delightful evening, following simple photographic instructions.

- ALL-AMAX SENIOR, three tubes and detector . . . Price, \$42.00
- ALL-AMAX JUNIOR, one tube and detector Price, \$22.00

ALL-AMERICAN RADIO CORPORATION

E. N. RAULAND, President

2680 Coyne Street

Chicago

ALL-AMERICAN

Institute Correction



Through an error, the illustrations of Tests No. 47 and 49 in the RADIO AGE Institute for May, 1925, were reversed. The Quam Condenser test was illustrated by an engraving of the Duplex Condenser, and vice versa.

We are reprinting views of the two condensers with their proper identifications. The top view here with shows the Quam condenser, and the cut at the bottom is a Duplex Matched Condenser.



Be A RADIO EXPERT

EARN \$50 to \$200 a Week

Send for my big FREE RADIO BOOK right now! See how many wonderful money making opportunities are waiting for you as a Trained Expert in the Hottest, Fastest Growing Business in the World—RADIO!

Superdon Radio Set FREE

Long distance super-powerful selective radio set FREE to every student who acts now! Not a cent extra charge.

Write Today for full particulars and proof that you can succeed quickly in the big pay business of Radio; also how to get the wonderful Twin Superdon set without cost. Write at once—Now! No obligation. I. J. Mendels, American Radio Engineers, 646 N. Michigan Ave., Dept. 92, Chicago

Log for Your Radio

NEW 64 page log. Holds 400 stations. Shows calls, cities, wave lengths, dial settings, remarks, etc. TUNING SUGGESTIONS. Station list by wave lengths—by states, etc. Owners' Map. TROUBLE AIDS. Other valuable information. So convenient. Worth many times small cost. A joy to use. GENUINE De Luxe leather cover. Only \$1. Pay postman after log arrives. Post-paid if pay with order. MONEY REFUNDED if not OUGHTED. Order today—NOW. Postal will do. RADIO PRINTERS, Dept. 8202 * Mendota, Illinois

Standard Radio Receivers

Recently RADIO AGE inaugurated a new department called "Know Before You Buy," to serve as a guide to the prospective radio purchaser in deciding on the receiver best suited to his individual needs. Fans throughout the country have shown an instantaneous response to this new feature, and accordingly it is continued and will be a feature of all forthcoming numbers of RADIO AGE. Readers are invited to write us concerning the sets in which they are interested, and manufacturers also are asked to send us material describing their sets

Selectivity Paramount in Chelsea Sets

THE Chelsea Three and Five Tube receivers have been designed with virtually one end in view: that of attaining the ultimate in selectivity.

The Chelsea Super Five, just announced, is a five tube receiver embodying this selectivity with unusual volume. Distortion is minimized so it is unnoticeable, as is any annoying squealing.

The Chelsea Five has all the principles of the perfected non-regenerative set, including remarkable distance. The cabinet, of the sloping type, is finished in rich mahogany with shielded Bakelite. The retail price is now \$50.

The Three Tube Chelsea

Clear volume on the loud speaker, with ability to bring in distant stations within reasonable range, is the feature of the Three-Tube Chelsea, Model 122. This set has been on the market for some time and has gained a reputation for its consistently remarkable performance. One station is received at a time, proving it is also selective.

The Chelsea 3-Tube Set is of the triple circuit type, controlled by a single tuner. No knowledge of radio is necessary to operate this simple receiver. The cabinet is slightly sloping, as in the Chelsea Super Five. It is of attractive finish.

The price is now \$40.00.

The Eaglet Receiver a "Prince of the Air"

THE EAGLET, a three tube dry cell neutrodyne, has been "weighed in the balance" of engineer's tests, and has proved that it possesses selectivity,

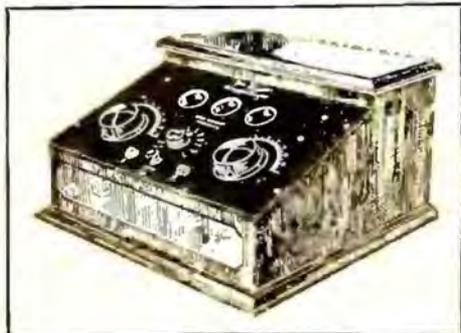

volume as well as simplicity, distance and tone volume. These qualities, coupled with good workmanship, finish and guarantee, constitute the last word in radio.

The Eaglet embodies the Eagle Balanced Neutrodyne circuit, using one

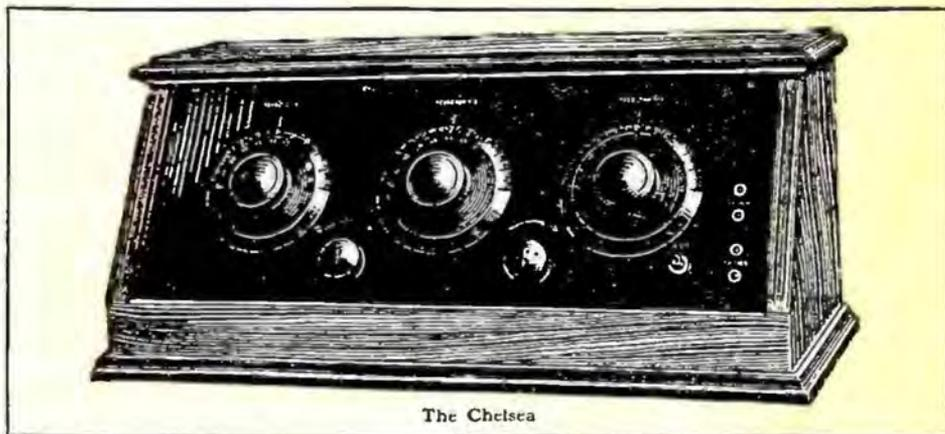

The Chelsea

step of tuned radio frequency amplification, vacuum tube detector and two steps of audio amplification. The first tube is reflexed; that is, it amplifies radio and audio frequency at the same time; making the Eaglet virtually a four tube receiver.

It gives reception equivalent to a four tube dry cell set, using only the current required by three tubes. The Eaglet is portable in the sense that it is light of weight, can be conveniently carried about the house and can be hooked up to different antennas, taken out in an auto, used on camping trips, Summer homes and hospitals.

For its operation it requires three No. 6 dry cell A batteries 1½ volt, and four No. 23½ B intermediate size or one 4½ volt unit C. The tubes are UV 199 vacuum tubes or their equivalent. The instrument can be operated with ear phones or loud speaker. The installation is the same as the Eagle model B; namely, approximately 100 feet antenna. Two antenna leads are provided, one for long and one for short aerial.

The receiver is a delicate, scientific instrument, and should not be tampered with by inexperienced people. The Eaglet has been welcomed both by the trade and the consumers and has already endeared itself to thousands of owners. Families spending the hot months in camps, mountains, or sea shore will find the Eaglet a source of great joy and will be able to keep in touch with the wonderful open air orchestra programs that are always broadcast during vacation time from the country's best stations. The water enthusiast can listen in and have a whale of a time with his Eaglet installed on yacht or motor boat, on account of its compact design and light weight.

The price is \$75.00.

"Tone Modulator" in Resas Receiver

THE perfected Resas Tone-A-Dyne receiver embodies every advantageous feature claimed for any five tube set, plus the Tone Modulator, a feature that is to be had only with the TONE-A-DYNE.

As its name implies, the Tone Modulator controls the tone and volume at all times and under all operating conditions. There is nothing complicated or difficult about it. Simply a turn of



the knob and the musical or vocal selection assumes its most pleasant volume.

The Tone-A-Dyne is non-radiating. Annoyance from squeals and howls is eliminated.

The selectivity of the Tone-A-Dyne is unusually satisfactory. With local stations broadcasting on a wavelength only 5 meters away, station WHAS (Louisville) has been readily tuned in without interference on a short indoor aerial.

The Tone-A-Dyne is so designed that it can be operated by anyone without previous experience. The three tuning dials are accurately calibrated and matched so that their settings practically correspond. There is only one filament control, and this can be set at the best operating point on reception of the first station. A snap switch controls all tubes. Clearly marked binding posts are provided in the rear for all connections.

The price is \$78.00. (Turn to page 54)

Learning the Various Tube Characteristics

(Continued from page 12)

operation. This condition usually comes suddenly; it is not spread out over the life of the tube as would be expected. It is sometimes caused by applying excessive voltage to the filament of an otherwise good tube. If such is the case, it is possible to restore the tube to normal by the rejuvenation process, or by applying the rated voltage to the filament with the plate voltage cut off, for about a half hour.

From the above it will be seen how an old or defective tube will cause the aging of the other tubes in a circuit. This condition is readily noted by the necessity of increased "A" battery voltage—but most fans just turn the rheostats on and let it go at that—paralyzing or otherwise decreasing the efficiency of all of the tubes, which is a rather expensive performance in the end.

Amplification Factor

TO DETERMINE the amplification factor of a vacuum tube experimentally, a high frequency current of about 1,000 cycles is necessary—along with a hot wire galvanometer and other associated equipment. However, it is possible to determine this factor by use of the plate current values of the tube under test, substituting approximate values for functions of the various voltages in the tube. Thus, $I - \alpha (\gamma E_b + E_c + \epsilon)^2$ in which I equals the Thermionic current in milliamperes, E_b equals the potential (voltage) difference between the plate and filament, E_c equals the potential (voltage) of the grid and ϵ is an arbitrary quantity representing the small differences of potential (voltage) existing in the tube under various conditions. α is a structural constant.

The quantity γ in this equation is as explained in volume 47—1918—"Physical Review" by Van der Bijl—"That for equivalent values of E_b and E_c , a change in the cinode (plate) voltage E_b produces γ times as great a change in the current to the cinode as an equal change in the grid voltage E_c ."—or non-technically—a change in voltage on the plate would have to be γ times the voltage change on the grid that would be required to produce a given change in the plate current. The voltage amplification factor μ is the reciprocal of this quantity or $\mu = 1/\gamma$.

This is shown graphically in figure 2—where the grid and plate curves are drawn to the same scale on the same chart, indicating that a much smaller change in grid voltage will produce a greater change in plate current than a like change in plate voltage will produce.

The ratio of the two voltages required to produce a given change in plate current is the amplification factor (μ^2) on the chart; the ratio of the slopes of the straight portions of these curves is the amplification factor.

The amplification factor of the tube plotted on this chart will be between 6 and 6.25 or an average of 6.125. With this average factor we have $\gamma = 1/6.125$ (Turn to page 56)

The "Better Tuning" Control

A New B-T Product



\$2.50

Exclusive features fully protected by patents pending.

Hairline Control, Easy Action, Simple Mounting.

No side strain or pull on shaft to wear out bearings or destroy alignment of your condenser or coil.

Reads 0 to 100 or 100 to 0,—settling the argument as to "clockwise" or "anti-clockwise" instruments.

Registers dial numbers, wave lengths, or call letters.

Improves the tuning as well as appearance of any set.

The new Tuning Control is distinctively a B-T product. It is of the same sensible design and careful construction that has characterized radio parts bearing the B-T name.

You should know about the new B-T socket. Send your name and address for circulars on this and other new B-T developments.

BREMER-TULLY MFG. CO.

532 S. Canal St., Chicago

\$3.50 Volume with **CLEARNESS** is obtained by using **FLINT AUDIO** Frequency Transformers. We will supply if your dealer cannot. **FLINT RADIO CO.** 1884 Wilson Ave. Chicago

RADIO BOOK only **\$1**

514 PAGES—Greatest book on Radio ever written. New—authoritative—complete. Packed with sound, practical information useful to every radio fan. Hundreds of illustrations. Send \$1 today. Money back if not satisfied. International Correspondence Schools, Box 8783-D, Scranton, Penna.

Get this great new MAP of THE AIR

A MARVELOUS new way to chart your radio exploits—a beautiful Air Map, printed in three colors with every station clearly marked and Time zones outlined! Size 28x34 inches.

There's no limit to the useful and amusing ways you can use Collier's new Radio Map of the U. S. and Canada. With its help—

You can find out INSTANTLY how far any station is

If you use a directional aerial, you can point the loop exactly toward the station you want to get. The map also outlines the radio districts and gives an alphabetical list of all stations and their operators.

Thousands have already been sold. Get yours today! At your news-stand or radio dealer's, only twenty-five cents—or just mail a quarter to us.

P. F. COLLIER & SON COMPANY
256 Park Avenue New York City

LIFE, LIBERTY and the Pursuit of HAPPINESS!



You Won't Have to Pursue HAPPINESS

You can have it right at your elbow to while away the time 'til old Lady Static gets off the line!

You'll have no trouble getting station Z-I-F-S, because you'll find it is always tuned in to catch your funny bone's wavelength, and is more ticklish to your giggle box than the finest cat whisker!

ZIFFS, Badzib's Book of Art and Wit, is the only humorous monthly of its kind on the market, and is crammed full of the best artists and funsters in the world!

Exclusive Photo Section! Complete gallery of French-American Art Studies in color! Fifty pages of illustrations! Pep, Ginger, Punch!

ALL FOR TWO BITS!

Pick This Out On Your Piccolo!

*Even tho' your set is growling
'Til you think a cat is howling
And the music comes in wailing, hissing sniffs,
You will giggle, grin and chuckle
'Til you hafta loose the buckle
On your belt, if you've the latest book of ZIFFS*

You wouldn't go fishing without bait, would you? Well, then, don't try to get Hong Kong on a stormy night with a crystal set, till you've put your John Henry on the tag below:

ZIFFS,
608 South Dearborn,
Chicago, Ill.

Dear Badzib:
I got a radio. I got Hawaii. I got drowned out. I got peeved.
I don't see nothin' to laugh at, you big bum! Here's two bits. Send me the July ZIFFS, and I will!

They Call Me.....

And I live at.....

Standard Radio Receivers; The Atwater Kent

(Continued from page 52)



Atwater Kent Carefully Designed

THE careful construction of Atwater Kent Radio is apparent to the most casual observer—the easy movement of the tuning dials; the absence of intricate wiring; the sturdiness and rigidity of the various parts, are but a few of its features. Other structural details worthy of particular note are:

Variable condensers: plates—counterbalanced; bearings—adjustable cone, machine ground; contact spring—phosphor bronze.

Dials: drilled and reamed after moulding, assuring balance and accurate fit on the condenser shaft.

Rheostats: phosphor bronze spring contact, sliding on spiral resistance coil, giving smooth and positive action.

Tube sockets: heavy brass set in moulded Bakelite base with phosphor bronze contact springs, corrugated to make good contact.

Transformers: special Atwater Kent design capable of receiving all broadcasting.

Grid leak: special cartridge type, absolutely quiet in operation.

Wiring: tinned copper with all joints firmly soldered, spaghetti covered where there is a difference in potential.

Shielding: a metal panel on the cabinet receivers and metal shields on condensers of the open models entirely eliminate all body capacity.

Loud speaker: fabricated entirely of metal, the same as the vast majority of the finest band instruments.

Diaphragms: of special alloy metal, unusually large in diameter, assuring great volume without distortion.

Magnets: special Atwater Kent, requiring no extra batteries.

Many types of radio receiving sets deliver a sufficient volume of sound from distant broadcasting stations, but they are not selective—that is, they cannot separate two stations, both broadcasting at the same time on waves of nearly the same wavelength.

Atwater Kent Receiving Sets overcome these difficulties to a marked degree, so that two or more stations broadcasting at the same time can be separated and the desired station tuned in clearly and without troublesome interference.

One of the most pleasing features of Atwater Kent receiving sets is their sureness of securing a desired broadcasting station.

A printed list is supplied with each set which gives the approximate dial setting of many of the well-known broadcasting stations. With this key list in hand, the owner of an Atwater Kent can tune in a series of desired stations, or stations operating on similar wavelengths. By writing down the dial readings opposite the names of the stations, make up a list or "log."

Model '20 is a powerful receiver capable of operating a loud speaker under all conditions where broadcasting is at all practicable—hence ear phones are unnecessary. It comprises two stages of tuned radio frequency amplification, a detector and two stages of audio frequency amplification with three tuning dials. It is non-radiating and non-squealing.

Dimensions: Height, 8 1-2 in.; length, 26 in.; depth, 8 3-4 in. Number of tubes required, 5.

Part No. 4640, Model 20 Cabinet Receiving Set, \$100.00.

Open receiver, same as Model 20 but without cabinet—\$85.00.

New Studios Ready for WCCO

Work has started on the new Saint Paul studios of the Gold Medal Station, Saint Paul-Minneapolis, WCCO. These studios will be among the most uniquely located in the world. They are being built in Saint Paul's new Union Depot, used by nine railroads. The studios, reception room, and executive offices, will be at the left of the concourse through which all persons pass going to and from the trains.

THE LATEST

parts and sets are always featured in our Salespeaker. If you are a live-wire dealer, write for your copy, now.

**HUDSON-ROSS—116 S. Wells St.
Chicago**



A regular \$25 loud speaker for \$16. Loud, clear, mellow tone. Bell 13 3/4 in. diameter, horn 22 in. high, equipped with Lakeside Adjustable Unit. Agents wanted, write for particulars.

Lakeside Supply Co.*
73 W. Van Buren St., Chicago

A Simplified Portable Super-Het

(Continued from page 23)

Lead No. 14 of the battery cable is attached to A1 on the battery switch.

Attach the lug at the end of the 2 3-4 inch section of Lead No. 17 to the potentiometer at A2. The tap is attached to the battery switch at A3 and the last lug is attached to the rheostat at A4.

Lead No. 27 is now run between the rheostat at A5 and the negative filament line at A6.

Lead No. 18 runs from the potentiometer at B2 to the positive filament line at B3.

The lug at the end of the 8 3-4 inch section of lead No. 12 is attached to the center of the potentiometer at G. The other taps of this lead are attached to the terminals marked "F" on the third, second, and first intermediate frequency transformers. These are points G1, G2, and G3 respectively.

Attach the lug at the 4 1-4 inch section of lead No. 2 to the rotor plates of the loop tuning condenser at H1. The tap on this same lead connects to the stator plates of the balancing condenser at H2. The other end of this lead later connects to one side of the loop.

Attach the lug at the end of the 7 1-4 inch section of lead No. 15 to the rotor plates of the balancing condenser at I1. The tap in this lead connects to the plate of the first detector tube at I2 and the remaining lug attaches to the "Plus" terminal of the first intermediate frequency transformer at I3.

The lug at the end of the 7 1-2 inch section of lead No. 6 attaches to the lower Jack at D1. The next tap connects to the B Positive terminal on the second audio frequency transformer at D2. The remaining lugs attach to the "Plus" terminals on the fourth (or filter transformer), the third and second intermediate transformers respectively. These connections are made at points D3, D4, and D5.

The oscillator coupler should now be bolted to the sub base. Use 6-32x5-16 inch machine screws for this purpose.

Before attaching the socket strip be sure that all of the wires which you have attached so far are as close to the base board as possible. This is one of the few "don'ts" in these instructions and should be observed.

The socket strip is attached by means of 6-32x1 3-4 inch machine screws. Run the bolt through the base board, place a brass washer under a 6-32 3-8 inch nut and secure it firmly. Then run another 3-8 inch nut down the bolt about three quarters of the way. The socket strip is now placed in position and the loose nuts on the underside of the strip run up to the correct point. Fasten the strip firmly in place by nuts screwed on from the top and you are ready to resume wiring.

Lead No. 25 is now completed from G4 on the .006 to G1, the Filament terminal of the third intermediate frequency transformer.

Lead No. 22 is completed by connecting from D6 on the other .006 condenser to the "Plus" terminal on the fourth or filter transformer, D3.

Connect lead No. 26 from C4 on the .005 condenser to the B plus terminal on the first audio frequency transformer, C2.

Now complete lead No. 32 from A7, the inside terminal of the pickup coil to the negative filament line of the socket strip at A8.

(Turn to page 56)



Radio Fans

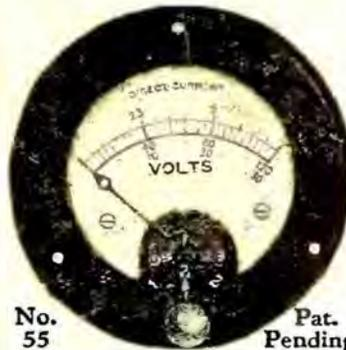

No. 55 Pat. Pending

Multiple reading instrument with self contained switch



—can thank Jewell for developing a small receiving set instrument with self contained switch for multiple readings.

☞ SAVES—Space and cost of additional instruments.

☞ PERMITS—Testing of "A" and "B" batteries from panel of your set.

☞ Every Radio "Fan" should have our 15-B catalog.

Order from Dealer

Jewell Electrical Instrument Co.

1650 Walnut St. - Chicago

"25 Years Making Good Instruments"

The Radio Age Annual for 1924! ONLY A FEW LEFT AT 50c EACH

If you have not bought your copy of the famous RADIO AGE ANNUAL for 1924, you may get one at a special price of 50 cents by filling in the coupon below and sending it with stamps, money order or draft, at once. The supply is nearly exhausted, and no more will be printed, so ACT NOW!

1924 ANNUAL COUPON

Radio Age, Inc.,
500 N. Dearborn St.,
Chicago, Ill.

Gentlemen: Please find enclosed 50 cents, for which you may send me a copy of the RADIO AGE ANNUAL for 1924, in accordance with your special price offer for April.

Name.....
Address.....
City..... State.....

Burns *

Perfect Reproducer

Tone loud and pleasing.
Handsome material and design.
Black, \$22.50 Shell, \$25.00

AMERICAN ELECTRIC COMPANY
State and 64th Sts., Chicago



* **RAULF** RADIO CONSOLE
MFG. CO. 562 VEDDER ST.

CHICAGO. WRITE FOR CIRCULAR

Some Sidelights on Tube Characteristics

(Continued from page 53)

or .16. Substituting the values of the co-ordinates of two points on the straight portion of the plate characteristic in this equation, and solving simultaneously—with E_c as zero—we get for the other constants— $\epsilon = 3.28$ Volts and $\alpha = .0134$ the equation of the curve is then $I = .0134 (.16. E_b + E_c + 3.28)^2$

For greater amplification, higher plate voltage will be necessary and a negative grid bias with a "C" battery in series will be used—the correct "C" battery for the desired amplification may be readily determined by use of the tube test set from experiment. The average grid voltages for the 199 type of tubes are:—

Plate Voltage	Grid Bias Voltage
45 Volts	0.5 to 1.0 volts negative
67½ volts	1.5 to 3.0 volts negative
90 volts	3.0 to 4.5 volts negative
112½ volts	4.5 to 6.0 volts negative

The output impedance of a tube may be taken as an average for solving this equation. The following values are as correct as necessary for this purpose and may be used with a close degree of accuracy.

Mutual Conductance

The mutual conductance is the usual average for each type shown. A tube should show close to that noted to operate efficiently.

Type of tube	Output impedance of tube	Average mutual conductance (micro-mohs) of tube
199	19,600 ohms	315
200 (detector)	10,000 ohms	Varies
201	22,000 ohms	273
201A	15,400 ohms	345
WD-11 or WD-12	17,500 ohms	290
VT or 215A	18,500 ohms	350
216A (power tube)	4,400 ohms	1360

The mutual conductance shown in the above table is the usual average for tubes of their type—a tube should show close to that to be in good condition.

To make it more easily understood, the type of tube in the table is the usual code number used by most manufacturers. However, to more clearly explain them, the following table shows the rated filament voltage—plate voltage, Plate R "B" battery current drain, and average amplification factor for each—

Type of Tube	Filament		Plate		Amplification factor
	Volts	Amperes	Volts	Amperes	
199	3.0	0.06	40	.0009	6.125
200	5.0	1.00	22.5	.0003	Varies
201	5.0	1.00	45	.0009	6.000
201A	5.0	0.25	45	.0007	6.500
WD11-WD12	1.1	0.25	45	.0012	5.200
VT or 215A	1.1	0.25	45	.0008	6.500
216A	6.0	1.10	125	.0110	6.000

The Chart shown in Figure four is an example of matching tubes graphically and is a good explanation of the plate current of two tubes under identical conditions. The curve No. 1 shows an efficient tube, to work well at normal filament current, while curve No. 2 shows a tube that is old or defective, producing about half as much as the other tube.

Simplicity of Construction is Vital in Portable

(Continued from page 55)

Lead No. 19 is completed from J, the inside terminal of the plate section to the plate of the oscillator tube, J1.

Complete lead No. 5 by running from the outside terminal of the plate section C1 to the B positive terminal on the first audio transformer, C2, and to the "Plus" terminal of the first intermediate transformer, C3.

Lead No. 11 is completed from the inside terminal of the grid section, E1, to the filament terminal on the first audio transformer, E3, and to the filament terminal on the second audio transformer E2.

From the outside terminal of the grid section, K run lead No. 13 to the grid of the oscillator tube, K1, and to the stator plates of the oscillator condenser at K2.

Lead No. 10 is attached from the battery cable to the filament terminal of the first audio transformer at E3. This is the C battery negative connection.

Lead No. 21 is the positive filament wire in the battery cable and attaches to the positive filament line on the socket strip. The second socket from the left can be used for this purpose.

The B battery positive detector line of the battery cable, lead No. 39, may now be attached to the "Plus" terminal on the first intermediate frequency transformer at C3.

Lead No. 20 is the B battery positive amplifier of the battery cable and attaches to the "Plus" terminal of the second intermediate frequency transformer at D5.

The tap on lead No. 1 is now attached from the first grid condenser at H5 to the stator plates of the loop tuning condenser at H6.

Lead No. 24 runs from the rotor plates of the oscillator condenser, E4, to the filament terminal of the first audio frequency transformer, E3.

Lead No. 16 is connected by the lug at the end of the 4 inch section to the upper Jack, V. The tap connects to the plate of the first audio tube, V1, and the remaining tap is connected to the plate terminal of the second audio frequency transformer, V2.

Lead No. 36 runs from the grid of the first intermediate frequency tube, M, to the grid terminal on the first intermediate frequency transformer, M1.

Lead No. 37 runs from the grid of the second intermediate frequency tube, O, to the grid terminal on the second intermediate frequency transformer, O1.

Lead No. 38, connects the grid of the third intermediate frequency tube, Q, to the grid terminal of the third intermediate frequency transformer, Q1.

Lead No. 29 connects the plate of the first intermediate frequency tube, N, with the plate terminal on the second intermediate frequency transformer, N1.

Lead No. 30 runs from the plate of the second intermediate frequency tube, P, to the plate terminal on the third intermediate frequency transformer, P1.

Lead No. 31 runs from the plate of the third intermediate frequency tube, R, to the plate connection on the fourth or filter transformer, R1.

Lead No. 33 connects the positive filament line at B3 with the filament

terminal on the fourth or filter transformer at B5.

Lead No. 28 attaches to the plate terminal of the first audio transformer at L1 and runs to the plate of the second detector tube, L.

Lead No. 34 connects the grid of the first audio frequency tube, U, with the grid terminal on the first audio frequency transformer, U1.

Lead No. 42 runs from the grid of the second audio frequency tube, W, to the grid terminal of the second audio frequency transformer, W1.

The grid condenser for the second detector tube is now mounted on the transformer as shown in the diagram and photograph. The easiest way to do this is to remove the regular nut from the grid terminal of the filter transformer and screw down tightly a small 6-32 nut. The regular nut is now replaced and as a sufficient amount of thread is now exposed the condenser can be fastened securely by a 6-32 machine screw which has been cut or filed to the correct length. Lead No. 41 is then attached to the grid condenser at S1 and to the grid of the second detector tube at S.

Lead No. 4 is then attached to the plate of the second detector tube and the wiring is completed in the set itself.

Lead No. 7 shown on the diagram is later used to connect one of the loud speaker terminals with the B battery positive amplifier and can be laid aside until it is needed.

Three 22 1-2 volt B Batteries, six ordinary dry cells, and a C Battery are the battery supply.

When the set is completed, pass the battery cable through a hole drilled in front of the battery partition and cut the covering of the cable until leads of suitable length are exposed. The battery layout shown in the sketch leaves everything snug but there are several combinations you might try. Lead No. 7 now comes in for a useful career as the connection from one loud speaker terminal to the B Battery positive amplifier.

Leads No. 1 and No. 2 are now connected to the outside terminals of the loop windings and Lead No. 3 connects with the center tap terminal of the loop.

When all the tubes are in the set, the batteries hooked up and the loud speaker connected, pull the filament switch and adjust the rheostat to a point about three quarters of the way on. This is probably a little too high but a few minutes of excess current won't hurt the tubes particularly and we are at least certain of having enough. Set the balancing condenser at its minimum capacity and advance the potentiometer until a slight hiss is heard in the speaker. If this control is advanced too far some very violent whistles which soon merge into a loud roar are likely to be heard. The loop dial and the oscillator dial both tube very closely together if the loop specifications have been followed and it is only necessary to run the two dials together from about five on the dials up to eighty. If no station is heard, advance the position of the balancing condenser slightly and again cover the broadcast range. When a station is tuned in, it may be brought maximum volume by continuing to advance the balancing

condenser and the potentiometer until the circuit "spills over." Selectivity in this circuit is governed chiefly by the amount of regeneration present in the first detector tube and by the position of the potentiometer. The more regeneration in these circuits, the sharper the set becomes. Excess regeneration in the first detector circuit will be recognized by the "mushy" quality of the received signal and by the fact that the oscillator dial becomes very broad in tuning, as the detector is then combining the functions of both a detector and oscillator.

The grid leaks recommended are 3 megohms in the first detector circuit and 5 megohms in the second detector circuit. If the circuit tunes too sharply or if volume is less than expected on local signals, substitute a lower value leak in the first detector circuit.

Body capacity should not be present on any of the controls except the small balancing condenser. Even here it will not be particularly noticeable except on distant signals. If body capacity exists on any of the other controls, look over all connections, particularly those of the bypass condensers.

5KW Power for Cincinnati Stations

WLW and WSAI, two broadcasters located near Cincinnati, have been authorized to use power as high as 5000 watts. This information may come as a shock to some skeptical fans who have feared any great increase in power, for they are the first two 5KW stations. The new licenses catalogue the power as "500 to 5000 watts." It is requested that they use discretion, observing suggestions of the district radio supervisor if interference is created by the increased power.

The main factor, which influenced the Department of Commerce to grant these licenses, was the fact that they are both located out of town where any reasonable interference would not be detrimental to the local reception of distant stations. WLW, the Crosley station is in Harrison, and WSAI, The U. S. Playing Card Station is in Mason, Ohio. Radio officials in Washington are disposed to grant qualified Class B stations similar authority for increased power, if their transmitters are set up outside the crowded urban districts.

WEAF, the A. T. & T. Co., station in New York has been authorized to increase its power to 2500 watts, being now the next highest powered station.

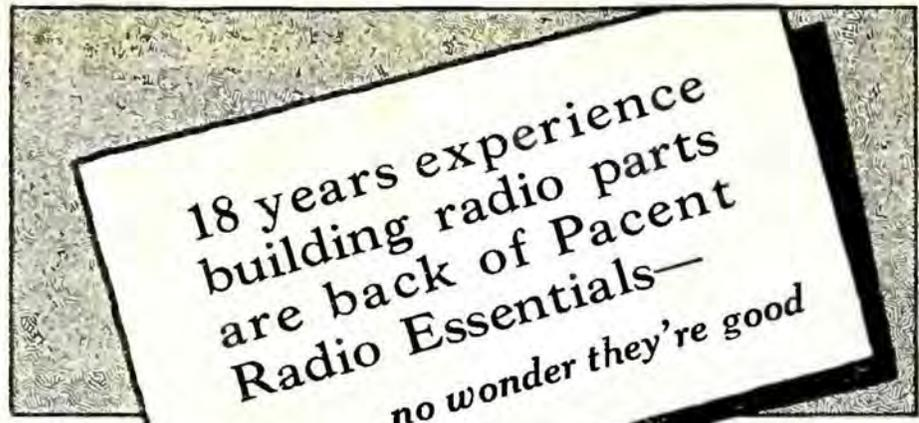

*
"Don't
Improvise—
Pacentize!"

**Pacent
RADIO ESSENTIALS**

Watch
for our
interest-
ing
catalog

Chicago
Washington
San Francisco
Philadelphia
Jacksonville
Minneapolis

PACENT ELECTRIC COMPANY, Inc.
91 Seventh Ave., New York City
Canadian Licensees: R. H. White Radio Co., Hamilton, Ont.

St. Louis
Boston
Birmingham
Buffalo
Detroit
Pittsburgh

Make \$100 Weekly—sell RADIO

Demonstrate Once—Results Mean Sure Sale
Coast to coast, lowest prices, attractive four-tube instrument \$39.50. Big commission to you. Exclusive territory to proven salesmen. Territory going fast, write today for large illustrated book No. 100. Don't fail to name your county.



WANTED-MEN TO LEARN RADIO

\$75 to \$200 a Week
Right now, everywhere, big, easy money is being made in Radio. Field unlimited. You can master radio quickly at home in spare time. No previous experience necessary. Now is the time to enter this new, uncrowded field.

1,000 Mile Receiving Set—FREE
Our new home-study methods make everything about radio amazingly simple. No other course like it. Makes you expert on radio operation, repairs and installations of all kinds. Send for literature telling all about opportunities and how we give 1,000 mile receiving set FREE. Don't miss this big offer—ACT. Write now for big free book.

Radio Association of America
4513 Ravenswood Ave., Dept. 27 Chicago

IF readers wish to show their approval of RADIO AGE'S stand against the Radio Corporation of America, they can do it in the most practical way by sending in \$2.50 for a year's subscription or if they are already subscribers, urge a friend to subscribe. We believe the fans are with us. Address RADIO AGE, Inc., 500 N. Dearborn St., Chicago, Ill.

MARVELOUS NEW AUDIO TRANSFORMER
adds musical quality to any set far beyond anything you ever heard before.
KARAS HARMONIK
Amplifies low, middle and high tones—all to the same big volume, thus eliminating distortion. Brings out the vits, harmonics and over tones of music. Price \$7.00. Write Karas Electric Co., Dept. 58-93 4042 N. Rockwell St., Chicago

Round-Up Number of RADIO AGE—August—on sale July 15. Blueprints of a complete radio education.

Radio Dealers HEADQUARTERS

Dealers—if you want the best products, the fastest shipments and the most liberal discounts, write on your letterhead for our catalog L1003.

WAKEM & McLAUGHLIN
225 E. ILLINOIS ST — CHICAGO

RADIO AGE SUBSCRIPTION BLANK

Radio Age, Inc.,
500 North Dearborn Street,
Chicago

\$2.50 A YEAR

Gentlemen: Please enter my subscription for RADIO AGE, the Magazine of the Hour, for one year, beginning with your next issue, for which I enclose \$2.50.

Name _____

Street Address _____

City _____

State _____

Send cash, money order or draft.

Tracing the Interesting Ancestry of Your Receiver

By FRANK D. PEARNE

IT DOES not seem so long ago that we were listening to the now almost forgotten spark signals with the simple little crystal set, which at that time was considered one of the wonders of the age.

Interest in this, however, was confined to a few amateurs who studied the code and enjoyed an evening's chat with their friends. Then came the radio telephone, by means of which voice and music could be heard with these rudely constructed and inefficient sets. Two broadcasting stations began to send out musical programs and the amateur began to be popular. People began to call at his little station and marvel at this new scientific toy, to ask his advice as to how they, too, might build a set and enjoy this pleasure, not because of any particular desire to learn the principles of radio communication, but because they wanted to hear this music coming from the air and to entertain their friends with this newly found amusement.

More broadcasting stations began to operate and the fever spread until at the present time radio has grown to be one of the greatest industries in the world. In the beginning, it was difficult to construct even the simple crystal set, the parts having to be constructed by the operator himself. We hadn't a radio store on every corner as we now have. It was real work.

Improvement Arrives

WITH the opening up of more broadcasting stations and the increase in the number of fans, came the demand for something better in the way of a receiving set. Vacuum tubes began to replace the crystal, because by their use the signals were not only detected as they were with the crystal, but they were amplified also, this being made possible by the addition of the third element in the tube, called the grid, which was produced by the inventive genius of Dr. Lee De Forest. These vacuum tubes, however, were expensive in the old days and only those who could afford luxuries were lucky enough to possess them.

Today they may be had for the price of one dollar and up, and the simple little crystal has lost its prestige. With the advent of the vacuum tube more of these amateurs became interested in the actual science and as a result of their untiring efforts, we now have radio as it is today. They created the demand for better apparatus and improved upon the few basic circuits until we now have hundreds of circuits in use, with more coming all the time.

But what of these circuits? As a matter of fact, there are only a few of these basic circuits, most of the new

arrangements being only improvements which are bound to come from this vast army of experimenters. Before the World War, Major Armstrong announced his regenerative circuit, which was a basic idea, but since that time the only distinctive new circuit which has appeared is the reflex, the production of which is generally attributed to Prof. Marius Latour of France, and Armstrong's Superheterodyne.

Today there are hundreds of sets advertised, all of which are merely modifications and additions to these five or six basic circuits. Among these are the single-circuit regenerative, three circuit regenerative, superregenerative, and other forms of regenerative or radio frequency amplification. From this list many combinations have been made, radio frequency amplification has been added and hundreds of little kinks here and there have been incorporated, but a close analysis will reveal the fact that no radical changes in the old basic principles have been made. There are many people at the present time who want to purchase sets and who are holding off and waiting in the fear that something new is shortly going to develop which will make their selection obsolete.

A Foolish Idea

THIS is a foolish idea which is not borne out by the past. It is true, perhaps, and very probable that many new sets will appear on the market in the next year, but it is not at all probable that any radical change will take place. There is, of course, a possibility that the wave band of the broadcasting stations may be slightly increased, due to the fact that so many applications for licenses are being received by the Government that they find the present wave band too narrow to accommodate all of them and keep the proper separation. But one may rest assured that nothing will be done to make the present type of receiving set obsolete.

Experiments have shown that it is possible to broadcast on wavelengths as low as 100 meters, but it will probably be a long time before the wave band will be broadened to this point. The fact that so many stations are now in operation has made the question of selectivity one of vital importance. In the old days, when only a few stations were sending out their programs, it made little difference whether or not the set was selective, but today things are changed. Selectivity is the watchword. The question of distant reception has been well taken care of, and many of the present day receivers will pick up programs from coast to coast and from Alaska to South America, but if the set is not selective,

this great range is of no particular value.

Regeneration and radio frequency amplification have made distant reception possible. Here, again, we find that we are back to the old basic circuits. Radio frequency amplification is not new but the method of tuning it, the construction of the transformers, neutralizing the feed-back, and many other improvements are to be found in these improved circuits.

The one bad feature of radio frequency amplification has always been the tendency of one stage to feed back energy to another, thus setting up undesirable oscillations with the resultant howling and squealing. Different methods of overcoming this are found in many of the standard sets now in use. The neutrodyne, for example, overcomes this difficulty, by neutralizing the inherent capacity of the tube. By this means all the advantages of radio frequency amplification are realized and distant reception is easily obtained.

Importance of Selectivity

ON the other hand, this radio frequency amplification of the neutrodyne would be of little value if the set were not selective. The regenerative receiver, however, makes use of the feed-back method to gain amplification. It has the bad feature of radiation, which is one of the greatest troubles the broadcast listener has to contend with. Radiation from a nearby set will sometimes completely detune a receiver which is tuned to a distant station and will cause enough shrieks and howls to spoil a good program. This is not the fault of the regenerative set, but rather the carelessness of the person operating it, for it is quite possible to so adjust it that no radiation takes place.

Amplification by regeneration is caused by feeding back some of the amplified signal in the plate circuit to the grid. This builds up the strength of the signal and is really a method of amplification. When a signal strikes the grid, it is rectified and amplified in the usual way. A tuned plate circuit is employed and when part of the varying current in the plate circuit is fed back to the grid, the plate current is again varied. This in turn again increases the plate circuit current, which is again fed back to the grid. This process continues until the signal becomes stabilized and has the effect of prolonging and building up the signal. The time required for all of this building up is so short that it does not in any way distort the signal.

There are many types of regenerative circuits on the market today, but they all work on the same basic principle.

But many of them are better than others, due to the fact that different types of inductances are used, and varying methods of coupling the circuits. A loose coupling between the primary and secondary circuits will always give much better selectivity than a tight one. A fair example of this is seen in the ultra-audion receiver. Here there are many variations. Sometimes the tuning inductance consists of a variometer which is connected in series with a variable condenser. Both the inductance and the condenser are variable. The same circuit is often used with a fixed inductance and a variable condenser. Either of these work very well, but naturally a closer adjustment may be made if both the inductance and the capacity are adjustable.

Loses Its Selectivity

THIS type of receiver is known to have a long range, but because of the direct coupling between the primary and secondary circuits, it loses much of its selectivity. By using a single inductance in the aerial circuit, and placing it near the variometer so as to afford an inductive coupling, it still retains its long range and the selectivity is greatly increased. The super-heterodyne is well known for long range and selectivity. In this arrangement another bad feature of radio frequency amplification is overcome. This is the tendency of such transformers to work at their greatest efficiency at one certain frequency and the dropping off of this efficiency as the frequency varies from their natural frequency. In this set, a local oscillator is used, which sets up oscillations of nearly the same frequency as that of the incoming wave, causing a beat frequency which is the result of the two, to pass through the radio frequency transformers. As the local oscillator is under the control of the operator, this beat frequency may be made the same in any case, regardless of the frequency of the incoming wave, making it possible to always work the transformers at their natural frequency, regardless of what the frequency of the incoming wave may be. Thus the set is always working at its greatest efficiency and even the most feeble wave may be picked up and amplified to great volume.

The reflex set is peculiar in that it will produce more amplification with less tubes. This is done by making some of the tubes do double duty. After the radio frequency tubes have amplified the signal and it has passed through the detector and reduced to audio frequency, it is again passed through the radio frequency tubes at audio frequency, thus operating them at both radio and audio frequency. This is not only a saving in the original cost of installation, but less battery is also required to operate the filaments than would be necessary in other types of receivers. Many different reflex circuits have been devised, but while they differ in the apparatus used, they all come back to the same basic principle.

Because of the many deviations from these basic circuits, there are hundreds of different sets for sale and it is no wonder

JEFFERSON TRANSFORMERS



SIFT OUT THE SUMMER STATIC

It's the season when aggravating radio imps seriously interfere with smooth reception on most sets—but there's a way to make *your* set behave better. Jefferson Transformers will bring in summer programs with almost cold-weather clearness. Extra care in manufacture and the benefit of greater experience by the world's largest manufacturers of small transformers give Jefferson Transformers the lead in audio tone amplification. They will give remarkable results for you this summer. You'll find them at the best radio dealers.

JEFFERSON ELECTRIC MFG. CO.

501 So. Green St.
Chicago, Illinois

Makers of Jefferson Radio Tube Rejuvenators; Radio, Bell Ringing and Toy Transformers; Jefferson Spark Coils for Automobile, Stationary and Marine Engines; Jefferson Oil Burner Ignition Coils and Transformers.

that the uninitiated beginner has a hard time to decide on which one to purchase.

In the August issue of the RADIO AGE, all of the basic circuits will be shown in blueprint form, which has made this magazine so popular with the fans. In this issue, which is to be a deluxe number, approximately eighty pages will be given over to this subject. Aside from the blueprints of original circuits, many modifications and methods of amplification will be shown, making it possible for one to trace the history of almost any set in existence. A careful study of these circuits will in a measure give an idea of just what changes they have gone through in the last few years.

A Laboratory Product

CRESCENT LAMPE RESISTANCES

for Distortionless Amplification

12,000, 48,000, 50,000, 100,000 Ohms. List \$1.50 each. Special Sizes to Order \$2.50 each.

Dealers, write for discounts. When Better Resistances are made they will be Crescents.

Crescent Radio Supply Co., 5 Liberty St., Jamaica, N. Y.

SALESPEAKER

is the name of the most interesting radio bulletin published. If you are a dealer, we will mail you a copy, on request.

HUDSON-ROSS—116 S. Wells St.
Chicago

FREE Subscriptions to RADIO AGE For Your Time!

Radio Age will give a year's free subscription to this magazine to any reader who will obtain for us a news-dealer who will handle our magazine in a town where we are not already represented.

If you are now a subscriber to RADIO AGE, you can refer this notice to one of your friends, who will doubtless be pleased to take advantage of this opportunity. Or you may extend your own subscription for one year without cost.

This offer is to remain in effect until further notice.

Free Subscription Blank

RADIO AGE, Inc.,
500 N. Dearborn St., Chicago, Ill.
Gentlemen: In order to get a free subscription to RADIO AGE for one year—I herewith send you the name of a dealer who will sell RADIO AGE in the city mentioned. It is understood that if you already have a dealer in this city that the offer of a free subscription does not hold good.

Dealer's name.....

Street No.....

City.....State.....

My name.....

City.....State.....(7-25)



The 100%
Self Shielded
Transformer

has made a big hit with both set makers and set manufacturers because of its small size, its amazing volume and, most of all, because of its pure undistorted tone. It is half the size of other transformers, but its results are unsurpassed. Absolutely new and scientific design and construction. Ratios 1 to 3, 1 to 4, 1 to 5, \$3.50. Ratio 1 to 10, \$4.50.

SEND FOR BULLETIN No. 94. Read all the exclusive features of this and other Premier Parts. Tells how to get free hookup diagrams, beautifully printed in two colors.

PREMIER ELECTRIC COMPANY
3803 Ravenswood Ave. CHICAGO

PREMIER Quality
Radio Parts

The Traffic Cop of the Air

Add a Ferbend Wave Trap to your Radio Set and "Police" your reception. Regulate traffic. Guaranteed to tune out any interfering station. Widely imitated but never equalled. The original and only successful WAVE TRAP. Now in its third year. Sent Postpaid upon receipt of \$3.50 or C. O. D. plus postage. Send for Free Booklet.

FERBEND ELECTRIC CO.
16 E. So. Water St. Chicago

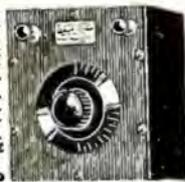

REBUILD YOUR NEUT—Use same panel, same parts. No neutralization. 22 feet gold wire, only extra part, circuit and complete, simple instructions—\$5.00 prepaid. Hundreds of Neut owners use this kit. Details—10c. 48 page catalog parts—10c. Stamps accepted. KLABAG RADIO LABORATORIES, KENT, O.

Some of the Tricks Summer Static Plays

(Continued from page 24)

its atmosphere during that season. Unfortunately, no way of avoiding this difficulty is known today. The trans-oceanic radio stations have to be equipped with high power apparatus in order to work through the bad periods of the day and year, although at certain times of the year and day less power may be used, as evidenced by the successful trans-atlantic transmission by low power amateur stations.

For the sake of clearness, we have so far described the cause of fading signals as due to obstructions in the path of the radio waves. Actually, the radio clouds sometimes reflect the waves, much as a mirror does a light wave, and so very peculiar reception effects are sometimes noticed. Sometimes the signals are made stronger instead of weaker, sometimes they may be lost altogether, as the several effects of reflection and absorption combine.

And now, let us consider that arch enemy of radio—Old Man Static. When Marconi first began to receive messages over distances of a few miles, he noted, besides the signals he was listening for, noises which had nothing to do with the signals, and every receiving operator since that time has heard those same disturbing and interfering noises.

These noises have been called strays, or atmospheric, or static, and the elimination of them is the most important problem in radio communication today. There are at least two or three kinds of static, but the most troublesome kind is the one which is due to travelling electric waves, in nature just like radio waves, and caused by electrical disturbances somewhere in space.

A LIGHTNING flash produces a traveling electric wave, much like a radio wave, and if we can assume that lightning flashes, large and small, are occurring continuously somewhere, we have a reasonable explanation of static.

We know that static is worse in the Summer when variations in the atmosphere are greater and more frequent. Also, it is often observed in the Wintertime that the formation of snow causes static.

Without knowing definitely the origin of this disturbance, it seems safe to assume that the actions which take place in our atmosphere, due to the air, the sun, sun spots, water vapor, etc., are responsible for the creation of these irregular, irresponsible and very troublesome waves which we call static. Since they are so much like the radio waves in nature, no way has yet been found of eliminating them completely.

Progress has been made in the last few years, however, and the trans-oceanic stations are much more free of this interference than formerly. The problem of complete elimination of static is the most difficult one in radio, and if solved, we shall have a new epoch in radio because the power of transmitting stations can be greatly reduced and the reliability of communication increased.

The Radio Spies

(Continued from page 51)

such a position, to secure certain private papers, papers and specifications and other papers of the De Forest Company and deliver the same to him. She declined to take the position."

Sylvester W. Crowley, manager of the audio division of the De Forest Radio Company, said he employed Cecelia Lambert, mentioned in the Bowby and Jennings affidavits. She was discharged April 16, 1925, "because it was discovered that she was employed by the Radio Corporation of America, paid a salary by them and was making reports of complainant's business secrets to that company."

Crowley says he was present on April 16, 1925, when Miss Lambert admitted having furnished confidential reports to Harley, who assigned her to work for various concerns, receiving wages from her employer as well as salary and expenses from Harley.

Mr. Luce, President of the De Forest Company, says that for eleven years his concern has been making, leasing and selling radio receiving apparatus and audio tubes. For several years the defendant has been carrying on the same business with the possible exception of manufacturing, he declares. While he has no definite information regarding the defendant's manufacturing business, he says that as a result of agreements between the defendant, the General Electric Company and the Westinghouse Electric and Manufacturing Company the defendant was required to buy part of what it sells from each company. These three companies, with the American Telephone and Telegraph Company have licensed each other under various patents. He adds, "the legality of this combination has been challenged by the Federal Trade Commission and is now under judicial investigation by it."

The temporary injunction, obtained by the De Forest Radio Company from Vice Chancellor John H. Backes of New Jersey, directs the Radio Corporation to appear in Chancery Chambers, Newark, on May 12, to show cause why a permanent injunction restraining it from obtaining information secretly from the De Forest plant should not be issued.

A recent issue of the Radio Guide publishes a full page editorial on the situation as outlined above. One paragraph from this editorial follows:

"Never in its palmy days of throttling and cut-throat competition did the old Standard Oil Company of New Jersey, the original octopus, undertake anything as dastardly, as contemptibly criminal, as the 'dirty work' which the Radio Corporation, already cited in a government antimonopoly suit, is now accused of."

Vacuum Tubes and How They Distort

(Continued from page 18)

grid increases, you will find that the line is not straight, but becomes steeper over quite a range, there being a definite curvature (See Fig. 1). Such a line or curve is spoken of as the plate current-grid voltage characteristic of the tube and circuit. The more nearly straight it is, the more faithfully does it repeat the impulses put on the grid; i. e., the less distortion does it introduce. This is a condition to be desired, then. However, the tube is to be used as an amplifier.

The curvature of the characteristic depends on the design of the tube, and in any given tube may be emphasized by the circuit with which it is associated.

Suppose we have a tube circuit which has curvature and we impress on the grid two electric currents of different frequencies. It can then be shown theoretically and is found experimentally that there are present in the plate circuit currents of the original frequencies and also currents of frequencies equal to the sum and equal to the difference of these frequencies. In other words, the

resultant current is not a faithful reproduction of the original impulses, but shows some distortion.

This is a very useful thing, as may be seen if we apply the principle to a broadcasting station. Suppose, for example, that we combine in a tube circuit the radio frequency of one million cycles with a musical frequency of one thousand. Then, in accordance with what was said above, we would have set up in the plate circuit the original frequencies and the sum and difference frequencies; i. e. we would have in the plate circuit frequencies of 1000; 1,000,000; 1,000,000 plus 1000 and 1,000,000 minus 1000. The first of these is of too low frequency to affect the radiating antenna of the station, but the other three, being of suitable high frequency, would be radiated. It is these three waves of slightly different frequency which would travel out to your receiving set. The middle one of these, one million, is called the carrier wave and the others may be called the upper and the lower side waves. The three together constitute the modulated wave; i. e. the wave on which has been impressed the message which is to be transmitted. The side waves or frequencies are the important ones, and it should be noted that they were not originally present, but were brought in only by the distorting effect of the tube. The mixture of the original frequencies is a very intimate one. It is more than a mere addition of the two, but a scrambling of the two.

LET us now go to the receiving set where these waves are picked up. They finally reach a vacuum tube. If this tube shows no curvature or distortion, it will merely repeat the high frequency waves which arrived, but these, in that form, are of no use, for they are inaudible. What is desired is a message of the same as the original frequency; i. e. *one thousand*. Obviously it is going to take something radical to get this from three frequencies, each at or in the neighborhood of *one million*. Suppose, however, the tube and its circuit has distortion then by the same principle as given before; there will appear in the plate circuit currents which are the same as the three high frequencies and in addition there will be all the possible combinations of sum and difference frequencies. If you will set these down yourself, as can be easily done, you will find quite an array; in fact, there will be twelve of them in the simplest case. Most of these will not be of use, but you will find two which are of the frequency 1000, the original signal frequency. They represent the difference between the carrier of 1,000,000 and the side waves of 1,000,000 plus 1000 and 1,000,000 minus 1000.

Thus we see that it is as a result of its distorting characteristic that a tube can first modulate a carrier frequency with a message frequency; i. e. "scramble" the two together so that one carries the other, and then at the receiving station "unscramble" them and give us the original message.

Haynes-Griffin

RADIO SERVICE, Inc. 41 W. 43rd St., New York City
250 W. 49th St. New York MAIL ORDER DEPARTMENTS 111 S. Clark St. Chicago

A Portable Super-Heterodyne Designed by A. J. Haynes

Complete description in this month's "Radio Age"

This new Super-Heterodyne has been made completely portable without the least sacrifice in operating efficiency. The entire equipment, set, batteries, loop aerial and loud speaker is contained within a strong carrying case 20 $\frac{7}{8}$ " x 17 $\frac{3}{8}$ " x 8 $\frac{3}{4}$ ".

Reports from far and near state that this new 8-tube portable is daily giving reception fully equal to standard laboratory model super-heterodynes.

Right in the heart of New York City this splendid portable gets distant stations

Mr. J. K. Cronin using the set on East 36th Street, only 4 blocks from station WMCA, 5 blocks from WGBS, and 8 blocks from powerful stations WJZ and WJY, brought in stations KDKA, WWAD and KYW in twelve minutes with all these local stations broadcasting!

Many larger super-heterodynes used in the same location failed to bring in distant stations through this strong local interference.

Complete Constructional Blueprints Ready Now!

Construction of this new Portable has been reduced to simplicity itself. Each set of blueprints shows complete panel and instrument layout; schematic wiring diagram; the exact length of each lead. Every lead and connection is numbered to make wiring easy.

Complete dimensions and specifications given for the carrying case for those who want to build it.



Complete Parts \$98.50

This price includes all parts required to build the set itself, including attractive portable carrying case, strongly made and finished in imitation leather.

Special combination price of \$98.50 also includes Crosley Musicone Speaker and all material to build the loop aerial. Tubes and batteries are not included.

The panel is supplied completely drilled, ready to mount the instruments.

Detailed price list will be mailed FREE upon request.



We Equip You

To be a Federal Radio Dealer and guarantee your success under the "Gould Plan" which allows you to return merchandise which you are unable to sell. We sell wholesale to dealers only. Write for our price list and FREE Instructions "HOW TO SELL RADIO."

FEDERAL RADIO CO.
115 East 13th St., Kansas City, Mo.

* Tested and Approved by RADIO AGE *

Tell your friends about the Deluxe August number of Radio Age—out July 15.

FREE This Wonderful Radio Book

Big Money-Saving Radio Catalog containing a thousand bargains of everything in radio; parts, supplies, complete parts for sets, complete sets, etc., also a mine of very latest information on all different circuits, complete list of broadcasting stations and other valuable data.

Easy to build your own radio set. All complete parts of sets consist of standard advertised guaranteed parts and include drilled bakelite panels and wiring diagrams for easy assembling. Everything guaranteed on money-back basis. Our Free Service Department helps you solve all your radio problems.

Save 1/2 to 3/4. Send name, address for free catalog. Send names of friends; we will mail them catalogs.

RANDOLPH RADIO CORPORATION
180 North Union Avenue, Dept. 444 CHICAGO

PATENTS

To the Man with an Idea

I offer a comprehensive, experienced efficient service for his prompt, legal protection and the development of his proposition.

Send sketch of model and description, for advice as to cost, search through prior United States patents, etc. Preliminary advice gladly furnished without charge.

My experience and familiarity with various arts frequently enable me to accurately advise clients as to probable patentability before they go to any expense.

Booklet of valuable information and form for properly disclosing your idea free on request. Write today.

RICHARD B. OWEN, Patent Lawyer
81 Owen Bldg., Washington, D. C.
2278-M Woolworth Bldg., N. Y. City



\$3.25 **RADIO Storage "B" Battery**

32 Cells 24 Volts **Lasts Indefinitely—Pays for Itself**

Economy and performance unheard of before. Recharged at a negligible cost. Approved and listed as Standard by leading Radio Authorities, including Pop. Radio Laboratories, Pop. Sci. Inst. Standard, Radio News Lab., Lefax, Inc., and other important institutions. Equipped with Solid Rubber Cases, an insurance against acid and leakage. Extra heavy glass jars. Heavy, rugged plates. Order yours today!

SEND NO MONEY Just state number of batteries wanted and we will ship day order is received. Extra Offer: 4 batteries in series (96 volts), \$12.75. Pay expressions after examining batteries. 5 per cent discount for cash with order. Mail your order now!

WORLD BATTERY COMPANY
1219 So. Wabash Ave., Dept. 81, Chicago, Ill.
Makers of the Famous World Radio "A" Storage Battery.
Prices: 6-volt, 100 Amp., \$12.55; 120 Amp., \$14.25; 140 Amp., \$15.00.
All equipped with Solid Rubber Cases.

World FOR STORAGE BATTERIES

WJKA - WFAF - WGN - WJIS - KHLJ - RGO - KEAF - WJLY - KOF

SILVER

Dealers!

Send for our illustrated dealers' catalog, with latest wholesale and retail radio bargains. Also ask for our attractive proposition to radio dealers on nationally advertised lines.

SILVER-MARSHALL, INC.
105A-S Wabash Av. Chicago

MARSHALL

Free Mailing Lists

Will help you increase sales. Send for FREE catalog giving counts and prices on thousands of classified names of your best prospective customers—National, State and Local—Individuals, Professions, Business Concerns.

99% Guaranteed 5¢ each

ROSS-Gould Co. 589 N. St. Louis

Wherein One of Horatio Alger's Plots Comes True

By R. H. Hopkins

THE proper way to tell about McMurdo Silver would no doubt be to say "Once Upon a Time," or, to become somewhat more modern, we might head the dissertation "From Nothing to Something," or one might even resort to the time-honored, and (we hope) buried, style of Horatio Alger.

But none of these styles seems to fit properly, so we will confine ourselves (not the regal, but the editorial "we") to a plain statement of facts concerning the not altogether uneventful life of a young man badly bitten with the radio bug, who at the age of 22 is the president of a prominent radio concern and whose name is more than well known to many thousands of radio fans.

Born in a small college town in western New York, the son of a college professor, his early years were spent uneventfully in causing his fond parents just a little bit more than the usual amount of consternation, for at a very early age his thoughts turned to things mechanical. The result was no more than could be expected. Many peculiar and supposedly original contrivances made their appearance, most of them designed to provide a hearty and stimulating welcome for the college students who called upon his father in search of wisdom.

Frequently the searchers were discouraged, but it is interesting to the casual observer of later years to perceive that these and sundry other arrangements most frequently resulted in the acquisition of wisdom.

Radio first entered McMurdo Silver's consciousness early in 1912. Someone, desiring to keep the young hopeful's mind well abreast of the times, read him an account of "Wireless Telegraphy" and how it enabled ships at sea to keep in unbroken touch with the world while they were out upon the bosom of the bounding brine.

At the same time an account was also read, with true relevance, of the Mexican Rurales, a troop of mounted police recruited from criminals by the simple and masterly expedient of catching one, putting a rope around his neck, placing him upon a horse all ready to be gently stroked with a whip, and asking the individual so situated if he wished to become a Rurale, or if he preferred to dismount from his steed post-haste and remain in the unenviable position of hanging by his neck to a nice tree limb, separated from it by several feet of rope, and from the ground by several more feet. The answer, unless choked off by the culprit's emotion, or

the executioner's desire for a negative reply, was invariably "yes."

Practice Makes Perfect

STRANGE as it may seem, these two bits of instruction stuck firmly in the young man's mind. The next day the cook, called to the back yard of the family residence by unearthly yells, beheld a strange sight. Sitting astride a saw-horse was a young Mexican boy hurriedly conscripted for the part of the convict.

His hands were tightly tied, and a very heavy rope, almost thicker than his pudgy arms, connected his unwilling neck with the limb of a small tree directly above him. He was calling loudly upon all the saints known to him in a somewhat unintelligible imitation of Spanish. Next to him stood one of the "Silver Gang," asking loudly and repeatedly whether he "joined or died." The executioner, in anticipation of the reply, held the nozzle of a length of garden hose in his hand.

Some distance away, in the wash-boiler, stood the instigator of this new game, holding the other end of the hose

in one hand, while in the other was another piece of hose which reached back to the gibbet and terminated in the grimy grip of the assistant executioner. As the victim's cries were uttered, the executioner shouted them into one hose, through which they were presumably transmitted to the ship at sea, simulated by the wash-boiler. From there, through the other hose, the verdict was again shouted in a high falsetto to the assistant executioner, who in turn put the all-important question to the prisoner.

In this way, wisdom was assimilated by the analytical mind of the young; communication with ships could only be through rubber hose, since one couldn't shout several thousand miles. And to use "wireless telegraphy" one had to have a reason, which was opportunely provided by the recalcitrant son of a Mexican villager, who might even yet be reclaimed to the cause of the law by strong-rope methods and the marvels of radio.

Thus was the youth of this young man spent, alternating between the heights of the Sierras and the ordered calm of a college town, the main street of which was shaded by towering elms almost as drowsy as the village itself. But this was not for long, and the association of garden hose and radio having been demolished along with other illusions, the big city claimed our subject. There, more strenuous pastimes being taboo, radio was taken up with renewed vigor, and a posi-

(Turn to page 72)



McMurdo Silver

MATCHED DUPLIX CONDENSERS

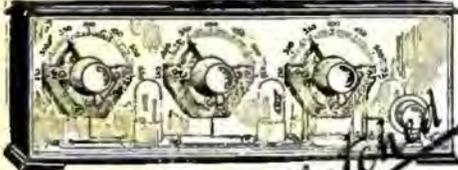

Always Read Alike
Because They Are *Matched*

Know the satisfaction and ease of tuning that come when all dials read alike or eliminate logging and dial by wavelengths. Use **DUPLIX Matched Condensers**. Made in strict accordance with Bureau of Standards specifications. Used in the famous Thermodyne. Tested, matched, packed and sealed, to remain unopened until used. Ask your dealer.



Interesting illustrated folders sent free on request.

DUPLIX CONDENSER & RADIO CORP.
42 Flatbush Avenue Extension, Brooklyn, N. Y.

Underground Radio from Coast to Coast

By **JAMES E. SMITH**
President of National Radio Institute

Dr. James Harris Rogers, whose achievements with underground transmission are far famed, has climaxed all his tests by sending radio waves from Hyattsville, Md., to Los Angeles, Calif., a distance of 3,000 miles. Signals at Los Angeles, according to the report, "were coming in finely with little fading."

This record eclipses all previous underground records (these also having been set by Dr. Rogers' experiments), and opens the way, according to many leading scientists, to an immeasurable development and improvement in methods of radio transmission.

This achievement of coast to coast transmission through the ground crowns with success an undertaking which was first brought forward and attempted by Dr. Rogers in 1908. It overthrows the dicta of men no less eminent than Marconi, who scoffed at the proposal to radiate waves through the earth's crust.

As a direct result of Dr. Rogers' latest accomplishment, it is now possible that the broadcasting tower, the expensive aerial extending sometimes 400 to 600 feet in the air, may become in the near future as obsolete and unnecessary as cable connections between stations. The "aerial" will simply be taken out and buried.

The "aerial" which Dr. Rogers uses consists simply of 4 copper cables fifty feet long, extending toward the four points of the compass. Copper tubing, 3-4" in diameter, is laid inside eighteen inch terra cotta pipe, insulated and supported throughout by glass rods. The pipe is buried 3 feet underground outside the Rogers Research Laboratory at Hyattsville.

Through it the waves are radiated into the crust of the earth, and carried through the ground—without atmospheric disturbance, without diminishing in strength through the 24 hours of the day.

The earth's crust is the most efficient medium for radio waves, Dr. Rogers claims, and he believes his experiments now have disproved the Heaviside theory.

"Radio waves transmitted through the atmosphere," says Dr. Rogers, "obey the laws of light—that is, travel in a straight direction—and these atmospheric waves are thus dissipated, not being reflected by the Heaviside mirror. The earth crust to a much greater extent retains the waves, and less power is required to transmit great distances."

During the war Dr. Rogers developed and placed at the service of the Government, applications of his theory which made possible communication not only between submarine and submarine, but also between submarine and shore. His private station at Hyattsville, using his own "underground," was pressed into secret service by the officials of the Government, and received messages clearly and strongly when the great station at Arlington was hopelessly deafened by static.

Should the day ever come when a few hundred feet of buried wire will supplant and replace the towering and costly aeriels which now identify the radio station, all the laurels will be on the brow of this modest, indefatigable man of science, of whose sixty-odd patents surely none can be of more far-reaching importance than this discovery which brings the signals "in finely, at 4 in the afternoon"—across the continent!



More Money For You in **RADIO**

THE amazing expansion of Radio has opened up hundreds of wonderful new positions on land and sea. Big salaries, fascinating, easy work, short hours, and a wonderful future are offered to ambitious men to get into Radio now.

Take advantage of these wonderful opportunities to step into a big paying position in this great new field. You can stay at home and work up to a position paying up to \$10,000 a year, or Radio offers you an opportunity to travel and see the world, with all expenses paid, and a fine salary besides. One of our recent graduates, Emmett Welch of Peculiar, Mo., secured a position one week after graduating, paying a salary of \$300 per month. Hundreds of others report equal success.

Easy to Learn Radio at Home

Thousands of Certified Radio-tricians are wanted to design Radio Sets; to make new Radio improvements; to manufacture Radio equipment and to install it; to maintain and operate great broadcasting stations and home Radio sets; to repair and sell Radio apparatus; to go into business for themselves; to operate aboard ship and at land stations.

You can easily and quickly qualify in your spare time at home through the help of the National Radio Institute, first school to teach Radio successfully by mail, established 1914. No previous experience or training needed. Prominent Radio Experts will help you in every problem, giving you personal attention.

You learn by actually doing, as we furnish free with the course, circuits and parts for building latest receiving sets, making the work thoroughly practical. You learn quickly and easily—right at home.

This is an absolutely complete course which qualifies for the real "big pay jobs" in Radio and our big Employment Department helps you get one.

Send for FREE BOOK

No other field today offers such great opportunities as Radio. Take your choice of the many wonderful openings everywhere. Prepare now to step into the most interesting and best paid profession today. Read about the opportunities open now—the different kinds of work—the salaries paid. Write today for the 32-page book that tells how America's biggest Radio correspondence school (government recognized) can teach you to become a Certified Radio-trician in your spare time and also Special Offer to those who act at once! Mail coupon or write letter now. **National Radio Institute, Dept. 53-JB, Washington, D. C.**

National Radio Institute, Dept. 53-JB, Washington, D. C.

Without obligation, send me your book, "Rich Rewards in Radio," which tells all about the opportunities in Radio, how spare time study at home will qualify me quickly as a Certified Radio-trician so I can get one of these splendid positions and how your Employment Service helps me to secure a big pay job. (Please Write Plainly.)

Name.....Age.....
Street.....
City.....State.....

WRITTEN 2-YEAR GUARANTEE

ARROW BATTERY

Battery Prices SMASHED!

To Consumers Only

Here is a real battery quality, guaranteed to you at prices that will astound the entire battery-buying public. Order Direct From Factory. Put the Dealer's Profit in your own pocket. You actually save much more than half, and so that you can be convinced of true quality and performance, we give a **Written 2-Year Guarantee**. Here is your protection! No need to take a chance. Our battery is right—and the price is lowest ever made. Convince yourself. Read the prices!

Auto Batteries	Radio Batteries
5 Volt, 11 Plate, \$9.50	6 Volt, 100 Amp, \$9.50
6 Volt, 13 Plate, 11.50	6 Volt, 120 Amp, 11.50
12 Volt, 7 Plate, 13.00	6 Volt, 140 Amp, 13.00

Buy Direct—Send No Money

We ask no deposit. Simply send name and address and style wanted. Batteries will be shipped same day we receive your order Express C.O.D. subject to your examination on arrival. Our guarantee accompanies each battery. We allow 6% discount for cash in full with order. You cannot lose! Send your order today—**NOW!**

ARROW BATTERY CO.
Dept. 11, 1215 So. Wabash Ave., Chicago

"Get Away From Me Boys, You Bother Me"

is a favorite of ours. Our Salespeaker will be a favorite of yours. Dealers write for it.

HUDSON-ROSS—116 S. Wells St. Chicago

Corrected List of Broadcasting Stations

KDKA	Westinghouse Electric & Mfg. Co.	East Pittsburgh, Pa.	309	KFUZ	Y. M. C. A.	Virginia, Minn.	244
KDLR	Radio Electric Co.	Devils Lake, N. D.	231	KFVC	Banahera's Music Co.	Garden, Arkansas	248
KDYL	Westinghouse Electric & Mfg. Co.	Cleveland, Ohio	270	KFVD	McWhinnie Electric Co.	Sao Pedro, Calif.	202
KDZB	Newhouse Hotel	Lake City, Utah	250	KFEV	Film Corporation of America	St. Louis, Mo.	245
KDZB	Frank A. Steier	Baker, Idaho	240	KFEW	Chicago	Hollywood, Calif.	208
KFAD	Electric Supply Co.	Wenatchee, Wash.	360	KFV	First M. E. Church	Independence, Kansas	218
KFAE	McArthur Bros. Mercantile Co.	Phoenix, Ariz.	273	KFVH	Whan Radio Shop (Herbert Whan)	Manhattan, Kansas	218
KFAF	State College of Washington	Pullman, Wash.	348	KFVI	Headquarters Troop, 56th Cavalry	Houston, Texas	248
KFAF	Western Radio Corporation	Denver, Colo.	278	KFVJ	First Baptist Church	San Jose, Calif.	226
KFAJ	University of Colorado	Boulder, Colo.	360	KFVK	Sacramento Chamber of Commerce	Sacramento, Calif.	248
KFAN	University of Idaho	Moscow, Ida.	230	KFVL	Lt. Richard F. Lussier, 5th Inf. U.S.A.	Vancouver Barracks, Wash.	231
KFAW	Boise High School	Boise, Idaho	280	KFVN	Carl E. Bagley	Weloona, Minn.	227
KFCB	The Radio Den (W. B. Ashford)	Santa Ana, Calif.	280	KFVW	Cape Girardeau Battery Station	Kirksville, Mo.	226
KFCB	Y. A. Moore	Havre, Mont.	360	KFWA	Browning Bros. Co.	Cape Girardeau, Mo.	224
KFCB	W. K. Ashill	San Diego, Calif.	278	KFWB	Warner Bros.	Ordan, Utah	214
KFCB	First Presbyterian Church	Tacoma, Wash.	250	KFWC	L. E. Wall and C. S. Myers	Hollywood, Calif.	252
KFCB	Kiuhall-Upson Co.	Sacramento, Calif.	283	KFWD	Arkansas Light & Power Co.	Upland, Calif.	211
KFCB	Lease Bros.	Everett, Wash.	224	KFWF	St. Louis Truth Center	Arkadelphia, Arkansas	266
KFCB	The Cathedral	Laramie, Wyo.	283	KFWG	Moonlight Ranch	St. Louis, Mo.	214
KFCB	Nielson Radio Supply Co.	Phoenix, Ariz.	238	KFWH	F. M. Henry	Denver, Colo.	246
KFCF	The First Congregational Church	Helena, Mont.	248	KG	Tacoma Daily Ledger	Chicago, Calif.	254
KFCF	Frank A. Moore	Wain Walla, Wash.	256	KGB	General Electric Co.	Oakland, Calif.	361
KFCZ	Omaha Central High School	Omaha, Nebr.	258	KGC	Marion A. Mulroay	Honolulu, Hawaii	370
KFDD	St. Michaels Cathedral	Boise, Idaho	252	KGD	Portland Mornig Oregonian	Portland, Oreg.	491
KFDD	University of Arizona	Tucson, Ariz.	368	KGE	St. Martins College (Rev. Sebastiao Ruth)	Lacy, Wash.	253
KFDF	Oregon Agricultural College	Corvallis, Oreg.	254	KGF	Times-Mirror Co.	Los Angeles, Calif.	405
KFDM	Magnolia Petroleum Co.	Beaumont, Tex.	315	KGF	Louis Waxmer	Seattle, Wash.	273
KFDX	First Baptist Church	Shreveport, La.	360	KGF	Northwest Radio Service Co.	Seattle, Wash.	384
KFDY	South Dakota State College	Sioux Falls, S. Dak.	360	KGF	Bible Institute of Los Angeles, Inc.	Los Angeles, Calif.	293
KFEF	Harry O. Iverson	Minneapolis, Minn.	231	KGJ	Warner Brothers Radio Supplies Co.	Oakland, Calif.	242
KFEK	Mear & Frank Co.	Portland, Oreg.	248	KGL	Tribune Publishing Co.	Oakland, Calif.	508
KFEK	Auxbury Seminary	Minneapolis, Minn.	261	KLM	Reynolds Radio Co.	Denver, Colo.	283
KFEL	Winner Radio Corp.	Denver, Colo.	254	KLN	San Joaquin Light & Power Corp.	Fresno, Calif.	243
KFEQ	J. L. Serogin	Oak, Nahr.	268	KLO	Love Electric Co.	Tacoma, Wash.	250
KFER	Auto Electric Service Co.	Fort Dodge, Iowa	231	KLP	Los Angeles Evening Express	Los Angeles, Calif.	337
KFEY	Bunker Hill & Sullivan Mining and Concentrating Co.	Kellogg, Idaho	233	KLR	General Electric Co.	Los Angeles, Calif.	323
KFFP	First Baptist Church	Lemoore, Calif.	280	KLB	San Mexico College of Agriculture & Mechanic Arts	State College, N. Mex.	288
KFFP	Grassland College	Lamoni, Iowa	280	KOB	Detroit Police Department	Detroit, Mich.	286
KFFB	Heildreder Radio Supply Co.	Utica, Neb.	224	KOP	Hale Bros.	San Francisco, Calif.	428
KFFC	Louisiana State University	Baton Rouge, La.	254	KPO	Paadena Presbyterian Church	Paadena, Calif.	229
KFFD	Chickasha Radio & Electric Co.	Chickasha, Okla.	248	KPPC	Houston Post-Dispatch	Houston, Texas	270
KFFG	Leland Stanford University	Stanford University, Calif.	273	KPRC	Douglas-Hill Electric Co.	Pittsburgh, Pa.	270
KFGQ	Crary Hardware Co.	Boone, Iowa	226	KQV	Charles D. Herrroll	San Jose, Calif.	226
KFHH	Western State College of Colorado	Guinn, Colo.	252	KRE	V. C. Battery & Electric Co.	San Jose, Calif.	275
KFHH	Amthrose A. McCue	Neuh Bay, Wash.	283	KSC	Kansas State Agricultural College	Manhattan, Kansas	248
KFHL	Peon College	Oakdale, Iowa	240	KSD	Post Dispatch (Pulitzer Pub. Co.)	St. Louis, Mo.	543
KFHL	R. C. Anthony, Inc.	Los Angeles, Calif.	468	KSL	Radio Service Corp. of Utah	Salt Lake City, Utah	299
KFHL	Benson Polytechnic Institute	Portland, Oreg.	248	KTCL	American Radio Telephone Co., Inc.	Seattle, Wash.	306
KFHO	North Central High School	Spokane, Wash.	252	KTHS	New Arlington Hotel Co.	Hot Springs, Ark.	375
KFHO	First Methodist Church	Yakima, Wash.	242	KTW	First Presbyterian Church	Seattle, Wash.	455
KFHO	Alaska Electric Light & Power Co.	Juneau, Alaska	226	KUO	Examiner Printing Co.	San Francisco, Calif.	248
KFHO	Reorganized Church of Jesus Christ of Latter Day Saints	Independence, Mo.	240	KUOM	State University of Montana	Missoula, Montana	244
KFHO	Daily Commonwealth and Oscar A. Huelman	Fond du Lac, Wis.	243	KWG	Portable Wireless Telephone Co.	Stockton, Calif.	248
KFHO	Marshall Electrical Co.	Marshalltown, Iowa	248	KWKC	Wilson Duncan Studios	Kansas City, Mo.	236
KFHO	H. B. Pezan (Episcopal Church)	Juneteau City, Kansas	219	KYO	Electric Shop	Honolulu, Hawaii	270
KFHO	National Radio Manufacturing Co.	Oklahoma City, Okla.	252	KYW	Westinghouse Electric & Mfg. Co.	Chicago, Ill.	635
KFHO	Liberty Theatre (E. E. Marsh)	Astoria, Oreg.	252	KZM	Preston D. Allen	Oakland, Calif.	242
KFHO	Hardware Manufacturing Co.	Ottumwa, Iowa	242	WAAB	Valdemar Jensen	New Orleans, La.	283
KFHO	University of North Dakota	Grand Forks, N. Dak.	280	WAAC	Yulane University	New Orleans, La.	278
KFHO	Ashley C. Dixon & Son	Stevensville, Mont. (near)	258	WAAD	Ohio Mechanical Institute	Cincinnati, Ohio	244
KFHO	Iowa State Teacher's College	Fort Dodge, Iowa	240	WAAF	Chicago Daily Drivers Journal	Chicago, Ill.	286
KFHO	Tunwal Radio Co.	Fort Worth, Texas	254	WAAG	I. R. Nelson Co.	Newark, N. J.	263
KFHO	W. E. Branch	Greeley, Colo.	273	WAAP	Omaha Grain Exchange	Omaha, Nebr.	285
KFHO	Colorado State Teachers College	Millford, Kans.	288	WABA	Lake Forest University	Lake Forest, Ill.	227
KFHO	Brinkley-Jones Hospital Association	Conway, Ark.	250	WABB	Harrisburg Sporting Goods Co.	Harrisburg, Pa.	266
KFHO	Conway Radio Laboratories (Ben H. Woodruff)	Lawrence, Kans.	275	WABI	Bangor Railway & Electric Co.	Bangor, Me.	240
KFHO	The University of Kansas	Hastings, Nebr.	288	WABL	Connecticut Agricultural College	Sorrs, Conn.	283
KFHO	Westinghouse Electric & Manufacturing Co.	Menominee, Mich.	248	WAB	Mt. Radio Institute	Rochester, N. Y.	283
KFHO	Signal Electric Manufacturing Co.	Franklin, Ia.	234	WABO	Lake Avenue Baptist Church	Haverford, Pa.	281
KFHO	Paul E. Greenlaw	Cedar Rapids, Ia.	256	WABQ	Haverford College Radio Club	Toledo, Ohio	270
KFHO	Everett M. Foster	Albuquerque, New Mexico	254	WABR	Scott High School, N. W. B. Foley	Camden, N. J.	224
KFHO	University of New Mexico	San Benito, Texas	236	WABU	Victor Talking Machine Co.	Wooster, Ohio	234
KFHO	Rio Grande Radio Supply House	Rockford, Ill.	229	WABW	Henry B. Joy	Mt. Clemens, Mich.	270
KFHO	Rev. A. T. Frykman	Galveston, Tex.	240	WABX	John Magaldi, Jr.	Philadelphia, Pa.	242
KFHO	George Roy Clough	Atlantic, Ia.	273	WABY	Coliseum Place Baptist Church	New Orleans, La.	258
KFHO	Atlantic Automobile Co.	Little Rock, Ark.	299	WADC	Allen T. Simmonds (Allen Theatre)	Fort Huron, Mich.	233
KFHO	Christian Churches	Fayetteville, Ark.	299	WADF	Albert B. Parfet Co.	Richmond Hill, N. Y.	315
KFHO	University of Arkansas	Sioux City, Iowa	261	WAHG	A. H. Grebe & Co.	Minneapolis, Minn.	244
KFHO	Morningside College	Minneapolis, Minn.	231	WAMD	Hulbard and Co.	W. Lafayette, Ind.	283
KFHO	D. George W. Young	Houghton, Mich.	266	WBAA	Purdue University	Clemson College, S. C.	331
KFHO	M. G. Stetson	Northfield, Minn.	336	WBAC	Clemson Agric. College	Minneapolis, Minn.	417
KFHO	Carleton College	Shenandoah, Iowa	266	WBAH	The Dayton Co.	Harrisburg, Pa.	275
KFHO	Henry Field Seed Co.	Colliwater, Miss.	248	WBAK	Pennsylvania State Police	Decatur, Ill.	360
KFHO	Wooten's Radio Shop	Warrensburg, Mo.	234	WBAO	James Millikan University	Fort Worth, Tex.	478
KFHO	Central Mo. State Teachers College	Paso Holes, Calif.	240	WBAP	Wortham-Carter Publishing Co. (Star Telegram)	Columbus, Ohio	282
KFHO	Radio Broadcast Ass'n.	Santa Rosa, Calif.	234	WBAV	Erner & Hopkins Co.	Wilkes-Barre, Pa.	254
KFHO	L. A. Drake Battery and Radio Supply Shop	Whittier, Calif.	236	WBAX	Western Electric Co.	New York, N.Y.	492
KFHO	Montana Phonograph Co.	Mohrly, Missouri	246	WBAY	Irving Vermilya	Mattapoisett, Mass.	248
KFHO	Rhodes Department Store	Marengo, Iowa	234	WBBC	Grace Covenant Presbyterian Church	Richmond, Va.	253
KFHO	First Christian Church	Lea Beach, Fla.	234	WBBD	Lea's Athens	Chicago, Ill.	286
KFHO	Mohrly High School Radio Club	Salt Lake City, Utah	216	WBEN	Blake A. E.	Wilmington, N. C.	276
KFHO	Leslie M. Behrman	Marshfield, Ore.	240	WBEP	Petokey High School	Petokey, Mich.	246
KFHO	Echophone Radio Shop	David City, Nebraska	226	WBFR	Peoples Pulpit Assn.	Rossville, N. Y.	273
KFHO	Latter Day Saints University	Wichita, Kansas	231	WBGS	First Baptist Church	New Orleans, La.	252
KFHO	Behrman Electric Co.	Omaha, Nebraska	248	WBHU	Jenks Motor Sales Co.	Monroeville, Ill.	224
KFHO	David City Tire & Electric Co.	St. Paul, Minn.	226	WBHV	Johnston Radio Co.	Johnstown, Pa.	246
KFHO	College Hill Radio Club	Los Angeles, Calif.	238	WBIB	Ruffner Junior High School	Norfolk, Va.	228
KFHO	Board of Education, Technical High School	Los Angeles, Calif.	238	WBIC	Washington Light Infantry Co. "B" 118th Inf.	Charleston, S. C.	258
KFHO	Beacon Radio Service	Greenville, Texas	242	WBIZ	Noble B. Watson	Indianapolis, Ind.	227
KFHO	Gurston and Dennis	Los Angeles, Calif.	231	WBNC	Foster & McDoland	Chicago, Ill.	266
KFHO	C. C. Baxter	Salt Lake City, Utah	268	WBDC	Baxter Laundry Co.	Grand Rapids, Mich.	256
KFHO	The New Furnace Co.	San Francisco, Calif.	236	WBES	Bless Electrical School	Takoma Park Md.	222
KFHO	Los Angeles Co. Forestry Dept.	Cartersville, Mo.	268	WBGA	Jonas Elec. & Radio Mfg. Co.	Baltimore Md.	234
KFHO	Caps & Johnson	Spokane, Wash.	283	WBHQ	A. H. Grebe & Co., Inc.	Richmond Hill, N. Y.	238
KFHO	Heintz & Kohlmoos, Inc.	St. Louis, Mo.	264	WBIR	Pennsylvania State Police	Butler, Pa.	286
KFHO	St. Johns M. E. Church	Fort Worth, Tex.	221	WBRC	Be Radio Corporation	Birmingham, Ala.	236
KFHO	Symons Investment Co.	Taft, Calif.	258	WBRE	Baltimore Radio Exchange	Wilkes-Barre, Pa.	231
KFHO	The Principia	Bu linkame, Calif.	231	WBS	D. W. May, Inc.	Newark, N. J.	252
KFHO	The Searchlight Publishing Co.	Iowa City, Ia.	284	WBT	Southern Radio Corp.	Charlotte, N. C.	275
KFHO	Kidd Brothers Radio Shop	Oklahoma City, Okla.	252	WBZ	Westinghouse E. & M. Co.	Springfield, Mass.	333
KFHO	Radio Co.	Dennison, Texas	220	WCAD	St. Lawrence University	Canton, N. Y.	280
KFHO	G. S. Carson, Jr.	Holy City, Calif.	253	WCAG	Kaufmann & Baer Co. and The Pittsburgh Pres.	Pittsburgh, Pa.	461
KFHO	Walter LaFayette Falls	North Bend, Wash.	248	WCAL	Clyde R. Randall	New Orleans, La.	262
KFHO	Texas National Guard	Helena, Mont.	261	WCAT	Enrich Electric Co.	Columbus, Ohio	286
KFHO	C. F. Klierim	Hollywood, Calif.	240	WCBA	Nebraska Wesleyan University	University Place, Neb.	283
KFHO	Farmers State Bank	San Francisco, Calif.	268	WCBO	St. Olaf College	Northfield, Minn.	336
KFHO	Taft Radio Co.	Fort Hill, Okla.	263	WCAP	Shawlers & Stayman Co.	Baltimore Md.	273
KFHO	City of Paris Dry Goods Co.	Bristow, Okla.	394	WCAR	Chesapeake & Potomac Telephone Co.	Washington, D. C.	468
KFHO	James F. Boland	Olympia, Wash.	220	WCAS	Alamo Radio Electric Co.	San Antonio, Tex.	263
KFHO	Ethical Radio Co.	Pullman, Wash.	217	WCAT	W. H. Dunwoody Industrial Institute	Minneapolis, Minn.	280
KFHO	United Churches of Olympia	Houston, Tex.	222	WCBB	State College of Mines	Rapid City, S. Dak.	240
KFHO	J. Gordon Klemmard	Los Angeles, Calif.	272	WCBC	Durham & Co.	Philadelphia, Pa.	278
KFHO	The Electric Shop	Helena, Mont.	261	WCAC	University of Vermont	Burlington, Vt.	250
KFHO	Angelus Temple	Breckenridge, Minn.	242	WCAD	Carthage College	Carthage, Ill.	246
KFHO	The Varsity Barber Co.	Galveston, Tex.	258	WCBA	Charles W. Heibach	Allentown, Pa.	280
KFHO	Hopper Plumbing and Heating Co.	Colorado Springs, Colo.	242	WCBC	University of Michigan	Ann Arbor, Mich.	280
KFHO	Thomas Grogan & Bros. Music Co.	St. Louis, Mo.	549	WCBD	Wilbur C. Voliva	Zion, Ill.	344
KFHO	W. D. Corley	Denver, Colo.	234	WCBE	Uhalt Radio Co.	New Orleans, La.	283
KFHO	Concordia Seminary	San Francisco, Calif.	234	WCBF	Paul J. Miller	Pittsburgh, Pa.	236
KFHO	Fitzsimmons General Hospital	Ordan, Utah	224	WCBG	Howard S. Williams (Portland)	Peasop, Miss.	268
KFHO	Julius Branton and Sons Co.	Oakland, Calif.	233	WCBI	University of Miss.	Osford, Miss.	242
KFHO	H. W. Peers and C. Redfield	Salt Lake City, Utah	271	WCBJ	Nicoll, Duncan & Rush	Bemis, Tennessee	240
KFHO	Louis L. Sherman	San Leandro, Calif.	231	WCBK	J. C. Maus	Jennings, Louisiana	244
KFHO	University of Utah	Butte, Mont.	254	WCBM	Charles Swarz	Baltimore, Md.	225
KFHO	Colburn Radio Labs.						
KFHO	Irvine M. Bouchard						

Another Broadcasting Boom Opens

INSTEAD of quieting down for the Summer months, interest in radio broadcasting is reported as increasing by many exponents of this art. At least prospective broadcasting station owners are showing more activity than ever before, Department of Commerce records indicate. Although there are 566 stations on the air today, utilizing every available broadcast wavelength, there are at least twenty applicants for class B broadcast privileges and about a hundred individuals or organizations are said to be seeking licenses for class A operation. Not all these stations have made formal application to the Department of Commerce, however. This is not a requirement and is seldom the usual method of procedure. Ordinarily, a prospective broadcaster first leases a site, then buys expensive equipment and set it up before he asks the Department if there is a vacant air channel for him. No shipping company would buy its boats and equipment before it found out if it could get a route and a license to do business; neither would an auto bus line, but in this new game of broadcasting, some of the more practical essentials and necessary requirements seem to be neglected to the cost of the would-be radio-phone station operators.

Some citizens now seem to realize that there is no more room for Class B, high-power, stations, but the congestion among the smaller class A stations, in consequence of the few channels assigned to them, is worse. There are 468 stations now, 54 of them operating on 500 watts, the maximum power allotted to this class and there are dozens of them on the same wavelength. As the power increases, and there is rumor that many A's will be permitted to go up in power this Summer in an effort to overcome static, the situation becomes worse, from a reception point of view. With increased power, they cover more territory and therefore interfere with more stations, just as the higher-powered B stations do, even when there are but two or three to a wavelength. In the low A wave band of 226 meters for example, there are six-teen stations now operating.

There is no record kept of proposed stations until formal applications are filed with the district radio supervisor, but from one western supervisor comes the statement that there are 32 stations in California alone planning to ask for broadcasting licenses as soon as their stations are completed. This official can not possibly satisfy more than ten or a dozen of his prospective customers, many of whom are understood to have already bought or ordered their equipment, despite the reiterated statement that the broadcasting lanes through the ether are all crowded, and rights of way are no longer available except in some of the still "open spaces."

The fans seem to take the view that there are enough broadcasters now, and that no more should be permitted to come on the air unless they can guarantee unique programs. This, however, is just

what each potential radio entertainer is glad to assert, believing that he is telling the truth. Probably some of them could introduce new stars, but there are plenty as it is. They soon find that the field is pretty well covered by the 566 stations, which are all experienced and have their own talent well lined up and trained, not to mention a large following of regular fans. Every one of these stations in operation is trying its best to learn what the listeners want and to give it to them; many stations which failed so to do, have fallen by the wayside, their experiments constituting a considerable financial loss.

Some organizations believe they could serve a special group in the great radio audience not now furnished with what they desire. In a few instances this is true, particularly as some religious orders are not on the air in certain sections.

All Europe, it is pointed out, has not so many broadcasting stations as there are in the United States alone. When the question of international broadcasting comes up at the Paris or Washington conference, it may be that we shall have to release some of our much desired and used radio channels for inter-continental use, it will be pointed out, and rightly so, that we have no more right to the 205-545 meter band than other countries, and that we should share the wave lengths. If this is the case, the situation will become worse unless a number of our stations drop out of the game.

The increase in numbers, however, is continuing gradually; in April twenty-four stations, mostly smaller ones, ceased to broadcast, but twenty-seven new ones opened, increasing the total on the air May 1, by three over the figure on March 1st.

Russo and Fiorito Open WIBO

STATION WIBO came on the air last month, in Chicago. Harry Geise, Director and Announcer, promises the radio audience several new and novel surprises and features, and with the assistance of Dan Russo and Ted Fiorito, who have already gained a multitude of radio friends, will endeavor to please the radio audience with the best programs obtainable.



Harry Geise

Dan and Ted, co-conductors of the Oriole Orchestra, formerly playing at the Edgewater Beach Hotel, and Harry Geise, known as the "How-Do-You-Do Man," are on the air each night to to answer requests. WIBO is located at 6310 Broadway, Chicago, the studio and reception room on the second floor, and the operating room on the third floor. The studio is equipped with Celotex walls, designed in rather a unique manner, handsomely furnished, with perfect acoustics for broadcasting. The eighty-foot towers are completed and Philip I. Latin, Chief Engineer, is working every effort to assure the public of successful broadcasting from this station.

* Tested and Approved by RADIO AGE *

60-page Reference Book

Free

POLK'S REFERENCE BOOK FOR DIRECT MAIL ADVERTISERS

Mailing List Catalog No. 55

POLK'S REFERENCE BOOK FOR DIRECT MAIL ADVERTISERS

Shows how to increase your business by the use of Direct Mail Advertising, 60 pages full of vital business facts and figures. Who, where and how many prospects you have. Over 8,000 lines of business covered.

Write for your FREE copy.

R. L. POLK & CO., Detroit, Mich.
599 POLK DIRECTORY BUILDING
Branches in principal cities of U. S.

Get Cuba or Mexico City

While Big Local Stations Are Broadcasting, The New York Evening World got 46 stations in One Evening including Dallas, Los Angeles, and Porto Rico; while testing the wonderful sensitivity of the

New in Principle—New in Design

WERNER Radio Frequency TRANSFORMERS For All Circuits

Insist on getting them, if your dealer can't supply you, send your order to us.

Price \$4.00, All Types

Send for Diagrams

A wonderful interesting book "Radio Frequency Amplification" contains popular and technical information with many up-to-date R. F. circuit diagrams of greatest interest to both radio user and engineer.

25c postpaid

R. Werner Radio Mfg. Co.
204-206 Ninth St. Brooklyn, N. Y.

BAKELITE

Insulated condensers give lasting satisfaction. Write for booklet 31.

BAKELITE CORPORATION
247 Park Avenue, New York, N. Y.
Chicago Office: 636 West 22d Street

MARSHALL Radio Frequency Receivers

Embodying a marvelous New * Non-Oscillating Principle

Sold Direct on Free Trial and Easy Terms

Write for catalog and Special Offer

Marshall Radio Products, Inc.
Dept. B-589 Marshall Blvd. & 19th St. Chicago

Advertising Takes Its Place In Radio Programs

WASHINGTON:—That advertising is insidiously creeping into broadcast programs and that radio "entertainment" will eventually become "thinly veiled publicity," is charged by some of the leading exponents of radio and advertising.

We have all heard what are virtually publicity talks on coffee, candy, flour, chewing gum and other commodities, through the air, and also enjoyed entertainment by playing-card quartettes, automobile-tire orchestras, safety razor and grocery store musicians. The butcher, the baker, the candlestick maker and the whole of industry has been broadcasting of late. What is it coming to?

The question "whether advertisers should pay for broadcasting" is causing concern among the broadcasters and national advertisers, as well as the radio industry itself, but since it will be up to the fans to decide eventually, a brief of a survey recently made by Albert E. Haase follows:

Radio and Business

"The radio industry is discovering that good broadcasting means good business, and extraordinary broadcasting, extraordinary business," Mr. Haase points out. "Conversely, poor broadcasting means poor business. Many who are in the industry realize that if the mad rush to get the advertisers' dollar for the support of radio continues, radio itself will suffer. Today, advertising agencies are offered 15% commission by a number of broadcasting stations for business. One salesman has secured the advertising rights from fifteen stations.

"On the other hand, stations which do not sell space on the air are besieged by publicity men who seek to talk on certain business and collect from the manufacturers.

"Overdoing advertising, will kill radio and at the same time hurt advertising, a representative of the Colgate Co., is quoted as saying. The whole problem of radio advertising is being studied by the Association of Advertising Agencies, which already has decided that the present methods of radio advertising are not agreeable nor desirable to fans, and that the unwise use of radio advertising will be bad for all advertising."

So far the American Tel. & Tel. Co., through WEAf and a chain of interconnected stations, appears to be the main channel for radio advertising. The charges according to Mr. Haase, vary from \$25 a minute for talks, and \$250 a half hour for entertainment, from one station, up to \$1,600 an hour for entertainment distributed through seven stations. The advertisers, of course, furnish all the talent. Circulation is part of sales talks, but figures are naturally only estimates. These rates are not guaranteed as fixed, but may be increased, unless

the Interstate Commerce Commission should take a hand, claiming that telephone lines are a public utility or that connecting lines are between states.

Statements from a number of the representative manufacturers show that there is no unanimity of opinion against paid radio advertising, but they all believe in good broadcasting.

Lee DeForest believes that as more concerns take up radio advertising, their programs become less interesting to the public, that advertising is insidious and becoming more flagrant; and he asserts that he has actually become prejudiced against several of the broadcasters' products. He looks forward to a time when the great majority of programs will be for "thinly veiled advertising purposes."

Secretary Hoover is opposed to censorship, but through the radio conferences it has been made known that "indirect advertising" only is permitted via broadcasts by The Department of Commerce. However, Mr. Haase sees possible Governmental intervention and ultimately a decision from receiving set owners.

Views of concerns which have tried paid advertising are interesting. The Eveready entertainers, considered unique by many, actually pay the National Carbon Co., in good will. One day 3,000 letters came in, according to J. R. Crawford of that company. But he does not think radio advertising, even indirect, would pay all types of manufacturers, except experimentally.

As a contrast, Stuart Peabody of the Borden Milk Co., claims that two broadcasting trials failed to bring adequate responses. The Macy Co. failed to derive substantial benefits from broadcasting. But Nat Lewis, owner of two gift and haberdashery shops, found fashion talks via radio, which he calls "publicity," better than some other forms of advertising. He received 5,000 letters following one talk.

Officials of the United Retail Candy Stores, backers of the "Happiness Boys," say after fifteen months of broadcasting entertainment stunts, that they feel it is "publicity" rather than "advertising," which they use simultaneously.

The Fisher Co., Astor Coffee manufacturers, continue radio programs after fifteen months' trial, having received over 100,000 communications from all parts of the country.

Through co-operation with the A. T. & T. Co., the Victor Talking Machine Co. is said not to pay for space, when its stars sing and play. It is studying the results, however, and will soon report on broadcasting. Advertising experts feel that radio has a time limit and that its circulation is uncertain, compared to other mediums; they believe it is probably an accessory.



FREE!

12-Cell — 24-Volt Storage 'B' Battery

Positively given free with each purchase of a WORLD "A" Storage Battery. You must send this ad with your order. WORLD Batteries are famous for their guaranteed quality and service. Backed by years of successful manufacture and thousands of satisfied users. Equipped with Solid Rubber Cases, an insurance against acid and leakage. You save 50 per cent and get a **2-Year Guarantee**



Bond in Writing WORLD Battery owners tell their friends. That's our best proof of performance. Send your order in today. **Solid Rubber Case Radio Batteries**
 6-Volt, 100-Amperes \$11.25
 6-Volt, 120-Amperes 13.25
 6-Volt, 140-Amperes 14.00
Solid Rubber Case Auto Batteries
 6-Volt, 11-Plate \$11.25
 6-Volt, 13-Plate 13.25
 12-Volt, 7-Plate 16.00

Approved and Listed as Standard by Leading Authorities including Radio News Laboratories, Popular Science Institute of Standards, Popular Radio Laboratories, Radio Broadcast Lab., Popular Radio in the Home, and Lofax, Inc.

Send No Money Just state but we will ship any order is received, by Express C. O. subject to your examination on arrival. **FREE "B" Battery** included. Extra Offer: 5 per cent discount for cash in full with order. Buy now and get a guaranteed battery at 50 per cent saving to you.

WORLD BATTERY COMPANY
 1219 So. Wabash Ave., Dept. 36 CHICAGO, ILL.

World STORAGE BATTERIES For AUTO and RADIO

WEAF WGA WLS WLSO WLSG WLSR WLSU WLV WY 2 KDKA

The Five Tube Set which startled the World!

*** the World!**

FRESHMAN MASTERPIECE

The Greatest Value Ever Offered in A Radio Receiving Set

At Authorized Dealers

P W X

is easy to get with the right kind of set. Profits are easy to get with the right kind of goods. Dealers write for facts.

HUDSON-ROSS—116 S. Wells St. Chicago

A 62-page Blueprint Section in the August RADIO AGE

WSMB	Saenger Amusement Co. and Maison Blanche Co.	New Orleans, La.	319
WSMH	Shattuck Music House	Owosso, Mich.	249
WSMK	S. M. K. Radio Corp.	Dayton, Ohio	275
WSOE	School of Engineering	Milwaukee, Wis.	246
WSRF	Hardem Sales and Service	Broadlands, Ill.	233
WSTA	Camp Marienfeld	Cheban, N. H.	229
WSUI	State University of Iowa	Iowa City, Iowa	498
WTAB	Fall River Daily Herald Publishing Co.	Fall River, Mass.	248
WTAC	Penn Traffic Co.	Johnstown, Pa.	360
WTAL	Toledo Radio & Electric Co.	Toledo, Ohio	252
WTAP	Cambridge Radio & Electric Co.	Cambridge, Ill.	242
WTAQ	S. H. Van Gordon & Son	Ossau, Wis.	220
WTAR	Reliance Electric Co.	Norfolk, Va.	280
WTAS	Charles E. Erbstein	Elicio, Ill.	303
WTAT	Edison Electric Illuminating Co.	(portable) Boston, Mass.	244

WTAU	Ruegg Battery & Electric Co.	Tecumseh, Nebr.	242
WTAW	Agricultural & Mechanical College of Texas	College Station, Tex.	280
WTAX	Williams Hardware Co.	Streator, Ill.	231
WTAZ	Thomas J. McGuire	Lambertville, N. J.	283
WTHS	Flint Senior High School	Flint, Mich.	218
WTTG	Kansas State Agricultural College	Manhattan, Kans.	273
WTTI	Travelers Insurance Co.	Hartford, Conn.	323
WTX	H. G. Snel Co.	Chicago, Ill.	268
WVAD	Wright & Wright (Inc.)	Philadelphia, Pa.	360
WVAE	The Alamo Ball Room	Joliet, Ill.	442
WVVI	Ford Motor Co.	Dearborn, Mich.	273
WVWJ	Detroit News (Evening News Assn.)	Detroit, Mich.	352
WVWL	Loyola University	New Orleans, La.	260
WVWOA	Michigan College of Mines	Houghton, Mich.	244

Canadian Stations

CFAC	Calgary Herald	Calgary, Alberta	430
CFCA	Star Pub. & Prtg. Co.	Toronto, Ontario	400
CFCF	Marconi Wireless Tele. Co. Canada	Montreal, Quebec	440
CFCH	Abitibi Power & Paper Co.	Iroquois Falls, Ont.	400
CFCL	La Cite de L'Evenement	Quebec, Quebec	410
CFCK	Radio Supply Co.	Edmonton, Alberta	410
CFCN	W. W. Grant Radio (Ltd.)	Calgary, Alberta	410
CFCO	Radio Specialties (Ltd.)	Vancouver, B. C.	450
CFCR	Laurentide Air Service	Sudbury, Ont.	410
CFCT	Victoria City Temple	Victoria, B. C.	410
CFCU	The Jack Elliott Radio Limited	Hamilton, Ont.	410
CFCW	The Radio Shop	London, Ont.	420
CFCD	Sparks Co.	Nanaimo, B. C.	430
CFHC	Henry Birks & Sons	Calgary, Alta.	440
CFHL	Chas. Guy Hunter	551 Adelaide St., London, Ont.	410
CFHQ	The Electric Shop (Ltd.)	Saskatoon, Saskatchewan	400
CFHR	Queens University	Kingston, Ontario	450
CFHU	University of Montreal	Montreal, Quebec	400
CFHX	Westminster Trust Co.	New Westminster, B. C.	440
CFYC	Victor Wentworth Odlum	Vancouver, B. C.	400
CHBC	Radio Engineers	Halifax, Nova Scotia	400
CHBD	Albertan Publishing Co.	Calgary, Alberta	410
CHBE	Marconi Canada	Toronto, Ont.	410
CHBF	Canadian Wireless & Elec. Co.	Quebec, Quebec	410
CHBG	Western Canada Radio Sup. (Ltd.)	Victoria, B. C.	400
CHBH	Vancouver Merchants Exchange	Vancouver, B. C.	440
CHBI	Riley & McCormack	Calgary, Alberta	415
CHBJ	The Hamilton Spectator	Hamilton, Ont.	420
CHBK	Northern Electric Co.	Toronto, Ont.	356
CHBL	Toronto Radio Research	Toronto, Ont.	350
CHXC	J. R. Booth	Ottawa, Ont.	435
CHYC	Northern Electric Co.	Montreal, Quebec	410
CJBC	Jarvis Baptist Church	Toronto, Ont.	312
CJCA	Edmonton Journal	Edmonton, Alberta	455
CJCC	London Free Press Prtg. Co.	London, Ont.	410
CJCD	The Alamo Ball Room	Joliet, Ill.	442
CJCE	Sprott-Shaw Radio Co.	Vancouver, B. C.	420
CJCF	The News Record	Kitchener, Ont.	295
CJCI	Maritime Radio Corp.	St. John, New Brunswick	400
CJCK	Radio Corp. of Calgary	Calgary, Alta.	316
CJCM	J. L. Philippe	Mont Joli, Quebec	430
CJCN	Simons Agnew & Co.	Toronto, Ont.	410
CJCS	Evening Telegram	Toronto, Ont.	430
CJCC	La Presse Pub. Co.	Montreal, Quebec	430
CKAC	Vancouver Daily Province	Vancouver, B. C.	410
CKCE	Canadian Indep. Telephone Co.	Toronto, Ont.	450
CKCK	Leader Pub. Co.	Regina, Saskatchewan	420
CKCO	Ottawa Radio Association	Ottawa, Ont.	440
CKCX	P. Burns & Co.	Calgary, Alberta	440
CKLC	Wilkinson Electric Company	Calgary, Alberta	400
CKOC	Westworth Radio Supply Co.	Hamilton, Ont.	410
CKAC	Canadian National Railways	Moncton, N. E.	313
CNRC	Canadian National Railways	Calgary, Canada	357
CNRE	Canadian National Railways	Edmonton, Alta.	455
CNRM	Canadian National Railways	Montreal, P. Q.	410
CNRO	Canadian National Railways	Ottawa, Ont.	430
CNRR	Canadian National Railways	Regina, Sask.	312
CNRS	Canadian National Railways	Saskatoon, Sask.	329
CNRT	Canadian National Railways	Toronto, Ont.	357
CNRW	Canadian National Railways	Winnipeg, Man.	384

Cuban Stations

PWX	Cuban Telephone Co.	Havana	400
2DW	Pedro Zayas	Havana	309
2AB	Alberto S. de Bustamante	Havana	240
2OK	Mario Garcia Velez	Havana	360
2BY	Frederick W. Borton	Havana	260
2CX	Frederick W. Borton	Havana	320
2EV	Westinghouse Elec. Co.	Havana	220
2TW	Roberto E. Ratinos	Havana	230
2HC	Heraldo de Cuba	Havana	275
2LC	Luis Casas	Havana	250
2KD	E. Sanchez de Fuentes	Havana	350
2MN	Fausto Simon	Havana	270
2MG	Manuel C. Salas	Havana	280
2JD	Raul Perez Falcon	Havana	150
2K	Alvaro Daza	Havana	200
2HS	Julio Power	Havana	180
2OL	Oscar Collado	Havana	290
2WW	Amadeo Saenz	Havana	210
5EV	Leopoldo E. Figueroa	Colon	360
6KW	Frank H. Jones	Tuinucu	340
6KJ	Frank H. Jones	Tuinucu	275
6CX	Antonio T. Figueroa	Cienfuegos	170
6DW	Eduardo Terry	Cienfuegos	225
6BY	Jose Candux	Cienfuegos	300
6AZ	Valentin Ullivarri	Cienfuegos	200
8BY	Alberto Ravelo	Stgo. de Cuba	250
8FU	Andres Vinnet	Stgo. de Cuba	225
8DW	Pedro C. Andus	Stgo. de Cuba	275

European Broadcasting Stations

British Stations					
2LO	London	365	5NO	Newcastle	400
5IT	Birmingham	475	5SC	Glasgow	420
5WA	Cardiff	350	2BD	Aberdeen	492
6BM	Bournemouth	385	6SL	Sheffield (relay station)	303
2ZY	Manchester	375			
French Stations					
YN	Lyons	740	8AJ	Paris	1,780
FL	Paris (Eiffel Tower)	2,600	ESP	Paris	450

End your Radio Troubles for 30c in Stamps

We have laid aside a limited number of back issues of RADIO AGE for your use. Below are listed hookups to be found in these volumes. Select the ones you want and enclose 30c in stamps for each desired. The supply is limited, so enrich your store of radio knowledge by laying in an ample stock of copies NOW!

- | | |
|---|---|
| January, 1924
—Tuning Out Interference—Wave Traps—Eliminators
—Filters
—A Junior Super-Heterodyne
—Push-Pull Amplifier
—Rosenbloom Circuit.
March, 1924
—An Eight-Tube Super-Heterodyne
—A simple, low loss tuner
—A Tuned Radio Frequency Amplifier
—Simp's Reflex Set.
April, 1924
—An Efficient Super-Heterodyne (fully illustrated)
—A Ten-Dollar Receiver
—Anti-Body Capacity Hookups
—Reflexing the Three-Circuit Tuner
—Index and first two installments of Radio Age Data Sheets.
May, 1924
—Construction of a Simple Portable Set.
—Radio Panels
—Third Installment of Radio Age Data Sheets.
June, 1924
—Important Factors in Constructing a Super-Heterodyne
—A Universal Amplifier
—A Sure Fire Reflex Set
—Adding Radio and Audio to Baby Heterodyne
—Radio Age Data Sheets.
July, 1924
—A Portable Tuned Impedance Reflex
—Operating Detector Tube by Grid Bias
—A Three-Tube Wizard Circuit
—Data Sheets.
August, 1924
—Breaking Into Radio Without a Diagram
—The English 4-Element Tube
—Filtered Heterodyne Audio Stages
—An Audio Amplifier Without an "A" Battery
—Data Sheets.
September, 1924
—How Careful Mounting Will Improve Reception
—One Tuning Control for Hair's Breadth Selectivity
—Four Pages of Real Blueprints of a New Baby Heterodyne and an Aperiodic Variometer Set.
—Data Sheets.
October, 1924
—An Easily Made Super-Het.
—Two Radio and Two Audio for Clear Tone
—A Simple Regenerative Set
—The Ultradyne for Real DX
—Real Blueprints of a 3-Tube Neutrodyne and a Midset Reflex Set.
November, 1924
—Blueprints of a Single Tube Loop Set and a Capacity Feedback Receiver
—A 3-Tube Low Loss Regenerator
—Mastering the 3-Circuit Tuner.
December, 1924
—Blueprints of a New 8-Tube Super-Heterodyne
—How to Make a Receiver that Minimizes Static
—A Trans-Atlantic DX Receiver
—How to Make a Home Made Battery Charger and a Loud Speaker at a Small Cost.
January, 1925
—A Reflexed Neutrodyne
—A Six Tube Super-Het.
—An Efficient Portable Set
—A Tuned Plate Regenerator
—Making a Station-Finder. | February, 1925
—A Sure Shot Super-Het.
—A Three Circuit Regenerator
—A Real, Low Loss Set
—Blueprints of a 3-tube Reflex.
March, 1925
—A Permanent Super-Het.
—A 5-Tube R. F. Receiver
—How to Wind Low Loss Coils
—A Short Wave Receiver
—Blue Prints of a Two-Tube Ultra Audion and a Regenerative Reflex.
April, 1925
—A 3-Tube Portable Set
—"B" Voltage from the A. C. Socket
—An Amplifier for the 3-Circuit Tuner
—Blueprints of a Five-Tube Radio Frequency Receiver
May, 1925
—A "Quiet" Regenerator
—A Power Supply Receiver
—How to Make a Tube-Tester
—A Unique Super-Het and an Improved Reinartz
—A Six Tube Portable Receiver Illustrated with Blueprints.
June, 1925
—Reducing Static Disturbances
—A Seven-Tube Super-Heterodyne
—The Double Grid Tube in Ordinary Sets
—Browning-Drake Receiver
—Overcoming Oscillations in the Roberts Receiver
—An Ideal Set in Practical Form
—Soldering Secrets |
|---|---|

RADIO AGE, Inc. 500 N. Dearborn St., Chicago

WITH THE MANUFACTURERS



Dry Cell Tests Held for First Time

ON May 10, from the Great Lakes Naval Training Station, Great Lakes, Ill., the first tests in history were made from an airplane in flight, using the new 37 meter radio transmitter and receiver operated by dry cells only.

Heretofore, all airplane radio equipment has had its source of power from a small generator which was driven through a fan-shaped propeller by the force of the wind. In other words, when the engine and the airplane were out of commission—so was the radio. This new transmitter which is being tested is the first of its kind and is one of the transmitters which will be used by the MacMillan Polar Expedition which sails from Boston, Bunker Hill Day, June 17, under the auspices of the National Geographic Society.

The value of this type of equipment can be immediately realized when it is remembered that the airplanes that are to accompany the MacMillan Expedition manned by U. S. Navy personnel, under the command of Commander R. E. Byrd, U. S. N., will fly over that great unexplored area lying between Point Barrow and the North Pole, in quest of new land. Should a landing be forced, this type of apparatus, if efficient, will be able to communicate after the airplane itself is out of commission, and the flyers will be able to call for help from the planes held in reserve back at the advance base of Axel Heiberg Land.

The Zenith Radio Laboratory announced that the tests made at Great Lakes Naval Training Station on 37 meters were not satisfactory, as the greatest distances at which they were heard were Newton, Iowa, and Minneapolis. Failure to reach greater distances is attributed to the fact that the amateurs of the United States were not properly advised of the time at which these tests would take place.

Campaign for Jewett

E. H. WILKINSON and T. F. W. Meyer, General Manager and General Sales Manager, respectively, for the Jewett Radio and Phonograph Co., Pontiac, Michigan, have returned to the factory after an extended trip through the East putting the finishing touches on the new distributors' and dealers' franchise plan in that territory which has been under way for several months.

The Jewett slogan, "Fair prices, rigidly maintained" must be very strictly adhered to under this new system, because every dealer handling Jewett products throughout the country must

Stewart-Warner Radio, Model 305

The Stewart-Warner Speedometer Corporation, 1826 Diversey Parkway, Chicago has placed on the market a complete ensemble of matched radio units. This ensemble consists of the line of Stewart-Warner Radio Instruments; the Stewart-Warner Reproducer especially built to give perfect harmony with Stewart-Warner Instruments; Stewart-Warner Radio Tubes, designed to give beautiful tone quality; Batteries, Aerial and Ground Equipment.



The Stewart-Warner Instrument shown is Model 305—a five tube set in which is incorporated the U. S. Navy Circuit. There are three tuning controls, mounted on a sloping front panel. The cabinet is finished in dark walnut.

In this instrument, the special Navy tuned radio frequency circuit has been developed to a high stage of perfection, and the set is especially suited to operation by men or women without technical knowledge or training.

The Stewart-Warner Reproducer is built by the Stewart-Warner Speedometer Corporation of Chicago, especially for use with Stewart-Warner Radio Instruments. This Reproducer is so designed and constructed that it covers the entire musical scale with full, rich tone volume and without distortion or scratching noises. The horn is made from fibre by special process and is vulcanized on its outer surface. The core of the horn is allowed to remain soft which absolutely prevents the horn from vibrating at any note.

The Stewart-Warner Reproducer is finished in a dark walnut, leather-like surface, and stands on a metal base which is deep green with gold-bronze highlighting. This Reproducer harmonizes perfectly with the walnut cabinet work of Stewart-Warner Radio Instruments.

come well recommended as to their stability by a Jewett Distributor, or one of the factory district representatives in the field, it is announced.

The dealer will be benefited in this same respect by knowing that his customer cannot buy a Jewett product from any but another authorized dealer who is holding to the standard Jewett prices.

Freshman Announces New Sales Policy

The Chas. Freshman Co., Inc. of New York has just announced its sales policy for the coming season. This concern, manufacturers of the line of Freshman Masterpiece Receiving Sets, has decided to eliminate the jobber and distributor in the sale of their products. Freshman Masterpiece Sets will be sold to Authorized Freshman Dealers, carefully selected, and granted an exclusive franchise in their territory. In towns of approximately 25,000 and under, one representative dealer will be appointed to exclusively handle the line, and in larger cities, additional dealers will be granted franchises in proportion to the population and trading area. A staff of salesmen is now at work signing up dealers to the Freshman Masterpiece Contract, which assures dealers of absolute protection, as far as stability of prices is concerned; also, all business from each individual dealers' territory will be credited to him. In this way, the appointed dealers will be practically direct factory representatives of Freshman.

The Freshman Company enjoyed remarkable success with their one model, the original Freshman Masterpiece, during the last year. The fact that with one model, priced at \$60.00, over 125,000 sets were sold from July 1924 until February 1925, speaks highly for the tremendous hold this product has taken with the radio public. With the realization that the trend in radio buying is leaning strongly towards furniture effects, the company has placed a complete line of Freshman Masterpiece Receivers on the market, ranging in price from a Five Tube Radio Frequency Set, in a massive cabinet with sloping panel at \$39.50, up to the Franklin Console, a dignified piece of furniture of vigorous lines and fine proportions, made entirely of genuine solid mahogany by the manufacturers of the highest class talking machine Company in the world at \$115. The Franklin Console is composed of two separate and distinct units, one of which is a receiving set with built-in loud speaker, and the other the console for batteries and accessories—everything being concealed.

New "Hercules" Masts

S. W. HULL & Company, 2048 East S. 79th St., Cleveland, Ohio, announce a new series of "Hercules" Aerial Mast. These masts are made in three standard lengths, 20 ft., 40 ft., and 60 ft., all steel construction.

All masts are made of a special angle construction that gives great strength and light weight, thus making a rugged mast easily erected, at the same time presenting a pleasing appearance by its graceful lines. (Turn to page 72)

CLASSIFIED ADVERTISEMENTS

If you have anything to buy or sell, don't overlook the value of RADIO AGE'S classified advertisements. Many such messages have paved the way to independent incomes.

The classified advertising rates are but ten cents per word for a single insertion. Liberal discounts are allowed on three, six and twelve-time insertions, of five, fifteen and thirty per cent respectively. Unless placed through an accredited advertising agency, cash should accompany all orders. Name and address must be included at foregoing rates and no advertisement of less than ten words will be accepted.

All classified ads for the August issue must be sent in by July 1.

AGENTS WANTED

FORDS, 60 miles on one gallon of Gas. It has been proven such mileage can be made. **AIRLOCK** guarantees to increase gas mileage; also prevents radiator boiling in summer or freezing in winter. Cools, Fuels, Decarbonizes the Ford motor. Splendid territory open. **AIRLOCK PRODUCTS**, Box 703G, Willow Street, Long Beach, Calif.

RADIO—Join our sales organization and make big money. We want a man in every county to sell well advertised sets and parts made by the leading manufacturers. Widener of Kansas City makes \$150.00 weekly. No capital or experience required. Write today for catalog, and discounts. Name your county. **Waveland Radio Company, Div. 52, 1027 No. State St., Chicago, Ill.**

MANUFACTURER'S AGENT calling on Radio-Electrical Jobbers, Chicago and vicinity, has opening for 3 additional lines carrying volume business, as we cater to large jobbers. **Edelstein, 1804 McCormick Bld., Chicago.**

AGENTS—WRITE FOR FREE SAMPLES. Sell Madison "Better-Made" Shirts for large manufacturer direct to wearers. No capital or experience required. Many earn \$100 weekly and bonus. **MADISON MFGRS., 501 Broadway, New York.**

90c an hour to advertise and distribute samples to consumer. Write quick for territory and particulars. **American Products Co., 2130 American Building, Cincinnati, Ohio.**

Man wanted for this territory to sell wonderful value men's, women's, Children's shoes direct, saving consumer over 40%. Experience unnecessary. Samples supplied. Big weekly permanent income. Write today **Tanners Mfg. Co., 1334C St., Boston, Mass.**

"B" BATTERIES

100 VOLT EDISON TYPE "B" BATTERY, knocked down. Parts and plans—complete, \$12.50. **Lane Mfg. 2937 W. Lake, Chicago.**

BATTERIES FOR SALE—Four 24-volt "Main" Storage "B" Batteries, never used, shipped and ready to wire for \$18.00. First order gets the batteries. Address **Box B, Radio Age, 500 N. Dearborn St., Chicago, Ill.**

BUSINESS OPPORTUNITY

MR. MANUFACTURER: Would you be interested in a national advertising campaign to reach more than two million prospective buyers of quality radio products—each week? Do you want to establish agencies in new territory and create national interest in your product—at very conservative cost? It can be done. Let us explain our system without obligation to you. Drop a card to **Radiograph Laboratories, 1234 Rosemont Ave., Chicago, Ill., Box 5.**

CRYSTALS

TESTED CALENA CRYSTALS, 50c pound bulk. **Buekett, Geologist, Joplin, Mo.**

HELP WANTED

RADIO SALESMEN and SET BUILDERS—We need you and you need us. If you are reliable and well known in your community, we will appoint you our representative and furnish you with standard well advertised sets and parts at prices that will enable you to sell at a handsome profit. Write at once for catalog and sales plan. **Waveland Radio Co., Div. 53, 1027 N. State St., Chicago, Ill.**

MEN wanting forest ranger, railway clerk and other government positions, write for free particulars of exams. **Mokane, Dept. B-33, Denver, Colo.**

Classified ad. copy for the August **RADIO AGE** must be sent in by **July 1, 1925.**

INVENTIONS

NEW IDEAS WANTED—Well known Radio Manufacturer whose products are nationally advertised and sold everywhere wants new Radio device to sell. Will pay outright or royalty for idea or invention which is really new and saleable. Address: **Mr. R. F. Devine, Room 1101, 116 West 32nd St., New York, N. Y.**

MAGAZINES

DREAMS. A magazine for all who dream. If you are interested in the subjects of science, sex, psychology, health, love and romance, you cannot afford to be without this magazine. Three dollars will bring this most fascinating monthly publication to your home for one year. **M. E. Smith Publishing Co., 508 N. Dearborn St., Chicago, Ill.**

MANUFACTURING FACILITIES

AN OLD AND WELL ESTABLISHED MANUFACTURING COMPANY IN THE MIDDLE WEST WITH LARGE WELL EQUIPPED PLANTS AND UNUSUAL FINANCIAL RESOURCES, DESIRING TO ENTER THE RADIO FIELD WILL CONSIDER THE MANUFACTURE AND SALE OF RADIO SETS OR DEVICES OF OUTSTANDING AND UNUSUAL MERIT ON A ROYALTY BASIS. ADDRESS BOX 1A, RADIO AGE.

PATENTS

FOR SALE: U. S. and Canadian Patent on an Attachment for Phonographs; is the most beautiful invention of the age. Address **Chas. F. Smith, Huff, N. Dak.**

PERSONAL

LONELY HEARTS: Exchange letters; make interesting new friends in our jolly club. **Eva Moore, Box 908, Jacksonville, Florida.** Enclose stamp.

Look! You Radio Bug! Join Radio Correspondence Club. Entirely new. Broaden your acquaintance, exchange ideas. Membership pen to **LADY BUGS** also. Dime stamp brings pamphlet and Radio Novelty Cards. **Radio Rose, Box 662, Cleveland, Ohio.**

PRINTING

We print Stationery, Booklets, Catalogs, Circulars. Samples. **Commercial Press, Batavia, Ohio.**

RADIO

A PRACTICAL TUBE RECEIVING SET FOR \$10. Postpaid, less phones and tube. Complete with phones, tube and battery, \$18.00. **J. B. RATHBUN, 1067 Winona St., Chicago, Ill.**

Standard solderless radio Jacks. Binding post attachments. Double circuit. One dollar bill. Postpaid. **Clinton Seward, Jr., New Paltz, New York, N. Y.**

Three Cosmopolitan Physiformers, each \$5.50, book of instructions included. **F. A. Mall, Triplii, Iowa.**

FOR SALE—3 Pfanatihel tuning units, 3 Cardwell Condensers, 1 Bradlevometer, 2 Bradlevostats. All goods New. **Earl Price, Lodi, Wis.**

15 to 25 per cent discount on nationally advertised sets and parts. Every item guaranteed. Tell us your needs. **IMPERIAL RADIO COMPANY, Delaware, Ohio.**

RADIO SETS. Our prices save you money. Lists free. **The Radio Shoppe, Box 645, East Liverpool, Ohio.**

AT LAST The Radco Static Eliminator. Eliminates 50 to 90% Static. Many satisfied users. Write for particulars. **Radio Specialties Company, Sioux Falls, South Dakota.**

Maybe an
Opportunity
awaits You in the
Radio Age Classified
Section

RADIO CIRCUITS

SPECIAL FOR JULY

The Reinartz Radio Booklet, by Frank D. Pearne, fully illustrated, and **RADIO AGE**, for \$2.50. Price of Booklet alone is 50c. Send check, currency or money order to **RADIO AGE, 500 N. Dearborn Street, Chicago.**

RADIO DEALERS

DEALERS—Write for our illustrated catalog of reliable Radio Merchandise. **Rossiter-Manning Corporation, Dept. D, 1830 Wilson Ave., Chicago, Ill.**

RADIO SUPPLIES

Ten per cent discount on all standard radio parts, from condensers to transformers to tubes, etc. Send for our latest price list, with special bargains on Static-eliminators, portable loud speakers, Radiotrons, German silver wire, etc. **RADIOGRAPH LABORATORIES, 1234 Rosemont Ave., Dept. 4, Chicago, Ill.**

STAMPS AND COINS

158 Genuine Foreign Stamps. Mexico War Issues: Venezuela, Salvador and India Service, Guatemala, China, etc., only 5c. Finest approval sheets, 50 to 60 per cent. Agents Wanted. Big 72-p. Lists Free. We Buy Stamps. Established 20 Years. **Husman Stamp Co., Dept. 152, St. Louis, Mo.**

VOCATIONS

Make Big Money. Safe and Lock Expert. **Wayne Strong, 3800 Lan Franco St., Los Angeles, Calif.**

WANTED

WANTED—To complete my set **RADIO AGE** need August, September, October, November, 1923, issues, bound or unbound. Advise price. **Lloyd C. Henning, Hellbrook, Arizona.**

WIRELESS

WANT TO MEMORIZE THE WIRELESS CODE? The Coryden Snyder Code Method. Patented, is quickest. Send 50c coin, stamps or M. O. to **C. C. Snyder, 1423 Elmdale Ave., Chicago, Ill.**

WRITERS

NEW WRITERS WANTED—Articles, stories, poems, scenarios, etc. \$13,500 just paid to unknown writer. Entirely new field. (No. bunk.) **NOT A CORRESPONDENCE COURSE.** Moving picture industry and publishers crying for new original material. **YOU CAN DO IT.** We buy manuscripts for books and magazines. Send self addressed envelope for list of 100 subjects. **CALIFORNIA STUDIOS, P. O. Box 697, Los Angeles, Calif.**

WRITERS—Cash in on your knowledge of radio by writing for Radio Magazines and Newspaper Supplements. Write up your radio experiences, your new hook-up, your knowledge of broadcasting stations and artists. Experienced authors will correct and improve your manuscripts—make them typically professional work. **FREE Criticism and Advisory Service** until your manuscript is sold! **ALL Magazines and Papers** demanding fiction and articles dealing with radio. Here is **YOUR OPPORTUNITY to profit!** Send for **FREE** booklet, "How You Can Sell Your Manuscripts." **Willis Arnold and Associates, 210 East Ohio St., Chicago, Ill.**

Make big money writing Movie Plays. Circulars free. **W. C. Krug, Ashton, Illinois.**

Have you ordered your
August Radio Age?

Going Horatio Alger One Better

(Continued from page 62)

tion finally obtained in the tube laboratories of the Westinghouse Lamp Company. This was before the public ever saw even the old UV200 and UV201 tubes—when 199's were but a dream, and filament currents of one to two amperes were tolerated for receiving tubes.

From this Mr. Silver graduated to a large wholesale house where his alert mind quickly grasped the fundamentals of what was at that time the radio business of the booming early twenties. Then another change, this time to a concern which then consisted of but the chief and himself, but which soon grew to deserve the title of "New York's foremost radio shop," where he served as assistant to a prominent engineer, and contributed toward the design of what proved to be the first popular super-heterodyne receiver over offered for broadcast reception. Next, a trip to Paris, and meditation coupled with the salt sea air fired his never latent ambition.

"A New Era"

THUS, in the early summer of 1924, Chicago saw the retail store of silver-Marshall, Inc., with the erstwhile vigilante as its head. Events followed each other with a rapidity characteristic of the radio industry, and by fall the young concern marketed a line of products designed by Mr. Silver which met with instant favor. The old story was repeated—production could not catch up with demand, and winter saw Silver and his partner working shoulder to shoulder with the ever increasing force of the new growing concern. By spring the partners saw the rewards of their labors in the ever-extending business they had built up.

Mr. Silver is probably best known to the radio public as the designer of many pieces of radio equipment and a number of receiving circuits of exceptional merit, several of which have been described in this publication. In addition to his combination of business and engineering ability, his capacity for describing radio apparatus involving complex circuits in a manner so simple that the average layman can easily comprehend, is one seldom met with. His articles have appeared in practically every important radio publication and newspaper in this country.

Desiring to see the *genus homo* in his lair, we called upon Mr. Silver one day. We were ushered into the presence of a mere stripling seated at an unimposing desk, who, when he arose, proved to be over six feet. In the course of our getting several words in edgewise, telegrams flew out, apparently important matters were settled, and ideas evolved and rushed to the laboratory for immediate experiment.

From a shelf he selected one of a number of receivers, handed it to an assistant, and in an instant a volume of sound poured out of the loud speaker that was amazing, yet with perfect quality.

"What is it?" we asked. After a moment the answer came, briefly: "Just a six-tube super-heterodyne. I call it the 'Super-Autodyne,' because it uses an autodyne frequency changer."

"Autodyne frequency changers" not being in our vocabulary, we left after a few minutes conversation, impressed primarily with the sudden transition of the man from the capacity of executive to engineer and back again, and the sincerity, certainty and energy that seemed to pour forth with every word he uttered, either as president or engineer.

With the Manufacturers

(Continued from page 69)

Loop Set Preferable To Antenna, Says Priess

A RADIO statistician recently conducted a research among radio merchants and learned that approximately 53% of persons who enter stores to buy radio receivers indicate a preference for loop sets.

William H. Priess, a well known engineer and president of the Priess Radio Corporation, whose work for a number of years has been exclusively identified with loop reception, is naturally one of its strongest proponents. The percentage of favor toward the loop which the statistician's research showed did not surprise him.

"A loop set has a number of advantages," he said. "The set can be installed quickly and moved to various locations without entailing the services of a steeplejack. It is the ideal set to take in the car on a day's outing or to the country on a week-end. It can be installed in places where the connection of antennae is forbidden or impossible.

"In addition to its inherent mobility, the loop receiver has the remarkable property of directional reception and freedom from certain types of 'static' disturbance. Two interfering signals of approximately the same strength and wavelength but coming from different directions cannot be separated by the ordinary antenna set. With the loop receiver, however, this separation can be made complete by turning the loop so that one of the stations disappears, and tuning in sharply on the other station.

"With the right set and the right loop, satisfaction over the antenna set is certain."

Gain in Squeals Very Small, Says Expert

THE GAIN in radio reception by making the single circuit receiving set oscillate and thus set up a discordant howl in all the other receiving sets in the neighborhood, is so very small that it does not begin to compensate for the added annoyance, L. W. Chubb, Manager of the radio engineer staff, Westinghouse Electric & Manufacturing Company, points out.

The gain in reception through setting up oscillation, when receiving from a one kilowatt station, actually is a small fraction of one per cent. The electrical engineers have determined an infinitesimal gain in comparison with the loss caused in the sets of peoples within a radius of two or three miles who are listening in on the station.

The remedy for the interference caused by single circuit radio sets is not in prohibiting the sale of these sets, as advocated in some quarters, but in proper use of the sets, according to Mr. Chubb.

"The situation is somewhat analogous to use of the automobile," Mr. Chubb says. "On occasion the automobile has destroyed lives of passengers and pedestrians, or otherwise caused great suffering and distress. To stop this, we might outlaw the use of the automobile, but this would deprive millions of people of the enjoyment of a perfectly legitimate pastime, that of automobile riding; would

Fall Radio Season Now On, Is Claim

THE FALL radio season will commence in June, as far as manufacturers of radio apparatus are concerned, declared E. Alden, general sales manager for the Shaw Insulator Co., of Irvington-Newark, N. J. Mr. Alden based his conclusions on a trade survey which he recently completed from coast to coast, during which he learned from manufacturers in every section that the demand for radio apparatus by the buying public has caused the manufacturers to advance their time for production on new equipment to the month of June.

"Strange as it may seem," declared Mr. Alden, "the new date will have a favorable reaction on the trade and will be the means of allowing the manufacturers to more properly gauge the buying demand throughout the country. At the present time it is apparent that there will be many new advancements made in set and parts construction during the coming season.

"Notable among these will be a greater standard of development, together with refinements in general construction calculated to make radio equipment have a greater appeal to the public, and, incidentally, be the means of giving radio its rightful place in the ranks of the world's greatest medium for good entertainment and instruction.

"The entry of many new and substantial concerns into radio fields during the coming season will be one of the greatest means of stabilizing the industry. From present indications there will be a variety of manufacturers sound financially, and with progressive ideas in manufacturing in mind, which will have a stimulating tone for the entire industry and be the means of placing it on a more substantial basis than ever before in its history.

"Parts will be again popular factors during the coming season," declared Mr. Alden. "One of the leading dealers in this country with whom I talked during my recent trip declared that the parts end of his business has been holding up as good during the early Spring season as it did during the past Winter. The trend during the coming season will be in the direction of better merchandise, appealing prices, and merchandise, which is calculated to bring radio to higher levels in the public's buying and mind, and consistent with the great appeal that radio has heretofore generally enjoyed."

deny them the pleasure of their present frequent visits with relatives and friends in distant locations, would slow down business and in numerous ways would be a drawback. The ideal remedy for the losses caused by use of the automobile lies in bringing the individual to so drive his machine that the losses will be eliminated and the gains conserved.

"So it is with the single circuit radio receiving set. This type of set represents the most for the money that the individual can buy. This simple device using one or two small tubes and inexpensive dry cell batteries, gets strong signals from the broadcasting station and is capable of getting great distances."

Is The "ANNUAL" on your Summer List?



IF YOU intend to take a trip this Summer, you're surely going to keep in touch with Radio, either by bringing a set along or building one during the dull afternoons, from parts you can take with you.

AND how are you going to build this set or study up on radio for the big season that is bound to come in September?

The answer is simple. All you have to do is to invest **ONE DOLLAR** in a **RADIO AGE ANNUAL** for 1925, the world's most complete and authoritative hookup book, and take it with you, whether you go to Eagle River or the River of Doubt.

Let the **ANNUAL** for 1925 be your Radio Companion this Summer! It will tell you whatever you want to know in the radio line—from troubleshooting of the little faults that may develop far from home—to the actual construction of simple portable sets or elaborate multi-tubers.

GET THE ANNUAL NOW—and **THEN** go on your vacation! It will be your radio safeguard!

A Big Blueprint Section for your Dollar!

How many blueprints could you buy for a dollar if you started out to buy them, one by one? Very few, you'll admit. Yet in the **RADIO AGE ANNUAL** for 1925 you'll find sixteen full pages of blueprints in actual color, explaining concisely every important simple and complicated hookup developed during the past year! The 32-page blueprint section of the **ANNUAL** is worth many times the purchase price of the book alone. Order the **ANNUAL NOW**—for the limited first edition is rapidly being bought up by eager radio enthusiasts.

**\$1.00 a
Copy**

**RADIO AGE ANNUAL
FOR 1925**

**\$1.00 a
Copy**

Some of the Features

How to read and understand hookups.
How to understand radio phenomena.
Building your first simple set.
How to select the right receiver.
Substituting a tube for a crystal—building the first tube set.
How to amplify any kind of set.
Making a reflex set.
Building your first Reinartz set.
The renowned Baby Heterodyne No. 1.
Adding audio and radio stages to the Baby Het.
How to make a battery charger.
How to make a loud speaker.
RADIO AGE ANNUAL BLUEPRINT SECTION with such popular hookups as the aperiodic variometer, loop sets, feed-

back receivers, neutrodynes, reflex hookups, Baby Het No. 2, a Wonder Super-Het, and others.
How to get rid of interference.
How to make an amplifying unit.
How to recognize and deal with every kind of tube trouble.
Another super-heterodyne for the super experimenters.
Hints on tracing troubles in super-heterodyne circuits.
A three-tube long distance regenerator.
A 3-tube set that easily receives KGO on the loud speaker from Ohio.
Improving the ever popular Reinartz.
AND MANY OTHER UP-TO-THE-MINUTE HOOKUPS AND ARTICLES.

RADIO AGE ANNUAL COUPON

RADIO AGE, INC.,
500 North Dearborn St., Chicago, Ill.

Gentlemen: I want to be one of the first to get the **RADIO AGE ANNUAL FOR 1925**. Enclosed find \$1.00. If I am not satisfied with the **ANNUAL** I will return it within five days and you will refund my dollar.

Name.....

Address.....

City..... State.....

7-25

ZENITH

TRADE MARK REG.

RADIO

→ LONG DISTANCE ←
TRADE MARK REG.

* While MacMillan Charts the Arctic Zenith Broadcasts to the World!

Between Alaska and the North Pole stretches an unexplored area one million square miles in extent—the last remaining "blind spot" on the face of the globe.

Over this vast area will fly, this summer, two great planes of the amphibian type, piloted by U.S. Navy air pilots and equipped with the most highly perfected scientific apparatus obtainable by the United States Government. This entire expedition, which has rightly been described as the greatest expedition of modern times, is under the direction of Commander Donald B. MacMillan.

The purpose of the expedition is the study and photographic charting of this unknown area—and—new tests in radio transmission and reception of unparalleled importance. The section to be explored has never been heard from by radio. Communication will of necessity be *day-light* communication, for in this area the days are six months long.

On an expedition representing so

great a risk, both in capital and human life, only the *best* in radio equipment can possibly command a place. Once more, therefore, MacMillan chooses ZENITH exclusively, both for his ships and for the two great planes flying across uncharted seas of ice.

Thus, while the world awaits reports from this greatest expedition of modern times, it is worth remembering that the only way these reports can possibly be transmitted is by Zenith radio.

Never in all your life, it is safe to say, will you require of a radio set such *outstanding* performance as MacMillan requires of ZENITH in the Arctic. But can you imagine greater satisfaction than to know that your receiving set can *deliver* such performance, any time it's called upon to do so?

Call this evening at your nearest ZENITH dealer, and ask him for a demonstration.

Zenith Radio Corporation
310 S. Michigan Ave., Chicago, Ill.



Super-Zenith IX

Costs More—But Does More

THE complete Zenith line ranges in price from \$100 to \$475.

With either Zenith 3R or Zenith 4R, satisfactory reception over distances of 2,000 to 3,000 miles is readily accomplished, using any *ordinary loud speaker*. Models 3R and 4R licensed under Armstrong U. S. Patent No. 1,113,149. They are NON-RADIATING.

Zenith 4R - \$100
Zenith 3R - \$175

The new Super-Zenith is a six-tube set with a new, unique, and really different patented circuit, controlled exclusively by the Zenith Radio Corporation. It is NOT regenerative

SUPER-ZENITH VII—Six tubes—2 stages tuned frequency amplification—detector and 3 stages audio frequency amplification. Installed in a beautifully finished cabinet of solid mahogany—44½ inches long, 16¼ inches wide, 10¼ inches high. Compartments at either end for dry batteries. Price (exclusive of tubes and batteries).....**\$240**

SUPER-ZENITH VIII—Same as VII except—console type. Price (exclusive of tubes and batteries).....**\$260**

SUPER-ZENITH IX—Console model with additional compartments containing built-in Zenith loud speaker and generous storage battery space. Price (exclusive of tubes and batteries).....**\$355**

SUPER-ZENITH X—Contains built-in, patented, Super-Zenith Duo-Loud Speakers (harmonically synchronized *twin* speakers and horns), designed to

reproduce both high and low pitch tones otherwise impossible with single-unit speakers. Price (exclusive of tubes and batteries) **\$475**

All Prices F. O. B. Factory

Zenith Radio Corporation

Dept. C-7
310 S. Michigan Avenue, Chicago, Illinois
Gentlemen:

Please send me illustrated literature about Zenith Radio.

Name.....

Address.....

This file including all text and images are from scans of a private personal collection and have been scanned for archival and research purposes. This file may be freely distributed, but not sold on ebay or on any commercial sites, catalogs, booths or kiosks, either as reprints or by electronic methods. This file may be downloaded without charge from the Radio Researchers Group website at <http://www.otrr.org/>

Please help in the preservation of old time radio by supporting legitimate organizations who strive to preserve and restore the programs and related information.