

Blueprint Section Every Month

RADIO AGE

The Magazine of the Hour



JUNE 1925
25 CENTS

MEET YOUR BROADCAST FAVORITES

ZENITH

TRADE MARK REG.

RADIO

→ LONG DISTANCE ←
TRADE MARK REG.

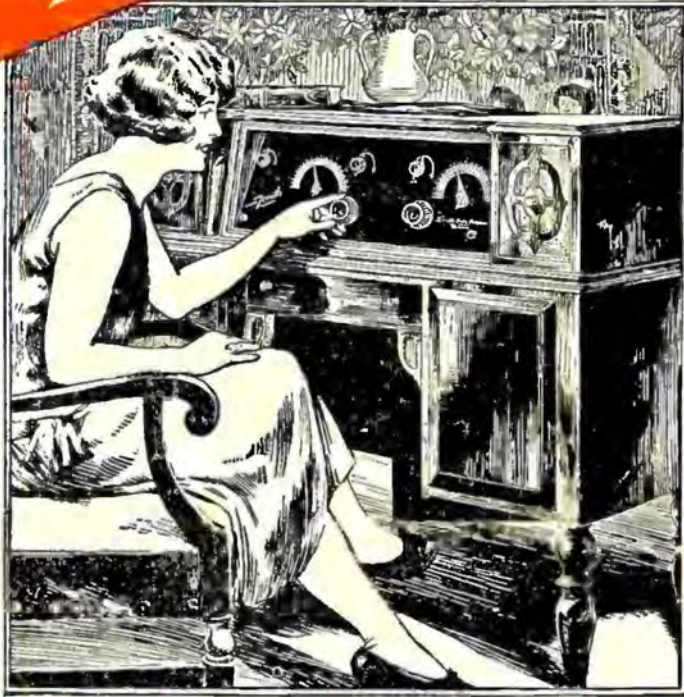

*Super-Zenith IX—
the ideal radio set
for the fine home,
built-in loud-
speaker; batteries
concealed and out
of the way.*

Only the Best is "Good Enough"—

The difference between a radio set that "works"—even one that "works well"—and *Zenith*, is the difference between always longing for "something better" and the supreme pleasure of owning the best that money can buy.

True, *Zenith* costs a bit more, but evening after evening, month after month, *year in and year out*, you will thank your lucky stars that you paid that trifling difference and made sure of the best in radio results.

—Tuning, for instance, so simple that with two dials only you can bring in every important station on the air clearly and in ample volume. Powerful locals may be on full blast, yet you tune straight through at will, get distant stations.

—*More stations in a given length of time than with any other make.* Direct comparisons invited.

The proof that *Zenith* is the set you want is yours for the asking. Only selected dealers who are prepared to *give service* handle *Zenith*. Ask your nearest *Zenith* dealer for a demonstration.

ZENITH RADIO - Costs More - But Does More

ZENITH RADIO CORPORATION

332 South Michigan Avenue, Chicago

ZENITH—the exclusive choice of MacMillan for his North Polar Expedition

The complete *Zenith* line ranges in price from \$100 to \$475.

With either *Zenith 3R* or *Zenith 4R*, satisfactory reception over distances of 2,000 to 3,000 miles is readily accomplished, using *any ordinary loud speaker*. Models *3R* and *4R* licensed under Armstrong U. S. Pat. No. 1,113,149. They are NON-RADIATING.

Zenith 4R - - \$100
Zenith 3R - - \$175

The new *Super-Zenith* is a six-tube set with a new, unique, and really different patented circuit, controlled exclusively by the *Zenith Radio Corporation*. It is NOT regenerative.

SUPER-ZENITH VII—Six tubes—2 stages tuned frequency amplification—detector and 3 stages audio frequency amplification. Installed in a beautifully finished cabinet of solid mahogany—44½ inches long, 16¾ inches wide, 10½ inches high. Compartments at either end for dry batteries. Price (exclusive of tubes and batteries) **\$240**

SUPER-ZENITH VIII—Same as VII except—console type. Price (exclusive of tubes and batteries) **\$260**

SUPER-ZENITH IX—Console model with additional compartments containing built-in *Zenith* loud speaker and generous storage battery space. Price (exclusive of tubes and batteries) **\$355**

SUPER-ZENITH X—Contains built-in, patented, *Super-Zenith Duo-Loud Speakers* (harmonically synchronized *twin speakers* and horns), designed to reproduce both high and low pitch tones otherwise impossible with single-unit speakers. Price (exclusive of tubes and batteries) **\$475**

All Prices F. O. B. Factory.

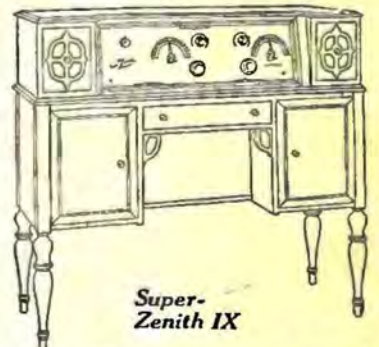

ZENITH RADIO CORPORATION
Dept. C-6

332 S. Michigan Ave., Chicago, Ill.

Gentlemen: Please send me illustrated literature about *Zenith* radio.

Name _____

Address _____

Earn \$50 to \$200 a Week in RADIO

You can! Hundreds of ambitious men are already earning thousands of dollars in this wonderful new industry—you, too, can get your share. Mail coupon below for Free Book which describes fully the amazing money-making opportunities in Radio and tells you how YOU can earn from \$5,000 to over \$10,000 a year.



THE astounding growth of Radio has created thousands of big money opportunities. Millions of dollars were spent during the past year on Radio, and thousands of young men are needed right now to meet the ever-increasing demand of work.

Men are needed to build, sell and install Radio sets—to design, test, repair—as Radio engineers and executives—as operators at land stations and on ships traveling the world over—as operators at the hundreds of broadcasting stations. And these are just a few of the wonderful opportunities.

Easy to Learn Radio at Home in Spare Time

No matter if you know nothing about Radio now, you can quickly become a Radio expert, by our marvelous new method of practical instruction—instruction which includes all the material for building the latest up-to-date Radio apparatus.

Scores of young men who have taken our course are already earn-

ing from \$75 to \$200 a week. Merle Wetzel of Chicago Heights, Ill., advanced from lineman to Radio Engineer, increasing his salary 100% *even while taking our course!* Emmett Welch, right after finishing his training, started earning \$300 a month and expenses. Another graduate is now an operator of a broadcasting station—PWX of Havana, Cuba—and earns \$250 a month. Still another graduate, only 16 years old, is averaging \$70 a week in a Radio store.

Wonderful Opportunities

Hardly a week goes by without our receiving urgent calls for our graduates. "We need the services of a competent Radio Engineer." "We want men with executive ability in addition to Radio knowledge to become our local managers." "We require the services of several resident demonstrators"—these are just a few small indications of the great variety of opportunities open to our graduates.

Take advantage of our practical training and the unusual conditions in Radio to step into a big paying position in this wonderful new field. Radio offers you more money than you probably ever dreamed possible—fascinating, easy work—a chance to travel and see the world if you care to, or to take any one of the many Radio positions all around you at home. And Radio offers you a glorious future!

The National Radio Institute is one of America's Pioneer Radio Schools—established in 1914. Our course is an absolutely complete one which qualifies for a government first-class commercial license. It gets you *bigger* paying jobs in Radio.

Send for FREE RADIO BOOK

Learn more about this tremendous new field and its remarkable opportunities. Learn how you can quickly become a radio expert and make big money in Radio.

We have just prepared a new 32-page booklet which gives a thorough outline of the field of Radio—and describes our amazing, practical training in detail. This Free Book, "Rich Rewards in Radio," will be sent to you without the slightest obligation. Mail coupon for it *now!*

For a short time we are offering a reduced rate to those who enroll at once. Act promptly and save money.

National Radio Institute

Dept. 53HB
Washington,
D. C.



**NATIONAL RADIO INSTITUTE,
Dept. 53HB, Washington, D. C.**

Please send me without the slightest obligation your Free Book, "Rich Rewards in Radio," and full details of your special Free Employment Service. Please write plainly.

Name.....
Address.....
City..... State.....



PAY INCREASES OVER \$100 A MONTH
I am averaging anywhere from \$75 to \$150 a month more than I was making before enrolling with you. I would not consider \$10,000 too much for the course.
(Signed) A. N. LONG,
Greenburg, Pa.



DOUBLES SALARY
I can very easily make double the amount of money now than before I enrolled with you. Your course has benefited me approximately \$3,000 over and above what I would have earned had I not taken it.
T. WINDER,
Grand Junction, Colo.



FROM \$15 TO \$90 A WEEK
Before I enrolled with you I was making \$15 a week on a farm. Now I earn from \$2,080 to \$4,420 a year, and the work is a hundred times easier than before. Since graduating a little over a year ago, I have earned almost \$4,000, and I believe the course will be worth at least \$100,000 to me.
(Signed) GEO. A. ADAMS,
Tamaqua, Pa.

RADIO AGE

The Magazine of the Hour

Established March, 1922

WITH WHICH IS COMBINED RADIO TOPICS

Volume 4

June, 1925

Number 6

CONTENTS

Cover Design by Fred I. Good

	Page
Radio Editorials.....	4
Overcoming Static Disturbances	7
By Roscoe Bundy	
The Joys of Outdoor Radio.....	11
By Armstrong Perry	
A Portable Super-Heterodyne.....	13
By H. Frank Hopkins	
Experimental Circuits for the Double Grid Tube.....	16
By C. R. Bluzat	
A Scientific Five-Tube Receiver	17
By M. B. Sleeper	
The Roberts Receiver.....	19
By Frank D. Pearne	
An Ideal Set in Practical Form.....	21
By McMurdo Silver	
How to Attain Proper Soldering.....	23
Page of Technical Pictures	
RADIO AGE "What the Broadcasters Are Doing"	
—Studio-Land Feature Section	24-33
RADIO AGE Institute Monthly Tests.....	34
RADIO AGE BLUEPRINT SECTION.....	35
A Three-Tube Portable Set	
By John B. Rathbun	
Pickups and Hookups by Our Readers.....	43
Corrected List of Broadcasting Stations.....	64
With the Radio Manufacturers	69, 72

Radio Age is published monthly by RADIO AGE, Inc.
Member: Audit Bureau of Circulations.

Address all communications to RADIO AGE, INC.
Executive, Editorial and Advertising Offices
500 N. Dearborn Street, Chicago, Ill.
Publication Office, Mount Morris, Ill.

FREDERICK A. SMITH, *Editor*
RUSSELL H. HOPKINS, *Associate Editor*
FRANK D. PEARNE, *Technical Editor*
M. B. SMITH, *Business Manager*

Advertising Director
HARRY A. ACKERBURG
500 N. Dearborn St., Chicago, Ill.

Eastern Representative
DAVIDSON & HEVEY, 17 West 42nd St., New York City

Final Advertising forms close on the 20th of the 2nd month
preceding date of issue

Vol. 4, No. 6. Issued monthly. Subscription price \$2.50 a year. June, 1925.
Entered as second-class matter at post office at Mount Morris, Illinois, under the
Act of March 3, 1879.

Copyright, 1925, by RADIO AGE, Inc.

A Chat With the Editor

ANY editor who attempts to follow the winding trail pursued by the Radio Corporation of America cuts out a man's job for himself. Month after month and year after year the court records add voluminously to the serious charges brought by independent radio manufacturers against the \$33,000,000 concern. This in addition to the charges made by the United States government through the Federal Trade Commission, which accuses the Radio Corporation of America of being a party to a conspiracy in restraint of trade.

The latest accusation against the R. C. A. is made by the DeForest Radio Company, which has obtained an injunction in the New Jersey courts restraining the Radio Corporation of America from attempting to steal business from the DeForest Corporation and filch scientific secrets from the DeForest Corporation. It is alleged in the bill that the Radio Corporation of America, to quote the New York Times, "introduced spies into its (DeForest Company's) offices to steal business and technical secrets and had seduced DeForest employes into acts of treachery." The Radio Corporation was ordered by the court to turn over all records obtained by the alleged system of espionage and warned the Radio Corporation not to destroy any such records, pending hearing of arguments to make the injunction permanent.

And this is free and glorious America!

It is enough to make a good American blush with shame that such a rotten mess as this should reach the point where it breaks into news-print. We have observed that various big chiefs of big radio interests have acquired a mania for rough-riding the industry. They are riding to their own destruction and riding fast.

Frederick Smith

Editor of RADIO AGE

Evereadys have long-lasting power

THE long-lasting power of Evereadys more than justifies their price. It is false economy to buy batteries that may be cheaper in first cost, but which are much shorter lived. Considering price and size, Evereadys are the most economical batteries there are, and in addition they are most satisfactory. Buy Eveready "B" Batteries. To light the filaments of all radio dry cell tubes, use the famous Eveready Columbia Ignitor.

Manufactured and guaranteed by
NATIONAL CARBON COMPANY, Inc.
 New York San Francisco
 Canadian National Carbon Co., Limited, Toronto, Ontario

EVEREADY Radio Batteries

- they last longer

EVEREADY HOUR
EVERY TUESDAY AT 8 P. M.
Eastern Standard Time

For real radio enjoyment, tune in the "Eveready Group." Broadcast through stations—

WEAF	New York	WEAR	Cleveland
WJAR	Providence	WSAI	Cincinnati
WEEI	Boston	WWJ	Detroit
WPT	Philadelphia	WCCO	Minneapolis
WGR	Buffalo		St. Paul
WCAE	Pittsburgh	WOC	Davenport

*The proven
 Dry Cell for all
 Radio Dry Cell
 Tubes*

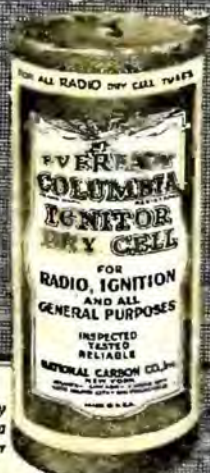

Eveready Columbia Ignitor "A" Battery for all radio dry cell tubes 1½ volts

No. 766
 22½-volt
 Large Horizontal
 Price \$2.00



No. 772
 45-volt
 Large Vertical
 Price \$3.75



No. 764
 22½-volt
 Medium Vertical "B" Battery
 Price \$1.75

RADIO EDITORIALS

RADIO CORPORATION of America sent one of its patent attorneys all the way from New York to Iowa City, Iowa, to take the deposition of a woman who formerly was a newsdealer in that city. The testimony was wanted by the Radio Corporation for the purpose of convincing the Patent Office in Washington that this magazine was injuring the business of "Wireless Age" by continuing to use the title "Radio Age". The "Wireless Age" is owned and controlled by the Radio Corporation of America.

This magazine was represented at the Iowa City proceedings, May 4. We are going to tell what took place down there in Iowa so that those who have paid good money for stock in the Radio Corporation of America may know how the Broadway radio patriots spend their time and money. We think radio manufacturers, dealers and the radio public generally will be interested, also.

Mrs. C. Merton Sulser, of Iowa City, in June of last year was a wholesale news agent in Iowa City. She received a telegram from "Wireless Age" asking her to undertake the sale of that magazine. Mrs. Sulser did not then, and apparently does not now, know much about radio publications. In spite of the fact that the telegram from the "Wireless Age" carried a New York date line, Mrs. Sulser on June 24 sent a telegram to "Radio Age" in Chicago ordering twenty copies of this magazine monthly. This magazine promptly replied that it already had a wholesale distributor in Iowa City and therefore, could not serve her. On the same day Mrs. Sulser received this letter from "Radio Age" she received a letter from "Wireless Age" supplementing the telegram which had solicited her services as a wholesale agent. Mrs. Sulser waited until July 18 of that year and then wrote a letter to "Wireless Age" telling them she had made a mistake and had sent a telegram to "Radio Age" instead of to "Wireless Age."

Oh joy! Oh Paine's Fireworks! Whoopla! Here was the evidence at last. "Radio Age" had turned down an order from a woman who thought she was ordering something else but was not quite sure which or what. Therefore "Radio Age" was injuring the business of "Wireless Age." Off to Iowa City with lawyers and depositions and everything. Let the welkin ring and the streets grow dark with mystery and let the Patent Office in Washington hold its breath. Let the cashiers dig down for traveling expenses and busy men leave their work.

Yes, the president of Radio Age, Inc. was present to hear the deposition taken. It may be that some other woman in Portland, Ore., Portland, Me., Amarillo, Tex., Birmingham, Ala., Pasadena, Cal., Skunkville, Miss., or Timbuctoo, down near King Tut's tomb, may have made a mistake in ordering magazines and picked as her first choice an independent publication instead of one owned and controlled by the Radio Corporation of America, which admits it entered the radio game from patriotic motives.

It may be that "Radio Age" may be dragged hither

and thither and yon. But not all the harassing tactics of the Broadway people can change the facts.

"Radio Age" rightfully uses its title. It was the first to use that title in interstate commerce. It began the use of the title in March, 1922.

"Wireless Age" wants to grab our name because it is the best name in the radio publication field. It has already changed its own title to read "Wireless Age, the Radio Magazine." The Radio Corporation of America should have changed its name from "Wireless Age" to "Radio Age" before "Radio Age" came into the field. Then it would have some rights.

We suggest to readers that they turn to the contents page and read what the DeForest Radio Company says of the Radio Corporation's espionage system. It makes one wonder what stockholders in the Radio Corporation think of it all. Radio Corporation perhaps does not relish the fact that this magazine hits from the shoulder when it talks about trust practices. We have only one answer to that. Radio fans and dealers and manufacturers are with us, thousands strong.

Having left Iowa City, Iowa, with our depositions, where do we go from here?

THE New York Evening Graphic of April 22 published on the first page an interview in which the following statement was attributed to Gen. J. G. Harbord, president of the Radio Corporation of America:

I understand some of the smaller manufacturers have had a slump in their business. This, I think, in the long run, will be beneficial to the radio business as it will tend to eliminate the weaker manufacturers and make the industry more solidified.

Radio Age wrote to Gen. Harbord and asked him if he had been correctly quoted. He replied that the article was a "mis-statement."

We are glad to present this correction for Gen. Harbord because we are aware of the fact that the radio industry as a whole was astonished by the publication of such an interview. The trade was surprised that the head of a corporation that is under federal charges as a trust conspirator should so frankly discuss the removal of the "smaller" manufacturers from the field of activity.

We have asked the editor of the New York Evening Graphic to let us know as to how the paragraph quoted came to find the light in his newspaper. As we go to press we have had no reply from the editor of the Graphic. We hope he will confirm Gen. Harbord's statement and once and for all clear the Radio Corporation of America of the suspicion that it wishes to "solidify" the radio industry by the "elimination" of the smaller manufacturers. Such elimination would leave Radio Corporation the king of all it surveys. We feel sure that in these days of free competition and all our carefully built bulwarks against restraint of trade and unfair competition, the Radio Corporation would not wish to live if its survival depended upon the death of the independents. NO SIR-REE

Look out for "The Radio Spies!" Read About Them in July "Radio Age"

Vigilance

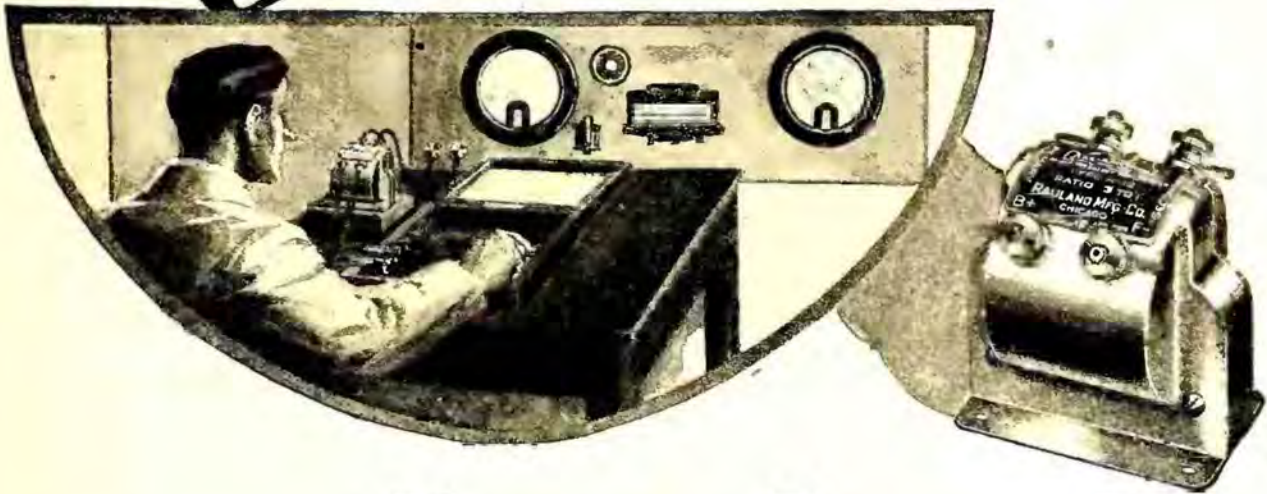

Leadership



Every All-American transformer has stamped upon it a serial number which identifies the record of its individual test at the factory. The manufacturer stands behind it absolutely provided this serial number is not effaced. Look for the number, and for the famous red guarantee tag with the inspector's punch marks.



Of what importance is it to you, as a user of radio transformers, to know that any particular brand, such as ALL-AMERICAN, has held continuously for a number of years the position of proven leadership in quantity of sales?

Simply this: that such an achievement is the best possible proof of continued satisfaction given to other users of ALL-AMERICANS. The average purchaser of

a transformer chooses, above all, an instrument which has been recommended to him by a person whose judgment he respects.

Only by the most thorough accuracy and care in manufacturing, and unusual care in testing, is it possible for ALL-AMERICAN to maintain, year after year, this position of commanding leadership. Let it be your protection!



A new edition of the Radio Key Book, just off the press, illustrates an eight-tube set which is the sensation of the year. Send 10 cents for it now, coin or stamps.

ALL-AMERICAN RADIO CORPORATION, 2680 Coyne St., Chicago, Ill.
E. N. Rauland, President

ALL-AMERICAN

Largest Selling Transformers in the World

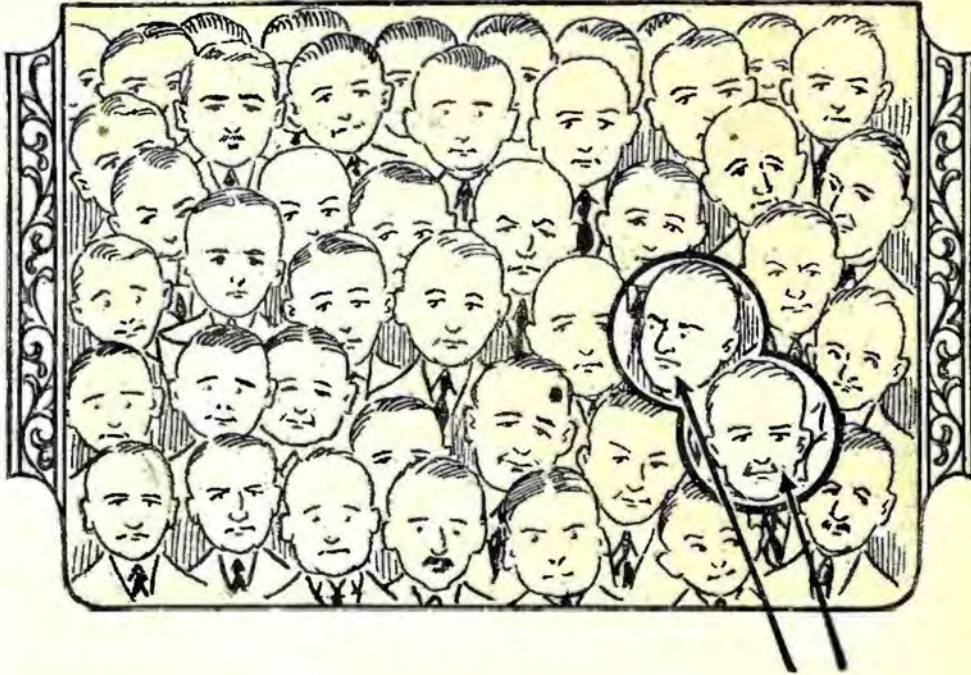

Mr. Manufacturer

**Would you write 100 letters
to 100 people
to reach just two men?**

Then, before you invest your advertising dollars—THINK!

*This Association
is comprised of
the leading Ra-
dio Magazines.*

An analysis shows that publications of general circulation, newspapers and magazines, devote less than 2% of their reading columns to Radio—proving that in the opinion of their own Editors less than 2% of their readers are interested in Radio. In fact, many general publications carry no Radio editorial matter. Therefore—98% of your investment is lost!

On the contrary, the Radio magazine offers 100% Radio editorial—attracts 100% potential buyers.

Spend your advertising appropriation in Radio Magazines. Be sure of the greatest possible return on your advertising dollar.

Radio Magazine Publishers' Association, Inc.

RADIO AGE is a member of the Radio Magazine Publishers Association, Inc.

RADIO AGE

The Magazine of the Hour

M. B. Smith
Business Manager

A Monthly Publication
Devoted to Practical
Radio

Frederick A. Smith
Editor

Make This a Radio Summer by Reducing STATIC Disturbances

AS the Summer season advances, the "static belt" creeps farther and farther north from the equatorial zone, and by the time that this issue of RADIO AGE is off the press it is certain that the great majority of our readers will have been given a taste of imported tropical conditions, and will be in the market for any ideas or devices which will enable them to tune out that roaring, crackling and crashing that mars their reception and subdues their DX ambitions. We can be grateful that the northerner is treated to only a few months of this sort of trouble instead of having static at his door all the year around as they do in the tropics.

Many anti-static devices have been suggested from time to time which are either wholly or partly successful in reducing the intensity of the static crashes so that the signals can be distinguished above the general uproar. Some are simple and others are rather complicated in theory, but all of them are well worth a tryout until one particular arrangement is found that most perfectly meets your local conditions. Any static eliminator which so reduces the interference to a point where the crackling is not audible during the program, and can only be heard faintly during the intermissions, can be considered highly successful from the broadcast listener's point of view, and with careful attention to the following matter, the amateur can generally rig up some sort of contraption which will greatly improve the clarity of the signals and somewhat extend the range of his receiver.

As noise from static and radio signals are both the result of electrical disturbances, and since both strike the aerial at the same time, it is rather a difficult matter to "unscramble" them so that the charges induced by the electromagnetic radio waves are retained, and the impulses due to atmospheric electric charges are grounded and rejected. In fact, this separation is partly made possible by the fact that some radio signals are of much higher frequency (or shorter wavelength), than the static impulses, and hence the two can sometimes be

By ROSCOE BUNDY

How to Make a Good "Anti-Static" Device

separated by some form of tuning or filter system. By suitable arrangement of choke coils, which will stop the radio waves but which will allow low frequency and D. C. static to escape to earth, it is possible to greatly reduce the rattlings and other disagreeable noises.

Atmospheric Electricity

STATIC may be due to two causes: (1) To strong electrical charges deposited on the aerial by the highly charged air particles of the atmosphere, and (2) True electromagnetic waves sent out by lightning discharges or by emanations from the Aurora Borealis. That the atmosphere is a highly charged envelope may prove a novel explanation to many of our readers, but it has been proved repeatedly by meteorologists that the

upper strata of the earth's atmosphere may be charged to hundreds of millions of volts above the potential of the earth itself. These charges may not be directly evident to our senses, but they can be measured by the proper instruments carried in sounding balloons or airplanes. Variations in these charges are painfully evident to the listener-in during the Summer season.

By some means, not universally agreed upon by scientists, each molecule or minute particle of air carries an electrical charge. This charge may have been produced originally by the friction of the air molecule in rubbing over solid objects or over other molecules surrounding it. Again it may have been the result of the action of sunlight or of evaporation. Whatever the cause, it can be easily demonstrated that the air is a strongly charged mass of varying intensity and polarity, sometimes positive and sometimes negative, but always with the charge in evidence.

At high altitudes the potential or intensity of the charge is greater than at points near the earth's surface, and at cloud levels the concentration during thunderstorms may reach hundreds of millions of volts. In fair weather, the charge may have a much lower potential, but in general we can estimate at least 50,000 volts near the normal cloud levels. One investigator estimates the increase to amount to approximately 100 volts per foot of height under average conditions in northern latitudes, but this is only the roughest sort of a guess. Actually, the potentials change day by day at any locality and also through a still greater range with the seasons.

The relative polarities of the earth and atmosphere may change completely within a few hours, and again, the polarity may not be the same at all altitudes, alternating strata of positive and negative charges being found at different heights. As with all natural phenomena it is an irregular and complex proposition.

Fig. 1 illustrates what is known as a "uniform potential gradient," that is, it shows the even and gradual increase in voltage or potential as we increase our

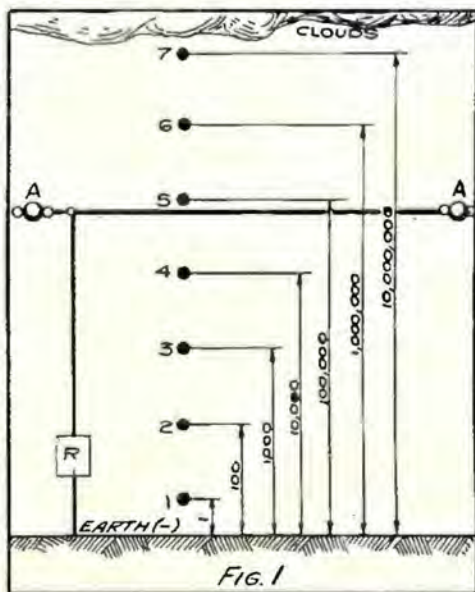

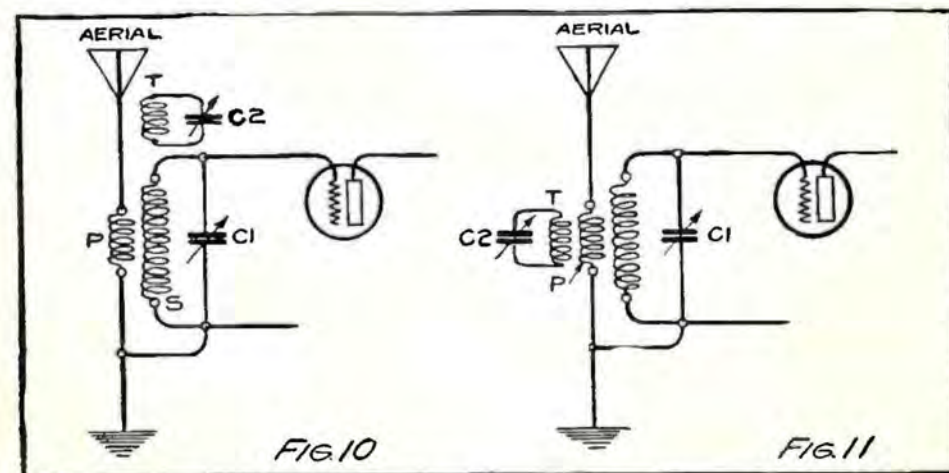
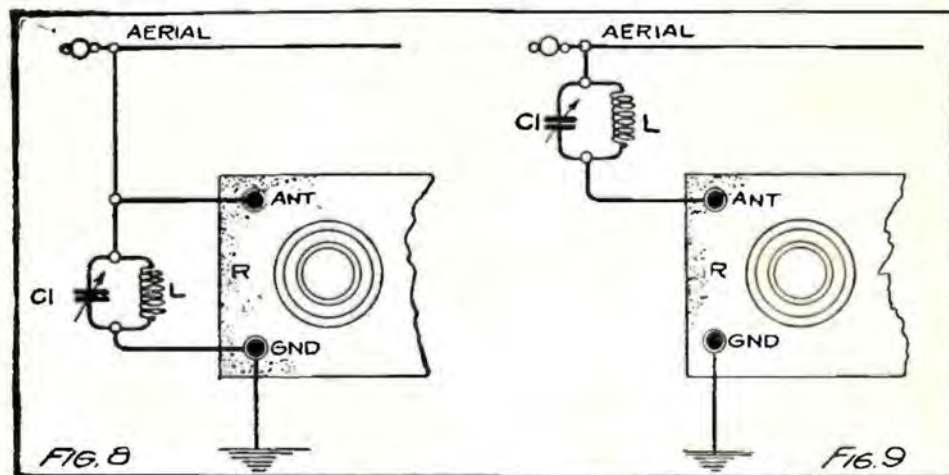
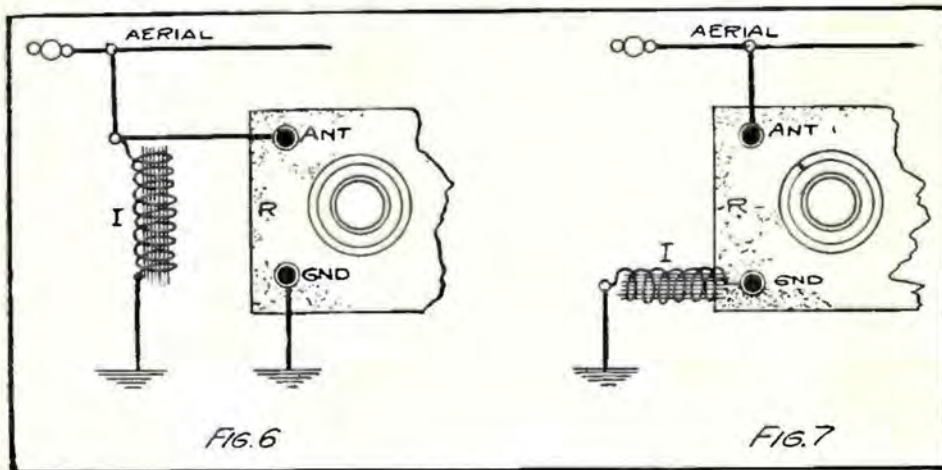
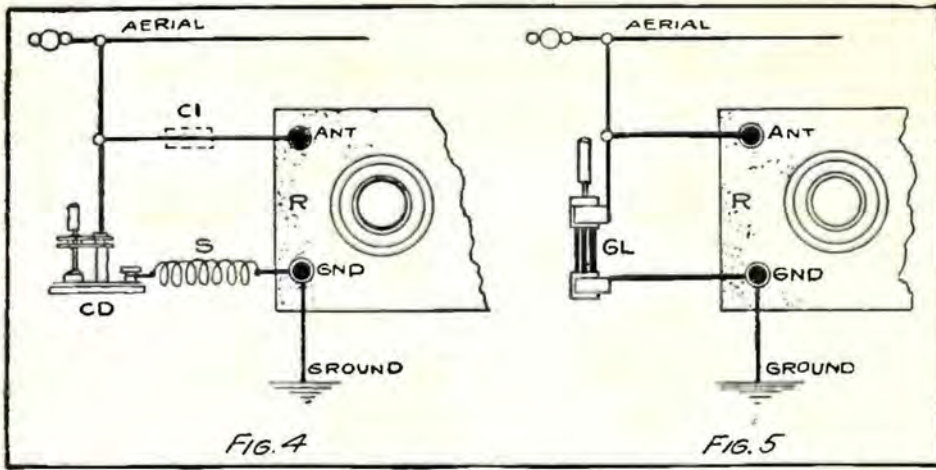

height above the earth at the stations (1-2-3-4-5-6-7), we assuming that a constant polarity is maintained at all heights. At a very small elevation (1), the difference in potential between the air particle (1) and the earth is one volt. At (2) we have risen about one foot and at this point the potential has increased to 100 volts. At (3) we have moved up by 20 feet and the potential difference is now 1,000 volts. This increase goes on step by step until we reach the elevation (7) where a potential of 10,000,000 volts is indicated.

Puncturing a Foot of Air

UNDER the conditions shown in Fig. 1 no discharge can take place and no damage can be done to objects resting on the earth for the reason that the resistance of a one foot layer of air is far too great for 100 volts to puncture. For example, if station (2) exceeds the potential of station (1) by 100 volts, then no flow of current can take place through the one foot strata of air separating these stations. To puncture an air strata one foot thick would require hundreds of thousands of volts. While the voltage is accumulative with increasing altitudes, the air resistance is also accumulative, thus preventing any discharge from taking place as long as the charge is distributed through the mass of the air. Discharge can only take place when the charges are all concentrated over a small area, as in the case of a thunder and lightning storm.

So long as the charges remain at rest, as shown, they can have no audible effort on an aerial hung at any altitude. To produce sounds in the headset requires that the intensity or polarity be varied so that the diaphragms of the headset are moved back and forth. With an (A-A) aerial hung high above the earth, and grounded through the radio receiver (R), a continuous unvarying depletion of potential will take place which has no effect whatever upon the diaphragm of the phones. Thus, at the aerial (A-A) a potential of approximately 100,000 volts will be maintained which will flow through the grounded receiver (R) to earth. The flow in amperes will be exceedingly low as the air particles give up their charges to the aerial very slowly. The flow of current increases with the area of contact made between the aerial and the air, and hence the flow of atmospheric current is greater with large diameters and long wires than with small diameter short aerials.

When the sun beats down upon the earth, the layer of air next to the earth is heated to a higher temperature than the layers far above it. The heating continues until the buoyancy of the heated air strata becomes so great that it finally breaks through the envelope of cold air and starts a vertical circulation as in Fig. 2. This is a complete circuit, the "up-comer" arising at (a-a), and the "down-comer" descending at (b-b). This is illustrative of the "air pockets" so commonly mentioned by aviators.

When this vertical circulation or "remous" is established, our potentials and polarities are all upset. Negative earth

charges are carried up to the aerial at one end by the stream (a-a), and positive high potential air charges are brought into contact with the aerial (A-A) by the down-coming stream (b-b). The total result is that the aerial is subjected to rapidly varying potentials and polarities, and rattling sounds are now heard in the phones of the receiver (R). A high positive charge on the aerial is rapidly succeeded by a low potential negative charge, and again by another positive charge of different intensity; hence there is a rapidly fluctuating series of charges on the aerial which result in the rattle and crashing known as "static." This is one of the many causes of static which may be called "local static."

The hotter the sun, the more rapid the air circulation, and the greater will be the crashing and crackling. When the sun is overcast by clouds, the circulation is reduced or entirely stopped, hence the trouble with local static is greatest with a bright, hot sun and is least in cool, cloudy weather. As any aviator will tell you, "bumpy" air is the worst on hot, still days with no horizontal wind, and practically does not exist in cold weather or with strong horizontal winds which mow down the, vertical currents.

Thunderstorm Mechanism

A THUNDERSTORM is another source of snapping and crackling in the receivers, for the flashes of lightning act like the spark of the old time spark transmitter used in sending code. Further, the thunderstorm sets up violent, vertical air currents, highly charged, which affect the aerial according to the method already described. A high local temperature, a high degree of moisture in the air, and an opportunity to develop vertical air currents give birth to a thunderstorm. Such storms cannot start with strong horizontal winds, although they may afterward cause high winds indirectly after they are thoroughly established.

Fig. 3 is a diagrammatic representation of a thunderstorm during its development. The whole affair starts in with the establishment of a vertical air current on a hot, sultry day with the air containing sufficient moisture to condense rapidly at a slightly reduced temperature. The moist air starts to ascend along (a-a), and in the course of time builds up to an altitude (T) where the temperature is low enough to cause condensation and to form visible clouds of water vapor. At this height, the air is cooled and descends along the line (b-b) until it strikes the earth and is again heated sufficiently to re-ascend along (a-a). This continues until a considerable area of clouds is formed at the altitude (TG), and as each minute particle of water carries an electrical charge with it, the cloud bank finally becomes a highly concentrated, charged mass formed by the accumulation of the individual charges. The ever-increasing velocity of the vertical current throws the vapor higher and higher until some of it is thrown up into an altitude where the temperature is low enough to cause freezing. The water vapor now becomes an intensely white

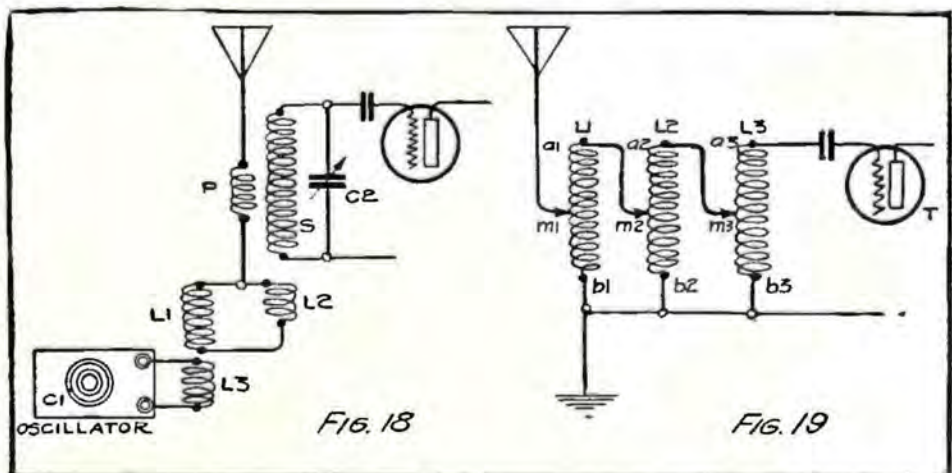
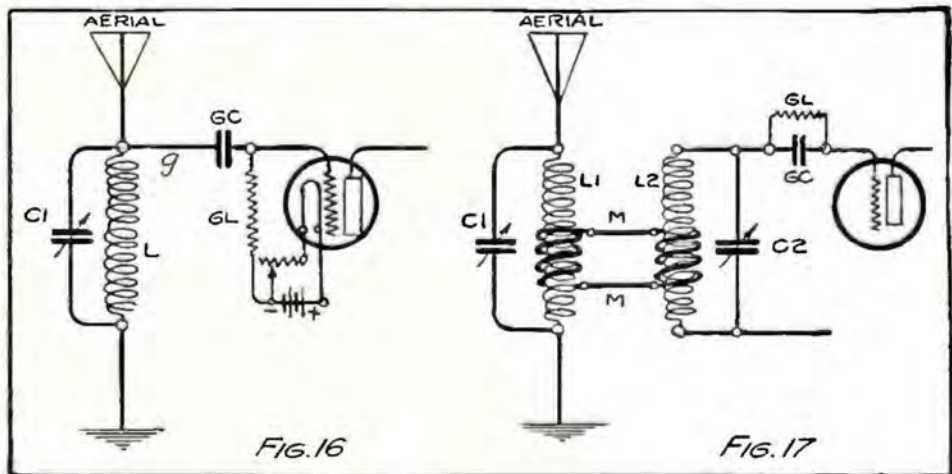
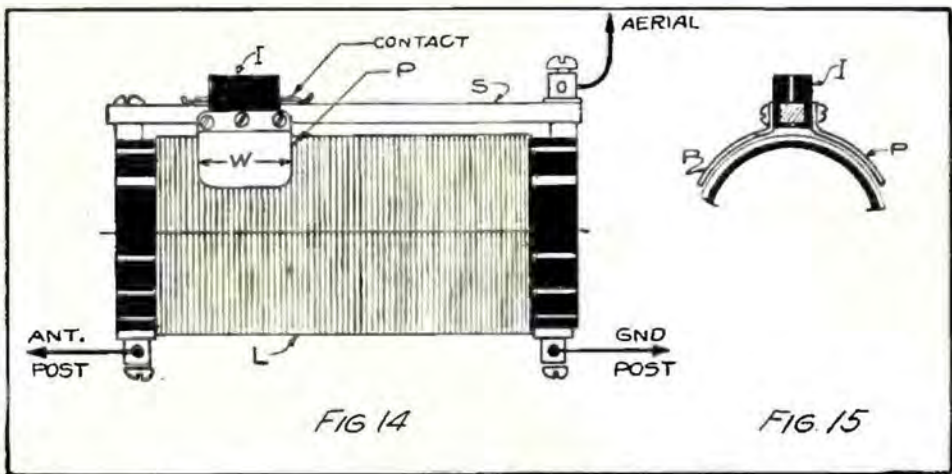
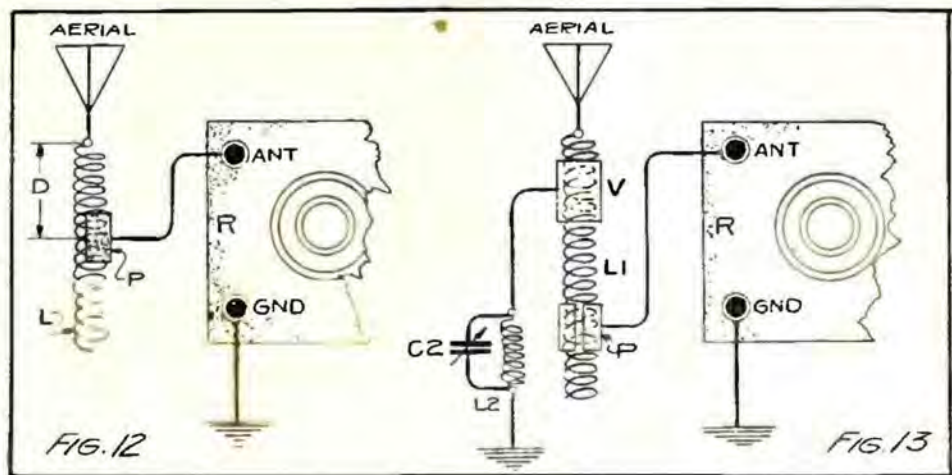

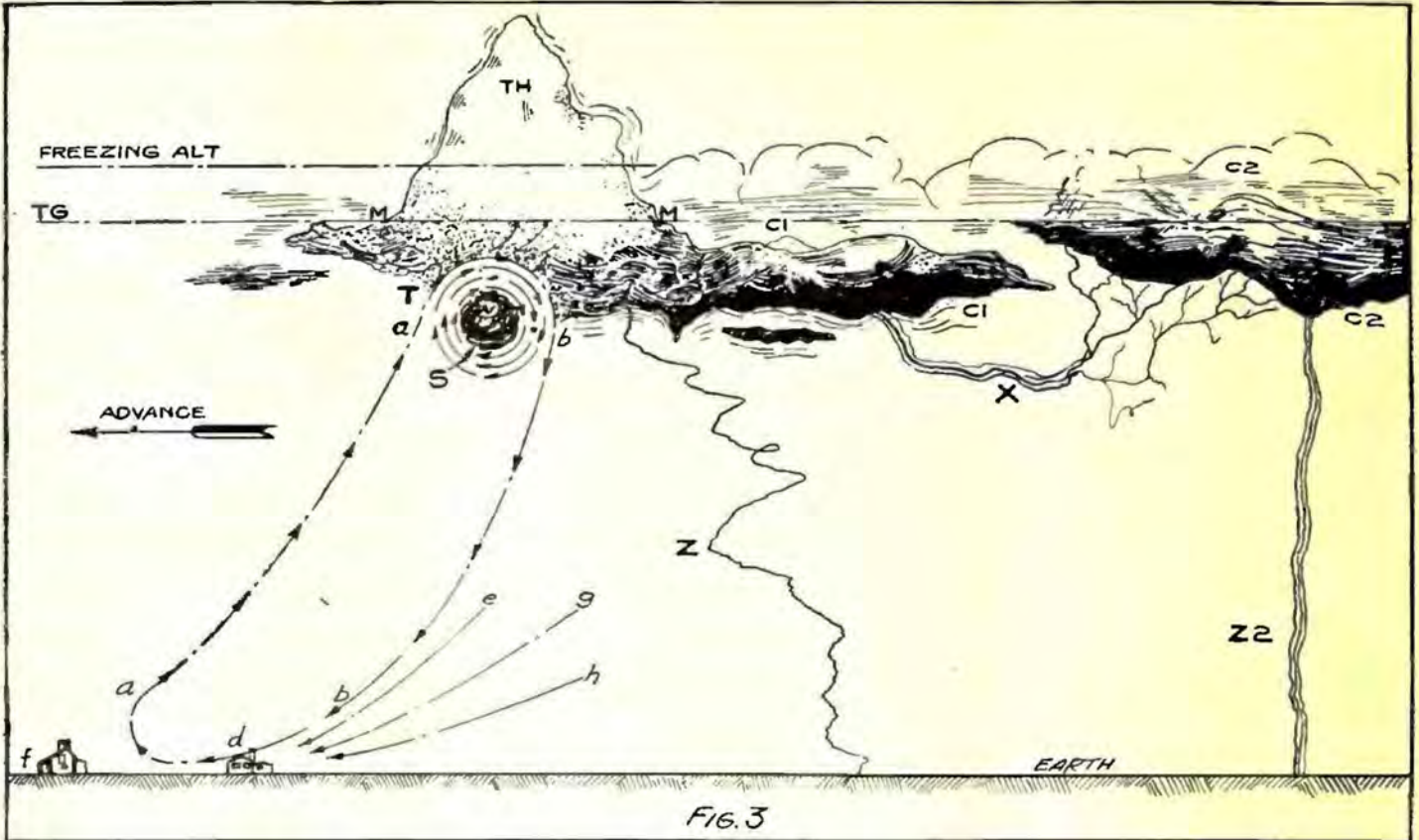

FIG. 3

mass of tiny ice particles at (TH), the brilliantly white peaked mass commonly called the "thunderhead."

In passing from an invisible vapor to a visible cloud composed of small water and ice droplets, the intensity of the vapor charge is increased by condensation. As each drop of visible moisture or droplet contains thousands upon thousands of the vapor particles, the droplet therefore also contains the concentrated charges of all of the vapor particles and the potential of the water drop is therefore enormously greater than that of the vapor. This goes on and on until a terrific, concentrated potential is established at (T) and (TH), which is powerful enough to break down and to discharge to earth through the resistance of several miles of air. This discharge is "lightning," and occurs in its familiar form as at (Z). The total charges of the moisture gathered from many square miles of earth surface are concentrated into the small area (M-M).

With the storm advancing to the left as shown by the arrow, a person at (f) will feel no wind, but when the clouds have moved so that we are standing at (d) we will feel the first blast of ice cold air brought down by the downcomer (b-b). The current is now more inclined to the horizontal so that we feel the wind strongly, and on glancing up we will see the familiar rolling, tumbling "scud" of clouds (S) caught between the up and down moving columns of air. The currents become more and more horizontal as the storm advances and the earth velocities become higher and higher as at (g) and (h). Lightning flashes issue at rapid intervals at (Z), extending from the clouds to earth.

In the course of time, the charge gradually extends to the clouds at the rear (right)

for horizontal equalizing flashes of lightning (X) run back from the thunderhead to the clouds of lower potential as at (C2). We will now have a considerable area of charged cloud (C1-C2), and vertical strokes of lightning will take place at any point in this zone. Continued flashes (X) from cloud to cloud soon bring the potential of (C2) up to that of (C1), and finally one flash (X) will overcharge (C2) so that the heavy earth flash (Z2) will take place. The latter gives the sharp, single, gun-like report that indicates danger. Both (X) or (Z) are reverberating, rumbling and rattling discharges.

Strange to say, the heavy flashes (Z) or (Z2) have little effect on the radio receiver unless they are very close to it, for the reason that the magnetic flux set

up by vertical flashes lies in a horizontal plane and therefore does not cut through the aerial. The real source of noise is in the horizontal transfer discharges such as (X), for these are parallel to the aerial and therefore induce charges in it. Lightning discharges are oscillatory and have much the effect of a spark transmitter producing damped waves. The clouds and the earth form the two plates of the transmitting condenser and the path of the stroke is the inductance. This makes it difficult to tune out such discharges.

Static Crashes and Tuning

WHEN a radio receiving circuit is tuned for the reception of a given wavelength, it will oscillate when the aerial is cut by a wave of that frequency. Unfortunately, the radio receiving circuit will also oscillate at the given wavelength when any other disturbance strikes the aerial, such as the contact charges of the air or the oscillation waves of the lightning discharge. This is independent of the frequency of the disturbing system.

For example, let us say that we have our set tuned to a wavelength of 360 meters. As soon as the 360 meter wave comes from the transmitter, the receiver will oscillate in step with the incoming wave as usual. Now let us say that a strong atmospheric contact charge comes into contact with the aerial with the receiver tuned as before, the charge itself having no frequency. If the charge is heavy enough it will set the receiver circuit to oscillating at 360 meters as before, making it impossible to tune out heavy static charges by the usual means. To make a receiver static-free, it must be arranged so that it will not oscillate when "shocked" by any external force except by the desired radio wave. (To page 52)

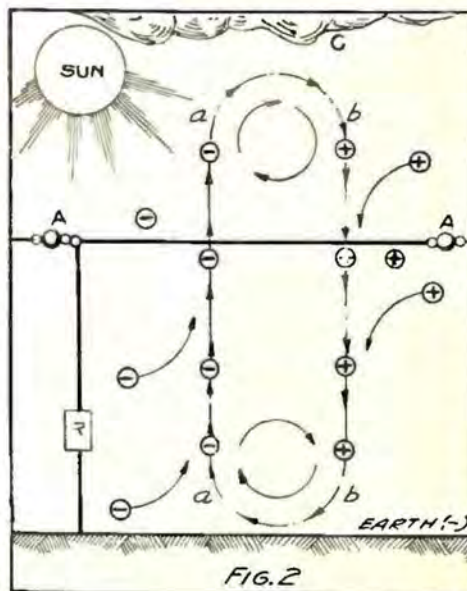
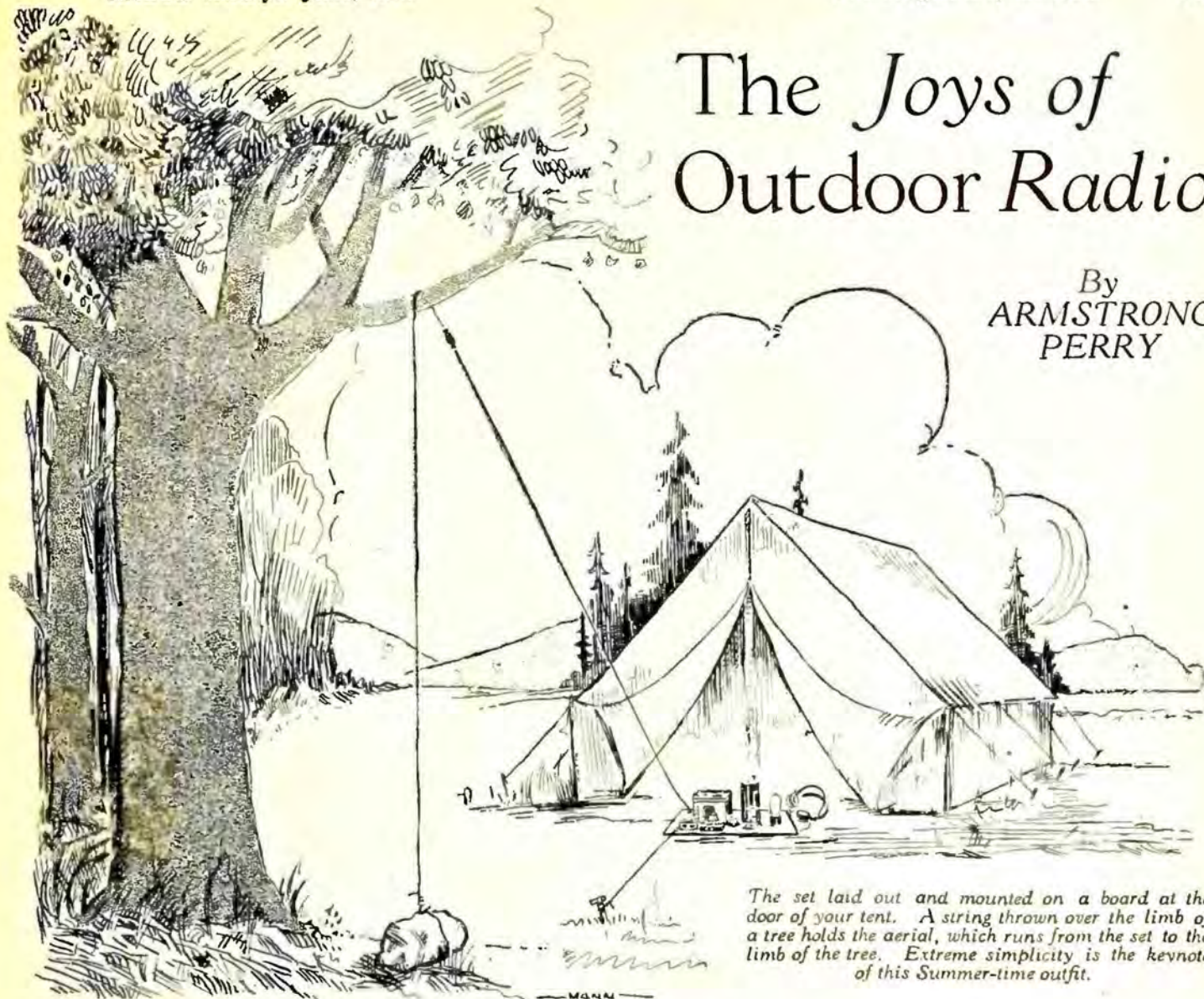

FIG. 2

The Joys of Outdoor Radio

By
ARMSTRONG
PERRY



The set laid out and mounted on a board at the door of your tent. A string thrown over the limb of a tree holds the aerial, which runs from the set to the limb of the tree. Extreme simplicity is the keynote of this Summer-time outfit.

ROUGHING it nowadays consists principally of seeing how many of our city comforts and conveniences we can lug to some locality where, because the trees have not all been cut nor complete sewage systems, water front developments and paving plans completed, city folks can huddle with enough change of scene to make a topic of conversation for the ensuing winter.

The touring car of the Summer traveler carries more equipment and supplies than many a prairie schooner that was both home and transportation for a large family for several months in the pioneer days. Adventurous spirits read eagerly how Enos A. Mills spent days at a time on the summit of the Continental Divide in Winter with only a handful of raisins for food and no shelter at all except possibly his elk-skin sleeping bag, but Enos had to build log cabins with steam heat, hot and cold water and bath tubs in order to tempt said adventurous spirits to go out and have a look at the mountains that he loved.

And we simply must have radio!

Radio Easy to Handle

IT IS easy enough to carry a radio outfit on any outing, long or short. It is risky to carry the home outfit,

even if its bulk and weight are not too great, for cabinets and insulation designed for indoor use are likely to absorb enough moisture in the open on a rainy day to ruin the set. A better method is to improvise a rough and ready outfit that can be used without anxiety, because even if it should be damaged, the loss would not be great.

Reduced to the minimum, a tube set consists of a single-wire aerial, one inductance coil, one variable condenser, one grid leak and condenser, one tube, one rheostat, one "A" battery, one "B" battery, a pair of phones and a ground connection. Amplifier units and a loud speaker can be added if desired.

It is just as much fun to figure out how these devices can be mounted in the smallest space as it is to get out the old fishing rod, shellac the woodwork and oil the joints, but it is not necessary to mount them at all. Unmounted, they can be tucked away in the corners of a haversack or traveling bag in which, ensemble, they would present a problem comparable to that of finding room for the things she forgot in the wife's trunk.

The aerial wire can be of small size that will coil easily. A quarter-pound or half-pound spool of No. 20 or 22 is all right and it can be respoled in a

minute after it is taken down. Insulators are necessary, but a length of twine soaked in oil will serve the purpose. Where there are trees the aerial can be elevated to a better height than the usual home aerial. It is not necessary to climb the trees unless a too inquisitive bull moose appears during the process of erection. A ball of chalk line and a plumb bob, or any piece of twine with a weight on the end, can be whirled like a sling to throw the weight over a high branch, after which the wire can be hauled aloft at your leisure. Trees themselves have been used as aerials. There was a spasm of it in the early days of broadcasting. So there need be no undue anxiety over accidental contacts between wire and branches unless results at the receiver are poor.

Assortment of Coils

A 50-turn honeycomb coil, mounted, costs only about one dollar, and its weight adds little to a pack. To insure a tuning range to suit all tastes, it is well to have a size or two on each side of this—say 35 turns and 75 turns. A single-coil mount is a convenience but is not indispensable.

The plate type of variable condenser is easily injured, but the danger can



A simple set to take along on your vacation trip and assemble at your leisure. Notice that only parts absolutely necessary are used and yet this outfit will produce satisfactory results at minimum expense.

be eliminated by purchasing one in knock-down form and assembling it as wanted. The assembly occupies even the novice only a few minutes and the second or third time it is put together the operation becomes almost mechanical. Forty-three plates will make the largest condenser commonly used in radio receiving. If you have that many, you can make condensers of any desired size merely by assembling more or less plates. Book-type condensers, ready-made, occupy less room and weigh less. There are also some very small condensers, operated by dials, that have capacities similar to the 11-plate, 23-plate, 43-plate and other sizes.

Grid leaks and grid condensers are so cheap and small as to present no problems. It is only necessary to make sure that you have the correct resistances and capacities for the tube to be used. Low-voltage tubes that can be lighted by dry cells are usually preferred in portable outfits, but if the automobile with its storage battery is sure to be where it is wanted at all times, then the larger tubes with their greater output of energy are practicable. It is unnecessary to say to anyone except the novice that the tube should remain in the original package, swathed in cotton wool and corrugated paper, except when in use. The rest of us have paid our five dollars for that lesson. The little Myers tube is a glutton for punishment and is perhaps the best for vacation purposes.

Folks generally prefer rheostats that are finely variable. They are especially desirable in an out-door outfit which is more or less crudely assembled and needs such advantage as can be gained without adding to the weight. Pressure type rheostats, and those made with sliding contacts that travel the entire length of a wire, instead of passing from turn to turn, give finest control.

Some tubes require only a single No. 6 dry cell, to light the filament. "B" batteries can be purchased in small sizes for portable outfits where weight must be reduced to the minimum. Very sensitive phones with mica diaphragms will make up, to some extent, for the lack of amplification. A short length of the aerial wire with one end in the water or attached to a spike driven into wet earth provides a ground connection.

A book of hook-ups like the RADIO

AGE ANNUAL will come in handy, because even so small an outfit can be assembled in many different ways.

To tell the unvarnished truth, most of the pictures showing folks listening to radio broadcasts around the campfire are especially posed for enterprising photographers and for home consumption. Any city man who has enough honest-to-goodness love of Nature to have braved the mosquitoes and punkies, the investigative ants and the too-neighborly porcupines, through even two or three nights in a real wilderness, knows that by the time darkness brings the ideal radio conditions everybody is snoring unless there happens to be a poker game with an easy mark at one corner of it. He hears enough of "Red Hot Mamma" when he gets back where she is and tries to explain why he is a week late, and he cannot see why those who wail "I Want to Be Happy" cannot get that way without disturbing the whole world about it.

On Being Kindhearted

NEVERTHELESS, there are, in every out-door jaunt, plenty of opportunities for the use of radio. One of them is in giving pleasure to humble folks whose only contact with cultured people

from the centers of population is that provided by an occasional sportsman or tourist.

Few city dwellers realize how scarce money and luxuries are in many rural areas where we are enraptured by the wealth of the things provided by Nature. Nor can we who are buffeted by crowds from day to day appreciate the heart hunger of lonely souls who, even when they do meet a person from the big world outside, are sensitive and awkward because they feel they are being laughed at. All improvements reach those on the fringes of civilization last of all. Without going very far from town, it is always possible to find, on the poor roads, households where not even the sewing machine has arrived.

I have visited many of these. In one of them I showed a long-haired, bare-foot boy how to put up the aerial and connect the apparatus according to a wiring diagram. With grand-dad and parents and a half dozen half-scared brothers and sisters watching, open-mouthed, he turned on the juice.

Before my eyes an epoch in that family's history opened. The announcer's voice so startled the youth that he snatched the phones from his head, but he quickly replaced them, then passed them around.

To each of the awe-stricken, simple-minded sons of the forest, the miracle was unbelievable but true. There was no sleep in the house that night and before dawn there came slipping in from a dozen woodland trails the folks whom God forgot.

This obscure family suddenly had become a social center. The boy, whose chief claim to distinction was that he could hit a squirrel or a revenooer in the eye with his 22 rifle, could now shoot at and hit far more distant marks.

The battery ran low and that brought up the question of expense. There were fresh ones in the car, and as for the crude little set, I told them I might call for
(Continued on page 56)

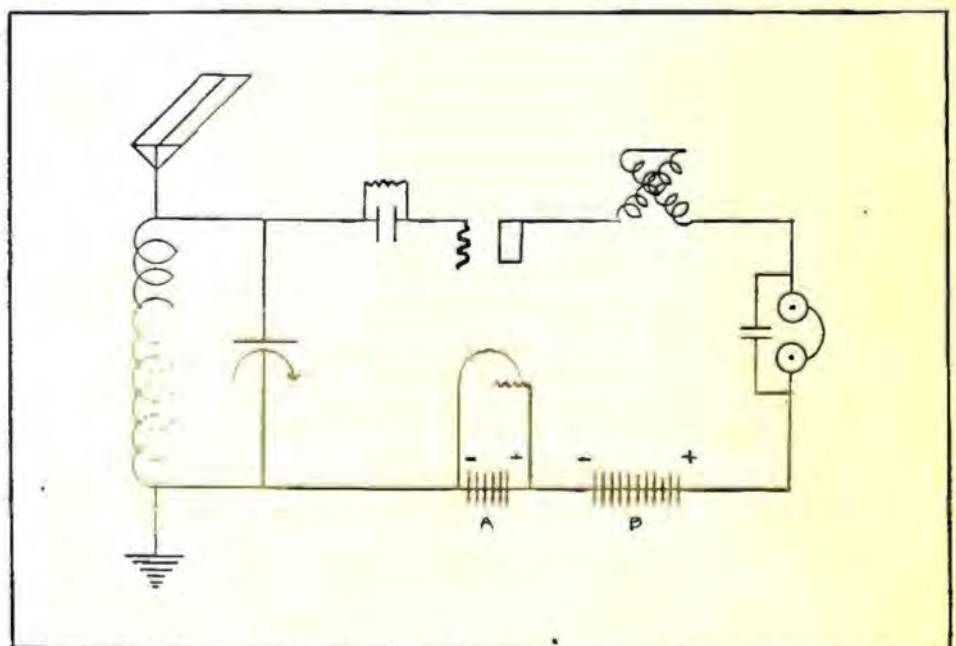

The wiring diagram for Mr. Perry's simple outdoor radio. Adding a variometer as shown above will make the set regenerative and help a bit.

☞ A Receiver that Can Be Used All Year 'Round—At Home and Afield

A Seven-Tube Portable Super-Heterodyne

By H. FRANK HOPKINS

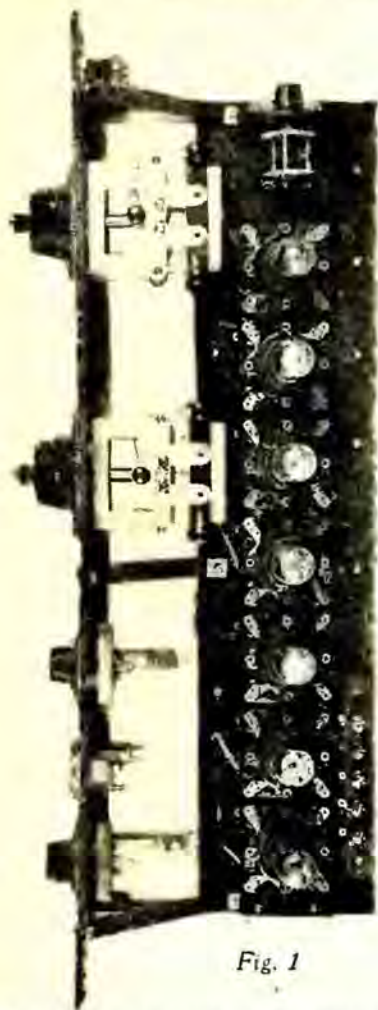

Fig. 1

The top view of the portable super, showing arrangement of the equipment on the tube socket sub-panel and the front panel.

WHY should our radios be shut down when the balmy days of Summer approach and the fish start to bite, when the great open spaces call and we respond?

Some of us can afford to have a good radio receiver at home and another in portable form, but there are many of us who cannot. Then there are those who want the last word in receivers, both at home and afield. They would not be satisfied with the usual type of portable set, so, after much searching and experimenting, the writer has at last found the ideal super-heterodyne circuit that can be built into a combination set. It is a receiver that will fit nicely in the home surroundings during the long Winter months, and still be ultra portable for Summer week-end trips and for extended vacations.

This set is very compact and efficient, utilizing every piece of equipment to its utmost, with some parts doing dual duty, as in the well-known reflex type of circuit, so desirable in portable receivers. Yet neither tone, volume nor distance is sacrificed.

This receiver uses seven "199" tubes, requiring six dry-cell batteries for filament current and 90 volts "B" battery for the plate. Unlike the so-called "portable" receiver, which is usually so unwieldy and heavy, the batteries, loud speaker, loop and such accessories in this

set are carried in one compact case. The load is thus made evenly balanced and not so cumbersome to carry. This case, when the set is used at home, will fit in very nicely with most any surroundings without the usual array of a separate loop, batteries and reproducer.

Analyzing the Circuit

BEFORE going into the details of building the set, let us analyze the circuit, so that we will know its good points and be better enabled to understand why and how it works so well, for there is not doubt it *does* work well, producing clear tone and plenty of volume with surprising selectivity, making it possible to tune in distant stations without interference from nearby powerful stations. Separations of four or five meters in wavelength are easy with this receiver. This is accomplished by using transformers that have been built with great care and have been accurately matched and tested, and are well shielded from outside interference and from each other.

Now, the wave emitted from a broadcasting station is naturally broad. This is necessitated because of the presence of what are called "side bands" or side frequencies, which carry the modulation of the voice or sound being broadcast. The transformers used in this set are designed with a peak of amplification sufficiently broad to cover these side bands or side frequencies efficiently, yet narrow enough to perfectly separate stations of four or five meters difference.

By referring to the circuit diagram, we find that the first tube serves as a "short wave" radio frequency amplifier. This is a feature not usually incorporated in super-heterodyne combinations, and makes for very efficient long distance reception. The grid of the first tube accepts the signal picked up by the loop or antenna and passes it to the short wave radio frequency transformer, where it is amplified and passed to the grid of the second tube. This tube serves as a rectifier and frequency changer, thereby doing double duty. There is no loss of efficiency in this arrangement, and a saving of one tube is effected. The output of the frequency-changing tube has two frequencies; one of short wave or high frequency, and one of long wave or low frequency. The short wave, high

frequency is by-passed and used no more. However, we preserve the long wave or low frequency and pass it on to the first long wave transformer, usually called "intermediate frequency" transformer. There it is amplified and passed to the grid of the first tube, and now the first tube is doing its second duty; that of amplifying at intermediate frequency.

The first tube now passes the intermediate frequency on to the primary coil of the second intermediate frequency transformer, and here it is amplified again through the remaining two stages of the intermediate frequency amplifier. It is readily seen that the first tube has done two duties; that of amplification at short wave or high frequency and also amplification at long wave or intermediate frequency.

"Heterodyne Action"

THE second tube has done the service of amplification at short wave or high frequency and also has created a third frequency known as the long wave radio frequency or "heterodyne" action. From the last intermediate amplifier tube the signal is rectified in the detector tube and passed to the audio frequency tubes and transformers for amplification at "audio" or voice frequency.

Most super-heterodyne receivers employ a potentiometer to control oscillation, by bringing the grid return leads of all of the radio frequency transformers to the center point of the potentiometer and adjusting it so that a positive potential is impressed upon the grid of the tubes, thus preventing oscillation. But in doing so the "B" battery current is raised considerably, thus placing an unusually heavy drain on the "B" batteries and materially shortening their life. This feature is unnecessary in this set, as the intermediate frequency transformers are "neutralized" so that the tubes will operate equally as efficient with a negative grid bias through a $4\frac{1}{2}$ volt "C" battery. The use of the "C" battery in the grid circuit reduces the drain on the "B" batteries and greatly prolongs their life. While the average seven tube radio receiver draws around 50 milliamperes of "B" battery current, this set operates around ten milliamperes, and no potentiometer is necessary.

Volume is controlled by a 60-ohm rheostat in the filament circuit of the first



Fig. 2

Rear view of Mr. Hopkins' receiver, showing the assembly of the sub-panel, including the transformers, which are so arranged as to conserve the maximum amount of space and make the set truly portable as well as compact.

intermediate frequency amplifier tube, the intermediate frequency transformers being so well balanced or neutralized that there is no tendency toward oscillation.

When a regenerative loop is used, the strength of the signal impressed upon the first tube is greatly increased. This is accomplished by a capacitive coupling between the grid and plate of the first tube.

Feedback is obtained by a midget variable condenser to the center of the loop. A regenerative loop is a loop having two windings running in the same direction, parallel to one another, and tapped in the center. Another unusual feature of this receiver is the design of the transformers. All of them are enclosed in drawn brass cases, which completely shield the windings from outside interference and prevent internal coupling and oscillation. The windings are all well impregnated with a high grade insulating compound which prevents moisture absorption and protects the windings from damage through rough handling.

The first transformer (R-201) is a long wave, radio frequency transformer having a peak of amplification sufficiently sharp to permit close and accurate tuning without the elimination of the "side band" frequencies which are so necessary to true tonal reproduction. This transformer is peaked by two fixed condensers (.0001 and .001.)

The second transformer (R-202) is a radio frequency transformer having high amplification as low as 225 meters and as high as 700 meters.

The third transformer (R-203) is a long wave, radio frequency transformer.

The fourth group (R-200), contains three intermediate frequency transformers whose curve covers a wide band of frequency. The fifth and last group (R-204) contains two audio frequency transformers completely shielded and of as high amplification ratio as is consistent with

LIST OF MATERIALS FOR THE PORTABLE SUPER-HET

- 1 R-200, 3-stage tuned radio frequency transformer.
- 1 R-201, long wave radio frequency transformer.
- 1 R-202 short wave, radio frequency transformer.
- 1 R-203, long wave radio frequency transformer.
- 1 R-204, 2 stage, radio frequency transformer.
- 2 .0005 variable condensers and dials, vernier adjustment. (VC and WC).
- 1 Midget variable condenser, maximum capacity .0001 mfd. (LC).
- 7 Type 199 tube sockets, spring base.
- 1 30-ohm rheostat (TR).
- 1 60-ohm rheostat. (VR).
- 2 .001 mfd. mica-fixed condensers (A and B).
- 2 .005 mfd. mica-fixed condensers (E and F).
- 1 .0001 mfd. mica-fixed condenser (C).
- 1 .00025 mfd. mica-fixed condenser (D).
- 2 grid leak mountings (for FG and VG).
- 1 Tubular grid leak (2 to 7 megohms, to suit tube used.) (FG).
- 1 Variable grid leak. (200,000 to 300,000 ohms.) (VG).
- 1 Single circuit jack (LP).
- 1 Two-circuit jack (DP).
- 1 "A" Battery switch (S).
- 1 Panel mounting ammeter .0 to 1.8 scale (if desired).
- 3 Single contact jacks and plugs for loop terminals (No. 1, 2, 3).
- 5 Binding posts (A+, A-, B+, B-, B+5, and B+).
- 1 front panel, (7" x 22" x $\frac{1}{16}$ ").
- 1 Transformer sub panel (4 $\frac{1}{2}$ " x 21" x $\frac{1}{16}$ ").
- 1 Socket sub panel (2 $\frac{1}{2}$ " x 21" x $\frac{1}{16}$ ").
- 1 Binding post strip (2" x 6" x $\frac{3}{16}$ ").
- 4 Brass brackets for supporting front panel to sub panel assembly.
- 2 Brass spring clips for supporting "C" battery.
- 1 $\frac{1}{2}$ -volt "C" Battery.
- Miscellaneous screws, nuts, spacers, wire, terminals, solder, etc.
- 1 $\frac{1}{2}$ " x $\frac{1}{2}$ " brass angle, 12" long for stiffening transformer sub panel.
- 1 cabinet or case, to fit 7" by 22" panel as desired.

good tonal quality. The circuit diagram, together with the views of the assembled set, gives a very accurate idea of the method of mounting the parts of the receiver. When set is laid out as shown, all leads can be run in the shortest distance and no trouble need be expected from feed-back or capacity in the wiring.

The list of parts to build the set is given in an accompanying column. All of the parts bear the same designating letters and numbers as are used in the diagram and throughout this article. This is to better enable the prospective builder to identify each part more easily and to aid him in mounting and wiring the equipment.

Layout of Panels

WHEN all of the parts are secured, we can lay out and drill the transformer sub-panel, the socket sub-panel, and the front panel, to mount the apparatus as shown in the views of the set. This is best done by placing the parts in their respective places and marking the mounting holes with a punch or sharp awl. These holes should be drilled a bit larger than actually required, so as to prevent the mounting screws from binding when lining up the parts.

In preparing the tube socket panel, we will drill two holes for each socket, in addition to those required for mounting the sockets. They will line up with the filament terminals of the tube sockets. The filament terminals will be removed from the sockets and replaced when the sockets are mounted, so that the nut or terminal side is below the sub-panel, making it possible to run the filament current or power leads away from the high frequency leads.

When the transformer sub-panel is drilled, it should be stiffened by mounting the $\frac{1}{2}$ " by $\frac{1}{2}$ " x 12" brass angle on the reverse side to the transformers, in line with the center of the sub-panel, as noted in Fig. 1. The transformers and



Fig. 3

A front panel view of the portable super-heterodyne, showing the tuning and volume controls and the ammeter for filament current.

grid mountings will then be fastened to the panel and we are ready to assemble the two sub panels.

The two sub panels are assembled with six No. 6 brass machine screws and nuts, 1 1/4" long, mounting the socket sub-panel directly over the 1/2" angle and using 1/2" spaces between the two sub panels as noted in Fig. 2.

The two variable condensers (VC) and (WC) will be mounted to the front panel as will be the two jacks (LP and DP), the three loop jacks (Nos. 1, 2 and 3), the battery switch (S) and the ammeter, if an ammeter is to be included. Now we will lay this panel aside until most of the wiring is completed for the sub-panels.

It will be well to run all of the connections possible on the sub panel assembly, before mounting the front panel, as most of the wiring is required here, making it much easier to reach. The set will be wired with sixty-strand, double silk covered copper wire, except where the fixed condensers are to be supported. For this we will use bus wire covered with a good insulator such as spaghetti.

When mounting the fixed condenser, (C), be sure to place it at least two inches or more from all other wires or transformers. If it is too close, coupling is liable to take place between the plate circuit and grid circuit of the first tube, causing noise or making it hard to tune properly.

Ordinary Loop Possible

THE front panel will be mounted to the sub panel assembly when this wiring is completed and the parts connected up. The four brass brackets will be used for his purpose, as shown in the views of the completed set. A regenerative loop should be used with this set for best results, as covered earlier in this article. However, an ordinary loop may be used by connecting one terminal to loop jack No. 1 and the other terminal to loop jacks No. 2, and 3.

An antenna may also be used if desired, but a two-circuit coil will be required for this. It should be wound on a 3" diameter tube. The primary is to have eight turns of No. 22 double silk covered copper wire, wound in an even layer, one end to be connected to the antenna and the other to a good ground. The secondary coil will have fifty turns of the same wire wound in the same direction on the same tube, one end to be connected to loop jack No. 1 and the other to loop jacks No. 2 and 3.

The set is made ready for operation by connecting the six dry cells in series multiple; that is, two sets of three cells connected in series and the positive terminals of each set connected to binding post A+, and the negative terminals to binding post A-. The 90 volts of B battery will be connected in series and the negative terminal connected to binding post B-, taking a tap off at 45 volts and connecting it to binding post B45, the 90 volt positive lead to be connected to the binding post B+.

Tuning is very simple. It is done by the two dials (VC and WC) and by moving the loop in an arc of 180 degrees.

The nidget condenser (LC), when once adjusted, need not be changed. Volume is controlled by the rheostat (VR) and when the set is once logged, one can be certain that when he turns his loop and two dials (VC and WC) to the same setting he will get the same station—if it is on the air, as this setting does not vary when properly built and operated.

Logging the Set

To prepare an accurate log of the dial settings of condensers VC and WC it will be well to secure the regular cross section paper usually used for this purpose and plot a curve for each dial. This can be done by first tuning a station to its best maximum setting on the true wave and spotting a point on the chart for each dial, corresponding to the point of the

dial and the wavelength of the station. For example, suppose we tune in a station whose wavelength is three hundred meters; the setting of dial VC will be approximately 5-32. That is, the sliding element of the condenser will be pulled out until number five is in line with the dial and the dial rotated until it reads thirty-two. This will be spotted on the chart for dial VC at three hundred meters on the vertical scale and fifty-three on the horizontal scale.

The same procedure will be followed for the dial WC. The rheostat dials need not be logged, as they will vary as the filament batteries grow weaker.

QUITE an improvement may be made in the results obtained by this set if the tubes are matched. This may be done by using a tube tester similar to that described by the writer in the May issue of RADIO AGE.

If no tube tester is available, the next best way to match them would be to tune in a station, and then by shifting the tubes until the best results are obtained, with the smallest filament current drain.

The tubes should then be marked so that they will be put back in their proper places in the circuit when once removed. A tube whose characteristics vary to a very great extent from those used for a like purpose on the same filament control, will cause considerable noise in the set and sometimes will be the direct cause of aging the other tubes by requiring excessive filament current to be supplied to the circuit to make this tube operate.

Note: It would be advisable to communicate with the writer in care of RADIO AGE before starting to build this set, and secure a detailed list of parts as used in the original receiver. Detailed panel layouts and bracket dimensions may be had at cost if desired.

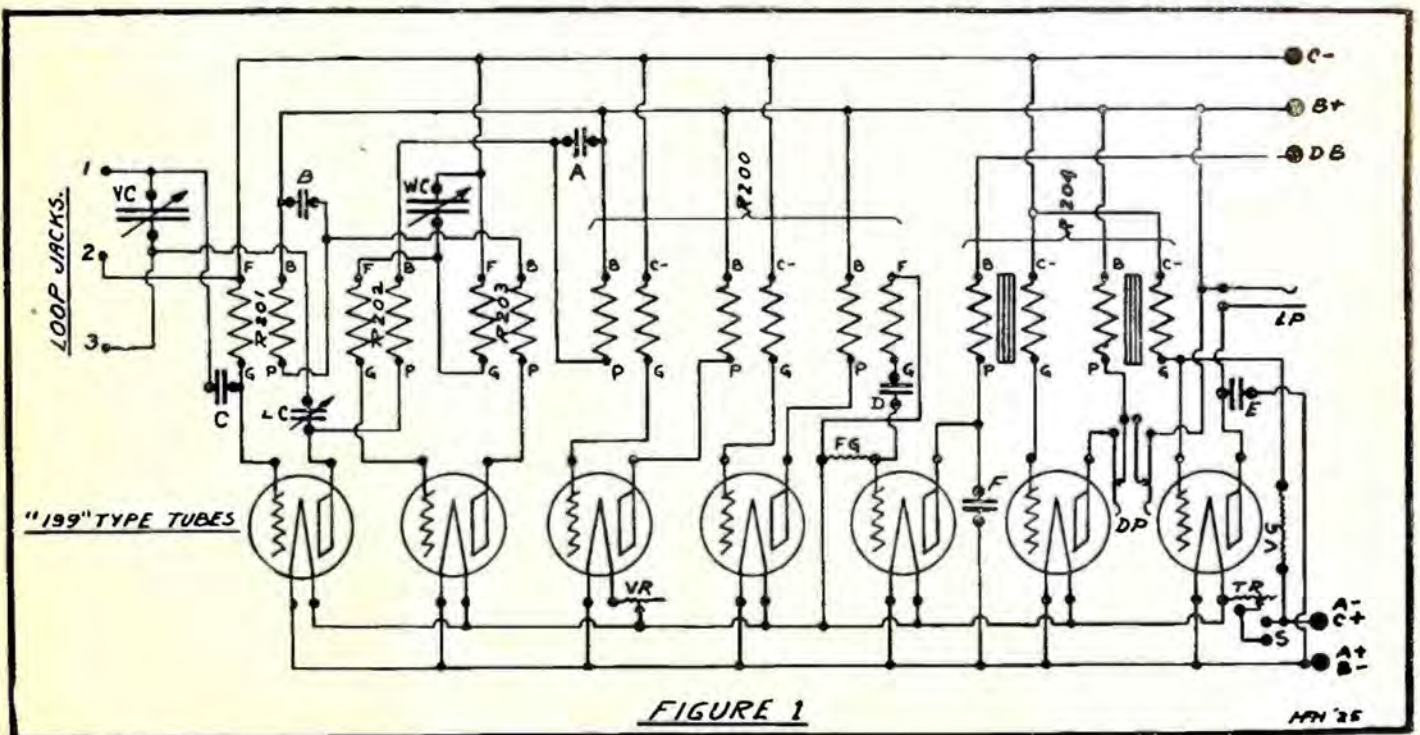

The Double-Grid Tube in Ordinary Sets

Low Voltage In Regenerative And Reflex Receivers

By C. R. BLUZAT

IN the first part of this article, published in the March RADIO AGE, use was made of only the plate characteristic of the tube, the extra grid being merely used as a means of cutting down the resistance of the plate filament space. The benefit consisted in a low plate potential to obtain a good utilization of the tube. If we increase the plate voltage, the inner grid voltage being constant, we obtain a family of curves very similar to that obtained for the ordinary three-electrode tube, the steepness of the plate current curve increasing as the plate potential is increased.

This is an important feature, as the steepness of these curves is a measure of the amplification factor; the steeper the curve, the bigger the amplification factor and the more efficient is the tube as a straight amplifier or as a regenerative detector.

Referring to Fig. 1 of the first part of the article, we notice that the inner grid current curve is very similar to the plate current curve. This means that the tube may also be used with this grid playing the part of a plate.

Hookups for the ordinary tube apply readily to the two grid tube, tying the "B" battery voltage to the inner grid and disregarding the plate, low voltage "B" battery being used. But the fact that the inner grid current curve is similar to the plate current curve enables one to use both inner grid and plate in an amplifying role.

The theory shows indeed that, in an oscillary state, the maximum power delivered by either grid or plate is VI divided by 2, V being the average voltage; I the average current.

Thus, if both circuits are used together, the output will be about VI if the proper point of functioning is used.

For the same reason, use of both circuits is very advantageous for reception.

Getting Full Efficiency

FIG. 1 shows a hookup where the full efficiency of the tube is obtained. $L1$ and $C1$ are the secondary circuit. $L2$ and $L3$ are two inductances respectively connected to the inner grid and the plate. The electromagnetic coupling between $L2$, $L3$ and $L1$ is variable and the coils act to give a double regeneration. With such a combination, as low as 6 volts for the "B" battery will not cut the volume of the reception in an appreciable manner.

The operation of the set will be very similar to an ordinary regenerative hook-

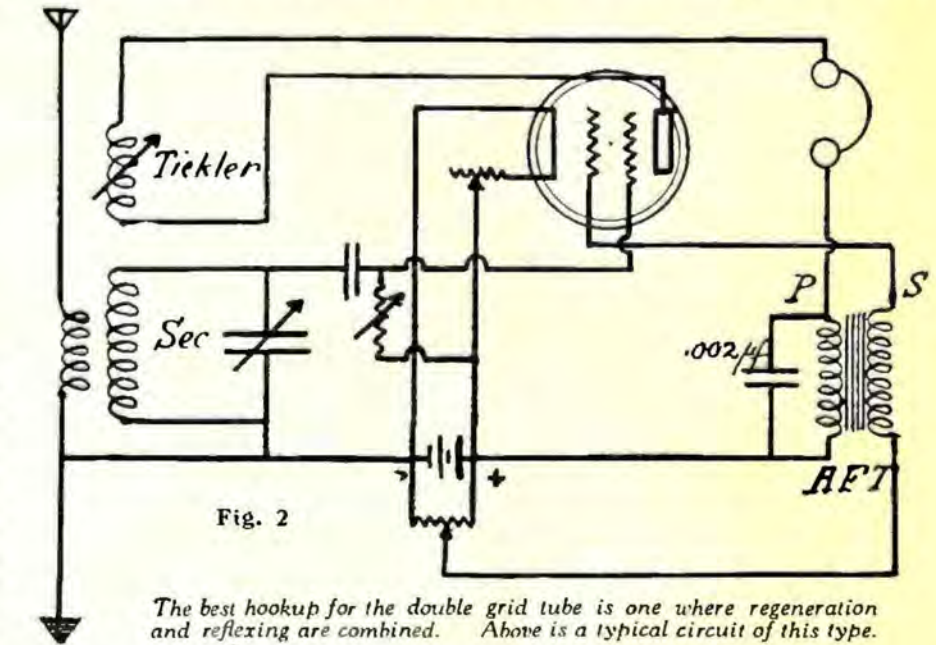

Fig. 2
The best hookup for the double grid tube is one where regeneration and reflexing are combined. Above is a typical circuit of this type.

up as $L1$ and $L2$ act like two ticklers. $L1$ and $C1$ are the same as the usual found in the ordinary receiver to cover the broadcasting range. $L2$ and $L3$ should be about 80 microhenries. Such an inductance value will be obtained by winding 30 turns of No. 18 wire on a tube 3 inches in diameter.

The width of the winding will be about one and a half inch if double cotton covered wire is used. If spiderwebs are preferred, they may be used, the number of turns to get the same inductance being about the same as above if the inside diameter of the winding is the same as the diameter of the tube. Honeycomb coils may also be used—for the secondary and the two ticklers; the aperiodic primary being obtained by winding about 10 turns on top of the secondary honeycomb coil.

The double grid tube may also be used in reflex circuits. The more efficient hookup is one where regeneration and reflexing are combined. Fig. 2 is a

typical circuit of this class. Detection is obtained in the usual fashion with the grid condenser and leak, this function being performed by the control grid. Regeneration is obtained through the action of the tickler. The detected current goes through the primary of the audio transformer. The audio frequency voltage is stepped up in the secondary winding and this amplified voltage is applied to the inner grid. This voltage in turn causes greater variations of current in the plate circuit of the tube and it is this amplified current which actuates the receiver.

THE .002 microfarad condenser is a by-pass condenser for the radio frequency current in the plate circuit. The values of inductances and condensers are much the same as in an ordinary reflex circuit. The circuit is shown with no "B" battery, as good results may be obtained, and also to emphasize the simplicity of the set. The plate, being tied to the positive post of the "A" battery, is at a slightly higher potential than the middle of the filament; if the voltage of the "A" battery is 6v and the drop in the rheostat is 2v, the plate is 4v more positive than the middle of the filament.

This positive voltage is enough to secure good results. The inner grid is tied to the arm of a 200 ohm potentiometer and its potential as regards the filament may be adjusted by moving the potentiometer knob. This hookup will be more efficient, of course, if a higher voltage is impressed on the plate, but the no "B" battery feature is important, as it is a great step toward the simplification of the set. The tube is of the low consumption type, requiring only .35 A and 3v8. This current is low enough to be furnished by dry cells, three being used in series to give the necessary voltage. An efficient one-tube portable set may be made following the hookup of Fig. 2.

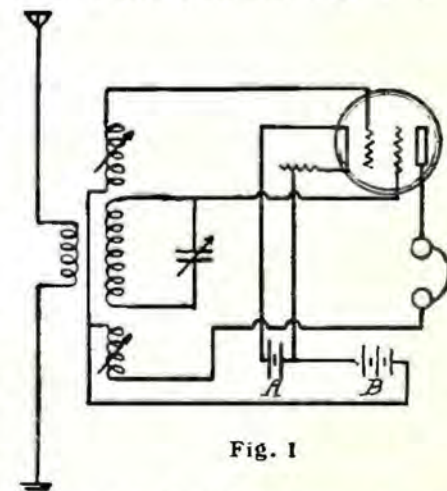

Fig. 1
A simple hookup of the regenerative type, where the full efficiency of the double grid tube is utilized. As low as 6 volts for the "B" battery will not cut the volume of the reception appreciably in this hookup.

A SCIENTIFIC RECEIVER

By M. B. Sleeper

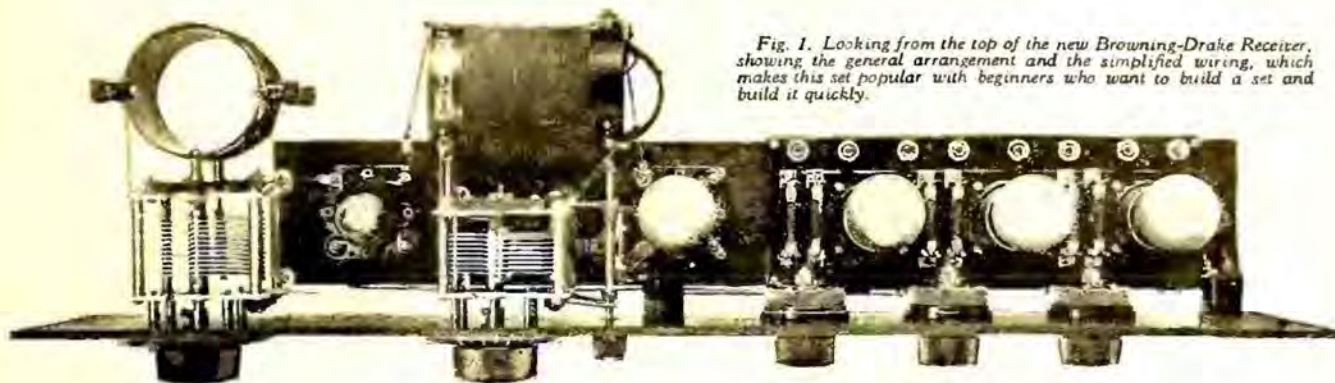

Fig. 1. Looking from the top of the new Browning-Drake Receiver, showing the general arrangement and the simplified wiring, which makes this set popular with beginners who want to build a set and build it quickly.

Mathematical Determination of Constants of Coils and Condensers a Feature of Browning-Drake Set; Has Half as Many Connections as Ordinary 5-Tube

WHEN Messrs. Browning and Drake delivered a lecture on their work before a gathering of radio engineers some time ago, it is doubtful if either of them had any conception of the unusual popularity that their set was destined to receive within the course of a few months. The Browning-Drake receiver is all-popular in the New England States and its popularity, based on sheer merit, is growing day by day.

The Browning-Drake does not employ a trick hookup. Its success is due to the scientific methods applied in determining mathematically the various constants of the coils and condensers when used with the vacuum tubes now available. This can be seen by studying the circuit diagram in Fig. 4.

A special feature of this new receiver is that it has about half as many connections as an ordinary five-tube receiver. Therefore, it is a particularly fine outfit for the beginner or for the set builder who wants something that can be constructed very quickly. As a Summer time proposition, this is an ideal outfit because it can be operated with a small indoor antenna, with correspondingly lower static pick-up.

Tests on this outfit settled definitely the question of B battery consumption. With five tubes in operation, under normal receiving conditions, the total plate current was 10 milliamperes. Five-tube neutrodynes, for example, draw 20 to 30 milliamperes. This is a positive evidence that the resistance coupled amplifier draws less current than the transformer type. Moreover, when strong signals come in, the current is decreased and not increased.

The publication of complete construction data for these receivers has resulted in a demand for a set of this kind employing resistance coupled audio amplification, and representing one of the highest types of radio receivers in use today, combining as it does the extreme sensitivity and selectivity peculiar to this set, with a faithfulness of reproduction, through the use of resistance amplification, which will satisfy even the most critical music lover.

Construction Very Simple

By using a Daven Super-Amplifier unit which comes already wired, the construction of the set has been made very simple and neat, without any appreciable increase in cost. Practically all of the wiring has been kept under the tube panel, adding greatly to the appearance of the outfit when installed in a cabinet.

The tuning is accomplished by means of the two large vernier dials. The one on the left tunes the R. F. amplifier while the right hand dial tunes the detector.

The R. F. amplifier tube filament is regulated by a 30-ohm rheostat. One of 20 ohms controls the detector, and another, of 6 ohms, is connected to the three A. F. amplifier tubes. Tri-jacks are used for plugging in on the detector or last A. F. stage. Below the center rheostat dial is a filament switch, by means of which the tubes can be turned on or off without disturbing the rheostat settings. This switch is provided with an ON-OFF sign which fits against the panel, and the fact that its depth behind the panel is very small makes it just right.

The Browning-Drake receiver will not interfere with reception of other stations,

because the detector tube is not used in an oscillating condition, and the R. F. tube does not oscillate at all.

Standard Parts Required

THE front panel is of Formica measuring 7 by 28 by 3-16-in., and the base panel, of the same material, measures 3½ by 23 by 3-16-in. The panels must be strong mechanically because they support the weight of the instruments and any extreme bending or sagging will probably result in open or short circuited connections.

The two tuning units come already assembled with the coils mounted on the condensers. The first unit consists of a 0.0005 mfd. condenser with the antenna coil, while the second is made up of a 0.00035 mfd. condenser with the radio frequency coil. Both of the condensers are provided with vernier dials. These dials have a reduction ratio of about 5 to 1, and are perfectly smooth and positive in operation.

On the front panel are mounted the three rheostats, battery switch, and two Tri-Jacks. The base panel carries the amplifier unit, one standard socket, one 199 socket, a 0.001 mfd., a fixed condenser, and a 0.00025 mfd. fixed condenser with gridleak mounting clips for the 2-megohm gridleak. Three binding posts are used on the antenna coil.

For hardware, one angle bracket and twelve coil mounting pillars are required. One of the pillars holds the tube panel to the front panel at the right hand end; nine of them are used for extending connections from the amplifier, while the other two are fastened to the underside of the tube panel as supports, for they



Fig. 2. A picture of the wiring arrangement of the Browning-Drake set. By bringing the terminals from the amplifier to the under side of the base panel, most of the wiring is kept out of sight.

rest on the bottom of the cabinet when the set is installed.

Fig. 2 gives the picture wiring for the set. It shows the connections and wiring exactly as they were arranged in the original receiver. The base panel is dropped down in order to show the parts more clearly.

Put soldering lugs on the terminals of the various instruments as you mount them. The short heavy lines in the picture wiring diagram show the directions in which these lugs must point. Use a good rosin core solder, or plain soft solder with paste put on very sparingly. We have found that the familiar spreading of the soldering paste over the panel at each connection can be eliminated entirely by slipping a small piece of ordinary newspaper, which is quite absorbent, under each lug while the soldering is being done. The paper absorbs the soldering paste, leaving a clean, neat connection. Have the iron thoroughly tinned and hot enough to make the solder flow freely. If you cannot afford an electric soldering iron, you can use a soldering kit, which comes complete at a low cost.

1. Remove the nut under the binding post marked P input on the amplifier. Also remove the short connecting strip to the screw holding the end resistor clip. Put the nut back, and on top of it, screw a coil mounting pillar. This will be the +90V binding post. Remove the screw which fastens the clip of this resistor,

enlarge the hole in the clip and amplifier base, and slip in a 1/2-in. 6-32 R. H. screw. Put a nut and a coil mounting pillar on the screw underneath the base. This will be terminal No. 28 later.

Remove nut under binding post, B Input, on Daven Super-Amplifier. Disconnect connecting bus going to this post, and put back the nut and a coil mounting pillar. This will be the Det+ binding post. Now remove the bus wire which

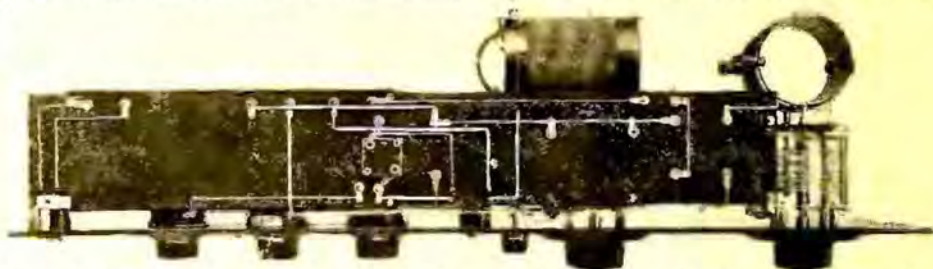

Fig. 3. The clean cut design of the Browning-Drake five-tube receiver, so free from complicated wiring, makes the set unusually attractive as well as efficient for all kinds of radio reception.

ran from this post to the front clip of the first resistor. Enlarge the hole in this clip and the amplifier base and put in a 1/2-in. 6-32 R. H. screw. Put a nut and a coil mounting pillar on this screw under the base. This will be terminal 26 later. Remove the nut under the binding post marked A Bat-, disconnect and remove the bus wire which runs over to the A- feeder bus, and put back the nut with a coil mounting pillar on

mounting pillars under the amplifier base. These serve to bring the connections up to the amplifier. Put the necessary lugs under the heads of these screws, as shown in the bottom view, Fig. 3, of the set. When putting in the screws for terminals 26 and 28 be sure to fasten the tabs on the 0.001 mfd. fixed condenser with them.

2. Remove the screws and nuts from the + and - terminals of the 201-A (Turn to page 50)

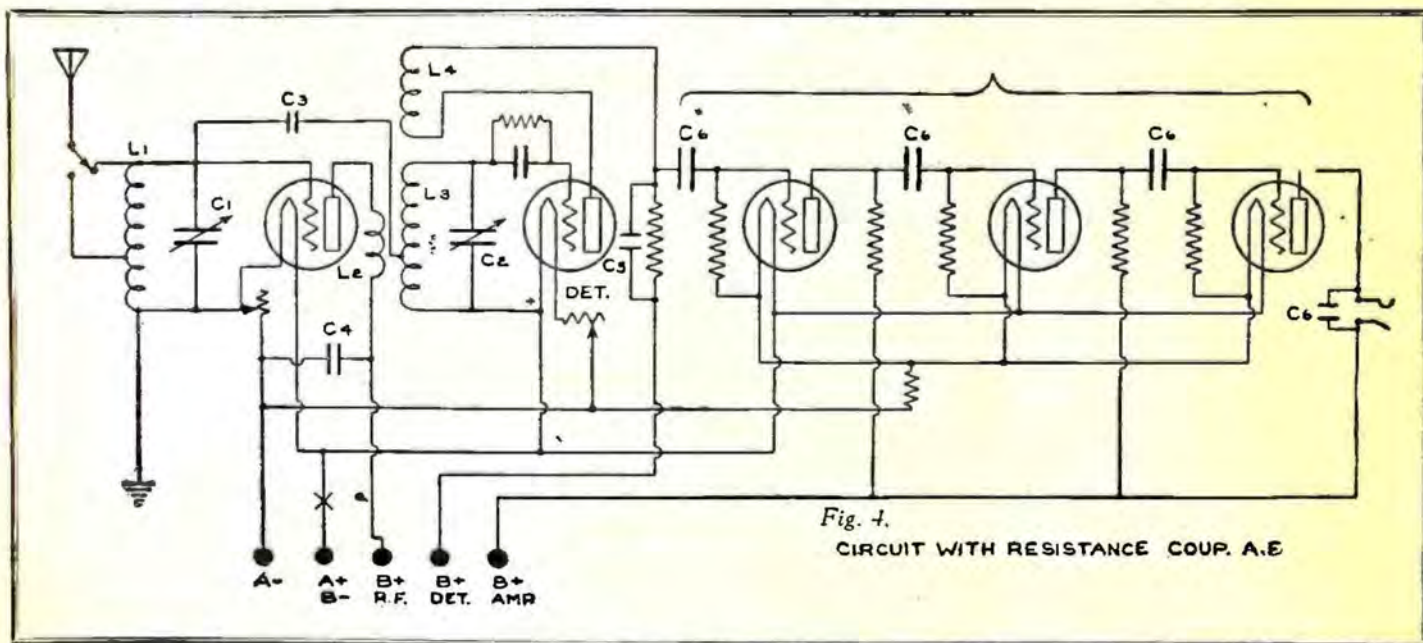

Fig. 4. CIRCUIT WITH RESISTANCE COUP. A.E.

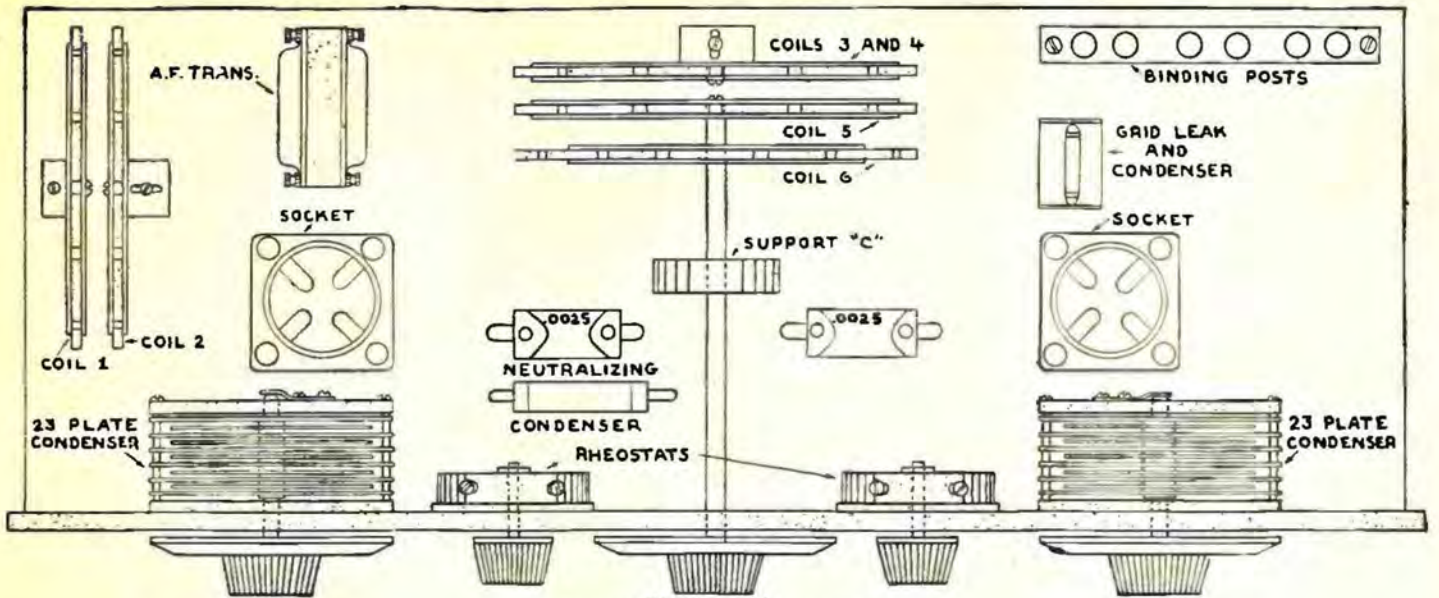

FIGURE 4
GENERAL LAYOUT OF PARTS

Overcoming Radio Frequency Oscillations in the ROBERTS RECEIVER

By FRANK D. PEARNE

IN building any kind of a set which employs radio frequency amplification, the one essential feature is to provide some way to overcome the oscillations of the radio frequency amplifier. This type of amplification is absolutely necessary if the best results are to be expected.

It is very true that some regenerative sets which are not equipped with high frequency amplifiers will produce remarkable results in some cases, but for all-round, continuous performance, there is nothing to be compared with radio frequency amplification.

There are several ways of overcoming these undesired oscillations, but the method used by Mr. Roberts is one of the most dependable. In accomplishing this, he makes use of a primary winding consisting of two wires wound together, which really forms two coils wound in the same direction; as the turns of these coils lay side by side, they are very effective.

Only one of these windings is used for the primary, similar to the primary in other radio frequency sets, and the purpose of the other is to prevent oscillations.

The coil which is used as the primary is connected in such a way that it is opposed in inductive relation to the one which is used to neutralize the feed-back. This neutralizing coil is connected to the grid through a condenser, as will be noticed upon looking over the drawing shown in Figure 2, which is a schematic arrangement of the circuit.

Mounting the Coils

IN Figure 3, a simple method of mounting the coils is shown. Coils 3 and 4 are the two parallel windings mentioned before, and are wound on one form. This form is fastened to a wooden block, "A," which has a slotted hole for the screw

which is to hold it to the baseboard, and which will allow a slight shifting of the position of these coils in relation to the others. The secondary, which is coil "5," is mounted in a permanent position on the end of the wooden block, "B," and the tickler coil, which is adjustable, is mounted on the end of a long wooden dowel pin which extends through the wooden support "C" and through the panel, where it terminates in a knob by means of which the coil is drawn forward or back to vary the coupling between it and the secondary coil.

One of the slots in the fiber form on which the tickler coil is wound is made to

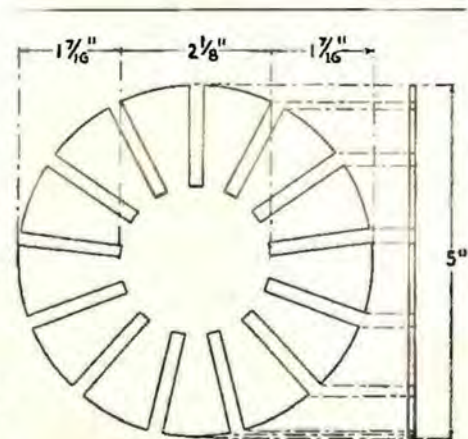

FIGURE 1
SHOWING DIMENSIONS OF FIBER FORM FOR COILS 1-2-3-4-5 AND 6

fit loosely over the wooden strip "B" for the purpose of preventing the turning of the coil. In other words, the wooden block "B" forms a sort of a track to keep the coil from moving to either side. The connections to this coil are made with flexible leads which will allow a back-and-forth

movement without breaking off the leads. The dimensions of all the wooden pieces are given in Figure 3. All of the coils used in this set are wound upon fiber forms of the same size as shown in Figure 1. To construct these forms, procure some sheet fiber 1-16 of an inch thick. This fiber sheet should be perfectly flat and not warped out of shape. Bakelite will also answer for the purpose, but this is more expensive. From this material, cut out five pieces 5 inches in diameter and draw a circle 2 1-8 inches in diameter in the center of each, and divide the outside edge into 13 equal parts and cut a slot 1-4 of an inch wide from the outside edge to the edge of the circle drawn in the center.

These slots will be 1 7-16 inches deep, which will give ample space for the turns of wire which are to be wound in them. Coils 1, 2 and 6 are wound with No. 22 double silk covered wire. The wire is placed in one of the slots, leaving an end about 6 inches long, and wound over two of the lugs; then through the slot and over the next two lugs on the other side; then through a slot, over the next two on the other side, etc.

Using a Spring Clasp

COIL No. 1 consists of 30 turns wound in this way, and at each fifth turn a small loop is made in the wire, just large enough to solder a wire to, when the set is wired. A better method of making this connection after scraping the insulation

off from these loops is by using a small spring clasp which is connected to a flexible lead. In this way the number of turns used may be varied easily by simply snapping the clasp on the desired tap. Coils No. 2 and 5 are wound just like Coil No. 1, the only difference being that each of these coils must have 45 turns of No. 22 wire.

The coil No. 6, which is the tickler, which is to slide back and forth, is also wound in the same way, but has only 20 turns. If after the set is assembled it is found that

oscillations occur, the number of turns on this coil should be reduced. The coils No. 3 and 4 are wound on one form. They are wound with No. 26 double silk covered wire. For ease of winding, this wire should be first wound on two spools. Place the ends together in one of the slots and wind with the two strands of wire, instead of the single strand as in the other coils. Here the method of winding changes slightly.

Instead of winding over two teeth or lugs as before, wind over only one, pass through the slot and over the other lug on the other side, etc. There should be 22 turns of this double winding; that is, 22 turns of each. After all the winding is completed, there will be five forms and six coils. The coil 1 is the aerial inductance. Coils 2 and 5 are the secondary coils, coils 3 and 4 are the plate and neutralizing coils, and coil 6 is the tickler.

In assembling the set, coils 1 and 2 are mounted on wooden blocks as shown at "A," Figure 3. These are made adjust-

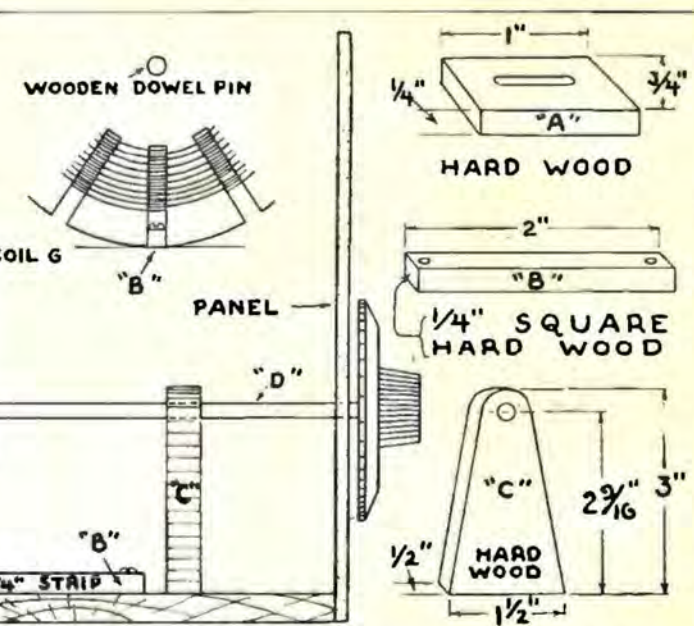

FIGURE 3
SHOWING METHOD OF MOUNTING COILS 3-4-5 AND 6

able by means of the slots in the blocks and should be placed about 1-2 inch apart and afterward adjusted until the best position is found, where they are fastened securely and left in this position. Coils 3 and 4, 5 and 6 are mounted at least six inches from 1 and 2, and at right angles to them as shown in Figure 4. By mounting coils 3, 4, 5 and 6 back away from the panel, all chance of body capacity interference will be eliminated. It is just as easy to mount them in this position as any other, as it will require only a longer wooden rod to accomplish this.

Mounting the Parts

THE parts should be mounted about as shown in Figure 4. This arrangement may be varied somewhat, providing the condensers and coils are not placed too close together. In connecting up the various coils, one must be careful to see that the outside terminal of coil No. 1 is connected to the aerial and that the ground connection is made to one of the

coil is connected through the neutralizing condenser to the grid of the first tube. This neutralizing condenser should be the smallest variable condenser which can be obtained.

One which has only two plates will best serve the purpose.

There are many of these midget condensers on the market which are sold for this purpose, but if such cannot be obtained, the ordinary method of using bus bar wire with spaghetti insulation, such as is employed in the neutrodyne circuit, may be used. It will be found, however, that considerably more capacity will be required than that used in the neutrodyne circuit. This part of the set will be more or less experimental, until the proper value is found. The correct capacity at this point is the most important part of the receiver.

The parts required for the construction of this receiver are as follows:

- Six coils as described, two 23 plate

(Turn to page 49)

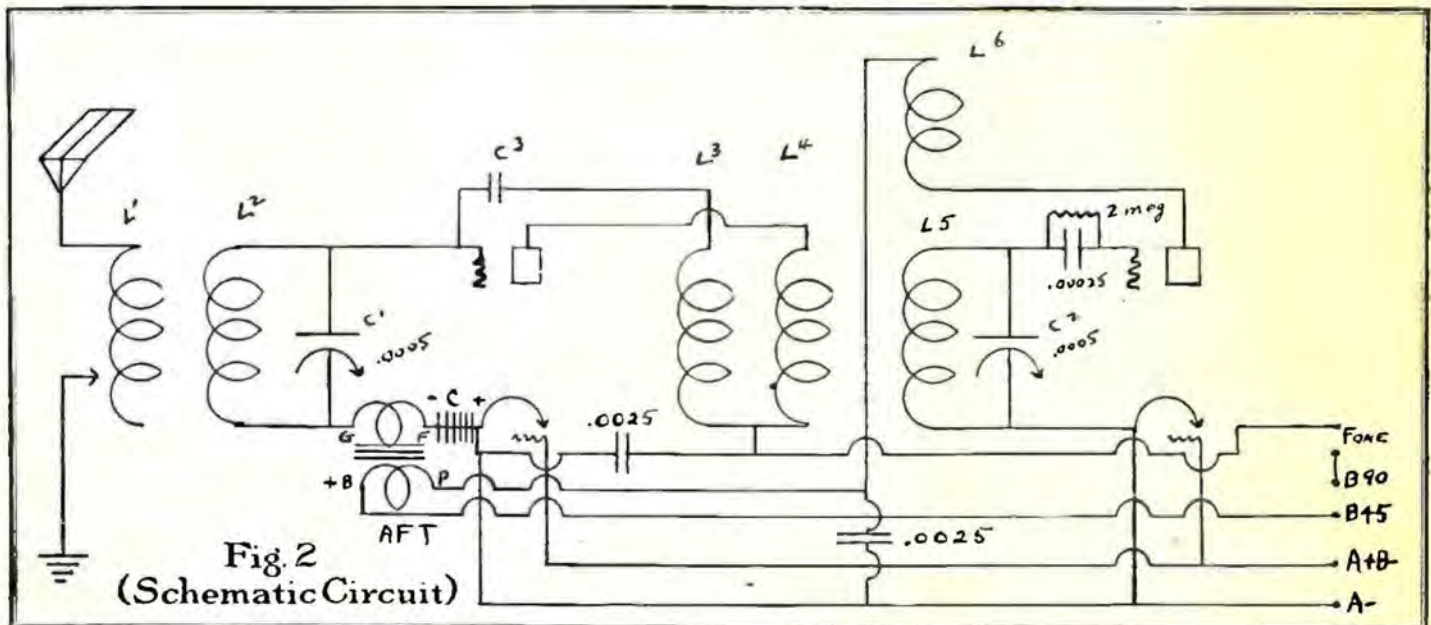

taps, or to the inside terminal (whichever arrangement gives the best results). The outside terminals of the coils 2 and 5 must be connected to their respective grids and the outside terminal of the plate coil is connected to the plate of the first tube. The inside terminal of the plate coil must be connected to the outside terminal of the neutralizing coil as shown. A reversal of this connection would ruin the neutralizing effect of the coil. The bottom or inside terminal of the neutralizing

An IDEAL Set in Practical Form



Fig. 1 Rear panel view of set described by Mr. Silver. All apparatus is mounted on the panel, there being no need for a baseboard.



Fig. 2. Front view of the completed set, showing controls

A Four-Tube, Neutralized Radio Frequency Receiver; Stable Hookup Gives High Efficiency Over Entire Range by Using Regenerative Detector and Usual Amplifier

By **McMURDO SILVER**
Assoc., I. R. E.

THEORETICALLY, a broadcasting receiver consisting of one or more stages of regenerative radio frequency amplification, preceding a vacuum tube detector circuit which would also be regenerative and which would be followed by one or two stages of audio amplification, would be just about ideal from the standpoint of the average radio fan who is interested in results, low cost and general simplicity.

As far back as several years ago, this combination was realized to be highly desirable, and a number of text-books can be found in which some such layout was given, generally followed by a notation to the effect that while the system had wonderful possibilities, it would indeed be a good man who could get it to function really satisfactorily. This, it must be remembered, was several years ago when the neutrodyne was but a dream and low-capacity, low-impedance tubes were practically unheard of.

Before going into the details of a practical form of this circuit, it might be well to consider the neutrodyne system and the allied systems of tuned radio frequency amplification. Essentially a neutrodyne is nothing more than a tuned radio frequency amplifier, the neutrodyne principle being merely an arrangement whereby an excessive amount of energy due to regeneration, which might cause oscillation, is so balanced out that oscil-

lation cannot take place. Actually, a neutrodyne is highly regenerative on the shortest wavelengths at which it will operate, but it is so balanced that oscillation cannot take place upon the shortest wave to be received—say 200 meters. When the receiver is tuned to its highest wave, —550 meters,—the amount of regeneration present will have fallen off, with the result that the selectivity and sensitivity are very much poorer than on the lower waves. This is the basic fault of tuned radio frequency amplifying systems—if they are to be simple in operation and thoroughly stable, their efficiency will not remain anywhere near constant over their full wavelength range. Tuned radio amplifiers not employing neutralization must have losses introduced into their circuits if they are to be kept stable, another common stabilizing method being to so arrange the coupling coils that energy, fed through on the low waves, will be insufficient to cause oscillation. Due to the fall-off in regeneration with an increase in wavelength, most such sets are poor performers on the high waves.

Stability a Feature

ONE of the advantages of the neutrodyne is its stability; hence it is possible to realize, by using a neutralized

R. F. amplifier, our ideal receiver, for we can combine a regenerative detector circuit in conjunction with a neutrodyne amplifier that will do much to even up the efficiency of the set over its entire range. If such a combination is carefully designed, the losses in amplification in the R. F. section on the high waves may be compensated for appreciably by the controllable regeneration in the detector circuit; yet the fact that the detector may be oscillating will not unbalance the system.

Before considering the design of a circuit which renders this combination possible and entirely practical, we must realize that in this design we have accomplished two very important operating improvements, almost at one stroke. The first is the eliminating of radiation from the receiver due to the transmission of energy from the detector circuit, when it is oscillating, to the antenna system. This is prevented by the neutralized or balanced condition of the R. F. amplifier, which prevents the passage of energy from its plate circuit back through to its grid circuit.

This permits the detector to be operated in an oscillating condition with no fear of the receiver radiating and disturbing the neighbors. Here, then, is the second important operating improvement—the detector may be made to oscillate and stations located with but

one dial, merely by turning the detector tuning condenser until the desired whistle is heard, as on a regenerative set. The R. F. amplifier is then adjusted until the whistle is loudest, and the detector stopped from oscillating by reducing its tickler coupling. Actually three or more controls are used on such system, of which only one need be used to find unknown stations.

In practically constructing such a system, there are several ends to be achieved, and upon them will depend the means employed. The first point is that the receiver must go down to the noise level and bring in with loud-speaker volume any signals heard with sufficiently greater intensity than the ever-present atmospheric noise to be distinguished from it satisfactorily. Then, the receiver must be selective enough to cut through the entire group of local stations in centers such as Chicago or New York, and bring in dependably stations all over the country. The set must be simple to construct and operate, the upkeep cost must be low, a minimum numbers of tubes should be used, and all parts should be procurable on the open market.

Layout Insures Efficiency

THE practical answer to these and many other more involved requirements, both from the standpoint of theoretical as well as practical efficiency, is illustrated in Figures 1 and 2. Figure 2 is a front view, showing all controls mounted on a standard 7 x 24 panel. The left dial is the antenna, or R. F. stage condenser, the next the detector condenser, and the next the tickler. To the right is the rheostat knob and the battery binding posts. The lay-out is not only pleasing to the eye, but makes for the greatest possible efficiency.

Figure 1 is a rear view of the set. At the right is the antenna inductance, mounted on the back of its tuning condenser. Next is the R. F. tube socket, with the neutralizing condenser mounted directly on its grid post. To its left is the detector condenser, then the detector

socket with its grid-condenser and leak. Next is about the most important piece of equipment in the set, the R. F. coupler, with its adjustable tickler. Upon the design and construction of this coupler depends the stability of the outfit, for even a very slight variation in the size or location of the primary coil, placed inside the bottom end of the stator coil, would throw the results of the whole receiver off. At the left end of the panel are the two audio tube sockets, placed over the audio transformers, and behind the rheostat controlling all four tubes. On the left end of the panel are the battery binding posts, on-off switch and jacks. No sub-base is used, all parts mounting directly upon the panel.

The receiver illustrated consists of one stage of tuned, neutralized R. F. amplification, a regenerative second detector and two stages of distortionless audio amplification. The condensers used are of the grounded rotor, low-loss type, and aside from preventing hand-capacity, are extremely efficient. The antenna coil and R. F. coupler are especially designed for the circuit, and employ self-supporting windings, rendered rigid by a special treating compound. As a matter of fact, tests by Armour of Chicago indicated that these coils so treated have less resistance on a dry day than untreated coils supported with two strips of adhesive tape, while for a damp day the doped coil showed 26 ohms less resistance than the undoped coils. This figured out to be about 500 per cent greater resistance for the untreated winding. These tests indicate that the high efficiency claimed for the untreated coils, with which the market is now flooded, is purely mythical, but much depends upon the use of a good dope, such as is not available on the open market.

Results Obtained

THE test of any design is what it will do, and merely figuring out an ideal receiver on paper is far from building it, and testing it under a variety of conditions.

A large number of these sets have been built and used in and around Chicago, with the results obtained by one builder typical of those obtained by the others, with due allowance for location and conditions. A physician in Wilmette built the set in a period of three hours, hooked it up at four in the afternoon, and before eight o'clock had gotten 27 stations on his loud speaker, ranging from Toronto to Fort Worth, in daylight! In a week he logged over 100 stations, never once resorting to head-phones.

The material required to build the receiver is given in the list below, with an accessory list farther along. It is strongly recommended that the builder adhere strictly to this list. If, however, the experimenter desires to deviate, he should only do so where his knowledge is sufficient to effect the necessary design changes attendant upon the use of material other than those specified.

- 2 Low loss condensers .0005.
 - 3 4-inch Moulded dial—tapered knobs.
 - 1 8½ Ohm rheostat.
 - 6 Insulated top binding posts
 - 1 2 Spring jack.
 - 1 1 Spring jack.
 - 1 Low loss coupler.
 - 1 Low loss antenna coil.
 - 4 Panel mounting sockets.
 - 2 3½:1 Audio transformers.
 - 1 On-Off switch.
 - 1 .00025 Mica Condenser with leak clips.
 - 1 .002 Mica Condenser.
 - 1 .0075 Mica Condenser
 - 1 2 Meg Grid leak.
 - 1 22x13-16" panel.
- TOOLS REQUIRED:** Screw driver, pliers, soldering iron, hand drill with drills, and countersink.

If a plain panel is used, it should be drilled in accordance with the layout given, and the necessary holes countersunk. If desired, it may be given a grained finish by rubbing in one direction only with sand-paper and oil. Indicating marks for the dials may be scratched with a scribe and filled in with Chinese white.

The antenna coil should be attached to one of the variable condensers. Care should be taken to see that the loop, or tap on the coil comes near the right-hand end of the condenser, when viewed from the rear, with the stator or fixed plate

(Turn to Page 56)

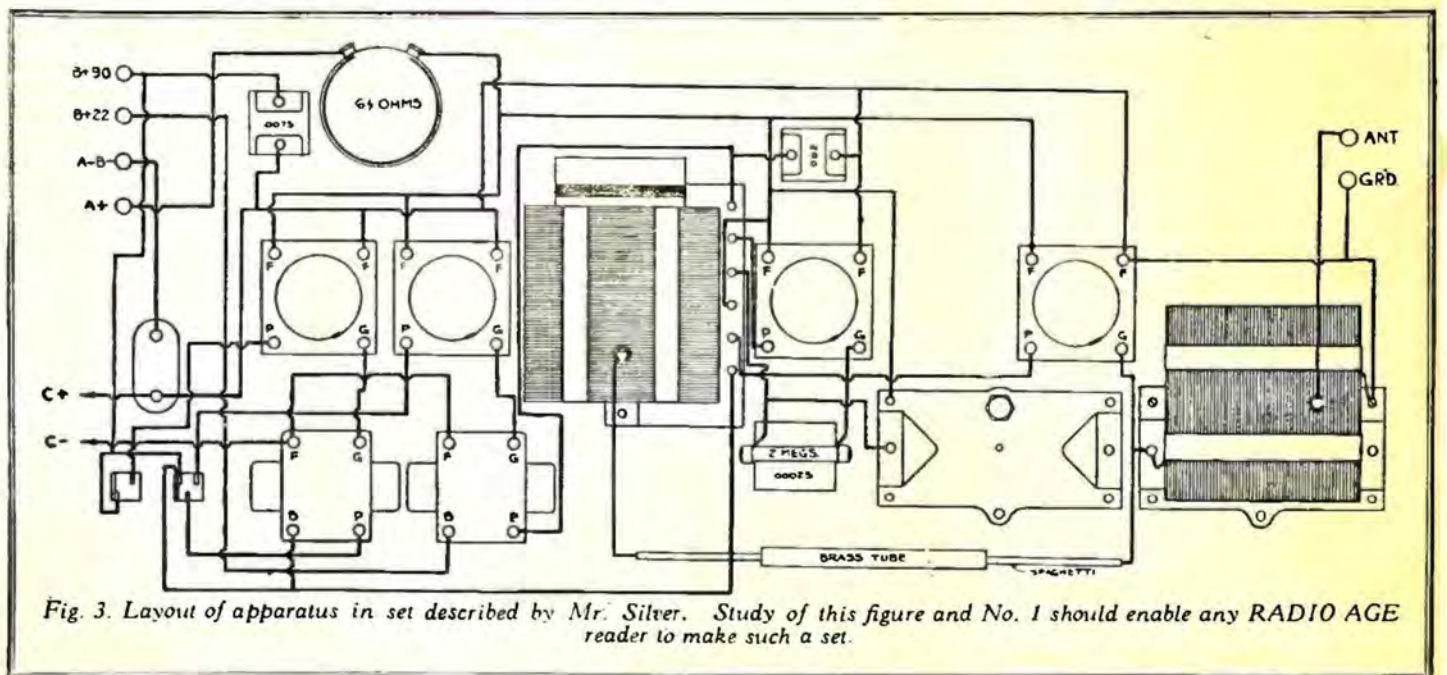
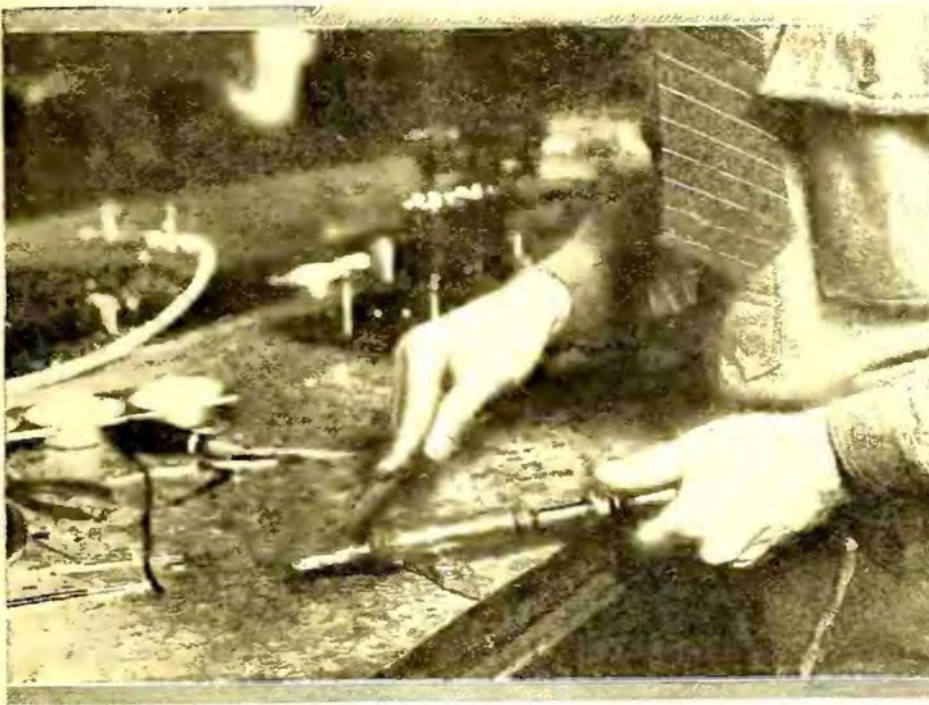

Fig. 3. Layout of apparatus in set described by Mr. Silver. Study of this figure and No. 1 should enable any RADIO AGE reader to make such a set.

Proper SOLDERING Insures Efficient Circuit Operation

Pictorial Tips for the Set-BUILDER on This Essential Radio Topic



GOOD connections mean good contacts and perfect circuits. These the set-builder must have if he is to be repaid for his efforts with good reception and pure tonal quality. The first thing to be done in setting out on a soldering job is to clean the soldering iron thoroughly, as shown in the photograph at the left. Use a file for this preliminary job, and see that all grit and other impedimenta are removed before actually turning to the solder. This means the solder will be absolutely clean.



PROCEDURE Number Two in doing good soldering is to clean the connections to be soldered with the same care that was given the iron itself. The first photograph at the right illustrates this method. When both iron and wire are clean, good contact is assured. Next, apply the soldering flux, as shown in the photo to the left. Be sparing in the application of the flux, for many poor connections are often caused by the use of the flux in excessive quantities. Do it right the first time and you won't be taking your set apart time and again after it has been put into operation.



AT the right is a good idea of how to apply the solder to the joint. Note that only a small amount of the solder is necessary on the tip of the iron. Rub it over the joint to be soldered until it runs freely, and then let the joint cool. Some radio experts have said that the best test of a soldering job is to drop your wired set on the floor, and if the wires stay intact, the soldering is satisfactory! However, this method often proves disastrous to the rest of the set, so be on the safe side by testing the soldered joints with your hands. And once you are sure the job is satisfactory, leave it alone.





What the Broadcasters are Doing



WJZ Broadcasts for the Tired Business Man

FOR once the male radio fans have come into their own. Women listeners, for whom special "Women's Hour" programs have been instituted and featured since radio began, now have no consideration at the hands of station WJZ, New York City. The long-suffering, bill-paying husbands are being given something for nothing; and the something is designed for their ears and theirs alone.

"For T. B. M's. Only." So read the WJZ program between 8:40 and 10 o'clock on March 9. What a T. B. M. is, every follower of the Great White Way knows; he is the gold-digger's delight, the Great Mogul to whom all Broadway bows low while they relieve him of vast fortunes; viz., the "Tired Business Man." And WJZ has planned to bring him surcease from his suffering, to relieve the chronic ennui of the peculiar species without relieving his pocketbook. Truly radio is a Marvell!

Enter the "Chics"

The Two Maries crooned the kind of blues that only men appreciate; George Laval Chesterton rendered an episode entitled "Wa-a-a-ah!" which was directed straight to the sorely-trying hearts of the T. B. M's.; the World's Worst Radio Speaker unburdened his soul to an audience which shouldn't have contained any women!; Fay Marbe, Broadway's Peppiest Play-Girl, put across a radio act that made WJZ request a special police guard at the studio to fight off the admiring "studio-door Johnnies;" Sam Hermann, with Muriel Pavellock, arranged an act that brings \$5.50 top anywhere in civilization; John C. Cutting, the Baldest Man in Three Continents, described the harrowing night-life which made his hair fall out; and Norman E. Brokenshire mounted his ukelele and sang a song that made the well-known "Parley-Vous" fade into the background of respectability.

"For T. B. M's. Only!" WJZ has given full warning to all feminine listeners to remain away from the loudspeakers and ear-phones on these nights; and for the sake of peace in the family it advises all married men to keep their wives away from the receiving set. And above all, WJZ earnestly entreats all men not to tell their feminine contingents what they are laughing at—if they should stop laughing long enough to be able to tell!



Above is Herbert Sidney Mintz, musical director and announcer of the new Wrigley-Hermann-Thompson radio station, WHT, which has opened towers in Deerfield, Ill., and studios in Chicago. Mintz is an old KYW artist.

ALBERT HAY MALOTTE, the concert organist at McVicker's Theatre, Chicago, has firmly established himself as one of Chicago's favorite radio stars. Mr. Malotte's supreme artistry as well as his natural faculty for picking selections and arranging programs, has, in the short period of time he has been on the air, made him a midnight feature worth staying up late to hear. His concerts start every Wednesday and Friday night at fifteen minutes after midnight at KYW.

Malotte has had a wide and varied experience, having been a professional aviator on the Pacific Coast several years ago. After flying for some time he went to Alaska to fill concert engagements and in a country where almost every man is a dead shot, he won the first prize in a rifle contest. He has been a big game hunter in the Rockies and proudly displays an enormous mountain lion skin whose owner fell under his unerring aim.



Albert Hay Malotte, concert organist at McVicker's Theater, Chicago, who is gaining friends among the Middle Western radio fans through his midnight broadcasts from KYW.

Some Sidelights on Radio and the Stage

By Wilson J. Wetherbee, Director, Westinghouse KYW

OF LATE producers of the drama and its melodious kin, the musical comedy, have seen spectres stalking in the rapidly increasing popularity of radio. Evidently they are convinced that broadcasting is here to stay and that no amount of scoffing can stem its advance. These folk of the theater appear disconsolate when they should be rejoicing over the discovery of a new medium for popularizing the American stage.

Just why the theatrical world has levelled its guns on radio is a difficult question to answer. There is no one kind of diversion which will satisfy all of the desires of the public. Good showmanship is builded upon no one factor so much as experience, but with the coming of radio, the theatrical producers have apparently been blinded to the words of wisdom which appear in every primer devoted to theatricals.

For the moment let us grant that radio broadcasting will divert the public from the box office. Let us say that the amusement seekers turn to a quiet evening at home and a receiving set for recreation.

The Reaction to Radio

Now that we have the former theatergoer safely at home with his new radio, let us also study his reaction. He hears a clever monologue, enjoys a medley played by a deft fingered pianist, discovers that his feet want to dance to a tune being played by an orchestra and learns also that he would like to see the possessor of the sweet voice which thrilled him with a love ballad. He listens attentively as the announcer gives the name of the artist. Perhaps the performer is an amateur whose only public appearance is over the radio. Again he may recognize the name as that belonging to a famous star who is appearing in some production in his own city. In the latter case the chances are ten to one the listener will buy a seat for the show in which his radio favorite is appearing.

Perhaps the theater manager will scoff at this assumption. The directors of KYW have good reason to believe that their assumption is true. The broadcasting of "Abie's Irish Rose" brought 2,876 persons to the box office within forty-eight hours after the production was broadcast.

California is Leading the Country in the Development of Efficient Radio Stations

The Broadcast Favorites of Southern California

Some Notes from the Sunny Radioland

By RALPH L. POWER

Up at KHJ the Lost Angels go on the air at midnight Saturday for a two or three hour program of fun and frolic, similar to the Hoot Owl program up in Portland. Then, again, they have a Saturday afternoon frolic that is becoming a classic in radioland. One of the most popular instrumentalists from this sta-

gigantic beauty contest prize in the metropolis of Southern California and is a prime favorite with radio fans.

AL WILSON has just finished a film, "The Cloud Rider," and he often tells his radio audience about his stunts in the clouds as a stunt man for filmland.

Tune in on Southern California stations and hear their programs.

If you tune in on KFI on alternate Wednesday nights from 9 to 10, Pacific Standard time, you will hear the Wampas program, given by the official organization of the film colony. These programs have presented Adolphe Menjou, Adolpha Menjou, Trixie Friganza, Louise Fazenda, Viola Yorba, Betty Blythe, Bert Lytell, Marguerite de la Motte, John Bowers, Fred Stanton and hundreds of other screen celebrities who entertain by song and speech.

Los Angeles stations now include KFI, on 1,500 watts, and the following on 500: KHJ, KFSG, KNX and KFVB, the last two being in Hollywood. KFON at Long Beach is also a 500 watter.



"Herb" Rawlinson, popular movie star, seems to be having a good time showing his radio listeners how to solve that intricate cross-word puzzle.

WITH its six 500-watt sets, and one 1,500-watt station, Southern California can be tuned in 'most any time and radio fans from the East and Middle Western states are picking up programs from the Pacific Southwest with somewhat more regularity than a year or so ago.

"Herb" Rawlinson, veteran film player, has given speeches and bedtime stories from most of the Los Angeles stations. In fact, he acted as a radio announcer during the recent radio show in that city. But Rawlinson can't get away from rehearsal habits. In the picture we find him trying to explain a cross-word puzzle joke to radioland with the use of a dictionary.

Over at KFSG there are church services on the air day and night. One of the most interesting is the Thursday night water baptismal, at which nearly a hundred people go through the baptismal process. The musical part of the broadcast includes songs by the Southern jubilee singers and the temple silver band music. But the most popular entertainer from this Los Angeles station is Esther Fricke Greene, who presents an hour's program of organ selections three times a week.



(McHenry Photo, Hollywood)

Al Wilson, a stunt aviator for the movies, thrills the radio listeners regularly from KFI, Los Angeles.

tion—the oldest 500 watter in Southern California—is Jules Lepske, member of the famous Philharmonic Orchestra and leader of the Philharmonic Quintet which plays from KHJ twice a week.

Hollywood now has two stations—KNX and KFVB—at which a goodly number of screen stars talk. But the radio public is fairly well fed up with patter and demands entertainment. Herb Rawlinson, by the way, always carries his favorite uke along.

So the Hollywood stations are providing a good deal of musical entertainment. During the Summer months the Hollywood Bowl, a civic enterprise, conducts a series of ten weeks' open air concerts and as a forerunner of these they are now providing some radio concerts.

Their radio pianist is Raymond McFeeters, talented young composer, who acts as concert pianist at the Bowl and as organist at one of the local churches.

Little Peggy Lynne recently won a



(Photo by Witzel)

Raymond McFeeters, the wistful youth shown above, is a regular concert pianist from KNX, Hollywood, where the movie stars come from.



(Photo by Bloom, Chicago)

"STAY A WHILE WITH W-Q-J."

In this intimate way, "Jerry" Sullivan, the unusual announcer and entertainer at WQJ, the Calumet-Rainbo Gardens Station at Chicago, begins his popular jazz programs every evening at 10 o'clock. Jerry has a style of announcing all his own, and needless to say, it has won him hosts of admirers. He was one of the first devotees of the "crooning" method of broadcasting. He is also a pianist of unusual ability.

Trials and Triumphs of an Announcer

*Catering
to the Whims
of a Fickle
Audience
Is No
Child's Play
at KDKA*



H. W. Arlin, "World's Pioneer Announcer"

H. W. Arlin, the
World's Pioneer
Announcer, Has
Never Tired of
the Radio Game;
Here are Some
of His Reasons

ANNOUNCING radio programs might be called the world's most recent profession, because announcers for broadcasting stations were introduced first about four years ago when KDKA, the world's pioneer station of the Westinghouse Company at East Pittsburgh, Pa., was started.

H. W. Arlin, the world's pioneer radio announcer, made his debut early in 1921 and has been continuously "on the air" since. Thus his long service entitles him to the honors of being the veteran of radio announcers.

Mr. Arlin's studio experiences have been many and varied. Life as a radio announcer is not a drab affair, as there is a necessity of being continually on the "qui vive."

In the following interview Mr. Arlin tells of some of his studio experiences and some interesting contacts with his radio public.

He Never Tires

IAM often asked the question, 'Do you become tired of announcing?' or 'Does radio work become monotonous?' My answers to such questions are always in the negative, thanks to an ever-curious and an assisting public. By such an answer, I mean that any monotony which might otherwise tend to creep into the almost continual execution of programs is quickly dispelled by a multitude of extraneous duties with which an announcer is confronted.

"Probably one of the most interesting phases of studio work comes through contact with the public, not entirely by personal association, but also through the telephone and telegraph. No work can become monotonous or tiresome where the public is involved. On the contrary, I have found that a study of the whims and fancies of the public has been an exceedingly interesting one.

Paraphrasing the famous expression of Abraham Lincoln, 'You can please some of the people all of the time, and all of the people some of the time; but you can't please all of the people all of the time.' Not radio, at any extent. This statement could be applied to the view of the public on any one phase of radio entertainment such as music or sports. When applied to all of the phases of radio, it becomes many more times effective. What one person likes, another dislikes, and what one person condemns, another approves; so an announcer is almost justified in concluding that a 'fifty-fifty break' with the listening public is fair enough. However, 100 per cent satisfaction is always the goal.

"In telling of the announcer's contact with the public we may take into consideration only one phase of this contact; that of telephone conversations. The nature of the telephone messages received, together with the conversations that follow, tend to create in one a desire for the study of people. The thoughts and ideas which prompt these many calls are perhaps innumerable; perhaps some one conceives an idea by which radio can be of aid to him in his own personal advancement or the advancement of some pet theory, or possibly some one desires some information which may vary from that of a query regarding what is the proper food to give a sick baby to that of certain details regarding a program to be broadcast several weeks hence.

Some of the Questions

AFEW of the seemingly endless number of such questions and requests may be of interest. A confiding interest in our listeners, (this same public) will necessitate the omission of the names of any personalities involved in the following:

"One of our good Canadian friends recently called to tell us about a circular parking station he had invented for automobiles which would handle two hundred cars and which could be operated by one man. Appreciating the need for better parking service and predicting great success for his venture, he requested that we advise the radio public of his invention with full details as to where to purchase these stations.

"A lady calls us and requests that we announce that she has just left a package of pajamas on the street car and would like to have the service of the radio in recovering them. After being informed that we never make local announcements except in cases of robberies, kidnapping, lost persons and such emergencies, she replies, 'Well, this is an emergency case, because it is the only package I had.'

"An elderly lady, apparently a student of nature, calls and gives us the following important news item: 'Will you please announce that there is about four inches of snow in my back yard and that I have just seen two cardinal red birds?' Of course, a very unusual sight for this time of the year.

"No sooner is the telephone receiver on the hook than the bell again rings and an innocent feminine voice pops the following impression: 'I just heard you announce that you had received a telegram from New York commenting on the program. I would like to know if you are also broadcasting to Ohio tonight, as I would like to request a number for some friends out there who do not have the advantages of a radio.'

"It has also been brought very forcibly to my attention that radio has made a greater impression upon the public than has music. Of the many proofs of this statement, I might cite an occasion on which a program was being presented by the great Fritz Kreisler. (To page 62)

Radio Reveals a New Civilization

Unpublished Details of a Newly Discovered Race, Twenty-Two Centuries Old, Given For First Time From KOA, at Denver.

By FRANK J. McENIRY

WIDELY scattered remains of a vast, altogether unknown civilization which for twenty-two centuries has been buried under three to ten feet of waste and crumbled rock, are just being opened in southwestern United States. They definitely establish, archeologists declare, that Colorado's Cliff Dwellers were not the oldest prehistoric race to flourish on the North American continent.

How long this newly discovered civilization thrived, from whence it came and how and when it was wiped away are facts which excavators from the Colorado State museum are now endeavoring to determine.

In the meantime, however, scientists have been dumbfounded at finding a lost city of pithouses extending along the tops of a straggling series of mesas in southwestern Colorado, which swing from a point near the Colorado-Utah border in the Paradox valley to Pagosa Springs, Colo., and thence south, well into New Mexico.

Unpublished details of this astounding settlement, a comprehensive civilization in itself and the largest yet determined of prehistoric America, were presented by radio on April 8 over KOA, the General Electric station at Denver, by Joseph Emerson Smith, member of a recent archeological expedition into this region by the Colorado museum. This unique program, which was being sponsored by the Denver Tourist bureau, was given as part of a studio presentation beginning at 8:10 p. m.

1000 Years Before Cliff Dwellings

THIS lost city comprised scores of separate and distinct units, which for the sake of defense advantages were confined to the tops of mesas or table lands, high above the valleys below. Five hundred pithouses in one group alone have just been mapped in what is now known as the Chimney Rock-Piedra

region. This area measures fourteen miles in length and one and one-half mile in width.

That the lost city antedated cliff dwellings by at least 1000 years, archeologists are certain.

"When Socrates, condemned to death, was drinking hemlock in his cell at Athens, in the 'old' world, this great

population of a brown race, that builded, flourished and then disappeared mysteriously, had emerged from a semi-savage state to one of distinct culture," Mr. Smith told his radio audience.

"There is little doubt that the city was a continuous habitation of many thousands of humans," he continued. "Tens of thousands of pithouses, (To page 48)

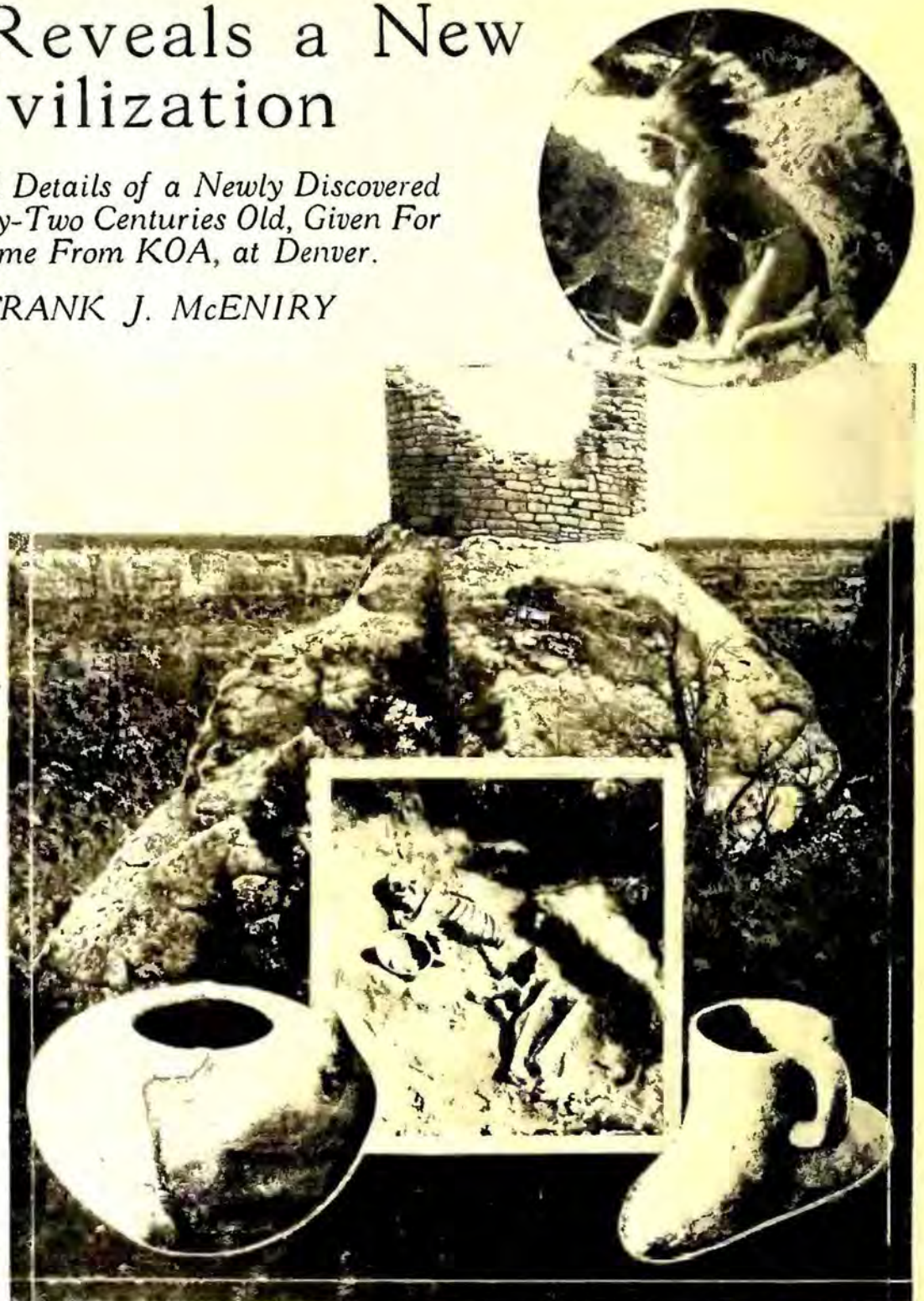

Above are the ruins of a prehistoric watch tower in Colorado, which once commanded a valley 1,600 feet below. The insert shows the skeleton of a prehistoric woman and remarkably symmetrical pieces of gray ware, which were uncovered in a nearby pit-house, inhabited twenty-two centuries ago.

In the circle at the upper right is Chief Evergreen Tree, whose war-bonneted ancestors looked in awe upon the advances of the encroaching white men. Radio station KOA, located in the heart of this age-old civilization, broadcast the first information concerning the discoveries a few weeks ago.

The World's Biggest Radio Organ

—And The Littlest Organist

BY MARIE SHIELDS
HALVEY

QHow the Prim Little Organist of Station WOO is Proving All Bobbed Heads Are Not Empty



Here is Mary E. Vogt, the diminutive organist of station WOO, in a restful moment before the console of the great Wanamaker organ in Philadelphia. Miss Vogt is a human though serious-minded young person, and she thinks girls can amount to something besides serving as stylish ornaments.

THE Wanamaker Grand Organ is an institution in Philadelphia. Visitors are taken to see it along with the Navy Yard and the house where Betsy Ross lived. Thousands stand daily in the transept of the store to listen to its splendid harmonies. It has five manuals and more than eighteen thousand pipes, and the organist who sits at the console and makes all this magnificence "go," is a little slip of a girl, not much more than five feet in height and slender as a boy, with a mop of thick black curls and bright, snapping brown eyes.

Her name is Mary E. Vogt, and the story of her life reads like a fairy tale where the fairy godmother arrived at life's darkest moment and the good child was started on the road to success.

Obliged to leave school when she was fourteen to help with the support of younger children at home, fate guided Miss Vogt into the employ of a great and good man; a man whose far-reaching vision saw the little girls and boys in his great store not as poor little wage earners, handling stock or running errands, but as citizens of the future; as men and women who must take their places eventually in the social, business and artistic life of the city that he loved.

Real Talents Developed

HE was the first to develop in his own establishment the idea later embodied by the Board of Education in what are now known as continuation schools. Attendance at the store school was compulsory. Trained educators supervised the studies and watched for signs of any natural aptitude in one field or another. Salesmen, buyers,

accountants, mechanical experts of various kinds were developed under this plan. Whatever the kind of ability the child showed, he or she was encouraged to specialize along that line.

It was not long before the little, brown-eyed Mary Vogt gave evidence in plenty that her future, rightly directed, lay in the world of music. From that point the fairy godmother took her in hand. She was set to study music under Dr. J. Lewis Brown, then musical director for the Wanamaker stores. In a surprisingly short time, she was working in the sheet music department, playing selections requested by customers. For five years now she has been the official performer on the great organ and musical director for the store.

The music of the grand organ was introduced to the radio public two years ago through the medium of WOO, the broadcasting station of the Wanamaker store in Philadelphia. Miss Vogt does not do any announcing. Among the things she emphatically dislikes are women's voices over the radio, germs and cross-word puzzles. She has the radio headquarters regularly scrubbed and disinfected, and she won't allow the girls in her office to work at the puzzles.

"The young mind of today," said Miss Vogt, "needs to read good books and hear real music. To see in the dic-

tionary the meaning of an obsolete or little used word from a cross-word puzzle has no educational value. They might be more profitably employed listening to a good concert."

Interested in "Kids"

THE young mind of today interests her even more than the gorgeous organ she plays so well. She teaches now in the store school where she received her own training, and she finds her greatest delight in guiding these young girls and boys into the career for which they are fitted, even as she herself was guided into the realm of music.

Miss Vogt is deeply interested in the development of the radio. Like other directors who arrange programs for broadcasting, she deplores the tendency of the fans to explore the air—in other words, to jump from one program to another as the signals indicate what they have picked up. Any cultural value radio may have is ruined by this practice. Miss Vogt hopes to see at no distant date broadcasting reduced to a few great high-power stations, with programs of the highest quality relayed by local broadcasters.

She is right up-to-date on the mechanical end of radio, too, and can talk familiarly about the latest inventions for improving transmission

Review of Radio Age's Contest Shows

"The Three Musketeers"

FIGHTING For Winner's SHIELD

By HARRY ALDINE

MIDNIGHT of June fifteen will see the end of the RADIO AGE Popularity Contest, and because of the closeness of the hour, we were tempted to digress from our usual custom of naming a monthly winner. The fact is that in reviewing the three leading contestants there is named the man who secured the greatest number of ballots for the month of April—Bert Davis—but were we to devote this page exclusively to him, we would be doing a grave injustice to the other two, Karl Bonawitz and Bill Hay.

At the beginning of this contest it was the opinion of the Contest Editor that there might be aroused a greater personal interest in the candidates by each month selecting one of them for a brief story. Whom to choose each month without a show of partiality was the next factor to consider. And so it was decided to put this problem squarely up to the readers of RADIO AGE. This was accomplished by naming as a monthly winner the candidate receiving the greatest number of votes through the period of each thirty days.

How It Was Done

IT SO happened that in seven of these ten months the honor was attained by different candidates, but in the other months where a candidate repeated his former record by coralling the greatest number of ballots, the writeup was handed to the next favorite in line.

Karl Bonawitz, Bert Davis and Bill Hay are the three to whom goes the distinction of having twice secured the greatest number of monthly votes, and reference to the "standing to April 15"

will show these same "Three Musketeers" at the point of vantage at the head of the list. There is always present the probability of a dark horse coming to the front, but if present figures mean anything, it will be one of these three who heads the list when the final count is taken.

Of the three, Karl Bonawitz has so far proven to be most consistent. Getting off for an early start, he improved his position, reaching first place seven months ago, which standing he has held up to the present time. This popular organist, however, is being closely pressed by the other two artists.

Bert Davis, on the other hand, performed in an erratic manner, twice having secured a good lead only to lose ground in succeeding months. The period from March 16 to April 15 saw him suddenly spurt from seventh to second place. The next thirty days will decide the fate of this eccentric entertainer.

Bill Hay Holds Own

HOLDING a close third position, Bill Hay had been sharing second and third place with H. W. Arlin in the earlier stages of the contest. At one time he was first on the list and at no time has he dropped below third. He has held second post during the two preceding months. This popular Announcer-Entertainer is to be reckoned with before the final count is taken.

It will be seen by further reference to the present standing that Art Linick and Lee Sims have strengthened their positions. The latter, although a newcomer in the field, leaped the hurdles from twenty-second to twelfth place. The Gold Dust Twins of WEAf also appear upon the scene.

H. W. Arlin, Coon and Sanders' Night-hawks, Jack Nelson and Harry Snodgrass all seem to be within striking distance of the victor's shield. But that is a story in itself to be told after

the final ballots have been cast and counted.

WHEN this contest was started, RADIO AGE expected an enthusiastic response from readers and radio fans, but nothing was dreamed of that compares with the avalanche of votes which has deluged the Contest Editor during the past few months.

A separate department had to be created to handle the volume of correspondence and votes, and every effort was made to see that the contest was conducted according to Hoyle, and that no one received more than his just share.

It has been gratifying indeed to learn with what respect the army of radio fans hold the announcers and entertainers who perform for them nightly over the ether waves. It is only fitting that the beautiful shield RADIO AGE has obtained be presented to the winner of the RADIO AGE Radio Favorite Popularity Contest. A reproduction of the shield will be published in the July RADIO AGE, and the final count in the August issue.

Here's the way it looks to date:

THE WINNERS FOR APRIL

A review of the three leading candidates:

Karl Bonawitz, Bert Davis, Bill Hay.

WINNERS OF PRECEDING MONTHS

July.....	Duncan Sisters, KYW
August.....	Bill Hay, KFKX
September.....	Karl Bonawitz, WIP
October.....	H. W. Arlin, KDKA
November.....	Bert Davis, WOJ
December.....	Jack Nelson, WJJD
January.....	Art Linick, KYW
February.....	Coon-Sanders Orchestra, KYW
March.....	John S. Daggett, KHJ

STANDING TO APRIL 15

Name and Classification	Where Heard
Karl Bonawitz, Organist.....	WIP, Philadelphia
Bert Davis, Entertainer.....	WOJ, Chicago
Bill Hay, Announcer.....	KFKX, Hastings
H. W. Arlin, Announcer.....	KDKA, Pittsburgh
Coon-Sanders' Night-hawks, Orchestra, KYW, Chi.	
Jack Nelson, Announcer.....	WJJD, Mooseheart
Harry M. Snodgrass, Entertainer.....	
WOS, Jefferson City	
Art Linick, Entertainer.....	KYW, Chicago
John S. Daggett, Announcer.....	KHJ, Los Angeles
Ford & Glenn, Entertainers.....	WLS, Chicago
Duncan Sisters, Entertainers.....	KYW, Chicago
Lee Sims, Pianist.....	KYW, Chicago
Lambdin Kay, Announcer.....	WSB, Atlanta
J. Remington Welsch, Organist.....	KYW, Chicago
Fred Smith, Announcer.....	WLW, Cincinnati
E. L. Tyson, Announcer.....	WWJ, Detroit
Hired Hand, Announcer.....	WBAP, Fort Worth
"Sen" Kaney, Announcer.....	KYW, Chicago
Nick B. Harris, Entertainer.....	KFI, Los Angeles
Jerry Sullivan, Announcer-Entertainer, WOJ, Chi.	
Edward H. Smith, Director-Player.....	
WGY, Schenectady	
Charles E. Erbstein, Announcer.....	WTAS, Elgin
Wendell Hall, Entertainer.....	WDAF, Kansas City
Howard Milholland, Announcer.....	KGO, Oakland
Scottish Rite, Orchestra.....	KGO, Oakland
Banks Kennedy, Entertainer.....	WEBH, Chicago
S. Hastings, Announcer.....	KFI, Los Angeles
Robert Boniel, Announcer.....	WEBH, Chicago
Arion Trio, Instrumental.....	KGO, Oakland
Gold Dust Twins, Entertainers.....	WEAF, New York

There remains but thirty days from the time this June issue first reaches the news-stands in which to cast your final vote for your radio favorite. If you have not voted before, your ballot may be the one to decide the contest for your choice. Those who have been casting their ballots each month are invited to clip the coupon for the last time and send it in with the name of your candidate.

Let's go for the final pull, and may the best man win!

POPULARITY CONTEST COUPON

Harry Aldine, Contest Editor
RADIO AGE, 500 N. Dearborn St., Chicago.

I wish to cast my vote for:

Name of favorite.....

Classification.....

Station..... Date Heard.....

Name (optional).....

Address (optional).....

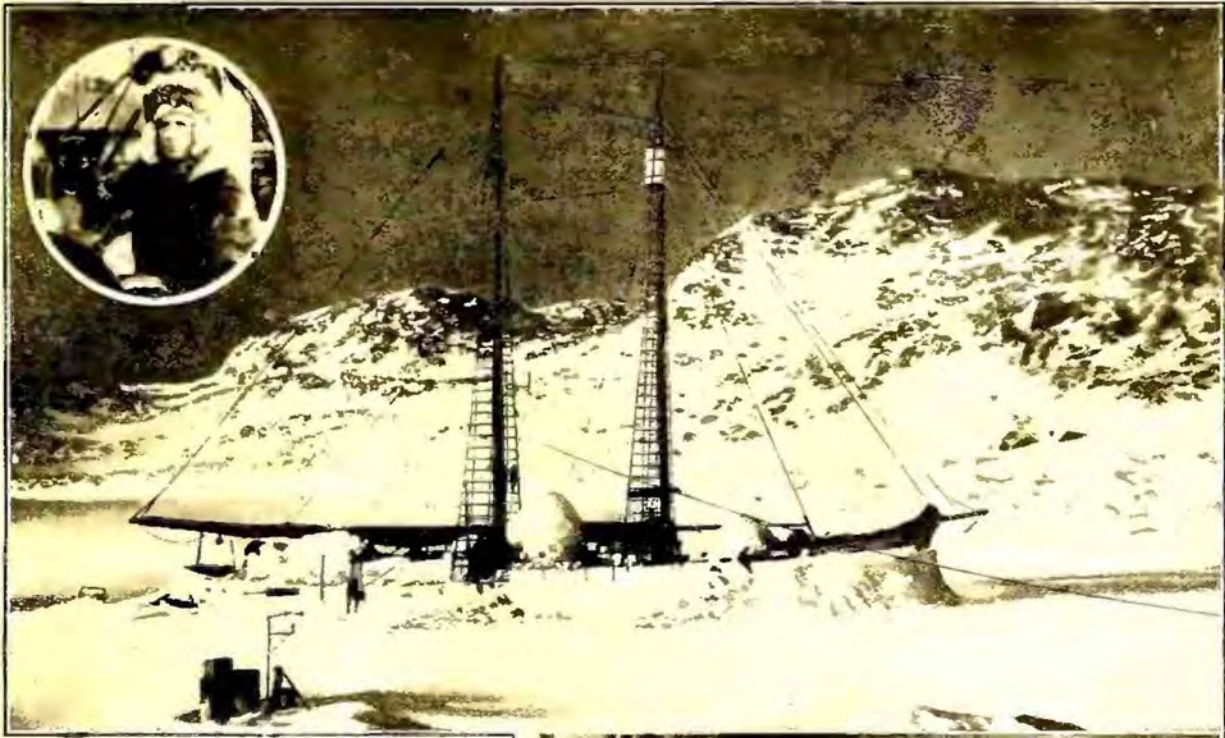

Opening a NEW ERA in Radio

Three Radio Pioneers to Lead Short Wave Expedition into Far North to Explore the Arctics and Test Out New Radio Theories



Above is shown the "Bowdoin," the ship which carried MacMillan to the Arctics last year. It is seen frozen in, near the Pole. Commander MacMillan is shown in the inset. The lower photo shows H. C. Forbes, John L. Reinartz and Karl Hassel, designers of the Zenith-Reinartz transmitter to be used in the 1925 expedition.

By FREDERICK SMITH

RADIO, history and science are likely to share richly in the results of the arctic expedition which will set off from Wiscasset, Me., about June 20 of this year. There will be one ship and at least two seaplanes to carry northward a group of men who will include in their number distinguished radio engineers, world-famous navigators and explorers, and some of the best aviators to be found in the United States Navy.

By the efforts of these men it is hoped that a new era in short wave radio transmission will be inaugurated. It is an-

anticipated that we, in the more comfortable latitudes, may even be privileged to listen to the folks songs of the polar Esquimeaux, for both ship and airplanes will carry equipment for transmitting and receiving radio messages.

It is hoped that a lost arctic continent may be located and that landing posts may be arranged in such hitherto inaccessible spots that the cause of world commerce and communication will be immensely benefited. Planes equipped with mapping, still picture and moving picture cameras, will fly beyond limits

of dog team travel and bring back facts about what lies in the land of frozen mystery.

To Delve Into History

IN addition there will be original research into such historical data as may still exist relating to the landing of the Norsemen in the farthest North. An effort also will be made to obtain copies of the important records left by Peary at Cape Columbia.

Among those who will participate in
(Turn the page)

this series of dashes into lands where white men have not before been privileged to go are the following:

Donald B. MacMillan, Commander in the navy and leader of the expedition. Commander MacMillan is a scientist, explorer, author, navigator, lecturer.

Eugene F. McDonald, Jr., President of the National Association of Broadcasters and President of the Zenith Radio Corporation, Chicago. Commander McDonald, himself an experienced navigator and hunter, was responsible for the installation of radio equipment on the little schooner "Bowdoin" when it carried Dr. MacMillan to the Arctic in 1923. This was the first demonstration of the value of radio in Arctic explorations. Communication was established with the "Bowdoin" after it went into "winter quarters" within thirteen degrees of the North Pole and was maintained for months.

U. J. Herrmann, showman, sportsman, founder of the two great annual national radio expositions in Chicago and New York and one of the owners of the new station, WHT, on the Wrigley Building tower, Chicago.

John L. Reinartz, famous radio inventor, designer of the Reinartz circuit, official of the American Radio Relay League, pioneer in short wave development. Lieut. Reinartz will be official broadcaster for the MacMillan expedition and will conduct tests with short wave transmission, which will engage the attention of the entire radio world. He has been employed permanently by the Zenith Radio Corporation, 332 South Michigan avenue, Chicago and will devote much of his time before the expedition sets off in assisting amateurs in the United States and Canada to learn the construction of short wave transmitters and receivers, which will be of vital importance in getting messages to and from the MacMillan expedition. The Zenith Corporation will build these receivers and transmitters only for its own use, both on the MacMillan ship and in its own transmitting stations in Chicago. But it will assist all who wish to build the instruments with free in-



The upper photograph shows Commander MacMillan greeting Eugene F. McDonald, one of the sponsors of the 1925 trip and a seasoned navigator himself, as well as one of radio's leading pioneers. In the circle is U. J. ("Sport") Herrmann, widely known sportsman and showman, who will accompany the expedition.

formation on application by mail to Lieut. Reinartz. The Zenith Corporation says it hopes to have 1,000 amateurs equipped with short wave transmitters before the MacMillan expedition sails.

Information as to the volunteer naval aviation personnel which will be a part of the expedition will be given RADIO AGE readers in a later issue.

Short Waves Are "Coming"

COMMANDER McDonald predicted to the writer more than a year ago that the radio world would soon be paying more serious attention to the use of short waves as an effective means of radio communications. His plans for the equipment of the arctic expedition prove that he has more faith than ever in this employment of high frequencies

under the most difficult conditions.

He submitted the following facts in a recent interview:

Will Carry Transmitters

"The Expedition is to have four transmitters, 20, 40, 80, and 180 meter wavelengths. We will be in twenty-four hour daylight after we pass 66°30' north latitude. The 20 meter transmitter will be used when we are communicating during the period of the day when this part of the globe is in daylight; 40 meters when this part of the globe is in darkness. The 80 meter transmitter is merely to be used to get us wider circulation among the amateurs that will be able to reach

down to that point, and not down to 20 meters. The 180 meter transmitter is taken along merely for the purpose of proving that it will not work in these high latitudes, and twenty-four hour daylight.

"I have employed Reinartz at the highest salary ever paid any radio operator, \$1,000.00 a month, and this is not stage money. I secured him because I believed him to be the short wave wizard of the United States, and money is no object. We must get these messages back from the Arctic even though we are going into the most difficult section of the globe for radio transmission. One hundred meter signals have never been heard in Smith Sound between 55° n.l. and 75° n.l. You will recall the MacMillan signals came back only after they had passed 75°. His port from which he sent most of the communications last year was from 78:30.

Planes Will Transmit

"We are equipping the airplanes with a new type of transmitter using 40 meters. The reason we cannot use 20 meters on the airplanes is that 20 meters are not audible at distances under 2500 miles. Forty meters, however, are audible at all short distances. Lieut. Reinartz pointed out an interesting phenomenon the other day when he told me that while it was necessary to be 500 miles away to hear 20 meter signals in the daytime, it was necessary to be 3,000 miles or over to hear them at night.

"The transmitters for the airplanes will weigh under 100 lbs., and be operated by dry batteries only. The Government radio equipment today for airplanes is operated by a generator propelled by an aeroplane propeller, and therefore will function only while the airplane is in



Here is a typical airplane used for exploring trips, and similar to the planes which will be taken with the MacMillan-McDonald Expedition in June, when they set out for their perilous dash to the mysteries of the north-land. The planes will aid the explorers in guiding the ships and reaching points which are closed to navigation.

commission. If the airplane motor is out of commission, so is the radio, and we cannot take that risk. We want a transmitter capable of sending word back to the ship for the emergency plane to come out in case our motor fails us and we are forced to make a landing far from our base.

Daily "Letters" Home

"We hope to transmit messages back every day. Reinartz confidently hopes that we will be able to send voice back from the Arctic on 20 meters. If this is possible, we'll give you the Esquimeaux Folk Songs by radio. It may be possible if we can transmit the voice back to pick it up, boost it in wavelength, and put it out over the broadcasting station WJAZ."

THE foregoing shows rather impressively what a degree of thought and effort and careful engineering is being devoted to the radio phases of this adventurous enterprise.

While the expedition has the cordial indorsement of the National Geographic Society, to which plans of the itinerary already have been submitted, and although President Coolidge has not only given the expedition his approval but has authorized the participation of the Navy Department, it is, after all, a private enterprise.

It should be remembered by those who prefer to know who are the most useful friends of radio that the negotiations in Washington were conducted successfully only through the earnest co-operation of Secretary Wilbur, of the Navy Department; Rear Admiral William A. Moffett, in charge of naval aviation, and Congressman Fred A. Britten, an Illinois representative who repeatedly has come to the aid of the radio industry and the radio fan. It was the vision of these three men and their vigorous prosecution of the official plans which made the project what it is today, one of the most important scientific ventures ever undertaken.

Will Test High Frequencies

As a result of all this, radio high frequencies will have their chance while the world stands by as referee. The ancient ruins in Labrador and Greenland will be

explored to connect then, if possible, with Eric the Red. The exploring ship will try to make its way to Axel Heiburg land. It is planned to establish an airplane base 250 miles away from the ship at the northernmost point of the land.

The airplanes will have a cruising radius of 1,000 miles and a speed of 120 miles an hour. They will try to fly over the Greenland ice cap, where no man has ever been before. One of the most important missions of these planes will be the mapping of Ellesmere Land and Baffin Bay, in the vicinity of the magnetic north pole.

The party will attempt to make a comprehensive survey of the only remaining "blind spot" in the world—that region of more than a million square miles in extent, which is hidden away at the top of the world between Alaska and the pole.

In the projected exploration of Baffin Land there is a fascinating invitation for Commander McDonald and "Sport" Herrman, both doughty disciples of Isaak Walton. For they probably will find thousands of lakes, hitherto unfinished by white men. Esquimeau have told of enormous numbers of seal, caribou and other wild animals in these wilds.

The "Bowdoin" will sail about June 20 and from that date forward many hundreds of thousands of persons will await daily the news of this intrepid assault on the phalanxes of the proud and stubborn north.

England Hears Radio From Hawaii

WASHINGTON, D. C.—NRRL, the amateur experimental radio station operated by Lieutenant F. H. Schnell, traffic manager of the American Radio Relay League, with the United States fleet in European waters, has succeeded in piling up some enviable records in the way of constant communication on short wave lengths.

Several stations in the East and some on the Pacific Coast have worked with Lieutenant Schnell, while stations that have heard NRRL run from California to England. British station g5NN

picked his message put on the air and relayed the information back to League Headquarters in the United States by radio.

Stations in Rochester, N. Y., Brooklyn, N. Y., and Longmeadow, Mass., were the ones on the Eastern seaboard that successfully conversed with Lieutenant Schnell, while Minneapolis, Long Beach, Cal., Altedena, Cal., and Ellensburg, Wash., also carried out two way telegraphy with Station NRRL.

Reports have been made to the American Radio Relay League headquarters in this city by stations at Gadsen, Ala., Baltimore, Attleboro, Mass.; Schuylkill, Pa., New York City; Red Bank, N. J.; Port Arthur, Ont.; Hilton, N. J.; Mt. Ranier, Md.; Los Angeles and Baker, Ore., that Lieutenant Schnell's messages from the special short wave station were heard and copied by the operators.

China to Admit Radio Supplies

Hartford, Conn.—The central Chinese government is planning to lift the embargo on radio material and supplies, according to correspondence of the American Radio Relay League, whose headquarters are in this city.

The Peking government Department of the Telegraph is reported at work on the first drafts of the regulations governing conditions of import.

Those who advocate the removal of the restrictions point out that in Manchuria there are radio stations in operation at Mukden, Changchun, Harbin, Tungkiang, Marchuli, Yinkow and Hula-tao. Others are in course of construction at Antung, Tsitsihar and Tetropavlovsk, while plans for other stations are being considered.

The American Radio Relay League correspondent points out that all of these stations are used for official purposes only, but it is the hope of radio enthusiasts in the Chinese republic that they may be opened to commercial and other uses in the near future.

Vigilance committees designed to reduce interference in radio communication have been formed by the traffic department of the American Radio Relay League and are already functioning.

Radio Age Institute

Manufacturers' Testing Service

MEMBERS of the staff of RADIO AGE will be pleased to test devices and materials for radio manufacturers with the object of determining their efficiency and worth. All apparatus which meets with the approval of various tests imposed by members of the technical staff of RADIO AGE will be awarded our endorsement, and the seal shown to the right will be furnished free of charge. Materials for testing should be sent to

RADIO AGE INSTITUTE
504 N. Dearborn Street, Chicago, Ill.



DEVICES

displaying this seal have been tested and approved by the RADIO AGE INSTITUTE.

Apparatus illustrated and described below has successfully passed our tests for June, 1925.



Test No. 59. THOROLA Low Loss Doughnut Coils. Manufactured and submitted by the Reichmann Company of Chicago. These coils embody a new type of winding, which produces a very good ratio of resistance to inductance, which is a true measure of coil efficiency. This winding minimizes energy losses in inductance.

Due to a unique and scientific shape employed in this coil, called "doughnut" or toroidal, selective operation is easily secured, and there is no undesirable "pick-up" as in open coils. The coil submitted for tests was found to satisfactorily pass the tests and requirements of the RADIO AGE Institute over the period in which it was used in our laboratory.



Test No. 62. SONORA RADIO SPEAKER, with concealed horn. Submitted by the manufacturers. The Sonora Phonograph Company of New York. This loud speaker, besides being of unusually attractive design, produces very clear and deep tone; in fact, the tone is almost identical with that produced by high class phonograph, having been designed after that style and with that end in view. A patented all-wood horn, the same as used in the Sonora Phonograph, and a Sonora tone arm and radio reproducer, are encased in the beautiful cabinet, which blends with the furniture of any home. The speaker is small enough to be placed on a table, mantel or on the radio set itself. Satisfactorily passed the tests and requirements of the RADIO AGE Institute.

Test No. 66. SILVER "TWO-TENS" and "TWO-ELEVEN'S." Long wave transformers. Supplied in sets of 2 or 3 210s (iron core interstage and one 211, (filter for input or output) with identical peaks and separate curves. The feature of these transformers lies in the fact that the makers plot the curve in their own laboratory and record them directly on a tag attached to each transformer before it is placed on sale. Tests to determine the accuracy of these charted and matched transformers were conducted in this magazine's laboratory and in every instance the tag attached to each transformer was found to have the correct curve. Manufactured and submitted by Silver-Marshall, Inc., 105 S. Wabash Ave., Chicago. Satisfactorily passed the tests and requirements of the RADIO AGE Institute.

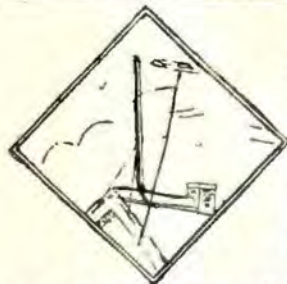
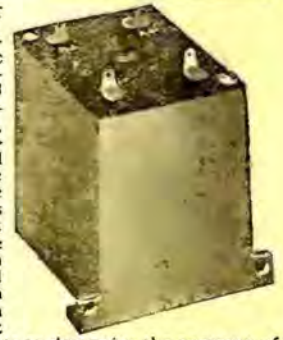

Test No. 60. The UNIVERSAL AERIAL MAST FITTINGS, manufactured and submitted by the Universal Mast Company of 3215 Montrose ave., Chicago, Ill. These fittings come complete in one box and are a welcome surcease from the bother of making new aerial supports every time a fan wishes to

erect a new aerial, after moving, etc. The material for masts using these fittings should preferably be 2 x 2 in. cypress or yellow pine. The bases can be attached to such masts very easily. The guy attachment, also contained in the kit, is fastened one-third up from the bottom of the mast. The ends of the base plates may be flattened down to give additional bearing surface. These fittings were tested both on wooden and on apartment building roofs, and were found practicable for both, besides being unusually firm against the wear and tear of wind, rain, etc. Satisfactorily passed the tests and requirements of the RADIO AGE Institute.



Test No. 63. MICA FIXED CONDENSER, manufactured and submitted by the Sangamo Electric Company of Springfield, Ill., makers of electric meters. This condenser is guaranteed accurate within 10 per cent of the marked capacity and

to sustain its original accuracy under all conditions. Their accuracy is likewise not affected by the heat or acid used in soldering. These condensers show up best in reflex circuits because of their accuracy. The condenser is sealed in a smooth brown bakelite case, making it impervious to atmospheric changes. Also presents a neat appearance. Satisfactorily passed the tests and requirements of the RADIO AGE Institute.



Test No. 67. The Remo RADIO TUBE REACTIVATOR. Manufactured by the Remo Corporation of Meriden, Connecticut. An instrument selling at a reasonable price for reviving weak or old tubes and bringing them back in volume as good or better than new ones. Designed for standard amplifying tubes of the UV201A type or UV199 tubes. Three UV201A or two UV199 tubes can be accommodated at once. Detector tubes of the UV200 or WD12 type cannot be revived. The Remo Reactivator is used only with regular 110 volt 60 cycle AC current and is furnished with cord and plug. While such a device is comparatively new in the radio field, the Remo Reactivator satisfactorily passed strict tests of the RADIO AGE Institute in the tests for which it was used.



Test No. 64. RADIO PLUG submitted by Pacent Electric Co., Inc., 91 Seventh Ave., New York City, N. Y. A plug for connecting either a loud speaker or a headset to the output jack of any receiving set. It is well made, having firm grip for the telephone or loud-speaker tips. Tested and approved by RADIO AGE Institute.



Test No. 68. 1926 MODEL NEUTROWOUND RECEIVER. A new principle—incorporated in the Neutrowound Radio Receiving Set—enables the operator to "tune in" near or distant stations, and operate at the highest peak of radio-frequency amplification—at all wave lengths—insuring consistent reception, over very great distances with the maximum selectivity—free from outside interference. The all-metal case not only serves as a sturdy protection for the vital parts of the receiving set, but also acts as an electro-magnetic shielding against outside interference. Hums, noises and distortions are eliminated. Satisfactorily passed the tests and requirements of RADIO AGE Institute.



Test No. 61. RADION BUILT-IN LOUD SPEAKER HORN, Manufactured and submitted by the American Hard Rubber Co. of 11 Mercer St., New York City. A unique horn barely a foot high, which can be built in a portable or other receiving set, and a standard telephone unit attached to its base. May also be used for a loud speaker in a hotel room, etc., where intense volume is not desired. Instead clear and sweet tone is produced. The horn is made of RADION, the American Hard Rubber Company's material, also used for radio panels, etc. The horn sent to this magazine was tested both for portable and built-in sets, and in every way satisfactorily passed the tests and requirements of the RADIO AGE Institute.



Test No. 65. Metallized Grid Leak, submitted by Durham and Co., Inc., 1936 Market St., Philadelphia, Pa. Consists briefly of a glass rod of small and uniform diameter, coated with a metallized high resistance material by means of a high temperature and gas process. Resistance then impregnated in a non-hydroscopic insulating fluid, and after an aging period, is cut and assembled in the air tight cartridge. The end caps are soldered to the resistance unit instead of using low melting alloy. Tested and approved by RADIO AGE Institute.



Test No. 69. VALLEY BATTERY CLIP. Submitted by the Valley Electric, Company of St. Louis, Mo. This clip is of the conventional type in use for A battery connections, having firm, toothed jaws for gripping the positive or negative posts on batteries. A screw is provided for making firm contact with the wire. Satisfactorily passed the tests and requirements of RADIO AGE Institute.

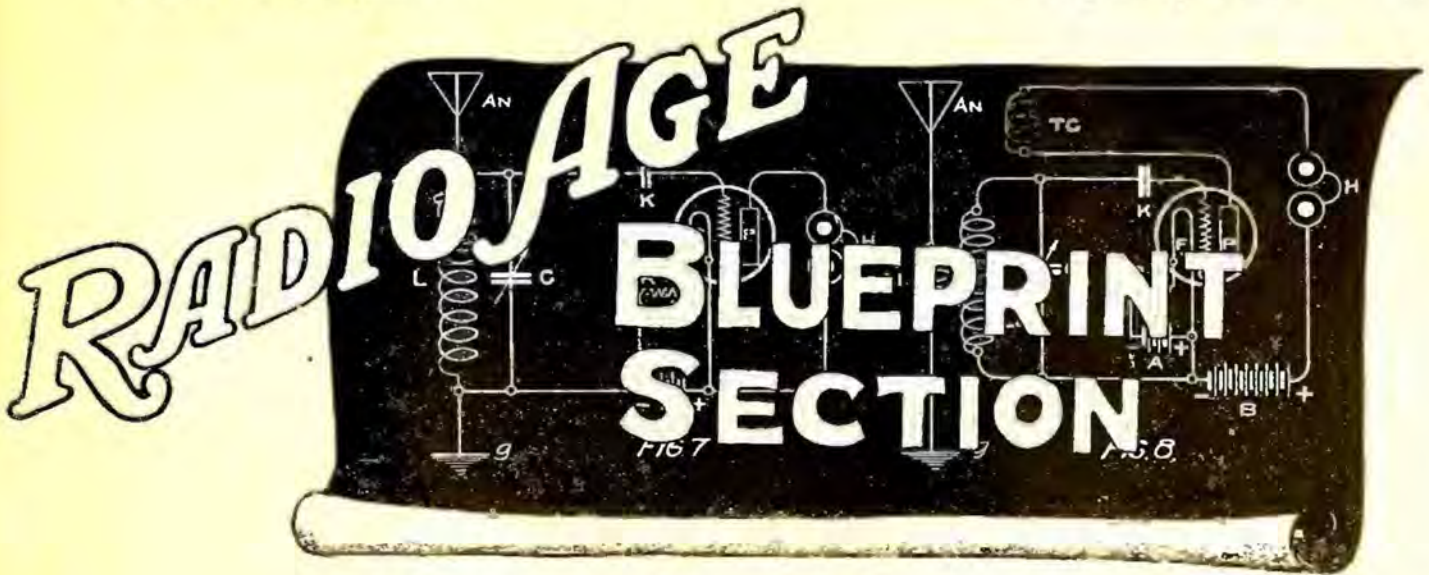

Economy of Parts and Space in A 3-Tube Portable Reflex

By JOHN B. RATHBUN

Copyright: 1925

TO BE truly portable, according to my idea, means that a receiving set should be easily carried about from place to place without seriously straining its owner's physiology, and at the same time it should be so compact that it will not take up any more room than necessary in a trunk. There are portables and portables, but the absolute zero in portability is the set made up in a traveler's sample case which weighs about 100 pounds and occupies about fifty per cent of the trunk space. On the other extreme is the freak midget set which has been variously fitted into pill boxes, fountain pens and pickle bottles, and which has absolutely no purpose in life except to exhibit the maker's ingenuity. The real portable should have a good range and sufficient volume to operate a loud speaker, and yet at the same time should not take up a great deal more space than a camera, even when fully equipped with batteries.

No really practicable portable has been turned out with less than three tubes, for it is impossible to operate a loud speaker satisfactorily with less tubes on anything but local stations. For this reason I will assume a three tube set from the beginning and will build up all the other data about this premise. Whether this is to be a regenerative, radio frequency or reflex still remains to be seen, but as the maximum volume is to be obtained from a minimum number of tubes and batteries, I have strong leanings for the reflex type. The reflex circuit is not always the greatest distance getter, but what it does get, it gets good and loud.

Batteries Consume Space

PROBABLY the most important item in a portable is that of the batteries, for the batteries weigh more and take up more space than the rest of the equip-

Reversed Capacity Feedback Cuts Out Free Oscillations

ment. Our current supply system must be reduced to the lowest possible limit even at some sacrifice in the life of the batteries. If the batteries stand up for a month while traveling about, it is generally considered satisfactory for vacation tours. At home, we can substitute larger batteries installed outside the set,

but in touring, the space and weight are the principal items. With this idea in mind, we will study the battery situation and the proper tubes to go with these batteries.

Storage batteries are out of the question, of course, hence only dry cells are available for the filament and plate current. This means that the tubes must either be of the WD-12 or the UV-199 type, which are specially designed for dry cell service. They do not give the volume of the 201A power tubes used with storage batteries, but they give excellent results if properly handled.

The WD-11 and WD-12 are the same tube with the exception of the base. The base of the WD-11 is a special small size, while the WD-12 fits in a standard socket. Both tubes operate on the 1.5 volts produced by a single dry cell and take 0.25 ampere per tube. Each tube therefore takes $1.5 \times 0.25 = 0.375$ watt, or 3-8 watt. One No. 6 dry cell is provided for each tube, which can be connected independently to each tube of a multi-tube set or to a multiple connected battery with as many cells as tubes. As 0.25 ampere is the rated discharge rate for a No. 6 cell, it is not possible to use a smaller battery.

Next come the UV-199 or the C-299 tubes, which require 3.0 volts at the filament, and which take only 0.06 ampere of current. As the voltage of a battery falls off with use, we must use three dry cells in series, which gives us a total of 4.5 with a fresh battery. This excess is taken care of by a 30 to 40-ohm rheostat, which permits the use of a battery between the limits of 4.5 volts and 3.0 volts, the battery being discarded when the voltage drops to the latter point. The power taken is therefore: $4.5 \times 0.06 = 0.27$ watt, very much less power than is required with the WD-12.

(Turn to page 38)

"EVERYTHING I NEED IN RADIO"

"I bought a copy of the RADIO AGE ANNUAL for 1925 and I found that everything I wanted to know about radio, from crystal sets to complicated multi-tubers, was contained between its two covers," wrote an enthusiastic beginner.

"I never knew so much could be contained in one book without crowding or omitting necessary details. But you haven't left a thing out of the ANNUAL for 1925."

Letters such as the above are sent to us every day, voicing sincere appreciation of the ANNUAL for 1925, the most complete radio hookup book ever printed. And the price for the 120 pages of technical "nuggets" is but ONE DOLLAR, postpaid.

Send your order now while our supply of the limited first edition lasts.

Blueprints of the 3-Tube Portable Reflex on Two Pages Following

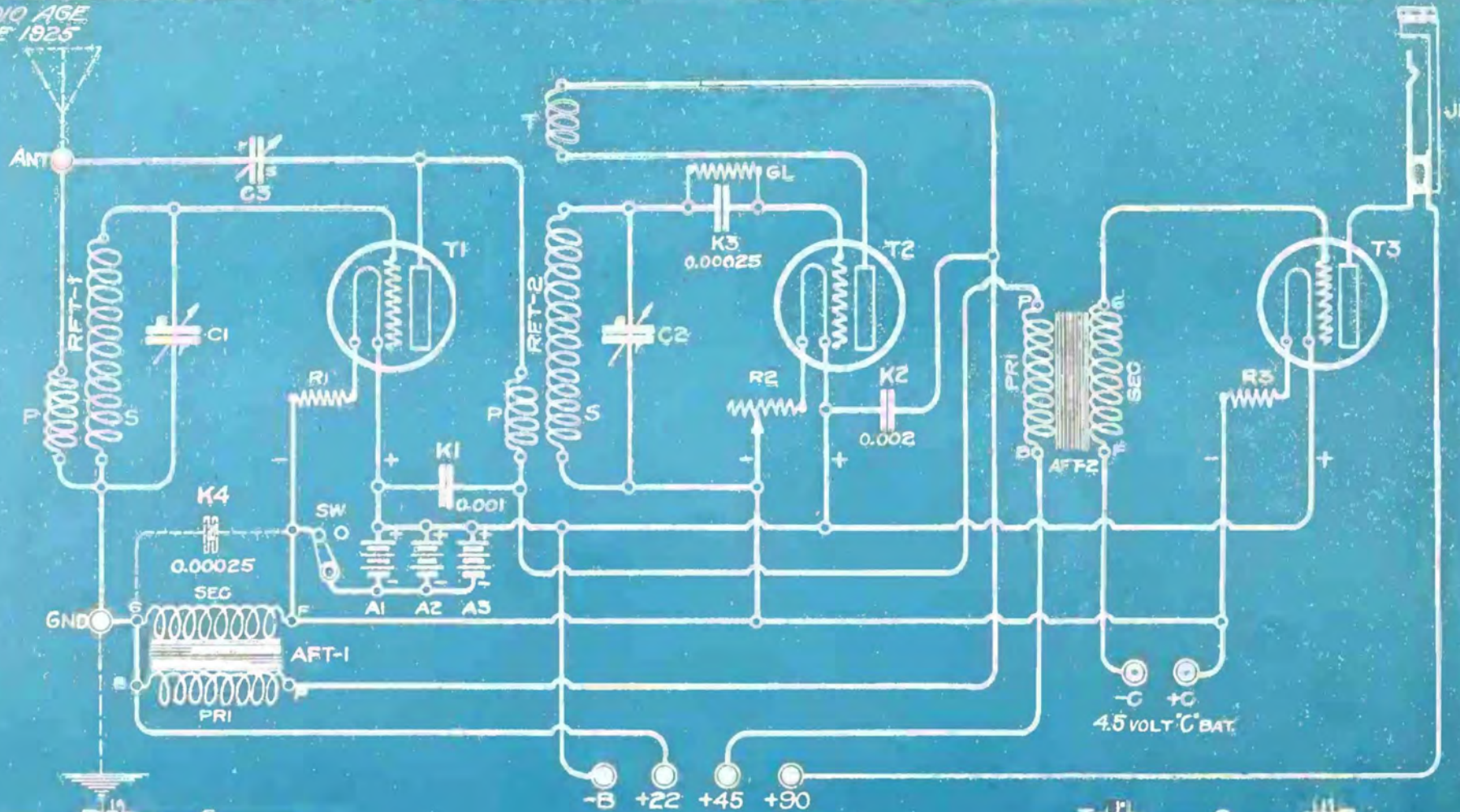

FIG. 1A
CIRCUIT DIAGRAM

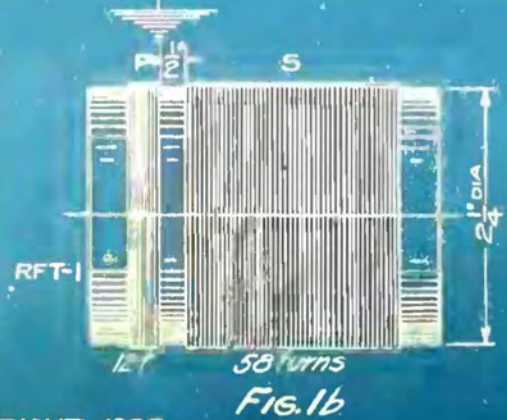

Fig. 1b

"JUNIOR PORTABLE"
ONE REFLEXED STAGE, REGENERATIVE
TUBE DETECTOR, ONE STAGE OF AUDIO
AMPLIFICATION ON THREE TUBES.

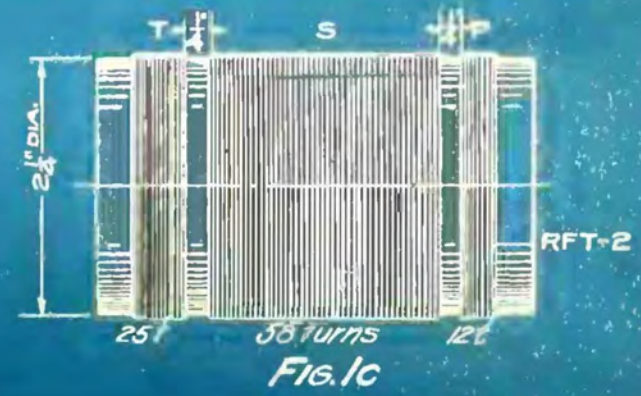

Fig. 1c

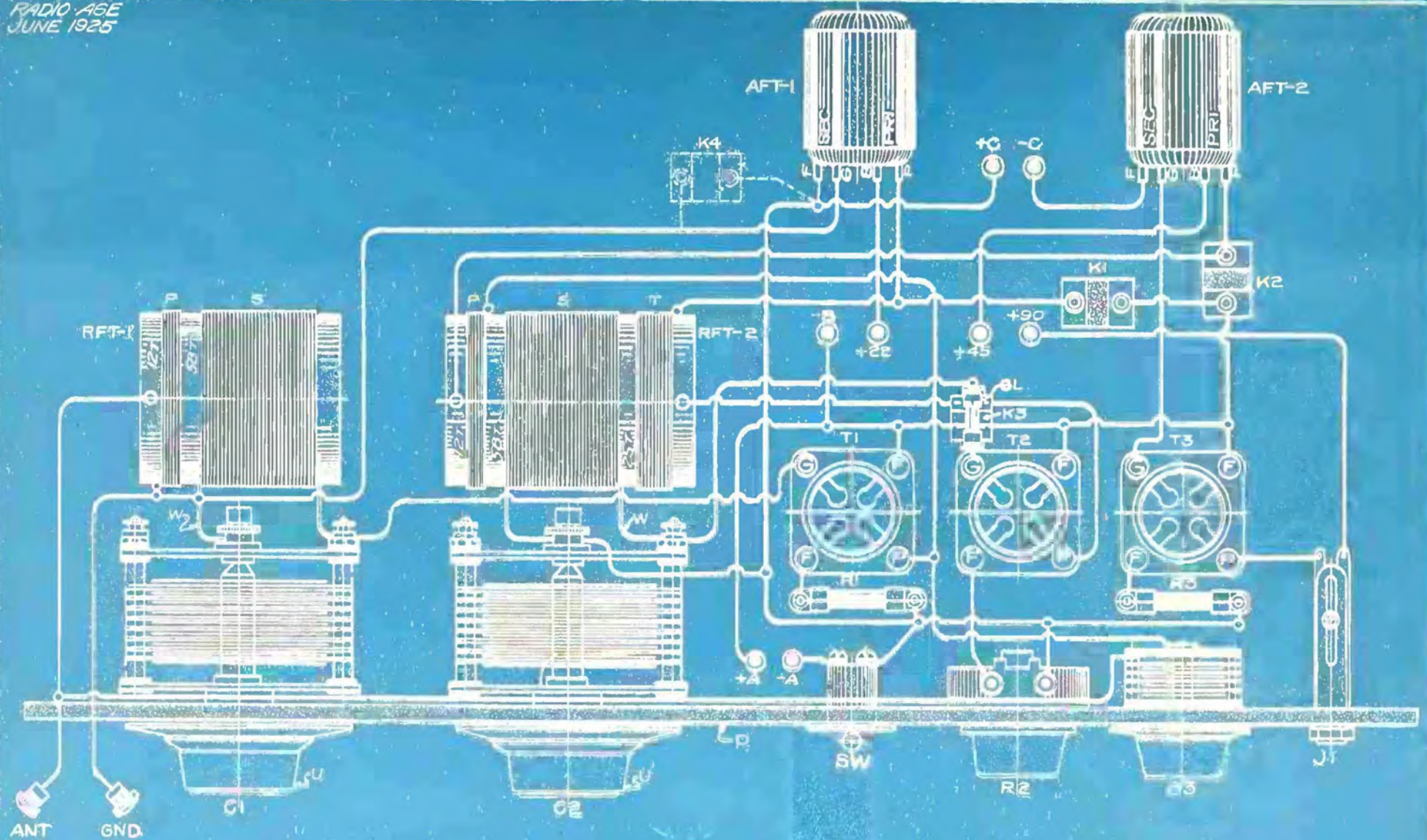

FIG. 2
"JUNIOR PORTABLE"

"PICTURE" WIRING DIAGRAM SHOWING ELECTRICAL CONNECTIONS BUT NOT ACTUAL MECHANICAL ARRANGEMENT OF PARTS. THE COILS RFT-1 AND RFT-2 ARE REALLY AT RIGHT ANGLES TO EACH OTHER, AND THE CAPACITORS C1 AND C2 ARE IN A VERTICAL ROW.

(Continued from page 35)

Qualities of "199" Tube

NOT only is the power loss with the UV-199 tube, but the amplification is greater than with the WD-12, and the 199 is much more satisfactory in the amplification of radio frequency currents in reflex sets. In fact, the 199 comes next to the 201A tube in regard to amplification and only takes one-quarter of the current. Three No. 6 "A" batteries will operate three 199 tubes for a long time, for the discharge rate is only $3 \times 0.06 = 0.18$ ampere, or less than a single WD-12 tube. The 199 is the ideal tube for a portable set from many stand-points, and takes up a minimum of room.

As the rating of a No. 6 dry cell is 0.25 ampere for filament lighting, this size of cell will operate three 199 tubes for a very long period, much longer, in fact, than would be absolutely necessary with a portable receiver. For this reason, we can use a smaller filament battery with satisfactory results, and if the set is not used for too long a period, a 4.5 volt C battery can be used for each tube. As the C battery takes up much less space and weighs much less than a No. 6 cell, we can use a 4.5 volt C for each tube or a total of three C batteries in all. For home use, where less frequent replacements are desirable, we can use a larger external battery—a storage battery if necessary.

An alternative will be to use two C batteries in parallel for each tube. This will give longer life than the singles as connected above, but will take less space than three No. 6 cells. The following table will give the comparative sizes:

NO. OF CELLS	SIZE OF CELLS	SPACE OCCUPIED
3 No. 6	5"x5"x6.5"	= 162.5 cubic in.
3 C	4.1"x3"x4"	= 49.5 cubic in.
6 C	4.1"x6"x4"	= 99.0 cubic in.

In effect, the three C batteries will be connected in parallel through a switch, and we will use the C batteries, as we wish to get the smallest possible set. If longer service from No. 6 cells is required, then the only change necessary will be to use a single group of three cell in series of the No. 6 type, and to correspondingly enlarge the battery compartment of the set.

The Hookup in Detail

In general, the "Junior Reflex" is a regenerative reflex using a tube detector with a tickler coil feed-back and equipped with one additional stage of straight audio frequency amplification. This arrangement gives us one stage of radio frequency amplification, a regenerative stage, and two stages of audio amplification. Enough for three tubes. A short, temporary aerial of from 40 to 60 feet will be all that is ordinarily required, either of the indoor or outdoor type, and I have had good service with a 30 foot indoor aerial run around the picture moulding of the room. So far as possible, small or miniature parts are used to economize space, and it is surprising how much apparatus we can get into a small cabinet when we make up our mind to concentrate our efforts to this end.

A special method of avoiding oscillations by means of a reversed capacity feed-back is applied to the radio frequency tube, which has proved effective in all the cases experimented upon by the writer. The plate current is fed back into the primary of the tuning coil through a very small variable condenser in such a way that it opposes the free oscillation tendency of the first tube. It is a simple application of the reversed feed-back system without the necessity of a tickler coil. As the suppression of free oscillations is one of the most difficult propositions met with by the amateur

with a separation between the two coils of approximately 1-2 inch. The wire is No. 26 D. S. C. magnet wire.

Condenser for Suppression

OSCILLATIONS in the radio frequency circuit are suppressed by the very small variable condenser (C) connected between the primary coil (on the aerial side) and the plate of the first tube (T1). This is a condenser such as the "Chelton Midget" or the "Amplex" neutralizing condenser, having a maximum capacity of from 0.000025 to 0.00006 mf. This is somewhat critical on most sets, hence the condenser (C3) is represented by a dial on the front of the panel. When properly adjusted the first stage can be cleared up quickly and easily by this simple adjustment.

The output of the first tube passes through the primary (P) of the special transformer (RFT-2) which transfers the radio frequency current to the detector tube (T2). This coil (P) is located about 1-4 inch from the end of the secondary coil (S), and at the other end of (S) is the tickler coil (T) provided for regeneration in the detector stage. All three coils are in fixed relation on the same tube, and the detector circuit is tuned to wavelength by the variable condenser (C2) connected across the secondary coil (S). The tickler (T) has about 25 turns, the secondary (S) has 58 turns and the primary (P) is a 12 turn coil. The general details of this coil or transformer are shown by Fig. 1C, but it may be found necessary to give a few more or less turns on (T) until the proper regeneration is obtained with the vernier rheostat (R2) turned to the "half-on" position.

As the current flowing through the coil (T) is almost entirely dependent upon the filament emission, and hence the rheostat adjustment, a very accurate rheostat will be required. A 40-ohm rheostat will be found about right at this point for the proper control of regeneration by the filament emission system. If the tube has to be turned up bright for the regenerative effect, increase the number of turns on (T) until it starts to "flop over" with the rheostat turned about half way on. The regulating resistance for the radio reflex tube (T1) is an Amperite shown at (R1), and a second Amperite is at (R3) for the automatic control of the amplifier filaments. The amplifier tubes (T1-T3) are not critical, but the detector tube (T2) is very critical so that a rheostat must be used instead of an Amperite at this point.

The detector tube circuit is a conventional feed-back circuit and has the usual grid condenser (K3) and grid leak (GL). The grid leak is from 1 to 2 megohms, and the condenser (K3) is probably best at 0.00025 mf. A bypass condenser (fixed) is placed at (K2) which is of assistance in reducing the R. F. resistance of the detector plate circuit. The value may range from 0.001 mf to 0.002 mf, depending upon conditions in the circuit. The circuit tuning condenser (C2) has a capacity of 0.00035 mf., so that (C1) and (C2) will "log" well together.

As is usual, the output of the detector

MATERIALS FOR "JUNIOR PORTABLE"

Code Letters	No. of Pcs.	Name	Size
A-3		"C" batteries, large, 4.5 volt.	
AFT-2		Audio Frequency Transformers, 4-1 to 6-1 ratio.	
B-4		"B" batteries, 22.5 volt blocks, small size (1200 m. h.).	
C1-C2		Vernier variable condensers, 0.00035 mf. 17 plate.	
C3		Equalizing variable condenser, Chelton Midget, 0.00006 mf.	
C		Small bias battery.	
D-1		Bakelite panel 10"x8.3-4"x3-16".	
E-1		Bakelite tube shelf 4"x6-1-8"x1-8".	
F-6		Marked binding posts.	
GL-1		Grid leak (adjustable or fixed), 1.0 to 2.0 megohms.	
J1		Single circuit jack.	
K1-1		Fixed condenser, mica ins. type 0.001 mf.	
K3-1		Fixed condenser, mica ins. type 0.002 mf.	
K3-1		Fixed condenser with leak lugs 0.00025 mf.	
K4-1		Fixed condenser mica ins. type 0.00025 mf.	
R1-R3		2 Amperites for fila. control (199, 4.5 volts).	
R2-1		Filament rheostat, vernier, 40 ohm type.	
RFT-1		Standard air core R. F. transform neutrodyne type.	
RFT-2		1 Bakelite tube, 2 1/4" diam. 3" long.	
RFT-2		1-4 lb. silk covered magnet wire No. 26 D. S. C.	
S		Small brass shell or support angles	
12"		Bus wire, No. 14, tinned copper.	
1'		Rosin core solder.	
1'		Spaghetti.	
25		Miscellaneous machine screws.	
U-2		Condenser dials (if not with con.) 3" Diam	
SW-1		Battery cutout switch, Standard.	
T1-T2-T3		3 UV-199 tubes.	
V-3		"199" tube sockets, absorb. base.	
W-4		Condenser angles for holding coils on condensers.	
X-3		Flexible fixture cord for battery connections.	
Y-1		Special cabinet (Complete).	
1		Phone plug.	
60'		Annunciator wire, wax cotton or No. 18 flexible fixture wire for aerial.	

in the construction of a reflex circuit, he will find this a most important point.

Fig. 1A is a schematic diagram of the "Junior Portable," showing the three tubes, the transformers, and all connections. The tube (T1) is the reflexed radio frequency and audio frequency tube; tube (T2) is the detector, and (T3) is the straight audio frequency amplifier. All radio frequency stages are tuned by variable condensers so that the maximum amplification peak is attained, and at this same time this is a valuable aid to the selectivity of the set. The second tuning coil or radio frequency transformer is of a special type, as it contains three coils which act respectively as the primary, secondary and tickler coils. Only two dials are required for the tuning operation proper, the regeneration being controlled by the detector rheostat, a method that is entirely practicable with a vernier rheostat, and which greatly simplifies the construction and tuning.

At RFT1 we have the usual aperiodic tuning coil with the primary (P) and the secondary (S) which is tuned by the 17 plate (0.00035 mf) variable condenser (C1) connected across the secondary in the conventional manner. A detail of this tuning unit is shown in Fig. 1B, which shows the principal dimensions. There are 58 turns on the secondary and 12 turns on the primary coil (P),

tube is reflexed back to the first tube (T1) by means of the audio frequency transformer (AFT-1), the latter being in the grid return circuit of the first stage. This can be any make of transformer having a ratio varying from 4-1 to 6-1, but as we wish to gain every inch possible, I have shown the miniature Premier Hegehog transformer in the picture diagrams. In some cases, a 0.00025 mf fixed condenser (K4) improves results when connected across the secondary coil of (AFT-1), and again, this seems to have but little effect. It seems to be a matter of experiment with each individual set to determine whether (K4) should be used. Its effect is principally on DX rather than on volume with local stations, so that we should try for distance in making this adjustment rather than to experiment for volume alone.

The output of the reflexed tube (T1) now passes to the primary coil of the second audio transformer (AFT-2), and this latter transformer is a part of a straight audio stage that is not reflexed. Connections are made to (T3) in the usual standard manner, and the total output of all three tubes passes out through the output jack (J1) to the phones or loud speaker. This is not a complicated circuit to hook up, but it requires some readjustments as with any reflex circuit, particularly in regard to the values of the bypass condensers.

For the smallest portable set, three 4.5 volt "C" batteries are used for the filament current as at (A1-A2-A3), the cells being in parallel and connected to the circuit through the battery cutout switch marked (SW).

22.5 Volts for Detector

PLATE or "B" battery connections are tapped according to the requirements of the various stages. A voltage of 22.5 volts generally proves best for the detector circuit under all around conditions, although 45 volts may give greater volume and selectivity on local stations. A potential of 45 volts is most effective on the radio frequency tubes on distance, hence a 45 volt tap is indicated for this stage. The audio stage requires 90 volts for the best performance, and 67 volts gives nearly as good results with one less block of "B" battery. The set can also be operated with 45 volts on the audio stage, but with greatly diminished volume on all stations. I do not recommend placing the full 90 volts on the radio frequency stage, and never on the detector stage, and after experimenting extensively I find that the best all around results will be found with the plate battery connections as indicated.

Four small B batteries (90 volts total) can be used for this set and will last most of the season. The smallest B batteries are the 450 milliampere-hour cells which measure 2" wide, 3-3-8" long and 2-9-16" high. The next largest size take up very little more space and give much longer service. This is the 1200 milliampere-hour size which is 2-9-16" wide, 4-1-6" long and 2-3-4" high. The latter size are the more practicable, especially

with three tubes, and are shown in the assembly diagram. With three tubes kicking out from 10 to 12 milliamperes, the 450 m. a. h. type does not last very long before the voltage runs down and the volume falls off.

In the table on page 38 is listed all of the material required for building this set, each item in the list being preceded by a letter corresponding to the letters on the diagram. All of these parts are standard and the majority are built by a number of radio concerns so that it will not be difficult to pick up all of the parts at your dealer's. The only special parts are the cabinet, which must be built to fit the job at hand, and the tuning coils and RF transformer, which can easily be wound up at home. A neutroformer or tuning unit can be purchased for use in place of RFT-1, but RFT-2 is special and is not stocked.

**Outdoors or
Indoors—You
Will Find All Your
Radio Needs
Satisfied In
RADIO AGE
Every Month.**

**Another Blueprint
Hookup In July
RADIO AGE—Out June 15**

Fig. 2 shows all of the parts connected up in "picture" form for the benefit of the novice who does not understand conventional or symbolic diagrams. Either Fig. 1 or Fig. 2 can be used in making the actual connections, for both show the same circuit and the parts are lettered with corresponding letters.

Fig. 3 is a rear elevation of the set with the back panel removed and shows how the parts are assembled, ready for wiring. The three tubes and sockets are mounted on the top of the shelf (E) while the audio transformers are hung underneath. This not only saves room but it also shortens and simplifies the wiring. Of course, machine screws must be used for this assembly instead of the more usual wood screws, as all parts are fastened to bakelite. The shelf is attached to the panel by means of the small brass angle brackets (S) which can be made at home or purchased at almost any radio store.

I wish to call your attention to the fact that the two radio frequency transformers or tuning coils (RFT-1) and (RFT-2) must be placed at right angles to one another, as shown, to prevent coupling back between stages and to prevent oscillations being set up by induction. The coils are supported by brass lug connections to the terminals of the variable condensers so that their weight is substantially supported. It should be particularly noted that the stator or sta-

tionary plates of the variable condensers (C1-C2-C3) connect to the grids of the tubes to prevent the body capacity effect from being carried out to the front of the panel through the shafts of the condensers. The grids are at a high potential, and anything connected to the grids is easily affected by the capacity of the hand and is detuned by this capacity effect.

All of the batteries are carried in the bottom of the cabinet, very closely packed together to prevent movement, and connections are made with the circuit above through the flexible cords (X). Connections are more certain and more easily made if "spade" type clips are soldered to the ends of these cords. Do not use solid wire for this purpose or simple cotton covered wire, as such wire is likely to short-circuit. Flexible fixture wire has a rubber covering which is further protected by a cotton braid, making a short circuit unlikely.

The Aerial Wire

THE aerial wire can be a temporary affair run around the picture moulding of the room, strung up temporarily from room to room, hung between trees or other supports. It is connected to the antenna post (ANT) with the other end left free and unconnected. For indoor service about 60 feet of annunciator will be sufficient and no supporting insulators will be needed, as the waxed cotton cover will be sufficient insulation when laid along the plaster of the walls or along wood surfaces. For outdoor work, or where it is likely to be damp, a wire with rubber insulation should be used, such as flexible fixture wire or lamp cord. Lamp cord is excellent for this purpose, as it has a low R. F. resistance and is sufficiently flexible to allow winding up in a small coil.

After cutting the batteries into circuit by means of the battery switch (SW), the detector rheostat (R2) and the equalizing condenser (C3) are adjusted until all whistling and howling stop. There should be a slight hissing or frying noise which will indicate that the tubes are functioning, but the adjustments should not be much above this point. Next, turn the wavelength adjustment condensers (C1) and (C2) very slowly and at about the same rate of speed until a "station whistle" or voice is picked up. Juggle the condenser dials until the signal is at a maximum, and then manipulate the detector rheostat (R2) just under the point where it is about to break down into free oscillations and where the signal is at a maximum. Working the detector rheostat in connection with the condenser (C3) will give the maximum volume.

Remember that (C3) is for the purpose of checking oscillations in the radio frequency circuit, and that this controls the radio frequency circuit in about the same way that the detector rheostat controls the detector. Howling can be checked by either (C3) or (R2) depending upon whether the trouble is in the radio frequency or detector circuits.

The selectivity depends upon the
(Turn to page 42)

Blueprints of the 3-Tube Portable Reflex on Two Pages Following

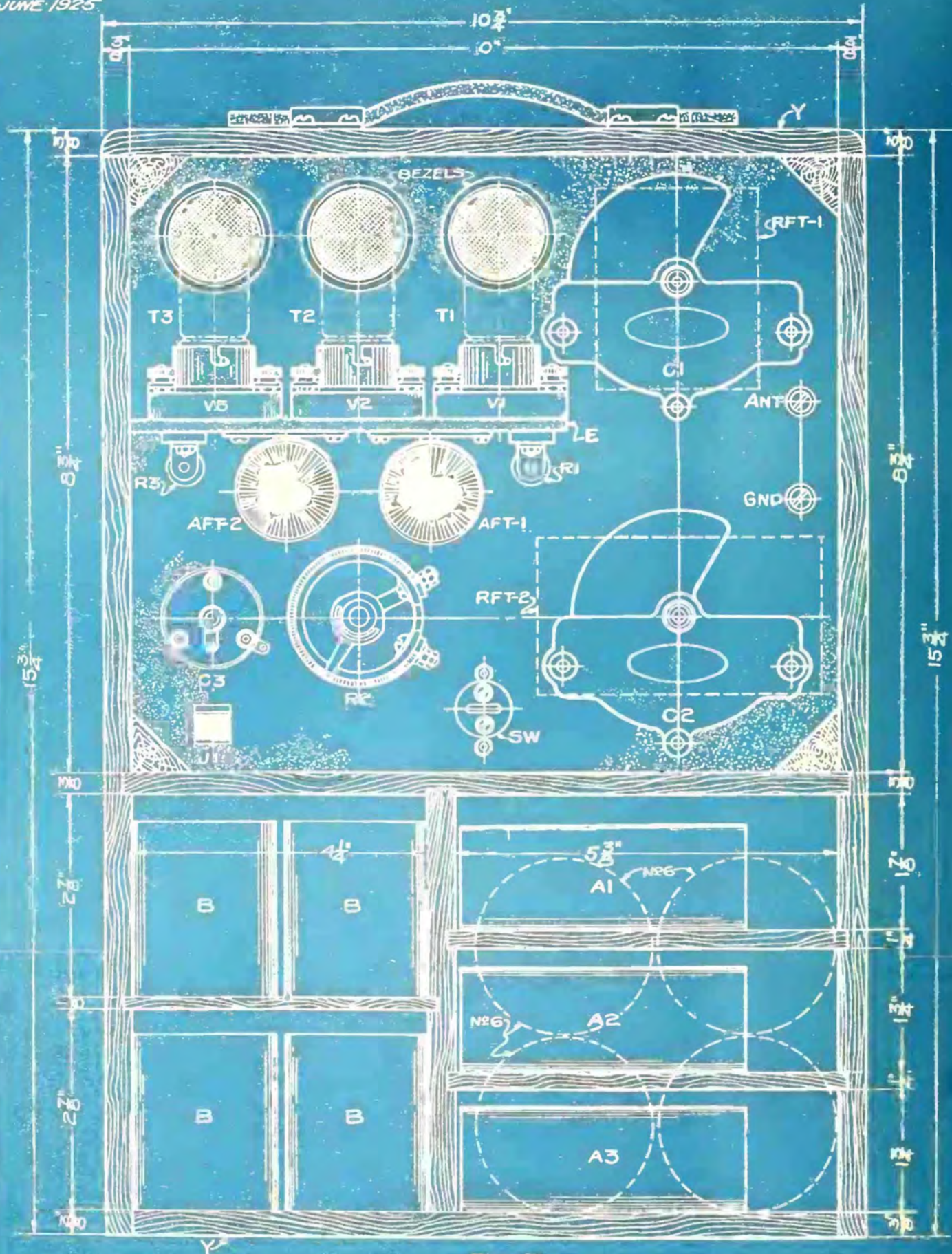
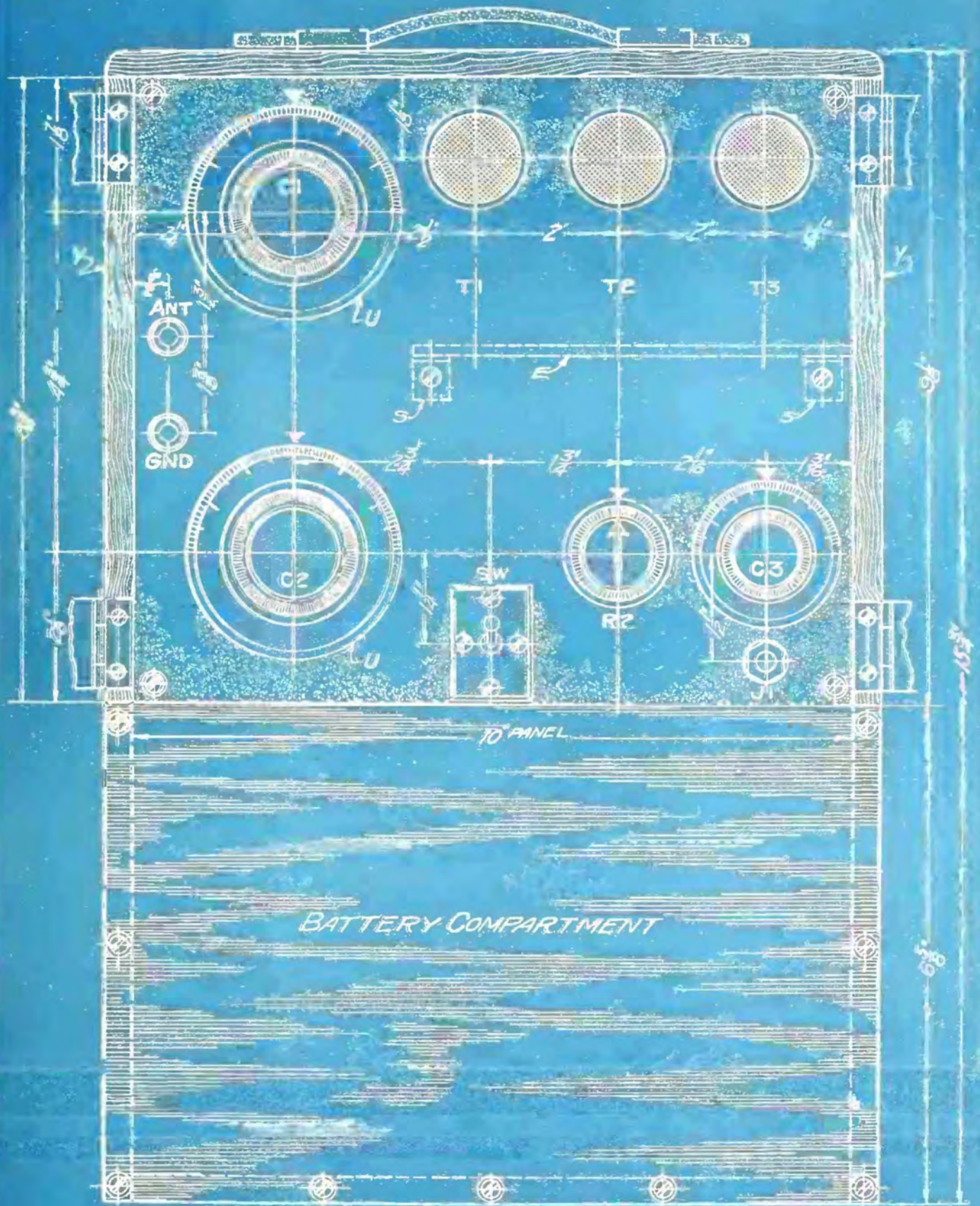

FIG. 3

COPYRIGHT 1925
RADIO AGE, INC. (PROCESS PAT. PEND)
CHICAGO, ILL.

JUNIOR PORTABLE
REAR ELEVATION OF PANEL-CABINET

J.B. RATHBUN
RF-X-126



BATTERY COMPARTMENT

FIG. 4

"JUNIOR PORTABLE"
FRONT ELEVATION "A"

(PROCESS PAT. PEND.)

Battery Problem Easily Handled

(Continued from page 39)

distance of the primary coil (P) from the secondary (S). The greater the distance the looser will be the coupling and the greater the selectivity. This applies to both (RFT-1) and (RFT-2). Usually the best spacing of the coils is as shown by Figs. 1B and 1C, but with some types of audio frequency transformers, this must be increased. The wavelength range is determined by the number of turns on the secondary coils (S), and as shown, will cover a range of from 200 to 600 meters.

Fig. 4 is a front elevation of the panel, showing the dials and other controls. It is advisable to allow the cabinet to project beyond the panel in front for the protection of the dials, and to provide a door at this point, so that the set can be completely closed.

Trouble Shooting

WHEN the signals are weak and the selectivity seems poor, the trouble is usually due to coil reversal; that is, the various coils in the tuner or transformer do not bear the proper inductive relation to one another. If, for example, the primary coil should be connected so that it produces a magnetic field that opposes the field of the secondary coil, then the output will be practically neutralized and there will be little reception. It is for this reason that I suggest that you connect up all of the primary coils permanently when you wire the set, and make temporary connections to the secondary coils and tickler coil with magnet wire.

After you connect up the set, you can tune in, and if results are not satisfactory at the first attempt, try reversing the connections to the secondary and tickler one at a time, until you get the best results. After the best point is found, you can complete the wiring by substitut-

ing soldered bus wire connections for the temporary wires. This may save you a lot of work and should be observed.

Be sure that the prongs of the tubes are making proper contact with the springs in the sockets, and try this out before you screw the sockets down into place. A loose tube or loose contacts mean all kinds of trouble, and trouble that is difficult to remedy after the set is completed and in the cabinet. Also carefully examine the jack connections, and make sure that a projecting lump of solder is not short-circuiting the jack. The lugs are very close together and it is easy to short-circuit at this point.

Use only the small "midget" type variable condensers for the transfer (C3). A standard condenser, even as small as a three plate, is much too large to cover the range even with all of the plates out of engagement. The zero capacity of standard condensers is very frequently greater than the maximum capacity desired at (C3).

Sometimes reception is improved by connecting a 0.001 mf fixed condenser across the ends of the jack (J1), and sometimes this has no effect at all. It all depends upon the winding characteristics of the coils in your phones and speaker.

In making battery connections, be sure that the positive pole of your "B" battery is connected into circuit at the point indicated in the drawings, that is, the positive of the "B" battery must always go to the plate directly, or to the plate through the tickler coil or transformer primary. If this polarity is not observed, the set will be absolutely dead without a hiss or grunt to be heard.

A biasing "C" battery for the grid of the audio amplifying tube (T3) can be connected in at (-C) and (+C) as shown just under the audio transformer (AFT-2)

in Figs. 1-2. This will save enough "B" battery current to pay its way, but if it is not desired at the present time, the binding posts or connections (-C) and (+C) can be short circuits as indicated by the dotted line running between these two connections. The "C" battery can be the smallest type of "C" battery or else can be a small flash light battery, either giving a total potential of 4.5 volts on the grid of the tube (T3).

Phonograph Music Directors Set New Standards

THE broadcasting of music has grown like Topsy. In the case of a single artist it has been comparatively easy to indicate a definite position before the microphone and one which is likely to secure the best results. But where several artists are concerned or there are a number of musicians, as in an orchestra, the problem has become more and more complicated, and in the rapid development of broadcasting it has been one which has not had as much attention in the past as it unquestionably will have in the future.

However, it was not new to the phonograph people, for in the making of records they have been experimenting for years in the proper placing of the instruments. An orchestra forming in a broadcasting studio as a rule looks like an orchestra playing any place else, but in a phonograph recording laboratory, it is a most unusual sight.

The man playing the cello may be on a chair with legs so long that the player's head almost touches the ceiling. On the other hand, the tuba player may almost be sitting on the floor. Sometimes the music racks are suspended from the ceiling; again they are giraffe-like affairs rising from the floor.

End your Radio Troubles for 30c in Stamps

We have laid aside a limited number of back issues RADIO AGE for your use. Below are listed hookups to be found in these issues. Select the ones you want and enclose 30c in stamps for each desired. The supply is limited, so enrich your store of radio knowledge by laying in an ample stock of copies NOW!

January, 1924

- Tuning Out Interference—Wave Traps—Eliminators
- Filters
- A Junior Super-Heterodyne
- Push-Pull Amplifier
- Rosenbloom Circuit

March, 1924

- An Eight-Tube Super-Heterodyne
- A simple, low loss tuner
- A Tuned Radio Frequency Amplifier
- Simple Reflex Set

April, 1924

- An Efficient Super-Heterodyne (fully illustrated)
- A Ten-Dollar Receiver
- Anti-Body Capacity Hookups
- Reflexing the Three-Circuit Tuner
- Index and first two installments of Radio Age Data Sheets

May, 1924

- Construction of a Simple Portable Set
- Radio Panels
- Third Installment of Radio Age Data Sheets

June, 1924

- Important Factors in Constructing a Super-Heterodyne
- A Universal Amplifier
- A Sure Fire Reflex Set
- Adding Radio and Audio to Baby Heterodyne
- Radio Age Data Sheets

July, 1924

- A Portable Tuned Impedance Reflex
- Operating Detector Tube by Grid Bias
- A Three-Tube Wizard Circuit
- Data Sheets

August, 1924

- Breaking Into Radio Without a Diagram
- The English 4-Element Tube
- Filtered Heterodyne Audio Stages
- An Audio Amplifier Without an "A" Battery
- Data Sheets

September, 1924

- How Careful Mounting Will Improve Reception
- One Tuning Control for Hair's Breadth Selectivity
- Four Pages of Real Blueprints of a New Baby Heterodyne and an Aperiodic Variometer Set
- Data Sheets

October, 1924

- An Easily Made Super-Het
- Two Radio and Two Audio for Clear Tone
- A Simple Regenerative Set
- The Ultradyne for Real DX
- Real Blueprints of a 3-Tube Neutrodyne and a Midget Reflex Set

November, 1924

- Blueprints of a Single Tube Loop Set and a Capacity Feedback Receiver
- A 3-Tube Low Loss Regenerator
- Mastering the 3-Circuit Tuner

December, 1924

- Blueprints of a New 8-Tube Super-Heterodyne
- How to Make a Receiver that Minimizes Static
- A Trans-Atlantic DX Receiver
- How to Make a Home Made Battery Charger and a Loud Speaker at a Small Cost

January, 1925

- A Reflexed Neutrodyne
- A Six Tube Super-Het
- An Efficient Portable Set
- A Tuned Plate Regenerator
- Making a Station-Finder

February, 1925

- A Sure Shot Super-Het
- A Three Circuit Regenerator
- A Real, Low Loss Set
- Blueprints of a 3-tube Reflex

March, 1925

- A Permanent Super-Het
- A 5-Tube R. F. Receiver
- How to Wind Low Loss Coils
- A Short Wave Receiver
- Blue Prints of a Two-Tube Ultra Audion and a Regenerative Reflex

April, 1925

- A 3-Tube Portable Set
- "B" Voltage from the A. C. Socket
- An Amplifier for the 3-Circuit Tuner
- Blueprints of a Five-Tube Radio Frequency Receiver

May, 1925

- A "Quiet" Regenerator
- A Power Supply Receiver
- How to Make a Tube-Tester
- A Unique Super-Het and an Improved Reinartz
- A Six Tube Portable Receiver Illustrated with Blueprints

RADIO AGE, Inc.

500 N. Dearborn St., Chicago



Pick-ups and Hook-ups by our Readers



THE material appearing under the title "Pickups and Hookups by Our Readers" in RADIO AGE, is contributed by our readers. It is a department wherein our readers exchange views on various circuits and the construction and operation thereof. Many times our readers disagree on technical points, and it should be understood that RADIO AGE is not responsible for the views presented herein by contributors, but publishes the letters and drawings merely as a means of permitting the fans to know what the other fellow is doing and thinking.

BRIDES and static. One is about as hard to silence as the other in the merry month of June, as many of our Dial Twisters can testify after sitting up half the night coyly fishing for the elusive DX signals while the Better Eight-Tenths wonders why she, of all the people in the world, should have been manacled to a radio maniac. (We have often wondered what the feminine portion of the Dial Twister's family thinks of the RADIO AGE button).

Returning from our buttons to our muttens, nothing startling has been discovered since our last issue of RADIO AGE, although the low-loss campaign goes ahead rapidly. The outstanding feature along this line is the figure 8 coil, the binocular coil, the doughnut coil and other coils of a similar type wherein by the form of windings the magnetic field of the coil itself is kept within its own bounds, thus cutting down the interstage coupling which has been the bugbear of any radio fan who ever tried his hand at tuned or untuned radio frequency amplifiers.

With this type of coil and the proper design of the set, the necessity for neutralization of the tubes can be done away with, which should prove a boon to all radio experimenters. Let's see which one of our Dial Twisters will report the best results with the new type of coils.

They say musicians have no home, but since radio came into such popularity, the musician's home is wherever he parks his loudspeaker (not referring to the ladies, however.) Thomas V. McLaughlin, musical director of the Hello Jake Company, and now on the road, says he bought his first copy of RADIO AGE in May, 1923, and has not missed an issue since that time. Mr. McLaughlin made the Reinartz described in that particular month's RADIO AGE and later added two stages of audio. Travelling as he does, he is not permitted the pleasure of an antenna, so at night in the hotel room he uses the radiator for an antenna and the cold water faucet for the ground. Once he forgot to connect the radiator while at Newcastle, Pa., and heard WOAW in spite of that fact. His first set was made on the side of a prune box, since he had no panel. Despite the fact Mr. McLaughlin comes from Brooklyn, N. Y., he signs off with the following poetry:

*I have no five tube neurodyne,
Nor an eight tube super-het—
But RADIO AGE, from page to page,
Is the best that I've seen yet.*

Lloyd H. Shera, San Miguel, California, using a two tube reflex, is bringing in the East Coast and Canada quite well. Some of his stations shown are:

CONTRIBUTOR.

O. C. Wallace, Jr., 205 Lewis Bldg., Montreal, Canada.

DIAL TWISTERS

Name	Address	City
Thomas V. McLaughlin		En Route
Lloyd Stove	Box 363	National City, Calif.
Lloyd H. Shera		San Miguel, Calif.
Raymond Breeden	1105 Orange, N. W.	Roanoke, Va.
J. W. Landon	113 Scoville Way	Pittsburgh, Pa.
A. P. Smith	R. F. D. 8	Bangor, Me.
W. C. Dukes, Jr.	P. O. Box 449	Mobile, Ala.
J. W. McCullah		Soldiers Home, Calif.
S. Stansfield	8035 Wilson Ave.	Detroit, Mich.
Guy Arthur	P. O. Box 245	Massilon, Ohio
Fern Frame	768 Adams St.	Gary, Ind.
W. G. McDonald	19 Marlborough Apts.	Calgary, Alta., Can.
Jack Warwick	217 St. James St.	Port Arthur, Ont., Can.
Eugene Arneson	470 Exchange St.	Kenosha, Wisc.
F. S. Reed	9123 Baltimore Ave.	Chicago, Ill.
Harry Emerick	311 Bedford St.	Johnstown, Pa.
T. F. Hyland	R. 3. Box 459	Sebastapool, Calif.
Harry T. Adams	379 Going St.	Pontiac, Mich.
Otto C. Glatt	87 Dunn Ave.	Toronto, Can.
Arthur C. Wilson	557 West 1st South	Salt Lake City, Utah
J. A. McCormick	24 South 6th St.	Fort Dodge, Iowa
Paul Nelson	223 Du Page St.	Michigan City, Ind.
W. G. Mortimer	144 Central Ave.	London, Ont., Can.
Eric Gustafson	6 Bergen Ave.	Jamaica, L. I., N. Y.
N. J. Hiscox	Box 761	Brampton, Ont., Can.
Clarence Fairfield, Jr.	315 N. F St.	Hamilton, Ohio
Frank J. Sanzone	244 Hull St.	Brooklyn, N. Y.
R. A. DeVries	114 Eighth Ave.	New York City, N. Y.
J. J. Griffiths	2782 Rouen St.	Montreal, Can.
Harry S. Chasen	1724 N. Payson St.	Baltimore, Md.
Charles P. Smith	129 E. Pomona Terrace	Germantown, Pa.
Wm. A. Swicky	1045 Maple Ave.	Los Angeles, Calif.

KDEA, KOA, WCN, WBAB, WDAF, WEBB, WFAA, WGN, WGY, WHAA, WHO, WLS, WOAL, WOC, WQJ, WSAI, WTAM, WTAB, WCCO, WLW, WFCN, CFDC, CFRC, and a long list of others which we think would stagger our linotype operators.

Harry S. Chasen, 1724 N. Payson St., Baltimore, Md. sends in a sketch of what he calls the "Bearcat Roamer" consisting of a tapped secondary coil and condenser, untuned primary, and a variometer in the plate circuit, a typical regenerative circuit, with which he is having great success. He is using all low-loss parts and believes much of his success can be attributed to that fact.

John James Griffiths, 2782 Rouen St., Montreal, Canada, using a three circuit set and the "peanut" tubes which are available in that country, sends in a good list of stations which entitles him to the button.

Here's a most interesting letter from

Robert A. DeVries, 114 Eighth Ave., New York City, who says: "I am writing to give my views on your interesting magazine and also to qualify for a Dial Twister's button. I've been buying your magazine for over two years, when I used to have to wait until the middle of the month to get it, and then I used to enjoy it more than now. Your magazine was then devoted to radio beginners, enthusiasts and experimenters. Your magazine was then only a few pages but in those few pages was printed matter interesting enough for the type of radio fans I've mentioned, and interesting enough to make it grow to its present proportions. Here's what I am getting at. You are now printing radio stories and elaborate interviews of announcers, etc.; reach the set-owner by telling him what the other fellow is doing; that is why Dial Twisters and their hook-ups are the most interesting

(Turn the page)



part of the magazine. How about a column devoted to queer and unusual things that happen in radio, contributed by the readers? For instance, I have push-pull amplifiers in my set and when I removed the loud speaker plug I lifted the lid on the cabinet and could hear music from one of our powerful locals. Also, Saturday, February 7, Stations KFI, KOA and WMBF were broadcasting the song 'My Best Girl' at the same time. Isn't that unusual? My set is a three-circuit tuner built from the March issue of RADIO AGE, and to it I have added one stage of r. f. I am sending a list of some of the stations over 1,000 miles which I have logged."

N. J. Hiscox, Box 761, Brampton, Ontario, Canada, tells us he is using a honeycomb coil set with detector and one stage of audio which is now in its fifth year, and like Johnny Walker, still going strong. It is a home-made set and was the first set in his vicinity.

Eric Gustafson, 6 Bergen Ave., Jamaica, N. Y., has found that by putting a fixed capacity from the upper phone binding post to the negative lead of the A battery, he gets much better results. This is what is known as "by-passing" and is one of the kinks that every dyed-in-the-wool experimenter does almost unconsciously. If more fans did like Mr. Gustafson, the "What's wrong with my set" type of letter would not be so abundant around these parts.

O. C. Wallace, Jr., 205 Lewis Bldg., Montreal, Que., Canada, sends in a neat little design of one stage of radio frequency amplification to be added to the conventional Reinartz tuner. He says it has increased his range and selectivity. He uses a separate A and B battery. His r. f. coil is wound on a $3\frac{1}{2}$ inch tube. The aperiodic primary consists of ten turns and is spaced about a quarter-of-an-inch from the secondary, which consists

of 42 turns. The diagram herewith is being amended so that you do not have to have separate A and B batteries but can add your r. f. stage to your present Reinartz. The condenser used across the secondary is a .0005 mfd.

Arthur O. Wilson, 557 West First South St., Salt Lake City, Utah, says his second attempt at set building was the ultra-audion, blueprinted in the March RADIO AGE, and he is now starting on the one described by Mr. Sonn in the April number. He found best results with a 120 turn tapped astatic wound coil, which type of winding he will be glad to describe to any one who writes him. His list of stations is not only a testimonial for the ultra-audion; but gets him the D. T. button.

Another ultra-audion fan is found in Otto C. Glatt, 87 Dunn Ave., Toronto, Canada (goodness, how these Canadians are coming to the front in radio). He is an inveterate RADIO AGE fan and asks us to fade, if we can, his record on the night of March 7th, of WMBF, KOA, 6KW, KGO, KHJ, KFI, KNX, all of which have been verified.

T. F. Hyland, R. 3, Box 459, Sebastapol, Calif., built up a tuned plate regenerator as described in the January RADIO AGE, on which he gets as far East as KDKA and as far North as Calgary. He thinks this is a fine set for the novice to build.

Using a one tube set, Harry Emerick, 311 Bedford St., Johnstown, Pa., drags them in from CNRO to PWX and from WBZ to KGO. He declares he is an avid RADIO AGE reader and especially delights in turning to this portion of the magazine on its arrival each month.

F. S. Reed, 9123 Baltimore Ave., Chicago, Ill., comes to bat with this one: "Let's rule out the U. S. as far as signals are concerned. Most any good set will bring in the worth-while stations in this

country. Let the Dial Twisters enlarge their territory. Have been building hook-ups for many years and never found so very much new. I use an Armstrong three circuit with a stage of radio ahead. It will bring in anything on a 75 foot aerial that a super will do on a loop. I have logged PWX, 2LO, CKY, CNRO, KFI. Why bother about a portable set? Just use dry cell tubes if you are not intending traveling by auto. The old three circuit with a wire thrown up in a tree will go it o. k. So what's left?"

Here's a crystal hound; that is, he used to be. Raymond Breeden, 1105 Orange Ave., N. W. Roanoke, Va., who tells us his first experience in picking up KDKA, WGY and WEA; later this was increased to WEBJ, WJZ, WOR, WOC, WLW, his maximum distance being somewhat over 600 miles on a crystal. Then he went in for a single tube set and got all of the old stations he had heard on crystal and a new bunch in addition, which included KGO, CNRO, CKAC. Raymond is only a youngster in years, but he turns them out like a veteran at logging.

Lloyd Stove, Box 363, National City, Calif., with a super, using loop and ground, reports the Canadians, Hawaiians, Mexicans and our friend 2-LO. He tuned in 115 stations with an average mileage per station of 1315 miles. All except London were heard on the loud speaker.

Since Mr. Stove is located in California, the full list of his stations might be of interest to our readers. The list follows:

KFNV, KOB, KDYL, KEPT, KFL, KFHA, CZF, KFAU, KFUM, KFAJ, KFEL, KIL, KOA, KFCF, KGV, KFAE, KIQ, KUOM, WCAE, KFOA, KFQX, KHG, KFHR, KJL, WQAI, WCAR, WBAP, KFCK, WIAD, WFAA, KFRU, GKCD, KFEB, KSAC, GRCM, CFAL, DFCN, CKCX, CNRC, KFAB, WEAY, KFKU, WOAV, WAAW, KPNF, KFMQ, WDAF, WHB, KTHS, WGAQ, KFDM, WHO, WOI, CYL, GYB, GYX, WOS, WCAL, KFHX, WCCO, WSUI, KSD, KFUO, WMC, WSAB, CKY, CNRW, WJJD, WHA, WEBW, WLBL, WTAS, WCEE, WHAD, KVV, WEBH, WGN, WGN, WLS, WMAQ, WQJ, WBCN, WCBD, WHAS, WLV, WBAI, WGST, WSB, WREO, WBVA, WEAQ, WCX, WEAR, WTAM, WCAE, KQV, KDKA, WGR, WMAK, WCAP, WMBF, KGU, WCAU, WFI, PWX, WAHG, WEAJ, WJZ, WNYC, WGY, WHAZ, WBZ, WEEL and last but not least 2-LO. London: (Verified by the British Broadcasting Co.)

Then from south of the Smith and Wesson line comes a letter from W. C. Dukes, Jr., P. O. Box 449, Mobile, Alabama, telling us of his work with a three circuit regenerative set using WD-11 tubes. On headset he has brought in the East and West coasts, Canadian stations, two of the Mexican stations and Havana, Cuba. A short list of stations follows:

WTAS, KDKA, KFDM, KPIX, WBBM, WKAA, WORD, KFKE, KFMQ, WSAL, WEBH, WHB, KTHS, WGY, WMBF, WQAI, WOS, WQAW, KSD, KYW, WBAP, WMC, WQJ, WSB, KFRU, WMB, WLS, WFAA, KFI, WIO, WDAF.

Al P. Smith, R. F. D. No. 8, Bangor, Me., gives a list of stations heard, one of which was during the tests, being 5NO at Newcastle, England. He uses the dry cell type of tubes and has a neutralized stage of r. f. detector regenerative and one stage of audio. He has also built a three circuit receiver with three stage resistance coupling, which he used for short wave work. The list follows:

WEEL, WNAO, WMAF, GWI, WBZ, KYW, WDBH, WTAS, WGN, WEBH, WREO, WGR, WHN, WEAF, WJY, WJZ, WAHG, WGY, WHAS, WTAM, KDKA, WIP, WJAR, WCAP, WRG, GHAC, CFCE, CHYG, CKAC, WKAQ, PWX, WMO, WQBD, WQAM, WDAE, WOC, WHAS, KFEX.

S. Stansfield, 8035 Wilson Ave., Detroit, Mich., who is a faithful follower of RADIO AGE blueprints and diagrams, made up a Reinartz with two stages of audio, using WD-11 tubes. Stations

heard by him, mileage greater than 500, follow:

WPG, KFNF, WBZ, KFKB, KFEK, WOAW, WFAF, WGY, WEEL, KFEZ, WDAF, WCCO, WHB, WEAJ, WAHG, WHN, KOA, WCAL, WMAK.

Guy Arthur, P. O. Box 245, Massillon, Ohio, a constant reader of RADIO AGE, spends most of his spare time experimenting with circuits furnished by this magazine. He relies on his "squaler"—a three tube regenerative, for distance. During the tests he picked up 2LO. He now gets 'em from coast to coast, and is now interested in a reflex set using two tubes.

Jack Warwick, 217 St. James St., Port Arthur, Ont., Can., writes as follows: "I have studied with great interest contributions under 'Pickups and Hookups,' and thought perhaps some of the readers might be interested in my experiences. During construction lost the diagram and had to finish it the best I could, with good results. As near as I can remember, it is a regenerative (that's as much as I know about radio, Mr. Editor); couldn't tell you the 'diff' between or names of any hookups. The equipment for my set is 2 tubes (Myers) six volt detector tube, 2 1-2 volt amplifier tube, Crosley vari-coil, with 10 taps; 23 plate aluminum condenser, couple of 6 ohm rheostats, etc., with a 125 foot single strand aerial. Here are some of the stations I pick up: CKAC, CNRO, GFGA, CNRW, CNRT, KDKA, KFI, KFKX, KFNF, KFRU, WOAW, WDAF, WOC, WHO, WSUL, WFAF, WEEL, WBZ, WTAS, WTAM, WCB, WCCO, WCAE, WGN, WGY, WGR, WFAA, WCX, WIP, WLS, WOS, WREO, WCAL, WQJ, WSAI, WSB, WWJ, WMC.

Harry T. Adams, 379 Going St., Pontiac, Mich., tells us he made a three tube neutrodyne from the blueprints in the October, 1924, issue of RADIO AGE and has since added a pair of push-pull transformers. He now gets both of the coasts most of the time on the loud speaker, getting good quality and selectivity.

W. G. McDonald, 19 Marlborough Apts., Calgary, Alberta, Canada, has the following interesting letter for this section:

"I have been a reader of your excellent magazine for some time, and admire the way in which it is gotten up. The department to which this letter is addressed is the best of the lot, and I always read it the first of any. The communications from the DX fans are always interesting in their various viewpoints and contentions. I would like to tell you about the results which I have obtained with the old 'dumb-bell' single circuit, made up by myself with only middling quality parts, using that excellent little tube, the Canadian peanut, which is really the W. E. 'N' Tube, and which you Americans are very unlucky, in my estimation, to be unable to procure.

"I have used all makes of American, French and English tubes besides our various Canadian ones, and considering the dry-cell A Battery, our little peanut has them all beaten a mile. My aerial is two wires, 65 feet long and 20 feet high. We have in this city seven active stations, six of whom never heard of a sharply tuned transmitter, and having outputs at the present time which I believe are as strong or stronger than your best stations.

"That is one fault of Canadian broadcasting, and when it takes receivers of the super or neutrodyne class of excellent construction to get rid of locals, you can understand under what difficulties my

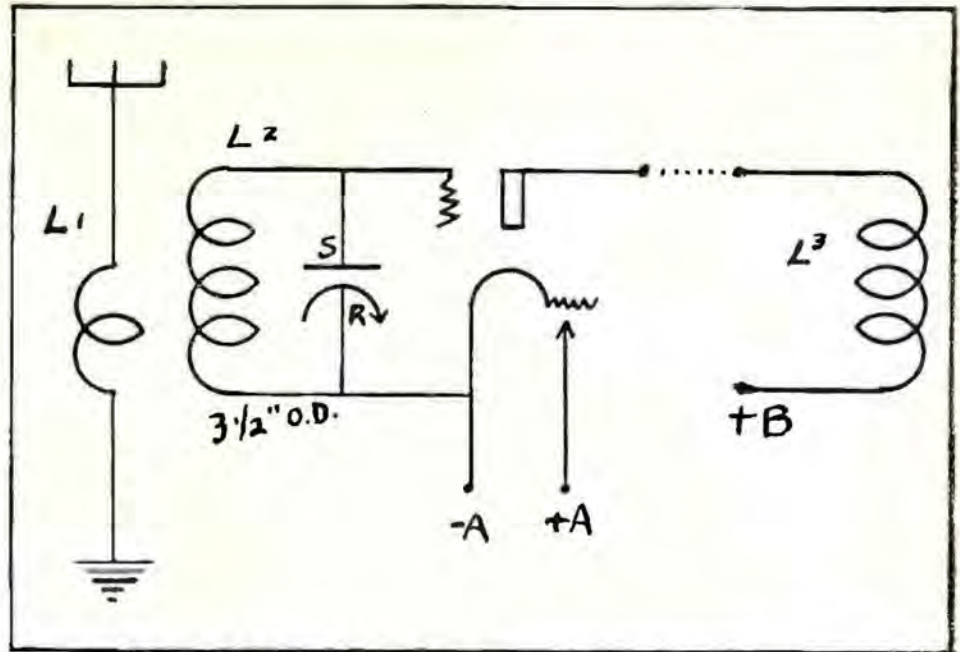

O. C. Wallace's contribution for the Reinartz fan who desires to add a stage of radio frequency amplification ahead of the present detector in the Reinartz circuit. L1 is an inductance of 10 turns wound on the lower end of an insulating tube 3 1-2 inches in diameter. This can be wound with No. 20 DCC. L2 is the secondary inductance consisting of 42 turns of the same sized wire. This winding is started about a quarter of an inch away from the primary. L3 is the primary (be sure it is thoroughly isolated from the other parts of the old Reinartz tuner) of your present tuner. It now becomes the primary of the radio frequency transformer. The condenser shown is a .0005 mfd variable, any good make. The dotted line shows the connection of one end of the old primary to the plate of the new r. f. unit, the other end of L3 going to the positive of the B battery. Wires can be run from -A and plus A to the usual binding posts on your set so a separate A and B battery will not be required. The stator of the variable condenser goes to the grid and the rotor to the filament line.

little single circuit is working. The list of stations I have received over 500 miles is as follows:

KDKA, KDYL, KDZB, KFAF, KFAW, KFRK, KFEK, KFEL, KFI, KFJM, KFPA, KFKA, KFKX, KGO, KIJ, KJS, KLA, KLD, KPO, KSD, KUO, KVG, KWH, KYW, WAAW, WBAD, WBAP, WBZ, WCAE, WCAL, WCAP, WCB, WDAF, WFAF, WEBH, WFAA, WGN, WGI, WGY, WHA, WHAA, WHAS, WHB, WHO, WJY, WJZ, WLW, WSAI, WOAW, WOI, WOR, WOS, WRC, WSAI, WTAM, WTAS, CJCE, CKOD, CKY.

"I have a total of 104 stations in my log book, but some of them are last year's reception, and a great number under 500 miles.

"Besides these BCL stations, I have received amateurs in almost every district of U. S. and Canada; ships in the Atlantic, and off the coast of Asia. Altogether, I think that the single circuit is hard to beat where one does not get QRM from broadcasters, and does not cause it by unwise use of the tickler. Considering the situation of Canada with regard to the U. S. stations, I think we Canadians are doing very well. Would like to hear from some more Canucks through the pages of RADIO AGE. Canadian 4-IM signing off."

Some of our readers who belong to the dot and dash fraternity might be interested in a new record made by the Naval Radio Laboratory at Bellevue, D. C., in establishing two way communication with Australia on twenty meters on the night of April 20.

Around midnight, according to reports which have reached RADIO AGE, the operator on watch at Bellevue heard the Australian station calling England. He immediately broke in and called the Australian. The two stations then communicated with each other for more than thirty minutes. There was a particular absence of static and other forms of interference.

Bellevue Laboratory has been making some rather remarkable distance feats on short waves. Australia has been copied before at Bellevue, but the first time two way communication was established was on April 20.

The transmitter used at Bellevue employed less than two kilowatts, while the antenna was of the vertical cage type with a four wire counterpoise. It is of incidental interest that during the two way conversation it was morning in Australia while it was midnight at Bellevue.

While the above feat was accomplished by the use of 2,000 watts in the antenna, and American amateurs have communicated before with much less power, nevertheless, this fact does not detract from the importance of the achievement on behalf of the Navy.

Loop Record

E. H. Scott, of Chicago, but now at Tasman, Nelson, New Zealand, has written RADIO AGE telling of his reception of many American stations, nineteen in all, among which some of the Chicago stations figure prominently.

To make certain of his reception Mr. Scott wrote all the stations and asked them to send their verifications to the RADIO AGE, and to date quite a number have been received.

Chicago Stations heard by Mr. Scott were: WEBH, WGN, WQJ, WJJD, KYW. He also heard KGO, KNX, KFI, WFAA, WDAF, KPO, KOA, WCB, CFCN and KHJ.

World's "Record"

The Editor of The Dominion, a newspaper at Wellington, gives Mr. Scott credit for a world's record for reception on a loop. He is using an eight tube super. The time difference between Chicago and New Zealand is seventeen and a half hours, New Zealand being ahead of Chicago time.

The above seems to be a pretty good test for a super using a loop, since most of the distances are in excess of five thousand miles while the maximum runs up to 8,000 miles.

Standard Radio Receivers

Recently RADIO AGE inaugurated a new department called "Know Before You Buy," to serve as a guide to the prospective radio purchaser in deciding on the receiver best suited to his individual needs. Fans throughout the country have shown an instantaneous response to this new feature, and accordingly it is continued and will be a feature of all forthcoming numbers of RADIO AGE. Readers are invited to write us concerning the sets in which they are interested, and manufacturers also are asked to send us material describing their sets.

High or Low Waves, Here's a Receiver That Brings 'Em All In

IF AN extended use of lower wavelengths in broadcasting is to be, as many leading radio engineers believe, the answer to the problem of providing wavelength designations not only for the broadcasters already operating but also for broadcasters who have asked for licenses and are awaiting allocations, here is a set with which the fan may tune in on any of wave frequencies, from forty meters on up to 555 meters or more, by means of a very ingenious but simple adjustment of transformers.

One of the chief drawbacks to universal broadcasting on low wave-lengths is the fact that millions of sets now in use will not tune in carrier waves below 200 meters or above 600 meters.

Stations such as KDKA and WGY are taking advantage of the extraordinary qualities of extremely low wavelengths to transmit programs over tremendous distances in the daytime. These low waves are picked up by stations in other countries and rebroadcast. With the set described herein, it will not be necessary to hear these programs over the repeat stations but the original low wave transmitters may be tuned in and listened to with equal ease. In fact, this set has demonstrated that the extremely low wavelengths carry programs better in every respect than do the customary carrier waves, and an interesting and



rapidly growing field of low wavelength entertainment is opening up for and awaiting the audience that can tune it in.

The accompanying illustration reveals how the Washburn Interchangeable Five turns the trick and also how easily and quickly the set may be adapted to receive carrier waves from 40 meters on up. The receiver employs five tubes, utilizing a radio frequency circuit and is controlled by three dials. The transformers are of a rigid type, air core, low loss and built to stand rough usage. They are mounted on special bakelite adapters that will fit into standard tube sockets, so that they are interchanged exactly as standard base tubes are interchanged and with the same ease and quickness. The picture shows three sets of the

interchangeable transformer coils. When Set No. 1 is in position, waves from 224 to 555 meters may be tuned in. The intermediate set of transformer coils permits of tuning in carrier waves between 170 and 235 meters. The low set will tune in carrier waves from 40 to 160. It will be seen that the three sets have overlapping capacities. Special additional coils render possible the reception of wavelengths indefinitely upward.

The Washburn Interchangeable Five recently was subjected to a series of rigid tests by the Jefferson Electric Laboratories, Chicago, and as a result given the highest commendation.

The Washburn Interchangeable Five is manufactured by the Washburn Burner Corporation of Kokomo, Indiana.

The Freshman Masterpiece Unique Circuit

The Freshman "Masterpiece" is a five tube tuned radio frequency receiver, built of the finest low loss material and priced to fit the layman's purse, manufactured by Chas. Freshman Co., Inc., New York City.

The Freshman Masterpiece utilizes a circuit designed by A. W. Franklin, a well known radio and electrical engineer. This system totally eliminates oscillations by the use of scientifically designed radio frequency units in which low loss coils of special construction are employed.

The set is known throughout the world for its ability to receive those far-off stations. It is mounted in a genuine solid mahogany cabinet, and the price, without accessories, is \$60.00.

Thousands of communications from users of the Freshman Masterpiece testify to the Chas. Freshman Company's claim that these sets furnish

selectivity, volume, ease of operation and perfect tone qualities.

Many distance records have been achieved with the Freshman Masterpiece, bringing in distant broadcasting stations with local volume.

There are but three tuning controls, each of which is set at approximately the same dial reading; therefore, once a station is tuned in, one can rely upon getting the same station each time at the same dial setting.



The Grebe Synchronphase and the

"Thermiodyne"

Described on page 61

ULTRA-LOWLOSS CONDENSER



CAP .0005 mfd.

\$5.00

As positive as Big Ben

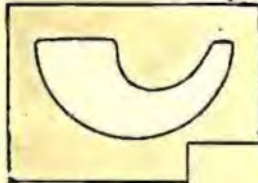

Curless Stator Plate exclusively an Ultra-Lowloss feature



A guarantee of satisfaction and Lacault design



ULTRA-VERNIER TUNING CONTROL

Simplifies radio tuning. Pencil-record a station on the dial—thereafter, simply turn the finder to your pencil mark to get that station instantly. Easy—quick to mount. Eliminates fumbling, guessing. Furnished clockwise or anti-clockwise in gold or silver finish. Gear ratio 20 to 1.

Silver \$2.50 Gold \$3.50

SET Big Ben at seven and at seven o'clock you're bound to get the alarm.

Just so, the Ultra-Lowloss condenser can be set at any wave-length—the corresponding station will come in clear and sharp. You know instantly where to turn, once a station of known wavelength is located. Makes tuning easy—direct—positive. Special Cutless Stator Plates spread wavelengths evenly over a 100 degree scale dial so that each degree represents approximately $3\frac{1}{2}$ meters.

Ultra-Lowloss condensers are designed by R. E. Lacault, originator of the famous Ultradynic Receivers, and built upon scientific principles which overcome losses usually experienced in other condensers.

At your dealer's, otherwise send purchase price and you will be supplied postpaid.

Design of lowloss coils furnished free with each condenser for amateur and broadcast wavelengths showing which will function most efficiently with the condenser.

To Manufacturers Who Wish to Improve Their Sets

Mr. Lacault will gladly consult with any manufacturer regarding the application of this condenser to his circuit for obtaining best possible efficiency.

ULTRA-LOWLOSS CONDENSER

PHENIX RADIO CORPORATION, 116-B East 25th St.
New York City

Free Subscriptions to Radio Age for Your Time!

RADIO AGE, Inc., will give a year's free subscription to this magazine to any reader who will obtain for us a news-dealer who will handle our magazine in a town or city where we are not already represented.

If you are now a subscriber to RADIO AGE, we suggest that you refer this notice to one of your friends who will doubtless be pleased to take advantage of this opportunity. Or you may extend your own subscription for one year without cost.

This offer is to remain in effect until further notice.

Free Subscription Blank

RADIO AGE, Inc.,
500 N. Dearborn Street,
Chicago, Ill.

Gentlemen: In order to get a free subscription to RADIO AGE, "The Magazine with Blueprints," for one year, I herewith send you the name of a dealer who will sell RADIO AGE in the city mentioned. It is understood that if you already have a dealer in this city that the offer of a free subscription does not hold good.

Dealer's name.....

Street Number.....

City.....State.....

My name.....

Street Number.....

City.....State.....

4-25

Instruct Deaf via Radio

Radio Amplification applied successfully to acoustic training for the deaf. Moderate priced device that can be used in your own home. Write for particulars.

AUDIOTONE, INC. P. O. Box 325
GREEN BAY, WIS.

Burns

Perfect Reproducer

Tone loud and pleasing.
Handsome material and design.

Black, \$22.50 Shell, \$25.00

AMERICAN ELECTRIC COMPANY
State and 64th Sts., Chicago



REFLEX

Eria—Acme—Harkness

Dealers: Send for Discounts

HUDSON-ROSS

123 W. Madison St. Chicago

BAKELITE DIALS

are accurate in dimension and will not warp. Write for booklet 31.

BAKELITE CORPORATION

247 Park Avenue, New York, N. Y.
Chicago Office: 636 West 22d Street



Radio Discovers a New Civilization

(Continued from page 28)

large and small, dotted the tops of the 'mesas'. Archeological surveys indicate they were excavated by the original builders to a depth of three to five feet and were surrounded by sleeping chambers and granaries. The roofs originally were of the tepee style, willow or oak beams being fastened together by a wattling or weaving of pliable branches. The outer surface was then plastered with adobe, and over this thin slabs of rock were laid. Walls were of stone.

Habits of the Lost "Race"

ENTRANCE was through a steep decline or tunnel, sufficiently large to accommodate only one body at a time. Doors were large, close-fitting slabs of rock. Fires were built in the exact center of the large or main room according to mute evidences, and a circular opening at the apex of the sharply sloping roof permitted the escape of smoke and furnished ventilation."

One pithouse revealed a handsome bowl showing a design of four stars or equilateral crosses, a symbol still found among Pueblo and Navajo Indians and said to designate the evening star. This specimen was accompanied by a badly decomposed skeleton. Beneath the well-packed adobe floor of another prehistoric dwelling, excavators found a virtually perfect skeleton of a woman between 35 and 40 years of age and approximately five feet ten inches in height.

"She was buried in a most unusual position," Smith observed. "The right cheek was resting on the right hand and the left arm was placed across the breast. The knees were flexed. Beside the skeleton was an unusually elaborate gray bowl decorated with the designs of conventionalized butterflies. Close at hand we found a complete pottery face—that of a doll, which was supported originally on a body consisting of a corn cob."

Excavators are agreed that the final stage of development of this prehistoric civilization was exemplified by an ancient "apartment" house—thirty-nine rooms of which already have been opened—and two monumental watch towers, now in ruins. These were found on top a precipitous table rock, overlooking a valley 1600 feet below, in the San Juan National forest in southern Colorado.

The next step is one of mystery, Smith points out. Was this prehistoric race overpowered and completely obliterated or was it ravaged by disease?

Smith's description to KOA's international audience was accompanied by incidental Indian music by native tribesmen, including Chief Evergreen Tree of the Cochiti tribe. The subject was presented in three sections as follows: "Legends of a Lost People—the Brown Man of Colorado," "Legends of a Vanishing People—the Red Man of Colorado" and "Legends of a Conquering People—the White Man of Colorado."

"Tube Characteristics and How to Understand Them", a continuation of the article on Making a Tube Tester, will be H. Frank Hopkins' contribution for the July RADIO AGE.

How to Make the Roberts Receiver

(Continued from page 20)

variable vernier condensers, one audio frequency transformer having a ratio of about 4 to 1, one standard socket, one UV-199 socket, one midget variable condenser, two .0025 M.F. fixed mica condensers, one .00025 M.F. fixed mica grid condenser, one 2 megohm grid leak, one bakelite panel 7x14x3-16 inches, one baseboard 6x13 1-2x1-2 inches, one 25 ohm rheostat, one 60 ohm rheostat, ten binding posts, one UV-201-A vacuum tube, one UV-199 vacuum tube, four dry cells, one 4 1-2 volt "C" battery, two 45 volt plate batteries, about 20 feet of No. 14 bus bar wire, a loud speaker and a pair of good phones.

Wiring the Set

THE set is wired as follows: from the aerial binding post to the outside terminal of coil 1 and from one of the taps on coil 1, or the inside end, whichever gives the best results, to the ground binding post. From the outside terminal of coil 2 to the stationary plates on the first variable condenser and to the grid post on the first socket, which is to take the UV-201-A tube. The inside terminal of coil 2 is connected to the rotating plates of the first variable condenser. The positive of the "C" battery is connected to the filament. One terminal of the midget neutralizing condenser is also connected to the grid of the first tube and the other terminal of this condenser is connected to the inside terminal of coil 3. The outside terminal of this coil 3 is connected to the inside terminal of coil 4, to the remaining terminal of one of the .0025 M.F. condensers, and to one of the output terminals, which may be the top spring of a single circuit jack or a binding post as desired.

The outside terminal of the coil 5 is connected to the plate post on the first tube. The outside terminal of coil 5 is connected to the stationary plates of the second variable condenser and to one terminal of the grid leak and condenser, the other terminal of the grid leak and condenser being connected to the grid post on the second socket, which is the UV-199.

The inside terminal of coil 6 is connected to the plate post on the second socket and the outside terminal is connected to the remaining terminal of the second .0025 fixed condenser and to the post "B" on the audio frequency transformer. The other post on the transformer marked "P" is connected to the 45 volt tap on the plate battery. (This is at the junction between the two batteries.) The negative terminal of the plate battery is connected to the positive terminal of the filament batteries (the dry cells) and to the levers of both of the rheostats.

The other rheostat terminals are connected to the remaining filament posts on their respective sockets, as shown. The 90 volt positive post on the plate battery is connected to the other output terminal, which may be either the lower spring on a single circuit jack, or a binding post as desired.



You too Can Build a "NAMELESS"

Did you ever listen to a "NAMELESS"?

Did you note the ease with which its owner picked his way thru nearby stations to bring in "distance"? Were you startled to hear call letters from the other side of the continent when you thought it was just "local"?

You can build a set that will do all these and more.

A carefully worked out system of progressive instructions enables even the most inexperienced to build the "NAMELESS"; testing as he goes step by step with the assurance that when completed the "set is right."

All high grade dealers handle "NAMELESS" Kits containing especially balanced parts.

Build a "NAMELESS" for real radio satisfaction.

"New York Swept By 'NAMELESS'."

The above headline from the New York Telegram-Mail of March 28th. The article continues:

"Out of the Windy City, has blown the wonder circuit of 1925. The entire Middle West has been shaken by a tornado of popularity attending its introduction, and now New York radio opinion is beginning to shake under the gale of approval that is greeting this circuit."

"This veritable wizard of the ether is the B-T 'NAMELESS'."

"The Last Word in Selectivity On An Outside Antenna."

Freund in the Chicago Evening Post of April 2nd., thus gives his opinion of the "NAMELESS."

B-T Kits for building the "NAMELESS" are on sale at all reliable dealers.

Send for descriptive bulletins.

Bremer-Tully Mfg. Co.

532 S. CANAL ST.,

CHICAGO, ILLINOIS



\$3.25 RADIO Storage "B" Battery *
Lasts Indefinitely—Pays for Itself

Economy and performance unheard of before. Recharged at a negligible cost. Approved and listed as Standard by leading Radio Authorities, including Pop Radio Laboratories, Pop. Sci. Inst. Standards, Radio News Lab., Leaflet, Inc., and other important institutions. Equipped with Solid Rubber Case, an insurance against acid and leakage. Extra heavy glass jars. Heavy, rugged plates. Order yours today!

SEND NO MONEY Just state number of batteries wanted and we will ship day order is received. Extra Offer: 4 batteries in series (96 volts), \$12.75. Pay expressman after examining batteries. 5 per cent discount for cash with order. Mail your order now!

WORLD BATTERY COMPANY
1219 So. Wabash Ave., Dept. 81, Chicago, Ill.
Makers of the Famous World Radio "A" Storage Battery
Prices: 6-volt, 100 Amp. \$11.25; 120 Amp. \$13.25; 140 Amp. \$14.00.
All equipped with Solid Rubber Case.

World FOR **RADIO**
STORAGE BATTERIES

KDKA • WEA • WGN • WJS • KHL • KGO • KFA • WJY • KOP

SILVER

Dealers!

Send for our illustrated dealers' catalog, with latest wholesale and retail radio bargains. Also ask for our attractive proposition to radio dealers on nationally advertised lines.

SILVER-MARSHALL, INC.
105A-S Wabash Av. Chicago

MARSHALL

* Log for Your Radio

NEW 64 page log. Holds 400 stations. Shows calls, cities, wave lengths, 4 dial settings, remarks, etc. **TUNING SUGGESTIONS.** Stations list by wave lengths—by station, etc. Owners. Map. **TROUBLE AIDS.** Other valuable information. So convenient. Worth many times small cost. A joy to use. **GENUINE De Luxe leather cover.** Only \$1.

Send No Money Pay postman after log arrives. Postpaid if pay with order. **MONEY REFUNDED** if not DELIGHTED. Order today—NOW. Postal will do **RADIO PRINTERS, Dept. A202 Mendota, Illinois**

WITH better and more powerful broadcasting—

and with a sensitive, responsive Telomonic III receiver—the fascination of radio continues this year, regardless of the calendar.

Write to Danziger-Jones, Inc., Dept. C, 25 Waverly Place, New York, for booklet, "The Kit of a Thousand Possibilities."

**TELOS
RADIO**



**POLK'S REFERENCE BOOK
FOR DIRECT MAIL ADVERTISERS**

Shows how to increase your business by the use of Direct Mail Advertising, 60 pages full of vital business facts and figures. Who, where and how many prospects you have. Over 8,000 lines of business covered.

Write for your FREE copy.

R. L. POLK & CO., Detroit, Mich.
599 POLK DIRECTORY BUILDING
Branches in principal cities of U. S.

HUDSON-ROSS

**Sells only Guaranteed
Radio Apparatus.**
Send for discounts.

123 W. Madison St. Chicago

**MARVELOUS NEW
AUDIO TRANSFORMER**
adds a musical quality to any set far beyond anything you ever heard before.

KARAS HARMONIK
Amplifies low, middle and high tones—all to the same big volume, thus eliminating distortion. Brings out the vital harmonics and overtones of music. Price \$7.00. Write Karas Electric Co., Dept. 58-93, 4042 N. Rockwell St., Chicago.



A Five Tube Set that Reduces Wiring Worries

(Continued from page 18)

socket. Replace them with two 3-4-in. 6-32 R. H. screws in the opposite direction, with the round heads resting directly on top of the contact springs. Put the thumb nuts on the screws under the base of the socket, and then put the protruding ends of the screws tight through the tube panel and fasten them with nuts on the underside. Put a 3-4-in. 6-32 R. H. screw through the mounting hole near the G terminal, into a nut between the socket base and the tube panel. Fasten with another nut under the tube panel. Slip the eyelet hole of the 0.00025 mfd. grid condenser through the G terminal screw, and fasten it with the thumb nut. Snap the gridleak in place on the condenser.

Remove all four terminal screws of the UV-199 socket, replacing them with 3-4-in. 6-32 R. H. screws, and fasten the socket to the tube panel in the same way as the other, remembering to put the necessary lugs under the nuts below the panel, and being careful to keep the socket turned in the position shown in the picture wiring diagram.

Take two 1/2-in. 6-32 R. H. screws and put a lug under the head of each. Put these through the two holes at 2 and 6 in the tube panel, put a lug on each, under the panel, and fasten with nuts.

3. Now proceed with the wiring of the tube panel. While doing this be sure to keep the panel perfectly flat so that no wires will sag when it is finally fastened to the front panel.

Connect 1, the right hand binding post of the amplifier unit, looking at the tube panel from the rear, to 2. Connect 3, one of the lugs under the + terminal of the standard socket, to 4, the F terminal of the UV-199 socket. Connect 5, the P terminal of this socket, to 6.

4. Mount the three rheostats on the front panel, in the order shown in the picture wiring diagram, using the screws provided. Put lugs on the terminal screws, bent as shown. Remove the two binding posts from the switch, and replace them with 6-32 nuts, putting a soldering lug under each nut. Mount the switch on the panel, being sure to place the Off-On sign against the panel and behind the mounting nut. The slot for the key must be in a horizontal position. Make sure that the soldering lug which rests on the small insulating washer does not touch the metal switch case for this will short the switch.

Mount the two jacks with the terminals arranged in the order shown and fasten the lugs under the terminal nuts.

Take four of the mounting legs and fasten the long parts to the four screws which hold the front and rear end plates of condenser C₂ to the lower spacing pillars. Remove these screws one at a time, put them through the upper holes of the mounting leg, and turn them back into the pillars again. Keep the short ends of the legs pointing toward the rear of the set. Fasten two mounting legs

to the left hand side of condenser C₁, looking at the set from the rear, in the same way. Take the three binding posts and slip the screws into the A₁, A₂, and GND eyelet terminals of the antenna coil, fastening them with the nuts on the inside. Put a lug on the inside at the A₁ post, under the nut.

To remove the dial from the variable condenser, first loosen the set screw which holds the knob to the shaft and remove the knob. Take out the three R. H. screws which fasten the large dial to the friction disc box, remove the four screws holding the box to the condenser mounting posts, and loosen the set screw on the collar which fits over the condenser shaft. You can now pull the box and collar off the shaft. You will find three washers on each condenser mounting post. Take off all but one from each post.

Remove the set screw from the collar, put the collar through the large hole in the front panel, and screw the set screw back again. Put the condenser behind the panel, and put in the screws which go through the friction disc box and thread into the mounting pillars, put back the three small screws holding the dial to the gear box and, finally, fasten the knob in place by tightening the set screw in it. Turn the condenser plates so that they are totally interleaved, loosen the set screw on the collar over the condenser shaft, set the dial so that the 100 division line coincides with the index line engraved on the panel, and tighten the set screw again. Screw the small knob on to the threaded end of the tickler shaft. Fasten a coil mounting pillar to the front panel at the right hand end with a 1-2-in. 6-32 F. H. screw. No put the three knobs on the rheostats, locking them to the contact arms by means of the thumb nuts at the rear. The index line on each knob should coincide with the off mark on the dial when the contact arm is all the way around to the left.

5. Connect the three terminals 7, 8, 9 of the rheostats together. This wire should run close to the front panel. Connect 8 to 10. Fasten the front panel to the tube panel by means of 1-2-in. 6-32 R. H. screws and nuts through the short ends of the mounting legs on the variable condensers. Put a lug under the front mounting screw nut on condenser C₁ and a lug under each nut of the rear mounting screws on C₂. Fasten the angle bracket at the amplifier end of the tube panel to the coil mounting pillar on the front panel with a 1/2-in. 6-32 R. H. screw. About 1/4-in. of this screw will have to be clipped off before inserting it.

Testing and Installation

THIS completes the wiring of the set. The antenna and ground connections are made directly to binding posts on the

antenna coil. The battery connections are made to the binding posts on the A. F. amplifier unit. The two binding posts marked Input P and B should have these markings removed. The post formerly marked P now becomes the +90V terminal, and the one formerly marked B is now the DET+ terminal. These markings are shown correctly in the picture wiring diagram. The markings for the rest of the binding posts remain as they are.

Connect a 6-volt storage A battery to the A+ and A- binding posts. Insert the tubes and turn the key in the lock switch to the right. When the rheostats are turned up, the tubes should light. If everything seems all right, connect 90 volts of B battery across the B- and 90V+ binding post, and bring off a 45-volt tap to the DET+ binding post. Connect either the 135 or 150-volt tap to the +150V. binding post. Light the filaments and plug the phones or loud speaker first into the detector jack and then into the last stage jack. A strong click should be heard in both cases.

Connect the antenna and ground and set the tickler coil at right angles to the main winding. Revolve the left hand condenser slowly while the other is turned back and forth.

Co-op Radio Station Being Planned

A cooperative broadcasting station to be owned and operated in or near Chicago by local radio fans themselves may be on the air some time next Winter if plans proposed by Gustave Frankel, president of the Mohawk Electric Corporation, materialize. The idea has received the endorsement of scores of leading citizens, besides winning instant approval from many other quarters.

Such a station, it is believed, would be a forward step in the history of broadcasting. While there is at this time no imminent danger of anything like a decline in broadcasting the establishing of this station would aid immensely in solving any impending problem of that nature.

"We have been altogether too dependent upon others for our daily radio programs," said Mr. Frankel in discussing the project recently. "The air has been filled with so much entertainment that we have come to take it for granted, as if it had always been there. There is no gainsaying that while listening over the radio is no longer a fad, broadcasting still is. The people who are providing us with entertainment today are doing it at their own expense, some of them for the sake of the advertising derived, but most of them for more or less philanthropical reasons. In time some of these stations will go out of commission.

"Then, again, there are well-founded rumors that a certain powerful trust is seeking a monopoly of broadcasting with a view toward ultimately making listeners pay for their service. Cooperative stations, supported by the people by popular subscription, would guard against any such monopoly. Other advantages would be the privilege of arranging their own programs and selecting their own talent."

The expense of building and maintaining such a station, Mr. Frankel pointed out, could be easily defrayed if 25,000 persons contributed.

Silver-Marshall

RADIO EQUIPMENT

114 South Wabash Avenue

Chicago, Illinois



McMURDO SILVER
Assoc., I.R.E.
Designer of the 4-Tube
Knockout

Specified Parts For the Silver 4-Tube "Ideal" Receiver Described in This Month's Radio Age

The famous Silver Four-Tube "Ideal" Receiver will positively do on a seventy-foot aerial what any super will do on a loop. This receiver is the ultimate in four-tube design, being one of the latest developments of McMurdo Silver, Assoc., I. R. E., and designer of the Silver Super. Anyone can build it by simply following a few clear and accurate construction details. Complete parts for this receiver, as shown below, for

2 Silver .0005 Low Loss Condensers No. 301	Each \$4.50	1 On-off Switch60
3 3-in. Moulded Dials—Tapered Knobs Each 1.00	1 .00025 Mica Condenser with Leak Clips45
1 Howard 6 1-2 Ohm Rheostat 1.10	1 .002 Mica Condenser40
6 Insulated Top Binding Posts Each .85	1 .0075 Mica Condenser75
1 Carter 103A Jack80	1 2 Merc. Grid Leak50
1 Carter 101 Jack70	1 2x2x3-16 Bakelite Panel, Drilled, Grained and Engraved 7.00
1 Silver Low Loss Coupler No. 105 5.00	Bus-Bar, Spachetti, Screws, Nuts, Solder, Lugs, Etc. 1.00
1 Silver Low Loss Antenna Coil No. 205 2.50		
1 Hoosick Falls Panel Mounting Sockets	Each 60		
1 Thordarson 3 1-2:1 Audio Transformer 4.00		



Complete constructional data for the famous Silver Super is now available. Included are a full-size baseboard layout, pictorial diagram, assembly and testing details and point-to-point wiring instructions. Price 50c



Bring your Super up-to-date with 210 and 211 charted and matched S-M Transformers—acknowledged the finest made. Each one is supplied with individual curve. Filter (211) is supplied with proper tuning condenser.
210 S-M Transformer..... Each \$8.00
211 S-M Transformer..... Each 8.00
101B S-M Coupling Unit..... Each 2.50

Let Your Dealer Show You S-M Products or Send for Descriptive Folder

FREE This Wonderful Radio Book

Big Money-Saving Radio Catalog containing a thousand bargains of everything in radio; parts, supplies, complete parts for sets, complete sets, etc., also a mine of very latest information on all different circuits, complete list of broadcasting stations and other valuable data.

Easy to build your own radio set. All complete parts of sets consist of standard advertised guaranteed parts and include drilled bakelite panels and wiring diagrams for easy assembling. Everything guaranteed on money-back basis. Our Free Service Department helps you solve all your radio problems.

Send name, address for free catalog. Send names of friends; we will mail them catalogs.

RANDOLPH RADIO CORPORATION
188 North Union Avenue, Dept. 445 CHICAGO

BUY DIRECT AND SAVE THE MIDDLEMAN'S PROFIT

**RADIO \$1.50
TUBES * 1 Each**

Fully Guaranteed

All tubes tested on laboratory Radio tube testing machine.

**Mail Orders Promptly Filled
WE SHIP C. O. D.**

Style 0199 .06 Amp. 3-4 Volts—Amplifier—Detector
Style 0201A 1/2 Amp. 5-6 Volts—Amplifier—Detector
Style 012 .25 Amp. 1 1/2 Volts—Amplifier—Detector
Style 0200A 1/4 Amp. 5-6 Volts—Detector

RADIO TUBE MFG. CO.
154 Nassau St. Dept. 25, New York City

For Real Values, Turn to Radio Age's Classified "Ad" Section.

* Tested and Approved by RADIO AGE *

Sales Distributor Wanted

Reliable Man Who Is Mechanically Inclined As Factory Distributor and Sales Representative for the well known

MUSIC BOX * RADIO RECEIVER

In Your District.

The man we select must be financially responsible and willing to learn our methods of sales and distribution, and his earnings should be \$100 to \$300 weekly. No radio knowledge is necessary as he will be required to come to Chicago for intensive training at our expense—and learn our method of sales and service—about \$500 temporarily required for the initial shipment of merchandise.

Give brief outline of past history—and for full and complete information address your letter to:

Mr. Higgins, Sales Manager
1207 North Shore Ave., Chicago



The 100%
Self Shielded
Transformer

has made a big hit with both set makers and set manufacturers because of its small size, its amazing volume and, most of all, because of its pure undistorted tone. It is half the size of other transformers, but its results are unsurpassed. Absolutely new and scientific design and construction. Ratios 1 to 3, 1 to 4, 1 to 5, \$3.50. Ratio 1 to 10, \$4.50.
SEND FOR BULLETIN No. 94. Read all the exclusive features of this and other Premier Parts. Tells how to get free hookup diagrams, beautifully printed in two colors.

PREMIER ELECTRIC COMPANY
3803 Ravenswood Ave. CHICAGO

PREMIER Quality
Radio Parts

IF readers wish to show their approval of RADIO AGE'S stand against the Radio Corporation of America, they can do it in the most practical way by sending in \$2.50 for a year's subscription or if they are already subscribers, urge a friend to subscribe. We believe the fans are with us. Address RADIO AGE, Inc., 500 N. Dearborn St., Chicago, Ill.

REBUILD YOUR NEUT—Use same panel, same parts. No neutralization. 22 feet gold wire, only extra part, circuit and complete, simple instructions—\$5.00 prepaid. Hundreds of Neut owners use this kit. Details—10c. 48 page catalog parts—10c. Stamps accepted. KLDAG RADIO LABORATORIES, KENT, O.

Reducing STATIC Disturbances This Summer

(Continued from page 10)

Tuned circuits, tuned to a given wavelength, are not set to oscillating by other wavelengths unless these waves are unusually strong. We all know that most receivers will oscillate at their tuned frequency when in the vicinity of a powerful broadcasting station, even when the station is operating on a widely different wavelength. The shock must be many times the ordinary signal strength to set up such conditions, and the atmospheric contact charges are heavy enough to do this very thing. In other words, we now have no means of separating the desired signal from the undesired static, since both disturbances oscillate the set at the same frequency. The tuning unit is ineffective in such a case and must be given outside aid. This may be compared to the case of a tuning fork which is free to vibrate at a fixed frequency, but which will also vibrate at this frequency when struck by a force of any other frequency.

Simple Static Reducers

It is an old saying that the elimination of static means a reduction of signal strength, and this is true of most static eliminators so far devised. However, the weakening of the signal is not of so much importance as the relative weakening of the static and the signal, or the "Signal Static ratio" as it is called. If a certain system weakens the static at a more rapid rate than it weakens the signal, then we will eventually reach a point where the static will disappear entirely with some of the signal still in evidence. It is only when the strength of the static greatly exceeds the signal that it becomes highly objectionable, and even when they are equal the practical effect is not bad.

One of the simplest eliminators of the "high loss" type is the crystal eliminator of Fig. 4. A crystal detector (CD) is connected across the aerial and ground posts (ANT) and (GND) of the receiver (R) and through the choke coil (S). The choke coil can be adjusted so that the high frequency radio waves are retarded, while the low frequency static goes to ground. It makes no difference how carefully this device may be adjusted for there will always be some loss of radio waves to ground and half the static waves or charges will always be thrown over into the set for half the static waves cannot pass through the detector (CD). However, this is frequently of service and is at least a partial solution of the problem. A low capacity condenser (C1) placed in the cross-aerial-line to the receiver, is adjusted so that the high frequency radio waves will pass into the set, but so that the capacity will not be great enough to pass the low frequency static waves. This may or may not be of assistance with lightning discharges, but is usually effective with local "contact static" met with in clear weather. As the crystal detector passes half the waves, it tends to give a signal static ratio of one to one.

Another stunt, but not so good as the first, is to place a high resistance (GL) or grid leak across the posts of the receiver (R) as shown in Fig. 5. This should be a variable resistance or leak which may vary from 50,000 ohms to one megohm according to conditions. It is strictly an emergency aid, for it allows a greater percentage of the signal to escape to ground than the crystal detector type.

Ground Chokes (Static Drains)

A simple and often very effective method is the "ground choke coil" method shown by Figs. 6-7. These are suitable only with inductively coupled receivers having a primary aerial circuit electrically separated from the secondary circuit. This includes sets equipped with loose-couplers, vario-couplers, or other two and three circuit tuning units.

In Fig. 6, a choke coil (I) is connected directly from the aerial to ground. This choke must have a sufficiently high inductive value to hold back the longest radio waves that we expect to receive. The long wave static will pass freely through the choke without the high frequency radio waves following. I have seen all sorts of values used, for (I), ranging from a 400 turn honeycomb coil to the secondary winding of an audio transformer. I have had the best results by connecting the primary coil of an audio transformer at (I), leaving the secondary coil open, but this may not suit every case as well as it does mine. In any event, the inductance must be very much higher than that employed for tuning in broadcasting wavelengths.

Fig. 7 is an alternative arrangement of the same choke coil (I) in which the choke is placed in series with the ground wire of the receiver. In some cases, and with certain types of receivers, this may work better than the arrangement in Fig. 6. It is easy to try, and therefore I will put the selection up to you.

Tuned Traps (Selectors)

VERY often the wave trap idea works out successfully, and has the further advantage that it can also be used to increase the selectivity of the receiver. In Fig. 8 we have a combination of a variable condenser (C1) and a honeycomb coil (L) connected across the aerial and ground posts of the receiver (R). This arrangement is adapted only to two or three circuit tuners with inductively coupled aerial circuits. It will short-circuit a single circuit receiver of the ultra-audion type.

By tuning the variable condenser (C1), the wavelength of the trap will be varied so that all the radio frequency signals are shunted into the receiver while the undesired waves of different wavelengths pass through to ground without entering the receiver. Under some conditions this is highly effective. It is difficult to prescribe any definite sizes for the condenser and coil owing to the great variation in conditions, but as a starter I would say that a 23 plate (0.0005 mf) variable condenser with a 50 turn coil

(L) would be about right. A vernier must be used, as the trap tunes very sharply and there is a certain hot spot on the dial which covers only one or two divisions.

Fig. 9 shows the same scheme adapted to single circuit tuners with the trap placed in series with the set. This also works well with certain two circuit tuners, and both methods should be tried out with two circuit tuners until the best results are obtained. The condenser and coil can be mounted in a separate cabinet, making a convenient unit for tuning your set.

Aerial Specifications

For the minimum reception of static, the aerial conditions must be carefully controlled, even when static drains are employed. For Summer reception a low aerial is the best, an aerial that is not more than 25 or 30 feet above the ground. This follows from the data in Fig. 1, which shows that atmospheric potentials increase rapidly for every increase in altitude. A single wire not more than 60 feet long is the best, and while this may reduce the signal strength slightly, it also decreases the static more rapidly, thus giving a better signal static ratio than a longer wire. The lower the natural period of the aerial system, the less likely it is to respond to low frequency static impulses.

Where possible, the aerial should have strong directional qualities so that it will embrace as small an area of static disturbance as possible. The fact that a loop aerial is very directional, picking up only the signals that lie in the plane of the loop, makes this type almost ideal for Summer use. Umbrella or "V" type aerials are to be avoided.

Inductive Type Reducers

A type of tuned absorption reducer is frequently very successful and is easily adjusted to local conditions. This is a modified form of the traps already described. In addition to reducing static, it also makes the circuit more selective. In Fig. 10 we have the common form of coupler having the aperiodic primary (P) and the secondary (S), the latter being tuned as usual by the variable condenser (C1). This is the common tuning unit employed on the majority of present day sets. An addition is made by winding the coil (T) on the end of the secondary in inductive relation to (S). A variable condenser (C2) across coil (T) makes very close tuning possible, and a very marked reduction in static generally follows. The coil (T) may contain from 40 to 60 turns of small wire, say No 30 or No. 32. This will save space and will make the unit more compact. The coil (T) is located about 1-2 inch from the end of (S). Condenser (C2) is usually about 0.0005 mf capacity. Still sharper tuning is possible by placing the coil near the primary instead of near the secondary. This is shown in Fig. 11, where the same size units are used. In fact, the sharper the tuning and the looser the coupling, the less static we will receive.

Resonance Coils

Probably the most effective static reducer yet devised is the "resonance" type



No. 84
Price, \$2.75

BE SURE

* That your "B" batteries are not run down. 60% of all radio trouble is traceable to run-down and poor batteries.

§ The Jewell "B" Battery Voltmeter No. 84 will save you a lot of grief and disappointment. It's a real instrument—sturdy and accurate.

§ Buy from your dealer. Ask him for a Jewell 15-A Radio Catalog.

Jewell Electrical Instrument Co.

1650 Walnut St. - Chicago

"25 Years' Experience Making Good Instruments"

Obsolete *

The HEART of the Circuit IS AMPERITE

The "Self-Adjusting" Rheostat

As the heart controls the flow of blood through the body, so AMPERITE, the self-adjusting rheostat, controls the flow of current through the tubes—automatically—never allowing too much to injure the tubes, and always permitting true tone qualities with proper volume. No hand rheostats. No guessing. Simplifies wiring. Improves operation. Used in over 50 leading sets and circuits. \$1.10 everywhere.

RADIALL COMPANY
Dept. RA6 50 Franklin Street, New York City

Write for **FREE** Hook-ups

AMPERITE
"means right amperes"

BIG MONEY!
\$3,000 to \$10,000 a year

Want to make big, easy money? Learn how to install, operate, repair, construct and sell Radios. Write now for facts about the amazing opportunities for Radio experts, and our special offer of a FREE 1000-mile receiving set, and how you can quickly train at home by mail.

Be a Radio Expert
No previous experience necessary. Anyone with ordinary education can now learn Radio quickly under our simplified home-study plan. We need men right now to represent our Association. Be the Radio expert in your neighborhood. Get your share of the big profits. Hundreds about you want Radios and advice how to operate. You can earn enough money right from the start to pay for course. Nothing difficult about it. Low cost and easy terms.

FREE 1,000-MILE Receiving Set

Don't miss this big special offer to supply FREE all parts necessary to construct a high-grade 1000-mile receiving set. You can sell this set alone for practically the entire cost of the course. Send for the facts now. Find out all about this high-pay field. Address

Radio Association of America
4513 Ravenswood Ave., Dept. 26 Chicago, Ill.

Do you keep the RADIO AGE Broadcast List, to be found in every issue, as an ever-ready guide to stations, their call letters, locations and wavelengths? The RADIO AGE broadcast list, corrected every month, is the most up-to-date list you can find anywhere.

* Tested and Approved by RADIO AGE *

ARROW BATTERY

* SLASHES Prices

Prices Smashed!

Quality Not Sacrificed

Here is real battery quality, guaranteed to you, at prices that will astound the entire battery-buying public. Order direct from factory. Put the Dealer's Profit in your own pocket. You actually save much more than half, and so that you can be convinced of true quality and performance, we give a

Written Two-Year Guarantee

Here is your protection! No need to take a chance. Our battery is right—and the price is the lowest ever made. Convince yourself. Read the prices!

Special 2-Volt Radio Storage Battery, \$3.75
 Special 4-Volt Radio Storage Battery, 6.00
 6-Volt, 60 Amp. Radio Storage Battery, 7.00
 6-Volt, 80 Amp. Radio Storage Battery, 8.00
 6-Volt, 100 Amp. Radio Storage Battery, 9.50
 6-Volt, 120 Amp. Radio Storage Battery, 11.50
 6-Volt, 140 Amp. Radio Storage Battery, 13.00

We ask for no deposit. Simply send name and address and style wanted. Battery will be shipped the day we receive your order Express C. O. D., subject to your examination on arrival. Our guarantee accompanies each battery. We allow 5% discount for cash in full with order. You cannot lose! Act quick. Send your order today—NOW.

Arrow Battery Co.

1215 South Wabash Ave.

Dept. 1 Chicago, Ill.



developed by the Signal Corps of the United States Army. This is an artificial antenna in very compact form made by wrapping about 400 turns of wire around a long cylinder, and then capacitatively connecting the receiving circuit at critical points on the coil. Remarkable results are said to have been obtained with this arrangement without materially reducing the strength of the signals.

Fig. 12 shows the circuit where (L) is the coil and (P) is a sliding split ring, which closely embraces the coil but does not make actual electrical contact with the wire. In effect, (P) is the plate of a condenser connected to the antenna post (ANT) of the set (R) which picks up certain desired impulses in the coil and transmits them to the receiver. The ring (P) is split or made discontinuous so that eddy currents will not be formed in the metal. When working on long wavelengths, the coil (L) is about 38 inches long and is wound on a 2 3/4 inch diameter tube. This is a single layer winding and is therefore objectionably long.

For work on broadcasting wavelengths, the coil can be much condensed by using a single layer winding of No. 30 gauge wire on a tube 18 inches long and with a diameter of from three to four inches. A further reduction in size may be had by employing a double banked winding, the winding being divided up into sections one inch long. With a banked winding, the length is shortened to about 12 inches with the diameter remaining as before. The size of the wire is not of importance and it may be that even finer wire than No. 30 could be used with good results.

The sliding ring (P) by capacity collection picks up radio waves that correspond in wavelength to the inductive portion of the coil (L) included between the ring and the aerial connection; hence any desired wavelength can be picked up in this manner and transferred to the grid of the tube. By using two collector rings on a single coil, and located in different positions along the length, two different wavelengths or frequencies can be picked up, which immediately suggest that one ring can be used for grounding static discharges while the second ring can be used to transmit the desired radio signal to the receiving set.

Fig. 13 shows how two collector rings, (P) and (V) can be employed for the elimination of static. In this figure, the guard ring (V) is connected to earth through the trap (C2-L2) while the collector ring (P) carries the radio signal to the antenna post of the receiver (R). The ground from (V) can be a direct ground, or it can be arranged with the trap (C2-L2) as shown, for better control. Once adjusted, (V) remains constantly in one position on the coil, for the length is so chosen that it includes the band of static waves having a frequency of between 200 and 300 cycles per second. The length of (V) is from one-third to one-half the total length of the coil (L1).

Fig. 14 is a simplified version of the resonance coil that can be built by the home experimenter, the construction recalling the old time single-slide tuner

except that the slider does not make actual metal-to-metal contact with the wire coil. This is by far the best arrangement that can be used by the amateur, but it is somewhat cumbersome. The coil (L) consists of about 400 turns of No. 18 D. C. C. wire wound on a four-inch diameter tube. The square brass rod slider guide (S) is fastened to the tube so that free movement of (P) can be had from end to end of the coil.

It is essential that (P) be split to prevent the circulation of eddy currents, and this is effectively attained by making (P) in two pieces with a strip of insulation between them. In Fig. 15 is a cross-section through the assembly showing the two halves (P) attached to and separated by the hard insulation (I), the insulation (I) also acting with a sliding fit on the slider guide (S). The parts (P) can be made of sheet copper bent to an arc which closely fits over the wire. The arc of embrace is about one-third the total circumference or 120 degrees, although this is not an exact or critical dimension. Returning to Fig. 14, the width of the slider may be equal to from eight to ten turns of the coil.

Loose Coupling Methods

There is a distinct relation between loose coupling and static, or between selectivity and static. A very loose coupling between the primary and secondary coils of your tuning unit will be of great assistance in getting rid of the noises. If you have a single circuit tuner or a very closely coupled two circuit tuner, then it will be difficult to get rid of the trouble without outside assistance. Unipolar tuners or Marconi "link" couplers are of great assistance in ridding your circuit of static and at the same time increasing their selectivity. Selectivity of this sort reduces the signal strength somewhat, but as it can reduce the static at a still greater rate, the ratio of signal strength to static is greatly improved.

A "unipolar tuner" is one in which there is only a single connection (g) running from the tuning inductance to the grid of the tube, as in Fig. 16. There is no grid return wire. The coil (L) is tuned by the variable condenser (C1) as usual. This is an exceedingly sharp tuner, and one in which static capacity effects can be reduced to minimum. The values of (C1) and (L) are as usual with this tuner.

A type of tuner once used by the Marconi Company is shown in Fig. 17, which also provides for extreme selectivity. The primary inductance (L1) is tuned by the variable condenser (C1), and instead of being directly coupled by induction to the secondary coil (L2), the connection is made by the "link" of wire (M). The connection (M) consists of two or three turns of lamp cord about each of the coils (L1) and (L2), and then the two coils (L1-L2) are placed about one foot apart or at right angles to one another so that there can be no direct inductive coupling between the primary and secondary circuits. As a heavy current flows in (M), it must be of very heavy low-resistance wire or preferably of heavy lamp cord. The secondary (L2) is tuned by the second variable condenser in the usual manner. (To page 55)

PATENTS

To the Man with an Idea

I offer a comprehensive, experienced efficient service for his prompt, legal protection and the development of his proposition.

Send sketch of model and description, for advice as to cost, search through prior United States patents, etc. Preliminary advice gladly furnished without charge.

My experience and familiarity with various arts frequently enable me to accurately advise clients as to probable patentability before they go to any expense.

Booklet of valuable information and form for properly disclosing your idea free on request. Write today.

RICHARD B. OWEN, Patent Lawyer
 81 Owen Bldg., Washington, D. C.
 2278-M Woolworth Bldg., N. Y. City

IF readers wish to show their approval of the stand taken by RADIO AGE against the Radio Corporation of America, they can do it in the most practical way by sending \$2.50 for a year's subscription to our magazine, or if they are already subscribers, urge a friend to subscribe. We believe the fans are with us. Address Radio Age, Inc., 500 N. Dearborn St., Chicago.

Figs. 16-17 show only the "front ends" of the receiving circuits for simplicity in describing the methods. The rest of the circuit can be of any imaginable type; regenerative, radio frequency or reflex. In the unipolar type, you should note that the grid leak (GL) runs from the grid directly to the (-A) of the battery and is not in parallel with the grid condenser. This is made necessary for the reason that there is no grid return line in this circuit, and if the parallel connection were used, the circuit through the grid leak would not be completed.

Modulated Primary Type

BASED on the theory that any tuned circuit will oscillate at a given frequency determined by the tuning when excited by the impact of any strong wave of any frequency, a very original eliminator has been devised by Dr. McCaa. This is a rather complicated circuit, both in construction and theory, and rather suggests a combination of the super-heterodyne and the super-regenerative principles in oscillating the circuit and in opening and electrically closing the circuit for the admission of signals only. An external oscillator circuit and tube is supplied for the excitation of the receiving circuit, which is tuned to the wavelength of the incoming signal or to a harmonic of the signal. Static is not entirely eliminated but it is reduced in strength until it is equal to the signal strength. This is a greater advance than would be considered at first glance.

A schematic diagram is shown in Fig. 18 where (P) and (S) are the primary and secondary coils respectively of the usual tuning unit. The secondary (S) of the receiver is tuned to wavelength by the variable condenser (C2) as in the majority of receiving circuits. An oscillator circuit of the super-heterodyne type is inductively coupled to the secondary coil (S) of the receiving circuit by the coupling coil (L2) of the intermediate circuit (L1-L2). By varying the condenser dial (C1) of the oscillator, the impressed oscillations on (S) can be controlled to meet the requirements of the incoming signal just as with the oscillator circuit of a super-heterodyne. When the oscillator creates a wave that exactly opposes the signal wave entering the aerial, the intermediate circuit (L1-L2) is neutralized, and (S) is excited by the signal together with a little of the static. The signal is received, and all of the static whose voltage does not exceed the voltage of the signal. In other words, the worst that can happen is to have a static "bump" that is equal to the signal strength. The static can never exceed the signal, and generally is somewhat less.

Cascade Balanced System

Getting rid of the static by means of successive elimination has been proposed many times with varying results. In other words, the output of the aerial is led through a succession of inductances until all of the undesired waves are grounded and only the desired signals reach the tube. In general, this is exactly the reason for the selectivity of the common five tube tuned radio frequency receiver, for three stages of tuning



Now a reality

the clear, undistorted amplification you have long wanted—is now a fact

Here it is. The Pacent Improved Audioformer gives you *uniform* high amplification over the *entire* band of sound frequencies. Every note—vocal or instrumental—comes in with a natural, undistorted clearness that is unusual. There's a real thrill awaiting you when you hear your radio stations through this finely balanced, improved audioformer.

All better class dealers carry it, or can easily get it for you.

Write today for interesting catalog of complete Pacent line.

PACENT ELECTRIC CO., Inc., 91 Seventh Ave., New York City

Washington Boston Chicago Philadelphia
 Minneapolis St. Louis Buffalo Birmingham
 San Francisco Detroit **Pacent** Pittsburgh Jacksonville
 RADIO ESSENTIALS

Canadian Licensees: R. H. White Radio Co., Hamilton, Ont.

- PACENT Radio Essentials**
- Adapters
 - Improved Audioformer
 - Autoping
 - Coil Plug
 - Coil Plug Interchange
 - Condensers, Low Loss
 - Detector Stand
 - Diapitch
 - Drumming
 - Dist. Lateral Coils
 - Headsets, Evergreen
 - Jack
 - Jack Set
 - Radio Loop
 - Loop Plug
 - Loop Jack
 - Multi Jack
 - Pinch
 - Potentiometer
 - Refractor
 - Resistors, Laboratory
 - Socket
 - Transformer, etc., etc.

"DON'T IMPROVISE - PACENTIZE"

Built and Fitted to the New Conditions

ORIOLE

Model 7 Receiver

Separates Distant Stations on 1.5 Meters Difference—or Less . . . Tunes Through the Locals—Highest Known Selectivity.

W-K ELECTRIC CO.

DEALERS
Write for Information

KENOSHA, WIS.

Jobbers and
Distributors Wanted



CABINETS

If you are interested in a radio cabinet in which is combined both beauty and practicability, just write **LAKESIDE SUPPLY CO., Dept. R**
 73 West Van Buren St.
CHICAGO, ILL.
 Telephone, Harrison 3840

MARSHALL Radio Frequency Receivers

Embodying a marvelous New * Non-Oscillating Principle
 Sold Direct on Free Trial and Easy Terms
 Write for catalog and Special Offer
Marshall Radio Products, Inc.
 Dept. A-589 Marshall Blvd. & 19th St., Chicago

HOW MUCH COUPLING?

Coupling is a subject that interests every experimenter desiring to improve the operation of his set. How about your coupling troubles? Brainard Foote takes them up one by one and solves them in an enlightening article he has written for the July RADIO AGE, on the stands June 15.

* Tested and Approved by RADIO AGE *

eliminate what can not be accomplished by one stage alone.

Fig. 19 shows a typical example of this sort of arrangement employing three inductance coils (L1), (L2) and (L3) connected in cascade with the receiver tube (T). The lower ends of the coils are all grounded at (b1-b2-b3) for the elimination of the static. The other ends of the coils (a1-a2-a3) lead indirectly to the grid of the tube through a series of intermediate taps (m1-m2-m3). By varying the position of the taps (m1-m2-m3) we have a means of separating low frequencies from high frequencies or a total of three different wavelengths.

For example, if (m1) is nearer to (a1) than to (b1), then the inductance of the upper end of the coil will be less than the lower, and the high frequency current will pass out through (a1) to (m2) of the succeeding coil, while the low wavelengths will be grounded at (b1-b2), and so on through the series.

(Copyright, 1925, By Radio Age, Inc.)

The Joys of Outdoor Radio

(Continued from page 12)

it if I came back that way; otherwise they could keep it until my next trip, which might be a year or more later.

But I did not charge it to profit and loss. In the car they placed a "snack" before I started on. There was a leg of 'possum, a wild strawberry shortcake, and enough wild honey to sweeten life for weeks. Also a quart of a liquid, colorless product of the corn fields which was of no use to me but which would have brought a good price on the New York stock exchange. Beside me for a distance rode a pale-eyed, long-whiskered guide who showed me where well-stocked trout pools lay, where deer and b'ar abounded, where roads were only bad and where they were worse.

By some underground system my identity was so quickly and so thoroughly established that wherever I went in those mountains in the days that followed I was received with friendly nods and abundant hospitality instead of with the suspicion with which city fellers are likely to be watched.

IF YOU DON'T See what you need in RADIO AGE'S Advertising Columns, write to the Radio Age Buyers' Service, 500 N. Dearborn St., Chicago, and all buying specifications will be furnished you free of charge.

Maybe an
Opportunity
awaits You in the
Radio Age Classified
Section
See page 70

An Ideal Four-Tube Set in Practical Form

(Continued from page 22)

section of the condenser turned down, as in Figure 2. This will provide a firm mounting for the antenna coil on the back of the condenser.

All screws and nuts on condensers, transformers, sockets, etc. should be tightened up, and jacks and sockets carefully checked for proper contact and spring tension. Jack springs should make good contact with the phone plug, and socket springs should be bent up to make good contact with the tube-base pins. Soldering lugs should be put on the tube sockets, the filament lugs pointing toward the panel except in the case of audio frequency sockets. The two lugs, one on either of these sockets that will be adjacent when the sockets are on the panel, should be turned toward each other so that the wires to them can be put in without touching the rheostat.

Binding posts should be put on the panel, with lugs pointing straight in under the screw heads of each post. The binding posts now being on the panel, the four sockets, rheostats, jacks, on-off switch and audio transformers should be fastened on with screws and nuts.

Precautions Before Wiring

BEFORE starting the wiring, a well-tinned soldering iron should be heated, or an electric one used, and a quantity of rosin-core solder and a can of non-corrosive soldering paste procured.

The wiring should be done according to the pictorial diagram, placing the additional parts in position on the panel as it progresses to facilitate easy placing of the various wires. If the diagram and Figure 2 are studied, no difficulty should be encountered. Upon completion the set is ready for test, and the following accessories will be needed:

- 1 100 Volt B-battery (4 22½ volt or 2-45 volt batteries).
- 1 6 Volt storage battery, if storage battery tubes are used, or three dry cells, if UV 199 tubes are used.
- 1 4½ volt C-battery.
- 4 tubes (UV 201-A for storage battery recommended) or UV 199 with adapters if dry cell. (The use of 100 sockets was not considered as there are no satisfactory panel-mounting 100 sockets, and adapters with standard sockets make a satisfactory electrical arrangement, and an excellent mechanical one).
- 1 Pair of phones with phone plug, or loud speaker with plug, or preferably both (any standard make).

A suitable antenna would consist of a 70 to 100 foot single wire run between two trees or two buildings. The lead-in wire should not be over fifty feet long.

The set should now be connected to the antenna and ground and to the A-battery, but not the B or C batteries. The tubes, upon insertion in their sockets, should light up if the on-off switch is pulled out and the rheostat turned on. If they do, disconnect the A +battery lead and connect it first to the B22 and then to the B 90 binding post. If the tubes then light, the wiring is incorrect and should be checked. Assuming they do not, the A battery should be reconnected properly, and the B and C batteries connected. The C +post connects to the flexible lead soldered to the on-off switch, and the C - post connects to the

flexible lead attached to the F terminals of the audio transformers. The B batteries should be connected in series so that 22 volts will come between the AB - and the 22 + posts, and 67 volts between the 22 + and 90 + posts, or 90 volts between the AB - and the 90 + posts.

Operation

The tickler dial should be turned to zero and the tubes lighted up by turning the rheostat about three-quarters on for UV 201-A tubes or one-quarter on for UV 199 tubes, and once set it need not be varied, but should always be operated as low as is consistent with good signal strength. The first two condenser dials should be rotated, holding about the same settings over their entire scales, with the phones in the three-contact, or first stage jack. These two condenser dials will operate as the first two dials on a neutrodyne, keeping about the same relative separation in degrees over the entire wavelength range of the receiver. If there is any tendency for the RF amplifier to oscillate, it will be evidenced by clicking in the phones at certain dial settings on the lower, and possibly on the higher waves. If stations are heard as a whistle, it means the amplifier is oscillating and must be neutralized. The tickler has been left set at zero.

A station should now be tuned in on the lower waves, or with little of either condenser in use. When the clicking or squealing is noticed, the neutralizing condenser should be adjusted in small steps until this clicking or whistling disappears. The set is then neutralized. This method is both simple and effective, although there are others that might be employed.

The set now operating, the tickler coil should be turned toward 100 on its dial until a plunk is heard, and stations come in again as a whistle. This is entirely correct, as the whistle can be cut out by reducing the tickler coupling. If the "plunk" cannot be heard, even using 45 volts on the detector instead of 22, the two top lugs on the vario coupler should be reversed.

In tuning the set, either of two methods may be used. The first one is to tune in a station with the two condensers, leaving the tickler at zero, and then strengthening the signal, with the tickler when heard. The second and preferable one is to turn the tickler up until stations come in as a squeal, rotate the detector condenser until a squeal is heard, then vary the first condenser for maximum intensity, following this by turning the tickler back until the squeal disappears and the station modulation is heard. In either case final adjustments will have to be made on all dials when receiving weak signals.

If the receiver is broad in tuning, a small fixed condenser connected in series with the antenna lead-in will remedy matters. It should be either .0001, .00025 or .0005, mfd capacity arranged

so that it can be short-circuited by a single-pole, single-throw knife switch when desired.

If an indoor antenna is to be used, it may be put up in an attic, and should consist of several wires run parallel to each other and connected together at both ends, or it may be as long a wire as is convenient run around a picture moulding. Some difficulty may be experienced in neutralizing the set on such indoor antennas, however.

[Further specifications and diagrams concerning this receiver may be had by sending 25 cents in stamps to McMurdo Silver, care this magazine.]

WJJD Tries Some Intentional Fading

What movie fan doesn't know what a "fade-out" is? And now comes the radio fade-out.

When Jack Nelson was at old WDAF, he established the custom of singing his song, "May You Laugh in Your Dreams," as the finale to late programs, after all signing off announcements had been made. He does the same now on the late programs of WJJD, the Loyal Order of Moose station at Mooseheart, Illinois, where he is Director and Announcer, but Ralph Shugart, the Engineer has added the new twist which is receiving many comments.

When Mr. Nelson is half way through the song, it begins to decrease in volume until the last notes of his singing and playing fade away into silence. The effect is such that the listeners feel they are drifting into space. One listener said that the only way he could describe it was to say, "It makes me feel just as though I were dropping off to sleep in a clover field in the middle of a drowsy summer afternoon. Boy, he certainly gives me the spring fever!"

WBBM Inaugurates Sunday Jazz

A Tea Dance Program featuring the Dixie Boys' Orchestra, interspersed with popular numbers was heard from WBBM Sunday, April 19, from four to six p. m. It has been announced that this was the beginning of a regular Sunday afternoon Jazz Frolic from WBBM to be broadcast from their studio in the Broadmoor Hotel, Chicago.

The popularity of this hour was shown by the immense volume of 'phone calls which were received during the program. Six trunk lines were kept busy during the entire program, and many calls undoubtedly were missed. The next day's mail was strong in its praise of this popular program, and it would seem that the idea has made a big hit with the Sunday radio listeners. Out of all the comments received, only one criticism was noted, showing beyond much doubt that the Sunday afternoon listeners approved of the idea of a popular program.

WBBM announces that hereafter this will be a regular feature of their Sunday afternoon program, running from four to six p. m. The Dixie Boys Orchestra will be a feature regularly on this program as well as popular artists of the lighter music.

Creative Lighting Effects Feature New WJAZ Studio

DISTINCTIVE developments in lighting effects will play an important and unusual part in WJAZ studio broadcasting from their new location in the Straus Building, Chicago.

In 1923-4, the Zenith Radio Corporation owned and operated Station WJAZ at the Edgewater Beach Hotel, Chicago. This station was known to the entire radio world and when Zenith sold this station, hundreds of thousands of letters were received appealing to WJAZ to come back on the air. Although the station was sold, the call letters were retained and the radio listening public will soon hear the familiar WJAZ going out over the radio waves. These old listeners and a host of new friends will again be able to hear the high class, pleasing programs previously associated with Zenith WJAZ broadcasting.

The new studio will mark an epoch in the construction of radio broadcasting apparatus. The entire 23rd floor in the beautiful new Straus Building will be utilized by the studio, reception room, and executive offices of the Zenith Corporation. The studio architectural furnishings will be in Spanish style with Louis XVI period furniture. Oriental rugs, heavy drapes and rich tapestries will further enhance the effect. Acoustician experts have arranged interiors so that the delicate pitch of the violin and the deep resonant tones of the bass viol will all be harmoniously perfect in their transmission.

Dr. M. Luckiesh, Director of the Lighting Research Laboratory, has been secured to plan and direct the indirect illumination for this studio. Dr. Luckiesh is the author of books which are generally accepted as authoritative works on lighting.

Lights—soft gradations of light and bold, illuminative effects, will make the atmosphere of this studio fit in with the mood of the selection being given by the artist. It has long been a problem in radio to secure the proper settings for artistic broadcasting. Many times renditions of music from broadcasting stations have been below standard. The operatic stars on the stage are surrounded by appropriate settings which help create in them the spirit of the character being portrayed, while on the other hand, in a bare room, an invisible audience handicaps these same artists in giving strength and realism to their selections. Although the stage settings will not be available, this new thought in lighting will take the place of painted scenery and effect a perfect rendition.

Artists broadcasting from this new studio will not experience that strangeness associated with the knowledge that they are entertaining vast audiences, to them invisible. An entirely novel and new microphonic speaker will be part of the modern equipment installed. This speaker will be so designed that by the use of motion picture photography—an audience is thrown on the screen of the micro-speakaphone and is constantly before the artist performing. Grand Opera stars have enthused over the arrangement and have voiced their whole-hearted approval.

LIFE, LIBERTY and the Pursuit of HAPPINESS



You Wont Have to PURSUE HAPPINESS

You can have it right at your elbow to while away the time 'til old Lady Static gets off the line!

You'll have no trouble getting station Z-I-F-F-S, because you'll find it is always tuned in to catch your funny bone's wavelength, and is more ticklish to your giggle box than the finest cat whisker!

ZIFFS, Badzib's Book of Art and Wit, is the only humorous monthly of its kind on the market, and is crammed full of the best artists and funsters in the world!

Exclusive Photo Section! Complete gallery of French-American Art Studies in color! Fifty pages of illustrations! Pep, Ginger, Punch!

ALL FOR TWO BITS!

Pick This Out On Your Piccolo!

*Even tho' your set is growling
'Til you think a cat is howling
And the music comes in wailing, hissing sniffs,
You will giggle, grin and chuckle
'Till you hafta loose the buckle
On your belt, if you're the latest book of ZIFFS*

You wouldn't go fishing without bait, would you? Well, then, don't try to get Hong Kong on a stormy night with a crystal set, till you've put your John Henry on the tag below:

**ZIFF'S BUZZARDS ROOST
Maywood, Ill.**

Dear Badzib:
I got a radio. I got Hawaii. I got drowned out. I got peeved.
I don't see nothin' to laugh at, you big burn!
Here's two bits. Send me the May ZIFFS, and I will!

They Call Me.....

And I live at.....

Some Progress Toward Non-Oscillating Circuits

By JOHN B. RATHBUN and P. D. LOWELL

KNOWING that RADIO AGE readers, especially at this time, when sets are being rebuilt for the Winter radio session, are deeply interested in any advances in the construction of tuning units whereby stabilized radio frequency amplification may become an established fact, we are printing two articles in this issue which should shed a great deal of light on the subject.

The first is written by John B. Rathbun, well known to our readers as the conductor of the blueprint diagrams section, a department enjoying well merited popularity. His article is on tests made with a toroid, so constructed that its field is self-contained.

The other article, more from the manufacturing standpoint, is written by P. D. Lowell, research engineer with A. H. Grebe and Co., Inc.

Both of these writers have treated the subject in a concise and illuminating manner, so much that we feel our readers will have no trouble in following and absorbing the data given.

Balloon Tires for the Radio Set

By John B. Rathbun

FOR more than a year radio manufacturers have been concentrating their attention on the development of tuning inductances and radio frequency transformers, appreciating the fact that the efficiency and selectivity of a circuit is no greater than the efficiency of the inductance employed. As a result, almost numberless "low-loss" coils have been placed on the market within the last few months which possess many points of merit, but which are very similar in general design and which from the standpoint of the magnetic circuit are really nothing but refined editions of the old solenoid type coil.

Dielectric losses have been reduced to a minimum, distributed capacity has made its farewell bow to the radio public, but little attention was paid to the stray magnetic fields set up by the coils which still cause trouble through back-coupling and other inductive disturbances.

Open magnetic circuit inductances of the conventional

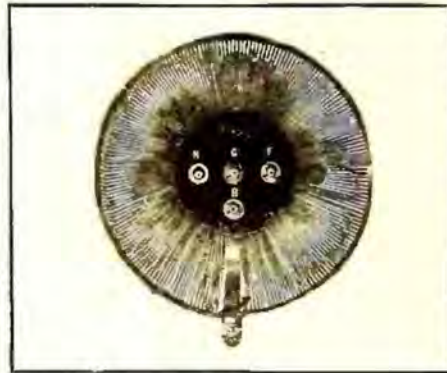

Fig. 1

The above is the type of fieldless inductance described in this article by Mr. Rathbun.

type, no matter what their construction may be, are by their very nature quite susceptible to stray magnetic fields from nearby broadcasting stations or from other parts of the circuit, and therefore suffer from a variety of undesirable interferences and couplings which reduce the selectivity and result in disagreeable noises. With powerful local broadcasting stations, such coils act as miniature loop aerials, picking up signals within the receiving set and making selectivity

impossible. Further, the solenoid type air core transformer shoots out a magnetic field for several feet around the set which may produce excessive regeneration in one or more of the radio frequency stages, with the accompanying howling and shrieking that has been experienced by all radio experimenters.

All this has been done away with by the new ring-like inductances which are variously known as Balloon Circloids, Toroidal coils, or the Terus, the latter being the geometrical term for a ring having a circular cross-section. Electrically, there is nothing new about this form of magnetic circuit, but it is decidedly novel in its application to radio circuits as a means of eliminating inductive interferences. Consider a long hollow coil of wire wrapped around a circular core, with its two ends meeting, and you have the Balloon Circloid or Toroid which forms the subject of this article. With the two ends of the coil meeting, it is evident that we can have no poles, and having no external poles, it cannot produce nor be affected by an external magnetic field.

Fig. 1 is a photographic view of a new zero field coil, and is one of several now being produced for the market. The ring-like coil is bent around the center core, which acts both as a support for the coil and the connection posts while

around the outer periphery is a narrow band of insulating material which stiffens and protects the coils against mechanical injury. This is a two-circuit transformer or tuning unit with a primary and secondary winding as in any coil used for coupling, and can be used in any radio frequency or reflex circuit as a transformer and tuning unit. As all of the magnetic field is within the coil, there is no dielectric loss due to the supports, and it is therefore a low-loss coil in every sense of the word.

So far as the coil itself is concerned, it is absolutely neutral to radio waves or magnetic fields, no matter in which direction they may strike the windings, and the coil can therefore be crowded close to other inductances without coupling to

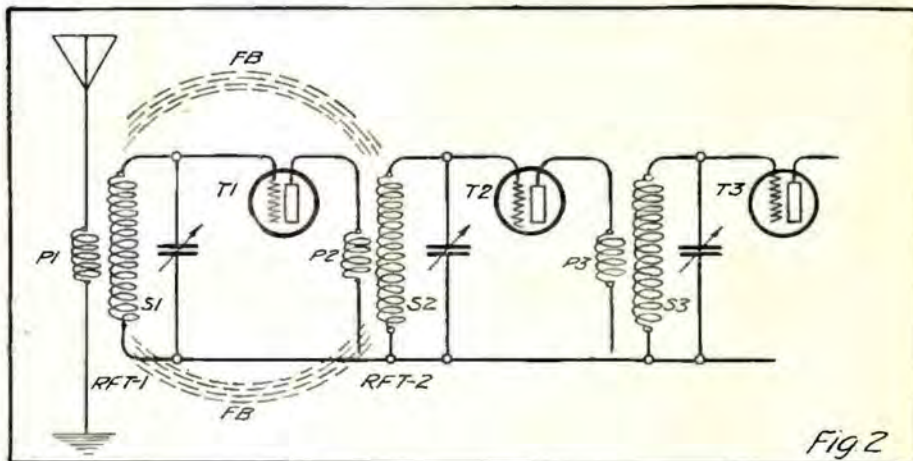

Fig. 2

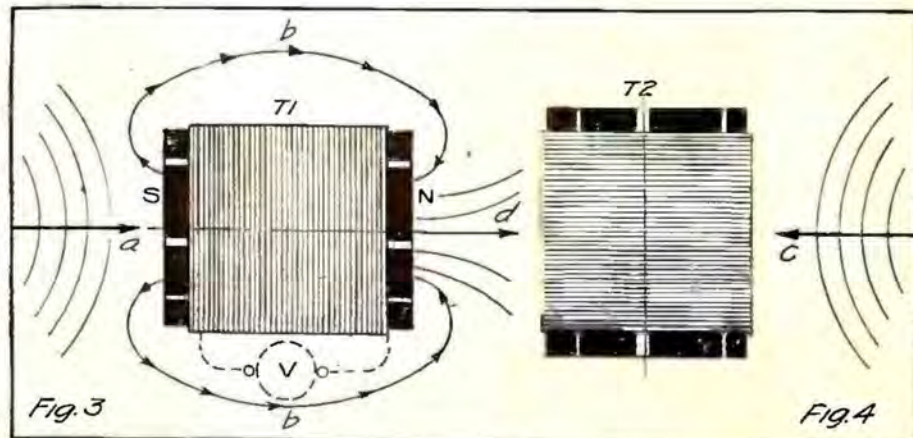

Fig. 3

Fig. 4

(Turn to page 60)

2nd Radio World's Fair to Excel 1924 Show

New York City—Practically all of the exhibiting space in the Second Radio World's Fair to be held here in the 258th Field Artillery Armory, September 14 to 19, is now under reservation and even at this early date the success of the gigantic enterprise is assured. All signs indicate that it will be the greatest trade show of any sort ever held in America.

Not only will there be an overflow of exhibits by the leading manufacturers of all countries, but a record breaking attendance is already a certainty in spite of the fact that the opening date is still five months away. Tremendous interest is being manifested by radio manufacturers, dealers, inventors and enthusiasts both here and abroad, and the patronage is sure to exceed that of the First Radio World's Fair of last September in Madison Square Garden and the 69th Regiment Armory.

The Echophone Portable Receiver

An ideal portable receiver which combines high efficiency with light weight and attractive appearance. Takes up no more room than an ordinary travelling bag, weighing only 28 lbs. fully equipped six 9" x 12 1/2" x 18".

One of the distinctive features of the set is the standard 60 foot aerial which winds on a reel built into the case. A few turns of the wrist and it is ready for use. For carrying purposes the aerial quickly winds back into place and out of sight. This unique and complete aerial eliminates entirely the usual loss of volume and efficiency.

Finished in Du Pont Leather, the Echophone Portable is in keeping with the finest living room appointments, yet it has ample strength for severe vacation service. Available with "3" tube receiving unit of exceptional power. Range of 1,800 to 2,000 miles. Simple to operate—only two dials to tune.

Jefferson Transformers

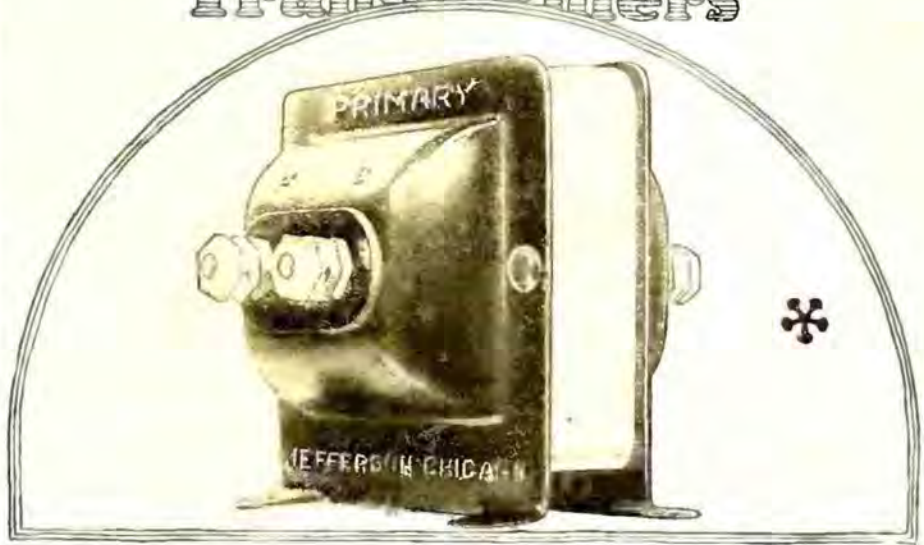

-the choice of experts

THE fact that Jefferson Transformers are preferred for experimental work by many radio experts and authorities is a clear indication of Jefferson supremacy.

Proper amplification—perfect reproduction—clear, undistorted reception; that's the why and wherefore! To radio authorities the country over Jefferson means the utmost in transformer performance.

Jefferson Transformers are the result of twenty years experience in the manufacture of transformers. To maintain a uniform quality every Jefferson Transformer is subjected to a series of exacting electrical and mechanical tests which must be successfully passed before leaving our hands.

Jefferson Transformers meet matched construction specifications.

Jefferson Electric Mfg. Co.
501 S. Green St. - Chicago

Manufacturers of



Jump Spark—Make and Break Coils
Auto Transformers
Toy Transformers

Sign Lighting Transformers
Radio Transformers
Testing Instruments
Bell Ringing Transformers

Automobile Ignition Coils
Oil Burner Ignition Coils
Furnace and Oil Burner Transformers



BUILD AN ALL WAVE RECEIVER

Listen to KDKA on 64 Meters



INTERCHANGEABLE COILS

Each kit contains three matched low loss interchangeable coils; complete diagram and wiring instructions for building five tube tuned Radio frequency set. Interchangeable coils are mounted in Bakelite bases designed for use in standard tube sockets. Kit No. 1—40 to 180 meters, \$7.00; Kit No. 2—100 to 300 meters, \$8.00; Kit No. 3—224 to 555 meters, \$9.00.

THE WASHBURN BURNER CORP.

Kokomo Indiana



We Equip You

To be a Federal Radio Dealer and guarantee your success under the "Gould Plan" which allows you to return merchandise which you are unable to sell. We sell wholesale to dealers only. Write for our price list and FREE Instructions "HOW TO SELL RADIO."

FEDERAL RADIO CO.

115 East 13th St., Kansas City, Mo.

* Tested and Approved by RADIO AGE *

A Laboratory Product



CRESCENT LAVITE RESISTANCES

for Distortionless Amplification

12,000, 48,000, 50,000, 100,000 Ohms. List \$1.50 each. Special Sizes to Order \$2.50 each.

Dealers write for discounts. When Better Resistances are made they will be Crescents.

Crescent Radio Supply Co., 5 Liberty St., Jamaica, N. Y.

HUDSON-ROSS

Largest exclusive Radio Jobbers in middle West.

Write for discounts.

123 W. Madison St. Chicago

High Powered Broadcasters Satisfactory

WASHINGTON.—There are today thirty stations broadcasting with power in excess of 500 watts, and complaints filed with the Department of Commerce are very few. On the whole, the increased power seems satisfactory and probably before the Summer is over more higher-powered stations will be operating.

When the question of increased broadcasting power was raised during the national radio conference, some of the smaller station owners and many fans expressed the fear that hundreds of stations would be blanketed or that receivers would only be able to pick up the high-powered stations. This has not proven to be the case. On the contrary, broadcasting seems to have improved, in that more distant stations are available to listeners, some even tune sharper than before the increase in power; interference from static has been decreased, fading is less pronounced, and daylight reception is better. Even the fans situated near the higher-powered stations have not complained, nor have the regular A and B stations objected.

An examination of the list of thirteen stations using over 1000 watts, which is the ordinary limit set for Class B stations, shows that four are using 2000 watts, and nine, 1500 watts. Most of the fans know the calls of those stations by heart, which indicates that they come in well almost anywhere in the country on good receiving sets. The four 2KW stations are: WEAf, American Tel. & Tel. Co., New York; WLW, Crosley, Harrison, Ohio; KGO, General Electric Co., Oakland, Calif.; and KF1, Earle C. Anthony, Los Angeles, Calif. Those using 1500 Watts, or 1½ KWS are: KYW, Chicago; WBZ, Springfield; KFKN, Hastings; WGY, Schenectady; WTAM, Cleveland; WOC, Davenport; WCCO, Anoko, Minn.; WCBd, Zion; and KOA, Denver.

They are all pretty well distributed. They are owned by private organizations except that three are General Electric Co., stations, and three are owned by the Westinghouse Electric Manufacturing Co. The Bell System operates one, the others being owned by radio manufacturers, and other organizations. It does not seem to indicate a radio monopoly. The Radio Corporation is not represented directly, although two large electric manufacturing companies control six stations together. There is, of course, another high-power station, but it operates under a rather unique license: it is the broadcasting development station KDKA at Pittsburgh. This station, owned by the Westinghouse Co., is licensed to use varying power up to 10KW but ordinarily it is understood to operate with about 5KW, except when conducting special tests, usually when other stations are silent. It is never complained of.

None of these stations is really a super-power station, which was decried as impractical and undesirable when mentioned at the last radio conference. Before many months, however, it is expected that the Radio Corporation will open a very high powered station somewhere outside New York for national broadcasting. Originally it was intended that it was to be a 50KW station, but the Department has never officially stated this power would be authorized.

Balloon Tires for Your Radio

(Continued from page 58)

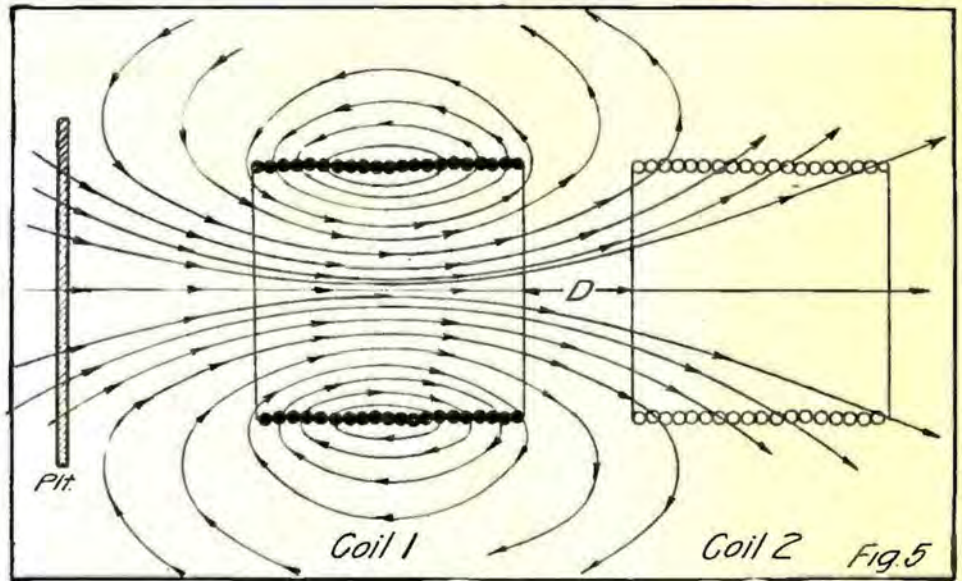

them. It is responsive only to currents which are electrically connected to the windings through the binding posts.

Interstage Feed-back

IN ANY radio frequency or reflex circuit using inductances and transformers of the conventional type, there is always some exchange of energy between the various radio stages, due to magnetic coupling, and if this magnetic coupling is tight enough, we will produce audio frequency oscillations and counter oscillations which will interfere with reception. Feed-back through the grid to plate capacity may be easily suppressed by neutralizing condensers, reversed feed-back or other devices, but it is not such an easy matter to dispose of magnetic coupling.

Even with the elaborate precautions taken in the neutrodyne circuits, magnetic coupling between stages is not altogether avoided by placing the transformers at critical angles or by neutralizing the grids. The trouble will always exist to some extent as long as there is an external field, and further, the coils used in such circuits are always free to pick up disturbances, no matter how they may be arranged. Up to the present time all effort has been put toward suppressing excessive regeneration after it was finally

started, but with the circloid the trouble is eliminated by coils which do not permit of inductive disturbances in the first place.

Fig. 2 is a diagrammatic circuit of a radio frequency set where (P1) and (S1) are the primary and secondary of the tuning unit (RFT-1), and (P2) and (S2) are the primary and secondary coils of the first radio frequency transformer (RFT-2). The third stage equipment does not concern us at present. When the set is in operation, the first R. F. tube (T1) delivers its output to the transformer primary (P2), and by induction, energizes the secondary (S2) which is connected to the second radio frequency tube (T2).

A powerful magnetic field is built up around the transformer (T2) by the plate current, and if close enough to the tuner unit (RFT-1), the stray field (FB) indicated by the dotted lines, will cause magnetic coupling between the tuner and transformer. In other words, the coils (P2-S2) act on the tuning coil just like the tickler coil of the regenerative circuit, and may either cause excessive regeneration and howling in the first tube (T1) or cause counter impulses which will act against the incoming signals and weaken them. If the inten-

(Continued on page 63)

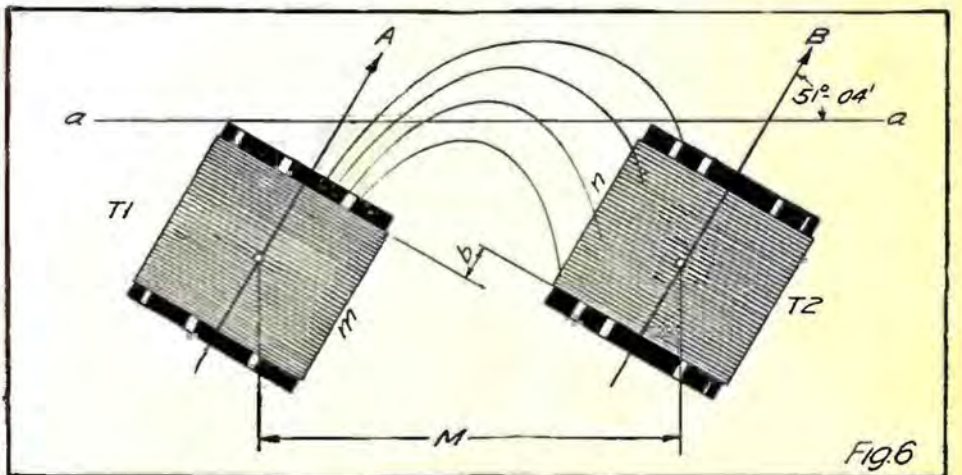

Standard Radio Receivers

(Continued from page 46)



Craftsmanship Big Feature of the Grebe

A RECEIVER that combines mechanical efficiency with beautiful craftsmanship of design has been achieved by the A. H. Grebe Company, Richmond Hill, N. Y., makers of the Grebe Synchronphase Radio Receiver.

This set is distinctive for its appearance, the tuning dials being built horizontally into the set instead of vertically, as is the custom with most radio manufacturers.

Several experts have found that sharper and more comfortable tuning is possible with controls of this type, and accordingly the Grebe Company incorporated the idea when they designed their famous "Synchronphase" several years ago.

The Grebe Synchronphase is a receiver

of the tuned radio frequency type, containing five tubes. Greater sensitivity has been attained through two stages of balanced tuned radio frequency—the result of years of research. Extreme selectivity is achieved by the use of the popular binocular coils, which have come into favor with hosts of set builders lately.

The settings for various broadcast stations are equally spaced over the dials, being accomplished by straight-line-frequency condensers. The three dial readings are identical for a given station.

The Synchronphase is made in two types, MU-1, for storage battery operation, and MU-2, for dry cell operation. The price is \$155.



Only One Tuning Control with the Thermiodyne

THE Thermiodyne 6-tube Tuned Radio Frequency Receiver has as its predominating feature one tuning control for all six tubes.

The Thermiodyne was one of the first commercial receivers to adopt this form of tuning design, and it has gained followers among many fans.

Furthermore, this single control is so logged in the factory that stations and wavelengths are marked on the tuning dial, thus making it possible to receive stations immediately without any tiresome "fishing."

No outdoor antenna is necessary with

this receiver. Neither is a directional loop needed.

The Thermiodyne company also claims that its receiver does not squeal, cannot radiate and cannot distort.

The circuit consists of three stages of thermionic frequency, detector and two stages of audio frequency. Distance and volume are very satisfactory on the loud speaker.

The single tuning control in the center of the panel consists of 180 degrees.

The Thermiodyne sells for \$140 and is manufactured by the Thermiodyne Corporation of New York City.

Which will survive—the five or the six-tube set? Roscoe Bundy Gives Some Real Reasons For His Decision—in July Radio Age —Out June 15

Biggest dollar's worth in RADIO



Compiled by HARRY F. DART, E.E. Formerly with the Western Electric Co., and U. S. Army Instructor of Radio Technically edited by F. H. DOANE 514 PAGES—ONLY \$1

ONE of the most complete books of its kind ever published. Written, compiled and edited by practical radio experts of national reputation. Packed with concise, sound information useful to every radio fan—from beginner to veteran hard-boiled owl. Contents—

Electrical terms and circuits, antennas, batteries, generators and motors, electron (vacuum) tubes, most receiving hook-ups, radio and audio frequency amplification, broadcast and commercial transmitters and receivers, wave meters, super-regeneration, codes, license rules. Many other features.

Just mail the coupon printed below with a dollar bill and your name and address, and we will send you this 514-page I. C. S. Radio Handbook or any of the other I. C. S. Handbooks that you want by return mail. Money back if not satisfied.

International Correspondence Schools
Box 8782-D, Scranton, Penna.

I enclose \$_____ for which send me, post-paid, the Handbooks marked X, at \$1 each. It is understood that if I am not entirely satisfied I may return them within five days and you will refund my money.

RADIO HANDBOOK, \$1

<input type="checkbox"/> Automobile Handbook	\$1
<input type="checkbox"/> Electrical Handbook	\$1
<input type="checkbox"/> Chemistry Handbook	\$1
<input type="checkbox"/> Pharmacy Handbook	\$1
<input type="checkbox"/> Traffic Handbook	\$1
<input type="checkbox"/> Building Trades Handbook	\$1
<input type="checkbox"/> Machine Shop Handbook	\$1
<input type="checkbox"/> Salesman's Handbook	\$1
<input type="checkbox"/> Advertising Handbook	\$1
<input type="checkbox"/> Bookkeeper's Handbook	\$1
<input type="checkbox"/> Civil Engineer's Handbook	\$1
<input type="checkbox"/> Steam Engineer's Handbook	\$1

Name: _____

Address: _____

Summer Profits

The Wood's Laboratory Type Re-Juv-A-Tube opens a new field for live dealers. Be the exclusive "Tube Reactivating Center" in your community. Brings back paralyzed or run down tubes to full life in five (5) minutes. Write for literature and proposition.

TAY SALES CO. ✻
6 No. Franklin St., Chicago

Fall Radio Conference Seems Probable

Secretary Hoover will probably call another national radio conference this fall, in continuation of his policy to hold conferences annually. The definite plans and date are as yet undecided, but it is believed that invitations will go out calling the sessions in Washington in November, certainly before Congress reassembles.

Results secured at the three past conferences have been so valuable to the Secretary of Commerce that he is disposed to refer all questions involving the different elements of the radio industry and art to a representative assembly of all interests from the manufacturing and commercial concerns to the amateurs and listeners.

Paris Conference on September First

The International Telegraph Convention scheduled for Paris in May has been definitely postponed until September 1, according to advices reaching Washington. As it is believed this parley will require at least a month's time, following which delegates will have to return to their own countries to report and for further instructions, the International Radio Conference here will probably not be called until after the first of the year. It is probable that the date will be approximately in March or April, 1926.

It is understood that the Government of the United States will be represented at the telegraph conference by officials of the State, War, Navy and Commerce Departments.

Trials and Triumphs of the Announcers

(Continued from page 27)

The telephone rings and the following question comes from one of our listeners: 'Do I have to listen to that novice all evening?' A very provoking question to ask an announcer on such an occasion. He was then asked if he knew who he was listening to and after replying in the negative, he was very politely told that if his set was not working properly or that if he didn't appreciate the music, he was in no way obligated to keep on listening the rest of the evening. This, apparently, answered his first question satisfactorily, and was an answer which fortunately savored very little of the thoughts that were running through the announcer's brain.

The Fickle Public

A LACK of appreciation for the success of artists or for the repertoire used by them sometimes results in requests which provoke a smile from the person to whom they are addressed. When presenting a program at KDKA recently, Mrs. Christine Miller Clemson who before her marriage was one of the country's contraltos and a concert singer with an enviable record, was requested to sing the jazz number 'Red Hot Mama.'

"Perhaps one of the most common requests received is that requesting an artist to sing a particular number. In spite of the fact that there are thousands of songs, a good many listeners cannot quite understand why the singer does not have the particular number they request. Song pluggers are requested to sing 'Arias' and grand opera stars are requested to sing jazz numbers by the well-meaning audience. It also happens quite often that in spite of the fact that we receive hundreds of requests for numbers during a particular evening, some well meaning individual is at a loss to know why his or her particular request was not granted.

"Oftentimes a party will call and ask the following question or a similar one: 'I have a five-tube neutrodyne set and cannot hear anything. Will you please tell me what is the matter with my set?' The opinion seems to be quite prevalent among a good many listeners that the wavelength determines the distance which a station can be heard, and usually the belief prevails that the distance a station can be heard varies directly with its wavelength. This opinion is the cause of some very humorous questions being asked.

"Among the innumerable questions are such questions as these: What time is it? Where is station WXY located? What is the name of the waltz the band played last Saturday night? What is the wavelength of station WXY? How far are you broadcasting tonight? Who is going to give your program on the 2nd of next month?"

"And so the announcer soon finds himself converted into an information bureau from which the dissemination of news adds a very colorful diversion to his vocation."

Model L-2 Ultradyne



The All Year Round Super-Heterodyne

This new model super-heterodyne receiver is the last word in radio sets, and may be had completely assembled and wired for only \$121.90.

Accessories

Atlas Loud Speaker, 2 45-volt Eveready B batteries,
8 Radiotrons, tested and matched 90 A. H. Mogul A battery, in
Nazeley Portenna Loop. mahogany case.

These accessories list at \$83.50. If ordered with the Ultradyne, the price will be only \$53.50.

New Freshman Masterpiece Kit.

Contains all necessary parts to build the famous Freshman "Masterpiece" 5-tube tuned radio frequency receiver. The kit sells for only \$39.50. A solid walnut cabinet may be had for \$7.00.

See Our Ad in Last Month's
Radio Age For Bargains in Kits

Erla Superflex—Factory Sealed Kits.

1-tube kit.....	\$19.50	4-tube kit.....	44.50
2-tube kit.....	29.50	5-tube kit.....	49.50
3-tube kit.....	39.50	5-tube kit, for loop aerial use..	49.50

We Will Wire Any Kit For \$5 Per Tube Size

OSTERMEIER RADIO & ELECTRIC COMPANY
1720 So. Douglas Ave., Springfield, Illinois

Order Now For Quick Deliveries

RADIO AGE SUBSCRIPTION BLANK

Radio Age, Inc.,
500 North Dearborn Street,
Chicago

\$2.50 A YEAR

Gentlemen: Please enter my subscription for RADIO AGE, the Magazine of the Hour, for one year, beginning with your next issue, for which I enclose \$2.50.

Name _____

Street Address _____

City _____

State _____

Send cash, money order or draft.

The Binocular Coil

(Continued from page 60)

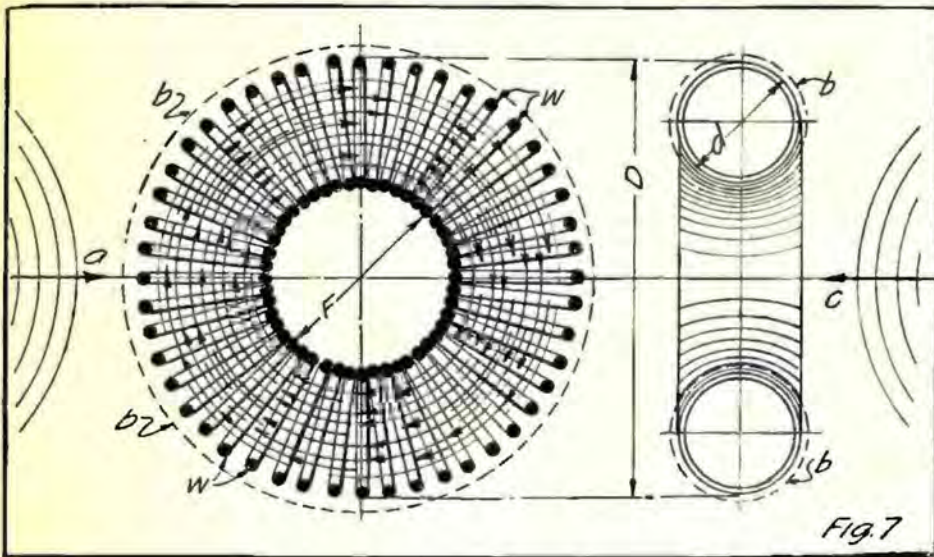

Fig. 7

sity of the stray feed-back (FB) could be controlled, it might be even desirable, but as it cannot be controlled, it means trouble. The closer the two coils and the more nearly that they are in line, the greater will be the feed-back.

This figure will explain why many radio frequency sets will produce aerial radiations and annoy the neighbors although a radio frequency set is said to be proof against this trouble. With the stray feed-back (FB), we have a truly regenerative circuit in the first stage which is just as capable of "tweet-tweet-tweeting" in a nearby receiver as the most violent of single tube ultra-audions. This condition at once eliminates every advantage of an R. F. circuit.

One of the greatest advances in the

suppression of self-oscillation was made by Prof. Hazeltine in the development of the Neurodyne circuit. He not only

overcame the grid-plate capacity feed-back by means of the opposing neutralizing condensers, but he also devised a fairly effective method of reducing the magnetic inter-linkage between the radio frequency transformers which helped a whole lot in the advancement of the radio frequency amplifier. However, he still used the conventional solenoid

type open coil with strongly marked poles, and therefore did not entirely eliminate magnetic feed-back. By placing his transformer coils at definite angles, he reduced the linkage, but of course there was always some stray field

(Continued on page 65)

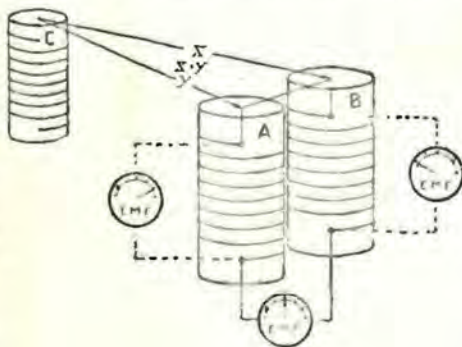

Fig. 9

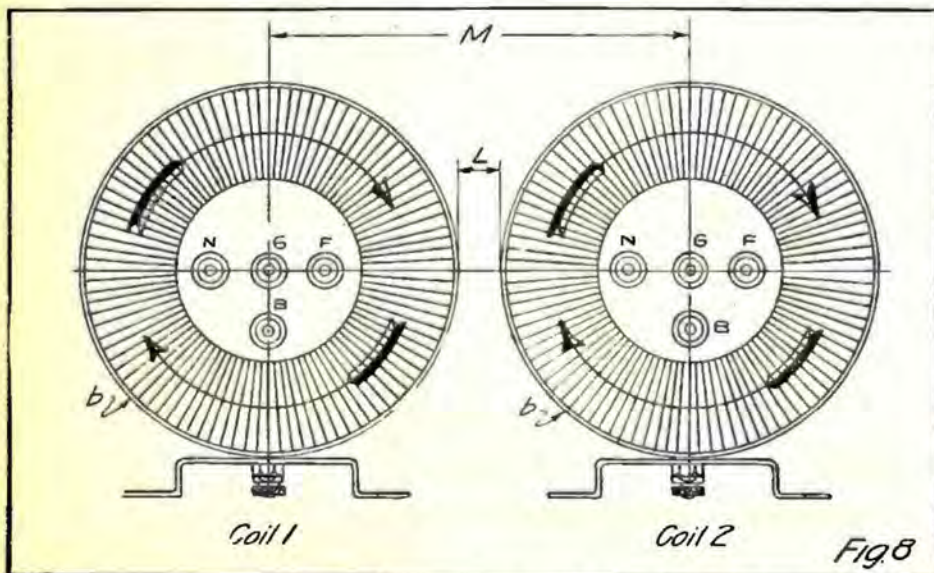

Fig. 8

DUPLEX MATCHED CONDENSERS

Afford Uniform Dial Settings



And Simplify Logging

Know the satisfaction and ease of tuning that come when all dials read alike. Use **DUPLEX Matched Condensers**—the supreme achievement in condenser building. Condensers are the "heart" of any set and matched condensers are absolutely necessary if your set is to be free from "heart" trouble. **DUPLEX Matched Condensers** are made in strict accordance with Bureau of Standards specifications for lowest losses and best electrical characteristics. They are tested, matched, packed and sealed in the laboratory, to remain unopened until used. **DUPLEX Matched Condensers** are used in the famous Thermodyne. Matching is essential. Folder explaining how and why matched condensers are essential sent on request. **DUPLX CONDENSER & RADIO CORP.** 42 Flatbush Ave. E., Bklyn, N. Y.



ANTENELLA

No Aerial or Antenna Needed

The Complete Efficient and Economical Aerial



Why pay \$10 **Only \$1.25**

or more to have an aerial spoil the appearance of your home? Antenella eliminates all unsightly wiring, lightning arresters, etc., and precludes the possibility of dangerous grounding on a power line. It also stops "canary bird" re-radiation from nearby oscillating sets interfering.

ANTENELLA

is not only a real distance getter, but also overcomes troublesome static.

At your Dealer, otherwise send purchase price and you will be supplied postpaid.



Chas. Freshman Co. Inc.
Radio Receivers and Parts
FRESHMAN BUILDING
240-245 WEST 40TH ST - NEW YORK, N.Y.

Corrected List of Broadcasting Stations

KDKA	Westinghouse Electric & Mfg. Co.	East Pittsburgh, Pa.	309	KFUL	Thomas Goggan & Bros. Music Co.	Calveston, Tex.	288
KDLR	Radio Electric Co.	Davis Lake, N. D.	231	KFUM	W. D. Corley	Colorado Springs, Colo.	242
KDPM	Westinghouse Electric & Mfg. Co.	Cleveland, Ohio	270	KFUO	Concordia Seminary	St. Louis, Mo.	534
KDYL	Westinghouse Hotel	Lake City, Ark.	270	KFUP	First Simmons General Hospital	Denver, Colo.	234
KDZB	Francis E. Suter	Hakensack, Calif.	240	KFUQ	John Brunton and Sons Co.	San Francisco, Calif.	234
KDZD	Electric Supply Co.	Wenatchee, Wash.	360	KFUR	H. W. Peery and C. Redfield	Ogden, Utah	224
KFAD	McArthur Bros. Mercantile Co.	Phoenix, Ariz.	273	KFUS	Louis L. Sherman	Oakland, Calif.	233
KFAE	State College of Washington	Pullman, Wash.	348	KFUT	University of Utah	Salt Lake City, Utah	271
KFAF	Western Radio Corporation	Denver, Colo.	278	KFUU	Colburn Radio Labs	San Leandro, Calif.	231
KFAJ	University of Colorado	Boulder, Colo.	360	KFUZ	Irvine M. Bouchard	Butte, Mont.	254
KFAN	University of Idaho	Moscow, Ida.	230	KFV	Y. M. C. A.	Virginia, Minn.	244
KFAU	Boise High School	Boise, Idaho	271	KFV2	Beasner's Music Co.	Camden, Arkansas	248
KFAW	The Radio Dan (W. B. Ashford)	Santa Ana, Calif.	350	KFV3	McWhinnie Electric Co.	San Pedro, Calif.	202
KFC	F. A. Suttrey & Co.	Havre, Mont.	360	KFV4	Film Corporation of America	St. Louis, Mo.	245
KFCB	W. K. Azbill	San Diego, Calif.	278	KFV5	Clarence B. Juncau	Hollywood, Calif.	208
KFCBE	Horn & Wilson's "Radioland"	San Luis Obispo, Calif.	218	KFV6	First M. E. Church	Independence, Kansas	236
KFCBG	First Presbyterian Church	Tacoma, Wash.	250	KFV7	Whan Radio Shop (Herbert Whan)	Manhattan, Kansas	218
KFCBK	Kimball-Upton Co.	Sacramento, Calif.	283	KFV8	Headquarters Troop, 56th Cavalry	Houston, Texas	248
KFCBL	Loese Bros.	Everett, Wash.	224	KFV9	Browning Bros. Co.	Ogden, Utah	214
KFCBU	The Cathedral	Laramie, Wyo.	283	KFW	Warner Bros.	Hollywood, Calif.	252
KFCBR	Nielson Radio Supply Co.	Phoenix, Ariz.	238	KFW2	L. E. Wall and C. S. Myers	Upland, Calif.	211
KFCFC	First Congregational Church	Helena, Mont.	248	KFW3	Arkansas Light & Power Co.	Arkadelphia, Arkansas	266
KFCFF	Frank A. Moore	Walla Walla, Wash.	256	KFW4	St. Louis Truth Center	St. Louis, Mo.	214
KFCFL	Leslie E. Rice	Los Angeles, Cal.	236	KGB	Tacoma Daily Ledger	Tacoma, Wash.	252
KFCZ	Omaha Central High School	Omaha, Nebr.	258	KGO	General Electric Co.	Oakland, Calif.	361
KFDD	St. Michaels Cathedral	Boise, Idaho	252	KGU	Marion A. Mulrony	Honolulu, Hawaii	360
KFDDH	University of Arizona	Tucson, Ariz.	368	KGW	Portland Morning Oregonian	Portland, Oreg.	491
KFDJ	Oregon Agricultural College	Corvallis, Oreg.	254	KGY	St. Martins College (Rev. Sebastian Ruth)	Lacy, Wash.	253
KFDM	Magnolia Petroleum Co.	Beaumont, Tex.	315	KHJ	Times-Mirror Co.	Los Angeles, Calif.	405
KFDX	First Baptist Church	Shreveport, La.	360	KHQ	W. C. Wessner	Seattle, Wash.	273
KFDY	South Dakota State College	Brookings, S. Dak.	360	KJQ	C. O. Gould	Stockton, Calif.	273
KFDZ	Harry O. Iverson	Minneapolis, Minn.	231	KJR	Northwest Radio Service Co.	Seattle, Wash.	384
KFE	Meier & Frank Co.	Portland, Oreg.	248	KJS	Bible Institute of Los Angeles, Inc.	Los Angeles, Calif.	293
KFEK	Augsburg Seminary	Minneapolis, Minn.	261	KLS	Warner Brothers Radio Supplies Co.	Oakland, Calif.	242
KFEL	Winner Radio Corp.	Denver, Colo.	254	KLX	Tribuna Publishing Co.	Oakland, Calif.	508
KFEQ	J. L. Scroggin	Oak, Nebr.	268	KLZ	Reynolds Radio Co.	Denver, Colo.	283
KFER	Auto Electric Service Co.	Fort Dodge, Iowa	231	KMJ	San Joaquin Light & Power Corp.	Fresno, Calif.	243
KFEY	Bunker Hill & Sullivan Mining and Concentrating Co.	Kellogg, Idaho	233	KMY	Love Electric Co.	Tacoma, Wash.	250
KFF	First Baptist Church	Moberly, Mo.	266	KNX	Los Angeles Evening Express	Los Angeles, Calif.	331
KFFB	Newspaper Journal (Jim Kirk)	Sparks, Nev.	226	KOA	General Electric Co.	Denver, Colo.	328
KFFV	Oracland College	Lamoni, Iowa	280	KOB	New Mexico College of Agriculture & Mechanic Arts State College, N. Mex.	College, N. Mex.	343
KFFY	Pineas & Murphy Music House	Alexandria, La.	275	KOP	Detroit Police Department	Detroit, Mich.	286
KFCB	Hoidbreder Radio Supply Co.	Utica, Neb.	224	KPO	Hale Bros.	San Francisco, Calif.	428
KFCG	Louisiana State University	Baton Rouge, La.	254	KPPC	Passena Presbyterian Church	Passena, Calif.	229
KFCD	Chickasha Radio & Electric Co.	Chickasha, Okla.	248	KPPD	Douglas-Hill Electric Co.	Pittsburgh, Pa.	270
KFCF	Leland Stanford University	Stanford University, Calif.	273	KQW	Charles D. Herrold	San Jose, Calif.	226
KFCQ	Crary Hardware Co.	Yakima, Wash.	226	KRY	Y. C. Battery & Electric Co.	Berkeley, Calif.	275
KFCR	First Presbyterian Church	Oranke, Tex.	250	KSAC	Kansas State Agricultural College	Manhattan, Kans.	241
KFHA	Western State College of Colorado	Guanion, Colo.	252	KSD	Post Dispatch (Pulitzer Pub. Co.)	St. Louis, Mo.	545
KFHH	Ambross A. McCue	Neah Bay, Wash.	261	KSL	Radio Service Corp. of Utah	Salt Lake City, Utah	299
KFHL	Fallon & Co.	Santa Barbara, Calif.	360	KTHS	New Arlington Hotel Co.	Hot Springs, Ark.	375
KFHL	Penn College	Oskaloosa, Iowa	240	KTW	First Presbyterian Church	Seattle, Wash.	455
KFI	E. C. Anthony, Inc.	Los Angeles, Calif.	468	KUO	Examiner Printing Co.	San Francisco, Calif.	246
KFIF	Benson Polytechnic Institute	Portland, Oreg.	248	KUOM	State University of Montana	Missoula, Montana	244
KFIO	North Central High School	Spokane, Wash.	252	KUW	Portable Wireless Telephone Co.	Stockton, Calif.	248
KFIP	First Methodist Church	Yukon, Wash.	42	KYO	Electric Shop	Honolulu, Hawaii	270
KFIU	Alaska Electric Light & Power Co.	Yukon, Alaska	226	KYW	Westinghouse Electric & Mfg. Co.	Chicago, Ill.	325
KFIZ	Reorganized Church of Jesus Christ of Latter Day Saints	Independence, Mo.	240	KZM	Preston D. Allen	Oakland, Calif.	242
KFIZ	Daily Commonwealth and Oscar A. Huelsman	Fond du Lac, Wis.	273	WAAB	Veddemar Jensen	New Orleans, La.	263
KFJB	Marshall Electrical Co.	Marshalltown, Iowa	248	WAAC	Tulane University	New Orleans, La.	275
KFJF	National Radio Manufacturing Co.	Oklahoma City, Okla.	252	WAAD	Ohio Mechanics Institute	Cincinnati, Ohio	248
KFJI	Liberty Theatre (E. E. Marsh)	Astoria, Oreg.	252	WAAP	Chicago Daily Drivers Journal	Chicago, Ill.	266
KFJL	Hardace Manufacturing Co.	Ottumwa, Iowa	42	WAAP	J. R. Nelson Co.	Newark, N. J.	283
KFJM	University of North Dakota	Grand Forks, N. D.	280	WAB	Omaha Grain Exchange	Omaha, Nebr.	285
KFJR	Lahley Dixon & Son	Stevensville, Mont. (near)	258	WABA	Lake Forest University	Lake Forest, Ill.	275
KFJX	Iowa State Teacher's College	Cedar Falls, Iowa	280	WABB	Harrisburg Sporting Goods Co.	Harrisburg, Pa.	266
KFJY	Tuwall Radio Co.	Fort Dodge, Iowa	246	WABI	Beaor Railway & Electric Co.	Bangor, Me.	280
KFJZ	Texas National Guard, One hundred and twelfth Cavalry	Fort Worth, Texas	254	WABL	Connecticut Agricultural College	Borrr, Conn.	283
KFJZ	W. E. Branch	Fort Worth, Texas	254	WABN	F. A. Doherty Automotive and Radio Equipment Co.	Saginaw, Mich.	254
KFKA	Colorado State Teachers College	Greeley, Colo.	273	WABO	Ott Radio, Inc.	LaCrosse, Wis.	244
KFKB	Brinkley-Jones Hospital Association	Millford, Kans.	286	WABO	Lake Avenue Baptist Church	Rochester, N. Y.	263
KFKC	Conway Radio Laboratories (Ben H. Woodruff)	Conway, Ark.	250	WABO	Haverford College Radio Club	Haverford, Pa.	281
KFKD	The University of Kansas	Lawrence, Kans.	286	WABR	State High School, N. W. B. Foley	Toldeo, Ohio	230
KFKX	Westinghouse Electric & Manufacturing Co.	Hastings, Nebr.	288	WABU	Victor Talking Machine Co.	Camden, N. J.	224
KFLB	Sinal Electric Manufacturing Co.	Menominee, Mich.	248	WABW	College of Wooster	Wooster, Ohio	234
KFLD	Paul E. Greenlaw	Franklinton, La.	234	WABX	Henry B. Joy	Mt. Clemens, Mich.	270
KFLP	Everett M. Foster	Cedar Rapids, Ia.	256	WABY	John Masteldi, Jr.	Philadelphia, Pa.	242
KFLR	University of New Mexico	Albuquerque, New Mexico	254	WABZ	Coliseum Place Baptist Church	New Orleans, La.	253
KFLU	Rio Grande Radio Supply House	San Benito, Texas	236	WADC	Allen T. Simmons (Allen Theatre)	Akron, Ohio	268
KFLV	Rev. A. T. Frykman	Rockford, Ill.	229	WADF	Albert B. Parlet Co.	Port Huron, Mich.	233
KFLX	George Roy Clough	Galveston, Tex.	240	WAG	A. H. Grebe Co.	Richmond Hill, N. Y.	315
KFLZ	Atlantic Automobile Co.	Atlanta, Ga.	273	WAMD	Hubbard and Co.	Minneapolis, Minn.	244
KFMB	Christian Churches	Little Rock, Ark.	254	WBAA	Purdue University	W. Lafayette, Ind.	283
KFMQ	University of Arkansas	Fayetteville, Ark.	299	WBAC	Clemson Agric. College	Clemson College, S. C.	331
KFMR	Morningside College	Sioux City, Iowa	261	WBAH	The Dayton Co.	Minneapolis, Minn.	417
KFMT	Dr. George W. Young	Minneapolis, Minn.	231	WBAK	Pennsylvania State Police	Harrisburg, Pa.	275
KFMW	M. O. Sateran	Houghton, Mich.	266	WBAN	Wireless Phone Corp.	Peteron, N. J.	244
KFMX	Carleton College	Northfield, Minn.	336	WBAP	James Millikan University	Decatur, Ill.	360
KFNF	Henry Field Seed Co.	Shenandoah, Iowa	266	WBAP	Wortham-Carter Publishing Co. (Star Telegram)	Fort Worth, Tex.	476
KFNG	Wagoner Radio Shop	Coldwater, Miss.	254	WBAY	Erce & Hopkins Co.	Columbus, Ohio	274
KFNJ	Central Mo. State Teachers College	Warrensburg, Mo.	234	WBAX	John H. Steinger, Jr.	Wilkes-Barre, Pa.	254
KFNL	Radio Broadcast Ass'n.	Paso Robles, Calif.	240	WBAY	Western Electric Co.	New York, N.Y.	492
KFNV	L. A. Drake Battery and Radio Supply Shop	Santa Rosa, Calif.	234	WBBG	Irving Vermilya	Matapoisett, Mass.	248
KFNY	Montana Phonograph Co.	Helena, Mont.	261	WBBH	J. Irving Bell	Port Huron, Mich.	246
KFOA	Rhodes Department Store	Seattle, Wash.	384	WBBL	Grace Covenant Presbyterian Church	Richmond, Va.	253
KFOC	First Christian Church	Whittier, Calif.	236	WBBS	H. Leslie Atlas	Chicago, Ill.	226
KFOJ	Moberly High School Radio Club	Moberly, Missouri	246	WBBS	Blake A. B.	Wilmington, N. C.	275
KFOL	Leslie M. Schaffner	Marango, Iowa	234	WBBS	Petoseky High School	Petoseky, Mich.	246
KFON	Echelon Radio Shop	Long Beach, Calif.	234	WBBS	People Pulpit Ass'n.	Rosville, N. Y.	273
KFOO	Latter Day Saints University	Salt Lake City, Utah	261	WBBS	First Baptist Church	New Orleans, La.	252
KFOP	Robber Elec. Co.	Marshallfield, Oreg.	240	WBBS	Jenks Motor Sales Co.	Monmouth, Ill.	224
KFOR	David City Tire & Electric Co.	David City, Nebraska	226	WBBS	Johnstown Radio Co.	Johnstown, Pa.	245
KFOT	College Hill Radio Club	Wichita, Kansas	231	WBBS	Ruffner Junior High School	Norfolk, Va.	222
KFOX	Board of Education, Technical High School	Omaha, Nebraska	248	WBBS	Washington Light Infantry Co. "B" 118th Inf.	Charleston, S. C.	268
KFOY	Bacon Radio Service	St. Paul, Minn.	226	WBBS	Noble B. Watson	Indianapolis, Ind.	227
KFCG	Garretton and Dennis	Los Angeles, Calif.	238	WBBS	Foster & McDoland	Chicago, Ill.	266
KFCFL	C. C. Baxter	Dublin, Texas	242	WBBS	Baxter Laundry Co.	Grand Rapids, Mich.	258
KFPM	The New Furniture Co.	Greenville, Texas	242	WBBS	Bias Electrical School	Takoma Park Md.	222
KFPR	Los Angeles Co. Forestry Dept.	Los Angeles, Calif.	231	WBBS	Jones Elec. & Radio Mfg. Co.	Baltimore, Md.	254
KFFT	Cope & Johnson	Salt Lake City, Utah	268	WBBS	A. H. Grebe & Co., Inc.	Richmond Hill, N. Y.	286
KFPV	Heintz & Kohlmoos, Inc.	San Francisco, Calif.	236	WBBS	Pennsylvania State Police	Butler, Pa.	236
KFPW	St. Johns M. E. Church	Cartersville, Mo.	268	WBBS	Baltimore Radio Exchange	Wilkes-Barre, Pa.	231
KFPX	First Presbyterian Church	Pine Bluff, Ark.	242	WBBS	D. W. May, Inc.	Newark, N. J.	252
KFQA	Simons Investment Co.	Spokane, Wash.	283	WBBS	Southern Radio Corp.	Charlotte, N. C.	275
KFQB	The Principles	St. Louis, Mo.	264	WBBS	Washington E. & M. Co.	Springfield, Mass.	280
KFOR	The Sunlight Publishing Co.	Fort Worth, Tex.	221	WBBS	St. Lawrence University	Canton, N. Y.	280
KFOC	Kidd Brothers Radio Shop	Taft, Calif.	258	WBBS	Kaufmann & Baer Co. and The Pittsburgh Pres.	Pittsburgh, Pa.	461
KFOG	Southern Calif. Radio Ass'n	Los Angeles, Calif.	226	WBBS	Clyde R. Randall	New Orleans, La.	262
KFOH	Radio Service Co.	Burlingame, Calif.	231	WBBS	Entekin Electric Co.	Columbus, Ohio	286
KFOI	Texas Highway Bulletin	Austin, Tex.	228	WBBS	Nebraska Wesleyan University	University Place, Nebr.	283
KFOR	G. S. Carson, Jr.	Iowa City, Ia.	284	WBBS	St. Olaf College	Northfield, Minn.	336
KFOR	Walter LaFayette Ellis	Oklahoma City, Okla.	226	WBBS	Sanders & Sisyan Co.	Baltimore, Md.	275
KFOR	First National Guard	Denonon, Texas	252	WBBS	Chaparrack & Potomac Telephone Co.	Washington, D. C.	280
KFOU	W. Riker	Holy City, Calif.	253	WBBS	Omaha Radio Electric Co.	San Antonio, Tex.	263
KFOV	C. F. Kaierim	North Bend, Wash.	248	WBBS	W. H. Dunwoody Industrial Institute	Minneapolis, Minn.	280
KFOY	Farmers State Bank	Belden, Neb.	273	WBBS	State College of Mines	Rapid City, S. Dak.	240
KFOZ	Taft Radio Co.	Hollywood, Calif.	240	WBBS	Durham & Co.	Philadelphia, Pa.	278
KFR	City of Paris Dry Goods Co.	San Francisco, Calif.	268	WBBS	University of Vermont	Burlington, Vt.	250
KFRM	James F. Boland	Fort Sill, Okla.	263	WBBS	Carthage College	Carthage, Ill.	246
KFRN	M. Laurence Short	Hanford, Calif.	224	WBBS	Charles W. Hasbachm	Allentown, Pa.	280
KFRU	United Radio Co.	Bristow, Okla.	384	WBBS	William C. Volz	Ann Arbor, Mich.	280
KFRW	Ethical Churches of Olympia	Olympia, Wash.	220	WBBS	Wilbur C. Volz	Zion, Ill.	344
KFRX	J. Gordon Klemzard	Pullman, Wash.	217	WBBS	Ubat Radio Co.	New Orleans, La.	263
KFRZ	The Electric Shop	Hartington, Neb.	222	WBBS	Paul J. Miller	Pittsburgh, Pa.	236
KFSG	Angelus Temple	Los Angeles, Calif.	272	WBBS	Howard S. Williams (Portable)	Pascagoula, Miss.	268
KFSY	The Van Blaricon Co.	Helena, Mont.	261	WBBS	University of Miss.	Oxford, Miss.	242
KFUJ	Hopper Plumbing and Heating Co.	Breckenridge, Minn.	242	WBBS	Nicoll, Duncan & Rush	Bemis, Tennessee	240

Developments Toward Non-Oscillating Circuits

(Continued from page 63)

which could not be conquered, and he depended upon his neutralizing scheme to stop such oscillations as might be started magnetically. In short, all attempts up to a very recent date have been toward suppressing oscillations after they had started rather than prevent their formation.

Magnetic Fields

A MAGNETIC field is set up around any conductor that carries an electric current, and conversely, an electric current is set up in the conductor when it is "cut" at right angles by a moving magnetic field. This is illustrated by Fig. 3 where (T1) is an air core solenoid coil with an electric current passing through the turns of wire wound on the tube. Magnetic lines of force or the "field" (b) are established by the current for a considerable distance around the coil, and any conductor within the area embraced by the curved lines will be magnetically affected. When carrying high frequency radio currents, the effects of the field may be sometimes detected for several feet from the coil, particularly in the direction of the axis (d). At each end are the magnetic poles marked (N) and (S), which with direct current are the "north" and "south" poles.

Now let us say that the source of current is disconnected from the coil, and that some type of current indicator such as a voltmeter is connected across the ends of the coil as at (V) in dotted lines. If a magnetic field or radio wave-front (a) now advances and cuts through the coil along the axis in the direction of (a), a current will be "induced" in the coil, and the current indicator (V) will be deflected as long as the magnetic field moves in respect to the wire. If (a) is a rapidly oscillating radio wave-front, then oscillating currents will be induced in the coil continuously as long as the field continues.

Now let us consider the second coil (T2) in Fig. 4 which has been set up at right angles to the first coil (C1), and in line with the magnetic flux (d). As the field (d) now acts along the wires instead of at right angles to them, practically no current will be induced in the wire of (T2). Similarly a radio wave-front (C) will induce no current as long as it travels exactly in line with the conductors. In practice, however, there will be a little induced current for the reason that the flux travels in curved lines instead of along a straight line, and for the reason that the turns of wire are curved helices and not straight. In other words, the magnetic flux cannot ever be exactly parallel to the wire, and there will always be some component that will travel at an angle to the wire.

Fig. 5 shows the actual conditions very clearly when two coils are placed end to end or axially in line, so that the magnetic flux from coil (1) cuts through the length of coil (2). The black dots on Coil (1) indicate current carry supply wires, while the open circles on Coil (2) are wires carrying induced currents. An arrangement of this sort is absolutely impracticable in a radio set, for the flux may travel as far as two or three feet from Coil (1) and induce currents or cause regeneration in the circuit of Coil (2). It is also bad practice to place a metal plate in this

field as shown at the left by "Plt." The magnetic flux will induce eddy currents in the plate and cause other trouble.

Placing the coils at right angles is of great assistance, but does not entirely prevent back-coupling in strong fields. Besides the magnetic coupling there will also be electro-static coupling due to the condenser effect between the coils, if they are very close together. With (D) equal to as much as 12 inches, there will be a very perceptible coupling.

Standard radio frequency practice with solenoid type transformers is shown by Fig. 6, this arrangement being originally devised by Prof. Hazeltine for use in the Neutrodyne circuit. The transformers are mounted at an angle of 51°-04', and are spaced apart by the center to center distance (M) until the adjacent faces (M) and (n) of the two coils are separated by the distance (b). The latter spacing prevents electrostatic coupling between the two coils for the coils no longer face each other. The angle chosen is such that the stray magnetic flux induces as little current as possible, the curvature of the lines of force being nearly parallel to the turns of wire under these conditions. However, there will always be some coupling as indicated by the curved flux lines. It can't be avoided as long as there is an external field.

The Circloid Field

AT LAST we are at the point where we can appreciate the advantages of the circloid transformer coil, the coil without an external field. A pair of sectional views of this coil are shown in Fig. 7 which will explain the path of the flux and the low leakage coefficient and also its indifference to stray fields from other coils or from random aerial action. In effect, this is simply an ordinary solenoid bent around a circle having a diameter (F), the coil diameter being (d) and the external diameter (D). Each round, black dot represents a wire in section as at (W). The wires, of course, are spaced farther apart on the outer circumference than around (D) so that the inner circle appears almost like a solid black line.

Inside the coil will be seen the arrows indicating the path of the magnetic flux which in all cases faithfully follows the outline of the wire strands. The flux of one wire tends to start out tangentially to the circle along a straight line, but is pulled back into place by the influence of the next turn so that the main portion of the flux is within the conductor area. There is no end and hence no definite polarity is indicated at any point that would induce external leakage.

Now let the arrow (a) at the left of the figure represent a stray field or the wave-front from a local broadcasting station travelling toward the coil. As such a wave embraces the entire coil, it will induce no current for the turns in the upper half run in the opposite direction to those in the lower half, and therefore all induced charges oppose each other so that no current can flow. In other words, we will suffer no interference from the coil considered as an aerial. Taking the right hand view, we see that the advancing wave-front (C) moving at

(Turn to page 67)

OLD MAN STATIC "KILLED" AT LAST

Statichoke Has Startled the Radio World—Insures Clear, Long Distance, Summer Reception.

The long promised invention which insures clear, long distance, "summer radio" without the agony of static, has just been announced. Radio experts and fans who have tested this new imported invention pronounce it marvelous. Awarded Certificate of Merit by Radio News of Canada.

In addition to reducing static to a minimum, the Statichoke increases the volume as well as clarity of distant reception, sharpens the selectivity of tuning in, eliminates that harshness of the tubes so noticeable on local loud speaker reception and acts as a safety lightning arrester.

The Statichoke somewhat resembles a small transformer, and by a system of coils it allows only the correct current value to enter the set, choking out other high current variation from the aerial, which is passed off through a secondary ground connection.

So confident are the American distributors that Statichoke will give you clear long distance summer reception that they have set aside 25,000 units for initial distribution direct to the radio fans at a special price of only \$2.50 each.

If interested write today to Radio Dept., Imperial Laboratories, 9575 Coca Cola Bldg., Kansas City, Mo., and the Statichoke will be sent you by insured mail. Write today as this is a special offer and may not appear again.

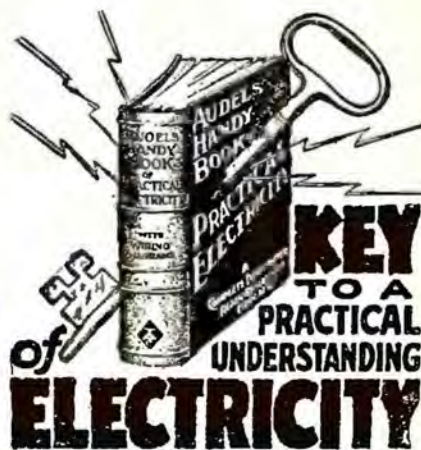

Audel's Handy Book of Electricity, Price \$4.
A quick simplified ready reference, giving complete instruction and inside information. Handy to use. Easy to understand. For Engineers, Professional Electricians, Students and all interested in Electricity. A reliable authority and a handy helper for every electrical worker.

INFORMATION

The 1040 pages and 2600 diagrams give accurate, up-to-date and complete information on—Rules and Laws, RADIO, Storage Batteries, WIRING DIAGRAMS, Power and House Wiring, Automatic Phones, Auto Ignition, Motor Troubles, ARMATURE WINDING, Cable Splicing, Elevators and Cranes, Sign Flashers, Transformers, Practical Management, Modern Applications—READY REFERENCE on every electrical subject. Pocket Size, handsomely bound in flexible Red LEATHER. Easy Terms. Shipped for Free Examination. No obligation to buy unless satisfied.

FREE EXAMINATION COUPON The Audel Co., 65 W. 23 St., New York
Please send me Audel's Handy Book of Practical Electricity for free examination. If satisfactory, I will send you \$1 in 7 days, then \$1 monthly until \$4 is paid.

Name
Address
Occupation
Employed by 6T302

WCBJ	J. C. Matus	Jennings, Louisiana	244	WHBO	Y. M. C. A., Summer Street	Pawtucket, Rhode Island	231
WCBM	Northern Radio Mfg. Co.	Houlton, Mo.	280	WHBP	Johnston Automobile Co.	Johantown, Pennsylvania	256
WCBN	Charles Swartz	Baltimore, Md.	229	WHBR	St. John's M. E. Church South	Memphis, Tenn.	233
WCBP	James E. Boland	Ft. Ben., Harrison, Ind.	256	WHBS	Scientific Electric Mfg. Co., 3604 Vine St.	Cincinnati, Ohio	216
WCBR	First Baptist Church	Nashville, Tenn.	236	WHBT	Edward Wm. Locke	Mechanicsville, Ohio	208
WCBT	C. H. Meester	Providence, R. I.	249	WHBU	Thomas W. Tizard, Jr.	Downers Grove, Ill.	206
WCBU	Clark University, Collegiate Dept.	Worcester, Mass.	238	WHBV	B. L. Bing's Sons	Anderson, Ind.	218
WCBX	Arnold Wireless Supply Co.	Arnold, Pa.	254	WHBW	Fred Ray's Radio Shop	Columbus, Ga.	244
WCBZ	Radio Shop of Newark (Herman Lubinick)	Newark, N. J.	233	WHBX	D. R. Kienale	Philadelphia, Pa.	215
WCCO	The Forks Electrical Shop	Buck Hill Falls, Pa.	248	WHBY	J. W. Bowser	Pittsburgn, Pa.	213
WCE	Neutrowound Radio Mfg. Co.	Chicago Heights, Ill.	278	WHCC	St. Norbert's College	West De Pore, Wis.	250
WCK	Washington Radio Mfg. Co.	Chicago, Ill.	278	WHCF	Hickson Electric Co., Inc.	Rockester, Fla.	222
WCK	Charles E. Erbelein, Villa Olivia	Two Cities, Minn.	416	WHCK	Radiovox Company	Cleveland, Ohio	213
WCK	Stir-Baer-Fuller D. O. Co.	near Elgin, Ill.	217	WHCN	George Schubert	New York, N. Y.	360
WCK	Free Press	St. Louis, Mo.	275	WHCO	Bankers' Life Co.	Dea Moines, Ia.	526
WDAE	Tampa Daily Times	Detroit, Mich.	516	WIAD	Howard R. Miller	Philadelphia, Pa.	254
WDAF	Kansas City Star	Tampa, Fla.	365	WIAK	Journal-Stockman Co.	Omaha, Nebr.	273
WDAH	J. Laurence Martin	Kansas City, Mo.	365	WIAQ	Chronicle Publishing Co.	Marion, Ind.	226
WDAI	Trinity Methodist Church (South)	Amarillo, Tex.	263	WIAS	Home Electric Co.	Burlington, Iowa	283
WDAJ	Lit Brothers	El Paso, Tex.	268	WIBA	The Capital Times Studio	Madison, Wis.	236
WDBA	Radio Equipment Corp.	Philadelphia, Pa.	384	WIBC	L. M. Tate Post. No. 39, Veterans of Foreign Wars	St. Petersburg, Florida	222
WDBB	Fred Ray	Columbus, Ga.	236	WIBD	N-L Radio Service	Joliet, Illinois	200
WDBC	A. H. Waite & Co., Inc.	Taunton, Mass.	229	WIBE	Martinsburg Radio Broadcasting Co.	Martinsburg, W. Va.	210
WDBD	Kirk Johnson & Co.	Lancaster, Pa.	258	WIBF	S. P. Miller Dance Activities	Wheatland, Wis.	231
WDBE	Herman Edwin Buras	Martinsburg, W. Va.	268	WIBG	St. Paul's Protestant Episcopal Church	Elkins Park, Pa.	222
WDBF	Gilham-Schoen Elec. Co.	Atlantic, Ga.	278	WIBO	Nelson Brothers	Chicago, Ill.	226
WDBH	Robert G. Phillips	Youngstown, Ohio	315	WIL	Continental Electric Supply Co.	Washington, D. C.	360
WDBI	C. T. Scherer Co.	Worcester, Mass.	288	WIP	Gimbel Bros.	Philadelphia, Pa.	509
WDBJ	Richardson Wayland Electric Corp.	Roanoke, Va.	278	WIAB	American Electric Co.	Lincoln, Nebr.	229
WDBK	M. E. Broz	Cleveland, Ohio	277	WIAD	Jackson Radio Engineering Laboratories	Lincoln, Texas	352
WDBL	Wisc. Dept. of Markets	Stevens Point, Wis.	278	WIAG	Non-folk Daily News	Norfolk, Nebr.	283
WDBN	Electric Light & Power Co.	Banner, Me.	252	WIAM	Clifford L. White	Greentown, Iowa	254
WDBO	Rollins College Inc.	Winter Park, Fla.	240	WIAP	D. M. Perham	Cedar Rapids, Iowa	268
WDBP	Superior State Normal School	Superior, Wis.	261	WIAR	The Outlet Co. (J. Samuels & Bro.)	Providence, R. I.	306
WDBQ	Morton Radio Supply Co.	Salem, N. J.	234	WIAS	Pittsburgh Radio Supply House	Pittsburgh, Pa.	286
WDBR	Tremont Temple Baptist Church	Boston, Mass.	256	WIAT	Chicago Radio Laboratory	Chicago, Ill.	268
WDBS	S. M. K. Radio Corp.	Dayton, Ohio	283	WIAC	Hummer Furniture Co.	LaSalle, Ill.	234
WDBT	Taylor Book Store	Hattiesburg, Miss.	236	WIAD	Asland Broadcasting Committee	Ashland, Wis.	283
WDBU	The Strand Theatre	Fort Payne, Ind.	258	WIJE	Denison University	Graniteville, Ohio	303
WDBV	The Radio Den	Columbia, Tenn.	268	WIJD	Supreme Lodge, Loyal Order of Moose	Mooseheart, Ill.	303
WDBW	Otto Baur	New York, N. Y.	233	WIJY	Radio Corp. of Am.	New York, N. Y.	455
WDBX	North Shore Congregational Church	Chicago, Ill.	258	WIJZ	Radio Corp. of Am.	New York, N. Y.	455
WDBY	Boy Scouts, City Hall	Kingstown, N. Y.	233	WKAA	H. F. Paar	Cedar Rapids, Iowa	278
WDBZ	Church of the Covenant	Washington, D. C.	234	WKAB	Chas. Looff (Crescent Park)	East Providence, R. I.	240
WDOD	Chattanooga Radio Co., Inc.	Chattanooga, Tenn.	256	WKAC	Dutes W. Flint	Cranston, R. I.	334
WDOW	Dutox Wilcox Flint, Inc.	Cranston, R. I.	441	WKAD	Radio Corp. of Porto Rico	San Juan, P. R.	240
WDWF	J. L. Hubb	Lincoln, Ill.	278	WKAE	Michigan Agricultural College	East Lansing, Mich.	288
WEAA	F. D. Fallala	Flint, Mich.	250	WKAF	Laocnia Radio Club	Laocnia, N. H.	254
WEAB	American Telephone & Telegraph Co.	New York, N. Y.	485	WKBE	K. & B. Electric Co.	Webster, Massachusetts	231
WEAC	Wichita Board of Trade	Wichita, Kans.	280	WKBF	Dutox Wilcox Flint	Cranston, Rhode Island	286
WEAD	Cornell University	Ithaca, N. Y.	286	WKY	Wky Radio shop	Oklahoma City, Okla.	273
WEAE	University of South Dakota	Vermillion, S. Dak.	283	WLAA	Cutting & Washington Radio Corp.	Minneapolis, Minn.	417
WEAF	Borough of North Plainfield (W. Citson Buttfeld)	North Plainfield, N. J.	286	WLAL	First Christian Church	Tulsa, Okla.	250
WEAG	Shepard Co.	Providence, R. I.	273	WLAP	Wm. V. Jordan	Louisville, Ky.	288
WEAH	Ohio State University	Columbus, Ohio	283	WLAR	Yacht Club	Hannover, Mich.	283
WEAI	Radio Radio Co.	Mobile, Ala.	263	WLAX	Putnam Electric Co.	Greencastle, Ind.	231
WEAJ	Goodyear Tire and Rubber Co.	Cleveland, Ohio	389	WLBY	University of Minnesota	Minneapolis, Minn.	278
WEAK	Davidson Bros. Co.	Sioux City, Iowa	275	WLB	Wisconsin State Dept. of Markets	Stevenspoint, Wis.	278
WEAL	Iris Theatre (Will Horowitz, Jr.)	Houston, Texas	270	WLS	Sears Roebuck & Co.	Chicago, Ill.	344
WEAM	Benwood Co.	St. Louis, Mo.	273	WLW	Crosley Mfg. Co.	Cincinnati, Ohio	422
WEAN	Electric Shop	Highland Park, N. J.	233	WLX	J. Edw. Page (Olive B. Meredith)	Capeziovia, N. Y.	261
WEAO	Walter Cecil Bridges	Superior, Wis.	242	WLAF	Round Hills Radio Corp.	Dartmouth, Mass.	360
WEAP	Electrical Equipment and Service Co.	Anderson, Ind.	246	WLAW	Norton Laboratories	Lockport, N. Y.	273
WEAQ	Rich W. Walker	Cambridge, Ohio	248	WLBN	Trenton Hardware Co.	Trenton, N. J.	256
WEAR	Edegar's Hotel, Chicago Evening Post Station	Chicago, Ill.	370	WLBP	First Baptist Church	Columbus, Ohio	286
WEAS	Third Avenue Railway Co.	New York, N. Y.	273	WLBR	Chicago Daily News	Chicago, Ill.	447
WEAT	Radio Corporation of America	Portable	226	WLBS	Alabama Polytechnic Institute	Auburn, Ala.	250
WEAU	E. B. Pedicord	New Orleans, La.	280	WLBT	Kingshighway Presbyterian Church	St. Louis, Mo.	280
WEAV	The Dayton Coop. Industrial High School	Dayton, Ohio	270	WLBU	Mercer University	Macon, Ga.	261
WEAW	Beloit College	Beloit, Wis.	283	WLBY	Tranon Ball Room	Chicago, Ill.	250
WEAX	Hobart Radio Co.	Rosindale, Mass.	226	WLCA	Commercial Appeal	Miami Beach, Fla.	384
WEAY	The Edison Electric Illuminating Co.	Boston, Mass.	475	WLCC	Hotel Alapia (Geleley Square Hotel Co.)	Memphis, Tenn.	501
WEAZ	All-American Radio Corporation	Barric Barric, Mich.	285	WLCD	Ainsworth-Cates Radio Co.	New York City	523
WEBA	St. Louis University	Chicago, Illinois	266	WLCE	Douledad-Hill Elec. Co.	Cincinnati, O.	301
WEBC	Dallas News & Dallas Journal	St. Louis, Mo.	280	WLCH	The Sheppard Stores	Washington, D. C.	260
WEBD	Times Publishing Co.	Dallas, Tex.	472	WLCK	University of Oklahoma	Boston, Mass.	250
WEBE	University of Nebraska, Department of Electrical Engineering, Lincoln	St. Cloud, Minn.	273	WLCL	Omaha Central High School	Norman, Okla.	258
WEBF	Eureka College	Eureka, Ill.	240	WLDM	Wittenberg College	Omaha, Nebr.	255
WEBG	First Baptist Church	Knoxville, Tenn.	250	WLDR	First Christian Church	Springfield, Ohio	271
WEBH	Gethsemane Baptist Church	Philadelphia, Pa.	234	WLDS	Lennie Brothers Co. (Frederick Lennie)	Butler, Mo.	230
WEBI	John D. Balle	Scranton, Pa.	226	WLDT	Dakota Radio Apparatus Co.	Philadelphia, Pa.	254
WEBJ	The Wm. F. Cable Co.	Altoona, Pa.	261	WLDU	Dept. of Plant and Structures	Yankton, S. Dak.	244
WEBK	Concourse Radio Corporation	New York, N. Y.	273	WLDV	Pace Organ Co.	New York, N. Y.	526
WEBL	St. John's University	Collegeville, Minn.	236	WLDE	Midland College	Lima, Ohio	280
WEBM	Wynne Radio Co.	Raleigh, N. C.	255	WLDF	Tyler Commercial College	Fremont, Nebr.	280
WEBN	Fifth Inf. Md. Nat' Guard, 5th Rec. Armory	Baltimore, Md.	452	WLDG	Apollo Theater (Belvidere Amusement Co.)	Tyler, Texas	363
WEBO	Gloucester Co., Civic League	Pitman, N. J.	331	WLDA	Southern Equipment Co.	Belvidere, Ill.	274
WEBP	Signal Officer	Cincinnati, Ohio	209	WLDB	Yanich Conservatory of Music (James D. Vaurhal)	San Antonio, Texas	392
WEBQ	Knox College	Ft. Ben Harrison, Ind.	258	WLDC	Lyondon Mfg. Co.	Lawrenceburg, Tenn.	280
WEBR	Strawbridge and Clothier	Chesburg, Ill.	254	WLDD	Lyndon Mfg. Co.	Mishawaka, Ind.	369
WEBS	Francis K. Bridgman	Philadelphia, Pa.	394	WLDE	Lansdown, Henry P.	Kenosha, Wis.	225
WEBT	C. Pearson Ward	Chicago, Ill.	217	WLDF	Boyd M. Hamp	Wilmingtom, Del.	360
WEBU	Earl William Lewis	Springfield, Mo.	252	WLDF	Pennsylvania National Guard, 2d Battalion, 112th Infantry	Erie, Pa.	242
WEBV	Lancaster Electric Supply & Construction Co.	Moberly, Mo.	233	WLDF	Woodmen of the World	Omaha, Nebraska	526
WEBW	Young Hotel	Lancaster, Pa.	248	WLDF	Franklyn J. Wolf	Trenton, N. J.	240
WEBY	South Beach Tribune	Shreveport, La.	252	WLDF	Palmer School of Chiropractic	Davenport, Iowa	484
WEBC	Itta H. Carnan, 217 Bedell St.	South Bend, Ind.	244	WLDF	Hotel Jameson, Inc.	Jamestown, N. Y.	275
WEBD	First Baptist Church	Fresport, N. Y.	242	WLDF	James K. O'Des	Pateron, New Jersey	275
WEBE	Fink Furniture Co.	Memphis, Tenn.	266	WLDF	Iowa State College	Ames, Ia.	207
WEBF	Brietenbach's Radio Shop	Evansville, Ind.	217	WLDF	John Wamamaker	Philadelphia, Pa.	509
WEBG	Fall River Herald Pub. Co.	Thrifton, Va.	226	WLDF	L. Bamberger and Co.	Newark, N. J.	405
WEBH	Frank S. Merarce	(Portable)	209	WLDF	Peoples Pulpit Assn	Batavia, Ill.	275
WEBI	Lawrence Campbell	Scranton, Pa.	240	WLDF	State Marketing Bureau	Jefferson City, Mo.	440
WEBJ	Theodore N. Spagy	Johnstown, Pa.	248	WLDF	Ohio Battery Company	New Orleans, La.	270
WEBK	Hub Radio Shop	Ironton, I.	234	WLDF	Pennsylvania State College	State College, Pa.	283
WEBL	Dr. Ross Artan	LaSalle, Ill.	263	WLDF	Doddard Radio Co.	Greenville, Okla.	360
WEBM	Elyria Radio Asso. (Albert H. Ernst)	San Juan, P. R.	275	WLDF	Doolittle Radio Corp.	New Haven, Conn.	283
WEBN	Stout Institute	Elyria, Ohio	227	WLDF	North Dakota Agricultural College	Agricultural College, N. D.	283
WEBO	Marshfield Broadcaster Assn.	Menominee, Wis.	224	WLDF	Superior Radio & Telephone Equipment Co.	Columbus, Ohio	286
WEBP	Gimbel Brothers	Marshfield, Wis.	229	WLDF	John R. Koch (Dr.)	Charleston, W. Va.	273
WEBQ	Furnon University	New York, N. Y.	315	WLDF	The Municipality of Atlantic City	Atlantic City, N. J.	300
WEBR	Village Theatre	Greenville, S. C.	236	WLDF	Horace A. Beale, Jr.	Parkerburg, Pa.	270
WEBS	University of Maine	Spring Valley, Ill.	212	WLDF	E. B. Gibb	Amarillo, Texas	234
WEBT	Progress Sales Co.	Orono, Me.	235	WLDF	Moore Radio News Station (Edmund B. Moore)	Springfield, Vt.	273
WEBU	American R. & R. Co.	R. R. No. 2	218	WLDF	Electrical Equipment Co.	Miami, Fla.	283
WEBV	The Tribune Co.	Medford Hills, Mass.	261	WLDF	Scranton Times	Scranton, Pa.	280
WEBW	Federal T. and T. Co.	Chicago, Ill.	370	WLDF	Calvary Baptist Church	New York, N. Y.	360
WEBY	General Elec. Co.	Buffalo, N. Y.	319	WLDF	Prince-Walter Co.	Lowell, Mass.	266
WEBC	University of Wisconsin	Schenectady, N. Y.	379	WLDF	Calumet Rainbo Broadcasting Co.	Chicago, Ill.	447
WEBD	Marquette University	Madison, Wis.	535	WLDF	The Rice Institute	Houston, Tex.	257
WEBE	University of Cincinnati	Milwaukee, Wis.	280	WLDF	The Radio Club (Inc.)	Laporte, Ind.	224
WEBF	Hafer Supply Co.	Cincinnati, Ohio	283	WLDF	Economy Light Co.	Escanaba, Mich.	256
WEBG	University of Rochester (Eastman School of Music)	Joplin, Mo.	283	WLDF	Lombard College	Calburg, Ill.	244
WEBH	H. Alvin Simmons, 290 Flatbush Ave	Rochester, N. Y.	278	WLDF	Black Hawk Electrical Co.	Waterloo, Iowa	246
WEBO	Seaside House	Brooklyn, N. Y.	274	WLDF	St. Louis Radio Service Co.	St. Louis, Mo.	236
WEBP	Courier-Journal & Louisville Times	Atlantic City, N. J.	275	WLDF	Antioch College	Yellow Springs, Ohio	242
WEBQ	Wilmington Electrical Specialty Co.	Louisville, Ky.	399	WLDF	Avenue Radio Shop (Horace D. Cood)	Reading, Pa.	238
WEBR	Wesseler Polytechnic Institute	Wilmington, Del.	360	WLDF	Faxon's Garage	Clouesster City, N. J.	268
WEBS	Sweeney School Co.	Troy, N. Y.	385	WLDF	Immanuel Lutheran Church	Valparaiso, Ind.	278
WEBT	C. C. Shaffer	Kansas City, Mo.	250	WLDF	Radio Corp. of Am.	Washington, D. C.	468
WEBU	Hobel's Store	Oil City, Pa.	250	WLDF	Res. Motor Co.	Carsing, Mich.	286
WEBV	Rev. E. P. Crahan	Stevens Point, Wis.	245	WLDF	Washington Radio Hospital Fund.	Washington, D. C.	260
WEBY	Chas. W. Howard	Canton, Ohio	245	WLDF	Doron Bros.	Hamilton, Ohio	360
WGBJ	Beardsley Specialty Company	Bellefontaine, Ohio	222	WLDF	Union College	Schenectady, N. Y.	270
WGBK	John S. Skane	Rock Island, Illinois	222	WLDF	University of Illinois	Urbana, Ill.	273
WGBL	Culver Military Academy	Harrisburg, Pa.	331	WLDF	Police and Fire Signal Department	Dallas, Tex.	261
WGBM	Chemical Electric Co.	Culver, Ind.	222	WLDF	Tarrytown Radio Res. Lab.	Tarrytown, N. Y.	275
WGBN	Lauer Auto Co.	Chester, Mich.	234	WLDF	Southeast Missouri State Teachers College	Cape Girardeau, Mo.	273
WGBP	Franklin St. Carriage, Inc.	Ft. Wayne, Ind.	234	WLDF	Central State College	Clemson College, S. C.	336
WGBQ	James H. Slusser	Ellsworth, Maine	220	WLDF	J. A. Foster Co.	Providence, R. I.	321
WGBR	C. L. Carroll, Portable Station	Lokansport, Ind.	231	WLDF	Loren Vanderheek Davis	St. Petersburg, Fla.	264
WGBS	First Ave. Methodist Church	Chicago, Ill.	233	WLDF	United States Playing Cards Co.	Cincinnati, Ohio	325
WGBT		St. Petersburg, Florida	258	WLDF	Grove City College	Crova City, Pa.	258

The Latest in Binocular Coils

(Continued from page 65)

right angles to the plane of the coil cannot generate a current, as opposing currents will be generated on the near and far sides of the conductors. No matter in which direction a stray field may strike the coil, it is wholly unable to induce a troublesome current.

In Fig. 8 are shown two of the coils mounted side by side with the center-to-center distance (M). By experiment it has been shown that the faces of the coil can be spaced so that (L) is from $\frac{1}{4}$ " to $\frac{1}{2}$ " without trouble from feed-back.

Here (b) represents the extreme of field as before, and the heavy arrows show the course of the magnetic flux. In the center is the disc which supports the coil and the connection posts, and at the bottom is the floor bracket used for base mounting. This bracket can also be used for mounting the coil on the back of a variable condenser, when such construction is desired. The connections are plainly marked and the transformer can be hooked up in any circuit just as with any other air core transformer for straight R. F. amplification, reflexing or as a tuning coil. A .00035 condenser is recommended for the broadcasting range of wavelengths.

The Binocular Coil

By P. D. Lowell, Research Engineer, A. H. Grebe & Co.

IN DESIGNING and constructing a radio frequency amplifier having a plurality of tuned stages, it is extremely important that all electro-magnetic induction between the coils of the tuned stages shall be eliminated; otherwise a feeding back of energy will occur, thereby causing violent oscillations in the whole amplifier circuit. These oscillations are of course very objectionable and an amplifier is entirely useless in this condition.

It has been customary heretofore, in order to reduce the magnetic induction between stages, to mount the inductance coils in such a position that their axes are at a 90° angle with respect to one another. This method is fairly satisfactory, provided that they are really positioned at exactly the 90° angle. It is very clear, however, that this would be a difficult practice to follow, inasmuch as the slightest variation from the 90° angle will cause instability in the operation of the receiving apparatus.

The same line of reasoning holds true for any method where the faces of the coils must be at a certain angle with respect to one another in order that electromagnetic induction shall be reduced.

Our laboratory has produced a new form of inductance unit which is composed of two solenoidal coils mounted closely together with their axes parallel and with the two windings connected in such a manner that their electromagnetic fields are opposing each other.

This means that as soon as one coil of the unit starts to radiate a magnetic field, the other coil of the unit at the same time radiates a magnetic field of equal intensity but of opposite direction, and the two fields immediately counter-balance each other and the resulting field becomes zero.

The great advantages in the use of such inductance units in the tuned stages of an amplifier are very apparent. The units may be mounted at quite a variety of positions with respect to one another and their positioning does not need to be as accurate as with the usual form of inductance coils.

In a receiver comprising a number of tuned stages, maximum overall selectivity is obtained only when the energy from the aerial must pass through each tuned stage before reaching the detector. Quite frequently it is found that a receiving set which is amply selective for moderately distant stations, sets up no tuning barrier for powerful nearby stations. The fault usually lies in the cylindrical coils which, because of their external field, pick up the interfering signal directly in the detector and intermediate stages. The filtering effect of the tuned stages is thus greatly reduced and the undesirable station allowed to come through.

This phenomenon is entirely eliminated when binocular coils are used, because the inherent selectivity of each tuned stage is maintained even when the set is operated close to a powerful broadcasting station.

The following is an explanation of the schematic diagram, Fig. 9.

"A" and "B" are two similar coils connected in series or parallel in such a manner that their electromagnetic field are opposing each other.

When a source of electromagnetic field is radiated from an exterior source such as coil "C," we can assume that E. M. F. of X + 2 units value is induced in coil "A" and an E. M. F. of -2 units is induced in coil "B". Therefore "A" and "B" being connected in the proper manner, the X + 2 units and the -2 units will counter-balance one another and the resulting E. M. F. across the terminals of the whole inductance will be zero.

The DAVEN RESISTANCE COUPLED AMPLIFIER KIT

Those who build their own can easily achieve perfect reproduction. There's nothing to equal Resistance Coupling. The DAVEN AMPLIFIER KIT

comes with full instructions for assembly. Easy to build—efficient in operation. (Without sockets and condensers.)

Supplied in either 3 or 4 stages. Sold Everywhere.

Ask your dealer for the "RESISTOR MANUAL." It's full of information on Resistance Coupling. Price 25c. Postpaid 35c.

DAVEN RADIO CORP. "Resistor Specialists" Newark, New Jersey



The Famous Truly Portable TELMACO P-1 Receiver

Four Tubes Do the Work of Seven

The peer of portables in size, weight, ease of tuning, selectivity, distance, volume, workmanship and price. Aerial, loud speaker and batteries self contained. Complete with tubes and batteries. \$125.00 \$143.50. Receiver only

P-1 Kit Saves You Money!

Our offer of the Telmaco P-1 Receiver in kit form best met with enthusiastic reception. This contains all parts, as built by us, including case, drilled and engraved panel, and illustrated instructions. \$80.00 Complete kit. Ask your dealer or write us. Descriptive folder free.

Radio Division:

Telephone Maintenance Co. 20 So. Wells St. Dept. C Chicago, Ill.



Quality Radio Exclusively Established 1918

FLINT A. F. TRANSFORMERS

For Guaranteed Results. * \$3.50 For This Transformer Will Assure Positive Performance For All Hookups.

If your dealer cannot supply, order direct.

FLINT RADIO CO. 1874 Wilsor Ave., Chicago, Ill.



The Radio Age Annual for 1924!

ONLY A FEW LEFT AT 50c EACH

If you have not bought your copy of the famous RADIO AGE ANNUAL for 1924, you may get one at a special price of 50 cents by filling in the coupon below and sending it with stamps, money order or draft, at once. The supply is nearly exhausted, and no more will be printed, so ACT NOW!

1924 ANNUAL COUPON

Radio Age, Inc., 500 N. Dearborn St., Chicago, Ill.

Gentlemen: Please find enclosed 50 cents, for which you may send me a copy of the RADIO AGE ANNUAL for 1924, in accordance with your special price offer for April.

Name.....
 Address.....
 City..... State.....

R-25

HUDSON-ROSS

Wholesale radio only. One of the first and still in the lead. Write for discounts.

123 W. Madison St. Chicago

WSAN Allentown Call Publishing Co.	Allentown, Pa.	229	WTAQ S. H. Van Gordon & Son	Osséo, Wis.	220
WSAP Seventh Day Adventist Church	New York, N. Y.	263	WTAR Reliance Electric Co.	Norfolk, Va.	280
WSAR Doughty & Welch Electrical Co.	Fall River, Mass.	254	WTAS Charles E. Erbstein	Elgin, Ill.	303
WSTA Camp Mariefeld	Chesham, N. H.	229	WTAT Edison Electric Illuminating Co.	(portable) Boston, Mass.	244
WSAY C. W. Vick Radio Construction Co.	Houston, Tex.	360	WTAU Ruegg Battery & Electric Co.	Tecumseh, Nebr.	242
WSAZ Irving Austin (Port Chester Chamber of Commerce)	Port Chester, N. Y.	233	WTAW Agricultural & Mechanical College of Texas	College Station, Tex.	280
WSB Chas. Electric Shop	Pomeroy, Ohio	258	WTAX Williams Hardware Co.	Streator, Ill.	231
WSBK Atlanta Journal	Atlanta, Ga.	428	WTAY Oak Leaves Broadcastng Station	Oak Park, Ill.	283
WSK World's Star Knitting Co.	Bay City, Mich.	261	WTB Thomas J. McGuire	Lambertville, N. J.	283
WSL J. and M. Elec. Co.	Bay City, Mich.	261	WTC First Senior High School	Flint, Mich.	218
WSMB Saenger Amusement Co. and Maison Blanche Co.	New Orleans, La.	319	WTHS Kansas State Agricultural College	Manhattan, Kans.	273
WSMH Shattuck Music House	Owosso, Mich.	240	WTIC Travelers Insurance Co.	Hartford, Conn.	323
WSOE School of Engineers	Milwaukee, Wis.	246	WTX H. G. Saal Co.	Chicago, Ill.	268
WSRF Hardem Sales and Service	Broadlands, Ill.	233	WWAD Wright & Wright (Inc.)	Philadelphia, Pa.	360
WSUI State University of Iowa	Iowa City, Iowa	498	WWAE The Alamo Ball Room	Joliet, Ill.	242
WTAB Fall River Daily Herald Publishing Co.	Fall River, Mass.	248	WWI Ford Motor Co.	Dearborn, Mich.	273
WTAC Penn Traffic Co.	Johnstown, Pa.	242	WWJ Detroit News (Evening News Assn.)	Detroit, Mich.	352
WTAF Louis J. Gallo	New Orleans, La.	242	WWL Loyola University	New Orleans, La.	250
WTAL Toledo Radio & Electric Co.	Toledo, Ohio	252	WWO Michigan College of Mines	Houghton, Mich.	244
WTAP Cambridge Radio & Electric Co.	Cambridge, Ill.	242			

Canadian Stations

CFAC Calgary Herald	Calgary, Alberta	430	CHXC J. R. Booth	Ottawa, Ont.	435
CFCA Star Pub. & Prtg. Co.	Toronto, Ontario	400	CHYC Northern Electric Co.	Montreal, Quebec	410
CFCF Marconi Wireless Tele. Co. Canada	Montreal, Quebec	440	CJBC Jarvis Baptist Church	Toronto, Ont.	312
CFCH Abitibi Power & Paper Co.	Iroquois Falls, Ont.	400	CJCA Edmonton Journal	Edmonton, Alberta	455
CFCK Le C. Crevecoeur	Quebec, Quebec	261	CJCB London Free Press Prtg. Co.	London, Ont.	430
CFCL Radio Supply Co.	Edmonton, Alberta	410	CJCD T. Eaton Co.	Toronto, Ont.	410
CFCN W. W. Grant Radio (Ltd.)	Calgary, Alberta	440	CJCE Spratt-Shaw Radio Co.	Vancouver, B. C.	420
CFCQ Radio Specialties (Ltd.)	Vancouver, B. C.	450	CJCF The News Record	Kitchener, Ont.	295
CFCR Laurentide Air Service	Sudbury, Ont.	410	CJCI Maritime Radio Corp.	St. John, New Brunswick	400
CFCT Victoria City Temple	Victoria, B. C.	410	CJCK Radio Corp. of Calgary	Calgary, Alta.	316
CFCU The Jack Elliott Radio Limited	Hamilton, Ont.	410	CJCM J. L. Phillips	Mont Joli, Quebec	430
CFCW The Radio Shop	London, Ont.	420	CJCN Simons Agnew & Co.	Toronto, Ont.	410
CFDX Sparks Co.	Nanaimo, B. C.	430	CJCS Evening Telegram	Toronto, Ont.	430
CFEH Henry Birds & Sons	Calgary, Alta.	440	CKAC La Presse Pub. Co.	Montreal, Quebec	430
CFEL Chas. Guy Hunter	551 Adelaide St., London, Ont.	410	CKCD Vancouver Daily Province	Vancouver, B. C.	410
CFEQ The Electric Shop (Ltd.)	Saskatoon, Saskatchewan	400	CKCE Canadian Independ. Telephone Co.	Toronto, Ont.	450
CFER Queens University	Kingston, Ontario	450	CKCK Leader Pub. Co.	Regina, Saskatchewan	420
CFEU University of Montreal	Montreal, Quebec	400	CKCO Ottawa Radio Association	Ottawa, Ont.	440
CFEX Westminster Trust Co.	New Westminster, B. C.	440	CKCX P. Burns & Co.	Calgary, Alberta	440
CFYV Victor Westworth Odium	Vancouver, B. C.	400	CKLC Wilkinson Electric Company	Calgary, Alberta	400
CHAC Radio Engineers	Halifax, Nova Scotia	400	CJCN Wentworth Radio Supply Co.	Hamilton, Ont.	410
CHBC Albertan Publishing Co.	Calgary, Alberta	410	CNRA Canadian National Railways	Montreal, N. B.	313
CHCB Marconi Company	Toronto, Ont.	410	CNRC Canadian National Railways	Calgary, Canada	357
CHCD Canadian Wireless & Elec. Co.	Quebec, Quebec	410	CNRE Canadian National Railways	Edmonton, Alta.	455
CHCE Western Canada Radio Sup. (Ltd.)	Victoria, B. C.	400	CNRM Canadian National Railways	Montreal, P. Q.	410
CHCL Vancouver Merchants Exchange	Vancouver, B. C.	440	CNRO Canadian National Railways	Ottawa, Ont.	430
CHCM Riley & McCormack	Calgary, Alberta	415	CNRR Canadian National Railways	Regina, Sask.	312
CHCS The Hamilton Spectator	Hamilton, Ont.	420	CNRS Canadian National Railways	Saskatoon, Sask.	329
CHIC Northern Electric Co.	Toronto, Ont.	356	CNRT Canadian National Railways	Toronto, Ont.	357
CHNC Toronto Radio Research	Toronto, Ont.	350	CNRW Canadian National Railways	Winnipeg, Man.	384

Cuban Stations

PWX Cuban Telephone Co.	Havana	400	2K Alvira Diaz	Havana	200
2DW Pedro Zayas	Havana	300	2HS Julio Power	Havana	180
2AB Alberto S. de Bustamante	Havana	240	2OL Oscar Collado	Havana	290
2OK Mario Garcia Velez	Havana	360	2WW Amadeo Saenz	Havana	210
2BY Frederick W. Horton	Havana	260	5EV Leopoldo E. Figueroa	Colon	360
2CX Frederick W. Horton	Havana	320	6KW Frank H. Jones	Tuinucu	340
2EV Wentworth Elec. Co.	Havana	220	6KI Antonio T. Figueroa	Cienfuegos	275
2TW Roberto E. Ramirez	Havana	430	6CX Eduardo Terry	Cienfuegos	225
2HC Heraldo de Cuba	Havana	275	6DW Jose Ganduxa	Cienfuegos	300
2LC Luis Casas	Havana	250	6BY Valentin Ullivarri	Cienfuegos	200
2KD E. Sanchez de Fuentes	Havana	350	6AZ Alberto Revelo	Sigo. de Cuba	250
2MN Fausto Simon	Havana	270	8BY Andres Vianet	Sigo. de Cuba	225
2MG Manuel G. Salas	Havana	280	8FU Pedro C. Anduz	Sigo. de Cuba	275
2JD Raul Pares Falcon	Havana	150	8DW		

European Broadcasting Stations

2LO London	365	5NO Newcastle	400
5IT Birmingham	475	5SC Glasgow	420
5WA Cardiff	350	2BD Aberdeen	492
6BM Bournemouth	385	6SL Sheffield (relay station)	303
2ZY Manchester	375		
YN Lyons	740	8AJ Paris	1,780
FL Paris (Eiffel Tower)	2,600	ESP Paris	459

DeForest License



*** HONEYCOMB COILS**
The Universal all-wave inductance. Back and front panel mountings. Send 25c for Super Het., R. F. and Honeycomb Coil Circuits and Complete Catalog.
Chas. A. Brantson, Inc.
Dept. 13
815 Main St., Buffalo, N. Y.

5000 RADIO DEALERS
buy from
HUDSON-ROSS
123 W. Madison St. Chicago
Send for dealers discount.

Free Mailing Lists
Will help you increase sales
Send for FREE catalog giving counts and prices on thousands of classified names of your best prospective customers—National, State and Local—Individuals, Professions, Business Concerns.
99% Guaranteed 5¢ each
by refund of 5¢ each
ROSS-Gould Co. 589N 10th St. St. Louis

In the July Radio Age

Brainard Foote, Frank D. Pearne, Roscoe Bundy, H. Frank Hopkins, John B. Rathbun, and others will give you

Radio Circuit Forecasts for the Fall of 1925!

A real insight into the future of Radio—theoretical and technical!

Out June 15

RAULF RADIO CONSOLE
MFG. CO. 562 VEDDER ST.
CHICAGO. * WRITE FOR CIRCULAR

Radio Dealers HEADQUARTERS

Dealers—if you want the best products, the fastest shipments and the most liberal discounts, write on your letterhead for our catalog L1003.

WAKEM & McLAUGHLIN
225 E. ILLINOIS ST. — CHICAGO

WITH THE MANUFACTURERS



Brandes' New Adjustable Table-Talker

The new Adjustable Table-Talker recently announced by C. Brandes, Inc., makers of the Matched Tone Headsets and pioneers of the \$10 loud speaker market, is another step forward in the loud speaker development. It has always been Brandes' idea, says their sales manager, to give to the radio purchaser the "greatest buy in radio" and the new Brandes Table-Talker is today the best value on the market for the price.

It is another pioneering step in that it offers not only an adjustment feature, but a gooseneck fibre horn which gives much better reproduction than the ordinary straight neck horn.

The adjustment lever is located at the back of the base in an inconspicuous place and yet in a very convenient position. This adjustment greatly increases the volume of sound produced and sensitivity of the Table-Talker and makes tuning-in distant stations much easier. All adjustments can be made as shown above without lifting the Table-Talker from the table.

The horn over all is 18 inches high having a 10 inch bell. It is finished in a neutral shade of dark brown and has a felt padded base. It requires no extra batteries for operation and is furnished with a five foot polarity-indicating cord.

Hudson-Ross History Reads Like a Fable

How the smallness of Cinderella's slipper made her a princess was once looked upon as a mere fable. But Gloria Swanson's trim ankle lifted her out of a stove heated flat to the titled position of a marchioness.

Only three years ago Hudson-Ross was nothing more than an idea. But the idea was like Cinderella's slipper or Gloria's ankle. It was what has made this company leap into leadership almost overnight.

Modest quarters were secured in the Madison Square Building on Madison Street. The unusual service Hudson-Ross gave their dealers in handling only nationally advertised radio, increased their business until every available foot of their space in the building was taken up.

Now comes the coach and four of the Princess that called for Cinderella. Business has reached such proportions that more commodious quarters were rented at 116-118 So. Wells St., Chicago.

May 1st, of course, was the great date. From that day on Hudson-Ross occupied the finest offices of any radio house in the west.

But mere physical property is not enough to keep pace with the demands of their dealers. Service is the company's outstanding feature.

A Pencil Looks Tall Beside Amplion Dragonfly

People who room, live in kitchenette apartments, thin-walled flat buildings or other places where a "Loud" Loud speaker might invite the wrath of neighbors, must have been in mind when this Amplion "Dragonfly" was created.



Although it measures only "knee high" to the usual loud speaker (being but nine inches tall), it is in no sense a toy. Without being forced it fills a room with reception of surprising clarity and natural tone. In fact, one is inclined to disbelieve his ears on first hearing it reproduce.

The explanation of The Amplion Corporation of America, 280 Madison Ave., New York City, is that this "Dragonfly" is a replica on a reduced scale of a larger Amplion, with all its features. A rubber bushing insulates the horn from the tone conduit. Another rubber bushing insulates the tone conduit from the unit. The curve of the tone conduit provides long tone travel, with gradual amplification, in compact space.

The unit itself is the same as is supplied to set makers for built-in loud speakers. It has the Amplion "Floating Diaphragm" feature and an adjustment for "tuning" it to each set.

The Adapto Radio Cabinet

A beautiful console now on the market, encloses everything radio from sight in an uncommonly safe and accessible way. Because it accommodates practically any sized receiver with absolutely no fuss or cabinet work, through the use of special adapter frames, it is called the Adapto Radio Cabinet. This console represents a significant step forward in radio consoles. It comes in either mahogany or walnut, soft-toned wood, harmonious with the finest receiver and the most distinctive room. The radio receiver may be removed instantly without removing a single nail or screw. There is a drawer that represents the utmost in convenience—it opens easily, smoothly, and holds storage battery, battery charger, distilled water, hydrometer. A built-in switch throws the battery charger in operation instantly while in place. The horn is in built at the top. There is a small drawer for tools, a spacious shelf for B batteries. Further information about the Adapto Radio Cabinet may be had by writing L. R. Donchue Co., Perth Amboy, N. J.

The Hemco Loop Aerial

The Hemco Loop Aerial, manufactured by George Richards & Company, Inc., 557 West Monroe Street, Chicago, was designed to meet the demand for a reasonable priced and durable loop aerial that would insure efficient reception.

The manufacturers of the Hemco Loop Aerial feel that this has been accomplished as the Hemco Loop Aerial possesses a number of advantages over many of the Loops on the market today. Made in sizes of 18" and 24" it is constructed of a 65 strand wire, 5 strands of which are phosphorus bronze spirally wound on specially treated arms which are protected at both ends by ferrules. These wooden arms are nicely finished and trimmed with nickel.

The binding posts on the Hemco Loop Aerial are carried on a hard rubber base, and the three tap feature permits the use of this Aerial on circuits where Rice methods of regeneration is used.

Probably the most important feature of the Hemco Loop Aerial is the fact that the patented spring arm feature keeps the wire taut at all times. Concealed springs hold the wires under tension from the moment the Loop is opened.

Dongan Voltmeters to Be Standard

An announcement has just been made by the radio Division of the Dongan Electric Manufacturing Company, Detroit, of interest both to the trade and the set manufacturers. In line with the tendency on the part to set manufacturers to build more complete receiving sets, Dongan has brought out a line of voltmeters that many of the manufacturers have already adopted as standard equipment.

The commercial set builders realize that the apparently inefficient operation of the set is often due to improper tube or "B" battery voltage. Frequently the owner of the set does not realize this, and blames the unsatisfactory results upon the set itself. In fact, several of the large set builders have found that much of the service work required is due to improper tube or B battery voltage.

Many of the sets now being designed for next season include Dongan Voltmeters mounted on the panels. Obviously this addition as standard equipment is going to serve the double purpose of protecting the good will of the manufacturer and improving the consistent reception of the set to the pleasure of the owner.

Dongan is best known in radio as the manufacturer of Dongan Audio Transformers, a product this company builds for thirty-five set manufacturers as well as the jobbing trade. (Turn to page 72)

CLASSIFIED ADVERTISEMENTS

Don't overlook the value of RADIO AGE'S classified advertisements. Many such messages have paved the way to independent incomes.

The classified advertising rates are but ten cents per word for a single insertion. Liberal discounts are allowed on three, six and twelve-time insertions, of five, fifteen and thirty per cent respectively. Unless placed through an accredited advertising agency, cash should accompany all orders. Name and address must be included at foregoing rates and no advertisement of less than ten words will be accepted.

All classified ads for the July issue must be sent in by June 1.

AGENTS WANTED

FORDS. 60 miles on one gallon of Gas. It has been proven such mileage can be made. AIRLOCK guarantees to increase gas mileage; also prevents radiator boiling in summer or freezing in winter. Cools, Fuels, Decarbonizes the Ford motor. Splendid territory open. AIRLOCK PRODUCTS, Box 703C, Willow Street, Long Beach, Calif.

RADIO—Join our sales organization and make big money. We want a man in every county to sell well advertised sets and parts made by the leading manufacturers. Widener of Kansas City makes \$150.00 weekly. You can do as well or better. Write today for catalog and discounts. Name your county. Waveland Radio Company, Div. 52, 1027 No. State St., Chicago, Ill.

MANUFACTURER'S AGENT calling on Radio-Electrical Jobbers, Chicago and vicinity, has opening for 3 additional lines carrying volume business, as we cater to large jobbers. Edelstein, 1801 McCormick Bld., Chicago.

AGENTS—WRITE FOR FREE SAMPLES. Sell Madison "Better-Made" Shirts for large manufacturer direct to wearer. No capital or experience required. Many earn \$100 weekly and bonus. MADISON MFGRS., 501 Broadway, New York.

90c an hour to advertise and distribute samples to consumer. Write quick for territory and particulars. American Products Co., 2130 American Building, Cincinnati, Ohio.

Man wanted for this territory to sell wonderful value men's, women's, children's shoes direct, saving consumer over 40%. Experience unnecessary. Samples supplied. Big weekly permanent income. Write today Tanners Mfg. Co., 1334C St., Boston, Mass.

RADIO DEALERS

DEALERS—Write for our illustrated catalog of reliable Radio Merchandise. Rossiter-Manning Corporation, Dept. D, 1830 Wilson Ave., Chicago, Ill.

STAMPS AND COINS

158 Genuine Foreign Stamps. Mexico War Issues. Venezuela, Salvador and India Service. Guatemala, China, etc., only 5c. Finest approval sheets. 50 to 60 per cent. Agents Wanted. Big 72-p. Lists Free. We Buy Stamps. Established 20 Years. Hussman Stamp Co., Dept. 152, St. Louis, Mo.

WANTED

WANTED—To complete my set RADIO AGE need August, September, October, November, 1923, issues bound or unbound. Advise price. Lloyd C. Henning, Hellbrook, Arizona.

INVENTIONS

NEW IDEAS WANTED—Well known Radio Manufacturer whose products are nationally advertised and sold everywhere wants new Radio device to sell. Will pay outright or royalty for idea or invention which is really new and saleable. Address: Mr. R. F. Devine, Room 1101, 116 West 32nd St., New York, N. Y.

Make \$100 Weekly—sell RADIO

Demonstrate Once—Results Mean Sure Sale
Coast to coast, lowest prices, attractive four-tube instrument \$39.50. Big commission to you. Exclusive territory to proven salesmen. Territory going fast, write today for large illustrated book No. 100. Don't fail to name your county.

OZARKA, Inc.
829 Washington Blvd. Chicago, Ill.

Easy Sales
Big Profits



HELP WANTED

RADIO SALESMEN and SET BUILDERS—We need you and you need us. If you are reliable and well known in your community, we will appoint you our representative and furnish you with standard well advertised sets and parts at prices that will enable you to sell at a handsome profit. Write at once for catalog and sales plan. Waveland Radio Co., Div. 53, 1027 N. State St., Chicago, Ill.

MANUFACTURING FACILITIES

AN OLD AND WELL ESTABLISHED MANUFACTURING COMPANY IN THE MIDDLE WEST WITH LARGE WELL EQUIPPED PLANTS AND UNUSUAL FINANCIAL RESOURCES, DESIRING TO ENTER THE RADIO FIELD WILL CONSIDER THE MANUFACTURE AND SALE OF RADIO SETS OR DEVICES OF OUTSTANDING AND UNUSUAL MERIT ON A ROYALTY BASIS. ADDRESS BOX 1A, RADIO AGE.

RADIO

A PRACTICAL TUBE RECEIVING SET FOR \$10. Postpaid, less phones and tube. Complete with phones, tube and battery, \$18.00. J. B. KATHBUN, 1067 Winona St., Chicago, Ill.

Standard solderless radio Jacks. Binding post attachments. Double circuit. One dollar bill. Postpaid. Clinton Seward, Jr., New Paltz, New York, N. Y.

Three Cosmopolitan Phisiformers, each \$5.50, book of instructions included. F. A. Mall, Tripoli, Iowa.

FOR SALE—3 Pfanstiehl tuning units, 3 Cardwell Condensers, 1 Bradleyometer, 2 Bradleystats. All goods new. Earl Price, Lodi, Wis.

15 to 25 per cent discount on nationally advertised sets and parts. Every item guaranteed. Tell us your needs. IMPERIAL RADIO COMPANY, Delaware, Ohio.

RADIO SETS. Our prices save you money. Lists free. The Radio Shoppe, Box 645, East Liverpool, Ohio.

JOIN THE RADIO Parts Exchange Club. Your parts inspected (Fee 25c), and exchanged for the parts you need. What have you; what parts do you require? Write us for details. The Radio Parts Exchange Club, 112 So. Homan Ave., Chicago.

"B" BATTERIES

100 VOLT EDISON TYPE "B" BATTERY, knocked down. Parts and plans—complete, \$12.50. Lane Mfg. 2937 W. Lake, Chicago.

BATTERIES FOR SALE—Four 24-volt "Main" Storage "B" Batteries, never used, shipped and ready to wire for \$38.00. First order gets the batteries. Address Box B, Radio Age, 500 N. Dearborn St., Chicago, Ill.

BUSINESS OPPORTUNITY

MR. MANUFACTURER: Would you be interested in a national advertising campaign to reach more than two million prospective buyers of quality radio products—each week? Do you want to establish agencies in new territory and create national interest in your product—at a very conservative cost? It can be done. Let us explain our system without obligation to you. Drop a card to Radiograph Laboratories, 1234 Rosemont Ave., Chicago, Ill., Box 6.

The Traffic Cop of the Air
*
FERBEND Wave Trap

Add a Ferbend Wave Trap to your Radio Set and "Police" your reception. Regulate traffic. Guaranteed to tune out any interfering station. Widely imitated but never equaled. The original and only successful WAVE TRAP. Now in its third year. Sent Postpaid upon receipt of \$5.00 or C. O. D. plus postage. Send for Free Booklet FERBEND ELECTRIC CO. 16 E. So. Water St. Chicago

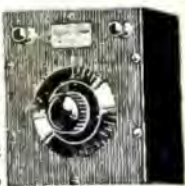

WRITERS

NEW WRITERS WANTED—Articles, stories, poems, scenarios, etc. \$13.500 just paid to unknown writer. Entirely new field. (No. bunk.) NOT A CORRESPONDENCE COURSE. Moving picture industry and publishers crying for new original material. YOU CAN DO IT. We buy manuscripts for books and magazines. Send self addressed envelope for list of 100 subjects. CALIFORNIA STUDIOS, P. O. Box 697, Los Angeles, Calif.

WRITERS—Cash in on your knowledge of radio by writing for Radio Magazines and Newspaper Supplements. Write up your radio experiences, your new hook-up, your knowledge of broadcasting stations and artists. Experienced authors will correct and improve your manuscripts—make them typically professional work. FREE Criticism and Advisory Service until your manuscript is sold! ALL Magazines and Papers demanding fiction and articles dealing with radio. Here is YOUR OPPORTUNITY to profit! Send for FREE booklet, "How You Can Sell Your Manuscripts." Willis Arnold and Associates, 210 East Ohio St. Chicago, Ill.

Make big money writing Movie Plays. Circulars free. W. C. Krug, Aston, Illinois.

RADIO CIRCUITS

SPECIAL FOR MAY
The Reinartz Radio Booklet, by Frank D. Pearne, fully illustrated, and RADIO AGE, for \$2.50. Price of Booklet alone is 50c. Send check, currency or money order to RADIO AGE, 500 N. Dearborn Street, Chicago.

VOCATIONS

Make Big Money. Safe and Lock Expert. Wayne Strong, 3800 Lan Franco St., Los Angeles, Calif.

RADIO SUPPLIES

Ten per cent discount on all standard radio parts, from condensers to transformers to tubes, etc. Send for our latest price list, with special bargains on Static-eliminators, portable loud speakers, Radiotrons, German silver wire, etc. RADIOGRAPH LABORATORIES, 1234 Rosemont Ave., Dept. 4, Chicago, Ill.

PATENTS

FOR SALE: U. S. and Canadian Patent on an Attachment for Phonographs; is the most beautiful invention of the age. Address Chas. F. Smith, Huff, N. Dak.

CRYSTALS

TESTED GALENA CRYSTALS, 50c pound bulk. Buskett, Geologist, Joplin, Mo.

PERSONAL

LONELY HEARTS: Exchange letters; make interesting new friends in our jolly club. Eva Moore, Box 908, Jacksonville, Florida. Enclose stamp.

Look! You Radio Bug! Join Radio Correspondence Club. Entirely new. Broaden your acquaintance, exchange ideas. Membership open to LADY BUGS also. Dime stamp brings pamphlet and RADIO NOVELTY Cards. Radio Rose, Box 662, Cleveland, Ohio.

PRINTING

WE print Stationery, Booklets, Catalogs, Circulars, Samples. Commercial Press, Batavia, Ohio.

MAGAZINES

DREAMS. A magazine for all who dream. If you are interested in the subjects of science, sex, psychology, health, love and romance, you cannot afford to be without this magazine. Three dollars will bring this most fascinating monthly publication to your home for one year. M. P. Smith Publishing Co., 508 N. Dearborn St., Chicago, Ill.

Classified ad. copy for the July RADIO AGE must be sent in by June 1, 1925.

THE RADIO AGE BUYERS' SERVICE

What do you want to purchase in the radio line? Let the staff of RADIO AGE save you time and money by sending in the coupon below. Enter the number of the article you would like to know more about in the spaces provided in the coupon.

- | | | |
|--|------------------------------------|--|
| 1 "A" Batteries | 95 Grid leak holders | 186 Rheostats, automatic |
| 2 Aerial protectors | 96 Grid, transmitting leaks | 187 Rheostats, battery |
| 3 Aerial insulators | 97 Grid leaks, tube | 188 Rheostats, dial |
| 4 Aerials | 98 Grid leaks, variable | 189 Rheostats, filament |
| 5 Aerials, loop | 99 Grinders, electric | 190 Rheostats, potentiometer |
| 6 Amplifiers | 100 Ground clamps | 191 Rheostats, power |
| 7 Amplifying units | 101 Ground rods | 192 Rheostats, vernier |
| 8 Ammeters | 102 Handles, switch | 193 Rods, ground |
| 9 "B" batteries | 103 Head bands | 194 Rotors |
| 10 Batteries (state voltage) | 104 Head phones | 195 Scrapers, wire |
| 11 Batteries, dry cell | 105 Head sets | 196 Screw drivers |
| 12 Batteries, storage | 106 Honeycomb coil adapters | 197 Screws |
| 13 Battery chargers | 107 Hook ups | 198 Schools, radio |
| 14 Battery clips | 108 Horns, composition | 199 Sets, receiving—cabinet |
| 15 Battery plates | 109 Horns, fibre | 200 Sets, receiving—crystal |
| 16 Battery substitutes | 110 Horns, mache | 201 Sets, receiving—knock-down |
| 17 Bezels | 111 Horns, metal | 202 Sets, receiving—Neutrodyne |
| 18 Binding posts | 112 Horns, wooden | 203 Sets, receiving—portable |
| 19 Binding posts, insulated | 113 Hydrometers | 204 Sets, receiving—radio frequency |
| 20 Books | 114 Indicators, polarity | 205 Sets, receiving—reflex |
| 21 Boxes, battery | 115 Inductances, C. W. | 206 Sets, receiving—regenerative |
| 22 Boxes, grounding | 116 Insulation, molded | 207 Sets, receiving—Reinartz |
| 23 Bridges, wheatstone | 117 Insulation material | 208 Sets, receiving—sectional |
| 24 Broadcasting equipment | 118 Insulators, aerial | 209 Sets, receiving—short wave |
| 25 Bushings | 119 Insulators, composition | 210 Sets, receiving—super-regenerative |
| 26 Buzzers | 120 Insulators, fibre | 211 Sets, transmitting |
| 27 Cabinets | 121 Insulators, high voltage | 212 Slate |
| 28 Cabinets, battery | 122 Insulators, cloth | 213 Shellac |
| 29 Cabinets, loud speaker | 123 Insulators, glass | 214 Sliders |
| 30 Carbons, battery | 124 Insulators, hard rubber | 215 Socket adapters |
| 31 Cat whiskers | 125 Insulators, porcelain | 216 Sockets |
| 32 Code practisers | 126 Irons, soldering | 217 Solder |
| 33 Coils | 127 Jacks | 218 Soldering irons, electric |
| 34 Coils, choke | 128 Filament control | 219 Soldering paste |
| 35 Coils, coupling | 129 Jars, battery | 220 Solder flux |
| 36 Coils, filter | 130 Keys, transmitting | 221 Solder salts |
| 37 Coils, grid | 131 Knobs | 222 Solder solution |
| 38 Coils, honeycomb | 132 Knock-down panel units | 223 Spaghetti tubing |
| 39 Coils, inductance | 133 Laboratories, testing | 224 Spark coils |
| 40 Coils, Reinartz | 134 Lever, switch | 225 Spark gaps |
| 41 Coils, stabilizer | 135 Lightning arresters | 226 Stampings |
| 42 Coils, tuning | 136 Loosecouplers | 227 Stators |
| 43 Condenser parts | 137 Loud speakers | 228 Stop points |
| 44 Condenser plates | 138 Loud speaker units | 229 Switch arms |
| 45 Condensers, antenna coupling | 139 Lugs, battery | 230 Switch levers |
| 46 Condensers, by-pass | 140 Lugs, terminal | 231 Switch points |
| 47 Condensers, coupling | 141 Measuring instruments | 232 Switch stops |
| 48 Condensers, filter | 142 Megohmmeters | 233 Switches, aerial |
| 49 Condensers, fixed (paper, grid, or phone) | 143 Meters, A. C. | 234 Switches, battery |
| 50 Condensers, variable grid | 144 Meters, D. C. | 235 Switches, filament |
| 51 Condensers, variable mica | 145 Mica | 236 Switches, ground |
| 52 Condensers, vernier | 146 Mica sheets | 237 Switches, inductance |
| 53 Contact points | 147 Milliammeters | 238 Switches, panel |
| 54 Contacts, switch | 148 Minerals | 239 Switches, single and double throw |
| 55 Cord tips | 149 Molded insulation | 240 Tone wheels |
| 56 Cords, for head sets | 150 Molybdenum | 241 Towers, aerial |
| 57 Couplers, loose | 151 Mountings, coil | 242 Transformers, audio frequency |
| 58 Couplers, molded | 152 Mountings, condenser leak | 243 Transformers, filament |
| 59 Couplers, vario | 153 Mountings, end | 244 Transformers, modulation |
| 60 Crystal alloy | 154 Mountings, grid leak | 245 Transformers, power |
| 61 Crystal holders | 155 Mountings, honeycomb coil | 246 Transformers, push-pull |
| 62 Crystals, rough | 156 Mountings, inductance switch | 247 Transformers, radio frequency |
| 63 Crystals, mineral | 157 Name plates | 248 Transformers, variable |
| 64 Crystals, synthetic | 158 Neutrodyne set parts | 249 Transmitters |
| 65 Crystals, unmounted | 159 Nuts | 250 Tubes, vacuum—peanut |
| 66 Crystals, mounted | 160 Ohmmeters | 251 Tubes, vacuum—two element |
| 67 Decks, radio | 161 Oscillators | 252 Tubes, vacuum—three element |
| 68 Detector units | 162 Panel cutting and drilling | 253 Tuners |
| 69 Detectors, crystal | 163 Panels, drilled and un-drilled | 254 Variocouplers, hard rubber |
| 70 Detectors, fixed crystal | 164 Panels, fibre | 255 Variocouplers, molded |
| 71 Dial, adjusters | 165 Panels, hard rubber | 256 Variometers, hard rubber |
| 72 Dials, composition | 166 Parts | 257 Variometers, molded |
| 73 Dials, hard rubber | 167 Paste, soldering | 258 Variometers, wooden |
| 74 Dials, rheostat | 168 Patent attorneys | 260 Varnish, insulating |
| 75 Dials, metal | 169 Phone connectors, multiple | 261 Voltmeters |
| 76 Dials, vernier | 170 Phonograph adapters | 262 Washers |
| 77 Dials with knobs | 171 Plates, condenser | 263 Wave meters |
| 78 Dies | 172 Plugs, coil | 264 Wave traps |
| 79 Drills, electric | 173 Plugs, telephone | 265 Wire, aerial |
| 80 Dry cells | 174 Pointers, dial and knob | 266 Wire, braided and stranded |
| 81 Earth grounds | 175 Poles, aerial | 267 Wire, copper |
| 82 Electrolyte | 176 Potentiometers | 268 Wire, insulated |
| 83 Enamels, battery | 177 Punching machines | 269 Wire, Litz |
| 84 Enamels, metal | 178 Reinartz set parts | 270 Wire, magnet |
| 85 End stops | 179 Regenerative set parts | 271 Wire, platinum |
| 86 Eyelets | 180 Receiver caps | 272 Wire, tungsten |
| 87 Experimental work | 181 Rectifiers, battery | |
| 88 Fibre sheet, vulcanized | 182 Resistance leaks | |
| 89 Filter reactors | 183 Resistance units | |
| 90 Fixtures | 184 Rheostat bases | |
| 91 Fuse cut outs | 185 Rheostat strips | |
| 92 Fuses, tube | | |
| 93 Generators, high frequency | | |
| 94 Grid choppers, rotary | | |



You Save 50%

World 6-Volt Storage Batteries are famous for their guaranteed quality and service. Backed by years of Successful Manufacture and Thousands of Satisfied Users. You save 50% and get a

2-Year Guarantee Bond In Writing
World Battery owners "tell their friends." That's our best proof of performance. Send your order in today.

- RADIO BATTERIES**
 6-Volt, 100-Amperes . . . \$12.25
 6-Volt, 120-Amperes . . . 14.25
 6-Volt, 140-Amperes . . . 15.00
- AUTO BATTERIES**
 6-Volt, 11-Plate . . . \$12.25
 6-Volt, 12-Plate . . . 14.25
 12-Volt, 7-Plate . . . 17.00

SEND NO MONEY
Just state battery wanted and we will ship day order is received, by Express C. O. D., subject to your examination on arrival.
Extra Offer: 5% discount for cash in full with order. Buy now and get a guaranteed battery at 60% saving to you.

WORLD BATTERY COMPANY
1219 S. Washburn Ave., Dept. 36 Chicago, Ill.



Solid Rubber Case

Approved and Listed as Standard by Leading Authorities including Radio News Laboratories, Popular Science Institute of Standards, Popular Radio Laboratories, Radio Broadcast Laboratories and Lefax, Inc.

Solid Rubber Container
Now Standard equipment on all World Storage Batteries. No more leakage or breakage of jars or rotting of box.



Easy to tune—
New principle prevents all back lash, gives infinite tuning precision. Fits all standard condenser shafts.
At all Dealers, \$3.50.
MYDAR RADIO CO.
9-K Campbell St. Newark, N. J.

ACCURATUNE
REGISTERED GEARED BUILT US PAT OFF
MICROMETER CONTROLS

RADIO AGE BUYERS' SERVICE, 500 N. Dearborn St., Chicago, Ill.

Please see that I am supplied with buying specifications and prices on the articles numbered herewith:

--	--	--	--	--	--	--	--	--	--

I am a — Dealer Jobber Mfgs.' Rep. Manufacturer

Firm [If identified with Radio industry]

My Occupation

My Name

Address

City State

SUPER-HETERODYNE
 Ultradyne—Haynes Griffin—Remier
 Dealers: Send for Discounts
HUDSON-ROSS
 123 W. Madison St. Chicago

With the Radio Manufacturers

(Continued from page 69)

Ultra-Lowloss Condenser

Here is a departure in condenser construction. Every detail in the construction of Ultra-Lowloss Condensers has been designed with one predominating thought in mind—highest possible efficiency by overcoming losses usually experienced in other condensers.

Special design and cut of stator plates produces a straight line wavelength curve—separates stations evenly over the dial.



Minimum of metal in the field and frame of high resistance material reduces eddy current losses. Monoblock mounting with plates cast into block reduces series resistance and insures perfect contact with all plates. The use of only one strip of insulation answers the function of two and four pieces and reduces leakage losses proportionately. Adjustable ball bearing insures smooth rotation and constant capacity calibration.

In addition to low-loss features, the Ultra-Lowloss Condenser is specially designed to simplify close accurate tuning. With two stations of known wavelengths located on the dial, other stations separated by the same number of meters are the same number of degrees apart on the dial. The dials may therefore be accurately calibrated.

Radio Faking on the Wane

Radio advertising is becoming more accurate, the first issue of the new publication of the merchandising section of the Better Business Bureau, "Accuracy," says in an article headed "Radio Faking on the Wane." With this good news for the buyers of radio equipment, "Accuracy" also refers to the recent steps taken by various trade groups to cooperate with the Better Business Bureau in its efforts to keep radio advertising free from misrepresentation, and says:

"This situation is not merely contemporaneous with the launching of the merchandising section of this Bureau and the tangible corrective actions taken in numerous specific cases. Constructive efforts which have been put forth from several directions are bearing fruit.

"First, the industry is outgrowing its infancy and leaders are, by example, establishing standards of selling practice. Second, for months past, the radio trade press has devoted much space to educational articles and to strong editorials urging that the fair name of the industry be protected. Third, local newspapers, jealous of reader-confidence, are on the alert to reject deceptive radio advertising.

New Crosley "Musicone" On the Market

The Crosley Radio Corporation of Cincinnati, Ohio, have placed their new loud speaker, the "Musicone," on the market for radio fans, thus entering into the loud speaker field in addition to the manufacture of the famous Crosley line of radio receivers.

The Crosley Musicone has many new and unusual features, which are described in the illustration and explanatory table on this page. The speaker sells at a comparatively low price.

A new unit noted for its clarity and volume has been incorporated into the Musicone, which is now being distributed to Crosley dealers throughout the country.

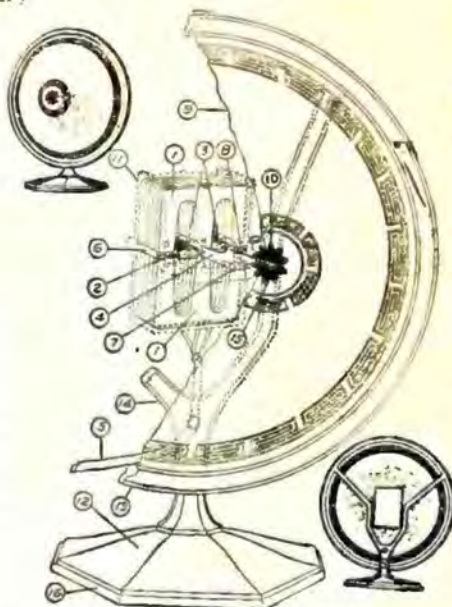

Parts in the Crosley Musicone

- | | |
|----------------------|-------------------------|
| 1. Laminated magnets | 9. Cone diaphragm |
| 2. Armature | 10. Set screw |
| 3. Armature coils | 11. Magnet frame |
| 4. Armature lever | 12. Base |
| 5. Cord | 13. Rim |
| 6. Pure rubber pads | 14. Frame |
| 7. Lever spring | 15. Metal reinforcement |
| 8. Lever rod | 16. Felt base |

"Who's On The Air" Published

Those who have not as yet made the acquaintance of the new book called, "Who's on the Air," have a pleasant surprise in store for them.

This book is the only radio book of its kind and contains a ready reference to who is on the air between the hours of 8:50 a. m. and 3 p. m., Eastern Time. All the listener has to do is look at his watch and open the book and he can immediately ascertain who is on the air according to their regular broadcasting schedules.

The author of this book must have been an enthusiastic radio fan, because he has certainly tried to give his brother fans their full dollar's worth. The center spread is a distance map. There are six pages of broadcasting stations arranged by call letters and three pages arranged geographically, a page showing the power of the station, four pages for logging stations, and numerous other pages showing symbols, terms, etc.

"Who's on the Air" fills a real need in radio reception and is made up in a way that makes it a very convenient aid to

Wade Square Law Condenser

The Wade Condenser is unusual in design and incorporates many features which are new and found in no other condenser. Both sets of plates are specially insulated from frame. A grounding terminal is provided on the frame; thus the frame becomes a shield and the condenser may be used in the most sensitive circuits, eliminating body capacity effects.

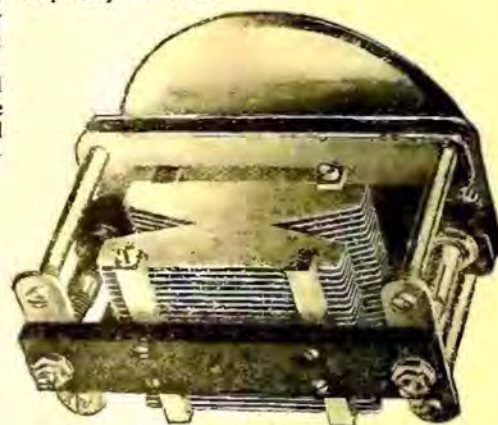

Angular cutting of the plates gives perfect straight line wavelength curve, which distributes the stations evenly over the dial. This feature not only simplifies tuning, but adapts the condenser for use in wave meter and standard circuits. It also makes it possible to locate any station on the dial after once having located any station of given wavelength.

Equipped with a four inch vernier silver finished dial graduated in three hundred and sixty degrees. Gear ratio, sixteen to one, which is equal to thirty-two to one on the ordinary one hundred and eighty degree dial. This three hundred and sixty degree dial gives greater distance between stations for tuning.

Plates are stamped brass, soldered together in one unit. This arrangement reduces series resistance and skin effect losses.

Wade Condensers are manufactured by the Wade Manufacturing Company, Inc., 1819 Broadway, New York.

WENR Now on the Air

Station WENR, owned and operated by the All-American Radio Corporation, at 2650 Coyne Street, Chicago, Illinois, after a successful initial test program, went on the air last month with a regular schedule.

The power used for the present is 100 watts, with a wavelength of 266 meters, and will divide time with station WBCN, also of Chicago and on the same wavelength. The present schedule of WENR is: Tuesday, Thursday and Friday evenings from 7 to 8 and from 9 to 10; Saturday 6 to 8 p. m., and 2:30 to 4 p. m. Sundays.

The program director of the new station is Frank Westphal.

the broadcast listener. Although the need of such a book has existed for some time, the tremendous amount of patience and monotonous labor has probably discouraged its production before.

Further information can be obtained from the Air Guide Publishers, 409 National Bldg., Cleveland, Ohio.

Is The "ANNUAL" in your Vacation Kit?



IF YOU intend to take a trip this Summer, you're surely going to keep in touch with Radio, either by bringing a set along or building one during the dull afternoons, from parts you can take with you. **AND** how are you going to build this set or study up on radio for the big season that is bound to come in September?

The answer is simple. All you have to do is to invest **ONE DOLLAR** in a **RADIO AGE ANNUAL** for 1925, the world's most complete and authoritative hookup book, and take it with you, whether you go to Eagle River or the River of Doubt.

Let the **ANNUAL** for 1925 be your Radio Companion this Summer! It will tell you whatever you want to know in the radio line—from troubleshooting of the little faults that may develop far from home—to the actual construction of simple portable sets or elaborate multi-tubers.

GET THE ANNUAL NOW—and **THEN** go on your vacation! It will be your radio safeguard!

A Wealth of Blueprints for your Dollar!

How many blueprints could you buy for a dollar if you started out to buy them, one by one? Very few, you'll admit. Yet in the **RADIO AGE ANNUAL** for 1925 you'll find sixteen full pages of blueprints in actual color, explaining concisely every important simple and complicated hookup developed during the past year! The 32-page blueprint section of the **ANNUAL** is worth many times the purchase price of the book alone. Order the **ANNUAL NOW**—for the limited first edition is rapidly being bought up by eager radio enthusiasts.

**\$1.00 a
Copy**

**RADIO AGE ANNUAL
FOR 1925**

**\$1.00 a
Copy**

Some of the Features

How to read and understand hookups.
How to understand radio phenomena.
Building your first simple set.
How to select the right receiver.
Substituting a tube for a crystal—building the first tube set.
How to amplify any kind of set.
Making a reflex set.
Building your first Reinartz set.
The renowned Baby Heterodyne No. 1.
Adding audio and radio stages to the Baby Het.
How to make a battery charger.
How to make a loud speaker.
RADIO AGE ANNUAL BLUEPRINT SECTION with such popular hookups as the aperiodic variometer, loop sets, feed-

back receivers, neutrodynes, reflex hookups, Baby Het No. 2, a Wonder Super-Het, and others.
How to get rid of interference.
How to make an amplifying unit.
How to recognize and deal with every kind of tube trouble.
Another super-heterodyne for the super experimenters.
Hints on tracing troubles in super-heterodyne circuits.
A three-tube long distance regenerator.
A 3-tube set that easily receives KGO on the loud speaker from Ohio.
Improving the ever popular Reinartz.
AND MANY OTHER UP-TO-THE-MINUTE HOOKUPS AND ARTICLES.

RADIO AGE ANNUAL COUPON

RADIO AGE, INC.,
500 North Dearborn St., Chicago, Ill.

Gentlemen: I want to be one of the first to get the **RADIO AGE ANNUAL FOR 1925**. Enclosed find \$1.00. If I am not satisfied with the **ANNUAL** I will return it within five days and you will refund my dollar.

Name.....

Address.....

City..... State.....

What the Trirdyn gets where it's hotter than Summer!

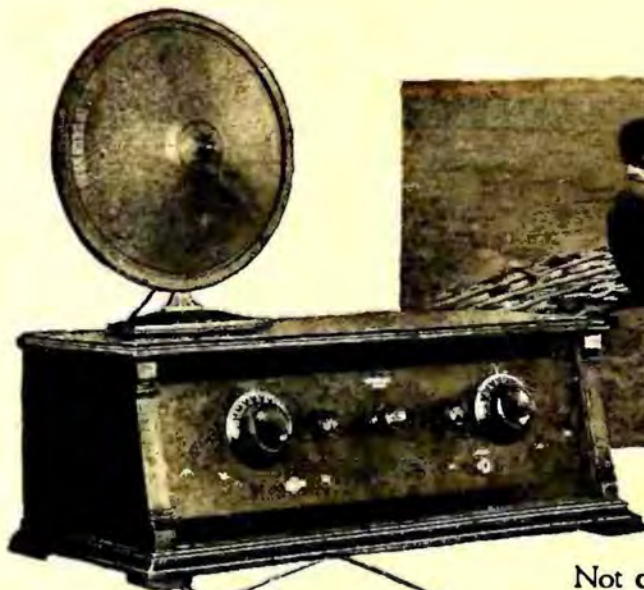

Crosley Trirdyn—on the Sahara Desert at mid-day—brings in Radio-Paris on the loud-speaker!

Not only at mid-day, but in February—in Northern Africa and far hotter than any American summer.

The picture above, a post card snap shot sent from Tunis to Mr. Crosley, by D.F. Keith of Toronto, Ont., tells this story on the other side:—

Tunis, North Africa, March 3, 1925

Dear Mr. Crosley:

Fishing here is rotten but radio is fine. On the Sahara, using three tubes on the Trirdyn circuit, reception from Paris came through on the loud-speaker. Along the south coast of the Mediterranean, using this set, six or eight high power European stations came in with good volume by day-light and all of them after dark. Can usually get a few American after 1 a. m. Can you fish with us this year?

Cordially,
(Signed) D. F. Keith

Further details on the margins of the picture:—

Sahara Desert, 250 miles south of Algiers, February, 1925. Receiving noon-day concert from "Radio-Paris", Paris, using aerial and counterpoise.

Who said summer in America is a poor time for radio—if the receiver is a Crosley Trirdyn?

Every radio fan—actual and aspiring—is invited to think this over and then act.

On the Trirdyn is the beautiful new Crosley Musicone, radio's most startling development. The Musicone's abilities and its beauty are so superior that we expect it to replace half a million loud-speakers this year. \$17.50.

The Crosley Radio Corporation, 663 Sassafras St., Cincinnati
Powel Crosley, Jr., President

\$65⁰⁰
Accessories Extra

*** Crosley Trirdyn Special**

Three tubes better the results of five or six

A highly efficient, non-radiating combination of tuned radio frequency, Armstrong regeneration and reflexed amplification.

New cabinet, sloping panel
Battery self-contained
Exclusive Crosley
3-tube circuit



CROSLEY
RADIO
Better—Costs Less

This file including all text and images are from scans of a private personal collection and have been scanned for archival and research purposes. This file may be freely distributed, but not sold on ebay or on any commercial sites, catalogs, booths or kiosks, either as reprints or by electronic methods. This file may be downloaded without charge from the Radio Researchers Group website at <http://www.otrr.org/>

Please help in the preservation of old time radio by supporting legitimate organizations who strive to preserve and restore the programs and related information.